



Harmonized European Standard

**IMT cellular networks;
Harmonized EN covering the essential requirements
of article 3.2 of the R&TTE Directive;
Part 13: Evolved Universal Terrestrial Radio Access (E-UTRA)
User Equipment (UE)**

Reference

REN/MSG-TFES-010-13

Keywords

3G, 3GPP, cellular, digital, E-UTRA, IMT, LTE,
mobile, radio, regulation, UMTS

ETSI

650 Route des Lucioles
F-06921 Sophia Antipolis Cedex - FRANCE

Tel.: +33 4 92 94 42 00 Fax: +33 4 93 65 47 16

Siret N° 348 623 562 00017 - NAF 742 C
Association à but non lucratif enregistrée à la
Sous-Préfecture de Grasse (06) N° 7803/88

Important notice

Individual copies of the present document can be downloaded from:

<http://www.etsi.org>

The present document may be made available in more than one electronic version or in print. In any case of existing or perceived difference in contents between such versions, the reference version is the Portable Document Format (PDF). In case of dispute, the reference shall be the printing on ETSI printers of the PDF version kept on a specific network drive within ETSI Secretariat.

Users of the present document should be aware that the document may be subject to revision or change of status. Information on the current status of this and other ETSI documents is available at

<http://portal.etsi.org/tb/status/status.asp>

If you find errors in the present document, please send your comment to one of the following services:

http://portal.etsi.org/chaicor/ETSI_support.asp

Copyright Notification

No part may be reproduced except as authorized by written permission.
The copyright and the foregoing restriction extend to reproduction in all media.

© European Telecommunications Standards Institute 2013.
All rights reserved.

DECT™, PLUGTESTS™, UMTS™ and the ETSI logo are Trade Marks of ETSI registered for the benefit of its Members.
3GPP™ and LTE™ are Trade Marks of ETSI registered for the benefit of its Members and
of the 3GPP Organizational Partners.
GSM® and the GSM logo are Trade Marks registered and owned by the GSM Association.

Contents

Intellectual Property Rights	7
Foreword.....	7
Introduction	7
1 Scope	8
2 References	9
2.1 Normative references	9
2.2 Informative references.....	9
3 Definitions, symbols and abbreviations	10
3.1 Definitions	10
3.2 Symbols.....	12
3.3 Abbreviations	14
4 Technical requirements specifications	15
4.1 Environmental profile.....	15
4.2 Conformance requirements	15
4.2.1 Introduction.....	15
4.2.2 Transmitter Maximum Output Power	16
4.2.2.1 Transmitter maximum output power for Single Carrier	16
4.2.2.1.1 Definition.....	16
4.2.2.1.2 Limits	16
4.2.2.1.3 Conformance	16
4.2.2.2 Transmitter output power for intra-band contiguous Carrier Aggregation (DL CA and UL CA).....	16
4.2.2.2.1 Definition.....	16
4.2.2.2.2 Limits	16
4.2.2.2.3 Conformance	17
4.2.2.3 Transmitter output power for UL-MIMO	17
4.2.2.3.1 Definition.....	17
4.2.2.3.2 Limits	18
4.2.2.3.3 Conformance	18
4.2.3 Transmitter Spectrum Emission Mask.....	18
4.2.3.1 Transmitter spectrum emission mask for Single Carrier.....	18
4.2.3.1.1 Definition.....	18
4.2.3.1.2 Limits	18
4.2.3.1.3 Conformance	19
4.2.3.2 Transmitter spectrum emission mask for intra-band contiguous Carrier Aggregation (DL CA and UL CA)	20
4.2.3.2.1 Definition.....	20
4.2.3.2.2 Limits	20
4.2.3.2.3 Conformance	20
4.2.3.3 Transmitter spectrum emission mask for UL-MIMO	21
4.2.3.3.1 Definition.....	21
4.2.3.3.2 Limits	21
4.2.3.3.3 Conformance	21
4.2.4 Transmitter Spurious Emissions	21
4.2.4.1 Transmitter spurious emissions for Single Carrier.....	21
4.2.4.1.1 Definition.....	21
4.2.4.1.2 Limits	21
4.2.4.1.3 Conformance	24
4.2.4.2 Transmitter spurious emissions for intra-band contiguous Carrier Aggregation (DL CA and UL CA).....	24
4.2.4.2.1 Definition.....	24
4.2.4.2.2 Limits	24
4.2.4.2.3 Conformance	25
4.2.4.3 Transmitter spurious emissions for UL-MIMO	26

4.2.4.3.1	Definition.....	26
4.2.4.3.2	Limits	26
4.2.4.3.3	Conformance	26
4.2.5	Transmitter Minimum Output Power.....	26
4.2.5.1	Transmitter minimum output power for Single Carrier.....	26
4.2.5.1.1	Definition.....	26
4.2.5.1.2	Limits	26
4.2.5.1.3	Conformance	26
4.2.5.2	Transmitter minimum output power for intra-band contiguous Carrier Aggregation (DL CA and UL CA)	26
4.2.5.2.1	Definition.....	26
4.2.5.2.2	Limits	27
4.2.5.2.3	Conformance	27
4.2.5.3	Transmitter minimum output power for UL-MIMO	27
4.2.5.3.1	Definition.....	27
4.2.5.3.2	Limits	27
4.2.5.3.3	Conformance	27
4.2.6	Receiver Adjacent Channel Selectivity (ACS)	27
4.2.6.1	Definition	27
4.2.6.2	Limits	28
4.2.6.3	Conformance.....	28
4.2.7	Receiver Blocking Characteristics.....	29
4.2.7.1	Definition	29
4.2.7.2	Limits	29
4.2.7.3	Conformance.....	30
4.2.8	Receiver Spurious Response.....	31
4.2.8.1	Definition	31
4.2.8.2	Limits	31
4.2.8.3	Conformance.....	31
4.2.9	Receiver Intermodulation Characteristics	31
4.2.9.1	Definition	31
4.2.9.2	Limits	31
4.2.9.3	Conformance.....	32
4.2.10	Receiver Spurious Emissions.....	32
4.2.10.1	Definition	32
4.2.10.2	Limits	32
4.2.10.3	Conformance.....	32
4.2.11	Transmitter Adjacent Channel Leakage Power Ratio.....	33
4.2.11.1	Transmitter adjacent channel leakage power ratio for Single Carrier	33
4.2.11.1.1	Definition.....	33
4.2.11.1.2	Limits	33
4.2.11.1.3	Conformance	34
4.2.11.2	Transmitter adjacent channel leakage power ratio for intra-band contiguous Carrier Aggregation (DL CA and UL CA).....	34
4.2.11.2.1	Definition.....	34
4.2.11.2.2	Limits	35
4.2.11.2.3	Conformance	35
4.2.11.3	Transmitter adjacent channel leakage power ratio for UL-MIMO.....	35
4.2.11.3.1	Definition.....	35
4.2.11.3.2	Limits	36
4.2.11.3.3	Conformance	37
5	Testing for compliance with technical requirements.....	37
5.1	Environmental conditions for testing	37
5.2	Interpretation of the measurement results	38
5.3	Essential radio test suites.....	39
5.3.1	Transmitter Maximum Output Power	39
5.3.1.1	Transmitter maximum output power for Single Carrier.....	39
5.3.1.1.1	Method of test.....	39
5.3.1.1.2	Test requirements	39
5.3.1.2	Transmitter maximum output power for intra-band contiguous Carrier Aggregation (DL CA and UL CA)	40

5.3.1.2.1	Method of test.....	40
5.3.1.2.2	Test requirements	40
5.3.1.3	Transmitter maximum output power for UL-MIMO	41
5.3.1.3.1	Method of test.....	41
5.3.1.3.2	Test requirements	41
5.3.2	Transmitter Spectrum Emission Mask.....	42
5.3.2.1	Transmitter spectrum emission mask for Single Carrier.....	42
5.3.2.1.1	Method of test.....	42
5.3.2.1.2	Test requirements	42
5.3.2.2	Transmitter spectrum emission mask for intra-band contiguous Carrier Aggregation (DL CA and UL CA)	42
5.3.2.2.1	Method of test.....	42
5.3.2.2.2	Test requirements	43
5.3.2.3	Transmitter spectrum emission mask for UL-MIMO	43
5.3.2.3.1	Method of test.....	43
5.3.2.3.2	Test requirements	44
5.3.3	Transmitter Spurious Emissions	44
5.3.3.1	Transmitter spurious emissions for Single Carrier.....	44
5.3.3.1.1	Method of test.....	44
5.3.3.1.2	Test requirements.....	45
5.3.3.2	Transmitter spurious emissions for intra-band contiguous Carrier Aggregation (DL CA and UL CA).....	45
5.3.3.2.1	Method of test.....	45
5.3.3.2.2	Test requirements	46
5.3.3.3	Transmitter spurious emissions for UL-MIMO	46
5.3.3.3.1	Method of test.....	46
5.3.3.3.2	Test requirements	47
5.3.4	Transmitter Minimum Output Power.....	47
5.3.4.1	Transmitter minimum output power for Single Carrier.....	47
5.3.4.1.1	Method of test.....	47
5.3.4.1.2	Test requirements	48
5.3.4.2	Transmitter minimum output power for intra-band contiguous Carrier Aggregation (DL CA and UL CA)	48
5.3.4.2.1	Method of test.....	48
5.3.4.2.2	Test requirements	48
5.3.4.3	Transmitter minimum output power for UL-MIMO	49
5.3.4.3.1	Method of test.....	49
5.3.4.3.2	Test requirements	49
5.3.5	Receiver Adjacent Channel Selectivity (ACS)	49
5.3.5.1	Method of test	49
5.3.5.1.1	Initial conditions	49
5.3.5.1.2	Procedure.....	50
5.3.5.2	Test requirements.....	50
5.3.6	Receiver Blocking Characteristics	51
5.3.6.1	Method of test	51
5.3.6.1.1	Initial conditions	51
5.3.6.1.2	In-Band Procedure.....	51
5.3.6.1.3	Out-Of-Band Procedure.....	52
5.3.6.1.4	Narrow-Band Procedure	52
5.3.6.2	Test requirements.....	52
5.3.7	Receiver Spurious Response.....	53
5.3.7.1	Method of test	53
5.3.7.1.1	Initial conditions	53
5.3.7.1.2	Procedure.....	53
5.3.7.2	Test requirements.....	53
5.3.8	Receiver Intermodulation Characteristics	53
5.3.8.1	Method of test	53
5.3.8.1.1	Initial conditions	53
5.3.8.1.2	Procedure.....	54
5.3.8.2	Test requirements.....	54
5.3.9	Receiver Spurious Emissions.....	54
5.3.9.1	Method of test	54

5.3.9.1.1	Procedure.....	55
5.3.9.2	Test requirements.....	55
5.3.10	Transmitter Adjacent Channel Leakage Power Ratio.....	55
5.3.10.1	Transmitter adjacent channel leakage power ratio for Single Carrier.....	55
5.3.10.1.1	Method of test.....	55
5.3.10.1.2	Test requirements.....	56
5.3.10.2	Transmitter adjacent channel leakage power ratio for intra-band contiguous Carrier Aggregation (DL CA and UL CA).....	56
5.3.10.2.1	Method of test.....	56
5.3.10.2.2	Test requirements.....	57
5.3.10.3	Transmitter adjacent channel leakage power ratio for UL-MIMO.....	57
5.3.10.3.1	Method of test.....	57
5.3.10.3.2	Test requirements.....	58
Annex A (normative):	HS Requirements and conformance Test specifications Table (HS-RTT).....	59
Annex B (normative):	Environmental profile.....	61
B.1	General.....	61
B.1.1	Introduction.....	61
B.1.2	Temperature.....	61
B.1.3	Voltage.....	61
B.1.4	Test environment.....	62
Annex C:	Void.....	63
Annex D (informative):	Bibliography.....	64
History.....		65

Intellectual Property Rights

IPRs essential or potentially essential to the present document may have been declared to ETSI. The information pertaining to these essential IPRs, if any, is publicly available for **ETSI members and non-members**, and can be found in ETSI SR 000 314: "*Intellectual Property Rights (IPRs); Essential, or potentially Essential, IPRs notified to ETSI in respect of ETSI standards*", which is available from the ETSI Secretariat. Latest updates are available on the ETSI Web server (<http://ipr.etsi.org>).

Pursuant to the ETSI IPR Policy, no investigation, including IPR searches, has been carried out by ETSI. No guarantee can be given as to the existence of other IPRs not referenced in ETSI SR 000 314 (or the updates on the ETSI Web server) which are, or may be, or may become, essential to the present document.

Foreword

This final draft Harmonized European Standard (EN) has been produced by ETSI Technical Committee Mobile Standards Group (MSG), and is now submitted for the Vote phase of the ETSI standards EN Approval Procedure.

The present document has been produced by ETSI in response to mandates M/284 and M/406 issued from the European Commission under Directive 98/34/EC [i.1] as amended by Directive 98/48/EC [i.10].

The title and reference to the present document are intended to be included in the publication in the Official Journal of the European Union of titles and references of Harmonized Standard under the Directive 1999/5/EC [i.2].

See article 5.1 of Directive 1999/5/EC [i.2] for information on presumption of conformity and Harmonized Standards or parts thereof the references of which have been published in the Official Journal of the European Union.

The requirements relevant to Directive 1999/5/EC [i.2] are summarized in annex A.

The present document is part 13 of a multi-part deliverable. Full details of the entire series can be found in part 1 [5].

Proposed national transposition dates	
Date of latest announcement of this EN (doa):	3 months after ETSI publication
Date of latest publication of new National Standard or endorsement of this EN (dop/e):	6 months after doa
Date of withdrawal of any conflicting National Standard (dow):	18 months after doa

Introduction

The present document is part of a set of standards developed by ETSI and is designed to fit in a modular structure to cover all radio and telecommunications terminal equipment within the scope of the R&TTE Directive [i.2]. The modular structure is shown in EG 201 399 [i.3].

1 Scope

The present document applies to the following radio equipment type:

- User Equipment for Evolved Universal Terrestrial Radio Access (E-UTRA).

This radio equipment type is capable of operating in all or any part of the frequency bands given in tables 1-1 and 1-2.

Table 1-1: E-UTRA UE operating bands

E-UTRA Band	Direction of transmission	E-UTRA operating bands
1	Transmit	1 920 MHz to 1 980 MHz
	Receive	2 110 MHz to 2 170 MHz
3	Transmit	1 710 MHz to 1 785 MHz
	Receive	1 805 MHz to 1 880 MHz
7	Transmit	2 500 MHz to 2 570 MHz
	Receive	2 620 MHz to 2 690 MHz
8	Transmit	880 MHz to 915 MHz
	Receive	925 MHz to 960 MHz
20	Transmit	832 MHz to 862 MHz
	Receive	791 MHz to 821 MHz
33	Transmit and Receive	1 900 MHz to 1 920 MHz
34	Transmit and Receive	2 010 MHz to 2 025 MHz
38	Transmit and Receive	2 570 MHz to 2 620 MHz
40	Transmit and Receive	2 300 MHz to 2 400 MHz
42	Transmit and Receive	3 400 MHz to 3 600 MHz
43	Transmit and Receive	3 600 MHz to 3 800 MHz

Table 1-2: E-UTRA UE Intra-band contiguous CA operating bands

E-UTRA CA Band	E-UTRA Band	Direction of transmission	E-UTRA operating bands
CA_1	1	Transmit	1 920 MHz to 1 980 MHz
		Receive	2 110 MHz to 2 170 MHz
CA_7	7	Transmit	2 500 MHz to 2 570 MHz
		Receive	2 620 MHz to 2 690 MHz
CA_38	38	Transmit and Receive	2 570 MHz to 2 620 MHz
CA_40	40	Transmit and Receive	2 300 MHz to 2 400 MHz

The present document covers requirements for E-UTRA FDD User Equipment from 3GPP Releases 8, 9 and 10.

NOTE 1: For Band 20:

- For user equipment designed to be mobile or nomadic, the requirements in the present document measured at the antenna port also show conformity to the corresponding requirement defined as TRP (total radiated power), as described in Commission Decision 2010/267/EU [i.7], ECC Decision (09)03 [i.8] and CEPT Report 30 [i.9].
- For user equipment designed to be fixed or installed, the present document does not address the requirements described in Commission Decision 2010/267/EU [i.7], ECC Decision (09)03 [i.8] and CEPT Report 30 [i.9].

The present document is intended to cover the provisions of Directive 1999/5/EC [i.2] (R&TTE Directive), article 3.2, which states that "... radio equipment shall be so constructed that it effectively uses the spectrum allocated to terrestrial/space radio communications and orbital resources so as to avoid harmful interference".

In addition to the present document, other ENs that specify technical requirements in respect of essential requirements under other parts of article 3 of the R&TTE Directive [i.2] may apply to equipment within the scope of the present document.

NOTE 2: A list of such ENs is included on the web site <http://www.newapproach.org>.

2 References

References are either specific (identified by date of publication and/or edition number or version number) or non-specific. For specific references, only the cited version applies. For non-specific references, the latest version of the reference document (including any amendments) applies.

Referenced documents which are not found to be publicly available in the expected location might be found at <http://docbox.etsi.org/Reference>.

NOTE: While any hyperlinks included in this clause were valid at the time of publication ETSI cannot guarantee their long term validity.

2.1 Normative references

The following referenced documents are necessary for the application of the present document.

- [1] ETSI TS 136 521-1 (V11.1.0) (07-2013): "LTE; Evolved Universal Terrestrial Radio Access (E-UTRA); User Equipment (UE) conformance specification; Radio transmission and reception; Part 1: Conformance testing (3GPP TS 36.521-1 version 11.1.0 Release 11)".
- [2] ETSI TS 136 508 (V11.1.1) (07-2013): "LTE; Evolved Universal Terrestrial Radio Access (E-UTRA) and Evolved Packet Core (EPC); Common test environments for User Equipment (UE) conformance testing (3GPP TS 36.508 version 11.1.0 Release 11)".
- [3] Void.
- [4] ETSI TS 136 101 (V10.11.0) (07-2013): "LTE; Evolved Universal Terrestrial Radio Access (E-UTRA); User Equipment (UE) radio transmission and reception (3GPP TS 36.101 version 10.11.0 Release 10)".
- [5] ETSI EN 301 908-1 (V6.2.1) (04-2013): "IMT cellular networks; Harmonized EN covering the essential requirements of article 3.2 of the R&TTE Directive; Part 1: Introduction and common requirements".
- [6] Void.
- [7] ETSI EN 301 908-2 (V6.2.1) (06-2013): "IMT cellular networks; Harmonized EN covering the essential requirements of article 3.2 of the R&TTE Directive; Part 2: CDMA Direct Spread (UTRA FDD) User Equipment (UE)".
- [8] IEC 60068-2-1 (2007): "Environmental testing - Part 2-1: Tests - Test A: Cold".
- [9] IEC 60068-2-2 (2007): "Environmental testing - Part 2-2: Tests - Test B: Dry heat".

2.2 Informative references

The following referenced documents are not necessary for the application of the present document but they assist the user with regard to a particular subject area.

- [i.1] Directive 98/34/EC of the European Parliament and of the Council of 22 June 1998 laying down a procedure for the provision of information in the field of technical standards and regulations.
- [i.2] Directive 1999/5/EC of the European Parliament and of the Council of 9 March 1999 on radio equipment and telecommunications terminal equipment and the mutual recognition of their conformity (R&TTE Directive).
- [i.3] ETSI EG 201 399: "Electromagnetic compatibility and Radio spectrum Matters (ERM); A guide to the production of Harmonized Standards for application under the R&TTE Directive".
- [i.4] Void.
- [i.5] Recommendation ITU-R SM.329-12 (2012): "Unwanted emissions in the spurious domain".

- [i.6] ETSI TR 100 028 (all parts) (V1.4.1): "Electromagnetic compatibility and Radio spectrum Matters (ERM); Uncertainties in the measurement of mobile radio equipment characteristics".
- [i.7] Commission Decision 2010/267/EU of 6 May 2010 on harmonised technical conditions of use in the 790-862 MHz frequency band for terrestrial systems capable of providing electronic communications services in the European Union.
- [i.8] ECC Decision (09)03 of 30 October 2009 on harmonised conditions for mobile/fixed communications networks (MFCN) operating in the band 790 - 862 MHz .
- [i.9] CEPT Report 30 of 30 October 2009 to the European Commission in response to the Mandate on "The identification of common and minimal (least restrictive) technical conditions for 790 - 862 MHz for the digital dividend in the European Union".
- [i.10] Directive 98/48/EC of the European Parliament and of the Council of 20 July 1998 amending Directive 98/34/EC laying down a procedure for the provision of information in the field of technical standards and regulations.
- [i.11] ETSI TS 136 509 (V10.0.0) (10-2012): "LTE; Evolved Universal Terrestrial Radio Access (E-UTRA) and Evolved Packet Core (EPC); Special conformance testing functions for User Equipment (UE) (3GPP TS 36.509 version 10.0.0 Release 10)".

3 Definitions, symbols and abbreviations

3.1 Definitions

For the purposes of the present document, the following terms and definitions apply:

aggregated Channel Bandwidth: RF bandwidth in which a UE transmits and receives multiple contiguously aggregated carriers

aggregated Transmission Bandwidth Configuration: number of resource block allocated within the aggregated channel bandwidth

carrier aggregation: aggregation of two or more component carriers in order to support wider transmission bandwidths

carrier aggregation band: set of one or more operating bands across which multiple carriers are aggregated with a specific set of technical requirements

carrier aggregation bandwidth class: class defined by the aggregated transmission bandwidth configuration and maximum number of component carriers supported by a UE

Table 3.1-1: CA bandwidth classes and corresponding nominal guard bands

CA Bandwidth Class	Aggregated Transmission Bandwidth Configuration	Maximum number of CC	Nominal Guard Band BW_{GB}
A	$N_{RB,agg} \leq 100$	1	$0,05 BW_{Channel(1)}$
C	$100 < N_{RB,agg} \leq 200$	2	$0,05 \max(BW_{Channel(1)}, BW_{Channel(2)})$
NOTE: $BW_{Channel(1)}$ and $BW_{Channel(2)}$ are channel bandwidths of two E-UTRA component carriers according to table 5.6.1-1, TS 136 101 [4].			

carrier aggregation configuration: combination of CA operating band(s) and CA bandwidth class(es) supported by a UE

channel bandwidth: RF bandwidth supporting a single E-UTRA RF carrier with the transmission bandwidth configured in the uplink or downlink of a cell

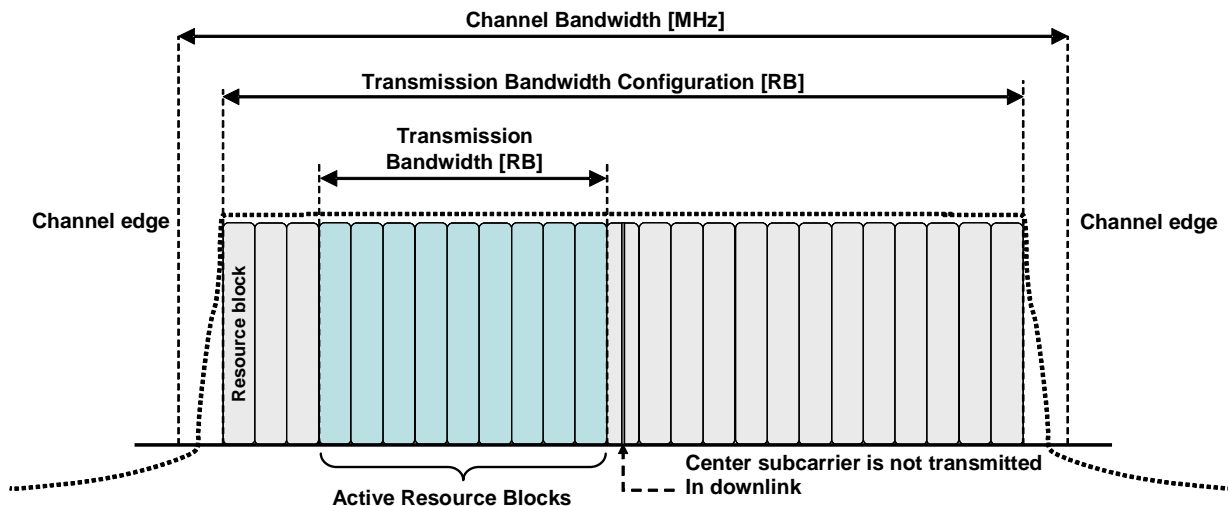

Figure 3.1-1: Definition of Channel Bandwidth and Transmission Bandwidth Configuration for one E-UTRA carrier

NOTE: The channel bandwidth is measured in MHz and is used as a reference for transmitter and receiver RF requirements.

channel bandwidth for Carrier Aggregation: RF bandwidth aggregated from more than one E-UTRA RF carriers with the transmission bandwidth configured in the uplink or downlink of different cells

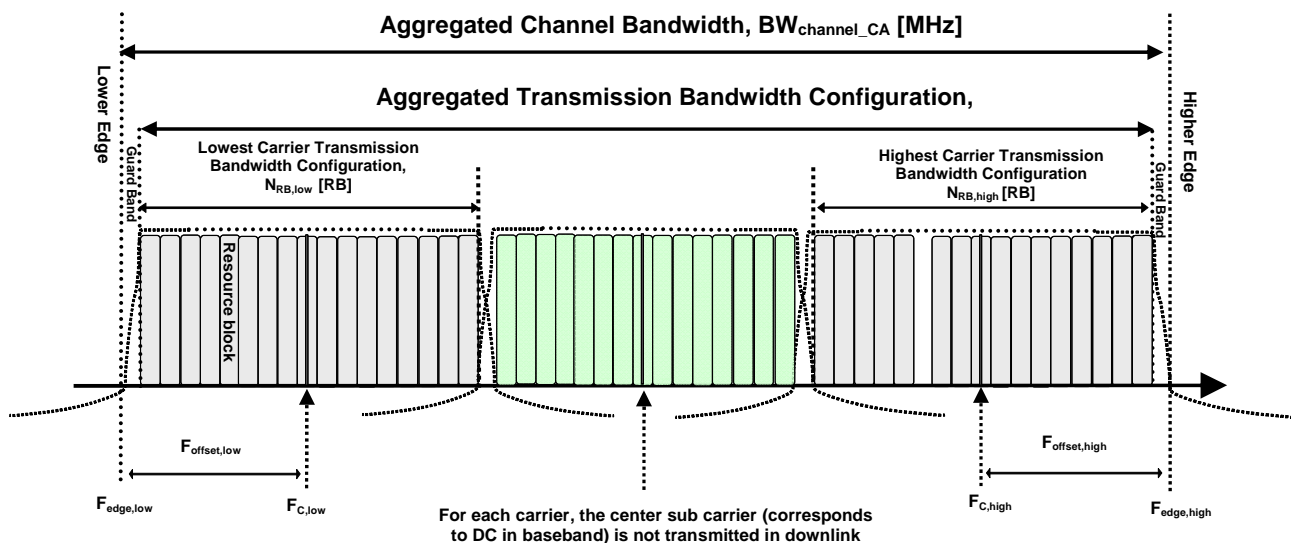

Figure 3.1-2: Definition of Aggregated channel bandwidth and aggregated channel bandwidth edges for more than one E-UTRA carrier

channel edge: lowest and highest frequency of the carrier, separated by the channel bandwidth

contiguous carriers: set of two or more carriers configured in a spectrum block where there are no RF requirements based on co-existence for un-coordinated operation within the spectrum block

inter-band carrier aggregation: carrier aggregation of component carriers in different operating bands

NOTE: Carriers aggregated in each band can be contiguous or non-contiguous.

intra-band contiguous carrier aggregation: contiguous carriers aggregated in the same operating band

intra-band non-contiguous carrier aggregation: non-contiguous carriers aggregated in the same operating band

Maximum Output Power (MOP): mean power level per carrier of UE measured at the antenna connector in a specified reference condition

mean power: when applied to E-UTRA transmission this is the power measured in the operating system bandwidth of the carrier

NOTE: The period of measurement is assumed to be at least one subframe (1 ms) unless otherwise stated.

occupied bandwidth: width of a frequency band such that, below the lower and above the upper frequency limits, the mean powers emitted are each equal to a specified percentage $\beta/2$ of the total mean power of a given emission

operating band: frequency range (paired or unpaired) that is defined with a specific set of technical requirements, in which E-UTRA operates

NOTE: Operating bands for E-UTRA are designated with Arabic numerals, while the corresponding operating bands for UTRA are designated with Roman numerals.

output power: mean power of one carrier of the UE, delivered to a load with resistance equal to the nominal load impedance of the transmitter

reference bandwidth: bandwidth in which an emission level is specified

resource block: physical resource consisting of a number of symbols in the time domain and a number of consecutive subcarriers spanning 180 kHz in the frequency domain

transmission bandwidth: bandwidth of an instantaneous transmission from a UE or BS, measured in Resource Block units

NOTE: See figure 3.1-1.

transmission bandwidth configuration: highest transmission bandwidth allowed for uplink or downlink in a given channel bandwidth, measured in Resource Block units

NOTE: See figure 3.1-1.

transmit diversity: transmit diversity is based on space-frequency block coding techniques complemented with frequency-shift time diversity when four transmit antennas is used

3.2 Symbols

For the purposes of the present document, the following symbols apply:

ΔF_{OOB}	Δ Frequency of Out-of-band emission
BW_{Channel}	Channel bandwidth
$BW_{\text{Channel_CA}}$	Aggregated channel bandwidth, expressed in MHz
BW_{GB}	Virtual guard band to facilitate transmitter (receiver) filtering above/below edge CCs
$BW_{\text{Interferer}}$	Channel Bandwidth of the interferer
E_{RS}	Transmitted energy per RE for reference symbols during the useful part of the symbol, i.e. excluding the cyclic prefix, (average power normalized to the subcarrier spacing) at the eNode B transmit antenna connector
\hat{E}_s	The received energy per RE during the useful part of the symbol, i.e. excluding the cyclic prefix, averaged across the allocated RB(s) (average power within the allocated RB(s)), divided by the number of RE within this allocation and normalized to the subcarrier spacing) at the UE antenna connector
F	Frequency
$F_{\text{Interferer (offset)}}$	Frequency offset of the interferer
$F_{\text{Interferer}}$	Frequency of the interferer
F_{Ioffset}	Frequency offset of the interferer

F_C	Frequency of the carrier centre frequency
F_{CA_low}	The centre frequency of the <i>lowest carrier</i> , expressed in MHz
F_{CA_high}	The centre frequency of the <i>highest carrier</i> , expressed in MHz
F_{DL_low}	The lowest frequency of the downlink operating band
F_{DL_high}	The highest frequency of the downlink operating band
F_{UL_low}	The lowest frequency of the uplink operating band
F_{UL_high}	The highest frequency of the uplink operating band
F_{edge_low}	The <i>lower edge</i> of aggregated channel bandwidth, expressed in MHz
F_{edge_high}	The <i>higher edge</i> of aggregated channel bandwidth, expressed in MHz
I_o	The power spectral density of the total input signal (power averaged over the useful part of the symbols within the transmission bandwidth configuration, divided by the total number of RE for this configuration and normalized to the subcarrier spacing) at the UE antenna connector, including the own-cell downlink signal or the power spectral density of the total input signal at the UE antenna connector (power averaged over the useful part of the symbols within a given bandwidth and normalized to the said bandwidth), including the own-cell downlink signal
I_{or}	The total transmitted power spectral density of the own-cell downlink signal (power averaged over the useful part of the symbols within the transmission bandwidth configuration, divided by the total number of RE for this configuration and normalized to the subcarrier spacing) at the eNode B transmit antenna connector
\hat{I}_{or}	The total received power spectral density of the own-cell downlink signal (power averaged over the useful part of the symbols within the transmission bandwidth configuration, divided by the total number of RE for this configuration and normalized to the subcarrier spacing) at the UE antenna connector
I_{ot}	The received power spectral density of the total noise and interference for a certain RE (average power obtained within the RE and normalized to the subcarrier spacing) as measured at the UE antenna connector
N_{cp}	Cyclic prefix length
N_{DL}	Downlink EARFCN
N_{oc}	The power spectral density of a white noise source (average power per RE normalized to the subcarrier spacing), simulating interference from cells that are not defined in a test procedure, as measured at the UE antenna connector
N_{oc1}	The power spectral density of a white noise source (average power per RE normalized to the subcarrier spacing), simulating interference in non-CRS symbols in ABS subframe from cells that are not defined in a test procedure, as measured at the UE antenna connector
N_{oc2}	The power spectral density of a white noise source (average power per RE normalized to the subcarrier spacing), simulating interference in CRS symbols in ABS subframe from all cells that are not defined in a test procedure, as measured at the UE antenna connector
N_{oc3}	The power spectral density of a white noise source (average power per RE normalised to the subcarrier spacing), simulating interference in non-ABS subframe from cells that are not defined in a test procedure, as measured at the UE antenna connector
$N_{Offs-DL}$	Offset used for calculating downlink EARFCN
$N_{Offs-UL}$	Offset used for calculating uplink EARFCN
N_{RB}	Transmission bandwidth configuration, expressed in units of resource blocks
N_{RB_agg}	Aggregated Transmission Bandwidth Configuration The number of the aggregated RBs within the fully allocated Aggregated Channel bandwidth
N_{RB_alloc}	Total number of simultaneously transmitted resource blocks in Aggregated Channel Bandwidth configuration
N_{UL}	Uplink EARFCN
P	Number of cell-specific antenna ports
p	Antenna port number
$P_{Interferer}$	Modulated mean power of the interferer

P_{UMAX}	Maximum UE Power with possible power reduction due to modulation type, network signalling values and location near the edge of the band
R_{av}	Minimum average throughput per RB

3.3 Abbreviations

For the purposes of the present document, the following abbreviations apply:

ACLR	Adjacent Channel Leakage Ratio
ACS	Adjacent Channel Selectivity
BS	Base Station
BW	BandWidth
CA	Carrier Aggregation
CA_NS	Network Signalled value in Carrier Aggregation
CA_X	CA for band X where X is the applicable E-UTRA operating band
CA_X-Y	CA for band X and Band Y where X and Y are the applicable E-UTRA operating band
CC	Component Carrier
CDMA	Code Division Multiple Access
CW	Continuous Wave
DCI	Downlink Control Information
DL	DownLink
EARFCN	E-UTRA Absolute Radio Frequency Channel Number
ERM	Electromagnetic compatibility and Radio spectrum Matters
EUT	Equipment Under Test
E-UTRA	Evolved UMTS Terrestrial Radio Access
FDD	Frequency Division Duplex
HARQ	Hybrid Acknowledge Request
LTE	Long Term Evolution
MAC	Medium Access Control
MBW	Measurement BandWidth
MOP	Maximum Output Power
MSG	Mobile Standards Group
OFDMA	Orthogonal Frequency Division Multiple Access
PCC	Primary Component Carrier
PDCCH	Physical Downlink Control CHannel
RB	Resource Block
RE	Resource Element
REFSENS	Reference Sensitivity power level
RMC	Reference Measurement Channel
RNTI	Radio Network Temporary Identifier
RRC	Radio Resource Control
SCC	Secondary Component Carrier
SS	System Simulator
TDD	Time Division Duplex
TDMA	Time Division Multiple Access
TFES	Task Force for European Standards for IMT
TH	Temperature High
TH/VH	High extreme Temperature/High extreme Voltage
TH/VL	High extreme Temperature/Low extreme Voltage
TL	Temperature Low
TL/VH	Low extreme Temperature/High extreme Voltage
TL/VL	Low extreme Temperature/Low extreme Voltage
TRP	Total Radiated Power
UE	User Equipment
UL	Uplink
UL-MIMO	Uplink Multiple Antenna transmission
UMTS	Universal Mobile Telecommunications System
UTRA	UMTS Terrestrial Radio Access
UTRA	Universal Terrestrial Radio Access
VH	Higher extreme Voltage

VL Lower extreme Voltage
 WMAN Wireless Metropolitan Area Network

4 Technical requirements specifications

4.1 Environmental profile

The technical requirements of the present document apply under the environmental profile for operation of the equipment, which shall be declared by the supplier. The equipment shall comply with all the technical requirements of the present document at all times when operating within the boundary limits of the declared operational environmental profile.

4.2 Conformance requirements

The requirements in the present document are based on the assumption that the operating band (e.g. band 1, 3, 7, 8, 20, 33, 34, 38, 40, 42 and 43) is shared between systems of the IMT family (for band 3 and 8 also GSM) or systems having compatible characteristics.

4.2.1 Introduction

To meet the essential requirement under article 3.2 of Directive 1999/5/EC [i.2] (R&TTE Directive) for IMT User Equipment (UE) seven essential parameters in addition to those in EN 301 908-1 [5] have been identified. Table 4.2.1-1 provides a cross reference between these seven essential parameters and the corresponding nine technical requirements for equipment within the scope of the present document.

Table 4.2.1-1: Cross references

Essential parameter	Corresponding technical requirements
Spectrum emissions mask	4.2.3 Transmitter Spectrum emissions mask
	4.2.11 Transmitter adjacent channel leakage power ratio
Conducted spurious emissions in active mode	4.2.4 Transmitter spurious emissions
Accuracy of maximum output power	4.2.2 Transmitter maximum output power
Prevention of harmful interference through control of power	4.2.5 Transmitter minimum output power
Conducted spurious emission in idle mode	4.2.10 Receiver spurious emissions
Impact of interference on receiver performance	4.2.7 Receiver Blocking characteristics
	4.2.8 Receiver spurious response
	4.2.9 Receiver Intermodulation characteristics
Receiver adjacent channel selectivity	4.2.6 Receiver Adjacent Channel Selectivity (ACS)
Control and Monitoring functions	EN 301 908-1 [5], clause 4.2.4 Control and Monitoring functions
NOTE: Out of synchronization requirement in EN 301 908-2 [7] is not included in the present document due to fact that E-UTRA has network controlled dynamic resource allocation mitigating the risk of interference in out of synchronization situation.	

Unless otherwise stated, the transmitter and receiver characteristics are specified at the antenna connector(s) of the UE. For UE(s) with an integral antenna only, a reference antenna(s) with a gain of 0 dBi should be assumed for each antenna port(s). A UE with integral antenna(s) may be taken into account by converting these power levels into field strength requirements, assuming a 0 dBi gain antenna.

4.2.2 Transmitter Maximum Output Power

4.2.2.1 Transmitter maximum output power for Single Carrier

4.2.2.1.1 Definition

The following UE Power Classes define the maximum output power for any transmission bandwidth within the channel bandwidth. The period of measurement shall be at least one sub-frame (1 ms).

4.2.2.1.2 Limits

The UE maximum output power shall be within the shown value in table 4.2.2.1.2-1.

Table 4.2.2.1.2-1: UE power classes

E-UTRA Band	Power Class 3 (dBm)	Tolerance (dB)
1	23	±2,7
3	23	±2,7 (see note)
7	23	±2,7 (see note)
8	23	±2,7 (see note)
20	23	±2,7 (see note)
33	23	±2,7
34	23	±2,7
38	23	±2,7
40	23	±2,7
42	23	+3,0/-4,0
43	23	+3,0/-4,0
NOTE: For transmission bandwidths (TS 136 521-1 [1], clause 5) confined within F_{UL_low} and $F_{UL_low} + 4$ MHz or $F_{UL_high} - 4$ MHz and F_{UL_high} , the maximum output power requirement is relaxed by reducing the lower tolerance limit by 1,5 dB (tolerance = +2,7/-4,2).		

NOTE 1: These requirements do not take into account the maximum power reductions allowed to the UE in subject to certain transmission conditions specified in TS 136 101 [4], clauses 6.2.3 and 6.2.4.

NOTE 2: The range of UE maximum output power for the various power classes are specified in TS 136 101 [4] clause 6.2.2. The values in table 4.2.2.1.2-1 correspond to the measurement limits taking into account the measurement uncertainty of measurement equipment (see clause 5.2).

4.2.2.1.3 Conformance

Conformance tests described in clause 5.3.1 shall be carried out.

4.2.2.2 Transmitter output power for intra-band contiguous Carrier Aggregation (DL CA and UL CA)

4.2.2.2.1 Definition

The following UE Power Classes define the maximum output power for any transmission bandwidth within the aggregated channel bandwidth.

The maximum output power is measured as the sum of the maximum output power at each UE antenna connector. The period of measurement shall be at least one sub frame (1 ms).

4.2.2.2.2 Limits

For intra-band contiguous carrier aggregation the maximum output power is specified in table 4.2.2.2.2-1.

Table 4.2.2.2-1: UE power class for CA

E-UTRA CA band	Power Class 3 (dBm)	Tolerance (dB)
CA_1C	23	$\pm 2,7$
CA_7C	23	$\pm 2,7$ (see note 1)
CA_38C	23	$\pm 2,7$
CA_40C	23	$\pm 2,7$
NOTE 1: For transmission bandwidths (TS 136 521-1 [1], clause 5) confined within F_{UL_low} and $F_{UL_low} + 4$ MHz or $F_{UL_high} - 4$ MHz and F_{UL_high} , the maximum output power requirement is relaxed by reducing the lower tolerance limit by 1,5 dB.		
NOTE 2: For intra-band contiguous carrier aggregation the maximum power requirement should apply to the total transmitted power over all component carriers (per UE).		

NOTE 1: These requirements do not take into account the maximum power reductions allowed to the UE in subject to certain transmission conditions specified in TS 136 101 [4], clauses 6.2.3A and 6.2.4A.

NOTE 2: The range of UE maximum output power for the various power classes are specified in TS 136 101 [4] clause 6.2.2A. The values in table 4.2.2.2-1 correspond to the measurement limits taking into account the measurement uncertainty of measurement equipment (see clause 5.2).

4.2.2.2.3 Conformance

Conformance tests described in clause 5.3.1 shall be carried out.

4.2.2.3 Transmitter output power for UL-MIMO

4.2.2.3.1 Definition

The following UE Power Classes define the maximum output power for UE with two transmit antenna connectors in closed-loop spatial multiplexing scheme. The UL-MIMO configurations are specified in table 4.2.2.3.1-1.

Table 4.2.2.3.1-1: UL-MIMO configuration in closed-loop spatial multiplexing scheme

Transmission mode	DCI format	Codebook Index
Mode 2	DCI format 4	Codebook index 0

The maximum output power is measured as the sum of the maximum output power at each UE antenna connector. The period of measurement shall be at least one sub frame (1 ms).

4.2.2.3.2 Limits

The UE maximum output power shall be within the shown value in table 4.2.2.3.2-1.

Table 4.2.2.3.2-1: UE power class for UL-MIMO in closed loop spatial multiplexing scheme

E-UTRA Band	Power Class 3 (dBm)	Tolerance (dB)
1	23	+2,7/-3,7
3	23	+2,7/-3,7 (see note)
7	23	+2,7/-3,7 (see note)
8	23	+2,7/-3,7 (see note)
20	23	+2,7/-3,7 (see note)
33	23	+2,7/-3,7
34	23	+2,7/-3,7
38	23	+2,7/-3,7
40	23	+2,7/-3,7
42	23	+3,0/-5,0
43	23	+3,0/-5,0
NOTE: For transmission bandwidths (TS 136 521-1 [1], clause 5) confined within F_{UL_low} and $F_{UL_low} + 4$ MHz or $F_{UL_high} - 4$ MHz and F_{UL_high} , the maximum output power requirement is relaxed by reducing the lower tolerance limit by 1,5 dB (tolerance = +2,7/-4,2).		

NOTE 1: These requirements do not take into account the maximum power reductions allowed to the UE in subject to certain transmission conditions specified in TS 136 101 [4], clauses 6.2.3 and 6.2.4.

NOTE 2: The range of UE maximum output power for the various power classes are specified in TS 136 101 [4] clause 6.2.2B. The values in table 4.2.2.3.2-1 correspond to the measurement limits taking into account the measurement uncertainty of measurement equipment (see clause 5.2).

4.2.2.3.3 Conformance

Conformance tests described in clause 5.3.1 shall be carried out.

4.2.3 Transmitter Spectrum Emission Mask

4.2.3.1 Transmitter spectrum emission mask for Single Carrier

4.2.3.1.1 Definition

The spectrum emission mask of the UE applies to frequencies (Δf_{OOB}) starting from the \pm edge of the assigned E-UTRA channel bandwidth.

4.2.3.1.2 Limits

The power of any UE emission shall fulfil requirements in tables 4.2.3.1.2-1 and 4.2.3.1.2-2.

Table 4.2.3.1.2-1: General E-UTRA spectrum emission mask, E UTRA bands ≤ 3 GHz

Δf_{OOB} (MHz)	1,4 MHz	3,0 MHz	5 MHz	10 MHz	15 MHz	20 MHz	Measurement bandwidth
±0 to 1	-8,5	-11,5	-13,5	-16,5	-18,5	-19,5	30 kHz
±1 to 2,5	-8,5	-8,5	-8,5	-8,5	-8,5	-8,5	1 MHz
±2,5 to 2,8	-23,5	-8,5	-8,5	-8,5	-8,5	-8,5	1 MHz
±2,8 to 5		-8,5	-8,5	-8,5	-8,5	-8,5	1 MHz
±5 to 6		-23,5	-11,5	-11,5	-11,5	-11,5	1 MHz
±6 to 10			-23,5	-11,5	-11,5	-11,5	1 MHz
±10 to 15				-23,5	-11,5	-11,5	1 MHz
±15 to 20					-23,5	-11,5	1 MHz
±20 to 25						-23,5	1 MHz

NOTE 1: The first and last measurement position with a 30 kHz filter is at Δf_{OOB} equals to 0,015 MHz and 0,985 MHz.

NOTE 2: The first and last measurement position with a 1 MHz filter for 1 MHz - 2,5 MHz offset range is at Δf_{OOB} equals to 1,5 MHz and 2,0 MHz. Similarly for other Δf_{OOB} ranges.

NOTE 3: The measurements are to be performed above the upper edge of the channel and below the lower edge of the channel.

NOTE 4: For the 2,5 MHz - 2,8 MHz offset range with 1,4 MHz channel bandwidth, the measurement position is at Δf_{OOB} equals to 3 MHz.

Table 4.2.3.1.2-2: General E-UTRA spectrum emission mask, 3 GHz < E-UTRA bands ≤ 4,2 GHz

Δf_{OOB} (MHz)	Spectrum emission limit (dBm)/ Channel bandwidth						Measurement bandwidth
	1,4 MHz	3,0 MHz	5 MHz	10 MHz	15 MHz	20 MHz	
0 to 1	-8,2	-11,2	-13,2	-16,2	-18,2	-19,2	30 kHz
1 to 2,5	-8,2	-8,2	-8,2	-8,2	-8,2	-8,2	1 MHz
2,5 to 2,8	-23,2						1 MHz
2,8 to 5							1 MHz
5 to 6		-23,2	-11,2	-11,2	-11,2	-11,2	1 MHz
6 to 10			-23,2				1 MHz
10 to 15				-23,2			1 MHz
15 to 20					-23,2		1 MHz
20 to 25						-23,2	1 MHz

NOTE 1: The first and last measurement position with a 30 kHz filter is at Δf_{OOB} equals to 0,015 MHz and 0,985 MHz.

NOTE 2: At the boundary of spectrum emission limit, the first and last measurement position with a 1 MHz filter is the inside of +0,5 MHz and -0,5 MHz, respectively.

NOTE 3: The measurements are to be performed above the upper edge of the channel and below the lower edge of the channel.

NOTE 4: For the 2,5-2,8 MHz offset range with 1,4 MHz channel bandwidth, the measurement position is at Δf_{OOB} equals to 3 MHz.

4.2.3.1.3 Conformance

Conformance tests described in clause 5.3.2 shall be carried out.

4.2.3.2 Transmitter spectrum emission mask for intra-band contiguous Carrier Aggregation (DL CA and UL CA)

4.2.3.2.1 Definition

For intra-band contiguous carrier aggregation the spectrum emission mask of the UE applies to frequencies (Δf_{OOB}) starting from the \pm edge of the aggregated channel bandwidth.

4.2.3.2.2 Limits

For intra-band contiguous carrier aggregation the bandwidth class C, the power of any UE emission shall not exceed the levels specified in tables 4.2.3.2.2-1 and 4.2.3.2.2-2 for the specified channel bandwidth.

Table 4.2.3.2.2-1: General E-UTRA spectrum emission mask for CA, E UTRA bands \leq 3 GHz

Spectrum emission limit [dBm]/BW _{Channel CA}					
Δf_{OOB} (MHz)	50RB+100RB (29,9 MHz)	75RB+75RB (30 MHz)	75RB+100RB (34,85 MHz)	100RB+100RB (39,8 MHz)	Measurement bandwidth
± 0 to 1	-21,0	-21,0	-22,0	-22,5	30 kHz
± 1 to 5	-8,5	-8,5	-8,5	-8,5	1 MHz
± 5 to 29,9	-11,5	-11,5	-11,5	-11,5	1 MHz
$\pm 29,9$ to 30	-23,5	-23,5	-23,5	-23,5	1 MHz
± 30 to 34,85					1 MHz
$\pm 34,85$ to 34,9					1 MHz
$\pm 34,9$ to 35					1 MHz
± 35 to 39,8					1 MHz
$\pm 39,8$ to 39,85				-23,5	1 MHz
$\pm 39,85$ to 44,8					1 MHz

Table 4.2.3.2.2-2: General E-UTRA spectrum emission mask for CA, 3 GHz < E UTRA bands \leq 4,2 GHz

Spectrum emission limit [dBm]/BW _{Channel CA}					
Δf_{OOB} (MHz)	50RB+100RB (29,9 MHz)	75RB+75RB (30 MHz)	75RB+100RB (34,85 MHz)	100RB+100RB (39,8 MHz)	Measurement bandwidth
± 0 to 1	-20,7	-20,7	-21,7	-22,2	30 kHz
± 1 to 5	-8,2	-8,2	-8,2	-8,2	1 MHz
± 5 to 29,9	-11,2	-11,2	-11,2	-11,2	1 MHz
$\pm 29,9$ to 30	-23,2	-23,2	-23,2	-23,2	1 MHz
± 30 to 34,85					1 MHz
$\pm 34,85$ to 34,9					1 MHz
$\pm 34,9$ to 35					1 MHz
± 35 to 39,8					1 MHz
$\pm 39,8$ to 39,85				-23,2	1 MHz
$\pm 39,85$ to 44,8					1 MHz

4.2.3.2.3 Conformance

Conformance tests described in clause 5.3.2 shall be carried out.

4.2.3.3 Transmitter spectrum emission mask for UL-MIMO

4.2.3.3.1 Definition

For UE supporting UL-MIMO, the requirements for Out of band emissions resulting from the modulation process and non-linearity in the transmitters are specified at each transmit antenna connector.

The spectrum emission mask of the UE applies to frequencies (Δf_{OOB}) starting from the edge of the assigned E-UTRA channel bandwidth.

4.2.3.3.2 Limits

For UEs with two transmit antenna connectors in closed-loop spatial multiplexing scheme, the requirements in clause 4.2.3.1.2 apply to each transmit antenna connector. The requirements shall be met with the UL-MIMO configurations specified in tables 4.2.2.3.1-1 and 4.2.2.3.1-2.

4.2.3.3.3 Conformance

Conformance tests described in clause 5.3.2 shall be carried out.

4.2.4 Transmitter Spurious Emissions

4.2.4.1 Transmitter spurious emissions for Single Carrier

4.2.4.1.1 Definition

Spurious emissions are emissions which are caused by unwanted transmitter effects such as harmonics emission, parasitic emissions, intermodulation products and frequency conversion products, but exclude out-of-band emissions. The spurious emission limits are specified in terms of general requirements in line with Recommendation ITU-R SM.329-12 [i.5] and E-UTRA operating band requirement to address UE co-existence.

To improve measurement accuracy, sensitivity and efficiency, the resolution bandwidth may be smaller than the measurement bandwidth. When the resolution bandwidth is smaller than the measurement bandwidth, the result should be integrated over the measurement bandwidth in order to obtain the equivalent noise bandwidth of the measurement bandwidth.

4.2.4.1.2 Limits

The spurious emission limits in table 4.2.4.1.2-2 apply for the frequency ranges that are more than Δf_{OOB} (MHz) from the edge of the channel bandwidth shown in table 4.2.4.1.2-1.

The measured average power of spurious emission for general requirements shall not exceed the described values in table 4.2.4.1.2-2.

The measured average power of spurious emission for E-UTRA operating band specific requirements to protected bands shall not exceed the described values in tables 4.2.4.1.2-3 and 4.2.4.1.2-4.

Table 4.2.4.1.2-1: Δf_{OOB} boundary between E-UTRA channel and spurious emission domain

Channel bandwidth	1,4 MHz	3,0 MHz	5 MHz	10 MHz	15 MHz	20 MHz
Δf_{OOB} (MHz)	2,8	6	10	15	20	25

Table 4.2.4.1.2-2: General spurious emissions limits

Frequency range	Maximum level	Measurement bandwidth	Comment
$9 \text{ kHz} \leq f < 150 \text{ kHz}$	-36 dBm	1 kHz	
$150 \text{ kHz} \leq f < 30 \text{ MHz}$	-36 dBm	10 kHz	
$30 \text{ MHz} \leq f < 1\,000 \text{ MHz}$	-36 dBm	100 kHz	
$1 \text{ GHz} \leq f < 12,75 \text{ GHz}$	-30 dBm	1 MHz	
$12,75 \text{ GHz} \leq f < 5^{\text{th}}$ harmonic of the upper frequency edge of the UL operating band in GHz	-30 dBm	1 MHz	See note
NOTE: Applies for Band 42 and Band 43.			

NOTE 1: In order that the measurement of spurious emissions falls within the frequency ranges that are more than Δf_{OOB} (MHz) from the edge of the channel bandwidth, the minimum offset of the measurement frequency from each edge of the channel should be $\Delta f_{\text{OOB}} + \text{MBW}/2$. MBW denotes the measurement bandwidth defined in table 4.2.4.1.2-2.

The additional requirements in table 4.2.4.1.2-3 apply for the frequency ranges that are more and less than Δf_{OOB} (MHz) from the edge of the channel bandwidth shown in table 4.2.4.1.2-1.

Table 4.2.4.1.2-3: Spurious emission band UE co-existence limits

E-UTRA Band	Spurious emission						
	Protected band	Frequency range (MHz)		Maximum Level (dBm)	MBW (MHz)	Comment	
1	E-UTRA Band 1, 7, 8, 20, 38, 40, 42, 43	F_{DL_low}	-	F_{DL_high}	-50	1	
	E-UTRA Band 3, 34	F_{DL_low}	-	F_{DL_high}	-50	1	Note 3
	Frequency range	1 900	-	1 915	-15,5	5	
	Frequency range	1 915	-	1 920	+1,6	5	
3	E-UTRA Band 1, 7, 8, 20, 33, 34, 38, 43	F_{DL_low}	-	F_{DL_high}	-50	1	
	E-UTRA Band 3	F_{DL_low}	-	F_{DL_high}	-50	1	Note 3
	E-UTRA Band 42	F_{DL_low}	-	F_{DL_high}	-50	1	Note 2
7	E-UTRA Band 1, 3, 7, 8, 20, 33, 34, 42, 43	F_{DL_low}	-	F_{DL_high}	-50	1	
	Frequency range	2 570	-	2 575	+1,6	5	Note 3
	Frequency range	2 575	-	2 620	-15,5	5	Note 3
8	E-UTRA Band 1, 20, 33, 34, 38, 40	F_{DL_low}	-	F_{DL_high}	-50	1	
	E-UTRA band 3	F_{DL_low}	-	F_{DL_high}	-50	1	Note 2
	E-UTRA band 7	F_{DL_low}	-	F_{DL_high}	-50	1	Note 2
	E-UTRA Band 8	F_{DL_low}	-	F_{DL_high}	-50	1	Note 3
	E-UTRA Band 42, 43	F_{DL_low}	-	F_{DL_high}	-50	1	Note 2
20	E-UTRA Band 1, 3, 7, 8, 33, 34, 43	F_{DL_low}	-	F_{DL_high}	-50	1	
	E-UTRA Band 20	F_{DL_low}	-	F_{DL_high}	-50	1	Note 3
	E-UTRA Band 38, 42	F_{DL_low}	-	F_{DL_high}	-50	1	Note 2
33	E-UTRA Band 1, 7, 8, 20, 34, 38, 40, 42, 43	F_{DL_low}	-	F_{DL_high}	-50	1	
	E-UTRA Band 3	F_{DL_low}	-	F_{DL_high}	-50	1	Note 3
34	E-UTRA Band 1, 3, 7, 8, 20, 33, 38, 40, 42, 43	F_{DL_low}	-	F_{DL_high}	-50	1	
38	E-UTRA Band 1, 3, 8, 20, 33, 34, 42, 43	F_{DL_low}	-	F_{DL_high}	-50	1	
	Frequency range	2 620	-	2 690	-15,5	5	
40	E-UTRA Band 1, 3, 33, 34, 42, 43	F_{DL_low}	-	F_{DL_high}	-50	1	
42	E-UTRA Band 1, 3, 7, 8, 20, 33, 34, 38, 40	F_{DL_low}	-	F_{DL_high}	-50	1	
	E-UTRA Band 43	F_{DL_low}	-	F_{DL_high}	-50	1	
43	E-UTRA Band 1, 3, 7, 8, 20, 33, 34, 38, 40	F_{DL_low}	-	F_{DL_high}	-50	1	
	E-UTRA Band 42	F_{DL_low}	-	F_{DL_high}	-50	1	
NOTE 1: F_{DL_low} and F_{DL_high} refer to each frequency range of the protected E-UTRA band.							
NOTE 2: As exceptions, measurements with a level up to the applicable requirements defined in table 4.2.4.1.2-2 are permitted for each assigned E-UTRA carrier used in the measurement due to 2 nd , 3 rd or 4 th harmonic spurious emissions. An exception is allowed if there is at least one individual RB within the transmission bandwidth (see figure 5.4.2-1 in TS 136 521-1 [1]) for which the 2 nd , 3 rd or 4 th harmonic totally or partially overlaps the measurement bandwidth (MBW). For frequency with 2 nd , 3 rd or 4 th harmonic spurious emissions, the measurements are covered in table 4.2.4.1.2-2.							
NOTE 3: These requirements also apply for the frequency ranges that are less than Δf_{OOB} (MHz) in table 4.2.4.1.2-1 from the edge of the channel bandwidth.							

NOTE 2: For measurement conditions at the edge of each frequency range, the lowest frequency of the measurement position in each frequency range should be set at the lowest boundary of the frequency range plus MBW/2. The highest frequency of the measurement position in each frequency range should be set at the highest boundary of the frequency range minus MBW/2. MBW denotes the measurement bandwidth defined for the protected band.

Table 4.2.4.1.2-4: Additional spurious emissions limits

Operating band	Frequency bandwidth	Maximum Level (dBm)	Measurement bandwidth (MHz)
20	470 MHz \leq f \leq 790 MHz	-65	8
NOTE: The conformance shall be assessed using the measurement position placed at the following centre frequencies: 474 MHz, 586 MHz, 690 MHz, 754 MHz, 770 MHz and 786 MHz.			

4.2.4.1.3 Conformance

Conformance tests described in clause 5.3.3 shall be carried out.

4.2.4.2 Transmitter spurious emissions for intra-band contiguous Carrier Aggregation (DL CA and UL CA)

4.2.4.2.1 Definition

Spurious emissions are emissions which are caused by unwanted transmitter effects such as harmonics emission, parasitic emissions, intermodulation products and frequency conversion products, but exclude out-of-band emissions. The spurious emission limits are specified in terms of general requirements in line with Recommendation ITU-R SM.329-12 [i.5] and E-UTRA operating band requirement to address UE co-existence.

To improve measurement accuracy, sensitivity and efficiency, the resolution bandwidth may be smaller than the measurement bandwidth. When the resolution bandwidth is smaller than the measurement bandwidth, the result should be integrated over the measurement bandwidth in order to obtain the equivalent noise bandwidth of the measurement bandwidth.

4.2.4.2.2 Limits

For intra-band contiguous carrier aggregation the spurious emission limits apply for the frequency ranges that are more than Δf_{OOB} (MHz) in table 4.2.4.2.2-1 from the \pm edge of the aggregated channel bandwidth. For frequencies Δf_{OOB} greater than F_{OOB} as specified in table 4.2.4.2.2-1 the spurious requirements in table 4.2.4.2.2-2 are applicable.

For frequencies Δf_{OOB} greater than F_{OOB} as specified in table 4.2.4.2.2-1 the measured average power of spurious emission for general requirements, shall not exceed the described values in table 4.2.4.2.2-2.

For the specified carrier aggregation configurations for co-existence with protected bands, the measured average power of spurious emission, shall not exceed the described value in table 4.2.4.2.2-3.

Table 4.2.4.2.2-1: Boundary between E-UTRA Δf_{OOB} and spurious emission domain for intra-band contiguous CA

CA Bandwidth Class	OOB boundary F_{OOB} (MHz)
A	table 4.2.4.1.2-1
C	$BW_{\text{Channel_CA}} + 5$

Table 4.2.4.2.2-2: General spurious emissions limits for intra-band contiguous CA

Frequency Range	Maximum Level	Measurement Bandwidth	Comment
$9 \text{ kHz} \leq f < 150 \text{ kHz}$	-36 dBm	1 kHz	
$150 \text{ kHz} \leq f < 30 \text{ MHz}$	-36 dBm	10 kHz	
$30 \text{ MHz} \leq f < 1\,000 \text{ MHz}$	-36 dBm	100 kHz	
$1 \text{ GHz} \leq f < 12,75 \text{ GHz}$	-30 dBm	1 MHz	
$12,75 \text{ GHz} \leq f < 5^{\text{th}}$ harmonic of the upper frequency edge of the UL operating band in GHz	-30 dBm	1 MHz	See note

NOTE: Applicability of this test requirement is FFS.

NOTE: In order that the measurement of spurious emissions falls within the frequency ranges that are more than Δf_{OOB} (MHz) from the edge of the channel bandwidth, the minimum offset of the measurement frequency from each edge of the channel should be $\Delta f_{\text{OOB}} + \text{MBW}/2$. MBW denotes the measurement bandwidth defined in table 4.2.4.2.2-2.

Table 4.2.4.2.2-3: Spurious emission band UE co-existence limits for intra-band contiguous CA

E-UTRA CA Configuration	Spurious emission						
	Protected band	Frequency range (MHz)		Maximum Level (dBm)	MBW (MHz)	Comment	
CA_1C	E-UTRA Band 1, 3, 7, 8, 20, 38, 40, 42, 43	$F_{\text{DL_low}}$	-	$F_{\text{DL_high}}$	-50	1	
	Frequency range	1 900	-	1 915	-15,5	5	Note 3
	Frequency range	1 915	-	1 920	+1,6	5	Note 3
	E-UTRA band 34	$F_{\text{DL_low}}$	-	$F_{\text{DL_high}}$	-50	1	Note 3
CA_7C	E-UTRA Band 1, 3, 7, 8, 20, 33, 34, 42, 43	$F_{\text{DL_low}}$	-	$F_{\text{DL_high}}$	-50	1	
	Frequency range	2 570	-	2 575	+1,6	5	
	Frequency range	2 575	-	2 595	-15,5	5	Note 4
	Frequency range	2 595	-	2 620	-40	1	Note 4
CA_38C	E-UTRA Band 1, 3, 8, 20, 33, 34, 42, 43	$F_{\text{DL_low}}$	-	$F_{\text{DL_high}}$	-50	1	
	Frequency range	2 620	-	2 645	-15,5	5	Notes 5, 6, 7
	Frequency range	2 645	-	2 690	-40	1	Notes 5, 6, 7
CA_40C	E-UTRA Band 1, 3, 33, 34, 42, 43	$F_{\text{DL_low}}$	-	$F_{\text{DL_high}}$	-50	1	

NOTE 1: $F_{\text{DL_low}}$ and $F_{\text{DL_high}}$ refer to each E-UTRA frequency band specified in table 5.2-1, in TS 136 521-1 [1].

NOTE 2: As exceptions, measurements with a level up to the applicable requirements defined in table 4.2.4.1.2-2 are permitted for each assigned E-UTRA carrier used in the measurement due to 2nd or 3rd harmonic spurious emissions. An exception is allowed if there is at least one individual RE within the transmission bandwidth (see figure 5.4.2-1 in TS 136 521-1 [1]) for which the 2nd or 3rd harmonic, i.e. the frequency equal to two or three times the frequency of that RE, is within the measurement bandwidth (MBW).

NOTE 3: Applicable when CA_NS_02 is signalled by the network.

NOTE 4: Applicable when CA_NS_06 is signalled by the network.

NOTE 5: Applicable when CA_NS_05 is signalled by the network.

NOTE 6: The requirement also applies for the frequency ranges that are less than Δf_{OOB} (MHz) in tables 6.6.3.1-1 and 6.6.3.1A-1 from the edge of the channel bandwidth.

NOTE 7: This requirement is applicable for carriers with bandwidths are confined in 2 570-2 615 MHz. For assigned carriers with bandwidths overlapping the frequency range 2 615-2 620 MHz the requirements apply with the maximum output power configured to +20 dBm.

4.2.4.2.3 Conformance

Conformance tests described in clause 5.3.3 shall be carried out.

4.2.4.3 Transmitter spurious emissions for UL-MIMO

4.2.4.3.1 Definition

For UE supporting UL-MIMO, the requirements for Spurious emissions which are caused by unwanted transmitter effects such as harmonics emission, parasitic emissions, intermodulation products and frequency conversion products are specified at each transmit antenna connector.

4.2.4.3.2 Limits

For UEs with two transmit antenna connectors in closed-loop spatial multiplexing scheme, the requirements in clause 4.2.4.1.2 apply to each transmit antenna connector. The requirements shall be met with the UL-MIMO configurations specified in table 4.2.2.3.1-1.

For single-antenna port scheme, the general requirements in clause 4.2.4.1.2 apply.

4.2.4.3.3 Conformance

Conformance tests described in clause 5.3.3 shall be carried out.

4.2.5 Transmitter Minimum Output Power

4.2.5.1 Transmitter minimum output power for Single Carrier

4.2.5.1.1 Definition

The minimum controlled output power of the UE is defined as the broadband transmit power of the UE, i.e. the power in the channel bandwidth for all transmit bandwidth configurations (resource blocks), when the power is set to a minimum value.

4.2.5.1.2 Limits

The minimum output power measured shall not exceed the values specified in table 4.2.5.1.2-1.

Table 4.2.5.1.2-1: Minimum output power

	Channel bandwidth/minimum output power/measurement bandwidth					
	1,4 MHz	3,0 MHz	5 MHz	10 MHz	15 MHz	20 MHz
Minimum output power	For carrier frequency $f \leq 3,0$ GHz: ≤ -39 dBm For carrier frequency $3,0$ GHz $< f \leq 4,2$ GHz: $\leq -38,7$ dBm					
Measurement bandwidth	1,08 MHz	2,7 MHz	4,5 MHz	9,0 MHz	13,5 MHz	18 MHz

4.2.5.1.3 Conformance

Conformance tests described in clause 5.3.4 shall be carried out.

4.2.5.2 Transmitter minimum output power for intra-band contiguous Carrier Aggregation (DL CA and UL CA)

4.2.5.2.1 Definition

For intra-band contiguous carrier aggregation, the minimum controlled output power of the UE is defined as the transmit power of the UE per component carrier, i.e. the power in the channel bandwidth of each component carrier for all transmit bandwidth configurations (resource blocks), when the power on both component carriers are set to a minimum value.

4.2.5.2.2 Limits

For intra-band contiguous carrier aggregation the minimum output power is defined as the mean power in one sub-frame (1 ms). The minimum output power shall not exceed the values specified in table 4.2.5.2.2-1.

Table 4.2.5.2.2-1: Minimum output power for intra-band contiguous CA UE

	CC Channel bandwidth/Minimum output power/Measurement bandwidth					
	1,4 MHz	3,0 MHz	5 MHz	10 MHz	15 MHz	20 MHz
Minimum output power	For carrier frequency $f \leq 3,0$ GHz: ≤ -39 dBm For carrier frequency $3,0$ GHz $< f \leq 4,2$ GHz: $\leq -38,7$ dBm					
Measurement bandwidth				9,0 MHz	13,5 MHz	18 MHz

4.2.5.2.3 Conformance

Conformance tests described in clause 5.3.4 shall be carried out.

4.2.5.3 Transmitter minimum output power for UL-MIMO

4.2.5.3.1 Definition

For UE supporting UL-MIMO, the minimum controlled output power is defined as the broadband transmit power of the UE, i.e. the sum of the power in the channel bandwidth for all transmit bandwidth configurations (resource blocks) at each transmit antenna connector, when the UE power is set to a minimum value.

For UE with two transmit antenna connectors in closed-loop spatial multiplexing scheme, the minimum output power is defined as the sum of the mean power at each UE antenna connector in one sub-frame (1 ms).

4.2.5.3.2 Limits

The minimum sum of mean output power of the UE at each antenna connector measured shall not exceed the values specified in table 4.2.5.3.2-1.

Table 4.2.5.3.2-1: Minimum output power for UL-MIMO

	Channel bandwidth/Minimum output power/Measurement bandwidth					
	1,4 MHz	3,0 MHz	5 MHz	10 MHz	15 MHz	20 MHz
Minimum output power	For carrier frequency $f \leq 3,0$ GHz: ≤ -39 dBm For carrier frequency $3,0$ GHz $< f \leq 4,2$ GHz: $\leq -38,7$ dBm					
Measurement bandwidth	1,08 MHz	2,7 MHz	4,5 MHz	9,0 MHz	13,5 MHz	18 MHz

4.2.5.3.3 Conformance

Conformance tests described in clause 5.3.4 shall be carried out.

4.2.6 Receiver Adjacent Channel Selectivity (ACS)

4.2.6.1 Definition

Adjacent Channel Selectivity (ACS) is a measure of a receiver's ability to receive an E-UTRA signal at its assigned channel frequency in the presence of an adjacent channel signal at a given frequency offset from the centre frequency of the assigned channel. ACS is the ratio of the receive filter attenuation on the assigned channel frequency to the receive filter attenuation on the adjacent channel(s).

4.2.6.2 Limits

The throughput R_{av} shall be ≥ 95 % of the maximum throughput of the reference measurement channels as specified in TS 136 521-1 [1] under the conditions specified in table 4.2.6.2-2 and also under the conditions specified in table 4.2.6.2-3.

Table 4.2.6.2-1: Adjacent channel selectivity

Rx Parameter	Units	Channel bandwidth					
		1,4 MHz	3 MHz	5 MHz	10 MHz	15 MHz	20 MHz
ACS	dB	33,0	33,0	33,0	33,0	30	27

Table 4.2.6.2-2: Test parameters for Adjacent channel selectivity, Case 1

Rx Parameter	Units	Channel bandwidth					
		1,4 MHz	3 MHz	5 MHz	10 MHz	15 MHz	20 MHz
Power in Transmission Bandwidth Configuration	dBm	REFSENS + 14 dB					
$P_{\text{Interferer}}$	dBm	REFSENS +45,5 dB	REFSENS +45,5 dB	REFSENS +45,5 dB	REFSENS +45,5 dB	REFSENS +42,5 dB	REFSENS +39,5 dB
$BW_{\text{Interferer}}$	MHz	1,4	3	5	5	5	5
$F_{\text{Interferer}}$ (offset)	MHz	1,4025	3,0075	5,0025	7,5075	10,0125	12,5025
NOTE 1: The transmitter shall be set to 4 dB below $P_{\text{CMAX_L}}$ or $P_{\text{CMAX_L_CA}}$ as defined in clause 6.2.5 in TS 136 101 [4].							
NOTE 2: The interferer consists of the Reference measurement channel specified in clause A.3.2 of TS 136 521-1 [1] with set-up according to clause C.3.1 of TS 136 521-1 [1].							
NOTE 3: REFSENS as defined in TS 136 521-1 [1].							

Table 4.2.6.2-3: Test parameters for Adjacent channel selectivity, Case 2

Rx Parameter	Units	Channel bandwidth					
		1,4 MHz	3 MHz	5 MHz	10 MHz	15 MHz	20 MHz
Power in Transmission Bandwidth Configuration	dBm	-56,5	-56,5	-56,5	-56,5	-53,5	-50,5
$P_{\text{Interferer}}$	dBm	-25					
$BW_{\text{Interferer}}$	MHz	1,4	3	5	5	5	5
$F_{\text{Interferer}}$ (offset)	MHz	1,4025	3,0075	5,0025	7,5075	10,0125	12,5025
NOTE 1: The transmitter shall be set to 24 dB below $P_{\text{CMAX_L}}$ or $P_{\text{CMAX_L_CA}}$ as defined in clause 6.2.5 in TS 136 101 [4].							
NOTE 2: The interferer consists of the Reference measurement channel specified in clause A.3.2 of TS 136 521-1 [1] with set-up according to clause C.3.1 of TS 136 521-1 [1].							

4.2.6.3 Conformance

Conformance tests described in clause 5.3.5 shall be carried out.

4.2.7 Receiver Blocking Characteristics

4.2.7.1 Definition

The blocking characteristic is a measure of the receiver's ability to receive a wanted signal at its assigned channel frequency in the presence of an unwanted interferer on frequencies other than those of the spurious response or the adjacent channels, without this unwanted input signal causing a degradation of the performance of the receiver beyond a specified limit. The blocking performance shall apply at all frequencies except those at which a spurious response occur.

4.2.7.2 Limits

With parameters specified in tables 4.2.7.2-1 and 4.2.7.2-2, the throughput shall be ≥ 95 % of the maximum throughput of the reference measurement channels as specified in TS 136 521-1 [1].

With parameters specified in tables 4.2.7.2-3 and 4.2.7.2-4, the throughput shall be ≥ 95 % of the maximum throughput of the reference measurement channels as specified in TS 136 521-1 [1], except for the spurious response frequencies.

For table 4.2.7.2-4 in frequency range 1, 2 and 3, up to $\max(24, 6 \cdot \lceil N_{RB} / 6 \rceil)$ exceptions are allowed for spurious response frequencies in each assigned frequency channel when measured using a 1 MHz step size, where N_{RB} is the number of resource blocks in the downlink transmission bandwidth configuration. For these exceptions the requirements of clause 4.2.8 Spurious response are applicable.

With parameters specified in table 4.2.7.2-5, the throughput shall be ≥ 95 % of the maximum throughput of the reference measurement channels as specified in TS 136 521-1 [1].

Table 4.2.7.2-1: In-band blocking parameters

Rx Parameter	Units	Channel bandwidth					
		1,4 MHz	3 MHz	5 MHz	10 MHz	15 MHz	20 MHz
Power in Transmission Bandwidth Configuration	dBm	REFSENS + channel bandwidth specific value below					
		6	6	6	6	7	9
BW _{Interferer}	MHz	1,4	3	5	5	5	5
F _{offset, case 1}	MHz	2,1125	4,5075	7,5125	7,5025	7,5075	7,5125
F _{offset, case 2}	MHz	3,5075	7,5075	12,5075	12,5125	12,5025	12,5075
NOTE 1: The transmitter shall be set to 4 dB below P _{C_{MAX}L} at the minimum uplink configuration specified in TS 136 101 [4] (table 7.3.1-2 with P _{C_{MAX}L} as defined in clause 6.2.5).							
NOTE 2: The interferer consists of the Reference measurement channel specified in clause A.3.2 of TS 136 521-1 [1] with a set-up according to clause C.3.1 of TS 136 521-1 [1].							
NOTE 3: REFSENS as defined in TS 136 521-1 [1].							

Table 4.2.7.2-2: In-band blocking

E-UTRA band	Parameter	Units	Case 1	Case 2
		$P_{\text{Interferer}}$	dBm	-56
	$F_{\text{Interferer}}$ (Offset)	MHz	= $-BW/2 - F_{\text{offset, case 1}}$ and = $+BW/2 + F_{\text{offset, case 1}}$	$\leq -BW/2 - F_{\text{offset, case 2}}$ and $\geq +BW/2 + F_{\text{offset, case 2}}$
1, 3, 7, 8, 20, 33, 34, 38, 40	$F_{\text{Interferer}}$	MHz	(note 2)	$F_{\text{DL_low}} - 15$ to $F_{\text{DL_high}} + 15$

NOTE 1: For certain bands, the unwanted modulated interfering signal may not fall inside the UE receive band, but within the first 15 MHz below or above the UE receive band.

NOTE 2: For each carrier frequency the requirement is valid for two frequencies:
a) the carrier frequency $-BW/2 - F_{\text{offset, case 1}}$; and
b) the carrier frequency $+BW/2 + F_{\text{offset, case 1}}$.

NOTE 3: $F_{\text{Interferer}}$ range values for unwanted modulated interfering signal are interferer center frequencies.

Table 4.2.7.2-3: Out-of-band blocking parameters

Rx Parameter	Units	Channel bandwidth					
		1,4 MHz	3 MHz	5 MHz	10 MHz	15 MHz	20 MHz
Power in Transmission Bandwidth Configuration	dBm	REFSENS + channel bandwidth specific value below					
		6	6	6	6	7	9

NOTE 1: The transmitter shall be set to 4 dB below $P_{\text{CMAX_L}}$ at the minimum uplink configuration specified in TS 136 101 [4] (table 7.3.1-2 with $P_{\text{CMAX_L}}$ as defined in clause 6.2.5).

NOTE 2: Reference measurement channel is clause A.3.2 of TS 136 521-1 [1].

NOTE 3: REFSENS as defined in TS 136 521-1 [1].

Table 4.2.7.2-4: Out-of-band blocking

E-UTRA band	Parameter	Units	Frequency		
			Range 1	Range 2	Range 3
	$P_{\text{Interferer}}$	dBm	-44	-30	-15
1, 3, 7, 8, 20, 33, 34, 38, 40	$F_{\text{Interferer}}$ (CW)	MHz	$F_{\text{DL_low}} - 15$ to $F_{\text{DL_low}} - 60$	$F_{\text{DL_low}} - 60$ to $F_{\text{DL_low}} - 85$	$F_{\text{DL_low}} - 85$ to 1 MHz
$F_{\text{DL_high}} + 15$ to $F_{\text{DL_high}} + 60$			$F_{\text{DL_high}} + 60$ to $F_{\text{DL_high}} + 85$	$F_{\text{DL_high}} + 85$ to +12 750 MHz	

NOTE: Range 3 shall be tested only with the highest channel bandwidth.

Table 4.2.7.2-5: Narrow-band blocking

Parameter	Unit	Channel Bandwidth					
		1,4 MHz	3 MHz	5 MHz	10 MHz	15 MHz	20 MHz
P_w	dBm	P_{REFSENS} + channel-bandwidth specific value below					
		22	18	16	13	14	16
P_{uw} (CW)	dBm	-55	-55	-55	-55	-55	-55
F_{uw} (offset for $\Delta f = 15$ kHz)	MHz	0,9075	1,7025	2,7075	5,2125	7,7025	10,2075

NOTE 1: The transmitter shall be set a 4 dB below $P_{\text{CMAX_L}}$ at the minimum uplink configuration specified in TS 136 101 [4] (table 7.3.1-2 with $P_{\text{CMAX_L}}$ as defined in clause 6.2.5).

NOTE 2: Reference measurement channel is in clause A.3.2 of TS 136 521-1 [1].

NOTE 3: REFSENS as defined in TS 136 521-1 [1].

4.2.7.3 Conformance

Conformance tests described in clause 5.3.6 shall be carried out.

4.2.8 Receiver Spurious Response

4.2.8.1 Definition

Spurious response is a measure of the receiver's ability to receive a wanted signal on its assigned channel frequency without exceeding a given degradation due to the presence of an unwanted CW interfering signal at any other frequency at which a response is obtained i.e. for which the out-of-band blocking limit as specified in table 4.2.7.2-4 is not met.

4.2.8.2 Limits

The throughput shall be ≥ 95 % of the maximum throughput of the reference measurement channels as specified in TS 136 521-1 [1] with parameters specified in tables 4.2.8.2-1 and 4.2.8.2-2.

Table 4.2.8.2-1: Spurious response parameters

Rx Parameter	Units	Channel bandwidth					
		1,4 MHz	3 MHz	5 MHz	10 MHz	15 MHz	20 MHz
Power in Transmission Bandwidth Configuration	dBm	REFSENS + channel bandwidth specific value below					
		6	6	6	6	7	9
NOTE 1: The transmitter shall be set to 4 dB below P_{CMAX_L} at the minimum uplink configuration specified in TS 136 101 [4] (table 7.3.1-2 with P_{CMAX_L} as defined in clause 6.2.5).							
NOTE 2: Reference measurement channel is clause A.3.2 of TS 136 521-1 [1].							
NOTE 3: REFSENS as defined in TS 136 521-1 [1].							

Table 4.2.8.2-2: Spurious Response

Parameter	Unit	Level
$P_{\text{Interferer}} \text{ (CW)}$	dBm	-44
$F_{\text{Interferer}}$	MHz	Spurious response frequencies

4.2.8.3 Conformance

Conformance tests described in clause 5.3.7 shall be carried out.

4.2.9 Receiver Intermodulation Characteristics

4.2.9.1 Definition

Intermodulation response rejection is a measure of the capability of the receiver to receive a wanted signal on its assigned channel frequency in the presence of two or more interfering signals which have a specific frequency relationship to the wanted signal.

4.2.9.2 Limits

The throughput shall be ≥ 95 % of the maximum throughput of the reference measurement channels as specified in TS 136 521-1 [1] with parameters specified in table 4.2.9.2-1 for the specified wanted signal mean power in the presence of two interfering signals.

Table 4.2.9.2-1: Test parameters for Wide band intermodulation

Rx Parameter	Units	Channel bandwidth					
		1,4 MHz	3 MHz	5 MHz	10 MHz	15 MHz	20 MHz
Power in Transmission Bandwidth Configuration	dBm	REFSENS + channel bandwidth specific value below					
		12	8	6	6	7	9
$P_{\text{Interferer 1 (CW)}}$	dBm	-46					
$P_{\text{Interferer 2 (Modulated)}}$	dBm	-46					
$BW_{\text{Interferer 2}}$		1,4	3	5			
$F_{\text{Interferer 1 (Offset)}}$	MHz	-BW/2 - 2,1 / +BW/2 + 2,1	-BW/2 - 4,5 / +BW/2 + 4,5	-BW/2 - 7,5 / +BW/2 + 7,5			
$F_{\text{Interferer 2 (Offset)}}$		MHz	$2 \times F_{\text{Interferer 1}}$				
NOTE 1: The transmitter shall be set to 4 dB below $P_{\text{C}_{\text{MAX_L}}}$ at the minimum uplink configuration specified in TS 136 101 [4] (table 7.3.1-2 with $P_{\text{C}_{\text{MAX_L}}}$ as defined in clause 6.2.5).							
NOTE 2: Reference measurement channel is clause A.3.2 of TS 136 521-1 [1].							
NOTE 3: The modulated interferer consists of the Reference measurement channel specified in clause A.3.2 of TS 136 521-1 [1] with set-up according to clause C.3.1 of TS 136 521-1 [1].The interfering modulated signal is 5 MHz E-UTRA signal as described in annex D for channel bandwidth ≥ 5 MHz.							
NOTE 4: REFSENS as defined in TS 136 521-1 [1].							

4.2.9.3 Conformance

Conformance tests described in clause 5.3.8 shall be carried out.

4.2.10 Receiver Spurious Emissions

4.2.10.1 Definition

The spurious emissions power is the power of emissions generated or amplified in a receiver that appear at the UE antenna connector.

4.2.10.2 Limits

The measured spurious emissions derived in clause 5.3.9 shall not exceed the maximum level specified in table 4.2.10.2-1.

Table 4.2.10.2-1: General receiver spurious emission requirements

Frequency Band	Measurement bandwidth	Maximum level	Note
$30 \text{ MHz} \leq f < 1 \text{ GHz}$	100 kHz	-57 dBm	
$1 \text{ GHz} \leq f \leq 12,75 \text{ GHz}$	1 MHz	-47 dBm	
NOTE: Unused PDCCH resources are padded with resource element groups with power level given by PDCCH_RA/RB as defined in TS 136 101 [4] clause C.3.1.			

4.2.10.3 Conformance

Conformance tests described in clause 5.3.9 shall be carried out.

4.2.11 Transmitter Adjacent Channel Leakage Power Ratio

4.2.11.1 Transmitter adjacent channel leakage power ratio for Single Carrier

4.2.11.1.1 Definition

Adjacent Channel Leakage power Ratio (ACLR) is the ratio of the filtered mean power centred on the assigned channel frequency to the filtered mean power centred on an adjacent channel frequency.

4.2.11.1.2 Limits

If the measured adjacent channel power is greater than -50 dBm then the measured E-UTRA_{ACLR} shall be higher than the limits in table 4.2.11.1.2-1.

Table 4.2.11.1.2-1: E-UTRA UE ACLR

	Channel bandwidth/E-UTRA _{ACLR1} /measurement bandwidth					
	1,4 MHz	3,0 MHz	5 MHz	10 MHz	15 MHz	20 MHz
E-UTRA_{ACLR1}	29,2 dB	29,2 dB	29,2 dB	29,2 dB	29,2 dB	29,2 dB
E-UTRA channel Measurement bandwidth	1,08 MHz	2,7 MHz	4,5 MHz	9,0 MHz	13,5 MHz	18 MHz
UE channel	+1,4 MHz or -1,4 MHz	+3 MHz or -3 MHz	+5 MHz or -5 MHz	+10 MHz or -10 MHz	+15 MHz or -15 MHz	+20 MHz or -20 MHz

If the measured UTRA channel power is greater than -50 dBm then the measured UTRA_{ACLR1}, UTRA_{ACLR2} shall be higher than the limits in table 4.2.11.2-2.

Table 4.2.11.1.2-2: UTRA UE ACLR

	Channel bandwidth/UTRA _{ACLR1/2} /measurement bandwidth					
	1,4 MHz	3,0 MHz	5 MHz	10 MHz	15 MHz	20 MHz
UTRA _{ACLR1}	32,2 dB	32,2 dB	32,2 dB	32,2 dB	32,2 dB	32,2 dB
Adjacent channel centre frequency offset (in MHz)	0,7 + BW _{UTRA} /2 / -0,7 - BW _{UTRA} /2	1,5 + BW _{UTRA} /2 / -1,5 - BW _{UTRA} /2	2,5 + BW _{UTRA} /2 / -2,5 - BW _{UTRA} /2	5 + BW _{UTRA} /2 / -5 - BW _{UTRA} /2	7,5 + BW _{UTRA} /2 / -7,5 - BW _{UTRA} /2	10 + BW _{UTRA} /2 / -10 - BW _{UTRA} /2
UTRA _{ACLR2}	-	-	35,2 dB	35,2 dB	35,2 dB	35,2 dB
Adjacent channel centre frequency offset (in MHz)	-	-	2,5 + 3 × BW _{UTRA} /2 / -2,5 - 3 × BW _{UTRA} /2	5 + 3 × BW _{UTRA} /2 / -5 - 3 × BW _{UTRA} /2	7,5 + 3 × BW _{UTRA} /2 / -7,5 - 3 × BW _{UTRA} /2	10 + 3 × BW _{UTRA} /2 / -10 - 3 × BW _{UTRA} /2
E-UTRA channel Measurement bandwidth	1,08 MHz	2,7 MHz	4,5 MHz	9,0 MHz	13,5 MHz	18 MHz
UTRA 5 MHz channel Measurement bandwidth (see note 1)	3,84 MHz	3,84 MHz	3,84 MHz	3,84 MHz	3,84 MHz	3,84 MHz
UTRA 1,6 MHz channel measurement bandwidth (see note 2)	1,28 MHz	1,28 MHz	1,28 MHz	1,28 MHz	1,28 MHz	1,28 MHz
NOTE 1: Applicable for E-UTRA FDD co-existence with UTRA FDD in paired spectrum.						
NOTE 2: Applicable for E-UTRA TDD co-existence with UTRA TDD in unpaired spectrum.						
NOTE 3: BW _{UTRA} for UTRA FDD is 5 MHz and for UTRA TDD is 1,6 MHz.						

4.2.11.1.3 Conformance

Conformance tests described in clause 5.3.10 shall be carried out.

4.2.11.2 Transmitter adjacent channel leakage power ratio for intra-band contiguous Carrier Aggregation (DL CA and UL CA)

4.2.11.2.1 Definition

For intra-band contiguous carrier aggregation the UTRA Adjacent Channel Leakage power Ratio (UTRA_{ACLR}) is the ratio of the filtered mean power centred on the assigned carrier aggregated channel bandwidth to the filtered mean power centred on an adjacent(s) UTRA channel frequency.

UTRA Adjacent Channel Leakage power Ratio is specified for both the first UTRA adjacent channel (UTRA_{ACLR1}) and the 2nd UTRA adjacent channel (UTRA_{ACLR2}). The UTRA channel power is measured with a RRC bandwidth filter with roll-off factor $\alpha = 0,22$. The assigned aggregated channel bandwidth power is measured with a rectangular filter with measurement bandwidth specified in table 4.2.11.2.2-1.

For intra-band contiguous carrier aggregation the carrier aggregation E-UTRA Adjacent Channel Leakage power Ratio (CA E-UTRA_{ACLR}) is the ratio of the filtered mean power centred on the aggregated channel bandwidth to the filtered mean power centred on an adjacent aggregated channel bandwidth at nominal channel spacing. The assigned aggregated channel bandwidth power and adjacent aggregated channel bandwidth power are measured with rectangular filters with measurement bandwidth specified in table 4.2.11.2.2-2.

4.2.11.2.2 Limits

If the measured adjacent UTRA channel power is greater than -50 dBm then the measured $UTRA_{ACLR1}$ and $UTRA_{ACLR2}$, shall be higher than the limits in table 4.2.11.2.2-1.

Table 4.2.11.2.2-1: UTRA UE ACLR for CA

	CA bandwidth class/ $UTRA_{ACLR1/2}$ / measurement bandwidth
	CA bandwidth class C
$UTRA_{ACLR1}$	32,2 dB
Adjacent channel centre frequency offset (in MHz)	$\frac{+ BW_{Channel_CA} / 2 + BW_{UTRA} / 2}{- BW_{Channel_CA} / 2 - BW_{UTRA} / 2}$
$UTRA_{ACLR2}$	35,2 dB
Adjacent channel centre frequency offset (in MHz)	$\frac{+ BW_{Channel_CA} / 2 + 3 \times BW_{UTRA} / 2}{- BW_{Channel_CA} / 2 - 3 \times BW_{UTRA} / 2}$
CA E-UTRA channel Measurement bandwidth	$BW_{Channel_CA} - 2 \times BW_{GB}$
UTRA 5 MHz channel Measurement bandwidth (note 1)	3,84 MHz
UTRA 1,6 MHz channel measurement bandwidth (note 2)	1,28 MHz
NOTE 1: Applicable for E-UTRA FDD co-existence with UTRA FDD in paired spectrum.	
NOTE 2: Applicable for E-UTRA TDD co-existence with UTRA TDD in unpaired spectrum.	

If the measured adjacent E-UTRA channel power is greater than -50 dBm then the measured CA E- $UTRA_{ACLR}$, shall be higher than the limits in table 4.2.11.2.2-2.

Table 4.2.11.2.2-2: CA E-UTRA ACLR

	CA bandwidth class/CA E- $UTRA_{ACLR}$ /Measurement bandwidth
	CA bandwidth class C
CA E- $UTRA_{ACLR}$	29,2 dB
CA E-UTRA channel Measurement bandwidth	$BW_{Channel_CA} - 2 * BW_{GB}$
Adjacent channel centre frequency offset (in MHz)	$\frac{+ BW_{Channel_CA}}{- BW_{Channel_CA}}$

4.2.11.2.3 Conformance

Conformance tests described in clause 5.3.10 shall be carried out.

4.2.11.3 Transmitter adjacent channel leakage power ratio for UL-MIMO

4.2.11.3.1 Definition

E-UTRA ACLR (E-UTRAACLR) is the ratio of the filtered mean power centred on the assigned channel frequency to the filtered mean power centred on an adjacent channel frequency at nominal channel spacing. The assigned E-UTRA channel power and adjacent E-UTRA channel power are measured with rectangular filters with measurement bandwidth specified in table 4.2.11.3.2-1.

For UEs with two transmit antenna connectors in closed-loop spatial multiplexing scheme, the requirements in table 4.2.11.3.2-1 apply to each transmit antenna connector with the UL-MIMO configurations specified in table 4.2.2.3.1-1.

UTRA ACLR ($UTRA_{ACLR}$) is the ratio of the filtered mean power centred on the assigned E-UTRA channel frequency to the filtered mean power centred on an adjacent UTRA channel frequency.

UTRA ACLR is specified for both the first UTRA adjacent channel ($UTRA_{ACLR1}$) and the 2nd UTRA adjacent channel ($UTRA_{ACLR2}$). The UTRA channel power is measured with a RRC bandwidth filter with roll-off factor $\alpha=0,22$. The assigned E-UTRA channel power is measured with a rectangular filter with measurement bandwidth specified in table 4.2.11.3.2-2.

For UEs with two transmit antenna connectors in closed-loop spatial multiplexing scheme, the requirements in table 4.2.11.3.2-2 apply to each transmit antenna connector with the UL-MIMO configurations specified in table 4.2.2.3.1-1.

4.2.11.3.2 Limits

If the measured E-UTRA adjacent channel power is greater than -50 dBm then the $E-UTRA_{ACLR}$ shall be higher than the valued specified in table 4.2.11.3.2-1.

Table 4.2.11.3.2-1: General requirements for $E-UTRA_{ACLR}$

	Channel bandwidth/ $E-UTRA_{ACLR1}$ /measurement bandwidth					
	1,4 MHz	3,0 MHz	5 MHz	10 MHz	15 MHz	20 MHz
$E-UTRA_{ACLR1}$	29,2 dB	29,2 dB	29,2 dB	29,2 dB	29,2 dB	29,2 dB
E-UTRA channel Measurement bandwidth	1,08 MHz	2,7 MHz	4,5 MHz	9,0 MHz	13,5 MHz	18 MHz
UE channel	+1,4 MHz or -1,4 MHz	+3 MHz or -3 MHz	+5 MHz or -5 MHz	+10 MHz or -10 MHz	+15 MHz or -15 MHz	+20 MHz or -20 MHz

If the measured UTRA channel power is greater than -50 dBm then the $UTRA_{ACLR1}$ and $UTRA_{ACLR2}$ shall be higher than the valued specified in table 4.2.11.3.2-2.

Table 4.2.11.3.2-2: General requirements for UTRA_{ACLR1/2}

	Channel bandwidth/E-UTRA _{ACLR1/2} /measurement bandwidth					
	1,4 MHz	3,0 MHz	5 MHz	10 MHz	15 MHz	20 MHz
E-UTRA _{ACLR1}	32,2 dB	32,2 dB	32,2 dB	32,2 dB	32,2 dB	32,2 dB
Adjacent channel centre frequency offset (in MHz)	0,7 + BW _{UTRA} /2 / -0,7 - BW _{UTRA} /2	1,5 + BW _{UTRA} /2 / -1,5 - BW _{UTRA} /2	2,5 + BW _{UTRA} /2 / -2,5 - BW _{UTRA} /2	5 + BW _{UTRA} /2 / -5 - BW _{UTRA} /2	7,5 + BW _{UTRA} /2 / -7,5 - BW _{UTRA} /2	10 + BW _{UTRA} /2 / -10 - BW _{UTRA} /2
UTRA _{ACLR2}	-	-	35,2 dB	35,2 dB	35,2 dB	35,2 dB
Adjacent channel centre frequency offset (in MHz)	-	-	2,5 + 3 × BW _{UTRA} /2 / -2,5 - 3 × BW _{UTRA} /2	5 + 3 × BW _{UTRA} /2 / -5 - 3 × BW _{UTRA} /2	7,5 + 3 × BW _{UTRA} /2 / -7,5 - 3 × BW _{UTRA} /2	10 + 3 × BW _{UTRA} /2 / -10 - 3 × BW _{UTRA} /2
E-UTRA channel Measurement bandwidth	1,08 MHz	2,7 MHz	4,5 MHz	9,0 MHz	13,5 MHz	18 MHz
UTRA 5MHz channel Measurement bandwidth ¹	3,84 MHz	3,84 MHz	3,84 MHz	3,84 MHz	3,84 MHz	3,84 MHz
UTRA 1,6 MHz channel measurement bandwidth ²	1,28 MHz	1,28 MHz	1,28 MHz	1,28 MHz	1,28 MHz	1,28 MHz
NOTE 1: Applicable for E-UTRA FDD co-existence with UTRA FDD in paired spectrum.						
NOTE 2: Applicable for E-UTRA TDD co-existence with UTRA TDD in unpaired spectrum.						

4.2.11.3.3 Conformance

Conformance tests described in clause 5.3.10 shall be carried out.

5 Testing for compliance with technical requirements

5.1 Environmental conditions for testing

Tests defined in the present document shall be carried out at representative points within the boundary limits of the declared operational environmental profile.

Where technical performance varies subject to environmental conditions, tests shall be carried out under a sufficient variety of environmental conditions (within the boundary limits of the declared operational environmental profile) to give confidence of compliance for the affected technical requirements.

Normally it should be sufficient for all tests to be conducted using normal test conditions except where otherwise stated. For guidance on the use of other conditions to be used in order to show compliance reference can be made to TS 136 521-1 [1].

Many tests in the present document are performed with appropriate frequencies in the low, middle and high range of the operating frequency band of the UE. These frequencies are defined in TS 136 508 [2].

5.2 Interpretation of the measurement results

The interpretation of the results recorded in a test report for the measurements described in the present document shall be as follows:

- the measured value related to the corresponding limit shall be used to decide whether an equipment meets the requirements of the present document;
- the value of the measurement uncertainty for the measurement of each parameter shall be documented in the test report;
- the recorded value of the measurement uncertainty shall be, for each measurement, equal to or lower than the figures in table 5.2-1.

For the test methods, according to the present document, the measurement uncertainty figures shall be calculated and shall correspond to an expansion factor (coverage factor) $k = 1,96$ (which provides a confidence level of 95 % in the case where the distributions characterizing the actual measurement uncertainties are normal (Gaussian)). Principles for the calculation of measurement uncertainty are contained in TR 100 028 [i.6], in particular in annex D of TR 100 028-2 [i.6]. For guidance on other measurement conditions reference can be made to annex (s) of TS 136 521-1 [1].

Table 5.2-1 is based on this expansion factor.

Table 5.2-1: Maximum measurement uncertainty of the test system

Parameter	Conditions	Test system uncertainty
Transmitter maximum output power		±0,7 dB
Transmitter spectrum emissions mask		±1,5 dB
Transmitter spurious emissions	9 kHz < f ≤ 4 GHz: ±2,0 dB 4 GHz < f ≤ 12,75 GHz: ±4,0 dB	±2,0 dB ±4,0 dB
Transmitter Minimum output power		±1,0 dB
Receiver Adjacent Channel Selectivity (ACS)		±1,1 dB
Receiver Blocking characteristics	1 MHz < f _{interferer} ≤ 3 GHz 3 GHz < f _{interferer} ≤ 12,75 GHz	±1,3 dB ±3,2 dB
Receiver spurious response	1 MHz < f _{interferer} ≤ 3 GHz 3 GHz < f _{interferer} ≤ 12,75 GHz	±1,3 dB ±3,2 dB
Receiver intermodulation characteristics		±1,4 dB
Receiver spurious emissions	30 MHz ≤ f ≤ 4,0 GHz: ±2,0 dB 4 GHz < f ≤ 12,75 GHz: ±4,0 dB	±2,0 dB ±4,0 dB
Transmitter adjacent channel leakage power ratio	-	±0,8 dB
NOTE 1: For RF tests it should be noted that the uncertainties in table 5.2-1 apply to the test system operating into a nominal 50 Ω load and do not include system effects due to mismatch between the EUT and the test system.		
NOTE 2: If the test system for a test is known to have a measurement uncertainty greater than that specified in table 5.2-1, this equipment can still be used provided that an adjustment is made follows: any additional uncertainty in the test system over and above that specified in table 5.2-1 should be used to tighten the test requirements - making the test harder to pass (for some tests, e.g. receiver tests, this may require modification of stimulus signals). This procedure will ensure that a test system not compliant with table 5.2-1 does not increase the probability of passing an EUT that would otherwise have failed a test if a test system compliant with table 5.2-1 had been used.		

5.3 Essential radio test suites

5.3.1 Transmitter Maximum Output Power

5.3.1.1 Transmitter maximum output power for Single Carrier

5.3.1.1.1 Method of test

5.3.1.1.1.1 Initial conditions

Test environment: normal, TL/VL, TL/VH, TH/VL, TH/VH; as specified in annex B.

Frequencies to be tested: low range, mid range, high range; as specified in TS 136 508 [2], clause 4.3.1.

Channel bandwidths to be tested: lowest, 5 MHz and highest channel bandwidth as defined in TS 136 508 [2], clause 4.3.1.

Uplink/Downlink configurations: as specified in TS 136 521-1 [1]:

- 1) Connect the SS to the UE antenna connectors.
- 2) The parameter settings for the cell are set up according to TS 136 508 [2], clause 4.4.3.
- 3) Downlink signals are initially set up according to TS 136 521-1 [1], clauses C.0, C.1 and C.3.0 and uplink signals according to clauses H.1 and H.3.0.
- 4) The UL Reference Measurement channels are set according to TS 136 521-1 [1].
- 5) Propagation conditions are set according to TS 136 521-1 [1], clause B.0.
- 6) Ensure the UE is in State 3A-RF according to TS 136 508 [2], clause 5.2A.2.

NOTE: When reference is made to test set up, call set up and test mode, guidance on the applicability of these can be found in TS 136 521-1 [1], TS 136 508 [2] and TS 136 509 [i.11] respectively.

5.3.1.1.1.2 Procedure

- 1) SS sends uplink scheduling information for each UL HARQ process via PDCCH DCI format 0 for C_RNTI to schedule the UL RMC according to table 6.2.2.1.4.1-1 of TS 136 521-1 [1]. Since the UE has no payload and no loopback data to send the UE sends uplink MAC padding bits on the UL RMC.
- 2) Send continuously uplink power control "up" commands in every uplink scheduling information to the UE; allow at least 200 ms for the UE to reach P_{UMAX} level.
- 3) Measure the mean power of the UE in the channel bandwidth of the radio access mode. The period of measurement shall be at least the continuous duration of one sub-frame (1 ms). For TDD slots with transient periods are not under test.
- 4) Repeat for applicable test frequencies, channel bandwidths, operating band combinations and environmental conditions.

Details of the test method can be found in TS 136 521-1 [1], clause 6.2.2.

5.3.1.1.2 Test requirements

The results obtained shall be compared to the limits in clause 4.2.2.1.2 in order to show compliance.

5.3.1.2 Transmitter maximum output power for intra-band contiguous Carrier Aggregation (DL CA and UL CA)

5.3.1.2.1 Method of test

5.3.1.2.1.1 Initial conditions

Test environment: normal, TL/VL, TL/VH, TH/VL, TH/VH; as specified in annex B.

Frequencies to be tested: low range, high range; as specified in TS 136 508 [2], clause 4.3.1.

Test CC Combination setting (N_{RB_agg}): lowest N_{RB_agg} , highest N_{RB_agg} , as specified in TS 136 521-1 [1], in clause 5.4.2A.1 for the CA Configuration

Uplink/Downlink configurations: as specified in TS 136 521-1 [1]:

- 1) Connect the SS to the UE antenna connectors.
- 2) The parameter settings for the cell are set up according to TS 136 508 [2], clause 4.4.3.
- 3) Downlink signals for PCC are initially set up according to TS 136 521-1 [1], clauses C.0, C.1 and C.3.0 and uplink signals according to clauses H.1 and H.3.0.
- 4) The UL Reference Measurement channels are set according to TS 136 521-1 [1], clause 6.2.2A.1.
- 5) Propagation conditions are set according to TS 136 521-1 [1], clause B.0.
- 6) Ensure the UE is in State 3A-RF according to TS 136 508 [2], clause 5.2A.2.

NOTE: When reference is made to test set up, call set up and test mode, guidance on the applicability of these can be found in TS 136 521-1 [1], TS 136 508 [2] and TS 136 509 [i.11] respectively.

5.3.1.2.1.2 Procedure

- 1) Configure SCC according to TS 136 521-1 [1], clauses C.0, C.1 and C.3.0 for all downlink physical channels, except PHICH.
- 2) The SS shall configure SCC as per TS 136 508 [2], clause 5.2A.4.
- 3) SS activates SCC by sending the activation MAC-CE. Wait for at least 2 seconds.
- 4) SS sends uplink scheduling information for each UL HARQ process via PDCCH DCI format 0 for C_RNTI to schedule the UL RMC according to table 6.2.2A.1.4.1-1 of TS 136 521-1 [1] on both PCC and SCC. Since the UE has no payload and no loopback data to send the UE sends uplink MAC padding bits on the UL RMC.
- 5) Send continuously uplink power control "up" commands in every uplink scheduling information to the UE; allow at least 200 ms for the UE to reach PUMAX level.
- 6) Measure the mean transmitted power over all component carriers in the CA configuration of the radio access mode. The period of measurement shall be at least the continuous duration of one sub-frame (1 ms). For TDD slots with transient periods are not under test.
- 7) Repeat for applicable test frequencies, channel bandwidths, operating band combinations and environmental conditions.

Details of the test method can be found in TS 136 521-1 [1], clause 6.2.2A.1.

5.3.1.2.2 Test requirements

The results obtained shall be compared to the limits in clause 4.2.2.2.2 in order to show compliance.

5.3.1.3 Transmitter maximum output power for UL-MIMO

5.3.1.3.1 Method of test

5.3.1.3.1.1 Initial conditions

Test environment: normal, TL/VL, TL/VH, TH/VL, TH/VH; as specified in annex B.

Frequencies to be tested: low range, mid range, high range; as specified in TS 136 508 [2], clause 4.3.1.

Channel bandwidths to be tested: lowest, 5 MHz and highest channel bandwidth as defined in TS 136 508 [2], clause 4.3.1.

Uplink/Downlink configurations: as specified in TS 136 521-1 [1]:

- 1) Connect the SS to the UE antenna connectors.
- 2) The parameter settings for the cell are set up according to TS 136 508 [2], clause 4.4.3.
- 3) Downlink signals are initially set up according to TS 136 521-1 [1], clauses C.0, C.1 and C.3.0 and uplink signals according to clauses H.1 and H.3.0.
- 4) The UL Reference Measurement channels are set according to TS 136 521-1 [1], clause 6.2.2B.
- 5) Propagation conditions are set according to TS 136 521-1 [1], clause B.0.
- 6) Ensure the UE is in State 3A-RF according to TS 136 508 [2], clause 5.2A.2.

NOTE: When reference is made to test set up, call set up and test mode, guidance on the applicability of these can be found in TS 136 521-1 [1], TS 136 508 [2] and TS 136 509 [i.11] respectively.

5.3.1.3.1.2 Procedure

- 1) SS sends uplink scheduling information for each UL HARQ process via PDCCH DCI format 0 for C_RNTI to schedule the UL RMC according to table 6.2.2B.4.1-1 of TS 136 521-1 [1]. Since the UE has no payload and no loopback data to send the UE sends uplink MAC padding bits on the UL RMC.
- 2) Send continuously uplink power control "up" commands in every uplink scheduling information to the UE; allow at least 200 ms for the UE to reach P_{UMAX} level.
- 3) Measure the mean power of the UE in the channel bandwidth of the radio access mode. The period of measurement shall be at least the continuous duration of one sub-frame (1 ms). For TDD slots with transient periods are not under test.
- 4) Repeat for applicable test frequencies, channel bandwidths, operating band combinations and environmental conditions.

Details of the test method can be found in TS 136 521-1 [1], clause 6.2.2B.

5.3.1.3.2 Test requirements

The results obtained shall be compared to the limits in clause 4.2.2.3.2 in order to show compliance.

5.3.2 Transmitter Spectrum Emission Mask

5.3.2.1 Transmitter spectrum emission mask for Single Carrier

5.3.2.1.1 Method of test

5.3.2.1.1.1 Initial conditions

Test environment: normal, as specified in annex B.

Frequencies to be tested: low range, mid range and high range; as specified in TS 136 508 [2], clause 4.3.1.

Channel bandwidths to be tested: lowest, 5 MHz, 10 MHz and highest channel bandwidth as defined in TS 136 508 [2], clause 4.3.1.

Uplink/Downlink configurations: as specified in TS 136 521-1 [1]:

- 1) Connect the SS to the UE antenna connectors.
- 2) The parameter settings for the cell are set up according to TS 136 508 [2], clause 4.4.3.
- 3) Downlink signals are initially set up according to TS 136 521-1 [1], clauses C.0, C.1 and C.3.0 and uplink signals according to clauses H.1 and H.3.0.
- 4) The UL Reference Measurement channels are set according to TS 136 521-1 [1].
- 5) Propagation conditions are set according to TS 136 521-1 [1], clause B.0.
- 6) Ensure the UE is in State 3A-RF according to TS 136 508 [2], clause 5.2A.2.

5.3.2.1.1.2 Procedure

- 1) SS sends uplink scheduling information via PDCCH DCI format 0 for C_RNTI to schedule the UL RMC according to TS 136 521-1 [1], table 6.6.2.1.4.1-1. Since the UE has no payload data to send, the UE transmits uplink MAC padding bits on the UL RMC.
- 2) Send continuously uplink power control "up" commands in the uplink scheduling information to the UE until the UE transmits at P_{UMAX} level.
- 3) Measure the power of the transmitted signal with a measurement filter of bandwidths according to tables 4.2.3.1.2-1 or 4.2.3.1.2-2, as applicable. The center frequency of the filter shall be stepped in continuous steps according to the same table. The measured power shall be recorded for each step. The measurement period shall capture the active TSs.
- 4) Repeat for applicable test frequencies, channel bandwidths and operating band combinations.

Details of the test method can be found in TS 136 521-1 [1], clause 6.6.2.1.

5.3.2.1.2 Test requirements

The results obtained shall be compared to the limits in clause 4.2.3.1.2 in order to show compliance.

5.3.2.2 Transmitter spectrum emission mask for intra-band contiguous Carrier Aggregation (DL CA and UL CA)

5.3.2.2.1 Method of test

5.3.2.2.1.1 Initial conditions

Test environment: normal, TL/VL, TL/VH, TH/VL, TH/VH; as specified in annex B.

Frequencies to be tested: low range, high range; as specified in TS 136 508 [2], clause 4.3.1.

Test CC Combination setting (N_{RB_agg}): lowest N_{RB_agg} , highest N_{RB_agg} , as specified in TS 136 521-1 [1], in clause 5.4.2A.1 for the CA Configuration

Uplink/Downlink configurations: as specified in TS 136 521-1 [1]:

- 1) Connect the SS to the UE antenna connectors.
- 2) The parameter settings for the cell are set up according to TS 136 508 [2], clause 4.4.3.
- 3) Downlink signals for PCC are initially set up according to TS 136 521-1 [1], clauses C.0, C.1 and C.3.0 and uplink signals according to clauses H.1 and H.3.0.
- 4) The UL Reference Measurement channels are set according to TS 136 521-1 [1], clause 6.6.2.1A.1.
- 5) Propagation conditions are set according to TS 136 521-1 [1], clause B.0.
- 6) Ensure the UE is in State 3A-RF according to TS 136 508 [2], clause 5.2A.2.

NOTE: When reference is made to test set up, call set up and test mode, guidance on the applicability of these can be found in TS 136 521-1 [1], TS 136 508 [2] and TS 136 509 [i.11] respectively.

5.3.2.2.1.2 Procedure

- 1) Configure SCC according to TS 136 521-1 [1], clauses C.0, C.1 and C.3.0 for all downlink physical channels, except PHICH.
- 2) The SS shall configure SCC as per TS 136 508 [2], clause 5.2A.4.
- 3) SS activates SCC by sending the activation MAC-CE. Wait for at least 2 seconds.
- 4) SS sends uplink scheduling information for each UL HARQ process via PDCCH DCI format 0 for C_RNTI to schedule the UL RMC according to table 6.6.2.1A.1.4.1-1 of TS 136 521-1 [1] on both PCC and SCC. Since the UE has no payload and no loopback data to send the UE sends uplink MAC padding bits on the UL RMC.
- 5) Send continuously uplink power control "up" commands in every uplink scheduling information to the UE; allow at least 200 ms for the UE to reach PUMAX level.
- 6) Measure the power of the transmitted signal with a measurement filter of bandwidths according to tables 4.2.3.2.2-1 or 4.2.3.2.2-2, as applicable. The centre frequency of the filter shall be stepped in continuous steps according to the same table. The measured power shall be recorded for each step. The measurement period shall capture the active TSs.
- 7) Repeat for applicable test frequencies, channel bandwidths, operating band combinations and environmental conditions.

Details of the test method can be found in TS 136 521-1 [1], clause 6.6.2.1A.1.

5.3.2.2.2 Test requirements

The results obtained shall be compared to the limits in clause 4.2.3.2.2 in order to show compliance.

5.3.2.3 Transmitter spectrum emission mask for UL-MIMO

5.3.2.3.1 Method of test

5.3.2.3.1.1 Initial conditions

Test environment: normal, as specified in annex B.

Frequencies to be tested: low range, mid range and high range; as specified in TS 136 508 [2], clause 4.3.1.

Channel bandwidths to be tested: lowest, 5 MHz, 10 MHz and highest channel bandwidth as defined in TS 136 508 [2], clause 4.3.1.

Uplink/Downlink configurations: as specified in TS 136 521-1 [1]:

- 1) Connect the SS to the UE antenna connectors.
- 2) The parameter settings for the cell are set up according to TS 136 508 [2], clause 4.4.3.
- 3) Downlink signals are initially set up according to TS 136 521-1 [1], clauses C.0, C.1 and C.3.0 and uplink signals according to clauses H.1 and H.3.0.
- 4) The UL Reference Measurement channels are set according to TS 136 521-1 [1], clause 6.6.2.1B.
- 5) Propagation conditions are set according to TS 136 521-1 [1], clause B.0.
- 6) Ensure the UE is in State 3A-RF according to TS 136 508 [2], clause 5.2A.2.

5.3.2.3.1.2 Procedure

- 1) SS sends uplink scheduling information via PDCCH DCI format 0 for C_RNTI to schedule the UL RMC according to TS 136 521-1 [1], table 6.6.2.1B.4.1-1. Since the UE has no payload data to send, the UE transmits uplink MAC padding bits on the UL RMC.
- 2) Send continuously uplink power control "up" commands in the uplink scheduling information to the UE until the UE transmits at P_{UMAX} level.
- 3) Measure the power of the transmitted signal with a measurement filter of bandwidths according to tables 4.2.3.1.2-1 or 4.2.3.1.2-2, as applicable. The center frequency of the filter shall be stepped in continuous steps according to the same table. The measured power shall be recorded for each step. The measurement period shall capture the active TSs.
- 4) Repeat for applicable test frequencies, channel bandwidths and operating band combinations.

Details of the test method can be found in TS 136 521-1 [1], clause 6.6.2.1B.

5.3.2.3.2 Test requirements

The results obtained shall be compared to the limits in clause 4.2.3.3.2 in order to show compliance.

5.3.3 Transmitter Spurious Emissions

5.3.3.1 Transmitter spurious emissions for Single Carrier

5.3.3.1.1 Method of test

5.3.3.1.1.1 Initial conditions

Test Environment: normal, as specified in annex B.

Frequencies to be tested: low range, mid range, high range; see TS 136 508 [2].

Channel bandwidth to be tested: lowest, 5 MHz and highest channel bandwidth as defined in TS 136 508 [2].

Uplink/Downlink configurations: as specified in TS 136 521-1 [1]:

- 1) Connect the SS to the UE antenna connectors.
- 2) The parameter settings for the cell are set up according to TS 136 508 [2], clause 4.4.3.
- 3) Downlink signals are initially set up according to TS 136 521-1 [1], clauses C.0, C.1 and C.3.0 and uplink signals according to clauses H.1 and H.3.0.
- 4) The UL Reference Measurement channels are set according to TS 136 521-1 [1].
- 5) Propagation conditions are set according to TS 136 521-1 [1], clause B.0.

- 6) Ensure the UE is in State 3A-RF according to TS 136 508 [2], clause 5.2A.2.

NOTE: When reference is made to test set up, call set up and test mode, guidance on the applicability of these can be found in TS 136 521-1 [1], TS 136 508 [2] and TS 136 509 [i.11] respectively.

5.3.3.1.1.2 Procedure

- 1) SS sends uplink scheduling information for each UL HARQ process via PDCCH DCI format 0 for C_RNTI to schedule the UL RMC according to TS 136 521-1 [1], table 6.6.3.1.4.1-1. Since the UE has no payload data to send, the UE transmits uplink MAC padding bits on the UL RMC.
- 2) Send continuously Up power control commands in the uplink scheduling information to the UE until the UE transmits at P_{UMAX} level.
- 3) For each applicable requirement in tables 4.2.4.1.2-2, 4.2.4.1.2-3 and 4.2.4.1.2-4; Measure the power of the transmitted signal with a measurement filter of bandwidths. The center frequency of the filter shall be stepped in contiguous steps according to the tables. The measured power shall be verified for each step. The measurement period shall capture the active time slots.
- 4) Repeat for applicable test frequencies, channel bandwidths and operating band combinations.

Details of the test method can be found in TS 136 521-1 [1], clauses 6.6.3.1 and 6.6.3.2.

5.3.3.1.2 Test requirements

The results obtained shall be compared to the limits in clause 4.2.4.1.2 in order to show compliance.

5.3.3.2 Transmitter spurious emissions for intra-band contiguous Carrier Aggregation (DL CA and UL CA)

5.3.3.2.1 Method of test

5.3.3.2.1.1 Initial conditions

Test environment: normal; as specified in annex B.

Frequencies to be tested: low range, high range; as specified in TS 136 508 [2], clause 4.3.1.

Test CC Combination setting (N_{RB_agg}): lowest N_{RB_agg} , highest N_{RB_agg} , as specified in TS 136 521-1 [1], in clause 5.4.2A.1 for the CA Configuration

Uplink/Downlink configurations: as specified in TS 136 521-1 [1]:

- 1) Connect the SS to the UE antenna connectors.
- 2) The parameter settings for the cell are set up according to TS 136 508 [2], clause 4.4.3.
- 3) Downlink signals for PCC are initially set up according to TS 136 521-1 [1], clauses C.0, C.1 and C.3.0 and uplink signals according to clauses H.1 and H.3.0.
- 4) The UL Reference Measurement channels are set according to TS 136 521-1 [1], clause 6.6.3.1A.1.
- 5) Propagation conditions are set according to TS 136 521-1 [1], clause B.0.
- 6) Ensure the UE is in State 3A-RF according to TS 136 508 [2], clause 5.2A.2.

NOTE: When reference is made to test set up, call set up and test mode, guidance on the applicability of these can be found in TS 136 521-1 [1], TS 136 508 [2] and TS 136 509 [i.11] respectively.

5.3.3.2.1.2 Procedure

- 1) Configure SCC according to TS 136 521-1 [1], clauses C.0, C.1 and C.3.0 for all downlink physical channels, except PHICH.

- 2) The SS shall configure SCC as per TS 136 508 [2], clause 5.2A.4.
- 3) SS activates SCC by sending the activation MAC-CE. Wait for at least 2 seconds.
- 4) SS sends uplink scheduling information for each UL HARQ process via PDCCH DCI format 0 for C_RNTI to schedule the UL RMC according to table 6.6.3.1A.1.4.1-1 of TS 136 521-1 [1] on both PCC and SCC. Since the UE has no payload and no loopback data to send the UE sends uplink MAC padding bits on the UL RMC.
- 5) Send continuously uplink power control "up" commands in every uplink scheduling information to the UE; allow at least 200 ms for the UE to reach PUMAX level.
- 6) For each applicable requirement in tables 4.2.4.2.2-2 and 4.2.4.2.2-3; Measure the power of the transmitted signal with a measurement filter of bandwidths for each component carrier. The centre frequency of the filter shall be stepped in contiguous steps according to the tables. The measured power shall be verified for each step. The measurement period shall capture the active time slots.
- 7) Repeat for applicable test frequencies, channel bandwidths, operating band combinations and environmental conditions.

Details of the test method can be found in TS 136 521-1 [1], clauses 6.6.3.2A.1 and 6.6.3.2A.2.

5.3.3.2.2 Test requirements

The results obtained shall be compared to the limits in clause 4.2.4.2.2 in order to show compliance.

5.3.3.3 Transmitter spurious emissions for UL-MIMO

5.3.3.3.1 Method of test

5.3.3.3.1.1 Initial conditions

Test Environment: normal, as specified in annex B.

Frequencies to be tested: low range, mid range, high range; see TS 136 508 [2].

Channel bandwidth to be tested: lowest, 5 MHz and highest channel bandwidth as defined in TS 136 508 [2].

Uplink/Downlink configurations: as specified in TS 136 521-1 [1]:

- 1) Connect the SS to the UE antenna connectors.
- 2) The parameter settings for the cell are set up according to TS 136 508 [2], clause 4.4.3.
- 3) Downlink signals are initially set up according to TS 136 521-1 [1], clauses C.0, C.1 and C.3.0 and uplink signals according to clauses H.1 and H.3.0.
- 4) The UL Reference Measurement channels are set according to TS 136 521-1 [1], clause 6.6.3B.1.
- 5) Propagation conditions are set according to TS 136 521-1 [1], clause B.0.
- 6) Ensure the UE is in State 3A-RF according to TS 136 508 [2], clause 5.2A.2.

NOTE: When reference is made to test set up, call set up and test mode, guidance on the applicability of these can be found in TS 136 521-1 [1], TS 136 508 [2] and TS 136 509 [i.11] respectively.

5.3.3.3.1.2 Procedure

- 1) SS sends uplink scheduling information for each UL HARQ process via PDCCH DCI format 0 for C_RNTI to schedule the UL RMC according to TS 136 521-1 [1], table 6.6.3B.1.4.1-1. Since the UE has no payload data to send, the UE transmits uplink MAC padding bits on the UL RMC.
- 2) Send continuously Up power control commands in the uplink scheduling information to the UE until the UE transmits at P_{UMAX} level.

- 3) For each applicable requirement in tables 4.2.4.1.2-2 and 4.2.4.1.2-3; Measure the power of the transmitted signal with a measurement filter of bandwidths. The center frequency of the filter shall be stepped in contiguous steps according to the tables. The measured power shall be verified for each step. The measurement period shall capture the active time slots.
- 4) Repeat for applicable test frequencies, channel bandwidths and operating band combinations.

Details of the test method can be found in TS 136 521-1 [1], clauses 6.6.3B.1 and 6.6.3B.2.

5.3.3.3.2 Test requirements

The results obtained shall be compared to the limits in clause 4.2.4.3.2 in order to show compliance.

5.3.4 Transmitter Minimum Output Power

5.3.4.1 Transmitter minimum output power for Single Carrier

5.3.4.1.1 Method of test

5.3.4.1.1.1 Initial conditions

Test Environment: normal, TL/VL, TL/VH, TH/VL, TH/VH; as specified in annex B.

Frequencies to be tested: low range, mid range and high range; see TS 136 508 [2].

Channel bandwidths to be tested: lowest, 5 MHz and highest channel bandwidth, as specified in TS 136 508 [2], clause 4.3.1.

Uplink/Downlink configurations: as specified in TS 136 521-1 [1]:

- 1) Connect the SS to the UE antenna connectors.
- 2) The parameter settings for the cell are set up according to TS 136 508 [2], clause 4.4.3.
- 3) Downlink signals are initially set up according to TS 136 521-1 [1], clauses C.0, C.1 and C.3.0 and uplink signals according to clauses H.1 and H.3.0.
- 4) The UL Reference Measurement channels are set according to TS 136 521-1 [1].
- 5) Propagation conditions are set according to TS 136 521-1 [1], clause B.0.
- 6) Ensure the UE is in State 3A-RF according to TS 136 508 [2], clause 5.2A.2.

NOTE: When reference is made to test set up, call set up and test mode, guidance on the applicability of these can be found in TS 136 521-1 [1], TS 136 508 [2] and TS 136 509 [i.11] respectively.

5.3.4.1.1.2 Procedure

- 1) SS sends uplink scheduling information for each UL HARQ process via PDCCH DCI format 0 for C_RNTI to schedule the UL RMC according to TS 136 521-1 [1], table 6.3.2.1.4.1-1. Since the UE has no payload and no loopback data to send the UE sends uplink MAC padding bits on the UL RMC.
- 2) Send continuous uplink power control "down" commands in the uplink scheduling information to the UE to ensure that the UE transmits at its minimum output power.
- 3) Measure the mean power of the UE in the associated measurement bandwidth specified in table 4.5.2.1-1 for the specific channel bandwidth under test. The period of measurement shall be the continuous duration of one sub-frame (1 ms). For TDD slots with transient periods are not under test.
- 4) Repeat for applicable test frequencies, channel bandwidths, operating band combinations and environmental conditions.

Details of the test method can be found in TS 136 521-1 [1], clause 6.3.2.

5.3.4.1.2 Test requirements

The results obtained shall be compared to the limits in clause 4.2.5.1.2 in order to show compliance.

5.3.4.2 Transmitter minimum output power for intra-band contiguous Carrier Aggregation (DL CA and UL CA)

5.3.4.2.1 Method of test

5.3.4.2.1.1 Initial conditions

Test environment: normal, TL/VL, TL/VH, TH/VL, TH/VH; as specified in annex B.

Frequencies to be tested: low range, high range; as specified in TS 136 508 [2], clause 4.3.1.

Test CC Combination setting (N_{RB_agg}): lowest N_{RB_agg} , highest N_{RB_agg} , as specified in TS 136 521-1 [1], in clause 5.4.2A.1 for the CA Configuration

Uplink/Downlink configurations: as specified in TS 136 521-1 [1]:

- 1) Connect the SS to the UE antenna connectors.
- 2) The parameter settings for the cell are set up according to TS 136 508 [2], clause 4.4.3.
- 3) Downlink signals for PCC are initially set up according to TS 136 521-1 [1], clauses C.0, C.1 and C.3.0 and uplink signals according to clauses H.1 and H.3.0.
- 4) The UL Reference Measurement channels are set according to TS 136 521-1 [1], clause 6.3.2A.1.
- 5) Propagation conditions are set according to TS 136 521-1 [1], clause B.0.
- 6) Ensure the UE is in State 3A-RF according to TS 136 508 [2], clause 5.2A.2.

NOTE: When reference is made to test set up, call set up and test mode, guidance on the applicability of these can be found in TS 136 521-1 [1], TS 136 508 [2] and TS 136 509 [i.11] respectively.

5.3.4.2.1.2 Procedure

- 1) Configure SCC according to TS 136 521-1 [1], clauses C.0, C.1 and C.3.0 for all downlink physical channels, except PHICH.
- 2) The SS shall configure SCC as per TS 136 508 [2], clause 5.2A.4.
- 3) SS activates SCC by sending the activation MAC-CE. Wait for at least 2 seconds.
- 4) SS sends uplink scheduling information for each UL HARQ process via PDCCH DCI format 0 for C_RNTI to schedule the UL RMC according to table 6.3.2A.1.4.1-1 of TS 136 521-1 [1] on both PCC and SCC. Since the UE has no payload and no loopback data to send the UE sends uplink MAC padding bits on the UL RMC.
- 5) Send continuously uplink power control "down" commands in every uplink scheduling information to the UE to ensure that the UE transmits at its minimum output power.
- 6) Measure the mean transmitted power of each component carrier in the CA configuration of the radio access mode. The period of measurement shall be at least the continuous duration of one sub-frame (1 ms). For TDD slots with transient periods are not under test.
- 7) Repeat for applicable test frequencies, channel bandwidths, operating band combinations and environmental conditions.

Details of the test method can be found in TS 136 521-1 [1], clause 6.3.2A.1.

5.3.4.2.2 Test requirements

The results obtained shall be compared to the limits in clause 4.2.5.2.2 in order to show compliance.

5.3.4.3 Transmitter minimum output power for UL-MIMO

5.3.4.3.1 Method of test

5.3.4.3.1.1 Initial conditions

Test environment: normal, TL/VL, TL/VH, TH/VL, TH/VH; as specified in annex B.

Frequencies to be tested: low range, mid range, high range; as specified in TS 136 508 [2], clause 4.3.1.

Channel bandwidths to be tested: lowest, 5 MHz and highest channel bandwidth as defined in TS 136 508 [2], clause 4.3.1.

Uplink/Downlink configurations: as specified in TS 136 521-1 [1]:

- 1) Connect the SS to the UE antenna connectors.
- 2) The parameter settings for the cell are set up according to TS 136 508 [2], clause 4.4.3.
- 3) Downlink signals are initially set up according to TS 136 521-1 [1], clauses C.0, C.1 and C.3.0 and uplink signals according to clauses H.1 and H.3.0.
- 4) The UL Reference Measurement channels are set according to TS 136 521-1 [1], clause 6.3.2B.
- 5) Propagation conditions are set according to TS 136 521-1 [1], clause B.0.
- 6) Ensure the UE is in State 3A-RF according to TS 136 508 [2], clause 5.2A.2.

NOTE: When reference is made to test set up, call set up and test mode, guidance on the applicability of these can be found in TS 136 521-1 [1], TS 136 508 [2] and TS 136 509 [i.11] respectively.

5.3.4.3.1.2 Procedure

- 1) SS sends uplink scheduling information for each UL HARQ process via PDCCH DCI format 0 for C_RNTI to schedule the UL RMC according to table 6.3.2B.1.4.1-1 of TS 136 521-1 [1]. Since the UE has no payload and no loopback data to send the UE sends uplink MAC padding bits on the UL RMC.
- 2) Send continuously uplink power control control "down" commands in the uplink scheduling information to the UE to ensure that the UE transmits at its minimum output power.
- 3) Measure the sum of mean power of the UE at each UE antenna connector in the associated measurement bandwidth specified in table 4.2.5.3.2-1 for the specific channel bandwidth under test. The period of measurement shall be the continuous duration of one sub-frame (1 ms). For TDD slots with transient periods are not under test.
- 4) Repeat for applicable test frequencies, channel bandwidths, operating band combinations and environmental conditions.

Details of the test method can be found in TS 136 521-1 [1], clause 6.3.2B.

5.3.4.3.2 Test requirements

The results obtained shall be compared to the limits in clause 4.2.5.3.2 in order to show compliance.

5.3.5 Receiver Adjacent Channel Selectivity (ACS)

5.3.5.1 Method of test

5.3.5.1.1 Initial conditions

Test Environment: normal, as specified in annex B.

Frequencies to be tested: mid range see TS 136 508 [2].

Channel bandwidth to be tested: lowest, 5 MHz and highest channel bandwidth as defined in TS 136 508 [2], clause 4.3.1.

Uplink/Downlink configurations: as specified in TS 136 521-1 [1]:

- 1) Connect the SS and interfering source to the UE antenna connectors.
- 2) The parameter settings for the cell are set up according to TS 136 508 [2], clause 4.4.3.
- 3) Downlink signals are initially set up according to TS 136 521-1 [1], clauses C.0, C.1 and C.3.0 and uplink signals according to clauses H.1 and H.3.0.
- 4) The UL and DL Reference Measurement channels are set according to TS 136 521-1 [1], table 7.5.4.1-1.
- 5) Propagation conditions are set according to TS 136 521-1 [1], clause B.0.
- 6) Ensure the UE is in State 3A-RF according to TS 136 508 [2], clause 5.2A.2.

NOTE: When reference is made to test set up, call set up and test mode, guidance on the applicability of these can be found in TS 136 521-1 [1], TS 136 508 [2] and TS 136 509 [i.11] respectively.

5.3.5.1.2 Procedure

- 1) SS transmits PDSCH via PDCCH DCI format 1A for C_RNTI to transmit the DL RMC according to TS 136 521-1 [1], table 7.5.4.1-1. The SS sends downlink MAC padding bits on the DL RMC.
- 2) SS sends uplink scheduling information for each UL HARQ process via PDCCH DCI format 0 for C_RNTI to schedule the UL RMC according to TS 136 521-1 [1], table 7.5.4.1-1. Since the UE has no payload data to send, the UE transmits uplink MAC padding bits on the UL RMC.
- 3) Set the Downlink signal level to the value as defined in table 4.2.6.2-2 (Case 1). Send Uplink power control commands to the UE (less or equal to 1 dB step size should be used), to ensure that the UE output power is within +0, -3,4 dB of the target level in table 4.2.6.2-2 (Case 1) for carrier frequency $f \leq 3,0$ GHz or within +0, -4,0 dB of the target level for carrier frequency $3,0 \text{ GHz} < f \leq 4,2 \text{ GHz}$, for at least the duration of the Throughput measurement (obtain correct UE output power as specified in TS 136 521-1 [1]).
- 4) Set the Interferer signal level to the value as defined in table 4.2.6.2-2 (Case 1) and frequency below the wanted signal, using a modulated interferer as defined in TS 136 521-1 [1], annex D.
- 5) Measure the average throughput for a duration sufficient to achieve statistical significance according to clause G.2 of TS 136 521-1 [1].
- 6) Set the Downlink signal level to the value as defined in table 4.2.6.2-3 (Case 2). Send Uplink power control commands to the UE (less or equal to 1 dB step size should be used), to ensure that the UE output power is within +0, -3,4 dB of the target level in table 4.2.6.2-3 (Case 2) for carrier frequency $f \leq 3,0$ GHz or within +0, -4,0 dB of the target level for carrier frequency $3,0 \text{ GHz} < f \leq 4,2 \text{ GHz}$, for at least the duration of the throughput measurement (obtain correct UE output power as specified in TS 136 521-1 [1]).
- 7) Set the Interferer signal level to the value as defined in table 4.2.6.2-3 (Case 2) and frequency below the wanted signal, using a modulated interferer as defined in TS 136 521-1 [1], annex D.
- 8) Measure the average throughput for a duration sufficient to achieve statistical significance according to TS 136 521-1 [1], annex G.
- 9) Repeat for applicable channel bandwidths in both Case 1 and Case 2.
- 10) Repeat for applicable test frequencies, channel bandwidths and operating band combinations.

Details of the test method can be found in TS 136 521-1 [1], clause 7.5.

5.3.5.2 Test requirements

The results obtained shall be compared to the limits in clause 4.2.6.2 in order to show compliance.

5.3.6 Receiver Blocking Characteristics

5.3.6.1 Method of test

5.3.6.1.1 Initial conditions

Test Environment: normal, as specified in annex B.

For In-band blocking, the frequencies to be tested are mid range as defined in TS 136 508 [2].

For Out of band blocking, the frequency to be tested is low or high range as defined in TS 136 508 [2].

For Narrow-band blocking, the frequencies to be tested are mid range as defined in TS 136 508 [2].

Channel bandwidth to be tested: lowest, 5 MHz and highest channel bandwidth as defined in TS 136 508 [2], clause 4.3.1. Range 3 of out-of-band blocking is tested only with highest bandwidth.

Uplink/Downlink configurations: as specified in TS 136 521-1 [1]:

- 1) Connect the SS to the UE antenna connectors.
- 2) The parameter settings for the cell are set up according to TS 136 508 [2], clause 4.4.3.
- 3) Downlink signals are initially set up according to TS 136 521-1 [1], clauses C.0, C.1 and C.3.1 and uplink signals according to clauses H.1 and H.3.0.
- 4) The UL and DL Reference Measurement channels are set according to TS 136 521-1 [1], table 7.6.2.4.1-1.
- 5) Propagation conditions are set according to TS 136 521-1 [1], clause B.0.
- 6) Ensure the UE is in State 3A-RF according to TS 136 508 [2], clause 5.2A.2.

NOTE: When reference is made to test set up, call set up and test mode, guidance on the applicability of these can be found in TS 136 521-1 [1], TS 136 508 [2] and TS 136 509 [i.11] respectively.

5.3.6.1.2 In-Band Procedure

- 1) SS transmits PDSCH via PDCCH DCI format 1A for C_RNTI to transmit the DL RMC according to TS 136 521-1 [1], table 7.6.1.4.1-1. The SS sends downlink MAC padding bits on the DL RMC.
- 2) SS sends uplink scheduling information for each UL HARQ process via PDCCH DCI format 0 for C_RNTI to schedule the UL RMC according to TS 136 521-1 [1], table 7.6.1.4.1-1. Since the UE has no payload data to send, the UE transmits uplink MAC padding bits on the UL RMC.
- 3) Set the parameters of the signal generator for an interfering signal below the wanted signal in Case 1 according to tables 4.2.7.2-1 and 4.2.7.2-2 as specified in TS 136 521-1 [1].
- 4) Set the downlink signal level according to the table 4.2.7.2-1. Send uplink power control commands to the UE (less or equal to 1 dB step size should be used), to ensure that the UE output power is within +0, -3,4 dB of the target level in table 4.2.7.2-1 for carrier frequency $f \leq 3,0$ GHz or within +0, -4,0 dB of the target level for carrier frequency $3,0$ GHz $< f \leq 4,2$ GHz, for at least the duration of the throughput measurement as specified in TS 136 521-1 [1].
- 5) Measure the average throughput for a duration sufficient to achieve statistical significance according to clause G.2 of TS 136 521-1 [1].
- 6) Repeat steps from 3 to 5, using an interfering signal above the wanted signal in Case 1 at step 3.
- 7) Repeat steps from 3 to 6, using interfering signals in Case 2 at step 3) and 6). The ranges of case 2 are covered in steps equal to the interferer bandwidth. The test frequencies are chosen in analogy to TS 136 521-1 [1], table 7.6.1.4.2-1.
- 8) Repeat for applicable test frequencies, channel bandwidths and operating band combinations.

Details of the test method can be found in TS 136 521-1 [1], clause 7.6.1.

5.3.6.1.3 Out-Of-Band Procedure

- 1) SS transmits PDSCH via PDCCH DCI format 1A for C_RNTI to transmit the DL RMC according to TS 136 521-1 [1], table 7.6.2.4.1-1. The SS sends downlink MAC padding bits on the DL RMC.
- 2) SS sends uplink scheduling information for each UL HARQ process via PDCCH DCI format 0 for C_RNTI to schedule the UL RMC according to TS 136 521-1 [1], table 7.6.2.4.1-1. Since the UE has no payload data to send, the UE transmits uplink MAC padding bits on the UL RMC.
- 3) Set the parameters of the CW signal generator for an interfering signal according to table 4.2.7.2-4 as specified in TS 136 521-1 [1]. The frequency step size is 1 MHz.
- 4) Set the downlink signal level according to the table 4.2.7.2-3. Send uplink power control commands to the UE (less or equal to 1 dB step size should be used), to ensure that the UE output power is within +0, -3,4 dB of the target level in table 4.2.7.2-3 for carrier frequency $f \leq 3,0$ GHz or within +0, -4,0 dB of the target level for carrier frequency $3,0 \text{ GHz} < f \leq 4,2 \text{ GHz}$, for at least the duration of the throughput measurement as specified in TS 136 521-1 [1].
- 5) Measure the average throughput for a duration sufficient to achieve statistical significance according to clause G.2 of TS 136 521-1 [1].
- 6) For table 4.2.7.2-4 record the frequencies for which the throughput does not meet the requirements.
- 7) Repeat for applicable test frequencies, channel bandwidths and operating band combinations.

Details of the test method can be found in TS 136 521-1 [1], clause 7.6.2.

5.3.6.1.4 Narrow-Band Procedure

- 1) SS transmits PDSCH via PDCCH DCI format 1A for C_RNTI to transmit the DL RMC according to TS 136 521-1 [1], table 7.6.3.4.1-1. The SS sends downlink MAC padding bits on the DL RMC.
- 2) SS sends uplink scheduling information for each UL HARQ process via PDCCH DCI format 0 for C_RNTI to schedule the UL RMC according to TS 136 521-1 [1], table 7.6.3.4.1-1. Since the UE has no payload data to send, the UE transmits uplink MAC padding bits on the UL RMC.
- 3) Set the parameters of the CW signal generator for an interfering signal below the wanted signal according to table 4.2.7.2-5 as specified in TS 136 521-1 [1].
- 4) Set the downlink signal level according to the table 4.2.7.2-5. Send uplink power control commands to the UE (less or equal to 1 dB step size should be used), to ensure that the UE output power is within +0, -3,4 dB of the target level in table 4.2.7.2-5 for carrier frequency $f \leq 3,0$ GHz or within +0, -4,0 dB of the target level for carrier frequency $3,0 \text{ GHz} < f \leq 4,2 \text{ GHz}$, for at least the duration of the throughput measurement as specified in TS 136 521-1 [1].
- 5) Measure the average throughput for a duration sufficient to achieve statistical significance according to clause G.2 of TS 136 521-1 [1].
- 6) Repeat steps from 3 to 5, using an interfering signal above the wanted signal at step 3.
- 7) Repeat for applicable test frequencies, channel bandwidths and operating band combinations.

Details of the test method can be found in TS 136 521-1 [1], clause 7.6.3.

5.3.6.2 Test requirements

The results obtained shall be compared to the limits in clause 4.2.7.2 in order to show compliance.

5.3.7 Receiver Spurious Response

5.3.7.1 Method of test

5.3.7.1.1 Initial conditions

The initial conditions shall be the same as for those in Out-of-band blocking in clause 5.3.6.1.1 in order to test spurious responses obtained in clause 5.3.6.1.2 under the same conditions.

5.3.7.1.2 Procedure

- 1) SS transmits PDSCH via PDCCH DCI format 1A for C_RNTI to transmit the DL RMC according to TS 136 521-1 [1], table 7.6.2.4.1-1. The SS sends downlink MAC padding bits on the DL RMC.
- 2) SS sends uplink scheduling information for each UL HARQ process via PDCCH DCI format 0 for C_RNTI to schedule the UL RMC according to TS 136 521-1 [1], table 7.6.2.4.1-1. Since the UE has no payload data to send, the UE transmits uplink MAC padding bits on the UL RMC.
- 3) Set the parameters of the CW signal generator for an interfering signal according to table 4.2.8.2-2. The spurious frequencies are taken from step 5) records in clause 5.3.6.1.2.
- 4) Set the downlink signal level according to the table 4.2.8.2-1. Send uplink power control commands to the UE (less or equal to 1 dB step size should be used), to ensure that the UE output power is within +0, -3,4 dB of the target level in table 4.2.8.2-1 for carrier frequency $f \leq 3,0$ GHz or within +0, -4,0 dB of the target level for carrier frequency $3,0$ GHz $< f \leq 4,2$ GHz, for at least the duration of the throughput measurement as specified in TS 136 521-1 [1].
- 5) For the spurious frequency, measure the average throughput for a duration sufficient to achieve statistical significance.

Details of the test method can be found in TS 136 521-1 [1], clause 7.7.

5.3.7.2 Test requirements

The results obtained shall be compared to the limits in clause 4.2.8.2 in order to show compliance.

5.3.8 Receiver Intermodulation Characteristics

5.3.8.1 Method of test

5.3.8.1.1 Initial conditions

Test Environment: normal, as specified in annex B.

Frequencies to be tested: mid range; see TS 136 508 [2].

Channel bandwidths to be tested: lowest, 5 MHz and highest channel bandwidth as defined in TS 136 508 [2], clause 4.3.1.

Uplink/Downlink configurations: as specified in TS 136 521-1 [1]:

- 1) Connect the SS and interfering sources to the UE antenna connectors.
- 2) The parameter settings for the cell are set up according to TS 136 508 [2], clause 4.4.3.
- 3) Downlink signals are initially set up according to TS 136 521-1 [1], clauses C.0, C.1, C.3.1 and uplink signals according to clauses H.1 and H.3.1.
- 4) The UL and DL Reference Measurement channels are set according to TS 136 521-1 [1], table 7.8.4.1-1.
- 5) Propagation conditions are set according to TS 136 521-1 [1], clause B.0.

- 6) Ensure the UE is in State 3A-RF according to TS 136 508 [2], clause 5.2A.2.

NOTE: When reference is made to test set up, call set up and test mode, guidance on the applicability of these can be found in TS 136 521-1 [1], TS 136 508 [2] and TS 136 509 [i.11] respectively.

5.3.8.1.2 Procedure

- 1) SS transmits PDSCH via PDCCH DCI format 1A for C_RNTI to transmit the DL RMC according to TS 136 521-1 [1], table 7.8.1.4.1-1. The SS sends downlink MAC padding bits on the DL RMC.
- 2) SS sends uplink scheduling information for each UL HARQ process via PDCCH DCI format 0 for C_RNTI to schedule the UL RMC according to TS 136 521-1 [1], table 7.8.1.4.1-1. Since the UE has no payload data to send, the UE transmits uplink MAC padding bits on the UL RMC.
- 3) Set the Downlink signal level to the value as defined in table 4.2.9.2-1. Send uplink power control commands to the UE (less or equal to 1 dB step size should be used), to ensure that the UE output power is within +0, -3,4 dB of the target level in table 4.2.9.2-1 for carrier frequency $f \leq 3,0\text{GHz}$ or within +0, -4,0 dB of the target level for carrier frequency $3,0\text{ GHz} < f \leq 4,2\text{ GHz}$, for at least the duration of the throughput measurement as specified in TS 136 521-1 [1].
- 4) Set the Interfering signal levels to the values as defined in table 4.2.9.2-1, using a modulated interferer bandwidth as defined in annex D of TS 136 521-1 [1].
- 5) Measure the average throughput for a duration sufficient to achieve statistical significance according to clause G.2 of TS 136 521-1 [1].
- 6) Repeat for applicable test frequencies, channel bandwidths and operating band combinations.

Details of the test method can be found in TS 136 521-1 [1], clause 7.8.

5.3.8.2 Test requirements

The results obtained shall be compared to the limits in clause 4.2.9.2 in order to show compliance.

5.3.9 Receiver Spurious Emissions

5.3.9.1 Method of test

Test Environment: normal, as specified in annex B.

Frequencies to be tested: low range, mid range and high range; as specified in TS 136 508 [2], clause 4.3.1.

Channel bandwidth to be tested: highest channel bandwidth as defined in TS 136 508 [2], clause 4.3.1.

Uplink/Downlink configurations: as specified in TS 136 521-1 [1]:

- 1) Connect a spectrum analyzer (or other suitable test equipment) to the UE antenna connectors.
- 2) The parameter settings for the cell are set up according to TS 136 508 [2], clause 4.4.3.
- 3) Downlink signals are initially set up according to TS 136 521-1 [1], clauses C.0, C.1 and C.3.1.
- 4) The DL Reference Measurement channels are set according to TS 136 521-1 [1].
- 5) Propagation conditions are set according to TS 136 521-1 [1], clause B.0.
- 6) Ensure the UE is in State 3A-RF according to TS 136 508 [2], clause 5.2A.2.

NOTE: When reference is made to test set up, call set up and test mode, guidance on the applicability of these can be found in TS 136 521-1 [1], TS 136 508 [2] and TS 136 509 [i.11] respectively.

5.3.9.1.1 Procedure

- 1) Sweep the spectrum analyser (or other suitable test equipment) over a frequency range from 30 MHz to 12,75 GHz and measure the average power of the spurious emissions.
- 2) Repeat step 1) for all E-UTRA Rx antennas of the UE.
- 3) Repeat for applicable test frequencies, channel bandwidths and operating band combinations.

Details of the test method can be found in TS 136 521-1 [1], clause 7.9.

5.3.9.2 Test requirements

The results obtained shall be compared to the limits in clause 4.2.10.2 in order to show compliance.

5.3.10 Transmitter Adjacent Channel Leakage Power Ratio

5.3.10.1 Transmitter adjacent channel leakage power ratio for Single Carrier

5.3.10.1.1 Method of test

5.3.10.1.1.1 Initial conditions

Test Environment: normal, TL/VL, TL/VH, TH/VL and TH/VH, as specified in annex B.

Frequencies to be tested: low range, mid range and high range; see TS 136 508 [2].

Channel bandwidth to be tested: lowest, 5 MHz, 10 MHz and highest channel bandwidth as defined in TS 136 508 [2], clause 4.3.1.

Uplink/Downlink configurations: as specified in TS 136 521-1 [1]:

- 1) Connect the SS to the UE to the UE antenna connectors.
- 2) The parameter settings for the cell are set up according to TS 136 508 [2], clause 4.4.3.
- 3) Downlink signals are initially set up according to TS 136 521-1 [1], clauses C.0, C.1 and C.3.0 and uplink signals according to clauses H.1 and H.3.0.
- 4) The UL Reference Measurement channels are set according to TS 136 521-1 [1].
- 5) Propagation conditions are set according to TS 136 521-1 [1], clause B.0.
- 6) Ensure the UE is in State 3A-RF according to TS 136 508 [2], clause 5.2A.2.

NOTE: When reference is made to test set up, call set up and test mode, guidance on the applicability of these can be found in TS 136 521-1 [1], TS 136 508 [2] and TS 136 509 [i.11] respectively.

5.3.10.1.1.2 Procedure

- 1) SS sends uplink scheduling information for each UL HARQ process via PDCCH DCI format 0 for C_RNTI to schedule the UL RMC according to TS 136 521-1 [1], table 6.6.2.3.4.1-1. Since the UE has no payload data to send, the UE transmits uplink MAC padding bits on the UL RMC.
- 2) Send continuous uplink power control "up" commands in the uplink scheduling information to the UE to ensure that the UE transmits at P_{UMAX} level.
- 3) Measure the mean power of the UE in the channel bandwidth of the radio access mode according to the test configuration, which shall meet the requirements described in tables 4.2.11.1.2-1 and 4.2.11.1.2-2. The period of the measurement shall be at least the continuous duration of one sub-frame (1 ms). For TDD slots with transient periods are not under test.
- 4) Measure the filtered mean power for E-UTRA.

- 5) Measure the filtered mean power of the first E-UTRA adjacent channel.
- 6) Measure the RRC filtered mean power of the first and the second UTRA adjacent channel.
- 7) Calculate the ratio of the power between the values measured in step 4) over step 5) for $E\text{-UTRA}_{\text{ACLR}}$.
- 8) Calculated the ratio of the power between the values measured in step 4) over step 6) for $\text{UTRA}_{\text{ACLR1}}$, $\text{UTRA}_{\text{ACLR2}}$.
- 9) Repeat for applicable test frequencies, channel bandwidths, operating band combinations and environmental conditions.

Details of the test method can be found in TS 136 521-1 [1], clause 6.6.2.3.

5.3.10.1.2 Test requirements

The results obtained shall be compared to the limits in clause 4.2.11.1-2 in order to show compliance.

5.3.10.2 Transmitter adjacent channel leakage power ratio for intra-band contiguous Carrier Aggregation (DL CA and UL CA)

5.3.10.2.1 Method of test

5.3.10.2.1.1 Initial conditions

Test environment: normal, TL/VL, TL/VH, TH/VL and TH/VH, as specified in annex B.

Frequencies to be tested: low range, high range; as specified in TS 136 508 [2], clause 4.3.1.

Test CC Combination setting ($N_{\text{RB_agg}}$): lowest $N_{\text{RB_agg}}$, highest $N_{\text{RB_agg}}$, as specified in TS 136 521-1 [1], in clause 5.4.2A.1 for the CA Configuration

Uplink/Downlink configurations: as specified in TS 136 521-1 [1]:

- 1) Connect the SS to the UE antenna connectors.
- 2) The parameter settings for the cell are set up according to TS 136 508 [2], clause 4.4.3.
- 3) Downlink signals for PCC are initially set up according to TS 136 521-1 [1], clauses C.0, C.1 and C.3.0 and uplink signals according to clauses H.1 and H.3.0.
- 4) The UL Reference Measurement channels are set according to TS 136 521-1 [1], clause 6.6.2.3A.1.
- 5) Propagation conditions are set according to TS 136 521-1 [1], clause B.0.
- 6) Ensure the UE is in State 3A-RF according to TS 136 508 [2], clause 5.2A.2.

NOTE: When reference is made to test set up, call set up and test mode, guidance on the applicability of these can be found in TS 136 521-1 [1], TS 136 508 [2] and TS 136 509 [i.11] respectively.

5.3.10.2.1.2 Procedure

- 1) Configure SCC according to TS 136 521-1 [1], clauses C.0, C.1 and C.3.0 for all downlink physical channels, except PHICH.
- 2) The SS shall configure SCC as per TS 136 508 [2], clause 5.2A.4.
- 3) SS activates SCC by sending the activation MAC-CE. Wait for at least 2 seconds.
- 4) SS sends uplink scheduling information for each UL HARQ process via PDCCH DCI format 0 for C_RNTI to schedule the UL RMC according to table 6.6.2.3A.1.4.1-1 of TS 136 521-1 [1] on both PCC and SCC. Since the UE has no payload and no loopback data to send the UE sends uplink MAC padding bits on the UL RMC.

- 5) Send continuously uplink power control "up" commands in every uplink scheduling information to the UE; allow at least 200 ms for the UE to reach PUMAX level.
- 6) Measure the mean power over all component carriers of the UE in the CA configuration of the radio access mode according to the test configuration, which shall meet the requirements described in tables 4.2.11.2.2-1 and 4.2.11.2.2-2. The period of the measurement shall be at least the continuous duration of one sub-frame (1 ms). For TDD slots with transient periods are not under test.
- 7) Measure the rectangular filtered mean power for CA E-UTRA.
- 8) Measure the rectangular filtered mean power of the first CA E-UTRA adjacent channel on both lower and upper side of the CA E-UTRA channel, respectively.
- 9) Measure the RRC filtered mean power of the first and the second UTRA for CA adjacent channel on both lower and upper side of the CA E-UTRA channel, respectively.
- 10) Calculate the ratio of the power between the values measured in step 7) over step 8) for CA E-UTRA_{ACLR}.
- 11) Calculated the ratio of the power between the values measured in step 7) over step 9) for UTRA_{ACLR1}, UTRA_{ACLR2}.
- 12) Repeat for applicable test frequencies, channel bandwidths, operating band combinations and environmental conditions.

Details of the test method can be found in TS 136 521-1 [1], clause 6.6.2.3A.1.

5.3.10.2.2 Test requirements

The results obtained shall be compared to the limits in clause 4.2.11.2.2 in order to show compliance.

5.3.10.3 Transmitter adjacent channel leakage power ratio for UL-MIMO

5.3.10.3.1 Method of test

5.3.10.3.1.1 Initial conditions

Test environment: normal, TL/VL, TL/VH, TH/VL, TH/VH; as specified in annex B.

Frequencies to be tested: low range, mid range, high range; as specified in TS 136 508 [2], clause 4.3.1.

Channel bandwidths to be tested: lowest, 5 MHz, 10 MHz and highest channel bandwidth as defined in TS 136 508 [2], clause 4.3.1.

Uplink/Downlink configurations: as specified in TS 136 521-1 [1]:

- 1) Connect the SS to the UE antenna connectors.
- 2) The parameter settings for the cell are set up according to TS 136 508 [2], clause 4.4.3.
- 3) Downlink signals are initially set up according to TS 136 521-1 [1], clauses C.0, C.1 and C.3.0 and uplink signals according to clauses H.1 and H.3.0.
- 4) The UL Reference Measurement channels are set according to TS 136 521-1 [1], clause 6.6.2.3B.
- 5) Propagation conditions are set according to TS 136 521-1 [1], clause B.0.
- 6) Ensure the UE is in State 3A-RF according to TS 136 508 [2], clause 5.2A.2.

NOTE: When reference is made to test set up, call set up and test mode, guidance on the applicability of these can be found in TS 136 521-1 [1], TS 136 508 [2] and TS 136 509 [i.11] respectively.

5.3.10.3.1.2 Procedure

- 1) SS sends uplink scheduling information for each UL HARQ process via PDCCH DCI format 0 for C_RNTI to schedule the UL RMC according to table 6.6.2.3B.1.4.1-1 of TS 136 521-1 [1]. Since the UE has no payload and no loopback data to send the UE sends uplink MAC padding bits on the UL RMC.
- 2) Send continuously uplink power control "up" commands in every uplink scheduling information to the UE; allow at least 200 ms for the UE to reach P_{UMAX} level.
- 3) Measure the sum of the mean power at each antenna connector of UE in the channel bandwidth of the radio access mode according to the test configuration, which shall meet the requirements described in tables 4.2.11.3.2-1 and 4.2.11.3.2-2. The period of the measurement shall be at least the continuous duration of one sub-frame (1 ms). For TDD slots with transient periods are not under test.
- 4) Measure the rectangular filtered mean power for E-UTRA at each antenna connector of UE.
- 5) Measure the rectangular filtered mean power of the first E-UTRA adjacent channel at each antenna connector of UE.
- 6) Measure the RRC filtered mean power of the first and the second UTRA adjacent channel at each antenna connector of UE.
- 7) Calculate the ratio of the power between the values measured in step 4) over step 5) for $E-UTRA_{ACLR}$.
- 8) Calculated the ratio of the power between the values measured in step 4) over step 6) for $UTRA_{ACLR1}$, $UTRA_{ACLR2}$.

Details of the test method can be found in TS 136 521-1 [1], clause 6.6.2.3B.

5.3.10.3.2 Test requirements

The results obtained shall be compared to the limits in clause 4.2.11.3.2 in order to show compliance.

Annex A (normative): HS Requirements and conformance Test specifications Table (HS-RTT)

The HS Requirements and conformance Test specifications Table (HS-RTT) in table A-1 serves a number of purposes, as follows:

- it provides a statement of all the requirements in words and by cross reference to (a) specific clause(s) in the present document or to (a) specific clause(s) in (a) specific referenced document(s);
- it provides a statement of all the test procedures corresponding to those requirements by cross reference to (a) specific clause(s) in the present document or to (a) specific clause(s) in (a) specific referenced document(s);
- it qualifies each requirement to be either:
 - Unconditional: meaning that the requirement applies in all circumstances; or
 - Conditional: meaning that the requirement is dependent on the manufacturer having chosen to support optional functionality defined within the schedule.
- in the case of Conditional requirements, it associates the requirement with the particular optional service or functionality;
- it qualifies each test procedure to be either:
 - Essential: meaning that it is included with the Essential Radio Test Suite and therefore the requirement shall be demonstrated to be met in accordance with the referenced procedures;
 - Other: meaning that the test procedure is illustrative but other means of demonstrating compliance with the requirement are permitted.

Table A-1: HS Requirements and conformance Test specifications Table (HS-RTT)

Harmonized Standard EN 301 908-13						
The following technical requirements and test specifications are relevant to the presumption of conformity under the article 3.2 of the R&TTE Directive [i.2]						
Technical Requirement			Requirement Conditionality		Test Specification	
No	Description	Reference: Clause No	U/C	Condition	E/O	Reference: Clause No
1	Transmitter maximum output power	4.2.2	U		E	5.3.1
2	Transmitter spectrum emission mask	4.2.3	U		E	5.3.2
3	Transmitter spurious emissions	4.2.4	U		E	5.3.3
4	Transmitter minimum output power	4.2.5	U		E	5.3.4
5	Receiver adjacent channel selectivity (ACS)	4.2.6	U		E	5.3.5
6	Receiver blocking characteristics	4.2.7	U		E	5.3.6
7	Receiver spurious response	4.2.8	U		E	5.3.7
8	Receiver intermodulation characteristics	4.2.9	U		E	5.3.8
9	Receiver spurious emissions	4.2.10	U		E	5.3.9
10	Transmitter adjacent channel leakage power ratio	4.2.11	U		E	5.3.10

Key to columns:**Requirement:**

No A unique identifier for one row of the table which may be used to identify a requirement or its test specification.

Description A textual reference to the requirement.

Clause Number Identification of clause(s) defining the requirement in the present document unless another document is referenced explicitly.

Requirement Conditionality:

U/C Indicates whether the requirement is to be *unconditionally* applicable (U) or is *conditional* upon the manufacturers claimed functionality of the equipment (C).

Condition Explains the conditions when the requirement shall or shall not be applicable for a technical requirement which is classified "conditional".

Test Specification:

E/O Indicates whether the test specification forms part of the Essential Radio Test Suite (E) or whether it is one of the Other Test Suite (O).

NOTE: All tests whether "E" or "O" are relevant to the requirements. Rows designated "E" collectively make up the Essential Radio Test Suite; those designated "O" make up the Other Test Suite; for those designated "X" there is no test specified corresponding to the requirement. The completion of all tests classified "E" as specified with satisfactory outcomes is a necessary condition for a presumption of conformity. Compliance with requirements associated with tests classified "O" or "X" is a necessary condition for presumption of conformity, although conformance with the requirement may be claimed by an equivalent test or by manufacturer's assertion supported by appropriate entries in the technical construction file.

Clause Number Identification of clause(s) defining the test specification in the present document unless another document is referenced explicitly. Where no test is specified (that is, where the previous field is "X") this field remains blank.

Annex B (normative): Environmental profile

B.1 General

B.1.1 Introduction

This annex specifies the environmental profile of the UE.

B.1.2 Temperature

The UE shall fulfil all the requirements in the full temperature range of:

Table B.1.2-1: Temperature Test Environment

+15 °C to +35 °C	For normal conditions (with relative humidity up to 75 %)
-10 °C to +55 °C	For extreme conditions (see IEC 60068-2-1 [8] and IEC 60068-2-2 [9])

Outside this temperature range the UE, if powered on, shall not make ineffective use of the radio frequency spectrum. In no case shall the UE exceed the transmitted levels as defined in TS 136 101 [4] for extreme operation.

The normative reference for this requirement is TS 136 101 [4], clause E.1.

Some tests are performed also in extreme temperature conditions. These test conditions are denoted as TL (Temperature Low, -10 °C) and TH (Temperature High, +55 °C).

B.1.3 Voltage

The UE shall fulfil all the requirements in the full voltage range, i.e. the voltage range between the extreme voltages.

The manufacturer shall declare the lower and higher extreme voltages and the approximate shutdown voltage. For the equipment that can be operated from one or more of the power sources listed below, the lower extreme voltage shall not be higher and the higher extreme voltage shall not be lower than that specified below.

Table B.1.3-1: Voltage Test Environment

Power source	Lower extreme Voltage	Higher extreme voltage	Normal conditions voltage
AC mains	0,9 × nominal	1,1 × nominal	nominal
Regulated lead acid battery	0,9 × nominal	1,3 × nominal	1,1 × nominal
Non regulated batteries:			
Leclanché	0,85 × nominal	Nominal	Nominal
Lithium	0,95 × nominal	1,1 × Nominal	1,1 × Nominal
Mercury/nickel and cadmium	0,90 × nominal		Nominal

Outside this voltage range the UE if powered on, shall not make ineffective use of the radio frequency spectrum. In no case shall the UE exceed the transmitted levels as defined in TS 136 101 [4] for extreme operation. In particular, the UE shall inhibit all RF transmissions when the power supply voltage is below the manufacturer declared shutdown voltage.

The normative reference for this requirement is TS 136 101 [4], clause E.2.

Some tests are performed also in extreme voltage conditions. These test conditions are denoted as VL (Lower extreme Voltage) and VH (Higher extreme Voltage).

B.1.4 Test environment

Where a normal environment is required then the normal conditions shown in clauses B.1.2 and B.1.3 shall be applied.

Where an extreme environment is required then the various combinations of extreme temperatures together with the extreme voltages shown in clauses B.1.2 and B.1.3 shall be applied. The combinations are:

- Low extreme Temperature/Low extreme Voltage (TL/VL);
- Low extreme Temperature/High extreme Voltage (TL/VH);
- High extreme Temperature/Low extreme Voltage (TH/VL);
- High extreme Temperature/High extreme Voltage (TH/VH).

Annex C:
Void

Annex D (informative): Bibliography

- Directive 2004/108/EC of the European Parliament and of the Council of 15 December 2004 on the approximation of the laws of the Member States relating to electromagnetic compatibility and repealing Directive 89/336/EEC (EMC Directive).
- CEPT/ERC/REC 74-01 (Siófok 1998, Nice 1999, Sesimbra 2002, Hradec Kralove 2005, Cardiff 2011): "Unwanted Emissions in the Spurious Domain".
- Directive 2006/95/EC of the European Parliament and of the Council of 12 December 2006 on the harmonisation of the laws of Member States relating to electrical equipment designed for use within certain voltage limits (LV Directive).
- Commission Decision 2008/477/EC of 13 June 2008 on the harmonisation of the 2 500-2 690 MHz frequency band for terrestrial systems capable of providing electronic communications services in the Community.
- Commission Decision 2010/267/EU of 6 May 2010 on harmonised technical conditions of use in the 790-862 MHz frequency band for terrestrial systems capable of providing electronic communications services in the European Union.

History

Document history			
V4.2.1	March 2010	Publication	
V5.2.1	May 2011	Publication	
V6.1.1	February 2013	EN Approval Procedure	AP 20130608: 2013-02-08 to 2013-06-10
V6.1.3	August 2013	Vote	V 20131005: 2013-08-06 to 2013-10-07