

ETSI TS 100 392-2 V3.9.2 (2020-06)



Terrestrial Trunked Radio (TETRA); Voice plus Data (V+D); Part 2: Air Interface (AI)

Reference

RTS/TCCE-03267

Keywords

air interface, radio, TETRA, V+D

ETSI

650 Route des Lucioles
F-06921 Sophia Antipolis Cedex - FRANCE

Tel.: +33 4 92 94 42 00 Fax: +33 4 93 65 47 16

Siret N° 348 623 562 00017 - NAF 742 C
Association à but non lucratif enregistrée à la
Sous-Préfecture de Grasse (06) N° 7803/88

Important notice

The present document can be downloaded from:

<http://www.etsi.org/standards-search>

The present document may be made available in electronic versions and/or in print. The content of any electronic and/or print versions of the present document shall not be modified without the prior written authorization of ETSI. In case of any existing or perceived difference in contents between such versions and/or in print, the prevailing version of an ETSI deliverable is the one made publicly available in PDF format at www.etsi.org/deliver.

Users of the present document should be aware that the document may be subject to revision or change of status.

Information on the current status of this and other ETSI documents is available at

<https://portal.etsi.org/TB/ETSIDeliverableStatus.aspx>

If you find errors in the present document, please send your comment to one of the following services:

<https://portal.etsi.org/People/CommiteeSupportStaff.aspx>

Copyright Notification

No part may be reproduced or utilized in any form or by any means, electronic or mechanical, including photocopying and microfilm except as authorized by written permission of ETSI.

The content of the PDF version shall not be modified without the written authorization of ETSI.

The copyright and the foregoing restriction extend to reproduction in all media.

© ETSI 2020.

All rights reserved.

DECT™, **PLUGTESTS™**, **UMTS™** and the ETSI logo are trademarks of ETSI registered for the benefit of its Members.

3GPP™ and **LTE™** are trademarks of ETSI registered for the benefit of its Members and of the 3GPP Organizational Partners.

oneM2M™ logo is a trademark of ETSI registered for the benefit of its Members and of the oneM2M Partners.

GSM® and the GSM logo are trademarks registered and owned by the GSM Association.

Contents

Intellectual Property Rights	45
Foreword.....	45
Modal verbs terminology.....	46
1 Scope	47
2 References	48
2.1 Normative references	48
2.2 Informative references.....	50
3 Definition of terms, symbols and abbreviations.....	51
3.1 Terms.....	51
3.2 Symbols.....	59
3.3 Abbreviations	59
4 Radio aspects.....	66
4.1 Introduction	66
4.2 Set of logical channels.....	66
4.3 Reference configuration	66
4.4 Error control schemes.....	67
4.5 Multiple access and timeslot structure.....	67
4.5.1 General.....	67
4.5.2 Hyperframes, multiframe and frames.....	68
4.5.3 Timeslots and bursts	68
4.5.4 Mapping of logical channels onto physical channels.....	69
4.6 Coding, interleaving and scrambling.....	69
4.7 Modulation	69
4.8 Transmission and reception.....	69
4.9 Other radio-related functions.....	69
4.10 Performance	70
4.11 TETRA modes of operation	70
4.11.0 General.....	70
4.11.1 Main control channel modes of operation.....	71
4.11.1.1 Conventional Access (CA) mode.....	71
4.11.1.2 Direct Access (DA) mode	71
4.11.2 Transmission modes	71
4.11.2.1 Downlink-Continuous Transmission (D-CT) mode.....	71
4.11.2.2 Downlink-Carrier Timesharing Transmission (D-CTT) mode.....	71
4.11.2.3 Downlink-Main Control Channel Timesharing Transmission (D-MCCTT) mode.....	71
4.11.2.4 Multiple Slot Transmission (MST) mode	71
4.11.3 Control modes.....	71
4.11.3.1 Normal Control Mode (NCM)	71
4.11.3.2 Minimum Control Mode (MCM).....	72
5 Modulation	73
5.1 Introduction	73
5.2 Modulation type	73
5.3 Modulation rate	73
5.4 Modulation symbol definition	73
5.5 Modulated signal definition.....	75
5.6 Modulation filter definition	75
5.7 Modulation block diagram	76
5.8 Introduction to QAM channels.....	76
5.9 Modulation type	76
5.10 Use of sub-carriers in QAM carriers	76
5.11 Modulation rate	76
5.12 Modulation symbol definition	77
5.13 Bit to symbol mapping	77
5.14 Data, synchronization and pilot symbol multiplexing	80

5.15	Sub-carrier frequency domain multiplexing	81
5.16	Modulated signal definition	81
5.17	Modulation filter definition	82
5.18	Modulation block diagram	83
6	Radio transmission and reception	84
6.1	Introduction	84
6.2	Frequency bands and channel arrangement	84
6.3	Reference test planes	84
6.4	Transmitter characteristics	85
6.4.1	Output power for phase modulation	85
6.4.1.0	General	85
6.4.1.1	Base Station (BS)	85
6.4.1.2	Mobile Station (MS)	86
6.4.2	Unwanted conducted emissions for phase modulation	86
6.4.2.1	Definitions	86
6.4.2.2	Unwanted emissions close to the carrier	87
6.4.2.2.0	General	87
6.4.2.2.1	Emission during the useful part of the burst	87
6.4.2.2.2	Emission during the switching transients	87
6.4.2.3	Unwanted emissions far from the carrier	88
6.4.2.4	Unwanted emissions during the CLCH and BLCH	88
6.4.2.5	Unwanted emissions in the non-transmit state	89
6.4.3	Unwanted radiated emissions for phase modulation	89
6.4.4	RF tolerance for phase modulation	89
6.4.5	RF Output power time mask for phase modulation	89
6.4.5.0	General	89
6.4.5.1	BS	90
6.4.5.2	MS	90
6.4.6	Transmitter intermodulation attenuation for phase modulation	90
6.4.6.1	Definition	90
6.4.6.2	BS	91
6.4.6.3	MS	91
6.4.7	Intra-BS intermodulation requirements	91
6.4.8	Output power for QAM	91
6.4.8.0	General	91
6.4.8.1	BS	92
6.4.8.2	MS	92
6.4.9	Unwanted conducted emissions for QAM	93
6.4.9.1	Definitions	93
6.4.9.2	Unwanted emissions close to the carrier	93
6.4.9.2.0	General	93
6.4.9.2.1	Emission during the useful part of the burst	93
6.4.9.2.2	Emission during the switching transients	94
6.4.9.3	Unwanted emissions far from the carrier	94
6.4.9.4	Unwanted emissions during the CLCH-Q and BLCH-Q	95
6.4.9.5	Unwanted emissions in the non-transmit state	96
6.4.10	RF Output power time mask for QAM	96
6.4.10.0	General	96
6.4.10.1	BS	97
6.4.10.2	MS	97
6.4.11	Transmitter intermodulation attenuation	97
6.4.12	Intra-BS intermodulation requirements	97
6.5	Receiver characteristics	97
6.5.0	General	97
6.5.1	Blocking characteristics	97
6.5.1.1	Definition	97
6.5.1.2	Specification for Phase Modulation	98
6.5.1.3	Specification for QAM	98
6.5.2	Spurious response rejection	99
6.5.2.1	Definition	99
6.5.2.2	Specification for phase modulation	99

6.5.2.3	Specification for QAM.....	99
6.5.3	Intermodulation response rejection.....	100
6.5.3.1	Definition	100
6.5.3.2	Specification for Phase Modulation	100
6.5.3.3	Specification for QAM.....	100
6.5.4	Unwanted conducted emissions.....	101
6.5.4.1	Definition	101
6.5.4.2	Specification.....	101
6.5.5	Unwanted radiated emissions	101
6.6	Transmitter/receiver performance for phase modulation.....	101
6.6.0	General.....	101
6.6.1	Transmitter performance for phase modulation.....	101
6.6.1.1	Modulation accuracy for phase modulation	101
6.6.1.2	Vector error magnitude requirement at symbol time for phase modulation.....	102
6.6.2	Receiver performance for phase modulation	103
6.6.2.0	General	103
6.6.2.1	Nominal error rates for phase modulation.....	103
6.6.2.1.1	Nominal error rates for $\pi/4$ -DQPSK modulation	103
6.6.2.1.2	Nominal error rates for $\pi/8$ -D8PSK modulation	103
6.6.2.2	Dynamic reference sensitivity performance for phase modulation	104
6.6.2.2.0	General	104
6.6.2.2.1	BS receiver performance	104
6.6.2.2.2	MS receiver performance	106
6.6.2.3	Receiver performance at reference interference ratios for Phase Modulation.....	107
6.6.2.3.0	General	107
6.6.2.3.1	BS receiver performance	108
6.6.2.3.2	MS receiver performance	109
6.6.2.4	Static reference sensitivity performance for phase modulation.....	110
6.6.2.4.0	General	110
6.6.2.4.1	BS receiver performance	110
6.6.2.4.2	MS receiver performance	111
6.6.2.5	MS receiver performance for synchronization burst acquisition.....	112
6.7	Transmitter/receiver performance for QAM	112
6.7.0	General.....	112
6.7.1	Transmitter performance for QAM.....	112
6.7.1.1	Modulation accuracy for QAM.....	112
6.7.1.2	Vector error magnitude requirement at symbol time for QAM.....	113
6.7.2	Receiver performance for QAM	114
6.7.2.0	General.....	114
6.7.2.1	Nominal error rates for QAM.....	114
6.7.2.2	Dynamic reference sensitivity performance for QAM.....	114
6.7.2.3	Receiver performance at reference interference ratios for QAM.....	117
6.7.2.3.1	Adjacent channel interference	117
6.7.2.3.2	Co-channel interference.....	117
6.7.2.4	Static reference sensitivity performance for QAM	118
6.7.2.5	MS receiver performance for frequency correction burst acquisition on a DA cell.....	118
6.8	Propagation conditions	118
6.8.0	General.....	118
6.8.1	Propagation conditions - introduction.....	118
6.8.2	Tap-gain process types.....	119
6.8.3	Propagation models.....	119
7	Radio sub-system synchronization	121
7.1	Introduction	121
7.2	General description of synchronization system.....	121
7.3	Timebase counters for phase modulation	121
7.3.1	Timing counters for phase modulation	121
7.3.2	Values of the counters for phase modulation.....	121
7.4	Timing of phase modulation signals.....	122
7.5	Timebase counters for QAM	122
7.5.1	Timing counters for QAM.....	122
7.5.2	Values of the counters for QAM.....	122

7.6	Timing of QAM signals	123
7.7	BS requirements for synchronization	123
7.8	MS requirements for synchronization	124
8	Channel coding and scrambling	125
8.1	Introduction	125
8.2	General	125
8.2.1	Interfaces in the error control structure	125
8.2.1.1	Interfaces for phase modulation	125
8.2.1.2	Interfaces for QAM	127
8.2.2	Notation	128
8.2.3	Definition of error control codes	128
8.2.3.1	16-state Rate-Compatible Punctured Convolutional (RCPC) codes	128
8.2.3.1.0	General	128
8.2.3.1.1	Encoding by the 16-state mother code of rate 1/4	128
8.2.3.1.2	Puncturing of the mother code	129
8.2.3.1.3	Puncturing scheme of the RCPC code of rate 2/3	129
8.2.3.1.4	Puncturing scheme of the RCPC code of rate 1/3	129
8.2.3.1.5	Puncturing scheme of the RCPC code of rate 292/432	129
8.2.3.1.6	Puncturing scheme of the RCPC code of rate 148/432	129
8.2.3.2	Shortened (30,14) Reed-Muller (RM) code	130
8.2.3.3	($K_I + 16, K_I$) block code	130
8.2.3.4	8-state Parallel Concatenated Convolutional Code (PCCC) for QAM	131
8.2.3.4.0	General	131
8.2.3.4.1	Encoding by the upper 8-state RSC encoder of rate 1/2	131
8.2.3.4.2	Interleaving by the quadratic-congruence interleaver	132
8.2.3.4.3	Encoding the interleaved bits by the lower 8-state RSC encoder of rate 1/2	133
8.2.3.4.4	Merging the systematic and parity bits for the PCCC encoder	133
8.2.3.4.5	Puncturing scheme for the PCCC encoder	134
8.2.3.4.6	Puncturing scheme for the PCCC encoder with coding rate 2/3	134
8.2.3.4.7	Puncturing scheme for the PCCC encoder with coding rate 1/2	134
8.2.3.5	(16,5) Reed-Muller (RM) code for QAM	134
8.2.4	Definition of interleaving schemes	134
8.2.4.1	Block interleaving for phase modulation	134
8.2.4.2	Interleaving over N blocks	135
8.2.4.3	Block interleaving for QAM	135
8.2.5	Definition of scrambling	136
8.2.5.1	Scrambling method	136
8.2.5.2	Scrambling sequence	136
8.3	Error control schemes	137
8.3.1	Error control schemes for phase modulation	137
8.3.1.0	General	137
8.3.1.1	Access Assignment Channel (AACH)	139
8.3.1.2	Broadcast Synchronization Channel (BSCH)	139
8.3.1.3	Traffic channels in circuit switched mode	140
8.3.1.3.1	Frame stealing and multi-slot transmission	140
8.3.1.3.2	Traffic CHannel, net rate = 4,8 kbit/s (TCH/4,8)	140
8.3.1.3.3	Traffic CHannel, net rate = 2,4 kbit/s (TCH/2,4)	141
8.3.1.3.4	Traffic CHannel, net rate = 7,2 kbit/s (TCH/7,2)	141
8.3.1.3.5	Traffic Channel-P8, net rate = 10,8 kbit/s (TCH-P8/10,8)	142
8.3.1.3.6	Speech Traffic Channel, full slot (TCH/S)	142
8.3.1.3.7	Speech Traffic Channel, half slot (TCH/S)	142
8.3.1.4	Signalling channels for signalling and packet mode data	143
8.3.1.4.1	Signalling CHannel for mapping onto Half-bursts on the Downlink (SCH/HD), Broadcast Network CHannel (BNCH), and STEaling CHannel (STCH)	143
8.3.1.4.2	Signalling CHannel for mapping onto Half-bursts on the Downlink (SCH-P8/HD)	143
8.3.1.4.3	Signalling CHannel for mapping onto Half-bursts on the Uplink (SCH/HU)	144
8.3.1.4.4	Signalling CHannel for mapping onto Half-bursts on the Uplink (SCH-P8/HU)	144
8.3.1.4.5	Signalling CHannel for mapping onto Full bursts (SCH/F)	144
8.3.1.4.6	Signalling CHannel for mapping onto Full bursts (SCH-P8/F)	145
8.3.2	Error control schemes for QAM	146
8.3.2.0	General	146

8.3.2.1	Slot Information Channel - QAM/Uplink (SICH-Q/U)	146
8.3.2.2	Slot Information Channel - QAM/Downlink (SICH-Q/D).....	147
8.3.2.3	Access Assignment Channel - QAM (AACH-Q)	147
8.3.2.4	Signalling Channel - QAM/Half slot Uplink (SCH-Q/HU)	148
8.3.2.5	Signalling Channel - QAM/Uplink (SCH-Q/U).....	148
8.3.2.6	Signalling Channel - QAM/Downlink (SCH-Q/D) and Broadcast Network Channel - QAM (BNCH-Q).....	149
8.3.2.7	Signalling Channel - QAM/Random Access (SCH-Q/RA)	150
8.3.2.8	Broadcast Synchronization Channel - QAM (BSCH-Q).....	150
8.3.2.9	Signalling Channel Data set B - QAM (SCH-Q/B).....	151
9	Channel multiplexing	152
9.1	Introduction	152
9.2	Logical channels.....	152
9.2.0	General.....	152
9.2.1	Logical channels hierarchy	152
9.2.2	Traffic channels for $\pi/4$ -DQPSK	152
9.2.2a	Traffic channels for $\pi/8$ -D8PSK	152
9.2.3	Control CHannels (CCH) for phase modulation.....	153
9.2.3.1	General	153
9.2.3.2	BCCH.....	153
9.2.3.3	LCH.....	153
9.2.3.4	SCH for $\pi/4$ -DQPSK.....	153
9.2.3.4a	SCH for $\pi/8$ -D8PSK	154
9.2.3.5	AACH	154
9.2.3.6	STCH	154
9.2.4	QAM Control CHannels (CCH-Q)	154
9.2.4.1	General	154
9.2.4.2	BCCH-Q	154
9.2.4.3	LCH-Q	155
9.2.4.4	SCH-Q.....	155
9.2.4.4a	SCH-Q/B	156
9.2.4.5	AACH-Q	156
9.2.4.6	SICH-Q	156
9.3	The physical resource	157
9.3.1	General.....	157
9.3.2	RF channels for phase modulation.....	157
9.3.2a	RF channels for QAM.....	158
9.3.2b	Random access RF channels for QAM	158
9.3.3	Timeslots	158
9.3.4	TDMA frame	159
9.3.5	Timeslot numbering	159
9.3.6	Subslot	159
9.3.6a	Random access uplink RF channel subslots for QAM.....	159
9.3.7	Multiframe	159
9.3.8	Hyperframe	159
9.3.9	Frame alignment	159
9.4	Physical channels	159
9.4.1	General.....	159
9.4.2	Types of physical channels for phase modulation	160
9.4.2.0	General	160
9.4.2.1	CP channel for phase modulation.....	160
9.4.2.2	TP channel.....	160
9.4.2.3	UP channel	160
9.4.3	Bursts for phase modulation	160
9.4.3.1	General	160
9.4.3.2	Phase modulation symbol numbering	161
9.4.3.3	Phase modulation bit numbering.....	161
9.4.3.4	Burst timing.....	161
9.4.4	Type of bursts for phase modulation	162
9.4.4.1	General	162
9.4.4.2	Modulation bits allocation.....	164

9.4.4.2.0	General	164
9.4.4.2.1	Control uplink Burst (CB)	165
9.4.4.2.2	Linearization uplink Burst (LB)	165
9.4.4.2.3	Linearization downlink burst	165
9.4.4.2.4	Normal Uplink Burst (NUB)	165
9.4.4.2.5	Normal continuous downlink burst	166
9.4.4.2.6	Synchronization continuous downlink burst	167
9.4.4.2.7	Normal discontinuous downlink burst	167
9.4.4.2.8	Synchronization discontinuous downlink burst	168
9.4.4.3	Burst fields	168
9.4.4.3.1	Frequency correction field	168
9.4.4.3.2	Normal training sequence	168
9.4.4.3.3	Extended training sequence	169
9.4.4.3.4	Synchronization training sequence	169
9.4.4.3.5	Tail bits	170
9.4.4.3.6	Phase adjustment bits	170
9.4.5	Transmission modes for phase modulation	171
9.4.5.1	BS continuous transmission	171
9.4.5.2	BS timesharing transmission	171
9.4.5.3	MS multiple slot transmission	172
9.4.6	Types of physical channels for QAM	173
9.4.6.0	General	173
9.4.6.1	CP channel for QAM	173
9.4.6.2	UP channel	173
9.4.7	Bursts for QAM	173
9.4.7.1	General	173
9.4.7.2	Modulation symbol numbering	173
9.4.7.3	Modulation bit numbering	174
9.4.7.4	Burst timing	174
9.4.8	Type of bursts for QAM	175
9.4.8.1	General	175
9.4.8.2	Modulation symbols allocation	176
9.4.8.3	Burst sub-carrier symbol sets	176
9.4.8.3.1	General on burst sub-carrier symbol sets	176
9.4.8.3.2	Uplink sync sequence set	176
9.4.8.3.3	Downlink sync sequence set	177
9.4.8.3.3a	Secondary sync sequence set	177
9.4.8.3.4	Half-slot uplink pilots set	177
9.4.8.3.5	Full-slot uplink pilots set	177
9.4.8.3.6	Full-slot downlink pilots set	178
9.4.8.3.7	Filler sets	178
9.4.8.3.8	Linearization downlink zeroed set	178
9.4.8.3.9	Frequency correction set	178
9.4.8.3.10	Frequency correction data set A	178
9.4.8.3.11	Frequency correction data set B	179
9.4.9	Transmission modes for QAM	179
9.4.9.1	BS transmission	179
9.4.9.2	MS multiple slot transmission	179
9.5	Mapping of logical channels into physical channels	179
9.5.0	General	179
9.5.1	General mapping of logical channels into $\pi/4$ -DQPSK physical channels	180
9.5.1a	General mapping of logical channels into D8PSK physical channels	181
9.5.1b	General mapping of logical channels into unallocated physical channels for phase modulation	182
9.5.2	Mapping of BCCH and CLCH for phase modulation	182
9.5.3	Mapping of SCH for $\pi/4$ -DQPSK physical channels	183
9.5.3a	Mapping of SCH for $\pi/8$ -D8PSK physical channels	183
9.5.4	Mapping of TCH and STCH for phase modulation	184
9.5.5	Mapping of AACH for phase modulation	184
9.5.6	General mapping of logical channels for QAM	184
9.5.7	General mapping of logical channels into unallocated physical channels for QAM	185
9.5.8	Mapping of BCCH-Q and CLCH-Q for QAM	185

9.5.9	Mapping of SCH-Q for QAM.....	186
9.5.10	Mapping of SICH-Q and AACH-Q for QAM	186
9.6	Monitoring pattern for transmitting MSs.....	187
9.7	BS timesharing transmission	187
9.7.1	Carrier sharing for Phase Modulation.....	187
9.7.2	MCCH sharing for Phase Modulation	187
9.7.3	BS timesharing transmission for QAM.....	188
9.8	Modes of control	188
9.8.0	General.....	188
9.8.1	Normal Control Mode.....	188
9.8.2	Minimum Control Mode.....	189
10	Radio subsystem link control	190
10.1	Introduction	190
10.2	RF power control.....	190
10.3	Radio link measurements	190
10.3.0	General.....	190
10.3.1	Received signal strength	190
10.3.1.1	Signal strength measurement	190
10.3.1.2	Sample duration for signal strength measurement	190
10.3.2	Signal quality	190
10.3.3	Round-trip MS-BS path delay	190
10.4	Link adaptation.....	191
11	Call Control (CC) service description	192
11.1	Introduction	192
11.2	Services offered.....	192
11.3	CC service	193
11.3.1	CC primitives exchanged through the TNCC-SAP	193
11.3.2	Service primitives at the TNCC-SAP	193
11.3.3	Primitive description.....	194
11.3.3.0	General	194
11.3.3.1	TNCC-ALERT primitive	194
11.3.3.2	TNCC-COMPLETE primitive	195
11.3.3.3	TNCC-DTMF primitive	195
11.3.3.4	TNCC-MODIFY primitive	196
11.3.3.5	TNCC-NOTIFY primitive	196
11.3.3.6	TNCC-PROCEED primitive	197
11.3.3.7	TNCC-RELEASE primitive.....	197
11.3.3.8	TNCC-SETUP primitive	197
11.3.3.9	TNCC-TX primitive.....	199
11.3.4	Parameter description	199
11.4	States for CC SAP	207
12	Supplementary Service (SS) service description.....	208
12.1	Introduction	208
12.2	Services offered.....	208
12.3	SS service	208
12.3.1	Primitives exchanged through TNSS-SAP	208
12.3.2	Parameter description	209
13	Short Data Service (SDS) service description.....	209
13.1	Introduction	209
13.2	Services offered.....	209
13.3	SDS	209
13.3.1	SDS primitives exchanged through the TNSDS-SAP	209
13.3.2	Service primitives at the TNSDS-SAP	210
13.3.2.0	General	210
13.3.2.1	TNSDS-STATUS primitive	210
13.3.2.2	TNSDS-REPORT primitive.....	211
13.3.2.3	TNSDS-UNITDATA primitive.....	211
13.3.2.4	TNSDS-CANCEL primitive	212
13.3.3	Parameter description	212

13.3.4	State description.....	215
13.3.4.1	NULL state.....	215
13.3.4.2	SHORT DATA INITIATED state	215
13.3.5	Service state diagram for the TNSDS-SAP	215
14	CMCE protocol	216
14.1	Introduction	216
14.2	Overview of CMCE.....	216
14.2.0	General.....	216
14.2.1	Communication routes of the CMCE model.....	217
14.2.2	Protocol structure and protocol stack.....	217
14.2.3	Addressing rules	219
14.2.4	CC, SS and SDS sub-entities	219
14.2.4.0	General	219
14.2.4.1	CC sub-entity	220
14.2.4.2	SS sub-entity	220
14.2.4.3	SDS sub-entity	220
14.2.5	PC sub-entity	220
14.2.6	Internal routes	221
14.2.7	Intra-CMCE primitive summary	223
14.2.7.0	General	223
14.2.7.1	Down link CC PDU parameters	223
14.2.7.2	Uplink CC PDU parameters.....	223
14.2.7.3	Downlink SS PDU parameters.....	224
14.2.7.4	Uplink SS PDU parameters.....	224
14.2.7.5	Down link SDS PDU parameters	224
14.2.7.6	Uplink SDS PDU parameters.....	224
14.2.7.7	CMCE management primitives.....	225
14.2.7.7.0	ACTIVITY request.....	225
14.2.7.7.1	BREAK indication.....	225
14.2.7.7.1a	BUSY indication	225
14.2.7.7.2	CANCEL request.....	225
14.2.7.7.3	CLOSE indication	225
14.2.7.7.4	CONFIGURE indication	225
14.2.7.7.5	CONFIGURE request.....	226
14.2.7.7.6	IDENTITIES request.....	226
14.2.7.7.6a	IDLE indication	226
14.2.7.7.6b	INFO indication.....	226
14.2.7.7.7	OPEN indication.....	226
14.2.7.7.8	REOPEN indication.....	226
14.2.7.7.9	REPORT indication.....	226
14.2.7.7.10	RESUME indication.....	227
14.3	Overview of services required by the CMCE.....	227
14.4	CMCE protocol states	227
14.4.0	General.....	227
14.4.1	States for PC	227
14.4.1.0	General	227
14.4.1.1	CLOSED	227
14.4.1.2	OPEN	227
14.4.2	States for CC.....	228
14.4.2.0	General	228
14.4.2.1	IDLE	230
14.4.2.2	MO-CALL-SETUP.....	230
14.4.2.3	MT-CALL-SETUP	230
14.4.2.4	CALL ACTIVE.....	231
14.4.2.5	CALL DISCONNECT	231
14.4.2.6	WAIT	231
14.4.3	States for SS.....	231
14.4.4	States for SDS.....	232
14.5	Procedures	232
14.5.0	General.....	232
14.5.1	Individual CC procedures	233

14.5.1.0	General	233
14.5.1.1	Call set-up procedures.....	233
14.5.1.1.0	General	233
14.5.1.1.1	Incoming call	234
14.5.1.1.2	Outgoing call	236
14.5.1.1.3	Colliding calls.....	237
14.5.1.1.4	Unsuccessful call set-up	237
14.5.1.1.5	Call rejection	238
14.5.1.2	Call maintenance procedures	238
14.5.1.2.0	General	238
14.5.1.2.1	Transmission control procedures.....	239
14.5.1.2.2	Call status information procedures	243
14.5.1.2.3	Call modification procedures.....	244
14.5.1.2.4	Call restoration procedures.....	245
14.5.1.2.5	DTMF procedures	247
14.5.1.2.6	Calls to and from external subscribers.....	249
14.5.1.3	Call disconnection procedures	249
14.5.1.3.0	General	249
14.5.1.3.1	User initiated disconnection	249
14.5.1.3.2	Network initiated disconnection.....	250
14.5.1.3.3	Reception of disconnection request	250
14.5.1.3.4	Expiry of timers.....	250
14.5.1.3.5	Colliding disconnection.....	251
14.5.1.4	U-Plane switching	251
14.5.1.4.0	General	251
14.5.1.4.1	End of call set-up phase.....	252
14.5.1.4.2	During call maintenance phase.....	252
14.5.1.4.3	Call disconnection phase	253
14.5.2	Group CC procedures	253
14.5.2.0	General	253
14.5.2.1	Call set-up procedures.....	253
14.5.2.1.0	General	253
14.5.2.1.1	Incoming call	255
14.5.2.1.2	Outgoing call	255
14.5.2.1.3	Colliding calls.....	256
14.5.2.1.4	Unsuccessful call set-up	257
14.5.2.1.5	Call rejection	257
14.5.2.2	Call maintenance procedures	257
14.5.2.2.0	General	257
14.5.2.2.1	Transmission control procedures.....	258
14.5.2.2.2	Call status information procedures	262
14.5.2.2.3	Call modification procedures.....	263
14.5.2.2.4	Call restoration procedures.....	264
14.5.2.2.5	DTMF procedures	267
14.5.2.2.6	Temporary address handling procedures	267
14.5.2.2.7	Calls to and from external subscribers.....	268
14.5.2.3	Call disconnection procedures	268
14.5.2.3.0	General	268
14.5.2.3.1	User initiated disconnection	269
14.5.2.3.2	Network initiated disconnection.....	270
14.5.2.3.3	Reception of disconnection request	270
14.5.2.3.4	Colliding disconnection.....	270
14.5.2.3.5	Expiry of timers.....	270
14.5.2.4	U-Plane switching.....	271
14.5.2.4.0	General	271
14.5.2.4.1	End of call set-up phase.....	271
14.5.2.4.2	During call maintenance phase.....	272
14.5.2.4.3	Call disconnection phase	273
14.5.2.5	Void.....	273
14.5.2.6	Acknowledged group call procedures	273
14.5.2.7	Call ownership	274
14.5.3	Traffic channel assignment procedures.....	274

14.5.3.1	SwMI related procedures	274
14.5.3.2	MS related procedures.....	275
14.5.3.2.1	General procedures.....	275
14.5.3.2.2	Procedures for acceptance of individually-addressed channel allocation.....	276
14.5.3.2.3	Procedures for acceptance of group-addressed channel allocation.....	277
14.5.4	SS procedures	278
14.5.5	SDS procedures	278
14.5.5.0	General	278
14.5.5.1	Incoming short data message	278
14.5.5.2	Outgoing short data messages.....	279
14.5.6	PC procedures.....	279
14.5.6.0	General.....	279
14.5.6.1	Access to the communication resources.....	279
14.5.6.2	Access priority handling	279
14.5.6.2.0	General	279
14.5.6.2.1	Cancel.....	280
14.5.6.3	CMCE PDU exchange	281
14.5.6.3.0	General	281
14.5.6.3.1	Choice of layer 2 service	281
14.5.6.4	Control information exchange.....	281
14.5.6.5	PC protocol error conditions	281
14.5.6.5.1	PDU type error	281
14.5.6.5.2	Invalid call identifier	282
14.5.6.5.3	MS busy.....	282
14.5.6.6	Temporary Disablement.....	282
14.5.7	Subscriber class	282
14.5.8	Activity handling	283
14.5.9	Not-permitted cells	283
14.6	Protocol timers	283
14.7	PDU descriptions.....	284
14.7.0	General.....	284
14.7.1	PDU description tables - downlink	285
14.7.1.1	D-ALERT.....	285
14.7.1.2	D-CALL PROCEEDING.....	286
14.7.1.3	D-CALL RESTORE	286
14.7.1.4	D-CONNECT.....	287
14.7.1.5	D-CONNECT ACKNOWLEDGE.....	287
14.7.1.6	D-DISCONNECT	288
14.7.1.7	D-FACILITY	288
14.7.1.8	D-INFO	289
14.7.1.9	D-RELEASE.....	289
14.7.1.10	D-SDS-DATA.....	290
14.7.1.11	D-STATUS	290
14.7.1.12	D-SETUP	291
14.7.1.13	D-TX CEASED.....	291
14.7.1.14	D-TX CONTINUE.....	292
14.7.1.15	D-TX GRANTED	292
14.7.1.16	D-TX INTERRUPT	293
14.7.1.17	D-TX WAIT.....	293
14.7.2	PDU description tables - uplink	294
14.7.2.1	U-ALERT.....	294
14.7.2.2	U-CALL RESTORE	294
14.7.2.3	U-CONNECT.....	295
14.7.2.4	U-DISCONNECT	295
14.7.2.5	U-FACILITY	295
14.7.2.6	U-INFO	296
14.7.2.7	U-STATUS	296
14.7.2.8	U-SDS-DATA.....	297
14.7.2.9	U-RELEASE.....	298
14.7.2.10	U-SETUP	298
14.7.2.11	U-TX CEASED.....	299
14.7.2.12	U-TX DEMAND.....	299

14.7.3	PDU description tables - downlink and uplink	299
14.7.3.1	General rules for function not supported.....	299
14.7.3.2	CMCE FUNCTION NOT SUPPORTED	299
14.8	Information elements coding	300
14.8.0	General.....	300
14.8.1	Area Selection.....	300
14.8.2	Basic service information	301
14.8.3	Call identifier	301
14.8.3a	Call identifier present.....	301
14.8.4	Call ownership	301
14.8.5	Called party type identifier	302
14.8.6	Called party SNA.....	302
14.8.7	Called party extension	302
14.8.8	Called party SSI.....	302
14.8.9	Calling party type identifier	303
14.8.10	Calling party extension	303
14.8.11	Calling party SSI.....	303
14.8.12	Call priority.....	303
14.8.13	Call status	304
14.8.14	Call queued	304
14.8.15	Continue.....	304
14.8.16	Call time-out	305
14.8.17	Call time-out, set-up phase	305
14.8.17a	Circuit mode type	306
14.8.17b	CLIR control.....	306
14.8.17c	Communication type.....	306
14.8.18	Disconnect cause	307
14.8.18a	DM-MS address	307
14.8.19	DTMF	307
14.8.19a	DTMF digit.....	308
14.8.19b	DTMF type	308
14.8.20	External subscriber number	309
14.8.21	Encryption control	309
14.8.21a	Encryption flag	309
14.8.22	Facility	310
14.8.23	Hook method selection	310
14.8.24	Length indicator.....	310
14.8.25	New call identifier	310
14.8.26	Modify	310
14.8.27	Notification indicator.....	311
14.8.27a	Other party type identifier.....	311
14.8.27b	Other party SNA	311
14.8.27c	Other party extension.....	311
14.8.27d	Other party SSI	311
14.8.28	PDU type	312
14.8.29	Poll request	312
14.8.30	Poll response	312
14.8.31	Poll response addresses.....	313
14.8.32	Poll response number.....	313
14.8.33	Poll response percentage.....	313
14.8.34	Pre-coded status	314
14.8.35	Proprietary	314
14.8.36	Request to transmit/send data	314
14.8.37	Reset call time-out timer (T310).....	315
14.8.38	Short data type identifier.....	315
14.8.39	Simplex/duplex selection.....	315
14.8.39a	Slots per frame	315
14.8.40	Speech service	315
14.8.41	Temporary address.....	316
14.8.42	Transmission grant.....	316
14.8.43	Transmission request permission.....	316
14.8.44	Transmitting party type identifier	316

14.8.45	Transmitting party extension	316
14.8.46	Transmitting party SSI.....	317
14.8.47	TX demand priority	317
14.8.48	Type 3 element identifier	317
14.8.49	User defined data-1	317
14.8.50	User defined data-2.....	318
14.8.51	User defined data-3.....	318
14.8.52	User defined data-4.....	318
15	Mobility Management (MM) service description	319
15.1	Introduction	319
15.2	Services offered.....	319
15.3	Primitive description	319
15.3.0	General.....	319
15.3.1	Service state model for the MS.....	320
15.3.2	Service primitives at the TNMM-SAP, MS/LS side.....	320
15.3.3	Primitive description.....	321
15.3.3.0	General	321
15.3.3.1	TNMM-ATTACH DETACH GROUP IDENTITY primitive	321
15.3.3.2	TNMM-DEREGISTRATION primitive	321
15.3.3.3	TNMM-DISABLING primitive.....	321
15.3.3.4	TNMM-ENABLING primitive.....	321
15.3.3.5	TNMM-ENERGY SAVING primitive	322
15.3.3.6	TNMM-REPORT primitive	322
15.3.3.7	TNMM-REGISTRATION primitive	322
15.3.3.8	TNMM-SERVICE primitive.....	323
15.3.3.9	TNMM-STATUS primitive	323
15.3.4	Parameters description.....	324
15.3.5	State description for the MS	329
15.3.5.0	General	329
15.3.5.1	Not updated	329
15.3.5.2	Wait updating.....	329
15.3.5.3	Updated	329
15.3.5.4	Temporary disabled.....	329
15.3.5.5	Permanently disabled	329
15.3.6	Service state diagram for the TNMM-SAP.....	330
16	MM protocol	334
16.1	Introduction	334
16.2	MM procedures	334
16.2.1	General.....	334
16.2.2	Services provided by the protocol.....	335
16.2.3	Underlying services assumed by the protocol.....	335
16.2.4	Services assumed from the local environment.....	335
16.3	Protocol functions.....	335
16.3.0	General.....	335
16.3.1	Activation and control of underlying MLE Service.....	337
16.3.1.1	Activation procedure.....	337
16.3.1.2	Deactivation procedure	338
16.3.1.3	Maintenance procedures.....	338
16.3.1.3.1	Report and cancel handling	338
16.3.1.3.2	Stealing permission and stealing repeats flag handling	338
16.3.1.3.3	Busy handling.....	339
16.3.1.3.4	Activity handling	339
16.4	Registration procedure	339
16.4.0	General.....	339
16.4.1	MLE initiated registration procedure.....	340
16.4.1.0	General	340
16.4.1.1	Normal registration	340
16.4.1.2	Forward registration	346
16.4.2	User application initiated registration procedure	349
16.4.3	Infrastructure initiated registration procedure.....	354

16.4.4	Colliding registrations.....	357
16.4.5	Expiry of timer T351	357
16.4.6	Expiry of LA timers.....	357
16.4.7	Lifetime of ASSI/(V)ASSI	357
16.4.7.0	General	357
16.4.7.1	ASSI/(V)ASSI validity at migration	358
16.4.7.2	ASSI/(V)ASSI validity by MS initiative.....	358
16.4.7.3	ASSI/(V)ASSI validity at registration rejection.....	358
16.4.8	Temporary registration	358
16.4.9	Subscriber class procedures	359
16.4.10	Frequency band capability procedures.....	359
16.4.11	Air to ground reporting procedure	360
16.4.12	Cell type preference or requirement	361
16.4.13	Cell load.....	362
16.5	Enable and disable procedures	362
16.6	De-registration procedure.....	363
16.6.1	Trunking mode de-registration	363
16.6.2	Direct mode related de-registration	363
16.7	Energy economy.....	364
16.7.1	Energy economy mode procedure	364
16.7.2	Procedures for requesting Direct Mode dual watch operation.....	365
16.7.2.1	Introduction.....	365
16.7.2.2	MS requesting to start, modify or resume dual watch mode.....	366
16.7.2.3	MS terminating dual watch mode	367
16.7.2.4	SwMI modifying or terminating dual watch mode	368
16.7.2.5	Changing between modes	368
16.7.2.6	General dual watch procedures	369
16.7.2.7	Idle dual watch without informing SwMI	369
16.7.3	Expiry of timer T352	370
16.8	Attachment/detachment of group identities and group reporting procedures.....	370
16.8.0	General.....	370
16.8.1	Infrastructure initiated attachment/detachment of group identities procedure.....	371
16.8.2	MS initiated attachment/detachment of group identities procedure.....	372
16.8.3	SwMI initiated group report procedure.....	373
16.8.4	MS initiated group report procedure.....	374
16.8.5	Expiry of timer T353	375
16.8.6	Colliding requests for group attachment/detachment and group reporting	375
16.8.7	Group Identity Address Type (GIAT) usage in group identity downlink/uplink.....	375
16.8.8	PDU or function not supported.....	376
16.9	MM PDU structures and contents	377
16.9.1	MM PDU general description.....	377
16.9.2	MM PDU description tables - downlink.....	377
16.9.2.1	D-ATTACH/DETACH GROUP IDENTITY	377
16.9.2.2	D-ATTACH/DETACH GROUP IDENTITY ACKNOWLEDGEMENT.....	378
16.9.2.3	Void.....	378
16.9.2.4	Void.....	378
16.9.2.5	D-MM STATUS	378
16.9.2.5.1	D-MM STATUS generic structure	378
16.9.2.5.2	D-CHANGE OF ENERGY SAVING MODE REQUEST	379
16.9.2.5.3	D-CHANGE OF ENERGY SAVING MODE RESPONSE	379
16.9.2.5.4	D-DUAL WATCH MODE RESPONSE.....	380
16.9.2.5.5	D-TERMINATING DUAL WATCH MODE RESPONSE	380
16.9.2.5.6	D-CHANGE OF DUAL WATCH MODE REQUEST	381
16.9.2.5.7	Direct mode gateway related D-MM STATUS	381
16.9.2.5.8	D-MS FREQUENCY BANDS REQUEST	381
16.9.2.5.9	DISTANCE REPORTING REQUEST	382
16.9.2.6	Void.....	382
16.9.2.7	D-LOCATION UPDATE ACCEPT	382
16.9.2.8	D-LOCATION UPDATE COMMAND	383
16.9.2.9	D-LOCATION UPDATE REJECT	383
16.9.2.10	D-LOCATION UPDATE PROCEEDING	384
16.9.3	MM PDU descriptions - uplink.....	384

16.9.3.1	U-ATTACH/DETACH GROUP IDENTITY	384
16.9.3.2	U-ATTACH/DETACH GROUP IDENTITY ACKNOWLEDGEMENT	385
16.9.3.3	U-ITSI DETACH	385
16.9.3.4	U-LOCATION UPDATE DEMAND	386
16.9.3.5	U-MM STATUS	387
16.9.3.5.1	U-MM STATUS generic construction	387
16.9.3.5.2	U-CHANGE OF ENERGY SAVING MODE REQUEST	387
16.9.3.5.3	U-CHANGE OF ENERGY SAVING MODE RESPONSE	388
16.9.3.5.4	U-DUAL WATCH MODE REQUEST	388
16.9.3.5.5	U-TERMINATING DUAL WATCH MODE REQUEST	389
16.9.3.5.6	U-CHANGE OF DUAL WATCH MODE RESPONSE	389
16.9.3.5.7	U-START OF DIRECT MODE OPERATION	389
16.9.3.5.8	Direct mode gateway related U-MM STATUS	390
16.9.3.5.9	U-MS FREQUENCY BANDS INFORMATION	390
16.9.4	PDU description tables - downlink and uplink	391
16.9.4.1	MM PDU/FUNCTION NOT SUPPORTED	391
16.10	MM information elements coding	391
16.10.1	Address extension	391
16.10.1a	Cell type control	392
16.10.2	Cipher control	392
16.10.3	Ciphering parameters	393
16.10.4	Void	393
16.10.5	Class of MS	393
16.10.6	Class of usage	394
16.10.7	Disabling type	395
16.10.7a	Default group attachment lifetime	395
16.10.7b	Distance reporting timer	395
16.10.7c	Distance reporting validity	395
16.10.8	Distribution on 18 th frame	395
16.10.8a	DMO carrier	396
16.10.8b	Dual watch mode	396
16.10.9	Energy saving mode	397
16.10.10	Energy saving information	397
16.10.10a	Extended capabilities	398
16.10.11	Frame Number	399
16.10.11a	Frequency band definition	399
16.10.12	Group identity accept/reject	399
16.10.13	Group identity acknowledgement request	400
16.10.14	Group identity acknowledgement type	400
16.10.15	Group identity address type	400
16.10.16	Group identity attachment lifetime	400
16.10.17	Group identity attach/detach mode	401
16.10.18	Group identity attach/detach type identifier	401
16.10.19	Group identity attachment	401
16.10.20	Group identity detachment downlink	401
16.10.21	Group identity detachment uplink	402
16.10.22	Group identity downlink	402
16.10.23	Group identity location accept	402
16.10.24	Group identity location demand	403
16.10.25	Void	403
16.10.26	Group identity report	403
16.10.27	Group identity uplink	403
16.10.27a	Group report response	403
16.10.28	Group Short Subscriber Identity (GSSI)	404
16.10.29	KSG number	404
16.10.30	LA	404
16.10.31	LACC	404
16.10.32	LANC	404
16.10.33	LA timer	405
16.10.34	LA information	405
16.10.34a	Length of the copied PDU	405
16.10.35	Location update type	406

16.10.35a	Location update accept type.....	406
16.10.36	Mobile Country Code (MCC).....	406
16.10.37	Mobile Network Code (MNC).....	406
16.10.37a	Mode change information.....	407
16.10.37b	MS operating with type 2 repeater.....	407
16.10.38	Multiframe Number (MN).....	407
16.10.38a	Not-supported PDU type.....	407
16.10.38b	Number of frequency band definitions.....	408
16.10.39	PDU type.....	408
16.10.40	New registered area.....	409
16.10.40a	Preferred cell type.....	409
16.10.40b	Preferred cell type list control.....	409
16.10.41	Proprietary.....	410
16.10.41a	QAM capabilities.....	410
16.10.41b	Reason for dual watch change by SwMI.....	411
16.10.42	Reject cause.....	411
16.10.43	Request to append LA.....	412
16.10.43a	Required cell type.....	412
16.10.43b	Required cell type list control.....	412
16.10.43c	Re-send interval.....	413
16.10.43d	Result of dual watch request.....	413
16.10.43e	Revert to user application setting.....	413
16.10.44	SSI.....	413
16.10.45	SCCH information.....	414
16.10.46	SCCH information and distribution on 18 th frame.....	414
16.10.47	SCK number.....	414
16.10.47a	Start of direct mode operation cause.....	415
16.10.48	Status downlink.....	415
16.10.48a	Status uplink.....	416
16.10.49	Subscriber class.....	416
16.10.50	Void.....	417
16.10.51	Type 3/4 element identifier.....	417
16.10.52	(V)GSSI.....	418
16.10.53	Zero bit.....	418
16.11	Parameters.....	418
16.11.1	Timers.....	418
16.11.1.1	Timer T351: Registration response time.....	418
16.11.1.2	Timer T352: Energy mode response time.....	418
16.11.1.3	Timer T353: Attach/Detach response time.....	418
16.11.1.4	Timer T354: Authentication protocol time.....	418
16.11.2	Constants.....	418
16.11.2.1	N351: Maximum system rejection count.....	418
17	MLE service description.....	419
17.1	Introduction.....	419
17.2	Summary of services offered by MLE protocol.....	419
17.3	Service descriptions.....	420
17.3.0	General.....	420
17.3.1	Service state diagram for the LMM-SAP.....	420
17.3.2	Service primitives for the LMM-SAP.....	422
17.3.3	Service state diagram for the LCMC-SAP.....	424
17.3.4	Service primitives for LCMC-SAP.....	425
17.3.5	Service state diagram for the LTPD-SAP.....	427
17.3.6	Service primitives for LTPD-SAP.....	430
17.3.7	Void.....	431
17.3.8	Void.....	431
17.3.9	Parameter summary.....	431
18	MLE protocol.....	440
18.1	Introduction.....	440
18.2	Overview of the sub-layer.....	440
18.2.0	General.....	440

18.2.1	Protocol environment.....	440
18.2.2	Services and primitives offered by the MLE to the MM entity	441
18.2.3	Services and primitives offered by the MLE to the CMCE entities.....	442
18.2.4	Services and primitives offered by the MLE to the SNDCP entity.....	443
18.2.5	Void.....	445
18.2.6	Services and primitives offered by layer 2 to MLE.....	445
18.2.7	Services and primitives between the MLE and the LLME	446
18.2.8	Protocol sequences.....	446
18.3	MLE functions.....	450
18.3.1	Overview	450
18.3.2	Access to the communication resources and activation of the MLE	451
18.3.3	Deactivation of the MLE	452
18.3.4	Attachment management sub-entity	452
18.3.4.0a	General.....	452
18.3.4.0b	Cell types and identifiers.....	452
18.3.4.0b.1	Conventional Access and Direct Access cells.....	452
18.3.4.0b.2	Conventional Access and Direct Access MSs.....	452
18.3.4.0b.3	Co-sited cells	453
18.3.4.0b.4	Shared channels.....	453
18.3.4.0b.5	Cell identifiers.....	454
18.3.4.0b.6	Channel class identifiers and channel identifiers.....	454
18.3.4.1	Scanning of cells	455
18.3.4.2	Monitoring of neighbour cells.....	455
18.3.4.3	Surveillance of the serving cell	456
18.3.4.4	Ranking of neighbour cells	457
18.3.4.4.0	General	457
18.3.4.4.1	Ranking of monitored cells.....	457
18.3.4.4.2	Ranking of scanned cells	458
18.3.4.5	Criteria used during cell reselection.....	458
18.3.4.5.0	General	458
18.3.4.5.1	Criterion for starting the neighbour cell monitoring process.....	458
18.3.4.5.2	Criterion for starting scanning.....	458
18.3.4.5.3	Criterion for radio link failure	458
18.3.4.5.4	Criterion for radio relinquishable cell.....	459
18.3.4.5.5	Criterion for radio improvable cell.....	460
18.3.4.5.6	Criterion for radio usable cell.....	460
18.3.4.5.6a	Criterion for radio tolerable cell.....	460
18.3.4.5.6b	Criterion for expedited cell reselection.....	461
18.3.4.5.7	Criteria for initiating the cell reselection procedures.....	461
18.3.4.6	Initial cell selection	466
18.3.4.7	Cell reselection.....	467
18.3.4.7.0	Overview of cell reselection	467
18.3.4.7.1	Determination of which type of reselection to apply.....	470
18.3.4.7.1a	Conditions determining when registration is required during cell reselection	472
18.3.4.7.2	Undeclared cell reselection.....	472
18.3.4.7.3	Unannounced cell reselection.....	474
18.3.4.7.4	Announced cell reselection - type 3.....	477
18.3.4.7.5	Announced cell reselection types 1 and 2.....	481
18.3.4.7.6	Unsuccessful type 1/2 cell reselection.....	491
18.3.4.8	Change of broadcast parameters by the SwMI.....	493
18.3.4.9	Assigned channel replacement on the serving cell.....	493
18.3.4.9.0	General	493
18.3.4.9.1	Types of assigned channels	493
18.3.4.9.2	Serving cell channel class assessment	497
18.3.4.9.3	Main carrier monitoring with assessment of channel classes	497
18.3.4.9.4	Neighbour cell channel class assessment.....	498
18.3.4.9.5	Ranking of channel classes.....	498
18.3.4.9.6	Irregular channel monitoring.....	499
18.3.4.9.7	Ranking of monitored irregular channels	499
18.3.4.9.8	Criterion for starting and using the channel class assessment and channel monitoring processes.....	499
18.3.4.9.9	Criteria used for requesting an assigned channel replacement	500

18.3.4.9.10	Assigned channel replacement request procedure	503
18.3.4.9.11	Channel class and irregular channel advice procedure	504
18.3.5	Data transfer sub-entity	505
18.3.5.0	General	505
18.3.5.1	Address handling	505
18.3.5.1.0	General	505
18.3.5.1.1	Link addressing	506
18.3.5.1.2	Link addresses to be placed in layer 2	506
18.3.5.1.3	Layer 2 end point identifier	506
18.3.5.1.4	Subscriber class	506
18.3.5.1.5	Permitted LAs, permitted cells and not-permitted cells	506
18.3.5.2	MLE connection handling	507
18.3.5.2.0	Data transfer states	507
18.3.5.2.1	Data transfer states	507
18.3.5.3	Selection of LLC services	507
18.3.5.3.1	Selection of LLC services via TLA-SAP	507
18.3.5.3.2	Selection of LLC services via TLB-SAP	512
18.3.5.3.3	Selection of LLC services via TLC-SAP	513
18.3.5.4	Routing of local control information	514
18.3.6	Network broadcast sub-entity	515
18.3.6.1	Summary	515
18.3.6.2	System information	516
18.3.6.3	Message formats for system information	517
18.3.6.4	Network broadcast procedures	517
18.3.6.5	Neighbour cell enquiry procedure	517
18.3.6.6	Addition and replacement of neighbour cell information	518
18.3.6.7	Removal of neighbour cell information	519
18.3.7	Management sub-entity	520
18.4	PDU descriptions	520
18.4.0	General	520
18.4.1	Data transfer PDUs at the TLA-SAP	520
18.4.1.1	Protocol discriminator	520
18.4.1.2	PDU type	521
18.4.1.3	MLE service user PDUs	521
18.4.1.4	MLE protocol PDUs	521
18.4.1.4.0	General	521
18.4.1.4.1	D-NWRK-BROADCAST	521
18.4.1.4.1a	D-NWRK-BROADCAST-DA	522
18.4.1.4.1b	D-NWRK-BROADCAST EXTENSION	524
18.4.1.4.1c	D-NWRK-BROADCAST REMOVE	525
18.4.1.4.2	D-NEW-CELL	526
18.4.1.4.3	D-PREPARE-FAIL	526
18.4.1.4.4	D-RESTORE-ACK	527
18.4.1.4.5	D-RESTORE-FAIL	527
18.4.1.4.5a	D-CHANNEL RESPONSE	527
18.4.1.4.6	U-PREPARE	528
18.4.1.4.6a	U-PREPARE-DA	528
18.4.1.4.7	U-RESTORE	529
18.4.1.4.8	U-CHANNEL CLASS ADVICE	529
18.4.1.4.9	U-CHANNEL REQUEST	530
18.4.1.4.10	U-IRREGULAR CHANNEL ADVICE	531
18.4.2	Broadcast PDUs at the TLB-SAP	532
18.4.2.0	General	532
18.4.2.1	D-MLE-SYNC	532
18.4.2.1a	D-MLE-SYNC-DA	533
18.4.2.2	D-MLE-SYSINFO	533
18.4.2.2a	D-MLE-SYSINFO-DA	534
18.4.2.3	D-MLE-SYSINFO-Q	535
18.5	Information elements coding	535
18.5.1	Cell reselection types supported	535
18.5.1a	Cell reselection types supported DA	535
18.5.1b	AL roaming supported	536

18.5.1c	Bandwidth.....	536
18.5.2	BS service details and related information elements	537
18.5.2.1	BS service details	537
18.5.2.2	BS service details DA	538
18.5.2a	BS transmit power relative to the main carrier	539
18.5.2b	C/I path measurements.....	540
18.5.2c	Carrier number.....	540
18.5.2d	Carrier number extension.....	540
18.5.2e	Carrier number extension flag	541
18.5.3	Cell identifier CA	541
18.5.3a	Cell identifier DA	542
18.5.3b	Cell load CA	542
18.5.3c	Cell load DA	542
18.5.3d	Cell load known	543
18.5.4	Cell re-select parameters.....	543
18.5.5	Cell type change registration	543
18.5.5a	Channel characteristics	544
18.5.5b	Channel class	544
18.5.5c	Channel class identifier.....	544
18.5.6	Channel command valid	544
18.5.6a	Channel identifier	545
18.5.6b	Channel request retry delay	545
18.5.6c	Channel response type	545
18.5.6d	Data priority.....	546
18.5.6e	De-registration	546
18.5.6f	Discriminator for SDU protocol present.....	546
18.5.7	Fail cause	546
18.5.8	Late entry supported	547
18.5.8a	Local cell identifier DA	547
18.5.9	Location Area (LA)	547
18.5.10	Main carrier number	547
18.5.11	Main carrier number extension	548
18.5.11a	Main control channel modulation mode	548
18.5.12	Minimum Rx access level.....	548
18.5.13	Maximum MS transmit power	549
18.5.14	MCC	549
18.5.15	MNC	549
18.5.15a	Modulation mode.....	549
18.5.16	Neighbour cell broadcast	550
18.5.16a	Neighbour cell channel class for CA	550
18.5.16b	Neighbour cell channel class for DA	550
18.5.17	Neighbour cell information for CA.....	551
18.5.17a	Neighbour cell information for DA	552
18.5.17b	Neighbour cell irregular channel detail for CA.....	553
18.5.17c	Neighbour cell irregular channel detail for DA	553
18.5.18	Neighbour cell synchronized	553
18.5.18a	Number of CA cells for removal	553
18.5.18b	Number of CA neighbour cell channel classes	554
18.5.18c	Number of CA neighbour cells.....	554
18.5.18d	Number of CA neighbour cell irregular channel details	554
18.5.18e	Number of channel classes (for serving cell).....	555
18.5.18f	Number of channel class identifiers.....	555
18.5.18g	Number of channel classes for removal.....	555
18.5.18h	Number of channel identifiers	556
18.5.18i	Number of channels for removal	556
18.5.19	Number of DA cells for removal	556
18.5.19a	Number of DA neighbour cells.....	557
18.5.19b	Number of DA neighbour cell channel classes	557
18.5.19c	Number of DA neighbour cell irregular channel details	557
18.5.19d	Number of requested channel class identifiers.....	558
18.5.19e	Number of requested channel identifiers	558
18.5.19f	Number of irregular channels details (for serving cell)	558

18.5.20	PDU type	559
18.5.20a	PDU type extension	559
18.5.21	Protocol discriminator.....	559
18.5.21a	Reason for the channel request	560
18.5.21b	Registration.....	560
18.5.21c	Removal data for CA cell	560
18.5.21d	Removal data for DA cell	561
18.5.21e	Removal data for serving cell	561
18.5.21f	Remove cell or channels	561
18.5.21g	Roaming control for individual services.....	562
18.5.21h	Roaming control for group services and idle MSs.....	562
18.5.21i	Irregular channel detail	562
18.5.22	Subscriber class	563
18.5.22a	Subscriber class included.....	563
18.5.23	TDMA frame offset	564
18.5.24	TETRA network time	564
18.5.25	Timeshare cell information or security parameters.....	565
18.5.26	Wide-area cell.....	565
18.6	Timers	566
18.6.1	Timer related actions	566
18.6.2	Timer T370 - cell reselection preparation response time.....	566
18.6.3	Timer T371 - Neighbour cell broadcast enquiry response time.....	566
18.6.4	Timer T372 - new channel pause time.....	566
18.6.5	Timer T373 - repeat channel request delay time.....	566
18.6.6	Timer T374 - threshold-crossing pause time	566
18.6.7	Timer T375 - air cell margin timer	566
19	Layer 2 overview.....	567
19.1	Introduction	567
19.2	Layer 2 architecture.....	567
19.2.0	General.....	567
19.2.1	Access to the DLL	567
19.2.2	Information flow inside the DLL.....	568
19.2.2.0	General	568
19.2.2.1	Basic link	570
19.2.2.2	Advanced link	570
19.2.2.3	Segmentation and fragmentation.....	570
19.2.2.4	Layer 2 signalling.....	572
19.2.3	Sub-layers	573
19.2.3.0	General	573
19.2.3.1	LLC sub-layer	574
19.2.3.2	MAC sub-layer.....	574
19.2.4	Logical channels	575
19.2.4.1	Logical channels at the LLC-SAP.....	575
19.2.4.2	Logical channels at the MAC-SAP.....	575
19.2.4.3	MAC internal logical channels.....	575
19.2.4.4	Logical channels at the lower MAC.....	576
19.2.5	Lower layer management at the DLL	580
19.3	System modes of operation	581
19.3.0	General.....	581
19.3.1	Normal mode	581
19.3.1.0	General	581
19.3.1.1	Normal mode for Conventional Access (CA).....	581
19.3.1.2	Normal mode for Direct Access (DA)	581
19.3.2	Extended mode	581
19.3.2.1	Usage of extended mode	581
19.3.2.1.1	Extended mode for Conventional Access (CA).....	581
19.3.2.1.2	Extended mode for Direct Access (DA).....	582
19.3.2.1.3	Extended mode with sharing between cells.....	582
19.3.2.2	Modulation modes.....	583
19.3.2.2.0	General	583
19.3.2.2.1	$\pi/4$ -DQPSK channel	583

19.3.2.2.2	D8PSK channel	583
19.3.2.2.3	QAM channel	583
19.3.3	Minimum mode	584
19.3.4	Discontinuous transmission mode	584
19.3.5	Time sharing mode	584
19.3.5.0	General	584
19.3.5.1	Carrier sharing mode.....	584
19.3.5.2	MCCH sharing mode	584
19.3.6	No service mode	584
19.4	MS modes of operation	584
19.4.1	Idle mode	584
19.4.2	Signalling and packet mode	585
19.4.2.1	Common control channel	585
19.4.2.2	Secondary control channels.....	585
19.4.2.3	Associated Control Channel (ACCH)	585
19.4.2.4	Full and half slot signalling.....	586
19.4.2.4.1	Full and half slot signalling on a $\pi/4$ -DQPSK channel.....	586
19.4.2.4.2	Full and half slot signalling on a D8PSK channel	588
19.4.2.4.3	Full and half slot signalling on a QAM channel.....	588
19.4.3	Traffic mode	588
19.4.3.0	General	588
19.4.3.1	Normal operation	589
19.4.3.2	Stealing mechanism	590
19.4.4	Selection of the mode of operation	590
19.4.5	Energy economy mode	591
19.4.6	Support of concurrent calls	591
19.4.7	Support of air-interface encryption.....	591
19.5	Scenarios for primitives and PDU transfer on the air interface	591
20	Layer 2 service description.....	596
20.1	Introduction	596
20.2	Layer 2 service description.....	596
20.2.1	LLC SAPs.....	596
20.2.2	MAC SAPs	597
20.2.3	Generic primitive types.....	597
20.2.3a	Usage of primitives at the TLE-SAP	597
20.2.4	Parameters definition for LLC and MAC service primitives	597
20.2.4.1	Address type.....	597
20.2.4.2	Advanced link service	598
20.2.4.3	Call release.....	598
20.2.4.4	Channel number	598
20.2.4.5	Channel change accepted	598
20.2.4.6	Channel change handle	598
20.2.4.7	Channel change response required.....	598
20.2.4.8	Channel class label.....	598
20.2.4.9	Channel information.....	598
20.2.4.10	Characteristics of channel class to be assessed	599
20.2.4.10a	Characteristics of RF channel to be cell-read.....	599
20.2.4.11	Characteristics of RF channel to be monitored	599
20.2.4.11a	Characteristics of RF channel to be scanned.....	600
20.2.4.12	CSS endpoint identifier	600
20.2.4.13	Data category	600
20.2.4.14	Data class activity information.....	601
20.2.4.15	Data class information.....	601
20.2.4.16	Data priority	601
20.2.4.17	Data priority random access delay factor	601
20.2.4.18	Distribution on the 18th frame	601
20.2.4.19	Dual watch energy economy group.....	601
20.2.4.20	Dual watch startpoint	601
20.2.4.21	Encryption, air interface.....	602
20.2.4.22	Endpoint identifier	602
20.2.4.23	Energy economy group	602

20.2.4.24	Energy economy startpoint	602
20.2.4.25	FCS flag	602
20.2.4.25a	Graceful service degradation mode	602
20.2.4.25b	Graceful service degradation mode control	602
20.2.4.26	Half slot condition	602
20.2.4.27	Half slot content	602
20.2.4.28	Half slot importance	602
20.2.4.29	Half slot position	603
20.2.4.30	Half slot synchronization	603
20.2.4.31	Handle to the request	603
20.2.4.32	Layer 2 data priority lifetime	603
20.2.4.33	Layer 2 data priority signalling delay	603
20.2.4.34	Layer 2 signalling message	603
20.2.4.35	Layer 2 signalling message length	603
20.2.4.36	Link identifier	603
20.2.4.37	Link performance information	603
20.2.4.38	LLC timer status	604
20.2.4.39	Lower layer resource availability	604
20.2.4.40	MAC broadcast information	604
20.2.4.41	Main address	604
20.2.4.42	Maximum schedule interval	604
20.2.4.43	MLE activity indicator	604
20.2.4.44	MS default data priority	604
20.2.4.45	New endpoint identifier	604
20.2.4.46	Number of $\pi/4$ -DQPSK timeslots	605
20.2.4.47	Number of repetitions of layer 2 signalling message	605
20.2.4.48	Number of repetitions of TL-SDU	605
20.2.4.49	Operating mode	605
20.2.4.50	Packet data flag	605
20.2.4.51	Path loss	605
20.2.4.52	PDU priority	605
20.2.4.53	Periodic reporting timer	605
20.2.4.54	Quality indication	606
20.2.4.55	Quality of Service (QoS)	606
20.2.4.56	Reconnection result	607
20.2.4.57	Report	607
20.2.4.58	Scanning measurement method	608
20.2.4.59	SCCH information	608
20.2.4.60	Scheduled data status	608
20.2.4.61	Schedule repetition information	609
20.2.4.62	Scrambling code	609
20.2.4.63	Set-up report	609
20.2.4.64	Stealing permission	609
20.2.4.65	Stealing repeats flag	609
20.2.4.66	Stolen indication	609
20.2.4.67	Subscriber class	610
20.2.4.68	Threshold level	610
20.2.4.69	Threshold values	610
20.2.4.70	TL-SDU	610
20.2.4.71	TL-SDU length	610
20.2.4.72	TM-SDU	610
20.2.4.73	TM-SDU length	610
20.2.4.74	User device	610
20.2.4.75	Valid addresses	610
20.3	Services provided by LLC	610
20.3.1	Services at the TLA-SAP	610
20.3.2	Services at the TLB-SAP	611
20.3.3	Services at the TLC-SAP	612
20.3.3a	Services at the TLE-SAP	612
20.3.4	LLC service primitives	612
20.3.5	Service primitive descriptions	613
20.3.5.0	General	613

20.3.5.1	Primitives at the TLA-SAP (MLE-LLC)	613
20.3.5.1.1	TL-CANCEL primitive	613
20.3.5.1.2	TL-CONNECT primitive	613
20.3.5.1.3	TL-DATA primitive for the advanced link.....	614
20.3.5.1.4	TL-DATA primitive for the basic link	615
20.3.5.1.5	TL-DISCONNECT primitive	616
20.3.5.1.5a	TL-RECEIVE primitive	617
20.3.5.1.6	TL-RECONNECT primitive	617
20.3.5.1.7	TL-RELEASE primitive.....	617
20.3.5.1.8	TL-REPORT primitive (TLA-SAP).....	618
20.3.5.1.9	TL-UNITDATA primitive.....	618
20.3.5.2	Signals at the TLA-SAP (MLE-LLC)	620
20.3.5.3	Primitives at the TLB-SAP (MLE-LLC).....	620
20.3.5.3.0	General	620
20.3.5.3.1	TL-SYNC primitive.....	620
20.3.5.3.2	TL-SYSINFO primitive.....	620
20.3.5.3.3	TL-SYSINFO-Q primitive	621
20.3.5.3.4	TL-SYNC-DA primitive.....	621
20.3.5.3.5	TL-SYSINFO-DA primitive.....	622
20.3.5.4	Primitives at the TLC-SAP (MLE-LLC).....	622
20.3.5.4.0	General	622
20.3.5.4.1	TL-ASSESSMENT primitive.....	622
20.3.5.4.1a	TL-ASSESSMENT-LIST primitive	623
20.3.5.4.1b	TL-CELL-READ primitive	623
20.3.5.4.1c	TL-CONFIGURE primitive	624
20.3.5.4.2	TL-MEASUREMENT primitive.....	624
20.3.5.4.3	TL-MONITOR primitive.....	625
20.3.5.4.4	TL-MONITOR-LIST primitive.....	625
20.3.5.4.5	TL-REPORT primitive (TLC-SAP)	626
20.3.5.4.6	TL-SCAN primitive.....	626
20.3.5.4.7	TL-SCAN-REPORT primitive.....	627
20.3.5.4.8	TL-SELECT primitive.....	628
20.3.5.5	Primitives at the TLE-SAP (MAC-LLC)	628
20.3.5.5.0	General	628
20.3.5.5.1	TLE-CANCEL primitive.....	628
20.3.5.5.2	TLE-REPORT primitive.....	629
20.3.5.5.3	TLE-UNITDATA primitive	629
20.3.6	State diagram for the basic link	630
20.3.7	State diagram for advanced link	630
20.3.8	State diagram for the layer 2 signalling service	631
20.4	Services provided by the MAC	631
20.4.0	General.....	631
20.4.1	Services at the TMA-SAP.....	632
20.4.1.0	General	632
20.4.1.1	Service primitives at the TMA-SAP	632
20.4.1.1.1	TMA-CANCEL primitive	632
20.4.1.1.2	TMA-RELEASE primitive.....	632
20.4.1.1.3	TMA-REPORT primitive	633
20.4.1.1.4	TMA-UNITDATA primitive.....	633
20.4.1.2	Signals at the TMA-SAP.....	633
20.4.1.3	Mapping of the service primitives between LLC and MAC at the TMA-SAP	636
20.4.2	Service provided at the TMB-SAP	637
20.4.3	Service provided at the TMC-SAP	637
20.4.4	Service provided at the TMD-SAP	638
20.4.4.0	General	638
20.4.4.1	Service primitives and parameters at the TMD-SAP	638
20.4.4.1.1	TMD-REPORT primitive	638
20.4.4.1.2	TMD-UNITDATA primitive.....	639
21	Layer 2 PDU description.....	640
21.0	General	640
21.1	DLL PDU structure	640

21.1.1	DLL overhead	640
21.1.2	LLC PDU structure	640
21.1.2.0	General	640
21.1.2.1	LLC header	640
21.1.2.2	Format of LLC header.....	640
21.1.2.3	LLC FCS	641
21.1.3	MAC PDU structure	641
21.1.3.1	MAC overhead	641
21.1.3.2	Format of the MAC header	641
21.1.3.2.0	General	641
21.1.3.2.1	MAC type	641
21.1.3.2.2	MAC information	642
21.1.3.2.3	MAC address	642
21.1.4	DLL PDU building	642
21.1.4.1	Basic link illustration	642
21.1.4.2	Advanced link illustration	642
21.1.5	PDU description format	643
21.2	Logical Link Control (LLC) PDUs description.....	643
21.2.0	General.....	643
21.2.1	LLC PDU types	644
21.2.2	Basic link PDU definitions	645
21.2.2.0	General	645
21.2.2.1	BL-ACK.....	645
21.2.2.2	BL-ADATA	646
21.2.2.3	BL-DATA	647
21.2.2.4	BL-UDATA	647
21.2.3	Advanced link PDU definitions	648
21.2.3.0	General	648
21.2.3.1	AL-ACK, AL-RNR.....	649
21.2.3.1a	AL-X-ACK, AL-X-RNR	652
21.2.3.2	AL-FINAL, AL-FINAL-AR	656
21.2.3.2a	AL-X-FINAL, AL-X-FINAL-AR.....	657
21.2.3.3	AL-DATA, AL-DATA-AR	658
21.2.3.3a	AL-X-DATA, AL-X-DATA-AR	658
21.2.3.4	AL-DISC.....	659
21.2.3.4a	AL-RECONNECT	660
21.2.3.5	AL-SETUP.....	660
21.2.3.6	AL-UDATA	664
21.2.3.6a	AL-X-UDATA.....	665
21.2.3.7	AL-UFINAL	665
21.2.3.7a	AL-X-UFINAL	666
21.2.4	Layer 2 signalling PDU definitions	666
21.2.4.0	General	666
21.2.4.1	L2-DATA-PRIORITY	667
21.2.4.2	L2-SCHEDULE-SYNC	668
21.2.4.3	L2-LINK-FEEDBACK-CONTROL.....	669
21.2.4.4	L2-LINK-FEEDBACK-INFO	671
21.2.4.5	L2-LINK-FEEDBACK-INFO-AND-RESIDUAL-DATA-PRIORITY	672
21.3	LLC elements	673
21.3.1	FCS	673
21.3.2	TL-SDU size.....	673
21.3.3	Bit rate feedback information	674
21.3.4	E _s /N ₀ feedback information	674
21.4	MAC PDU description	675
21.4.0	General.....	675
21.4.1	MAC PDU types.....	675
21.4.2	TMA-SAP: MAC PDU structure for the uplink	676
21.4.2.0	General	676
21.4.2.1	MAC-ACCESS	676
21.4.2.2	MAC-END-HU	679
21.4.2.3	MAC-DATA	681
21.4.2.4	MAC-FRAG (uplink).....	683

21.4.2.5	MAC-END (uplink)	685
21.4.2.6	MAC-U-BLCK	686
21.4.3	TMA-SAP: MAC PDU structure for the downlink	688
21.4.3.0	General	688
21.4.3.1	MAC-RESOURCE	688
21.4.3.2	MAC-FRAG (downlink)	692
21.4.3.3	MAC-END (downlink)	694
21.4.3.4	MAC-D-BLCK	696
21.4.4	TMB-SAP: MAC PDU structure for broadcast	698
21.4.4.0	General	698
21.4.4.1	SYSINFO	699
21.4.4.1a	SYSINFO-Q	703
21.4.4.1b	SYSINFO-DA	705
21.4.4.2	SYNC	709
21.4.4.2a	SYNC-DA	710
21.4.4.3	ACCESS-DEFINE	712
21.4.5	TMD-SAP: MAC PDU structure for U-plane signalling	714
21.4.6	TMD-SAP: MAC PDU structure for U-plane traffic	714
21.4.7	MAC PDU structure for access assignment broadcast	714
21.4.7.1	Contents of AACH-Q logical channel	714
21.4.7.2	ACCESS-ASSIGN	715
21.4.8	MAC PDU structure for slot information channel	716
21.4.8.1	QAM-SLOTINFO (uplink)	716
21.4.8.2	QAM-SLOTINFO (downlink)	717
21.5	MAC elements	718
21.5.0	General	718
21.5.1	Access field	718
21.5.2	Channel allocation	719
21.5.2a	BS link imbalance	723
21.5.2b	BS transmit power relative to main carrier	724
21.5.2c	Napping information	725
21.5.2d	Conditional element A	726
21.5.3	Power control	726
21.5.4	Reservation requirement	727
21.5.5	TS_COMMON_FRAMES	728
21.5.6	Basic slot granting	728
21.5.7	Multiple slot granting	729
21.6	Units used in length indication	729
22	LLC protocol	731
22.0	General	731
22.1	Overview of LLC	731
22.1.0	General	731
22.1.1	LLC protocol	731
22.1.2	Communication routes of the LLC model	732
22.2	Scenarios on LLC procedures	735
22.2.0	General	735
22.2.1	Basic link mode	735
22.2.1.0	General	735
22.2.1.1	Acknowledged PDU transfer (BL-DATA + BL-ACK)	735
22.2.1.2	Unacknowledged data transfer (BL-UDATA PDU)	738
22.2.1.3	Unacknowledged data transfer with presence indication (BL-DATA + BL-ACK PDU)	739
22.2.2	Advanced link	739
22.2.2.0	General	739
22.2.2.1	Setting up the connection mode (AL-SETUP PDU)	740
22.2.2.2	Setting up the unacknowledged transfer mode (AL-SETUP PDU)	743
22.2.2.3	Data exchange in the connection mode (AL-DATA or AL-X-DATA PDU)	744
22.2.2.4	Data exchange in the unacknowledged transfer mode (AL-UDATA or AL-X-UDATA PDU)	747
22.2.2.5	Window mechanism	748
22.2.2.6	Selective re-transmission of segments (AL-ACK or AL-X-ACK PDU)	749
22.2.2.7	Flow control (AL-RNR or AL-X-RNR PDU)	750
22.2.2.8	Connection reset	751

22.2.2.8a	LLC reconnecting an advanced link (AL-RECONNECT PDU).....	751
22.2.2.9	Releasing an acknowledged advanced link (AL-DISC PDU).....	752
22.2.2.10	Releasing an unacknowledged advanced link (AL-DISC PDU).....	752
22.2.3	Layer 2 signalling	753
22.3	LLC procedures.....	754
22.3.0	General.....	754
22.3.1	Common procedures for all services.....	754
22.3.1.0	General	754
22.3.1.1	Link identifiers, endpoint identifiers and handle to the request	754
22.3.1.2	Addressing	755
22.3.1.3	User data buffering.....	755
22.3.1.4	Cancelling SDU transmission	755
22.3.1.5	Extended error protection.....	756
22.3.1.6	Timers and counters	756
22.3.1.7	Formatter protocol.....	756
22.3.1.7.0	General	756
22.3.1.7.1	MS formatter receiving entity.....	757
22.3.1.7.2	MS formatter sending entity	757
22.3.1.7.3	Combination PDUs on D8PSK or QAM channel.....	758
22.3.1.8	Data priority	759
22.3.1.8.0	Introduction	759
22.3.1.8.1	General	759
22.3.1.8.2	Sending order of TL-SDUs.....	760
22.3.1.8.3	Providing data priority information to the MAC	761
22.3.1.8.4	Sending of L2-DATA-PRIORITY PDU	762
22.3.1.9	Scheduled data	762
22.3.1.10	Data category	763
22.3.2	Basic link procedures.....	765
22.3.2.0	General	765
22.3.2.1	Establishment of information transfer in basic link	765
22.3.2.2	Quality of service selection.....	766
22.3.2.3	Acknowledged data transmission in basic link	766
22.3.2.4	Unacknowledged data transfer in the basic link.....	769
22.3.2.4.0	General	769
22.3.2.4.1	Actions on TL-UNITDATA request primitive (sending entity).....	769
22.3.2.4.2	Actions on BL-UDATA PDU (receiving entity).....	770
22.3.3	Advanced link procedures for the acknowledged service.....	771
22.3.3.0	General	771
22.3.3.1	Advanced link establishment for the acknowledged service.....	772
22.3.3.1.0	General	772
22.3.3.1.1	Actions on TL-CONNECT request primitive (set-up phase sending entity).....	773
22.3.3.1.2	Actions on AL-SETUP PDU reception (set-up phase receiving entity).....	774
22.3.3.1.3	Actions on AL-SETUP PDU reception (data transfer state).....	775
22.3.3.1.4	Actions on original AL-SETUP PDU reception on different link number (data transfer state)	775
22.3.3.2	Acknowledged data transfer on the original advanced link	776
22.3.3.2.0	General	776
22.3.3.2.1	Segmentation and sequencing	776
22.3.3.2.2	Re-assembly	776
22.3.3.2.3	Acknowledgement and segment re-transmission mechanisms.....	777
22.3.3.2.4	TL-SDU re-transmission	778
22.3.3.2.5	Flow control	778
22.3.3.2.6	Actions on TL-DATA request primitive (data sending entity).....	779
22.3.3.2.7	Data reception from the peer entity (data receiving entity)	780
22.3.3.2a	Acknowledged data transfer on an extended advanced link.....	782
22.3.3.3	Release of acknowledged service advanced link.....	783
22.3.3.3.0	General	783
22.3.3.3.1	Actions on TL-DISCONNECT request primitive (MS sending entity)	783
22.3.3.3.2	Actions on AL-DISC PDU reception (MS receiving entity)	784
22.3.3.4	Abnormal release of advanced link	785
22.3.3.5	LLC reconnection of acknowledged service advanced link.....	785
22.3.4	Advanced link procedures for unacknowledged service.....	786
22.3.4.0	General	786

22.3.4.1	Advanced link unacknowledged service establishment	786
22.3.4.2	Reception of unacknowledged service data on the original advanced link	786
22.3.4.2a	Reception of unacknowledged service data on an extended advanced link	787
22.3.4.3	Sliding SDU window in unacknowledged service	787
22.3.4.4	Disconnection of unacknowledged data transfer.....	788
22.3.5	Channel change request handling	788
22.3.6	Activity handling	789
22.3.7	Layer 2 signalling procedures	789
22.3.7.0	General	789
22.3.7.1	Layer 2 signalling procedures (sending entity)	789
22.3.7.2	Layer 2 signalling procedures (receiving entity).....	791
23	MAC protocol	792
23.0	General	792
23.1	MAC services	792
23.1.1	Functions of MAC	792
23.1.2	Service primitives	793
23.1.2.0	General	793
23.1.2.1	Services at the TMA-SAP	793
23.1.2.1.0	General	793
23.1.2.1.1	Reports.....	794
23.1.2.1.2	Buffering mechanism	794
23.1.2.1.3	Usage of signals.....	796
23.1.2.1.4	Priority, subscriber class and scheduled data information.....	800
23.1.2.2	Services at the TMB-SAP	801
23.1.2.3	Services at the TMC-SAP	801
23.1.2.4	Services at the TMD-SAP	801
23.1.2.5	Use of channels and endpoint identifiers	802
23.1.2.5.1	Channel usage.....	802
23.1.2.5.2	Endpoint identifiers	802
23.1.3	MS capabilities	803
23.1.3.0	General	803
23.1.3.1	Frequency half duplex operation	803
23.1.3.1.1	Frequency half duplex capability.....	803
23.1.3.1.2	Fast switching capability	803
23.1.3.2	Frequency full duplex operation	804
23.1.3.3	Basic capabilities of the physical layer	804
23.1.3.4	Modulation and bandwidth capabilities	805
23.1.3.4.1	General	805
23.1.3.4.2	MS modulation and bandwidth capabilities.....	805
23.1.3.4.3	BS modulation and bandwidth capabilities	806
23.1.4	Services provided by the LLC to the MAC	807
23.2	Services provided by the lower MAC and channel modes	808
23.2.1	Services at the TMV-SAP.....	808
23.2.2	PDU mapping of the logical channels at the TMV-SAP	813
23.2.3	$\pi/4$ -DQPSK, D8PSK and QAM channels.....	813
23.3	Control channel usage	817
23.3.1	Control channel types	817
23.3.1.0	General	817
23.3.1.1	Main control channels.....	817
23.3.1.1.1	Conventional Access (CA) and Direct Access (DA) cells.....	817
23.3.1.1.2	MCCH	818
23.3.1.1.3	MCCH-Q	820
23.3.1.2	SCCH.....	821
23.3.1.2.0	Introduction	821
23.3.1.2.1	Common SCCH.....	821
23.3.1.2.2	Assigned SCCH.....	824
23.3.1.3	ACCH	825
23.3.1.4	Monitoring pattern during multi-timeslot traffic operation	827
23.3.2	Discontinuous transmission for CA	827
23.3.2.0	General	827
23.3.2.1	Carrier sharing operation for CA	828

23.3.2.2	MCCH sharing operation for CA	828
23.3.2.3	Traffic carrier sharing operation for CA	829
23.3.2a	Discontinuous transmission for DA	829
23.3.3	Minimum mode operation	830
23.3.3.0	General	830
23.3.3.1	Beginning of minimum mode or no service mode	830
23.3.3.2	MS operation during frames 1 to 17	830
23.3.3.3	MS operation during frame 18	831
23.3.3.4	MS operation in energy economy or dual watch mode	831
23.3.3.5	End of minimum mode	831
23.3.3.6	Restrictions on usage of minimum mode	831
23.3.4	Independent allocation of uplink and downlink	832
23.3.5	Usage of a multi-slot channel	833
23.3.6	Usage of a 50 kHz, 100 kHz or 150 kHz channel	833
23.4	General MAC procedures	834
23.4.1	PDU header analysis for signalling messages	834
23.4.1.1	MAC PDU types	834
23.4.1.2	Addressing at the TMA-SAP	834
23.4.1.2.0	General	834
23.4.1.2.1	Downlink message	834
23.4.1.2.2	Uplink message	835
23.4.1.2.3	Event labels	836
23.4.1.2.4	Usage of SMI	839
23.4.1.2.5	Usage of USSI	839
23.4.1.3	Addressing at the TMB-SAP	840
23.4.1.4	Addressing at the TMD-SAP	840
23.4.2	PDU composition for signalling messages	841
23.4.2.0	General	841
23.4.2.1	Fragmentation (TMA-SAP only)	841
23.4.2.1.0	General	841
23.4.2.1.1	Fragmentation of downlink TM-SDU	843
23.4.2.1.2	Fragmentation of uplink TM-SDU	844
23.4.2.1.3	Fragmentation in minimum mode	847
23.4.2.1.4	Fragmentation on time-shared control channel	848
23.4.2.1.5	Fragmentation on assigned channel if downlink is in SACCH	848
23.4.2.1.6	Fragmentation on assigned channel if downlink is in FACCH or assigned SCCH	850
23.4.2.1.7	Fragmentation on stealing channel	850
23.4.2.2	Fill bit addition	850
23.4.2.3	PDU association	851
23.4.3	PDU decomposition for signalling messages	853
23.4.3.1	Reconstruction (TMA-SAP only)	853
23.4.3.1.0	General	853
23.4.3.1.1	Reconstruction of downlink TM-SDU	853
23.4.3.1.2	Reconstruction of uplink TM-SDU	855
23.4.3.1.3	Reconstruction in minimum mode	856
23.4.3.1.4	Reconstruction on time-shared control channel	856
23.4.3.1.5	Reconstruction on assigned channel if downlink is in SACCH	857
23.4.3.1.6	Reconstruction on assigned channel if downlink is in FACCH or assigned SCCH	858
23.4.3.1.7	Reconstruction on stealing channel	859
23.4.3.2	Fill bit deletion	859
23.4.3.3	PDU dissociation	860
23.4.3.4	PDU error detection	860
23.4.4	Power control	861
23.4.4.1	Overall process	861
23.4.4.2	MS open loop power control	861
23.4.4.2.1	Obtaining values of MS_TXPWR_MAX_CELL and ACCESS_PARAMETER	861
23.4.4.2.2	MS open loop power control procedure	862
23.4.4.3	MS closed loop power control	863
23.4.5	MS linearization	863
23.4.5.1	MS linearization on $\pi/4$ -DQPSK or D8PSK channel	863
23.4.5.2	MS linearization on QAM channel	864
23.4.6	BS synchronization	865

23.4.7	Data priority	865
23.4.7.0	Introduction	865
23.4.7.1	General	866
23.4.7.2	Content of L2-DATA-PRIORITY message	866
23.4.7.2.1	Formats of L2-DATA-PRIORITY message	866
23.4.7.2.2	Content of L2-DATA-PRIORITY message if using format 1)	867
23.4.7.2.3	Content of L2-DATA-PRIORITY message if using format 2)	867
23.4.7.2.4	Sending L2-DATA-PRIORITY message	868
23.4.7.3	Expiry of short-term data priority information	869
23.4.7.4	Criteria for sending L2-DATA-PRIORITY message	870
23.4.7.5	Reverting to random access if MS supports data priority	872
23.4.7.5.1	General	872
23.4.7.5.2	Reverting to random access to send L2-DATA-PRIORITY message	873
23.4.7.5.3	Reverting to random access to send non-packet-data message	875
23.4.7.6	BS procedures for data priority	876
23.4.7.6.1	Packet data on uplink	876
23.4.7.6.2	Packet data on downlink	876
23.4.8	Napping	877
23.4.8.1	General	877
23.4.8.2	MS criteria for napping	878
23.4.8.3	MS reception requirements	879
23.4.8.3.1	Generation of napping reception pattern	879
23.4.8.3.2	Reception requirements when MS is in napping mode	880
23.4.8.3.3	Reception requirements when MS is in full reception mode	881
23.4.8.4	MS use of napping status element	881
23.4.8.5	Independent allocation of uplink and downlink	882
23.4.8.6	BS procedures for supporting MS napping	882
23.4.9	Link adaptation on D8PSK or QAM channel	883
23.4.9.1	General	883
23.4.9.2	MS choice of bit rate	885
23.4.9.2.1	General on MS choice of bit rate	885
23.4.9.2.2	Suggested predefined bit rates for background class and telemetry class data	887
23.4.9.3	BS choice of bit rate	889
23.4.9.4	Link adaptation feedback control by BS	889
23.4.9.5	Link adaptation feedback by MS	890
23.4.9.5.1	Sending link adaptation feedback	890
23.4.9.5.2	MS feedback information	892
23.4.9.6	Link adaptation feedback by BS	892
23.4.10	MAC aspects of assigned channel replacement on serving cell	893
23.4.10.1	MS-MAC advice to MLE on assigned channel replacement	893
23.4.10.2	Assigned channel replacement by BS	894
23.5	PDU transfer for signalling messages (TMA-SAP)	895
23.5.1	Random access protocol	895
23.5.1.1	Introduction	895
23.5.1.2	Overview	895
23.5.1.2.1	General	895
23.5.1.2.2	Overview of random access channel on a 25 kHz channel	896
23.5.1.2.3	Overview of random access channel on a 50 kHz, 100 kHz or 150 kHz QAM channel	898
23.5.1.3	Access control facilities for BS	898
23.5.1.3.0	General	898
23.5.1.3.1	Transmission of ACCESS-DEFINE and ACCESS-ASSIGN PDU	898
23.5.1.3.2	BS response to access request	899
23.5.1.3.3	Reserving subslots on uplink	900
23.5.1.4	MS-MAC random access protocol	900
23.5.1.4.0	General	900
23.5.1.4.1	Reception of ACCESS-DEFINE PDU	900
23.5.1.4.2	Reception of ACCESS-ASSIGN PDU	901
23.5.1.4.3	Initiating a random access	901
23.5.1.4.4	Checking for appropriate access code	902
23.5.1.4.5	First try procedure	903
23.5.1.4.6	Choosing from a new access frame	903
23.5.1.4.7	Counting subslots in an access frame	904

23.5.1.4.8	Re-try procedure	904
23.5.1.4.9	Abandoning random access attempt	905
23.5.1.4.10	Random access operation after acquiring main carrier	905
23.5.1.4.11	Random access operation on a new channel	906
23.5.1.4.12	Random access operation on ACCH	907
23.5.1.4.13	Random access operation in minimum mode	907
23.5.1.4.14	Random access operation on time-shared control channel	907
23.5.1.4.15	Random access operation on CSS channel	908
23.5.1.4.16	Random access operation with extended random access channel	908
23.5.1.4.17	Random access operation on D8PSK channel	909
23.5.1.4.18	Random access operation on QAM channel	909
23.5.2	Reserved access	913
23.5.2.0	General	913
23.5.2.1	Reservation requirement	913
23.5.2.2	Slot granting	914
23.5.2.2.1	General	914
23.5.2.2.2	Basic slot granting	915
23.5.2.2.3	Multiple slot granting	916
23.5.2.2.4	Slot granting in normal mode	918
23.5.2.2.5	Slot granting in minimum mode	919
23.5.2.2.6	Slot granting on time-shared control channel	920
23.5.2.2.7	BS slot granting operation	920
23.5.2.3	Use of reserved slots	921
23.5.2.3.1	Individual address or event label	921
23.5.2.3.2	Group address	923
23.5.2.4	Reverting to random access	923
23.5.2.4.1	Reverting to random access for unscheduled signalling messages	923
23.5.2.4.2	Reverting to random access for fully scheduled signalling messages	924
23.5.2.5	Example of reservation process	924
23.5.2.6	Scheduled access	925
23.5.2.6.1	General	925
23.5.2.6.2	MS operation for sending scheduled messages	925
23.5.2.6.3	Schedule timing in MS	926
23.5.2.6.4	BS operation for granting slots for schedule	927
23.5.2.6.5	Schedule synchronization by BS	928
23.5.3	Cancel request	929
23.5.4	Channel allocation	929
23.5.4.1	Transmission of channel allocation	929
23.5.4.2	Reception of channel allocation	930
23.5.4.2.1	Channel allocation types	930
23.5.4.2.2	Reception of channel allocation on MS's common control channel	933
23.5.4.2.3	Reception of channel allocation on assigned channel	935
23.5.4.2.4	Reception of channel allocation on CSS channel	938
23.5.4.3	Channel change	939
23.5.4.3.1	Timing of channel change	939
23.5.4.3.2	Use of "timeslot assigned"	943
23.5.4.3.3	Use of "up/downlink assigned" and "Up/downlink assigned for augmented channel allocation"	944
23.5.4.3.4	CLCH(-Q) permission	945
23.5.4.3.5	Monitoring pattern information	946
23.5.4.3.6	Bandwidth, modulation mode and related parameters	946
23.5.4.3.7	Napping status and napping information	948
23.5.4.3.8	Elements following napping status and napping information	949
23.5.4.3.9	DA conforming channel status and BS transmit power relative to current carrier	949
23.5.5	Usage marker assignment	950
23.5.6	Maintenance of assigned channel	951
23.5.6.0	General	951
23.5.6.1	Criteria for leaving assigned channel	952
23.5.6.1.0	General	952
23.5.6.1.1	Checking of AACH or AACH-Q	952
23.5.6.1.2	Inactivity time-out	954
23.5.6.2	Criteria for leaving carrier specific signalling channel	955

23.5.6.3	Traffic on downlink for other users.....	955
23.5.7	Maintenance of common channel	956
23.6	PDU transfer for broadcast messages (TMB-SAP)	957
23.6.1	Broadcast logical channels.....	957
23.6.1.1	General	957
23.6.1.2	CA broadcast logical channels	957
23.6.1.3	DA broadcast logical channels	958
23.6.2	Acquiring cell synchronization on a CA cell	959
23.6.3	Acquiring network information on a CA cell	960
23.6.4	Receiving SYNC and SYSINFO PDUs on D8PSK channel - CA MS	960
23.6.5	Receiving SYSINFO-Q PDU on QAM channel - CA MS	960
23.6.6	Power control and cell/channel reselection parameters for CA	961
23.6.6.0	General	961
23.6.6.1	$\pi/4$ -DQPSK channel.....	962
23.6.6.2	D8PSK channel	962
23.6.6.3	QAM channel	962
23.6.7	Acquiring cell synchronization on a DA cell	963
23.6.8	Acquiring network information on a DA cell	964
23.6.9	Receiving SYNC and SYSINFO PDUs on $\pi/4$ -DQPSK or D8PSK channel - DA MS	964
23.6.10	Receiving SYSINFO-DA PDU on $\pi/4$ -DQPSK or D8PSK channel - DA MS.....	965
23.6.11	Power control and cell/channel reselection parameters for DA	965
23.6.11.0	General	965
23.6.11.1	QAM channel	966
23.6.11.2	$\pi/4$ -DQPSK channel.....	967
23.6.11.3	D8PSK channel	967
23.7	Layer management communication (TMC-SAP).....	968
23.7.0	General.....	968
23.7.1	Path loss calculation.....	970
23.7.1.0	General	970
23.7.1.1	Path loss parameter C1	971
23.7.1.2	Path loss parameter C2.....	972
23.7.1.3	Path loss parameter C3.....	974
23.7.1.4	Path loss parameter C4.....	975
23.7.1.5	Path loss parameter C5.....	976
23.7.2	Cell selection	977
23.7.3	Serving cell measurement.....	978
23.7.3.0	General	978
23.7.3.1	Downlink measurements.....	980
23.7.3.1.1	Downlink measurements on current channel.....	980
23.7.3.1.2	Assessment of the main carrier from a non-conforming assigned channel.....	985
23.7.3.1.3	Serving cell channel class assessment	986
23.7.3.1.4	Concurrent channels on the serving cell.....	987
23.7.3.2	Uplink measurements.....	988
23.7.4	Monitoring	989
23.7.4.0	General	989
23.7.4.1	Monitoring scenario	989
23.7.4.2	Monitoring measurements.....	990
23.7.4.3	Signal strength measurement	991
23.7.4.4	Neighbour cell monitoring with assessment of channel classes	991
23.7.4.5	Main carrier monitoring with assessment of channel classes.....	992
23.7.5	Scanning	993
23.7.5.0	General	993
23.7.5.1	Scanning scenario	993
23.7.5.2	Scanning measurement.....	994
23.7.5.2.0	General	994
23.7.5.2.1	Foreground scanning	994
23.7.5.2.2	Background scanning	995
23.7.5.2.3	Interrupting scanning.....	996
23.7.5.3	Scanning with assessment of channel classes on adjacent cell.....	996
23.7.5.4	Reading SYSINFO-DA PDU on DA adjacent cell	997
23.7.6	Selection of energy economy mode	997
23.7.7	Selection of dual watch mode with energy economy group	1000

23.7.8	Part-time reception for DA MS on multi-slot MCCH-Q	1004
23.8	PDU transfer for traffic (TMD-SAP)	1005
23.8.0	General.....	1005
23.8.1	Introduction.....	1005
23.8.2	Criteria for transmission and reception of traffic	1006
23.8.2.0	General	1006
23.8.2.1	Use of TMC-CONFIGURE primitive.....	1006
23.8.2.2	Timing of change of mode	1007
23.8.2.3	AACH mechanisms.....	1009
23.8.2.3.0	General	1009
23.8.2.3.1	MS transmitting traffic	1009
23.8.2.3.2	MS receiving traffic.....	1011
23.8.2.3.3	Multi-slot interleaving with interruption	1012
23.8.3	Exchange of information at the TMD-SAP	1013
23.8.3.0	General.....	1013
23.8.3.1	Interface at transmitting MS.....	1014
23.8.3.2	Interface at receiving MS	1016
23.8.4	Stealing from circuit mode capacity	1017
23.8.4.1	Uplink stealing	1017
23.8.4.1.1	Transmission on uplink STCH	1017
23.8.4.1.2	Criteria for uplink stealing.....	1017
23.8.4.1.3	Stealing repeats mechanism.....	1018
23.8.4.1.4	Reception on uplink STCH.....	1019
23.8.4.2	Downlink stealing	1020
23.8.4.2.1	Transmission on downlink STCH	1020
23.8.4.2.2	Reception on downlink STCH.....	1021
23.8.5	BS operation	1021
24	Void.....	1022
25	Void.....	1022
26	Void.....	1022
27	Void.....	1022
28	TETRA Packet Data Protocol	1023
28.0	General	1023
28.1	Subnetwork Dependent Convergence Protocol (SNDCP) overview.....	1025
28.2	SNDCP service description	1026
28.2.1	Introduction.....	1026
28.2.2	Services offered	1026
28.2.3	Service Primitives.....	1027
28.2.3.0	General	1027
28.2.3.1	Primitive descriptions.....	1028
28.2.3.2	Parameter descriptions	1031
28.2.4	Definition of SNDCP states and state transitions	1041
28.2.4.0	General	1041
28.2.4.1	CLOSED	1041
28.2.4.2	IDLE	1042
28.2.4.3	IDLE-temporary break	1042
28.2.4.4	STANDBY.....	1042
28.2.4.5	STANDBY-temporary break	1044
28.2.4.6	RESPONSE-WAITING	1044
28.2.4.7	READY	1046
28.2.4.8	READY-temporary break	1049
28.2.5	State transitions and functions	1051
28.2.5a	MLE-UNITDATA request primitive	1056
28.2.5b	Other MLE primitives.....	1057
28.2.6	STANDBY, READY, CONTEXT_READY and RESPONSE_WAIT timer functions.....	1057
28.2.6.1	STANDBY timer function	1057
28.2.6.2	READY timer and CONTEXT_READY timer functions	1059
28.2.6.3	RESPONSE_WAIT Timer Function.....	1061
28.2.6.4	SERVICE_CHANGE Timer Function.....	1061

28.3	SNDCP Procedures	1062
28.3.1	Services provided by the protocol.....	1062
28.3.2	Underlying services assumed by the protocol.....	1064
28.3.3	Context activation, modification and deactivation procedures	1064
28.3.3.0	General	1064
28.3.3.0a	SNDCP QoS requests.....	1065
28.3.3.1	Internet Protocol addressing support.....	1066
28.3.3.1.1	IPv4 - Static and dynamic IP addresses	1066
28.3.3.1.2	Mobile IPv4.....	1067
28.3.3.1.3	IPv6	1068
28.3.3.2	NSAPI usage	1068
28.3.3.3	SNDCP network endpoint identifier	1069
28.3.3.4	Definition of Packet data MS Types	1070
28.3.3.4.0	General	1070
28.3.3.4.1	Type A - Parallel	1070
28.3.3.4.2	Type B - Alternating.....	1071
28.3.3.4.3	Type C - IP single mode.....	1071
28.3.3.4.4	Type D - Restricted IP single mode.....	1071
28.3.3.5	PDP Context Activation Procedure.....	1071
28.3.3.5a	PDP context modification procedure	1074
28.3.3.6	PDP context deactivation procedure	1078
28.3.3.6.0	General	1078
28.3.3.6.1	MS originated PDP context deactivation procedure.....	1078
28.3.3.6.2	SwMI originated context deactivation procedure.....	1079
28.3.3a	Assignment of layer 2 logical links to PDP contexts.....	1079
28.3.3b	Choice of layer 2 logical link parameters	1081
28.3.4	Packet Data Channel (PDCH) handling procedures	1081
28.3.4.0	General	1081
28.3.4.1	Logical link handling	1082
28.3.4.2	Logical link setup.....	1083
28.3.4.3	Logical Link disconnection.....	1091
28.3.4.4	Advanced link reconnection.....	1092
28.3.4.5	Releasing the advanced link.....	1096
28.3.4.6	Physical channel handling.....	1096
28.3.4.7	Loss of Radio Resource	1097
28.3.4.8	Selection of physical channel.....	1097
28.3.5	Packet Data transmission and reception procedures	1099
28.3.5.0	General	1099
28.3.5.1	Acknowledged data service.....	1099
28.3.5.2	Unacknowledged data service (advanced link)	1108
28.3.5.2a	Usage of Resource request.....	1109
28.3.5.2b	Unacknowledged data service (basic link).....	1110
28.3.5.3	Protocol header compression	1112
28.3.5.3.1	Header compression types	1112
28.3.5.3.2	TCP/IP header compression	1113
28.3.5.3.3	IP header compression.....	1113
28.3.5.4	Data compression.....	1114
28.3.5.4.0	General	1114
28.3.5.4.1	Support of multiple compression types	1114
28.3.5.4.2	Management of V.42bis data compression.....	1115
28.3.5.4.3	Management of BSD data compression	1115
28.3.5.4.4	Management of Predictor data compression.....	1116
28.3.5.5	Data Priority.....	1116
28.3.5.5.1	General	1116
28.3.5.5.2	Network default data priority and initial MS default data priority	1117
28.3.5.5.3	NSAPI data priority.....	1118
28.3.5.5.4	Changing the MS default data priority	1119
28.3.5.5.5	Short-term data priorities.....	1120
28.3.5.5.6	Short term data priority control	1120
28.3.5.5.7	Data priority of SN-DATA TRANSMIT REQUEST and SN-RECONNECT PDUs	1121
28.3.5.6	Scheduled Access.....	1121
28.3.6	Packet data paging mechanism.....	1123

28.3.7	TETRA IP user authentication.....	1124
28.3.8	TETRA Packet data over the air provisioning	1126
28.3.9	QoS filters	1126
28.4	SN-PDU formats	1127
28.4.0	General.....	1127
28.4.1	PDU priority	1128
28.4.2	Maximum N-PDU size	1128
28.4.3	PDU not supported	1129
28.4.4	SN PDU description tables	1129
28.4.4.1	SN-ACTIVATE PDP CONTEXT ACCEPT	1129
28.4.4.2	SN-ACTIVATE PDP CONTEXT DEMAND	1130
28.4.4.3	SN-ACTIVATE PDP CONTEXT REJECT	1131
28.4.4.4	SN-DATA	1131
28.4.4.4a	SN-DATA-PRIORITY ACKNOWLEDGEMENT	1132
28.4.4.4b	SN-DATA-PRIORITY INFORMATION.....	1132
28.4.4.4c	SN-DATA-PRIORITY REQUEST.....	1133
28.4.4.5	SN-DATA TRANSMIT REQUEST.....	1133
28.4.4.6	SN-DATA TRANSMIT RESPONSE.....	1134
28.4.4.7	SN-DEACTIVATE PDP CONTEXT DEMAND.....	1134
28.4.4.8	SN-DEACTIVATE PDP CONTEXT ACCEPT	1135
28.4.4.9	SN-END OF DATA.....	1135
28.4.4.9a	SN-MODIFY PDP CONTEXT REQUEST.....	1136
28.4.4.9b	SN-MODIFY PDP CONTEXT RESPONSE.....	1136
28.4.4.9c	SN-MODIFY PDP CONTEXT AVAILABILITY	1137
28.4.4.9d	SN-MODIFY PDP CONTEXT USAGE	1137
28.4.4.10	SN-NOT SUPPORTED	1138
28.4.4.11	SN-PAGE REQUEST.....	1138
28.4.4.12	SN-PAGE RESPONSE.....	1139
28.4.4.13	SN-RECONNECT	1140
28.4.4.14	SN-UNITDATA.....	1141
28.4.5	SNDCP information elements coding.....	1141
28.4.5.1	Accept/Reject.....	1141
28.4.5.2	Access point name index.....	1141
28.4.5.3	Activation reject cause	1142
28.4.5.3a	Additional QoS information A.....	1142
28.4.5.3b	Additional QoS information A included	1143
28.4.5.3c	Additional QoS information B	1143
28.4.5.3d	Additional QoS information B included	1143
28.4.5.4	Address Type Identifier in Demand	1143
28.4.5.4a	Asymmetrical QoS.....	1143
28.4.5.4b	Background class request.....	1144
28.4.5.5	BSD data compression parameters.....	1144
28.4.5.6	BSD compression version	1144
28.4.5.7	BSD dictionary size.....	1144
28.4.5.7a	CONTEXT_READY timer	1145
28.4.5.7b	Data class	1145
28.4.5.7c	Data priority details.....	1145
28.4.5.7d	Data priority random access delay factor	1146
28.4.5.7e	Data priority request result.....	1146
28.4.5.7f	Data priority request type.....	1146
28.4.5.7g	Data priority sub-type	1146
28.4.5.8	Data to send.....	1147
28.4.5.8a	Delay class	1147
28.4.5.9	DCOMP	1147
28.4.5.10	DCOMP negotiation.....	1147
28.4.5.11	Deactivation type	1148
28.4.5.11a	Diffserv filter.....	1148
28.4.5.12	Enhanced $\pi/4$ -DQPSK service	1148
28.4.5.13	Immediate service change	1148
28.4.5.14	IP address Ipv4.....	1148
28.4.5.15	Largest header size in octets that may be compressed	1149
28.4.5.15a	Layer 2 data priority lifetime	1149

28.4.5.15b	Layer 2 data priority signalling delay.....	1149
28.4.5.16	Logical link status	1149
28.4.5.17	Maximum interval between full headers	1150
28.4.5.18	Maximum time interval between full headers	1150
28.4.5.19	Maximum transmission unit.....	1150
28.4.5.19a	Mean active throughput.....	1151
28.4.5.19b	Mean throughput	1151
28.4.5.19c	Minimum peak throughput.....	1152
28.4.5.19d	Modification reject cause	1152
28.4.5.19e	Modification result.....	1152
28.4.5.19f	Modify sub-type	1153
28.4.5.19g	MS default data priority	1153
28.4.5.19h	MS default data priority flag	1153
28.4.5.19i	Network default data priority	1153
28.4.5.20	Not supported SN PDU type	1154
28.4.5.21	N-PDU	1154
28.4.5.22	NSAPI	1154
28.4.5.22a	NSAPI additional	1154
28.4.5.22b	NSAPI for reconnection	1155
28.4.5.23	Number of compression state slots, TCP	1155
28.4.5.24	Number of compression state slots, non-TCP	1155
28.4.5.25	Number of Van Jacobson compression state slots	1155
28.4.5.26	Packet data MS Type	1156
28.4.5.27	PCOMP	1156
28.4.5.28	PCOMP negotiation	1157
28.4.5.29	PD service status	1157
28.4.5.29a	PDP context availability.....	1157
28.4.5.29b	PDP context usage	1158
28.4.5.30	PDU priority max.....	1158
28.4.5.30a	Port.....	1158
28.4.5.31	Protocol configuration options	1159
28.4.5.31a	QoS	1160
28.4.5.31b	QoS filter.....	1161
28.4.5.31c	QoS filter included	1161
28.4.5.31d	QoS filter operation.....	1161
28.4.5.31e	QoS filter type.....	1162
28.4.5.31f	QoS set	1162
28.4.5.32	READY timer	1162
28.4.5.32a	Reliability class	1163
28.4.5.33	Reply requested.....	1163
28.4.5.34	Resource request	1164
28.4.5.35	RESPONSE_WAIT timer.....	1165
28.4.5.35a	Scheduled access.....	1166
28.4.5.35b	Scheduled access information included	1166
28.4.5.36	SNDCP version	1167
28.4.5.37	SNDCP network endpoint identifier	1167
28.4.5.38	SN PDU type.....	1167
28.4.5.39	STANDBY timer	1168
28.4.5.40	SwMI IPv6 Information	1168
28.4.5.41	SwMI Mobile IPv4 Information.....	1169
28.4.5.42	Transmit response reject cause.....	1169
28.4.5.43	Type identifier in accept.....	1169
28.4.5.44	Type 3/4 element identifier	1170
28.4.5.45	V.42bis compression request, P ₀	1170
28.4.5.46	V.42bis data compression parameters.....	1170
28.4.5.47	V.42bis maximum string length, P ₂	1170
28.4.5.48	V.42bis number of codewords, P ₁	1171
28.5	Timers and constants	1171
28.5.1	Timers	1171
28.5.1.1	PDP_ACTIVATE_WAIT	1171
28.5.1.2	PDP_DEACTIVATE_WAIT	1171

28.5.1.2a	PDP_MODIFY_WAIT	1171
28.5.1.3	READY	1171
28.5.1.4	STANDBY	1171
28.5.1.5	DATA_PRIORITY_REQUEST_WAIT	1171
28.5.1.6	RESPONSE_WAIT	1171
28.5.1.7	SERVICE_CHANGE	1171
28.5.1.8	CONTEXT_READY	1171
28.5.2	Constants	1172
29	SDS-TL service and protocol	1173
29.0	General	1173
29.1	Overview of SDS-TL	1174
29.1.1	Protocol architecture	1174
29.1.2	Addressing	1175
29.1.3	SDS-TL Requirement to SDS and STATUS services	1175
29.1.3.1	Requirements to MS	1175
29.1.3.2	Requirements to the SwMI	1175
29.2	SDS-TL Service Descriptions	1175
29.2.0	General	1175
29.2.1	Services available at the SDS-TL-SAP	1175
29.2.2	Service primitives at the SDS-TL-SAP	1176
29.2.3	SDS-TL primitives' parameters	1181
29.2.4	State description	1182
29.3	Protocol description	1182
29.3.1	Addressing mechanism	1182
29.3.2	Description of protocol elements	1186
29.3.2.0	General	1186
29.3.2.1	Protocol identifier	1187
29.3.2.2	End-to-end acknowledgement types	1187
29.3.2.3	Service selection/short form report	1189
29.3.2.4	Storage/forward control	1189
29.3.2.5	Message reference	1190
29.3.2.6	Validity period	1190
29.3.2.7	Forward address	1190
29.3.2.8	Data coding scheme	1191
29.3.2.9	Time stamp	1191
29.3.2.10	User data length	1191
29.3.3	Procedures	1191
29.3.3.1	General description	1191
29.3.3.2	MS sending a message	1194
29.3.3.3	MS receiving a message	1195
29.3.3.4	Sending an acknowledgement from the destination MS	1195
29.3.3.4.1	General	1195
29.3.3.4.2	Positive acknowledgement from an MS	1196
29.3.3.4.3	Negative acknowledgement from an MS	1197
29.3.3.4.4	Short form acknowledge	1197
29.3.3.5	Sending an acknowledgement from the source MS	1197
29.3.3.6	Sending an acknowledgement from the SwMI	1198
29.3.3.6.1	General	1198
29.3.3.6.2	Positive acknowledgement from the SwMI	1199
29.3.3.6.3	Negative acknowledgement from the SwMI	1199
29.3.3.6.4	Temporary negative acknowledgement from the SwMI	1199
29.3.3.7	Sending an acknowledgement from the SwMI to destination MS	1199
29.3.3.8	Using SDS-TL for system broadcast messages	1200
29.3.3.8.1	General	1200
29.3.3.8.2	Sending a broadcast message	1200
29.3.3.8.3	Receiving a broadcast message	1200
29.4	Coding requirements	1201
29.4.1	PDU general structure	1201
29.4.2	PDU Descriptions	1201
29.4.2.0	General	1201
29.4.2.1	SDS-ACK	1202

29.4.2.2	SDS-REPORT	1202
29.4.2.3	SDS-SHORT REPORT	1203
29.4.2.4	SDS-TRANSFER	1204
29.4.3	Information elements coding	1204
29.4.3.1	Acknowledgement required	1204
29.4.3.2	Delivery status	1205
29.4.3.3	Delivery report request	1207
29.4.3.4	Dummy digit	1207
29.4.3.5	Forward address type	1207
29.4.3.6	Forward address	1207
29.4.3.7	Message reference	1208
29.4.3.8	Message type	1208
29.4.3.9	Protocol identifier	1209
29.4.3.10	Service selection/short form report	1210
29.4.3.11	Short report type	1210
29.4.3.12	Storage/forward control	1210
29.4.3.13	User data	1211
29.4.3.14	Validity period	1211
29.5	Protocol specific definitions	1211
29.5.0	General	1211
29.5.1	Standardized protocols using SDS Type 4 without SDS-TL	1211
29.5.1.0	General	1211
29.5.1.1	Protocol sequences	1211
29.5.1.2	PDU Description tables	1212
29.5.2	Simple text messaging	1212
29.5.2.0	General	1212
29.5.2.1	Protocol sequences	1212
29.5.2.2	PDU description tables	1212
29.5.2.3	Simple text messaging	1212
29.5.3	Text messaging using SDS-TL	1213
29.5.3.0	General	1213
29.5.3.1	Protocol sequences	1213
29.5.3.2	PDU description tables	1213
29.5.3.3	Text message transfer SDU	1213
29.5.3.4	Text message short form acknowledgement	1213
29.5.4	Text messaging information elements	1213
29.5.4.1	Text coding scheme	1213
29.5.4.2	Character packing	1216
29.5.4.3	7-bit alphabet table	1218
29.5.4.4	Time stamp	1219
29.5.4.5	Timestamp used	1219
29.5.5	Simple location system	1219
29.5.5.0	General	1219
29.5.5.1	Protocol sequences	1219
29.5.5.2	PDU description tables	1219
29.5.5.3	Simple location system PDU	1220
29.5.6	Location system using SDS-TL data transfer services	1220
29.5.6.0	General	1220
29.5.6.1	Protocol sequences	1220
29.5.6.2	PDU description tables	1220
29.5.6.3	Location system transfer SDU	1220
29.5.7	Location system coding scheme	1221
29.5.8	Wireless Application Protocol (WAP)	1221
29.5.8.0	General	1221
29.5.8.1	Protocol sequences	1221
29.5.8.2	PDU description tables	1221
29.5.9	Message with user data header (UDH)	1221
29.5.9.0	General	1221
29.5.9.1	Protocol sequences	1222
29.5.9.2	PDU description tables	1222
29.5.9.3	User Data Header transfer SDU	1222
29.5.9.4	UDH transfer SDU information elements	1222

29.5.9.4.1	User Data Header Information Element	1222
29.5.10	Concatenated text messaging	1223
29.5.10.0	General	1223
29.5.10.1	Protocol sequences	1223
29.5.10.2	PDU description tables	1223
29.5.10.3	Concatenated text message transfer SDU	1223
29.5.10.4	Concatenated text message short form acknowledgement	1224
29.5.11	Concatenated text messaging information elements	1224
29.5.11.1	Text coding scheme	1224
29.5.11.2	Time stamp	1224
29.5.11.3	Time stamp used	1224
29.5.11.4	User data header length	1224
29.5.11.5	UDH information element ID	1224
29.5.11.6	UDH information element length	1224
29.5.11.7	Message reference number	1225
29.5.11.8	Maximum number of messages	1225
29.5.11.9	Sequence number of current message	1225
29.5.11.10	User text (Text segment)	1225
29.5.12	Location information transport	1225
29.5.12.1	General	1225
29.5.12.2	Protocol sequences at SDS-TL	1225
29.5.12.3	Location information protocol architecture	1225
29.5.12.3.1	System architecture	1225
29.5.12.3.2	MS architecture	1226
29.5.12.4	Addressing at SDS-TL	1226
29.5.12.5	Location information transport protocol	1226
29.5.12.6	SDS-TL overhead	1226
29.5.13	Net assist protocol	1227
29.5.13.1	General	1227
29.5.13.2	Protocol sequences at SDS-TL	1227
29.5.13.3	Location information protocol architecture	1227
29.5.13.3.1	System architecture	1227
29.5.13.3.2	MS architecture	1227
29.5.13.4	Addressing at SDS-TL	1228
29.5.13.5	Net Assist Protocol	1228
29.5.13.6	SDS-TL overhead	1228
29.5.14	Concatenation of SDS-TL messages protocol	1228
29.5.14.1	Introduction	1228
29.5.14.2	MS protocol stack	1228
29.5.14.3	Concatenation service	1229
29.5.14.3.1	General overview	1229
29.5.14.3.2	Concatenation service primitives	1229
29.5.14.3.3	Concatenation service primitive parameters	1236
29.5.14.4	Concatenation protocol	1237
29.5.14.5	Concatenated message structures	1238
29.5.14.6	General on concatenated messages transport	1238
29.5.14.7	Concatenated messages transport without SDS-TL service	1239
29.5.14.7.1	Sending concatenated SDS-TL messages without SDS-TL service	1239
29.5.14.7.2	Receiving concatenated SDS-TL messages without SDS-TL service	1239
29.5.14.7.3	Acknowledgement of concatenated SDS-TL messages without SDS-TL service	1239
29.5.14.7.4	Concatenated message lifetime	1239
29.5.14.7.5	Exceptional conditions	1240
29.5.14.8	Concatenated messages transport with SDS-TL transport service	1240
29.5.14.8.1	Acknowledgements in transport of concatenated SDS-TL messages	1240
29.5.14.8.2	Sending concatenated SDS-TL messages with SDS-TL service	1240
29.5.14.8.3	Receiving concatenated SDS-TL messages with SDS-TL service	1241
29.5.14.8.4	Acknowledgements of SDS-REPORT PDUs	1242
29.5.14.8.5	Exceptional conditions	1242
29.5.14.9	Concatenation management	1242
29.5.14.10	Timestamp usage	1242
29.5.14.11	Concatenation coding requirements	1243
29.5.14.11.1	Concatenation control	1243

29.5.14.11.2	Concatenation control PDU type	1243
29.5.14.12	Concatenation message examples	1243
29.5.14.12.1	Concatenation of SDS messages without SDS-TL data transport service	1243
29.5.14.12.2	Concatenation of SDS messages with SDS-TL data transport service	1244
29.5.15	Simple AGNSS	1244
29.5.15.1	General	1244
29.5.15.2	Protocol sequences	1244
29.5.15.3	PDU description tables	1244
29.5.15.4	Simple AGNSS unitdata	1245
29.5.16	AGNSS using SDS-TL data transfer services	1245
29.5.16.1	General	1245
29.5.16.2	Protocol sequences	1245
29.5.16.3	PDU description tables	1245
29.5.16.4	AGNSS transfer SDU	1245
29.5.16.5	AGNSS constellation	1245
29.5.16.6	AGNSS coding scheme	1246
30	Multimedia Exchange Layer	1247
30.1	General	1247
30.2	MEX Layer Overview	1251
30.2.1	General	1251
30.2.2	QoS Classes	1251
30.2.2.1	Data Class	1251
30.2.2.2	Delay Class	1252
30.2.2.3	Reliability Class	1252
30.2.2.4	MEX QoS abstract class	1252
30.2.3	QoS Attributes	1255
30.2.3.1	General	1255
30.2.3.2	Data Throughput	1255
30.2.3.3	MEX Precedence	1256
30.2.3.4	Data Priority	1258
30.2.3.5	PDU Priority	1258
30.2.3.6	Data Importance	1258
30.2.3.7	Scheduled Access Option	1258
30.2.3.8	CONTEXT_READY timer	1259
30.2.3.9	Escalated Priority	1259
30.2.4	Definition of MEX states and state transitions	1261
30.2.4.1	General	1261
30.2.4.2	Secondary PDP contexts	1262
30.2.4.3	MEX QoS Filter and Address/NSAPI mapping tables	1262
30.3	MEX Procedures	1263
30.3.1	Services provided by the protocol and QoS negotiations	1263
30.3.2	MEX access procedure	1263
30.3.3	MEX-CONNECT Procedure	1264
30.3.4	MEX-MODIFY Procedure	1265
30.3.5	MEX connection termination procedure	1268
30.3.6	MEX QoS Abstract Class Table Management	1269
30.3.7	MEX data routing procedure	1270
30.3.7.1	Uplink Data Service	1270
30.3.7.2	Downlink Data Service	1271
30.3.7.3	Maximum Transmission Unit	1271
30.3.7.4	Scheduled access	1271
30.3.7.5	MEX-QOS	1272
30.3.7.6	Packet mode Paging	1272
30.4	MEX service description	1272
30.4.1	Introduction	1272
30.4.2	Services offered	1272
30.4.3	Service Primitives	1272
30.4.3.1	General on service primitives	1272
30.4.3.2	MEX-CAPABILITY	1273
30.4.3.3	MEX-CONNECT	1274
30.4.3.4	MEX-BYPASS DATA	1274

30.4.3.5	MEX-DELIVERY	1275
30.4.3.6	MEX-END	1275
30.4.3.7	MEX-HANDLE	1275
30.4.3.8	MEX-MODIFY	1276
30.4.3.9	MEX-PAGE	1276
30.4.3.10	MEX-QOS	1276
30.4.3.11	MEX-QOSCLASS	1277
30.4.4	MEX Parameters.....	1277
30.4.4.0	General	1277
30.4.4.1	Data Handle.....	1277
30.4.4.2	Data Importance	1277
30.4.4.3	Data Priority	1277
30.4.4.4	DCOMP	1277
30.4.4.5	Maximum Transmission Unit.....	1277
30.4.4.6	MEX Capability	1277
30.4.4.7	MEX Connect Reject Cause.....	1278
30.4.4.8	MEX Connect Report.....	1279
30.4.4.9	MEX Deactivation Type	1279
30.4.4.10	MEX Delay Class.....	1279
30.4.4.11	MEX Delivery Header	1279
30.4.4.12	MEX Delivery Report	1279
30.4.4.13	MEX Escalate DSCP5 Flag Enable.....	1279
30.4.4.14	MEX Escalate DSCP5 Flag Reset.....	1280
30.4.4.15	MEX Filter	1280
30.4.4.16	MEX Filter Operation	1280
30.4.4.17	MEX Filter Type	1280
30.4.4.18	MEX Handle	1280
30.4.4.19	MEX IP Request	1280
30.4.4.20	MEX Mode	1280
30.4.4.21	MEX Modify Report	1281
30.4.4.22	MEX Modify Reject Cause.....	1281
30.4.4.23	MEX N-PDU.....	1281
30.4.4.24	MEX NSAPI Usage	1281
30.4.4.25	MEX PDP Address	1282
30.4.4.26	MEX PDP Type	1282
30.4.4.27	MEX Peer IP Filter.....	1282
30.4.4.28	MEX Precedence.....	1282
30.4.4.29	MEX QoS.....	1282
30.4.4.30	MEX QoS Class	1283
30.4.4.31	MEX QoS Class Uplink/Downlink Upper/Lower.....	1283
30.4.4.32	MEX QoS Class Access	1283
30.4.4.33	MEX QoS Filter	1283
30.4.4.34	MEX Scheduled Access.....	1283
30.4.4.35	MEX Transaction Type.....	1283
30.4.4.36	Mobile IPv4 Information.....	1284
30.4.4.37	NSAPI	1284
30.4.4.38	NSAPI Data Priority	1284
30.4.4.39	NSAPI QoS Negotiation	1284
30.4.4.40	PCOMP	1284
30.4.4.41	PDU Priority	1284
30.4.4.42	PDU Priority Max	1284
30.4.4.43	Schelude availability.....	1284
30.4.4.44	Schedule Surplus Flag.....	1284
Annex A (normative):	LLC timers and constants.....	1285
A.0	General	1285
A.1	LLC timers	1285
A.2	LLC constants	1286
Annex B (normative):	MAC timers and constants.....	1288

B.0	General	1288
B.1	MAC timers.....	1288
B.2	MAC constants.....	1290
Annex C (normative):	Mathematical definition of Frame Check Sequence (FCS).....	1291
Annex D (informative):	MAC scenarios for use of traffic channel	1292
Annex E (normative):	PDU encoding rules and examples	1302
E.0	General	1302
E.1	PDU encoding rules for CMCE, MM and SNDCP PDUs	1302
E.1.1	General PDU encoding rules for CMCE, MM and SNDCP PDUs	1302
E.1.2	PDU encoding examples for CMCE PDUs.....	1307
E.1.3	PDU encoding examples for MM PDUs	1311
E.2	PDU encoding rules for MLE PDUs	1314
E.2.1	General PDU encoding rules for MLE PDUs.....	1314
E.2.2	PDU encoding examples for MLE PDUs.....	1317
Annex F (normative):	TETRA frequency bands, duplex spacings and channel numbering	1322
Annex G (normative):	TETRA group management scenarios.....	1323
G.0	Introduction	1323
G.1	General requirements	1323
G.2	MS-INITIATED GROUP ATTACHMENT/DETACHMENT	1325
G.2.1	SCENARIO 1	1325
G.2.2	SCENARIO 2.....	1326
G.2.3	SCENARIO 3.....	1327
G.2.4	SCENARIO 4.....	1327
G.2.5	SCENARIO 5.....	1328
G.2.6	SCENARIO 6.....	1328
G.2.7	SCENARIO 7.....	1330
G.2.8	SCENARIO 8.....	1331
G.2.9	SCENARIO 9.....	1332
G.2.10	SCENARIO 10.....	1333
G.2.11	SCENARIO 11.....	1334
G.2.12	SCENARIO 12.....	1336
G.2.13	SCENARIO 13.....	1337
G.3	SwMI-INITIATED GROUP ATTACHMENT/DETACHMENT	1338
Annex H (normative):	TETRA proprietary information element owner	1339
H.0	General	1339
H.1	Proprietary information element	1339
H.2	Application for the proprietary element owner value.....	1339
Annex I (normative):	TETRA SDS-TL Location system coding scheme information element owner	1342
I.0	General	1342
I.1	Location system coding scheme information element	1342
I.2	Application for the Location system coding scheme identifier value	1342
Annex J (normative):	TETRA SDS-TL protocol identifier information element owner	1345
J.0	General	1345

J.1	Protocol identifier information element	1345
J.2	Application for the protocol identifier value	1346
Annex K (informative): TETRA Mobile Country Code information element values		1349
K.1	Management of TETRA Mobile Country Codes	1349
K.2	TETRA Mobile Country Code information element values	1349
Annex L (informative): Bibliography		1350
Annex M (informative): Table and figure numbering		1351
Annex N (informative): Example for coding of SDS Transfer SDU with UDH information elements		1366
N.0	General	1366
N.1	Multiple Information Elements with Network Layer User Data (Text Message)	1366
Annex O (normative): Air - Ground - Air service		1368
O.1	Introduction	1368
O.2	Air - Ground - Air service overview	1368
O.3	System requirements regarding AGA	1369
O.4	Signalling protocol	1369
O.4.1	General	1369
O.4.2	Distance reporting	1369
O.4.3	Excessive path delay	1370
O.4.4	Cell re-selection	1371
O.4.5	Neighbour cells	1371
O.4.6	Base station fallback	1371
O.4.7	Subscriber class	1371
O.5	Range extension	1372
O.5.1	Background for phase modulated channels	1372
O.5.2	Extended range requirements for phase modulation	1376
O.5.3	Background for QAM channels	1376
O.5.4	Extended range requirements for QAM	1380
O.6	Subscriber class procedures	1380
O.6.1	Purpose of the subscriber class	1380
O.6.2	Preferred subscriber classes	1380
O.7	Amendments and modifications due to the AGA service	1381
O.7.1	Modified information elements	1381
O.7.1.1	General	1381
O.7.1.2	Amendment to clause 16.10.49 Subscriber class	1381
O.7.1.3	Amendment to clause 18.5.22 Subscriber class	1381
O.7.1.4	Modification of clause 21.5.3 Power control	1382
O.7.2	Modified protocols	1382
O.7.2.1	General	1382
O.7.2.2	Monitoring modification of clauses 18.3.4.2 and 18.3.4.5.1	1382
O.7.2.3	MS cell selection modification of clause 18.3.4.5.7	1382
O.7.2.4	Modification of clause 23.4.4.3	1384
O.8	Example of subscriber class values used by operators and users in some networks	1384
O.9	Requirements for air MSs	1384
O.10	Requirements for AGA BSs	1385
Annex P (normative): QAM modulation symbol allocations and symbol set definitions		1386

P.1	QAM modulation symbol sub-carrier allocation.....	1386
P.1.0	General	1386
P.1.1	Control uplink Burst (CB).....	1386
P.1.2	Random Access uplink Burst (RAB).....	1389
P.1.3	Linearization uplink Burst (LB)	1389
P.1.4	Normal Uplink Burst (NUB)	1390
P.1.5	Normal Downlink Burst (NDB)	1395
P.1.6	Linearization downlink burst (LDB)	1400
P.1.7	Frequency Correction downlink burst (FCB).....	1405
P.2	Burst sub-carrier symbol sets	1410
P.2.1	Uplink sync sequence set	1410
P.2.2	Downlink sync sequence set.....	1412
P.2.3	Half-slot uplink pilots set	1414
P.2.4	Full-slot uplink pilots set.....	1415
P.2.5	Full-slot downlink pilots set	1420
P.2.6	Filler sets	1424
P.2.7	Linearization downlink zeroed set.....	1430
P.2.8	Frequency correction set	1430
P.2.9	Secondary sync sequence set.....	1430
Annex Q (normative): Graceful service degradation mode.....		1432
Q.1	General	1432
Q.2	Procedures	1432
Q.2.1	Entering graceful service degradation mode	1432
Q.2.2	Operating in graceful service degradation mode	1432
Q.2.3	Criterion for temporary break of service in graceful service degradation mode	1433
Q.2.4	Criterion for leaving graceful service degradation mode due to service aggradation.....	1434
Q.2.5	Criterion for leaving graceful service degradation mode due to catastrophic service degradation	1434
Q.2.6	Criterion for starting scanning of neighbour cells in graceful service degradation mode	1434
Q.2.7	Criterion for starting scanning of non-neighbour cells in graceful service degradation mode	1434
Q.3	Constants and Timers	1434
Annex R (normative): Subscriber Class Preference levels.....		1436
R.1	Introduction	1436
R.2	Subscriber Class preference levels	1436
Annex S (informative): Multiple CA cells sharing a channel - interim method.....		1437
Annex T (informative): Change Requests.....		1438
History	1448

Intellectual Property Rights

Essential patents

IPRs essential or potentially essential to normative deliverables may have been declared to ETSI. The information pertaining to these essential IPRs, if any, is publicly available for **ETSI members and non-members**, and can be found in ETSI SR 000 314: "*Intellectual Property Rights (IPRs); Essential, or potentially Essential, IPRs notified to ETSI in respect of ETSI standards*", which is available from the ETSI Secretariat. Latest updates are available on the ETSI Web server (<https://ipr.etsi.org/>).

Pursuant to the ETSI IPR Policy, no investigation, including IPR searches, has been carried out by ETSI. No guarantee can be given as to the existence of other IPRs not referenced in ETSI SR 000 314 (or the updates on the ETSI Web server) which are, or may be, or may become, essential to the present document.

Trademarks

The present document may include trademarks and/or tradenames which are asserted and/or registered by their owners. ETSI claims no ownership of these except for any which are indicated as being the property of ETSI, and conveys no right to use or reproduce any trademark and/or tradename. Mention of those trademarks in the present document does not constitute an endorsement by ETSI of products, services or organizations associated with those trademarks.

Foreword

This Technical Specification (TS) has been produced by ETSI Technical Committee TETRA and Critical Communications Evolution (TCCE).

The present document is part 2 of a multi-part deliverable covering the Terrestrial Trunked Radio (TETRA); Voice plus Data (V+D), Release 2, as identified below:

- Part 1: "General network design";
- Part 2: "Air Interface (AI)";**
- Part 3: "Interworking at the Inter-System Interface (ISI)";
- Part 4: "Gateways basic operation";
- Part 5: "Peripheral Equipment Interface (PEI)";
- Part 7: "Security";
- Part 9: "General requirements for supplementary services";
- Part 10: "Supplementary services stage 1";
- Part 11: "Supplementary services stage 2";
- Part 12: "Supplementary services stage 3";
- Part 13: "SDL model of the Air Interface (AI)";
- Part 14: "Protocol Implementation Conformance Statement (PICS) proforma specification";
- Part 15: "TETRA frequency bands, duplex spacings and channel numbering";
- Part 16: "Network Performance Metrics";
- Part 17: "TETRA V+D and DMO specifications";
- Part 18: "Air interface optimized applications";
- Part 19: "Interworking between TETRA and Broadband systems".

NOTE 1: Part 3, sub-parts 6 and 7 (Speech format implementation), part 4, sub-part 3 (Data networks gateway), part 10, sub-part 15 (Transfer of control), part 13 (SDL) and part 14 (PICS) of this multi-part deliverable are in status "historical" and are not maintained.

NOTE 2: Some parts are also published as Technical Specifications such as ETSI TS 100 392-2 (the present document) and those may be the latest version of the document.

Modal verbs terminology

In the present document "**shall**", "**shall not**", "**should**", "**should not**", "**may**", "**need not**", "**will**", "**will not**", "**can**" and "**cannot**" are to be interpreted as described in clause 3.2 of the [ETSI Drafting Rules](#) (Verbal forms for the expression of provisions).

"**must**" and "**must not**" are **NOT** allowed in ETSI deliverables except when used in direct citation.

1 Scope

The present document defines the Air Interface (AI) for the Terrestrial Trunked Radio (TETRA) system supporting Voice plus Data (V+D) conventional access (CA) and direct access (DA) and contains the specifications of the physical layer, the data link layer and the network layer according to the ISO model.

First, it establishes the TETRA radio aspects (layer 1):

- it defines and specifies the modulation;
- it defines and specifies the radio transmission and reception;
- it defines and specifies the synchronization;
- it defines and specifies the channel coding;
- it defines and specifies the channel multiplexing;
- it defines and specifies the control over the radio link.

Secondly, it establishes the services, messages and protocols used for voice and circuit mode data transfer, starting with the upper layers:

- it defines and specifies the services provided by the CC sub-entity;
- it defines and specifies the services provided by the SS sub-entity;
- it defines and specifies the services provided by the SDS sub-entity;
- it defines and specifies the protocol used by the Circuit Mode Control Entity (CMCE) to communicate across the air interface in order to offer the services of the Call Control (CC), Supplementary Service (SS) and Short Data Service (SDS) sub-entities;
- it defines and specifies the services and protocol used for the management of the users' mobility inside and across TETRA networks, namely the ones of the Mobility Management (MM) entity and the MLE;
- it defines and specifies the services and protocol used in the data link layer subdivided in two sub-entities, the Logical Link Control (LLC) and the Medium Access Control (MAC) entities.

Thirdly, it establishes the services, messages and protocols used for packet data transfer:

- it defines and specifies the services provided by the Sub-Network Specific Data Control Protocol (SNDCP) sub-entity;
- it defines and specifies the protocol used by Sub-Network Specific Data Control Protocol (SNDCP).

2 References

2.1 Normative references

References are either specific (identified by date of publication and/or edition number or version number) or non-specific. For specific references, only the cited version applies. For non-specific references, the latest version of the referenced document (including any amendments) applies.

Referenced documents which are not found to be publicly available in the expected location might be found at <https://docbox.etsi.org/Reference/>.

NOTE: While any hyperlinks included in this clause were valid at the time of publication, ETSI cannot guarantee their long term validity.

The following referenced documents are necessary for the application of the present document.

- [1] ETSI TS 100 900 (V7.2.0): "Digital cellular telecommunications system (Phase 2+) (GSM); Alphabets and language-specific information (GSM 03.38 version 7.2.0 Release 1998)".
- [2] ETSI TS 123 040: "Digital cellular telecommunications system (Phase 2+); Universal Mobile Telecommunications System (UMTS); Technical realization of Short Message Service (SMS) (3GPP TS 23.040)".
- [3] ETSI ES 202 109: "Terrestrial Trunked Radio (TETRA); Security; Synchronization mechanism for end-to-end encryption".
- [4] ETSI EN 300 113-1: "Electromagnetic compatibility and Radio spectrum Matters (ERM); Land mobile service; Radio equipment intended for the transmission of data (and/or speech) using constant or non-constant envelope modulation and having an antenna connector; Part 1: Technical characteristics and methods of measurement".
- [5] ETSI ETS 300 125: "Integrated Services Digital Network (ISDN); User-network interface data link layer specification; Application of CCITT Recommendations Q.920/I.440 and Q.921/I.441".
- [6] ETSI EN 300 392-1: "Terrestrial Trunked Radio (TETRA); Voice plus Data (V+D); Part 1: General network design".
- [7] ETSI EN 300 392-5: "Terrestrial Trunked Radio (TETRA); Voice plus Data (V+D); Part 5: Peripheral Equipment Interface (PEI)".
- [8] ETSI EN 300 392-7: "Terrestrial Trunked Radio (TETRA); Voice plus Data (V+D); Part 7: Security".
- [9] ETSI EN 300 392-9: "Terrestrial Trunked Radio (TETRA); Voice plus Data (V+D); Part 9: General requirements for supplementary services".
- [10] ETSI EN/ETSI ETS 300 392-12 (all sub-parts): "Terrestrial Trunked Radio (TETRA); Voice plus Data (V+D); Part 12: Supplementary services stage 3".
- [11] ETSI EN 300 392-12-1: "Terrestrial Trunked Radio (TETRA); Voice plus Data (V+D); Part 12: Supplementary services stage 3; Sub-part 1: Call Identification (CI)".
- [12] ETSI EN 300 392-12-3: "Terrestrial Trunked Radio (TETRA); Voice plus Data (V+D); Part 12: Supplementary services stage 3; Sub-part 3: Talking Party Identification (TPI)".
- [13] ETSI ETS 300 392-12-7: "Terrestrial Trunked Radio (TETRA); Voice plus Data (V+D); Part 12: Supplementary services stage 3; Sub-part 7: Short Number Addressing (SNA)".
- [14] ETSI EN 300 392-12-8: "Terrestrial Trunked Radio (TETRA); Voice plus Data (V+D); Part 12: Supplementary services stage 3; Sub-part 8: Area Selection (AS)".
- [15] ETSI EN 300 392-12-10: "Terrestrial Trunked Radio (TETRA); Voice plus Data (V+D); Part 12: Supplementary services stage 3; Sub-part 10: Priority Call (PC)".

- [16] ETSI EN 300 392-12-16: "Terrestrial Trunked Radio (TETRA); Voice plus Data (V+D); Part 12: Supplementary services stage 3; Sub-part 16: Pre-emptive Priority Call (PPC)".
- [17] ETSI EN 300 392-12-22: "Terrestrial Trunked Radio (TETRA); Voice plus Data (V+D); Part 12: Supplementary services stage 3; Sub-part 22: Dynamic Group Number Assignment (DGNA)".
- [18] ETSI TS 100 392-15: "Terrestrial Trunked Radio (TETRA) Voice plus DATA (V+D); Part 15: TETRA frequency bands, duplex spacings and channel numbering".
- [19] ETSI TS 100 392-18-1: "Terrestrial Trunked Radio (TETRA); Voice plus Data (V+D) and Direct Mode Operation (DMO); Part 18: Air interface optimized applications; Sub-part 1: Location Information Protocol (LIP)".
- [20] ETSI TS 100 392-18-2: "Terrestrial Trunked Radio (TETRA); Voice plus Data (V+D) and Direct Mode Operation (DMO); Part 18: Air interface optimized applications; Sub-part 2: Net Assist Protocol (NAP)".
- [21] ETSI EN 300 395-2: "Terrestrial Trunked Radio (TETRA); Speech codec for full-rate traffic channel; Part 2: TETRA codec".
- [22] ETSI EN 300 396-3: "Terrestrial Trunked Radio (TETRA); Technical requirements for Direct Mode Operation (DMO); Part 3: Mobile Station to Mobile Station (MS-MS) Air Interface (AI) protocol".
- [23] ETSI EN 300 396-4: "Terrestrial Trunked Radio (TETRA); Technical requirements for Direct Mode Operation (DMO); Part 4: Type 1 repeater air interface".
- [24] ETSI EN 300 396-5: "Terrestrial Trunked Radio (TETRA); Technical requirements for Direct Mode Operation (DMO); Part 5: Gateway air interface".
- [25] ETSI EN 300 396-7: "Terrestrial Trunked Radio (TETRA); Technical requirements for Direct Mode Operation (DMO); Part 7: Type 2 repeater air interface".
- [26] ETSI EN 300 396-10: "Terrestrial Trunked Radio (TETRA); Technical requirements for Direct Mode Operation (DMO); Part 10: Managed Direct Mode Operation (M-DMO)".
- [27] Recommendation ITU-T V.42bis: "Data compression procedures for data circuit-terminating equipment (DCE) using error correcting procedures".
- [28] Recommendation ITU-T X.25: "Interface between Data Terminal Equipment (DTE) and Data Circuit-terminating Equipment (DCE) for terminals operating in the packet mode and connected to public data networks by dedicated circuit".
- [29] IETF RFC 1144: "Compressing TCP/IP Headers for Low-Speed Serial Links".
- [30] IETF RFC 1661: "The Point-to-Point Protocol (PPP)".
- [31] IETF RFC 1662: "PPP in HDLC-like Framing".
- [32] IETF RFC 1977: "PPP BSD Compression Protocol".
- [33] IETF RFC 1978: "PPP Predictor Compression Protocol".
- [34] IETF RFC 1994: "PPP Challenge Handshake Authentication Protocol (CHAP)".
- [35] IETF RFC 2507: "IP Header Compression".
- [36] IETF RFC 2508: "Compressing IP/UDP/RTP Headers for Low-Speed Serial Links".
- [37] IETF RFC 2865: "Remote Authentication Dial In User Service (RADIUS)".
- [38] IETF RFC 3232: "Assigned Numbers: RFC 1700 is Replaced by an On-line Database".

[39] IETF RFC 5944: "IP Mobility Support for IPv4".

NOTE: Obsoletes IETF RFC 3344.

[40] ISO/IEC 8859 (all parts): "Information technology -- 8-bit single-byte coded graphic character sets".

[41] ISO/IEC 10646: "Information technology -- Universal Multiple-Octet Coded Character Set (UCS)".

[42] Recommendation ITU-T E.218: "Management of the allocation of terrestrial trunk radio Mobile Country Codes".

[43] IETF RFC 2474 (December 1998): "Definition of the Differentiated Services Field (DS Field) in the IPv4 and IPv6 Headers".

NOTE: Available at <http://www.ietf.org/rfc/rfc2474.txt>.

[44] IETF RFC 2475 (December 1998): "An Architecture for Differentiated Services".

NOTE: Available at <http://www.ietf.org/rfc/rfc2475.txt>.

[45] IETF RFC 2597 (June 1999): "Assured Forwarding PHB Group".

NOTE: Available at <http://www.ietf.org/rfc/rfc2597.txt>.

[46] IETF RFC 3246 (March 2002): "An Expedited Forwarding PHB (Per-Hop Behavior)".

[47] IETF RFC 1456 (May 1993): "Conventions for Encoding the Vietnamese Language; VISCII: VIetnamese Standard Code for Information Interchange; VIQR: VIetnamese Quoted-Readable Specification".

NOTE: Available at <http://www.ietf.org/rfc/rfc1456.txt>.

[48] ETSI TS 100 392-18-3: "Terrestrial Trunked Radio (TETRA); Voice plus Data (V+D) and Direct Mode Operation (DMO); Part 18: Air interface optimized applications; Sub-part 3: Direct mode Over The Air Management protocol (DOTAM)".

[49] ETSI TS 100 392-18-4: "Terrestrial Trunked Radio (TETRA); Voice plus Data (V+D) and Direct Mode Operation (DMO); Part 18: Air interface optimized applications; Sub-part 4: Net Assist Protocol 2 (NAP2)".

2.2 Informative references

References are either specific (identified by date of publication and/or edition number or version number) or non-specific. For specific references, only the cited version applies. For non-specific references, the latest version of the referenced document (including any amendments) applies.

NOTE: While any hyperlinks included in this clause were valid at the time of publication, ETSI cannot guarantee their long term validity.

The following referenced documents are not necessary for the application of the present document but they assist the user with regard to a particular subject area.

[i.1] ETSI TR 102 300-5: "Terrestrial Trunked Radio (TETRA); Voice plus Data (V+D); Designers' guide; Part 5: Guidance on Numbering and addressing".

[i.2] ETSI TS 144 012 (V7.0.0): "Digital cellular telecommunications system (Phase 2+); Short Message Service Cell Broadcast (SMSCB) support on the mobile radio interface; (3GPP TS 44.012 version 7.0.0 Release 7)".

[i.3] ETSI EN 300 392-3-5: "Terrestrial Trunked Radio (TETRA); Voice plus Data (V+D); Part 3: Interworking at the Inter-System Interface (ISI); Sub-part 5: Additional Network Feature for Mobility Management (ANF-ISIMM)".

- [i.4] ETSI ETS 300 392-10-7: "Terrestrial Trunked Radio (TETRA); Voice plus Data (V+D); Part 10: Supplementary services stage 1; Sub-part 7: Short number addressing".
 - [i.5] ETSI ETS 300 392-11-7: "Terrestrial Trunked Radio (TETRA); Voice plus Data (V+D); Part 11: Supplementary services stage 2; Sub-part 7: Short Number Addressing (SNA)".
 - [i.6] ETSI EN 300 396-6: "Terrestrial Trunked Radio (TETRA); Direct Mode Operation (DMO); Part 6: Security".
 - [i.7] ISO/IEC 8348: "Information technology - Open Systems Interconnection - Network service definition".
 - [i.8] ISO/IEC 13239: "Information technology - Telecommunications and information exchange between systems - High-level data link control (HDLC) procedures".
 - [i.9] Open Mobile Alliance, Ltd. Technical-WAP2-0-20021106: "The WAP 2.0 conformance release".
- NOTE: Available at <http://www.openmobilealliance.org/tech/affiliates/wap/wapindex.html#wap20>.
- [i.10] ETSI TS 122 060: "Digital cellular telecommunications system (Phase 2+); Universal Mobile Telecommunications System (UMTS); General Packet Radio Service (GPRS); Service description; Stage 1 (3GPP TS 22.060)".
 - [i.11] ETSI EN 301 344: "Digital cellular telecommunications system (Phase 2+) (GSM); General Packet Radio Service (GPRS); Service description; Stage 2 (GSM 03.60)".
 - [i.12] ETSI TR 102 021-8: "Terrestrial Trunked Radio (TETRA); User Requirement Specification TETRA Release 2; Part 8: Air - Ground - Air services".
 - [i.13] ETSI EN 300 394-1: "Terrestrial Trunked Radio (TETRA); Conformance testing specification; Part 1: Radio".
 - [i.14] IETF RFC 792: "Internet Control Message Protocol".
 - [i.15] IETF RFC 1191: "Path MTU discovery".
 - [i.16] ETSI EN 300 392-2 (V3.4.1 and earlier versions): "Terrestrial Trunked Radio (TETRA); Voice plus Data (V+D); Part 2: Air Interface (AI)".
 - [i.17] Digital land mobile radio communications : COST 207 final report (14 March 1984 - 13 September 1988).

3 Definition of terms, symbols and abbreviations

3.1 Terms

For the purposes of the present document, the following terms apply:

$\pi/4$ -DQPSK channel: channel on which signalling and data messages are sent using $\pi/4$ -DQPSK bursts

access code: subdivision of mobiles for random access opportunities

acknowledged data transfer: service provided by the layer below which gives an acknowledgement back over the air interface from the lower layer peer entity

NOTE: This service is used by the layer 3 entities to get a secure transmission including retransmissions.

advanced link: bidirectional connection-oriented path between an MS and a BS using the acknowledged service - or unidirectional connection-oriented path between a BS and one or several MSs using the unacknowledged service - with provision of windowing, segmentation, extended error protection and choice among several throughputs

NOTE: The advanced link requires a set-up phase.

announced cell reselection: cell reselection where the MS-MLE informs the SwMI both in the old cell (leaving cell) and in the new cell (arriving cell) that cell change is performed

NOTE: There can be three types of announced cell reselection:

- type 1: the MS-MLE knows the new cell and the channel allocations (e.g. the traffic channel) on the new cell before leaving the old cell;
- type 2: the MS-MLE knows the new cell before changing to it, but does not know the channel allocation on the new cell in advance;
- type 3: the MS-MLE does not need to know the new cell before leaving the old cell. The old cell is only informed by the MS-MLE that it wants to change cell.

TETRA V+D may support all three types of announced cell reselection.

assessment: estimation of the path loss parameter of the serving cell main carrier or of a channel class (on the serving cell or an adjacent cell), based on measurements made on another channel or carrier radiated from the same site and applying conversion factors to those measurements

assigned channel: channel allocated by the infrastructure to certain MSs using channel allocation command(s) addressed to those MSs

NOTE: An assigned channel may be allocated for secondary control purposes or for a circuit mode call.

Associated Control Channel (ACCH): dedicated signalling channel associated with a channel that has been assigned for circuit mode traffic

NOTE: It comprises the Fast Associated Control Channel (FACCH) which uses frames 1 to 18 when there is no traffic in a given direction or the Slow Associated Control Channel (SACCH) which is always available in frame 18 when there is traffic.

attached to a cell: MS is said to be attached to a cell when the MS is camped on a cell and, if registration is required, has registered on the cell

NOTE: The MS may be in idle mode (i.e. not actively processing a transaction) or in active mode (i.e. actively processing a transaction in reception and/or in transmission). It is the MM which decides when an MS is said to be attached.

background class data: data that requires high delivery reliability but can tolerate delay

background measurement: measurements performed by the lower layers while maintaining current service toward the service users, i.e. MS-MLE

basic link: bidirectional connectionless path between one or several MSs and a BS, with a provision of both unacknowledged and acknowledged services on a single message basis

Bit Error Ratio (BER): limit ratio of the bits wrongly received to all bits received in a given logical channel

broadcast: unidirectional point to multi-point mode of transmission

C-plane: plane for control and packet data signalling

call-related service: service requested from call set-up initiation until call disconnection and related to that call

NOTE: The call-related service can also be valid a certain short time after disconnection but before next call set-up is initiated.

call unrelated service: service either requested outside a call or inside a call but not referring to that call

called user application: user application which receives an incoming call

calling user application: user application which initiates an outgoing call

camped: MS is said to be camped on a cell when the MS is synchronized on the cell BS, and has decoded the Broadcast Network Channel (BNCH) of a conventional access cell or the QAM Broadcast Network Channel (BNCH-Q) of a direct access cell, and has selected the cell as its serving cell

NOTE: The synchronization procedure is performed by the MAC and the interpretation of the network information from the BNCH or BNCH-Q is performed by a procedure in the MLE. It is the MLE which decides when an MS is said to be camped on a cell.

carrier specific signalling: additional $\pi/4$ -DQPSK common signalling channel allocated in conjunction with a traffic channel specific to the carrier

cell reselection: act of changing the serving cell from an old cell to a new cell

NOTE: The cell reselection is performed by procedures located in the MLE and in the MAC. When the reselection is made and possible registration is performed, the MS is said to be attached to the cell.

channel class: set of values indicating the general RF characteristics of a concentric channel or fully super-sectored channel

common control channels: control channels transmitted by the infrastructure to control the MS population

NOTE: The common control channels comprise the $\pi/4$ -DQPSK Main Control Channel (MCCH) or QAM Main Control Channel (MCCH-Q), and common Secondary Control Channels (SCCH).

concatenated text message: part of a chain of single SDS text messages belonging to a longer text message

NOTE: Each single SDS text message can be concatenated to other SDS text messages using either the UDH protocol or concatenation of SDS-TL messages.

concatenation-part: single SDS message that is sent as part of a concatenated SDS-TL message

concentric channel: channel that has essentially the same azimuthal radiation pattern as the main carrier and is radiated from the same site as the main carrier

NOTE: A concentric channel may have a larger or smaller range and coverage area than the main carrier (i.e. it may be a non-conforming channel); and it may use a different modulation mode, RF bandwidth and RF power from the main carrier.

confirmed service: service provided by the layer below which ensures that a message is responded to by the peer entity before new messages are allowed

NOTE: The service may be used for synchronization of peer entities or for provision of sequential behaviour.

conforming channel: channel that has essentially the same azimuthal radiation pattern as the main carrier, is radiated from the same site as the main carrier and has essentially the same range and coverage area as the main carrier

NOTE: A conforming channel is a special case of a concentric channel: it is a concentric channel that has essentially the same range and coverage area as the main carrier.

Conventional Access (CA): method of operation in which the main carrier uses phase modulation

Conventional Access (CA) cell: cell on which the main carrier uses phase modulation

Conventional Access (CA) MS: MS that is currently camped on a conventional access cell

current serving BS: BS on one of whose channels the MS is currently operating

D8PSK channel: channel on which signalling and data messages are sent using either $\pi/4$ -DQPSK bursts or $\pi/8$ -D8PSK bursts

data/speech item: all of the functions associated with a complete unidirectional transmission of information during a circuit mode call

NOTE: A call can be made up of one or more call transactions. In a half-duplex call these data/speech items are sequential and unidirectional on one user's point of view.

differentiated services code point: value of the Differentiated Services (DS) field in IPv4 headers

NOTE: The differentiated services code point may be used to select the per hop behaviour that an IP packet experiences at each node.

diffserv: Differentiated Services (DS) field in IPv4 headers

Direct Access (DA): method of operation in which the main carrier uses QAM

Direct Access (DA) cell: cell on which the main carrier uses QAM

Direct Access (DA) MS: MS that is currently camped on a direct access cell

direct set-up signalling: signalling procedure where immediate communication can take place between the calling and the called users without the alerting process and without an explicit response from the called user that he has answered

dummy call identity: call identity used by MS or LS before the SwMI has allocated a valid call identity

NOTE: In TETRA the value of the dummy call identity is zero.

duplex frequency spacing: fixed frequency spacing between up and downlink frequencies directions

NOTE: The duplex spacing is defined in clause 6 and in ETSI TS 100 392-15 [18].

eccentric channel: channel that is not radiated from the same site as the main carrier

NOTE 1: The present document supports up to a maximum separation of 4 km between the eccentric channel's transmitter site and the main carrier's transmitter site.

NOTE 2: An eccentric channel is a non-conforming channel and is not a concentric, sectored or super-sectored channel.

foreground measurement: measurements performed by the lower layers while employing the whole capacity, e.g. no concurrent service is maintained

fully super-sectored channel: super-sectored channel that is radiated from the same site as the main carrier, and has an azimuthal extent that is greater than, and entirely contains, the azimuthal extent of the main carrier

group home SwMI: SwMI which owns the MCC and the MNC of the group identity

NOTE: This definition is for the purposes of the air interface. In the inter system interface standard ETSI EN 300 392-3-5 [i.3] the group home SwMI is referring to the data base locations and not directly to the MCC or MNC of the group identity.

Group TETRA Subscriber Identity (GTSI): identity used to set up and receive group calls and messages

NOTE: A TETRA user may have multiple GTSIs associated to its ITSI. Multiple users may have the same GTSI as a valid reception address.

half duplex operation: each MS asks for permission to transmit for each transaction

NOTE: In TETRA trunked mode operation half duplex means two-frequency simplex operation.

home network: network where an MS has a subscription

NOTE: This means that a subscriber identity has been allocated in advance of any network access.

Individual TETRA Subscriber Identity (ITSI): identity used to specify an individual TETRA user

NOTE: An ITSI cannot be shared by multiple users.

initial cell selection: act of searching for and choosing a serving cell when the MS has no knowledge of any usable cells e.g. at power on or after a previous deactivation has taken place

NOTE: The initial cell selection is performed by procedures located in the MLE and in the MAC. When the cell has been selected and camped on and, if required, registration has been performed, the MS is said to be attached to the cell.

interrupted measurement: measurements performed by the lower layers interrupting current services

irregular channel: non-conforming channel that needs to be monitored by the MS in order for the MS to discover whether the channel would be usable as an assigned channel

NOTE 1: Sectorized channels and semi-super-sectorized channels are irregular channels. An eccentric channel is an irregular channel, if it does not fully cover the area of the cell. The SwMI may broadcast information about a fully super-sectorized channel as either a channel class or an irregular channel, if broadcast is needed (for example, if the channel does not fully cover the area of the cell).

NOTE 2: The SwMI does not need to broadcast information about channels that fully cover the area of the cell, since the MS does not normally need to monitor or assess these channels or inform the SwMI that these channels would be usable as an assigned channel. Nevertheless, the SwMI may choose to broadcast information about channels that fully cover the area of the cell; for example, in some cases, this may aid MSs that are sending or receiving real-time class data.

irregular channel monitoring: monitoring of irregular channels on the serving cell or on adjacent cells

link adaptation: process of adaptively changing the modulation level on a D8PSK channel, or the modulation level and/or coding rate on a QAM channel

LLC frame: generic name given to one LLC data message, regardless the type of link (basic or advanced) used

NOTE: An LLC frame comprises of a TL-SDU and LLC headers and a frame check sequence if applied. An LLC frame may be segmented for transmission.

Location Area (LA): cell or group of cells within which the SwMI transmits the same value of the "location area" information element

logical channel: generic term for any distinct data path

NOTE: Logical channels are considered to operate between logical endpoints.

MAC block: unit of information transferred between the upper MAC and lower MAC for a particular logical channel

NOTE: Logical channels are e.g. SCH/F, SCH/HD or SCH/HU. The lower MAC performs channel coding for insertion into the appropriate physical slot, half slot or subslot.

main carrier: carrier containing the common control channel(s) transmitted by the infrastructure to control the MS population

NOTE: The frequency of the main carrier is broadcast by the infrastructure.

Main Control Channel (MCCH): principal common control channel transmitted by the infrastructure to control the MSs in a conventional access cell

NOTE: The frequency of the main carrier for the conventional access cell is broadcast by the infrastructure, and the MCCH is located on timeslot 1 of the main carrier. The MCCH is a $\pi/4$ -DQPSK channel.

Main Control Channel - QAM (MCCH-Q): principal common control channel transmitted by the infrastructure to control the MSs in a direct access cell

NOTE: The frequency of the main carrier for the direct access cell is broadcast by the infrastructure, and the MCCH-Q is located on timeslot 1 of the main carrier or timeslots 1 and 2 of the main carrier or timeslots 1, 2 and 3 of the main carrier or all four timeslots of the main carrier. The MCCH-Q is a QAM channel.

Message Erasure Rate (MER): limit ratio of the messages detected as wrong by the receiver to all messages received in a given logical channel

message trunking: traffic channel is permanently allocated for the complete duration of the call

NOTE: The call may include several separate call transactions (several pressel activations by separate terminals). The channel is only de-allocated if the call is (explicitly) released or if a time-out expires.

migration: changing between two networks that have different MNCs and/or MCCs, where the user does not have a subscription (ITSI) for at least one of the two networks

NOTE: Migration occurs when an MS moves to, or powers up in, a network other than the home network. The term is also used for returning to the home network.

minimum mode: mode of operation in which the infrastructure allocates all four timeslots of a conventional access main carrier for traffic or assigned control purposes

NOTE 1: In this mode, only frame 18 can be used for common control without disturbing the established services.

NOTE 2: Minimum mode is not supported for direct access.

monitoring: act of measuring the power of the main carrier on neighbour cells and calculating the path loss parameter C2 based upon information on neighbour cells broadcasted by the serving cell, or of measuring the power of an irregular carrier on the serving cell or a neighbour cell and calculating the path loss parameter C2, or of measuring the power of the main carrier on the serving cell and calculating the path loss parameter C2

MS timing offset: delay of the received signal relative to the expected signal from an MS at zero distance under static channel conditions

network: collection of interconnected cells broadcasting the same MNC and MCC

NOTE: A TETRA network may be connected to another TETRA network with a different MNC and/or MCC. In addition, entities outside the scope of the present document may be connected to a TETRA network.

non-conforming channel: channel that is not a conforming channel

NOTE: A non-conforming channel:

- has a different azimuthal radiation pattern from the main carrier; and/or
- has a different range and coverage area from the main carrier; and/or
- is not radiated from the same site as the main carrier.

non-conforming concentric channel: channel that has essentially the same azimuthal radiation pattern as the main carrier and is radiated from the same site as the main carrier, but has a different range and coverage area from the main carrier

normal mode: mode of operation in which the MCCH is present in timeslot 1 of all frames 1 to 18 or in which the MCCH-Q is present in at least timeslot 1 of all frames 1 to 18

on/off hook signalling: signalling procedure which includes an alerting process to the called user

NOTE: An explicit response from the called user that he has answered is waited before the call can be set up.

phase modulation carrier: carrier that is currently carrying $\pi/4$ -DQPSK and/or D8PSK channel(s)

piggy-backing: method of sending a layer 3 message concatenated with a layer 2 acknowledgement in the same air interface transmission

Probability of Undetected Erroneous Message (PUEM): limit ratio of the erroneous messages detected as right by the receiver to all messages received in a given logical channel

protocol entity instance: instance of a protocol entity refers to one independent process related to the protocol defined by that entity

NOTE: There may be multiple protocol entity instances e.g. circuit mode calls running simultaneously but independently from each other.

QAM carrier: carrier that is currently carrying QAM channel(s)

QAM channel: channel on which signalling and data messages are sent using QAM bursts

quasi transmission trunking: traffic channel is allocated for each call transaction (while the pressel is activated) and in addition the channel de-allocation is delayed for a short period at the end of the transaction (after the pressel release)

NOTE: During this "channel hang-time" the channel allocation may be re-used for a new call transaction that is part of the same call. A delayed channel de-allocation procedure applies at the end of each transaction.

random access attempt: period from the initiation of the random access procedure until the MS receives a response from the BS or abandons the procedure

NOTE: The random access is abandoned e.g. after sending the maximum permitted number of retries.

ranking: procedural method of listing cells in descending order from the most suitable for communication to the least suitable for communication

NOTE: As inputs to the ranking procedure are:

- outputs from the monitor process (e.g. C2 parameters);
- outputs from the scanning process (e.g. C1 parameters);
- network parameters received in the MLE broadcast.

real-time class data: data that cannot tolerate delay but can tolerate some packet loss

received SDU number: received SDU number N(R) is the number of the received data TL-SDU

received segment sequence number: number of the currently received segment

registered area: area of the MS's present LA or the areas of a group of LAs notified to the MS by the SwMI

NOTE: The SwMI may send the MS a list of LAs comprising the MS's registered area (always including the MS's present LA) in a D-LOCATION UPDATE ACCEPT PDU. If the SwMI does not include this information in the PDU, the MS assumes that the registered area is limited to its present LA.

roaming: changing LA within a network of the same MNC/MCC

scanning: act of measuring the power of the main carrier on neighbour cells and calculating the path loss parameter C1 based upon the information on the neighbour cells broadcast by the neighbour cells themselves

SDU number: number on the advanced link to keep TL-SDUs in order

Secondary Control Channel (SCCH): control channel other than the MCCH or MCCH-Q

NOTE: There are two types of SCCH:

- a common SCCH, which has the same functionality as the MCCH (for Conventional Access) or MCCH-Q (for Direct Access) but is used only by a subset of the MS population; and
- an assigned SCCH, which may be allocated to certain MSs after an initial random access or paging message.

sectored channel: channel that has an azimuthal extent that is smaller than, and contained entirely within, the azimuthal extent of the main carrier, and is radiated from the same site as the main carrier

NOTE: A sectored channel is a non-conforming channel and is not a concentric, super-sectored or eccentric channel.

segment: LLC segment is the advanced link unit of transmission and re-transmission

NOTE: A segment is the numbered piece of a TL-SDU, normally fitting into one MAC layer PDU.

semi-super-sectored channel: super-sectored channel that is radiated from the same site as the main carrier, and has an azimuthal extent that exceeds the azimuthal extent of the main carrier in one azimuthal direction and is less than the azimuthal extent of the main carrier in the other azimuthal direction

sent SDU number (N(S)): number of the current TL-SDU

sent segment sequence number (S(S)): number of the currently sent segment

serving cell: cell that is currently providing service to the MS

simplex: half-duplex operation

NOTE: Mainly used in TETRA standardization to differentiate half-duplex from (full) duplex communication.

subscriber class: subdivision of the subscriber population

NOTE: The operator may define the values and meaning of each class.

subscription: permit for an MS to use a network, characterized by the MS possessing a subscriber identity (ITSI) provided by the network and, optionally, an authentication key provided by the network

NOTE: The network for which the MS has a subscription is the MS's home network.

super-sectored channel: channel that has an azimuthal extent that exceeds the azimuthal extent of the main carrier in at least one azimuthal direction, and is radiated from the same site as the main carrier

NOTE 1: A super-sectored channel may be either a fully super-sectored channel or a semi-super-sectored channel.

NOTE 2: A super-sectored channel is a non-conforming channel and is not a concentric, sectored or eccentric channel.

surveillance: process of monitoring the quality of the radio link to the serving cell

telemetry class data: data that can tolerate moderate delays and limited packet loss, and is intermittent or periodic in nature

Time Division Multiple Access (TDMA) frame number: timing of TDMA frames within a multiframe

timebase: device which determines the timing state of signals transmitted by a BS or MS

timeslot number: timing of timeslots within a TDMA frame

TLA: layer 2 SAP (TLA-SAP)

TLB: layer 2 SAP (TLB-SAP)

TLC: layer 2 SAP (TLC-SAP)

TLC-SAP: management Service Access Point (SAP)

NOTE: The TLC-SAP is a way of modelling layer-to-layer communication for management and control purpose.

TL-SDU: SDU from the service user (i.e. MLE)

TM-SDU: SDU from the layer above MAC (i.e. LLC)

transmission trunking: traffic channel is individually allocated for each call transaction (for each activation of the pressel)

NOTE: The channel is immediately de-allocated at the end of the call transaction (subject to unavoidable protocol delays).

U-plane: plane for user traffic signalling

umbrella channel: assignable channel that fully covers the areas of multiple cells

unacknowledged data transfer: service provided by the layer below which does not give any acknowledgement back over the air interface from the lower layer peer entity

unannounced cell reselection: cell reselection where the MS-MLE does not inform the old cell (leaving cell) that it intends to change to a new cell

NOTE: Only the new cell (arriving cell) is informed about the cell reselection.

unconfirmed service: service provided by the layer below which does not ensure response from peer entities before allowing new messages

NOTE: This implies that messages to be transported may arrive in a different order at the peer entity since the sequence cannot be ensured.

undeclared cell reselection: cell reselection where the MS-MLE does not inform the old cell (leaving cell) or the new cell (arriving cell) that cell change is performed

useful part of a burst: modulation symbol times $SN0$ to $SNmax$ of a burst for phase modulation, or modulation symbol times $SN-Q1$ to $SN-Qmax$ of a burst for QAM

visited SwMI: SwMI which is broadcasting an MCC and/or MNC which is different than the MCC and MNC of the related TETRA identity

NOTE: This definition is for the purposes of the air interface. In the inter system interface standard ETSI EN 300 392-3-5 [i.3] the visited SwMI is referring to the data base locations and not directly to the MCC or MNC of the MS and SwMI.

3.2 Symbols

Void.

3.3 Abbreviations

For the purposes of the present document, the following abbreviations apply:

$\pi/4$ -DQPSK	$\pi/4$ -shifted Differential Quaternary Phase Shift Keying
$\pi/8$ -D8PSK	$\pi/8$ -shifted Differential 8 Phase Shift Keying
(V)ASSI	Visited Alias Short Subscriber Identity
(V)GSSI	Visited Group Short Subscriber Identity
AAA	Authentication, Authorization, Accounting
AACH	Access Assignment CHannel
AACH-Q	Access Assignment CHannel, QAM
ACCH	Associated Control CHannel
ACELP	Algebraic Code-Excited Linear Prediction
ACK	ACKnowledgement
AGA	Air - Ground - Air service
AGC	Automatic Gain Control
AGNSS	Assisted Global Navigation Satellite System
AI	Air Interface
AL	Advanced Link
ALLOC	Allocate
APP	Approved
AR	Acknowledgement Request
ASCII	American Standard Code for Information Interchange
ASSI	Alias Short Subscriber Identity
AT	ATtention
ATID	Address Type Identifier in Demand
ATSI	Alias TETRA Subscriber Identity
BBK	Broadcast BloCk
BCCH	Broadcast Control CHannel
BCCH-Q	Broadcast Control CHannel, QAM
BE	Big Endian
BER	Bit Error Rate
BKN1	Broadcast bloCk 1
BKN2	Broadcast bloCk 2
BL	Basic Link
BLCH	Base station Linearization CHannel
BLCH-Q	Base station Linearization Channel, QAM
BN	Bit Number
BNCH	Broadcast Network CHannel

BNCH-Q	Broadcast Network CHannel, QAM
BOM	Byte Order Mark
BS	Base Station
BSC	Basic Subscriber Class
BSCH	Broadcast Synchronization CHannel
BSCH-Q	Broadcast Synchronization CHannel, QAM
BSD	Berkeley Software Distribution
BU	Bad Urban
BW	BandWidth
C	Conditional
C1	Path loss parameter - see clause 23.7.1.1
C2	Path loss parameter - see clause 23.7.1.2
C3	Path loss parameter - see clause 23.7.1.3
C4	Path loss parameter - see clause 23.7.1.4
C5	Path loss parameter - see clause 23.7.1.5
CA	Conventional Access
CB	Control uplink Burst
CC	Call Control
CCH	Control CHannel
CCH-Q	Control CHannel, QAM
CCK	Common Cipher Key
CEPT	The European Conference of Postal and Telecommunications Administrations
CHAP	Challenge Handshake Authentication Protocol
CK	Cipher Key
CLCH	Common Linearization CHannel
CLCH-Q	Common Linearization CHannel, QAM
CLIR	Calling Line Identification Restriction
CMCE	Circuit Mode Control Entity
CODEC	Coder-decoder
CONS	Connection Orientated Network Service
CoU	Class of Usage
CP	Control Physical channel
CPTI	Calling Party Type Identifier
C-SAP	Control Service Access Point
CR	Carriage Return
CR	Change Request
CRC	Cyclic Redundancy Check
CSS	Carrier Specific Signalling
CT	Continuous Transmission
CTT	Carrier Timesharing Transmission
DA	Direct Access
DCCP	Datagram Congestion Control Protocol
DCK	Dynamic Cipher Key
DCOMP	Data COMpression Protocol
DEALLOC	Deallocate
D-CT	Downlink-Continuous Transmission
D-CTT	Downlink-Carrier Timesharing Transmission
DGNA	Dynamic Group Number Assignment
DHCPv6	Dynamic Host Configuration Protocol version 6
DIV	Integer Division
DL	DownLink
DLL	Data Link Layer
D-MCCTT	Downlink - Main Control Channel Timesharing Transmission
DM-MS	Direct Mode MS
DMO	Direct Mode Operation
DNS	Domain Name Server
DOTAM	Direct mode operation Over The Air Management
DPRI	Data Priority
DQPSK	Differential Quadrature Phase Shift Keying
DSCP	Differentiated Services Code Point
DSS	Downlink sync Sequence Set
DTMF	Dual Tone Multiple Frequency

DTX	Discontinuous Transmission
ECCH	Extended Control CHannel
EGNOS	European Geostationary Navigation Overlay Service
EPT	ETSI Project TETRA
EQ200	Equalizer Test 200 km/h
ERP	Effective Radiated Power
ES	ETSI Standard
FA	Foreign Agent
FACCH	Fast Associated Control CHannel
FCB	Frequency Correction downlink Burst
FCS	Frame Check Sequence
FDPS	Full-slot Downlink Pilots Set
FEC	Forward Error Correction
FiSA	Filler Set A
FiSB	Filler Set B
FN	Frame Number
FrCS	Frequency Correction Set
FUPS	Full-slot Uplink Pilots Set
GCK	Group Cipher Key
GIADTI	Group Identity Attach/Detach Type Id
GIAT	Group Identity Address Type
GITI	Group Identify Type Identifier
GNSS	Global Navigation Satellite Systems
GPRS	General Packet Radio Service
GPS	Global Positioning System
GRE	Generic Routing Encapsulation
GSDM	Graceful Service Degradation Mode
GSM	Global System for Mobile Communications
GSSI	Group Short Subscriber Identity
GTSI	Group TETRA Subscriber Identity
HA	Home Agent
HDLC	High-Level Data Link Control
HLR	Home Location Register
HPSC	Highly Preferred Subscriber Class
HT200	Hilly Terrain 200 km/h
HU	Half burst on the Uplink
HUPS	Half-slot Uplink Pilots Set
ICMP	Internet Control Message Protocol
ID	IDentifier
IE	Information Element
IEC	International Electrotechnical Commission
IETF	Internet Engineering Task Force
IMM	IMMediate access parameter
IP	Internet Protocol
IPCP	Internet Protocol Control Protocol
IPv4	IP version 4
IPv6	IP version 6
IRC	Implicit Repeat Count
IRNSS	Indian Regional Navigational Satellite System
ISBN	International Standard Book Number
ISDN	Integrated Services Digital Network
ISO	International Organization for Standardization
ISSI	Individual Short Subscriber Identity
ITSI	Individual TETRA Subscriber Identity
ITU	International Telecommunications Union
ITU-T	ITU - Telecommunication standardization sector
KSG	Key Stream Generator
L2	Layer 2
LA	Location Area
LAC	Location Area Code
LACC	Location Area Country Code
LANC	Location Area Network Code

LB	Linearization Burst
LCH	Linearization CHannel
LCH-Q	Linearization CHannel, QAM
LCMC-SAP	Link entity Circuit Mode Control entity - Service Access Point
LCP	Link Control Protocol
LDB	Linearization Downlink Burst
LIP	Location Information Protocol
LIP-SAP	Location Information Protocol - Service Access Point
LLC	Logical Link Control
LLME	Lower Layer Management Entity
LMM-SAP	Link entity Mobility Management - Service Access Point
LS	Line Station
LSB	Least Significant Bit
LTPD-SAP	Link entity TETRA Packet Data - Service Access Point
LZS	Linearization downlink Zeroed Set
M	Mandatory
MAC	Medium Access Control
M-bit	More bit
MCC	Mobile Country Code
MCCH	Main Control CHannel
MCCH-Q	Main Control CHannel, QAM
MCCTT	Main Control Channel Timesharing Transmission
MCM	Minimum Control Mode
MER	Message Erasure Rate
MEX	Multimedia EXchange layer
MLE	Mobile Link Entity
MM	Mobility Management
MN	Multiframe Number
MNC	Mobile Network Code
MNI	Mobile Network Identity
MO	Mobile station Originating
mod	modulo (base for counting)
MPEG	Moving Picture Experts Group
MPN	Monitoring Pattern Number
MS	Mobile Station
MSAS	Multi-functional Satellite Augmentation System
MSB	Most Significant Bit
MS-ISDN	Mobile Station - ISDN number
MST	Multiple Slot Transmission
MT	Mobile station Termination
MT0	Mobile station Termination type 0
MT2	Mobile station Termination type 2
MTU	Maximum Transmission Unit
N(R)	Received SDU (TL-SDU) Number
N(S)	Sent SDU (TL-SDU) Number
NAP	Net Assist Protocol
NBNS	Net BIOS Name Server
NC	Network Connection
NCM	Normal Control Mode
NCON	Network CONnection
NDB	Normal Downlink Burst
NET	Network
NMEA	National Marine Electronics Association
N-PDU	Network layer protocol Protocol Data Unit
NSAPI	Network Service Access Point Identifier
NUB	Normal Uplink Burst
O	Optional
O-bit	Optional bit
OPTI	Other Party Type Identifier
OTAK	Over The Air Keying
OTAR	Over The Air Rekeying
PA	Power Amplifier

PACQ	Probability of synchronization burst ACQuisition
PAP	Password Authentication Protocol
PC	Protocol Control
PCCC	Parallel Concatenated Convolutional Code
PCOMP	Protocol COMpression Protocol
PCON	Physical CONnection
PD	Packet Data
PDCH	Packet Data CHannel
PDF	Probability Density Function
PDN	Public Data Network
PDP	Packet Data Protocol
PDS	Power Density Spectrum
PDU	Protocol Data Unit
PEI	Peripheral Equipment Interface
PHB	Per-Hop Behavior
PID	Protocol Identifier
PIN	Personal Identification Number
PL	Physical Layer
PMTUD	Path MTU discovery
PPP	Point-to-Point Protocol
PSC	Preferred Subscriber Class
PSK	Phase Shift Keying
PSTN	Public Switched Telephone Network
PTT	Push To Talk
PUEM	Probability of Undetected Erroneous Message
QAM	Quadrature Amplitude Modulation
QoS	Quality of Service
QPSK	Quadrature phase-shift keying
QZSS	Quasi-Zenith Satellite System
RA	Registered Area
RAB	Random Access uplink Burst
RADIUS	Remote Authentication Dial In User Service
RCPC	Rate Compatible Punctured Convolutional
RDC	Radio Downlink Counter
RDC-DA	Radio Downlink Counter - Direct Access
RDC-DA-P	Radio Downlink Counter - Direct Access, $\pi/4$ -DQPSK or D8PSK channel
RDC-DA-Q	Radio Downlink Counter - Direct Access, QAM channel
RDC-NC	Radio Downlink Counter - Non-Conforming channel
RDC-Q	Radio Downlink Counter - QAM channel
REJ	REJected
RF	Radio Frequency
RFC	Request For Comments
RM	Reed-Muller
RMS	Root Mean Square
RNR	Receive Not Ready
RNR	Receiver Not Ready
RSC	Recursive Systematic Code
RSIM	Differential Navstar GPS Reference Stations and Integrity Monitors
RSSI	Received Signal Strength Indication
RTCM	Radio Technical Commission for Maritime Services
RTP	Realtime Transport Protocol
RUA	Radio User Assignment
Rx	Receive(r)
S(R)	Received segment Sequence number
S(S)	Sent segment Sequence number
SACCH	Slow Associated Control CHannel
SAP	Service Access Point
SB	Synchronization downlink Burst
SCCH	Secondary Control CHannel
SCH	Signalling CHannel
SCH/F	Signalling CHannel, Full size
SCH/HD	Signalling CHannel, Half size Downlink

SCH/HU	Signalling CHannel, Half size Uplink
SCH-P8/F	Signalling CHannel, $\pi/8$ -D8PSK, Full size
SCH-P8/HD	Signalling CHannel, $\pi/8$ -D8PSK, Half size Downlink
SCH-P8/HU	Signalling CHannel, $\pi/8$ -D8PSK, Half size Uplink
SCH-Q	Signalling CHannel, QAM
SCH-Q/B	Signalling CHannel, QAM data set B Downlink
SCH-Q/D	Signalling CHannel, QAM Full size Downlink
SCH-Q/HU	Signalling CHannel, QAM Half size Uplink
SCH-Q/RA	Signalling CHannel, QAM Random Access Uplink
SCH-Q/U	Signalling CHannel, QAM Full size Uplink
SCK	Static Cipher Key
SCLNS	Specific ConnectionLess Network Service
SCTP	Stream Control Transmission Protocol
SD	Sample Duration
SDL	Specification and Description Language
SDS	Short Data Service
SDS-TL	SDS-Transport Layer
SDTI	Short Data Type Identifier
SDU	Service Data Unit
SF	Slot Flag
SFPG	Security and Fraud Prevention Group
SICH-Q	Slot Information CHannel, QAM
SICH-Q/D	Slot Information CHannel, QAM Downlink
SICH-Q/U	Slot Information CHannel, QAM Uplink
SIM	Subscriber Identity Module
SMI	Short Management Identity
SMS	Short Message Service (in GSM)
SN	Symbol Number or SNDCP
SNA	Short Number Address
SNDCP	SubNetwork Dependent Convergence Protocol
SNEI	SNDCP Network Endpoint Identifier
SN-PDU	SNDCP - Protocol Data Unit
SN-Q	Symbol Number in QAM
SN-SAP	SNDCP-Service Access Point
SS	Supplementary Service
SS-AL	Supplementary Service – Ambience Listening.
SS-AS	Supplementary Service Area Selection
SS-CC	Supplementary Service - Call Completion
SSI	Short Subscriber Identity
SSN	SubSlot Number
SSN-Q	Subslot Number-QAM
SS-PC	Supplementary Service Priority Call
SS-PDU	Supplementary Service – Protocol Data Unit
SS-PPC	Supplementary Service Pre-emptive Priority Call
SSS	Secondary sync Sequence Set
SS-SNA	Supplementary Service Short Number Addressing
SSVE	Sum Square Vector Error
STCH	STealing CHannel
SwMI	Switching and Management Infrastructure
TCH	Traffic CHannel
TCH/2,4	Traffic CHannel, net rate = 2,4 kbit/s
TCH/4,8	Traffic CHannel, net rate = 4,8 kbit/s
TCH/7,2	Traffic CHannel, net rate = 7,2 kbit/s
TCH/S	Speech Traffic CHannel
TCH-P8/10,8	Traffic CHannel, $\pi/8$ -D8PSK, net rate = 10,8 kbit/s
TCP	Transmission Control Protocol
TCP/IP	Transmission Control Protocol/Internet Protocol
TDMA	Time Division Multiple Access
TE	Terminal Equipment
TE2	TE presenting a TETRA interface
TEDS	TETRA Enhanced Data Service
TEI	Terminal Equipment Identity

TL	TETRA LLC
TLA-SAP	TETRA LLC Service Access Point A
TLB-SAP	TETRA LLC Service Access Point B
TLC-SAP	TETRA LLC Service Access Point C
TLE-SAP	TETRA LLC Service Access Point E
TM	TETRA MAC
TMA-SAP	TETRA MAC Service Access Point A
TMB-SAP	TETRA MAC Service Access Point B
TMC-SAP	TETRA MAC Service Access Point C
TMD-SAP	TETRA MAC Service Access Point D
TMI	TETRA Management Identity
TMV-SAP	TETRA MAC Virtual SAP
TN	Timeslot Number
TNCC	TETRA Network layer Call Control
TNCC-SAP	TETRA Network layer Call Control - Service Access Point
TNMM	TETRA Network Mobility Management
TNMXIT-SAP	TETRA MEX layer internal application - Service Access Point
TNMXPI-SAP	TETRA MEX layer PEI - Service Access Point
TNSDS-SAP	TETRA Network layer Short Data Service - Service Access Point
TNSS	TETRA Network layer Supplementary Service
TNSS-SAP	TETRA Network layer Supplementary Services - Service Access Point
TP	Traffic Physical channel
TPTI	Transmitting Party Type Identifier
TP-UD	Transfer Protocol - User Data (in GSM)
TS	Time Sharing
TSI	TETRA Subscriber Identity
TU50	Typical Urban 50 km/h
Tx	Transmit(ter)
UCS	Universal Character Set
UCS-2	Universal Character Set coded in 2 octets
UDH	User Data Header
UDP	User Datagram Protocol
UDP/IP	User Datagram Protocol / Internet Protocol
UL	UpLink
UMTS	Universal Mobile Telecommunications System
UNACK	UNACKnowledged
UP	Unallocated Physical channel
USC	Unpreferred Subscriber Class
USSI	Unexchanged Short Subscriber Identity
UTC	Coordinated Universal Time
UTF-16BE	Unicode Transformation Format serialized as two bytes in Big-Endian format
V+D	Voice plus Data
VGSSI	Visitor GSSI
WAAS	Wide Area Augmentation System
WAP	Wireless Application Protocol
WCMP	Wireless Control Message Protocol
WT	Waiting Time

4 Radio aspects

4.1 Introduction

This clause is an introduction to the radio aspects of the TETRA V+D standard. It consists of a general description of the organization of the radio-related functions with reference to the clauses where each part is specified in detail. Furthermore, it introduces the reference configuration that will be used throughout the present document.

4.2 Set of logical channels

The radio subsystem provides a certain number of logical channels as defined in clause 9. The logical channels represent the interface between the protocol and the radio.

4.3 Reference configuration

For the purpose of elaborating the specification of the radio-related functions, a reference configuration of the transmission chain is used as shown in figures 4.1 and 4.2.

NOTE: Only the transmission part is specified, the receiver being specified via overall performance requirements.

With reference to this configuration, the radio clauses address the following functional units:

- clause 5: bit-to-symbol mapping encoding and modulation;
- clause 6: characteristics of transmitter and receiver;
- clause 8: channel coding, interleaving and scrambling;
- clause 9: burst building and logical channel multiplexing.

This reference configuration also defines a number of points of vocabulary in relation to the names of bits at different levels in the configuration.

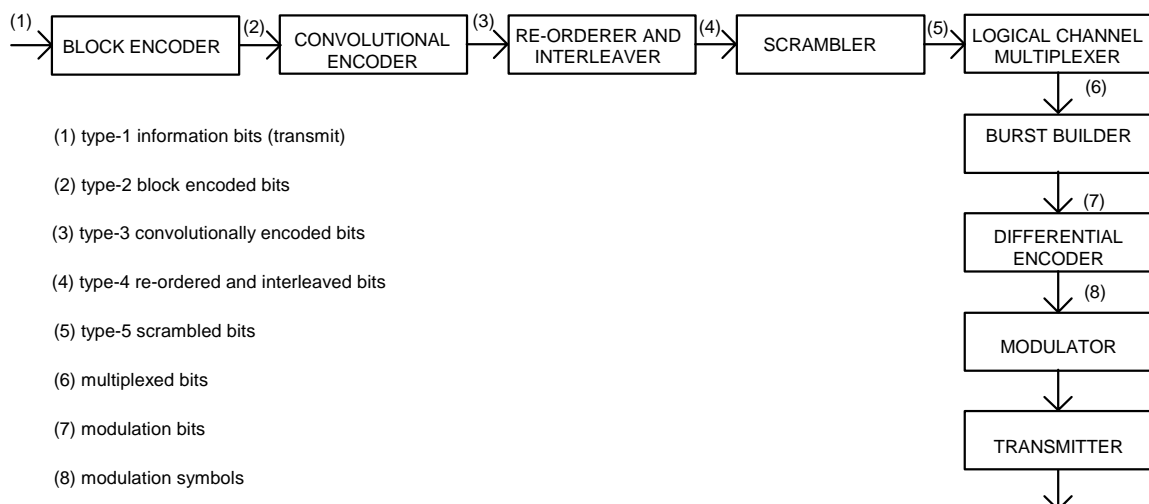

Figure 4.1: Reference configuration for phase modulation

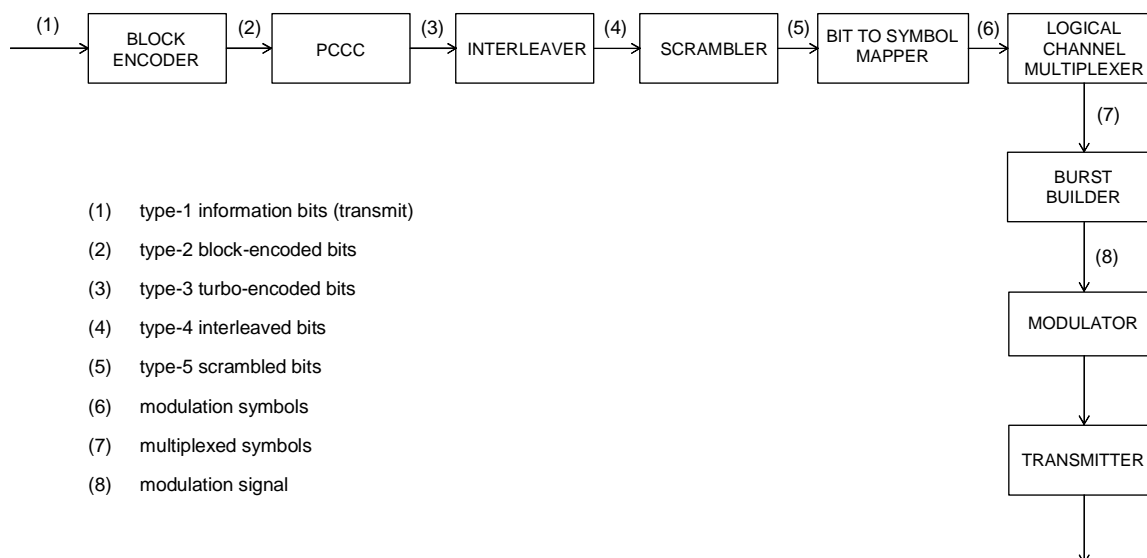

Figure 4.2: Reference configuration for QAM modulation

4.4 Error control schemes

The different error control schemes are described in detail in clause 8.

4.5 Multiple access and timeslot structure

4.5.1 General

The access scheme is TDMA with 4 physical channels per carrier. For phase modulation the carrier bandwidth is 25 kHz. For QAM the carrier bandwidth is 25 kHz, 50 kHz, 100 kHz or 150 kHz.

The following clauses briefly introduce the structures of hyperframe, multiframe, frame, timeslot, and burst, as well as the mapping of the logical channels onto the physical channels. The appropriate specifications are found in clause 9.

4.5.2 Hyperframes, multiframes and frames

A diagrammatic representation of the TDMA structure is shown in figure 4.3.

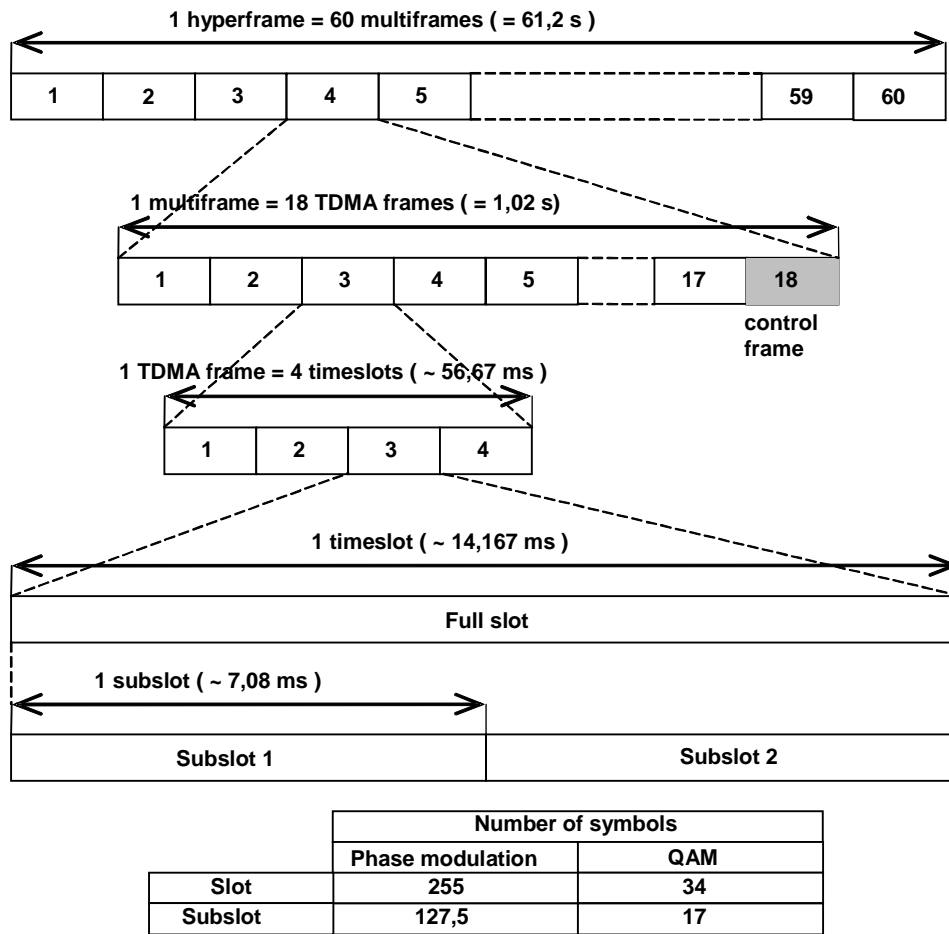

Figure 4.3: V+D TDMA structure

The hyperframe level defines the top-level frame hierarchy. One hyperframe is subdivided into 60 multiframes and lasts 61,2 s.

One multiframe is subdivided in 18 frames, and has a duration of 1,02 s. The eighteenth frame in a multiframe is a control frame.

One frame is subdivided into 4 timeslots and has duration of $170/3$ ms $\approx 56,67$ ms.

4.5.3 Timeslots and bursts

The timeslot is a time interval of $85/6$ ms $\approx 14,167$ ms. For phase modulation the timeslot corresponds to 255 symbol durations, each one with a duration of $500/9$ μ s $\approx 55,56$ μ s. For QAM the timeslot is divided into 34 modulation symbol durations, each one with a duration of $5/12$ ms $\approx 416,7$ μ s. The uplink timeslots may be subdivided into 2 subslots.

The physical content of a timeslot or subslot is carried by a burst. The different types of bursts are defined in clause 9.

4.5.4 Mapping of logical channels onto physical channels

Three types of physical channels are defined:

- the Traffic Physical (TP) channel carrying mainly circuit mode traffic;
- the Control Physical (CP) channel carrying exclusively the control channel. One CP channel is defined as the MCCH (for Conventional Access) or MCCH-Q (for Direct Access); the others, if any, are called Extended Control Channel (ECCH). The Radio Frequency (RF) carrier containing the MCCH or MCCH-Q is called the main carrier; and
- the Unallocated Physical (UP) channel is a physical channel not allocated to one or more Mobile Stations (MSs).

The mapping of the logical channels onto the physical channels, according to the mode of operation, is defined in clause 9.

NOTE: Conventional Access (CA) is a method of operation in which the main carrier is a phase modulation carrier. Direct Access (DA) is a method of operation in which the main carrier is a QAM carrier.

4.6 Coding, interleaving and scrambling

The coding, interleaving and scrambling schemes associated with each logical channel shall be as specified in clause 8.

4.7 Modulation

For phase modulation the modulation scheme is $\pi/4$ -shifted Differential Quaternary Phase Shift Keying ($\pi/4$ -DQPSK) or $\pi/8$ -shifted Differential 8 PSK ($\pi/8$ -D8PSK). The modulation rate is 36 kbit/s for $\pi/4$ -DQPSK and 54 kbit/s for $\pi/8$ -D8PSK.

For QAM the modulation scheme is 4-QAM, 16-QAM or 64-QAM. A multi sub-carrier approach with 8 sub-carriers per 25 kHz is used, i.e. 8, 16, 32 and 48 sub-carriers in 25 kHz, 50 kHz, 100 kHz and 150 kHz carriers respectively. The modulation symbol rate on each sub-carrier is 2 400 symbols/s.

These schemes are specified in detail in clause 5.

4.8 Transmission and reception

The modulated stream is transmitted on a RF carrier.

The specific RF channels, together with the requirements on the transmitter and the receiver characteristics, are specified in clause 6.

For Base Stations (BSs) and MSs, power classes are defined in clause 6.

4.9 Other radio-related functions

Transmission involves other functions. These functions, which may necessitate the handling of specific protocols between BS and MS, are the radio subsystem synchronization, the radio subsystem adaptive power control and, for D8PSK and QAM channels, the radio subsystem adaptive link control.

The synchronization:

- incorporates frequency and time acquisition by the receiver;
- incorporates adjustment of the timebase of the MSs.

The requirements on synchronization are specified in clause 7.

The adaptive power control:

- adjusts the RF transmit power, in order to ensure that the required quality of transmission is achieved with the least possible radiated power;
- is managed by the MS during the initial access, and by the MS or BS during operational use;
- is provided for battery saving and reduction of interference levels.

The requirements on adaptive power control are specified in clause 10.

The adaptive link control:

- adjusts the modulation and coding to achieve the required Quality of Service.

The measurements required for adaptive link control are specified in clause 10.

4.10 Performance

Under typical urban fading conditions (i.e. multipath delays no greater than 5 μ s), the quality thresholds for speech using the full-rate ACELP Codec (ETSI EN 300 395-2 [21]) with $\pi/4$ -DQPSK modulation are reached at a C/I_c (co-channel interference) value of 19 dB, and a dynamic reference sensitivity level of -106 dBm for BSs and -103 dBm for mobile equipment.

Details of performance requirements of phase modulation and QAM modulation in various channel conditions are given in clause 6.

4.11 TETRA modes of operation

4.11.0 General

The TETRA modes of operation which are supported by the present document and which impact on the radio descriptions are:

- Main control channel modes of operation:
 - Conventional Access (CA) mode.
 - Direct Access (DA) mode.
- Transmission modes:
 - Downlink-Continuous Transmission (D-CT) mode:
 - the D-CT mode is mandatory for MSs, i.e. such equipment shall be able to interwork with a TETRA BS that would be in the D-CT mode.
 - Downlink-Carrier Timesharing Transmission (D-CTT) mode.
 - Downlink-Main Control Channel Timesharing Transmission (D-MCCTT) mode.
 - Multiple Slot Transmission (MST) mode.
- Control modes:
 - Normal Control Mode (NCM):
 - the NCM is mandatory for all TETRA equipment.
 - Minimum Control Mode (MCM):
 - the MCM is mandatory only for MSs using CA mode.

In the following clauses, each of the above modes of operations is defined.

4.11.1 Main control channel modes of operation

4.11.1.1 Conventional Access (CA) mode

A CA cell is a cell on which the main carrier uses phase modulation. The bandwidth of the CA main carrier is 25 kHz. The MCCH is a single-slot $\pi/4$ -DQPSK channel that occupies slot 1 of the main carrier in normal control mode; it is used for common control signalling. The BS may also operate up to three single-slot $\pi/4$ -DQPSK common secondary control channels on the CA main carrier if it requires more capacity for common control signalling.

A CA MS is an MS that is currently camped on a CA cell, so it receives a $\pi/4$ -DQPSK common control channel unless it is directed by the BS to an assigned channel - assigned for a circuit mode call or for secondary control. (An assigned channel may be a $\pi/4$ -DQPSK, D8PSK or QAM channel, and may be either a single-slot or a multi-slot channel.)

4.11.1.2 Direct Access (DA) mode

A DA cell is a cell on which the main carrier uses QAM. The bandwidth of the DA main carrier is 25 kHz, 50 kHz, 100 kHz or 150 kHz. The MCCH-Q occupies one, two, three or four timeslots of the main carrier per TDMA frame, whereas a QAM common secondary control channel is a single-slot channel. If the BS needs more than one slot for common control, it may use either a multi-slot MCCH-Q or multiple single-slot QAM common control channels.

A DA MS is an MS that is currently camped on a DA cell, so it receives a QAM common control channel unless it is directed by the BS to an assigned channel - assigned for secondary control or for a circuit mode call. (An assigned channel may be a QAM, $\pi/4$ -DQPSK or D8PSK channel, and may be either a single-slot or a multi-slot channel.)

4.11.2 Transmission modes

4.11.2.1 Downlink-Continuous Transmission (D-CT) mode

In the D-CT mode, the BS always uses the continuous downlink bursts. The transmission is continuous on the main carrier. On the other carriers discontinuous downlink transmission is allowed for phase modulation carriers but is transparent for the MSs. Discontinuous downlink transmission is not supported on QAM carriers.

4.11.2.2 Downlink-Carrier Timesharing Transmission (D-CTT) mode

In the D-CTT mode, a phase modulation carrier frequency may be shared by several cells, each of its four physical channels being allocated independently to these cells. The BS uses the discontinuous downlink bursts.

4.11.2.3 Downlink-Main Control Channel Timesharing Transmission (D-MCCTT) mode

In the D-MCCTT mode, the MCCH is shared by several CA cells, each of its frames being allocated independently to these cells. The BS uses the discontinuous downlink bursts.

4.11.2.4 Multiple Slot Transmission (MST) mode

In the MST mode, two to four physical channels are used for the same communication. This is used, for example, to increase the data transmission rate or to mix voice and data.

4.11.3 Control modes

4.11.3.1 Normal Control Mode (NCM)

The Normal Control Mode (NCM) provides the TETRA services with full performance. It requires the assignment of one MCCH (for CA) or MCCH-Q (for DA).

4.11.3.2 Minimum Control Mode (MCM)

The Minimum Control Mode (MCM) on a CA cell provides the TETRA services with reduced performance. In the MCM, all physical channels of each RF carrier should be devoted to traffic. Minimum mode is not supported for DA.

5 Modulation

5.1 Introduction

The clauses 5.2 to 5.7 apply to the baseband part of the transmitter in the case of phase modulation channels, and clauses 5.8 to 5.18 apply to the baseband part of the transmitter in the case of QAM channels.

5.2 Modulation type

The modulation used shall be $\pi/4$ -shifted Differential Quaternary Phase Shift Keying ($\pi/4$ -DQPSK) or $\pi/8$ -shifted Differential 8 PSK ($\pi/8$ -D8PSK).

5.3 Modulation rate

The modulation rate shall be 36 kbit/s for $\pi/4$ -DQPSK and 54 kbit/s for $\pi/8$ -D8PSK.

5.4 Modulation symbol definition

$B(m)$ denotes the modulation bit of a sequence to be transmitted, where m is the bit number. The sequence of modulation bits shall be mapped onto a sequence of modulation symbols $S(k)$, where k is the corresponding symbol number.

The modulation symbol $S(k)$ shall result from a differential encoding. This means that $S(k)$ shall be obtained by applying a phase transition $D\phi(k)$ to the previous modulation symbol $S(k-1)$, hence, in complex notation:

$$S(k) = S(k-1) \exp(jD\phi(k))$$

$$S(0) = 1 \tag{5.1}$$

The above expression for $S(k)$ corresponds to the continuous transmission of modulation symbols carried by an arbitrary number of bursts. The symbol $S(0)$ is the symbol before the first symbol of the first burst and shall be transmitted as a phase reference.

In the case of $\pi/4$ -DQPSK modulation, the phase transition $D\phi(k)$ shall be related to the modulation bits as shown in table 5.1 and figure 5.1.

Table 5.1: Phase transitions for $\pi/4$ -DQPSK modulation

$B(2k-1)$	$B(2k)$	$D\phi(k)$
1	1	$-3\pi/4$
0	1	$+3\pi/4$
0	0	$+\pi/4$
1	0	$-\pi/4$

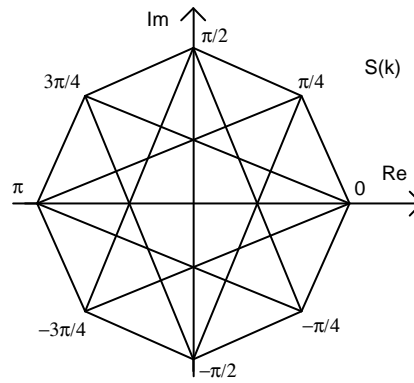

Figure 5.1: $\pi/4$ -DQPSK modulation symbol constellation and possible transitions

The complex modulation symbol $S(k)$ shall take one of the eight values $\exp(j n\pi/4)$, where $n = 2, 4, 6, 8$ for even k and $n = 1, 3, 5, 7$ for odd k . The constellation of the modulation symbols and the possible transitions between them are as shown in figure 5.1.

In the case of $\pi/8$ -D8PSK modulation, the phase transition $D\phi(k)$ shall be related to the modulation bits as shown in table 5.2 and figure 5.2.

Table 5.2: Phase transitions for $\pi/8$ -D8PSK modulation

B(3k-2)	B(3k-1)	B(3k)	$D\phi(k)$
0	0	0	$+\pi/8$
0	0	1	$+3\pi/8$
1	0	1	$+5\pi/8$
1	0	0	$+7\pi/8$
0	1	0	$-\pi/8$
0	1	1	$-3\pi/8$
1	1	1	$-5\pi/8$
1	1	0	$-7\pi/8$

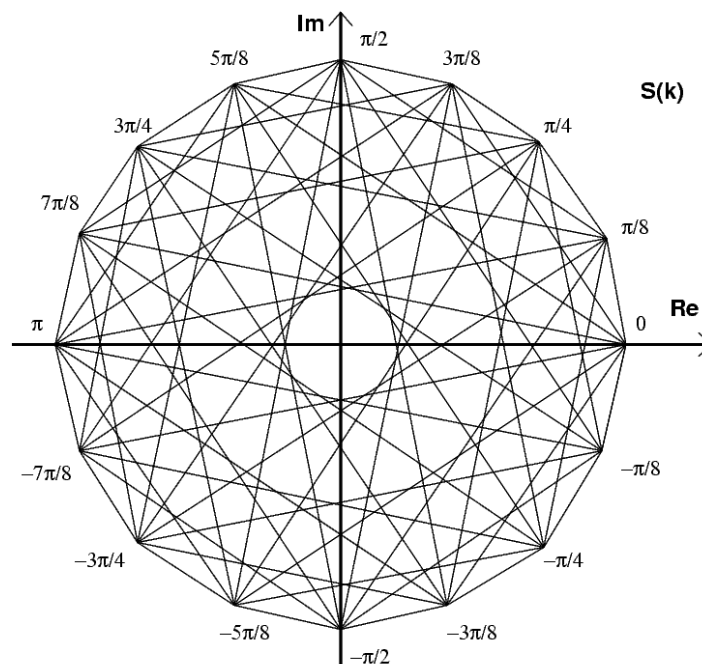

Figure 5.2: $\pi/8$ -D8PSK modulation symbol constellation and possible transitions

The complex modulation symbol $S(k)$ shall take one of the sixteen values $\exp(j n \pi/8)$, where $n = 2, 4, 6$ to 16 for even k and $1, 3, 5$ to 15 for odd k . The constellation of the modulation symbols and the possible transitions between them are as shown in figure 5.2.

5.5 Modulated signal definition

The modulated signal, at carrier frequency f_c , shall be given by:

$$M(t) = \text{Re}\{s(t) \exp(j(2\pi f_c t + \phi_0))\} \quad (5.2)$$

Where:

- ϕ_0 is an arbitrary phase;
- $s(t)$ is the complex envelope of the modulated signal defined as:

$$s(t) = \sum_{k=0}^K S(k)g(t - t_k) \quad (5.3)$$

Where:

- K is the maximum number of symbols;
- T is the symbol duration;
- $t_k = kT$ is the symbol time corresponding to modulation symbol $S(k)$;
- $g(t)$ is the ideal symbol waveform, obtained by the inverse Fourier transform of a square root raised cosine spectrum $G(f)$, defined as follows:

$$\begin{aligned} G(f) &= 1 && \text{for} && |f| \leq (1 - \alpha)/2T \\ G(f) &= \sqrt{0.5(1 - \sin(\pi(2|f|T - 1)/2\alpha))} && \text{for} && (1 - \alpha)/2T \leq |f| \leq (1 + \alpha)/2T \\ G(f) &= 0 && \text{for} && |f| \geq (1 + \alpha)/2T \end{aligned} \quad (5.4)$$

Where α is the roll-off factor, which determines the width of the transmission band at a given symbol rate. The value of α shall be 0,35. For practical implementation, a time limited windowed version of $g(t)$, designed under the constraints given by the specified modulation accuracy and adjacent channel attenuation may be applied.

5.6 Modulation filter definition

The ideal modulation filter shall be a linear phase filter which is defined by the magnitude of its frequency response $|H(f)| = G(f)$.

5.7 Modulation block diagram

A block diagram of the modulation process is shown on figure 5.3. This diagram is for explanatory purposes and does not prescribe a specific implementation. The modulation filter excited by the complex Dirac impulse function $S(k)\delta(t-t_k)$ ideally has an impulse response $g(t)$.

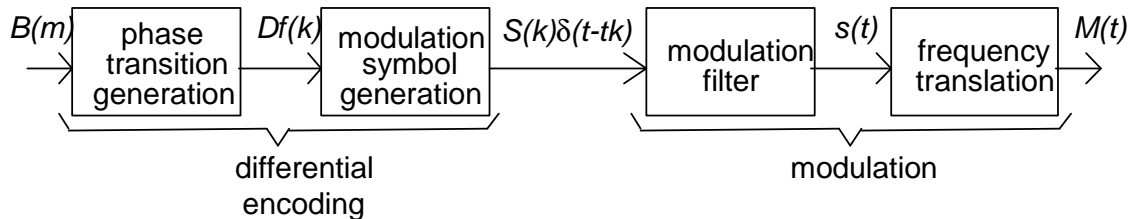

Figure 5.3: Block diagram of the modulation process

5.8 Introduction to QAM channels

Given the discrete channelization ranging from single 25 kHz carriers up to 150 kHz, there is insufficient bandwidth to permit resolution of individual multi-path echoes in the transmission path. It is thus necessary to ensure that the channel time delay is a small fraction of the symbol period for negligible channel induced Inter Symbol Interference. For this reason, each QAM carrier is divided into a number of frequency-division multiplexed sub-carriers, each carrying a complex signal using the QAM modulation. The sub-carrier approach is used because the low symbol rate in each sub-carrier gives the modulation inherent resistance to time dispersion hence avoiding the need for an adaptive equalizer.

Clauses 5.9 to 5.18 apply to the baseband part of the transmitter.

5.9 Modulation type

The modulation types used on each sub-carrier shall be 4-QAM, 16-QAM or 64-QAM.

5.10 Use of sub-carriers in QAM carriers

A multi sub-carrier approach with 8 sub-carriers per 25 kHz is used, i.e. 8, 16, 32 and 48 sub-carriers in 25 kHz, 50 kHz, 100 kHz and 150 kHz carriers respectively.

5.11 Modulation rate

The modulation symbol rate on each sub-carrier shall be 2 400 symbols/s. The overall carrier symbol rate shall be 19 200 symbol/s for 25 kHz carriers, 38 400 symbol/s for 50 kHz carriers, 76 800 symbol/s for 100 kHz carriers and 115 200 symbol/s for 150 kHz carriers. The modulation gross bit rates are given in table 5.3.

Table 5.3: Gross bit rates for QAM Carriers (kbit/s)

Modulation type	Carrier bandwidth			
	25 kHz	50 kHz	100 kHz	150 kHz
4-QAM	38,4	76,8	153,6	230,4
16-QAM	76,8	153,6	307,2	460,8
64-QAM	115,2	230,4	460,8	691,2

5.12 Modulation symbol definition

In this clause the term **symbol** refers to the composite signal, which is emitted from the modulator at a 2 400 symbol/s rate. Each sub-carrier symbol may carry data, time domain pilots, or time domain synchronization information. The term **sub-carrier symbol** refers to a generic symbol in a particular sub-carrier. Each **data sub-carrier symbol** conveys a predetermined number of bits of information dependent on the symbol constellation complexity. The **synchronization sub-carrier symbols** and **pilot sub-carrier symbols** convey no data information.

5.13 Bit to symbol mapping

Figures 5.4, 5.5 and 5.6 show the three different mappings of QAM symbols onto a complex plane. It can be seen from the three constellation diagrams that the pilot sub-carrier symbols and synchronization sub-carrier symbols are not constrained to lie on the constellation points, instead, they can take on any phase angle as long as the magnitude of these symbols corresponds to the synchronization/pilot locus. A circle of unity amplitude is selected as this locus independent of the modulation. Note that this circle is not the outer circle of 16-QAM and 64-QAM constellations. The header sub-carrier symbols also lie on this circle but use 4-QAM in all three cases.

Tables 5.4, 5.5 and 5.6 show the vector and bit definition for 4-QAM, 16-QAM and 64-QAM respectively.

The modulation symbol $S_m(k)$ shall be related to the modulation bits defined in tables 5.4, 5.5 and 5.6, subject to the appropriate scaling factors:

- For 4-QAM the values in table 5.4 shall be multiplied by $1/\sqrt{2}$.
- For 16-QAM the values in table 5.5 shall be multiplied by $1/\sqrt{10}$.
- For 64-QAM the values in table 5.6 shall be multiplied by $1/\sqrt{42}$.

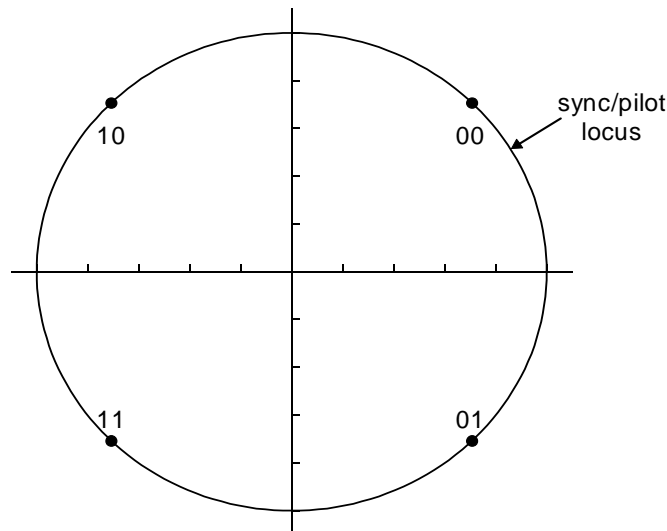

Figure 5.4: 4-QAM Symbol Constellation

Table 5.4: Vector and bit definition (4-QAM)

B(2k-1)	B(2k)	X+Yj
0	0	+1+1j
0	1	+1-1j
1	0	-1+1j
1	1	-1-1j

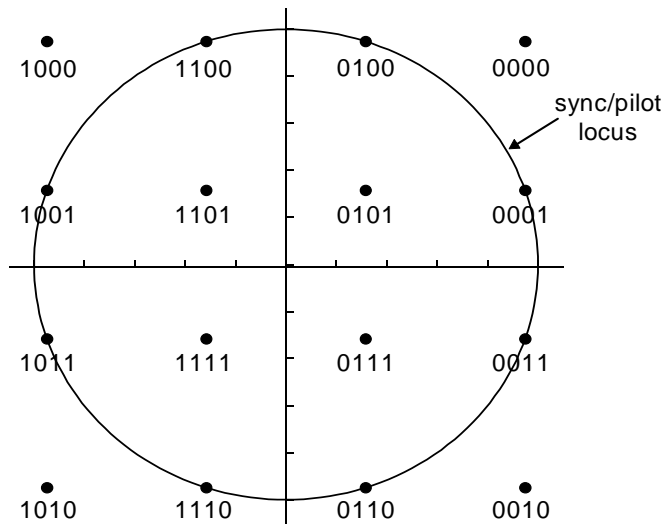

Figure 5.5: 16-QAM Symbol Constellation

Table 5.5: Vector and bit definition (16-QAM)

$B(4k-3)$	$B(4k-2)$	$B(4k-1)$	$B(4k)$	$X+Yj$
0	0	0	0	$+3+3j$
0	0	0	1	$+3+1j$
0	0	1	0	$+3-3j$
0	0	1	1	$+3-1j$
0	1	0	0	$+1+3j$
0	1	0	1	$+1+1j$
0	1	1	0	$+1-3j$
0	1	1	1	$+1-1j$
1	0	0	0	$-3+3j$
1	0	0	1	$-3+1j$
1	0	1	0	$-3-3j$
1	0	1	1	$-3-1j$
1	1	0	0	$-1+3j$
1	1	0	1	$-1+1j$
1	1	1	0	$-1-3j$
1	1	1	1	$-1-1j$

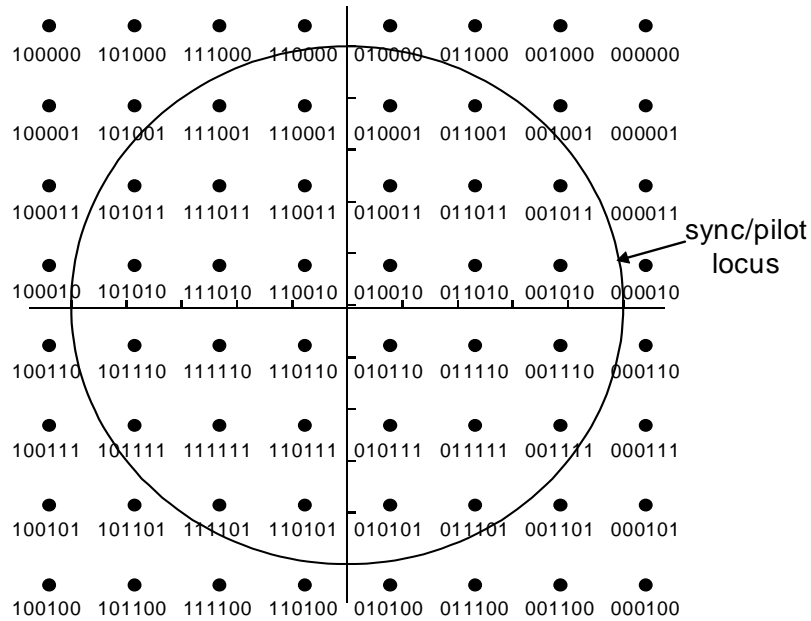

Figure 5.6: 64-QAM Symbol Constellation

Table 5.6: Vector and bit definition (64-QAM)

B(6k-5)	B(6k-4)	B(6k-3)	B(6k-2)	B(6k-1)	B(6k)	X+Yj
0	0	0	0	0	0	+7+7j
0	0	0	0	0	1	+7+5j
0	0	0	0	1	0	+7+1j
0	0	0	0	1	1	+7+3j
0	0	0	1	0	0	+7-7j
0	0	0	1	0	1	+7-5j
0	0	0	1	1	0	+7-1j
0	0	0	1	1	1	+7-3j
0	0	1	0	0	0	+5+7j
0	0	1	0	0	1	+5+5j
0	0	1	0	1	0	+5+1j
0	0	1	0	1	1	+5+3j
0	0	1	1	0	0	+5-7j
0	0	1	1	0	1	+5-5j
0	0	1	1	1	0	+5-1j
0	0	1	1	1	1	+5-3j
0	1	0	0	0	0	+1+7j
0	1	0	0	0	1	+1+5j
0	1	0	0	1	0	+1+1j
0	1	0	0	1	1	+1+3j
0	1	0	1	0	0	+1-7j
0	1	0	1	0	1	+1-5j
0	1	0	1	1	0	+1-1j
0	1	0	1	1	1	+1-3j
0	1	1	0	0	0	+3+7j
0	1	1	0	0	1	+3+5j
0	1	1	0	1	0	+3+1j
0	1	1	0	1	1	+3+3j
0	1	1	1	0	0	+3-7j
0	1	1	1	0	1	+3-5j
0	1	1	1	1	0	+3-1j
0	1	1	1	1	1	+3-3j
1	0	0	0	0	0	-7+7j
1	0	0	0	0	1	-7+5j
1	0	0	0	1	0	-7+1j
1	0	0	0	1	1	-7+3j
1	0	0	1	0	0	-7-7j

B(6k-5)	B(6k-4)	B(6k-3)	B(6k-2)	B(6k-1)	B(6k)	X+Yj
1	0	0	1	0	1	-7-5j
1	0	0	1	1	0	-7-1j
1	0	0	1	1	1	-7-3j
1	0	1	0	0	0	-5+7j
1	0	1	0	0	1	-5+5j
1	0	1	0	1	0	-5+1j
1	0	1	0	1	1	-5+3j
1	0	1	1	0	0	-5-7j
1	0	1	1	0	1	-5-5j
1	0	1	1	1	0	-5-1j
1	0	1	1	1	1	-5-3j
1	1	0	0	0	0	-1+7j
1	1	0	0	0	1	-1+5j
1	1	0	0	1	0	-1+1j
1	1	0	0	1	1	-1+3j
1	1	0	1	0	0	-1-7j
1	1	0	1	0	1	-1-5j
1	1	0	1	1	0	-1-1j
1	1	0	1	1	1	-1-3j
1	1	1	0	0	0	-3+7j
1	1	1	0	0	1	-3+5j
1	1	1	0	1	0	-3+1j
1	1	1	0	1	1	-3+3j
1	1	1	1	0	0	-3-7j
1	1	1	1	0	1	-3-5j
1	1	1	1	1	0	-3-1j
1	1	1	1	1	1	-3-3j

5.14 Data, synchronization and pilot symbol multiplexing

Figure 5.7 shows the multiplexing of data, synchronization and pilot symbols.

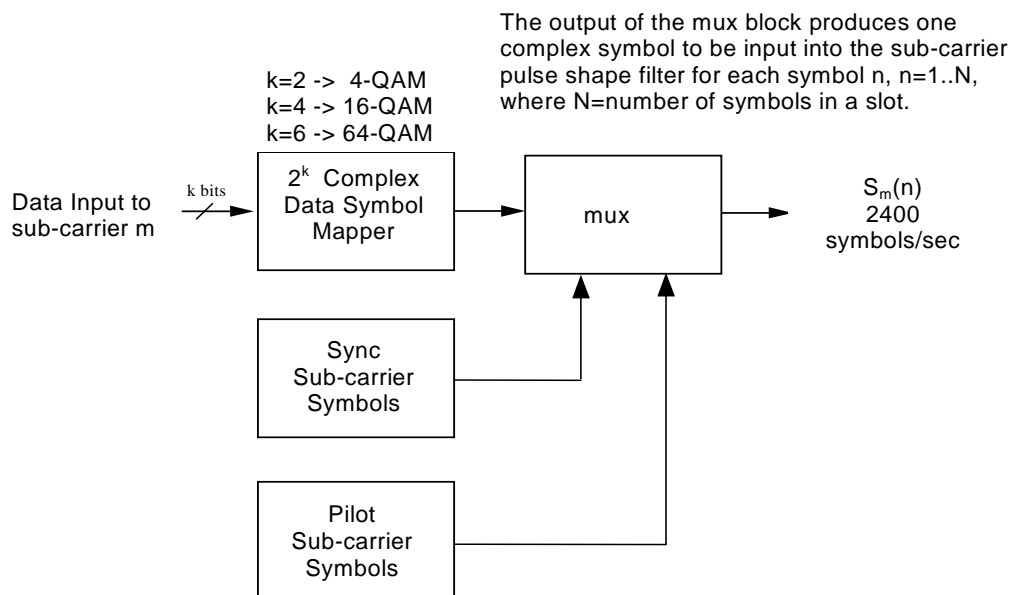

Figure 5.7: Symbol multiplexing

5.15 Sub-carrier frequency domain multiplexing

The number of sub-carriers M shall be 8, 16, 32 and 48 respectively for 25 kHz, 50 kHz, 100 kHz and 150 kHz carrier bandwidths. The sub-carrier centre frequency f_m in Hz shall be defined by the following formula:

$$f_m = (0,5625 - (M/2-m) \times 1,125)/T \quad (5.5)$$

for $m = 0, 1, \dots, M-1$

where T is the symbol duration in s as defined in clause 5.11. This leads to a sub-carrier spacing of 2,7 kHz.

5.16 Modulated signal definition

The modulated signal, at carrier frequency f_c , shall be given by:

$$M(t) = \text{Re}\{s(t) \exp(j(2\pi f_c t + \phi_0))\} \quad (5.6)$$

Where:

- ϕ_0 is an arbitrary phase;
- $s(t)$ is the complex envelope of the modulated signal defined as:

$$s_m(t) = \sum_{n=1}^N S_m(n) g(t - t_n) e^{j(\omega_m t + \varphi_m)} \quad (5.7)$$

$$s(t) = \sum_{m=0}^{M-1} s_m(t) = \sum_{m=0}^{M-1} \sum_{n=1}^N S_m(n) g(t - t_n) e^{j(\omega_m t + \varphi_m)}$$

Where:

- M is the number of sub-carriers;
- N is the number of modulated symbols on each sub-carrier in one slot;
- T is the symbol duration on each sub-carrier;
- $t_n = nT$ is the symbol time corresponding to modulation symbol $S_m(n)$;
- $S_m(n)$ is the modulation symbol at time t_n on sub-carrier m ;
- $\omega_m = 2\pi f_m$ is sub-carrier angular frequency;
- φ_m is the phase control for sub-carrier m during the slot;
- $g(t)$ is the ideal symbol waveform, obtained by the inverse Fourier transform of a square root raised cosine spectrum $G(f)$, defined as follows:

$$\begin{aligned} G(f) &= 1 && \text{for} && |f| \leq (1 - \alpha)/2T \\ G(f) &= \sqrt{0,5 \left(1 - \sin\left(\pi \left(2|f|T - 1 \right) / 2\alpha \right) \right)} && \text{for} && (1 - \alpha)/2T \leq |f| \leq (1 + \alpha)/2T \\ G(f) &= 0 && \text{for} && |f| \geq (1 + \alpha)/2T \end{aligned} \quad (5.8)$$

Where α is the roll-off factor, which determines the width of the transmission band at a given symbol rate. The value of α shall be 0,20. For practical implementation, a time limited windowed version of $g(t)$, designed under the constraints given by the specified modulation accuracy and adjacent channel attenuation may be applied.

5.17 Modulation filter definition

The ideal modulation filter shall be a linear phase filter which is defined by the magnitude of its frequency response $|H(f)| = G(f)$.

The frequency domain specification $G(f)$ of the transmit pulse-shape filter results in a unique specification for the time domain impulse response $g(t)$. Figure 5.8 shows a sample implementation of the impulse response. Time t_0 in figure 5.8, the peak of the impulse response for the first modulated symbol in a slot is an important parameter in the multi sub-carrier modulation specification.

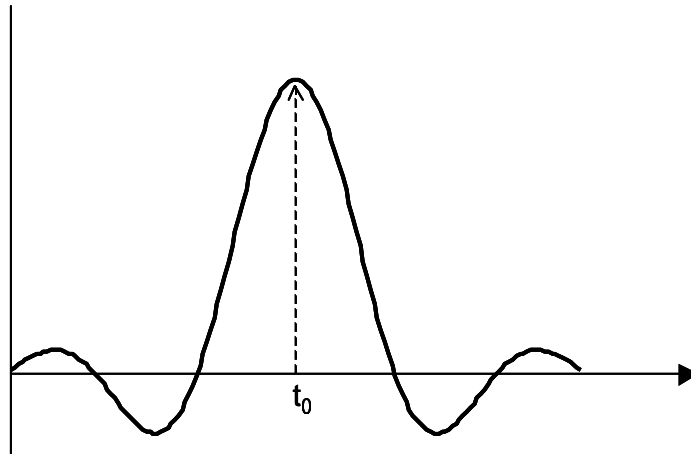

Figure 5.8: Sample impulse response

The phase relationship of the sub-carriers to the synchronization sub-carrier symbols and the pilot sub-carrier symbols is important in multi sub-carrier modulation. For the synchronization sub-carrier symbols to produce a correct time synchronization pattern, the phase relationship of the synchronization sub-carrier symbols to the instantaneous sub-carrier frequency domain multiplexers in equation 5.7 has to be controlled. Also, by exercising control over the phase relationship of the sub-carrier frequency domain multiplexers to the pilot sub-carrier symbols, the pilots may be designed to achieve lowest peak-to-average power ratio for the composite multi sub-carrier modulation. Time t_0 in figure 5.8 defines the time reference at the start of modulation when all sub-carrier frequency domain multiplexers shall have a value of 0 radians, i.e. $\omega_m t_0 + \varphi_m = 0$, which is equivalent to say that the sub-carrier frequency domain multiplexers all have a phase of 0 radians at $t = t_0$.

The condition $\omega_m t_0 + \varphi_m = 0$ needs to be fulfilled for every transmitted slot. This mathematical expression is correct if the notation in equation 5.7, i.e. $\sum_{n=1}^N$, refers to a single slot.

NOTE: This condition can be fulfilled by pre-rotating all sub-carrier symbols of each transmitted slot n by $-\omega_m(t_0 + n \times N \times T)$ radians, where $N \times T$ is the slot duration and n is an integer equal or greater than 0.

In downlink timeslots, the time reference t_0 coincides with the start of the timeslot. In uplink timeslots or for the first uplink subslot, the time reference t_0 occurs two QAM symbol periods after the start of the timeslot; for the second uplink subslot, the time reference t_0 occurs 19 QAM symbol periods after the start of the timeslot.

5.18 Modulation block diagram

A block diagram of the modulation process is shown on figure 5.9. Figure 5.9 is for explanatory purposes and does not prescribe a specific implementation.

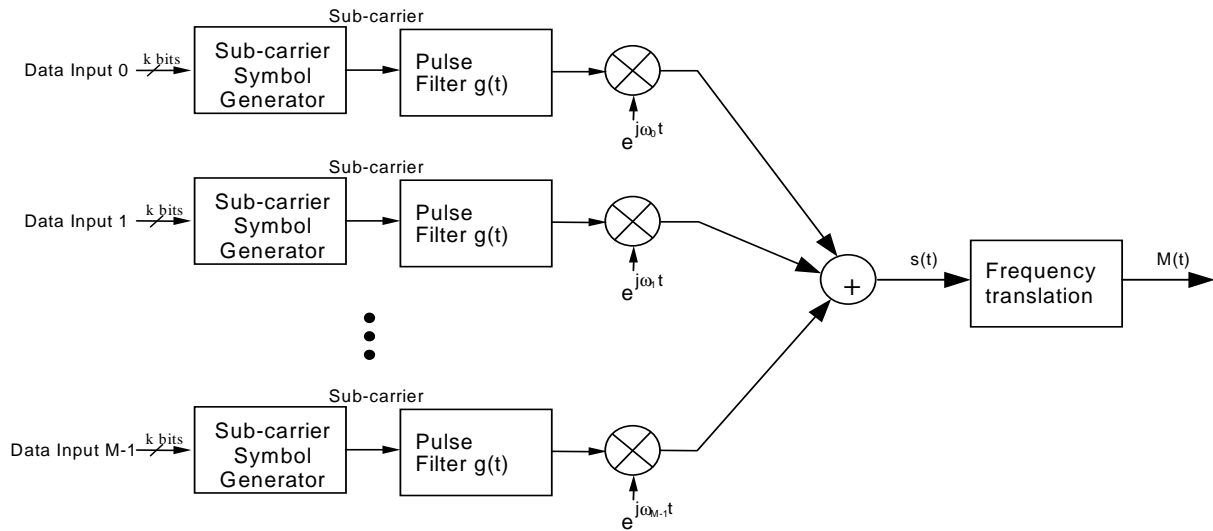

Figure 5.9: Block diagram of the modulation process

6 Radio transmission and reception

6.1 Introduction

Clause 6 defines the requirements for the MS and the BS transceiver of the TETRA $\pi/4$ -DQPSK, D8PSK and QAM systems. Clause 6 is applicable to TETRA systems operating at radio frequencies of 138 MHz to 1 GHz.

NOTE: Simulations for setting the receiver requirements were performed using $\pi/4$ -DQPSK modulation at 138 MHz. Statements about the other modulation methods are presented in relevant places for frequencies below 300 MHz.

6.2 Frequency bands and channel arrangement

When used in dedicated TETRA frequency bands, TETRA MSs shall transmit in the TETRA uplink frequency band, and TETRA BSs shall transmit in the TETRA downlink frequency band. The uplink and downlink frequency bands are of equal width. Their edges shall be as follows:

- $F_{up, min}$ to $F_{up, max}$ (MHz): mobile transmit, base receive.
- $F_{dw, min}$ to $F_{dw, max}$ (MHz): base transmit, mobile receive.

The TETRA RF channel raster shall be 25 kHz, or multiples thereof for higher bandwidth carriers. Multiples of 6,25 kHz and 12,5 kHz shall also be supported for cases where either there is an offset for some frequencies within a band, or where adjacent carriers have different bandwidths. In order to ensure compliance with the radio regulations outside the band, a guard band may be needed at each side of both uplink and downlink bands.

The centre frequencies of downlink RF carriers, $F_{down,c}$ shall be given by the value of downlink carrier frequency defined in clause 21, the corresponding centre frequency of uplink RF carriers, $F_{up,c}$, shall be given by:

$$F_{up,c} = F_{down,c} - D \quad (6.1)$$

The uplink and downlink transmit and receive centre frequencies and the duplex spacing (D) are allocated by national regulatory authorities, refer to clause 21 and ETSI TS 100 392-15 [18].

6.3 Reference test planes

For the purposes of testing, all TETRA stations shall have at least one antenna connector as specified by the manufacturer.

The base station equipment may include, at the discretion of the manufacturer, some or all of the optional items shown in figure 6.1 if they are necessary to meet the requirements of the present document, with the antenna connection(s) at Points 1T, 1R or 2. The equipment has to comply with the present document at the antenna connector(s) specified.

In the case of equipment comprising several transmitters, only one transmitter shall be transmitting during all measurements, except for measuring intermodulation attenuation.

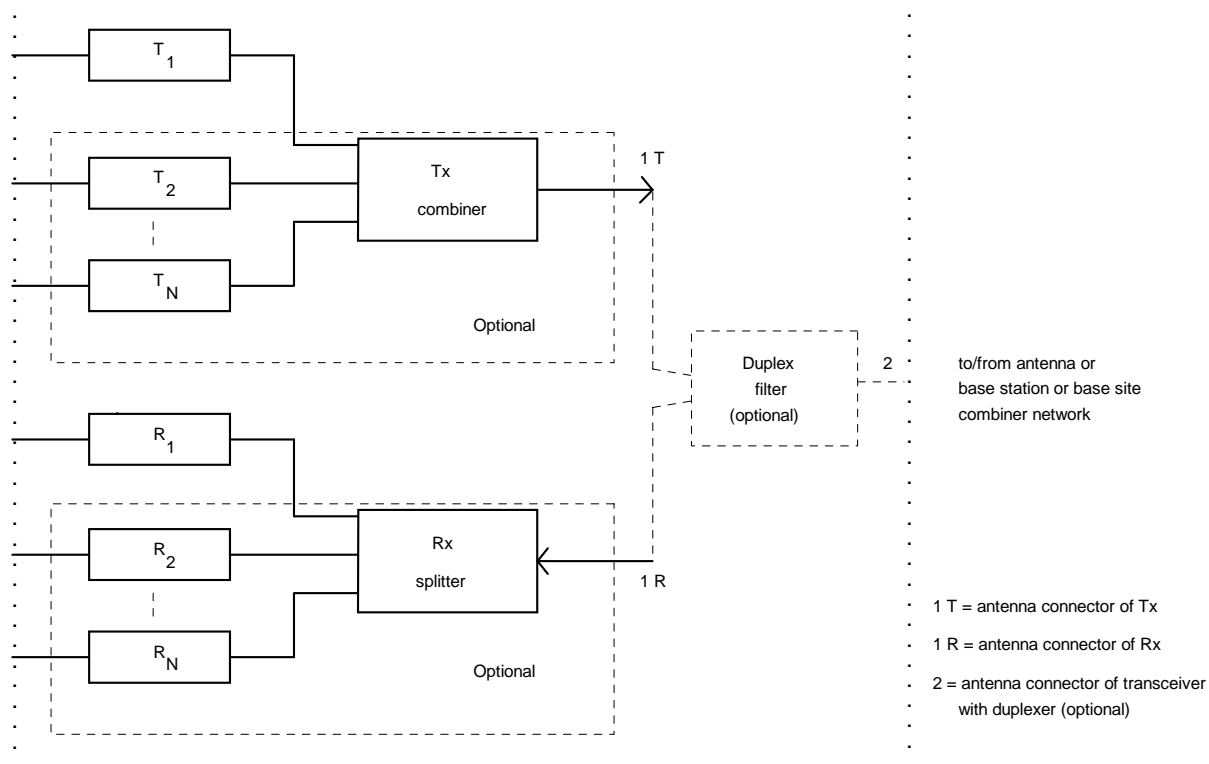

Figure 6.1: Reference interconnection of transmitters and receivers at BS

6.4 Transmitter characteristics

6.4.1 Output power for phase modulation

6.4.1.0 General

In clauses 6.4.1.1 and 6.4.1.2, power is defined as the average power, measured through the square root raised cosine filter defined in clause 5 over the useful part of the burst as defined in clause 9.

The powers at which MSs or BSs may operate are specified in clauses 6.4.1.1 and 6.4.1.2.

6.4.1.1 Base Station (BS)

The BS transmitter nominal power shall be as defined in table 6.1 according to its power class.

Table 6.1: Nominal power of BS transmitters

Power class	Nominal power per carrier
1 (40 W)	46 dBm
2 (25 W)	44 dBm
3 (15 W)	42 dBm
4 (10 W)	40 dBm
5 (6,3 W)	38 dBm
6 (4 W)	36 dBm
7 (2,5 W)	34 dBm
8 (1,6 W)	32 dBm
9 (1 W)	30 dBm
10 (0,6 W)	28 dBm

NOTE: The tolerances of the nominal power per carrier are given in ETSI EN 300 394-1 [i.13].

6.4.1.2 Mobile Station (MS)

The MS nominal power shall be as defined in table 6.2 according to its power class.

Table 6.2: Nominal power of MS transmitters

Power class	Nominal power
1 (30 W)	45 dBm
1L (17,5 W)	42,5 dBm
2 (10 W)	40 dBm
2L (5,6 W)	37,5 dBm
3 (3 W)	35 dBm
3L (1,8 W)	32,5 dBm
4 (1 W)	30 dBm
4L (0,56 W)	27,5 dBm

NOTE 1: The tolerances of the nominal power per carrier are given in ETSI EN 300 394-1 [i.13].

The different power levels needed for adaptive power control (see clause 10) shall have the values as defined in table 6.3, starting from the minimum power control level of 15 dBm (step level 7) up to the nominal power level corresponding to the class of the particular MS as stated in table 6.2.

Table 6.3: Nominal MS power control levels

Step level	Power
1	45 dBm
2	40 dBm
3	35 dBm
4	30 dBm
5	25 dBm
6	20 dBm
7	15 dBm

NOTE 2: The tolerances of the nominal power per carrier are given in ETSI EN 300 394-1 [i.13].

6.4.2 Unwanted conducted emissions for phase modulation

6.4.2.1 Definitions

Unwanted emissions are defined as conducted emissions at frequencies or time intervals outside the allocated channel. The specified limits shall be met under realistic conditions, for instance under varying antenna mismatch. Unless otherwise stated, unwanted emissions are specified for an equipment in the active transmit (act Tx) state, i.e. whenever this equipment transmits bursts, or whenever it ramps-up/linearizes or ramps-down. The non-active transmit (nonact Tx) state is a state occurring during two timeslot durations (approximately 28 ms) before and after any active transmit state.

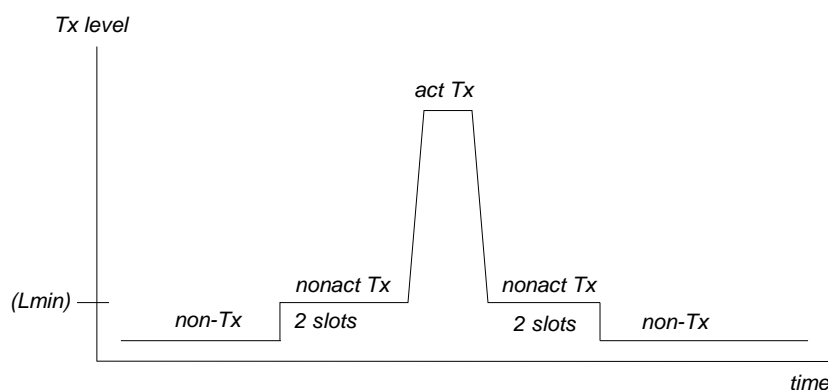

Figure 6.2: Schematic presentation of transmitter states

An equipment is said to be in the non-transmit (non-Tx) state whenever it is not in the active or non-active transmit state (refer to figure 6.2).

6.4.2.2 Unwanted emissions close to the carrier

6.4.2.2.0 General

The emissions in clauses 6.4.2.2.1 and 6.4.2.2.2 shall be measured through the square root raised cosine filter with a roll-off factor of 0,35 and a symbol duration of 500/9 μ s, as defined in clauses 5.5 and 5.6.

Measurements shall be done at the nominal centre frequency and at the frequency offsets specified in tables 6.4 and 6.5. When applicable, relative measurements (dBc) shall refer to the level measured at the nominal centre frequency.

6.4.2.2.1 Emission during the useful part of the burst

The levels given in tables 6.4 and 6.5 shall not be exceeded at the listed frequency offsets from the nominal carrier frequency.

Table 6.4: Maximum adjacent power levels for frequencies below 700 MHz

Frequency offset	Maximum level for MS power classes 4 and 4L	Maximum level for other power classes
25 kHz	-55 dBc	-60 dBc
50 kHz	-70 dBc	-70 dBc
75 kHz	-70 dBc	-70 dBc

In any case, no requirement less than -36 dBm shall apply i.e. the maximum power level need not be less than -36 dBm.

Table 6.5: Maximum adjacent power levels for frequencies above 700 MHz

Frequency offset	Maximum level
25 kHz	-55 dBc
50 kHz	-65 dBc
75 kHz	-65 dBc (see note)
NOTE: A level of -70 dBc shall apply for: BS Power Classes 1, 2 and 3 and for MS Power Classes 1 and 1L.	

In any case, no requirement less than -36 dBm shall apply i.e. the maximum power level need not be less than -36 dBm.

The specifications assume that the centre frequency is at the above listed frequency offsets from the nominal carrier frequency. The measured values shall be averaged over the useful part of the burst (see clause 9). The scrambled bits shall have a pseudo-random distribution from burst to burst.

6.4.2.2.2 Emission during the switching transients

At the frequency offset from the nominal carrier frequency given below, peak power measurements shall be done, covering at least the ramp-up period and the ramp-down period (figure 6.3, periods t_1 and t_3) (see clause 6.4.5 for definition of t_1 and t_3).

The maximum hold level of -45 dBc for MS Power Classes 4 and 4L and -50 dBc for other Power Classes at a frequency offset of 25 kHz shall not be exceeded. This requirement does not apply to linearization channels.

In any case no requirement less than -36 dBm shall apply i.e. the maximum peak power level need not be less than -36 dBm.

6.4.2.3 Unwanted emissions far from the carrier

These unwanted emissions are emissions (discrete, wideband noise, modulated or un-modulated) occurring at offsets of equal to, or greater than, 100 kHz from the carrier frequency, measured in the frequency range 9 kHz to 4 GHz.

a) Discrete spurious:

- the maximum allowed power for each spurious emission shall be less than -36 dBm measured in 100 kHz bandwidth in the frequency range 9 kHz to 1 GHz and -30 dBm measured in 1 MHz bandwidth in the frequency range 1 GHz to 4 GHz (1 GHz to 12,75 GHz for equipment capable of operating at frequencies above 470 MHz). Specific measurement methods are required both when measuring within $\pm f_{rb}$ of carrier frequency, due to the presence of wideband noise, and in the lower part of the spectrum.

b) Wideband noise:

- the wideband noise levels, measured through the modulation filter defined in clause 5.6 should not exceed the limits shown in tables 6.6 and 6.7, for the nominal power levels as stated, and at the listed offsets from the nominal carrier frequency. The requirements apply symmetrically to both sides of the transmitter band.

Table 6.6: Wideband noise limits for frequencies below 700 MHz

Frequency offset	Maximum wideband noise level		
	MS nominal power level ≤ 1 W (class 4)	MS nominal power level = 1,8 W or 3 W (class 3L or 3)	MS nominal power level $\geq 5,6$ W (class 2L) BS all classes
100 kHz to 250 kHz	-75 dBc	-78 dBc	-80 dBc
250 kHz to 500 kHz	-80 dBc	-83 dBc	-85 dBc
500 kHz to f_{rb}	-80 dBc	-85 dBc	-90 dBc
$> f_{rb}$	-100 dBc	-100 dBc	-100 dBc

NOTE: f_{rb} denotes the frequency offset corresponding to the near edge of the receive band or 5 MHz (10 MHz for frequencies above 520 MHz) whichever is greater.

Table 6.7: Wideband noise limits for frequencies above 700 MHz

Frequency offset	Maximum wideband noise level		
	MS nominal power level ≤ 1 W (class 4)	MS nominal power levels from 1,8 W to 10 W and BS Nominal power levels ≤ 10 W	MS and BS nominal power levels from 15 W to 40 W
100 kHz to 250 kHz	-74 dBc	-74 dBc	-80 dBc
250 kHz to 500 kHz	-80 dBc	-80 dBc	-85 dBc
500 kHz to f_{rb}	-80 dBc	-85 dBc	-90 dBc
$> f_{rb}$	-100 dBc	-100 dBc	-100 dBc

NOTE: f_{rb} denotes the frequency offset corresponding to the near edge of the received band or 10 MHz whichever is greater.

All levels in tables 6.6 and 6.7 are expressed in dBc relative to the actual transmitted power level, and in any case no limit tighter than -55 dBm for offsets $< f_{rb}$ or -70 dBm for offsets $> f_{rb}$ shall apply.

6.4.2.4 Unwanted emissions during the CLCH and BLCH

The following emissions shall be measured through a square root raised cosine filter with a roll-off factor of 0,35 and a symbol duration of 500/9 μ s as defined in clauses 5.5 and 5.6.

The sum of the time periods during which the peak power, at a frequency offset of ± 25 kHz during the BLCH/CLCH, is above -45 dBc shall not exceed 1 ms. This peak power shall never exceed -30 dBc.

NOTE: 0 dBc refers to the transmit power during normal operation after the CLCH or BLCH.

6.4.2.5 Unwanted emissions in the non-transmit state

The specifications of clause 6.5.4.2 apply.

6.4.3 Unwanted radiated emissions for phase modulation

Unwanted radiated emissions are emissions (whether modulated or un-modulated) radiated by the cabinet and structure of the equipment (MS or BS). This is also known as cabinet radiation.

The limits given in clause 6.4.2.3 shall apply for frequencies between 30 MHz and 4 GHz only.

6.4.4 RF tolerance for phase modulation

The RF tolerance for BSs and MSs is defined in clause 7.

6.4.5 RF Output power time mask for phase modulation

6.4.5.0 General

The transmit level versus time mask for TETRA station transmission is shown in figure 6.3. For the time mask the power level of 0 dBc refers to the output power level of the TETRA station under consideration.

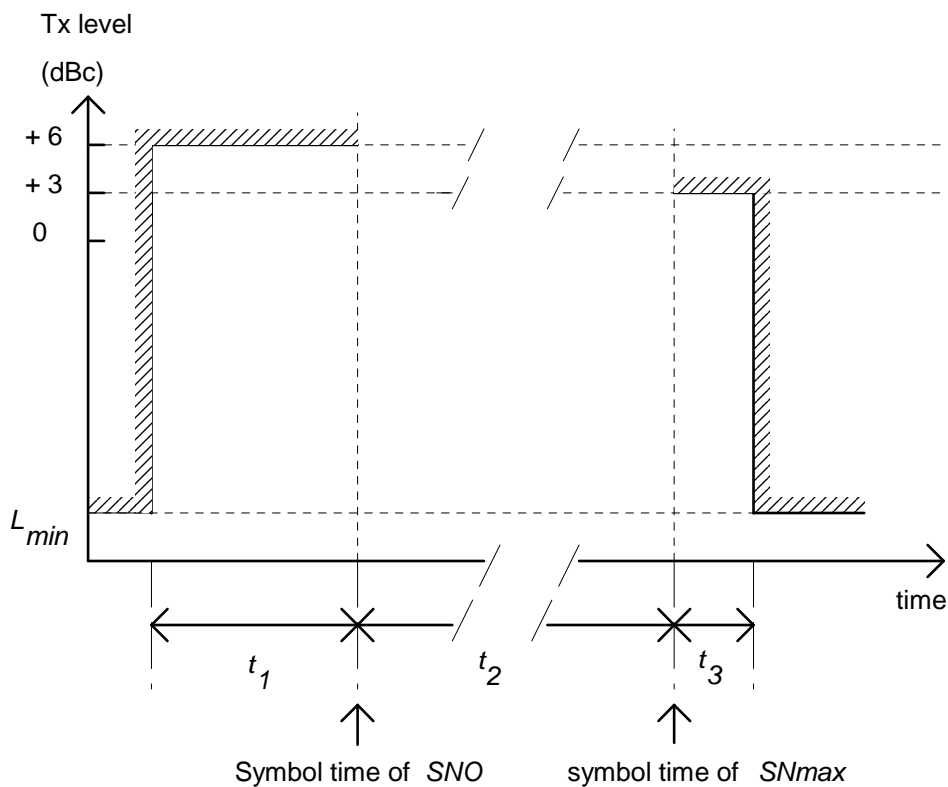

Figure 6.3: Transmit level versus time mask

Table 6.8: Transmit level versus time mask symbol durations (refer figure 6.3)

Burst Type	t_1	t_2	t_3
Control uplink	16	103	15
Linearization uplink	119	0	15
Linearization downlink	107	0	0
Normal uplink	16	231 (see note)	15
Discontinuous downlink	7	246 (see note)	7
Continuous downlink	Unspecified	Unspecified	Unspecified
NOTE: In the case of single slot transmission.			

Whenever bursts are consecutively transmitted by the same TETRA station on the same frequency, the transmit level versus time mask applies at the beginning of the transmission of the first burst and at the end of the transmission of the last burst.

The symbol numbers referred to as SNO and $SNmax$ are defined in clause 9. The timing of the transmitted bursts is specified in clause 7. The time periods t_1 , t_2 and t_3 , whose durations are stated in table 6.8, are defined in the following way:

- the time t_1 starts at the beginning of the ramp-up of the first burst, and expires just before the symbol time of SNO ;
- the time t_2 starts at the symbol time of SNO of the first burst and finishes at the symbol time of $SNmax$ of the last burst;
- the time t_3 starts just after the symbol time of $SNmax$ of the last burst and finishes at the end of the ramp-down.

In this clause, the specifications of clauses 6.4.1 and 6.6.1 shall apply during the time t_2 . The output power shall be measured through the square root raised cosine filter with a roll off factor of 0,35 and a symbol duration of 500/9 μ s as defined in clauses 5.5 and 5.6.

6.4.5.1 BS

The BS output power shall be at the nominal level, as specified in clause 6.4.1.1. Power control shall not be applied to the downlink transmissions.

In the non-active transmit state the specification $L_{min} = -40$ dBc shall apply.

The peak transmit power during BLCH shall not exceed +6 dBc.

6.4.5.2 MS

The MS output power shall be able to be reduced to levels defined in table 6.3, down to a minimum level of 15 dBm. The power levels that can be achieved, according to the class of the MS, are detailed in clause 6.4.1.2.

During the non-active transmit state the specification $L_{min} = -70$ dBc or $L_{min} = -36$ dBm, whichever is greater, shall apply.

6.4.6 Transmitter intermodulation attenuation for phase modulation

6.4.6.1 Definition

The intermodulation attenuation is the ratio of the power level of the wanted signal to the power level of an intermodulation component. It is a measure of the capability of the transmitter to inhibit the generation of signals in its non-linear elements caused by the presence of the useful carrier and an interfering signal reaching the transmitter via its antenna.

6.4.6.2 BS

The intermodulation attenuation of the BS equipment shall be at least 70 dB for any intermodulation component when measured in a 30 kHz bandwidth. The interfering signal shall be un-modulated and have a frequency offset of at least 500 kHz from the carrier frequency. The power level of the interfering signal shall be 30 dB below the power level of the modulated output signal from the transmitter under test. If the intermodulation attenuation is achieved by additional, internal or external, isolating devices they shall be included in the measurements.

However, in the case of BS equipment with only one transmitter and which is not intended to be co-located with other radio equipment operating in the same frequency band, an intermodulation attenuation of at least 40 dB shall be sufficient.

In any case no requirement less than -36 dBm shall apply to intermodulation components i.e. the power of any intermodulation component need not be less than -36 dBm.

All power levels stated in the cases above refer to the antenna connector of the BS described in clause 6.3.

6.4.6.3 MS

In an MS, intermodulation may be caused when operating transmitters in the close vicinity of each other.

For an MS transmitter operating at the nominal power defined by its class, the intermodulation attenuation shall be at least 60 dB for any intermodulation component when measured in 30 kHz bandwidth. The interfering signal shall be un-modulated and have a frequency offset of at least 500 kHz from the carrier frequency. The power level of the interfering signal shall be 50 dB below the power level of the modulated output signal from the transmitter under test.

6.4.7 Intra-BS intermodulation requirements

In a BS, intermodulation may be caused by combining several transmitters and carriers to feed a single antenna.

For all transmitters of a single TETRA BS, the power of any intermodulation components, when measured in a 30 kHz bandwidth, shall not exceed -60 dBc in the relevant downlink frequency band. In any case no requirement less than -36 dBm shall apply i.e. the power of any intermodulation component need not be less than -36 dBm.

NOTE: The value of -60 dBc refers to the carrier power of the transmitter with the highest output power measured at the antenna connector of the BS described in clause 6.3.

In the case where the performance is achieved by additional internal or external isolating devices (such as circulators) they shall be supplied at the time of conformance testing and shall be used for measurements.

6.4.8 Output power for QAM

6.4.8.0 General

In clauses 6.4.8.1 and 6.4.8.2, power for QAM is defined as the sum of the powers of each of the sub-carriers within the RF channel bandwidth. For each sub-carrier, reference power is defined as the average power, measured at symbol time through the square root raised cosine filter defined in clause 5.16, over the pilot and sync symbols within the QAM burst as defined in clause 9.

The powers at which MSs or BSs may operate are specified in clauses 6.4.8.1 and 6.4.8.2.

6.4.8.1 BS

The BS transmitter nominal power shall be as defined in table 6.9 according to its power class.

The power tolerances are defined in clause 7.1.1.2 of ETSI EN 300 394-1 [i.13].

Table 6.9: Nominal power of BS QAM transmitters

Power class	Nominal power per modulated RF carrier (see note)
1 (40 W)	46 dBm
2 (25 W)	44 dBm
3 (15 W)	42 dBm
4 (10 W)	40 dBm
5 (6,3 W)	38 dBm
6 (4 W)	36 dBm
7 (2,5 W)	34 dBm
8 (1,6 W)	32 dBm
9 (1 W)	30 dBm
10 (0,6 W)	28 dBm

NOTE: "Modulated RF carrier" has an RF channel bandwidth of 25 kHz, 50 kHz, 100 kHz or 150 kHz, comprising 8, 16, 32 or 48 modulated sub-carriers respectively.

6.4.8.2 MS

The MS nominal power shall be as defined in table 6.10 according to its power class.

The power tolerances are defined in clause 6 of ETSI EN 300 394-1 [i.13].

Table 6.10: Nominal power of MS QAM transmitters

Power class	Nominal power
1 (30 W)	45 dBm
1L (17,5 W)	42,5 dBm
2 (10 W)	40 dBm
2L (5,6 W)	37,5 dBm
3 (3 W)	35 dBm
3L (1,8 W)	32,5 dBm
4 (1 W)	30 dBm
4L (0,56 W)	27,5 dBm
5 (0,32 W)	25 dBm
5L (0,18 W)	22,5 dBm

The different power levels needed for adaptive power control (see clause 10.2) shall have the values as defined in table 6.11, starting from the minimum power control level of 15 dBm (step level 7) up to the nominal power level corresponding to the class of the particular MS as stated in table 6.10.

The power tolerances are defined in clause 6 of ETSI EN 300 394-1 [i.13].

Table 6.11: Nominal MS QAM power control levels

Step level	Power
1	45 dBm
2	40 dBm
3	35 dBm
4	30 dBm
5	25 dBm
6	20 dBm
7	15 dBm

6.4.9 Unwanted conducted emissions for QAM

6.4.9.1 Definitions

The definitions in clause 6.4.2.1 apply.

6.4.9.2 Unwanted emissions close to the carrier

6.4.9.2.0 General

The unwanted emissions in clauses 6.4.9.2.1 and 6.4.9.2.2 shall be measured through the square root raised cosine filter with a roll-off factor of 0,35 and a symbol duration of 500/9 μ s, as defined in clauses 5.5 and 5.6.

Measurements shall be done at the nominal centre frequency and at the frequency offsets specified in tables 6.12, 6.13, 6.14 and 6.15. When applicable, relative measurements (dBc) shall refer to the power level measured at the nominal centre frequency as defined in clause 6.4.8.

6.4.9.2.1 Emission during the useful part of the burst

The levels given in tables 6.12, 6.13, 6.14 and 6.15 shall not be exceeded at the listed frequency offsets from the nominal carrier frequency.

Table 6.12: Maximum adjacent power levels for 25 kHz QAM

Frequency offset	Maximum level for MS and BS
25 kHz	-55 dBc
50 kHz	-65 dBc
75 kHz	-67 dBc

NOTE: The maximum adjacent channel power levels for 25 kHz QAM channel are applicable also for the RAB channels on 50 kHz, 100 kHz and 150 kHz QAM channels.

Table 6.13: Maximum adjacent power levels for 50 kHz QAM

Frequency offset	Maximum level for MS and BS
37,5 kHz	-55 dBc
62,5 kHz	-63 dBc
87,5 kHz	-65 dBc

Table 6.14: Maximum adjacent power levels for 100 kHz QAM

Frequency offset	Maximum level for MS and BS
62,5 kHz	-55 dBc
87,5 kHz	-60 dBc
112,5 kHz	-60 dBc

Table 6.15: Maximum adjacent power levels for 150 kHz QAM

Frequency offset	Maximum level for MS and BS
87,5 kHz	-55 dBc
112,5 kHz	-60 dBc
137,5 kHz	-60 dBc

In any case, no requirement less than -36 dBm shall apply i.e. the maximum power level need not be less than -36 dBm.

The specifications assume that the centre frequency is at the above listed frequency offsets from the nominal carrier frequency. The measured values shall be averaged over the useful part of the burst (see clause 9). The scrambled bits shall have a pseudo-random distribution from burst to burst.

6.4.9.2.2 Emission during the switching transients

At the frequency offset from the nominal carrier frequency given below, peak power measurements shall be done, covering at least the ramp-up period and the ramp-down period (figure 6.4, periods t_1 and t_3) (see clause 6.4.10 for definition of t_1 and t_3).

For 25 kHz QAM the maximum hold level of -45 dBc at a frequency offset of 25 kHz shall not be exceeded.

For 50 kHz QAM the maximum hold level of -45 dBc at a frequency offset of 37,5 kHz shall not be exceeded.

For 100 kHz QAM the maximum hold level of -45 dBc at a frequency offset of 62,5 kHz shall not be exceeded.

For 150 kHz QAM the maximum hold level of -45 dBc at a frequency offset of 87,5 kHz shall not be exceeded.

This requirement does not apply to linearization channels.

In any case no requirement less than -36 dBm shall apply i.e. the maximum peak power level need not be less than -36 dBm.

6.4.9.3 Unwanted emissions far from the carrier

These unwanted emissions are emissions (discrete, wideband noise, modulated or un-modulated) occurring at offsets of equal to, or greater than, 100 kHz from the carrier frequency, measured in the frequency range 9 kHz to 4 GHz.

a) Discrete spurious:

- the maximum allowed power for each spurious emission shall be less than -36 dBm measured in 100 kHz bandwidth in the frequency range 9 kHz to 1 GHz and -30 dBm measured in 1 MHz bandwidth in the frequency range 1 GHz to 4 GHz (1 GHz to 12,75 GHz for equipment capable of operating at frequencies above 470 MHz). Specific measurement method are required both when measuring within $\pm f_{rb}$ of carrier frequency, due to the presence of wideband noise, and in the lower part of the spectrum.

b) Wideband noise:

- the wideband noise levels, measured through the modulation filter defined in clause 5.6 should not exceed the limits shown in tables 6.16, 6.17, 6.18 and 6.19, for the nominal power levels as stated, and at the listed offsets from the nominal carrier frequency. When applicable, relative measurements (dBc) shall refer to the power level measured at the nominal centre frequency as defined in clause 6.4.8. The requirements apply symmetrically to both sides of the transmitter band.

Table 6.16: Wideband noise limits 25 kHz QAM

Frequency offset	Maximum wideband noise level for MS and BS		
	MS nominal power level ≤ 1 W (class 4)	MS nominal power level = 1,8 W or 3 W (class 3L or 3)	MS nominal power level $\geq 5,6$ W (class 2L) BS all classes
100 kHz to 250 kHz	-70 dBc	-70 dBc	-70 dBc
250 kHz to 500 kHz	-74 dBc	-74 dBc	-80 dBc
500 kHz to 2 500 kHz	-80 dBc	-80 dBc	-80 dBc
2 500 kHz to f_{rb}	-80 dBc	-80 dBc	-90 dBc
$> f_{rb}$	-95 dBc	-95 dBc	-95 dBc

NOTE: f_{rb} denotes the frequency offset corresponding to the near edge of the receive band or 5 MHz (10 MHz for frequencies above 520 MHz) whichever is greater.

Table 6.17: Wideband noise limits 50 kHz QAM

Frequency offset	Maximum wideband noise level for MS and BS		
	MS nominal power level ≤ 1 W (class 4)	MS nominal power level = 1,8 W or 3 W (class 3L or 3)	MS nominal power level $\geq 5,6$ W (class 2L) BS all classes
112,5 kHz to 262,5 kHz	-68 dBc	-68 dBc	-70 dBc
262,5 kHz to 500 kHz	-72 dBc	-72 dBc	-75 dBc
500 kHz to f_{rb}	-78 dBc	-78 dBc	-80 dBc
$> f_{rb}$	-95 dBc	-95 dBc	-95 dBc

NOTE: f_{rb} denotes the frequency offset corresponding to the near edge of the receive band or 5 MHz (10 MHz for frequencies above 520 MHz) whichever is greater.

Table 6.18: Wideband noise limits 100 kHz QAM

Frequency offset	Maximum wideband noise level for MS and BS	
	MS nominal power level ≤ 3 W (class 3)	MS nominal power level $\geq 5,6$ W (class 2L) BS all classes
137,5 kHz to 287,5 kHz	-60 dBc	-70 dBc
287,5 kHz to 537,5 kHz	-65 dBc	-70 dBc
537,5 kHz to 1 000 kHz	-73 dBc	-75 dBc
1 000 kHz to f_{rb}	-73 dBc	-80 dBc
$> f_{rb}$	-95 dBc	-95 dBc

NOTE: f_{rb} denotes the frequency offset corresponding to the near edge of the receive band or 5 MHz (10 MHz for frequencies above 520 MHz) whichever is greater.

Table 6.19: Wideband noise limits 150 kHz QAM

Frequency offset	Maximum wideband noise level for MS and BS	
	MS nominal power level ≤ 3 W (class 3)	MS nominal power level $\geq 5,6$ W (class 2L) BS all classes
162,5 kHz to 312,5 kHz	-60 dBc	-60 dBc
312,5 kHz to 562,5 kHz	-63 dBc	-70 dBc
562,5 kHz to 1 500 kHz	-70 dBc	-75 dBc
1 500 kHz – f_{rb}	-70 dBc	-80 dBc
$> f_{rb}$	-95 dBc	-95 dBc

NOTE: f_{rb} denotes the frequency offset corresponding to the near edge of the receive band or 5 MHz (10 MHz for frequencies above 520 MHz) whichever is greater.

All levels in tables 6.16 to 6.19 are expressed in dBc relative to the actual transmitted power level, and in any case no limit tighter than -55 dBm for offsets $< f_{rb}$ or -70 dBm for offsets $> f_{rb}$ shall apply.

6.4.9.4 Unwanted emissions during the CLCH-Q and BLCH-Q

The following emissions shall be measured through a square root raised cosine filter with a roll-off factor of 0,35 and symbol duration of 500/9 μ s as defined in clauses 5.5 and 5.6.

For 25 kHz QAM the sum of the time periods during which the peak power, at a frequency offset of ± 25 kHz during the BLCH-Q/CLCH-Q, is above -45 dBc shall not exceed 1 ms. This peak power shall never exceed -30 dBc.

For 50 kHz QAM the sum of the time periods during which the peak power, at a frequency offset of $\pm 37,5$ kHz during the BLCH-Q/CLCH-Q, is above -45 dBc shall not exceed 1 ms. This peak power shall never exceed -30 dBc.

For 100 kHz QAM the sum of the time periods during which the peak power, at a frequency offset of $\pm 62,5$ kHz during the BLCH-Q/CLCH-Q, is above -45 dBc shall not exceed 1 ms. This peak power shall never exceed -30 dBc.

For 150 kHz QAM the sum of the time periods during which the peak power, at a frequency offset of $\pm 87,5$ kHz during the BLCH-Q/CLCH-Q, is above -43 dBc shall not exceed 1 ms. This peak power shall never exceed -30 dBc.

NOTE: 0 dBc refers to the transmit power during normal operation after the CLCH-Q or BLCH-Q.

6.4.9.5 Unwanted emissions in the non-transmit state

The specifications of clause 6.5.4.2 apply.

6.4.10 RF Output power time mask for QAM

6.4.10.0 General

The QAM transmit level versus time mask for TETRA mobile station transmission is shown in figure 6.4 and table 6.20. For the time mask the power level of 0 dBc refers to the output power level of the TETRA mobile station under consideration. Unwanted emissions due to switching transients are specified in clause 6.4.9.2.2.

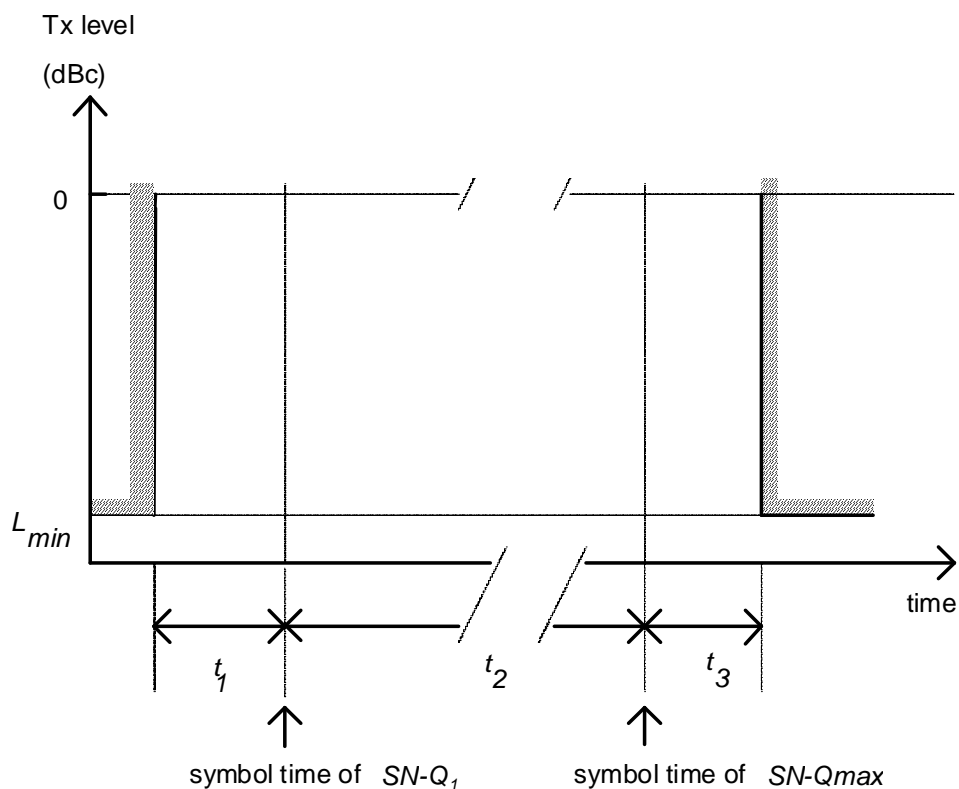

Figure 6.4: Transmit level versus time mask for QAM

Table 6.20: Transmit level versus time mask symbol durations (refer figure 6.4)

Burst Type	t_1	t_2	t_3
Control/random access uplink	2,0	13,0	2,5
Linearization uplink	15,0	0,0	2,5
Normal uplink	2,0	30,0 (note)	2,5
NOTE: In the case of single slot transmission.			

Whenever bursts are consecutively transmitted by the same TETRA mobile station on the same frequency, the transmit level versus time mask applies at the beginning of the transmission of the first burst and at the end of the transmission of the last burst.

The symbol numbers referred to as $SN-Q1$ and $SN-Qmax$ are defined in clause 9 for QAM. The timing of the transmitted bursts is specified in clause 7 for QAM. The time periods t_1 , t_2 and t_3 , whose durations are stated in table 6.20, are defined in the following way:

- the time t_1 starts at the beginning of the ramp-up of the first burst, and expires just before the symbol time of $SN-Q1$;
- the time t_2 starts at the symbol time of $SN-Q1$ of the first burst and finishes at the symbol time of $SN-Qmax$ of the last burst;
- the time t_3 starts just after the symbol time of $SN-Qmax$ of the last burst and finishes at the end of the ramp-down.

In this clause, the specifications of clauses 6.4.8 and 6.7.1.2 shall apply during the time t_2 .

6.4.10.1 BS

The BS QAM output power shall be at the nominal level, as specified in clause 6.4.8.1, excluding linearization bursts.

6.4.10.2 MS

The MS QAM output power shall be able to be reduced to levels defined in table 6.11, down to a minimum level of 15 dBm. The power levels that can be achieved, according to the class of the MS, are detailed in clause 6.4.8.2.

During the non-active transmit state the specification $L_{min} = -70$ dBc or $L_{min} = -36$ dBm, whichever is greater, shall apply.

6.4.11 Transmitter intermodulation attenuation

Requirements in clause 6.4.6 apply.

6.4.12 Intra-BS intermodulation requirements

Requirements in clause 6.4.7 apply.

6.5 Receiver characteristics

6.5.0 General

In this clause, the levels of the test signals are given in terms of power levels (dBm) at the antenna connector of the receiver. For the definition of power level refer to clauses 6.4.1 and 6.4.8.

Sources of test signals shall be connected in such a way that the impedance presented to the receiver input is a 50 Ω non-reactive impedance.

This requirement shall be met irrespective of whether one or more signals using a combining network are applied to the receiver simultaneously.

Static propagation conditions are assumed in all cases, for both wanted and unwanted signals.

6.5.1 Blocking characteristics

6.5.1.1 Definition

Blocking is a measure of the capability of the receiver to receive a modulated wanted input signal in the presence of an unwanted un-modulated input signal on frequencies other than those of the spurious responses or the adjacent channels, without this unwanted input signal causing a degradation of the performance of the receiver beyond a specified limit.

6.5.1.2 Specification for Phase Modulation

The blocking performance specification given in table 6.21 shall apply at all frequencies except those at which spurious responses occur (see clause 6.5.2).

Table 6.21: Blocking levels of the receiver

Offset from nominal Rx freq.	Level of interfering signal
50 kHz to 100 kHz	-40 dBm
100 kHz to 200 kHz	-35 dBm
200 kHz to 500 kHz	-30 dBm
> 500 kHz	-25 dBm

The static reference sensitivity performance as specified in clause 6.6.2.4 shall be met when the following signals are simultaneously input to the receiver:

- a wanted signal at the nominal receive frequency f_o , 3 dB above the static reference sensitivity level as specified in clause 6.6.2.4;
- a continuous sine wave signal at a frequency offset from f_o and level as defined in table 6.21.

6.5.1.3 Specification for QAM

The blocking performance specification given in tables 6.22, 6.23, 6.24 and 6.25 shall apply at all frequencies except those at which spurious responses occur (see clause 6.5.2).

Table 6.22: Blocking levels of the 25 kHz (8 subchannels) QAM receiver

Offset from nominal Rx freq.	Level of interfering signal
50 kHz to 100 kHz	-40 dBm
100 kHz to 200 kHz	-35 dBm
200 kHz to 500 kHz	-30 dBm
> 500 kHz	-25 dBm

Table 6.23: Blocking levels of the 50 kHz (16 subchannels) QAM receiver

Offset from nominal Rx freq.	Level of interfering signal
100 kHz to 200 kHz	-40 dBm
200 kHz to 400 kHz	-35 dBm
400 kHz to 1 000 kHz	-30 dBm
> 1 000 kHz	-25 dBm

Table 6.24: Blocking levels of the 100 kHz (32 subchannels) QAM receiver

Offset from nominal Rx freq.	Level of interfering signal
200 kHz to 400 kHz	-40 dBm
400 kHz to 600 kHz	-35 dBm
600 kHz to 1 000 kHz	-30 dBm
> 1 000 kHz	-25 dBm

Table 6.25: Blocking levels of the 150 kHz (48 subchannels) QAM receiver

Offset from nominal Rx freq.	Level of interfering signal
300 kHz to 500 kHz	-40 dBm
500 kHz to 800 kHz	-35 dBm
800 kHz to 1 000 kHz	-30 dBm
> 1 000 kHz	-25 dBm

The static reference sensitivity performance as specified in clause 6.7.2.4 shall be met when the following signals are simultaneously input to the receiver:

- a wanted signal at the nominal receive frequency f_o , 3 dB above the static reference sensitivity level as specified in clause 6.7.2.4;
- a continuous sine wave signal at a frequency offset from f_o and level as defined in tables 6.22, 6.23, 6.24 and 6.25.

6.5.2 Spurious response rejection

6.5.2.1 Definition

Spurious response rejection is a measure of the capability of a receiver to receive a wanted modulated signal without exceeding a given degradation due to the presence of an unwanted un-modulated signal at any other frequency at which a response is obtained, i.e. for which the blocking limit is not met.

6.5.2.2 Specification for phase modulation

- a) The static reference sensitivity performance as specified in clause 6.6.2.4 shall be met when the following signals are simultaneously applied to the receiver:
 - a wanted signal at nominal receive frequency f_o , 3 dB above the static reference sensitivity level as specified in clause 6.6.2.4;
 - a continuous sine wave signal with any offset from nominal Rx frequency ≥ 50 kHz at a level of -45 dBm.
- b) The number of frequencies within a limited frequency range, defined below, at which the blocking specification of clause 6.5.1.2 is not met shall not exceed $0,05 \times$ (number of frequency channels in the limited frequency range).

The limited frequency range is defined as the frequency of the local oscillator signal f_{lo} applied to the first mixer of the receiver plus or minus the sum of the intermediate frequencies (f_{i1}, \dots, f_{in}) and a half of the switching range (sr) of the receiver.

Hence the frequency f_l of the limited frequency range is:

$$f_{lo} - \sum_{j=1}^n f_{ij} - \frac{sr}{2} \leq f_l \leq f_{lo} + \sum_{j=1}^n f_{ij} + \frac{sr}{2} \quad (6.2)$$

Where receiver switching range (sr) is the maximum frequency range over which the receiver can be operated without reprogramming or realignment as declared by the manufacturer.

6.5.2.3 Specification for QAM

- a) The static reference sensitivity performance as specified in clause 6.7.2.4 shall be met when the following signals are simultaneously applied to the receiver:
 - a wanted signal at nominal receive frequency f_o , 3 dB above the static reference sensitivity level as specified in clause 6.7.2.4;
 - a continuous sine wave signal with any offset from nominal Rx frequency $\geq f_{spur}$ at a level of -45 dBm. The value of f_{spur} is defined in table 6.26.

Table 6.26: Continuous sine wave offset frequency f_{spur}

QAM Channel bandwidth	Offset from nominal Rx freq.
25 kHz	50 kHz
50 kHz	100 kHz
100 kHz	200 kHz
150 kHz	300 kHz

- b) The number of frequencies within a limited frequency range, defined below, at which the blocking specification of clause 6.5.1.3 is not met shall not exceed $0,05 \times$ (number of frequency channels in the limited frequency range).

The limited frequency range is defined as the frequency of the local oscillator signal f_{lo} applied to the first mixer of the receiver plus or minus the sum of the intermediate frequencies (f_{i1}, \dots, f_{in}) and a half of the switching range (sr) of the receiver.

Hence the frequency f_l of the limited frequency range is:

$$f_{lo} - \sum_{j=1}^n f_{ij} - \frac{sr}{2} \leq f_l \leq f_{lo} + \sum_{j=1}^n f_{ij} + \frac{sr}{2} \quad (6.3)$$

Where receiver switching range (sr) is the maximum frequency range over which the receiver can be operated without reprogramming or realignment as declared by the manufacturer.

6.5.3 Intermodulation response rejection

6.5.3.1 Definition

Intermodulation response rejection is a measure of the capability of the receiver to receive a wanted modulated signal without exceeding a given degradation due to the presence of two or more unwanted signals with a specific frequency relationship to the wanted signal frequency as defined in ETSI EN 300 113-1 [4].

6.5.3.2 Specification for Phase Modulation

The static reference sensitivity performance as specified in clause 6.6.2.4 shall be met when the following signals are simultaneously input to the receiver:

- a wanted signal at the nominal receive frequency f_o , 3 dB above the static reference sensitivity level;
- a continuous sine wave signal at frequency f_1 and with a level of -47 dBm;
- a pseudo-random sequence TETRA $\pi/4$ -DQPSK modulating a signal at frequency f_2 , with a level of -47 dBm, such that $f_o = 2f_1 - f_2$ and $|f_2 - f_1| = 200$ kHz.

6.5.3.3 Specification for QAM

The static reference sensitivity performance as specified in clause 6.7.2.4 shall be met when the following signals are simultaneously input to the receiver:

- a wanted signal at the nominal receive frequency f_o , 3 dB above the static reference sensitivity level;
- a continuous sine wave signal at frequency f_1 and with a level of -47 dBm;
- a pseudo-random sequence TETRA $\pi/4$ -DQPSK modulating a signal at frequency f_2 , with a level of -47 dBm, such that $f_o = 2f_1 - f_2$ and $|f_2 - f_1| = f_x$. Where f_x is defined in table 6.27.

Table 6.27: f_x definition

QAM Channel bandwidth	Offset from nominal Rx freq.
25 kHz	200 kHz
50 kHz	400 kHz
100 kHz	800 kHz
150 kHz	1 200 kHz

6.5.4 Unwanted conducted emissions

6.5.4.1 Definition

Unwanted emissions from the equipment when in reception are defined as conducted emissions at any frequency, when the equipment is in the non-transmit state.

6.5.4.2 Specification

The peak power emitted by the equipment shall not exceed -57 dBm at frequencies between 9 kHz and 1 GHz, as measured in a bandwidth of 100 kHz.

For equipment only capable of operating below 470 MHz the power emitted by the equipment shall not exceed -47 dBm from 1 GHz to 4 GHz, as measured in a bandwidth of 1 MHz.

For equipment capable of operating above 470 MHz the power emitted by the equipment shall not exceed -47 dBm from 1 GHz to 12,75 GHz, as measured in a bandwidth of 1 MHz.

6.5.5 Unwanted radiated emissions

Unwanted radiated emissions are emissions radiated by the cabinet and structure of the equipment (MS or BS) in the non-transmit state. This is also known as cabinet radiation.

The limits given in clause 6.5.4.2 shall apply for frequencies between 30 MHz and 4 GHz only.

6.6 Transmitter/receiver performance for phase modulation

6.6.0 General

Clause 6.6.1 specifies the modulation accuracy requirement, by setting limits on the Root Mean Square (RMS) error between the actual transmitted signal waveform and the ideal signal waveform. Clause 6.6.2 specifies the receiver performance, assuming that transmit errors do not occur. Clause 6.8 specifies all the propagation models that are defined in the present document.

6.6.1 Transmitter performance for phase modulation

6.6.1.1 Modulation accuracy for phase modulation

The specified requirement is vector error magnitude; this does not only take into account modulation filtering linear distortion (amplitude and phase) or modulator impairments (quadrature offset, phase and linear amplitude errors in the modulation symbol constellation) but is a measure of the whole transmitter quality. It also takes into account local oscillator phase noise, filter distortion, and non-linearity of amplifiers. Vector error magnitude shall be specified at symbol time (see clause 6.6.1.2) and the vector error magnitude requirement shall be fulfilled by the TETRA equipment with maximum and with minimum power levels (as defined in clause 6.4.1).

The modulation symbol $s(t)$ transmitted by an ideal transmitter having a filter impulse response $g(t)$ is defined in clause 5.

Let $Z(k)$ denote the output of an ideal receive filter with impulse response:

$$g^*(-t)|_{t=t_k} \quad (6.4)$$

The ideal transmit and receive filters in cascade form a raised cosine Nyquist filter, having a symbol waveform going through zero at symbol duration intervals, so there is no inter-symbol interference at any instant $t = t_k$, where t_k is the symbol time corresponding to the k -th symbol (as defined in clause 5).

In this case, the output of an ideal receive filter at any instant t_k , stimulated by an ideal transmitter, will be equal to the k -th modulation symbol $S(k)$:

$$Z(k) = s(t) * g^*(-t)|_{t=t_k} = S(k) \quad (6.5)$$

In this clause, the numbering of the modulation symbols used is the one defined in clause 9.

6.6.1.2 Vector error magnitude requirement at symbol time for phase modulation

Let $Z(k)$ be the output produced by observing the real transmitter through the ideal receive filter at symbol time $t_k \times Z(k)$ is modelled as:

$$Z(k) = \{C_0 + [S(k) + E(k)]\} C_1 W(k) \quad (6.6)$$

Where:

- $E(k)$ is the vector error of modulation symbol $S(k)$;
- $W(k) = \exp(jk\Theta)$ accounts for a frequency offset giving Θ radians per symbol phase rotation due to transmitter frequency inaccuracy (see clause 7). The possible amplitude variations shall be integrated in the vector error;
- C_0 is a complex constant characterizing the residual carrier;
- C_1 is a complex constant representing the output amplitude and initial phase of the transmitter.

The magnitude of C_0 shall be less than 5 % of the magnitude of $S(k)$. The task of the test receiver is then to:

- estimate the symbol time for processing the receive part;
- estimate the values of C_0 , C_1 and Θ . The resulting estimates shall be denoted by C_0' , C_1' and Θ' respectively;
- perform a normalization of the modulation symbol $Z(k)$ accordingly. The modulation symbol that results from this normalization shall be denoted by $Z'(k)$:

$$Z'(k) = \left[Z(k) \exp(-jk\Theta') / C_1' \right] - C_0' \quad (6.7)$$

With the above notations, the Sum Square Vector Error (SSVE) is defined as:

$$SSVE = \sum_{k=1}^{SNmax} |Z'(k) - S(k)|^2 \quad (6.8)$$

Where $SNmax$ is the number of symbols in the burst.

The RMS vector error is then computed as the square root of the sum-square vector error divided by the number of symbols in the burst:

$$RMSVE = \sqrt{SSVE / SNmax} \quad (6.9)$$

The RMS vector error in any burst shall be less than 0,1 and the peak vector error magnitude $|Z'(k) - S(k)|$ shall be less than 0,3 for any symbol.

6.6.2 Receiver performance for phase modulation

6.6.2.0 General

This clause specifies the minimum required receiver performance in terms of Bit Error Ratio (BER), Message Erasure Rate (MER) or Probability of Undetected Erroneous Message (PUEM) (whichever is appropriate), taking into account that transmitter errors do not occur, and that the transmitter shall be tested separately (see clause 6.6.1).

In this clause, the levels of the test signals are given in terms of power levels (dBm) at the antenna connector of the receiver. For the definition of power level refer to clause 6.4.1.

Three equipment classes are specified, distinguishing their intended operating environments and testing conditions. The classes have preferred operating conditions, as follows:

- **Class B:** equipment is optimized for use in built-up and urban areas. The present document guarantees good performance at the reference sensitivity and interference level in static and TU50 conditions, but not in extreme propagation conditions (hilly terrain);
- **Class A:** equipment is optimized for use in urban areas and in areas with hilly or mountainous terrain. It is resilient to extreme propagation conditions (hilly terrain) and is specified in static, TU50 and HT200 conditions;
- **Class D:** equipment has the same performance requirements as class A for $\pi/4$ -DQPSK modulation, and is further optimized to enhance the performance of $\pi/8$ -D8PSK modulation in hilly or mountainous terrain using equalization or other techniques. It is resilient to extreme propagation conditions (hilly terrain) and is specified in static, TU50 and HT200 conditions;
- **Class E:** equipment comprises an equalizer and is specified for $\pi/4$ -DQPSK modulation in static, TU50, HT200 (PACQ only) and EQ200 conditions. It is not applicable to BS equipment. Class E performance is specified only for $\pi/4$ -DQPSK modulation.

6.6.2.1 Nominal error rates for phase modulation

6.6.2.1.1 Nominal error rates for $\pi/4$ -DQPSK modulation

This clause describes the transmission requirements in terms of error ratios in nominal conditions i.e. without interference and with an input level of -85 dBm. The relevant propagation conditions are given in clause 6.8.

Under the following propagation conditions, the BER of the non-protected bits, equivalent to the TCH/7,2 shall have the limits given in table 6.28.

Table 6.28: Nominal error rates

Propagation model	BER	Equipment class
STATIC	0,01 %	A, B, E
TU50	0,4 %	A, B, E
HT200	3 %	A
EQ200	2 %	E

This performance shall be maintained up to -40 dBm input level for the static conditions, and multipath conditions. Furthermore, for static conditions, a BER of < 0,1 % shall be maintained up to -20 dBm.

6.6.2.1.2 Nominal error rates for $\pi/8$ -D8PSK modulation

This clause describes the transmission requirements in terms of error ratios in nominal conditions i.e. without interference and with an input level of -85 dBm. The relevant propagation conditions are given in clause 6.8.

Under the following propagation conditions, the BER of the non-protected bits, equivalent to the TCH-P8/10,8 shall have the limits given in table 6.29.

Table 6.29: Nominal error rates

Propagation model	BER	Equipment class
STATIC	0,01 %	A, B, D
TU50	0,4 %	A, B, D
HT200	5 %	A, D

This performance shall be maintained up to -40 dBm input level for the static conditions, and multipath conditions. Furthermore, for static conditions, a BER of < 0,1 % shall be maintained up to -20 dBm.

6.6.2.2 Dynamic reference sensitivity performance for phase modulation

6.6.2.2.0 General

The minimum required dynamic reference sensitivity performance is specified according to the logical channel, the propagation condition and the receiver class at the dynamic reference sensitivity level. The dynamic reference sensitivity level shall be:

- for MS $\pi/4$ -DQPSK modulation: -103 dBm;
- for MS $\pi/8$ -D8PSK modulation: -97 dBm;
- for BS $\pi/4$ -DQPSK modulation: -106 dBm;
- for BS $\pi/8$ -D8PSK modulation: -100 dBm.

Tables 6.31 and 6.33a give the maximum permissible receiver MER or BER at dynamic reference sensitivity performance for TU50, HT200 or EQ200 propagation conditions with $\pi/4$ -DQPSK modulation. For BSCH, SCH/HD, SCH/HU, SCH/F and BNCH, a PUEM < 10^{-5} shall be achieved at the $\pi/4$ -DQPSK dynamic reference sensitivity level. For AACH, a PUEM < 10^{-4} shall be achieved at the $\pi/4$ -DQPSK dynamic reference sensitivity level.

Tables 6.32 and 6.34 give the maximum permissible receiver MER or BER at dynamic reference sensitivity performance for TU50 or HT200 propagation conditions with $\pi/8$ -D8PSK modulation. For SCH-P8/HD, SCH-P8/HU and SCH-P8/F, a PUEM < 10^{-5} shall be achieved at the $\pi/8$ -D8PSK dynamic reference sensitivity level.

6.6.2.2.1 BS receiver performance

Table 6.30 gives the maximum permissible receiver MER or BER at dynamic reference sensitivity performance with $\pi/4$ -DQPSK modulation for frequencies below 300 MHz.

Table 6.30: Maximum permissible BS receiver MER or BER at dynamic reference sensitivity level with $\pi/4$ -DQPSK modulation for frequencies below 300 MHz

Logical channel	Error count type	Class A		Class B
		Propagation condition		Propagation condition
		TU50	HT200	TU50
SCH/HU	MER	10,5 %	11 %	10,5 %
SCH/F	MER	11 %	11 %	9,2 %
TCH/7,2	BER	2,5 %	4 %	2,2 %
TCH/4,8 N = 1	BER	4 %	4 %	2,2%
TCH/4,8 N = 4	BER	1,2 %	4 %	1,2 %
TCH/4,8 N = 8	BER	0,4 %	4 %	0,06 %
TCH/2,4 N = 1	BER	1,2 %	1,3 %	0,55 %
TCH/2,4 N = 4	BER	0,08 %	0,3 %	0,08 %
TCH/2,4 N = 8	BER	0,015 %	0,15 %	0,015 %
STCH	MER	10,5 %	11 %	10,5 %

NOTE: N gives the interleaving depth in number of blocks (see clause 8).

Table 6.31 gives the maximum permissible receiver MER or BER at dynamic reference sensitivity performance with $\pi/4$ -DQPSK modulation for frequencies above 300 MHz.

Table 6.31: Maximum permissible BS receiver MER or BER at dynamic reference sensitivity level with $\pi/4$ -DQPSK modulation for frequencies above 300 MHz

Logical channel	Error count type	Class A		Class B
		Propagation condition		Propagation condition
		TU50	HT200	TU50
SCH/HU	MER	8 %	9,5 %	8 %
SCH/F	MER	11 %	11 %	8 %
TCH/7,2	BER	2,5 %	4 %	2,2 %
TCH/4,8 N = 1	BER	4 %	4 %	2 %
TCH/4,8 N = 4	BER	1,2 %	4 %	0,4 %
TCH/4,8 N = 8	BER	0,4 %	4 %	0,06 %
TCH/2,4 N = 1	BER	1,2 %	1,3 %	0,35 %
TCH/2,4 N = 4	BER	0,02 %	0,3 %	0,01 %
TCH/2,4 N = 8	BER	0,01 %	0,15 %	0,01 %
STCH	MER	9 %	11 %	8 %

NOTE: N gives the interleaving depth in number of blocks (see clause 8).

Table 6.32 gives the maximum permissible receiver MER or BER at dynamic reference sensitivity performance with $\pi/8$ -D8PSK modulation. The performance with $\pi/8$ -D8PSK modulation below 300 MHz is outside the scope of the present document.

Table 6.32: Maximum permissible BS receiver MER or BER at dynamic reference sensitivity level with $\pi/8$ -D8PSK modulation

Logical channel	Error count type	Class A, class D			Class B
		Propagation condition			Propagation condition
		TU50 classes A and D	HT200 class A	HT200 class D	TU50
SCH-P8/HU	MER	7,4 %	19 %	14 %	6,3 %
SCH-P8/F	MER	10 %	29 %	18 %	8,9 %
TCH-P8/10,8	BER	1,6 %	4,5 %	3,6 %	1,4 %

6.6.2.2.2 MS receiver performance

Table 6.33 gives the maximum permissible receiver MER or BER at dynamic reference sensitivity performance with $\pi/4$ -DQPSK modulation for frequencies below 300 MHz.

Table 6.33: Maximum permissible MS receiver MER or BER at dynamic reference sensitivity level with $\pi/4$ -DQPSK modulation for frequencies below 300 MHz

Logical channel	Error count type	Continuous downlink mode			Discontinuous downlink mode		Propagation condition	
		Propagation condition			Propagation condition			
		TU50	HT200	EQ200	TU50	HT200		TU50
		Class A, E	Class A	Class E	Class A	Class A		Class B
AACH	MER	10 %	17 %	16 %	10 %	17 %	11 %	
BSCH	MER	8 %	13 %	22 %	8 %	11 %	8 %	
SCH/HD	MER	10,5 %	11 %	21 %	11 %	11 %	11 %	
BNCH	MER	10,5 %	11 %	21 %	11 %	11 %	11 %	
SCH/F	MER	9,2 %	11 %	22 %	11 %	11 %	9,2 %	
TCH/7,2	BER	2,5 %	4 %	4,5 %	2,5 %	4 %	2,2 %	
TCH/4,8 N = 1	BER	2,2 %	4 %	6,4 %	4 %	4 %	2,2 %	
TCH/4,8 N = 4	BER	1,1 %	3,3 %	2,7 %	1,2 %	4 %	1,1 %	
TCH/4,8 N = 8	BER	0,4 %	3 %	1,5 %	0,4 %	4 %	0,4 %	
TCH/2,4 N = 1	BER	0,55 %	1,1 %	0,82 %	1,2 %	1,3 %	0,55 %	
TCH/2,4 N = 4	BER	0,08 %	0,4 %	0,017 %	0,08 %	0,4 %	0,08 %	
TCH/2,4 N = 8	BER	0,015 %	0,13 %	0,01 %	0,015 %	0,2 %	0,015 %	
STCH	MER	10,5 %	11 %	21 %	11 %	11 %	11 %	

NOTE 1: N gives the interleaving depth in number of blocks (see clause 8).
NOTE 2: Class B receiver performance are for both Continuous and Discontinuous downlink mode.

Table 6.33a gives the maximum permissible receiver MER or BER at dynamic reference sensitivity performance with $\pi/4$ -DQPSK modulation for frequencies above 300 MHz.

Table 6.33a: Maximum permissible MS receiver MER or BER at dynamic reference sensitivity level with $\pi/4$ -DQPSK modulation for frequencies above 300 MHz

Logical channel	Error count type	Continuous downlink mode			Discontinuous downlink mode		Propagation condition	
		Propagation condition			Propagation condition			
		TU50	HT200	EQ200	TU50	HT200		TU50
		Class A, E	Class A	Class E	Class A	Class A		Class B
AACH	MER	10 %	17 %	16 %	10 %	17 %	11 %	
BSCH	MER	8 %	11 %	22 %	8 %	11 %	8 %	
SCH/HD	MER	8 %	11 %	21 %	9 %	11 %	8 %	
BNCH	MER	8 %	11 %	21 %	9 %	11 %	8 %	
SCH/F	MER	8 %	11 %	22 %	11 %	11 %	8 %	
TCH/7,2	BER	2,5 %	4 %	4,5 %	2,5 %	4 %	2,2 %	
TCH/4,8 N = 1	BER	2 %	4 %	6,4 %	4 %	4 %	2 %	
TCH/4,8 N = 4	BER	0,4 %	3,3 %	2,7 %	1,2 %	4 %	0,4 %	
TCH/4,8 N = 8	BER	0,06 %	3 %	1,5 %	0,4 %	4 %	0,06 %	
TCH/2,4 N = 1	BER	0,35 %	1,1 %	0,82 %	1,2 %	1,3 %	0,35 %	
TCH/2,4 N = 4	BER	0,01 %	0,4 %	0,017 %	0,02 %	0,4 %	0,01 %	
TCH/2,4 N = 8	BER	0,01 %	0,13 %	0,01 %	0,01 %	0,2 %	0,01 %	
STCH	MER	8 %	11 %	21 %	9 %	11 %	8 %	

NOTE 1: N gives the interleaving depth in number of blocks (see clause 8).
NOTE 2: Class B receiver performance are for both Continuous and Discontinuous downlink mode.

Table 6.34 gives the maximum permissible receiver MER or BER at dynamic reference sensitivity performance with $\pi/8$ -D8PSK modulation.

Table 6.34: Maximum permissible MS receiver MER or BER at dynamic reference sensitivity level with $\pi/8$ -D8PSK modulation

Logical channel	Error count type	Continuous downlink mode			Discontinuous downlink mode			Propagation condition
		propagation condition			propagation condition			
		TU50	HT200	HT200	TU50	HT200	HT200	TU50
		Class A, D	Class A	Class D	Class A, D	Class A	Class D	Class B
SCH-P8/HD	MER	8,3 %	21 %	15 %	8,1 %	21 %	15 %	7,1 %
SCH-P8/F	MER	10 %	29 %	18 %	10 %	29 %	18 %	9,0 %
TCH-P8/10,8	BER	1,6 %	4,5 %	3,4 %	1,6 %	4,5 %	3,6 %	1,4 %

6.6.2.3 Receiver performance at reference interference ratios for Phase Modulation

6.6.2.3.0 General

The minimum required reference interference performance (for co-channel, C/I_c , or adjacent channel, C/I_a) is specified according to the logical channel, the propagation condition and the receiver class at the reference interference ratio. The reference interference ratio shall be, for BS and all types of MS for $\pi/4$ -DQPSK modulation:

- for co-channel interference $C/I_c = 19$ dB for MS and BS;
- for adjacent channel interference below 700 MHz $C/I_a = -40$ dB for MS; and
 $C/I_a = -45$ dB for BS;
- for adjacent channel interference above 700 MHz $C/I_a = -40$ dB for MS and BS.

The reference interference ratio shall be, for BS and all types of MS for $\pi/8$ -D8PSK modulation:

- for co-channel interference $C/I_c = 25$ dB for MS and BS;
- for adjacent channel interference below 700 MHz $C/I_a = -34$ dB for MS; and
 $C/I_a = -39$ dB for BS;
- for adjacent channel interference above 700 MHz $C/I_a = -34$ dB for MS and BS.

In case of co-channel interference these specifications apply for a wanted input signal level of -85 dBm, and in case of adjacent channel interference for a wanted input signal level 3 dB above the dynamic reference sensitivity level. In case of co-channel interference the interference shall be a continuous TETRA random signal of the same modulation type subjected to an independent realization of the same propagation condition as the wanted signal. In the case of adjacent channel interference the interference shall be a continuous TETRA random modulated signal of the same modulation type subjected to static propagation conditions.

In tables 6.36 and 6.39 the performance for TU50, HT200 or EQ200 propagation conditions is given for the reference interference level. For BSCH, SCH/HD, SCH/HU, SCH/F, BNCH, a PUEM $< 10^{-5}$ shall be achieved at the $\pi/4$ -DQPSK reference interference level. For AACH a PUEM $< 10^{-4}$ shall be achieved at the $\pi/4$ -DQPSK reference interference level.

In tables 6.37 and 6.40 the performance for TU50 or HT200 propagation conditions is given for the reference interference level. For SCH-P8/HD, SCH-P8/HU and SCH-P8/F, a PUEM $< 10^{-5}$ shall be achieved at the $\pi/8$ -D8PSK reference interference level.

6.6.2.3.1 BS receiver performance

Table 6.35 gives the maximum permissible receiver MER or BER at reference interference with $\pi/4$ -DQPSK modulation for frequencies below 300 MHz.

Table 6.35: Maximum permissible BS receiver MER or BER at reference interference level with $\pi/4$ -DQPSK modulation for frequencies below 300 MHz

Logical channel	Error count type	Class A		Class B
		Propagation condition		Propagation condition
		TU50	HT200	TU50
SCH/HU	MER	6,7 %	9,5 %	6,7 %
SCH/F	MER	6 %	9,2 %	6 %
TCH/7,2	BER	2 %	3,7 %	2 %
TCH/4,8 N= 1	BER	4 %	4 %	2 %
TCH/4,8 N= 4	BER	1,2 %	4 %	0,45 %
TCH/4,8 N= 8	BER	0,4 %	4 %	0,15 %
TCH/2,4 N= 1	BER	1,2 %	1,3 %	0,35 %
TCH/2,4 N= 4	BER	0,028 %	0,3 %	0,028 %
TCH/2,4 N= 8	BER	0,01 %	0,15 %	0,01 %
STCH	MER	7 %	9,2 %	7 %

NOTE: N gives the interleaving depth in number of blocks (see clause 8).

Table 6.36 gives the maximum permissible receiver MER or BER at reference interference with $\pi/4$ -DQPSK modulation for frequencies above 300 MHz.

Table 6.36: Maximum permissible BS receiver MER or BER at reference interference level with $\pi/4$ -DQPSK modulation for frequencies above 300 MHz

Logical channel	Error count type	Class A		Class B
		Propagation condition		Propagation condition
		TU50	HT200	TU50
SCH/HU	MER	6,5 %	9,5 %	6,5 %
SCH/F	MER	6 %	9,2 %	6 %
TCH/7,2	BER	2 %	3,7 %	2 %
TCH/4,8 N= 1	BER	4 %	4 %	2 %
TCH/4,8 N= 4	BER	1,2 %	4 %	0,4 %
TCH/4,8 N= 8	BER	0,4 %	4 %	0,06 %
TCH/2,4 N= 1	BER	1,2 %	1,3 %	0,35 %
TCH/2,4 N= 4	BER	0,02 %	0,3 %	0,01 %
TCH/2,4 N= 8	BER	0,01 %	0,15 %	0,01 %
STCH	MER	7 %	9,2 %	7 %

NOTE: N gives the interleaving depth in number of blocks (see clause 8).

Table 6.37 gives the maximum permissible receiver MER or BER at reference interference with $\pi/8$ -D8PSK modulation. The performance with $\pi/8$ -D8PSK modulation below 300 MHz is outside the scope of the present document.

Table 6.37: Maximum permissible BS receiver MER or BER at reference interference level with $\pi/8$ -D8PSK modulation for frequencies above 300 MHz

Logical channel	Error count type	Class A		Class B	Class D	
		propagation condition		propagation condition	propagation condition	
		TU50	HT200	TU50	TU50	HT200
SCH-P8/HU	MER	7,3 %	19 %	6,6 %	7,3 %	13 %
SCH-P8/F	MER	10 %	29 %	9,1 %	10 %	18 %
TCH-P8/10,8	BER	1,6 %	4,5 %	1,4 %	1,6 %	3,7 %

6.6.2.3.2 MS receiver performance

Table 6.38 gives the maximum permissible receiver MER or BER at reference interference with $\pi/4$ -DQPSK modulation for frequencies below 300 MHz.

Table 6.38: Maximum permissible MS receiver MER or BER at reference interference level for frequencies below 300 MHz

Logical channel	Error count type	Continuous downlink mode			Discontinuous downlink mode		Propagation condition
		Propagation condition			Propagation condition		
		TU50 Class A, E	HT200 Class A	EQ200 Class E	TU50 Class A	HT200 Class A	TU50 Class B
AACH	MER	9 %	16 %	14 %	9 %	16 %	9 %
BSCH	MER	6 %	10 %	20 %	6 %	10 %	6 %
SCH/HD	MER	7 %	9,2 %	20 %	7 %	9,2 %	7 %
BNCH	MER	7 %	9,2 %	20 %	7 %	9,2 %	7 %
SCH/F	MER	6,5 %	9,2 %	20 %	6,5 %	7,5 %	6,5 %
TCH/7,2	BER	2 %	3,8 %	4,2 %	2 %	3,8 %	2 %
TCH/4,8 N = 1	BER	2 %	4 %	6,2 %	4 %	4 %	2 %
TCH/4,8 N = 4	BER	0,45 %	3,3 %	2,5 %	1,2 %	4 %	0,45 %
TCH/4,8 N = 8	BER	0,15 %	3 %	1,2 %	0,4 %	4 %	0,15 %
TCH/2,4 N = 1	BER	0,35 %	1,1 %	0,84 %	1,2 %	1,3 %	0,35 %
TCH/2,4 N = 4	BER	0,028 %	0,4 %	0,01 %	0,028 %	0,4 %	0,028 %
TCH/2,4 N = 8	BER	0,01 %	0,13 %	0,01 %	0,01 %	0,2 %	0,01 %
STCH	MER	7 %	9,2 %	20 %	7 %	9,2 %	7 %

NOTE 1: N gives the interleaving depth in number of blocks (see clause 8).
NOTE 2: Class B receiver performance are for both Continuous and Discontinuous downlink mode.

Table 6.39 gives the maximum permissible receiver MER or BER at reference interference with $\pi/4$ -DQPSK modulation for frequencies above 300 MHz.

Table 6.39: Maximum permissible MS receiver MER or BER at reference interference level for frequencies above 300 MHz

Logical channel	Error count type	Continuous downlink mode			Discontinuous downlink mode		Propagation condition
		Propagation condition			Propagation condition		
		TU50 Class A, E	HT200 Class A	EQ200 Class E	TU50 Class A	HT200 Class A	TU50 Class B
AACH	MER	9 %	16 %	14 %	9 %	16 %	9 %
BSCH	MER	6 %	10 %	20 %	6 %	10 %	6 %
SCH/HD	MER	7 %	9,2 %	20 %	7 %	9,2 %	7 %
BNCH	MER	7 %	9,2 %	20 %	7 %	9,2 %	7 %
SCH/F	MER	6,5 %	9,2 %	20 %	6,5 %	7,5 %	6,5 %
TCH/7,2	BER	2 %	3,8 %	4,2 %	2 %	3,8 %	2 %
TCH/4,8 N = 1	BER	2 %	4 %	6,2 %	4 %	4 %	2 %
TCH/4,8 N = 4	BER	0,4 %	3,3 %	2,5 %	1,2 %	4 %	0,4 %
TCH/4,8 N = 8	BER	0,06 %	3 %	1,2 %	0,4 %	4 %	0,06 %
TCH/2,4 N = 1	BER	0,35 %	1,1 %	0,84 %	1,2 %	1,3 %	0,35 %
TCH/2,4 N = 4	BER	0,01 %	0,4 %	0,01 %	0,02 %	0,4 %	0,01 %
TCH/2,4 N = 8	BER	0,01 %	0,13 %	0,01 %	0,01 %	0,2 %	0,01 %
STCH	MER	7 %	9,2 %	20 %	7 %	9,2 %	7 %

NOTE 1: N gives the interleaving depth in number of blocks (see clause 8).
NOTE 2: Class B receiver performance are for both Continuous and Discontinuous downlink mode.

Table 6.40 gives the maximum permissible receiver MER or BER at reference interference with $\pi/8$ -D8PSK modulation. The performance with $\pi/8$ -D8PSK modulation below 300 MHz is outside the scope of the present document.

Table 6.40: Maximum permissible MS receiver MER or BER at reference interference level with $\pi/8$ -D8PSK modulation for frequencies above 300 MHz

Logical channel	Error count type	Continuous downlink mode			Discontinuous downlink mode			Propagation condition
		Propagation condition			Propagation condition			
		TU50	HT200	HT200	TU50	HT200	HT200	TU50
		Class A, D	Class A	Class D	Class A, D	Class A	Class D	Class B
SCH-P8/HD	MER	7,6 %	21 %	16 %	7,9 %	21 %	15 %	6,6 %
SCH-P8/F	MER	10 %	29 %	19 %	19 %	29 %	18 %	8,9 %
TCH-P8/10,8	BER	1,6 %	4,5 %	3,5 %	3,5 %	4,5 %	3,6 %	1,4 %

NOTE 1: N gives the interleaving depth in number of blocks (see clause 8).
NOTE 2: Class B receiver performance are for both Continuous and Discontinuous downlink mode.

6.6.2.4 Static reference sensitivity performance for phase modulation

6.6.2.4.0 General

The minimum required static reference sensitivity performance is specified according to the logical channel and the receiver class at the static reference sensitivity level. The static reference sensitivity level shall be:

- for MS $\pi/4$ -DQPSK modulation: -112 dBm;
- for MS $\pi/8$ -D8PSK modulation: -107 dBm;
- for BS $\pi/4$ -DQPSK modulation: -115 dBm;
- for BS $\pi/8$ -D8PSK modulation: -110 dBm.

Tables 6.41 and 6.43 give the minimum required reference sensitivity performance for $\pi/4$ -DQPSK. For BSCH, SCH/HD, SCH/HU, SCH/F, BNCH, a PUEM $< 10^{-5}$ shall be achieved at the static reference sensitivity level. For AACH a PUEM $< 10^{-4}$ shall be achieved at the static reference sensitivity level.

Tables 6.42 and 6.44 give the minimum required reference sensitivity performance for $\pi/8$ -D8PSK. For SCH-P8/HD, SCH-P8/HU, SCH-P8/F, a PUEM $< 10^{-5}$ shall be achieved at the static reference sensitivity level.

6.6.2.4.1 BS receiver performance

Table 6.41 gives the minimum required reference sensitivity performance for $\pi/4$ -DQPSK.

Table 6.41: Maximum permissible BS receiver MER or BER at static reference sensitivity level with $\pi/4$ -DQPSK modulation

Logical channel	Error count type	Class A	Class B
SCH/HU	MER	3 %	3 %
SCH/F	MER	10 %	10 %
TCH/7,2	BER	3 %	4 %
TCH/4,8 N = 1	BER	3,3 %	0,3 %
TCH/4,8 N = 4	BER	1 %	0,2 %
TCH/4,8 N = 8	BER	0,4 %	0,2 %
TCH/2,4 N = 1	BER	0,2 %	0,01 %
TCH/2,4 N = 4	BER	0,01 %	0,01 %
TCH/2,4 N = 8	BER	0,01 %	0,01 %
STCH	MER	8 %	5 %

NOTE: N gives the interleaving depth in number of blocks (see clause 8).

Table 6.42 gives the minimum required reference sensitivity performance for $\pi/8$ -D8PSK.

Table 6.42: Maximum permissible BS receiver MER or BER at static reference sensitivity level with $\pi/8$ -D8PSK modulation

Logical channel	Error count type	Class A, D	Class B
SCH-P8/HU	MER	4,5 %	4,3 %
SCH-P8/F	MER	9,3 %	9,3 %
TCH-P8/10,8	BER	3,8 %	3,1 %

6.6.2.4.2 MS receiver performance

Table 6.43 gives the minimum required reference sensitivity performance for $\pi/4$ -DQPSK.

Table 6.43: Maximum permissible MS receiver MER or BER at static reference sensitivity level

Logical channel	Error count type	Continuous downlink mode	Discontinuous downlink mode	Class B
		Class A, E	Class A	
AACH	MER	28 %	28 %	38 %
BSCH	MER	3 %	3 %	3 %
SCH/HD	MER	2,5 %	8 %	5 %
BNCH	MER	2,5 %	8 %	5 %
SCH/F	MER	4,5 %	9 %	9 %
TCH/7,2	BER	3,5 %	3,5 %	4 %
TCH/4,8 N = 1	BER	0,3 %	2 %	0,3 %
TCH/4,8 N = 4	BER	0,2 %	0,8 %	0,2 %
TCH/4,8 N = 8	BER	0,15 %	0,4 %	0,15 %
TCH/2,4 N = 1	BER	0,01 %	0,01 %	0,01 %
TCH/2,4 N = 4	BER	0,01 %	0,01 %	0,01 %
TCH/2,4 N = 8	BER	0,01 %	0,01 %	0,01 %
STCH	MER	2,5 %	8 %	5 %

NOTE 1: N gives the interleaving depth in number of blocks (see clause 8).
NOTE 2: Class B receiver performance are for both Continuous and Discontinuous downlink mode.

Table 6.44 gives the minimum required reference sensitivity performance for $\pi/8$ -D8PSK.

Table 6.44: Maximum permissible MS receiver MER or BER at static reference sensitivity level with $\pi/8$ -D8PSK modulation

Logical channel	Error count type	Continuous downlink mode	Discontinuous downlink mode	Class B
		Class A, D	Class A, D	
SCH-P8/HD	MER	5,6 %	5,6 %	1,6 %
SCH-P8/F	MER	10 %	10 %	9,3 %
TCH-P8/10,8	BER	3,9 %	3,9 %	3,2 %

NOTE: Class B receiver performance are for both Continuous and Discontinuous downlink modes.

6.6.2.5 MS receiver performance for synchronization burst acquisition

This clause specifies reference sensitivity performance of a MS receiver for the acquisition of the phase modulation Synchronization (sub) Burst (SB), refer to table 6.45. The performance is defined in terms of the probability PACQ of detecting a single transmitted SB and correctly decoding its BSCH information for the condition where the MS is listening on the frequency while the SB is transmitted and where the MS is already frequency synchronized but not synchronized in terms of time slots.

Table 6.45: MS receiver performance for synchronization burst acquisition

Propagation condition/eq. class	TU50/class B	HT200/class A, E
PACQ	0,8	0,8
NOTE: This specification applies for continuous and discontinuous downlink mode.		

6.7 Transmitter/receiver performance for QAM

6.7.0 General

Clause 6.7.1 specifies the modulation accuracy requirement, by setting limits on the Root Mean Square (RMS) error between the actual transmitted signal waveform and the ideal signal waveform. Clause 6.7.2 specifies the receiver performance, assuming that transmit errors do not occur. Clause 6.8 specifies all the propagation models that are defined in the present document.

6.7.1 Transmitter performance for QAM

6.7.1.1 Modulation accuracy for QAM

The specified requirement is vector error magnitude; this does not only take into account modulation filtering linear distortion (amplitude and phase) or modulator impairments (quadrature offset, phase and linear amplitude errors in the modulation symbol constellation) but is a measure of the whole transmitter quality. It also takes into account local oscillator phase noise, filter distortion, non-linearity of amplifiers and overlap of sub-carriers. Vector error magnitude is specified at symbol time (see clause 6.7.1.2) and the vector error magnitude requirement shall be fulfilled by the TETRA QAM equipment over all sub-carriers within the channel bandwidth with maximum and with minimum power levels (as defined in clause 6.4.8).

The modulation symbol $s_m(t)$ transmitted on an individual sub-carrier m by an ideal transmitter having a filter impulse response $g(t)$ is defined in clause 5.16.

Let $Z_m(k)$ denote the output of an ideal sub-carrier receive filter with impulse response:

$$g^*(-t)\Big|_{t=t_k} \quad (6.10)$$

The ideal sub-carrier transmit and receive filters in cascade form a raised cosine Nyquist filter, having a sub-carrier symbol waveform going through zero at symbol duration intervals, so there is no inter-symbol interference at any instant $t = t_k$, where t_k is the symbol time corresponding to the k -th symbol (as defined in clause 5.16). In the frequency domain, the ideal sub-carrier transmit and receive filters have a bandwidth slightly greater than the sub-carrier spacing, so there is some sub-carrier overlap and limited inter-sub-carrier-symbol interference.

In this case, the output of an ideal sub-carrier receive filter at any instant t_k , stimulated by an ideal transmitter, will be equal to the k -th modulation symbol $S_m(k)$ for the associated sub-carrier SC_m :

$$Z_m(k) = s_m(t) * g^*(-t)\Big|_{t=t_k} = S_m(k) + I_m(k) \quad (6.11)$$

where $I_m(k)$ is the inter-sub-carrier-symbol interference.

In this clause, the numbering of the modulation symbols used is the one defined in clause 9 for QAM.

6.7.1.2 Vector error magnitude requirement at symbol time for QAM

Let $Z_m(k)$ for an individual sub-carrier m be the output produced by observing the real transmitter through the ideal sub-carrier receive filter at symbol time t_k . $Z_m(k)$ is modelled as:

$$Z_m(k) = \{S_m(k) + E_m(k)\}C_m W(k) \quad (6.12)$$

Where:

- $E_m(k)$ is the vector error of modulation symbol $S_m(k)$ on sub-carrier m ;
- $W(k)$ accounts for phase and amplitude variations common to all sub-carriers as a function of symbol number k ;
- C_m is a complex constant representing the output amplitude and initial phase of the transmitter, characterized for the initial sync symbols on the m -th sub-carrier.

The task of the test receiver is then to:

- estimate the symbol time for processing the receive part;
- estimate the values of C_m from all sync and pilot symbols on each sub-carrier m ;
- estimate the values of $W(k)$ as a best fit for all pilot symbols in the burst;
- estimate the values of $W(k)$ across the burst in time by interpolation. The resulting estimates shall be denoted by $W'(k)$ respectively;
- perform a normalization of the modulation symbol $Z_m(k)$ accordingly. The modulation symbol that results from this normalization shall be denoted by $Z'_m(k)$:

$$Z'_m(k) = \left[Z_m(k) / (C_m W'(k)) \right] \quad (6.13)$$

With the above notations, the Sum Square Vector Error (SSVE) is defined as:

$$SSVE = \sum_{m=0}^{M-1} \sum_{k=1}^{SN_{max}} \left| Z'_m(k) - S_m(k) \right|^2 \quad (6.14)$$

where SN_{max} is the number of symbols per sub-carrier in the burst and M is the number of sub-carriers. $S_m(k)$ includes pilot and sync sub-carrier symbols.

The RMS vector error across all sub-carriers is then computed as the square root of the sum-square vector error divided by the total number of sub-carrier symbols in the burst including pilot and sync sub-carrier symbols:

$$RMSVE = \sqrt{SSVE / (M \times SN_{max})} \quad (6.15)$$

The RMS vector error in any burst shall be less than 0,1.

NOTE 1: It is recommended that the transmitter's RMS vector error in 64-QAM $r = 1$ bursts should be significantly less than 0,1 (e.g. 0,04 to 0,06).

Additional tasks of the test receiver are to:

- Calculate $\theta(k)$, the difference in phase of $W'(k)$ between successive symbols:

$$\theta(k) = \arg(W'(k)) - \arg(W'(k+1)) \text{ for } k = 1 \text{ to } (SN_{max} - 1) \quad (6.16)$$

- Calculate the mean frequency error df_{mean} over the burst:

$$df_{mean} = 1 / (2\pi T \cdot (SN_{max} - 1)) \sum_{k=1}^{SN_{max}-1} \theta(k) \quad (6.17)$$

where:

df_{mean} is expressed in Hz and T is the symbol duration in s;

- Calculate the peak frequency error df_{peak} over the burst:

$$df_{peak} = 1/(2\pi T)\theta(k) \text{ for the greatest absolute value of } \theta(k) \quad (6.18)$$

NOTE 2: In the present clause identifier " SN_{max} " is used instead of "SNmax" used elsewhere.

6.7.2 Receiver performance for QAM

6.7.2.0 General

This clause specifies the minimum required receiver performance in terms of Bit Error Ratio (BER), Message Erasure Rate (MER) or Probability of Undetected Erroneous Message (PUEM) (whichever is appropriate), taking into account that transmitter errors do not occur, and that the transmitter shall be tested separately (see clause 6.7.1).

In this clause, the levels of the test signals are given in terms of power levels (dBm) at the antenna connector of the receiver. For the definition of power level refer to clause 6.4.8.

The performance below 300 MHz is outside the scope of the present document.

NOTE: The multicarrier QAM is tolerant to the most of the propagation effects down to 138 MHz, but deep slow fading may increase MER above the values defined for frequencies above 300 MHz.

6.7.2.1 Nominal error rates for QAM

For SCH-Q/RA, SCH-Q/HU, SCH-Q/U, SCH-Q/D, SCH-Q/B, BNCH-Q and BSCH-Q a PUEM $< 10^{-5}$ shall be achieved at the dynamic reference sensitivity level. For AACH-Q, a PUEM $< 5 \times 10^{-4}$ shall be achieved at the dynamic reference sensitivity levels.

For QAM the nominal error rates for non-protected bits are outside the scope of the present document.

For static conditions, an MER less than 10 % shall be maintained up to -20 dBm on 4-QAM $r=1/2$ and 16-QAM $r=1/2$ channels.

6.7.2.2 Dynamic reference sensitivity performance for QAM

The minimum required dynamic reference sensitivity performance is specified according to the logical channel, the propagation condition, coding rate, modulation and channel bandwidth.

Tables 6.46, 6.47 and 6.48 specify dynamic reference sensitivity for frequencies below 700 MHz for 4-QAM, 16-QAM and 64-QAM respectively.

Table 6.49 specifies the maximum permissible receiver MER for frequencies below 700 MHz at dynamic reference sensitivities specified in tables 6.46, 6.47 and 6.48.

Tables 6.50, 6.51 and 6.52 specify dynamic reference sensitivity for frequencies above 700 MHz for 4-QAM, 16-QAM and 64-QAM respectively.

Table 6.53 specifies the maximum permissible receiver MER for frequencies above 700 MHz at dynamic reference sensitivities specified in tables 6.50, 6.51 and 6.52.

Table 6.46: 4-QAM BS and MS dynamic reference sensitivity for frequencies below 700 MHz

Channel BW	BS, $r = 1/2$	MS, $r = 1/2$
25 kHz	-111 dBm	-108 dBm
50 kHz	-108 dBm	-105 dBm
100 kHz	-105 dBm	-102 dBm
150 kHz	-104 dBm	-101 dBm

Table 6.47: 16-QAM BS and MS dynamic reference sensitivity for frequencies below 700 MHz

Channel BW	BS, $r = 1/2$	MS, $r = 1/2$
25 kHz	-106 dBm	-103 dBm
50 kHz	-102 dBm	-100 dBm
100 kHz	-100 dBm	-97 dBm
150 kHz	-99 dBm	-96 dBm

Table 6.48: 64-QAM BS and MS dynamic reference sensitivity for frequencies below 700 MHz

Channel BW	BS, $r = 1/2$	BS, $r = 2/3$	MS, $r = 1/2$	MS, $r = 2/3$
25 kHz	-101 dBm	-98 dBm	-98 dBm	-95 dBm
50 kHz	-98 dBm	-94 dBm	-95 dBm	-91 dBm
100 kHz	-95 dBm	-92 dBm	-92 dBm	-88 dBm
150 kHz	-94 dBm	-91 dBm	-91 dBm	-87 dBm

Table 6.49: Maximum permissible MS and BS receiver MER at dynamic reference sensitivity level for frequencies below 700 MHz

Type of channel	Payload modulation	BS/MS	Code rate	25 kHz		50 kHz		100 kHz		150 kHz	
				TU50	HT200	TU50	HT200	TU50	HT200	TU50	HT200
SCH-Q/RA	4-QAM	BS	1/2	11,1 %	7,4 %	-	-	-	-	-	-
SICH-Q/U in CB	4-QAM	BS	1/2	5,5 %	1,8 %	3,6 %	1,6 %	3,8 %	1,2 %	5,3 %	2,0 %
SCH-Q/HU	4-QAM	BS	1/2	11 %	7,7 %	9,3 %	5,6 %	9,0 %	3,3 %	12,9 %	7,6 %
SICH-Q/U in NUB	4-QAM	BS	1/2	3,6 %	1,4 %	3,5 %	1,3 %	3,6 %	1,1 %	3,9 %	1,6 %
SCH-Q/U	4-QAM	BS	1/2	8,3 %	3,7 %	9,4 %	2,0 %	9,0 %	1,5 %	8,1 %	3,2 %
SICH-Q/D	4-QAM	MS	1/2	1,9 %	0,8 %	2,1 %	0,9 %	2,1 %	0,9 %	2,3 %	0,9 %
AACH-Q	4-QAM	MS	1/2	10 %	2,5 %	10 %	2,7 %	10 %	2,8 %	10 %	2,8 %
BNCH-Q, SCH-Q/D	4-QAM	MS	1/2	7,8 %	2,3 %	10 %	1,8 %	8,7 %	1,8 %	8,4 %	1,8 %
BSCH-Q	4-QAM	MS	1/2	13,3 %	3,6 %	11,5 %	3,0 %	10,8 %	2,9 %	13,3 %	3,4 %
SCH-Q/B	4-QAM	MS	1/2	-	-	7,6 %	1,1 %	8,1 %	0,9 %	10 %	1,2 %
SCH-Q/HU	16-QAM	BS	1/2	11,9 %	8,2 %	7,9 %	3,6 %	9,9 %	3,5 %	13,2 %	7,5 %
SCH-Q/U	16-QAM	BS	1/2	8,8 %	3,9 %	7,0 %	1,1 %	9,5 %	1,6 %	8,9 %	3,5 %
BNCH-Q, SCH-Q/D	16-QAM	MS	1/2	8,6 %	2,9 %	7,2 %	1,0 %	9,0 %	1,9 %	8,7 %	1,8 %
SCH-Q/HU	64-QAM	BS	1/2	11 %	7,0 %	8,9 %	4,8 %	8,7 %	3,0 %	12,1 %	6,2 %
SCH-Q/U	64-QAM	BS	1/2	7,8 %	3,7 %	9,9 %	3,0 %	7,7 %	1,6 %	6,9 %	2,7 %
BNCH-Q, SCH-Q/D	64-QAM	MS	1/2	7,4 %	2,6 %	9,3 %	1,9 %	7,3 %	1,8 %	7,4 %	1,6 %
SCH-Q/HU	64-QAM	BS	2/3	11,2 %	11,2 %	7,8 %	7,6 %	9,9 %	7,1 %	14,1 %	11,8 %
SCH-Q/U	64-QAM	BS	2/3	9,5 %	7,7 %	8,3 %	4,4 %	9,6 %	5,1 %	9,3 %	8,1 %
BNCH-Q, SCH-Q/D	64-QAM	MS	2/3	9,3 %	6,2 %	8,1 %	3,0 %	7,3 %	3,6 %	6,9 %	3,9 %

Table 6.50: 4-QAM BS and MS dynamic reference sensitivity for frequencies above 700 MHz

Channel BW	BS, $r = 1/2$	MS, $r = 1/2$
25 kHz	-111 dBm	-108 dBm
50 kHz	-108 dBm	-105 dBm
100 kHz	-105 dBm	-102 dBm
150 kHz	-104 dBm	-101 dBm

Table 6.51: 16-QAM BS and MS dynamic reference sensitivity for frequencies above 700 MHz

Channel BW	BS, $r = 1/2$	MS, $r = 1/2$
25 kHz	-107 dBm	-103 dBm
50 kHz	-103 dBm	-100 dBm
100 kHz	-100 dBm	-97 dBm
150 kHz	-99 dBm	-96 dBm

Table 6.52: 64-QAM BS and MS dynamic reference sensitivity for frequencies above 700 MHz

Channel BW	BS, $r = 1/2$	BS, $r = 2/3$	MS, $r = 1/2$	MS, $r = 2/3$
25 kHz	-102 dBm	-98 dBm	-99 dBm	-95 dBm
50 kHz	-98 dBm	-94 dBm	-95 dBm	-91 dBm
100 kHz	-96 dBm	-92 dBm	-93 dBm	-89 dBm
150 kHz	-94 dBm	-90 dBm	-92 dBm	-88 dBm

Table 6.53: Maximum permissible MS and BS receiver MER at dynamic reference sensitivity level for frequencies above 700 MHz

Type of channel	Payload modulation	BS/MS	Code rate	25 kHz		50 kHz		100 kHz		150 kHz	
				TU50	HT200	TU50	HT200	TU50	HT200	TU50	HT200
SCH-Q/RA	4-QAM	BS	1/2	14,2 %	5,9 %	-	-	-	-	-	-
SICH-Q/U in CB	4-QAM	BS	1/2	4,6 %	1,0 %	5,3 %	1,1 %	3,0 %	1,2 %	4,2 %	1,4 %
SCH-Q/HU	4-QAM	BS	1/2	14,3 %	5,5 %	14,2 %	4,4 %	10,3 %	3,5 %	13,4 %	5,2 %
SICH-Q/U in NUB	4-QAM	BS	1/2	2,6 %	1,0 %	3,2 %	0,9 %	1,2 %	1,0 %	3,7 %	1,4 %
SCH-Q/U	4-QAM	BS	1/2	7,0 %	2,0 %	8,5 %	1,1 %	6,8 %	0,9 %	9,1 %	1,6 %
SICH-Q/D	4-QAM	MS	1/2	1,4 %	0,7 %	1,9 %	0,7 %	1,7 %	0,6 %	2,1 %	1,0 %
AACH-Q	4-QAM	MS	1/2	6,0 %	2,2 %	6,0 %	2,0 %	6,0 %	1,9 %	6,3 %	3,1 %
BNCH-Q, SCH-Q/D	4-QAM	MS	1/2	7,6 %	1,7 %	10 %	0,8 %	7,4 %	0,6 %	7,6 %	1,4 %
BSCH-Q	4-QAM	MS	1/2	10,6 %	2,3 %	9,1 %	2,2 %	10,4 %	2,3 %	12,4 %	4,3 %
SCH-Q/B	4-QAM	MS	1/2	-	-	6,4 %	0,3 %	5,7 %	0,7 %	7,6 %	1,3 %
SCH-Q/HU	16-QAM	BS	1/2	16,5 %	10,8 %	14,2 %	4,8 %	11,1 %	4,1 %	13,4 %	5,2 %
SCH-Q/U	16-QAM	BS	1/2	9,0 %	5,7 %	8,6 %	1,4 %	6,3 %	1,1 %	8,9 %	2,5 %
BNCH-Q, SCH-Q/D	16-QAM	MS	1/2	7,2 %	2,1 %	8,4 %	0,9 %	7,2 %	0,9 %	7,5 %	1,7 %
SCH-Q/HU	64-QAM	BS	1/2	16 %	11 %	13 %	5,7 %	12,2 %	8,4 %	11,3 %	5,0 %
SCH-Q/U	64-QAM	BS	1/2	7,5 %	6,7 %	10 %	4,8 %	8,3 %	4,4 %	6,5 %	2,9 %
BNCH-Q, SCH-Q/D	64-QAM	MS	1/2	9,4 %	5,6 %	7,0 %	1,8 %	8,1 %	2,7 %	8,9 %	6,0 %
SCH-Q/HU	64-QAM	BS	2/3	15,4 %	16,6 %	12,9 %	13,2 %	11,7 %	16 %	10,9 %	12,1 %
SCH-Q/U	64-QAM	BS	2/3	8,0 %	16,6 %	7,8 %	12,5 %	7,7 %	14 %	7,2 %	15,3 %
BNCH-Q, SCH-Q/D	64-QAM	MS	2/3	9,2 %	18,6 %	7,1 %	7,9 %	8,7 %	11,9 %	9,1 %	20,7 %

6.7.2.3 Receiver performance at reference interference ratios for QAM

6.7.2.3.1 Adjacent channel interference

The minimum required reference adjacent channel interference performance is specified in table 6.54 according to the wanted signal channel bandwidth.

Table 6.54: Adjacent channel interferer frequency offsets and mean power levels for QAM

QAM Channel bandwidth	TETRA $\pi/4$ -DQPSK Interferer offset from f_o	TETRA $\pi/4$ -DQPSK Interferer level for MS	TETRA $\pi/4$ -DQPSK Interferer level for BS
25 kHz	25 kHz	-63 dBm	-62 dBm
50 kHz	37,5 kHz	-65 dBm	-65 dBm
100 kHz	62,5 kHz	-65 dBm	-65 dBm
150 kHz	87,5 kHz	-65 dBm	-65 dBm

The static reference sensitivity performance as specified in clause 6.7.2.4 shall be met when the following signals are simultaneously input to the receiver:

- a wanted signal at the nominal receive frequency f_o , 3 dB above the static reference sensitivity level as specified in clause 6.7.2.4; and
- a TETRA $\pi/4$ -DQPSK random modulated continuous signal at a frequency offset from f_o and level as defined in table 6.54.

6.7.2.3.2 Co-channel interference

The minimum required reference co-channel interference performance is specified according to channel bandwidth, modulation, coding rate and propagation conditions. For BS co-channel interference ratio is defined for SCH-Q/U logical channel. For MS co-channel interference ratio is defined for SCH-Q/D logical channel. Co-channel interference specifications apply for a wanted input signal level of 25 dB above dynamic reference sensitivity (as specified in tables 6.50, 6.51, 6.52, 6.46, 6.47 and 6.48).

Table 6.55 defines co-channel interference ratios C/I_c , for frequencies below 700 MHz. Table 6.56 defines co-channel interference ratios C/I_c , for frequencies above 700 MHz. The maximum permissible MER for reference co-channel interference ratios is 10 %.

Table 6.55: BS and MS minimum dynamic reference interference ratio (C/I_c for 10 % MER) for frequencies below 700 MHz

Modulation	$r = 1/2$ TU50	$r = 1/2$ HT200	$r = 2/3$ TU50	$r = 2/3$ HT200
4-QAM	14 dB	12 dB	-	-
16-QAM	19 dB	17 dB	-	-
64-QAM	23 dB	22 dB	27 dB	26 dB

Table 6.56: BS and MS minimum dynamic reference interference ratio (C/I_c for 10 % MER) for frequencies above 700 MHz

Modulation	$r = 1/2$ TU50	$r = 1/2$ HT200	$r = 2/3$ TU50	$r = 2/3$ HT200
4-QAM	14 dB	12 dB	-	-
16-QAM	19 dB	17 dB	-	-
64-QAM	24 dB	23 dB	27 dB	29 dB

6.7.2.4 Static reference sensitivity performance for QAM

The minimum required static reference sensitivity performance for MS is specified in table 6.57.

Table 6.57: QAM Sensitivity levels for MS

Channel BW	4-QAM 3 % BER Sensitivity	16-QAM 3 % BER Sensitivity	64-QAM 3 % BER Sensitivity
25 kHz	-113 dBm	-106 dBm	-101 dBm
50 kHz	-110 dBm	-103 dBm	-97 dBm
100 kHz	-107 dBm	-100 dBm	-95 dBm
150 kHz	-105 dBm	-99 dBm	-93 dBm

The minimum required static reference sensitivity performance for BS is specified in table 6.58.

Table 6.58: QAM Sensitivity levels for BS

Channel BW	4-QAM 3 % BER Sensitivity	16-QAM 3 % BER Sensitivity	64-QAM 3 % BER Sensitivity
25 kHz	-116 dBm	-109 dBm	-104 dBm
50 kHz	-113 dBm	-106 dBm	-100 dBm
100 kHz	-110 dBm	-103 dBm	-98 dBm
150 kHz	-108 dBm	-102 dBm	-96 dBm

6.7.2.5 MS receiver performance for frequency correction burst acquisition on a DA cell

This clause specifies reference sensitivity performance of a MS receiver for the acquisition of the QAM Frequency Correction Burst (FCB), refer to table 6.59. The performance is defined in terms of the probability PACQ of detecting a single transmitted FCB and correctly decoding its BSCH-Q information for the condition where the MS is listening on the frequency while the FCB is transmitted and where the MS is already frequency synchronized but not synchronized in terms of time slots.

Table 6.59: MS receiver performance for frequency correction burst acquisition on a DA cell

Propagation condition	TU50	HT200
PACQ	0,8	0,8

6.8 Propagation conditions

6.8.0 General

The following clauses contain all necessary information on the propagation models that are referred to in the present document.

6.8.1 Propagation conditions - introduction

Radio wave propagation in the mobile radio environment is described by dispersive multipath caused by reflection, diffraction and scattering. Different paths may exist between a BS and a MS due to large distant reflectors and/or scatterers and due to scattering in the vicinity of the mobile, giving rise to a number of partial waves arriving with different amplitudes and delays. Since the mobile will be moving, a Doppler shift is associated with each partial wave, depending on the mobile's velocity and the angle of incidence. The delayed and Doppler shifted partial waves interfere at the receiver causing frequency and time selective fading on the transmitted signal.

When system bandwidth and propagation path lengths are sufficiently small (which is the case for TETRA), the resulting frequency and time selective fading process may be simulated by a simplified propagation model. Such a model exhibits only a few discrete paths which are independently fading. For practical channel simulation, stationary Gaussian processes with a power density spectrum equal to the classical Doppler spectrum are commonly assumed.

Based on extensive investigations (Digital Land Mobile Radiocommunications, M. Failli (Ed.), Final Report 14.3.1984-13.9.1988, published by European Commission, Directorate of General Telecommunication, Information Industries and Innovation. Luxembourg. ISBN 92-825-9946-9. (1989) [i.17]) some tapped delay line models which are typical for urban, rural, or hilly area propagation conditions or for quasi-synchronous operation were derived. These models are defined in the following terms (see also table 6.60):

- number of discrete taps;
- relative delay of each tap;
- average relative power of the complex tap-gain process of each tap;
- type of the complex tap-gain process of each tap.

All stochastic tap-gain processes are mutually statistically independent.

6.8.2 Tap-gain process types

This clause defines the statistical properties of the stationary complex tap-gain processes, to be applied for the propagation models, in terms of a Probability Density Function (PDF) and a Power Density Spectrum (PDS) which models the Doppler spectrum. The complex tap-gain processes, denoted by $a(t)$ and defined hereunder, are normalized to unity power.

CLASS is the tap-gain process having a PDS equal to the classical Doppler spectrum. The real and imaginary parts of $a(t)$ exhibit an identical Gaussian PDF, an identical PDS and are mutually statistically independent. Hence $|a(t)|$ is Rayleigh distributed. The PDS of $a(t)$ is defined by:

$$S(f) = S_{CLASS}(f, f_d) = \frac{1}{\pi f_d \sqrt{1 - (f/f_d)^2}} \quad \text{for } -f_d < f < f_d, \text{ and}$$

$$S(f) = 0 \quad \text{elsewhere} \quad (6.19)$$

Where the parameter f_d represents the maximum Doppler shift (in Hz), defined as $f_d = v/\lambda$ with the vehicle speed v (in m/s) and the wavelength λ (in m).

STATIC(f_s) is a tap-gain process with a constant magnitude $|a(t)| = 1$. The PDS of $a(t)$ is defined by:

$$S(f) = S_{STATIC}(f, f_s) = \delta(f - f_s) \quad (6.20)$$

Where $\delta(\cdot)$ represents the Dirac delta function and f_s the Doppler shift (in Hz).

RICE is a tap-gain process which is the sum process of the two processes CLASS and STATIC(f_s), with $f_s = 0,7 f_d$, each contributing half of the total power. Hence $|a(t)|$ is Rician distributed and the PDS is:

$$S(f) = S_{RICE}(f, f_d) = 0,5 S_{CLASS}(f, f_d) + 0,5 S_{STATIC}(f, 0,7 f_d) \quad (6.21)$$

6.8.3 Propagation models

In this clause, the propagation models that are referred to in the present document are defined. For Phase modulation three models are used TU50, HT200 and EQ200, refer to table 6.60. For QAM two models are used: TU50 and HT200 refer to table 6.61. For Phase modulation the vehicle speed x (in km/h), which affects f_d (see clause 6.8.2), is attributed to the model designation in the frequency range 380 MHz to 520 MHz (e.g. HT200 means Hilly Terrain for 200 km/h in the 380 MHz to 520 MHz frequency range).

For Phase Modulation to keep the Doppler shift constant relative to 430 MHz, for frequencies outside the 380 MHz to 520 MHz range, for testing purposes only, the vehicle speed in the model is adjusted according the formula:

- $v = 20 \text{ [Hz]} \times \lambda \text{ [m]}$, when TU50 is specified;
- $v = 80 \text{ [Hz]} \times \lambda \text{ [m]}$, when HT200 and EQ200 are specified.

NOTE: $x = v \times 3,6$.

Table 6.60: Propagation models for Phase Modulation

Propagation model	Tap number	Relative delay (μs)	Average relative power (dB)	Tap-gain process
Static	1	0	0	STATIC(0)
Rural Area (RAx)	1	0	0	RICE
Typical Urban (TUx)	1	0	0	CLASS
	2	5	-22,3	CLASS
Bad Urban (BUx)	1	0	0	CLASS
	2	5	-3,0	CLASS
Hilly Terrain (HTx)	1	0	0	CLASS
	2	15	-8,6	CLASS
Equalizer Test (EQx)	1	0	0	CLASS
	2	11,6	0	CLASS
	3	73,2	-10,2	CLASS
	4	99,3	-16	CLASS

Table 6.61: Propagation models for QAM

Propagation model	Tap number	Relative delay (μs)	Average relative power (dB)	Tap-gain process
Typical Urban (TUx)	1	0,0	-3,0	CLASS
	2	0,2	0,0	CLASS
	3	0,6	-2,0	CLASS
	4	1,6	-6,0	CLASS
	5	2,4	-8,0	CLASS
	6	5,0	-10,0	CLASS
Hilly Terrain (HTx)	1	0,0	0,0	CLASS
	2	0,2	-2,0	CLASS
	3	0,4	-4,0	CLASS
	4	0,6	-7,0	CLASS
	5	15,0	-6,0	CLASS
	6	17,2	-12,0	CLASS

7 Radio sub-system synchronization

7.1 Introduction

Clauses 7.2 to 7.8 define the requirements for synchronization on the TETRA V+D radio sub-system, for carrier frequencies of between 300 MHz and 1 GHz. It does not define the synchronization algorithms to be used in the BS and MS. These are up to the manufacturer to specify.

7.2 General description of synchronization system

This clause gives a general description of the synchronization system. Detailed requirements are given in the subsequent clauses.

The BS sends signals on the BSCH to enable an MS to synchronize itself to a phase modulation channel and if necessary correct its frequency standard to be in line with that of the BS. The BS sends signals on the BSCH-Q to enable an MS to synchronize itself to a QAM channel on a DA cell and if necessary correct its frequency standard to be in line with that of the BS. The signals sent by the BS for these purposes are frequency correction signals and synchronization signals.

The timings of timeslots, TDMA frames and multiframe are all related to a common set of counters which run continuously whether the MS and BS are transmitting or not (see clauses 7.3 and 7.5). Thus, once the MS has determined the correct setting of these counters, all its processes are synchronized to the current serving BS.

The MS has to time its transmissions to the BS in line with those received from the BS. This process is called "mobile timebase adjustment".

7.3 Timebase counters for phase modulation

7.3.1 Timing counters for phase modulation

The timing state of the signals transmitted by a BS or MS shall be defined by the following counters:

- Symbol Number (SN)(1 - 255);
- Timeslot Number (TN)(1 - 4);
- TDMA Frame Number (FN)(1 - 18);
- TDMA Multiframe Number (MN)(1 - 60).

NOTE: $SN0$ indicates the last symbol of the previous timeslot, i.e. $SN0$ equals $SN255$ of the previous timeslot.

7.3.2 Values of the counters for phase modulation

The relationship between these counters shall be as follows:

- SN increments every $500/9 \mu\text{s}$ (for an MS, this holds unless otherwise required by the mobile timebase adjustment);
- TN increments at the beginning of each timeslot (at symbol time of $SN0$ of the downlink for a continuous downlink transmission);
- FN increments whenever TN changes from count 4 to 1;
- MN increments whenever FN changes from 18 to 1.

The simultaneous change of state of all counters to 1 defines the timebase reference. This timebase reference takes into account the offset required in the case of MCCH sharing (± 18 frames).

7.4 Timing of phase modulation signals

The timing of modulation symbols transmitted by the MS and BS is defined in clause 9.

The MS may use the timing of receipt of the synchronization burst to set-up its timebase counters. If it does, it shall do so as follows:

- the value of TN shall be read from the BSCH, when received. In any other case, augmentation of TN shall be given by:

$$TN: = TN \bmod (4) + 1 \quad (7.1)$$

- the value of FN shall be read from the BSCH, when received. In any other case, augmentation of FN shall be given by:

$$FN: = FN \bmod (18) + 1 \quad (7.2)$$

- the value of MN is read from the BSCH, when received. In any other case, augmentation of MN shall be given by:

$$MN: = MN \bmod (60) + 1 \quad (7.3)$$

When BSs that differ from the current serving BS are being monitored for call re-establishment or handover purposes, the MS may choose to store the values of TN , FN and MN for all the BSs whose synchronization bursts have been detected relative to TN , FN and MN for its current serving BS.

7.5 Timebase counters for QAM

7.5.1 Timing counters for QAM

The timing state of the signals transmitted by a BS or MS on a QAM channel shall be defined by the following counters:

- QAM Symbol Number ($SN-Q$)(1 - 34);
- Timeslot Number (TN)(1 - 4);
- TDMA Frame Number (FN)(1 - 18);
- TDMA Multiframe Number (MN)(1 - 60).

7.5.2 Values of the counters for QAM

The relationship between these counters shall be as follows:

- $SN-Q$ increments every 5/12 msec (for an MS, this holds unless otherwise required by the mobile timebase adjustment);
- TN increments at the beginning of each timeslot (at symbol time of $SN-QI$ on the downlink);
- FN increments whenever TN changes from count 4 to 1;
- MN increments whenever FN changes from 18 to 1.

The simultaneous change of state of all counters to 1 defines the timebase reference.

7.6 Timing of QAM signals

The timing of modulation symbols transmitted by the MS and BS on a QAM channel is defined in clause 9.

The initial values of the *TN*, *FN* and *MN* counters are transmitted by the BS only in a synchronization burst on phase modulated channels and in a FCB on QAM channels as defined in clause 9. In the case of a CA MS these counters can be initialized by the MS only when the MS is on a phase modulated channel.

On a QAM channel, a CA MS shall set-up its timebase counters as follows:

- *SN-Q* shall be set by the timing of the synchronization symbols.
- The value of *TN*, *FN* and *MN* shall be retained from the values read from the BSCH on one of the phase modulated channels of the BS. While being on a QAM channel, the MS shall update *TN*, *FN* and *MN* as defined in clause 7.4 and clause 7.5.2.

On a QAM channel a DA MS may set *SN-Q* by the timing of the synchronization symbols. A DA MS may use the timing of receipt of the FCB to set-up its timebase counters. If it does, it shall do so as follows:

- the value of *TN* shall be read from the BSCH-Q, when received. In any other case, augmentation of *TN* shall be given by:

$$TN: = TN \bmod (4) + 1 \quad (7.4)$$

- the value of *FN* shall be read from the BSCH-Q, when received. In any other case, augmentation of *FN* shall be given by:

$$FN: = FN \bmod (18) + 1 \quad (7.5)$$

- the value of *MN* is read from the BSCH-Q, when received. In any other case, augmentation of *MN* shall be given by:

$$MN: = MN \bmod (60) + 1 \quad (7.6)$$

NOTE: FCB is not necessarily sent on QAM carriers other than the DA main carrier.

When BSs that differ from the current serving BS are being monitored for call re-establishment or handover purposes, the MS may choose to store the values of *TN*, *FN* and *MN* for all the BSs whose FCBs have been detected relative to *TN*, *FN* and *MN* for its current serving BS.

7.7 BS requirements for synchronization

The BS shall use a single frequency source with accuracy better than $\pm 0,2$ ppm ($\pm 0,1$ ppm for frequencies above 520 MHz) for both RF frequency generation and clocking the timebase. The same source shall be used for all carriers of the BS.

It is optional whether the timebase counters of different BSs are synchronized together.

The channels of different carriers transmitted by a BS shall be synchronized together, i.e. controlled by the same set of counters. The timing difference between the start of timeslots transmitted on different carriers shall be less than $125/9 \mu\text{s}$. This includes carriers that are carrying eccentric channels.

NOTE 1: When the MS moves to an eccentric channel within the cell, the timing difference seen by the MS depends additionally on the difference between its distance from the eccentric channel's transmitter site and its distance from the main carrier's transmitter site.

The present document supports up to a maximum separation of 4 km between an eccentric channel's transmitter site and the main carrier's transmitter site.

Additionally, the BS shall not send a channel allocation to an MS that is using an eccentric channel allocating the MS to another eccentric channel on the same cell where the separation between the transmitter sites of the two eccentric channels is more than 4 km.

In case of timesharing of the same carrier by different BSs, the timing difference between the timebase references of two any such BS shall be less than $250/9 \mu\text{s}$.

When the neighbour cell information broadcast indicates that the cells are synchronized, then the timing difference between the start of timeslots transmitted by those BSs should be less than $250/9 \mu\text{s}$. TDMA frame synchronization and offset is defined in clause 18.5.23.

NOTE 2: The timing difference seen by MSs depends additionally on the distances to the basestations.

The timing of any QAM channels used by a CA cell shall be synchronized to the timing of the phase modulated channels. This shall be done so that:

- The start of timeslots on QAM channels shall be synchronized with the start of timeslots on phase modulated channels of the BS. This means that for continuous downlink transmission, the symbol time of *SN-QI* on QAM channels shall be coincident with the symbol time of *SNO* (*SN255* of the previous timeslot) on phase modulated channels of that BS;
- *TN*, *FN* and *MN* shall be synchronized for QAM channels and phase modulated channels of the BS.

The timing of any phase modulated channels used by a DA cell shall be synchronized to the timing of QAM channels. This shall be done so that:

- The start of timeslots on phase modulated channels shall be synchronized with the start of timeslots on QAM channels of the BS. This means that for continuous downlink transmission, the symbol time of *SNO* (*SN255* of the previous timeslot) on phase modulated channels shall be coincident with the symbol time of *SN-QI* on QAM channels of that BS;
- *TN*, *FN* and *MN* shall be synchronized for QAM channels and phase modulated channels of the BS.

7.8 MS requirements for synchronization

The MS shall only transmit to the BS if the requirements of items a) to c) below are met:

- a) The MS carrier frequency shall be accurate to within ± 100 Hz compared to signals received from the BS (these signals may have an apparent frequency error due to BS frequency error and Doppler shift). The signals from the BS shall be averaged by the MS over sufficient time that errors due to noise or interference are allowed for within the above ± 100 Hz figure.
- b) The MS shall adjust its internal timebase in line with that of signals received from the BS. If the MS determines that the timing difference exceeds $125/9 \mu\text{s}$, it shall adjust its timebase in steps of not greater than $125/9 \mu\text{s}$. This adjustment shall be performed at intervals of not less than 1 second and not greater than 3 seconds until the timing difference is less than $125/9 \mu\text{s}$.
- c) In determining the timing of signals from the BS, the timings shall be assessed in such a way that the timing assessment error is less than $125/18 \mu\text{s}$. The assessment algorithm shall be such that the requirements of (b) can be met.

The conditions under which the requirements of items a) to c) shall be met shall be 3 dB below the reference sensitivity level defined in clause 6 and 3 dB less carrier to interference ratio than the reference interference ratios defined in clause 6. Static or dynamic reference sensitivity levels shall be used depending on the applied propagation conditions.

When the MS obeys a channel allocation for an eccentric channel on the current cell, and when it moves from an eccentric channel, the timing difference perceived by the MS on the new channel relative to the old channel may be up to $\pm 250/9 \mu\text{s}$ (caused by BS timing imperfections and geographical delay) in addition to any further propagation delay effects. See also clause 7.7.

8 Channel coding and scrambling

8.1 Introduction

A reference configuration of the TETRA transmission chain is given in clause 4. According to the reference configuration, clause 8 defines the error control process which applies to the information bits packed in MAC blocks (see definition in clause 19), and which provides multiplexed bits packed in multiplexed blocks.

Clause 8 applies to all logical channels, however channel coding for speech service is defined in ETSI EN 300 395-2 [21], clause 5. The definition of logical channels is given in clause 9.

Clause 8 includes the specification of encoding, re-ordering and interleaving, and scrambling, but does not specify any data processing on the receive part.

A definition of the error control process is provided for each kind of logical channel.

8.2 General

8.2.1 Interfaces in the error control structure

8.2.1.1 Interfaces for phase modulation

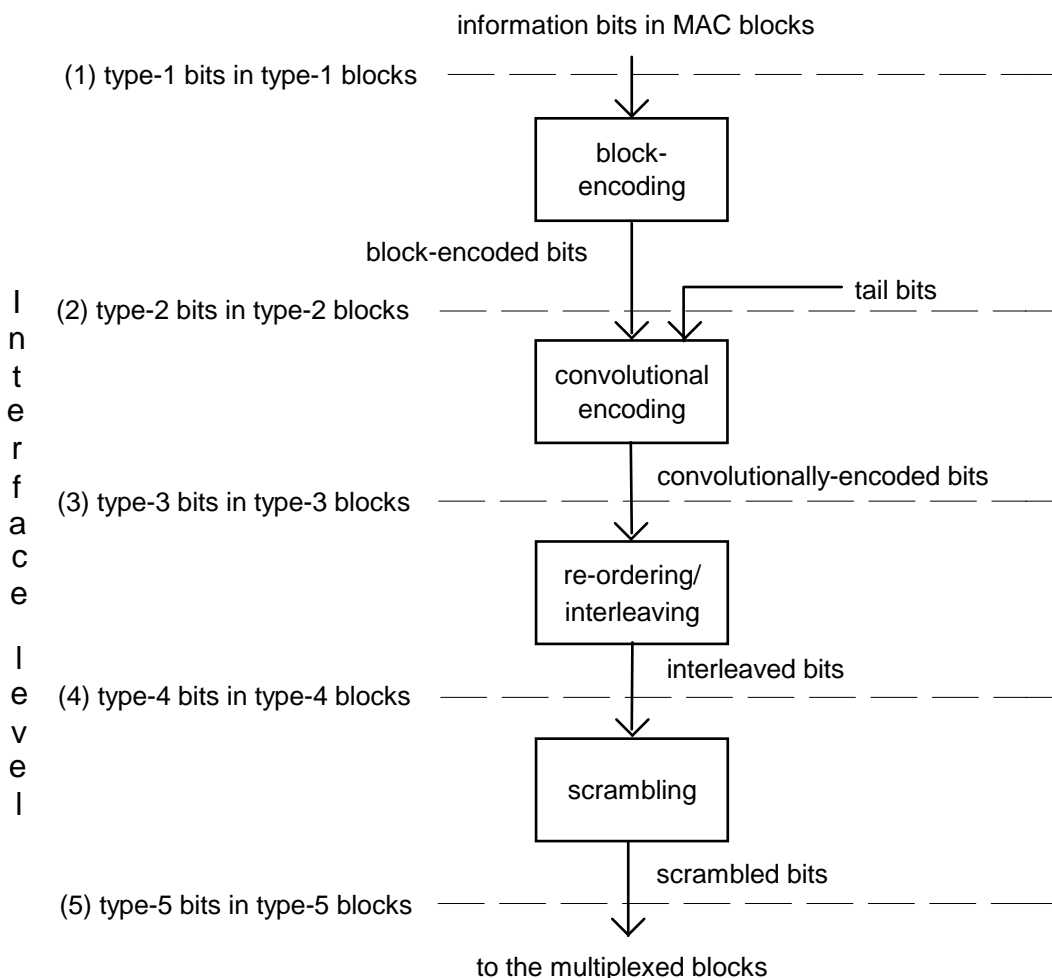

Figure 8.1: Interfaces in the error control structure for phase modulation

The definition of interfaces within the error control structure is given by figure 8.1.

Each logical channel shall have its own error control scheme. For each one, the information bits (possibly including one or more MAC headers (see clause 23.4.2.3)) are referred to as type-1 bits. The type-1 bits are packed in MAC blocks (see clause 19), which are referred to as type-1 blocks, this defines interface (1) in figure 8.1.

The processing in the transmit part shall be as follows:

- the type-1 bits shall be encoded by a block code, providing block-encoded bits. In some cases tail bits shall be appended to these block-encoded bits. The block-encoded bits and the tail bits (if added) are referred to as type-2 bits and shall be packed in a type-2 block, this defines interface (2);
- the type-2 bits shall be encoded by a convolutional code, which provides the convolutionally encoded bits. The convolutionally-encoded bits are referred to as type-3 bits and shall be packed in a type-3 block, this defines interface (3);
- the type-3 bits shall be reordered and interleaved, into interleaved bits: the interleaved bits are referred to as type-4 bits and shall be packed in encoded blocks (see clause 19). Encoded blocks are referred to as type-4 blocks, this defines interface (4);
- the type-4 bits shall be scrambled, into type-5 bits, which compose type-5 blocks: this defines the interface (5). These bits shall then be mapped into multiplexed blocks. A multiplexed block shall be one of 5 different kinds:
 - control block;
 - broadcast block;
 - synchronization block;
 - block-1 block; or
 - block-2 block.

All these operations are made on a per type-1 block basis. The sizes of type-1 blocks and of type-5 blocks and multiplexed blocks depend on the logical channel with which they are associated.

8.2.1.2 Interfaces for QAM

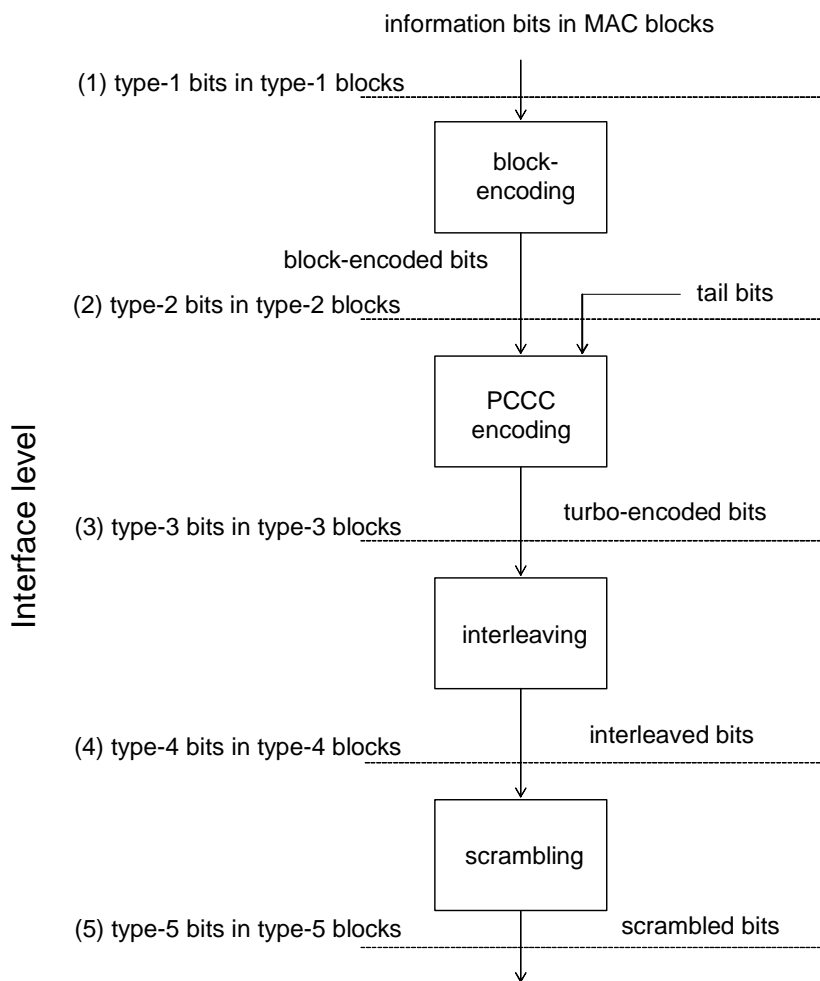

NOTE: The tail bits are used only if PCCC is used.

Figure 8.2: Interfaces in the error control structure for QAM

The definition of interfaces within the error control structure is given by figure 8.2. Each logical channel shall have its own error control scheme. For each one, the information bits (including one or more MAC headers, see clause 23.4.2.3) are referred to as type-1 bits. The type-1 bits are packed in MAC blocks, which are referred to as type-1 blocks. This defines interface (1) in figure 8.2.

The processing in the transmit part shall be as follows:

- the type-1 bits shall be encoded by a block code, providing block-encoded bits. When the block-encoded bits are to be further encoded by a PCCC (see next point), three tail bits shall be appended to them. The block-encoded bits and the tail bits (if added) are referred to as type-2 bits and shall be packed in a type-2 block, this defining interface (2);
- the type-2 bits shall be in some cases encoded by a parallel-concatenated convolutional code (hereinafter referred to as a PCCC), which provides the PCCC encoded bits. Alternatively, no further encoding shall be carried out on the type-2 bits (uncoded case). The PCCC encoded bits or alternatively the uncoded bits are referred to as type-3 bits and shall be packed in a type-3 block, this defining interface (3);
- the type-3 bits shall be reordered into interleaved bits: the interleaved bits are referred to as type-4 bits and shall be packed in encoded blocks. Encoded blocks are referred to as type-4 blocks, this defining interface (4);
- the type-4 bits shall be scrambled into type-5 bits, which compose type-5 blocks: this defines the interface (5).

All these operations are made on a per type-1 block basis. The sizes of type-1 blocks and of type-5 blocks depend on the logical channel with which they are associated and on the modulation format and PCCC coding rate employed.

8.2.2 Notation

For ease of understanding, a notation for bits and blocks is given for use throughout clause 8:

- x is the interface number, as defined in figures 8.1 and 8.2;
- n is a block number;
- $Bx(n)$ is the type- x block number n ;
- Kx is the number of bits that are carried by one type- x block;
- k is a bit number;
- $bx(n,k)$ is the bit number k in the type- x block number n ;
- alternatively $bx(k)$ is the type- x bit number k in a type- x block (for ease of notation), with $k = 1, 2, \dots, Kx$ and $n = 1, 2, \dots$

The bits of the multiplexed blocks shall be denoted as:

- $cb(k)$: bit number k in an control block;
- $bb(k)$: bit number k in a broadcast block;
- $sb(k)$: bit number k in a synchronization block;
- $bkn1(k)$: bit number k in a block-1 block;
- $bkn2(k)$: bit number k in a block-2 block.

8.2.3 Definition of error control codes

8.2.3.1 16-state Rate-Compatible Punctured Convolutional (RCPC) codes

8.2.3.1.0 General

The RCPC codes shall encode K_2 type-2 bits $b_2(1), b_2(2), \dots, b_2(K_2)$ into K_3 type-3 bits $b_3(1), b_3(2), \dots, b_3(K_3)$. This encoding shall be performed in two steps:

- encoding by a 16-state mother code of rate 1/4;
- puncturing of the mother code so to obtain a 16-state RCPC code of rate K_2/K_3 .

A general description of these two steps is given in clauses 8.2.3.1.1 and 8.2.3.1.2 respectively. The puncturing co-efficients of the 16-state RCPC codes of rates 2/3, 1/3, 292/432 and 148/432 are given in clauses 8.2.3.1.3, 8.2.3.1.4, 8.2.3.1.5 and 8.2.3.1.6 respectively.

8.2.3.1.1 Encoding by the 16-state mother code of rate 1/4

The input to the mother code of any type-2 bit $b_2(k)$, $k = 1, 2, \dots, K_2$, implies the output, by the mother code, of 4 bits, denoted by $V(4(k-1)+i)$, $i = 1, 2, 3, 4$, which shall be calculated as follows.

Any of the 4 generator polynomials of the mother code, $G_i(D)$, $i = 1, 2, 3, 4$, can be written as:

$$G_i(D) = \sum_{j=0}^4 g_{i,j} D^j \quad \text{for } i = 1, 2, 3, 4 \quad (8.1)$$

Where $g_{i,j} = 0$ or 1, $j = 0, 1, 2, 3, 4$.

This means that the encoded bits are defined by:

$$V(4(k-1) + i) = \sum_{j=0}^4 b_2(k-j)g_{i,j} \quad \text{for } i = 1, 2, 3, 4, \text{ and } k = 1, 2, \dots, K_2 \quad (8.2)$$

Where the sum is meant modulo 2, and where $b_2(k-j) = 0$ for $k \leq j$.

The generator polynomials of the mother code shall be:

$$G_1(D) = 1 + D + D^4 \quad (8.3)$$

$$G_2(D) = 1 + D^2 + D^3 + D^4 \quad (8.4)$$

$$G_3(D) = 1 + D + D^2 + D^4 \quad (8.5)$$

$$G_4(D) = 1 + D + D^3 + D^4 \quad (8.6)$$

8.2.3.1.2 Puncturing of the mother code

The puncturing of the mother code into a 16-state RCPC code of rate (K_2/K_3) is achieved by selecting K_3 type-3 bits out of the $(4 K_2)$ bits encoded by the mother code. This selection shall be as follows.

Denoting by $P(1), P(2), \dots, P(t)$ the t puncturing coefficients (each one being equal to 1, 2, 3, 4, 5, 6, 7 or 8), the type-3 bits are given by:

$$b_3(j) = V(k) \quad \text{for } j = 1, 2, \dots, K_3 \quad (8.7)$$

with $k = 8((i-1) \text{ div } t) + P(i - t((i-1) \text{ div } t))$

Where i and t are defined in the following puncturing schemes.

8.2.3.1.3 Puncturing scheme of the RCPC code of rate 2/3

The $t = 3$ puncturing co-efficients shall be:

$$P(1) = 1, P(2) = 2, P(3) = 5, \text{ and } i = j \quad (8.8)$$

8.2.3.1.4 Puncturing scheme of the RCPC code of rate 1/3

The $t = 6$ puncturing co-efficients shall be:

$$P(1) = 1, P(2) = 2, P(3) = 3, P(4) = 5, P(5) = 6, P(6) = 7, \text{ and } i = j \quad (8.9)$$

8.2.3.1.5 Puncturing scheme of the RCPC code of rate 292/432

The $t = 3$ puncturing co-efficients shall be:

$$P(1) = 1, P(2) = 2, P(3) = 5, \text{ and } i = j + (j-1) \text{ div } 65, \text{ with } j = 1, 2, \dots, 432 \quad (8.10)$$

8.2.3.1.6 Puncturing scheme of the RCPC code of rate 148/432

The $t = 6$ puncturing co-efficients shall be:

$$P(1) = 1, P(2) = 2, P(3) = 3, P(4) = 5, P(5) = 6, P(6) = 7, \text{ and } i = j + (j-1) \text{ div } 35, \text{ with } j = 1, 2, \dots, 432 \quad (8.11)$$

8.2.3.2 Shortened (30,14) Reed-Muller (RM) code

The shortened (30,14) RM code shall encode 14 type-1 bits $b_1(1), b_1(2), \dots, b_1(14)$ into 30 type-2 bits $b_2(1), b_2(2), \dots, b_2(30)$.

The vector of the 30 type-2 bits shall be derived from:

$$[b_2(1), b_2(2), \dots, b_2(30)] = [b_1(1), b_1(2), \dots, b_1(14)] \times \mathbf{G} \quad (8.12)$$

Where \mathbf{G} is the generator matrix:

$$\mathbf{G} = \mathbf{I}_{14} \begin{bmatrix} 1 & 0 & 0 & 1 & 1 & 0 & 1 & 1 & 0 & 1 & 1 & 0 & 0 & 0 & 0 & 0 \\ 0 & 0 & 1 & 0 & 1 & 1 & 0 & 1 & 1 & 1 & 1 & 0 & 0 & 0 & 0 & 0 \\ 1 & 1 & 1 & 1 & 1 & 1 & 0 & 0 & 0 & 0 & 1 & 0 & 0 & 0 & 0 & 0 \\ 1 & 1 & 1 & 0 & 0 & 0 & 0 & 0 & 0 & 0 & 1 & 1 & 1 & 1 & 0 & 0 \\ 1 & 0 & 0 & 1 & 1 & 0 & 0 & 0 & 0 & 0 & 1 & 1 & 1 & 0 & 1 & 0 \\ 0 & 1 & 0 & 1 & 0 & 1 & 0 & 0 & 0 & 0 & 1 & 1 & 0 & 1 & 1 & 0 \\ 0 & 0 & 1 & 0 & 1 & 1 & 0 & 0 & 0 & 0 & 1 & 0 & 1 & 1 & 1 & 0 \\ 1 & 1 & 1 & 1 & 1 & 1 & 1 & 1 & 1 & 1 & 0 & 1 & 1 & 1 & 1 & 1 \\ 1 & 0 & 0 & 0 & 0 & 0 & 1 & 1 & 0 & 0 & 1 & 1 & 1 & 0 & 0 & 1 \\ 0 & 1 & 0 & 0 & 0 & 0 & 1 & 0 & 1 & 0 & 1 & 1 & 0 & 1 & 0 & 1 \\ 0 & 0 & 1 & 0 & 0 & 0 & 0 & 1 & 1 & 0 & 1 & 0 & 1 & 1 & 0 & 1 \\ 0 & 0 & 0 & 1 & 0 & 0 & 1 & 0 & 0 & 1 & 1 & 1 & 0 & 0 & 1 & 1 \\ 0 & 0 & 0 & 0 & 1 & 0 & 0 & 1 & 0 & 1 & 1 & 0 & 1 & 0 & 1 & 1 \\ 0 & 0 & 0 & 0 & 0 & 1 & 0 & 0 & 1 & 1 & 1 & 0 & 0 & 1 & 1 & 1 \end{bmatrix} \quad (8.13)$$

Where \mathbf{I}_{14} denotes the (14 x 14) identity matrix.

8.2.3.3 $(K_1 + 16, K_1)$ block code

The $(K_1 + 16, K_1)$ code shall encode K_1 type-1 bits $b_1(1), b_1(2), \dots, b_1(K_1)$ into $(K_1 + 16)$ type-2 bits $b_2(1), b_2(2), \dots, b_2(K_1 + 16)$. The encoding rule shall be as follows (see Recommendation ITU-T X.25 [28]).

The type-1 bits are treated as the co-efficients of the polynomial:

$$M(X) = \sum_{k=1}^{K_1} b_1(k) X^{K_1-k} \quad (8.14)$$

Let $F(X)$ be:

$$F(X) = \left[\left(X^{16} M(X) + X^{K_1} \sum_{i=0}^{15} X^i \right) \bmod G(X) \right] + \sum_{i=0}^{15} X^i \quad (8.15)$$

Where all operations are meant modulo 2, and $G(X)$ is the generator polynomial of the code:

$$G(X) = X^{16} + X^{12} + X^5 + 1 \quad (8.16)$$

$F(X)$ is of degree 15, with co-efficients denoted by $f(0), f(1), \dots, f(15)$:

$$F(X) = \sum_{i=0}^{15} f(i) X^i \quad (8.17)$$

The K_2 type-2 bits, with $K_2 = K + 16$, are then given by:

$$\begin{aligned} b_2(k) &= b_1(k) && \text{for } k = 1, 2, \dots, K_1; \text{ and} \\ b_2(k) &= f(K_1 + 16 - k) && \text{for } k = K_1 + 1, K_1 + 2, \dots, K_1 + 16. \end{aligned} \quad (8.18)$$

8.2.3.4 8-state Parallel Concatenated Convolutional Code (PCCC) for QAM

8.2.3.4.0 General

With reference to figure 8.3, the PCCC shall encode K_2 type-2 input bits $b_2(1), b_2(2), \dots, b_2(K_2)$ into K_3 type-3 bits $b_3(1), b_3(2), \dots, b_3(K_3)$. The K_2 type-2 input bits include three tail bits $b_2(K_2 - 2), b_2(K_2 - 1), b_2(K_2)$, that force the final state of the upper constituent recursive systematic convolutional (RSC) encoder to zero. A second set of three tail bits $b'_2(K_2 - 2), b'_2(K_2 - 1), b'_2(K_2)$ is appended to the interleaved $K_2 - 3$ type-2 bits $b'_2(1), b'_2(2), \dots, b'_2(K_2 - 3)$ to force the final state of the lower RSC encoder to zero. The initial state of both constituent encoders shall be zero. As sketched in figure 8.3, this encoding shall be performed in four steps:

- encoding by a 8-state RSC encoder of rate 1/2 (the upper RSC encoder in figure 8.3);
- interleaving the $K_2 - 3$ type-2 bits $b_2(1), b_2(2), \dots, b_2(K_2 - 3)$ by means of a quadratic-congruence inner interleaver;
- appending three tail bits $b'_2(K_2 - 2), b'_2(K_2 - 1), b'_2(K_2)$ to the $K_2 - 3$ interleaved bits and encoding the resulting K_2 bits by a second 8-state RSC encoder of rate 1/2 identical to the encoder in a), and retaining only the parity bits;
- puncturing the parity bits at the output of the two RSC encoders so to obtain an 8-state PCCC of overall rate K_2 / K_3 .

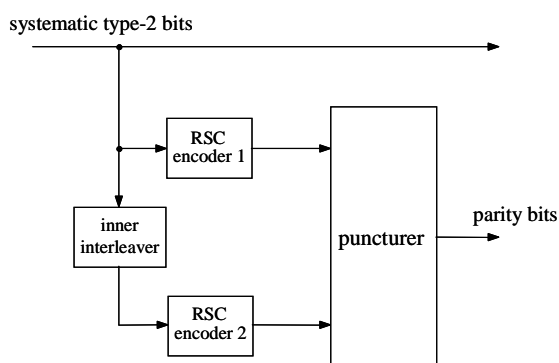

Figure 8.3: PCCC encoder

A general description of these four steps is given in clauses 8.2.3.4.1, 8.2.3.4.2, 8.2.3.4.3 and 8.2.3.4.5, respectively. The puncturing scheme of the 8-state PCCC encoders of rates 2/3 and 1/2 are given in clauses 8.2.3.4.6 and 8.2.3.4.7, respectively.

8.2.3.4.1 Encoding by the upper 8-state RSC encoder of rate 1/2

The RSC upper encoder structure is shown in figure 8.4. The input to the RSC encoder of any type-2 bit $b_2(k)$, $k = 1, 2, \dots, K_2$, implies the output of 2 bits, denoted by $V_1[2(k-1) + i]$, $i = 1, 2$, which shall be calculated as follows.

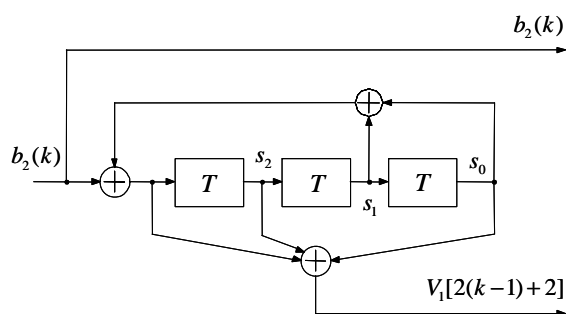

Figure 8.4: RSC encoder

The first bit is systematic, i.e.:

$$V_1[2(k-1) + i] = b_2(k) \quad \text{for } k = 1, 2, \dots, K_2 \text{ and } i = 1. \quad (8.19)$$

The second (parity) bit is generated through the generator $G_1(D)/G_0(D)$ where $G_0(D)$ and $G_1(D)$ are polynomials identifying the recursive and non-recursive sections of the encoder, and can be written as:

$$G_0(D) = \sum_{i=0}^3 g_{0,i} D^i \quad (8.20)$$

$$G_1(D) = \sum_{i=0}^3 g_{1,i} D^i \quad (8.21)$$

where $g_{0,0} = 1$ and $g_{0,i}$, $i = 1, 2, 3$, and $g_{1,i}$, $i = 0, 1, 2, 3$, are equal to 0 or 1.

This means that the parity bits are calculated as:

$$V_1[2(k-1) + 2] = \sum_{i=1}^3 V_1[2(k-i-1) + 2] g_{0,i} + \sum_{i=0}^3 b_2(k-i) g_{1,i} \quad \text{for } k = 1, 2, \dots, K_2, \quad (8.22)$$

where the sum is meant modulo 2, and where $V_1[2(k-i-1) + 2] = 0$ and $b_2(k-i) = 0$ for $k \leq i$.

The generator polynomials of the parity bit shall be:

$$G_0(D) = 1 + D^2 + D^3 \quad (8.23)$$

$$G_1(D) = 1 + D + D^3 \quad (8.24)$$

The three type-2 tail bits $b_2(K_2 - 2)$, $b_2(K_2 - 1)$, $b_2(K_2)$ depend on the state of the convolutional encoder after application of the bit $b_2(K_2 - 3)$ to its input, and force the final encoder state to zero. The tail bits are chosen as shown in table 8.1.

Table 8.1: Tail bits for the RSC encoder

Encoder state [s_2 s_1 s_0] [s'_2 s'_1 s'_0]	Tail bits $b_2(K_2 - 2)$ $b_2(K_2 - 1)$ $b_2(K_2)$ $b'_2(K_2 - 2)$ $b'_2(K_2 - 1)$ $b'_2(K_2)$
000	000
001	100
010	110
011	010
100	011
101	111
110	101
111	001

8.2.3.4.2 Interleaving by the quadratic-congruence interleaver

A quadratic-congruence block interleaver shall re-order $K_2 - 3$ type-2 bits $b_2(1)$, $b_2(2)$, ..., $b_2(K_2 - 3)$ into $K_2 - 3$ type-2 permuted bits $b'_2(1)$, $b'_2(2)$, ..., $b'_2(K_2 - 3)$, by means of the following two-step algorithm:

- first, the sequence of indices c_m , $m = 0, 1, \dots, S - 1$ is calculated, where S is the smallest power of 2 larger than or equal to $K_2 - 3$, as follows:

$$c_0 = 0, \text{ and}$$

$$c_m = [c_{m-1} + m] \bmod S, \quad m = 1, 2, \dots, S - 1 \quad (8.25)$$

b) Second, the $K_2 - 3$ type-2 bits $b_2(1), b_2(2), \dots, b_2(K_2 - 3)$ undergo the following procedure:

```

flag ← false
i ← 0
while i ≤ (S - 2)/2
    x ← ci+1
    y ← [ci + S/2] mod S
    if (x < K2 - 3 and y < K2 - 3)
        swap bits b2(x + 1) and b2(y + 1)
    else if (x < K2 - 3 and y ≥ K2 - 3)
        if (flag = true)
            swap bits b2(x + 1) and b2(t + 1)
            flag ← false
        else
            t ← x
            flag ← true
    else if (x ≥ K2 - 3 and y < K2 - 3)
        if (flag = true)
            swap positions b2(y + 1) and b2(t + 1)
            flag ← false
        else
            t ← y
            flag ← true
    i ← i + 1

```

(8.26)

Upon completion of the above procedure, the input sequence of $K_2 - 3$ type-2 bits $b_2(1), b_2(2), \dots, b_2(K_2 - 3)$ is turned into the sequence of $K_2 - 3$ type-2 interleaved bits $b'_2(1), b'_2(2), \dots, b'_2(K_2 - 3)$.

NOTE: Any bits that are not swapped remain in their original positions.

8.2.3.4.3 Encoding the interleaved bits by the lower 8-state RSC encoder of rate 1/2

This convolutional encoder shall be identical to the one described in clause 8.2.3.4.1 and shall operate on the sequence of K_2 type-2 interleaved bits $b'_2(1), b'_2(2), \dots, b'_2(K_2 - 3)$ and tail bits $b'_2(K_2 - 2), b'_2(K_2 - 1), b'_2(K_2)$, yielding at its output the sequence denoted by $V_2[2(k - 1) + i], i = 1, 2, k = 1, 2, \dots, K_2$. Only the sequence of parity bits is taken into account, that is generated as follows:

$$V_2[2(k - 1) + 2] = \sum_{i=1}^3 V_2[2(k - i - 1) + 2]g_{0,i} + \sum_{i=0}^3 b'_2(k - i)g_{1,i} \text{ for } k = 1, 2, \dots, K_2, \quad (8.27)$$

where the sum is meant modulo 2, and where $V_2[2(k - i - 1) + 2] = 0$ and $b'_2(k - i) = 0$ for $k \leq i$.

The three type-2 tail bits $b'_2(K_2 - 2), b'_2(K_2 - 1), b'_2(K_2)$ depend on the state of the lower convolutional encoder after application of the bit $b'_2(K_2 - 3)$ to its input, and force the final encoder state to zero. The tail bits are chosen as shown in table 8.1.

8.2.3.4.4 Merging the systematic and parity bits for the PCCC encoder

The systematic and parity bits at the output of the two RSC encoders are merged together so as to generate a single sequence of $3K_2$ bits, as follows:

$$V(k) = \begin{cases} V_1[k \bmod 3 + 2(k \operatorname{div} 3)], & (k - 1) \bmod 3 = 0, 1 \\ V_2[2(k \operatorname{div} 3)], & (k - 1) \bmod 3 = 2 \end{cases}, \quad k = 1, 2, \dots, 3K_2 \quad (8.28)$$

8.2.3.4.5 Puncturing scheme for the PCCC encoder

Puncturing the sequence $V(k)$, $k = 1, 2, \dots, 3K_2$ permits to achieve a code of rate K_2/K_3 . This is done by selecting K_3 type-3 bits out of the $3K_2$ encoded bits $V(k)$, $k = 1, 2, \dots, 3K_2$. This selection shall be as follows:

Denoting by $P(1); P(2); \dots; P(t)$ the t puncturing coefficients (each one being equal to 1, 2, 3, 4, 5, 6, 7, 8, 9, 10, 11 or 12), the type-3 bits are given by:

$$b_3(j) = V(k), j = 1, 2, \dots, K_3, \text{ with } k = 12[(i-1)\text{div } t] + P\{i - t[(i-1)\text{div } t]\} \quad (8.29)$$

Where i and t are defined in the puncturing schemes defined in clauses 8.2.3.4.6 and 8.2.3.4.7.

8.2.3.4.6 Puncturing scheme for the PCCC encoder with coding rate 2/3

The $t = 6$ puncturing co-efficients shall be:

$$P(1) = 1, P(2) = 2, P(3) = 4, P(4) = 7, P(5) = 9, P(6) = 10, \text{ and } i = j \quad (8.30)$$

8.2.3.4.7 Puncturing scheme for the PCCC encoder with coding rate 1/2

The $t = 8$ puncturing co-efficients shall be:

$$P(1) = 1, P(2) = 2, P(3) = 4, P(4) = 6, P(5) = 7, P(6) = 8, P(7) = 10, P(8) = 12, \text{ and } i = j \quad (8.31)$$

8.2.3.5 (16,5) Reed-Muller (RM) code for QAM

The (16,5) RM code shall encode 5 type-1 bits $b_1(1), b_1(2), \dots, b_1(5)$ into 16 type-2 bits $b_2(1), b_2(2), \dots, b_2(16)$.

The vector of the 16 type-2 bits shall be derived from:

$$[b_2(1), b_2(2), \dots, b_2(16)] = [b_1(1), b_1(2), \dots, b_1(5)] \times \mathbf{G} \quad (8.32)$$

where \mathbf{G} is the generator matrix:

$$\mathbf{G} = \begin{bmatrix} 0 & 1 & 1 & 1 & 0 & 1 & 1 & 1 & 1 & 0 & 0 \\ 0 & 0 & 0 & 0 & 1 & 1 & 1 & 1 & 1 & 1 & 1 \\ \mathbf{I}_5 & 1 & 1 & 1 & 0 & 0 & 0 & 0 & 1 & 1 & 1 & 1 \\ 1 & 0 & 1 & 1 & 1 & 0 & 1 & 0 & 1 & 0 & 1 \\ 1 & 1 & 0 & 1 & 1 & 1 & 0 & 0 & 1 & 1 & 0 \end{bmatrix} \quad (8.33)$$

\mathbf{I}_5 denoting the (5×5) identity matrix.

8.2.4 Definition of interleaving schemes

8.2.4.1 Block interleaving for phase modulation

A (K, a) block interleaver shall re-order K_3 type-3 bits $b_3(1), b_3(2), \dots, b_3(K_3)$ into K_4 type-4 bits $b_4(1), b_4(2), \dots, b_4(K_4)$, with $K = K_3 = K_4$, in the following way:

$$b_4(k) = b_3(i), \quad i = 1, 2, \dots, K \quad (8.34)$$

with $k = 1 + ((a \times i) \bmod K)$

8.2.4.2 Interleaving over N blocks

Interleaving over N blocks use two steps to interleave a sequence of M type-3 blocks $B_3(1), B_3(2), \dots, B_3(M)$ of 432 bits each into a sequence of $(M + N - 1)$ type-4 blocks $B_4(1), B_4(2), \dots, B_4(M + N - 1)$ of 432 bits each, where M is an integer and N has values 1, 4, or 8. This interleaving shall be as follows.

Firstly, a diagonal interleaver interleaves the M blocks $B_3(1), B_3(2), \dots, B_3(M)$ into $(M+N-1)$ blocks $B'_3(1), B'_3(2), \dots, B'_3(M + N - 1)$. Denoting by $b'_3(m,k)$ the k -th bit of block $B'_3(m)$, with $k = 1, 2, \dots, 432$ and $m = 1, 2, \dots, M + N - 1$,

$$b'_3(m,k) = b_3(m - j, j+1+(i \times N)) \text{ for } 1 \leq m - j \leq M;$$

$$b'_3(m,k) = 0, \text{ otherwise;} \quad (8.35)$$

with:

$$j = (k - 1) \text{ div } (432/N) \text{ and } i = (k - 1) \text{ mod } (432/N).$$

A block interleaver then interleaves each block $B'_3(m)$ into type-4 block $B_4(m)$, $m = 1, 2, \dots, M + N - 1$:

$$b_4(m,i) = b'_3(m,k) \quad (8.36)$$

with:

$$k = 1, 2, \dots, 432, \text{ and } i = 1 + [(103 \times k) \text{ mod } 432]$$

8.2.4.3 Block interleaving for QAM

A (K, a) block interleaver shall re-order K_3 type-3 bits $b_3(1), b_3(2), \dots, b_3(K_3)$ into K_4 type-4 bits $b_4(1), b_4(2), \dots, b_4(K_4)$, with $K = K_3 = K_4$, in the following way:

$$b_4(k) = b_3(i), \quad i = 1, 2, \dots, K \quad (8.37)$$

$$\text{with } k = 1 + (a \times i) \text{ mod } K$$

The values of K and a for the various logical channels, bandwidths and modulation formats are specified below in table 8.2 (relevant to logical channels mapping on burst headers) and tables 8.3 to 8.6 (relevant to logical channels mapping on burst payloads). Detailed error control schemes for logical channels for QAM can be found in clause 8.3.2. The last row of table 8.2 means that the block-encoded bits relevant to logical channels SICH-Q/D and AACH-Q are concatenated and then interleaved.

Table 8.2: Values of K and a for logical channels mapping on burst headers, for any bandwidth

Logical channel	4/16/64-QAM
SICH-Q/U	$K = 16, a = 5$
SICH-Q/D + AACH-Q	$K = 64, a = 9$

Table 8.3: Values of K and a for logical channels mapping on burst payloads, 8 subcarriers

Logical channel	4-QAM	16-QAM	64-QAM
SCH-Q/HU	$K = 152, a = 13$	$K = 304, a = 17$	$K = 456, a = 23$
SCH-Q/U	$K = 400, a = 21$	$K = 800, a = 29$	$K = 1200, a = 37$
SCH-Q/D, BNCH-Q	$K = 408, a = 23$	$K = 816, a = 29$	$K = 1224, a = 35$
SCH-Q/RA	$K = 168, a = 13$	-	-
BSCH-Q	$K = 272, a = 19$	-	-

Table 8.4: Values of K and a for logical channels mapping on burst payloads, 16 subcarriers

Logical channel	4-QAM	16-QAM	64-QAM
SCH-Q/HU	$K = 320, a = 17$	$K = 640, a = 27$	$K = 960, a = 31$
SCH-Q/U	$K = 816, a = 29$	$K = 1\,632, a = 41$	$K = 2\,448, a = 49$
SCH-Q/D, BNCH-Q	$K = 880, a = 29$	$K = 1\,760, a = 41$	$K = 2\,640, a = 53$
BSCH-Q	$K = 272, a = 19$	-	-
SCH-Q/B	$K = 472, a = 21$	-	-

Table 8.5: Values of K and a for logical channels mapping on burst payloads, 32 subcarriers

Logical channel	4-QAM	16-QAM	64-QAM
SCH-Q/HU	$K = 656, a = 25$	$K = 1\,312, a = 37$	$K = 1\,968, a = 47$
SCH-Q/U	$K = 1\,648, a = 41$	$K = 3\,296, a = 57$	$K = 4\,944, a = 71$
SCH-Q/D, BNCH-Q	$K = 1\,824, a = 43$	$K = 3\,648, a = 61$	$K = 5\,472, a = 73$
BSCH-Q	$K = 272, a = 19$	-	-
SCH-Q/B	$K = 1\,416, a = 37$	-	-

Table 8.6: Values of K and a for logical channels mapping on burst payloads, 48 subcarriers

Logical channel	4-QAM	16-QAM	64-QAM
SCH-Q/HU	$K = 992, a = 33$	$K = 1\,984, a = 45$	$K = 2\,976, a = 55$
SCH-Q/U	$K = 2\,480, a = 49$	$K = 4\,960, a = 71$	$K = 7\,440, a = 89$
SCH-Q/D, BNCH-Q	$K = 2\,768, a = 53$	$K = 5\,536, a = 75$	$K = 8\,304, a = 91$
BSCH-Q	$K = 272, a = 19$	-	-
SCH-Q/B	$K = 2\,360, a = 49$	-	-

8.2.5 Definition of scrambling

8.2.5.1 Scrambling method

Scrambling shall transform K_4 type-4 bits $b_4(1), b_4(2), \dots, b_4(K_4)$ into K_5 type-5 bits $b_5(1), b_5(2), \dots, b_5(K_5)$, with $K_5 = K_4$, as follows:

$$b_5(k) = b_4(k) + p(k) \quad \text{for } k = 1, 2, \dots, K_5 \quad (8.38)$$

Where the addition is meant modulo 2, and $p(k)$ is the k -th bit of the scrambling sequence.

8.2.5.2 Scrambling sequence

The scrambling sequence $\{p(k), k = 1, 2, \dots, K_5\}$ shall be generated from the 30 bits of the extended colour code $e(1), e(2), \dots, e(30)$ (see clauses 19 and 23), except for the BSCH and BSCH-Q, by means of linear feedback registers. For the scrambling of BSCH and BSCH-Q, all bits $e(1), e(2), \dots, e(30)$ shall be set equal to zero.

NOTE: Normal colour code is applied to SCH-Q/B although it is sent in the same burst as BSCH-Q. Normal colour code is also applied to SICH-Q, even when it is sent in the same burst as BSCH-Q.

The scrambling sequence generator shall be based upon the following connection polynomial:

$$c(x) = \sum_{i=0}^{32} c_i X^i \quad (8.39)$$

With $c_i = 1$ for $i = 0, 1, 2, 4, 5, 7, 8, 10, 11, 12, 16, 22, 23, 26$ and 32 , and $c_i = 0$ elsewhere and where all operations are meant modulo 2. The resultant polynomial is therefore:

$$c(x) = 1 + X + X^2 + X^4 + X^5 + X^7 + X^8 + X^{10} + X^{11} + X^{12} + X^{16} + X^{22} + X^{23} + X^{26} + X^{32} \quad (8.40)$$

The k -th bit of the scrambling sequence is given by:

$$p(k) = \sum_{i=1}^{32} c_i p(k-i) \tag{8.41}$$

With the following initialization:

$$p(k) = e^{j(1-k)} \quad \text{for } k = -29, -28, \dots, 0; \text{ and}$$

$$p(k) = 1 \quad \text{for } k = -31, -30 \tag{8.42}$$

8.3 Error control schemes

8.3.1 Error control schemes for phase modulation

8.3.1.0 General

The error control scheme associated with each logical channel is defined in clauses 8.3.1.1 to 8.3.1.4 for phase modulation. Figures 8.5, 8.6 and 8.7 give the error control structure.

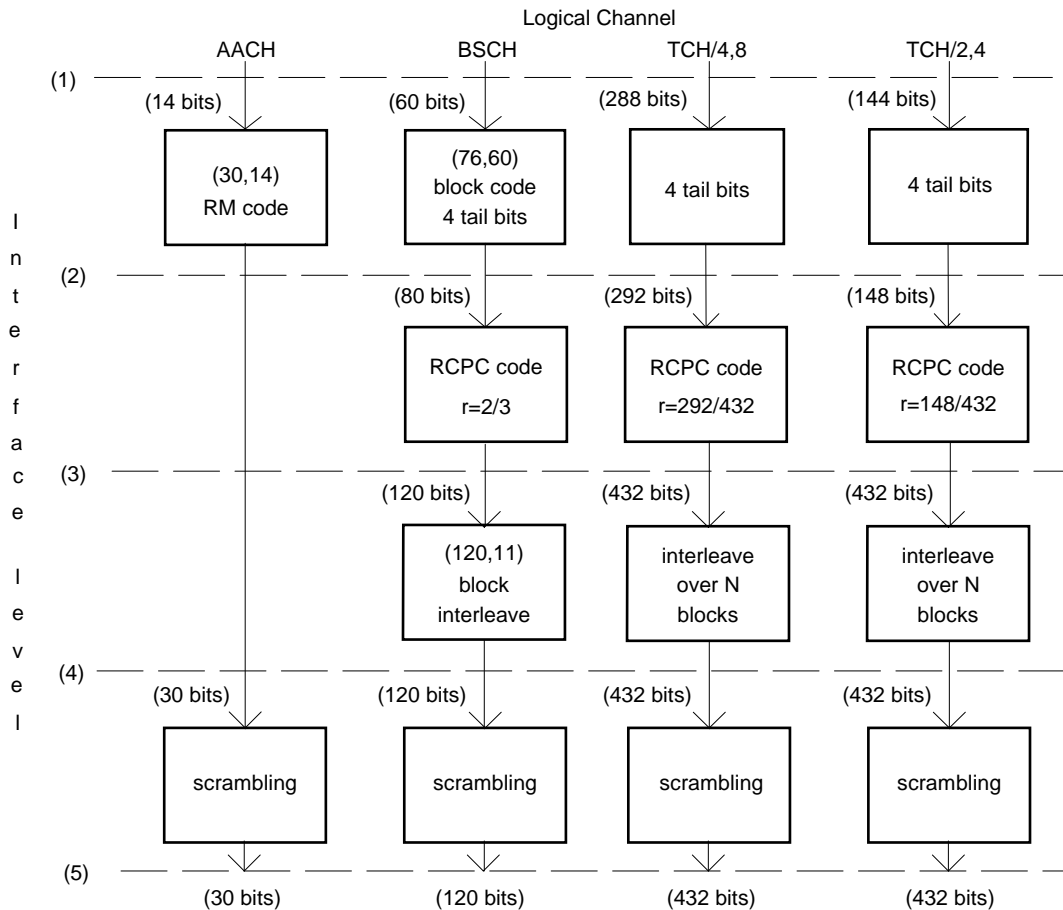

Figure 8.5: Error control structure for $\pi/4$ DQPSK logical channels (part 1)

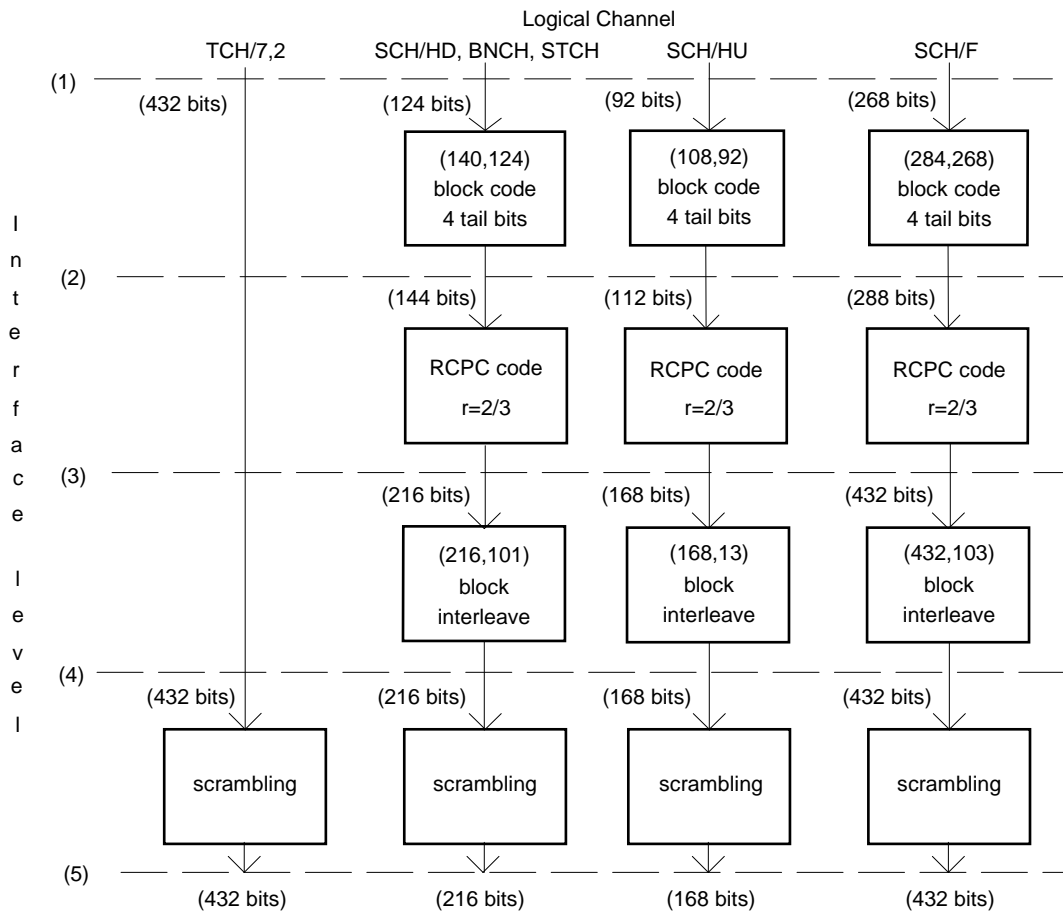

Figure 8.6: Error control structure for $\pi/4$ DQPSK logical channels (part 2)

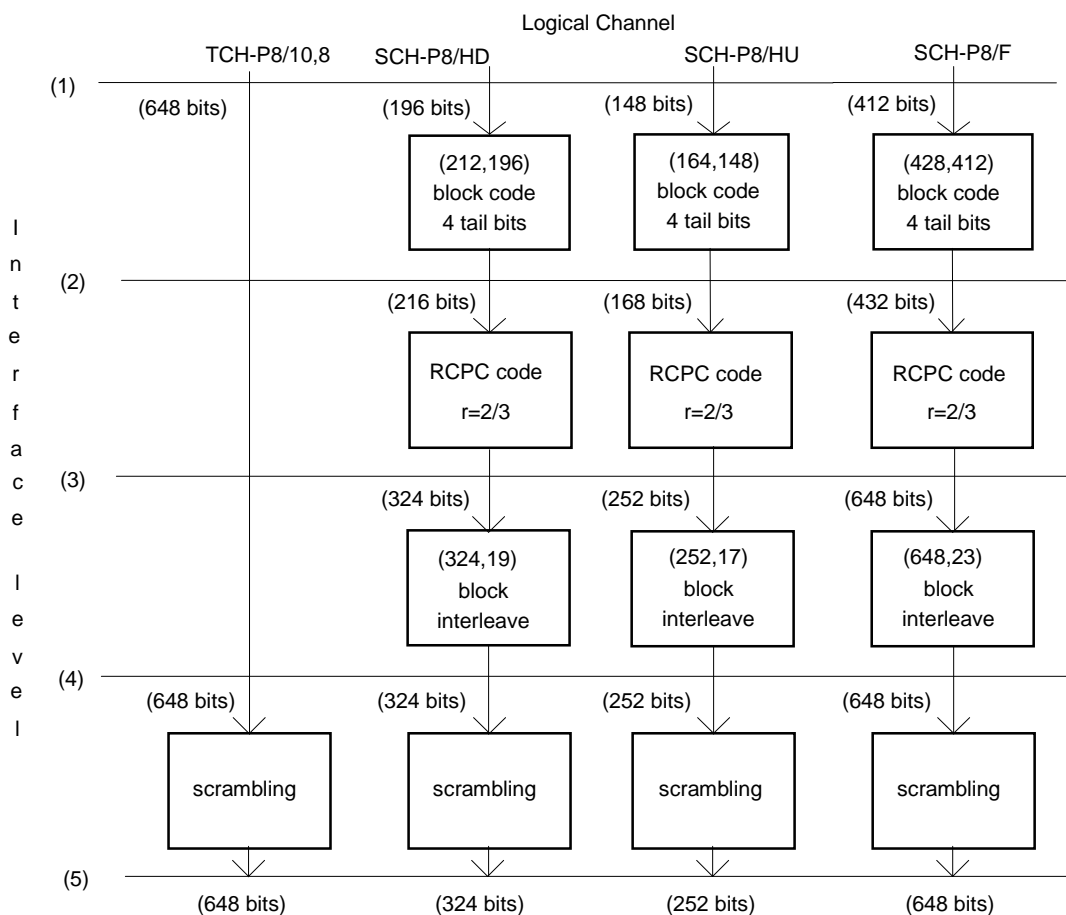

Figure 8.7: Error control structure for $\pi/8$ D8PSK logical channels

8.3.1.1 Access Assignment Channel (AACH)

One type-1 block shall contain 14 type-1 bits $b_1(1), b_1(2), \dots, b_1(14)$.

A shortened (30,14) RM code (see clause 8.2.3.2) shall encode the 14 type-1 bits into 30 type-2 bits, $b_2(1), b_2(2), \dots, b_2(30)$.

The type-4 bits shall be the same as the type-2 bits:

$$b_4(k) = b_2(k) \quad \text{for } k = 1, 2, \dots, 30 \quad (8.43)$$

The 30 type-4 bits $b_4(1), b_4(2), \dots, b_4(30)$, compose the type-4 block for AACH. They shall be scrambled into bits $b_5(1), b_5(2), \dots, b_5(30)$, according to clause 8.2.5.1, with the scrambling sequence as defined in clause 8.2.5.2. The multiplexed bits of the BBK shall be defined as:

$$bb(k) = b_5(k), \quad \text{for } k = 1, 2, \dots, 30 \quad (8.44)$$

8.3.1.2 Broadcast Synchronization Channel (BSCH)

One type-1 block shall contain 60 type-1 bits $b_1(1), b_1(2), \dots, b_1(60)$.

A (76,60) block code shall encode the 60 type-1 bits into 76 block-encoded bits, $b_2(1), b_2(2), \dots, b_2(76)$. This code is the (K_1+16, K_1) block code as defined in clause 8.2.3.3, with $K_1 = 60$.

Four tail bits, $b_2(77), b_2(78), b_2(79), b_2(80)$, all set equal to zero, shall be appended to the 76 block-encoded bits.

The resultant bits $b_2(1), b_2(2), \dots, b_2(80)$ shall be the type-2 bits.

A 16-state RCPC code with rate 2/3 (see clause 8.2.3.1), shall encode the 80 type-2 bits into 120 type-3 bits, $b_3(1), b_3(2), \dots, b_3(120)$.

A (120, 11) block interleaving (see clause 8.2.4.1) shall re-order the 120 type-3 bits into 120 type-4 bits, $b_4(1), b_4(2), \dots, b_4(120)$.

The 120 type-4 bits, $b_4(1), b_4(2), \dots, b_4(120)$ compose the type-4 block for BSCH. They shall be scrambled into bits $b_5(1), b_5(2), \dots, b_5(120)$, according to clause 8.2.5.1, with the scrambling sequence as defined in clause 8.2.5.2.

The multiplexed bits of the synchronization block shall be defined as:

$$sb(k) = b_5(k), \quad \text{for } k = 1, 2, \dots, 120 \quad (8.45)$$

8.3.1.3 Traffic channels in circuit switched mode

8.3.1.3.1 Frame stealing and multi-slot transmission

In case frame stealing is activated for one of the data traffic channels defined in clauses 8.3.1.3.2 to 8.3.1.3.7 the multiplexed bits either of block-1 or of block-1 and block-2 are replaced by STCH bits. This means that the bits are replaced after coding, interleaving and scrambling. The construction of STCH bits is defined in clause 8.3.1.4.1.

NOTE: Frame stealing on speech traffic channels modifies the type of logical channel which the speech channel encoder is using, refer to ETSI EN 300 395-2 [21] clause 5 and see notes in clauses 8.3.1.3.6 and 8.3.1.3.7.

In the case of multi-slot transmission, up to four low bit rate traffic channels shall be multiplexed. This is further described in clause 23.

8.3.1.3.2 Traffic CHannel, net rate = 4,8 kbit/s (TCH/4,8)

A sequence of M type-1 blocks, $B_1(m)$, $m = 1, 2, \dots, M$, shall be transmitted, whereby M is not limited.

One type-1 block shall contain 288 type-1 bits, $b_1(1), b_1(2), \dots, b_1(288)$.

The $K_2 = 292$ type-2 bits shall comprise the 288 type-1 bits mapped as follows:

$$b_2(j) = b_1(j), \quad \text{for } j = 1, 2, \dots, 288 \quad (8.46)$$

with the addition of four tail bits, $b_2(289), b_2(290), b_2(291), b_2(292)$, all set equal to zero.

A 16-state RCPC code with rate 292/432 (see clause 8.2.3.1) shall encode the 292 type-2 bits into 432 type-3 bits, $b_3(1), b_3(2), \dots, b_3(432)$.

An interleaving over N blocks (see clause 8.2.4.2) shall interleave bits from M type-3 blocks (of 432 bits each) into $(M+N-1)$ type-4 blocks (of 432 bits each): the bits in one type-4 block shall be denoted by $b_4(1), b_4(2), \dots, b_4(432)$. The parameter N shall be pre-set at the call set-up, and may take the values 1, 4 or 8.

The 432 type-4 bits $b_4(1), b_4(2), \dots, b_4(432)$ shall compose the type-4 block for TCH/4,8. They shall be scrambled into bits $b_5(1), b_5(2), \dots, b_5(432)$, according to clause 8.2.5.1, with the scrambling sequence as defined in clause 8.2.5.2.

The multiplexed bits of block-1 are defined as:

$$bkn1(k) = b_5(k), \quad \text{for } k = 1, 2, \dots, 216 \quad (8.47)$$

In case of frame stealing of block-1 $bkn1(1), bkn1(2), \dots, bkn1(216)$ shall be discarded, and replaced with the STCH bits as defined in clause 8.3.1.4.1 for block-1.

The multiplexed bits of block-2 are defined as:

$$bkn2(k) = b_5(k+216), \quad \text{for } k = 1, 2, \dots, 216 \quad (8.48)$$

In case of frame stealing of block-2, $bkn2(1), bkn2(2), \dots, bkn2(216)$ shall be discarded, and replaced with the STCH bits as defined in clause 8.3.1.4.1 for block-2.

8.3.1.3.3 Traffic CHannel, net rate = 2,4 kbit/s (TCH/2,4)

A sequence of M type-1 blocks, $B_1(m)$, $m = 1, 2, \dots, M$, shall be transmitted, whereby M is not limited.

One type-1 block shall contain 144 type-1 bits, $b_1(1), b_1(2), \dots, b_1(144)$.

The $K_2 = 148$ type-2 bits shall comprise the 144 type-1 bits mapped as follows:

$$b_2(j) = b_1(j), \quad \text{for } j = 1, 2, \dots, 144 \quad (8.49)$$

with the addition of four tail bits, $b_2(145), b_2(146), b_2(147), b_2(148)$, all set equal to zero.

A 16-state RCPC code with rate 148/432 (see clause 8.2.3.1) encodes the 148 type-2 bits into 432 type-3 bits, $b_3(1), b_3(2), \dots, b_3(432)$.

An interleaving over N blocks (see clause 8.2.4.2) shall interleave bits from M type-3 blocks (of 432 bits each) into $(M + N - 1)$ type-4 blocks (of 432 bits each): the bits in one type-4 block shall be denoted by $b_4(1), b_4(2), \dots, b_4(432)$. The parameter N shall be pre-set at the call set-up, and may take the values 1, 4 or 8.

The 432 type-4 bits $b_4(1), b_4(2), \dots, b_4(432)$ shall compose the type-4 block for TCH/2,4. They shall be scrambled into bits $b_5(1), b_5(2), \dots, b_5(432)$, according to clause 8.2.5.1, with the scrambling sequence as defined in clause 8.2.5.2.

The multiplexed bits of block-1 are defined as:

$$bkn1(k) = b_5(k), \quad \text{for } k = 1, 2, \dots, 216 \quad (8.50)$$

In case of frame stealing of block-1 $bkn1(1), bkn1(2), \dots, bkn1(216)$ shall be discarded, and replaced with the STCH bits as defined in clause 8.3.1.4.1 for block-1.

The multiplexed bits of block-2 are defined as:

$$bkn2(k) = b_5(k+216), \quad \text{for } k = 1, 2, \dots, 216 \quad (8.51)$$

In case of frame stealing of block-2, $bkn2(1), bkn2(2), \dots, bkn2(216)$ shall be discarded, and replaced with the STCH bits as defined in clause 8.3.1.4.1 for block-2.

8.3.1.3.4 Traffic CHannel, net rate = 7,2 kbit/s (TCH/7,2)

A sequence of M type-1 blocks, $B_1(m)$, $m = 1, 2, \dots, M$, shall be transmitted, whereby M is not limited.

One type-1 block shall contain 432 type-1 bits, $b_1(1), b_1(2), \dots, b_1(432)$.

There shall be 432 type-4 bits, which are the same as the type-1 bits:

$$b_4(k) = b_1(k), \quad \text{for } k = 1, 2, \dots, 432 \quad (8.52)$$

The 432 type-4 bit $b_4(1), b_4(2), \dots, b_4(432)$ shall compose the type-4 block for TCH/7,2. They shall be scrambled into bits $b_5(1), b_5(2), \dots, b_5(432)$, according to clause 8.2.5.1, with the scrambling sequence as defined in clause 8.2.5.2.

The multiplexed bits of block-1 shall be defined as:

$$bkn1(k) = b_5(k), \quad \text{for } k = 1, 2, \dots, 216 \quad (8.53)$$

In case of frame stealing of block-1 $bkn1(1), bkn1(2), \dots, bkn1(216)$ shall be discarded, and replaced with the STCH bits as defined in clause 8.3.1.4.1 for block-1.

The multiplexed bits of block-2 shall be defined as:

$$bkn2(k) = b_5(k+216), \quad \text{for } k = 1, 2, \dots, 216 \quad (8.54)$$

In case of frame stealing of block-2, $bkn2(1), bkn2(2), \dots, bkn2(216)$ shall be discarded, and replaced with the STCH bits as defined in clause 8.3.1.4.1 for block-2.

8.3.1.3.5 Traffic Channel-P8, net rate = 10,8 kbit/s (TCH-P8/10,8)

A sequence of M type-1 blocks, $B_1(m)$, $m = 1, 2, \dots, M$, shall be transmitted, whereby M is not limited.

One type-1 block shall contain 648 type-1 bits, $b_1(1), b_1(2), \dots, b_1(648)$.

There shall be 648 type-4 bits, which are the same as the type-1 bits:

$$b_4(k) = b_1(k), \quad \text{for } k = 1, 2, \dots, 648 \quad (8.55)$$

The 648 type-4 bit $b_4(1), b_4(2), \dots, b_4(648)$ shall compose the type-4 block for TCH-P8/10,8. They shall be scrambled into bits $b_5(1), b_5(2), \dots, b_5(648)$, according to clause 8.2.5.1, with the scrambling sequence as defined in clause 8.2.5.2.

The multiplexed bits of block-1 shall be defined as:

$$bkn1(k) = b_5(k), \quad \text{for } k = 1, 2, \dots, 324 \quad (8.56)$$

The multiplexed bits of block-2 shall be defined as:

$$bkn2(k) = b_5(k+324), \quad \text{for } k = 1, 2, \dots, 324 \quad (8.57)$$

8.3.1.3.6 Speech Traffic Channel, full slot (TCH/S)

ETSI EN 300 395-2 [21] defines in clause 5.5.3 432 type-4 bits $C_4(1), C_4(2), \dots, C_4(432)$. For the purpose of scrambling those bits are mapped into $b_4(k) = C_4(k)$ for $k = 1, 2, \dots, 432$. The $b_4(1), b_4(2), \dots, b_4(432)$ bits shall be scrambled into bits $b_5(1), b_5(2), \dots, b_5(432)$, according to clause 8.2.5.1, with the scrambling sequence as defined in clause 8.2.5.2.

The multiplexed bits of block-1 shall be defined as:

$$bkn1(k) = b_5(k), \quad \text{for } k = 1, 2, \dots, 216 \quad (8.58)$$

and the multiplexed bits of block-2 shall be defined as:

$$bkn2(k) = b_5(k + 216), \quad \text{for } k = 1, 2, \dots, 216 \quad (8.59)$$

NOTE: It is considered that the MS is not stealing from a full slot speech channel but the MAC first informs the speech channel encoder which discards the type-1 bits of speech frame A and then uses half slot speech channel encoding for the type-1 bits of speech frame B.

8.3.1.3.7 Speech Traffic Channel, half slot (TCH/S)

ETSI EN 300 395-2 [21] defines in clauses 5.4.3.2, 5.6.2 and 5.6.2.1 216 type-3 bits $C_3(1), C_3(2), \dots, C_3(216)$. For the purpose of further processing those bits are mapped into $b_3(k) = C_3(k)$ for $k = 1, 2, \dots, 216$.

As specified in ETSI EN 300 395-2 [21] clause 5.6.3, a (216, 101) block interleaver (see clause 8.2.4.1) shall re-order the 216 type-3 bits $b_3(1), b_3(2), \dots, b_3(216)$, into 216 type-4 bits, $b_4(1), b_4(2), \dots, b_4(216)$.

The 216 type-4 bits $b_4(1), b_4(2), \dots, b_4(216)$ shall compose the type-4 block for the half slot speech channel. They shall be scrambled into bits $b_5(1), b_5(2), \dots, b_5(216)$, according to clause 8.2.5.1, with the scrambling sequence as defined in clause 8.2.5.2.

The multiplexed bits of block-2 shall be defined as:

$$bkn2(k) = b_5(k), \quad \text{for } k = 1, 2, \dots, 216 \quad (8.60)$$

NOTE: The MAC does not use block-1 for half slot speech transmission.

8.3.1.4 Signalling channels for signalling and packet mode data

8.3.1.4.1 Signalling CHannel for mapping onto Half-bursts on the Downlink (SCH/HD), Broadcast Network CHannel (BNCH), and STealing CHannel (STCH)

One type-1 block shall contain 124 type-1 bits, $b_1(1), b_1(2), \dots, b_1(124)$.

A (140,124) block code shall encode the 124 type-1 bits into 140 block-encoded bits $b_2(1), b_2(2), \dots, b_2(140)$. This code shall be the (K_I+16, K_I) block code as defined in clause 8.2.3.3, with $K_I = 124$.

Four tail bits, $b_2(141), b_2(142), b_2(143), b_2(144)$, all set equal to zero, shall be appended to the 140 block-encoded bits.

The resultant bits $b_2(1), b_2(2), \dots, b_2(144)$ shall be the type-2 bits.

A 16-state RCPC code with rate 2/3 (see clause 8.2.3.1) shall encode the 144 type-2 bits into 216 type-3 bits, $b_3(1), b_3(2), \dots, b_3(216)$.

A (216,101) block interleaver (see clause 8.2.4.1) shall re-order the 216 type-3 bits into 216 type-4 bits, $b_4(1), b_4(2), \dots, b_4(216)$.

The 216 type-4 bits $b_4(1), b_4(2), \dots, b_4(216)$ shall compose the type-4 block for SCH/HD, BNCH, and STCH. They shall be scrambled into bits $b_5(1), b_5(2), \dots, b_5(216)$, according to clause 8.2.5.1, with the scrambling sequence as defined in clause 8.2.5.2.

The type-5 bits may be multiplexed onto block-1, in which case the multiplexed bits are defined as:

$$bkn1(k) = b_5(k), \quad \text{for } k = 1, 2, \dots, 216 \quad (8.61)$$

or they may be multiplexed into block-2, in which case the multiplexed bits shall be defined as:

$$bkn2(k) = b_5(k), \quad \text{for } k = 1, 2, \dots, 216 \quad (8.62)$$

8.3.1.4.2 Signalling CHannel for mapping onto Half-bursts on the Downlink (SCH-P8/HD)

One type-1 block shall contain 196 type-1 bits, $b_1(1), b_1(2), \dots, b_1(196)$.

A (212,196) block code shall encode the 196 type-1 bits into 212 block-encoded bits $b_2(1), b_2(2), \dots, b_2(212)$. This code shall be the (K_I+16, K_I) block code as defined in clause 8.2.3.3, with $K_I = 196$.

Four tail bits, $b_2(213), b_2(214), b_2(215), b_2(216)$, all set equal to zero, shall be appended to the 212 block-encoded bits.

The resultant bits $b_2(1), b_2(2), \dots, b_2(216)$ shall be the type-2 bits.

A 16-state RCPC code with rate 2/3 (see clause 8.2.3.1) shall encode the 216 type-2 bits into 324 type-3 bits, $b_3(1), b_3(2), \dots, b_3(324)$.

A (324,19) block interleaver (see clause 8.2.4.1) shall re-order the 324 type-3 bits into 324 type-4 bits, $b_4(1), b_4(2), \dots, b_4(324)$.

The 324 type-4 bits $b_4(1), b_4(2), \dots, b_4(324)$ shall compose the type-4 block for SCH-P8/HD. They shall be scrambled into bits $b_5(1), b_5(2), \dots, b_5(324)$, according to clause 8.2.5.1, with the scrambling sequence as defined in clause 8.2.5.2.

The type-5 bits may be multiplexed onto block-1, in which case the multiplexed bits are defined as:

$$bkn1(k) = b_5(k), \quad \text{for } k = 1, 2, \dots, 324 \quad (8.63)$$

or they may be multiplexed into block-2, in which case the multiplexed bits shall be defined as:

$$bkn2(k) = b_5(k), \quad \text{for } k = 1, 2, \dots, 324 \quad (8.64)$$

8.3.1.4.3 Signalling CHannel for mapping onto Half-bursts on the Uplink (SCH/HU)

One type-1 block shall contain 92 type-1 bits $b_1(1), b_1(2), \dots, b_1(92)$.

A (108,92) block code shall encode the 92 type-1 bits into 108 block-encoded bits, $b_2(1), b_2(2), \dots, b_2(108)$. This code is the (K_I+16, K_I) block code as defined in clause 8.2.3.3, with $K_I=92$.

Four tail bits, $b_2(109), b_2(110), b_2(111), b_2(112)$, all set equal to zero, shall be appended to the 108 block-encoded bits.

The resultant bits $b_2(1), b_2(2), \dots, b_2(112)$ shall be the type-2 bits.

A 16-state RCPC code with rate 2/3 (see clause 8.2.3.1) shall encode the 112 type-2 bits into 168 type-3 bits, $b_3(1), b_3(2), \dots, b_3(168)$.

A (168, 13) block interleaver (see clause 8.2.4.1) shall re-order the 168 type-3 bits into 168 type-4 bits, $b_4(1), b_4(2), \dots, b_4(168)$.

The 168 type-4 bits $b_4(1), b_4(2), \dots, b_4(168)$ shall compose the type-4 block for SCH/HU. They shall be scrambled into bits $b_5(1), b_5(2), \dots, b_5(168)$, according to clause 8.2.5.1, with the scrambling sequence as defined in clause 8.2.5.2.

The multiplexed bits of the control block (which is the type-5 block for SCH/HU) are defined as:

$$cb(k) = b_5(k), \quad \text{for } k = 1, 2, \dots, 168 \quad (8.65)$$

8.3.1.4.4 Signalling CHannel for mapping onto Half-bursts on the Uplink (SCH-P8/HU)

One type-1 block shall contain 148 type-1 bits $b_1(1), b_1(2), \dots, b_1(148)$.

A (164,148) block code shall encode the 148 type-1 bits into 164 block-encoded bits, $b_2(1), b_2(2), \dots, b_2(164)$. This code is the (K_I+16, K_I) block code as defined in clause 8.2.3.3, with $K_I = 148$.

Four tail bits, $b_2(165), b_2(166), b_2(167), b_2(168)$, all set equal to zero, shall be appended to the 164 block-encoded bits.

The resultant bits $b_2(1), b_2(2), \dots, b_2(168)$ shall be the type-2 bits.

A 16-state RCPC code with rate 2/3 (see clause 8.2.3.1) shall encode the 168 type-2 bits into 252 type-3 bits, $b_3(1), b_3(2), \dots, b_3(252)$.

A (252, 17) block interleaver (see clause 8.2.4.1) shall re-order the 252 type-3 bits into 252 type-4 bits, $b_4(1), b_4(2), \dots, b_4(252)$.

The 252 type-4 bits $b_4(1), b_4(2), \dots, b_4(252)$ shall compose the type-4 block for SCH-P8/HU. They shall be scrambled into bits $b_5(1), b_5(2), \dots, b_5(252)$, according to clause 8.2.5.1, with the scrambling sequence as defined in clause 8.2.5.2.

The multiplexed bits of the control block (which is the type-5 block for SCH-P8/HU) are defined as:

$$cb(k) = b_5(k), \quad \text{for } k = 1, 2, \dots, 252 \quad (8.66)$$

8.3.1.4.5 Signalling CHannel for mapping onto Full bursts (SCH/F)

One type-1 block shall contain 268 type-1 bits, $b_1(1), b_1(2), \dots, b_1(268)$.

A (284,268) block code shall encode the 268 type-1 bits into 284 block-encoded bits $b_2(1), b_2(2), \dots, b_2(284)$. This code shall be the (K_I+16, K_I) block code as defined in clause 8.2.3.3, with $K_I = 268$.

Four tail bits, $b_2(285), b_2(286), b_2(287), b_2(288)$, all set equal to zero, shall be appended to the 284 block-encoded bits.

The resultant bits $b_2(1), b_2(2), \dots, b_2(288)$ shall be the type-2 bits.

A 16-state RCPC code with rate 2/3 (see clause 8.2.3.1) encodes the 288 type-2 bits into 432 type-3 bits, $b_3(1), b_3(2), \dots, b_3(432)$.

A (432,103) block interleaver (see clause 8.2.4.1) shall re-order the 432 type-3 bits into 432 type-4 bits, $b_4(1), b_4(2), \dots, b_4(432)$.

The 432 type-4 bits $b_4(1), b_4(2), \dots, b_4(432)$ shall compose the type-4 block for SCH/F. They shall be scrambled into bits $b_5(1), b_5(2), \dots, b_5(432)$, according to clause 8.2.5.1, with the scrambling sequence as defined in clause 8.2.5.2.

The multiplexed bits of block-1 are defined as:

$$b_{kn1}(k) = b_5(k), \quad \text{for } k = 1, 2, \dots, 216 \quad (8.67)$$

and the multiplexed bits of block 2 are defined as:

$$b_{kn2}(k) = b_5(k+216), \quad \text{for } k = 1, 2, \dots, 216 \quad (8.68)$$

8.3.1.4.6 Signalling CHannel for mapping onto Full bursts (SCH-P8/F)

One type-1 block shall contain 412 type-1 bits, $b_1(1), b_1(2), \dots, b_1(412)$.

A (428,412) block code shall encode the 412 type-1 bits into 428 block-encoded bits $b_2(1), b_2(2), \dots, b_2(428)$. This code shall be the (K_I+16, K_I) block code as defined in clause 8.2.3.3, with $K_I = 412$.

Four tail bits, $b_2(429), b_2(430), b_2(431), b_2(432)$, all set equal to zero, shall be appended to the 428 block-encoded bits.

The resultant bits $b_2(1), b_2(2), \dots, b_2(432)$ shall be the type-2 bits.

A 16-state RCPC code with rate 2/3 (see clause 8.2.3.1) encodes the 432 type-2 bits into 648 type-3 bits, $b_3(1), b_3(2), \dots, b_3(648)$.

A (648,23) block interleaver (see clause 8.2.4.1) shall re-order the 648 type-3 bits into 648 type-4 bits, $b_4(1), b_4(2), \dots, b_4(648)$.

The 648 type-4 bits $b_4(1), b_4(2), \dots, b_4(648)$ shall compose the type-4 block for SCH-P8/F. They shall be scrambled into bits $b_5(1), b_5(2), \dots, b_5(648)$, according to clause 8.2.5.1, with the scrambling sequence as defined in clause 8.2.5.2.

The multiplexed bits of block-1 are defined as:

$$b_{kn1}(k) = b_5(k), \quad \text{for } k = 1, 2, \dots, 324 \quad (8.69)$$

and the multiplexed bits of block 2 are defined as:

$$b_{kn2}(k) = b_5(k+324), \quad \text{for } k = 1, 2, \dots, 324 \quad (8.70)$$

8.3.2 Error control schemes for QAM

8.3.2.0 General

The error control scheme associated with each logical channel employing QAM is defined in clauses 8.3.2.1 to 8.3.2.9. Figure 8.8 gives the error control structure.

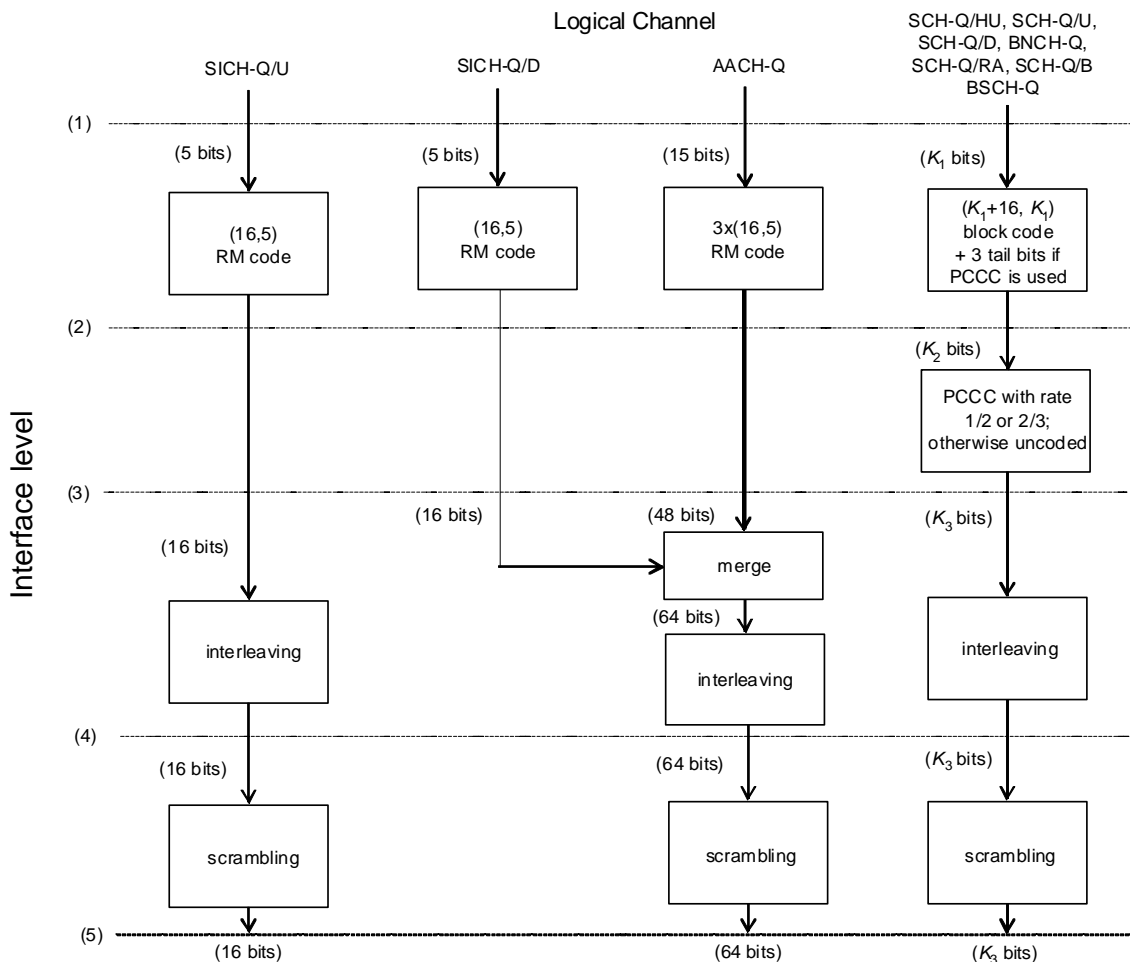

Figure 8.8: Error control structure for QAM logical channels

8.3.2.1 Slot Information Channel - QAM/Uplink (SICH-Q/U)

A type-1 block shall contain 5 type-1 bits $b_1(1), b_1(2), \dots, b_1(5)$.

A (16,5) RM code (see clause 8.2.3.5) shall encode the 5 type-1 bits into 16 type-2 bits, $b_2(1), b_2(2), \dots, b_2(16)$.

The type-3 bits shall be the same as the type-2 bits:

$$b_3(k) = b_2(k), \quad k = 1, 2, \dots, 16 \tag{8.71}$$

The 16 type-3 bits $b_3(1), b_3(2), \dots, b_3(16)$ compose the type-3 block for SICH-Q/U. They shall be interleaved into 16 type-4 bits $b_4(1), b_4(2), \dots, b_4(16)$ according to clause 8.2.4.3, with interleaving parameters given by the second row of table 8.2.

The 16 type-4 bits $b_4(1), b_4(2), \dots, b_4(16)$ shall be scrambled into 16 type-5 bits $b_5(1), b_5(2), \dots, b_5(16)$ according to clause 8.2.5.1, with scrambling sequence as defined in clause 8.2.5.2.

8.3.2.2 Slot Information Channel - QAM/Downlink (SICH-Q/D)

A type-1 block shall contain 5 type-1 bits $b_1(1), b_1(2), \dots, b_1(5)$.

A (16,5) RM code (see clause 8.2.3.5) shall encode the 5 type-1 bits into 16 type-2 bits, $b_2(1), b_2(2), \dots, b_2(16)$.

The type-3 bits shall be the same as the type-2 bits:

$$b_3(k) = b_2(k), \quad k = 1, 2, \dots, 16 \quad (8.72)$$

The 16 type-3 bits $b_3(1), b_3(2), \dots, b_3(16)$ compose the type-3 block for SICH-Q/D. As described in clause 8.3.2.3, they shall be merged with the type-3 bits relevant to the AACH-Q and shall then undergo block interleaving and scrambling.

8.3.2.3 Access Assignment Channel - QAM (AACH-Q)

A type-1 block shall contain 15 type-1 bits $b_1(1), b_1(2), \dots, b_1(15)$. This sequence is split into three 5-bit sub-sequences, as follows:

- 1st sub-sequence: $b_1(1), b_1(2), \dots, b_1(5)$;
- 2nd sub-sequence: $b_1(6), b_1(7), \dots, b_1(10)$;
- 3rd sub-sequence: $b_1(11), b_1(12), \dots, b_1(15)$.

A (16,5) RM code (see clause 8.2.3.5) shall encode each of the above three sub-sequences into 16 type-2 bits, as follows:

- the sequence $b_1(1), b_1(2), \dots, b_1(5)$ shall produce the sequence $b_2(1), b_2(2), \dots, b_2(16)$;
- the sequence $b_1(6), b_1(7), \dots, b_1(10)$ shall produce the sequence $b_2(17), b_2(18), \dots, b_2(32)$;
- the sequence $b_1(11), b_1(12), \dots, b_1(15)$ shall produce the sequence $b_2(33), b_2(34), \dots, b_2(48)$.

The three encoded sequences are then merged into a single 48 type-2 bits sequence $b_2(1), b_2(2), \dots, b_2(48)$.

The type-3 bits shall be the same as the type-2 bits:

$$b_3(k) = b_2(k), \quad k = 1, 2, \dots, 48 \quad (8.73)$$

The 48 type-3 bits $b_3(1), b_3(2), \dots, b_3(48)$ compose the type-3 block for AACH-Q. They shall be merged with the type-3 bits relevant to the SICH-Q/D so as to generate the 64 type-3 bits $b'_3(1), b'_3(2), \dots, b'_3(64)$, as follows:

- the first 16 bits $b'_3(1), b'_3(2), \dots, b'_3(16)$ shall coincide with the type-3 block for SICH-Q/D (see clause 8.3.2.2);
- the remaining 48 bits $b'_3(17), b'_3(18), \dots, b'_3(64)$ shall coincide with the type-3 block for AACH-Q.

The 64 type-3 bits $b'_3(1), b'_3(2), \dots, b'_3(64)$ shall be interleaved into 64 type-4 bits $b_4(1), b_4(2), \dots, b_4(64)$ according to clause 8.2.4.3, with interleaving parameters given by the last row of table 8.2.

The 64 type-4 bits $b_4(1), b_4(2), \dots, b_4(64)$ shall be scrambled into 64 type-5 bits $b_5(1), b_5(2), \dots, b_5(64)$ according to clause 8.2.5.1, with scrambling sequence as defined in clause 8.2.5.2.

8.3.2.4 Signalling Channel - QAM/Half slot Uplink (SCH-Q/HU)

One type-1 block shall contain K_1 type-1 bits $b_1(1), b_1(2), \dots, b_1(K_1)$ where K_1 depends on the bandwidth, the modulation and the PCCC coding rate. Table 8.7 shows the values of K_1 for all allowed bandwidths, modulations and coding rates.

Table 8.7: Values of K_1 for logical channel SCH-Q/HU

Number of sub-carriers	4-QAM	16-QAM		64-QAM		
	$r = 1/2$	$r = 1/2$	uncoded	$r = 1/2$	$r = 2/3$	uncoded
8	57	133	288	209	285	440
16	141	301	624	461	621	944
32	309	637	1 296	965	1 293	1 952
48	477	973	1 968	1 469	1 965	2 960

A $(K_1 + 16, K_1)$ block code shall encode the K_1 type-1 bits into $K_1 + 16$ block-encoded type-2 bits $b_2(1), b_2(2), \dots, b_2(K_1 + 16)$. This code is the $(K_1 + 16, K_1)$ block code defined in clause 8.2.3.3, with K_1 one of the values of table 8.7.

In case a PCCC encoder is used with coding rate r equal to $1/2$ or $2/3$ (see clause 8.2.3.4), three tail bits, $b_2(K_1 + 17), b_2(K_1 + 18), b_2(K_1 + 19)$, whose values are as specified in table 8.1, shall be appended to the $K_1 + 16$ block-encoded bits. If PCCC is not used (uncoded case), no tail bits shall be appended to the $K_1 + 16$ block-encoded bits.

The resultant bits $b_2(1), b_2(2), \dots, b_2(K_2)$ shall be the type-2 bits, with $K_2 = K_1 + 19$ or $K_2 = K_1 + 16$ depending on whether PCCC is used or not, respectively.

As already mentioned, a PCCC scheme with coding rate r equal to $1/2$ or $2/3$ may be used to encode the K_2 type-2 bits into K_3 type-3 bits, $b_3(1), b_3(2), \dots, b_3(K_3)$. Alternatively, no PCCC encoder may be used (uncoded case) and in this case $K_3 = K_2 = K_1 + 16$. The possible values of K_3 depending on bandwidth and modulation are shown in table 8.8.

Table 8.8: Values of K_3 for logical channel SCH-Q/HU

Number of subcarriers	4-QAM K_3	16-QAM K_3	64-QAM K_3
8	152	304	456
16	320	640	960
32	656	1 312	1 968
48	992	1 984	2 976

A (K_3, a) block interleaver (see clause 8.2.4.3, tables 8.3 to 8.6) shall re-order the K_3 type-3 bits into $K_4 = K_3$ type-4 bits, $b_4(1), b_4(2), \dots, b_4(K_4)$. The K_4 type-4 bits $b_4(1), b_4(2), \dots, b_4(K_4)$ shall compose the type-4 block for SCH-Q/HU. They shall be scrambled into $K_5 = K_4$ bits $b_5(1), b_5(2), \dots, b_5(K_5)$, according to clause 8.2.5.1, with the scrambling sequence as defined in clause 8.2.5.2.

8.3.2.5 Signalling Channel - QAM/Uplink (SCH-Q/U)

One type-1 block shall contain K_1 type-1 bits $b_1(1), b_1(2), \dots, b_1(K_1)$, where K_1 depends on the bandwidth, the modulation and the PCCC coding rate. Table 8.9 shows the values of K_1 for all allowed bandwidths, modulations and coding rates.

Table 8.9: Values of K_1 for logical channel SCH-Q/U

Number of sub-carriers	4-QAM	16-QAM		64-QAM		
	$r = 1/2$	$r = 1/2$	uncoded	$r = 1/2$	$r = 2/3$	uncoded
8	181	381	784	581	781	1 184
16	389	797	1 616	1 205	1 613	2 432
32	805	1 629	3 280	2 453	3 277	4 928
48	1 221	2 461	4 944	3 701	4 941	7 424

A $(K_I + 16, K_I)$ block code shall encode the K_I type-1 bits into $K_I + 16$ block-encoded type-2 bits $b_2(1), b_2(2), \dots, b_2(K_I + 16)$. This code is the $(K_I + 16, K_I)$ block code defined in clause 8.2.3.3, with K_I one of the values of table 8.9.

In case a PCCC encoder is used with coding rate r equal to 1/2 or 2/3 (see clause 8.2.3.4), three tail bits, $b_2(K_I + 17)$, $b_2(K_I + 18)$, $b_2(K_I + 19)$, whose values are as specified in table 8.1, shall be appended to the $K_I + 16$ block-encoded bits. If PCCC is not used (uncoded case), no tail bits shall be appended to the $K_I + 16$ block-encoded bits.

The resultant bits $b_2(1), b_2(2), \dots, b_2(K_2)$ shall be the type-2 bits, with $K_2 = K_I + 19$ or $K_2 = K_I + 16$ depending on whether PCCC is used or not, respectively.

As already mentioned, a PCCC scheme with coding rate r equal to 1/2 or 2/3 may be used to encode the K_2 type-2 bits into K_3 type-3 bits, $b_3(1), b_3(2), \dots, b_3(K_3)$. Alternatively, no PCCC encoder may be used (uncoded case) and in this case $K_3 = K_2 = K_I + 16$. The possible values of K_3 depending on bandwidth and modulation are shown in table 8.10.

Table 8.10: Values of K_3 for logical channel SCH-Q/U

Number of subcarriers	4-QAM K_3	16-QAM K_3	64-QAM K_3
8	400	800	1 200
16	816	1 632	2 448
32	1 648	3 296	4 944
48	2 480	4 960	7 440

A (K_3, a) block interleaver (see clause 8.2.4.3, tables 8.3 to 8.6) shall re-order the K_3 type-3 bits into $K_4 = K_3$ type-4 bits, $b_4(1), b_4(2), \dots, b_4(K_4)$. The K_4 type-4 bits $b_4(1), b_4(2), \dots, b_4(K_4)$ shall compose the type-4 block for SCH-Q/U. They shall be scrambled into $K_5 = K_4$ bits $b_5(1), b_5(2), \dots, b_5(K_5)$, according to clause 8.2.5.1, with the scrambling sequence as defined in clause 8.2.5.2.

8.3.2.6 Signalling Channel - QAM/Downlink (SCH-Q/D) and Broadcast Network Channel - QAM (BNCH-Q)

One type-1 block shall contain K_I type-1 bits $b_1(1), b_1(2), \dots, b_1(K_I)$, where K_I depends on the bandwidth, the modulation and the PCCC coding rate. Table 8.11 shows the values of K_I for all allowed bandwidths, modulations and coding rates.

Table 8.11: Values of K_I for logical channels SCH-Q/D and BNCH-Q

Number of sub-carriers	4-QAM		16-QAM		64-QAM	
	$r = 1/2$	$r = 1/2$	uncoded	$r = 1/2$	$r = 2/3$	uncoded
8	185	389	800	593	797	1 208
16	421	861	1 744	1 301	1 741	2 624
32	893	1 805	3 632	2 717	3 629	5 456
48	1 365	2 749	5 520	4 133	5 517	8 288

A $(K_I + 16, K_I)$ block code shall encode the K_I type-1 bits into $K_I + 16$ block-encoded type-2 bits $b_2(1), b_2(2), \dots, b_2(K_I + 16)$. This code is the $(K_I + 16, K_I)$ block code defined in clause 8.2.3.3, with K_I one of the values of table 8.11.

In case a PCCC encoder is used with coding rate r equal to 1/2 or 2/3 (see clause 8.2.3.4), three tail bits, $b_2(K_I + 17)$, $b_2(K_I + 18)$, $b_2(K_I + 19)$, whose values are as specified in table 8.1, shall be appended to the $K_I + 16$ block-encoded bits. If PCCC is not used (uncoded case), no tail bits shall be appended to the $K_I + 16$ block-encoded bits.

The resultant bits $b_2(1), b_2(2), \dots, b_2(K_2)$ shall be the type-2 bits, with $K_2 = K_I + 19$ or $K_2 = K_I + 16$ depending on whether PCCC is used or not, respectively.

As already mentioned, a PCCC scheme with coding rate r equal to 1/2 or 2/3 may be used to encode the K_2 type-2 bits into K_3 type-3 bits, $b_3(1), b_3(2), \dots, b_3(K_3)$. Alternatively, no PCCC encoder may be used (uncoded case) and in this case $K_3 = K_2 = K_I + 16$. The possible values of K_3 depending on bandwidth and modulation are shown in table 8.12.

Table 8.12: Values of K_3 for logical channels SCH-Q/D and BNCH-Q

Number of subcarriers	4-QAM K_3	16-QAM K_3	64-QAM K_3
8	408	816	1 224
16	880	1 760	2 640
32	1 824	3 648	5 472
48	2 768	5 536	8 304

A (K_3, a) block interleaver (see clause 8.2.4.3, tables 8.3 to 8.6) shall re-order the K_3 type-3 bits into $K_4 = K_3$ type-4 bits, $b_4(1), b_4(2), \dots, b_4(K_4)$. The K_4 type-4 bits $b_4(1), b_4(2), \dots, b_4(K_4)$ shall compose the type-4 block for SCH-Q/D or BNCH-Q. They shall be scrambled into $K_5 = K_4$ bits $b_5(1), b_5(2), \dots, b_5(K_5)$ according to clause 8.2.5.1, with the scrambling sequence as defined in clause 8.2.5.2.

8.3.2.7 Signalling Channel - QAM/Random Access (SCH-Q/RA)

One type-1 block shall contain $K_1 = 65$ type-1 bits $b_1(1), b_1(2), \dots, b_1(65)$.

A (81,65) block code shall encode the 65 type 1 bits into 81 block-encoded bits $b_2(1), b_2(2), \dots, b_2(81)$. This code shall be the ($K_1 + 16, K_1$) block code defined in clause 8.2.3.3, with $K_1 = 65$.

Three tail bits, $b_2(82), b_2(83), b_2(84)$, whose values are as specified in table 8.1, shall be appended to the 81 block-encoded bits. The resultant bits $b_2(1), b_2(2), \dots, b_2(K_2)$, with $K_2 = 84$, shall be the type-2 bits.

A PCCC scheme with coding rate r equal to 1/2 shall be used to encode the 84 type-2 bits into $K_3 = 168$ type-3 bits, $b_3(1), b_3(2), \dots, b_3(168)$.

A (168,13) block interleaver (see clause 8.2.4.3, table 8.3) shall re-order the 168 type-3 bits into $K_4 = K_3 = 168$ type-4 bits, $b_4(1), b_4(2), \dots, b_4(168)$. The type-4 bits $b_4(1), b_4(2), \dots, b_4(168)$ shall compose the type-4 block for SCH-Q/RA. They shall be scrambled into $K_5 = K_4 = 168$ bits $b_5(1), b_5(2), \dots, b_5(168)$, according to clause 8.2.5.1, with the scrambling sequence as defined in clause 8.2.5.2.

8.3.2.8 Broadcast Synchronization Channel - QAM (BSCH-Q)

One type-1 block shall contain 117 type-1 bits $b_1(1), b_1(2), \dots, b_1(117)$. Only the 4-QAM modulation is applicable. Only coding rate r equal to 1/2 is applicable.

A (133,117) block code shall encode the 117 type-1 bits into 133 block-encoded bits, $b_2(1), b_2(2), \dots, b_2(133)$. This code is the (K_1+16, K_1) block code as defined in clause 8.2.3.3, with $K_1 = 117$.

Three tail bits, $b_2(134), b_2(135), b_2(136)$, whose values are as specified in table 8.1, shall be appended to the 133 block-encoded bits.

The resultant bits $b_2(1), b_2(2), \dots, b_2(136)$ shall be the type-2 bits.

A PCCC scheme with coding rate 1/2 (see clause 8.2.3.4) shall encode the 136 type-2 bits into 272 type-3 bits, $b_3(1), b_3(2), \dots, b_3(272)$.

A (272,19) block interleaving (see clause 8.2.4.3) shall re-order the 272 type-3 bits into 272 type-4 bits, $b_4(1), b_4(2), \dots, b_4(272)$.

The 272 type-4 bits, $b_4(1), b_4(2), \dots, b_4(272)$ compose the type-4 block for BSCH-Q. They shall be scrambled into bits $b_5(1), b_5(2), \dots, b_5(272)$, according to clause 8.2.5.1, with the scrambling sequence as defined in clause 8.2.5.2.

The multiplexed bits of the synchronization block shall be defined as:

$$sb(k) = b_5(k), \quad \text{for } k = 1, 2, \dots, 272 \quad (8.74)$$

8.3.2.9 Signalling Channel Data set B - QAM (SCH-Q/B)

One type-1 block shall contain K_1 type-1 bits $b_1(1), b_1(2), \dots, b_1(K_1)$, where K_1 depends on the bandwidth. Only the 4-QAM modulation is applicable. Only coding rate r equal to 1/2 is applicable. Table 8.13 shows the values of K_1 for all allowed bandwidths.

Table 8.13: Values of K_1 for logical channel SCH-Q/B

Number of sub-carriers	4-QAM
	$r = 1/2$
8	-
16	217
32	689
48	1 161

A $(K_1 + 16, K_1)$ block code shall encode the K_1 type-1 bits into $K_1 + 16$ block-encoded type-2 bits $b_2(1), b_2(2), \dots, b_2(K_1 + 16)$. This code is the $(K_1 + 16, K_1)$ block code defined in clause 8.2.3.3, with K_1 one of the values of table 8.13.

Three tail bits, $b_2(K_1 + 17), b_2(K_1 + 18), b_2(K_1 + 19)$, whose values are as specified in table 8.1, shall be appended to the $K_1 + 16$ block-encoded bits.

The resultant bits $b_2(1), b_2(2), \dots, b_2(K_2)$ shall be the type-2 bits, with $K_2 = K_1 + 19$.

A PCCC scheme with coding rate 1/2 shall encode the K_2 type-2 bits into K_3 type-3 bits, $b_3(1), b_3(2), \dots, b_3(K_3)$. The possible values of K_3 depending on bandwidth are shown in table 8.14.

Table 8.14: Values of K_3 for logical channel SCH-Q/B

Number of subcarriers	4-QAM K_3
8	-
16	472
32	1 416
48	2 360

A (K_3, a) block interleaver (see clause 8.2.4.3, tables 8.4 to 8.6) shall re-order the K_3 type-3 bits into $K_4 = K_3$ type-4 bits, $b_4(1), b_4(2), \dots, b_4(K_4)$. The K_4 type-4 bits $b_4(1), b_4(2), \dots, b_4(K_4)$ shall compose the type-4 block for SCH-Q/B. They shall be scrambled into $K_5 = K_4$ bits $b_5(1), b_5(2), \dots, b_5(K_5)$ according to clause 8.2.5.1, with the scrambling sequence as defined in clause 8.2.5.2.

9 Channel multiplexing

9.1 Introduction

Clauses 9 defines the physical channels of the V+D radio sub-system required to support the logical channels. They include a description of the logical channels and the definitions of TDMA frames, timeslots and bursts.

9.2 Logical channels

9.2.0 General

A logical channel is defined as a logical communication pathway between two or more parties. The logical channels represent the interface between the protocol and the radio subsystem.

The definition of the logical channels that are supported by the radio subsystem is given below.

9.2.1 Logical channels hierarchy

The logical channels may be separated into two categories: the traffic channels carrying speech or data information in circuit switched mode and the control channels carrying signalling messages and packet data. The logical channels supported by the MAC are described here, with their hierarchical relationship.

9.2.2 Traffic channels for $\pi/4$ -DQPSK

The traffic channels shall carry user information. Different traffic channels are defined for speech or data applications and for different data message speeds:

- Speech Traffic Channel (TCH/S);
- Circuit mode traffic channels as follows:
 - 7,2 kbit/s net rate (TCH/7.2);
 - 4,8 kbit/s net rate (TCH/4.8);
 - 2,4 kbit/s net rate (TCH/2.4).

Higher net rate up to 28,8 kbit/s, 19,2 kbit/s or 9,6 kbit/s may be used. They are obtained by allocating up to 4 Traffic Physical (TP) channels to the same communication.

NOTE: Three different depths of interleaving (with $N = 1, 4, \text{ or } 8$) may be applied to the traffic channels TCH/4,8 and TCH/2,4 as detailed in clause 8.2.4.2.

9.2.2a Traffic channels for $\pi/8$ -D8PSK

A single uncoded traffic channel is defined for $\pi/8$ -D8PSK which enables nominal error rate references to be determined.

- Uncoded traffic channel as follows:
 - 10,8 kbit/s net rate (TCH-P8/10,8).

9.2.3 Control CHannels (CCH) for phase modulation

9.2.3.1 General

The CCH shall carry signalling messages and packet data. Five categories of control channel are defined:

- Broadcast Control CHannel (BCCH);
- Linearization CHannel (LCH);
- Signalling CHannel (SCH);
- Access Assignment CHannel (AACH); and
- STealing CHannel (STCH).

9.2.3.2 BCCH

The BCCH shall be a uni-directional channel for common reception by all MSs. It shall broadcast general information to all MSs.

Two categories of BCCHs are defined, network and synchronization:

- Broadcast Network Channel (BNCH):
 - down-link only, broadcasts network information to MSs.
- Broadcast Synchronization Channel (BSCH):
 - down-link only, broadcast information used for frequency, time and scrambling synchronization of the MSs.

9.2.3.3 LCH

The LCH shall be used by the BSs and MSs to linearize their transmitter.

Two categories of LCHs are defined, common and BS:

- Common Linearization Channel (CLCH):
 - up-link, shared by all the MSs.
- BS Linearization CHannel (BLCH):
 - downlink, used by the BS.

9.2.3.4 SCH for $\pi/4$ -DQPSK

The SCH is shared by all MSs, and carries messages. A message may be specific to an MS, a group of MSs or all MSs. SCH has 3 categories:

- Full size Signalling Channel (SCH/F):
 - uplink and downlink, where messages are coded across an entire timeslot.
- Half size Downlink Signalling Channel (SCH/HD):
 - downlink only, where messages are separately coded in each half of a timeslot.
- Half size Uplink Signalling Channel (SCH/HU):
 - uplink only, where messages are coded across one subslot.

9.2.3.4a SCH for $\pi/8$ -D8PSK

As in the case of $\pi/4$ -DQPSK, the SCH has 3 categories:

- Full size Signalling Channel (SCH-P8/F):
 - uplink and downlink, where messages are coded across an entire timeslot.
- Half size Downlink Signalling Channel (SCH-P8/HD):
 - downlink only, where messages are separately coded in each half of a timeslot.
- Half size Uplink Signalling Channel (SCH-P8/HU):
 - uplink only, where messages are coded across one subslot.

9.2.3.5 AACH

The AACH shall be present on all transmitted downlink slots. It shall be used to indicate on each physical channel the assignment of the uplink and downlink slots. The AACH shall be internal to the MAC.

9.2.3.6 STCH

The STCH is a channel associated to a TCH that temporarily "steals" a part of the associated TCH capacity to transmit control messages. It may be used when fast signalling is required. In half duplex mode the STCH is unidirectional and has the same direction as the associated TCH.

9.2.4 QAM Control Channels (CCH-Q)

9.2.4.1 General

The CCH-Q shall carry signalling messages and packet data. Five categories of control channel are defined:

- QAM Broadcast Control Channel (BCCH-Q);
- QAM Linearization Channel (LCH-Q);
- QAM Signalling Channel (SCH-Q);
- QAM Access Assignment Channel (AACH-Q); and
- QAM Slot Information Channel (SICH-Q).

9.2.4.2 BCCH-Q

The BCCH-Q shall be a uni-directional channel for common reception by all MSs. It shall broadcast general information to all MSs.

Two categories of BCCH-Q are defined:

- QAM Broadcast Network Channel (BNCH-Q):
 - downlink only, broadcasts network information to MSs.
- QAM Broadcast Synchronization Channel (BSCH-Q):
 - downlink only, broadcasts information used for frequency, time and scrambling synchronization of the direct access MSs and network information.

9.2.4.3 LCH-Q

The LCH-Q shall be used by the base and MSs to linearize their transmitter.

Two categories of LCH-Qs are defined, common and BS:

- QAM Common Linearization Channel (CLCH-Q):
 - uplink, shared by all the MSs.
- QAM BS Linearization Channel (BLCH-Q):
 - downlink, used by the BS.

Each of these two categories may be further subdivided according to channel bandwidth (25 kHz, 50 kHz, 100 kHz and 150 kHz). For all channel bandwidths, the sole use of the LCH-Q is to linearize the transmitter using part of or all of the channel bandwidth.

9.2.4.4 SCH-Q

The SCH-Q is shared by all MSs, and carries messages. A message may be specific to an MS, a group of MSs or all MSs. SCH-Q has 4 categories:

- QAM Full size Downlink Signalling Channel (SCH-Q/D):
 - downlink only, where messages are coded across an entire timeslot.
- QAM Full size Uplink Signalling Channel (SCH-Q/U):
 - uplink only, where messages are coded across an entire timeslot.
- QAM Half size Uplink Signalling Channel (SCH-Q/HU):
 - uplink only, where messages are coded across one subslot.
- QAM Random Access Uplink Signalling Channel (SCH-Q/RA):
 - uplink only, used for random access messages.

Each of the first 3 categories may be further subdivided according to channel bandwidth (25 kHz, 50 kHz, 100 kHz and 150 kHz), and modulation / coding combination. The fourth category (SCH-Q/RA) is 25 kHz only and fixed modulation/coding.

For the first 3 categories, the channel subdivision is indicated as channel bandwidth followed by modulation followed by coding:

$$\text{SCH-Q/}\{D|U|HU\}\{25|50|100|150\}\{-\{4|16|64\}\{H|M|U\}}$$

Where {D|U|HU} denotes one of D, U or HU indicating that the channel is for the downlink (D), uplink (U) or half slot uplink (HU) respectively, {4|16|64} denotes one of 4, 16 or 64 indicating that the channel is using 4-QAM, 16-QAM or 64-QAM modulation, and {H|M|U} denotes one of H, M or U indicating that the channel is using high protection (rate 1/2) (H), medium protection (rate 2/3) (M) or unprotected (rate 1/1) (U). The SCH-Q/D channel for 25 kHz using 4-QAM modulation and high protection (rate 1/2) is according to the naming convention named as SCH-Q/D25-4H.

The total list of valid SCH-Q for 25 kHz operations is then:

- SCH-Q/D25-4H, SCH-Q/D25-16H, SCH-Q/D25-64H, SCH-Q/D25-64M, SCH-Q/D25-16U, SCH-Q/D25-64U;
- SCH-Q/U25-4H, SCH-Q/U25-16H, SCH-Q/U25-64H, SCH-Q/U25-64M, SCH-Q/U25-16U, SCH-Q/U25-64U;
- SCH-Q/HU25-4H, SCH-Q/HU25-16H, SCH-Q/HU25-64H, SCH-Q/HU25-64M, SCH-Q/HU25-16U, SCH-Q/HU25-64U;
- SCH-Q/RA.

This gives a total of 19 SCH-Q for 25 kHz operations, and a total of 73 SCH-Q for all channel bandwidths.

9.2.4.4a SCH-Q/B

The SCH-Q/B is shared by all MSs, and carries messages. A message may be specific to an MS, a group of MSs or all MSs. SCH-Q/B is used only in the downlink direction and only on 50 kHz, 100 kHz and 150 kHz QAM channels.

SCH-Q/B is subdivided according to channel bandwidth (50 kHz, 100 kHz and 150 kHz).

The channel subdivision is indicated as channel bandwidth:

SCH-Q/B {50|100|150}

The SCH-Q/B logical channel uses 4-QAM modulation and high protection (rate 1/2).

NOTE: A value of the element contained in the SICH-Q/D in the downlink header block indicates that a burst is an FCB. All MSs that understand the FCB value in the SICH-Q/D will decode the SCH-Q/B. However BS designers should note that some conventional access MSs may not understand the FCB value in the SICH-Q/D.

9.2.4.5 AACH-Q

The AACH-Q shall be present on all transmitted downlink slots (except slots containing BLCH-Q). It shall be used to indicate on each QAM physical channel the assignment of the uplink and downlink slots. The AACH-Q shall be internal to the MAC.

9.2.4.6 SICH-Q

The SICH-Q shall be present on all transmitted slots, except slots carrying SCH-Q/RA or containing BLCH-Q. On the downlink, it shall be used to indicate the modulation and coding used in the remainder of the slot or whether the burst is an FCB. On the uplink, it shall be used to indicate the modulation and coding used in the remainder of the slot or subslot. The SICH-Q shall be internal to the MAC.

Two categories of SICH-Qs are defined, downlink and uplink:

- QAM Downlink Slot Information Channel (SICH-Q/D):
 - downlink only, included in all downlink slots (except slots containing BLCH-Q);
- QAM Uplink Slot Information Channel (SICH-Q/U):
 - uplink only, included in all uplink slots or subslots, except subslots carrying SCH-Q/RA or containing CLCH-Q.

Each of the 2 categories may be further subdivided according to channel bandwidth (25 kHz, 50 kHz, 100 kHz and 150 kHz). The notation for SICH-Q is:

SICH-Q/{D|U}{25|50|100|150}

NOTE 1: The content of the SICH-Q/D and SICH-Q/U channels is the same in all channel bandwidths.

NOTE 2: The multiple channels are defined here for testing purpose. The target performance of the various channels will not vary significantly in terms of required E_b/N_0 as the channel bandwidth changes, but since the fraction of power devoted to headers goes down as the channel bandwidth goes up, the reference sensitivity will vary.

9.3 The physical resource

9.3.1 General

The physical resource available to the radio sub-system is an allocation of part of the radio spectrum. This resource shall be partitioned both in frequency and time. Frequency shall be partitioned by RF channels divided into bands as defined in clause 6. Time shall be partitioned by timeslots and TDMA frames as defined in clauses 9.3.2 to 9.3.9.

The access scheme shall be TDMA.

The TDMA structure shall be composed of hyperframes, multiframes, frames, slots and subslots. Figure 9.1 repeats the representation of the TDMA structure given in figure 4.3.

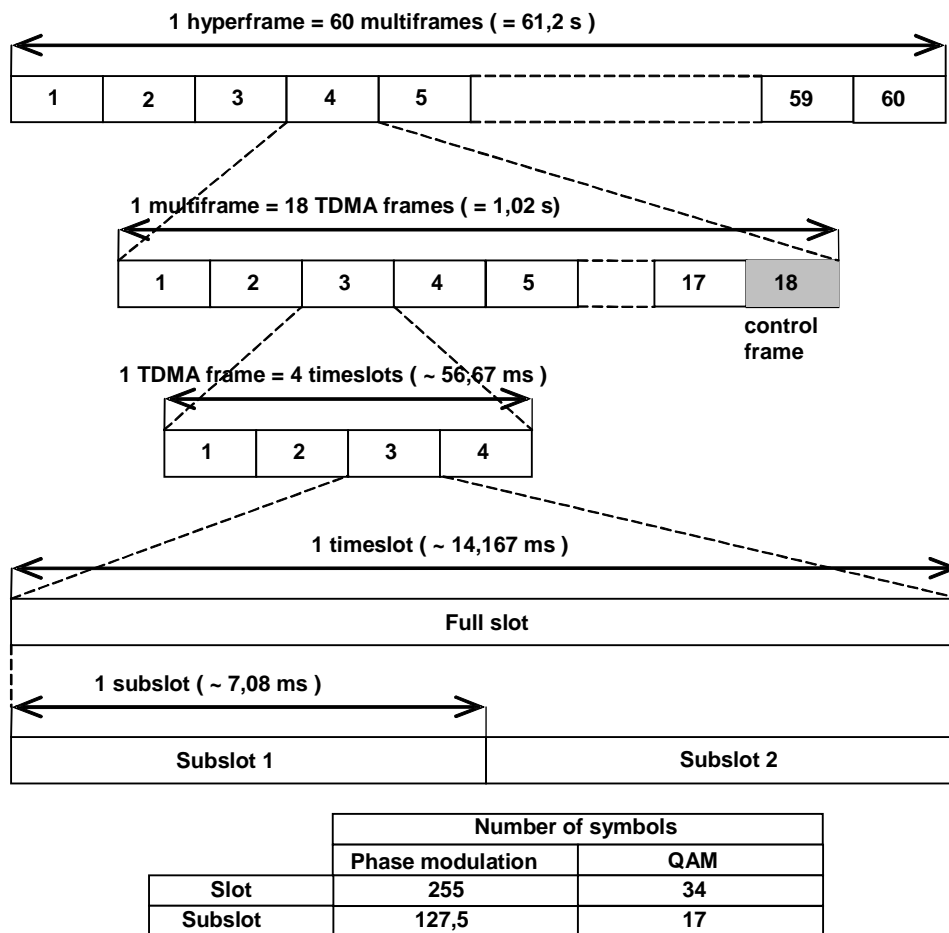

Figure 9.1: TDMA structure

9.3.2 RF channels for phase modulation

A RF channel is defined as a specified portion of the RF spectrum. Clause 6 defines the carrier separation which applies to TETRA channels.

The DownLink (DL) comprises RF channels used in the BS to MS direction.

The UpLink (UL) comprises RF channels used in the MS to BS direction.

In case of conventional access one pair of phase modulated radio frequencies (uplink and downlink) of the cell allocation shall be used to carry the MCCCH (see clauses 9.4.2.1 and 9.5.1) and shall be known as the CA main carrier.

9.3.2a RF channels for QAM

Clause 6 defines the carrier separation which applies to TETRA QAM channels. These channels can exist in addition to the phase modulation channels or independent of them.

The DownLink (DL) comprises RF channels used in the BS to MS direction.

The UpLink (UL) comprises RF channels used in the MS to BS direction.

The QAM channel TDMA structure is identical to the phase modulation TDMA structure as shown in figure 9.1.

In case of conventional access one pair of phase modulated radio frequencies (uplink and downlink) of the cell allocation shall be used to carry the MCCH (see clauses 9.4.2.1 and 9.5.1) and shall be known as the CA main carrier.

In case of direct access one pair of QAM radio frequencies (uplink and downlink) of the cell allocation shall be used to carry the MCCH-Q (see clauses 9.4.6.1 and 9.5.6) and shall be known as the DA main carrier.

9.3.2b Random access RF channels for QAM

The Uplink Random Access comprises RF channels used in the MS to BS direction, see figure 9.2.

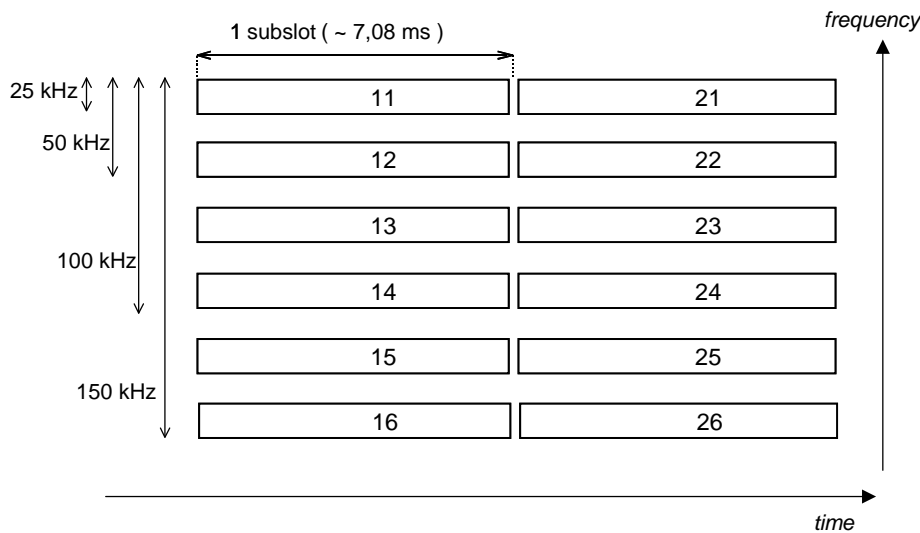

Figure 9.2: Random access time / frequency structure

RAB channels are independent 25 kHz channels and the separation of the center frequency from the center frequency of the neighbour RAB channel is 25 kHz as shown in table 9.1.

Table 9.1: Centre frequency offset of RAB channels from QAM channel centre frequency

RAB #	Offset from allocated BW centre (kHz)			
	25 kHz	50 kHz	100 kHz	150 kHz
11/21	0	12,5	37,5	62,5
12/22	-	-12,5	12,5	37,5
13/23	-	-	-12,5	12,5
14/24	-	-	-37,5	-12,5
15/25	-	-	-	-37,5
16/26	-	-	-	-62,5

9.3.3 Timeslots

The basic unit of the TDMA structure is the timeslot. A timeslot shall have a duration of 85/6 ms (approximately 14,17 ms) which corresponds to 255 phase modulation symbols duration in the Phase Modulation case and to 34 symbols duration in the QAM case.

9.3.4 TDMA frame

Four timeslots shall form a TDMA frame. The TDMA frame has a duration of $170/3$ ms (approximately 56,67 ms).

The TDMA frames shall be numbered by a Frame Number (*FN*). The *FN* shall be cyclically numbered from 1 to 18. The *FN* shall be incremented at the end of each TDMA frame.

The frame *FN18* (also termed the control frame) shall be exclusively devoted to control channels.

9.3.5 Timeslot numbering

The timeslots within a TDMA frame shall be numbered from 1 to 4 and a particular timeslot shall be referenced by its Timeslot Number (TN).

9.3.6 Subslot

The uplink timeslots may be divided into 2 subslots. The subslots within a timeslot shall be numbered from 1 to 2 and a particular subslot shall be referenced by its SubSlot Number (SSN).

A subslot shall have a duration of $85/12$ ms (approximately 7,08 ms) which corresponds to 127,5 phase modulation symbols duration in the Phase Modulation case and to 17 symbols duration in the QAM case.

9.3.6a Random access uplink RF channel subslots for QAM

For QAM, the random access uplink RF channel subslots shall be numbered from 11 and 21 in 25 kHz QAM channels, 11 to 12 and 21 to 22 in 50 kHz QAM channels, 11 to 14 and 21 to 24 in 100 kHz QAM channels and 11 to 16 and 21 to 26 in 150 kHz QAM channels. A particular random access uplink RF channel subslot shall be referenced by its QAM Subslot Number (SSN-Q).

A random access uplink RF channel subslot shall have a duration of $85/12$ ms (approximately 7,08 ms), which corresponds to 17 symbols duration, and use 25 kHz of channel bandwidth, as depicted in figure 9.2.

9.3.7 Multiframe

Eighteen TDMA frames shall form a multiframe. The multiframe shall have a duration of 1,02 s.

The multiframes shall be numbered by a Multiframe Number (*MN*). The *MN* shall be cyclically numbered from 1 to 60. The *MN* shall be incremented whenever the TDMA *FN* returns to 1.

9.3.8 Hyperframe

The hyperframe is the longest recurrent time period of the TDMA structure. Sixty multiframes shall form a hyperframe. The hyperframe shall have a duration of 61,2 s.

9.3.9 Frame alignment

At the BS, the start of the hyperframe, multiframe and TDMA frame on the uplink shall be delayed by the fixed period of 2 timeslots from the start of the hyperframe, multiframe and TDMA frame on the downlink.

9.4 Physical channels

9.4.1 General

A physical channel is defined by a pair of radio carrier frequencies (downlink and uplink) and a *TN*. There shall be 4 physical channels per pair of radio frequencies.

Clauses 9.4.2 to 9.4.5 apply to Phase Modulation channels.

Clauses 9.4.6 to 9.4.9 apply to QAM channels.

9.4.2 Types of physical channels for phase modulation

9.4.2.0 General

Three types of physical channel are defined:

- the Control Physical channel;
- the Traffic Physical channel; and
- the Unallocated Physical channel.

The type of physical channel shall be indicated in the AACH.

9.4.2.1 CP channel for phase modulation

The CP channel is a physical channel carrying exclusively CCH. Two types of CP channels are defined:

- the Main Control CHannel (MCCH); and
- the Secondary Control CHannel (SCCH).

In each conventional access cell one phase modulated RF carrier shall be defined as the main carrier (CA main carrier).

Whenever a MCCH is used, the MCCH shall be located on timeslot 1 of the main carrier.

SCCH may be common SCCH or assigned SCCH:

- Phase modulation common SCCH(s) are used only in the case of conventional access. If provided, they are used to extend the signalling capacity of the MCCH.
- Phase modulation assigned SCCHs may be allocated both by conventional access cells and by direct access cells. MSs may be directed to a phase modulation assigned SCCH by the BS. For example, conventional access MSs may be directed from the MCCH or a $\pi/4$ -DQPSK common SCCH to a phase modulation assigned SCCH and direct access MSs may be directed from the MCCH-Q or a QAM common SCCH to a phase modulation assigned SCCH.

9.4.2.2 TP channel

The TP channel is a physical channel carrying TCH.

9.4.2.3 UP channel

The UP channel is a physical channel not allocated to one or more MS.

9.4.3 Bursts for phase modulation

9.4.3.1 General

A burst is a period of RF carrier that is modulated by a data stream. A burst, therefore, represents the physical content of a timeslot or subslot.

The description of a physical channel will be made in terms of timeslots and TDMA frames and not in terms of bursts. This is because there is not a one-to-one mapping between a particular physical channel and the use of a particular burst.

A given physical channel shall use the same timeslot number in every TDMA frame.

9.4.3.2 Phase modulation symbol numbering

A timeslot shall be divided into 255 phase modulation symbol durations, each one with a duration of 1/18 ms (approximately 55,56 μ s). A particular modulation symbol within a burst shall be referenced by a Symbol Number (SN), with the first modulation symbol numbered $SN1$ and the last modulation symbol numbered $SNmax$.

Different types of bursts are defined, having different durations.

At the beginning of the transmission of a single burst or of consecutive bursts, a supplementary symbol $SN0$ is defined. It does not carry information but shall be used as phase reference for the differential modulation.

9.4.3.3 Phase modulation bit numbering

In the following sections the content of the burst is defined in terms of phase modulation bits.

A particular modulation bit within a burst shall be referenced by a Bit Number (BN), with the first modulation bit numbered $BN1$ and the last modulation bit numbered $BNmax$. At the modulator the modulation bits shall be grouped together and converted into one modulation symbol as described in clause 5. $\pi/4$ -DQPSK symbols contain two information bits and $\pi/8$ -D8PSK symbols contain three information bits.

9.4.3.4 Burst timing

The symbol time is defined as the instant at which the transmitted symbol waveform is at a maximum for the symbol of interest. The timing of a modulation symbol is determined by its symbol time.

The bits $BN(2n-1)$ and $BN(2n)$ shall determine the symbol $SN(n)$ for $\pi/4$ -DQPSK and the bits $BN(3n-2)$, $BN(3n-1)$ and $BN(3n)$ shall determine the symbol $SN(n)$ for $\pi/8$ -D8PSK. The symbol time of the modulation symbol $SN(n)$ shall be delayed by $(n+d)$ modulation symbol durations with respect to the start of the slot, with:

- n : integer (1 to $SNmax$);
- d : is defined as the burst delay. The burst delay represents the delay between the start of the timeslot and the symbol time of the symbol $SN0$. The burst delay is expressed in modulation symbol duration and varies with the type of burst and the SSN. The values of the burst delays are given in table 9.2.
- *useful part of the burst* is defined as shown in figure 9.3.

NOTE: Symbol time of the symbol $SN0$ is same as symbol time of the symbol $SN255$ of the previous slot.

The symbol time of the symbol $SN0$ occurs one modulation symbol duration before the symbol time of the symbol $SN1$ of the first burst of a transmission.

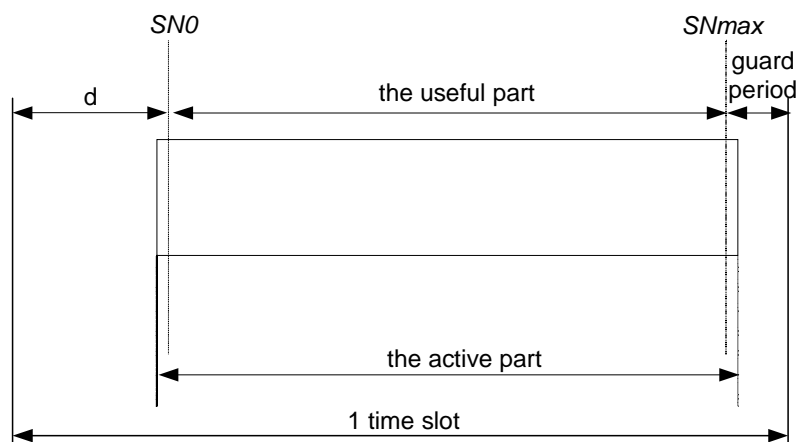

NOTE 1: For certain burst types d and the guard period may be of length zero.

NOTE 2: The active part of the burst is the period during which modulation symbols are present; it is longer than the useful part by an amount equal to the sum of the time necessary for symbol rise and decay.

Figure 9.3: Burst timing for phase modulation

9.4.4 Type of bursts for phase modulation

9.4.4.1 General

Eight types of $\pi/4$ -DQPSK burst exist in the system. Figure 9.4 summarizes the description of the $\pi/4$ -DQPSK bursts and their timing with respect to the timeslot. Five types of $\pi/8$ -D8PSK burst exist in the system. Figure 9.4 summarizes the description of the $\pi/8$ -D8PSK bursts and their timing with respect to the timeslot. Table 9.2 lists burst types.

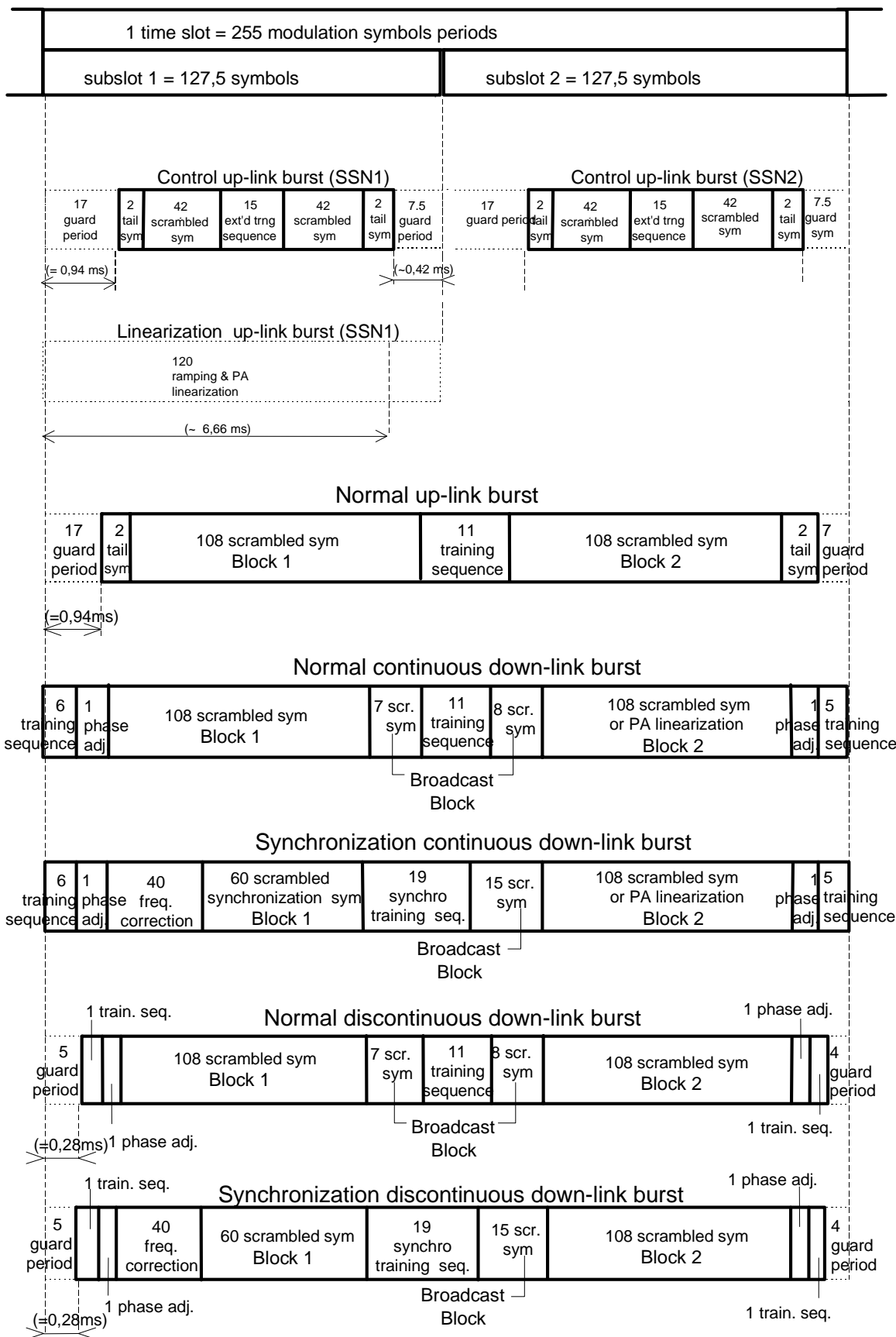

Figure 9.4: Types of bursts for phase modulation

NOTE 1: $\pi/8$ -D8PSK modulation is not used in the synchronization continuous down-link burst or the synchronization discontinuous down-link burst but may be used in all other types of burst. $\pi/4$ -DQPSK modulation may be used for all types of burst. The modulation of the linearization up-link burst is undefined.

NOTE 2: The power-time mask is defined in clause 6, figure 6.3 and table 6.8. The t_1 period defined in clause 6, table 6.8 may be used for ramping and PA linearization.

Table 9.2: Burst types for Phase Modulation

Burst type	S_{nmax}	d burst delay (in symbol duration)		Bit allocation
		SSN 1	SSN 2	
control uplink burst (CB) (see note 1)	103	17	144,5	see clause 9.4.4.2.1
linearization uplink burst (LB)	not applicable	not applicable	not allowed	see clause 6.4.5
linearization downlink burst (LDB)	not applicable	not allowed	not applicable	see clause 6.4.5
normal uplink burst (NUB) (see note 1)	231	17		see clause 9.4.4.2.4
normal continuous downlink burst (NDB) (see note 1)	255	0		see clause 9.4.4.2.5
synchronization continuous downlink burst (SB) (see note 2)	255	0		see clause 9.4.4.2.6
normal discontinuous downlink burst (NDB) (see note 1)	246	5		see clause 9.4.4.2.7
synchronization discontinuous downlink burst (SB) (see note 2)	246	5		see clause 9.4.4.2.8
NOTE 1: May use either $\pi/4$ -DQPSK or $\pi/8$ -D8PSK modulation.				
NOTE 2: Shall use $\pi/4$ -DQPSK modulation only.				

The generic name for normal continuous and discontinuous downlink burst is Normal Downlink Burst (NDB). The generic name for synchronization continuous and discontinuous downlink burst is Synchronization downlink Burst (SB).

9.4.4.2 Modulation bits allocation

9.4.4.2.0 General

The bursts are divided into burst fields containing contiguous modulation bits of the same type. The burst fields are described in clause 9.4.4.3.

The downlink bursts contain 3 independent blocks, called Broadcast Block (BBK), Block 1 ($BKN1$) and Block 2 ($BKN2$). The normal uplink bursts contains two independent blocks, called Block 1 ($BKN1$) and Block 2 ($BKN2$). A separate logical channel may be mapped on each block. The broadcast block shall be made of the two scrambled broadcast bits fields and shall contain 30 bits.

For $\pi/4$ -DQPSK, block 1 and block 2 shall be made of one field and shall contain 216 scrambled bits. In the case of synchronization bursts, block 1 contains 120 bits.

For $\pi/8$ -D8PSK, block 1 and block 2 shall be made of one field and shall contain 324 scrambled bits.

9.4.4.2.1 Control uplink Burst (CB)

The allocation of the modulation bits in the $\pi/4$ -DQPSK CB shall be in accordance with table 9.3. The CB shall be used by MS to transmit control messages to the BS.

Table 9.3: Control uplink Burst (CB) for $\pi/4$ -DQPSK

Bit Number (BN)	Field length (bits)	Field content	Field bits number	Definition
1 to 4	4	tail bits	$t1$ to $t4$	see clause 9.4.4.3.5
5 to 88	84	scrambled control bits	$cb(1)$ to $cb(84)$	see clause 8
89 to 118	30	extended training sequence	$x1$ to $x30$	see clause 9.4.4.3.3
119 to 202	84	scrambled control bits	$cb(85)$ to $cb(168)$	see clause 8
203 to 206	4	tail bits	$t1$ to $t4$	see clause 9.4.4.3.5
NOTE: All fields shall be sent using $\pi/4$ -DQPSK modulation.				

The allocation of the modulation bits in the $\pi/8$ -D8PSK CB shall be in accordance with table 9.4. The CB shall be used by MS to transmit control messages to the BS.

Table 9.4: Control uplink Burst (CB) for $\pi/8$ -D8PSK

Bit Number (BN)	Field length (bits)	Field content	Field bits number	Definition
1 to 6	6	tail bits -P8	$T1$ to $T6$	see clause 9.4.4.3.5
7 to 132	126	scrambled control bits	$cb(1)$ to $cb(126)$	see clause 8
133 to 177	45	extended training sequence -P8	$X1$ to $X45$	see clause 9.4.4.3.3
178 to 303	126	scrambled control bits	$cb(127)$ to $cb(252)$	see clause 8
304 to 309	6	tail bits -P8	$T1$ to $T6$	see clause 9.4.4.3.5
NOTE: All fields shall be sent using $\pi/8$ -D8PSK modulation.				

9.4.4.2.2 Linearization uplink Burst (LB)

The LB may be used by the MSs to linearize their transmitters. The LB contains no useful bits and its timing shall only be determined by the time mask (see clause 6).

9.4.4.2.3 Linearization downlink burst

The linearization downlink burst replaces BKN2 of either a normal continuous downlink burst or a synchronization continuous downlink burst.

The linearization downlink burst may be used by the BS to linearize its transmitter. The linearization downlink burst contains no useful bits and its timing shall be determined only by the time mask (see clause 6).

9.4.4.2.4 Normal Uplink Burst (NUB)

The allocation of the modulation bits in the NUB for $\pi/4$ -DQPSK shall be in accordance with table 9.5. The NUB shall be used by MSs to transmit control or traffic messages to the BS.

Table 9.5: Normal Uplink Burst (NUB) for $\pi/4$ -DQPSK

Bit Number (BN)	Field length (bits)	Field content	Field bits number	Definition
1 to 4	4	tail bits	$t1$ to $t4$	see clause 9.4.4.3.5
5 to 220	216	scrambled block 1 bits	$bkn1(1)$ to $bkn1(216)$	see clause 8
221 to 242	22	normal training sequence	$n1$ to $n22$ or $p1$ to $p22$	see clause 9.4.4.3.2
243 to 458	216	scrambled block 2 bits	$bkn2(1)$ to $bkn2(216)$	see clause 8
459 to 462	4	tail bits	$t1$ to $t4$	see clause 9.4.4.3.5
NOTE: All fields shall be sent using $\pi/4$ -DQPSK modulation.				

The allocation of the modulation bits in the NUB for $\pi/8$ -D8PSK shall be in accordance with table 9.6. The NUB shall be used by MSs to transmit control or traffic messages to the BS.

Table 9.6: Normal Uplink Burst (NUB) for $\pi/8$ -D8PSK

Bit Number (BN)	Field length (bits)	Field content	Field bits number	Definition
1 to 6	6	tail bits -P8	$T1$ to $T6$	see clause 9.4.4.3.5
7 to 330	324	scrambled block 1 bits	$bkn1(1)$ to $bkn1(324)$	see clause 8
331 to 363	33	normal training sequence-P8	$N1$ to $N33$ or $P1$ to $P33$	see clause 9.4.4.3.2
364 to 687	324	scrambled block 2 bits	$bkn2(1)$ to $bkn2(324)$	see clause 8
688 to 693	6	tail bits -P8	$T1$ to $T6$	see clause 9.4.4.3.5

NOTE: All fields shall be sent using $\pi/8$ -D8PSK modulation.

9.4.4.2.5 Normal continuous downlink burst

The allocation of the modulation bits in the normal continuous downlink $\pi/4$ -DQPSK burst shall be in accordance with table 9.7. The normal continuous downlink burst shall be used by the BS in continuous transmission mode to transmit control or traffic messages to the MS.

Table 9.7: Normal continuous downlink burst for $\pi/4$ -DQPSK

Bit Number (BN)	Field length (bits)	Field content	Field bits number	Definition
1 to 12	12	normal training sequence 3	$q11$ to $q22$	see clause 9.4.4.3.2
13 to 14	2	phase adjustment bits	$ha1$ to $ha2$	see clause 9.4.4.3.6
15 to 230	216	scrambled block 1 bits	$bkn1(1)$ to $bkn1(216)$	see clause 8
231 to 244	14	scrambled broadcast bits	$bb(1)$ to $bb(14)$	see clause 8
245 to 266	22	normal training sequence	$n1$ to $n22$ or $p1$ to $p22$	see clause 9.4.4.3.2
267 to 282	16	scrambled broadcast bits	$bb(15)$ to $bb(30)$	see clause 8
283 to 498	216	scrambled block 2 bits	$bkn2(1)$ to $bkn2(216)$	see clause 8
499 to 500	2	phase adjustment bits	$hb1$ to $hb2$	see clause 9.4.4.3.6
501 to 510	10	normal training sequence 3	$q1$ to $q10$	see clause 9.4.4.3.2

NOTE: All fields shall be sent using $\pi/4$ -DQPSK modulation.

The allocation of the modulation bits in the normal continuous downlink $\pi/8$ -D8PSK burst shall be in accordance with table 9.8.

Table 9.8: Normal continuous downlink burst for $\pi/8$ -D8PSK

Bit Number (BN)	Field length (bits)	Field content	Field bits number	Definition
1 to 12	12	normal training sequence 3 (see note 1)	$q11$ to $q22$	see clause 9.4.4.3.2
13 to 15	3	phase adjustment bits (see note 2)	$ha1$ to $ha3$	see clause 9.4.4.3.6
16 to 339	324	scrambled block 1 bits (see note 2)	$bkn1(1)$ to $bkn1(324)$	see clause 8
340 to 353	14	scrambled broadcast bits (see note 1)	$bb(1)$ to $bb(14)$	see clause 8
354 to 386	33	normal training sequence-P8 (see note 2)	$N1$ to $N33$ or $P1$ to $P33$	see clause 9.4.4.3.2
387 to 402	16	scrambled broadcast bits (see note 1)	$bb(15)$ to $bb(30)$	see clause 8
403 to 726	324	scrambled block 2 bits (see note 2)	$bkn2(1)$ to $bkn2(324)$	see clause 8
727 to 729	3	phase adjustment bits (see note 2)	$hb1$ to $hb3$	see clause 9.4.4.3.6
730 to 739	10	normal training sequence 3 (see note 1)	$q1$ to $q10$	see clause 9.4.4.3.2

NOTE 1: This field shall be sent using $\pi/4$ -DQPSK modulation.
NOTE 2: This field shall be sent using $\pi/8$ -D8PSK modulation.

9.4.4.2.6 Synchronization continuous downlink burst

The allocation of the modulation bits in the synchronization continuous downlink burst shall be in accordance with table 9.9. The synchronization continuous downlink burst shall be used by BSs in continuous transmission mode to broadcast synchronization messages and to transmit control messages to the MSs.

Table 9.9: Synchronization continuous downlink burst

Bit Number (BN)	Field length (bits)	Field content	Field bits number	Definition
1 to 12	12	normal training sequence 3	$q11$ to $q22$	see clause 9.4.4.3.2
13 to 14	2	phase adjustment bits	$hc1$ to $hc2$	see clause 9.4.4.3.6
15 to 94	80	frequency correction	$f1$ to $f80$	see clause 9.4.4.3.1
95 to 214	120	scrambled synchronization block 1 bits	$sb(1)$ to $sb(120)$	see clause 8
215 to 252	38	synchronization training sequence	$y1$ to $y38$	see clause 9.4.4.3.4
253 to 282	30	scrambled broadcast bits	$bb(1)$ to $bb(30)$	see clause 8
283 to 498	216	scrambled block 2 bits	$bkn2(1)$ to $bkn2(216)$	see clause 8
499 to 500	2	phase adjustment bits	$hd1$ to $hd2$	see clause 9.4.4.3.6
501 to 510	10	normal training sequence 3	$q1$ to $q10$	see clause 9.4.4.3.2

NOTE: All fields shall be sent using $\pi/4$ -DQPSK modulation

9.4.4.2.7 Normal discontinuous downlink burst

The allocation of the modulation bits in the $\pi/4$ -DQPSK normal discontinuous downlink burst shall be in accordance with table 9.10. The normal discontinuous downlink burst shall be used by BS in timesharing transmission mode to transmit control or traffic messages to the MS.

Table 9.10: Normal discontinuous downlink burst for $\pi/4$ -DQPSK

Bit Number (BN)	Field length (bits)	Field content	Field bits number	Definition
1 to 2	2	normal training sequence 3	$q21$ to $q22$	see clause 9.4.4.3.2
3 to 4	2	phase adjustment bits	$hg1$ to $hg2$	see clause 9.4.4.3.6
5 to 220	216	scrambled block 1 bits	$bkn1(1)$ to $bkn1(216)$	see clause 8
221 to 234	14	scrambled broadcast bits	$bb(1)$ to $bb(14)$	see clause 8
235 to 256	22	normal training sequence	$n1$ to $n22$ or $p1$ to $p22$	see clause 9.4.4.3.2
257 to 272	16	scrambled broadcast bits	$bb(15)$ to $bb(30)$	see clause 8
273 to 488	216	scrambled block 2 bits	$bkn2(1)$ to $bkn2(216)$	see clause 8
489 to 490	2	phase adjustment bits	$hh1$ to $hh2$	see clause 9.4.4.3.6
491 to 492	2	normal training sequence 3	$q1$ to $q2$	see clause 9.4.4.3.2

NOTE: All fields shall be sent using $\pi/4$ -DQPSK modulation.

The allocation of the modulation bits in the $\pi/8$ -D8PSK normal discontinuous downlink burst shall be in accordance with table 9.11.

Table 9.11: Normal discontinuous downlink burst for $\pi/8$ -D8PSK

Bit Number (BN)	Field length (bits)	Field content	Field bits number	Definition
1 to 2	2	normal training sequence 3 (see note 1)	$q21$ to $q22$	see clause 9.4.4.3.2
3 to 5	3	phase adjustment bits (see note 2)	$hg1$ to $hg3$	see clause 9.4.4.3.6
6 to 329	324	scrambled block 1 bits (see note 2)	$bkn1(1)$ to $bkn1(324)$	see clause 8
330 to 343	14	scrambled broadcast bits (see note 1)	$bb(1)$ to $bb(14)$	see clause 8
344 to 376	33	normal training sequence-P8 (see note 2)	$N1$ to $N33$ or $P1$ to $P33$	see clause 9.4.4.3.2
377 to 392	16	scrambled broadcast bits (see note 1)	$bb(15)$ to $bb(30)$	see clause 8
393 to 716	324	scrambled block 2 bits (see note 2)	$bkn2(1)$ to $bkn2(324)$	see clause 8
717 to 719	3	phase adjustment bits (see note 2)	$hh1$ to $hh3$	see clause 9.4.4.3.6
720 to 721	2	normal training sequence 3 (see note 1)	$q1$ to $q2$	see clause 9.4.4.3.2

NOTE 1: This field shall be sent using $\pi/4$ -DQPSK modulation.
NOTE 2: This field shall be sent using $\pi/8$ -D8PSK modulation.

9.4.4.2.8 Synchronization discontinuous downlink burst

The allocation of the modulation bits in the synchronization discontinuous downlink burst shall be in accordance with table 9.12. The synchronization discontinuous downlink burst shall be used by the BS in timesharing transmission mode to broadcast synchronization messages and to transmit control messages to the MS.

Table 9.12: Synchronization discontinuous downlink burst

Bit Number (BN)	Field length (bits)	Field content	Field bits number	Definition
1 to 2	2	normal training sequence 3	$q21$ to $q22$	see clause 9.4.4.3.2
3 to 4	2	phase adjustment bits	$hi1$ to $hi2$	see clause 9.4.4.3.6
5 to 84	80	frequency correction	$f1$ to $f80$	see clause 9.4.4.3.1
85 to 204	120	scrambled synchronization block 1 bits	$sb(1)$ to $sb(120)$	see clause 8
205 to 242	38	synchronization training sequence	$y1$ to $y38$	see clause 9.4.4.3.4
243 to 272	30	scrambled broadcast bits	$bb(1)$ to $bb(30)$	see clause 8
273 to 488	216	scrambled block 2 bits	$bkn2(1)$ to $bkn2(216)$	see clause 8
489 to 490	2	phase adjustment bits	$hj1$ to $hj2$	see clause 9.4.4.3.6
491 to 492	2	normal training sequence 3	$q1$ to $q2$	see clause 9.4.4.3.2
NOTE: All fields shall be sent using $\pi/4$ -DQPSK modulation.				

9.4.4.3 Burst fields

9.4.4.3.1 Frequency correction field

The frequency correction field shall contain 80 bits:

$$(f1, f2, \dots, f8) = (1, 1, \dots, 1) \quad (9.1)$$

$$(f9, f10, \dots, f72) = (0, 0, \dots, 0) \quad (9.2)$$

$$(f73, f74, \dots, f80) = (1, 1, \dots, 1) \quad (9.3)$$

The frequency correction field generates an un-modulated carrier at 2,25 kHz above the nominal carrier frequency, preceded and followed by a short period (4 symbol durations) of un-modulated carrier at 6,75 kHz below the nominal carrier frequency.

9.4.4.3.2 Normal training sequence

Three 22 bit normal training sequences are defined for $\pi/4$ -DQPSK modulation.

The first two $\pi/4$ -DQPSK normal training sequences shall be used on the $\pi/4$ -DQPSK normal uplink and downlink bursts. The type of training sequence shall be used as a flag indicating the presence of one or two logical channels on the blocks 1 and 2 of the burst, according to table 9.13.

Table 9.13: Training sequence mapping to logical channels

Normal training sequence	Logical channel
1	TCH SCH/F
2	STCH + TCH STCH + STCH SCH/HD + SCH/HD SCH/HD + BNCH

The third $\pi/4$ -DQPSK training sequence shall be a supplementary training sequence spread over two consecutive downlink bursts.

The $\pi/4$ -DQPSK normal training sequence 1 shall be:

$$(n1, n2, \dots, n22) = (1, 1, 0, 1, 0, 0, 0, 0, 1, 1, 1, 0, 1, 0, 0, 1, 1, 1, 0, 1, 0, 0) \quad (9.4)$$

The $\pi/4$ -DQPSK normal training sequence 2 shall be:

$$(p1, p2, \dots, p22) = (0,1, 1,1, 1,0, 1,0, 0,1, 0,0, 0,0, 1,1, 0,1, 1,1, 1,0) \quad (9.5)$$

The $\pi/4$ -DQPSK normal training sequence 3 shall be:

$$(q1, q2, \dots, q22) = (1,0, 1,1, 0,1, 1,1, 0,0, 0,0, 0,1, 1,0, 1,0, 1,1, 0,1) \quad (9.6)$$

Two 33 bit normal training sequences are defined for $\pi/8$ -D8PSK.

The $\pi/8$ -D8PSK normal training sequences shall be used on the $\pi/8$ -D8PSK normal uplink and downlink bursts. The type of training sequence shall be used as a flag indicating the presence of one or two logical channels on the blocks 1 and 2 of the burst, according to table 9.14.

Table 9.14: Training sequence mapping to logical channels for $\pi/8$ -D8PSK

Normal training sequence	Logical channel
1	SCH-P8/F
2	SCH-P8/HD + SCH-P8/HD

The normal training sequence 1-P8 shall be:

$$(N1, N2, \dots, N33) = (1,1,1, 0,0,1, 1,0,1, 1,1,1, 0,0,0, 1,1,1, 1,0,0, 0,1,1, 1,1,0, 0,0,0, 0,0,0) \quad (9.7)$$

The normal training sequence 2-P8 shall be:

$$(P1, P2, \dots, P33) = (1,0,1, 0,1,1, 1,1,1, 1,0,1, 0,1,0, 1,0,1, 1,1,0, 0,0,1, 1,0,0, 0,1,0, 0,1,0) \quad (9.8)$$

On a $\pi/8$ -D8PSK channel, receivers determine whether a slot contains a $\pi/4$ -DQPSK normal uplink or downlink burst or a $\pi/8$ -D8PSK normal uplink or downlink burst by determining whether normal training sequence 1 or normal training sequence 2 uses the $\pi/4$ -DQPSK form or the $\pi/8$ -D8PSK form.

9.4.4.3.3 Extended training sequence

The extended training sequence for $\pi/4$ -DQPSK shall be a 30 bit synchronization word used for the uplink control burst.

The extended training sequence for $\pi/4$ -DQPSK shall be:

$$(x1, x2, \dots, x30) = (1,0, 0,1, 1,1, 0,1, 0,0, 0,0, 1,1, 1,0, 1,0, 0,1, 1,1, 0,1, 0,0, 0,0, 1,1) \quad (9.9)$$

The extended training sequence for $\pi/8$ -D8PSK shall be a 45 bit synchronization word used for the uplink control burst.

The extended training sequence for $\pi/8$ -D8PSK shall be:

$$(X1, X2, \dots, X45) = (0,1,1,1,0,0,1,1,0,1,0,0,0,0,1,0,0,0,1,1,1,0,1,1,0,1,0,1,0,1,1,1,1,1,0,1,0,0,0,0,0,1,1,1,0) \quad (9.10)$$

On a D8PSK channel, receivers determine whether a subslot contains a $\pi/4$ -DQPSK control uplink burst or a $\pi/8$ -D8PSK control uplink burst by determining whether the extended training sequence uses the $\pi/4$ -DQPSK form or the $\pi/8$ -D8PSK form.

9.4.4.3.4 Synchronization training sequence

The synchronization training sequence shall be a 38 bit synchronization word used for the synchronization downlink burst.

The synchronization training sequence shall be:

$$(y1, y2, \dots, y38) = (1,1, 0,0, 0,0, 0,1, 1,0, 0,1, 1,1, 0,0, 1,1, 1,0, 1,0, 0,1, 1,1, 0,0, 0,0, 0,1, 1,0, 0,1, 1,1) \quad (9.11)$$

9.4.4.3.5 Tail bits

The tail bit field for $\pi/4$ -DQPSK shall contain 4 bits used for reducing the effect of filter transient response at the beginning and end of the bursts and for equalization purposes.

The contents of the $\pi/4$ -DQPSK tail bit field shall be:

$$(t1, t2, t3, t4) = (1, 1, 0, 0) \quad (9.12)$$

The tail bit field for $\pi/8$ -D8PSK shall contain 6 bits used for reducing the effect of filter transient response at the beginning and end of the bursts.

The contents of the $\pi/8$ -D8PSK tail bit field shall be:

$$(T1, T2, \dots, T6) = (1, 1, 1, 0, 0, 0) \quad (9.13)$$

9.4.4.3.6 Phase adjustment bits

The $\pi/4$ -DQPSK phase adjustment bits shall be used on the $\pi/4$ -DQPSK bursts defined in clauses 9.4.4.2 and 9.4.5.3 to provide a known phase relationship between the different training sequences of the burst, whatever is the content of the blocks.

The value of the pair of phase adjustment bits shall be set so that the phase shift $D\phi$ they generate (see clause 5) is equal to:

$$D\phi = - \sum_{n=n1}^{n2} D\phi(n) \quad (9.14)$$

Where $D\phi(n)$ is the phase transition generated by the bits $BN(2n-1)$, $BN(2n)$, $n1$ and $n2$ are given by table 9.15 for $\pi/4$ -DQPSK.

Table 9.15: $\pi/4$ -DQPSK Phase adjustment bits

phase adjustment bits	$n1$	$n2$
$(ha1, ha2)$	8	122
$(hb1, hb2)$	123	249
$(hc1, hc2)$	8	108
$(hd1, hd2)$	109	249
$(he1, he2)$	112	230 (see note)
$(hf1, hf2)$	1	111
$(hg1, hg2)$	3	117
$(hh1, hh2)$	118	244
$(hi1, hi2)$	3	103
$(hj1, hj2)$	104	244
NOTE: The $n2$ value 230 does not include the second symbol of the tail in the phase balance causing a non-zero phase change.		

The $\pi/8$ -D8PSK phase adjustment bits shall be used on the $\pi/8$ -D8PSK bursts defined in clauses 9.4.4.2 and 9.4.5.3 to provide a known phase relationship between the different training sequences of the burst, whatever the content of the blocks. The value of the three phase adjustment bits shall be set so that the phase shift $D\phi$ they generate (see clause 5) is equal to a phase as defined by equation 9.14 or 9.15 (see table 9.16).

$$D\phi = - \sum_{n=n1}^{n2} D\phi(n) + \frac{\pi}{8} \quad (9.15)$$

Where $D\phi(n)$ is the phase transition generated by the bits $BN(3n-2)$, $BN(3n-1)$, $BN(3n)$, $n1$ and $n2$ are given by table 9.16 for $\pi/8$ -D8PSK.

Table 9.16: Phase adjustment bits for $\pi/8$ -D8PSK

phase adjustment bits	$n1$	$n2$
$(ha1, ha2, ha3)$	8	122 (see note 1)
$(hb1, hb2, hb3)$	123	249 (see note 2)
$(he1, he2, he3)$	111	231 (see note 1)
$(hf1, hf2, hf3)$	1	110 (see note 1)
$(hg1, hg2, hg3)$	3	117 (see note 1)
$(hh1, hh2, hh3)$	118	244 (see note 2)

NOTE 1: In this case, $D\phi$ has a resultant phase shift of $\pi/8$ (see expression 9.15).
NOTE 2: In this case, $D\phi$ has a resultant phase shift of 0 (see expression 9.14).

9.4.5 Transmission modes for phase modulation

9.4.5.1 BS continuous transmission

When the BS is in continuous transmission mode normal downlink bursts or synchronization bursts shall be transmitted on all unused downlink slots of the main carrier and may be transmitted on the unallocated physical channels of the other carriers.

On the main carrier the BS shall only be allowed to ramp down and up during a BLCH. On the other carriers the BS may ramp down and up during the slots of an UP channel.

The first burst after ramp up of a downlink continuous transmission (D-CT) shall be preceded by a start burst ($SN_{max} = 5$), according to table 9.17.

Table 9.17: Start burst

Bit Number (BN)	Field length (bits)	Field content	Field bits number	Definition
1 to 10	10	normal training sequence 3	$q1$ to $q10$	clause 9.4.4.3.2

The last burst before ramp down of a D-CT shall be followed by a stop burst ($SN_{max} = 6$), according to table 9.18.

Table 9.18: Stop burst

Bit Number (BN)	Field length (bits)	field content	field bits number	definition
1 to 12	12	normal training sequence 3	$q11$ to $q22$	clause 9.4.4.3.2

9.4.5.2 BS timesharing transmission

The BS in timesharing transmission mode need not to ramp down and up between adjacent discontinuous downlink bursts. In the case where the BS does not perform the ramping, the discontinuous burst shall be followed by 4 symbols (corresponding to the guard period) according to table 9.19, and the subsequent burst shall be preceded by 5 symbols (corresponding to the ramp up and linearization period) according to table 9.20.

Table 9.19: Bits following the burst

Bit number	Field length (bits)	Field content	Field bits number	Definition
1 to 8	8	normal training sequence 3	$q3$ to $q10$	clause 9.4.4.3.2

Table 9.20: Bits preceding the burst

Bit number	Field length (bits)	Field content	Field bits number	Definition
1 to 10	10	normal training sequence 3	$q11$ to $q20$	clause 9.4.4.3.2

9.4.5.3 MS multiple slot transmission

The MS transmitting on more than 1 physical channel need not to ramp down and up between adjacent normal uplink bursts. In the case where the MS does not perform the ramping, the burst shall be followed by 7 symbols (corresponding to the guard period) defined in table 9.21 for $\pi/4$ -DQPSK and in table 9.23 for $\pi/8$ -D8PSK, the subsequent burst shall be preceded by 17 symbols (corresponding to the ramp up and linearization period), according table 9.22 for $\pi/4$ -DQPSK and table 9.24 for $\pi/8$ -D8PSK.

Table 9.21: Bits following a $\pi/4$ -DQPSK burst

Bit number	Field length (bits)	Field content	Field bits number	Definition
1 to 2	2	phase adjustment bits	$he1$ to $he2$	clause 9.4.4.3.6
3 to 4	2	tail bits	$t1$ to $t2$	clause 9.4.4.3.5
5 to 14	10	normal training sequence 3	$q1$ to $q10$	clause 9.4.4.3.2

Table 9.22: Bits preceding a $\pi/4$ -DQPSK burst

Bit number	Field length (bits)	Field content	Field bits number	Definition
1 to 30	30	extended training sequence	$x1$ to $x30$	clause 9.4.4.3.3
31 to 32	2	tail bits	$t3$ to $t4$	clause 9.4.4.3.5
33 to 34	2	phase adjustment bits	$hf1$ to $hf2$	clause 9.4.4.3.6

Table 9.23: Bits following a $\pi/8$ -D8PSK burst

Bit number	Field length (bits)	Field content	Field bits number	Definition
1 to 3	3 (see note 2)	phase adjustment bits	$he1$ to $he3$	clause 9.4.4.3.6
4 to 5	2 (see note 1)	tail bits	$t1$ to $t2$	clause 9.4.4.3.5
6 to 15	10 (see note 1)	normal training sequence 3	$q1$ to $q10$	clause 9.4.4.3.2
NOTE 1: This field shall be sent using $\pi/4$ -DQPSK modulation.				
NOTE 2: This field shall be sent using $\pi/8$ -D8PSK modulation.				

Table 9.24: Bits preceding a $\pi/8$ -D8PSK burst

Bit number	Field length (bits)	Field content	Field bits number	Definition
1 to 30	30 (see note 1)	extended training sequence	$x1$ to $x30$	clause 9.4.4.3.3
31 to 32	2 (see note 1)	tail bits	$t3$ to $t4$	clause 9.4.4.3.5
33 to 35	3 (see note 2)	phase adjustment bits	$hf1$ to $hf3$	clause 9.4.4.3.6
NOTE 1: This field shall be sent using $\pi/4$ -DQPSK modulation.				
NOTE 2: This field shall be sent using $\pi/8$ -D8PSK modulation.				

9.4.6 Types of physical channels for QAM

9.4.6.0 General

In QAM channels, two types of physical channel are defined:

- the Control Physical (CP) Channel; and
- the Unallocated Physical channel.

9.4.6.1 CP channel for QAM

The CP channel is a physical channel carrying exclusively CCH. Two types of CP channels for QAM are defined:

- the Main Control CHannel (MCCH-Q); and
- the QAM Secondary Control CHannel (SCCH).

In each direct access cell one QAM RF carrier shall be defined as the main carrier (DA main carrier).

The DA main carrier shall have one MCCH-Q. The MCCH-Q shall be 1 to 4 slots wide. The MCCH-Q shall start on timeslot 1 of the DA main carrier.

QAM SCCH may be common SCCH or assigned SCCH:

- QAM common SCCH(s) are used only for direct access. If provided they are used to extend the signalling capacity of the MCCH-Q.
- QAM assigned SCCHs may be allocated both by conventional access cells and by direct access cells. MSs may be directed to a QAM assigned SCCH by the BS, for example, from the MCCH or a $\pi/4$ -DQPSK common SCCH for conventional access or from the MCCH-Q or a QAM common SCCH for direct access.

9.4.6.2 UP channel

The UP channel is a physical channel not allocated to one or more MS.

9.4.7 Bursts for QAM

9.4.7.1 General

A burst is a period of RF carrier that is modulated by a data stream. A burst therefore represents the physical content of a timeslot or subslot.

9.4.7.2 Modulation symbol numbering

A timeslot shall be divided into 34 QAM modulation symbol durations, each one with a duration of $5/12$ ms (approximately $416,6 \mu\text{s}$). A particular modulation symbol within a burst shall be referenced by a Symbol Number (SN), with the first modulation symbol numbered $SN1$ and the last modulation symbol numbered $SNmax$.

Different types of bursts are defined, having different durations. The content of the burst is defined in terms of modulation symbols. Each modulation symbol is composed of several sub-carrier symbols (see clause 5.10). Sub-carrier symbols (SS) within a burst shall be referenced by two indices and shall be denoted as $SS(i,j)$, the first index i being a time index numbered from 1 to N and the second index j being the sub-carrier index from 0 to $M-1$, where M is the number of sub-carriers. The relation between sub-carrier index and its frequency is defined in clause 5.

Sub-carrier symbols can be either **data sub-carrier symbol** (Dx), **synchronization sub-carrier symbols** (Sx), **pilot sub-carrier symbols** (Px), **header sub-carrier symbols** (Hx), **frequency-correction sub-carrier symbols** (Fx), **filler sub-carrier symbols** (Fix) or **zeroed sub-carrier symbols** (Zx).

9.4.7.3 Modulation bit numbering

Only data sub-carrier symbols convey information bits. The number of bits in each data sub-carrier symbol is a function of the QAM constellation used.

The number of information bits in a burst is also a function of the burst type. A particular modulation bit within a burst shall be referenced by a Bit Number (BN), with the first modulation bit numbered $BN1$ and the last modulation bit numbered $BNmax$.

At the modulator, the modulation bits shall be grouped according to the constellation used. For 4-QAM, they shall be grouped in pairs of consecutive numbered bits. For 16-QAM, they shall be grouped in sets of four consecutive numbered bits. For 64-QAM, they shall be grouped in sets of six consecutive numbered bits. Each group shall be converted into one modulation symbol as described in clause 5.4.

The mapping of information bits into data sub-carrier symbols for all burst types is presented in clause 5.5.

9.4.7.4 Burst timing

The symbol time is defined as the instant at which the transmitted symbol waveform is at a maximum for the symbol of interest. The timing of a modulation symbol is determined by its symbol time.

The symbol time of the modulation symbol $SN(n)$ shall be delayed by $(n+d-1)$ modulation symbol durations with respect to the start of the slot, with:

- n : integer (1 ... ($SNmax$));
- d : is defined as the burst delay. The burst delay represents the delay between the start of the timeslot and the symbol time of the symbol $SN1$. The burst delay shall be expressed in modulation symbol duration and varies with the type of burst and the SSN. The values of the burst delays are given in table 9.25.
- *useful part of the burst* is defined as shown in figure 9.5.

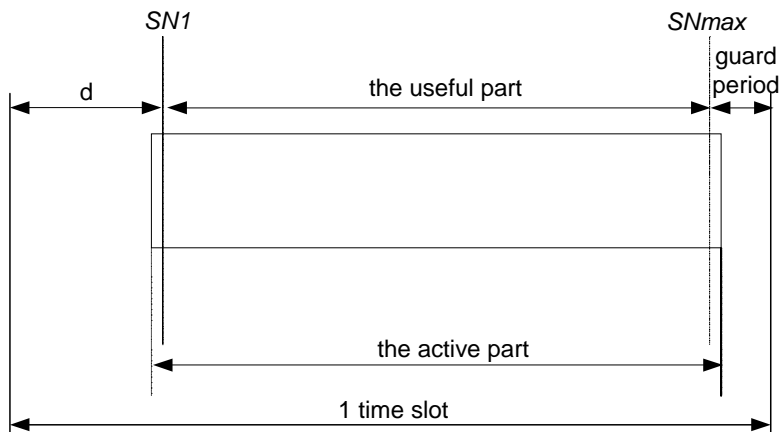

NOTE 1: For certain burst types d and the guard period may be of length zero.

NOTE 2: The active part of the burst is the period during which modulation symbols are present; it is longer than the useful part by an amount equal to the sum of the time necessary for symbol rise and decay.

Figure 9.5: Burst timing for QAM

9.4.8 Type of bursts for QAM

9.4.8.1 General

Seven types of QAM bursts shall exist in the system. Figure 9.6 summarizes the description of the bursts and their timing with respect to the timeslot.

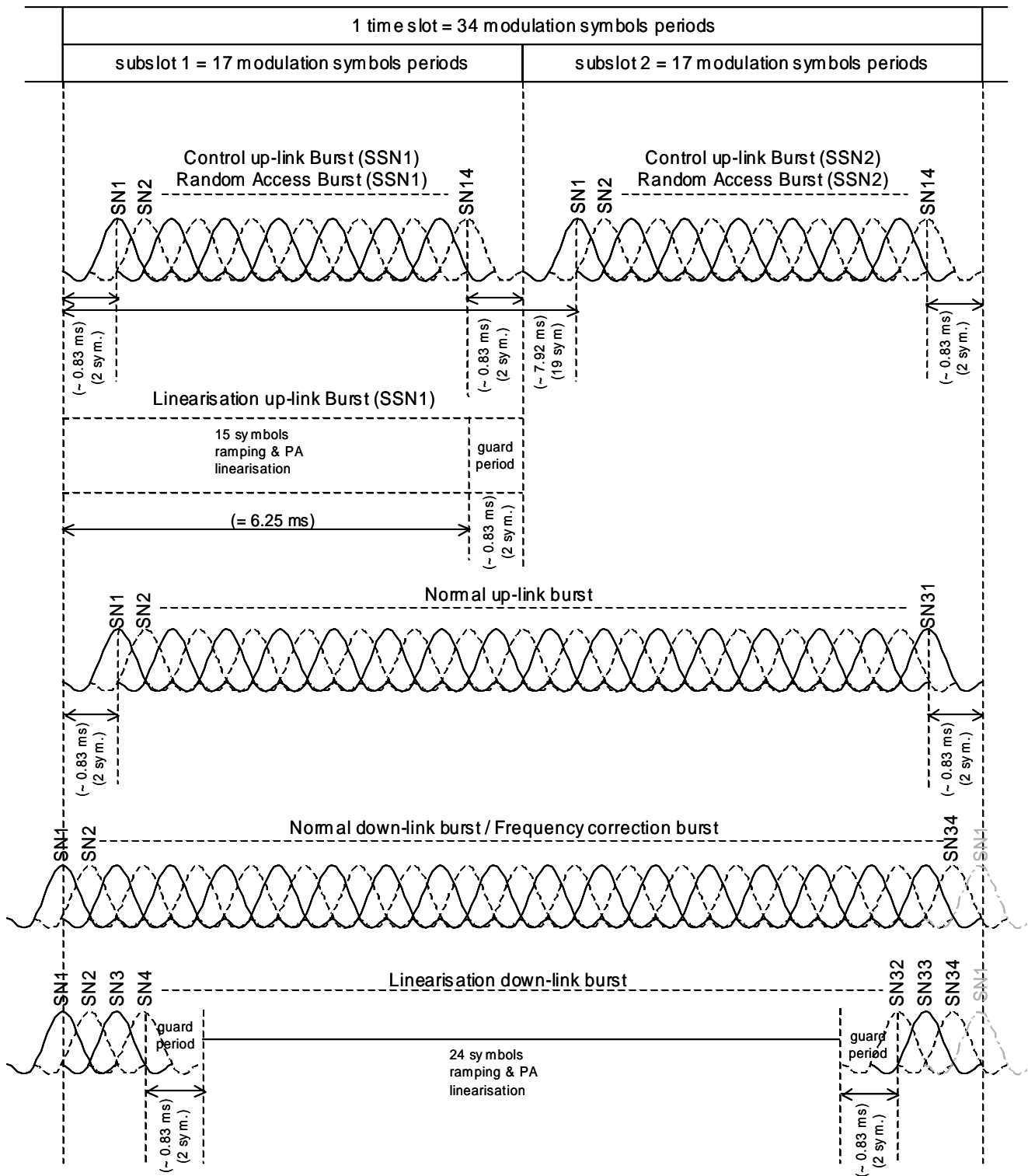

Figure 9.6: Types of bursts for QAM

NOTE: The power-time mask is defined in clause 6.4.10. The t_1 period defined in clause 6.4.10 may be used for ramping and PA linearization.

Table 9.25: Burst types for QAM

Burst type	SNmax	d burst delay (in symbol duration)		Symbol allocation
		SSN 1	SSN 2	
Control uplink burst (CB)	14	2	19	See clause P.1.1
Random access uplink burst (RAB)	14	2	19	See clause P.1.2
Linearization uplink burst (LB)	not applicable	not applicable	not allowed	See clause P.1.3
Normal uplink burst (NUB)	31	2		See clause P.1.4
Normal downlink burst (NDB)	34	0		See clause P.1.5
Linearization downlink burst (LDB)	34	0		See clause P.1.6
Frequency correction burst (FCB)	34	0		See clause P.1.7

9.4.8.2 Modulation symbols allocation

The bursts are composed of sub-carrier symbol sets containing symbols of the same modulation type. When considered together, the sets compose either a valuable information for a proper operation of the physical layer or carry logical channel information.

The sub-carrier symbol sets used with QAM modulation are sync sequence set, secondary sync sequence set, pilots set, header set, data set, frequency correction set, filler set and zeroed symbols set.

Sync sequence set, secondary sync sequence set, pilot set and filler set use symbols that lie in the unit circle of the constellation as described in clause 5.13. The frequency correction set uses symbols that lie in the unit circle of the constellation as described in clause 5.13 or zeroed (null) sub-carrier symbols. The header set uses only 4-QAM modulation sub-carrier symbols. The zeroed set use symbols whose magnitude is equal to zero. The data set may generally use any 4-QAM, 16-QAM or 64-QAM modulation sub-carrier symbols.

The sub-carrier symbol sets are described in clause 9.4.8.3.

The allocation of the sub-carrier symbols and their content for each of the seven types of QAM burst shall be as defined in clauses P.1.1 to P.1.7. However, note that the Linearization uplink Burst (LB) contains no useful symbols and its timing shall only be determined by the time mask (see clause 6.4.10).

9.4.8.3 Burst sub-carrier symbol sets

9.4.8.3.1 General on burst sub-carrier symbol sets

All of the sub-carrier symbol sets in the clauses 9.4.8.3.2 to 9.4.8.3.8 have been defined such that the sub-carrier frequency domain multiplexers will all start at phase 0 radians, at $t = t_0 = 0$, at the beginning of each burst, where t_0 is shown in figures 5.8. This includes bursts transmitted in SubSlot Number 2. This makes their definition independent of the waveform filter.

In a physical implementation, the defined sub-carrier symbols should be pre-rotated to compensate for the delay through the transmit symbol waveform $g(t)$ in order to maintain proper phasing. For example, a filter with delay t_d should rotate each sub-carrier symbol by $-2\pi f_m t_d$ radians, where f_m is the sub-carrier frequency and t_0 is the time delay through the symbol waveform $g(t)$ prior to modulation to insure that proper phasing of the sub-carrier frequency domain multiplexers is achieved.

9.4.8.3.2 Uplink sync sequence set

The Uplink Sync sequence Sets contain $2M$ sub-carrier symbols where M is the number of sub-carriers used.

They are denoted $USSx$, where x is the number of sub-carriers. For example, $USS8$ denotes the Uplink Sync Sequence Set in the case of 8 sub-carriers.

The amplitude of the symbols is as described in clause 5.13. The symbol waveform filter independent phases are defined as a multiple of π radians.

The values of the phases shall be as expressed in clause P.2.1.

The $USSx$ are used in all control uplink bursts and normal uplink bursts of the corresponding number of sub-carriers x . $USS8$ is used in the Random Access burst.

9.4.8.3.3 Downlink sync sequence set

The Downlink sync Sequence Sets contain $1.5M$ sub-carrier symbols where M is the number of sub-carriers used.

They are denoted $DSSx$, where x is the number of sub-carriers. For example, $DSS8$ denotes the Downlink Sync Sequence Set in the case of 8 sub-carriers.

The amplitude of the symbols is as described in clause 5.13. The symbol waveform filter independent phases are defined as a multiple of π radians.

The values of the phases shall be as expressed in clause P.2.2.

The $DSSx$ are used in all normal downlink bursts and in the linearization downlink bursts of the corresponding number of sub-carriers x .

9.4.8.3.3a Secondary sync sequence set

The secondary sync sequence set contains 8 sub-carrier symbols independent of the number of sub-carriers used.

They are denoted SSS.

The values of the phases shall be as expressed in clause P.2.9. The symbol waveform filter independent phases are defined as a multiple of π radians.

The SSS are used in all frequency correction bursts and help the MS, together with its surrounding pilots, time synchronize to the BS, following successful frequency correction.

9.4.8.3.4 Half-slot uplink pilots set

The Half-slot Uplink Pilots Set contain $1.5M$ sub-carrier symbols where M is the number of sub-carriers used.

They are denoted $HUPSx$, where x is the number of sub-carriers. For example, $HUPS8$ denotes the Half-slot Uplink Pilots Set in the case of 8 sub-carriers.

The amplitude of the symbols is as described in clause 5.13. The symbol waveform filter independent phases are defined as a multiple of π radians.

The values of the phases shall be as expressed in clause P.2.3.

The $HUPSx$ are used in all control uplink bursts of the corresponding number of sub-carriers x . $HUPS8$ is used in the Random Access burst.

9.4.8.3.5 Full-slot uplink pilots set

The Full-slot Uplink Pilots Set contains $3M$ sub-carrier symbols where M is the number of sub-carriers used.

They are denoted $FUPSx$, where x is the number of sub-carriers. For example, $FUPS8$ denotes the Full-slot Uplink Pilots Set in the case of 8 sub-carriers.

The amplitude of the symbols is as described in clause 5.13. The symbol waveform filter independent phases are defined as a multiple of π radians.

The values of the phases shall be as expressed in clause P.2.4.

The $FUPSx$ are used in all normal uplink bursts of the corresponding number of sub-carriers x .

9.4.8.3.6 Full-slot downlink pilots set

The Full-slot Downlink Pilots Set contain $3M$ sub-carrier symbols where M is the number of sub-carriers used.

They are denoted $FDPS_x$, where x is the number of sub-carriers. For example, $FDPS_8$ denotes the Full-slot Downlink Pilots Set in the case of 8 sub-carriers.

The amplitude of the symbols is as described in clause 5.13. The symbol waveform filter independent phases are defined as a multiple of π radians.

The values of the phases shall be as expressed in clause P.2.5.

The $FUPS_x$ are used in all normal downlink bursts of the corresponding number of sub-carriers x .

9.4.8.3.7 Filler sets

Two different filler sets are defined. Filler Set A is used in the Linearization Downlink Burst as shown in clause P.1.6 and when a NUB is appended to a second NUB or to a CB. In the latter case, Filler Set A is appended to the end of the first NUB. Filler Set B is used when a CB is concatenated with a second CB or a NUB, and is appended to the end of the first CB.

The Filler Sets contains $3M$ sub-carrier symbols where M is the number of sub-carriers used.

They are denoted $FiSQ_x$, where Q can be equal to A or B and x is the number of sub-carriers. For example, $FiSA_8$ denotes the Filler Set A used, for example, in the LDB in the case of 8 sub-carriers.

The amplitude of the symbols is as described in clause 5.13. The symbol waveform filter independent phases are defined as a multiple of π radians.

The values of the phases shall be as expressed in clause P.2.6.

The $FiSA_x$ are used in all linearization downlink bursts.

The MS transmitting on more than 1 slot need not to ramp down and up between adjacent normal uplink bursts. In the case where the MS does not perform the ramping, the burst shall be followed by 3 filler symbols ($FiSA$ or $FiSB$, depending on the particular concatenation) corresponding to the guard period (total of $3M$ sub-carrier symbols, where M is the number of sub-carriers) defined in clause P.2.6.

9.4.8.3.8 Linearization downlink zeroed set

The linearization downlink zeroed set is a set of sub-carrier symbols whose magnitude is equal to zero. The number of sub-carrier symbols in the set is equal to $2,5M$ where M is the number of sub-carriers.

They are denoted LZS_x , where x is the number of sub-carriers. For example, LZS_8 denotes the Linearization downlink Zeroed Set in the case of 8 sub-carriers.

LZS_8 is composed of sub-carrier symbols $Z1$ to $Z20$. LZS_{16} is composed of sub-carrier symbols $Z1$ to $Z40$. LZS_{32} is composed of sub-carrier symbols $Z1$ to $Z80$. LZS_{48} is composed of sub-carrier symbols $Z1$ to $Z120$, see clause P.1.6.

9.4.8.3.9 Frequency correction set

The Frequency Correction Set contains 60 sub-carrier symbols independent of the number of sub-carriers used.

They are denoted FrCS. The amplitude of the non-zero symbols is as described in clause 5.13 for pilots. The rest have zero amplitude.

The values of the phases shall be as expressed in clause P.2.8.

9.4.8.3.10 Frequency correction data set A

The Frequency Correction data set A contains 136 sub-carrier symbols independent of the number of sub-carriers used.

9.4.8.3.11 Frequency correction data set B

The Frequency Correction data set B is used on 50 kHz, 100 kHz and 150 kHz QAM channels. The table 9.26 shows the number of sub-carrier symbols for different numbers of subcarriers.

Table 9.26: Number of sub-carrier symbols for data set B

Number of sub-carriers	Number of subcarrier symbols
8	-
16	236
32	708
48	1 180

9.4.9 Transmission modes for QAM

9.4.9.1 BS transmission

For QAM modulation, only BS continuous transmission is supported.

9.4.9.2 MS multiple slot transmission

The MS transmitting on more than 1 physical channel need not to ramp down and up between adjacent normal uplink bursts. In the case where the MS does not perform the ramping, the burst shall be followed by 3 filler symbols (FiSA or FiSB, depending on the particular concatenation) corresponding to the guard period (total of $3M$ sub-carrier symbols, where M is the number of sub-carriers) defined in clause P.2.6.

9.5 Mapping of logical channels into physical channels

9.5.0 General

Clauses 9.5.1 to 9.5.5 apply to phase modulation and clauses 9.5.6 to 9.5.10 to QAM.

9.5.1 General mapping of logical channels into $\pi/4$ -DQPSK physical channels

$\pi/4$ -DQPSK physical channels use $\pi/4$ -DQPSK bursts. $\pi/4$ -DQPSK bursts use $\pi/4$ -DQPSK modulation. Table 9.27 defines the mapping in time of logical channels into $\pi/4$ -DQPSK physical channel types.

Table 9.27: Mapping of logical channels into $\pi/4$ -DQPSK physical channels

Logical channel	Direction	Burst type	SSN/Block	Physical channel	FN	TN
BSCH	DL	SB	<i>BKN1</i> <i>BKN1</i>	CP, TP UP	18 1...18	4-(<i>MN</i> +1)mod4# 1...4
BNCH	DL	NDB NDB SB	<i>BKN2</i> <i>BKN2</i> <i>BKN2</i>	CP,TP CP UP	18 1...18 1...18	4-(<i>MN</i> +3)mod4# 1...4 1...4
AACH	DL	NDB, SB	<i>BBK</i>	CP, TP, UP	1...18	1...4#
BLCH	DL	NDB,SB	<i>BKN2</i>	CP, UP TP	1...18 18	1...4 1...4
CLCH	UL	LB	<i>SSN1</i> <i>SSN1</i>	CP, TP CP, UP	18 1...18	4-(<i>MN</i> +1)mod4# 1...4
SCH/F	DL	NDB	<i>BKN1</i> + <i>BKN2</i>	CP TP	1...18 18	1...4 1...4
	UL	NUB	<i>BKN1</i> + <i>BKN2</i>	CP TP	1...18 18	1...4 1...4
SCH/HD	DL	NDB, SB	<i>BKN1</i> , <i>BKN2</i>	CP, UP TP	1...18 18	1...4 1...4
SCH/HU	UL	CB	<i>SSN1</i> , <i>SSN2</i>	CP TP	1...18 18	1...4 1...4
TCH	DL	NDB	<i>BKN1</i> , <i>BKN2</i>	TP	1...17	1...4
	UL	NUB	<i>BKN1</i> , <i>BKN2</i>	TP	1...17	1...4
STCH	DL	NDB	<i>BKN1</i> , <i>BKN2</i>	TP	1...17	1...4
	UL	NUB	<i>BKN1</i> , <i>BKN2</i>	TP	1...17	1...4

NOTE: # indicates a mandatory mapping.

The mapping for $\pi/4$ -DQPSK TP and CP physical channels shall be as summarized in tables 9.28 and 9.29.

Table 9.28: TDMA frame mapping on $\pi/4$ -DQPSK TP channel

Frame FN	DOWNLINK		UPLINK	
	Block <i>BKN1</i>	Block <i>BKN2</i>	Subslot <i>SSN1</i> or Block <i>BKN1</i>	Subslot <i>SSN2</i> or Block <i>BKN2</i>
1 to 17	TCH STCH + TCH STCH + STCH		TCH STCH + TCH STCH + STCH	
18	SCH/HD BSCH SCH/HD	SCH/HD SCH/HD BNCH	SCH/HU CLCH	SCH/HU SCH/HU

Table 9.29: TDMA frame mapping on $\pi/4$ -DQPSK CP channel

Frame FN	DOWNLINK		UPLINK	
	Block <i>BKN1</i>	Block <i>BKN2</i>	Subslot <i>SSN1</i> or Block <i>BKN1</i>	Subslot <i>SSN2</i> or Block <i>BKN2</i>
1 to 18	SCH/F SCH/HD SCH/HD		SCH/F SCH/HU CLCH	
18	BSCH	SCH/HD		SCH/HU

In all cases the AACH shall be mapped onto the broadcast block of each downlink slot. On the downlink the BLCH may replace the SCH/HD of the block *BKN2*.

9.5.1a General mapping of logical channels into D8PSK physical channels

D8PSK is the general name for a channel that allows both $\pi/4$ -DQPSK and $\pi/8$ -D8PSK bursts. $\pi/4$ -DQPSK bursts use $\pi/4$ -DQPSK modulation. $\pi/8$ -D8PSK bursts use both $\pi/4$ -DQPSK modulation and $\pi/8$ -D8PSK modulation, as defined in clause 9.4.4.2. The transmitter may send a $\pi/4$ -DQPSK burst or a $\pi/8$ -D8PSK burst independently of the preceding type of burst. The uplink and downlink burst types are chosen independently.

Table 9.30 defines the mapping in time of logical channels within a D8PSK physical channel.

Table 9.30: Mapping of logical channels into D8PSK physical channels

Logical channel	Direction	Burst type	SSN/Block	Physical channel	FN	TN
BSCH	DL	SB ($\pi/4$ -DQPSK)	<i>BKN1</i>	CP	18	$4-(MN+1)\text{mod}4\#$
BNCH	DL	NDB ($\pi/4$ -DQPSK)	<i>BKN2</i>	CP	18	$4-(MN+3)\text{mod}4\#$
		NDB ($\pi/4$ -DQPSK)	<i>BKN2</i>	CP	1...18	1...4
AACH	DL	NDB ($\pi/4$ -DQPSK)	<i>BBK</i>	CP	1...18	1...4#
		NDB ($\pi/8$ -D8PSK) (see note 2) SB ($\pi/4$ -DQPSK)				
BLCH	DL	NDB, SB ($\pi/4$ -DQPSK) NDB ($\pi/8$ -D8PSK)	<i>BKN2</i>	CP	1...18	1...4
CLCH	UL	LB	<i>SSN1</i>	CP	18	$4-(MN+1)\text{mod}4\#$
			<i>SSN1</i>	CP	1...18	1...4
SCH/F	DL	NDB ($\pi/4$ -DQPSK)	<i>BKN1+BKN2</i>	CP	1...18	1...4
	UL	NUB ($\pi/4$ -DQPSK)	<i>BKN1+BKN2</i>	CP	1...18	1...4
SCH-P8/F	DL	NDB ($\pi/8$ -D8PSK)	<i>BKN1+BKN2</i>	CP	1...18	1...4
	UL	NUB ($\pi/8$ -D8PSK)	<i>BKN1+BKN2</i>	CP	1...18	1...4
SCH/HD	DL	NDB, SB ($\pi/4$ -DQPSK)	<i>BKN1, BKN2</i>	CP	1...18	1...4
SCH-P8/HD	DL	NDB ($\pi/8$ -D8PSK)	<i>BKN1, BKN2</i>	CP	1...18	1...4
SCH/HU	UL	CB ($\pi/4$ -DQPSK)	<i>SSN1, SSN2</i>	CP	1...18	1...4
SCH-P8/HU	UL	CB ($\pi/8$ -D8PSK)	<i>SSN1, SSN2</i>	CP	1...18	1...4

NOTE 1: # indicates a mandatory mapping.
NOTE 2: Transmitted using $\pi/4$ -DQPSK modulation in a $\pi/8$ -D8PSK burst.

The mapping of TDMA frames onto D8PSK physical channels shall be as summarized in table 9.31.

Table 9.31: TDMA frame mapping on D8PSK channel

Frame FN	DOWNLINK		UPLINK	
	Block <i>BKN1</i>	Block <i>BKN2</i>	Subslot <i>SSN1</i> or Block <i>BKN1</i>	Subslot <i>SSN2</i> or Block <i>BKN2</i>
1 to 18	SCH/F SCH-P8/F		SCH/F SCH-P8/F	
	SCH/HD SCH-P8/HD SCH/HD	SCH/HD SCH-P8/HD BNCH	SCH/HU SCH-P8/HU SCH/HU SCH-P8/HU CLCH CLCH	SCH/HU SCH-P8/HU SCH-P8/HU SCH/HU SCH/HU SCH-P8/HU
	18	BSCH	SCH/HD	

In all cases the AACH shall be mapped onto the broadcast block of each downlink slot. On the downlink the BLCH may replace the SCH/HD or SCH-P8/HD of the block *BKN2*.

9.5.1b General mapping of logical channels into unallocated physical channels for phase modulation

Unallocated physical channels shall use $\pi/4$ -DQPSK bursts. The mapping shall be as summarized in table 9.32.

Table 9.32: TDMA frame mapping on unallocated physical channel

Frame <i>FN</i>	DOWNLINK		UPLINK	
	Block <i>BKN1</i>	Block <i>BKN2</i>	Subslot <i>SSN1</i>	Subslot <i>SSN2</i>
1 to 18	SCH/HD BSCH	SCH/HD BNCH	CLCH	

The AACH shall be mapped onto the broadcast block of each downlink slot. On the downlink the BLCH may replace the SCH/HD of the block *BKN2*.

NOTE: When a phase modulation channel first becomes unallocated after being used as an assigned channel (assigned for a circuit mode call or for secondary control), it is recommended that the BS maps SCH/HD + SCH/HD onto some slots of the unallocated physical channel(s) for several multiframes i.e. the BS should not map BSCH + BNCH onto all slots.

This is because any MSs that did not receive the channel allocation sent before the channel became unallocated will not receive the AACH in slots containing BSCH + BNCH (except when $FN = 18$ and $(MN + TN) \bmod 4 = 3$). However, when the BS maps SCH/HD + SCH/HD onto slots of the unallocated physical channel(s) (except when $FN = 18$ and $(MN + TN) \bmod 4 = 3$), any MSs remaining on the channel may receive the AACH; the MSs may then recognize quickly that the channel has become unallocated (see clause 23.5.6.1.1) instead of having to wait for the inactivity time-out to expire (see clause 23.5.6.1.2) or for RDC failure (see clause 23.7.3.1.1).

9.5.2 Mapping of BCCH and CLCH for phase modulation

The BCCH and CLCH shall be mapped on the control frame of $\pi/4$ -DQPSK and $\pi/8$ -D8PSK CP and TP channels. BCCH shall be transmitted within a $\pi/4$ -DQPSK burst.

Table 9.33: Mapping of the BCCH onto the control frame

Multiframe	Frame <i>FN18</i>	Timeslot			
		<i>TN1</i>	<i>TN2</i>	<i>TN3</i>	<i>TN4</i>
$(MN) \bmod 4 = 1$	downlink <i>BKN1</i>		BSCH		
	downlink <i>BKN2</i>				BNCH
	uplink <i>SSN1</i>		CLCH		
$(MN) \bmod 4 = 2$	downlink <i>BKN1</i>	BSCH			
	downlink <i>BKN2</i>			BNCH	
	uplink <i>SSN1</i>	CLCH			
$(MN) \bmod 4 = 3$	downlink <i>BKN1</i>				BSCH
	downlink <i>BKN2</i>		BNCH		
	uplink <i>SSN1</i>				CLCH
$(MN) \bmod 4 = 0$	downlink <i>BKN1</i>			BSCH	
	downlink <i>BKN2</i>	BNCH			
	uplink <i>SSN1</i>			CLCH	

The mapping of the BCCH and CLCH on the control frame shall be a function of the time slot and multiframe numbers and shall be obtained from the following algorithms or from table 9.33.

- Down-link:
 - BNCH mapped if:

$$FN = 18 \text{ and } (MN + TN) \bmod 4 = 1 \quad (9.16)$$

- BSCH mapped if:

$$FN = 18 \text{ and } (MN + TN) \bmod 4 = 3 \quad (9.17)$$

- Up-link:

- CLCH mapped if:

$$FN = 18 \text{ and } (MN + TN) \bmod 4 = 3 \quad (9.18)$$

The BSCH shall always be transmitted on a synchronization burst.

NOTE: Downlink slots for which $FN = 18$ and $(MN + TN) \bmod 4 = 1$ or 3 are sent using $\pi/4$ -DQPSK modulation.

In addition to this mapping the BS may map the CLCH onto the up-link subslot 1 and the BNCH on the downlink block 2 of a CP channel. The mapping shall be performed on a slot to slot basis. The mapping of the CLCH shall be indicated on the AACH.

A MS may linearize its transmitter at any CLCH occurrence, even from another physical channel, provided this does not violate other mapping rules. The number of MS transmitter linearizations on one carrier is limited to once per multiframe period.

The BLCH may be mapped onto block 2 of the downlink slots, when a SCH/HD, SCH-P8/HD or a BSCH is mapped onto block 1. The number of BLCH occurrences on one carrier shall not exceed one per 4 multiframe periods.

At initial power-on of an RF carrier, the BS may linearize its transmitter using the BLCH. In this case the BLCH is mapped on a burst similar to the downlink linearization burst, but with an unspecified duration preceding the start burst.

Slots of an unallocated physical channel may be filled up with the BCCH, the BSCH is mapped onto block 1 and BNCH onto block 2. Whenever a BCCH is mapped on the downlink, a CLCH may also be mapped into the up-link.

9.5.3 Mapping of SCH for $\pi/4$ -DQPSK physical channels

On the up-link one SCH/F or two SCH/HU (one on each subslot) may be mapped, except if a CLCH is mapped on subslot 1 (equation 9.18) then only one SCH/HU may be mapped, onto subslot 2. On the down-link one SCH/F or two SCH/HD may be mapped on block 1 and block 2 except on the control frame if a BNCH is mapped onto block 2, then only one SCH/HD shall be mapped onto block 1.

Whenever a normal downlink burst is transmitted on an UP channel and if no BCCH is transmitted then the SCH/HD shall be mapped onto block 1 and block 2. The SCH/HD shall contain dummy messages (null SDU as described in clause 21).

The BS shall indicate on the AACH the type of logical channel(s) to be used on the next up-link subslot (SCH/HU or CLCH) or slot (SCH/F). This indication shall only be valid within one frame and for one physical channel.

In the case where several downlink TP channels are allocated to one single communication, the uplink and downlink SCH shall be mapped onto frame $FN18$ of the allocated physical channel showing the lowest timeslot number TN .

In the case where several uplink TP channels are allocated to one single communication, the uplink and downlink SCH shall be mapped onto frame $FN18$ of the allocated physical channel showing the highest timeslot number TN .

In the case where several downlink and uplink TP channels have been allocated simultaneously to one single communication, the uplink and downlink SCH shall be mapped onto frame $FN18$ of the allocated physical channel showing the lowest timeslot number TN .

9.5.3a Mapping of SCH for $\pi/8$ -D8PSK physical channels

On the up-link one SCH/F or SCH-P8/F may be mapped. Any combination of SCH/HU and SCH-P8/HU (one on each subslot) may be mapped. If a CLCH is mapped on subslot 1 (equation 9.18) then SCH/HU or SCH-P8/HU may be mapped onto subslot 2.

On the downlink, one SCH/F or one SCH-P8/F or two SCH/HD or two SCH-P8/HD may be mapped on block 1 and block 2 except on the control frame if a BNCH is mapped onto block 2, and then only one SCH/HD shall be mapped onto block 1.

The BS shall indicate on the AACH the type of logical channel(s) to be used on the next up-link subslot or slot. This indication shall only be valid within one frame and for one physical channel.

9.5.4 Mapping of TCH and STCH for phase modulation

The TCH shall be mapped onto block 1 and block 2 of the frames 1 to 17 of a TP channel.

The STCH may be mapped onto any frame allowed for traffic. The STCH steals a part or all of the TCH bits within a burst.

The presence of stolen traffic in one burst shall be indicated by the type of training sequence.

In case of stealing, the STCH shall always steal first the first half slot of the burst.

9.5.5 Mapping of AACH for phase modulation

The AACH is mapped onto the broadcast block of each downlink slot for both $\pi/4$ -DQPSK and $\pi/8$ -D8PSK bursts.

9.5.6 General mapping of logical channels for QAM

Table 9.34 defines the mapping in time of logical channels into physical channel types.

Table 9.34: Mapping of QAM logical channel into QAM physical channels

Logical channel	Direction	Burst type	SSN	Physical channel	FN	TN
BSCH-Q	DL	FCB	-	CP, UP	18 1...18	$4-(MN+1)\text{mod}4\#$ 1...4
BNCH-Q	DL	NDB, FCB	-	CP, UP	18 1...18	$4-(MN+3)\text{mod}4\#$ 1...4
AACH-Q	DL	NDB, FCB	-	CP, UP	1...18	1...4#
SICH-Q/D	DL	NDB, FCB	-	CP, UP	1...18	1...4#
SICH-Q/U	UL	NUB, CB	-	CP	1...18	1...4#
BLCH-Q	DL	LDB	-	CP, UP	1...18	1...4
CLCH-Q	UL	LB	SSN1	CP	18	$4-(MN+1)\text{mod}4\#$ (see note 2)
			SSN1	CP, UP	1...18	1...4
SCH-Q/D	DL	NDB	-	CP, UP	1...18	1...4
SCH-Q/U	UL	NUB	-	CP	1...18	1...4
SCH-Q/HU	UL	CB	SSN1, SSN2	CP	1...18	1...4
SCH-Q/RA	UL	RAB	SSN11 through SSN26	CP	1...18	1...4
SCH-Q/B	DL	FCB	-	CP, UP	18 1...18	$4-(MN+1)\text{mod}4\#$ 1...4

NOTE 1: # indicates a mandatory mapping. Mandatory mapping of BSCH-Q and BNCH-Q applies only to DA main carriers.

NOTE 2: The MS shall only use the CLCH-Q in the lowest numbered TN of its channel.

The mapping to the CP channel shall be as summarized in table 9.35.

Table 9.35: TDMA frame mapping on QAM CP channel

Frame <i>FN</i>	DOWNLINK		UPLINK	
			Subslot <i>SSN1</i> or <i>SSN11</i> through <i>SSN16</i>	Subslot <i>SSN2</i> or <i>SSN21</i> through <i>SSN26</i>
1 to 18		SCH-Q/D BLCH-Q BNCH-Q BSCH-Q SCH-Q/B	SCH-Q/HU SCH-Q/RA CLCH-Q SCH-Q/HU SCH-Q/RA CLCH-Q	SCH-Q/U SCH-Q/HU SCH-Q/RA SCH-Q/HU SCH-Q/RA SCH-Q/HU SCH-Q/RA

9.5.7 General mapping of logical channels into unallocated physical channels for QAM

The mapping to UP channel shall be as presented in table 9.36.

Table 9.36: TDMA frame mapping on QAM unallocated physical channel

Frame <i>FN</i>	DOWNLINK		UPLINK	
			Subslot <i>SSN1</i> or <i>SSN11</i> through <i>SSN16</i>	Subslot <i>SSN2</i> or <i>SSN21</i> through <i>SSN26</i>
1 to 18		SCH-Q/D BLCH-Q BNCH-Q BSCH-Q SCH-Q/B	CLCH-Q	

9.5.8 Mapping of BCCH-Q and CLCH-Q for QAM

The CLCH-Q shall be mapped on the control frame of CP channels as presented in table 9.37.

Table 9.37: Mapping of the BCCH-Q onto the control frame

Multiframe	Frame <i>FN18</i>	Timeslot			
		<i>TN1</i>	<i>TN2</i>	<i>TN3</i>	<i>TN4</i>
$(MN) \bmod 4 = 1$	downlink		BSCH-Q (note 2)		BNCH-Q (note 2)
	uplink <i>SSN1</i>		CLCH-Q (note 1)		
$(MN) \bmod 4 = 2$	downlink	BSCH-Q (note 2)		BNCH-Q (note 2)	
	uplink <i>SSN1</i>	CLCH-Q (note 1)			
$(MN) \bmod 4 = 3$	downlink		BNCH-Q (note 2)		BSCH-Q (note 2)
	uplink <i>SSN1</i>				CLCH-Q (note 1)
$(MN) \bmod 4 = 0$	downlink	BNCH-Q (note 2)		BSCH-Q (note 2)	
	uplink <i>SSN1</i>			CLCH-Q (note 1)	

NOTE 1: On a multi-slot channel CLCH-Q is only mapped and the MS shall only use the slot for linearization, when it is the lowest numbered timeslot of the channel.

NOTE 2: Mandatory mapping of BSCH-Q and BNCH-Q applies only for DA main carriers.

The mapping of the BCCH-Q and CLCH-Q on the control frame shall be a function of the time slot and multiframe numbers and shall be obtained from the following algorithms or from table 9.37.

- Down-link (mandatory mapping only on the DA main carrier):

- BNCH-Q mapped if:

$$FN = 18 \text{ and } (MN + TN) \bmod 4 = 1 \quad (9.19)$$

- BSCH-Q mapped if:

$$FN = 18 \text{ and } (MN + TN) \bmod 4 = 3 \quad (9.20)$$

NOTE 1: Whenever BSCH-Q is used on a 50 kHz, 100 kHz or 150 kHz channel, there will also be an SCH-Q/B.

- Up-link:

- CLCH-Q mapped if:

$$FN = 18 \text{ and } (MN + TN) \bmod 4 = 3 \text{ and } TN \text{ is the lowest numbered timeslot of the MS's channel} \quad (9.21)$$

NOTE 2: If the channel is a multislot channel, and $FN = 18$ and $(MN + TN) \bmod 4 = 3$ and TN is not the lowest numbered timeslot of the multislot channel, then CLCH-Q is not mapped.

In addition to this mapping the BS may map the CLCH-Q onto the up-link subslot 1 and the BSCH-Q and/or the BNCH-Q on the downlink of a CP channel. The mapping shall be performed on a slot to slot basis. The mapping of the CLCH-Q shall be indicated on the AACH-Q.

The number of BLCH-Q occurrences on one carrier shall not exceed one per 4 multiframe periods.

At initial power-on of an RF carrier, the BS may linearize its transmitter using the BLCH-Q. In this case the BLCH-Q is mapped on a burst similar to the downlink linearization burst, but with an unspecified duration preceding the start burst.

On a UP channel, the BS may map the BSCH-Q and/or the BNCH-Q on the downlink and may map CLCH-Q onto the uplink subslot 1.

9.5.9 Mapping of SCH-Q for QAM

On the up-link one SCH-Q/U or two SCH-Q/HU (one on each subslot) may be mapped, except if a CLCH-Q is mapped on subslot 1 (equation 9.21) then only one SCH/HU may be mapped, onto subslot 2. Alternatively SCH-Q/RA may be mapped on the up-link (see table 9.35). On the down-link one SCH-Q/D may be mapped.

The BS shall indicate on the AACH-Q the type of logical channel(s) to be used on the next up-link subslot (SCH-Q/HU, SCH-Q/RA or CLCH-Q) or slot (SCH-Q/U). This indication shall only be valid within one frame and for one physical channel.

NOTE: On 50 kHz, 100 kHz and 150 kHz QAM channels SCH-Q/B mapping is same as for BSCH-Q. SCH-Q/B is not mapped on a 25 kHz channel.

9.5.10 Mapping of SICH-Q and AACH-Q for QAM

The SICH-Q/D and AACH-Q shall be mapped onto the header block of each downlink slot except slots containing BLCH-Q, and the SICH-Q/U shall be mapped onto the header block of each uplink slot or subslot, except subslots containing CLCH-Q or SCH-Q/RA.

The details of the mapping of the SICH-Q/D and AACH-Q into the bits that define the header block in the downlink slot are defined in clause 8.

9.6 Monitoring pattern for transmitting MSs

A particular monitoring pattern shall be referenced by its Monitoring Pattern Number (*MPN*). The monitoring patterns shall be numbered from 1 to 3. The BS shall assign 0 to 3 patterns to each up-link TCH during the call or transaction set-up. The transmitting MS shall monitor at least all frames belonging to the assigned monitoring pattern(s). In some cases, the BS may allocate no monitoring pattern, but, as a result, the MS may not be so easily reachable.

For a given monitoring pattern, the frame sequence may be obtained with the following equation or by using table 9.38.

$$(MN + MPN - 1) \bmod 3 = (FN) \bmod 3 \quad (9.22)$$

Table 9.38: Monitoring patterns for transmitting MSs

Multiframe	Monitoring Patterns		
	MPN 1	MPN 2	MPN 3
$(MN) \bmod 3 = 1$	<i>FN</i> 1, 4, 7, 10, 13, 16	<i>FN</i> 2, 5, 8, 11, 14, 17	<i>FN</i> 3, 6, 9, 12, 15, 18
$(MN) \bmod 3 = 2$	<i>FN</i> 2, 5, 8, 11, 14, 17	<i>FN</i> 3, 6, 9, 12, 15, 18	<i>FN</i> 1, 4, 7, 10, 13, 16
$(MN) \bmod 3 = 0$	<i>FN</i> 3, 6, 9, 12, 15, 18	<i>FN</i> 1, 4, 7, 10, 13, 16	<i>FN</i> 2, 5, 8, 11, 14, 17

9.7 BS timesharing transmission

9.7.1 Carrier sharing for Phase Modulation

In carrier sharing mode one carrier frequency shall be shared among up to four cells, each cell being allocated at least one physical channel. The mapping of logical channels into physical channels shall follow the general mapping rules, except that on the downlink discontinuous bursts shall be used (see also clause 23.3.2.1).

9.7.2 MCCH sharing for Phase Modulation

In MCCH sharing mode, the MCCH shall be shared among several cells. The TDMA frames of the MCCH shall be divided into frames reserved to one BS (reserved frames) and frames shared by all cells (common frames). The BS shall transmit during the reserved frames and may transmit during the common frames. The transmission during the common frames should be managed by the network (see also clause 23.3.2.2).

The frames reserved for a BS shall be calculated from the *TS_RESERVED_FRAMES* parameter that indicates the number of reserved frames per two multiframes. This parameter may take one of the following values:

- 1, 2, 3, 4, 6, 9, 12, 18;

and shall be broadcast on the BSCH. Up to 36 cells may share the same MCCH. The *FN* of the reserved frames may be obtained from the following equation or from table 9.39.

- the frame *FN* in the multiframe *MN* is reserved to the BS if:

$$FN + 18 [(MN + 1) \bmod 2] \text{ is a multiple of } 36 / \text{TS_RESERVED_FRAMES} \quad (9.23)$$

For any value of *TS_RESERVED_FRAMES*, frame 18 of the even multiframes shall be reserved, in order to transmit the BCCH. The TDMA frame and multiframe numbering of all cells sharing one MCCH shall be offset in order to avoid collision of the transmitted bursts.

The allocation of the common frames shall be sent on the BNCH.

The mappings of logical channel into physical channel shall follow for the reserved and common frames the same rules as for continuous transmission, except that on the downlink the discontinuous bursts shall be used.

Table 9.39: Reserved frames in BS timing

Multi-frame MN	Frame FN	RESERVED FRAMES							
		1	2	3	4	6	9	12	18
odd	1								
	2								
	3								
	4								
	5								
	6								
	7								
	8								
	9								
	10								
	11								
	12								
	13								
	14								
	15								
	16								
	17								
	18								
even	1								
	2								
	3								
	4								
	5								
	6								
	7								
	8								
	9								
	10								
	11								
	12								
	13								
	14								
	15								
	16								
	17								
	18								

9.7.3 BS timesharing transmission for QAM

QAM channels shall not use BS timesharing transmission.

9.8 Modes of control

9.8.0 General

Two modes of control are defined:

- Normal Control Mode (NCM); and
- Minimum Control Mode (MCM).

9.8.1 Normal Control Mode

The NCM is a mode of operation providing the TETRA services with full performance. In NCM a MCCH or MCCH-Q shall be assigned.

9.8.2 Minimum Control Mode

The MCM is a mode of operation on a CA cell providing the TETRA services with reduced performance. In MCM all physical channels may be assigned channels.

10 Radio subsystem link control

10.1 Introduction

Clauses 10.2 to 10.4 specify the radio subsystem link control implementation in MSs and BSs for V+D. The following aspects of radio subsystem link control are addressed:

- RF power control;
- the basis for signal strength measurement;
- link adaptation (applicable to D8PSK and QAM channels only).

10.2 RF power control

Adaptive RF power control shall be used by the MS. By minimizing the transmit power levels, interference to co-channel and adjacent channel users is reduced and MS power consumption could be reduced. Adaptive RF power control shall not be used by the BS.

10.3 Radio link measurements

10.3.0 General

The radio link measurements include signal strength, signal quality and round-trip MS-BS path delay as presented in clauses 10.3.1, 10.3.2 and 10.3.3.

10.3.1 Received signal strength

10.3.1.1 Signal strength measurement

The received signal strength shall be measured over the range from -115 dBm to -50 dBm with an absolute accuracy of ± 4 dB. The relative accuracy between two measurements on the same carrier or on different carriers shall be ± 3 dB.

10.3.1.2 Sample duration for signal strength measurement

To enable correct measurement of the received signal strength, the minimum Sample Duration (SD) shall be one of the following defined values:

- SD1 = 1 ms sample duration (1 ms integration time);
- SD2 = 4 ms sample duration (4 ms integration time).

10.3.2 Signal quality

The quality of the radio downlink shall be estimated from the success rate of decoding the AACH or AACH-Q (see clause 23).

10.3.3 Round-trip MS-BS path delay

The round-trip MS-BS path delay may be used by the BS as a criterion to relinquish a radio uplink. The path delay of the MS is a representation of the distance of the MS to the serving BS. This distance may be used to prevent MS grossly exceeding the planned cell boundaries. This information may be sent by the BS to the MS when appropriate. The allowable distance may be restricted on a cell to cell basis by the network operator, as required.

10.4 Link adaptation

Link adaptation may be used by the BS and MS to improve usage of the channel. This is achieved by the BS and/or MS transmitters changing the modulation type and/or coding rate, refer to clause 23.2.3. Link adaptation methods may include measurements of the radio link quality and/or the use of BS-MS link adaptation signalling, refer to clauses 23.1.4 and 23.4.9.

11 Call Control (CC) service description

11.1 Introduction

This clause describes the services offered by the CC sub-entity in the Circuit Mode Control Entity (CMCE). The CC Service Access Point (SAP) is used in conformance testing as a normative boundary in TETRA MSs and TETRA LSs.

11.2 Services offered

The CC services shall be provided with a CC sub-entity at the service access point TNCC-SAP. In order to cater for concurrent services there may exist multiple instances of the TNCC-SAP running at the same time.

At the TNCC-SAP one instance of the call control shall consist a set of the following calling user application and called user application services:

- basic call set-up (with attributes);
- call maintenance;
- Dual Tone Multiple Frequency (DTMF) encoding and sending;
- PTT requests/grants/information;
- call clearance;
- change of tele/bearer service within a call.

11.3 CC service

11.3.1 CC primitives exchanged through the TNCC-SAP

The flow of CC primitives shall be as illustrated in figure 11.1.

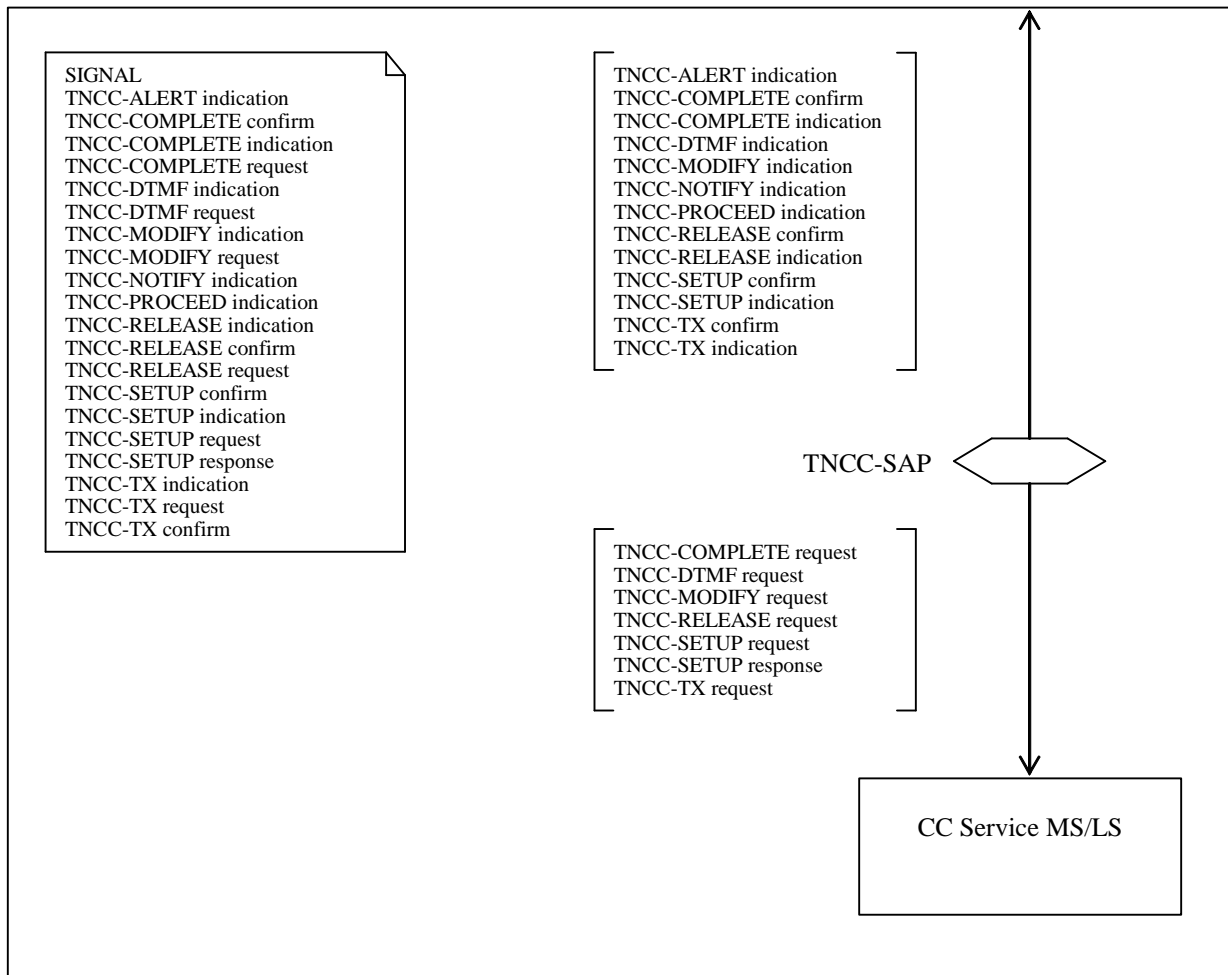

Figure 11.1: CC services provided at TNCC-SAP MS-side

11.3.2 Service primitives at the TNCC-SAP

Each TNCC-SAP shall be characterized by a SAP and the set of service primitives available for each SAP shall be as specified in this clause.

TNCC-ALERT indication: the primitive shall be used in the call set-up phase towards the calling user application when on/off hook signalling is employed.

TNCC-COMplete request/indication/confirm: the primitives shall be used as a termination of the call set-up phase at the called user application.

TNCC-DTMF request/indication: the primitives may be used during a circuit mode call to exchange DTMF information between user applications.

TNCC-MODIFY request/indication: the primitives may be used during call active phase as an indication that an existing tele or bearer service has been modified.

TNCC-NOTIFY indication: the primitives may be used during call set-up and call active phases to notify the user application about the status of the call.

TNCC-PROCEED indication: the primitive may be used during call set-up phase to indicate progress of the call set-up.

TNCC-RELEASE request/indication/confirm: the primitives shall be used to initiate the call release phase. Further it shall be used to indicate the termination of the call release phase. The primitives may also be used during the call set-up phase to request or indicate rejection of a call.

TNCC-SETUP request/indication/response/confirm: the primitives shall be used to initiate the call set-up phase and shall also be used to indicate the termination of the call set-up phase.

TNCC-TX request/indication/confirm: the primitives shall be used during call active phase to request and indicate change in the transmission permission.

11.3.3 Primitive description

11.3.3.0 General

The information contained in the primitive description tables which follow corresponds to the following key:

- M: Mandatory;
- C: Conditional;
- O: Optional;
- : Not used.

11.3.3.1 TNCC-ALERT primitive

TNCC-ALERT indication: the primitive shall be used to indicate to the calling user application, that the call has been received, and alerting at the called user application has been initiated. The called user application is using on/off hook signalling and the primitive indicates that the called user application is alerting.

The parameters are defined in table 11.1.

Table 11.1: Parameters for the primitive TNCC-ALERT

Parameter	Indication
Basic service information (offered):	
Circuit mode service	O
Communication type	O
Data call capacity	C (see note)
Data service	C (see note)
Encryption flag	O
Speech service	C (see note)
Call queued	O
Call time-out, set-up phase	M
Notification indicator	O
Simplex/duplex	M
NOTE: Depending on the value of circuit mode service.	

11.3.3.2 TNCC-COMplete primitive

TNCC-COMplete request: the primitive shall be used by the called user application to complete individual call set-up.

TNCC-COMplete indication: the primitive shall be used as an indication to the called user application that the call set-up has been completed. The called user application shall also be informed whether the SwMI has granted transmission permission to the calling user application or whether the right to transmit has been handed over to the another user application.

TNCC-COMplete confirm: the primitive shall be used to confirm to the called user application that the call set-up has been completed.

The parameters are defined in table 11.2.

Table 11.2: Parameters for the primitive TNCC-COMplete

Parameter	Request	Indication	Confirm
Access priority	O	-	-
Basic service information (offered):			
Circuit mode service	O	-	-
Communication type	O	-	-
Data call capacity	C (see note)	-	-
Data service	C (see note)	-	-
Encryption flag	O	-	-
Speech service	C (see note)		
Call time-out	-	M	M
Hook method	M	-	-
Notification indicator	-	O	O
Simplex/duplex	M	-	-
Transmission grant	-	M	M
Transmission request permission	-	M	M
Transmission status	-	M	M
Traffic stealing	O	-	-
NOTE:	Depending on the value of circuit mode service.		

11.3.3.3 TNCC-DTMF primitive

TNCC-DTMF request: the primitive shall be used as a request from the user application to send a number of DTMF digits to another user application.

TNCC-DTMF indication: the primitive shall be used as an indication to the user application that a number of DTMF digits has arrived from another user application.

The parameters are defined in table 11.3.

Table 11.3: Parameters for the primitive TNCC-DTMF

Parameter	Request	Indication
Access priority	O	-
DTMF tone delimiter	M	O (see note 4)
DTMF result	-	C (see note 3)
Number of DTMF digits	C (see note 1)	C (see note 2)
DTMF digits	C (see note 1)	C (see note 2)
Traffic stealing	O	-
NOTE 1:	Present when the value of DTMF tone delimiter is "DTMF tone start".	
NOTE 2:	Present when DTMF tone delimiter is present and set to "DTMF tone start".	
NOTE 3:	Present when DTMF tone delimiter is not present.	
NOTE 4:	The time difference between "DTMF tone start" and "DTMF tone end" may not correspond to the tone duration at the originator.	

11.3.3.4 TNCC-MODIFY primitive

TNCC-MODIFY request: the primitive shall be used as a request from the user application to the SwMI to change the call attributes and/or the simplex/duplex selection.

NOTE: If a change in call attribute is requested, it cannot change from point-to-multipoint to point-to-point.

TNCC-MODIFY indication: the primitive shall be used as an indication to a user application that the call attribute has changed from one tele/bearer service to another tele/bearer service. The primitive shall also be used for indicating a change in the call timer or a change in the simplex/duplex operation.

The parameters are defined in table 11.4.

Table 11.4: Parameters for the primitive TNCC-MODIFY

Parameter	Request	Indication
Access priority	O	-
Basic service information (new):		
Circuit mode service	O	O
Communication type	O	O
Data call capacity	C (see note)	C (see note)
Data service	C (see note)	C (see note)
Encryption flag	O	O
Speech service	C (see note)	C (see note)
Call time-out	-	O
Notification indicator	-	O
Simplex/duplex	O	O
Traffic stealing	O	-
NOTE: Depending on the value of circuit mode service.		

11.3.3.5 TNCC-NOTIFY primitive

TNCC-NOTIFY indication: the primitive shall provide information from the SwMI to the user application about a circuit mode call.

The parameters are defined in table 11.5.

NOTE: ETSI EN 300 392-9 [9] defines in clause 5.2 "NOTIFICATION indication primitive" that the NOTIFICATION indication is also providing information to the user application about the circuit mode call.

Table 11.5: Parameters for the primitive TNCC-NOTIFY

Parameter	Indication
Call status	O
Call time-out in set-up phase	O
Call time-out	O
Call ownership	O
Notification indicator	O
Poll response percentage	O (see note)
Poll response number	O (see note)
Poll response addresses	O (see note)
Poll request	O
NOTE: Only one of these values is applicable in a service primitive.	

11.3.3.6 TNCC-PROCEED primitive

TNCC-PROCEED indication: the primitive shall be used as an indication to the user application that call establishment has been initiated in the SwMI. The indication may also contain information about changes in call attributes, changes in the hook method or the simplex/duplex operation.

The parameters are defined in table 11.6.

Table 11.6: Parameters for the primitive TNCC-PROCEED

Parameter	Indication
Basic service information (offered):	
Circuit mode service	O
Communication type	O
Data call capacity	C (see note)
Data service	C (see note)
Encryption flag	O
Speech service	C (see note)
Call status	O
Hook method	O
Notification indicator	O
Simplex/duplex	O
NOTE: Depending on the value of circuit mode service.	

11.3.3.7 TNCC-RELEASE primitive

TNCC-RELEASE request: the primitive shall be used by the user application to either leave a continuing call or request disconnection of the call. If he wants to disconnect the call the SwMI is requested to release the connection. The SwMI is also requested to release the call identifier and all connections associated with it.

TNCC-RELEASE indication: the primitive shall be used as an indication to the user application, that the SwMI has released the call identifier and the corresponding connection. This primitive may also indicate a loss of resources at a lower layer.

TNCC-RELEASE confirm: the primitive shall be used to indicate to the initiator of the call release, that the SwMI has released the call identifier and the connection.

The parameters are defined in table 11.7.

Table 11.7: Parameters for the primitive TNCC-RELEASE

Parameter	Request	Indication	Confirm
Access priority	O	-	-
Disconnect cause	M	M	M
Disconnect status	-	-	M
Disconnect type	M	-	-
Notification indicator	-	O	O
Traffic stealing	O	-	-

11.3.3.8 TNCC-SETUP primitive

TNCC-SETUP request: the primitive shall be used to initiate the call establishment of a circuit switched call by a calling user application.

TNCC-SETUP indication: the primitive shall be used as an indication to a called user application that a call establishment has been initiated and a circuit switched call is in progress or has been established.

TNCC-SETUP response: the primitive shall be used by the called user application to indicate that the call has been accepted and call set-up can now proceed towards the call active phase. The user application may change the attributes of the call and the simplex/duplex operation may be changed.

TNCC-SETUP confirm: the primitive shall be used as a confirmation to the calling user application that the call set-up phase has now been terminated by the SwMI and an end-to-end connection has been set-up. The call shall now be considered as being in its active phase.

The parameters are defined in table 11.8.

Table 11.8: Parameters for the primitive TNCC-SETUP

Parameter	Request	Indication	Response	Confirm
Access priority	O	-	O	-
Area selection	O (see note 6)	-	-	-
Basic service information:				
Circuit mode service	M	M	O	M
Communication type	M	M	O	M
Data call capacity	C (see note 1)	C (see note 1)	C (see note 1)	C (see note 1)
Data service	C (see note 1)	C (see note 1)	C (see note 1)	C (see note 1)
Encryption flag	M	M	O	M
Speech service	C (see note 1)	C (see note 1)	C (see note 1)	C (see note 1)
Call priority	M	M	-	O
Call ownership	-	-	-	M
Call amalgamation	-	-	-	M
Call time-out	-	M	-	M
Called party type identifier	M	-	-	-
Called party SNA	C (see note 2)	-	-	-
Called party SSI	C (see notes 2 and 3)	M	-	-
Called party extension	C (see note 2)	O (see note 8)	-	-
External subscriber number (called)	O	-	-	-
Calling party:				
Calling party SSI	-	O	-	-
Calling party extension	-	O (see note 4)	-	-
External subscriber number (calling)	-	O	-	-
CLIR control	O (see note 7)	O (see note 7)	O (see note 7)	-
Hook method selection	M	M	M	M
Notification indicator	-	O	-	O
Request to transmit/send data	M	-	-	-
Simplex/duplex selection	M	M	M	M
Traffic stealing	O	-	O	-
Transmission grant	-	M (see note 5)	-	M (see note 5)
Transmission request permission	-	M	-	M
NOTE 1: Depending on the value of circuit mode service type.				
NOTE 2: Depending on the value of called party type identifier.				
NOTE 3: The application should ensure that individual calls (basic service) use called party ISSI, and group calls use GSSI.				
NOTE 4: If not present, the user application shall assume that the address extension is the MNI of the current network.				
NOTE 5: Transmission grant is applicable also in duplex calls.				
NOTE 6: Usage of this parameter is defined in ETSI EN 300 392-12-8 [14].				
NOTE 7: Usage of this parameter is defined in ETSI EN 300 392-12-1 [11].				
NOTE 8: MSs that do not support migration i.e. registers only to the home network need not provide the Called party extension for incoming group calls except, if MS support foreign network group addresses for which the Called party extension is mandatory. The support of foreign group addresses and how the user of the MS knows that migration limitation are outside the scope of the present document. For individual calls the Called party extension is not needed in any network in the present document as the MS can have only a single ITSI.				

11.3.3.9 TNCC-TX primitive

TNCC-TX request: the primitive shall be used as a request from the user application that it wants to transmit or that it has ceased its transmission. In the request for transmission the requested priority and the encryption mode shall be indicated. The user application should use a TNCC-TX request for a request to transmit only when a previous TNCC-TX indication has indicated that a request for transmission is allowed.

TNCC-TX indication: the primitive shall be used as an indication to the user application concerning the transmit status of the call. The primitive shall also be used to inform the user application about whether another user has been granted transmission or ceased its transmission. The encryption state of the actual transmission is indicated in the encryption control parameter.

TNCC-TX confirm: the primitive shall be used as a confirmation to the user application that the request to transmit has been granted. The encryption state of the actual transmission is indicated in the encryption control parameter.

The parameters are defined in table 11.9.

Table 11.9: Parameters for the primitive TNCC-TX

Parameter	Request	Indication	Confirm
Access priority	O	-	-
Encryption flag	M	M	M
Notification indicator	-	O	-
Transmitting party SSI	-	O	-
Transmitting party extension	-	O (see note)	-
External subscriber number	-	O	-
Traffic stealing	O	-	-
Transmission condition	M	-	-
Transmit request permission	-	M	M
Transmission status	-	M	M
Tx demand priority	M	-	-
NOTE:	If not present, the user application shall assume that the address extension is the MNI of the current network.		

11.3.4 Parameter description

Parameters shall be part of the primitives described in clause 11.3.3 and if applied the parameters shall contain the values specified in this clause. These values are selected to correspond to element values used in the air interface protocol:

- Access priority =
 - low priority;
 - high priority;
 - emergency priority.

The default value of the access priority parameter shall be "low priority", which will be applied when no access priority parameter is explicitly defined:

- Area selection =
 - area not defined;
 - area 1;
 - etc.;
 - area 14;
 - all areas in this system.

The default value of the area selection parameter shall be "area not defined", which will be applied when area selection is not used:

- Basic service information (a set of parameters) =
 - circuit mode service;
 - communication type;
 - data service;
 - data call capacity (data service only);
 - encryption flag;
 - speech service.
- Call amalgamation =
 - call not amalgamated;
 - call amalgamated.
- Call ownership =
 - a call owner;
 - not a call owner.
- Call priority =
 - priority not defined;
 - lowest priority;
 - etc.;
 - highest non-pre-emptive priority;
 - lowest pre-emptive priority;
 - etc.;
 - second highest pre-emptive priority;
 - emergency pre-emptive priority.
- Call queued =
 - call is not queued;
 - call is queued.
- Call status =
 - call status unknown;
 - call is progressing;
 - call is queued;
 - requested subscriber is paged;
 - call continue;
 - hang timer has expired.

- Call time-out =
 - call time-out infinite;
 - call time-out value-1;
 - call time-out value-2;
 - etc.;
 - call time-out value-15.

Refer to clause 14.7.1 for the time-out values:

- Call time-out in set-up phase =
 - call time-out pre-defined;
 - call time-out value-1;
 - call time-out value-2;
 - etc.;
 - call time-out value-7.

Refer to clause 14.7.2 for the time-out values:

- Called party extension =
 - country code and network code part of TSI.
- Called party SNA =
 - Short Number Address (SNA).
- Called party SSI =
 - Short Subscriber Identity (SSI).
- Called party type identifier =
 - SNA;
 - SSI;
 - TETRA subscriber identity (TSI).
- Calling party extension =
 - Mobile Country Code (MCC) + Mobile Network Code (MNC).
- Calling party SSI =
 - Individual Short Subscriber Identity (ISSI).
- Circuit mode service =
 - data service;
 - speech service.

- CLIR control =
 - not implemented or use default mode;
 - presentation not restricted;
 - presentation restricted.
- Communication type =
 - point-to-point;
 - point-to-multipoint;
 - point-to-multipoint acknowledged;
 - broadcast.
- Data service (service per one time slot) =
 - unprotected: 7,2 kbit/s, no interleaving;
 - low protection: 4,8 kbit/s, short interleaving depth = 1;
 - low protection: 4,8 kbit/s, medium interleaving depth = 4;
 - low protection: 4,8 kbit/s, long interleaving depth = 8;
 - high protection: 2,4 kbit/s, short interleaving depth = 1;
 - high protection: 2,4 kbit/s, medium interleaving depth = 4;
 - high protection: 2,4 kbit/s, long interleaving depth = 8.

NOTE 1: The increase in interleaving depth gives a better error protection, but also generates a longer transmission delay.

- Data call capacity =
 - one time slot;
 - two time slots;
 - three time slots;
 - four time slots.
- Disconnect cause =
 - cause not defined or unknown;
 - user requested disconnection;
 - non-call owner requested disconnection;
 - called party busy;
 - called party not reachable;
 - called party does not support encryption;
 - congestion in infrastructure;
 - not allowed traffic case;
 - incompatible traffic case;
 - requested service not available;

- pre-emptive use of resource;
 - invalid call identifier;
 - call rejected by the called party;
 - no idle CC entity;
 - expiry of timer;
 - SwMI requested disconnection;
 - acknowledged service not completed;
 - loss of resources;
 - usage marker failure;
 - called party requires encryption;
 - concurrent set-up not supported;
 - called party is under the same DM-GATE of the calling party.
- Disconnect status =
 - disconnection successful;
 - disconnection unsuccessful, the user is released from the call;
 - disconnection unsuccessful, not the call owner, the user is released from the call;
 - disconnection unsuccessful, user not authorized, the user is released from the call;
 - the user is released from the call.
- Disconnect type =
 - disconnect call;
 - leave call without disconnection;
 - leave call temporarily.
- DTMF digits =
 - Each digit shall be one of the following:
 - digit 0;
 - etc.;
 - digit 9;
 - digit *;
 - digit #;
 - digit A;
 - digit B;
 - digit C;
 - digit D.

- DTMF result =
 - DTMF not supported;
 - DTMF not subscribed.
- DTMF tone delimiter =
 - DTMF;
 - tone end.

NOTE 2: The length of the received DTMF tone may be modified by the lower layer protocol depending on the signalling capacity availability.

- Encryption flag =
 - clear end-to-end transmission;
 - encrypted end-to-end transmission.
- External subscriber number digits =
 - Up to 24 digits. Each digit shall be one of the following:
 - digit 0;
 - etc.;
 - digit 9;
 - digit *;
 - digit #;
 - digit +.
- Hook method selection =
 - no hook signalling (direct through-connect);
 - hook on/hook off signalling (individual call); and call acceptance signalling (group call).
- Notification indicator =
 - refer to ETSI EN 300 392-9 [9], clause 7.2.2.
- Number of DTMF digits =
 - 1 to 254.
- Poll request =
 - no poll answer requested;
 - poll answer requested.
- Poll response addresses =
 - TSI addresses 1-N.

- Poll result identifier =
 - poll result not known;
 - the percentage of responding group members;
 - the number of responding group members;
 - the addresses of the responding group members.
- Poll response number =
 - no poll response;
 - 1 poll response;
 - etc.;
 - 63 or more poll responses.
- Poll response percentage =
 - 0 %;
 - 1 %;
 - etc.;
 - 100 %.
- Request to transmit/send data =
 - request to transmit/send data;
 - request that other MS/LS may transmit/send data.
- Simplex/duplex selection =
 - simplex operation;
 - duplex operation.
- Speech service =
 - TETRA encoded one timeslot speech;
 - proprietary encoded one timeslot speech.
- Traffic stealing =
 - do not steal traffic;
 - steal traffic.

The default value of the traffic stealing parameter shall be "do not steal traffic", which will be applied when no traffic stealing parameter is explicitly defined, not used or otherwise defined in the protocol.

- Transmission condition =
 - request to transmit;
 - transmission ceased.

- Transmission grant =
 - transmission granted;
 - transmission not granted;
 - transmission request queued;
 - transmission granted to another user.
- Transmission request permission =
 - allowed to request for transmission;
 - not allowed to request for transmission.
- Transmission status =
 - transmission ceased;
 - transmission granted;
 - transmission not granted;
 - transmission request queued;
 - transmission granted to another user;
 - transmission interrupt;
 - transmission wait;
 - transmission request failed.
- Transmitting party extension =
 - Mobile Country Code (MCC) + Mobile Network Code (MNC).
- Transmitting party SSI =
 - Individual Short Subscriber Identity (ISSI); or
 - Group Short Subscriber Identity (GSSI).
- Tx demand priority =
 - low priority;
 - high priority;
 - pre-emptive priority;
 - emergency pre-emptive priority.

The default value of the TX demand priority parameter shall be "low priority", which will be applied when no TX demand priority parameter is explicitly defined.

11.4 States for CC SAP

The state transitions visible at the TNCC-SAP shall be as shown in figure 11.2.

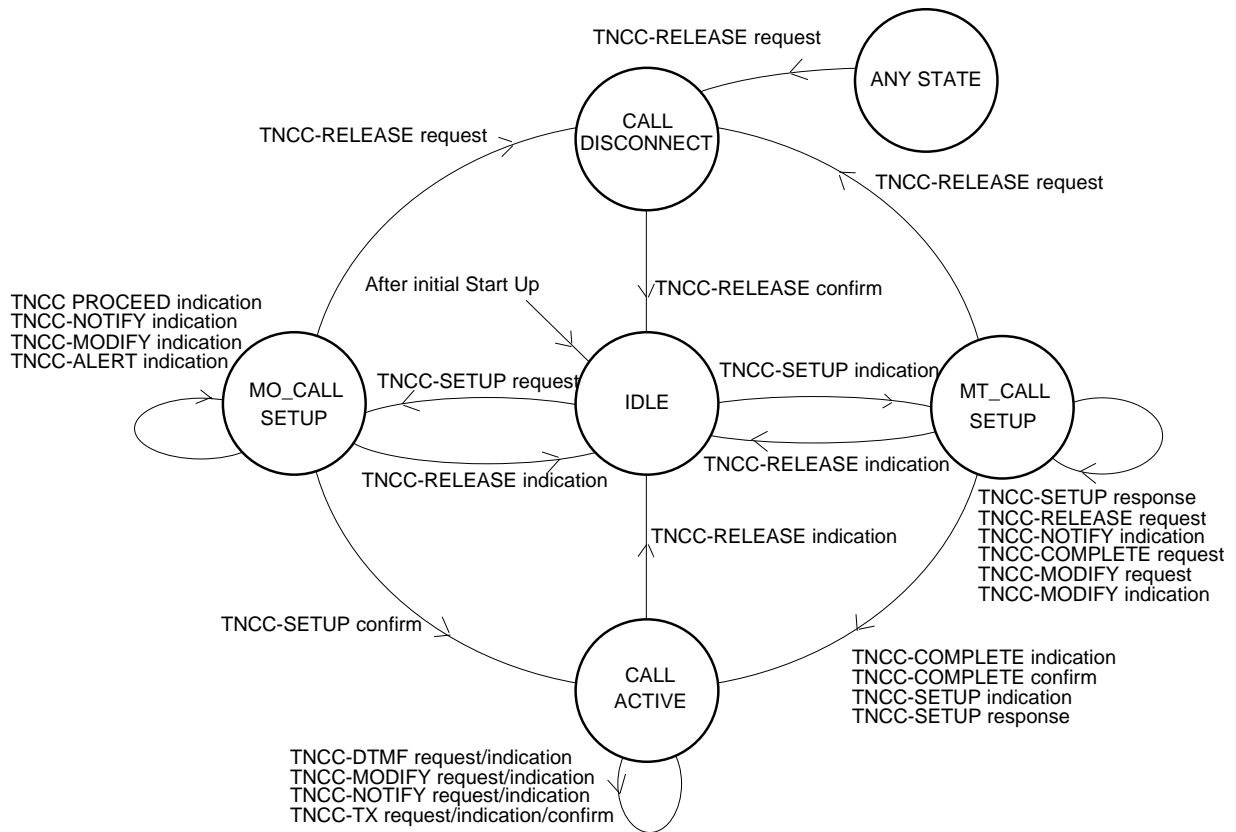

Figure 11.2: State transition diagram for one instance at the CC SAP

12 Supplementary Service (SS) service description

12.1 Introduction

This clause describes general services offered by the CMCE at the SS SAP of the TETRA V+D layer 3 service boundary. This SAP with the CC SAP is used in supplementary service conformance testing as a normative boundary in TETRA MSs and in TETRA LSs.

12.2 Services offered

The SS services are provided at the TNSS-SAP and TNCC-SAP. Refer to clause 11.3 on those supplementary services which utilize also TNCC-SAP. For call related actions the TNSS-SAP and TNCC-SAP are linked together by the call instance and, therefore, there is no "call identifier" parameter in the primitives.

The SS may consist of the following services:

- invocation of an SS;
- activation/deactivation of an SS;
- definition of an SS;
- cancellation of an SS;
- interrogation of an SS;
- registration of a user to a supplementary service;
- reception of supplementary service messages.

12.3 SS service

12.3.1 Primitives exchanged through TNSS-SAP

The SS primitives are defined in ETSI EN 300 392-9 [9] and in each supplementary service stage 3 description ETSI EN/ETS 300 392-12 [10], when available.

The supplementary service primitives shall contain in addition to supplementary services specific parameters also the access priority parameter as defined in table 12.1.

Table 12.1: Parameters for the supplementary service primitives

Parameter	Request	Indication	Response	Confirm
Access priority	O	-	O	-
Supplementary service dependent parameters				

12.3.2 Parameter description

Parameters shall be part of the primitives described in clause 12.3.1 and if applied the parameters shall contain the values specified in this clause. These values are selected to correspond to element values used in the air interface protocol.

- Access priority =
 - low priority;
 - high priority;
 - emergency priority.

The default value of the access priority parameter shall be "low priority", which will be applied when no access priority parameter is explicitly defined.

13 Short Data Service (SDS) service description

13.1 Introduction

This clause describes the services offered by the short data service sub-entity in the CMCE at the SDS SAP of the TETRA V+D layer 3 service boundary. The SDS SAP is used in conformance testing as a normative boundary in TETRA MSs.

13.2 Services offered

The SDS shall be provided by a single SDS functional entity at the TNSDS-SAP.

The short data functional entity shall consist of the following mobile originated and mobile terminated services:

- a) user defined short message reception and transmission:
 - individual message;
 - group message.
- b) pre-defined short message reception and transmission:
 - individual message;
 - group message.

13.3 SDS

13.3.1 SDS primitives exchanged through the TNSDS-SAP

TNSDS-CANCEL request: the primitive may be used by the user application to cancel sending of a message before it is sent at least once over the air interface.

TNSDS-STATUS request/indication: the primitives shall be used to send or receive a pre-coded message defined by either the present document or by the network operator.

TNSDS-REPORT indication: the primitive shall be used to indicate whether a TNSDS-UNITDATA request or a TNSDS-STATUS request has been either transmitted successfully or the transmission failure reason.

TNSDS-UNITDATA request/indication: the primitives shall be used to send or receive a user defined message.

The flow of short data service primitives shall be as illustrated in figure 13.1.

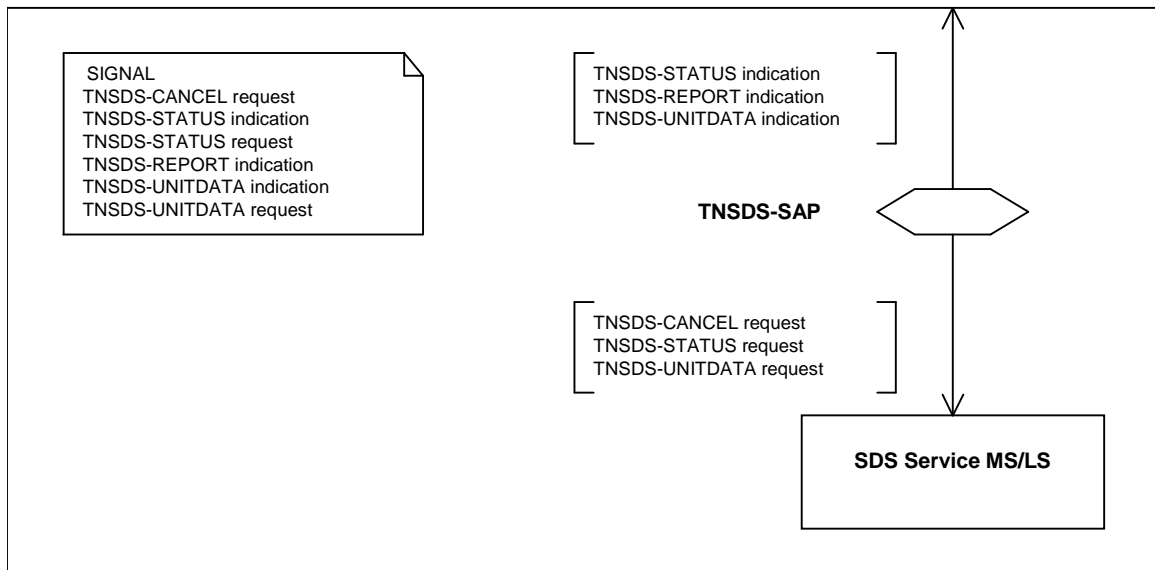

Figure 13.1: SDS provided at TNSDS-SAP (MS-side)

13.3.2 Service primitives at the TNSDS-SAP

13.3.2.0 General

The information contained in the primitive description tables which follow corresponds to the following key:

- M: Mandatory;
- C: Conditional;
- O: Optional;
- : Not used.

The SDS-TL protocol modifies the TNSDS primitives so that a certain range of Status number values of the TNSDS-STATUS primitives are used by the SDS-TL protocol and the User defined data-4 parameter is only available via the SDS-TL-SAP, refer to clause 29.1.1.

13.3.2.1 TNSDS-STATUS primitive

TNSDS-STATUS request: the primitive shall be used by the user application to send a pre-defined message to another user or users given in the address parameter.

NOTE: The status message is selected from a set of pre-coded messages and only the status number is given as a parameter.

TNSDS-STATUS indication: the primitive shall indicate to the user application that a pre-coded status message from another user application has been received.

The parameters are defined in table 13.1.

Table 13.1: Parameters for the TNSDS-STATUS primitive

Parameter	Request	Indication
Access priority	O	-
Traffic stealing	O	-
Graceful service degradation mode	O	O
Area selection	O (see note 3)	-
Called party type identifier	M	-
Called party SNA	C (see note 1)	-
Called party SSI	C (see note 1)	M
Called party extension	C (see note 1)	O (see note 2)
Called party address type	-	O
External subscriber number (called)	O	
Calling party SSI	-	M
Calling party extension	-	O (see note 2)
External subscriber number (calling)		O
Status number	M	M
Handle	M	-
NOTE 1: Depending on the value of called party type identifier.		
NOTE 2: If not present, the user application shall assume that the address extension is the MNI of the current network.		
NOTE 3: Usage of this parameter is defined in ETSI EN 300 392-12-8 [14].		

13.3.2.2 TNSDS-REPORT primitive

TNSDS-REPORT indication: the primitive shall be used as an indication to the user application that the PDU belonging to a request, i.e. the TNSDS-UNITDATA request or the TNSDS-STATUS request, has been either transmitted successfully or lost.

The parameters are defined in table 13.2.

Table 13.2: Parameters for the TNSDS-REPORT primitive

Parameter	Indication
Transfer result	M
Handle	M

13.3.2.3 TNSDS-UNITDATA primitive

TNSDS-UNITDATA request: the primitive shall be used by the user application to send a user defined message to another user application or applications given in the address parameter.

TNSDS-UNITDATA indication: the primitive shall be used as an indication to the user that a user application defined message from another user application has been received. The message may either be a user defined individual message or a user defined group message.

The parameters are defined in table 13.3.

Table 13.3: Parameters for the TNSDS-UNITDATA primitive

Parameter	Request	Indication
Access priority	O	-
Traffic stealing	O	-
Graceful service degradation mode	O	O
Area selection	O (see note 5)	-
Called party type identifier	M	-
Called party SNA	C (see note 1)	-
Called party SSI	C (see note 1)	M
Called party extension	C (see note 1)	O (see note 2)
Called party address type	-	O
External subscriber number (called)	O	-
Calling party:		
Calling party SSI	-	M
Calling party extension	-	O (see note 2)
External subscriber number (calling)	-	O
Short data type identifier	M	M
User defined data-1	C (see note 3)	C (see note 3)
User defined data-2	C (see note 3)	C (see note 3)
User defined data-3	C (see note 3)	C (see note 3)
User defined data-4	C (see notes 3 and 4)	C (see notes 3 and 4)
NOTE 1: Depending on the value of called party type identifier.		
NOTE 2: If not present, the user application shall assume that the address extension is the MNI of the current network.		
NOTE 3: Depending on the value of short data type identifier.		
NOTE 4: This parameter is modified by the SDS-TL protocol and it contains always a protocol identifier, and is available via the SDS-TL-SAP, refer to clause 29.1.1.		
NOTE 5: Usage of this parameter is defined in ETSI EN 300 392-12-8 [14].		

13.3.2.4 TNSDS-CANCEL primitive

TNSDS-CANCEL request: the primitive may be used by the user application to cancel sending of a message before it is sent at least once over the air interface.

13.3.3 Parameter description

Parameters shall be part of the primitives at the TNSDS SAP. When applied the parameters shall contain the values specified in this clause:

- Access priority =
 - low priority;
 - high priority;
 - emergency priority.

The default value of the access priority parameter shall be low priority, which will be applied when no access priority parameter is used:

- Area Selection =
 - area not defined;
 - area 1;
 - etc.;
 - area 14;
 - all areas in this system.

The default value of the area selection parameter shall be "area not defined", which will be applied when area selection is not used:

- Called party address type =
 - broadcast;
 - individual;
 - group.
- Called party extension =
 - MCC + MNC.
- Called party short number address =
 - SNA.
- Called party SSI =
 - ISSI;
 - GSSI.
- Called party type identifier =
 - SNA;
 - SSI;
 - TSI.
- Calling party extension =
 - MCC + MNC.
- Calling party SSI =
 - ISSI.

- External Subscriber Number =
 - Up to 24 digits. Each digit shall be one of the following:
 - digit 0;
 - etc.;
 - digit 9;
 - digit *;
 - digit #;
 - digit +.
- Graceful service degradation mode =
 - not eligible for sending in graceful service degradation mode;
 - eligible for sending in graceful service degradation mode;
 - message received in graceful service degradation mode.
- Handle =
 - a local SDU identifier.
- Status number =
 - 0 emergency call;
 - 1 to 19 999 reserved;
 - 20 000 to 20 999 status values for international co-operation;
 - 21 000 to 31 743 reserved;
 - 32 768 to 65 535 available for TETRA network specific definition.

NOTE 1: Further status number definitions may be added in the maintenance of the present document as an annex.

NOTE 2: Pre-defined status values from 31 744 to 32 767 are used by SDS-TL protocol and will not be available as pre-defined status values.

NOTE 3: The meaning of the status values for international co-operation is outside the scope of the present document.

- Short data type identifier =
 - user defined data-1;
 - user defined data-2;
 - user defined data-3;
 - user defined data-4.

- Traffic stealing =
 - do not steal traffic;
 - steal traffic.

The default value of the traffic stealing parameter shall be do not steal traffic, which will be applied when no traffic stealing parameter is used:

- Transfer result =
 - success;
 - failure, no more re-tries;
 - delayed transmission due to the graceful service degradation mode, still trying transmit.
- User defined data 1 =
 - 16 bit user defined data.
- User defined data 2 =
 - 32 bit user defined data.
- User defined data 3 =
 - 64 bit user defined data.
- User defined data-4 =
 - protocol identifier; and
 - user defined data bits, maximum length 2 039 bits.

13.3.4 State description

13.3.4.1 NULL state

No short data message shall be in progress.

13.3.4.2 SHORT DATA INITIATED state

Short data message sending in progress state. Waiting for the completion of a message transfer.

13.3.5 Service state diagram for the TNSDS-SAP

Supplementary services state diagram is presented in figure 13.2.

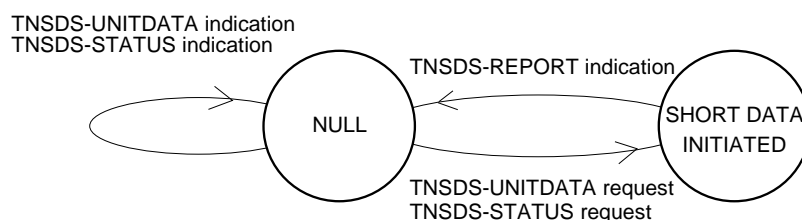

Figure 13.2: Service state diagram for the mobile terminated short data message

14 CMCE protocol

14.1 Introduction

This clause defines the layer 3.2 CMCE air interface protocol for the MS. There shall be a peer-to-peer relationship between the layers on the terminal side and the SwMI side. The protocol for the SwMI side is, however, outside the scope of the present document. The CMCE protocol is the network layer protocol that shall be used to provide services to an end user application in the area of CC services, of SDS and of supplementary services.

This clause specifies:

- the functional requirements for implementations claiming conformance to the present document;
- procedures for specific transmission of:
 - control information for circuit mode services;
 - call unrelated short data messages;
 - control information for call related/call unrelated supplementary service messages;
- the encoding of the Protocol Data Units (PDUs) used for the transmission of data and control information;
- procedures for the correct interpretation of protocol control information.

14.2 Overview of CMCE

14.2.0 General

Figure 14.1 shows the position of the CMCE protocols in both the MS and in the BS protocol stack. The present document does not define a BS protocol architecture or user application SAPs for the CMCE within the SwMI.

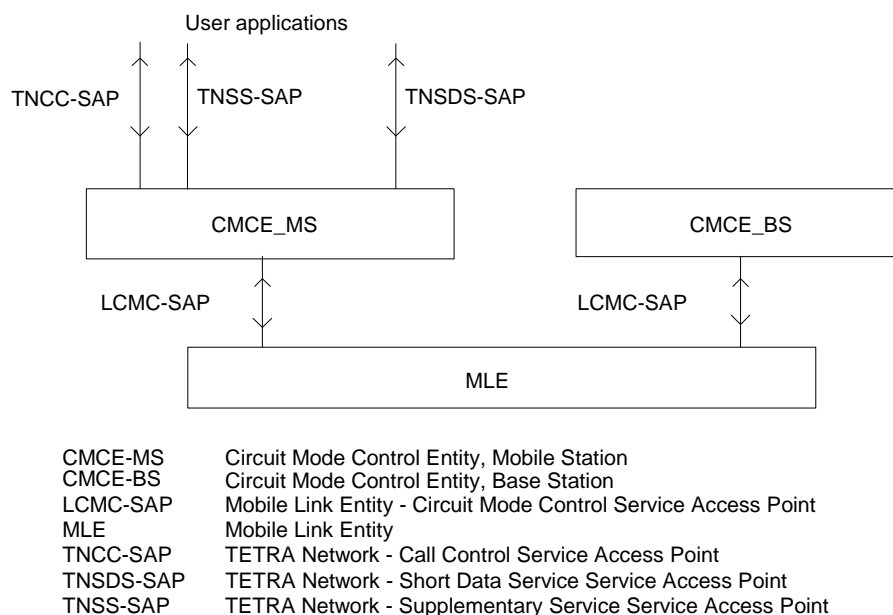

Figure 14.1: System view

14.2.1 Communication routes of the CMCE model

The CMCE model defines routes used for information exchange between the sub-entities as shown in figure 14.2.

The external routes are routes between a sub-entity of the CMCE and an entity in another layer. Each external route shall be mapped onto a SAP.

There are four external routes:

- The ra route shall correspond to the TNCC-SAP. The primitives exchanged on that route are described in clause 11.
- The rb route shall correspond to the TNSS-SAP. The primitives exchanged on that route are described in clause 12.
- The rc route shall correspond to the TNSDS-SAP. The primitives exchanged on that route are described in clause 13.
- The ri route shall correspond to the LCMC-SAP. The primitives exchanged on that route are described in clause 17.

The internal routes are routes between sub-entities of the CMCE.

There are five internal routes:

- the rd route shall be a route between the CC sub-entity and the PC sub-entity;
- the re route shall be a route between the SS sub-entity and the PC sub-entity;
- the rg route shall be a route between the SS sub-entity and the CC sub-entity;
- the rf route shall be a route between the SDS sub-entity and the PC sub-entity;
- the rh route shall be a route between the SS sub-entity and the SDS sub-entity.

14.2.2 Protocol structure and protocol stack

The CMCE is the layer 3 sub-layer for circuit mode CC, SS and SDS as described in clauses 11, 12 and 13 respectively. CMCE shall provide services to the user applications through service primitives defined for the following three SAPs:

- TNCC-SAP for CC services;
- TNSS-SAP for SS services;
- TNSDS-SAP for SDS.

NOTE: Although there are separate SAPs defined for CC and SS, the protocol description is based on the CC service primitives, which contain a mixture of CC and SS parameters.

CMCE shall obtain services from the underlying voice and data MLE through the LCMC-SAP.

There shall be one instance of the CMCE entity per TSI family within the MS.

The CMCE is internally subdivided into four different sub-entities:

- CC;
- SS;
- SDS; and
- Protocol Control (PC).

The information exchange between the CC and the SS sub-entities is defined in the supplementary service definitions. The structure is as shown in figure 14.2.

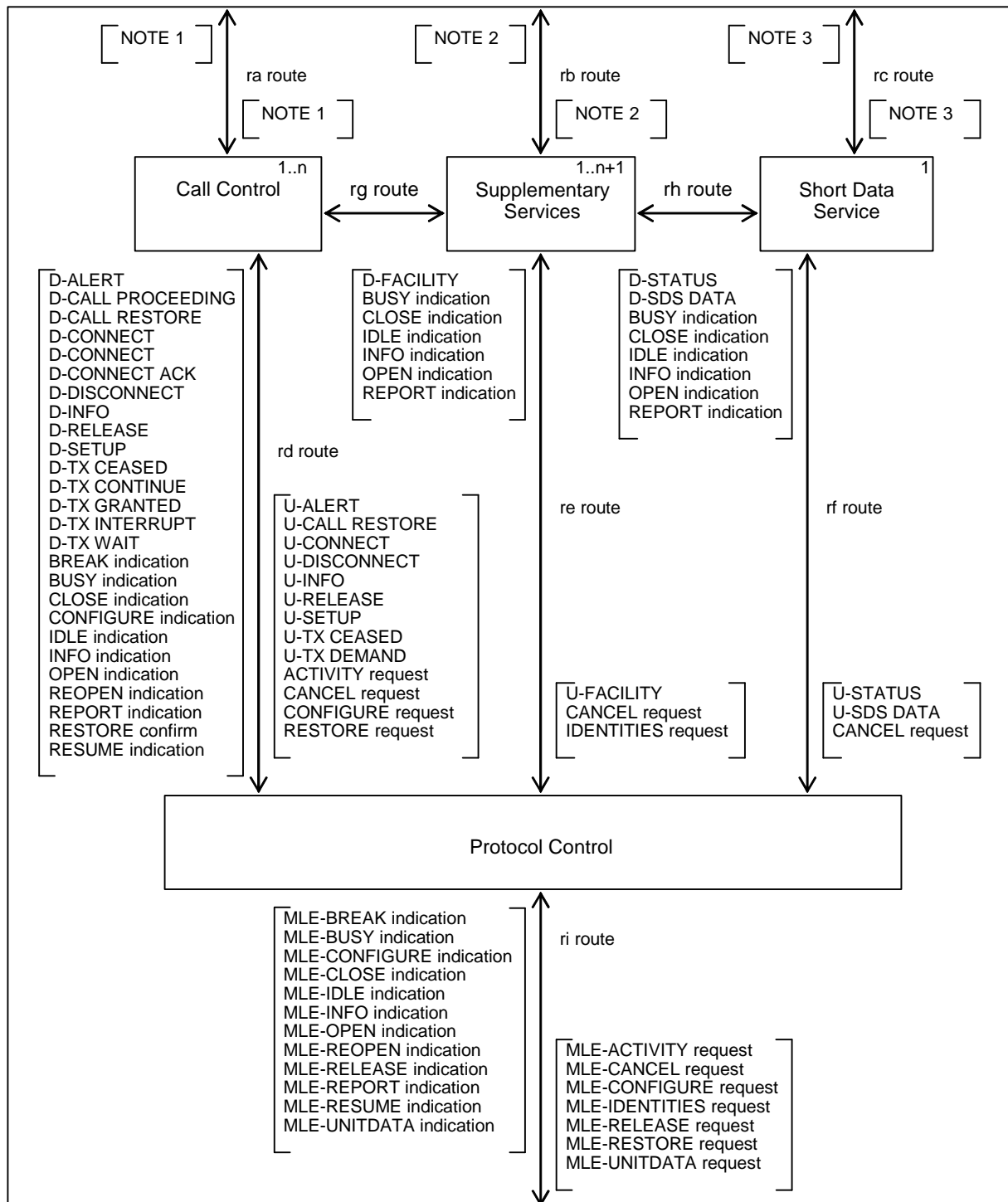

NOTE 1: Service primitives for the TNCC-SAP are defined in clause 11.

NOTE 2: Service primitives for the TNSS-SAP are defined in clause 12.

NOTE 3: Service primitives for the TNSDS-SAP are defined in clause 13.

Figure 14.2: Block view of CMCE-MS

PC uses on route rf BREAK (GSDM) indication and RESUME indication also for SDS in the graceful service degradation mode, those primitives are not presented in figure 14.2.

14.2.3 Addressing rules

In addition to the normal TSI which is used in different forms in the initial call set-up messages (ITSI, GTSI, SSI), the CMCE entity shall also use the call identifier for call handling.

The call identifier shall be used as a unique reference to a call between a call participant and the SwMI. A call identifier is allocated at call set-up time by the SwMI and the call identifier may be changed by the SwMI by allocating a new call identifier to the MS for the call. Once allocated, the call identifier shall be used in subsequent call related CMCE messages for that call. Where the call spans more than one LA, the call identifier may be different in different LAs. In the case of a group call, the call identifier shall be the same for all participating MSs in each LA (except as described in note 1). In the case of an individual call, the call identifier may be different for two MS in the same LA participating in the same individual call.

NOTE 1: When an MS requests a type 1/2 cell reselection, the SwMI may send the MS a call identifier for the requested LA while the MS is still using the original LA (see clause 18.3.4.7.5).

The layer 3 air interface messages may contain only the SSI part of an address. The following rules define how the receiving entity shall, if it needs to do so, derive the MNI (i.e. convert the SSI to full ITSI or GTSI) if the MNI is not supplied over the air interface.

- The SwMI shall interpret the "Called party SSI" or "Other party SSI" on received uplink messages as belonging to the SwMI (i.e. the "missing" MNI is the MNI of the current network).
- The MS shall interpret the "Calling party address SSI" or "Transmitting party address SSI" on received downlink messages as belonging to the current SwMI (i.e. the "missing" MNI is the MNI of the current network).

NOTE 2: The MNI of the SwMI (MCC and MNC) is sent in the broadcast D-MLE-SYNC PDU (refer to clause 18.4.2.1) or the D-MLE-SYNC-DA PDU (refer to clause 18.4.2.1a).

NOTE 3: The first rule forces the MS to send the MNI over the air interface also when the called user address belongs to the home network of the MS and MS has migrated to a foreign network - edition 1 of the Dialling and Addressing Designer's Guide, ETSI TR 102 300-5 [i.1], describes a different approach which is no longer valid.

NOTE 4: The second rule allows to use only SSI addressing so that all MSs in the same SwMI, independently of whether they are in their home or in a visited SwMI, will understand it in the same manner (for example group calls having participants belonging to different networks).

NOTE 5: The supplementary service related information in U/D-FACILITY PDU or in facility information element may use SSI differently, refer to supplementary service definitions.

NOTE 6: The visiting GSSI ((V)GSSI) is used only as a layer 2 address in reception and also by MM in layer 3 PDUs in the group attachment/detachment procedures.

- V-GSSI shall not be used as "Called party SSI" or "Other party SSI" in CMCE PDUs.

NOTE 7: If a SwMI allocates a temporary address the MS will consider that the MNI of it is the one of the current SwMI.

14.2.4 CC, SS and SDS sub-entities

14.2.4.0 General

The CMCE model describes the protocol behaviour of CC, SS and SDS functional entities.

14.2.4.1 CC sub-entity

The CC process is a functional sub-entity which provides a set of procedures for the establishment, maintenance and release of circuit switched services. It provides support for the TETRA basic call signalling. The CC shall manage invocation of the SS-Access Priority.

The CC process shall use the ra signalling route for communication with the user application (see clause 11) and the rd signalling route for communication with the protocol control process. The information exchange of SS related parameters needed for SS information exchange is not defined.

There can be multiple instances of CC per CMCE entity. Depending on its physical capabilities an MS may be able to support up to four active concurrent circuit mode calls at the same time.

14.2.4.2 SS sub-entity

The SS process is a functional sub-entity which provides procedures for transfer of information related to SSs. The transfer of SS information is either call related or call unrelated.

The SS processes shall use the rb signalling route for communication with the user application over the TNSS-SAP (see clause 12) and the re signalling route for communication with the protocol control process. Internal communication between the CC process and the SS process is outside the scope of the present document.

SSs related to a call in progress shall have a fixed relationship with the corresponding CC entity instance and these SS instances shall cease to exist after the CC instance ceases to exist.

There shall be also a SS entity, which is not related to any calls in progress. That entity may use either a U/D-FACILITY PDU or any CC PDU, when appropriate, to exchange SS information between a MS and a SwMI. The facility field of the CC PDUs shall only be used to exchange SS information between a MS and the SwMI.

14.2.4.3 SDS sub-entity

The SDS process shall be a functional sub-entity which provides procedures for transfer of short data and status messages. The SDS entity shall also manage invocation of the SS- Access Priority for the short data PDU exchange.

The SDS process shall use the rc signalling route for communication with the user application over the TNSDS-SAP (see clause 13) and the rf signalling route for communication with the protocol control process.

The SDS entity shall not be related to any call and it shall provide SDS services independently of whether the SDS message is directed to a user application involved in an active CC call, or not.

There shall only be one instance of SDS entity per CMCE entity.

14.2.5 PC sub-entity

The PC sub-entity shall provide the following functionality:

- PC shall act as an upwards/downwards router by discriminating the upper sub-entities within CMCE. The analysis of the content of the various information elements in the PDUs shall be done by the sub-entity which is responsible for and owns the individual elements. Outgoing PDUs shall be routed to the MLE in primitives.
- PC shall ensure that there is only one mobile originated call set-up in progress at any one time by only allowing one CC sub-entity at a time to be actively setting up a call until SwMI allocates a call identifier to that call or the call set-up is discarded.
- MLE shall give indications of the progress of the PDU transmission to PC by MLE-REPORT indication primitives. PC shall be responsible for handling of general error procedures for the CMCE protocol.
- PC shall use the signalling routes rd, re, rf for communication with the CC, SS and SDS sub-entities and the ri signalling route for communication with the MLE over the LCMC-SAP.
- there shall only be one instance of PC per CMCE entity.

14.2.6 Internal routes

The PDUs and local primitives are grouped per each sub-entity and internal route.

From PC to CC on rd route:

- D-ALERT;
- D-CALL PROCEEDING;
- D-CALL RESTORE;
- D-CONNECT;
- D-CONNECT ACKNOWLEDGE;
- D-DISCONNECT;
- D-INFO;
- D-RELEASE;
- D-SETUP;
- D-TX CEASED;
- D-TX CONTINUE;
- D-TX GRANTED;
- D-TX INTERRUPT;
- D-TX WAIT;
- BREAK indication;
- BUSY indication;
- CLOSE indication;
- CONFIGURE indication;
- IDLE indication;
- INFO indication;
- OPEN indication;
- REOPEN indication;
- REPORT indication;
- RESTORE confirm;
- RESUME indication.

From CC to PC on rd route:

- U-ALERT;
- U-CALL RESTORE;
- U-CONNECT;
- U-DISCONNECT;
- U-INFO;

- U-RELEASE;
- U-SETUP;
- U-TX CEASED;
- U-TX DEMAND;
- ACTIVITY request;
- CANCEL request;
- CONFIGURE request;
- RESTORE request.

From PC to SS on re route:

- D-FACILITY;
- BUSY indication;
- CLOSE indication;
- IDLE indication;
- INFO indication;
- OPEN indication;
- REPORT indication.

From SS to PC on re route:

- U-FACILITY;
- IDENTITIES request;
- CANCEL request.

NOTE 1: U/D-FACILITY PDUs are used to transport SS information, which is not related to any ongoing call or related to a call during SS-CC retention time after the call.

NOTE 2: SS information, which relates to an ongoing call is transported either as a predefined element in a CC PDU or as a facility element in a CC or in a U/D-INFO PDU (see clause 14.7).

From PC to SDS on rf route:

- D-STATUS;
- D-SDS-DATA;
- BUSY indication;
- CLOSE indication;
- IDLE indication;
- INFO indication;
- OPEN indication;
- REPORT indication.

In addition in the graceful service degradation mode from PC to SDS on rf route, refer to annex Q:

- BREAK indication;
- BREAK (GSDM) indication;
- RESUME indication.

From SDS to PC on rf route:

- U-STATUS;
- U-SDS-DATA;
- CANCEL request.

14.2.7 Intra-CMCE primitive summary

14.2.7.0 General

The sub-entities inside CMCE shall be responsible for setting parameters in each PDU it is sending. These parameters are used in the lower layers in the transmission process. These parameters are not visible outside the MS protocol stack, but shall affect to the functions inside the protocol stack.

14.2.7.1 Down link CC PDU parameters

The following parameters shall accompany each PDU in addition to the PDU contents (SDU). The contents of the SDUs are defined in clause 14.7. These parameters shall be valid for rd route (see clause 17.3.4 for ri route parameters):

- received TETRA address;
- received address type;
- channel change response required.

The D-CALL RESTORE PDU should be a SDU in the RESTORE confirm primitive and the parameters used in this primitive shall be:

- SDU;
- restoration result.

14.2.7.2 Uplink CC PDU parameters

Each PDU shall convey following information as parameters in addition to the PDU contents. The contents of the PDUs are defined in clause 14.7. These parameters shall be valid for rd route (see clause 17.3.4 for ri route parameters):

- endpoint identifier;
- layer 2 service;
- PDU priority;
- stealing permission;
- stealing repeats flag.

The MS shall send the U-RESTORE REQUEST PDU as an SDU in the RESTORE request primitive.

The parameters used in this primitive shall be:

- SDU;
- layer 2 service;
- PDU priority;
- stealing permission;
- stealing repeats flag.

14.2.7.3 Downlink SS PDU parameters

Each PDU shall convey following information as parameters in addition to the PDU contents. The contents of the PDUs are defined in clause 14.7. These parameters shall be valid for re route (see clause 17.3.4 for ri route parameters):

- channel change response required;
- received TETRA address;
- received address type.

14.2.7.4 Uplink SS PDU parameters

Each PDU shall convey following information as parameters in addition to the PDU contents. The contents of the PDUs are defined in clause 14.7. These parameters shall be valid for re route (see clause 17.3.4 for ri route parameters):

- layer 2 service;
- PDU priority;
- stealing permission.

14.2.7.5 Down link SDS PDU parameters

Each PDU shall convey following information as parameters in addition to the PDU contents. The contents of the PDUs are defined in clause 14.7. These parameters shall be valid for rf route (see clause 17.3.3 for ri route parameters):

- received TETRA address;
- received address type.

14.2.7.6 Uplink SDS PDU parameters

Each PDU shall convey following information as parameters in addition to the PDU contents. The contents of the PDUs are defined in clause 14.7. These parameters shall be valid for rf route (see clause 17.3.4 for ri route parameters):

- layer 2 service;
- PDU priority;
- stealing permission;
- link identifier;
- eligible for graceful service degradation mode.

14.2.7.7 CMCE management primitives

14.2.7.7.0 ACTIVITY request

The parameter used in this primitive shall be:

- call state (see clause 17.3.9).

14.2.7.7.1 BREAK indication

The parameter used in this primitive shall be:

- none; or
- permitted services in MS graceful service degradation mode; indicated as "BREAK (GSDM) indication".

NOTE: The value "none" indicates that no service is temporarily available.

14.2.7.7.1a BUSY indication

There are no parameters associated with this primitive.

14.2.7.7.2 CANCEL request

The parameter used in this primitive shall be:

- handle.

14.2.7.7.3 CLOSE indication

There are no parameters associated with this primitive.

14.2.7.7.4 CONFIGURE indication

The parameters used in this primitive shall be:

- endpoint identifier;
- endpoint status.

14.2.7.7.5 CONFIGURE request

The parameters used in this primitive shall be:

- add temporary GSSI;
- circuit mode type (see clause 14.8.2);
- channel change accepted (see clause 17.3.9);
- leave assigned channel;
- delete temporary GSSI;
- encryption flag;
- call identifier;
- endpoint identifier;
- simplex/duplex;
- slots per frame;
- switch U-plane on/off;
- Tx grant.

14.2.7.7.6 IDENTITIES request

The parameter used with this primitive shall be:

- list of attached GSSIs;
- list of detached GSSIs.

14.2.7.7.6a IDLE indication

There are no parameters associated with this primitive.

14.2.7.7.6b INFO indication

The parameters used with this primitive shall be:

- broadcast parameters (see clause 17.3.9);
- subscriber class match (see clause 17.3.9).

14.2.7.7.7 OPEN indication

There are no parameters associated with this primitive.

14.2.7.7.8 REOPEN indication

There are no parameters associate with this primitive.

14.2.7.7.9 REPORT indication

The parameter used in this primitive shall be:

- transfer result.

14.2.7.7.10 RESUME indication

There are no parameters associated with this primitive.

14.3 Overview of services required by the CMCE

In order to transfer messages over the air interface, CMCE shall use the services of the MLE, which in turn shall rely on the service from underlying layers. The services required from MLE shall be as described in clause 17.

14.4 CMCE protocol states

14.4.0 General

CMCE shall comprise 4 sub-entities each of them having a separate state transition diagram as shown in figures 14.3, 14.4, 14.5 and 14.6.

Only the main states are shown.

14.4.1 States for PC

14.4.1.0 General

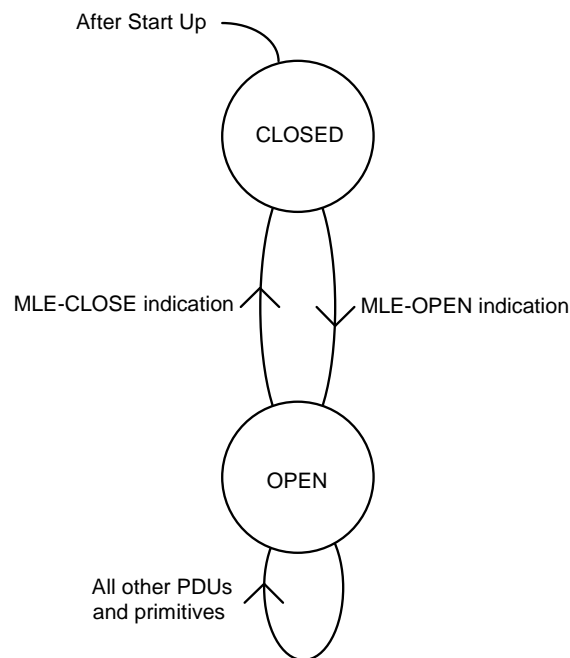

Figure 14.3: State transition diagram for the PC sub-entity

14.4.1.1 CLOSED

This state exists after an MLE-CLOSE indication primitive has been received from the MLE indicating that access to communication resources is no longer allowed and the PC sub-entity shall inform the CC, SS and SDS sub-entities with CLOSE indication primitives. The PC sub-entity shall also enter state CLOSED after initial start up.

14.4.1.2 OPEN

This is the normal state and indicates that a communication path to a peer entity is open. It is set after an MLE-OPEN indication primitive has been received from the MLE. When PC receives a MLE-OPEN indication primitive and goes to state OPEN, the CC, SS and SDS sub-entities shall be informed with OPEN indication primitives.

14.4.2 States for CC

14.4.2.0 General

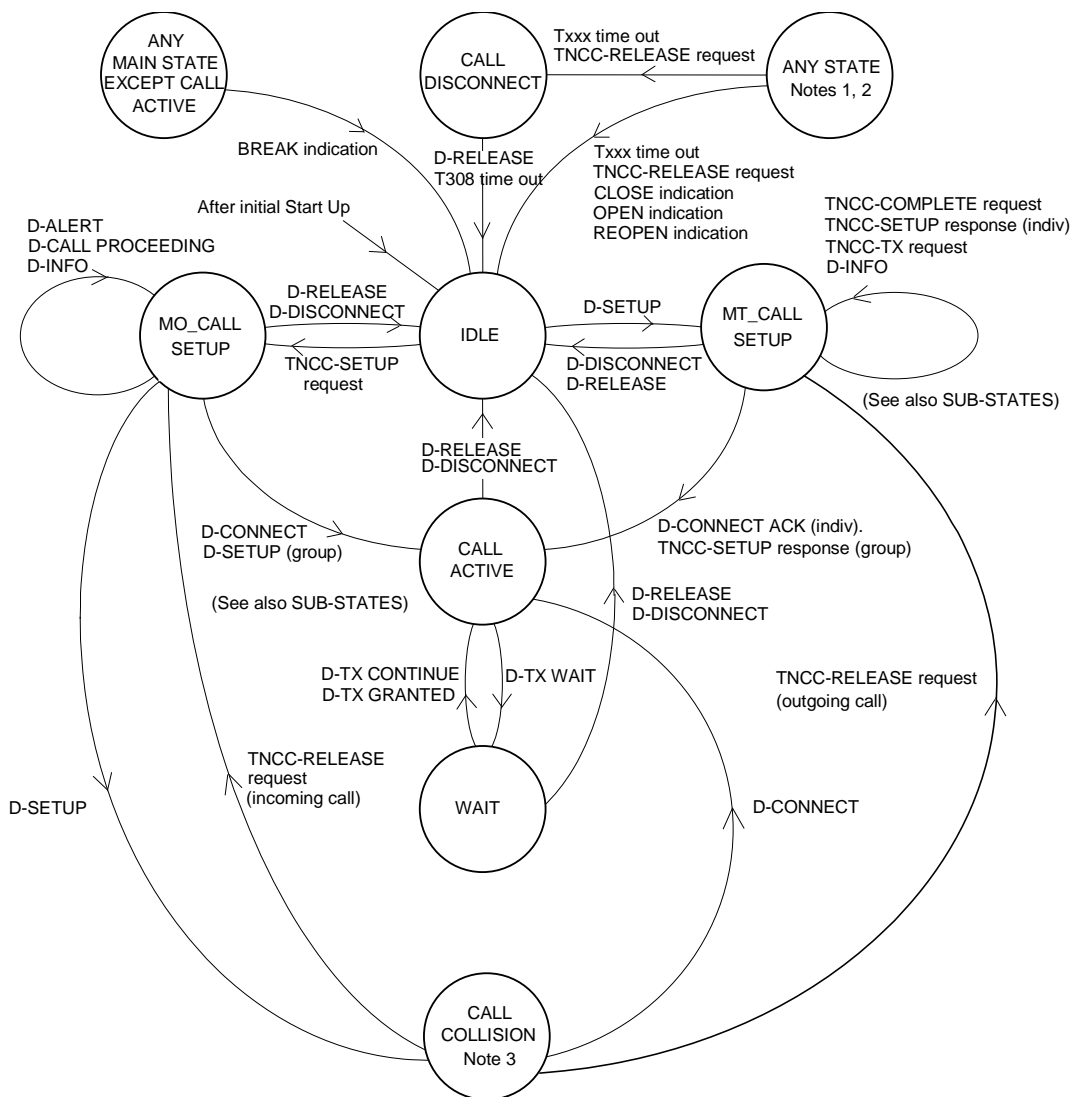

- NOTE 1: The TNCC-RELEASE request primitive transitions from the state "ANY STATE" are not applicable for the "CALL COLLISION" state.
- NOTE 2: The selection of the TNCC-RELEASE request primitive transition from the state "ANY STATE" is dependent on the need for sending disconnection message over the air interface, refer to clauses 14.5.1.1.3 and 14.5.2.1.3.
- NOTE 3: The TNCC-RELEASE request primitive transitions from CALL COLLISION state present interactions between two call control instances and show a simplified view, refer to clauses 14.5.1.1.3 and 14.5.2.1.3.

Figure 14.4: State transition diagram for the CC sub-entity

A further subdivision of the main states MT-CALL-SETUP and CALL-ACTIVE belonging to the CC sub-entity may be considered as detailed in figures 14.5 and 14.6.

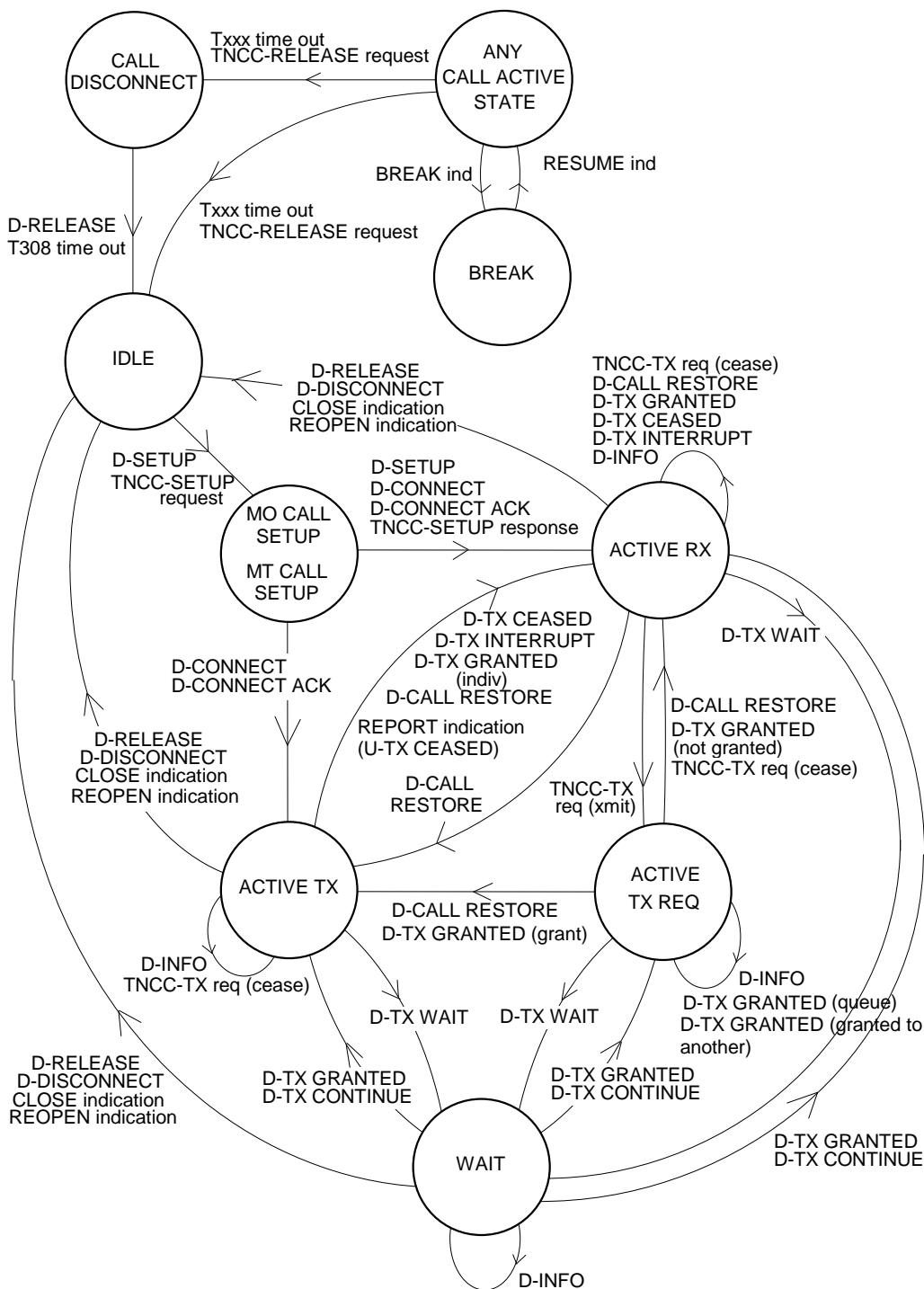

Figure 14.5: Sub state transition diagram for the CALL-ACTIVE state

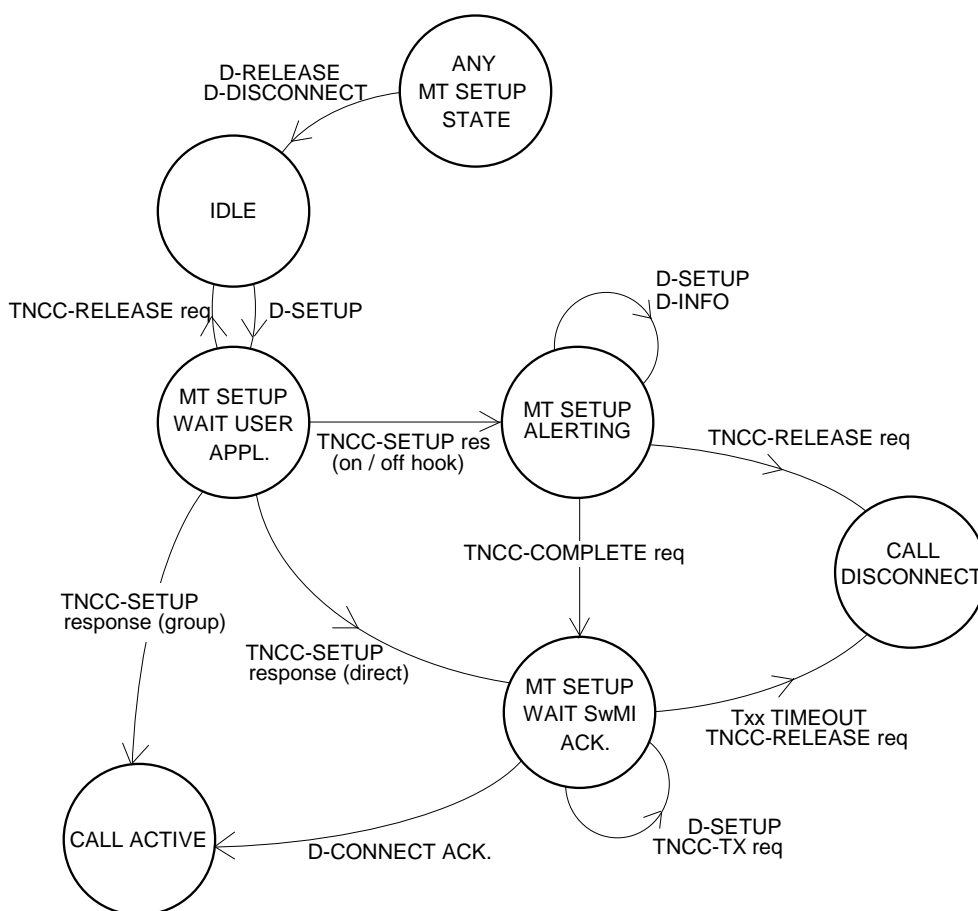

Figure 14.6: Sub state transition diagram for the MT-CALL-SETUP state

14.4.2.1 IDLE

This is the normal state when no calls exist and indicates that the CC sub-entity is available to handle a call set-up. This is the state that CC shall enter after initial start up.

NOTE: Any transition to or from the IDLE state should be accompanied with the generation of an **ACTIVITY** request primitive (see clause 14.2.7.7.0), containing the appropriate call state, to the PC entity.

14.4.2.2 MO-CALL-SETUP

This state exists when a MS originated call set-up has been initiated but the call has not been established. It exists after a U-SETUP PDU has been sent as the result of the receipt of a TNCC-SETUP request primitive until a D-CONNECT PDU is received indicating that the call set-up is successful. If the call set-up is unsuccessful or the user application disconnects the call the CC sub-entity shall leave this state.

14.4.2.3 MT-CALL-SETUP

This state exists during a call set-up where the CC sub-entity is the call terminating CC sub-entity. It exists after the receipt of a D-SETUP PDU, until the receipt of a D-CONNECT ACKNOWLEDGE PDU, for point-to-point calls only, or receipt of a TNCC-SETUP response primitive for point-to-multipoint calls only. The MT-CALL SETUP state is also left if the call set-up is unsuccessful, or if the user application rejects the call.

14.4.2.4 CALL ACTIVE

This state exists when the call has been established.

NOTE: Transitions between the ACTIVE RX and ACTIVE TX sub-states should be accompanied with the generation of an ACTIVITY request primitive (see clause 14.2.7.7.0), containing the appropriate call state, to the PC entity.

14.4.2.5 CALL DISCONNECT

This state exists when an established call is in the progress of disconnecting. It exists after the receipt of a TNCC-RELEASE request primitive from the user application, or if a timer initiated disconnection occurs, until either a D-RELEASE PDU is received, or the call disconnect timer expires.

14.4.2.6 WAIT

The state exists if there is a temporary interruption to the call. The CC shall enter this state upon receipt of a D-TX WAIT PDU and remain in this state until a D-TX CONTINUE PDU or D-TX GRANTED PDU is received, or the call is disconnected.

14.4.3 States for SS

There shall only exist 2 general generic states for the SS sub-entity as shown in figure 14.7. Each individual service shall then have its own state transition diagrams associated with its protocol.

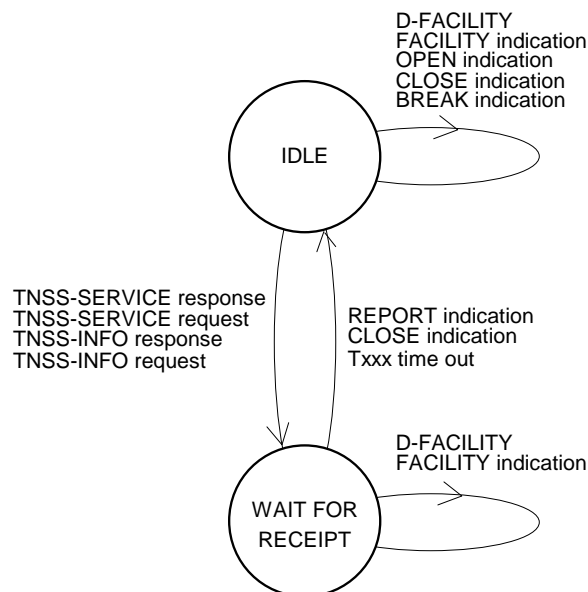

Figure 14.7: State transition diagram for the SS sub-entity

14.4.4 States for SDS

There shall only exist 2 generic states for the SDS sub-entity as shown in figure 14.8.

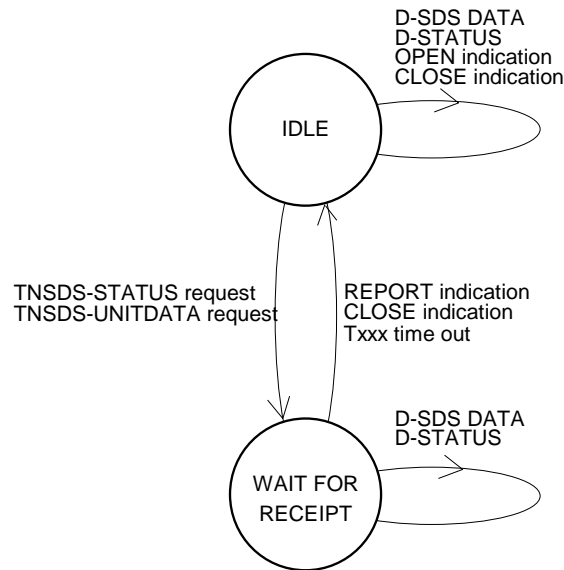

Figure 14.8: State transition diagram for the SDS

14.5 Procedures

14.5.0 General

In this protocol the routing of PDUs and primitives is implicit by the PDU and primitive name as defined in clause 14.2.

The timers in the following procedures are:

- started - meaning that the timer shall start to measure time as indicated in the parameter value T3xx independently of the current timer count; or
- stopped - meaning that the timer shall be stopped at the current timer count; or
- reset - meaning that the timer count shall be set to its initial value, be it zero or parameter value T3xx.

Depending on timer T3xx the starting value shall either be pre-defined or dynamically set by air interface protocol procedures.

NOTE 1: In IDLE state all timers T3xx are stopped and whenever a timer is started it will get a proper value as stored, or from a PDU as appropriate.

NOTE 2: There is no call identifier associated to a CC instance in IDLE state.

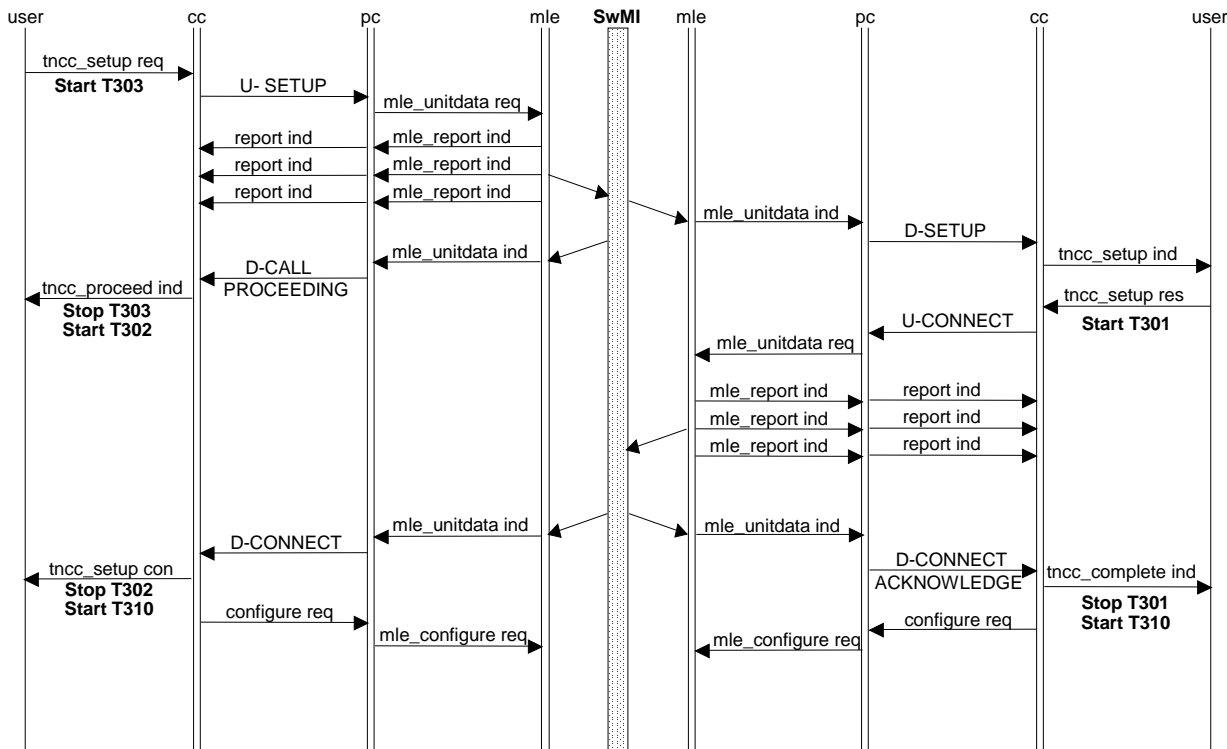

Figure 14.10: Individual call set-up scenario using direct set-up signalling

14.5.1.1.1 Incoming call

Notification of the arrival of an incoming call to the CC sub-entity shall be made by the reception of a D-SETUP PDU which shall be delivered to the user application in a TNCC-SETUP indication primitive via the TNCC-SAP. If the user application can support the call it shall immediately return a TNCC-SETUP response primitive otherwise it shall return a TNCC-RELEASE request primitive (see clause 14.5.1.1.5).

On receipt of a D-SETUP PDU the CC sub-entity shall enter state MT-CALL-SETUP and take the following actions, which are dependent upon the information contained within the D-SETUP PDU:

- the call identifier shall be used as the reference to this call in subsequent PDUs during the call;
- it shall be indicated to the called MS in the D-SETUP PDU if on/off hook signalling or direct set-up signalling is used for this call set-up;
- if on/off hook signalling is requested and the CC receives a TNCC-SETUP response primitive indicating that the called user application has accepted on/off hook signalling, the CC shall send a U-ALERT PDU indicating that the called party is alerted, see figure 14.9 right hand side. The CC sub-entity shall remain in state MT-CALL-SETUP;
- when on/off hook signalling is used and the CC receives a TNCC-COMPLETE request primitive indicating that the called user application has answered, the CC shall send a U-CONNECT PDU and start timer T301. The CC sub-entity shall remain in state MT-CALL-SETUP. Upon receipt of a D-CONNECT ACKNOWLEDGE PDU, the CC shall inform the user application with a TNCC-COMPLETE confirm primitive, enter state CALL-ACTIVE, stop timer T301 and start timer T310, see figure 14.9 right hand side. The D-CONNECT ACKNOWLEDGE PDU shall contain an indication as to which party is permitted to transmit. The CC sub-entity shall send a CONFIGURE request primitive for lower layer configuration;
- in a duplex call the SwMI shall grant permission to talk in the D-CONNECT ACKNOWLEDGE PDU;

- if direct set-up signalling is used and the CC receives a TNCC-SETUP response primitive indicating that the called user application has accepted direct call set-up signalling, the CC shall send a U-CONNECT PDU indicating that the MS is ready for immediate communication, and shall start timer T301. Upon receipt of the U-CONNECT PDU the SwMI should send a D-CONNECT ACKNOWLEDGE PDU in return. The CC sub-entity shall then inform the user application with a TNCC-COMPLETE indication primitive and shall enter state CALL-ACTIVE, stop timer T301 and start timer T310, see figure 14.10 right hand side. The D-CONNECT ACKNOWLEDGE PDU shall contain an indication as to which party is permitted to transmit. The CC sub-entity shall send a CONFIGURE request primitive for lower layer configuration;
- if transmission is not granted but the D-CONNECT ACKNOWLEDGE PDU contains an indication that the MS is allowed to request transmission permission, the CC shall follow the transmission control procedures outlined in clause 14.5.1.2.1;
- where the called MS is unable to accept the request for a basic service, it may according to the rules stated below, offer a different basic service to the calling party. The offered value shall be indicated in the U-CONNECT or U-ALERT PDU. Where the called MS is unable to offer a different service according to the rules below then the call shall be rejected using a U-DISCONNECT PDU as defined in clause 14.5.1.1.5, e.g. if circuit mode data is requested but the terminal cannot support data;
- for circuit mode unprotected bearer services:
 - if 28,8 kbit/s requested, 21,6 kbit/s, 14,4 kbit/s or 7,2 kbit/s may be offered;
 - if 21,6 kbit/s requested, 14,4 kbit/s or 7,2 kbit/s may be offered;
 - if 14,4 kbit/s requested, 7,2 kbit/s may be offered;
- for circuit mode protected (low) bearer services:
 - if 19,2 kbit/s requested, 14,4 kbit/s, 9,6 kbit/s or 4,8 kbit/s may be offered;
 - if 14,4 kbit/s requested, 9,6 kbit/s or 4,8 kbit/s may be offered;
 - if 9,6 kbit/s requested, 4,8 kbit/s may be offered;
 - if interleaving depth $N = 8$ requested, $N = 4$ or $N = 1$ may be offered;
 - if interleaving depth $N = 4$ requested, $N = 1$ may be offered;
- for circuit mode protected (high) bearer services:
 - if 9,6 kbit/s requested, 7,2 kbit/s, 4,8 kbit/s or 2,4 kbit/s (high) may be offered;
 - if 7,2 kbit/s requested, 4,8 kbit/s or 2,4 kbit/s (high) may be offered;
 - if 4,8 kbit/s requested, 2,4 kbit/s (high) may be offered;
 - if interleaving depth $N = 8$ requested, $N = 4$ or $N = 1$ may be offered;
 - if interleaving depth $N = 4$ requested, $N = 1$ may be offered;
- if the called MS is requested to support a duplex call and is unable to do so, then it shall offer a simplex call by setting the simplex/duplex element accordingly in either the U-ALERT or U-CONNECT PDU;
- if the called MS is requested to use direct call set-up and it is unable to support this, but does support on/off hook signalling, then it shall offer this service by sending the U-ALERT PDU;
- if the called MS is requested to use on/off hook signalling and is unable to support this, but does support direct call set-up, then it shall offer this service by setting the hook method element accordingly in the U-CONNECT PDU;
- if the called user application during the call set-up cannot continue to support of the call for other reasons that those stated above the request for call set-up shall be rejected by issuing a TNCC-RELEASE request primitive. The request to release the call set-up shall be mapped to a U-DISCONNECT PDU and follow the procedure defined in clause 14.5.1.3.

During the call set-up phase, the SwMI may send the D-INFO PDU containing a new value for T301 to prolong the call set-up time. If the CC in the called MS receives an D-INFO PDU containing a Call time-out, set-up phase element the CC shall start timer T301 using the specified value.

14.5.1.1.2 Outgoing call

To initiate the call establishment, the user application shall transfer a TNCC-SETUP request primitive across the TNCC SAP to the CC sub-entity. The TNCC-SETUP request primitive shall be handled by a CC sub-entity instance that is in state IDLE.

The CC shall select a PDU priority based on the requested access priority value as defined in clause 14.5.6.2. The CC shall convert the TNCC-SETUP request primitive into a corresponding U-SETUP PDU and send it. The CC sub-entity shall then enter the MO-CALL-SETUP state and start timer T303.

The following describes the normal call set-up procedures:

- The progress of the transmission of the U-SETUP PDU may be reported to the CC in one or more REPORT indication primitives. If the PDU transfer has failed, the CC shall stop timer T303, inform the user application with a TNCC-RELEASE indication primitive and return to state IDLE.
- The SwMI may respond to the receipt of the U-SETUP PDU with a D-CALL PROCEEDING PDU indicating that the SwMI has received all information concerning the call set-up necessary to effect the call establishment. On reception of the PDU, the CC shall inform the user application with a TNCC-PROCEED indication primitive. In the case where On/Off Hook Signalling is requested or the called user application selects that method and alerting information is ready at the time when the D-CALL PROCEEDING PDU should have been sent, the SwMI may respond with a D-ALERT PDU instead of the D-CALL PROCEEDING PDU. Also if the call through connection is ready at the time when the D-CALL PROCEEDING PDU should have been sent, the SwMI may send a D-CONNECT PDU instead. On receipt of any of the above PDUs, Timer T303 shall be stopped, see figure 14.9 left hand side.
- The D-CALL PROCEEDING, D-ALERT or D-CONNECT PDU shall contain a Call Identifier which shall be used as the reference to this call in subsequent PDUs for the duration of the call.
- The D-INFO PDU shall not be used to allocate a call identifier.
- On reception of the DU-CALL PROCEEDING PDU the CC shall start timer T302, see figure 14.9 left hand side. The CC sub-entity shall remain in state MO-CALL-SETUP.
- If on/off hook signalling is requested and the CC receives a D-ALERT PDU, the CC shall inform the user application by issuing a TNCC-ALERT indication primitive.
- On reception of a D-ALERT PDU, the timer T302 shall be started using the specified value, see figure 14.9 left hand side.
- During the call set-up phase, the SwMI may send the D-INFO PDU containing a new T302 to prolong the call set-up time. Upon reception of a D-INFO PDU containing Call time out, set-up phase element, the timer T302 shall be started using the specified value.
- In a duplex call the SwMI shall grant permission to talk in the D-CONNECT PDU.
- When a D-CONNECT PDU is received, the CC shall send a CONFIGURE request primitive for lower layer configuration and inform the user application with a TNCC-SETUP confirm primitive and enter state CALL-ACTIVE. The timer T302 shall be stopped, and timer T310 shall be started, see figure 14.9 left hand side. The D-CONNECT PDU shall contain an indication which party is permitted to transmit.
- If transmission is not granted but the D-CONNECT PDU contains an indication that the MS is allowed to request transmission permission it shall follow the transmission control procedures defined in clause 14.5.1.2.1.
- Where the D-CALL PROCEEDING, D-CONNECT or the D-ALERT PDU indicates that the offered service is different to the one requested, and if the service offered is acceptable to the user application, the call shall continue. If the service is not acceptable, then the user application shall disconnect the call and the CC shall enter IDLE state, refer to clause 14.5.1.3.

EXAMPLE: If the user application has requested a 28,8 kbit/s circuit mode data, but considers that any data rate equal to or greater than 14,4 kbit/s is acceptable, then if a data rate of 14,4 kbit/s is offered the call shall continue. If a data rate of less than 14,4 kbit/s is offered (i.e. 7,2 kbit/s) then the user application shall disconnect the call.

NOTE: Handling of the TNCC-SETUP request primitive may be affected by the MS being active in a MM procedure, this being indicated to CC from MLE via the MLE-BUSY indication primitive, refer to clause 18.3.5.4. The exact nature of the interaction between MM/MLE and CC is outside the scope of this part of the present document but it is recommended that CC not accept a TNCC-SETUP request primitive while MM is busy.

14.5.1.1.3 Colliding calls

Call collisions can occur when both the SwMI and the MS simultaneously send a D/U-SETUP PDU. Two call set-ups are colliding when a D-SETUP PDU is received within the window where the CC waits for a Call Identifier from the SwMI after a U-SETUP PDU has been issued. If this occurs and the MS cannot support more concurrent calls, the MS shall behave as follows:

- if the MS wishes to keep its own call attempt then it shall respond to the incoming call with a U-DISCONNECT PDU with a disconnect cause "called party busy"; or
- if the MS wishes to accept the incoming call then the CC shall accept the call as defined in clause 14.5.1.1.1. The CC shall also send a CANCEL request primitive to the lower layers to cancel the sending of the U-SETUP PDU. If the lower layers indicate that the PDU has already been completely sent, then the CC shall send a U-DISCONNECT PDU for its own call set-up.

Another case of call collision may sometimes be detected and resolved by the SwMI. If the colliding calls are call set-up attempts between the same user applications and the requested basic services are the same, then the SwMI may merge the calls. The SwMI should inform both parties by a D-CONNECT PDU with an amalgamation indication that the calls are merged together, see the call ownership element. The CC should pass this information on to the application in the TNCC-SETUP confirm primitive.

14.5.1.1.4 Unsuccessful call set-up

Unsuccessful call set-up shall refer specifically to those instances where a circuit mode connection was not successfully established. It shall not refer to call disconnection or call rejection. If a PDU is not responded to prior to the expiry of the corresponding timer the procedure in clause 14.5.1.3.4. shall apply. All timers available are listed in clause 14.6.

When CC receives a REPORT indication primitive, indicating that the lower layers have not been successful (failed transfer) in the sending of any of the call set-up PDUs, then the CC sub-entity shall return to state IDLE and shall inform the user application with a TNCC-RELEASE indication primitive accompanied with a cause of the disconnection.

14.5.1.1.5 Call rejection

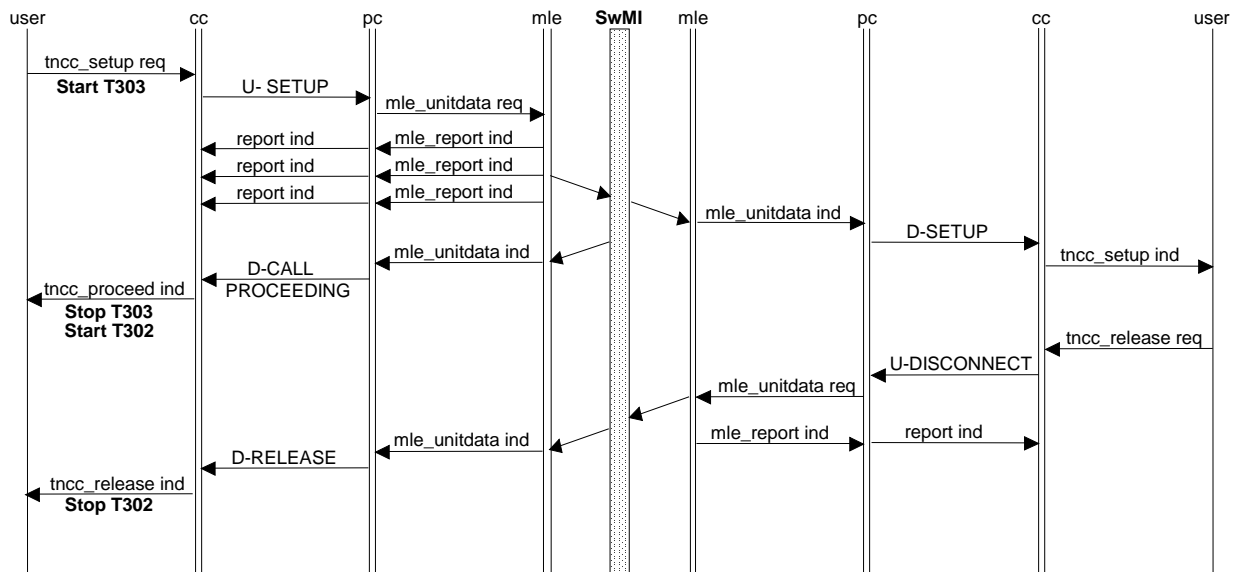

Figure 14.11: Individual call set-up phase - called user application rejects the call

If the user application cannot accept an incoming call as defined in clause 14.5.1.1.1, it shall immediately transfer a TNCC-RELEASE request primitive to the CC sub-entity. The CC sub-entity shall send a U-DISCONNECT PDU along with the disconnection cause "Call Rejected by the called party", see figure 14.11. In case the rejection results from unsupported encryption flag state the disconnect cause shall be "Called party does not support encryption" or "Called party requires encryption". The CC sub-entity shall then change to state IDLE.

NOTE: If the SwMI sends the D-RELEASE PDU as the first response to the calling MS, then it should contain the dummy call reference.

For the busy case refer to clause 14.5.6.5.3.

14.5.1.2 Call maintenance procedures

14.5.1.2.0 General

The call maintenance procedures described in this clause may be applied when the MS is in states MO-CALL SETUP, MT-CALL SETUP or CALL-ACTIVE. The main state CALL-ACTIVE can comprise several sub-states which are presented in informative figure 14.5.

NOTE: The D-INFO PDU can be used for other purposes than those defined in the protocol specifications contained in the present document.

14.5.1.2.1 Transmission control procedures

Only the transmission control procedures defined in clauses 14.5.1.2.1 c) and d) shall apply in duplex call. In a duplex call the SwMI shall grant permission to talk to both parties in the D-CONNECT and D-CONNECT ACKNOWLEDGE PDUs.

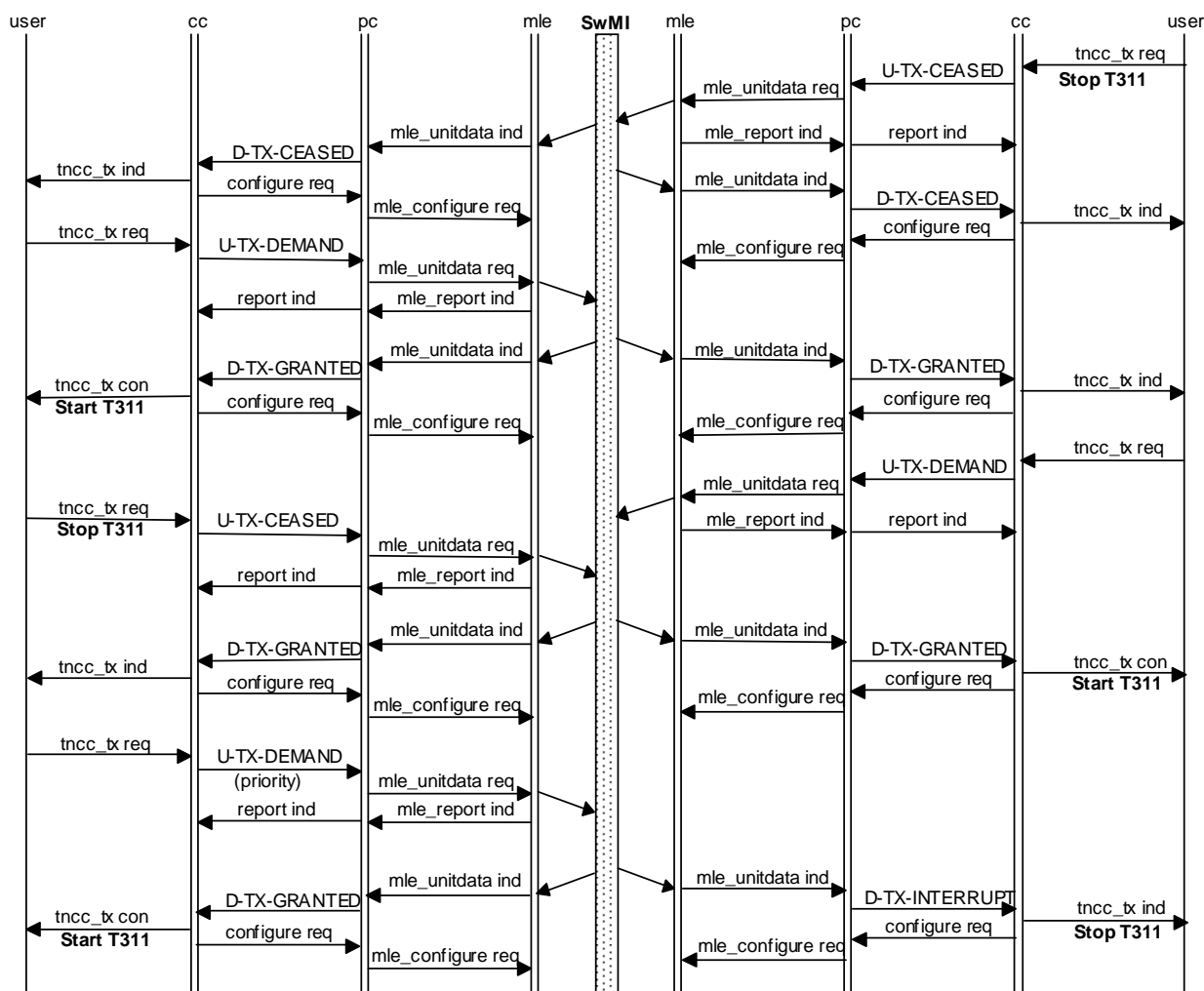

NOTE: For the purposes of clarity, only one instance of mle_report is shown.

Figure 14.12: Individual call request-to-transmit

a) Request-to-Transmit

The SwMI shall fully control which MS is allowed to transmit. To facilitate this the MS shall request permission to transmit from the SwMI and shall receive a permission to transmit before the MS may begin a circuit mode U-plane transmission. If the SwMI allows, in a "transmission request permission" element, then the MS may request a permission to transmit even if the other party is already transmitting. In this case the SwMI should normally wait for that party to finish the transmission before granting the other user application. Pre-emptive priority requests are dealt with in clause 14.5.1.2.1 f).

If on/off hook signalling is used, the normal mode of operation shall be that the called MS shall be given permission to transmit by setting the transmission grant element accordingly in the D-SETUP PDU. However, if desired, the calling MS can ask for permission to transmit by setting the "request to transmit" bit accordingly in the U-SETUP PDU. This is dealt with in clauses 14.5.1.1.1 and 14.5.1.1.2.

If direct set-up signalling is used, the normal mode of operation shall be that the calling MS shall be given the permission to transmit. However the calling user application may in the U-SETUP PDU allow the called user application to request the permission to transmit first by setting the "request to transmit" bit accordingly in the U-SETUP PDU.

An MS restoring a call on a new cell, which was either transmitting in the previous cell or had a transmission request queued in the previous cell, may request to continue to transmit or retain its transmission request in the SwMI's transmission request queue by setting the "request to transmit/send data" element in the U-CALL RESTORE PDU accordingly. This is dealt with in clause 14.5.1.2.4.

When a user application within a call wants to transmit, a TNCC-TX request primitive shall be sent to the CC via the TNCC-SAP. The CC shall send this request in a U-TX DEMAND PDU, see figure 14.12. The TX demand priority should be set to low or high priority, unless this is a pre-emptive request, see clause 14.5.1.2.1 f).

The progress of the transmission of the U-TX DEMAND PDU shall be given locally to the CC in one or more REPORT indication primitives. If the CC receives a REPORT indication primitive with a failed transmission indication as a response to the sending of the U-TX DEMAND PDU the CC shall inform the user application by a TNCC-TX confirm primitive.

If a user application wants to withdraw its request-to-transmit before it has been granted, a TNCC-TX request primitive shall be issued to the TNCC-SAP. The CC shall send this request in a U-TX CEASED PDU or the previous request should be cancelled locally if still possible. The CC shall send the U-TX CEASED PDU with the stealing permission set to "immediate stealing" and stealing repeats flag set, so that the permission to transmit will be released immediately if allocated.

b) Response to Request-to-Transmit

During the call set-up phase: the response to the calling MS's request to transmit is dealt with in clauses 14.5.1.1.1 and 14.5.1.1.2. The MS given permission to transmit shall start timer T311.

During call restoration, the response to the restoring MS's request to transmit is dealt with in clause 14.5.1.2.4.

During a call in progress and when SwMI has decided which MS shall be given permission to transmit, the SwMI shall send a D-TX GRANTED PDU to the granted MS with the transmission grant element set to "transmission granted". The CC sub-entity shall send this information further on to the user application in a TNCC-TX confirm primitive. The other MS involved in the call shall also be informed with a D-TX GRANTED PDU indicating that transmission has been granted to another user. This CC sub-entity shall send this information further on to the user application in a TNCC-TX indication primitive, see figure 14.12.

If the SwMI rejects the transmission request this shall be indicated to the MS concerned by the "transmission not granted" parameter value in the D-TX GRANTED PDU.

If the SwMI places the transmission request in a queue this shall be indicated to the MS concerned by the "transmission request queued" parameter value in the D-TX GRANTED PDU. The MS can then assume that the request-to-transmit will be held in the queue until it is either granted by the SwMI or withdrawn by the MS, or the MS receives a D-TX GRANTED PDU containing the "transmission not granted" parameter value.

On reception of a D-TX GRANTED PDU indicating "transmission granted" or "transmission granted to another user", the CC sub-entity shall issue a CONFIGURE request primitive. The primitive shall carry as a parameter whether the transmit permission has been granted to this MS and a parameter to switch the U-Plane on. The MS given permission to transmit shall start timer T311.

Though the MS shall switch to U-Plane receive if it receives a "transmission granted to another user" response to its transmission request, the MS shall require an explicit response to its transmission request: one of "transmission granted", "transmission not granted" or "transmission request queued".

If the CC sends a U-TX DEMAND PDU whilst the other MS is transmitting, then the SwMI should normally wait for that party to finish the transmission (identified by the receipt of a U-TX CEASED message) before granting transmission to the other user application. On receipt of the U-TX DEMAND PDU, the SwMI may send a D-TX GRANTED PDU indicating whether the request-to-transmit is queued or rejected. Pre-emptive requests are dealt with under clause 14.5.1.2.1 f).

The SwMI shall not send an unsolicited D-TX GRANTED PDU but it is recognized that a race/error condition may result in the MS receiving one. The CC may choose to follow an unsolicited individually addressed D-TX GRANTED PDU indicating "transmission granted" but if the CC does not want to transmit/send data then it shall use the U-TX CEASED PDU, as it does normally at the end of a speech or data item, to reject the transmission grant.

c) Permission to Transmit withdrawn

The SwMI may decide to interrupt transmission when resources are required for another call or when the SwMI requires that the call should temporarily pause. In this case the SwMI should send a D-TX WAIT PDU to each MS (permitting or denying transmission requests according to the "transmission request permission" element). Upon receipt of the D-TX WAIT PDU, the CC sub-entity shall send a TNCC-TX indication primitive to the user application indicating that the transmission is waiting. The CC shall stop timer T311 if activated, enter state WAIT and send a CONFIGURE request primitive to switch the U-Plane off. The MSs shall accept any layer 2 channel assignment and await further instructions on the channel that they have been directed to.

If a request-to-transmit has been queued at the time when the D-TX WAIT PDU is received, the MS shall be allowed to withdraw its request-to-transmit by means of the U-TX CEASED PDU as described in clause 14.5.1.2.1 e).

If the SwMI sends a D-TX WAIT PDU because it wishes to use an assigned channel for another call, it shall send a layer 2 channel assignment with the D-TX WAIT PDU directing the MS to a signalling channel other than the assigned channel. This is to prevent the change in usage marker associated with re-allocation of the assigned channel to the other call causing the waiting MS to drop the interrupted call.

d) Permission to Continue with withdrawn call

When the SwMI has decided that the call can continue, the SwMI should send either a D-TX CONTINUE PDU or a D-TX GRANTED PDU to each MS. When the CC sub-entity receives the notification of the continuation of the call in a D-TX CONTINUE or D-TX GRANTED PDU it shall return to state CALL-ACTIVE.

The D-TX CONTINUE PDU shall contain an indication (the continue element) to specify whether the same transmission permission applies as at the time of the interruption. If the continue element is set to "continue", and if the MS was either transmitting or receiving traffic when it received the D-TX WAIT PDU, then the CC sub-entity shall send a CONFIGURE request primitive to switch the U-plane on and to accept the channel change if requested. The MS granted permission to transmit shall start timer T311. If the continue element is set to "not continue", or if the MS was neither transmitting nor receiving traffic when it received the D-TX WAIT PDU, then the U-plane shall not be switched on and the MS shall assume that any previous transmission permission no longer applies.

If the D-TX CONTINUE PDU contains an indication that the MS is allowed to request transmission permission, it may follow the transmission control procedures described in clause 14.5.1.2.1 a).

There are three cases as follows:

- 1) if no MS was granted transmission at the time when the SwMI sent the D-TX WAIT PDU, or if an MS was granted transmission at the time of the D-TX WAIT PDU but the SwMI does not wish that transmission to continue, then either a D-TX CONTINUE PDU with the continue element set to "not continue" or D-TX GRANTED PDU with transmission grant element set to "not granted" shall be sent individually to both MSs in the call. The CC shall accept any layer 2 channel allocation. All CC sub-entities shall return to state CALL-ACTIVE but the U-plane shall not be switched on and the MS shall assume that any previous transmission permission no longer applies. If the D-TX CONTINUE PDU or D-TX GRANTED PDU contains an indication that the MS is allowed to request transmission permission, it may follow the transmission control procedures described in clause 14.5.1.2.1 a).
- 2) If there was at least one MS granted transmission at the time when the SwMI sent the D-TX WAIT PDU, and if the SwMI wishes the transmission to continue, then either a D-TX CONTINUE PDU with the Continue element set to "continue" or D-TX GRANTED PDU with transmission grant element set to "transmission granted" or "transmission granted to another" shall be sent individually to both MSs and the CC shall accept any layer 2 channel allocation. If a D-TX CONTINUE PDU with the Continue element set to "continue" is sent, it shall give the earlier granted MS permission to continue transmission. The MS granted permission to transmit shall start timer T311. All CC sub-entities shall return to state CALL ACTIVE and shall send a CONFIGURE request primitive to the lower layers to switch the U-plane on.

- 3) If there was one MS granted transmission at the time when the SwMI sent the D-TX WAIT PDU but the SwMI wishes to give the transmission permission to the other party or if no MS was granted transmission at the time when the SwMI sent the D-TX WAIT PDU and the SwMI wishes to give the transmission permission now to another party, the SwMI may first send a D-TX CONTINUE PDU with the Continue element set to "not continue" individually to both MSs. A D-TX GRANTED PDU shall then be sent as an individual message to the granted MS with information element transmission grant set to "transmission granted" and with information element transmission grant set to "transmission granted to another user" to not-granted MS (if any). When receiving either D-TX CONTINUE or D-TX GRANTED PDU the CC sub-entity shall return to state CALL-ACTIVE. In addition when receiving D-TX GRANTED PDU CC shall send a CONFIGURE request primitive to the lower layers to switch the U-plane on.

If the MS is in state WAIT and it receives a D-TX GRANTED PDU then it shall obey the instruction in the D-TX GRANTED PDU.

e) End of Transmission

At the end of a transmission, the user application shall send a TNCC-TX request primitive to the TNCC-SAP indicating ceased transmission. The CC sub-entity shall send this information in a U-TX CEASED PDU, remain in state CALL-ACTIVE and stop timer T311. The CC shall send the U-TX CEASED PDU with the stealing permission set to "immediate stealing" and the stealing repeats flag set. Upon receipt of the U-TX CEASED PDU, the SwMI may send a D-TX CEASED PDU to each MS informing them that the transmission has now ceased.

Upon reception of a D-TX CEASED PDU, the CC shall send this information further on to the user application in a TNCC-TX indication primitive (transmission ceased). The CC sub-entity shall send a CONFIGURE request primitive to the lower layers to switch the U-Plane off.

Also, if the CC that is sending the U-TX CEASED PDU receives a REPORT indication primitive of either successful or unsuccessful transmission of that PDU by the lower layers, then it shall behave as if it had received a D-TX CEASED PDU i.e. it shall send a TNCC-TX indication primitive (transmission ceased) to the user application and shall send a CONFIGURE request primitive to the lower layers to switch the U-Plane off.

If there was a request for transmission already queued in the SwMI when the U-TX CEASED PDU was received, then the SwMI should send a D-TX GRANTED PDU to each MS as described in clause 14.5.1.2.1 b), without sending an explicit D-TX CEASED PDU. The CC sub-entity shall send a CONFIGURE request primitive to the lower layers to indicate the change in the transmit permission.

NOTE: The End of Transmission procedure is not valid for a duplex call.

The SwMI shall not send an unsolicited D-TX CEASED PDU but it is recognized that a race/error condition may result in the MS receiving one. If CC receives an unsolicited D-TX CEASED PDU it shall send this information further on to the user application in a TNCC-TX indication primitive (transmission ceased) and shall send a CONFIGURE request primitive to the lower layers to switch the U-Plane off.

f) Stop Transmission order

If, during the course of a transmission, a MS wishes to interrupt the transmitting MS, it shall send a U-TX DEMAND PDU indicating the wanted level of pre-emptive priority in the TX demand priority element. If the SwMI supports transmission interruption, it shall then send a D-TX INTERRUPT PDU to the MS that currently has the permission to transmit. Upon reception of a D-TX INTERRUPT PDU, the CC shall stop transmission and remain in state CALL-ACTIVE, stop timer T311, send a TNCC-TX indication primitive to the user application indicating transmission interrupt and send a CONFIGURE request primitive to lower layers to indicate the loss of transmit permission. The SwMI should then send a D-TX GRANTED PDU to the requesting MS indicating that the permission to transmit has been awarded as described in clause 14.5.1.2.1 b).

The D-TX INTERRUPT PDU shall indicate that transmission is granted to another user and then the MS shall switch to U-plane reception. Otherwise, if there is a delay before the pre-emptive priority transmission, the SwMI may indicate "transmission not granted" in the D-TX INTERRUPT PDU. Then the MS shall switch the U-plane off and wait for a D-TX GRANTED PDU.

g) Expiry of timer T311; call transmission timer

Upon expiry of timer T311, CC shall remain in state ACTIVE, send a TNCC-TX indication primitive to the user application and a U-TX CEASED PDU to the peer entity. The CC shall send the U-TX CEASED PDU with the stealing permission set to "immediate stealing" and stealing repeats flag set.

14.5.1.2.2 Call status information procedures

The D-INFO PDU can be used for carrying call status messages from SwMI to the MS. When a D-INFO PDU is received, depending on the notification, the following actions are taken by CC.

a) Call in queue

When the SwMI has put a call into a queue it may send a D-INFO PDU. If the D-INFO PDU contains a value for the call time-out, set-up phase, the CC shall start timer T301 or T302, as appropriate, using the specified value. The CC shall send the information to the application in a TNCC-NOTIFY indication primitive. If the call is queued at call set-up time the D-INFO PDU should be preceded by a D-CALL PROCEEDING PDU.

b) Call is proceeding

This may be sent to the calling user application during the call set-up phase to indicate e.g. that the call set-up time through a gateway will be longer than for a normal call set-up time. The information that the timer value shall be changed is made available to the CC sub-entity in the D-INFO PDU. The CC shall start T302 with the indicated timer value. The CC shall send the information further on to the application in a TNCC-NOTIFY indication primitive.

c) SwMI is paging called user

When the SwMI is paging a called user, e.g. when the called user is on another network, the SwMI may send a D-INFO PDU with the call status parameter indicating this situation. If the D-INFO PDU contains a value for the call time-out, call set-up phase element, the CC shall start timer T302 using the specified value.

d) Prolonging the call time-out time

The SwMI may decide to change the call time-out time by sending a D-INFO PDU with a new T310 value. Upon reception of the D-INFO PDU containing the "call time-out" element, T310 shall be started using the defined value. If the SwMI supplies a T310 value in the D-INFO PDU, it shall set the value of the "reset call time-out timer" element of the PDU to indicate reset of T310.

The SwMI may also choose to reset the call time-out time and start it again using the current defined value. Upon reception of the D-INFO PDU with the "reset call time-out timer" element indicating that T310 shall be reset, T310 shall be started using the value defined earlier.

In either case, the Timer value shall be sent further on to the application in a TNCC-NOTIFY indication primitive.

The SwMI may also change the call timeout time during call restoration by supplying the "call time-out" element in the D-CALL RESTORE PDU, refer to clause 14.5.1.2.4. If the SwMI supplies a T310 value in the D-CALL RESTORE PDU, it shall set the value of the "reset call time-out timer" element of the PDU to indicate reset of T310.

NOTE 1: This procedure is applicable both in semi-duplex and full-duplex calls.

e) Change of call identifier

The SwMI may decide to change the call identifier used by an MS in an on-going call by sending a D-INFO PDU containing a new call identifier. The SwMI may also use this method to change the MS's call identifier in preparation for a type 1 cell reselection (i.e. just before sending the MS the D-NEW CELL PDU granting the type 1 cell reselection) if the new cell uses a different call identifier from the old cell. The individually-addressed D-INFO PDU should be sent using an acknowledged service.

NOTE 2: If the MS and the SwMI have different perceptions of the value of a call identifier the MS could lose the call.

f) Imminent call disconnection

The SwMI may also inform MS that the call is about to end by sending D-INFO PDU with notification value "Notice of imminent call disconnection" shortly before the actual call disconnection. Upon reception of notification "Notice of imminent call disconnection" CC may send this notification to the application in a TNCC-NOTIFY indication primitive.

NOTE 3: The time between notification and disconnection is outside the scope of the present document.

Most downlink CC PDUs may contain a Notification indicator information element (in addition to the D-INFO PDU) and SwMI may inform calling/called user about offered or connected service using the Notification indicator information element. CC may send this notification to the application in corresponding TNCC service primitive.

14.5.1.2.3 Call modification procedures

The MS service user may modify the service of an existing call. To initiate a modification the user application shall issue a TNCC-MODIFY request primitive and the CC sub-entity shall send a U-INFO PDU and wait for a D-INFO PDU from the SwMI before changing any of the current service parameters. The SwMI should not send D-INFO PDU to modify a service while an ongoing U-plane transmission is in progress.

When a service has been changed by the SwMI, e.g. when a point-to-point call has been changed to a point-to-multipoint call, the SwMI should indicate this to the calling and called parties by sending a D-INFO PDU. Upon reception of a D-INFO PDU the CC sub-entity shall send it to the application in a TNCC-MODIFY indication primitive. Finally the CC shall send a CONFIGURE request primitive for lower layer configuration.

If the SwMI is unable to provide the requested service, it should either send a D-INFO PDU to the requesting party containing the current service (unchanged), or send a D-INFO PDU to the calling and called parties containing an alternative service. For example, if a user application requests an increase from a 1-slot per frame call to a 4-slots per frame call, and the SwMI is unable to allocate more than 2-slots to the call, it may offer a 2-slots per frame call in the D-INFO PDUs.

If the call has changed from point-to-point to point-to-multipoint, a temporary group address and a group call reference number (call identifier) shall be given. The new group call reference number can be the current call identifier of the including party.

The service may be changed between any combination of one or more of the following:

- duplex operation may be changed to simplex operation; or
- simplex operation may be changed to duplex operation;
- a point-to-point call may be changed to a point-to-multipoint call;
- a clear call may be changed to an encrypted call; or
- an encrypted call may be changed to a clear call;
- a 4-slots per frame call may be changed to a 1-slot, 2-slot or 3-slot call;
- a 3-slot call may be changed to a 1-slot, 2-slot or 4-slot call;
- a 2-slot call may be changed to a 1-slot, 3-slot or 4-slot call;
- a 1-slot call may be changed to a 2-slot, 3-slot or 4-slot call;
- a circuit mode type (TCH/S, TCH/7.2, TCH/4.8 or TCH/2.4) may be changed to a different circuit mode type (with the requested interleaving depth in the case of TCH/4.8 or TCH/2.4);
- a protected circuit mode data type (TCH/4.8 or TCH/2.4) may be changed to a different interleaving depth from the set of permissible values ($N = 1, 4$ or 8).

NOTE: The clear and encrypted calls refer to the end-to-end clear and encrypted calls. The end-to-end encryption control is independent of the air interface encryption control.

It is also possible to change between the circuit mode speech teleservices.

The encryption state of each transmission, defined using D-TX GRANTED PDU, can be set independently by the encryption control element in the U-TX DEMAND PDU. The SwMI should not change the requested encryption state in the responding D-TX GRANTED PDU from that requested in the U-TX DEMAND PDU.

If the MS cannot support a new service combination, indicated by D-INFO, D-TX GRANTED or D-TX INTERRUPT PDU, the user application or the CC, as appropriate, shall disconnect the call (see clause 14.5.1.3.1). The U-DISCONNECT PDU shall contain disconnection cause "requested service not available" or in case of incompatible encryption control, the disconnect cause shall be "Called party does not support encryption" or "Called party requires encryption".

14.5.1.2.4 Call restoration procedures

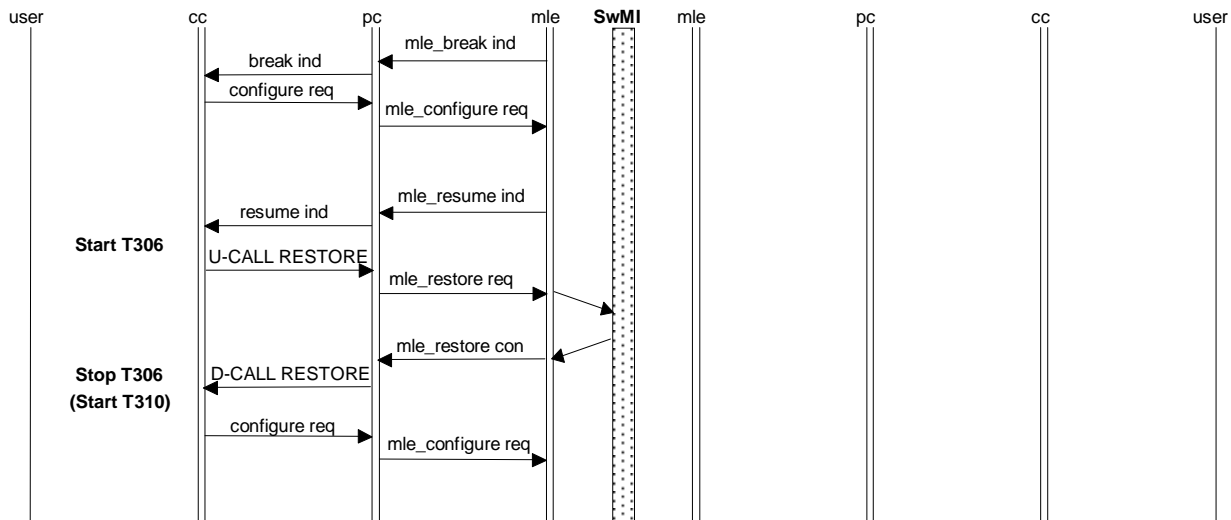

Figure 14.13: Individual call - successful call restoration

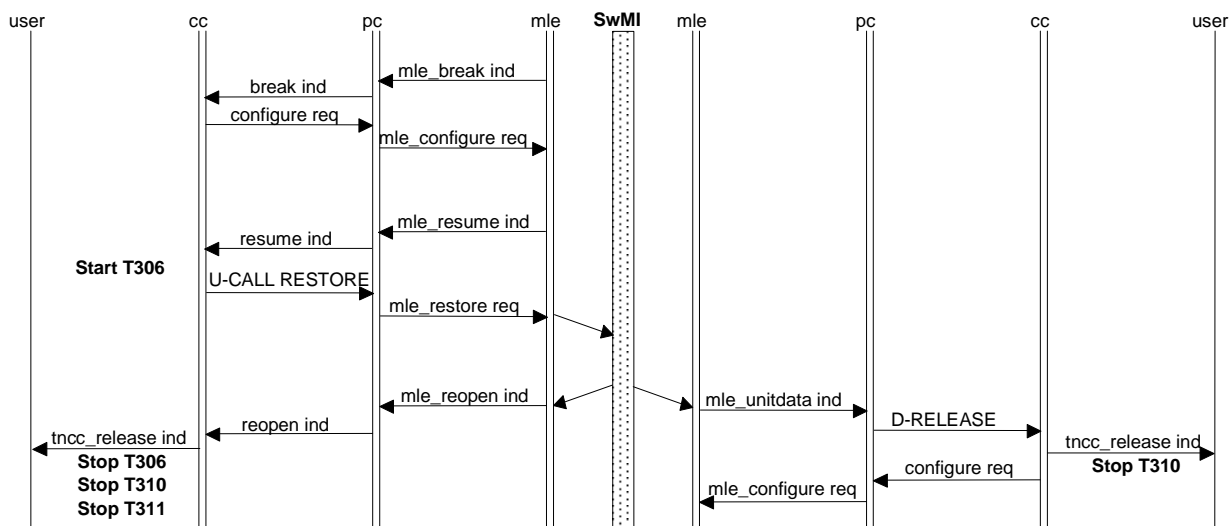

Figure 14.14: Individual call - unsuccessful call restoration

The responsibility of the procedure shall be to restore the call when the temporary break condition has been resolved by lower layers.

When the CC receives a BREAK indication primitive, then the CC sub-entity shall try to restore the call as described in this clause:

- When the CC receives a BREAK indication primitive, the CC shall send a CONFIGURE request primitive to switch the U-plane off as described in clause 14.5.1.4 and remain in state CALL-ACTIVE. If the CC had permission to transmit/send data at that time the CC shall assume that the permission is now ended as if the CC had sent a U-TX CEASED PDU or SwMI had withdrawn permission to talk. If the MS is in state WAIT when it receives a BREAK indication primitive then it shall behave as if it had received a D-TX CONTINUE PDU with the continue element set to "not continue". It shall then obey the instructions in the D-CALL RESTORE PDU.
- If the CC receives a RESUME indication primitive indicating that the C-plane may now be used again, it shall issue a U-CALL RESTORE PDU in a RESTORE request primitive containing the SSI, TSI or SNA of the other party in the individual call and the call identifier of the call which CC wants to restore. If the other party address is not available, then the dummy address (all zeroes) shall be used. The CC shall set the request to transmit/send data information element in the U-CALL RESTORE PDU as indicated below:
 - Duplex call - always request to transmit/send data.
 - Simplex call - an MS that wishes to continue transmission in the new cell shall request to transmit/send data. An MS that has requested for transmit permission on a previous cell and received a "transmission request queued" response or no response at all on that cell, and wishes to refresh the transmission request, shall request to transmit/send data. Otherwise, the MS shall request that the other MS may transmit/send data.

NOTE 1: It is not the intention that the MS uses the transmit/send data information element in the U-CALL RESTORE PDU for a new transmission request in the new cell; it should only be used for refreshing a request in the previous cell or to continue transmission in the new cell. It is outside the scope of the present document if used for a new transmission request but it is likely that a SwMI may deny the request for transmission. The intention is that the transmission request in the new cell is achieved using standard call maintenance signalling after the restoration is complete.

After sending a U-CALL RESTORE PDU, CC shall start timer T306 and wait for a D-CALL RESTORE PDU.

- When the CC receives a D-CALL RESTORE PDU in a RESTORE indication primitive, timer T306 shall be stopped, and the call shall be resumed with the new parameters, see figure 14.13. Timer T310 shall be reset and started only if the "Reset call timeout" information element value is 1 (Reset call time-out timer T310); the T310 value shall be taken from the D-CALL RESTORE PDU call timeout information element and, if not present in the PDU, from the previous value (provided in D-CONNECT, D-CONNECT ACKNOWLEDGE or D-INFO PDU). The CC shall obey the transmission granting in the transmission grant information element for both simplex and duplex calls:
 - Transmission granted: The MS shall switch the U-plane on (refer to clause 14.5.1.4) and the MS is authorized to transmit, and in the case of a duplex call, also authorized to receive.
 - Transmission not granted: This value is only applicable for simplex calls. The MS shall assume that it has neither transmission permission nor a transmission request queued in the SwMI and the U-plane remains switched off.
 - Transmission request queued: The MS shall assume that the request-to-transmit remains queued in the SwMI until it is either granted or withdrawn by the SwMI, or withdrawn by the MS and the U-plane remains switched off.
 - Transmission granted to another user: This value is only applicable for simplex calls. The MS shall switch the U-plane on (refer to clause 14.5.1.4) and the MS is authorized to receive. If the MS requested transmission in the U-CALL RESTORE PDU, the MS shall assume that its transmission request is still queued in the SwMI until it is either granted or withdrawn by the SwMI, or withdrawn by the MS.

If the U-plane is to be switched on, a layer 2 channel allocation shall accompany the D-CALL RESTORE PDU. If the U-plane is not to be switched on, and a traffic channel is available, the layer 2 channel allocation may accompany the D-CALL RESTORE PDU or be attached to later signalling. If a traffic channel is not available, the D-CALL RESTORE PDU shall contain a "Call status" information element with value "Call is queued".

NOTE 2: If the D-CALL RESTORE PDU is sent without a layer 2 channel allocation and includes a new call identifier it should be sent using an acknowledged layer 2 service. (This reduces the possibility of the MS responding to subsequent copies of the D-CALL RESTORE PDU with a U-DISCONNECT PDU, which occurs if the D-CALL RESTORE PDU changes the call identifier - see clause 14.5.6.5.2).

- After processing the D-CALL RESTORE, the call restoration is considered complete; however, if the U-plane remains switched off after the call restoration e.g. due to call is queued, the SwMI would typically send one or more D-TX GRANTED PDUs to continue the call or to award transmission permission. Those D-TX GRANTED PDUs may be a direct result of the call restoration, for example to provide the channel allocation in the new cell in the event of queuing for a channel, or it may be associated with further call maintenance signalling following a transmission request from one of the call participants (refer to clause 14.5.1.2.1). The CC shall obey the transmission granting in the transmission grant information element:
 - Transmission granted: The MS shall switch the U-plane on (refer to clause 14.5.1.4) and the MS is authorized to transmit. If the restored MS has not yet been sent to the traffic channel, the D-TX GRANTED PDU shall be accompanied by a layer 2 channel allocation.
 - Transmission not granted: The MS shall assume that it has neither transmission permission nor a transmission request queued in the SwMI and the U-plane remains switched off. If the restored MS has not yet been sent to the traffic channel, the D-TX GRANTED PDU may be accompanied by a layer 2 channel allocation.
 - Transmission request queued: The MS shall continue to assume that the request-to-transmit remains queued in the SwMI until it is either granted or withdrawn by the SwMI, or withdrawn by the MS and the U-plane remains switched off. If the restored MS has not yet been sent to the traffic channel, the D-TX GRANTED PDU may be accompanied by a layer 2 channel allocation.
 - Transmission granted to another user: The MS shall switch the U-plane on (refer to clause 14.5.1.4) and the MS is authorized to receive. If the restored MS has not yet been sent to the traffic channel, the D-TX GRANTED PDU shall be accompanied by a layer 2 channel allocation.

On expiry of Timer T306, the procedure defined in clause 14.5.1.3.4 shall apply.

The call length timer T310 shall continue running during the call restoration and on expiry of T310, the procedure defined in clause 14.5.1.3.4 shall apply.

If the call cannot be resumed the CC should receive a REOPEN indication primitive indicating that the call is lost. The CC shall then stop Timer T306 and return to state IDLE, and it shall send a TNCC-RELEASE indication primitive to the user application with the cause of disconnection, see figure 14.14.

If the SwMI provides a new call identifier with the D-CALL RESTORE PDU, CC shall use it in all subsequent signalling relating to that call. After a cell change, the MS shall not send any other call related signalling than U-CALL RESTORE PDU until it has received a D-CALL RESTORE PDU (and possible new call identifier) from the SwMI.

A MS which is queueing for a traffic channel during restoration and which has an outstanding transmission request, may cancel that transmission request by sending a U-TX CEASED PDU. A MS which is queueing for a traffic channel during restoration and which does not have an outstanding transmission request, may make a transmission request by sending a U-TX DEMAND PDU, providing the SwMI has not disallowed transmission requests (via the "transmission request permission" element).

If there is more than one circuit mode call active at the time when the MLE-BREAK indication primitive was received, each call shall be restored separately and hence U-CALL RESTORE and D-CALL RESTORE PDUs shall be exchanged one by one for each call.

14.5.1.2.5 DTMF procedures

When a user application requires to transfer DTMF digits to another user application during a circuit mode call, it shall issue a TNCC-DTMF request primitive (DTMF tone delimiter = "DTMF tone start") to the CC entity, followed by a TNCC-DTMF request primitive (DTMF tone delimiter = "DTMF tone end") to the CC entity. The duration of time between the "start" and "end" primitives, and the number of digits contained in the start primitive, shall be application-dependent, though normally generation of the start primitive will correspond with a DTMF key press, generation of the end primitive will correspond with the release of that key and the start primitive will contain the digit corresponding to the key press.

CC shall generate U-INFO PDUs corresponding to the TNCC-DTMF request primitives (see clauses 14.8.19, 14.8.19a and 14.8.19b), the only restriction being that CC shall not send a "DTMF tone end" U-INFO PDU if layer 2 has not indicated successful transmission of the preceding "DTMF tone start" U-INFO PDU.

On the reception of a D-INFO "DTMF tone start" PDU the CC shall forward the DTMF digits contained in the PDU to the user application in a "start" TNCC-DTMF indication primitive. On the reception of a D-INFO "DTMF tone end" PDU the CC shall send an "end" TNCC-DTMF indication primitive to the user application. If CC receives two identical "start" PDUs (i.e. containing the same DTMF digits) without an intervening "end" PDU it shall ignore the second "start" PDU. If CC receives two "end" PDUs without an intervening "start" PDU it shall ignore the second "end" PDU. If CC receives two different "start" PDUs without an intervening "end" PDU it shall forward the digits contained in both PDUs to the user application.

A SwMI may choose to filter repeated "start" and "end" DTMF U-INFO PDUs in the manner described in the previous clause before forwarding DTMF digits to a MS (in a D-INFO PDU) or gateway (see below).

A receiving MS or gateway which does not support or subscribe to DTMF signalling may respond to a DTMF D-INFO PDU with a U-INFO PDU, the DTMF type element (refer clause 14.8.19b) having value "DTMF not supported" or "DTMF not subscribed". The SwMI should forward this response to the addressed MS (i.e. the MS which initiated the DTMF signalling) in a D-INFO PDU.

A receiving SwMI which does not support or subscribe to DTMF signalling may respond to a DTMF U-INFO PDU with a D-INFO PDU, the DTMF type element (refer clause 14.8.19b) having value "DTMF not supported" or "DTMF not subscribed".

On the reception of a D-INFO "DTMF not supported" or "DTMF not subscribed" PDU (refer clause 14.8.19b), CC shall forward the failure to the user application in a TNCC-DTMF indication primitive containing a "DTMF result" parameter specifying the nature of the failure (refer clause 11.3.3.3). Note that a user application should receive such an indication only after having generated DTMF digits itself. It is outside the scope of the present document how the user application should handle the rejection of DTMF signalling.

The U-INFO PDU may be routed to a gateway. In this case, the receiving user application can be for example, either an external network subscriber application or an exchange of the external network that uses two stage dialling to set-up calls in the external network. The gateway shall convert the DTMF digits into dual tone multi-frequency signals towards the external network. The gateway shall support the filtering of repeated "start" and "end" DTMF U-INFO PDUs described above.

A receiving entity (i.e. MS or gateway) shall start generation of one or more DTMF tones at the first reception of a "start" PDU. The receiving entity shall ignore any repeated "start" PDUs. It is outside the scope of the present document how DTMF tones are generated if the receiving entity receives two or more different "start" PDUs without an intervening "end" PDU.

The "end" PDU shall stop the generation of tone or tones after the minimum period of tone/no-tone sequence or sequences as defined for the application e.g. PSTN gateway. When the reception of the "end" PDU is delayed longer than the minimum tone period of the single or last digit in the "start" PDU the tone generating application may continue to generate tone for a predefined time; the generation time is outside the scope of the present document. The receiving entity shall ignore any repeated "end" PDUs.

The next "start" PDU after an "end" PDU shall start generation of the DTMF tone only after a valid no-tone period as defined for the application.

The minimum length of tone generated by the tone generating application, e.g. a gateway, should be suitable for potential applications in analog telecommunication networks.

NOTE 1: The DTMF signalling can be used only after either a D-CONNECT or D-CONNECT ACK PDU has been received and the TETRA call is established.

NOTE 2: DTMF signalling may not function correctly during a circuit mode data call (a data modem signal will seriously disturb and be disturbed by DTMF signalling). The support of DTMF signalling during data calls is outside the scope of the present document.

14.5.1.2.6 Calls to and from external subscribers

An MS can make a call to a subscriber in an external network using a gateway. The call set-up message shall address the gateway using a particular SSI as the called party address and the U-SETUP PDU shall contain the external network subscriber number in the corresponding element. The gateway shall then set-up the call to the external network subscriber using that number without further call set-up messages from the calling MS.

NOTE 1: The particular SSI address or addresses which identify the gateway or gateways are not defined by this part of the present document.

NOTE 2: Calls from external network subscribers to TETRA subscribers are supported in the air interface including presentation of the external user number, if available. This part of the present document does not describe gateway functions, which are independent of the air interface protocol.

14.5.1.3 Call disconnection procedures

14.5.1.3.0 General

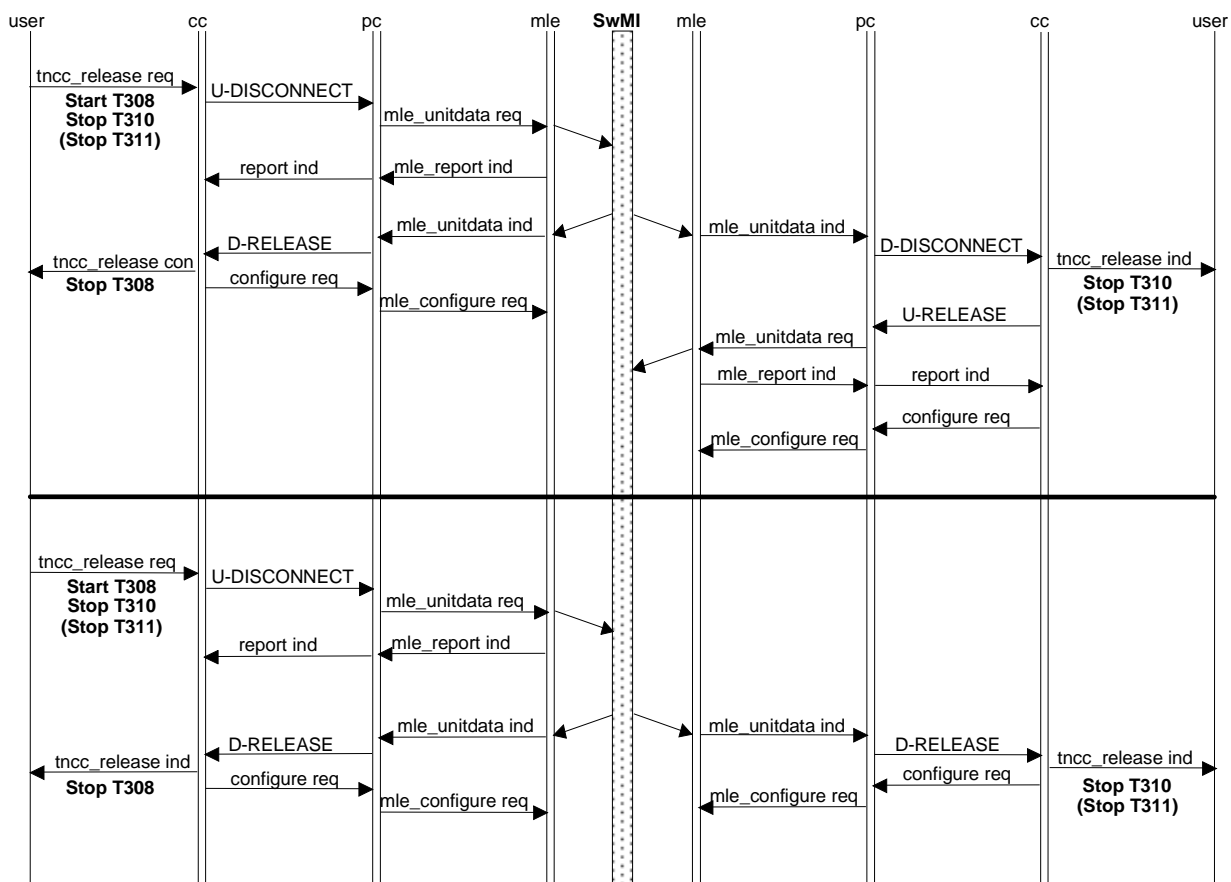

NOTE: For the purposes of clarity, only 1 instance of mle_report has been shown.

Figure 14.15: Individual call request-to-disconnect

14.5.1.3.1 User initiated disconnection

Either the calling or called user application may initiate a call disconnection at any state of a call. This shall be done by sending a TNCC-RELEASE request primitive to the CC sub-entity.

- During call set-up phase until the U-SETUP PDU has been transmitted to the SwMI, a disconnection can be handled locally using a CANCEL request primitive. Information regarding the local progress of the transmission of a PDU is received in REPORT indication primitives. After a local cancellation the CC sub-entity shall stop timer T303 and return to state IDLE.

- On receipt of a TNCC-RELEASE request primitive the CC sub-entity shall enter state CALL-DISCONNECT, send a U-DISCONNECT PDU, start timer T308 and stop all other T3xx timers. The progress of the disconnection PDU sending shall be reported back to CC with REPORT indication primitives.
- Should the user application disconnect the call during the window between transmission of a U-SETUP and reception of a D-CALL PROCEEDING, D-ALERT or D-CONNECT PDU (i.e. before the MS has received a call identifier for the call), it shall use the dummy call identifier (all zeroes).
- After sending a U-DISCONNECT PDU the CC shall wait for a D-RELEASE PDU. When a D-RELEASE PDU or a REPORT indication primitive with reason PDU transfer failed is received, or timer T308 expires, the CC sub-entity shall clear the call identifier and shall return to state IDLE, issuing a TNCC-RELEASE confirm primitive to the user application, see figure 14.15. The CC sub-entity shall send a CONFIGURE request primitive to the lower layers to switch the U-Plane off, reject any pending channel change response request for that call (refer to clause 14.5.3.2), and leave the assigned channel (if the MS is on an assigned channel when the CONFIGURE request primitive is sent). If a channel change response is required for the D-RELEASE PDU, CC shall accept that channel change (refer to clause 14.5.3.2).

The SwMI should inform the other MS in the call of the call clearance either by a D-DISCONNECT PDU or by a D-RELEASE PDU, see clause 14.5.1.3.3.

14.5.1.3.2 Network initiated disconnection

In the case where the SwMI cannot support a request for a call from the calling MS, the SwMI should send a D-RELEASE PDU, containing the reason for disconnection, to the calling MS.

In the case where the SwMI can no longer support an established call, it should send D RELEASE PDUs to the calling and called MSs containing the reason for disconnection, and should subsequently release the call.

Refer to clause 14.5.1.3.3 for the MS actions.

14.5.1.3.3 Reception of disconnection request

The BS may send a disconnection request at any phase of the call and the MS shall react as follows:

- when the CC sub-entity receives a D-DISCONNECT PDU the CC shall respond by sending a U-RELEASE PDU;
- when the CC sub-entity receives a D-RELEASE PDU the CC shall not send any response;
- in both cases the CC shall inform the user application with a TNCC-RELEASE indication primitive, clear the call identifier, stop all T3xx timers and enter state IDLE, see figure 14.15. The CC sub-entity shall send a CONFIGURE request primitive informing the lower layers to switch the U-Plane off, reject any pending channel change response request for that call (refer to clause 14.5.3.2), and leave the assigned channel (if the MS is on an assigned channel when the CONFIGURE request primitive is sent). If a channel change response is required for the D-RELEASE PDU or D-DISCONNECT PDU, CC shall accept that channel change (refer to clause 14.5.3.2).

14.5.1.3.4 Expiry of timers

a) Timer T301; call set-up timer for called MS

Upon expiry of timer T301, CC shall send a TNCC-RELEASE indication primitive to the user application, send a U-DISCONNECT PDU and follow the procedures in clause 14.5.1.3.1. The value of the disconnect cause element shall be set to "expiry of timer".

b) Timer T302; call set-up timer for calling MS

Upon expiry of timer T302, CC shall send a TNCC-RELEASE indication primitive to the user application, send a U-DISCONNECT PDU and follow the procedures in clause 14.5.1.3.1. The value of the disconnect cause element shall be set to "expiry of timer".

c) Timer T303; call initiated timer for calling MS

Upon expiry of timer T303, CC shall send a TNCC-RELEASE indication primitive to the user application, send a U-DISCONNECT PDU and follow the procedures in clause 14.5.1.3.1. The value of the Disconnect Cause element shall be set to "expiry of timer".

d) Timer T306; call restoration timer for point-to-point calls

Upon expiry of timer T306, CC shall return to state IDLE, and send a TNCC-RELEASE indication primitive to the user application. The value of the disconnect cause element shall be set to "expiry of timer".

e) Timer T308; call disconnect timer

Upon expiry of timer T308, CC shall return to state IDLE, send a TNCC-RELEASE confirm primitive to the user application and shall send a CANCEL request primitive to the lower layers to cancel the sending of the U-DISCONNECT PDU. The CC sub-entity shall send a CONFIGURE request primitive to the lower layer to switch the U-Plane off, reject any pending channel change response request for that call (refer to clause 14.5.3.2), and leave the assigned channel (if the MS is on an assigned channel when the CONFIGURE request primitive is sent).

f) Timer T310; call length timer

Upon expiry of timer T310, CC shall send a TNCC-RELEASE indication primitive to the user application, send a U-DISCONNECT PDU and follow the procedures in clause 14.5.1.3.1. The value of the disconnect cause element shall be set to "expiry of timer".

g) Timer T311; call transmission timer

Refer to clause 14.5.1.2.1 g).

14.5.1.3.5 Colliding disconnection

Disconnection collision can occur when both sides simultaneously send DISCONNECT PDUs specifying the same call identifier value. If a CC sub-entity receives a D-DISCONNECT PDU when CC has just issued a U-DISCONNECT PDU, the CC sub-entity shall discard the outgoing disconnection request and respond to the incoming D-DISCONNECT PDU as defined in clause 14.5.1.3.3.

If the U-DISCONNECT PDU collides with a D-RELEASE PDU, the CC sub-entity shall release the call immediately as defined in clause 14.5.1.3.3.

In either case the CC shall send a CANCEL request primitive to the lower layers to cancel the sending of the U-DISCONNECT PDU.

14.5.1.4 U-Plane switching

14.5.1.4.0 General

The U-Plane switching procedure ensures that traffic/signalling synchronization between CMCE and MAC is maintained during the lifetime of a call. The CC informs the MAC when it has permission to transmit traffic (i.e. TCH or STCH) and when to stop. The CC also informs the MAC when it may process received traffic (and when to stop). The latter procedure also assists the MAC to interpret when the received bit-stream on the assigned channel is TCH/STCH and when it is SCH.

The CC changes the U-plane operation in the MAC by issuing the CONFIGURE request primitive, indicating "Switch U-plane = On" or "Switch U-plane = Off", "Tx grant = true" or "Tx grant = false" and "simplex/duplex = simplex" or "simplex/duplex = duplex". There shall be only four valid combinations:

- 1) Switch U-plane = On, Tx grant = true, simplex/duplex = simplex:
 - MS is authorized to transmit traffic.

- 2) Switch U-plane = On, Tx grant = false, simplex/duplex = simplex:
 - MS is authorized to receive traffic.
- 3) Switch U-plane = On, Tx grant = true, simplex/duplex = duplex:
 - MS is authorized to transmit and receive traffic.
- 4) Switch U-plane = Off:
 - withdraws previous authorization to transmit and/or receive traffic.

14.5.1.4.1 End of call set-up phase

When the CC in a MO call receives a D-CONNECT PDU, or when the CC in a MT call receives a D-CONNECT ACKNOWLEDGE PDU, it shall issue a CONFIGURE request primitive to the lower layers containing information about the call e.g. the type of traffic, the interleaving depth, the call identifier and whether the call is end-to-end encrypted.

If the transmission grant element in the PDU is set to "transmission granted" then the CONFIGURE request primitive shall contain the parameter value "Switch U-Plane = On" and "Tx grant = true" to indicate that the MAC has permission to transmit traffic. If the transmission grant element is set to "transmission granted to another user" then the CONFIGURE request primitive shall contain the parameter value "Switch U-Plane = On" but shall contain "Tx grant = false" to indicate that the MAC should receive traffic.

For the other values of the transmission grant element, the U-plane shall not be switched on.

14.5.1.4.2 During call maintenance phase

a) Transmission grant control

When the CC receives a D-TX GRANTED PDU, and if the transmission grant element is set to "transmission granted" or "transmission granted to another user", then the CC shall issue a CONFIGURE request primitive containing the parameter value "Switch U-Plane = On" and indicating whether the MAC has permission to transmit traffic ("Tx grant = true" or "Tx grant = false" respectively). For the other values of the transmission grant element, the U-plane state shall not be changed.

NOTE: Sometimes consecutive CONFIGURE request primitives issued to the lower layers will both contain the instruction to "Switch U-plane On" but will change the traffic transmit permission.

b) Transmission ceased

When CC receives a D-TX CEASED PDU, or on receipt of a REPORT indication primitive of either successful or unsuccessful transmission of a U-TX CEASED PDU, the CC shall issue a CONFIGURE request primitive containing the parameter value "Switch U-Plane = Off".

c) Temporary pause

When the CC receives a D-TX WAIT PDU, and if the U-plane is currently switched on for either transmission or reception, the CC shall issue a CONFIGURE request primitive containing the parameter value "Switch U-plane = Off".

When the CC receives a D-TX CONTINUE PDU, and if the Continue element is set to "continue" and the U-plane was switched on at the time of receipt of the D-TX WAIT PDU, then the CC shall issue a CONFIGURE request primitive containing the same parameter values as before the temporary interruption. Otherwise, the U-plane shall not be switched on.

d) Interruption

When the CC receives a D-TX INTERRUPT PDU, and if the transmission grant element is set to "transmission granted to another user", the CC shall issue a CONFIGURE request primitive containing the parameter value "Switch U-Plane = On" but shall contain "Tx grant = false" to indicate that the MAC should receive traffic (and no longer has permission to transmit traffic). For the other values of the transmission grant element, the CC shall issue a CONFIGURE request primitive containing the parameter value "Switch U-Plane = Off".

e) Call restoration

When CC receives a BREAK indication primitive indicating that a temporary break in the radio link has occurred, the CC shall issue a CONFIGURE request primitive containing the parameter value "Switch U-Plane = Off".

When CC receives a D-CALL RESTORE PDU indicating that the call has now been restored after a temporary break in the radio link, and if the transmission grant element is set to "transmission granted" or "transmission granted to another user", then the CC shall issue a CONFIGURE request primitive containing the parameter value "Switch U-Plane = On" and indicating whether the MS has permission to transmit traffic ("Tx grant = true" or "Tx grant = false" respectively). For the other values of the transmission grant element, the U-plane shall not be switched on.

14.5.1.4.3 Call disconnection phase

When CC receives a D-RELEASE PDU or a D-DISCONNECT PDU, or on receipt of a REPORT indication primitive of either successful or unsuccessful transmission of a U-DISCONNECT PDU, the CC shall issue a CONFIGURE request primitive to the lower layers containing the parameter value "Switch U-Plane = Off".

14.5.2 Group CC procedures

14.5.2.0 General

The CC procedures handled by CC shall be applicable for circuit mode calls for both speech and data. The circuit mode speech and data group calls shall be set-up as point-to-multipoint calls. The specification below shall be applicable for the procedures that reside in the MS.

14.5.2.1 Call set-up procedures

14.5.2.1.0 General

a) Normal group call

The normal group call procedures provide support for one type of call set-up, where the MS is placed immediately into the call upon receipt of the D-SETUP PDU if the called user application can support the call and with immediate action being taken by the called user application, refer to figure 14.16.

The set-up signalling procedures shall allow immediate communication to take place between the calling and called user applications without the possibility of having an alerting process and without an explicit response from the called user application stating that the user has answered. The call priority may affect whether the user application accepts the call or not.

NOTE: The behaviour of the user application between the reception of the incoming set-up signalling and the acceptance/reject of the call is outside the scope of the present document.

The MS does not signal that acceptance or rejection to the BS.

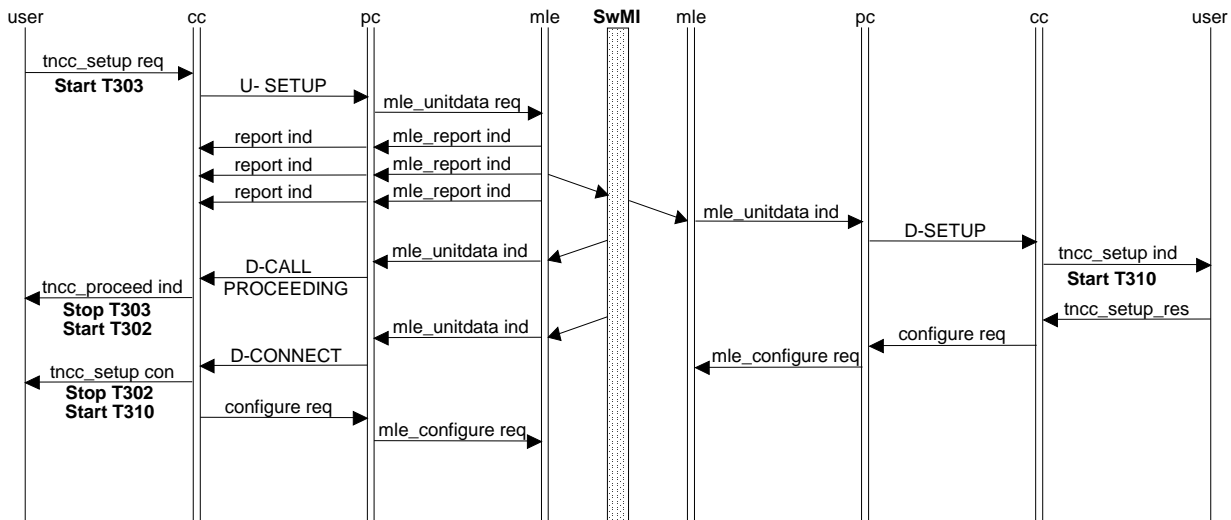
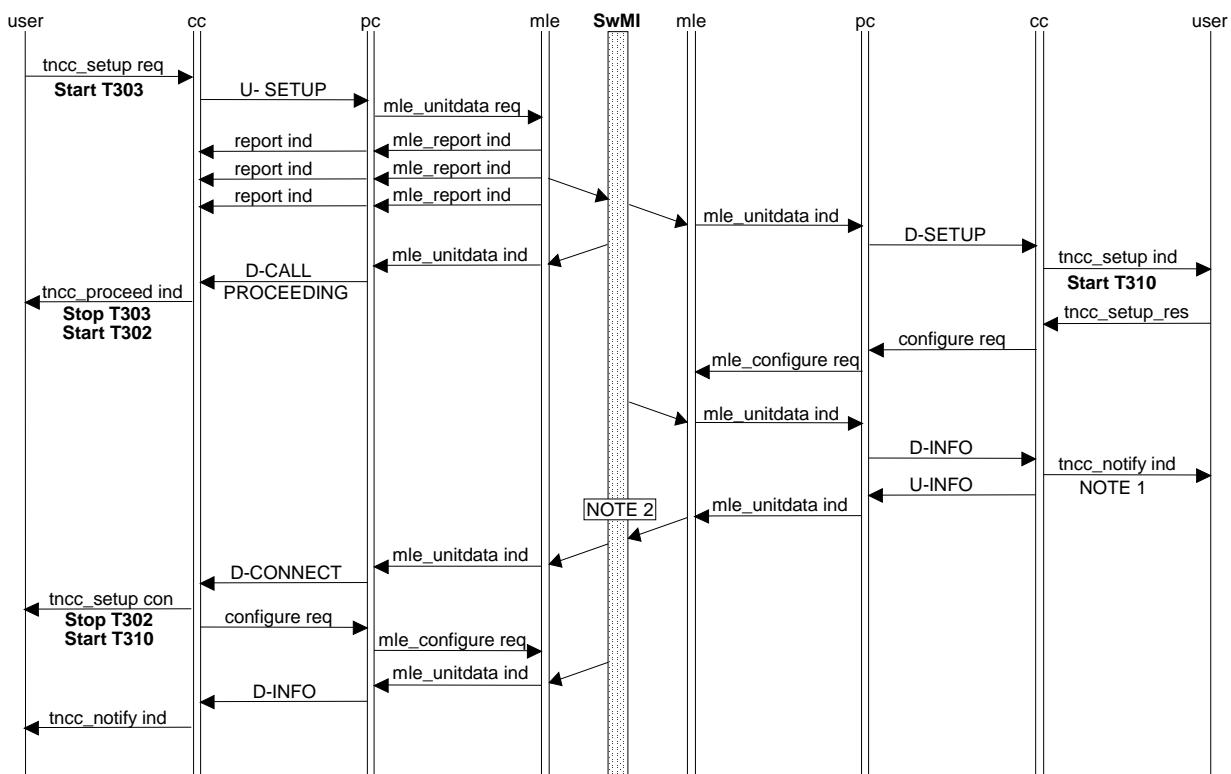

Figure 14.16: Group call - set-up phase

b) Acknowledged group call

An acknowledged group call allows the SwMI to poll members of the called group during the call. The call may be through connected to the calling MS either before polling or after polling has taken place (see clause 14.5.2.6), refer to figure 14.17.



NOTE 1: The Poll request may also be presented to the user for information only.
 NOTE 2: As an option, the call may not be allowed to proceed until certain criteria have been met.

Figure 14.17: Acknowledged group call - set-up phase

c) Broadcast call

The call set-up procedure for broadcast call shall be the same as that for group call as shown in figure 14.16. However, in this case the called MSs shall not be allowed to subsequently request transmit permission.

14.5.2.1.1 Incoming call

Notification of the arrival of an incoming call to the CC sub-entity shall be made by the reception of a D-SETUP PDU which shall be delivered to the user application in a TNCC-SETUP indication primitive via the TNCC-SAP. The CC shall enter state MT-CALL-SETUP. If the user application can support the call, it shall immediately return a TNCC-SETUP response primitive.

On reception of a TNCC-SETUP response primitive the CC sub-entity shall enter state CALL ACTIVE and take the following actions, which are dependent upon the information contained within the PDU elements, see figure 14.16, right hand side:

- the call identifier shall be used as the reference to this call in subsequent PDUs for the duration of the call;
- when CC receives TNCC-SETUP response primitive indicating that the called user application has accepted the incoming call, the CC sub-entity shall enter state CALL ACTIVE and start timer T310. The D-SETUP PDU shall contain an indication in the transmission grant element whether the MS should switch to U-plane reception. If the D-SETUP PDU contains an indication that the MS is allowed to request transmission permission it may follow the transmission control procedures described in clause 14.5.2.2.1 a). The CC sub-entity shall send a CONFIGURE request primitive for lower layer configuration accepting the channel change;
- where the called user application is unable to accept the request for a certain target service, the call shall be rejected locally by issuing a TNCC-RELEASE request primitive via the TNCC-SAP and the CC shall enter state IDLE. No negotiation with the BS shall be possible. The CC sub-entity shall send a CONFIGURE request primitive for lower layer configuration rejecting the channel change.

14.5.2.1.2 Outgoing call

A user application initiates call establishment by transferring a TNCC-SETUP request primitive across the TNCC-SAP to the CC sub-entity. The TNCC-SETUP request primitive shall be handled by a CC sub-entity that is in state IDLE. The CC shall select a PDU priority based on the requested access priority value as defined in clause 14.5.6.2. The CC shall convert this request into a U-SETUP PDU and send it. The CC sub-entity shall then enter the MO-CALL-SETUP state and start timer T303, see figure 14.16 - left hand side.

The following text describes the normal call set-up procedures:

- to indicate the progress of the transmission of the U-SETUP PDU the CC may receive one or more REPORT indication primitives. If the CC receives a REPORT indication primitive informing that the PDU transmission has failed, timer T303 shall be stopped, and the CC sub-entity shall inform the user application with a TNCC-RELEASE indication primitive and return to state IDLE;
- the SwMI may respond to the reception of the U-SETUP PDU with a D-CALL PROCEEDING PDU. Upon reception of the D-CALL PROCEEDING PDU, the CC shall inform the user application by issuing a TNCC-PROCEED indication primitive, stop timer T303, and start timer T302;
- the D-CALL PROCEEDING PDU shall contain a call identifier which shall be used as the reference to this call in subsequent PDUs for the duration of the call;
- the D-INFO PDU shall not be used to allocate a call identifier;
- on reception of a D-INFO PDU after reception of D-CALL PROCEEDING PDU but before the call set-up is completed, the CC shall start timer T302 from the value indicated in the call time out, set-up phase element if that element is present;
- if the call through connection is ready at the time when the D-CALL PROCEEDING PDU should have been sent, a D-CONNECT PDU should be sent instead. In this instance the D-CONNECT PDU shall allocate the call identifier;

- on receipt of a D-CONNECT PDU, the CC shall enter state CALL-ACTIVE, and inform the user application with a TNCC-SETUP confirm primitive, and stop timer T302 or T303 and start timer T310. The D-CONNECT PDU shall contain an indication as to whether the CC has been given permission to transmit. If transmission is not granted and the D-CONNECT PDU contains an indication that the MS is allowed to request transmission permission it may follow the transmission control procedures defined in clause 14.5.2.2.1. The CC sub-entity shall send a CONFIGURE request primitive for lower layer configuration accepting the channel change. If the CC has been given permission to transmit then it shall start timer T311;
- where the D-CONNECT or D-CALL PROCEEDING PDU indicates that the offered service is different to the one requested, and if the service offered is acceptable to the CC sub-entity according to the selected lowest service in the TNCC-SETUP request primitive, then the call shall continue. If it is not acceptable, then the CC shall disconnect the call using the procedures in clause 14.5.2.3.1;
- the network may support other signalling from the calling MS to the SwMI and vice versa during the call set-up phase using U-INFO and D-INFO PDUs, for example, for the purpose of showing the progress of a call set-up;
- on reception of a group addressed D-SETUP PDU after reception of D-CALL PROCEEDING PDU (and optionally D-INFO PDU), if the call identifier in the D-SETUP is the same as the call identifier in the D-CALL PROCEEDING PDU and the calling party address in the D-SETUP PDU does not contain the MS's own address, the CC sub-entity shall enter state CALL ACTIVE, stop timer T302 and start timer T310. The D-SETUP PDU shall contain an indication in the transmission grant element whether the MS should switch to U-plane reception. If the D-SETUP PDU contains an indication that the MS is allowed to request transmission permission it may follow the transmission control procedures described in clause 14.5.2.2.1 a). The CC sub-entity shall send a CONFIGURE request primitive for lower layer configuration accepting the channel change. CC shall ignore the D-SETUP PDU if the calling party address is the same as the MS's own address and shall send a CONFIGURE request primitive for lower layer configuration ignoring the channel change. A MS following a group addressed D-SETUP in the manner described in this clause shall cancel its request to transmit if it requested to transmit in the U-SETUP PDU.

NOTE 1: The SwMI should either send the D-CONNECT PDU granting transmit permission first or supply the calling party address in the D-SETUP PDU (or both) to prevent the MS that is about to be granted transmit permission following the group addressed D-SETUP PDU.

NOTE 2: Handling of the TNCC-SETUP request primitive may be affected by the MS being active in a MM procedure, this being indicated to CC from MLE via the MLE-BUSY indication primitive, refer to clause 18.3.5.4. The exact nature of the interaction between MM/MLE and CC is outside the scope of this part of the present document but it is recommended that CC not accept a TNCC-SETUP request primitive while MM is busy.

14.5.2.1.3 Colliding calls

Call collisions can occur when both the SwMI and the MS simultaneously send a D-SETUP PDU and a U-SETUP PDU. Two call set-ups are colliding when a D-SETUP PDU is received within the window where the CC waits for a call identifier from the SwMI after a U-SETUP PDU has been issued. The MS shall be able to handle two types of call collision:

- if the colliding calls are call set-up attempts for the same group and the requested basic services are compatible and the calling MS is a member of that group and layer 2 has not indicated successful transmission of the U-SETUP PDU, then the MS CC shall attempt to discard the outgoing call set-up attempt by sending a CANCEL request primitive to the lower layers to cancel sending of the U-SETUP PDU. If cancellation is successful, the MS shall accept the incoming call. If cancellation is unsuccessful or if layer 2 has indicated successful transmission of the U-SETUP PDU, the MS shall continue its own call set-up and wait for a D-CALL PROCEEDING and/or D-CONNECT PDU (and/or D-RELEASE PDU);
- if the call set-up attempts are not to the same group, then the MS shall either keep its call attempt or accept the incoming call as defined in clause 14.5.2.1.1. In the latter case the MS shall first cancel its call set-up locally, if still possible, or otherwise send a U-DISCONNECT PDU for its own call set-up, refer clause 14.5.2.3.1. If MAC requested a response with the parameter channel change response required value set to "true" with the CC message the CC shall select the proper radio resource by issuing MLE-CONFIGURE request primitive with value "reject" in the first case or "accept" in the latter case. Refer to clause 14.5.3.2.

14.5.2.1.4 Unsuccessful call set-up

Unsuccessful call set-up shall refer specifically to those instances where a circuit mode connection was not successfully established. It shall not refer to call disconnection or call rejection. If a PDU is not responded to prior to the expiry of the corresponding timer, the procedure in clause 14.5.2.3.5 shall apply. All timers available are listed in clause 14.6.

When CC receives a REPORT indication primitive indicating that the lower layers have not been successful (failed transfer) in the sending of any of the call set-up PDUs, then the CC sub-entity shall return to state IDLE and inform the user application with a TNCC-RELEASE indication primitive accompanied with a cause of the disconnection.

14.5.2.1.5 Call rejection

If the user application decides to reject the incoming call set-up request as defined in clause 14.5.2.1.1, it shall immediately transfer a TNCC-RELEASE request primitive to the CC sub-entity. This request shall locally clear the call identifier. The CC sub-entity shall then change to state IDLE.

14.5.2.2 Call maintenance procedures

14.5.2.2.0 General

The call maintenance procedures described in this clause may be applied when the MS is in states MO-CALL SETUP, MT-CALL SETUP or CALL-ACTIVE. The main state CALL-ACTIVE can comprise several sub-states.

NOTE: The D-INFO PDU can be used for other purposes than those defined in the protocol specifications contained in the present document.

14.5.2.2.1 Transmission control procedures

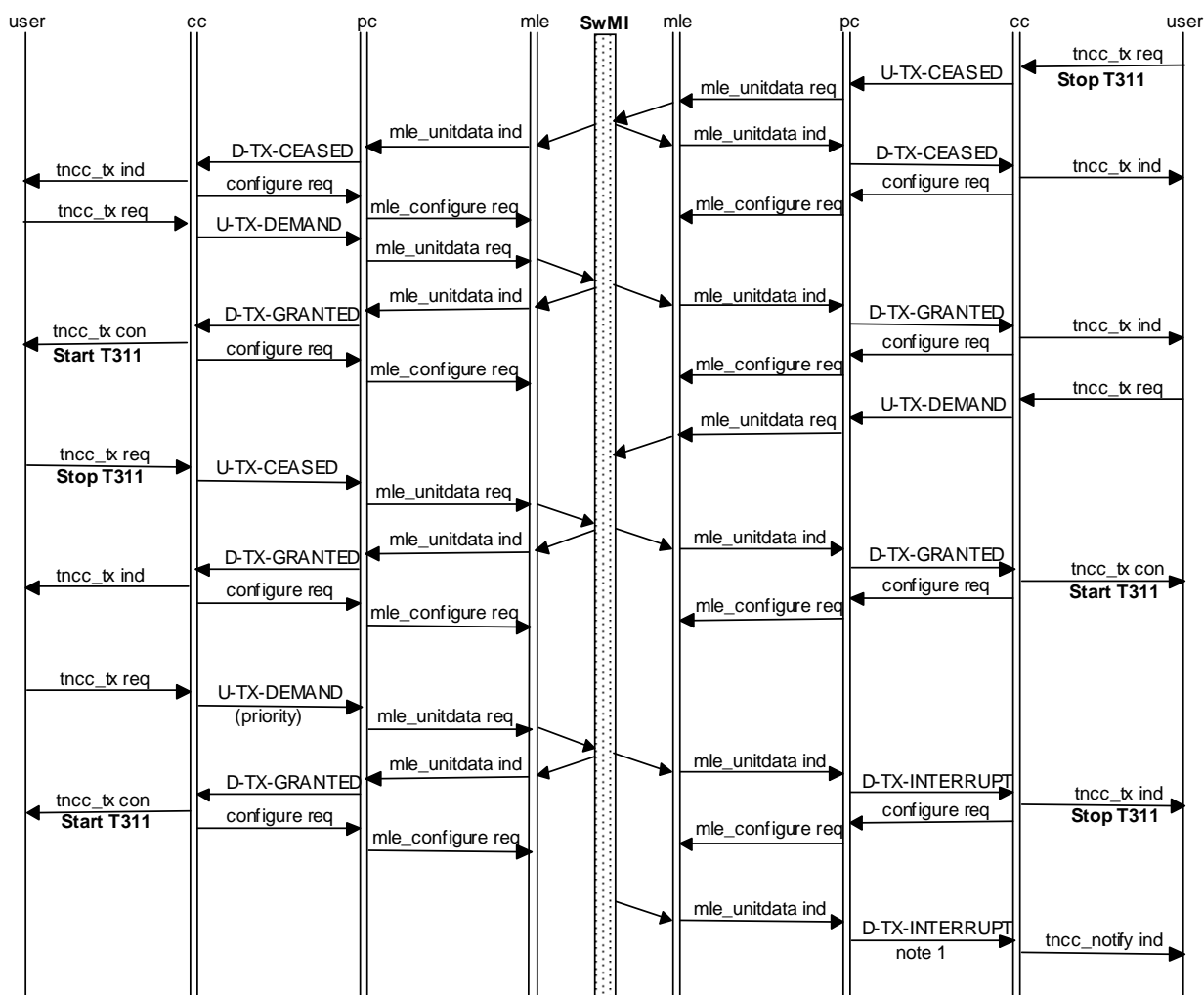

NOTE 1: D-TX INTERRUPT PDU is sent to the remaining members of the group upon permission award to the MS shown on the left hand side of this figure.

NOTE 2: For the purposes of clarity, instances of mle_report are not shown.

Figure 14.18: Group call - request-to-transmit

a) Request-to-transmit

The SwMI shall fully control which MS is allowed to transmit. To facilitate this, the MS shall request permission to transmit, and permission shall be granted before the MS can begin circuit mode traffic permission. MSs may request permission to transmit, if the SwMI allows it by a "transmission request permission" element even if another party is transmitting. In this case the SwMI should normally wait for that party to finish the transmission before granting the other user application. Pre-emptive priority requests are dealt with in clause 14.5.2.2.1 f).

The SwMI normally gives the first permission to transmit to the calling MS when a new call has been set-up. However, the calling user application may allow the called users to request permission to transmit first. The calling CC shall in that case set the "request to transmit" bit accordingly in the U-SETUP PDU.

An MS restoring a call on a new cell, which was either transmitting in the previous cell or had a transmission request queued in the previous cell, may request to continue to transmit or retain its transmission request in the SwMI's transmission request queue by setting the "request to transmit/send data" element in the U-CALL RESTORE PDU accordingly. This is dealt with in clause 14.5.2.2.4.

When a user within a call wants to transmit, a TNCC-TX request primitive shall be sent to CC via the TNCC-SAP. The CC shall send this request in a U-TX DEMAND PDU. The TX-DEMAND Priority level should be set to low or high priority, unless this is a pre-emptive priority request, see clause 14.5.2.2.1 f), see figure 14.18.

The progress of the transmission of the U-TX DEMAND PDU shall be given locally to the CC in one or more REPORT indication primitives. If the CC receives a REPORT indication primitive as a response to the sending of the U-TX DEMAND PDU informing that the PDU transmission has failed, the CC shall inform the user application by a TNCC-TX confirm primitive.

If a user application wants to withdraw his request-to-transmit before it has been granted, a TNCC-TX request primitive shall be sent from the user application to the TNCC-SAP. The CC shall send this request in a U-TX CEASED PDU. The CC shall send the U-TX CEASED PDU with the stealing permission set to "immediate stealing" and stealing repeats flag set so that the permission to transmit will be released immediately if allocated. No CC protocol response shall be received from the SwMI for this message.

b) Response to request-to-transmit

During the call set-up phase, the response to the calling MS's request to transmit is dealt with in clauses 14.5.2.1.1 and 14.5.2.1.2. The calling MS, if given permission to transmit, shall start timer T311.

During call restoration, the response to the restoring MS's request to transmit is dealt with in clause 14.5.2.2.4.

During a call in progress and when the SwMI has decided which MS shall be given permission to transmit, the SwMI shall send a D-TX GRANTED PDU as an individual message to the granted MS. Upon reception of a D-TX GRANTED PDU indicating "transmission granted", the CC sub-entity shall send this information to the user application in a TNCC-TX confirm primitive. The other MSs involved in the call shall be informed with a D-TX GRANTED PDU addressed with the group address. That D-TX GRANTED PDU shall indicate that permission to transmit has been granted to another user. The CC shall send this information to the user application in a TNCC-TX indication primitive and shall remain in state CALL-ACTIVE, see figure 14.18.

If the SwMI places the transmission request in a queue this shall be indicated to the MS concerned using the "transmission request queued" parameter value in the D-TX GRANTED PDU. If the SwMI rejects the transmission request this may be indicated to the MS concerned using the "transmission not granted" parameter value in the D-TX GRANTED PDU. In either case, the MSs concerned shall remain in state CALL-ACTIVE.

Upon reception of a D-TX GRANTED PDU indicating "transmission granted" or "transmission granted to another user", the CC sub-entity shall issue a CONFIGURE request primitive. The primitive shall carry as a parameter whether the transmit permission has been granted to this CC sub-entity or to another CC sub-entity, and to switch the U-Plane on. The MS given permission to transmit shall start timer T311. If the D-TX GRANTED PDU indicates "transmission granted to another user" and contains the MS's own address as the transmitting party address then that MS should not switch to U-plane reception. However it shall not switch to U-plane transmission until it receives a D-TX GRANTED PDU indicating "transmission granted".

Though the MS shall switch to U-Plane receive if it receives a "transmission granted to another user" response to its transmission request and the transmitting party address in the D-TX GRANTED PDU is not the MS's own address, the MS shall require an explicit response to its transmission request: one of "transmission granted", "transmission not granted" or "transmission queued".

NOTE 1: The SwMI should either send the individually addressed D-TX GRANTED PDU ("transmission granted") first or supply the transmitting party address in the group addressed D-TX GRANTED PDU ("transmission granted to another user") to prevent the MS that is about to be granted transmit permission switching to U-plane receive.

As defined in ETSI EN 300 396-5 [24], clause 9, the recommendation in the note 1 is mandatory for the SwMI when granting transmit permission to a Direct Mode MS which is operating through a Direct Mode gateway. (This mandatory requirement applies only if the SwMI has accepted a request from the gateway to operate as a Direct Mode gateway.)

Upon reception of a D-TX GRANTED PDU indicating "transmission granted to another user", and if the CC sub-entity has issued a U-TX DEMAND PDU to the lower layers and has not yet received a REPORT indication primitive indicating successful or unsuccessful transmission, then the CC sub-entity shall send a CANCEL request primitive to the lower layers to cancel transmission (and retransmissions) of that PDU.

NOTE 2: The above procedure may sometimes stop retransmissions by the awarded MS as well as retransmissions by any other MSs that are requesting transmit permission.

NOTE 3: If the SwMI queues any other transmission requests that it received then it should, at a convenient time, send D-TX GRANTED PDUs containing the "transmit request queued" parameter value to the MSs concerned. For transmission requests that are neither granted nor queued, and if the user application still wishes to transmit, then it has to send another TNCC-TX request primitive to the CC.

After reception of a D-TX GRANTED PDU indicating "transmission granted", and while it still has permission to transmit, the CC shall ignore any group addressed D-TX GRANTED or D-TX INTERRUPT PDUs it may receive (and any layer 2 channel assignment received with those PDUs by issuing an MLE-CONFIGURE request primitive ignoring the channel change, if requested).

If the CC sends a U-TX DEMAND PDU whilst another MS is transmitting, the SwMI should normally wait for that party to finish the transmission (identified by the receipt of a U-TX CEASED PDU), before granting transmission permission to the other user application. On receipt of the U-TX DEMAND PDU, the SwMI may send a D-TX GRANTED PDU indicating whether the request-to-transmit is queued or rejected. Pre-emptive priority requests are dealt with in clause 14.5.2.2.1 f).

The SwMI shall not send an unsolicited D-TX GRANTED PDU but it is recognized that a race/error condition may result in the MS receiving one. The CC may choose to follow an unsolicited individually addressed D-TX GRANTED PDU indicating "transmission granted" but if the CC does not want to transmit/send data then it shall use the U-TX CEASED PDU, as it does normally at the end of a speech or data item, to reject the transmission grant.

c) Permission to transmit withdrawn

The SwMI may decide to interrupt transmission when resources are required for another call or when the SwMI requires that the call should temporarily pause. In this case the SwMI should send a D-TX WAIT PDU to all MSs in that call (permitting or denying transmission requests according to the "transmission request permission" element). On reception of the D-TX WAIT PDU the CC sub-entity shall send a TNCC-TX indication primitive to the user application indicating that the transmission is waiting. The CC shall stop timer T311, if activated, enter state WAIT, and send a CONFIGURE request primitive to switch the U-Plane off. The CC shall accept any layer 2 channel allocation and await further instructions on the channel that they have been directed to.

If a request-to-transmit has been queued at the time when the D-TX WAIT PDU is received, the MS shall be allowed to withdraw its request-to-transmit by means of the U-TX CEASED PDU as described in clause 14.5.2.2.1 e).

A group-addressed D-TX WAIT PDU shall apply to all the MSs in the call (including the transmitting MS). Optionally, the D-TX WAIT PDU may also be sent individually addressed to the transmitting MS enabling the SwMI to obtain a layer 2 acknowledgement from that MS.

If the SwMI sends a D-TX WAIT PDU because it wishes to use an assigned channel for another call, it shall send a layer 2 channel allocation with the D-TX WAIT PDU directing the MS to a signalling channel other than the assigned channel. This is to prevent the change in usage marker associated with re-allocation of the assigned channel to the other call causing the waiting MS to drop the interrupted call.

d) Permission to continue with withdrawn call

There are three cases as follows:

- 1) If no MS was granted transmission at the time when the SwMI sent the D-TX WAIT PDU, or if an MS was granted transmission at the time of the D-TX WAIT PDU but the SwMI does not wish that transmission to continue, then either a D-TX CONTINUE PDU with the continue element set to "not continue", or a D-TX GRANTED PDU with the transmission grant element set to "transmission not granted", shall be sent as a group message to all MSs in the group. The CC shall accept any layer 2 channel allocation. All CC sub-entities shall return to state CALL-ACTIVE but the U-plane shall not be switched on and the MS shall assume that any previous transmission permission no longer applies. If the D-TX CONTINUE PDU contains an indication that the MS is allowed to request transmission permission, it may follow the transmission control procedures described in clause 14.5.2.2.1 a).

- 2) If there was one MS granted transmission at the time when the SwMI sent the D-TX WAIT PDU, and if the SwMI wishes that transmission to continue, then either a D-TX CONTINUE PDU with the Continue element set to "continue" shall be sent as a group message to the group, or a D-TX GRANTED PDU with the transmission grant element set to "transmission granted" shall be sent to the granted MS and a D-TX GRANTED PDU with the transmission grant element set to "transmission granted to another" shall be sent as a group message to the group. The CC shall accept any layer 2 channel allocation. If a D-TX CONTINUE PDU with the Continue element set to "continue" is sent, it shall give the earlier granted MS permission to continue transmission. The MS granted permission to transmit shall start timer T311. All CC sub-entities shall return to state CALL ACTIVE and shall send a CONFIGURE request primitive to the lower layers to switch the U-plane on.

A group-addressed D-TX CONTINUE PDU shall apply to all the MSs in the call (including the awarded MS). Optionally, the D-TX CONTINUE PDU may also be sent individually addressed to the awarded MS enabling the SwMI to obtain a layer 2 acknowledgement from that MS.

- 3) If there was one MS granted transmission at the time when the SwMI sent the D-TX WAIT PDU but the SwMI wishes to give the transmission permission to the other party or if no MS was granted transmission at the time when the SwMI sent the D-TX WAIT PDU and the SwMI wishes to give the transmission permission now to one party, the SwMI may first send a D-TX CONTINUE PDU. If a MS has requested permission to transmit during the period when the transmission was withdrawn, the SwMI should first send a D-TX CONTINUE PDU as a group message with the Continue element set to "not continue". A D-TX GRANTED PDU should then be sent as an individual message to the granted MS with information element transmission grant set to "transmission granted" and as a group message to the rest of the group with information element transmission grant set to "transmission granted to another user". When receiving either D-TX CONTINUE or D-TX GRANTED PDU the CC sub-entity shall return to state CALL-ACTIVE. In addition when receiving D-TX GRANTED PDU CC shall send a CONFIGURE request primitive to the lower layers to switch the U-plane on.

If the MS is in state WAIT and it receives a D-TX GRANTED PDU, it shall return to state CALL-ACTIVE and obey the instruction in the D-TX GRANTED PDU.

e) End of Transmission

At the end of a transmission the user application shall send a TNCC-TX request primitive to the TNCC-SAP indicating ceased transmission. The CC sub-entity shall send this information in a U-TX CEASED PDU and stop timer T311. The CC shall send the U-TX CEASED PDU with the stealing permission set to "immediate stealing" and the stealing repeats flag set. Upon reception of the U-TX CEASED PDU, the SwMI normally sends a D-TX CEASED PDU to the group informing the group members that the transmission has now ceased.

Upon reception of a D-TX CEASED PDU the CC shall send this information to the user application in a TNCC-TX indication primitive (transmission ceased) and the CC shall send a CONFIGURE request primitive to the lower layers to switch the U-Plane off, see figure 14.18.

Also, if the CC that is sending the U-TX CEASED PDU receives a REPORT indication of either successful or unsuccessful transmission of that PDU by the lower layers, then it shall behave as if it had received a D-TX CEASED PDU i.e. it shall send a TNCC-TX indication (transmission ceased) to the user application and shall send a CONFIGURE request primitive to the lower layers to switch the U-Plane off. If a D-TX CEASED PDU is received but no REPORT indication of successful transmission of the U-TX CEASED PDU then the CC shall send a CANCEL request primitive to the lower layers to stop retransmissions of the U-TX CEASED PDU.

NOTE 4: The requirement for the CC to cancel retransmissions may apply if the SwMI sends only a group-addressed D-TX CEASED PDU and the transmitting MS does not receive a layer 2 acknowledgement.

If there was a request for transmission already queued in the SwMI when the U-TX CEASED PDU was received, the SwMI may send a D-TX GRANTED PDU as an individual message to the granted MS and another D-TX GRANTED PDU as a group message to the rest of the group as described in clause 14.5.2.2.1. b), without sending an explicit D-TX CEASED PDU. However, the SwMI should first send at least a layer 2 acknowledgement to the MS that sent the U-TX CEASED PDU so that the MS can stop its U-plane transmission and start accepting group addressed D-TX GRANTED PDUs.

The SwMI shall not send an unsolicited, individually addressed D-TX CEASED PDU but it is recognized that a race/error condition may result in the MS receiving one. If CC receives an unsolicited, individually addressed D-TX CEASED PDU it shall send this information further on to the user application in a TNCC-TX indication primitive (transmission ceased) and shall send a CONFIGURE request primitive to the lower layers to switch the U-Plane off.

f) Stop-transmission order

If a MS wishes to interrupt the transmitting MS with a pre-emptive priority request, it shall send a U-TX DEMAND PDU indicating the level of priority in the "TX demand priority" element. If the SwMI supports transmission interruption, it shall send a D-TX INTERRUPT PDU to the MS which currently has permission to transmit. Upon reception of an individually addressed D-TX INTERRUPT PDU the CC sub-entity shall stop transmission and remain in state CALL-ACTIVE, and shall stop timer T311. The CC shall send information to the user application in a TNCC TX indication primitive indicating transmission interrupt and the CC sub-entity shall send a CONFIGURE request primitive to the lower layers to indicate the loss of transmit permission and to switch the U-Plane accordingly (see clause 14.5.2.4).

The SwMI should send a D-TX INTERRUPT PDU as a group message to the rest of the group indicating that the permission to transmit has been (or will be) allocated to another user, see figure 14.18. Upon reception of the D-TX INTERRUPT PDU the CC sub-entity shall remain in state CALL ACTIVE and shall send a TNCC-TX indication primitive to the user application indicating transmission interrupt.

If the pre-emptive priority transmission starts immediately the D-TX INTERRUPT PDUs shall indicate that transmission is granted to another user and then the MS shall switch to (or remain in) U-plane reception and the SwMI shall send a D-TX GRANTED PDU (transmission granted) as an individual message to the MS that requested the priority transmission. If there is a delay before the pre-emptive priority transmission, the SwMI shall indicate "transmission not granted" in the D-TX INTERRUPT PDUs, and the MS shall switch the U-plane off and wait for a D-TX GRANTED PDU. The SwMI should then send a D-TX GRANTED PDU (transmission granted) as an individual message to the MS that requested the priority transmission and a group addressed D-TX GRANTED PDU (transmission granted to another user) for the receiving parties, as described in clause 14.5.2.2.1 b).

g) Expiry of timer T311: call transmission timer

Upon expiry of timer T311, CC shall remain in state ACTIVE, shall send a TNCC-TX indication primitive to the user application and a U-TX CEASED PDU to the peer entity.

14.5.2.2.2 Call status information procedures

The D-INFO PDU can be used for carrying call status messages from SwMI to the MS. When a D-INFO PDU is received, depending on the notification, the following actions are taken by CC.

a) call in queue

When the SwMI has put a call into a queue, if the D-INFO PDU contains a value for the call time-out, set-up phase, the CC shall start timer T302 using that value. The CC shall send the information further on to the application in a TNCC-NOTIFY indication primitive. If the call is queued at call set-up time the D-INFO PDU should be preceded by a D-CALL PROCEEDING PDU.

b) call is proceeding

This may be sent to the calling user application during the call set-up phase to indicate that the call set-up time will be longer than for a normal call set-up. The information that the call time-out, set-up phase value shall be changed is made available to the CC sub-entity in the D-INFO PDU. The CC shall start T302 using the new timer value. The CC shall send the information further on to the application in a TNCC-NOTIFY indication primitive.

c) prolonging the call time-out time

The following text describes prolonging the call time-out time:

- the SwMI may decide to change the call time-out time by sending a D-INFO PDU with a new T310 value. Upon reception of the D-INFO PDU containing the "call time-out" element, T310 shall be started using the defined value. If the SwMI supplies a T310 value in the D-INFO PDU, it shall set the value of the "reset call time-out timer" element of the PDU to indicate reset of T310;
- the SwMI may also choose to reset the call time-out time and start it again using the current defined value. Upon reception of the D-INFO PDU with the "reset call time-out timer" element indicating that T310 shall be reset, T310 shall be started using the value defined earlier;
- in either case, the Timer value shall be sent further on to the application in a TNCC-NOTIFY indication primitive;
- the SwMI may also change the call timeout time during call restoration by supplying the "call time-out" element in the D-CALL RESTORE PDU, refer to clause 14.5.2.2.4. If the SwMI supplies a T310 value in the D-CALL RESTORE PDU, it shall set the value of the "reset call time-out timer" element of the PDU to indicate reset of T310.

d) Change of call identifier

The SwMI may decide to change the call identifier used by a group of MSs in an on-going call by sending a D-INFO PDU containing a new call identifier. The SwMI may also use this method to change a call identifier in an MS in preparation for a type 1 cell reselection (i.e. just before sending the MS the D-NEW CELL PDU granting the type 1 cell reselection) if the new cell uses a different call identifier from the old cell. If individually addressed, the D-INFO PDU should be sent using an acknowledged service.

NOTE 1: If the MS and the SwMI have different perceptions of the value of a call identifier the MS could experience interruptions in the call or could lose the call.

Most downlink CC PDUs may contain a Notification indicator information element (in addition to the D-INFO PDU) and SwMI may inform calling/called user about offered or connected service using the Notification indicator information element. CC may send this notification to the application in corresponding TNCC service primitive.

When a Notification indication is received following actions are taken by CC.

e) Limited group coverage

At the call set-up SwMI may inform that it is connecting a group call that covers a smaller area than expected. It may be used during a call to indicate that the group coverage is made smaller. CC may send this notification to the application using TNCC-NOTIFY indicator service primitive.

NOTE 2: The expected area could be pre-defined, defined by the Area selection supplementary service or known by other means that are outside the scope of the present document.

14.5.2.2.3 Call modification procedures

The MS service user may modify the service of an existing call. To initiate a modification the user application shall issue a TNCC-MODIFY request primitive and the CC sub-entity shall send a U-INFO PDU and wait for a D-INFO PDU from the SwMI before changing any of the current service parameters. The SwMI should not send D-INFO PDU to modify a service while an ongoing U-Plane transmission is in progress.

When a service has been changed by the SwMI, the SwMI should indicate this to all parties by issuing the D-INFO PDU. Upon reception of a D-INFO PDU indicating an acceptable service modification the CC sub-entity shall send it to the application in a TNCC-MODIFY indication primitive, and the CC sub-entity shall send a CONFIGURE request primitive for lower layer configuration.

If the SwMI is unable to provide the requested service, it should either send a D-INFO PDU to the requesting party containing the current service (unchanged), or send a D-INFO PDU to all parties containing an alternative service. For example, if a user application requests an increase from a 1-slot per frame call to a 4-slots per frame call, and the SwMI is unable to allocate more than 2 slots to the call, it may offer a 2-slots per frame call in the D-INFO PDUs.

The service may be changed between any combination of one or more of the following:

- a clear call may be changed to an encrypted call; or
- an encrypted call may be changed to a clear call;
- a 4-slots-per-frame call may be changed to a 1-slot, 2-slot or 3-slot call;
- a 3-slot call may be changed to a 1-slot, 2-slot or 4-slot call;
- a 2-slot call may be changed to a 1-slot, 3-slot or 4-slot call;
- a 1-slot call may be changed to a 2-slot, 3-slot or 4-slot call;
- a circuit mode type (TCH/S, TCH/7.2, TCH/4.8 or TCH/2.4) may be changed to a different circuit mode type (with the requested interleaving depth in the case of TCH/4.8 or TCH/2.4);
- a protected circuit mode data type (TCH/4.8 or TCH/2.4) may be changed to a different interleaving depth from the set of permissible values (N = 1, 4 or 8).

NOTE: The clear and encrypted calls refer to the end-to-end clear and encrypted calls. The end-to-end encryption control is independent of the air interface encryption control.

It is also possible to change between the circuit mode speech teleservice and a circuit mode unprotected (speech, encrypted) bearer service.

The encryption state of each transmission, defined using D-TX GRANTED, can be set independently by the encryption control element in the U-TX DEMAND PDU. The SwMI should not change the requested encryption state in the responding D-TX GRANTED PDU from that requested in the U-TX DEMAND PDU.

If the MS cannot support a new service combination indicated by D-INFO, D-TX GRANTED or D-TX INTERRUPT, the user application or the CC as appropriate shall disconnect or leave the call, refer to clause 14.5.2.3. The U-DISCONNECT PDU shall contain disconnection cause "requested service not available". In case the rejection results from unsupported encryption flag state the disconnection cause shall be "Called party does not support encryption" or "Called party requires encryption".

14.5.2.2.4 Call restoration procedures

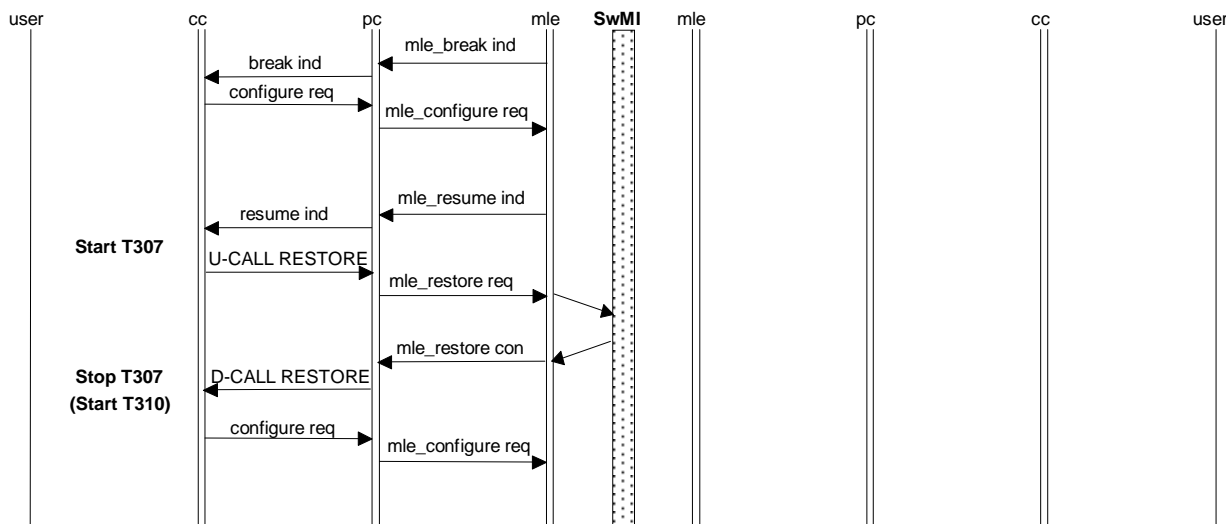

Figure 14.19: Group call - successful call restoration

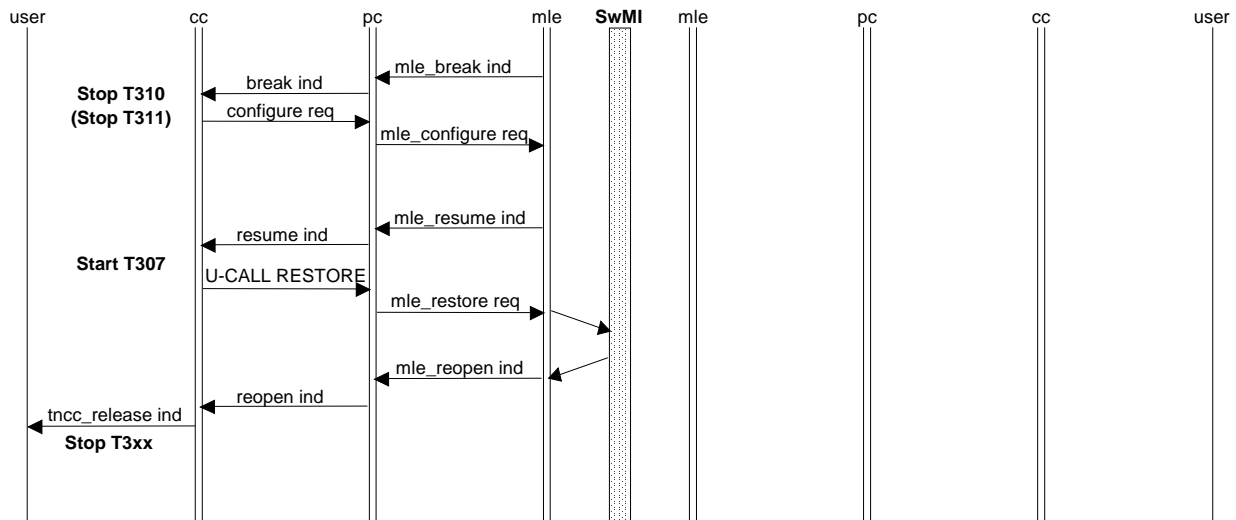

Figure 14.20: Group call - unsuccessful call restoration

Call restoration of a group call shall only take place in the CC sub-entity when the CC has entered state CALL-ACTIVE. The CC sub-entity should keep information on whether it is active in a group call or an individual call.

When the CC receives a BREAK indication primitive, then the CC sub-entity shall try to restore the call as described in this clause:

- When the CC receives a BREAK indication primitive, the CC shall switch the U-Plane off as described in clause 14.5.2.4 and shall remain in state CALL-ACTIVE. If the CC had permission to transmit/send data at that time the CC shall assume that the permission is now ended as if the CC had sent a U-TX CEASED PDU. If the MS is in state WAIT when it receives a BREAK indication primitive then it shall behave as if it had received a D-TX CONTINUE PDU with the continue element set to "not continue". It shall then obey the instructions in the D-CALL RESTORE PDU.
- If the CC receives a RESUME indication primitive indicating that the C-Plane may now be used again, it shall issue a U-CALL RESTORE PDU containing the GSSI or GTSI and the call identifier of the call which CC wants to restore. If a temporary address is used in the call then it shall be used as the GSSI. If the MS is participating in a call within a group that does not belong to current network (e.g. the MS has migrated and the group belongs to its home network) the CC shall use the full GTSI of the group in the U-CALL RESTORE PDU.
- If the CC wishes to continue transmission in the new cell, or keep a queued transmission request valid in the new cell, it shall indicate so in the request to transmit/send data information element in the U-CALL RESTORE PDU. A MS which has requested for transmit permission on a previous cell and has received a "transmission request queued" response or no response at all on that cell, may either refresh the transmission request by requesting for transmit permission in the U-CALL RESTORE PDU on the new cell, or withdraw the transmission request by requesting for receive permission in the U-CALL RESTORE PDU on the new cell.

NOTE 1: It is not the intention that the MS uses the transmit/send data information element in the U-CALL RESTORE PDU for a new transmission request in the new cell; it should only be used for refreshing a request in the previous cell or to continue transmission in the new cell. It is outside the scope of the present document if used for a new transmission request but it is likely that a SwMI may deny the request for transmission. The intention is that the transmission request in the new cell is achieved using standard call maintenance signalling after the restoration is complete.

After sending a U-CALL RESTORE PDU, the CC shall start Timer T307 and wait for a D-CALL RESTORE PDU.

- When the CC receives a D-CALL RESTORE PDU, timer T307 shall be stopped and the call shall be resumed with the new parameters, see figure 14.19. Timer T310 shall be reset and started only if the "Reset call timeout" information element value is 1 (Reset call time-out timer T310); the T310 value shall be taken from the D-CALL RESTORE PDU call timeout information element and, if not present in the PDU, from the previous value (provided in D-CONNECT, D-CONNECT ACKNOWLEDGE, D-SETUP or D-INFO PDU). The CC shall obey the transmission granting in the transmission grant information element:
 - Transmission granted: The MS shall switch the U-plane on (refer to clause 14.5.2.4) and the MS is authorized to transmit;
 - Transmission not granted: The MS shall assume that it has neither transmission permission nor a transmission request queued in the SwMI and the U-plane remains switched off;
 - Transmission request queued: The MS shall assume that the request-to-transmit remains queued in the SwMI until it is either granted or withdrawn by the SwMI, or withdrawn by the MS and the U-plane remains switched off;
 - Transmission granted to another user: The MS shall switch the U-plane on (refer to clause 14.5.2.4) and the MS is authorized to receive. If the MS requested transmission in the U-CALL RESTORE PDU, the MS shall assume that its transmission request is still queued in the SwMI until it is either granted or withdrawn by the SwMI, or withdrawn by the MS.

If the U-plane is to be switched on, a layer 2 channel allocation shall accompany the D-CALL RESTORE PDU. If the U-plane is not to be switched on, and a traffic channel is available, the layer 2 channel allocation may accompany the D-CALL RESTORE PDU or be attached to later signalling. If a traffic channel is not available, the D-CALL RESTORE PDU shall contain a "Call status" information element with value "Call is queued".

NOTE 2: If the D-CALL RESTORE PDU is sent without a layer 2 channel allocation and includes a new call identifier it should be sent using an acknowledged layer 2 service. (This reduces the possibility of the MS responding to subsequent copies of the D-CALL RESTORE PDU with a U-DISCONNECT PDU, which occurs if the D-CALL RESTORE PDU changes the call identifier - see clause 14.5.6.5.2).

- After processing the D-CALL RESTORE PDU, the call restoration is considered complete; however, if the U-plane remains switched off after the call restoration e.g. due to call is queued, the SwMI would typically send one or more D-TX GRANTED PDUs to continue the call or to award transmission permission. These D-TX GRANTED PDUs may be a direct result of the call restoration, for example to provide the channel allocation in the new cell in the event of queuing for a channel, or it may be associated with further call maintenance signalling following a transmission request from one of the call participants (refer to clause 14.5.2.2.1). The CC shall obey the transmission granting in the transmission grant information element:
 - Transmission granted: The MS shall switch the U-plane on (refer to clause 14.5.2.4) and the MS is authorized to transmit. If the restored MS has not yet been sent to the traffic channel, the individually addressed D-TX GRANTED PDU shall be accompanied by a layer 2 channel allocation;
 - Transmission not granted: The MS shall assume that it has neither transmission permission nor a transmission request queued in the SwMI and the U-plane remains switched off. If the restored MS has not yet been sent to the traffic channel, the individually or group addressed D-TX GRANTED PDU may be accompanied by a layer 2 channel allocation;
 - Transmission request queued: The MS shall continue to assume that the request-to-transmit remains queued in the SwMI until it is either granted or withdrawn by the SwMI, or withdrawn by the MS and the U-plane remains switched off. If the restored MS has not yet been sent to the traffic channel, the individually addressed D-TX GRANTED PDU may be accompanied by a layer 2 channel allocation;
 - Transmission granted to another user: The MS shall switch the U-plane on (refer to clause 14.5.2.4) and the MS is authorized to receive. If the restored MS has not yet been sent to the traffic channel, the individually or group addressed D-TX GRANTED PDU shall be accompanied by a layer 2 channel allocation.

The call length timer T310 shall continue running during the call restoration and on expiry of T310, the procedure defined in clause 14.5.2.3.4 shall apply.

If the call cannot be restored the CC shall receive a REOPEN indication primitive indicating that the call is lost.

Upon reception of REOPEN indication primitive or on expiry of timer T307, the CC shall then stop all T3xx timers, clear the call identifier and temporary group address if applicable, and return to state IDLE and it shall send a TNCC-RELEASE indication primitive to the user application with the cause for disconnection, see figure 14.20.

If the SwMI provides a new call identifier with the D-CALL RESTORE PDU, CC shall use it in all subsequent signalling relating to that call. The MS shall not send any other call related signalling than U-CALL RESTORE PDU, after a cell change, before it has received a D-CALL RESTORE PDU (and possible new call identifier) from the SwMI.

A MS which is queueing for a traffic channel during restoration and which has an outstanding transmission request, may cancel that transmission request by sending a U-TX CEASED PDU. A MS which is queueing for a traffic channel during restoration and which does not have an outstanding transmission request, may make a transmission request by sending a U-TX DEMAND PDU, providing the SwMI has not disallowed transmission requests (via the "transmission request permission" element).

If there is more than one circuit mode call active at the time when the MLE-BREAK indication primitive was received, each call shall be restored separately and hence U-CALL RESTORE and D-CALL RESTORE PDUs shall be exchanged one by one for each call.

14.5.2.2.5 DTMF procedures

When a user application requires to transfer DTMF digits to other user applications during a circuit mode call, it shall issue a TNCC-DTMF request primitive to the CC entity. The DTMF protocol to be used is specified in clause 14.5.1.2.5.

NOTE 1: The DTMF signalling can be used only after either a D-CONNECT or D-SETUP PDU has been received and the TETRA call is established.

NOTE 2: DTMF signalling may not function correctly during a group call (group addressed basic link LLC acknowledged service is required). The support of DTMF signalling during group calls is outside the scope of the present document.

14.5.2.2.6 Temporary address handling procedures

The SwMI may allocate a temporary group address for a group call in a D-CONNECT, D-SETUP, D-CALL RESTORE or D-INFO PDU. The temporary address shall be a valid layer 2 address in the MS for reception of group addressed messages for the duration of the call.

In addition, if the MS calls a group that is not attached in the MS (i.e. the group address is not a valid layer 2 address) when it is registered in the home SwMI of that group, and if the D-CONNECT PDU does not contain the temporary address element, then the MS shall implicitly assume temporary membership of the called group address for the duration of the call. This temporary membership shall apply only after receipt of the D-CONNECT PDU. However, if the D-CONNECT PDU contains the basic service information element with the communication type sub-element indicating "point to point" then the MS shall not adopt the called address as a temporary address. If the call was set up using a SNA, the calling MS shall not implicitly assume temporary membership of the called group address to which the SNA corresponds; this restriction is imposed because the MS may not know the called group address to which the SNA corresponds, in which case it cannot assume temporary membership of the group.

NOTE 1: If the SwMI is unsure whether the group address for the call is a valid layer 2 address for the calling MS, the SwMI should allocate the group address as a temporary address to the calling MS; this recommendation is made because if the group address for the call is not a valid layer 2 address, and the SwMI doesn't allocate the group address for the call as a temporary address, the MS will participate in the call but will ignore all group addressed call maintenance signalling.

NOTE 2: In this procedure, if the MS calls a group that it is not a member of (when it is registered in the home SwMI of that group) then it may assume temporary membership of the called group address without having received a temporary address element in the D-CONNECT PDU. If the calling user has made an erroneous selection of communication type then this could result in the calling MS adopting another MS's individual address as a temporary group address. Therefore the SwMI should check that the called address in a requested group call is actually a group address; if it is not then the SwMI should either disconnect the call or correct the communication type to "point to point" when sending the D-CONNECT PDU (the SwMI may also choose to correct the communication type to "point to point" in a D-CALL PROCEEDING, D-INFO or D-ALERT PDU).

NOTE 3: ETSI EN 300 392-7 [8] clause 6.5 includes a note on the choice of temporary address where class 3 air-interface encryption is in use.

The CC sub-entity shall send a CONFIGURE request primitive informing the lower layers of the new temporary address and if required the change of basic service from individual to group call.

When the call is then released, the CC sub-entity shall send a CONFIGURE request primitive informing the lower layers that the temporary group address is not longer valid (see clause 14.5.2.3).

14.5.2.2.7 Calls to and from external subscribers

An external subscriber can call TETRA group numbers. The signalling needed between an external subscriber and a gateway is outside the scope of the present document. The signalling between the SwMI and the called group is the same as that for a mobile originated group call.

14.5.2.3 Call disconnection procedures

14.5.2.3.0 General

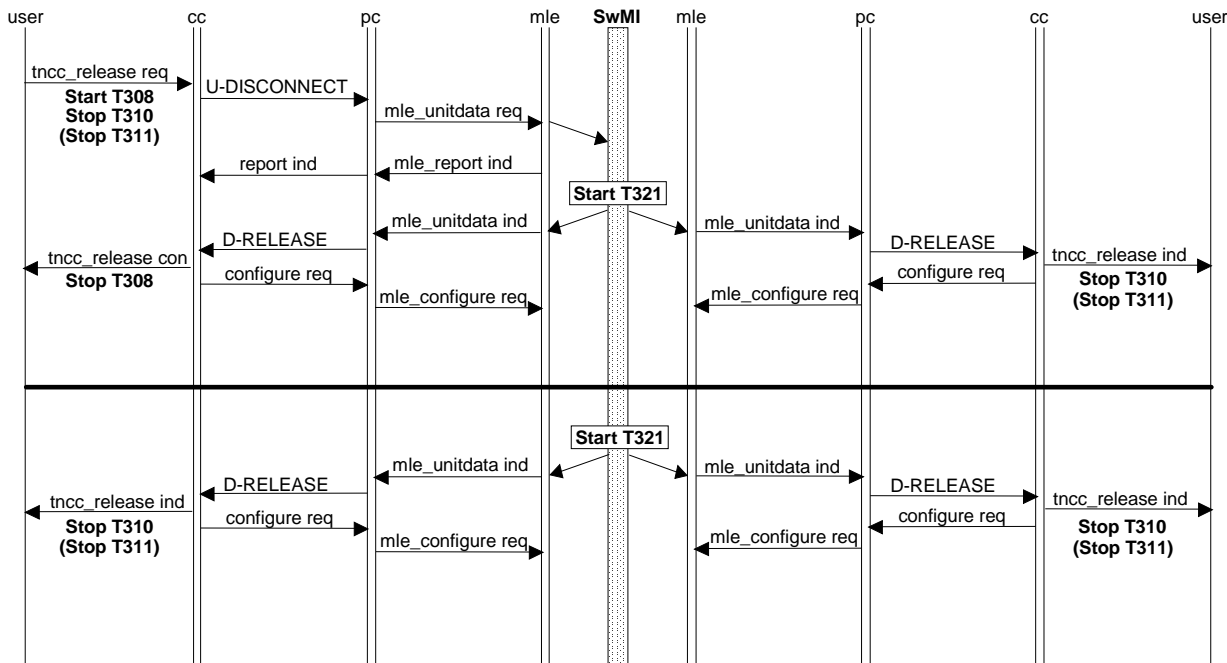

Figure 14.21: Group call - request-to-disconnect

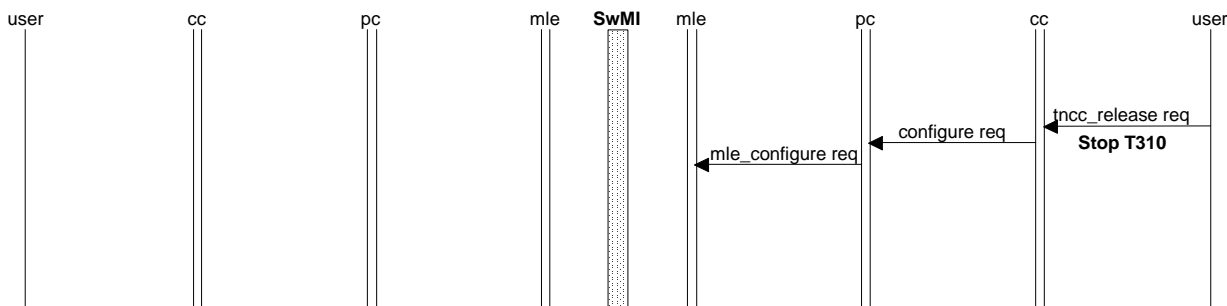

Figure 14.22: Group call - group member leaves ongoing group call

14.5.2.3.1 User initiated disconnection

A user application may initiate call disconnection at any state of a call by sending a TNCC-RELEASE request primitive to the CC sub-entity. A call owner shall signal call disconnection to the SwMI by sending a U-DISCONNECT PDU. A non-call owner may either leave the call without disconnecting it or may in exceptional cases try to disconnect it. When the non-call owner leaves the call without disconnecting it there shall not be any disconnection related signalling from the MS to the SwMI. When a non-call owner tries to disconnect the call it shall signal disconnection to the SwMI by sending a U-DISCONNECT PDU with the Disconnect cause set to "Non-call owner requested disconnection".

NOTE 1: A non-call owner should use disconnection possibility only in exceptional cases e.g. when call owner is not available for disconnection. The MS or the user may know whether it is authorized to disconnect the call.

NOTE 2: SwMI may check before call disconnection whether the MS or the user is authorized to disconnect the call.

The disconnect type parameter in the TNCC-RELEASE request primitive indicates whether the CC should disconnect the call or leave the call without disconnection. Refer to clause 14.5.2.7 for the definition of call ownership.

The following procedures shall apply to the user application that is disconnecting the call, figure 14.21 refers:

- during call set-up phase until U-SETUP PDU has been transmitted to the SwMI, a disconnection can be handled locally using a CANCEL request primitive. Information regarding the local progress of the transmission of a PDU is received in REPORT indication primitives. After a local cancellation the CC sub-entity shall stop timer T303 and shall return to state IDLE;
- on receipt of a TNCC-RELEASE request primitive in the CC sub-entity from the user application requesting call disconnection, the CC shall send a U-DISCONNECT PDU, start timer T308 and enter state CALL-DISCONNECT. All other T3xx Timers shall be stopped. The progress of the disconnection shall be reported to the CC with REPORT indication primitive;
- should the user application disconnect the call during the window between transmission of a U-SETUP and reception of a D-CALL PROCEEDING or D-CONNECT PDU (i.e. before the MS has received a call identifier for the call), it shall use the dummy call identifier (all zeroes);
- if a U-DISCONNECT is issued, CC shall await a D-RELEASE PDU. When a D-RELEASE PDU or a REPORT indication primitive with reason PDU transfer failed is received, or timer T308 expires, the CC sub-entity shall clear the call identifier, stop timer T308 and return to state IDLE, issuing a TNCC-RELEASE confirm primitive to the user application. The CC sub-entity shall send a CONFIGURE request primitive to the lower layers to clear the temporary group address (if the temporary address is applicable to the call), switch the U-Plane off, reject any pending channel change response request for that call (refer to clause 14.5.3.2), and leave the assigned channel (if the MS is on an assigned channel when the CONFIGURE request primitive is sent). If a channel change response is required for the D-RELEASE PDU, CC shall accept that channel change (refer to clause 14.5.3.2). The SwMI may also choose to send only a group address D-RELEASE PDU and the CC shall behave as if it had received it individually addressed;
- if a non-call owner requested disconnection and SwMI does not disconnect the call, then SwMI may send D-RELEASE PDU with a disconnect reason set to "Requested service not available" addressed to the non-call owner requesting the disconnection.

The SwMI should inform the other MSs in the call of the call clearance using a D-RELEASE PDU (see clause 14.5.2.3.3 for MS actions).

If a group participant wishes to leave the group call, without disconnecting the call, the user application shall issue a TNCC-RELEASE request primitive with disconnect type parameter equal to "leave call without disconnection":

- if the user leaves the call without disconnection, the CC sub-entity shall clear the call identifier, stop all T3xx Timers and return to state IDLE, see figure 14.22. The CC sub-entity shall send a CONFIGURE request primitive to the lower layers to clear the temporary group address (if the temporary address is applicable to the call), switch the U-Plane off, reject any pending channel change response request for that call (refer to clause 14.5.3.2), and leave the assigned channel (if the MS is on an assigned channel when the CONFIGURE request primitive is sent).

14.5.2.3.2 Network initiated disconnection

In the case where the SwMI cannot support a request for a call from the calling MS, the SwMI shall send a D-RELEASE PDU containing the reason for disconnection, to the calling MS.

In the case where the SwMI can no longer support an established call, the SwMI should send a D-RELEASE PDU to all the MSs in the group containing the reason for disconnection, and subsequently release the call.

The MS actions are defined in clause 14.5.2.3.3.

14.5.2.3.3 Reception of disconnection request

The BS may send a disconnection request at any phase of the call and the MS shall react as follows:

- when the CC sub-entity receives a D-RELEASE PDU the CC shall not send any response;
- the CC shall inform the user application with a TNCC-RELEASE indication primitive, clear the call identifier, stop all T3xx timers and enter state IDLE, refer figure 14.21. The CC sub-entity shall send a CONFIGURE request primitive to the lower layer to clear the temporary group address (if the temporary address is applicable to the call), switch the U-Plane off, reject any pending channel change response request for that call (refer to clause 14.5.3.2), and leave the assigned channel (if the MS is on an assigned channel when the CONFIGURE request primitive is sent). If a channel change response is required for the D-RELEASE PDU, CC shall accept that channel change (refer to clause 14.5.3.2).

14.5.2.3.4 Colliding disconnection

If the CC entity receives a D-RELEASE PDU when CC has just sent a U-DISCONNECT PDU, the CC sub-entity shall release the call immediately as defined in 14.5.2.3.3. In addition, the CC shall issue a CANCEL request primitive to the lower layers to cancel any ongoing re-transmission of the U-DISCONNECT PDU.

14.5.2.3.5 Expiry of timers

a) Timer T302: call set-up timer for calling MS

Upon expiry of timer T302, CC shall send a TNCC-RELEASE indication primitive to the user application, send a U-DISCONNECT PDU, and follow the procedures in clause 14.5.2.3.1. The value of the disconnect cause element shall be set to "expiry of timer".

b) Timer T303: call initiated timer for calling MS

Upon expiry of timer T303, CC shall send a TNCC-RELEASE indication primitive to the user application, send a U-DISCONNECT PDU, and follow the procedures in clause 14.5.2.3.1. The value of the disconnect cause element shall be set to "expiry of timer".

c) Timer T307: call restoration timer for point-to-multipoint calls

Upon expiry of timer T307, CC shall apply procedures described in clause 14.5.2.2.4. The value of the disconnect cause element shall be set to "expiry of timer".

d) Timer T308: call disconnect timer

Upon expiry of timer T308, CC shall return to state IDLE, send a TNCC-RELEASE confirm primitive to the user application and shall send a CANCEL request primitive to the lower layers to cancel the sending of the U-DISCONNECT PDU. The CC sub-entity shall send a CONFIGURE request primitive to the lower layers to clear the temporary group address (if the temporary address is applicable to the call), switch the U-Plane off, reject any pending channel change response request for that call (refer to clause 14.5.3.2), and leave the assigned channel (if the MS is on an assigned channel when the CONFIGURE request primitive is sent).

e) Timer T310: call length timer

Upon expiry of timer T310, if the MS is the call owner, the CC shall send a TNCC-RELEASE indication primitive to the user application, send a U-DISCONNECT PDU and follow the procedures in clause 14.5.2.3.1. The value of the disconnect cause element shall be set to "expiry of timer".

If the MS is not the call owner, CC shall return to state IDLE, and shall send a TNCC-RELEASE indication primitive to the user application and a CONFIGURE request primitive to the lower layers. The value of the disconnect cause element shall be set to "expiry of timer".

f) Timer T311: call transmission timer

Refer to clause 14.5.2.2.1 g).

g) Timer T330: call set-up delay timer

Upon expiry of timer T330 CC can no longer accept the corresponding channel change.

14.5.2.4 U-Plane switching

14.5.2.4.0 General

The U-Plane switching procedure ensures that traffic/signalling synchronization between the CMCE and the MAC shall be maintained during the lifetime of a call. The CC informs the MAC when it has permission to transmit traffic (i.e. TCH or STCH) and when to stop. The CC also informs the MAC when it may process received traffic (and when to stop). The latter procedure also assists the MAC to interpret when the received bit-stream on the assigned channel is TCH/STCH and when it is SCH.

The CC changes the U-plane operation in the MAC by issuing the CONFIGURE request primitive, indicating "Switch U-plane = On" or "Switch U-plane = Off", "Tx grant = true" or "Tx grant = false" and "Simplex/duplex = simplex". There shall be only three valid combinations.

- 1) Switch U-plane = On, Tx grant = true, Simplex/duplex = simplex:
 - MS is authorized to transmit traffic.
- 2) Switch U-plane = On, Tx grant = false, Simplex/duplex = simplex:
 - MS is authorized to receive traffic.
- 3) Switch U-plane = Off:
 - withdraws previous authorization to transmit and/or receive traffic.

14.5.2.4.1 End of call set-up phase

When the CC in a MO call receives a D-CONNECT PDU or when the CC in a MT call receives a D-SETUP PDU, it shall issue a CONFIGURE request primitive to the lower layers containing information about the call e.g. the type of traffic, the interleaving depth, the call identifier and whether the call is end-to-end encrypted.

If the transmission grant element in the D-CONNECT PDU is set to "transmission granted" then the CONFIGURE request primitive shall contain the parameter value "Switch U-Plane = On" and "Tx grant = true" to indicate that the MAC has permission to transmit traffic. If the transmission grant element is set to "transmission granted to another user" then the CONFIGURE request primitive shall contain the parameter value "Switch U-Plane = On" but shall contain "Tx grant = false" to indicate that the MAC should receive traffic. For the other values of the transmission grant element, the U-plane shall not be switched on.

If the transmission grant element in the D-SETUP PDU is set to "transmission granted to another user" then the CONFIGURE request primitive shall contain the parameter value "Switch U-Plane = On" but shall contain "Tx grant = false" to indicate that the MAC should receive traffic. For the other values of the transmission grant element, the U-plane shall not be switched on.

The only valid values of the transmission grant element in a group-addressed PDU shall be "transmission granted to another user" and "transmission not granted".

14.5.2.4.2 During call maintenance phase

a) Transmission grant control

When the CC does not have permission to transmit, and if it receives a D-TX GRANTED PDU with the transmission grant element set to "transmission granted" or "transmission granted to another user", then the CC shall send a CONFIGURE request primitive containing the parameter "Switch U-Plane = On" and indicating whether the MAC has permission to transmit traffic ("Tx grant = true" or "Tx grant = false" respectively). For the other values of the transmission grant element, the U-plane state shall not be changed.

While the CC has permission to transmit, it shall ignore group addressed D-TX GRANTED PDUs (see clause 14.5.2.2.1 b)).

b) Transmission ceased

When the CC receives a D-TX CEASED PDU or on receipt of a REPORT indication primitive of either successful or unsuccessful transmission of a U-TX CEASED PDU, the CC shall issue a CONFIGURE request primitive containing the parameter value "Switch U-Plane = Off".

c) Temporary pause

When the CC receives a D-TX WAIT PDU, and if the U-plane is currently switched on for either transmission or reception, the CC shall issue a CONFIGURE request primitive containing the parameter value "Switch U-plane = Off".

When the CC receives a D-TX CONTINUE PDU then:

- if the continue element is set to "continue" and the MS had permission to transmit traffic at the time of receipt of the D-TX WAIT PDU, then the CC shall issue a CONFIGURE request primitive containing the parameter values "Switch U-Plane = On" and "Tx grant = true";
- if the continue element is set to "continue" and the MS did not have permission to transmit traffic at the time of receipt of the D-TX WAIT PDU, then the CC shall issue a CONFIGURE request primitive containing the parameter value "Switch U-Plane = On" but containing "Tx grant = false".

If the Continue element is set to "not continue" then the U-plane shall not be switched on.

d) Interruption

When the CC receives a D-TX INTERRUPT PDU, and if the transmission grant element is set to "transmission granted to another user", then the CC shall issue a CONFIGURE request primitive containing the parameter value "Switch U-Plane = On" but containing "Tx grant = false" to indicate that the MAC should receive traffic. For the other values of the transmission grant element, the CC shall issue a CONFIGURE request primitive containing the parameter value "Switch U-Plane = Off".

While the CC has permission to transmit, it shall ignore group addressed D-TX INTERRUPT PDUs.

e) Call restoration

When CC receives a BREAK indication primitive indicating that a temporary break in the radio link has occurred, the CC shall issue a CONFIGURE request primitive containing the parameter value "Switch U-Plane = Off".

When CC receives a D-CALL RESTORE PDU indicating that the call has now been restored after a temporary break in the radio link, and if the transmission grant element is set to "transmission granted" or "transmission granted to another user", then the CC shall issue a CONFIGURE request primitive containing the parameter value "Switch U-Plane = On" and indicating whether the MS has permission to transmit traffic ("Tx grant = true" or "Tx grant = false" respectively). For the other values of the transmission grant element, the U-plane shall not be switched on.

14.5.2.4.3 Call disconnection phase

When the CC receives a D-RELEASE PDU, or if it receives a REPORT indication primitive of either successful or unsuccessful transmission of a U-DISCONNECT PDU, or if it receives a TNCC-RELEASE request primitive from the user application indicating that the user wishes to leave the call (without disconnecting the call), then the CC shall issue a CONFIGURE request primitive to the lower layers containing the parameter value "Switch U-Plane = Off".

14.5.2.5 Void

14.5.2.6 Acknowledged group call procedures

The MS procedures for handling of an acknowledged group call shall be in accordance with the procedures described for a normal group call in clauses 14.5.2.1 to 14.5.2.4 with the following additions, which for the SwMI side are informative.

The SwMI should poll the individuals within the called group on the traffic channel after call set-up.

It is an operator option defined in the SwMI if the call should proceed immediately by giving the calling user permission to transmit before, during or after the called members of the group have been polled on the traffic channel.

The SwMI may optionally use one of the following criteria for giving the calling user permission to transmit:

- the D-SETUP PDU has been sent to the called users and the polling will take place in parallel with the ongoing call;
- a certain number of users have responded to the poll;
- all users have been polled.

As a poll request, all MS shall be prepared to receive a D-INFO PDU during the call from the SwMI.

Upon reception of a D-INFO PDU indicating a poll request the CC entity shall send this information further on to the user in a TNCC-NOTIFY and send a U-INFO PDU to the SwMI. The U-INFO shall be sent immediately by the CC on receipt of the poll request, see figure 14.17.

As an operator option the SwMI may disconnect the call after a certain time if insufficient number of members are present, before the permission to transmit is given.

It is a SwMI option how and when to inform the calling user or any other user the result of the polling. An MS shall, during the call set-up phase or during an ongoing call, be prepared to receive one or more D-INFO PDU with the following alternative poll results:

- percentage of responding number of group members;
- number of responding group members;
- list of identities of the responding group members.

The CC shall send the poll result in the D-INFO PDU to the user application in a TNCC NOTIFY indication primitive.

14.5.2.7 Call ownership

The CC states and state transitions described in this clause are defined in clause 14.4.2.

Upon entry to the MO-CALL-SETUP state from the IDLE state, the MS shall assume it is a call owner.

Upon entry to the MT-CALL-SETUP state from the IDLE state, the MS shall assume it is not a call owner.

Upon entry to the CALL ACTIVE state from the MO-CALL-SETUP state or MT-CALL-SETUP state, the MS shall assume it is not a call owner unless it transitioned to the CALL ACTIVE state as a result of receiving a D-CONNECT PDU with the "Call ownership" element set to "A call owner".

In any non-IDLE state, if a MS which is a call owner receives an individually addressed or group addressed D-INFO PDU with the "Call ownership" element set to "Not a call owner", the MS shall no longer be a call owner. In any non-IDLE state, if a MS which is not a call owner receives an individually addressed or group addressed D-INFO PDU with the "Call ownership" element set to "A call owner", the MS shall become a call owner.

14.5.3 Traffic channel assignment procedures

14.5.3.1 SwMI related procedures

This clause describes procedures which shall be applicable only to the SwMI. Depending on the traffic case, alternative methods for traffic channel assignment can be used as presented in table 14.1.

Table 14.1: Traffic channel assignment

TRAFFIC CASE	Early traffic channel assignment	Medium traffic channel assignment	Late traffic channel assignment
Message trunked system; Individual call; On/Off hook signalling;	Yes	Yes	Yes
Message trunked system; Individual call; Direct set-up signalling;	Yes	No	Yes
Transmission trunked system; Individual call; On/Off hook signalling;	No	No	Yes
Transmission trunked system; Individual call; Direct set-up signalling;	No	No	Yes
Quasi-transmission trunked system; Individual call; On/Off hook signalling;	No	No	Yes
Quasi-transmission trunked system; Individual call; Direct set-up signalling;	No	No	Yes
Message trunked system; Group call;	Yes	No	Yes
Transmission trunked system; Group call;	No	No	Yes
Quasi-transmission trunked system; Group call;	No	No	Yes

For the called MSs in a group call, the traffic channel assignment should always be given along with the D-SETUP PDU.

The following methods are available for assigning a traffic channel to a call:

- Early assignment:
 - the traffic channels are assigned and indicated to the calling and called MS along with the D-CALL PROCEEDING and D-SETUP PDUs respectively (contained in the lower layer part of those messages). In this case the calling MS moves immediately to the traffic channel in anticipation of the call and should receive CC messages on this channel;
- Medium assignment:
 - the traffic channels are assigned and indicated to the calling MS along with the D-ALERT PDU and are indicated to the called MS in a layer 2 acknowledgement to the called MS U-ALERT PDU. In this case the calling MS moves to the traffic channel in anticipation of the call and should receive CC messages on this channel;
- Late assignment individual call:
 - the traffic channels are not assigned until the called MS sends a U-CONNECT PDU. Upon reception of this PDU the traffic channels may be indicated to the calling and called MS along with the D-CONNECT and D-CONNECT ACKNOWLEDGE PDUs respectively. In this case the calling MS shall remain listening on the control channel until it is told to move to the traffic channel;
- Late assignment group call:
 - the traffic channels are not assigned until appropriate conditions are met. These conditions may be as a result of the finite time required to locate group members, or as a result of the call being acknowledged. The traffic channel may be indicated to the calling MS along with the D-CONNECT PDU.

NOTE 1: When a MS is said to be sent to a traffic channel in the text above, it means that the MS is ordered to go to an assigned channel. For early and medium assignment, the assigned channel starts as a FACCH until the MS is instructed to switch the U-plane on. For late assignment, the MS may be instructed to switch the U-plane on when it moves to the assigned channel.

NOTE 2: In this edition of the present document, the implications for the MS-related traffic channel assignment procedures (refer to clause 14.5.3.2) of the traffic channel assignment type used by the SwMI have not been fully considered for the "early" and "medium" channel assignment types.

14.5.3.2 MS related procedures

14.5.3.2.1 General procedures

The MAC layer manages radio channel changes as described in clause 23.5.4. It is possible that the MAC layer may receive conflicting channel allocations when the MS is already involved in a service and receives a new service indication. Also, the SwMI may re-allocate radio resources so that concurrent services a MS is using are no longer utilizing resources which are within the capabilities of the MS e.g. sharing the same radio channel. In those situations, the MAC layer needs to ask from the higher layers which channel allocation it will follow so that the preferred service continues or replaces the current service.

The CMCE may receive a "channel change response required" request with any of the following primitives:

a) MLE-UNITDATA indication

For this primitive, the channel assignment is associated with a CC PDU; the primitive is derived from a layer 2 TL-DATA indication primitive or TL-UNITDATA indication primitive, refer to clauses 18.3.5.3.1, 20.3.5.1.4, 20.3.5.1.9, 22.2.1.1 and 22.2.1.2.

b) MLE-REPORT indication

For this primitive, the channel assignment is associated with a layer 2 acknowledgement; the primitive is derived from a layer 2 TL-DATA confirm primitive, refer to clauses 18.3.5.3.1, 20.3.5.1.4 and 22.2.1.1.

c) MLE-CONFIGURE indication

For this primitive, the channel assignment is associated with neither a CC PDU nor a layer 2 acknowledgement; the primitive is derived from a layer 2 TL-REPORT indication primitive, refer to clauses 18.3.5.4, 20.3.5.1.9 and 22.3.5.

NOTE 0: Though the SwMI does not have to send a CC PDU with a traffic channel assignment, it is recommended that the SwMI sends a CC PDU with any channel assignment not sent with a layer 2 acknowledgement in order to facilitate routing of the channel assignment to the correct CC instance. It is recommended that the SwMI use the D-INFO PDU if it sends a CC PDU solely for the purpose of associating a channel assignment with a call.

If a channel change response is required the CMCE shall send a MLE-CONFIGURE request primitive with the "channel change accepted" parameter set to one of the following values (refer to clause 17.3.9):

- accept;
- reject;
- ignore.

NOTE 1: "ignore" is reserved for specific call situations and is not available for other purposes, refer to clause 14.5.3.2.3.

The CC will normally immediately return "accept" when it accepts the service, and "reject" when it does not accept the offered service. The CC may need to return "ignore" in response to a group addressed channel allocation, in which case the response will be immediate, refer to clause 14.5.3.2.3 for a description of those scenarios in which "ignore" is used. In group call case the MS may also delay the sending of the MLE-CONFIGURE request primitive for up to time T330. For late traffic channel assignment, CC shall not reject the channel allocation whilst accepting the service.

NOTE 2: How CMCE or CC entity knows which of the offered or existing services it will accept/select or how it negotiates with other network layers or user application to find out the preferred service is outside the scope of this part of the present document.

NOTE 3: The MAC actions for "reject" and "ignore" are generally the same except for specific situations, see clauses 23.5.4.2.3 and 23.5.4.2.4 for details.

NOTE 4: Handling of channel allocations may also be affected by the MS being active in a MM procedure, this being indicated to CC from MLE via the MLE-BUSY indication primitive, refer to clause 18.3.5.4. The exact nature of the interaction between MM/MLE and CC is outside the scope of this part of the present document but it is recommended that CC not accept a channel allocation while MM is busy.

14.5.3.2.2 Procedures for acceptance of individually-addressed channel allocation

As described in clauses 14.5.1.1.1, 14.5.1.1.3 and 14.5.6.5.3, it is optional whether the MS accepts an incoming individual call. Therefore, when the MAC receives a channel allocation addressed to it, it refers to the higher layers for instruction about whether to accept the channel allocation.

The lower layers indicate that instruction is required by setting the "channel change response required" parameter to "true". This parameter is passed (via LLC, MLE and PC) to CC along with the PDU. If the CC decides to accept the channel allocation then it shall return a CONFIGURE request primitive with the parameter "channel change accepted" set to "accept". The CC may also decide to reject a channel allocation in which case CC shall use "channel change accepted" parameter value "reject". The CC shall decide whether to accept or reject a channel allocation by applying the following rules:

- if the PDU relates to an ongoing call (i.e. if the call identifier in the received PDU is the call identifier of any current call that the MS is active in) and if the CC obeys the received PDU then the CC shall accept the channel change;
- if the PDU relates to an ongoing call and if the CC does not obey the received PDU then the CC shall reject the channel change;
- if the PDU relates to a new service and if the CC obeys the received PDU then the CC shall accept the channel change;

- if the PDU relates to a new service and if the CC does not obey the received PDU then the CC shall reject the channel change.

NOTE: The "ignore" value is not used as a response to any individually addressed channel allocation.

14.5.3.2.3 Procedures for acceptance of group-addressed channel allocation

As described in clause 14.5.2.1.1, it is optional whether the MS accepts an incoming group call. Therefore, when the MAC receives a channel allocation addressed to a group that the MS belongs to, it refers to the higher layers for instruction about whether to accept the channel allocation.

The lower layers indicate that instruction is required by setting the "channel change response required" parameter to "true". This parameter is passed (via LLC, MLE and PC) to CC along with the PDU. If the CC decides to accept the channel allocation then it shall return a CONFIGURE request primitive with the parameter "channel change accepted" set to "accept". The CC may also decide to reject a channel allocation in which case CC shall use "channel change accepted" parameter value "reject". The CC shall decide whether to accept, reject or in specific cases ignore a channel allocation by applying the following rules:

- if the PDU is a group addressed D-SETUP PDU then:
 - if the MS is not currently attempting to call this group then the CC shall accept the channel change if the user application accepts the incoming call using TNCC-SETUP response primitive, refer to clauses 14.5.2.1.1 and 14.5.2.1.3 for other actions;
 - if the MS is not currently attempting to call this group then the CC shall reject the channel change if the user application rejects the incoming call using TNCC-RELEASE request primitive;
 - if the MS is currently attempting to call this group, and has not received a REPORT indication primitive of successful transmission of the U-SETUP PDU from the lower layers, then:
 - if it is requesting a "basic service information" compatible with that in the D-SETUP PDU then it shall send a CANCEL request primitive to the lower layers to stop transmission of the U-SETUP PDU then:
 - if cancellation is successful, the MS shall accept the channel change;
 - if cancellation is unsuccessful, the MS shall ignore the channel change and shall wait on the current channel for further signalling: a D-CALL PROCEEDING and/or D-CONNECT PDU (and/or D-RELEASE PDU).
 - if it is requesting a "basic service information" not compatible with that in the D-SETUP PDU then it shall accept the channel change if the user application accepts the incoming call using TNCC-SETUP response primitive, refer to clause 14.5.2.1.3 for other actions;
 - if it is requesting a "basic service information" not compatible with that in the D-SETUP PDU then it shall reject the channel change if the user application rejects the incoming call using TNCC-RELEASE request primitive.
 - if the MS is attempting to call this group and has received a REPORT indication primitive of successful transmission of the USETUP PDU by the LLC but not yet received a call identifier then it shall ignore the channel change and shall wait on the current channel for further signalling: a D-CALL PROCEEDING and/or D-CONNECT PDU (and/or D-RELEASE PDU);
 - if the MS is attempting to call this group and has received D-CALL PROCEEDING PDU and the call identifier in the D-SETUP PDU is the same as the call identifier in the D-CALL PROCEEDING PDU and the calling party address in the D-SETUP PDU does not contain the MS's own address then the CC shall accept the channel change;
 - if the MS is attempting to call this group and has received D_CALL PROCEEDING PDU and the call identifier in the D-SETUP PDU is the same as the call identifier in the D-CALL PROCEEDING PDU and the calling party address in the D-SETUP PDU contains the MS's own address then the CC shall ignore the channel change.

- if the PDU relates to an ongoing call (i.e. if the call identifier in the received PDU is the call identifier of any current call that the MS is active in) and if the CC obeys the received PDU then the CC shall accept the channel change;
- if the PDU relates to an ongoing call and if the CC does not obey the received PDU then:
 - if the MS is transmitting traffic and the PDU is a group addressed D-TX GRANTED or D-TX INTERRUPT PDU then the CC shall ignore the channel change;
 - in all other cases the CC shall reject the channel change.

14.5.4 SS procedures

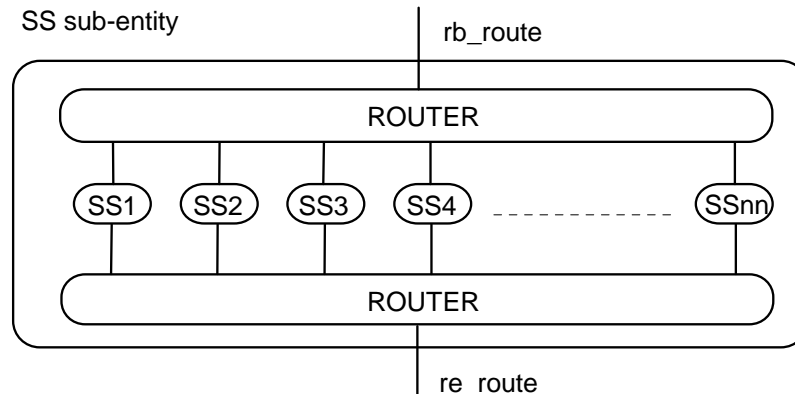

Figure 14.23: Internal view of SS sub-entity

Figure 14.23 shows the internal architecture of the SS sub-entity. The user application shall communicate with SS entities via the rb-route, when the information of the requested service is not incorporated into TNCC-SAP service primitives, see clauses 11 and 12. All messages to and from PC shall be communicated over the re-route. When a SS message is received from the peer entity, it shall be passed via the SS router to the appropriate SS entity.

Each individual SS entity shall receive and send call related SS messages as facility elements in CC PDUs, or if no other call related PDU is available, in a U/D-INFO PDU. The call identifier element shall link the SS facility element to the related call.

If the SS message is not related to any existing call, it shall be conveyed as a facility element in a U/D-FACILITY PDU.

Some SS messages may be sent or received at any stage of a call, after the call during SS-CC retention time and when no call exists.

14.5.5 SDS procedures

14.5.5.0 General

The SDS procedures handled by the SDS sub-entity shall be applicable for the MS side. The procedures relating to the SwMI are outside the scope of the present document.

In the SDS protocol there is no relationship defined between SDS messages using different transmission directions and the SDS sub-entity shall be able to handle colliding messages, e.g. shall receive messages to be sent to the peer entity and shall deliver received messages from the peer entity at the same time.

14.5.5.1 Incoming short data message

On reception of D-STATUS or D-SDS-DATA PDUs the SDS sub-entity shall inform the user application with a TNSDS-STATUS indication primitive containing the pre-coded status or with a TNSDS-UNITDATA indication primitive containing user defined data, respectively.

14.5.5.2 Outgoing short data messages

A user application initiates the SDS message transfer by issuing either a TNSDS-STATUS request primitive or a TNSDS-UNITDATA request primitive. The SDS sub-entity shall select an appropriate PDU priority based on the requested access priority value as described in clause 14.5.6.2.

Upon reception of a TNSDS-STATUS or a TNSDS-UNITDATA request primitive the SDS sub-entity shall send the corresponding U-STATUS or U-SDS-DATA PDU respectively. The SDS sub-entity may suggest the use of an advanced link by using the U-SDS DATA primitive's link identifier parameter.

NOTE: The advanced link may use less air interface resource than the basic link in certain conditions when transmitting a long PDU in an imperfect channel. It may be desirable to use an advanced link when the U-SDS-DATA PDU cannot be carried by the basic link within a MAC-ACCESS PDU plus two or three full slots, particularly where the MS may be using a 25 kHz QAM channel.

The SDS sub-entity shall not accept further short data request primitives from the user application before a REPORT indication primitive indicating successful transmission of the PDU has been received. The received report shall be forwarded to the user application in a TNSDS-REPORT indication primitive.

If the SDS entity receives a REPORT indication primitive informing that the PDU transmission was unsuccessful, the SDS sub-entity shall inform the user application using a TNSDS-REPORT indication primitive with parameter "failure" and the SDS sub-entity may continue to accept new SDS service requests.

14.5.6 PC procedures

14.5.6.0 General

This clause contains various protocol elements which are common to one or more sub-entities within the CMCE. The description does not define or limit implementations to be inside the PC sub-entity.

14.5.6.1 Access to the communication resources

When the MS is powered up all the CMCE sub-entities except the PC sub-entity shall start in state IDLE. The PC sub-entity shall start in state CLOSED. When the PC sub-entity receives a MLE-OPEN indication primitive, the PC sub-entity shall change state to OPEN and inform other sub-entities with an OPEN indication primitive. When the PC is in state CLOSED the other sub-entities shall not send any PDUs. When the PC receives a MLE-CLOSE indication primitive, the PC sub-entity shall change state to CLOSED and shall inform the other sub-entities with a CLOSE indication primitive.

MLE-BREAK indication primitive, REOPEN indication primitive, RESTORE confirm primitive and RESUME indication primitive shall not change the state of the PC, but PC shall pass those to other sub-entities as defined in clause 14.2.6.

14.5.6.2 Access priority handling

14.5.6.2.0 General

When any CMCE sub-entity receives an access priority value in a TNCC, TNSS or TNSDS primitive, the sub-entity shall set the PDU priority value according to the access priority value. If the corresponding PDU priority is not defined by other means, then the sub-entity shall use default values as defined in table 14.2.

Table 14.2: Low/high/emergency PDU priority default values

PDU	PDU priority	Remark
U-ALERT	2/4/7	Stealing repeats flag not set
U-CALL-RESTORE	5	Stealing repeats flag not set
U-CONNECT	2/4/7	Stealing repeats flag not set
U-DISCONNECT	6	Immediate stealing and Stealing repeats flag set
U-INFO	2/4/7	Stealing repeats flag not set
U-RELEASE	6	Stealing repeats flag not set
U-SETUP	0/4/7	Stealing repeats flag not set
U-STATUS	1/4/7	Stealing repeats flag not set
U-SDS DATA	1/4/7	Stealing repeats flag not set
U-TX CEASED	6	Immediate stealing and Stealing repeats flag set
U-TX DEMAND	2/4/7	Stealing repeats flag not set

For PDUs other than U-TX CEASED and U-DISCONNECT, the CC sub-entity shall set the stealing permission parameter according to the following rules:

- if "traffic stealing = steal traffic" and "access priority = emergency" in the service access primitive, the stealing permission parameter shall be set to "steal immediately";
- if "traffic stealing = steal traffic" and access priority is not equal to "emergency" in the service access primitive, the stealing permission parameter shall be set to "steal when convenient";
- otherwise the stealing permission parameter shall be set to "stealing not required".

14.5.6.2.1 Cancel

The cancel procedures may be implemented in an MS and if used the following shall apply:

- the MLE-CANCEL request primitive can minimize the risk of adding extra load to the air interface, e.g. when a user application requests a call set-up and the request is buffered by the lower layers waiting for allowance to make a random access attempt, which in the case of a low priority call and high system load can take a considerable amount of time. If the user application, during this waiting period, changes its decision and wants to disconnect the call, the application shall send a TNCC-RELEASE request primitive to the CC sub-entity. The CC sub-entity shall know the status of the transmission from the REPORT indication primitives received from the lower layers;
- when any sub-entity wishes to stop transmission of a PDU it may use cancel procedure with the limitations defined below. The cancel process shall be controlled by REPORT indication primitives from lower layers;
- incoming MLE-REPORT indication primitives should indicate the following events:
 - a PDU has been stored by the DLL ready for transmission. At this stage the transmission may be cancelled using a CANCEL request primitive and no information will be sent over the air interface;
 - the first transmission of whole PDU. The BS may have received the PDU, but MS has not yet received an acknowledgement. At this stage the layer 2 process may be stopped using a CANCEL request primitive, but the sending sub-entity cannot rely on the cancellation and may receive a response to the sent PDU;
 - the transfer of a PDU has failed in layer 2. Cancellation is no longer possible, but the BS may have received the PDU correctly and the sending sub-entity may receive a response to the sent PDU;
 - a PDU has been successfully transmitted by layer 2. Cancellation is no longer possible.

14.5.6.3 CMCE PDU exchange

14.5.6.3.0 General

The PC shall forward PDUs from the other CMCE sub-entities to MLE using a MLE-UNITDATA request primitive without modifying any parameters supplied with the PDU. However the U-CALL RESTORE PDU shall use a MLE-RESTORE request primitive instead of the MLE-UNITDATA request primitive.

The PC shall forward the SDU contained in a received MLE-UNITDATA indication primitive to the corresponding sub-entity as defined by the PDU type element without modifying any parameters. The D-CALL RESTORE PDU should be received in a MLE-RESTORE confirm primitive instead of the MLE-UNITDATA indication primitive.

14.5.6.3.1 Choice of layer 2 service

When sending the following PDUs, the layer 2 service parameter shall be set to "acknowledged response":

- U-ALERT PDU;
- U-CONNECT PDU for direct call set-up;
- U-DISCONNECT PDU when sent as a response to a D-SETUP PDU;
- U-RELEASE.

For other uplink PDUs, the PC should set the layer 2 service parameter to "acknowledged request".

14.5.6.4 Control information exchange

CMCE sub-entities exchange local control information with the PC using service primitives.

The PC shall forward service primitives from other CMCE sub-entities to the MLE using MLE service primitives as defined in clause 17.3.4 without any modification of the parameters.

The PC shall forward service primitives from MLE, as defined in clause 17.3.4 to the relevant sub-entity or sub-entities without any modification of parameters.

The primitive names and parameters between the PC and the other sub-entities are same as the primitive names at the MLE-SAP except that the "MLE-" is not present.

The CC protocol cannot support overlapping call set-up signalling within the window where the CC awaits a call identifier from the SwMI after a U-SETUP PDU is issued. A method to prevent concurrent call set-up attempt during the window is described as follows:

- when a CC instance initiates a call set-up, it shall inform PC that a call set-up has been initiated, and the PC shall inform other CC instances that currently no more call set-up attempts are possible;
- when the CC instance either receives a call identifier for the new call or discards the call set-up, it shall inform completion of call set-up to the PC, and the PC shall forward that information to the other CC instances.

This method enables correct mapping between the call identifier and the appropriate CC instance.

14.5.6.5 PC protocol error conditions

14.5.6.5.1 PDU type error

When a PDU is received with a PDU type not recognizable, the MS may, if the PDU is individually addressed, send a CMCE FUNCTION NOT SUPPORTED PDU, refer to clause 14.7.3.2. The MS shall ignore the unrecognizable PDU.

If the MS receives an individually addressed CMCE PDU with a valid PDU type but some unrecognized element or element values prevent the MS from interpreting the PDU correctly, the MS may send a CMCE FUNCTION NOT SUPPORTED PDU.

The behaviour of the requesting party when receiving a CMCE FUNCTION NOT SUPPORTED PDU is outside the scope of the present document.

14.5.6.5.2 Invalid call identifier

If a MS receives any individually addressed down link PDU except D-SETUP and D-RELEASE PDUs specifying a call identifier element which is not recognized as relating to a call for which a call identifier exists, the PC shall send a U-DISCONNECT PDU with the received invalid call identifier and with the cause "Invalid call identifier".

In all other cases, no action shall be taken by PC.

14.5.6.5.3 MS busy

If the MS is engaged in another service or services e.g. circuit mode call or packet data service, and cannot support more concurrent calls and the user application, when it receives an individually addressed D-SETUP PDU, does not release any calls and does not reject the incoming call (refer to clause 14.5.1.1.5), the MS shall send a U-DISCONNECT PDU back to the SwMI with cause "Called party busy".

14.5.6.6 Temporary Disablement

When the PC receives a MLE-DISABLE indication primitive, CMCE shall cease all communication with MLE apart from:

- reception of MLE-CLOSE indication, MLE-OPEN indication and MLE-ENABLE indication primitives;
- if the MLE-DISABLE indication primitive included LIP as a permitted service:
 - primitives transporting LIP protocol via SDS PDUs;
- if the MLE-DISABLE indication primitive included ambience listening as a permitted service:
 - primitives transporting signalling related to ambience listening.

The method by which CMCE permits only these services while preventing all others is outside the scope of the present document.

When the PC receives a MLE-ENABLE indication primitive, CMCE shall resume full communication with MLE.

PC shall sustain its temporary disablement condition through power cycles, through loss and regain of radio resources, and through switching to DMO and back.

NOTE: An MS that is temporarily disabled during V+D operation remains disabled during DMO operation, but the method by which the MS achieves this is outside the scope of the present document.

14.5.7 Subscriber class

Where the CMCE receives a MLE-INFO indication primitive which indicates that the subscriber class associated with the ITSI is not valid on a cell the CMCE shall filter service requests until the subscriber class becomes valid, or a new cell is selected where the subscriber class is valid, this being indicated from MLE to CMCE via the MLE-INFO indication primitive. The CMCE may respond normally to existing circuit mode calls and all SwMI-initiated procedures including, for example, incoming calls, SDS-TL messages and consequent SDS-TL reports and acknowledgements, and SS messages and responses (including, for example, DGNA signalling messages and responses).

Only the following MS-initiated procedures are permitted:

- emergency calls;
- signalling with PDU priority 7;
- restoration of existing circuit mode calls;
- in established circuit mode calls: signalling with any PDU priority (e.g. transmit permission requests) and speech transmission;

- user application responses to incoming SDS-TL messages.

See also clause 16.4.9.

14.5.8 Activity handling

PC shall send an MLE-ACTIVITY request primitive to the MLE when it receives an ACTIVITY request primitive from a CC entity.

14.5.9 Not-permitted cells

When CMCE receives an MLE-INFO indication primitive which indicates that the present cell is a not-permitted cell (see clause 18.3.5.1.5), the CMCE shall filter service requests until a different cell is selected. When using a not-permitted cell CMCE shall locally terminate existing non-emergency circuit mode calls.

Only the following MS-initiated procedures are permitted:

- emergency calls;
- restoration of existing emergency calls;
- signalling with PDU priority 7.

See also clause 18.3.4.5.7.

NOTE 1: An MS sending LIP and emergency STATUS messages in not-permitted cells should use PDU priority 7 to guarantee that the message is sent.

The MS shall ignore all non-emergency SwMI-initiated procedures including, for example, non-emergency incoming calls, non-emergency SDS-TL messages and consequent SDS-TL reports and acknowledgements, and SS messages and responses (including, for example, DGNA signalling messages and responses).

The MS should accept incoming emergency calls and PDU priority 7 signalling. The MS is permitted to send and receive acknowledgements to signalling related to emergency calls and signalling sent with PDU priority 7.

NOTE 2: There is no requirement for the SwMI to be aware of the MS's not-permitted cells. However, if the SwMI is aware of the MS's not-permitted cells, it may filter out non-emergency signalling when the MS is using a not-permitted cell.

14.6 Protocol timers

Table 14.3 lists the protocol timers and the information associated with them.

Table 14.3: Timers

Timer No.	Timer value	Call state	Cause for start	Normally terminated	Action when timer expires	I/C side	O/G side
T301 (see note 1)	Maximum 30 s	MT-CALL-Set-up	On the sending of U-CONNECT, On receipt of D-INFO	On receipt of D-CONNECT ACK, D-DISCONNECT, D-RELEASE, Report (failed) ind	Disconnect as specified in clause 14.5.1.3.4 a)	M	-
T302 (see note 2)	Max. 60 s	MO-CALL-Set-up	On receipt of D-CALL PROCEEDING, D-ALERT or D-INFO	On receipt of D-CONNECT, D-SETUP, D-DISCONNECT, D-RELEASE, Report (failed) ind	Disconnect as specified in clauses 14.5.1.3.4 b) and 14.5.2.3.5 a)	-	M

Timer No.	Timer value	Call state	Cause for start	Normally terminated	Action when timer expires	I/C side	O/G side
T303	60 s	MO-CALL-Set-up	On the sending of U-SETUP	On receipt of D-CALL PROCEEDING, D-ALERT, D-CONNECT, D-RELEASE, Report (failed) ind On transmission of U-DISCONNECT	Disconnect as specified in clauses 14.5.1.3.4 c) and 14.5.2.3.5 b)	-	M
T306	Min 4 sec Max 6 sec	Break	On sending of U-CALL RESTORE (Pt to Pt calls only)	On receipt of D-CALL RESTORE, Reopen ind	Disconnect as specified in clause 14.5.1.3.4 e)	M	M
T307	Min 2 sec Max 8 sec	Break	On sending of U-CALL RESTORE (Pt to MtPt calls only)	Receipt of D-CALL RESTORE, Reopen ind	Disconnect as specified in clause 14.5.2.3.5 c)	M	M
T308 (see note 3)	Max. 10 sec	Any State	On transmission of U-DISCONNECT	Receipt of D-RELEASE, Report (failed) ind	Disconnect as specified in clauses 14.5.1.3.4 f) and 14.5.2.3.5 d)	M	M
T310 (see note 4)	Min 30 sec No Max.	Call Active	On receipt of D-CONNECT, D-CONNECT ACKNOWLEDGE, D-TX CONTINUE, D-SETUP (Pt to MtPt calls only), D-INFO, D-CALL RESTORE	On receipt of D-RELEASE, D-TX WAIT, Report (failed) ind On transmission of U-DISCONNECT, U-RELEASE	Disconnect as specified in clauses 14.5.1.3.4 g) and 14.5.2.3.5 e)	M	M
T311	Max. 300 sec	Call Active TX	On receipt of D-TX GRANTED (transmit), D-TX CONTINUE (continue) (see note 5), D-CONNECT (transmit), D-CONNECT ACKNOWLEDGE (transmit)	On transmission of U-TX CEASED, U-DISCONNECT On receipt of D-TX INTERRUPT, D-RELEASE, D-TX WAIT, D-TX CONTINUE (not continue), Report (failed) ind	Forced Ceased Transmission. Transmission of U-TX CEASED	M	M
T330	10 sec	MT-CALL-Set-up	On receipt of a channel change response required set to "yes"	On sending corresponding channel change accepted set to any value	CC can no longer accept the channel change	M	-
<p>NOTE 1: This timer is started with a fixed duration of 30 s on the sending of U-CONNECT; the timer may be started again on receipt of D-INFO (with the duration specified in the D-INFO).</p> <p>NOTE 2: This timer may be started again during the call on receipt of D-INFO.</p> <p>NOTE 3: This timer may have 0 (zero) duration in which case the MS does not wait for D-RELEASE after having sent U-DISCONNECT.</p> <p>NOTE 4: This timer may be started again during the call on receipt of D-INFO or D-CALL RESTORE.</p> <p>NOTE 5: The timer is started as a result of receiving D-TX CONTINUE (continue) only if the MS had transmit permission when it received D-TX WAIT.</p>							

14.7 PDU descriptions

14.7.0 General

The PDUs detailed within this clause shall be visible at the Um reference point.

Refer to annex E for PDU encoding rules and examples.

Various supplementary services use the notification information element in some PDUs, refer to ETSI EN 300 392-9 [9].

The information contained in the following PDU description tables corresponds to the following key:

- Length: length of the element in bits;
- Type: element type (1, 2 or 3) as defined above;
- Owner: sub-entity responsible for (or owner of) the element data;
- C/O/M: conditional/optional/mandatory information in the PDU;
- Remark: comment.

14.7.1 PDU description tables - downlink

14.7.1.1 D-ALERT

- Message: D-ALERT
- Response to: U-SETUP
- Response expected: -
- Short description: This PDU shall be an information to the originating MS that the call is proceeding and the connecting party has been alerted.

Table 14.4: D-ALERT PDU contents

Information element	Length	Type	Owner	C/O/M	Remark
PDU Type	5	1	CC	M	D-ALERT
Call identifier	14	1	CC	M	
Call time-out, set-up phase	3	1	CC	M	
Reserved	1	1	CC	M	See note 1
Simplex/duplex selection	1	1	CC	M	
Call queued	1	1	CC	M	
Basic service information	8	2	CC	O	See note 2
Notification indicator	6	2	SS	O	
Facility		3	SS	O	
Proprietary		3	-	O	
NOTE 1: This information element is not used in this edition of the present document and its value shall be set to "1" (equivalent to "Hook on/Hook off signalling" for backwards compatibility with edition 1 of the present document - refer to table 14.62).					
NOTE 2: If different from requested.					

14.7.1.2 D-CALL PROCEEDING

- Message: D-CALL PROCEEDING
- Response to: U-SETUP
- Response expected: -
- Short description: This PDU shall be the acknowledgement from the infrastructure to call set-up request indicating that the call is proceeding.

Table 14.5: D-CALL PROCEEDING PDU contents

Information element	Length	Type	Owner	C/O/M	Remark
PDU Type	5	1	CC	M	D-CALL PROCEEDING
Call identifier	14	1	CC	M	
Call time-out, set-up phase	3	1	CC	M	
Hook method selection	1	1	CC	M	
Simplex/duplex selection	1	1	CC	M	
Basic service information	8	2	CC	O	See note
Call status	3	2	CC	O	
Notification indicator	6	2	SS	O	
Facility		3	SS	O	
Proprietary		3	-	O	
NOTE: If different from requested.					

14.7.1.3 D-CALL RESTORE

- Message: D-CALL RESTORE
- Response to: U-CALL RESTORE
- Response expected: -
- Short description: This PDU shall indicate to the MS that a call has been restored after a temporary break of the call.

Table 14.6: D-CALL RESTORE PDU contents

Information element	Length	Type	Owner	C/O/M	Remark
PDU Type	5	1	CC	M	D-CALL RESTORE
Call identifier	14	1	CC	M	
Transmission grant	2	1	CC	M	
Transmission request permission	1	1	CC	M	
Reset call time-out timer (T310)	1	1	CC	M	
New call identifier	14	2	CC	O	
Call time-out	4	2	CC	O	
Call status	3	2	CC	O	
Modify	9	2	CC	O	
Notification indicator	6	2	SS	O	
Facility		3	SS	O	
Temporary address		3	CC	O	
DM-MS address		3	CC	O	
Proprietary		3	-	O	

14.7.1.4 D-CONNECT

- Message: D-CONNECT
- Response to: U-SETUP
- Response expected: -
- Short description: This PDU shall be the order to the calling MS to through-connect.

Table 14.7: D-CONNECT PDU contents

Information element	Length	Type	Owner	C/O/M	Remark
PDU Type	5	1	CC	M	D-CONNECT
Call identifier	14	1	CC	M	
Call time-out	4	1	CC	M	
Hook method selection	1	1	CC	M	
Simplex/duplex selection	1	1	CC	M	
Transmission grant	2	1	CC	M	
Transmission request permission	1	1	CC	M	
Call ownership	1	1	CC	M	
Call priority	4	2	CC	O	
Basic service information	8	2	CC	O	See note
Temporary address	24	2	CC	O	
Notification indicator	6	2	SS	O	
Facility		3	SS	O	
Proprietary		3	-	O	
NOTE: If different from requested.					

14.7.1.5 D-CONNECT ACKNOWLEDGE

- Message: D-CONNECT ACKNOWLEDGE
- Response to: U-CONNECT
- Response expected: -
- Short description: This PDU shall be the order to the called MS to through-connect.

Table 14.8: D-CONNECT ACKNOWLEDGE PDU contents

Information element	Length	Type	Owner	C/O/M	Remark
PDU Type	5	1	CC	M	D-CONNECT ACKNOWLEDGE
Call identifier	14	1	CC	M	
Call time-out	4	1	CC	M	
Transmission grant	2	1	CC	M	
Transmission request permission	1	1	CC	M	
Notification indicator	6	2	SS	O	
Facility		3	SS	O	
Proprietary		3	-	O	

14.7.1.6 D-DISCONNECT

- Message: D-DISCONNECT
- Response to: -
- Response expected: U-RELEASE
- Short description: This PDU shall be the disconnect request message sent from the infrastructure to the MS.

Table 14.9: D-DISCONNECT PDU contents

Information element	Length	Type	Owner	C/O/M	Remark
PDU Type	5	1	CC	M	D-DISCONNECT
Call identifier	14	1	CC	M	
Disconnect cause	5	1	CC	M	
Notification indicator	6	2	SS	O	
Facility		3	SS	O	
Proprietary		3	-	O	

14.7.1.7 D-FACILITY

- Message: D-FACILITY
- Response to: -
- Response expected: -
- Short description: This PDU shall be used to send call unrelated SS information.

Table 14.10: D-FACILITY PDU contents

Information element	Length	Type	Owner	C/O/M	Remark
PDU Type	5	1	SS	M	D-FACILITY, see note
NOTE: Contents of this PDU shall be defined by SS protocols.					

14.7.1.8 D-INFO

- Message: D-INFO
- Response to: -
- Response expected: -
- Short description: This PDU shall be the general information message to the MS.

Table 14.11: D-INFO PDU contents

Information element	Length	Type	Owner	C/O/M	Remark
PDU Type	5	1	CC	M	D-INFO
Call identifier	14	1	CC	M	See note 1
Reset call time-out timer (T310)	1	1	CC	M	
Poll request	1	1	CC	M	See note 2
New call identifier	14	2	CC	O	
Call time-out	4	2	CC	O	
Call time-out set-up phase (T301, T302)	3	2	CC	O	
Call ownership	1	2	CC	O	
Modify	9	2	CC	O	
Call status	3	2	CC	O	
Temporary address	24	2	CC	O	
Notification indicator	6	2	SS	O	
Poll response percentage	6	2	CC	O	See note 3
Poll response number	6	2	CC	O	See note 3
DTMF		3	CC	O	
Facility		3	SS	O	
Poll response addresses		3	CC	O	See note 3
Proprietary		3	-	O	

NOTE 1: If the message is sent connectionless the call identifier shall be the dummy call identifier.
NOTE 2: Shall be valid for acknowledged group call only. For other types of calls it shall be set = 0.
NOTE 3: Shall be valid for acknowledged group call only.

14.7.1.9 D-RELEASE

- Message: D-RELEASE
- Response to: -/U-DISCONNECT
- Response expected: -
- Short description: This PDU shall be a message from the infrastructure to the MS to inform that the connection has been released.

Table 14.12: D-RELEASE PDU contents

Information element	Length	Type	Owner	C/O/M	Remark
PDU Type	5	1	CC	M	D-RELEASE
Call identifier	14	1	CC	M	
Disconnect cause	5	1	CC	M	
Notification indicator	6	2	SS	O	
Facility		3	SS	O	
Proprietary		3	-	O	

14.7.1.10 D-SDS-DATA

- Message: D-SDS-DATA
- Response to: -
- Response expected: -
- Short description: This PDU shall be for receiving user defined SDS data.

Table 14.13: D-SDS-DATA PDU contents

Information element	Length	Type	Owner	C/O/M	Remark
PDU Type	5	1	SDS	M	D-SDS-DATA
Calling party type identifier	2	1	SDS	M	
Calling party address SSI	24		SDS	C	See note 1
Calling party extension	24		SDS	C	See note 1
Short data type identifier	2	1	SDS	M	
User defined data-1	16		SDS	C	See note 2
User defined data-2	32		SDS	C	See note 2
User defined data-3	64		SDS	C	See note 2
Length indicator	11		SDS	C	See note 2
User defined data-4			SDS	C	See note 2
External subscriber number		3	SDS	O	
DM-MS address		3	CC	O	
NOTE 1: Shall be conditional on the value of Calling Party Type Identifier (CPTI):					
- CPTI = 1; Calling Party SSI;					
- CPTI = 2; Calling Party SSI + Calling Party Extension.					
NOTE 2: Shall be conditional on the value of Short Data Type Identifier (SDTI):					
- SDTI = 0; User Defined Data-1;					
- SDTI = 1; User Defined Data-2;					
- SDTI = 2; User Defined Data-3;					
- SDTI = 3; Length Indicator + User Defined Data-4.					

14.7.1.11 D-STATUS

- Message: D-STATUS
- Response to: -
- Response expected: -
- Short description: This PDU shall be the PDU for receiving a pre-coded status message.

Table 14.14: D-STATUS PDU contents

Information element	Length	Type	Owner	C/O/M	Remark
PDU Type	5	1	SDS	M	D-STATUS
Calling party type identifier	2	1	SDS	M	
Calling party address SSI	24		SDS	C	See note
Calling party extension	24		SDS	C	See note
Pre-coded status	16	1	SDS	M	
External subscriber number		3	SDS	O	
DM-MS address		3	CC	O	
NOTE: Shall be conditional on the value of Calling Party Type Identifier (CPTI):					
- CPTI = 1; Calling Party SSI;					
- CPTI = 2; Calling Party SSI + Calling Party Extension.					

14.7.1.12 D-SETUP

- Message: D-SETUP
- Response to: -
- Response expected: U-ALERT/U-CONNECT/-
- Short description: This PDU shall be the call set-up message sent to the called MS.

Table 14.15: D-SETUP PDU contents

Information element	Length	Type	Owner	C/O/M	Remark
PDU Type	5	1	CC	M	D-SETUP
Call identifier	14	1	CC	M	
Call time-out	4	1	CC	M	
Hook method selection	1	1	CC	M	
Simplex/duplex selection	1	1	CC	M	
Basic service information	8	1	CC	M	
Transmission grant	2	1	CC	M	
Transmission request permission	1	1	CC	M	
Call priority	4	1	SS	M	See note 1
Notification indicator	6	2	SS	O	
Temporary address	24	2	CC	O	
Calling party type identifier	2	2	CC	O	See note 2
Calling party address SSI	24		CC	C	See note 3
Calling party extension	24		CC	C	See note 3
External subscriber number		3	CC	O	
Facility		3	SS	O	
DM-MS address		3	CC	O	
Proprietary		3	-	O	
NOTE 1: This information element is used by SS-PC, refer to ETSI EN 300 392-12-10 [15] and SS-PPC and ETSI EN 300 392-12-16 [16].					
NOTE 2: For resolution of possible Facility (Talking Party Identifier)/Calling party identifier conflicts, refer to ETSI EN 300 392-12-3 [12], clause 5.2.1.5 and ETSI EN 300 392-12-1 [11], clause 4.3.5.					
NOTE 3: Shall be conditional on the value of Calling Party Type Identifier (CPTI):					
- CPTI = 1; Calling Party SSI;					
- CPTI = 2; Calling Party SSI + Calling Party Extension.					

14.7.1.13 D-TX CEASED

- Message: D-TX CEASED
- Response to: U-TX CEASED
- Response expected: -
- Short description: This PDU shall be the PDU from the SwMI to all MS within a call that a transmission has ceased.

Table 14.16: D-TX CEASED PDU contents

Information element	Length	Type	Owner	C/O/M	Remark
PDU Type	5	1	CC	M	D-TX CEASED
Call identifier	14	1	CC	M	
Transmission request permission	1	1	CC	M	
Notification indicator	6	2	SS	O	
Facility		3	SS	O	
DM-MS address		3	CC	O	
Proprietary		3	-	O	

14.7.1.14 D-TX CONTINUE

- Message: D-TX CONTINUE
- Response to: -
- Response expected: -
- Short description: This PDU shall be the information from the SwMI to the MS that the interruption of the call has ceased.

Table 14.17: D-TX CONTINUE PDU contents

Information element	Length	Type	Owner	C/O/M	Remark
PDU Type	5	1	CC	M	D-TX CONTINUE
Call identifier	14	1	CC	M	
Continue	1	1	CC	M	
Transmission request permission	1	1	CC	M	
Notification indicator	6	2	SS	O	
Facility		3	SS	O	
DM-MS address		3	CC	O	
Proprietary		3	-	O	

14.7.1.15 D-TX GRANTED

- Message: D-TX GRANTED
- Response to: U-TX DEMAND
- Response expected: -
- Short description: This PDU shall inform the MS concerned with a call that permission to transmit has been granted by the SwMI to a MS, and to inform that MS that it has been granted permission to transmit. This PDU shall also inform a MS that its request to transmit has been rejected or queued.

Table 14.18: D-TX GRANTED PDU contents

Information element	Length	Type	Owner	C/O/M	Remark
PDU Type	5	1	CC	M	D-TX GRANTED
Call identifier	14	1	CC	M	
Transmission grant	2	1	CC	M	
Transmission request permission	1	1	CC	M	
Encryption control	1	1	CC	M	
Reserved	1	1	CC	M	See note 1
Notification indicator	6	2	SS	O	
Transmitting party type identifier	2	2	CC	O	
Transmitting party address SSI	24		CC	C	See note 2
Transmitting party extension	24		CC	C	See note 2
External subscriber number		3	CC	O	
Facility		3	SS	O	
DM-MS address		3	CC	O	
Proprietary		3	-	O	
NOTE 1: This information element is not used in this version of the present document and its value shall be set to "0".					
NOTE 2: Shall be conditional on the value of Transmitting Party Type Identifier (TPTI):					
- TPTI = 1; Transmitting Party SSI;					
- TPTI = 2; Transmitting Party SSI + Transmitting Party Extension.					

14.7.1.16 D-TX INTERRUPT

- Message: D-TX INTERRUPT
- Response to: -
- Response expected: -
- Short description: This PDU shall be a message from the SwMI indicating that a permission to transmit has been withdrawn.

Table 14.19: D-TX INTERRUPT PDU contents

Information element	Length	Type	Owner	C/O/M	Remark
PDU Type	5	1	CC	M	D-TX INTERRUPT
Call identifier	14	1	CC	M	
Transmission grant	2	1	CC	M	
Transmission request permission	1	1	CC	M	
Encryption control	1	1	CC	M	
Reserved	1	1	CC	M	See note 1
Notification indicator	6	2	SS	O	
Transmitting party type identifier	2	2	CC	O	
Transmitting party address SSI	24		CC	C	See note 2
Transmitting party extension	24		CC	C	See note 2
External subscriber number		3	CC	O	
Facility		3	SS	O	
DM-MS address		3	CC	O	
Proprietary		3	-	O	
NOTE 1: This information element is not used in this version of the present document and its value shall be set to "0".					
NOTE 2: Shall be conditional on the value of Transmitting Party Type Identifier (TPTI):					
- TPTI = 1; Transmitting Party SSI;					
- TPTI = 2; Transmitting Party SSI + Transmitting Party Extension.					

14.7.1.17 D-TX WAIT

- Message: D-TX WAIT
- Response to: U-TX DEMAND
- Response expected: -
- Short description: This PDU shall be a message from the SwMI that the call is being interrupted.

Table 14.20: D-TX WAIT PDU contents

Information element	Length	Type	Owner	C/O/M	Remark
PDU Type	5	1	CC	M	D-TX WAIT
Call identifier	14	1	CC	M	
Transmission request permission	1	1	CC	M	
Notification indicator	6	2	SS	O	
Facility		3	SS	O	
DM-MS address		3	CC	O	
Proprietary		3	-	O	

14.7.2 PDU description tables - uplink

14.7.2.1 U-ALERT

- Message: U-ALERT
- Response to: D-SETUP
- Response expected: -
- Short description: This PDU shall be a acknowledgement from the called MS that the called user has been alerted.

Table 14.21: U-ALERT PDU contents

Information element	Length	Type	Owner	C/O/M	Remark
PDU Type	5	1	CC	M	U-ALERT
Call identifier	14	1	CC	M	
Reserved	1	1	CC	M	See note
Simplex/duplex selection	1	1	CC	M	
Basic service information	8	2	CC	O	
Facility		3	SS	O	
Proprietary		3	-	O	

NOTE: This information element is not used in this edition of the present document and its value shall be set to "1" (equivalent to "Hook on/Hook off signalling" for backwards compatibility with edition 1 of the present document - refer to table 14.62).

14.7.2.2 U-CALL RESTORE

- Message: U-CALL RESTORE
- Response to: -
- Response expected: D-CALL RESTORE
- Short description: This PDU shall be the order from the MS for restoration of a specific call after a temporary break of the call.

Table 14.22: U-CALL RESTORE PDU contents

Information element	Length	Type	Owner	C/O/M	Remark
PDU Type	5	1	CC	M	U-CALL RESTORE
Call identifier	14	1	CC	M	
Request to transmit/send data	1	1	CC	M	
Other party type identifier	2	1	CC	M	
Other party short number address	8		CC	C	See notes 1 and 2
Other party SSI	24		CC	C	See note 1
Other party extension	24		CC	C	See note 1
Basic service information	8	2	CC	M	See note 3
Facility		3	SS	O	
DM-MS address		3	CC	O	
Proprietary		3	-	O	

NOTE 1: Shall be conditional on the value of Other Party Type Identifier (OPTI):
 - OPTI = 0; Other Party SNA;
 - OPTI = 1; Other Party SSI;
 - OPTI = 2; Other Party SSI + Other Party Extension.

NOTE 2: A use of SNA in call restoration is strongly discouraged as all other call maintenance signalling uses SSI and the SS-SNA may not be supported in all networks.

NOTE 3: Although the coding of this information element is of type 2 the element is mandatory. The information element informs the new cell of the basic service of the current call in progress.

14.7.2.3 U-CONNECT

- Message: U-CONNECT
- Response to: D-SETUP
- Response expected: D-CONNECT ACKNOWLEDGE
- Short description: This PDU shall be the acknowledgement to the SwMI that the called MS is ready for through-connection.

Table 14.23: U-CONNECT PDU contents

Information element	Length	Type	Owner	C/O/M	Remark
PDU Type	5	1	CC	M	U-CONNECT
Call identifier	14	1	CC	M	
Hook method selection	1	1	CC	M	
Simplex/duplex selection	1	1	CC	M	
Basic service information	8	2	CC	O	
Facility		3	SS	O	
Proprietary		3	-	O	

14.7.2.4 U-DISCONNECT

- Message: U-DISCONNECT
- Response to: -
- Response expected: D-DISCONNECT/D-RELEASE
- Short description: This PDU shall be the MS request to the SwMI to disconnect a call.

Table 14.24: U-DISCONNECT PDU contents

Information element	Length	Type	Owner	C/O/M	Remark
PDU Type	5	1	CC	M	U-DISCONNECT
Call identifier	14	1	CC	M	
Disconnect cause	5	1	CC	M	
Facility		3	SS	O	
Proprietary		3	-	O	

14.7.2.5 U-FACILITY

- Message: U-FACILITY
- Response to: -
- Response expected: -
- Short description: This PDU shall be used to send call unrelated SS information.

Table 14.25: U-FACILITY PDU contents

Information element	Length	Type	Owner	C/O/M	Remark
PDU Type	5	1	SS	M	U-FACILITY, see note
NOTE: Contents of this PDU shall be defined by SS protocols.					

14.7.2.6 U-INFO

- Message: U-INFO
- Response to: -
- Response expected: -
- Short description: This PDU shall be the general information message from the MS.

Table 14.26: U-INFO PDU contents

Information element	Length	Type	Owner	C/O/M	Remark
PDU Type	5	1	CC	M	U-INFO
Call identifier	14	1	CC	M	See note 1
Poll response	1	1	CC	M	See note 2
Modify	9	2	CC	O	
DTMF		3	CC	O	
Facility		3	SS	O	
Proprietary		3	-	O	

NOTE 1: If the message is sent connectionless then the call identifier shall be equal to the dummy call identifier.
NOTE 2: Shall be valid for acknowledged group call only. For other types of call it shall be set equal to zero.

14.7.2.7 U-STATUS

- Message: U-STATUS
- Response to: -
- Response expected: -
- Short description: This PDU shall be used for sending a pre-coded status message.

Table 14.27: U-STATUS PDU contents

Information element	Length	Type	Owner	C/O/M	Remark
PDU Type	5	1	SDS	M	U-STATUS
Area selection	4	1	SS	M	See note 1
Called party type identifier	2	1	SDS	M	Short/SSI/TSI
Called party short number address	8		SDS	C	See note 2
Called party SSI	24		SDS	C	See note 2
Called party extension	24		SDS	C	See note 2
Pre-coded status	16	1	SDS	M	
External subscriber number		3	SDS	O	
DM-MS address		3	CC	O	

NOTE 1: This information element is used by SS-AS, refer to ETSI EN 300 392-12-8 [14].
NOTE 2: Shall be conditional on the value of Called Party Type Identifier (CPTI):
- CPTI = 0; Called Party SNA; refer to ETSI ETS 300 392-12-7 [13];
- CPTI = 1; Called Party SSI;
- CPTI = 2; Called Party SSI + Called Party Extension.

14.7.2.8 U-SDS-DATA

- Message: U-SDS-DATA
- Response to: -
- Response expected: -
- Short description: This PDU shall be for sending user defined SDS data.

Table 14.28: U-SDS-DATA PDU contents

Information element	Length	Type	Owner	C/O/M	Remark
PDU Type	5	1	SDS	M	U-SDS-DATA
Area selection	4	1	SS	M	See note 1
Called party type identifier	2	1	SDS	M	Short/SSI/TSI
Called party short number address	8		SDS	C	See note 2
Called party SSI	24		SDS	C	See note 2
Called party extension	24		SDS	C	See note 2
Short data type identifier	2	1	SDS	M	See note 4
User defined data-1	16		SDS	C	See notes 3 and 4
User defined data-2	32		SDS	C	See notes 3 and 4
User defined data-3	64		SDS	C	See notes 3 and 4
Length indicator	11		SDS	C	See note 3
User defined data-4			SDS	C	See notes 3 and 5
External subscriber number		3	SDS	O	
DM-MS address		3	CC	O	

NOTE 1: This information element is used by SS-AS, refer to ETSI EN 300 392-12-8 [14].

NOTE 2: Shall be conditional on the value of Called Party Type Identifier (CPTI):

- CPTI = 0; Called Party SNA; refer to ETSI ETS 300 392-12-7 [13];
- CPTI = 1; Called Party SSI;
- CPTI = 2; Called Party SSI + Called Party Extension.

NOTE 3: Shall be conditional on the value of Short Data Type Identifier (SDTI):

- SDTI = 0; User Defined Data-1;
- SDTI = 1; User Defined Data-2;
- SDTI = 2; User Defined Data-3;
- SDTI = 3; Length indicator + User Defined Data-4.

NOTE 4: Any combination of address and user defined data type is allowed. However, the intention is to fit TNSDS-UNITDATA request into one subslot when possible. It is recommended that always the shortest appropriate user defined data type is used. One subslot signalling is possible on a $\pi/4$ -DQPSK or D8PSK channel by using one of the following combinations:

- Short Number Address and User Defined Data 1 or 2;
- Short Subscriber Identity and User Defined Data 1.

NOTE 5: The length of user defined data 4 is between 0 and 2 047 bits. However, if the basic link is to be used, then the longest recommended length of the user defined data 4 is 1 017 bits while using Short Subscriber Identity and FCS on a $\pi/4$ -DQPSK channel (see clause 23.4.2.1, see note 2). Clause 23.4.2.1 also indicates the longest recommended size of TM-SDU for fragmentation for other modulations and channel bandwidths; the longest recommended length of the user defined data 4 using the basic link while using Short Subscriber Identity and FCS may be obtained by subtracting 89 bits from the longest recommended size of TM-SDU (subject to the maximum length of 2 047 bits for user defined data 4). In order to avoid needing to know the modulation level to be used to send the SDS data on a D8PSK or QAM channel, the longest recommended length of the user defined data 4 using the basic link on a D8PSK channel may be regarded as being the value for $\pi/4$ -DQPSK modulation, and the longest recommended length of the user defined data 4 using the basic link on a QAM channel may be regarded as being the value for 4-QAM rate = $\frac{1}{2}$ for the appropriate channel bandwidth.

14.7.2.9 U-RELEASE

- Message: U-RELEASE
- Response to: D-DISCONNECT
- Response expected: -
- Short description: This PDU shall be the acknowledgement to a disconnection.

Table 14.29: U-RELEASE PDU contents

Information element	Length	Type	Owner	C/O/M	Remark
PDU Type	5	1	CC	M	U-RELEASE
Call identifier	14	1	CC	M	
Disconnect cause	5	1	CC	M	
Facility		3	SS	O	
Proprietary		3	-	O	

14.7.2.10 U-SETUP

- Message: U-SETUP
- Response to: -
- Response expected: D-CALL PROCEEDING/D-ALERT/D-CONNECT
- Short description: This PDU shall be the request for a call set-up from a MS.

Table 14.30: U-SETUP PDU contents

Information element	Length	Type	Owner	C/O/M	Remark
PDU Type	5	1	CC	M	U-SETUP
Area selection	4	1	SS	M	See note 1
Hook method selection	1	1	CC	M	
Simplex/duplex selection	1	1	CC	M	
Basic service information	8	1	CC	M	
Request to transmit/send data	1	1	CC	M	
Call priority	4	1	SS	M	See note 2
CLIR control	2	1	SS	M	See note 3
Called party type identifier	2	1	CC	M	Short/SSI/TSI
Called party short number address	8		CC	C	See note 4
Called party SSI	24		CC	C	See note 4
Called party extension	24		CC	C	See note 4
External subscriber number		3	CC	O	
Facility		3	SS	O	
DM-MS address		3	CC	O	
Proprietary		3	-	O	
NOTE 1: This information element is used by SS-AS, refer to ETSI EN 300 392-12-8 [14].					
NOTE 2: This information element is used by SS-PC, refer to ETSI EN 300 392-12-10 [15] and SS-PPC, refer to ETSI EN 300 392-12-16 [16].					
NOTE 3: Refer to ETSI EN 300 392-12-1 [11].					
NOTE 4: Shall be conditional on the value of Called Party Type Identifier (CPTI):					
- CPTI = 0; Called Party SNA; refer to ETS 300 392-12-7 [13] ;					
- CPTI = 1; Called Party SSI;					
- CPTI = 2; Called Party SSI + Called Party Extension.					

14.7.2.11 U-TX CEASED

- Message: U-TX CEASED
- Response to: -
- Response expected: D-TX CEASED/D-TX GRANTED/D-TX WAIT
- Short description: This PDU shall be the message to the SwMI that a transmission has ceased.

Table 14.31: U-TX CEASED PDU contents

Information element	Length	Type	Owner	C/O/M	Remark
PDU Type	5	1	CC	M	U-TX CEASED
Call identifier	14	1	CC	M	
Facility		3	SS	O	
DM-MS address		3	CC	O	
Proprietary		3	-	O	

14.7.2.12 U-TX DEMAND

- Message: U-TX DEMAND
- Response to: D-TX GRANTED
- Response expected: -
- Short description: This PDU shall be the message to the SwMI that a transmission is requested.

Table 14.32: U-TX DEMAND PDU contents

Information element	Length	Type	Owner	C/O/M	Remark
PDU Type	5	1	CC	M	U-TX DEMAND
Call identifier	14	1	CC	M	
TX demand priority	2	1	CC	M	
Encryption control	1	1	CC	M	
Reserved	1	1	CC	M	See note
Facility		3	SS	O	
DM-MS address		3	CC	O	
Proprietary		3	-	O	
NOTE:	This information element is not used in this version of the present document and its value shall be set to "0".				

14.7.3 PDU description tables - downlink and uplink

14.7.3.1 General rules for function not supported

The PDU defined in clause 14.7.3.2 may be used to indicate to the peer entity that the received PDU is not supported. Is shall be used only as a response to individually addressed PDUs.

14.7.3.2 CMCE FUNCTION NOT SUPPORTED

- Message: CMCE FUNCTION NOT SUPPORTED
- Response to: Any individually addressed CMCE PDU
- Response expected: -
- Short description: This PDU may be sent by the MS or SwMI to indicate that the received PDU is not supported.

Table 14.33: CMCE FUNCTION NOT SUPPORTED PDU contents

Information element	Length	Type	Owner	C/O/M	Remark
PDU type	5	1	CC	M	See note 1
Not-supported PDU type	5	1	CC	M	See note 2
Call identifier present	1	1	CC	M	
Call identifier	14		CC	C	See note 3
Function-not-supported pointer	8	1	CC	M	See note 4
Length of received PDU extract	8		CC	C	See note 5
Received PDU extract	variable		CC	C	See notes 5 and 6
NOTE 1: This information element shall have value "CMCE FUNCTION NOT SUPPORTED" as specified in clause 14.8.28.					
NOTE 2: This information element shall identify the PDU which contains the function which cannot be supported. The element shall have one of the values specified in clause 14.8.28.					
NOTE 3: This information element shall be present if the value of the Call identifier present information element is "1"; this information element shall not be present if the value of the Call identifier present information element is "0" (zero).					
NOTE 4: Element can have any value from 0 to 255 ₁₀ ; if non-zero, shall point to the first bit of the element in the received PDU which indicates the function that cannot be supported by the receiving entity. If zero, shall indicate that the PDU type itself (and hence the entire PDU specified by the "Not-supported PDU type" element) cannot be supported.					
NOTE 5: Shall be conditional on the value of Function-not-supported pointer: if Function-not-supported pointer is non-zero, this element shall be present; if Function-not-supported pointer is zero, this element shall not be present.					
NOTE 6: The total length of this element should be not less than the value of Function-not-supported pointer plus enough bits to identify the element in the received PDU which indicates the function that cannot be supported. This element shall not contain the PDU Type element of the received PDU because this is already specified by the "Not-supported PDU type" element (see note 2).					

14.8 Information elements coding

14.8.0 General

Any of the following elements can be coded as Type 1, 2 or 3 depending on the PDU (see clause 14.7).

14.8.1 Area Selection

The area selection information element shall indicate to the SwMI the distribution of the call as defined in table 14.34. The SS-AS uses this information element, refer to ETSI EN 300 392-12-8 [14].

Table 14.34: Area selection information element contents

Information element	Length	Value	Remark
Area Selection	4	0000 ₂	Area not defined using this information element
		0001 ₂	Refer to ETSI EN 300 392-12-8 [14]
		etc.	etc.
		1111 ₂	Refer to ETSI EN 300 392-12-8 [14]

14.8.2 Basic service information

The basic service information element shall inform the other communication party what basic service is requested as defined in table 14.35. The total element length shall be 8 bits.

Table 14.35: Basic service information element contents

Information sub-element	Length	Type	C/O/M	Remark
Circuit mode type	3	1	M	
Encryption flag	1	1	M	
Communication type	2	1	M	
Slots per frame	2		C	See note
Speech service	2		C	See note
NOTE: Shall be conditional on the value of Circuit mode type:				
- Circuit mode type = 000 ₂ (Speech); Speech service;				
- Circuit mode type = any other value; Slots per frame.				

14.8.3 Call identifier

The call identifier information element shall uniquely identify a specific call as defined in table 14.36.

Table 14.36: Call identifier information element contents

Information element	Length	Value	Remark
Call identifier	14	0	Dummy call identifier
		1 ₁₀ - 16 383 ₁₀	Identifies call uniquely

14.8.3a Call identifier present

The call identifier present information element shall indicate presence or otherwise of the call identifier element, as defined in table 14.37.

Table 14.37: Call identifier present information element contents

Information element	Length	Value	Remark
Call identifier present	1	0	Call identifier element not present
		1	Call identifier element present

14.8.4 Call ownership

The call ownership information element in a group call shall indicate to the MS whether it is capable to disconnect the call or not as defined in table 14.38. In individual call it indicates to both parties if it is a normal call set-up or if it is amalgamated call.

Table 14.38: Call ownership information element contents

Information element	Length	Value	Remark
Call ownership	1	0	Not a call owner (Group call); Normal call set-up (Individual call)
		1	A call owner (Group call); Amalgamated call (Individual call)

14.8.5 Called party type identifier

The called party type identifier information element shall indicate the type of address which shall follow in the PDU as defined in table 14.39.

Table 14.39: Called party type identifier information element contents

Information element	Length	Value	Remark
Called party type identifier	2	00 ₂	Short Number Address (SNA)
		01 ₂	Short Subscriber Identity (SSI)
		10 ₂	TETRA Subscriber Identity (TSI)
		11 ₂	Reserved

14.8.6 Called party SNA

The called party SNA element shall indicate to the SwMI the SNA of the called user as defined in table 14.40.

Table 14.40: Called party SNA information element contents

Information element	Length	Value	Remark
Called party Short Number Address	8	0 - 255 ₁₀	See ETSI ETS 300 392-12-7 [13]

14.8.7 Called party extension

The called party extension information element shall be to indicate to the SwMI the extended part of the TSI address of the called user as defined in table 14.41.

Table 14.41: Called party extension information element contents

Information sub-element	Length	Value	Remark
Country Code	10		See ETSI EN 300 392-1 [6], clause 7
Network Code	14		See ETSI EN 300 392-1 [6], clause 7

14.8.8 Called party SSI

The Called party SSI information element shall indicate to the SwMI the SSI address of the called user as defined in table 14.42.

Table 14.42: Called party SSI information element contents

Information element	Length	Value	Remark
Short Subscriber Identity (SSI)	24		See ETSI EN 300 392-1 [6], clause 7

14.8.9 Calling party type identifier

The calling party type identifier information element shall indicate the type of address which shall follow in the PDU as defined in table 14.43.

Table 14.43: Calling party type identifier information element contents

Information element	Length	Value	Remark
Calling Party Type Identifier	2	00 ₂	Reserved
		01 ₂	Short Subscriber Identity (SSI)
		10 ₂	TETRA Subscriber Identity (TSI)
		11 ₂	Reserved

14.8.10 Calling party extension

The calling party extension information element shall indicate the extended part of the TSI address of the calling user as defined in table 14.44.

Table 14.44: Calling party extension information element contents

Information sub-element	Length	Value	Remark
Country Code	10		See ETSI EN 300 392-1 [6] clause 7
Network Code	14		See ETSI EN 300 392-1 [6] clause 7

14.8.11 Calling party SSI

The Calling party SSI information element shall indicate the SSI address of the calling user as defined in table 14.45.

Table 14.45: Calling party SSI information element contents

Information element	Length	Value	Remark
Short Subscriber Identity (SSI)	24		See ETSI EN 300 392-1 [6] clause 7

14.8.12 Call priority

The call priority information element shall inform the SwMI or the MS about the call priority as defined in table 14.46. The SS-PC and SS-PPC use this element, refer to ETSI EN 300 392-12-10 [15] and ETSI EN 300 392-12-16 [16].

Table 14.46: Call priority information element contents

Information element	Length	Value	Remark
Call priority	4	0000 ₂	Priority not defined
		0001 ₂	Priority 1 (Lowest Priority)
		0010 ₂	Priority 2
		etc.	etc.
		1011 ₂	Priority 11
		1100 ₂	Pre-emptive priority 1
		1101 ₂	Pre-emptive priority 2
		1110 ₂	Pre-emptive priority 3
1111 ₂	Pre-emptive priority 4 (Emergency)		

14.8.13 Call status

The call status information element shall inform the MS about the status of the call as defined in table 14.47.

Table 14.47: Call status information element contents

Information element	Length	Value	Remark
Call status	3	000 ₂	Call is proceeding
		001 ₂	Call is queued
		010 ₂	Requested subscriber is paged
		011 ₂	Call continue
		100 ₂	Hang time expired
		101 ₂	Reserved
		110 ₂	Reserved
		111 ₂	Reserved

14.8.14 Call queued

The call queued information element shall inform the calling MS that the call has been put in queue as defined in table 14.48.

Table 14.48: Call queued information element contents

Information element	Length	Value	Remark
Call queued	1	0	Call is not queued
		1	Call is queued

14.8.15 Continue

The continue information element shall inform the MS if it shall continue after a pause in the same state as before the pause as defined in table 14.49.

Table 14.49: Continue information element contents

Information element	Length	Value	Remark
Continue	1	0	Not continue
		1	Continue

14.8.16 Call time-out

The call time-out information element shall set the maximum call time (T310) as defined in table 14.50.

Table 14.50: Call time-out information element contents

Information element	Length	Value	Remark
Call time-out	4	0000 ₂	Infinite Time
		0001 ₂	30 s
		0010 ₂	45 s
		0011 ₂	60 s
		0100 ₂	2 min
		0101 ₂	3 min
		0110 ₂	4 min
		0111 ₂	5 min
		1000 ₂	6 min
		1001 ₂	8 min
		1010 ₂	10 min
		1011 ₂	12 min
		1100 ₂	15 min
		1101 ₂	20 min
		1110 ₂	30 min
		1111 ₂	Reserved

14.8.17 Call time-out, set-up phase

The call time-out, set-up phase information element (T301 and T302) shall set the maximum set-up time valid for the call set-up phase as defined in table 14.51.

Table 14.51: Call time-out, set-up phase information element contents

Information element	Length	Value	Remark
Call time-out, set-up phase	3	000 ₂	Use predefined value (see note)
		001 ₂	1 s
		010 ₂	2 s
		011 ₂	5 s
		100 ₂	10 s
		101 ₂	20 s
		110 ₂	30 s
		111 ₂	60 s

NOTE: This value shall indicate that the MS shall use a predefined value for the timer.

14.8.17a Circuit mode type

The circuit mode type information element shall indicate the TCH type and the interleaving depth N as defined in table 14.52 (see clause 8).

Table 14.52: Circuit mode type information element contents

Information element	Length	Value	Remark
Circuit mode type	3	000 ₂	Speech: TCH/S
		001 ₂	Unprotected: TCH/7,2
		010 ₂	Low Protection: TCH/4,8, N = 1
		011 ₂	Low Protection: TCH/4,8, N = 4
		100 ₂	Low Protection: TCH/4,8, N = 8
		101 ₂	High Protection: TCH/2,4, N = 1
		110 ₂	High Protection: TCH/2,4, N = 4
		111 ₂	High Protection: TCH/2,4, N = 8

14.8.17b CLIR control

The CLIR control information element shall define whether the calling user invokes or overrides calling user identity presentation restriction as defined in table 14.53, refer to ETSI EN 300 392-12-1 [11].

Table 14.53: CLIR control information element contents

Information element	Length	Value	Remark
CLIR control	2	00 ₂	Not implemented or use default mode
		01 ₂	Reserved
		10 ₂	Presentation not restricted
		11 ₂	Presentation restricted

14.8.17c Communication type

The communication type information element shall inform the other communication party which type of communication service is requested as defined in table 14.54.

Table 14.54: Communication type information element contents

Information sub-element	Length	Value	Remark
Communication type	2	00 ₂	Point-to-point
		01 ₂	Point-to-multipoint
		10 ₂	Point-to-multipoint Acknowledged
		11 ₂	Broadcast

14.8.18 Disconnect cause

The disconnect cause information element shall inform the MS or the infrastructure of the reason for the release/disconnection as defined in table 14.55.

Table 14.55: Disconnect cause information element contents

Information element	Length	Value	Remark
Disconnect cause	5	00000 ₂	Cause not defined or unknown
		00001 ₂	User requested disconnection
		00010 ₂	Called party busy
		00011 ₂	Called party not reachable
		00100 ₂	Called party does not support encryption
		00101 ₂	Congestion in infrastructure
		00110 ₂	Not allowed traffic case
		00111 ₂	Incompatible traffic case
		01000 ₂	Requested service not available
		01001 ₂	Pre-emptive use of resource
		01010 ₂	Invalid call identifier
		01011 ₂	Call rejected by the called party
		01100 ₂	No idle CC entity
		01101 ₂	Expiry of timer
		01110 ₂	SwMI requested disconnection
		01111 ₂	Acknowledged service not completed
		10000 ₂	Unknown TETRA identity
		10001 ₂	SS-specific disconnection
		10010 ₂	Unknown external subscriber identity
		10011 ₂	Call restoration of the other user failed
		10100 ₂	Called party requires encryption
		10101 ₂	Concurrent set-up not supported
		10110 ₂	Called party is under the same DM-GATE of the calling party
10111 ₂	Non-call owner requested disconnection		
11000 ₂	Reserved		
etc.	etc.		
11111 ₂	Reserved		

14.8.18a DM-MS address

For the definition of the DM-MS address information element refer to ETSI EN 300 396-5 [24].

14.8.19 DTMF

The DTMF information element shall transfer DTMF digits (n digits where n shall be less than or equal to 254) to another user application as defined in table 14.56.

Table 14.56: DTMF information element contents

Information element	Length	Type	C/O/M	Remark
DTMF type	3	1	M	
DTMF digit	4		C	See notes 1 and 2
NOTE 1: Shall be conditional on the value of DTMF type: - DTMF type = 000 ₂ (DTMF tone start); DTMF digit(s) present; - DTMF type = any other value; DTMF digit information element not present.				
NOTE 2: This element, if present, shall be repeated for each digit in the DTMF number. The number of DTMF digits in the DTMF number information element is: (the length of the DTMF information element - 3) / 4.				

14.8.19a DTMF digit

The DTMF digit information element shall define the numerical values for DTMF digits as defined in table 14.57.

Table 14.57: DTMF digit information element contents

Information element	Length	Value	Remark
DTMF digit	4	0000 ₂	Digit "0"
		0001 ₂	Digit "1"
		0010 ₂	Digit "2"
		0011 ₂	Digit "3"
		0100 ₂	Digit "4"
		0101 ₂	Digit "5"
		0110 ₂	Digit "6"
		0111 ₂	Digit "7"
		1000 ₂	Digit "8"
		1001 ₂	Digit "9"
		1010 ₂	Digit "*"
		1011 ₂	Digit "#"
		1100 ₂	Digit "A"
		1101 ₂	Digit "B"
		1110 ₂	Digit "C"
1111 ₂	Digit "D"		

14.8.19b DTMF type

The DTMF type information element shall define DTMF tone characteristics as defined in table 14.58.

NOTE: The length of this information element is chosen so that a receiving application can differentiate between the DTMF signalling mechanisms used in edition 1 and this version of the present document based on the total length of the DTMF information element (length is exactly divisible by 4 for the edition 1 mechanism and not exactly divisible by 4 for this version).

Table 14.58: DTMF type information element contents

Information element	Length	Value	Remark
DTMF type	3	000 ₂	DTMF tone start
		001 ₂	DTMF tone end
		010 ₂	DTMF not supported
		011 ₂	DTMF not subscribed
		100 ₂	Reserved
		etc.	etc.
		111 ₂	Reserved

14.8.20 External subscriber number

The external subscriber number information element shall transfer a subscriber number from a TETRA subscriber to a gateway or from a gateway to a TETRA subscriber. The external subscriber number can consist of n digits where n shall be less than or equal to 24. The number of digits is indicated by the preceding type 3 element length divided by four.

The digits of the external subscriber number shall be in descending order (as normally dialled in man machine interface) in the information element. Each digit in the external subscriber number information element shall be encoded as defined in table 14.59.

Table 14.59: Encoding of the digits in the external subscriber number information element

Information element	Length	Value	Remark
External subscriber number digit	4	0000 ₂	Digit "0"
		0001 ₂	Digit "1"
		0010 ₂	Digit "2"
		0011 ₂	Digit "3"
		0100 ₂	Digit "4"
		0101 ₂	Digit "5"
		0110 ₂	Digit "6"
		0111 ₂	Digit "7"
		1000 ₂	Digit "8"
		1001 ₂	Digit "9"
		1010 ₂	Digit "*"
		1011 ₂	Digit "#"
		1100 ₂	Digit "+"
		1101 ₂	Reserved
1110 ₂	Reserved		
1111 ₂	Reserved		

14.8.21 Encryption control

The encryption control information element shall enable an MS to request for encryption/clear mode and then be informed about the granting result of this request as defined in table 14.60.

Table 14.60: Encryption control information element contents

Information element	Length	Value	Remark
Encryption control	1	0	Clear
		1	End-to-end encrypted

14.8.21a Encryption flag

The encryption flag information element shall indicate whether the circuit mode speech or data is end-to-end encrypted as defined in table 14.61.

Table 14.61: Encryption flag information element contents

Information sub-element	Length	Value	Remark
Encryption flag	1	0	Clear Mode
		1	TETRA end-to-end encryption

14.8.22 Facility

The facility information element shall be an optional variable length element and shall be used to send and receive SS information appended to the PDUs which can carry the facility element.

The size and the structure of the facility information element shall be dependent on each individual SS and shall be further detailed in the SS protocol clauses, refer to ETSI EN/ETS 300 392-12 [10].

There can be multiple facility information elements in the same PDU although a single facility information element can carry multiple supplementary services, refer to ETSI EN 300 392-9 [9].

14.8.23 Hook method selection

The hook method selection information element shall inform the infrastructure and the called user(s) of the preferred hook method as defined in table 14.62.

Table 14.62: Hook method selection information element contents

Information element	Length	Value	Remark
Hook method selection	1	0	No hook signalling (direct through-connect)
		1	Hook on/Hook off signalling

14.8.24 Length indicator

The length Indicator information element shall define the length of the user defined data-4 as defined in table 14.63.

Table 14.63: Length indicator information element contents

Information element	Length	Value	Remark
Length indicator	11	0	0 bits
		1	1 bit
		etc.	etc.
		($2^{11}-1$)	2 047 bits

14.8.25 New call identifier

The new call identifier information element coding shall be the same as for the call identifier element.

14.8.26 Modify

The modify information element shall change an ongoing call either to a new basic service or the behaviour from simplex to duplex or reverse as defined in table 14.64.

Table 14.64: Modify information element contents

Information sub-element	Length	Value	Remark
Simplex/duplex selection	1		See description of "Simplex/duplex selection" element
Basic service information	8		See description of "Basic service information" element

14.8.27 Notification indicator

The notification indicator information element shall be used in SSs by the SwMI to inform a MS of various events as defined in table 14.65.

Table 14.65: Notification indicator information element contents

Information element	Length	Value	Remark
Notification indicator	6	0 to 63 ₁₀	Refer to ETSI EN 300 392-9 [9] clause 7.2.2

14.8.27a Other party type identifier

The other party type identifier information element coding shall be the same as for the called party type identifier element, refer to clause 14.8.5.

14.8.27b Other party SNA

The other party SNA information element coding shall be the same as for the called party SNA element, refer to clause 14.8.6.

14.8.27c Other party extension

The other party extension information element coding shall be the same as for the called party extension element, refer to clause 14.8.7.

14.8.27d Other party SSI

The other party SSI information element coding shall be the same as for the called party SSI element, refer to clause 14.8.8.

14.8.28 PDU type

The PDU type information element shall identify the type of CMCE PDU sent over the air interface. The PDU type information element shall have separate definitions in the uplink and downlink directions as defined in table 14.66.

Table 14.66: PDU type information element contents

Information element	Length	Value	Remark	
			Downlink	Uplink
PDU Type	5	00000 ₂	D-ALERT	U-ALERT
		00001 ₂	D-CALL-PROCEEDING	Reserved
		00010 ₂	D-CONNECT	U-CONNECT
		00011 ₂	D-CONNECT ACKNOWLEDGE	Reserved
		00100 ₂	D-DISCONNECT	U-DISCONNECT
		00101 ₂	D-INFO	U-INFO
		00110 ₂	D-RELEASE	U-RELEASE
		00111 ₂	D-SETUP	U-SETUP
		01000 ₂	D-STATUS	U-STATUS
		01001 ₂	D-TX CEASED	U-TX CEASED
		01010 ₂	D-TX CONTINUE	U-TX DEMAND
		01011 ₂	D-TX GRANTED	Reserved
		01100 ₂	D-TX WAIT	Reserved
		01101 ₂	D-TX INTERRUPT	Reserved
		01110 ₂	D-CALL-RESTORE	U-CALL-RESTORE
		01111 ₂	D-SDS-DATA	U-SDS-DATA
		10000 ₂	D-FACILITY	U-FACILITY
		10001 ₂	Reserved	Reserved
		10010 ₂	Reserved	Reserved
		etc.	etc.	etc.
11111 ₂	CMCE FUNCTION NOT SUPPORTED	CMCE FUNCTION NOT SUPPORTED		

14.8.29 Poll request

This poll request information element shall be used by the SwMI to request a poll response back from the MS when an acknowledged group call has been initiated as defined in table 14.67.

Table 14.67: Poll request information element contents

Information element	Length	Value	Remark
Poll request	1	0	No poll answer requested
		1	Poll answer requested

14.8.30 Poll response

This poll response information element shall be used by the MS to respond to a poll request in an acknowledged group call from the SwMI as defined in table 14.68.

Table 14.68: Poll response information element contents

Information element	Length	Value	Remark
Poll response	1	0	No poll response
		1	Poll response

14.8.31 Poll response addresses

The poll response addresses information element shall provide the addresses on responding group members in an acknowledged group call as defined in table 14.69.

Table 14.69: Poll response addresses information element contents

Information element	Length	Value	Remark
1st TSI address	48		See ETSI EN 300 392-1 [6], clause 7
2nd TSI address	48		
etc.	etc.		
nth TSI address	48		

14.8.32 Poll response number

The poll response number information element shall provide the number of responding group members in an acknowledged group call as defined in table 14.70.

Table 14.70: Poll response number information element contents

Information element	Length	Value	Remark
Number of responding group members	6	0 to 63 ₁₀	

14.8.33 Poll response percentage

The poll response percentage information element shall provide the percentage of responding group members in an acknowledged group call as defined in table 14.71.

Table 14.71: Poll response percentage information element contents

Information element	Length	Value	Remark
Percentage of responding number of group members	6	0	0 %
		1	2 %
		etc.	etc.
		50 ₁₀	100 %
		51 ₁₀	Reserved
		etc.	etc.
		63 ₁₀	Reserved

14.8.34 Pre-coded status

The pre-coded status information element shall define general purpose status messages known to all TETRA systems as defined in table 14.72 and shall provide support for the SDS-TL "short reporting" protocol.

Table 14.72: Pre-coded status information element contents

Information element	Length	Value	Remark
Pre-coded status	16	0	Emergency
		1	Reserved
		etc.	etc.
		19 999 ₁₀	Reserved
		20 000 ₁₀	Status values for International co-operation (see NOTE)
		etc.	etc.
		20 999 ₁₀	Status values for International co-operation (see NOTE)
		21 000 ₁₀	Reserved
		etc.	etc.
		31 743 ₁₀	Reserved
		31 744 ₁₀	Refer to SDS-TL in clause 29
		etc.	etc.
		32 767 ₁₀	Refer to SDS-TL in clause 29
		32 768 ₁₀	Available for TETRA network and user specific definitions
		etc.	etc.
65 535 ₁₀	Available for TETRA network and user specific definitions		
NOTE: The meaning of the status values for international co-operation is outside the scope of the present document.			

14.8.35 Proprietary

Proprietary is an optional, variable length information element and shall be used to send and receive proprietary defined information appended to the PDUs as defined in table 14.73. The proprietary element is terminated in CMCE.

The use, the size and the structure of the proprietary element is outside the scope of the present document.

Table 14.73: Proprietary information element contents

Information element	Length	Value	Remark
Proprietary element owner	8	variable	Refer to annex H
Proprietary information	variable	variable	Contents is outside the scope of the present document

14.8.36 Request to transmit/send data

The request to transmit/send data information element shall inform the infrastructure about immediate request to transmit or data transmission at through-connection as defined in table 14.74.

Table 14.74: Request to transmit/send data information element contents

Information element	Length	Value	Remark
Request to transmit/send data	1	0	Request to transmit/send data
		1	Request that other MS may transmit/send data

14.8.37 Reset call time-out timer (T310)

The reset call time-out timer information element shall reset and start the overall call length timer T310 in the MS as defined in table 14.75.

Table 14.75: Reset call time-out timer information element contents

Information element	Length	Value	Remark
Reset call time-out value	1	0	No reset of call time-out timer T310
		1	Reset call time-out timer T310

14.8.38 Short data type identifier

The short data type identifier information element shall identify the length of the user defined data sent to or received from the SwMI as defined in table 14.76.

Table 14.76: Short data type identifier information element contents

Information element	Length	Value	Remark
Short data type identifier	2	00 ₂	User Defined Data 1 element is 16 bits long
		01 ₂	User Defined Data 2 element is 32 bits long
		10 ₂	User Defined Data 3 element is 64 bits long
		11 ₂	User Defined Data 4 element is 0 to 2 047 bits long (variable length)

14.8.39 Simplex/duplex selection

The simplex/duplex selection information element shall be to inform the infrastructure the preferred mode of operation as defined in table 14.77.

Table 14.77: Simplex/duplex selection information element contents

Information element	Length	Value	Remark
Simplex/duplex selection	1	0	Simplex requested
		1	Duplex requested

14.8.39a Slots per frame

The slots per frame information element shall indicate the required bit rate for a circuit mode data call as defined in table 14.78. For TCH/7,2, TCH/4,8 and TCH/2,4 the resulting bit rate is the TCH bit rate multiplied by the number of slots per frame. (e.g. TCH/7,2 in four time slots per frame gives a circuit mode data rate of 28,8 kbit/s).

Table 14.78: Slots per frame information element contents

Information sub-element	Length	Value	Remark
Slots per frame	2	00 ₂	One slot
		01 ₂	Two slots
		10 ₂	Three slots
		11 ₂	Four slots

14.8.40 Speech service

The speech service information element shall indicate the required speech and channel encoding as defined in table 14.79.

Table 14.79: Speech service information element contents

Information element	Length	Value	Remark
Speech service	2	00 ₂	TETRA encoded speech
		01 ₂	Reserved
		10 ₂	Reserved
		11 ₂	Proprietary encoded speech

14.8.41 Temporary address

The temporary address information element coding shall be the same as for the SSI element.

14.8.42 Transmission grant

The transmission grant information element shall inform the MS about permission to transmit as defined in table 14.80.

Table 14.80: Transmission grant information element contents

Information element	Length	Value	Remark
Transmission grant	2	00 ₂	Transmission granted
		01 ₂	Transmission not granted
		10 ₂	Transmission request queued
		11 ₂	Transmission granted to another user

14.8.43 Transmission request permission

The transmission request permission information element shall inform the MS if it is allowed to request for transmit permission as defined in table 14.81.

Table 14.81: Transmission request permission information element contents

Information element	Length	Value	Remark
Transmission request permission	1	0	Allowed to request for transmission
		1	Not allowed to request for transmission

14.8.44 Transmitting party type identifier

The transmitting party type identifier information element coding shall indicate the type of address which shall follow in the PDU as defined in table 14.82.

Table 14.82: Transmitting party type identifier information element contents

Information element	Length	Value	Remark
Transmitting party type identifier	2	00 ₂	Reserved
		01 ₂	Short Subscriber Identity (SSI)
		10 ₂	TETRA Subscriber Identity (TSI)
		11 ₂	Reserved

14.8.45 Transmitting party extension

The transmitting party extension information element shall indicate the extended part of the TSI address of the transmitting user as defined in table 14.83.

Table 14.83: Transmitting party extension information element contents

Information sub-element	Length	Value	Remark
Country Code	10		See ETSI EN 300 392-1 [6], clause 7
Network Code	14		See ETSI EN 300 392-1 [6], clause 7

14.8.46 Transmitting party SSI

The transmitting party SSI information element shall indicate the SSI address of the transmitting user as defined in table 14.84.

Table 14.84: Transmitting party SSI information element contents

Information element	Length	Value	Remark
Short Subscriber Identity (SSI)	24		See ETSI EN 300 392-1 [6], clause 7

14.8.47 TX demand priority

The TX demand priority information element shall inform the SwMI about the importance of a TX-Demand as defined in table 14.85.

Table 14.85: Tx demand priority information element contents

Information element	Length	Value	Remark
TX demand priority	2	00 ₂	Low priority level
		01 ₂	High priority level
		10 ₂	Pre-emptive priority level
		11 ₂	Emergency pre-emptive priority level

14.8.48 Type 3 element identifier

The type 3 element identifier information element shall indicate the type of the following type 3 element in the PDU as defined in table 14.86.

Table 14.86: Type 3 element identifier information element contents

Information element	Length	Value	Remark
Type 3 element identifier	4	0000 ₂	Reserved
		0001 ₂	DTMF
		0010 ₂	External subscriber number
		0011 ₂	Facility
		0100 ₂	Poll response addresses
		0101 ₂	Temporary address
		0110 ₂	DM-MS address
		0111 ₂	Reserved for any future specified Type 3 element
		etc.	etc.
1111 ₂	Proprietary		

14.8.49 User defined data-1

The User Defined Data-1 information element shall enable the user applications to determine their own interpretation of the SDS message as defined in table 14.87.

Table 14.87: User Defined Data-1 information element contents

Information element	Length	Value	Remark
User Defined Data-1	16	0 to $(2^{16} - 1)$	All values available for the user application

14.8.50 User defined data-2

The User Defined Data-2 information element shall enable the user applications to determine their own interpretation of the SDS message as defined in table 14.88.

Table 14.88: User Defined Data-2 information element contents

Information element	Length	Value	Remark
User Defined Data-2	32	0 to $(2^{32} - 1)$	All values available for the user application

14.8.51 User defined data-3

The User Defined Data-3 information element shall enable the user applications to determine their own interpretation of the SDS message as defined in table 14.89.

Table 14.89: User Defined Data-3 information element contents

Information element	Length	Value	Remark
User Defined Data-3	64	0 to $(2^{64} - 1)$	All values available for the user application

14.8.52 User defined data-4

The User Defined Data-4 information element shall enable the user applications to determine their own interpretation of the SDS message as defined in table 14.90. The first 8 bits of the user defined data-4 element shall contain a protocol identifier as defined in clause 29.

Table 14.90: User Defined Data-4 information element contents

Information element	Length	Value	Remark
Protocol identifier	8	variable	Refer to clause 29
Protocol dependent User Defined Data-4	variable (0 to 2 039 bits)	variable	Refer to clause 29

15 Mobility Management (MM) service description

15.1 Introduction

This clause describes the services offered by the MM entity (see ETSI EN 300 392-1 [6], clause 6) for the V+D TETRA layer 3 air interface. The MM SAP is used in conformance testing as a normative boundary in TETRA MSs.

15.2 Services offered

The MM shall be a service provider for mobility service users on the layer 3 MS air interface. The services shall be made available through a TETRA Network Mobility Management Service Access Point (TNMM-SAP) (see ETSI EN 300 392-1 [6], clause 6) which is shown in figure 15.1. The protocol description is defined in clause 16.

The services offered by MM are:

- registration (mandatory), this service shall allow a user to register manually to the network, the user shall be then informed of the result of the registration. When a MS roams or migrates the user application shall be also informed that the MS is ready for use or that registration was not possible (see ETSI EN 300 392-1 [6], clause 9);
- de-registration (detach) (optional), this service allows a user to request cancellation of the registration;
- change of energy saving mode (optional), this service shall allow the user to ask for changing the energy saving mode with confirmation or to receive and to respond to an energy saving mode allocation;
- change of dual watch mode (optional), this service allows the user to ask for dual watch operation with an appropriate energy economy group or to end dual watch operation;
- attachment/detachment of group identities (optional), this service shall allow the user application to either activate or deactivate already defined group identities in the MS/LS. The service shall also inform the user applications of the result of the attachment/detachment of the group identities both when the user application initiates the attachment/detachment or when the SwMI initiates the attachment/detachment;
- information concerning state of the mobile (optional).

NOTE: Enable, disable service is defined in ETSI EN 300 392-7 [8], this service allows a user to be aware of the temporary or permanent disabling asked by the network. The user application is also made aware of the cessation of a temporary disable.

15.3 Primitive description

15.3.0 General

The services shall be provided through primitives at the TNMM-SAP. Clauses 15.3.1 to 15.3.4 describe the primitives and their parameters. Clauses 15.3.5 and 15.3.6 describe states and state transitions.

15.3.1 Service state model for the MS

The primitives provided at the TNMM-SAP are illustrated in figure 15.1.

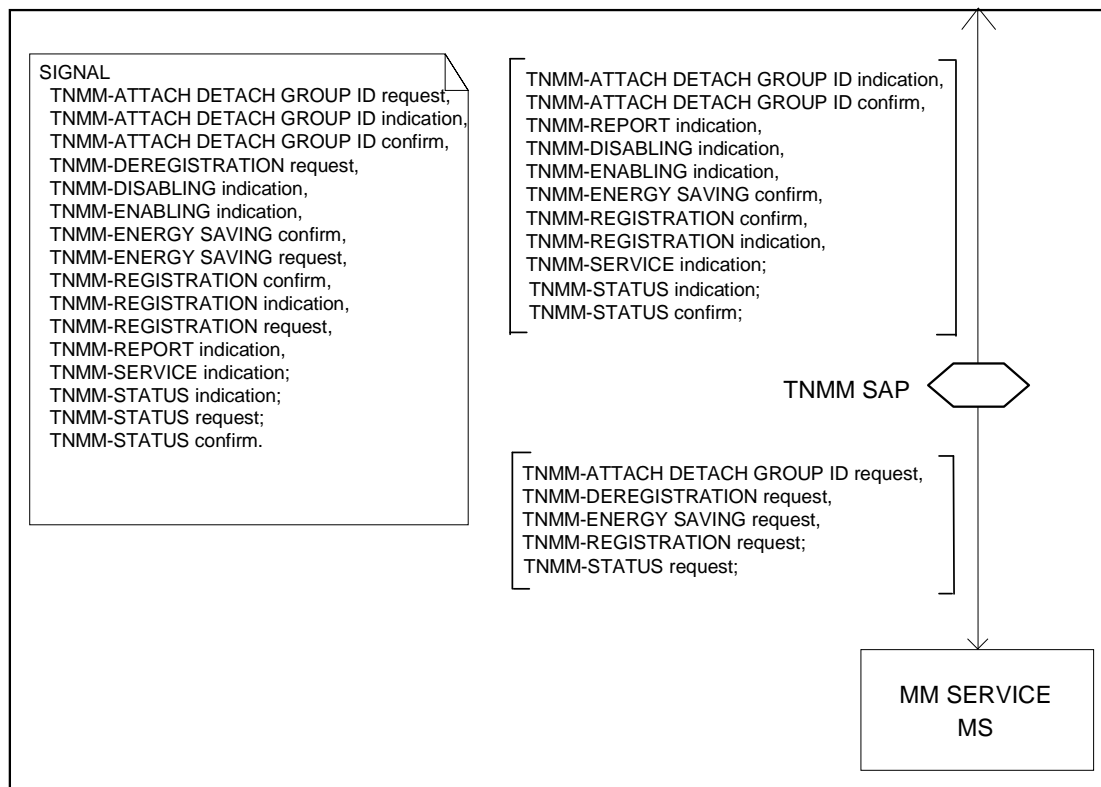

NOTE: TNMM-DISABLING and TNMM-ENABLING primitives are defined in ETSI EN 300 392-7 [8].

Figure 15.1: Services provided at TNMM-SAP/MS-side

15.3.2 Service primitives at the TNMM-SAP, MS/LS side

The set of MM primitives that are available to provide the specified service to the user application shall be:

- **TNMM-ATTACH DETACH GROUP IDENTITY request/indication/confirm:** the primitives shall be used to handle activation and deactivation of defined GTSIs in the MS/LS or to request group report from SwMI;
- **TNMM-DEREGISTRATION request:** the primitive shall be used to handle detachment of attached ITSIs;
- **TNMM-ENERGY SAVING indication /request/confirm:** the primitives shall be used to exchange energy saving mode of operation to the SwMI;
- **TNMM-REGISTRATION request/indication/confirm:** the primitives shall be used to handle attachment of ITSIs and can as well be used for activation/de-activation of GSSIs;
- **TNMM-REPORT indication:** the primitive shall be used to inform the user application of a successful or unsuccessful transmission of U-ITSI DETACH;
- **TNMM-SERVICE indication:** the primitive shall be used as an indication to the user application to reflect the service state of the MS, i.e. whether it shall be possible to initiate or receive communication using the current network;
- **TNMM-STATUS request/indication/response/confirm:** the primitives shall be used for various mobility management services.

15.3.3 Primitive description

15.3.3.0 General

The information contained in the primitive description tables which follow corresponds to the following key:

M: Mandatory;

C: Conditional;

O: Optional;

-: Not used.

15.3.3.1 TNMM-ATTACH DETACH GROUP IDENTITY primitive

TNMM-ATTACH DETACH GROUP IDENTITY request: the primitive shall be used by the user application to activate or deactivate one or more defined group identities in the MS/LS or ask for group report.

TNMM-ATTACH DETACH GROUP IDENTITY indication: the primitive shall be used as an indication to the user application when the SwMI has activated or de-activated one or more defined group identities in the MS/LS.

TNMM-ATTACH DETACH GROUP IDENTITY confirm: the primitive shall be used as an indication to the user, that the requested activation or de-activation of group identities is negotiated between the MS/LS and the SwMI.

The parameters shall be as defined in table 15.1.

Table 15.1: Parameters for the primitive TNMM-ATTACH DETACH GROUP IDENTITY

Parameter	Request	Indication	Confirm
Group identity attach detach mode	M	-	M
Group identity request	M	-	-
Group identity report	O	-	O
Group identities	-	M	M

15.3.3.2 TNMM-DEREGISTRATION primitive

TNMM-DEREGISTRATION request: the primitive shall be used to request to cancel the registration, stimulated either by removing the "ITSI identity" or a "log-off" application or automatically in the power off phase.

The parameters shall be as defined in table 15.2.

Table 15.2: Parameters for the primitive TNMM-DEREGISTRATION

Parameter	Request
ISSI	O
MCC	O
MNC	O
NOTE:	In case all the attached ITSIs are detached, the parameters need not to be present.

15.3.3.3 TNMM-DISABLING primitive

Refer to ETSI EN 300 392-7 [8], clause 5.

15.3.3.4 TNMM-ENABLING primitive

Refer to ETSI EN 300 392 7 [8], clause 5.

15.3.3.5 TNMM-ENERGY SAVING primitive

TNMM-ENERGY SAVING indication: the primitive shall be used to indicate to the user application a start or change of energy economy mode the SwMI wants to use.

TNMM-ENERGY SAVING request: the primitive shall be used by the user application to change or re-state to the SwMI what energy economy mode the MS wants to use.

TNMM-ENERGY SAVING confirm: the primitive shall be used as a confirmation to the user application that the changed or re-stated energy economy mode has been reported to the SwMI.

The parameters shall be as defined in table 15.3.

Table 15.3: Parameters for the primitive TNMM-ENERGY SAVING

Parameter	Request	Confirm	Indication
Energy economy mode	M	M	O
Energy economy mode status	-	M	O

15.3.3.6 TNMM-REPORT primitive

TNMM-REPORT indication: the primitive shall be used to inform the user application of a successful or unsuccessful transmission of U-ITSI DETACH.

The parameters shall be as defined in table 15.4.

Table 15.4: Parameters for the TNMM-REPORT primitive

Parameter	Indication
Transfer result	M

15.3.3.7 TNMM-REGISTRATION primitive

TNMM-REGISTRATION request: the primitive shall be used by the user application to initiate attachment and registration of the terminal.

TNMM-REGISTRATION indication: the primitive shall be used as an indication to the user application that the LS/MS has carried out registration procedure (either successfully or unsuccessfully) or that LA registration is expired.

TNMM-REGISTRATION confirm: the primitive shall be used to inform the user application that registration is confirmed. The primitive may be used to inform the user that the MS/LS is ready for use.

The parameters shall be as defined in table 15.5.

Table 15.5: Parameters for the primitive TNMM-REGISTRATION

Parameter	Request	Indication	Confirm
Registration status	-	M	M
Registration reject cause (see note 1)	-	C	C
Cell type (where registered)	-	M	M
LA (where registered)	-	M	M
MCC (where registered)	-	M	M
MNC (where registered)	-	M	M
Registration type	M	-	-
Required cell type list	O	-	-
Preferred cell type list (see note 4)	O	-	-
SwMI's required cell types (see note 5)	-	O	-
Preferred LA list (see note 2)	O	-	-
Preferred MCC list (see note 3)	O	-	-
Preferred MNC list (see note 3)	O	-	-
ISSI	M	-	-
MCC (of the ISSI)	M	-	-
MNC (of the ISSI)	M	-	-
Energy economy mode	O	O	O
Energy economy mode status	-	O	O
Group identities	-	O	O
Group identity request	O	-	-
Group identity attach/detach mode	O	O	O
NOTE 1: Shall be present if Registration Status = "failure".			
NOTE 2: Shall be present if Registration Type = "no new ITSI - forward registration".			
NOTE 3: Shall be present if Registration Type = "New ITSI"; or Registration Type = "No new ITSI - forward registration".			
NOTE 4: If both the "required cell type list" and the "preferred cell type list" parameters are included, the "preferred cell type list" shall comprise a subset of the "Required cell type list".			
NOTE 5: Shall be present if Registration Status = "no permitted cell types".			

15.3.3.8 TNMM-SERVICE primitive

TNMM-SERVICE indication: the primitive shall be used as an indication to the user application to reflect the service state of the MS, i.e. whether it shall be possible to initiate or receive communication using the current network.

The parameters shall be as defined in table 15.6.

Table 15.6: Parameters for the primitive TNMM-SERVICE

Parameter	Indication
Service status	M
Disable status	M

15.3.3.9 TNMM-STATUS primitive

TNMM-STATUS request: the primitive shall be used to request various mobility management services.

TNMM-STATUS indication: the primitive shall indicate to the user application a mobility management service or action request.

TNMM-STATUS confirm: the primitive shall indicate to the user application the result of a request.

The parameters shall be as defined in table 15.7.

NOTE: The energy economy mode is also managed by this primitive.

Table 15.7: Parameters for the primitive TNMM-STATUS

Parameter	Request	Indication	Confirm
Service status		M	
Disable status		M	
Direct mode	O	-	-
Dual watch	O	O	O
Energy economy mode (see note)	O	O	O
Cell load	-	O	-
NOTE: This parameter is applicable with the dual watch parameter.			

15.3.4 Parameters description

Parameters shall be part of the primitives described in clause 15.3.3 and if applied the parameters shall contain the values specified in this clause.

- Cell load =
 - Cell load unknown;
 - Low cell load for CA;
 - Medium cell load for CA;
 - High cell load for CA;
 - Cell load information is not available for CA;
 - Low TCH load DA;
 - Reserved;
 - High TCH load DA;
 - Cell load information is not available for TCH in DA;
 - Low PDCH load DA;
 - High PDCH load DA;
 - Cell load information is not available for PDCH in DA;
 - Low CCH/SDS load DA;
 - High CCH/SDS load DA;
 - Cell load information is not available for CCH/SDS in DA.
- Cell type (where registered) =
 - CA cell;
 - DA cell.

- Class of usage =
 - Class of Usage 1;
 - Class of Usage 2;
 - Class of Usage 3;
 - Class of Usage 4;
 - Class of Usage 5;
 - Class of Usage 6;
 - Class of Usage 7;
 - Class of Usage 8.
- Disable status =
 - enabled;
 - temporary disabled;
 - permanently disabled.
- Dual watch =
 - starting dual watch mode;
 - modify or resume dual watch mode;
 - dual watch mode accepted;
 - dual watch mode rejected;
 - dual watch mode not supported;
 - terminating dual watch mode;
 - terminating dual watch mode response;
 - dual watch energy economy group changed by SwMI;
 - dual watch mode terminated by SwMI.
- Direct mode =
 - start of direct mode operation.

NOTE: A return to trunking mode is a normal registration.

- Energy economy mode =
 - stay alive;
 - energy economy mode 1;
 - energy economy mode 2;
 - energy economy mode 3;
 - energy economy mode 4;
 - energy economy mode 5;
 - energy economy mode 6;
 - energy economy mode 7.

- Energy economy mode status =
 - accepted;
 - rejected.
- Group identities =

Table 15.8: Group identities parameter

Parameter	C/O/M	Remark
GTSI	M	
Group Identity Attach/detach Type Identifier	M	
Group Identity Lifetime	C	See note
Class of Usage	C	See note
Group Identity Detachment Reason	C	See note
NOTE: Shall be conditional on the value of Group Identity Type Identifier (GITI). <ul style="list-style-type: none"> - GITI = Attachment; Group Identity Lifetime + Class of Usage; - GITI = Detachment; Group Identity Detachment Reason. 		

- Group identity attach/detach mode =
 - amendment;
 - detach the currently active group identities.
- Group identity request =

Table 15.9: Group identity request parameter

Parameter	C/O/M	Remark
GTSI	M	
Group Identity Attach/detach Type Identifier	M	
Class of Usage	C	See note
Group Identity Detachment Request	C	See note
NOTE: Shall be conditional on the value of Group Identity Type Identifier (GITI). <ul style="list-style-type: none"> - GITI = Attachment; Class of Usage; - GITI = Detachment; Group Identity Detachment. 		

- Group identity Attach/detach type identifier =
 - attachment;
 - detachment.
- Group identity lifetime =
 - permanent, attachment not needed;
 - attachment needed for next ITSI-Attach;
 - attachment not allowed after next ITSI-Attach;
 - attachment needed for next location update.
- Group identity detachment =
 - permanently detached;
 - temporary 1 detached;
 - temporary 2 detached;
 - unknown group identity.

- Group identity detachment request =
 - user initiated detachment.
- Group identity report =
 - report requested;
 - report not requested.
- GTSI =
 - Group TETRA Subscriber Identity.
- ISSI =
 - Individual Short Subscriber Identity.
- LA =
 - location area.
- MCC =
 - Mobile Country Code (see ETSI EN 300 392-1 [6], clause 7).
- MNC =
 - MNC (see ETSI EN 300 392-1 [6], clause 7).
- Preferred cell type list =
 - list of cell types.
- Preferred LA list =
 - list of preferred and/or permitted LA identities and associated MCCs and MNCs.
- Preferred MCC list =
 - list of preferred and/or permitted MCC identities.
- Preferred MNC list =
 - list of preferred and/or permitted MNC identities.

- Registration reject cause =
 - ITSI unknown;
 - illegal MS;
 - LA not allowed;
 - LA unknown;
 - network failure;
 - congestion;
 - forward registration failure;
 - service not subscribed;
 - mandatory element error;
 - message consistency error;
 - roaming not supported;
 - migration not supported;
 - no cipher KSG;
 - identified cipher KSG not supported;
 - requested cipher key type not available;
 - identified cipher key not available;
 - ciphering required;
 - authentication failure.
- Registration status =
 - success;
 - failure;
 - LA registration expired;
 - no preferred cell found;
 - no permitted cell types.
- Registration type =
 - periodic registration;
 - registration to indicated cell.
- Required cell type list =
 - list of cell types.

- Service status =
 - in service;
 - in graceful service degradation mode;
 - in service waiting for registration;
 - out of service;
 - MM busy;
 - MM idle.
- Transfer result =
 - transfer successful done;
 - transfer fail.

15.3.5 State description for the MS

15.3.5.0 General

The following clauses define the status of the different states used within the SDL description given in clause 15.3.6.

15.3.5.1 Not updated

This state shall be used when the MS is ready for a registration request.

15.3.5.2 Wait updating

This shall be an intermediate state while the network is processing the registration request.

15.3.5.3 Updated

This shall be the state that is used while registered. The MS shall be ready for transactions.

15.3.5.4 Temporary disabled

This state shall be used after receiving a <disable> message with parameter "temporary". The only way out of the state shall be a <enable> message.

15.3.5.5 Permanently disabled

This state shall be used after receiving a <disable> message with parameter "permanently". There shall be no way out of the state using the air interface protocol as defined in the present document.

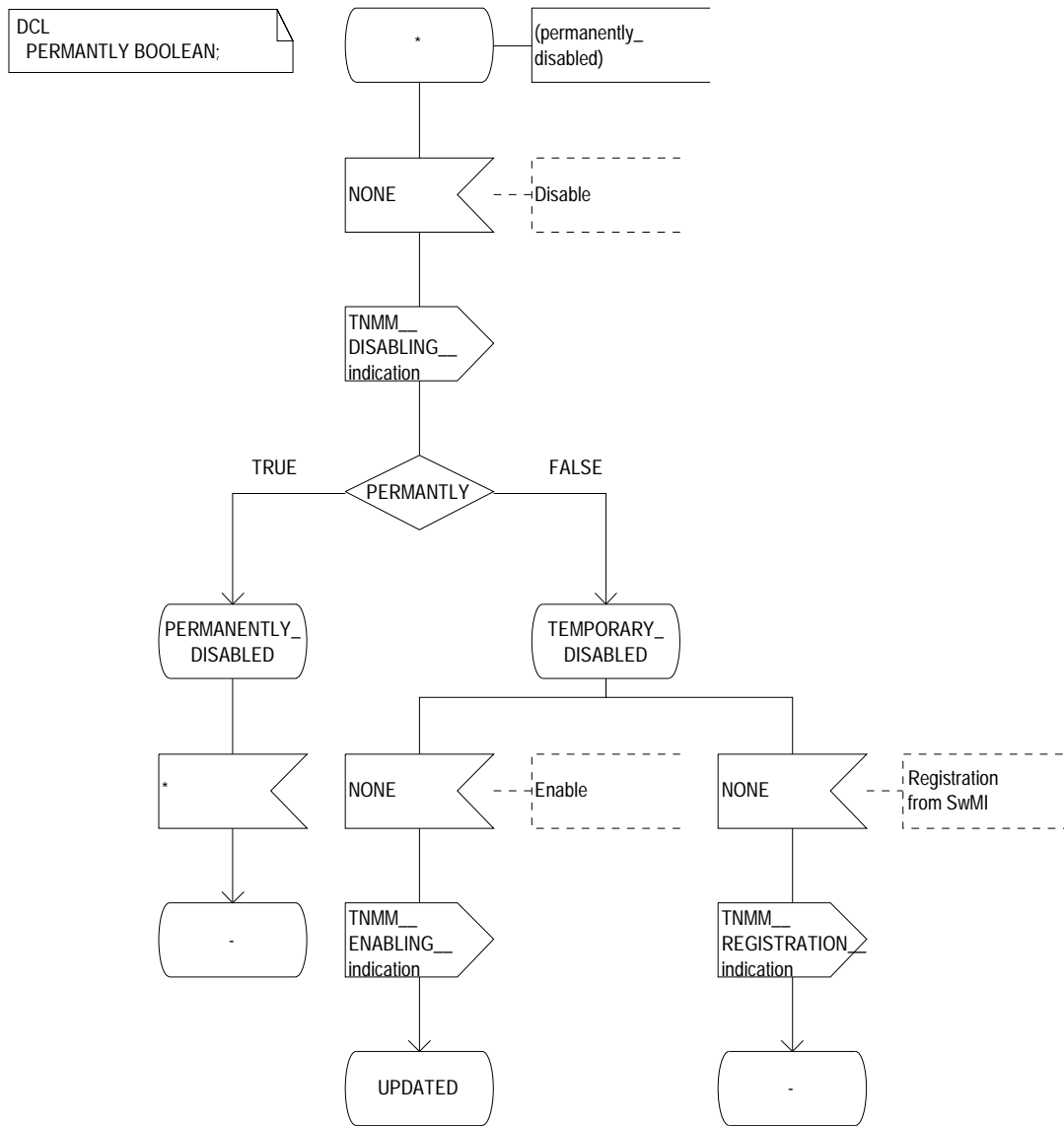

Figure 15.3: MM service state diagram (sheet 2 of 4)

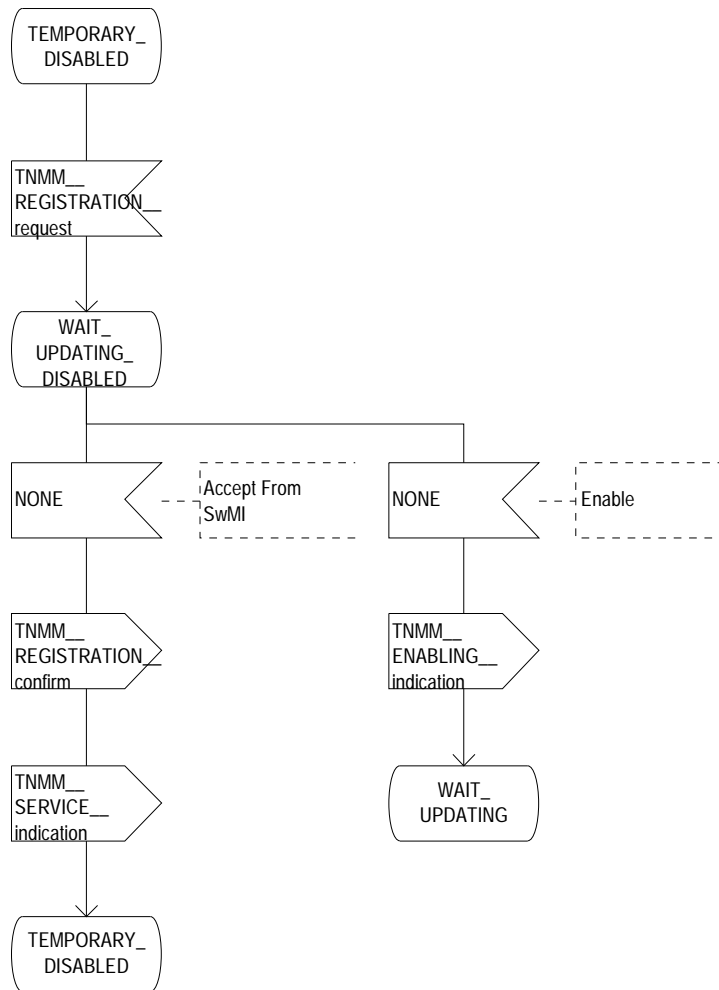

Figure 15.4: MM service state diagram (sheet 3 of 4)

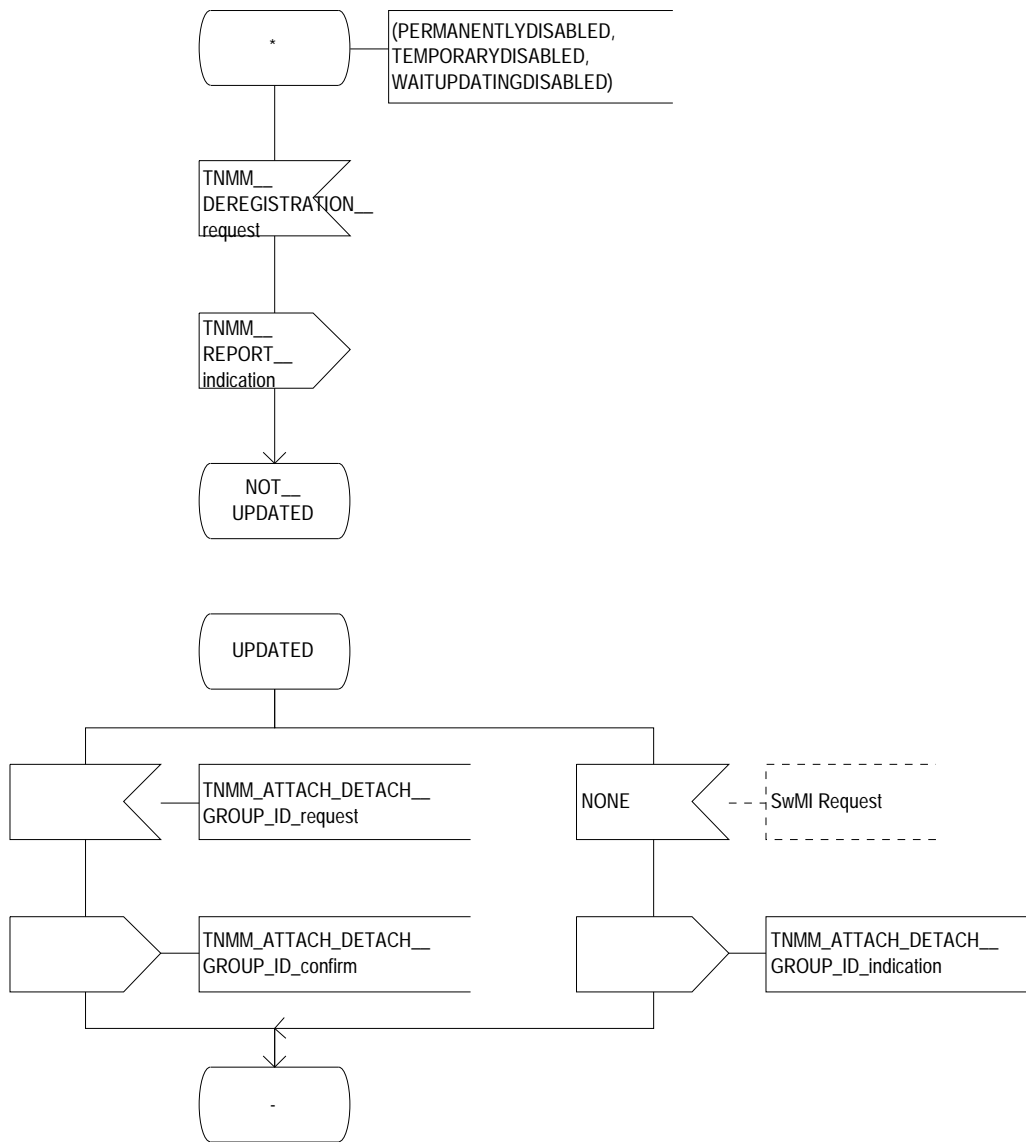

Figure 15.5: MM service state diagram (sheet 4 of 4)

16 MM protocol

16.1 Introduction

This clause defines for the MS the TETRA MM protocol. This is the network layer protocol that shall be used to provide the MM service (see clause 15). This clause defines the protocol functions required for operation as an end system (i.e. providing service to an end user).

This clause specifies:

- procedures for registration and de-registration of a MS;
- procedures for negotiating the energy saving scheme to be used;
- procedures for moving to direct mode and returning to trunking mode operation;
- procedures for requesting direct mode dual watch operation; and
- procedures for attachment/detachment of group identities.

In addition to this clause ETSI EN 300 392-7 [8] specifies security related parts of the MM protocol and ETSI EN 300 396-5 [24] specifies direct mode gateway related parts of the MM protocol.

The procedures are defined in terms of:

- interactions among peer network entities through the exchange of PDUs;
- interactions between a network entity and a network service user through the exchange of network service primitives;
- interaction between a network entity and an underlying service provider through the exchange of service primitives.

The timer actions in the following procedures are defined:

- start: the timer shall be reset and started to measure time as indicated in the timer parameter value (independently of the current timer count); and
- stop: the timer shall be stopped and no further actions shall be taken against that timer any more before next starting of the timer.

NOTE: This clause does not use any timer re-start where the timer is halted for a period of time and then counting continues without resetting the timer.

16.2 MM procedures

16.2.1 General

The internal organization of the network layer including the MM entity is described in the V+D protocol architectures (see ETSI EN 300 392-1 [6], clause 6).

The underlying services offered are those of the MLE, refer to clause 17 and ETSI EN 300 392-1 [6], annex H.

16.2.2 Services provided by the protocol

The following services offered have been described in clause 15:

- registration on user demand (including at power up);
- registration initiated by MLE (caused by roaming or migration);
- registration requested by SwMI;
- de-registration due to user request;
- energy saving mode change to user request;
- moving to direct mode and returning to trunking mode operation to user request;
- direct mode dual watch operation to user request;
- attachment/detachment of group identities by user request; and
- attachment/detachment of group identities by SwMI request.

In addition to this clause ETSI EN 300 392-7 [8] specifies security related MM services and ETSI EN 300 396-5 [24] specifies direct mode gateway related MM services.

16.2.3 Underlying services assumed by the protocol

On the air interface the protocol shall use the MLE as defined in clause 17. The data transferring type when sending MLE-UNITDATA request shall be type "acknowledged" if not defined otherwise in this clause.

16.2.4 Services assumed from the local environment

No specific service shall be assumed from the Lower Layer Management Entity (LLME).

16.3 Protocol functions

16.3.0 General

The basic functions of the protocol defined in the present document for the MS are:

- to initiate PDU composition and decomposition;
- to initiate header error detection;
- to initiate activation of the selection of a cell sent to the MLE through an MLE-ACTIVATE request primitive at power up;
- to send a registration request in response to a request from MLE (passed to MM via the MLE-LINK indication primitive) - this includes conducting a network code check to determine the type of registration required;
- to send a registration request in response to a valid command from the infrastructure (passed to MM via the D-LOCATION UPDATE COMMAND PDU) - this includes conducting a network code check on the validity of the command;
- to send a registration request in response to a user application request for a periodic registration (passed to MM via the TNMM-REGISTRATION request primitive);
- to request MLE to locate a cell with a preferred and/or permitted MCC, MNC, LA and/or cell type in response to a user application request that is not for a periodic registration (passed to MM via the TNMM-REGISTRATION request primitive) sent to the MLE through an MLE-ACTIVATE request primitive at some time other than power up;

- to update the MLE with a new registered area through an MLE-UPDATE request primitive;
- to initiate handling of exceptional procedures reported by the MLE (failures to requests);
- to supply or update the SSI (ASSI or ISSI) to be used to the MLE through MLE-IDENTITIES request primitive. This information may be either in the D-LOCATION PROCEEDING or in the D-LOCATION UPDATE ACCEPT PDU received by the MM;
- to supply or update the complete list of GSSIs to be used to the MLE through MLE-IDENTITIES request primitive. This information shall be either in the D-LOCATION UPDATE ACCEPT, D-ATTACH/DETACH GROUP IDENTITY or D-ATTACH/DETACH GROUP IDENTITY ACKNOWLEDGEMENT PDU received by the MM;
- to send and receive PDUs to and/or from the sub-layer MLE through MLE-UNITDATA request and indication primitive. The received PDUs can be handled locally by the MM or routed to the user application;
- to send and receive PDUs to and/or from the sub-layer MLE through MLE-PREPARE request and indication primitive;
- to initiate the update criteria with the monitoring of other possible cells using an MLE-UPDATE request primitive following an infrastructure request;
- to initiate detach handling through a TNMM-DEREGISTRATION request primitive from the user, the MM shall then send a message to the infrastructure;
- to initiate energy saving mode handling following a change requested by the user: the new value may be negotiated by the MM through transmitting it to the network in a energy saving mode information element;
- to allow the MLE to indicate to other layer 3 entities that MM is involved in an individually addressed signalling exchange with the SwMI by sending (to the MLE) an MLE-BUSY request primitive;
- to allow the MLE to indicate to other layer 3 entities that MM is no longer busy by sending an MLE-IDLE request primitive at the conclusion of such an exchange;
- to request the MLE to place the MS into a state of temporary disablement by sending MLE-DISABLE request primitive;
- to request the MLE to recover the MS from its state of temporary disablement by sending MLE-ENABLE request primitive;
- to allow the MLE to remove access to communication resources for the other layer 3 entities by sending MLE-CLOSE request primitive;
- to allow the MLE to provide access to communication resources for other layer 3 entities after successful registration and after recovery from temporary disablement by sending MLE-OPEN request primitive.

On the infrastructure side, the MM functions should be symmetrical, except activation of the selection of a cell which does not exist. Figure 16.1 summarizes the MM functions.

The different protocol procedures are shown in the present document by the primitive sequences and PDU exchanges. The scenarios outlined are:

- de-registration;
- energy saving mode change;
- user request registration;
- network request registration;
- MLE initiated registration;
- user request attachment/detachment of group identities;
- network request attachment/detachment of group identities;

- moving to direct mode and returning to trunking mode operation; and
- requesting direct mode dual watch operation.

Figure 16.1 indicates the main functions of the MM.

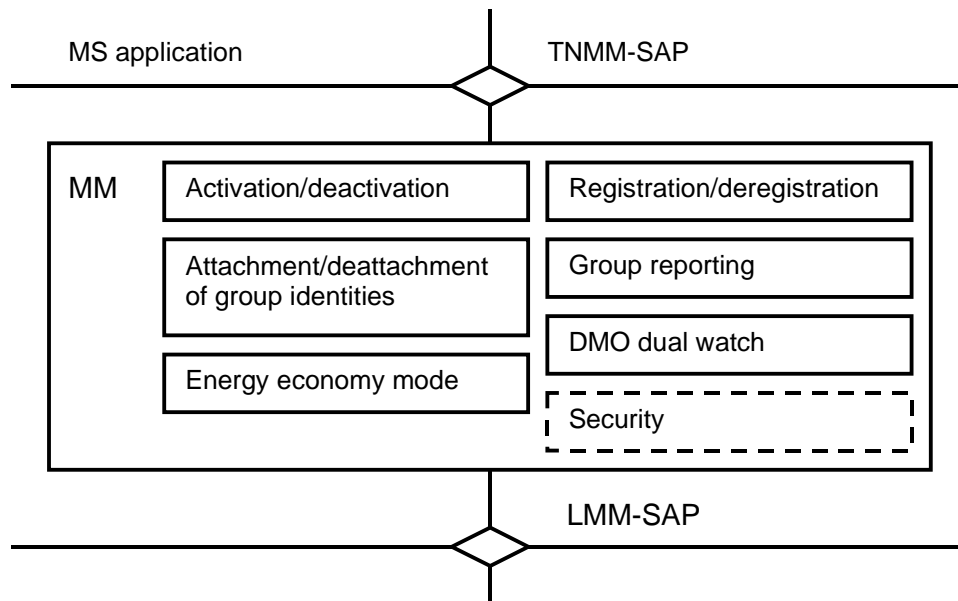

NOTE: Security functions are defined in ETSI EN 300 392-7 [8].

Figure 16.1: MM main functions on the MS

16.3.1 Activation and control of underlying MLE Service

16.3.1.1 Activation procedure

If the MS has its ITSI or TEI or both permanently disabled the MS shall remain disabled at power up and shall not activate any of the protocol entities, refer to ETSI EN 300 392-7 [8]. The following describes the procedure for MSs that have not been permanently disabled; refer to figure 16.2.

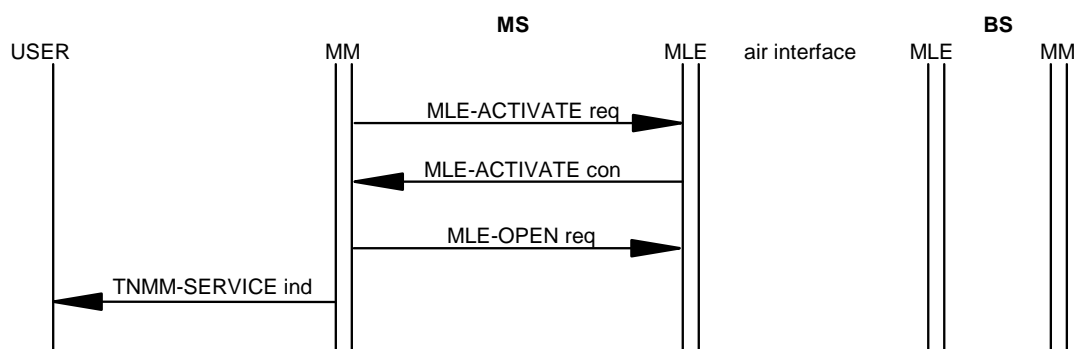

Figure 16.2: MM Activation procedure, successful cell selection

At power up, or similar start up such as a change of SIM card, the MM shall issue an MLE-ACTIVATE request primitive. The MLE-ACTIVATE request primitive shall contain a list of valid mobile network identities, valid LAs and MM's "cell type preference or requirement" (see clause 16.4.12).

When the MS performs initial cell selection (see clause 18.3.4.6), MM shall wait for the reception of either a MLE-ACTIVATE confirm or MLE-ACTIVATE indication primitive.

Upon receipt of an MLE-ACTIVATE indication primitive, the MM entity may issue a new MLE-ACTIVATE request primitive with a revised list of cell selection parameters. If no new parameters for a cell selection are available MM shall then inform the user application with a TNMM-SERVICE indication primitive issuing that the MS is "out of service".

Upon receipt of an MLE-ACTIVATE confirm primitive, the MM entity shall check whether the selected cell requires registration as follows:

- a) registration mandatory:
 - the MM shall inform the user application with TNMM-SERVICE indication primitive issuing that the MS is "in service waiting for registration".
- b) registration is not required:
 - the MM shall open the communication resources to the other higher layer entities by issuing an MLE-OPEN request primitive to MLE which shall pass it to other entities. This MLE-OPEN request primitive shall be accompanied by a list of currently valid subscriber identities (ITSI, GTSI) in an MLE-IDENTITIES request primitive. The MM shall inform the user application with TNMM-SERVICE indication primitive indicating that the MS is "in service". The TNMM-SERVICE indication primitive shall not be issued if the MS has previously been temporarily disabled and not subsequently enabled by the infrastructure.

16.3.1.2 Deactivation procedure

This procedure shall be invoked at power down or if the ITSI is detached from the MS. The MM shall issue an MLE-CLOSE request primitive to MLE to indicate that access to the communication resources has been closed to the other higher layer entities; SNDPCP and CMCE. MM shall then issue an MLE-DEACTIVATE request primitive.

16.3.1.3 Maintenance procedures

16.3.1.3.1 Report and cancel handling

The cancel and report procedure may be implemented in the MS and if used the following shall apply.

Incoming MLE-REPORT indication primitives should indicate the following events:

- a PDU has been stored by the DLL ready for transmission. At this stage the transmission may be cancelled using a MLE-CANCEL request primitive and no information will be sent over the air interface;
- the first transmission of whole PDU. The BS may have received the PDU, but MS has not yet received an acknowledgement. At this stage the layer 2 process may be stopped using a MLE-CANCEL request primitive, but MM cannot rely on the cancellation and may receive a response to the sent PDU;
- a PDU has not been successfully transmitted by layer 2. Cancellation is no longer possible, but the BS may have received the PDU correctly and MM cannot rely on the cancellation and may receive a response to the sent PDU;
- a PDU has been successfully transmitted by layer 2. Cancellation is no longer possible.

The MLE-CANCEL request primitive can minimize the risk of adding extra load to the air interface, e.g. when a user application initiated registration request is buffered by the lower layers waiting for allowance to make random access attempt, which can take a considerable amount of time. If the user application during this waiting period changes its decision and wants to de-register, the application shall send a TNMM-DEREGISTRATION request primitive which will be converted to a MLE-CANCEL request primitive depending on the status of the transmission as stated above.

16.3.1.3.2 Stealing permission and stealing repeats flag handling

For each PDU sent by MM, stealing permission and stealing repeats flag are set to some value. The values used are outside of the scope of the present document.

16.3.1.3.3 Busy handling

An MLE-BUSY request primitive shall be sent to the MLE by the MM when it initiates an individually addressed signalling exchange with the SwMI, e.g. registration, authentication, group management, etc., and an MLE-IDLE request primitive shall be sent to the MLE when the MM has completed any such signalling. This allows the MLE to indicate to other entities that MM is currently busy. MM shall also inform the state to the user application by sending TNMM-SERVICE indication primitive with "MM busy" or "MM idle" indication. The behaviour of the user application is outside the scope of the present document. However it is recommended that the user application does not initiate new signalling exchange (e.g. group attachment) while the MM is busy in another action.

16.3.1.3.4 Activity handling

An MLE-ACTIVITY request primitive with indication "stay alive" shall be sent to the MLE by the MM when it initiates a signalling exchange with the SwMI for which it waits for layer 3 response. An MLE-ACTIVITY request primitive with indication "sleep permitted" shall be sent to the MLE when the MM has completed any such signalling. This allows the MLE to temporarily withdraw the energy economy mode when MM is waiting for a response from the SwMI.

16.4 Registration procedure

16.4.0 General

The registration procedures are illustrated in figures 16.3 to 16.6 respectively. Registration can be initiated by the MLE, by the user application or it can be requested by the infrastructure.

Security related information elements and their usage are defined in ETSI EN 300 392-7 [8].

A MS in the temporarily disabled state shall set the location update type information element to "disabled MS updating" in all registration cases except a request for identity exchange (the first U-LOCATION UPDATE PDU of the two that the MS sends in normal registration case b)). The MS shall remain in the temporarily disabled state (i.e. access to the communication resources shall remain open only for the MM entity and those services in CMCE listed in the "permitted services" parameter of the MLE-DISABLE request primitive that was sent by MM to the MLE to initiate the temporarily disabled state). The temporarily disabled state is defined in ETSI EN 300 392-7 [8].

After the MS has sent a registration request, it shall consider itself unregistered until it receives a response, except in the case of a periodic registration (see clause 16.4.2).

After the MS has sent a forward registration (see clause 16.4.1.2), it may consider itself still attached to the cell from which it sent the forward registration while the registration response timer T351 (see clause 16.4.5) remains active. If the MS receives a rejection to a forward registration request, the MS shall consider itself still attached to the cell from which it sent the forward registration request. If the MS decides to perform a cell reselection before receiving an acknowledgement to the forward registration request, the MS shall consider itself unregistered and shall send a registration request on the new cell. The location update element type applied shall be the same as for the interrupted registration, except in case when MS was performing periodic registration; then MS shall use either value "roaming location updating" or "service restoration roaming location updating" depending whether there is an active circuit mode call. If T351 expires, the MS shall consider itself not attached to a cell (see also clause 18.3.4.7.6).

The behaviour of an MS in case it has to perform cell reselection before receiving acknowledgement to other requests related to MM procedures (e.g. group attachment/detachment), is outside the scope of the present document.

NOTE: The SwMI may request and receive the MS's TEI and hardware and software version numbers during the registration process. The procedures are specified in ETSI EN 300 392-7 [8].

16.4.1 MLE initiated registration procedure

16.4.1.0 General

Clause 18.3.4.7.1a specifies the conditions determining when registration is required during cell reselection. In summary, the MLE initiates normal or forward registration if:

- the new cell does not belong to the same network as the current cell; or
- cell reselection into a location area outside of the current registered area is indicated and the new cell requires registration; or
- the old cell is a conventional access (CA) cell, the new cell is a direct access (DA) cell, or vice versa, and cell type change registration is required; or
- the MS received a temporary registration on the old cell; or
- the MS selects a cell that indicates in the BS service details that "System wide services temporarily not supported" (the MLE indicates a need for normal registration even if the new cell belongs to the registered area of the MS and even if the new cell does not indicate that registration is required).

When the MLE determines that registration is necessary, it notifies MM by sending MM an MLE-LINK indication primitive. The MLE-LINK indication primitive supplies the MNC, MCC, LA and cell type of the new cell.

The registration type can be either normal, forward or periodic registration indicated by registration type parameter received in the MLE-LINK indication primitive from the MLE. The normal registration is described in clause 16.4.1.1, the forward registration in clause 16.4.1.2 and periodic registration in clause 16.4.2. Forward registration shall be applied only in case there is a circuit mode call active and the MS is attempting announced type 1/2 cell reselection.

NOTE: If the status of the cell changes from "Systemwide services temporarily not supported" to "Normal mode" and the MS is temporary registered with the cell (see clause 16.4.8), the MLE indicates a need for periodic registration.

16.4.1.1 Normal registration

The registration procedure can be carried out with, or without, identity exchange (see ETSI EN 300 392-1 [6], clause 9). Identity exchange shall be required where the MS migrates to a new TETRA network other than the home network.

Normal registration case a) "roaming" shall be applied when the MS has already successfully registered to the network with the same ITSI, refer to figure 16.3.

Normal registration case b) "migrating; MS migrates to other than its home network" shall be applied when the MNC or MCC of the ITSI differ from the LANC and LACC of the new cell to which the MS now registers (visited SwMI) and there is no valid registration of the ITSI to the new network.

Normal registration case c) "migrating; MS migrates back to its home network" shall be applied when the MNC and MCC of the ITSI are the same as the LANC and LACC of the new cell to which the MS now registers (home SwMI) and there is no valid registration of the ITSI to the new network, refer to figure 16.3.

Normal registration case d) "temporarily disabled MS" shall always be applied if the TEI or ITSI of the MS has been temporarily disabled, refer to figure 16.3.

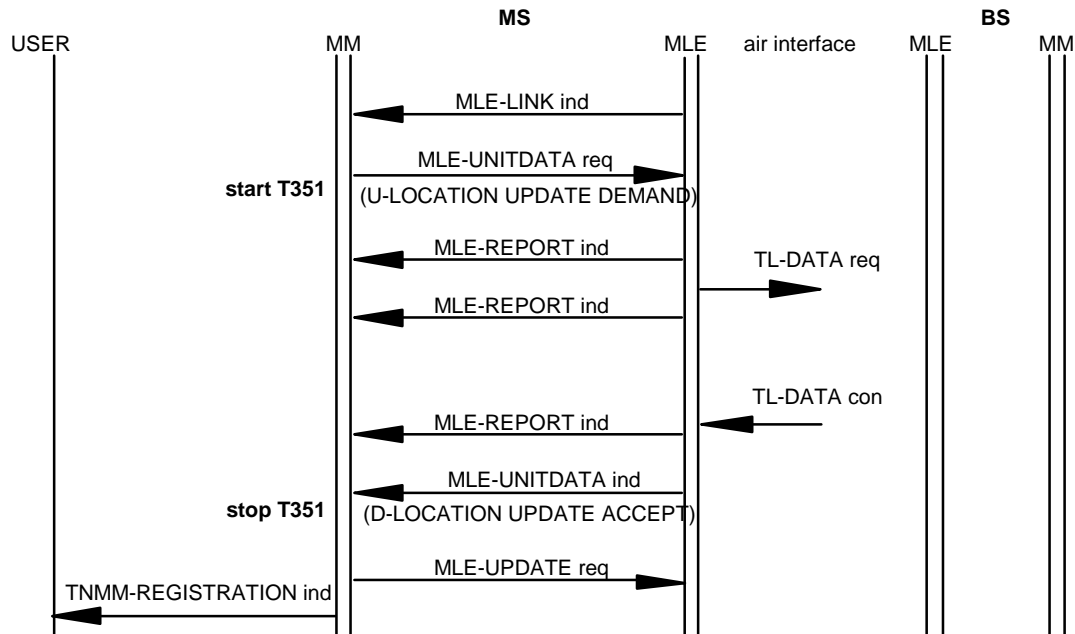

NOTE: MLE-REPORT shown in this figure applies to all scenarios where MM sends a PDU.

Figure 16.3: MLE initiated registration in cases a), b) and d)

For all cases a) to d) the information element "Group report response" shall not be present in these registration PDUs.

a) roaming:

- The MM entity shall send a U-LOCATION UPDATE DEMAND PDU to the MLE with an MLE-UNITDATA request primitive. Except when the MS is temporarily disabled (see case d) the location update type information element in the PDU shall be set either to "roaming location updating", or if there was a circuit mode call active, to "service restoration roaming location updating". If "roaming location updating", PDU priority shall be set to 3 and if "service restoration roaming location updating", PDU priority shall be set to 5. Upon sending the U-LOCATION UPDATE DEMAND PDU the MM shall assume that group identities with parameter value "Attachment for next location update required" are no longer attached. If MS wishes to receive signalling on those group identities either the U-LOCATION UPDATE DEMAND PDU may include a request for attachment/detachment of those group identities in the group identity location demand information element or MM may later attach the groups using attach mechanism, see clause 16.8.2. The PDU may contain the SSI (or SSI + address extension) information elements. If present, they shall contain the ISSI of the MS and MNI of the MS, respectively. The PDU may contain characteristics of the MS terminal in the class of MS information element and the extended capabilities information element (e.g. if the MS wishes to change the information it sent to the SwMI in its last successful registration request - but see note 1). The PDU may also contain energy economy mode information in the energy saving mode information element; if so, the timer T352 shall be started. The MS may also request to append the new LA into the current RA in the request to append LA information element. The information element LA information shall not be present in the PDU because this is not a forward registration. The MLE-UNITDATA request primitive parameters shall indicate that the identity to be used shall be the ASSI/(V)ASSI, if one has been issued, or the ISSI in the case where an ASSI/(V)ASSI has not been issued. Timer T351 shall be started.

NOTE 1: The MS is not required to include the extended capabilities information element in the U-LOCATION UPDATE DEMAND PDU if the only change in extended capabilities since the last successful registration request is the type of cell to which the MS is attempting to register.

NOTE 2: If the "class of MS" information element or the "extended capabilities" information element is not included in the U-LOCATION UPDATE DEMAND PDU and the SwMI needs to receive either of those information elements, the SwMI may accept the registration request and then send the MS a D-LOCATION UPDATE COMMAND PDU. (This could happen if, e.g. the SwMI has no record of a previous successful registration by the MS.)

NOTE 3: If ASSI or (V)ASSI is available at layer 2, it is recommended that the MS does not reveal its true identity by sending ISSI in layer 3.

b) Migrating; MS migrates to other than its home network:

- The MM entity shall request identity exchange by sending a U-LOCATION UPDATE DEMAND PDU to the MLE with an MLE-UNITDATA request primitive. The location update type information element in the PDU shall be set either to "migrating location updating", or if there was a circuit mode call active, to "service restoration migrating location updating". The location update type information element shall not be set to "disabled MS updating" in this first U-LOCATION UPDATE DEMAND PDU. If "migrating location updating", PDU priority shall be set to 3 and if "service restoration migrating location updating", PDU priority shall be set to 5. The PDU shall include the MNI of the MS in the address extension information element and may include the ISSI of the MS in the SSI information element. This first U-LOCATION UPDATE DEMAND PDU shall not include optional information elements class of MS, extended capabilities, energy saving mode and group identity location demand. The information element LA information shall not be present in the PDU because this is not a forward registration. The primitive parameters shall indicate to the lower layers that the USSI of the MS shall be used. Timer T351 shall be started.

NOTE 4: The use of the SSI information element in the U-LOCATION UPDATE DEMAND PDU is not recommended. In particular, for migration to a CA cell, inclusion of the SSI information element in the U-LOCATION UPDATE DEMAND PDU would cause the message to exceed the capacity of the MAC layer random access request. (For migration to a DA cell, the U-LOCATION UPDATE DEMAND PDU will always exceed the capacity of the MAC layer random access request.)

- If the SwMI is ready to reject the registration at this stage it shall send a D-LOCATION UPDATE REJECT PDU which shall include the MNI of the MS. The SSI in the layer 2 shall be the USSI. Otherwise the SwMI shall complete the identity exchange by sending a D-LOCATION UPDATE PROCEEDING PDU allocating a (V)ASSI.
- Upon receipt of the D-LOCATION UPDATE PROCEEDING, the MM shall check whether the MCC and MNC, included in the address extension information element, correspond to those values held in the MS. If the MNC or MCC do not correspond to the transmitted values, no further action shall be taken against that PDU. If the MNC and MCC do correspond to the transmitted values, the MM shall extract the (V)ASSI from the SSI field and send this to the MLE by using MLE-IDENTITIES request primitive. Timer T351 shall be stopped. The MS shall immediately change to use the (V)ASSI in all subsequent signalling except for the layer 2 acknowledgement for the received D-LOCATION UPDATE PROCEEDING PDU, where the USSI shall be used.

- The MM entity shall send a second U-LOCATION UPDATE DEMAND PDU to the MLE with an MLE-UNITDATA request primitive. This shall have PDU priority 6. The PDU shall contain the MNI of the MS in the address extension information element and the ISSI of the MS in the SSI information element. The PDU shall contain characteristics of the MS terminal in the class of MS information element. If the MS supports one or more of the items listed in the extended capabilities information element (other than support of CA), the PDU shall also include the extended capabilities information element. The MS should not include the extended capabilities information element if the MS supports none of the items listed in the extended capabilities information element other than support of CA (and the MS is thus requesting registration to a CA cell). The PDU may contain energy economy mode information in the energy saving mode information element; if so, the timer T352 shall be started. Upon sending the U-LOCATION UPDATE DEMAND PDU the MM shall assume that the group identities are no more attached. If MS wishes to receive signalling on those group identities either the U-LOCATION UPDATE DEMAND PDU may include a request for attachment/detachment of those group identities in the group identity location demand information element or MM may later attach the groups using attach mechanism, see clause 16.8.2. The MM shall not request to append the new LA into the current RA in the request to append LA information element. The information element LA information shall not be present in the PDU because this is not a forward registration. The location update type information element in the PDU shall be set to "demand location updating" unless the MS is temporarily disabled, in which case the element shall be set to "disabled MS updating" (see case d). The primitive parameters shall indicate that the identity to be used shall be the SSI ((V)ASSI). Timer T351 shall be started.
- c) Migrating; MS migrates back to its home network:
- The MM entity shall send a U-LOCATION UPDATE DEMAND PDU to the MLE with an MLE-UNITDATA request primitive. Except when the MS is temporarily disabled (see case d) the location update type information element in the PDU shall be set either to "migrating location updating", or if there was a circuit mode call active, to "service restoration migrating location updating". If "migrating location updating", PDU priority shall be set to 3 and if "service restoration migrating location updating", PDU priority shall be set to 5. The PDU shall include the MNI of the MS in the address extension information element and may include the ISSI of the MS in the SSI information element. The PDU shall contain characteristics of the MS terminal in the class of MS information element. If the MS supports one or more of the items listed in the extended capabilities information element (other than support of CA), the PDU shall also include the extended capabilities information element. The MS should not include the extended capabilities information element if the MS supports none of the items listed in the extended capabilities information element other than support of CA (and the MS is thus requesting registration to a CA cell). The PDU may contain energy economy mode information in the energy saving mode information element; if so, the timer T352 shall be started. Upon sending the U-LOCATION UPDATE DEMAND PDU the MM may assume that the group identities which have earlier been attached in the home network with parameter value "Attachment not needed" are attached and shall assume that all other group identities with other parameter values are no more attached. If MS wishes to receive signalling on those unattached group identities either the U-LOCATION UPDATE DEMAND PDU may include request for attachment/detachment of group identities in the group identity location demand information element or MM may later attach the groups using attach mechanism, see clause 16.8.2. The MM should not try to attach the group identities with parameter values "Attachment not allowed for next ITSI attach" or which have been permanently detached in the home network. The MS shall not request to append the new LA into the current RA in the request to append LA information element. The information element LA information shall not present in the PDU because this is not a forward registration. The primitive parameters shall indicate to the lower layers that the address to be appended shall be the ISSI. Timer T351 shall be started.
- d) Temporarily disabled MS:
- a), b) or c) shall apply with the location update type information element set to "disabled MS updating" in every instance except a request for identity exchange (the first U-LOCATION UPDATE DEMAND PDU of case b)). The MS shall remain in the temporarily disabled state (i.e. access to the communication resources shall remain open only for the MM entity and those services in CMCE listed in the "permitted services" parameter of the MLE-DISABLE request primitive that was sent by MM to the MLE to initiate the temporarily disabled state). The temporarily disabled state is defined in ETSI EN 300 392-7 [8]. In the temporarily disabled state group attachments are not allowed.

If SwMI accepts the registration it shall send a D-LOCATION UPDATE ACCEPT PDU.

For cases a), b), c) and d): upon receipt of the D-LOCATION UPDATE ACCEPT PDU received with an MLE-UNITDATA indication primitive, MM shall if present, extract the MNI from the address extension information element and check that it is the same as MNI of the MS ITSI and, if that is the case or the MNI is not present, then the MM shall:

NOTE 5: The address extension information element cannot act as complete safe guard because there is no information element for the ISSI in the PDU.

- If present, extract the ASSI or (V)ASSI from the SSI field.
- If the U-LOCATION UPDATE DEMAND contained a request for attachment/detachment of group identities, the MM shall inspect the group identity location accept information element to find out if the SwMI accepted them. In case the group identity location accept information element is not present in the D-LOCATION UPDATE ACCEPT PDU, the MS shall assume the group attachment/detachment failed. The MS shall treat the failure as equivalent to T353 timer expiry. If the group attachment acknowledgement does not contain explicit group lifetime, then the applied lifetime is outside the scope of the present document.
- The MM shall inform the MLE of ASSI or (V)ASSI and the accepted and thus attached group identities with related (V)GSSIs when applicable and shall command MLE to remove detached group identities with an MLE-IDENTITIES request primitive, see clause 16.8. The MS shall immediately change to use the ASSI or (V)ASSI in layer 2 in all subsequent signalling except for the layer 2 acknowledgement for the received D-LOCATION UPDATE ACCEPT PDU, where the SSI used shall be the same as the layer 2 address used to transfer the D-LOCATION UPDATE ACCEPT PDU.
- Timer T351 shall be stopped.
- MM shall, if information elements are present, extract from the PDU the information concerning SCCHs and minimum mode (18th frame) monitoring, energy saving information, subscriber class and new registered area information, and inform these to the lower layers in an MLE-INFO request primitive, refer to clauses 16.7.1 and 16.4.9.
- If the new registered area information element is not present in the PDU, the MS shall consider the current RA to include only the current LA the MS just registered on with no registration timeout.
- If the new registered area information element is present, then the new RA is that defined by the LAs in the New Registered Area information element and the LA timer associated with each LA shall be started. SwMI shall include the LA into which the registration was made in the New registered area information element. Refer to clause 16.4.6 for LA time-out.
- MM shall update its "cell type preference or requirement" as described in clause 16.4.12.
- The MS MM shall issue an MLE-UPDATE request primitive indicating a registration result of "Success" or "Temporary registration", the LAs in the RA, and MM's "cell type preference or requirement". MM shall inform the user application that the MS is ready for use by issuing a TNMM-REGISTRATION indication primitive containing registration, group attachment/detachment and cell type information.
- Where an energy economy mode has been requested and the MS is not informed of the outcome of this request in the D-LOCATION UPDATE ACCEPT PDU, the information shall be conveyed in a separate D-MM STATUS PDU as described in clause 16.7.1.
- For subscriber class procedures, see clause 16.4.9.

For cases b) and c) (MS migration to other than its home network, or MS migrates back to its home network), the optional Default group attachment lifetime information element may be present in the D-LOCATION UPDATE ACCEPT PDU. If the element is not present, the MS shall assume the lifetime "Attachment for next ITSI-Attach required" to be the default lifetime.

If SwMI rejects the registration it shall send a D-LOCATION UPDATE REJECT PDU. Upon receipt of a D-LOCATION UPDATE REJECT PDU MM shall if present, extract the MNI from the address extension information element and check that it is the same as MNI of the MS ITSI and shall check if timers T351 or T354 are active. If either timer T351 or T354 is active and either the MNI is present in the PDU and matches the MNI of the MS's ITSI or the MNI is not present, then the MM shall:

NOTE 6: The address extension information element cannot act as complete safe guard because there is no information element for the ISSI in the PDU.

- stop timers T351 and T352, if started;
- inform the user application about registration failure by issuing a TNMM-REGISTRATION indication primitive containing "failure" and the reject cause;
- analyse the reject cause:
 - in the event that a Congestion or Network failure is reported, MM may re-try registration after a suitable time or issue an MLE-UPDATE request primitive with a registration result of "cell rejection" in order that the MLE initiates cell reselection procedures as defined in clause 18.3.4.7;
 - in the event that "use of CA cell not permitted" or "use of DA cell not permitted" is reported, MM shall update its "cell type preference or requirement" as described in clause 16.4.12 and shall issue an MLE-UPDATE request primitive with a registration result of "cell type rejection" in order that the MLE initiates cell reselection procedures as defined in clause 18.3.4.7;
 - in the event that "LA not allowed", "Service not subscribed" or "Roaming not supported" is reported, MM shall issue an MLE-UPDATE request primitive with a registration result of "LA rejection" in order that the MLE initiates cell reselection procedures as defined in clause 18.3.4.7;
 - in the event that a ITSI/ATSI unknown is reported, if the MAC header contains ASSI or (V)ASSI, the MS shall re-try registration using the USSI or ISSI in layer 2 depending whether the MS is registering to its home network. In case MS is registering to its home network, it shall perform registration as defined in clause 16.4.2 case b) new ITSI. In case MS is registering to foreign network, it shall perform registration as defined in clause 16.4.1.1 case b) migrating; MS migrates to other than its home network. If the MAC header contains ISSI or USSI, then:
 - if the MS has received fewer than N351 registration results of type "system rejection" without a successful registration, MM shall issue an MLE-UPDATE request primitive with a registration result of "LA rejection"; or
 - if the MS has received N351 registration results of type "system rejection" without a successful registration, MM shall issue an MLE-UPDATE request primitive with a registration result of "system rejection" in order that the MLE initiates cell reselection procedures as defined in clause 18.3.4.7;
 - in the event of a Mandatory element error or Message inconsistency error is reported, the MS shall be allowed at least one registration re-try;
 - in the event of an Illegal MS or Migration not supported is reported, then:
 - if the MS has received fewer than N351 registration results of type "system rejection" without a successful registration, MM shall issue an MLE-UPDATE request primitive with a registration result of "LA rejection"; or
 - if the MS has received N351 registration results of type "system rejection" without a successful registration, MM shall issue an MLE-UPDATE request primitive with a registration result of "system rejection" in order that the MLE initiates cell reselection procedures as defined in clause 18.3.4.7;
 - the reject cause Forward registration failure is not applicable to normal registration;

- in the event of any other registration result of type "system rejection":
 - if the MS has received fewer than N351 registration results of type "system rejection" without a successful registration, MM shall issue an MLE-UPDATE request primitive with a registration result of "LA rejection"; or
 - if the MS has received N351 registration results of type "system rejection" without a successful registration, MM shall issue an MLE-UPDATE request primitive with a registration result of "system rejection" in order that the MLE initiates cell reselection procedures as defined in clause 18.3.4.7;
- all other reject causes are outside the scope of this clause of the present document;

In the event that a registration failure leaves the MS with no available cells, MLE sends MM an MLE-ACTIVATE indication primitive indicating "no cell available for any service" in response to an MLE-UPDATE request primitive from MM that includes a registration failure result. On receipt of an MLE-ACTIVATE indication primitive from MLE indicating "no cell available for any service", MM shall issue an MLE-CLOSE request primitive to the MLE and shall issue a TNMM-SERVICE indication primitive to the TNMM-SAP indicating that the MS is "out of service". The MM shall consider the MS to be de-registered and hence apply the activation procedure as defined in clause 16.3.1.1 in order to get into service again.

NOTE 7: When to apply the activation procedure, after no service is obtained, is outside the scope of the present document.

If neither timer T351 nor T354 was active when the MS MM received the D-LOCATION UPDATE REJECT PDU, MM shall discard the PDU without making a response at layer 3.

In the case of authentication failure during a registration procedure, the rules in ETSI EN 300 392-7 [8] clause 4.4.2 apply.

16.4.1.2 Forward registration

Forward registration shall be applied by MM on receipt of an MLE-LINK indication primitive with its "registration type" parameter set to "forward". This occurs when there is a circuit mode call active and the MS is attempting announced type 1/2 cell reselection and the MS has already successfully registered with the same ITSI to the present network and the cell to which it now registers does not belong to its current RA (home and visited SwMI).

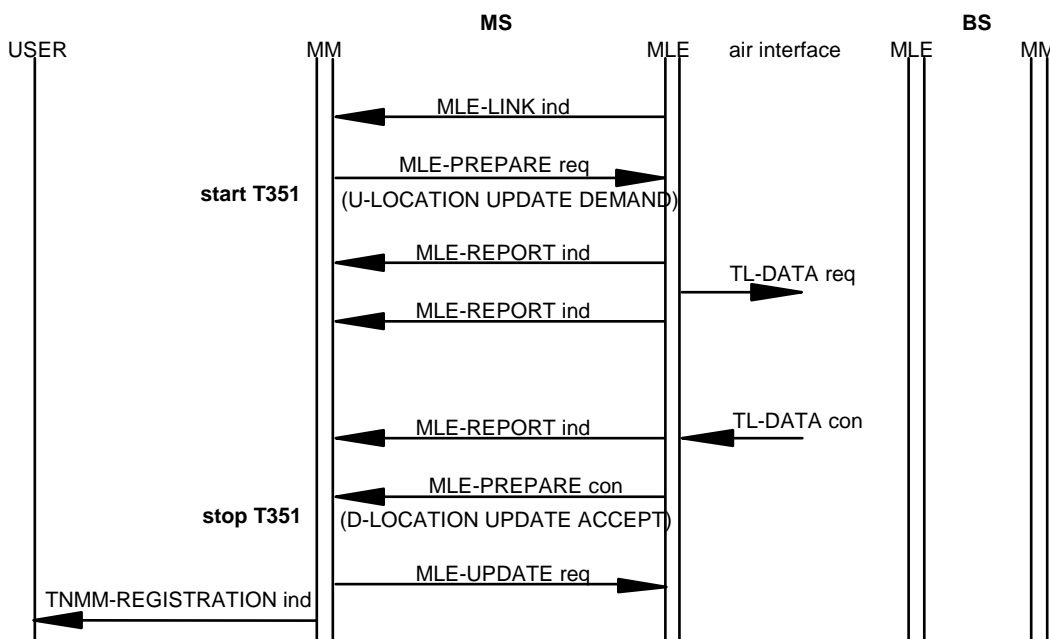

Figure 16.4: MLE initiated forward registration

The location update type information element in the U-LOCATION UPDATE DEMAND PDU shall be set to "service restoration roaming location updating" or "service restoration migrating location updating" unless the MS is temporarily disabled, in which case the element shall be set to "disabled MS updating". The U-LOCATION UPDATE DEMAND PDU may contain energy economy mode information in the energy saving mode information element; if so, the timer T352 shall be started. The PDU may contain the SSI and address extension information elements, if present, the information elements shall contain the ISSI of the MS and MNI of the MS, respectively. The PDU may also contain characteristics of the MS terminal in the class of MS information element and the extended capabilities information element (e.g. if the MS wishes to change the information it sent to the SwMI in its last successful registration request - but see note 1). The MS may also request to append the new LA into the current RA in the request to append LA information element. The PDU shall contain the location area identification of the new cell, where to the MS is forward registering, in the LA information element. Upon sending the U-LOCATION UPDATE DEMAND PDU the MM shall assume that group identities with parameter value "Attachment for next location update required" are not attached on the new LA. If MS wishes to receive signalling on those group identities the U-LOCATION UPDATE DEMAND PDU shall include a request for attachment/detachment of those group identities in the group identity location demand information element or MM may later attach the groups using attach mechanism, see clause 16.8.2. The MLE-UNITDATA request primitive parameters shall indicate that the identity to be used shall be the ASSI/(V)ASSI, if one has been issued, or the ISSI in the case where an ASSI/(V)ASSI has not been issued. Timer T351 shall be started.

NOTE 1: The MS should not include the extended capabilities information element in the U-LOCATION UPDATE DEMAND PDU if the only change in extended capabilities since the last successful registration request is the type of cell to which the MS is attempting to register.

NOTE 2: If the "class of MS" information element or the "extended capabilities" information element is not included in the U-LOCATION UPDATE DEMAND PDU and the SwMI needs to receive either of those information elements, the SwMI may accept the registration request and then send the MS a D-LOCATION UPDATE COMMAND PDU.

NOTE 3: If ASSI or (V)ASSI is available at layer 2, it is recommended that the MS does not reveal its true identity by sending ISSI in layer 3.

NOTE 4: If a temporarily disabled MS was engaged in an ambience listening call at the time that it issued the forward registration and the SwMI does not direct the MS to a traffic channel, the MS should initiate restoration of the ambience listening call on the new cell by sending a U-RESTORE PDU.

NOTE 5: In the temporarily disabled state group attachments are not allowed.

"Group report response" shall not be present in forward registration PDUs.

If the SwMI accepts the registration it shall send a D-LOCATION UPDATE ACCEPT PDU in an MLE D-NEW-CELL PDU as defined in clause 18.3.4.

Upon receipt of the D-LOCATION UPDATE ACCEPT PDU by the MLE-PREPARE confirm primitive the MM shall, if present, extract the MNI from the address extension information element and check that it is the same as MNI of the MS ITSI and, if that is either the case or the MNI is not present, then the MM shall:

- Extract the ASSI or (V)ASSI from the SSI field. The MS shall immediately change to use the ASSI/(V)ASSI in layer 2 in all subsequent signalling except for the layer 2 acknowledgement for the received D-LOCATION UPDATE ACCEPT PDU, where the same SSI shall be used as was used in layer 2 in the D-LOCATION UPDATE ACCEPT PDU. MM shall, if present, extract the MNI of the MS from the address extension information element. If the U-LOCATION UPDATE DEMAND contained request for attachment/detachment of group identities, the MM shall inspect the group identity location accept information element to find out if the SwMI accepted them. In case the group identity location accept information element is not present in the D-LOCATION UPDATE ACCEPT PDU, the MS shall assume the group attachment/detachment failed. The MS shall treat the failure as equivalent to T353 timer expiry. If the group attachment acknowledgement does not contain explicit group lifetime, then the applied lifetime is outside the scope of the present document. MM shall inform the MLE of ASSI or (V)ASSI and accepted and thus attached group identities and related (V)GSSI, when applicable with an MLE-IDENTITIES request primitive. MM shall, if information element is present, extract from the PDU the information concerning new registered area information, and inform these to the lower layers in an MLE-INFO request primitive.

NOTE 6: The address extension information element cannot act as complete safe guard because there is no information element for the ISSI in the PDU.

- If the new registered area information element is not present in the PDU, the MS shall consider the current RA to include only the current LA the MS just registered on with no registration timeout.
- If the new registered area information element is present, then the new RA is that defined by the LA's in the New registered area information element and the LA timer associated with each new LA shall be started.

NOTE 7: The LA from which the MS is roaming is not part of the new RA unless that LA is included in the New registered area information element.

- MM shall update its "cell type preference or requirement" as described in clause 16.4.12.
- Timer T351 shall be stopped. MM shall, if information elements are present, extract from the PDU the information concerning SCCH, energy saving information (economy mode, and minimum mode (18th frame) monitoring), subscriber class, if present, and inform these to the lower layers in an MLE-INFO request primitive, refer to clauses 16.7.1 and 16.4.9.
- For subscriber class procedures see clause 16.4.9.

The MS MM shall issue an MLE-UPDATE request primitive indicating a registration result of "Success" or "Temporary registration", the LAs in the RA and MM's "cell type preference or requirement". MM shall inform the user application that the MS is ready for use by issuing a TNMM-REGISTRATION indication primitive containing registration, group attachment/detachment and cell type information. Where an energy economy mode has been requested and the MS is not informed of the outcome of this request in the D-LOCATION UPDATE ACCEPT PDU, the information shall be conveyed in a separate D-MM STATUS PDU as described in clause 16.7.1.

If the SwMI rejects the registration it shall send a D-LOCATION UPDATE REJECT PDU. Upon receipt of a D-LOCATION UPDATE REJECT, MM shall if present, extract the MNI from the address extension information element and check that it is the same as MNI of the MS ITSI and shall check if timers T351 or T354 are active. If either timer T351 or T354 is active and either the MNI is present in the PDU and matches the MNI of the MS's ITSI or the MNI is not present, then the MM shall:

NOTE 8: The address extension information element cannot act as complete safe guard because there is no information element for the ISSI in the PDU.

- stop timers T351 and T352, if started;
- inform the user application about registration failure by issuing a TNMM-REGISTRATION indication primitive containing "failure" and the reject cause;
- remain registered in the current cell with previous ASSI, (V)ASSI, GSSIs and (V)GSSIs as appropriate;
- analyse the reject cause:
 - in the event that a "forward registration failure" is reported, MM shall issue an MLE-UPDATE request primitive with a registration result of "forward registration failure", refer to clause 17.3.9, in order that the MLE initiates cell reselection procedures as defined in clause 18.3.4.7;
 - in the event that "LA unknown" is reported, MM shall issue an MLE-UPDATE request primitive with a registration result of "LA rejection" in order that the MLE initiates cell reselection procedures as defined in clause 18.3.4.7;
 - all other reject causes are analysed and acted similarly as with normal registration (clause 16.4.1.1).

If neither timer T351 nor T354 was active when the MS MM received the D-LOCATION UPDATE PDU, MM shall discard the PDU without making a response at layer 3.

In the case of authentication failure during a registration procedure, the rules in ETSI EN 300 392-7 [8] clause 4.4.2 apply.

In the temporary disabled state service restoration and forward registration are applicable only in the case of ambience listening.

16.4.2 User application initiated registration procedure

User application initiated registration shall be available whenever the MS is camped on a cell, i.e. has received TNMM-SERVICE indication primitive stating that the MS is "in service waiting for registration" or "in service". It shall be applied whenever an identity is attached to the MS. The user application initiated registration can be used at power up and at any time provided that an ITSI is available either within the MS, and shall be applied using the TNMM-REGISTRATION request primitive, see figure 16.5.

In case the status of the BS changes from "system wide services temporarily not supported " to "normal mode" and the MS has a temporary registration to the cell, the MLE indicates a need for periodic registration to MM by sending an MLE-LINK indication primitive. In such a case or if a LA timer expires and the LA is the current LA, the MM shall inform the user application by sending a TNMM-REGISTRATION indication primitive with registration status parameter set to "LA registration expired", LA parameter to the current LA and cell type parameter to the current cell type, so that the application could initiate registration in a suitable time e.g. after completing on-going call.

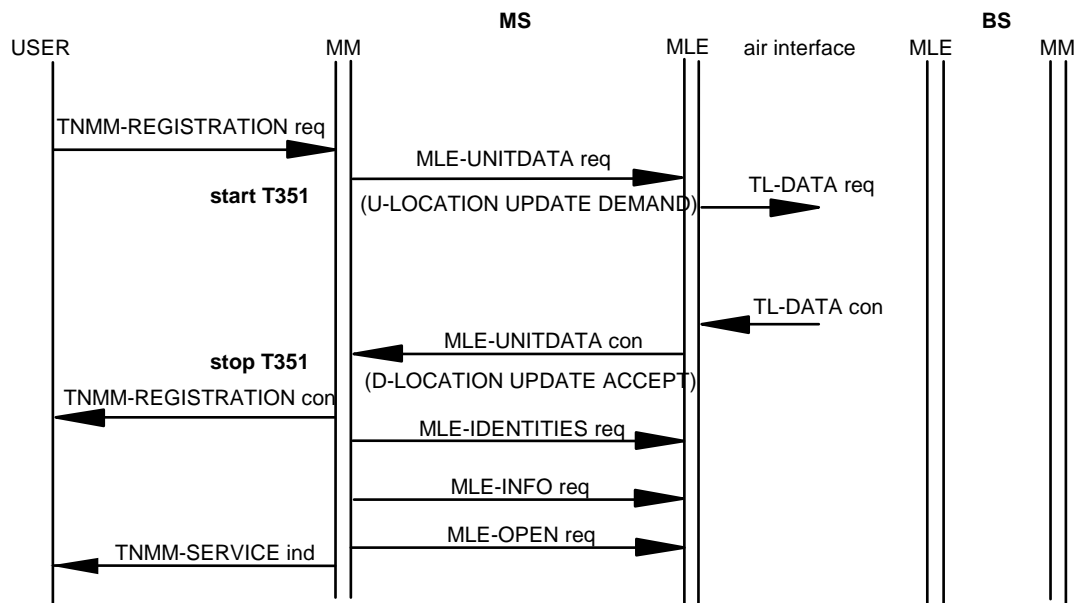

Figure 16.5: User application initiated registration in cases a) and b)

MM shall check whether the TNMM-REGISTRATION request primitive contains a request to perform a periodic registration or to select a specified MCC and MNC, LA(s) and/or cell type(s). In case the TNMM-REGISTRATION request primitive is not a periodic registration request, MM shall send the preferred network/LA list and its "cell type preference or requirement" (see clause 16.4.12) in an MLE-LINK request primitive to MLE and shall wait for MLE-LINK indication primitive. If MM receives MLE-ACTIVATE indication primitive from MLE indicating "no cell available for any service" (because MLE is not able to select from the requested MCC, MNC, LA(s) or cell types), MM shall inform the user application by issuing a TNMM-REGISTRATION confirm primitive indicating "no preferred cell found". The user application may then provide new MCC, MNC, LA information and/or cell type information to MM using a TNMM-REGISTRATION request primitive.

If MM has sent the user application a TNMM-SERVICE indication primitive stating that the MS is "in service" and the user application was not requesting periodic registration, MM shall wait for an MLE-LINK indication primitive from the MLE and perform registration as specified in clause 16.4.1. See also note 1.

If MM has sent the user application a TNMM-SERVICE indication primitive stating that the MS is "in service waiting for registration", MM shall send an MLE-LINK request primitive to MLE and wait for MLE-LINK indication primitive.

For a periodic registration request or after receiving an MLE-LINK indication primitive from the MLE, MM shall ascertain whether there is a new ITSI being attached as follows:

- case a) "no new ITSI" shall be applied when the MS with the same ITSI has already successfully registered to the same location area (home and visited SwMI) (see note 1);
- case b) "new ITSI" shall be applied at power up registration or when there is no valid registration of the ITSI to the network and the MNC and MCC of the ITSI are the same as the LANC and LACC of the cell the MS is camped on (home SwMI);
- case c) "new un-exchanged ITSI" shall be applied at power up registration or when there is no valid registration of the ITSI to the network and the MNC or MCC of the ITSI differ from the LANC or LACC of the cell the MS is camped on (visited SwMI).

In addition a temporarily disabled MS shall follow case d).

NOTE 1: When MM makes a "no new ITSI" registration request to a different location area from that where the ITSI is already successfully registered the MS performs registration as specified in clause 16.4.1.

a) no new ITSI:

- MM shall send a U-LOCATION UPDATE DEMAND PDU to the MLE with an MLE-UNITDATA request primitive. This shall have PDU priority 3.
- The location update type information element in the PDU shall be set to "periodic location updating" unless the MS is temporarily disabled, in which case the element shall be set to "disabled MS updating" (see case d).
- The PDU may contain the SSI and address extension information elements, if present, the information elements shall contain the ISSI of the MS and MNI of the MS, respectively. The PDU may also contain the class of MS information element and the extended capabilities information element (e.g. if the MS wishes to change the information it sent the SwMI in a previous successful registration request). The PDU may include the energy saving mode information element; if so, the timer T352 shall be started. Upon sending the U-LOCATION UPDATE DEMAND PDU the MM shall assume that group identities with parameter value "Attachment for next location update required" are no more attached. If MS wishes to receive signalling on those group identities either the U-LOCATION UPDATE DEMAND PDU may include request for attachment of those group identities in the group identity location demand information element or MM may later attach the groups using attach mechanism, see clause 16.8.2. The MLE-UNITDATA request primitive parameters shall indicate that the identity to be used shall be the ASSI/(V)ASSI, if one has been issued, or the ISSI in the case where an ASSI/(V)ASSI has not been issued. Timer T351 shall be started.

NOTE 2: If the "class of MS" information element or the "extended capabilities" information element is not included in the U-LOCATION UPDATE DEMAND PDU and the SwMI needs to receive either of those information elements, the SwMI may accept the registration request and then send the MS a D-LOCATION UPDATE COMMAND PDU. (This could happen if, e.g. the SwMI has no record of a previous successful registration by the MS or if the SwMI has any uncertainty about the type of cell to which the MS is registering.)

NOTE 3: If ASSI or (V)ASSI is available at layer 2, it is recommended that the MS does not reveal its true identity by sending ISSI in layer 3.

b) new ITSI:

- in this case at the beginning the communication resources are closed. The MM shall register with the home network using ISSI. MM shall send a U-LOCATION UPDATE DEMAND PDU to the MLE with an MLE-UNITDATA request primitive. This shall have PDU priority 6. The location update type information element in the PDU shall be set to "ITSI attach" unless the MS is temporarily disabled, in which case the element shall be set to "disabled MS updating" (see case d). The PDU shall contain the characteristics of the MS terminal in the class of MS information element. If the MS supports one or more of the items listed in the extended capabilities information element (other than support of CA), the PDU shall also include the extended capabilities information element. The MS should not include the extended capabilities information element if the MS supports none of the items listed in the extended capabilities information element other than support of CA (and the MS is thus requesting registration to a CA cell). The PDU may contain the SSI and address extension information elements, if present, the information elements shall contain the ISSI of the MS and MNI of the MS, respectively. The PDU may also contain energy economy mode information in the energy saving mode information element; if so, the timer T352 shall be started. Upon sending the U-LOCATION UPDATE DEMAND PDU the MM may assume that group identities which have earlier been attached in the home network with parameter value "Attachment not needed" are attached and shall assume that all other group identities are no more attached. If MS wishes to receive signalling on the unattached group identities either the U-LOCATION UPDATE DEMAND PDU may include request for attachment/detachment of those group identities in the group identity location demand information element or MM may later attach the groups using attach mechanism, see clause 16.8.2. The MM should not try to attach the group identities with parameter values "Attachment not allowed for next ITSI attach" or which have been permanently detached in the home network. The MS shall not request to append the new LA into the current RA in the request to append LA information element. The information element LA information is not present in the PDU because this is not a forward registration. The primitive parameters shall indicate that the identity to be appended by the MAC shall be the SSI (ISSI). Timer T351 shall be started;

c) new un-exchanged ITSI:

- in this case at the beginning the communication resources are closed. The MM shall register on a visited network using identity exchange. The MM entity shall request identity exchange by sending a U-LOCATION UPDATE DEMAND PDU with PDU priority 3 to the MLE with an MLE-UNITDATA request primitive and issue an MLE-BUSY request primitive to the MLE. The location update type information element in the PDU shall be set to "migrating location updating". The location update type information element shall not be set to "disabled MS updating" in this first U-LOCATION UPDATE DEMAND PDU. The PDU shall include the MNI of the MS in the address extension information element and may include the ISSI of the MS in the SSI information element. There shall be no optional information elements class of MS, extended capabilities, energy saving mode and group identity location demand in the PDU because they shall be present in the second U-LOCATION UPDATE DEMAND PDU, if needed. The information element LA information shall not be present in the PDU because this is not a forward registration. The primitive parameters shall indicate to the lower layers that the USSI of the MS shall be used. Timer T351 shall be started;

NOTE 4: The use of the SSI information element in the U-LOCATION UPDATE DEMAND PDU is not recommended. In particular, for migration to a CA cell, inclusion of the SSI information element in the U-LOCATION UPDATE DEMAND PDU would cause the message to exceed the capacity of the MAC layer random access request. (For migration to a DA cell, the U-LOCATION UPDATE DEMAND PDU will always exceed the capacity of the MAC layer random access request.)

- if SwMI is ready to reject the registration at this stage it shall send D-LOCATION UPDATE REJECT PDU which shall include the MNI of the MS. The SSI in the layer 2 shall be the USSI. Otherwise SwMI shall send D-LOCATION UPDATE PROCEEDING PDU allocating (V)ASSI;
- upon receipt of the D-LOCATION UPDATE PROCEEDING PDU, the MM shall, if present, extract the MNI from the address extension information element and check that it is the same as MNI of the MS ITSI and, if that is either the case or the MNI is not present, then MM shall:
 - extract the (V)ASSI from the SSI field and send this to the MLE by using MLE-IDENTITIES request primitive. The MS shall immediately change to use the (V)ASSI in all subsequent signalling except for the layer 2 acknowledgement for the received D-LOCATION UPDATE PROCEEDING PDU, where the USSI shall be used;

- stop timer T351;
- as the message is a response to a request made using the USSI, MM shall check that the MCC and the MNC included in the address extension information element, correspond to the MNI of the MS. This shall be used to ensure that if two mobiles request registrations using the same USSI that MM can distinguish between them:
 - if the MNIs do not match no action shall be taken;
 - if the MCC and the MNC do correspond the transmitted values, the MM entity shall reply with a second U-LOCATION UPDATE DEMAND PDU containing the MNI of the MS in the address extension information element and ISSI of the MS in the SSI information element, thus comprising the full ITSI to the MLE with an MLE-UNITDATA request primitive. The PDU shall contain the class of MS information element. If the MS supports one or more of the items listed in the extended capabilities information element (other than support of CA), the PDU shall also include the extended capabilities information element. The MS should not include the extended capabilities information element if the MS supports none of the items listed in the extended capabilities information element other than support of CA (and the MS is thus requesting registration to a CA cell). The PDU may also contain economy mode information in the energy saving mode information element; if so, the timer T352 shall be started. Upon sending the U-LOCATION UPDATE DEMAND PDU the MM shall assume that all group identities are no more attached. If MS wishes to receive signalling on those unattached group identities either the U-LOCATION UPDATE DEMAND PDU may include request for attachment/detachment of group identities in the group identity location demand information element or MM may later attach the groups using attach mechanism, see clause 16.8.2. The MS shall not request to append the new LA into the current RA in the request to append LA information element. The information element LA information is not present in the PDU because this is not a forward registration. This shall have PDU priority 6. The location update type information element in the PDU shall be set to "demand location updating" unless the MS is temporarily disabled, in which case the element shall be set to "disabled MS updating" (see case d). The primitive parameters shall indicate that the address to be appended by the MAC shall be the SSI ((V)ASSI). Timer T351 shall be started.

d) Temporarily disabled MS:

- a), b) or c) shall apply with the location update type set to "disabled MS updating" in every instance except a request for identity exchange (the first U-LOCATION UPDATE DEMAND PDU of case c)) but there shall be no group attachment or reporting signalling. The MS shall remain in the temporarily disabled state (i.e. access to the communication resources shall remain open only for the MM entity and those services in CMCE listed in the "permitted services" parameter of the MLE-DISABLE request primitive that was sent by MM to the MLE to initiate the temporarily disabled state). The temporarily disabled state is defined in ETSI EN 300 392-7 [8]. In the temporarily disabled state group attachments are not allowed.

If SwMI accepts the registration it shall send a D-LOCATION UPDATE ACCEPT PDU.

For cases a), b), c) and d) upon receipt of the D-LOCATION UPDATE ACCEPT PDU, which shall be received with an MLE-UNITDATA indication primitive, MM shall, if present, extract the MNI of the MS from the address extension information element and check that it is the same as MNI of the MS ITSI and, if that is the case or the MNI is not present, then the MM shall:

NOTE 5: The address extension information element cannot act as safe guard because there is no information element for the ISSI in the PDU.

- stop timer T351;

- extract any ASSI or (V)ASSI from the SSI field. If the U-LOCATION UPDATE DEMAND PDU contained request for attachment/detachment of group identities, the MM shall inspect the group identity location accept information element to find out if the SwMI accepted them. In case the group identity location accept information element is not present in the D-LOCATION UPDATE ACCEPT PDU, the MS shall assume the group attachment/detachment failed. The MS shall treat the failure as equivalent to T353 timer expiry. If the group attachment acknowledgement does not contain explicit group lifetime, then the applied lifetime is outside the scope of the present document. MM shall inform the MLE of ASSI or (V)ASSI and attached group identities with related (V)GSSIs when applicable with an MLE-IDENTITIES request primitive, see clause 16.8. The MS shall immediately change to use the ASSI or (V)ASSI in layer 2 in all subsequent signalling except for the layer 2 acknowledgement for the received D-LOCATION UPDATE ACCEPT PDU, where the SSI used shall be the same as the layer 2 address used to transfer the D-LOCATION UPDATE ACCEPT PDU;
- extract from the PDU, if information elements are present, the information concerning SCCHs and minimum mode (18th frame) monitoring, energy saving information, subscriber class and new registered area and pass these to the lower layers in an MLE-INFO request primitive, refer to clauses 16.7.1 and 16.4.9. If the new registered area information element is not present in the PDU, the MS shall consider the current RA to include only the current LA the MS just registered on with no registration timeout. If the new registered area information element is present, then the new RA is that defined by the LAs in the New registered area information element and the LA timer associated with each new LA shall be started (if applicable; i.e. if the LA Timer value is not 111₂). SwMI shall include the LA into which registration was made in the New registered area information element;
- update its "cell type preference or requirement" as described in clause 16.4.12;
- issue an MLE-UPDATE request primitive indicating a registration result of "Success" or "Temporary registration", the LAs in the RA and MM's "cell type preference or requirement". MM shall inform the user application that the MS is ready for use by issuing a TNMM-REGISTRATION confirm primitive indicating "success" and containing registration, group attachment/detachment and cell type information. Where an energy economy mode has been requested and the MS is not informed of the outcome of this request in the D-LOCATION UPDATE ACCEPT PDU, the information shall be conveyed in a separate D-MM STATUS PDU as described in clause 16.7.1;
- if registration is successful and communication resources were closed, then the MM shall open the communication resources to the other higher layer entities by issuing an MLE-OPEN request primitive. The MM shall inform the user application with TNMM-SERVICE indication primitive stating that the MS is "in service" unless the MS has previously been temporarily disabled and not subsequently enabled by the infrastructure.

In cases b) (new ITSI) and c) (new unexchanged ITSI) the D-LOCATION UPDATE ACCEPT PDU may contain the optional Default group attachment lifetime information element. If the element is not present, the MS shall assume the lifetime "Attachment for next ITSI-Attach required" to be the default lifetime.

If the SwMI rejects the registration it shall send a D-LOCATION UPDATE REJECT PDU.

Upon receipt of the D-LOCATION UPDATE REJECT PDU, MM shall, if present, extract the MNI from the address extension information element and check that it is the same as MNI of the MS ITSI and shall check if timers T351 or T354 are active. If either timer T351 or T354 is active and either the MNI is present in the PDU and matches the MNI of the MS's ITSI or the MNI is not present, then MM shall:

NOTE 6: The address extension information element cannot act as complete safe guard because there is no information element for the ISSI in the PDU.

- stop timers T351 and T352, if started;
- inform the user application about registration failure by issuing a TNMM-REGISTRATION indication primitive containing "failure" and the reject cause;
- analyse the reject cause and act similarly as in normal registration, see clause 16.4.1.1.
- further registration requests can be made in response to the receipt of further TNMM-REGISTRATION requests primitive from the user application, once a new cell has been selected.

In the event that a registration failure leaves the MS with no available cells, MLE sends MM an MLE-ACTIVATE indication primitive indicating "no cell available for any service" in response to an MLE-UPDATE request primitive from MM that includes a registration failure result. On receipt of an MLE-ACTIVATE indication primitive from MLE indicating "no cell available for any service", MM shall issue an MLE-CLOSE request primitive to the MLE and shall issue a TNMM-SERVICE indication primitive to the TNMM-SAP indicating that the MS is "out of service". The MM shall consider the MS to be de-registered and hence apply the activation procedure as defined in clause 16.3.1.1 in order to get into service again.

NOTE 7: When to apply the activation procedure, after no service is obtained is outside the scope of the present document.

If neither timer T351 nor T354 was active when the MS MM received the D-LOCATION UPDATE PDU, MM shall discard the PDU without making a response at layer 3.

In the case of authentication failure during a registration procedure, the rules in ETSI EN 300 392-7 [8] clause 4.4.2 apply.

16.4.3 Infrastructure initiated registration procedure

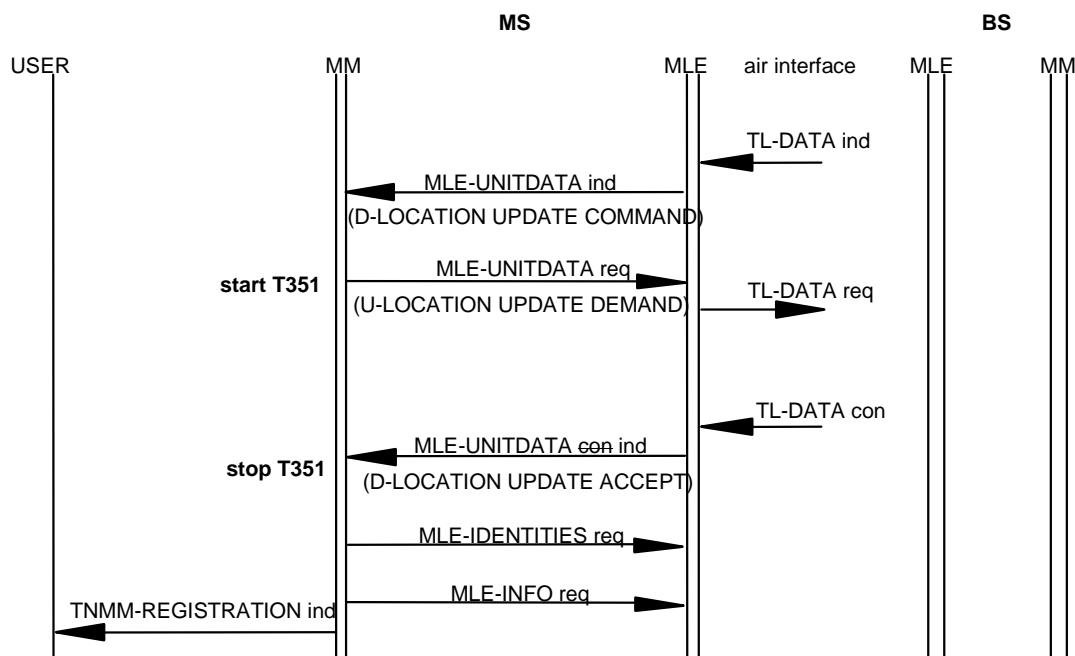

NOTE: Infrastructure initiated registration is carried out following information given by the MLE through an MLE-UNITDATA indication primitive.

Figure 16.6: Infrastructure initiated registration

The SwMI may initiate registration at any time by sending a D-LOCATION UPDATE COMMAND PDU, which may contain a group report request.

Upon receipt of the D-LOCATION UPDATE COMMAND PDU, the MM shall, if present, extract the MNI from the address extension information element. If the MNI is the same as the MNI of the MS ITS (or the MNI is not present), then:

- if the "cell type control" information element is present, MM shall update its "cell type preference or requirement" as described in clause 16.4.12;

- if MM's updated "cell type preference or requirement" does not permit use of the serving cell, MM shall issue an MLE-LINK request primitive containing MM's "cell type preference or requirement", thus causing MLE to attempt to reselect a cell that matches MM's updated "cell type preference or requirement". If MM then receives an MLE-ACTIVATE indication primitive from MLE indicating "no cell available for any service" (because MLE is not able to select from the specified cell types), MM shall issue an MLE-CLOSE request primitive to the MLE and shall issue a TNMM-SERVICE indication primitive to the TNMM-SAP indicating that the MS is "out of service". MM shall consider the MS to be de-registered and hence apply the activation procedure as defined in clause 16.3.1.1 in order to get into service again.
- If MM's updated "cell type preference or requirement" permits use of the serving cell, then:
 - MM shall send a U-LOCATION UPDATE DEMAND PDU which shall contain the MNI of the MS in the address extension information element and the ISSI of the MS in the SSI information element, thus providing the true ITSI. This shall have PDU priority 6. The location update type information element in the PDU shall be set to "demand location updating" or "disabled MS updating" depending whether the MS is enabled or disabled. The MLE-UNITDATA request primitive parameters shall indicate that the identity to be used shall be the ASSI/(V)ASSI, if one has been issued, or the ISSI in the case where an ASSI/(V)ASSI has not been issued;
 - upon receipt of the D-LOCATION UPDATE COMMAND PDU including a group report request from the MLE, the MM shall regard all the group identities no more attached. If the MS wishes to receive signalling on those group identities, the MM may include group attachments to the U-LOCATION UPDATE DEMAND PDU or re-attach all the groups using U-ATTACH/DETACH GROUP IDENTITY PDUs (but see note 3). If the MS has no groups to attach, it shall send U-LOCATION UPDATE DEMAND PDU containing a group report response information element indicating "group report complete". When sending the first group attachment, either in U-LOCATION UPDATE DEMAND PDU or U-ATTACH/DETACH GROUP IDENTITY PDU, the group identity attach/detach mode information element shall be set to "detach all currently attached group identities and attach group identities defined in the group identity..." and the group identity report information element to "not report request". If all the reported groups are sent in this one PDU it shall contain a group report response information element indicating "group report complete", or otherwise not include this information element. The PDU priority shall be set to 3. Timer T353 shall be started. For further discussion of the use of the U-ATTACH/DETACH GROUP IDENTITY PDU in this context see clause 16.8.3;
 - upon receipt of the D-LOCATION UPDATE COMMAND PDU without a group report request, the MM shall assume that group identities with parameter value "Attachment for next location update required" are no more attached. If MS wishes to receive signalling on those group identities either the U-LOCATION UPDATE DEMAND PDU may include request for attachment of those group identities in the group identity location demand information element or MM may later attach the groups using attach mechanism, see clause 16.8.2 (but see note 3);
 - the U-LOCATION UPDATE DEMAND PDU shall contain the class of MS element. If the MS supports one or more of the items listed in the extended capabilities information element (other than support of CA), the PDU shall also include the extended capabilities information element. The MS should not include the extended capabilities information element if the MS supports none of the items listed in the extended capabilities information element other than support of CA (and the MS is thus requesting registration to a CA cell);
 - the U-LOCATION UPDATE DEMAND PDU shall contain economy mode information in the energy saving mode information element if energy saving is activated; if so, timer T352 shall be started;
 - the MS shall not request to append the new LA into the current RA in the request to append LA information element. The information element LA information shall not be present in the PDU because this is not a forward registration;
 - timer T351 shall be started.

- Upon receipt of the D-LOCATION UPDATE ACCEPT PDU MM shall, if present, extract the MNI from the address extension information element and check that it is the same as MNI of the MS ITSI and, if that is either the case or the MNI is not present, then MM shall:
 - extract any ASSI or (V)ASSI from the SSI field. The MS shall immediately change to use the ASSI/(V)ASSI in layer 2 in all subsequent signalling except for the layer 2 acknowledgement for the received D-LOCATION UPDATE ACCEPT PDU, where the same SSI shall be used as was used in layer 2 in the D-LOCATION UPDATE ACCEPT PDU;
 - if the U-LOCATION UPDATE DEMAND PDU contained request for attachment/detachment of group identities, the MM shall inspect the group identity location accept information element to find out if the SwMI accepted them. In case the group identity location accept information element is not present in the D-LOCATION UPDATE ACCEPT PDU, the MS shall assume the group attachment/detachment failed. The MS shall treat the failure as equivalent to T353 timer expiry. If the group attachment acknowledgement does not contain explicit group lifetime, then the applied lifetime is outside the scope of the present document. MM shall inform the MLE of ASSI or V(ASSI) and accepted and thus attached group identities and related (V)GSSIs with an MLE-IDENTITIES request primitive, see clause 16.8. The MS shall immediately change to use the ASSI or (V)ASSI in all subsequent signalling except for the layer 2 acknowledgement for the received D-LOCATION UPDATE ACCEPT PDU, where the SSI used shall be the same as in D-LOCATION UPDATE ACCEPT PDU;
 - stop timer T351;
 - update its "cell type preference or requirement" as described in clause 16.4.12;
 - if information elements are present, extract from the PDU the information concerning SCCHs and minimum mode (18th frame) monitoring, energy saving information, subscriber class and new registered area information and inform these to the lower layers in an MLE-INFO request primitive, refer to clauses 16.7.1 and 16.4.9. If the new registered area information element is not present in the PDU, the MS shall consider the current RA to include only the current LA the MS just registered on with no registration timeout. If the new registered area information element is present, then the new RA is that defined by the LAs in the New registered area information element and the LA timer associated with each LA shall be started. The LA into which the registration was made shall be included in the New registered area information element;
 - issue an MLE-UPDATE request primitive indicating a registration result of "Success" or "Temporary registration", the LAs in the RA and MM's "cell type preference or requirement". MM shall inform the user application about infrastructure initiated registration by issuing a TNMM-REGISTRATION indication primitive containing registration, group attachment/detachment and cell type information.
- If the SwMI rejects the registration it shall send a D-LOCATION UPDATE REJECT PDU. Upon receipt of a D-LOCATION UPDATE REJECT PDU, MM shall, if present, extract the MNI from the address extension information element and check that it is the same as MNI of the MS ITSI and shall check if timers T351 or T354 are active. If either timer T351 or T354 is active and either the MNI is present in the PDU and matches the MNI of the MS's ITSI, or the MNI is not present, then MM shall:

NOTE 1: The address extension information element cannot act as complete safe guard because there is no information element for the ISSI in the PDU:

- stop and reset timer T351 and T352, if started;
- inform the user application about registration failure by issuing a TNMM-REGISTRATION indication primitive containing "failure" and the reject cause;
- analyse the reject cause and act similarly as in normal registration, see clause 16.4.1.1.

In the event that a registration failure leaves the MS with no available cells, MLE sends MM an MLE-ACTIVATE indication primitive indicating "no cell available for any service" in response to an MLE-UPDATE request primitive from MM that includes a registration failure result. On receipt of an MLE-ACTIVATE indication primitive from MLE indicating "no cell available for any service", MM shall issue an MLE-CLOSE request primitive to the MLE and shall issue a TNMM-SERVICE indication primitive to the TNMM-SAP indicating that the MS is "out of service". The MM shall consider the MS to be de-registered and hence apply the activation procedure as defined in clause 16.3.1.1 in order to get into service again.

NOTE 2: When to apply the activation procedure after no service is obtained is outside the scope of the present document.

If neither timer T351 nor T354 was active when the MS MM received the D-LOCATION UPDATE PDU, MM shall discard the PDU without making a response at layer 3.

In the case of authentication failure during a registration procedure, the rules in ETSI EN 300 392-7 [8] clause 4.4.2 apply.

NOTE 3: In the temporarily disabled state group attachments are not allowed.

16.4.4 Colliding registrations

In the event that the MS MM requests registration at the same time that the infrastructure demands that the MS MM registers, the MS MM should respond to the D-LOCATION UPDATE COMMAND PDU using the procedure defined in clause 16.4.3. On successful outcome, MM shall inform the user application with a TNMM-REGISTRATION indication primitive containing registration, group attachment/detachment and cell type information.

16.4.5 Expiry of timer T351

This timer is intended to control how often an MS may try to register to a BS. On the expiry of timer T351, if it is still possible to solely cancel the outstanding PDU according to clause 16.3.1.3, MM shall issue an MLE-CANCEL request primitive with the handle of the transmission request it corresponds to.

If it is no longer possible to solely cancel the outstanding PDU according to clause 16.3.1.3, MM may issue a U-ITSI DETACH PDU using the de-registration procedures described in clause 16.6 or resend the U-LOCATION UPDATE DEMAND PDU using the procedures described in clauses 16.4.1 and 16.4.2. The MS may wish to select a new serving cell before further registration attempts should be made.

16.4.6 Expiry of LA timers

The LA timer is intended to clear out LAs from the current RA. LA timer shall be mandatory for MS. If SwMI utilizes optional LA timer and it expires in the SwMI it may no more page the MS on that LA. The optional LA timer in SwMI should have a longer timeout value than the value attached to the MS. If a LA timer expires and the LA is not the current LA, then the LA shall be removed from the current RA in the MS and the MM shall issue an MLE-UPDATE request primitive to the MLE containing the valid LAs of the RA. If a LA timer expires and the LA is the current LA, MM shall inform user application by sending a TNMM-REGISTRATION indication primitive with registration status parameter set to "LA registration expired", LA parameter to the current LA and cell type parameter to the current cell type, so that the application could initiate registration in a suitable time e.g. after completing on-going call as defined in clause 16.4.2 a).

16.4.7 Lifetime of ASSI/(V)ASSI

16.4.7.0 General

Only one alias SSI (ASSI or (V)ASSI) shall be valid per ITSI at one time. When the SwMI allocates a new ASSI or VASSI to MS (ITSI), the previous ASSI or (V)ASSI becomes invalid.

If SwMI allocates ISSI of the MS as ASSI, the previous ASSI, if any, becomes invalid.

Once ASSI or (V)ASSI has been allocated, MS shall use it as defined in clauses 23.4.1.2.1 and 23.4.1.2.2. Even if ASSI has been allocated, SwMI may send PDUs using ISSI in home network (refer to clause 23.4.1.2.1, note 4) in which case the layer 2 acknowledgement sent by MS shall contain ISSI.

16.4.7.1 ASSI/(V)ASSI validity at migration

The ASSI/(V)ASSI is valid only within the SwMI which allocated it. When MS migrates (i.e. MS sends location update with type "migrating location updating" or "service restoration migrating location updating") the previous ASSI/(V)ASSI becomes invalid and the migrated to SwMI shall allocate a new (V)ASSI or may allocate an ASSI as appropriate.

16.4.7.2 ASSI/(V)ASSI validity by MS initiative

Whenever MS makes an "ITSI Attach" registration attempt (either successful or unsuccessful), the current ASSI, if any, becomes invalid. Whenever MS makes de-registration (sends U-ITSI DETACH PDU), the current ASSI/(V)ASSI, if any, becomes invalid.

16.4.7.3 ASSI/(V)ASSI validity at registration rejection

If SwMI rejects the registration attempt either with reason "Migration not supported", "ITSI/ATSI unknown", "Illegal MS" or "Authentication failure", the current ASSI/(V)ASSI, if any, shall become invalid for this MS. With any other reject reason the ASSI/(V)ASSI remains valid, if the MS has a valid registration in this SwMI as described in clauses 16.4.1 and 16.4.2.

NOTE 1: If the authentication of the MS fails the SwMI is supposed to use the reject cause "Authentication failure". In that case the V-ASSI for this MS is not anymore valid, but SwMI still keeps the V-ASSI valid for the MS, which was earlier successfully authenticated, even if the MS has the same V-ASSI allocated.

NOTE 2: It is useful not to withdraw the ASSI/(V)ASSI in every case when registration is rejected. For example in case the SwMI rejects the registration attempt because the LA is not allowed for the MS, the MS may send next registration (to some other LA) using the ASSI/(V)ASSI and thus not revealing its own identity (ISSI).

However, in case SwMI wants to reject visiting MS permanently the (V)ASSI shall be withdrawn.

NOTE 3: There are no means for SwMI to withdraw the ASSI explicitly within registration rejection because D-LOCATION UPDATE REJECT PDU does not contain ASSI/(V)ASSI information element.

16.4.8 Temporary registration

In case the status of the BS changes from "normal mode" to "system wide services temporarily not supported " the MSs which have already registered there stay normally registered (no action needed).

In case MS registers to a BS which is in state "system wide services temporarily not supported" and gets a registration accepted response with status "Temporary registration", the MS shall consider its registration to be temporarily accepted in the system. The MM shall pass this "Temporary registration" information to MLE within "Registration status" parameter in MLE-UPDATE request primitive.

NOTE 1: In "system wide services temporarily not supported " state, the SwMI may either accept the registration normally or use the "temporary registration" acknowledgement.

In case the status of the BS changes from "system wide services temporarily not supported" to "normal mode" the MSs which have received a "Temporary registration" response have to register again (with type "periodic location updating"). The MLE detects the change to normal mode and indicates the need for periodic registration to MM by sending MLE-LINK indication primitive. Those MSs that have received a normal registration accept acknowledgement shall not register again.

In case MS, which has received a "Temporary registration" acknowledgement, makes a cell reselection it has to register to the new cell even if the cell belongs to the Registered area of the MS. In this case MLE indicates the need for registration to MM by sending MLE-LINK indication primitive.

NOTE 2: SwMI should use the "Temporary registration" acknowledge only in case the BS is in state "system wide services temporarily not supported".

16.4.9 Subscriber class procedures

Upon reception of a D-LOCATION UPDATE ACCEPT PDU which contains the subscriber class information element:

- if a network provides a subscriber class profile in the subscriber class information element, this shall override any previous subscriber class information previously supplied for this network (at subscription or earlier registration) and the MS will inform this to MLE in an MLE-INFO request primitive as defined registration protocols;
- if the home network provides no subscriber class information in a subscriber class information element, the MS shall use the subscriber class profile allocated at subscription;
- if a visited network provides no subscriber class information in a subscriber class information element, the MS should use the subscriber class profile most recently supplied (if any) for this visited network (configured for this visited network or provided at an earlier migration). If no subscriber class profile has been provided for this network, the MS shall assume that all subscriber classes are valid.

NOTE 1: A subscriber class profile is valid only within the network which allocated it.

NOTE 2: Class 1 and/or class 2 membership may be reserved by the SwMI for AGA MSs (see clauses O.4.4 and O.7.1.2).

Upon receiving an MLE-INFO indication primitive indicating no match between the subscriber class being broadcast by the SwMI and the subscriber class of the MS, the MM shall respond to all SwMI-initiated procedures normally but shall restrict the MS-initiated requests so that only the following MS-initiated procedures are permitted:

- location updating (including migration and type 1/2 cell reselection requests);
- group attachment signalling (together with or separately from location updating PDUs);
- de-registration;
- security related procedures described in ETSI EN 300 392-7 [8].

All the other MS initiated procedures are rejected and MM shall send a failure report to the SAP and the user application should assume that the requested service has failed.

16.4.10 Frequency band capability procedures

After reception of a D-LOCATION UPDATE ACCEPT PDU the MS may send a U-MM STATUS PDU carrying a U-MS FREQUENCY BANDS INFORMATION PDU to inform which frequency bands it supports.

The SwMI may at any time send a D-MM STATUS PDU carrying a D-MS FREQUENCY BANDS REQUEST PDU. When receiving this PDU the MS should respond with sending a U-MM STATUS PDU carrying a U-MS FREQUENCY BANDS INFORMATION PDU to inform which frequency bands it supports. In addition MS should re-send the U-MS FREQUENCY BANDS INFORMATION PDU at the occasions specified in the "Re-send interval" element of the D-MS FREQUENCY BANDS REQUEST PDU.

The frequency of the lower and upper edge carrier shall be defined by the following information elements:

- lower/upper edge carrier;
- lower/upper edge frequency band;
- duplex spacing;
- reverse operation.

The upper/lower edge frequency band field shall map to a specific frequency which shall map to a defined base frequency (in MHz) for the carrier numbering scheme. The lower/upper edge carrier field shall indicate the carrier frequency relative to the base frequency defined by the corresponding frequency band field. The frequency so defined shall be the approximate downlink frequency of the lower/upper carrier. This calculation shall be summarized by the following equation:

- downlink lower/upper edge carrier frequency = base frequency + (upper/lower edge carrier * 25 kHz).

The uplink frequency of the lower/upper edge carrier shall be determined using the duplex spacing and reverse operation fields. The duplex spacing field shall map to a defined duplex spacing (in MHz) for the carrier numbering scheme. The duplex spacing shall be dependent on the frequency band element. The reverse operation field shall indicate whether to add or subtract the duplex spacing to arrive at the uplink frequency of the main carrier. If normal operation, the duplex spacing shall be subtracted. If reverse operation, the duplex spacing shall be added. This calculation is summarized by the following equations:

- normal operation:
 - uplink upper/lower edge carrier frequency = downlink main carrier frequency - duplex spacing.
- reverse operation:
 - uplink upper/lower edge carrier frequency = downlink main carrier frequency + duplex spacing.

The mapping of the frequency band field values to actual base frequencies and the duplex spacing field values to actual duplex frequency spacing are defined in annex F.

NOTE 1: These rules for calculation of uplink and downlink carrier frequency are also used for calculation of the carrier frequency in clause 21 with an exception of the offset.

NOTE 2: An MS may support a frequency range which may be larger or smaller than the actual frequency allocation defines in each country.

SwMI actions due to this information are outside the scope of the present document.

16.4.11 Air to ground reporting procedure

The SwMI may at any time send a D-MM STATUS PDU carrying a D-DISTANCE REPORTING REQUEST PDU. If the MS supports this optional procedure it shall upon reception of the D-DISTANCE REPORTING REQUEST PDU start the reporting timer with value defined by the Distance reporting timer information element unless MM has received an MLE-CONFIGURE indication primitive from MLE containing a distance reporting time. If the value received from the SwMI in a D-DISTANCE REPORTING REQUEST PDU is "No reporting/stop reporting" the MS shall not start or continue reporting unless requested by an MLE-CONFIGURE indication primitive from MLE.

If MM receives an MLE-CONFIGURE indication primitive from MLE containing a distance reporting time, MM shall start (or restart) distance reporting using the distance reporting time provided in the MLE-CONFIGURE indication primitive. If MM receives an MLE-CONFIGURE indication primitive from MLE containing the value "use periodic reporting time requested by SwMI", MM shall set the distance reporting time to the value indicated by the most recently received D-DISTANCE REPORTING REQUEST PDU (if still valid) or, if the MM does not possess a valid distance reporting time sent by the SwMI, the MS shall stop distance reporting.

While the MS is starting transmission for any reason it shall stop the distance reporting timer and upon ceasing the transmission MS shall start the distance reporting timer.

Upon expiry of the distance reporting timer the MS shall send a Null PDU unless there is something else already waiting for sending.

After each location update the MS shall check, whether the reporting is to be continued based on the distance reporting validity.

NOTE 1: The protocol model supports various implementation possibilities:

- the MM sends null PDUs to the lower layers at reporting intervals and the MAC layer may send the null PDUs without taking into account any other transmissions or the MAC may discard sending of the Null PDU when it has some else to be sent at the time the Null PDU is due to sending. In those options a usage of the MLE-CONFIGURE request primitive is not needed;
- the MM informs the MAC layer by the MLE-CONFIGURE request primitive the periodic reporting timer value and the MAC layer manages the sending of the Null PDUs. In that case the MM need not send Null PDUs.

If the MS does not support this procedure it should respond to the D-DISTANCE REPORTING REQUEST PDU by a U-MM PDU/FUNCTION NOT SUPPORTED PDU as defined in clause 16.8.8.

NOTE 2: There is no MM protocol confirmation that the MS has accepted the distance reporting request.

16.4.12 Cell type preference or requirement

This clause applies only to MSs or SwMIs that support more than one cell type.

The user application may provide MM with a "required cell type list" and a "preferred cell type list" in the TNMM-REGISTRATION request primitive. These two lists comprise the user application's "cell type preferences and requirements". If the MS indicated during registration that it supports more than one cell type, the SwMI may provide MM with "required cell type" and "preferred cell type" information by including the "cell type control" information element in a D-LOCATION UPDATE ACCEPT, D-LOCATION UPDATE COMMAND or D-LOCATION UPDATE REJECT PDU. (The SwMI should not send a "cell type control" information element to an MS that indicated during registration that it supports only one cell type.) The SwMI's "required cell type" and "preferred cell type" information comprise the SwMI's "cell type preferences and requirements".

MM shall determine its "cell type preference or requirement" as described below:

- a) MM shall retain any record it may have of the SwMI's "cell type preferences and requirements" until SIM replacement or power-off, until changing to direct mode or a different SwMI, or until receipt of a D-LOCATION UPDATE ACCEPT, D-LOCATION UPDATE COMMAND or D-LOCATION UPDATE REJECT PDU that contains the "cell type control" information element;
- b) at power up or SIM replacement, or on return to the present SwMI after changing to direct mode or a different SwMI, MM shall delete any record it may have of the SwMI's "cell type preferences and requirements" and shall set MM's "cell type preference or requirement" to the user application's "cell type preferences and requirements" (if any);
- c) on receipt of a D-LOCATION UPDATE ACCEPT, D-LOCATION UPDATE COMMAND or D-LOCATION UPDATE REJECT PDU that contains the "cell type control" information element:
 - MM shall delete any previous record of the SwMI's "cell type preferences and requirements"; then
 - if the "cell type control" information element indicates "revert to user application's cell type preferences and requirements", MM shall set its "cell type preference or requirement" in accordance with the user application's "cell type preferences and requirements" (if any); or
 - if the "cell type control" information element indicates "use SwMI's cell type preferences and requirements", MM shall record any included SwMI "cell type preferences and requirements" and shall set its "cell type preference or requirement" to a combination of the SwMI's and the user application's "cell type preferences and requirements" as described in item d) of the present clause;
- d) MM shall combine the SwMI's and the user application's "cell type preferences and requirements" as follows:
 - if neither the SwMI nor the user application has specified a cell type requirement, MM's "cell type preference or requirement" shall not include a cell type requirement, meaning that the MS is permitted to use a cell of any cell type;

- if MM has received and recorded the SwMI's required cell types and the user application has provided MM with a "required cell type list", MM shall set its "cell type preference or requirement" to include only cell types that are common to both the SwMI's required cell types and the user application's "required cell type list". If there are no common cell types, MM shall inform the user application by issuing a TNMM-REGISTRATION confirm primitive containing the registration status "no permitted cell types". The user application may then provide a new "required cell type list" to MM using a TNMM-REGISTRATION request primitive;
 - the MM's "cell type preference or requirement" shall give the SwMI's preferred cell types precedence over the user application's "preferred cell type list";
- e) if the SwMI rejects a registration request with reject cause "use of CA cell not permitted" or "use of DA cell not permitted" and the D-LOCATION UPDATE REJECT PDU does not include a "cell type control" information element, MM shall reduce the level of preference of the rejecting cell type in MM's "cell type preference or requirement";
- f) if the SwMI rejects a registration request and the D-LOCATION UPDATE REJECT PDU includes a "cell type control" information element, MM shall follow the procedure given in item c) of the present clause;
- g) if the SwMI accepts a registration request to a previously rejecting cell type, MM shall restore the level of preference of the previously rejecting cell type in MM's "cell type preference or requirement" to a combination of the SwMI's and the user application's "cell type preferences and requirements", as described in item d) of the present clause.

NOTE: If MM's "cell type preference or requirement" does not include any required cell types, the MS is permitted to use a cell of any type. If MM's "cell type preference or requirement" includes required cell types the MS is only permitted to use cells of the required types.

16.4.13 Cell load

When MLE-INFO indication service primitive informs a change in the cell load parameters of the serving cell MM may pass that information to network layer users in a MM-STATUS indication primitive using the "Cell load" parameter.

16.5 Enable and disable procedures

MS enable and disable utilizes MM procedures, refer to ETSI EN 300 392-7 [8] clause 5.

16.6 De-registration procedure

16.6.1 Trunking mode de-registration

The de-registration procedure need not be applied. Examples of where the user application may request de-registration can be at power down, or if the user specific information, including the ITSI, is removed from the TE.

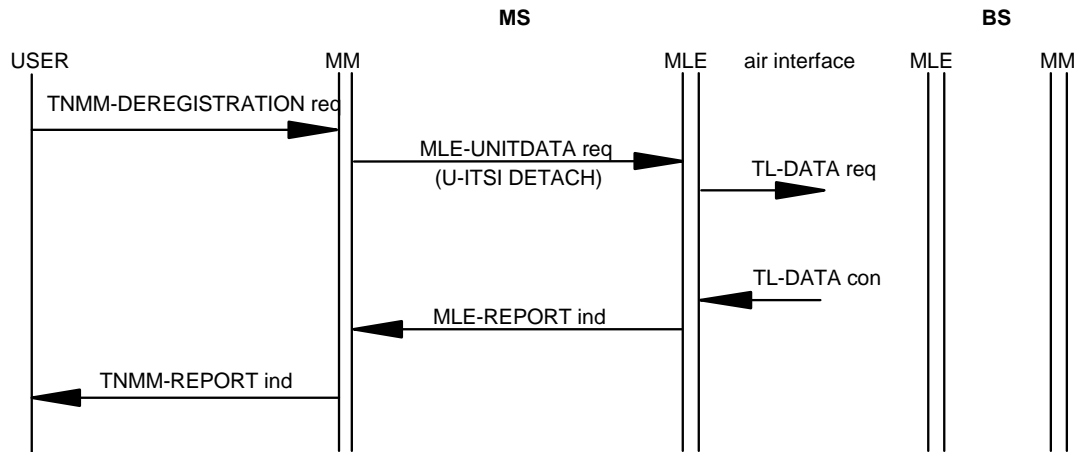

Figure 16.7: De registration of MS (detach)

Upon receipt of a TNMM-DEREGISTRATION request primitive from the user application the MS MM shall send a U-ITSI DETACH PDU to the MLE with an MLE-UNITDATA request primitive. This shall have PDU priority 3. MM may include the MNI of the MS in the address extension information element the U-ITSI DETACH PDU.

NOTE: The address extension information element cannot act as complete safe guard because there is no information element for the ISSI in the PDU.

Upon receipt of the MLE-REPORT indication primitive indicating that the U-ITSI DETACH PDU has been successfully or unsuccessfully transmitted by the DLL, MM shall inform the user application of this by issuing a TNMM-REPORT indication primitive.

A MS in the temporarily disabled state shall remain in this state after de-registration. The temporarily disabled state is defined in ETSI EN 300 392-7 [8].

16.6.2 Direct mode related de-registration

MS station may optionally inform SwMI that it leaves trunking mode and goes to direct mode operation without dual watch operation and in effect will be no more reachable in the trunking mode.

Upon reception TNMM-STATUS request primitive with value "Start of direct mode operation" MS shall inform SwMI that it is leaving to direct mode operation by sending a U-MM STATUS PDU with status "Start of direct mode operation" in a MLE-UNITDATA request PDU. The information element DMO carrier may indicate the DMO RF channel to which MS is moving for direct mode operation and the information elements start of direct mode operation cause and mode change information may provide further information. The PDU shall use PDU priority 3. MM should wait for a MLE-REPORT indication primitive before leaving trunking mode.

Return to trunking mode operation shall use appropriate registration such as user application initiated periodic registration or MLE initiated registration in case the MS has camped on a new cell outside the current RA.

16.7 Energy economy

16.7.1 Energy economy mode procedure

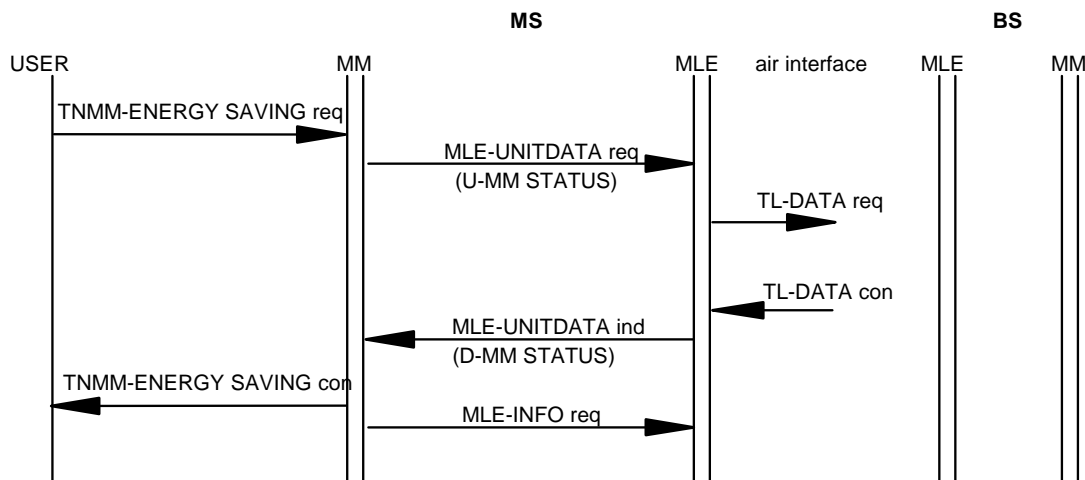

Figure 16.8: Change energy economy mode

MS shall initiate this procedure upon receipt of a TNMM-ENERGY SAVING request primitive and the MS MM shall issue an MLE-UNITDATA request primitive with a U-MM STATUS PDU carrying U-CHANGE OF ENERGY SAVING MODE REQUEST sub-PDU to the infrastructure to request a specific energy economy mode. This PDU shall have PDU priority 1. Timer T352 shall be started. The MS shall inform MAC that no energy economy mode is applicable by sending an MLE-INFO request primitive with value "stay alive".

The energy economy mode may also be requested at registration using U-LOCATION UPDATE DEMAND PDU as defined in clauses 16.4.1.1, 16.4.1.2, 16.4.2 and 16.4.3. The BS may respond to this by either normal registration PDU or after registration by a D-MM STATUS PDU carrying a D-CHANGE OF ENERGY SAVING MODE RESPONSE sub-PDU.

Upon receipt of a D-MM STATUS PDU carrying a D-CHANGE OF ENERGY SAVING MODE RESPONSE sub-PDU or a D-LOCATION UPDATE ACCEPT PDU containing an energy saving information element, timer T352 shall be stopped and MM shall:

- if the received information element energy saving mode has another value than "stay alive" MM shall inform the lower layers of the energy economy parameters in an MLE-INFO request primitive. The energy economy parameters are in the energy economy mode configuration parameter, which shall contain the energy saving mode and energy economy start point, the latter shall define the absolute frame and multiframe number of the start point. MM shall inform the user application the start of the energy saving mode and its value with a TNMM-ENERGY SAVING confirm primitive;

NOTE 1: The BS may allocate a different energy saving mode than requested and the BS assumes that the allocated value will be used.

- if the received information element energy saving mode has value "stay alive" MM shall inform the user application with a TNMM-ENERGY SAVING confirm primitive by setting the energy economy mode status parameter value to "rejected" (except in the case of a request to stay alive) and the energy economy mode parameter value to "stay alive".

NOTE 2: If the BS rejected the energy saving mode the MS may try to invoke energy saving mode upon next registration.

BS may change (i.e. modify or stop) or allocate an energy saving mode of an MS at any time by sending a D-MM STATUS PDU carrying a D-CHANGE OF ENERGY SAVING MODE REQUEST sub-PDU.

Upon reception of the D-MM STATUS PDU carrying the D-CHANGE OF ENERGY SAVING MODE REQUEST sub-PDU the MS shall respond to the allocation by sending a U-CHANGE OF ENERGY SAVING MODE RESPONSE PDU. In the response the MS shall use the same energy saving mode value as in the D-CHANGE OF ENERGY SAVING MODE REQUEST sub-PDU or reject the allocation by using energy saving mode value "stay alive". The MM shall inform the user application the start or a change of the energy saving mode and its value with a TNMM-ENERGY SAVING indication primitive. Energy economy mode may be applicable to a MS in the temporarily disabled state.

MM shall assume that the energy economy mode is lost when RA is changed, and the MS will then need to re-request an energy economy mode if it wishes to apply energy saving.

16.7.2 Procedures for requesting Direct Mode dual watch operation

16.7.2.1 Introduction

Dual watch may be performed by an MS that is capable of both V+D and TETRA Direct Mode operation (see ETSI EN 300 396-3 [22]). A full dual watch MS is capable of periodically receiving the V+D common control channel while in a Direct Mode call, a Direct Mode RF carrier while in a V+D call and, when idle, it periodically receives both the Direct Mode RF carrier and the V+D common control channel. In order for the MS to periodically receive the V+D common control channel while in a Direct Mode call, the MS needs to negotiate with the SwMI to use a periodic reception procedure similar to energy economy mode with an appropriate energy economy group. See also clause 23.7.7.

An MS supporting idle dual watch is capable of periodically receiving both the Direct Mode RF carrier and the V+D common control channel when idle. The MS may not be capable of receiving the V+D common control channel while in a Direct Mode call or a Direct Mode RF carrier while in a V+D call. An MS may be forced to operate in idle dual watch mode in the case that the MS cannot negotiate a satisfactory energy economy mode with the SwMI or it may be totally dependent on the capabilities of the MS. When requesting idle dual watch mode, the MS may negotiate with the SwMI to use a periodic reception procedure similar to energy economy mode. When the MS requests direct mode dual watch operation, it indicates whether it is requesting full dual watch or idle dual watch by using the "dual watch mode" information element of the U-DUAL WATCH MODE REQUEST sub-PDU.

NOTE: SwMI designers should note that also a full dual watching MS will not always be able to receive in the V+D slots corresponding to the agreed energy economy group and, even if the MS receives a V+D message, it may not always be able to send a layer 3 response e.g. if it is currently in a Direct Mode call. Also, the MS sometimes may not be able to send even a layer 2 response e.g. if it is currently in an emergency Direct Mode call. Therefore, if a dual watching MS does not respond to any V+D messages, the SwMI should not assume that the MS has left the V+D network unless the MS fails to transmit or respond to V+D messages over a long period of time. This time may be longer for an MS that is using idle dual watch mode. See also clause 23.7.7.

The MS shall inform the SwMI when it wishes to start or resume full dual watch operation with an appropriate energy economy group, when it wishes to change the energy economy group associated with its full dual watch operation and when it wishes to stop full dual watch operation. The MS may inform the SwMI when it wishes to start or resume idle dual watch operation and shall inform the SwMI when it wishes to change the energy economy group associated with its dual watch operation; also, if the MS informed the SwMI when it started or resumed idle dual watch operation then it shall inform the SwMI when it wishes to stop idle dual watch operation. The procedures defined in the remainder of this clause, and in clauses 16.7.2.2 to 16.7.2.6, relate to the full dual watching procedure; they relate also to the idle dual watching procedure in the case when the MS informs the SwMI that it is performing idle dual watch. Clause 16.7.2.7 describes the idle dual watching procedure in the case when the MS does not inform the SwMI that it is performing idle dual watch.

When the MS wishes to start or resume full or idle dual watch operation with an appropriate energy economy group, or when it wishes to start or resume idle dual watch operation without using an energy economy group, or when it wishes to change the energy economy group associated with its dual watch operation, it uses a U-MM STATUS PDU carrying a U-DUAL WATCH MODE REQUEST sub-PDU (see clause 16.7.2.2). When the MS wishes to stop dual watch operation, it uses a U-MM STATUS PDU carrying a U-TERMINATING DUAL WATCH MODE REQUEST sub-PDU (see clause 16.7.2.3).

When the MS is in dual watch mode, the SwMI may at any time change the energy economy group associated with the MS's dual watch operation or withdraw its acceptance of the MS's dual watch request by sending a D-MM STATUS PDU carrying a D-CHANGE OF DUAL WATCH MODE REQUEST sub-PDU (see clause 16.7.2.4).

16.7.2.2 MS requesting to start, modify or resume dual watch mode

Upon receipt of a TNMM-STATUS request primitive with the "dual watch" parameter value set to "starting dual watch mode" or "modify or resume dual watch mode", the MS MM shall issue an MLE-UNITDATA request primitive with a U-MM STATUS PDU carrying a U-DUAL WATCH MODE REQUEST sub-PDU. If the MS is requesting full dual watch mode, the MM shall set the "energy saving mode" information element to request an appropriate energy economy group. If the MS is requesting idle dual watch mode, it may include a request for an energy economy group in the PDU; alternatively it may set the "energy saving mode" information element to "stay alive". MM shall set the "dual watch mode" information element according to the MS capabilities.

The U-DUAL WATCH MODE REQUEST sub-PDU shall have PDU priority 3. When MM sends the PDU, timer T352 shall be started and MM shall instruct the MAC to "stay alive" by issuing an MLE-INFO request primitive.

On receiving a D-MM STATUS PDU carrying a D-DUAL WATCH MODE RESPONSE sub-PDU, timer T352 shall be stopped and MM shall perform the following procedure a), b), c) or d) as appropriate:

- a) If the MS requested for full dual watch and the "result of dual watch request" information element indicates "Request accepted ..." and the received information element "energy saving mode" has a value appropriate for full dual watch, MM shall inform the lower layers of the dual watch parameters in an MLE-INFO request primitive. The dual watch parameters are in the "dual watch mode configuration" parameter, which shall contain the energy saving mode and the starting frame and multiframe. The energy saving mode shall define the dual watch energy economy group and the frame number and multiframe number shall define the dual watch start point. The D-DUAL WATCH MODE RESPONSE sub-PDU may contain the "SCCH information and distribution on 18th frame" information element, in which case MM shall include the information concerning SCCHs and minimum mode configuration in the MLE-INFO request primitive. MM shall inform the user application of the acceptance of the dual watch and the value of the energy saving mode with a TNMM-STATUS confirm primitive.

NOTE 1: The SwMI may allocate a different energy saving mode than requested and the SwMI assumes that the allocated value will be used. However, the SwMI should not allocate a value of energy saving mode that is not appropriate for full dual watch operation (as defined in ETSI EN 300 396-3 [22], ETSI EN 300 396-4 [23] and ETSI EN 300 396-7 [25]).

NOTE 2: For a dual watch activation:

- the SwMI should assign a starting point to a full dual watching MS such that the MS's reception cycle includes V+D frame 18;
- the SwMI may need to include the "SCCH information and distribution on 18th frame" information element in the D-MM STATUS PDU because it should assign the same common control channel to all full dual watching MSs on the same direct mode RF carrier on a cell.

This allows MSs to maintain V+D synchronization and enables compatible cycles for all full dual watching MSs on a Direct Mode RF carrier.

- b) If the MS requested for full dual watch and the "result of dual watch request" information element indicates "Request accepted ..." but the received information element "energy saving mode" has a value not appropriate for full dual watch, MM may either convert to idle dual watch procedures or abandon the dual watch mode completely.

If the MS converts to idle dual watch mode, MM shall inform the lower layers of the dual watch parameters in an MLE-INFO request primitive. The dual watch parameters are in the "dual watch mode configuration" parameter, which shall contain the energy saving mode and the starting frame and multiframe. The energy saving mode shall define the dual watch energy economy group and the frame number and multiframe number shall define the dual watch start point. The D-DUAL WATCH MODE RESPONSE sub-PDU may contain the "SCCH information and distribution on 18th frame" information element, in which case MM shall include the information concerning SCCHs and minimum mode configuration in the MLE-INFO request primitive. MM shall inform the user application of the offered idle dual watch and the value of the energy saving mode with a TNMM-STATUS confirm primitive.

NOTE 3: If the SwMI cannot support an energy saving mode appropriate for full dual watch mode, the SwMI should not reject the dual watch request but offer a different energy saving mode or no energy saving mode ("stay alive") to the MS. This allows the MS to perform idle dual watch procedures. If the SwMI allocates a value of energy saving mode that is not appropriate for full dual watch operation, the SwMI should assume that the MS is only capable of the idle dual watch procedure.

If the user application abandons the offered idle dual watch mode it may either stay in V+D mode or go totally to direct mode. If the MS wishes to stay in V+D mode, the MM shall send a U-MM STATUS PDU carrying a U-TERMINATING DUAL WATCH MODE REQUEST sub-PDU (see clause 16.7.2.3). If MS wants to go to the direct mode, the MM may send a U-MM STATUS PDU carrying a U-START OF DIRECT MODE OPERATION sub-PDU (see clause 16.6.2).

- c) If the MS requested for idle dual watch and the "result of dual watch request" information element indicates "Request accepted ...", MM shall inform the lower layers of the dual watch parameters in an MLE-INFO request primitive. The dual watch parameters are in the "dual watch mode configuration" parameter, which shall contain the energy saving mode and the starting frame and multiframe. The energy saving mode shall define the dual watch energy economy group and the frame number and multiframe number shall define the dual watch start point. The D-DUAL WATCH MODE RESPONSE sub-PDU may contain the "SCCH information and distribution on 18th frame" information element, in which case MM shall include the information concerning SCCHs and minimum mode configuration in the MLE-INFO request primitive. MM shall inform the user application of the acceptance of the idle dual watch and the value of the energy saving mode with a TNMM-STATUS confirm primitive.

NOTE 4: The SwMI may allocate a different energy saving mode than requested and the SwMI assumes that the allocated value will be used.

NOTE 5: If the SwMI cannot support the requested energy saving mode, the SwMI should not reject the dual watch request but offer a different energy saving mode or no energy saving mode ("stay alive") to the MS. An MS is able to perform idle dual watch procedures with a different energy saving mode or with no energy saving mode.

- d) If the "result of dual watch request" information element indicates "Request rejected for undefined reason" or "Dual watch not supported", MM shall inform the user application of the rejection of the dual watch request with a TNMM-STATUS confirm primitive with the "dual watch" parameter value set appropriately and the "energy economy mode" parameter value set according to received "energy saving information" information element.

If the SwMI rejects the dual watch request then the user application may choose to leave V+D operation and go to Direct Mode operation, or remain in V+D operation, or use the idle dual watching procedure described in clause 16.7.2.7. If the MS leaves V+D operation and goes to Direct Mode operation then the MM may send a U-MM STATUS PDU carrying a U-START OF DIRECT MODE OPERATION sub-PDU (see clause 16.6.2). If the MS remains in V+D operation then the user application may choose to request normal energy economy mode, as defined in clause 16.7.1. The MS may try to request dual watch again after its next registration.

16.7.2.3 MS terminating dual watch mode

Upon receipt of a TNMM-STATUS request primitive with the "dual watch" parameter value set to "terminating dual watch mode", the MS MM shall issue an MLE-UNITDATA request primitive with a U-MM STATUS PDU carrying a U-TERMINATING DUAL WATCH MODE REQUEST sub-PDU containing the "energy saving mode" information element set to "stay alive". This PDU shall have PDU priority 3. Timer T352 shall be started. MM shall instruct the MAC to "stay alive" by issuing an MLE-INFO request primitive.

On receiving a D-MM STATUS PDU carrying a D-TERMINATING DUAL WATCH MODE RESPONSE sub-PDU, timer T352 shall be stopped and MM shall inform the user application with a TNMM-STATUS confirm primitive with the "dual watch" parameter value set to "terminating dual watch mode response" and the "energy economy mode" parameter value set to "stay alive".

NOTE: The procedure if the MS wishes to start normal energy economy mode when it terminates dual watch mode is described in clause 16.7.2.5 b).

16.7.2.4 SwMI modifying or terminating dual watch mode

If an MS in dual watch mode receives a D-MM STATUS PDU carrying a D-CHANGE OF DUAL WATCH MODE REQUEST sub-PDU, the MS MM shall respond to the PDU by sending a U-MM STATUS PDU carrying a U-CHANGE OF DUAL WATCH MODE RESPONSE sub-PDU. In the response the MS shall use the same "energy saving mode" value as in the D-CHANGE OF DUAL WATCH MODE REQUEST sub-PDU.

If the "reason for dual watch change by SwMI" information element contains value "change of dual watch energy economy group" then the MS shall perform procedure a) or b) as appropriate:

- a) If the MS performs full dual watch and the received "energy saving information" information element contains a value appropriate for full dual watch, or the MS performs idle dual watch, MM shall inform the lower layers of the modified dual watch parameters in an MLE-INFO request primitive. MM shall inform the user application of the modified value of the energy saving mode with a TNMM-STATUS indication primitive.
- b) If the MS performs full dual watch and the received "energy saving information" information element contains a value not appropriate for full dual watch, MM may either convert to idle dual watch procedures or abandon the dual watch mode completely.

If the MS converts to idle dual watch mode, MM shall inform the lower layers of the modified dual watch parameters in an MLE-INFO request primitive. MM shall inform the user application of the change to idle dual watch and the modified value of the energy saving mode with a TNMM-STATUS primitive.

If the user application abandons the offered idle dual watch mode it may either stay in V+D mode or go totally to direct mode. If the MS wishes to stay in V+D mode, the MM shall send a U-MM STATUS PDU carrying a U-TERMINATING DUAL WATCH MODE REQUEST sub-PDU (see clause 16.7.2.3). If MS wants to go to the direct mode, the MM may send a U-MM STATUS PDU carrying a U-START OF DIRECT MODE OPERATION sub-PDU (see clause 16.6.2).

NOTE 1: If the SwMI allocates a value of energy saving mode that is not appropriate for full dual watch operation, the SwMI should assume that the MS is only capable of the idle dual watch procedure.

NOTE 2: In the case that the user application abandons the offered idle dual watch mode, the MM is not allowed to respond to the D-CHANGE OF DUAL WATCH MODE REQUEST PDU by sending a U-TERMINATING DUAL WATCH MODE REQUEST sub-PDU or U-START OF DIRECT MODE OPERATION sub-PDU without first sending U-CHANGE OF DUAL WATCH MODE RESPONSE sub-PDU.

If the "reason for dual watch change by SwMI" information element contains value "dual watch terminated for undefined reason" then MM shall inform the user application of the termination of dual watch mode by issuing a TNMM-STATUS indication primitive and shall instruct the MAC to "stay alive" by issuing an MLE-INFO request primitive. The user application may choose to leave V+D operation and go to Direct Mode operation, or remain in V+D operation, or use the idle dual watching procedure described in clause 16.7.2.7. If the MS leaves V+D operation and goes to Direct Mode operation then the MM may send a U-MM STATUS PDU carrying a U-START OF DIRECT MODE OPERATION sub-PDU (see clause 16.6.2). If the MS remains in V+D operation then the user application may choose to request normal energy economy mode, as defined in clause 16.7.1. The MS may try to request dual watch again after its next registration.

If an MS not in dual watch mode receives a D-MM STATUS PDU carrying a D-CHANGE OF DUAL WATCH MODE REQUEST sub-PDU, the MS MM shall respond to the PDU by sending a U-MM STATUS PDU carrying a U-CHANGE OF DUAL WATCH MODE RESPONSE sub-PDU with the "energy saving mode" value set to "stay alive". This requirement applies only for an MS capable of dual watch operation.

16.7.2.5 Changing between modes

An MS cannot operate in both normal energy economy mode and dual watch mode at one time. If the MS wishes to change from one mode to the other mode, it shall perform procedure a) or b) as appropriate:

- a) If an MS in energy economy mode receives a TNMM-STATUS request primitive with the "dual watch" parameter value set to "starting dual watch mode" then it needs to send only a U-MM STATUS PDU carrying a U-DUAL WATCH MODE REQUEST sub-PDU requesting to start dual watch mode (without first sending a PDU requesting to end energy economy mode). The procedure shall be as defined in clause 16.7.2.2.

- b) If an MS in dual watch mode receives a TNMM-ENERGY SAVING request primitive indicating a request to start energy economy mode then it shall send a U-MM STATUS PDU carrying a U-TERMINATING DUAL WATCH MODE REQUEST sub-PDU containing the "energy saving mode" information element set to the value requested for the energy economy mode. This PDU shall have PDU priority 3. Timer T352 shall be started. The procedure on receiving a D-MM STATUS PDU carrying a D-TERMINATING DUAL WATCH MODE RESPONSE sub-PDU shall then be as defined in clause 16.7.1 for receipt of a D-MM STATUS PDU carrying a D-CHANGE OF ENERGY SAVING MODE RESPONSE sub-PDU.

At the time of sending the PDU requesting the new mode, MM shall instruct the MAC to end the old reception cycle by issuing an MLE-INFO request primitive for the old mode indicating "stay alive". Then, if it receives a PDU accepting its request, MM shall inform the MAC of the new parameters by issuing an MLE-INFO request primitive for the new mode.

16.7.2.6 General dual watch procedures

Dual watch mode may be applicable to an MS in the temporarily disabled state.

NOTE 1: An enable or disable applied to a subscription or an equipment in V+D will also apply in Direct Mode and vice versa (see ETSI EN 300 392-7 [8] and ETSI EN 300 396-6 [i.6]).

Thus, if a dual watching MS receives a disable message then that disable message applies to both V+D and Direct Mode. In the case of a temporary disablement, the MS should then continue to receive, looking for an enable message; during this time, the MS may continue to use the dual watch periodic reception procedure on the V+D control channel. If the MS receives an enable message then that enable message applies to both V+D and Direct Mode.

MM shall assume that the dual watch mode is lost when the RA is changed or if the MS needs to re-register for any reason other than for a periodic registration. Having successfully re-registered, the MS then needs to send again the U-MM STATUS PDU carrying a U-DUAL WATCH MODE REQUEST sub-PDU if it wishes to resume dual watch operation.

NOTE 2: Unlike normal energy economy mode (see clause 16.7.1), the MS cannot use the U-LOCATION UPDATE DEMAND PDU to request dual watch operation.

Both in full and idle dual watch mode the MS may not be able to receive the V+D common control channel while in a Direct Mode call, see clause 23.7.7. It is assumed that in both modes, when the MS is participating in a V+D call or packet data transfer, it shall receive all the required V+D slots.

An idle dual watching MS shall obey the normal criteria for registration as if it had been receiving the V+D common control channel throughout Direct Mode calls in which it participates. So, at the end of a Direct Mode call, the MS is not required to re-register unless the RA has changed or the LA timer has expired (or the MS has received a D-LOCATION UPDATE COMMAND PDU from the SwMI). This applies also to a full dual watching MS.

16.7.2.7 Idle dual watch without informing SwMI

The procedures defined in clauses 16.7.2.2 to 16.7.2.6 relate to the full dual watching procedure. They relate also to the idle dual watching procedure, but only in the case when the MS informs the SwMI that it is performing idle dual watch.

Alternatively, upon receipt of a TNMM-STATUS request primitive with the "dual watch" parameter value set to "starting dual watch mode", the MS may perform the idle dual watching procedure without informing the SwMI that it is performing idle dual watch. As in normal idle dual watch, an MS using this form of idle dual watch:

- is capable of periodically receiving both the Direct Mode RF carrier and the V+D common control channel when idle; and
- may not be capable of receiving the V+D common control channel while it is in a Direct Mode call or a Direct Mode RF carrier while it is in a V+D call.

It is assumed that, when the MS is participating in a V+D call or packet data transfer, it shall receive all the required V+D slots.

When performing this form of idle dual watch, the MS shall obey the normal V+D procedures except that it is not required to receive the V+D common control channel while it is in a Direct Mode call.

An MS using this form of idle dual watch shall obey the normal criteria for registration as if it had been receiving the V+D common control channel throughout Direct Mode calls in which it participates. So, at the end of a Direct Mode call, the MS is not required to re-register unless the RA has changed or the LA timer has expired (or the MS has received a D-LOCATION UPDATE COMMAND PDU from the SwMI).

An MS using this form of idle dual watch may choose to request normal energy economy mode, as defined in clause 16.7.1.

This form of idle dual watch mode may be applicable to an MS in the temporarily disabled state. The description in clause 16.7.2.6, note 1 applies also to this form of idle dual watch.

16.7.3 Expiry of timer T352

On the expiry of timer T352, if it is still possible to solely cancel the outstanding PDU according to clause 16.3.1.3, MM shall issue an MLE-CANCEL request primitive with the handle of the transmission request it corresponds to. If it is no longer possible to solely cancel the outstanding PDU according to clause 16.3.1.3, MM shall return a TNMM-ENERGY SAVING or TNMM-STATUS confirm primitive with energy saving mode value "stay alive" and a failure report to the SAP and the user application should assume that the requested service has failed.

16.8 Attachment/detachment of group identities and group reporting procedures

16.8.0 General

The attachment/detachment of group identities procedures are illustrated in figures 16.9 and 16.10. Group reporting procedures are illustrated in figures 16.11 and 16.12. Attachment/detachment of group identities and group reporting can be initiated by the user application or it can be requested by the infrastructure.

The attached group identities, used as valid layer 2 group addresses, shall be defined as follows:

- 1) attached by the SwMI, by using D-ATTACH/DETACH GROUP IDENTITY PDU and accepted by the MS using the corresponding U-ATTACH/DETACH GROUP IDENTITY ACKNOWLEDGEMENT PDU;
- 2) previously attached group identities if the attachment/detachment mode in the D-ATTACH/DETACH GROUP IDENTITY PDU were an "amendment";
- 3) previously attached group identities which were not detached by the SwMI in the D-ATTACH/DETACH GROUP IDENTITY PDU;
- 4) attachment requested by the MS by using U-ATTACH/DETACH GROUP IDENTITY or U-LOCATION UPDATE DEMAND PDU, and accepted by the SwMI in the corresponding D-ATTACH/DETACH GROUP IDENTITY ACKNOWLEDGEMENT or D-LOCATION UPDATE ACCEPT PDU;
- 5) previously attached group identities if the attachment/detachment mode in the U-ATTACH/DETACH GROUP IDENTITY PDU or U-LOCATION UPDATE DEMAND PDU were an "amendment";
- 6) previously attached group identities which were not detached by the MS by using U-ATTACH/DETACH GROUP IDENTITY or U-LOCATION UPDATE DEMAND PDU;
- 7) defined with the attachment mode "attachment is not needed". This may be defined either by using group identity attachment lifetime information element in the attachment/detachment PDUs or by using other means outside of the scope of the present document;
- 8) defined to be temporary group address, active during a call (see CMCE protocol in clause 14);
- 9) defined and attached by SS-DGNA, refer to ETSI EN 300 392-12-22 [17] and not detached by any of the previous actions;
- 10) previously attached group identities whose group identity attachment lifetime is still valid.

The MS shall always use a (V)GSSI as lower layer receiving address instead of the GSSI when the (V)GSSI is assigned for the MS in the currently registered SwMI. GSSI shall not be used as an active group identity if the currently registered network MCC and MNC is not the same as the MCC and MNC related to the GSSI.

In case the MS has been temporarily disabled and then enabled by the SwMI, the MS may assume that the groups that were attached at the time when the temporary disabling was done are still attached if not otherwise defined by the attachment lifetime. However, after enabling the MS shall re-attach the groups having lifetime "Attachment for next location update required" if the MS wishes the groups to remain attached. MS may also re-attach any groups.

Examples of group attachment/detachment message flows are in annex G.

16.8.1 Infrastructure initiated attachment/detachment of group identities procedure

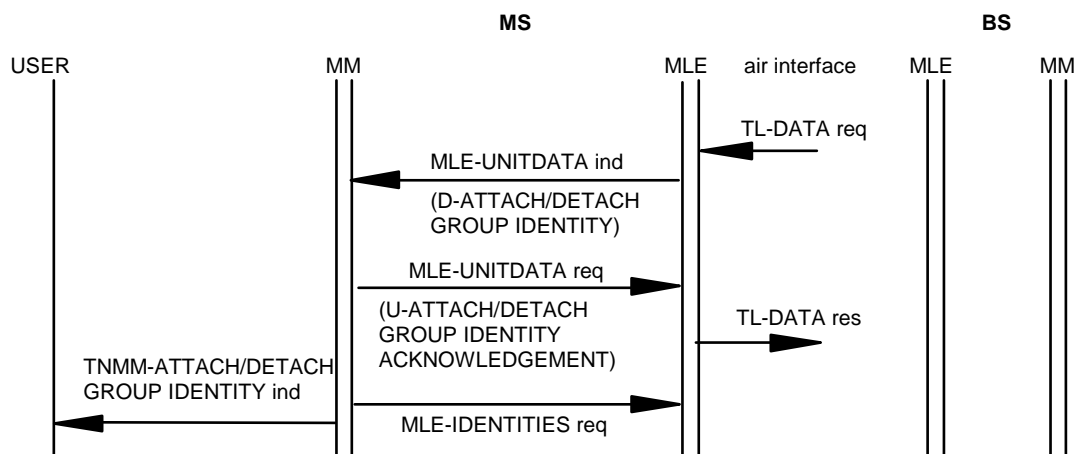

Figure 16.9: SwMI initiated attachment/detachment of group identities

When SwMI initiates group attachment/detachment by sending a D-ATTACH/DETACH GROUP IDENTITY PDU it shall set the group identity report to "not report request" and the group report response information element shall not be included into the PDU. If SwMI wishes to add to or remove some of the group identities attached in the MS it shall set the group identity attach/detach mode information element to "amendment". If SwMI wishes to detach all attached group identities from the MS and replace the attached group identities by new ones it shall set the group identity attach/detach mode information element to "detach all currently attached group identities and attach group identities defined in the group identity".

Upon receipt the D-ATTACH/DETACH GROUP IDENTITY PDU, MM shall inspect the attachment/detachment requests for group identities from the PDU. MM shall send valid group identities and related (V)GSSIs with an MLE-IDENTITIES request primitive to the MLE. If the group identity acknowledgement request field is set to acknowledgement requested, then the MM shall send a U-ATTACH/DETACH GROUP IDENTITY ACKNOWLEDGEMENT PDU to the MLE in an MLE-UNITDATA request primitive. The U-ATTACH/DETACH GROUP IDENTITY ACKNOWLEDGEMENT PDU shall contain rejected attachments and may contain accepted attachments and detachments, refer to annex F. Those group identities which were in the D-ATTACH/DETACH GROUP IDENTITY PDU but are not contained in the U-ATTACH/DETACH GROUP IDENTITY ACKNOWLEDGEMENT PDU are accepted. PDU priority shall be set to 6. Finally the MM shall inform the user application about changes in attached/detached group identities by issuing a TNMM-ATTACH/DETACH GROUP IDENTITY indication primitive. The MM shall inform the user application using only the GTSIs while the (V)GSSIs is not known by the user application.

Infrastructure initiated attachment/detachment of group identities is not applicable to a MS in the temporarily disabled state and MS shall not send U-ATTACH/DETACH GROUP IDENTITY ACKNOWLEDGEMENT PDU or modify group information.

16.8.2 MS initiated attachment/detachment of group identities procedure

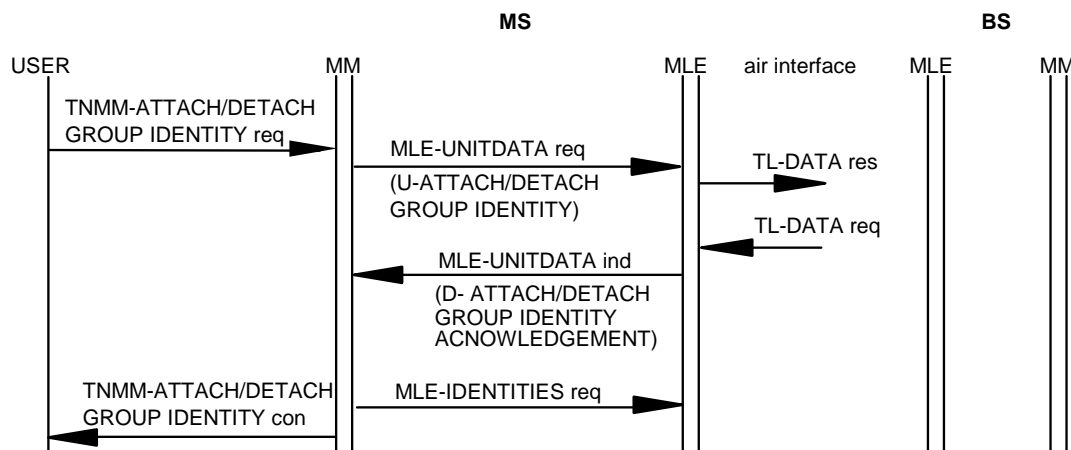

Figure 16.10: MS initiated attachment/detachment of group identities, acknowledgement requested

Upon receipt of a TNMM-ATTACH/DETACH GROUP IDENTITY request primitive from the user application the MM shall send a U-ATTACH/DETACH GROUP IDENTITY PDU to the MLE in an MLE-UNITDATA request primitive using parameters defined in the TNMM-ATTACH/DETACH GROUP IDENTITY request primitive (see clause 17). MM shall set the group identity report to "not report request" and the group report response information element shall not be included into the PDU. If MS wishes to add to or remove some of the group identities attached in the MS it shall set the group identity attach/detach mode information element to "amendment". If MS wishes to detach all attached group identities from the MS and replace the attached group identities by new ones it shall set the group identity attach/detach mode information element to "detach all currently attached group identities and attach group identities defined in the group identity". PDU priority shall be set to 3. Timer T353 shall be started.

The MM should not try to attach those group identities which have been permanently detached by the current network. In addition the MM should not try to attach those group identities which have earlier been attached in the current network with parameter values "Attachment not allowed for next ITSI attach" if the group is not already attached.

NOTE: Independently of the attachment lifetime the MS is allowed to re-attach a group which is currently attached, when the user application within MS for example changes the class of usage value of the group.

Upon receipt of a D-ATTACH/DETACH GROUP IDENTITY ACKNOWLEDGEMENT PDU, timer T353 shall be stopped. The D-ATTACH/DETACH GROUP IDENTITY ACKNOWLEDGEMENT PDU shall indicate those group identities which were not accepted with a rejection reason in the group identity detachment downlink information element, refer to clause 16.10.20, and it may contain also accepted group identities. The SwMI may reject group identity detachment by adding the group attachment into the D-ATTACH/DETACH GROUP IDENTITY ACKNOWLEDGEMENT PDU.

If the MS requested attachment/detachment of group identities, the MM shall examine whether the attachments and/or detachments requested were accepted by the SwMI. The MM shall send the attached group identities and related (V)GSSIs with MLE-IDENTITIES request primitive to the MLE.

If the group identity downlink information element does not explicitly contain the group attachment lifetime information element, then the applied lifetime is outside the scope of the present document.

Finally the MM shall inform the user application by issuing a TNMM-ATTACH/DETACH GROUP IDENTITY confirm primitive. The MM shall inform the user application using only the GTSIs since the (V)GSSIs is not known by the user application.

MS initiated attachment/detachment of group identities is not applicable to a MS in the temporarily disabled state. In the temporary disabled state upon receipt of a TNMM-ATTACH/DETACH GROUP IDENTITY request primitive MM shall not send a U-ATTACH/DETACH GROUP IDENTITY PDU and may issue a TNMM-DISABLING indication primitive to the user application.

16.8.3 SwMI initiated group report procedure

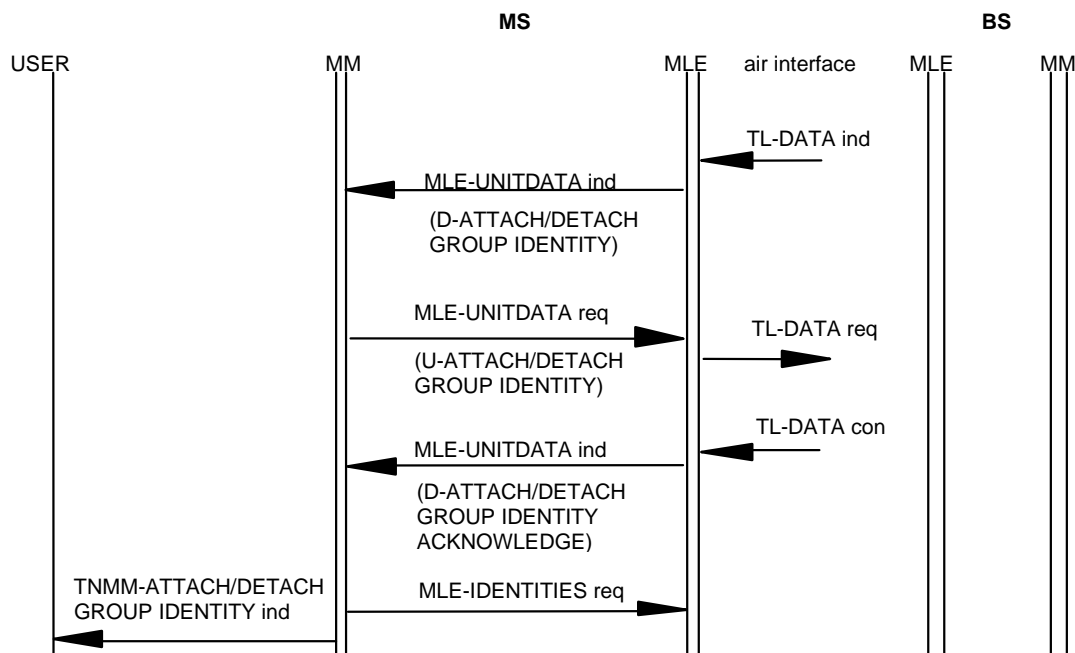

Figure 16.11: SwMI initiated group report

In the SwMI initiated group report procedure, the SwMI requests the MS to start group attachment and the MS shall re-attach those groups it wishes to remain valid, including group identities with lifetime parameter value "attachment not needed". When receiving the group report request, the MM shall regard all the group identities no more attached. If the MS wishes to receive signalling on those group identities, the MM has to re-attach them. The MM should not try to attach those group identities which have been permanently detached by the current network. In addition the MM should not try to attach those group identities which have earlier been attached in the current network with parameter values "attachment not allowed for next ITSI attach" if the group is not already attached. The attachment request may also contain group identities which were temporarily detached or indicated as unknown by the SwMI, refer to clause 16.10.20.

Upon receipt of the D-ATTACH/DETACH GROUP IDENTITY PDU from the MLE, MM shall check that the group identity report information element indicates that a "group report" is requested. The group identity acknowledgement request information element value shall be "acknowledgement not requested", MS shall ignore the value of the group identity attach/detach mode information element and group identity downlink information elements shall not be present in the PDU. As the response MM shall send a U-ATTACH/DETACH GROUP IDENTITY PDU containing the reported groups, the group identity attach/detach mode information element shall be set to "detach all currently attached group identities and attach group identities defined in the group identity" and the group identity report information element to "not report request" and if all the reported groups do fit into one U-ATTACH/DETACH GROUP IDENTITY PDU it shall contain a group report response information element indicating "group report complete". The PDU priority shall be set to 3. Timer T353 shall be started. If the reported groups do not fit in one U-ATTACH/DETACH GROUP IDENTITY PDU, the group report response information element shall not be included and subsequent groups shall be reported using U-ATTACH/DETACH GROUP IDENTITY PDUs as presented above except that the group identity attach/detach mode information element shall be set to "amendment". The PDU priority shall be set to 3. Timer T353 shall be started. MM shall expect that each U-ATTACH/DETACH GROUP IDENTITY PDU is acknowledged individually before sending next U-ATTACH/DETACH GROUP IDENTITY PDU by the corresponding D-ATTACH/DETACH GROUP IDENTITY ACKNOWLEDGEMENT PDU.

Upon receipt of each D-ATTACH/DETACH GROUP IDENTITY ACKNOWLEDGEMENT PDU, timer T353 shall be stopped. MM shall send the accepted and thus attached group identities and related (V)GSSIs with the MLE-IDENTITIES request primitive to the MLE.

In the last U-ATTACH/DETACH GROUP IDENTITY PDU containing the last reported group, the "group report response" information element shall be present and set to "group report complete".

If the MS has no groups to report, the "group report response" information element shall be present and set to "group report complete", the "group identity uplink" information element shall not be present and the "group identity attach/detach mode" information element shall be set to "detach all currently attached group identities and attach group identities defined in the group identity".

Infrastructure initiated group reporting is not applicable to a MS in the temporarily disabled state and MS shall not send U-ATTACH/DETACH GROUP IDENTITY PDU or modify group information.

16.8.4 MS initiated group report procedure

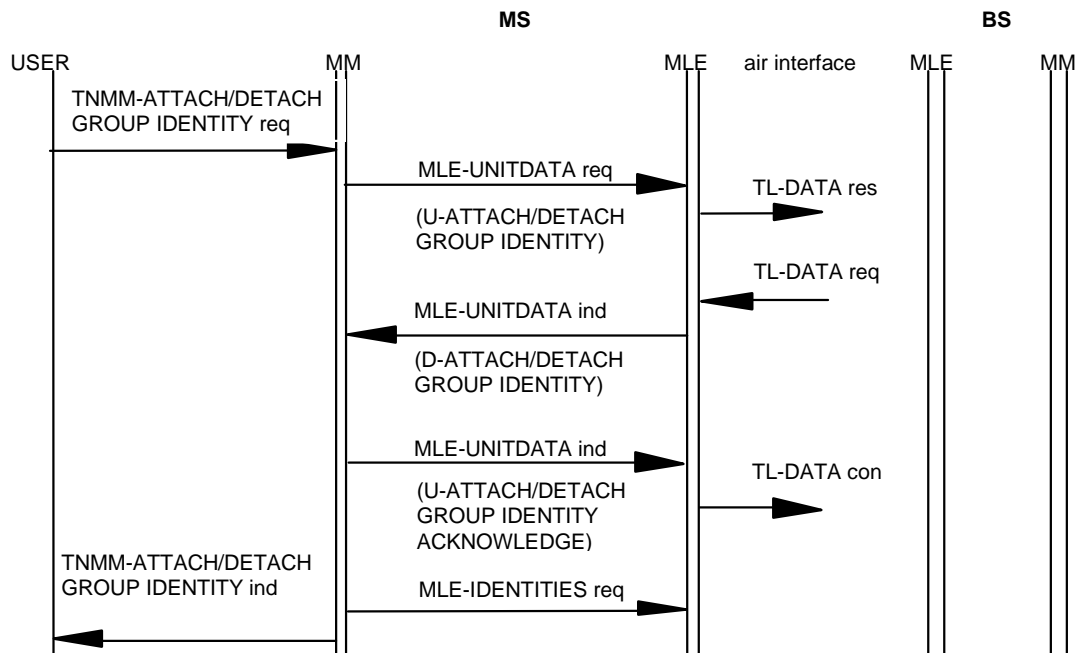

Figure 16.12: MS initiated group report

In the MS initiated group report procedure MS requests SwMI to start group attachment and the SwMI shall re-attach those groups it wishes to be attached in the MS and thus be valid downlink identities.

Upon receipt of a TNMM-ATTACH/DETACH GROUP IDENTITY request primitive containing group report request from the user application the MM shall send a U-ATTACH/DETACH GROUP IDENTITY PDU containing the value "report request" in the "group identity report" information element. The "group identity attach/detach mode" information element value shall be "amendment", and "group identity uplink" information elements shall not be present in the PDU. The PDU priority shall be set to 3. Timer T353 shall be started.

If the SwMI accepts the group report request it shall send a D-ATTACH/DETACH GROUP IDENTITY PDU containing the "group identity attach/detach mode" information element set to "detach all currently attached group identities and attach group identities defined in the group identity..." and the "group identity acknowledgement request" information element set either to "acknowledgement requested" or "acknowledgement not requested" and if all reported groups fit into one D-ATTACH/DETACH GROUP IDENTITY PDU, the group report response information element shall be included and indicate "group report complete".

If the "group identity downlink" information element is not present and the "group report response" information element indicates "group report complete", then the SwMI has no groups to report.

If the reported groups do not fit in one D-ATTACH/DETACH GROUP IDENTITY PDU, the "group report response" information element shall not be included and subsequent groups shall be reported using D-ATTACH/DETACH GROUP IDENTITY PDUs as presented above except that the "group identity attach/detach mode" information element shall be set to "amendment".

In the last D-ATTACH/DETACH GROUP IDENTITY PDU the "group report response" information element shall be included and shall indicate "group report complete".

Upon receipt of each D-ATTACH/DETACH GROUP IDENTITY PDU, T353 shall be stopped, if running. The MS shall check that the "group identity attach/detach mode" information element is "detach all currently attached group identities and attach group identities defined in the group identity...". The MM shall send the attached group identities and related (V)GSSIs with MLE-IDENTITIES request to the MLE. When the "group report response" information element indicates that the group report is complete MS knows that it has received the whole group information. If the "group identity acknowledgement request" information element was set to "acknowledgement requested", MM shall individually acknowledge each D-ATTACH/DETACH GROUP IDENTITY PDU by sending the corresponding U-ATTACH/DETACH GROUP IDENTITY ACKNOWLEDGEMENT PDU. PDU priority shall be set to 6.

If the MS initiated group reporting collides with a SwMI initiated group attachment the MS can detect it when the attach/detach mode is "amendment" and the MS shall assume that the actual report will follow later and shall not send the corresponding U-ATTACH/DETACH GROUP IDENTITY ACKNOWLEDGEMENT PDU as long as the timer T353 is running.

MS initiated group reporting is not applicable to a MS in the temporarily disabled state. In the temporary disabled state upon receipt of a TNMM-ATTACH/DETACH GROUP IDENTITY request primitive MM shall not send a U-ATTACH/DETACH GROUP IDENTITY PDU and may issue a TNMM-DISABLING indication primitive to the user application.

16.8.5 Expiry of timer T353

On the expiry of timer T353, if it is still possible to solely cancel the outstanding PDU according to clause 16.3.1.3, MM shall issue an MLE-CANCEL request primitive with the handle of the transmission request it corresponds to. If it is no longer possible to solely cancel the outstanding PDU according to clause 16.3.1.3, MM shall return a failure report to the SAP and the user application should assume that the requested service has failed.

16.8.6 Colliding requests for group attachment/detachment and group reporting

In the event that one party (MS/SwMI) sends attachment/detachment requests by its own initiative at the same time as the other party is requesting group report, the report request shall override the other requests. Therefore MS/SwMI shall respond to the report request and abandon its own attachment/detachment request.

In case MS is attempting registration or SwMI is initiating registration at the same time as the other party is sending group report request or attachment/detachment requests, the registration shall override the other requests.

16.8.7 Group Identity Address Type (GIAT) usage in group identity downlink/uplink

The Group Identity Address Type (GIAT) shall be used in the "group identity downlink" and "group identity uplink" information elements to signify the group address information present for each group.

The group address information present in the "group identity uplink" information element shall be as follows:

- if MS attaches/acknowledges groups belonging to its home network, i.e. MNI of the group is the same as MNI of the home network of MS:
 - if the MS is registered to its home system, the GSSI information element shall be present (GIAT shall be set to 0);
 - if the MS is registered to a foreign system and the SwMI has not previously allocated a (V)GSSI to the group, the GSSI and address extension information elements shall be present (GIAT shall be set to 1);
 - if the MS is registered to a foreign system and the SwMI has previously allocated (V)GSSI, the (V)GSSI information element shall be present (GIAT shall be set to 2).
- if the MS is registered to a foreign network and attaches/acknowledges groups belonging to the current network, i.e. MNI of the group is the same as MNI of the foreign network MS is registered to:
 - the GSSI information element shall be present (GIAT shall be set to 0); or
 - the GSSI and address extension information elements shall be present (GIAT shall be set to 1).

The group address information present in the "group identity downlink" information element shall be as follows:

- if SwMI attaches/acknowledges groups belonging to the home network of MS, i.e. MNI of the group is the same as MNI of the home network of MS:
 - if the MS is registered to its home system, the GSSI information element shall be present (GIAT shall be set to 0);
 - if the MS is registered to a foreign network, the GSSI and address extension information elements were present in the "group identity uplink" information element and the SwMI rejected the attachment then the GSSI and address extension information elements shall be present (GIAT shall be set to 1);
 - if the MS is registered to a foreign network and the (V)GSSI was present in the "group identity uplink" information element, the (V)GSSI information element (which shall be the same (V)GSSI as present in the "group identity uplink" information element) shall be present (GIAT shall be set to 2);
 - if the MS is registered to a foreign network and the SwMI is initiating a group attachment/detachment and a (V)GSSI has not yet been allocated to the group, the GSSI, address extension and (V)GSSI information elements shall be present (GIAT shall be set to 3);
 - if the MS is registered to a foreign network and the SwMI is initiating a group attachment/detachment, and a (V)GSSI has already been allocated to the group, then either the (V)GSSI information element shall be present (GIAT shall be set to 2) or the GSSI, address extension and (V)GSSI information elements shall be present (GIAT shall be set to 3);
 - if the MS is registered to a foreign network, the GSSI and address extension information elements were present in the "group identity uplink" information element and the SwMI accepted the attachment then the GSSI, address extension and (V)GSSI information elements shall be present (GIAT shall be set to 3);
 - if the MS is registered to a foreign network and the SwMI requires to allocate a new (V)GSSI to a GTSI which has previously been allocated a (V)GSSI (i.e. the new (V)GSSI replaces the existing (V)GSSI) then the GSSI, address extension and (V)GSSI information elements shall be present (GIAT shall be set to 3);
 - if the MS is registered to a foreign network and the MS has initiated a group report for a GTSI and the SwMI has previously allocated a (V)GSSI for the GTSI, then the GSSI, address extension and (V)GSSI information elements shall be present (GIAT shall be set to 3).
- if the MS is registered to a foreign network and SwMI attaches/acknowledges groups belonging to the current network, i.e. MNI of the group is the same as MNI of the current network MS is registered to:
 - the GSSI information element shall be present (GIAT shall be set to 0); or
 - the GSSI and address extension information elements shall be present (GIAT shall be set to 1).

16.8.8 PDU or function not supported

In case MS/SwMI receives an individually addressed unknown MM PDU or a request for a MM function which is not supported, the receiving entity may send MM PDU/FUNCTION NOT SUPPORTED PDU. The behaviour of the requesting party when receiving MM PDU/FUNCTION NOT SUPPORTED PDU is outside the scope of the present document.

NOTE: The same PDU may be used for several functions, e.g. by sending U-LOCATION UPDATE DEMAND PDU the MS may request either group attachment/detachment or group report and D-LOCATION UPDATE COMMAND PDU may also include a group report request in addition to the registration request.

16.9 MM PDU structures and contents

16.9.1 MM PDU general description

Refer to annex E for PDU encoding rules and examples. The usage of security related information elements is presented in ETSI EN 300 392-7 [8] and the usage of DMO gateway related information elements is presented in ETSI EN 300 396-5 [24].

The information contained in the PDU description tables which follow corresponds to the following key:

- Length: length of the information element in bits;
- Type: information element type (1, 2 or 3) as defined below;
- C/O/M: conditional/optional/mandatory information in the PDU;
- Remark: comment.

16.9.2 MM PDU description tables - downlink

16.9.2.1 D-ATTACH/DETACH GROUP IDENTITY

- Message: D-ATTACH/DETACH GROUP IDENTITY
- Response to: -/U-ATTACH/DETACH GROUP IDENTITY (report request)
- Response expected: -/U-ATTACH/DETACH GROUP IDENTITY ACKNOWLEDGEMENT
- Short description: The infrastructure sends this message to the MS to indicate attachment/detachment of group identities for the MS or to initiate a group report request or give a group report response.

Table 16.1: D-ATTACH/DETACH GROUP IDENTITY PDU contents

Information element	Length	Type	C/O/M	Remark
PDU type	4	1	M	D-ATTACH/DETACH GROUP IDENTITY
Group identity report	1	1	M	
Group identity acknowledgement request	1	1	M	
Group identity attach/detach mode	1	1	M	
Proprietary		3	O	See note
Group report response		3	O	See note
Group identity downlink		4	O	See note
Group Identity Security Related Information		4	O	See ETSI EN 300 392-7 [8] and note
NOTE: The MS shall accept the type 3/4 information elements both in the numerical order as described in annex E and in the order shown in this table.				

16.9.2.2 D-ATTACH/DETACH GROUP IDENTITY ACKNOWLEDGEMENT

- Message: D-ATTACH/DETACH GROUP IDENTITY ACKNOWLEDGEMENT
- Response to: U-ATTACH/DETACH GROUP IDENTITY
- Response expected: -
- Short description: The infrastructure sends this message to the MS to acknowledge MS initiated attachment/detachment of group identities.

Table 16.2: D-ATTACH/DETACH GROUP IDENTITY ACKNOWLEDGEMENT PDU contents

Information element	Length	Type	C/O/M	Remark
PDU type	4	1	M	D-ATTACH/DETACH GROUP IDENTITY ACKNOWLEDGEMENT
Group identity accept/reject	1	1	M	
Reserved	1	1	M	
Proprietary		3	O	See note
Group identity downlink		4	O	See note
Group Identity Security Related Information		4	O	See ETSI EN 300 392-7 [8] and note
NOTE: The MS shall accept the type 3/4 information elements both in the numerical order as described in annex E and in the order shown in this table.				

16.9.2.3 Void

16.9.2.4 Void

16.9.2.5 D-MM STATUS

16.9.2.5.1 D-MM STATUS generic structure

- Message: D-MM STATUS
- Response to: -/U-MM STATUS
- Response expected: -/U-MM STATUS
- Short description: The infrastructure sends this message to the MS to request or indicate/reject a change of an operation mode.

Table 16.3: D-MM STATUS PDU generic contents

Information element	Length	Type	C/O/M	Remark
PDU type	4	1	M	D-MM STATUS
Status downlink	6	1	M	See notes 1 and 3
Status downlink dependant information	variable			See note 2
NOTE 1: This information element shall indicate the requested service or a response to a request and the sub-type of the D-MM STATUS PDU.				
NOTE 2: This information element or set of information elements shall be as defined by the status downlink information element, refer to clauses 16.9.2.5.1 to 16.9.2.5.7.				
NOTE 3: This Status downlink element is indicating which sub-PDU this D-MM STATUS PDU contains. In case the receiving party does not support indicated function but is able to recognize this PDU structure, it should set the received value of Status downlink element to Not-supported sub PDU type element.				

16.9.2.5.2 D-CHANGE OF ENERGY SAVING MODE REQUEST

The status downlink information element value "Change of energy saving mode request" defines the D-CHANGE OF ENERGY SAVING MODE REQUEST PDU and the D-MM STATUS PDU shall contain information elements as defined in table 16.4.

- Message: D-CHANGE OF ENERGY SAVING MODE REQUEST
- Response to: -
- Response expected: U-CHANGE OF ENERGY SAVING MODE RESPONSE
- Short description: The infrastructure sends this message to the MS to modify or stop a current energy economy mode, or allocate an energy economy mode.

Table 16.4: D-CHANGE OF ENERGY SAVING MODE REQUEST PDU contents

Information element	Length	Type	C/O/M	Remark
PDU type	4	1	M	D-MM STATUS
Status downlink	6	1	M	D-CHANGE OF ENERGY SAVING MODE REQUEST
Energy saving information	14	1	M	
Proprietary	variable	3	O	

16.9.2.5.3 D-CHANGE OF ENERGY SAVING MODE RESPONSE

The status downlink information element value "Change of energy saving mode response" defines the D-CHANGE OF ENERGY SAVING MODE RESPONSE PDU and the D-MM STATUS PDU shall contain information elements as defined in table 16.5.

- Message: D-CHANGE OF ENERGY SAVING MODE RESPONSE
- Response to: U-CHANGE OF ENERGY SAVING MODE REQUEST
- Response expected: -
- Short description: The infrastructure sends this message to the MS to indicate the start point of an accepted energy economy mode or to reject a request for energy economy mode.

Table 16.5: D-CHANGE OF ENERGY SAVING MODE RESPONSE PDU contents

Information element	Length	Type	C/O/M	Remark
PDU type	4	1	M	D-MM STATUS
Status downlink	6	1	M	D-CHANGE OF ENERGY SAVING MODE RESPONSE
Energy saving information	14	1	M	
Proprietary	variable	3	O	

16.9.2.5.4 D-DUAL WATCH MODE RESPONSE

The status downlink information element value "Dual watch mode response" defines the D-DUAL WATCH MODE RESPONSE PDU and the D-MM STATUS PDU shall contain information elements as defined in table 16.6.

- Message: D-DUAL WATCH MODE RESPONSE
- Response to: U-DUAL WATCH MODE REQUEST
- Response expected: -
- Short description: The infrastructure sends this message to the MS to indicate the start point of an accepted dual watch energy economy mode or to reject a request for dual watch mode.

Table 16.6: D-DUAL WATCH MODE RESPONSE PDU contents

Information element	Length	Type	C/O/M	Remark
PDU type	4	1	M	D-MM STATUS
Status downlink	6	1	M	D-DUAL WATCH MODE RESPONSE
Energy saving information	14	1	M	
Result of dual watch request	3	1	M	
Reserved	8	1	M	Default value = 00000000 ₂
SCCH information and distribution on 18 th frame	6	2	O	
Proprietary		3	O	

16.9.2.5.5 D-TERMINATING DUAL WATCH MODE RESPONSE

The status downlink information element value "Terminating dual watch mode response" defines the D-TERMINATING DUAL WATCH MODE RESPONSE PDU and the D-MM STATUS PDU shall contain information elements as defined in table 16.7.

- Message: D-TERMINATING DUAL WATCH MODE RESPONSE
- Response to: U-TERMINATING DUAL WATCH MODE REQUEST
- Response expected: -
- Short description: The infrastructure sends this message to the MS to accept a request to terminate dual watch and may optionally indicate the start point of an accepted energy economy mode after dual watch operation.

Table 16.7: D-TERMINATING DUAL WATCH MODE RESPONSE PDU contents

Information element	Length	Type	C/O/M	Remark
PDU type	4	1	M	D-MM STATUS
Status downlink	6	1	M	D-TERMINATING DUAL WATCH MODE RESPONSE
Reserved	8	1	M	Default value = 00000000 ₂
Energy saving information	14	2	O	
SCCH information and distribution on 18 th frame	6	2	O	
Proprietary		3	O	

16.9.2.5.6 D-CHANGE OF DUAL WATCH MODE REQUEST

The status downlink information element value "Change of dual watch mode request" defines the D-CHANGE OF DUAL WATCH MODE REQUEST PDU and the D-MM STATUS PDU shall contain information elements as defined in table 16.8.

- Message: D-CHANGE OF DUAL WATCH MODE REQUEST
- Response to: -
- Response expected: U-CHANGE OF DUAL WATCH MODE RESPONSE
- Short description: The infrastructure sends this message to the MS to change the energy economy group associated with the MS's dual watch operation or to withdraw its previous acceptance of the MS's dual watch request.

Table 16.8: D-CHANGE OF DUAL WATCH MODE REQUEST PDU contents

Information element	Length	Type	C/O/M	Remark
PDU type	4	1	M	D-MM STATUS
Status downlink	6	1	M	D-CHANGE OF DUAL WATCH MODE REQUEST
Energy saving information	14	1	M	
Reason for dual watch change by SwMI	3	1	M	
Reserved	8	1	M	Default value = 00000000 ₂
SCCH information and distribution on 18 th frame	6	2	O	
Proprietary		3	O	

16.9.2.5.7 Direct mode gateway related D-MM STATUS

The status downlink information element the values in the range 010000₂ to 011111₂ indicate a DMO gateway function and the D-MM STATUS PDU shall contain information elements as defined in ETSI EN 300 396-5 [24], annex B.

16.9.2.5.8 D-MS FREQUENCY BANDS REQUEST

The status downlink information element value "MS frequency bands request" defines the D-FREQUENCY BANDS REQUEST PDU and the D-MM STATUS PDU shall contain information elements as defined in table 16.9.

- Message: D-MS FREQUENCY BANDS REQUEST
- Response to: -
- Response expected: U-MS FREQUENCY BANDS INFORMATION
- Short description: The infrastructure sends this message to the MS to interrogate the frequency bands that are supported by the MS.

Table 16.9: D-MS FREQUENCY BANDS REQUEST PDU contents

Information element	Length	Type	C/O/M	Remark
PDU type	4	1	M	D-MM STATUS
Status downlink	6	1	M	D-MS FREQUENCY BANDS REQUEST
Proprietary	variable	3	O	

16.9.2.5.9 DISTANCE REPORTING REQUEST

The status downlink information element value "Distance reporting request" defines the D-DISTANCE REPORTING REQUEST PDU and the D-MM STATUS PDU shall contain information elements as defined in table 16.10.

- Message: D-DISTANCE REPORTING REQUEST
- Response to: -
- Response expected: -
- Short description: The infrastructure sends this message request that the MS shall send a Null PDU, if the timer has elapsed. The Null PDU will be used to measure the path delay for that MS.

Table 16.10: D-DISTANCE REPORTING REQUEST PDU contents

Information element	Length	Type	C/O/M	Remark
PDU type	4	1	M	D-MM STATUS
Status downlink	6	1	M	D-DISTANCE REPORTING REQUEST
Distance reporting timer	7	1	M	
Distance reporting validity	1	1	M	
Proprietary		3	O	

16.9.2.6 Void

16.9.2.7 D-LOCATION UPDATE ACCEPT

- Message: D-LOCATION UPDATE ACCEPT
- Response to: U-LOCATION UPDATE DEMAND
- Response expected: -
- Short description: The infrastructure sends this message to the MS to indicate that updating in the network has been completed.

Table 16.11: D-LOCATION UPDATE ACCEPT PDU contents

Information element	Length	Type	C/O/M	Remark
PDU type	4	1	M	D-LOCATION UPDATE ACCEPT
Location update accept type	3	1	M	
SSI	24	2	O	ASSI/(V)ASSI of MS
Address extension	24	2	O	MNI of MS
Subscriber class	16	2	O	
Energy saving information	14	2	O	
SCCH information and distribution on 18 th frame	6	2	O	
New registered area		4	O	See note
Security downlink		3	O	See ETSI EN 300 392-7 [8]
Group identity location accept		3	O	See note
Default group attachment lifetime		3	O	See note
Authentication downlink		3	O	See ETSI EN 300 392-7 [8]
Group Identity Security Related Information		4	O	See ETSI EN 300 392-7 [8]
Cell type control		3	O	
Proprietary		3	O	
NOTE:	The MS shall accept the type 3/4 information elements both in the numerical order as described in annex E and in the order shown in this table.			

16.9.2.8 D-LOCATION UPDATE COMMAND

- Message: D-LOCATION UPDATE COMMAND
- Response to: -
- Response expected: U-LOCATION UPDATE DEMAND
- Short description: The infrastructure sends this message to the MS to initiate a location update demand in the MS.

Table 16.12: D-LOCATION UPDATE COMMAND PDU contents

Information element	Length	Type	C/O/M	Remark
PDU type	4	1	M	D-LOCATION UPDATE COMMAND
Group identity report	1	1	M	
Cipher control	1	1	M	
Ciphering parameters	10		C	See note
Address extension	24	2	O	MNI of the MS
Cell type control		3	O	
Proprietary		3	O	
NOTE:	Information element "Ciphering parameters" is not present if "Cipher control" is set to "0", "ciphering off". Information element "ciphering parameters" is present if "Cipher control" is set to "1", "ciphering on".			

16.9.2.9 D-LOCATION UPDATE REJECT

- Message: D-LOCATION UPDATE REJECT
- Response to: U-LOCATION UPDATE DEMAND
- Response expected: -
- Short description: The infrastructure sends this message to the MS to indicate that updating in the network is not accepted.

Table 16.13: D-LOCATION UPDATE REJECT PDU contents

Information element	Length	Type	C/O/M	Remark
PDU type	4	1	M	D-LOCATION UPDATE REJECT
Location update type	3	1	M	
Reject cause	5	1	M	
Cipher control	1	1	M	
Ciphering parameters	10		C	See note
Address extension	24	2	O	MNI of the MS
Cell type control		3	O	
Proprietary		3	O	
NOTE:	Information element "Ciphering parameters" is not present if "Cipher control" is set to "0", "ciphering off". Information element "Ciphering parameters" is present if "Cipher control" is set to "1", "ciphering on".			

16.9.2.10 D-LOCATION UPDATE PROCEEDING

- Message: D-LOCATION UPDATE PROCEEDING
- Response to: U-LOCATION UPDATE DEMAND
- Response expected: -
- Short description: The infrastructure sends this message to the MS on registration at accepted migration to assign a (V) ASSI.

Table 16.14: D-LOCATION UPDATE PROCEEDING PDU contents

Information element	Length	Type	C/O/M	Remark
PDU type	4	1	M	D-LOCATION UPDATE PROCEEDING
SSI	24	1	M	(V)ASSI of the MS
Address extension	24	1	M	MNI of the MS
Proprietary		3	O	

16.9.3 MM PDU descriptions - uplink

16.9.3.1 U-ATTACH/DETACH GROUP IDENTITY

- Message: U-ATTACH/DETACH GROUP IDENTITY
- Response to: -/D-ATTACH/DETACH GROUP IDENTITY (report request)
- Response expected: D-ATTACH/DETACH GROUP IDENTITY ACKNOWLEDGEMENT
- Short description: The MS sends this message to the infrastructure to indicate attachment/detachment of group identities in the MS or to initiate a group report request or give a group report response.

Table 16.15: U-ATTACH/DETACH GROUP IDENTITY PDU contents

Information element	Length	Type	C/O/M	Remark
PDU type	4	1	M	U-ATTACH/DETACH GROUP IDENTITY
Group identity report	1	1	M	
Group identity attach/detach mode	1	1	M	
Group report response		3	O	
Group identity uplink		4	O	
Proprietary		3	O	

16.9.3.2 U-ATTACH/DETACH GROUP IDENTITY ACKNOWLEDGEMENT

- Message: U-ATTACH/DETACH GROUP IDENTITY ACKNOWLEDGEMENT
- Response to: D-ATTACH/DETACH GROUP IDENTITY
- Response expected: -
- Short description: The MS sends this message to the infrastructure to acknowledge SwMI initiated attachment/detachment of group identities.

Table 16.16: U-ATTACH/DETACH GROUP IDENTITY ACKNOWLEDGEMENT PDU contents

Information element	Length	Type	C/O/M	Remark
PDU type	4	1	M	U-ATTACH/DETACH GROUP IDENTITY ACKNOWLEDGEMENT
Group identity acknowledgement type	1	1	M	
Group identity uplink		4	O	
Proprietary		3	O	

16.9.3.3 U-ITSI DETACH

- Message: U-ITSI DETACH
- Response to: -
- Response expected: -/D-MM STATUS
- Short description: The MS sends this message to the infrastructure to announce that the MS will be de-activated.

Table 16.17: U-ITSI DETACH PDU contents

Information element	Length	Type	C/O/M	Remark
PDU type	4	1	M	U-ITSI DETACH
Address extension	24	2	O	MNI of the MS
Proprietary		3	O	

16.9.3.4 U-LOCATION UPDATE DEMAND

- Message: U-LOCATION UPDATE DEMAND
- Response to: -/D-LOCATION UPDATE COMMAND
- Response expected: D-LOCATION UPDATE ACCEPT/D-LOCATION UPDATE REJECT
- Short description: The MS sends this message to the infrastructure to request update of its location registration.

Table 16.18: U-LOCATION UPDATE DEMAND PDU contents

Information element	Length	Type	C/O/M	Remark
PDU type	4	1	M	U-LOCATION UPDATE DEMAND
Location update type	3	1	M	
Request to append LA	1	1	M	
Cipher control	1	1	M	
Ciphering parameters	10		C	See note 1
Class of MS	24	2	O	See note 2
Energy saving mode	3	2	O	
LA information		2	O	
SSI	24	2	O	ISSI of the MS
Address extension	24	2	O	MNI of the MS
Group identity location demand		3	O	
Group report response		3	O	
Authentication uplink		3	O	See ETSI EN 300 392-7 [8]
Extended capabilities		3	O	See note 2
Proprietary		3	O	
NOTE 1: Information element "Ciphering parameters" is not present if "Cipher control" is set to "0", "ciphering off". Information element "ciphering parameters" is present if "Cipher control" is set to "1", "ciphering on".				
NOTE 2: If the "class of MS" or the "extended capabilities" element is not included in this PDU and the SwMI needs to receive either of those information elements, the SwMI may accept the registration request and then send the MS a D-LOCATION UPDATE COMMAND PDU. (This could happen if, e.g. the SwMI has no record of a previous successful registration by the MS or if the SwMI has any uncertainty about the type of cell to which the MS is registering.)				

16.9.3.5 U-MM STATUS

16.9.3.5.1 U-MM STATUS generic construction

- Message: U-MM STATUS
- Response to: -/D-MM STATUS
- Response expected: -/D-MM STATUS
- Short description: The MS sends this message to the infrastructure to request or respond to a mode change.

Table 16.19: U-MM STATUS PDU generic contents

Information element	Length	Type	C/O/M	Remark
PDU type	4	1	M	U-MM STATUS
Status uplink	6	1	M	See notes 1 and 3
Status uplink dependent information	variable			See note 2
NOTE 1: This information element shall indicate the requested service or a response to a request and the sub-type of the U-MM STATUS PDU.				
NOTE 2: This information element or set of information elements shall be as defined by the status uplink information element, refer to clauses 16.9.3.5.1 to 16.9.3.5.8.				
NOTE 3: This Status uplink element is indicating which sub-PDU this U-MM STATUS PDU contains. In case the receiving party does not support indicated function but is able to recognize this PDU structure, it should set the received value of Status uplink element to Not-supported sub PDU type element.				

16.9.3.5.2 U-CHANGE OF ENERGY SAVING MODE REQUEST

The status uplink information element value "Change of energy saving mode request" indicates the U-CHANGE OF ENERGY SAVING MODE REQUEST PDU and the U-MM STATUS PDU shall contain information elements as defined in table 16.20.

- Message: U-CHANGE OF ENERGY SAVING MODE REQUEST
- Response to: -
- Response expected: D-CHANGE OF ENERGY SAVING MODE RESPONSE
- Short description: The MS sends this message to the infrastructure to change its energy economy mode i.e. to start or end energy economy operation or to change the energy economy group.

Table 16.20: U-CHANGE OF ENERGY SAVING MODE REQUEST PDU contents

Information element	Length	Type	C/O/M	Remark
PDU type	4	1	M	U-MM STATUS
Status uplink	6	1	M	U-CHANGE OF ENERGY SAVING MODE REQUEST
Energy saving mode	3	1	M	
Proprietary	variable	3	O	

16.9.3.5.3 U-CHANGE OF ENERGY SAVING MODE RESPONSE

The status uplink information element value "Change of energy saving mode response" indicates the U-CHANGE OF ENERGY SAVING MODE RESPONSE PDU and the U-MM STATUS PDU shall contain information elements as defined in table 16.21.

- Message: U-CHANGE OF ENERGY SAVING MODE RESPONSE
- Response to: D-CHANGE OF ENERGY SAVING MODE REQUEST
- Response expected: -
- Short description: The MS sends this message to the infrastructure to accept or reject a change of its energy economy mode.

Table 16.21: U-CHANGE OF ENERGY SAVING MODE RESPONSE PDU contents

Information element	Length	Type	C/O/M	Remark
PDU type	4	1	M	U-MM STATUS
Status uplink	6	1	M	U-CHANGE OF ENERGY SAVING MODE RESPONSE
Energy saving mode	3	1	M	
Proprietary	variable	3	O	

16.9.3.5.4 U-DUAL WATCH MODE REQUEST

The status uplink information element value "Dual watch mode request" indicates the U-DUAL WATCH MODE REQUEST PDU and the U-MM STATUS PDU shall contain information elements as defined in table 16.22.

- Message: U-DUAL WATCH MODE REQUEST
- Response to: -
- Response expected: D-DUAL WATCH MODE RESPONSE
- Short description: The MS sends this message to the infrastructure to request start of dual watch operation with an appropriate energy economy group or to change the energy economy group associated with its dual watch operation or to re-request dual watch operation after a re-registration.

Table 16.22: U-DUAL WATCH MODE REQUEST PDU contents

Information element	Length	Type	C/O/M	Remark
PDU type	4	1	M	U-MM STATUS
Status uplink	6	1	M	U-DUAL WATCH MODE REQUEST
Energy saving mode	3	1	M	
MS operating with type 2 repeater	1	1	M	
Dual watch mode	1	1	M	
DMO carrier	13/25	2	O	
Start of Direct Mode Operation cause	3	2	O	
Mode change information	6	2	O	
Proprietary		3	O	

16.9.3.5.5 U-TERMINATING DUAL WATCH MODE REQUEST

The status uplink information element value "Terminating dual watch mode request" indicates the U-TERMINATING DUAL WATCH MODE REQUEST PDU and the U-MM STATUS PDU shall contain information elements as defined in table 16.23.

- Message: U-TERMINATING DUAL WATCH MODE REQUEST
- Response to: -
- Response expected: D-TERMINATING DUAL WATCH MODE RESPONSE
- Short description: The MS sends this message to the infrastructure to indicate an end of dual watch mode and, optionally, requesting energy economy operation.

Table 16.23: U-TERMINATING DUAL WATCH MODE REQUEST PDU contents

Information element	Length	Type	C/O/M	Remark
PDU type	4	1	M	U-MM STATUS
Status uplink	6	1	M	U-TERMINATING DUAL WATCH MODE REQUEST
Reserved	8	1	M	Default value = 00000000 ₂
Energy saving mode	3	2	O	
Proprietary		3	O	

16.9.3.5.6 U-CHANGE OF DUAL WATCH MODE RESPONSE

The status uplink information element value "Change of dual watch mode response" indicates the U-CHANGE OF DUAL WATCH MODE RESPONSE PDU and the U-MM STATUS PDU shall contain information elements as defined in table 16.24.

- Message: U-CHANGE OF DUAL WATCH MODE RESPONSE
- Response to: D-CHANGE OF DUAL WATCH MODE REQUEST
- Response expected: -
- Short description: The MS sends this message to the infrastructure to accept a change to its dual watch operation (or to reject the change if it is not currently operating in dual watch).

Table 16.24: U-CHANGE OF DUAL WATCH MODE RESPONSE PDU contents

Information element	Length	Type	C/O/M	Remark
PDU type	4	1	M	U-MM STATUS
Status uplink	6	1	M	U-CHANGE OF DUAL WATCH MODE RESPONSE
Energy saving mode	3	1	M	
Reserved	8	1	M	Default value = 00000000 ₂
Proprietary		3	O	

16.9.3.5.7 U-START OF DIRECT MODE OPERATION

The status uplink information element value "Start of direct mode operation" indicates the U-START OF DIRECT MODE OPERATION PDU and the U-MM STATUS PDU shall contain information elements as defined in table 16.25.

- Message: U-START OF DIRECT MODE OPERATION
- Response to: -
- Response expected: -
- Short description: The MS sends this message to the infrastructure to indicate a start of direct mode operation without dual watch.

Table 16.25: U-START OF DIRECT MODE OPERATION PDU contents

Information element	Length	Type	C/O/M	Remark
PDU type	4	1	M	U-MM STATUS
Status uplink	6	1	M	U-START OF DIRECT MODE OPERATION
Reserved	5	1	M	Default value = 00000 ₂
DMO carrier	13/25	2	O	
Start of direct mode operation cause	3	2	O	
Mode change information	6	2	O	
Proprietary		3	O	

16.9.3.5.8 Direct mode gateway related U-MM STATUS

For the status uplink information element the values in the range 010000₂ to 011111₂ indicate a DMO gateway function and the U-MM STATUS PDU shall contain information elements as defined in ETSI EN 300 396-5 [24], annex B.

16.9.3.5.9 U-MS FREQUENCY BANDS INFORMATION

The status uplink information element value "MS frequency bands information" defines the U-MS FREQUENCY BANDS INFORMATION PDU and the U-MM STATUS PDU shall contain information elements as defined in table 16.26.

- Message: U-MS FREQUENCY BANDS INFORMATION
- Response to: -/D-MS FREQUENCY BANDS REQUEST
- Response expected: -
- Short description: The MS sends this message to the infrastructure to indicate which frequency bands it supports.

Table 16.26: U-MS FREQUENCY BANDS PDU contents

Information element	Length	Type	C/O/M	Remark
PDU type	4	1	M	U-MM STATUS
Status uplink	6	1	M	MS FREQUENCY BANDS REQUEST
Number of frequency band definitions	3	1	M	
Frequency band definition	37		C	See note
Proprietary		3	O	
NOTE:	This information element shall be present as many times as defined by the number of frequency band definitions information element. If the element has value 0, the Frequency band definition element is not present.			

16.9.4 PDU description tables - downlink and uplink

16.9.4.1 MM PDU/FUNCTION NOT SUPPORTED

- Message: MM PDU/FUNCTION NOT SUPPORTED
- Response to: Any individually addressed MM PDU
- Response expected: -
- Short description: This PDU may be sent by the MS/LS or SwMI to indicate that the received MM PDU or the function indicated in the PDU is not supported.

Table 16.27: MM PDU/FUNCTION NOT SUPPORTED PDU contents

Information element	Length	Type	Owner	C/O/M	Remark
PDU type	4	1	MM	M	MM PDU/FUNCTION NOT SUPPORTED
Not-supported PDU type	4	1	MM	M	See note 1
Not-supported sub PDU type	variable	2	MM	O	See note 2
Length of the copied PDU	8	2	MM	O	
Received PDU contents	variable		MM	C	See notes 3 and 4
NOTE 1: This information element shall identify the received PDU which contains the function which cannot be supported.					
NOTE 2: In case the receiving party recognizes the PDU and the PDU contains a sub-PDU field (like in U/M-MM STATUS PDU, U/D-OTAR, U/D-ENABLE, etc.) this element contains the element indicating which sub-PDU this is.					
NOTE 3: The length of this element is indicated by the Length of the copied PDU element. This element is not present if the Length of the copied PDU element is not present.					
NOTE 4: This element contains the received PDU beginning from and excluding the PDU type element.					

16.10 MM information elements coding

16.10.1 Address extension

The address extension information element shall indicate the extended part of TSI address as defined in table 16.28.

Table 16.28: Address extension information element contents

Information sub-element	Length	Type	C/O/M	Remark
Mobile Country Code (MCC)	10	1	M	
Mobile Network Code (MNC)	14	1	M	

16.10.1a Cell type control

The cell type control information element permits the SwMI to alter the MS's preferred or required cell types, as defined in table 16.29.

Table 16.29: Cell type control information element contents

Information sub-element	Length	Type	C/O/M	Remark
Revert to user application setting	1	1	M	
Required cell type list control	4		C	See notes 1 and 2.
Required cell type	3		C	See notes 1, 3 and 4.
Preferred cell type list control	4		C	See notes 1 and 5.
Preferred cell type	3		C	See notes 1, 6 and 7.
Reserved	4	2	O	Shall not be included in the present document.
NOTE 1: This element shall be included only if the "revert to user application setting" element has the value "use SwMI's cell type preference or requirement".				
NOTE 2: Refer to clause 16.10.43b for the meaning of the values.				
NOTE 3: This element shall be present as many times as indicated by the "required cell type list control" element.				
NOTE 4: The "required cell type list control" element indicates whether repeated "required cell type" elements are given in order of decreasing preference or in no particular order.				
NOTE 5: Refer to clause 16.10.40b for the meaning of the values.				
NOTE 6: This element shall be present as many times as indicated by the "preferred cell type list control" element.				
NOTE 7: The "preferred cell type list control" element indicates whether repeated "preferred cell type" elements are given in order of decreasing preference or in no particular order.				

NOTE: If the "cell type control" information element includes an ordered list of "required cell type" information elements, there is no benefit in also including "preferred cell type" information elements. However, there may be benefit in including both a list of "preferred cell type" information elements and an unordered list of "required cell type" information elements. For example, if a short ordered preferred list is included with an unordered required list, cell types that are included in both the required list and the preferred list should be given preferences in the order they appear in the ordered preferred list; cell types that are included only in the required list should be given a lower preference than the cell types that are included in both the preferred list and the required list. If a short unordered preferred list is included with an unordered required list, cell types that are included in both the required list and the preferred list should be regarded as having a higher preference than cell types that are included in the required list but not in the preferred list. (If both a required list and a preferred list are included in the "cell type control" information element, the cell types in the preferred list should be included in the required list.)

16.10.2 Cipher control

The cipher control information element shall indicate whether ciphering is on or off as defined in table 16.30.

Table 16.30: Cipher control information element contents

Information element	Length	Value	Remark
Cipher Control	1	0	Ciphering off
		1	Refer to ETSI EN 300 392-7 [8]

16.10.3 Ciphering parameters

For the ciphering parameters information element refer to ETSI EN 300 392-7 [8].

16.10.4 Void

16.10.5 Class of MS

The class of MS information element shall indicate to the infrastructure the characteristics of the MS terminal, both hardware and software. The total information element length is 24 bits and the values can be given both as a bit map and as values. The decoding shall be as defined in table 16.31.

Table 16.31: Class of MS information element contents

Information sub-element	Length	Value	Remark
Frequency simplex/duplex	1	0	Frequency simplex supported
		1	Frequency duplex and simplex supported
Single/multislot for phase modulation (see notes 6, 7 and 8)	1	0	Single slot supported
		1	Multislot and single slot supported
Concurrent multicarrier operation	1	0	Single carrier operation supported
		1	Multi and single carrier operation supported
Voice (see note 3)	1	0	No voice calls supported
		1	Voice calls supported
End-to-end encryption	1	0	End-to-end encryption supported
		1	End-to-end encryption not supported
Circuit mode data (see note 3)	1	0	No circuit mode data supported
		1	Circuit mode data supported
TETRA packet data (see notes 4 and 5)	1	0	TETRA packet data not supported
		1	TETRA packet data supported
Fast switching on a phase-modulated channel	1	0	Fast switching not supported on a phase-modulated channel
		1	Fast switching supported on a phase-modulated channel
DCK air interface encryption	1	0	DCK air interface encryption not supported
		1	DCK air interface encryption supported
CLCH needed on carrier change	1	0	No CLCH needed on carrier change
		1	CLCH needed on carrier change
Concurrent circuit mode services (see note 1)	1	0	Concurrent circuit mode services not supported
		1	Concurrent circuit mode services supported
Original advanced link	1	0	Original advanced link not supported
		1	Original advanced link supported
Minimum mode	1	0	Minimum mode not supported
		1	Minimum mode supported
Carrier specific signalling channel	1	0	Carrier specific signalling channel not supported
		1	Carrier specific signalling channel supported
Authentication	1	0	Authentication not supported
		1	Authentication supported
SCK air interface encryption	1	0	SCK air interface encryption not supported
		1	SCK air interface encryption supported

Information sub-element	Length	Value	Remark
TETRA air interface standard version number	3	000 ₂	ETSI ETS 300 392-2 (edition 1), no security functions
		001 ₂	ETSI ETS 300 392-2 (edition 1) and ETSI EN 300 392-7 [8] V2.1.1
		010 ₂	ETSI EN 300 392-2 V2.3.2 to V2.6.1 and ETSI EN 300 392-7 [8] V2.1.1 to V2.4.1
		011 ₂	ETSI EN 300 392-2 V3.1.1 to the version of the present document and ETSI EN 300 392-7 [8] V3.1.1 to V3.2.1, see note 2
		100 ₂	Reserved
		etc.	etc.
		111 ₂	Reserved
Common SCCH	1	0	Common SCCH not supported
		1	Common SCCH supported
Reserved	1	0	Default value
		1	Reserved for future expansion
MAC-D-BLCK PDU and augmented channel allocation	1	0	MAC-D-BLCK PDU not supported and augmented channel allocations not supported
		1	MAC-D-BLCK PDU supported and augmented channel allocations supported
Extended advanced link(s)	1	0	Extended advanced link(s) not supported
		1	Extended advanced link(s) supported
D8PSK	1	0	D8PSK modulation mode not supported
		1	D8PSK modulation mode supported
<p>NOTE 1: If concurrent circuit mode services are supported it is implicit that concurrent channels are supported. If concurrent circuit mode services are not supported concurrent channels are implicitly supported if the Packet Data MS type is of type "A" see clause 28.3.3.4.1.</p> <p>NOTE 2: The version of the present document and ETSI EN 300 392-7 [8] may change in future enhancements of these documents without a change of the TETRA air interface standard version number.</p> <p>NOTE 3: Voice and circuit mode data refer to the $\pi/4$-DQPSK circuit mode voice and circuit mode data services.</p> <p>NOTE 4: "TETRA packet data" refers to the MS's support for the Sndcp service. This applies to all modulation types supported by the MS, except that a DA MS indicates separately its support for $\pi/4$-DQPSK packet data (see clause 16.10.10a).</p> <p>NOTE 5: In the present document, a DA MS should indicate that it supports the Sndcp service.</p> <p>NOTE 6: "Single/multislot for phase modulation" refers to the MS's support of multislot channels for those phase modulation types that it supports i.e. it refers to support of multislot $\pi/4$-DQPSK channels (if $\pi/4$-DQPSK is supported) and multislot D8PSK channels (if D8PSK is supported).</p> <p>NOTE 7: If the MS indicates that it supports both multislot and single-slot phase modulation channels, it shall support at least one-slot and two-slot channels (for those phase modulation types that it supports); and it is recommended that the MS supports three-slot and four-slot channels (for those phase modulation types that it supports).</p> <p>NOTE 8: In a previous version of the present document, this element indicated the MS's single/multislot capability for both phase modulation and QAM.</p>			

16.10.6 Class of usage

The class of usage information element shall define priority of the group identity as defined in table 16.32. The class of usage has meaning only for the user application.

Table 16.32: Class of Usage information element contents

Information element	Length	Value	Remark
Class of usage	3	000 ₂	Class of usage 1
		001 ₂	Class of usage 2
		010 ₂	Class of usage 3
		011 ₂	Class of usage 4
		100 ₂	Class of usage 5
		101 ₂	Class of usage 6
		110 ₂	Class of usage 7
		111 ₂	Class of usage 8

16.10.7 Disabling type

For the disabling type information element refer to ETSI EN 300 392-7 [8].

16.10.7a Default group attachment lifetime

The default group attachment lifetime information element shall indicate the default lifetime of the attachment of all group identities attached by the infrastructure for a MS as defined in table 16.33.

Table 16.33: Default group attachment lifetime information element contents

Information element	Length	Value	Remark
Default group attachment lifetime	2	00 ₂	Attachment not needed
		01 ₂	Attachment for next ITSI attach required
		10 ₂	Attachment not allowed for next ITSI attach
		11 ₂	Attachment for next location update required

16.10.7b Distance reporting timer

The distance reporting timer information element shall indicate the maximum time between MS transmissions as defined in table 16.34.

Table 16.34: Distance reporting timer information element contents

Information element	Length	Value	Remark
Distance reporting timer	7	0	No reporting/stop reporting
		1	15 s
		2	30 s
		etc.	etc.
		127	31 min 45 s

16.10.7c Distance reporting validity

The distance reporting validity information element shall indicate the reporting validity as defined in table 16.35.

Table 16.35: Distance reporting validity information element contents

Information element	Length	Value	Remark
Distance reporting validity	1	0	Report until next location update
		1	Report until next ITSI attach or migration

16.10.8 Distribution on 18th frame

The distribution on 18th frame information element shall indicate on which of the 4 time slots the MS shall monitor down link information in the case of minimum mode as defined in table 16.36.

Table 16.36: Distribution on 18th frame information element contents

Information element	Length	Value	Remark
Distribution on 18 th frame	2	00 ₂	Time slot 1
		01 ₂	Time slot 2
		10 ₂	Time slot 3
		11 ₂	Time slot 4

16.10.8a DMO carrier

The DMO carrier information element shall indicate the DMO radio channel as defined in table 16.37.

Table 16.37: DMO carrier

Information sub-element	Length	Type	C/O/M	Value	Remark
Carrier number	12	1	M		Carrier frequency number (see note 1)
Extended carrier numbering flag	1	1	M	0	No extended carrier numbering
				1	Extended carrier numbering
Frequency band	4		C		Provision for different frequency bands (see notes 1 and 2)
Offset	2		C		Provision for different offsets, (see notes 2 and 3)
Duplex spacing	3		C		Provision for different duplex spacing (see notes 1, 2 and 4)
DMO normal/reverse operation	1		C	0	DMO uplink frequency = DMO downlink frequency + duplex spacing (see notes 2 and 4)
				1	DMO uplink frequency = DMO downlink frequency - duplex spacing (see notes 2 and 4)
Reserved	2		C	00 ₂	Default value = 00 ₂ (see note 2)
NOTE 1: Refer to annex F for meaning of the values.					
NOTE 2: These information elements shall be present only when the extended carrier numbering flag has value "extended carrier numbering".					
NOTE 3: Refer to clause 21.4.4.1, table 21.65 for the meaning of the offset values.					
NOTE 4: When an MS requesting dual watch mode or indicating start of Direct Mode operation transmits the DMO carrier information element, it shall set the carrier number to indicate the Direct Mode RF carrier where it intends to receive. If using extended carrier numbering, the MS shall set the duplex spacing information element to indicate 0,0 MHz duplex value unless the MS expects to use a two-frequency Direct Mode repeater during its dual watch operation in which case it may set the duplex spacing information element with the DMO normal/reverse operation information element to indicate the uplink Direct Mode RF carrier. When a Direct Mode gateway transmits the DMO carrier information element (see ETSI EN 300 396-5 [24]), it shall indicate the Direct Mode RF carrier where it intends to transmit. In the case of a two-frequency combined repeater/gateway, the repeater/gateway shall set the duplex spacing information element with the DMO normal/reverse operation information element to indicate the uplink Direct Mode RF carrier.					

16.10.8b Dual watch mode

The dual watch mode information element shall indicate whether the MS is requesting to use full dual watch or idle dual watch as defined in table 16.38.

Table 16.38: Dual watch mode information element contents

Information element	Length	Value	Remark
Dual watch mode	1	0	Full dual watch
		1	Idle dual watch

16.10.9 Energy saving mode

The energy saving mode information element shall indicate which energy saving or dual watch scheme is requested (if any) as defined in table 16.39, refer to clause 23.7.6 for the meaning of the values.

Table 16.39: Energy saving mode information element contents

Information element	Length	Value	Remark
Energy saving mode	3	000 ₂	Stay Alive
		001 ₂	Economy mode 1 (EG1)
		010 ₂	Economy mode 2 (EG2)
		011 ₂	Economy mode 3 (EG3)
		100 ₂	Economy mode 4 (EG4)
		101 ₂	Economy mode 5 (EG5)
		110 ₂	Economy mode 6 (EG6)
		111 ₂	Economy mode 7 (EG7)

16.10.10 Energy saving information

The energy saving information element shall indicate which energy saving or dual watch scheme is allocated (if any) and starting point of the energy economy mode as defined in table 16.40.

Table 16.40: Energy saving information element contents

Information sub-element	Length	Type	C/O/M	Remark
Energy saving mode	3	1	M	
Frame Number	5	1	M	See note 1
Multiframe Number	6	1	M	See note 2
NOTE 1: When the Energy saving mode information element value is "Stay alive" this information element has no meaning and it shall be set to "00000 ₂ ".				
NOTE 2: When the Energy saving mode information element value is "Stay alive" this information element has no meaning and it shall be set to "000000 ₂ ".				

16.10.10a Extended capabilities

The extended capabilities information element shall be a collection of sub-elements as defined in table 16.41. It shall indicate to the infrastructure additional capabilities supported by the MS terminal, both hardware and software.

Table 16.41: Extended capabilities information element contents

Information sub-element	Length	Type	C/O/M	Value	Remark
Air to ground	1	1	M	0	MS does not support air to ground service
				1	MS supports air to ground service
Cell type request (see note 1)	3	1	M	000 ₂	Conventional access registration request
				001 ₂	Direct access registration request
				010 ₂	Reserved
				etc.	etc.
				111 ₂	Reserved
$\pi/4$ -DQPSK packet data (see note 2)	1		C	0	DA MS does not support the use of $\pi/4$ -DQPSK modulation for packet data
				1	DA MS supports the use of $\pi/4$ -DQPSK modulation for packet data
Part-time reception (see notes 2, 3 and 4)	1		C	0	DA MS does not support part-time reception (and does not use enhanced energy economy)
				1	DA MS supports part-time reception (and may use enhanced energy economy)
Reserved (see note 5)	2		C	00 ₂	Shall be set to zero in the present document
CA capability	1	1	M	0	MS does not support conventional access except in the case described in note 6
				1	MS supports conventional access
DA capability	1	1	M	0	MS does not support direct access
				1	MS supports direct access
Reserved	10	1	M		Shall be set to all zeros in the present document
QAM capabilities	16	2	O		
Reserved	16	2	O		Shall not be included in the present document
Reserved	16	2	O		Shall not be included in the present document
Reserved	16	2	O		Shall not be included in the present document
Reserved	16	2	O		Shall not be included in the present document
Reserved	16	2	O		Shall not be included in the present document
Reserved	16	2	O		Shall not be included in the present document
Reserved	16	2	O		Shall not be included in the present document
NOTE 1: In the case of a forward registration request, this element refers to the new cell (not the present cell).					
NOTE 2: This element shall be included only if "cell type request" = "direct access registration request".					
NOTE 3: If the MS supports the use of part-time reception but does not wish to use it, the MS may indicate that it does not support part-time reception.					
NOTE 4: If the MS indicates that it supports part-time reception, it may also use enhanced energy economy if it requests energy economy mode or dual watch mode with an energy economy group. If the MS indicates that it does not support part-time reception, it shall not use enhanced energy economy if it requests energy economy mode or dual watch mode with an energy economy mode.					
NOTE 5: This element shall be included only if "cell type request" is not equal to "direct access registration request".					
NOTE 6: If the MS requests a conventional access registration and also indicates that conventional access is not supported, the SwMI shall treat this as meaning that conventional access is supported (this combination may occur in the case of some older conventional access MSs).					

16.10.11 Frame Number

The Frame Number (FN) information element shall indicate TDMA frame number as defined in table 16.42.

Table 16.42: Frame number information element contents

Information element	Length	Value	Remark
Frame Number	5	00000 ₂	Reserved
		00001 ₂	FN1
		00010 ₂	FN2
		etc.	etc.
		10010 ₂	FN18
		10011 ₂	Reserved
		etc.	etc.
		11111 ₂	Reserved

16.10.11a Frequency band definition

The frequency band definition information element shall indicate the frequency capabilities of the MS as defined in table 16.43.

Table 16.43: Frequency band definition information element contents

Information element	Length	Type	C/O/M	Value	Remark
Lower edge carrier	12	1	M		See notes 1 and 2
Lower edge frequency band	4	1	M		See note 1
Upper edge carrier	12	1	M		See notes 1 and 2
Upper edge frequency band	4	1	M		See note 1
Duplex spacing	3	1	M		See note 1
Reverse operation types	2	1	M	00 ₂	Reserved
				01 ₂	Reverse operation only
				10 ₂	Normal operation only
				11 ₂	Both normal and reverse operation
NOTE 1: Refer to ETSI TS 100 392-15 [18].					
NOTE 2: The frequency band shall be defined as the BS transmitter frequency range.					

16.10.12 Group identity accept/reject

The group identity accept/reject information element shall indicate the infrastructure response type to the MS initiated attachment/detachment of group identities as defined in table 16.44.

Table 16.44: Group identity accept/reject information element contents

Information element	Length	Value	Remark
Group identity accept/reject	1	0	All attachment/detachments accepted
		1	At least one attachment/detachment rejected

16.10.13 Group identity acknowledgement request

The group identity acknowledgement request information element shall indicate the MS response to the infrastructure initiated attachment/detachment of group identities as defined in table 16.45.

Table 16.45: Group identity acknowledgement request information element contents

Information element	Length	Value	Remark
Group identity acknowledgement request	1	0	Acknowledgement not requested
		1	Acknowledgement requested

16.10.14 Group identity acknowledgement type

The group identity acknowledgement type information element shall indicate the MS response type to the infrastructure initiated attachment/detachment of group identities as defined in table 16.46.

Table 16.46: Group identity acknowledgement type information element contents

Information element	Length	Value	Remark
Group identity acknowledgement type	1	0	All attachment/detachments accepted
		1	At least one attachment rejected

16.10.15 Group identity address type

The group identity address type information element shall indicate type of group identity address type in the attachment/detachment of group identities as defined in table 16.47.

Table 16.47: Group identity address type information element contents

Information element	Length	Value	Remark
Group identity address type	2	00 ₂	GSSI
		01 ₂	GTSI
		10 ₂	(V)GSSI
		11 ₂	GTSI+(V)GSSI

16.10.16 Group identity attachment lifetime

The group identity attachment lifetime information element shall indicate a lifetime of the attachment of the group identity defined by the infrastructure for a MS as defined in table 16.48.

Table 16.48: Group identity attachment lifetime information element contents

Information element	Length	Value	Remark
Group identity attachment lifetime	2	00 ₂	Attachment not needed
		01 ₂	Attachment for next ITSI attach required
		10 ₂	Attachment not allowed for next ITSI attach
		11 ₂	Attachment for next location update required

16.10.17 Group identity attach/detach mode

The group identity attach/detach mode information element shall indicate a mode of the attachment/detachment of group identities as defined in table 16.49.

Table 16.49: Group identity attach/detach mode information element contents

Information element	Length	Value	Remark
Group identity attach/detach mode	1	0	Amendment
		1	Detach all currently attached group identities and attach group identities defined in the group identity (downlink/uplink) element (if any)

16.10.18 Group identity attach/detach type identifier

The group identity attach/detach type identifier information element shall indicate the whether a group identity is attached or detached as defined in table 16.50.

Table 16.50: Group identity attach/detach type identifier information element contents

Information element	Length	Value	Remark
Group identity attach/detach type identifier	1	0	Attachment
		1	Detachment

16.10.19 Group identity attachment

The group identity attachment information element shall be a collection of sub elements and defined in table 16.51.

Table 16.51: Group identity attachment information element contents

Information sub-element	Length	Type	C/O/M	Remark
Group identity attachment lifetime	2	1	M	
Class of Usage	3	1	M	

16.10.20 Group identity detachment downlink

The group identity detachment downlink information element shall indicate the infrastructure detachment reasons as defined in table 16.52.

Table 16.52: Group identity detachment downlink information element contents

Information element	Length	Value	Remark
Group identity detachment downlink	2	00 ₂	Unknown group identity
		01 ₂	Temporary 1 detachment (see note)
		10 ₂	Temporary 2 detachment (see note)
		11 ₂	Permanent detachment
NOTE: These values are network dependent.			

16.10.21 Group identity detachment uplink

The group identity detachment uplink information element shall indicate the MS detachment reasons as defined in table 16.53.

Table 16.53: Group identity detachment uplink information element contents

Information element	Length	Value	Remark
Group identity detachment uplink	2	00 ₂	Unknown group identity
		01 ₂	No valid encryption key (end-to-end)
		10 ₂	User initiated
		11 ₂	Capacity exceeded

16.10.22 Group identity downlink

The group identity downlink information element shall be a collection of sub elements and defined in table 16.54.

Table 16.54: Group identity downlink information element contents

Information sub-element	Length	Type	C/O/M	Remark
Group identity attach/detach type identifier	1	1	M	
Group identity attachment	5		C	See note 1
Group identity detachment downlink	2		C	See note 1
Group identity address type	2	1	M	
GSSI	24		C	See note 2
Address EXTENSION	24		C	See note 2
(V) GSSI	24		C	See note 2
NOTE 1: Shall be conditional on the value of Group Identity Attach/Detach Type Identifier (GIADTI):				
- GIADTI = 0; Group Identity Attachment;				
- GIADTI = 1; Group Identity Detachment Downlink.				
NOTE 2: Shall be conditional on the value of Group Identity Address Type (GIAT):				
- GIAT = 0; GSSI;				
- GIAT = 1; GSSI + Address Extension (GTSI);				
- GIAT = 2; Visitor Group Short Subscriber Identity ((V)GSSI);				
- GIAT = 3; GSSI + Extension + Visitor Group Short Subscriber Identity (GTSI-V(GSSI)).				

16.10.23 Group identity location accept

The group identity location accept information element shall be a collection of sub elements and defined in table 16.55.

Table 16.55: Group identity location accept information element contents

Information sub-element	Length	Type	C/O/M	Remark
Group identity accept/reject	1	1	M	See note
Reserved	1	1	M	
Group identity downlink		4	O	
NOTE: Accept/reject has meaning only when acknowledging MS group identity attachment/detachment.				

16.10.24 Group identity location demand

The group identity location demand information element shall be a collection of sub elements and defined in table 16.56.

Table 16.56: Group identity location demand information element contents

Information sub-element	Length	Type	C/O/M	Remark
Reserved	1	1	M	
Group identity attach/detach mode	1	1	M	
Group identity uplink		4	O	

16.10.25 Void

16.10.26 Group identity report

The group identity report information element shall indicate that all MS's active group identities shall be reported as defined in table 16.57.

Table 16.57: Group identity report information element contents

Information element	Length	Value	Remark
Group identity report	1	0	Not report request
		1	Report request

16.10.27 Group identity uplink

The group identity uplink information element shall be a collection of sub elements and defined in table 16.58.

Table 16.58: Group identity uplink information element contents

Information sub-element	Length	Type	C/O/M	Remark
Group identity attach/detach type identifier	1	1	M	
Class of usage	3		C	See note 1
Group identity detachment uplink	2		C	See note 1
Group identity address type	2	1	M	
GSSI	24		C	See note 2
Address extension	24		C	See note 2
(V) GSSI	24		C	See note 2
NOTE 1: Shall be conditional on the value of Group Identity Attach/Detach Type Identifier (GIADTI):				
- GIADTI = 0; Class of Usage;				
- GIADTI = 1; Group Identity Detachment uplink.				
NOTE 2: Shall be conditional on the value of Group Identity Address Type (GIAT):				
- GIAT = 0; GSSI;				
- GIAT = 1; GSSI + Address Extension (GTSI);				
- GIAT = 2; Visitor Group Short Subscriber Identity ((V)GSSI);				
- GIAT = 3; Reserved.				

16.10.27a Group report response

The group report response information element shall indicate that the group report is complete as defined in table 16.59.

Table 16.59: Group report response information element contents

Information element	Length	Value	Remark
Group report response	1	0	Group report complete
		1	Reserved

16.10.28 Group Short Subscriber Identity (GSSI)

The GSSI information element shall indicate the GSSI or (V)GSSI that the MS shall use in subsequent contacts with the SwMI. It is also used during attachment/detachment to explicitly inform the full GTSI when used in conjunction with the extension element as defined in table 16.60.

Table 16.60: GSSI information element contents

Information element	Length	Value	Remark
GSSI	24		See ETSI EN 300 392-1 [6], clause 7

16.10.29 KSG number

For the KSG number information element refer to ETSI EN 300 392-7 [8].

16.10.30 LA

The LA information element shall indicate the area in which a cell is located, either the serving cell or a neighbour cell as defined in table 16.61.

Table 16.61: LA information element contents

Information element	Length	Value	Remark
LA	14		

16.10.31 LACC

The LACC information element shall indicate which LACC the MS wants to use as defined in table 16.62. The element shall only be signalled if it is different from the country code used in the network, i.e. the MS is migrating.

Table 16.62: Location Area Country Code information element contents

Information element	Length	Value	Remark
Location Area Country Code	10		See ETSI EN 300 392-1 [6], clause 7 (MCC)

16.10.32 LANC

The LANC information element shall indicate which LANC the MS wants to use as defined in table 16.63. The element is only signalled if it is different from the network code used in the network, i.e. the MS is roaming.

Table 16.63: LANC information element contents

Information element	Length	Value	Remark
Location Area Network Code	14		See ETSI EN 300 392-1 [6], clause 7 (MNC)

16.10.33 LA timer

The LA timer information element shall indicate the time a LA is valid as defined in table 16.64.

Table 16.64: LA timer information element contents

Information element	Length	Value	Remark
LA timer	3	000 ₂	10 min
		001 ₂	30 min
		010 ₂	1 hour
		011 ₂	2 hours
		100 ₂	4 hours
		101 ₂	8 hours
		110 ₂	24 hours
		111 ₂	no timing

16.10.34 LA information

The LA information element shall be a collection of information elements as defined in table 16.65.

Table 16.65: LA information element contents

Information sub-element	Length	Type	C/O/M	Remark
Location Area (LA)	14	1	M	
Zero bit	1	1	M	

16.10.34a Length of the copied PDU

The Length of the copied PDU information element shall indicate the length of the Received PDU contents information element as defined in table 16.66.

Table 16.66: Length of the copied PDU information element contents

Information sub-element	Length	Value	Remark
Length of the copied PDU	8	00000000 ₂	0 bit
		00000001 ₂	1 bit
		00000010 ₂	2 bits
		etc.	etc.
		11111111 ₂	255 bits

16.10.35 Location update type

The purpose of the location updating type Information element shall indicate what type of registration is wanted as defined in table 16.67.

Table 16.67: Location update type information element contents

Information element	Length	Value	Remark
Location update type	3	000 ₂	Roaming location updating
		001 ₂	Migrating location updating
		010 ₂	Periodic location updating
		011 ₂	ITSI attach
		100 ₂	Service restoration roaming location updating
		101 ₂	Service restoration migrating location updating
		110 ₂	Demand location updating
		111 ₂	Disabled MS updating

16.10.35a Location update accept type

The location update accept type information element shall indicate the type of registration in the D-LOCATION UPDATE ACCEPT PDU as defined in table 16.68.

Table 16.68: Location update accept type information element contents

Information element	Length	Value	Remark
Location update accept type	3	000 ₂	Roaming location updating
		001 ₂	Temporary registration
		010 ₂	Periodic location updating
		011 ₂	ITSI attach
		100 ₂	Service restoration roaming location updating
		101 ₂	Migrating or service restoration migrating location updating
		110 ₂	Demand location updating
		111 ₂	Disabled MS updating

16.10.36 Mobile Country Code (MCC)

The MCC information element shall indicate to which MCC the MS is subscribed as defined in table 16.69.

Table 16.69: MCC information element contents

Information element	Length	Value	Remark
MCC	10		See ETSI EN 300 392-1 [6], clause 7 (MCC)

16.10.37 Mobile Network Code (MNC)

The MNC information element shall indicate to which MNC the MS is subscribed as defined in table 16.70.

Table 16.70: MNC information element contents

Information element	Length	Value	Remark
MNC	14		See ETSI EN 300 392-1 [6], clause 7 (MNC)

16.10.37a Mode change information

Mode change information element shall indicate additional information related to a direct mode or dual watch invocation as defined in table 16.71.

Table 16.71: Mode change information element contents

Information element	Length	Value	Remark
Mode change information	6	000000 ₂	Reserved
		etc.	etc.
		111111 ₂	Reserved

16.10.37b MS operating with type 2 repeater

The MS operating with type 2 repeater information element shall indicate whether the MS expects to use a type 2 Direct Mode repeater during its dual watch operation, as defined in table 16.72. This may affect the appropriate energy economy (see ETSI EN 300 396-7 [25]).

Table 16.72: MS operating with type 2 repeater information element contents

Information element	Length	Value	Remark
MS operating with type 2 repeater	1	0	MS does not expect to use a type 2 Direct Mode repeater
		1	MS expects to use a type 2 Direct Mode repeater

16.10.38 Multiframe Number (MN)

The Multiframe Number (MN) information element shall indicate TDMA multiframe number as defined in table 16.73.

Table 16.73: Multiframe number information element contents

Information element	Length	Value	Remark
Multiframe Number (MN)	6	000000 ₂	Reserved
		000001 ₂	MN1
		000010 ₂	MN2
		etc.	etc.
		111100 ₂	MN60
		111101 ₂	Reserved
		etc.	etc.
		111111 ₂	Reserved

16.10.38a Not-supported PDU type

See clause 16.10.39 PDU type element.

16.10.38b Number of frequency band definitions

The Number of the frequency band definitions information element shall indicate the how many frequency band definitions the PDU contains as defined in table 16.74.

Table 16.74: Number of the frequency band definitions information element contents

Information sub-element	Length	Value	Remark
Number of the frequency band definitions	3	000 ₂	0
		001 ₂	1
		010 ₂	2
		etc.	etc.
		111 ₂	7

16.10.39 PDU type

The PDU type information element shall identify an up-link and down-link message. The PDU type information element shall have a separate definition in the uplink and downlink directions as defined in table 16.75.

Table 16.75: PDU type information element contents

Information element	Length	Value	Remark	
			Downlink	Uplink
PDU type	4	0000 ₂	D-OTAR, see ETSI EN 300 392-7 [8].	U-AUTHENTICATION, see ETSI EN 300 392-7 [8]
		0001 ₂	D-AUTHENTICATION, see ETSI EN 300 392-7 [8]	U-ITSI DETACH
		0010 ₂	D-CK CHANGE DEMAND, see ETSI EN 300 392-7 [8]	U-LOCATION UPDATE DEMAND
		0011 ₂	D-DISABLE, see ETSI EN 300 392-7 [8]	U-MM STATUS
		0100 ₂	D-ENABLE, see ETSI EN 300 392-7 [8]	U-CK CHANGE RESULT, see ETSI EN 300 392-7 [8]
		0101 ₂	D-LOCATION UPDATE ACCEPT	U-OTAR, see ETSI EN 300 392-7 [8]
		0110 ₂	D-LOCATION UPDATE COMMAND	U-INFORMATION PROVIDE, see ETSI EN 300 392-7 [8]
		0111 ₂	D-LOCATION UPDATE REJECT	U-ATTACH/DETACH GROUP IDENTITY
		1000 ₂	Reserved	U-ATTACH/DETACH GROUP IDENTITY ACK
		1001 ₂	D-LOCATION UPDATE PROCEEDING	U-TEI PROVIDE, see ETSI EN 300 392-7 [8]
		1010 ₂	D-ATTACH/DETACH GROUP IDENTITY	Reserved
		1011 ₂	D-ATTACH/DETACH GROUP IDENTITY ACK	U-DISABLE STATUS, see ETSI EN 300 392-7 [8]
		1100 ₂	D-MM STATUS	Reserved
		1101 ₂	Reserved	Reserved
		1110 ₂	Reserved	Reserved
1111 ₂	MM PDU/FUNCTION NOT SUPPORTED	MM PDU/FUNCTION NOT SUPPORTED		

16.10.40 New registered area

The new registered area information element shall be a collection of information elements as defined in table 16.76.

Table 16.76: New registered area information element contents

Information sub-element	Length	Type	C/O/M	Remark
LA timer	3	1	M	
LA	14	1	M	
LACC	10	2	O	See note
LANC	14	2	O	See note
NOTE: Not used in this version of the present document.				

16.10.40a Preferred cell type

The preferred cell type information element shall indicate a type of cell, as defined in table 16.77.

Table 16.77: Preferred cell type information element contents

Information element	Length	Value	Remark
Preferred cell type	3	000 ₂	CA cell
		001 ₂	DA cell
		010 ₂	Reserved
		etc.	etc.
		111 ₂	Reserved

16.10.40b Preferred cell type list control

The preferred cell type list control information element shall indicate how many preferred cell types are listed after this element, and whether the list of cell types is unordered or whether the list of cell types is given in order of decreasing preference, as defined in table 16.78.

Table 16.78: Preferred cell type list control information element contents

Information element	Length	Value	Remark
Preferred cell type list control	4	0000 ₂	No cell types listed
		0001 ₂	One cell type listed
		0010 ₂	Two cell types listed in order of decreasing preference
		0011 ₂	Three cell types listed in order of decreasing preference
		0100 ₂	Four cell types listed in order of decreasing preference
		0101 ₂	Five cell types listed in order of decreasing preference
		0110 ₂	Six cell types listed in order of decreasing preference
		0111 ₂	Seven cell types listed in order of decreasing preference
		1000 ₂	Eight cell types listed in order of decreasing preference
		1001 ₂	Reserved (shall not be used in the present document)
		1010 ₂	Two cell types listed (unordered)
		1011 ₂	Three cell types listed (unordered)
		1100 ₂	Four cell types listed (unordered)
		1101 ₂	Five cell types listed (unordered)
1110 ₂	Six cell types listed (unordered)		
1111 ₂	Seven cell types listed (unordered)		

16.10.41 Proprietary

Proprietary is an optional, variable length information element and shall be used to send and receive proprietary defined information appended to the PDUs.

The use, the size and the structure of the proprietary information element is outside the scope of the present document except the first octet which shall indicate the owner of the proprietary information element as defined in annex H.

16.10.41a QAM capabilities

The QAM capabilities information element shall be a collection of information elements as defined in table 16.79.

Table 16.79: QAM capabilities information element contents

Information sub-element	Length	Type	C/O/M	Value	Remark
Maximum downlink QAM modulation level (see note 1)	3	1	M	000 ₂	Reserved
				001 ₂	16-QAM
				010 ₂	64-QAM
				011 ₂	Reserved
				etc.	etc.
				111 ₂	Reserved
QAM fast switching	1	1	M	0	QAM fast switching not supported
				1	QAM fast switching supported
QAM in 25 kHz bandwidth	1	1	M	0	QAM in 25 kHz bandwidth not supported
				1	QAM in 25 kHz bandwidth supported
QAM in 50 kHz bandwidth	1	1	M	0	QAM in 50 kHz bandwidth not supported
				1	QAM in 50 kHz bandwidth supported
QAM in 100 kHz bandwidth	1	1	M	0	QAM in 100 kHz bandwidth not supported
				1	QAM in 100 kHz bandwidth supported
QAM in 150 kHz bandwidth	1	1	M	0	QAM in 150 kHz bandwidth not supported
				1	QAM in 150 kHz bandwidth supported
Reserved	6	1	M		Shall be set to 000000 ₂ in the present document
Multislot/single-slot for QAM (see notes 3, 4 and 5)	1	1	M	0	Multislot and single slot supported
				1	Only single slot supported
CLCH-Q needed on carrier change	1	1	M	0	CLCH-Q not needed on carrier change except in the case described in note 2
				1	CLCH-Q needed on carrier change
NOTE 1: If the BS does not understand the value of this element, it should assume the MS supports all downlink modulation levels up to the maximum downlink modulation level supported by the BS.					
NOTE 2: If the MS indicates in the "class of MS" element that CLCH is needed on carrier change but indicates here that CLCH-Q is not needed on carrier change, the SwMI shall treat this as meaning that CLCH-Q is needed on carrier change (this combination may occur in the case of some older conventional access MSs).					
NOTE 3: It is optional for a CA MS to be capable of using a multislot QAM channel; therefore a QAM-capable CA MS shall set the "multislot/single-slot for QAM" element to indicate whether it supports both multislot and single-slot QAM channels or only single-slot QAM channels. It is mandatory for a DA MS to be capable of using a multislot QAM channel (see clauses 23.1.2.5 and 23.1.3.3); therefore a DA MS shall indicate that it supports both multislot and single-slot QAM channels i.e. it shall set the "multislot/single-slot for QAM" element to value 0 to indicate "Multislot and single slot supported".					
NOTE 4: If the MS indicates that it supports both multislot and single-slot QAM channels, it shall support one-slot, two-slot, three-slot and four-slot QAM channels.					
NOTE 5: The polarity of this element is different from the polarity of the "single/multislot for phase modulation" element in the "class of MS" element.					

16.10.41b Reason for dual watch change by SwMI

The reason for dual watch change by SwMI information element shall inform the MS of the reason why the SwMI is changing the MS's dual watch operation, as defined in table 16.80.

Table 16.80: Reason for dual watch change by SwMI information element contents

Information element	Length	Value	Remark
Reason for dual watch change by SwMI	3	000 ₂	Dual watch terminated for undefined reason
		001 ₂	Change of dual watch energy economy group
		010 ₂	Reserved
		etc.	etc.
		111 ₂	Reserved

16.10.42 Reject cause

The reject cause information element shall indicate what type of rejection has been detected as defined in table 16.81.

Table 16.81: Reject cause information element contents

Information element	Length	Value	Remark
Reject cause	5	00000 ₂	Reserved
		00001 ₂	ITSI/ATSI unknown (system rejection)
		00010 ₂	Illegal MS (system rejection)
		00011 ₂	LA not allowed (LA rejection)
		00100 ₂	LA unknown (LA rejection)
		00101 ₂	Network failure (cell rejection)
		00110 ₂	Congestion (cell rejection)
		00111 ₂	Forward registration failure (cell rejection)
		01000 ₂	Service not subscribed (LA rejection)
		01001 ₂	Mandatory element error (system rejection)
		01010 ₂	Message consistency error (system rejection)
		01011 ₂	Roaming not supported (LA rejection)
		01100 ₂	Migration not supported (system rejection)
		01101 ₂	No cipher KSG (cell rejection)
		01110 ₂	Identified cipher KSG not supported (cell rejection)
		01111 ₂	Requested cipher key type not available (cell rejection)
		10000 ₂	Identified cipher key not available (cell rejection)
		10001 ₂	Reserved
		10010 ₂	Ciphering required (cell rejection)
		10011 ₂	Authentication failure (system rejection)
		10100 ₂	Use of CA cell not permitted (cell type rejection)
		10101 ₂	Use of DA cell not permitted (cell type rejection)
		10110 ₂	Reserved
etc.	etc.		
11111 ₂	Reserved		

16.10.43 Request to append LA

The request to append LA information element shall indicate whether the MS user wants to append the new LA into the current registered area or not as defined in table 16.82.

Table 16.82: Request to Append LA information element contents

Information element	Length	Value	Remark
Request to append LA	1	0	No request to append LA to registered area (i.e. Registered area to include only this new LA)
		1	Request to append LA to registered area

16.10.43a Required cell type

The required cell type information element shall indicate a type of cell, as defined in table 16.83.

Table 16.83: Required cell type information element contents

Information element	Length	Value	Remark
Required cell type	3	000 ₂	CA cell
		001 ₂	DA cell
		010 ₂	Reserved
		etc.	etc.
		111 ₂	Reserved

16.10.43b Required cell type list control

The required cell type list control information element shall indicate how many required cell types are listed following this element, and whether the list of cell types is unordered or whether the list of cell types is given in order of decreasing preference, as defined in table 16.84.

Table 16.84: Required cell type list control information element contents

Information element	Length	Value	Remark
Required cell type list control	4	0000 ₂	No cell types listed
		0001 ₂	One cell type listed
		0010 ₂	Two cell types listed in order of decreasing preference
		0011 ₂	Three cell types listed in order of decreasing preference
		0100 ₂	Four cell types listed in order of decreasing preference
		0101 ₂	Five cell types listed in order of decreasing preference
		0110 ₂	Six cell types listed in order of decreasing preference
		0111 ₂	Seven cell types listed in order of decreasing preference
		1000 ₂	Eight cell types listed in order of decreasing preference
		1001 ₂	Reserved (shall not be used in the present document)
		1010 ₂	Two cell types listed (unordered)
		1011 ₂	Three cell types listed (unordered)
		1100 ₂	Four cell types listed (unordered)
		1101 ₂	Five cell types listed (unordered)
		1110 ₂	Six cell types listed (unordered)
1111 ₂	Seven cell types listed (unordered)		

16.10.43c Re-send interval

The re-send interval information element shall indicate the occasion when the MS should re-send the U-MS FREQUENCY BANDS INFORMATION PDU as defined in table 16.85.

Table 16.85: Re-send interval information element contents

Information element	Length	Value	Remark
Re-send interval	2	00 ₂	Re-sending not needed
		01 ₂	Re-send after each ITSI-Attach location update
		10 ₂	Re-send after each location update
		11 ₂	Reserved

16.10.43d Result of dual watch request

The result of dual watch request information element shall inform the MS of the result of its dual watch request as defined in table 16.86.

Table 16.86: Result of dual watch request information element contents

Information element	Length	Value	Remark
Result of dual watch request	3	000 ₂	Request rejected for undefined reason
		001 ₂	Dual watch not supported
		010 ₂	Request accepted with the dual watch energy economy group given in the "energy saving information" information element
		011 ₂	Reserved
		etc.	etc.
		111 ₂	Reserved

16.10.43e Revert to user application setting

The revert to user application setting information element indicates if MM shall set its "cell type preference or requirement" (see clause 16.4.12) to that provided by the user application, or if MM shall also use requirements and preferences provided by the SwMI, as defined in table 16.87.

Table 16.87: Revert to user application setting information element contents

Information element	Length	Value	Remark
Revert to user application setting	1	0	Use SwMI's cell type preference or requirement
		1	Revert to user application's cell type preference or requirement

16.10.44 SSI

The SSI information element shall indicate the ASSI or (V)ASSI that the MS shall use in subsequent contacts with the SwMI as defined in table 16.88. It can also be used during registration to explicitly inform the SwMI of the full ITSI when used in conjunction with the MCC and MNC.

Table 16.88: SSI information element contents

Information element	Length	Value	Remark
Short Subscriber Identity (SSI)	24		See ETSI EN 300 392-1 [6], clause 7

16.10.45 SCCH information

The SCCH information element shall assign a parameter used by the MAC to calculate which common control channel to use when common SCCHs are in operation as defined in table 16.89. See clauses 23.3.1.2.1.2 and 23.3.1.2.1.3.

The parameter in the SCCH information element may also be used by the MAC in a Direct Access MS on a multi-slot MCCH-Q if enhanced energy economy is available:

- when the MS is in energy economy mode, the SCCH information parameter is used by the MAC to calculate its reception slot in the reception TDMA frames when in the sleeping cycle (see clause 23.7.6); or
- when the MS is in dual watch mode with an energy economy group, the SCCH information parameter is used by the MAC to calculate its reception slot in the reception TDMA frames when in the dual watch reception cycle (see clause 23.7.7).

The parameter in the SCCH information element may also be used by the MAC in a Direct Access MS if part-time reception on a multi-slot MCCH-Q is permitted. When the MS is using part-time reception on a multi-slot MCCH-Q, the SCCH information parameter is used by the MAC to calculate its reception slot (see clause 23.7.8).

Table 16.89: SCCH information element contents

Information element	Length	Value	Remark
SCCH information	4	0000 ₂	MS SCCH allocation 0
		0001 ₂	MS SCCH allocation 1
		etc.	etc.
		1011 ₂	MS SCCH allocation 11
		1100 ₂	Reserved
		etc.	etc.
		1111 ₂	Reserved

16.10.46 SCCH information and distribution on 18th frame

The SCCH information and distribution on 18th frame information element shall inform the MS of any SCCH information and on which of the 4 time slots the MS shall monitor down link information in the case of minimum mode as defined in table 16.90.

Table 16.90: SCCH information and distribution on 18th frame information element contents

Information sub-element	Length	Type	C/O/M	Remark
SCCH information	4	1	M	
Distribution on 18 th frame	2	1	M	

16.10.47 SCK number

For the SCK number information element refer to ETSI EN 300 392-7 [8].

16.10.47a Start of direct mode operation cause

Start of direct mode operation cause information element shall indicate the reason for entering direct mode operation as defined in table 16.91.

Table 16.91: Start of direct mode operation cause information element contents

Information element	Length	Value	Remark
Start of direct mode operation cause	3	000 ₂	User initiated mode change
		001 ₂	MS initiated mode change due to a potential loss of SwMI coverage
		010 ₂	MS initiated mode change due to SwMI load
		011 ₂	Reserved
		etc.	etc.
		111 ₂	Reserved

16.10.48 Status downlink

The status downlink information element shall indicate the requested service or a response to a request, and the sub-type of the D-MM STATUS PDU as defined in table 16.92.

Table 16.92: Status downlink information element contents

Information element	Length	Value	Remark
Status downlink	6	000000 ₂	Reserved
		000001 ₂	Change of energy saving mode request
		000010 ₂	Change of energy saving mode response
		000011 ₂	Dual watch mode response
		000100 ₂	Terminating dual watch mode response
		000101 ₂	Change of dual watch mode request
		000110 ₂	Reserved (for an energy saving or dual watch purpose)
		000111 ₂	MS frequency bands request
		001000 ₂	Periodic distance reporting
		001001 ₂	Reserved
		etc.	etc.
		001111 ₂	Reserved
		010000 ₂	Refer to ETSI EN 300 396-5 [24]
		etc.	etc.
		011111 ₂	Refer to ETSI EN 300 396-5 [24]
		100000 ₂	Available for TETRA network and user specific definitions
		etc.	etc.
		101111 ₂	Available for TETRA network and user specific definitions
		110000 ₂	Reserved
		etc.	etc.
111111 ₂	Reserved		

16.10.48a Status uplink

Status uplink information element shall indicate the requested service or a response to a request and the sub-type of the U-MM STATUS PDU as defined in table 16.93.

Table 16.93: Status uplink information element contents

Information element	Length	Value	Remark
Status uplink	6	000000 ₂	Reserved
		000001 ₂	Change of energy saving mode request
		000010 ₂	Change of energy saving mode response
		000011 ₂	Dual watch mode request
		000100 ₂	Terminating dual watch mode request
		000101 ₂	Change of dual watch mode response
		000110 ₂	Start of direct mode operation
		000111 ₂	MS frequency bands information
		001000 ₂	Reserved
		etc.	etc.
		001111 ₂	Reserved
		010000 ₂	Refer to ETSI EN 300 396-5 [24]
		etc.	etc.
		011111 ₂	Refer to ETSI EN 300 396-5 [24]
		100000 ₂	Available for TETRA network and user specific definitions
		etc.	etc.
		101111 ₂	Available for TETRA network and user specific definitions
		110000 ₂	Reserved
		etc.	etc.
		111111 ₂	Reserved

16.10.49 Subscriber class

The subscriber class information element shall subdivide the MS population in up to 16 classes (see definition) represented as a bit map as defined in table 16.94.

Table 16.94: Subscriber class information element contents

Information element	Length	Value	Remark
Class 1 (see note)	1	0	Not a member of class 1
		1	Member of class 1
Class 2 (see note)	1	0	Not a member of class 2
		1	Member of class 2
Class 3	1	0	Not a member of class 3
		1	Member of class 3
Class 4	1	0	Not a member of class 4
		1	Member of class 4
etc.	1	0	etc.
		1	etc.
Class 16	1	0	Not a member of class 16
		1	Member of class 16
NOTE: Class 1 and/or class 2 membership may be reserved by the SwMI for AGA MSs (see clauses O.4.4 and O.7.1.2).			

16.10.50 Void

16.10.51 Type 3/4 element identifier

The Type 3/4 element identifier information element for downlink shall indicate the type of the following Type 3/4 element in the PDU as defined in table 16.95.

Table 16.95: Type 3/4 element identifier information element contents for downlink

Information element	Length	Value	Remark
Type 3/4 element identifier	4	0000 ₂	Reserved for future extension
		0001 ₂	Default group attachment lifetime
		0010 ₂	New registered area
		0011 ₂	Security downlink, see ETSI EN 300 392-7 [8]
		0100 ₂	Group report response
		0101 ₂	Group identity location accept
		0110 ₂	DM-MS address, see ETSI EN 300 396-5 [24]
		0111 ₂	Group identity downlink
		1000 ₂	Reserved for any future specified Type 3/4 element
		1001 ₂	Reserved for any future specified Type 3/4 element
		1010 ₂	Authentication downlink, see ETSI EN 300 392-7 [8]
		1011 ₂	Reserved for any future specified Type 3/4 element
		1100 ₂	Group Identity Security Related Information, see ETSI EN 300 392-7 [8]
		1101 ₂	Cell type control
		1110 ₂	Reserved for any future specified Type 3/4 element
		1111 ₂	Proprietary

The Type 3/4 element identifier information element for uplink shall indicate the type of the following Type 3/4 element in the PDU as defined in table 16.95a.

Table 16.95a: Type 3/4 element identifier information element contents for uplink

Information element	Length	Value	Remark
Type 3/4 element identifier	4	0000 ₂	Reserved for future extension
		0001 ₂	Reserved for any future specified Type 3/4 element
		0010 ₂	Reserved for any future specified Type 3/4 element
		0011 ₂	Group identity location demand
		0100 ₂	Group report response
		0101 ₂	Reserved for any future specified Type 3/4 element
		0110 ₂	DM-MS address, see ETSI EN 300 396-5 [24]
		0111 ₂	Reserved for any future specified Type 3/4 element
		1000 ₂	Group identity uplink
		1001 ₂	Authentication uplink, see ETSI EN 300 392-7 [8]
		1010 ₂	Reserved for any future specified Type 3/4 element
		1011 ₂	Extended capabilities
		1100 ₂	Reserved for any future specified Type 3/4 element
		1101 ₂	Reserved for any future specified Type 3/4 element
		1110 ₂	Reserved for any future specified Type 3/4 element
		1111 ₂	Proprietary

16.10.52 (V)GSSI

The (V)GSSI information element shall indicate the (V)GSSI that the MS shall use in subsequent contacts with the SwMI as defined in table 16.96.

Table 16.96: (V)GSSI information element contents

Information element	Length	Value	Remark
Visitor Group Short Subscriber Identity	24		See ETSI EN 300 392-1 [6], clause 7

16.10.53 Zero bit

The Zero bit information element shall be as defined in table 16.97.

Table 16.97: Zero bit information element contents

Information element	Length	Value	Remark
Zero bit	1	0	This guarantees the backward compatibility to edition 1

16.11 Parameters

16.11.1 Timers

16.11.1.1 Timer T351: Registration response time

This shall be the maximum time MM is waiting for a response for a registration request. The timer T351 value shall be 10 s.

16.11.1.2 Timer T352: Energy mode response time

This shall be the maximum time MM is waiting for a response for an energy saving or dual watch mode request. The timer T352 value shall be 30 s.

16.11.1.3 Timer T353: Attach/Detach response time

This shall be the maximum time MM is waiting for a response for a U-Attach/Detach Group Identity PDU. The timer T353 value shall be 10 s.

16.11.1.4 Timer T354: Authentication protocol time

Refer to ETSI EN 300 392-7 [8].

16.11.2 Constants

16.11.2.1 N351: Maximum system rejection count

When an MS has received N351 registration rejections of type "system rejection" without a successful registration on a system, it shall leave the system and shall not attempt to register again on that system until after a power cycle. N351 shall have a value in the range 1 to 4 with a default value of 4.

17 MLE service description

17.1 Introduction

This clause describes the services offered by the MLE.

The assumed underlying protocol is a MLE protocol, which is assumed to be positioned in the lowest sub-layer of layer 3 of the air interface stack.

The MLE services are provided through a set of SAPs, with each SAP corresponding to one type of service user (one upper layer 3 protocol).

The MLE protocol has been designed to hide most of the radio aspects of the air interface, and the resulting MLE services are intended to be comparable to non-radio (line) layer 2 protocols.

NOTE: Identical service definitions should also be used for LSs to allow the use of identical upper layer 3 protocols in LSs.

The MLE service boundary is an internal sub-layer boundary that is defined to clarify the description of the air interface layer 3. It is not intended to be a testable boundary. Conformance to this service should be achieved by providing conformance to one of the assumed MLE protocols.

17.2 Summary of services offered by MLE protocol

The MLE provides services to MLE service users. These services should be made available through SAPs. This relationship is shown in figure 17.1.

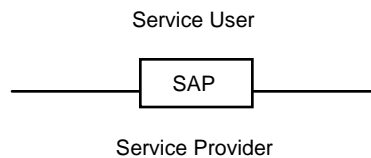

Figure 17.1: Relationship between a service user and a service provider

The entities listed below shall be permitted to use MLE services:

- Mobility Management (MM) entity (see clause 16);
- Circuit Mode Control Entity (CMCE) (see clause 14);
- Subnetwork Dependent Convergence Protocol (SNDTCP) entity (see clause 28).

All of the permitted MLE service users need not be present. However, in order that the MLE services may be requested, at least some of the permitted MLE service users should be present. For example, a V+D MS may choose not to implement the SNDTCP entity. The MLE shall not be required to support the MLE service users which are not present.

The MLE services are represented by the set of MLE service primitives which are available via the various SAPs listed in table 17.1.

Table 17.1: MLE SAPs

SAP name	Upper layer 3 protocol (service user)	Reference
LMM-SAP	Mobility Management (MM)	Clauses 17.3.1 and 17.3.2
LCMC-SAP	Circuit Mode Control Entity (CMCE)	Clauses 17.3.3 and 17.3.4
LTPD-SAP	Subnetwork Dependent Convergence Protocol (SNDTCP)	Clauses 17.3.5 and 17.3.6

With the exception of the LMM-SAP, the services offered at each SAP should be independent of each other, and the service at each of the other SAPs should operate using an independent set of primitives. The LMM-SAP can act as a "master SAP", enabling and disabling service provision at the other SAPs.

The LTPD-SAP may support multiple independent instances of higher protocol (multiple instances of SNDCP, each with an independent set of primitives) but each instance shall be associated with a different TSI family. All TSI families associated with SNDCP within 1 MS/LS shall be associated with a single instance of MM protocol.

NOTE: Multiple TSI families are the normal situation on the TETRA infrastructure side. Most MSs contain only one TSI family, but multiple TSI families may co-exist in one MS (see ETSI EN 300 392-1 [6], clause 7).

Figure 17.2 shows the service relationships relating to the MLE services.

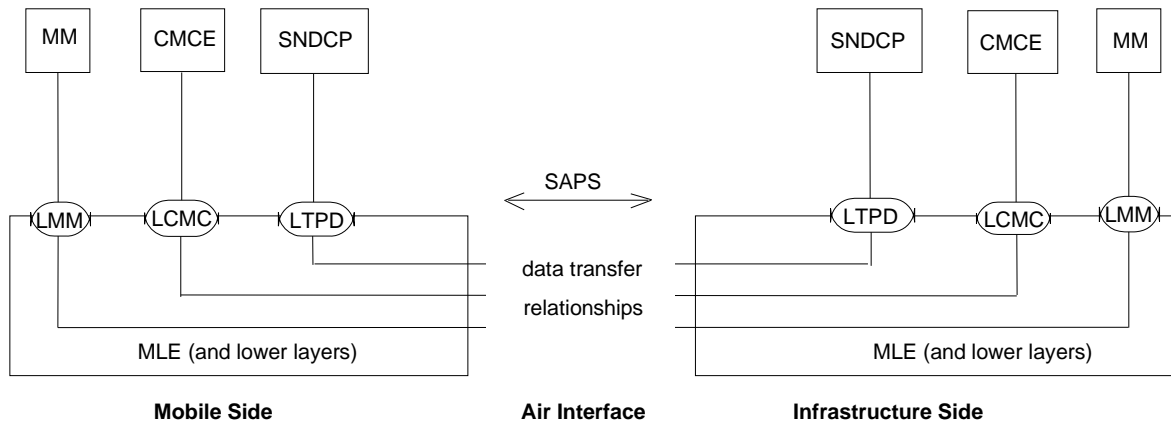

Figure 17.2: Services relationships offered by the MLE in the air interface

17.3 Service descriptions

17.3.0 General

The following service descriptions describe the MLE services provided to the higher layers in the MS protocol stack. The services are described for the protocol model purposes and present no testable requirements.

17.3.1 Service state diagram for the LMM-SAP

The primitives provided by the MLE to the MM entity shall be as shown in table 17.2.

Table 17.2: Primitives and parameters at the LMM-SAP

Primitives generic name	Specific name	Parameters
MLE-ACTIVATE	Request	List of MCC List of MNC List of LA Cell type preference or requirement
	Confirm	Registration required LA Cell type
	Indication	Cell availability
MLE-ACTIVITY	Request	Sleep mode
MLE-BUSY	Request	-
MLE-CANCEL	Request	Handle
MLE-CLOSE	Request	-
MLE-CONFIGURE	Request	Periodic reporting timer
	Indication	Periodic reporting timer
MLE-DEACTIVATE	Request	-
MLE-DISABLE	Request	Permitted services in temporary disabled mode
MLE-ENABLE	Request	-

Primitives generic name	Specific name	Parameters
MLE-IDENTITIES	Request	ISSI ASSI Attached GSSIs Detached GSSIs
MLE-IDLE	Request	-
MLE-INFO	Request	Subscriber class SCCH configuration Energy economy mode configuration Minimum mode configuration Dual watch mode configuration
	Indication	Broadcast parameters Subscriber class match
MLE-LINK	request	MCC MNC List of LA Cell type preference or requirement
	indication	MCC MNC LA Registration type Security parameters Cell type
MLE-OPEN	request	-
MLE-PREPARE	request	SDU Handle Layer 2 service PDU priority Stealing permission Stealing repeats flag
	confirm	SDU Handle
MLE-REPORT	indication	Handle Transfer result
MLE-UNITDATA	request	SDU Handle Address type Address Layer 2 service PDU priority Stealing permission Stealing repeats flag Encryption flag Null PDU, (see note)
	indication	SDU Handle Received address Received address type
MLE-UPDATE	request	MCC MNC RA Cell type preference or requirement Registration result
NOTE: When a null PDU is indicated then the PDU priority shall be the lowest value and stealing shall not be permitted. The SDU, Layer 2 service and Stealing repeats flag parameters are not applicable with a null PDU.		

The transactions between the states shall be as shown in figure 17.3.

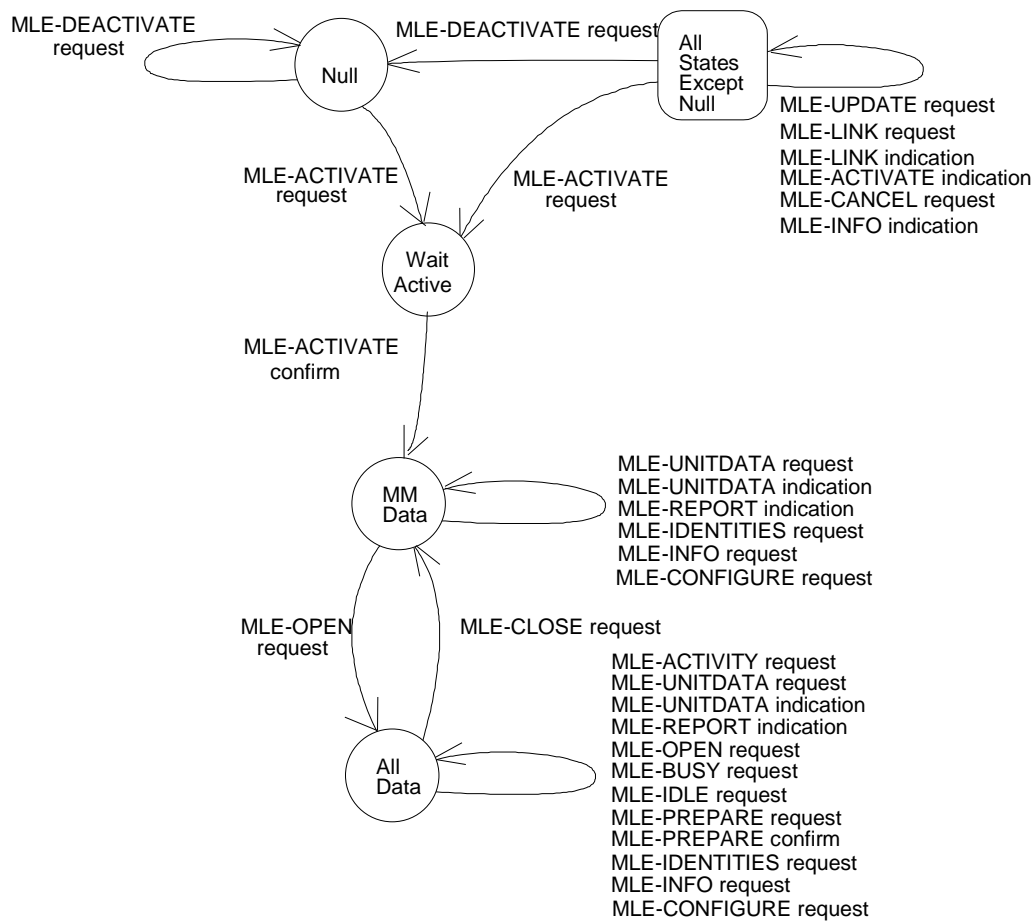

Figure 17.3: LMM-SAP state transition diagram

17.3.2 Service primitives for the LMM-SAP

MLE-ACTIVATE request: this shall be used as a request to initiate the selection of a cell for communications. The request shall always be made after power on and may be made at any time thereafter.

MLE-ACTIVATE confirm: this shall be used as a confirmation to the MM entity that a cell has been selected with the required characteristics.

MLE-ACTIVATE indication: this shall be used as an invitation to the MM to react as no suitable cell is available. It may be used indicate that MLE is in graceful service degradation mode.

MLE-ACTIVITY request: this shall be used by the MM entity to inform the MLE when the MS is to "stay alive" and when sleeping is permitted. It is used during a signalling exchange with the SwMI, which requires a layer 3 response.

MLE-BUSY request: this shall be used by the MM entity to indicate to MLE that a MM protocol exchange is in progress.

MLE-CANCEL request: this may be used by the MM to delete a previous request issued but not yet transmitted. The ability to cancel shall be removed when the MLE-REPORT indication is received, indicating transmission of the MM PDU.

MLE-CLOSE request: this shall be used by the MM entity to instruct the MLE to remove access to communication resources for the other layer 3 entities, but keeping access to the communication resources for the MM entity.

MLE-CONFIGURE request: this primitive shall be used by the MM entity to pass inter layer management information relating to mobility management.

MLE-DEACTIVATE request: this shall be used by the MM entity to request the de-activation of all MLE procedures and to return to the NULL state. No communication resources are available for use after this primitive has been issued.

MLE-DISABLE request: this primitive shall be used by the MM entity to request MLE to put the MS into the temporarily disabled state.

MLE-ENABLE request: this primitive shall be used by the MM entity to request MLE to recover the MS from the temporarily disabled state.

MLE-IDENTITIES request: this primitive shall be used to transfer the identities that have been received from the SwMI to the MLE, and layer 2.

MLE-IDLE request: this shall be used by the MM entity to indicate to MLE that a MM protocol exchange has completed.

MLE-INFO request: this primitive shall be used to transfer control parameters received from the SwMI to the MLE and layer 2. These control parameters include information on energy economy modes, control channel configurations and subscriber class.

MLE-INFO indication: this primitive shall be used by MLE to inform the MM of a change in system broadcast parameters or to indicate whether there is any match between the subscriber class being broadcast by the SwMI and the subscriber class of the MS.

MLE-LINK request: this shall be used by the MM entity to request that MLE select a specified MCC, MNC and possible LA.

MLE-LINK indication: this shall be used by the MLE to indicate to the MM entity that the MS has selected or is about to select a cell and registration is needed on the new cell, or the MS is required to re-register on the current cell.

MLE-OPEN request: this shall be used by the MM entity to instruct the MLE to provide access to communication resources for other layer 3 entities after successful registration.

MLE-PREPARE request: this shall be used by the MM entity to instruct the MLE to forward register during announced type 1 cell reselection.

MLE-PREPARE confirm: this shall be used by the MLE to confirm forward registration during announced type 1 cell reselection.

MLE-REPORT indication: this shall be used by the MLE to report on the completion of an MLE-UNITDATA request procedure. The result of the transfer attempt is passed as a parameter. Errors detected during the MLE-UNITDATA request procedure are indicated using this primitive.

MLE-UNITDATA request: this shall be used by the MM entity to request a data transmission A parameter indicates which layer 2 service is required.

MLE-UNITDATA indication: this shall be used by the MLE to pass to the MM entity data which has been received from the SwMI.

MLE-UPDATE request: this shall be used by the MM entity to inform the MLE about new criteria concerned with the monitoring of other possible cells.

17.3.3 Service state diagram for the LCMC-SAP

The primitives provided by the MLE to the CMCE shall be as shown in table 17.3.

Table 17.3: Primitives and parameters at the LCMC-SAP

Generic name	Specific name	Parameters
MLE-ACTIVITY	request	Call state
MLE-BREAK	indication	Permitted services in MS graceful service degradation mode
MLE-BUSY	indication	-
MLE-CANCEL	request	Handle
MLE-CLOSE	indication	-
MLE-CONFIGURE	request	Endpoint identifier Channel change accepted Channel change handle Call release Encryption flag Circuit mode type Simplex/duplex Add temporary GSSI Delete temporary GSSI Tx grant Switch U Plane
MLE-CONFIGURE	indication	Endpoint identifier Channel change response required Channel change handle Reason for configuration indication Conflicting endpoint identifier
MLE-DISABLE	indication	Permitted services in temporary disabled mode
MLE-ENABLE	indication	-
MLE-IDENTITIES	request	List of GSSIs
MLE-IDLE	indication	-
MLE-INFO	indication	Broadcast parameters Subscriber class match Permitted cell information
MLE-OPEN	indication	MCC (current network) MNC (current network)
MLE-REOPEN	indication	-
MLE-REPORT	indication	Handle Transfer result Channel change response required Channel change handle
MLE-RESTORE	request	SDU Handle Layer 2 service PDU priority Stealing permission Stealing repeats flag
	confirm	SDU Handle
MLE-RESUME	indication	MCC (current network) MNC (current network)

Generic name	Specific name	Parameters
MLE-UNITDATA	request	SDU Handle Endpoint identifier Link identifier Layer 2 service PDU priority Quality of Service (QoS) for layer 2 Stealing permission Stealing repeats flag Eligible for graceful service degradation mode
	indication	SDU Handle Endpoint identifier Link identifier Received TETRA address (ITSI/GTSI) Received address type Channel change response required Channel change handle

The state transitions visible at this SAP shall be as shown in figure 17.4.

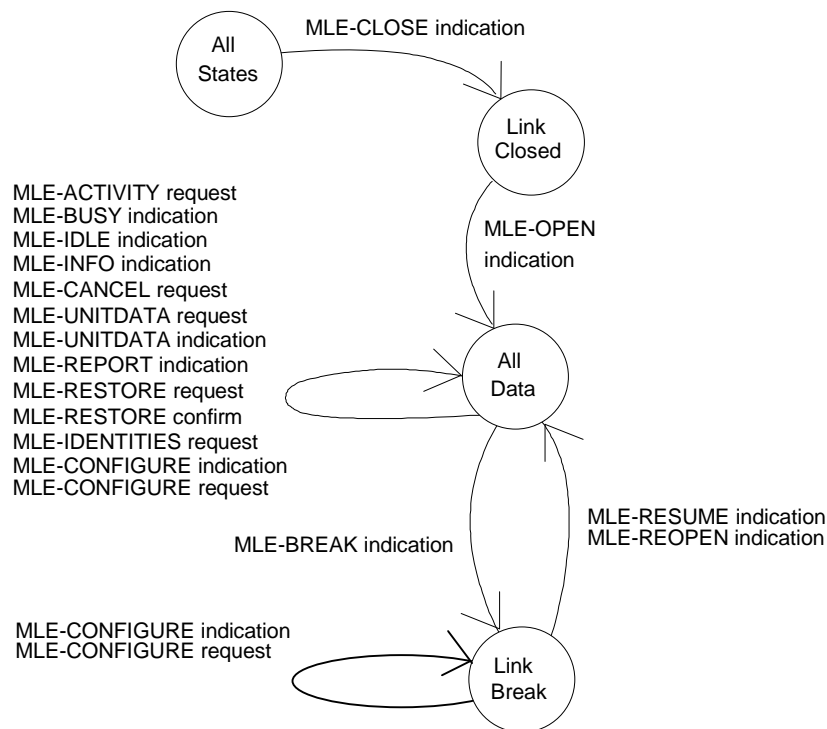

Figure 17.4: State transition diagram of LCMC-SAP

17.3.4 Service primitives for LCMC-SAP

MLE-ACTIVITY request: this primitive shall be used by the CMCE to inform the MLE of the state of any circuit mode call(s).

MLE-BREAK indication: this primitive shall be used by the MLE to inform the CMCE that access to the communication resources is temporarily unavailable and that the data transfer service cannot be used. In the graceful service degradation mode this primitive indicates which services can access communication resources.

MLE-BUSY indication: this shall be used by the MLE to inform the CMCE that a MM protocol exchange is in progress.

MLE-CANCEL request: this primitive shall be used by the CMCE to delete a previous request issued but not yet transmitted.

NOTE: The ability to cancel is removed when an MLE-REPORT indication is received indicating transmission of the CMCE PDU.

MLE-CLOSE indication: this primitive shall be used by the MLE to indicate to the CMCE that access to the communications resources has been removed and that data transfer service cannot be used.

MLE-CONFIGURE request: this primitive shall be used to pass inter layer management information relating to circuit mode calls, e.g. whether Tx grant has been given, type of traffic, etc.

MLE-CONFIGURE indication: this primitive shall be used to pass inter layer management information relating to circuit mode calls and packet data conflicts.

MLE-DISABLE indication: this primitive shall be used by the MLE entity to instruct the CMCE entity to enter the temporarily disabled state.

MLE-ENABLE indication: this primitive shall be used by the MLE entity to instruct the CMCE entity to recover from the temporarily disabled state.

MLE-IDENTITIES request: this primitive shall be used by the CMCE to inform the MLE and layer 2 of a change to the list of group identities.

MLE-IDLE indication: this shall be used by the MLE to inform the CMCE that a MM protocol exchange has completed.

MLE-INFO indication: this primitive shall be used by MLE to inform the CMCE of a change in system broadcast parameters, to indicate whether there is any match between the subscriber class being broadcast by the SwMI and the subscriber class of the MS, and to indicate if the present cell is a permitted cell.

MLE-OPEN indication: this primitive shall be used by the MLE to inform the CMCE that it has access to the communication resources and that the data transfer service can be used.

MLE-REOPEN indication: this primitive shall be used by the MLE to inform the CMCE that access to the communication resources is once again available. MLE-REOPEN indication indicates the failure of current call restoration to CMCE but does not prevent CMCE from restoring other circuit-mode calls. The data transfer service can now be used.

MLE-REPORT indication: this shall be used by the MLE to report on the completion of an MLE-UNITDATA request procedure. The result of the transfer attempt shall be passed as a parameter.

MLE-RESTORE request: this primitive shall be used by the CMCE to restore a call after a successful cell reselection.

MLE-RESTORE confirm: this primitive indicates the success or failure of call restoration to the CMCE as a result of a previously issued MLE-RESTORE request.

MLE-RESUME indication: this primitive shall be used by the MLE to inform the CMCE that access to the communication resources is once again available. The data transfer service can now be used and the CMCE may attempt to restore any circuit mode calls.

MLE-UNITDATA request: this primitive shall be used by the CMCE to send unconfirmed data to a peer entity on the TETRA infrastructure side. Parameter indicates which layer 2 service is required.

MLE-UNITDATA indication: this primitive shall be used by the MLE to pass to the CMCE entity data which has been received from a peer entity on the TETRA infrastructure side.

17.3.5 Service state diagram for the LTPD-SAP

The primitives provided by the MLE to the SNDCP entities shall be as shown in table 17.4.

Table 17.4: Primitives and parameters at the LTPD-SAP

Generic name	Specific name	Parameters
MLE-ACTIVITY	request	Sleep mode
MLE-BREAK	indication	-
MLE-BUSY	indication	-
MLE-CANCEL	request	Handle
MLE-CLOSE	indication	-
MLE-CONFIGURE	request	Channel change accepted Channel change handle Call release Endpoint identifier Encryption flag MS default data priority Layer 2 data priority lifetime Layer 2 data priority signalling delay Data priority random access delay factor Data class information Schedule repetition information SNDCP status
MLE-CONFIGURE	indication	Endpoint identifier Channel change response required Channel change handle Reason for configuration indication Conflicting endpoint identifier
MLE-CONNECT	request	Address Endpoint identifier Link identifier Reservation information PDU priority Quality of Service (QoS) for layer 2 Encryption flag Setup report
	indication	Address Endpoint identifier New endpoint identifier Link identifier Quality of Service (QoS) for layer 2 Encryption flag Channel change response required Channel change handle Setup report
	response	Address Endpoint identifier Link identifier PDU priority Stealing permission Quality of Service (QoS) for layer 2 Encryption flag Setup report
	confirm	Address Endpoint identifier Link identifier Quality of Service (QoS) for layer 2 Encryption flag Channel change response required Channel change handle Setup report

Generic name	Specific name	Parameters
MLE-DISABLE	indication	Permitted services in temporary disabled mode
MLE-DISCONNECT	request	Endpoint identifier Link identifier PDU priority Encryption flag Report
	indication	Endpoint identifier New endpoint identifier Link identifier Encryption flag Channel change response required Channel change handle Report
MLE-ENABLE	indication	-
MLE-INFO	indication	Broadcast parameters Subscriber class match Schedule timing prompt Permitted cell information
MLE-IDLE	indication	-
MLE-OPEN	indication	MCC (current network) MNC (current network)
MLE-RECEIVE	indication	Endpoint identifier Received TETRA address (ITSI/GTSI) Received address type
MLE-RECONNECT	request	Endpoint identifier Link identifier Reservation information PDU priority Encryption flag Stealing permission
	confirm	Endpoint identifier New endpoint identifier Link identifier Encryption flag Report Reconnection result
	indication	Endpoint identifier New endpoint identifier Link identifier Encryption flag Report Reconnection result
MLE-RELEASE	request	Link identifier
MLE-REPORT	indication	Handle Transfer result
MLE-RESUME	indication	MCC (current network) MNC (current network)

Generic name	Specific name	Parameters
MLE-UNITDATA	Request	SDU Handle Layer 2 service Unacknowledged basic link repetitions PDU priority Endpoint identifier Link identifier Stealing permission Stealing repeats flag Channel advice flag Data class information Data priority MLE data priority flag Packet data flag Scheduled data status Maximum schedule interval FCS flag
	Indication	SDU Endpoint identifier Link identifier Received TETRA address (ITSI/GTSI) Received address type Channel change response required Channel change handle

The state transitions visible at the LTPD-SAP should be as shown in figure 17.5.

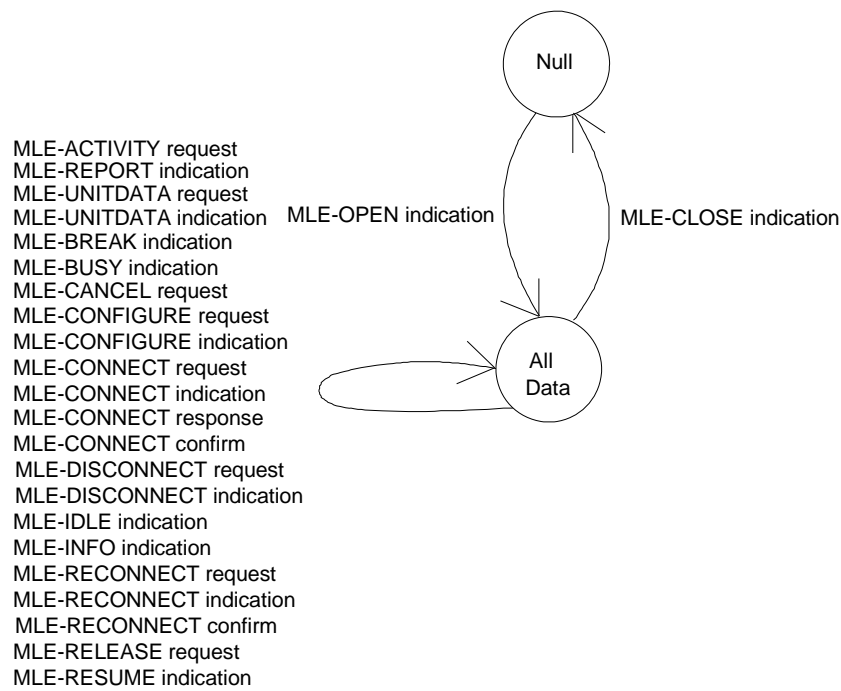

Figure 17.5: State transition diagram of LTPD-SAP

17.3.6 Service primitives for LTPD-SAP

The service primitives at the LTPD-SAP shall be the following:

MLE-ACTIVITY request: this primitive shall be used by the SNDCP to inform the MLE when the MS is to "stay alive" and when sleeping is permitted. It is used during MS initiated signalling exchanges with the SwMI.

MLE-BREAK indication: this shall be used by the MLE to inform the SNDCP entity that the resources needed for communication are temporarily not available. This can be due to a lower layer failure, or due to a MLE controlled cell change.

MLE-BUSY indication: this shall be used by the MLE to inform the SNDCP entity that a MM protocol exchange is in progress.

MLE-CANCEL request: this primitive shall be used by the SNDCP to delete a previous request issued but not yet transmitted.

NOTE: The ability to cancel is removed when an MLE-REPORT indication is received indicating transmission of the SNDCP PDU.

MLE-CLOSE indication: this shall be used by the MLE to indicate to the SNDCP entity that access to the communications resources has been removed and the SNDCP entity is not permitted to communicate with its peer entity.

MLE-CONFIGURE request: this primitive shall be used by the SNDCP entity to pass inter layer management information relating to packet data.

MLE-CONFIGURE indication: this primitive shall be used to pass inter layer management information relating to circuit mode calls and packet data conflicts.

MLE-CONNECT request: this primitive shall be used by the SNDCP entity to convey QoS parameters used in the advanced link set up. It also shall be used to trigger the MLE to reset the advanced link. It also applies as a cancel request which deletes previous requests issued and not yet transmitted.

MLE-CONNECT indication: this primitive shall be used by the MLE entity to inform the SNDCP entity that the establishment of an advanced link with a certain quality of service or the reset of the current advanced link has been requested.

MLE-CONNECT response: this primitive may be used by the SNDCP entity to accept the establishment or reset of the advanced link with a certain quality of service. According to the available resources, the value of the service parameters may be modified (lower grade of service) in the response. In such a case the advanced link characteristics will match these new features.

MLE-CONNECT confirm: this primitive shall be used by the MLE entity to inform the SNDCP entity that the establishment or reset of the advanced link has been completed with a certain quality of service as indicated in the confirm primitive.

MLE-DISABLE indication: this primitive shall be used by the MLE entity to instruct the SNDCP entity to enter the temporarily disabled state.

MLE-DISCONNECT request: this primitive shall be used by the SNDCP entity to trigger MLE to disconnect the advanced link. It also applies as a CANCEL Request which deletes previous requests issued and not yet transmitted.

MLE-DISCONNECT indication: this primitive shall be used by the MLE entity to inform the SNDCP entity on advanced link disconnection for any reason.

MLE-ENABLE indication: this primitive shall be used by the MLE entity to instruct the SNDCP entity to recover from the temporarily disabled state.

MLE-IDLE indication: this shall be used by the MLE to inform the SNDCP entity that a MM protocol exchange has completed.

MLE-INFO indication: this primitive shall be used by MLE to inform the SNDCP of a change in system broadcast parameters or to indicate whether there is any match between the subscriber class being broadcast by the SwMI and the subscriber class of the MS, and to indicate if the present cell is a permitted cell.

MLE-OPEN indication: this primitive shall be used by the MLE to inform the SNDCP that it has access to the communication resources and that the data transfer service can be used.

MLE-RECEIVE indication: this primitive shall be used by the MLE entity to inform the SNDCP entity that the reception of data from the peer entity on the LLC has started or is ongoing. This primitive is valid for SwMI only.

MLE-RECONNECT request: this primitive shall be used by the MS SNDCP entity after cell reselection to request the reconnection of the advanced link.

MLE-RECONNECT confirm: this primitive shall be used by the MS MLE entity to inform the SNDCP entity of the success or failure of an attempt to reconnect the advanced link.

MLE-RECONNECT indication: this primitive shall be used by the SwMI MLE entity to inform the SNDCP entity of the success or failure of an attempt by a MS to reconnect an advanced link.

MLE-RELEASE request: this primitive shall be used by the MS SNDCP entity to request the local disconnection of an advanced link.

MLE-REPORT indication: this shall be used by the MLE to report on the completion of a MLE-UNITDATA request procedure. The result of the transfer attempt shall be passed as a parameter. Errors detected during the MLE-UNITDATA request procedure shall be indicated using this primitive.

MLE-RESUME indication: this shall be used to indicate that a temporary break in access to the communications resources has been recovered. All previous MLE associations between peer MLE entity have been successfully recovered.

MLE-UNITDATA request: this shall be used by the SNDCP entity to send data to a peer entity. Parameters indicate whether layer 2 acknowledged or unacknowledged service is required.

MLE-UNITDATA indication: this shall be used by the MLE to pass to the SNDCP entity data which has been received from a peer entity.

17.3.7 Void

17.3.8 Void

17.3.9 Parameter summary

The following list summarizes the parameters used in the primitives described in this clause.

- Add temporary GSSI =
 - GSSI.
- Address =
 - TETRA address (ISSI,ASSI or USSI).
- Address type =
 - individual short subscriber identity (ISSI);
 - aliased short subscriber identity (ASSI);
 - unexchanged short subscriber identity (USSI).
- ASSI =
 - TETRA address.
- Attached GSSIs =
 - TETRA address.

- Broadcast parameters =
 - Broadcast information extracted from SYNC, SYNC-DA, SYSINFO, SYSINFO-Q and SYSINFO-DA PDUs. Refer to clauses 18.4.2.1, 18.4.2.1a, 18.4.2.2, 18.4.2.2a, 18.4.2.3, 21.4.4.1, 21.4.4.1a, 21.4.4.1b, 21.4.4.2 and 21.4.4.2a.
- Call release =
 - true;
 - false.
- Call state =
 - idle;
 - group call with transmit permission;
 - group call without transmit permission;
 - individual call with transmit permission;
 - individual call without transmit permission.
- Cell availability =
 - no cell available for any service;
 - current cell available for graceful service degradation mode;
 - current cell available for normal service mode.

NOTE 1: The "no cell available for any service" is the only value used, when the graceful service degradation mode is not supported.

- Cell type =
 - CA;
 - DA.
- Cell type preference or requirement =
 - CA preferred;
 - CA required;
 - DA preferred;
 - DA required;
 - any.
- Channel advice flag =
 - channel advice not requested;
 - channel advice requested.
- Channel change accepted =
 - accept;
 - reject;
 - ignore.

- Channel change handle =
 - an identifier of a "channel change response required" request.
- Channel change response required =
 - true;
 - false.
- Circuit mode type =
 - speech (TCH/S);
 - unprotected data (TCH/7,2);
 - low protection data (TCH/4,8), N = 1;
 - low protection data (TCH/4,8), N = 4;
 - low protection data (TCH/4,8), N = 8;
 - high protection data (TCH/2,4), N = 1;
 - high protection data (TCH/2,4), N = 4;
 - high protection data (TCH/2,4), N = 8.
- Conflicting endpoint identifier =
 - conflicting radio resource identifier.
- Data class information =
 - Background class data;
 - Telemetry class data;
 - Real-time class data;
 - other data (see note 2).

NOTE 2: In an implementation, the "other data" may be subdivided into multiple classes.

- Data priority =
 - nine possible values, 0 to 7 and "undefined".
- Data priority random access delay factor =
 - eight possible values, 0 to 7.
- Delete temporary GSSI =
 - GSSI.
- Detached GSSIs =
 - TETRA address(es).
- Dual watch mode configuration =
 - a set of group (0 to 7), start frame (1 to 18) and start multiframe (1 to 60).

- Eligible for graceful service degradation mode =
 - not eligible for graceful service degradation mode; or
 - eligible for graceful service degradation mode.
- Encryption flag =
 - on;
 - off.
- Endpoint identifier =
 - radio resource identifier.
- Energy economy mode configuration =
 - a set of group (0 to 7), start frame (1 to 18) and start multiframe (1 to 60).
- FCS flag=
 - use FCS;
 - do not use FCS.
- Handle
 - a local SDU identifier.
- ISSI =
 - TETRA address.
- LA.
- Layer 2 data priority lifetime =
 - a value ranging from 2 to 126 multiframe.
- Layer 2 data priority signalling delay =
 - a value ranging from 6 to 90 TDMA frames.
- Layer 2 service =
 - acknowledged request;
 - acknowledged response;
 - unacknowledged.
- Link identifier =
 - A local identifier of the layer 2 basic link, a specified advanced link or an unspecified (i.e. any) advanced link.
- List of GSSIs =
 - TETRA address(es).
- List of LA=
 - a list of preferred and/or permitted LAs, or "any LA".
- List of MCC =
 - a list of preferred and/or permitted MCCs, or "any MCC".

- List of MNC =
 - a list of preferred and/or permitted MNCs, or "any MNC".
- Maximum schedule interval =
 - number of timeslot durations (5 to 834).
- MLE data priority flag =
 - MLE data priority signalling not required;
 - MLE data priority signalling required.
- Minimum mode configuration =
 - frame 18 timeslot (1 to 4).
- MCC (see ETSI EN 300 392-1 [6], clause 7).
- MNC (see ETSI EN 300 392-1 [6], clause 7).
- MS default data priority =
 - nine possible values, 0 to 7 and "not applicable".
- New endpoint identifier:
 - a new endpoint identifier shall refer to a new resource allocation (typically in addition to an existing resource allocation).
- Null PDU =
 - a null PDU is due to sending;
 - an SDU is due to sending.
- Packet data flag =
 - PDU does not contain packet data;
 - PDU contains packet data.
- PDU priority =
 - eight possible values, 0 to 7.
- Periodic reporting timer =
 - no reporting/stop reporting;
 - values 15 s to 31 min 45 s;
 - use periodic reporting time requested by SwMI (only used by an "indication" primitive).
- Permitted cell information =
 - the present cell is a permitted cell;
 - the present cell is not a not-permitted cell.

- Permitted services in graceful service degradation mode =
 - none;
 - SDS-TL for callout service;
 - LIP.

NOTE 3: It is outside the scope of the present document which other SDS services may be allowed in the graceful service degradation mode.

- Permitted services in temporary disabled mode =
 - none; or
 - a list of one or more of :
 - ambience listening;
 - LIP protocol via CMCE (see ETSI TS 100 392-18-1 [19]).
- Quality of Service (QoS) for layer 2 =
 - A set of:
 - Throughput information; and
 - Original or extended advanced link; and
 - Acknowledged advanced link window size (1 to 15); and
 - Maximum number of TL-SDU retransmissions (0 to 7); and
 - Maximum number of segment retransmissions (0 to 15).
- RA =
 - a set of one or more LAs.
- Reason for configuration indication =
 - reception stopped;
 - transmission stopped;
 - usage marker mismatch;
 - loss of radio resources;
 - recovery of radio resources.
- Received TETRA address =
 - TETRA address (ITSI or GTSI).
- Received address type =
 - individual allocated identity (ITSI);
 - individual un-exchanged identity (ITSI);
 - group (GTSI).

NOTE 4: The individual un-exchanged identity is valid only in some migration PDUs, refer to clause 23.4.1.2.5.

- Reconnection result =
 - success;
 - reject.
- Registration type =
 - normal;
 - forward;
 - periodic.
- Registration required =
 - true;
 - false.
- Registration Result =
 - success;
 - cell rejection;
 - cell type rejection;
 - LA rejection;
 - system rejection;
 - forward registration failure;
 - temporary registration.
- Reservation information =
 - amount of data available for sending, refer to clause 28.3.4.2 a).
- Report
 - report shall generally indicate the progress of information transfer. Refer to clause 20.2.4.57.
- Set-up report =
 - this shall be used to report on the setup phase of an advanced link.
- SCCH configuration =
 - 0 to 11.
- Schedule repetition information =
 - set of NSAPI (1 to 14), "start-stop flag" (start or stop) and "schedule repetition period" (4 to 706).
- Schedule timing prompt =
 - NSAPI (1 to 14).
- Scheduled data status =
 - not scheduled;
 - initial scheduled data;
 - scheduled data.

- SDU.
- Security parameters =
 - Security related broadcast information extracted from SYSINFO PDU. Refer to see ETSI EN 300 392-7 [8].
- Simplex/duplex =
 - simplex;
 - duplex.
- Sleep mode =
 - stay alive;
 - sleep permitted.
- SNDCP status =
 - idle, standing-by or ready.
- Stealing permission =
 - steal immediately;
 - steal when convenient;
 - stealing not required.
- Stealing repeats flag =
 - set;
 - not set.
- Subscriber class
 - a set of classes 1 to 16.
- Subscriber class match =
 - true;
 - false.
- Switch U-plane =
 - on;
 - off.
- Transfer result =
 - success, more data in the LLC buffer;
 - success, LLC buffer empty;
 - delayed transmission due to the graceful service degradation mode, still trying transmit;
 - failure, data item removed from LLC buffer;
 - transfer rejected due to an emergency call.

- Tx-grant =
 - true;
 - false.
- Unacknowledged basic link repetitions
 - 0 to 5.

18 MLE protocol

18.1 Introduction

This clause defines the protocol for the V+D MLE. This shall be the lowest sub-layer of the network layer as described in ETSI EN 300 392-1 [6]. It may be used to provide sub-network services to higher network layer entities at the air interface according to the MLE service description (see clause 17). This clause defines the MLE protocol functions required for MS operation.

This clause specifies:

- the protocol procedures;
- the protocol services;
- the PDUs and associated information elements.

See clause 17 for the MLE service description (SAPs, services and primitives).

18.2 Overview of the sub-layer

18.2.0 General

The MLE protocol should be used to mask mobility and radio resources from the higher entities.

It shall provide a sub-network dependent protocol (convergence) and a sub-network access protocol to the V+D layer 2 (see clause 20).

18.2.1 Protocol environment

The V+D MLE shall be the layer 3, sub-layer 3.1 which provides services to the layer 3, sub-layer 3.2, as shown in figure 18.1. This protocol shall provide services to the following higher entities:

- MM entity (see clause 16);
- CMCE entity (see clause 14);
- SNDTCP entity (see clause 28).

The MLE services shall be represented by the MLE service primitives which shall apply to the following SAPs:

- LCMC-SAP for CMCE;
- LTPD-SAP for SNDTCP; and
- LMM-SAP for MM.

The services offered at the MM SAP may interact with the services offered at the CMCE and SNDTCP SAPs.

The underlying protocol should be the V+D layer 2 (see clauses 22 and 23).

The MLE protocol may also interface to the Lower Layer Management Entity (LLME) and the interface is defined by the C-SAP. However, the exact implementation of the interface is outside the scope of the present document.

The protocol architecture can be similar on the BS side of the air interface.

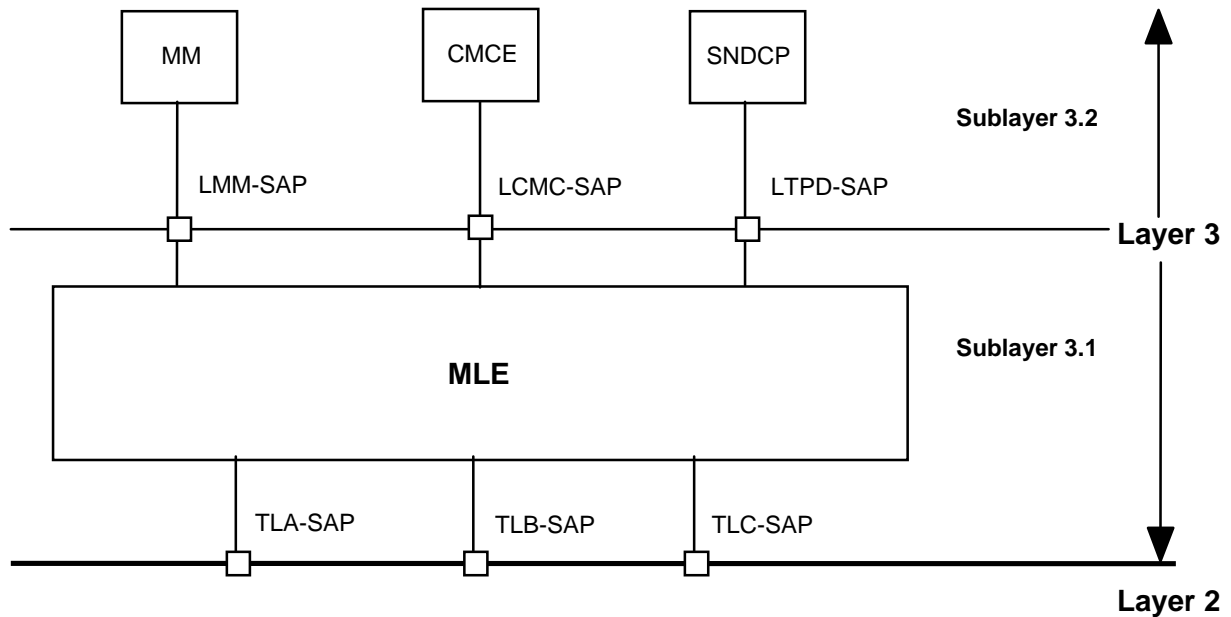

Figure 18.1: The MLE (sub-layer 3.1) in the MS protocol stack

The MS-MLE shall establish the basis for communication with a cell (BS) by camping on the cell and the MS-MLE shall check the quality using the information received from the layer 2. Once the cell has been found suitable by the MS-MLE, the MM entity may intervene in order to register the MS. When the cell has been registered, the MS is said to be attached and the MLE can now offer data transfer services to the CMCE and SNDCP entities as well. Data transfer shall be regulated by the MM entity which may allow access for MM only or for all entities.

The MLE shall perform surveillance of the quality of the radio communication path. It may report any break or loss of the path and, when necessary it should try to re-establish the communication with the same or another BS in either the same or a different LA.

18.2.2 Services and primitives offered by the MLE to the MM entity

The services and primitives offered to the MM entity are described in clause 17.

The services offered shall be:

- a) activation of MLE procedures:
 - MLE-ACTIVATE request/confirm/indication.
- b) opening of link access to other layer 3 entities:
 - MLE-OPEN request.
- c) data transfer:
 - MLE-UNITDATA request/indication;
 - MLE-REPORT indication.
- d) closing the access to other entities:
 - MLE-CLOSE request.
- e) deactivation of the MLE procedures:
 - MLE-DEACTIVATE request.

- f) information on a network, cell or LA:
 - MLE-LINK request/indication.
- g) updating current registered area:
 - MLE-UPDATE request.
- h) cancellation of issued primitive requests:
 - MLE-CANCEL request.
- i) informing MLE that MM signalling exchange is in progress:
 - MLE-BUSY request.
- j) informing MLE that MM signalling exchange has completed:
 - MLE-IDLE request.
- k) informing MLE when the MS is to "stay alive" and when sleeping is permitted by MM:
 - MLE-ACTIVITY request.
- l) performing forward registration during cell reselection:
 - MLE-PREPARE request/confirm.
- m) exchange of information between layers:
 - MLE-IDENTITIES request;
 - MLE-INFO request/indication.
- n) informing MLE of the air to ground periodic reporting timer value:
 - MLE-CONFIGURE request.
- o) requesting temporary disablement:
 - MLE-DISABLE request.
- p) requesting recovery from temporary disablement:
 - MLE-ENABLE request.

18.2.3 Services and primitives offered by the MLE to the CMCE entities

The services and primitives offered to the CMCE entity are described in clause 17.

The services offered shall be:

- a) indication that access to resources is enabled:
 - MLE-OPEN indication.
- b) indication that access to resources is disabled:
 - MLE-CLOSE indication.
- c) indicating a temporary break in the access to the communication resources:
 - MLE-BREAK indication.

- d) indicating resumption (or reopening) in the access to the communication resources:
 - MLE-RESUME indication;
 - MLE-REOPEN indication.
- e) restoration of circuit mode calls after cell reselection:
 - MLE-RESTORE request/confirm.
- f) data transfer:
 - MLE-UNITDATA request/indication;
 - MLE-REPORT indication.
- g) cancellation of issued primitive requests:
 - MLE-CANCEL request.
- h) exchange of information between layers:
 - MLE-CONFIGURE request;
 - MLE-CONFIGURE indication;
 - MLE-IDENTITIES request;
 - MLE-INFO indication.
- i) indicating that MM signalling exchange is in progress:
 - MLE-BUSY indication.
- j) indicating that MM signalling exchange has completed:
 - MLE-IDLE indication.
- k) informing MLE when the MS is to "stay alive" and when sleeping is permitted by CMCE:
 - MLE-ACTIVITY request.
- l) indicating that CMCE shall become temporarily disabled:
 - MLE-DISABLE indication.
- m) indicating that CMCE shall recover from temporary disablement:
 - MLE-ENABLE indication.

18.2.4 Services and primitives offered by the MLE to the SNDSCP entity

The services and primitives offered to the SNDSCP entity are described in clause 17.

The service offered shall be:

- a) indication that access to resources is enabled:
 - MLE-OPEN indication.
- b) indication that access to resources is disabled:
 - MLE-CLOSE indication.
- c) indicating a temporary break in the access to the communication resources:
 - MLE-BREAK indication.

- d) indicating resumption in the access to the communication resources:
 - MLE-RESUME indication.
- e) advanced link setup/ advanced link reset:
 - MLE-CONNECT request/indication/response/confirm.
- f) advanced link disconnection:
 - MLE-DISCONNECT request/indication;
 - MLE-RELEASE request.
- g) data transfer:
 - MLE-UNITDATA request/indication;
 - MLE-RECEIVE indication;
 - MLE-REPORT indication.
- h) exchange of information between layers:
 - MLE-CONFIGURE request;
 - MLE-CONFIGURE indication;
 - MLE-INFO indication.
- i) advanced link reconnection:
 - MLE-RECONNECT request/indication/confirm.
- j) indicating that MM signalling exchange is in progress:
 - MLE-BUSY indication.
- k) indicating that MM signalling exchange has completed:
 - MLE-IDLE indication.
- l) informing MLE when the MS is to "stay alive" and when sleeping is permitted by SNDTCP:
 - MLE-ACTIVITY request.
- m) cancellation of issued primitive requests:
 - MLE-CANCEL request.
- n) indicating that SNDTCP shall become temporarily disabled:
 - MLE-DISABLE indication.
- o) indicating that SNDTCP shall recover from temporary disablement:
 - MLE-ENABLE indication.

18.2.5 Void

18.2.6 Services and primitives offered by layer 2 to MLE

Layer 2 shall provide the MLE with different services, which enable the MLE to provide the services requested by its services users. The following primitives are defined for that purpose.

On the TLA-SAP the following services and primitives should be available, depending on the supported services (see clause 20 for service definitions):

- a) establishing a data link connection by using the LLC advanced link mechanism:
 - TL-CONNECT request/indication/response/confirm.
- b) reconnection of an established data link connection (i.e. an LLC advanced link) after a cell reselection:
 - TL-RECONNECT request/confirm.
- c) transfer of data using a layer 2 acknowledged service:
 - TL-DATA request/indication/response/confirm.
- d) disconnection of an established data link connection, i.e. an LLC advanced link:
 - TL-DISCONNECT request/indication/confirm.
- e) transfer of data using a layer 2 unacknowledged service:
 - TL-UNITDATA request/indication.
- f) receive report information on the progress of issued request primitives and unrecoverable transmission errors detected in the data link:
 - TL-REPORT indication.
- g) cancellation of issued request primitives:
 - TL-CANCEL request.
- h) release or loss of radio resources:
 - TL-RELEASE request;
 - TL-RELEASE indication (optional).

On the TLB-SAP the following service and primitives should be available, see clause 20 for service definitions:

- reception of layer 3 information in the synchronization broadcast and system information broadcast. The broadcast shall be recognized by layer 2 and forwarded to layer 3 as SDU information elements inside primitives:
 - TL-SYNC indication;
 - TL-SYNC-DA indication;
 - TL-SYSINFO indication;
 - TL-SYSINFO-Q indication;
 - TL-SYSINFO-DA indication.

18.2.7 Services and primitives between the MLE and the LLME

The LLME may be used for exchanging layer-to-layer information. In the protocol stack (see figure 18.1) the access to the LLME is modelled in the TLC-SAP.

The following primitives should be defined for this SAP:

- a) control of scanning (MS side only):
 - TL-SCAN request/confirm;
 - TL-SCAN-REPORT indication.
- b) receive additional information on a DA neighbour cell (MS side only):
 - TL-CELL-READ request/confirm.
- c) selecting cell for attachment (MS side only):
 - TL-SELECT request/indication/response/confirm.
- d) control of neighbour cell monitoring and channel monitoring (MS side only):
 - TL-MONITOR-LIST request;
 - TL-MONITOR indication.
- e) control of channel assessment (MS side only):
 - TL-ASSESSMENT-LIST request;
 - TL-ASSESSMENT indication.
- f) receive quality information on the serving cell and current channel (MS side only):
 - TL-MEASUREMENT indication.
- g) receive path loss information (MS side only):
 - TL-REPORT indication.
- h) set up and configure layer 2 according to commands from service SAP users (MS side only):
 - TL-CONFIGURE request/confirm.
- i) layer 2 configuration information to service SAP users (MS side only):
 - TL-CONFIGURE indication.

18.2.8 Protocol sequences

The basic protocol primitive sequences are shown in figures 18.2 to 18.4. The operation of the protocol should be modelled as a finite state automaton governed by a state variable. A transition of the automaton should be prompted by the occurrence of an event at one of three interfaces:

- a) the interface to any of the service users (MM, CMCE, SNDCP);
- b) the interface to the underlying service which is the V+D layer 2;
- c) the interface to the LLME.

Break and resume communication on a MLE connection

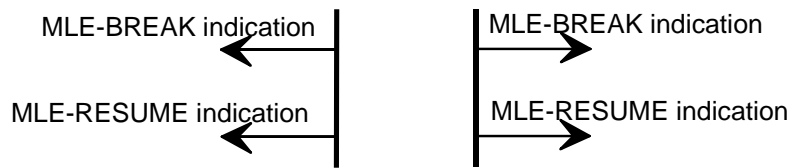

Opening or closing of network access

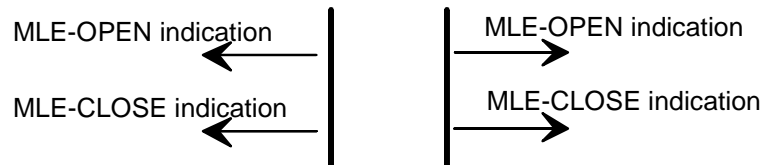

Setup of advanced Link or Reset of advanced link

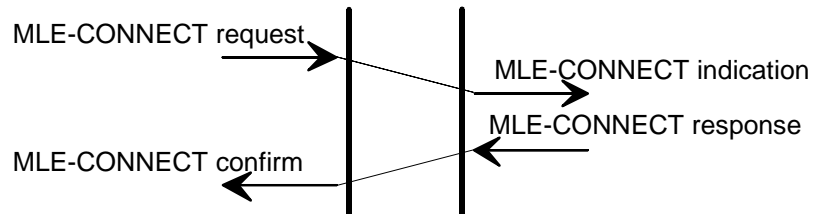

Disconnection of advanced link

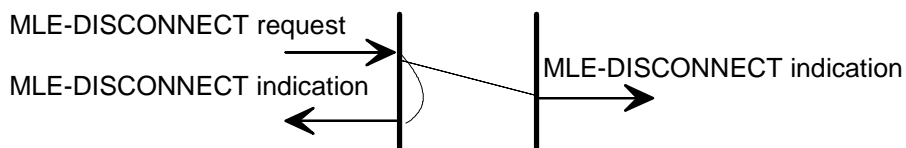

Data transfer

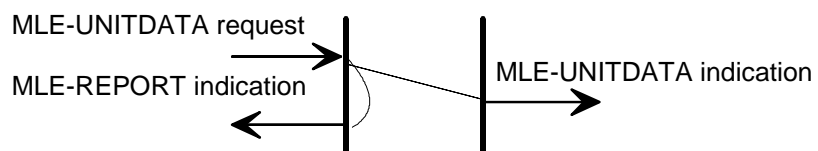

Figure 18.2: Primitive time sequence at the LTPD-SAP

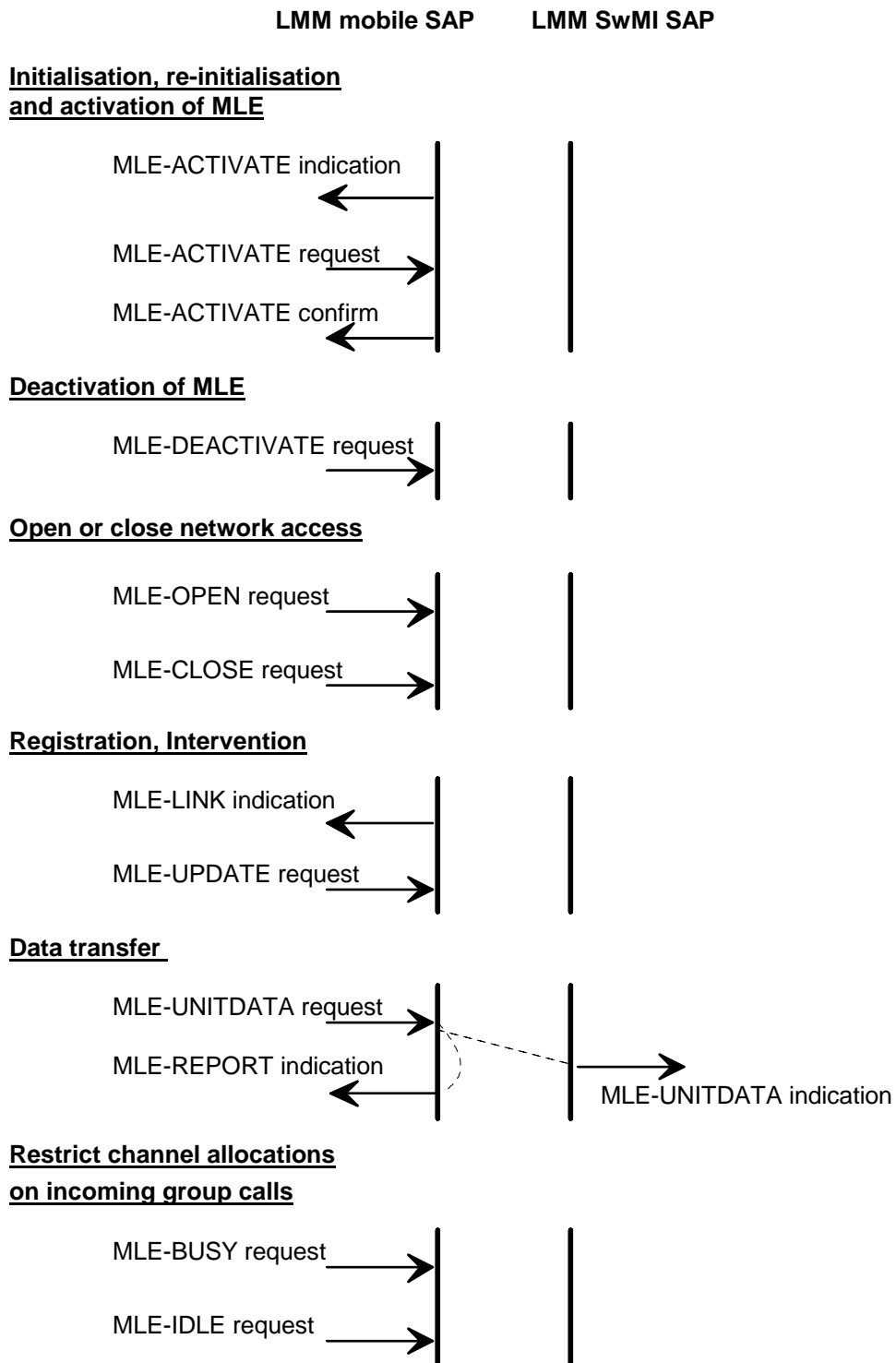

Figure 18.3: Primitive time sequence at the LMM-SAP

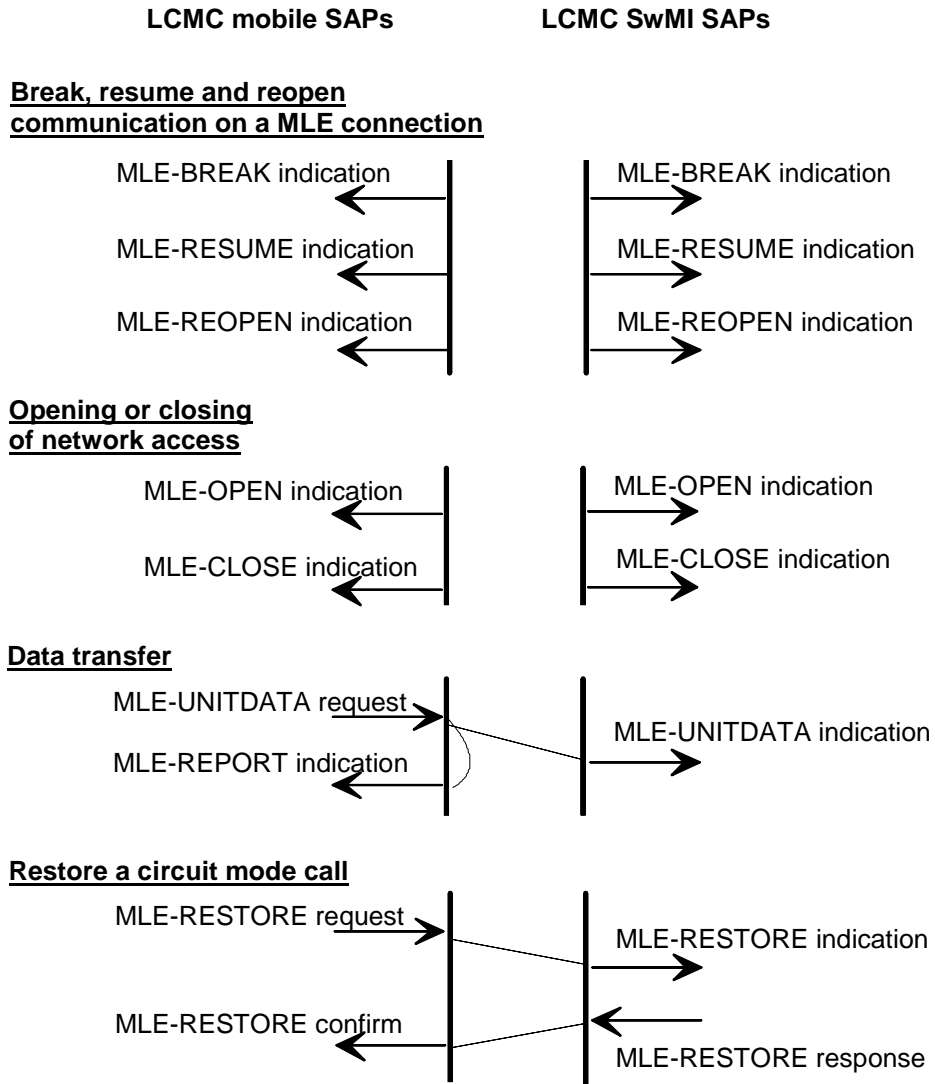

Figure 18.4: Primitive time sequence at the LCMC-SAP

18.3 MLE functions

18.3.1 Overview

The MLE functional groups are shown in figure 18.5.

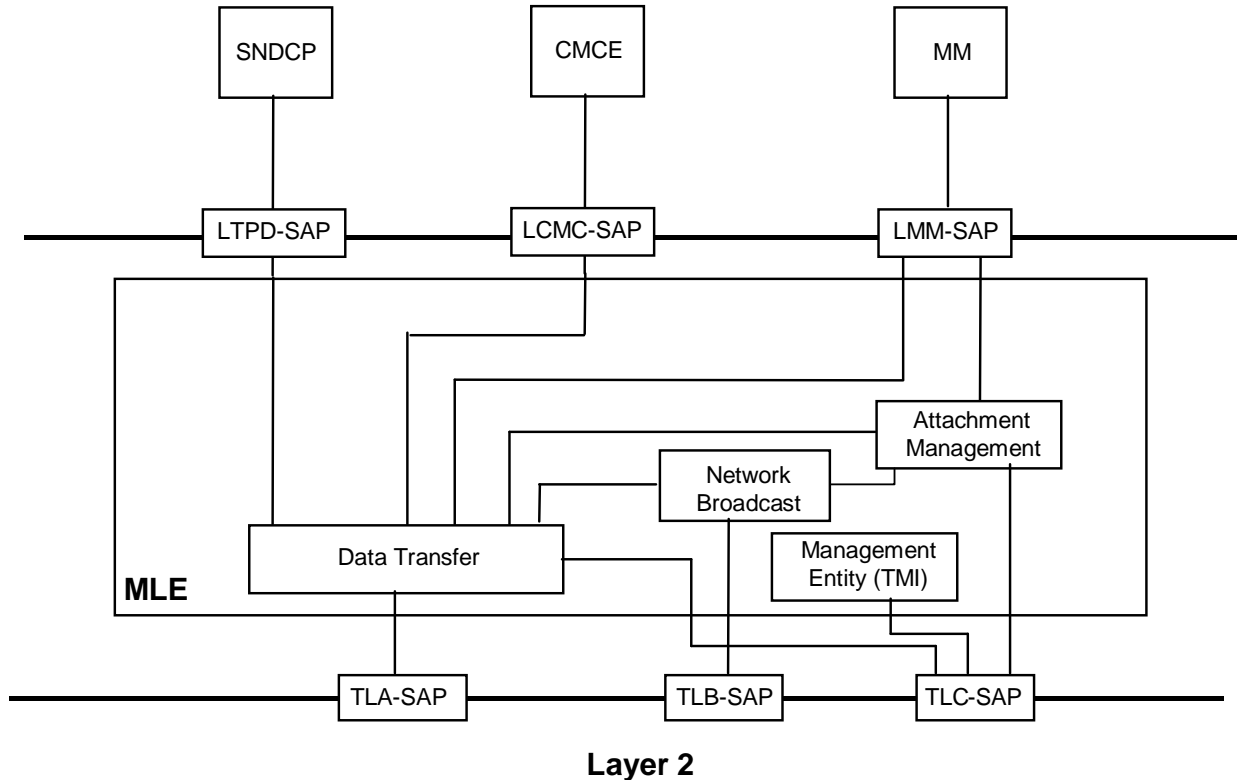

Figure 18.5: MLE functional model

The MLE functional entities are:

- a) attachment management:
 - management of monitoring and scanning procedures;
 - surveillance of the serving cell quality;
 - management of the ranking procedure;
 - management of the cell relinquishable, improvable and usable radio criteria;
 - management of the channel relinquishable, improvable and usable radio criteria;
 - management of the roaming announcements and declarations;
 - informing upper entities CMCE and SNDCP of broken and restored MLE connections via the data transfer sub-entity;
 - informing the SwMI about usable irregular channels and channel classes.

- b) data transfer:
 - selection of underlying LLC service;
 - address handling (ISSI, GSSI and TMI);
 - informing the upper entities CMCE and SNDCP of enabled and disabled access to the communication resources;
 - routing and multiplexing to layer 2 service end points and links (including addition/removal of MLE protocol control information);
 - routing and multiplexing to MLE SAPs and other MLE functional entities;
 - quality of service mapping (e.g. PDU priority, data priority, throughput, delay, reliability, data class, scheduled access and transfer service).
- c) network broadcast:
 - formatting and broadcasting of the network information (SwMI);
 - reception and analysis of network information (MS/LS);
 - configuring of MAC layer 2 with synchronization and system information broadcast.
- d) management:
 - handling network management procedures, e.g. addressed to the TETRA Management Identity (TMI);
 - handling local management information from the management entity to the lower layers.

18.3.2 Access to the communication resources and activation of the MLE

Access to all communication resources is controlled by the MLE, according to requests received from the MM entity.

At power on or other start-up, there is no requirement that the MLE shall have any prior knowledge of the suitability of any cell. In order that the MS can communicate, the MLE shall select a suitable cell. A suitable cell should be one in which the MS can reliably decode downlink data, and which has a high probability of uplink communication, and that the MS may request and obtain service.

The procedures defined in the following clauses describe methods by which the MS can select a cell.

The MLE cell selection procedure is initiated by the MM entity defining the cell selection criteria (e.g. mobile network identity) in an MLE-ACTIVATE request primitive. When a suitable cell has been found the MLE issues an MLE-ACTIVATE confirm primitive to the MM to report the cell details. Initially the radio communications link may only be used for MM data transfer until the MM issues an MLE-OPEN request primitive thereby instructing the MLE to open access to the other layer 3 entities. The MM entity issues the MLE-OPEN request primitive after completion of any MM procedures (e.g. registration). An MLE-OPEN request primitive is received by both the attachment management and the data transfer sub-entities within the MLE. The opening of link access is reported to the CMCE and SNDCP with an MLE-OPEN indication primitive.

NOTE 1: If no MM procedures are required, the MM may issue the MLE-OPEN request primitive immediately after the MLE-ACTIVATE confirm primitive is received.

The MLE on the MS side can take the decision to change cell from measurement processing and threshold comparisons. MM shall be informed with an MLE-LINK indication primitive in the event that the cell reselection results in the selection of a cell in a LA that is not in the current registration area or in the event that a change of cell type occurs and the new cell requires the MS to register when changing cell type. The parameters associated with the MLE-LINK indication primitive inform the MM of the LA, MNC, MCC and cell type of the new cell.

NOTE 2: The current registration area consists of all of the LAs in which the MS is currently registered.

If the MLE is unable to find a suitable cell, it issues an MLE-ACTIVATE indication primitive to MM.

18.3.3 Deactivation of the MLE

Upon receipt of an MLE-DEACTIVATE request primitive the MLE shall cease all functions. The MLE-DEACTIVATE request primitive should be preceded by an MLE-CLOSE request primitive to the data transfer sub-entity.

18.3.4 Attachment management sub-entity

18.3.4.0a General

The attachment management sub-entity shall be responsible for the initial cell selection and cell reselection procedures. The initial cell selection and cell reselection procedures comprise the functions listed below. These following functions shall be activated at power on:

- management of the monitoring and scanning procedures;
- surveillance of the serving cell quality;
- management of the neighbour cell ranking procedure;
- management of the cell reselection criteria;
- management of the cell reselection announcements and declarations;
- informing upper entities CMCE and SNDCP of broken and restored MLE connections via the data transfer sub-entity.

Cell selection and reselection shall only be carried out using the individual or alias subscriber identities. Cell reselection shall not be carried out using group addresses. Any cell reselection messages received on a GSSI shall be ignored.

Where the MS is engaged in more than one call, the MS shall only apply the cell reselection procedures once and not for each call in progress. Once a cell has been re-selected the CMCE may restore the calls.

18.3.4.0b Cell types and identifiers

18.3.4.0b.1 Conventional Access and Direct Access cells

In the present document there are two types of cell: Conventional Access (CA) cells and Direct Access (DA) cells.

A CA cell's main carrier (the CA main carrier) uses phase modulation and occupies a bandwidth of 25 kHz. The MCCH is a single slot $\pi/4$ -DQPSK channel that occupies slot 1 of the CA main carrier in normal mode. A DA cell's main carrier (the DA main carrier) uses QAM modulation and occupies a bandwidth of 25 kHz, 50 kHz, 100 kHz or 150 kHz. The MCCH-Q may occupy one, two, three or four slots of the DA main carrier.

The MS's access to a CA cell is through the CA main carrier (except when the SwMI uses the type 1 announced cell reselection procedure to send the MS directly to an assigned channel on a CA cell). When a CA MS returns to common control mode, it returns to the CA main carrier.

The MS's access to a DA cell is through the DA main carrier (except when the SwMI uses the type 1 announced cell reselection procedure to send the MS directly to an assigned channel on a DA cell). When a DA MS returns to common control mode, it returns to the DA main carrier.

See also clause 23.3.1.1.1.

18.3.4.0b.2 Conventional Access and Direct Access MSs

An MS may support using only CA cells or using only DA cells, or may support using both types of cell. An MS that supports using CA cells is a "CA capable MS". An MS that supports using DA cells is a "DA capable MS".

A CA MS is an MS that is currently camped on a CA cell. A DA MS is an MS that is currently camped on a DA cell. An MS may switch between being a CA MS and a DA MS (depending on the cells currently available to it), or may permanently use only one type of cell.

The SwMI may require the MS to register when it changes between a CA cell and a DA cell or vice versa (as indicated by the "cell type change registration" information element in the D-MLE-SYSINFO-DA PDU).

18.3.4.0b.3 Co-sited cells

Co-sited cells share a common base station site. They may have different transmitter powers, ranges and azimuthal extent, and may have different coverage areas.

18.3.4.0b.4 Shared channels

Cells may share channels. The following rules apply:

- a channel may be shared by multiple DA cells (but no CA cells), or by one DA cell and one CA cell, or by multiple DA cells and one CA cell – the CA cell, if present, is called the "local CA cell";
- cells that share channels shall be either:
 - co-sited; or
 - within the permitted separation for eccentric channels i.e. the shared channel's transmitter site shall be within 4 km of the main carrier's transmitter site for each of the sharing cells (see clause 7.7);
- cells that share channels shall use the same scrambling code (indicated in the SYNC and SYNC-DA PDUs);
- cells that share channels and use air-interface encryption shall use the same static cipher key or common cipher key (indicated in the SYSINFO, SYSINFO-Q and SYSINFO-DA PDUs) - see also ETSI EN 300 392-7 [8];
- MSs camped on the local CA cell and MSs camped on different DA cells may use a shared channel (provided that the sharing cells are co-sited or within the permitted separation for eccentric channels);
- CA MSs camped on the local CA cell may be assigned to a channel that is being used in common control mode by DA MSs camped on one DA cell;
- the present document does not support use of any channel on a DA main carrier as an assigned channel for MSs that are camped on a different DA cell.

NOTE 1: The present document does not provide a general method for sharing of an assigned channel by MSs that are camped on different CA cells. However, annex S notes a restricted method that SwMIs may be able to use without the MSs being aware of the usage.

NOTE 2: When channels are shared by cells from more than one LA, the SwMI should take care in interpreting MS registration attempts and other MS requests that may depend on the LA where the MS is presently camped.

When MSs assigned to a shared channel revert to common control mode they return to their appropriate common control channels (see clause 23.3.1).

A cell may broadcast information about neighbouring cells (see clause 18.3.6). The D-NWRK-BROADCAST PDU may inform MSs about the frequencies of the CA main carriers of neighbouring CA cells. The D-NWRK-BROADCAST-DA PDU may inform MSs about the frequencies and bandwidths of the DA main carriers of neighbouring DA cells. The D-NWRK-BROADCAST-DA PDU may also inform DA MSs about the main carrier frequency of the (if any) local CA cell.

NOTE 3: Information about the main carrier frequency of the (if any) local CA cell is not included in the D-NWRK-BROADCAST PDU to avoid having CA MSs accidentally reselect their present serving cell.

NOTE 4: If a DA MS obtains information about different local CA cells (i.e. about local CA cells with different "cell identifier CA" values) in different D-NWRK BROADCAST-DA PDUs received on the same DA serving cell, the DA MS should store the details of all the local CA cells that it received on the serving cell. The DA MS should not overwrite the details about one local CA cell with the details of another local CA cell (with a different cell identifier CA) received on the same DA serving cell.

The SwMI may include the DA serving cell identifier in D-NWRK-BROADCAST-DA PDUs sent on channels that are not shared with MSs from other DA cells. The DA serving cell identifier shall not be included in D-NWRK-BROADCAST-DA PDUs sent on channels that are used by MSs from more than one DA cell. The D-NWRK-BROADCAST-DA PDU shall include only information common to all DA cells using that channel.

NOTE 5: A DA MS needs to know its serving cell's identifier when interpreting "neighbour cell information for DA" information elements received on a channel shared by other DA cells (e.g. to avoid having the MS accidentally reselect its present serving cell). To ensure the MS receives the correct value, the identifier of a DA serving cell is sent only on channels not shared by other DA cells (e.g. it is sent on the DA main carrier).

NOTE 6: When a channel is used by MSs from more than one DA cell, a DA MS using that channel may receive a D-NWRK-BROADCAST-DA PDU containing information about its serving cell either in the serving cell information (if present) or in neighbour cell information. (The BS does not include serving cell information on a channel shared by MSs from more than one DA cell unless the information is appropriate to all DA cells using the channel.) A DA MS can recognize a "neighbour cell information for DA" information element describing its serving cell by inspecting the included "cell identifier DA" information element. The DA MS may use any contained channel class or channel information, but it should not attempt to reselect to its serving cell.

18.3.4.0b.5 Cell identifiers

Certain MLE PDUs (e.g. the D-NWRK-BROADCAST, D-NWRK-BROADCAST-DA, U-PREPARE and U-PREPARE-DA PDUs) refer to neighbour cells. CA cells are referenced by a "cell identifier CA". DA cells are referenced by a "cell identifier DA".

When a cell does not share channels with other cells, the "cell identifier CA" and the "cell identifier DA" values used by that cell may be independent of those used by other cells.

Cells that share channels with each other shall use the same "cell identifier CA" values to identify the same CA neighbour cells and the same "cell identifier DA" values to identify the same DA neighbour cells.

A DA cell that shares channels with other cells shall identify itself (in D-NWRK-BROADCAST-DA PDUs on its main carrier) using the "cell identifier DA" value used by the other cells to identify it, so that the cells that share channels are uniquely and consistently identified within those sharing cells.

NOTE 1: This allows the BS to identify a neighbour cell referenced by an uplink PDU without having to first identify the sending MS's serving cell.

NOTE 2: It is recommended that the SwMI should, where possible, identify each cell within an LA by a different cell identifier. This helps an MS to recognize when it has returned to a cell it has previously used (see clause 18.3.6.6).

18.3.4.0b.6 Channel class identifiers and channel identifiers

Certain MLE PDUs reference channel classes and irregular channels (see clause 18.3.4.9.1) by channel class identifiers and channel identifiers. The following rules apply to the values used for these identifiers:

- when a channel class or irregular channel is available only to MSs from a single cell, the value of the channel class identifier or channel identifier may be local to that cell;
- when one or more of the channels comprising a channel class are shared by more than one cell, the cells that share those channels shall all use the same channel class identifier for that channel class;
- when an irregular channel is shared by more than one cell, the cells that share that irregular channel shall use the same channel identifier for that irregular channel.

NOTE: This avoids the need for the SwMI to identify the sending MS's cell when it receives a PDU containing channel class identifiers or channel identifiers on a shared channel.

18.3.4.1 Scanning of cells

Scanning is where an MS is synchronized to a cell, directly measures the received power of that cell and directly obtains the broadcast and synchronization information for that cell by decoding the SYNC and SYSINFO PDUs (in the case of a CA cell) or the SYNC-DA PDU (in the case of a DA cell). The scanning sub-function enables the MLE to directly obtain the path loss measurements from the cells. To obtain the C1 path loss parameter from layer 2, the MS-MLE shall per cell issue a TL-SCAN request primitive to the TLC-SAP along with the parameters indicating which cell is to be scanned and the characteristics of the RF channel that is to be scanned. The MS may find it useful to also decode the SYSINFO-DA PDU if it happens to be included in the same burst (i.e. in dataset B).

The MS-MLE shall know locally which channels the MS is capable of scanning and shall not instruct the lower layers to scan any channel that the MS-MLE knows to be outside the capabilities of the equipment. When layer 2 has completed scanning of one cell, the C1 path loss shall be part of the report parameter of the TL-SCAN confirm primitive or of the TL-SCAN-REPORT indication primitive, both given by layer 2. The C1 formula is defined in clause 23. The MS-MLE may use the list of neighbour cells in the D-NWRK-BROADCAST PDU or the D-NWRK-BROADCAST-DA PDU (or both) to specify the channels to be scanned. There are three types of scanning defined in clause 23. These are:

- foreground, where scanning is the only activity;
- background, where communications with the current serving cell are maintained in parallel with the scanning, and the scanning causes no interruption to that service;
- interrupting, where communications with the current serving cell are maintained in parallel with the scanning, but the scanning causes limited interruptions to that service.

Scanning shall have been performed within the last 60 s for a scanning measurement to be considered valid.

If the "main control channel modulation mode" information element in the "neighbour cell information for DA" information element is not set to "QAM" the MS shall not use the cell indicated by the "neighbour cell information for DA" information element in this version of the present document.

NOTE: It is possible that the MLE may request scanning of a channel that the MS is currently receiving, for example, if a CA MS is currently receiving an assigned channel on a DA main carrier, or if a DA MS is currently receiving an assigned channel on the (if any) local CA main carrier.

18.3.4.2 Monitoring of neighbour cells

Neighbour cell monitoring is where the MS calculates the path loss parameter C2 of neighbour cells using information about the neighbour cells broadcast by the serving cell. It differs from C1 in that the serving cell provides the cell selection parameters for the neighbour cell. However, the MS is still required to directly measure the received power of the neighbour cell.

In order to be able to monitor the neighbour cells the MS-MLE shall have received a D-NWRK-BROADCAST PDU or a D-NWRK-BROADCAST-DA PDU containing a list of the neighbour cells. The procedures concerning network broadcast PDUs are dealt with in clause 18.3.6. Once the network broadcast information has been received, the monitoring can be started by issuing a TL-MONITOR-LIST request primitive through the TLC-SAP. The TL-MONITOR-LIST request primitive informs layer 2 of the cells to be monitored. The parameters passed down with the TL-MONITOR-LIST request primitive shall be a list of channels corresponding to main carriers. The MS-MLE shall know locally which channels the MS is capable of monitoring and shall not instruct the lower layers to monitor any channel that the MS-MLE knows to be outside the capabilities of the equipment. For each channel the lower layers return a TL-MONITOR indication primitive containing the C2 path loss parameter or a TL-SCAN-REPORT indication primitive containing the C1 path loss parameter. C1 and C2 are defined in clause 23. Neighbour cell monitoring is a background procedure and is defined in clause 23. Monitoring of neighbour cells shall have been performed during the last 60 s for a monitoring measurement to be considered valid.

If it is required to stop the neighbour cell monitoring process, the MLE shall issue a TL-MONITOR-LIST request primitive with an empty list of neighbour cell channels as parameter.

NOTE: It is possible that the MLE may request neighbour cell monitoring of a channel that the MS is currently receiving, for example, if a CA MS is currently receiving an assigned channel on a DA main carrier, or if a DA MS is currently receiving an assigned channel on the (if any) local CA main carrier.

18.3.4.3 Surveillance of the serving cell

Serving cell surveillance is the procedure whereby the MS analyses the received information on the quality of the link to the serving cell's main carrier. Once the MS-MLE has chosen the serving cell, the MLE shall select that cell by issuing a TL-SELECT request primitive to the TLC-SAP. Once the cell has been selected the lower layers return a TL-SELECT confirm primitive and periodically send TL-MEASUREMENT indication primitives containing the C1 path loss parameter for the current channel. If the current channel is a non-conforming concentric channel or a sectored channel (see clause 18.3.4.9.1), the lower layers include the C3 path loss parameter for the main carrier in the TL-MEASUREMENT indication primitive.

If the current channel is a conforming channel (clause 18.3.4.9.1), the MS-MLE shall assess the quality of the link to the serving cell's main carrier using the C1 path loss parameter for the conforming channel or channels.

If the current channel is a non-conforming concentric channel or a sectored channel (indicated in the channel information parameter of the TL-SELECT indication primitive), the MS-MLE shall assess the quality of the link to the serving cell's main carrier using either the C3 path loss parameter or the C2 path loss parameter. The MS-MLE may obtain the C2 path loss parameter by requesting layer 2 to monitor the serving cell's main carrier using the TL-MONITOR-LIST request primitive. When the MS-MLE receives the C2 path loss parameter for the main carrier, it shall use C2 in preference to C3 for determining the quality of the link to the serving cell. (Whereas C2 gives a direct measurement of the main carrier's performance, C3 predicts the main carrier performance from measurements made on the current channel.) The C1, C2 and C3 path loss parameters are described in clause 23.

NOTE 1: On a sectored channel, the C2 path loss parameter is more reliable than the C3 path loss parameter. For example, C3 may be lower than C2 (i.e. the C3 path loss may be overestimated) when the MS is near the azimuthal boundary of a sectored channel. If the MS-MLE relies on the C3 path loss parameter near an azimuthal boundary, the MS-MLE might decide to perform a cell reselection at a time when a sectored channel change would be more appropriate. To take account of this, the MS-MLE could request C2 measurements (i.e. monitoring of the serving cell's main carrier) when the C3 path loss parameter suggests that the main carrier may be failing. When the MS is monitoring the main carrier, the MS-MLE could use comparisons between the C2 and C3 path loss parameters to decide if the MS can cease monitoring the main carrier.

NOTE 2: The MS may choose to monitor the serving cell's main carrier when using a non-conforming concentric channel.

If the current channel is a super-sectored channel or an eccentric channel (indicated in the channel information parameter of the TL-SELECT indication primitive), or if the MS did not understand the conforming channel status for the channel, the MS-MLE shall assess the quality of the link to the serving cell's main carrier using the C2 path loss parameter. The MS-MLE shall obtain the C2 path loss parameter by requesting layer 2 to monitor the serving cell's main carrier using the TL-MONITOR-LIST request primitive.

NOTE 3: If the current channel is a super-sectored channel or an eccentric channel, or if the MS did not understand the conforming channel status for the channel, the MS cannot predict the main carrier performance from measurements made on the current channel. Therefore the MS needs to monitor the serving cell's main carrier (path loss parameter C2) instead of estimating a path loss parameter C3 for the main carrier from measurements made on the current channel.

Additionally the surveillance sub-function shall be responsible for the analysis of any network broadcast information received from the serving cell via the network broadcast sub-entity.

If a serving cell radio link failure occurs (see clause 18.3.4.5.3), the MLE shall inform the upper entities SMDCP and CMCE by issuing an MLE-BREAK indication primitive via the data transfer sub-entity.

If a current channel radio link failure occurs (see clause 18.3.4.5.3), the MLE shall send layer 2 a TL-SELECT request primitive requesting selection of the common control channel. The MLE data transfer sub-entity shall send an MLE-CONFIGURE indication primitive containing "loss of radio resource" to the service user(s) who is using this radio resource as indicated by the endpoint identifier parameter.

If the MLE receives a TL-REPORT indication primitive from the lower layers indicating "usage marker failure" then a TL-CONFIGURE request primitive shall be generated to move the MS to the common control channel and the upper entities CMCE and SMDCP shall be informed via a MLE-CONFIGURE indication primitive containing "loss of radio resource".

If the MLE receives a TL-SELECT indication primitive via the TLC-SAP, outside of cell reselection, indicating that the MAC has been instructed to change channels and no response is required, the surveillance function shall note the new serving cell channel.

If the MS is using concurrent channels, layer 2 may send the MS-MLE a C1 path loss parameter for each separate channel. If none of the concurrent channels are conforming channels, and one or more of the concurrent channels are non-conforming concentric or sectored channels, layer 2 shall send the MS-MLE one or more C3 values for the main carrier. The MS-MLE should combine multiple C3 values for the purposes of assessing the performance of the main carrier. The method of combining multiple C3 values is outside the scope of the present document.

18.3.4.4 Ranking of neighbour cells

18.3.4.4.0 General

The ranking sub-function can use the path loss measurements C1 and C2 to maintain a ranked list of neighbour cells.

The ranking algorithm shall rank the neighbour cells which have been monitored or scanned in strict order of downlink radio connection quality. The results of this algorithm can be used to determine when a cell is deemed to be radio usable, radio relinquishable or radio improvable according to clauses 18.3.4.5.4, 18.3.4.5.5 and 18.3.4.5.6. The use of a ranking algorithm based only on C1 or C2 is essential in order to facilitate network coverage planning.

NOTE 1: If there is more than one suitable neighbour cell when the MS initiates cell reselection, the MS chooses the cell which has the highest ranking in the ranking list and which best satisfies the service requirements for the MS (see clause 18.3.4.5.7).

A cell shall meet the following minimum criteria in order to be included in the ranking list of neighbour cells:

- $C1 > 0$ or $C2 > 0$;
- if the neighbour cell has a different MCC or MNC, the neighbour cell shall support migration (which is broadcast as part of the "BS service details" or "BS service details DA" information element).

If these criteria are not satisfied, an MS shall not include that cell in the ranking list and so shall not consider that cell for cell reselection.

If the information about the MCC or MNC is not broadcast by the serving cell as part of the neighbour cell information, the MS may assume that it is free to include that cell in its ranking list provided the $C1 > 0$ or $C2 > 0$ criterion is met.

An MS may build a valid ranking list by obtaining the cell reselection parameters for the neighbour cells from the D-NWRK-BROADCAST PDUs or the D-NWRK-BROADCAST-DA PDUs (or both) transmitted on the serving cell. In this case, the MS shall monitor the neighbour cells specified by the D-NWRK-BROADCAST PDUs or the D-NWRK-BROADCAST-DA PDUs (or both) and shall calculate C2 for each one using the cell reselection parameters for the neighbour cell sent in the D-NWRK-BROADCAST PDU or the D-NWRK-BROADCAST-DA PDU (or both) on the serving cell. A valid ranking list can then be derived using the C2 measurements.

An MS may also build a valid ranking list by scanning the neighbour cells to obtain the cell reselection parameters directly. In this case, the MS shall calculate C1 for each of the neighbour cells and shall derive a valid ranking list using the C1 measurements.

NOTE 2: When an MS leaves a cell, it may update the ranking list with information about the cell it is leaving.

18.3.4.4.1 Ranking of monitored cells

Ranking of monitored neighbour cells shall be based upon the received path loss parameter C2 from the layer 2 monitoring process, issued in a TL-MONITOR indication primitive.

The ranking should produce a ranked cell list which can be used as a scanning list, if the scanning function is applied. This ranked cell list may be used for making the decision of whether and when to change cell, according to clause 18.3.4.7.

18.3.4.4.2 Ranking of scanned cells

Ranking of scanned neighbour cells shall be based upon the received path loss parameter C1 from the layer 2 scanning process, issued in a TL-SCAN confirm primitive or a TL-SCAN-REPORT indication primitive.

The ranking should produce a ranked cell list which may be used for making the decision of whether and when to change cell, according to clause 18.3.4.7.

18.3.4.5 Criteria used during cell reselection

18.3.4.5.0 General

The following clauses define the criteria which shall be used to initiate the cell reselection procedures described in clause 18.3.4.6.

18.3.4.5.1 Criterion for starting the neighbour cell monitoring process

The neighbour cell monitoring process may be permanently enabled or enabled only when some criterion is met, e.g. the serving cell ceases to support the service level required by the MS, or the serving cell quality falls below a pre-determined threshold. In the latter case it is assumed that the neighbour cell monitoring process would be disabled when the serving cell quality rises above the threshold plus some hysteresis factor.

The exact method for the selection of the thresholds and hysteresis values is outside the scope of the present document.

Where the neighbour cell monitoring process is not permanently enabled and the MS-MLE receives system broadcast information informing it that the service level required by that MS is no longer supported, e.g. that the subscriber class that the MS belongs to is no longer able to access the system, the neighbour cell monitoring process should be started.

Where the neighbour cell monitoring process is not permanently enabled, but started when a threshold value is crossed, the threshold value should be chosen to be a value greater than the threshold parameters, FAST_RESELECT_THRESHOLD, SLOW_RESELECT_THRESHOLD, to allow the MS enough time to successfully select a new cell prior to the complete loss of service from the current serving cell.

If the ranking list contains at least one neighbour cell that recommends expedited cell reselection in the "cell reselection types supported" or "cell reselection types supported DA" information element, then the MS should use a higher threshold for starting to monitor those neighbour cells that are recommended for expedited cell reselection, or the MS may monitor those neighbour cells continuously.

18.3.4.5.2 Criterion for starting scanning

The individual criteria for starting scanning in the different selection and reselection procedures are defined in clauses 18.3.4.6 and 18.3.4.7.1 to 18.3.4.7.6.

18.3.4.5.3 Criterion for radio link failure

Radio link failure occurs when the quality of the uplink or downlink radio connection falls below a certain level. A radio link failure shall be declared if any of the following events occur:

- layer 2 declares C1 path loss parameter failure ($C1 < 0$) via the TL-MEASUREMENT indication primitive:
 - if the current channel is a non-conforming channel (see clause 18.3.4.9.1) this shall be considered a current channel radio link failure; or
 - if the current channel is a conforming channel (see clause 18.3.4.9.1) this shall be considered a serving cell radio link failure and a current channel radio link failure;
- layer 2 reports path loss parameter $C3 < 0$ for the serving cell's main carrier via the TL-MEASUREMENT indication primitive:
 - this shall be considered a serving cell radio link failure unless the MS-MLE immediately initiates or has already initiated monitoring of the main carrier;

- layer 2 reports path loss parameter $C2 < 0$ for the serving cell's main carrier via the TL-MONITOR indication primitive:
 - this shall be considered a serving cell radio link failure;
- layer 2 reports an AACH or AACH-Q decoding failure as described in clause 23 for a current channel via the TL-REPORT indication primitive (downlink failure); then:
 - if the current channel is a non-conforming channel (see clause 18.3.4.9.1) this shall be considered a current channel radio link failure; or
 - if the current channel is a conforming $\pi/4$ -DQPSK or D8PSK channel:
 - a CA MS shall consider this to be a serving cell radio link failure and a current channel radio link failure;
 - a DA MS shall consider this to be a current channel radio link failure;
 - if the current channel is a conforming QAM channel:
 - a CA MS shall consider this to be a current channel radio link failure;
 - if the current channel is not on the main carrier, a DA MS shall consider this to be a current channel radio link failure; or
 - if the current channel is on the main carrier, a DA MS shall consider this to be a serving cell radio link failure and a current channel radio link failure;
- an error is reported via the TL-REPORT indication primitive indicating either:
 - that the maximum path delay has been exceeded - this shall be considered a serving cell radio link failure and a current channel radio link failure; or
 - that an uplink failure has occurred; then:
 - if the channel on which the uplink failure occurred is a non-conforming channel this shall be considered a current channel radio link failure; or
 - if the channel on which the uplink failure occurred is a conforming channel this shall be considered a serving cell radio link failure and a current channel radio link failure;
- layer 2 declares that the BS has entered no service mode for the serving cell via the TL-REPORT indication primitive (common channel deallocated); this shall be considered a serving cell radio link failure and a current channel radio link failure.

NOTE: The maximum path delay exceeded condition and the uplink failure condition can be reported to the MS MAC from the SwMI in a MAC-RESOURCE PDU.

18.3.4.5.4 Criterion for radio relinquishable cell

A serving cell becomes radio relinquishable when there is a neighbour cell which has a downlink radio connection of sufficient quality and either the quality of the serving cell's main carrier downlink radio connection falls below a certain level or the MS receives a TL-REPORT indication primitive reporting "maximum path delay almost exceeded".

Following receipt of a TL-REPORT indication primitive reporting "maximum path delay almost exceeded" the MS shall start the air cell margin timer T375 and shall send MM an MLE-CONFIGURE indication primitive setting the distance reporting time to a value of 15 s.

NOTE: The "maximum path delay almost exceeded" report is only used by an MS that supports the AGA service (see annex O).

The following conditions shall be met simultaneously in order to declare the serving cell radio relinquishable:

- the main carrier path loss parameter, C1 or C2, of at least one of the neighbour cells in the ranking list has exceeded by FAST_RESELECT_HYSTERESIS the main carrier path loss parameter, C1, C2 or C3 of the current serving cell for the last 5 s (where C2, if available, takes precedence over C3); and

- no successful cell reselection has taken place within the last 15 s (unless MM requested a cell reselection); and
- either:
 - the serving cell main carrier path loss parameter C1, C2 or C3 has for the last 5 s been below FAST_RESELECT_THRESHOLD (where C2, if available, takes precedence over C3); or
 - the air cell margin timer T375 is active;

If the air cell margin timer T375 expires, the above "air cell margin timer T375 is active" condition is no longer fulfilled and the MS shall send MM an MLE-CONFIGURE indication primitive instructing MM to use the periodic reporting time requested by the SwMI.

The MS-MLE shall check the criterion for serving cell relinquishment as often as one neighbour cell is scanned or monitored.

18.3.4.5.5 Criterion for radio improvable cell

A serving cell becomes radio improvable when the quality of a neighbour cell downlink radio connection exceeds that of the serving cell by a certain amount. The following conditions shall be met simultaneously in order to declare the serving cell radio improvable:

- the serving cell main carrier path loss parameter C1, C2 or C3 shall, for a period of 5 s, fall below SLOW_RESELECT_THRESHOLD (where C2, if available, takes precedence over C3);
- the main carrier path loss parameter, C1 or C2, of at least one of the neighbour cells in the ranking list shall exceed by SLOW_RESELECT_HYSTERESIS the main carrier path loss parameter C1, C2 or C3 of the current serving cell for a period of 5 s (where C2, if available, takes precedence over C3);
- no successful cell reselection shall have taken place within the previous 15 s unless MM requests a cell reselection.

The MS-MLE shall check the criterion for improving the serving cell as often as one neighbour cell is scanned or monitored.

18.3.4.5.6 Criterion for radio usable cell

A neighbour cell becomes radio usable when it has a downlink main carrier radio connection of sufficient quality. The following condition shall be met in order to declare a neighbour cell radio usable:

- the neighbour cell shall for a period of 5s have a main carrier path loss parameter, C1 or C2, which is greater than (FAST_RESELECT_THRESHOLD + FAST_RESELECT_HYSTERESIS);
- no successful cell reselection shall have taken place within the previous 15 s unless MM requests a cell reselection.

The MS-MLE shall check the criterion for a neighbour cell being usable each time the neighbour cell is scanned or monitored.

18.3.4.5.6a Criterion for radio tolerable cell

A neighbour cell becomes radio tolerable when it has a downlink main carrier radio connection of sufficient quality. The following condition shall be met in order to declare a neighbour cell radio tolerable:

- The neighbour cell shall have a main carrier path loss parameter, C1 or C2, which is greater than a threshold above zero.

NOTE: The threshold should lie in the range between 0 and (FAST_RESELECT_THRESHOLD + FAST_RESELECT_HYSTERESIS).

The MS-MLE shall check the criterion for a neighbour cell being radio tolerable each time the neighbour cell is scanned or monitored.

18.3.4.5.6b Criterion for expedited cell reselection

A neighbour cell becomes a candidate for expedited cell reselection when the following conditions are met simultaneously:

- the main carrier path loss parameter, C1 or C2, of at least one of the neighbour cells in the ranking list shall exceed by FAST_RESELECT_HYSTERESIS the main carrier path loss parameter, C1, C2 or C3 of the current serving cell for a period of 2 s (where C2, if available, takes precedence over C3);
- the neighbour cell in question is indicated to recommend expedited cell reselection (in the "cell reselection types supported" information element of the D-NWRK-BROADCAST PDU or the "cell reselection types supported DA" information element of the D-NWRK-BROADCAST-DA PDU)); and
- no successful cell reselection shall have taken place within the previous 15 s unless MM requests a cell reselection.

NOTE 1: In order to successfully perform an expedited cell reselection to the cells that are recommended for expedited cell reselection the MS implementation should consider the following aspects:

- The required time for a cell reselection criterion to be in effect should be reduced from 5 s to 2 s for the cells that are recommended for expedited cell reselection.
- The neighbour cell monitoring of the cells that are recommended for expedited cell reselection should be performed at the fastest available rate.
- If the MS attempts announced cell reselection the waiting time for D-NEW-CELL, T370, should be shortened to 3 s for the cells that are recommended for expedited cell reselection.
- Reduce the filtering of RSSI and C1/C2 measurements for the cells that are recommended for expedited cell reselection.

NOTE 2: Where encryption is used, either DCK forwarding should be used with a reduced T370 timer of 3 s or DCK retrieval should be used to avoid clear location update on the new cell.

18.3.4.5.7 Criteria for initiating the cell reselection procedures

Cell reselection shall be initiated by the MLE if the serving cell is declared radio improvable (as defined in clause 18.3.4.5.5) and the service criteria as defined below are the same on both the serving cell and the neighbour cell. If the service provided by the neighbour cell is lower than that provided by the serving cell, the cell reselection may be postponed until the serving cell is declared radio relinquishable (as defined in clause 18.3.4.5.4). If the neighbour cell does not provide all essential service requirements for the MS and the serving cell does provide all essential service requirements, the MS should postpone cell reselection even after the serving cell becomes radio relinquishable. If the service provided by the neighbour cell is higher than that provided by the serving cell, then the cell reselection may be performed as soon as the neighbour cell is declared radio usable (as defined in clause 18.3.4.5.6).

If cell reselection is initiated by the user application (see clause 16.4.2), the MLE receives a MLE-LINK request primitive from MM containing the MCC and MNC and possibly also the LA and cell type preference or requirement of the desired cell. If, within the MCC, MNC, LA(s) and cell type(s) specified in the MLE-LINK primitive request, the MLE is able to find a cell fulfilling the criterion where service provided by the neighbour cell is the same or higher than provided by the serving cell, then the cell reselection may be performed as soon as the neighbour cell is declared radio usable (as defined in clause 18.3.4.5.6). Upon selection of the new cell, or if the present serving cell satisfies the requirements of the MLE-LINK request primitive, the MLE shall send a MLE-LINK indication primitive to MM. If the MLE is unable to find a suitable cell, it shall respond to MM with a MLE-ACTIVATE indication primitive.

The MLE shall maintain a record of the most recent cell type preference or requirement requested by MM, and shall use that cell type preference or requirement in future cell reselections unless modified by MM in an MLE-ACTIVATE request, MLE-LINK request or MLE-UPDATE request primitive. The same may apply for the MCC, MNC and LA(s), if provided by the user application.

The following service criteria may be used to compare the service provided by a serving cell and a neighbour cell:

- support for subscriber class (broadcast as part of the D-MLE-SYSINFO, D-MLE-SYSINFO-Q, D-MLE-SYNC-DA and D-MLE-SYSINFO-DA PDUs and may be broadcast as part of the D-NWRK-BROADCAST and the D-NWRK-BROADCAST-DA PDUs for neighbour cells);

- preference level of the supported subscriber class(es) (see clause R.2);
- support for system wide services (broadcast as part of the "BS service details" information element and the "BS service details DA" information element);
- priority cell indication (broadcast as part of the "BS service details" information element and the "BS service details DA" information element);
- support for TETRA voice service (broadcast as part of the "BS service details" information element and the "BS service details DA" information element);
- support for TETRA circuit mode data service (broadcast as part of the "BS service details" information element and the "BS service details DA" information element);
- support for TETRA packet data (SNDCP) service (broadcast by CA cells as part of the "BS service details" information element; always supported by DA cells when indicating "normal mode" (system wide services supported) in the "BS service details DA" information element);
- support for air interface encryption (broadcast as part of the "BS service details" information element and the "BS service details DA" information element);
- cell load (broadcast as part of the D-MLE-SYNC, D-MLE-SYSINFO-Q, D-MLE-SYNC-DA, D-MLE-SYSINFO-DA, D-NWRK-BROADCAST and (optionally) D-NWRK-BROADCAST-DA PDUs for the serving cell and may be broadcast as part of the D-NWRK-BROADCAST and the D-NWRK-BROADCAST-DA PDUs for neighbour cells);
- whether or not the LA of the current serving cell is preferred over the LA of the neighbour cell and whether or not the MS is permitted to use the LA of the neighbour cell (either or both of which may be stored in the MS at subscription; a list of preferred and/or permitted MCCs, MNCs and LAs may be provided to MLE in the MLE-ACTIVATE request primitive) - see note 1;
- whether or not a circuit mode call or C-plane signalling transfer is in progress;
- support for the QAM modulation mode (broadcast by CA cells as part of the "extended services broadcast" information element; always supported by DA cells);
- support for the $\pi/4$ -DQPSK modulation mode (support for the $\pi/4$ -DQPSK TETRA circuit mode voice and TETRA circuit mode data services is broadcast by DA cells as part of the "BS service details DA" information element; support for the $\pi/4$ -DQPSK TETRA packet data (SNDCP) service is broadcast by DA cells as part of the "extended services broadcast section 1da" element; CA cells always support $\pi/4$ -DQPSK modulation);
- support for the D8PSK modulation mode (broadcast as part of the "extended services broadcast" element and the "extended DA services broadcast" element);
- the bandwidths supported (broadcast in the "extended services broadcast section 2" element);
- support for QoS negotiation during PDP context activation (broadcast by CA cells as part of the "extended services broadcast" element; always supported by DA cells when indicating "normal mode" (system wide services supported) in the "BS service details DA" information element);
- a recognized system code (see clauses 21.4.4.2 and 21.4.4.2a);
- whether the MS prefers to use a CA cell or a DA cell;
- whether or not the neighbour cell or serving cell is a wide-area cell (broadcast in the D-MLE-SYNC-DA PDU and the "neighbour cell information for DA" information element).

The MS shall not use an unrecognized system code (i.e. a value defined as reserved according to all system codes known by the MS) in the V + D range to identify the service provided by a cell. The MS shall not reject the cell based only on an unrecognized system code in the V+D range.

NOTE 1: A preferred LA belongs to a specific MCC and a specific MNC. A permitted LA belongs to a specific MCC and a specific MNC (see also clause 18.3.5.1.5).

NOTE 2: The system code is a shorthand indication for what the system is supporting or more accurately what the system is not supporting. The system code may vary between cells belonging to the same system.

NOTE 3: Clause O.7.2.3 describes the criteria that may be used by MSs supporting the air-ground-air service to compare the service provided by a serving cell and a neighbour cell.

The "BS service details" information element for a CA serving cell is broadcast in the D-MLE-SYSINFO PDU and the D-MLE-SYSINFO-Q PDU. The "BS service details DA" element for a DA serving cell is broadcast in the D-MLE-SYNC-DA PDU and the D-MLE-SYSINFO-DA PDU. The "cell load CA" information element for a CA serving cell is broadcast in the D-MLE-SYNC PDU, and the D-MLE-SYSINFO-Q PDU. The "cell load DA" information element for a DA serving cell is broadcast in the D-MLE-SYNC-DA PDU and the D-MLE-SYSINFO-DA PDU. The "extended services broadcast" element for a CA serving cell is broadcast in the MAC SYSINFO PDU and the MAC SYSINFO-Q PDU. The "extended DA services broadcast" element for a DA serving cell is broadcast in the MAC SYSINFO-DA PDU. The "extended services broadcast section 2" element is broadcast in the MAC SYSINFO, MAC SYSINFO-Q, MAC SYSINFO-DA and MAC SYNC-DA PDUs. The "extended services broadcast section 1da" element is broadcast in the "extended DA services broadcast" element of the MAC SYSINFO-DA PDU.

The "BS service details" and the "cell load CA" information elements for CA neighbour cells may be included in "neighbour cell information for CA" information elements which may be broadcast in the D-NWRK-BROADCAST PDU.

The "BS service details DA" and the "cell load DA" information elements for DA neighbour cells may be included in "neighbour cell information for DA" information elements which may be broadcast in the D-NWRK-BROADCAST-DA PDU.

The D-MLE-SYNC PDU and the D-MLE-SYSINFO PDU shall be transmitted on all phase modulation carriers. The D-MLE-SYSINFO-Q may be transmitted on any QAM channel of a CA cell.

The D-MLE-SYSINFO-DA PDU may be transmitted on any channel that is not being used by MS(s) from more than one DA cell. The D-MLE-SYNC-DA PDU may be transmitted on any QAM channel that is not being used by MS(s) from more than one DA cell. The D-MLE-SYNC-DA PDU and the D-MLE-SYSINFO-DA PDU shall be transmitted on the main carrier of the DA cell.

The D-NWRK-BROADCAST and the D-NWRK-BROADCAST-DA PDUs may be transmitted on any channel.

Using the above criteria, an MS may decide whether or not a neighbour cell can be considered to offer better service than the current serving cell. The following conditions shall cause the MS to rate a neighbour cell to have better service than the current serving cell:

- the neighbour cell satisfies all essential service requirements for the MS and the serving cell does not;
- the neighbour cell is a priority cell and the serving cell is not a priority cell;
- the neighbour cell supports a service (i.e. TETRA voice, circuit mode data or TETRA packet data (SND)CP services) which is not supported by the serving cell and the MS prefers that service to be available;
- the neighbour cell supports a modulation mode (e.g. $\pi/4$ -DQPSK, D8PSK, QAM) which is not supported by the serving cell and the MS prefers that modulation mode to be available;
- the neighbour cell supports a higher bandwidth matching the MS's capabilities than does the serving cell, and the MS prefers the ability to use that higher bandwidth;
- the neighbour cell supports QoS negotiation during PDP context activation and the serving cell does not, and the MS prefers the use of services accessed via QoS negotiation (e.g. scheduled access or any QoS other than background class with unspecified throughput, reliability and delay);
- the neighbour cell supports air interface encryption, the serving cell does not, and the MS prefers that air interface encryption is available;
- the neighbour cell supports system wide services and the serving cell does not;
- the cell load indicates that the neighbour cell is more lightly loaded than the serving cell (see notes 4 and 5);
- the neighbour cell belongs to a preferred LA and the serving cell does not;

- the neighbour cell is a CA cell, the present cell is a DA cell and the MS prefers to use a CA cell;
- the neighbour cell is a DA cell, the present cell is a CA cell and the MS prefers to use a DA cell;
- the neighbour cell is a wide-area cell, the present cell is not a wide-area cell, and the MS prefers to use a wide-area cell (see note 6 and example 1);
- the neighbour cell is not a wide-area cell, the present cell is a wide-area cell, and the MS prefers not to use a wide-area cell (see note 6 and example 1);
- the neighbour cell supports subscriber class(es) of higher preference level (see clause R.2) in the MS's subscriber class profile than does the current serving cell, and the MS supports the use of subscriber class preference levels;

NOTE 4: The "roaming control for individual services" and the "roaming control for group services and idle MSs" information elements in the D-MLE-SYSINFO-DA PDU indicate whether a DA MS is permitted to perform a cell reselection because the neighbour cell is more lightly loaded than the serving cell.

NOTE 5: The method by which an MS compares the cell load of a CA cell with the cell load of a DA cell is outside the scope of the present document.

NOTE 6: An MS may be configured to prefer using wide-area cells or to prefer not using wide-area cells. Or it may have no particular preference. Or its preference may depend on its present activities.

EXAMPLE 1: The MS might give preference to a wide-area cell if the MS is aware that it is travelling at high speed or using wide-area group calls. An MS might prefer not to use a wide-area cell if the MS is a hand-held device or if the MS wishes to set up an individually addressed circuit mode call.

In these cases the MS may choose to initiate cell reselection as soon as the neighbour cell becomes radio usable as defined in clause 18.3.4.5.6. If there is more than one neighbour cell which is radio usable, the MS should choose the one which has the highest ranking in the ranking list and which best satisfies the service requirements for the MS.

If the service provided by a radio usable neighbour cell is higher than that provided by the serving cell, but an assigned channel on the serving cell provides a better service than any neighbour cell channel that is currently radio usable, the MS-MLE may postpone cell reselection (the MS-MLE discovers this by monitoring the neighbour cell irregular channels and assessing the quality of the neighbour cell channel classes - see clauses 18.3.4.9.4 to 18.3.4.9.8).

The following conditions shall cause the MS to rate a neighbour cell to have lower service than the current serving cell:

- the serving cell satisfies all essential services requirements for the MS and the neighbour cell does not;
- the serving cell supports subscriber class(es) of higher preference level (see clause R.2) in the MS's subscriber class profile than does the neighbour cell, and the MS supports the use of subscriber class preference levels;
- the serving cell is a priority cell and the neighbour cell is not a priority cell;
- the serving cell supports a service (i.e. TETRA voice, circuit mode data or TETRA packet data (SND)CP services) which is not supported by the neighbour cell and the MS prefers that service to be available;
- the serving cell supports a modulation mode (e.g. $\pi/4$ -DQPSK, D8PSK, QAM) which is not supported by the neighbour cell and the MS prefers that modulation mode to be available;
- the serving cell supports a higher bandwidth matching the MS's capabilities than does the neighbour cell, and the MS prefers the ability to use that higher bandwidth;
- the serving cell supports QoS negotiation during PDP context activation and the neighbour cell does not, and the MS prefers the use of services accessed via QoS negotiation (e.g. scheduled access or any QoS other than background class with unspecified throughput, reliability and delay);
- the serving cell supports air interface encryption, the neighbour cell does not, and the MS prefers that air interface encryption is available;
- the serving cell supports system wide services and the neighbour cell does not;
- the cell load indicates that the serving cell is loaded more lightly than the neighbour cell (see note 5);

- the serving cell belongs to a preferred LA and the neighbour cell does not;
- the neighbour cell is a CA cell, the present cell is a DA cell and the MS prefers to use a DA cell;
- the neighbour cell is a DA cell, the present cell is a CA cell and the MS prefers to use a CA cell;
- the neighbour cell is not a wide-area cell, the present cell is a wide-area cell, and the MS prefers to use a wide-area cell (see note 6 and example 1);
- the neighbour cell is a wide-area cell, the present cell is not a wide-area cell, and the MS prefers not to use a wide-area cell (see note 6 and example 1).

NOTE 7: See also clause O.7.2.3 concerning the air-ground-air service.

In these cases the MS should postpone cell reselection until the serving cell becomes radio relinquishable as defined in clause 18.3.4.5.4.

EXAMPLE 2: An example is that the MS should postpone cell re-selection until the serving cell becomes radio relinquishable as defined in clause 18.3.4.5.4, if the serving cell is a priority cell and the neighbour cell is not a priority cell.

The following conditions should cause the MS to rate a cell as not satisfying an essential service requirement for the MS:

- the MS subscriber class is not supported on the cell and the MS requires the support of the MS subscriber class;
- the cell does not support a service (i.e. TETRA voice, circuit mode data or TETRA packet data services) and the MS requires that service to be available;
- the cell does not support a modulation mode (e.g. $\pi/4$ -DQPSK, D8PSK, QAM) and the MS requires that modulation mode to be available;
- the cell does not support a particular bandwidth and the MS requires that particular bandwidth;
- the cell does not support air interface encryption and the MS requires that air interface encryption is available;
- the cell does not support system wide services and the MS requires system wide services to be supported.
- the cell is a not-permitted cell (i.e. the cell does not belong to a permitted LA - see clause 18.3.5.1.5).

In the case where the current serving cell satisfies essential service requirements for the MS and there is no neighbour cell that satisfies essential service requirements for the MS, the MS should postpone cell reselection even after the serving cell becomes radio relinquishable.

EXAMPLE 3: An example of MS specific combination of cell re-selection criteria and service requirements for a neighbour cell is that an MS should choose not to perform cell re-selection to a cell with a subscriber class mismatch, or it may select a cell with subscriber class mismatch only if there is no cell with a subscriber class match in its ranking list, and then only after an initial cell selection procedure involving at least one full scan of all of its prearranged frequencies (or frequency lists) where no other cell is found with $C1 > 0$ that has a matching subscriber class.

If there is more than one neighbour cell which satisfies the MS specific combination of cell re-selection criteria and service requirements, the MS should choose the highest ranked cell in the ranking list which satisfies the MS's specific combination of cell re-selection criteria and service requirements.

In the case where the current serving cell does not satisfy essential service requirements for the MS and there is a neighbour cell that satisfies essential service requirements for the MS, the MS should initiate cell reselection when the neighbour cell becomes radio tolerable i.e. even before the neighbour cell becomes radio usable.

In the case where the current serving cell does not support system wide services and the MS is unable to locate a cell that does support system wide services, the MS may either go out of service or remain in the current cell and offer reduced services. The MS behaviour in this case i.e. decision between the two alternatives should be configurable but is outside the scope of the present document. However if the MS supports emergency voice calls and the level of service offered by the current cell includes voice calls, the MS should not go out of service.

NOTE 8: An MS that supports emergency voice calls should be capable of remaining in service as long as the current cell supports voice calls, even if system wide services are not currently available, so that emergency calls can be received by any MSs in the area where voice calls can be routed. However some users may prefer the MS to go out of service if the current cell supports local voice calls but does not support system wide voice calls. For example, a user may choose to configure the MS to go out of service if it is not possible to route voice calls to the user's control room. (It may be noted that if the MS goes out of service it will not be able to make an emergency call even to other local MSs.)

If the service provided by a radio usable neighbour cell is lower than that provided by the serving cell, but the neighbour cell is advertising a radio usable irregular channel or a radio usable channel class which offers a higher service than is available on a currently assigned channel (the MS-MLE discovers this by monitoring the neighbour cell irregular channels and assessing the neighbour cell channel classes - see clauses 18.3.4.9.4 to 18.3.4.9.8), the MS-MLE may initiate cell reselection immediately if more than 15 s has elapsed since a previous cell reselection.

If the neighbour cell is deemed to offer neither better service nor lower service than the serving cell, the service shall be deemed to be equal and the MS shall initiate the cell reselection procedures as soon as a neighbour cell becomes radio improvable over the current serving cell as defined in clause 18.3.4.5.5. A neighbour cell shall be deemed to be equal with respect to the above service criteria if the information is not available for either the serving or neighbour cell e.g. the cell load of a neighbour cell may be declared "unknown" in the D-NWRK-BROADCAST PDU or the D-NWRK-BROADCAST-DA PDU, causing the service to be deemed equal with respect to cell load.

If a neighbour cell is deemed to provide equal or better service than the current serving cell and the neighbour does not recommend expedited cell reselection, the cell reselection should be postponed if there is a circuit mode call or ongoing signalling currently in progress. In this case, the cell reselection should be postponed until the serving cell becomes radio relinquishable, even if there are neighbour cells which meet the radio improvable or radio usable criteria.

If serving cell radio link failure occurs (which can occur when there are no neighbour cells of sufficient radio connection quality to make the serving cell relinquishable), the MS may re-select any neighbour cell in the ranking list whose main carrier path loss parameter, C1 or C2, is greater than zero. If there are multiple cells in the ranking list which meet this radio criterion, the MS should choose the highest ranked cell which satisfies the service requirement for the MS. If there are no cells which meet this minimum radio criterion, the initial cell selection procedure shall be invoked.

18.3.4.6 Initial cell selection

The MS shall implement the initial cell selection procedure when the MS-MLE receives an MLE-ACTIVATE request primitive from MM e.g. when not attached to a cell, at power on, or after a previous deactivation has taken place. The exact detailed implementation of the procedure and any associated algorithms is outside the scope of the present document. The MS shall be required to fulfil certain conditions as stated below. The procedure shall be referred to as the "initial cell selection" procedure. This does not imply that the procedure shall necessarily be different from any procedures applied for cell reselection.

The initial cell selection procedure shall ensure that the MS selects a cell in which it can reliably decode downlink data, i.e. on a main control channel (MCCH or MCCH-Q)), and which has a high probability of uplink communication. The minimum conditions that shall have to be met are that $C1 > 0$. Access to the network shall be conditional on the successful selection of a cell.

The procedure shall be initiated by the receipt of the MLE-ACTIVATE request primitive from the MM entity. This primitive has parameters which include the MCC and the MNC of the particular network and the cell type (e.g. CA, DA or any type) which the MS should select. The MS-MLE shall then use this information, and initiate the foreground scanning procedure and thus obtain the path loss parameter C1 and the network broadcast information for each cell. This information can be used to produce a list of preferred cells. These cells shall then be ranked by the MS-MLE. The ranking algorithm is outside the scope of the present document.

In the event that there are no suitable cells available when all cells in the list have been scanned, the MLE shall inform the MM entity with an MLE-ACTIVATE indication primitive that no suitable cell has been found. The MLE shall continue the scanning of cells until a suitable cell is found, or until the MS is powered down. The exact procedures, algorithms and parameters applied for the continued scanning of cells are outside the scope of the present document.

The MS shall select a cell which has $C1 > 0$. The MS should choose the cell which has the highest ranking according to the initial cell selection ranking procedure.

NOTE: The initial cell selection ranking procedure is not defined by the present document.

The cell shall be selected by issuing a TL-SELECT request primitive to the TLC-SAP, to cause the MAC to switch to the main carrier of the cell. The parameters of the TL-SELECT request primitive inform the lower layers of the channel and the parameters, "maximum MS transmit power" and "minimum RX access level" for the cell. Once the cell has been selected the lower layers return a TL-SELECT confirm primitive. The MLE shall issue an MLE-ACTIVATE confirm primitive to the MM. If registration is required in the cell, the MM shall then register. If the registration is successful or if no registration is required, the MLE may receive an MLE-UPDATE request primitive from MM supplying information regarding updated search areas or cell types for further monitoring.

If the registration is to a cell which has its "System wide services" parameter set to "System wide services temporarily not supported" and the registration is accepted with a Location update accept type value of "Temporary registration" then the MS shall consider itself to be temporarily registered.

If the MS has received a "Temporary registration" acknowledgement and then initiates a cell reselection, it shall register to the new cell even if the cell belongs to the Registered Area of the MS.

In the event that the initial cell selection is unsuccessful as a result of registration or authentication failure, MM shall instruct the MLE attachment management sub-entity, using an MLE-UPDATE request primitive, to suspend the ranking of that cell. This shall result in the selection of a different cell by the MLE, unless all opportunities have been used, in which case MM shall close the MLE service.

Upon receipt of the MLE-OPEN request primitive from MM, the MLE shall send MLE-OPEN indication primitive to the higher layer 3 entities (CMCE and SNDCCP) and shall initiate the serving cell surveillance procedures for the new cell as defined in clause 18.3.4.3 and may also initiate monitoring or background/interrupting scanning of neighbour cells.

See also ETSI EN 300 392-7 [8], clause 6.6.2.2.

18.3.4.7 Cell reselection

18.3.4.7.0 Overview of cell reselection

This clause defines the overall process of the cell reselection procedure.

The cell reselection procedure shall ensure that the MS selects a cell in which it can reliably decode downlink data, i.e. on a main control channel, and in which it has a high probability of uplink communication according to the criteria in clause 18.3.4.5.7. The minimum conditions which shall have to be met are that $C1 > 0$ and that the maximum path delay is not exceeded.

NOTE 1: The SwMI informs the MS that maximum path delay is exceeded in a MAC-RESOURCE PDU.

If the cell reselection procedure is unsuccessful, such that the MLE is left with no usable radio channels, the MS-MLE shall indicate this to the MM using an MLE-ACTIVATE indication primitive. MM may give further instructions, e.g. new LAs or cell types, or, if all opportunities have been used, MM shall close the MLE services (see clause 16). When the MM eventually opens up the services again, MS-MLE shall be activated and the initial cell selection procedures as specified in clause 18.3.4.6 shall apply.

Cell reselection can be performed by the MS-MLE when a MS is attached to a cell in idle or traffic mode. The procedure can handle the following categories as listed below:

- undeclared;
- unannounced;
- announced type 3;
- announced type 2;
- announced type 1.

Where an MS is not involved in any voice or circuit mode data calls, then the MS-MLE shall perform undeclared cell reselection. Where a MS is involved in a voice or circuit mode data call, then cell reselection shall be performed based on the criteria set out below and in figure 18.6. In the case where there are one or more advanced links established and the MS does not support advanced link roaming, it is recommended that the MS-MLE disconnects these advanced links prior to performing cell reselection.

Undeclared cell reselection is performed by the MLE when there are no calls in progress. The MS may attempt to recover SNDTCP and/or advanced link connections on the new cell unless a subscriber class mismatch has occurred on the new cell (see clause 28.2.5b) or the new cell is a not-permitted cell (see clause 18.3.5.1.5).

Unannounced cell reselection is used when the MS is unable to or, in the case of listening to group calls, has no need to send the announcement signalling to the serving cell prior to performing the cell reselection. The MS should perform unannounced cell reselection also when the selected neighbour cell's "cell reselection types supported" or "cell reselection types supported DA" indicates that expedited cell reselection is recommended. The MS may attempt to recover any CMCE emergency connections on the new cell. The MS may attempt to recover any non-emergency CMCE connections unless the new cell is a not-permitted cell (see clause 18.3.5.1.5). The MS may attempt to recover SNDTCP and/or advanced link connections on the new cell unless a subscriber class mismatch has occurred on the new cell (see clause 28.2.5b) or the new cell is a not-permitted cell (see clause 18.3.5.1.5).

Announced cell reselection is used when the MS informs the serving cell prior to the cell change, and attempts to restore the call(s) upon arrival at the new serving cell. This maximizes the probability of restoring the CMCE and SNDTCP connections on the new cell. Announced cell reselection is divided into three categories to reflect different levels of SwMI and MS functionality. The MS may attempt to recover CMCE connections on the new cell (if they were not recovered automatically), The MS may attempt to recover SNDTCP (and /or advanced link connections) on the new cell unless a subscriber class mismatch has occurred on the new cell (see clause 28.2.5b).

Type 3 reselection is provided for MSs which are unable to perform background scanning of a selected neighbour cell, and which therefore have to break the call(s) for a period and perform foreground scanning in order to acquire broadcast and synchronization information for the new cell. Upon selecting the new cell, call restoration signalling can be used to restore the call(s).

Type 2 reselection requires that the MS has performed background scanning of a selected neighbour cell and, in the case that the selected cell is a DA cell, has received a SYSINFO-DA PDU from the selected cell, so is therefore in a position to immediately switch to the new cell. In type 2 the SwMI does not direct the MS to a channel in the new cell. The MS selects the MCCH or MCCH-Q on the new cell and performs call restoration signalling and may then be allocated a traffic channel upon successful completion of this signalling.

Type 1 reselection requires that the MS has performed background scanning and, in the case that the selected cell is a DA cell, has received a SYSINFO-DA PDU from the selected cell, and that the SwMI is able to direct the MS from the traffic channel on the original cell to the MCCH or MCCH-Q or directly to a traffic channel on the new cell. If the SwMI directs the MS to the MCCH or MCCH-Q, the SwMI may later allocate a traffic channel; no call restoration signalling is required from the MS.

NOTE 2: The MS does not explicitly attempt either type 1 or type 2 cell reselection. The MS includes the cell to which it intends to move in the cell reselection request. If the MS is required to register on the new cell, and both the MS and the SwMI support forward registration, then the MS also includes a forward registration request with the cell reselection request. It is the SwMI, not the MS, which determines whether type 1 or type 2 cell reselection is to be applied. For this reason the following clauses refer to the MS initiating "type 1/2 cell reselection"; this indicates that the MS has included the cell to which it intends to move in the cell reselection request.

NOTE 3: The MS cannot request a type 1/2 cell reselection if it has been unable to scan a suitable cell by the time that the cell reselection is required. In the case that the suitable cell is a DA cell, the MS needs to have also received a SYSINFO-DA PDU on that cell before requesting the type 1/2 cell reselection.

Unannounced and the three types of announced cell reselection shall apply to an MS engaged in a circuit mode call.

All MS-MLE shall support undeclared, unannounced and announced type 3 cell reselection. An MS-MLE may also support announced type 1/2 cell reselection. It is not necessary for the SwMI to know which type of cell reselection procedures the MS can support in order for these procedures to work. The MS may determine if forward registration is supported by the SwMI and if expedited cell reselection is recommended from the "neighbour cell information for CA" information element transmitted in the D-NWRK-BROADCAST PDU and the D-NWRK-BROADCAST-DA PDU, and the "neighbour cell information for DA" information element transmitted in the D-NWRK-BROADCAST-DA PDU.

If the SwMI does not support neighbour cell information in the D-NWRK-BROADCAST PDU or D_NWRK-BROADCAST-DA PDU transmissions (see clause 18.3.6.1), the SwMI shall only be able to support undeclared, unannounced and announced type 3 cell reselection.

If the SwMI supports neighbour cell information in the D-NWRK-BROADCAST PDU or D-NWRK-BROADCAST-DA PDU transmissions, the MS shall attempt announced type 1/2 cell reselection only to a neighbour cell that it has received neighbour cell information about in a D-NWRK-BROADCAST PDU or D-NWRK-BROADCAST-DA PDU on the current cell.

If the SwMI provides neighbour cell information, it shall support at least type 2 cell reselection to those cells included in the neighbour cell information i.e. if an MS requests type 1/2 cell reselection to a cell included in the neighbour cell information, the SwMI shall apply either type 1 or type 2 cell reselection (but see note 4).

NOTE 4: If, in exceptional circumstances, a temporary failure occurs, the SwMI may reject a valid type 1/2 cell reselection request with fail cause "cell reselection type not supported" (see clauses 18.4.1.4.3 and 18.5.7).

If the air cell margin timer T375 is active when MLE initiates a cell reselection, MM shall stop the T375 and shall send MM an MLE-CONFIGURE indication primitive instructing MM to use the periodic reporting time requested by the SwMI.

NOTE 5: T375 is only used by an MS that supports the AGA service (see annex O).

18.3.4.7.1 Determination of which type of reselection to apply

Figure 18.6 recommends a method for choosing a cell reselection type.

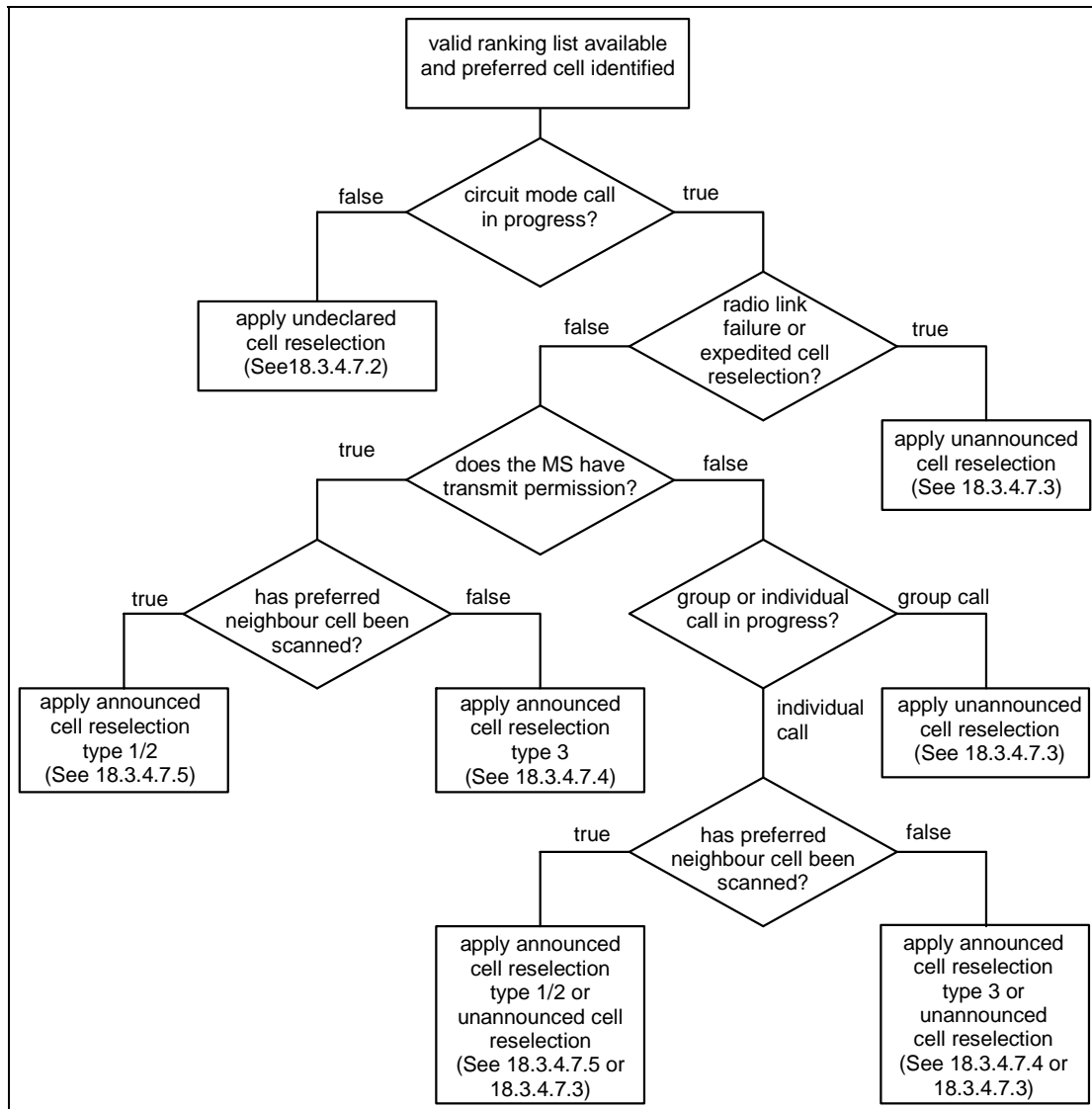

NOTE: If there is no circuit mode in progress, MLE applies undeclared cell reselection and, if SMDCP is in the READY-temporary break state and has data awaiting transmission, the MS SMDCP sends the SwMI an SN-RECONNECT PDU, refer to clause 28.3.4.2.

Figure 18.6: Recommended decision tree for choosing a cell reselection type

The MS shall normally perform cell reselection as a result of building a ranking list from monitoring or scanning of neighbour cells. From the neighbour cell measurements, one of the cell reselection criteria defined in clause 18.3.4.7.0 may be met causing cell reselection to be initiated. The cell chosen as the one to which the MS will attempt to select is known as the preferred neighbour cell.

In the case where the MS has knowledge of the neighbour cells (e.g. from the D-NWRK-BROADCAST or D-NWRK-BROADCAST-DA PDU or from scanning or pre-programmed at subscription), but has not yet built a valid ranking list, serving cell radio link failure may occur or the maximum path delay may be exceeded. If this happens, the MS shall apply undeclared cell reselection if not currently participating in a circuit mode call. If the MS is participating in a call or data transfer, the MS shall apply unannounced cell reselection.

If the MS has no knowledge of neighbour cells, the MS should apply cell reselection according to initial cell selection procedures, and then on the new cell the MS shall apply undeclared cell reselection procedure if not currently participating in a circuit mode call. If the MS is participating in a call, the MS may apply either unannounced or undeclared cell reselection procedure.

The MS shall initiate cell reselection subject to the criteria specified in clause 18.3.4.7.0. It should determine which type of reselection is to be applied from figure 18.6. The type of reselection to be employed shall depend on the following criteria:

- whether or not a circuit mode call is in progress;
- whether the preferred neighbour cell is a permitted cell or a not-permitted cell (see clause 18.3.5.1.5);
- whether radio link failure has occurred or expedited cell reselection is recommended;
- whether the call is an individual or group call;
- whether or not transmit permission has been granted;
- whether or not the MS has scanned the preferred neighbour cell.

The cell reselection procedure is usually initiated after the MS has built a valid ranking list and one of the cell reselection criteria as defined in clause 18.3.4.7.0 has resulted in selection of a preferred neighbour cell. An MS shall scan the preferred neighbour cell before it can select that cell. If the MS has performed background scanning of a preferred neighbour cell and, in the case that the preferred neighbour cell is a DA cell, has received a SYSINFO-DA PDU from the preferred neighbour cell, then it may attempt to use announced type 1/2 cell reselection.

If a circuit mode call is in progress and the preferred neighbour cell is a not-permitted cell, the MS shall use unannounced cell reselection.

If a circuit mode call is in progress and the MS has not performed background scanning of a preferred neighbour cell or, in the case that the preferred neighbour cell is a DA cell, the MS has not received a SYSINFO-DA PDU from that cell, the MS shall use unannounced or announced type 3 cell reselection.

If the MS has performed background scanning of a preferred neighbour cell and, in the case that the preferred neighbour cell is a DA cell, has received a SYSINFO-DA PDU from the preferred neighbour cell, and the decision tree in figure 18.6 indicates that announced type 1/2 cell reselection may be used, then it is recommended that the MS uses announced type 1/2 cell reselection. Otherwise, the MS shall use unannounced or announced type 3 cell reselection.

The SwMI chooses if type 1 or 2 cell reselection is to be applied, depending on its capabilities. If the new cell does not support forward registration (as indicated in the "cell reselection types supported" or "cell reselection types supported DA" information element broadcast as part of the D-NWRK-BROADCAST and D-NWRK-BROADCAST-DA PDUs), or the MS does not support forward registration, and registration is required on the new cell, and the MS requests announced type 1/2 cell reselection, the SwMI shall apply type 2 cell reselection or shall reject the request with a suitable fail cause.

Where the decision tree indicates that the MS should choose type 1/2 cell reselection, and the MS attempts type 1/2 cell reselection, the SwMI may either:

- respond with a type 2 cell reselection procedure causing the MS to select the MCCH or MCCH-Q and perform call restoration on the neighbour cell; or
- direct the MS to a traffic channel (or the MCCH or MCCH-Q) on the new cell: the MS is not required to perform call restoration on the new cell. This is the type 1 cell reselection procedure.

If the new cell supports forward registration, and registration is required, but the MS does not support forward registration the SwMI will apply type 2 cell reselection caused by the MS omitting to supply a forward registration request in the cell reselection request.

18.3.4.7.1a Conditions determining when registration is required during cell reselection

An MS shall be required to register when any of the following conditions are satisfied:

- the preferred neighbour cell does not belong to the same network as the current cell;
- the preferred neighbour cell is in a LA which is outside the current registered area of the MS and registration is required in the new cell as indicated in the "BS service details" information element for a new CA cell or the D-MLE-SYSINFO-DA PDU broadcast by a new DA cell. (The "BS service details" information element for a new CA cell is either received as part of the neighbour cell information in the D-NWRK-BROADCAST PDU or in the D-MLE-SYSINFO PDU or D-MLE-SYSINFO-Q PDU broadcast on the new cell);
- the MS has reselected from a CA cell to a DA cell (or vice versa) and registration is required when the MS changes cell type, as indicated by the "cell type change registration" information element in the D-MLE-SYSINFO-DA PDU received on the DA cell;
- the MS has received a "temporary registration" on the serving cell i.e. MS is temporarily registered - the MS shall register to the new cell even if the new cell belongs to the registered area of the MS and even if the new cell does not indicate that registration is required (in the "BS service details" information element for a new CA cell or the D-MLE-SYSINFO-DA PDU broadcast by a new DA cell);
- the preferred neighbour cell has its "System wide services" parameter set to "System wide services temporarily not supported" - the MS shall register to the new cell even if the new cell belongs to the registered area of the MS and even if the new cell does not indicate that registration is required (in the "BS service details" information element for a new CA cell or the D-MLE-SYSINFO-DA PDU broadcast by a new DA cell).

NOTE 1: The registered area consists of all the LAs in which the MS is currently registered.

NOTE 2: If the MS leaves a first cell and then returns to the first cell after a failed registration attempt sent on a second cell, or if the MS decides to stay on the first cell after requesting an announced type 3 cell reselection on the first cell for a second cell, it is recommended that the MS should regard the first cell as "the preferred neighbour cell" and should register if any of the normal conditions for registration apply. If the MS returns to a first cell type after a failed registration attempt sent on a second cell type (i.e. after attempting to change from CA to DA or vice versa), the MS should regard the return to the first cell type as a change of cell type and should register if any of the normal conditions for registration apply.

See also clause 16.4.1.

18.3.4.7.2 Undeclared cell reselection

Undeclared cell reselection shall be initiated by an MS if it is not currently involved in any circuit mode calls and one of the cell reselection criteria described in clause 18.3.4.7.0 is met causing a preferred neighbour cell to be selected. If cell reselection is initiated as a result of a radio relinquishable, radio improvable or radio usable condition, a preferred neighbour cell shall have been identified by the MS-MLE. This preferred neighbour cell may or may not have been scanned by the MS-MLE before cell reselection is initiated. If cell reselection is initiated as a result of serving cell radio link failure, a preferred neighbour cell may not yet have been identified.

Upon initiation of the undeclared cell reselection procedure, the MS-MLE shall perform the following actions:

- a) issue MLE-BREAK indication primitive, informing the higher layer 3 entities, SNDTCP and CMCE, that the radio link to the current serving cell is unavailable for C-plane signalling;
- b) where the MS does not support advanced link roaming, locally disconnect any advanced links by issuing TL-RELEASE request primitive via the TLA-SAP to layer 2;
- c) if no preferred neighbour cell has been selected, initiate foreground scanning of neighbour cells to select a preferred neighbour cell;
- d) if a preferred neighbour cell has been selected and background scanning of the preferred neighbour cell has not been performed, initiate foreground scanning of the preferred neighbour cell to confirm the selection;
- e) issue TL-SELECT request primitive via the TLC-SAP to cause the MAC to switch to the main carrier of the new cell; the MAC responds with TL-SELECT confirm primitive once the new cell has been selected;

- f) if the selected cell has a subscriber class mismatch (see clause 18.3.5.1.4), inform CMCE and SNDCP that there is no subscriber class match on the selected cell by sending MLE-INFO indication primitives;
- g) if the selected cell is a not-permitted cell (see clause 18.3.5.1.5), inform CMCE and SNDCP that the selected cell is a not-permitted cell by sending MLE-INFO indication primitives.

NOTE 1: If a DA cell is selected as the preferred neighbour cell then, in addition to the scanning in c) or d) above, the MS needs to obtain information necessary to use the cell by receiving a SYSINFO-DA PDU from the preferred neighbour cell. The MS may obtain this before issuing the TL-SELECT request primitive (including concurrently with scanning) by issuing a TL-CELL-READ request primitive via the TLC-SAP. The cell reselection will generally proceed more quickly if the MS has received a recent SYSINFO-DA PDU on the preferred neighbour cell before the MS-MLE issues the TL-SELECT request as otherwise layer 2 will wait until it receives a SYSINFO-DA PDU on a new DA cell before completing selection of the new cell.

NOTE 2: Some contents of the SYSINFO-DA PDU may change quite frequently. If the MS misses a change in the preferred neighbour cell's SYSINFO-DA PDU (e.g. if the CCK identifier changes), the MS may initially miss signalling addressed to itself on the new cell. So the MS may choose to periodically refresh its record of the preferred neighbour cell's SYSINFO-DA PDU.

Registration shall be required if the conditions specified in clause 18.3.4.7.1a are satisfied.

If registration is required, MLE shall issue an MLE-LINK indication primitive to MM. MM indicates the registration result by issuing MLE-UPDATE request primitive to MLE confirming or rejecting the cell. If registration was successful or if no registration was necessary, MLE shall send MLE-REOPEN indication primitive to the upper layer 3 entity CMCE, to indicate that the radio link is once again available for C-plane signalling. MLE shall send MLE-RESUME indication primitive to SNDCP, to indicate that the radio link is once again available for C-plane signalling.

If the registration is to a cell which has its "System wide services" parameter set to "System wide services temporarily not supported" and the registration is accepted with a Location update accept type value of "Temporary registration" then the MS shall consider itself to be temporarily registered.

If the registration result indicates "cell rejection":

- if the rejecting cell was the only cell available, the MLE shall send to MM an MLE-ACTIVATE indication primitive indicating "no cell available for any service"; or
- if the rejecting cell was not the only cell available, the MLE may attempt to select another cell from the ranking list.

The rejecting cell shall not be included in the ranking list again until the MLE has attempted reselection to another cell on the same SwMI or to a different SwMI, or until the MS is next powered on or goes to and returns from direct mode.

If the registration result indicates "cell type rejection" the MLE shall remove the rejecting cell from the ranking list. Then:

- if the rejecting cell was the only cell available, the MLE shall send to MM an MLE-ACTIVATE indication primitive indicating "no cell available for any service"; or
- if the rejecting cell was not the only cell available, the MLE may attempt to select another cell from the ranking list.

The rejecting cell shall not be included in the ranking list again until MLE receives a primitive from MM indicating that the rejecting cell type is a preferred cell type, or until MLE has attempted reselection to another cell on the same SwMI or to a different SwMI, or until the MS is next powered on or goes to and returns from direct mode.

NOTE 3: MM may advise MLE that the rejecting cell type is not a preferred cell type in the MLE-UPDATE request primitive that informs MLE of a cell type rejection. Following successful reselection to a different cell of the rejecting cell type, MM may advise MLE that the rejecting cell type is once more a preferred cell type (see clause 16.4.12).

If the registration result indicates "LA rejection", the MLE shall remove all cells with the LA in this MNC/MCC from the ranking list. The MLE may attempt to select another cell from the ranking list and re-apply cell reselection procedures. In all registration cases, cells with the rejecting LA may be included in the ranking list again when one of the following conditions apply:

- after successful location update to a cell in a different LA;
- the MS is next powered on;
- the MS goes to and returns from direct mode.

NOTE 4: Cells with the rejecting LA may also be included in the ranking list again after a suitable time or when the LA becomes available through the use of a "denied LA list". An MS may manage such a list, for example, to avoid oscillating between two rejecting cells.

If no cells remain in the ranking list after cells from the rejecting LA have been removed, the MLE shall send to MM an MLE-ACTIVATE indication primitive indicating "no cell available for any service".

If the registration result indicates "system rejection", the MLE shall remove all cells with the rejecting MNC/MCC from the ranking list. The MLE may attempt to select another cell from the ranking list and re-apply cell reselection procedures. In all registration cases, cells with the rejecting MNC/MCC may be included in the ranking list again after an attempted reselection to a cell with a different MNC/MCC or when the MS is next powered on or when the MS goes to and returns from direct mode.

If no cells remain in the ranking list after cells from the rejecting MNC/MCC have been removed, the MLE shall send to MM an MLE-ACTIVATE indication primitive indicating "no cell available for any service".

SNDCP may re-establish packet data communications as described in clause 28.3.4.2 (unless there is a subscriber class mismatch on the new cell or the new cell is a not-permitted cell), by re-establishing advanced links on the new cell. Where the MS supports advanced link roaming, SNDCP may attempt to reconnect the advanced links as described in clause 28.3.4.4 unless there is a subscriber class mismatch on the new cell or the new cell is a not-permitted cell.

See also ETSI EN 300 392-7 [8], clause 6.6.2.2.

18.3.4.7.3 Unannounced cell reselection

Unannounced cell reselection shall be initiated by an MS if one of the cell reselection criteria described in clause 18.3.4.7.0 is met and unannounced cell reselection is chosen according to the decision tree in figure 18.6. If cell reselection is initiated as a result of a radio relinquishable, radio improvable or radio usable condition, a preferred neighbour cell shall have been identified by the MS-MLE. This preferred neighbour cell may or may not have been scanned by the MS-MLE before cell reselection is initiated. If cell reselection is initiated as a result of serving cell radio link failure, a preferred neighbour cell may not yet have been identified.

Upon initiation of the unannounced cell reselection procedure, the MS-MLE shall perform the following actions:

- a) issue MLE-BREAK indication primitive, informing the higher layer 3 entities, SNDCP and CMCE, that the radio link to the current serving cell is unavailable for C-plane signalling;
- b) where the MS does not support advanced link roaming, locally disconnect any advanced links by issuing TL-RELEASE request primitive via the TLA-SAP to layer 2;
- c) if no preferred neighbour cell has been selected, initiate foreground scanning of neighbour cells to select a preferred neighbour cell;
- d) if a preferred neighbour cell has been selected and background scanning of the preferred neighbour cell has not been performed, initiate foreground scanning of the preferred neighbour cell to confirm the selection;
- e) issue TL-SELECT request primitive via the TLC-SAP to cause the MAC to switch to the main carrier of the new cell; the MAC responds with TL-SELECT confirm primitive once the new cell has been selected;
- f) if the selected cell has a subscriber class mismatch (see clause 18.3.5.1.4), inform CMCE and SNDCP that there is no subscriber class match on the selected cell by sending MLE-INFO indication primitives;
- g) if the selected cell is a not-permitted cell (see clause 18.3.5.1.5), inform CMCE and SNDCP that the selected cell is a not-permitted cell by sending MLE-INFO indication primitives.

NOTE 1: If a DA cell is selected as the preferred neighbour cell then, in addition to the scanning as in c) or d) above, the MS needs to obtain information necessary to use the cell by receiving a SYSINFO-DA PDU from the preferred neighbour cell. The MS may obtain this before issuing the TL-SELECT request primitive (including concurrently with scanning) by issuing a TL-CELL-READ request primitive via the TLC-SAP. The cell reselection will generally proceed more quickly if the MS has received a recent SYSINFO-DA PDU on the preferred neighbour cell before the MS-MLE issues the TL-SELECT request as otherwise layer 2 will wait until it receives a SYSINFO-DA PDU on a new DA cell before completing selection of the new cell.

NOTE 2: Some contents of the SYSINFO-DA PDU may change quite frequently. If the MS misses a change in the preferred neighbour cell's SYSINFO-DA PDU (e.g. if the CCK identifier changes), the MS may initially miss signalling addressed to itself on the new cell. So the MS may choose to periodically refresh its record of the preferred neighbour cell's SYSINFO-DA PDU.

Registration shall be required if the conditions specified in clause 18.3.4.7.1a are satisfied.

If registration is required, MLE shall issue an MLE-LINK indication primitive to MM.

If the registration is to a cell which has its "System wide services" parameter set to "System wide services temporarily not supported" and the registration is accepted with a Location update accept type value of "Temporary registration" then the MS shall consider itself to be temporarily registered.

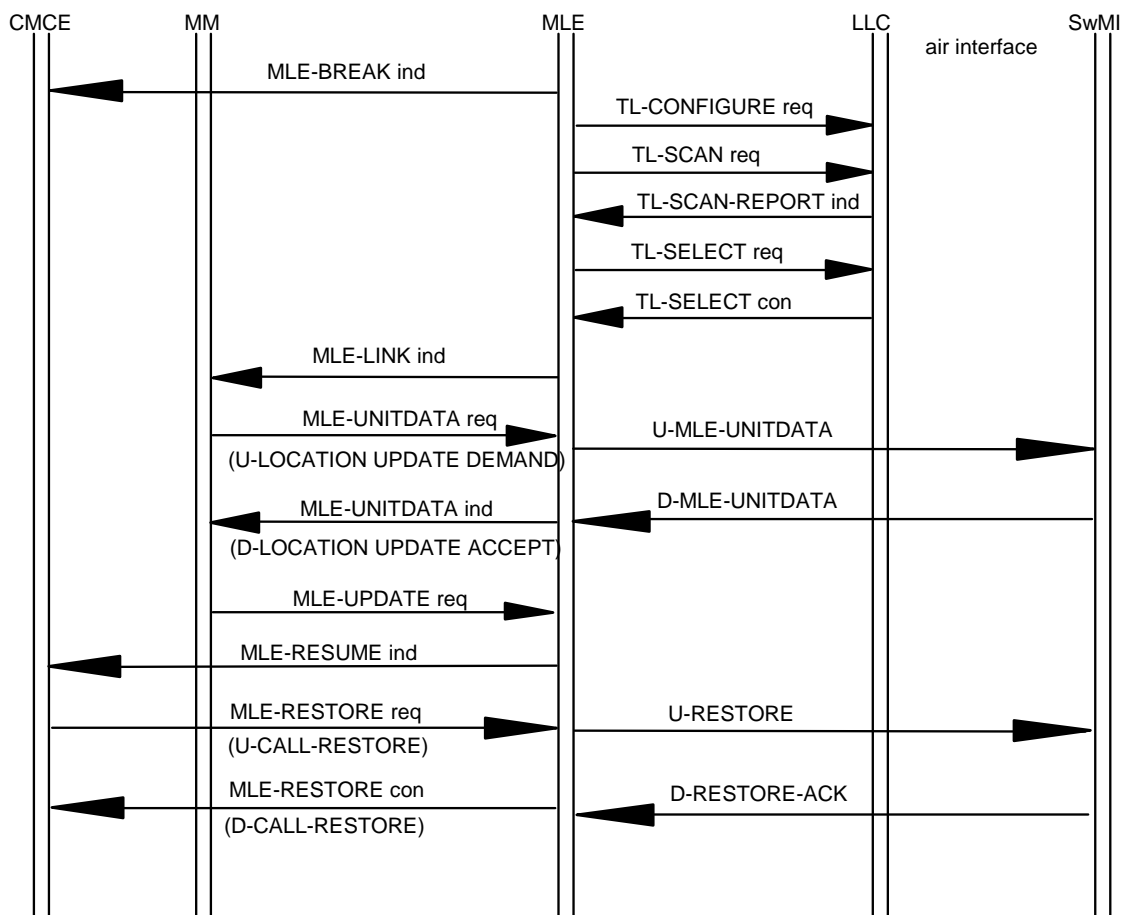

Figure 18.7: Unannounced cell reselection procedure

If the registration result indicates "cell rejection":

- if the rejecting cell was the only cell available, the MLE shall send to MM an MLE-ACTIVATE indication primitive indicating "no cell available for any service"; or
- if the rejecting cell was not the only cell available, the MLE may attempt to select another cell from the ranking list.

The rejecting cell shall not be included in the ranking list again until the MLE has attempted reselection to another cell on the same SwMI or to a different SwMI, or until the MS is next powered on or goes to and returns from direct mode.

If the registration result indicates "cell type rejection" the MLE shall remove the rejecting cell from the ranking list. Then:

- if the rejecting cell was the only cell available, the MLE shall send to MM an MLE-ACTIVATE indication primitive indicating "no cell available for any service"; or
- if the rejecting cell was not the only cell available, the MLE may attempt to select another cell from the ranking list.

The rejecting cell shall not be included in the ranking list again until MLE receives a primitive from MM indicating that the rejecting cell type is a preferred cell type, or until MLE has attempted reselection to another cell on the same SwMI or to a different SwMI, or until the MS is next powered on or goes to and returns from direct mode.

NOTE 3: MM may advise MLE that the rejecting cell type is not a preferred cell type in the MLE-UPDATE request primitive that informs MLE of a cell type rejection. Following successful reselection to a different cell of the rejecting cell type, MM may advise MLE that the rejecting cell type is once more a preferred cell type (see clause 16.4.12).

If the registration result indicates "LA rejection", the MLE shall remove all cells with the LA in this MNC/MCC from the ranking list. The MLE may attempt to select another cell from the ranking list and re-apply cell reselection procedures. In all registration cases, cells with the rejecting LA may be included in the ranking list again when one of the following conditions apply:

- after a successful location update to a cell in a different LA;
- the MS is next powered on;
- the MS goes to and returns from direct mode.

NOTE 4: Cells with the rejecting LA may also be included in the ranking list again after a suitable time or when the LA becomes available through the use of a "denied LA list". An MS may manage such a list, for example, to avoid oscillating between two rejecting cells.

If no cells remain in the ranking list after cells from the rejecting LA have been removed, the MLE shall send to MM an MLE-ACTIVATE indication primitive indicating "no cell available for any service".

If the registration result indicates "system rejection", the MLE shall remove all cells with the rejecting MNC/MCC from the ranking list. The MLE may attempt to select another cell from the ranking list and re-apply cell reselection procedures. In all registration cases, cells with the rejecting MNC/MCC may be included in the ranking list again after an attempted reselection to a cell with a different MNC/MCC or when the MS is next powered on or when the MS goes to and returns from direct mode.

If no cells remain in the ranking list after cells from the rejecting MNC/MCC have been removed, the MLE shall send to MM an MLE-ACTIVATE indication primitive indicating "no cell available for any service".

MM shall indicate successful registration by issuing MLE-UPDATE request primitive to MLE confirming the cell. If registration was successful or if no registration was necessary, MLE shall send MLE-RESUME indication primitive to the upper layer 3 entities, CMCE and SNDPCP, to indicate that the radio link is once again available for C-plane signalling.

- CMCE may attempt to restore any circuit mode calls which were in existence before the cell change (unless the present cell is a not-permitted cell, in which case CMCE may only restore emergency circuit mode calls). CMCE shall restore a call by responding to the MLE-RESUME indication primitive with MLE-RESTORE request primitive, containing a CMCE call restoration PDU. MLE shall send a U-RESTORE PDU, containing the CMCE call restoration.

NOTE 5: The MCC, MNC and LA refer to the old cell.

If call restoration is successful, MLE shall receive a D-RESTORE ACK PDU from the SwMI which shall contain the CMCE downlink call restoration signalling PDU. Upon receipt of the D-RESTORE ACK PDU indicating successful call restoration, MLE shall issue MLE-RESTORE confirm primitive to the CMCE. The MLE-RESTORE confirm primitive which is passed to CMCE shall contain the CMCE restoration signalling PDU.

NOTE 6: CMCE may attempt to restore multiple circuit mode calls using the above restoration procedure for each call. Calls are restored one at a time with a call restoration signalling sequence for each one.

NOTE 7: A successful call restoration, indicated by a D-CALL RESTORE/D-RESTORE ACK PDU, should include a channel allocation in the MAC header if the restored call currently has a traffic channel allocation.

If the D-RESTORE FAIL PDU is received instead, it shall indicate that call restoration was unsuccessful. The "fail cause" information element of the D-RESTORE FAIL PDU shall contain value "Restoration cannot be done on cell". MLE shall then issue MLE-REOPEN indication primitive to the CMCE to indicate that the radio path is restored, but that the calls have not been restored. The D-RESTORE FAIL PDU shall not carry an SDU for any of the higher layer 3 entities.

SNDTCP may re-establish packet data communications as described in clause 28.3.4.2 (unless there is a subscriber class mismatch on the new cell, or the new cell is a not-permitted cell), by re-establishing advanced links on the new cell. Where the MS supports advanced link roaming, SNDTCP may attempt to reconnect the advanced links as described in clause 28.3.4.4 unless there is a subscriber class mismatch on the new cell or the new cell is a not-permitted cell.

See also ETSI EN 300 392-7 [8], clause 6.6.2.3.

18.3.4.7.4 Announced cell reselection - type 3

Announced type 3 cell reselection shall be initiated by an MS if one of the cell reselection criteria described in clause 18.3.4.7.0 is met and announced type 3 cell reselection is chosen according to the decision tree in figure 18.6. If cell reselection is initiated as a result of a radio relinquishable, radio improvable or radio usable condition, a preferred neighbour cell shall have been identified by the MS-MLE. This preferred neighbour cell may or may not have been scanned by the MS-MLE before cell reselection is initiated. If cell reselection is initiated as a result of serving cell radio link failure and current channel radio link failure (see clause 18.3.4.5.3), or expedited cell reselection is recommended on the new cell (as indicated in a D-NWRK-BROADCAST or D-NWRK-BROADCAST-DA PDU), announced type 3 cell reselection shall not be attempted by the MS.

NOTE 1: If cell reselection is initiated as a result of serving cell radio link failure when the current channel has not failed, the MS may attempt announced type 3 cell selection.

Upon initiation of the announced type 3 cell reselection procedure, the MS-MLE of an MS presently using a CA cell shall send a U-PREPARE PDU to the SwMI. The U-PREPARE PDU shall not contain the "cell identifier CA" information element and the PDU shall not carry an SDU. The MS-MLE of an MS presently using a DA cell shall send a U-PREPARE-DA PDU to the SwMI. The U-PREPARE-DA PDU shall not contain the "cell identifier DA" information element or an SDU.

NOTE 2: The fact that the "cell identifier CA" or "cell identifier DA" information element is not present in the PDU informs the SwMI that a preferred neighbour cell has not yet been selected and that the MS-MLE is attempting announced type 3 cell reselection.

MLE shall send the U-PREPARE or U-PREPARE-DA PDU by issuing TL-DATA request primitive to layer 2 with the primitive parameters set as follows:

- PDU priority shall be set to 6;
- stealing permission shall be set to "steal immediately";
- the stealing repeats flag shall not be set.

NOTE 3: By transmitting the U-PREPARE or U-PREPARE-DA PDU, the MS informs the SwMI that it is about to change cell. The SwMI should also recognize the effect of the cell change on any circuit mode calls that the MS is currently involved in.

MLE shall start timer, T370, and shall await the response from the SwMI. The SwMI shall respond with a D-NEW-CELL PDU with the channel command valid information element set either to "Change channel immediately" or "No channel change". If set to "Change channel immediately", MLE shall reset timer T370 and initiate the cell change procedure described below. If set to "No channel change", MLE shall restart timer, T370, and wait for another D-NEW-CELL PDU from the SwMI. If, while waiting for a D-NEW-CELL PDU from the SwMI, current channel radio link failure occurs, the MS shall abandon the announcement signalling and initiate the unannounced cell reselection procedure immediately.

NOTE 4: The value "Follow MAC Channel Change" cannot be used for type 3 reselection. It can be used only for type 1 reselection.

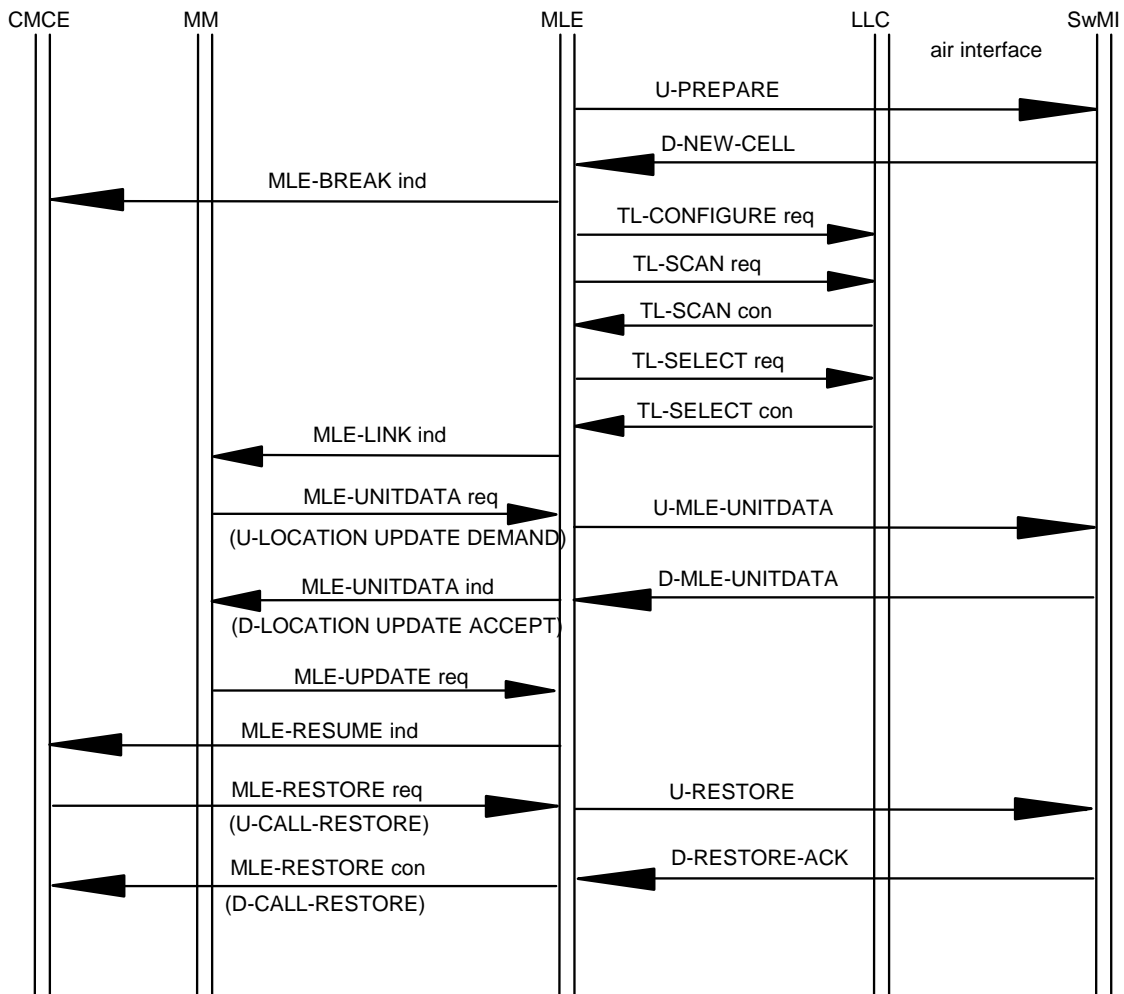

Figure 18.8: Announced type 3 cell reselection procedure

If timer T370 expires, the MS shall immediately initiate the cell change procedure as described below.

The SwMI shall not respond to U-PREPARE or U-PREPARE-DA PDU with a D-PREPARE-FAIL PDU in the case where the MS-MLE has not indicated a preferred neighbour cell in the U-PREPARE or U-PREPARE-DA PDU. Therefore a D-PREPARE-FAIL PDU shall not be a valid response for announced type 3 cell reselection.

Initiation of the cell change procedure

Upon initiation of the cell change procedure, the MS-MLE shall:

- issue MLE-BREAK indication primitive, informing the higher layer 3 entities, SNDTCP and CMCE, that the radio link to the current serving cell is unavailable for C-plane signalling;
- where the MS does not support advanced link roaming, locally disconnect any advanced links by issuing TL-RELEASE request primitive via the TLA-SAP to layer 2;
- initiate foreground scanning of the preferred neighbour cell (which has been selected as a result of monitoring and ranking) to confirm selection;
- issue TL-SELECT request primitive via the TLC-SAP to cause the MAC to switch to the main carrier of the new cell; the MAC responds with TL-SELECT confirm primitive once the new cell has been selected;
- if the selected cell has a subscriber class mismatch (see clause 18.3.5.1.4), inform CMCE and SNDTCP that there is no subscriber class match on the selected cell by sending MLE-INFO indication primitives.

NOTE 5: If the BS receives a U-PREPARE or U-PREPARE-DA PDU from an MS transmitting in a circuit mode call, the BS may remove the transmit permission by sending D-TX CEASED PDU to the other MS(s) in the cell. Alternatively, the BS may allow the MS changing cell to keep the transmit permission for a period of time or until it selects a new cell and restores the call on that cell.

NOTE 6: If a DA cell is selected as the preferred neighbour cell then, in addition to the scanning in c) above, the MS needs to obtain information necessary to use the cell by receiving a SYSINFO-DA PDU from the preferred neighbour cell. The MS may obtain this before issuing the TL-SELECT request primitive (including concurrently with scanning) by issuing a TL-CELL-READ request primitive via the TLC-SAP. The cell reselection will generally proceed more quickly if the MS has received a recent SYSINFO-DA PDU on the preferred neighbour cell before the MS-MLE issues the TL-SELECT request as otherwise layer 2 will wait until it receives a SYSINFO-DA PDU on a new DA cell before completing selection of the new cell.

NOTE 7: Some contents of the SYSINFO-DA PDU may change quite frequently. If the MS misses a change in the preferred neighbour cell's SYSINFO-DA PDU (e.g. if the CCK identifier changes), the MS may initially miss signalling addressed to itself on the new cell. So the MS may choose to periodically refresh its record of the preferred neighbour cell's SYSINFO-DA PDU.

Registration shall be required if the conditions specified in clause 18.3.4.7.1a are satisfied:

- If registration is required, MLE shall issue an MLE-LINK indication primitive to MM.
- If the registration is to a cell which has its "System wide services" parameter set to "System wide services temporarily not supported" and the registration is accepted with a Location update accept type value of "Temporary registration" then the MS shall consider itself to be temporarily registered.
- If the registration result indicates "cell rejection":
 - if the rejecting cell was the only cell available, the MLE shall send to MM an MLE-ACTIVATE indication primitive indicating "no cell available for any service"; or
 - if the rejecting cell was not the only cell available, the MLE may attempt to select another cell from the ranking list.

The rejecting cell shall not be included in the ranking list again until the MLE has attempted reselection to another cell on the same SwMI or to a different SwMI, or until the MS is next powered on or goes to and returns from direct mode.

If the registration result indicates "cell type rejection" the MLE shall remove the rejecting cell from the ranking list. Then:

- if the rejecting cell was the only cell available, the MLE shall send to MM an MLE-ACTIVATE indication primitive indicating "no cell available for any service"; or
- if the rejecting cell was not the only cell available, the MLE may attempt to select another cell from the ranking list.

The rejecting cell shall not be included in the ranking list again until MLE receives a primitive from MM indicating that the rejecting cell type is a preferred cell type, or until MLE has attempted reselection to another cell on the same SwMI or to a different SwMI, or until the MS is next powered on or goes to and returns from direct mode.

NOTE 8: MM may advise MLE that the rejecting cell type is not a preferred cell type in the MLE-UPDATE request primitive that informs MLE of a cell type rejection. Following successful reselection to a different cell of the rejecting cell type, MM may advise MLE that the rejecting cell type is once more a preferred cell type (see clause 16.4.12).

If the registration result indicates "LA rejection", the MLE shall remove all cells with the LA in this MNC/MCC from the ranking list. The MLE may attempt to select another cell from the ranking list and re-apply cell reselection procedures. In all registration cases, cells with the rejecting LA may be included in the ranking list again when one of the following conditions apply:

- after a successful location update to a cell in a different LA;
- the MS is next powered on;

- the MS goes to and returns from direct mode.

NOTE 9: Cells with the rejecting LA may also be included in the ranking list again after a suitable time or when the LA becomes available through the use of a "denied LA list". An MS may manage such a list, for example, to avoid oscillating between two rejecting cells.

If no cells remain in the ranking list after cells from the rejecting LA have been removed, the MLE shall send to MM an MLE-ACTIVATE indication primitive indicating "no cell available for any service".

If the registration result indicates "system rejection", the MLE shall remove all cells with the rejecting MNC/MCC from the ranking list. The MLE may attempt to select another cell from the ranking list and re-apply cell reselection procedures. In all registration cases, cells with the rejecting MNC/MCC may be included in the ranking list again after an attempted reselection to a cell with a different MNC/MCC or when the MS is next powered on or when the MS goes to and returns from direct mode.

If no cells remain in the ranking list after cells from the rejecting MNC/MCC have been removed, the MLE shall send to MM an MLE-ACTIVATE indication primitive indicating "no cell available for any service".

MM shall indicate successful registration by issuing MLE-UPDATE request primitive to MLE confirming the cell. If registration was successful or if no registration was necessary, MLE shall send MLE-RESUME indication primitive to the upper layer 3 entities, CMCE and SNDPCP, to indicate that the radio link is once again available for C-plane signalling.

CMCE may attempt to restore any circuit mode calls which were in existence before the cell change. CMCE shall restore calls by responding to the MLE-RESUME indication primitive with MLE-RESTORE request primitive, containing a CMCE call restoration PDU. MLE shall send a U-RESTORE PDU, containing the CMCE call restoration SDU using the LLC acknowledged service. The U-RESTORE PDU shall contain each of the following information elements only if the value on the new cell is different from that on the old cell:

- MNC;
- MCC;
- LA.

If call restoration is successful, MLE shall receive a D-RESTORE ACK PDU from the SwMI which shall contain the CMCE downlink call restoration signalling PDU. Upon receipt of the D-RESTORE ACK PDU indicating successful call restoration, MLE shall issue MLE-RESTORE confirm primitive to the CMCE. The MLE-RESTORE confirm primitive which is passed to CMCE shall contain the CMCE restoration signalling PDU.

NOTE 10: CMCE may attempt to restore multiple circuit mode calls using the above restoration procedure for each call. Calls are restored one at a time with a call restoration signalling sequence for each one.

If the D-RESTORE FAIL PDU is received instead, it shall indicate that call restoration was unsuccessful. The "fail cause" information element of the D-RESTORE FAIL PDU shall contain value "Restoration cannot be done on cell". MLE shall then issue MLE-REOPEN indication primitive to the CMCE to indicate that the radio path is restored, but that the call has not been restored. The D-RESTORE FAIL PDU shall not carry an SDU for any of the higher layer 3 entities.

SNDPCP may re-establish packet data communications as described in clause 28.3.4.2 (unless there is a subscriber class mismatch on the new cell), by re-establishing advanced links on the new cell. Where the MS supports advanced link roaming, SNDPCP may attempt to reconnect the advanced links as described in clause 28.3.4.4 unless there is a subscriber class mismatch on the new cell.

See also ETSI EN 300 392-7 [8], clause 6.6.2.4.

18.3.4.7.5 Announced cell reselection types 1 and 2

Announced type 1/2 cell reselection shall be initiated by an MS if one of the cell reselection criteria described in clause 18.3.4.7.0 is met and announced type 1/2 cell reselection is chosen according to the decision tree in figure 18.6. A preferred neighbour cell shall have been identified by the MS-MLE and shall have been scanned prior to initiating the cell reselection procedure. If the preferred neighbour cell is a DA cell, the MS shall also have received a SYSINFO-DA PDU from that cell prior to initiating the cell reselection procedure.

NOTE 1: When the MS scans a CA cell the MS receives both the SYNC and SYSINFO PDUs transmitted by that cell. When the MS scans a DA cell the MS receives the SYNC-DA PDU transmitted by that cell. It is possible that the MS may also receive a SYSINFO-DA PDU during scanning; however, the MS does not need to receive a SYSINFO-DA PDU during scanning.

If a SYSINFO-DA PDU was not received during scanning then, prior to initiating the cell reselection procedure, the MS-MLE shall request that the MAC attempts to receive a SYSINFO-DA PDU from the preferred DA neighbour cell by issuing a TL-CELL-READ request primitive via the TLC-SAP.

NOTE 2: Some contents of the SYSINFO-DA PDU may change quite frequently. If the MS misses a change in the preferred neighbour cell's SYSINFO-DA PDU (e.g. if the CCK identifier changes), the MS may be unable to rejoin its ongoing circuit mode calls when it reaches the new cell. So the MS may choose to periodically refresh its record of the preferred neighbour cell's SYSINFO-DA PDU. (The cell reselection will generally proceed more quickly if the MS has received a recent SYSINFO-DA PDU on the preferred neighbour cell before the MS-MLE issues the TL-SELECT request as otherwise layer 2 may wait until it receives a SYSINFO-DA PDU on a new DA cell before completing selection of the new cell.)

If cell reselection is initiated as a result of serving cell and current channel radio link failure (see clause 18.3.4.5.3), if expedited cell reselection is recommended on the new cell (as indicated in a D-NWRK-BROADCAST or D-NWRK-BROADCAST-DA PDU), or if the preferred neighbour cell has not yet been scanned, announced type 1/2 cell reselection shall not be attempted by the MS.

NOTE 3: If cell reselection is initiated as a result of serving cell radio link failure when the current channel has not failed, the MS may attempt announced type 1/2 cell selection.

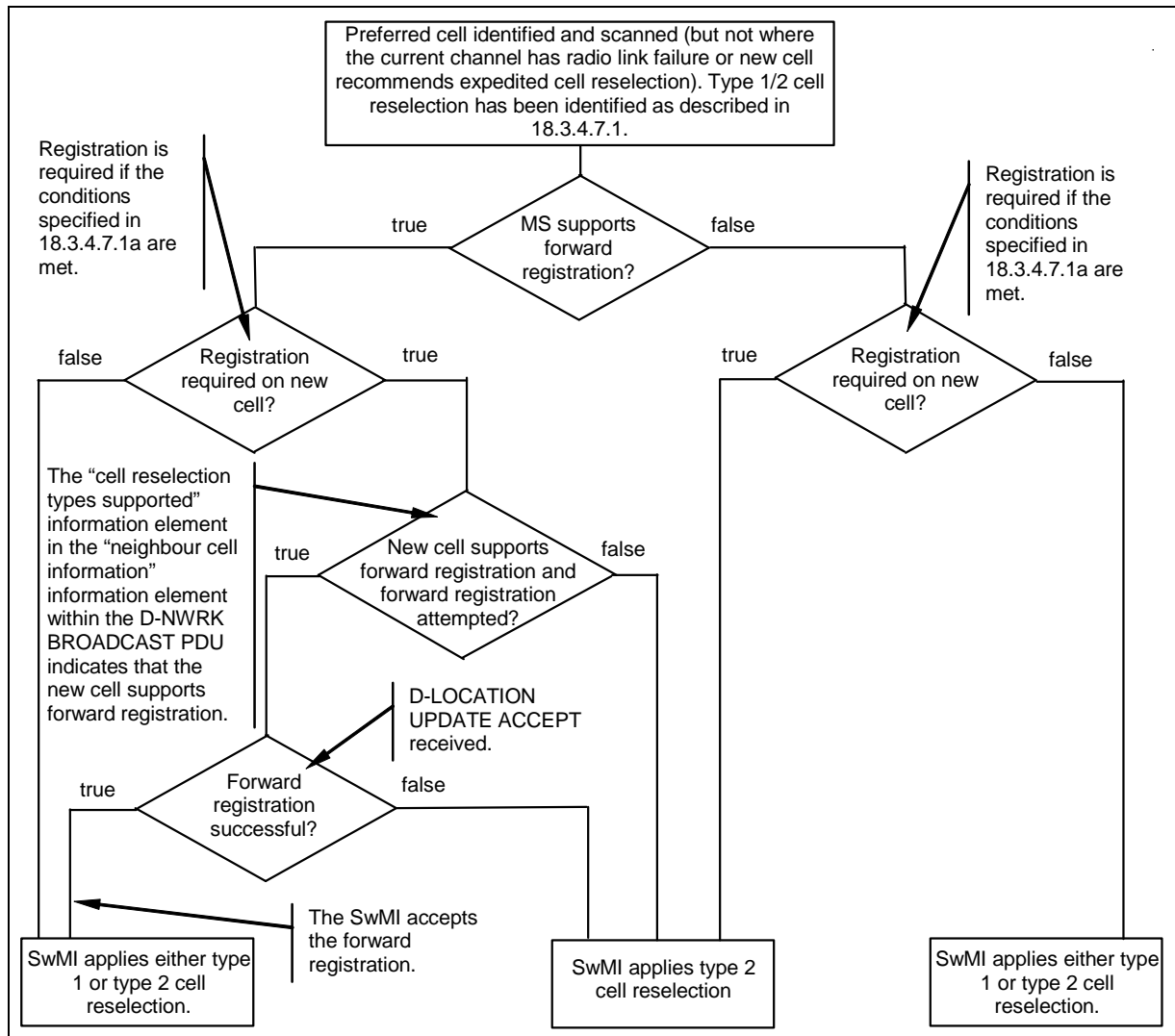

Figure 18.9: Decision tree to identify the type 1/2 reselection type applied by the SwMI

Upon initiation of the announced type 1/2 cell reselection procedure, the MS shall determine if registration is required in the new cell, refer to figure 18.9.

Registration shall be required if the conditions specified in clause 18.3.4.7.1a are satisfied.

If registration is required, the MS supports forward registration, and the new cell supports forward registration (see note 4), then the MLE shall issue MLE-LINK indication primitive to MM which shall have the following parameters:

- MCC of the preferred neighbour cell;
- MNC of the preferred neighbour cell;
- LA of the preferred neighbour cell;
- cell type of the preferred neighbour cell;
- registration type shall be set to "forward" to indicate that forward registration (i.e. registration in a cell other than the current serving cell) is required.

NOTE 4: The new cell's support for forward registration is indicated in the "cell reselection types supported" information element (in the "neighbour cell information for CA" information element within the D-NWRK BROADCAST PDU and the D-NWRK BROADCAST-DA PDU) and the "cell reselection types supported DA" information element (in the "neighbour cell information for DA" information element within the D-NWRK BROADCAST-DA PDU).

Upon initiation of the announced cell reselection type 1/2 procedure, the MS-MLE of an MS wishing to reselect to a CA cell shall send a U-PREPARE PDU to the SwMI. The MS-MLE of an MS wishing to reselect to a DA cell shall send a U-PREPARE-DA PDU. If registration is required, the MS supports forward registration, and the new cell supports forward registration (see note 4), then the U-PREPARE or U-PREPARE-DA PDU shall carry a U-LOCATION UPDATE DEMAND SDU. The U-PREPARE PDU shall contain the "cell identifier CA" information element which shall uniquely identify a cell defined by the D-NWRK-BROADCAST or D-NWRK-BROADCAST-DA PDU. The U-PREPARE-DA PDU shall contain a "cell identifier DA" information element referencing a cell announced by a D-NWRK-BROADCAST-DA PDU.

The MS may combine an OTAR CCK request with the cell reselection either by including a U-OTAR CCK DEMAND PDU within the U-PREPARE or U-PREPARE-DA PDU or by requesting the CCK within the U-LOCATION UPDATE DEMAND PDU as described in clause 4.5.1.3 of ETSI EN 300 392-7 [8].

NOTE 5: The fact that the U-PREPARE or U-PREPARE-DA PDU contains details which identify a preferred neighbour cell informs the SwMI that the MS is attempting announced type 1/2 cell reselection.

MLE shall send the U-PREPARE or U-PREPARE-DA PDU by issuing TL-DATA request primitive to layer 2 with the primitive parameters set as follows:

- PDU priority shall be set to 6;
- stealing permission shall be set to "steal immediately";
- the stealing repeats flag shall not be set.

NOTE 6: By transmitting the U-PREPARE or U-PREPARE-DA PDU, the MS informs the SwMI that it is about to change cell. The SwMI should also recognize the effect of the cell change on any circuit mode calls that the MS is currently involved in.

MLE shall start timer, T370, and shall await the response from the SwMI. The SwMI shall respond with a D-NEW-CELL PDU with the channel command valid information element set either to "Change channel immediately", "No channel change" or "Follow MAC channel change" or with a D-PREPARE-FAIL PDU (see clause 18.3.4.7.6).

If the SwMI decides to grant a type-1 cell reselection and the call identifier on the new cell differs from the call identifier on the present cell, the SwMI should send the MS the new call identifier in a D-INFO PDU before sending the MS a D-NEW-CELL PDU indicating "Follow MAC channel change" (i.e. granting a type 1 cell reselection). The D-INFO PDU should be sent using an acknowledged service and the BS should await receipt of a layer 2 acknowledgement to the D-INFO PDU before sending the D-NEW CELL PDU.

NOTE 7: The call identifier for the new cell should not be sent to the MS until the SwMI is ready to grant a type 1 cell reselection. The D-NEW-CELL PDU granting the type 1 cell reselection should be sent as soon as possible after the MS acknowledges the new call identifier because during the gap between receiving the new call identifier and receiving the D-NEW-CELL PDU the MS could receive group-addressed call related signalling using the old call identifier which would interrupt the MS's reception of the ongoing call. (If the BS uses an unacknowledged service to send the D-INFO PDU, it should send the D-INFO PDU several times before sending the D-NEW-CELL PDU.)

If forward registration was requested, the SwMI may or may not accept registration on the new cell. If forward registration was requested, and the SwMI accepts the registration, the D-NEW-CELL PDU shall contain an MM SDU accepting registration on the new cell. On receipt in the MS, the MM SDU shall be passed to MM using a MLE-PREPARE confirm primitive. A MLE-UPDATE request primitive shall then indicate successful registration to MLE.

NOTE 8: The SwMI controls whether type 1 or type 2 cell reselection is to be applied: generally, this is independent of whether the MS attempts forward registration. If the MS is required to register on the new cell, and it does not attempt to forward register, then the SwMI applies type 2 cell reselection: the MS registers on arrival in the new cell prior to call restoration.

The MS may receive OTAR CCK information from either a D-OTAR CCK PROVIDE PDU or D-LOCATION UPDATE ACCEPT PDU within the D-NEW-CELL PDU, and process it as described in clause 4.5.1.3 of ETSI EN 300 392-7 [8].

If the SwMI responds to the U-PREPARE or U-PREPARE-DA PDU with a D-NEW-CELL PDU which has the "Channel command valid" information element set to "No channel change", MLE shall restart timer T370 and shall wait for a further D-NEW-CELL PDU from the SwMI. The "No channel change" D-NEW-CELL PDU shall not contain a MM SDU.

Following the initial "No channel change" D-NEW-CELL PDU, the SwMI may continue to refresh timer T370 by sending further "No channel change" D-NEW-CELL PDUs. A "Change channel immediately" or "Follow MAC channel change" D-NEW-CELL PDU, received after a "No channel change" D-NEW-CELL PDU, shall contain a MM SDU and cause processing to continue, as described below, as if only a single D-NEW-CELL PDU containing "Change channel immediately" or "Follow MAC channel change" respectively has been received.

If cell reselection is successful, the SwMI responds to the cell reselection preparation with a D-NEW-CELL PDU, that shall contain a MM SDU. The "Channel command valid" information element is set to either "Change channel immediately" or "Follow MAC channel change". The content of the "Channel command valid" information element of the D-NEW-CELL PDU defines the type of cell reselection that the SwMI is applying. These options are described below:

1) Successful type 2 cell reselection:

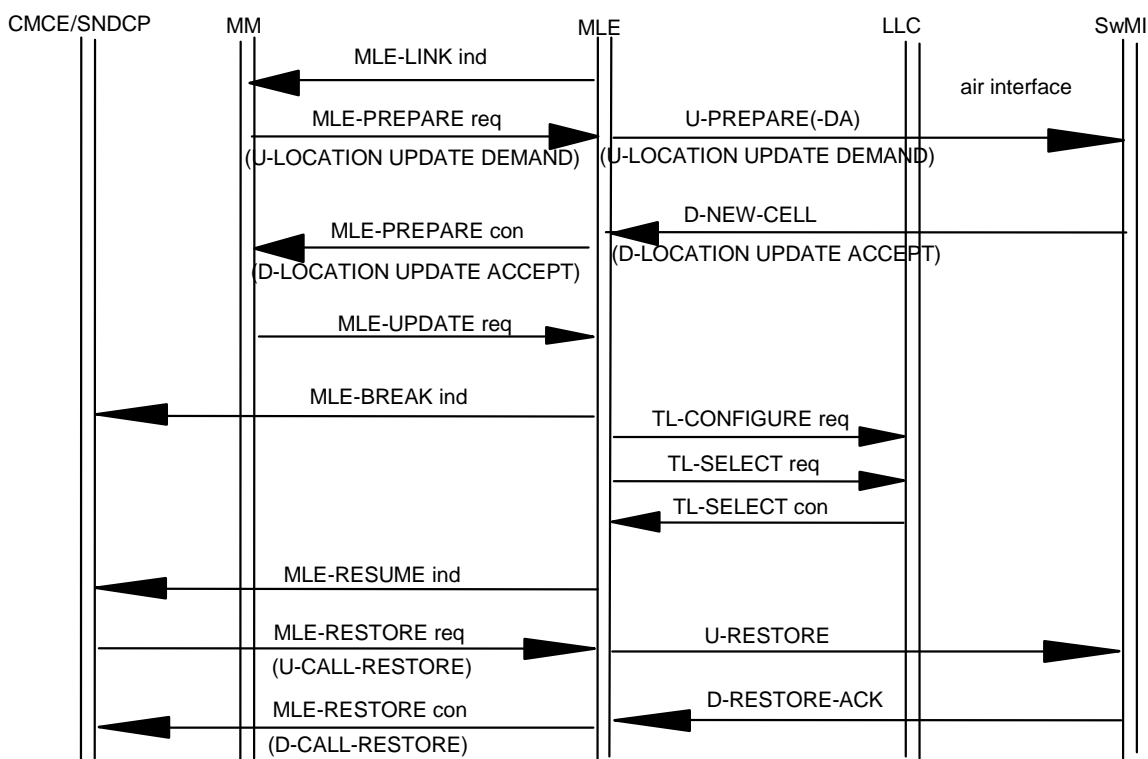

Figure 18.10: Announced type 2 cell reselection procedure, registration required, successful forward registration

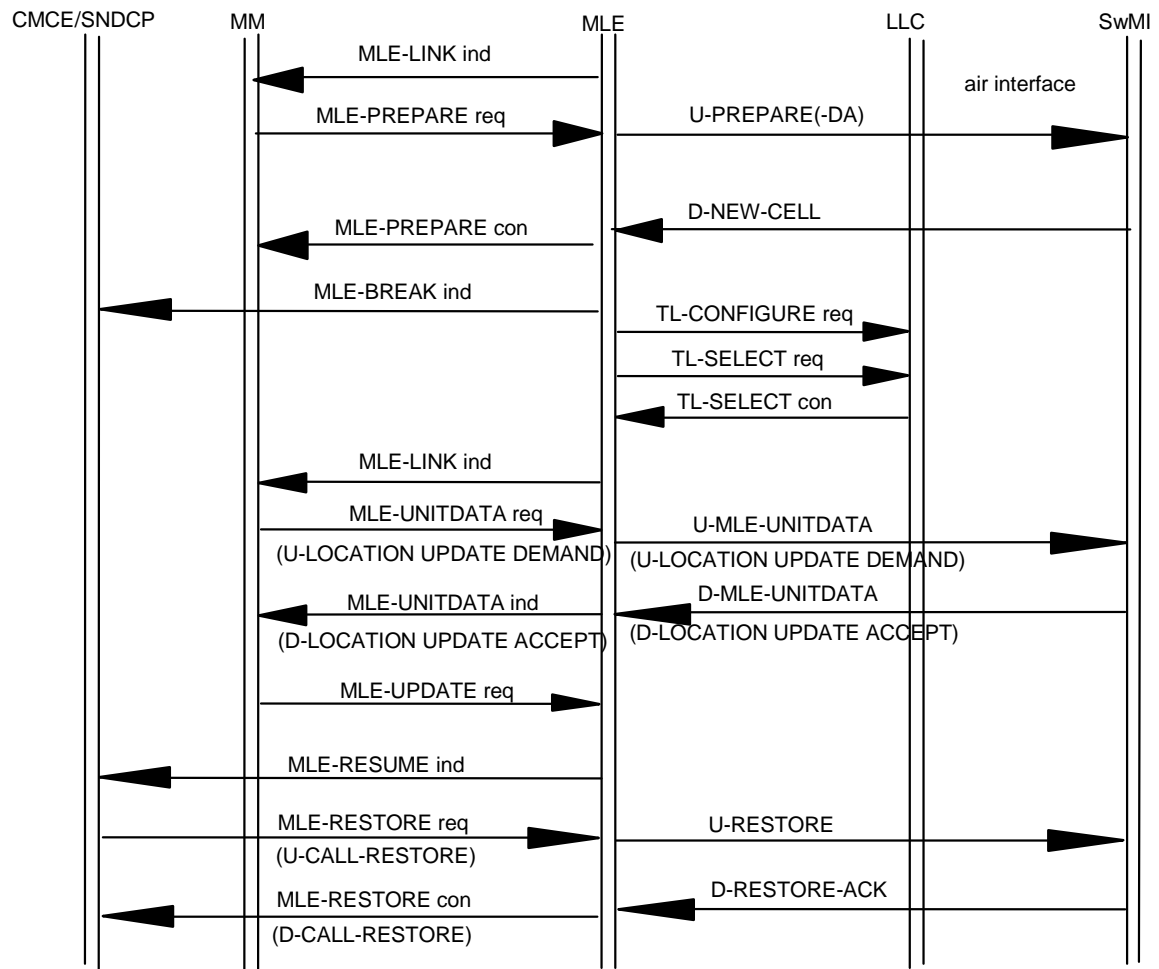

Figure 18.11: Announced type 2 cell reselection procedure, registration required, no forward registration

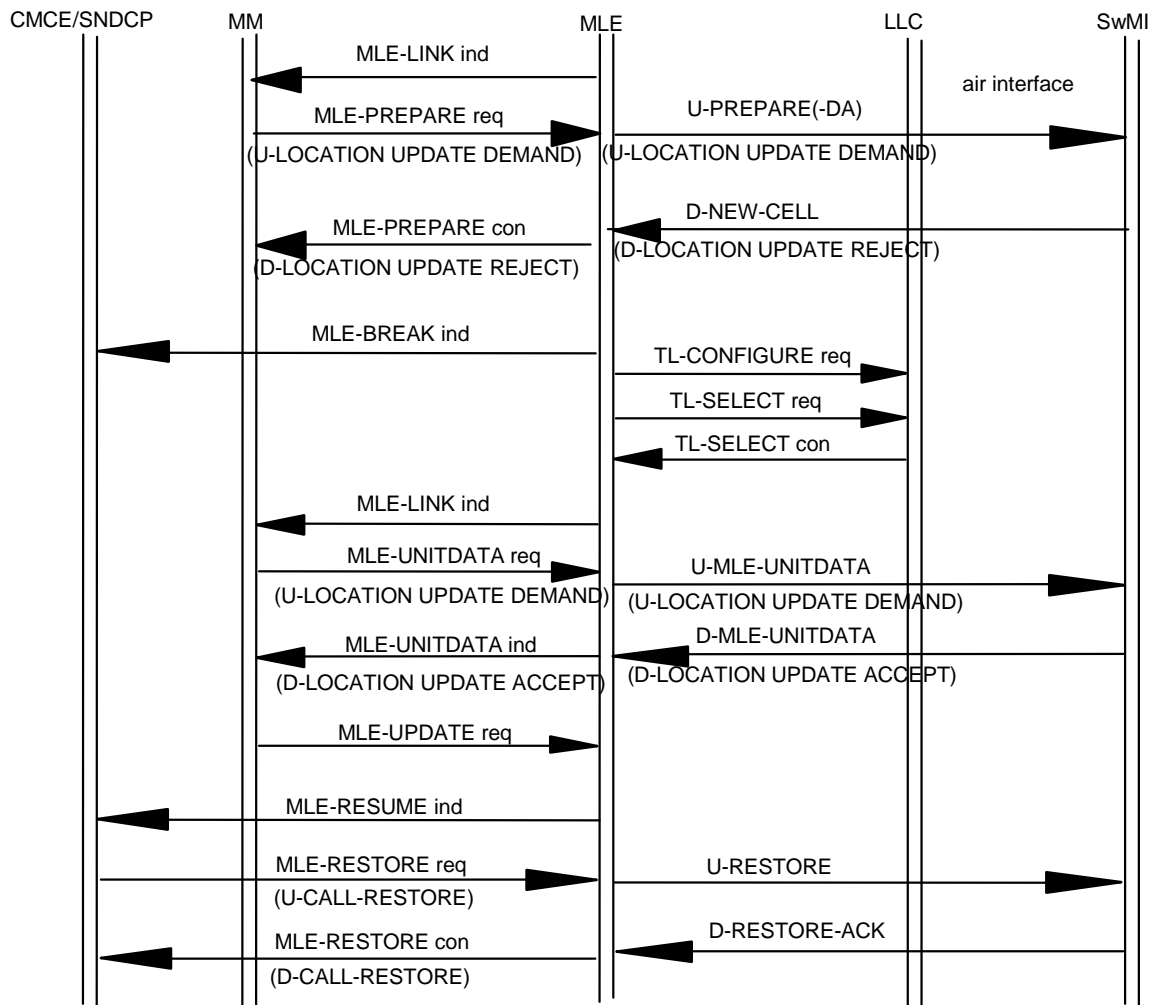

Figure 18.12: Announced type 2 cell reselection procedure, registration required, failed forward registration

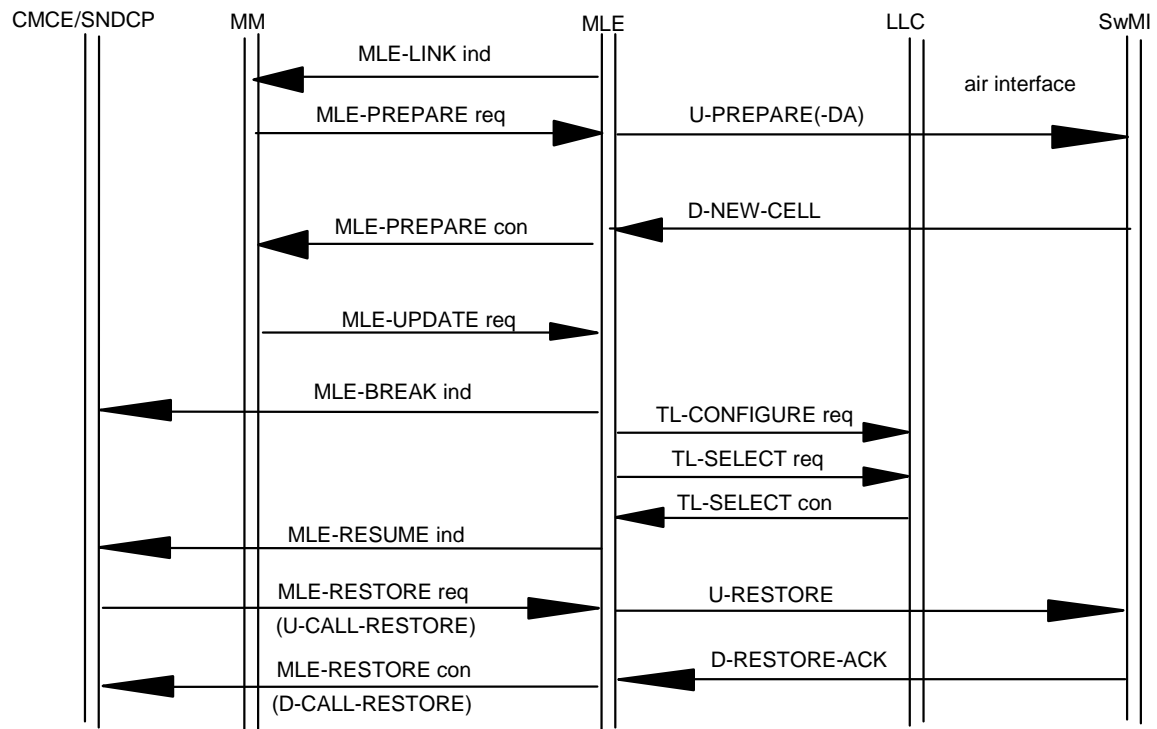

Figure 18.13: Announced type 2 cell reselection procedure, no registration required

If the "channel command valid" information element in the D-NEW-CELL PDU is set to "Change channel immediately" this shall cause the MS to switch autonomously to the MCCH or MCCH-Q of the new cell, reset T370 and initiate the cell change procedure as follows:

- issue MLE-BREAK indication primitive, informing the higher layer 3 entities, SNDCP and CMCE, that the radio link to the current serving cell is unavailable for C-plane signalling;
- where the MS does not support advanced link roaming, locally disconnect any advanced links by issuing TL-RELEASE request primitive via the TLA-SAP to layer 2;
- issue TL-SELECT request primitive via the TLC-SAP to cause the MAC to switch to the main carrier of the new cell; the MAC responds with TL-SELECT confirm primitive once the new cell has been selected;
- issue MLE-RESUME indication primitive to the upper layer 3 entities, CMCE and SNDCP to indicate that the radio link is once again available for C-plane signalling;
- if the selected cell has a subscriber class mismatch (see clause 18.3.5.1.4), inform CMCE and SNDCP that there is no subscriber class match on the selected cell by sending MLE-INFO indication primitives.

If registration is required and the MS did not attempt forward registration, MLE shall issue an MLE-LINK indication primitive to MM.

If the registration is to a cell which has its "System wide services" parameter set to "System wide services temporarily not supported" and the registration is accepted with a Location update accept type value of "Temporary registration" then the MS shall consider itself to be temporarily registered.

If the registration result indicates "cell rejection":

- if the rejecting cell was the only cell available, the MLE shall send to MM an MLE-ACTIVATE indication primitive indicating "no cell available for any service"; or
- if the rejecting cell was not the only cell available, the MLE may attempt to select another cell from the ranking list.

The rejecting cell shall not be included in the ranking list again until the MLE has attempted reselection to another cell on the same SwMI or to a different SwMI, or until the MS is next powered on or goes to and returns from direct mode.

If the registration result indicates "cell type rejection" the MLE shall remove the rejecting cell from the ranking list. Then:

- if the rejecting cell was the only cell available, the MLE shall send to MM an MLE-ACTIVATE indication primitive indicating "no cell available for any service"; or
- if the rejecting cell was not the only cell available, the MLE may attempt to select another cell from the ranking list.

The rejecting cell shall not be included in the ranking list again until MLE receives a primitive from MM indicating that the rejecting cell type is a preferred cell type, or until MLE has attempted reselection to another cell on the same SwMI or to a different SwMI, or until the MS is next powered on or goes to and returns from direct mode.

NOTE 9: MM may advise MLE that the rejecting cell type is not a preferred cell type in the MLE-UPDATE request primitive that informs MLE of a cell type rejection. Following successful reselection to different cell of the rejecting cell type, MM may advise MLE that the rejecting cell type is once more a preferred cell type (see clause 16.4.12).

If the registration result indicates "LA rejection", the MLE shall remove all cells with the LA in this MNC/MCC from the ranking list. The MLE may attempt to select another cell from the ranking list and re-apply cell reselection procedures. In all registration cases, cells with the rejecting LA may be included in the ranking list again when one of the following conditions apply:

- after successful location update to a cell in a different LA;
- the MS is next powered on;
- the MS goes to and returns from direct mode.

NOTE 10: Cells with the rejecting LA may also be included in the ranking list again after a suitable time or when the LA becomes available through the use of a "denied LA list". An MS may manage such a list, for example, to avoid oscillating between two rejecting cells.

If no cells remain in the ranking list after cells from the rejecting LA have been removed, the MLE shall send to MM an MLE-ACTIVATE indication primitive indicating "no cell available for any service".

If the registration result indicates "system rejection", the MLE shall remove all cells with the rejecting MNC/MCC from the ranking list. The MLE may attempt to select another cell from the ranking list and re-apply cell reselection procedures. In all registration cases, cells with the rejecting MNC/MCC may be included in the ranking list again after an attempted reselection to a cell with a different MNC/MCC or when the MS is next powered on or when the MS goes to and returns from direct mode.

If no cells remain in the ranking list after cells from the rejecting MNC/MCC have been removed, the MLE shall send to MM an MLE-ACTIVATE indication indicating "no cell available for any service".

MM shall indicate successful registration by issuing MLE-UPDATE request primitive to MLE confirming the cell. If registration was successful or if no registration was necessary, MLE shall send MLE-RESUME indication primitive to the upper layer 3 entities, CMCE and SNDCP, to indicate that the radio link is once again available for C-plane signalling.

CMCE may attempt to restore any circuit mode calls which were in existence before the cell change. CMCE shall restore calls by responding to the MLE-RESUME indication primitive with MLE-RESTORE request primitive, containing a CMCE call restoration PDU. MLE shall send a U-RESTORE PDU, containing the CMCE call restoration SDU using the LLC acknowledged service. The U-RESTORE PDU shall contain each of the following information elements only if the value on the new cell is different from that on the old cell:

- MCC;
- MNC;
- LA.

If call restoration is successful, MLE shall receive a D-RESTORE ACK PDU from the SwMI which shall contain the CMCE downlink call restoration signalling PDU. Upon receipt of the D-RESTORE ACK PDU indicating successful call restoration, MLE shall issue a MLE-RESTORE confirm primitive to CMCE. The MLE-RESTORE confirm primitive which is passed to CMCE shall contain the CMCE restoration signalling PDU.

NOTE 11: CMCE may attempt to restore multiple circuit mode calls using the above restoration procedure for each call. Calls are restored one at a time with a call restoration signalling sequence for each one.

If the D-RESTORE FAIL PDU is received instead, it shall indicate that call restoration was unsuccessful. The "fail cause" information element of the D-RESTORE FAIL PDU shall contain value "Restoration cannot be done on cell". MLE shall then issue MLE-REOPEN indication primitive to the CMCE to indicate that the radio path is restored, but that the call has not been restored. The D-RESTORE FAIL PDU shall not carry an SDU for any of the higher layer 3 entities.

SNDCP may re-establish packet data communications as described in clause 28.3.4.2 (unless there is a subscriber class mismatch on the new cell), by re-establishing advanced links on the new cell. Where the MS supports advanced link roaming, SNDCP may attempt to reconnect the advanced links as described in clause 28.3.4.4 unless there is a subscriber class mismatch on the new cell.

2) Successful type 1 cell reselection:

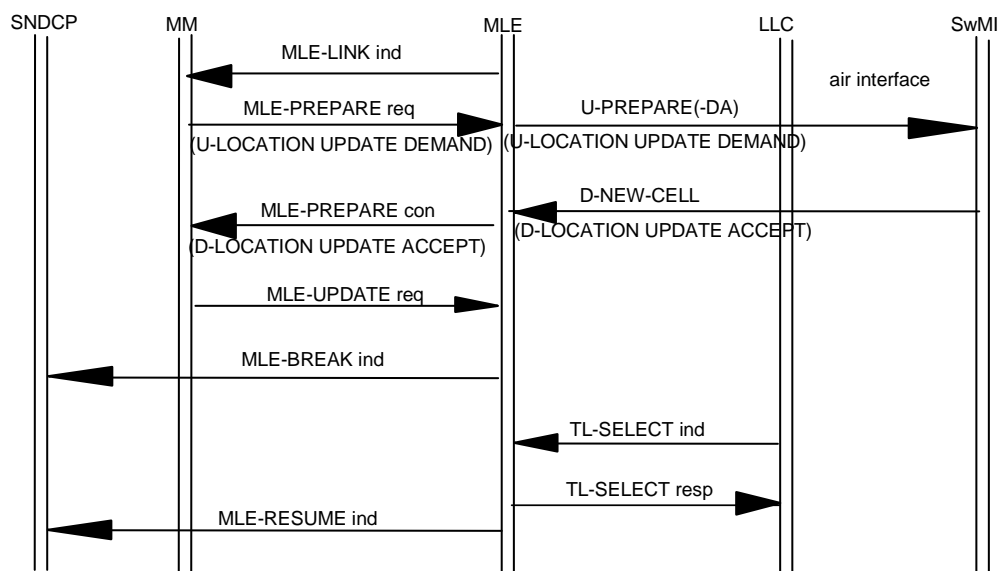

Figure 18.14: Announced type 1 cell reselection procedure, with forward registration

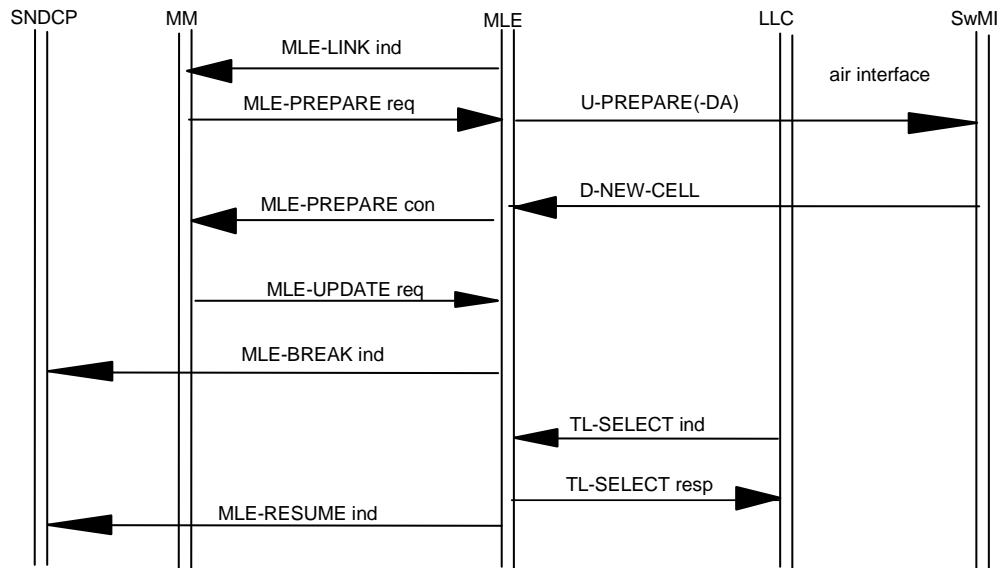

Figure 18.15: Announced type 1 cell reselection procedure, forward registration not required

If the "channel command valid" information element in the D-NEW-CELL PDU is set to "Follow MAC channel allocation" this indicates that a TCH has been allocated on the new cell to continue the circuit mode call, or that the MS has to switch to the MCCH or MCCH-Q of the new cell to continue the call. Upon reception of a D-NEW-CELL PDU, MS-MLE shall initiate the cell change procedure as follows:

- issue MLE-BREAK indication primitive, informing the higher layer 3 entity, SNDCP, that the radio link to the current serving cell is unavailable for C-plane signalling;
- where the MS does not support advanced link roaming, locally disconnect any advanced links by issuing TL-RELEASE request primitive via the TLA-SAP to layer 2;
- receive a TL-SELECT indication, indicating the channel change, and respond with a TL-SELECT response;
- issue MLE-RESUME indication primitive to SNDCP to indicate that the radio link is once again available for C-plane signalling;
- if the selected cell has a subscriber class mismatch (see clause 18.3.5.1.4), inform CMCE and SNDCP that there is no subscriber class match on the selected cell by sending MLE-INFO indication primitives.

The MAC shall automatically follow the channel allocation in the MAC header. The MAC indicates the channel change using TL-SELECT indication primitive to which the MLE shall respond with TL-SELECT response primitive containing a parameter to inform the MAC of the main carrier frequency on the new cell (see clause 20.3.5.4..8). On receiving TL-SELECT indication primitive indicating that the channel change has been completed by the MAC, the MLE shall send indication to SNDCP to indicate that the radio link is once again available for C-plane signalling. The MS shall continue the call on the new cell assuming the same U-plane/C-plane mode and transmit permission as it had on the old cell unless it has been directed to the MCCH or MCCH-Q on the new cell (i.e. the MS shall not assume that U-plane mode continues on MCCH or MCCH-Q);

NOTE 12: In this case, there is no need for the MS to send call restoration signalling on the new cell. If the SwMI directs the MS to the MCCH or MCCH-Q, the SwMI should then later complete the call restoration by directing the MS to a traffic channel.

SNDCP may re-establish packet data communications as described in clause 28.3.4.2 of the present document (unless there is a subscriber class mismatch on the new cell) by re-establishing advanced links on the new cell. Where the MS supports advanced link roaming, SNDCP may attempt to reconnect the advanced links as described in clause 28.3.4.4 of the present document unless there is a subscriber class mismatch on the new cell.

See also ETSI EN 300 392-7 [8], clauses 6.6.2.5 and 6.6.2.6.

18.3.4.7.6 Unsuccessful type 1/2 cell reselection

If, while waiting for a D-NEW-CELL PDU from the SwMI, current channel radio link failure occur or timer T370 expires, the MS shall abandon the announcement signalling and shall immediately initiate the unannounced cell reselection procedure described in clause 18.3.4.7.3.

Following the initial "No channel change" D-NEW-CELL PDU, the SwMI may continue to refresh timer T370 by sending further "No channel change" D-NEW-CELL PDUs. However, it is recommended that the total amount of time the SwMI keeps the MS waiting for a D-NEW-CELL PDU with "channel command valid" information element set to "Change channel immediately" or "Follow MAC channel change" is less than the duration of timer T351 (the registration response time) - refer to clause 16.11.1.1. When the timer T351 or timer T354 expires the MS shall abandon the announcement signalling and shall immediately initiate the unannounced cell reselection described in clause 18.3.4.7.3.

NOTE 1: Timer T354 would not normally be running during a type 1/2 cell reselection. However there may be exception conditions that result in T354 replacing T351 (refer to ETSI EN 300 392-7 [8]).

If the SwMI does not accept the cell reselection request (i.e. U-PREPARE or U-PREPARE-DA PDU) it shall respond to the MS with a D-PREPARE FAIL PDU. The "fail cause" information element of the D-PREPARE FAIL PDU may contain any of the values specified in clause 18.5.7, "Fail cause".

If forward registration was attempted, the D-PREPARE FAIL PDU shall carry an MM PDU rejecting registration on the new cell:

- If the "fail cause" information element of the D-PREPARE-FAIL PDU contains the value "Temporary break in service", "Cell reselection type not supported" or "Restoration cannot be done on cell", the "Reject cause" information element of the D-LOCATION UPDATE REJECT PDU shall have value "Forward registration failure".
- If the "fail cause" information element of the D-PREPARE-FAIL PDU contains the value "MS not allowed on cell" then the "reject cause" information element of the D-LOCATION UPDATE REJECT PDU shall have any value other than "Forward Registration failure".

The MM SDU shall be passed to MM using an MLE-PREPARE confirm primitive. MLE-UPDATE request primitive shall then inform MLE that the cell reselection was not successful.

If the MS-MLE receives a D-PREPARE-FAIL PDU with the fail cause value "MS not allowed on cell", "Restoration cannot be done on cell" or "Temporary break in service" from the SwMI, the MS-MLE may attempt announced cell reselection to another neighbour cell in the ranking list which meets one of the cell reselection criteria described in clause 18.3.4.7.0.

If the fail cause is "MS not allowed on cell":

- If forward registration was not attempted, or the reject cause in the MLE-UPDATE request primitive indicates "cell rejection" or "cell type rejection" (refer to clause 16.10.42), MM shall stay registered on the current serving cell. MLE shall remove the rejecting cell from the ranking list; if, following this action, the ranking list still contains other cells, MLE may attempt to select another cell from the list. The rejecting cell shall not be included in the ranking list again until one of the following events occurs:
 - an attempted reselection to another cell on the same SwMI or to a different SwMI; or
 - the MS is next powered on; or
 - the MS goes to and returns from direct mode; or
 - (only in the case of a "cell type rejection") MLE receives a primitive from MM indicating that the rejecting cell type is a preferred cell type.

NOTE 2: MM may advise MLE that a rejecting cell type is not a preferred cell type in the MLE-UPDATE request primitive that informs MLE of a cell type rejection. Following successful reselection to different cell of the rejecting cell type, MM may advise MLE that the rejecting cell type is once more a preferred cell type (see clause 16.4.12).

- If forward registration was attempted, and the reject cause in the MLE-UPDATE request primitive indicates "LA rejection" (refer to clause 16.10.42), the MLE shall remove all cells in the LA with this MNC/MCC from the ranking list. The MM shall stay registered on the current serving cell. The MLE may attempt to select another cell from the ranking list and re-apply cell reselection procedures. In all registration cases, cells with the rejecting LA may be included in the ranking list again when one of the following conditions apply:
 - after a successful location update to a cell in a different LA;
 - the MS is next powered on;
 - the MS goes to and returns from direct mode.

NOTE 3: Cells with the rejecting LA may also be included in the ranking list again after a suitable time or when the LA becomes available through the use of a "denied LA list". An MS may manage such a list, for example, to avoid oscillating between two rejecting cells.

- If forward registration was attempted, and the reject cause in the MLE-UPDATE request primitive indicates "system rejection" (refer to clause 16.10.42), the MLE shall remove all cells, with the rejecting MNC/MCC, from the ranking list. The MS remains registered on the current serving cell. The MLE may attempt to select another cell from the ranking list and re-apply cell reselection procedures. In all registration cases, cells with the rejecting MNC/MCC may be included in the ranking list again after an attempted reselection to a cell with a different MNC/MCC or when the MS is next powered on or when the MS goes to and returns from direct mode.

If the fail cause is "Restoration cannot be done on cell" (i.e. cell reselection has failed for call-related reasons), either:

- MM shall stay registered on the current serving cell and, if the rejecting cell is not the only cell in the ranking list, MLE may attempt to select another cell from the list and re-apply cell reselection procedures. MLE shall not remove the rejecting cell from the ranking list but if the rejecting cell is chosen as the preferred neighbour cell again during this cell reselection procedure, announced or unannounced cell reselection should not be attempted to that cell; or
- MLE may, if the rejecting cell is the only cell in the ranking list, force the call associated with the cell reselection to be dropped and then select the rejecting cell using the undeclared cell reselection procedures defined in clause 18.3.4.7.2.

NOTE 4: If the call is dropped, the MS should send a U-DISCONNECT PDU on the old cell in case the MS is the call owner of a group call or a party in an individual call.

If the fail cause is "Temporary break in service", (i.e. cell reselection has failed for network related reasons e.g. there are no free traffic channels on the new cell) either:

- MM shall stay registered on the current serving cell and, if the rejecting cell is not the only cell in the ranking list, MLE may attempt to select another cell from the list and re-apply cell reselection procedures. MLE shall not remove the rejecting cell from the ranking list but if the rejecting cell is chosen as the preferred neighbour cell again during this cell reselection procedure, announced cell reselection type 1/2 should not be attempted to that cell; or
- MLE may, if the rejecting cell is the only cell in the ranking list, attempt announced type 3 or unannounced cell reselection to the rejecting cell using the procedures defined in clauses 18.3.4.7.4 or 18.3.4.7.3.

If the MS-MLE receives a D-PREPARE-FAIL PDU with the fail cause value "Cell reselection type not supported", (i.e. forward registration has failed for network related reasons), either:

- MLE shall attempt unannounced cell reselection to the rejected cell using the procedure defined in clause 18.3.4.7.3; or
- MM shall stay registered on the current serving cell and MLE may attempt to select another cell from the ranking list and re-apply cell reselection procedures. MLE shall not remove the rejected cell from the ranking list but if the rejected cell is chosen as the preferred neighbour cell again during this cell reselection procedure, MLE should attempt neither announced cell reselection type 1/2 nor announced cell reselection type 3 to that cell.

NOTE 5: In the case of the MS attempting an unannounced cell reselection to the rejected cell, the U-PREPARE or U-PREPARE-DA PDU sent to the SwMI during the MS's failed announced type 1/2 cell reselection request may be used by the SwMI in restoring the CMCE and SNDCP connections on the new cell.

NOTE 6: If, in exceptional circumstances, a temporary failure occurs, the SwMI may reject a valid type 1/2 cell reselection request with fail cause "cell reselection type not supported" (see clauses 18.4.1.4.3 and 18.5.7).

All other combinations of the D-NEW-CELL/D-PREPARE-FAIL PDU and MM registration PDUs shall not be sent by the SwMI during announced type 1/2 cell reselection.

18.3.4.8 Change of broadcast parameters by the SwMI

Changes in broadcast parameters by the SwMI affect the behaviour of the MS. The broadcast parameters that affect MLE and the other layer 3 entities are obtained from the SYNC, SYNC-DA, SYSINFO, SYSINFO-DA and SYSINFO-Q PDUs. The parameters fall into two categories:

- information about the general services that are supported by the SwMI on a particular cell e.g. BS service details;
- information concerning the security services that are supported by the SwMI on a particular cell e.g. security information in extended services broadcast.

The behaviour of the MS is dependent upon the broadcast parameter that has changed. MLE shall determine if the parameter(s) that has changed requires the MS to re-register, whereon MLE shall issue an MLE-LINK indication primitive to MM.

If the status of the cell changes from "System wide services temporarily not supported" to "Normal mode" (system wide services supported) and the MS is temporarily registered with the cell then the MLE shall indicate a need for periodic registration to MM.

The behaviour of the MS when there is a change in the security parameters is defined in ETSI EN 300 392-7 [8].

The behaviour of a DA MS when there is a change in the cell identifier of its serving cell is defined in clause 18.3.6.6.

In addition to the above, MLE shall inform MM, CMCE and SNDCP of the change in broadcast parameter(s) via a MLE-INFO indication primitive.

18.3.4.9 Assigned channel replacement on the serving cell

18.3.4.9.0 General

This clause describes when and how an MS may request the SwMI to replace an assigned channel on the serving cell. Clauses 18.3.4.9 to 18.3.4.9.10 apply only to MSs which support the use of non-conforming channels.

Clause 18.3.4.9.11 applies to MSs which support the use of non-conforming channels and also applies to MSs which support data priority.

18.3.4.9.1 Types of assigned channels

18.3.4.9.1.1 General description of types of assigned channels

The assigned channel replacement request procedure allows the MS to request replacement of an assigned channel by a channel offering greater packet data throughput (e.g. at short range) or greater reliability (e.g. at long range). It also enables the MS to request a change of channel in cells using irregular channels (e.g. a change of sector in the case of a cell using sectored channels).

NOTE 1: Also, when an MS is on an assigned channel, the SwMI may choose to move the MS to a different channel at any time (for example, from one QAM channel to another QAM channel with a different bandwidth) - based on its observations of the performance of the current channel and the MS's capabilities.

A SwMI may offer the following types of assigned channels:

- A "conforming channel" has the same azimuthal radiation pattern as the main carrier, is radiated from the same site as the main carrier and has the same range (measured by the C1 path loss parameter) as the main carrier. It is a special case of a concentric channel. A channel which is not a conforming channel is called a non-conforming channel.
- A "concentric channel" has the same azimuthal radiation pattern as the main carrier and is radiated from the same site. It may use a different modulation mode, RF bandwidth and RF power to the main carrier and may have a higher or lower range and coverage area than the main carrier (i.e. it may be a non-conforming channel). Where the SwMI offers multiple concentric channels with different RF characteristics, a concentric channel offering a higher bandwidth will generally have a shorter range.
- A "channel class" is defined as a set of values indicating the general RF characteristics of a concentric channel or fully super-sectored channel (see clause 18.5.5b). A cell may offer more than one channel belonging to the same channel class. The MS predicts the performance of a channel class from measurements on a current channel (see clause 18.3.4.9.2) or by monitoring the main carrier (see clause 18.3.4.9.3) and advises the SwMI of the channel classes which it can currently use (see clauses 18.3.4.9.10 and 18.3.4.9.11).
- A "sectored channel" has an azimuthal extent that is smaller than, and contained entirely within, the azimuthal extent of the main carrier, and is radiated from the same site as the main carrier. It is a non-conforming channel and is not a concentric channel. The MS cannot predict the performance of a sectored channel by measurements on any other channel. The MS discovers which sectored channels it can use by monitoring each sectored channel (see clause 18.3.4.9.6) and advises the SwMI of the sectored channels which it can currently use (see clauses 18.3.4.9.10 and 18.3.4.9.11).
- A "super-sectored channel" has an azimuthal extent that exceeds the azimuthal extent of the main carrier in at least one azimuthal direction, and is radiated from the same site as the main carrier; it is a non-conforming channel and is not a concentric or sectored channel. A super-sectored channel may be either a semi-super-sectored channel or a fully super-sectored channel:
 - A "semi-super-sectored channel" is radiated from the same site as the main carrier, and has an azimuthal extent that exceeds the azimuthal extent of the main carrier in one azimuthal direction and is less than the azimuthal extent of the main carrier in the other azimuthal direction. Since the azimuthal extent of a semi-super-sectored channel is less than the azimuthal extent of the main carrier in one azimuthal direction, the MS cannot predict the performance of a semi-super-sectored channel by measurements on any other channel. The MS discovers which semi-super-sectored channels it can use by monitoring each semi-super-sectored channel (see clause 18.3.4.9.6) and advises the SwMI of the semi-super-sectored channels which it can currently use (see clauses 18.3.4.9.10 and 18.3.4.9.11).
 - A "fully super-sectored channel" is radiated from the same site as the main carrier, and has an azimuthal extent that is greater than, and entirely contains, the azimuthal extent of the main carrier. The BS may choose whether to broadcast information about fully super-sectored channels individually or as a channel class. (Broadcast is not needed if the channel fully covers the area covered by the main carrier i.e. if the radial range of the channel is the same as, or larger than, the radial range of the main carrier; see note 4.)
- An "eccentric channel" is a channel that is not radiated from the same site as the main carrier; it is a non-conforming channel and is not a concentric, sectored or super-sectored channel. The MS cannot predict the performance of an eccentric channel by measurements on any other channel. The MS discovers which eccentric channels it can use by monitoring each eccentric channel (if the SwMI broadcasts information about the channel, for example, if the channel does not fully cover the area covered by the main carrier). The MS then advises the SwMI of the eccentric channels which it can currently use. The present document supports up to a maximum separation of 4 km between the eccentric channel's transmitter site and the main carrier's transmitter site; see clauses 7.7 and 7.8.

NOTE 2: On a CA cell, a $\pi/4$ -DQPSK channel is normally a conforming channel.

NOTE 3: The present document does not support use of channels for which there is a greater separation than 4 km between the assigned channel's transmitter site and the main carrier's transmitter site.

An "irregular channel" is a non-conforming channel that needs to be monitored by the MS in order for the MS to discover whether the channel would be usable as an assigned channel. Sectored channels and semi-super-sectored channels are irregular channels. An eccentric channel is an irregular channel (if it does not fully cover the area covered by the main carrier). The SwMI may broadcast information about a fully super-sectored channel as either a channel class or an irregular channel. (Broadcast is not needed if the channel fully covers the area covered by the main carrier.)

NOTE 4: The SwMI does not need to broadcast information about conforming channels or those non-conforming channels that fully cover the area covered by the main carrier, since the MS does not normally need to assess or monitor these channels or inform the SwMI that these channels would be usable as an assigned channel. Nevertheless, the SwMI may choose to broadcast information about channels that fully cover the area covered by the main carrier; for example, in some cases, this may aid MSs that are sending or receiving real-time class data. (An MS that is sending or receiving real-time class data might prefer a channel that is more reliable than conforming when it is near the edge of the service area of the cell.)

The MS-MLE discovers if a cell supports the use of non-conforming channels by reception of a D-NWRK-BROADCAST-EXTENSION or D-NWRK-BROADCAST-DA PDU indicating the presence of non-conforming channels on that cell. The MS-MLE is informed by layer 2 about whether an assigned channel is a conforming channel, a non-conforming concentric channel, a sectored channel, a super-sectored channel or an eccentric channel (or whether the MS does not understand the conforming channel status of the channel); this information is provided by the channel information parameter in the TL-SELECT indication primitive.

The MS-MLE discovers which channel classes and irregular channels are available by inspection of D-NWRK-BROADCAST EXTENSION and D-NWRK-BROADCAST-DA PDUs.

The characteristics of available channel classes are given in the "channel class", "neighbour cell channel class for CA" and "neighbour cell channel class for DA" information elements. A cell may possess more than one channel of a particular channel class, but the MS-MLE is only interested in the existence of a channel class, not in the individual channels of that channel class.

The characteristics of irregular channels are given in the "irregular channel detail", "neighbour cell irregular channel detail for CA" and "neighbour cell irregular channel detail for DA" information elements. Each irregular channel is described individually so that the MS has enough information to monitor it.

CA MSs discover if the following cells provide non-conforming channels as described below:

- serving cell:
 - reception in D-NWRK-BROADCAST EXTENSION PDUs of "channel class" and "irregular channel detail" information elements;
- CA neighbour cells:
 - reception in D-NWRK-BROADCAST EXTENSION PDUs of "neighbour cell channel class for CA" and "neighbour cell irregular channel detail for CA" information elements;
- DA neighbour cells:
 - reception in D-NWRK-BROADCAST-DA PDUs of "neighbour cell channel class for DA" and "neighbour cell irregular channel detail for DA" information elements;
 - reception of serving cell "channel class" and "irregular channel detail" information elements in D-NWRK-BROADCAST-DA PDUs that contain a "cell identifier DA" information element. If the "cell identifier DA" information element is not present in the PDU, CA MSs shall not use the serving cell "channel class" and "irregular channel detail" information elements. If the "cell identifier DA" information element is present in the PDU, CA MSs shall interpret serving cell "channel class" and "irregular channel detail" information elements as channels available on the cell identified by the "cell identifier DA" information element. (However, a CA MS cannot use the indicated DA cell unless it receives a "neighbour cell information for DA" information element about that cell in a D-NWRK-BROADCAST-DA PDU. The CA MS requires that information before it can scan or monitor the relevant cell.)

DA MSs discover if the following cells provide non-conforming channels as described below:

- serving cell:
 - reception in D-NWRK-BROADCAST-DA PDUs of serving cell "channel class" and "irregular channel detail" information elements (see note 5);
 - reception in D-NWRK-BROADCAST-DA PDUs of "neighbour cell channel class for DA" or "neighbour cell irregular channel detail for DA" information elements containing "cell identifier DA" information elements that match the DA MS's serving cell (see note 6);
- CA neighbour cells:
 - reception in D-NWRK-BROADCAST EXTENSION PDUs of "neighbour cell channel class for CA" and "neighbour cell irregular channel detail for CA" information elements;
 - reception in D-NWRK-BROADCAST EXTENSION PDUs of serving cell "channel class" and "irregular channel detail" information elements. These shall be interpreted by DA MSs as channel classes and channels available on the local CA cell identified by a D-NWRK-BROADCAST-DA PDU;
- DA neighbour cells:
 - reception in D-NWRK-BROADCAST-DA PDUs of "neighbour cell channel class for DA" and "neighbour cell irregular channel detail for DA" information elements.

NOTE 5: When serving cell non-conforming channel information is included in a D-NWRK-BROADCAST-DA PDU on a channel used by MSs from more than one DA cell, each DA MS assumes the information relates to its own serving cell. (The "cell identifier DA" information element is not included in D-NWRK-BROADCAST-DA PDUs sent on channels used by MSs from more than one DA cell.) The SwMI can use this to broadcast common non-conforming channel information to MSs from more than one DA cell; however, the main carriers of the affected DA cells all have to operate at the same BS transmit power if channel class information is to be shared in this way. Otherwise, the SwMI can send out the information separately for each DA cell in "neighbour cell channel class for DA" and "neighbour cell irregular channel detail for DA" information elements.

NOTE 6: When a DA MS receives a D-NWRK-BROADCAST-DA PDU containing a "cell identifier DA" information element, it interprets that as the identifier of its serving cell.

There is no requirement for the SwMI to advertise the existence of channel classes with the same or greater coverage area than the main carrier (including conforming channel classes) in the D-NWRK-BROADCAST EXTENSION or D-NWRK-BROADCAST-DA PDUs. The SwMI assigns the MS to channels in these channel classes without assistance from the MS. When the MS-MLE wishes to make an assigned channel replacement request, it may assume that a conforming channel class is available.

There is also no requirement for the SwMI to advertise the existence of fully super-sectored and eccentric channels that fully cover the area covered by the main carrier in the D-NWRK-BROADCAST EXTENSION or D-NWRK-BROADCAST-DA PDUs. The SwMI may assign the MS to these channels without assistance from the MS.

NOTE 7: The SwMI does not need to broadcast information about conforming channels or those non-conforming channels that fully cover the area covered by the main carrier. Nevertheless, the SwMI may choose to broadcast information about non-conforming channels that fully cover the area covered by the main carrier; for example, in some cases, this may aid MSs that are sending or receiving real-time class data.

18.3.4.9.1.2 Umbrella channels

An umbrella channel is an assignable channel that fully covers the areas of multiple cells:

- A concentric channel that covers the radial extent of all its associated cells may be used as a umbrella channel.
- A fully super-sectored channel that also covers the radial extent of all its associated cells may be used as a umbrella channel.
- An eccentric channel that fully covers the areas of all its associated cells may be used as an umbrella channel. (Conversely an eccentric channel could cover a smaller area than its associated cell, for example, with several short-range eccentric channels between them covering the area covered by the associated cell.)

A case of usage of a fully super-sectored channel might be for a channel that is radiated from the same site as the main carrier and exceeds the azimuthal extent of the main carrier in both azimuthal directions and also has at least the same range as the main carrier, so fully encompasses the coverage of the main carrier. This could allow an assigned channel to fully cover the areas of multiple cells, as an umbrella channel, allowing a multi-cell group call to use a single assigned channel throughout the cells covered by the channel. For example, if three co-sited DA cells each have an azimuthal extent of 120° covering different azimuths and are co-sited with a CA cell with 360° azimuthal extent, a single $\pi/4$ -DQPSK assigned channel with 360° azimuthal extent could be used for a group speech call involving MSs from all four cells. (In this example, the $\pi/4$ -DQPSK assigned channel is concentric with the CA main carrier, so the CA MSs joining the group call would receive a channel allocation indicating that the channel is a conforming or non-conforming concentric channel.)

18.3.4.9.2 Serving cell channel class assessment

Serving cell channel class assessment is the procedure whereby the MS assesses the quality of channel classes on the serving cell from measurements made on the current channel or channels. The current channel(s) may be either conforming channel(s) or non-conforming concentric or sectored channel(s) (see note).

NOTE: If the current channel is a super-sectored or eccentric channel, or if the MS did not understand the conforming channel status for the current channel, the MS cannot assess the quality of channel classes on the serving cell based on measurements made on the current channel. Therefore, if the MS is currently receiving only super-sectored and/or eccentric channel(s) and/or channel(s) for which it does not understand the conforming channel status, and it wishes to assess the quality of channel classes, it needs to perform main carrier monitoring with assessment of channel classes (see clause 18.3.4.9.3).

Serving cell channel class assessment is not required for conforming channel classes or channel classes with greater coverage area (at the lowest modulation level) than the main carrier.

The criteria for starting and using serving cell channel class assessment are defined in clause 18.3.4.9.8.

If the criteria are fulfilled, the serving cell channel class assessment is started by issuing a TL-ASSESSMENT-LIST request primitive through the TLC-SAP informing layer 2 of the channel classes to be assessed. The parameters passed down with the TL-ASSESSMENT-LIST request primitive, for each channel class to be assessed, shall be a channel class label and the characteristics of the channel class that is to be assessed (obtained from the "channel class" information element in the D-NWRK-BROADCAST EXTENSION or D-NWRK-BROADCAST-DA PDU). The lower layers return a TL-ASSESSMENT indication primitive containing the C4 path loss parameter for each channel class which has been assessed. C4 is defined in clause 23.

Serving cell channel class assessment shall have been performed during the last 60 s for a measurement to be considered valid.

If it is required to stop the serving cell channel class assessment process, the MLE shall issue a TL-ASSESSMENT-LIST request primitive which does not contain a serving cell channel class as a parameter.

18.3.4.9.3 Main carrier monitoring with assessment of channel classes

Main carrier monitoring with assessment of channel classes is the procedure which allows the MS to assess the quality of channel classes on the serving cell from monitoring measurements on the serving cell's main carrier.

The criteria for starting and using main carrier monitoring with assessment of channel classes are defined in clause 18.3.4.9.8.

If the criteria are fulfilled, the main carrier monitoring with assessment of channel classes is started by issuing a TL-MONITOR-LIST request primitive through the TLC-SAP informing layer 2 of the channel to be monitored (the main carrier) and the channel classes to be assessed. The parameters passed down with the TL-MONITOR-LIST request primitive shall include the channel number of the main carrier and, for each channel class to be assessed, a channel class label and the characteristics of the channel class that is to be assessed (obtained from the "channel class" information element in the D-NWRK-BROADCAST EXTENSION or D-NWRK-BROADCAST-DA PDU). The lower layers return a TL-MONITOR indication primitive containing the C2 path loss for the main carrier and the C5 path loss parameter for each channel class which has been assessed. C5 is defined in clause 23.

Main carrier monitoring with assessment of channel classes shall have been performed during the last 60 s for a measurement to be considered valid.

If it is required to stop assessing a particular channel class within the main carrier monitoring with assessment of channel classes process, the MS-MLE shall issue a TL-MONITOR-LIST request primitive which does not contain the channel class for which assessment is to be stopped. If it is also required to stop monitoring the main carrier, the MS-MLE shall issue a TL-MONITOR-LIST request primitive which does not contain the channel number of the main carrier.

18.3.4.9.4 Neighbour cell channel class assessment

Neighbour cell channel class assessment is the procedure whereby the MS assesses the quality of channel classes on a neighbour cell.

Neighbour cell channel class assessment is not required for conforming channel classes or channel classes with greater coverage area than the main carrier of that neighbour cell.

The criteria for starting and using neighbour cell channel class assessment are defined in clause 18.3.4.9.8.

If the criteria are fulfilled, the neighbour cell channel class assessment is started by issuing a TL-MONITOR-LIST request primitive or a TL-SCAN request primitive through the TLC-SAP informing layer 2 of the main carrier of the neighbour cell to be monitored or scanned and the channel classes to be assessed.

The parameters passed down with the TL-MONITOR-LIST request primitive shall include the channel number and the RF characteristics of the neighbour cell main carrier to be monitored and, for each channel class to be assessed, a channel class label and the characteristics of the channel class that is to be assessed. The lower layers return a TL-MONITOR indication primitive or a TL-SCAN-REPORT indication primitive containing the C5 path loss parameter for each channel class. C5 is defined in clause 23. The parameters passed down with the TL-SCAN request primitive shall include the channel number and the RF characteristics of the neighbour cell main carrier to be scanned and, for each channel class to be assessed, a channel class label and the characteristics of the channel class to be assessed. The lower layers return a TL-SCAN confirm primitive containing the C5 path loss parameter for each channel class.

The channel number and RF characteristics of a CA neighbour cell's main carrier may be obtained from D-NWRK-BROADCAST PDUs and (for the local CA cell) D-NWRK-BROADCAST-DA PDUs. The channel class labels and characteristics of the channel classes may be obtained from D-NWRK-BROADCAST EXTENSION PDUs.

The channel number and RF characteristics of a DA neighbour cell's main carrier, the channel class labels and the characteristics of the channel classes may be obtained from D-NWRK-BROADCAST-DA PDUs.

Channel class assessment shall have been performed during the last 60 s for a measurement to be considered valid.

If it is required to stop assessing a particular channel class within the neighbour cell channel class monitoring with assessment of channel classes process, the MS-MLE shall issue a TL-MONITOR-LIST request primitive which does not contain the channel class for which assessment is to be stopped. If it is also required to stop monitoring the neighbour cell main carrier, the MS-MLE shall issue a TL-MONITOR-LIST request primitive which does not contain the channel number of the neighbour cell main carrier.

NOTE: The MS-MLE may decide to use the TL-SCAN request primitive instead of the TL-MONITOR-LIST request primitive to initiate channel class assessment on a neighbour cell if the MS-MLE needs to scan the neighbour cell main carrier for another reason.

18.3.4.9.5 Ranking of channel classes

Ranking of channel classes shall be based upon the received path loss parameters C1, C4 and C5 for the channel classes.

The ranking should produce a ranked channel class list. The list should always include a conforming channel class ranked by the path loss parameter C1 or C3 derived from serving cell surveillance measurements (refer to clause 18.3.4.3).

This ranked list may be used for making the decision of whether and when to change channel or cell, as described in clause 18.3.4.9.5.

18.3.4.9.6 Irregular channel monitoring

Irregular channel monitoring allows the MS to measure the path loss parameters C2 of irregular channels using information about the irregular channels broadcast by the serving cell. The MS is required to directly measure the received power of a monitored irregular channel. The irregular channels may be on the serving cell or on a neighbour cell.

In order to be able to monitor irregular channels, the MS-MLE shall have received a D-NWRK-BROADCAST EXTENSION or D-NWRK-BROADCAST-DA PDU containing a list of the irregular channels. The procedures concerning network broadcast PDUs are dealt with in clause 18.3.6. The criteria for starting and using irregular channel monitoring are defined in clause 18.3.4.9.8. If the criteria are fulfilled, the irregular channel monitoring is started by issuing a TL-MONITOR-LIST request primitive through the TLC-SAP. The TL-MONITOR-LIST request primitive informs layer 2 of the irregular channels to be monitored. The parameters passed down with the TL-MONITOR-LIST request primitive shall include the channel number and the RF characteristics of each channel to be monitored. The MS-MLE shall know locally which channels the MS is capable of monitoring and shall not instruct the lower layers to monitor any channel that the MS-MLE knows to be outside the capabilities of the equipment. For each channel the lower layers return a TL-MONITOR indication containing the C2 path loss parameter. C2 is defined in clause 23.

The channel numbers and RF characteristics of irregular channels on CA cells may be obtained from D-NWRK-BROADCAST EXTENSION PDUs. The channel numbers and RF characteristics of irregular channels on DA cells may be obtained from D-NWRK-BROADCAST-DA PDUs (see clause 18.3.4.9.1).

Monitoring is a background procedure and is defined in clause 23. Irregular channel monitoring shall have been performed during the last 60 s for an irregular channel monitoring measurement to be considered valid.

If it is required to stop the irregular channel monitoring process, the MLE shall issue a TL-MONITOR-LIST which does not contain an irregular channel as a parameter.

18.3.4.9.7 Ranking of monitored irregular channels

Ranking of monitored irregular channels shall be based upon the received path loss parameters C2 from the layer 2 monitoring process, issued in a TL-MONITOR indication primitive.

The ranking should produce a ranked irregular channel list. This ranked channel list may be used for making the decision of whether and when to change irregular channel (see clause 18.3.4.9.9.5) or cell.

18.3.4.9.8 Criterion for starting and using the channel class assessment and channel monitoring processes

This clause applies only to MSs which support the use of non-conforming channels.

The MS determines whether non-conforming channels exist on a CA cell from inspection of D-NWRK-BROADCAST EXTENSION and (for the local CA cell) D-NWRK-BROADCAST-DA PDUs. The MS determines whether non-conforming channels exist on a DA cell from inspection of D-NWRK-BROADCAST-DA PDUs (see clause 18.3.4.9.1).

The MS should assess the non-conforming channel classes (see clause 18.3.4.9.2) and monitor the irregular channels (see clause 18.3.4.9.6) on the serving cell if the MS SMDCP has requested the MS-MLE to prepare for transmitting or receiving packet data (as advised by a MLE-CONFIGURE request primitive from SMDCP containing an SMDCP status parameter set to "standing-by").

When the MS SMDCP advises the MLE that it is actively transmitting or receiving packet data (SMDCP status parameter set to "ready") the channel class assessment and irregular channel monitoring processes for channels on the serving cell should either be permanently enabled or should be enabled when some criterion is met, e.g. when the assigned channel path loss value C1 falls below a pre-determined threshold, or when a TL-REPORT indication primitive from layer 2 indicates that channel replacement is advisable or channel replacement may be beneficial.

When the MS-MLE needs to assess the quality of available channel classes, the MS-MLE may request layer 2 to perform main carrier monitoring with assessment of channel classes (see clause 18.3.4.9.3) in addition to, or instead of, serving cell channel class assessment.

NOTE 1: When the current channel is a sectored channel (indicated in the channel information parameter of the TL-SELECT indication primitive), main carrier monitoring with assessment of channel classes results (C5) are more reliable than channel class assessment results (C4). For example, C4 may be lower than C5 (i.e. the C4 path loss may be overestimated) when the MS is near the azimuthal boundary of a sectored channel. If the MS-MLE relies on the C4 path loss parameter near an azimuthal boundary, the MS-MLE could fail to detect channel classes that are radio usable. The MS-MLE may periodically initiate main carrier monitoring with assessment and compare the C4 and C5 path loss parameters to decide if it is necessary to continue to use main carrier monitoring with assessment.

NOTE 2: The MS is not precluded from using main carrier monitoring with channel class assessment on a concentric channel.

NOTE 3: If the current channel is a super-sectored or eccentric channel, or if the MS did not understand the conforming channel status, the MS cannot perform serving cell channel class assessment. Therefore, if the MS is currently receiving only super-sectored and/or eccentric channel(s) and/or channel(s) for which it does not understand the conforming channel status, and it wishes to assess the quality of channel classes, it needs to perform main carrier monitoring with assessment of channel classes.

It is assumed that the channel class assessment and irregular channel monitoring processes may be disabled when the quality of the currently-selected channel rises above the threshold plus some hysteresis factor, and a TL-REPORT indication primitive from layer 2 indicates that the current channel performance is acceptable. However, the MS may choose to continue channel class assessment or irregular channel monitoring if the MS requires a better service (see clause 18.3.4.9.9.5) than that provided by the current assigned channel.

To assist a cell reselection decision (clause 18.3.4.5.7) and to speed selection of a suitable packet data channel after a cell reselection, the MS may decide to assess any channel classes on neighbour cells and monitor any irregular channels on neighbour cells if the MS has received a D-NWRK-BROADCASTTEXTENSION or D-NWRK-BROADCAST-DA PDU indicating their existence and the SNDPCP status is "ready" or "standing-by" and the quality of the main carrier (as indicated by C1, C2 or C3 for the main carrier) falls below a pre-determined threshold.

MLE should terminate channel class assessment, main carrier monitoring with channel assessment, and irregular channel monitoring when SNDPCP advises MLE that the SNDPCP status is "idle".

It is a designer choice for the MS to assess channel classes and monitor irregular channels on the serving cell and neighbour cells at other times.

Where the channel class assessment and irregular channel monitoring processes are not permanently enabled, but started when a threshold value is crossed on a current channel, the threshold value should be chosen to be a value greater than the threshold parameters, FAST_CHANNEL_CHANGE_THRESHOLD, SLOW_CHANNEL_CHANGE_THRESHOLD, to allow the MS enough time to assess the channel classes and monitor the irregular channels and propose a new channel class or irregular channel prior to the complete loss of service from the current channel.

The exact method for the selection of the thresholds and hysteresis values for starting and stopping assessment and monitoring is outside the scope of the present document.

18.3.4.9.9 Criteria used for requesting an assigned channel replacement

18.3.4.9.9.0 General

The following clauses, and also clause 18.3.4.5.3, define the criteria which shall be used to initiate the assigned channel replacement procedure described in clause 18.3.4.9.10.

18.3.4.9.9.1 Data class offset

The DATA_CLASS_OFFSET is used to adjust the decision threshold for using a channel to take account of the differing reliability requirements of the various data classes being transmitted and received by SNDPCP. The value of DATA_CLASS_OFFSET depends on the data class most recently advised to the MS-MLE by SNDPCP in the data class information parameter of the MLE-CONFIGURE request primitive. The data class information parameter in the MLE-CONFIGURE primitive indicates the most demanding data class currently in active use by the MS. The value of the DATA_CLASS_OFFSET for each data class is a MS designer choice, and may be zero, but shall not be negative.

NOTE: The real-time data class is more demanding than the telemetry data class, and the telemetry data class is more demanding than the background data class.

18.3.4.9.9.2 Criterion for radio relinquishable assigned channel

An assigned channel becomes radio relinquishable when the quality of the downlink radio connection falls below a certain level and there is another channel class or irregular channel in the same cell which has a downlink radio connection of sufficient quality. The assigned channel may also be regarded as radio relinquishable when the MS-MAC indicates that channel replacement is advisable. The following conditions shall be met in order to declare the assigned channel radio relinquishable:

- the MS has been on the current assigned channel for at least time T372; and
- either:
 - a) the assigned channel path loss parameter C1 shall, for period T374, fall below (FAST_CHANNEL_CHANGE_THRESHOLD + DATA_CLASS_OFFSET) and the path loss parameter C2, C4 or C5 of at least one of the sectorized channels or channel classes in the ranking lists for the serving cell shall exceed by FAST_CHANNEL_CHANGE_HYSTERESIS the path loss parameter C1 of the assigned channel for period T374; or
 - b) the MS-MLE is informed by a TL-REPORT indication primitive that channel replacement is advisable (see note 2).

The MS-MLE shall check the criterion for channel relinquishment as often as one channel class is assessed or one irregular channel is monitored and on receipt of a TL-REPORT indication primitive indicating that channel replacement is advisable or may be beneficial.

NOTE 1: The values of FAST_CHANNEL_CHANGE_THRESHOLD and FAST_CHANNEL_CHANGE_HYSTERESIS may be set equal or relative to cell reselect parameters FAST_RESELECT_THRESHOLD and FAST_RESELECT_HYSTERESIS (see clause 18.5.4).

NOTE 2: In case b), the MS-MLE may regard the assigned channel as radio relinquishable even if none of the irregular channels or channel classes in the ranking lists for the serving cell exceed by FAST_CHANNEL_CHANGE_HYSTERESIS the path loss parameter C1 of the assigned channel. For example, this scenario could apply if the SwMI does not broadcast information about channels that fully cover the area covered by the main carrier and the MS is sending or receiving real-time class data and would like a more reliable channel when it is near the edge of the service area of the cell.

18.3.4.9.9.3 Criterion for radio improvable assigned channel

An assigned channel becomes radio improvable when the quality of another channel downlink radio connection on the serving cell exceeds that of the assigned channel by a certain amount. The following conditions shall be met in order to declare the assigned channel radio improvable:

- the MS has been on the current assigned channel for at least time T372; and
- the assigned channel path loss parameter C1 shall, for period T374, fall below (SLOW_CHANNEL_CHANGE_THRESHOLD + DATA_CLASS_OFFSET) and the path loss parameter C2, C4 or C5 of at least one of the irregular channels or channel classes in the ranking list for the serving cell shall exceed by SLOW_CHANNEL_CHANGE_HYSTERESIS the path loss parameter C1 of the assigned channel for period T374.

The MS-MLE shall check the criterion for improving the assigned channel or channels as often as one channel class is assessed or one irregular channel is monitored and on receipt of a TL-REPORT indication primitive indicating that channel replacement is advisable or may be beneficial.

NOTE: The values of SLOW_CHANNEL_CHANGE_THRESHOLD and SLOW_CHANNEL_CHANGE_HYSTERESIS may be set equal or relative to cell reselect parameters SLOW_RESELECT_THRESHOLD and SLOW_RESELECT_HYSTERESIS (see clause 18.5.4).

18.3.4.9.9.4 Criterion for radio usable channel or channel class

An irregular channel or a channel class becomes radio usable when it has a downlink radio connection of sufficient quality. The following conditions shall be met in order to declare an irregular channel or a channel class radio usable:

- the MS has been on the current assigned channel for at least time T372; and
- the irregular channel or channel class shall, for period T374, have a path loss parameter, C2, C4 or C5, which is greater than (FAST_CHANNEL_CHANGE_THRESHOLD + DATA_CLASS_OFFSET + FAST_CHANNEL_CHANGE_HYSTERESIS).

The MS-MLE shall check the criterion for a channel class being usable each time the channel class is assessed and shall check the criterion for an irregular channel being usable each time the irregular channel is monitored.

18.3.4.9.9.5 Criteria for initiating the assigned channel replacement procedures

Assigned channel replacement may be requested by the MS-MLE if an assigned channel is declared radio relinquishable (as defined in clause 18.3.4.9.9.2) and the SNDCP status is "ready" (as advised by the SNDCP status parameter in an MLE-CONFIGURE request primitive).

Assigned channel replacement may be requested by the MS-MLE if an assigned channel is declared radio improvable (as defined in clause 18.3.4.9.9.3), the SNDCP status is "ready" (as advised by the SNDCP status parameter in an MLE-CONFIGURE request primitive) and the service criteria as defined below are the same on both the assigned channel and another radio usable channel or channel class.

If the service provided by other channels on the present cell is lower than that provided by an assigned channel, the assigned channel replacement request may be postponed until the assigned channel is declared radio relinquishable (as defined in clause 18.3.4.9.9.2).

If the service provided by another irregular channel or channel class is higher than that provided by an assigned channel, then a channel replacement may be requested by the MS as soon as the other irregular channel or channel class is declared radio usable (as defined in clause 18.3.4.9.9.4).

Assigned channel replacement shall not be requested by the MS-MLE if the SNDCP status is not "ready".

The following service criteria may be used to compare the service provided by an assigned channel and another channel:

- bandwidth;
- modulation mode.

The bandwidth and modulation mode of available channel classes and individual irregular channels which do not cover all the area covered by the main carrier are broadcast in the D-NWRK-BROADCAST EXTENSION and D-NWRK-BROADCAST-DA PDUs.

Using the above criteria, an MS may decide whether another irregular channel or channel class on the present cell can be considered to offer better service than an assigned channel. The following conditions shall cause the MS to rate another irregular channel or channel class to have better service than an assigned channel:

- the other irregular channel or channel class has a higher bandwidth than the assigned channel, and the MS prefers that higher bandwidth;
- the other irregular channel or channel class uses the QAM modulation mode, the assigned channel uses the D8PSK or $\pi/4$ -DQPSK modulation mode and the MS prefers the use of the QAM modulation mode;
- the other irregular channel or channel class uses the D8PSK modulation mode, the assigned channel uses the $\pi/4$ -DQPSK modulation mode and the MS prefers the use of the D8PSK modulation mode;
- the other irregular channel or channel class uses the $\pi/4$ -DQPSK modulation mode, the assigned channel uses the QAM modulation mode and the MS prefers the use of the $\pi/4$ -DQPSK modulation mode.

The following conditions shall cause the MS to rate another channel to have lower service than an assigned channel:

- the other irregular channel or channel class has a lower bandwidth than the assigned channel, and the lower bandwidth is supported by the MS but the MS prefers not to use the lower bandwidth;
- the other irregular channel or channel class uses the $\pi/4$ -DQPSK or the D8PSK (if supported by the MS) modulation mode, the assigned channel uses the QAM modulation mode and the MS prefers the use of the QAM modulation mode;
- the other irregular channel or channel class uses the $\pi/4$ -DQPSK modulation mode, the assigned channel uses the D8PSK modulation mode and the MS prefers the use of the D8PSK modulation mode;
- the other irregular channel or channel class uses the QAM modulation mode, the assigned channel uses the D8PSK modulation mode and the MS prefers the use of the D8PSK or $\pi/4$ -DQPSK modulation mode;
- the other irregular channel or channel class uses the QAM modulation mode, the assigned channel uses the $\pi/4$ -DQPSK modulation mode and the MS prefers the use of the $\pi/4$ -DQPSK modulation mode.

In these cases the MS may postpone requesting a channel replacement until the assigned channel becomes radio relinquishable as defined in clause 18.3.4.9.9.2.

If an irregular channel or channel class uses a modulation mode or bandwidth which is not supported by the MS, the MS shall rate that irregular channel or channel class as providing no service to the MS.

If the other channel is deemed to offer neither better service or lower service than an assigned channel, the service shall be deemed to equal and the MS shall initiate the assigned channel replacement procedures as soon as another irregular channel or channel class becomes radio improvable over the assigned channel as defined in clause 18.3.4.9.9.3.

18.3.4.9.10 Assigned channel replacement request procedure

The assigned channel replacement procedure permits the MS to propose channel replacement by irregular channels and channel classes where it can reliably decode downlink data and where it has a high probability of uplink communication according to the criteria in clause 18.3.4.9.9.5.

An assigned channel replacement request may be made by the MS-MLE if one of the channel replacement criteria described in clause 18.3.4.9.9.5 is met, causing one or more irregular channels or channel classes to be selected by the MS-MLE. MS-MLE makes the request by sending a U-CHANNEL REQUEST PDU to the SwMI indicating a list of acceptable irregular channels and channel classes.

NOTE 1: If the MS requires replacement of the present channel but none of the channel classes or irregular channels broadcast by the SwMI are usable, the MS should send a U-CHANNEL REQUEST PDU with:

- a) the "channel class identifier" information element set to "conforming channel class", if the MS wishes to propose channel replacement by a conforming channel; or
- b) the "channel class identifier" information element set to "unspecified channel class", if the MS wishes to propose channel replacement by either a conforming channel or another channel that fully covers the area of the main carrier.

In case b), if the SwMI accepts the request, it should attempt to give the MS a channel with better coverage than the current channel. For example, if the current channel is a conforming channel, the SwMI should allocate a channel class with greater coverage than the main carrier or a fully super-sectored or eccentric channel that fully covers the area covered by the main carrier. This scenario could apply if the MS is sending or receiving real-time class data and would like a channel that is more reliable than conforming when it is near the edge of the service area of the cell.

The SwMI should respond to the request by sending the D-CHANNEL RESPONSE PDU, indicating acceptance or rejection of the request. If the response indicates that the request has been accepted, the D-CHANNEL RESPONSE PDU should be accompanied by a channel assignment which need not be to an irregular channel or channel class requested by the MS.

NOTE 2: For example, in some cases, it may be appropriate for the SwMI to allocate a channel whose existence has not been broadcast to MSs because the channel fully covers the area covered by the main carrier (i.e. a channel class with the same or greater coverage area than the main carrier or a fully super-sectored or eccentric channel that fully covers the area covered by the main carrier).

The following conditions determine when the MS-MLE may transmit a U-CHANNEL REQUEST PDU:

- the MS shall have been on the current assigned channel for time T372; and
- the time T373 shall have elapsed after transmission of a previous U-CHANNEL REQUEST PDU; and
- if a D-CHANNEL RESPONSE PDU received since the MS switched to the current channel contained the same value of "reason for the channel request" as that in the new U-CHANNEL REQUEST PDU, the MS-MLE shall not transmit the U-CHANNEL REQUEST PDU until the time "channel request retry delay" that was included in the D-CHANNEL RESPONSE PDU has elapsed since reception of that D-CHANNEL RESPONSE PDU.

NOTE 3: The MS is not required to remember old "channel request retry delay" values after the current channel has been replaced.

18.3.4.9.11 Channel class and irregular channel advice procedure

This clause applies to MSs which support the use of non-conforming channels and also applies to MSs which support data priority.

When non-conforming channels exist on a cell, and the MS wishes to be able to use one (e.g. for the transmission or reception of packet data), it should advise the SwMI which channel classes or irregular channels the MS can currently use. The advice is provided to the SwMI in a U-CHANNEL CLASS ADVICE or U-IRREGULAR CHANNEL ADVICE PDU.

The SwMI should use the MS's advice on usable channel classes and irregular channels when assigning the MS to a channel. However, the channel assignment need not be to a channel class or irregular channel included in the MS's advice PDU. For example, in some cases, it may be appropriate for the BS to allocate a channel whose existence has not been broadcast to MSs because the channel fully covers the area covered by the main carrier.

The method by which the MS-MLE is either requested or required by SNDCCP to send a U-CHANNEL CLASS ADVICE or U-IRREGULAR CHANNEL ADVICE PDU with certain SNDCCP PDUs is described in clause 18.3.5.3.1 item c).

When the MS-MLE is requested by the MS SNDCCP to transmit a U-CHANNEL CLASS ADVICE PDU or U-IRREGULAR CHANNEL ADVICE PDU, the MS-MLE should examine its ranked channel class list and its ranked irregular channel list for channel classes and channels which are radio usable, and determine its preferred channel classes and its preferred irregular channels. Then:

- if the MS-MLE has not received an indication that the current cell supports non-conforming channels (see clause 18.3.4.9.1), or if no radio usable non-conforming channel class or irregular channel has been advertised by broadcast on the current cell (see clause 18.3.4.9.9.4), the MS-MLE shall transmit the SNDCCP PDU without an attached U-CHANNEL CLASS ADVICE or U-IRREGULAR CHANNEL ADVICE PDU; or
- if the MS-MLE has received an indication that the current cell supports non-conforming channels (see clause 18.3.4.9.1) and the MS-MLE wishes to use a non-conforming concentric channel (or fully super-sectored channel), the MS-MLE should transmit the SNDCCP PDU with a U-CHANNEL CLASS ADVICE PDU identifying at least the channel class that offers the best service of those channel classes that are currently radio usable (see clause 18.3.4.9.9.5 for the definition of service criteria); or
- if the MS-MLE has received an indication that the current cell supports non-conforming channels (see clause 18.3.4.9.1) and the MS-MLE wishes to use an irregular channel, the MS-MLE should transmit the SNDCCP PDU with a U-IRREGULAR CHANNEL ADVICE PDU indicating one or more radio usable channels which offer the best service of those irregular channels that are currently radio usable.

When the MS-MLE is required by SNDSCP to transmit a U-CHANNEL CLASS ADVICE PDU or U-IRREGULAR CHANNEL ADVICE PDU (this occurs when SNDSCP requires the MS-MLE to send the "data priority" information element), the MS-MLE should determine its preferred channel classes and its preferred irregular channels, if any exist. Then:

- if the MS-MLE has not received an indication that the current cell supports non-conforming channels (see clause 18.3.4.9.1), or if the MS does not support the use of non-conforming channels, the MS-MLE shall transmit the SNDSCP PDU with a U-CHANNEL CLASS ADVICE PDU and shall set the "channel class identifier" information element to "unspecified channel class"; or
- if the MS-MLE has received an indication that the current cell supports non-conforming channels (see clause 18.3.4.9.1), but no radio usable non-conforming channel class or irregular channel has been advertised by broadcast on the current cell (see clause 18.3.4.9.9.4), and the MS supports the use of non-conforming channels, the MS-MLE shall transmit the SNDSCP PDU with a U-CHANNEL CLASS ADVICE PDU and shall set the "channel class identifier" information element to "unspecified channel class" or "conforming channel class"; or
- if the MS-MLE has received an indication that the current cell supports non-conforming channels (see clause 18.3.4.9.1) on the current cell and the MS-MLE wishes to use a non-conforming concentric channel (or fully super-sectored channel), the MS-MLE shall transmit the SNDSCP PDU with a U-CHANNEL CLASS ADVICE PDU and should indicate at least the channel class that offers the best service of those channel classes that are currently radio usable (see clause 18.3.4.9.9.5 for the definition of service criteria); or
- if the MS-MLE has received an indication that the current cell supports non-conforming channels (see clause 18.3.4.9.1) and the MS-MLE wishes to use an irregular channel, the MS-MLE shall transmit the SNDSCP PDU with a U-IRREGULAR CHANNEL ADVICE PDU identifying at least the irregular channel that offers the best service of those irregular channels that are currently radio usable (see clause 18.3.4.9.9.5 for the definition of service criteria).

The U-CHANNEL CLASS ADVICE and U-IRREGULAR CHANNEL ADVICE PDUs shall be transmitted attached to an SNDSCP PDU using the method described in clause 18.3.5.3.1 item c).

18.3.5 Data transfer sub-entity

18.3.5.0 General

The services and primitives offered by the MLE are described in clause 17.

18.3.5.1 Address handling

18.3.5.1.0 General

The MLE manages all of the subscriber addresses (i.e. ITSIs and GTSIs) plus the management identity (i.e. TMI). These addresses and identities are described in ETSI EN 300 392-1 [6], clause 7.

System subscriber Identities which are received or attached and detached by the MM entity should be transferred to MLE in an MLE-IDENTITIES request primitive. After being recorded locally and any lists amended, the list of currently valid short subscriber and management identities shall be transferred to the lower layers via the TLC-SAP in a TL-CONFIGURE request primitive as described in clause 18.3.5.1.2.

Active group system subscriber identities which are received by the SS sub-entity shall be transferred to MLE in an MLE-IDENTITIES request primitive. After being recorded locally and any lists amended, the list of currently valid short subscriber and management identities shall be transferred to the lower layers via the TLC-SAP in a TL-CONFIGURE request primitive as described in clause 18.3.5.1.2. The MLE-IDENTITIES request primitive from the LCMC-SAP contains request to add and/or remove group identities

Temporary group addresses allocated by SwMI or assumed by MS when setting up a group call, is informed to MLE by CMCE using the MLE-CONFIGURE request primitive. The MLE-CONFIGURE request primitive from the LCMC-SAP contains request to add and/or remove temporary group identities. The updated lists shall be transferred to the lower layers via the TLC-SAP in a TL-CONFIGURE request primitive as described in clause 18.3.5.1.2.

18.3.5.1.1 Link addressing

The MLE defines the MAIN ADDRESS and the ADDRESS TYPE parameters in all TL-CONNECT, TL-DATA, TL-DISCONNECT, TL-RECONNECT and TL-UNITDATA primitives issued to layer 2. The MAIN ADDRESS shall comprise of a valid SSI.

For messages containing higher layer information, the MLE sets the MAIN ADDRESS SSI parameter to a valid SSI, as defined in ETSI EN 300 392-1 [6], clause 7. During migration, exchanged addresses shall be used, using the exchanged addresses issued by the MM in the MLE-IDENTITIES request primitive.

If there is no valid SSI the MLE shall use an un-exchanged SSI (USSI) as defined in ETSI EN 300 392-1 [6], clause 7. An un-exchanged SSI may only be used for MM messages, refer clause 23.4.1.2.5.

For messages from the MLE management entity, the MLE shall always add the SMI. The SMI is defined in ETSI EN 300 392-1 [6], clause 7.

The MLE shall remove the MAIN ADDRESS and the ADDRESS TYPE parameters from all primitives received from layer 2. These parameters can be used for upward routing. In the service primitives to layer 3 MLE shall use ITSI or GTSI as appropriate.

18.3.5.1.2 Link addresses to be placed in layer 2

In order to be able to filter, in layer 2, those messages received by the MS that are not applicable, layer 2 requires to be informed of all addresses that are valid for the MS. The MLE shall inform layer 2 by means of a TL-CONFIGURE request primitive the short subscriber and management identities that are valid for the MS.

In the event that a SSI ceases to be valid, then the MLE shall inform layer 2 by means of a TL-CONFIGURE request primitive via the TLC-SAP.

18.3.5.1.3 Layer 2 end point identifier

The MLE may receive the layer 2 endpoint identifier in primitives exchanged with the layer 2. Endpoint identifier is assumed to be a local layer-to-layer matter, and is not defined in the present document.

Endpoint identifiers uniquely identify radio resources, not fixed radio channels or timeslots.

18.3.5.1.4 Subscriber class

The MM informs the MLE of the MS subscriber class membership for a particular ITSI using an MLE-INFO request primitive. The MLE shall then use this value to determine if there is a match between the subscriber class being broadcasted by the SwMI and the subscriber class of the MS. The subscriber class is a bit mapped field which shall indicate which subscriber classes the MS is a member of. The values are specified in clause 18.5. The subscriber class parameter may be allocated at subscription or registration. If the MS does not have a subscriber class from registration or subscription, the MS shall assume membership of all subscriber classes. The indication of whether there is a subscriber class match shall be indicated by MLE to the other layer 3 entities via the MLE-INFO indication service primitive.

18.3.5.1.5 Permitted LAs, permitted cells and not-permitted cells

An MS may be limited by its application to using only certain specified LAs. If such a limitation exists, MM informs MLE about the permitted LAs (including their MNCs and MCCs) in the MLE-ACTIVATE request primitive. Cells within permitted LAs are called "permitted cells". If MM provides MLE with a list of permitted LAs, MLE shall regard all other LAs as "not-permitted LAs". Cells in not-permitted LAs are called "not-permitted" cells.

If MM does not provide MLE with a list of permitted LAs, MLE shall regard all LAs as permitted LAs and shall regard all cells as permitted cells.

MLE may select a not-permitted cell only if there is no available permitted cell, as described in clause 18.3.4.5.7. When MLE selects a not-permitted cell, MLE shall advise the CMCE and SNDCP entities with MLE-INFO indication primitives.

NOTE: The MS's preferred LAs, if they exist, are a subset of the MS's permitted LAs.

18.3.5.2 MLE connection handling

18.3.5.2.0 Data transfer states

An MLE connection is the logical association of the MLE peer entities in the MS/LS and the SwMI. The association is made by the mobile when it acquires a radio channel and camps on a cell. No explicit signalling is required in order to establish the connection.

18.3.5.2.1 Data transfer states

The following states shall exist in the data transfer entity.

NOTE 1: In the state machine the states themselves are provided for information, but conformance to the signalling specified for the output of the state machine is a requirement.

NOTE 2: These states are the MLE state machine states, which are different to the service states presented in clause 17.

a) Closed:

- the data transfer sub-entity shall enter state Closed after initial start up. This state shall also be entered after an MLE-CLOSE request primitive has been received from the MM entity indicating that there shall be no access to communication resources allowed.

b) All Data:

- the data transfer sub-entity shall enter the state All Data if it has received an MLE-OPEN request primitive and has not subsequently received an MLE-CLOSE request primitive or MLE-BREAK indication primitive.

c) Broken:

- the data transfer sub-entity enters this state upon receipt of an MLE-BREAK indication primitive from the attachment management sub-entity and indicates that the connection is temporarily broken. Upon receiving an MLE-RESUME indication primitive or an MLE-REOPEN indication primitive the data transfer sub-entity shall return to the all data state.

18.3.5.3 Selection of LLC services

18.3.5.3.1 Selection of LLC services via TLA-SAP

Two types of data transfer are available at the layer 2 TLA-SAP:

- acknowledged PDU transfer; and
- unacknowledged PDU transfer.

The acknowledged service provides bidirectional data transfer, the unacknowledged service is unidirectional.

The required service shall be interpreted from the information contained in the primitives from the higher entities according to the procedures specified below.

The PDU priority, stealing permission and stealing repeats flag parameters shall be set by the sending higher layer 3 entity and simply passed on to layer 2 by the MLE. The data priority of SN-DATA and SN-UNITDATA PDUs shall be set by the MS SNDCP and passed on to layer 2 by the MLE. In addition, for TL-CONNECT request and response primitives and TL-DISCONNECT request primitives which are issued by the MLE, the stealing permission parameter shall be set to "stealing not required" and the stealing repeats flag shall not be set. The PDU priority shall be equal to 3 for TL-CONNECT request and response primitives and 6 for the TL-DISCONNECT request primitive.

SNDCP uses both basic and advanced link services in the layer 2. The discrimination between the link types is based on the SN-PDU type and it is defined in clause 28. The following clauses define the SNDCP data transfer functionality for basic link and advanced link separately.

a) Outgoing messages from MM and CMCE

All outgoing messages shall be subject to the following handshake procedure with the LLC.

MLE shall allocate a handle to all TL-DATA request primitives. Upon receipt of the TL-DATA request primitive the LLC immediately acknowledges this with a TL-REPORT indication primitive containing the same handle as in the request, refer to clause 22.3.2.3. The handle shall be retained locally and used for routing subsequent MLE-REPORT indication primitives. The handle remains valid until a TL-DATA confirm primitive is received indicating that the PDU has been (successfully) transmitted, or until a TL-REPORT indication primitive is received indicating that the PDU transmission has failed or been aborted; the handle is then deleted.

TL-CANCEL request primitives may be issued until the receipt of the TL-DATA confirm primitive or until receipt of a TL-REPORT indication primitive indicating that the PDU transmission has failed.

NOTE 1: The normal sequence of primitives received from LLC after MLE issues a basic link TL-DATA request primitive is: TL-REPORT (contains handle but no particular report), TL-REPORT (reporting "first complete transmission") and finally TL-DATA confirm.

On receipt of the TL-DATA confirm primitive indicating successful transmission, the MLE shall issue an MLE-REPORT indication primitive to the SAP which sent the MLE-UNITDATA request primitive initiating the original TL-DATA request primitive (as indicated by the "handle to the request" parameter), to inform the higher layer 3 entity that the PDU has been successfully transmitted by layer 2. If the TL-DATA confirm primitive contains an SDU, the data transfer sub-entity shall then remove and analyse the SDU's MLE PDU header. The PDU header indicates the protocol to which the PDU belongs. MLE protocol PDUs are processed by the MLE protocol entity and TETRA management entity PDUs are processed by the TETRA management functional entity. For other protocols, the SDU contained in the TL-DATA indication primitive shall be routed to the correct SAP as an MLE-UNITDATA indication primitive.

On receipt of an MLE-UNITDATA request primitive, the data transfer sub-entity shall append prefix the SDU in the MLE-UNITDATA request primitive with an MLE header comprising a protocol discriminator information element indicating the originating SAP (i.e. MM or CMCE) as described in clause 18.4.1.3. The data transfer sub-entity shall determine the length of the PDU and pass that information to the LLC as a primitive parameter.

The underlying service selected shall be the basic link or advanced link and determined according to the layer 2 service parameter in the MLE-UNITDATA request primitive. The MLE shall set up an advanced link when needed by MM and/or CMCE.

If the layer 2 service parameter has the value "acknowledged request" then the MLE UNITDATA PDU shall be transferred to the LLC in a TL-DATA request primitive.

If the layer 2 service parameter has the value "acknowledged response" then the MLE UNITDATA PDU shall be transferred to the LLC in a TL-DATA response primitive.

If the layer 2 service parameter has the value "unacknowledged" then the MLE UNITDATA PDU shall be transferred to the LLC in a TL-UNITDATA request primitive.

On receipt of an MLE-CANCEL request primitive from the CMCE or MM SAP, the data transfer sub-entity shall issue a TL-CANCEL request primitive to the TLA-SAP.

The basic link shall be used for all MM signalling and CMCE call related signalling. The FCS flag may be set to indicate the use of the optional FCS for basic link transfer. Whether or not the optional FCS is selected for basic link transfer is not defined in the present document.

The advanced link may also be used for transfer of long SDUs. This may be required for the short data service which can send up to 2 047 bits of data or for transfer of SS information. A separate or the same advanced link can be used by MM and/or CMCE to that used by SNDPCP for packet data transfer.

NOTE 2: CMCE SDS and SS information may be up-linked to the BS and down-linked to the MS on an existing advanced link which was negotiated on behalf of packet data entity at some earlier time.

NOTE 3: The MLE may negotiate an advanced link specifically for the up-linking of CMCE SDS and SS signalling.

NOTE 4: The BS may negotiate an advanced link specifically for the down-linking of CMCE SDS and SS signalling.

NOTE 5: The MLE should take into account the QoS requirements of other advanced link users when selecting a particular advanced link for the up-linking of CMCE SDS and SS signalling. The MLE should, if possible, select an advanced link adapted to the transport of background class data.

b) Incoming messages to MM and CMCE

On receipt of a TL-UNITDATA indication primitive, the data transfer sub-entity shall remove and analyse the MLE PDU header and address. The PDU header indicates the destination SAP. The address may indicate that this is a network broadcast message. The data contained in the TL-UNITDATA indication primitive shall then be routed to the correct SAP or sub-entity as an MLE-UNITDATA indication primitive. Network broadcast PDUs (D-NWRK-BROADCAST, D-NWRK-BROADCAST EXTENSION and D-NWRK-BROADCAST-DA) shall be routed by the data transfer sub-entity to the network broadcast sub-entity. Late entry supported information from the D-MLE-SYNC PDU, the D-MLE-SYSINFO-Q PDU and the D-MLE-SYSINFO-DA PDU shall be routed to the CMCE SAP.

On receipt of a TL-DATA indication primitive, the data transfer sub-entity shall remove and analyse the MLE PDU header. The PDU header indicates the destination SAP. The data contained in the TL-DATA indication primitive shall then be routed to the correct SAP or sub-entity as an MLE-UNITDATA indication primitive.

On receipt of a TL-DATA confirm primitive containing an SDU, the MLE shall issue an MLE-REPORT indication primitive as described in a). The data transfer sub-entity shall then transfer the SDU to the appropriate entity or sub-entity as described in a).

c) Outgoing basic link messages from SND CP

The data transfer sub-entity shall reject service requests when in state closed. When in the broken state, messages shall not be passed by the MLE.

All outgoing messages shall be subject to the following handshake procedure with the LLC.

MLE shall allocate a handle to all TL-DATA and TL-UNITDATA request primitives. Upon receipt of the TL-DATA, or TL-UNITDATA request primitive the LLC may immediately acknowledge this with a TL-REPORT indication primitive containing the handle, refer to clauses 22.3.2.3 and 22.3.2.4.1. The handle shall be retained locally and used for routing subsequent MLE-REPORT indication primitives.

Where the outgoing message has resulted in the MLE requesting an unacknowledged service from the LLC, the handle remains valid until a further TL-REPORT indication primitive is received indicating that the PDU has been transmitted, has failed, or has been aborted; the handle is then deleted. Where the outgoing message has resulted in the MLE requesting an acknowledged service from the LLC, the handle remains valid until a TL-DATA confirm primitive is received indicating that the PDU has been successfully transmitted, or until a TL-REPORT indication primitive is received indicating that the PDU has failed or has been aborted; the handle is then deleted.

TL-CANCEL request primitives may be issued until the receipt of a TL-DATA confirm or TL-REPORT indication primitive indicating that the PDU has been transmitted, or until receipt of a TL-REPORT indication primitive reporting that the PDU has failed.

NOTE 6: The normal sequence of primitives received from LLC after MLE issues a basic link TL-DATA request primitive is: TL-REPORT (handle but no report), TL-REPORT (reporting "first complete transmission") and finally TL-DATA confirm. The normal sequence of primitives received from LLC after MLE issues a basic link TL-UNITDATA request primitive is: TL-REPORT (optional, contains handle but no particular report) and TL-REPORT (reporting "transfer completed" or "failed transfer").

On receipt of a TL-DATA confirm primitive, the MLE shall issue an MLE-REPORT indication primitive to SND CP indicating successful transmission of the PDU transmitted as a result of the previous TL-DATA request primitive on that endpoint identifier and link identifier. If the TL-DATA confirm primitive contains an SDU, the data transfer sub-entity shall then remove and analyse the SDU's MLE PDU header. The PDU header indicates the protocol to which the PDU belongs. MLE protocol PDUs are processed by the MLE protocol entity and TETRA management entity PDUs are processed by the TETRA management functional entity. For other protocols, the SDU contained in the TL-DATA indication primitive shall be routed to the correct SAP or sub-entity as an MLE-UNITDATA indication primitive.

On receipt of an MLE-UNITDATA request primitive, the data transfer sub-entity shall determine the state of the MLE data priority flag parameter and the state of the channel advice request flag parameter. Then:

- If MLE data priority signalling is not required by the MLE data priority flag parameter, and channel advice is not requested by the channel advice request flag parameter, the data transfer sub-entity shall prefix the SN-SDU with an MLE header comprising a protocol discriminator information element indicating that the originating SAP is SNDCCP as described in clause 18.4.1.3.
- If MLE data priority signalling is required and channel advice is not requested, the MS-MLE is required to transmit a U-CHANNEL CLASS ADVICE PDU indicating a single channel class with value "0000₂" (i.e. an unspecified channel class). The data transfer sub-entity shall set the "discriminator for SDU protocol present" information element to "0", shall insert the SN-PDU into the "SDU" information element of a U-CHANNEL CLASS ADVICE PDU (see clause 18.3.4.9.11), shall include the value of the data priority parameter from the MLE-UNITDATA request primitive in the U-CHANNEL CLASS ADVICE PDU, and shall prefix the U-CHANNEL CLASS ADVICE PDU with an MLE PDU header comprising a protocol discriminator information element indicating that the originating SAP is MLE, as described in clauses 18.4.1.1 and 18.4.1.4.
- If MLE data priority signalling is required and channel advice is requested, the MS-MLE is required to transmit a U-CHANNEL CLASS ADVICE or U-IRREGULAR CHANNEL ADVICE PDU. The data transfer sub-entity shall set the "discriminator for SDU protocol present" information element to "0", shall insert the SN-PDU into the "SDU" information element of a U-CHANNEL CLASS ADVICE PDU or a U-IRREGULAR CHANNEL ADVICE PDU (see clause 18.3.4.9.11), shall include the value of the data priority parameter from the MLE-UNITDATA request primitive in the U-CHANNEL CLASS ADVICE or U-IRREGULAR CHANNEL ADVICE PDU, and shall prefix the U-CHANNEL CLASS ADVICE or U-IRREGULAR CHANNEL ADVICE PDU with an MLE header comprising a protocol discriminator information element indicating that the originating SAP is MLE as described in clauses 18.4.1.1 and 18.4.1.4.
- If MLE data priority signalling is not required and channel advice is requested, the MS-MLE is requested to transmit a U-CHANNEL CLASS ADVICE or U-IRREGULAR CHANNEL ADVICE PDU if the MS-MLE has received an indication that the current cell supports non-conforming channels (see clause 18.3.4.9.1). The data transfer sub-entity may insert the SN-PDU into the "SDU" information element of a U-CHANNEL CLASS ADVICE PDU or U-IRREGULAR CHANNEL ADVICE PDU (see clause 18.3.4.9.11). In this case, the MS-MLE shall set the "discriminator for SDU protocol present" information element to "0" but shall not include a "data priority" information element. The MS-MLE shall prefix the U-CHANNEL CLASS ADVICE or U-IRREGULAR CHANNEL ADVICE PDU with an MLE header comprising a protocol discriminator indicating that the originating SAP is MLE as described in clauses 18.4.1.1 and 18.4.1.4.

The data transfer sub-entity shall determine the length of the PDU and pass that information to the LLC as a primitive parameter.

If the layer 2 service parameter has the value "acknowledged request" then the MLE UNITDATA PDU shall be transferred to the LLC in a TL-DATA request primitive.

If the layer 2 service parameter has the value "acknowledged response" then the MLE UNITDATA PDU shall be transferred to the LLC in a TL-DATA response primitive.

If the layer 2 service parameter has the value "unacknowledged" then the MLE UNITDATA PDU shall be transferred to the LLC in a TL-UNITDATA request primitive.

Whether or not the optional FCS is selected in basic link transfer is not defined in the present document.

The SDU shall be sent to the TLA SAP in a TL-DATA request primitive unless an unacknowledged data transfer is specifically requested, in which case the SDU shall be sent in a TL-UNITDATA request primitive.

d) Incoming basic link messages to SNDCCP

On receipt of a TL-UNITDATA indication primitive, the data transfer sub-entity shall remove and analyse the MLE PDU header and address. The PDU header indicates the destination SAP. The data contained in the TL-UNITDATA indication primitive shall then be routed to the correct SAP or sub-entity as an MLE-UNITDATA indication primitive.

On receipt of a TL-DATA indication primitive, the data transfer sub-entity shall remove and analyse the MLE PDU header. The PDU header indicates the destination SAP. The data contained in the TL-DATA indication primitive shall then be routed to the correct SAP or sub-entity as an MLE-UNITDATA indication primitive.

On receipt of a TL-DATA confirm primitive containing an SDU, the MLE shall issue an MLE-REPORT indication primitive to SNDSCP as described in c). The data transfer sub-entity shall then transfer the SDU to the appropriate entity or sub-entity as described in c).

e) Outgoing advanced link messages from SNDSCP

The data transfer sub-entity shall reject service requests when in state closed. When in the broken state, messages shall not be passed by the MLE.

All outgoing messages shall be subject to the following handshake procedure with the LLC.

Upon receipt of the TL-CONNECT, TL-DISCONNECT, TL-DATA, TL-RECONNECT or TL-UNITDATA request primitive the LLC will immediately acknowledge this with a TL-REPORT indication primitive containing the handle. The handle shall be retained locally and used for routing subsequent REPORT indication primitives.

Where the outgoing message has resulted in the MLE requesting an unacknowledged service from the LLC, the handle remains valid until LLC informs MLE that the PDU has been transmitted, has failed, or has been aborted; the handle is then deleted.

Where the outgoing message has resulted in the MLE requesting an acknowledged service from the LLC, the handle remains valid until a TL-DATA confirm primitive is received or until a TL-REPORT indication primitive is received indicating that the PDU transmission has failed or been aborted; the handle is then deleted.

TL-CANCEL request primitives may be issued until LLC informs MLE that the PDU has been transmitted or has failed. If the LLC responds with a TL-REPORT indication primitive containing the report "Layer two transmission activities continuing", transmission of the PDU can only be stopped by resetting the advanced link.

NOTE 7: In the case of the acknowledged advanced link, the normal sequence of primitives received from LLC after MLE issues an advanced link TL-DATA request primitive is: TL-REPORT (optional, contains handle but no particular report) followed by TL-DATA confirm or TL-REPORT ("failed transfer").

On receipt of a TL-DATA confirm primitive, the MLE shall issue an MLE-REPORT indication primitive to SNDSCP indicating successful transmission of the PDU transmitted as a result of the previous TL-DATA request primitive on that endpoint identifier and link identifier.

When sending background class and telemetry class data, the SNDSCP shall use the advanced link to ensure reliable transmission of long packets (i.e. longer than about 3 TDMA slots worth of data). The MS shall only attempt to set up an advanced link if both the SwMI supports SNDSCP operation and if the advanced link is supported by the SwMI on this cell. Information about the support by a CA cell for the original advanced link is indicated in the "BS service details" information element broadcast as part of the D-MLE SYSINFO and D-MLE SYSINFO-Q PDUs. Information about the support by a CA cell for extended advanced links is broadcast in section 1 of the "extended services broadcast" information element of the MAC SYSINFO and MAC SYSINFO-Q PDUs. A DA cell always supports original and extended advanced links when the "system wide services" information element in the D-MLE-SYSINFO-DA (and D-MLE-SYNC-DA) PDU indicates "normal mode" (system wide services supported). When the "system wide services" information element in the D-MLE-SYSINFO-DA (and D-MLE-SYNC-DA) PDU indicates "system wide services temporarily not supported", it is optional for the DA cell to support original and extended advanced links.

NOTE 8: When sending real-time class data, the MS SNDSCP uses the unacknowledged basic link.

If the SwMI indicates that it does not support SNDSCP on this cell, the MS shall not send SNDSCP PDUs on this cell. If the SwMI indicates that it does not support advanced links on this cell, the MS shall not attempt to use an advanced link on this cell.

The quality of service parameters passed down by SNDSCP using MLE-CONNECT request and response primitives shall be used by the MS in negotiating the advanced link service during set up. How the "Quality of Service (QoS) for layer 2" parameters in the MLE-CONNECT request and response primitives map onto the advanced link quality of service selection in the AL-SETUP PDU is not defined by the present document.

On receipt of a MLE-CONNECT request primitive from SNDSCP, the data transfer sub-entity shall issue a TL-CONNECT request primitive to the TLA-SAP. Upon receipt of the corresponding TL-CONNECT confirm primitive, the data transfer sub-entity shall issue a MLE-CONNECT confirm primitive to SNDSCP.

On receipt of a MLE-CONNECT response primitive from SNDPCP, the data transfer sub-entity shall issue a TL-CONNECT response primitive to the TLA-SAP.

On receipt of a MLE-DISCONNECT request primitive from SNDPCP, the data transfer sub-entity shall issue a TL-DISCONNECT request primitive to the TLA-SAP. Upon receipt of the corresponding TL-DISCONNECT confirm primitive, the data transfer sub-entity shall issue a MLE-DISCONNECT indication primitive to SNDPCP.

On receipt of a MLE-RECONNECT request primitive from SNDPCP, the data transfer sub-entity shall issue a TL-RECONNECT request primitive to the TLA-SAP. Upon receipt of the corresponding TL-RECONNECT confirm primitive, the data transfer sub-entity shall issue a MLE-RECONNECT confirm primitive to SNDPCP.

On receipt of an MLE-UNITDATA request primitive, the data transfer sub-entity shall prefix the SDU in the MLE-UNITDATA request primitive with an MLE header comprising a protocol discriminator information element indicating that the originating SAP is SNDPCP as described in clause 18.4.1.3. The data transfer sub-entity shall determine the length of the PDU and pass that information to the LLC as a primitive parameter.

If the layer 2 service parameter has the value "acknowledged request" then the MLE UNITDATA PDU shall be transferred to the LLC in a TL-DATA request primitive.

For messages using the advanced link, the layer 2 service parameter shall not be set to "acknowledged response".

If the layer 2 service parameter has the value "unacknowledged" then the MLE UNITDATA PDU shall be transferred to the LLC in a TL-UNITDATA request primitive.

On receipt of a MLE-RELEASE request primitive from SNDPCP, the data transfer sub-entity shall issue a TL-RELEASE request primitive to the TLA-SAP. All references to the advanced link in question shall be deleted.

f) Incoming advanced link messages to SNDPCP

On receipt of a TL-CONNECT indication primitive, the data transfer sub-entity shall issue MLE-CONNECT indication primitive to the SNDPCP.

On receipt of a TL-CONNECT confirm primitive, the data transfer sub-entity shall issue MLE-CONNECT confirm primitive to the SNDPCP.

On receipt of a TL-RECONNECT confirm primitive, the data transfer sub-entity shall issue MLE-RECONNECT confirm primitive to the SNDPCP.

On receipt of a TL-DISCONNECT indication primitive, the data transfer sub-entity shall issue MLE-DISCONNECT indication primitive to the SNDPCP if the TL-DISCONNECT indication primitive refers to an established advanced link. This can be established by using the link identifier. If it does refer to an established advanced link, any local reference to that advanced link shall be deleted.

On receipt of a TL-DISCONNECT confirm primitive, the data transfer sub-entity shall issue MLE-DISCONNECT indication primitive to the SNDPCP.

On receipt of a TL-UNITDATA indication primitive, the data transfer sub-entity shall remove and analyse the MLE PDU header and address. The PDU header indicates the destination SAP. The data contained in the TL-UNITDATA indication primitive shall then be routed to the correct SAP or sub-entity as an MLE-UNITDATA indication primitive.

On receipt of a TL-DATA indication primitive, the data transfer sub-entity shall remove and analyse the MLE PDU header. The PDU header indicates the destination SAP. The data contained in the TL-DATA indication primitive shall then be routed to the correct SAP or sub-entity as an MLE-UNITDATA indication primitive.

On receipt of a TL-DATA confirm primitive, the MLE shall issue an MLE-REPORT indication primitive as described in e).

18.3.5.3.2 Selection of LLC services via TLB-SAP

There are no services available at the TLB-SAP in the MS.

Data received via the TLB-SAP is routed to the network broadcast sub-entity and is dealt with in clause 18.3.6.

18.3.5.3.3 Selection of LLC services via TLC-SAP

a) Locally generated TL-CONFIGURE request primitives

The data transfer sub-entity shall supply TL-CONFIGURE request primitives to the TLC-SAP to inform the lower layers of the state of any MM signalling, SMDCP signalling or circuit mode calls in progress. The MLE activity indicator parameter in the TL-CONFIGURE request primitive allows the lower layers to decide when to apply the energy economy sleeping cycle (see clause 23.7.6), the dual watch reception cycle (see clause 23.7.7) or part-time reception on a multi-slot MCCH-Q (see clause 23.7.8).

NOTE 1: It is possible to apply an energy economy group that has been notified to, and agreed by, the SwMI for energy economy or dual watch mode. The SwMI broadcasts whether part-time reception on a multi-slot MCCH-Q is permitted.

The TL-CONFIGURE request primitive shall be sent with the MLE-Activity indicator parameter set to "stay alive" when there is any explicit or implicit connection active. The TL-CONFIGURE request primitive may only be sent with the MLE activity indicator parameter set to "sleep permitted" when there is no MM, SMDCP or CMCE e.g. circuit mode call activity.

MM indicates its activity by an MLE-ACTIVITY request primitive with sleep mode value "stay alive", and its non-activity with sleep mode value "sleep permitted" as defined in clause 16.3.1.3.4.

SMDCP indicates its activity by an MLE-ACTIVITY request primitive with sleep mode set to "stay alive", and its non-activity with sleep mode value "sleep permitted", see clauses 28.2.4.4, 28.2.4.6, 28.2.4.7, 28.2.4.8 and 28.2.5.

CMCE indicates its activity by an MLE-ACTIVITY request primitive with call state value "group call with transmit permission", "group call without transmit permission", "individual call with transmit permission" and "individual call without transmit permission", and its non-activity with call state value "idle", see clauses 14.2.7.7.0 and 14.4.2.

NOTE 2: The MLE-ACTIVITY request primitive with call state values "group call without transmit permission" or "individual call without transmit permission" are sent at the beginning of a call set-up and the CMCE activity covers also the call set-up period before the voice communication is possible.

MLE shall combine activity indications from upper layers and inform using TL-CONFIGURE request primitive MLE activity indicator parameter, when sleeping is permitted.

Advanced link, on its own is active during set up, reset, reconnection and disconnection phases, see clause 22.3.6.

b) Locally received TL-SELECT indication primitives

Where the MLE receives a TL-SELECT indication primitive via the TLC-SAP indicating that the MAC has been instructed to change channels and no response is required, this is dealt with in clause 18.3.4.3.

The only case where the MLE is required to respond to a channel change TL-SELECT indication primitive is in the case of cell change in announced type 1 cell reselection. In this case the MLE shall respond with TL-SELECT response primitive containing a parameter which gives the frequency of the main carrier on the new cell.

c) Outgoing messages from MM

These are generally routed via the attachment management sub-entity (see clause 18.3.4).

There are two exceptions to this.

The first is the MLE-IDENTITIES request primitive which contains the valid ISSI(s) and attached/detached GSSIs. The procedures for dealing with this are described in clause 18.3.5.1.

The second is the MLE-INFO request primitive which after the local recording of the subscriber class within the data transfer sub-entity is transferred further to the lower layers in a TL-CONFIGURE request primitive.

d) Incoming messages to MM

These are routed via the attachment management sub-entity (see clause 18.3.4).

e) Outgoing messages from SNDTCP

On receipt of a MLE-CONFIGURE request primitive, the MLE shall pass on relevant information contained in its parameters to layer 2 using TL-CONFIGURE request primitive.

f) Incoming messages to SNDTCP

There are no messages routed from the TLC-SAP to SNDTCP.

g) Outgoing messages from CMCE

On receipt of an MLE-CONFIGURE request primitive, MLE shall pass on the information contained in its parameters to layer 2 using TL-CONFIGURE request primitive.

On receipt of an MLE-IDENTITIES request primitive, MLE shall pass on the information contained in its parameters to layer 2 using TL-CONFIGURE request primitive.

h) Incoming messages to CMCE

There are no CMCE primitives received on the TLC-SAP.

18.3.5.4 Routing of local control information

On receipt of an MLE-OPEN request primitive from the MM SAP, the data transfer sub-entity shall issue an MLE-OPEN indication primitive to the CMCE and SNDTCP SAPs. The data transfer sub-entity shall then open the SAPs and shall permit the transfer of data between layers. If the MLE-OPEN request primitive is received whilst the data transfer sub-entity is in state closed then the data transfer sub-entity shall enter state all data. In all other states it shall remain in that state.

On receipt of an MLE-CLOSE request primitive from the MM SAP the data transfer sub-entity shall relay this as an MLE-CLOSE indication primitive to the CMCE and SNDTCP SAPs. The data transfer sub-entity shall then close the SAPs and shall not permit the transfer of data between layers. The data transfer sub-entity shall enter state closed, and shall remain in that state until it receives an MLE-OPEN indication primitive.

On receipt of an MLE-DISABLE request primitive from the MM SAP, the data transfer sub-entity shall issue an MLE-DISABLE indication primitive to the CMCE SAP and the SNDTCP SAP.

On receipt of an MLE-ENABLE request primitive from the MM SAP, the data transfer sub-entity shall issue an MLE-ENABLE indication primitive to the CMCE SAP and the SNDTCP SAP.

On receipt of an MLE-BREAK indication primitive from the attachment management sub-entity, the data transfer sub-entity shall relay this MLE-BREAK indication primitive to the CMCE and SNDTCP SAPs. The data transfer sub-entity shall enter state broken. During a temporary link break data may be buffered in the data transfer sub-entity.

On receipt of an MLE-RESUME indication primitive from the attachment management sub-entity, the data transfer sub-entity shall relay this MLE-RESUME indication primitive to the CMCE and SNDTCP SAPs. The data transfer sub-entity shall return to its previous state. Any data buffered in the data transfer sub-entity during the temporary link break should now be (re)submitted for transmission.

On receipt of an MLE-REOPEN indication primitive from the attachment management sub-entity, the data transfer sub-entity shall relay this MLE-REOPEN indication primitive to the CMCE SAP. The data transfer sub-entity shall enter state idle. Any data buffered in the data transfer sub-entity during the temporary link break should now be discarded.

On receipt of an MLE-BUSY request primitive from the MM SAP, the data transfer sub-entity shall issue a MLE-BUSY indication primitive to the CMCE and SNDTCP SAPs.

On receipt of an MLE-IDLE request primitive from the MM SAP, the data transfer sub-entity shall issue a MLE-IDLE indication primitive to the CMCE and SNDTCP SAPs.

On receipt of a TL-REPORT indication primitive from LLC layer containing the reason "channel change", "transmission stopped", "reception stopped" the data transfer sub-entity shall relay it in an MLE-CONFIGURE indication primitive to the entity which is using the radio resource as indicated by the endpoint identifier parameter.

NOTE: The channel change is also conveyed in MLE-DATA and MLE-UNITDATA indication primitives.

On receipt of a TL-CONFIGURE indication primitive with "loss of radio resource" from lower layers the data transfer sub-entity shall relay it in an MLE-CONFIGURE indication primitive into the service user(s) who is using this radio resource as indicated by the endpoint identifier parameter.

18.3.6 Network broadcast sub-entity

18.3.6.1 Summary

The system broadcast function broadcasts system information from the SwMI to all MSs.

There are two formats for this system information:

- immediate system information;
- network broadcast system information.

The immediate system information is supplied to layer 2 in the SwMI and broadcast in the SYNC, SYNC-DA, SYSINFO, SYSINFO-Q and SYSINFO-DA PDUs as defined in clause 23. The exact method by which the information is supplied to layer 2 is outside the scope of the present document. At the MS, the MLE-PDUs containing immediate system information shall be received by the network broadcast sub-entity in TL-SYNC, TL-SYNC-DA, TL-SYSINFO, TL-SYSINFO-Q and TL-SYSINFO-DA indication primitives via the TLB-SAP.

The network broadcast system information and late entry information is supplied to layer 2 in the SwMI and broadcast as requested. The exact method by which the information is supplied to layer 2 is outside the scope of the present document. At the MS the MLE-PDUs shall be received by the network broadcast sub-entity as D-NWRK-BROADCAST, D-NWRK-BROADCAST EXTENSION and D-NWRK-BROADCAST-DA PDUs with a TL-UNITDATA indication primitive via the TLA-SAP and data transfer sub-entity. The MLE is able to route the network broadcast system information to the network broadcast sub-entity by virtue of the PDU header it arrives with, and the late entry information to CMCE-SAP by virtue of the PDU header it arrives with.

The D-NWRK-BROADCAST and D-NWRK-BROADCAST EXTENSION PDUs convey information to CA MSs about CA serving cells and to CA and DA MSs about CA neighbour cells. The D-NWRK-BROADCAST-DA PDU conveys information to DA MSs about DA serving cells and to CA and DA MSs about DA neighbour cells and may contain information for DA MSs about the (if any) local CA cell. CA MSs may obtain information about their serving cells from D-NWRK-BROADCAST and D-NWRK-BROADCAST EXTENSION PDUs. DA MSs may obtain information about their serving cells from D-NWRK-BROADCAST-DA PDUs. This serving cell information includes the cell reselect parameters and the cell load. On a DA cell, the serving cell information may additionally include the "cell identifier DA" information element (a DA MS needs to know its serving cell's cell identifier when interpreting D-NWRK-BROADCAST-DA PDUs sent on a channel used by MSs from more than one DA cell).

Only serving cell information common to all DA MSs using the channel shall be included in a D-NWRK-BROADCAST-DA PDU. In particular, the SwMI shall only include the "cell identifier DA" information element in the D-NWRK-BROADCAST-DA PDU when the "cell identifier DA" information element represents the serving cell of all DA MSs using the channel - this is always the case when sent on a DA main carrier.

The SwMI shall indicate whether or not it supports transmission of the D-NWRK-BROADCAST or D-NWRK-BROADCAST-DA PDUs using the "neighbour cell broadcast" information element which is transmitted as part of the D-MLE-SYNC, D-MLE-SYSINFO-Q and D-MLE-SYSINFO-DA PDUs.

System broadcast information can be received whilst the MS is scanning or is camped on a cell. The MS-MLE shall ensure that system broadcast information received whilst scanning is applied to the correct cell.

An MS may also prompt the SwMI to transmit the network broadcast system information by using the neighbour cell enquiry procedure as described in clause 18.3.6.5.

See clause 18.3.4.0b for a description of cell types and cell identifiers.

18.3.6.2 System information

The system information is a series of messages that are broadcast at regular intervals from the SwMI to the MS-MLEs.

The immediate system information contains the following information:

- MNC;
- MCC;
- LA Code (LAC);
- subscriber class;
- cell load; and
- late entry information availability.

The network broadcast system information in the D-NWRK-BROADCAST PDUs contain a combination of the following information:

- frequencies of adjacent CA cells for cell selection and reselection;
- parameters for roaming (measurement levels, intervals) to be used by CA MSs;
- the cell load on the CA serving cell.

The network broadcast system information in the D-NWRK-BROADCAST EXTENSION PDUs may include a combination of the following information:

- the modulation modes and bandwidths of channel classes available on the CA serving cell;
- frequencies, modulation modes and bandwidths of irregular channels available on the CA serving cell;
- the modulation modes and bandwidths of channel classes available on CA neighbour cells;
- frequencies, modulation modes and bandwidths of irregular channels available on CA neighbour cells.

NOTE 1: DA MSs interpret "serving cell" information in the D-NWRK-BROADCAST EXTENSION PDUs as information about the local CA cell.

The network broadcast system information in the D-NWRK-BROADCAST-DA PDUs may include a combination of the following information:

- the cell identifier of the present DA cell - see note 2;
- parameters for roaming (measurement levels, intervals) to be used by DA MSs on the DA serving cell - see note 3;
- the cell load on the DA serving cell - see note 3;
- details of the (if any) local CA cell (not used by CA MSs);
- the modulation modes and bandwidths of channel classes available on the DA serving cell - see notes 3, 4 and 5;
- frequencies, modulation modes and bandwidths of irregular channels available on the DA serving cell - see notes 3, 4 and 5;
- frequencies and bandwidths of the main carriers of DA neighbour cells - but see note 6;
- parameters to be used for channel quality assessment (measurement levels) on DA neighbour cells;
- the modulation modes and bandwidths of channel classes available on DA neighbour cells;
- frequencies, modulation modes and bandwidths of irregular channels available on DA neighbour cells.

NOTE 2: The cell identifier of the present DA cell is sent only on channels that are not being used by MSs from another DA cell.

NOTE 3: If more than one DA cell is using the present channel, the following items about the DA serving cell are included only when their values are appropriate to all DA cells using the present channel:

- parameters for roaming;
- cell load of the DA serving cell;
- modulation modes and bandwidths of channel classes available on the DA serving cell;
- frequencies, modulation modes and bandwidths of irregular channels available on the DA serving cell.

NOTE 4: If the "cell identifier DA" information element is included in the PDU, CA MSs interpret serving cell channel class and irregular channel information in a D-NWRK-BROADCAST-DA PDU as being information about a DA cell. If the "cell identifier DA" information element is not included in the PDU, the CA MS does not use serving cell channel class and irregular channel information.

NOTE 5: When non-conforming channel information is included in a D-NWRK-BROADCAST-DA PDU on a channel used by MSs from more than one DA cell, each MS assumes the channel class and irregular channel information relates to its own serving cell. (The "cell identifier DA" information element is not included in D-NWRK-BROADCAST-DA PDUs sent on channels used by MSs from more than one DA cell.) The SwMI can use this to broadcast common non-conforming channel information to MSs from more than one DA cell; however, the main carriers of the affected DA cells all need to operate at the same BS transmit power if channel class information is to be shared in this way. Otherwise, the SwMI can send out the information separately for each DA cell in "neighbour cell channel class for DA" and "neighbour cell irregular channel detail for DA" information elements.

NOTE 6: When a channel is used by MSs from more than one DA cell, a DA MS may receive information about its serving cell in the information about neighbour cells. The DA MS should detect this (from the cell identifier included in the information about the neighbour cell) and should not attempt to reselect to its serving cell.

This information should be used by the MSs to guide the cell reselection and assigned channel replacement request procedures.

18.3.6.3 Message formats for system information

System information messages shall be constructed according to the rules described in clause 18.4. Each network broadcast system information may contain any combination of information elements, unless indicated otherwise in the individual PDU definitions.

18.3.6.4 Network broadcast procedures

On receiving a TL-SYNC, a TL-SYNC-DA, a TL-SYSINFO, a TL-SYSINFO DA or a TL-SYSINFO-Q indication primitive via the TLB-SAP, the network broadcast sub-entity shall analyse the contents. The information contained within shall either be passed to attachment management, e.g. to update cell rankings, or, in the case of a new subscriber class bit map, shall be passed to the data transfer sub-entity.

18.3.6.5 Neighbour cell enquiry procedure

The SwMI shall indicate whether or not the neighbour cell enquiry service is supported using the "neighbour cell broadcast" information element which is transmitted as part of the D-MLE-SYNC, D-MLE-SYSINFO-Q and D-MLE-SYSINFO-DA PDUs.

If the SwMI supports the neighbour cell enquiry service, an MS may prompt the SwMI to transmit the D-NWRK-BROADCAST PDU and the D-NWRK-BROADCAST EXTENSION PDU by sending a U-PREPARE or U-PREPARE-DA PDU to the SwMI. An MS may prompt the SwMI to transmit the D-NWRK-BROADCAST-DA PDU by sending a U-PREPARE-DA PDU to the SwMI.

The U-PREPARE PDU shall not contain an SDU. The U-PREPARE PDU shall contain the "cell identifier CA" information element which shall be set to "00000₂" and which shall indicate to the SwMI that the MS is requesting transmission of the D-NWRK-BROADCAST PDU and (if supported) the D-NWRK-BROADCAST EXTENSION PDU.

The U-PREPARE-DA PDU shall not contain an SDU. The U-PREPARE-DA PDU shall contain the "cell identifier DA" information element which shall be set either to "00000000₂", indicating that the MS is requesting transmission of the D-NWRK-BROADCAST-DA PDU, or to "11111111₂", indicating that the MS is requesting D-NWRK-BROADCAST-DA, D-NWRK-BROADCAST and D-NWRK-BROADCAST EXTENSION PDUs.

NOTE: The MS may request transmission of the D-NWRK-BROADCAST and D-NWRK-BROADCAST EXTENSION PDUs and/or the D-NWRK-BROADCAST-DA PDU because it has not yet received the neighbour cell or channel class or irregular channel information on the current serving cell and the MS needs this in order to initiate cell reselection or assigned channel replacement request procedures. This may occur if the current serving cell or assigned channel signal level is falling and the MS cannot wait for the normal D-NWRK-BROADCAST PDU, D-NWRK-BROADCAST EXTENSION PDU or D-NWRK-BROADCAST-DA PDU broadcast to be sent.

An MS may not receive the normal D-NWRK-BROADCAST PDU broadcast, for example, as a result of being in energy economy and sleeping while the D-NWRK-BROADCAST PDU is being transmitted by the SwMI.

MLE shall send the U-PREPARE or U-PREPARE-DA PDU by issuing a TL-DATA request primitive to layer 2 with the primitive parameters set as follows:

- PDU priority shall be set to 3;
- stealing permission shall be set to "steal immediately";
- the stealing repeats flag shall not be set.

MLE shall, if supported, start timer T371 and shall await the response from the SwMI. If the SwMI supports the neighbour cell enquiry service, the SwMI shall respond to the U-PREPARE PDU by transmitting the D-NWRK-BROADCAST PDU and, if supported, the D-NWRK-BROADCAST EXTENSION PDU. If supported, the SwMI shall respond to the U-PREPARE-DA PDU by transmitting the D-NWRK-BROADCAST-DA PDU and, if requested by use of a "cell identifier DA" information element set to "11111111₂", shall also transmit the D-NWRK-BROADCAST and D-NWRK-BROADCAST EXTENSION PDUs. These PDUs may be individually addressed to the MS using the layer 2 acknowledged service or may be sent unacknowledged to a group address or to the broadcast address ("all ones" address).

On reception of the D-NWRK-BROADCAST PDU or D-NWRK-BROADCAST-DA PDU, the MLE shall reset timer T371. If timer T371 expires the MS shall assume that the cell enquiry service has failed and may resend the U-PREPARE PDU or U-PREPARE-DA PDU.

If the neighbour cell enquiry service is not supported, the MS shall not attempt to send the U-PREPARE PDU with the "cell identifier CA" information element set to "00000₂" or the U-PREPARE-DA PDU with the "cell identifier DA" information element set to "00000000₂" or "11111111₂". If the the SwMI does not support the neighbour cell enquiry service, the SwMI may respond to the U-PREPARE PDU or U-PREPARE-DA with a D-PREPARE-FAIL PDU which has the "fail cause" information element set equal to "Neighbour cell enquiry not available".

18.3.6.6 Addition and replacement of neighbour cell information

The MS constructs a record of neighbour cells available from its present serving cell from information in D-NWRK-BROADCAST, D-NWRK-BROADCAST EXTENSION and D-NWRK-BROADCAST-DA PDUs, as follows:

- if the PDU contains information that the MS has not previously recorded about a neighbour cell (identified by a cell identifier) or a non-conforming channel or channel class on the serving cell, the MS shall record the new information;

- if the PDU contains an item of information about a neighbour cell (identified by a cell identifier) or about a non-conforming channel or channel class on the serving cell, and the MS has previously recorded different information about this item, the MS shall replace the old information about this item with the new information.

The MS should retain its record of information about neighbour cells, channel classes and irregular channels until it leaves the cell, is powered off, or is requested by the SwMI to remove the information (whichever occurs first). The MS shall not use the information received on one cell when camped on another cell.

The MS may retain its record of information about neighbour cells, channel classes and irregular channels received on a particular cell after it leaves that cell, for re-use when it returns to that cell (as identified by the cell identifier and LA).

EXAMPLE: The ability to store broadcast information for use on return to the cell where it was received may be useful to train-mounted MSs which repeatedly follow the same route.

The method by which the MS recognizes that it has returned to a previously used cell is outside the scope of the present document.

NOTE 1: The method could include a prearrangement with the MS that the SwMI uses only one cell per LA.

NOTE 2: The MS may be able to recognize that it has returned to a previously used DA cell by comparing the cell identifier of its serving cell (included in a D-NWRK-BROADCAST-DA PDU) with the cell identifiers of DA cells it has previously used within the present LA (see clause 18.3.4.0b.5). The method could include a prearrangement with the MS that the SwMI uses stable cell identifiers for DA cells that are unique per LA.

As a further aid to a DA MS, the "local cell identifier DA" information element may be included in the "neighbour cell information for DA" information element. This indicates the cell identifier that a DA neighbour cell is using to identify itself to MSs that are camped on that DA neighbour cell. The MS may be able to use this (in combination with the LA of the DA neighbour cell) to recognize that it is returning to a DA cell for which it has retained neighbour cell information, and may use it for other purposes where the MS needs to know the cell identifier of its serving cell in advance of receiving it in a D-NWRK-BROADCAST-DA PDU. The "local cell identifier DA" information element thus indicates the value that the DA neighbour cell uses for the "cell identifier DA" information element when the DA neighbour cell sends a D-NWRK-BROADCAST-DA PDU that includes the "cell identifier DA" information element.

NOTE 3: Cell identifiers and neighbour cell information may change, so the MS's previous record of information about neighbour cells, channel classes and irregular channels received on a particular cell may not be useful when it returns to that cell.

NOTE 4: A future edition of the present document may provide a method for the MS to determine if the information about a DA serving cell and its DA neighbour cells has remained stable since the MS's previous visit to the cell.

If a DA MS detects a change in the cell identifier of its serving cell, the MS shall delete its previous record of serving cell and neighbour cell information for the present cell. It may then build up a new record of serving cell and neighbour cell information, referenced by the new cell identifier.

18.3.6.7 Removal of neighbour cell information

The SwMI may instruct MSs to delete information about neighbour cells and/or information about channel classes and irregular channels on the serving cell. The instruction is sent using the D-NWRK-BROADCAST REMOVE PDU. It applies only to information that the MS stores about neighbour cells of its present serving cell and the channel classes and irregular channels of its present serving cell. The D-NWRK-BROADCAST REMOVE PDU cannot be used to remove information that was received on cells other than the present serving cell.

When sent on a channel used by MSs from multiple cells, each MS interprets the PDU as relating to the neighbour cell and channel information it has received on its present serving cell. The "removal data for serving cell" information element shall not be included unless its value is appropriate to all cells using the channel on which the PDU is sent.

If the PDU indicates "remove this neighbour cell", the MS should remove the indicated neighbour cell from its record of neighbour cells of the present serving cell.

If the PDU indicates "remove channel classes or channels", the MS should remove the indicated channel classes and/or channels from its record of information about the indicated cell.

If the PDU includes the "removal data for serving cell" information element, the MS should remove the indicated channel classes and/or channels from its record of information about its present serving cell.

If the cell identifier of a neighbour cell to be removed matches the cell identifier of a DA MS's serving cell (this could happen when the DA MS is using a channel shared by MSs from other cells), the DA MS should delete all its information about channel classes and channels of its present serving cell.

If the cell identifier of a neighbour cell with channel classes or channels to be removed matches the cell identifier of a DA MS's serving cell (this could happen when the DA MS is using a channel shared by MSs from other cells), the DA MS should delete its information about the indicated channel classes and/or channels of its present serving cell.

See clause 18.3.6.6 for the case where a DA MS detects a change in the cell identifier of its serving cell.

18.3.7 Management sub-entity

The management sub-entity shall be responsible for communication of management information between the MS and the SwMI. MLE PDUs to and from the management sub-entity shall have a protocol discriminator set to "110₂". The PDUs shall be transferred between the MS and the SwMI using the TMI as the source address on the uplink and as the destination address on the downlink.

No TETRA management PDUs are defined in the present document.

18.4 PDU descriptions

18.4.0 General

The following PDU descriptions contain a mapping of the information elements into an MLE PDU specifying the length of the information element, the type of the information element and whether the information element is mandatory, conditional or optional. The contents of the information elements themselves are further detailed in clause 18.5.

The information contained in the PDU description tables corresponds to the following key:

- Length: length of the information element in bits;
- Type: information element type 1 or 2 as defined below;
- C/O/M: conditional/optional/mandatory information in the PDU;
- Remark: comment.

18.4.1 Data transfer PDUs at the TLA-SAP

18.4.1.1 Protocol discriminator

The contents of an MLE PDU sent and received at the TLA-SAP shall be determined by a 3 bit protocol discriminator. The discriminator shall be the first information element field in the MLE PDU.

The protocol discriminator shall determine the MLE user SAP endpoint, i.e. it is used as routing information within the MLE data transfer sub-entity.

If the protocol discriminator indicates CMCE, MM, or SNDCCP, then the MLE shall remove the protocol discriminator and route the SDU to the relevant upper layer 3 protocol entity.

If the protocol discriminator indicates TETRA management entity, then the MLE shall remove the protocol discriminator and route the SDU to the TETRA management functional entity within the MLE protocol entity.

If the protocol discriminator indicates MLE, then the MLE shall remove the protocol discriminator and process the remainder of the PDU according to the MLE protocol.

18.4.1.2 PDU type

When the protocol discriminator indicates the MLE protocol, a "PDU type" information element shall follow which shall indicate the particular MLE protocol PDU type.

18.4.1.3 MLE service user PDUs

PDUs which have the protocol discriminator equal to one of the following: MM, SNDTCP, CMCE or TETRA Management Entity shall be defined as in table 18.1.

Table 18.1: MLE service PDU layout

Information element	Length	Value	Remark
Protocol discriminator	3		See clause 18.5.21 for element definition
SDU	variable		MM, CMCE, SNDTCP or Management Entity SDU

The SDUs sent/received at the LMM-SAP, LTPD-SAP, LCMC-SAP and to/from the management entity shall be transparent to the MLE. The MLE shall simply route these SDUs according to the protocol discriminator.

18.4.1.4 MLE protocol PDUs

18.4.1.4.0 General

MLE PDUs which have the protocol discriminator MLE protocol shall comprise both cell change PDUs and network broadcast PDUs.

Refer to annex E for description of the general format of the MLE protocol PDU.

18.4.1.4.1 D-NWRK-BROADCAST

- Message: D-NWRK-BROADCAST
- Response to: -/U-PREPARE/U-PREPARE-DA
- Response expected: -
- Short description: Upon receipt from the SwMI, the message shall inform the MS-MLE about parameters for the CA serving cell and parameters for one or more CA neighbour cells.

Table 18.2: D-NWRK-BROADCAST PDU

Information element	Length	Type	C/O/M	Remark
PDU type	3	1	M	D-NWRK-BROADCAST
Cell re-select parameters	16	1	M	See note 1
Cell load CA	2	1	M	See note 1
TETRA network time	48	2	O	
Number of CA neighbour cells	3	2	O	See note 2
Neighbour cell information for CA	variable			See note 3
NOTE 1: This element shall not be used by a DA MS.				
NOTE 2: If present, the element shall indicate how many "Neighbour cell information for CA" elements follow. If not present, no neighbour cell information shall follow.				
NOTE 3: The element definition is contained in clause 18.5 which gives the type and length for each sub-element which is included in this element. The element shall be present as many times as indicated by the "number of CA neighbour cells" element. There shall be no P-bit preceding each "neighbour cell information for CA" element which is carried by this PDU.				

18.4.1.4.1a D-NWRK-BROADCAST-DA

- Message: D-NWRK-BROADCAST-DA
- Response to: -/U-PREPARE-DA
- Response expected: -
- Short description: Upon receipt from the SwMI, the message shall inform the MS-MLE about parameters for the DA serving cell, one or more DA neighbour cells and the (if any) local CA cell.

Table 18.3: D-NWRK-BROADCAST-DA PDU

Information element	Length	Type	C/O/M	Remark
PDU type	3	1	M	Extended PDU
PDU type extension	4	1	M	D-NWRK-BROADCAST-DA
Reserved	3	1	M	See note 1
Reserved	14	2	O	See note 2
Cell identifier DA	8	2	O	See note 3
Cell re-select parameters	16	2	O	See notes 4 and 5
Cell load DA	3	2	O	See notes 4 and 5
TETRA network time	48	2	O	
Neighbour cell information for CA	variable	2	O	See notes 5 and 6
Number of DA neighbour cells	3	2	O	See note 7
Neighbour cell information for DA	variable			See note 8
Number of channel classes (for serving cell)	4	2	O	For DA serving cell. See note 9
Channel class	variable			See notes 10, 11 and 12
Number of DA neighbour cell channel classes	5	2	O	See note 13
Neighbour cell channel class for DA	variable			See note 14
Number of irregular channel details (for serving cell)	5	2	O	For DA serving cell. See note 15
Irregular channel detail	variable			See notes 10, 12 and 16
Number of DA neighbour cell irregular channel details	6	2	O	See note 17
Neighbour cell irregular channel detail for DA	variable			See note 18
Reserved	32	2	O	See note 2
Reserved	32	2	O	See note 2
NOTE 1: Shall be set to '000 ₂ ' in the present document.				
NOTE 2: Shall not be used in the present document.				
NOTE 3: This element shall not be included if the channel on which this PDU is sent is being used by MSs from more than one DA cell.				
NOTE 4: This element shall be included only if its value is appropriate to all DA cells using the channel on which this PDU is sent.				
NOTE 5: This element shall not be used by CA MSs.				
NOTE 6: If present, this element shall contain information about the local CA cell.				
NOTE 7: If present, the element shall indicate how many "neighbour cell information for DA" elements follow. If not present, no "neighbour cell information for DA" elements shall follow.				
NOTE 8: The element definition is contained in clause 18.5 which gives the type and length for each sub-element which is included in this element. The element shall be present as many times as indicated by the "number of DA neighbour cells" element. There shall be no P-bit preceding each "neighbour cell information for DA" element carried by this PDU.				
NOTE 9: If present, the element shall indicate how many "channel class" elements follow. If not present, no "channel class" elements shall follow.				
NOTE 10: This element shall not be included unless its value is appropriate to all DA cells using the channel on which this PDU is sent.				
NOTE 11: The element definition is contained in clause 18.5 which gives the type and length for each sub-element which is included in this element. The element shall be present as many times as indicated by the "number of channel classes (for serving cell)" element. There shall be no P-bit preceding each "channel class" element which is carried by this PDU.				

<p>NOTE 12: If the "cell identifier DA" element is present, CA MSs shall regard this element as containing information about the cell identified by the "cell identifier DA" element. If the "cell identifier DA" element is not present, CA MSs shall not use this element.</p> <p>NOTE 13: If present, the element shall indicate how many "neighbour cell channel class for DA" elements follow. If not present, no "neighbour cell channel class for DA" elements shall follow.</p> <p>NOTE 14: The element definition is contained in clause 18.5 which gives the type and length for each sub-element which is included in this element. The element shall be present as many times as indicated by the "number of DA neighbour cell channel classes" element. There shall be no P-bit preceding each "neighbour cell channel class for DA" element which is carried by this PDU.</p> <p>NOTE 15: If present, the element shall indicate how many "irregular channel detail" elements follow. If not present, no "irregular channel detail" elements shall follow.</p> <p>NOTE 16: The element definition is contained in clause 18.5 which gives the type and length for each sub-element which is included in this element. The element shall be present as many times as indicated by the "number of irregular channel details (for serving cell)" element. There shall be no P-bit preceding each "irregular channel detail" element which is carried by this PDU.</p> <p>NOTE 17: If present, the element shall indicate how many "neighbour cell irregular channel detail for DA" elements follow. If not present, no "neighbour cell irregular channel detail for DA" elements shall follow.</p> <p>NOTE 18: The element definition is contained in clause 18.5 which gives the type and length for each sub-element which is included in this element. The element shall be present as many times as indicated by the "number of DA neighbour cell irregular channel details" element. There shall be no P-bit preceding each "neighbour cell irregular channel detail for DA" element which is carried by this PDU.</p>
--

NOTE: The "neighbour cell information for CA" information element may be included in this PDU to enable DA MSs to discover the details of the (if any) local CA cell. Information about other CA neighbour cells is broadcast in the D-NWRK-BROADCAST PDU.

18.4.1.4.1b D-NWRK-BROADCAST EXTENSION

- Message: D-NWRK-BROADCAST EXTENSION
- Response to: -/U-PREPARE/U-PREPARE-DA
- Response expected: -
- Short description: Upon receipt from the SwMI, the message shall inform the MS-MLE about parameters for the CA serving cell and parameters for one or more CA neighbour cells.

Table 18.4: D-NWRK-BROADCAST EXTENSION PDU

Information element	Length	Type	C/O/M	Remark
PDU type	3	1	M	D-NWRK-BROADCAST EXTENSION
Number of channel classes (for serving cell)	4	2	O	For CA serving cell. See note 1
Channel class	variable			See notes 2 and 3
Number of CA neighbour cell channel classes	5	2	O	See note 4
Neighbour cell channel class for CA	variable			See note 5
Number of irregular channel details (for serving cell)	5	2	O	For CA serving cell. See note 6
Irregular channel detail	variable			See notes 2 and 7
Number of CA neighbour cell irregular channel details	6	2	O	See note 8
Neighbour cell irregular channel detail for CA	variable			See note 9
Reserved	32	2	O	See note 10
Reserved	32	2	O	See note 10
NOTE 1: If present, the element shall indicate how many "channel class" elements follow. If not present, no "channel class" elements shall follow.				
NOTE 2: DA MSs shall regard this as information about the local CA cell.				
NOTE 3: The element definition is contained in clause 18.5 which gives the type and length for each sub-element which is included in this element. The element shall be present as many times as indicated by the "Number of channel classes (for serving cell)" element. There shall be no P-bit preceding each channel class element carried by this PDU.				
NOTE 4: If present, the element shall indicate how many "neighbour cell channel class for CA" elements follow. If not present, no "neighbour cell channel class for CA" elements shall follow.				
NOTE 5: The element definition is contained in clause 8.5 which gives the type and length for each sub-element which is included in this element. The element shall be present as many times as indicated by the "Number of CA neighbour cell channel classes" element. There shall be no P-bit preceding each "neighbour cell channel class for CA" information element carried by this PDU.				
NOTE 6: If present, the element shall indicate how many "irregular channel detail" elements follow. If not present, no "irregular channel detail" elements shall follow.				
NOTE 7: The element definition is contained in clause 18.5 which gives the type and length for each sub-element which is included in this element. The element shall be present as many times as indicated by the "Number of irregular channel details (for serving cell)" element. There shall be no P-bit preceding each "irregular channel detail" information element carried by this PDU.				
NOTE 8: If present, the element shall indicate how many "neighbour cell irregular channel detail for CA" elements follow. If not present, no "neighbour cell irregular channel detail for CA" elements shall follow.				
NOTE 9: The element definition is contained in clause 18.5 which gives the type and length for each sub-element which is included in this element. The element shall be present as many times as indicated by the "Number of CA neighbour cell irregular channel details" element. There shall be no P-bit preceding each "neighbour cell irregular channel detail for CA" element carried by this PDU.				
NOTE 10: Shall not be used in the present document.				

18.4.1.4.1c D-NWRK-BROADCAST REMOVE

- Message: D-NWRK-BROADCAST REMOVE
- Response to: -
- Response expected: -
- Short description: Upon receipt from the SwMI, the message shall inform the MS-MLE about broadcast neighbour cell and channel information received on the present cell that is to be removed from the MS's memory.

Table 18.5: D-NWRK-BROADCAST REMOVE PDU

Information element	Length	Type	C/O/M	Remark
PDU type	3	1	M	Extended PDU
PDU type extension	4	1	M	D-NWRK-BROADCAST REMOVE
Number of CA cells for removal	5	2	O	See note 1
Removal data for CA cell	variable			See note 2
Number of DA cells for removal	8	2	O	See note 3
Removal data for DA cell	variable			See note 4
Removal data for serving cell	variable	2	O	See note 5
Reserved	8	2	O	See note 6
Reserved	8	2	O	See note 6
Reserved	16	2	O	See note 6
Reserved	32	2	O	See note 6
NOTE 1: If present, the element shall indicate how many "removal data for CA cell" elements follow. If not present, no "removal data for CA cell " elements shall follow.				
NOTE 2: The element definition is contained in clause 18.5 which gives the type and length for each sub-element which is included in this element. The element shall be present as many times as indicated by the "number of CA cells for removal" element. There shall be no P-bit preceding each "removal data for CA cell" element which is carried by this PDU.				
NOTE 3: If present, the element shall indicate how many "removal data for DA cell" elements follow. If not present, no "removal data for DA cell " elements shall follow.				
NOTE 4: The element definition is contained in clause 18.5 which gives the type and length for each sub-element which is included in this element. The element shall be present as many times as indicated by the "number of DA cells for removal" element. There shall be no P-bit preceding each "removal data for DA cell" element which is carried by this PDU.				
NOTE 5: This element shall not be included unless its value is appropriate to all cells using the channel on which this PDU is sent.				
NOTE 6: Shall not be used in the present document.				

18.4.1.4.2 D-NEW-CELL

- Message: D-NEW-CELL
- Response to: U-PREPARE/U-PREPARE-DA
- Response expected: -
- Short description: Upon receipt from the SwMI the message shall inform the MS-MLE that it can select a new cell as previously indicated in the U-PREPARE or U-PREPARE-DA PDU.

Table 18.6: D-NEW-CELL PDU

Information element	Length	Type	C/O/M	Remark
PDU type	3	1	M	D-NEW-CELL
Channel command valid	2	1	M	
SDU				See note
NOTE: The SDU may carry an MM registration PDU which is used to forward register to a new cell during announced type 1 cell reselection or a D-OTAR CCK PROVIDE PDU which is used to identify the current CCK, it may also provide the future CCK for the LA which the MS has indicated in the U-OTAR CCK DEMAND PDU and whether the CCK provided is in use in other LAs or is used throughout the SwMI. The SDU is coded according to the MM protocol description. There shall be no P-bit in the PDU coding preceding the SDU information element.				

18.4.1.4.3 D-PREPARE-FAIL

- Message: D-PREPARE-FAIL
- Response to: U-PREPARE/U-PREPARE-DA
- Response expected: -
- Short description: Upon receipt from the SwMI the message shall be used by the MS-MLE as a preparation failure, while announcing cell reselection to the old cell.

Table 18.7: D-PREPARE-FAIL PDU

Information element	Length	Type	C/O/M	Remark
PDU type	3	1	M	D-PREPARE-FAIL
Fail cause	2	1	M	
SDU				See note
NOTE: The SDU may carry an MM registration PDU. The SDU is coded according to the MM protocol description. There shall be no P-bit in the PDU coding preceding the SDU information element.				

18.4.1.4.4 D-RESTORE-ACK

- Message: D-RESTORE-ACK
- Response to: U-RESTORE
- Response expected: -
- Short description: Upon receipt from the SwMI, the message shall indicate to the MS-MLE an acknowledgement of the C-Plane restoration on the new selected cell.

Table 18.8: D-RESTORE-ACK PDU

Information element	Length	Type	C/O/M	Remark
PDU type	3	1	M	D-RESTORE-ACK
SDU				See note
NOTE: This PDU shall carry a CMCE D-CALL RESTORE PDU which can be used to restore a call after cell reselection. The SDU is coded according to the CMCE protocol description. There shall be no P-bit in the PDU coding preceding the SDU information element.				

18.4.1.4.5 D-RESTORE-FAIL

- Message: D-RESTORE-FAIL
- Response to: U-RESTORE
- Response expected: -
- Short description: Upon receipt from the SwMI, the message shall indicate to the MS-MLE a failure in the restoration of the C-Plane on the new selected cell.

Table 18.9: D-RESTORE-FAIL PDU

Information element	Length	Type	C/O/M	Remark
PDU type	3	1	M	D-RESTORE-FAIL
Fail cause	2	1	M	

18.4.1.4.5a D-CHANNEL RESPONSE

- Message: D-CHANNEL RESPONSE
- Response to: U-CHANNEL REQUEST
- Response expected: -
- Short description: The message shall be sent by the SwMI in response to an MS request for an assigned channel replacement.

Table 18.10: D-CHANNEL RESPONSE PDU

Information element	Length	Type	C/O/M	Remark
PDU type	3	1	M	D-CHANNEL RESPONSE
Channel response type	1	1	M	
Reason for the channel request	3	1	M	
Channel request retry delay	4	1	M	
Reserved	8	2	O	See note
Reserved	8	2	O	See note
NOTE: In the present document, this element shall not be included.				

18.4.1.4.6 U-PREPARE

- Message: U-PREPARE
- Response to: -
- Response expected: D-NEW-CELL/D-NWRK-BROADCAST /D-PREPARE-FAIL
- Short description: The message shall be sent on the serving cell to the SwMI by the MS-MLE, when preparation of cell reselection to a neighbour cell is in progress.

Table 18.11: U-PREPARE PDU

Information element	Length	Type	C/O/M	Remark
PDU type	3	1	M	U-PREPARE
Cell identifier CA	5	2	O	
SDU				See note
NOTE: The SDU may carry an MM registration PDU which is used to forward register to a new CA cell during announced type 1 cell reselection or a U-OTAR CCK DEMAND PDU which is used to request the Common Cipher Key (CCK) of the new cell. The SDU is coded according to the MM protocol description. There shall be no P-bit in the PDU coding preceding the SDU information element.				

18.4.1.4.6a U-PREPARE-DA

- Message: U-PREPARE-DA
- Response to: -
- Response expected: D-NEW-CELL/D-NWRK-BROADCAST/
D-NWRK-BROADCAST-DA/D-PREPARE-FAIL
- Short description: The message shall be sent on the serving cell to the SwMI by the MS-MLE, when preparation of cell reselection to a neighbour cell is in progress.

Table 18.12: U-PREPARE-DA PDU

Information element	Length	Type	C/O/M	Remark
PDU type	3	1	M	U-PREPARE-DA
Cell identifier DA	8	2	O	
SDU				See note
NOTE: The SDU may carry an MM registration PDU which is used to forward register to a new DA cell during announced type 1 cell reselection or a U-OTAR CCK DEMAND PDU which is used to request the Common Cipher Key (CCK) of the new cell. The SDU is coded according to the MM protocol description. There shall be no P-bit in the PDU coding preceding the "SDU" information element.				

18.4.1.4.7 U-RESTORE

- Message: U-RESTORE
- Response to: -
- Response expected: D-RESTORE-ACK/D-RESTORE-FAIL
- Short description: The message shall be sent by the MS-MLE, when restoration of the C-Plane towards a new cell is in progress.

Table 18.13: U-RESTORE PDU

Information element	Length	Type	C/O/M	Remark
PDU type	3	1	M	U-RESTORE
MCC	10	2	O	See notes 1 and 2
MNC	14	2	O	See notes 1 and 2
LA	14	2	O	See notes 1 and 2
SDU				See note 3
NOTE 1: The element is present in the PDU if its value on the new cell is different from that on the old cell.				
NOTE 2: When included, this element gives the value for the old cell.				
NOTE 3: This PDU shall carry a CMCE U-CALL RESTORE PDU which shall be used to restore a call after cell reselection. The SDU is coded according to the CMCE protocol. There shall be no P-bit in the PDU coding preceding the "SDU" information element.				

18.4.1.4.8 U-CHANNEL CLASS ADVICE

- Message: U-CHANNEL CLASS ADVICE
- Response to: -
- Response expected: -
- Short description: The message advises the SwMI of usable channel classes and the data priority of SN PDUs awaiting access to a packet data channel.

Table 18.14: U-CHANNEL CLASS ADVICE PDU

Information element	Length	Type	C/O/M	Remark
PDU type	3	1	M	U-CHANNEL CLASS ADVICE
Number of channel class identifiers	2	1	M	See note 1
Channel class identifier	4		C	Repeatable, see note 2
Discriminator for SDU protocol present	1	1	M	See note 4
Protocol discriminator	3		C	See notes 5 and 6
Data priority	3	2	O	
SDU				See note 3
NOTE 1: Shall indicate the number of "channel class identifier" information elements: <ul style="list-style-type: none"> - 00₂ means one "channel class identifier" information element i.e. four bits; - 01₂ means two "channel class identifier" information elements i.e. eight bits; - 10₂ means three "channel class identifier" information elements i.e. 12 bits; - 11₂ means four "channel class identifier" information elements i.e. 16 bits. 				
NOTE 2: Shall be present as many times as indicated by the "number of channel class identifiers" information element.				
NOTE 3: There shall be no P-bit in the PDU coding preceding the "SDU" information element.				
NOTE 4: If the "discriminator for SDU protocol present" information element has the value "0", the SwMI shall decode the SDU using the SMDCP protocol. If the "discriminator for SDU protocol present" information element has the value "1", the SwMI shall decode the SDU using the protocol indicated by the "protocol discriminator" information element.				
NOTE 5: This instance of the "protocol discriminator" information element shall be present only if the "discriminator for SDU protocol present" information element is set to "1".				
NOTE 6: If present, this instance of the "protocol discriminator" information element indicates the SDU protocol.				

NOTE: This PDU uses a minimum of 14 bits before the SDU, including the MLE protocol identifier and the O-bit. It uses 18 bits (including a P-bit) when the "data priority" information element is present. For example, this allows the following U-CHANNEL CLASS ADVICE PDU plus SN-DATA TRANSMIT REQUEST PDU combinations to be transmitted with an SSI without fragmentation:

- In SCH-Q/RA:
 - one channel class identifier with data priority, without SNEI, without resource request, without the 20-bit reserved information element and without a reservation requirement from layer 2; or
 - two channel class identifiers without data priority, without SNEI, without resource request, without the 20-bit reserved information element and without a reservation requirement from layer 2; or
- In SCH/HU:
 - one channel class identifier without data priority, with SNEI, with the 10-bit resource request, without the 20-bit reserved information element and without a reservation requirement from layer 2; or
 - two channel class identifiers with data priority, without SNEI, without resource request, with the 20-bit reserved information element and without a reservation requirement from layer 2; or
 - four channel class identifiers without data priority, without SNEI, with the 10-bit resource request, without the 20-bit reserved information element and with a reservation requirement from layer 2.

18.4.1.4.9 U-CHANNEL REQUEST

- Message: U-CHANNEL REQUEST
- Response to: -
- Response expected: -
- Short description: The message shall be sent by the MS-MLE to request replacement of an assigned channel.

Table 18.15: U-CHANNEL REQUEST PDU

Information element	Length	Type	C/O/M	Remark
PDU type	3	1	M	U-CHANNEL REQUEST
Reason for the channel request	3	1	M	
Number of requested channel class identifiers	3	2	O	
Channel class identifier	4			See note 1
Number of requested channel identifiers	3	2	O	
Channel identifier	5			See note 2
Reserved	6	2	O	See note 3
NOTE 1: The element shall be included as many times as indicated by the "number of requested channel class identifiers" element. It shall not be included if the "number of requested channel class identifiers" element is not present. There shall be no P-bit preceding each "channel class identifier" element which is carried by this PDU.				
NOTE 2: The element shall be included as many times as indicated by the "number of requested channel identifiers" element. It shall not be included if the "number of requested channel identifiers" element is not present. There shall be no P-bit preceding each "channel identifier" element which is carried by this PDU.				
NOTE 3: Shall not be used in the present document.				

18.4.1.4.10 U-IRREGULAR CHANNEL ADVICE

- Message: U-IRREGULAR CHANNEL ADVICE
- Response to: -
- Response expected: -
- Short description: The message advises the SwMI of irregular channels on the current cell which the MS can use from its current location.

Table 18.16: U-IRREGULAR CHANNEL ADVICE PDU

Information element	Length	Type	C/O/M	Remark
PDU type	3	1	M	U-IRREGULAR CHANNEL ADVICE
Number of channel identifiers	2	1	M	See note 1
Channel identifier	5		C	Repeatable, see note 2
Discriminator for SDU protocol present	1	1	M	See note 4
Protocol discriminator	3		C	See notes 5 and 6
Data priority	3	2	O	
SDU				See note 3
<p>NOTE 1: Shall indicate the number of "channel identifier" information elements:</p> <ul style="list-style-type: none"> - 00₂ means one "channel identifier" information element i.e. five bits; - 01₂ means two "channel identifier" information elements i.e. 10 bits; - 10₂ means three "channel identifier" information elements i.e. 15 bits; - 11₂ means four "channel identifier" information elements i.e. 20 bits. <p>NOTE 2: Shall be present as many times as indicated by the "number of channel identifiers" information element.</p> <p>NOTE 3: There shall be no P-bit in the PDU coding preceding the "SDU" information element.</p> <p>NOTE 4: If the "discriminator for SDU protocol present" information element has the value "0", the SwMI shall decode the SDU using the SNDCP protocol. If the "discriminator for SDU protocol present" information element has the value "1", the SwMI shall decode the SDU using the protocol indicated by the "protocol discriminator" information element.</p> <p>NOTE 5: The "protocol discriminator" information element shall be present only if the "discriminator for SDU protocol present" information element is set to "1".</p> <p>NOTE 6: If present, this instance of the "protocol discriminator" information element indicates the SDU protocol.</p>				

NOTE: This PDU uses a minimum of 15 bits before the SDU, including the MLE protocol identifier and the O-bit. It uses 19 bits (including a P-bit) when the "data priority" information element is present. For example, this allows the following U-IRREGULAR CHANNEL ADVICE PDU plus SN-DATA TRANSMIT REQUEST PDU combinations to be transmitted with an SSI without fragmentation:

- in SCH-Q/RA:
 - with one suggested channel, with data priority, without SNEI, without resource request, without the 20-bit reserved information element, without NSAPI additional and without a reservation requirement from layer 2; or
- in SCH/HU:
 - with one suggested channel, without data priority, with SNEI, with the 10-bit resource request, without the 20-bit reserved element, without NSAPI additional and without a reservation requirement from layer 2; or
 - with one suggested channel, without data priority, without SNEI, without resource request, with the 20-bit reserved information element, without NSAPI additional and with a reservation requirement from layer 2; or
 - with four suggested channels, with data priority, without SNEI, with the 10-bit resource request, without the 20-bit reserved information element, without NSAPI additional and without a reservation requirement from layer 2.

18.4.2 Broadcast PDUs at the TLB-SAP

18.4.2.0 General

PDUs at the TLB SAP shall be transported using the layer 2 SYNC, SYNC-DA, SYSINFO, SYSINFO-Q and SYSINFO-DA PDUs. D-MLE-SYNC shall use the SYNC PDU, D-MLE-SYNC-DA shall use the SYNC-DA PDU, D-MLE-SYSINFO shall use the SYSINFO PDU, D-MLE-SYSINFO-Q shall use the SYSINFO-Q PDU and D-MLE-SYSINFO-DA shall use the SYSINFO-DA PDU.

18.4.2.1 D-MLE-SYNC

- Message: D-MLE-SYNC
- Response to: -
- Response expected: -
- Short description: This message informs CA MSs on a phase modulation channel about MLE information for the CA serving cell and gives CA (and DA) MSs information necessary for performing reselection to the CA cell on which the PDU is sent. The message can only be recognized within a MAC to MAC message on the $\pi/4$ -DQPSK Broadcast Synchronization CHannel (BSCH). The message is contained within a MAC SYNC PDU.

Table 18.17: D-MLE-SYNC PDU

Information element	Length	Type	C/O/M	Remark
MCC	10	1	M	
MNC	14	1	M	
Neighbour cell broadcast	2	1	M	
Cell load CA	2	1	M	
Late entry supported	1	1	M	

This PDU shall not contain an "O" bit and shall be 29 bits in length.

When received on its serving cell, a CA MS shall use the information in this message to update its record of information about its serving cell. A DA MS shall not use the information in this message to alter its record of information about its serving cell.

18.4.2.1a D-MLE-SYNC-DA

- Message: D-MLE-SYNC-DA
- Response to: -
- Response expected: -
- Short description: This message informs DA MSs on a QAM channel about MLE information for the DA serving cell and gives DA (and CA) MSs information necessary for performing reselection to the DA cell on which the PDU is sent. The message is contained within a MAC SYNC-DA PDU.

Table 18.18: D-MLE-SYNC-DA PDU

Information element	Length	Type	C/O/M	Remark
MCC	10	1	M	
MNC	14	1	M	
Cell load DA	3	1	M	
Subscriber class	16	1	M	
BS service details DA	7	1	M	
Wide-area cell	1	1	M	
C/I path measurements	2	1	M	See note
Reserved	1	1	M	Reserved for future use. Shall be set to 0 in the present document.

NOTE: If the "C/I path measurements" element is set to "10₂" or "11₂", the MS shall not use this cell in this version of the present document.

This PDU shall not contain an "O" bit and shall be 54 bits in length.

When received on its serving cell, a DA MS may use the information in this message to update its record of information about its serving cell. A CA MS shall not use this message to alter its record of information about its serving cell.

18.4.2.2 D-MLE-SYSINFO

- Message: D-MLE-SYSINFO
- Response to: -
- Response expected: -
- Short description: This message is used for informing CA MSs on a phase modulation channel about MLE information for the CA serving cell and for giving CA (and DA) MSs information necessary for performing reselection to the CA cell on which the PDU is sent. The message is contained within a MAC SYSINFO PDU.

Table 18.19: D-MLE-SYSINFO PDU

Information element	Length	Type	C/O/M	Remark
Location area (LA)	14	1	M	
Subscriber class	16	1	M	
BS service details	12	1	M	

This PDU shall not contain an "O" bit and shall be 42 bits in length.

When received on its serving cell, a CA MS shall use the information in this message to update its record of information about its serving cell. A DA MS shall not use this message to alter its record of information about its serving cell. However, a DA MS shall regard the "air interface encryption service" information element in BS service details as being relevant to its operation on the current channel - see also clause 23.6.9.

18.4.2.2a D-MLE-SYSINFO-DA

- Message: D-MLE-SYSINFO-DA
- Response to: -
- Response expected: -
- Short description: This message is used for informing DA MSs on a QAM (or phase modulation) channel about MLE information for the DA serving cell. It is also used for giving DA (and CA) MSs information necessary for performing reselection to the DA cell on which the PDU is sent. The message is contained within a MAC SYSINFO-DA PDU.

Table 18.20: D-MLE-SYSINFO-DA PDU

Information element	Length	Type	C/O/M	Remark
Neighbour cell broadcast	2	1	M	
Cell load DA	3	1	M	
Roaming control for individual services	1	1	M	
Roaming control for group services and idle MSs	1	1	M	
Late entry supported	1	1	M	
Subscriber class included	1	1	M	
Subscriber class	16		C	See notes 1 and 3
Location Area (LA)	14		C	See notes 2 and 3
Reserved	2		C	See note 2
BS service details DA	7	1	M	
Registration	1	1	M	
De-registration	1	1	M	
Cell type change registration	1	1	M	
AL roaming supported	1	1	M	
Reserved	11	1	M	Reserved for future use. Shall be set to zero in the present document.
NOTE 1: Shall be included only if "Subscriber class included" = 1.				
NOTE 2: Shall be included only if "Subscriber class included" = 0.				
NOTE 3: If either subscriber class or LA changes, the SwMI may wish to send the changed element several times in succession.				

This PDU shall not contain an "O" bit and shall be 47 bits in length.

When received on its serving cell, a DA MS shall use the information in this message to update its record of information about its serving cell. A CA MS shall not use this message to alter its record of information about its serving cell or current channel.

18.4.2.3 D-MLE-SYSINFO-Q

- Message: D-MLE-SYSINFO-Q
- Response to: -
- Response expected: -
- Short description: This message is used for informing CA MSs on a QAM channel about MLE information for the CA serving cell. The message is contained within a MAC SYSINFO-Q PDU.

Table 18.21: D-MLE-SYSINFO-Q PDU

Information element	Length	Type	C/O/M	Remark
Neighbour cell broadcast	2	1	M	
Cell load CA	2	1	M	
Late entry supported	1	1	M	
Location Area (LA)	14	1	M	
Subscriber class	16	1	M	
BS service details	12	1	M	

This PDU shall not contain an "O" bit and shall be 47 bits in length.

When received on its serving cell, a CA MS shall use the information in this message to update its record of information about the serving cell. A DA MS shall not use this message.

18.5 Information elements coding

18.5.1 Cell reselection types supported

The "cell reselection types supported" information element shall define whether SwMI supports forward registration and if expedited cell reselection is recommended on the neighbour cell as defined in table 18.22.

Table 18.22: Cell reselection types supported information element

Information element	Length	Value	Remark
Cell reselection types supported	2	00 ₂	Forward registration is not supported
		01 ₂	Forward registration is not supported, expedited cell reselection recommended
		10 ₂	Forward registration is supported
		11 ₂	Forward registration is supported, expedited cell reselection recommended

18.5.1a Cell reselection types supported DA

The "cell reselection types supported DA" information element shall define whether the SwMI supports forward registration and if expedited cell reselection is recommended on the neighbour cell as defined in table 18.23.

Table 18.23: Cell reselection types supported DA information element

Information element	Length	Value	Remark
Forward registration	1	0	Forward registration not supported
		1	Forward registration supported
Expedited cell reselection	1	0	Expedited cell reselection not recommended
		1	Expedited cell reselection recommended
Reserved	6	0	Shall be set to zero in the present document.

18.5.1b AL roaming supported

The "AL roaming supported" information element shall indicate to the MS whether or not this cell supports AL roaming, as defined in table 18.24.

Table 18.24: AL roaming supported information element

Information element	Length	Value	Remark
AL roaming supported	1	0 ₂	AL roaming not supported on this cell
		1 ₂	AL roaming supported on this cell

18.5.1c Bandwidth

The "bandwidth" information element shall indicate the RF bandwidth of a channel or channel class, as defined in table 18.25.

Table 18.25: Bandwidth information element

Information element	Length	Value	Remark
Bandwidth	3	000 ₂	25 kHz
		001 ₂	50 kHz
		010 ₂	100 kHz
		011 ₂	150 kHz
		100 ₂	Reserved
		etc.	etc.
		111 ₂	Reserved

18.5.2 BS service details and related information elements

18.5.2.1 BS service details

The "BS service details" information element shall contain information about which services are supported by the SwMI on a particular CA cell as defined in table 18.26.

Table 18.26: BS Service details information element

Information element	Length	Value	Remark
Registration	1	0	Registration not required on this cell
		1	Registration mandatory on this cell
De-registration	1	0	De-registration not required on this cell
		1	De-registration requested on this cell
Priority cell	1	0	Cell is not a priority cell
		1	Cell is a priority cell
Minimum mode service	1	0	Cell may use minimum mode
		1	Cell never uses minimum mode
Migration	1	0	Migration is not supported by this cell
		1	Migration is supported by this cell
System wide services	1	0	System wide services temporarily not supported
		1	Normal mode (system wide services supported)
TETRA voice service (see note 1)	1	0	TETRA voice service is not supported on this cell
		1	TETRA voice service is supported on this cell
Circuit mode data service (see note 1)	1	0	Circuit mode data service is not supported on this cell
		1	Circuit mode data service is supported on this cell
Reserved	1	0	Default value
		1	Reserved for future expansion
SNDP service	1	0	SNDP service is not available on this cell
		1	SNDP service is available on this cell
Air interface encryption service	1	0	Air interface encryption is not available on this cell
		1	Air interface encryption is available on this cell
Advanced link supported	1	0	Advanced link is not supported on this cell (see note 2)
		1	Advanced link is supported on this cell (see note 3)
NOTE 1: TETRA voice service and circuit mode data service refer to the $\pi/4$ -DQPSK circuit mode service. NOTE 2: If "0", neither the original advanced link nor the extended advanced link is supported on this cell. NOTE 3: If "1", the original advanced link is supported on this cell, and the extended advanced link may be supported on this cell (see the "extended services broadcast section 1" information element in clause 21.4.4.1).			

18.5.2.2 BS service details DA

The "BS service details DA" information element shall contain information about which services are supported by the SwMI on a particular DA cell as defined in table 18.27.

Table 18.27: BS Service details DA information element

Information element	Length	Value	Remark
Priority cell	1	0	Cell is not a priority cell
		1	Cell is a priority cell
Migration	1	0	Migration is not supported by this cell
		1	Migration is supported by this cell
System wide services (see note 1)	1	0	System wide services temporarily not supported
		1	Normal mode (system wide services supported)
TETRA voice service (see note 2)	1	0	TETRA voice service is not supported on this cell
		1	TETRA voice service is supported on this cell
Circuit mode data service (see note 2)	1	0	Circuit mode data service is not supported on this cell
		1	Circuit mode data service is supported on this cell
Reserved	1	0	Default value
		1	Reserved for future expansion
Air interface encryption service	1	0	Air interface encryption is not available on this cell
		1	Air interface encryption is available on this cell
NOTE 1: DA cells shall support the SMDCP service and original and extended advanced links (unless the "system wide services" element in the D-MLE-SYSINFO-DA (and D-MLE-SYNC-DA) PDU indicates "system wide services temporarily not supported", in which case support of the SMDCP service and advanced links by the BS is optional).			
NOTE 2: TETRA voice service and circuit mode data service refer to the $\pi/4$ -DQPSK circuit mode service.			

18.5.2a BS transmit power relative to the main carrier

The "BS transmit power relative to the main carrier" information element shall be used to give the ratio of the BS transmit power on an RF channel or channel class to the BS transmit power on the MCCCH or MCCCH-Q controlling use of that RF channel or channel class, as defined in table 18.28.

Table 18.28: BS transmit power relative to the main carrier information element

Information element	Length	Value	Remark
BS transmit power relative to the main carrier	5	00000 ₂	Reserved
		etc.	etc.
		00100 ₂	Reserved
		00101 ₂	-22 dB
		00110 ₂	-20 dB
		00111 ₂	-18 dB
		01000 ₂	-16 dB
		01001 ₂	-14 dB
		01010 ₂	-12 dB
		01011 ₂	-10 dB
		01100 ₂	-8 dB
		01101 ₂	-6 dB
		01110 ₂	-4 dB
		01111 ₂	-2 dB
		10000 ₂	0 dB
		10001 ₂	2dB
		10010 ₂	4 dB
		10011 ₂	6 dB
		10100 ₂	8 dB
		10101 ₂	10 dB
		10110 ₂	12 dB
		10111 ₂	14 dB
		11000 ₂	16 dB
		11001 ₂	18 dB
		11010 ₂	20 dB
11011 ₂	22 dB		
11100 ₂	Reserved		
etc.	etc.		
11111 ₂	Reserved		

The value of the BS transmit power relative to the main carrier information element shall include the BS relative antenna gains; i.e. it is the BS effective radiated power (ERP) into the RF channel or channel class relative to the BS ERP of the main carrier.

18.5.2b C/I path measurements

The "C/I path measurements" information element shall indicate to the MS whether or not this cell requires the MS to conduct C/I path measurements, as defined in table 18.29.

Table 18.29: C/I path measurements information element

Information element	Length	Value	Remark
C/I path measurements	2	00 ₂	RSSI measurements shall be used
		01 ₂	Either RSSI or C/I path measurements may be used. See note 1
		10 ₂	C/I path measurements shall be used. See note 2
		11 ₂	Reserved. See note 2
NOTE 1: If the "C/I path measurements" element is set to "01 ₂ ", MSs shall not use C/I measurements on this cell in the present document.			
NOTE 2: This value shall not be used in the present document.			

18.5.2c Carrier number

The "carrier number" information element shall define the carrier number for a channel as defined in table 18.30. See the "channel allocation" information element in clause 21 and ETSI TS 100 392-15 [18] for a full description of carrier numbering.

Table 18.30: Carrier number information element

Information element	Length	Value	Remark
Carrier number	12		Carrier number of channel as defined in clause 21 and ETSI TS 100 392-15 [18]

18.5.2d Carrier number extension

The "carrier number extension" information element shall define extended carrier numbering information as defined in table 18.31. See the channel allocation information element in clause 21 and ETSI TS 100 392-15 [18] for a full description of carrier numbering.

Table 18.31: Carrier number extension information element

Information element	Length	Value	Remark
Frequency band	4		Provision for different frequency bands as defined in clause 21 and ETSI TS 100 392-15 [18]
Offset	2	00 ₂	No offset
		01 ₂	+6,25 kHz offset
		10 ₂	-6,25 kHz offset
		11 ₂	+12,5 kHz offset
Duplex spacing	3		Provision for different duplex spacing as defined in clause 21 and ETSI TS 100 392-15 [18]
Reverse operation	1	0	Normal
		1	Reverse

18.5.2e Carrier number extension flag

The "carrier number extension flag" information element shall determine whether the "carrier number extension" information element is present, as defined in table 18.32.

Table 18.32: Carrier number extension flag information element

Information element	Length	Value	Remark
Carrier number extension flag	1	0	Carrier number extension not included
		1	Carrier number extension included

18.5.3 Cell identifier CA

The "cell identifier CA" information element shall be used to identify a CA neighbour cell as defined in table 18.33. The serving cell shall attach a cell identifier CA to each CA neighbour cell whenever the serving cell broadcasts information about that neighbour cell. The cell identifier CA can then be used subsequently to refer to that CA neighbour cell. When the SwMI assigns a cell identifier CA, it shall then be able to map this identifier to a physical CA cell whenever the MS uses the cell identifier CA (for example, in a U-PREPARE PDU).

The cell identifier CA may also be set equal to "00000₂" in a U-PREPARE PDU to initiate the neighbour cell enquiry procedure which prompts the SwMI to send the D-NWRK-BROADCAST and, if relevant, the D-NWRK-BROADCAST EXTENSION PDU when the MS does not yet have the CA neighbour cell information.

Table 18.33: Cell identifier CA information element

Information element	Length	Value	Remark
Cell identifier CA	5	00000 ₂	Neighbour cell enquiry
		00001 ₂	Valid cell identifier CA
		etc.	etc.
		11111 ₂	Valid cell identifier CA

18.5.3a Cell identifier DA

The "cell identifier DA" information element shall be used to identify a DA neighbour cell as defined in table 18.34. The serving cell shall attach a cell identifier DA to each DA neighbour cell whenever the serving cell broadcasts information about that DA neighbour cell. The cell identifier DA may then be used subsequently to refer to that DA neighbour cell. When the SwMI assigns a cell identifier DA, it shall then be able to map this identifier to a physical DA cell whenever the MS uses the cell identifier DA (for example, in a U-PREPARE-DA PDU).

A DA cell may also use the "cell identifier DA" information element (in the D-NWRK-BROADCAST-DA PDU) to broadcast its own identity.

The cell identifier DA may be set equal to "00000000₂" in a U-PREPARE-DA PDU to initiate the neighbour cell enquiry procedure which prompts the SwMI to send the D-NWRK-BROADCAST-DA PDU when the MS does not yet have the DA neighbour cell information. It may be set equal to "11111111₂" in a U-PREPARE-DA PDU to elicit D-NWRK-BROADCAST-DA, D-NWRK-BROADCAST and, if relevant, the D-NWRK-BROADCAST EXTENSION PDUs.

Table 18.34: Cell identifier DA information element

Information element	Length	Value	Remark
Cell identifier DA	8	00000000 ₂	DA neighbour cell enquiry
		00000001 ₂	Valid cell identifier DA
		etc.	etc.
		01111111 ₂	Valid cell identifier DA
		10000000 ₂	Reserved
		etc.	etc.
		11111110 ₂	Reserved
		11111111 ₂	CA neighbour cell and DA neighbour cell enquiry

18.5.3b Cell load CA

The "cell load CA" information element shall define the level of service an MS may receive in a CA cell as defined in table 18.35. It may relate to the TCH and PDCH loading in a cell.

Table 18.35: Cell load CA information element

Information element	Length	Value	Remark
Cell load CA	2	00 ₂	Cell load unknown
		01 ₂	Low cell load
		10 ₂	Medium cell load
		11 ₂	High cell load

NOTE: This information element was formerly known as "cell service level".

18.5.3c Cell load DA

The "cell load DA" information element shall define the level of service an MS may receive in a DA cell as defined in table 18.36.

Table 18.36: Cell load DA information element

Information element	Length	Value	Remark
TCH load	1	0	Low TCH load
		1	High TCH load
PDCH load	1	0	Low PDCH load
		1	High PDCH load
Control channel/SDS load	1	0	Low Control channel/SDS load
		1	High Control channel/SDS load

18.5.3d Cell load known

The "cell load known" information element shall indicate whether the cell load is known or unknown as defined in table 18.37.

Table 18.37: Cell load known information element

Information element	Length	Value	Remark
Cell load known	1	0	Cell load unknown
		1	Cell load known

18.5.4 Cell re-select parameters

The "cell re-select parameters" information element shall define the threshold parameters for the cell reselection procedures in the MS as defined in table 18.38.

SLOW_RESELECT_THRESHOLD is the maximum level above the FAST_RESELECT_THRESHOLD for a radio improvable link i.e. $SLOW_RESELECT_THRESHOLD = FAST_RESELECT_THRESHOLD + SLOW_RESELECT_THRESHOLD_ABOVE_FAST$.

FAST_RESELECT_THRESHOLD is the maximum level above C1 = "0" for a radio relinquishable link.

SLOW_RESELECT_HYSTERESIS is the hysteresis for a radio improvable link.

FAST_RESELECT_HYSTERESIS is the hysteresis for a radio relinquishable link.

Table 18.38: Cell re-select parameters information element

Information element	Length	Value	Remark
SLOW_RESELECT_THRESHOLD_ABOVE_FAST	4	0000 ₂	0 dB
		0001 ₂	2 dB
		etc.	etc.
		1111 ₂	30 dB
FAST_RESELECT_THRESHOLD	4	0000 ₂	0 dB
		0001 ₂	2 dB
		etc.	etc.
		1111 ₂	30 dB
SLOW_RESELECT_HYSTERESIS	4	0000 ₂	0 dB
		0001 ₂	2 dB
		etc.	etc.
		1111 ₂	30 dB
FAST_RESELECT_HYSTERESIS	4	0000 ₂	0 dB
		0001 ₂	2 dB
		etc.	etc.
		1111 ₂	30 dB

18.5.5 Cell type change registration

The "cell type change registration" information element indicates whether the MS is required to register with the SwMI if the MS reselects to a different cell type, as defined in table 18.39.

Table 18.39: Cell type change registration information element

Information element	Length	Value	Remark
Cell type change registration	1	0 ₂	Registration not required on cell type change within the RA
		1 ₂	Registration required on cell type change

18.5.5a Channel characteristics

The "channel characteristics" information element shall indicate the characteristics of an RF channel or channel class, as defined in table 18.40.

Table 18.40: Channel characteristics information element

Information element	Length	Type	C/O/M	Remark
Modulation mode	3	1	M	
Bandwidth	3	1	M	
Maximum MS transmit power	3	1	M	
Minimum RX access level	4	1	M	
Reserved	5	1	M	

18.5.5b Channel class

The "channel class" information element shall indicate a channel class, as defined in table 18.41.

Table 18.41: Channel class information element

Information element	Length	Type	C/O/M	Remark
Channel class identifier	4	1	M	
Channel characteristics	18	1	M	
BS transmit power relative to main carrier	5	1	M	

18.5.5c Channel class identifier

The "channel class identifier" information element provides a reference label to a channel class, as defined in table 18.42.

Table 18.42: Channel class identifier information element

Information element	Length	Value	Remark
Channel class identifier	4	0000 ₂	The channel class is not specified
		0001 ₂	Conforming channel class
		0010 ₂	Valid channel class identifier
		etc	etc.
		1111 ₂	Valid channel class identifier

18.5.6 Channel command valid

The "channel command valid" information element shall indicate to the MS-MLE when to initiate a channel change as a result of cell reselection as defined in table 18.43.

Table 18.43: Channel command valid information element

Information element	Length	Value	Remark
Channel command valid	2	00 ₂	Follow MAC channel change (follow channel allocation in MAC header)
		01 ₂	Change channel immediately
		10 ₂	No channel change - wait for next D-NEW-CELL
		11 ₂	Reserved

18.5.6a Channel identifier

The "channel identifier" information element provides a reference label to a channel, as defined in table 18.44.

Table 18.44: Channel identifier information element

Information element	Length	Value	Remark
Channel identifier	5	0000 ₂	Reserved
		00001 ₂	Valid channel identifier
		etc.	etc.
		11111 ₂	Valid channel identifier

18.5.6b Channel request retry delay

The "channel request retry delay" information element shall indicate the minimum delay, as defined in table 18.45, before the MS is permitted to transmit a U-CHANNEL REQUEST PDU containing the same value of "reason for the channel request" information element as used in a previously transmitted U-CHANNEL REQUEST PDU.

Table 18.45: Channel request retry delay information element

Information element	Length	Value	Remark
Channel request retry delay	4	0000 ₂	No delay
		0001 ₂	5 s
		0010 ₂	10 s
		0011 ₂	15 s
		0100 ₂	20 s
		0101 ₂	25 s
		0110 ₂	30 s
		0111 ₂	40 s
		1000 ₂	50 s
		1001 ₂	60 s
		1010 ₂	80 s
		1011 ₂	120 s
		1100 ₂	300 s
		1101 ₂	Reserved
		etc.	etc.
		1110 ₂	Reserved
1111 ₂	Retransmission not permitted		

18.5.6c Channel response type

The "channel response type" information element shall indicate the type of response, as defined in table 18.46.

Table 18.46: Channel response type information element

Information element	Length	Value	Remark
Channel response type	1	0 ₂	Request accepted
		1 ₂	Request rejected

18.5.6d Data priority

The "data priority" information element shall indicate to the SwMI the data priority of SN PDUs waiting for access to a packet data channel as defined in table 18.47.

Table 18.47: Data priority information element

Information element	Length	Value	Remark
Data priority	3	000 ₂	Data priority 0 (lowest data priority)
		001 ₂	Data priority 1
		etc.	etc.
		111 ₂	Data priority 7 (highest data priority)

18.5.6e De-registration

The "de-registration" information element shall indicate to the MS whether or not the MS is requested to de-register when it leaves the cell, as defined in table 18.48.

Table 18.48: De-registration information element

Information element	Length	Value	Remark
De-registration	1	0 ₂	De-registration not required on this cell
		1 ₂	De-registration requested on this cell

18.5.6f Discriminator for SDU protocol present

The "discriminator for SDU protocol present" information element shall be set to "0" in the present document, as defined in table 18.48a.

Table 18.48a: Discriminator for SDU protocol present information element

Information element	Length	Value	Remark
Discriminator for SDU protocol present	1	0 ₂	Protocol discriminator information element not present
		1 ₂	Protocol discriminator information element follows

18.5.7 Fail cause

The "fail cause" information element shall indicate to the MS the failure cause as a result of requesting an MLE service in the SwMI as defined in table 18.49.

Table 18.49: Fail cause information element

Information element	Length	Value	Remark
Fail cause	2	00 ₂	Neighbour cell enquiry not available (neighbouring cell enquiry); Temporary break in service (cell reselection);
		01 ₂	Cell reselection type not supported
		10 ₂	MS not allowed on cell
		11 ₂	Restoration cannot be done on cell

18.5.8 Late entry supported

The "late entry supported" information element shall indicate to the MS whether or not late entry can be supported by the cell as defined in table 18.50.

Table 18.50: Late entry supported information element

Information element	Length	Value	Remark
Late entry supported	1	0	Late entry not supported
		1	Late entry available

18.5.8a Local cell identifier DA

The "local cell identifier DA" information element indicates the cell identifier used by a DA neighbour cell to identify itself to MSs that are camped on that DA neighbour cell. The MS may be able to use this (in combination with the LA of the DA neighbour cell) to recognize a cell that it has used before (see clause 18.3.6.6). The "local cell identifier DA" information element is defined in table 18.51.

Table 18.51: Local cell identifier DA information element

Information element	Length	Value	Remark
Local cell identifier DA	8	00000000 ₂	Reserved
		00000001 ₂	Valid cell identifier DA
		etc.	etc.
		01111111 ₂	Valid cell identifier DA
		10000000 ₂	Reserved
		etc.	etc.
		11111111 ₂	Reserved

18.5.9 Location Area (LA)

The "Location Area (LA)" information element shall define the LA in which a cell is located, either the serving cell or a neighbour cell as defined in table 18.52.

Table 18.52: Location Area (LA) information element

Information element	Length	Value	Remark
Location Area (LA)	14		

18.5.10 Main carrier number

The "main carrier number" information element shall define the main carrier number for a neighbour cell as defined in table 18.53. See the "channel allocation" element in clause 21 and ETSI TS 100 392-15 [18] for a full description of carrier numbering.

Table 18.53: Main carrier number information element

Information element	Length	Value	Remark
Main carrier	12		Main carrier number of neighbour cell as defined in clause 21 and ETSI TS 100 392-15 [18]

18.5.11 Main carrier number extension

The "main carrier number extension" information element shall define extended carrier numbering information as defined in table 18.54. See the "channel allocation" element in clause 21 and ETSI TS 100 392-15 [18] for a full description of carrier numbering.

Table 18.54: Main carrier number extension information element

Information element	Length	Value	Remark
Frequency band	4		Provision for different frequency bands as defined in clause 21 and ETSI TS 100 392-15 [18]
Offset	2	00 ₂	No offset
		01 ₂	+6,25 kHz offset
		10 ₂	-6,25 kHz offset
		11 ₂	+12,5 kHz offset
Duplex spacing	3		Provision for different duplex spacing as defined in clause 21 and ETSI TS 100 392-15 [18]
Reverse operation	1	0	Normal
		1	Reverse

18.5.11a Main control channel modulation mode

The "main control channel modulation mode" information element indicates the neighbour cell's main control channel modulation mode as defined in table 18.55.

Table 18.55: Main control channel modulation mode information element

Information element	Length	Value	Remark
Main control channel modulation mode	3	000 ₂	Reserved
		001 ₂	Reserved
		010 ₂	QAM
		011 ₂	Reserved
		etc.	etc.
		111 ₂	Reserved

18.5.12 Minimum Rx access level

The "minimum RX access level" is the sum of the minimum power level at which the BS wishes to receive MSs and the link imbalance for an MS transmitting at "maximum MS transmit power" on a main carrier or assigned channel or channel class. It shall be encoded as defined in table 18.56. It is used by the MS for path loss calculation as defined in clauses 23.7.1.2, 23.7.1.4 and 23.7.1.5, where its values may be adjusted due to bandwidth differences before being used in the calculation.

Table 18.56: Minimum RX access level information element

Information element	Length	Value	Remark
Minimum RX access level (see notes 1, 2 and 3)	4	0000 ₂	-125 dBm
		0001 ₂	-120 dBm
		etc.	etc.
		1111 ₂	-50 dBm (5 dB steps)
NOTE 1: When received in a "neighbour cell information for CA" or "neighbour cell information for DA" element, the "minimum RX access level" element refers to the main carrier of the neighbour cell; when received in a "channel characteristics" element, the "minimum RX access level" element refers to the channel described by the "channel characteristics" element.			
NOTE 2: This parameter is used in the calculation of path loss parameter C2 (clause 23.7.1.2), where it is called RXLEV_ACCESS_MIN_MCELL(n) and path loss parameters C4 and C5 (clauses 23.7.1.4 and 23.7.1.5), where it is called RXLEV_ACCESS_MIN_MCELL(m).			
NOTE 3: The BS may use the "minimum RX access level" to limit the range of the cell or channel or channel class.			

18.5.13 Maximum MS transmit power

The "maximum MS transmit power" information element shall indicate to the MS the maximum power that is allowed to be transmitted in either a neighbour cell, or in an RF channel or channel class. It shall be encoded as defined in table 18.57.

Table 18.57: Maximum MS transmit power information element

Information element	Length	Value	Remark
Maximum MS transmit power (see note)	3	000 ₂	Reserved
		001 ₂	15 dBm
		010 ₂	20 dBm
		011 ₂	25 dBm
		100 ₂	30 dBm
		101 ₂	35 dBm
		110 ₂	40 dBm
		111 ₂	45 dBm
NOTE: This parameter is used in the calculation of path loss parameter C2 (clause 23.7.1.2), where it is called MS_TXPWR_MAX_MCELL(n) and path loss parameters C4 and C5 (clauses 23.7.1.4 and 23.7.1.5), where it is called MS_TXPWR_MAX_MCELL(m).			

18.5.14 MCC

The "MCC" information element shall indicate which country a cell is located in as defined in table 18.58. Refer to ETSI EN 300 392-1 [6], clause 7.2.5 for an explanation of how it is coded and refer to Recommendation ITU-T E.218 [42], <http://www.itu.int/>, for country code values.

Table 18.58: MCC information element

Information element	Length	Value	Remark
MCC	10		

18.5.15 MNC

The "MNC" information element shall indicate which network a cell is located in as defined in table 18.59.

Table 18.59: MNC information element

Information element	Length	Value	Remark
MNC	14		See ETSI EN 300 392-1 [6] clause 7.

18.5.15a Modulation mode

The "modulation mode" information element shall indicate to the MS the modulation mode of an RF channel or channel class, as defined in table 18.60.

Table 18.60: Modulation mode information element

Information element	Length	Value	Remark
Modulation mode	3	000 ₂	$\pi/4$ -DQPSK modulation mode
		001 ₂	D8PSK modulation mode
		010 ₂	QAM modulation mode
		011 ₂	Reserved
		etc.	etc.
		111 ₂	Reserved

18.5.16 Neighbour cell broadcast

The "neighbour cell broadcast" information element shall indicate how an MS can obtain information about neighbour cells as defined in table 18.61. The neighbour cell information may be broadcast by the SwMI using the D-NWRK-BROADCAST, D-NWRK-BROADCAST EXTENSION or D-NWRK-BROADCAST-DA PDUs, or the MS may use the U-PREPARE or U-PREPARE-DA PDU to enquire for the neighbour cell broadcast information.

Table 18.61: Neighbour cell broadcast information element

Information element	Length	Value	Remark
D-NWRK-BROADCAST or D-NWRK-BROADCAST-DA broadcast supported	1	0	Not supported
		1	Supported
D-NWRK-BROADCAST or D-NWRK-BROADCAST-DA enquiry supported	1	0	Not supported
		1	Supported

18.5.16a Neighbour cell channel class for CA

The "neighbour cell channel class for CA" information element shall indicate a channel class available on a CA neighbour cell, as defined in table 18.62.

Table 18.62: Neighbour cell channel class for CA information element

Information element	Length	Type	C/O/M	Remark
Cell identifier CA	5	1	M	
Channel class	27	1	M	

18.5.16b Neighbour cell channel class for DA

The "neighbour cell channel class for DA" information element shall indicate a channel class available on a DA neighbour cell, as defined in table 18.63.

Table 18.63: Neighbour cell channel class for DA information element

Information element	Length	Type	C/O/M	Remark
Cell identifier DA	8	1	M	
Channel class	27	1	M	

18.5.17 Neighbour cell information for CA

The "neighbour cell information for CA" information element shall contain information about a CA neighbour cell as defined in table 18.64.

Table 18.64: Neighbour cell information for CA element

Information element	Length	Type	C/O/M	Remark
Cell identifier CA	5	1	M	
Cell reselection types supported	2	1	M	
Neighbour cell synchronized	1	1	M	
Cell load CA	2	1	M	
Main carrier number	12	1	M	
Main carrier number extension	10	2	O	See note 1
MCC	10	2	O	See note 2
MNC	14	2	O	See note 2
Location Area (LA)	14	2	O	See note 2
Maximum MS transmit power	3	2	O	See note 2
Minimum RX access level	4	2	O	See note 2
Subscriber class	16	2	O	See note 2
BS service details	12	2	O	See note 2
Timeshare cell information or security parameters	5	2	O	See note 3
TDMA frame offset	6	2	O	See note 4
<p>NOTE 1: If not present, the "Main carrier number" element shall fully define the frequency of the neighbour cell main carrier. The neighbour cell extended carrier numbering information shall be assumed to be the same as that of the serving cell.</p> <p>NOTE 2: If not present, the neighbour cell parameter shall be assumed to be the same as that of the serving cell.</p> <p>NOTE 3: If not present, it shall be assumed that the neighbour cell is not operating in a discontinuous mode of operation and that the neighbour cell's security information is the same as that of the serving cell. If the element contains "reserved frames per two multiframes" (i.e. timeshare cell information), then the security information shall not be changed in the MS. If the element contains security parameters, then the timeshare cell information shall not be changed in the MS.</p> <p>NOTE 4: If present, the neighbour cell shall be synchronized to the serving cell and this element shall indicate the frame offset for the neighbour cell. If the cells are synchronized and this element is not present, it shall be assumed by the MS that the TDMA frame offset = 0.</p>				

For this information element there shall be a P-bit for each type 2 element contained within.

18.5.17a Neighbour cell information for DA

The "neighbour cell information for DA" information element shall contain information about a DA neighbour cell as defined in table 18.65.

Table 18.65: Neighbour cell information for DA information element

Information element	Length	Type	C/O/M	Remark
Cell identifier DA	8	1	M	
Cell reselection types supported DA	8	1	M	
Neighbour cell synchronized	1	1	M	
Wide-area cell	1	1	M	
C/I path measurements	2	1	M	See note 1
Cell load known	1	1	M	
Cell load DA	3		C	See note 2
Main carrier number	12	1	M	
Main control channel modulation mode	3	1	M	See note 3
Bandwidth	3	1	M	Bandwidth of the main carrier
Main carrier number extension	10	2	O	See note 4
MCC	10	2	O	See note 5
MNC	14	2	O	See note 5
Location Area (LA)	14	2	O	See note 5
Local cell identifier DA	8	2	O	See note 6
Maximum MS transmit power	3	2	O	See note 5
Minimum RX access level	4	2	O	See note 5
Subscriber class	16	2	O	See note 5
BS service details DA	7	2	O	See note 7
Security parameters	3	2	O	See notes 5 and 8
TDMA frame offset	6	2	O	See note 9
Reserved	3	2	O	See note 10
Reserved	4	2	O	See note 10
Reserved	8	2	O	See note 10

NOTE 1: If the "C/I path measurements" element is set to "10₂" or "11₂" the MS shall not use the indicated cell in this version of the present document.

NOTE 2: Shall be present only if "cell load known" element is set to value "cell load known".

NOTE 3: If the "main control channel modulation mode" is not set to "QAM" the MS shall not use the indicated cell in this version of the present document.

NOTE 4: If not present, the "Main carrier number" element shall fully define the frequency of the neighbour cell main carrier. The neighbour cell extended carrier numbering information shall be assumed to be the same as that of the serving cell. The SwMI should take this into account when this element is sent on a channel that is used by MSs from more than one cell.

NOTE 5: If not present, this neighbour cell element shall be assumed by the MS to be the same as for the serving cell. The SwMI should take this into account when this element is sent on a channel that is used by MSs from more than one cell.

NOTE 6: The "local cell identifier DA" element indicates the cell identifier that the DA neighbour cell uses to identify itself to MSs that are camped on that DA neighbour cell. The "local cell identifier DA" element thus indicates the value that the DA neighbour cell uses for the "cell identifier DA" element when the DA neighbour cell sends D-NWRK-BROADCAST-DA PDUs. The MS may be able to use this (in combination with the LA of the DA neighbour cell) to recognize a cell that it has used before (see clause 18.3.6.6).

NOTE 7: If not present, DA MSs shall assume that this neighbour cell element is the same as for the DA serving cell, and CA MSs shall assume that its constituent elements are the same as the equivalent elements in "BS service details" for the CA serving cell. The SwMI should take this into account when this element is sent on a channel that is used by MSs from more than one cell.

NOTE 8: The information element shall be used as defined in ETSI EN 300 392-7 [8].

NOTE 9: If present, the neighbour cell shall be synchronized to the serving cell and this element shall indicate the frame offset for the neighbour cell. If the cells are synchronized and this element is not present, it shall be assumed by the MS that the TDMA frame offset = 0.

NOTE 10: The reserved element shall not be used in the present document.

For this information element there shall be a P-bit for each type 2 information element contained within.

NOTE: When a channel is used by MSs from more than one DA cell, a DA MS may receive information about its serving cell in the "neighbour cell information for DA" information element. The DA MS should detect this and should not attempt to reselect to its serving cell.

18.5.17b Neighbour cell irregular channel detail for CA

The "neighbour cell irregular channel detail for CA" information element shall indicate an irregular channel available on a CA neighbour cell, as defined in table 18.66.

Table 18.66: Neighbour cell irregular channel detail for CA information element

Information element	Length	Type	C/O/M	Remark
Cell identifier CA	5	1	M	
Irregular channel detail	variable	1	M	

18.5.17c Neighbour cell irregular channel detail for DA

The "neighbour cell irregular channel detail for DA" information element shall indicate an irregular channel available on a DA neighbour cell, as defined in table 18.67.

Table 18.67: Neighbour cell irregular channel detail for DA information element

Information element	Length	Type	C/O/M	Remark
Cell identifier DA	8	1	M	
Irregular channel detail	variable	1	M	

18.5.18 Neighbour cell synchronized

The "neighbour cell synchronized" information element shall indicate whether or not the neighbour cell is synchronized to the serving cell as defined in table 18.68.

Table 18.68: Neighbour cell synchronized information element

Information element	Length	Value	Remark
Neighbour cell synchronized	1	0	Neighbour cell is not synchronized
		1	Neighbour cell is synchronized

NOTE: See clause 7.7 for the meaning of "synchronized" in this context.

18.5.18a Number of CA cells for removal

The "number of CA cells for removal" information element shall indicate how many "removal data for CA cell" elements follow as defined in table 18.69.

Table 18.69: Number of CA cells for removal information element

Information element	Length	Value	Remark
Number of CA cells for removal	5	00000 ₂	No "removal data for CA cell" elements contained in this PDU
		00001 ₂	Number of "removal data for CA cell" elements contained in this PDU
		etc.	etc.
		11111 ₂	Number of "removal data for CA cell" elements contained in this PDU

18.5.18b Number of CA neighbour cell channel classes

The "number of CA neighbour cell channel classes" information element shall indicate how many "Neighbour cell channel class for CA" information elements follow as defined in table 18.70.

Table 18.70: Number of CA neighbour cell channel classes information element

Information element	Length	Value	Remark
Number of CA neighbour cell channel classes	5	00000 ₂	No CA neighbour cell channel classes available
		00001 ₂	Number of "Neighbour cell channel class for CA" elements contained in this PDU
		etc.	etc.
		11111 ₂	Number of "Neighbour cell channel class for CA" elements contained in this PDU

18.5.18c Number of CA neighbour cells

The "number of CA neighbour cells" information element shall indicate how many "neighbour cell information for CA" elements follow as defined in table 18.71.

Table 18.71: Number of CA neighbour cells information element

Information element	Length	Value	Remark
Number of CA neighbour cells	3	000 ₂	No CA neighbour cell information available
		001 ₂	Number of "Neighbour cell information for CA" elements contained in this PDU
		etc.	etc.
		111 ₂	Number of "Neighbour cell information for CA" elements contained in this PDU

18.5.18d Number of CA neighbour cell irregular channel details

The "number of CA neighbour cell irregular channel details" information element shall indicate how many "neighbour cell irregular channel detail for CA" information elements follow as defined in table 18.72.

Table 18.72: Number of CA neighbour cell irregular channel details information element

Information element	Length	Value	Remark
Number of CA neighbour cell irregular channel details	6	000000 ₂	No CA neighbour cell irregular channel details available
		000001 ₂	Number of "neighbour cell irregular channel detail for CA" elements contained in this PDU
		etc.	etc.
		111111 ₂	Number of "neighbour cell irregular channel detail for CA" elements contained in this PDU

18.5.18e Number of channel classes (for serving cell)

The "number of channel classes (for serving cell)" information element shall indicate how many "channel class" information elements follow as defined in table 18.73.

Table 18.73: Number of channel classes (for serving cell) information element

Information element	Length	Value	Remark
Number of channel classes (for serving cell)	4	0000 ₂	No channel classes available
		0001 ₂	Number of "channel class" elements contained in this PDU
		etc.	etc.
		1111 ₂	Number of "channel class" elements contained in this PDU

18.5.18f Number of channel class identifiers

The "number of channel class identifiers" information element shall indicate how many "channel class identifier" information elements follow, as defined in table 18.74.

Table 18.74: Number of channel class identifiers information element

Information element	Length	Value	Remark
Number of channel class identifiers	2	00 ₂	One "channel class identifier" element is included in this PDU
		01 ₂	Two "channel class identifier" elements are included in this PDU
		10 ₂	Three "channel class identifier" elements are included in this PDU
		11 ₂	Four "channel class identifier" elements are included in this PDU

18.5.18g Number of channel classes for removal

The "number of channel classes for removal" information element shall indicate how many "channel class identifier" information elements follow, as defined in table 18.75.

Table 18.75: Number of channel classes for removal information element

Information element	Length	Value	Remark
Number of channel classes for removal	4	0000 ₂	No "channel class identifiers" elements follow this element
		0001 ₂	Number of "channel class identifier" elements that follow this element
		etc.	etc.
		1111 ₂	Number of "channel class identifier" elements that follow this element

18.5.18h Number of channel identifiers

The "number of channel identifiers" information element shall indicate how many "channel identifier" information elements follow, as defined in table 18.76.

Table 18.76: Number of channel identifiers information element

Information element	Length	Value	Remark
Number of channel identifiers	2	00 ₂	One "channel identifier" element is included in this PDU
		01 ₂	Two "channel identifier" elements are included in this PDU
		10 ₂	Three "channel identifier" elements are included in this PDU
		11 ₂	Four "channel identifier" elements are included in this PDU

18.5.18i Number of channels for removal

The "number of channels for removal" information element shall indicate how many "channel identifier" information elements follow, as defined in table 18.77.

Table 18.77: Number of channels for removal information element

Information element	Length	Value	Remark
Number of channels for removal	5	00000 ₂	No "channel identifiers" elements follow this element.
		00001 ₂	Number of "channel identifier" elements that follow this element.
		etc.	etc.
		11111 ₂	Number of "channel identifier" elements that follow this element.

18.5.19 Number of DA cells for removal

The "number of DA cells for removal" information element shall indicate how many "removal data for DA cell" information elements follow as defined in table 18.78.

Table 18.78: Number of DA cells for removal information element

Information element	Length	Value	Remark
Number of DA cells for removal	8	00000000 ₂	No "removal data for DA cell" elements contained in this PDU.
		00000001 ₂	Number of "removal data for DA cell" elements contained in this PDU.
		etc.	etc.
		11111111 ₂	Number of "removal data for DA cell" elements contained in this PDU.

18.5.19a Number of DA neighbour cells

The "number of DA neighbour cells" information element shall indicate how many "neighbour cell information for DA" information elements follow as defined in table 18.79.

Table 18.79: Number of DA neighbour cells information element

Information element	Length	Value	Remark
Number of DA neighbour cells	3	000 ₂	No DA neighbour cell information available
		001 ₂	Number of "neighbour cell information for DA" elements contained in this PDU
		etc.	etc.
		111 ₂	Number of "neighbour cell information for DA" elements contained in this PDU

18.5.19b Number of DA neighbour cell channel classes

The "number of DA neighbour cell channel classes" information element shall indicate how many "neighbour cell channel class for DA" information elements follow as defined in table 18.80.

Table 18.80: Number of DA neighbour cell channel classes information element

Information element	Length	Value	Remark
Number of DA neighbour cell channel classes	5	00000 ₂	No DA neighbour cell channel classes available
		00001 ₂	Number of "neighbour cell channel class for DA" elements contained in this PDU
		etc.	etc.
		11111 ₂	Number of "neighbour cell channel class for DA" elements contained in this PDU

18.5.19c Number of DA neighbour cell irregular channel details

The "number of DA neighbour cell irregular channel details" information element shall indicate how many "neighbour cell irregular channel detail for DA" information elements follow as defined in table 18.81.

Table 18.81: Number of DA neighbour cell irregular channel details information element

Information element	Length	Value	Remark
Number of DA neighbour cell irregular channel details	6	000000 ₂	No DA neighbour cell irregular channel details available
		000001 ₂	Number of "neighbour cell irregular channel detail for DA" elements contained in this PDU
		etc.	etc.
		111111 ₂	Number of "neighbour cell irregular channel detail for DA" elements contained in this PDU

18.5.19d Number of requested channel class identifiers

The "number of requested channel class identifiers" information element shall indicate how many "channel class identifier" information elements follow, as defined in table 18.82.

Table 18.82: Number of requested channel class identifiers information element

Information element	Length	Value	Remark
Number of requested channel class identifiers	3	000 ₂	One "channel class identifier" element is included in this PDU
		001 ₂	Two "channel class identifier" elements are included in this PDU
		etc.	etc.
		111 ₂	Eight "channel class identifier" elements are included in this PDU

18.5.19e Number of requested channel identifiers

The "number of requested channel identifiers" information element shall indicate how many "channel identifier" information elements follow, as defined in table 18.83.

Table 18.83: Number of requested channel identifiers information element

Information element	Length	Value	Remark
Number of channel identifiers	3	000 ₂	One "channel identifier" element is included in this PDU
		001 ₂	Two "channel identifier" elements are included in this PDU
		etc.	etc.
		111 ₂	Eight "channel identifier" elements are included in this PDU

18.5.19f Number of irregular channels details (for serving cell)

The "number of irregular channel details" information element shall indicate how many "irregular channel details (for serving cell)" information elements follow as defined in table 18.84.

Table 18.84: Number of irregular channel details (for serving cell) information element

Information element	Length	Value	Remark
Number of irregular channel details (for serving cell)	5	00000 ₂	No irregular channel details available
		00001 ₂	Number of "irregular channel detail" elements for serving cell contained in this PDU
		etc.	etc.
		11111 ₂	Number of "irregular channel detail" elements for serving cell contained in this PDU

18.5.20 PDU type

The "PDU type" information element shall indicate the PDU type for each of the MLE protocol PDUs. The "PDU type" information element has separate definitions for the uplink and downlink directions as shown in the table 18.85.

Table 18.85: PDU type information element

Information element	Length	Value	Remark	
			DOWNLINK	UPLINK
PDU type	3	000 ₂	D-NEW-CELL	U-PREPARE
		001 ₂	D-PREPARE-FAIL	U-PREPARE-DA
		010 ₂	D-NWRK-BROADCAST	U-IRREGULAR CHANNEL ADVICE
		011 ₂	D-NWRK-BROADCAST EXTENSION	U-CHANNEL CLASS ADVICE
		100 ₂	D-RESTORE-ACK	U-RESTORE
		101 ₂	D-RESTORE-FAIL	Reserved
		110 ₂	D-CHANNEL RESPONSE	U-CHANNEL REQUEST
		111 ₂	Extended PDU (see note)	Extended PDU (see note)
NOTE: Extended PDUs are differentiated by the "PDU type extension" information element.				

18.5.20a PDU type extension

The "PDU type extension" information element shall indicate the PDU type extension for each extended PDU (i.e. MLE protocol PDUs with PDU type value "111₂"). The "PDU type extension" information element has separate definitions for the uplink and downlink directions as shown in table 18.86.

Table 18.86: PDU type extension information element

Information element	Length	Value	Remark	
			DOWNLINK	UPLINK
PDU type extension	4	0000 ₂	D-NWRK-BROADCAST-DA	Reserved
		0001 ₂	D-NWRK-BROADCAST REMOVE	Reserved
		0010 ₂	Reserved	Reserved
		etc.	etc.	etc.
		1111 ₂	Reserved	Reserved

18.5.21 Protocol discriminator

The "protocol discriminator" information element shall indicate which protocol the PDU belongs to as defined in table 18.87. MM, CMCE and SNDCP PDUs are routed by the MLE to the relevant SAP. MLE protocol PDUs are processed by the MLE protocol entity and TETRA management entity PDUs by the TETRA management functional entity within the MLE.

Table 18.87: Protocol discriminator information element

Information element	Length	Value	Remark
Protocol discriminator	3	000 ₂	Reserved
		001 ₂	MM protocol
		010 ₂	CMCE protocol
		011 ₂	Reserved
		100 ₂	SNDCP protocol
		101 ₂	MLE protocol
		110 ₂	TETRA management entity protocol
		111 ₂	Reserved for testing

18.5.21a Reason for the channel request

The "reason for the channel request" information element shall indicate the reason for the MS's assigned channel replacement request, as defined in table 18.88.

Table 18.88: Reason for the channel request information element

Information element	Length	Value	Remark
Reason for the channel request	3	000 ₂	Unspecified reason
		001 ₂	Current channel is radio relinquishable
		010 ₂	Current channel is radio improvable
		011 ₂	Higher level of service is requested
		100 ₂	Reserved
		etc.	etc.
		111 ₂	Reserved

18.5.21b Registration

The "registration" information element shall indicate to the MS whether or not registration is required on this cell, as defined in table 18.89.

Table 18.89: Registration information element

Information element	Length	Value	Remark
Registration	1	0 ₂	Registration not required on this cell
		1 ₂	Registration mandatory on this cell

18.5.21c Removal data for CA cell

The "removal data for CA cell" information element shall indicate CA neighbour cell information to be removed from the MS's records as defined in table 18.90.

Table 18.90: Removal data for CA cell information element

Information element	Length	Type	C/O/M	Remark
Cell identifier CA	5		M	
Remove cell or channels	1		M	
Number of channel classes for removal	4		C	See note 1
Channel class identifier	4		C	See note 2
Number of channels for removal	5		C	See note 1
Channel identifier	5		C	See note 3
NOTE 1: Shall be present only if "remove cell or channels" has value "remove channel classes or channels".				
NOTE 2: Shall be present as many times as indicated by "number of channel classes for removal".				
NOTE 3: Shall be present as many times as indicated by "number of channels for removal".				

18.5.21d Removal data for DA cell

The "removal data for DA cell" information element shall indicate DA neighbour cell information to be removed from the MS's records as defined in table 18.91.

Table 18.91: Removal data for DA cell information element

Information element	Length	Type	C/O/M	Remark
Cell identifier DA	8		M	
Remove cell or channels	1		M	
Number of channel classes for removal	4		C	See note 1
Channel class identifier	4		C	See note 2
Number of channels for removal	5		C	See note 1
Channel identifier	5		C	See note 3
NOTE 1: Shall be present only if "remove cell or channels" has value "remove channel classes or channels".				
NOTE 2: Shall be present as many times as indicated by "number of channel classes for removal".				
NOTE 3: Shall be present as many times as indicated by "number of channels for removal".				

18.5.21e Removal data for serving cell

The "removal data for serving cell" information element shall indicate serving cell channel class and channel information to be removed from the MS's records as defined in table 18.92.

Table 18.92: Removal data for serving cell information element

Information element	Length	Type	C/O/M	Remark
Number of channel classes for removal	4		M	
Channel class identifier	4		C	See note 1
Number of channels for removal	5		M	
Channel identifier	5		C	See note 2
NOTE 1: Shall be present as many times as indicated by "number of channel classes for removal".				
NOTE 2: Shall be present as many times as indicated by "number of channels for removal".				

18.5.21f Remove cell or channels

The "remove cell or channels" information element shall indicate if a neighbour cell is to be totally removed from the MS's record of neighbour cell information relative to a particular cell, or if channel class and/or channel information is to be removed, as defined in table 18.93.

Table 18.93: Remove cell or channels information element

Information element	Length	Value	Remark
Remove cell or channels	1	0 ₂	Remove channel classes or channels
		1 ₂	Remove this neighbour cell

18.5.21g Roaming control for individual services

The "roaming control for individual services" element shall indicate if an MS is permitted to initiate cell reselection in response to a change in cell load on the serving cell or a neighbour cell when using (or preparing to use) an individual service, as defined in table 18.94.

Table 18.94: Roaming control for individual services information element

Information element	Length	Value	Remark
Roaming control for individual services	1	0 ₂	Cell load based roaming not permitted for individual service users
		1 ₂	Cell load based roaming permitted for individual service users

NOTE: If the MS is currently using (or preparing to use) both individual services and group services at the same time, it is permitted to perform cell load based roaming if either the "roaming control for individual services" information element or the "roaming control for group services and idle MSs" information element permits cell load based roaming.

18.5.21h Roaming control for group services and idle MSs

The "roaming control for group services and idle MSs" information element shall indicate if an MS is permitted to initiate cell reselection in response to a change in cell load on the serving cell or a neighbour cell when idle or using (or preparing to use) a group service, as defined in table 18.95.

Table 18.95: Roaming control for group services and idle MSs information element

Information element	Length	Value	Remark
Roaming control for group services and idle MSs	1	0 ₂	Cell load based roaming not permitted for group service users and idle MSs
		1 ₂	Cell load based roaming permitted for group service users and idle MSs

NOTE: If the MS is currently using (or preparing to use) both individual services and group services at the same time, it is permitted to perform cell load based roaming if either the "roaming control for individual services" information element or the "roaming control for group services and idle MSs" information element permits cell load based roaming.

18.5.21i Irregular channel detail

The "irregular channel detail" information element shall indicate the details of an individual irregular channel, as defined in table 18.96.

Table 18.96: Irregular channel detail information element

Information element	Length	Type	C/O/M	Remark
Channel identifier	5	1	M	
Channel characteristics	18	1	M	
Carrier number	12	1	M	
Carrier number extension flag	1	1	M	
Carrier number extension	10		C	See notes 1 and 2
NOTE 1: Shall be present only if carrier number extension flag has value "1" (carrier number extension included).				
NOTE 2: If not present, the "Carrier number" element shall fully define the frequency of the channel's RF carrier. The channel's extended carrier numbering information shall be assumed to be the same as that of the serving cell.				

18.5.22 Subscriber class

The "subscriber class" information element shall be used by the SwMI to indicate which subscriber classes are allowed to use this cell as defined in table 18.97.

Table 18.97: Subscriber class information element

Information element	Length	Value	Remark
Class 1 (see note)	1	0	Subscriber class not allowed on cell
		1	Subscriber class allowed on cell
Class 2 (see note)	1	0	Subscriber class not allowed on cell
		1	Subscriber class allowed on cell
Class 3	1	0	Subscriber class not allowed on cell
		1	Subscriber class allowed on cell
Class 4	1	0	Subscriber class not allowed on cell
		1	Subscriber class allowed on cell
Class 5	1	0	Subscriber class not allowed on cell
		1	Subscriber class allowed on cell
Class 6	1	0	Subscriber class not allowed on cell
		1	Subscriber class allowed on cell
Class 7	1	0	Subscriber class not allowed on cell
		1	Subscriber class allowed on cell
Class 8	1	0	Subscriber class not allowed on cell
		1	Subscriber class allowed on cell
Class 9	1	0	Subscriber class not allowed on cell
		1	Subscriber class allowed on cell
Class 10	1	0	Subscriber class not allowed on cell
		1	Subscriber class allowed on cell
Class 11	1	0	Subscriber class not allowed on cell
		1	Subscriber class allowed on cell
Class 12	1	0	Subscriber class not allowed on cell
		1	Subscriber class allowed on cell
Class 13	1	0	Subscriber class not allowed on cell
		1	Subscriber class allowed on cell
Class 14	1	0	Subscriber class not allowed on cell
		1	Subscriber class allowed on cell
Class 15	1	0	Subscriber class not allowed on cell
		1	Subscriber class allowed on cell
Class 16	1	0	Subscriber class not allowed on cell
		1	Subscriber class allowed on cell
NOTE: The SwMI may reserve class 1 and/or class 2 for use by air cells (see clauses O.4.4 and O.7.1.2).			

18.5.22a Subscriber class included

The "subscriber class included" information element shall indicate to the MS whether the subscriber class or the location area (LA) information element is included in a PDU, as defined in table 18.98.

Table 18.98: Subscriber class included information element

Information element	Length	Value	Remark
Subscriber class included	1	0 ₂	Subscriber class not included
		1 ₂	Subscriber class included

18.5.23 TDMA frame offset

The "TDMA frame offset" information element shall indicate the TDMA frame offset between the serving cell and a neighbour cell when both cells have synchronized carriers as defined in table 18.99. The information element may be used for the time-shared mode of operation or to indicate the TDMA frame offset for synchronized cells operating in continuous mode.

Table 18.99: TDMA frame offset information element

Information element	Length	Value	Remark
TDMA frame offset	6	000000 ₂	0 frame offset
		000001 ₂	1 frame offset
		etc.	etc.
		100011 ₂	35 frame offset
		100100 ₂	Reserved
		etc.	etc.
		111111 ₂	Reserved

If FN_n and FN_s denote the TDMA frame number of the neighbour cell and of the serving cell respectively, then:

$$FN_n = (FN_s - 1 + \text{TDMA frame offset}) \bmod 18 + 1; \quad (18.1)$$

where $FN_n = 1$ to 18 and $FN_s = 1$ to 18.

NOTE: See clause 7.7 for the meaning of "synchronized cells" in this context.

18.5.24 TETRA network time

The "TETRA network time" information element shall indicate the absolute TETRA network time to be used for time stamping as defined in table 18.100.

Table 18.100: TETRA network time information element

Information element	Length	Value	Remark
UTC time	24		See note 1
Local time offset sign	1		See note 2
Local time offset	6		See notes 2 and 3
Year	6		See note 4
Reserved	11		See note 5
<p>NOTE 1: Zero time (000000₁₆) is defined as 00:00 hours, Universal Time Co-ordinates (UTC time) on January 1st of every year. Each increment of this element above a value of zero shall correspond to a two-second increment of the absolute network time. The values, F142FF₁₆ to FFFFFE₁₆, are reserved. The value, FFFFFFF₁₆, is reserved and shall be used to indicate an invalid value of time and timestamps in the event of network malfunction.</p> <p>NOTE 2: The local time offset is coded as a signed integer containing information elements Local time offset sign and Local time offset. The value "0" shall indicate a positive offset and the value "1" shall indicate a negative offset. Zero offset shall be encoded with sign value "0".</p> <p>NOTE 3: The Local time offset information element shall indicate the difference between the local time (including daylight saving) and the UTC time. The step size is 15 minutes, the maximum permissible offset shall be ±14 hours. The values 39₁₆ to 3E₁₆ are reserved. 3F₁₆ shall be used to indicate an invalid offset.</p> <p>NOTE 4: Year is year since 2000 (e.g. year 2001 is encoded as 1). Maximum year value shall be 3E₁₆. The value 3F₁₆ shall be used to indicate an invalid year.</p> <p>NOTE 5: This field shall be set to all ones (7FF₁₆).</p>			

18.5.25 Timeshare cell information or security parameters

The "timeshare cell information or security parameters" information element shall indicate the mode of discontinuous operation for a CA neighbour cell or the security parameters as defined in table 18.101.

The "Discontinuous mode" field shall indicate whether security parameters are present, or which of the three types of discontinuous mode is in use.

If the discontinuous mode is "security parameters" the security parameters information element shall be present. Usage of the security parameters information element shall be as defined in ETSI EN 300 392-7 [8], clause A.8.77a.

If the mode is "MCCH sharing", the "Reserved frames per two multiframe" information element shall be present and shall indicate how many frames are reserved for that neighbour cell.

If the mode is "Carrier sharing" or "Traffic carrier sharing" sharing, the "Reserved frames per two multiframe" information element shall be present, but shall be ignored by the MS.

Table 18.101: Timeshare cell information or security parameters information element

Information element	Length	Type	C/O/M	Value	Remark
Discontinuous mode	2	1	M	00 ₂	Security parameters included
				01 ₂	Carrier sharing
				10 ₂	MCCH sharing
				11 ₂	Traffic carrier sharing
Security parameters (see note 1)	3		C	See note 2	See note 2
Reserved frames per two multiframe (see note 3)	3		C	000 ₂	1 frame reserved
				001 ₂	2 frames reserved
				010 ₂	3 frames reserved
				011 ₂	4 frames reserved
				100 ₂	6 frames reserved
				101 ₂	9 frames reserved
				110 ₂	12 frames reserved
111 ₂	18 frames reserved				
NOTE 1: Shall be present only if the discontinuous mode is "Security parameters included".					
NOTE 2: The information element shall be used as defined in ETSI EN 300 392-7 [8].					
NOTE 3: Shall be present only if the discontinuous mode is not "Security parameters included".					

18.5.26 Wide-area cell

The "wide-area cell" information element shall indicate to the MS whether or not this cell is a wide-area cell, as defined in table 18.102.

Table 18.102: Wide-area cell information element

Information element	Length	Value	Remark
Wide-area cell	1	0 ₂	This cell is not a wide-area cell
		1 ₂	This cell is a wide-area cell

NOTE: A wide-area cell is expected to have a larger coverage area than some other cells in the area, and may overlap with and/or fully cover the area covered by one or more of these cells. For example, the MS might give preference to a wide-area cell if the MS is aware that it is travelling at high speed or using wide-area group calls, or an MS might prefer not to use a wide-area cell if the MS is a hand-held device or if the MS wishes to set up an individually addressed circuit mode call.

18.6 Timers

18.6.1 Timer related actions

Timer related actions are defined in the protocols which use the timer.

18.6.2 Timer T370 - cell reselection preparation response time

This timer shall define the maximum time MLE shall wait for a response to sending a U-PREPARE or U-PREPARE-DA PDU that requests an announced type 1/2 or an announced type 3 cell selection. The timer T370 shall be of 5 s duration.

18.6.3 Timer T371 - Neighbour cell broadcast enquiry response time

This timer shall define the maximum time MLE shall wait for a D-NWRK-BROADCAST or D-NWRK-BROADCAST EXTENSION PDU in response to sending a U-PREPARE PDU, or for a D-NWRK-BROADCAST-DA, D-NWRK-BROADCAST or D-NWRK-BROADCAST EXTENSION PDU in response to sending a U-PREPARE-DA PDU. The timer T371 shall be of 15 s duration.

18.6.4 Timer T372 - new channel pause time

This timer shall define the minimum time MLE shall wait following assignment to a channel before transmitting a first U-CHANNEL REQUEST PDU on that channel. The timer T372 shall be of 15 s duration.

18.6.5 Timer T373 - repeat channel request delay time

This timer shall define the minimum time MLE shall wait following transmission of a U-CHANNEL REQUEST before MLE may transmit a further U-CHANNEL REQUEST PDU. The timer T373 shall be of 5 s duration.

18.6.6 Timer T374 - threshold-crossing pause time

This timer shall define the minimum time MLE shall wait following the threshold-crossing of an assigned channel path loss measurement before MLE may declare a change in the state of the channel path loss criterion. The timer T374 shall be of 5 s duration.

18.6.7 Timer T375 - air cell margin timer

Timer 375 defines the period for which MLE shall consider the serving cell to be "radio relinquishable" following receipt of a "maximum path delay almost exceeded" report. This timer shall be started (or restarted) whenever MLE receives a "maximum path delay almost exceeded" report. It shall be stopped when MLE performs a cell reselection. The recommended duration of T375 is 50 s.

NOTE: T375 is only used by MSs that support the AGA service (see annex O).

19 Layer 2 overview

19.1 Introduction

Clause 19 gives an overview of the V+D air interface layer 2 (Data Link Layer (DLL)) which is further defined in clauses 20, 21, 22 and 23. Clause 19 does not imply any requirement for the testability of any of the functions described.

The descriptions throughout clause 19 do not imply a specific implementation, but are provided for the guidance of the reader in understanding the operation of layer 2.

19.2 Layer 2 architecture

19.2.0 General

The model of the DLL comprises two sub-layers: the LLC entity and the MAC entity. The basic functionalities of these entities are as summarized in ETSI EN 300 392-1 [6], clause 6, and the services offered to the upper layer (the MLE) are explained in detail in clause 20. The error control schemes (FEC, CRC) are described in clause 8.

The following description applies to the protocol model of the DLL. The internal boundaries between the layers and sub-layers are not testable and do not imply any specific implementation, but are rather used for the description of the model. Throughout clause 19 the word "shall" is used for describing the SAPs for traceability reasons in the protocol model, but those SAPs are not testable.

19.2.1 Access to the DLL

Figure 19.1 shows the model of the DLL, its internal subdivision and its interaction with the upper layer (MLE) and lower layer (physical layer).

In the protocol model, the DLL shall provide services to the MLE through SAPs supporting different functions:

- TLA-SAP for all signalling messages;
- TLB-SAP for broadcasting system information; and
- TLC-SAP for layer management, status and configuration via data base access.

Internal communication between LLC and MAC shall use SAPs, namely TMA-SAP, TMB-SAP and TMC-SAP, for services provided by the MAC to the LLC. They shall correspond to the separation between signalling, broadcast and layer management, as can be seen from the upper layer (MLE). Internal communication between LLC and MAC may also use an additional SAP, namely TLE-SAP, for the layer 2 signalling service that the LLC may provide to the MAC. Primitives and parameters are used for protocol description to exchange information at this internal boundary (LLC-MAC). The upper MAC layer shall contain MAC protocol functions (see clause 23).

There shall be a (virtual) SAP TMV-SAP inside the MAC layer to allow a protocol description using primitives and logical channels. The selection of a specific logical channel triggers specific channel coding at the lower MAC, which is devoted to the channel coding (see clause 8). The selection of a specific logical channel also triggers a specific modulation.

The SAP TP-SAP shall be used for communication between MAC and Physical Layer (PL). To exchange information at the TP-SAP, pre-formed subslots and blocks with burst type indication shall be used (see clause 9).

The TMD-SAP shall be used to support traffic in circuit mode. It shows clearly that no LLC functionality shall be expected in circuit mode. However, clause 19.4.3.2 describes how some traffic capacity may be stolen for signalling purposes in circuit mode.

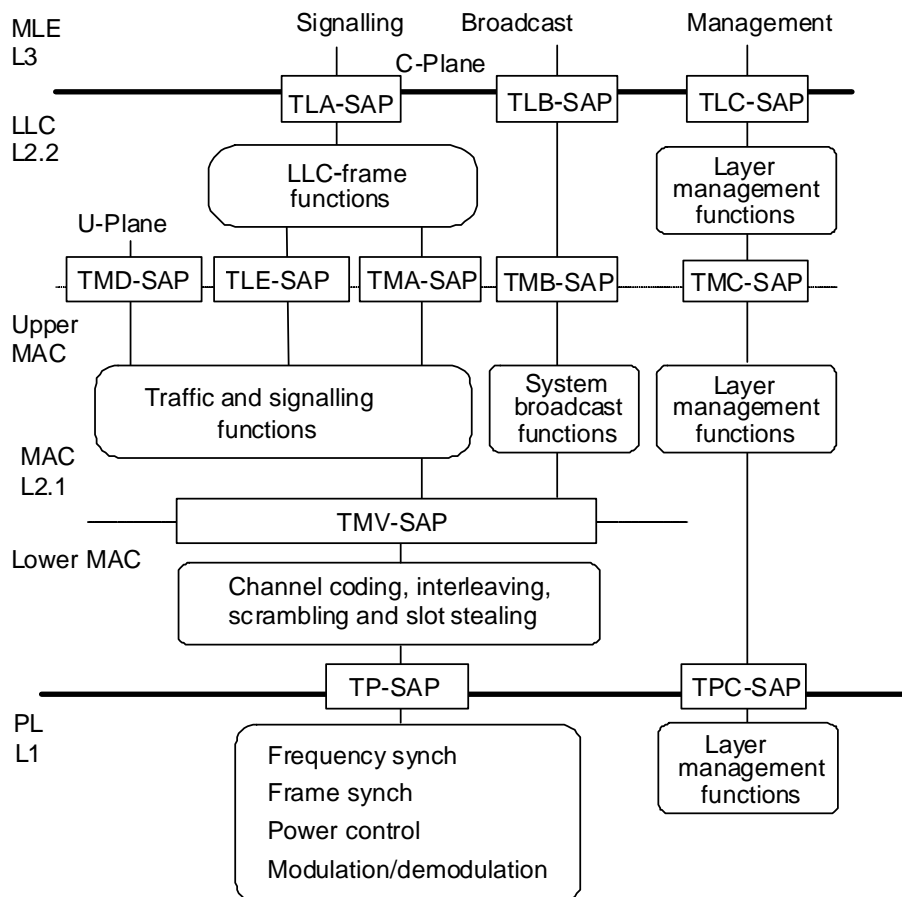

Figure 19.1: Layer 2 reference architecture

19.2.2 Information flow inside the DLL

19.2.2.0 General

The two types of communications links for TLA-SAP support on the DLL each have a specific quality of service. Before any communication establishment, one link shall exist whenever BS control channel reception is possible. This link is called the basic link and it offers a pre-defined quality of service which minimizes the LLC overhead over the air interface. A more powerful link may exist upon request. It is called the advanced link and it offers a more reliable and better service, especially for packet data transfer (see clause 22). When an advanced link is established, the basic link shall remain available. They may share the same timeslot in the multiframe structure.

Illustrations of the layer 2 functions applied to the information content present at the TLA-SAP are given on figures 19.2 and 19.3. On the left hand side, references to the relevant protocol layers are provided. The "other parameters" from the MLE may either be mapped into the LLC PDU or used by the DLL (e.g. PDU priority).

The advanced link offers segmentation and error control using a Frame Check Sequence (FCS). The advanced link may be used for more reliable and efficient exchange of large amount of data as in, for example, packet data transfer. There are two variants of advanced link: the original advanced link and the extended advanced link.

It is mandatory for the MS to support the basic link, whereas it is optional for the MS to support either or both variants of the advanced link.

NOTE 1: The MAC scheme on figures 19.2 and 19.3 does not display the exact multiframe structure nor the random access procedure (see clause 23).

NOTE 2: The CRC is added only to the completed "MAC block", which may contain multiple TM-SDUs (MAC messages) on figures 19.2 and 19.3.

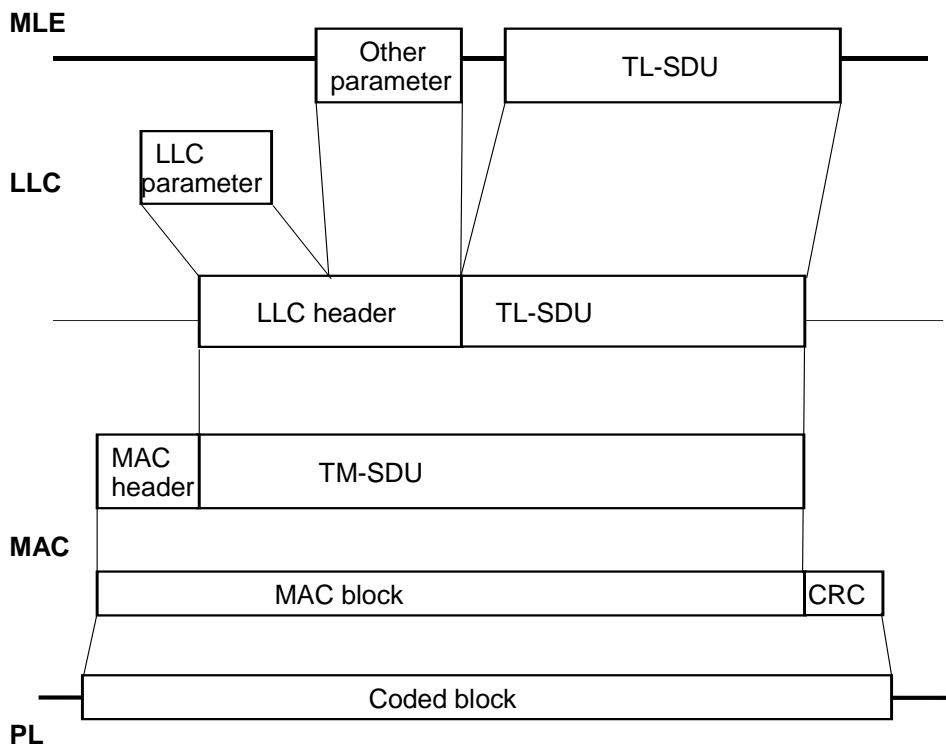

Figure 19.2: Layer 2 data structure for basic link (typically layer 3 signalling messages)

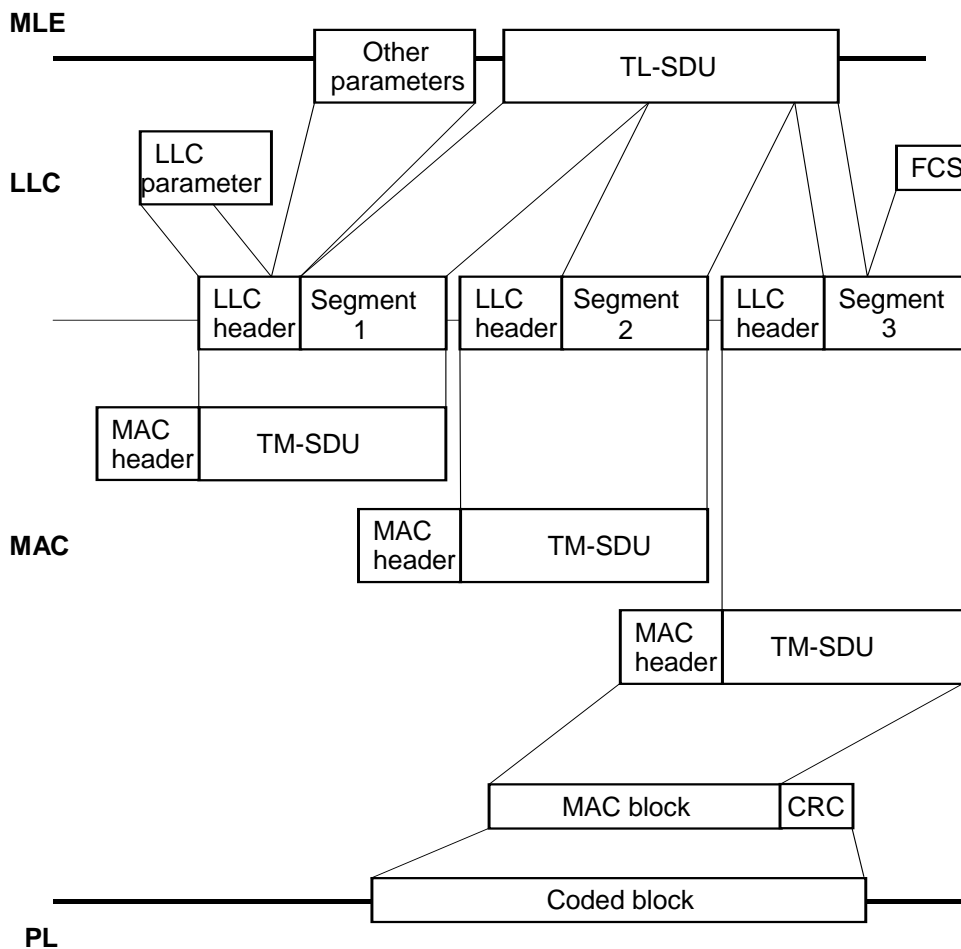

Figure 19.3: Layer 2 data structure for advanced link (e.g. packet data)

19.2.2.1 Basic link

The basic link should be used for general signalling messages (e.g. from the CMCE or MM). The unacknowledged basic link may be used by the SMDCP for some packet data messages (e.g. for real-time class data).

The basic link offers the following services:

- acknowledged message transmission;
- unacknowledged message transmission;
- un-numbered fragmentation of longer messages;
- optional extended error control using an FCS (e.g. for long messages that require fragmentation).

The principal basic link data structure without fragmentation is shown in figure 19.2. The protocol is defined in detail in clauses 22 and 23.

19.2.2.2 Advanced link

An advanced link should be used if a larger amount of data is to be transferred (e.g. for packet data transmission) or if a better service is required. The service of an advanced link is negotiable at the set-up phase. The advanced link offers the following services:

- acknowledged message transmission;
- unacknowledged message transmission for point-to-multipoint transfer in the downlink;
- window mechanism:
 - window size of up to 3 for the original advanced link;
 - window size of up to 15 for the extended advanced link;
- numbered segmentation of longer messages;
- selective re-transmission for point-to-point transfer;
- selective re-assembly for point-to-multipoint transfer;
- extended error control using an FCS:
 - always provided for the original advanced link;
 - optional for the extended advanced link.

The advanced link data structure is shown in figure 19.3. The protocol is defined in detail in clauses 22 and 23.

19.2.2.3 Segmentation and fragmentation

There are two methods of sending a long TL-SDU defined in the present document: fragmentation and segmentation, which are defined in detail in clauses 22 and 23. Fragmentation may be performed in the MAC for a basic link, while segmentation may be performed in the LLC for an advanced link (see figure 19.4).

Fragmentation shall be used for the basic link in case of an SDU exceeding the available capacity in the MAC (see figure 19.5). Fragments are not numbered so they shall be sent in sequence. No segmentation shall be performed by the LLC for the basic link.

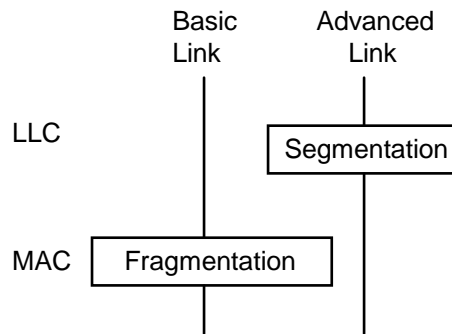

Figure 19.4: Segmentation and fragmentation in the DLL

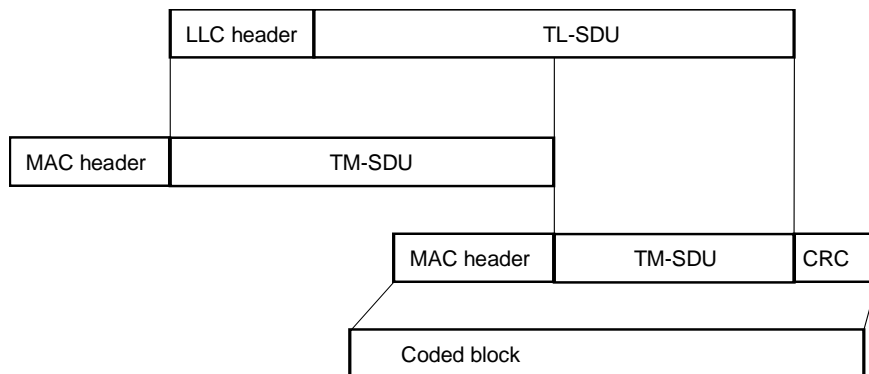

Figure 19.5: Fragmentation of long SDU in the MAC layer

For the advanced link, the LLC shall divide long data into segments (see figure 19.3). Each segment shall be individually recognizable by its LLC header. The segment size depends on the modulation mode of the channel (see clause 19.3.2.2).

- On a $\pi/4$ -DQPSK or D8PSK channel, the segment size should match the MAC transmission unit (MAC block). Therefore, on a D8PSK channel, segments may be of different sizes, depending on whether they are cut to be sent using $\pi/4$ -DQPSK or $\pi/8$ -D8PSK modulation for the first transmission of that segment.
- On a 25 kHz or 50 kHz QAM channel, the segment size is normally determined by the available space in a full-slot MAC block using 4-QAM with coding rate $r = 1/2$ at the current RF bandwidth; on a 100 kHz or 150 kHz QAM channel, the segment size is normally determined by the available space in half of a full-slot MAC block using 4-QAM with coding rate $r = 1/2$ at the current RF bandwidth. The first and last segment of a TL-SDU may be of different size.

The segment is defined as the unit of re-transmission. Therefore:

- on a $\pi/4$ -DQPSK channel, fragmentation should not be used for advanced link messages;
- on a D8PSK channel, fragmentation is needed when a segment cut for transmission using $\pi/8$ -D8PSK modulation is re-transmitted using $\pi/4$ -DQPSK modulation;
- on a QAM channel, fragmentation should not normally be used for advanced link messages (except for re-transmissions after a reduction of the RF bandwidth).

Use of these segment sizes on a QAM channel means that, on a 25 kHz or 50 kHz QAM channel:

- a full slot using 4-QAM with coding rate $r = 1/2$ can contain one advanced link segment;
- a full slot using 16-QAM with coding rate $r = 1/2$ can contain two advanced link segments;
- a full slot using 16-QAM with coding rate $r = 1$ can contain four advanced link segments;
- a full slot using 64-QAM with coding rate $r = 1/2$ can contain three advanced link segments;

- a full slot using 64-QAM with coding rate $r = 2/3$ can contain four advanced link segments;
- a full slot using 64-QAM with coding rate $r = 1$ can contain six advanced link segments.

This is illustrated in figure 19.6. Choice of the segment size corresponding to the smallest full-slot MAC block size (i.e. 4-QAM with coding rate $r = 1/2$) enables segments to be re-transmitted without fragmentation even if the modulation level and/or coding rate is changed.

NOTE: The same principle applies on a 100 kHz or 150 kHz QAM channel except that the segment size corresponds to half the size of the smallest full-slot MAC block, so that segments do not become too large.

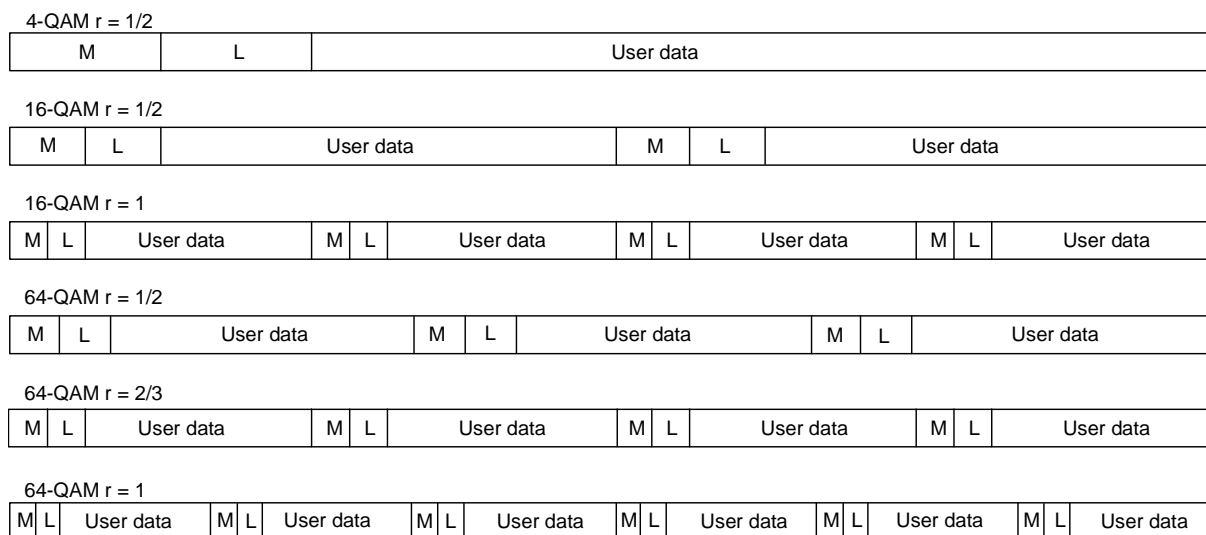

NOTE: In this figure, M represents MAC header and L represents LLC header.

Figure 19.6: Advanced link segments on a 25 kHz or 50 kHz QAM channel

19.2.2.4 Layer 2 signalling

In addition to the basic link and advanced link, the LLC may send and receive layer 2 signalling PDUs; these PDUs carry various types of general signalling information relating to layer 2 functions. The layer 2 functions may be either LLC or MAC functions. However, for the purposes of the data exchange mechanisms, the layer 2 signalling PDUs are treated as LLC PDUs.

The layer 2 signalling offers the following services:

- unacknowledged message transmission;
- un-numbered fragmentation of longer messages.

The current uses of layer 2 signalling are:

- for the MAC in the MS to indicate short-term variations in the MS's required data priority (temporarily modifying the default data priority negotiated with the SwMI by the SNDPCP);
- for the BS to send schedule synchronization information; and
- for the MAC in the MS and BS to send link adaptation feedback information on a D8PSK or QAM channel. Link adaptation feedback from the MS may aid the BS in its choice of the appropriate modulation (and coding rate for QAM) to use for transmission to that MS; link adaptation feedback from the BS may aid the MS in its choice of the appropriate modulation (and coding rate for QAM) to use for transmission; see clause 19.3.2.2.

Where a layer 2 signalling PDU relates to a MAC function, the LLC provides the layer 2 signalling service to the MAC through the TLE-SAP.

When the LLC sends or receives a layer 2 signalling PDU (relating to either an LLC or MAC function), it uses the data transfer service primitives offered by the MAC at the TMA-SAP.

19.2.3 Sub-layers

19.2.3.0 General

A detailed DLL illustration for peer-to-peer information exchange is presented in figure 19.7. The path followed by the information flow is shown from the C-plane SAPs - namely TLA and TLB. Information shall enter the MAC through the corresponding TMA and TMB SAP. The U-Plane information shall enter the MAC directly through the TMD-SAP. In either case, by using the TMV-SAP service primitive, the information shall then be placed into the appropriate logical channel and transmitted to the physical layer on the assigned timeslot in the multiframe.

NOTE 1: Layer 2 signalling is not used in this illustration so, for clarity, the TLE-SAP is not shown.

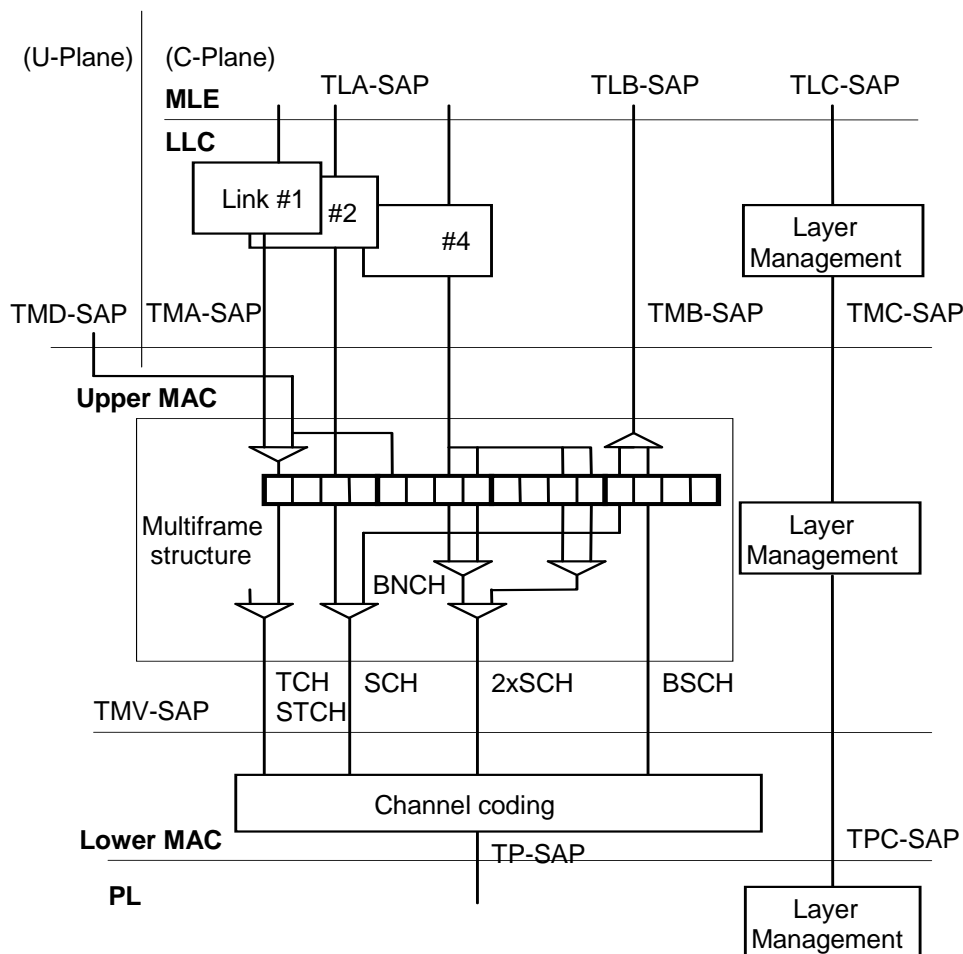

Figure 19.7: DLL protocol illustration for the MS side for $\pi/4$ -DQPSK operation

The information for layer management flows through the TLC-SAP to the LLC and MAC and further down to the physical layer.

In figure 19.7 an example is shown in which some LLC links (numbered from 1 to 4) are set up on the MS side.

NOTE 2: In figure 19.7 three links are considered as a possible scenario, but it is not mandatory for an MS to support multiple links.

Link 1 uses the timeslot 1 in the multiframe structure in the upper MAC. Timeslot 1 is used for traffic coming from the TMD-SAP. The first occurrence of this traffic is stolen by link 1. Link 2 is used to send a signalling message in the uplink on timeslot 3 (in this example a set-up of an advanced link). After that message exchange, link 4 is the newly set-up advanced link using timeslots 3 and 4 to increase the throughput. Finally, some broadcast information are received under the TxB-SAP in timeslots 1 and 2 of the last shown frame.

The various logical channels involved in this communication exchange are shown at the TMV-SAP. At the lower MAC, a specific channel coding is applied for each of them. All information in the MAC not related to layer management shall be exchanged to/from the physical layer through the TP-SAP.

Each sub-layer should contain its own layer management.

19.2.3.1 LLC sub-layer

The LLC shall deal with the LLC link establishment and maintenance for the C-plane under the TLA-SAP. From the MLE point of view, there may be multiple LLC instances, each dealing with a specific quality of service and identified by a number corresponding to the link identifier, see figure 19.7. The basic link shall be available when the MS is camped on the BS. In addition to the basic link, the MLE may request a higher quality of service from the LLC, and the LLC then may set up an advanced link or links as required depending on the capabilities of the MS. Each advanced link normally uses a fixed resource at the MAC layer, which may be shared by the basic link.

The number of simultaneous links in an MS depends on its capability. The MS may have up to four independent advanced links per service (i.e. acknowledged service or unacknowledged service) as either:

- one original advanced link per service plus up to three extended advanced links per service; or
- up to four extended advanced links per service.

If the MS has multiple simultaneous advanced links, some or all of the advanced links may share the same resource at the MAC layer, in which case there is only one basic link associated with those advanced links. Alternatively, the advanced links may use different resources at the MAC layer, in which case up to four basic links may be associated with the corresponding advanced links. (Scanning a different frequency or cell in search for a control channel uses a different link.)

Under the TLB-SAP, there is no LLC functionality and the MLE SDU is passed directly to/from the TMB-SAP. Therefore, peer-to-peer information exchange between LLC entities does not exist and there exists no LLC PDU for the broadcast under the TLB-SAP.

The TLC-SAP shall be used for layer management and layer-to-layer control communication.

19.2.3.2 MAC sub-layer

The main functionalities of the MAC are channel access control, radio resource control, data transfer and error detection, and also link adaptation on a D8PSK or QAM channel. Encryption over the air interface shall be performed in the upper MAC when required.

The LLC links defined at the TLA-SAP shall enter into the MAC using the TMA-SAP. Logical channel allocation and multiplexing shall be performed internally by the MAC. From the protocol point of view, the upper MAC shall communicate with the lower MAC by means of primitives through logical channels. From the architecture point of view, the choice of the logical channels permits selecting among different means of data protection (channel coding) and modulation which are part of the lower MAC and physical layer.

After the set-up of a circuit mode speech or data call, signalling messages may use the Associated Control Channel (ACCH) or may use the traffic channel stealing mechanism (Stealing Channel STCH).

Figure 19.7 illustrates how signalling from the LLC link 1 shares a timeslot with user traffic from U-plane by stealing and using the STCH logical channel. The user plane traffic uses the TCH logical channel. The broadcast information flowing via TMB-SAP may use specific BSCH logical channel or signalling logical channel SCH. The MAC layer allocates 2 timeslots ($2 \times \text{SCH}$) for the LLC instance 4 using an advanced link providing a higher transfer rate. All logical channels are then encoded at the lower MAC layer as defined by the logical channel (refer to clause 8).

19.2.4 Logical channels

19.2.4.1 Logical channels at the LLC-SAP

The MLE communicates to the LLC by using the relevant SAPs. Multiple LLC instances may be seen through the TLA-SAP. The MLE may choose to send a request on any available link, taking into account the associated quality of service.

Also the MAC communicates to the LLC through the TLE-SAP for the layer 2 signalling service.

19.2.4.2 Logical channels at the MAC-SAP

The LLC and U-plane shall communicate with the MAC via the relevant SAPs. The TMA-SAP shall be used for signalling, the TMB-SAP shall be used for downlink broadcast, the TMC-SAP shall be used for layer management and the TMD-SAP shall be used for circuit mode traffic and user signalling.

19.2.4.3 MAC internal logical channels

The logical channels may be separated into two categories:

- 1) traffic channels carrying U-plane information (circuit mode data and voice) plus end-to-end user signalling information; these shall carry information which is exchanged via the TMD-SAP at the MAC boundary;
- 2) control channels carrying C-plane information (control messages and packet data); these shall carry information which is exchanged via the TMA- and TMB-SAP at the boundary between MAC and LLC.

The following logical channels are defined within the upper MAC:

- Control Channel comprising:
 - Main Control Channel (MCCH or MCCH-Q);
 - Common Secondary Control Channel (Common SCCH);
 - Assigned Secondary Control Channel (Assigned SCCH).

These channels shall carry control information appearing at the TMA-SAP addressed to MS(s) not involved in a circuit mode call. Refer to clause 23.

- Associated Control Channel (ACCH) comprising:
 - Fast Associated Control Channel (FACCH);
 - Stealing Channel (STCH);
 - Slow Associated Control Channel (SACCH).

These channels shall carry control information appearing at the TMA-SAP intended for MS(s) involved in a circuit mode call.

- Broadcast Common Control Channel (BCCH) comprising:
 - Broadcast Synchronization Channel (BSCH or BSCH-Q);
 - Broadcast Network Channel (BNCH or BNCH-Q).

These channels shall carry the system broadcast information appearing at the TMB-SAP.

19.2.4.4 Logical channels at the lower MAC

Logical channels shall offer different physical paths to the information depending on the chosen error control scheme among those defined in clause 8.

The following generic logical channels shall be available at the lower MAC boundary for phase modulation (see figures 19.8 and 19.9):

- Access Assignment Channel (AACH);
- Broadcast Synchronization Channel (BSCH);
- Signalling Channel (SCH);
- Traffic Channel (TCH);
- Stealing Channel (STCH);
- Common Linearization Channel (CLCH).

The following generic logical channels shall be available at the lower MAC boundary for QAM (see figures 19.10 and 19.11):

- QAM Access Assignment Channel (AACH-Q);
- QAM Slot Information Channel (SICH-Q/D or SICH-Q/U);
- QAM Broadcast Synchronization Channel (BSCH-Q);
- QAM Signalling Channel (SCH-Q);
- QAM Common Linearization Channel (CLCH-Q).

As far as possible, the present document avoids defining specific physical architectures, but proposes instead to explain operation of the MAC sub-layer in terms of the functional blocks and logical channels. This reference model architecture applies equally to MSs and BSs. MSs transmission and reception for phase modulation are shown in figures 19.8 and 19.9 respectively. MSs transmission and reception for QAM are shown in figures 19.10 and 19.11 respectively.

NOTE: The only SAPs shown on these figures are the upper MAC, lower MAC and physical layer SAPs. The TLE-SAP, through which the LLC may provide a layer 2 signalling service to the MAC, is not shown.

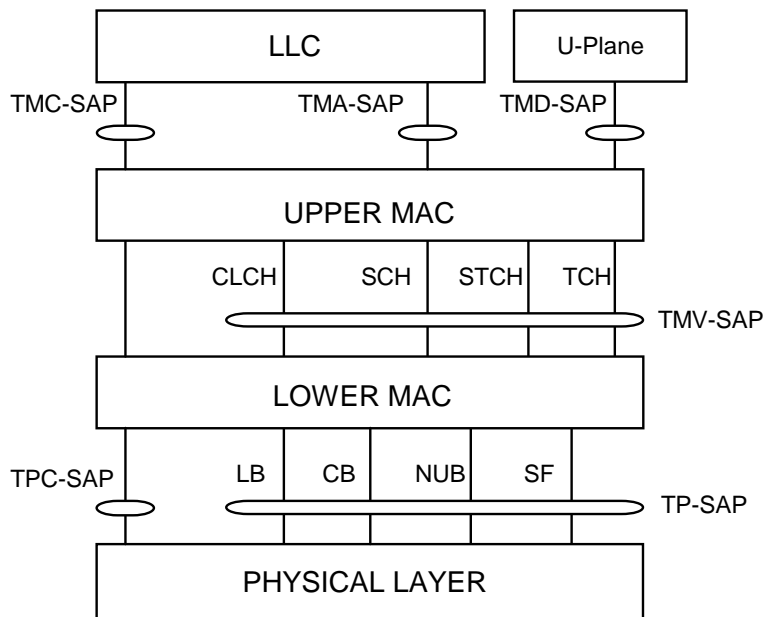

Figure 19.8: MAC sub-layers and logical channels for MS uplink transmission using phase modulation

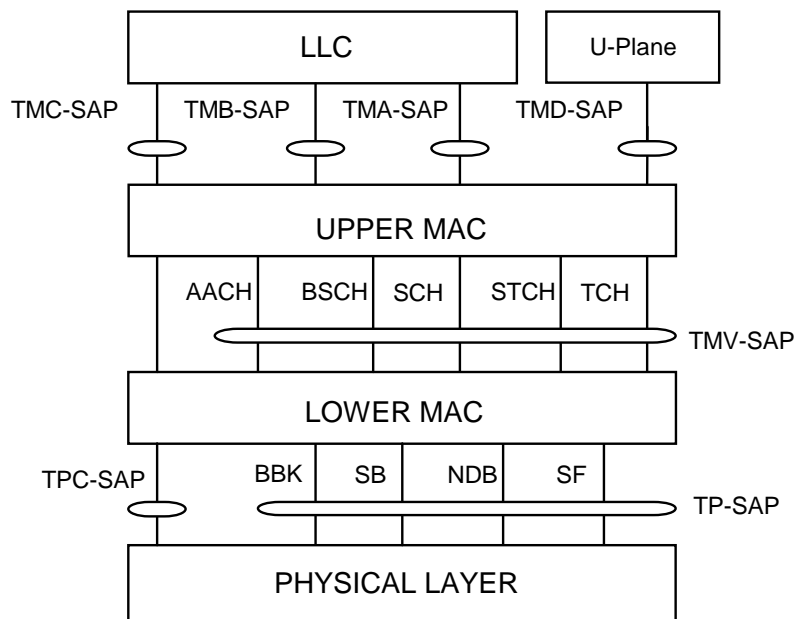

Figure 19.9: MAC sub-layers and logical channels for MS downlink reception using phase modulation

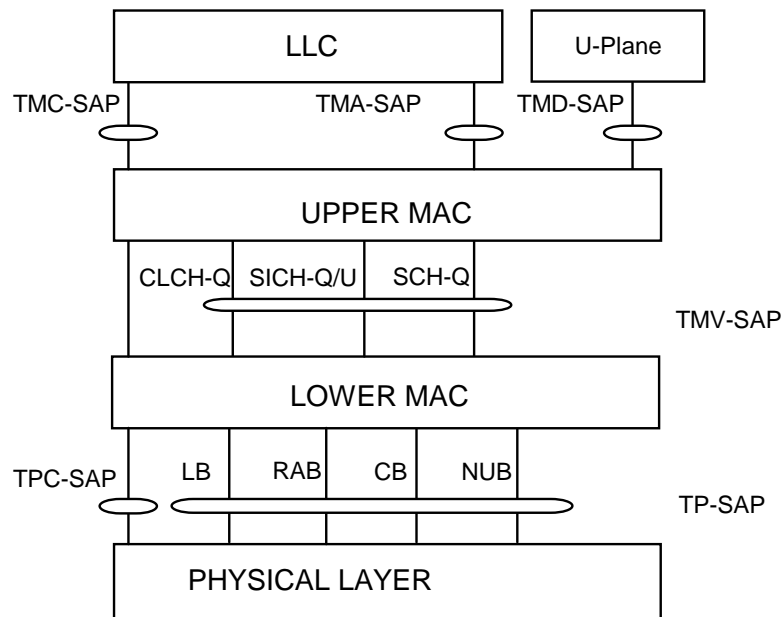

Figure 19.10: MAC sub-layers and logical channels for MS uplink transmission using QAM

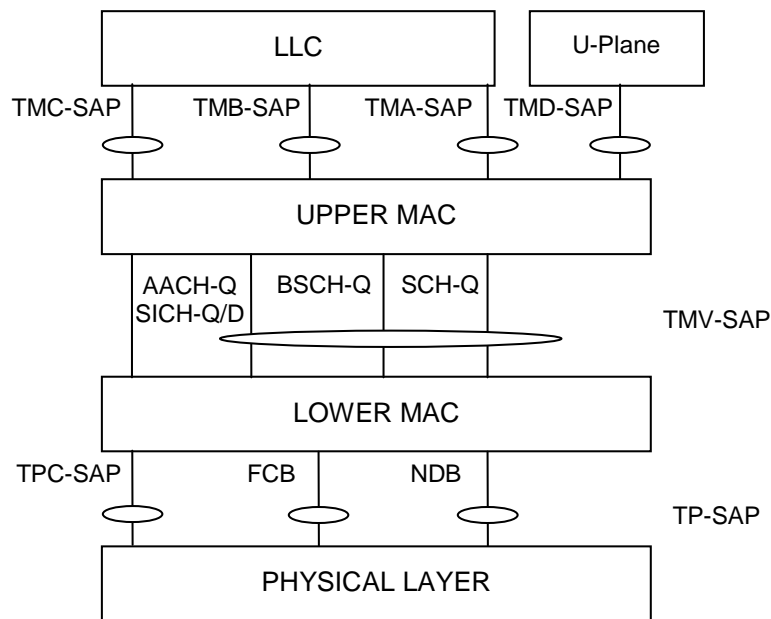

Figure 19.11: MAC sub-layers and logical channels for MS downlink reception using QAM

Tables 19.1, 19.2, 19.3 and 19.4 provide a summary of the logical channels shown in figures 19.8, 19.9, 19.10 and 19.11. The information mapping on these logical channels is presented starting with the MAC layer SAPs down to the physical bursts and blocks.

Table 19.1: Mapping between TMx-SAP and MAC logical channels for phase modulation

SAP	Definition	Logical channel in TMV-SAP	Definition (see note)
TMA	CA main control channel, or $\pi/4$ -DQPSK secondary control channel	SCH/F SCH/HD SCH/HU	signalling channel (full slot) signalling channel (1/2 slot downlink) signalling channel (1/2 slot uplink)
	D8PSK control channel	SCH/F SCH/HD SCH/HU SCH-P8/F SCH-P8/HD SCH-P8/HU	signalling channel (full slot) signalling channel (1/2 slot downlink) signalling channel (1/2 slot uplink) signalling channel ($\pi/8$ -D8PSK full slot) signalling channel ($\pi/8$ -D8PSK 1/2 slot downlink) signalling channel ($\pi/8$ -D8PSK 1/2 slot uplink)
	fast associated control channel or slow associated control channel	SCH/F SCH/HD SCH/HU	signalling channel (full slot) signalling channel (1/2 slot downlink) signalling channel (1/2 slot uplink)
	stealing channel (signalling)	STCH	stealing channel (signalling)
TMD	traffic channel (circuit mode)	TCH	traffic channel (circuit mode)
	stealing channel (user signalling)	STCH	stealing channel (user signalling)
TMB	broadcast synchronization channel	BSCH	broadcast synchronization channel
	broadcast network channel	BNCH on SCH/HD or STCH or SCH-P8/F or SCH-P8/HD	signalling channel (1/2 slot downlink) stealing channel (1/2 slot downlink) signalling channel ($\pi/8$ -D8PSK full slot) signalling channel ($\pi/8$ -D8PSK 1/2 slot downlink)
-	access assignment channel (generated inside the upper MAC)	AACH	access assignment channel
-	common linearization channel (generated inside the upper MAC)	CLCH	common linearization channel
NOTE: Signalling uses $\pi/4$ -DQPSK modulation unless stated otherwise.			

Table 19.2: Mapping between MAC logical channels and physical layer bursts for phase modulation

Logical channel in TMV-SAP	Definition (see note 1)	Physical burst (see note 2)	Definition (see note 2)
SCH/F	full slot signalling channel	NDB, NUB	normal downlink burst, normal uplink burst
SCH/HD	half slot downlink signalling channel	NDB + SF BKN2 of SB	normal downlink burst and slot flag 2nd half of synchronization burst
SCH/HU	half slot uplink signalling channel	CB	control uplink burst
SCH-P8/F	$\pi/8$ -D8PSK full slot signalling channel	$\pi/8$ -D8PSK NDB, $\pi/8$ -D8PSK NUB	$\pi/8$ -D8PSK normal downlink burst, $\pi/8$ -D8PSK normal uplink burst
SCH-P8/HD	$\pi/8$ -D8PSK half slot downlink signalling channel	$\pi/8$ -D8PSK NDB + SF	$\pi/8$ -D8PSK normal downlink burst and slot flag
SCH-P8/HU	$\pi/8$ -D8PSK half slot uplink signalling channel	$\pi/8$ -D8PSK CB	$\pi/8$ -D8PSK control uplink burst
STCH	stealing channel	NDB + SF, NUB + SF	normal downlink burst and slot flag, normal uplink burst and slot flag
TCH	traffic channel	NDB, NUB	normal downlink burst, normal uplink burst
BSCH	broadcast synchronization channel	SB	synchronization burst
AACH	access assignment channel	BBK (see note 3)	broadcast block
CLCH	common linearization channel	LB	linearization burst
NOTE 1: Signalling uses $\pi/4$ -DQPSK modulation unless stated otherwise.			
NOTE 2: Physical bursts are $\pi/4$ -DQPSK bursts unless stated otherwise.			
NOTE 3: The AACH is transmitted using $\pi/4$ -DQPSK modulation. (Thus, on a D8PSK channel, the AACH is transmitted using $\pi/4$ -DQPSK modulation in both $\pi/4$ -DQPSK and $\pi/8$ -D8PSK downlink bursts.)			

Table 19.3: Mapping between TMx-SAP and MAC logical channels for QAM

SAP	Definition	Logical channel in TMV-SAP	Definition
TMA	DA main control channel, or QAM secondary control channel	SCH-Q/D SCH-Q/B SCH-Q/U SCH-Q/HU SCH-Q/RA	QAM signalling channel (full slot downlink) QAM signalling channel (data set B downlink) QAM signalling channel (full slot uplink) QAM signalling channel (1/2 slot uplink) QAM signalling channel (random access)
TMB	QAM broadcast synchronization channel	BSCH-Q	QAM broadcast synchronization channel
	QAM broadcast network channel	BNCH-Q on SCH-Q/D or SCH-Q/B	QAM signalling channel (full slot downlink) QAM signalling channel (data set B downlink)
-	QAM access assignment channel (generated inside the upper MAC)	AACH-Q	QAM access assignment channel
-	QAM slot information channel (generated inside the upper MAC)	SICH-Q/D SICH-Q/U	QAM slot information channel (downlink) QAM slot information channel (uplink)
-	QAM common linearization channel (generated inside the upper MAC)	CLCH-Q	QAM common linearization channel

Table 19.4: Mapping between MAC logical channels and physical layer bursts for QAM

Logical channel in TMV-SAP	Definition	QAM physical burst	Definition
SCH-Q/D	QAM full slot downlink signalling channel	NDB	QAM normal downlink burst
SCH-Q/B	QAM data set B downlink signalling channel	FCB (see note)	QAM frequency correction burst
SCH-Q/U	QAM full slot uplink signalling channel	NUB	QAM normal uplink burst
SCH-Q/HU	QAM half slot uplink signalling channel	CB	QAM control uplink burst
SCH-Q/RA	QAM random access signalling channel	RAB	QAM random access uplink burst
BSCH-Q	QAM broadcast synchronization channel	FCB (see note)	QAM frequency correction burst
AACH-Q	QAM access assignment channel	Transmitted in the header symbols within the NDB and FCB	Transmitted in the header symbols within the QAM normal downlink burst and QAM frequency correction burst
SICH-Q/D	QAM downlink slot information channel	Transmitted in the header symbols within the NDB and FCB	Transmitted in the header symbols within the QAM normal downlink burst and QAM frequency correction burst
SICH-Q/U	QAM uplink slot information channel	Transmitted in the header symbols within the NUB and CB	Transmitted in the header symbols within the QAM normal uplink burst and QAM control uplink burst
CLCH-Q	QAM common linearization channel	LB	QAM linearization burst
NOTE: On a 50 kHz, 100 kHz or 150 kHz QAM channel, the FCB contains both the BSCH-Q and SCH-Q/B logical channels. On a 25 kHz QAM channel, the FCB contains only the BSCH-Q logical channel.			

19.2.5 Lower layer management at the DLL

The TETRA protocol architecture, ETSI EN 300 392-1 [6], clause 6 shows how the lower layer management entity is incorporated into all lower layers and is accessible via SAPs Tx-C-SAP as shown in figures 19.1 and 19.7 for the lowest layers. Those access points enable access to information such as measured values, status, general information. The services related to the management of LLC and MAC are described in clause 20.

The DLL should have its own set of functions and measured values. These parameters shall be exchanged using a set of primitives as described in the appropriate clause, namely clauses 22 and 23.

19.3 System modes of operation

19.3.0 General

Clauses 19.3.1 to 19.3.6 provide an outline description of system modes of operation and their impact on layer 2.

19.3.1 Normal mode

19.3.1.0 General

In the present document there are two types of cell: Conventional Access (CA) cells and Direct Access (DA) cells.

A CA cell is a cell on which the main carrier uses phase modulation. The bandwidth of the CA main carrier is 25 kHz. A CA MS is an MS that is currently camped on a CA cell.

A DA cell is a cell on which the main carrier uses QAM. The bandwidth of the DA main carrier is 25 kHz, 50 kHz, 100 kHz or 150 kHz. A DA MS is an MS that is currently camped on a DA cell.

NOTE: An MS may be both CA-capable and DA-capable. In that case it may sometimes be a CA MS and at other times a DA MS, depending on whether its current serving cell is a CA cell or a DA cell.

19.3.1.1 Normal mode for Conventional Access (CA)

In the normal mode of operation on a CA cell, the common control channel on the main carrier shall always be the MCCH and shall always be present in timeslot 1 of all frames 1 to 18. This common control channel is a single-slot $\pi/4$ -DQPSK channel that shall be used for all common control signalling on that CA cell. All CA MSs shall be able to locate and listen to the downlink transmissions of the MCCH. The BS shall transmit on all downlink slots of the main carrier during normal mode.

19.3.1.2 Normal mode for Direct Access (DA)

In the normal mode of operation on a DA cell, the common control channel on the main carrier shall always be the MCCH-Q and shall always be present in at least timeslot 1 of all frames 1 to 18. This common control channel is a one-slot, two-slot, three-slot or four-slot QAM channel that shall be used for all common control signalling on that DA cell. All DA MSs shall be able to locate and listen to the downlink transmissions of the MCCH-Q. The BS shall transmit on all downlink slots of the DA main carrier.

19.3.2 Extended mode

19.3.2.1 Usage of extended mode

19.3.2.1.1 Extended mode for Conventional Access (CA)

A BS may have more than one control channel (common or assigned) operational at a time. For CA, the ways to operate this may be as follows:

- in addition to the MCCH, the BS may have from one to three common SCCHs, which have the same functionality as the MCCH but are used only by a sub-set of the user population;
- in addition to the MCCH, the BS may have one or several assigned SCCHs used to continue control signalling and packet mode signalling after the initial random access or paging message;
- in minimum mode (without MCCH), the BS may have one or several assigned SCCHs used to continue control and packet mode signalling after the initial random access or paging message;
- in addition to the MCCH, the BS may have from one to three common SCCHs and one or several assigned SCCHs used to continue control and packet mode signalling after the initial random access or paging message.

The MCCH and common SCCHs cannot be extended to more than one timeslot per TDMA frame. For CA, the MCCH and common SCCHs are $\pi/4$ -DQPSK channels.

Assigned SCCH can be from one up to four timeslots per TDMA frame. An assigned SCCH may be allocated as a $\pi/4$ -DQPSK, D8PSK or QAM channel (see clause 19.3.2.2).

Common SCCHs for CA shall be in the same carrier as the MCCH. Assigned SCCHs may be allocated from any carrier.

NOTE: The extended mode does not necessarily increase the control channel capacity of an individual MS; only a multislot or D8PSK or QAM assigned SCCH provides a higher transfer rate.

19.3.2.1.2 Extended mode for Direct Access (DA)

A BS may have more than one control channel (common or assigned) operational at a time. For DA, the ways to operate this may be as follows:

- if the BS is using a single-slot MCCH-Q then, in addition to the MCCH-Q, the BS may have from one to three common SCCHs, which have the same functionality as the MCCH-Q but may be used only by a sub-set of the user population;

NOTE: The BS is not permitted to use QAM common SCCHs if it is using a multi-slot MCCH-Q. For DA, if the BS wishes to use more than one timeslot per TDMA frame for common control signalling, it may use either a single multi-slot MCCH-Q or multiple single-slot QAM common control channels.

- in addition to the MCCH-Q, the BS may have one or several assigned SCCHs used to continue control signalling and packet mode signalling after the initial random access or paging message;
- if the BS is using a single-slot MCCH-Q then, in addition to the MCCH-Q, the BS may have from one to three common SCCHs and one or several assigned SCCHs used to continue control and packet mode signalling after the initial random access or paging message.

The MCCH-Q can be from one up to four timeslots per TDMA frame, whereas common SCCHs cannot be extended to more than one timeslot per TDMA frame. For DA, the MCCH-Q and common SCCHs are QAM channels.

Assigned SCCH can be from one up to four timeslots per TDMA frame. An assigned SCCH may be allocated as a QAM, $\pi/4$ -DQPSK or D8PSK channel (see clause 19.3.2.2).

Common SCCHs for DA shall be in the same carrier as the MCCH-Q. Assigned SCCHs may be allocated from any carrier.

For DA, the BS may allocate the MCCH-Q physical channel(s) as a QAM assigned SCCH for some MSs that are camped on the cell. Then the MSs in common mode and the MSs in assigned mode share the channel. Similarly, the BS may allocate a physical channel used as a QAM common SCCH also as a QAM assigned SCCH for some MSs that are camped on the cell, with the channel shared between the MSs in common mode and the MSs in assigned mode.

19.3.2.1.3 Extended mode with sharing between cells

As described above, a CA MS is an MS that is currently camped on a CA cell, so it receives a $\pi/4$ -DQPSK common control channel (i.e. the MCCH or a $\pi/4$ -DQPSK common SCCH) unless it is directed by the BS to an assigned channel. A DA MS is an MS that is currently camped on a DA cell, so it receives a QAM common control channel (i.e. the MCCH-Q or a QAM common SCCH) unless it is directed by the BS to an assigned channel. From the perception of the MS, at any one time it is camped on either a CA cell or a DA cell.

However, for cells that share the same mobile country code, mobile network code, colour code and static cipher key or common cipher key (see ETSI EN 300 392-7 [8]), the same channel may sometimes be used by more than one cell (if within the permitted physical separation i.e. if the assigned channel's transmitter site is within 4 km of the main carrier's transmitter site for each of the sharing cells (see clause 7)). Then:

- MSs camped on a CA cell might be assigned to a channel used also by DA MSs. For example:
 - A channel on a carrier other than either main carrier might be used as an assigned channel shared by both CA MSs and DA MSs. This may apply for both phase modulation carriers and QAM carriers.

- If a channel on either main carrier is not being used for common control, it might be used as an assigned channel shared by both CA MSs and DA MSs.
- The MCCH-Q or a QAM common SCCH might be used as an assigned SCCH for CA MSs. As described in clause 19.3.2.1.2, the MCCH-Q or a QAM common SCCH might also be used as an assigned SCCH for DA MSs camped on the DA cell. Thus the channel could be shared between the DA MSs in common mode, DA MSs in assigned mode and CA MSs in assigned mode.
- In some cases, DA MSs might be assigned to a channel used also by DA MSs that are camped on a different DA cell as follows:
 - A channel on a carrier other than either DA main carrier might be used as an assigned channel shared by MSs from different DA cells. (The channel could also be shared by MSs from a CA cell.)

NOTE: The present document does not provide a general method for sharing of an assigned channel by MSs from different CA cells. However, annex S notes a restricted method that SwMIs may be able to use without the MSs being aware of the usage.

19.3.2.2 Modulation modes

19.3.2.2.0 General

There are three possible modulation modes for channels: $\pi/4$ -DQPSK, D8PSK and QAM. The signalling operation with the three modulation modes is outlined in clauses 19.3.2.2.1, 19.3.2.2.2 and 19.3.2.2.3.

19.3.2.2.1 $\pi/4$ -DQPSK channel

All signalling and data messages and traffic on a $\pi/4$ -DQPSK channel are sent using $\pi/4$ -DQPSK modulation.

The RF bandwidth of a $\pi/4$ -DQPSK channel is 25 kHz.

19.3.2.2.2 D8PSK channel

A "D8PSK channel" is the generic term for a channel on which signalling and data messages may be sent using either $\pi/4$ -DQPSK bursts or $\pi/8$ -D8PSK bursts. The transmitting BS or MS chooses whether to use a $\pi/4$ -DQPSK burst or a $\pi/8$ -D8PSK burst on a slot-by-slot basis. The receiving MS or BS determines whether a slot (or subslot) contains a $\pi/4$ -DQPSK burst or a $\pi/8$ -D8PSK burst by determining whether the training sequence uses the $\pi/4$ -DQPSK form or the $\pi/8$ -D8PSK form.

The RF bandwidth of a D8PSK channel is 25 kHz.

19.3.2.2.3 QAM channel

All signalling and data messages on a QAM channel are sent using QAM modulation. The transmitting BS or MS chooses which modulation level and coding rate to use on a slot-by-slot basis. There are six valid combinations:

- 4-QAM, coding rate $r = 1/2$;
- 16-QAM, coding rate $r = 1/2$ or 1;
- 64-QAM, coding rate $r = 1/2, 2/3, \text{ or } 1$.

The access assignment channel AACH-Q (in a QAM normal downlink burst or QAM frequency correction burst), and the slot information channels SICH-Q/D (in a QAM normal downlink burst or QAM frequency correction burst) and SICH-Q/U (in a QAM normal uplink burst or QAM control uplink burst), always use 4-QAM with coding rate $r = 1/2$. The downlink slot information channel SICH-Q/D indicates the modulation and coding rate used in the remainder of the downlink slot and indicates whether the burst is a frequency correction burst. The uplink slot information channel SICH-Q/U indicates the modulation and coding rate used in the remainder of the uplink slot or subslot.

The RF bandwidth of a QAM channel is 25 kHz, 50 kHz, 100 kHz or 150 kHz.

The random access burst always uses 4-QAM, coding rate $r = 1/2$ with a 25 kHz bandwidth - irrespective of the RF bandwidth of the QAM channel. For the purposes of the random access procedure, each subslot (i.e. half slot) that is available for random access is divided into 25 kHz frequency blocks. This provides 2, 4 or 6 parallel "random access uplink RF channel subslots" within a single subslot on a 50 kHz, 100 kHz or 150 kHz channel respectively.

19.3.3 Minimum mode

For CA, minimum mode allows a BS to assign all four timeslots on the CA main carrier for traffic or dedicated control purpose. In this mode, only frame 18 can be used for common control without disturbing the established services. A BS enters minimum mode when all four downlink timeslots on the CA main carrier are assigned so that there is no common control channel available in timeslot 1.

Minimum mode is not supported for DA.

19.3.4 Discontinuous transmission mode

A BS may transmit discontinuously on a CA main carrier when it operates in one of the following time sharing modes.

NOTE: Discontinuous downlink transmission is not supported on radio resources currently being used for QAM.

19.3.5 Time sharing mode

19.3.5.0 General

In the time shared mode, multiple BSs may use the same phase modulation radio resource for control channel purposes in a co-ordinated manner.

19.3.5.1 Carrier sharing mode

In carrier sharing mode, one carrier frequency used for phase modulation shall be shared among up to four cells, each cell being allocated at least one timeslot of the TDMA frame (see clause 9 for more details).

19.3.5.2 MCCH sharing mode

In the MCCH sharing mode, the MCCH shall be shared among several CA cells in a manner under the control of the infrastructure (see clause 9 for more details).

19.3.6 No service mode

A BS may be in a mode where it is not able to provide any services. In this mode, the BS may transmit unallocated physical channel (UP) on all of the timeslots of its main carrier.

For CA, the BS should also set the "BS Service Details" information element of the D-MLE-SYSINFO PDU to 000000000000₂, to further indicate that the BS does not provide any TETRA services in this mode. For DA, the BS should set the "BS Service Details DA" information element of the D-MLE-SYNC-DA and D-MLE-SYSINFO-DA PDUs to 0000000₂.

NOTE: A BS that is in this mode is not in normal mode.

19.4 MS modes of operation

19.4.1 Idle mode

The idle mode shall be the state of the registered MS not involved in any particular transmission. It shall consist of listening to the MCCH (for CA) or MCCH-Q (for DA) or to any signalling channel the MS could have been told by the SwMI. The MS shall be capable of monitoring adjacent cells in this mode as described in clause 23.

19.4.2 Signalling and packet mode

19.4.2.1 Common control channel

This channel shall support common signalling for all MSs (see clause 23). In a system, there may be in addition to the MCCH or MCCH-Q one or more common secondary control channels (common SCCHs). By default, the MS shall listen to the MCCH (for CA) or MCCH-Q (for DA) for paging and other signalling (see clause 19.4.5 for energy economy).

19.4.2.2 Secondary control channels

These channels may be used to supplement the capacity of the common control channel. They may have the same functionality as the MCCH (for CA) or MCCH-Q (for DA) for a subdivision of the population, or they may be devoted to support only certain type of transmission e.g. packet mode data. In that respect, they may serve as a control channel dedicated to packet data transmission (see clause 23). The BS shall command the MS to use the appropriate control channel by allocating additional resources or by commanding the MS to go to a certain control channel (refer to clause 19.3.2). The BS shall command MSs to use the appropriate control channel, either by a broadcast message indicating the number and location of common SCCHs in operation, or by commanding certain MSs to go to an assigned SCCH.

An assigned SCCH may be allocated as a $\pi/4$ -DQPSK, D8PSK or QAM channel. For CA, it is optional for the MS or BS to support D8PSK and/or QAM channels. For DA, it is optional for the MS or BS to support $\pi/4$ -DQPSK and/or D8PSK channels.

NOTE: A BS could use an assigned SCCH for continuing signalling for circuit mode call set-up.

The BS may decide to assign an SCCH for advanced link packet data transmission. There are different possible methods of usage.

EXAMPLE:

- a) The BS may use an assigned SCCH for only one advanced link (i.e. similar to the usage of a channel for a circuit mode call); or
- b) the BS may use an assigned SCCH as a general packet data channel, supporting advanced links for many MSs, where each MS may be offering/receiving data packets at a low rate or intermittently.

MS operation is the same in both cases. The channel usage is scheduled by the BS, and MSs transmit only under BS control (by random access or reserved access). When appropriate, an MS may be permitted to remain on the channel while its advanced link is connected, even though the MS is not necessarily using the link all the time. After a pause, the MS uses random access when it wishes to continue transmission.

An advanced link can also use a common control channel or, for MSs in a circuit mode call, an ACCH. However, if advanced links are used on a common control channel, the normal control channel performance may be degraded.

19.4.2.3 Associated Control Channel (ACCH)

This channel shall be used for signalling in conjunction with an established circuit (traffic channel). That signalling may be independent of the call the control channel is associated with. The lower MAC should be configured as shown in figure 19.12. Depending on the circuit mode call type and the capabilities of MS, the ACCH may be available during timeslots in frames 1 to 18 (if they are not being used for traffic), and it is always available during the 18th frame; refer to clause 23. The former is called Fast Associated Control Channel (FACCH) (frames 1 to 18), and the latter is called Slow Associated Control Channel (SACCH) (frame 18). The MS shall listen to the ACCH under control of the BS; refer to clause 19.4.4.

Circuit mode traffic transmissions apply only on $\pi/4$ -DQPSK channels. Therefore signalling on the ACCH is sent using $\pi/4$ -DQPSK modulation.

19.4.2.4 Full and half slot signalling

19.4.2.4.1 Full and half slot signalling on a $\pi/4$ -DQPSK channel

In figures 19.12 and 19.13, full slot ($SF = 0$) or half slot ($SF = 1$) downlink signalling shall be indicated by the appropriate slot flag (SF). The slot flag (SF) shall be a change between two training sequences, as described in clause 9. Downlink control messages may usually occupy a full slot, but the system Broadcast channels (BSCH and BNCH) shall be all one half slot long to enable them to be transmitted in frame 18 (BSCH, or BNCH on SCH/HD; see clause 9).

For the MS transmission on the uplink for initial access, a subslot is used - corresponding to the logical channel SCH/HU as described in clause 9.

Uplink control messages may be sent within a subslot using the logical channel SCH/HU. However, for packet data or when using fragmentation, the MS may need to use reserved full slots or subslots for the transmissions subsequent to the initial access. The allocation of MS reserved uplink slots and subslots shall be under the control of the BS.

Once the MS has switched into traffic mode, all transmissions shall be done over an entire timeslot. Distinction between full slot for traffic and half slot to indicate that the first half slot has been stolen for signalling purposes shall be indicated by a change between the two training sequence, in a manner identical to that used for the downlink.

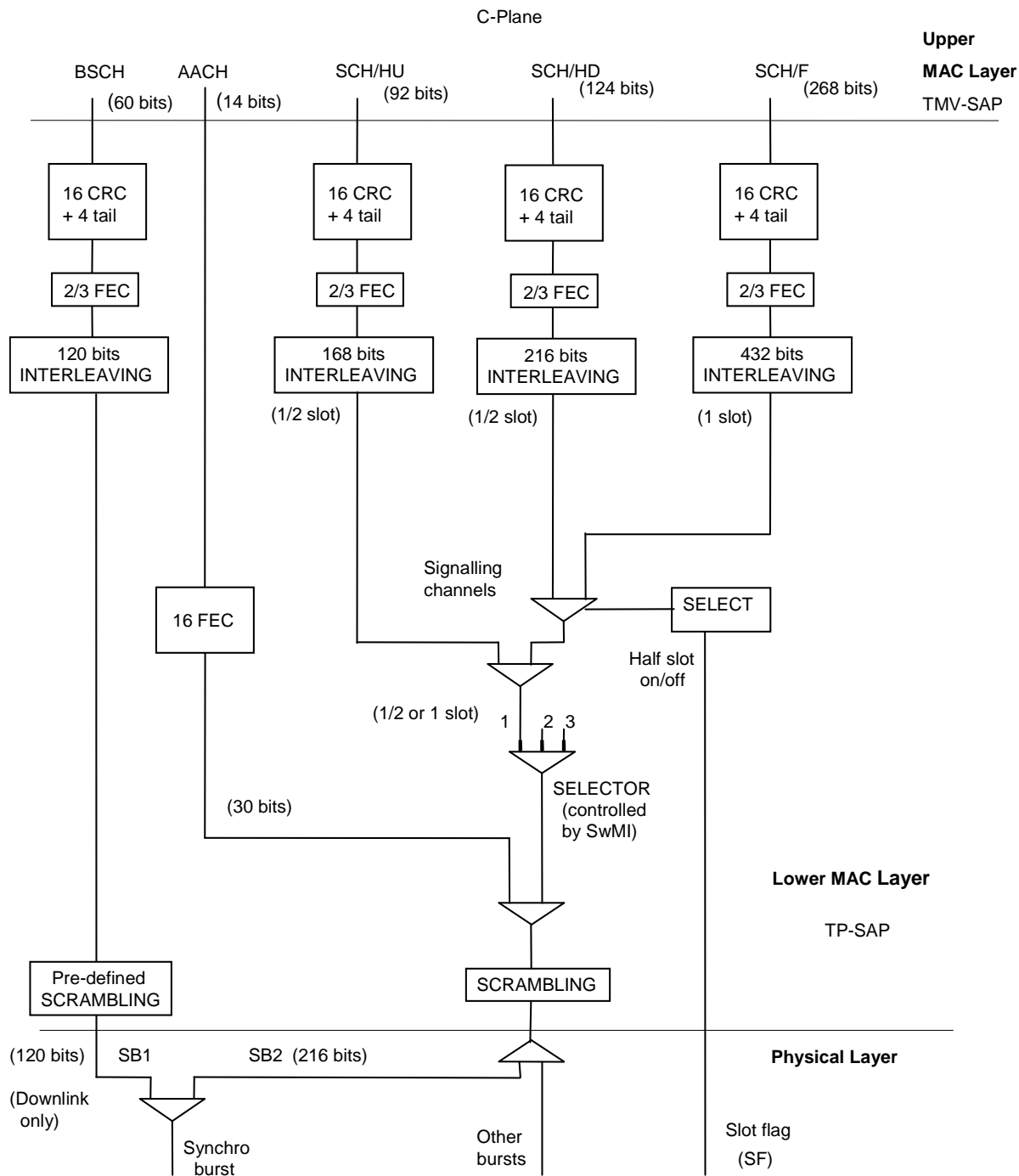

Figure 19.12: Configuration in signalling and packet mode on a $\pi/4$ -DQPSK channel

19.4.2.4.2 Full and half slot signalling on a D8PSK channel

For downlink signalling on a D8PSK channel, full slot ($SF = 0$) or half slot ($SF = 1$) downlink signalling shall be indicated by the appropriate Slot Flag (SF). The slot flag (SF) shall be a change between two training sequences, as described in clause 9. The training sequence also indicates whether the slot contains a $\pi/4$ -DQPSK normal downlink burst or a $\pi/8$ -D8PSK normal downlink burst. Thus there are four possible normal training sequences in a downlink slot on a D8PSK channel. (A further training sequence is used for the synchronization downlink burst.)

For the MS transmission on the uplink for initial access, a $\pi/4$ -DQPSK subslot is used - corresponding to the logical channel SCH/HU as described in clause 9.

Subsequent to the initial access, the MS may need to use full slots or subslots, reserved for that MS by the BS. Either a $\pi/4$ -DQPSK or $\pi/8$ -D8PSK normal uplink burst may be used in a reserved slot - corresponding to logical channel SCH/F or SCH-P8/F. Either a $\pi/4$ -DQPSK or $\pi/8$ -D8PSK control uplink burst may be used in a reserved subslot - corresponding to logical channel SCH/HU or SCH-P8/HU. For both reserved slots and subslots, the training sequence indicates the modulation of the burst.

19.4.2.4.3 Full and half slot signalling on a QAM channel

Full slot signalling is used on the downlink of a QAM channel - corresponding to logical channel SCH-Q/D in the QAM normal downlink burst or to logical channels BSCH-Q and SCH-Q/B in the QAM frequency correction burst. These bursts use the full RF bandwidth of the QAM channel.

NOTE: For 25 kHz channels:

- the BSCH-Q logical channel is contained within the QAM frequency correction burst;
- there is no SCH-Q/B logical channel in the QAM frequency correction burst.

For 50 kHz, 100 kHz and 150 kHz channels:

- the BSCH-Q logical channel is contained within the central 25 kHz of the QAM frequency correction burst;
- the SCH-Q/B logical channel is carried in the outer parts of the QAM frequency correction burst.

The BS chooses which modulation level and coding rate to use on a slot-by-slot basis for SCH-Q/D. The BS always uses 4-QAM, coding rate $r = 1/2$ for BSCH-Q and SCH-Q/B.

For the MS transmission on the uplink for initial access, a random access uplink RF channel subslot is used - corresponding to the logical channel SCH/RA as described in clause 9. The random access transmission uses a 25 kHz bandwidth, irrespective of the RF bandwidth of the QAM channel, and always uses 4-QAM, coding rate $r = 1/2$.

Subsequent to the initial access, the MS may need to use full slots or subslots, reserved for that MS by the BS - corresponding to the logical channel SCH-Q/U for a full slot or SCH-Q/HU for a reserved subslot. These use the full RF bandwidth of the QAM channel. The transmitting MS chooses which modulation level and coding rate to use in each slot or subslot.

19.4.3 Traffic mode

19.4.3.0 General

Traffic mode applies only on $\pi/4$ -DQPSK channels.

19.4.3.1 Normal operation

The traffic mode may be either speech or data circuit operation. The logical channels in use shall be TCH (traffic channels) for frames 1 to 17. Full slots (Slot Flag = 0) shall normally be used for traffic. Frame 18 shall be used for signalling only.

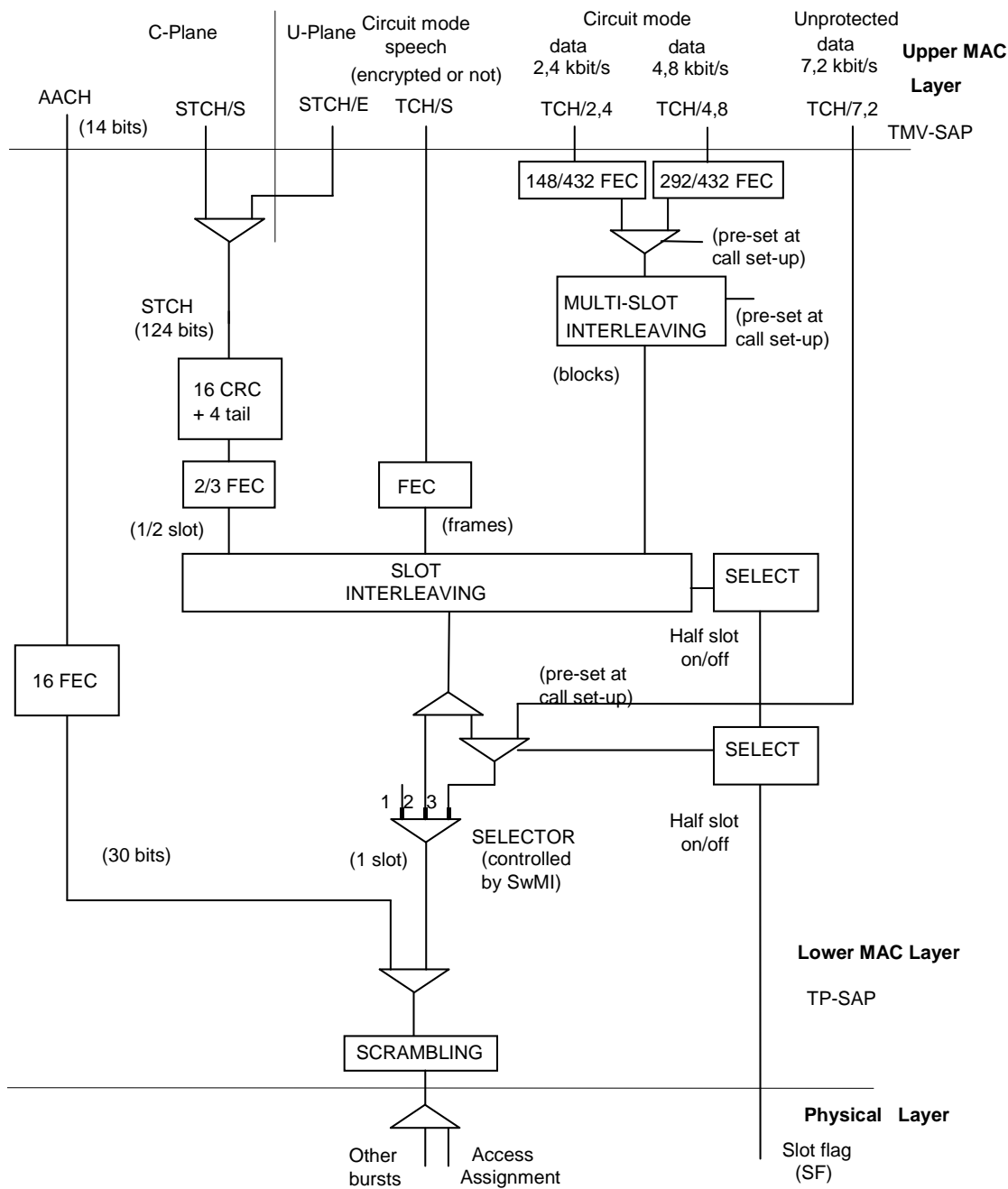

Figure 19.13: Configuration in traffic mode for frames 1 to 17 on a $\pi/4$ -DQPSK channel

19.4.3.2 Stealing mechanism

When in traffic mode (either speech or data circuit), capacity may be stolen for signalling purposes. This shall leave the current mode of operation unchanged. The appearance of half slot ($SF = 1$) in the transmission shall indicate that stealing has occurred. Half slot ($SF = 1$) operation shall be indicated by a change in the appropriate training sequence as described in clause 9. The MAC header of the first half of the slot shall indicate whether the other half has also been stolen or if it belongs to the normal traffic circuit. The MAC header shall contain an information on the intended destination of the signalling message: either C-plane or U-plane signalling. Stealing occurrence shall be locally reported to the U-plane application at the TMD-SAP (see figure 19.13).

This mechanism shall apply to both BS and MS transmissions.

19.4.4 Selection of the mode of operation

During a transaction on a $\pi/4$ -DQPSK channel, the MAC shall be considered to be switched into one of the following modes of operation:

- signalling mode; or
- traffic mode.

The selection mechanism is presented in figure 19.14. The default mode of the MAC layer shall be signalling mode (selector in position 1 on figure 19.14). The BS shall send CC messages to change the mode of operation in the MS MAC layer. This change shall be reflected from the CC into the MAC using layer management communication internal to the MS. In case of accidental loss of the CC message, a fall-back mechanism is specified using the AACH indications.

When stealing is initiated in circuit mode operation (either by the MS or the SwMI), the logical channel shall be temporarily taken (fully or partially) on a half slot by half slot basis for signalling purposes.

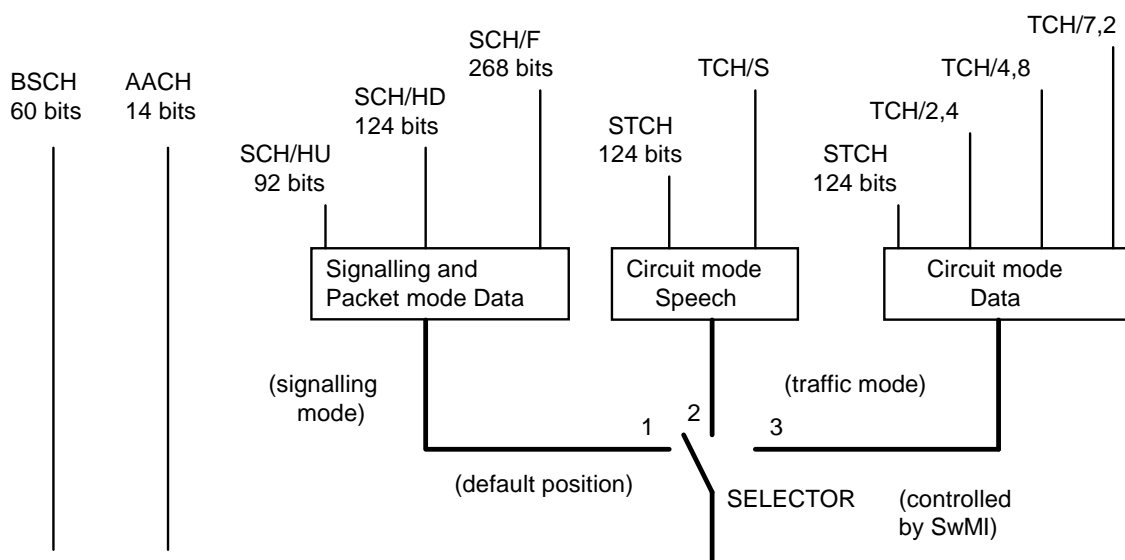

Figure 19.14: Selection of configuration for the current mode of operation on a $\pi/4$ -DQPSK channel

If traffic mode is selected, then the mode selector switch shall be considered to be set accordingly in the MS and in the SwMI.

In case of independent uplink and downlink assignment (e.g. to cover inter-site calls), the selector may be duplicated for uplink and downlink operation (i.e. for MS transmission and reception). Still, the selectors shall be set accordingly in the MS and SwMI.

NOTE: Traffic mode applies only to frames 1 to 17. Both MS and BS are in signalling mode on frame 18.

19.4.5 Energy economy mode

On the MS request, the BS MM may command the MS to energy economy mode on the MCCH or MCCH-Q or on a common SCCH. The start of the energy economy shall be indicated by the BS. Then:

- when the MS is idle on a single-slot common control channel, it follows a regular cycle of sleeping for N TDMA frames and then receiving in one timeslot;
- when a DA MS is idle on a multi-slot MCCH-Q:
 - if the BS does not permit enhanced energy economy, the MS follows a regular cycle of sleeping for N TDMA frames and then receiving all timeslots comprising the MCCH-Q in one TDMA frame;
 - if the BS permits enhanced energy economy, the MS may follow a regular cycle of sleeping for N TDMA frames and then receiving one of the MCCH-Q timeslots in one TDMA frame.

During energy economy mode, the MS shall remain synchronized to the BS transmission.

The part-time reception procedure is an alternative procedure which may apply on a multi-slot MCCH-Q. If part-time reception is permitted by the BS, this allows DA MSs when idle to receive just one downlink slot per TDMA frame.

Also, when the BS allocates an assigned channel, it may indicate that, when appropriate, MS "napping" is permitted on that assigned channel according to the specified napping reception pattern and napping reception frames. When the MS is in napping mode, it receives at least the downlink slot(s) indicated by the napping reception pattern in the napping reception frames.

19.4.6 Support of concurrent calls

Depending on the class of the mobile, concurrent calls may be supported by LLC (see clause 22) and MAC (see clause 23) protocols.

19.4.7 Support of air-interface encryption

The support of encryption is optional and shall be indicated as part of the MS capabilities (i.e. in the class of MS).

If this mode is supported, the MAC shall encrypt signalling messages as instructed by the upper layers on a message basis. Encrypted messages shall be indicated in the MAC header in order to enable the receiving end to decrypt the message content.

The MAC may in addition encrypt the content of the half slots coming from the TMD-SAP. This may also apply to an established encrypted call. The encrypted speech shall then be encrypted once more in the MAC. In this case, encryption synchronization messages shall also be encrypted at the MAC level and decrypted before being passed through the TMD-SAP at the receiving side.

19.5 Scenarios for primitives and PDU transfer on the air interface

Figures 19.15, 19.16, 19.17 and 19.18 show example scenarios illustrating message exchanges for set-up of a circuit mode call on a CA cell. Figures 19.15 and 19.16 show the primitives and PDUs on a calling MS air interface. Figures 19.17 and 19.18 show the primitives and PDUs on a called MS air interface.

NOTE 1: Some features represented here may be optional.

NOTE 2: Figures 19.15, 19.16, 19.17 and 19.18 illustrate message exchanges for set-up of a circuit mode call on a CA cell. Similar signalling applies for set-up of a circuit mode call on a DA cell. However, for example, different logical channels are used for signalling on the DA main carrier; and the U-SETUP PDU exceeds the available capacity in the QAM random access uplink burst, so the calling MS uses fragmentation.

Refer to clause 20 for definition of primitives and elements, and clause 21 for PDUs. Refer to clauses 11 and 14 for the call set-up definition. The involved MLE, LLC and MAC protocols are found in clauses 18, 22 and 23 respectively.

Calling MS Side

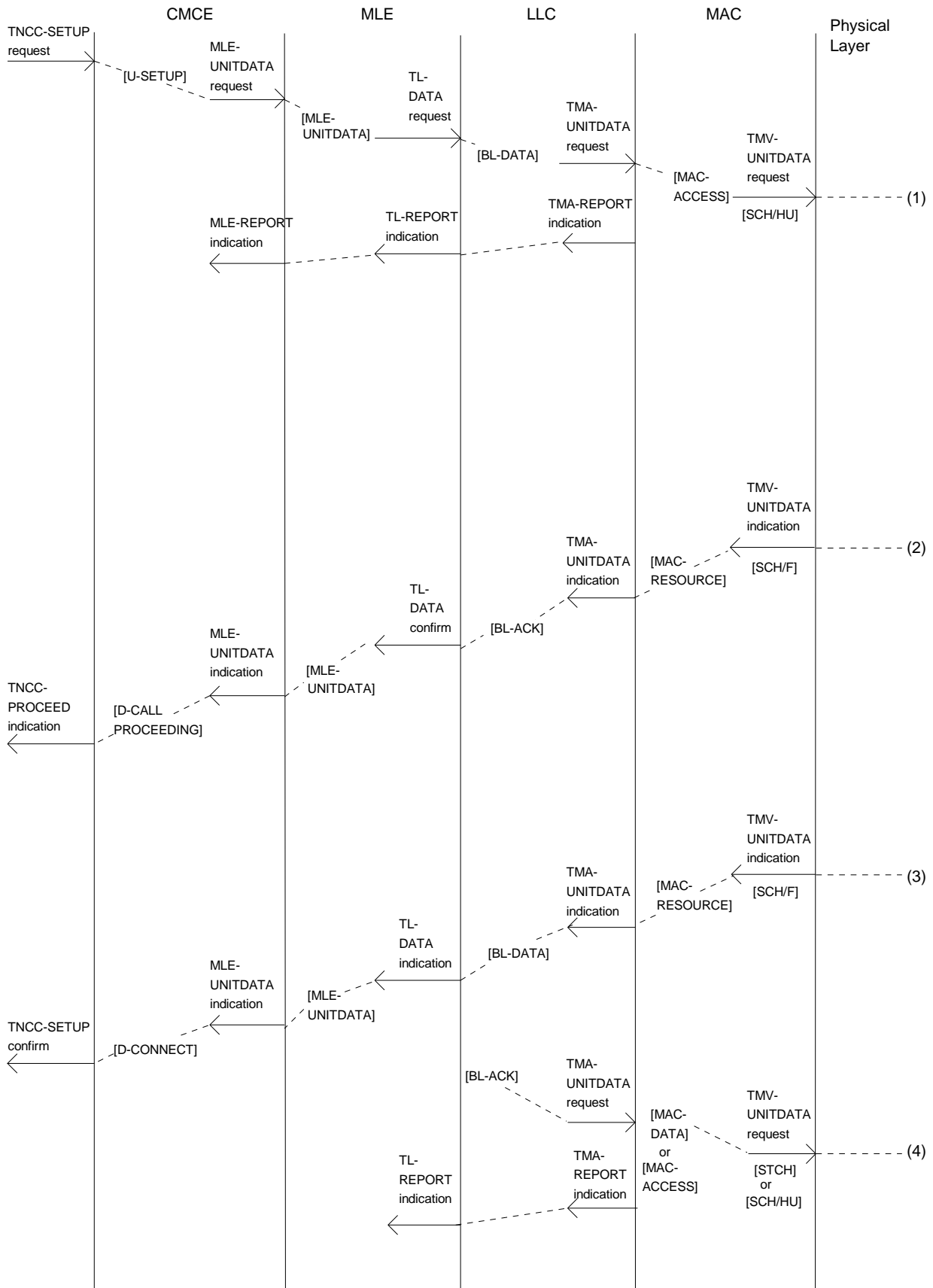

Figure 19.15: Primitives and PDUs on the calling MS air interface on a CA cell for an individual call with direct set-up signalling - Calling MS side

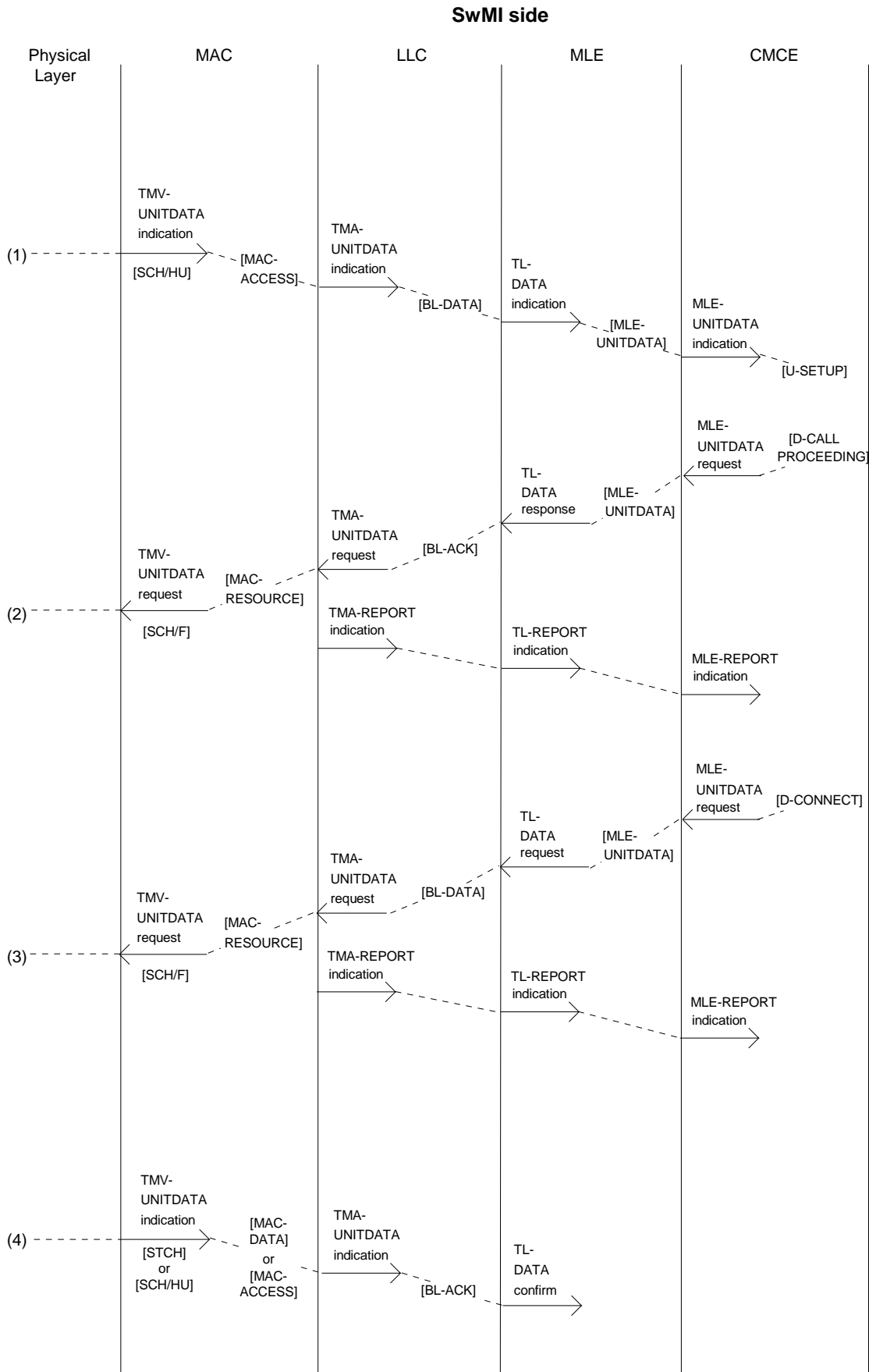

Figure 19.16: Primitives and PDUs on the calling MS air interface on a CA cell for an individual call with direct set-up signalling - SwMI side

SwMI Side

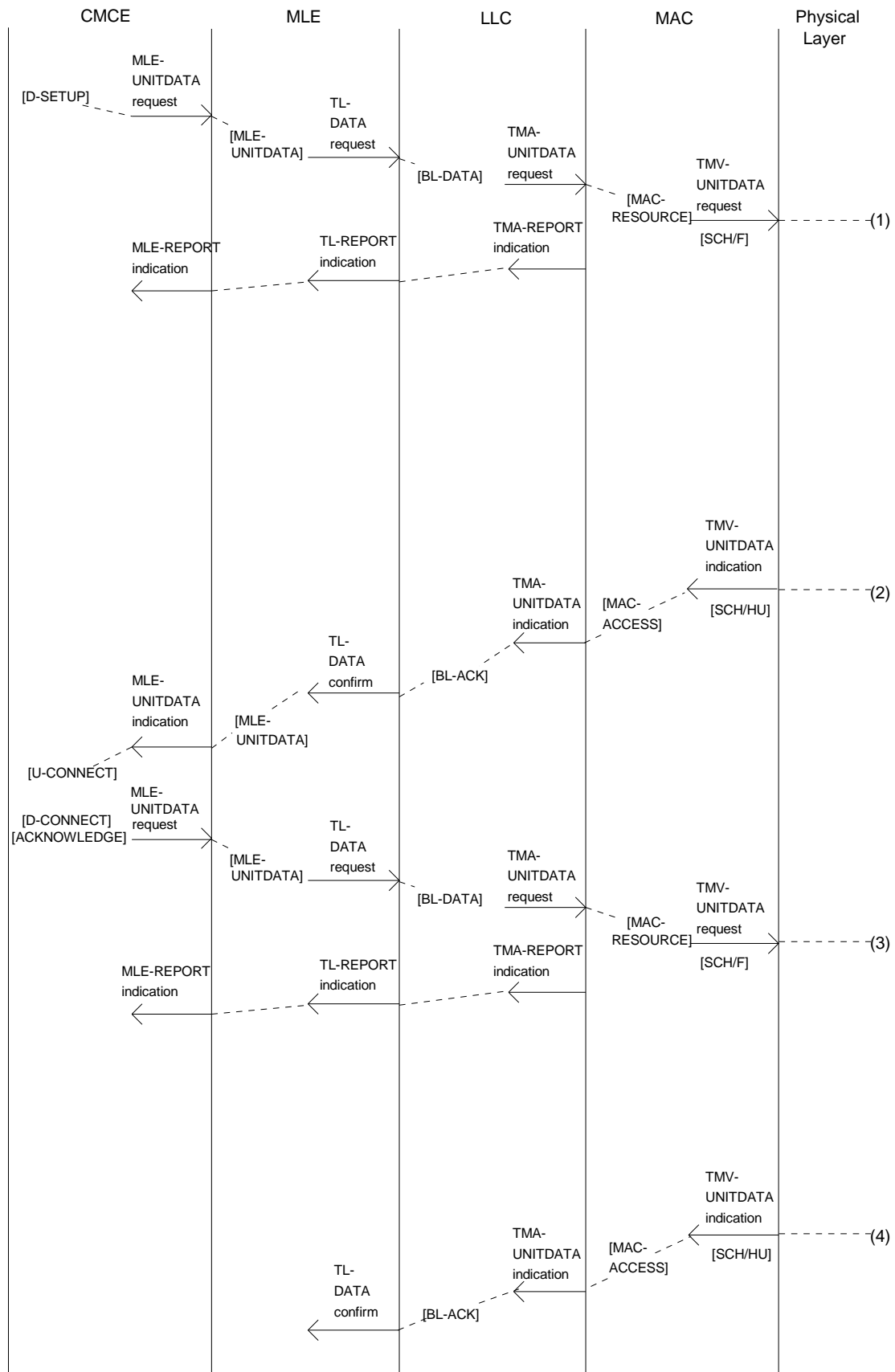

Figure 19.17: Primitives and PDUs on the called MS air interface on a CA cell for an individual call with direct set-up signalling - SwMI side

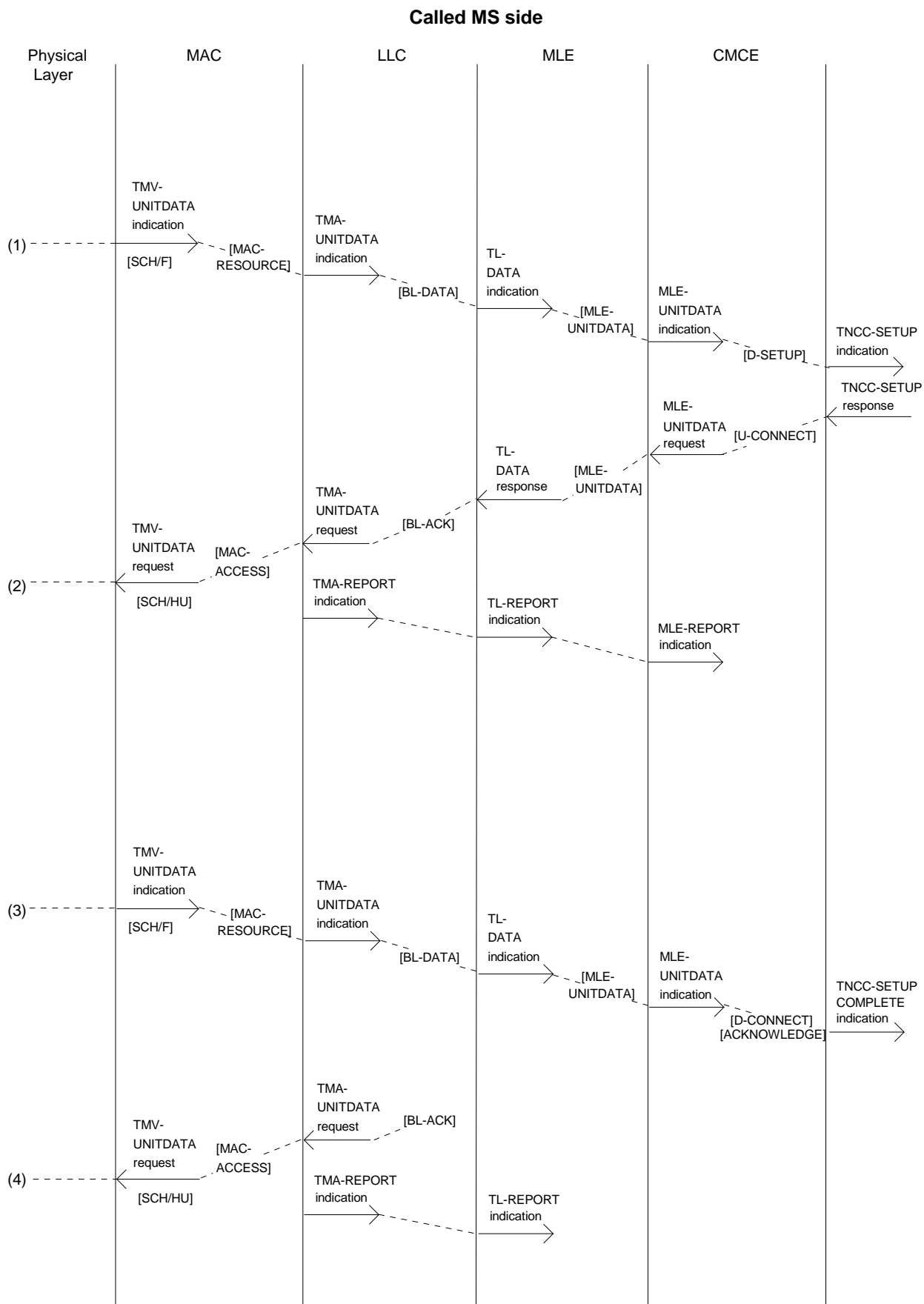

Figure 19.18: Primitives and PDUs on the called MS air interface on a CA cell for an individual call with direct set-up signalling - Called MS side

20 Layer 2 service description

20.1 Introduction

Clause 20 describes the services offered by layer 2 (see clauses 22 and 23) of the V+D TETRA air interface (see ETSI EN 300 392-1 [6], clause 6). The service description is done in terms of SAPs, primitives and their parameters. Throughout clause 20 the word "shall" is used with SAPs, service primitives and parameters for traceability reasons in the protocol model, but those SAPs and primitives are not testable. As this applies inside an MS at non-specified reference points (see ETSI EN 300 392-1 [6], clauses 4 and 5), the following description does not imply any specific implementation.

20.2 Layer 2 service description

20.2.1 LLC SAPs

The model of the DLL comprises two sub-layers: the LLC and the MAC. The layer architecture is presented in clause 19.

Layer 2 shall provide services to the MLE through three SAPs: TLA, TLB, TLC as shown in figure 20.1. These services are defined in terms of primitive actions and events of the service, parameters associated with each primitive action and event, interrelationship between primitives and the valid sequences of those actions following the ISO model ISO/IEC 8348 [i.7].

NOTE 1: The MLE layer is also called "service user" in the layer 2 descriptions.

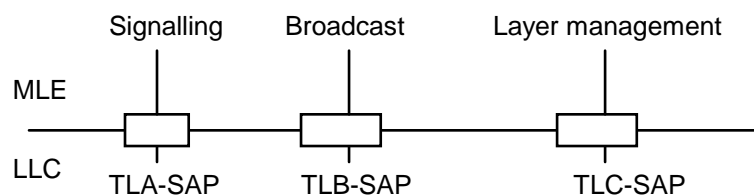

Figure 20.1: SAPs at the MLE-LLC boundary

The SAPs in this model are:

- TLA-SAP for signalling:
 - this SAP shall be used for data transfer and for control of the data transfer; the services are described in tables 20.8 and 20.9;
- TLB-SAP for broadcast:
 - this SAP shall be used for broadcasting purposes;
- TLC-SAP for layer management:
 - this SAP shall be used for the local control related to the cell selection/reselection in the MLE. In this model it is also used for local layer management inside one protocol stack. For example, it may be used for passing values (e.g. valid addresses, MNC, MCC) between the service user and the protocol layer 2.

NOTE 2: The peer-to-peer services provided by the TLA-SAP and the TLB-SAP correspond to services between one BS and one or several MSs. The services provided by the TLC-SAP correspond to the services within an MS.

In addition to these services to the MLE, the LLC may provide an additional SAP: the TLE-SAP. This is the layer 2 signalling SAP. The LLC offers layer 2 signalling services to the MAC through this SAP.

20.2.2 MAC SAPs

The MAC shall provide three SAPs to the LLC: TMA-SAP, TMB-SAP and TMC-SAP. Their role is the same as the corresponding TLA-SAP, TLB-SAP and TLC-SAP.

In addition to these, the MAC shall provide an additional SAP to the U-plane application: the TMD-SAP. The services offered at this SAP are illustrated in clause 19 and described in clause 23.

20.2.3 Generic primitive types

Four different types of primitives are used in this protocol model as defined in ISO/IEC 8348 [i.7] and further explained in ETSI ETS 300 125 [5]. TETRA specific explanations are shown below in the notes.

The REQUEST primitive type shall be used when a higher layer is requesting a service from the lower layer.

The INDICATION primitive type shall be used by a layer providing a service to notify the higher layer of any specific activity which is service related. The INDICATION primitive may be the result of an activity of the lower layer related to the primitive type REQUEST at the peer entity.

NOTE 1: Primitives at the TxC-SAP are not normally directly related to any data transfer service.

The RESPONSE primitive type shall be used by a layer to acknowledge receipt, from a lower layer, of the primitive type INDICATION.

NOTE 2: In TETRA, a RESPONSE primitive may be used with upper layer data in order to force transportation of acknowledgement and service user data (TL-SDU) in the same transmission. The TL-SDU will then be placed in the PDU containing the acknowledgement.

The CONFIRM primitive type shall be used by the layer providing the requested service to confirm that the activity has been completed.

NOTE 3: The CONFIRM primitive may be the result of an activity of the lower layer related to the primitive type RESPONSE at the peer entity and in that case it may contain service user data (TL-SDU).

20.2.3a Usage of primitives at the TLE-SAP

In TETRA, the TLE-SAP is an exceptional case where the LLC provides a service to a lower layer (i.e. the MAC). Two primitive types are used at this SAP.

The REQUEST primitive type shall be used when the MAC is requesting a service from the LLC.

The INDICATION primitive type shall be used by the LLC to notify the MAC of any specific activity which is service related. The INDICATION primitive may be the result of an activity of the LLC related to the primitive type REQUEST at the peer entity.

Additionally the CONFIRM primitive type may be used by the LLC to confirm that a requested activity has been completed.

20.2.4 Parameters definition for LLC and MAC service primitives

20.2.4.1 Address type

Address type shall be used by the service user to indicate to the MAC which address type will be used for transmission. It shall be used to distinguish between a user address (i.e. SSI), a management address (i.e. SMI) or an un-exchanged address (i.e. USSI).

20.2.4.2 Advanced link service

Advanced link service shall define which advanced link service is used:

- acknowledged; or
- unacknowledged.

20.2.4.3 Call release

This parameter shall indicate call release to the MS-MAC e.g. when a user within a group call wishes to leave that group call.

20.2.4.4 Channel number

The channel number parameter shall identify the frequency of the RF channel that the MS shall use for the requested service or that layer 2 has used for the indicated service.

20.2.4.5 Channel change accepted

The channel change accepted parameter shall be used by the higher layers to indicate whether the MAC should accept or not the channel allocation indicated by the "channel change handle" parameter, see clause 20.2.4.6.

20.2.4.6 Channel change handle

This parameter shall be a local identifier which acts as a reference to a particular channel allocation when the MAC requires an instruction about whether to accept that channel allocation (i.e. when the MAC sets the "channel change response required" parameter to "true"). Its implementation is outside the scope of the present document.

20.2.4.7 Channel change response required

This parameter shall be used for the MAC to indicate to the higher layers that a channel allocation command was received with a particular SDU and that the MAC requires an instruction about whether to accept the channel allocation. In this case the parameter shall be set to "true"; otherwise it shall be set to "false".

20.2.4.8 Channel class label

This parameter shall be a local identifier which acts as a reference to a particular channel class when the higher layers (i.e. MLE) request assessment of the path loss for that channel class. Its implementation is outside the scope of the present document.

NOTE: A channel class is defined as a set of values indicating the RF characteristics of a concentric channel or fully super-sectored channel.

20.2.4.9 Channel information

This parameter may be used for the MAC to provide information about a channel to the higher layers. For example, it may indicate the modulation mode and the bandwidth of the channel, and whether the channel is a conforming channel, non-conforming concentric channel, sectored channel, super-sectored channel or eccentric channel (or whether the MAC does not understand the conforming channel status of the channel).

NOTE: A conforming channel is a special case of a concentric channel. All sectored, super-sectored and eccentric channels are non-conforming channels.

This parameter may also be used to provide information to the MAC when the higher layers instruct the MAC to change channel (or when the higher layers provide information about the main carrier of a new cell). For example, it may indicate the modulation mode and the bandwidth of the channel.

20.2.4.10 Characteristics of channel class to be assessed

This parameter shall be used for the higher layers (i.e. MLE) to provide information to the MAC about a channel class that is to be assessed. It includes the following information:

- modulation mode for that channel class;
- maximum MS transmit power for that channel class;
- minimum RX access level for that channel class; and
- BS transmit power relative to main carrier (see note 1).

NOTE 1: For an assessment of a channel class on the serving cell, this refers to the BS transmit power for that channel class relative to the BS transmit power on the main carrier of the serving cell. For an assessment of a channel class on a neighbour cell, this refers to the BS transmit power for that channel class relative to the BS transmit power on the main carrier of that neighbour cell.

NOTE 2: Assessment of a channel class on the serving cell is performed by using measurements on the current channel or on the main carrier of the serving cell, together with the characteristics of the channel class to be assessed, to predict the path loss on channel(s) corresponding to that channel class. Assessment of a channel class on a neighbour cell is performed by using measurements on the main carrier of that neighbour cell, together with the characteristics of the channel class to be assessed, to predict the path loss on channel(s) corresponding to that channel class.

NOTE 3: The main carrier is a phase modulation carrier for a Conventional Access (CA) cell or a QAM carrier for a Direct Access (DA) cell.

20.2.4.10a Characteristics of RF channel to be cell-read

This parameter may be used for the higher layers (i.e. MLE) to provide information to the MAC about an RF channel on which the MAC is to read the SYSINFO-DA PDU. The RF channel is the main carrier of a DA neighbour cell. This parameter may include the following information:

- bandwidth of RF channel on which the MAC is to read the SYSINFO-DA PDU.

NOTE: The main carrier of the DA neighbour cell is a QAM carrier.

20.2.4.11 Characteristics of RF channel to be monitored

This parameter shall be used for the higher layers (i.e. MLE) to provide information to the MAC about an RF channel that is to be monitored. It may include the following information:

- modulation mode for RF channel to be monitored;
- bandwidth of RF channel to be monitored;
- maximum MS transmit power on RF channel to be monitored;
- minimum RX access level for RF channel to be monitored; and
- information about the discontinuous mode on the RF channel to be monitored.

It may also indicate whether the RF channel that is to be monitored is the main carrier of a neighbour cell, or an irregular carrier, or the main carrier of the serving cell.

NOTE: The main carrier is a phase modulation carrier for a CA cell or a QAM carrier for a DA cell.

20.2.4.11a Characteristics of RF channel to be scanned

This parameter shall be used for the higher layers (i.e. MLE) to provide information to the MAC about an RF channel that is to be scanned. The RF channel that is to be scanned is the main carrier of a neighbour cell. This parameter may include the following information:

- modulation mode for RF channel to be scanned;
- bandwidth of RF channel to be scanned.

NOTE: The main carrier of the neighbour cell is a phase modulation carrier for a CA neighbour cell or a QAM carrier for a DA neighbour cell.

20.2.4.12 CSS endpoint identifier

This parameter shall be an endpoint identifier which refers to a Carrier Specific Signalling (CSS) channel that has been allocated to the MS. Alternatively, it may refer to a common channel (MCCH or common SCCH) if a CA MS is allocated an assigned channel on the CA main carrier and is permitted to use the common channel.

20.2.4.13 Data category

This parameter may be used to indicate information about the type of data in the TM-SDU and the required reliability level for the transmission, enabling the MAC to make appropriate decisions about:

- the modulation to use to send the TM-SDU on a D8PSK channel; or
- the modulation level and coding rate to use to send the TM-SDU on a QAM channel.

This parameter is also used to indicate information about the data in the LLC sending buffer.

For example, this parameter may indicate whether the data is:

- background class data - reliability level 1; or
- background class data - reliability level 2; or
- background class data - reliability level 3; or
- telemetry class data - reliability level 1; or
- telemetry class data - reliability level 2; or
- telemetry class data - reliability level 3; or
- real-time class data; or
- non-classified data (i.e. TM-SDU does not contain packet data) - reliability level 1; or
- non-classified data (i.e. TM-SDU does not contain packet data) - reliability level 2; or
- non-classified data (i.e. TM-SDU does not contain packet data) - reliability level 3.

NOTE 1: In this example of possible data categories, it is intended that reliability level 3 refers to better (i.e. higher) reliability than reliability level 2, and reliability level 2 refers to better (i.e. higher) reliability than reliability level 1.

NOTE 2: In this example of possible data categories, three reliability levels are used for background class data, telemetry class data and non-classified data. In an implementation, fewer than three reliability levels could be used if preferred. For instance, if preferred, two reliability levels could be used for background class data and/or telemetry class data and/or non-classified data.

NOTE 3: In an implementation, the "non-classified data" may be subdivided into multiple classes.

20.2.4.14 Data class activity information

This parameter may be used for the higher layers to inform the MAC about the most demanding data class for currently active PDP contexts. It may indicate whether the most demanding data class is the background data class, the telemetry data class or the real-time data class (or no data class).

NOTE 1: The real-time data class is more demanding than the telemetry data class, and the telemetry data class is more demanding than the background data class.

NOTE 2: If the MS is using concurrent channels, the higher layers may provide data class activity information independently for each endpoint identifier i.e. specifying the most demanding data class for currently active PDP contexts using each endpoint identifier.

20.2.4.15 Data class information

This parameter may be used to indicate information about the type of data in the TL-SDU, enabling the DLL to make appropriate decisions about the modulation (and coding rate for QAM) to use to send the TL-SDU and any segment retransmissions on a D8PSK or QAM channel.

This parameter may indicate whether the data in the TL-SDU is:

- background class data; or
- telemetry class data; or
- real-time class data; or
- non-classified data (i.e. TL-SDU does not contain packet data).

NOTE: In an implementation, the "non-classified data" may be subdivided into multiple classes.

20.2.4.16 Data priority

The data priority parameter indicates the packet data priority. The data priority parameter may take one of eight defined values of data priority (0 to 7) or may contain the value "undefined".

NOTE: The data priority requirements for the data in the LLC's sending buffer may be used by the MAC to send the MS's current short-term data priority requirements for reserved access to the BS. Data priority may also be used in the LLC to define the sending order of TL-SDUs (together with the PDU priority).

20.2.4.17 Data priority random access delay factor

This parameter may be used for the higher layers to provide the MAC layer with the value of the data priority random access delay factor (in the range 0 to 7). The value of this parameter is sent by the SwMI to the MS at SND CP level, but is used by the MAC in its data priority procedures.

20.2.4.18 Distribution on the 18th frame

In the case of minimum mode, this parameter shall define on which timeslot the MS shall listen to the downlink on the frame 18. It may be received by the MS at subscription or at registration.

20.2.4.19 Dual watch energy economy group

This shall be one of the allowed dual watch energy economy duty cycles.

20.2.4.20 Dual watch startpoint

The dual watch startpoint shall be the absolute frame and multiframe number to which the MS shall listen (if practicable) before entering the duty cycle defined by the dual watch energy economy group.

20.2.4.21 Encryption, air interface

This parameter shall define whether the signalling message is to be encrypted (using air interface encryption) by the MAC before its transmission over the air interface. At the receiving side, it shall define whether the message has been encrypted for transmission over the air interface.

20.2.4.22 Endpoint identifier

This local identifier shall be used to distinguish between multiple concurrent MAC resources (i.e. MAC channels). It refers to which MAC resource may be used for that service. Its implementation is outside the scope of the present document.

NOTE: Refer to the handle to the request described in clause 20.2.4.31.

20.2.4.23 Energy economy group

This shall be one of the eight allowed energy economy duty cycles as defined in clause 23.

20.2.4.24 Energy economy startpoint

This shall be the absolute frame and multiframe number to which the MS shall listen before entering the duty cycle defined by the energy economy group.

20.2.4.25 FCS flag

The FCS flag shall be used to indicate to the LLC whether extended error protection shall be applied (for basic link and extended advanced link).

20.2.4.25a Graceful service degradation mode

This shall instruct LLC and MAC layers whether the SDU is eligible for graceful service degradation mode.

20.2.4.25b Graceful service degradation mode control

This shall instruct LLC and MAC layers on start and ending of the graceful service degradation mode and the repetition strategy of the messages during graceful service degradation mode.

20.2.4.26 Half slot condition

This shall indicate whether a half traffic slot was received successfully.

20.2.4.27 Half slot content

This shall define the U-plane information content that is to be carried (or was received) in a half slot in a circuit mode transmission.

20.2.4.28 Half slot importance

This shall define the importance of the U-plane information that is to be carried in the circuit. It may be defined according to table 20.1.

Table 20.1: Definition of half slot importance

Half slot importance	Meaning
0	No importance (could be used for discontinuous TX)
1	Low
2	Medium
3	High

20.2.4.29 Half slot position

This shall define the position of the U-plane information within the timeslot (i.e. first or second half slot).

20.2.4.30 Half slot synchronization

This shall be a local signal provided by the MS MAC to the U-plane application so that the first half slot and second half slot parameters correspond to the first and, respectively, second half slot of the timeslot. It is provided for the purpose of this description and does not imply any particular implementation. It requires that the application keeps synchronized to the half slot in the MAC transmission.

20.2.4.31 Handle to the request

This shall be a local identifier which acts as a reference to a specific service request (parent) and its children. Its implementation is outside the scope of the present document. It is considered that the handle to the request is unique over all link identifiers and endpoint identifiers and is independent of the link identifier and endpoint identifier. The handle to the request is also used on received data to link a potential acknowledgement to it.

20.2.4.32 Layer 2 data priority lifetime

This parameter may be used for the higher layers to provide the MAC layer with the value of the layer 2 data priority lifetime. The value of this timer is sent by the SwMI to the MS at SNDCP level, but is used by the MAC in its data priority procedures.

20.2.4.33 Layer 2 data priority signalling delay

This parameter may be used for the higher layers to provide the MAC layer with the value of the layer 2 data priority signalling delay. The value of this timer is sent by the SwMI to the MS at SNDCP level, but is used by the MAC in its data priority procedures.

20.2.4.34 Layer 2 signalling message

The layer 2 signalling message is the service user data message from the MAC layer to the LLC layer. It shall be the layer 2 signalling information in a layer 2 signalling PDU, including the layer 2 signalling subtype. It is considered here as a parameter of the service primitive.

20.2.4.35 Layer 2 signalling message length

The layer 2 signalling message length shall be the number of bits of the layer 2 signalling message.

20.2.4.36 Link identifier

This local identifier shall be used to distinguish between multiple concurrent service instances in the LLC. It indicates on which link the message shall be sent from the different basic and advanced links. Its implementation is outside the scope of the present document.

NOTE: Refer to the handle to the request described in clause 20.2.4.31.

20.2.4.37 Link performance information

This parameter may be used for the LLC to provide information to the MAC about current advanced link performance, in order to aid the MAC to make appropriate decisions about the modulation (and coding rate for QAM) to use to send TM-SDUs on a D8PSK or QAM channel for some data categories. For example, the LLC may provide information derived from the acknowledgement bit maps in received AL-ACK, AL-RNR, AL-X-ACK and AL-X-RNR PDUs. The method for derivation of this information is outside the scope of the present document.

20.2.4.38 LLC timer status

This parameter is used for the LLC to indicate to the MAC whether any of its timers that are measured in downlink signalling frames are currently running. The LLC timers that are measured in downlink signalling frames are timers T.251, T.252, T.261, T.263 and T.265; see annex A.

NOTE: The LLC timer status information may be used by the MAC in its napping procedures.

20.2.4.39 Lower layer resource availability

The lower layer resource availability shall indicate when MAC layer has lost physical resources identified by the endpoint identifier. It may be used when the physical resource is regained.

20.2.4.40 MAC broadcast information

This parameter shall indicate information in the MAC header of the SYSINFO, SYSINFO-Q, SYSINFO-DA or SYNC-DA PDU that is relevant to the higher layers.

EXAMPLE 1: Information in the SYSINFO, SYSINFO-Q and SYSINFO-DA PDU about support of data priority by the BS is used by the MAC in the MS but is also used by the SNDTCP.

EXAMPLE 2: Information about the Location Area (LA) is included in the MAC's SYNC-DA PDU (when the PDU is sent on the DA main carrier) but is used by the MLE in the MS.

20.2.4.41 Main address

The main address shall refer to the ASSI, ISSI, GSSI, SMI or USSI value as defined in ETSI EN 300 392-1 [6], clause 7. It shall consist of the MS source address for the uplink except for the low level group presence indication, for which the GSSI shall be used (refer to clause 23.5.2.3.2). It shall consist of the destination address for the downlink.

20.2.4.42 Maximum schedule interval

This parameter shall be used in the case of scheduled data to indicate the maximum valid schedule interval for this schedule. (This is the sum of the schedule repetition period and the schedule timing error negotiated for this schedule.)

20.2.4.43 MLE activity indicator

This parameter indicates whether any of the layer 3 entities or advanced links are currently active. Where the MS-MAC is capable of performing the energy economy or dual watch procedure, or the procedure for part-time reception on a multi-slot MCCH-Q, the MLE activity indicator shall be used by the MS-MAC in the management of these procedures.

20.2.4.44 MS default data priority

This parameter may indicate the MS default data priority that the higher layers have negotiated with the SwMI; in this case, the MS default data priority parameter takes one of eight defined values of data priority (0 to 7). Otherwise this parameter may contain the value "not applicable" to indicate that:

- the MS does not currently have an MS default data priority; or
- the SNDTCP is not in the READY state; or
- the current BS does not support data priority.

20.2.4.45 New endpoint identifier

This parameter shall be an endpoint identifier which refers to an additional resource allocation that has been given to the MS.

20.2.4.46 Number of $\pi/4$ -DQPSK timeslots

The number of $\pi/4$ -DQPSK timeslots shall be used to define the throughput of a circuit mode service (with the selected error protection). It may be used to define the maximum throughput of a packet mode service.

20.2.4.47 Number of repetitions of layer 2 signalling message

The number of repetitions of layer 2 signalling message may be used for the MAC to define the required number of repetitions. If it is not included, the LLC uses a predefined number.

20.2.4.48 Number of repetitions of TL-SDU

The number of repetitions of TL-SDU may be used for the higher layers to define the required number of repetitions of a TL-SDU on the unacknowledged basic link. If it is not included, the LLC uses a predefined number.

20.2.4.49 Operating mode

The operating mode shall be used for the higher layers (i.e. CMCE) to give instructions to the MS MAC to switch between signalling and traffic mode. It may comprise the following indications:

- switch U-plane on/off;
- TX-grant flag;
- simplex/duplex flag;
- type of circuit (i.e. TCH/S, TCH/7,2, TCH/4,8, TCH/2,4);
- interleaving depth N;
- end-to-end encryption flag;
- user device;
- endpoint identifier.

20.2.4.50 Packet data flag

This parameter shall indicate whether the TL-SDU contains packet data from the SNDCP or other signalling information. For example, it may be used by the LLC when it is deciding on the sending order of TL-SDUs.

20.2.4.51 Path loss

Related to the cell selection/reselection mechanism and the channel class / irregular channel advice and assigned channel replacement procedures, and based on measurements, the path loss consists of five variables (C1, C2, C3, C4 and C5) that may be calculated. Their definition and the formulas are in clause 23 together with the different procedures.

20.2.4.52 PDU priority

This priority field shall be used within the LLC and MAC local to one MS. It shall not be transported to the peer entity. It may be used in the LLC to define the sending order of TL-SDUs. It shall be used in the MAC as the priority in the random access protocol. The number of supported priority levels for random access control purposes shall be eight. PDU priority ordering in a queuing process is an optional feature. The random access procedure and PDU priorities are defined in clause 23.

20.2.4.53 Periodic reporting timer

The periodic reporting timer shall indicate the longest time between any transmissions from the MS to the BS, refer to clause 16.10.7b for definition of the values.

20.2.4.54 Quality indication

This quality indication may be used to indicate locally what the reception quality is.

20.2.4.55 Quality of Service (QoS)

The QoS parameters shall be used to facilitate the negotiation of the quality of service as defined in ETSI EN 300 392-1 [6]. The quality of service in this model is defined at the DLL as a set of TETRA specific parameters.

NOTE 1: Most of the parameters and selection of their values are either MS or network dependent.

NOTE 2: TETRA specific parameters may or may not control all aspects of each QoS parameter at the network layer SAP.

Parameter values for the throughput for constant delay services shall be as defined in table 20.2.

Table 20.2: Throughput for constant delay services

Parameter	Values	Remarks
Transmission rate	2 400 bit/s, 4 800 bit/s or 7 200 bit/s times the Number of $\pi/4$ -DQPSK timeslots	TMD-SAP (negotiable)

Parameter values for the throughput for variable delay services shall be as defined in table 20.3.

Table 20.3: Throughput for variable delay services

Parameter	Values	Remarks
Maximum transmission rate (optional at the DLL - see note)	Number of $\pi/4$ -DQPSK timeslots 1 to 4	AL-SETUP PDU (negotiable)
Mean transmission rate (optional at the DLL - see note)	See clause 21 for definition	AL-SETUP PDU (negotiable)
Maximum length of TL-SDU	N.251 for basic link	Predefined
	N.271 for advanced link	AL-SETUP PDU (negotiable)
Advanced link type	Original, extended	AL-SETUP PDU (negotiable)
TL-SDU window size	N.272	AL-SETUP PDU (negotiable)
NOTE: The maximum transmission rate and mean transmission rate may be negotiated in the AL-SETUP PDU, in terms of $\pi/4$ -DQPSK timeslots. Or the AL-SETUP PDU may indicate a request for any phase modulation channel (within the capabilities of that MS). Or, alternatively, the AL-SETUP PDU may provide no information related to radio resources (for example, if the MS wishes the BS to choose any appropriate channel (within the capabilities of that MS and using any QoS information negotiated by the SMDCP during PDP context activation)).		

The parameters for the residual error rate and residual error probability shall be as defined in table 20.4.

Table 20.4: Residual error rate

Parameter	Values	Remarks
The use of FCS	Included, not included	Local selection in the basic link services and the extended advanced link services

Parameters for the transfer failure probability shall be as defined in table 20.5.

Table 20.5: Transfer failure probability

Parameter	Values	Remarks
Maximum number of TL-SDU retransmissions	N.252 and N.253 for basic link	Predefined or, for N.253, optionally indicated by the service user for each TL-SDU
	N.273 and N.282 for advanced link	AL-SETUP PDU (negotiable)
	N.293 for layer 2 signalling	Predefined or indicated by the MAC for each layer 2 signalling message
Maximum number of segment retransmissions	N.274	AL-SETUP PDU (negotiable)

Parameters for the NC Release failure probability shall be as defined in table 20.6.

Table 20.6: NC Release failure probability

Parameter	Values	Remarks
Number of disconnection repeats	N.263	Predefined

20.2.4.56 Reconnection result

Reconnection result shall be used to indicate the result of the LLC advanced link reconnection. The values shall be:

- success;
- random access failure;
- reconnection failure;
- reject.

20.2.4.57 Report

Report shall generally indicate the progress or failure of information transfer and the cause of it.

The protocol model uses the report parameters in the protocol description at the A-SAP, C-SAP, D-SAP and E-SAP. The A-SAP, C-SAP and E-SAP reports (TLA-SAP, TLC-SAP, TLE-SAP, TMA-SAP and TMC-SAP) are defined in table 20.7.

Table 20.7: Reports at TMA-, TMC-, TLA-, TLC- and TLE-SAPs

Report	SAP
Aborted, SDU not completely sent	TMA, TLA, TLE
Aborted, SDU sent at least once	TMA, TLA, TLE
Channel replacement is advisable	TMC, TLC
Channel replacement may be beneficial	TMC, TLC
Close	TLA
Common channel deallocated	TMC, TLC
Complete transmission by stealing or by reserved access	TMA
Current channel performance is acceptable	TMC, TLC
Disconnection failure	TLA
Downlink failure	TMC, TLC
Failed transfer (e.g. maximum number of re-transmissions exceeded)	TLA, TLE
First complete transmission	TLA, TLE
First complete transmission by random access	TMA
Fragmentation failure	TMA

Report	SAP
Incoming disconnection	TLA
Layer two transmission activities continuing	TLA
Local disconnection	TLA
Maximum path delay exceeded	TMC, TLC
Maximum path delay almost exceeded (see note)	TMC, TLC
Network broadcast not received	TMC, TLC
Network broadcast received	TMC, TLC
Random access failure	TMA, TLA, TLE
Reject	TLA
Reset	TLA
Schedule timing prompt	TMC, TLC
Service change	TLA
Service definition	TLA
Service not supported	TLA
Service temporarily unavailable	TLA
Set-up failure	TLA
Successful complete transmission by random access	TMA, TLE
Success, successful transfer	TLA, TLE
Usage marker mismatch	TMC, TLC
Uplink failure	TMC, TLC
NOTE: The report "maximum path delay almost exceeded" is applicable only to an MS that supports the AGA service (see annex O).	

NOTE: The report parameter may be used to indicate a cause or a reason and possibly position of an error.

20.2.4.58 Scanning measurement method

This parameter shall specify which of the several methods of measurement the MAC shall use for the scanning process.

20.2.4.59 SCCH information

This parameter shall be used in the MAC to calculate which common control channel to use when common SCCHs are in operation. It may also be used by the MAC in a DA MS on a multi-slot MCCH-Q to derive the reception slot if the MS is using energy economy or dual watch mode on a BS that permits enhanced energy economy or if the MS is using the procedure for part-time reception on a multi-slot MCCH-Q.

This parameter may be received by the MS at subscription or at registration.

20.2.4.60 Scheduled data status

This parameter shall be used to indicate whether the TL-SDU should be treated as:

- not scheduled data; or
- initial scheduled data; or
- scheduled data.

NOTE: Within layer 2, a TL-SDU labelled as "initial scheduled data" is treated in the same way as "scheduled data" for the purposes of LLC ordering of TL-SDUs, but is treated in the same way as "not scheduled data" for the purposes of deciding when the MAC may use random access.

20.2.4.61 Schedule repetition information

This parameter shall be used for the higher layers (i.e. SNDCP) to instruct the MS MAC to start giving timing prompts at the specified intervals for the schedule corresponding to the specified NSAPI. It may also be used for the higher layers to instruct the MS MAC to stop giving timing prompts for the schedule corresponding to the specified NSAPI. It comprises the following subparameters:

- NSAPI;
- start-stop flag (start or stop);
- schedule repetition period (as a number of slot durations).

20.2.4.62 Scrambling code

This shall contain the Mobile Network Identity (MNI) as described in ETSI EN 300 392-1 [6], clause 7. It shall be given to the scrambling process in the lower MAC together with the colour code.

20.2.4.63 Set-up report

This shall be used to report set-up phase with the higher layer:

- success;
- service change (proposed parameters);
- parameters acceptable; and
- parameters not acceptable.

20.2.4.64 Stealing permission

This parameter shall define whether the MAC may use stealing to send this SDU. Within layer 2 it may have the following meanings:

- steal immediately;
- steal within time T.214;
- steal when convenient; or
- stealing not required.

The value "steal within time T.214" should be used for the reply to a BS message received while the MS is transmitting traffic.

20.2.4.65 Stealing repeats flag

This shall be used by the higher layers in the MS to trigger a special stealing method in the MAC (see clause 23). This method should only be used for signalling at the end of an uplink traffic transmission (e.g. for U-TX-CEASED or possibly U-DISCONNECT).

20.2.4.66 Stolen indication

This shall indicate whether or not the information content of a half slot is stolen for signalling purposes. At the transmitting side, this parameter may be used to force signalling mode in the MAC for either the first or both half slots within a timeslot to be transmitted. At the receiving side, this parameter shall be available to the U-plane application to enable correct handling of stolen information.

20.2.4.67 Subscriber class

A subscriber class shall define a population subdivision e.g. for random access control. The operator may define the values and meaning of each class. The subscriber class information is received by the MS at subscription or at registration. If the MS receives subscriber class information at subscription, and is then also assigned subscriber class information at registration, then the information given at registration shall be used.

The subscriber class parameter as supplied in primitives from layer 3 is a bit-mapped field which indicates for each class whether the MS belongs to that class.

20.2.4.68 Threshold level

Based on measurements as defined in clause 23, this shall be the calculated value of some global variable used in the MLE in the process of cell selection/reselection.

20.2.4.69 Threshold values

The values shall be thresholds imposed in the MAC by the MLE to take a relevant action (e.g. inform MLE using suitable primitive) if some measured and/or calculated MAC parameters exceed these limits.

20.2.4.70 TL-SDU

The TL-SDU is the service user data message from the MLE layer. It shall be the MLE PDU including the MLE header. It is considered here as a parameter of the service primitive.

20.2.4.71 TL-SDU length

The TL-SDU length shall be the number of bits of the TL-SDU.

20.2.4.72 TM-SDU

The TM-SDU is the service user data message from the LLC. It shall be the LLC PDU including the LLC header and optional FCS. It is considered here as a parameter of the service primitive.

20.2.4.73 TM-SDU length

The TM-SDU length shall be the number of bits of the TM-SDU.

20.2.4.74 User device

This parameter may indicate to which U-plane device the primitive is intended. The usage of user devices is outside the scope of the present document.

20.2.4.75 Valid addresses

Valid addresses are the addresses that the MS MAC shall recognize as the ones attached to the MS.

20.3 Services provided by LLC

20.3.1 Services at the TLA-SAP

The SAP may provide one or more logical channels marked by link identifiers. The service user shall select the wanted service by using a service request primitive with a link identifier as a parameter. The direction of the information flow can be from BS to MS, from MS to BS or both; it can also be local control information inside the MS or BS.

The TLA-SAP shall be used for addressed signalling and data transfer. Table 20.8 shows the relationship for one LLC instance. There shall be an individual instance of LLC for each valid address.

Table 20.8: Services provided at the TLA-SAP

Service description for TLA-SAP	Address	Direction of the information flow
Point-to-point acknowledged	individual SSI	Bi-directional
Point-to-point unacknowledged	individual SSI	Bi-directional
Point-to-multipoint unacknowledged	group SSI (GSSI)	Downlink
Point-to-multipoint with presence indication	group SSI (GSSI)	Bi-directional

NOTE: In the present document only the BS may initiate the presence indication service.

Under the TLA-SAP, the LLC shall use the TMA-SAP for transferring the information down to the MAC.

The LLC may offer basic link (connectionless mode) service and advanced link (connection orientated mode) service. Within each of these services both an acknowledged and an unacknowledged data transfer is defined in the protocol. These possibilities and normal usage are shown in table 20.9.

Table 20.9: Data transfer relationships available in the LLC

Service offered	Acknowledged data transfer	Unacknowledged data transfer
Basic link	Point-to-point signalling message or data transfer (short messages uplink and downlink)	Point-to-point signalling or data transfer (short messages uplink and downlink); and broadcast or point-to-multipoint signalling message or data transfer (short messages downlink)
Advanced link	Point-to-point signalling or data transfer (long messages uplink and downlink)	Point-to-multipoint signalling or data transfer (long messages downlink)

Downlink transmissions addressed to an individual MS, in most cases, use the acknowledged service. Uplink transmissions with a valid address, in most cases, use acknowledged transfer. However, the unacknowledged basic link may be used for some types of point-to-point signalling or data transfer on the request of the service user.

EXAMPLE: The SNDCP uses the unacknowledged basic link service for sending point-to-point real-time class data on both uplink and downlink.

Normal information transfer addressed to a group of MSs shall use unacknowledged transfer on the downlink. In the case of presence indication request the BS shall use a kind of acknowledged data transfer, with reserved access for the acknowledgement, knowing that if there are multiple responses from the MSs in the group, there is a risk of collision that will make the responses un-decodeable. If the message can be decoded, the BS will know that there was at least one responding MS. If the message cannot be decoded, the BS may assume presence of MSs from the measured RSSI on the uplink. How this measurement is done is outside the scope of the present document.

The advanced link acknowledged mode may be used in all cases where an acknowledged service is required for a point-to-point data transfer. The advanced link may also be used for point-to-multipoint data transfer in unacknowledged mode. In this case data transfer normally consists of set-up phase, data transfer phase possibly with repetition and selective re-assembly of received data and disconnection phase.

20.3.2 Services at the TLB-SAP

The TLB-SAP shall be used for un-addressed data transfer as presented in table 20.10. This includes the system information broadcast messages. In the protocol model there are no LLC functions under the TLB-SAP, and the LLC shall convey information directly to the MAC using the TMB-SAP.

Table 20.10: Services provided at the TLB-SAP

Service description for TLB-SAP	Address	Direction
Point-to-multipoint unacknowledged	none	Downlink

20.3.3 Services at the TLC-SAP

The TLC-SAP shall be used in this model for all local layer management control, such as scanning control and signal quality measurements (see table 20.11). TLC-SAP does not provide any data transfer service over the air interface.

Table 20.11: Services provided at the TLC-SAP

Service description for TLC-SAP	Address	Direction
Local management and control	None	Bi-directional within the MS protocol stack

20.3.3a Services at the TLE-SAP

The TLE-SAP shall be used for layer 2 signalling, for which the LLC may offer an unacknowledged data transfer service to the MAC (see table 20.12).

Table 20.12: Services provided at the TLE-SAP

Service description for TLE-SAP	Address	Direction of the information flow
Point-to-point unacknowledged	individual SSI	Bi-directional
Point-to-multipoint unacknowledged	group SSI (GSSI)	Downlink

20.3.4 LLC service primitives

Tables 20.13 to 20.16 summarize LLC service primitives. If the service primitive is provided or not provided in both the basic and advanced links, then yes and no are used respectively. In other cases the LLC link type is mentioned.

Table 20.13: TLA-SAP service primitives

Service primitive	Request	Indication	Response	Confirm
TL-CANCEL	yes	no	no	no
TL-CONNECT	advanced link	advanced link	advanced link	advanced link
TL-DATA	yes	yes	basic link	yes
TL-DISCONNECT	advanced link	advanced link	no	advanced link
TL-RECEIVE	no	advanced link	no	no
TL-RELEASE	advanced link	yes	no	no
TL-RECONNECT	advanced link	no	no	advanced link
TL-REPORT	no	yes	no	no
TL-UNITDATA	yes	yes	no	optional

NOTE: TL-RECEIVE primitive is valid for the BS only.

Table 20.14: TLB-SAP service primitives

Service primitive	Request	Indication	Response	Confirm
TL-SYNC	yes, BS	yes, MS	no	no
TL-SYSINFO	yes, BS	yes, MS	no	no
TL-SYSINFO-Q	yes, BS	yes, MS	no	no
TL-SYNC-DA	yes, BS	yes, MS	no	no
TL-SYSINFO-DA	yes, BS	yes, MS	no	no

Table 20.15: TLC-SAP service primitives

Service primitive	Request	Indication	Response	Confirm
TL-ASSESSMENT	no	yes	no	no
TL-ASSESSMENT-LIST	yes	no	no	no
TL-CELL-READ	yes	no	no	yes
TL-CONFIGURE	yes	yes	no	yes
TL-MEASUREMENT	no	yes	no	no
TL-MONITOR	no	yes	no	no
TL-MONITOR-LIST	yes	no	no	no
TL-REPORT	no	yes	no	no
TL-SCAN	yes	no	no	yes
TL-SCAN-REPORT	no	yes	no	no
TL-SELECT	yes	yes	yes	yes

Table 20.16: TLE-SAP service primitives

Service primitive	Request	Indication	Response	Confirm
TLE-CANCEL	yes	no	no	no
TLE-REPORT	no	yes	no	no
TLE-UNITDATA	yes	yes	no	optional

20.3.5 Service primitive descriptions

20.3.5.0 General

In tables 20.17 to 20.46 inclusive, which define parameters for the primitives, the following keys are used:

M: Mandatory;

C: Conditional;

-: Not used.

NOTE: The exact conditions of the presence for some conditional parameters are implied by the corresponding information flows and are not detailed in the service descriptions.

20.3.5.1 Primitives at the TLA-SAP (MLE-LLC)

20.3.5.1.1 TL-CANCEL primitive

TL-CANCEL request: this primitive may be used locally for an MS or BS to cancel a previous request. This primitive shall not send messages over the air interface. The parameters shall be as defined in table 20.17.

Table 20.17: Parameters used in the TL-CANCEL primitive

Parameter	Request
Handle to the request (see note)	M
NOTE: Not sent over the air interface.	

20.3.5.1.2 TL-CONNECT primitive

The connection primitives, if required prior to a transfer, shall be used to establish a LLC advanced link. The parameters shall be as defined in table 20.18.

TL-CONNECT request: this primitive shall be used by the layer 2 service user to initiate the establishment of an advanced link with a certain quality of service. It may also reset the established link.

TL-CONNECT indication: this primitive shall be used by the layer 2 to inform the layer 2 service users that the establishment of an advanced link with a certain quality of service or the reset of the current advanced link has been requested.

TL-CONNECT response: this primitive shall be used by the layer 2 service users to accept the establishment or the reset of the advanced link with a certain quality of service. According to the available resources, the value of the service parameters may also be modified (lower grade of service) in the response. In such a case, the advanced link characteristics will match these new features.

TL-CONNECT confirm: this primitive shall be used by the layer 2 to inform the layer 2 service users that the establishment or re-establishment (reset) of the advanced link has been completed with a certain quality of service as indicated in the request primitive.

Table 20.18: Parameters used in the TL-CONNECT primitive

Parameter	Request	Indication	Response	Confirm
Address type	M	M	M	M
Main address	M	M	M	M
Scrambling code (see note)	M	M	M	M
Link identifier (see note)	M	M	M	M
Endpoint identifier (see note)	M	M	M	M
New endpoint identifier (see note)	-	C	-	C
CSS endpoint identifier (see note)	-	C	-	C
PDU priority (see note)	M	-	M	-
Stealing permission (see note)	M	-	M	-
Subscriber class (see note)	M	-	M	-
Quality of Service	M	M	M	M
Advanced link service	M	M	M	M
Encryption, air interface	M	M	M	M
Channel change response required (see note)	-	M	-	M
Channel change handle (see note)	-	C	-	C
Channel information	-	C	-	C
Handle to the request (see note)	M	M	M	M
Set-up report	M	M	M	M
NOTE: Not sent over the air interface.				

NOTE: The usage of the advanced link service type indication in confirm primitive applies only to the BS side of the protocol.

20.3.5.1.3 TL-DATA primitive for the advanced link

Parameters in acknowledged advanced link service for the following primitives shall be as defined in table 20.19.

TL-DATA request: this primitive shall be used by the layer 2 service user to request transmission of a TL-SDU.

TL-DATA indication: this primitive shall be used by the layer 2 to deliver the received TL-SDU to the layer 2 service user.

TL-DATA confirm: this primitive shall be used by the layer 2 to inform the layer 2 service user that it has completed successfully the transmission of the requested TL-SDU.

Table 20.19: Parameters used in the TL-DATA primitive for advanced link

Parameter	Request	Indication	Confirm
Address type	M	M	M
Main address	M	M	M
Link identifier (see note 1)	M	M	M
Endpoint identifier (see note 1)	M	M	M
New endpoint identifier (see note 1)	-	C	C
CSS endpoint identifier (see note 1)	-	C	C
TL-SDU	M	C	-
TL-SDU length (see note 1)	M	C	-
Scrambling code	M	M	M
PDU priority (see note 1)	M	-	-
Stealing permission (see note 1)	M	-	-
Subscriber class (see note 1)	M	-	-
FCS flag	C	C	C
Encryption, air interface	M	M	M
Data priority (see note 2)	M	-	-
Packet data flag (see note 1)	M	-	-
Scheduled data status (see note 1)	M	-	-
Maximum schedule interval (see note 1)	C	-	-
Data class information (see note 1)	C	-	-
Channel change response required (see note 1)	-	M	M
Channel change handle (see note 1)	-	C	C
Channel information	-	C	C
Handle to the request (see note 1)	M	-	M
Report	-	-	M
Graceful service degradation mode (see note 1)	C	-	-
NOTE 1: Not sent over the air interface.			
NOTE 2: May be signalled over the air interface, collated with other data priority information.			

20.3.5.1.4 TL-DATA primitive for the basic link

In the acknowledged basic link data transfer service the parameters for the following primitives shall be as defined in table 20.20.

TL-DATA request: this primitive shall be used by the layer 2 service user to request transmission of a TL-SDU. The TL-SDU will be acknowledged by the peer entity.

TL-DATA indication: this primitive shall be used by the layer 2 to deliver the received TL-SDU to the layer 2 service user.

TL-DATA response: this primitive shall be used by the layer 2 service user to respond to the previous TL-DATA indication primitive. The TL-DATA response primitive may contain a TL-SDU. That TL-SDU will be sent without an explicit acknowledgement from the peer entity.

TL-DATA confirm: this primitive shall be used by the layer 2 to inform the layer 2 service user that it has completed successfully the transmission of the requested TL-SDU. Depending on the availability of the response primitive at the peer entity before transmission of the acknowledgement, the confirm primitive may or may not carry a TL-SDU.

Table 20.20: Parameters used in the TL-DATA primitive for basic link

Parameter	Request	Indication	Response	Confirm
Address type	M	M	M	M
Main address	M	M	M	M
Link identifier (see note)	M	M	M	M
Endpoint identifier (see note)	M	M	M	M
New endpoint identifier (see note)	-	C	-	C
CSS endpoint identifier (see note)	-	C	-	C
TL-SDU	M	C	M	C
TL-SDU length (see note)	M	C	M	C
Scrambling code	M	M	M	M
PDU priority (see note)	M	-	M	-
Stealing permission (see note)	M	-	M	-
Subscriber class (see note)	M	-	M	-
FCS flag	M	M	M	M
Encryption, air interface	M	M	M	M
Stealing repeats flag (see note)	C	-	C	-
Data class information (see note)	C	-	C	-
Channel change response required (see note)	-	M	-	M
Channel change handle (see note)	-	C	-	C
Channel information	-	C	-	C
Handle to the request (see note)	M	M	M	M
Report	-	-	-	M
Graceful service degradation mode (see note)	C	-	-	-

NOTE: Not sent over the air interface.

20.3.5.1.5 TL-DISCONNECT primitive

The disconnection primitives shall be used to disconnect a LLC advanced link. The parameters shall be as defined in table 20.21.

Table 20.21: Parameters used in the TL-DISCONNECT primitive

Parameter	Request	Indication	Confirm
Address type	M	M	M
Main address	M	M	M
Link identifier (see note)	M	M	M
Endpoint identifier (see note)	M	M	M
New endpoint identifier (see note)	-	C	C
CSS endpoint identifier (see note)	-	C	C
Scrambling code	M	M	M
PDU priority (see note)	M	-	-
Stealing permission (see note)	M	-	-
Subscriber class (see note)	M	-	-
Advanced link service	M	M	M
Encryption, air interface	M	M	M
Channel change response required (see note)	-	M	M
Channel change handle (see note)	-	C	C
Channel information	-	C	C
Handle to the request (see note)	M	-	M
Report	M	M	M

NOTE: Not sent over the air interface.

NOTE 1: The only valid value for the report field in TL-DISCONNECT request primitive is "Close".

NOTE 2: The usage of the advanced link service type indication in confirm primitive applies only to the BS side of the protocol.

20.3.5.1.5a TL-RECEIVE primitive

TL-RECEIVE indication: this primitive shall be used by the layer 2 to report to the layer 2 service user that the reception of a TL-SDU has started or is ongoing on the layer 2. This primitive is valid for the BS only.

Parameters for this primitive shall be as defined in table 20.22.

Table 20.22: Parameters used in the TL-RECEIVE primitive (TLA-SAP)

Parameter	Indication
Address type	M
Main address	M
Endpoint identifier (see note)	M
NOTE: Not sent over the air interface.	

20.3.5.1.6 TL-RECONNECT primitive

The reconnection primitives shall be used for LLC reconnection of an advanced link after a cell reselection. The parameters shall be as defined in table 20.23.

TL-RECONNECT request: this primitive shall be used by the layer 2 service user in the MS after a cell reselection to initiate the LLC reconnection of an advanced link which was being used in the previous cell. If successful, all parameters agreed for the advanced link in the previous cell shall apply in the new cell.

TL-RECONNECT confirm: this primitive shall be used by the LLC to inform the layer 2 service user that the attempt to reconnect the advanced link has been successfully completed. A successful reconnection shall result in no change to the parameters which were agreed during the establishment of the advanced link in question.

Table 20.23: Parameters used in the TL-RECONNECT primitive

Parameter	Request	Confirm
Address type	M	M
Main address	M	M
Link identifier (see note)	M	M
Endpoint identifier (see note)	M	M
New endpoint identifier (see note)	-	C
CSS endpoint identifier (see note)	-	C
Scrambling code	M	M
PDU priority (see note)	M	-
Stealing permission (see note)	M	-
Subscriber class (see note)	M	-
Encryption, air interface	M	M
Handle to the request (see note)	M	M
Reconnection result	-	M
NOTE: Not sent over the air interface.		

20.3.5.1.7 TL-RELEASE primitive

TL-RELEASE: this primitive shall be used to disconnect locally an LLC advanced link, when a disconnection is recognized by the service user and LLC might no longer perform a disconnection with the peer entity.

It may also be used when the MAC has indicated that the connection on this channel has been lost.

The parameters in this primitive shall be as defined in table 20.24.

Table 20.24: Parameters used in the TL-RELEASE primitive

Parameter	Request	Indication
Address type (see note)	M	M
Main address (see note)	M	M
Link identifier (see note)	M	C
Endpoint identifier (see note)	-	M
NOTE: Not sent over the air interface.		

20.3.5.1.8 TL-REPORT primitive (TLA-SAP)

TL-REPORT indication: this primitive shall be used by the layer 2 to report to the layer 2 service user the progress or failure of a request procedure. The progress indication shall be passed as the "Report" parameter. This primitive may be issued to the layer 2 service user as an indication that an unrecoverable error has occurred.

This primitive is also used to indicate that the MAC has received a channel change command without an SDU and cannot decide whether it should obey the request or not as the change will affect other concurrent services.

Parameters for this primitive shall be as defined in table 20.25.

NOTE: The completion of the requested service is indicated by the same primitive name with the type confirm.

Table 20.25: Parameters used in the TL-REPORT primitive (TLA-SAP)

Parameter	Indication
Handle to the request (see note 1)	C (see note 2)
Report (see note 1)	M
Channel change response required (see note 1)	C (see note 3)
Channel change handle (see note 1)	C (see note 3)
Channel information	C
Endpoint identifier (see note 1)	C (see note 3)
NOTE 1: Not sent over the air interface.	
NOTE 2: Mandatory when data transmission is reported.	
NOTE 3: Mandatory when a channel change is reported.	

20.3.5.1.9 TL-UNITDATA primitive

In the unacknowledged data transfer service the parameters for the following primitives shall be as defined in table 20.26 for the basic link and as defined in table 20.27 for the advanced link.

TL-UNITDATA request: this primitive shall be used by the layer 2 service user to request layer 2 to transmit a TL-SDU.

TL-UNITDATA indication: this primitive shall be used to deliver the received TL-SDU to the layer 2 service user.

TL-UNITDATA confirm: this primitive may be used to indicate completion of sending of the requested TL-SDU.

Table 20.26: Parameters used in the TL-UNITDATA primitive in basic link

Parameter	Request	Indication	Confirm (see note 2)
Address type	M	M	M
Main address	M	M	M
Link identifier (see note 1)	M	M	M
Endpoint identifier (see note 1)	M	M	M
New endpoint identifier (see note 1)	-	C	-
CSS endpoint identifier (see note 1)	-	C	-
TL-SDU	M	C	-
TL-SDU length (see note 1)	M	C	-
Scrambling code	M	M	-
PDU priority (see note 1)	M	-	-
Stealing permission (see note 1)	M	-	-
Subscriber class (see note 1)	M	-	-
FCS flag	M	M	-
Encryption, air interface	M	M	-
Data priority (see note 3)	M	-	-
Packet data flag (see note 1)	M	-	-
Number of repetitions of TL-SDU (see note 1)	C	-	-
Scheduled data status (see note 1)	M	-	-
Maximum schedule interval (see note 1)	C	-	-
Data class information (see note 1)	C	-	-
Channel change response required (see note 1)	-	M	-
Channel change handle (see note 1)	-	C	-
Channel information	-	C	-
Handle to the request (see note 1)	M	-	M
Report	-	C	C
NOTE 1: Not sent over the air interface.			
NOTE 2: In this case, the confirm is a local knowledge of the sending entity.			
NOTE 3: May be signalled over the air interface, collated with other data priority information.			

Table 20.27: Parameters used in the TL-UNITDATA primitive in advanced link

Parameter	Request	Indication	Confirm (see note 2)
Address type	M	M	M
Main address	M	M	M
Link identifier (see note 1)	M	M	M
Endpoint identifier (see note 1)	M	M	M
New endpoint identifier (see note 1)	-	C	-
CSS endpoint identifier (see note 1)	-	C	-
TL-SDU	M	M	-
TL-SDU length (see note 1)	M	M	-
Scrambling code	M	M	-
PDU priority (see note 1)	M	-	-
Stealing permission (see note 1)	M	-	-
Subscriber class (see note 1)	M	-	-
FCS flag	C	C	-
Encryption, air interface	M	M	-
Data class information (see note 1)	C	-	-
Channel change response required (see note 1)	-	M	-
Channel change handle (see note 1)	-	C	-
Channel information	-	C	-
Handle to the request (see note 1)	M	-	M
Report	-	C	C
NOTE 1: Not sent over the air interface.			
NOTE 2: In this case, the confirm is a local knowledge of the sending entity.			

20.3.5.2 Signals at the TLA-SAP (MLE-LLC)

The TLA-SAP signals (FLOW-READY signal and FLOW-NOT-READY signal) are used in the protocol description of the MS's message-buffering interface between the LLC service user (MLE) and LLC. As this is purely local to an MS, the following description is provided for information only.

The **FLOW-READY signal** shall be used by the LLC service user in the MS to indicate to the LLC when it is capable of receiving more user data TL-SDUs in TL-DATA indication primitives.

The **FLOW-NOT-READY signal** shall be used by the LLC service user in the MS to indicate to the LLC when it is not capable of receiving more user data TL-SDUs in TL-DATA indication primitives.

NOTE: The validity time of one FLOW-NOT-READY signal at the LLC is limited by T.271 and T.272 in the data sending and data receiving entities respectively.

The parameters in the flow control signal shall be:

- address type;
- main address; and
- link identifier.

The link identifier will not be sent over the air.

20.3.5.3 Primitives at the TLB-SAP (MLE-LLC)

20.3.5.3.0 General

In the present document the LLC layer does not have any TMB-SAP related functions. The request primitives at the TLB-SAP are directly mapped as request primitives at the TMB-SAP, and the indication primitives at the TMB-SAP are directly transported to TLB-SAP indication primitives.

20.3.5.3.1 TL-SYNC primitive

TL-SYNC request: this primitive shall be used in the BS to broadcast synchronization information on $\pi/4$ -DQPSK and D8PSK channels.

TL-SYNC indication: this primitive shall be used in the MS to transport the received TM-SDU part of the synchronization information via LLC to MLE.

The BS MAC will broadcast the information at suitable intervals. Every new request primitive may change the content of the broadcast information. The parameters shall be as defined in table 20.28.

Table 20.28: Parameters used in the TL-SYNC primitive

Parameter	Request	Indication
Endpoint identifier	M	M
TL-SDU	M	M
TL-SDU length	M	M
Priority (not sent over the air interface)	M	-

20.3.5.3.2 TL-SYSINFO primitive

TL-SYSINFO request: this primitive shall be used in the BS to broadcast system related information (needed, for example, in the process of CA cell selection) on $\pi/4$ -DQPSK and D8PSK channels.

TL-SYSINFO indication: this primitive shall be used in the MS to transport the received TM-SDU via LLC to MLE.

The BS MAC will broadcast the information at suitable intervals. Every new request primitive may change the content of the broadcast information. The parameters shall be as defined in table 20.29.

Table 20.29: Parameters used in the TL-SYSINFO primitive

Parameter	Request	Indication
Endpoint identifier	M	M
TL-SDU	M	M
TL-SDU length	M	M
MAC broadcast information	C	C
Priority (not sent over the air interface)	M	-

20.3.5.3.3 TL-SYSINFO-Q primitive

TL-SYSINFO-Q request: this primitive may be used in the BS to broadcast system related information to CA MSs on QAM channels.

TL-SYSINFO-Q indication: this primitive shall be used in CA MSs to transport the received TM-SDU via LLC to MLE.

The BS MAC will broadcast the information at suitable intervals. Every new request primitive may change the content of the broadcast information. The parameters shall be as defined in table 20.30.

Table 20.30: Parameters used in the TL-SYSINFO-Q primitive

Parameter	Request	Indication
Endpoint identifier	M	M
TL-SDU	M	M
TL-SDU length	M	M
MAC broadcast information	C	C
Priority (not sent over the air interface)	M	-

20.3.5.3.4 TL-SYNC-DA primitive

TL-SYNC-DA request: this primitive shall be used in the BS to broadcast synchronization information needed for MSs to operate using DA. This synchronization information shall be sent on the DA main carrier and may be sent on other QAM carriers.

TL-SYNC-DA indication: this primitive shall be used in the MS to transport the received TM-SDU part of the synchronization information via LLC to MLE.

The BS MAC will broadcast the information at suitable intervals. Every new request primitive may change the content of the broadcast information. The parameters shall be as defined in table 20.31.

Table 20.31: Parameters used in the TL-SYNC-DA primitive

Parameter	Request	Indication
Endpoint identifier	M	M
TL-SDU	M	M
TL-SDU length	M	M
MAC broadcast information	C	C
Priority (not sent over the air interface)	M	-

20.3.5.3.5 TL-SYSINFO-DA primitive

TL-SYSINFO-DA request: this primitive shall be used in the BS to broadcast system related information needed for MSs to operate using DA. This system related information shall be sent on the DA main carrier and may be sent on other carriers.

TL-SYSINFO-DA indication: this primitive shall be used in the MS to transport the received TM-SDU via LLC to MLE.

The BS MAC will broadcast the information at suitable intervals. Every new request primitive may change the content of the broadcast information. The parameters shall be as defined in table 20.32.

Table 20.32: Parameters used in the TL-SYSINFO-DA primitive

Parameter	Request	Indication
Endpoint identifier	M	M
TL-SDU	M	M
TL-SDU length	M	M
MAC broadcast information	C	C
Priority (not sent over the air interface)	M	-

20.3.5.4 Primitives at the TLC-SAP (MLE-LLC)

20.3.5.4.0 General

In the present document the LLC layer does not have any TLC-SAP related functions. The request and response primitives at the TLC-SAP are directly mapped as request and response primitives at the TMC-SAP, and the indication and confirm primitives at the TMC-SAP are directly transported to TLC-SAP indication and confirm primitives.

20.3.5.4.1 TL-ASSESSMENT primitive

TL-ASSESSMENT indication: this primitive shall be used at the TLC-SAP to indicate the result of the assessment of the path loss for one or more channel classes on the serving cell. This shall be a consequence of the action started by a TL-ASSESSMENT-LIST request primitive. The parameters shall be as defined in table 20.33.

Table 20.33: Parameters used in the TL-ASSESSMENT primitive

Parameter	Indication (see note 1)
Channel class label	M
Path loss C4	M
Channel class label (see note 2)	C
Path loss C4 (see note 2)	C
NOTE 1: Not sent over the air interface.	
NOTE 2: These two parameters may be repeated as a set.	

20.3.5.4.1a TL-ASSESSMENT-LIST primitive

TL-ASSESSMENT-LIST request: this primitive shall be used at the TLC-SAP to start the assessment of the path loss for a list of channel classes on the serving cell, given as parameters. The assessment is based on measurements made on the current channel, together with information about the characteristics of the channel class to be assessed. The parameters shall be as defined in table 20.34.

Table 20.34: Parameters used in the TL-ASSESSMENT-LIST primitive

Parameter	Request (see note 1)
Channel class label	M
Characteristics of channel class to be assessed	M
Channel class label (see note 2)	C
Characteristics of channel class to be assessed (see note 2)	C
NOTE 1: Not sent over the air interface.	
NOTE 2: These two parameters may be repeated as a set.	

NOTE: If the MS is on a super-sectored or eccentric channel, or if the MS did not understand the conforming channel status for the current channel, it cannot perform assessment of the path loss of channel classes on the serving cell based on the measurements made on the current channel. Therefore, if the MS is currently receiving only super-sectored and/or eccentric channel(s) and/or channel(s) for which it does not understand the conforming channel status, and it wishes to perform assessment of channel classes, it needs to perform main carrier monitoring with assessment of channel classes instead of performing the assessment based on measurements made on the current channel(s).

20.3.5.4.1b TL-CELL-READ primitive

TL-CELL-READ request, confirm: this primitive shall be used at the TLC-SAP to request that the SYSINFO-DA PDU is read on a DA neighbour cell. The parameters shall be as defined in table 20.35.

The RF channel on which the SYSINFO-DA PDU is to be read is the main carrier of the DA neighbour cell.

Table 20.35: Parameters used in the TL-CELL-READ primitive

Parameter	Request (see note)	Confirm (see note)
Channel number	M	M
Characteristics of RF channel to be cell-read	C	-
Report	-	M
NOTE: Not sent over the air interface.		

20.3.5.4.1c TL-CONFIGURE primitive

TL-CONFIGURE indication: this primitive shall be used to indicate when lower layer resources are lost. It may be used to indicate when the resources are regained. The parameters shall be as defined in table 20.36.

TL-CONFIGURE request, confirm: this primitive shall be used to set up and configure the layer 2 according to the chosen cell parameters and the current state of the MS. It may also be used to provide the LLC and MAC with retransmission strategy in graceful service degradation mode. The parameters shall be as defined in table 20.36.

Table 20.36: Parameters used in the TL-CONFIGURE primitive

Parameter	Request (see note)	Indication (see note)	Confirm (see note)
Threshold values	C	-	C
Distribution on 18th frame	C	-	C
SCCH information	C	-	C
Energy economy group	C	-	C
Energy economy startpoint	C	-	C
Dual watch energy economy group	C	-	C
Dual watch startpoint	C	-	C
MLE activity indicator	C	-	-
Channel change accepted	C	-	-
Channel change handle	C	-	-
Operating mode	C	-	C
Call release	C	-	C
Valid addresses	C	-	C
MS default data priority	C	-	C
Layer 2 data priority lifetime	C	-	C
Layer 2 data priority signalling delay	C	-	C
Data priority random access delay factor	C	-	C
Schedule repetition information	C	-	C
Data class activity information	C	-	C
Endpoint identifier	C	M	C
Lower layer resource availability	-	M	-
Periodic reporting timer	C	-	-
Graceful service degradation mode control	C	-	-
NOTE: Not sent over the air interface.			

20.3.5.4.2 TL-MEASUREMENT primitive

TL-MEASUREMENT indication: this primitive shall be used to indicate to the upper layer the quality of the link of the current channel on the serving cell, based on the weighted result of the measured and acquired parameters; also, if the MS is not receiving a conforming channel, and is on a non-conforming concentric or sectorized channel, it indicates the result of assessment of the path loss on the main carrier of the serving cell (see note). The parameters shall be as defined in table 20.37.

Table 20.37: Parameters used in the TL-MEASUREMENT primitive

Parameter	Indication (see note 1)
Endpoint identifier	M
Path loss C1	M
Quality indication	C
Path loss C3 on main carrier (see note 2)	C
NOTE 1: Not sent over the air interface.	
NOTE 2: Included when the MS is not receiving a conforming channel, and is on a non-conforming concentric or sectorized channel (see note).	

NOTE: If the MS is on a super-sectored or eccentric channel, or if the MS did not understand the conforming channel status for the current channel, it cannot perform assessment of the path loss on the main carrier based on the measurements made on the current channel. Therefore, if the MS is currently receiving only super-sectored and/or eccentric channel(s) and/or channel(s) for which it does not understand the conforming channel status, it needs to perform main carrier monitoring on the serving cell instead of performing assessment of the main carrier.

20.3.5.4.3 TL-MONITOR primitive

TL-MONITOR indication: this primitive shall be used at the TLC-SAP to indicate the result of the monitoring of one particular RF channel; it may also indicate the result of assessment of the path loss for one or more channel classes (using the measurements made on the monitored RF channel). This shall be a consequence of the action started by a TL-MONITOR-LIST request primitive. The parameters shall be as defined in table 20.38.

Table 20.38: Parameters used in the TL-MONITOR primitive

Parameter	Indication (see note 1)
Channel number	M
Path loss C2	M
Quality indication	C
Channel class label	C
Path loss C5	C
Channel class label (see note 2)	C
Path loss C5 (see note 2)	C
NOTE 1: Not sent over the air interface.	
NOTE 2: These two parameters may be repeated as a set.	

20.3.5.4.4 TL-MONITOR-LIST primitive

TL-MONITOR-LIST request: this primitive shall be used at the TLC-SAP to start the monitoring of a list of RF channels given as parameters; also, in the case of a request to monitor the main carrier of a neighbour cell or the main carrier of the serving cell, it may request the assessment of the path loss for a list of channel classes (using the measurements made on the monitored RF channel).

The listed RF channels may be on the serving cell and/or on neighbour cells, for example:

- the main carrier of neighbour cells, in which case the higher layers (i.e. MLE) may also request the assessment of the path loss for a list of channel classes on that neighbour cell; and/or
- the main carrier of the serving cell, in which case the higher layers (i.e. MLE) may also request the assessment of the path loss for a list of channel classes on the serving cell; and/or
- irregular RF channels on the serving cell; and/or
- irregular RF channels on neighbour cells.

The parameters shall be as defined in table 20.39.

Table 20.39: Parameters used in the TL-MONITOR-LIST primitive

Parameter	Request (see note 1)
Channel number	M
Characteristics of RF channel to be monitored	M
Information about channel class(es) to be assessed:	
Channel class label	C
Characteristics of channel class to be assessed	C
Channel class label (see note 2)	C
Characteristics of channel class to be assessed (see note 2)	C
Channel number (see note 3)	C
Characteristics of RF channel to be monitored (see note 3)	C
Information about channel class(es) to be assessed:	
Channel class label	C
Characteristics of channel class to be assessed	C
Channel class label (see note 2)	C
Characteristics of channel class to be assessed (see note 2)	C
NOTE 1: Not sent over the air interface.	
NOTE 2: These two parameters may be repeated as a set.	
NOTE 3: These two parameters, together with the optional information about channel class(es) to be assessed, may be repeated as a set.	

20.3.5.4.5 TL-REPORT primitive (TLC-SAP)

TL-REPORT indication: this primitive shall be used to report locally to the MLE about the status of an action undertaken at the reception of a request primitive. It may also be used to report usage marker mismatch, downlink failure, uplink failure or when the maximum path delay has been exceeded. It is used to give schedule timing prompts to the higher layers. It may also be used to report that a channel replacement is advisable or may be beneficial, or that the current channel performance is acceptable. The parameters shall be as defined in table 20.40.

Table 20.40: Parameters used in the TL-REPORT primitive (TLC-SAP)

Parameter	Indication (see note 1)
Handle to the request	C
Report	M
Endpoint identifier	C (see note 2)
NSAPI	C (see note 3)
NOTE 1: Not sent over the air interface.	
NOTE 2: Used to identify concurrent MAC resources.	
NOTE 3: Used to identify the NSAPI to which a schedule timing prompt applies.	

20.3.5.4.6 TL-SCAN primitive

TL-SCAN request, confirm: this primitive shall be used at the TLC-SAP to start the scanning of a defined RF channel given as a parameter, together with the type of scanning (e.g. interrupting or not). It may also request the assessment of the path loss for a list of channel classes on the scanned cell (using the measurements made on the scanned RF channel). The parameters shall be as defined in table 20.41.

The RF channel that is to be scanned is the main carrier of a neighbour cell. The main carrier of the neighbour cell is a phase modulation carrier for a CA neighbour cell or a QAM carrier for a DA neighbour cell.

Table 20.41: Parameters used in the TL-SCAN primitive

Parameter	Request (see note 1)	Confirm (see note 1)
Channel number	M	M
Scanning measurement method	M	M
Characteristics of RF channel to be scanned	C	-
Threshold level	C	M
Report	-	M
Channel class label	C	C
Characteristics of channel class to be assessed	C	-
Path loss C5	-	C
Channel class label (see notes 2 and 3)	C	C
Characteristics of channel class to be assessed (see note 2)	C	-
Path loss C5 (see note 3)	-	C
NOTE 1: Not sent over the air interface.		
NOTE 2: These two parameters may be repeated as a set in the request primitive.		
NOTE 3: These two parameters may be repeated as a set in the confirm primitive.		

20.3.5.4.7 TL-SCAN-REPORT primitive

TL-SCAN-REPORT indication: this primitive shall be used at the TLC-SAP to report locally the updated measurement of the path loss parameter after scanning has been completed. It shall be based on the updated signal strength measurements. It may also indicate the result of assessment of the path loss for one or more channel classes (using the measurements made on the scanned RF channel). The parameters shall be as defined in table 20.42.

NOTE: The TL-SCAN-REPORT indication primitive is used when the MLE has requested monitoring but the MS has already acquired synchronization on the neighbour cell and has decoded the broadcast parameters needed to calculate C1. Layer 2 then reports the value of C1 for the neighbour cell (and C5 values if appropriate) using the TL-SCAN-REPORT indication primitive instead of reporting C2 for that cell (and C5 values if appropriate).

The TL-SCAN confirm primitive is used to report the path loss measurements when the MLE has requested scanning (see clause 20.3.5.4.6).

Table 20.42: Parameters used in the TL-SCAN-REPORT primitive

Parameter	Indication (see note 1)
Channel number	M
Threshold level (path loss C1)	M
Report	C
Channel class label	C
Path loss C5	C
Channel class label (see note 2)	C
Path loss C5 (see note 2)	C
NOTE 1: Not sent over the air interface.	
NOTE 2: These two parameters may be repeated as a set.	

20.3.5.4.8 TL-SELECT primitive

TL-SELECT request, indication, response, confirm: these primitives shall be used at the TLC-SAP to choose the RF channel onto which the radio will have to tune. The request and confirm primitives shall be used when the MLE instructs the MAC to change channel. The indication primitive shall be used by the MAC to inform the MLE of a channel change under the control of the BS. The response primitive shall be used for a cell change. The parameters shall be as defined in table 20.43.

Table 20.43: Parameters used in the TL-SELECT primitive

Parameter	Request	Indication	Response	Confirm
Channel number (see note)	M	M	M	M
Channel information	C	M	-	-
Threshold level (see note)	C	C	C	C
Main carrier number (see note)	C	-	C	C
Channel information for main carrier (see note)	C	-	C	-
Report (see note)	-	C	C	C
NOTE: Not sent over the air interface.				

NOTE: The main carrier number is generally only used for announced type 1 cell reselection when a channel change directs the MS to a traffic channel on a new cell. On receiving the TL-SELECT indication primitive for a cell change channel allocation, the MLE returns a TL-SELECT response primitive indicating the main carrier of the new cell and enabling the MAC to reference the SYNC/SYSINFO or SYNC-DA/SYSINFO-DA information received when it previously scanned that main carrier (and, for DA, when it read the SYSINFO-DA PDU).

20.3.5.5 Primitives at the TLE-SAP (MAC-LLC)

20.3.5.5.0 General

In addition to the services provided to the MLE through the TLA-SAP, TLB-SAP and TLC-SAP, the LLC may provide an additional SAP: the TLE-SAP. This is the layer 2 signalling SAP. The LLC offers the layer 2 signalling service to the MAC through this SAP.

NOTE: The following description refers to the protocol definition, but does not imply any implementation. The LLC-MAC boundary and TLE-SAP are internal layer boundaries defined to clarify the protocol description. They are not testable boundaries.

20.3.5.5.1 TLE-CANCEL primitive

TLE-CANCEL request: this primitive may be used locally for the MAC to cancel a previous request. This primitive shall not send messages over the air interface. The parameters shall be as defined in table 20.44.

Table 20.44: Parameters used in the TLE-CANCEL primitive

Parameter	Request
Handle to the request (see note)	M
NOTE: Not sent over the air interface.	

20.3.5.5.2 TLE-REPORT primitive

TLE-REPORT indication: this primitive shall be used by the LLC to report to the MAC the progress or result of a request procedure. The progress or result indication shall be passed as the Report parameter.

Parameters for this primitive shall be as defined in table 20.45.

Table 20.45: Parameters used in the TLE-REPORT primitive

Parameter	Indication
Handle to the request (see note)	M
Report (see note)	M
NOTE: Not sent over the air interface.	

20.3.5.5.3 TLE-UNITDATA primitive

In the layer 2 signalling service the parameters for the following primitives shall be as defined in table 20.46.

TLE-UNITDATA request: this primitive shall be used by the MAC to request the LLC to transmit a layer 2 signalling message.

TLE-UNITDATA indication: this primitive shall be used to deliver a received layer 2 signalling message to the MAC.

TLE-UNITDATA confirm: this primitive may be used to indicate completion of sending of the requested layer 2 signalling message.

Table 20.46: Parameters used in the TLE-UNITDATA primitive

Parameter	Request	Indication	Confirm (see note 2)
Address type	M	M	M
Main address	M	M	M
Endpoint identifier (see note 1)	M	M	M
Layer 2 signalling message	M	M	-
Layer 2 signalling message length (see note 1)	M	M	-
Scrambling code	M	M	-
PDU priority (see note 1)	M	-	-
Stealing permission (see note 1)	M	-	-
Subscriber class (see note 1)	M	-	-
Encryption, air interface	M	M	-
Number of repetitions of layer 2 signalling message (see note 1)	C	-	-
Data category (see note 1)	C	-	-
Handle to the request (see note 1)	M	-	M
Report	-	-	M
NOTE 1: Not sent over the air interface.			
NOTE 2: In this case, the confirm is a local knowledge of the sending entity.			

20.3.6 State diagram for the basic link

The state transition diagram in figure 20.2 applies to the basic link services.

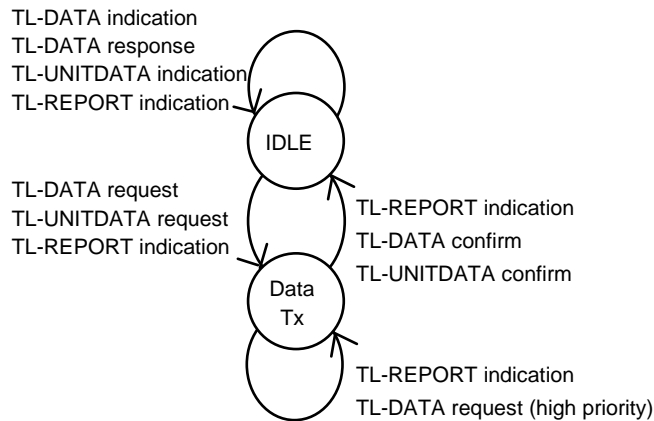

Figure 20.2: State transition diagram in basic link at TL-SAP

20.3.7 State diagram for advanced link

The state transition diagram in figure 20.3 applies to the advanced link.

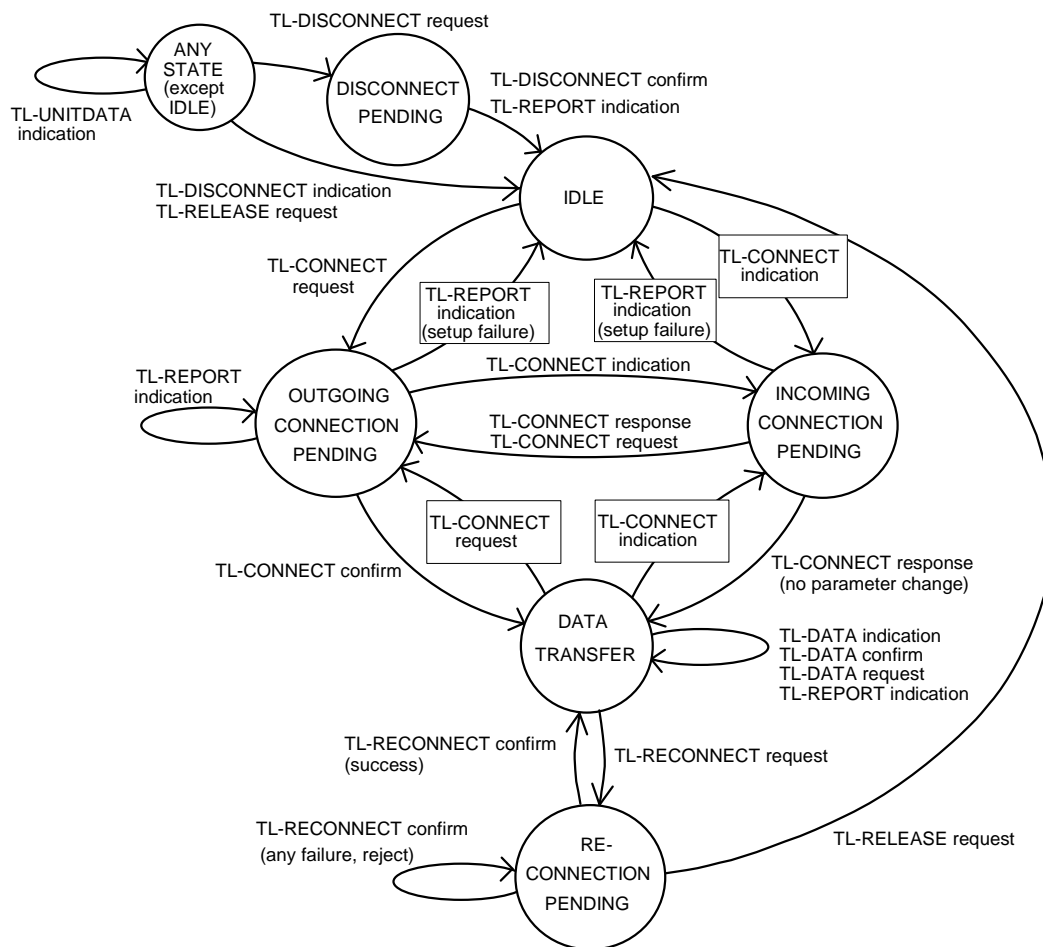

Figure 20.3: State transition in connection mode at MLE-LLC SAP (advanced link)

20.3.8 State diagram for the layer 2 signalling service

The state transition diagram in figure 20.4 applies to the layer 2 signalling service.

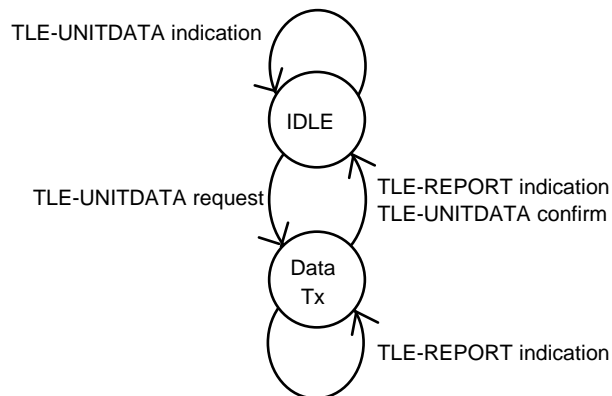

Figure 20.4: State transition diagram in layer 2 signalling service at TLE-SAP

20.4 Services provided by the MAC

20.4.0 General

The MAC shall provide services to higher layers in the protocol architecture via four SAPs. These are TMA-SAP, TMB-SAP, TMC-SAP and TMD-SAP. The first three correspond to the TLA-SAP, TLB-SAP and TLC-SAP in the LLC. TMD-SAP shall be used for transfer of user information in circuit mode. The MAC layer service primitives shall be as listed in tables 20.47 to 20.50 inclusive.

NOTE: The following description refers to the protocol definition, but does not imply any implementation. The LLC-MAC boundary and TMD-SAP are internal layer boundaries defined to clarify the protocol description. They are not testable boundaries.

Table 20.47: TMA-SAP service primitives

Service primitive	Request	Indication	Response	Confirm
TMA-CANCEL	yes	no	no	no
TMA-RELEASE	no	yes	no	no
TMA-REPORT	no	yes	no	no
TMA-UNITDATA	yes	yes	no	no

Table 20.48: TMB-SAP service primitives

Service primitive	Request	Indication	Response	Confirm
TMB-SYNC	yes, BS	yes, MS	no	no
TMB-SYSINFO	yes, BS	yes, MS	no	no
TMB-SYSINFO-Q	yes, BS	yes, MS	no	no
TMB-SYNC-DA	yes, BS	yes, MS	no	no
TMB-SYSINFO-DA	yes, BS	yes, MS	no	no

Table 20.49: TMC-SAP service primitives

Service primitive	Request	Indication	Response	Confirm
TMC-ASSESSMENT	no	yes	no	no
TMC-ASSESSMENT-LIST	yes	no	no	no
TMC-CELL-READ	yes	no	no	yes
TMC-CONFIGURE	yes	yes	no	yes
TMC-MEASUREMENT	no	yes	no	no
TMC-MONITOR	no	yes	no	no
TMC-MONITOR-LIST	yes	no	no	no
TMC-REPORT	no	yes	no	no
TMC-SCAN	yes	no	no	yes
TMC-SCAN-REPORT	no	yes	no	no
TMC-SELECT	yes	yes	yes	yes

Table 20.50: TMD-SAP service primitives

Service primitive	Request	Indication	Response	Confirm
TMD-REPORT	no	yes	no	no
TMD-UNITDATA	yes	yes	no	no

20.4.1 Services at the TMA-SAP

20.4.1.0 General

The TMA-SAP shall be used for transfer of signalling and packet data information on the air interface. The TMA-SAP provides the following services to the LLC layer:

- data manipulation (PDU composition/decomposition);
- transfer of PDUs as indicated in the following clauses.

20.4.1.1 Service primitives at the TMA-SAP

20.4.1.1.1 TMA-CANCEL primitive

TMA-CANCEL request: this primitive shall be used to cancel a TMA-UNITDATA request primitive that was submitted by the LLC. The parameters shall be as defined in table 20.51.

Table 20.51: Parameters used in the TMA-CANCEL primitive

Parameter	Request (see note)
Handle to the request	M
NOTE: Not sent over the air interface.	

20.4.1.1.2 TMA-RELEASE primitive

TMA-RELEASE indication: this primitive may be used when the MAC leaves a channel in order to indicate that the connection on that channel is lost (e.g. to indicate local disconnection of any advanced links on that channel). The parameters in this primitive shall be as defined in table 20.52.

Table 20.52: Parameters used in the TMA-RELEASE primitive

Parameter	Indication
Endpoint identifier (see note)	M
NOTE: Not sent over the air interface.	

20.4.1.1.3 TMA-REPORT primitive

TMA-REPORT indication: this primitive shall be used by the MAC to report on the progress or failure of a request procedure. The result of the transfer shall be passed as a report parameter. The parameters shall be as defined in table 20.53.

Table 20.53: Parameters used in the TMA-REPORT primitive

Parameter	Indication (see note)
Handle to the request	M
Report	M
NOTE: Not sent over the air interface.	

20.4.1.1.4 TMA-UNITDATA primitive

TMA-UNITDATA request: this primitive shall be used to request the MAC to transmit a TM-SDU.

TMA-UNITDATA indication: this primitive shall be used by the MAC to deliver a received TM-SDU. This primitive may also be used with no TM-SDU if the MAC needs to inform the higher layers of a channel allocation received without an associated TM-SDU.

The parameters shall be as defined in table 20.54.

Table 20.54: Parameters used in the TMA-UNITDATA primitive

Parameter	Request	Indication
Handle to the request (see note 1)	M	-
TM-SDU	M	C
TM-SDU length (see note 2)	M	C
Main address	M	M
Address type	M	M
Scrambling code	M	M
Endpoint identifier (see note 1)	M	M
New endpoint identifier (see note 1)	-	C
CSS endpoint identifier (see note 1)	-	C
PDU priority (see note 1)	M	-
Stealing permission (see note 1)	M	-
Subscriber class (see note 1)	M	-
Encryption, air interface	M	M
Stealing repeats flag (see note 1)	C	-
Data category (see note 1)	C	-
Channel change response required (see note 1)	-	M
Channel change handle (see note 1)	-	C
Channel information	-	C
NOTE 1: Not sent over the air interface.		
NOTE 2: If the length indicates a Null PDU, then PDU priority shall be the lowest value and stealing shall not be permitted.		

20.4.1.2 Signals at the TMA-SAP

The TMA-SAP signals (DATA-IN-BUFFER signal and MAC-READY signal) are used in the protocol description of the MS's message-buffering interface between LLC and MAC. As this is purely local to an MS, the following description is provided for information only.

The **DATA-IN-BUFFER signal** is used by the LLC in the MS to indicate to the MAC when it has signalling messages to send, and to indicate the amount of data outstanding.

The parameters in the DATA-IN-BUFFER signal are as follows:

- a) address type;
- b) main address;

c) amount of data in LLC buffer:

- this is the total amount of outstanding data ready to be sent with this address (on the channel corresponding to the specified endpoint identifier), and not yet given to the MAC;

NOTE 1: It is the total amount of data ready to be sent with this address for both basic link and advanced link messages, including acknowledgements.

d) highest stealing permission:

- this is the highest stealing permission parameter for messages in the LLC message buffer for this address (for the specified endpoint identifier);

e) PDU priority of highest priority unscheduled message:

- this is the highest PDU priority for unscheduled messages in the LLC message buffer for this address (for the specified endpoint identifier);

f) if the MS supports data priority:

- the data priority of the highest data-priority message:
 - this is the highest data priority for messages in the LLC message buffer for this address (for the specified endpoint identifier);
- information about type of data expected to be sent next:
 - this indicates whether or not the next message expected to be sent with this address (on the channel corresponding to the specified endpoint identifier) contains packet data;

g) if the channel corresponding to the specified endpoint identifier is a $\pi/4$ -DQPSK channel and the MS supports data priority:

- amount of data in LLC buffer per data priority:
 - this is the amount of outstanding data, for each data priority, to be sent with this address (on the channel corresponding to the specified endpoint identifier), and not yet given to the MAC;

NOTE 2: When indicating the amount of outstanding data for each data priority, the LLC may include all data in its queue for this address and endpoint identifier (including data that is not yet ready to be sent).

h) if the channel corresponding to the specified endpoint identifier is a D8PSK or QAM channel:

- amount of data in LLC buffer per data category:
 - this is the amount of outstanding data, for each data category, ready to be sent with this address (on the channel corresponding to the specified endpoint identifier), and not yet given to the MAC;

i) if the channel corresponding to the specified endpoint identifier is a D8PSK or QAM channel and the MS supports data priority:

- amount of data in LLC buffer per data category and per data priority:
 - this is the amount of outstanding data, for each data category and data priority, to be sent with this address (on the channel corresponding to the specified endpoint identifier), and not yet given to the MAC;

j) fully scheduled or unscheduled data information:

- this indicates whether all, some or none of the data in the LLC message buffer for this address (for the specified endpoint identifier) is fully scheduled data;

k) lowest value of maximum schedule interval:

- this indicates the lowest value of the maximum schedule interval for any fully scheduled data in the LLC message buffer for this address (for the specified endpoint identifier);

- l) PDU priority of highest priority fully scheduled message:
 - this is the highest PDU priority for fully scheduled messages in the LLC message buffer for this address (for the specified endpoint identifier);
- m) endpoint identifier.

The **MAC-READY signal** is issued by the MAC in the MS to the LLC when the MAC is ready to send a MAC block. Then the LLC will usually issue a TMA-UNITDATA request primitive to the MAC, containing a TM-SDU to be sent in the MAC block.

The parameters in the MAC-READY signal are as follows:

- a) address type;
- b) main address;
- c) size of TM-SDU in this MAC block:
 - this parameter is included if the MS is on a $\pi/4$ -DQPSK channel; it is the maximum size of TM-SDU that can be carried in the current MAC block (i.e. the maximum size without requiring fragmentation);
- d) normal advanced link segment size:
 - this parameter is included if the MS is on a QAM channel; it indicates the current normal segment size for new advanced link data segments;

NOTE 3: On a 25 kHz or 50 kHz QAM channel, the normal advanced link segment size is determined by the available space in a 4-QAM rate = 1/2 full-slot MAC block at the current bandwidth; on a 100 kHz or 150 kHz QAM channel, the normal advanced link segment size is determined by the available space in half of a 4-QAM rate = 1/2 full-slot MAC block at the current bandwidth.

- e) data categories for which a normal advanced link data segment may be sent in this MAC block:
 - this information is included if the MS is on a QAM channel; it indicates the data categories for which a normal advanced link data segment may be sent in the current MAC block;
- f) data categories for which a TM-SDU may be sent in this MAC block:
 - this information is included if the MS is on a D8PSK or QAM channel; it indicates the data categories for which a TM-SDU may be sent in the current MAC block;
- g) size of TM-SDU per data category in this MAC block:
 - this information is included if the MS is on a D8PSK channel; it indicates the maximum size of TM-SDU that can be carried in the current MAC block for each data category for which a TM-SDU may be sent (i.e. the maximum size without requiring fragmentation);
 - this information should be included for some or all categories if the MS is on a QAM channel; it indicates the maximum size of TM-SDU that can be carried in the current MAC block for appropriate data categories for which a TM-SDU may be sent (i.e. the maximum size without requiring fragmentation);

NOTE 4: The information in g) is needed on a D8PSK channel, for example, so that the data sending LLC knows what advanced link segment size to use when cutting a new segment of TL-SDU. Segments may be of different size, depending on whether the MAC considers that $\pi/4$ -DQPSK or $\pi/8$ -D8PSK modulation is currently appropriate for first transmissions of segments for this data category.

On a QAM channel, the information in d) and e) normally enables the data sending LLC to process advanced link segments correctly. However the information in g) is useful in some cases, for example:

- in order for the LLC to decide whether to use BL-ADATA or BL-ACK (see clause 22.3.2.3); or
- if the MS chooses not to fragment AL-ACK, AL-RNR, AL-X-ACK or AL-X-RNR PDUs (using multiple PDUs instead - see clauses 22.3.3.2.3 and 22.3.3.2a); or
- if the MS sends a first segment of TL-SDU in a random access message; or

- in order to facilitate transmissions or re-transmissions of short final segments or segment re-transmissions after a change of bandwidth.
- h) maximum size of TM-SDU:
- this is the maximum size of TM-SDU that can be handled in the MAC at this time (e.g. the maximum size of fragmented TM-SDU);
- i) endpoint identifier.

20.4.1.3 Mapping of the service primitives between LLC and MAC at the TMA-SAP

The LLC shall control the relationships between the LLC data transfer service primitives offered to the MLE and the data transfer service primitives offered by the MAC to the LLC. Table 20.55 shows these relationships at the TLA-SAP (MLE-LLC) and the TMA-SAP (LLC-MAC).

According to the protocol model, the LLC may offer a data transfer service to the MAC through the TLE-SAP, for layer 2 signalling. The LLC then uses the data transfer service primitives offered by the MAC at the TMA-SAP in order to send or receive layer 2 signalling PDUs. The LLC shall control the relationships between the LLC data transfer service primitives offered to the MAC for layer 2 signalling at the TLE-SAP and the data transfer service primitives offered by the MAC to the LLC at the TMA-SAP. Table 20.55 shows these relationships at the TLE-SAP (MAC-LLC) and the TMA-SAP (LLC-MAC).

Table 20.55: Correspondence between MAC and LLC at the TMA-SAP, TLA-SAP and TLE-SAP

LLC Service Primitives (TLA-SAP and TLE-SAP)	MAC Service Primitive (TMA-SAP)
TL-CONNECT request TL-CONNECT response TL-DATA request TL-DATA response TL-DISCONNECT request TL-RECONNECT request TL-UNITDATA request TLE-UNITDATA request	TMA-UNITDATA request
TL-CONNECT indication TL-CONNECT confirm TL-DATA indication TL-DATA confirm TL-DISCONNECT indication TL-DISCONNECT confirm TL-RECONNECT confirm TL-UNITDATA indication TLE-UNITDATA indication	TMA-UNITDATA indication
TL-CANCEL request TLE-CANCEL request	TMA-CANCEL request
TL-RELEASE indication	TMA-RELEASE indication
TL-RELEASE request	None
TL-REPORT indication TLE-REPORT indication	TMA-UNITDATA indication or TMA-REPORT indication or not applicable
NOTE 1: All the service primitives at the TMA-SAP use signalling channels (SCH or STCH), except for the local primitives (CANCEL, RELEASE, REPORT).	
NOTE 2: A TL-REPORT may be generated in the LLC without a report from the lower layer.	

20.4.2 Service provided at the TMB-SAP

The TMB-SAP shall be used for the transfer of un-addressed system broadcast messages, which carry network or system organization information from the BS to the MS.

In the present document the LLC layer does not have any TMB-SAP related functions. The request primitives at the TLB-SAP are directly mapped as request primitives at the TMB-SAP, and the indication primitives at the TMB-SAP are directly transported to TLB-SAP indication primitives. The service descriptions for the TLB-SAP are therefore valid for the TMB-SAP and are not repeated.

Table 20.56 shows these relationships at the TLB-SAP (MLE-LLC) and the TMB-SAP (LLC-MAC).

Table 20.56: Correspondence between MAC and LLC at the TMB-SAP and TLB-SAP

LLC Service Primitives (TLB-SAP)	MAC Service Primitive (TMB-SAP)	MAC Logical Channel (TMV-SAP)
TL-SYNC request, indication	TMB-SYNC request, indication	BSCH
TL-SYSINFO request, indication	TMB-SYSINFO request, indication	BNCH on SCH/HD, STCH, SCH-P8/HD, SCH-P8/F
TL-SYSINFO-Q request, indication	TMB-SYSINFO-Q request, indication	BNCH-Q on SCH-Q/D
TL-SYNC-DA request, indication	TMB-SYNC-DA request, indication	BSCH-Q
TL-SYSINFO-DA request, indication	TMB-SYSINFO-DA request, indication	BNCH-Q on SCH-Q/D or on SCH-Q/B, SCH/F, SCH-P8/HD, SCH-P8/F
NOTE: The received system synchronization and information messages in the MS are conveyed to the MLE via the LLC using the TxB-SAP. Parameters calculated when receiving broadcast information are conveyed using the TxC-SAP.		

20.4.3 Service provided at the TMC-SAP

The TMC-SAP shall be used for the transfer of local layer management information. It does not provide data transfer services over the air interface. The request and response primitives at the TLC-SAP shall be directly mapped as request and response primitives at the TMC-SAP, and the indication and confirm primitives at the TMC-SAP shall be directly transported to the TLC-SAP as indication and confirm primitives. The service descriptions for the TLC-SAP are therefore valid for the TMC-SAP and are not repeated. The LLC also may use the TMC-CONFIGURE request primitive.

TMC-CONFIGURE indication: this primitive shall be used to indicate loss of lower layer resources. It may be used to indicate regain of lower layer resources. The parameters shall be as defined in table 20.57.

TMC-CONFIGURE request: this primitive shall be used to accept or reject a channel change. It is also used for the LLC to provide the MAC with information about activity. It is used for the LLC to provide the MAC with timer information that may be needed in the napping procedure. It may also be used for the LLC to provide the MAC with information that the MAC may use to make choices about link adaptation. It may also be used to provide the MAC with retransmission strategy in graceful service degradation mode. The parameters shall be as defined in table 20.57.

Table 20.57: Parameters used in the TMC-CONFIGURE primitive

Parameter	Request	Indication
Channel change handle (see notes 1 and 2)	C	-
Channel change accepted (see notes 1 and 2)	C	-
MLE activity indicator (see notes 1 and 2)	C	-
LLC timer status (see note 1)	C	-
Link performance information (see note 1)	C	-
Endpoint identifier (see note 1)	C	M
Lower layer resource availability (see note 1)	-	M
Graceful service degradation mode control	C	-
NOTE 1: Not sent over the air interface.		
NOTE 2: These parameters are a subset of those TMC-CONFIGURE request parameters which are used when TL-CONFIGURE request primitive is mapped into TMC-CONFIGURE request primitive, refer to clause 20.3.5.4.1b.		

Table 20.58 shows relationships at the TLC-SAP (MLE-LLC) and the TMC-SAP (LLC-MAC).

Table 20.58: Correspondence between MAC and LLC at the TMC-SAP and TLC-SAP

LLC service primitives (TLC-SAP)	MAC service primitive (TMC-SAP)
TL-ASSESSMENT	TMC-ASSESSMENT
TL-ASSESSMENT-LIST	TMC-ASSESSMENT-LIST
TL-CELL-READ	TMC-CELL-READ
TL-CONFIGURE	TMC-CONFIGURE
TL-MEASUREMENT	TMC-MEASUREMENT
TL-MONITOR	TMC-MONITOR
TL-MONITOR-LIST	TMC-MONITOR-LIST
TL-REPORT	TMC-REPORT
TL-SCAN	TMC-SCAN
TL-SCAN-REPORT	TMC-SCAN-REPORT
TL-SELECT	TMC-SELECT

20.4.4 Service provided at the TMD-SAP

20.4.4.0 General

The TMD-SAP shall be used in the MS in circuit mode for the transfer of speech frames and/or synchronization information for end-to-end encryption purpose, and/or the transfer of data. It shall provide the interface between the MAC and the TETRA speech CODEC, and between the MAC and the other circuit mode applications.

The speech frames may contain either clear or end-to-end encrypted speech, but their actual information content (as also for data transported in circuit mode) is irrelevant to the MAC. Speech frames may be stolen by the MAC according to the parameter definition and the procedures as explained in clause 23. The same parameters may be used for circuit mode data.

Before transmission, speech frames and user data shall be coded and protected in the MAC in a way depending on whether they contain only speech or user data related information, one stolen half slot or two stolen half slots. Stolen half slots shall contain signalling information, either from C-plane or from U-plane (e.g. for end-to-end encryption synchronization).

For the purpose of the description in the rest of this clause, the unit of exchange at the TMD-SAP is always a half slot. Under normal circumstances in traffic mode, two primitive exchanges each containing the equivalent of half a slot capacity are required to fill the physical MAC block going to be transmitted over the air interface.

20.4.4.1 Service primitives and parameters at the TMD-SAP

20.4.4.1.1 TMD-REPORT primitive

TMD-REPORT indication: this primitive shall be used by the MAC to report on the progress of a request procedure. For example, it shall be used by the sending MAC to report to the U-plane application when the MAC has stolen traffic capacity.

The half slot synchronization shall be a parameter (or any local signal) that the MS MAC shall give internally to the U-plane application to enable a distinction between the first and the second half slot, i.e. a proper use of first half slot and second half parameters by the U-plane application. For the purpose of this description, a TMD-REPORT indication primitive shall be sent before any TMD-UNITDATA request primitive as an initial synchronization for the U-plane application.

The parameters shall be as defined in table 20.59.

Table 20.59: Parameters used in the TMD-REPORT primitive

Parameter	Indication (see note)
Half slot synchronization	C
TCH type and interleaving depth	C
Number of $\pi/4$ -DQPSK slots per TDMA frame	C
End-to-end encryption flag	C
User device	C
Report	M
NOTE: Not sent over the air interface.	

20.4.4.1.2 TMD-UNITDATA primitive

TMD-UNITDATA request: this primitive shall be used to request the MAC to transmit one half slot.

TMD-UNITDATA indication: this primitive shall be used by the MAC to deliver one half slot.

The parameters shall be as defined in table 20.60.

Table 20.60: Parameters used in the TMD-UNITDATA primitive

Parameter	Request	Indication
Half slot content	M	M
Half slot position (see note)	C	C
Half slot importance (see note)	M	-
Stolen indication	M	M
Half slot condition (see note)	-	M
User device (see note)	C	C
NOTE: Not sent over the air interface.		

NOTE: The half slot position may be implicit after the first synchronization phase.

The user device number shall identify the circuit which the information shall be transferred to, and from.

21 Layer 2 PDU description

21.0 General

This clause describes the PDUs for the V+D air interface at layer 2. An overview of the DLL architecture can be found in clause 19. The sub-layer interactions between MAC and LLC are described herein by the protocol elements.

This clause is intended to be read together with the MAC protocol (see clause 23) and LLC protocol (see clause 22). A detailed service description is provided in clause 20.

Binary values are indicated in this clause by a subscript 2, thus: 10110_2 .

21.1 DLL PDU structure

21.1.1 DLL overhead

The DLL overhead contains independent LLC and MAC headers. Therefore, the following description distinguishes first LLC overhead and then MAC overhead. Overhead shall be added by a sub-layer independently of the overhead attached by the other sub-layer.

21.1.2 LLC PDU structure

21.1.2.0 General

The LLC adds an LLC header to TL-SDUs to create LLC PDUs. The LLC PDU shall have the format illustrated in figure 21.1.

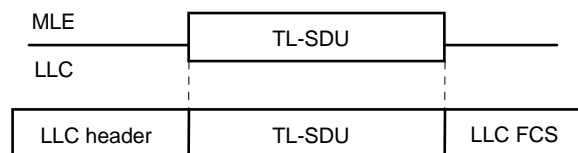

Figure 21.1: Construction of an LLC PDU (shown with optional FCS)

21.1.2.1 LLC header

The LLC header discriminates between various PDUs, see table 21.1. The uses of the different LLC PDUs are specified in clause 22.

21.1.2.2 Format of LLC header

The LLC PDU type illustrated in figure 21.2 is defined in clause 21.2.1. The LLC PDU type element shall have a length of 4 bits. The length of the LLC information structure depends on the PDU type.

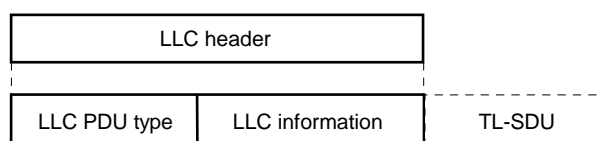

Figure 21.2: General format of an LLC header before the TL-SDU content

21.1.2.3 LLC FCS

For the original advanced link, and on request for the basic link or extended advanced link, the LLC shall calculate and add an FCS to the information being transmitted. Its size shall be 32 bits. This provides a Probability of Undetected Erroneous Message (PUEM) of about 10^{-13} or better. This may be requested for packet data transmission whereas the MAC error detection mechanism (16 bits CRC) guarantees a PUEM of 10^{-6} only. The LLC FCS shall be placed immediately after the end of the TL-SDU as shown in figure 21.1. The FCS as defined in clause 22 shall be used.

21.1.3 MAC PDU structure

21.1.3.1 MAC overhead

Each TM-SDU to be transmitted shall have a MAC header added as shown in figure 21.3.

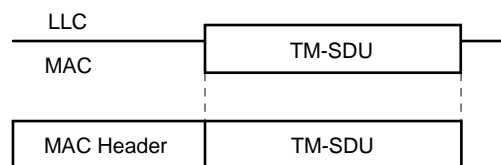

Figure 21.3: General format of the MAC PDU

21.1.3.2 Format of the MAC header

21.1.3.2.0 General

The MAC header enables the receiving MAC entity to identify the functions to be performed on the MAC PDU. The MAC type defines the structure of the MAC information. The MAC header shall have the format shown in figure 21.4.

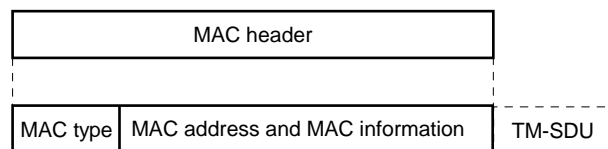

Figure 21.4: General format of a MAC header

Generally, the MAC header shall contain three types of element, the MAC type, the MAC address and some MAC information. In order to keep the overhead as small as possible, continuations and the end of fragmented data (MAC-FRAG and MAC-END) shall not contain any address.

The MAC header structure enables the MAC to associate and transmit several independent MAC PDUs in one MAC block. Unused bits should be filled with a NULL PDU as illustrated in figure 21.5, or fill bits may be used (not shown) (see clause 23).

NOTE: On uplink the Null PDU contains the normal MAC addressing and air interface encryption of the sending MS.

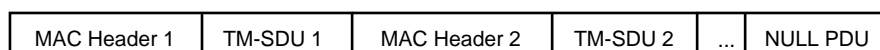

Figure 21.5: Association of several MAC PDUs in one MAC block

21.1.3.2.1 MAC type

The MAC type identifies the different PDUs and the different SAPs to which the receiving MAC should route the TM-SDU.

21.1.3.2.2 MAC information

The location and format of the MAC information is defined in the relevant MAC section for each MAC type.

21.1.3.2.3 MAC address

The location and format of the MAC address is defined in the relevant MAC section for each MAC type. For the layer 2 addressing particularities, refer to ETSI EN 300 392-1 [6], clause 7 and to clause 23 of the present document.

21.1.4 DLL PDU building

21.1.4.1 Basic link illustration

Figure 21.6 illustrates the method when a message (MAC header and TM-SDU) fits within the MAC block size.

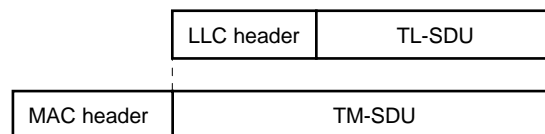

Figure 21.6: Building of DLL PDU (with no fragmentation)

If the size of the TM-SDU exceeds the available capacity in a MAC block, MAC fragmentation shall occur as shown in figure 21.7.

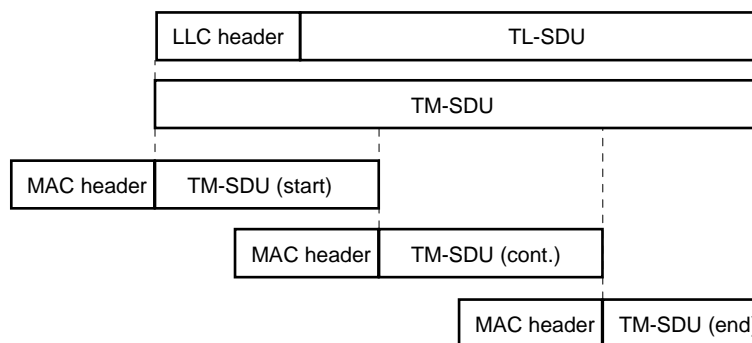

Figure 21.7: MAC fragmentation of a long TM-SDU

Optionally, the LLC may add a FCS as part of the TM-SDU. (This is not shown in figures 21.6 and 21.7, but is illustrated on figure 21.1. The whole TM-SDU contains only a single LLC header. Therefore, if an error occurs during transmission, the whole TM-SDU has to be re-transmitted. This is not the case for the advanced link illustrated in figure 21.8.

21.1.4.2 Advanced link illustration

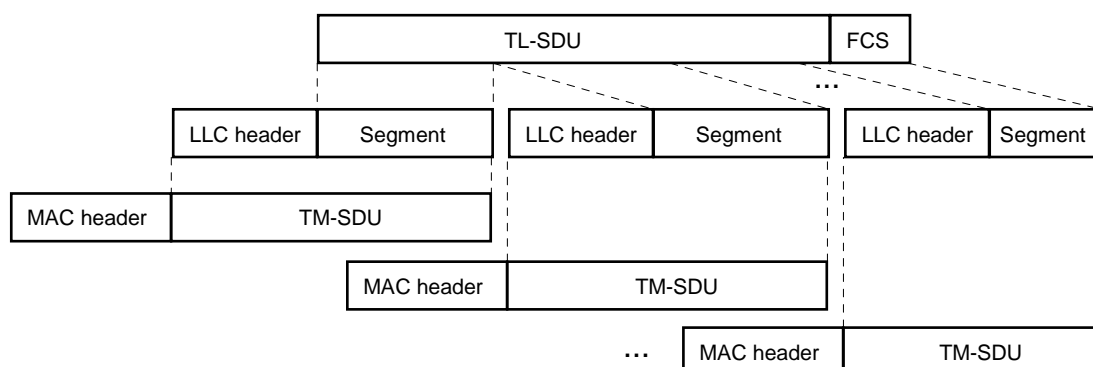

Figure 21.8: Segmentation provided by the advanced link

As opposed to fragmentation performed by the MAC, LLC segmentation shall label each segment with a sent segment sequence number $S(S)$ so that each of the segments shall be uniquely identified and used as the re-transmission unit (selective rejection applies under the advanced link, refer to clause 22). Figure 21.8 shows that each TM-SDU has its own LLC header in addition to the MAC header. For the original advanced link, the LLC shall add an FCS at the end of the last segment; for the extended advanced link, optionally the LLC may add an FCS at the end of the last segment. This FCS shall be calculated over the entire TL-SDU.

21.1.5 PDU description format

The following clauses contain descriptions of the LLC and MAC protocol PDUs and the information elements contained in the PDUs. The structure of the PDU definitions represented by the tables is as follows:

- The information element column is the name of the element.
- The element length column defines the length of the element in bits.
- The element types (C/O/M) are:
 - Mandatory (M): this element shall always be present and shall appear in the order shown;
 - Optional (O): these elements are optional and if they are used, then they shall appear in the order shown;
 - Conditional (C): this element is conditional depending on another field before that element. If this is used, then it shall appear in the order shown.

NOTE: Unlike the layer 3 PDUs, layer 2 PDUs do not use any "O" bits or "P" bits to indicate the presence of optional fields. Whether or not optional fields are present in the PDU can be derived by context.

- The value column denotes fixed values or a range of valid values. If this field is empty all bit combinations are valid.
- The remarks column defines meanings of the values or it may contain other information on the information element.

21.2 Logical Link Control (LLC) PDUs description

21.2.0 General

The information contained in the following PDU descriptions shall be read from top to bottom. The content within an information element shall start with the most significant bit (i.e. the leftmost bit shown in the information element descriptions) and shall continue until it reaches the least significant bit.

21.2.1 LLC PDU types

Table 21.1: Definition of LLC PDU types

LLC PDU type	PDU associated
0000 ₂	BL-ADATA without FCS
0001 ₂	BL-DATA without FCS
0010 ₂	BL-UDATA without FCS
0011 ₂	BL-ACK without FCS
0100 ₂	BL-ADATA with FCS
0101 ₂	BL-DATA with FCS
0110 ₂	BL-UDATA with FCS
0111 ₂	BL-ACK with FCS
1000 ₂	AL-SETUP
1001 ₂	AL-DATA/AL-DATA-AR/AL-FINAL/AL-FINAL-AR
1010 ₂	AL-UDATA/AL-UFINAL
1011 ₂	AL-ACK/AL-RNR
1100 ₂	AL-RECONNECT
1101 ₂	Supplementary LLC PDU: the PDU associated is given by the supplementary LLC PDU subtype (see table 21.3)
1110 ₂	Layer 2 signalling PDU: the PDU associated is given by the layer 2 signalling PDU subtype (see table 21.2)
1111 ₂	AL-DISC

The PDU type field shall have a length of 4 bits. The PDU type values shall be according to table 21.1. The names reflect the functionality inside the LLC. PDUs having the same LLC PDU type values are discriminated by additional information elements. Basic link PDUs start with prefix BL, advanced link PDUs start with prefix AL.

For LLC PDU type 1110₂, the PDU associated is given by the 4-bit layer 2 signalling PDU subtype field according to table 21.2. The name of each PDU reflects the functionality of that PDU within layer 2.

Table 21.2: Definition of layer 2 signalling PDU subtypes for LLC PDU type 1110₂

Layer 2 signalling PDU subtype	PDU associated
0000 ₂	L2-DATA-PRIORITY
0001 ₂	L2-SCHEDULE-SYNC
0010 ₂	L2-LINK-FEEDBACK-CONTROL
0011 ₂	L2-LINK-FEEDBACK-INFO
0100 ₂	L2-LINK-FEEDBACK-INFO-AND-RESIDUAL-DATA-PRIORITY
0101 ₂	Reserved
0110 ₂	Reserved
0111 ₂	Reserved
1000 ₂	Reserved
1001 ₂	Reserved
1010 ₂	Reserved
1011 ₂	Reserved
1100 ₂	Reserved
1101 ₂	Reserved
1110 ₂	Reserved
1111 ₂	Reserved

For LLC PDU type 1101₂, the PDU associated is given by the 2-bit supplementary LLC PDU subtype field according to table 21.3. PDUs having the same supplementary LLC PDU subtype values are discriminated by additional information elements.

Table 21.3: Definition of supplementary LLC PDU subtypes for LLC PDU type 1101₂

Supplementary LLC PDU subtype	PDU associated
00 ₂	AL-X-DATA/AL-X-DATA-AR/AL-X-FINAL/AL-X-FINAL-AR
01 ₂	AL-X-UDATA/AL-X-UFINAL
10 ₂	AL-X-ACK/AL-X-RNR
11 ₂	Reserved (see note)
NOTE: If supplementary LLC PDU subtype 11 ₂ is used in future editions of the present document, it is intended that a sub-subtype will be defined to indicate the PDU associated - thereby enabling further extension of the LLC PDUs.	

21.2.2 Basic link PDU definitions

21.2.2.0 General

The following 8 PDUs are defined for the basic link:

- BL-ACK without FCS for the acknowledgement of the previous transmission (BL-DATA or BL-ADATA);
- BL-ACK with FCS for the acknowledgement of the previous transmission (BL-DATA or BL-ADATA);
- BL-ADATA without FCS for acknowledgement and the transmission of acknowledged information;
- BL-ADATA with FCS for acknowledgement and the transmission of acknowledged information;
- BL-DATA without FCS for the transmission of acknowledged information;
- BL-DATA with FCS for the transmission of acknowledged information;
- BL-UDATA without FCS for the transmission of unacknowledged information;
- BL-UDATA with FCS for the transmission of unacknowledged information.

21.2.2.1 BL-ACK

- PDU: BL-ACK;
- service provided: Acknowledgement and optional data transfer in basic link;
- response to: BL-DATA or BL-ADATA;
- response expected: None;
- short description: This PDU shall be used to acknowledge one TL-SDU. There are 2 PDUs defined, one without and another one with a FCS. The BL-ACK PDUs can carry service user data from a TL-DATA response primitive.

The elements of BL-ACK PDU without FCS shall be as defined in table 21.4.

The elements of BL-ACK PDU with FCS shall be as defined in table 21.5. This PDU shall be used only if a TL-SDU is present.

Table 21.4: BL-ACK PDU without FCS contents

Information element	Length	Type	Value	Remark
LLC PDU type	4	M	see table 21.1	BL-ACK without FCS
N(R)	1	M		Received TL-SDU number
TL-SDU	variable	O		Data from TL-DATA response primitive

Table 21.5: BL-ACK PDU with FCS contents

Information element	Length	Type	Value	Remark
LLC PDU type	4	M	see table 21.1	BL-ACK with FCS
N(R)	1	M		Received TL-SDU number
TL-SDU	variable	M		Data from TL-DATA response primitive
FCS	32	M		Frame Check Sequence

21.2.2.2 BL-ADATA

- PDU: BL-ADATA;
- service provided: Basic link (acknowledged service in connectionless mode);
- response to: BL-DATA or BL-ADATA;
- response expected: BL-ADATA or BL-ACK;
- short description: There are two PDUs defined, one without and another one with FCS. These PDUs shall be used to acknowledge one TL-SDU and send acknowledged data.

The elements of BL-ADATA PDU without FCS shall be as defined in table 21.6.

The elements of BL-ADATA PDU with FCS shall be as defined in table 21.7.

Table 21.6: BL-ADATA PDU without FCS contents

Information element	Length	Type	Value	Remark
LLC PDU type	4	M	see table 21.1	BL-ADATA without FCS
N(R)	1	M		Received TL-SDU number
N(S)	1	M		Sent TL-SDU number
TL-SDU	variable	M		Data from TL-DATA request primitive

Table 21.7: BL-ADATA PDU with FCS contents

Information element	Length	Type	Value	Remark
LLC PDU type	4	M	see table 21.1	BL-ADATA with FCS
N(R)	1	M		Received TL-SDU number
N(S)	1	M		Sent TL-SDU number
TL-SDU	variable	M		Data from TL-DATA request primitive
FCS	32	M		Frame Check Sequence

21.2.2.3 BL-DATA

- PDU: BL-DATA;
- service provided: Basic link (acknowledged service in connectionless mode);
- response to: -;
- response expected: BL-ACK or BL-ADATA;
- short description: There are two PDUs defined, one without and another one with FCS. These PDUs shall be used to send acknowledged data.

The elements of BL-DATA PDU without FCS shall be as defined in table 21.8.

The elements of BL-DATA PDU with FCS shall be as defined in table 21.9.

Table 21.8: BL-DATA PDU without FCS contents

Information element	Length	Type	Value	Remark
LLC PDU type	4	M	see table 21.1	BL-DATA without FCS
N(S)	1	M		Sent TL-SDU number
TL-SDU	variable	M		Data from TL-DATA request primitive

Table 21.9: BL-DATA PDU with FCS contents

Information element	Length	Type	Value	Remark
LLC PDU type	4	M	see table 21.1	BL-DATA with FCS
N(S)	1	M		Sent TL-SDU number
TL-SDU	variable	M		Data from TL-DATA request primitive
FCS	32	M		Frame Check Sequence

21.2.2.4 BL-UDATA

- PDU: BL-UDATA;
- service provided: Basic link (unacknowledged service in connectionless mode);
- response to: -;
- response expected: None;
- short description: These PDUs shall be used to send unacknowledged data. There are two separate PDUs having a different LLC type to indicate whether the PDU contains the FCS or not.

The elements of BL-UDATA PDU without FCS shall be as defined in table 21.10.

The elements of BL-UDATA PDU with FCS shall be as defined in table 21.11.

Table 21.10: BL-UDATA PDU without FCS contents

Information element	Length	Type	Value	Remark
LLC PDU type	4	M	see table 21.1	BL-UDATA without FCS
TL-SDU	variable	M		Data from TL-UNITDATA request primitive

Table 21.11: BL-UDATA PDU with FCS contents

Information element	Length	Type	Value	Remark
LLC PDU type	4	M	see table 21.1	BL-UDATA with FCS
TL-SDU	variable	M		Data from TL-UNITDATA request primitive
FCS	32	M		Frame Check Sequence

21.2.3 Advanced link PDU definitions

21.2.3.0 General

The original advanced link uses 11 PDUs:

- AL-ACK for an acknowledgement of received information with receive ready flow control indication;
- AL-RNR for an acknowledgement of received information with receive not ready flow control indication;
- AL-FINAL for transmission of the last segment of an acknowledged information;
- AL-FINAL-AR for transmission of the last segment of an acknowledged information with an acknowledgement request;
- AL-DATA for transmission of an acknowledged information segment;
- AL-DATA-AR for transmission of an acknowledged information segment with acknowledgement request;
- AL-DISC for disconnecting the advanced link;
- AL-SETUP for establishment or reset of the advanced link with quality of service negotiation;
- AL-RECONNECT for LLC reconnection of an advanced link after cell reselection;
- AL-UDATA for transmission of a segment of an unacknowledged information;
- AL-UFINAL for transmission of the last segment of an unacknowledged information.

NOTE 1: The 11 different PDUs are presented by 6 different LLC PDU types; see table 21.1.

AL-DATA, AL-DATA-AR and AL-UDATA shall never contain an entire FCS and shall not be used as the last segment of a TL-SDU, while AL-FINAL, AL-FINAL-AR and AL-UFINAL shall always contain a FCS or the last part of it and shall be used as the last segment of a TL-SDU.

The extended advanced link uses the AL-SETUP, AL-RECONNECT and AL-DISC PDUs for establishment, reset, reconnection and disconnection of the advanced link. However, it uses different PDUs from the original advanced link for the data transmission and acknowledgements. The PDUs for data transmission and acknowledgements on the extended advanced link are as follows:

- AL-X-ACK for an acknowledgement of received information with receive ready flow control indication;
- AL-X-RNR for an acknowledgement of received information with receive not ready flow control indication;
- AL-X-FINAL for transmission of the last segment of an acknowledged information;
- AL-X-FINAL-AR for transmission of the last segment of an acknowledged information with an acknowledgement request;
- AL-X-DATA for transmission of an acknowledged information segment;
- AL-X-DATA-AR for transmission of an acknowledged information segment with acknowledgement request;
- AL-X-UDATA for transmission of a segment of an unacknowledged information;

- AL-X-UFINAL for transmission of the last segment of an unacknowledged information.

NOTE 2: These eight PDUs share a single LLC PDU type (supplementary LLC PDU) and are presented by three different supplementary LLC PDU subtypes; see tables 21.1 and 21.3.

Inclusion of an FCS is optional for the extended advanced link.

21.2.3.1 AL-ACK, AL-RNR

- PDU: AL-ACK (receiver ready with acknowledgement);
AL-RNR (receiver not ready with acknowledgement);
- service provided: acknowledgement in original advanced link (connection mode) flow control;
- response to: AL-DATA, AL-DATA-AR, AL-FINAL and AL-FINAL-AR;
- response expected: none;
- short description: these PDUs shall be used to acknowledge TL-SDUs and/or segments of TL-SDUs sent in the original advanced link. They support flow control by reporting "receiver ready" or "receiver not ready" to the peer sender.

The elements of AL-ACK and AL-RNR PDUs shall be as defined in table 21.12.

Table 21.12: AL-ACK and AL-RNR PDUs contents

Information element	Length	Type	Value	Remark
LLC PDU type	4	M	see table 21.1	AL-ACK and AL-RNR
Flow control	1	M	0	Receiver not ready (AL-RNR)
			1	Receiver ready (AL-ACK)
First Acknowledgement Block	variable	M		Acknowledgement block for the eldest TL-SDU being acknowledged
Other Acknowledgement Blocks	variable	O		Acknowledgement blocks for the same TL-SDU or the next TL-SDUs being acknowledged; may be repeated for up to window size N.272 TL-SDUs (see note)
NOTE: When appropriate, an acknowledgement block may contain a continuation of the previous acknowledgement block; refer to note 4 in table 21.13.				

The acknowledgement block shall be as defined in table 21.13.

Table 21.13: Acknowledgement block information element contents in AL-ACK and AL-RNR PDUs

Information element	Length	Type	Value	Remark
N(R)	3	M		The number of the TL-SDU (see note 4)
Acknowledgement length	6	M	000000 ₂	SDU correctly received
			000001 ₂	Number of acknowledged segments
			etc.	etc.
			111110 ₂	Number of acknowledged segments
			111111 ₂	Repeat the entire SDU (see note 5)
S(R)	8 see note 1	C	00000000 ₂	Sequence number of the eldest not yet correctly received segment (see note 4)
			etc.	etc.
			11111001 ₂	Sequence number of the eldest not yet correctly received segment (see note 4)
			11111010 ₂	Rest of SDU correctly received (see notes 6 and 7)
			11111011 ₂	Reserved
			etc.	etc.
			11111111 ₂	Reserved
Acknowledgement bit map	Variable see note 2 see note 3	C	0	Incorrectly or not yet received segment
			1	Correctly received segment
NOTE 1: The element is present if the acknowledgement length is in the range from 000001 ₂ to 111110 ₂ .				
NOTE 2: Length of the bit map is variable, each bit is set as defined.				
NOTE 3: The element is present if the acknowledgement length is in the range from 000010 ₂ to 111110 ₂ . The length of the bit map is acknowledgement length minus one.				
NOTE 4: On a π/4-DQPSK or D8PSK channel, when the maximum size of the TL-SDU is 4 096 octets, two acknowledgement blocks may refer to the same TL-SDU. On a QAM channel, when the available room in an acknowledgement block is not sufficient to indicate the reception status of the segments in a TL-SDU, two or more acknowledgement blocks may refer to the same TL-SDU. Thus an acknowledgement block may contain a continuation of the previous acknowledgement block, in which case the N(R) shall indicate the same number of the TL-SDU as in the previous acknowledgement block and the S(R) shall indicate the sequence number of the eldest not yet correctly received segment after the segments indicated by the previous acknowledgement block.				
NOTE 5: This value is used in case of FCS failure. Implementations may use this value to indicate that no segments of a TL-SDU have been received: however this could result in N.273 being exceeded without any segment retransmissions having taken place if N.273 is set to 0.				
NOTE 6: When using this value, the acknowledgement length shall be set to 000001 ₂ .				
NOTE 7: This value shall only be used when multiple acknowledgement blocks refer to the same TL-SDU, and shall only be used in the last acknowledgement block for such a TL-SDU.				

The correct reception of an entire TL-SDU shall be indicated by the acknowledgement length set to zero (000000₂). A TL-SDU FCS failure shall be indicated by the acknowledgement length set to 111111₂ binary. In these cases the acknowledgement block shall not contain the fields S(R) and acknowledgement bit map.

In the other cases the total number of the acknowledged segments shall be equal to the number in the acknowledgement length field. The "total number of the acknowledged segments" refers to the number of segments, which are incorporated into the acknowledgement PDU. In the case of 000001₂ binary, only S(R) is present and the bit map is empty. Because the segment indicated by S(R) is implicitly not acknowledged (not correctly received), the length of the bit map is Acknowledgement length minus one. The acknowledgement bit map shall indicate the reception status (STATUS) of each segment starting from the next segment after the S(R) and moving forwards one segment at a time, up to the segment with the highest sequence number that is covered by the acknowledgement block. The status of the segment shall be set to "1" if it is correctly received and to "0" if it is not correctly received. All segments prior to the one referred to by the S(R) shall be correctly received in the indicated TL-SDU except when more than one acknowledgement block refers to the same TL-SDU, see note 4 in table 21.13. When more than one acknowledgement block refers to the same TL-SDU in the same AL-ACK or AL-RNR PDU, there may be a range of correctly received segments between the segments indicated in the acknowledgement blocks (see note 1). Furthermore, if there are no missing segments to indicate in the last acknowledgement block, the S(R) shall be set to "Rest of SDU correctly received".

If only a single acknowledgement block refers to the TL-SDU, the acknowledgement block shall include the reception status for the first incorrectly received segment and all following segments up to the segment with highest sequence number that has been correctly received, if permitted by the available room in the AL-ACK or AL-RNR PDU.

If multiple acknowledgement blocks refer to the same TL-SDU, then:

- the first acknowledgement block shall include the reception status for the first incorrectly received segment, and may include a bitmap with the reception status of following segments (see note 1);
- the following (including the last) acknowledgement block(s) shall include the reception status for the first incorrectly received segment after the last segment for which the previous acknowledgement block indicated the reception status, and may include a bitmap with the reception status of following segments (see note 1);
- the data receiving entity shall complete the acknowledgement of the current TL-SDU in preference to including acknowledgement blocks for other TL-SDUs. I.e. when multiple acknowledgement blocks refer to a TL-SDU, the data receiving entity is not allowed to move to the next TL-SDU before completing the acknowledgement of the current TL-SDU (by including the reception status for the last correctly received segment of the current TL-SDU).

NOTE 1: In the multiple acknowledgement blocks case, the acknowledgement length of each block may be optimized so that as few bits as possible are used to send the acknowledgement information referring to the same TL-SDU.

EXAMPLE: If only segments 0 and 58 are missing of a TL-SDU consisting of 60 segments, the data receiving entity may either send: a) one acknowledgement block including a bitmap of length 59 bits to indicate the successful reception of segments 1 to 57 and 59, or b) two acknowledgement blocks with S(R) set to 0 for the first acknowledgement block and 58 for the second acknowledgement block, and not include a bitmap in the first acknowledgement block. In this case the gap between the two acknowledgement blocks indicates that segments 1 to 57 are correctly received. Method a) uses 76 bits; method b) uses 35 bits.

If the number of segments in the TL-SDU being acknowledged is unknown (i.e. the AL-FINAL segment has not been received), then:

- if the highest segment number received is N and all segments up to segment N have been received, then one acknowledgement block indicating segment N + 1 as not received shall be sent. This shall be done by setting "Acknowledgement length" to 1, and S(R) equal to N + 1;
- if the highest segment number received is N and there are missing segments below segment N, then one or more acknowledgement blocks shall be sent indicating the reception status of segments up to and including segment N, if permitted by the available room in the AL-ACK or AL-RNR PDU. In this case, the status of segment N + 1 shall not be included in any acknowledgement bitmap;
- if no segments have been received, then segment 0 may be indicated as not received ("Acknowledgement length" set to 1, and S(R) set to 0). Alternatively, the data receiving entity may set "Acknowledgement length" to "Repeat the entire SDU"; however this could result in N.273 being exceeded without any segment retransmissions having taken place if N.273 is set to 0.

On a $\pi/4$ -DQPSK or D8PSK channel, when the maximum size of the TL-SDU is 2 048 octets or less, then two acknowledgement blocks in the same AL-ACK or AL-RNR PDU shall not refer to the same TL-SDU.

NOTE 2: The use of "Rest of SDU correctly received" is not applicable on a $\pi/4$ -DQPSK or D8PSK channel, when the maximum size of the TL-SDU is 2 048 octets or less.

For the data sending entity on a $\pi/4$ -DQPSK or D8PSK channel, the support of two acknowledgement blocks which refer to the same TL-SDU, in the same AL-ACK or AL-RNR PDU, is mandatory when it supports 4 096 octets as the maximum size of the TL-SDU.

For the data sending entity on a QAM channel, the support of more than one acknowledgement block which refers to the same TL-SDU, in the same AL-ACK or AL-RNR PDU, is mandatory.

NOTE 3: Instead of using more than one acknowledgement block which refers to the same TL-SDU in the same AL-ACK or AL-RNR PDU, the acknowledging entity may wait for re-reception of the incorrectly received segments before including further segments into the acknowledgements.

If the acknowledging entity wishes to send more than one acknowledgement block which refers to the same TL-SDU, those acknowledgement blocks shall be included within the same AL-ACK or AL-RNR PDU (using fragmentation if necessary); the acknowledging entity shall not divide acknowledgement blocks which refer to the same TL-SDU between multiple AL-ACK or AL-RNR PDUs.

The AL-ACK or AL-RNR PDU may also contain acknowledgement for multiple TL-SDUs being sent on this advanced link. The AL-ACK or AL-RNR PDU contains acknowledgement blocks for TL-SDUs up to the number of TL-SDUs in the window for this advanced link.

21.2.3.1a AL-X-ACK, AL-X-RNR

- PDU: AL-X-ACK (receiver ready with acknowledgement);
AL-X-RNR (receiver not ready with acknowledgement);
- service provided: Acknowledgement in extended advanced link (connection mode) flow control;
- response to: AL-X-DATA, AL-X-DATA-AR, AL-X-FINAL and AL-X-FINAL-AR;
- response expected: None;
- short description: These PDUs shall be used to acknowledge TL-SDUs and/or segments of TL-SDUs sent in an extended advanced link. They support flow control by reporting "receiver ready" or "receiver not ready" to the peer sender.

The elements of AL-X-ACK and AL-X-RNR PDUs shall be as defined in table 21.14.

Table 21.14: AL-X-ACK and AL-X-RNR PDUs contents

Information element	Length	Type	Value	Remark
LLC PDU type	4	M	see table 21.1	Supplementary LLC PDU
Supplementary LLC PDU subtype	2	M	see table 21.3	AL-X-ACK and AL-X-RNR
Flow control	1	M	0	Receiver not ready (AL-X-RNR)
			1	Receiver ready (AL-X-ACK)
Advanced link number	2	M	00 ₂	Advanced link number 1
			01 ₂	Advanced link number 2
			10 ₂	Advanced link number 3
			11 ₂	Advanced link number 4
Link feedback information flag	1	M	0	"Link feedback information" information element not present
			1	"Link feedback information" information element present
Link feedback information (see note 1)	13	C		See table 21.16
First Acknowledgement Block	variable	M		Acknowledgement block for the eldest TL-SDU being acknowledged
Other Acknowledgement Blocks	variable	O		Acknowledgement blocks for the same TL-SDU or the next TL-SDUs being acknowledged; may be repeated for up to window size N.272 TL-SDUs (see note 2)
NOTE 1: This element shall be present only if the link feedback information flag is set to 1.				
NOTE 2: An acknowledgement block may contain a continuation of the previous acknowledgement block; refer to note 4 in table 21.15.				

The acknowledgement block shall be as defined in table 21.15.

Table 21.15: Acknowledgement block information element contents in AL-X-ACK and AL-X-RNR PDUs

Information element	Length	Type	Value	Remark
N(R)	5	M		The number of the TL-SDU (see note 4)
Acknowledgement length	6	M	000000 ₂	SDU correctly received
			000001 ₂	Number of acknowledged segments
			etc.	etc.
			111110 ₂	Number of acknowledged segments
			111111 ₂	Repeat the entire SDU (see note 5)
S(R)	8 see note 1	C	00000000 ₂	Sequence number of the eldest not yet correctly received segment (see note 4)
			etc.	etc.
			11111001 ₂	Sequence number of the eldest not yet correctly received segment (see note 4)
			11111010 ₂	Rest of SDU correctly received (see notes 6 and 7)
			11111011 ₂	Rest of SDU not received (see note 6)
			11111100 ₂	All SDUs prior to this SDU correctly received (see note 6)
			11111101 ₂	Reserved
			etc.	etc.
			11111111 ₂	Reserved
Acknowledgement bit map	Variable see note 2 see note 3	C	0	Incorrectly or not yet received segment
			1	Correctly received segment
NOTE 1: The element is present if the acknowledgement length is in the range from 000001 ₂ to 111110 ₂ .				
NOTE 2: Length of the bit map is variable, each bit is set as defined.				
NOTE 3: The element is present if the acknowledgement length is in the range from 000010 ₂ to 111110 ₂ .The length of the bit map is acknowledgement length minus one.				
NOTE 4: When the available room in an acknowledgement block is not sufficient to indicate the reception status of the segments in a TL-SDU, more than one acknowledgement block may refer to the same TL-SDU. Thus an acknowledgement block may contain a continuation of the previous acknowledgement block, in which case the N(R) shall indicate the same number of the TL-SDU as in the previous acknowledgement block and the S(R) shall indicate the sequence number of the eldest not yet correctly received segment after the segments indicated by the previous acknowledgement block.				
NOTE 5: This value shall only be used in case of FCS failure.				
NOTE 6: When using this value, the acknowledgement length shall be set to 000001 ₂ .				
NOTE 7: This value shall only be used when multiple acknowledgement blocks refer to the same TL-SDU, and shall only be used in the last acknowledgement block for such a TL-SDU.				

The "link feedback information" information element (if included) shall be as defined in table 21.16.

Table 21.16: "Link feedback information" information element contents

Information element	Length	Type	Value	Remark
Channel metric type	3	M	000 ₂	Bit rate feedback
			001 ₂	E _s /N ₀ feedback
			010 ₂	Reserved
			etc.	etc.
			111 ₂	Reserved
Bit rate feedback information (see note 1)	10	C		See "bit rate feedback information" information element definition
E _s /N ₀ feedback information (see note 2)	10	C		See "E _s /N ₀ feedback information" information element definition
Reserved (see note 3)	10	C	000000000 ₂	Not used in the present document
			etc.	etc.
			111111111 ₂	Not used in the present document
NOTE 1: This element shall be present only in the case of bit rate feedback i.e. channel metric type element set to 000 ₂ .				
NOTE 2: This element shall be present only in the case of E _s /N ₀ feedback i.e. channel metric type element set to 001 ₂ .				
NOTE 3: This element shall be present only in the case of channel metric type element greater than 001 ₂ . It is not used in the present document.				

The correct reception of an entire TL-SDU shall be indicated by the acknowledgement length set to zero (000000₂). A TL-SDU FCS failure shall be indicated by the acknowledgement length set to 111111₂ binary. In these cases the acknowledgement block shall not contain the fields S(R) and acknowledgement bit map.

In the other cases the total number of the acknowledged segments shall be equal to the number in the acknowledgement length field. The "total number of the acknowledged segments" refers to the number of segments, which are incorporated into the acknowledgement PDU. In the case of 000001₂ binary, only S(R) is present and the bit map is empty. Because the segment indicated by S(R) is implicitly not acknowledged (not correctly received), the length of the bit map is Acknowledgement length minus one. The acknowledgement bit map shall indicate the reception status (STATUS) of each segment starting from the next segment after the S(R) and moving forwards one segment at a time, up to the segment with the highest sequence number that is covered by the acknowledgement block. The status of the segment shall be set to "1" if it is correctly received and to "0" if it is not correctly received. All segments prior to the one referred to by the S(R) shall be correctly received in the indicated TL-SDU except when more than one acknowledgement block refers to the same TL-SDU, see note 4 in table 21.15. When more than one acknowledgement block refers to the same TL-SDU in the same AL-X-ACK or AL-X-RNR PDU, there may be a range of correctly received segments between the segments indicated in the acknowledgement blocks (see note). Furthermore, if there are no missing segments to indicate in the last acknowledgement block, the S(R) shall be set to "Rest of SDU correctly received".

The data receiving entity shall complete the acknowledgement of a TL-SDU in preference to including acknowledgement information for other TL-SDUs. I.e. the data receiving entity is not allowed to move to the next TL-SDU before completing the acknowledgement of the current TL-SDU (by including the reception status for the last correctly received segment of the current TL-SDU). If the number of segments to be acknowledged for the TL-SDU exceeds the maximum number of segments for one acknowledgement block, the data receiving entity shall include multiple acknowledgement blocks until the reception status for the segment with highest sequence number that has been correctly received has been indicated, in preference to including acknowledgement information for other TL-SDUs.

If only a single acknowledgement block refers to the TL-SDU, the acknowledgement block shall include the reception status for the first incorrectly received segment and all following segments up to the segment with highest sequence number that has been correctly received, if permitted by the available room in the AL-X-ACK or AL-X-RNR PDU.

If multiple acknowledgement blocks refer to the same TL-SDU, then:

- the first acknowledgement block shall include the reception status for the first incorrectly received segment, and may include a bitmap with the reception status of following segments (see note);
- the following (including the last) acknowledgement block(s) shall include the reception status for the first incorrectly received segment after the last segment for which the previous acknowledgement block indicated the reception status, and may include a bitmap with the reception status of following segments (see note).

The data receiving entity may use multiple acknowledgement blocks referring to the same TL-SDU instead of a single acknowledgement block, even in the case where the acknowledgement information could have fitted within one acknowledgement block.

NOTE: In the multiple acknowledgement blocks case, the acknowledgement length of each block may be optimized so that as few bits as possible are used to send the acknowledgement information referring to the same TL-SDU.

EXAMPLE 1: If only segments 0 and 58 are missing of a TL-SDU consisting of 60 segments, the data receiving entity may either send: a) one acknowledgement block including a bitmap of length 59 bits to indicate the successful reception of segments 1 to 57 and 59, or b) two acknowledgement blocks with S(R) set to 0 for the first acknowledgement block and 58 for the second acknowledgement block, and not include a bitmap in the first acknowledgement block. In this case the gap between the two acknowledgement blocks indicates that segments 1 to 57 are correctly received. Method a) uses 78 bits; method b) uses 39 bits.

If the number of segments in the TL-SDU being acknowledged is unknown (i.e. the AL-X-FINAL segment has not been received), then:

- if the highest segment number received is N and all segments up to segment N have been received, then one acknowledgement block indicating segment N + 1 as not received shall be sent. This shall be done by setting "Acknowledgement length" to 1, and S(R) equal to N + 1. This shall be followed by an acknowledgement block indicating "Rest of SDU not received", if permitted by the available room in the AL-X-ACK or AL-X-RNR PDU;
- if the highest segment number received is N and there are missing segments below segment N, then one or more acknowledgement blocks shall be sent indicating the reception status of segments up to segment N, if permitted by the available room in the AL-X-ACK or AL-X-RNR PDU. In this case, the status of segment N + 1 shall not be included in any acknowledgement bitmap. This shall be followed by an acknowledgement block indicating "Rest of SDU not received", if permitted by the available room in the AL-X-ACK or AL-X-RNR PDU;
- if no segments have been received, the data receiving entity shall include an acknowledgement block indicating "Rest of SDU not received" as the only acknowledgement block for the TL-SDU.

The data receiving entity may wish to inform the data transmitting entity about its current lower receive window boundary. In this case, an acknowledgement block for the oldest TL-SDU that has not been completely received shall be included, setting the S(R) to "All SDUs prior to this SDU correctly received". Such acknowledgement block may only be included once and only as the first acknowledgement block in an AL-X-ACK or AL-X-RNR. This acknowledgement block does not indicate anything about the TL-SDU itself (i.e. the N(R) TL-SDU); one or more additional acknowledgement blocks for the TL-SDU shall be included in the AL-X-ACK or AL-X-RNR for this purpose.

EXAMPLE 2: If the data receiving entity receives the AL-X-FINAL-AR for TL-SDU 7 and has completely received TL-SDU 7 and all older TL-SDUs, the data receiving entity may send an AL-X-ACK containing a first acknowledgement block for TL-SDU 7 indicating "All SDUs prior to this SDU correctly received" and a second acknowledgement block for TL-SDU 7 indicating "SDU correctly received" (the procedures in clause 22.3.3.2.7 first sends the acknowledgement, then updates the window).

EXAMPLE 3: If the data receiving entity receives the AL-X-FINAL-AR for TL-SDU 7 and has completely received TL-SDU 6 and all older TL-SDUs but not received all segments of TL-SDU 7, the data receiving entity may send an AL-X-ACK containing a first acknowledgement block for TL-SDU 7 indicating "All SDUs prior to this SDU correctly received" and a further acknowledgement block (or blocks) for TL-SDU 7 indicating which segments are missing for TL-SDU 7.

EXAMPLE 4: If the data receiving entity has completely received TL-SDU 7 and all older TL-SDUs, but not received any segments of TL-SDU 8 or newer TL-SDUs, and wishes to send an AL-X-ACK (for example for flow control reasons), the data receiving entity may send an AL-X-ACK containing an acknowledgement block for TL-SDU 7 indicating "All SDUs prior to this SDU correctly received" followed by an acknowledgement block for TL-SDU 7 indicating "SDU correctly received". The data receiving entity should not include any further acknowledgement blocks for TL-SDU 8 in this case.

For the data sending entity, the support of more than one acknowledgement block which refers to the same TL-SDU, in the same AL-X-ACK or AL-X-RNR PDU, is mandatory.

If the acknowledging entity wishes to send more than one acknowledgement block which refers to the same TL-SDU, those acknowledgement blocks shall be included within the same AL-X-ACK or AL-X-RNR PDU (using fragmentation if necessary); the acknowledging entity shall not divide acknowledgement blocks which refer to the same TL-SDU between multiple AL-X-ACK or AL-X-RNR PDUs.

The AL-X-ACK or AL-X-RNR PDU may also contain acknowledgement for multiple TL-SDUs being sent on this extended advanced link. The AL-X-ACK or AL-X-RNR PDU contains acknowledgement blocks for TL-SDUs up to the number of TL-SDUs in the window for this advanced link.

21.2.3.2 AL-FINAL, AL-FINAL-AR

- PDU: AL-FINAL (last data of a TL-SDU);
AL-FINAL-AR (last data of a TL-SDU with immediate acknowledgement required);
- service provided: Data transfer in original advanced link (connection mode);
- response to: -;
- response expected: AL-ACK to the AL-FINAL-AR;
- short description: These PDUs shall be used to send the last segment in a TL-SDU or a whole TL-SDU in the original advanced link. When an immediate response is required, AL-FINAL-AR shall be used.

The elements of AL-FINAL and AL-FINAL-AR PDUs shall be as defined in table 21.17.

Table 21.17: AL-FINAL and AL-FINAL-AR PDUs contents

Information element	Length	Type	Value	Remark
LLC PDU type	4	M	see table 21.1	AL-DATA, AL-DATA-AR, AL-FINAL and AL-FINAL-AR
FINAL	1	M	1	Last segment with FCS (AL-FINAL and AL-FINAL-AR)
AR	1	M	0	No immediate response (AL-FINAL)
			1	Immediate response required (AL-FINAL-AR)
N(S)	3	M		Sent TL-SDU number
S(S)	8	M		Sent segment sequence number
The last segment of TL-DATA SDU	Variable see note 1	O		The last segment of TL-DATA SDU
FCS	32 see note 2	M		Frame Check Sequence
NOTE 1: This PDU may contain no data from the TL-DATA request primitive, see note 2.				
NOTE 2: The size shown is the upper limit of the FCS field; a part of the FCS could be in the previous AL-DATA PDU.				

21.2.3.2a AL-X-FINAL, AL-X-FINAL-AR

- PDU: AL-X-FINAL (last data of a TL-SDU);
AL-X-FINAL-AR (last data of a TL-SDU with immediate acknowledgement required);
- service provided: Data transfer in extended advanced link (connection mode);
- response to: -;
- response expected: AL-X-ACK to the AL-X-FINAL-AR;
- short description: These PDUs shall be used to send the last segment in a TL-SDU or a whole TL-SDU in an extended advanced link. When an immediate response is required, AL-X-FINAL-AR shall be used.

The elements of AL-X-FINAL and AL-X-FINAL-AR PDUs shall be as defined in table 21.18.

Table 21.18: AL-X-FINAL and AL-X-FINAL-AR PDUs contents

Information element	Length	Type	Value	Remark
LLC PDU type	4	M	see table 21.1	Supplementary LLC PDU
Supplementary LLC PDU subtype	2	M	see table 21.3	AL-X-DATA, AL-X-DATA-AR, AL-X-FINAL and AL-X-FINAL-AR
FINAL	1	M	1	Last segment, optionally with FCS (AL-X-FINAL and AL-X-FINAL-AR)
AR	1	M	0	No immediate response (AL-X-FINAL)
			1	Immediate response required (AL-X-FINAL-AR)
Advanced link number	2	M	00 ₂	Advanced link number 1
			01 ₂	Advanced link number 2
			10 ₂	Advanced link number 3
			11 ₂	Advanced link number 4
N(S)	5	M		Sent TL-SDU number
S(S)	8	M		Sent segment sequence number
FCS flag	1	M	0	No FCS
			1	FCS used
The last segment of TL-DATA SDU	Variable see note 1	O		The last segment of TL-DATA SDU
FCS	32 see note 2	C		Frame Check Sequence. Included when FCS flag is set to 1
NOTE 1: This PDU may contain no data from the TL-DATA request primitive. This may occur in some cases when the FCS is used, see note 2. It may also occur occasionally even if the FCS is not used.				
NOTE 2: The size shown is the upper limit of the FCS field (when used); a part or all of the FCS could be in the previous AL-X-DATA PDU.				

The LLC header of AL-X-FINAL and AL-X-FINAL-AR is one bit longer than the LLC header of AL-X-DATA and AL-X-DATA-AR. Therefore there are occasional cases when the last part of the TL-SDU (and FCS when used) just fits within an AL-X-DATA or AL-X-DATA-AR PDU but would not fit within an AL-X-FINAL or AL-X-FINAL-AR PDU. In these cases, the data sending entity should send the last part of the TL-SDU (and FCS when used) within an AL-X-DATA or AL-X-DATA-AR PDU and then send an empty AL-X-FINAL or AL-X-FINAL-AR PDU (i.e. containing no information after the FCS flag) to complete the TL-SDU transmission.

21.2.3.3 AL-DATA, AL-DATA-AR

- PDU: AL-DATA (acknowledged information transfer);
AL-DATA-AR (acknowledged information transfer with immediate response);
- service provided: Data transfer in original advanced link (connection mode);
- response to: -;
- response expected: AL-ACK to the AL-DATA-AR;
- short description: These PDUs shall be used to send all other segments than the last one of a TL-SDU in the original advanced link. When the data sending entity requests an immediate acknowledgement, AL-DATA-AR shall be used. For the transmission of the last segment, see AL-FINAL/AL-FINAL-AR PDU.

The elements of AL-DATA and AL-DATA-AR PDUs shall be as defined in table 21.19.

Table 21.19: AL-DATA and AL-DATA-AR PDUs contents

Information element	Length	Type	Value	Remark
LLC PDU type	4	M	see table 21.1	AL-DATA, AL-DATA-AR, AL-FINAL and AL-FINAL-AR
FINAL	1	M	0	Not the last segment (AL-DATA and AL-DATA-AR)
AR	1	M	0	No immediate response (AL-DATA)
			1	Immediate response required (AL-DATA-AR)
N(S)	3	M		Sent TL-SDU number
S(S)	8	M		Sent segment sequence number
Segment of TL-SDU	Varies	M		A segment of TL-SDU. The length depends on the MAC block used (see clause 21.3.2).

21.2.3.3a AL-X-DATA, AL-X-DATA-AR

- PDU: AL-X-DATA (acknowledged information transfer);
AL-X-DATA-AR (acknowledged information transfer with immediate response);
- service provided: data transfer in extended advanced link (connection mode);
- response to: -;
- response expected: AL-X-ACK to the AL-X-DATA-AR;
- short description: these PDUs shall be used to send all other segments than the last one of a TL-SDU in an extended advanced link. When the data sending entity requests an immediate acknowledgement, AL-X-DATA-AR shall be used. For the transmission of the last segment, see AL-X-FINAL/AL-X-FINAL-AR PDU.

The elements of AL-X-DATA and AL-X-DATA-AR PDUs shall be as defined in table 21.20.

Table 21.20: AL-X-DATA and AL-X-DATA-AR PDUs contents

Information element	Length	Type	Value	Remark
LLC PDU type	4	M	see table 21.1	Supplementary LLC PDU
Supplementary LLC PDU subtype	2	M	see table 21.3	AL-X-DATA, AL-X-DATA-AR, AL-X-FINAL and AL-X-FINAL-AR
FINAL	1	M	0	Not the last segment (AL-X-DATA and AL-X-DATA-AR)
AR	1	M	0	No immediate response (AL-X-DATA)
			1	Immediate response required (AL-X-DATA-AR)
Advanced link number	2	M	00 ₂	Advanced link number 1
			01 ₂	Advanced link number 2
			10 ₂	Advanced link number 3
			11 ₂	Advanced link number 4
N(S)	5	M		Sent TL-SDU number
S(S)	8	M		Sent segment sequence number
Segment of TL-SDU	Varies	M		A segment of TL-SDU. The length depends on the MAC block used (see clause 21.3.2)

21.2.3.4 AL-DISC

- PDU: AL-DISC (disconnection phase of the advanced link);
- service provided: disconnection of an advanced link (connection mode);
- response to: AL-DISC, see protocol definition for parameters;
- response expected: AL-DISC or none, see protocol definition for parameters;
- short description: this PDU is used to disconnect an advanced link.

The elements of AL-DISC PDU shall be as defined in table 21.21.

Table 21.21: AL-DISC PDU contents

Information element	Length	Type	Value	Remark
LLC PDU type	4	M	see table 21.1	AL-DISC
Advanced link service	1	M	0	Unacknowledged service
			1	Acknowledged service
Advanced link number	2	M	00 ₂	Advanced link number 1
			01 ₂	Advanced link number 2
			10 ₂	Advanced link number 3
			11 ₂	Advanced link number 4
Report	3	M	000 ₂	Success
			001 ₂	Close
			010 ₂	Reject
			011 ₂	Service not supported
			100 ₂	Service temporarily unavailable
			101 ₂	Reserved
			110 ₂	Reserved
111 ₂	Reserved			

The advanced link number is used locally between MS and BS to distinguish concurrent advanced links. The link identifier in the MLE primitives is mapped against an advanced link number.

21.2.3.4a AL-RECONNECT

- PDU: AL-RECONNECT;
- service provided: LLC reconnection of advanced link after cell reselection;
- response to: AL-RECONNECT, see protocol definition for parameters;
- response expected: AL-RECONNECT, see protocol definition for parameters;
- short description: This PDU is used by the LLC in the MS to request that an advanced link which was used on the previous cell is reconnected on the current cell and all the advanced link parameters are maintained.

The elements of AL-RECONNECT PDU shall be as defined in table 21.22.

Table 21.22: AL-RECONNECT PDU contents

Information element	Length	Type	Value	Remark
LLC PDU type	4	M	see table 21.1	AL-RECONNECT
Advanced link service	1	M	0	Unacknowledged service (see note)
			1	Acknowledged service
Advanced link number N.261	2	M	00 ₂	Advanced link number 1
			01 ₂	Advanced link number 2
			10 ₂	Advanced link number 3
			11 ₂	Advanced link number 4
Reconnect report	2	M	00 ₂	Propose
			01 ₂	Reject
			10 ₂	Accept
			11 ₂	Reserved
NOTE: The present document does not support reconnection of an unacknowledged advanced link.				

21.2.3.5 AL-SETUP

- PDU: AL-SETUP (acknowledged or unacknowledged information containing advanced link set-up parameters);
- service provided: Advanced link establishment or reset;
- response to: AL-SETUP in point-to-point case, see protocol;
- response expected: AL-SETUP or none in point-to-multipoint case, see protocol;
- short description: This PDU is used to establish the advanced link and to reset an established advanced link.

The elements of AL-SETUP PDU shall be as defined in table 21.23.

Table 21.23: AL-SETUP PDU contents

Information element	Length	Type	Value	Remark
LLC PDU type	4	M	see table 21.1	AL-SETUP
Advanced link service	1	M	0	Unacknowledged service
			1	Acknowledged service
Advanced link number N.261	2	M	00 ₂	Advanced link number 1
			01 ₂	Advanced link number 2
			10 ₂	Advanced link number 3
			11 ₂	Advanced link number 4
Maximum length of a TL-SDU N.271	3	M	000 ₂	32 octets
			001 ₂	64 octets
			010 ₂	128 octets
			011 ₂	256 octets
			100 ₂	512 octets
			101 ₂	1 024 octets
			110 ₂	2 048 octets
Connection width (see note 11)	1	M	0	Single-slot phase modulation connection (if the "Data transfer throughput" element is not set to 110 ₂); or No information about radio resources (if the "Data transfer throughput" element is set to 110 ₂)
			1	Specified multislot phase modulation connection (if the "Data transfer throughput" element is not set to 110 ₂); or Unspecified phase modulation connection (if the "Data transfer throughput" element is set to 110 ₂) (see note 12)
Advanced link symmetry (see note 11)	1	M	0	Symmetric phase modulation advanced link, or unspecified phase modulation connection, or no information about radio resources
			1	Asymmetric phase modulation advanced link
Number of $\pi/4$ -DQPSK timeslots per TDMA frame on uplink or on uplink and downlink N.264 (see notes 1, 11 and 13)	2	C	00 ₂	1 timeslot
			01 ₂	2 timeslots
			10 ₂	3 timeslots
			11 ₂	4 timeslots
Number of $\pi/4$ -DQPSK timeslots per TDMA frame on downlink N.264 (see notes 2 and 11)	2	C	00 ₂	1 timeslot
			01 ₂	2 timeslots
			10 ₂	3 timeslots
			11 ₂	4 timeslots
Data transfer throughput (mean value) (see notes 3 and 11)	3	M	000 ₂	Network dependent minimum
			001 ₂	1/32 of maximum
			010 ₂	1/16 of maximum
			011 ₂	1/8 of maximum
			100 ₂	1/4 of maximum
			101 ₂	1/2 of maximum
			110 ₂	No information about radio resources (if the "Connection width" element is set to "0"); or Unspecified phase modulation connection (if the "Connection width" element is set to "1")
111 ₂	Maximum			

Information element	Length	Type	Value	Remark
TL-SDU window size N.272 or N.281 (see note 4)	2	M	00 ₂	Augmented AL-SETUP
			01 ₂	SDU window size = 1
			10 ₂	SDU window size = 2
			11 ₂	SDU window size = 3
Maximum number of TL-SDU retransmissions N.273 or TL-SDU repetition N.282 (see note 5)	3	M	000 ₂	no retransmissions
			001 ₂	1 retransmission
			etc.	etc.
			111 ₂	7 retransmissions
Maximum number of segment retransmissions N.274	4	M	0000 ₂	no retransmissions
			0001 ₂	1 retransmission
			etc.	etc.
			1111 ₂	15 retransmissions
Set-up report	3	M	000 ₂	Success
			001 ₂	Service definition
			010 ₂	Service change
			011 ₂	Reset
			100 ₂	Success, but SMDCP QoS incomplete
			101 ₂	Reserved
			110 ₂	Reserved
			111 ₂	Reserved
N(S) (see note 6)	8	C		Sent TL-SDU number
Advanced link type (see notes 7 and 8)	1	C	0	Original advanced link
			1	Extended advanced link
TL-SDU window size N.272 or N.281 for original advanced link using augmented AL-SETUP (see notes 4 and 9)	2	C	00 ₂	Reserved
			01 ₂	SDU window size = 1
			10 ₂	SDU window size = 2
			11 ₂	SDU window size = 3
TL-SDU window size N.272 or N.281 for extended advanced link (see notes 4 and 10)	4	C	0000 ₂	Reserved
			0001 ₂	SDU window size = 1
			etc.	etc.
			1111 ₂	SDU window size = 15
Reserved (see note 7)	3	C	000 ₂	Default value
			001 ₂	Not used in the present document
			etc.	etc.
			111 ₂	Not used in the present document
<p>NOTE 1: This element shall be present only for a specified multislot phase modulation connection or unspecified phase modulation connection (i.e. this element shall be present if the "Connection width" element is set to "1"). In case of a symmetric specified phase modulation advanced link, the "Number of $\pi/4$-DQPSK timeslots per TDMA frame on uplink or on uplink and downlink" element defines the number of phase modulation timeslots requested per TDMA frame on both uplink and downlink.</p> <p>NOTE 2: This element shall be present only for a specified multislot phase modulation connection with asymmetric phase modulation advanced link (i.e. "Connection width" element set to "1" and "Advanced link symmetry" element set to "1"). If present, this element defines the number of phase modulation timeslots requested per TDMA frame on the downlink. The usage of asymmetric phase modulation advanced link is outside the scope of the present document.</p>				

Information element	Length	Type	Value	Remark
NOTE 3:				The BS may use a control channel as a general packet data channel, supporting advanced links for many MSs, where each MS may be offering/receiving data packets at a low rate or intermittently. When the "Data transfer throughput" element is not set to 110 ₂ , it gives the BS the necessary information for planning its resource allocations; this data transfer throughput information is specified relative to the requested number of $\pi/4$ -DQPSK timeslots per TDMA frame. When the "Data transfer throughput" element is set to 110 ₂ and the "Connection width" element is set to "1", the AL-SETUP PDU is requesting a phase modulation connection without specifying the requested number of timeslots per frame or the mean data transfer throughput. In this case the BS should choose any phase modulation channel within the capabilities of that MS. (If a phase modulation channel is not available and the MS is QAM-capable, the BS may choose a QAM channel within the MS's capabilities.) When the "Data transfer throughput" element is set to 110 ₂ and the "Connection width" element is set to "0", the AL-SETUP PDU provides no information relating to radio resources, in which case the BS should choose any appropriate channel (within the capabilities of that MS and using any throughput information negotiated by the SMDCP during PDP context activation).
NOTE 4:				TL-SDU window sizes N.272 and N.281 are for the acknowledged and unacknowledged services respectively.
NOTE 5:				For the acknowledged service N.273 defines how many times the TL-SDU may be re-transmitted and, for the unacknowledged (point-to-multipoint) service, N.282 means the number of times the TL-SDU will be repeated by the sender.
NOTE 6:				This element shall be present only for the unacknowledged service (i.e. "advanced link service" element set to "0").
NOTE 7:				This element shall be present only for an augmented AL-SETUP (i.e. "TL-SDU window size" element set to 00 ₂).
NOTE 8:				In the present document there is no reason to use an augmented AL-SETUP for the original advanced link; however, the possibility is supported in order that the Reserved element can be used in the future for both types of advanced link. An augmented AL-SETUP is needed in the case of an extended advanced link.
NOTE 9:				This element shall be present only for an augmented AL-SETUP for the original advanced link (i.e. "TL-SDU window size" element set to 00 ₂ and "Advanced link type" element set to "0").
NOTE 10:				This element shall be present only for an augmented AL-SETUP for an extended advanced link (i.e. "TL-SDU window size" element set to 00 ₂ and "Advanced link type" element set to "1").
NOTE 11:				In the case of a request for a phase modulation connection, the BS should regard this as a request for either a $\pi/4$ -DQPSK connection or a D8PSK connection (if the MS has indicated that it supports D8PSK channels).
NOTE 12:				An MS that cannot use a multislot phase modulation channel shall not request an unspecified phase modulation connection. (A request for an unspecified phase modulation connection is indicated by setting the "Connection width" element to "1" and the "Data transfer throughput" element to 110 ₂ .)
NOTE 13:				If the MS requests an unspecified phase modulation connection (i.e. "Connection width" element set to "1" and "Data transfer throughput" element set to 110 ₂), the "Number of $\pi/4$ -DQPSK timeslots per TDMA frame on uplink or on uplink and downlink" element shall be set equal to the MS's maximum phase modulation capability.

The advanced link number is used locally between MS and BS to distinguish concurrent advanced links. The link identifier in the MLE primitives is mapped against an advanced link number.

The AL-SETUP PDU may contain information related to radio resources (for example, if an MS that supports QAM modulation specifically requires a phase modulation channel or if an MS that supports only phase modulation wishes to request a specific number of timeslots per TDMA frame). This facility in the AL-SETUP PDU provides radio resource information only in terms of $\pi/4$ -DQPSK timeslots:

- Inclusion of information requesting a specific number of phase modulation timeslots per TDMA frame is indicated by setting the "Data transfer throughput" element to a value other than 110₂. Then the combination of the "Connection width", "Advanced link symmetry", "Number of $\pi/4$ -DQPSK timeslots per TDMA frame on uplink or on uplink and downlink" and "Number of $\pi/4$ -DQPSK timeslots per TDMA frame on downlink" elements indicate the requested radio resources in terms of $\pi/4$ -DQPSK timeslots. The "Data transfer throughput" element indicates how much of the total throughput of the requested radio resources ($\pi/4$ -DQPSK timeslots) should be available for the advanced link. Maximum throughput will be realized when there is only one MS using the whole capacity of the radio resource allocation. The lower values indicate that the same radio resources may be used for multiple advanced links for one or more MSs. The values are mean values and the usage allocation during the lifetime of an advanced link is outside of the scope of the present document.

- A request for a phase modulation channel without requesting a specific number of timeslots per TDMA frame is indicated by setting the "Connection width" element to "1" and the "Data transfer throughput" element to 110_2 ("Unspecified phase modulation connection"). In this case the "Number of $\pi/4$ -DQPSK timeslots per TDMA frame on uplink or on uplink and downlink" element shall be set equal to the MS's maximum phase modulation capability and the "Advanced link symmetry" element shall be set to "0".

Alternatively (for example, if the MS wishes the BS to choose any appropriate channel (within the capabilities of that MS and using any QoS information negotiated by the SMDCP during PDP context activation)), the AL-SETUP PDU may provide no information related to radio resources. This is indicated by setting the "Connection width" element to "0" and the "Data transfer throughput" element to 110_2 ("No information about radio resources"). In this case the "Advanced link symmetry" element shall be set to "0".

If the AL-SETUP PDU provided no information related to radio resources and the SwMI SMDCP has a complete record of the QoS information for the MS, the SwMI LLC shall respond with the "Set-up report" information element in the responding AL-SETUP PDU set to "Success" (000_2).

If the AL-SETUP PDU provided no information related to radio resources and the SwMI SMDCP might have an incomplete record of the QoS information for the MS, the SwMI LLC shall respond with the "Set-up report" information element in the responding AL-SETUP PDU set to "Success, but SMDCP QoS incomplete" (100_2).

Values 01_2 , 10_2 , and 11_2 in the "TL-SDU window size" element indicate the SDU window size. Value 00_2 in the "TL-SDU window size" element indicates that this is an augmented AL-SETUP. In this case the following conditional elements shall be included:

- advanced link type;
- TL-SDU window size for original or extended advanced link using augmented AL-SETUP; and
- a reserved element.

If the AL-SETUP is not augmented, the recipient shall assume that the AL-SETUP is for the original advanced link.

21.2.3.6 AL-UDATA

- PDU: AL-UDATA (unacknowledged information transfer);
- service provided: Unacknowledged data transfer in original advanced link;
- response to: -;
- response expected: None;
- short description: This PDU is used to send one segment of unacknowledged TL-SDU in the original advanced link.

The elements of AL-UDATA PDU shall be as defined in table 21.24.

Table 21.24: AL-UDATA PDU contents

Information element	Length	Type	Value	Remark
LLC PDU type	4	M	see table 21.1	AL-UDATA and AL-UFINAL
FINAL	1	M	0	Not the last segment (AL-UDATA)
N(S)	8	M		Sent TL-SDU number
S(S)	8	M		Sent segment sequence number
Segment of TL-UNITDATA	Variable	M		Segment of TL-UNITDATA

21.2.3.6a AL-X-UDATA

- PDU: AL-X-UDATA (unacknowledged information transfer);
- service provided: Unacknowledged data transfer in extended advanced link;
- response to: -;
- response expected: None;
- short description: This PDU is used to send one segment of unacknowledged TL-SDU in an extended advanced link.

The elements of AL-X-UDATA PDU shall be as defined in table 21.25.

Table 21.25: AL-X-UDATA PDU contents

Information element	Length	Type	Value	Remark
LLC PDU type	4	M	see table 21.1	Supplementary LLC PDU
Supplementary LLC PDU subtype	2	M	see table 21.3	AL-X-UDATA and AL-X-UFINAL
FINAL	1	M	0	Not the last segment (AL-X-UDATA)
Advanced link number	2	M	00 ₂	Advanced link number 1
			01 ₂	Advanced link number 2
			10 ₂	Advanced link number 3
			11 ₂	Advanced link number 4
N(S)	8	M		Sent TL-SDU number
S(S)	8	M		Sent segment sequence number
Segment of TL-UNITDATA	Variable	M		Segment of TL-UNITDATA

21.2.3.7 AL-UFINAL

- PDU: AL-UFINAL (unacknowledged information transfer);
- service provided: Unacknowledged data transfer in original advanced link;
- response to: -;
- response expected: None;
- short description: This PDU is used to send the last segment of an unacknowledged TL-SDU in the original advanced link.

The elements of AL-UFINAL PDU shall be as defined in table 21.26.

Table 21.26: AL-UFINAL PDU contents

Information element	Length	Type	Value	Remark
LLC PDU type	4	M	see table 21.1	AL-UDATA and AL-UFINAL
FINAL	1	M	1	Last segment with FCS (AL-UFINAL)
N(S)	8	M		Sent TL-SDU number
S(S)	8	M		Sent segment sequence number
Last segment of TL-UNITDATA	Variable see note 1	O		Last segment of TL-UNITDATA
FCS	32 see note 2	M		Frame Check Sequence
NOTE 1: This PDU may contain no data from the TL-UNITDATA request primitive, see note 2.				
NOTE 2: The size shown is the upper limit of the FCS field; a part of the FCS could be in the previous AL-UDATA PDU.				

21.2.3.7a AL-X-UFINAL

- PDU: AL-X-UFINAL (unacknowledged information transfer);
- service provided: Data transfer in extended advanced link;
- response to: -;
- response expected: None;
- short description: This PDU is used to send the last segment of an unacknowledged TL-SDU in an extended advanced link.

The elements of AL-X-UFINAL PDU shall be as defined in table 21.27.

Table 21.27: AL-X-UFINAL PDU contents

Information element	Length	Type	Value	Remark
LLC PDU type	4	M	see table 21.1	Supplementary LLC PDU
Supplementary LLC PDU subtype	2	M	see table 21.3	AL-X-UDATA and AL-X-UFINAL
FINAL	1	M	1	Last segment, optionally with FCS (AL-X-UFINAL)
Advanced link number	2	M	00 ₂	Advanced link number 1
			01 ₂	Advanced link number 2
			10 ₂	Advanced link number 3
			11 ₂	Advanced link number 4
N(S)	8	M		Sent TL-SDU number
S(S)	8	M		Sent segment sequence number
FCS flag	1	M	0	No FCS
			1	FCS used
Last segment of TL-UNITDATA	Variable see note 1	O		Last segment of TL-UNITDATA
FCS	32 see note 2	C		Frame Check Sequence. Included when FCS flag is set to 1
NOTE 1: This PDU may contain no data from the TL-UNITDATA request primitive. This may occur in some cases when the FCS is used, see note 2. It may also occur occasionally even if the FCS is not used.				
NOTE 2: The size shown is the upper limit of the FCS field (when used); a part or all of the FCS could be in the previous AL-X-UDATA PDU.				

The LLC header of AL-X-UFINAL is one bit longer than the LLC header of AL-X-UDATA. Therefore there are occasional cases when the last part of the TL-SDU (and FCS when used) just fits within an AL-X-UDATA PDU but would not fit within an AL-X-UFINAL PDU. In these cases, the data sending entity should send the last part of the TL-SDU (and FCS when used) within an AL-X-UDATA PDU and then send an empty AL-X-UFINAL PDU (i.e. containing no information after the FCS flag) to complete the TL-SDU transmission.

21.2.4 Layer 2 signalling PDU definitions

21.2.4.0 General

The layer 2 signalling PDUs carry various types of general signalling information relating to layer 2 functions - either LLC or MAC functions.

NOTE: For convenience, the layer 2 signalling PDUs are treated as LLC PDUs in the PDU structures. Where a layer 2 signalling PDU relates to a MAC function:

- in the case of transmission, information to be included in the layer 2 signalling PDU is passed locally from the MAC to the LLC using the TLE-UNITDATA request primitive;
- in the case of reception, information that has been received in the layer 2 signalling PDU is passed locally from the LLC to the MAC using the TLE-UNITDATA indication primitive.

The following layer 2 signalling PDUs are defined:

- L2-DATA-PRIORITY;
- L2-SCHEDULE-SYNC;
- L2-LINK-FEEDBACK-CONTROL;
- L2-LINK-FEEDBACK-INFO;
- L2-LINK-FEEDBACK-INFO-AND-RESIDUAL-DATA-PRIORITY.

21.2.4.1 L2-DATA-PRIORITY

- PDU: L2-DATA-PRIORITY;
- response to: -;
- response expected: None;
- short description: This PDU is used for the MS to indicate its current short-term data priority requirements to the BS.

The elements of L2-DATA-PRIORITY PDU shall be as defined in table 21.28.

Table 21.28: L2-DATA-PRIORITY PDU contents

Information element	Length	Type	Value	Remark
LLC PDU type	4	M	see table 21.1	Layer 2 signalling PDU
Layer 2 signalling PDU subtype	4	M	see table 21.2	L2-DATA-PRIORITY
Number of data priority blocks	3	M	000 ₂	No data priority blocks
			001 ₂	One data priority block
			etc.	etc.
			111 ₂	7 data priority blocks
Data priority block	7	C		See notes 1 and 2
Residual data priority (see note 3)	3	M	000 ₂	Priority 0 (lowest)
			etc.	etc.
			111 ₂	Priority 7 (highest)
NOTE 1: This element shall be present as many times as indicated by the "number of data priority blocks" element. If the "number of data priority blocks" element has value 000 ₂ , the data priority block element is not present.				
NOTE 2: The data priority blocks shall be included in decreasing order of data priority (i.e. highest data priority first).				
NOTE 3: This is the data priority for slots following those enumerated in the data priority blocks.				

The data priority block shall be as defined in table 21.29.

Table 21.29: Data priority block information element contents in L2-DATA-PRIORITY PDU

Information element	Length	Type	Value	Remark
Temporary data priority	3	M	000 ₂	Priority 0 (lowest)
			etc.	etc.
			111 ₂	Priority 7 (highest)
Number of slots (see note)	4	M	0000 ₂	1 subslot required
			0001 ₂	1 slot required
			0010 ₂	2 slots required
			0011 ₂	3 slots required
			0100 ₂	4 slots required
			0101 ₂	5 slots required
			0110 ₂	6 slots required
			0111 ₂	8 slots required
			1000 ₂	10 slots required
			1001 ₂	13 slots required
			1010 ₂	17 slots required
			1011 ₂	24 slots required
			1100 ₂	34 slots required
			1101 ₂	51 slots required
1110 ₂	68 slots required			
1111 ₂	Reserved			
NOTE: This element indicates the number of slots required with the specified temporary data priority.				

21.2.4.2 L2-SCHEDULE-SYNC

- PDU: L2-SCHEDULE-SYNC;
- response to: -;
- response expected: None;
- short description: This PDU is used for the BS to give schedule synchronization to the MS for the specified NSAPI.

The elements of L2-SCHEDULE-SYNC PDU shall be as defined in table 21.30.

Table 21.30: L2-SCHEDULE-SYNC PDU contents

Information element	Length	Type	Value	Remark
LLC PDU type	4	M	see table 21.1	Layer 2 signalling PDU
Layer 2 signalling PDU subtype	4	M	see table 21.2	L2-SCHEDULE-SYNC
NSAPI	4	M	0000 ₂	Reserved
			0001 ₂	NSAPI 1
			etc.	etc.
			1110 ₂	NSAPI 14
			1111 ₂	Reserved
Timeslot number (see note)	2	M	00 ₂	Timeslot 1
			01 ₂	Timeslot 2
			10 ₂	Timeslot 3
			11 ₂	Timeslot 4
Frame number (see note)	5	M	00000 ₂	Reserved
			00001 ₂	Frame 1
			etc.	etc.
			10010 ₂	Frame 18
			Others	Reserved
Multiframe number (see note)	6	M	000000 ₂	Reserved
			000001 ₂	Multiframe 1
			etc.	etc.
			111100 ₂	Multiframe 60
			Others	Reserved
NOTE: The timeslot number, frame number and multiframe number together comprise the schedule synchronization point for the specified NSAPI.				

21.2.4.3 L2-LINK-FEEDBACK-CONTROL

- PDU: L2-LINK-FEEDBACK-CONTROL;
- response to: -;
- response expected: L2-LINK-FEEDBACK-INFO / -;
- short description: This PDU is used for the control of link adaptation feedback on a D8PSK or QAM channel; in the present document it is sent only by the BS.

The elements of L2-LINK-FEEDBACK-CONTROL PDU shall be as defined in table 21.31.

Table 21.31: L2-LINK-FEEDBACK-CONTROL PDU contents

Information element	Length	Type	Value	Remark
LLC PDU type	4	M	see table 21.1	Layer 2 signalling PDU
Layer 2 signalling PDU subtype	4	M	see table 21.2	L2-LINK-FEEDBACK-CONTROL
Link feedback control type	3	M	000 ₂	Feedback request
			001 ₂	Feedback termination
			010 ₂	Reserved
			etc.	etc.
			111 ₂	Reserved
Feedback request (see note 1)	variable	C		See table 21.32
Feedback termination (see note 2)	variable	C		See table 21.33
NOTE 1: This element shall be present only in the case of a feedback request i.e. link feedback control type element set to 000 ₂ .				
NOTE 2: This element shall be present only in the case of a feedback termination i.e. link feedback control type element set to 001 ₂ .				

The feedback request information element shall be as defined in table 21.32.

Table 21.32: Feedback request information element contents

Information element	Length	Type	Value	Remark
Channel metric type (see note 1)	3	M	000 ₂	Bit rate feedback
			001 ₂	E_s/N_0 feedback
			010 ₂	Reserved
			etc.	etc.
			111 ₂	Reserved
Feedback duration T.230 (see note 2)	6	M	000000 ₂	No unsolicited feedback messages permitted
			000001 ₂	2 multiframe
			000010 ₂	4 multiframe
			etc.	etc.
			111111 ₂	126 multiframe
Minimum feedback interval T.231 (see note 3)	3	C	000 ₂	6 TDMA frames
			001 ₂	9 TDMA frames
			010 ₂	12 TDMA frames
			011 ₂	18 TDMA frames
			100 ₂	27 TDMA frames
			101 ₂	36 TDMA frames
			110 ₂	54 TDMA frames
			111 ₂	Predefined (see note 4)

Information element	Length	Type	Value	Remark
Data class linkage (see note 5)	3	C	000 ₂	Background class
			001 ₂	Telemetry class
			010 ₂	Real-time class
			011 ₂	Reserved
			etc.	etc.
			111 ₂	Reserved
NOTE 1: This element indicates the preferred type of channel performance metric to which the feedback request applies.				
NOTE 2: This element indicates whether unsolicited feedback messages may be sent after the immediate response to this feedback request; if the element is not set to 000000 ₂ , it indicates the maximum time for which unsolicited feedback messages may be sent relating to this feedback request.				
NOTE 3: This element shall be present only if unsolicited feedback messages are permitted i.e. feedback duration element not set to 000000 ₂ . It indicates the minimum permitted time since the last feedback message for unsolicited feedback messages.				
NOTE 4: This value indicates that the MS shall use a predefined value for timer T.231; see annex B.				
NOTE 5: This element shall be present only in the case of a feedback request relating to bit rate feedback i.e. channel metric type element set to 000 ₂ . It indicates the specific data class to which the feedback request applies.				

The feedback termination information element shall be as defined in table 21.33.

Table 21.33: Feedback termination information element contents

Information element	Length	Type	Value	Remark
Channel metric type (see note 1)	3	M	000 ₂	Bit rate feedback
			001 ₂	E_s/N_0 feedback
			010 ₂	Reserved
			etc.	etc.
			111 ₂	Reserved
			Data class linkage (see note 2)	3
001 ₂	Telemetry class			
010 ₂	Real-time class			
011 ₂	Reserved			
etc.	etc.			
111 ₂	Reserved			
NOTE 1: This element indicates the type of channel performance metric to which the feedback termination applies.				
NOTE 2: This element shall be present only in the case of a feedback termination relating to bit rate feedback i.e. channel metric type element set to 000 ₂ . It indicates the specific data class to which the feedback termination applies.				

21.2.4.4 L2-LINK-FEEDBACK-INFO

- PDU: L2-LINK-FEEDBACK-INFO;
- response to: L2-LINK-FEEDBACK-CONTROL/-;
- response expected: -;
- short description: This PDU is used for the BS or MS to send link adaptation feedback information on a D8PSK or QAM channel.

The elements of L2-LINK-FEEDBACK-INFO PDU shall be as defined in table 21.34.

Table 21.34: L2-LINK-FEEDBACK-INFO PDU contents

Information element	Length	Type	Value	Remark
LLC PDU type	4	M	See table 21.1	Layer 2 signalling PDU
Layer 2 signalling PDU subtype	4	M	See table 21.2	L2-LINK-FEEDBACK-INFO
Channel metric type	3	M	000 ₂	Bit rate feedback
			001 ₂	E _s /N ₀ feedback
			010 ₂	Reserved (see note 1)
			etc.	etc.
			111 ₂	Reserved (see note 1)
Bit rate feedback information (see note 2)	10	C		See "bit rate feedback information" information element definition
E _s /N ₀ feedback information (see note 3)	10	C		See "E _s /N ₀ feedback information" information element definition
NOTE 1: The lengths of the feedback information for the reserved values of the channel metric type element in this PDU are not defined in the present document. If any reserved values of the channel metric type are used in future editions of the present document, the length of that feedback information in this PDU may be 10 bits, or it may be longer (or shorter) - whereas the length of each type of feedback information that can be sent within the AL-X-ACK or AL-X-RNR PDU is restricted to a fixed length of 10 bits (see clause 21.2.3.1a).				
NOTE 2: This element shall be present only in the case of bit rate feedback i.e. channel metric type element set to 000 ₂ .				
NOTE 3: This element shall be present only in the case of E _s /N ₀ feedback i.e. channel metric type element set to 001 ₂ .				

21.2.4.5 L2-LINK-FEEDBACK-INFO-AND-RESIDUAL-DATA-PRIORITY

- PDU: L2-LINK-FEEDBACK-INFO-AND-RESIDUAL-DATA-PRIORITY;
- response to: L2-LINK-FEEDBACK-CONTROL / -;
- response expected: -;
- short description: this PDU is used for the MS to send link adaptation feedback information and residual data priority on a D8PSK or QAM channel.

The elements of L2-LINK-FEEDBACK-INFO-AND-RESIDUAL-DATA-PRIORITY PDU shall be as defined in table 21.35.

Table 21.35: L2-LINK-FEEDBACK-INFO-AND-RESIDUAL-DATA-PRIORITY PDU contents

Information element	Length	Type	Value	Remark
LLC PDU type	4	M	see table 21.1	Layer 2 signalling PDU
Layer 2 signalling PDU subtype	4	M	see table 21.2	L2-LINK-FEEDBACK-INFO-AND-RESIDUAL-DATA-PRIORITY
Residual data priority	3	M	000 ₂	Priority 0 (lowest)
			etc.	etc.
			111 ₂	Priority 7 (highest)
Channel metric type	3	M	000 ₂	Bit rate feedback
			001 ₂	E_s/N_0 feedback
			010 ₂	Reserved (see note 1)
			etc.	etc.
			111 ₂	Reserved (see note 1)
Bit rate feedback information (see note 2)	10	C		See "bit rate feedback information" information element definition
E_s/N_0 feedback information (see note 3)	10	C		See " E_s/N_0 feedback information" information element definition
NOTE 1: The lengths of the feedback information for the reserved values of the channel metric type element in this PDU are not defined in the present document. If any reserved values of the channel metric type are used in future editions of the present document, the length of that feedback information in this PDU may be 10 bits, or it may be longer (or shorter) - whereas the length of each type of feedback information that can be sent within the AL-X-ACK or AL-X-RNR PDU is restricted to a fixed length of 10 bits (see clause 21.2.3.1a).				
NOTE 2: This element shall be present only in the case of bit rate feedback i.e. channel metric type element set to 000 ₂ .				
NOTE 3: This element shall be present only in the case of E_s/N_0 feedback i.e. channel metric type element set to 001 ₂ .				

21.3 LLC elements

21.3.1 FCS

This element is 32 bits long.

These bits shall be placed in decreasing order for the power of x . The co-efficient of x^{31} shall be mapped onto the most significant bit. The co-efficient of x^0 shall be mapped onto the least significant bit. The FCS calculation is defined in clause 22.

21.3.2 TL-SDU size

In the various LLC PDUs, one element often appears generally at the end of the PDU variously called "TL-SDU", "segment of TL-SDU" and "last segment of TL-SDU". This indicates the layer 3 information content which does not have a fixed length. Sometimes, this element is optional, which means that PDUs shall be exchanged even without layer 3 specific information. This is generally the case for responses, where the acknowledgement PDU is generated by the LLC and may be sent independently from the layer 3 message.

On the other hand, the segments in an advanced link shall be calculated so that:

- when using $\pi/4$ -DQPSK or $\pi/8$ -D8PSK modulation, they fit in the MAC offered capacity; or
- when using QAM modulation:
 - in the case of a 25 kHz or 50 kHz channel, the segment size (except possibly for the first and last segment of a TL-SDU) is determined by the available space in a 4-QAM rate = 1/2 full-slot MAC block at the current bandwidth;
 - in the case of a 100 kHz or 150 kHz channel, the segment size (except possibly for the first and last segment of a TL-SDU) is determined by the available space in half of a 4-QAM rate = 1/2 full-slot MAC block at the current bandwidth.

21.3.3 Bit rate feedback information

The "bit rate feedback information" information element shall be as defined in table 21.36.

Table 21.36: "Bit rate feedback information" information element contents

Information element	Length	Type	Value	Remark
Preferred bit rate	5	M	00000 ₂	4-QAM rate = 1/2 or $\pi/4$ -DQPSK (see note 1)
			00001 ₂	16-QAM rate = 1/2 or $\pi/8$ -D8PSK (see note 1)
			00010 ₂	16-QAM rate = 1
			00011 ₂	64-QAM rate = 1/2
			00100 ₂	64-QAM rate = 2/3
			00101 ₂	64-QAM rate = 1
			00110 ₂	Reserved
			etc.	etc.
			11111 ₂	Reserved
Data class linkage (see note 2)	3	M	000 ₂	Background class
			001 ₂	Telemetry class
			010 ₂	Real-time class
			011 ₂	Reserved
			etc.	etc.
			111 ₂	Reserved
Reserved	2	M	00 ₂	Default value
			01 ₂	Not used in the present document
			10 ₂	Not used in the present document
			11 ₂	Not used in the present document

NOTE 1: QAM bit rates apply only on a QAM channel; $\pi/4$ -DQPSK and $\pi/8$ -D8PSK bit rates apply only on a D8PSK channel.
NOTE 2: The data class linkage element indicates the data class to which the preferred bit rate applies.

21.3.4 E_s/N_0 feedback information

The " E_s/N_0 feedback information" information element shall be as defined in table 21.37.

Table 21.37: " E_s/N_0 feedback information" information element contents

Information element	Length	Type	Value	Remark
E_s/N_0 estimate	4	M	0000 ₂	Not specified
			0001 ₂	0 dB
			0010 ₂	3 dB
			0011 ₂	6 dB
			0100 ₂	9 dB
			0101 ₂	12 dB
			0110 ₂	15 dB
			0111 ₂	18 dB
			1000 ₂	21 dB
			1001 ₂	24 dB
			1010 ₂	27 dB
			1011 ₂	30 dB
			1100 ₂	33 dB
			1101 ₂	Reserved
1110 ₂	Reserved			
1111 ₂	Reserved			

Information element	Length	Type	Value	Remark
Channel model estimate	2	M	00 ₂	Not specified
			01 ₂	Low dispersion ($\leq 2,5 \mu\text{s RMS}$)
			10 ₂	High dispersion ($> 2,5 \mu\text{s RMS}$)
			11 ₂	Reserved
Speed estimate	4	M	0000 ₂	Not specified
			0001 ₂	Low speed ($\leq 10 \text{ Hz Doppler spread}$)
			0010 ₂	High speed ($> 10 \text{ Hz Doppler spread}$)
			0011 ₂	Reserved
			etc.	etc.
			1111 ₂	Reserved

21.4 MAC PDU description

21.4.0 General

The following clauses 21.4.1 to 21.4.8.2 describe the information content of the MAC PDUs.

The information contained in the following PDU descriptions shall be read from left to right, starting at the top and going down. The information content shall start with the most significant bit and shall continue until it reaches the least significant bit.

A MAC PDU is composed of a MAC header and a TM-SDU which is passed to the MAC from the LLC layer. The MAC header contains information about the content of the PDU. One MAC block (either a half or full timeslot) may contain several independent MAC PDUs, each with their own MAC header. The TM-SDU is transported by the MAC, but the MAC shall not have any visibility or knowledge of the SDU content.

21.4.1 MAC PDU types

These MAC PDU types as shown in table 21.38 shall be used for C-plane signalling messages, C-plane broadcast messages and end-to-end U-plane signalling.

Table 21.38: MAC PDU types for SCH/F, SCH/HD, STCH, SCH-P8/F, SCH-P8/HD, SCH-Q/D, SCH-Q/B and SCH-Q/U

Information element	Length	Type	Value	Remark
MAC PDU type	2	M	00 ₂	TMA-SAP: MAC-DATA (uplink) or MAC-RESOURCE (downlink)
			01 ₂	TMA-SAP: MAC-END or MAC-FRAG
			10 ₂	TMB-SAP: Broadcast
			11 ₂	TMA-SAP: Supplementary MAC PDU (see note) TMD-SAP: MAC-U-SIGNAL (U-plane signalling)
NOTE:	The supplementary MAC PDUs shall not be sent on STCH, SCH/HD or SCH-P8/HD. The MAC-U-SIGNAL PDU shall only be sent on STCH.			

A PDU subtype bit distinguishes between the supplementary MAC PDUs as shown in table 21.39.

Table 21.39: Supplementary MAC PDU subtype

Information element	Length	Type	Value	Remark
Supplementary MAC PDU subtype	1	M	0	TMA-SAP: MAC-U-BLCK (uplink) or MAC-D-BLCK (downlink)
			1	Reserved

The MAC PDU types shown in table 21.38 may be used for the transmission of signalling information in full slots on the uplink and downlink and in half slots on the downlink and in SCH-Q/B in the QAM frequency correction burst on the downlink. Under normal operation, the MS shall use MAC-DATA or MAC-U-BLCK for transmission on the uplink and the BS shall use MAC-RESOURCE or MAC-D-BLCK for transmission on the downlink. MAC-FRAG and MAC-END shall be used on the uplink and downlink for transmission of continuations and end of a fragmented SDU. Several types of broadcast PDU are defined, namely SYNC, SYNC-DA, SYSINFO, SYSINFO-Q, SYSINFO-DA and ACCESS-DEFINE. These PDUs shall be used by the BS to transmit broadcast information on the downlink. MAC-U-SIGNAL shall be used by both MS and BS for the transmission of U-plane signalling information.

Table 21.40: MAC PDU types for SCH/HU, SCH-P8/HU, SCH-Q/RA and SCH-Q/HU

Information element	Length	Type	Value	Remark
MAC PDU type in subslot	1	M	0	TMA-SAP: MAC-ACCESS
			1	TMA-SAP: MAC-END-HU

The MAC PDU types shown in table 21.40 may be used for the transmission of signalling information in half slots (i.e. subslots) on the uplink. The MS may transmit signalling information in an uplink subslot using the MAC-ACCESS PDU. The MS may also use the MAC-END-HU PDU for transmission of the end of a fragmented SDU.

The following clauses describe the contents of each of these uplink, downlink and broadcast PDUs.

21.4.2 TMA-SAP: MAC PDU structure for the uplink

21.4.2.0 General

The following clauses describe the MAC PDUs which may be sent on the uplink and which contain C-plane signalling information from the TMA-SAP in the MS.

21.4.2.1 MAC-ACCESS

This PDU may be used to send C-plane signalling data on the uplink in a subslot (SCH/HU, SCH-P8/HU, SCH-Q/RA or SCH-Q/HU). It shall be used for random access (SCH/HU or SCH-Q/RA) and may also be used for reserved access in a subslot (SCH/HU, SCH-P8/HU or SCH-Q/HU). Its contents shall be as shown in table 21.41.

Table 21.41: MAC-ACCESS PDU contents

Information element	Length	Type	Value	Remark
MAC PDU type in subslot	1	M	0	MAC-ACCESS
Fill bit indication	1	M	0	No fill bits present
			1	Fill bit(s) present
Encrypted flag	1	M	0	Not encrypted
			1	Encrypted
Address type	2	M	00 ₂	SSI
			01 ₂	Event Label (address length 10, see note 1)
			10 ₂	USSI (migrating MS un-exchanged address)
			11 ₂	SMI (management address)
Address	24/10	M		SSI, USSI, SMI or Event Label according to address type
Optional field flag	1	M	0	No length indication nor capacity request
			1	Length indication or capacity request
Length indication or capacity request	1	C	0	Length indication
			1	Capacity request (i.e. fragmentation flag + reservation requirement)

Information element	Length	Type	Value	Remark
Length indication	5	C	00000 ₂	Null PDU
			00001 ₂	Length of MAC PDU = value × Y ₁ octets (see note 2)
			etc.	etc.
			01110 ₂	Length of MAC PDU = value × Y ₁ octets
			01111 ₂	Length of MAC PDU = (14 × Y ₁ + (value - 14) × Z ₁) octets
			etc.	etc.
			11100 ₂	Length of MAC PDU = (14 × Y ₁ + (value - 14) × Z ₁) octets
			11101 ₂	Reserved
			11110 ₂	Reserved
			11111 ₂	Length of MAC PDU (see note 3) = 181 bits when PDU sent on a 25 kHz QAM channel 389 bits when PDU sent on a 50 kHz QAM channel 402 bits when PDU sent on a 100 kHz QAM channel 610 bits when PDU sent on a 150 kHz QAM channel else Reserved
Fragmentation flag	1	C	0	TM-SDU not fragmented
			1	Start of fragmentation
Reservation requirement	4	C		See reservation requirement information element definition
TM-SDU	varies	C		
NOTE 1: The address length of the other address types is 24.				
NOTE 2: For values of length indication up to 01110 ₂ , the unit of the length indication is Y ₁ octets whereas, for higher values, the incremental unit of the length indication is Z ₁ octets. The values of Y ₁ and Z ₁ depend on the bandwidth, modulation and coding rate with which the PDU is sent; the values of Y ₁ and Z ₁ are given in clause 21.6 for each combination.				
NOTE 3: The length of MAC PDU indicated by length indication 11111 ₂ is set to correspond to the normal size of an advanced link data segment on a QAM channel.				

The first bit of the MAC header distinguishes between the two possible PDU types which can be sent in a subslot.

The fill bit indication shall indicate if there are any fill bits, which shall be added whenever the size of the TM-SDU is less than the available capacity of the MAC block or less than the size of the TM-SDU indicated by the length indication field. The TM-SDU length is equal to the MAC PDU length minus the MAC PDU header length.

The encrypted flag shall indicate whether or not the TM-SDU contents are encrypted. The MAC header shall not be encrypted except that the address is encrypted when appropriate if the encrypted flag is set to 1 (for details of the address encryption method and when it is used, see ETSI EN 300 392-7 [8]). In the case of fragmentation, the setting of the encrypted flag in the MAC-ACCESS PDU shall apply to all fragments of that TM-SDU.

The address type field shall indicate the type of address contained in the address field. The length of the address field shall be 10 bits for an event label or 24 bits for SSI, USSI or SMI.

The optional field flag shall indicate whether any of the optional fields are present in the PDU header. If optional fields are present the next bit (length indication or capacity request) shall indicate whether the PDU header contains a length indication field or a capacity request field. If length indication is indicated, then the next field shall be length indication. Length indication shall refer to the length of the MAC PDU (which comprises the MAC PDU header and the TM-SDU) and should be used only if association within the uplink subslot is required or for transmission of the null PDU.

The units used for the length indication depend on the bandwidth, modulation and coding rate with which the PDU is sent; see clause 21.6. The defined values of the length indication cover up to the size of the MAC block or the maximum size of a MAC-ACCESS PDU (2 668 bits), whichever is the lesser.

The header length of a MAC-ACCESS PDU depends on the type of address in use and whether or not there is a length indication or capacity request. The header length is shown in table 21.42 for each of the possible combinations. Then the maximum TM-SDU length is shown in table 21.43 for each of the possible header lengths and logical channels.

Table 21.42: Length of MAC-ACCESS PDU header

Content of Header Fields	Header Length [bits]
Address = Event Label No length indication nor capacity request	16
Address = SSI, USSI or SMI No length indication nor capacity request	30
Address = Event Label Length indication or capacity request	22
Address = SSI, USSI or SMI Length indication or capacity request	36

The length indication field may be used to indicate a null PDU. If a null PDU is indicated, there shall be no further information in the PDU after the length indication field. The length of the null PDU, therefore, shall be 22 bits if an event label is used as an address or 36 bits if an SSI, USSI or SMI is used as an address. The null PDU, if it appears in a MAC block, shall always be the last PDU in that block. Any spare capacity after the null PDU shall be filled with fill bits.

NOTE 1: The null PDU information elements before the length indication field are used as for any other MAC PDU e.g. encryption state is the same as for the other MAC PDUs.

If capacity request is indicated in the length indication or capacity request bit, the next field shall be fragmentation flag followed by reservation requirement. Capacity request shall be used when the MS has further signalling to send, which may or may not be subsequent fragments of a fragmented SDU (as indicated by the fragmentation flag). The PDU may only contain either the length indication field or the capacity request field (comprising fragmentation flag and reservation requirement), but not both.

NOTE 2: An MS generally sets the "Optional field flag" to "1" only for transmission of the Null PDU or if PDU association is required within the subslot or if the MS has further signalling messages ready to be sent. Otherwise the flag is set to "0". For example, when the MAC-ACCESS PDU is sent on SCH/HU (i.e. using $\pi/4$ -DQPSK), this gives a maximum TM-SDU length of 62 bits (or 76 bits if an event label is used).

NOTE 3: The "Optional field flag" is provided in the PDU in order to economize on the use of bits for the most usual cases. It is not provided in the MAC-END-HU, MAC-DATA or MAC-END PDUs, in which the size constraint is less critical.

NOTE 4: For example, the defined structure of the MAC-ACCESS PDU allows the CMCE U-SETUP PDU to be sent within a $\pi/4$ -DQPSK subslot (i.e. using SCH/HU), provided that:

- (a) the full TSI of the called party is not needed in the U-SETUP PDU; and
- (b) the FCS is not added by the LLC; and
- (c) the MAC does not include a capacity request so that the optional field flag = "0" (or an event label is used for addressing).

Table 21.43: Maximum length of TM-SDU in MAC-ACCESS PDU

Logical channel	Maximum TM-SDU length [bits]			
	Event label. No length indication nor capacity request	SSI, USSI or SMI. No length indication nor capacity request	Event label. Length indication or capacity request	SSI, USSI or SMI. Length indication or capacity request
SCH/HU	76	62	70	56
SCH-P8/HU	132	118	126	112
SCH-Q/RA	49	35	43	29
SCH-Q/HU25-4H	41	27	35	21
SCH-Q/HU25-16H	117	103	111	97
SCH-Q/HU25-16U	272	258	266	252
SCH-Q/HU25-64H	193	179	187	173
SCH-Q/HU25-64M	269	255	263	249
SCH-Q/HU25-64U	424	410	418	404
SCH-Q/HU50-4H	125	111	119	105
SCH-Q/HU50-16H	285	271	279	265
SCH-Q/HU50-16U	608	594	602	588
SCH-Q/HU50-64H	445	431	439	425
SCH-Q/HU50-64M	605	591	599	585
SCH-Q/HU50-64U	928	914	922	908
SCH-Q/HU100-4H	293	279	287	273
SCH-Q/HU100-16H	621	607	615	601
SCH-Q/HU100-16U	1 280	1 266	1 274	1 260
SCH-Q/HU100-64H	949	935	943	929
SCH-Q/HU100-64M	1 277	1 263	1 271	1 257
SCH-Q/HU100-64U	1 936	1 922	1 930	1 916
SCH-Q/HU150-4H	461	447	455	441
SCH-Q/HU150-16H	957	943	951	937
SCH-Q/HU150-16U	1 952	1 938	1 946	1 932
SCH-Q/HU150-64H	1 453	1 439	1 447	1 433
SCH-Q/HU150-64M	1 949	1 935	1 943	1 929
SCH-Q/HU150-64U	2 632 (see note)	2 632 (see note)	2 632 (see note)	2 632 (see note)

NOTE: The maximum length of TM-SDU in this MAC block is constrained by the maximum permitted size of TM-SDU (N.202) rather than by the size of the MAC block.

21.4.2.2 MAC-END-HU

This PDU shall be used to send the last fragment of fragmented C-plane signalling data on the uplink using a reserved subslot (SCH/HU, SCH-P8/HU or SCH-Q/HU). Its contents shall be as shown in table 21.44.

Table 21.44: MAC-END-HU PDU contents

Information element	Length	Type	Value	Remark
MAC PDU type in subslot	1	M	1	MAC-END-HU
Fill bit indication	1	M	0	No fill bits present
			1	Fill bit(s) present
Length indication or capacity request	1	M	0	Length indication
			1	Reservation requirement (i.e. Capacity request)
Length indication	4	C	0000 ₂	Reserved
			0001 ₂	Length of MAC PDU = value × Z ₁ octets (see note)
			etc.	etc.
Length indication	4	C	1111 ₂	Length of MAC PDU = value × Z ₁ octets
				See reservation requirement information element definition
Reservation requirement	4	C		See reservation requirement information element definition
TM-SDU	varies	C		

NOTE: The unit of the length indication is Z₁ octets. The value of Z₁ depends on the bandwidth, modulation and coding rate with which the PDU is sent; the value of Z₁ is given in clause 21.6 for each combination.

The first bit of the MAC header distinguishes between the two possible PDU types which can be sent in a subslot.

The fill bit indication shall indicate if there are any fill bits, which shall be added whenever the size of the TM-SDU is less than the available capacity of the MAC block or less than the size of the TM-SDU indicated by the length indication field. The TM-SDU length is equal to the MAC PDU length minus the MAC PDU header length.

The length indication or capacity request field shall indicate whether the PDU header contains a length indication field or a capacity request field. If length indication is indicated, then the next field shall be length indication. Length indication shall refer to the length of the MAC PDU which comprises the MAC PDU header and the TM-SDU. The length indicator shall be used if association within the uplink subslot is required or if the MS has no further signalling to send. If reservation requirement is indicated, the next field shall be reservation requirement which shall be used when the MS has further C-plane signalling messages ready to send. In that case the length of the TM-SDU is defined by the fill bit mechanism. The PDU may only contain either the length indication field or the reservation requirement field.

The units used for the length indication depend on the bandwidth, modulation and coding rate with which the PDU is sent; see clause 21.6. The defined values of the length indication cover up to the size of the MAC block or the maximum size of a MAC-END-HU PDU (2 638 bits), whichever is the lesser.

The header length of a MAC-END-HU PDU shall be equal to 7 bits. The maximum TM-SDU length is shown in table 21.45.

Table 21.45: Maximum length of TM-SDU in MAC-END-HU PDU

Logical channel	Maximum TM-SDU length [bits]
SCH/HU	85
SCH-P8/HU	141
SCH-Q/HU25-4H	50
SCH-Q/HU25-16H	126
SCH-Q/HU25-16U	281
SCH-Q/HU25-64H	202
SCH-Q/HU25-64M	278
SCH-Q/HU25-64U	433
SCH-Q/HU50-4H	134
SCH-Q/HU50-16H	294
SCH-Q/HU50-16U	617
SCH-Q/HU50-64H	454
SCH-Q/HU50-64M	614
SCH-Q/HU50-64U	937
SCH-Q/HU100-4H	302
SCH-Q/HU100-16H	630
SCH-Q/HU100-16U	1 289
SCH-Q/HU100-64H	958
SCH-Q/HU100-64M	1 286
SCH-Q/HU100-64U	1 945
SCH-Q/HU150-4H	470
SCH-Q/HU150-16H	966
SCH-Q/HU150-16U	1 961
SCH-Q/HU150-64H	1 462
SCH-Q/HU150-64M	1 958
SCH-Q/HU150-64U	2 631 (see note)
NOTE:	The maximum length of TM-SDU in this MAC block is constrained by the maximum permitted size of TM-SDU (N.202) rather than by the size of the MAC block.

21.4.2.3 MAC-DATA

This PDU may be used to send C-plane signalling data on the uplink in a full slot (SCH/F, SCH-P8/F or SCH-Q/U).

It may also be used to send C-plane signalling data in the first half of a full uplink slot using the stealing channel (STCH). If the second half of a full uplink slot is also stolen, the MAC-DATA PDU may be used to send another C-plane PDU in the second half slot.

The contents of the MAC-DATA PDU shall be as shown in table 21.46.

Table 21.46: MAC-DATA PDU contents

Information element	Length	Type	Value	Remark
MAC PDU type	2	M	00 ₂	MAC-DATA
Fill bit indication	1	M	0	No fill bit present
			1	Fill bit(s) present
Encrypted flag	1	M	0	Not encrypted
			1	Encrypted
Address type	2	M	00 ₂	SSI
			01 ₂	Event Label (address length 10, see note 1)
			10 ₂	USSI (migrating MS un-exchanged address)
			11 ₂	SMI (management address)
Address	24/10	M		SSI, USSI, SMI or Event Label according to address type
Length indication or capacity request	1	M	0	Length indication
			1	Capacity request (i.e. fragmentation flag + reservation requirement + reserved bit)
Length indication	6	C	000000 ₂	Null PDU
			000001 ₂	Reserved
			000010 ₂	Length of MAC PDU = value × Y ₂ octets (see note 2)
			etc.	etc.
			010010 ₂	Length of MAC PDU = value × Y ₂ octets
			010011 ₂	Length of MAC PDU = (18 × Y ₂ + (value - 18) × Z ₂) octets
			etc.	etc.
			111000 ₂	Length of MAC PDU = (18 × Y ₂ + (value - 18) × Z ₂) octets
			111001 ₂	Reserved
			111010 ₂	Reserved
			111011 ₂	Reserved
			111100 ₂	Reserved
			111101 ₂	Length of MAC PDU (see note 3) = 181 bits when PDU sent on a 25 kHz QAM channel 389 bits when PDU sent on a 50 kHz QAM channel 402 bits when PDU sent on a 100 kHz QAM channel 610 bits when PDU sent on a 150 kHz QAM channel else Reserved
111110 ₂	Second half slot stolen on STCH			
111111 ₂	Start of fragmentation on STCH			
Fragmentation flag	1	C	0	TM-SDU not fragmented
			1	Start of fragmentation
Reservation requirement	4	C		See reservation requirement information element definition
Reserved	1	C	0	Default value
			1	Not used in the present document
TM-SDU	varies	C		
NOTE 1: The address length of the other address types is 24.				
NOTE 2: For values of length indication up to 010010 ₂ , the unit of the length indication is Y ₂ octets whereas, for higher values, the incremental unit of the length indication is Z ₂ octets. The values of Y ₂ and Z ₂ depend on the bandwidth, modulation and coding rate with which the PDU is sent; the values of Y ₂ and Z ₂ are given in clause 21.6 for each combination.				
NOTE 3: The length of MAC PDU indicated by length indication 111101 ₂ is set to correspond to the normal size of an advanced link data segment on a QAM channel.				

The first two bits of the MAC header distinguish between the possible PDU types which can be sent on the uplink SCH/F, SCH-P8/F, SCH-Q/U or STCH.

The fill bit indication shall indicate if there are any fill bits, which shall be added whenever the size of the TM-SDU is less than the available capacity of the MAC block or less than the size of the TM-SDU indicated by the length indication field. The TM-SDU length is equal to the MAC PDU length minus the MAC PDU header length.

The encrypted flag shall indicate whether or not the TM-SDU contents are encrypted. The MAC header shall not be encrypted except that the address is encrypted when appropriate if the encrypted flag is set to 1 (for details of the address encryption method and when it is used, see ETSI EN 300 392-7 [8]). In the case of fragmentation, the setting of the encrypted flag in the MAC-DATA PDU applies to all fragments of the TM-SDU.

The address type field shall indicate the type of address contained in the address field. The length of the address field shall be 10 bits for an event label or 24 bits for SSI, USSI or SMI.

The length indication or capacity request field shall indicate whether the PDU header contains a length indication field or a capacity request field. If length indication is indicated, then the next field shall be length indication. Length indication shall refer to the length of the MAC PDU (which comprises the MAC PDU header and the TM-SDU) and shall be used if association is required or if the MS has no further signalling to send. If capacity request is indicated, the next field shall be fragmentation flag followed by reservation requirement and the reserved bit. Capacity request shall be used on SCH/F, SCH-P8/F or SCH-Q/U when the MS has further signalling to send, which may or may not be subsequent fragments of a fragmented SDU (as indicated by the fragmentation flag). The PDU may only contain either the length indication field or the capacity request field (comprising fragmentation flag, reservation requirement and the reserved bit).

The units used for the length indication depend on the bandwidth, modulation and coding rate with which the PDU is sent; see clause 21.6. The defined values of the length indication cover up to the size of the MAC block or the maximum size of a MAC-DATA PDU (2 669 bits), whichever is the lesser.

The header length of a MAC-DATA PDU depends on the type of address in use. It shall be 37 bits when an SSI, USSI or SMI is used and 23 bits when an event label is used. The maximum TM-SDU length is shown in table 21.47 for each of the header lengths and logical channels.

The length indication field may be used to indicate a null PDU. If a null PDU is indicated, there shall be no further information in the PDU after the length indication field. The length of the null PDU, therefore, shall be 23 bits if an event label is used as an address or 37 bits if an SSI, USSI or SMI is used as an address. After a null PDU, there shall be no further PDUs in the MAC block and the remaining capacity shall contain fill bits.

NOTE: The null PDU information elements before the length indication field are used as for any other MAC PDU e.g. encryption state is the same as for the other MAC PDUs.

This MAC-DATA PDU shall also be used for C-plane signalling using the STCH on the uplink. By default, the STCH occupies only the first half slot. The second half slot may also be stolen, either for the last fragment of a fragmented SDU or for subsequent PDUs which the MAC may have ready to send or for U-plane signalling. A length indication of 11111_2 shall be used to indicate that the second half slot is stolen for the last fragment of a fragmented SDU. A length indication of 111110_2 shall be used to indicate that the second half slot is stolen for subsequent C-plane signalling or U-plane signalling. The last fragment shall use the MAC-END PDU, while subsequent C-plane PDUs shall use the MAC-DATA PDU and U-plane signalling shall use the MAC-U-SIGNAL PDU. It shall only be possible to fragment SDUs over the two halves of a full slot on the STCH.

Table 21.47: Maximum length of TM-SDU in MAC-DATA PDU

Logical channel	Maximum TM-SDU length [bits]	
	Using event label	Using SSI, USSI or SMI
SCH/F	245	231
STCH	101	87
SCH-P8/F	389	375
SCH-Q/U25-4H	158	144
SCH-Q/U25-16H	358	344
SCH-Q/U25-16U	761	747
SCH-Q/U25-64H	558	544
SCH-Q/U25-64M	758	744
SCH-Q/U25-64U	1 161	1 147
SCH-Q/U50-4H	366	352
SCH-Q/U50-16H	774	760
SCH-Q/U50-16U	1 593	1 579
SCH-Q/U50-64H	1 182	1 168
SCH-Q/U50-64M	1 590	1 576
SCH-Q/U50-64U	2 409	2 395
SCH-Q/U100-4H	782	768
SCH-Q/U100-16H	1 606	1 592
SCH-Q/U100-16U	2 632 (see note)	2 632 (see note)
SCH-Q/U100-64H	2 430	2 416
SCH-Q/U100-64M	2 632 (see note)	2 632 (see note)
SCH-Q/U100-64U	2 632 (see note)	2 632 (see note)
SCH-Q/U150-4H	1 198	1 184
SCH-Q/U150-16H	2 438	2 424
SCH-Q/U150-16U	2 632 (see note)	2 632 (see note)
SCH-Q/U150-64H	2 632 (see note)	2 632 (see note)
SCH-Q/U150-64M	2 632 (see note)	2 632 (see note)
SCH-Q/U150-64U	2 632 (see note)	2 632 (see note)

NOTE: The maximum length of TM-SDU in this MAC block is constrained by the maximum permitted size of TM-SDU (N.202) rather than by the size of the MAC block.

21.4.2.4 MAC-FRAG (uplink)

This PDU shall be used to send continuation fragments of fragmented C-plane signalling data on the uplink using a full slot (SCH/F, SCH-P8/F or SCH-Q/U). Its contents shall be as shown in table 21.48.

Table 21.48: MAC-FRAG (uplink) PDU contents

Information element	Length	Type	Value	Remark
MAC PDU type	2	M	01 ₂	MAC-FRAG or MAC-END
MAC PDU subtype	1	M	0	MAC-FRAG
Fill bit indication	1	M	0	No fill bits present
			1	Fill bit(s) present
TM-SDU	varies	M		

The first two bits of the MAC header distinguish between the possible PDU types which can be sent on the uplink using a full slot. A PDU subtype bit distinguishes between MAC-FRAG and MAC-END which share the same MAC PDU type.

The fill bit indication shall indicate if there are any fill bits which shall be added whenever the size of the TM-SDU fragment is less than the available capacity of a full slot. Fill bits may be required for this PDU because the MAC-END header length is greater than the header length of this PDU. This means that it is possible that the last fragment of an SDU may be too large to fit into a MAC-END PDU but too small to fill the maximum TM-SDU space available in the MAC-FRAG PDU. In this case, fill bits are required in the MAC-FRAG PDU and MAC-END shall be sent with a zero-length TM-SDU.

The header length of a MAC-FRAG shall be equal to 4 bits. The maximum TM-SDU length is shown in table 21.49.

Table 21.49: Maximum length of TM-SDU in uplink MAC-FRAG PDU

Logical channel	Maximum TM-SDU length [bits]
SCH/F	264
SCH-P8/F	408
SCH-Q/U25-4H	177
SCH-Q/U25-16H	377
SCH-Q/U25-16U	780
SCH-Q/U25-64H	577
SCH-Q/U25-64M	777
SCH-Q/U25-64U	1 180
SCH-Q/U50-4H	385
SCH-Q/U50-16H	793
SCH-Q/U50-16U	1 612
SCH-Q/U50-64H	1 201
SCH-Q/U50-64M	1 609
SCH-Q/U50-64U	2 428
SCH-Q/U100-4H	801
SCH-Q/U100-16H	1 625
SCH-Q/U100-16U	Not applicable (see note)
SCH-Q/U100-64H	2 449
SCH-Q/U100-64M	Not applicable (see note)
SCH-Q/U100-64U	Not applicable (see note)
SCH-Q/U150-4H	1 217
SCH-Q/U150-16H	2 457
SCH-Q/U150-16U	Not applicable (see note)
SCH-Q/U150-64H	Not applicable (see note)
SCH-Q/U150-64M	Not applicable (see note)
SCH-Q/U150-64U	Not applicable (see note)
NOTE:	For these logical channels, the MAC block is large enough to contain the maximum permitted size of TM-SDU so the MS has no need to use MAC-FRAG. (It completes the TM-SDU using MAC-END instead.)

21.4.2.5 MAC-END (uplink)

This PDU shall be used to send the last fragment of fragmented C-plane signalling data on the uplink using a full slot (SCH/F, SCH-P8/F or SCH-Q/U). It shall also be used to send the last fragment of fragmented C-plane signalling in the second half of a stolen full slot on the uplink. Its contents shall be as shown in table 21.50.

Table 21.50: MAC-END (uplink) PDU contents

Information element	Length	Type	Value	Remark
MAC PDU type	2	M	01 ₂	MAC-FRAG or MAC-END
MAC PDU subtype	1	M	1	MAC-END
Fill bit indication	1	M	0	No fill bits present
			1	Fill bit(s) present
Length indication / reservation requirement	6	M	000000 ₂	Reserved
			000001 ₂	Length of MAC PDU = value × Y ₂ octets (see note)
			etc.	etc.
			000110 ₂	Length of MAC PDU = value × Y ₂ octets
			000111 ₂	Length of MAC PDU = (6 × Y ₂ + (value - 6) × Z ₂) octets
			etc.	etc.
			101110 ₂	Length of MAC PDU = (6 × Y ₂ + (value - 6) × Z ₂) octets
			101111 ₂	Reserved
			11XXXX ₂	See reservation requirement information element definition
TM-SDU	varies	C		
NOTE: For values of length indication up to 000110 ₂ , the unit of the length indication is Y ₂ octets whereas, for higher values, the incremental unit of the length indication is Z ₂ octets. The values of Y ₂ and Z ₂ depend on the bandwidth, modulation and coding rate with which the PDU is sent; the values of Y ₂ and Z ₂ are given in clause 21.6 for each combination.				

The first two bits of the MAC header distinguish between the possible PDU types which can be sent on the uplink SCH/F, SCH-P8/F, SCH-Q/U or STCH. A PDU subtype bit distinguishes between MAC-FRAG and MAC-END which share the same MAC PDU type.

The fill bit indication shall indicate if there are any fill bits, which shall be added whenever the size of the PDU is less than the available capacity of the MAC block or less than the size of the PDU indicated by the length indication field. The TM-SDU length is equal to the MAC PDU length minus the MAC PDU header length.

The next 6-bit field shall indicate length indication or a reservation requirement. A value from 000001₂ to 101110₂ shall indicate the length of the PDU. A value beginning with 11₂ shall indicate a reservation requirement which shall be used on SCH/F, SCH-P8/F or SCH-Q/U when the MS has further C-plane signalling to send. The reservation requirement information is contained in the 4 least significant bits of these values, the meaning of which is given in the reservation requirement element definition.

The units used for the length indication depend on the bandwidth, modulation and coding rate with which the PDU is sent; see clause 21.6. The defined values of the length indication cover up to the size of the MAC block or the maximum size of a MAC-END PDU (2 641 bits), whichever is the lesser.

The header length of a MAC-END PDU shall be equal to 10 bits. The maximum TM-SDU length is shown in table 21.51. The length indicated in the MAC PDU header shall refer to the MAC PDU which comprises the MAC PDU header and the TM-SDU.

Table 21.51: Maximum length of TM-SDU in uplink MAC-END PDU

Logical channel	Maximum TM-SDU length [bits]
SCH/F	258
STCH	114
SCH-P8/F	402
SCH-Q/U25-4H	171
SCH-Q/U25-16H	371
SCH-Q/U25-16U	774
SCH-Q/U25-64H	571
SCH-Q/U25-64M	771
SCH-Q/U25-64U	1 174
SCH-Q/U50-4H	379
SCH-Q/U50-16H	787
SCH-Q/U50-16U	1 606
SCH-Q/U50-64H	1 195
SCH-Q/U50-64M	1 603
SCH-Q/U50-64U	2 422
SCH-Q/U100-4H	795
SCH-Q/U100-16H	1 619
SCH-Q/U100-16U	2 631 (see note)
SCH-Q/U100-64H	2 443
SCH-Q/U100-64M	2 631 (see note)
SCH-Q/U100-64U	2 631 (see note)
SCH-Q/U150-4H	1 211
SCH-Q/U150-16H	2 451
SCH-Q/U150-16U	2 631 (see note)
SCH-Q/U150-64H	2 631 (see note)
SCH-Q/U150-64M	2 631 (see note)
SCH-Q/U150-64U	2 631 (see note)
NOTE:	The maximum length of TM-SDU in this MAC block is constrained by the maximum permitted size of TM-SDU (N.202) rather than by the size of the MAC block.

21.4.2.6 MAC-U-BLCK

This PDU may optionally be used to send C-plane signalling data on the uplink in a full slot (SCH/F, SCH-P8/F or SCH-Q/U) in cases when an event label can be used and a pre-defined length is appropriate e.g. when sending an advanced link data segment. It cannot be used if SSI or SMI addressing or fragmentation is needed, or to indicate a null PDU; when any of these functions are needed, the MS should use the MAC-DATA PDU.

The MAC-U-BLCK PDU has a slightly smaller MAC header than the MAC-DATA PDU so can carry slightly more data. If the MS has a valid event label, it may choose to use the MAC-U-BLCK PDU instead of MAC-DATA e.g. when sending an advanced link data segment.

NOTE 1: The MAC-U-BLCK PDU should not be used when the pre-defined length is not appropriate. For example, when the MS is sending a basic link message or a short advanced link message or the last segment of an advanced link message, use of the MAC-DATA PDU may be more efficient.

The MAC-U-BLCK PDU uses the same MAC PDU type as the MAC-U-SIGNAL PDU, which is sent using the stealing channel (STCH). Therefore the MAC-U-BLCK PDU shall not be sent on STCH.

The contents of the MAC-U-BLCK PDU shall be as shown in table 21.52.

Table 21.52: MAC-U-BLCK PDU contents

Information element	Length	Type	Value	Remark
MAC PDU type	2	M	11 ₂	Supplementary MAC PDU
Supplementary MAC PDU subtype	1	M	0	MAC-U-BLCK
Fill bit indication	1	M	0	No fill bit present
			1	Fill bit(s) present
Encrypted flag	1	M	0	Not encrypted
			1	Encrypted
Address	10	M		Event label
Reservation requirement	4	M		See reservation requirement information element definition
TM-SDU	varies	C		

The length of the MAC-U-BLCK PDU is defined implicitly, as shown in table 21.53. The implicit length shall refer to the length of the MAC PDU, which comprises the MAC PDU header and the TM-SDU. For a $\pi/4$ -DQPSK or $\pi/8$ -D8PSK slot, the implicit length matches the size of the MAC block. On a QAM channel, the implicit length of the MAC-U-BLCK PDU is set to correspond to the normal size of an advanced link data segment i.e.:

- in the case of a 25 kHz or 50 kHz channel, the implicit length corresponds to the size of a 4-QAM rate = 1/2 full-slot MAC block at the current bandwidth;
- in the case of a 100 kHz or 150 kHz channel, the implicit length corresponds to half the size of a 4-QAM rate = 1/2 full-slot MAC block at the current bandwidth.

Table 21.53: Implicit length of MAC-U-BLCK PDU

Logical channel	Implicit length of MAC-U-BLCK PDU
SCH/F	268 bits
SCH-P8/F	412 bits
SCH-Q/U25	181 bits
SCH-Q/U50	389 bits
SCH-Q/U100	402 bits
SCH-Q/U150	610 bits

The first two bits of the MAC header distinguish between the possible PDU types which can be sent on the uplink SCH/F, SCH-P8/F or SCH-Q/U. The supplementary MAC PDU subtype bit distinguishes between supplementary PDUs which share the same MAC PDU type.

The fill bit indication shall indicate if there are any fill bits, which shall be added whenever the size of the TM-SDU is less than the available capacity of the MAC block or less than the size of the TM-SDU indicated by the implicit length of the MAC-U-BLCK PDU. The TM-SDU length is equal to the MAC PDU length minus the MAC PDU header length.

The encrypted flag shall indicate whether or not the TM-SDU contents are encrypted. The MAC header shall not be encrypted.

The address field shall contain an event label.

NOTE 2: As defined in ETSI EN 300 392-7 [8], the event label is not encrypted.

The reservation requirement field shall indicate the MS's current requirement for reserved slots. This field is mandatory in the MAC-U-BLCK PDU. (A specific value is defined in the reservation requirement when sent in MAC-U-BLCK for use when the MS has no further signalling to send.)

The header length of a MAC-U-BLCK PDU shall be equal to 19 bits. The maximum TM-SDU length is shown in table 21.54.

Table 21.54: Maximum length of TM-SDU in MAC-U-BLCK PDU

Logical channel	Maximum TM-SDU length [bits]
SCH/F	249
SCH-P8/F	393
SCH-Q/U25	162
SCH-Q/U50	370
SCH-Q/U100	383
SCH-Q/U150	591

21.4.3 TMA-SAP: MAC PDU structure for the downlink

21.4.3.0 General

The following clauses describe the MAC PDUs which may be sent on the downlink and which contain C-plane signalling information for the TMA-SAP in the MS.

21.4.3.1 MAC-RESOURCE

This PDU may be used to send C-plane signalling data on the downlink in a full slot (SCH/F, SCH-P8/F or SCH-Q/D), in the first or second half slot of a full slot (SCH/HD or SCH-P8/HD) or in SCH-Q/B in the QAM frequency correction burst on the downlink. It may also be used to send C-plane signalling data in the first half of a downlink slot using the Stealing Channel (STCH). If the second half of a downlink slot is also stolen, the MAC-RESOURCE PDU may be used to send another PDU in the second half slot.

This PDU may be sent without a TM-SDU in order to allocate uplink capacity, send a channel allocation or control mobile transmit power.

The contents of the MAC-RESOURCE PDU shall be as shown in table 21.55.

Table 21.55: MAC-RESOURCE PDU contents

Information element	Length	Type	Value	Remark
MAC PDU type	2	M	00 ₂	MAC-RESOURCE
Fill bit indication	1	M	0	No fill bits present
			1	Fill bit(s) present
Position of grant	1	M	0	Slot grant (if any) is on current channel
			1	Slot grant (if any) is on allocated channel
Encryption mode	2	M	00 ₂	Not encrypted
			01 ₂	See ETSI EN 300 392-7 [8]
			10 ₂	See ETSI EN 300 392-7 [8]
			11 ₂	See ETSI EN 300 392-7 [8]
Random access flag	1	M	0	Undefined
			1	Random Access Acknowledged

Information element	Length	Type	Value	Remark
Length indication	6	M	000000 ₂	Reserved
			000001 ₂	Length of MAC PDU = value × Y ₂ octets (see note 1)
			etc.	etc.
			010010 ₂	Length of MAC PDU = value × Y ₂ octets
			010011 ₂	Length of MAC PDU = (18 × Y ₂ + (value - 18) × Z ₂) octets
			etc.	etc.
			111010 ₂	Length of MAC PDU = (18 × Y ₂ + (value - 18) × Z ₂) octets
			111011 ₂	Reserved
			111100 ₂	Reserved
			111101 ₂	Length of MAC PDU (see note 2) = 185 bits when PDU sent on a 25 kHz QAM channel 421 bits when PDU sent on a 50 kHz QAM channel 446 bits when PDU sent on a 100 kHz QAM channel 682 bits when PDU sent on a 150 kHz QAM channel else Reserved
			111110 ₂	Second half slot stolen in STCH
111111 ₂	Start of fragmentation			
Address type	3	M	000 ₂	Null PDU
			001 ₂	SSI
			010 ₂	Event Label
			011 ₂	USSI (migrating MS un-exchanged address)
			100 ₂	SMI (management address)
			101 ₂	SSI + Event Label (event label assignment)
			110 ₂	SSI + Usage Marker (usage marker assignment)
			111 ₂	SMI + Event Label (event label assignment)
Address	34/ 30/ 24/ 10	M		SSI/SMI + Event Label SSI + Usage Marker SSI, USSI or SMI Event Label
Immediate napping permission flag (see note 3)	1	C	0	Immediate napping permission not given
			1	Immediate napping permission given
Power control flag	1	M	0	No power control information element in PDU
			1	Power control information element in PDU
Power control element	4	C		See power control information element definition
Slot granting flag	1	M	0	No slot granting information elements in PDU
			1	Slot granting information element in PDU
Multiple slot granting flag (see note 4)	1	C	0	Basic slot granting information element in PDU
			1	Multiple slot granting information element in PDU
Basic slot granting element (see note 5)	8	C		See basic slot granting information element definition
Multiple slot granting element (see note 6)	variable	C		See multiple slot granting information element definition
Channel allocation flag	1	M	0	No channel allocation information element in PDU
			1	Channel allocation information element in PDU
Channel allocation element	variable	C		See channel allocation information element definition
TM-SDU	variable	C		
NOTE 1: For values of length indication up to 010010 ₂ , the unit of the length indication is Y ₂ octets whereas, for higher values, the incremental unit of the length indication is Z ₂ octets. The values of Y ₂ and Z ₂ depend on the bandwidth, modulation and coding rate with which the PDU is sent; the values of Y ₂ and Z ₂ are given in clause 21.6 for each combination.				
NOTE 2: The length of MAC PDU indicated by length indication 111101 ₂ is set to correspond to the normal size of an advanced link data segment on a QAM channel.				
NOTE 3: The immediate napping permission flag shall be present when the PDU is sent using π/8-D8PSK or QAM modulation. It shall not be present when the PDU is sent using π/4-DQPSK modulation.				
NOTE 4: The multiple slot granting flag shall be present when the slot granting flag is set to 1 and the PDU is sent using QAM modulation. It shall not be present when the slot granting flag is set to 0 or the PDU is sent using π/4-DQPSK or π/8-D8PSK modulation.				
NOTE 5: The basic slot granting element shall be present when the slot granting flag is set to 1 and either the PDU is sent using π/4-DQPSK or π/8-D8PSK modulation, or the PDU is sent using QAM modulation and the multiple slot granting flag is set to 0.				
NOTE 6: The multiple slot granting element shall be present when the slot granting flag is set to 1 and the PDU is sent using QAM modulation and the multiple slot granting flag is set to 1.				

The first two bits of the MAC header distinguish between the possible PDU types which can be sent in the downlink MAC block.

The fill bit indication shall indicate if there are any fill bits, which shall be added whenever the size of the TM-SDU is less than the available capacity of the MAC block or less than the size of the TM-SDU indicated by the length indication field. The TM-SDU length is equal to the MAC PDU length minus the MAC PDU header length.

The position of grant element indicates the channel on which the optional slot grant is valid. If there is no slot granting in this PDU, the MAC shall ignore the content of this bit.

The encryption mode field shall indicate whether or not the TM-SDU contents are encrypted and, if so, the encryption algorithm used. The MAC header shall not be encrypted except that, if the encryption mode field is not set to 00₂:

- the channel allocation element (when present) shall be encrypted; and
- the address is encrypted when appropriate (for details of the address encryption method and when it is used, see ETSI EN 300 392-7 [8]).

NOTE 1: In the case of an event label assignment or usage marker assignment, the address element comprises two parts (SSI or SMI and event label or usage marker). The rules defined in ETSI EN 300 392-7 [8] for when address encryption is used apply independently to each part of the address.

In the case of fragmentation, the setting of the encryption mode field in the MAC-RESOURCE PDU shall apply to all fragments of the TM-SDU.

The random access flag shall be used for the BS to acknowledge a successful random access so as to prevent the MS sending further random access requests.

The length indication field shall indicate the length of the MAC PDU which comprises the MAC PDU header and the TM-SDU. If the length indication field has value of 11111₂, then this shall indicate the beginning of a fragmented signalling message.

The units used for the length indication depend on the bandwidth, modulation and coding rate with which the PDU is sent; see clause 21.6. The defined values of the length indication cover up to the size of the MAC block or a MAC-RESOURCE PDU of up to 2 848 bits, whichever is the lesser.

NOTE 2: A 2848-bit MAC-RESOURCE PDU can carry the maximum size of TM-SDU (2 632 bits) with a 216-bit MAC PDU header. A 216-bit MAC PDU header allows for most combinations of the optional elements. (The MAC PDU header is not restricted to 216 bits, provided that the TM-SDU length plus the MAC PDU header length does not exceed the maximum size of MAC-RESOURCE PDU.)

NOTE 3: In exceptional circumstances, if the 2848-bit limit would be exceeded due to the BS wishing to send a very long TM-SDU (maximum size or close to the maximum size) with a very long MAC header (more than 216 bits), the BS could, for example, choose to use a basic slot granting element instead of a multiple slot granting element (or use fewer slot granting sets).

The address type field shall indicate the type of address(es) contained in the address field. The length of the address field shall be 10 bits, 24 bits, 30 bits or 34 bits depending on the type of address information contained in it.

The immediate napping permission flag shall be present when the PDU is sent using $\pi/8$ -D8PSK or QAM modulation. This element indicates whether, after receiving this PDU, the MS may regard this address as eligible for napping.

The power control flag shall indicate whether the optional power control element is present in this PDU.

The slot granting flag shall indicate whether one of the optional slot granting elements is present in this PDU. If the slot granting flag is set to 1 then:

- if the PDU is sent using $\pi/4$ -DQPSK or $\pi/8$ -D8PSK modulation, the multiple slot granting flag shall not be present and the basic slot granting element shall be present; or
- if the PDU is sent using QAM modulation, the multiple slot granting flag shall be present; then:
 - if the multiple slot granting flag is set to 0, the basic slot granting element shall be present; or
 - if the multiple slot granting flag is set to 1, the multiple slot granting element shall be present.

The channel allocation flag shall indicate whether the optional channel allocation element is present in this PDU.

The header length of a MAC-RESOURCE PDU depends on the type of address information and on which of the optional fields are present. When an event label is used and there are no optional fields present, the minimum header length shall be 29 bits if the PDU is sent using $\pi/4$ -DQPSK modulation or 30 bits if the PDU is sent using $\pi/8$ -D8PSK or QAM modulation. The maximum TM-SDU length when an event label is used and there are no optional fields present is shown in table 21.56.

The address type field may be used to indicate a null PDU (address type = 000₂). If a null PDU is indicated, there shall be no further information in the PDU after the address type field. The length of the null PDU, therefore, shall be 16 bits. On STCH, the length indication field may indicate whether the second half slot is stolen. Otherwise the length indication shall be set according to the length of the null PDU (i.e. set to 000010₂ if Y_2 is 1 or to 000001₂ if Y_2 is 2). All other fields in a null PDU (i.e. Fill bit indication, Position of grant, Encryption mode, and Random access flag) may be set to any value by the BS and shall be ignored by the MS in the present document. If the null PDU is present in a MAC block, then there shall be no subsequent PDUs in that block and any spare capacity shall be filled with fill bits.

This PDU shall also be used for C-plane signalling using the STCH on the downlink. By default, the STCH occupies only the first half slot. The second half slot may also be stolen, either for the last fragment of a fragmented SDU or for subsequent PDUs which the MAC may have ready to send or for U-plane signalling. A length indication of 11111₂ shall be used to indicate that the second half slot is stolen for the last fragment of a fragmented SDU. A length indication of 111110₂ shall be used to indicate that the second half slot is stolen for subsequent C-plane signalling or U-plane signalling. The last fragment shall use the MAC-END PDU, while subsequent C-plane PDUs shall use the MAC-RESOURCE PDU and U-plane signalling shall use the MAC-U-SIGNAL PDU. It shall only be possible to fragment SDUs over the two halves of a full slot on the STCH.

Table 21.56: Maximum length of TM-SDU in downlink MAC-RESOURCE PDU

Logical channel	Maximum TM-SDU length [bits] with event label and no optional fields
SCH/F	239
SCH/HD	95
STCH	95
SCH-P8/F	382
SCH-P8/HD	166
SCH-Q/D25-4H	155
SCH-Q/D25-16H	359
SCH-Q/D25-16U	770
SCH-Q/D25-64H	563
SCH-Q/D25-64M	767
SCH-Q/D25-64U	1 178
SCH-Q/D50-4H	391
SCH-Q/B50	187
SCH-Q/D50-16H	831
SCH-Q/D50-16U	1 714
SCH-Q/D50-64H	1 271
SCH-Q/D50-64M	1 711
SCH-Q/D50-64U	2 594
SCH-Q/D100-4H	863
SCH-Q/B100	659
SCH-Q/D100-16H	1 775
SCH-Q/D100-16U	2 632 (see note)
SCH-Q/D100-64H	2 632 (see note)
SCH-Q/D100-64M	2 632 (see note)
SCH-Q/D100-64U	2 632 (see note)
SCH-Q/D150-4H	1 335
SCH-Q/B150	1 131
SCH-Q/D150-16H	2 632 (see note)
SCH-Q/D150-16U	2 632 (see note)
SCH-Q/D150-64H	2 632 (see note)
SCH-Q/D150-64M	2 632 (see note)
SCH-Q/D150-64U	2 632 (see note)
NOTE:	The maximum length of TM-SDU in this MAC block is constrained by the maximum permitted size of TM-SDU (N.202) rather than by the size of the MAC block.

21.4.3.2 MAC-FRAG (downlink)

This PDU shall be used to send continuation fragments of fragmented C-plane signalling data on the downlink using half slot (SCH/HD or SCH-P8/HD) or full slot (SCH/F, SCH-P8/F or SCH-Q/D) or SCH-Q/B signalling. Its contents shall be as shown in table 21.57.

Table 21.57: MAC-FRAG (downlink) PDU contents

Information element	Length	Type	Value	Remark
MAC PDU type	2	M	01 ₂	MAC-FRAG or MAC-END
MAC PDU subtype	1	M	0	MAC-FRAG
Fill bit indication	1	M	0	No fill bits present
			1	Fill bit(s) present
TM-SDU	varies	M		

The first two bits of the MAC header distinguish between the possible PDU types which can be sent on the downlink. A PDU subtype bit distinguishes between MAC-FRAG and MAC-END which share the same MAC PDU type.

The fill bit indication shall indicate if there are any fill bits, which shall be added whenever the size of the TM-SDU is less than the available capacity of the MAC block.

The header length of a MAC-FRAG PDU shall be equal to 4 bits. The maximum TM-SDU length is shown in table 21.58.

Table 21.58: Maximum length of TM-SDU in downlink MAC-FRAG PDU

Logical channel	Maximum TM-SDU length [bits]
SCH/F	264
SCH/HD	120
SCH-P8/F	408
SCH-P8/HD	192
SCH-Q/D25-4H	181
SCH-Q/D25-16H	385
SCH-Q/D25-16U	796
SCH-Q/D25-64H	589
SCH-Q/D25-64M	793
SCH-Q/D25-64U	1 204
SCH-Q/D50-4H	417
SCH-Q/B50	213
SCH-Q/D50-16H	857
SCH-Q/D50-16U	1 740
SCH-Q/D50-64H	1 297
SCH-Q/D50-64M	1 737
SCH-Q/D50-64U	2 620
SCH-Q/D100-4H	889
SCH-Q/B100	685
SCH-Q/D100-16H	1 801
SCH-Q/D100-16U	Not normally applicable (see note)
SCH-Q/D100-64H	Not normally applicable (see note)
SCH-Q/D100-64M	Not normally applicable (see note)
SCH-Q/D100-64U	Not normally applicable (see note)
SCH-Q/D150-4H	1 361
SCH-Q/B150	1 157
SCH-Q/D150-16H	Not normally applicable (see note)
SCH-Q/D150-16U	Not normally applicable (see note)
SCH-Q/D150-64H	Not normally applicable (see note)
SCH-Q/D150-64M	Not normally applicable (see note)
SCH-Q/D150-64U	Not normally applicable (see note)
NOTE:	For these logical channels, the MAC block is large enough to contain the maximum permitted size of TM-SDU so the BS normally has no need to use MAC-FRAG. (It completes the TM-SDU using MAC-END instead.) However the BS may sometimes need to use MAC-FRAG if it chooses to include a fragment of the TM-SDU by association, after sending other PDU(s), such that the TM-SDU cannot be completed within the slot.

21.4.3.3 MAC-END (downlink)

This PDU shall be used to send the last fragment of fragmented C-plane signalling data on the downlink in a full slot (SCH/F, SCH-P8/F or SCH-Q/D) or the first or second half of a full slot (SCH/HD or SCH-P8/HD) or SCH-Q/B. It shall also be used to send the last fragment of fragmented C-plane signalling in the second half of a stolen full slot on the downlink. Its contents shall be as shown in table 21.59.

Table 21.59: MAC-END (downlink) PDU contents

Information element	Length	Type	Value	Remark
MAC PDU type	2	M	01 ₂	MAC-FRAG or MAC-END
MAC PDU subtype	1	M	1	MAC-END
Fill bit indication	1	M	0	No fill bits present
			1	Fill bit(s) present
Position of grant	1	M	0	Slot grant is on current channel
			1	Slot grant is on allocated channel
Length indication	6	M	000000 ₂	Reserved
			000001 ₂	Length of MAC PDU = value × Y ₂ octets (see note 1)
			etc.	etc.
			010010 ₂	Length of MAC PDU = value × Y ₂ octets
			010011 ₂	Length of MAC PDU = (18 × Y ₂ + (value - 18) × Z ₂) octets
			etc.	etc.
			111010 ₂	Length of MAC PDU = (18 × Y ₂ + (value - 18) × Z ₂) octets
			111011 ₂	Reserved
Immediate napping permission flag (see note 2)	1	C	0	Immediate napping permission not given
			1	Immediate napping permission given
Slot granting flag	1	M	0	No slot granting information elements in PDU
			1	Slot granting information element in PDU
Multiple slot granting flag (see note 3)	1	C	0	Basic slot granting information element in PDU
			1	Multiple slot granting information element in PDU
Basic slot granting element (see note 4)	8	C		See basic slot granting information element definition
Multiple slot granting element (see note 5)	varies	C		See multiple slot granting information element definition
Channel allocation flag	1	M	0	No channel allocation information element in PDU
			1	Channel allocation information element in PDU
Channel allocation element	varies	C		See channel allocation information element definition
TM-SDU	varies	C		
NOTE 1: For values of length indication up to 010010 ₂ , the unit of the length indication is Y ₂ octets whereas, for higher values, the incremental unit of the length indication is Z ₂ octets. The values of Y ₂ and Z ₂ depend on the bandwidth, modulation and coding rate with which the PDU is sent; the values of Y ₂ and Z ₂ are given in clause 21.6 for each combination.				
NOTE 2: The immediate napping permission flag shall be present when the PDU is sent using π/8-D8PSK or QAM modulation. It shall not be present when the PDU is sent using π/4-DQPSK modulation.				
NOTE 3: The multiple slot granting flag shall be present when the slot granting flag is set to 1 and the PDU is sent using QAM modulation. It shall not be present when the slot granting flag is set to 0 or the PDU is sent using π/4-DQPSK or π/8-D8PSK modulation.				
NOTE 4: The basic slot granting element shall be present when the slot granting flag is set to 1 and either the PDU is sent using π/4-DQPSK or π/8-D8PSK modulation, or the PDU is sent using QAM modulation and the multiple slot granting flag is set to 0.				
NOTE 5: The multiple slot granting element shall be present when the slot granting flag is set to 1 and the PDU is sent using QAM modulation and the multiple slot granting flag is set to 1.				

The first two bits of the MAC header shall distinguish between the possible PDU types which can be sent on the downlink. A PDU subtype bit distinguishes between MAC-FRAG and MAC-END which share the same MAC PDU type.

The fill bit indication shall indicate if there are any fill bits, which shall be added whenever the size of the TM-SDU is less than the available capacity of the MAC block or less than the size of the TM-SDU indicated by the length indication field. The TM-SDU length is equal to the MAC PDU length minus the MAC PDU header length.

The position of grant element indicates the channel on which the optional slot grant is valid. If there is no slot granting in this PDU, the MAC shall ignore the content of this bit.

The length indication field shall indicate the length of the MAC PDU which comprises the MAC PDU header and the TM-SDU.

The units used for the length indication depend on the bandwidth, modulation and coding rate with which the PDU is sent; see clause 21.6. The defined values of the length indication cover up to the size of the MAC block or the maximum size of a MAC-END PDU, whichever is the lesser.

The immediate napping permission flag shall be present when the PDU is sent using $\pi/8$ -D8PSK or QAM modulation. This element indicates whether, after receiving this PDU, the MS may regard this address as eligible for napping.

The slot granting flag shall indicate whether one of the optional slot granting elements is present in this PDU. The slot granting element may be used to allocate some uplink reserved slots for an MS. If the slot granting flag is set to 1 then:

- if the PDU is sent using $\pi/4$ -DQPSK or $\pi/8$ -D8PSK modulation, the multiple slot granting flag shall not be present and the basic slot granting element shall be present; or
- if the PDU is sent using QAM modulation, the multiple slot granting flag shall be present; then:
 - if the multiple slot granting flag is set to 0, the basic slot granting element shall be present; or
 - if the multiple slot granting flag is set to 1, the multiple slot granting element shall be present.

The channel allocation flag shall indicate whether the channel allocation element is present in this PDU. The channel allocation element may be used to direct MS to a channel at the end of a fragmented downlink message.

The minimum header length of a MAC-END PDU shall be equal to 13 bits when sent using $\pi/4$ -DQPSK modulation or 14 bits when sent using $\pi/8$ -D8PSK or QAM modulation. The maximum TM-SDU length is shown in table 21.60.

Table 21.60: Maximum length of TM-SDU in downlink MAC-END PDU

Logical channel	Maximum TM-SDU length [bits] if no optional fields
SCH/F	255
SCH/HD	111
STCH	111
SCH-P8/F	398
SCH-P8/HD	182
SCH-Q/D25-4H	171
SCH-Q/D25-16H	375
SCH-Q/D25-16U	786
SCH-Q/D25-64H	579
SCH-Q/D25-64M	783
SCH-Q/D25-64U	1 194
SCH-Q/D50-4H	407
SCH-Q/B50	203
SCH-Q/D50-16H	847
SCH-Q/D50-16U	1 730
SCH-Q/D50-64H	1 287
SCH-Q/D50-64M	1 727
SCH-Q/D50-64U	2 610
SCH-Q/D100-4H	879
SCH-Q/B100	675
SCH-Q/D100-16H	1 791
SCH-Q/D100-16U	2 631 (see note)
SCH-Q/D100-64H	2 631 (see note)
SCH-Q/D100-64M	2 631 (see note)
SCH-Q/D100-64U	2 631 (see note)
SCH-Q/D150-4H	1 351
SCH-Q/B150	1 147
SCH-Q/D150-16H	2 631 (see note)
SCH-Q/D150-16U	2 631 (see note)
SCH-Q/D150-64H	2 631 (see note)
SCH-Q/D150-64M	2 631 (see note)
SCH-Q/D150-64U	2 631 (see note)
NOTE:	The maximum length of TM-SDU in this MAC block is constrained by the maximum permitted size of TM-SDU (N.202) rather than by the size of the MAC block.

21.4.3.4 MAC-D-BLCK

This PDU may optionally be used to send C-plane signalling data on the downlink in a full slot (SCH/F, SCH-P8/F or SCH-Q/D), or in SCH-Q/B100 or SCH-Q/B150, in cases when an event label can be used and a pre-defined length is appropriate e.g. when sending an advanced link data segment. The MAC-D-BLCK PDU has a smaller MAC header than the MAC-RESOURCE PDU so can carry more data.

The MAC-D-BLCK PDU should not be used when the pre-defined length is not appropriate. For example, when the BS is sending a basic link message or a short advanced link message or the last segment of an advanced link message, use of the MAC-RESOURCE PDU may be more efficient.

The MAC-D-BLCK PDU cannot be used if any of the following functions are needed:

- SSI or SMI addressing;
- fragmentation;
- acknowledgement of random access;
- event label or usage marker assignment;
- power control;

- channel allocation; or
- null PDU.

When any of these functions are needed, the BS should use the MAC-RESOURCE PDU.

The MAC-D-BLCK PDU uses the same MAC PDU type as the MAC-U-SIGNAL PDU, which is sent using the stealing channel (STCH). The MAC-D-BLCK PDU shall not be sent on STCH, SCH/HD or SCH-P8/HD.

The contents of the MAC-D-BLCK PDU shall be as shown in table 21.61.

Table 21.61: MAC-D-BLCK PDU contents

Information element	Length	Type	Value	Remark
MAC PDU type	2	M	11 ₂	Supplementary MAC PDU
Supplementary MAC PDU subtype	1	M	0	MAC-D-BLCK
Fill bit indication	1	M	0	No fill bit present
			1	Fill bit(s) present
Encryption mode	2	M	00 ₂	Not encrypted
			01 ₂	See ETSI EN 300 392-7 [8]
			10 ₂	See ETSI EN 300 392-7 [8]
			11 ₂	See ETSI EN 300 392-7 [8]
Address	10	M		Event label
Immediate napping permission flag	1	M	0	Immediate napping permission not given
			1	Immediate napping permission given
Slot granting flag.	1	M	0	No slot granting information element in PDU
			1	Slot granting information element in PDU
Basic slot granting element (see note)	8	C		See basic slot granting information element definition
TM-SDU	varies	C		

NOTE: The basic slot granting element shall be present when the slot granting flag is set to 1.

The length of the MAC-D-BLCK PDU is defined implicitly, as shown in table 21.62. The implicit length shall refer to the length of the MAC PDU, which comprises the MAC PDU header and the TM-SDU. For a $\pi/4$ -DQPSK or $\pi/8$ -D8PSK slot, the implicit length matches the size of the MAC block. On a QAM channel, the implicit length of the MAC-D-BLCK PDU is set to correspond to the normal size of an advanced link data segment i.e.:

- in the case of a 25 kHz or 50 kHz channel, the implicit length corresponds to the size of a 4-QAM rate = 1/2 full-slot MAC block at the current bandwidth;
- in the case of a 100 kHz or 150 kHz channel, the implicit length corresponds to half the size of a 4-QAM rate = 1/2 full-slot MAC block at the current bandwidth.

Table 21.62: Implicit length of MAC-D-BLCK PDU

Logical channel	Implicit length of MAC-D-BLCK PDU
SCH/F	268 bits
SCH-P8/F	412 bits
SCH-Q/D25	185 bits
SCH-Q/D50	421 bits
SCH-Q/D100, SCH-Q/B100	446 bits
SCH-Q/D150, SCH-Q/B150	682 bits

The first two bits of the MAC header distinguish between the possible PDU types which can be sent on the downlink SCH/F, SCH-P8/F, SCH-Q/D, SCH-Q/B100 or SCH-Q/B150. The supplementary MAC PDU subtype bit distinguishes between supplementary MAC PDUs which share the same MAC PDU type.

The fill bit indication shall indicate if there are any fill bits, which shall be added whenever the size of the TM-SDU is less than the available capacity of the MAC block or less than the size of the TM-SDU indicated by the implicit length of the MAC-D-BLCK PDU. The TM-SDU length is equal to the MAC PDU length minus the MAC PDU header length.

The encryption mode field shall indicate whether or not the TM-SDU contents are encrypted and, if so, the encryption algorithm used. The MAC header shall not be encrypted.

The address field shall contain an event label.

NOTE 1: As defined in ETSI EN 300 392-7 [8], the event label is not encrypted.

The immediate napping permission flag shall indicate whether, after receiving this PDU, the MS may regard this address as eligible for napping.

The slot granting flag shall indicate whether the optional basic slot granting element is present in this PDU.

NOTE 2: The BS may cut an advanced link TL-SDU into segments using the assumption that it will not include a slot grant until the end of the TL-SDU. Alternatively it may cut the TL-SDU into segments allowing for a possible slot grant and then include fill bits when the basic slot granting element is not present.

The header length of a MAC-D-BLCK PDU shall be equal to 18 bits if a basic slot granting element is not included. The maximum TM-SDU length is shown in table 21.63.

Table 21.63: Maximum length of TM-SDU in MAC-D-BLCK PDU

Logical channel	Maximum TM-SDU length [bits]
SCH/F	250
SCH-P8/F	394
SCH-Q/D25	167
SCH-Q/D50	403
SCH-Q/D100, SCH-Q/B100	428
SCH-Q/D150, SCH-Q/B150	664

21.4.4 TMB-SAP: MAC PDU structure for broadcast

21.4.4.0 General

Broadcast PDUs shall be used by the BS to send some broadcast information on the downlink to all MSs. There shall be no addresses contained in these PDUs and all MSs shall decode them as if they were addressed to each of them. The SYNC PDU shall be transmitted using the BSCH which shall be sent using the phase modulation synchronization burst. The SYNC-DA PDU shall be transmitted using the BSCH-Q which shall be sent using the QAM frequency correction burst.

There is no PDU type element in the SYNC PDU and SYNC-DA PDU. The other broadcast PDU types shall be distinguished by a PDU type and broadcast type as shown in table 21.64.

Table 21.64: Broadcast PDU contents

Information element	Length	Type	Value	Remark
MAC PDU type	2	M	10 ₂	Broadcast PDU
Broadcast type	2	M	00 ₂	SYSINFO PDU if sent using $\pi/4$ -DQPSK modulation or $\pi/8$ -D8PSK modulation; or SYSINFO-Q PDU if sent using QAM modulation
			01 ₂	ACCESS-DEFINE PDU
			10 ₂	SYSINFO-DA
			11 ₂	Reserved
Broadcast elements				See following definitions for SYSINFO, SYSINFO-Q, SYSINFO-DA and ACCESS-DEFINE PDUs

The following clauses describe the contents of the three types of broadcast PDU.

21.4.4.1 SYSINFO

The SYSINFO PDU shall be transmitted using the BNCH on SCH/HD. It may also be sent using the stealing channel (STCH). It may also be sent using association on SCH-P8/HD or SCH-P8/F. Its contents shall be as shown in table 21.65.

NOTE 1: The SYSINFO PDU is sent on $\pi/4$ -DQPSK and $\pi/8$ -D8PSK channels. It is sent using $\pi/4$ -DQPSK modulation on $\pi/4$ -DQPSK channels. It is also sent using $\pi/4$ -DQPSK modulation on $\pi/8$ -D8PSK channels according to a mandatory mapping, but it may be sent using either $\pi/4$ -DQPSK modulation or $\pi/8$ -D8PSK modulation in other positions.

Table 21.65: SYSINFO PDU contents

Information element	Length	Type	Value	Remark
MAC PDU type	2	M	10 ₂	Broadcast PDU
Broadcast type	2	M	00 ₂	SYSINFO PDU
Main carrier	12	M		Frequency of the CA main carrier (see note 3)
Frequency band	4	M		Frequency band of the CA main carrier (see note 3)
Offset	2	M	00 ₂	0 kHz offset
			01 ₂	+6,25 kHz offset
			10 ₂	-6,25 kHz offset
			11 ₂	+12,5 kHz offset
Duplex spacing	3	M		Provision for different duplex spacing
Reverse operation	1	M	0	Normal
			1	Reverse
Number of common secondary control channels in use on CA main carrier	2	M	00 ₂	None
			01 ₂	Timeslot 2 of main carrier
			10 ₂	Timeslots 2 and 3 of main carrier
			11 ₂	Timeslots 2, 3 and 4 of main carrier
MS_TXPWR_MAX_CELL (see note 1)	3	M	000 ₂	Reserved
			001 ₂	15 dBm
			etc.	etc. in 5 dB steps
			111 ₂	45 dBm
RXLEV_ACCESS_MIN (see note 1)	4	M	0000 ₂	-125 dBm
			etc.	etc. in 5 dB steps
			1111 ₂	-50 dBm
ACCESS_PARAMETER (see note 1)	4	M	0000 ₂	-53 dBm
			etc.	etc. in 2 dB steps
			1111 ₂	-23 dBm
RADIO_DOWNLINK_TIMEOUT (see note 1)	4	M	0000 ₂	Disable radio downlink counter
			0001 ₂	144 timeslots
			0010 ₂	288 timeslots
			etc.	etc. in multiples of 144
			1111 ₂	2 160 timeslots
Hyperframe / cipher key flag	1	M	0	Hyperframe number
			1	Common cipher key identifier
Hyperframe number	16	C		Cyclic count of hyperframes
CCK identifier or static cipher key version number	16	C		Common cipher key identifier or static cipher key version number, refer to ETSI EN 300 392-7 [8]
Optional field flag	2	M	00 ₂	Even multiframe definition for TS mode
			01 ₂	Odd multiframe definition for TS mode
			10 ₂	Default definition for access code A
			11 ₂	Extended services broadcast
TS_COMMON_FRAMES either for Even or Odd multiframes	20	C		Bit map of common frames for TS mode, see information element description in table 21.94
Default definition for access code A	20	C		See table 21.66
Extended services broadcast	20	C		See table 21.67

Information element	Length	Type	Value	Remark
Reserved (see note 2)	28	C		Reserved, value shall be set to all zeros
TM-SDU (MLE data)	42	M		As defined in clause 18 (D-MLE-SYSINFO)
NOTE 1: When sent on a D8PSK channel, the value of this element is specific to that D8PSK channel and may be different from the value for a $\pi/4$ -DQPSK channel.				
NOTE 2: This element shall be present when the PDU is sent using $\pi/8$ -D8PSK modulation. This element shall not be present when the PDU is sent using $\pi/4$ -DQPSK modulation.				
NOTE 3: If there is no CA main carrier, the parameters Main carrier and Frequency band are set to 0.				

The frequency of the conventional access main carrier shall be defined by the following information elements:

- main carrier;
- frequency band;
- offset;
- duplex spacing;
- reverse operation.

The frequency band field shall map to a specific frequency which shall map to a defined base frequency (in MHz) for the carrier numbering scheme. The main carrier field shall indicate the carrier frequency relative to the base frequency defined by the frequency band field. The main carrier field shall have step size of 25 kHz. The offset field shall then adjust the main carrier frequency by the given amount. (The offset field allows for the case where the carrier frequency is not $N \times 25$ kHz above the base frequency.) The frequency so defined shall be the downlink frequency of the main carrier. This calculation is summarized by the following equation:

- downlink main carrier frequency = base frequency + (main carrier \times 25 kHz) + offset kHz.

The uplink frequency of the main carrier shall be determined using the duplex spacing and reverse operation fields. The duplex spacing field shall map to a defined duplex spacing (in MHz) for the carrier numbering scheme. The duplex spacing shall be dependent on the frequency band element. The reverse operation field shall indicate whether to add or subtract the duplex spacing to arrive at the uplink frequency of the main carrier. If normal operation, the duplex spacing shall be subtracted. If reverse operation, the duplex spacing shall be added. This calculation is summarized by the following equations:

- normal operation:
 - uplink main carrier frequency = downlink main carrier frequency - duplex spacing.
- reverse operation:
 - uplink main carrier frequency = downlink main carrier frequency + duplex spacing.

The mappings of the frequency band field values to actual base frequencies and the duplex spacing field values to actual duplex frequency spacing are defined in ETSI TS 100 392-15 [18].

NOTE 2: These rules for calculation of uplink and downlink carrier frequency are also used for calculation of the uplink and downlink main carrier frequency from the elements in the SYSINFO-Q PDU.

RXLEV_ACCESS_MIN shall be used for cell selection and reselection. ACCESS_PARAMETER shall be used for subsequent power adjustments. MS_TXPWR_MAX_CELL shall be used for cell selection and reselection, and for power adjustments. RADIO_DOWNLINK_TIMEOUT shall be used in the criteria for radio downlink failure.

The hyperframe/cipher key flag shall indicate whether the following information element is the hyperframe number information element or the CCK identifier or static cipher key version number information element. The usage of the CCK identifier or static cipher key version number information element is defined in ETSI EN 300 392-7 [8].

The optional field flag information element indicates which one of the optional information elements is present.

The TS_COMMON_FRAMES information element shall only be present if "Discontinuous TX" and "MCCH sharing" is indicated in the SYNC broadcast PDU. The optional field shall indicate whether TS_COMMON_FRAMES refers to odd or even multiframe definition.

If the optional field flag indicates a default access definition, then the 20-bit field corresponding to the default access code definition for access code A shall be present. Its contents shall be as defined in table 21.66.

Table 21.66: Default definition for access code A information element contents

Information element	Length	Type	Value	Remark
IMM (immediate)	4	M	0000 ₂	Always randomize
			0001 ₂	Randomize after IMM TDMA frames
			etc.	etc.
			1110 ₂	Randomize after IMM TDMA frames
			1111 ₂	Immediate access allowed
WT (waiting time)	4	M	0000 ₂	Reserved
			0001 ₂	Response within WT downlink opportunities
			etc.	etc.
			1111 ₂	Response within WT downlink opportunities
Nu (number of random access transmissions on uplink)	4	M	0000 ₂	No random access transmission allowed
			0001 ₂	1 random access transmission allowed
			etc.	etc.
			1111 ₂	15 random access transmissions allowed
Frame-length factor	1	M	0	Multiply base frame-length by 1
			1	Multiply base frame-length by 4
Timeslot pointer	4	M	0000 ₂	Same as downlink slot assignment
			0001 ₂	Timeslot 4
			0010 ₂	Timeslot bit map
			etc.	etc.
			1110 ₂	Timeslot bit map
			1111 ₂	All four timeslots
Minimum PDU priority	3	M	000 ₂	Priority 0 (lowest)
			etc.	etc.
			111 ₂	Priority 7 (highest)

If optional field flag indicates an extended service broadcast, the bits shall be used to indicate the extended services provided according to table 21.67. In the present document only the extended services broadcast sections 1 and 2 may be used.

NOTE 3: The extended services broadcast sections 3 and 4 are not used in the present document. The setting of the reserved bits to 0000000₂ in tables 21.70 and 21.71 does not limit how those bits will be used in future editions of the present document.

Table 21.67: Extended services broadcast information element contents

Information element	Length	M/C/O	Value	Remark
Security information	8			Refer to ETSI EN 300 392-7 [8].
SDS-TL addressing method	2	M	00 ₂	Reserved
			01 ₂	Service centre addressing preferred (see note 1)
			10 ₂	Never use service centre addressing (see note 1)
			11 ₂	MS choice to use service centre addressing (see note 1)
GCK supported	1	M		Refer to ETSI EN 300 392-7 [8] (see note 2)
Section	2	M	00 ₂	Extended services broadcast section 1 is present
			01 ₂	Extended services broadcast section 2 is present
			10 ₂	Extended services broadcast section 3 is present
			11 ₂	Extended services broadcast section 4 is present
Extended services broadcast section 1 (see note 3)	7	C		See table 21.68
Extended services broadcast section 2 (see note 4)	7	C		See table 21.69
Extended services broadcast section 3 (see note 5)	7	C		See table 21.70
Extended services broadcast section 4 (see note 6)	7	C		See table 21.71
NOTE 1: Refer to clause 29 for further information.				
NOTE 2: This shall be ignored by the MS when AI encryption is not available (indicated in BS Service Details).				
NOTE 3: This element shall be present only if section element is set to 00 ₂ .				
NOTE 4: This element shall be present only if section element is set to 01 ₂ .				
NOTE 5: This element shall be present only if section element is set to 10 ₂ .				
NOTE 6: This element shall be present only if section element is set to 11 ₂ .				

Table 21.68: Extended services broadcast section 1 information element contents

Information element	Length	M/C/O	Value	Remark
Data priority supported	1	M	0	Data priority not supported on this cell
			1	Data priority supported on this cell
Extended advanced links and MAC-U-BLCK supported	1	M	0	Extended advanced links and MAC-U-BLCK PDU not supported on this cell (see note 1)
			1	Extended advanced links and MAC-U-BLCK PDU supported on this cell (see note 2)
QoS negotiation supported (see note 3)	1	M	0	QoS negotiation not supported on this cell
			1	QoS negotiation supported on this cell
D8PSK service	1	M	0	D8PSK operation not supported on this cell
			1	D8PSK operation supported on this cell
Section 2 information sent on this cell	1	M	0	No information in extended services broadcast section 2
			1	Further information in extended services broadcast section 2
Section 3 information sent on this cell	1	M	0	No information in extended services broadcast section 3
			1	Further information in extended services broadcast section 3
Section 4 information sent on this cell	1	M	0	No information in extended services broadcast section 4
			1	Further information in extended services broadcast section 4
NOTE 1: If the "extended advanced links and MAC-U-BLCK supported" element is set to 0, this indicates that the BS does not support extended advanced links and does not support the MAC-U-BLCK PDU. The BS may support the original advanced link (see the "BS service details" element in clause 18.5.2).				
NOTE 2: If the "extended advanced links and MAC-U-BLCK supported" element is set to 1, this indicates that the BS supports four extended advanced links for each service and for each MS address, and supports the original advanced link plus three extended advanced links for each service and for each MS address; it also indicates that the BS supports the MAC-U-BLCK PDU (if it has assigned an event label to the MS).				
NOTE 3: Cells that support D8PSK and/or QAM operation shall support QoS negotiation.				

Table 21.69: Extended services broadcast section 2 information element contents

Information element	Length	M/C/O	Value	Remark
25 kHz QAM service	1	M	0	25 kHz QAM operation not supported on this cell
			1	25 kHz QAM operation supported on this cell
50 kHz QAM service	1	M	0	50 kHz QAM operation not supported on this cell
			1	50 kHz QAM operation supported on this cell
100 kHz QAM service	1	M	0	100 kHz QAM operation not supported on this cell
			1	100 kHz QAM operation supported on this cell
150 kHz QAM service	1	M	0	150 kHz QAM operation not supported on this cell
			1	150 kHz QAM operation supported on this cell
Reserved	3	M		Reserved, value shall be set to 000 ₂

Table 21.70: Extended services broadcast section 3 information element contents

Information element	Length	M/C/O	Value	Remark
Reserved	7	M		Reserved, value shall be set to 0000000 ₂

Table 21.71: Extended services broadcast section 4 information element contents

Information element	Length	M/C/O	Value	Remark
Reserved	7	M		Reserved, value shall be set to 0000000 ₂

Each of the optional fields comprises 20 bits (including reserved bits). Therefore, when the SYSINFO PDU is sent using $\pi/4$ -DQPSK modulation, it fully occupies all 124 bits of the MAC block in all cases.

When the SYSINFO PDU is sent using $\pi/8$ -D8PSK modulation, there is an additional reserved element. Therefore, when the SYSINFO PDU is sent using $\pi/8$ -D8PSK modulation, the PDU length is 152 bits.

21.4.4.1a SYSINFO-Q

The SYSINFO-Q PDU may be transmitted by the BS to send broadcast information on a QAM channel to conventional access MSs.

The SYSINFO-Q PDU shall use the BNCH-Q on SCH-Q/D. It fully occupies a 4-QAM rate = 1/2 SCH-Q/D MAC block on a 25 kHz QAM channel (logical channel SCH-Q/D25-4H). It may be sent using PDU association within other SCH-Q/D MAC blocks (i.e. higher modulation level and/or bandwidth). Its contents shall be as shown in table 21.72.

NOTE 1: The SYSINFO-Q PDU may be sent on QAM channels. It is always sent using QAM modulation.

Table 21.72: SYSINFO-Q PDU contents

Information element	Length	Type	Value	Remark
MAC PDU type	2	M	10 ₂	Broadcast PDU
Broadcast type	2	M	00 ₂	SYSINFO-Q PDU
Main carrier	12	M		Frequency of the CA main carrier
Frequency band	4	M		Frequency band of the CA main carrier
Offset	2	M	00 ₂	0 kHz offset
			01 ₂	+6,25 kHz offset
			10 ₂	-6,25 kHz offset
			11 ₂	+12,5 kHz offset
Duplex spacing	3	M		Provision for different duplex spacing
Reverse operation	1	M	0	Normal
			1	Reverse
Number of common secondary control channels in use on CA main carrier	2	M	00 ₂	None
			01 ₂	Timeslot 2 of main carrier
			10 ₂	Timeslots 2 and 3 of main carrier
			11 ₂	Timeslots 2, 3 and 4 of main carrier
MS_TXPWR_MAX_CELL on this QAM carrier	3	M	000 ₂	Reserved
			001 ₂	15 dBm
			etc.	etc. in 5 dB steps
			111 ₂	45 dBm
RXLEV_ACCESS_MIN on this QAM carrier	4	M	0000 ₂	-125 dBm
			etc.	etc. in 5 dB steps
			1111 ₂	-50 dBm
ACCESS_PARAMETER on this QAM carrier	4	M	0000 ₂	-53 dBm
			etc.	etc. in 2 dB steps
			1111 ₂	-23 dBm
RADIO_DOWNLINK_TIMEOUT on this QAM carrier	4	M	0000 ₂	Disable radio downlink counter
			0001 ₂	144 timeslots
			0010 ₂	288 timeslots
			etc.	etc. in multiples of 144
			1111 ₂	2 160 timeslots
CCK identifier or static cipher key version number (see note)	16	M		Common cipher key identifier or static cipher key version number, refer to ETSI EN 300 392-7 [8]
Default definition for access code A	20	M		See table 21.66
Extended services broadcast	20	M		See table 21.67
Reserved	39	M		Reserved, value shall be set to all zeros
TM-SDU (MLE data)	47	M		As defined in clause 18 (D-MLE-SYSINFO-Q)
NOTE: This element has no meaning if Air Interface Encryption is not supported.				

NOTE 2: SYSINFO-Q PDU is not sent, if there is no CA main carrier.

The frequency of the conventional access main carrier shall be defined by the following information elements:

- main carrier;
- frequency band;
- offset;
- duplex spacing;
- reverse operation.

The downlink and uplink main carrier frequency shall be calculated using the same equations as defined for the main carrier frequency calculation in the SYSINFO PDU description; see clause 21.4.4.1.

RXLEV_ACCESS_MIN shall be used in the calculation of the path loss on the QAM channel.
 ACCESS_PARAMETER shall be used for power adjustments on the QAM channel. MS_TXPWR_MAX_CELL shall be used in the calculation of the path loss on the QAM channel, and for power adjustments on the QAM channel.
 RADIO_DOWNLINK_TIMEOUT shall be used in the criteria for radio downlink failure of the QAM channel.

The usage of the CCK identifier or static cipher key version number information element is defined in ETSI EN 300 392-7 [8].

The contents of the default definition for access code A information element shall be as defined in table 21.66.

The contents of the extended services broadcast information element shall be as defined in table 21.67.

The size of the SYSINFO-Q PDU is 185 bits. Therefore, when the SYSINFO-Q PDU is sent using 4-QAM rate = 1/2 on a 25 kHz channel, it fully occupies all 185 bits of the MAC block (SCH-Q/D25-4H). When the SYSINFO-Q PDU is sent using a higher modulation level and/or bandwidth, it may be sent with other PDU(s) in the SCH-Q/D MAC block using PDU association.

21.4.4.1b SYSINFO-DA

The SYSINFO-DA PDU may be transmitted by the BS to send broadcast information on a QAM channel to direct access MSs.

The SYSINFO-DA PDU shall use the BNCH-Q on SCH-Q/D or on SCH-Q/B. The SYSINFO-DA PDU fully occupies a 4-QAM rate = 1/2 SCH-Q/D MAC block on a 25 kHz QAM channel (logical channel SCH-Q/D25-4H). It may be sent using PDU association within other SCH-Q/D MAC blocks (i.e. higher modulation level and/or bandwidth) or within SCH-Q/B MAC blocks. Its contents shall be as shown in table 21.73.

The SYSINFO-DA PDU shall be sent on the DA main carrier and may be sent on QAM carriers other than the DA main carrier.

The SYSINFO-DA PDU may be transmitted on phase modulated channels using PDU association on SCH/F or SCH-P8/F or using SCH-P8/HD.

Table 21.73: SYSINFO-DA PDU contents

Information element	Length	Type	Value	Remark
MAC PDU type	2	M	10 ₂	Broadcast PDU
Broadcast type	2	M	10 ₂	SYSINFO-DA PDU
DA main carrier bandwidth	3	M	000 ₂	25 kHz
			001 ₂	50 kHz
			010 ₂	100 kHz
			011 ₂	150 kHz
			100 ₂	Reserved
			etc.	etc.
			111 ₂	Reserved
DA main carrier	12	M		Frequency of the DA main carrier
Frequency band	4	M		Frequency band of the DA main carrier
Offset	2	M	00 ₂	0 kHz offset
			01 ₂	+6,25 kHz offset
			10 ₂	-6,25 kHz offset
			11 ₂	+12,5 kHz offset
Duplex spacing	3	M		Provision for different duplex spacing
Reverse operation	1	M	0	Normal
			1	Reverse
Usage of common control channel slots on DA main carrier	1	M	0	One common control channel in use (MCCH-Q)
			1	Common SCCH(s) in use on DA main carrier
Number of slots used for MCCH-Q on DA main carrier (see note 1)	2	C	00 ₂	One-slot MCCH-Q (timeslot 1 of DA main carrier)
			01 ₂	Two-slot MCCH-Q (timeslots 1 and 2 of DA main carrier)
			10 ₂	Three-slot MCCH-Q (timeslots 1, 2 and 3 of DA main carrier)

Information element	Length	Type	Value	Remark
			11 ₂	Four-slot MCCH-Q (timeslots 1, 2, 3 and 4 of DA main carrier)
Number of common secondary control channels in use on DA main carrier (see note 2)	2	C	00 ₂	Reserved
			01 ₂	One common SCCH (in timeslot 2 of DA main carrier; MCCH-Q in timeslot 1)
			10 ₂	Two common SCCHs (in timeslots 2 and 3 of DA main carrier; MCCH-Q in timeslot 1)
			11 ₂	Three common SCCHs (in timeslots 2, 3 and 4 of DA main carrier; MCCH-Q in timeslot 1)
MS_TXPWR_MAX_CELL on this QAM carrier (see note 3)	3	C	000 ₂	Reserved
			001 ₂	15 dBm
			etc.	etc. in 5db steps
			111 ₂	45 dBm
RXLEV_ACCESS_MIN on this QAM carrier (see note 3)	4	C	0000 ₂	-125 dBm
			etc.	etc. in 5 dB steps
			1111 ₂	-50 dBm
ACCESS_PARAMETER on this QAM carrier (see note 3)	4	C	0000 ₂	-53 dBm
			etc.	etc. in 2 dB steps
			1111 ₂	-23 dBm
RADIO_DOWNLINK_TIMEOUT on this QAM carrier (see note 3)	4	C	0000 ₂	Disable radio downlink counter
			0001 ₂	144 timeslots
			0010 ₂	288 timeslots
			etc.	etc. in multiples of 144
			1111 ₂	2 160 timeslots
Reserved (see note 4)	15	C		Reserved, value shall be set to all zeros
Hyperframe number	16	M		Cyclic count of hyperframes
CCK identifier or static cipher key version number (see note 5)	16	M		Common cipher key identifier or static cipher key version number, refer to ETSI EN 300 392-7 [8]
Default definition for access code A (see note 3)	20	C		See table 21.66
Reserved (see note 4)	20	C		Reserved, value shall be set to all zeros
Extended DA services broadcast	20	M		See table 21.74
Maximum uplink QAM modulation level on the common control channels on DA main carrier (see note 6)	3	M	000 ₂	Reserved
			001 ₂	16-QAM
			010 ₂	64-QAM
			011 ₂	Reserved
			etc.	etc.
			111 ₂	Reserved
BS link imbalance on the common control channels on DA main carrier	4	M		See "BS link imbalance" information element definition
U-plane DTX	1	M	0	Discontinuous U-plane transmission is not allowed
			1	Discontinuous U-plane transmission is allowed
Phase modulation carrier sharing mode	1	M	0	Phase modulation carrier sharing is not used
			1	Phase modulation carrier sharing may be used
Enhanced Energy Economy available	1	M	0	Enhanced Energy Economy not available
			1	Enhanced Energy Economy available
Part-time reception	1	M	0	Part-time reception not permitted
			1	Part-time reception permitted
Reserved	8	M		Reserved, value shall be set to all zeros
TM-SDU (MLE data)	47	M		As defined in clause 18 (D-MLE-SYSINFO-DA)

Information element	Length	Type	Value	Remark
NOTE 1:				This element is present only when element "Usage of common control channel slots on DA main carrier" is set to 0.
NOTE 2:				This element is present only when element "Usage of common control channel slots on DA main carrier" is set to 1.
NOTE 3:				This element is present only when the SYSINFO-DA PDU is sent using QAM modulation.
NOTE 4:				This element is present only when the SYSINFO-DA PDU is sent using $\pi/4$ -DQPSK or $\pi/8$ -D8PSK modulation.
NOTE 5:				This element has no meaning if Air Interface Encryption is not supported.
NOTE 6:				If the MS does not understand the value of this element, it shall regard the value as indicating the maximum QAM modulation level supported by that MS.

The frequency of the DA main carrier shall be defined by the following information elements:

- DA main carrier;
- channel bandwidth;
- frequency band;
- offset;
- duplex spacing;
- reverse operation.

The frequency band field shall map to a specific frequency which shall map to a defined base frequency (in MHz) for the carrier numbering scheme. The DA main carrier field shall indicate the carrier frequency relative to the base frequency defined by the frequency band field. The DA main carrier field shall have step size of 25 kHz. The offset field shall then adjust the DA main carrier frequency by the given amount. The frequency so defined shall be the downlink frequency of the DA main carrier, but with an additional term to allow bandwidths greater than 25 kHz. This calculation is summarized by the following equation:

$$\text{downlink main carrier frequency} = \text{base frequency} + (\text{DA main carrier} \times 25 \text{ kHz}) + \text{offset kHz} \\ + ((\text{DA main carrier bandwidth} / 2) - 12,5) \text{ kHz}$$

The uplink frequency of the main carrier shall be determined using the duplex spacing and reverse operation fields. The duplex spacing field shall map to a defined duplex spacing (in MHz) for the carrier numbering scheme. The duplex spacing shall be dependent on the frequency band element. The reverse operation field shall indicate whether to add or subtract the duplex spacing to arrive at the uplink frequency of the main carrier. If normal operation, the duplex spacing shall be subtracted. If reverse operation, the duplex spacing shall be added. This calculation is summarized by the following equations:

- normal operation:
 - uplink main carrier frequency = downlink main carrier frequency - duplex spacing
- reverse operation:
 - uplink main carrier frequency = downlink main carrier frequency + duplex spacing.

The mappings of the frequency band field values to actual base frequencies and the duplex spacing field values to actual duplex frequency spacing are defined in ETSI TS 100 392-15 [18].

NOTE: For bandwidths greater than 25 kHz, the carrier number refers to the centre frequency of the lowest 25 kHz comprising the DA main carrier. The final term (relating to the bandwidth) in the equation for the downlink main carrier frequency then generates the centre frequency of the DA main carrier.

RXLEV_ACCESS_MIN shall be used in the calculation of the path loss on the QAM channel.

ACCESS_PARAMETER shall be used for power adjustments on the QAM channel. MS_TXPWR_MAX_CELL shall be used in the calculation of the path loss on the QAM channel, and for power adjustments on the QAM channel.

RADIO_DOWNLINK_TIMEOUT shall be used in the criteria for radio downlink failure of the QAM channel.

The usage of the CCK identifier or static cipher key version number information element is defined in ETSI EN 300 392-7 [8].

The contents of the default definition for access code A information element shall be as defined in table 21.66.

The contents of the extended DA services broadcast information element shall be as defined in table 21.74.

The size of the SYSINFO-DA PDU is 185 bits. Therefore, when the SYSINFO-DA PDU is sent using 4-QAM rate = 1/2 on a 25 kHz channel, it fully occupies all 185 bits of the MAC block (SCH-Q/D25-4H). When the SYSINFO-DA PDU is sent using a higher modulation level and/or bandwidth, it may be sent with other PDU(s) in the SCH-Q/D or SCH-Q/B MAC block using PDU association. When the SYSINFO-DA PDU is transmitted on a phase modulated channel, it may be sent with other PDU(s) in an SCH/F or SCH-P8/F MAC block using PDU association.

Table 21.74: Extended DA services broadcast information element contents

Information element	Length	M/C/O	Value	Remark
Security information	8			Refer to ETSI EN 300 392-7 [8].
SDS-TL addressing method	2	M	00 ₂	Reserved
			01 ₂	Service centre addressing preferred (see note 1)
			10 ₂	Never use service centre addressing (see note 1)
			11 ₂	MS choice to use service centre addressing (see note 1)
GCK supported	1	M		Refer to ETSI EN 300 392-7 [8] (see note 2)
Section	2	M	00 ₂	Extended services broadcast section 1da is present
			01 ₂	Extended services broadcast section 2 is present
			10 ₂	Extended services broadcast section 3 is present
			11 ₂	Extended services broadcast section 4 is present
Extended services broadcast section 1da (see note 3)	7	C		See table 21.75
Extended services broadcast section 2 (see note 4)	7	C		See table 21.69
Extended services broadcast section 3 (see note 5)	7	C		See table 21.70
Extended services broadcast section 4 (see note 6)	7	C		See table 21.71
NOTE 1: Refer to clause 29 for further information.				
NOTE 2: This shall be ignored by the MS when AI encryption is not available (indicated in BS Service Details DA).				
NOTE 3: This element shall be present only if section element is set to 00 ₂ .				
NOTE 4: This element shall be present only if section element is set to 01 ₂ .				
NOTE 5: This element shall be present only if section element is set to 10 ₂ .				
NOTE 6: This element shall be present only if section element is set to 11 ₂ .				

Table 21.75: Extended services broadcast section 1da information element contents

Information element	Length	M/C/O	Value	Remark
Data priority supported	1	M	0	Data priority not supported on this cell
			1	Data priority supported on this cell
Reserved	1	M	0	Reserved for further use. Default value 0.
$\pi/4$ -DQPSK Packet Data service supported	1	M	0	$\pi/4$ -DQPSK Packet Data service not supported on this cell.
			1	$\pi/4$ -DQPSK Packet Data service supported on this cell.
D8PSK service	1	M	0	D8PSK operation not supported on this cell
			1	D8PSK operation supported on this cell
Section 2 information sent on this cell	1	M	0	No information in extended services broadcast section 2
			1	Further information in extended services broadcast section 2
Section 3 information sent on this cell	1	M	0	No information in extended services broadcast section 3
			1	Further information in extended services broadcast section 3
Section 4 information sent on this cell	1	M	0	No information in extended services broadcast section 4
			1	Further information in extended services broadcast section 4
NOTE: DA cells shall support extended advanced links and QoS negotiation when system wide services are supported (i.e. when the "system wide services" element in the D-MLE-SYSINFO-DA (and D-MLE-SYNC-DA) PDU has value 1) and shall support reception of MAC-U-BLCK PDUs.				

21.4.4.2 SYNC

The SYNC PDU shall be transmitted using the BSCH and so shall be distinguishable by the synchronization burst which has a special training sequence. Its contents shall be as shown in table 21.76.

NOTE: The SYNC PDU is sent on $\pi/4$ -DQPSK and D8PSK channels. It is always sent using $\pi/4$ -DQPSK modulation.

The sharing mode field shall indicate whether the BS is using continuous transmission, carrier sharing, MCCH sharing or traffic carrier sharing. If MCCH sharing is indicated, the TS reserved frames field shall indicate which frames are reserved in this mode of operation. For the other values of sharing mode, the contents of the TS reserved frames field shall be ignored.

The frame 18 extension element shall indicate whether an MS is allowed to receive downlink information on all slots of the frame 18. If extension is allowed, only MSs which are capable of receiving consecutive slots are able to perform this function.

The U-plane DTX flag shall indicate whether discontinuous U-plane transmission is supported on traffic channels.

Table 21.76: SYNC PDU contents

Information element	Length	Type	Value	Remark
System code	4	M	0000 ₂	ETSI ETS 300 392-2 ed. 1 (no security functions)
			0001 ₂	ETSI ETS 300 392-2 ed. 1 and ETSI EN 300 392-7 [8] V2.1.1
			0010 ₂	ETSI EN 300 392-2 V2.3.2 to V2.6.1, and ETSI EN 300 392-7 [8] V2.1.1 to V2.4.1
			0011 ₂	ETSI EN 300 392-2 V3.1.1 to the version of the present document and ETSI EN 300 392-7 [8] V3.1.1 to V3.2.1, see note 2
			0XXX ₂	Other XXX ₂ values V+D reserved
			100y ₂	Reserved
			101y ₂	Direct Mode Operation, see ETSI EN/ETS 300 396 (DMO)
			11zz ₂	Direct Mode Operation, see ETSI EN/ETS 300 396
Colour code	6	M	000000 ₂	Pre-defined scrambling, see note 1
			000001 ₂	Operator defined scrambling, for cell identifier and scrambling process as defined in clause 8
			etc.	etc.
			111111 ₂	Operator defined scrambling, for cell identifier and scrambling process as defined in clause 8

Information element	Length	Type	Value	Remark
Timeslot number	2	M	00 ₂	Timeslot 1
			01 ₂	Timeslot 2
			10 ₂	Timeslot 3
			11 ₂	Timeslot 4
Frame number	5	M	00000 ₂	Reserved
			00001 ₂	Frame 1
			etc.	etc.
			10010 ₂	Frame 18
			Others	Reserved
Multiframe number	6	M	000000 ₂	Reserved
			000001 ₂	Multiframe 1
			etc.	etc.
			111100 ₂	Multiframe 60
Sharing mode	2	M	00 ₂	Continuous transmission
			01 ₂	Carrier sharing
			10 ₂	MCCH sharing
			11 ₂	Traffic carrier sharing
TS reserved frames	3	M	000 ₂	1 frame reserved per 2 multiframe
			001 ₂	2 frames reserved per 2 multiframe
			010 ₂	3 frames reserved per 2 multiframe
			011 ₂	4 frames reserved per 2 multiframe
			100 ₂	6 frames reserved per 2 multiframe
			101 ₂	9 frames reserved per 2 multiframe
			110 ₂	12 frames reserved per 2 multiframe
111 ₂	18 frames reserved per 2 multiframe			
U-plane DTX	1	M	0	Discontinuous U-plane transmission is not allowed
			1	Discontinuous U-plane transmission is allowed
Frame 18 extension	1	M	0	No frame 18 extension
			1	Frame 18 extension allowed
Reserved	1	M	0	Default value
			1	Not used in the present document
TM-SDU (MLE data)	29	M		As defined in clause 18 (D-MLE-SYNC)
NOTE 1: The element Colour code with the value "Predefined scrambling" means that all 30 bits of the scrambling vector are zeros.				
NOTE 2: The version of the present document and ETSI EN 300 392-7 [8] may change in future enhancements of these documents without a change of the System code value.				

21.4.4.2a SYNC-DA

The SYNC-DA PDU shall be transmitted using the BSCH-Q and so shall be distinguishable by the frequency correction burst which is a special burst. SYNC-DA PDUs contents shall be as shown in table 21.77.

NOTE 1: A value in the downlink QAM-SLOTINFO PDU indicates the presence of the frequency correction burst in a downlink slot.

The SYNC-DA PDU shall be sent on the DA main carrier and may be sent on QAM carriers other than the DA main carrier.

NOTE 2: The BS on QAM channels do not use carrier sharing or MCCH sharing.

Table 21.77: SYNC-DA PDU contents

Information element	Length	Type	Value	Remark
System code	4	M	0000 ₂	ETSI ETS 300 392-2 ed. 1 (no security functions)
			0001 ₂	ETSI ETS 300 392-2 ed. 1 and ETSI EN 300 392-7 [8] V2.1.1
			0010 ₂	ETSI EN 300 392-2 V2.3.2 to V2.6.1, and ETSI EN 300 392-7 [8] V2.1.1 to V2.4.1
			0011 ₂	ETSI EN 300 392-2 V3.1.1 to the version of the present document and ETSI EN 300 392-7 [8] V3.1.1 to V3.2.1, see note 1
			0XXX ₂	Other XXX ₂ values V+D reserved
			100y ₂	Reserved
			101y ₂	Direct Mode Operation, see ETSI EN/ETS 300 396 (DMO)
			11zz ₂	Direct Mode Operation, see ETSI EN/ETS 300 396
Colour code	6	M	000000 ₂	Pre-defined scrambling, see note 2
			000001 ₂	Operator defined scrambling, for cell identification and scrambling process as defined in clause 8
			etc.	etc.
			111111 ₂	Operator defined scrambling, for cell identification and scrambling process as defined in clause 8
Timeslot number	2	M	00 ₂	Timeslot 1
			01 ₂	Timeslot 2
			10 ₂	Timeslot 3
			11 ₂	Timeslot 4
Frame number	5	M	00000 ₂	Reserved
			00001 ₂	Frame 1
			etc.	etc.
			10010 ₂	Frame 18
			Others	Reserved
Multiframe number	6	M	000000 ₂	Reserved
			000001 ₂	Multiframe 1
			etc.	etc.
			111100 ₂	Multiframe 60
			Others	Reserved
DA main carrier bandwidth	3	M	000 ₂	25 kHz
			001 ₂	50 kHz
			010 ₂	100 kHz
			011 ₂	150 kHz
			100 ₂	Reserved
			101 ₂	Reserved
			110 ₂	Reserved
			111 ₂	Reserved
Carrier flag	1	M	0	This carrier is not the DA main carrier
			1	This carrier is the DA main carrier
DA main carrier (see note 3)	12	C		Frequency of the DA main carrier
Frequency band of the DA main carrier (see note 3)	4	C		Frequency band of the DA main carrier
Offset (see note 3)	2	C	00 ₂	0 kHz offset
			01 ₂	+6,25 kHz offset
			10 ₂	-6,25 kHz offset
			11 ₂	+12,5 kHz offset
Location Area (LA) (see note 4)	14	C		Location Area in which the cell is located
Reserved (see note 4)	4	C		Reserved, value shall be set to 0000 ₂

Information element	Length	Type	Value	Remark
MS_TXPWR_MAX_CELL of the DA main carrier	3	M	000 ₂	Reserved
			001 ₂	15 dBm
			etc.	etc. in 5 dB steps
			111 ₂	45 dBm
RXLEV_ACCESS_MIN of the DA main carrier	4	M	0000 ₂	-125 dBm
			etc.	etc. in 5 dB steps
			1111 ₂	-50 dBm
Security parameters	3	M		See ETSI EN 300 392-7 [8]
Extended services broadcast section 2	7	M		
Reserved (see note 5)	1	M	0	Default value
			1	Not used in the present document
TM-SDU (MLE data)	54	M		As defined in clause 18 (D-MLE-SYNC-DA)
NOTE 1: The version of the present document and ETSI EN 300 392-7 [8] may change in future enhancements of these documents without a change of the System code value.				
NOTE 2: The element Colour code with the value "Predefined scrambling" means that all 30 bits of the scrambling vector are zeros.				
NOTE 3: This element is present only when the carrier on which the SYNC-DA PDU is sent is not the DA main carrier i.e. when element "Carrier flag" is set to 0.				
NOTE 4: This element is present only when the carrier on which the SYNC-DA PDU is sent is the DA main carrier i.e. when element "Carrier flag" is set to 1.				
NOTE 5: The SYNC-DA PDU is 117 bits long.				

21.4.4.3 ACCESS-DEFINE

The ACCESS-DEFINE PDU may be sent by the BS using a half slot or full slot on the downlink (SCH/HD, SCH-P8/HD, SCH/F, SCH-P8/F or SCH-Q/D), on SCH-Q/B or on downlink STCH. It defines the random access parameters for the specified access code. Its contents shall be as shown in table 21.78.

Table 21.78: ACCESS-DEFINE PDU contents

Information element	Length	Type	Value	Remark
MAC PDU type	2	M	10 ₂	Broadcast PDU
Broadcast type	2	M	01 ₂	ACCESS-DEFINE PDU
Common or assigned control channel flag	1	M	0	ACCESS-DEFINE applies to common channel
			1	ACCESS-DEFINE applies to assigned channel
Access code	2	M	00 ₂	Access code A
			01 ₂	Access code B
			10 ₂	Access code C
			11 ₂	Access code D
IMM (immediate)	4	M	0000 ₂	Always randomize
			0001 ₂	Randomize after IMM TDMA frames
			etc.	etc.
			1110 ₂	Randomize after IMM TDMA frames
			1111 ₂	Immediate access allowed
WT (waiting time)	4	M	0000 ₂	Reserved
			0001 ₂	Response within WT downlink opportunities
			etc.	etc.
			1111 ₂	Response within WT downlink opportunities
Nu (number of random access transmissions on uplink)	4	M	0000 ₂	No random access transmission allowed
			0001 ₂	1 random access transmission allowed
			etc.	etc.
			1111 ₂	15 random access transmissions allowed
Frame-length factor	1	M	0	Multiply base frame-length by 1
			1	Multiply base frame-length by 4

Information element	Length	Type	Value	Remark
Timeslot pointer	4	M	0000 ₂	Same as downlink slot assignment
			0001 ₂	Timeslot 4
			0010 ₂	Timeslot bit map
			etc.	etc.
			1110 ₂	Timeslot bit map
			1111 ₂	All four timeslots
Minimum PDU priority	3	M	000 ₂	Priority 0 (lowest)
			etc.	etc.
			111 ₂	Priority 7 (highest)
Optional field flag	2	M	00 ₂	None
			01 ₂	Subscriber class bit map
			10 ₂	GSSI
			11 ₂	Reserved, see note
Subscriber class bit map	16	C		as defined in clause 18
GSSI	24	C		Group short subscriber identity
Filler bits	3	M	100 ₂	Reserved bits to make the PDU octet bounded
NOTE: Values 00 ₂ and 11 ₂ indicate that there is no added optional field.				

The definition of the various random access parameters is as follows:

- common or assigned flag:
 - this indicates whether the ACCESS-DEFINE PDU applies to MSs using the channel for common control or MSs using it for assigned control;
- access code:
 - this is used in the ACCESS-ASSIGN message to control access for a subdivision of the MS population;
- IMM:
 - this is the Aloha parameter defining when the MS may use the first valid access opportunity for its first random access transmission. This time is counted in terms of TDMA frames;
- WT:
 - this is the Aloha parameter defining the waiting time before the MS decides to initiate an access re-try. This time is counted in terms of BS downlink signalling opportunities for this control channel;
- Nu:
 - this is the Aloha parameter giving the number of random access transmissions an MS may send before abandoning the random access attempt;
- frame-length factor:
 - this is a multiplying factor applied to the base frame-length contained in the ACCESS-ASSIGN message;
- timeslot pointer:
 - this is a pointer to where the ACCESS-ASSIGN message shall be monitored.

21.4.5 TMD-SAP: MAC PDU structure for U-plane signalling

The MAC-U-SIGNAL PDU shall be used on the uplink and downlink for sending U-plane signalling information. This PDU shall only be sent using the STCH in conjunction with an established circuit mode. Its contents shall be as shown in table 21.79.

Table 21.79: MAC-U-SIGNAL PDU contents

Information element	Length	Type	Value	Remark
MAC PDU type	2	M	11 ₂	MAC-U-SIGNAL
Second half slot stolen flag	1	M	0	Second half slot not stolen
			1	Second half slot stolen
TM-SDU	121	M		

The first two bits of the MAC header shall distinguish this PDU as a MAC-U-SIGNAL PDU. The second half slot stolen flag shall indicate whether the second half of the full slot is also stolen. If the second half is stolen it may contain U-plane or C-plane signalling as indicated by the MAC header. The SDU contains the user information which is received from the U-plane for transmission in this PDU or passed to the U-plane on receipt of this PDU. It shall be the responsibility of the user application at the higher layer to specify the meaning of the contents of the TM-SDU. The TM-SDU length shall always be 121 bits. If the user application requires fewer bits, it is the responsibility of that application to insert filler bits to ensure a 121-bit TM-SDU length.

If MAC-U-SIGNAL is sent in the second half of a full slot, the second half slot stolen flag shall still be present but its content shall be ignored.

21.4.6 TMD-SAP: MAC PDU structure for U-plane traffic

The MAC-TRAFFIC PDU shall be used for sending U-plane traffic data on the uplink and downlink using TCH/S, TCH/7,2, TCH/4,8 or TCH/2,4. This PDU has no MAC header and all capacity shall be devoted to traffic information passed to and from the U-plane. When the MAC is in traffic mode, this PDU type shall be assumed unless the slot flag indicates the presence of the STCH.

When stealing does not occur, the MAC-TRAFFIC PDU shall occupy the full slot. If stealing occurs, and only the first half of the slot is stolen, the MAC-TRAFFIC PDU shall occupy the second half of the slot.

21.4.7 MAC PDU structure for access assignment broadcast

21.4.7.1 Contents of AACH-Q logical channel

The AACH-Q shall be sent by the BS on every downlink slot of a QAM channel (except slots containing BLCH-Q). The contents of the AACH-Q shall be as shown in table 21.80.

Table 21.80: Contents of AACH-Q

Information element	Length	Type	Value	Remark
AACH-Q mode	1	M	0	Contents of ACCESS-ASSIGN PDU are present
			1	Reserved element is present
Contents of ACCESS-ASSIGN PDU (see note 1)	14	C		This element contains the ACCESS-ASSIGN PDU, as defined in clause 21.4.7.2, tables 21.81 and 21.82
Reserved (see note 2)	14	C		Reserved, value shall be set to all zeros
NOTE 1: The contents of ACCESS-ASSIGN PDU shall be present when the AACH-Q mode element is set to 0.				
NOTE 2: The reserved element shall be present when the AACH-Q mode element is set to 1.				

The AACH-Q mode element indicates whether the ACCESS-ASSIGN PDU follows in the AACH-Q. The ACCESS-ASSIGN PDU is defined in clause 21.4.7.2.

In the present document, the BS should set the AACH-Q mode element to 0. However, in future editions of the present document, the BS may set the AACH-Q mode element to 1 in some downlink slots. Therefore, if the AACH-Q mode element is set to 1, the MS shall discard the following 14 bits and shall regard the ACCESS-ASSIGN PDU as not having been received in that downlink slot.

21.4.7.2 ACCESS-ASSIGN

The ACCESS-ASSIGN PDU is generated by the MAC and so shall not contain any TM-SDU from the layer above.

On a $\pi/4$ -DQPSK channel, or on a D8PSK channel, the ACCESS-ASSIGN PDU shall be sent by the BS on every downlink slot. It shall use the AACH logical channel, which is mapped onto the broadcast block (see clause 9).

When sent on a QAM channel, the ACCESS-ASSIGN PDU shall use the AACH-Q logical channel. The AACH-Q shall be sent by the BS on every downlink slot of a QAM channel (except slots containing BLCH-Q). However the ACCESS-ASSIGN PDU is present in the AACH-Q only if the AACH-Q mode element is set to 0; see clause 21.4.7.1.

NOTE 1: The phase modulation Access Assignment Channel AACH contains a single PDU: the ACCESS-ASSIGN PDU.

The QAM Access Assignment Channel AACH-Q contains the 1-bit AACH-Q mode element, followed by either the ACCESS-ASSIGN PDU or a reserved element (see clause 21.4.7.1).

The ACCESS-ASSIGN PDU shall be used to convey information about the downlink slot in which it appears and also the access rights for the corresponding (same-numbered) uplink slot. Its contents shall be dependent on whether it is being sent in frames 1 to 17 or in frame 18. The contents of this PDU shall be as shown in tables 21.81 and 21.82.

Table 21.81: ACCESS-ASSIGN PDU contents for frames 1 to 17

Information element	Length	Type	Value	Remark
Header	2	M	00 ₂	Downlink usage - common control Uplink access rights - common only
			01 ₂	Downlink usage - defined by field 1 Uplink access rights - common and assigned
			10 ₂	Downlink usage - defined by field 1 Uplink access rights - assigned only
			11 ₂	Downlink usage- defined by field 1 Uplink access rights - defined by field 2
Field 1	6	M	See note	Header 00 ₂ : Access field 1 Header 01 ₂ : Downlink usage marker Header 10 ₂ : Downlink usage marker Header 11 ₂ : Downlink usage marker
Field 2	6	M	See note	Header 00 ₂ : Access field 2 Header 01 ₂ : Access field Header 10 ₂ : Access field Header 11 ₂ : Uplink usage marker
NOTE: Content and values of the fields 1 and 2 depend on the Header values as defined in the Remarks column.				

Possible values for downlink usage marker in the field 1:

- Common and assigned control UMr 000011₂
- Common control UMc 000010₂
- Assigned control UMa 000001₂
- Unallocated UMx 000000₂
- Traffic UMt others (see note 2)

Possible values for uplink usage marker in the field 2:

- Unallocated UM_x 000000₂
- Traffic UM_t others (see note 2)

NOTE 2: The values of the UM_r , UM_c , UM_a and UM_x are excluded.

UM_r , UM_c , UM_a and UM_x are pre-set usage markers which shall not be assigned as traffic usage markers. UM_t is the traffic usage marker, assigned in the MAC-RESOURCE PDU which allocated the channel.

Access field 1 shall indicate the access restrictions for the first subslot of the corresponding uplink slot. Access field 2 shall indicate the access restrictions for the second subslot of the corresponding uplink slot. Access field (with no following number) shall indicate the access restrictions for both subslots of the corresponding uplink slot. The definition of the access field contents is given in the access field element definition.

Table 21.82: ACCESS-ASSIGN PDU contents for frame 18

Information element	Length	Type	Value	Remark
Header	2	M	00 ₂	Uplink access rights: common only
			01 ₂	Uplink access rights: common and assigned
			10 ₂	Uplink access rights: assigned only
			11 ₂	Uplink access rights: common and assigned
Field 1	6	M	See note	Header 00 ₂ : Access field 1 Header 01 ₂ : Access field 1 Header 10 ₂ : Access field 1 Header 11 ₂ : Traffic usage marker (UM_t)
Field 2	6	M	See note	Header 00 ₂ : Access field 2 Header 01 ₂ : Access field 2 Header 10 ₂ : Access field 2 Header 11 ₂ : Access field
NOTE: Content and values of the fields 1 and 2 depend on the Header values as defined in the Remarks column.				

21.4.8 MAC PDU structure for slot information channel

21.4.8.1 QAM-SLOTINFO (uplink)

This PDU is generated by the MAC and so shall not contain any TM-SDU from the layer above. This PDU shall be sent by the MS, within the SICH-Q/U, whenever it transmits a QAM slot or subslot by reserved access.

NOTE: The QAM Uplink Slot Information Channel SICH-Q/U contains a single PDU: the uplink QAM-SLOTINFO PDU.

This PDU indicates the format of the remainder of the uplink slot or subslot in which it appears. Its contents shall be as shown in table 21.83.

Table 21.83: QAM-SLOTINFO (uplink) PDU contents

Information element	Length	Type	Value	Remark
Slot format	5	M	00000 ₂	4-QAM rate = 1/2
			00001 ₂	16-QAM rate = 1/2
			00010 ₂	16-QAM rate = 1
			00011 ₂	64-QAM rate = 1/2
			00100 ₂	64-QAM rate = 2/3
			00101 ₂	64-QAM rate = 1
			00110 ₂	Reserved
			etc.	etc.
			11111 ₂	Reserved

21.4.8.2 QAM-SLOTINFO (downlink)

This PDU is generated by the MAC and so shall not contain any TM-SDU from the layer above. It shall be sent by the BS, within the SICH-Q/D, in every downlink slot on a QAM channel except slots containing BLCH-Q.

NOTE: The QAM Downlink Slot Information Channel SICH-Q/D contains a single PDU: the downlink QAM-SLOTINFO PDU.

This PDU indicates the format of the remainder of the downlink slot in which it appears (except the AACH-Q which always uses 4-QAM rate = 1/2). Its contents shall be as shown in table 21.84.

Table 21.84: QAM-SLOTINFO (downlink) PDU contents

Information element	Length	Type	Value	Remark
Slot format	5	M	00000 ₂	4-QAM rate = 1/2
			00001 ₂	16-QAM rate = 1/2
			00010 ₂	16-QAM rate = 1
			00011 ₂	64-QAM rate = 1/2
			00100 ₂	64-QAM rate = 2/3
			00101 ₂	64-QAM rate = 1
			00110 ₂	Reserved
			etc.	etc.
			01110 ₂	Reserved
			01111 ₂	Frequency correction burst (FCB) (which contains SYNC-DA PDU)
			10000 ₂	Reserved
			etc.	etc.
			11111 ₂	Reserved

21.5 MAC elements

21.5.0 General

Clauses 21.5.1 to 21.5.7 describe the information elements which are referred to in the MAC PDU descriptions. The contents of those information elements shall as defined in tables 21.85 to 21.96.

21.5.1 Access field

Table 21.85: Access field information element contents

Information element	Length	Type	Value	Remark
Access code	2	M	00 ₂	Access code A
			01 ₂	Access code B
			10 ₂	Access code C
			11 ₂	Access code D
Base frame-length	4	M	0000 ₂	Reserved subslot, see note 1
			0001 ₂	CLCH(-Q) subslot, see notes 1 and 2
			0010 ₂	Ongoing frame
			0011 ₂	1 subslot
			0100 ₂	2 subslots
			0101 ₂	3 subslots
			0110 ₂	4 subslots
			0111 ₂	5 subslots
			1000 ₂	6 subslots
			1001 ₂	8 subslots
			1010 ₂	10 subslots
			1011 ₂	12 subslots
			1100 ₂	16 subslots
			1101 ₂	20 subslots
1110 ₂	24 subslots			
1111 ₂	32 subslots			
NOTE 1: For these values access code has no meaning.				
NOTE 2: CLCH and CLCH-Q are permitted only in subslot 1 as specified in clauses 9.5.1, 9.5.1a and 9.5.6.				

21.5.2 Channel allocation

Table 21.86: Channel allocation information element contents

Information element	Length	Type	Value	Remark
Allocation type	2	M	00 ₂	Replace current channel with specified channel
			01 ₂	Additional channel allocation
			10 ₂	Quit current channel and go to specified channel
			11 ₂	Replace current channel with specified channel plus carrier specific signalling channel in slot 1
Timeslot assigned	4	M	0000 ₂	Go to appropriate common control channel (MCCH, MCCH-Q or common SCCH)
			0001 ₂	Timeslot number 4
			0010 ₂	Timeslot bit map
			etc.	etc.
			1110 ₂	Timeslot bit map
			1111 ₂	All four timeslots
Up/downlink assigned	2	M	00 ₂	Augmented channel allocation (see note 1)
			01 ₂	Downlink only
			10 ₂	Uplink only
			11 ₂	Both uplink and downlink
CLCH(-Q) permission	1	M	0	No immediate CLCH(-Q) permission
			1	Immediate CLCH(-Q) permission
Cell change flag	1	M	0	No cell change
			1	Cell change
Carrier number	12	M		Carrier frequency number
Extended carrier numbering flag	1	M	0	No extended carrier numbering
			1	Extended carrier numbering
Frequency band (see note 2)	4	C		Provision for different frequency bands
Offset (see note 2)	2	C	00 ₂	0 kHz offset
			01 ₂	+6,25 kHz offset
			10 ₂	-6,25 kHz offset
			11 ₂	+12,5 kHz offset
Duplex spacing (see note 2)	3	C		Provision for different duplex spacing
Reverse operation (see note 2)	1	C	0	Normal
			1	Reverse
Monitoring pattern (see clause 9)	2	M	00 ₂	No monitoring pattern
			01 ₂	One monitoring pattern
			10 ₂	Two monitoring patterns
			11 ₂	Three monitoring patterns
Frame 18 monitoring pattern (see note 3)	2	C	00 ₂	No monitoring pattern
			01 ₂	One monitoring pattern
			10 ₂	Two monitoring patterns
			11 ₂	Three monitoring patterns
Up/downlink assigned for augmented channel allocation (see note 4)	2	C	00 ₂	Reserved (see note 5)
			01 ₂	Downlink only
			10 ₂	Uplink only
			11 ₂	Both uplink and downlink
Bandwidth of allocated channel (see notes 4 and 6)	3	C	000 ₂	25 kHz
			001 ₂	50 kHz
			010 ₂	100 kHz
			011 ₂	150 kHz
			100 ₂	Reserved
			etc.	etc.
			111 ₂	Reserved

Information element	Length	Type	Value	Remark
Modulation mode of allocated channel (see note 4)	3	C	000 ₂	$\pi/4$ -DQPSK
			001 ₂	D8PSK
			010 ₂	QAM
			011 ₂	Reserved
			etc.	etc.
			111 ₂	Reserved
Maximum uplink QAM modulation level (see notes 7 and 8)	3	C	000 ₂	Reserved
			001 ₂	16-QAM
			010 ₂	64-QAM
			011 ₂	Reserved
			etc.	etc.
			111 ₂	Reserved
Reserved (see note 9)	3	C		Reserved, value shall be set to 000 ₂
Conforming channel status (see note 4)	3	C	000 ₂	Conforming channel (therefore concentric)
			001 ₂	Non-conforming channel: concentric
			010 ₂	Non-conforming channel: sectored
			011 ₂	Non-conforming channel: super-sectored
			100 ₂	Non-conforming channel: eccentric
			101 ₂	Reserved
			etc.	etc.
111 ₂	Reserved			
BS link imbalance (see note 4)	4	C		See "BS link imbalance" information element definition
BS transmit power relative to main carrier (see note 4)	5	C		See "BS transmit power relative to main carrier" information element definition
Napping status (see note 4)	2	C	00 ₂	Napping is not permitted on the allocated channel
			01 ₂	Napping information is included
			10 ₂	MS may use current napping information on the allocated channel
			11 ₂	Reserved
Napping information (see note 10)	11	C		See "napping information" information element definition
Reserved (see note 4)	4	C		Reserved, value shall be set to 0000 ₂
Conditional element A flag (see note 4)	1	C	0	Conditional element A not present
			1	Conditional element A present
Conditional element A (see note 11)	16	C		See table 21.90
Conditional element B flag (see notes 4 and 13)	1	C	0	Conditional element B not present
			1	Conditional element B present
Conditional element B (see notes 12 and 14)	16	C		Reserved
Further augmentation flag (see note 4)	1	C	0	No further augmentation of channel allocation
			1	Further augmentation of channel allocation (see note 15)

Information element	Length	Type	Value	Remark
NOTE 1:				If an MS that does not support augmented channel allocations receives a channel allocation with the up/downlink assigned element set to 00 ₂ , it shall discard the channel allocation and any TM-SDU carried in the MAC-RESOURCE or MAC-END PDU that contained the channel allocation.
NOTE 2:				This element shall be present only in the case of extended carrier numbering i.e. extended carrier numbering flag set to 1.
NOTE 3:				This element shall be present only in the case that no monitoring pattern is assigned i.e. monitoring pattern element set to 00 ₂ .
NOTE 4:				This element shall be present only for an augmented channel allocation i.e. up/downlink assigned element set to 00 ₂ .
NOTE 5:				If the MS receives a channel allocation with the up/downlink assigned for augmented channel allocation element set to 00 ₂ , it shall discard the channel allocation and any TM-SDU carried in the MAC-RESOURCE or MAC-END PDU that contained the channel allocation.
NOTE 6:				This element shall be set to 000 ₂ when allocating a $\pi/4$ -DQPSK channel or a D8PSK channel.
NOTE 7:				This element shall be present only for an augmented channel allocation allocating a QAM channel i.e. up/downlink assigned element set to 00 ₂ and modulation mode of allocated channel element set to 010 ₂ .
NOTE 8:				If the MS does not understand the value of this element, it shall regard the value as indicating the maximum QAM modulation level supported by that MS.
NOTE 9:				This element shall be present only for an augmented channel allocation not allocating a QAM channel i.e. up/downlink assigned element set to 00 ₂ and modulation mode of allocated channel element not set to 010 ₂ .
NOTE 10:				This element shall be present only for an augmented channel allocation with napping information included i.e. up/downlink assigned element set to 00 ₂ and napping status element set to 01 ₂ .
NOTE 11:				This element shall be present only for an augmented channel allocation with the Conditional element A flag indicating that the Conditional element A is present i.e. up/downlink assigned element set to 00 ₂ and Conditional element A flag set to 1.
NOTE 12:				This element shall be present only for an augmented channel allocation with the Conditional element B flag indicating that the Conditional element B is present i.e. up/downlink assigned element set to 00 ₂ and Conditional element B flag set to 1.
NOTE 13:				The Conditional element B flag shall be set to 0 in the present document.
NOTE 14:				Conditional element B shall not be included in the present document. However, if the MS receives a channel allocation with the Conditional element B flag set to 1, it shall assume that a 16-bit element is included following the Conditional element B flag.
NOTE 15:				The further augmentation flag shall be set to 0 in the present document. If the MS receives a channel allocation with the further augmentation flag set to 1, it shall discard the channel allocation and any TM-SDU carried in the MAC-RESOURCE or MAC-END PDU that contained the channel allocation.

When commanded to an assigned channel by channel allocation the MS moves to the assigned channel and back to the common control channel according to the received channel allocations as described in clause 23.5.4.

NOTE 1: If the number of $\pi/4$ -DQPSK common SCCHs is changed while a CA MS has been on an assigned channel, the change is indicated in the SYSINFO PDU (and in SYSINFO-Q PDU, if applicable); see clause 23.3.1.2.1.2.

NOTE 2: If the MCCH-Q width (in slots) or the number of QAM common SCCHs is changed while a DA MS has been on an assigned channel, the change is indicated in the SYSINFO-DA PDU; see clause 23.3.1.2.1.3.

The CLCH(-Q) permission field shall indicate to the MS whether the first sub-slot on the allocated channel shall be available for linearization purposes: CLCH on a $\pi/4$ -DQPSK or D8PSK channel, or CLCH-Q on a QAM channel. The MS need not examine the ACCESS-ASSIGN PDU in the AACH or AACH-Q in order to use CLCH or CLCH-Q if permission is given in the channel allocation field.

The carrier frequency shall be defined by the following elements:

- carrier number;
- extended carrier numbering flag;
- frequency band;
- offset;
- duplex spacing;

- reverse operation;
- bandwidth of allocated channel.

The extended numbering flag indicates whether the carrier frequency specification includes the frequency band, offset, duplex spacing and reverse operation fields. If this field indicates no extended numbering, then the MS shall assume the same frequency band, offset, duplex spacing and reverse operation values as contained in the SYSINFO or SYSINFO-Q PDU (for a CA MS) or SYSINFO-DA PDU (for a DA MS); this refers to the SYSINFO, SYSINFO-Q or SYSINFO-DA PDU received on the current cell (i.e. the cell on which the channel allocation was received), even when the cell change flag indicates a cell change. If the bandwidth of allocated channel field is not included, then the MS shall assume that the bandwidth is 25 kHz. The actual carrier frequency shall then be calculated using a similar method to that defined for the main carrier frequency calculation. The carrier frequency shall be as defined by the following equations:

$$\begin{aligned} \text{downlink carrier frequency} = & \text{base frequency} + (\text{carrier number} \times 25 \text{ kHz}) + \text{offset kHz} \\ & + ((\text{bandwidth of allocated channel} / 2) - 12,5) \text{ kHz} \end{aligned}$$

- normal operation:

$$\text{uplink carrier frequency} = \text{downlink carrier frequency} - \text{duplex spacing}$$

- reverse operation:

$$\text{uplink carrier frequency} = \text{downlink carrier frequency} + \text{duplex spacing.}$$

The mappings of the frequency band field values to actual base frequencies and the duplex spacing field values to actual duplex frequency spacing are defined in ETSI TS 100 392-15 [18].

NOTE 3: For bandwidths greater than 25 kHz, the carrier number refers to the centre frequency of the lowest 25 kHz comprising the allocated channel. The final term (relating to the bandwidth) in the equation for the downlink carrier frequency then generates the centre frequency of the allocated channel.

NOTE 4: If there are MSs from different cells sharing an assigned channel and the BS sends a channel allocation on the channel, particularly to a group of MSs from different cells, the BS includes the extended carrier numbering if there are any differences of frequency band, offset, duplex spacing or reverse operation between the main carriers of the sharing cells.

The monitoring pattern field applies to a transmitting MS on an assigned channel and it indicates which downlink slots shall be monitored while transmitting traffic. If one monitoring pattern is assigned, monitoring pattern number one as defined in clause 9 shall be used. If two monitoring patterns are assigned, monitoring pattern numbers one and two as defined in clause 9 shall be used. If three monitoring patterns are assigned, monitoring pattern numbers one, two and three as defined in clause 9 shall be used.

If no monitoring pattern is assigned, then the frame 18 monitoring pattern field shall be included to indicate which monitoring patterns shall be followed for frame 18. One, two or three monitoring patterns can be assigned for frame 18 in the same way as described before. So, for example, if one monitoring pattern is assigned, the MS shall monitor frame 18 if Multiframe Number mod 3 = 0; if two monitoring patterns are assigned, the MS shall monitor frame 18 if Multiframe Number mod 3 = 0 or 2.

Values 01₂, 10₂, and 11₂ in the up/downlink assigned field indicate whether either or both directions on the allocated channel have been assigned exclusively for the usage required by the MS. Value 00₂ in the up/downlink assigned field indicates that this is an augmented channel allocation. In this case the following conditional fields shall be included:

- up/downlink assigned for augmented channel allocation;
- bandwidth of the allocated channel;
- modulation mode of the allocated channel;
- the maximum uplink QAM modulation level, or a 3-bit reserved element;
- conforming channel status of the allocated channel;
- BS link imbalance on the allocated channel (see clause 21.5.2a);

- BS transmit power on the allocated channel relative to the main carrier (see clause 21.5.2b);
- napping status on the allocated channel and, optionally, napping information (see clause 21.5.2c);
- a 4-bit reserved element;
- a flag indicating whether a 16-bit conditional element A is present, and the conditional element A if appropriate;
- a flag indicating whether a 16-bit conditional element B is present, and the conditional element B if appropriate; and
- a flag indicating further augmentation of the channel allocation (allowing for future further extension).

If the channel allocation is not augmented:

- a CA MS shall assume that the allocated channel is a 25 kHz $\pi/4$ -DQPSK conforming channel, that the BS transmit power on the allocated channel relative to the CA main carrier is 0 dB and that use of the napping procedure is not permitted on the allocated channel;
- if element "timeslot assigned" \neq 0000₂, a DA MS shall assume that the allocated channel is a 25 kHz $\pi/4$ -DQPSK conforming channel, that the BS transmit power on the allocated channel relative to the DA main carrier is 0 dB and that use of the napping procedure is not permitted on the allocated channel;
- if element "timeslot assigned" = 0000₂, a DA MS shall make the assumptions specified in clause 23.5.4.3.2 (i.e. using the information about the DA main carrier from the last received SYSINFO-DA or SYNC-DA PDU).

21.5.2a BS link imbalance

Table 21.87: "BS link imbalance" information element contents

Information element	Length	Type	Value	Remark
BS link imbalance	4	M	0000 ₂	No information
			0001 ₂	Reserved
			0010 ₂	Reserved
			0011 ₂	-12,5 dB
			0100 ₂	-10 dB
			0101 ₂	-7,5 dB
			0110 ₂	-5 dB
			0111 ₂	-2,5 dB
			1000 ₂	0 dB
			1001 ₂	2,5 dB
			1010 ₂	5 dB
			1011 ₂	7,5 dB
			1100 ₂	10 dB
			1101 ₂	12,5 dB
			1110 ₂	Reserved
1111 ₂	Reserved			

The BS shall set the "BS link imbalance" information element to:

$$\begin{aligned}
 & (\text{BS transmit power} - \text{MS_TXPWR_MAX_CELL}) \\
 & + \text{Gain in the BS transmitter feeder and antenna} \\
 & - \text{Gain in the BS receiver feeder and antenna} \\
 & + (\text{BS static receive sensitivity} - \text{MS static reference sensitivity}),
 \end{aligned}$$

where all parameters are those applicable to the channel and the receive sensitivities are for the lowest modulation level supported by the channel (i.e. $\pi/4$ -DQPSK or 4-QAM).

The MS may use the BS link imbalance, together with an MS correction factor (see note 1), to estimate the uplink performance from measurements of the downlink channel; this information may be a criterion in the MS's link adaptation procedures for choice of the current appropriate bit rate on a D8PSK or QAM channel; see clause 23.4.9.

NOTE 1: The MS correction factor should allow for the MS's actual transmit power, its actual static sensitivity and any receive/transmit imbalance in the performance of its antenna. For example, the MS might choose to use the following or equivalent correction factor:

$$\begin{aligned} & (MS_TXPWR_MAX_CELL - MS \text{ actual transmit power}) \\ & - \text{Gain in the MS transmitter feeder and antenna} \\ & + \text{Gain in the MS receiver feeder and antenna} \\ & + (MS \text{ static reference sensitivity} - MS \text{ actual static sensitivity}). \end{aligned}$$

NOTE 2: In the above expressions for the BS link imbalance and the MS correction factor, the "gain in the receiver feeder and antenna" is assumed to include any diversity gain.

21.5.2b BS transmit power relative to main carrier

Table 21.88: "BS transmit power relative to main carrier" information element contents

Information element	Length	Type	Value	Remark
BS transmit power relative to main carrier	5	M	00000 ₂	Reserved
			etc.	etc.
			00100 ₂	Reserved
			00101 ₂	-22 dB
			00110 ₂	-20 dB
			etc.	etc. in 2 db steps
			10000 ₂	0 dB
			etc.	etc. in 2 dB steps
			11010 ₂	20 dB
			11011 ₂	22 dB
			11100 ₂	Reserved
			etc.	etc.
			11111 ₂	Reserved

The value of the BS transmit power relative to main carrier element shall include the BS relative antenna gains; i.e. it is the BS Effective Radiated Power (ERP) into the allocated channel relative to the BS ERP of the main carrier.

21.5.2c Napping information

Table 21.89: "Napping information" information element contents

Information element	Length	Type	Value	Remark
Napping reception timeslots	4	M	0000 ₂	Reserved
			0001 ₂	Timeslot number 4
			0010 ₂	Timeslot bit map
			etc.	etc.
			1110 ₂	Timeslot bit map
			1111 ₂	All four timeslots
Napping reception frames	3	M	000 ₂	All TDMA frames
			001 ₂	Odd-numbered TDMA frames i.e. frames 1, 3, 5, 7, 9, 11, 13, 15 and 17
			010 ₂	Even-numbered TDMA frames i.e. frames 2, 4, 6, 8, 10, 12, 14, 16 and 18
			011 ₂	Frames 1, 4, 7, 10, 13 and 16
			100 ₂	Frames 2, 5, 8, 11, 14 and 17
			101 ₂	Frames 3, 6, 9, 12, 15 and 18
			110 ₂	Reserved
			111 ₂	Reserved
Napping timer T.226	3	M	000 ₂	6 TDMA frames
			001 ₂	9 TDMA frames
			010 ₂	12 TDMA frames
			011 ₂	18 TDMA frames
			100 ₂	27 TDMA frames
			101 ₂	36 TDMA frames
			110 ₂	54 TDMA frames
			111 ₂	Reserved
Reduced reception in frame 18 flag	1	M	0	Use of reduced reception in frame 18 is not permitted
			1	Use of reduced reception in frame 18 is permitted

21.5.2d Conditional element A

Table 21.90: Conditional element A information element contents

Information element	Length	Type	Value	Remark
DA conforming channel status	3	M	000 ₂	Conforming channel (therefore concentric)
			001 ₂	Non-conforming channel: concentric
			010 ₂	Non-conforming channel: sectored
			011 ₂	Non-conforming channel: super-sectored
			100 ₂	Non-conforming channel: eccentric
			101 ₂	Reserved
			etc.	etc.
			111 ₂	Reserved
BS transmit power relative to current carrier	5	M	00000 ₂	Reserved
			etc.	etc.
			00100 ₂	Reserved
			00101 ₂	-22 dB
			00110 ₂	-20 dB
			etc.	etc. in 2 dB steps
			10000 ₂	0 dB
			etc.	etc. in 2 dB steps
			11010 ₂	20 dB
			11011 ₂	22 dB
			11100 ₂	Reserved
			etc.	etc.
11111 ₂	Reserved			
Reserved	8	M		Reserved, value shall be set to 00000000 ₂

The value of the BS transmit power relative to the current carrier element shall include the BS relative antenna gains; i.e. it is the BS Effective Radiated Power (ERP) into the allocated channel relative to the BS ERP of the current carrier.

21.5.3 Power control

Table 21.91: Power control information element contents

Information element	Length	Type	Value	Remark
Power control	4	M	0000 ₂	No change in power
			0001 ₂	Increase power by 1 step
			0010 ₂	Increase power by 2 steps
			0011 ₂	Increase power by 3 steps
			0100 ₂	Increase power by 4 steps
			0101 ₂	Increase power by 5 steps
			0110 ₂	Increase power by 6 steps (see note)
			0111 ₂	Maximum path delay exceeded
			1000 ₂	Revert to open loop power control
			1001 ₂	Decrease power by 1 step
			1010 ₂	Decrease power by 2 steps
			1011 ₂	Decrease power by 3 steps
			1100 ₂	Decrease power by 4 steps
			1101 ₂	Decrease power by 5 steps
			1110 ₂	Decrease power by 6 steps
1111 ₂	Radio uplink failure			
NOTE: The value 0110 ₂ may have a different meaning when sent to an air MS (see clause O.7.1.4).				

The power control step size is nominally 5 dB as defined in clause 6 except for power classes nL, where n is 1 to 4 (refer to the nominal power of MS transmitters defined in clause 6.4.1.2). For those power classes the step between the nominal power and the first lower power level is 2,5 db so that the nominal MS power control levels defined in clause 6.4.1.2 are applicable except for the highest power. The power shall not be decreased below the minimum power control level of 15 dBm or increased above the nominal power of that MS class.

21.5.4 Reservation requirement

Table 21.92: Reservation requirement information element contents in MAC-ACCESS, MAC-END-HU, MAC-DATA and uplink MAC-END PDUs

Information element	Length	Type	Value	Remark
Reservation requirement	4	M	0000 ₂	1 subslot required
			0001 ₂	1 slot required
			0010 ₂	2 slots required
			0011 ₂	3 slots required
			0100 ₂	4 slots required
			0101 ₂	5 slots required
			0110 ₂	6 slots required
			0111 ₂	8 slots required
			1000 ₂	10 slots required
			1001 ₂	13 slots required
			1010 ₂	17 slots required
			1011 ₂	24 slots required
			1100 ₂	34 slots required
			1101 ₂	51 slots required
1110 ₂	68 slots required			
1111 ₂	More than 68 slots required			

Table 21.93: Reservation requirement information element contents in MAC-U-BLCK PDU

Information element	Length	Type	Value	Remark
Reservation requirement	4	M	0000 ₂	1 subslot required
			0001 ₂	1 slot required
			0010 ₂	2 slots required
			0011 ₂	3 slots required
			0100 ₂	4 slots required
			0101 ₂	5 slots required
			0110 ₂	6 slots required
			0111 ₂	8 slots required
			1000 ₂	10 slots required
			1001 ₂	13 slots required
			1010 ₂	17 slots required
			1011 ₂	24 slots required
			1100 ₂	34 slots required
			1101 ₂	51 slots required
1110 ₂	68 or more slots required			
1111 ₂	No reservation requirement			

21.5.5 TS_COMMON_FRAMES

Table 21.94: TS_COMMON_FRAMES information element contents

Information element	Length	Type	Value	Remark
Frame 1	1	M	0	Not a common frame
			1	Common frame
Frame 2	1	M	0	Not a common frame
			1	Common frame
etc.	etc.	etc.	0	etc.
			1	etc.
Frame 18	1	M	0	Not a common frame
			1	Common frame
Reserved	1	M	0	Default value
			1	Not used in the present document
Reserved	1	M	0	Default value
			1	Not used in the present document

21.5.6 Basic slot granting

Table 21.95: Basic slot granting information element contents

Information element	Length	Type	Value	Remark
Capacity Allocation	4	M	0000 ₂	First subslot allocated
			0001 ₂	1 slot allocated
			0010 ₂	2 slots allocated
			0011 ₂	3 slots allocated
			0100 ₂	4 slots allocated
			0101 ₂	5 slots allocated
			0110 ₂	6 slots allocated
			0111 ₂	8 slots allocated
			1000 ₂	10 slots allocated
			1001 ₂	13 slots allocated
			1010 ₂	17 slots allocated
			1011 ₂	24 slots allocated
			1100 ₂	34 slots allocated
			1101 ₂	51 slots allocated
			1110 ₂	68 slots allocated
1111 ₂	Second subslot allocated			
Granting delay (see note)	4	M	0000 ₂	Capacity allocation at next opportunity
			0001 ₂	Number of opportunities delay to capacity allocation
			etc.	etc.
			1101 ₂	Number of opportunities delay to capacity allocation
			1110 ₂	Allocation starts at first opportunity in frame 18
			1111 ₂	Wait for another slot granting message
NOTE:	For basic slot granting, and for the first basic slot granting element in a multiple slot grant, the granting delay is counted from the slot containing the slot grant. For multiple slot granting, the granting delay in the second and subsequent basic slot granting elements (either explicitly included or implicit) is counted from the end of the grant defined by the previous basic slot granting element (either explicitly included or implicit).			

21.5.7 Multiple slot granting

Table 21.96: Multiple slot granting information element contents

Information element	Length	Type	Value	Remark
Number of slot granting sets (see note 1)	3	M	000 ₂	Reserved (see note 2)
			001 ₂	1 slot granting set
			etc.	etc.
			111 ₂	7 slot granting sets
Basic slot granting element (see note 3)	8	C		See basic slot granting information element definition
Implicit repeat count (see note 3)	4	C	0000 ₂	No implicit repetition of basic slot granting element
			0001 ₂	1 implicit repetition of basic slot granting element
			etc.	etc.
			1010 ₂	10 implicit repetitions of basic slot granting element
			1011 ₂	Reserved (see note 4)
			1100 ₂	Reserved (see note 4)
			1101 ₂	Reserved (see note 4)
			1110 ₂	Reserved (see note 4)
1111 ₂	Reserved (see note 4)			
<p>NOTE 1: The "number of slot granting sets" element indicates the number of slot granting sets that follow in the PDU. Each slot granting set comprises two information elements i.e. "basic slot granting element" and "implicit repeat count". The information elements in each repeated set shall be in the order specified. For example, if the "number of slot granting sets" element is set to 010₂, it is followed by: first basic slot granting element, implicit repeat count for first basic slot granting element, second basic slot granting element, implicit repeat count for second basic slot granting element.</p> <p>NOTE 2: If the MS receives a value of 000₂ in the "number of slot granting sets" element, it shall discard the "multiple slot granting" element and the remainder of the MAC-RESOURCE or MAC-END PDU that contains this "multiple slot granting" element.</p> <p>NOTE 3: Shall be repeated as a set as indicated by the "number of slot granting sets" element.</p> <p>NOTE 4: Reserved for future use. An MS receiving one of these values from a BS shall discard this slot granting set and any subsequent slot granting sets within the same "multiple slot granting" element.</p>				

21.6 Units used in length indication

The "length indication" element in some TMA-SAP MAC PDUs indicates the length of the MAC PDU in units of:

- Y_1 and Z_1 octets, for a PDU sent in a subslot (i.e. MAC-ACCESS or MAC-END-HU); and
- Y_2 and Z_2 octets, for a PDU sent in a slot (i.e. MAC-DATA, MAC-RESOURCE or MAC-END);

where the values of Y_1 , Z_1 , Y_2 and Z_2 depend on the bandwidth, modulation and coding rate with which the PDU is sent. The values of Y_1 , Z_1 , Y_2 and Z_2 are given in table 21.97 for each combination.

Table 21.97: Value of Y_1 , Z_1 , Y_2 and Z_2 in TMA-SAP MAC PDUs

Modulation and QAM coding rate and bandwidth with which PDU is sent	Y_1 (PDU sent in a subslot)	Z_1 (PDU sent in a subslot)	Y_2 (PDU sent in a slot)	Z_2 (PDU sent in a slot)
$\pi/4$ -DQPSK	1	1	1	1
$\pi/8$ -D8PSK	1	2	1	2
4-QAM rate=1/2, 25 kHz	1	1	1	1
16-QAM rate=1/2, 25 kHz	1	2	1	2
16-QAM rate=1, 25 kHz	2	3	2	3
64-QAM rate=1/2, 25 kHz	1	2	1	2
64-QAM rate=2/3, 25 kHz	2	3	2	3
64-QAM rate=1, 25 kHz	2	4	2	4
4-QAM rate=1/2, 50 kHz	1	2	1	2
16-QAM rate=1/2, 50 kHz	2	3	2	3
16-QAM rate=1, 50 kHz	2	6	2	5
64-QAM rate=1/2, 50 kHz	2	4	2	4
64-QAM rate=2/3, 50 kHz	2	6	2	5
64-QAM rate=1, 50 kHz	2	8	2	8
4-QAM rate=1/2, 100 kHz	2	3	2	3
16-QAM rate=1/2, 100 kHz	2	6	2	5
16-QAM rate=1, 100 kHz	2	11	2	8
64-QAM rate=1/2, 100 kHz	2	9	2	8
64-QAM rate=2/3, 100 kHz	2	11	2	8
64-QAM rate=1, 100 kHz	2	17	2	8
4-QAM rate=1/2, 150 kHz	2	4	2	4
16-QAM rate=1/2, 150 kHz	2	9	2	8
16-QAM rate=1, 150 kHz	2	17	2	8
64-QAM rate=1/2, 150 kHz	2	13	2	8
64-QAM rate=2/3, 150 kHz	2	17	2	8
64-QAM rate=1, 150 kHz	2	22	2	8

NOTE 1: When an MS sends a random access request on a QAM channel, it uses logical channel SCH-Q/RA in a subslot. This logical channel always uses 4-QAM modulation with rate = 1/2 in a 25 kHz bandwidth (irrespective of the bandwidth of the QAM channel). Therefore $Y_1 = Z_1 = 1$ applies.

NOTE 2: When the BS sends a PDU on logical channel SCH-Q/B, it always uses 4-QAM modulation with rate = 1/2. The values of Y_2 and Z_2 are those appropriate to the bandwidth of the burst. Therefore, for PDUs sent on SCH-Q/B50, $Y_2 = 1$ and $Z_2 = 2$ apply; for PDUs sent on SCH-Q/B100, $Y_2 = 2$ and $Z_2 = 3$ apply; for PDUs sent on SCH-Q/B150, $Y_2 = 2$ and $Z_2 = 4$ apply.

22 LLC protocol

22.0 General

This clause is intended to be read together with the MAC protocol, clause 23. This clause describes the LLC sub-layer framing functions for the V+D air interface. These sub-layer functions are closely integrated with the MAC sub-layer and together the MAC and LLC form the air interface layer 2, also called DLL. An overview of the DLL architecture can be found in clause 19.

22.1 Overview of LLC

22.1.0 General

See ETSI EN 300 392-1 [6], clause 6 for general architecture and functional description. See clause 19 for DLL architecture. See clause 20 for service description and SAPs. See clause 21 for PDU description.

The LLC procedures defined in the present document are applicable to the MS unless indicated to be valid for the BS. The LLC procedures used in the BS shall be compatible with the procedures described in the present document.

NOTE: Throughout clause 22 the word "shall" is used with service primitives for traceability reasons in the protocol model, but the primitives are not testable.

22.1.1 LLC protocol

LLC protocol for TETRA contains two entities, basic link and advanced link, both accessible via the same SAP TLA-SAP. Both the data links offer two different services, i.e. unacknowledged and acknowledged information transfer mechanisms. The basic link is available whenever the MS is synchronized to a BS. The advanced link provides a better quality of service than the basic link and uses a connection on demand. There are two variants of advanced link: the original advanced link and the extended advanced link.

The basic link offers an option for extended Frame Check Sequence (FCS) to minimize the number of undetected erroneous messages. The same frame check sequence is always used on the original advanced link and may optionally be used on the extended advanced link.

The MS LLC may support up to four advanced links per service, numbered from one to four. It may use either:

- one original advanced link per service plus up to three extended advanced links per service; or
- up to four extended advanced links per service.

The various link services will be discriminated locally by a different link identifier. Link identifiers in the peer entity may be independent of these local identifiers. In the LLC itself, the distinct PDU types shall differentiate both between a basic and an advanced link and unacknowledged and acknowledged service (see clause 21). For a certain advanced link number, there can exist one acknowledged service or one unacknowledged service or both. Unacknowledged and acknowledged services are set up and disconnected independently of each other. If they coexist on the same advanced link number, they may use the same physical allocation (same timeslot or timeslots), in which case there is only one basic link associated with both the advanced link services.

If an MS LLC supports more than one advanced link per service, those advanced links may share the same physical allocation (same timeslot or timeslots). So the MS LLC may support up to four advanced links per service on a single physical allocation, in which case there is only one basic link associated with those advanced links.

Alternatively, if the MS is capable of supporting more than one physical allocation concurrently, the MS LLC may have advanced link(s) on each of the physical allocations provided that the total number of advanced links is not more than four per service.

NOTE: The above three paragraphs refer to the services available for one address. ITSIs and GTSIs in an MS are independent of each other and LLC services recognize addresses to allow concurrent basic or advanced link services. The present document does not describe how addresses affect the LLC implementation.

There is one basic link per each advanced link (or per set of advanced links if multiple advanced links share the same physical allocation) and each circuit mode service, when an ACCH is available. The number of timeslots each basic link may use is the same as the number of timeslots of the corresponding advanced link(s) or circuit mode service.

The transfer mode of an LLC link is independent of the modes of the other LLC links forming a network layer connection. As an example, a point-to-multipoint call from an MS to multiple MSs may use an advanced LLC link from the data sending MS to the BS and the unacknowledged basic LLC link from the BS to the data receiving MSs.

This LLC protocol for TETRA operates using PDUs. The PDUs are described in clause 21. The basic link LLC PDU sizes are independent of the MAC layer block sizes, because the MAC can fragment an LLC PDU if needed. For the advanced link:

- when on a $\pi/4$ -DQPSK or D8PSK channel, the advanced link LLC protocol is constrained by the segment sizes matching the available room in MAC blocks; therefore, on a D8PSK channel, segments may be of different sizes, depending on whether they are cut to be sent using $\pi/4$ -DQPSK or $\pi/8$ -D8PSK modulation for the first transmission of that segment;
- when on a 25 kHz or 50 kHz QAM channel, the segment size is normally determined by the available space in a 4-QAM rate = 1/2 full-slot MAC block at the current bandwidth; when on a 100 kHz or 150 kHz QAM channel, the segment size is normally determined by the available space in half of a 4-QAM rate = 1/2 full-slot MAC block at the current bandwidth. The first and last segment of a TL-SDU may be of different size.

In addition to the basic link and advanced link entities, the LLC may contain a control entity (LLC-CTRL). This entity sends and receives layer 2 signalling PDUs, using unacknowledged information transfer mechanisms. Layer 2 signalling PDUs carry various types of general signalling information relating to layer 2 functions. The layer 2 functions may be either LLC or MAC functions. However, for the purposes of the data exchange mechanisms, the layer 2 signalling PDUs are treated as LLC PDUs. In cases where the layer 2 signalling relates to a MAC function, the LLC provides the information transfer service to the MAC via the TLE-SAP.

The data link operation may use the knowledge of the multiframe structure for transmission optimization.

22.1.2 Communication routes of the LLC model

Figure 22.1 shows relations of the MS LLC layer protocols in the TETRA protocol stack. The MLE selects service and signal route by selecting the link identifier at the TLA-SAP. There is also an LLC flow control provided between LLC peer entities on the advanced link. The flow control is accessible to the LLC service user via a MLE-LLC control route.

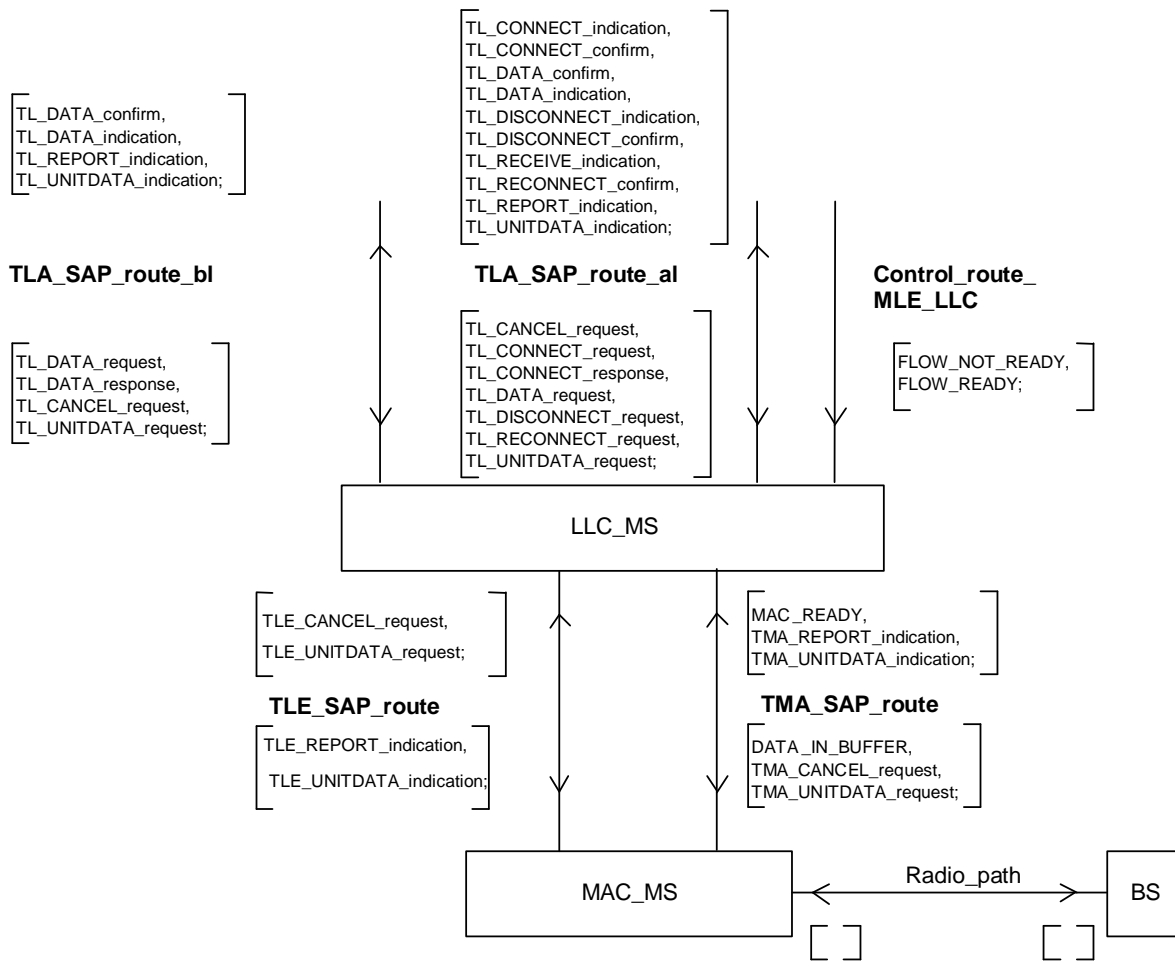

Figure 22.1: LLC relations

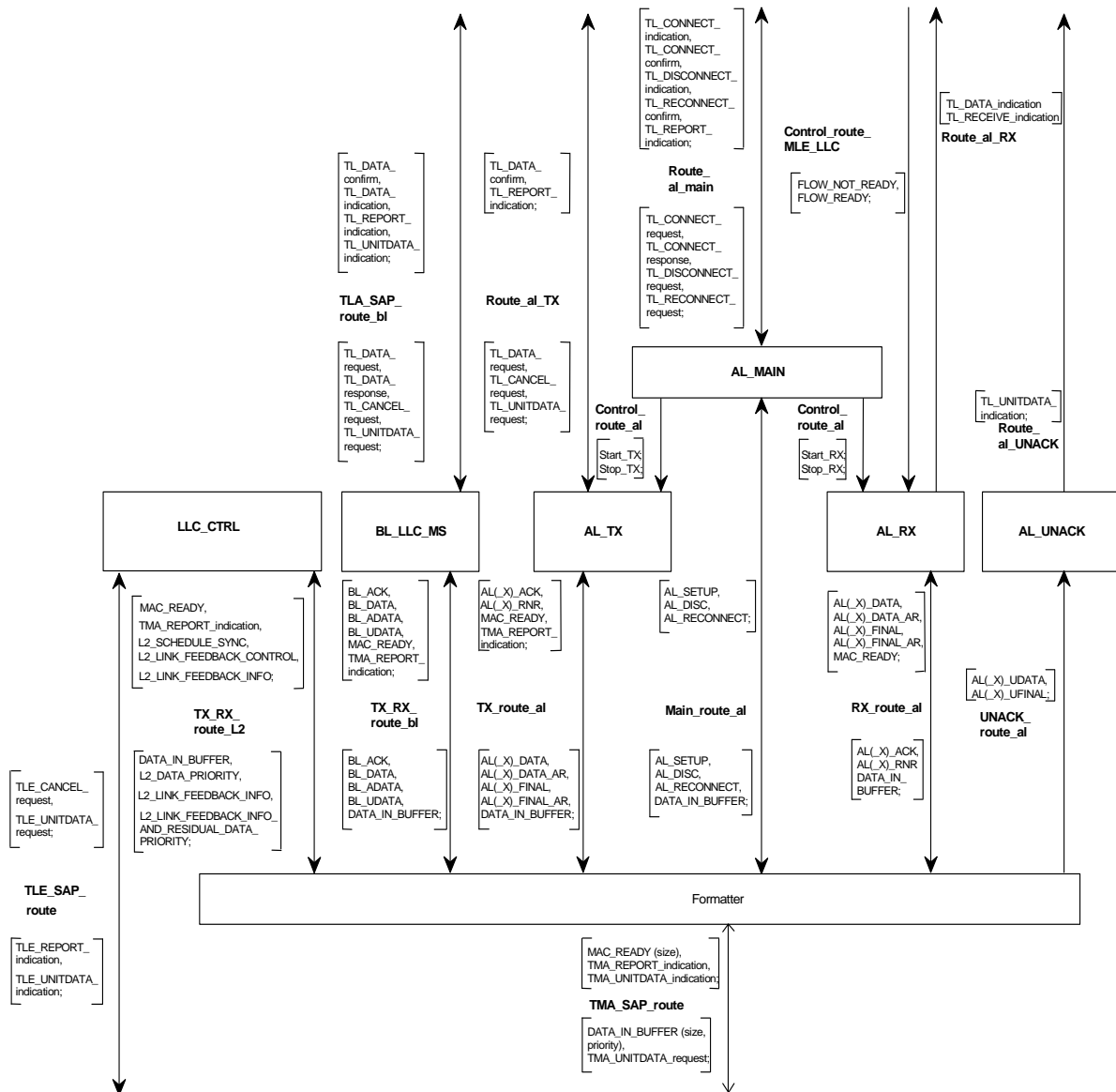

Figure 22.2: LLC protocol structure

Figure 22.2 shows the internal structure of the LLC presenting the basic and the advanced links, layer 2 signalling and layer composition of various processes.

The basic link protocol uses the following routes:

- the TLA-SAP route bl corresponds to the TLA-SAP;
- the TX-RX route bl corresponds to TMA-SAP showing LLC PDUs.

The advanced link protocol uses the following routes:

- the Route al main corresponds to the TLA-SAP for the connection set-up, LLC reconnection and disconnection;
- the Route al TX corresponds to the TLA-SAP for acknowledged data transmission;
- the Route al RX corresponds to the TLA-SAP for acknowledged data reception;
- the Control Route MLE-LLC corresponds to the TLA-SAP for flow control purposes;

- the Main route al corresponds to TMA-SAP and carries LLC PDUs for connection set-up, LLC reconnection and disconnection;
- the TX route al corresponds to TMA-SAP and carries LLC PDUs and control signals, which are used in acknowledged data transmission;
- the RX route al corresponds to TMA-SAP and carries LLC PDUs and control signals, which are used in acknowledged data reception;
- the Route al UNACK corresponds to TLA-SAP for unacknowledged service;
- the UNACK route al corresponds to TMA-SAP and carries LLC unacknowledged service PDUs;
- the Control route al carries local control of the advanced links.

The layer 2 signalling protocol uses the following routes:

- the TLE-SAP route corresponds to the TLE-SAP;
- the TX-RX route L2 corresponds to TMA-SAP and carries LLC PDUs which are used in layer 2 signalling.

Information exchange between LLC and MAC:

- the TMA-SAP route corresponds to the TMA-SAP, and carries primitives and local information exchange;
- the TLE-SAP route corresponds to the TLE-SAP, and carries primitives.

NOTE: The creation of the routes is considered to be an implementation issue and they are not shown in figure 22.2.

22.2 Scenarios on LLC procedures

22.2.0 General

This clause describes scenarios for normal TL-SDU transfer cases. For clarity many details such as TL-REPORT indication primitives are not included into message sequence diagrams.

22.2.1 Basic link mode

22.2.1.0 General

The basic link is available for information transfer whenever the MS is synchronized to a BS. There are two data transfer modes, acknowledged and unacknowledged PDU transfer. The acknowledged data transfer can be used for point-to-point communication and the unacknowledged data transfer can be used both for point-to-multipoint and point-to-point communication.

22.2.1.1 Acknowledged PDU transfer (BL-DATA + BL-ACK)

Figures 22.3 and 22.4 show the transfer of information when the basic link is used. This protocol supports a message pair exchange based on primitives TL-DATA request and TL-DATA indication in one direction and on primitives TL-DATA response and TL-DATA confirm in the other direction as shown in figure 22.3. The TL-SDU from the left hand side entity is transmitted in the BL-DATA PDU. The TL-SDU in the TL-DATA response primitive from the right hand side LLC to the left hand side LLC is transferred in the BL-ACK PDU. That TL-SDU is not acknowledged directly with an explicit transfer of an acknowledgement PDU (though the left hand side entity may retransmit its BL-DATA PDU if it does not receive the BL-ACK PDU). Each BL-DATA PDU carries a TL-SDU number N(S), which indicates the number of the present BL-DATA PDU in that direction of information flow. The peer entity acknowledges the successful reception of this BL-DATA PDU by sending the same TL-SDU number N(R) in the acknowledgement BL-ACK PDU, see figure 22.4 for the PDU exchange.

NOTE: This protocol uses in the acknowledgement message the same message number as in the received data message in contrary to most HDLC protocols, which typically rely on a continuous message exchange and use in the acknowledgement the next expected message number.

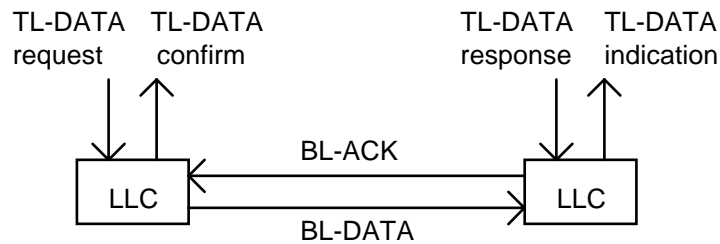
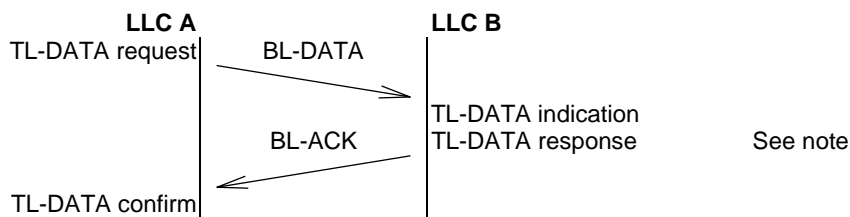

Figure 22.3: Basic link PDU exchange with acknowledgement carrying a layer 3 message



NOTE: BL-ACK includes the response data from the service user.

Figure 22.4: Basic link data transfer and acknowledgement with a layer 3 message

In the previous scenario there was a layer 3 TL-DATA response primitive available when the BL-ACK PDU was sent. If there is no layer 3 information available, then a short acknowledgement PDU is sent as shown in figures 22.5 and 22.6. The LLC assumes that the LLC service user will normally provide a TL-DATA response to the TL-DATA indication primitive before the LLC and MAC has the next opportunity to send the BL-ACK PDU as shown above. If the TL-DATA response primitive is offered to the LLC after the sending of the BL-ACK PDU, then the LLC sends it as if it were a TL-DATA request primitive using a BL-DATA PDU, which is presented to the receiving service user as a TL-DATA indication primitive and will be confirmed, see the second set of primitives in figures 22.5 and 22.6.

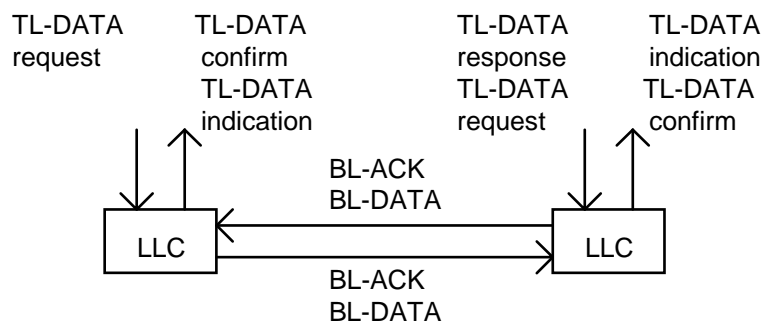
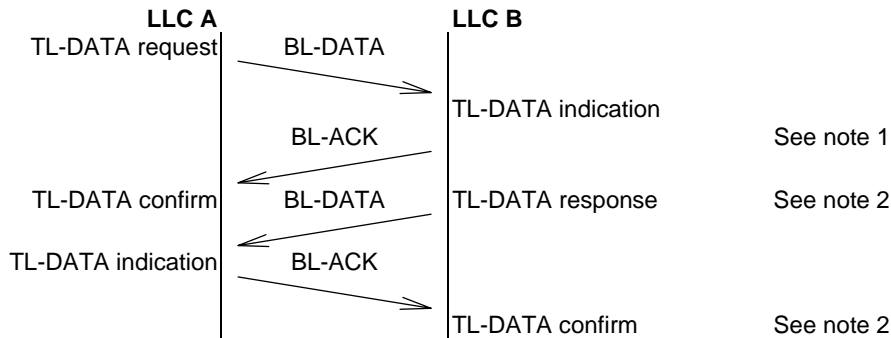

Figure 22.5: Basic link PDU exchange with LLC acknowledgement with a delayed response



NOTE 1: When there is no TL-DATA response available, then LLC sends an acknowledgement without data.

NOTE 2: The LLC transfers a delayed TL-SDU in the TL-DATA response primitive using normal acknowledged service as if it were a TL-DATA request primitive and a successful transfer will be confirmed with a TL-DATA confirm primitive to the service user.

Figure 22.6: Basic link data transfer and acknowledgement with a delayed layer 3 response

The basic link also allows concurrent data transfer in both directions independent of each other as shown generally in figure 22.7 and as an example in figure 22.8. A TL-DATA request primitive is sent in a BL-DATA PDU from the LLC A. The LLC B may combine the acknowledgement and the user data from a TL-DATA request primitive into a BL-ADATA PDU. At the LLC A receiver the acknowledgement will be delivered to the service user in a TL-DATA confirm primitive and the user data is delivered in an independent TL-DATA indication primitive. The example continues with the second TL-DATA request primitive and with the corresponding combined BL-ADATA PDU. To the resulting TL-DATA indication primitive the LLC B responds with a TL-DATA response primitive and the user data is sent in a BL-ACK PDU. This is delivered to the service user in a TL-DATA confirm primitive and there is no explicit acknowledgement sent to that data. The next user data PDU from the LLC A will be a BL-DATA PDU and it is in this example acknowledged by a BL-ACK PDU without data. If the user does not want to send a response but an independent data, see figure 22.8, note 1, then a TL-DATA request primitive is used and the LLC will acknowledge the received data either with a BL-ACK or with a BL-ADATA PDU. In figure 22.7 there are two sets of service primitives; the upper and lower are used in the information flow from left to right and from right to left respectively.

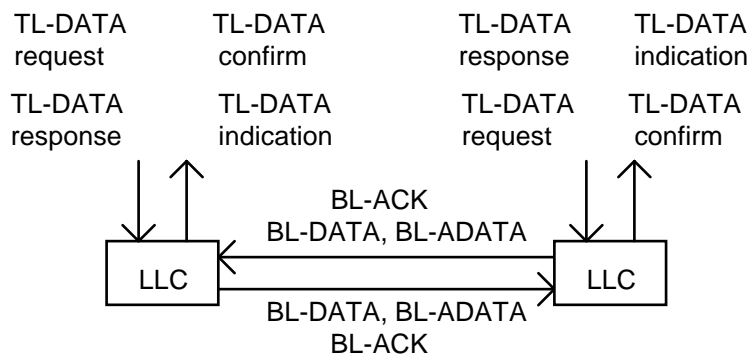
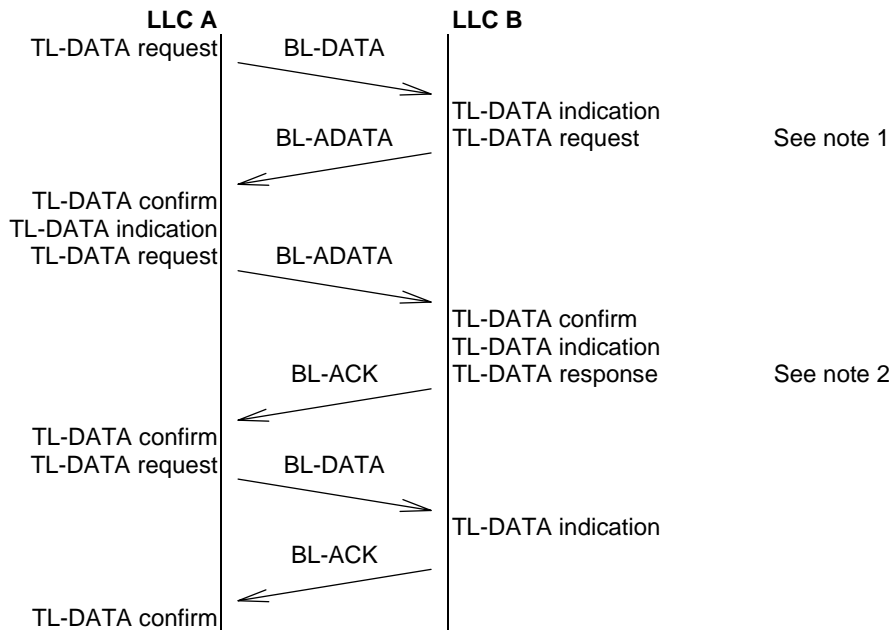

Figure 22.7: Concurrent independent message exchange in both directions



NOTE 1: Service user offers a data request instead of a response.

NOTE 2: There may be also a data response, which is carried in BL-ACK PDU and will not be acknowledged directly.

Figure 22.8: Concurrent independent message exchange in both directions

The LLC sends reports, or reports on the progress of data sending, to the service user based on information from MAC layer. Those reports will be explained in the protocol description and are not presented here.

In this protocol, a single TL-SDU, in a BL-DATA or BL-ADATA PDU, is sent and acknowledged at a time and the window size is equal to 1. There is no peer-to-peer flow control mechanism for the basic link.

22.2.1.2 Unacknowledged data transfer (BL-UDATA PDU)

Unacknowledged mode of operation may be used for sending data from the base station to a group of MSs (point-to-multipoint) as shown in figures 22.9 and 22.10, where the BL-UDATA PDU is used to transfer information. No responses nor acknowledgements are expected to a BL-UDATA PDU. The sending LLC entity may repeat a BL-UDATA PDU several times to increase the probability of a correct reception. The receiving protocol does not suppress received duplicates. The unacknowledged basic link service does not guarantee in-order delivery at the receiving entity if the BL-UDATA PDU is repeated. The LLC may send a report or reports on the progress of data sending to the service user.

The BL-UDATA PDU may be used also for sending data from the base station to an individual MS (point-to-point) or from an MS to the base station.

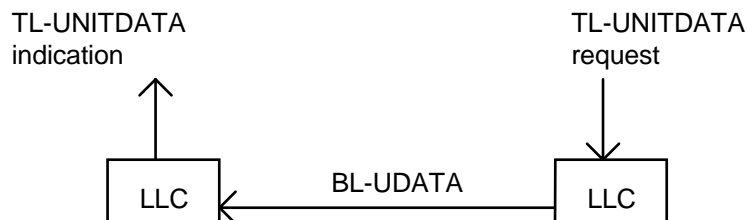

Figure 22.9: PDU exchange in unacknowledged mode

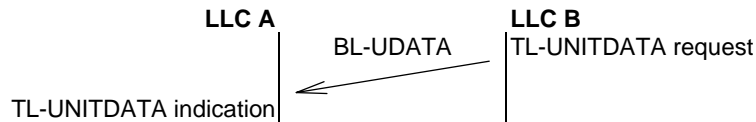

Figure 22.10: Basic link data transfer in unacknowledged mode

22.2.1.3 Unacknowledged data transfer with presence indication (BL-DATA + BL-ACK PDU)

This clause describes how a BS may implement presence checking in group call establishment.

This operation mode of the BS allows sending of unacknowledged data and requesting a low level presence indication from one or more recipient MS. The presence indication message carries only indication that at least one MS has received the message correctly and shall not contain a TL-SDU, see figures 22.11 and 22.12. In response to the TL-DATA request primitive with a presence indication parameter the base station sends a normal BL-DATA PDU and waits for an answer from one or more MSs. The MS LLC sends a normal acknowledgement, which is detected in the BS without actually decoding it especially if many MSs have answered at the same time. The BS LLC does not re-send the BL-DATA PDU to get back a decodeable BL-ACK PDU, but it may send BL-DATA PDU more than once for more reliable data transfer.

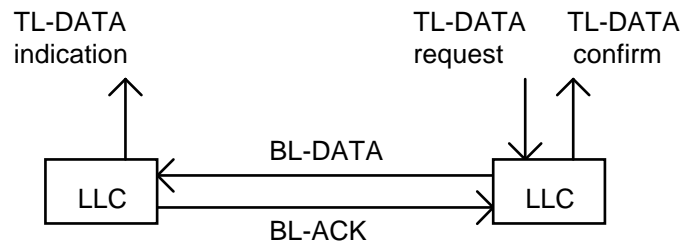

Figure 22.11: Basic link data transfer with presence indication

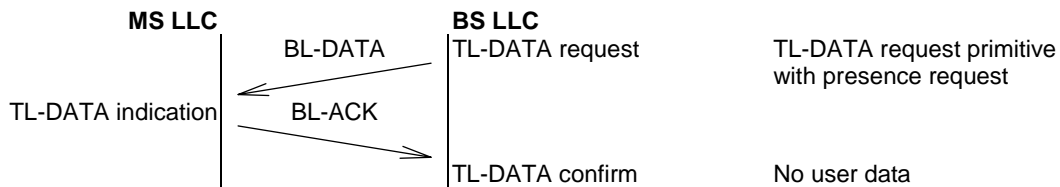

Figure 22.12: Basic link data transfer with presence indication

22.2.2 Advanced link

22.2.2.0 General

The advanced link provides two data transfer services, i.e. acknowledged and unacknowledged PDU transfer. The acknowledged data transfer can be used for point-to-point communication and the unacknowledged data transfer is intended to be used for point-to-multipoint communication, but may also be used for point-to-point information transfer on the downlink. Both services of the advanced link need to be set up before they can be utilized. The life of an advanced link comprises a connection set-up, data transfer and connection release. The life time of an advanced link may be limited or unlimited. After cell reselection, depending on the capabilities of the MS and SwMI, the advanced link may be reconnected, with the same parameters (e.g. QoS, timers, counters) as were used on the previous cell.

The advanced link protocol can send multiple TL-SDUs before an acknowledgement shall be sent or is received. The data transmitting station may send up to N.272 TL-SDUs before requesting and receiving a specific acknowledgement. The LLC may re-send TL-SDUs under a request from the data receiving LLC entity or due to a lack of an acknowledgement.

The advanced link segments TL-SDUs which are too long to be carried in one advanced link unit, and applies automatic selective re-transmission to badly received segments:

- When on a $\pi/4$ -DQPSK or D8PSK channel, the segment size is determined by the available room in a MAC transmission unit (MAC block). Therefore, on a D8PSK channel, segments may be of different sizes, depending on whether they are cut to be sent using $\pi/4$ -DQPSK or $\pi/8$ -D8PSK modulation for the first transmission of that segment.
- When on a 25 kHz or 50 kHz QAM channel, the segment size is normally determined by the available space in a 4-QAM rate = 1/2 full-slot MAC block at the current bandwidth; when on a 100 kHz or 150 kHz QAM channel, the segment size is normally determined by the available space in half of a 4-QAM rate = 1/2 full-slot MAC block at the current bandwidth. The first and last segment of a TL-SDU may be of different size.

There are two variants of advanced link: the original advanced link and the extended advanced link. The type of advanced link is negotiated during the call set-up.

For Conventional Access (CA), the BS indicates whether it supports:

- the original advanced link, using the "BS service details" element in the D-MLE-SYSINFO and D-MLE-SYSINFO-Q PDUs (see clause 18);
- both original and extended advanced links, using also the "extended services broadcast" element in the SYSINFO and SYSINFO-Q PDUs (see clause 21).

For Direct Access (DA), the BS shall support both original and extended advanced links (unless the "system wide services" element in the D-MLE-SYSINFO-DA (and D-MLE-SYNC-DA) PDU indicates "system wide services temporarily not supported", in which case support of advanced links by the BS is optional).

NOTE: CA is a method of operation in which the main carrier is a phase modulation carrier. DA is a method of operation in which the main carrier is a QAM carrier.

The MS indicates whether it supports the original advanced link and/or extended advanced link(s) using the "class of MS" element in the U-LOCATION UPDATE DEMAND PDU (see clause 16).

The MS is only permitted to support one original advanced link per service, whereas it may support more than one extended advanced link per service, provided that the total number of advanced links (original plus extended) is not more than four per service. (This refers to the services available for one address.)

- For the original advanced link, there is not explicit link numbering in the data transfer and acknowledgement PDUs; the advanced link number is implicitly assumed to be as indicated in the set-up message for the original advanced link. The FCS is mandatory for the original advanced link.
- In the extended advanced link, there is explicit link numbering in all the data transfer and acknowledgement PDUs. The FCS is optional for the extended advanced link. And the extended advanced link has a larger TL-SDU sequence number than the original advanced link, enabling a larger TL-SDU window size.

The PDUs used for advanced link set-up, release and LLC reconnection are the same for the original advanced link and the extended advanced link. However there are different PDUs for the data transfer and acknowledgements; extended advanced link PDUs are indicated by "-X" included in the name of the corresponding original advanced link PDU.

EXAMPLE: For example, the AL-DATA PDU is used on the original acknowledged advanced link to send segments other than the last - and the equivalent PDU for the extended advanced link is denoted AL-X-DATA.

22.2.2.1 Setting up the connection mode (AL-SETUP PDU)

The advanced LLC link connection for acknowledged service shall be negotiated between the two LLC entities as described in figures 22.13, 22.14 and 22.15. Either the MS or BS may initiate the advanced link connection set-up. A new connection set-up using the same advanced link number (and address) during an already existing connection overrides it and performs a link reset.

The resulting connection mode advanced link may coexist with an unacknowledged advanced link, refer to clause 22.2.2.2.

A new acknowledged advanced link set-up using a different advanced link number or address during an already existing acknowledged advanced link (or already existing acknowledged advanced links) sets up a new, independent, advanced link.

The connection request contains all parameters for negotiation (see notes 1 and 2):

- the maximum length of the TL-SDU N.271;
- the allowed number of TL-SDU retransmissions before LLC gives up N.273;
- the LLC TL-SDU window size N.272;
- the number of retransmissions of a segment N.274;
- optionally, the number of $\pi/4$ -DQPSK timeslots requested per TDMA frame N.264 (see notes 2 and 3);
- optionally, the requested mean value for the data transfer throughput (see notes 2 and 3);
- advanced link symmetry; and
- indication of whether the advanced link is an original or extended advanced link.

The negotiation uses AL-SETUP PDUs.

NOTE 1: These constants are part of the quality of service negotiation and are transmitted to the peer side. Depending on the mobile class and base station services, the peer entity may wish to respond with a lower quality of service or even refuse the connection set-up.

NOTE 2: During the advanced link negotiation, the peer entity is only permitted to respond with a lower quality of service or refuse the connection set-up; it is not permitted to respond with a higher quality of service. Permitted parameter negotiations are as follows:

- Parameters N.264, N.271, N.273 and N.274 may only be numerically lower or equal in the response AL-SETUP.
- If an extended advanced link has been proposed, the peer entity may offer an original advanced link (in which case it may respond to the augmented AL-SETUP PDU with either an augmented AL-SETUP PDU for the original advanced link or a non-augmented AL-SETUP PDU).
- If an original advanced link has been proposed using an augmented AL-SETUP PDU, the peer entity may respond with either an augmented AL-SETUP PDU for the original advanced link or a non-augmented AL-SETUP PDU.
- The TL-SDU window size N.272 may only be numerically lower or equal in the response AL-SETUP PDU.

If the peer entity is responding to an augmented AL-SETUP PDU with a non-augmented AL-SETUP PDU, this means that the TL-SDU window size in the non-augmented response AL-SETUP PDU is numerically lower than or equal to the TL-SDU window size that was proposed in the augmenting part of the augmented AL-SETUP PDU.

- The data transfer throughput may only be negotiated if it is not equal to 110_2 . It may only be numerically lower or equal in the response AL-SETUP; however it cannot be changed to 110_2 .
- The connection width may only be numerically lower or equal in the response, and may only be changed if the data transfer throughput is not equal to 110_2 .
- The advanced link symmetry may only be numerically lower or equal in the response. If an asymmetric phase modulation advanced link was proposed and the peer entity offers a symmetric phase modulation advanced link, parameter N.264 in the response AL-SETUP may only be numerically lower than or equal to the maximum of the two values of N.264 proposed for the uplink and downlink for the asymmetric advanced link.

Other parameter negotiations are not permitted.

The advanced link service (acknowledged service or unacknowledged service) and the advanced link number N.261 are not negotiable.

NOTE 3: The AL-SETUP PDU may contain information related to phase modulation radio resources; this facility in the AL-SETUP PDU provides radio resource information only in terms of $\pi/4$ -DQPSK timeslots:

- In the case of a specified phase modulation connection, the number of $\pi/4$ -DQPSK timeslots requested per TDMA frame indicates the maximum transmission rate for this advanced link in terms of $\pi/4$ -DQPSK timeslots; and the mean data transfer throughput information is given relative to the number of $\pi/4$ -DQPSK timeslots requested per TDMA frame. The actual channel allocated by the SwMI may comprise fewer or more timeslots than the negotiated number of $\pi/4$ -DQPSK timeslots per TDMA frame (within the MS's declared capabilities). Also, if the MS has indicated that it supports D8PSK channels, the BS should regard the radio resource information as a request for either a $\pi/4$ -DQPSK or D8PSK connection.
- In the case of an unspecified phase modulation connection, the AL-SETUP PDU indicates a request for any phase modulation channel (within the capabilities of that MS) i.e. without requesting a specific number of timeslots per TDMA frame. If the MS has indicated that it supports D8PSK channels, the BS should regard this as a request for either a $\pi/4$ -DQPSK or D8PSK connection.

Alternatively the AL-SETUP PDU may provide no information related to radio resources, for example, if the MS wishes the BS to choose any appropriate channel (within the capabilities of that MS and using any QoS information negotiated by the SNDSCP during PDP context activation).

NOTE 4: If the MS is using multiple advanced links, those advanced links may share the same physical allocation, in which case the allocated channel may need to comprise more timeslots (and/or a wider RF bandwidth) than would be needed for one of the advanced links.

The resulting connection will support two-way exchange of information between the peer LLC entities.

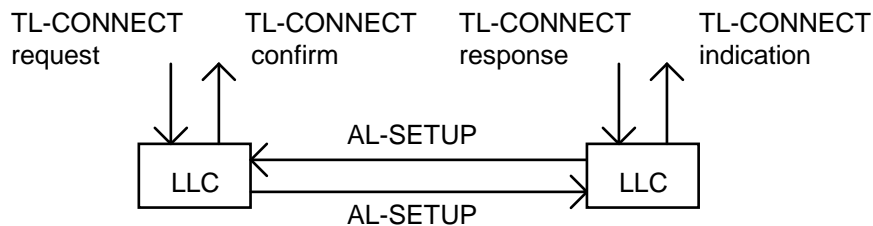

Figure 22.13: PDU setting up the advanced link

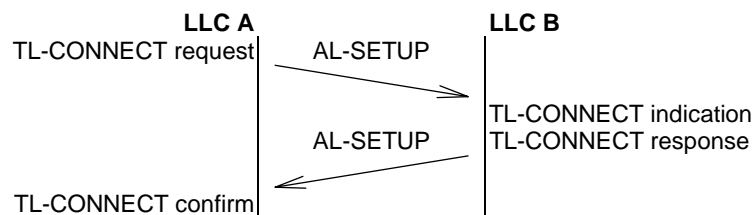
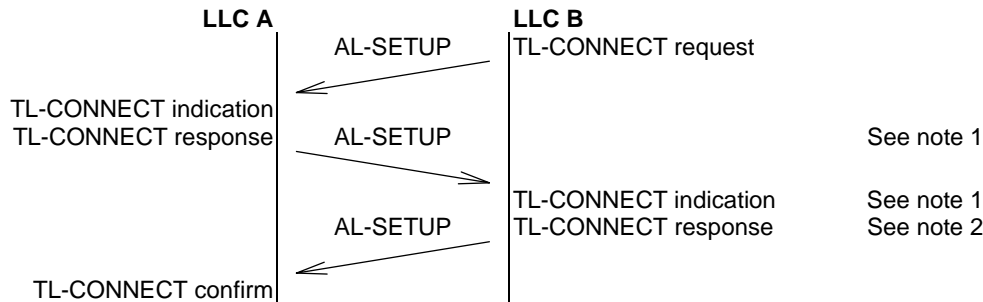

Figure 22.14: Advanced link set-up

NOTE 5: On establishment of an advanced link, the LLC prepares an AL-SETUP PDU with a set-up report "service definition" if the corresponding advanced link is not already set up. However, after advanced link continuation, the MS LLC may think that there is already an established advanced link and therefore use a set-up report value of "reset". Then the BS LLC entity should start normal connection establishment as if the received report were "service definition".



NOTE 1: Proposed QoS is not acceptable and a new QoS is proposed. The service negotiation may be performed as a direct negotiation between the LLC entities.

NOTE 2: The lower QoS is accepted.

Figure 22.15: Advanced link set-up to a lower quality of service

Figure 22.14 presents a message sequence diagram for an advanced link set-up, when the LLC B accepts the quality of service proposed by the LLC A. If the receiving station replies with a lower parameter setting, the transmitting station shall confirm those lower values and use these negotiated parameters for the advanced link as shown in figure 22.15. A receiving station shall not reply with higher parameter setting. On the other hand, the receiving station may refuse the connection by returning a TL-DISCONNECT request primitive (AL-DISC PDU).

The initial connect request shall set the TL-SDU and segment counters to the default values prior to the first transmission in both information flow directions.

If the LLC cannot support the advanced link, it may send an AL-DISC PDU, see figure 22.16.

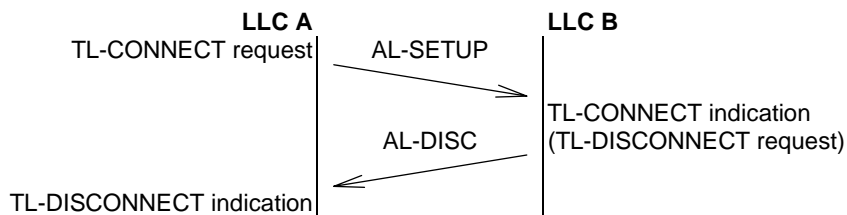

Figure 22.16: Unsupported service indication

22.2.2.2 Setting up the unacknowledged transfer mode (AL-SETUP PDU)

The advanced LLC link parameters shall be informed to the future participants of the unacknowledged transfer mode before the data transfer may commence successfully as described in figures 22.17 and 22.18. A new unacknowledged advanced link set-up using the same advanced link number and address during an already existing unacknowledged advanced link only modifies advanced link parameters without a reset functionality e.g. TL-SDU numbering shall continue without interruption. This set-up does not affect to the existing acknowledged advanced link service, if any, refer to clause 22.2.2.1.

A new unacknowledged advanced link set-up using a different advanced link number or address during an already existing unacknowledged advanced link (or already existing unacknowledged advanced links) sets up a new, independent, advanced link.

The set-up indication contains all relevant parameters for the unacknowledged advanced link: the maximum length of the TL-SDU N.271, the maximum number of TL-SDU retransmissions N.282, the LLC TL-SDU window size N.281 and indication of whether the advanced link being set up is an original or extended advanced link. The AL-SETUP PDU transmits these parameters. The AL-SETUP PDU may be sent several times (N.282+1 times) to increase the probability of correct reception. The further connection attempts for the same link are not passed to the service user unless the parameters in the following AL-SETUP PDUs change.

The resulting unacknowledged advanced link will support one-way exchange of information from the entity which sends the set-up information to the other peer LLC entities. The receiving entity may not be capable to conform to the selected parameters and may neglect the set-up.

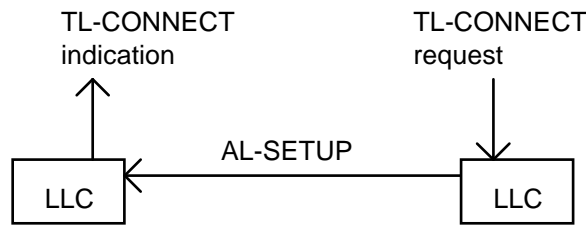

Figure 22.17: Unacknowledged transfer mode set-up of the advanced link

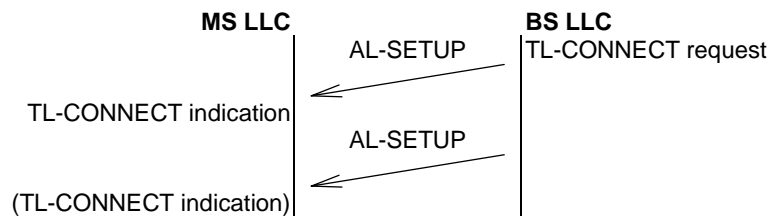

Figure 22.18: Unacknowledged transfer mode set-up of the advanced link

The unacknowledged advanced link entities shall set the TL-SDU and segments counters to the default values prior to the first transmission.

22.2.2.3 Data exchange in the connection mode (AL-DATA or AL-X-DATA PDU)

After the connection set-up the advanced LLC link is ready for a two-way exchange of information between the two peer LLC entities although actual information flow could be unidirectional and the other direction is used only for acknowledgements. The information flows in both directions (uplink and downlink) are independent of each other. Each AL-DATA or AL-X-DATA PDU contains two numbers: the actual TL-SDU number $N(S)$ and the absolute position of the segment inside the TL-SDU called segment sequence number $S(S)$. The segment sequence number is used in selective re-transmission in the AL-ACK or AL-X-ACK PDU. The AL-X-DATA PDU also contains the advanced link number.

The remainder of this clause describes scenarios for data exchange in the connection mode on the original advanced link. The methods of data exchange in the connection mode on an extended advanced link are similar to the methods on the original advanced link - except that PDUs AL-X-DATA, AL-X-DATA-AR, AL-X-FINAL, AL-X-FINAL-AR, AL-X-ACK and AL-X-RNR are used instead of PDUs AL-DATA, AL-DATA-AR, AL-FINAL, AL-FINAL-AR, AL-ACK and AL-RNR respectively.

NOTE: If an MS is using more than one advanced link, the data transfer procedures for each advanced link operate independently of the data transfer procedures for the other advanced link(s).

Data transfer in the advanced LLC link can be either unidirectional or bidirectional. In both cases data sending and data acknowledgements use the same PDUs and protocol. In the first case, the transfer flow is shown in figures 22.19 and 22.20 for the original advanced link. In this example LLC A sends a segmented TL-SDU using AL-DATA PDUs and marks the last segment of the TL-SDU by using an AL-FINAL-AR PDU. In reply to the AL-FINAL-AR PDU the data receiving LLC shall generate an acknowledgement using an AL-ACK PDU. The data sending LLC informs the service user of the correct transfer of the layer 3 TL-DATA by issuing a TL-DATA confirm primitive when a whole TL-SDU has been acknowledged. The data receiving BS LLC entity informs the service user of the incoming of data by issuing a TL-RECEIVE indication primitive.

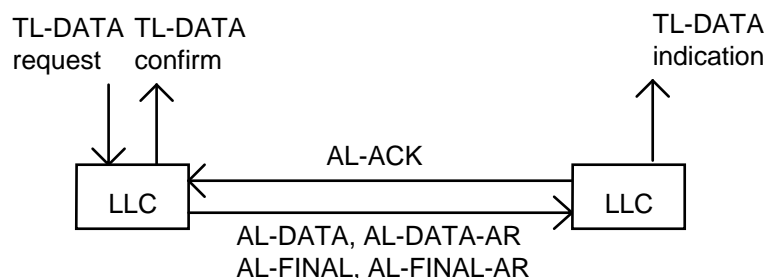
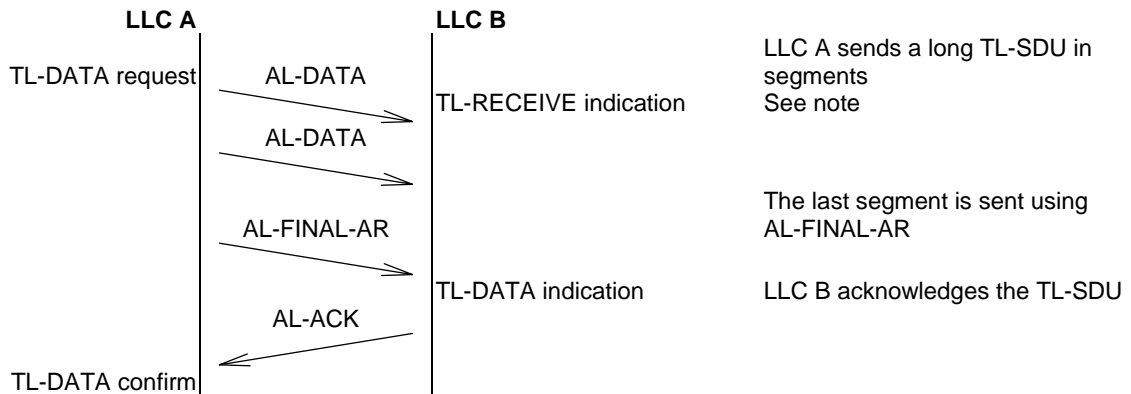

Figure 22.19: PDU exchange in a unidirectional transfer on the original advanced link



NOTE: LLC B refers to BS LLC entity in this figure. Exact mechanism when to send the TL-RECEIVE indication primitive is outside the scope of the present document.

Figure 22.20: PDU exchange in a unidirectional transfer on the original advanced link

The data sending LLC entity may request an acknowledgement from the peer entity at any time by using AL-DATA-AR or AL-FINAL-AR PDUs in place of the AL-DATA and AL-FINAL PDUs respectively. The data sender may continue transmission of data without waiting for the requested acknowledgements, if allowed by the SDU window size. In figure 22.21 the LLC B requests an acknowledgement in the middle of sending a TL-SDU and later does not request an immediate acknowledgement to the complete TL-SDU.

The data receiver may send an AL-ACK PDU at any time in addition to the requested acknowledgements, see also clause 22.2.2.7.

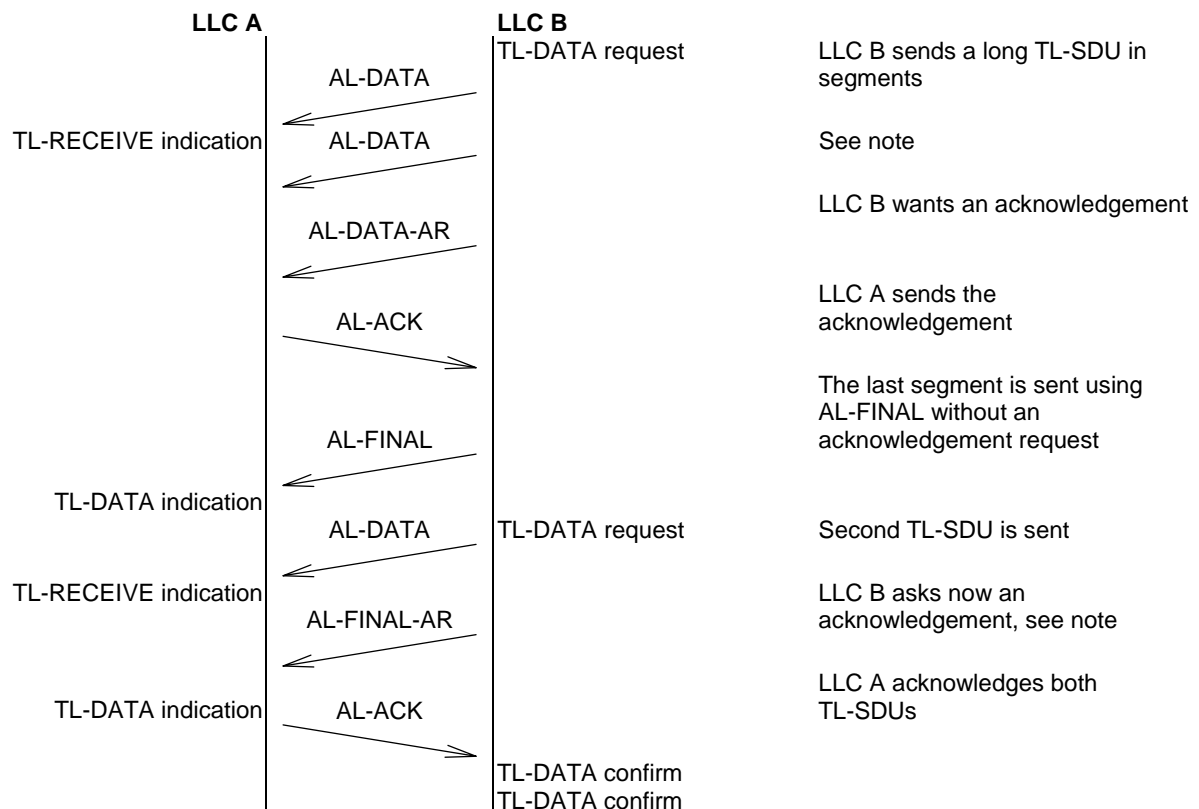

NOTE: LLC A refers to BS LLC entity in this figure. Exact mechanism when to send the TL-RECEIVE indication primitive is outside the scope of the present document.

Figure 22.21: A longer PDU transfer on the original advanced link

An example of bidirectional information transfer flow is shown in figures 22.22 and 22.23. The LLC A sends a message to the LLC B, and the LLC B responds with another message. The LLC A starts the sending by a segmented TL-SDU using AL-DATA PDUs and marks the last segment of the TL-SDU by using AL-FINAL-AR PDU. The LLC B delivers the received TL-SDU to the service user as a TL-DATA indication primitive. The LLC B generates an acknowledgement AL-ACK PDU as a response to the AL-FINAL PDU. The acknowledged TL-SDU shall be indicated to the data sending service user by a TL-DATA confirm primitive.

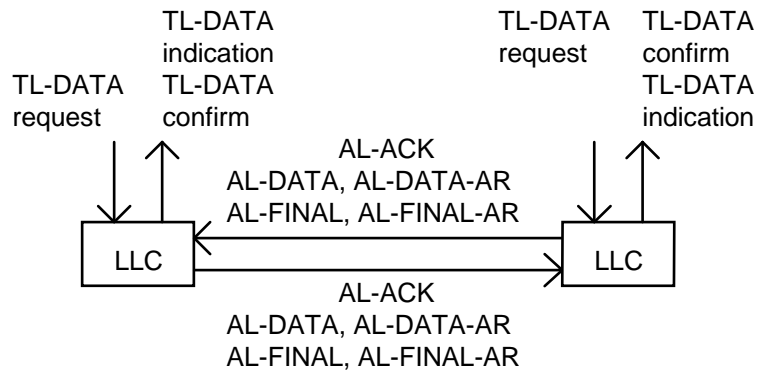
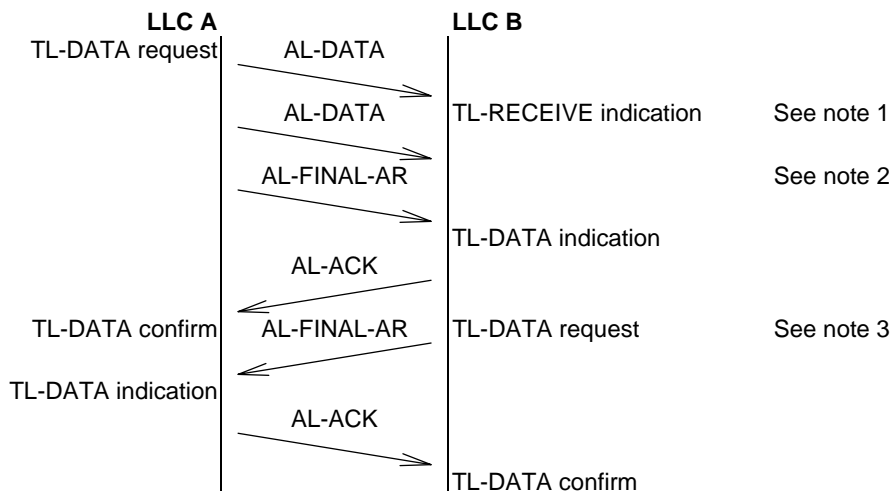

Figure 22.22: Bi-directional data transfer on the original advanced link



NOTE 1: LLC B refers to BS LLC entity in this figure. Exact mechanism when to send the TL-RECEIVE indication primitive is outside the scope of the present document.

NOTE 2: The last segment is sent using AL-FINAL-AR.

NOTE 3: LLC B sends a responding or independent TL-SDU.

Figure 22.23: Bi-directional PDU transfer on the original advanced link

The LLC can accept more than one TL-SDU for sending before completing the transfer of the previous TL-SDU. The LLC may also modify the sending order of TL-SDUs depending on the priorities of those SDUs, but all already started transmissions need to be completed before a new higher priority TL-SDU (non pre-emptive) may be transferred successfully. The LLC entity could also start sending of TL-SDUs at any time independently of the state of the other transfer direction.

Highest priority transmissions across an advanced link may reset the link to get fast access. This action may corrupt the ongoing lower priority transmission.

22.2.2.4 Data exchange in the unacknowledged transfer mode (AL-UDATA or AL-X-UDATA PDU)

After the unacknowledged data transfer set-up the advanced LLC link is ready for a one-way exchange of information. The service user data is transmitted in AL-UDATA or AL-X-UDATA PDUs. The AL-UDATA or AL-X-UDATA PDU contains two numbers: the actual TL-SDU number $N(S)$ and the absolute position of the segment inside the TL-SDU called segment sequence number $S(S)$. The segment sequence number is used in the rebuilding of the received TL-SDU from segments. The AL-X-UDATA PDU also contains the advanced link number.

The data transfer flow is shown in figures 22.24 and 22.25 for the original advanced link. The methods of unacknowledged data exchange on an extended advanced link are similar to the methods on the original advanced link - except that PDUs AL-X-UDATA and AL-X-UFINAL are used instead of PDUs AL-UDATA and AL-UFINAL respectively.

NOTE: If an MS is receiving more than one unacknowledged advanced link, the data transfer procedures for each advanced link operate independently of the data transfer procedures for the other advanced link(s).

In the example shown, the BS LLC sends a segmented TL-SDU using AL-UDATA PDUs and marks the last segment of the TL-SDU by using an AL-UFINAL PDU. The BS may send the TL-SDU several times up to maximum retransmissions ($N.282$) to increase the reception probability (and using the same segmentation for each repetition).

The data receiving LLC entity delivers the TL-SDU to the service user in a TL-UNITDATA indication primitive. The data sending entity may inform the completion of all repetitions to the service user using an informal TL-UNITDATA confirm primitive.

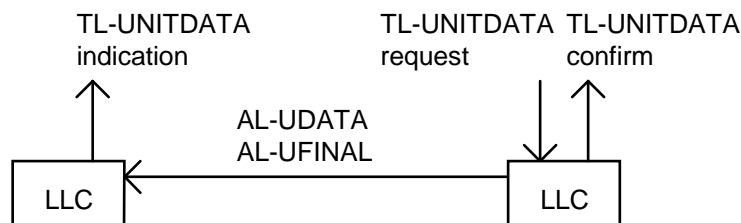

Figure 22.24: PDU sending in a unidirectional transfer on the original advanced link

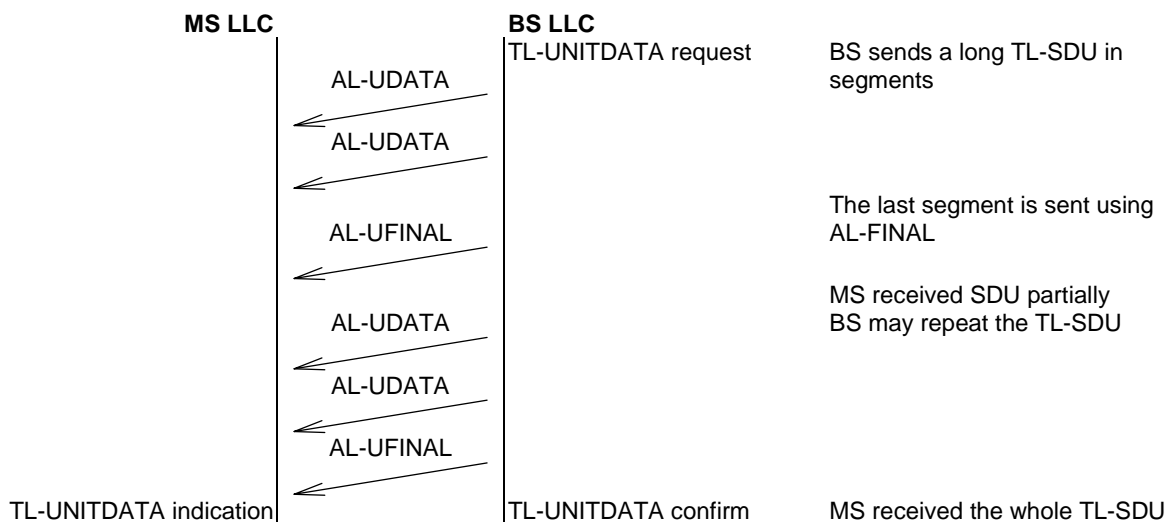

Figure 22.25: PDU sending in a unidirectional transfer on the original advanced link

The BS LLC may send repetitions of up to $N.281$ TL-SDUs in any order, but either the oldest TL-SDU within that SDU-window with all repetitions shall be sent, or transmission of the oldest TL-SDU within the SDU-window shall be stopped, before a new TL-SDU may commence. The BS LLC may also modify the sending order of TL-SDUs depending on the priorities of those SDUs.

The data receiving entity may combine segments from multiple transmissions of the same TL-SDU in order to reassemble a complete TL-SDU.

22.2.2.5 Window mechanism

In the advanced link LLC protocol there is a window mechanism for TL-SDU transmissions. The window mechanism allows more than one TL-SDU and LLC data PDU respectively to be sent before required acknowledgements stop LLC transmissions. The TL-SDU window size $N.272$ is negotiated during the advanced link set-up, refer to clause 22.2.2.1. The maximum window size that may be negotiated is:

- 3 for the original advanced link; or
- 15 for an extended advanced link.

The data receiving LLC entity may acknowledge each TL-SDU as soon as it is fully received, but the data sending LLC entity may continue to send up to a total of $N.272$ TL-SDUs before receiving acknowledgements for the previous TL-SDUs. (For window size $N.272 = 1$, the data receiving LLC entity acknowledges each TL-SDU before the data sending LLC entity may continue with the next TL-SDU.)

During a segment transmission the data sending LLC entity may force a sending of an acknowledgement whenever it sends the last segment of a TL-SDU, which is sent as the AL-FINAL-AR or AL-X-FINAL PDU, refer to clause 22.2.2.3. The data sending LLC entity may also request an acknowledgement at any time using an AL-DATA-AR or AL-X-DATA-AR PDU type, which also initiates an acknowledgement as soon as possible. This is illustrated for the original advanced link in figures 22.26 and 22.27.

This window mechanism shall not be used for flow control purposes, refer to clause 22.2.2.7.

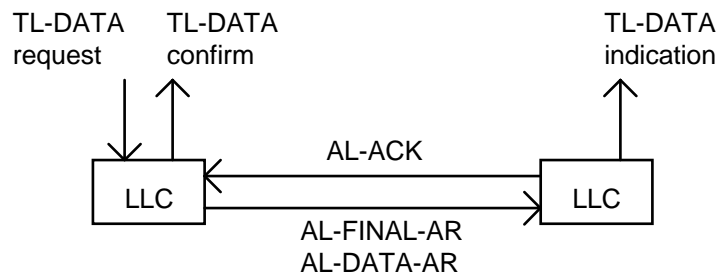
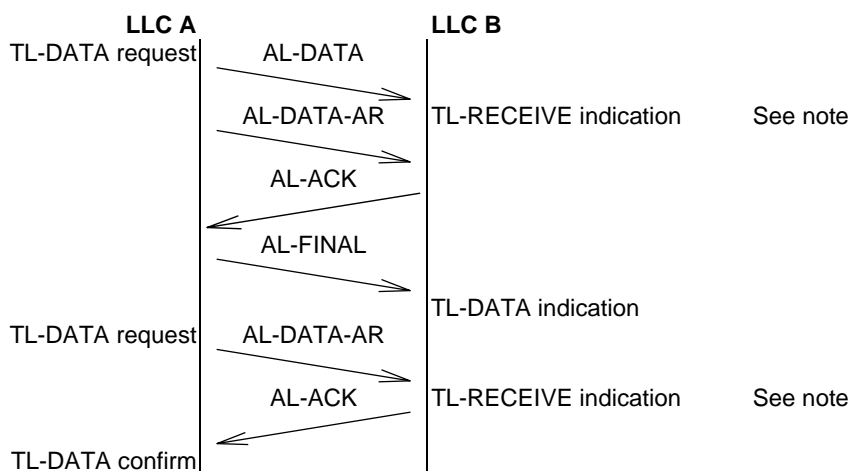

Figure 22.26: PDU exchange for forced acknowledgement on the original advanced link



NOTE: LLC B refers to BS LLC entity in this figure. Exact mechanism when to send the TL-RECEIVE indication primitive is outside the scope of the present document.

Figure 22.27: Forced acknowledgement on the original advanced link

22.2.2.6 Selective re-transmission of segments (AL-ACK or AL-X-ACK PDU)

The selective re-transmission is based on the segments (LLC PDUs) into which the data transmitting LLC divides a TL-SDU for sending. The data receiving LLC informs the data transmitting LLC which segments are not received correctly, and then the data transmitting LLC sends the missing segments in the later transmissions until the whole TL-SDU is received correctly as recognized by the MAC layer error detection. The whole TL-SDU may still be erroneous, and the data receiving entity shall ask for a re-transmission when an error in the TL-SDU is detected by the frame check sequence.

Figure 22.28 shows an example of a selective re-transmission sequence for the original advanced link. Line a) of figure 22.28 shows three TL-SDUs, which the data transmitting LLC divides into segments as shown in the line b). The end of each SDU is marked by "F" and the data transmitting LLC sends that segment using a AL-FINAL PDU. The SDU window size is 2 in this example.

The data transmitting LLC plans to send segments as shown on line b) of figure 22.28 and starts to send them in sequence using AL-DATA PDUs for all but the last one which it sends using AL-DATA-AR PDU marked by "A". The data receiving LLC receives correctly segments 1, 2, 4, 5 from the first SDU as shown on line c), and sends the first acknowledgement (ACK) as requested by the data sending entity. The acknowledgement contains bit maps as shown on line e) and corresponding segment numbers are shown on line f). The first part of the ACK (1/3) indicates the first segment, which is not received correctly, in this example segment number 3 in the first SDU and a bit map from that segment onwards. The acknowledgement tells that all segments before the 3rd segment of the first SDU (1/3) are received correctly and that segment 3 of the first SDU is not yet received correctly. Then the bitmap shows that segments 4 and 5 are received correctly.

The data transmitting LLC then modifies its transmission and adds those segments, which were not acknowledged or sent i.e. 3 and 6 from the first SDU (1/3 and 1/6), before continuing transmission of new segments in this case from the second SDU. The last segment of the second SDU is sent as AL-FINAL-AR PDU marked "F/A". The second and third acknowledgements on line d) indicate that again segments 3 and 6 from the first SDU are not yet received correctly, but the second SDU is received totally and correctly (2/A). The data transmitting LLC then re-sends segments 3 and 6 of the first SDU and cannot continue to the third SDU due to SDU window size of two in this example.

The data receiving LLC misses again the segment number 3 of the first SDU as shown on line g) and the data receiving LLC sends acknowledgement after receiving the 6th and final segment of the first SDU. The first acknowledgement indicates that only the third segment of the first SDU is not yet received correctly. The data transmitting LLC then re-sends the missing segment of the first SDU and after receiving the second acknowledgement on the line h) can send the third SDU, which fits into the new SDU window. That SDU is received correctly as indicated by each segment CRC, but the total frame check sequence does not match and the data receiving LLC sends an acknowledgement indicating a re-sending request (3/F) of the third SDU. After re-sending on line j) the third SDU is this time received correctly and acknowledged on line k) (3/A).

In this example the data receiving LLC will deliver the first TL-SDU to the MLE only after sending the second acknowledgement on the line i), which indicates that the first SDU is correctly received. The second SDU is already correctly received and acknowledged by the second acknowledgement on the line d), but the data receiving LLC cannot deliver it before the first SDU is received in order to keep the SDUs in the correct sequence.

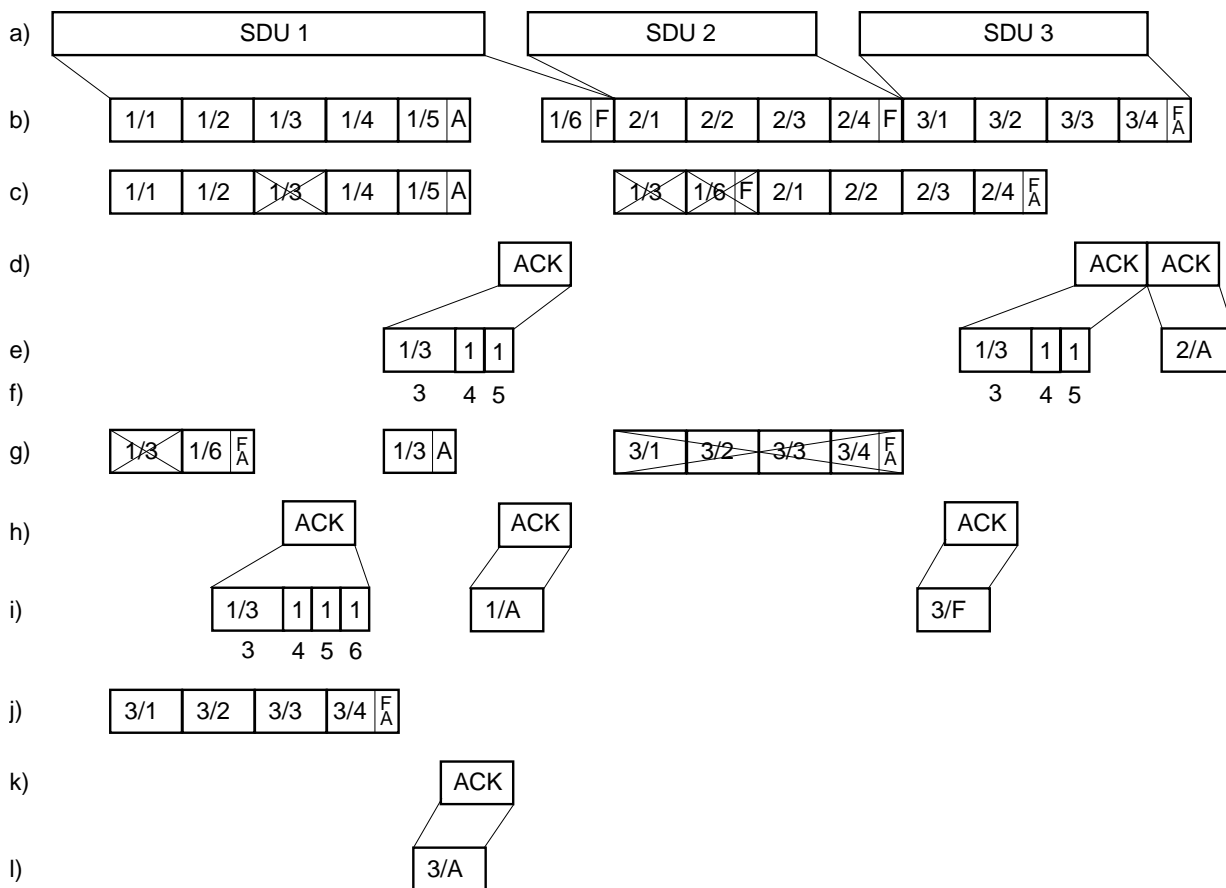

Figure 22.28: Selective re-transmission example

If the AL-FINAL-AR is lost and there is no more data to send or the transmission window is closed and the last acknowledgement is also lost, then the data sending entity may repeat the whole last sending or only the segments which were sent with the acknowledgement request.

22.2.2.7 Flow control (AL-RNR or AL-X-RNR PDU)

The data receiving advanced link entity may at any time request its peer entity to stop transmission of data PDUs on an advanced link by sending an AL-RNR PDU (for the original advanced link) or an AL-X-RNR PDU (for an extended advanced link). The AL-RNR or AL-X-RNR PDU replaces the AL-ACK or AL-X-ACK PDU, when the data receiver is not ready to receive new PDUs. The re-transmission of the segments or PDUs indicated in the AL-RNR or AL-X-RNR PDU shall continue. The data transmission may continue after the data receiving entity has sent an AL-ACK or AL-X-ACK PDU for this advanced link. This is illustrated for the original advanced link in figures 22.29 and 22.30.

The receiver not ready indication is valid from the last received AL-RNR or AL-X-RNR PDU for this advanced link for the duration of T.271 s, after which the data transmitter may try to re-start data sending.

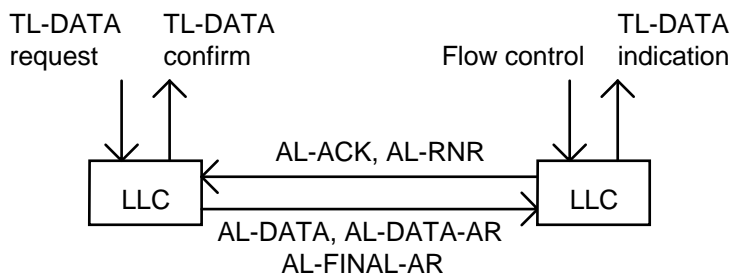
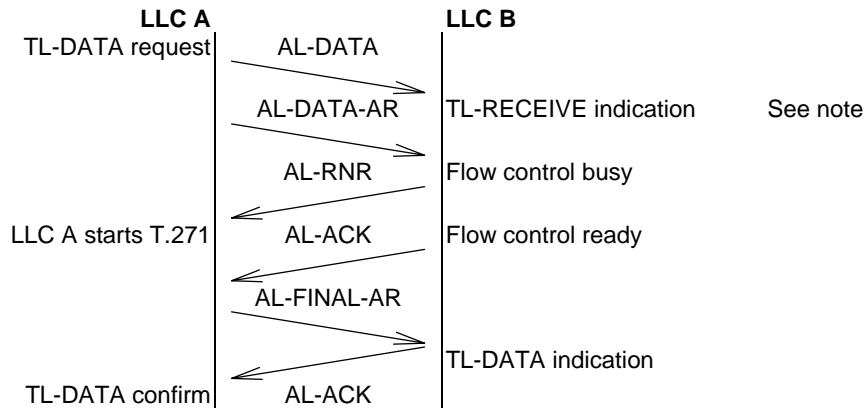

Figure 22.29: Flow control PDU exchange on the original advanced link



NOTE: LLC B refers to BS LLC entity in this figure. Exact mechanism when to send the TL-RECEIVE indication primitive is outside the scope of the present document.

Figure 22.30: Flow control on the original advanced link

22.2.2.8 Connection reset

The connection reset may be performed using connection set-up procedure, refer to clause 22.2.2.1.

22.2.2.8a LLC reconnecting an advanced link (AL-RECONNECT PDU)

Prior to performing a cell handover, the LLC service user may request that an advanced link is locally disconnected by using the TL-RELEASE request primitive. However, where the MS is involved in the transmission or reception of TL-SDU segments immediately prior to cell handover, the LLC service user may decide not to disconnect the advanced link but instead may request the LLC to reconnect the advanced link on the new cell by using TL-RECONNECT request primitive, when the SwMI supports or recognizes the advanced link roaming, and thus continue the transmission or reception of TL-SDU segments from where it finished on the previous cell.

When the MS initiates an LLC reconnection, see figures 22.31 and 22.32, the timer T.265 (Reconnection waiting timer) shall be started at the TL-RECONNECT request primitive. On reception of the AL-RECONNECT PDU, and where the LLC reconnection has been successful as indicated by the reconnect report field value "success", the LLC shall send a TL-RECONNECT confirm primitive to the service user to indicate the successful result of the LLC reconnection and a TMC-CONFIGURE request primitive to the MAC in order to accept the channel change when requested, and the MS LLC may continue using the advanced link on the new cell without a reset.

NOTE: When the MS moves to a new cell, it should not send any TMA-UNITDATA request primitives containing TL-SDU segments for an advanced link until that advanced link has been successfully reconnected on the new cell (or set up again or reset).

On reception of the AL-RECONNECT PDU, and where the LLC reconnection attempt has failed as indicated by the reconnect report field value "reject", or when timer T.265 has expired N.265 times (maximum number of reconnection retries), without success, then MS LLC shall consider that the reconnection of the advanced link has failed and inform the service user by a TL-RECONNECT confirm primitive with the reconnection result set to "reject" or "failed" respectively.

If the MS is involved in the transmission or reception of TL-SDU segments on more than one advanced link immediately prior to cell handover, the LLC service user may request the LLC to reconnect some or all of the advanced links on the new cell by using multiple TL-RECONNECT request primitives. The LLC then performs the reconnection procedure for each of those advanced links.

The MS may then continue the transmission or reception of TL-SDU segments on those advanced links for which reconnection was successful from where it finished on the previous cell.

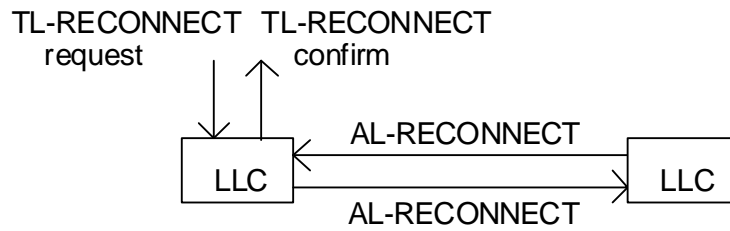
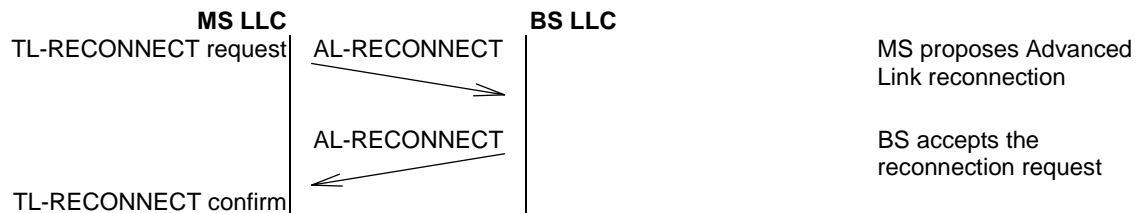

Figure 22.31: PDU exchange for LLC reconnection of the advanced link



NOTE: The AL-reconnection protocol is unsymmetrical in contrast to other LLC protocol parts.

Figure 22.32: LLC reconnection of an advanced link

22.2.2.9 Releasing an acknowledged advanced link (AL-DISC PDU)

An advanced link may be closed at any time by using the TL-DISCONNECT request primitive. Any ongoing data transfer shall be stopped immediately with the possible result of data loss, refer to figures 22.33 and 22.34. When the LLC starts a disconnection, see figure 22.34, then the timer T.263 shall be started at the TL-DISCONNECT request primitive. On a reception of AL-DISC or when timer T.263 has expired N.263 times without success, a TL-DISCONNECT confirm primitive is given to the service user. The LLC shall discontinue to use the advanced link immediately at the reception of an AL-DISC PDU.

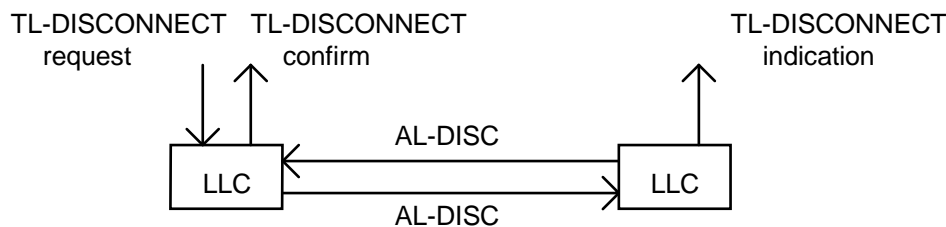

Figure 22.33: PDU exchange for releasing the advanced link

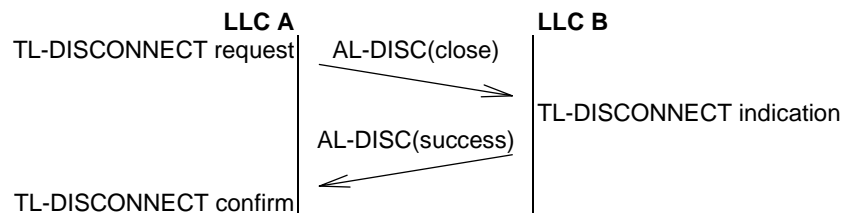

Figure 22.34: Disconnection of an advanced link

22.2.2.10 Releasing an unacknowledged advanced link (AL-DISC PDU)

An unacknowledged advanced link is suppressed by using the disconnect primitive, refer to figures 22.35 and 22.36. The AL-DISC PDU may be repeated to increase reception probability. The further disconnection attempts for the same link are not passed to the service user. Disconnection may occur at any time and after that instance that unacknowledged link does not support unacknowledged data transfer.

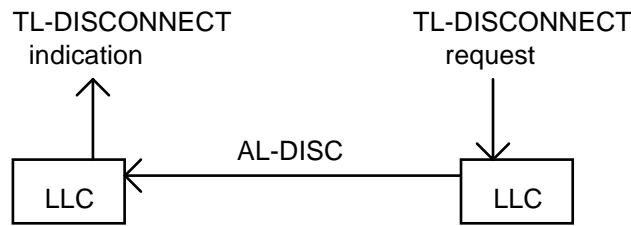
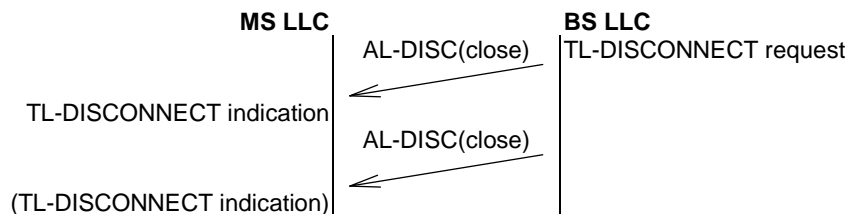

Figure 22.35: PDU exchange for releasing the unacknowledged advanced link



NOTE: AL-DISC may be repeated.

Figure 22.36: Disconnection of an unacknowledged advanced link

22.2.3 Layer 2 signalling

In addition to basic link and advanced link signalling PDUs, the LLC may send and receive layer 2 signalling PDUs; these PDUs carry various types of general signalling information relating to layer 2 functions. The layer 2 functions may be either LLC or MAC functions. However, for the purposes of the data exchange mechanisms, the layer 2 signalling PDUs are treated as LLC PDUs.

In the present document, the layer 2 signalling PDUs are used only for MAC functions. Valid layer 2 signalling PDUs are as follows:

- the MS may send the L2-DATA-PRIORITY or L2-LINK-FEEDBACK-INFO or L2-LINK-FEEDBACK-INFO-AND-RESIDUAL-DATA-PRIORITY PDU;
- the BS may send the L2-SCHEDULE-SYNC or L2-LINK-FEEDBACK-CONTROL or L2-LINK-FEEDBACK-INFO PDU.

Where a layer 2 signalling PDU relates to a MAC function, the LLC provides the layer 2 signalling service to the MAC through the TLE-SAP. Then:

- in the case of transmission, information to be included in the layer 2 signalling PDU is passed from the MAC to the LLC using the TLE-UNITDATA request primitive; then the LLC shall format and send the layer 2 signalling PDU;
- in the case of reception, the LLC shall pass the information contained in the layer 2 signalling PDU to the MAC using the TLE-UNITDATA indication primitive.

NOTE: The sending LLC entity may issue a report or reports to the MAC on the progress of the sending of the layer 2 signalling information.

When the LLC sends or receives a layer 2 signalling PDU, it uses the data transfer service primitives offered by the MAC at the TMA-SAP.

The data transfer is shown for an L2-DATA-PRIORITY PDU in figures 22.37 and 22.38.

The information transfer service provided by the layer 2 signalling procedures is an unacknowledged service.

The sending LLC entity may repeat a layer 2 signalling PDU to increase the probability of a correct reception. The receiving LLC protocol does not suppress received duplicates. The layer 2 signalling service does not guarantee in-order delivery at the receiving entity.

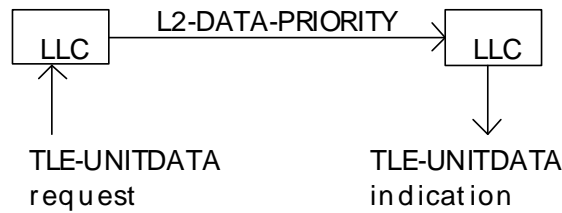

Figure 22.37: L2-DATA-PRIORITY PDU sending



Figure 22.38: L2-DATA-PRIORITY PDU sending

22.3 LLC procedures

22.3.0 General

In this clause the word "shall" is used with service primitives for traceability reasons in the protocol model, but the primitives are not testable and do not imply any implementation.

22.3.1 Common procedures for all services

22.3.1.0 General

This clause describes protocol procedures, which are used in all LLC services or which are common to all services.

22.3.1.1 Link identifiers, endpoint identifiers and handle to the request

Link identifiers between the service user (MLE) and LLC shall serve to distinguish between the multiple concurrent services, e.g. among several advanced links and their associated basic links. These identifiers may be local.

The endpoint identifiers between the MLE and LLC, and between the LLC and MAC, refer to the MAC resource that is currently used for that service. These identifiers may be local. There shall be a unique correspondence between the endpoint identifier and the physical allocation (timeslot or timeslots) used in the MAC. (This correspondence is known only within the MAC.) More than one advanced link may use one MAC resource.

Acknowledgement shall use the same endpoint identifier in the LLC.

When the LLC receives a service request primitive (except TL-RELEASE request) from the MLE, the primitive includes a local identifier for the service request, referred to as the "handle to the request". The handle should be retained locally and used for identifying subsequent related service primitives. It refers to all actions required in the LLC to accomplish the request. LLC shall also pass the handle to the request parameter to the MAC layer. In a similar way the MAC associates a handle to the request to each data request and the LLC shall use that handle to the request when it refers to that transmission.

The LLC shall generate a handle to the request for acknowledged data transfer service indication primitives (TL-DATA indication) and retain it for the corresponding response primitive (TL-DATA response).

The handle to the request shall cease to exist, when the requested or offered service is completed successfully or unsuccessfully.

22.3.1.2 Addressing

At the transmitting LLC entity, the LLC shall get the address in use as a parameter from the service user in the primitive types request and response and shall give it to the MAC as a parameter. At the receiving entity, the LLC shall get the address in use from the MAC and shall give it to the service user in the primitive types indication and confirm as a parameter. The LLC shall copy the same address parameters as in the corresponding TMA-UNITDATA indication primitive to the acknowledging TMA-UNITDATA request primitive.

NOTE: ITSIs and GTSIs in an MS are independent of each other and LLC services recognize addresses to allow concurrent basic or advanced link services. The present document does not describe how addresses affect to the LLC implementation.

If layer 3 response address is different to the address in TMA-UNITDATA indication primitive then the layer 3 response shall not be piggybacked on the layer 2 acknowledgement.

22.3.1.3 User data buffering

The sending LLC entity shall buffer TL-SDUs in order to offer re-transmission until individually marked as correctly received, or the maximum number of retransmissions is exceeded or the TL-SDU is cancelled by the service user or, in addition in the case of an advanced link, the link is either disconnected or re-set. When transmitting segmented TL-SDUs, the segmentation and the segments shall be preserved for further retransmissions until the TL-SDU is completely acknowledged or the maximum number of retransmissions is exceeded.

The LLC sub-entities shall update their part of the DATA_IN_BUFFER signal so often, that the MAC layer can update resource requests in time to prevent unnecessary breaks and random accesses in uplink data transfer, see clause 22.3.1.7.

The amount of data that may be buffered for transmission inside LLC layer is implementation dependent. This model deletes all not yet transmitted data in the advanced link buffers, when the advanced link is reset by a new set-up.

22.3.1.4 Cancelling SDU transmission

This procedure is local to the MS, but affects the data transfer over the air interface.

On the basic link the service user may cancel an ongoing transmission of a TL-SDU. On the reception of a TL-CANCEL request primitive from the service user the LLC shall delete the TL-SDU indicated by the handle to the request parameter in the TL-CANCEL request primitive, if that TL-SDU is still in the transmission buffer and no part of it is transferred to the MAC layer, and shall indicate the cancellation to the service user in a TL-REPORT indication primitive (aborted, TL-SDU not completely sent). Otherwise LLC shall forward cancellation request to the MAC as a TMA-CANCEL request primitive. If the corresponding MAC TMA-REPORT indication primitive (aborted, TM-SDU not completely sent) shows that the MAC has aborted the transmission and the TM-SDU has not been completely sent, then the LLC shall delete the corresponding TL-SDU from the sending buffer and shall indicate the cancellation to the service user in a TL-REPORT indication primitive (aborted, TL-SDU not completely sent). If the MAC has sent the whole SDU containing the TL-SDU for which a cancellation was requested, then the MAC will indicate with a TMA-REPORT indication primitive (aborted, TM-SDU sent at least once) that the whole TL-SDU is sent. The LLC shall then delete the corresponding TL-SDU from the sending buffer and indicate in a TL-REPORT indication primitive (aborted, TL-SDU sent at least once) to the service user that the DLL has aborted sending actions but the TL-SDU has been sent at least once.

NOTE 1: If the LLC has transferred the SDU to the MAC more than once, then it is the LLC's responsibility to issue the correct TL-REPORT indication primitive to the higher layers, taking into account also the results of the previous transmission attempts.

In the advanced link the DLL can cancel the transmission of the TL-SDU only if the first segment has not been sent at all. On the reception of a TL-CANCEL request primitive from the service user the LLC shall delete from the transmission buffer a TL-SDU, if sending has not started, and indicate in a TL-REPORT indication primitive that cancellation is completed and the TL-SDU is not sent. If the LLC has delivered only the first segment of the TL-SDU to the MAC and that segment is not yet acknowledged, then the LLC shall forward cancellation request to the MAC as a TMA-CANCEL request primitive. If the corresponding MAC TMA-REPORT indication primitive shows that the MAC has aborted the transmission and the TM-SDU corresponding to the first segment has not been sent at all, then the LLC shall delete the corresponding TL-SDU from the sending buffer and shall indicate the successful cancellation (the TL-SDU is not completely sent) to the service user in a TL-REPORT indication primitive.

If the TMA-REPORT indication primitive shows that the MAC has sent the TM-SDU corresponding to the first segment at least once, then the LLC shall indicate with a TL-REPORT indication primitive (layer two transmission activities continuing) and continue TL-SDU transmission.

NOTE 2: If the LLC has delivered the first segment of the TL-SDU to the MAC and that segment is not yet acknowledged, and the LLC has also delivered further segments of the TL-SDU to the MAC to be sent in the same MAC block as the first segment, the LLC may attempt cancellation of all those segments. If the corresponding MAC TMA-REPORT indication primitives show that the MAC has aborted the transmission of all the segments, the LLC may regard the cancellation as successful; whereas, if the MAC TMA-REPORT indication primitives show that the MAC has sent the TM-SDU corresponding to any of the segments of the TL-SDU, the LLC indicates to the service user that layer two transmission activities are continuing and continues the TL-SDU transmission.

NOTE 3: The above applies to an MS. A BS LLC sending TL-SDUs on an unacknowledged advanced link may stop transmission of a particular TL-SDU at any time without disconnecting or resetting that unacknowledged advanced link.

The advanced link service user may also stop transmission of a TL-SDU by disconnecting or resetting by a new set-up the corresponding advanced link, refer to clauses 22.3.3.3 and 22.3.3.1.

NOTE 4: The DLL always responds to a TL-CANCEL request primitive with a TL-REPORT indication primitive.

22.3.1.5 Extended error protection

An extended error detection (FCS) shall be offered as a selectable part of the service on the basic link or an extended advanced link and as a mandatory part of the service on the original advanced link. When appropriate the sending LLC shall calculate over the TL-SDU a FCS and shall append it to the TL-SDU.

When a FCS is appended to the TL-SDU, then the receiving LLC entity shall test the received TL-SDU against the FCS to detect whether errors have been introduced into the TL-SDU during transmission. When the receiving LLC detects errors in the received TL-SDU, the LLC shall not pass the erroneous TL-SDU to the service user, but instead the LLC shall discard the erroneous TL-SDU and enforce an SDU re-transmission if appropriate.

The FCS is defined in annex C.

22.3.1.6 Timers and counters

In the protocol description, timers and counters are referred to either by their names or by their value symbols or both e.g. set-up waiting timer T.261. Stopping of timers and counter re-settings are shown only when implicit reasons are not obvious. This protocol does not define or restrict any implementation of timers or counters.

Some of the LLC timers are defined in terms of downlink signalling frames for the channel on which the downlink message is expected (see annex A). If the MS supports the napping procedure (see clause 23.4.8), the LLC shall inform the MAC whether any of those timers are currently running, using the TMC-CONFIGURE request primitive. The LLC timers that are defined in downlink signalling frames are timers T.251, T.252, T.261, T.263 and T.265.

22.3.1.7 Formatter protocol

22.3.1.7.0 General

The sending formatter controls the transmission order of the LLC PDUs. It delivers LLC PDUs to the MAC conceivably according to the optional priority order of the PDUs using TMA-UNITDATA request primitives. The receiving formatter identifies LLC PDU headers in the MAC TMA-UNITDATA indication primitives and delivers the PDUs to the corresponding LLC entities.

NOTE: PDU priority is considered as an optional feature and it applies to all LLC data sending entities.

22.3.1.7.1 MS formatter receiving entity

Upon reception of a TMA-UNITDATA indication primitive the formatter shall decode the PDU type (and supplementary PDU subtype when appropriate). The formatter shall route the corresponding PDU according to the PDU type, endpoint identifier and address (and supplementary PDU subtype and advanced link number when appropriate) to the appropriate LLC protocol sub-entity instance. If the formatter recognizes a PDU which is not valid for the current composition of LLC entities, then the formatter shall discard the PDU without any further actions.

22.3.1.7.2 MS formatter sending entity

The LLC shall indicate to the MAC the availability of data to be transmitted with the DATA_IN_BUFFER signal, which specifies:

- the total amount of all outstanding data of all LLC sub-entities (including pending acknowledgements) that the LLC has ready to send with the specified address on the channel corresponding to the specified endpoint identifier;
- the highest stealing permission for that data;
- the highest PDU priority for outstanding unscheduled data that the LLC has ready to send with the specified address on the channel corresponding to the specified endpoint identifier;
- if the MS is on a D8PSK or QAM channel: the subdivision into data categories of the outstanding data that the LLC has ready to send with the specified address on the channel corresponding to the specified endpoint identifier;
- if the MS supports data priority:
 - the maximum data priority for the outstanding data to be sent with the specified address on the channel corresponding to the specified endpoint identifier;
 - a parameter indicating whether or not the next PDU expected to be sent with the specified address on the channel corresponding to the specified endpoint identifier contains packet data;
 - if the MS is on a $\pi/4$ -DQPSK channel: the subdivision into data priorities of the outstanding data to be sent with the specified address on the channel corresponding to the specified endpoint identifier;
 - if the MS is on a D8PSK or QAM channel: the subdivision into data categories and data priorities of the outstanding data to be sent with the specified address on the channel corresponding to the specified endpoint identifier;
- a parameter indicating whether all, some or none of the outstanding data that the LLC has ready to send with the specified address on the channel corresponding to the specified endpoint identifier is fully scheduled, and the lowest value of the maximum schedule interval for any outstanding fully scheduled data; and
- the highest PDU priority for outstanding fully scheduled data that the LLC has ready to send with the specified address on the channel corresponding to the specified endpoint identifier.

NOTE: When indicating the maximum data priority and the amount of outstanding data for each data priority, the LLC may include all data in its queue for the specified address and endpoint identifier (including data that is not yet ready to be sent).

In the case of an emergency message the formatter should deliver the corresponding DATA_IN_BUFFER signal to the MAC before a possible TMA-CANCEL request primitive so that MAC could make a new reservation request during the cancel process.

Upon reception of MAC-READY from the MAC, the LLC shall decide which of the outstanding PDUs have to be sent, depending on the protocol needs and the size of the next MAC block. Within the same service, acknowledgements shall be sent prior to any data PDUs. Acknowledged basic link PDUs shall be sent before unacknowledged basic link and advanced link PDUs (subject to the window size of 1 for the acknowledged basic link) unless the PDU priority of the unacknowledged basic link or advanced link PDUs is higher than the PDU priority of the acknowledged basic link PDUs. Layer 2 signalling PDUs shall be sent before basic link and advanced link PDUs unless the PDU priority of the basic link or advanced link PDUs is higher than the PDU priority of the layer 2 signalling PDUs. L2-DATA-PRIORITY PDUs shall be sent before other layer 2 signalling PDUs.

The LLC shall deliver the PDU to the MAC using a TMA-UNITDATA request primitive containing the handle to the request parameter from the corresponding TL-service primitive for further referencing; in the case of a layer 2 signalling PDU, the LLC shall include a handle to the request parameter for further referencing.

There may be multiple MAC-READY and TMA-UNITDATA request exchanges, if the MAC is performing an association of LLC PDUs into one MAC block.

If the MS is on a D8PSK channel, the first MAC-READY signal indicates the available size of the MAC block for each data category. (For example, advanced link segments may be of different size, depending on whether the MAC considers that $\pi/4$ -DQPSK or $\pi/8$ -D8PSK modulation would currently be appropriate for first transmissions of segments for this data category.) Any further MAC-READY signals for a MAC block also indicate any restrictions on the data categories for which an LLC PDU may be sent as the second or subsequent PDU in the MAC block; the LLC should use this information as an additional criterion when deciding which of the outstanding PDUs to send.

If the MS is on a QAM channel, the MAC-READY signal indicates the normal advanced link segment size. After the first MAC-READY signal, any further MAC-READY signals for a MAC block also indicate any restrictions on the data categories for which a normal data segment or other LLC PDU may be sent as the second or subsequent PDU in the MAC block. (In the case of a MAC block in a subslot, the first MAC-READY signal also indicates any restrictions on the data categories for which a normal advanced link data segment may be sent as the first PDU in the MAC block.) The LLC should use this information as an additional criterion when deciding which of the outstanding PDUs to send.

The MAC will select the relevant means to transfer the information, i.e. either by random or reserved access or frame stealing, as appropriate based on the selected PDU priority and stealing permission parameter.

If the MS is on a D8PSK or QAM channel, the MAC will also select the appropriate modulation level (and coding rate for QAM) to use for reserved access, based on the data category indicated in the TMA-UNITDATA request primitive(s).

22.3.1.7.3 Combination PDUs on D8PSK or QAM channel

22.3.1.7.3.0 General

Three LLC PDUs are defined with combined functions:

- on a D8PSK or QAM channel, AL-X-ACK and AL-X-RNR PDUs sent by both the MS and BS may optionally include link adaptation feedback information in addition to the usual acknowledgement information;
- on a D8PSK or QAM channel, the L2-LINK-FEEDBACK-INFO-AND-RESIDUAL-DATA-PRIORITY PDU may be used for the MS to send link adaptation feedback information and residual data priority within a single PDU.

According to the protocol model, the combining for sending is performed by the LLC upon reception of the MAC-READY signal from the MAC; the separation on reception is performed by the formatter receiving entity.

NOTE: This does not imply any specific implementation. In an implementation, the combining and/or separation may be performed using other equivalent methods.

22.3.1.7.3.1 MS formatter receiving entity for combination PDUs

Upon reception of a TMA-UNITDATA indication primitive, the formatter shall decode the PDU type (and supplementary PDU subtype when appropriate) - as defined in clause 22.3.1.7.1. If the PDU is an AL-X-ACK or AL-X-RNR PDU and the link feedback information flag is set to 1, the formatter shall construct an L2-LINK-FEEDBACK-INFO PDU from the "link feedback information" information element. It shall then route each PDU (AL-X-ACK or AL-X-RNR and L2-LINK-FEEDBACK-INFO) to the appropriate LLC protocol sub-entity instance for that PDU.

22.3.1.7.3.2 MS formatter sending entity for combination PDUs

Upon reception of MAC-READY from the MAC, the LLC shall decide which of the outstanding PDUs have to be sent, depending on the protocol needs and the size of the next MAC block - as defined in clause 22.3.1.7.2. The LLC may then check whether combining of PDUs is appropriate as follows:

- a) If the PDU to be sent is an L2-LINK-FEEDBACK-INFO PDU, the LLC may look through the outstanding PDUs for that endpoint identifier and address. If the LLC finds an AL-X-ACK or AL-X-RNR PDU, and assesses that a combined PDU could be sent in the MAC block without the combining causing fragmentation, it may construct and send a combined PDU i.e. an AL-X-ACK or AL-X-RNR PDU with the link feedback information flag set to 1 and with the link feedback information from the L2-LINK-FEEDBACK-INFO PDU included in the "link feedback information" information element.
- b) If the PDU to be sent is an AL-X-ACK or AL-X-RNR PDU, the LLC may look through the outstanding PDUs for that endpoint identifier and address. If the LLC finds an L2-LINK-FEEDBACK-INFO PDU, and assesses that a combined PDU could be sent in the MAC block without the combining causing fragmentation, it may construct and send a combined PDU i.e. an AL-X-ACK or AL-X-RNR PDU with the link feedback information flag set to 1 and with the link feedback information from the L2-LINK-FEEDBACK-INFO PDU included in the "link feedback information" information element.
- c) If the PDU to be sent is an L2-DATA-PRIORITY PDU containing no data priority blocks, the LLC may look through the outstanding PDUs for that endpoint identifier and address. If the LLC finds an L2-LINK-FEEDBACK-INFO PDU, and assesses that a combined PDU could be sent in the MAC block without the combining causing fragmentation, it may construct and send a combined PDU i.e. an L2-LINK-FEEDBACK-INFO-AND-RESIDUAL-DATA-PRIORITY PDU.

The LLC shall deliver the combined PDU to the MAC using a TMA-UNITDATA request primitive containing an appropriate handle for further referencing (and using the higher of the two PDU priorities if they are different). On receipt of a TMA-REPORT indication primitive for that handle, the formatter shall generate two TMA-REPORT indication primitives containing the same "Report" parameter - one for each of the original PDUs.

EXAMPLE: For example, in case c), on receipt of a TMA-REPORT indication primitive indicating successful complete transmission by random access, the formatter generates a TMA-REPORT indication primitive indicating successful complete transmission by random access for each of the constituent PDUs. Then, as defined in clause 22.3.7.1, the LLC generates equivalent TLE-REPORT indication primitives to the MAC independently for each of the PDUs.

22.3.1.8 Data priority

22.3.1.8.0 Introduction

Clauses 22.3.1.8.1, 22.3.1.8.2, 22.3.1.8.3 and 22.3.1.8.4 shall be applicable only to MSs which support data priority.

22.3.1.8.1 General

Data priority enables the MS to indicate a priority for obtaining reserved slots when it is sending packet data. For example, this permits the BS to grant slots to an MS with high data-priority PDUs to send ahead of other MSs with lower data-priority PDUs to send on the same channel.

NOTE: Data priority is distinct from PDU priority. PDU priority affects the MS's queue re-ordering in the LLC and the MS's random access procedure. Data priority principally affects the BS's criteria for slot granting on a shared packet data channel, but is also used for queue re-ordering in the LLC.

The SNDCP in an MS that uses data priority either regards the "MS default data priority" as being the "network default data priority" indicated by the SwMI or may negotiate a specific MS default data priority with the SwMI (see clause 28.3.5.5). In either case, the MS default data priority is a data priority which the BS applies by default to all reservation requirements indicated by that MS on a packet data channel.

Also, when the SNDCP sends each packet data PDU, it includes the data priority for that PDU within the primitive issued to the lower layers; the data priority parameter is set to one of the eight defined values of data priority (0 to 7) for data that is not scheduled or contains the value "undefined" in the case of scheduled data. This information enables the DLL in the MS to request short-term variations to the default data priority:

- the LLC collates the information on data priorities for TL-SDUs and LLC PDUs, and issues it to the MAC in the DATA_IN_BUFFER signal;
- when appropriate, the MAC sends an L2-DATA-PRIORITY message if it wishes to indicate a short-term variation to the default data priority - either indicating a single short-term data priority or indicating the current requirements for multiple data priorities (see clause 23.4.7); the L2-DATA-PRIORITY message is a layer 2 signalling message, so the MAC issues it to the LLC in a TLE-UNITDATA request primitive;
- the LLC sends the message using the procedures defined in clause 22.3.7.1.

The LLC also indicates to the MAC whether it currently expects that the next PDU to be sent will contain packet data. (This may affect the MAC criteria for initiating the random access procedure.)

22.3.1.8.2 Sending order of TL-SDUs

Packet data TL-SDUs to be sent on a channel are sent using the unacknowledged basic link for that channel or using an advanced link. The data priority of each packet data TL-SDU is indicated by the service user in the TL-DATA request primitive for an advanced link and in the TL-UNITDATA request primitive for the basic link (except in the case of scheduled data).

If the MS supports data priority, and the MS default data priority last provided by the higher layers in the TL-CONFIGURE request primitive contained one of the eight defined values (i.e. was not set to "not applicable"), then the LLC shall modify the sending order of packet data TL-SDUs to be sent on a channel (using the unacknowledged basic link or any advanced link) as follows:

- the LLC shall order the packet data TL-SDUs according to the PDU priority;
- the LLC shall order the packet data TL-SDUs within one PDU priority according to the data priority.

It is recommended that, within one PDU priority and data priority, the LLC sends unacknowledged basic link packet data TL-SDUs before advanced link packet data TL-SDUs.

When the higher layers issue scheduled data to the LLC (see clause 22.3.1.9), the data priority parameter in the TL-DATA or TL-UNITDATA request primitive is set to "undefined". The data priority parameter may have a defined value for initial scheduled data. For the purposes of the ordering of packet data TL-SDUs, the LLC should:

- regard scheduled data TL-SDUs as having data priority higher than 6 i.e. as having a data priority equivalent to "6,5";
- regard initial scheduled data TL-SDUs with "undefined" data priority as having data priority "6,5";
- regard initial scheduled data TL-SDUs with a defined data priority as having data priority equal to the maximum of "6,5" and the defined data priority.

NOTE 1: The definition of assumed data priority of "6,5" for scheduled data and initial scheduled data in these three points applies only for the purposes of LLC ordering of packet data TL-SDUs. It is not used when collating data priority information to provide to the MAC (see clause 22.3.1.8.3); the value of the data priority parameter in the TL-DATA or TL-UNITDATA request primitive (i.e. value "undefined" for scheduled data) applies in clause 22.3.1.8.3.

If already-started TL-SDUs being sent on an advanced link have lower PDU priority or data priority than an unstarted TL-SDU to be sent on that advanced link then, for the purposes of the ordering of packet data TL-SDUs, the LLC should promote those already-started TL-SDU(s) as follows:

- if already-started TL-SDU(s) being sent on an advanced link have lower PDU priority than an unstarted TL-SDU to be sent on that advanced link then, for the purposes of the ordering of packet data TL-SDUs, the LLC should promote those already-started TL-SDU(s) to the higher PDU priority; and

- if already-started TL-SDU(s) being sent on an advanced link have lower data priority, and have the same or lower PDU priority, than an unstarted TL-SDU to be sent on that advanced link then, for the purposes of the ordering of packet data TL-SDUs, the LLC should promote those already-started TL-SDU(s) to the higher data priority.

NOTE 2: Thus already-started and unstarted TL-SDUs for an advanced link with high maximum priority are sent before already-started (and unstarted) TL-SDUs for other advanced links with lower maximum priority; they are also sent before unacknowledged basic link packet data with lower maximum priority.

NOTE 3: The LLC may vary the sending order of TL-SDUs from the order defined above if there are temporary constraints on which TL-SDUs may be sent, for example, if the window of an advanced link is full or, on a D8PSK or QAM channel, if there are restrictions on the data categories for which an LLC PDU may be sent as the second or subsequent PDU in a MAC block.

NOTE 4: The LLC may choose not to fill up the advanced link sending window or may restrict the amount of data in the sending window if it expects that the higher layers may wish to send higher priority PDUs than those currently in the window. The criteria that the LLC uses to decide whether to restrict the number of TL-SDUs in the advanced link sending window are outside the scope of the present document.

There are other types of TL-SDUs and LLC PDUs that may need to be sent on the channel:

- TL-SDUs to be sent using the acknowledged basic link;
- TL-SDUs that do not contain packet data, and are to be sent using the unacknowledged basic link or an advanced link;
- AL-SETUP, AL-RECONNECT and AL-DISC PDUs;
- layer 2 signalling PDUs; and
- basic link and advanced link acknowledgements.

These TL-SDUs and LLC PDUs have a PDU priority but do not have a data priority. The LLC should choose an appropriate ordering, subject to the constraints given in clause 22.3.1.7.2.

EXAMPLE: In cases a), b), c) and d), the TL-SDU or LLC PDU may be sent ahead of packet data irrespective of the PDU priority, or may be included in the packet data ordering per PDU priority (ahead of the packet data with that PDU priority).
In case e), clause 22.3.1.7.2 requires that, within the same service, acknowledgements are sent prior to any data PDUs.

NOTE 5: In cases a), b), c) and d), it is recommended that TL-SDUs and LLC PDUs with PDU priority 2 or more are at least sent ahead of packet data with PDU priority 6; they may be sent ahead of packet data with PDU priority 7. Also TL-SDUs and LLC PDUs with PDU priority 0 or 1 may be sent ahead of packet data irrespective of PDU priority.

22.3.1.8.3 Providing data priority information to the MAC

If the MS supports data priority then, as described in clause 22.3.1.7.2, the DATA_IN_BUFFER signal shall indicate the maximum data priority for the outstanding data to be sent with the specified address on the channel corresponding to the specified endpoint identifier, and the subdivision of that outstanding data into data priorities (and data categories if the MS is on a D8PSK or QAM channel).

NOTE 1: When indicating the maximum data priority and the amount of outstanding data for each data priority, the LLC may include all data in its queue for the specified address and channel (including data that is not yet ready to be sent).

The LLC shall generate the information as follows.

The data priority of each TL-SDU is generally indicated by the service user in the TL-DATA request primitive for the advanced link and in the TL-UNITDATA request primitive for the basic link; in some cases the data priority parameter may contain the value "undefined" (for example, for scheduled data). In the case of a TL-DATA request primitive for the advanced link, the LLC shall regard the specified data priority as applying to the first transmission of segments of the TL-SDU and to any segment re-transmissions. In the case of a TL-UNITDATA request primitive for the basic link, the LLC shall regard the specified data priority as applying to all N.253 + 1 transmissions of the TL-SDU.

The LLC shall regard TL-SDUs to be sent on the acknowledged basic link as having "undefined" data priority. It shall also regard PDUs not containing a TL-SDU or TL-SDU segment as having "undefined" data priority (e.g. LLC acknowledgements, AL-SETUP, AL-RECONNECT, AL-DISC and layer 2 signalling PDUs).

If the LLC queue for an address and channel contains TL-SDUs with different defined data priorities or a mixture of defined data priorities and "undefined" data priority, the LLC should modify the data priorities as follows - after any re-ordering of the sending order of TL-SDUs and LLC PDUs. When a TL-SDU with defined data priority DPRI (denoted TL-SDU_N) is in the LLC queue (either already started or waiting to be sent):

- any data with lower data priority and preceding TL-SDU_N in the LLC queue for that address and channel (either already started or waiting to be sent) should be promoted to data priority DPRI;
- any data with undefined data priority and preceding TL-SDU_N in the LLC queue for that address and channel (either already started or waiting to be sent) should be promoted to data priority DPRI, except that any L2-DATA-PRIORITY PDU should retain data priority value "undefined".

Any data with undefined data priority, not preceding data with defined data priority, should retain data priority value "undefined". In particular, if there is no data with defined data priority in the LLC queue, then all data in the LLC queue retains data priority value "undefined" and the LLC shall set the maximum data priority parameter in the DATA_IN_BUFFER signal to "undefined".

NOTE 2: In an implementation, this process may be performed by initializing a "maximum data priority encountered so far" parameter to a null value of "undefined" and working forwards, keeping a record of the maximum data priority encountered so far (where any defined data priority is regarded as higher than the undefined data priority for the purposes of this process). Any data with undefined data priority (except the L2-DATA-PRIORITY PDU), or with lower data priority than the maximum data priority encountered so far, is promoted to the maximum data priority encountered so far.

After performing this process, if a TL-SDU that does not contain packet data has PDU priority 7 and has data priority less than 7, the LLC may promote that TL-SDU to data priority 7.

The LLC shall then collate the resulting modified data priority information and pass it to the MAC in the DATA_IN_BUFFER signal.

The LLC shall also indicate to the MAC (using the DATA_IN_BUFFER signal) whether or not it currently expects that the next PDU to be sent with the specified address on the channel corresponding to the specified endpoint identifier will contain packet data.

22.3.1.8.4 Sending of L2-DATA-PRIORITY PDU

When the LLC receives a TLE-UNITDATA request primitive from the MAC requesting sending of an L2-DATA-PRIORITY PDU, the LLC shall send the PDU using the procedures defined in clause 22.3.7.1.

When the MAC issues the TLE-UNITDATA request primitive, it sets the PDU priority to the highest PDU priority indicated in the DATA_IN_BUFFER signal (see clause 23.4.7) so that, on reception of the next MAC-READY signal, the LLC will normally send the L2-DATA-PRIORITY PDU (issuing the PDU to the MAC using a TMA-UNITDATA request primitive).

22.3.1.9 Scheduled data

When the LLC in an MS receives a TL-DATA request primitive for the advanced link, or a TL-UNITDATA request primitive for the basic link, the "scheduled data status" parameter in the primitive indicates whether the TL-SDU should be treated as:

- not scheduled data (i.e. if the data is not for a schedule); or
- initial scheduled data (i.e. for the first TL-SDU of a schedule or after a substantial gap in use of the schedule);
or
- scheduled data (i.e. for subsequent TL-SDUs of a schedule).

See also clause 28. For scheduled data, the primitive also indicates the maximum schedule interval for this schedule.

As described in clause 22.3.1.7.2, the DATA_IN_BUFFER signal from the LLC to the MAC indicates whether all, some or none of the outstanding data for the specified address and channel is "fully scheduled", and the lowest value of the maximum schedule interval for any outstanding "fully scheduled" data; it also indicates the maximum PDU priority for outstanding "unscheduled" and "fully scheduled" data. When generating this information, the LLC shall convert from the information in the "scheduled data status" parameter to the information about "fully scheduled" and "unscheduled" data in the buffer as follows:

- in the case of initial scheduled data sent by acknowledged transfer on an advanced link, the LLC shall regard the first transmission of the TL-SDU and any segment re-transmissions as unscheduled;
- in the case of initial scheduled data sent by unacknowledged data transfer on the basic link, the LLC shall regard all $N.253 + 1$ transmissions of the TL-SDU as unscheduled;
- in the case of scheduled data sent by acknowledged transfer on an advanced link, the LLC shall regard the first transmission of the TL-SDU as fully scheduled and should regard any segment re-transmissions as unscheduled;
- in the case of scheduled data sent by unacknowledged data transfer on the basic link, the LLC shall regard all $N.253 + 1$ transmissions of the TL-SDU as fully scheduled;
- the LLC shall regard all other types of data and signalling as unscheduled.

NOTE: The MAC uses the information about "fully scheduled" and "unscheduled" data in the buffer to decide when to initiate the random access procedure.

22.3.1.10 Data category

When on a D8PSK or QAM channel, the MAC selects the appropriate modulation level (and coding rate for QAM) to use when sending TM-SDUs by reserved access, based on the link conditions and the data category parameter in the TMA-UNITDATA request primitive(s); see clause 23.4.9.

The data category parameter is provided by the LLC in the TMA-UNITDATA request primitive (partly derived from the data class information parameter from the higher layers). It may be used to indicate information about the type of data in the TM-SDU and the required reliability level for the transmission - enabling the MAC to make decisions about the modulation level (and coding rate for QAM) to use when sending the TM-SDU. The implementer should choose an appropriate definition of the data category parameter for the chosen link adaptation algorithm.

For example, the data category parameter may indicate whether the data in the TM-SDU is:

- background class data - reliability level 1; or
- background class data - reliability level 2; or
- background class data - reliability level 3; or
- telemetry class data - reliability level 1; or
- telemetry class data - reliability level 2; or
- telemetry class data - reliability level 3; or
- real-time class data; or
- non-classified data (i.e. TM-SDU does not contain packet data) - reliability level 1; or
- non-classified data (i.e. TM-SDU does not contain packet data) - reliability level 2; or
- non-classified data (i.e. TM-SDU does not contain packet data) - reliability level 3.

NOTE 1: In this example of possible data categories, it is intended that reliability level 3 refers to better (i.e. higher) reliability than reliability level 2, and reliability level 2 refers to better (i.e. higher) reliability than reliability level 1.

NOTE 2: In this example of possible data categories, three reliability levels are used for background class data, telemetry class data and non-classified data. In an implementation, fewer than three reliability levels could be used if preferred. For instance, if preferred, two reliability levels could be used for background class data and/or telemetry class data and/or non-classified data.

NOTE 3: The MAC uses both the data class and the reliability level when it selects the appropriate modulation level (and coding rate for QAM). For example, the appropriate modulation level (and/or coding rate for QAM) for "telemetry class data - reliability level 1" may be different from that for "background class data - reliability level 1".

When indicating the required reliability level for the transmission, it is recommended that:

- a) TL-SDUs sent by acknowledged data transfer on the basic link should be sent using a high reliability for all transmissions (except possibly the first transmission(s) of short data messages).
- b) Basic link acknowledgements should be sent using a high reliability for all transmissions.
- c) AL-SETUP, AL-RECONNECT and AL-DISC PDUs should be sent using a high reliability for all transmissions.
- d) Advanced link acknowledgements (AL-ACK, AL-RNR, AL-X-ACK and AL-X-RNR) should be sent using a high reliability for all transmissions.

NOTE 4: Thus, in the example of possible data categories, items a), b), c) and d) could be sent using "non-classified data - reliability level 3" for all transmissions (except possibly the first transmission(s) of short data messages).

NOTE 5: The recommendation to use a high reliability for all transmissions for items a), b), c) and d) does not necessarily mean use of 4-QAM coding rate = 1/2 for all transmissions on a QAM channel when the current channel conditions are perceived as very good, for example, if low slot error rates are currently expected for 16-QAM coding rate = 1/2 (see also clause 23.4.9.2.1).

- e) Layer 2 signalling PDUs sent on request of the MAC should be sent using the data category indicated by the MAC in the TLE-UNITDATA request primitive.

NOTE 6: In the example of possible data categories, when the MAC issues the TLE-UNITDATA request primitive, it could indicate non-classified data with either reliability level 1, 2 or 3 depending on the required reliability of the information in the layer 2 signalling message. For example, reliability level 1 could be used when the layer 2 signalling message may be sent using the same modulation level and coding rate as any ongoing packet data, whereas reliability levels 2 and 3 could indicate a requirement for higher reliability.

- f) When a segment has been sent a number of times on an acknowledged advanced link, further retransmissions of that segment should be sent using a higher reliability. So, for example, for background class data or telemetry class data, if using three reliability levels, the MS (or BS) could use reliability level 1 for the first one or more transmissions of advanced link segments (enabling higher throughput when successful), then use reliability level 2 for the next one or more retransmissions of segments (if retransmissions are needed) and then revert to reliability level 3 for a segment either:
 - when the segment has been sent a specific number of times without success; and/or
 - when only a specific number of retransmissions remain before the maximum number of segment retransmissions N.274 of that segment is exceeded.

At least the last two possible retransmissions of a segment before the maximum number of segment retransmissions N.274 of that segment is exceeded should be sent using a high reliability.

NOTE 7: In the example of possible data categories, the maximum number of segment transmissions using reliability level 1 (and/or reliability level 2) may depend on the maximum number of segment retransmissions N.274 for that advanced link.

In an implementation, the maximum number of segment transmissions using reliability level 1 (and/or reliability level 2) may also vary according to the current channel conditions, based on information provided to the LLC by the MAC.

When appropriate, the MS (or BS) may revert to using fewer than three reliability levels.

NOTE 8: As indicated in point f), it is expected that, for acknowledged packet data, the reliability level may vary for transmissions of one segment according to the number of times that segment has been transmitted, starting with low reliability and increasing to higher reliability if the first transmission(s) of that segment are not successful. This contrasts with non-classified data (items a) to e)) for which the type of information may determine the reliability level for all transmissions of that PDU (except possibly for short data messages).

22.3.2 Basic link procedures

22.3.2.0 General

The basic link shall offer two services, acknowledged and unacknowledged data transfer. The acknowledged service supports also a data response service primitive for call set-up optimization. The data with the response primitive is transmitted using an acknowledge message without an explicit acknowledgement, see clause 22.2.1.1.

The basic link LLC protocol of the MS is modelled by two processes, BL_LLC_MS and Formatter, the latter being common with the advanced links and layer 2 signalling, refer to figure 22.2.

The present document models the numbering of TL-SDUs and acknowledgements and local function indicators by local variables. Each basic link shall employ separate sets of variables, parameters and timers. At the sending side variables and main parameters are:

- N(S) TL-SDU number in the sent data PDUs;
- N(R) TL-SDU number in the received acknowledgement PDUs;
- V(S) the next TL-SDU number to be sent or to be re-sent;

and at the receiving side:

- N(S) TL-SDU number in the received data PDUs;
- N(R) TL-SDU number in the sent acknowledgement PDUs;
- V(R) the last received TL-SDU number.

Timers and constants are defined in annex A.

NOTE: This protocol description is valid for one basic link, which uses one address.

22.3.2.1 Establishment of information transfer in basic link

No explicit establishment is required for the basic link. At least one basic link shall be available when the MS is synchronized to a BS. When there is no advanced link nor circuit mode connection, then there is a single basic link on the corresponding control channel. When there are any defined advanced links or circuit mode connections, then there is one basic link per each advanced link and circuit mode connection. If an advanced link uses the same physical resource allocations as a circuit mode connection, then there is only one basic link associated with the pair. If multiple advanced links use the same physical resource, then there is only one basic link associated with those multiple advanced links.

The MS shall keep all basic links that are not removed in the physical resource allocation, if the MS is capable of operation on concurrent channels, see clause 23. The BS may allocate e.g. the first advanced link and the basic link associated to a circuit mode call so that the previous basic link on the initiating control channel is released.

After power-on or in the first transmission, when roaming or migrating to a new BS, the MS LLC shall start TL-SDU numbering from "0" by setting local variable $V(S) = 0$.

22.3.2.2 Quality of service selection

The service user shall define the quality of service for each message by selecting a basic link and the primitive type either TL-DATA request or TL-UNITDATA request and by selecting the parameters in that primitive, see definition of parameters in clause 20. The undetected message error rate shall be defined by selecting the use of the FCS. The TL-SDU sending order in the selected basic link and in relation to any concurrent advanced link(s) and layer 2 signalling shall be defined by the conceivably requested PDU priority, which may change the transmission order of TL-SDUs. The PDU priority shall affect the transmission of a already started TL-SDU sending only if the highest priority (emergency) is used and the sending of the current TL-SDU is destroyed by cancellation.

NOTE: The maximum data transfer throughput of an associated basic link is defined by the associated advanced link(s) or circuit mode call.

22.3.2.3 Acknowledged data transmission in basic link

The acknowledged data transmission is modelled by the states in the sending process:

- TX_READY transmitter is ready to send next TL-SDU;

and in the receiving process:

- RX_READY receiver is ready to receive data from the MAC.

Each acknowledged information transfer is identified by a TL-SDU number $N(S)$ both in BL-DATA and BL-ADATA PDUs. The acknowledgement contains the number $N(R)$ of the correctly received TL-SDU both in BL-ACK and BL-ADATA PDUs. In addition, the receiver has the possibility to send data in a TL-DATA response primitive together with the acknowledgement without a sequence number. The $N(R)$ in that acknowledgement marks the TL-SDU sent using an acknowledgement BL-ACK PDU.

The LLC process may receive:

- service user service primitive:
 - a) a TL-DATA request primitive (handle to the request) and then the LLC shall:
 - i) issue an immediate TL-REPORT indication primitive confirming the handle to the request parameter;
 - ii) calculate FCS, when requested, and append it to TL-SDU;
 - iii) place the TL-SDU into transmission buffer according to the indicated PDU priority;
 - iv) indicate new data in the transmitting buffer to the formatter using DATA_IN_BUFFER signal;
 - v) in the case of a TL-DATA request primitive with the emergency priority and if there is an ongoing lower priority TL-DATA (or TL-UNITDATA) PDU in transmission on that basic link at the MAC layer, then the LLC may deliver a TMA-CANCEL request primitive via formatter to the MAC, see clause 22.3.1.4. The LLC shall not cancel a BL-ACK PDU with or without service user data. The LLC may cancel a BL-ADATA PDU and memorize the $N(R)$ in it.
 - b) a TL-DATA response primitive to the TL-DATA indication primitive (handle to the request) before the corresponding acknowledgement is sent and then the LLC shall:
 - i) calculate FCS, when requested, and append it to TL-SDU;
 - ii) format a BL-ACK PDU ($N(R) = V(R)$) with the (optional) TL-SDU from the TL-DATA response primitive;
 - iii) inform the formatter using DATA_IN_BUFFER signal.

- c) a TL-DATA response primitive (handle to the request) after sending the corresponding BL-ACK or BL-ADATA PDU, then the LLC shall:
 - i) issue an immediate TL-REPORT indication primitive confirming the handle to the request parameter (from the TL-DATA response primitive) as if it has received a TL-DATA request primitive;
 - ii) calculate FCS, when requested, and append it to TL-SDU;
 - iii) place the TL-SDU into transmission buffer according to the indicated PDU priority;
 - iv) indicate new data in the transmitting buffer to the formatter using DATA_IN_BUFFER signal;
 - v) in the case of a TL-DATA response primitive with emergency priority and if there is an ongoing lower priority TL-DATA (or TL-UNITDATA) PDU in transmission on that basic link at the MAC layer, then the LLC may deliver a TMA-CANCEL primitive via formatter to the MAC, see clause 22.3.1.4. The LLC shall not cancel a BL-ACK PDU (which in this situation should be without user data).
- local indications:
 - d) a MAC-READY indication from the formatter and then:
 - if a BL-ACK PDU is ready due to a TL-DATA response primitive, then the LLC shall issue it to the formatter with an acknowledgement number $N(R) = V(R)$;
 - if there is a waiting acknowledgement and a TL-DATA request primitive available, then the LLC shall:
 - i) set $N(S) = V(S)$ for the TL-SDU to be sent;
 - ii) set $N(R) = V(R)$ for the waiting acknowledgement;
 - iii) form the corresponding BL-ADATA PDU and issue it to the formatter;
 - if the size of the TL-DATA plus the size of the BL-ADATA LLC header exceeds the size of the TM-SDU in this MAC block, then the LLC shall issue a BL-ACK PDU with an acknowledgement number $N(R) = V(R)$ to the formatter without any service user data and send the TL-SDU using BL-DATA PDU;
 - if there is a waiting acknowledgement and neither a TL-DATA response nor a TL-DATA request primitive available, then the LLC shall issue a BL-ACK PDU with an acknowledgement number $N(R) = V(R)$ to the formatter without any service user data;
 - if there is no waiting acknowledgement but a TL-SDU is available, then the LLC shall set $N(S) = V(S)$ for the TL-SDU to be sent, form the corresponding BL-DATA PDU and issue it to the formatter.
 - e) a TMA-REPORT indication primitive confirming the handle to the request parameter;
 - f) a TMA-REPORT indication primitive (one of the complete TM-SDU transmission indications) and if it is due to a PDU which contained service user data in either a BL-DATA or BL-ADATA PDU and the PDU transmission was successful and complete transmission by random access or complete transmission by reserved access or stealing, then the LLC shall start the re-try timer T.251; and in any case, if this is the first transmission of the TL-SDU, then the LLC shall issue a TL-REPORT indication primitive (first complete transmission) to the service user;
 - g) a TMA-REPORT indication primitive (random access failure) and if it is due to a PDU which contained service user data, then the LLC shall inform the service user of unsuccessful transmission by TL-REPORT primitive (failed transfer), and delete the corresponding TL-SDU from the sending buffer. If the report was due to a BL-DATA or BL-ADATA PDU, the LLC shall increment $V(S)$;

- h) a TMA-REPORT indication primitive (fragmentation failure) and:
 - if it is due to a BL-ACK PDU, then the LLC shall discard the optional TL-SDU;
 - if the report is due to a BL-DATA or BL-ADATA PDU and the number of allowed retransmissions N.252 of the corresponding TL-SDU is not exceeded, then the LLC shall keep the TL-SDU for re-transmission and inform the formatter by a DATA_IN_BUFFER signal; or
 - otherwise the LLC shall inform the service user of unsuccessful transmission by TL-REPORT primitive (failed transfer), increment V(S) and delete TL-SDU from the sending buffer.
- i) re-try timer T.251 expires and
 - if the number of allowed retransmissions N.252 is not exceeded, then the LLC shall keep the TL-SDU in the sending buffer for re-transmission and inform the formatter by a DATA_IN_BUFFER signal; or
 - otherwise the LLC shall inform the service user of unsuccessful transmission by TL-REPORT primitive (failed transfer), increment V(S) and delete TL-SDU from the sending buffer;
- PDU from the peer entity:
 - j) a BL-ACK and then:
 - if there is a TL-SDU waiting for a re-transmission in the sending buffer, then:
 - if the TL-SDU number (in the BL-ACK PDU) $N(R) = V(S)$, then the LLC shall confirm the success of the transmission to the service user by a TL-DATA confirm (successful transfer) primitive and deliver the contained TL-SDU, if any upon condition that the FCS calculation is successful in case the optional FCS is used, increment V(S), delete the TL-SDU waiting for a re-sending from the sending buffer and stop the re-try timer T.251; or
 - if the TL-SDU number (in the BL-ACK PDU) $N(R)$ is not equal to V(S), then the LLC shall deliver contained TL-SDU, if any upon condition that the FCS calculation is successful in case the optional FCS is used, using TL-DATA indication primitive; and
 - if the number of allowed retransmissions N.252 of the TL-SDU is not exceeded, then the LLC shall keep the corresponding TL-SDU in the sending buffer for re-transmission and inform the formatter by the DATA_IN_BUFFER signal; or
 - if the number of allowed retransmissions N.252 of the TL-SDU is exceeded, then the LLC shall inform the service user of unsuccessful transmission by a TL-REPORT indication primitive (failed transfer), increment V(S), stop re-try timer T.251 and discard the corresponding TL-SDU from the sending buffer;
 - if there is no TL-SDU waiting for a re-transmission in the sending buffer, then the LLC shall deliver contained TL-SDU, if any upon condition that the FCS calculation is successful in case the optional FCS is used, using TL-DATA indication primitive;
 - k) a BL-DATA PDU and then:
 - i) the LLC shall delete the possible BL-ACK PDU from the sending buffer;
 - ii) the LLC shall:
 - if the FCS is used and it is correct or FCS is not used, then the LLC shall select a new handle to the request parameter value and deliver TL-SDU to the service user in a TL-DATA indication service primitive (handle to the request), memorize a waiting acknowledgement with number $V(R) = N(S)$, start to wait for TL-DATA response primitive and inform the formatter by the DATA_IN_BUFFER signal;

NOTE 1: As both MLE and LLC select handle to the request parameter values and both could select the same value a mechanism should be implemented to prevent it such as a sub-division of the value space.

- if the FCS is used and it is not correct and no other not yet acknowledged data received before the PDU with incorrect FCS was received, then no acknowledgement is sent, i.e. LLC action against the received BL-DATA with incorrect FCS is as that PDU was not received.
- l) a BL-ADATA PDU and then the LLC shall separate the acknowledgement N(R) and incoming TL-SDU including N(S) and shall continue as if LLC had received a BL-ACK PDU (without service user data) first (case j) and then a BL-DATA PDU (case k).

The LLC shall set the stealing permission parameter to "steal within time T.214" for the BL-ACK PDU in the basic link protocol in case the MAC currently has traffic transmit permission. The LLC should also set PDU priority level = 5 (though this parameter will not normally be used by the MAC).

NOTE 2: At the reception of a new BL-DATA PDU before acknowledging the previous received BL-DATA PDU the LLC stops all acknowledgement actions of the previous TL-SDU independently of the TL-SDU number N(S).

NOTE 3: The defined protocol and PDU numbering supports the receiving peer entity to request a TL-SDU re-sending, but it does not guarantee alone a safe mechanism for suppression of duplicate TL-SDUs.

NOTE 4: The transmission of a TL-SDU from a TL-DATA request primitive is totally independent of any data transmission in the other direction. On the other hand a TL-SDU from a TL-DATA response primitive is normally transferred in the corresponding acknowledgement of the TL-DATA indication primitive. If the TL-DATA response primitive is delayed too much, then the TL-SDU will be sent in a BL-DATA PDU and it will be acknowledged by a TL-DATA confirm primitive.

NOTE 5: The random access failure prevents further TL-SDU sending re-tries and, to increase the probability to get an emergency message through, the MAC will use more random access re-tries for higher priority TL-SDUs.

NOTE 6: The information "First complete transmission" by random access may be used in cancellation process in addition or in place of a request to the MAC.

22.3.2.4 Unacknowledged data transfer in the basic link

22.3.2.4.0 General

The procedures in an MS for unacknowledged data transfer in the basic link are described in the following clauses.

22.3.2.4.1 Actions on TL-UNITDATA request primitive (sending entity)

During sending of unacknowledged service user data the LLC may receive:

- a) a TL-UNITDATA request primitive (handle to the request) from the service user and then:
 - the LLC may issue an immediate TL-REPORT indication primitive containing the handle to the request parameter to the TL-UNITDATA request primitive;
 - if requested by the service user, then the LLC shall calculate and append a FCS to the SDU;
 - the LLC shall store TL-SDU in priority order into the sending buffer for sending N.253 + 1 times, and inform formatter with the DATA_IN_BUFFER signal;
- b) a MAC-READY from the formatter and then the LLC shall deliver the highest priority (unacknowledged service) TL-SDU as a BL-UDATA PDU to the formatter;
- c) a TMA-REPORT indication primitive confirming the handle to the request parameter;
- d) a TMA-REPORT indication primitive (successful complete transmission by random access), and then the LLC shall remove the TL-SDU from the transmitting buffer and deliver a TL-REPORT indication primitive (transfer completed) to the service user;

- e) a TMA-REPORT indication primitive (complete transmission by stealing or by reserved access), and if that TL-SDU has now been completely transmitted $N.253 + 1$ times, then the LLC shall remove the TL-SDU from the transmitting buffer and deliver a TL-REPORT indication primitive (transfer completed) to the service user;
- f) a TMA-REPORT indication primitive (failure of fragmentation process) and then:
 - if $N.253 > 0$, the LLC shall try to re-send the TL-SDU so that there shall be at maximum $N.253 + 1$ failed transmissions (in addition to the $N.253 + 1$ complete transmissions); if there have not been $N.253 + 1$ complete transmissions when the maximum number of failed transmissions $N.253 + 1$ has been reached, then the LLC shall remove the TL-SDU from the sending buffer and issue a TL-REPORT indication primitive (failed transfer) to the service user;
 - if $N.253 = 0$, the LLC shall try to re-send the TL-SDU so that there shall be at maximum two failed transmissions (or the TL-SDU has been completely transmitted); if there has not been one complete transmission when the maximum of two failed transmissions has been reached, then the LLC shall remove the TL-SDU from the sending buffer and issue a TL-REPORT indication primitive (failed transfer) to the service user;
- g) a TMA-REPORT indication primitive (random access failure) and then the LLC shall remove TL-SDU from the sending buffer and issue a TL-REPORT indication primitive (failed transfer) to the service user.

NOTE 1: The service user may indicate the required number of repetitions (i.e. $N.253$) in the TL-UNITDATA request primitive, in which case that value is applied for transmission of the TL-SDU. If the service user does not indicate the required number of repetitions, the value of $N.253$ chosen by the MS designer is used (see annex A).

NOTE 2: The MS may send more than one BL-UDATA PDU in one MAC block (using MAC PDU association).

NOTE 3: For $N.253 > 0$, the MS should not send the same BL-UDATA PDU more than once in one MAC block. The unacknowledged basic link service does not guarantee in-order delivery at the receiving entity. Therefore, in order to use the capacity of MAC blocks by PDU association, the MS may interleave retransmissions of multiple BL-UDATA PDUs.

NOTE 4: In the DATA_IN_BUFFER signal, the LLC may include all outstanding unacknowledged basic link data as outstanding data ready to be sent, so that the MAC can indicate a reservation requirement for that data.

22.3.2.4.2 Actions on BL-UDATA PDU (receiving entity)

Upon reception of a BL-UDATA PDU from the formatter:

- i) if indicated by the received PDU, LLC shall calculate FCS and:
 - if the FCS is correct, the LLC shall inform the service user of a reception of a TL-SDU using a TL-UNITDATA indication primitive;
 - if the FCS is not correct, the LLC shall discard the SDU.
- ii) if the received PDU does not contain FCS, then the LLC shall issue the TL-SDU to the service user using a TL-UNITDATA indication primitive.

NOTE: The basic link protocol does not suppress received duplicates.

22.3.3 Advanced link procedures for the acknowledged service

22.3.3.0 General

The LLC advanced link protocol of the MS is modelled by processes: AL_MAIN, AL_TX, AL_RX and Formatter, the latter being common also with the basic link and unacknowledged advanced link services and layer 2 signalling, refer to figure 22.2. Refer to clause 22.3.1.7 for formatter processes.

The present document models the numbering of TL-SDUs and acknowledgements and local function indicators by local variables. Each advanced link shall employ separate sets of variables, parameters and timers.

At the data sending entity:

- N(S) TL-SDU number in the sent data PDUs;
- N(R) TL-SDU number in the received acknowledgement PDUs;
- S(S) Segment number in the sent data PDU;
- S(R) Segment number in the received acknowledgement PDU.

At the data receiving entity:

- N(S) TL-SDU number in the received data messages;
- N(R) TL-SDU number in the sent acknowledgement messages;
- S(S) Segment number in the received data PDU;
- S(R) Segment number in the sent acknowledgement PDU.

Timers and constants are defined in annex A.

In figure 22.2 the AL-MAIN controls independently the state of each advanced link.

Each advanced link set-up, data transfer, LLC reconnection and disconnection phase is modelled by states:

- IDLE link is not ready for data transfer;
- WAIT_IN_CONNECT link is in the incoming set-up phase;
- WAIT_OUT_CONNECT link is in the outgoing set-up phase;
- WAIT_DISCONNECT link is waiting for outgoing disconnection;
- WAIT_RECONNECT link is waiting for LLC reconnection;
- CONNECTED link is ready for data transfer.

The acknowledged information transfer in the CONNECTED state of each advanced link (N.261) is modelled by a single state in the data sending process:

- AL_TX_READY transmitter is ready to send the next TL-SDU;

and respectively by a single state in the data receiving process:

- AL_RX_READY receiver is ready to receive data from the MAC.

NOTE 1: It is recommended that an MS which only supports $\pi/4$ -DQPSK operation does not use fragmentation for sending advanced link PDUs.

NOTE 2: If the MS supports D8PSK operation, fragmentation is needed when a segment cut for transmission using $\pi/8$ -D8PSK modulation is re-transmitted using $\pi/4$ -DQPSK modulation.

NOTE 3: It is recommended that an MS does not normally use fragmentation for sending advanced link data PDUs on a QAM channel. However, fragmentation may be needed in some cases. For example, after a reduction of bandwidth (for example, if the bandwidth changes from 50 kHz to 25 kHz), fragmentation may be needed for re-transmissions of segments cut for transmission on the old channel. Alternatively, the advanced link may be reset after a reduction of bandwidth.

22.3.3.1 Advanced link establishment for the acknowledged service

22.3.3.1.0 General

The service user shall set up the advanced link before any data transmission may occur. The advanced link is available for data transfer until the service user or the LLC entity disconnects it. The advanced link number may be used locally as a part of the link identifier related to an advanced link. The established advanced link can be used for two-way information transfer.

There can be only one connection set-up in progress at the same time. If there are colliding set-ups from both peer entities, then those will be merged into a single set-up process.

The service user shall define the quality of service by setting up an advanced link and later by selecting that advanced link for the data transmission. The quality of service parameters applicable to the LLC layer are defined in clause 20. The set-up report parameter shall be used to indicate the progress of the connection establishment.

The procedures for sending and reception of the AL-SETUP PDU are defined in clauses 22.3.3.1.1, 22.3.3.1.2, 22.3.3.1.3 and 22.3.3.1.4. The following rules also apply:

- a) The LLC should not send an AL-SETUP PDU for an extended acknowledged advanced link to an LLC that does not support extended advanced link(s).

NOTE 1: MS support of extended advanced link(s) is indicated in the "class of MS" element in the U-LOCATION UPDATE DEMAND PDU; see clause 16.

For CA, BS support of extended advanced links is indicated in the "extended services broadcast" element in the SYSINFO and SYSINFO-Q PDUs; see clause 21.

For DA, the BS always supports advanced links (both extended and original) when the "system wide services" element in the D-MLE-SYSINFO-DA (and D-MLE-SYNC-DA) PDU indicates "normal mode"; see clause 18. When the "system wide services" element in the D-MLE-SYSINFO-DA (or D-MLE-SYNC-DA) PDU indicates "system wide services temporarily not supported", the MS LLC may send an AL-SETUP PDU to the BS for an extended (or original) acknowledged advanced link; however the BS in this mode may temporarily not support advanced links, in which case the BS may send the AL-DISC PDU with a report "service temporarily unavailable"; if the MS receives an AL-DISC PDU with report "service temporarily unavailable", the MS should not continue to attempt to establish advanced links while the "system wide services" element indicates "system wide services temporarily not supported" (though the MS is not precluded from occasionally attempting to establish advanced links).

NOTE 2: The BS may send the AL-DISC PDU with a report "close" if it receives AL-DATA(-AR), AL-FINAL(-AR), AL-X-DATA(-AR) or AL-X-FINAL(-AR) PDUs when it temporarily does not support advanced links; see clause 22.3.3.3.2.

- b) When the LLC sends an AL-SETUP PDU for the original acknowledged advanced link, it shall use the lowest free (i.e. unused) advanced link number for that address.

NOTE 3: Therefore, if no extended acknowledged advanced links exist for that address, advanced link number 1 is used for the original acknowledged advanced link; in particular, if either LLC does not support extended advanced link(s) then advanced link number 1 is always used for the original acknowledged advanced link. If both LLCs support extended advanced link(s) and advanced link number 1 is in use for an extended acknowledged advanced link then the next free advanced link number is used.

If an extended acknowledged advanced link is proposed and the peer entity offers an original acknowledged advanced link, the advanced link number is unchanged in the response AL-SETUP PDU. Therefore, in this case, the advanced link number in the AL-SETUP PDU for the original acknowledged advanced link is not necessarily the lowest free advanced link number for that address.

22.3.3.1.1 Actions on TL-CONNECT request primitive (set-up phase sending entity)

Upon reception of a TL-CONNECT request primitive (handle to the request) in any state, the LLC shall:

- i) if the corresponding advanced link is already set up, then the LLC shall cease both sending and reception actions, if needed cancel the relevant MAC layer SDU by a TMA-CANCEL request primitive, empty relevant data buffers and prepare an AL-SETUP PDU with a report "reset"; or
if the corresponding advanced link is not already set up, then the LLC shall prepare an AL-SETUP PDU with a report "service definition";
- ii) set the re-try counter to allow the maximum number of connection set-up retries N.262;
- iii) inform the formatter using the DATA_IN_BUFFER signal and enter "WAIT_OUT_CONNECT" state.

NOTE: The LLC selects parameters for an AL-SETUP PDU according to the TL-CONNECT request primitive parameters and current LLC capabilities e.g. available buffer sizes; see clause 20 for parameter definitions and clause 21 for PDU definitions. Suitable parameters for a AL-SETUP PDU depend on the quality negotiation between the service user and the DLL. The negotiation method is implementation dependent.

In the "WAIT_OUT_CONNECT" state the LLC may receive:

Local indication:

- a) a MAC-READY signal and then the LLC shall deliver the waiting AL-SETUP PDU, if any, to the formatter;
- b) a TMA-REPORT indication primitive confirming the handle to the request;
- c) a TMA-REPORT indication primitive (complete transmission) and if reason is "successful complete transmission by random access" or "complete transmission by reserved access or stealing", then the LLC shall start set-up waiting timer T.261;
- d) a TMA-REPORT indication primitive (random access failure) and then the LLC shall inform a set-up failure to the service user by TL-REPORT indication primitive (set-up failure) and return into the "IDLE" state for this advanced link;
- e) set-up waiting time-out T.261 indication and:
 - if more retries (N.262) are available, then the LLC shall issue the previous AL-SETUP PDU into the transmission buffer and inform formatter by the DATA_IN_BUFFER signal;
 - if all retries (N.262) are used, then the LLC shall inform a set-up failure to the service user by TL-REPORT indication primitive (set-up failure) and return into the "IDLE" state for this advanced link;

PDU's from peer entity:

- f) an AL-SETUP PDU with the report "success" and then the LLC shall issue a TL-CONNECT confirm primitive to the service user, stop set-up waiting timer T.261, and prepare the advanced link for data transfer in state "CONNECTED";
- g) an AL-SETUP PDU with report "service change" and then the LLC shall inform the service user by a TL-CONNECT indication primitive. The service user shall respond with a TL-CONNECT response primitive and the LLC shall act accordingly depending on the value of "Set-up report" parameter (see clause 20.2.4.63) contained in the TL-CONNECT response primitive:
 - if the set-up report indicates that the parameters are acceptable, then the LLC shall prepare an AL-SETUP PDU with report "success" and inform formatter using DATA_IN_BUFFER signal. The LLC shall continue in the "WAIT_IN_CONNECT" state as defined in clause 22.3.3.1.2 e) to h);
 - if the set-up report indicates that the parameters are not acceptable, but there is a possibly suitable parameter set available, then the LLC shall prepare an AL-SETUP PDU with report "service change" and inform formatter using DATA_IN_BUFFER signal;

- if the parameters are not acceptable and there is no suitable parameter set available, the connection establishment is rejected and then the LLC shall prepare an AL-DISC PDU with report "service not supported" and inform formatter using DATA_IN_BUFFER signal and deliver the AL-DISC PDU to the formatter as the response to the MAC-READY signal and then inform the service user by a TL-DISCONNECT indication primitive "set-up failure" and return to the "IDLE" state for this advanced link.
- h) an AL-SETUP PDU with report "service definition" and then the LLC shall continue as described in clause 22.3.3.1.2 for the "IDLE" state;
- i) an AL-DISC PDU with report "service not supported", "service temporarily unavailable" or "reject" and then the LLC shall inform the service user by the corresponding TL-DISCONNECT indication primitive and return to the "IDLE" state for this advanced link.

The MS may receive in the TMA-UNITDATA indication primitive carrying an AL-SETUP PDU the "Channel change response required" parameter set to "true"; then the MS shall pass it in the corresponding TL-CONNECT primitive with the "Channel change handle" parameter to MLE.

22.3.3.1.2 Actions on AL-SETUP PDU reception (set-up phase receiving entity)

If the LLC is capable of supporting advanced link, then upon reception of an AL-SETUP PDU for an acknowledged advanced link with one of the reports "service definition", "service change" or "reset" when in the "IDLE" state for that advanced link number (and address), the LLC shall inform the service user by a TL-CONNECT indication primitive with corresponding report and start to wait in state "WAIT_IN_CONNECT".

If the LLC does not for the moment support advanced link, then upon reception of an AL-SETUP PDU the LLC shall prepare an AL-DISC PDU with a report "service temporarily unavailable", inform formatter by DATA_IN_BUFFER signal and issue the AL-DISC PDU as a response to the next MAC-READY signal.

If the LLC does not at all support advanced link, then upon reception of an AL-SETUP PDU the LLC may prepare an AL-DISC PDU with a report "service not supported", inform formatter by DATA_IN_BUFFER signal and issue the AL-DISC PDU as a response to the next MAC-READY signal.

While waiting in state "WAIT_IN_CONNECT" the LLC may receive:

Service user initiated service primitives:

- a) a TL-CONNECT response primitive with the same parameters as in the TL-CONNECT indication primitive and then the LLC shall prepare an AL-SETUP PDU with same parameters as in the received AL-SETUP PDU with a report "success" and inform the formatter by a DATA_IN_BUFFER signal;
- b) a TL-CONNECT response primitive with different parameters (less QoS) as in the TL-CONNECT indication primitive and then the LLC shall prepare an AL-SETUP PDU with suitable parameters (QoS) and with a report "service change", inform the formatter by DATA_IN_BUFFER signal and continue in the "WAIT_OUT_CONNECT" state as defined in clause 22.3.3.1.1;
- c) a TL-CONNECT request primitive and then the LLC shall continue as if it had received that primitive from the service user as a set-up phase sending entity, see clause 22.3.3.1.1;
- d) a TL-DISCONNECT request primitive and then the LLC shall prepare an AL-DISC PDU with a report "reject", inform formatter by DATA_IN_BUFFER signal and issue the AL-DISC PDU to the formatter as a response to the next MAC-READY signal and then return to the "IDLE" state for this advanced link.

Local indications due to the AL-SETUP PDU with the report "success" sending:

- e) a MAC-READY signal and then the LLC shall deliver the waiting AL-SETUP PDU to the formatter;
- f) a TMA-REPORT indication primitive confirming the handle to the request;
- g) a TMA-REPORT indication primitive (successful complete transmission by random access or complete transmission by reserved access or stealing) and then the LLC shall prepare the advanced link for data transfer in state "CONNECTED";
- h) a TMA-REPORT indication primitive (random access failure) and then the LLC may inform the service user by a TL-DISCONNECT indication primitive (set-up failure) and the LLC shall return into the "IDLE" state for this advanced link.

NOTE 1: The LLC entity should not normally receive an AL-SETUP PDU with a report "service change" or "reset" when in the "IDLE" state for that advanced link, but if this happens, then the LLC should start normal connection establishment as if the received report were "service definition".

NOTE 2: The LLC entity should not normally receive an AL-SETUP PDU with a report "success" in state "IDLE" for that advanced link or in state "WAIT_IN_CONNECT" but, if this happens, then:

- if in state WAIT-IN-CONNECT, the LLC should cancel any AL-SETUP PDU with the report "success" sending; and
- in either case, the LLC should start normal connection establishment sending an AL-SETUP PDU with a report "service definition" as defined in clause 22.3.3.1.1.

NOTE 3: A TL-CONNECT response primitive from the service user with a different set of parameters than in the corresponding TL-CONNECT indication primitive is taken as a new connect request and the LLC will respond to it with a TL-CONNECT confirm primitive before the data transfer may start.

The MS may receive in the TMA-UNITDATA indication primitive carrying an AL-SETUP PDU the "Channel change response required" parameter set to "true"; then the LLC shall pass it in the corresponding TL-CONNECT primitive with the "Channel change handle" parameter to MLE.

22.3.3.1.3 Actions on AL-SETUP PDU reception (data transfer state)

Upon reception of an AL-SETUP PDU for an acknowledged advanced link with a report "reset", "service definition" or "service change" when in the "CONNECTED" state for that advanced link number (and address) then:

- i) the LLC shall cease both sending and reception actions for that advanced link, empty relevant data buffers and, if needed, cancel any MAC layer sending by TMA-CANCEL request primitive; and
- ii) the LLC shall inform the service user of the reset by a TL-CONNECT indication primitive with the report "reset" and start to wait connection set-up progress in state "WAIT_IN_CONNECT" as defined in clause 22.3.3.1.2.

22.3.3.1.4 Actions on original AL-SETUP PDU reception on different link number (data transfer state)

Upon reception of an AL-SETUP PDU for an original acknowledged advanced link with a report "service definition", "service change" or "reset" when in the "CONNECTED" state for an original acknowledged advanced link for that address but with a different advanced link number then:

- i) the LLC shall cease both sending and reception actions for the existing original advanced link, empty relevant data buffers and, if needed, cancel any MAC layer sending by TMA-CANCEL request primitive; and
- ii) the LLC shall inform the service user of the implicit disconnection of the existing original advanced link and go into the "IDLE" state for that advanced link; and
- iii) the LLC shall inform the service user of the incoming set-up by a TL-CONNECT indication primitive and start to wait connection set-up progress in state "WAIT_IN_CONNECT" as defined in clause 22.3.3.1.2.

NOTE: This is an exceptional case which may occur occasionally for an LLC that supports extended advanced link(s). It should not occur for an LLC that does not support extended advanced link(s).

22.3.3.2 Acknowledged data transfer on the original advanced link

22.3.3.2.0 General

In the advanced link, each data PDU in the acknowledged information transfer is identified by two numbers: a TL-SDU sequence number $N(S)$ and a segment sequence number $S(S)$. For the original advanced link, the TL-SDU sequence number is a three-bit number incremented in a modulo manner with each transmitted TL-SDU. After the connection set-up or after a reset, the data sending LLC entity shall start the TL-SDU numbering from "0". The segment sequence number is an absolute eight-bit number indicating segments inside a TL-SDU. Those numbers are used in the segmentation and re-assembly processes and in the selective re-transmission process. The acknowledgement contains the corresponding TL-SDU sequence number $N(R)$ and, in the selective acknowledgement PDU, a segment sequence number $S(R)$. The acknowledgement cannot carry any layer 3 information.

For the original advanced link, the advanced link number is not included in the data transfer and acknowledgement PDUs. The advanced link number in the data transfer and acknowledgement PDUs shall be implicitly assumed to be as indicated in the AL-SETUP PDU for the original acknowledged advanced link.

The advanced link can be used for two-way information transfer.

NOTE: If the BS establishes or accepts an advanced link for the acknowledged service to carry TL-SDUs with a maximum length of 4 096 octets then, in the case of a 25 kHz QAM channel, the BS needs to assign an event label for that MS address for use on that channel; see clause 23.4.1.2.3.1. This is needed in order to enable absolute segment numbering with the eight-bit segment sequence number.

22.3.3.2.1 Segmentation and sequencing

The data sending advanced link LLC entity shall segment a TL-SDU, if the size of it exceeds:

- when on a $\pi/4$ -DQPSK or D8PSK channel: the available MAC SDU size; or
- when on a 25 kHz or 50 kHz QAM channel: the available MAC SDU size in a 4-QAM rate = 1/2 full-slot MAC block at the current bandwidth; or
- when on a 100 kHz or 150 kHz QAM channel: the available MAC SDU size in half of a 4-QAM rate = 1/2 full-slot MAC block at the current bandwidth.

The MAC sub-layer indicates the next available segment size in the MAC-READY signal and the LLC should use the whole available size with possible exception of the last segment.

Segments shall be sent in sequence. In order to allow a re-assembly in the selective re-transmission, the segments are numbered using a $S(S)$ starting from "0" for each TL-SDU. The segment numbering is absolute, therefore a TL-SDU shall not comprise more than 256 segments.

The re-transmission of a segment shall not change the size of that segment, refer to clause 22.3.3.2.3.

For the original advanced link, the LLC shall use either AL-DATA or AL-DATA-AR PDU for a segment sending if the segment is not the last segment of a TL-SDU, and the LLC shall use either AL-FINAL or AL-FINAL-AR PDU if the segment is the last segment of a TL-SDU. The LLC shall use either AL-FINAL or AL-DATA PDUs if no acknowledgement is needed at this moment from the peer entity, and either AL-FINAL-AR or AL-DATA-AR PDU if acknowledgement is needed at this moment from the peer entity, refer to clause 22.3.3.2.3.

NOTE: The TL-SDU, as used in this definition, contains the FCS.

22.3.3.2.2 Re-assembly

Re-assembly is an operation opposite to segmentation. The data receiving LLC entity shall re-assemble the TL-SDU from the received segments. The acknowledged advanced link protocol shall deliver received TL-SDUs to the service user in the TL-SDU sequence number order.

At the reception of the first received segment (or every received segment) of a new SDU, the BS LLC entity sends a TL-RECEIVE indication primitive to the service user indicating that data input is in progress.

22.3.3.2.3 Acknowledgement and segment re-transmission mechanisms

In this LLC protocol the data sending entity is responsible for requesting acknowledgements from the data receiving entity. The data sending LLC may request an acknowledgement from the peer LLC and potentially cease data transmission by using either the AL-DATA-AR or AL-FINAL-AR PDU. The data sending LLC shall request an acknowledgement at latest, when it cannot continue sending due to the closing of TL-SDU window. The data sending LLC should request an acknowledgement each time there is no more data for sending or there will be a pause in sending for other reasons. When on a $\pi/4$ -DQPSK channel, the data sending LLC should generally minimize acknowledgement requests in good propagation situations. When on a D8PSK or QAM channel, the choice of when the data sending LLC requests acknowledgements may be affected by the link adaptation algorithm used by the transmitting MS or BS.

In addition to the requested acknowledgements the data receiver may choose to send acknowledgements at any time for its own purposes e.g. to clean up receiving buffers. When on a D8PSK or QAM channel, the choice of when the data receiver sends acknowledgements may be affected by link adaptation aspects.

The data receiving entity acknowledges both whole TL-SDUs and selectively segments of TL-SDUs by either AL-ACK or AL-RNR PDUs depending on the flow control needs, refer to clause 22.3.3.2.5. The data sending entity shall re-transmit the segments marked as bad in the last received AL-ACK or AL-RNR PDU. The re-transmission of segments shall start from the oldest segment in the oldest TL-SDU and continue until all segments for which a re-transmission is requested are transmitted. If the data sending entity receives an acknowledgement for the whole TL-SDU, it informs the service user of the correct transfer of the layer 3 data by issuing a TL-DATA confirm primitive. A segment shall keep its original sent segment number S(S), which indicates its absolute position inside the corresponding TL-SDU. The same sent TL-SDU number N(S) shall be used until all its segments have been successfully transmitted and the whole TL-SDU has been acknowledged (see clause 22.3.3.2.6) or TL-SDU transmission is failed or the advanced link is disconnected.

Upon reception of the acknowledgement request indicated by the AL-DATA-AR or AL-FINAL-AR PDU, the data receiver entity shall send either the AL-ACK or the AL-RNR PDU, refer to clause 22.3.3.2.5 for flow control, with one or more acknowledgement blocks:

- i) the N(R) element shall indicate which TL-SDU is acknowledged;
- ii) if the acknowledgement is for a whole TL-SDU, then the LLC shall set the acknowledgement length element to:
 - value 000000₂ if the data receiver accepts the TL-SDU;
 - value 111111₂ if the data receiver requests a re-sending of the TL-SDU; and
 - there shall be no other elements in that acknowledgement block;
- iii) if the data receiver selectively acknowledges segments of the TL-SDU then:
 - the acknowledgement length element shall indicate the number of acknowledged segments; and
 - the S(R) element shall indicate the absolute position of the oldest not yet received segment in the TL-SDU; and
 - the bit map shall indicate the status of each segment starting from the next segment after the S(R) and moving forwards one segment at a time, up to the limit imposed by the last correctly received segment or by the available room in the AL-ACK or AL-RNR PDU; the status of the segment (STATUS) shall be set to "1" if it is correctly received and to "0" if it is not correctly received.

The data receiving entity shall note the TL-SDU number in the AL-DATA-AR or AL-FINAL-AR. The data receiving entity shall include an acknowledgement block for any older TL-SDUs that are not yet completely received or that have not yet been acknowledged as completely received, if permitted by the available room in the AL-ACK or AL-RNR PDU. The data receiving entity should also include an acknowledgement block for the TL-SDU corresponding to the AL-DATA-AR or AL-FINAL-AR. If an acknowledgement block for the TL-SDU corresponding to the AL-DATA-AR or AL-FINAL-AR is included, the data receiving entity may include an acknowledgement block for newer TL-SDUs. If the acknowledgement blocks do not fit within one MAC block, then the data receiving entity may send multiple AL-ACK (or AL-RNR) PDUs.

NOTE 1: If the data receiving entity wishes to send more than one acknowledgement block which refers to the same TL-SDU, those acknowledgement blocks should be included within the same AL-ACK (or AL-RNR) PDU, using fragmentation if necessary; the data receiving entity is not permitted to divide acknowledgement blocks which refer to the same TL-SDU between multiple AL-ACK (or AL-RNR) PDUs.

If the data sending entity does not receive an acknowledgement message either AL-ACK or AL-RNR PDU within acknowledgement waiting time T.252, then:

- if the SDU window size for TL-SDU N.272 is fully used, then the data sending LLC shall repeat its acknowledgement request as above by using an AL-DATA-AR or AL-FINAL-AR PDU, as appropriate, for an already transmitted segment; or
- if the SDU window size for TL-SDU N.272 is not fully used but there is currently no more data to send, then the data sending LLC should repeat its acknowledgement request as above by using an AL-DATA-AR or AL-FINAL-AR PDU, as appropriate, for an already transmitted segment; or
- if the SDU window size for TL-SDU N.272 is not fully used, and there is more data to send, then the data sending LLC may continue its transmission by using AL-DATA(-AR) or AL-FINAL(-AR) PDU as appropriate.

NOTE 2: The data sending entity may continue data transmission within the TL-SDU window independently of the acknowledgement waiting timer.

22.3.3.2.4 TL-SDU re-transmission

In the case that all the segments of a TL-SDU have been received, but the FCS verification has failed, the whole TL-SDU shall be re-transmitted if within the allowed number of TL-SDU retransmissions N.273. The data receiver shall indicate the FCS failure by setting value 11111₂ to the acknowledgement length information element in the AL-ACK or AL-RNR PDU. On the data transmitter side, this TL-SDU shall be re-transmitted using the same TL-SDU discriminator and starting transmission from the first segment.

Refer to clause 22.3.3.2.6 for reasons of the data sending entity to re-transmit a TL-SDU.

If the maximum number of TL-SDU re-transmissions N.273 is exceeded, the data sending LLC shall abandon the transmission of that TL-SDU and report an error to the service user using a TL-REPORT indication primitive "failed transfer". The service user should stop using the advanced link and either reset or disconnect it, refer to clauses 22.3.3.1.1 and 22.3.3.3 for protocol actions.

22.3.3.2.5 Flow control

During the transmission in an advanced link, the data receiving entity has the possibility to interrupt the data transmitting entity from sending new TL-SDUs. The data receiving entity shall use as acknowledgements either an AL-ACK or an AL-RNR PDU, if the data receiver may continue to receive more data or is not capable of receiving more data respectively. The AL-RNR PDU shall also acknowledge already received PDUs and/or segments of PDUs.

When an AL-ACK or AL-RNR PDU is sent over the air interface, it shall reflect the actual situation at the data receiver at the transmission time of this acknowledgement.

Upon reception of an AL-RNR PDU the data transmitting entity shall wait until either the peer entity sends an AL-ACK PDU or the receiver not ready validity timer for the data sending entity T.271 expires (or until the link is disconnected or reset). The data sender should continue sending of those TL-SDUs, which are partially acknowledged in the AL-RNR PDU or previously. The data receiving entity may need to send more than one AL-RNR PDU when there are more segments or PDUs waiting for positive or negative acknowledgement than fit into one AL-RNR PDU.

If the receiver not ready validity timer for the data sending entity T.271 expires, the data sending entity shall try to start the sending of the TL-SDUs from the first unacknowledged PDU if there is still room in the TL-SDU sending window N.272, or from the last segment of the last already acknowledged TL-SDU, if there is no room in the TL-SDU window. If the data receiving LLC cannot accept the new TL-SDU, it shall acknowledge the last already received and acknowledged TL-SDU by an AL-RNR PDU.

The data receiving entity starts the receiver not ready validity timer T.272 when it sends an AL-RNR PDU over the air interface. If T.272 expires and the data receiving entity is still incapable of receiving data, it may restart T.272 and send another AL-RNR PDU. T.272 is reset when the data receiving entity sends an AL-ACK PDU over the air interface which indicates that the data receiver is again capable of receiving data.

22.3.3.2.6 Actions on TL-DATA request primitive (data sending entity)

During acknowledged data transfer the LLC data sending entity may receive (in state "AL_TX_READY") from the service user:

- a) a TL-DATA request primitive (handle to the request) and then:
 - i) the data sending LLC may issue a TL-REPORT indication primitive confirming the handle to the request parameter;
 - ii) the LLC shall calculate the FCS and append it to the TL-SDU;
 - iii) the LLC shall save the TL-SDU with the FCS into sending buffer and inform the MAC layer how much data is available for sending by the DATA_IN_BUFFER signal, see clause 22.3.1.7.2;

Local indications:

- b) MAC-READY signal and then:
 - if there are no segments pending for re-transmission, the LLC shall format a new segment of the TL-SDU in the sending buffer as defined in clause 22.3.3.2.1 and issue it to the formatter and set the corresponding segment re-transmission counter;
 - if there is at least one segment pending for re-transmission and the maximum number of segment retransmissions N.274 of that segment is not exceeded, then the LLC shall select the oldest segment, for which there is a re-transmission request pending and issue the PDU to the formatter;
 - if there is at least one segment pending for re-transmission and the maximum number of the segment retransmissions N.274 of that segment is exceeded but the maximum number of TL-SDU retransmissions N.273 is not exceeded, then the LLC shall start re-sending of the complete TL-SDU (using the original segmentation) and issue it to the formatter;
 - if there is at least one segment pending for re-transmission and both the maximum number of segment retransmissions N.274 of that segment and the maximum number of TL-SDU retransmissions N.273 are exceeded, then the LLC shall inform the service user about TL-SDU transmission failure by a TL-REPORT indication primitive (failed transfer);
- c) an indication, that the acknowledgement waiting timer T.252 has expired, refer to acknowledgement mechanisms in clause 22.3.3.2.3 for actions;
- d) a TMA-REPORT indication primitive confirming the handle to the request;
- e) a TMA-REPORT indication primitive (successful complete transmission by random access or complete transmission by reserved access or stealing) and, if it is a response to either a AL-DATA-AR or AL-FINAL-AR PDU, the LLC shall start acknowledgement waiting timer T.252;
- f) a TMA-REPORT indication primitive (random access failure) and then:
 - i) for a CA MS, if the random access attempt was on a conforming $\pi/4$ -DQPSK or D8PSK channel, the LLC shall inform the service user by a TL-REPORT indication primitive (failed transfer) and the LLC shall delete the TL-SDU from the sending buffer;
 - ii) for a CA MS, if the random access attempt was on a non-conforming $\pi/4$ -DQPSK or D8PSK channel, or a QAM channel, the LLC may inform the service user by a TL-REPORT indication primitive (failed transfer) in which case the LLC shall delete the TL-SDU from the sending buffer;
 - iii) for a DA MS, the LLC may inform the service user by a TL-REPORT indication primitive (failed transfer) in which case the LLC shall delete the TL-SDU from the sending buffer;

NOTE 1: After receiving a TL-REPORT indication primitive reporting failed transfer (see b) and f) above) the service user should immediately either reset or disconnect the advanced link, which should be no more usable in the current state.

NOTE 2: In cases f)ii) and f)iii), if the LLC does not inform the service user by a TL-REPORT indication primitive (failed transfer), the LLC may continue to attempt to send the TL-SDU (using the current segmentation) and the service user need not reset or disconnect the advanced link. However the MS should not keep attempting random access excessively on the same channel after a random access failure.

PDU's from peer entity:

- g) an AL-ACK PDU either to acknowledge received segments and/or TL-SDUs or to indicate that the peer entity is capable to receive more data; refer to clause 22.3.3.2.3 for the actions on the acknowledgement;
- h) an AL-RNR PDU to acknowledge received TL-SDUs and/or segments and to indicate that the peer entity is currently not capable to receive more data; refer to flow control in clause 22.3.3.2.5.

NOTE 3: In this clause word segment is used instead of AL-DATA, AL-DATA-AR, AL-FINAL and AL-FINAL-AR PDU's, refer to segmentation in clause 22.3.3.2.1 and acknowledgement in clause 22.3.3.2.3 for selection of the correct PDU.

NOTE 4: The TL-SDU sending window is updated when the lowest SDU in the current window is completely acknowledged.

The MS may receive in the TMA-UNITDATA indication primitive carrying an AL-ACK or AL-RNR PDU the "Channel change response required" parameter set to "true"; then the MS shall pass it in a TL-REPORT indication primitive with the "Channel change handle" parameter to MLE.

22.3.3.2.7 Data reception from the peer entity (data receiving entity)

When advanced link LLC data receiving entity is ready for receiving data (in the state "AL_RX_READY"), it may receive:

Local indications:

- a) MAC-READY signal and then the LLC shall send the AL-ACK or AL-RNR PDU as appropriate, see later in this clause and in clause 22.3.3.2.3 for the acknowledgement procedure;

PDU's from the peer entity:

- b) AL-DATA or AL-FINAL PDU and then the LLC shall store the segment into the correct position for reassembling in the corresponding TL-SDU and shall check completeness and correctness of the received TL-SDU; and
 - if the TL-SDU is completely and correctly received (FCS matches) the LLC shall mark it received and ready for acknowledgement; and
 - if the number of the TL-SDU (N(S)) is the lowest SDU in the receiver window the LLC shall update both the lower and upper window boundary and deliver the received TL-SDU to the service user in a TL-DATA indication primitive; or

NOTE 1: If the next TL-SDU (or TL-SDUs) in the sequence have already been completely and correctly received, the LLC also delivers that TL-SDU (or those TL-SDUs) to the service user.

- if all segments of that TL-SDU are received, but the FCS calculation fails, then the LLC shall discard that SDU and mark that it needs to be re-transmitted.

- c) AL-DATA-AR or AL-FINAL-AR PDU and then the LLC shall store the segment into the correct position for reassembling in the corresponding TL-SDU and shall check completeness and correctness of the received TL-SDU; and
- if at least one new TL-SDU is completely and correctly received (FCS matches) the LLC shall mark it received and prepare either AL-ACK or AL-RNR PDU as defined in clauses 22.3.3.2.3 and 22.3.3.2.5, inform the formatter by the DATA_IN_BUFFER signal and, if the number of the TL-SDU (N(S)) is the lowest SDU in the receiver window, the LLC shall update the lower window boundary and deliver the received TL-SDU to the service user in a TL-DATA indication primitive;

NOTE 2: If the next TL-SDU (or TL-SDUs) in the sequence have already been completely and correctly received, the LLC also delivers that TL-SDU (or those TL-SDUs) to the service user.

NOTE 3: In case the BS LLC entity receives an AL-DATA(-AR) or AL-FINAL(-AR) PDU with a new TL-SDU number N(S), the BS LLC should indicate to the LLC service user that the reception of new TL-SDU has started by a TL-RECEIVE indication primitive.

- if all segments of that TL-SDU are received, but the FCS calculation fails, then the LLC shall discard that PDU and prepare either AL-ACK or AL-RNR PDU asking for re-transmission of that TL-SDU, with a possible bitmap of the unacknowledged segments in the other SDUs as defined in clauses 22.3.3.2.3 and 22.3.3.2.5 and inform the formatter by the DATA_IN_BUFFER signal;
- if no TL-SDU is received correctly, then the LLC shall mark the segment received and prepare either AL-ACK or AL-RNR PDU, with a bitmap of the unacknowledged segments as defined in clauses 22.3.3.2.3 and 22.3.3.2.5 and inform the formatter by the DATA_IN_BUFFER signal;

The LLC shall use PDU priority level = 5 and allow frame stealing for a response to an AL-DATA-AR or AL-FINAL-AR PDU (though in most cases neither of these parameters will actually be used in the MAC, since AL-ACK and AL-RNR PDUs are usually sent by reserved access).

indication from the service user:

- d) a FLOW-NOT-READY signal and then the LLC shall prepare an AL-RNR PDU, with a possible bitmap of the unacknowledged segments in the received SDUs and inform the formatter by the DATA_IN_BUFFER signal;
- e) a FLOW-READY signal and then the LLC shall prepare an AL-ACK PDU, with a possible bitmap of the unacknowledged segments in the received SDUs and inform the formatter by the DATA_IN_BUFFER signal, refer to flow control in clause 22.3.3.2.5.

NOTE 4: The data receiving process delivers TL-SDUs in the sequence defined by the N(S).

NOTE 5: If it receives any of the data transfer PDUs (AL-DATA, AL-DATA-AR, AL-FINAL or AL-FINAL-AR), when the corresponding advanced link is no more in "RX_READY" state, then the PDU will be discarded in this model by the formatter without any further actions.

NOTE 6: When the LLC data receiving entity has completely and correctly received a TL-SDU, and if the number of the TL-SDU is the lowest in the receiver window, then the LLC updates the lower window boundary and delivers the received TL-SDU to the service user. However, even when the LLC has sent an acknowledgement for the correctly received TL-SDU, that acknowledgement may not have been received by the data sending entity. Therefore the LLC may still receive AL-DATA(-AR) and AL-FINAL(-AR) PDUs for the N.272 TL-SDUs below the current receiver window. If this occurs, the data receiving LLC should discard the received segment(s) but should send an acknowledgement to indicate that the TL-SDU has been correctly received. If there is space within the MAC block, the data receiving LLC should also send acknowledgements indicating that the TL-SDU has been correctly received for any more recent TL-SDUs below the current receiver window.

NOTE 7: In the LLC advanced link protocol the data sending entity should retry transmission in case it does not receive an expected acknowledgement since the protocol actions taken in case of a transmission failure of an AL-ACK or AL-RNR PDU are not defined in the present document.

The MS may receive in the TMA-UNITDATA indication primitive carrying an AL-DATA(-AR) and AL-FINAL(-AR) PDU the "Channel change response required" parameter set to "true"; then the MS shall pass it in a TL-REPORT indication primitive or if available in the corresponding TL-DATA indication primitive with the "Channel change handle" parameter to MLE.

22.3.3.2a Acknowledged data transfer on an extended advanced link

For acknowledged data transfer on an extended advanced link, the procedures described in clause 22.3.3.2 shall apply for that extended advanced link with the following differences:

- i) PDUs AL-X-DATA, AL-X-DATA-AR, AL-X-FINAL, AL-X-FINAL-AR, AL-X-ACK and AL-X-RNR shall be used instead of PDUs AL-DATA, AL-DATA-AR, AL-FINAL, AL-FINAL-AR, AL-ACK and AL-RNR respectively.
- ii) The advanced link number shall be included in each PDU.
- iii) The TL-SDU sequence number shall be a five-bit number incremented in a modulo manner with each transmitted TL-SDU (instead of a three-bit number).
- iv) The window size N.272 may be larger for an extended advanced link than for the original advanced link.

NOTE 1: As in clause 22.3.3.2.3: when acknowledging TL-SDUs, if the acknowledgement blocks do not fit within one MAC block, the data receiving entity may send multiple AL-X-ACK (or AL-X-RNR) PDUs.

However, if the data receiving entity wishes to send more than one acknowledgement block which refers to the same TL-SDU, those acknowledgement blocks should be included within the same AL-X-ACK (or AL-X-RNR) PDU, using fragmentation if necessary; the data receiving entity is not permitted to divide acknowledgement blocks which refer to the same TL-SDU between multiple AL-X-ACK (or AL-X-RNR) PDUs.

- v) Use of the FCS is optional on an extended advanced link, so:
 - the data sending entity only calculates the FCS and appends it to the TL-SDU (see clause 22.3.3.2.6) if requested by the service user in the TL-DATA request primitive;
 - if the AL-X-FINAL or AL-X-FINAL-AR PDU indicates that the FCS is not present then, when the data receiving entity is re-assembling the TL-SDU (see clause 22.3.3.2.7), it shall check only for completeness of the TL-SDU instead of checking for completeness and correctness.
- vi) The LLC header of the AL-X-FINAL and AL-X-FINAL-AR PDU is one bit longer than the LLC header of the AL-X-DATA and AL-X-DATA-AR PDU. Therefore there are occasional cases when the last part of the TL-SDU (and FCS when used) just fits within an AL-X-DATA or AL-X-DATA-AR PDU but would not fit within an AL-X-FINAL or AL-X-FINAL-AR PDU. In these cases, the data sending LLC entity should send the last part of the TL-SDU (and FCS when used) within an AL-X-DATA or AL-X-DATA-AR PDU and then send an empty AL-X-FINAL or AL-X-FINAL-AR PDU (i.e. containing no information after the FCS flag) to complete the TL-SDU transmission.

Therefore the data receiving LLC entity may occasionally receive an AL-X-FINAL or AL-X-FINAL-AR PDU containing no information after the FCS flag. The AL-X-FINAL or AL-X-FINAL-AR PDU indicates the termination of the TL-SDU so, when all the other segments have been received, those other segments comprise the complete TL-SDU (and FCS when used).

For the purposes of the acknowledgement protocol, both the data sending entity and the data receiving entity shall process the empty AL-X-FINAL or AL-X-FINAL-AR PDU using the usual procedures for an AL-X-FINAL or AL-X-FINAL-AR PDU. For example, when required by the usual procedures, the data receiving entity shall include a bit in the acknowledgement bit map to indicate successful reception of the AL-X-FINAL or AL-X-FINAL-AR PDU.

- vii) On a D8PSK or QAM channel, link adaptation feedback information may be included within AL-X-ACK and AL-X-RNR PDUs; see clause 22.3.1.7.3.
- viii) For the extended advanced link, the data receiving entity may include an acknowledgement block indicating "All SDUs prior to this SDU correctly received". When included, this acknowledgement block shall be the first acknowledgement block in the AL-X-ACK (or AL-X-RNR) PDU; see clause 22.3.3.2.3.
- ix) For the extended advanced link, the data receiving entity shall select the acknowledgement blocks to be sent in an AL-X-ACK (or AL-X-RNR) PDU obeying the following rules:
 - a) the acknowledgement blocks shall be sorted with acknowledgement blocks for the oldest TL-SDUs being acknowledged first (see note 2);

- b) the acknowledgement blocks shall be for consecutive TL-SDU numbers (see note 2), except when acknowledgement blocks may be omitted as indicated in point d) below;
- c) if an acknowledgement for a TL-SDU cannot be sent using a single acknowledgement block, the data receiving entity shall include the necessary multiple acknowledgement blocks for the TL-SDU in preference to including acknowledgement information for the next TL-SDU(s);
- d) the data receiving entity may choose to leave out acknowledgement blocks for TL-SDUs that have been correctly received if another acknowledgement block follows in the AL-X-ACK (or AL-X-RNR). The data transmitting entity shall consider such TL-SDUs as "SDU correctly received".

NOTE 2: The acknowledgement block TL-SDU numbers are sorted and consecutive modulo 32. If the data receiving entity wishes to include an acknowledgement block for TL-SDUs 0, 1, 30 and 31, the correct order is: 30, 31, 0, 1.

NOTE 3: The above rules only apply within an AL-X-ACK (or AL-X-RNR). If the data transmitting entity receives two AL-X-ACKs (or AL-X-RNRs) with a gap in TL-SDU number between the TL-SDUs being acknowledged in the first and second AL-X-ACK (or AL-X-RNR), this gap conveys no information about the TL-SDUs in the gap. The data transmitting entity cannot consider the TL-SDUs in the gap as being acknowledged as a result of receiving the two AL-X-ACKs (or AL-X-RNRs).

EXAMPLE: If the data transmitting entity receives an AL-X-ACK including acknowledgement blocks for TL-SDUs 2 and 5, followed by a second AL-X-ACK including acknowledgement blocks for TL-SDUs 7 and 9, then this indicates that TL-SDUs 3, 4, and 8 have been correctly received, but indicates nothing about TL-SDU 6.

See clause 22.3.3.2.3.

- x) When the data receiving entity receives AL-X-DATA(-AR) or AL-X-FINAL(-AR) PDUs for the N.272 TL-SDUs below the current receiver window, instead of sending acknowledgements for each TL-SDU below the current receiver window, the data receiving entity should send an acknowledgement block indicating "All SDUs prior to this SDU correctly received" for the oldest TL-SDU which is not completely received or for the newest completely received TL-SDU in case there are no partially received TL-SDUs in the data receiving entity buffers; see note 6, clause 22.3.3.2.7.

If an MS is using more than one advanced link, the data transfer procedures for each advanced link operate independently of the data transfer procedures for the other advanced link(s).

22.3.3.3 Release of acknowledged service advanced link

22.3.3.3.0 General

In the advanced link the end of the transfer shall be notified by AL-DISC PDU with reason "close". In the acknowledged data transfer the disconnection shall be confirmed by sending a AL-DISC PDU with reason "success". Disconnection may occur at any time. When the receiving entity recognizes a disconnect it shall delete all partially received TL-SDUs for that advanced link.

22.3.3.3.1 Actions on TL-DISCONNECT request primitive (MS sending entity)

Upon reception of a TL-DISCONNECT request primitive in state WAIT_OUT_CONNECT or CONNECTED, the LLC shall:

- i) prepare an AL-DISC PDU with reason "Close" and inform the formatter by DATA_IN_BUFFER signal;
- ii) set re-try counter to allow the maximum number of connection disconnect retries N.263;
- iii) cease all sending and receiving any data and discard all TL-SDUs waiting for sending on this advanced link or which are partially received on this advanced link and start to wait in "WAIT_DISCONNECT" state.

In the "WAIT_DISCONNECT" state the LLC may receive:

Local indications:

- a) a MAC-READY signal and then the LLC shall issue the AL-DISC PDU to the formatter;
- b) a TMA-REPORT indication primitive (successful complete transmission by random access or complete transmission by reserved access or by stealing) and then the LLC shall start the disconnection waiting timer T.263;
- c) a TMA-REPORT indication primitive (random access failure) and then the LLC shall inform the service user by a TL-DISCONNECT confirm primitive (random access failure) and go into the "IDLE" state for this advanced link;
- d) an indication of the expiry of the disconnection waiting timer T.263 and:
 - if more retries (N.263) are available, then the LLC shall issue the previous AL-DISC PDU into the transmission buffer and inform formatter by the DATA_IN_BUFFER signal;
 - if all retries (N.263) are used, then the LLC shall inform the service user by a TL-DISCONNECT confirm primitive (disconnection failure) and go into the "IDLE" state for this advanced link.

A PDU from the peer entity:

- e) an AL-DISC PDU with reason "Success", then the LLC shall inform the service user by a TL-DISCONNECT confirm primitive and go into the "IDLE" state for this advanced link;
- f) an AL-DISC PDU with reason "Close", then the LLC shall deliver an AL-DISC PDU with reason "Success" to the formatter as a response to the next MAC-READY signal and go into the "IDLE" state for this advanced link.

22.3.3.3.2 Actions on AL-DISC PDU reception (MS receiving entity)

While being ready for data transfer the advanced link LLC may receive:

A PDU from the peer entity:

- a) an AL-DISC PDU with reason "Close" and then:
 - i) the LLC shall stop sending and receiving any data and discard both TL-SDUs waiting for sending on this advanced link and TL-SDUs which are partially received or fully received on this advanced link;
 - ii) prepare an AL-DISC PDU with a reason "Success" and inform the formatter by the DATA_IN_BUFFER signal;
 - iii) indicate to the service user the removal of the advanced link using a TL-DISCONNECT indication primitive "incoming disconnection";

Local indications after preparing an AL-DISC PDU:

- b) a MAC-READY signal and then the LLC shall issue the AL-DISC PDU to the formatter;
- c) a TMA-REPORT indication primitive (successful complete transmission by random access or complete transmission by reserved access or by stealing) and then the LLC shall go into the "IDLE" state for this advanced link;
- d) a TMA-REPORT indication primitive (random access failure) and then the LLC shall go into the "IDLE" state for this advanced link.

When the LLC receives in the "IDLE" state an AL-DISC PDU with reason "Close", the LLC shall deliver an AL-DISC PDU with reason "Success" to the formatter as a response to the next MAC-READY signal.

NOTE: An MS may receive an AL-DISC PDU also in other states of the LLC protocol, refer to advanced link establishment actions.

22.3.3.4 Abnormal release of advanced link

While in any state the advanced link LLC may receive:

- a) a TL-RELEASE request primitive from the service user and then the LLC shall close the advanced link without any signalling with the peer entity and go to the "IDLE" state for this advanced link;
- b) a TMA-RELEASE indication primitive and then the LLC shall close the advanced link(s) corresponding to this endpoint identifier without any signalling with the peer entity, indicate link disconnection to the service user by TL-DISCONNECT indication primitive(s) with a reason "local disconnection" and go to the "IDLE" state for that advanced link (or those advanced links).

22.3.3.5 LLC reconnection of acknowledged service advanced link

A request for the LLC to reconnect an advanced link shall be notified using the AL-RECONNECT PDU with a reconnect report "propose". A successful reconnection of the advanced link by the LLC shall be confirmed by the reception of an AL-RECONNECT PDU with the reconnect report "accept" and unsuccessful reconnection by the reception of an AL-RECONNECT PDU with the reconnect report "reject".

Upon reception of a TL-RECONNECT request primitive when in state "CONNECTED" for that advanced link, the LLC shall:

- i) prepare an AL-RECONNECT PDU with reason "propose" and inform the formatter by DATA_IN_BUFFER signal;
- ii) set re-try counter to allow the maximum number of reconnect retries N.265;
- iii) cease all sending and receiving any data and start to wait in "WAIT_RECONNECT" state.

In the "WAIT_RECONNECT" state the LLC may receive:

Local indications:

- a) a MAC-READY signal and then the LLC shall issue the AL-RECONNECT PDU to the formatter;
- b) a TMA-REPORT indication primitive (successful complete transmission by random access or complete transmission by reserved access or by stealing) and then the LLC shall start the reconnection waiting timer T.265;
- c) a TMA-REPORT indication primitive (random access failure) and then the LLC shall inform the service user by a TL-RECONNECT confirm primitive with the reconnection result set to "random access failure";
- d) an indication of the expiry of the reconnection waiting timer T.265, and:
 - if more retries (N.265) are available, then the LLC shall issue the previous AL-RECONNECT PDU into the transmission buffer and inform formatter by the DATA_IN_BUFFER signal;
 - if all retries (N.265) are used, then the LLC shall inform the service user by a TL-RECONNECT confirm primitive with the reconnection result set to "reconnection failure".

A PDU from the peer entity:

- e) an AL-RECONNECT PDU with reason "accept", then the LLC shall inform the service user by a TL-RECONNECT confirm primitive with the reconnection result set to "success" and go into the "CONNECTED" state for this advanced link, accept the channel change, if any, by issuing a TMC-CONFIGURE request primitive to MAC with the parameter channel change accepted set to "accept" and continue to transmit and receive TL-SDU segments without resetting the advanced link;
- f) an AL-RECONNECT PDU with reason "reject", then the LLC shall inform the service user by a TL-RECONNECT confirm primitive with the reconnection result set to "reject" and accept the channel change, if any, by issuing a TMC-CONFIGURE request primitive to MAC with the parameter channel change accepted set to "accept".

22.3.4 Advanced link procedures for unacknowledged service

22.3.4.0 General

The unacknowledged service uses the same mechanisms for sequencing, segmentation and re-assembling as the acknowledged service (see clauses 22.3.3.2.1 and 22.3.3.2.2). The window size for TL-SDU in unacknowledged service N.281 defines how many TL-SDUs may be in transit at the same time. The numbering of TL-SDUs N(S), contrary to the acknowledged service, may start at any value.

22.3.4.1 Advanced link unacknowledged service establishment

The BS should establish the unacknowledged service before it starts to send data.

The BS should start unacknowledged data transfer by sending one or more AL-SETUP PDUs. During unacknowledged data transfer the BS may repeat the AL-SETUP PDU using the current value for the TL-SDU number N(S) to re-synchronize receiving MSs. The TL-SDU numbering may start at any value to allow re-setting of an unacknowledged service without re-setting the TL-SDU window position. After the reception of an AL-SETUP PDU the TL-SDU window lower edge shall be the TL-SDU number N(S) and the upper edge shall be $N(S) + N.281 - 1$. (N.281 is the window size for TL-SDUs in the unacknowledged service.) After sending an AL-SETUP PDU the BS should not repeat any TL-SDU or segments of those having a TL-SDU sequence number lower than the one (N(S)) indicated in the AL-SETUP PDU.

NOTE: If the BS establishes an advanced link for the unacknowledged service to carry TL-SDUs with a maximum length of 4 096 octets then, in the case of a 25 kHz QAM channel, the BS needs to assign an event label for that address for use on that channel; see clause 23.4.1.2.3.1. This is needed in order to enable unique segment numbering with the eight-bit segment sequence number.

22.3.4.2 Reception of unacknowledged service data on the original advanced link

The LLC MS entity may receive at any state:

- a) an AL-SETUP PDU for unacknowledged information reception and then the LLC shall empty possible current buffer for this advanced link, prepare a new buffer for data reception, inform the service user by a TL-CONNECT indication primitive (unacknowledged service) and start to wait for data in the state "AL_UNACK_READY";
- b) an AL-DISC PDU and then the LLC shall discard all partially received TL-SDUs on this advanced link and may deliver a TL-DISCONNECT indication primitive to the service user.

If the LLC MS entity is in state AL_UNACK_READY for an original unacknowledged advanced link and it receives an AL-SETUP PDU for an original unacknowledged advanced link for that address but with a different advanced link number, the LLC shall empty possible current buffer for the existing original advanced link, prepare a new buffer for data reception, inform the service user by a TL-CONNECT indication primitive (unacknowledged service) and wait for data in the state "AL_UNACK_READY".

NOTE 1: If the LLC MS entity does not support the augmented AL-SETUP PDU and it receives an AL-SETUP PDU for the unacknowledged service (i.e. "advanced link service" element set to 0) with the "TL-SDU window size" element set to 00₂, it should discard the AL-SETUP PDU without performing any of the actions in the above paragraph or in procedure a).

While in the "AL_UNACK_READY" state the MS LLC may receive an AL-UDATA PDU or an AL-UFINAL PDU; and:

- if the corresponding TL-SDU is not earlier delivered to the service user, then the LLC shall store the segment into correct position of the relevant TL-SDU as indicated by N(S) and S(S) elements respectively; and
- if a TL-SDU is now completely and correctly received, then the LLC shall deliver the TL-SDU to the service user in a TL-UNITDATA indication primitive and mark the TL-SDU as received.

NOTE 2: The MS LLC may deliver the received TL-SDUs out of sequence.

NOTE 3: The advanced link protocol allows suppression of received duplicates.

Each time the LLC receives an AL-UDATA or an AL-UFINAL PDU the LLC shall upgrade the receiving window upper edge to the received N(S) if it is higher than the current upper edge and calculate a new lower edge. The LLC shall then check if there are any partially received TL-SDUs, which have TL-SDU number outside the new receiving window and then the LLC shall discard those partially received SDUs.

The advanced link number is not included in the AL-UDATA and AL-UFINAL PDUs. The advanced link number in the AL-UDATA and AL-UFINAL PDUs shall be implicitly assumed to be as indicated in the AL-SETUP PDU for the original unacknowledged advanced link.

NOTE 4: An AL-SETUP PDU for unacknowledged information reception (or an AL-UDATA or AL-UFINAL PDU) may be sent in a group addressed MAC PDU that contains a channel allocation. If the MS-MAC requires instruction on whether to accept the channel allocation, then it sets the "channel change response required" parameter to "true" in the TMA-UNITDATA indication primitive. If the MS decides to accept the channel allocation then the higher layers should issue a TMC-CONFIGURE request primitive to the MAC containing the "channel change handle" parameter and "channel change accepted" parameter set to "accept". However, if a channel change is not acceptable, a TMC-CONFIGURE request primitive should be issued with the "channel change parameter" set to "reject".

22.3.4.2a Reception of unacknowledged service data on an extended advanced link

For reception of unacknowledged service data on an extended advanced link, the procedures described in clause 22.3.4.2 shall apply for that extended advanced link with the following differences:

- i) PDUs AL-X-UDATA and AL-X-UFINAL shall be used instead of PDUs AL-UDATA and AL-X-UFINAL respectively.
- ii) The advanced link number is included in each PDU.
- iii) The window size N.281 may be larger for an extended advanced link than for the original advanced link.
- iv) Use of the FCS is optional on an extended advanced link so, if the AL-X-UFINAL PDU indicates that the FCS is not present, the LLC MS entity shall deliver the TL-SDU to the service user when it has received the complete TL-SDU (without checking for correctness).
- v) The LLC header of the AL-X-UFINAL PDU is one bit longer than the LLC header of the AL-X-UDATA PDU. Therefore there are occasional cases when the last part of the TL-SDU (and FCS when used) just fits within an AL-X-UDATA PDU but would not fit within an AL-X-UFINAL PDU. In these cases, the BS LLC may send the last part of the TL-SDU (and FCS when used) within an AL-X-UDATA PDU and then send an empty AL-X-UFINAL PDU (i.e. containing no information after the FCS flag) to complete the TL-SDU transmission.

Therefore the LLC MS entity may occasionally receive an AL-X-UFINAL PDU containing no information after the FCS flag. The AL-X-UFINAL PDU indicates the termination of the TL-SDU so, when all the other segments have been received, those other segments comprise the complete TL-SDU (and FCS when used).

If an MS is receiving more than one unacknowledged advanced link, the procedures for each advanced link operate independently of the procedures for the other advanced link(s).

22.3.4.3 Sliding SDU window in unacknowledged service

The BS LLC should send unacknowledged data using a TL-SDU window size of 1 to the maximum N.281. This means that the BS LLC may transmit with any repetitions up to N.281 different TL-SDUs at any time. The BS LLC may start to send a new TL-SDU if its window is not currently full. If the BS LLC wishes to send a new TL-SDU when its window is full then it may either:

- wait until all repetitions of the oldest TL-SDU in the window are completed and then start to send the new TL-SDU; or
- cease transmission of the oldest TL-SDU in the window (including any repetitions) and start to send the new TL-SDU.

The BS LLC indicates the TL-SDU window size at the establishment of the advanced link by sending one or more AL-SETUP PDUs.

NOTE: The window size N.281 may be larger for an extended advanced link than for the original advanced link.

22.3.4.4 Disconnection of unacknowledged data transfer

The BS may disconnect an unacknowledged service by sending one or more AL-DISC PDUs. When the MS receives an AL-DISC PDU it shall discard all partially received TL-SDUs on this advanced link and cease reception of all AL-UDATA PDUs (in the case of the original advanced link) or AL-X-UDATA PDUs (in the case of an extended advanced link).

22.3.5 Channel change request handling

The MAC layer may issue with TMA-UNITDATA indication primitive "channel change response required" parameter with value "true" indicating that an upper layer shall provide a response to MAC layer.

Upon reception of a "channel change response required" in a TMA-UNITDATA indication primitive:

- if the TMA-UNITDATA indication primitive contains a TL-SDU, the LLC shall pass the request to MLE in the corresponding TL-UNITDATA indication primitive;
- if the TMA-UNITDATA indication primitive contains no TL-SDU and the endpoint identifier refers to an advanced link service MAC resource, the LLC may pass the request to the MLE in a TL-REPORT indication primitive or decide to accept or reject the request based on the other LLC services and their importance;

NOTE 1: The same endpoint identifier refers to the advanced link(s) and to the related basic link when advanced link(s) exist.

NOTE 2: The service importance determination at the LLC is outside the scope of the present document.

- if the TMA-UNITDATA indication primitive contains no TM-SDU and the endpoint identifier refers only to the basic link service MAC resource and there is only a single user of LLC services, the LLC shall pass the request to the MLE in a TL-REPORT indication primitive;

NOTE 3: How LLC knows the number of service users is outside the scope of the present document.

- in other cases the actions are outside the scope of the present document.

The MAC layer may issue TMC-CONFIGURE indication primitive due to various resource conflicts. Upon reception of a TMC-CONFIGURE indication primitive with reason "loss of physical resources", the LLC shall indicate to the MLE in a TL-CONFIGURE indication primitive the loss of physical resources for that endpoint identifier. Also:

- if the TMC-CONFIGURE indication primitive is related to an advanced link and the MS supports advanced link continuation and there are one or more uncompleted TL-SDUs in the send or reception buffer, the LLC shall retain the advanced link for a potential continuation without sending any new TMA-UNITDATA request primitives for that advanced link;

NOTE 4: Only SNDCP layer can support advanced link continuation by the MS, refer to clause 28, and any upper layers may disconnect locally the advanced link by a TL-RELEASE request primitive. However, use of the advanced link may continue if the LLC receives data from the BS on the retained advanced link.

- if the TMC-CONFIGURE indication primitive is related to an advanced link and the MS supports advanced link continuation but there are no uncompleted TL-SDUs in the send or reception buffer, the LLC shall either:
 - locally disconnect the advanced link; or
 - retain the advanced link for a potential continuation without sending any new TMA-UNITDATA request primitives for that advanced link;
- if the TMC-CONFIGURE indication primitive is related to an advanced link (or links) and the MS does not support advanced link continuation, the LLC shall locally disconnect the advanced link (or links).

Upon reception of a TMC-CONFIGURE indication primitive with reason "gain of physical resources" the LLC may continue to use the indicated MAC resource.

NOTE 5: Before LLC can use the resource for a retained advanced link, the continuation of the link is first invoked by upper layer actions (refer to clause 28) or the LLC receives data from the BS on the retained advanced link.

The MAC layer may also issue a TMA-RELEASE indication primitive due to loss of radio resources, when the loss is detected locally without a signalling from BS. The LLC behaviour is defined in clause 22.3.3.4.

22.3.6 Activity handling

On reception of a TL-CONFIGURE request primitive and the MLE activity indicator parameter has sleep mode value "stay alive" the LLC shall send a TMC-CONFIGURE request primitive with MLE activity indicator parameter set to value "stay alive".

On reception of a TL-CONFIGURE request primitive and the MLE activity indicator parameter has sleep mode value "sleep permitted" the LLC shall check whether an advanced link is in advanced link establishment or reset phase, see clause 22.3.3.1, LLC advanced link reconnection phase, see clause 22.3.3.5 or in advanced link disconnection phase, see clause 22.3.3.3. If no advanced link is in any of those states, then the LLC shall send a TMC-CONFIGURE request primitive with MLE activity indicator parameter set to value "sleep permitted".

Upon the start of an advanced link establishment or reset phase, see clause 22.3.3.1, LLC advanced link reconnection phase, see clause 22.3.3.5 or advanced link disconnection phase, see clause 22.3.3.3, the LLC shall send a TMC-CONFIGURE request primitive with MLE activity indicator parameter set to value "stay alive", if LLC has not yet informed MAC to stay alive.

When all ongoing advanced link establishment or reset, LLC advanced link reconnection or advanced link disconnection phases have been completed, the LLC shall send a TMC-CONFIGURE request primitive with MLE activity indicator parameter set to value "sleep permitted" unless the MLE has asked in a TL-CONFIGURE request primitive to "stay alive".

NOTE: The MLE activity indicator parameter is used by the MS-MAC in its procedure to decide when it may use the energy economy sleeping cycle (see clause 23.7.6) or the dual watch reception cycle (see clause 23.7.7) or part-time reception on a multi-slot MCCH-Q (see clause 23.7.8).

22.3.7 Layer 2 signalling procedures

22.3.7.0 General

The layer 2 signalling PDUs carry various types of general signalling information relating to layer 2 functions - either LLC or MAC functions. For convenience, the layer 2 signalling PDUs are treated as LLC PDUs in the PDU structures.

In the present document, the layer 2 signalling PDUs are used only for MAC functions.

The LLC procedures in an MS for layer 2 signalling are described in the following clauses.

22.3.7.1 Layer 2 signalling procedures (sending entity)

During sending of layer 2 signalling data corresponding to a MAC function, the LLC may receive:

- a) a TLE-UNITDATA request primitive from the MAC and then the LLC shall:
 - store the message in PDU priority order into the sending buffer for sending $N.293 + 1$ times; and
 - indicate new data in the sending buffer to the formatter using the DATA_IN_BUFFER signal;
- b) a MAC-READY signal from the formatter and then the LLC shall form the highest priority layer 2 signalling PDU and issue it to the formatter;

NOTE 1: The formatter delivers the PDU to the MAC using a TMA-UNITDATA request primitive.

- c) a TLE-CANCEL request primitive from the MAC and then:
- if the LLC has already transferred the message to the MAC, it shall issue a TMA-CANCEL request primitive; on receipt of a TMA-REPORT indication primitive indicating the result of the cancellation, the LLC shall note whether the TM-SDU was completely sent;
 - the LLC shall inform the MAC whether the layer 2 signalling message was completely sent at least once, using a TLE-REPORT indication primitive; and
 - the LLC shall delete the message from the sending buffer;
- d) a TMA-REPORT indication primitive confirming the handle to the request;
- e) a TMA-REPORT indication primitive (first complete transmission by random access), and then the LLC shall inform the MAC that the message has been completely transmitted once using a TLE-REPORT indication primitive;
- f) a TMA-REPORT indication primitive (successful complete transmission by random access), and then the LLC shall:
- inform the MAC that the transfer of the layer 2 signalling message was completed by random access, using a TLE-REPORT indication primitive; and
 - delete the message from the sending buffer;
- g) a TMA-REPORT indication primitive (complete transmission by stealing or by reserved access), and then, if that message has now been completely transmitted once, the LLC shall inform the MAC using a TLE-REPORT indication primitive; also, if the message has now been completely transmitted $N.293 + 1$ times, the LLC shall:
- inform the MAC that the transfer of the layer 2 signalling message was completed, using a TLE-REPORT indication primitive; and
 - delete the message from the sending buffer;
- h) a TMA-REPORT indication primitive (failure of fragmentation process) and then:
- if $N.293 > 0$, the LLC shall try to re-send the layer 2 signalling message so that there shall be at maximum $N.293 + 1$ failed transmissions (in addition to the $N.293 + 1$ complete transmissions); if there have not been $N.293 + 1$ complete transmissions when the maximum number of failed transmissions $N.293 + 1$ has been reached, then the LLC shall:
 - inform the MAC that the transfer of the layer 2 signalling message failed, using a TLE-REPORT indication primitive; and
 - delete the message from the sending buffer;
 - if $N.293 = 0$, the LLC shall try to re-send the layer 2 signalling message so that there shall be at maximum two failed transmissions (or the message has been completely transmitted); if there has not been one complete transmission when the maximum of two failed transmissions has been reached, then the LLC shall:
 - inform the MAC that the transfer of the layer 2 signalling message failed, using a TLE-REPORT indication primitive; and
 - delete the message from the sending buffer;
- i) a TMA-REPORT indication primitive (random access failure) and then the LLC shall:
- inform the MAC that the transfer of the layer 2 signalling message failed, using a TLE-REPORT indication primitive; and
 - delete the message from the sending buffer.

- NOTE 2: The MAC may indicate the required number of repetitions (i.e. N.293) in the TLE-UNITDATA request primitive, in which case that value is applied for transmission of the message. If the MAC does not indicate the required number of repetitions, the value of N.293 chosen by the MS designer is used (see annex A).
- NOTE 3: The MS may send more than one layer 2 signalling message in one MAC block (using MAC PDU association).
- NOTE 4: For $N.293 > 0$, the MS should not send the same layer 2 signalling message more than once in one MAC block. The layer 2 signalling service does not guarantee in-order delivery at the receiving entity. Therefore, in order to use the capacity of MAC blocks by PDU association, the MS may interleave retransmissions of multiple layer 2 signalling messages.
- NOTE 5: In the DATA_IN_BUFFER signal, the LLC may include all outstanding layer 2 signalling messages as outstanding data ready to be sent, so that the MAC can indicate a reservation requirement for that data.
- NOTE 6: When appropriate, the information in an L2-LINK-FEEDBACK-INFO PDU may be combined into an AL-X-ACK or AL-X-RNR PDU; or the information in an L2-LINK-FEEDBACK-INFO and L2-DATA-PRIORITY PDU may be combined as an L2-LINK-FEEDBACK-INFO-AND-RESIDUAL-DATA-PRIORITY PDU. According to the protocol model, the combining is performed as described in clause 22.3.1.7.3.2.

22.3.7.2 Layer 2 signalling procedures (receiving entity)

Upon reception of a layer 2 signalling PDU from the formatter:

- in the case of an L2-SCHEDULE-SYNC or L2-LINK-FEEDBACK-CONTROL or L2-LINK-FEEDBACK-INFO PDU, the LLC shall inform the MAC of the contents of the PDU using a TLE-UNITDATA indication primitive.

- NOTE 1: In the present document, the L2-SCHEDULE-SYNC, L2-LINK-FEEDBACK-CONTROL and L2-LINK-FEEDBACK-INFO PDUs are the only types of layer 2 signalling PDU that the MS expects to receive.
- NOTE 2: The layer 2 signalling protocol does not suppress received duplicates.
- NOTE 3: The formatter receives the PDU from the MAC in a TMA-UNITDATA indication primitive.
- NOTE 4: The MS may also receive link adaptation feedback information within an AL-X-ACK or AL-X-RNR PDU. According to the protocol model, the formatter generates an L2-LINK-FEEDBACK-INFO PDU containing the link adaptation feedback information, as described in clause 22.3.1.7.3.1.

23 MAC protocol

23.0 General

This clause describes the V+D air interface layer 2 MAC protocol. It defines the operation of the MAC layer in the MS and includes some corresponding rules for the operation of the BS. However, the exact rules for how the BS allocates resources to MSs are outside the scope of the present document.

See ETSI EN 300 392-1 [6], clause 6 for the general architecture and a description of all layers including the functionality of the MAC sub-layer (see clause 19 for the architecture of the DLL). MAC timers and constants are defined in annex B.

23.1 MAC services

23.1.1 Functions of MAC

In the protocol model, internal communication between the LLC and the MAC uses three SAPs TMA-SAP, TMB-SAP and TMC-SAP for services provided by the MAC to the LLC, corresponding to signalling, broadcast and layer management functions respectively. A fourth SAP, the TMD-SAP, supports traffic in circuit mode; this service is offered directly from the MAC to the U-plane application (e.g. the CODEC).

Internal communication between the LLC and the MAC also uses a further SAP, TLE-SAP, for the layer 2 signalling service provided by the LLC to the MAC.

The MAC itself is divided into two sub-layers, i.e. the upper and lower MAC.

The lower MAC performs the channel coding, interleaving and scrambling, as described in clause 8. The upper MAC performs the other MAC protocol functions and is described within clause 23. Unless specified otherwise, references to "the MAC" throughout clause 23 mean the upper MAC.

The principal functions of the upper MAC are as follows:

- frame and multiframe synchronization;
- multiplexing/de-multiplexing of the logical channels;
- radio path establishment and channel allocation (for common control channels and for assigned channels);
- address management for the layer 2 address (the source address for the uplink, the destination address for the downlink);
- fragmentation of long messages received from the LLC (subdividing the LLC message between more than one MAC block);
- association of short messages received from the LLC (enabling more than one message to be sent within one MAC block);
- management of power control;
- the random access procedure (contention control);
- granting and use of reserved slots i.e. non-contentious slots reserved by the BS for one MS to send signalling message(s);
- path loss calculation: surveillance of the serving cell, monitoring and scanning of adjacent cells, monitoring of irregular channels and assessment of channel classes;
- energy economy, part-time reception and napping operation;
- short-term data priority procedure;

- link adaptation on D8PSK and QAM channels;
- providing service to circuit mode applications (e.g. speech CODEC or circuit mode data) on $\pi/4$ -DQPSK channels;
- stealing from the traffic channel capacity, when required, to send signalling messages on $\pi/4$ -DQPSK channels.

23.1.2 Service primitives

23.1.2.0 General

The MAC protocol is described in terms of primitives and valid sequences of actions resulting from those primitives. Refer to clause 20 for a detailed description of the service primitives.

The use of primitives throughout clause 23 refers to the protocol definition, but does not imply any specific implementation. The MAC boundary, as for other internal boundaries, is defined to clarify the protocol description. The word "shall" is used to describe the SAPs and primitives for traceability reasons in the protocol model, but those SAPs and primitives are not testable.

23.1.2.1 Services at the TMA-SAP

23.1.2.1.0 General

The TMA-SAP shall be used for the transmission of signalling and packet data information over the air interface. Service data units, TM-SDUs, shall be transferred to and from the LLC using the TMA-UNITDATA primitive. (The TM-SDU is the LLC PDU, including the LLC header and optional FCS.)

- The TMA-UNITDATA request primitive from LLC to MAC shall be used when the LLC wishes to send data to the peer entity.
- The TMA-UNITDATA indication primitive from MAC to LLC shall be used to deliver data received from the peer entity.

The MAC in the MS (MS-MAC) shall report the progress of a request procedure locally to the LLC using the TMA-REPORT indication primitive. The LLC may abort a TMA-UNITDATA request using the TMA-CANCEL request primitive.

The random access protocol is generally needed when the MS sends a message to initiate a call or transaction. However, when an MS is required to send a solicited message or when it has further signalling to send after the initial access, the BS may reserve slots for that particular MS. This enables a higher channel throughput to be achieved. Also the MS at SNDCP level may negotiate that the BS will grant reserved capacity with a specified repetition period (and specified timing accuracy), in order to support an application which requires regular transmissions of bursts of data; this is called scheduled access. When the schedule becomes active, the BS should reserve slots for that MS without the MS needing to use random access.

On a control channel, MSs may transmit only by random access or reserved access. Whereas, during a circuit mode call, the transmitting MS may "steal" from the traffic channel capacity to send signalling messages.

The signalling service offered by the MS-MAC to the LLC shall be an unacknowledged service in the case of non-contentious transmission (i.e. reserved access or stealing). The MAC receives a TM-SDU from the LLC, transmits the TM-SDU (in one or more MAC blocks) and then reports to the LLC when the message has been sent. Acknowledgements and retransmissions are under the control of the LLC.

However, for contentious access (i.e. random access), the MS-MAC is responsible for sending retries until it receives a MAC response from the BS indicating successful random access. The report to the LLC shall then indicate that the BS has acknowledged the random access message.

TMA-SAP signalling messages may generally be sent using the MAC-RESOURCE or MAC-D-BLCK PDU for the downlink, or the MAC-ACCESS PDU (in a subslot) or MAC-DATA or MAC-U-BLCK PDU (in a full slot) for the uplink. A general scenario for an exchange of two LLC messages is shown in figure 23.1. (Other PDUs, MAC-FRAG and MAC-END(-HU), are used for continuations and end of a fragmented TM-SDU.)

The uplink MAC-ACCESS, MAC-DATA and MAC-U-BLCK PDUs include the layer 2 address and usually carry a TM-SDU; they can also be used to request reserved slots for signalling messages. On the downlink, the MAC-RESOURCE PDU usually includes layer 2 addressing and may contain a TM-SDU; the MAC-D-BLCK PDU includes a layer 2 address and may contain a TM-SDU. The MAC-RESOURCE PDU may also include elements for granting reserved slots and/or for channel allocation and/or for power control, and the MAC-D-BLCK PDU may include an element for granting reserved slots. The MAC PDUs are defined in clause 21.

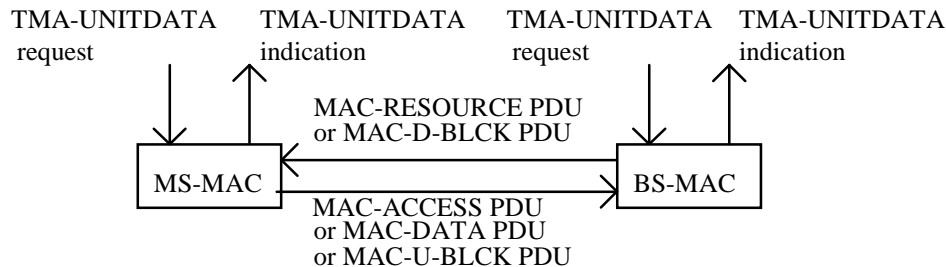

Figure 23.1: Scenario for exchange of two LLC messages

23.1.2.1.1 Reports

When the MS-MAC receives a TMA-UNITDATA request primitive from the LLC, the primitive includes a local identifier for the service request, referred to as the "handle to the request". The handle should be retained locally and used for routing subsequent reports (TMA-REPORT indication primitive). It refers to all actions required in the MAC to accomplish the request.

The MS-MAC shall issue reports to the LLC at the following times:

- i) first transmission of complete TM-SDU by random access;
- ii) when the BS acknowledges reception of a complete TM-SDU sent by random access;
- iii) complete TM-SDU (or final fragment of a fragmented TM-SDU) has been sent by reserved access or by stealing;
- iv) random access failure;
- v) failure of fragmentation process (TM-SDU not completely sent).

Also, in the case of a TMA-CANCEL request primitive, the MS-MAC shall report whether or not the TM-SDU has been completely sent.

After sending reports ii), iii), iv), v), or after cancellation, the MS-MAC shall regard the requested procedure as complete. The MS-MAC shall discard the TM-SDU and the handle becomes invalid.

23.1.2.1.2 Buffering mechanism

When the MS-MAC receives a downlink PDU addressed to that MS, it shall immediately deliver any TM-SDU to the LLC using the TMA-UNITDATA indication primitive (except in the case of a fragmented message, when the MS-MAC shall reconstruct the entire TM-SDU before delivering it to the LLC).

For an MS sending PDUs, there may be many messages to be sent. For the purposes of the protocol description, it is assumed that the layer 2 queue of messages is held in the LLC and that the MAC has a single-message sending buffer only.

According to this protocol description, there shall be two related signals between MS-MAC and MS-LLC.

- i) DATA-IN-BUFFER signal from LLC to MAC.

This shall indicate:

- the total amount of outstanding signalling data that the LLC has ready to send for a particular address on the channel corresponding to the specified endpoint identifier, and not yet given to the MAC;

- if the channel corresponding to the specified endpoint identifier is a $\pi/4$ -DQPSK channel and the MS supports data priority: the subdivision of the outstanding data into data priorities;
- if the channel corresponding to the specified endpoint identifier is a D8PSK or QAM channel: the subdivision of the outstanding data into data categories;
- if the channel corresponding to the specified endpoint identifier is a D8PSK or QAM channel and the MS supports data priority: the subdivision of the outstanding data into data categories and data priorities.

It shall also indicate:

- the maximum value of the stealing permission parameter for the messages in the LLC queue for that address and channel;
- the maximum value of the PDU priority parameter for unscheduled messages in the LLC queue for that address and channel;
- if the MS supports data priority:
 - the maximum value of the data priority parameter for the messages in the LLC queue for that address and channel; and
 - the type of the next message currently expected to be sent for that address and channel i.e. whether the next message will contain packet data or not;
- whether all, some or none of the messages in the LLC queue for that address and channel are fully scheduled data, and the lowest value of the maximum schedule interval for any fully scheduled data;
- the maximum value of the PDU priority parameter for fully scheduled messages in the LLC queue for that address and channel.

These parameters enable the MAC to decide on the appropriate means to transfer the information before receiving the actual service request.

ii) MAC-READY signal from MAC to LLC.

This signal shall be issued to the LLC when the MS-MAC is ready to send a MAC block.

If the MS is on a $\pi/4$ -DQPSK channel, it shall indicate:

- the maximum size of TM-SDU that can be carried within the MAC PDU that the MS-MAC intends to send, i.e. the maximum size without requiring fragmentation.

If the MS is on a D8PSK channel, it shall indicate:

- the data categories for which a TM-SDU may be sent in the current MAC block;
- the maximum size of TM-SDU that can be carried in the current MAC block for each data category for which a TM-SDU may be sent (i.e. the maximum size without requiring fragmentation).

If the MS is on a QAM channel, it shall indicate:

- the current normal data segment size for advanced link data segments;
- the data categories for which a normal advanced link data segment may be sent in the current MAC block;
- the data categories for which a TM-SDU may be sent in the current MAC block;
- the maximum size of TM-SDU that can be carried in the current MAC block for some or all of the data categories for which a TM-SDU may be sent (i.e. the maximum size without requiring fragmentation).

It shall also indicate the absolute maximum size of TM-SDU that can be handled in the MAC at this time. This is normally the maximum size of fragmented TM-SDU (up to N.202 bits), but shall be reduced in the case of stealing to either the size of the MAC block or to the capacity of two half slots if two-half-slot stealing is appropriate at this time.

On receipt of the MAC-READY signal, the LLC will usually issue a TMA-UNITDATA request primitive to the MAC (see also clause 22).

NOTE: The ISSI and its associated ASSI are equivalent for the purposes of the buffering mechanism, so the MS may use the same signal for the ISSI and ASSI.

23.1.2.1.3 Usage of signals

This clause describes the usage of the MAC-READY and DATA-IN-BUFFER signals. The actual MAC procedures for fragmentation, association, random access, reserved access and stealing are described later in clause 23.

The procedures a), b) and c) below relate to the protocol model of the interface with the LLC and do not imply any specific implementation.

a) Random access

If the DATA-IN-BUFFER signal from the LLC indicates that there is only unscheduled data to send, and if the MS-MAC has neither been granted any reserved slots nor asked for reserved slots for that address on that channel, then the MS-MAC should prepare to initiate the random access procedure. The MS-MAC shall issue the MAC-READY signal to the LLC. On a $\pi/4$ -DQPSK or D8PSK channel, the MAC-READY signal indicates the available size of TM-SDU within the MAC-ACCESS PDU. On a QAM channel, the MAC-READY signal indicates that there are no data categories for which a normal advanced link data segment may be sent in this MAC block; it may indicate the available size of TM-SDU within the MAC-ACCESS PDU:

- i) If the LLC issues a TMA-UNITDATA request primitive containing a TM-SDU that fits within the MAC block then the MAC-ACCESS PDU shall carry that TM-SDU. If there is still space within the MAC block for another PDU by association, the MS-MAC may repeat the MAC-READY/TMA-UNITDATA exchange process as required until there is not space for another MAC header.
- ii) If the LLC issues a TMA-UNITDATA request primitive containing a TM-SDU that does not fit within the MAC-ACCESS PDU then the MAC-ACCESS PDU shall carry a first fragment of the TM-SDU, using the fragmentation procedure and including a request for reserved capacity within the MAC-ACCESS PDU.
- iii) If the LLC does not issue a TMA-UNITDATA request primitive then the MAC-ACCESS PDU shall contain a request for reserved capacity but shall not carry a TM-SDU. This case may arise if the LLC has only advanced link messages to send at this time.

NOTE 1: The maximum available size of TM-SDU in the MAC-ACCESS PDU is variable, depending on whether the MS requests reserved capacity for further signalling.

NOTE 2: On a $\pi/4$ -DQPSK or D8PSK channel, the random access message is always sent using $\pi/4$ -DQPSK modulation (on SCH/HU). On a QAM channel, the random access message is always sent using 4-QAM modulation with coding rate = 1/2 and within a 25 kHz bandwidth (on SCH-Q/RA).

b1) Reserved access on a $\pi/4$ -DQPSK channel

When the MS-MAC has a reserved slot (or subslot) individually granted to it by the BS then, if it is already in the process of sending a fragmented TM-SDU, it shall send the next fragment. (In the case of a final fragment, if there is still space within the MAC block for another PDU by association, the MS-MAC may issue the MAC-READY signal as described below.) Or, if there is no data in the LLC buffer for that address and channel, the MS-MAC may send the Null PDU.

Otherwise, just before the transmission is due, the MS-MAC shall issue the MAC-READY signal to the LLC, announcing the maximum available size of TM-SDU in this MAC block (i.e. for a full slot, the maximum size of TM-SDU in a MAC-U-BLCK PDU (if supported and the MS has an event label) or otherwise in a MAC-DATA PDU; for a subslot, the maximum size of TM-SDU in a MAC-ACCESS PDU):

- i) If the LLC issues a TMA-UNITDATA request primitive containing a TM-SDU that fits within the MAC block then:
 - for a full slot, a MAC-DATA or MAC-U-BLCK PDU shall carry that TM-SDU; use of MAC-U-BLCK is appropriate if the MS has an event label and the TM-SDU occupies all, or most of, the MAC block;
 - for a subslot, a MAC-ACCESS PDU shall carry that TM-SDU.

In the case of a MAC-DATA or MAC-ACCESS PDU, if there is still space within the MAC block for another PDU by association, the MS-MAC may repeat the MAC-READY/TMA-UNITDATA exchange process as required until there is not space for another MAC header.

- ii) If the LLC issues a TMA-UNITDATA request primitive containing a TM-SDU that does not fit within the MAC block then the MAC-DATA PDU (for a full slot) or MAC-ACCESS PDU (for a subslot) shall carry a first fragment of the TM-SDU, using the fragmentation procedure and including a request for reserved capacity within the MAC-DATA or MAC-ACCESS PDU.
- iii) If the LLC does not issue a TMA-UNITDATA request primitive but the DATA-IN-BUFFER signal indicates that there is data to send then the MAC-DATA or MAC-ACCESS PDU shall contain a request for reserved capacity but shall not carry a TM-SDU. This case should not occur for the first PDU in a reserved full slot.

NOTE 3: The timing of the MAC-READY signal should be as late as possible, to allow the maximum time if the layer 3 in the MS is preparing a response to a BS message.

b2) Reserved access on a D8PSK channel

When on a D8PSK channel, the MS-MAC maintains an assessment of the appropriate modulation (i.e. $\pi/4$ -DQPSK or $\pi/8$ -D8PSK) for reserved access transmission for each of the data categories; see clause 23.4.9.

When the MS-MAC has a reserved slot (or subslot) individually granted to it by the BS then, if it is already in the process of sending a fragmented TM-SDU, it shall send the next fragment. (In the case of a final fragment, if there is still space within the MAC block for another PDU by association, the MS-MAC may issue the MAC-READY signal as described below.) Or, if there is no data in the LLC buffer for that address and channel, the MS-MAC may send the Null PDU.

Otherwise, just before the transmission is due, the MS-MAC shall issue the MAC-READY signal to the LLC, announcing the maximum available size of TM-SDU in this MAC block for each data category.

NOTE 4: The maximum available size of TM-SDU will take one of two values, depending on whether the MS-MAC would send data for each data category using $\pi/4$ -DQPSK or $\pi/8$ -D8PSK modulation. So, for example, if the MS-MAC currently intends to send the first transmission(s) of any advanced link segments for background class data using $\pi/8$ -D8PSK modulation, but would send the first transmission(s) of advanced link segments for telemetry class data using $\pi/4$ -DQPSK modulation, the information in the MAC-READY signal enables the LLC to cut new advanced link segments of the appropriate size.

Any TMA-UNITDATA request primitive issued by the LLC indicates the data category for the TM-SDU:

- i) If the LLC issues a TMA-UNITDATA request primitive containing a TM-SDU that fits within the MAC block using the modulation appropriate for the indicated data category then:
 - for a full slot, a MAC-DATA or MAC-U-BLCK PDU shall carry that TM-SDU; use of MAC-U-BLCK is appropriate if the MS has an event label and the TM-SDU occupies all, or most of, the MAC block;
 - for a subslot, a MAC-ACCESS PDU shall carry that TM-SDU.

In the case of a MAC-DATA or MAC-ACCESS PDU, if there is still space within the MAC block for another PDU by association, the MS-MAC may repeat the MAC-READY/TMA-UNITDATA exchange process as required until there is not space for another MAC header.

In the second (and subsequent) MAC-READY signal for a MAC block, the MS-MAC shall indicate the data categories for which a TM-SDU may be sent and the maximum available size of TM-SDU in this MAC block for each data category.

EXAMPLE 1: If the first TM-SDU can be sent using $\pi/8$ -D8PSK modulation and fits within a $\pi/8$ -D8PSK MAC block (with space remaining) but would not fit within a $\pi/4$ -DQPSK MAC block then, in the second MAC-READY signal, the MS-MAC should not invite data for data categories that need to use $\pi/4$ -DQPSK modulation. If the first TM-SDU can be sent using $\pi/8$ -D8PSK modulation but would fit within a $\pi/4$ -DQPSK MAC block (with space remaining) then, in the second MAC-READY signal, the MS-MAC may choose to invite data for all data categories.

If the second (or subsequent) TMA-UNITDATA request primitive indicates a data category for which a different modulation is appropriate, it is expected that the MS-MAC would use the lower of the modulation levels.

- ii) If the LLC issues a TMA-UNITDATA request primitive containing a TM-SDU that does not fit within the MAC block using the modulation appropriate for the indicated data category then the MAC-DATA PDU (for a full slot) or MAC-ACCESS PDU (for a subslot) shall carry a first fragment of the TM-SDU, using the fragmentation procedure and including a request for reserved capacity within the MAC-DATA or MAC-ACCESS PDU.
- iii) If the LLC does not issue a TMA-UNITDATA request primitive but the DATA-IN-BUFFER signal indicates that there is data to send then the MAC-DATA or MAC-ACCESS PDU shall contain a request for reserved capacity but shall not carry a TM-SDU. This case should not occur for the first PDU in a reserved full slot.

After performing the above process, the MS-MAC should use the appropriate modulation according to the data category (or categories) of the PDU(s) but with the following exception: if the appropriate modulation for the PDU(s) to be sent in a MAC block is $\pi/8$ -D8PSK according to the data category (or categories), but the PDU(s) would actually fit within a $\pi/4$ -DQPSK MAC block, the MS-MAC shall use $\pi/4$ -DQPSK modulation.

b3) Reserved access on a QAM channel

When on a QAM channel, the MS-MAC maintains an assessment of the appropriate modulation level and coding rate for reserved access transmission for each of the data categories; see clause 23.4.9.

When the MS-MAC has a reserved slot (or subslot) individually granted to it by the BS then, if it is already in the process of sending a fragmented TM-SDU, it shall send the next fragment. (In the case of a final fragment, if there is still space within the MAC block for another PDU by association, the MS-MAC may issue the MAC-READY signal as described below.) Or, if there is no data in the LLC buffer for that address and channel, the MS-MAC may send the Null PDU.

Otherwise, just before the transmission is due, the MS-MAC shall issue the MAC-READY signal to the LLC, announcing the current normal data segment size for advanced link data segments, the data categories for which a normal advanced link data segment may be sent in the current MAC block and the maximum available size of TM-SDU in this MAC block for appropriate data categories.

NOTE 5: On a 25 kHz or 50 kHz QAM channel, the normal advanced link segment size is determined by the available space in a 4-QAM rate = 1/2 full-slot MAC block at the current bandwidth; on a 100 kHz or 150 kHz QAM channel, the normal advanced link segment size is determined by the available space in half of a 4-QAM rate = 1/2 full-slot MAC block at the current bandwidth.

NOTE 6: In the first MAC-READY signal in a reserved slot, the MS-MAC should allow normal advanced link data segments for all data categories. For a reserved subslot, the MS-MAC should indicate any data categories for which a normal advanced link segment would fit into the subslot using the modulation level and coding rate appropriate for that data category.

Any TMA-UNITDATA request primitive issued by the LLC indicates the data category for the TM-SDU:

- i) If the LLC issues a TMA-UNITDATA request primitive containing a TM-SDU that fits within the MAC block using the modulation level and coding rate appropriate for the indicated data category then:
 - for a full slot, a MAC-DATA or MAC-U-BLCK PDU shall carry that TM-SDU; use of MAC-U-BLCK is appropriate if the MS has an event label and the TM-SDU would occupy all, or most of, the MAC-U-BLCK PDU;
 - for a subslot, a MAC-ACCESS PDU shall carry that TM-SDU.

NOTE 7: The implicit length of the MAC-U-BLCK PDU on a QAM channel is set to correspond to the size of a normal advanced link data segment.

If there is still space within the MAC block for another PDU by association, the MS-MAC may repeat the MAC-READY/TMA-UNITDATA exchange process as required until there is not space for another MAC header.

In the second (and subsequent) MAC-READY signal for a MAC block, the MS-MAC shall indicate the data categories for which a normal advanced link data segment may be sent in the current MAC block, the data categories for which a TM-SDU may be sent and the maximum available size of TM-SDU in this MAC block for appropriate data categories.

EXAMPLE 2: On a 25 kHz or 50 kHz channel, if the first TM-SDU is a normal data segment that can be sent using 16-QAM rate = 1/2, the MS-MAC should not invite any data (either a normal data segment or any other data) for data categories that need to use 4-QAM rate = 1/2. Similarly, on a 25 kHz or 50 kHz channel, if the first TM-SDU is a normal data segment that can be sent using 64-QAM rate = 1/2, the MS-MAC should not invite any data (either a normal data segment or any other data) for data categories that need to use 4-QAM rate = 1/2; however the MS-MAC may choose to invite data (either a normal data segment or any other data) for data categories that need to use 16-QAM rate = 1/2.

If the second (or subsequent) TMA-UNITDATA request primitive indicates a data category for which a different modulation level and/or coding rate is appropriate, it is expected that the MS-MAC would normally use the lower (or lowest) of the modulation levels and/or coding rates.

- ii) If the LLC issues a TMA-UNITDATA request primitive containing a TM-SDU that does not fit within the MAC block using the modulation level and coding rate appropriate for the indicated data category then the MAC-DATA PDU (for a full slot) or MAC-ACCESS PDU (for a subslot) shall carry a first fragment of the TM-SDU, using the fragmentation procedure and including a request for reserved capacity within the MAC-DATA or MAC-ACCESS PDU.
- iii) If the LLC does not issue a TMA-UNITDATA request primitive but the DATA-IN-BUFFER signal indicates that there is data to send then the MAC-DATA or MAC-ACCESS PDU shall contain a request for reserved capacity but shall not carry a TM-SDU. This case should not occur for the first PDU in a reserved full slot.

After performing the above process, the MS-MAC should use the appropriate modulation level and coding rate according to the data category (or categories) of the PDU(s) but with the following exception: if the PDU(s) would actually fit within a MAC block using a lower modulation and/or coding rate, the MS-MAC shall use that lower modulation level and/or coding rate.

NOTE 8: The above procedure relates to the protocol model of the interface with the LLC and does not imply any specific implementation. It may be noted that:

- on a 25 kHz or 50 kHz QAM channel, two, four, three, four or six advanced link data segments can be sent by association within a full slot when using 16-QAM rate = 1/2, 16-QAM rate = 1, 64-QAM rate = 1/2, 64-QAM rate = 2/3 or 64-QAM rate = 1 respectively;
- on a 100 kHz or 150 kHz QAM channel, two, four, eight, six, eight or twelve advanced link data segments can be sent by association within a full slot when using 4-QAM rate = 1/2, 16-QAM rate = 1/2, 16-QAM rate = 1, 64-QAM rate = 1/2, 64-QAM rate = 2/3 or 64-QAM rate = 1 respectively.

According to the protocol model, the data segments are provided by the LLC by using multiple MAC-READY and TMA-UNITDATA request exchanges. However implementers may choose to use a more optimized process.

c) Stealing

When the MS is transmitting in a circuit mode call on a $\pi/4$ -DQPSK channel, and if there is data in the LLC buffer for that channel for which the stealing permission parameter indicates that stealing may be used, then the MS-MAC shall issue the MAC-READY signal to the LLC indicating:

- the size of TM-SDU in this MAC block; and
- the maximum valid size of TM-SDU, given any current stealing limitations.

The fragmentation and association mechanisms may apply as described above for a $\pi/4$ -DQPSK channel. If the LLC does not issue a TMA-UNITDATA request primitive, for example because the message is too long, then the MS-MAC shall not perform the stealing but may use the TMA-SAP procedures (i.e. random access and/or reserved access) to send the messages in the LLC buffer.

NOTE 9: The MAC-U-BLCK PDU cannot be used on the stealing channel.

23.1.2.1.4 Priority, subscriber class and scheduled data information

The TMA-UNITDATA request primitive includes the layer 2 PDU priority of the message, the stealing permission parameter and the subscriber class parameter. The DATA-IN-BUFFER signal indicates the maximum PDU priority and stealing permission parameter in the LLC queue. The DATA-IN-BUFFER signal may also indicate the maximum data priority parameter in the LLC queue and the amount of data in the LLC queue for each data priority (and for each data category on a D8PSK or QAM channel), and may indicate whether the next message to be sent is expected to contain packet data; the TMC-CONFIGURE request primitive may indicate the MS default data priority that the higher layers have negotiated with the SwMI. Also the DATA-IN-BUFFER signal provides information about whether all, some or none of the messages in the LLC queue are fully scheduled data and the lowest value of the maximum schedule interval for any fully scheduled data. The MS-MAC shall use these parameters as follows:

- i) The MS-MAC may need to use the PDU priority and subscriber class parameter from the TMA-UNITDATA request primitive in the random access procedure, if the BS has announced PDU priority or subscriber class restrictions on random access at this time.
- ii) The PDU priority information from the DATA-IN-BUFFER signal may also be used to cut short the reserved access waiting time-out if there is an emergency message in the LLC buffer, so that the MS may initiate the random access procedure.
- iii) The stealing permission parameter may be used to trigger the stealing mechanism.
- iv) The information about the maximum data priority and/or the amount of data in the LLC queue for each data priority, together with the MS default data priority, may be used by the MS-MAC to decide when to send its current short-term data priority requirements to the BS and the appropriate information to include.
- v) The information about whether the LLC currently expects that the next PDU to be sent will contain packet data may be used by the MS-MAC to decide whether it may initiate the random access procedure.
- vi) The information about scheduled data enables the MS-MAC to decide whether and when to use random access to request to send the data in the LLC buffer.

There are eight possible levels of the layer 2 PDU priority, from the lowest priority 0, increasing to the highest priority 7 corresponding to an emergency message.

There are eight defined levels of the data priority and MS default data priority, from the lowest priority 0, increasing to the highest priority 7. Also the data priority parameter may contain the value "undefined", and the MS default data priority parameter may contain the value "not applicable".

There are 16 possible subscriber classes, allowing a population subdivision, e.g. for random access control. The operator defines the values and meaning of each class, and the MS may belong to one or more of those classes. The subscriber class parameter, as supplied in primitives from the higher layers, is a bit-mapped field which indicates, for each class, whether the MS belongs to that class.

The stealing permission parameter defines whether the MAC may use stealing to send this message, if the MS is currently transmitting traffic on a $\pi/4$ -DQPSK channel. It may have the following meanings:

- stealing not required;
- steal when convenient;
- steal within time T.214; or
- steal immediately.

NOTE: If the MS is not transmitting traffic, the MAC ignores the stealing permission parameter.

23.1.2.2 Services at the TMB-SAP

The TMB-SAP shall be used for the transfer of un-addressed system broadcast messages. The primitives shall be TMB-SYNC, TMB-SYSINFO, TMB-SYSINFO-Q, TMB-SYNC-DA and TMB-SYSINFO-DA. The request primitive shall be used in the BS. The indication primitive shall be used in the MS to deliver the TM-SDU to the higher layers.

The corresponding PDUs shall be the SYNC PDU (contained in the BSCH), SYSINFO PDU (contained in the BNCH), SYSINFO-Q PDU (contained in the BNCH-Q), SYNC-DA PDU (contained in the BSCH-Q) and SYSINFO-DA PDU (generally contained in the BNCH-Q). These PDUs contain many MAC elements, and also include a TM-SDU used by the MLE.

NOTE: The SYNC and SYSINFO PDUs are sent only on $\pi/4$ -DQPSK and D8PSK channels. The information from SYNC and SYSINFO PDUs is used by Conventional Access (CA) MSs - and also by Direct Access (DA) MSs when they are on a $\pi/4$ -DQPSK or D8PSK assigned channel.

The SYSINFO-Q PDU is sent only on QAM channels. The information from SYSINFO-Q PDUs is used only by CA MSs, when they are on a QAM assigned channel.

The SYNC-DA is sent only on QAM channels. The information from SYNC-DA PDUs is used only by DA MSs. (The BS should not send the SYNC-DA PDU on an assigned channel if that assigned channel is being used by DA MSs from more than one DA cell.)

The information from SYSINFO-DA PDUs is used only by DA MSs. The SYSINFO-DA PDU is sent mostly on QAM channels, but may also be sent on $\pi/4$ -DQPSK and D8PSK channels.

EXAMPLE: The BS may wish to send the SYSINFO-DA PDU on a $\pi/4$ -DQPSK or D8PSK assigned channel if it moves the DA main carrier while there are DA MSs on the $\pi/4$ -DQPSK or D8PSK assigned channel. (However, the BS should not send the SYSINFO-DA PDU on an assigned channel if that assigned channel is being used by DA MSs from more than one DA cell. Thus this example is not applicable if the $\pi/4$ -DQPSK or D8PSK assigned channel is being used by DA MSs from more than one DA cell.)

23.1.2.3 Services at the TMC-SAP

The TMC-SAP shall be used for the transfer of local layer management information. It provides no data transfer services over the air interface. It shall be used, for example, for the higher layers to instruct the MAC to reconfigure its parameters, for the MLE to direct monitoring and scanning procedures in the MAC and for the MAC to issue reports on progress.

23.1.2.4 Services at the TMD-SAP

The TMD-SAP shall provide the interface between the MAC and the circuit mode U-plane application, e.g. the speech CODEC. It shall be used for the transfer of speech frames or circuit mode data. It shall also be used if the U-plane application steals from the traffic capacity to send encryption synchronization information and/or user-to-user signalling messages.

NOTE: Circuit mode traffic transmission applies only on $\pi/4$ -DQPSK channels.

The TMD-UNITDATA request primitive from the U-plane application to the MAC shall be used when the U-plane application wishes to send data to the peer entity.

The TMD-UNITDATA indication primitive from the MAC to the U-plane application shall be used to deliver data from the peer entity.

There is also a TMD-REPORT indication primitive, which shall be used by the MAC to issue reports to the U-plane application e.g. when the MAC has stolen capacity from the traffic channel.

23.1.2.5 Use of channels and endpoint identifiers

23.1.2.5.1 Channel usage

A Conventional Access (CA) MS receives a $\pi/4$ -DQPSK common control channel, i.e. the MCCH or a $\pi/4$ -DQPSK common SCCH, unless directed by the BS to an assigned channel - assigned for a circuit mode call or for secondary control (see clause 23.3). A $\pi/4$ -DQPSK common control channel comprises one timeslot per TDMA frame, whereas an assigned channel comprises one or more timeslots per TDMA frame. It is optional for a CA MS to be capable of using a multi-slot channel.

NOTE 1: An assigned channel (either a single-slot or a multi-slot channel) may be a $\pi/4$ -DQPSK, D8PSK or QAM channel. It is optional for a CA MS to be capable of using a D8PSK or QAM channel.

A Direct Access (DA) MS receives a QAM common control channel, i.e. the MCCH-Q or a QAM common SCCH, unless directed by the BS to an assigned channel - assigned for secondary control or for a circuit mode call (see clause 23.3). The MCCH-Q comprises one or more timeslots per TDMA frame, whereas a QAM common SCCH comprises only one timeslot per TDMA frame. An assigned channel comprises one or more timeslots per TDMA frame. It is mandatory for a DA MS to be capable of using a multi-slot QAM channel.

NOTE 2: An assigned channel (either a single-slot or a multi-slot channel) may be a QAM, $\pi/4$ -DQPSK or D8PSK channel. It is optional for a DA MS to be capable of using a $\pi/4$ -DQPSK or D8PSK channel.

Support of multi-slot phase modulation channels and multi-slot QAM channels is indicated separately (see clause 16):

- If the MS supports multi-slot phase modulation channels then:
 - if the MS supports $\pi/4$ -DQPSK operation, it shall support at least one-slot and two-slot $\pi/4$ -DQPSK channels; and it is recommended that the MS supports three-slot and four-slot $\pi/4$ -DQPSK channels;
 - if the MS supports D8PSK operation, it shall support at least one-slot and two-slot D8PSK channels; and it is recommended that the MS supports three-slot and four-slot D8PSK channels.
- If the MS supports multi-slot QAM channels, it shall support one-slot, two-slot, three-slot and four-slot QAM channels.

23.1.2.5.2 Endpoint identifiers

The MS may be capable of processing only one channel at a time, either a common control channel or an assigned channel.

Other MSs may be capable of processing more than one channel simultaneously, allowing concurrent MAC services to be provided. The "endpoint identifier" is a local identifier used to distinguish between multiple concurrent service instances.

At the LLC-MAC boundary, the endpoint identifier shall refer to the use of a particular MAC channel, i.e. common control channel or assigned channel. It identifies the MAC channel to which a particular TMA-UNITDATA or TMD-UNITDATA or TLE-UNITDATA primitive (or DATA-IN-BUFFER or MAC-READY signal) applies. There shall be a unique correspondence between the endpoint identifier and the physical channel allocation used in the MAC (i.e. the timeslot for a single-slot channel or timeslots for a multi-slot channel).

NOTE 1: This correspondence is known only within the MAC. The endpoint identifier is used by the higher layers as a label to refer to a particular MAC resource, so the MAC may change (i.e. replace) the actual physical allocation without changing the endpoint identifier.

NOTE 2: A MAC channel may carry both the advanced link and basic link signalling. For the purposes of the procedures for transmission and reception of signalling messages, the MAC does not generally make any distinction between advanced link and basic link messages. However, on a D8PSK or QAM channel, advanced link and basic link messages may be treated differently for link adaptation purposes. Also, on a QAM channel, the MAC is aware of the normal advanced link data segment size.

23.1.3 MS capabilities

23.1.3.0 General

The following clauses describe the capabilities of a frequency full duplex and half duplex MS. All MSs shall provide frequency half duplex capability while an MS may also provide fast switching capability or support frequency full duplex operation.

23.1.3.1 Frequency half duplex operation

23.1.3.1.1 Frequency half duplex capability

A frequency half duplex MS has the ability either to transmit on an uplink frequency or receive on a downlink frequency at any time. It is not able to transmit and receive at the same time. This type of MS also requires time to switch from its transmit to receive frequency. This shall be no more than a timeslot duration.

Figure 23.2 shows the uplink and downlink slots of a single TDMA frame, with "x" marking an example of slots which can be used by a frequency half duplex MS. Only one downlink and the corresponding (same-numbered) uplink slot can be used in a single TDMA frame. If both the uplink and downlink slot in figure 23.2 are used by a single MS, time division duplex operation can be realized allowing a frequency half duplex MS to support single-slot duplex call services.

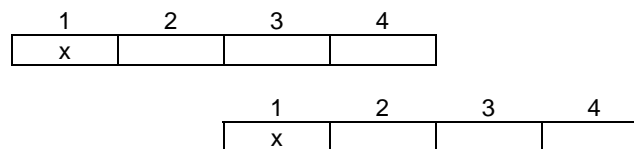

Figure 23.2: Frequency half duplex operation

In the example shown, the MS can receive the downlink slot and also transmit in the corresponding uplink slot. It is also possible for a frequency half duplex MS to operate with a multi-slot channel. However, in this case, the BS should not send signalling messages to that MS when the MS is transmitting traffic or transmitting in reserved slots (or switching from receive to transmit or from transmit to receive).

23.1.3.1.2 Fast switching capability

A frequency half duplex MS may be capable of switching from transmit to receive, and from receive to transmit, between contiguous slots (e.g. capable of transmitting in uplink slot 2 and then receiving in the immediately following downlink slot 1). This type of MS is defined as a fast switching MS. A fast switching MS may fully support e.g.:

- two concurrent single-slot channels; and/or
- a two-slot duplex call service;

provided that the BS allocates the two slots with adjacent numbers (i.e. slots 1 and 2, or 2 and 3, or 3 and 4, or 4 and 1). Figure 23.3 shows the uplink and downlink slots of a single TDMA frame, with "x" marking an example of slots which can be used by a fast switching MS.

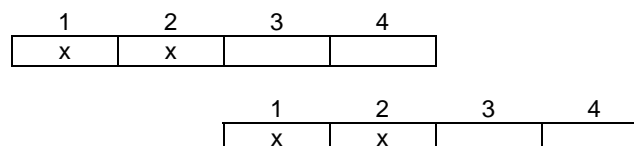

Figure 23.3: Frequency half duplex operation with fast switching capability

NOTE: Fast switching capability on a $\pi/4$ -DQPSK or D8PSK channel is indicated in the "class of MS" element; see clause 16. Fast switching capability on a QAM channel is indicated independently in the "extended capabilities" element; see clause 16.

23.1.3.2 Frequency full duplex operation

A frequency full duplex MS has the ability to transmit on an uplink frequency and receive on a downlink frequency at the same time. Therefore, this type of MS can use all timeslots in a TDMA frame. Figure 23.4 shows the uplink and downlink slots of a single TDMA frame, with "x" marking those slots which can be used by a frequency full duplex MS. Any combination of these slots may be used for a single call or for multiple calls.

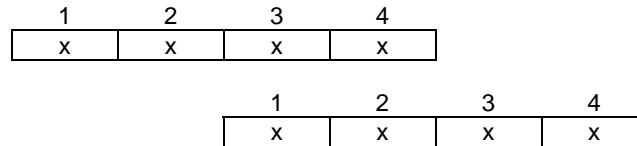

Figure 23.4: Frequency full duplex operation

NOTE: Frequency full duplex capability is indicated in the "class of MS" element; see clause 16.

23.1.3.3 Basic capabilities of the physical layer

The following performance is expected from the physical layer for a TETRA MS.

An MS shall be capable of changing from one frequency to another frequency in less than 1 timeslot duration.

An MS shall be capable of changing from reception to transmission or from transmission to reception in less than 1 timeslot duration.

An MS shall be capable of a combined frequency change and changing from reception to transmission or from transmission to reception in less than 1 timeslot duration.

A fast switching MS shall be capable of changing from reception to transmission or from transmission to reception between contiguous timeslots. Fast switching capability is optional in the MS.

NOTE 1: When changing from one frequency to another frequency, or when combining a frequency change with a change from reception to transmission or from transmission to reception, a fast switching MS operates like a normal frequency half duplex MS i.e. switching in less than 1 timeslot duration.

A frequency full duplex MS shall be capable of changing reception or transmission frequency (or both) in less than 1 timeslot duration. Frequency full duplex operation is optional in the MS.

An MS that is capable of operating on a $\pi/4$ -DQPSK or D8PSK channel should be capable of receiving and decoding the AACH in contiguous timeslots. A CA MS that is capable of operating on a QAM channel should be capable of receiving and decoding the AACH-Q in contiguous QAM timeslots. A DA MS shall be capable of receiving and decoding the AACH-Q in contiguous QAM timeslots.

A CA MS may be capable of receiving or transmitting full slots of information in contiguous timeslots. A DA MS shall be capable of receiving or transmitting full slots of information in contiguous timeslots on a QAM channel i.e. a DA MS shall be capable of using a multi-slot QAM channel. A DA MS may be capable of receiving or transmitting full slots of information in contiguous timeslots on a $\pi/4$ -DQPSK or D8PSK channel.

NOTE 2: When changing from reception, the MS may need to receive the downlink beyond the start of the next slot in order to decode the current slot. Similarly, when changing to reception, the MS may need to start receiving the downlink before the start of the slot in order to decode that slot. This reduces the time available for the change to less than 14,167 ms. See clauses 7, 9.4.3.4 and 9.4.7.4 for the definition of the start of the slot.

23.1.3.4 Modulation and bandwidth capabilities

23.1.3.4.1 General

There are three modulations modes for channels:

- $\pi/4$ -DQPSK (using $\pi/4$ -DQPSK bursts);
- D8PSK (using both $\pi/4$ -DQPSK and $\pi/8$ -D8PSK bursts); and
- QAM (using QAM bursts).

In the case of a $\pi/4$ -DQPSK or D8PSK channel, the bandwidth of the channel is 25 kHz. In the case of a QAM channel, the bandwidth of the channel is 25 kHz, 50 kHz, 100 kHz or 150 kHz.

23.1.3.4.2 MS modulation and bandwidth capabilities

An MS shall support Conventional Access (CA) operation or Direct Access (DA) operation or both (see note 3).

An MS that supports CA operation shall support $\pi/4$ -DQPSK channels. It may support D8PSK channels (see note 2), and it may support QAM channels (see note 3).

An MS that supports DA operation shall support QAM channels. It may support $\pi/4$ -DQPSK channels (see notes 2 and 3), and it may support D8PSK channels (see note 2).

If an MS supports QAM channels:

- it is optional which QAM channel bandwidths the MS supports (see note 3);
- the MS shall support transmission within random access uplink RF channel subslots (which have 25 kHz bandwidth irrespective of the QAM channel bandwidth);

NOTE 1: This requirement applies even if the MS does not support 25 kHz QAM channels.

- the MS shall support 4-QAM and 16-QAM, for both transmission and reception;
- the MS may support 64-QAM (see note 3);
- if the MS supports 64-QAM, it shall support either:
 - 64-QAM transmission and reception; or
 - 64-QAM reception only;
- the MS shall support reception of the following combinations of modulation level and coding rate:
 - 4-QAM, coding rate = 1/2;
 - 16-QAM, coding rate = 1/2; and
 - 16-QAM, coding rate = 1;
- the MS shall support transmission of the following combinations of modulation level and coding rate:
 - 4-QAM, coding rate = 1/2; and
 - 16-QAM, coding rate = 1/2;
- the MS may support transmission of 16-QAM, coding rate = 1;

- additionally, if the MS supports 64-QAM, it shall support reception of the following combinations of modulation level and coding rate:
 - 64-QAM, coding rate = 1/2;
 - 64-QAM, coding rate = 2/3; and
 - 64-QAM, coding rate = 1;
- if the MS supports 64-QAM for transmission, it shall support transmission of the following combinations of modulation level and coding rate:
 - 64-QAM, coding rate = 1/2; and
 - 64-QAM, coding rate = 2/3;

the MS may support transmission of 64-QAM, coding rate = 1.

NOTE 2: These MS capabilities are indicated in the "class of MS" element in the U-LOCATION UPDATE DEMAND PDU; see clause 16.

NOTE 3: These MS capabilities are indicated in the "extended capabilities" element in the U-LOCATION UPDATE DEMAND PDU; see clause 16.

23.1.3.4.3 BS modulation and bandwidth capabilities

A BS that is capable of CA operation shall support $\pi/4$ -DQPSK channels. It may support D8PSK channels (see note 2), and it may support QAM channels (see note 2).

A BS that is capable of DA operation shall support QAM channels. It may support $\pi/4$ -DQPSK channels (see notes 3 and 4), and it may support D8PSK channels (see note 3).

If the BS supports QAM channels:

- it is optional which QAM channel bandwidths the BS supports and provides (see notes 2 and 3);
- the BS shall support reception of random access uplink RF channel subslots (which have 25 kHz bandwidth irrespective of the QAM channel bandwidth);

NOTE 1: This requirement applies even if the BS does not support 25 kHz QAM channels.

- the BS shall support 4-QAM and 16-QAM, for both transmission and reception;
- the BS may support 64-QAM (see notes 5 and 6);
- if the BS supports 64-QAM, it shall support either:
 - 64-QAM transmission and reception; or
 - 64-QAM reception only;
- the BS shall support reception of the following combinations of modulation level and coding rate:
 - 4-QAM, coding rate = 1/2;
 - 16-QAM, coding rate = 1/2; and
 - 16-QAM, coding rate = 1;
- the BS shall support transmission of the following combinations of modulation level and coding rate:
 - 4-QAM, coding rate = 1/2; and
 - 16-QAM, coding rate = 1/2;
- the BS may support transmission of 16-QAM, coding rate = 1;

- additionally, if the BS supports 64-QAM, it shall support reception of the following combinations of modulation level and coding rate:
 - 64-QAM, coding rate = 1/2;
 - 64-QAM, coding rate = 2/3; and
 - 64-QAM, coding rate = 1;
- if the BS supports 64-QAM for transmission, it shall support transmission of the following combinations of modulation level and coding rate:
 - 64-QAM, coding rate = 1/2; and
 - 64-QAM, coding rate = 2/3;

the BS may support transmission of 64-QAM, coding rate = 1.

NOTE 2: For CA, support of these services is indicated in the "extended services broadcast" element in the SYSINFO and SYSINFO-Q PDUs; see clauses 21.4.4.1 and 21.4.4.1a.

NOTE 3: For DA, support of these services is indicated in the "extended DA services broadcast" element in the SYSINFO-DA PDU; see clause 21.4.4.1b. The SYNC-DA PDU also indicates the QAM channel bandwidths that the BS supports on this cell; see clause 21.4.4.2a.

NOTE 4: For DA, support of the TETRA voice service and circuit mode data service is indicated in the "BS service details DA" element in the D-MLE-SYNC-DA and D-MLE-SYSINFO-DA PDUs; see clause 18.

NOTE 5: The BS indicates the maximum modulation level that the MS is permitted to use on the uplink of a QAM assigned channel when it sends the channel allocation.

NOTE 6: For DA, the BS indicates in the SYSINFO-DA PDU the maximum modulation level that a DA MS is permitted to use on the uplink of a QAM common control channel.

23.1.4 Services provided by the LLC to the MAC

As described in clause 23.1, the MAC provides services to the LLC through the TMA-SAP, TMB-SAP and TMC-SAP (and to the U-plane application through the TMD-SAP).

There may be an additional SAP between the LLC and the MAC: the TLE-SAP; this is the layer 2 signalling SAP. The LLC provides a data transfer service to the MAC through this SAP, for layer 2 signalling. Layer 2 signalling PDUs carry various types of general signalling information relating to layer 2 functions; the layer 2 signalling PDUs are treated as LLC PDUs in the PDU structures.

The information transfer service provided by the LLC to the MAC is an unacknowledged service.

NOTE 1: However, if the LLC reports that the message transfer was successfully completed by random access, the MS-MAC can deduce that the message was received by the BS.

The MAC may request the LLC to repeat a layer 2 signalling message, to increase the probability of a correct reception. On reception, the LLC does not suppress received duplicates.

The LLC provides the layer 2 signalling service to the MAC using the following primitives:

- the TLE-UNITDATA request primitive from the MAC to the LLC shall be used when the MAC wishes to send a layer 2 signalling message;
- the TLE-UNITDATA indication primitive from the LLC to the MAC shall be used to deliver a layer 2 signalling message corresponding to a MAC function;
- the LLC shall report the progress of a request procedure locally to the MAC using the TLE-REPORT indication primitive;
- the MAC may abort a TLE-UNITDATA request using the TLE-CANCEL request primitive.

See clause 20 for a detailed description of the service primitives.

The TLE-SAP boundary is defined to clarify the protocol description and does not imply any specific implementation. The word "shall" is used to describe this SAP and the primitives for traceability reasons in the protocol model, but they are not testable.

When the LLC sends or receives a layer 2 signalling PDU, it uses the data transfer service offered by the MAC at the TMA-SAP (similar to the procedures when the LLC sends a PDU as a result of receiving a basic link TL-UNITDATA request primitive from the MLE).

NOTE 2: Therefore, when the MAC wishes to send a layer 2 signalling message, the following process applies according to the protocol model:

- the MAC issues a TLE-UNITDATA request primitive to the LLC containing the information to be sent in the layer 2 signalling PDU;
- the LLC indicates to the MAC that there is data to be sent, using the DATA-IN-BUFFER signal;
- on receipt of an appropriate MAC-READY signal from the MAC, the LLC forms the layer 2 signalling PDU and issues it to the MAC in a TMA-UNITDATA request primitive; this process may be repeated (in different MAC blocks) if the PDU is to be sent more than once;
- on receipt of TMA-REPORT indication primitive(s) from the MAC relating to the layer 2 signalling PDU, the LLC issues TLE-REPORT indication primitive(s) to the MAC in order to report the progress or result of the procedure;
- on receipt of a TLE-CANCEL request primitive from the MAC, the LLC issues a TMA-CANCEL request primitive (if the LLC has issued the message to the MAC); the LLC indicates the result of the cancellation to the MAC using the TLE-REPORT indication primitive.

In the case of reception of a layer 2 signalling message, the following process applies:

- the MAC issues a TMA-UNITDATA indication primitive to the LLC to deliver a received TM-SDU;
- if the received LLC PDU is a layer 2 signalling PDU corresponding to a MAC function, the LLC delivers the information in the PDU to the MAC using a TLE-UNITDATA indication primitive.

In the present document, the layer 2 signalling PDUs are used only for MAC functions - for data priority and link adaptation purposes:

- the MS may send the L2-DATA-PRIORITY PDU; see clause 23.4.7;
- the MS may send the L2-LINK-FEEDBACK-INFO PDU; see clause 23.4.9;
- the BS may send the L2-SCHEDULE-SYNC PDU; see clause 23.5.2.6;
- the BS may send the L2-LINK-FEEDBACK-CONTROL or L2-LINK-FEEDBACK-INFO PDU; see clause 23.4.9.

Also, the MS may send a combined L2-LINK-FEEDBACK-INFO-AND-RESIDUAL-DATA-PRIORITY PDU; however, for the purposes of the protocol model, the combining is performed by the LLC (see clause 22.3.1.7.3) so the MS-MAC does not issue the combined message.

NOTE 3: This does not imply any specific implementation.

23.2 Services provided by the lower MAC and channel modes

23.2.1 Services at the TMV-SAP

In the protocol model, the MAC layer is divided into two sub-layers, i.e. upper and lower MAC, as described in clause 19. The lower MAC shall provide the following services to the upper MAC protocol:

- transfer of MAC PDUs using suitable physical layer bursts in accordance with the chosen TDMA timeslot;
- report of PDU transfer related exceptions;

- signal strength measurement (i.e. RSSI);
- channel coding and scrambling as described in clause 8:
 - Cyclic Redundancy Check (CRC) calculation;
 - Forward Error Correction (FEC) and interleaving of MAC blocks;
 - scrambling and de-scrambling of MAC blocks;
- on a $\pi/4$ -DQPSK or D8PSK channel: choice of training sequence and channel coding corresponding to the slot flag value and vice versa;
- on a D8PSK channel: choice of training sequence corresponding to the modulation and vice versa;
- control of the transmitted power, frequency, frequency band, duplex spacing and precise time synchronization as described in clauses 6 and 10.

The lower MAC provides these services to the upper MAC via the TMV-SAP using the TMV-UNITDATA and TMV-CONFIGURE primitives:

- the TMV-UNITDATA request primitive shall be used to request the lower MAC to transmit a MAC block;
- the TMV-UNITDATA indication primitive shall be used by the lower MAC to deliver a received MAC block;
- the TMV-CONFIGURE primitive shall be used to provide the lower MAC with information about the configuration of the channel or about the format of a received slot.

NOTE 1: More than one TMV-UNITDATA request primitive may be needed to supply the information to be transmitted in a single slot or subslot. Similarly, more than one TMV-UNITDATA indication primitive may be needed to deliver the information received in a single slot (or subslot for the BS).

Tables 23.1 and 23.2 show the correspondence between the TMV-UNITDATA service primitives at the TMV-SAP and the associated parameters in the TMV-UNITDATA service primitive respectively. Table 23.3 shows the parameters in the TMV-CONFIGURE service primitive.

Table 23.1: Correspondence between the upper and lower MAC at the TMV-SAP

Upper MAC Service Primitive	Lower MAC Service Primitive (TMV-SAP)
TMA-UNITDATA request or TMB-SYNC request (BS only) or TMB-SYNC-DA request (BS only) or TMB-SYSINFO request (BS only) or TMB-SYSINFO-Q request (BS only) or TMB-SYSINFO-DA request (BS only) or TMD-UNITDATA request	TMV-UNITDATA request
TMA-UNITDATA indication or TMB-SYNC indication (MS only) or TMB-SYNC-DA indication (MS only) or TMB-SYSINFO indication (MS only) or TMB-SYSINFO-Q indication (MS only) or TMB-SYSINFO-DA indication (MS only) or TMD-UNITDATA indication	TMV-UNITDATA indication

Table 23.2: Parameters used in the TMV-UNITDATA primitive

Parameter	Request	Indication
MAC block	M	M
MAC block length (see note)	M	M
Logical channel (see note)	M	M
QAM random access uplink RF channel subslot (see note)	C	-
CRC pass/fail indication (see note)	-	M
Scrambling code (see note)	M	-
Report (see note)	-	C
NOTE: Not sent over the air interface.		
Key: M: Mandatory; C: Conditional; -: Not used.		

Table 23.3: Parameters used in the TMV-CONFIGURE primitive

Parameter	Request (see note)	Confirm (see note)
Information about channel	C	C
QAM slot format	C	-
Scrambling code for reception	C	-
Energy economy or part-time reception or napping information	C	-
Signalling or traffic mode	C	-
Second half slot stolen	C	-
TCH type and interleaving depth	C	-
Monitoring pattern information	C	-
NOTE: Not sent over the air interface.		
Key: M: Mandatory; C: Conditional; -: Not used.		

The TMV-SAP boundary is defined to clarify the protocol description and does not imply any specific MS implementation. The word "shall" is used to describe this SAP and the primitives for traceability reasons in the protocol model, but they are not testable.

Many of the parameters exchanged at the TMV-SAP are not sent over the air interface but may be deduced from the physical layer transmission or reception. For example, the scrambling code is not sent as part of the information content, but modifies the information so that reception with a wrong scrambling code will generate an erroneous CRC and so the information will be discarded. On the contrary, reception with the correct scrambling code will only be affected by the transmission medium errors.

The MAC block is the SDU from the upper MAC. The size of the MAC block shall be equal to the appropriate SDU size for the logical channel being used. For C-plane signalling, the upper MAC shall assure this size by fragmenting/associating suitably and by using the Null PDU and/or fill bits to make the MAC block up to the required size. The required size for MAC blocks that may contain TMA-SAP C-plane signalling is shown in tables 23.4 and 23.5.

Table 23.4: Size of uplink MAC blocks that may contain TMA-SAP signalling

Logical channel	Size of MAC block [bits]
SCH/HU	92
SCH/F	268
STCH	124
SCH-P8/HU	148
SCH-P8/F	412
SCH-Q/RA	65
SCH-Q/HU25-4H	57
SCH-Q/HU25-16H	133
SCH-Q/HU25-16U	288
SCH-Q/HU25-64H	209
SCH-Q/HU25-64M	285
SCH-Q/HU25-64U	440
SCH-Q/HU50-4H	141
SCH-Q/HU50-16H	301
SCH-Q/HU50-16U	624
SCH-Q/HU50-64H	461
SCH-Q/HU50-64M	621
SCH-Q/HU50-64U	944
SCH-Q/HU100-4H	309
SCH-Q/HU100-16H	637
SCH-Q/HU100-16U	1 296
SCH-Q/HU100-64H	965
SCH-Q/HU100-64M	1 293
SCH-Q/HU100-64U	1 952
SCH-Q/HU150-4H	477
SCH-Q/HU150-16H	973
SCH-Q/HU150-16U	1 968
SCH-Q/HU150-64H	1 469
SCH-Q/HU150-64M	1 965
SCH-Q/HU150-64U	2 960
SCH-Q/U25-4H	181
SCH-Q/U25-16H	381
SCH-Q/U25-16U	784
SCH-Q/U25-64H	581
SCH-Q/U25-64M	781
SCH-Q/U25-64U	1 184
SCH-Q/U50-4H	389
SCH-Q/U50-16H	797
SCH-Q/U50-16U	1 616
SCH-Q/U50-64H	1 205
SCH-Q/U50-64M	1 613
SCH-Q/U50-64U	2 432
SCH-Q/U100-4H	805
SCH-Q/U100-16H	1 629
SCH-Q/U100-16U	3 280
SCH-Q/U100-64H	2 453
SCH-Q/U100-64M	3 277
SCH-Q/U100-64U	4 928
SCH-Q/U150-4H	1 221
SCH-Q/U150-16H	2 461
SCH-Q/U150-16U	4 944
SCH-Q/U150-64H	3 701
SCH-Q/U150-64M	4 941
SCH-Q/U150-64U	7 424

Table 23.5: Size of downlink MAC blocks that may contain TMA-SAP signalling

Logical channel	Size of MAC block [bits]
SCH/F	268
SCH/HD	124
STCH	124
SCH-P8/F	412
SCH-P8/HD	196
SCH-Q/D25-4H	185
SCH-Q/D25-16H	389
SCH-Q/D25-16U	800
SCH-Q/D25-64H	593
SCH-Q/D25-64M	797
SCH-Q/D25-64U	1 208
SCH-Q/D50-4H	421
SCH-Q/D50-16H	861
SCH-Q/D50-16U	1 744
SCH-Q/D50-64H	1 301
SCH-Q/D50-64M	1 741
SCH-Q/D50-64U	2 624
SCH-Q/B50	217
SCH-Q/D100-4H	893
SCH-Q/D100-16H	1 805
SCH-Q/D100-16U	3 632
SCH-Q/D100-64H	2 717
SCH-Q/D100-64M	3 629
SCH-Q/D100-64U	5 456
SCH-Q/B100	689
SCH-Q/D150-4H	1 365
SCH-Q/D150-16H	2 749
SCH-Q/D150-16U	5 520
SCH-Q/D150-64H	4 133
SCH-Q/D150-64M	5 517
SCH-Q/D150-64U	8 288
SCH-Q/B150	1 161

For U-plane signalling on STCH, the MAC block shall comprise a single MAC-U-SIGNAL PDU. For TCH, the MAC block shall comprise a single MAC-TRAFFIC PDU. (For TCH/S, this PDU contains one or two speech frames and, for circuit mode data, it contains data equivalent to a full slot.)

The scrambling code passed to the MAC by the MLE shall be a 24-bit field composed of the MCC and MNC as defined in ETSI EN 300 392-1 [6], clause 7. The MCC and MNC shall be part of the MLE information contained within the SYNC or SYNC-DA PDU broadcast by the BS on the BSCH or BSCH-Q respectively. The upper MAC shall add to this a 6-bit colour code which shall be contained in the SYNC or SYNC-DA PDU. The combination of MCC, MNC and colour code shall make up the scrambling code which the upper MAC shall pass to the lower MAC via the TMV-SAP. This scrambling code shall correspond to the extended colour code used for scrambling and de-scrambling in the lower MAC as defined in clause 8. The scrambling code shall correspond to the 30-bit extended colour code $e(1)$, $e(2)$, ..., $e(30)$ as shown in figure 23.5.

NOTE 2: The SYNC and SYNC-DA PDUs (broadcast on the BSCH and BSCH-Q respectively) are transmitted with all bits $e(1)$, $e(2)$, ..., $e(30)$ set equal to zero; see clause 8.

10 bits Mobile Country Code (MCC) $e(1) - e(10)$ $e(1) = \text{msb of MCC}$	14 bits Mobile Network Code (MNC) $e(11) - e(24)$ $e(11) = \text{msb of MNC}$	6 bits Colour Code $e(25) - e(30)$ $e(25) = \text{msb of Colour Code}$
--	--	---

Figure 23.5: Mapping of scrambling code to extended colour code

23.2.2 PDU mapping of the logical channels at the TMV-SAP

Logical channel definitions are given in clause 9 and an overview of their use may be found in clause 19.

Table 23.6 defines the mapping of the MAC PDUs defined in clause 21 onto the various logical channels.

Table 23.6: Mapping of the MAC PDUs onto the logical channels

MAC PDU	Logical channel(s)	Note
ACCESS-ASSIGN	AACH, AACH-Q	MAC internal information
ACCESS-DEFINE	SCH/HD, SCH/F, STCH, SCH-P8/HD, SCH-P8/F, SCH-Q/D, SCH-Q/B	
QAM-SLOTINFO	SICH-Q/D, SICH-Q/U	
MAC-ACCESS	SCH/HU, SCH-P8/HU, SCH-Q/RA, SCH-Q/HU	TMA-SAP information
MAC-END-HU	SCH/HU, SCH-P8/HU, SCH-Q/HU	
MAC-DATA	SCH/F, STCH, SCH-P8/F, SCH-Q/U	
MAC-U-BLCK	SCH/F, SCH-P8/F, SCH-Q/U	
MAC-RESOURCE	SCH/HD, SCH/F, STCH, SCH-P8/HD, SCH-P8/F, SCH-Q/D, SCH-Q/B	
MAC-D-BLCK	SCH/F, SCH-P8/F, SCH-Q/D, SCH-Q/B	
MAC-FRAG	SCH/HD, SCH/F, SCH-P8/HD, SCH-P8/F, SCH-Q/D, SCH-Q/U, SCH-Q/B	
MAC-END	SCH/HD, SCH/F, STCH, SCH-P8/HD, SCH-P8/F, SCH-Q/D, SCH-Q/U, SCH-Q/B	
MAC-TRAFFIC	TCH	TMD-SAP information
MAC-U-SIGNAL	STCH	
SYNC	BSCH	TMB-SAP information
SYNC-DA	BSCH-Q	
SYSINFO	BNCH on SCH/HD, STCH, SCH-P8/HD, SCH-P8/F	
SYSINFO-Q	BNCH-Q on SCH-Q/D	
SYSINFO-DA	BNCH-Q on SCH-Q/D or on SCH-Q/B, SCH/F, SCH-P8/HD, SCH-P8/F	

23.2.3 $\pi/4$ -DQPSK, D8PSK and QAM channels

There are three possible modulation modes for channels:

- $\pi/4$ -DQPSK;
- D8PSK; and
- QAM.

In the present document, the modulation mode of a common control channel is:

- $\pi/4$ -DQPSK for Conventional Access; or
- QAM for Direct Access.

An assigned channel may be allocated as a $\pi/4$ -DQPSK, D8PSK or QAM channel.

The general signalling operation with the three modulation modes is described in the remainder of this clause.

a) $\pi/4$ -DQPSK channel

All signalling and data messages and traffic on a $\pi/4$ -DQPSK channel shall be sent using $\pi/4$ -DQPSK modulation.

The bandwidth of a $\pi/4$ -DQPSK channel is 25 kHz.

b) D8PSK channel

A "D8PSK channel" is the generic term for a channel on which signalling and data messages may be sent using either $\pi/4$ -DQPSK bursts or $\pi/8$ -D8PSK bursts. The following restrictions apply:

- Random access messages shall be sent using the $\pi/4$ -DQPSK control uplink burst.
- In frame 18, downlink slots for which $(MN + TN) \bmod 4 = 1$ or 3 shall be sent using $\pi/4$ -DQPSK bursts.

NOTE 1: BSCH (containing the SYNC PDU) + SCH/HD is mapped on a D8PSK channel in frame 18 if $(MN + TN) \bmod 4 = 3$; BNCH (containing the SYSINFO PDU) is mapped on a D8PSK channel in frame 18 if $(MN + TN) \bmod 4 = 1$; see clause 9.5.2. If the SYSINFO PDU is sent in other slots on a D8PSK channel, the BS may use either a $\pi/4$ -DQPSK burst or a $\pi/8$ -D8PSK burst.

For downlink transmissions on a D8PSK channel in the assigned slots in frames 1 to 17, and in the assigned slots in frame 18 for which $(MN + TN) \bmod 4 = 2$ or 4, the BS chooses whether to use a $\pi/4$ -DQPSK or $\pi/8$ -D8PSK burst on a slot-by-slot basis. A receiving MS shall determine whether a downlink slot contains a $\pi/4$ -DQPSK normal downlink burst or a $\pi/8$ -D8PSK normal downlink burst by determining whether normal training sequence 1 or normal training sequence 2 uses the $\pi/4$ -DQPSK form or the $\pi/8$ -D8PSK form (see clause 9.4.4.3.2).

NOTE 2: Thus there are four possible normal training sequences on the downlink of a D8PSK channel:

- normal training sequence 1 using the $\pi/4$ -DQPSK form, indicating one logical channel (e.g. SCH/F) on the blocks 1 and 2 of the $\pi/4$ -DQPSK normal downlink burst;
- normal training sequence 2 using the $\pi/4$ -DQPSK form, indicating two logical channels (e.g. SCH/HD + SCH/HD) on the blocks 1 and 2 of the $\pi/4$ -DQPSK normal downlink burst;
- normal training sequence 1 using the $\pi/8$ -D8PSK form, indicating one logical channel (e.g. SCH-P8/F) on the blocks 1 and 2 of the $\pi/8$ -D8PSK normal downlink burst;
- normal training sequence 2 using the $\pi/8$ -D8PSK form, indicating two logical channels (e.g. SCH-P8/HD + SCH-P8/HD) on the blocks 1 and 2 of the $\pi/8$ -D8PSK normal downlink burst.

NOTE 3: The ACCESS-ASSIGN PDU is sent using $\pi/4$ -DQPSK modulation in all downlink slots i.e. in both $\pi/4$ -DQPSK and $\pi/8$ -D8PSK bursts (see clause 9.4.4.2). The ACCESS-ASSIGN PDU uses the AACH logical channel which is mapped onto the broadcast block.

Similarly, for reserved slots and subslots on the uplink of a D8PSK channel, the transmitting MS shall choose whether to use a $\pi/4$ -DQPSK or $\pi/8$ -D8PSK burst in each slot or subslot (see clause 23.4.9). Then:

- the BS shall determine whether a reserved slot contains a $\pi/4$ -DQPSK normal uplink burst or a $\pi/8$ -D8PSK normal uplink burst by determining whether the normal training sequence uses the $\pi/4$ -DQPSK form or the $\pi/8$ -D8PSK form (see clause 9.4.4.3.2);
- the BS shall determine whether a reserved subslot contains a $\pi/4$ -DQPSK control uplink burst or a $\pi/8$ -D8PSK control uplink burst by determining whether the extended training sequence uses the $\pi/4$ -DQPSK form or the $\pi/8$ -D8PSK form (see clause 9.4.4.3.3).

The BS should look for a $\pi/4$ -DQPSK control uplink burst in subslots that it has designated as being available for random access.

In the present document, the only usage of D8PSK channels is for assigned SCCH (see clause 23.3.1.2.2). The BS indicates that an allocated channel is a D8PSK channel when it sends the channel allocation.

The bandwidth of a D8PSK channel is 25 kHz.

The BS may allocate D8PSK channel(s) on the same carrier as $\pi/4$ -DQPSK channel(s), in different timeslots - either on the main carrier (for CA) or on carriers other than the main carrier (for CA and DA).

c) QAM channel

All signalling and data messages on a QAM channel shall be sent using QAM modulation.

Signalling and data messages on a QAM channel may use various combinations of modulation level and coding rate as follows:

- 4-QAM, coding rate = 1/2;
- 16-QAM, coding rate = 1/2;
- 16-QAM, coding rate = 1;
- 64-QAM, coding rate = 1/2;
- 64-QAM, coding rate = 2/3;
- 64-QAM, coding rate = 1.

All downlink bursts shall use the full bandwidth of the channel (25 kHz, 50 kHz, 100 kHz or 150 kHz). The BS shall choose which modulation level and coding rate to use for the SCH-Q/D on a slot-by-slot basis.

NOTE 4: There is a QAM Broadcast Network Channel BNCH-Q containing the SYSINFO-Q PDU (used by CA MSs). This is sent on SCH-Q/D in any slot in frames 1 to 18 on a QAM channel.

The QAM Broadcast Network Channel BNCH-Q may alternatively contain the SYSINFO-DA PDU (used by DA MSs). There is a fixed mapping of the SYSINFO-DA PDU on the DA main carrier. The SYSINFO-DA PDU may also be sent in other slots - on the DA main carrier and also on other QAM carriers.

There is a QAM Broadcast Synchronization Channel BSCH-Q containing the SYNC-DA PDU (used by DA MSs that are attempting to synchronize and obtain initial information about a DA cell). The downlink burst that carries the SYNC-DA PDU is the QAM Frequency Correction Burst (FCB), which always uses 4-QAM, coding rate = 1/2. There is a fixed mapping of the SYNC-DA PDU on the DA main carrier. It may also be sent in other slots - on the DA main carrier and also on other QAM carriers.

The fixed mappings of SYSINFO-DA and SYNC-DA on a DA main carrier are described in clause 9.

Downlink slots (except slots containing the BLCH-Q) contain the AACH-Q and SICH-Q/D logical channels, both of which always use 4-QAM, coding rate = 1/2. The AACH-Q may contain the ACCESS-ASSIGN PDU (see clause 21.4.7). The SICH-Q/D contains the downlink QAM-SLOTINFO PDU (see clause 21.4.8.2). The downlink QAM-SLOTINFO PDU indicates the format of the remainder of the downlink slot in which it appears. This format information includes the modulation level and coding rate, and indicates whether the burst is an FCB.

For the purposes of the protocol description: when an MS receives a downlink slot, the following "two-stage" method applies for decoding the slot:

- The lower MAC shall decode the AACH-Q and SICH-Q/D and pass the information to the upper MAC using TMV-UNITDATA indication primitives.
- The upper MAC shall use the ACCESS-ASSIGN PDU (when included within the AACH-Q) as described in other clauses within clause 23.
- The upper MAC shall process the QAM-SLOTINFO PDU.
- If the upper MAC understands the value of the "slot format" element in the QAM-SLOTINFO PDU and the MS is capable of processing slots with the indicated format then:
 - the upper MAC shall inform the lower MAC about the format of the remainder of the slot (including the modulation level and coding rate, and whether the burst is an FCB), using the TMV-CONFIGURE request primitive;
 - if the burst is not an FCB, the lower MAC shall decode the SCH-Q/D and pass the information to the upper MAC using the TMV-UNITDATA indication primitive;

- if the burst is an FCB:
 - the lower MAC in a DA MS may decode the BSCH-Q, and may pass the information to the upper MAC using the TMV-UNITDATA indication primitive (see note 7 and note 8);
 - if the bandwidth of the channel is 50 kHz, 100 kHz or 150 kHz, the lower MAC shall decode the SCH-Q/B and pass the information to the upper MAC using the TMV-UNITDATA indication primitive (see note 9).

Otherwise (i.e. if the upper MAC does not understand the value of the "slot format" element or the MS is not capable of processing slots with the indicated format) the upper MAC shall instruct the lower MAC not to continue processing the remainder of the slot, using the TMV-CONFIGURE request primitive.

NOTE 5: The MS may perform error detection on the SICH-Q/D. If the SICH-Q/D is not decodeable, the MS designer may choose an appropriate method for attempting to process the remainder of the slot; for example, the MS might attempt to process the remainder of the slot as 4-QAM, coding rate = 1/2. Alternatively the MS may decide not to continue processing the remainder of the slot.

NOTE 6: The MS is required to perform error detection on the AACH-Q. The MS actions if the AACH-Q is not decodeable are specified in other clauses within clause 23.

NOTE 7: The information in the SYNC-DA PDU is intended primarily for MSs that are attempting to synchronize with and obtain initial information about the DA cell. It is optional whether DA MSs already camped on the cell continue to decode the SYNC-DA PDU.

NOTE 8: The information in the SYNC-DA PDU is not appropriate to CA MSs.

NOTE 9: All MSs that understand the FCB value of the "slot format" element are required to decode the SCH-Q/B. However the BS designer should note that some CA MSs may not understand the FCB value of the "slot format" element.

NOTE 10: The BSCH-Q and SCH-Q/B logical channels always use 4-QAM, coding rate = 1/2.

When the MS sends a random access message, it shall use the logical channel SCH-Q/RA. This logical channel uses 4-QAM, coding rate = 1/2 in a random access uplink RF channel subslot with a 25 kHz bandwidth.

Reserved uplink slots and subslots shall use the full bandwidth of the channel (25 kHz, 50 kHz, 100 kHz or 150 kHz). The transmitting MS shall choose which modulation level and coding rate to use for the SCH-Q/U in each slot or SCH-Q/HU in each subslot (see clause 23.4.9) - subject to the maximum uplink modulation level permitted by the BS.

Reserved uplink slots and subslots contain the SICH-Q/U logical channel, which always uses 4-QAM, coding rate = 1/2. The SICH-Q/U contains the uplink QAM-SLOTINFO PDU (see clause 21.4.8.1). The uplink QAM-SLOTINFO PDU indicates the format (including the modulation level and coding rate) of the remainder of the uplink slot or subslot in which it appears.

When an BS receives a reserved slot or subslot, it should use a "two-stage" method for decoding the slot - similar to the method described above for an MS (except that AACH-Q and the ACCESS-ASSIGN PDU and BSCH-Q and SCH-Q/B do not apply on the uplink).

For both CA and DA, QAM channels may be used for assigned SCCH (see clause 23.3.1.2.2). The BS indicates that an allocated channel is a QAM channel when it sends the channel allocation. It also indicates the bandwidth of the channel and the maximum QAM modulation level that the MS is permitted to use on the uplink.

For DA, QAM channel(s) are also used for common control. The BS indicates the bandwidth of the common control channel(s) in the SYNC-DA and SYSINFO-DA PDUs. The BS also indicates (in the SYSINFO-DA PDU) the maximum QAM modulation level that the MS is permitted to use on the uplink of the common control channel.

The BS should not allocate a QAM channel on the same carrier as $\pi/4$ -DQPSK or D8PSK channel(s). Similarly, the BS should not allocate a $\pi/4$ -DQPSK or D8PSK channel on the same carrier as QAM channel(s).

23.3 Control channel usage

23.3.1 Control channel types

23.3.1.0 General

This clause describes the MS procedures for using control channels.

23.3.1.1 Main control channels

23.3.1.1.1 Conventional Access (CA) and Direct Access (DA) cells

In the present document there are two types of cell: Conventional Access (CA) cells and Direct Access (DA) cells.

- a) In a CA cell, one 25 kHz phase modulation carrier is used as the main carrier. The MCCH is a single-slot $\pi/4$ -DQPSK channel that occupies slot 1 of the main carrier in normal mode. The MCCH is used for common control signalling. The BS may also operate up to three single-slot $\pi/4$ -DQPSK common secondary control channels ($\pi/4$ -DQPSK common SCCHs) on the CA main carrier if it requires more capacity for common control signalling; each common SCCH is used by a different subset of the MS population.

A CA MS is an MS that is currently camped on a CA cell, so it receives a $\pi/4$ -DQPSK common control channel (i.e. the MCCH or a $\pi/4$ -DQPSK common SCCH) unless it is directed by the BS to an assigned channel - assigned for a circuit mode call or for secondary control.

The BS may allocate all four timeslots of a CA main carrier for traffic or assigned control. Minimum mode operation then applies, in which the method of MCCH operation is changed (see clause 23.3.3).

- b) In a DA cell, one QAM carrier is used as the main carrier. The bandwidth of a DA main carrier is 25 kHz, 50 kHz, 100 kHz or 150 kHz.

The MCCH-Q comprises one, two, three or four timeslots per TDMA frame, whereas a QAM common SCCH comprises only one timeslot per TDMA frame. For DA, if the BS wishes to use more than one slot for common control signalling, it may use either a single multi-slot MCCH-Q or multiple single-slot QAM common control channels.

NOTE 1: The BS cannot use QAM common SCCH(s) if it is using a multi-slot MCCH-Q.

A DA MS is an MS that is currently camped on a DA cell, so it receives a QAM common control channel (i.e. the MCCH-Q or a QAM common SCCH) unless it is directed by the BS to an assigned channel - assigned for secondary control or for a circuit mode call.

For DA, the BS may allocate the MCCH-Q physical channel(s) as a QAM assigned channel for some MSs that are camped on the cell. Then the MSs in common mode and the MSs in assigned mode share the channel (though in some cases using slightly different procedures). Similarly, the BS may allocate a physical channel used as a QAM common SCCH also as a QAM assigned channel for some MSs, with the channel shared between the MSs in common mode and the MSs in assigned mode.

NOTE 2: A phase modulation carrier is a carrier that is currently carrying $\pi/4$ -DQPSK and/or D8PSK channels. A QAM carrier is a carrier that is currently carrying QAM channels.

NOTE 3: An assigned channel may be a $\pi/4$ -DQPSK, D8PSK or QAM channel. It may be either a single-slot or a multi-slot channel.

NOTE 4: An MS may be both CA-capable and DA-capable. In that case it may sometimes be a CA MS and at other times a DA MS, depending on whether its current serving cell is a CA cell or a DA cell.

From the perception of the MS, at any one time it is camped on either a CA cell or a DA cell, and it receives MLE broadcasts from the BS indicating which channel classes and/or irregular channels are available on that cell.

However, for cells that:

- are radiated from the same physical location or from locations sufficiently close together to permit sharing of eccentric channels; and
- share the same MCC, MNC, colour code and static cipher key or common cipher key (see ETSI EN 300 392-7 [8]);

there may be some flexibility in how channels are assigned. If wished, the same channel could be used by more than one cell as an assigned channel, provided that the shared channel is radiated from the same physical location as the cells or within the permitted separation for eccentric channels (i.e. if the assigned channel's transmitter site is within 4 km of the main carrier's transmitter site for each of the sharing cells - see clause 7.7). Therefore more than one cell may send MLE serving cell broadcasts about channel classes and irregular channels where those broadcasts relate to the same channels. Then:

- MSs camped on a CA cell may be assigned to a channel used also by DA MSs. For example:
 - A channel on a carrier other than either main carrier may be used as an assigned channel shared by both CA MSs and DA MSs. This may apply for both phase modulation carriers and QAM carriers.
 - If a channel on either main carrier is not being used for common control, it may be used as an assigned channel shared by both CA MSs and DA MSs.
 - The MCCH-Q or a QAM common SCCH may be used as an assigned channel for CA MSs. As outlined above, the MCCH-Q or a QAM common SCCH may also be used as an assigned channel for DA MSs camped on the DA cell. Thus the channel could be shared between the DA MSs in common mode, DA MSs in assigned mode and CA MSs in assigned mode.
- In some cases, DA MSs may be assigned to a channel used also by DA MSs that are camped on a different DA cell:
 - A channel on a carrier other than either DA main carrier may be used as an assigned channel shared by MSs from different DA cells. (The channel could also be shared by MSs from a CA cell.)

The present document does not support use of any channel on a DA main carrier as an assigned channel for MSs that are camped on a different DA cell.

NOTE 5: If an assigned channel is shared by MSs from different DA cells, the BS should not send the SYSINFO-DA or SYNC-DA PDU on that assigned channel.

NOTE 6: If the BS sends a group-addressed instruction to return to the appropriate common control channel to a group that includes MSs from more than one cell (CA cell or DA cell(s)) sharing the assigned channel, it should use a non-augmented channel allocation (in which case DA MSs use the main carrier information from the last received SYSINFO-DA or SYNC-DA PDU); see clause 23.5.4.

NOTE 7: Therefore, if an assigned channel is shared by MSs from different DA cells, and a DA main carrier is moved while some MSs from that cell are on the assigned channel, the BS should not use a group address that includes MSs from more than one cell sharing the channel when it instructs the MSs to return to the appropriate common control channel.

NOTE 8: The present document does not provide a general method for sharing of an assigned channel by MSs from different CA cells. However, annex S notes a restricted method that SwMIs may be able to use without the MSs being aware of the usage.

23.3.1.1.2 MCCH

In each CA cell, one 25 kHz RF carrier shall be defined as the main carrier frequency which shall be broadcast in the SYSINFO PDU on the Broadcast Network Channel BNCH (or, on a QAM channel, in the SYSINFO-Q PDU on the QAM Broadcast Network Channel BNCH-Q). The MCCH shall occupy slot 1 of the main carrier frequency of a BS in normal mode. A CA MS shall locate and receive the downlink MCCH, unless the BS has allocated any common SCCHs.

Signalling and data messages on the MCCH are sent using $\pi/4$ -DQPSK modulation.

The BS shall use SCH/HD, SCH/F, BNCH and BSCH for transmitting signalling and data messages on the downlink of the MCCH. An MS shall attempt to receive and decode any paging messages on the downlink MCCH addressed to that individual MS or to one of the MS's valid group addresses. An MS shall also attempt to receive and decode any broadcast signalling messages sent on the downlink of the MCCH.

NOTE 1: Energy economy or dual watch mode and the cell reselection procedures may take precedence over the requirements on the MS to attempt to receive and decode paging messages and broadcast messages on the MCCH, or on a common SCCH.

For uplink access on the MCCH, the MS shall follow the random access and reserved access procedures described in clauses 23.5.1 and 23.5.2 respectively. The MS shall use SCH/HU for random access on the uplink of the MCCH and shall use SCH/HU or SCH/F for reserved access on the uplink of the MCCH. The uplink shall occupy only a single slot per TDMA frame (i.e. slot 1) for reserved access but may use an extended uplink channel for random access purposes if indicated by the ACCESS-DEFINE or SYSINFO PDU.

The downlink of the MCCH shall not be extended to more than a single slot per TDMA frame. A BS in normal mode shall always have an MCCH. However, a BS may assign the MCCH for use as a $\pi/4$ -DQPSK traffic or assigned control channel in which case the BS enters minimum mode.

The ACCESS-ASSIGN PDU in the AACH in frames 1 to 17 shall indicate common control in the downlink direction for an MCCH. The ACCESS-ASSIGN PDU in frames 1 to 17 for the MCCH shall contain one of the following:

- a) Header value = 00_2 :
 - This is the normal case for an MCCH in which both the uplink and downlink are used for common control. "Field 1" shall indicate the access parameters for subslot 1 and "field 2" shall indicate the access parameters for subslot 2 of the uplink.
- b) Header value = 01_2 and "field 1" = UMc (000010_2):
 - The BS may assign the uplink of the MCCH as a $\pi/4$ -DQPSK assigned SCCH while still maintaining the MCCH on the downlink. In this case, the uplink may be shared between common control and assigned control. "Field 2" shall contain the access parameters for both of the uplink subslots and shall apply to both common and assigned control channels.

NOTE 2: The present document does not support use of UMr (000011_2) on a phase modulation channel.

- c) Header value = 10_2 and "field 1" = UMc (000010_2):
 - This is the same as for case b) above except that the random access parameters in "field 2" shall apply only for MSs using the uplink for assigned control. Any MS in common control mode shall not use the uplink for random access in this case.
- d) Header value = 11_2 and "field 1" = UMc (000010_2) and "field 2" = UMt ($xxxxxx_2$):
 - The BS may assign the uplink of the MCCH for transmission of traffic while still maintaining the MCCH on the downlink. "Field 2" shall contain the traffic usage marker for the uplink assigned channel.
- e) Header value = 11_2 and "field 1" = UMx (000000_2) and "field 2" = UMx (000000_2):
 - The BS may indicate that the MCCH on its main carrier has been deallocated and is no longer available for downlink or uplink signalling purposes. If N.215 successive ACCESS-ASSIGN PDUs received in frames 1 to 17 contain these values, then the MS-MAC should inform the higher layers of the de-allocation using a "common channel deallocated" TMC-REPORT indication primitive (indicating a downlink failure) in order to initiate the MLE cell reselection procedures.

The ACCESS-ASSIGN PDU in the AACH for frame 18 shall only indicate the uplink access rights. During normal mode operation, it shall always be assumed that slot 1 on the downlink is for common control as part of the MCCH. Any of the possible header values may be used during frame 18 for an MCCH.

23.3.1.1.3 MCCH-Q

In each DA cell, one RF carrier shall be defined as the main carrier frequency which shall be broadcast in the SYNC-DA PDU (when the PDU is sent on a QAM carrier other than the DA main carrier) and in the SYSINFO-DA PDU. The bandwidth of the DA main carrier is 25 kHz, 50 kHz, 100 kHz or 150 kHz.

The MCCH-Q may be one slot wide or alternatively may be a multi-slot channel i.e. two, three or four slots wide. The BS broadcasts the number of slots comprising the MCCH-Q in the SYSINFO-DA PDU.

- A single-slot MCCH-Q shall occupy slot 1 of the main carrier frequency.
- A two-slot MCCH-Q shall occupy slots 1 and 2 of the main carrier frequency.
- A three-slot MCCH-Q shall occupy slots 1, 2 and 3 of the main carrier frequency.
- A four-slot MCCH-Q shall occupy slots 1, 2, 3 and 4 of the main carrier frequency.

A DA MS shall locate and receive the downlink MCCH-Q, unless the BS has allocated any common SCCHs.

Signalling and data messages on the MCCH-Q are sent using QAM modulation.

The BS shall use SCH-Q/D, SCH-Q/B, BNCH-Q and BSCH-Q for transmitting signalling and data messages on the downlink of the MCCH-Q. An MS shall attempt to receive and decode any paging messages on the downlink MCCH-Q addressed to that individual MS or to one of the MS's valid group addresses. An MS shall also attempt to receive and decode any broadcast signalling messages sent on the downlink of the MCCH-Q.

NOTE 1: Energy economy or dual watch mode and the cell reselection procedures may take precedence over the requirements on the MS to attempt to receive and decode paging messages and broadcast messages on the MCCH-Q (single-slot or multi-slot MCCH-Q), or on a common SCCH. Also, part-time reception mode may take precedence over the requirements on the MS to attempt to receive and decode paging messages and broadcast messages on a multi-slot MCCH-Q.

For uplink access on the MCCH-Q, the MS shall follow the random access and reserved access procedures described in clauses 23.5.1 and 23.5.2 respectively. The MS shall use SCH-Q/RA for random access on the uplink of the MCCH-Q and shall use SCH-Q/HU or SCH-Q/U for reserved access on the uplink of the MCCH-Q. The uplink for reserved access shall occupy the same-numbered slots as the downlink of the MCCH-Q. An extended uplink channel may be used for random access purposes if indicated by the ACCESS-DEFINE or SYSINFO-DA PDU.

For DA, the BS shall have an MCCH-Q. However, the BS may allocate the MCCH-Q physical channel(s) as an assigned SCCH for some MSs (CA MSs and/or DA MSs), in which case the physical resource is shared between the MSs in common mode and the MSs in assigned mode.

NOTE 2: Minimum mode is not supported for DA.

The ACCESS-ASSIGN PDU in the AACH-Q in frames 1 to 17 shall indicate common control or common and assigned control in the downlink direction for an MCCH-Q. The ACCESS-ASSIGN PDU in frames 1 to 17 for the MCCH-Q shall contain one of the following:

- a) Header value = 00_2 :
 - This is the case for an MCCH-Q in which both the uplink and downlink are used exclusively for common control. "Field 1" shall indicate the access parameters for subslot 1 and "field 2" shall indicate the access parameters for subslot 2 of the uplink.
- b) Header value = 01_2 and "field 1" = UMr (000011_2):
 - The BS may assign the physical channel(s) used for the MCCH-Q as a QAM assigned SCCH while still maintaining the MCCH-Q for MSs in common control mode. In this case, the uplink may be shared between common control and assigned control. "Field 2" shall contain the access parameters for both of the uplink subslots and shall apply to both common and assigned control channels.

- c) Header value = 10_2 and "field 1" = UMr (000011₂):
- This is the same as for case b) above except that the random access parameters in "field 2" shall apply only for MSs using the channel for assigned control. Any MS in common control mode shall not use the uplink for random access in this case.
- d) Header value = 11_2 and "field 1" = UMx (000000₂) and "field 2" = UMx (000000₂):
- The BS may indicate that the MCCH-Q on its main carrier has been deallocated and is no longer available for downlink or uplink signalling purposes. If N.215 successive ACCESS-ASSIGN PDUs received in frames 1 to 17 contain these values, then the MS-MAC should inform the higher layers of the de-allocation using a "common channel deallocated" TMC-REPORT indication primitive (indicating a downlink failure) in order to initiate the MLE cell reselection procedures.

The ACCESS-ASSIGN PDU in the AACH-Q for frame 18 shall only indicate the uplink access rights. Any of header values 00_2 , 01_2 and 10_2 may be used during frame 18 for an MCCH-Q.

NOTE 3: When sent on a QAM channel, the ACCESS-ASSIGN PDU uses the AACH-Q logical channel. The AACH-Q is sent by the BS in every downlink slot of a QAM channel (except slots containing BLCH-Q). However the ACCESS-ASSIGN PDU is present in the AACH-Q only if the "AACH-Q mode" element is set to 0 (see clause 21.4.7.1). In the present document, the BS should set the "AACH-Q mode" element to 0. However, in future editions of the present document, the BS may set the "AACH-Q mode" element to 1 in some slots; therefore, the MS should expect that the ACCESS-ASSIGN PDU may not be present in the AACH-Q.

The BS may change the number of slots comprising the MCCH-Q by modifying the appropriate parameter in the SYSINFO-DA PDU. A DA MS shall decode the SYSINFO-DA PDU and recognize if the number of slots comprising the MCCH-Q has changed. When decreasing the number of slots used for the MCCH-Q the BS shall not change its MCCH-Q configuration before first transmitting the new configuration in the SYSINFO-DA PDU. When increasing the number of slots used for the MCCH-Q the BS shall change its MCCH-Q configuration and then transmit the new configuration in the SYSINFO-DA PDU.

23.3.1.2 SCCH

23.3.1.2.0 Introduction

The BS may designate a secondary control channel (SCCH) for use as a main control channel by a subset of the user population. Alternatively, an SCCH may be allocated to certain MSs for subsequent data transfer. These two cases will subsequently be referred to as common and assigned SCCHs respectively.

23.3.1.2.1 Common SCCH

23.3.1.2.1.1 General

For CA, the BS may designate up to three $\pi/4$ -DQPSK common SCCHs for use as a main control channel by a subset of the CA MSs, as described in clause 23.3.1.2.1.2.

For DA, if the BS has a single-slot MCCH-Q, it may designate up to three QAM common SCCHs for use as a main control channel by a subset of the DA MSs, as described in clause 23.3.1.2.1.3.

NOTE: The BS cannot provide QAM common SCCH(s) if it has a multi-slot MCCH-Q.

23.3.1.2.1.2 $\pi/4$ -DQPSK common SCCH

For CA, the BS may operate up to three common SCCHs for the purposes of common control signalling. Common SCCHs shall each occupy only one slot capacity on the main carrier and shall be used as the main control channel by a subset of the CA population. Therefore, a BS may operate up to a maximum of three common SCCHs in addition to the MCCH.

For CA, signalling and data messages on a common SCCH are sent using $\pi/4$ -DQPSK modulation.

The BS shall indicate the number of common SCCHs in operation on the main carrier by setting a two-bit field in the SYSINFO PDU transmitted on BNCH (or, on any QAM channels, in the SYSINFO-Q PDU transmitted on BNCH-Q). This two-bit field maps to the number of common SCCHs in operation on this BS. If no common SCCHs are in operation, only the MCCH in slot 1 shall be available for common control signalling on the main carrier. If one common SCCH is indicated by the SYSINFO (or SYSINFO-Q) PDU, then slot 2 of the main carrier shall be used for this SCCH. If two SCCHs are in operation, slots 2 and 3 shall be used and if three SCCHs are in operation, slots 2, 3 and 4 shall be used.

In idle mode, a CA MS shall receive either the MCCH (slot 1) or one of the common SCCHs on the main carrier. Therefore, a CA MS shall receive one of the four downlink slots on the main carrier for common control purposes. On registration or at subscription, an MS receives a parameter which indicates to the MS which one of the downlink slots on the main carrier shall be used. If an MS has received this value at subscription and then also is assigned a value at registration, the value given at registration shall be used. The following rule shall then be applied by the MS:

- N_SCCH = number of common SCCHs in operation on CA main carrier:
 - two-bit field transmitted by BS in the SYSINFO (or SYSINFO-Q) PDU, value = 0 to 3;
- MS_SCCH = MS SCCH allocation:
 - four-bit field transmitted by BS to MS at registration or received by MS at subscription, value = 0 to 11 (eleven);
- Main carrier downlink slot = $1 + (MS_SCCH \bmod (N_SCCH + 1))$:
 - value = 1 to 4;

where mod = remainder after integer division.

This rule enables a CA MS to derive the slot that shall be used on the main carrier from its MS_SCCH parameter received at registration or subscription and the number of common SCCHs currently in operation as indicated by the BS in the SYSINFO PDU. If the MS does not have a value of MS_SCCH on this network, and has no value from subscription, it shall use the MCCH (i.e. slot 1 on the main carrier).

NOTE: Subscription is applicable only for the MS's home network.

The BS may change the number of common SCCHs by modifying the N_SCCH parameter. An MS shall decode the SYSINFO PDU and recognize if N_SCCH has changed. If N_SCCH has changed the MS shall re-calculate, according to the above rule, the main carrier slot that it should use for common control signalling. When decreasing the number of common control channels the BS shall not change its SCCH configuration before first transmitting the new configuration in the SYSINFO PDU. When increasing the number of common control channels the BS shall change its SCCH configuration and then transmit the new configuration in the SYSINFO PDU.

A common SCCH, like the MCCH, shall always occupy only one slot per TDMA frame on the downlink of the main carrier. The uplink shall occupy only one slot per TDMA frame for reserved access but may use an extended uplink channel for random access purposes if indicated by the ACCESS-DEFINE or SYSINFO PDU (see clause 23.5.1 for more detailed explanation of random access procedures).

A CA MS returning to the common control channel after, for example, a traffic channel assignment, shall return to the MCCH or common SCCH that it was using before the assignment unless it has received, in the meantime, a SYSINFO or SYSINFO-Q PDU indicating a change in the SCCH configuration. (An MS may return to the common control channel due to the MS deciding to leave the call or as a result of receiving a MAC-RESOURCE or MAC-END PDU with a "Timeslot assigned" value of 0000_2 to indicate that it should go to the MCCH or appropriate common SCCH.) In this case it shall return to the main carrier slot defined by the new configuration. When decreasing the number of common control channels the BS should transmit the SYSINFO PDU in all slots of frame 18 on $\pi/4$ -DQPSK and D8PSK channels, and should transmit the SYSINFO-Q PDU on any QAM channels, before changing the SCCH configuration to ensure that all CA MSs including those on assigned channels receive the configuration change. When increasing the number of common control channels the BS should change its SCCH configuration and then transmit the new configuration in the SYSINFO PDU (and in the SYSINFO-Q PDU on any QAM channels).

The ACCESS-ASSIGN PDU for a $\pi/4$ -DQPSK common SCCH shall contain one of the combinations of elements a) to e) as described for the MCCH during frames 1 to 17 and shall follow the same rules defined for the MCCH for frame 18.

23.3.1.2.1.3 QAM common SCCH

In a DA cell, the MCCH-Q may be one, two, three or four slots wide.

If the BS is using a single-slot MCCH-Q, it may operate up to three common SCCHs for the purposes of common control signalling. Common SCCHs shall each occupy only one slot capacity on the main carrier and shall be used as the main control channel by a subset of the DA population. Therefore, the BS may operate up to a maximum of three common SCCHs in addition to a single-slot MCCH-Q.

NOTE 1: Thus, for DA, if the BS wishes to use more than one slot for common control signalling, it may use either a single multi-slot MCCH-Q or multiple single-slot common control channels. (The BS cannot use common SCCH(s) if it is using a multi-slot MCCH-Q.)

For DA, signalling and data messages on a common SCCH are sent using QAM modulation.

The BS shall indicate whether common SCCHs are in operation on the main carrier by setting a one-bit field in the SYSINFO-DA PDU. If common SCCHs are being used, the BS shall indicate the number of common SCCHs in operation by setting a two-bit field in the SYSINFO-DA PDU; this two-bit field maps to the number of common SCCHs in operation on this BS.

If one common SCCH is indicated by the SYSINFO-DA PDU, then slot 2 of the main carrier shall be used for this SCCH. If two SCCHs are in operation, slots 2 and 3 shall be used and if three SCCHs are in operation, slots 2, 3 and 4 shall be used.

In idle mode, a DA MS shall receive either the MCCH-Q or one of the common SCCHs on the main carrier.

On registration or at subscription, a DA MS receives a parameter which indicates to the MS which one of the downlink slots on the main carrier shall be used when common SCCHs are in operation. If an MS has received this value at subscription and then also is assigned a value at registration, the value given at registration shall be used. The following rule shall then be applied by the MS when common SCCHs are in operation:

- N_SCCH-Q = number of common SCCHs in operation on DA main carrier:
 - from the two-bit field transmitted by BS in the SYSINFO-DA PDU, value = 1 to 3;
- MS_SCCH = MS SCCH allocation:
 - four-bit field transmitted by BS to MS at registration or received by MS at subscription, value = 0 to 11 (eleven);
- Main carrier downlink slot = $1 + (MS_SCCH \bmod (N_SCCH-Q + 1))$:
 - value = 1 to 4;

where mod = remainder after integer division.

This rule enables a DA MS to derive the slot that shall be used on the main carrier when common SCCHs are in operation from its MS_SCCH parameter received at registration or subscription and the information about the number of common SCCHs currently in operation as indicated by the BS in the SYSINFO-DA PDU. If the MS does not have a value of MS_SCCH on this network, and has no value from subscription, it shall use the MCCH-Q.

NOTE 2: Subscription is applicable only for the MS's home network.

The BS may change the number of common SCCHs by modifying the N_SCCH-Q parameter. An MS shall decode the SYSINFO-DA PDU and recognize if the number of common SCCHs has changed. If the number of common SCCHs has changed the MS shall re-calculate, according to the above rule, the main carrier slot that it should use for common control signalling. When decreasing the number of slots used for common control signalling the BS shall not change its SCCH configuration before first transmitting the new configuration in the SYSINFO-DA PDU. When increasing the number of slots used for common control signalling the BS shall change its SCCH configuration and then transmit the new configuration in the SYSINFO-DA PDU.

A common SCCH shall always occupy only one slot per TDMA frame on the downlink of the main carrier. The uplink shall occupy only one slot per TDMA frame for reserved access but may use an extended uplink channel for random access purposes if indicated by the ACCESS-DEFINE or SYSINFO-DA PDU (see clause 23.5.1 for more detailed explanation of random access procedures).

A DA MS returning to the common control channel after a channel assignment shall return to the MCCH-Q or common SCCH that it was using before the assignment unless it has received, in the meantime, a SYSINFO-DA PDU indicating a change in the common control channel configuration. (An MS may return to the common control channel due to the MS deciding to leave the assigned channel or as a result of receiving a MAC-RESOURCE or MAC-END PDU with a "Timeslot assigned" value of 0000_2 to indicate that it should go to the appropriate common control channel.) In this case it shall return to the common control channel defined by the new configuration. When decreasing the number of slots used for common control signalling the BS should transmit the SYSINFO-DA PDU on QAM channels (and may transmit the SYSINFO-DA PDU on any $\pi/4$ -DQPSK and D8PSK channels), before changing the common control channel configuration to ensure that all DA MSs including those on assigned channels receive the configuration change. When increasing the number of slots used for common control signalling the BS should change its common control channel configuration and then transmit the new configuration in the SYSINFO-DA PDU.

The ACCESS-ASSIGN PDU for a QAM common SCCH shall contain one of the combinations of elements a) to d) as described for the MCCH-Q during frames 1 to 17 and shall follow the same rules defined for the MCCH-Q for frame 18.

23.3.1.2.2 Assigned SCCH

An SCCH may be assigned by the BS for subsequent data transfer in response to an initial random access or after an initial paging message on its common control channel (i.e. on the MCCH or MCCH-Q, or the appropriate $\pi/4$ -DQPSK or QAM common SCCH). This type of SCCH is referred to as an assigned SCCH. An MS shall be directed to an assigned SCCH by a MAC-RESOURCE or MAC-END PDU (see clause 21) transmitted by the BS. The assigned SCCH may be used by a certain group of MSs for a particular signalling message or data exchange (e.g. packet data); or it may be shared between several MSs each with intermittent bursts of signalling to send.

NOTE 1: The BS may use an assigned SCCH as a general packet data channel supporting advanced links for several MSs, where each MS may be intermittently offering data packets.

An assigned SCCH may be allocated as a $\pi/4$ -DQPSK, D8PSK or QAM channel - as indicated by the "channel allocation" element in the MAC-RESOURCE or MAC-END PDU. The bandwidth of a $\pi/4$ -DQPSK or D8PSK assigned SCCH is 25 kHz. The bandwidth of a QAM assigned SCCH is 25 kHz, 50 kHz, 100 kHz or 150 kHz - as indicated by the "channel allocation" element in the MAC-RESOURCE or MAC-END PDU.

An assigned SCCH may be allocated as occupying up to four slots per TDMA frame as indicated by the MAC-RESOURCE or MAC-END PDU. If both the uplink and downlink are assigned for this purpose then the uplink for reserved access shall occupy the same-numbered slots as the downlink; i.e. an assigned SCCH cannot be allocated with a different number of slots for the uplink for reserved access and downlink. (An extended uplink channel may be used for random access purposes if indicated by the ACCESS-DEFINE PDU.)

The number of slots allocated to a particular assigned SCCH by the BS may be increased or decreased by sending a MAC-RESOURCE (or MAC-END) PDU on the assigned SCCH.

An MS shall attempt to receive and decode all downlink signalling transmitted by the BS on all allocated slots of an assigned SCCH (within the constraints of the napping procedures and the cell reselection procedures, and linearization and transmission requirements). Similarly, the MS may transmit uplink signalling on all allocated slots of the uplink of an assigned SCCH in accordance with the random access and reserved access procedures defined in clauses 23.5.1 and 23.5.2 respectively.

NOTE 2: The MS may operate with multi-slot channels without the need for the MS to support frequency full duplex operation. These MS capabilities are indicated in the mobile class ("class of MS" element, see clause 16). If an MS is not frequency full duplex and is operating on a multi-slot channel, the BS should not send signalling messages to that MS when the MS is transmitting in reserved slots or switching from receive to transmit or from transmit to receive.

If the BS allocates an assigned SCCH on the downlink, the ACCESS-ASSIGN PDU (when present) in frames 1 to 17 shall contain a header value of 01_2 , 10_2 or 11_2 and:

- "field 1" shall be equal to $UMa (000001_2)$ for a $\pi/4$ -DQPSK or D8PSK assigned SCCH;
- "field 1" shall be equal to $UMa (000001_2)$ or $UMr (000011_2)$ for a QAM assigned SCCH.

If the BS allocates an assigned SCCH in the uplink direction, the ACCESS-ASSIGN PDU (when present) in frames 1 to 17 shall contain a header value of 01_2 or 10_2 depending on whether the uplink is also to be shared with common control uplink accesses. For a unidirectional assigned SCCH, any control slots in the opposite direction shall also be part of the assigned SCCH for the purposes of applying the general procedures for transmission and reception of signalling messages.

If the BS allocates an assigned SCCH in both directions, the ACCESS-ASSIGN PDU (when present) in frames 1 to 17 shall contain a header value of 01_2 or 10_2 depending on whether the uplink is also to be shared with common control uplink accesses. "Field 1" shall be set as indicated above.

NOTE 3: In the present document, a D8PSK or QAM assigned SCCH is always allocated in both directions. However, in future editions of the present document, the BS may be permitted to allocate a D8PSK or QAM assigned SCCH in only one direction. Therefore the MS should expect that a D8PSK or QAM assigned SCCH may be allocated in only one direction.

The assigned slot(s) during frame 18 may be used for any combination of common or assigned control signalling on the downlink, and the ACCESS-ASSIGN PDU (when present) shall indicate the uplink access restrictions.

NOTE 4: When sent on a $\pi/4$ -DQPSK or D8PSK channel, the ACCESS-ASSIGN PDU uses the AACH logical channel; the ACCESS-ASSIGN PDU is sent by the BS in every downlink slot.

When sent on a QAM channel, the ACCESS-ASSIGN PDU uses the AACH-Q logical channel. The AACH-Q is sent by the BS in every downlink slot of a QAM channel (except slots containing BLCH-Q). However the ACCESS-ASSIGN PDU is present in the AACH-Q only if the "AACH-Q mode" element is set to 0 (see clause 21.4.7.1). In the present document, the BS should set the "AACH-Q mode" element to 0. However, in future editions of the present document, the BS may set the "AACH-Q mode" element to 1 in some slots. Therefore, the MS should expect that the ACCESS-ASSIGN PDU may not be present in the AACH-Q.

The BS shall always transmit in the downlink slots of an assigned SCCH except during a BLCH or BLCH-Q. This applies even while there is no signalling information to send. (The BS may send broadcast PDUs (except the SYNC PDU) or Null PDUs during these times.) This is required in order for the MS to carry out correctly its channel maintenance procedures for an assigned channel.

NOTE 5: The BS should send the SYNC PDU on a $\pi/4$ -DQPSK common control channel or on a $\pi/4$ -DQPSK or D8PSK assigned channel only in the defined positions, which are in frame 18 (see clause 9); this is because the SYNC PDU is sent with the synchronization training sequence. The SYNC PDU is not used on a QAM channel.

For DA, the BS may send the SYNC-DA PDU on QAM channels at any time (for example, when there is no signalling information to send), in addition to the defined positions on the DA main carrier. (This is possible because the QAM-SLOTINFO PDU indicates whether each downlink burst is an FCB.)

23.3.1.3 ACCH

An ACCH is a control channel associated with an assigned traffic channel. There shall be two types of ACCH dependent on the current usage of the assigned channel. When the uplink or downlink of the assigned channel are not in use for traffic, the corresponding assigned slots in frames 1 to 18 shall be available for control signalling. This control channel is known as a Fast Associated Control Channel (FACCH). When the assigned channel is carrying traffic either in the uplink or downlink direction, only frame 18 is available for control signalling in that direction. This control channel is known as a Slow Associated Control Channel (SACCH).

NOTE 1: A traffic channel may be allocated as bidirectional but sometimes may only carry traffic either in the uplink or downlink direction e.g. for an inter-site call. Then the opposite direction is a FACCH. In this case, therefore, a FACCH will be available in one direction and a SACCH in the other direction.

NOTE 2: When an assigned channel is carrying traffic either in the uplink or downlink direction then, in addition to the SACCH in that direction, capacity may be "stolen" from the circuit in frames 1 to 17 for signalling purposes, without changing the mode of operation (see clause 23.8). Stealing uses the STCH logical channel, whereas the FACCH and SACCH are mapped onto SCH.

An ACCH shall have the same modulation as the associated traffic channel. Circuit mode traffic transmission applies only on $\pi/4$ -DQPSK channels. Therefore signalling messages on an ACCH are sent using $\pi/4$ -DQPSK modulation.

An ACCH shall have the same number of slots per TDMA frame as the associated traffic channel. The uplink and downlink shall have an equal number of slots per TDMA frame (see note 3). Therefore, for a multi-slot traffic channel, the ACCH shall assume the same uplink and downlink slot allocation as assigned for the traffic channel (see note 3).

NOTE 3: The exception is that an extended uplink channel may be used for random access purposes if indicated by the ACCESS-DEFINE PDU.

A receiving MS shall attempt to receive and decode all of the downlink slots of an ACCH (within the constraints of the napping procedures and the cell reselection procedures, and linearization and transmission requirements) to receive any addressed messages from the BS for that MS. An MS shall also receive any broadcast messages on the downlink ACCH.

As an option, if the BS indicates that frame 18 extension is allowed (indicated by the "frame 18 extension" element in the SYNC PDU), an MS may receive and decode PDUs on all four slots of frame 18. However, the MS should not attempt to reconstruct any fragmented PDUs on frame 18 slots other than the ACCH for that MS. This restriction applies because an MS cannot know in which slot subsequent fragments will be sent for slots other than the ACCH for that MS. The MS shall not attempt to use random access transmission on slots of frame 18 other than its own ACCH (unless permitted by the "timeslot pointer" element from its own ACCH). The application of the normal procedures for transmission and reception of signalling messages shall apply only to the ACCH (i.e. FACCH and/or SACCH) as indicated by the "timeslot assigned" element in the channel allocation.

An MS transmitting in traffic mode shall attempt to receive and decode downlink slots in frames 1 to 17 when required by the assigned monitoring pattern(s) (given with the channel allocation). This allows the BS to send signalling, for example using the STCH, to a transmitting MS. The MS shall only be expected to adhere to the assigned monitoring pattern(s) within its duplex and switching capability (see clause 23.3.1.4).

An MS transmitting in traffic mode shall attempt to receive and decode the ACCH in frame 18 when required by the assigned monitoring pattern(s). For multi-slot operation, the MS shall attempt to receive and decode at least the highest numbered downlink slot allocated for the circuit mode call in frame 18. (The MS shall also be capable of transmitting in the highest numbered uplink slot in frame 18 in case it has to respond to a paging message from the BS.) Similarly, an MS receiving in traffic mode shall attempt to receive and decode at least the lowest numbered slot allocated for the circuit mode call in frame 18 for SACCH downlink signalling (and it shall be capable of transmitting uplink signalling during the lowest numbered slot in frame 18).

NOTE 4: This means that the MS may operate with multi-slot channels without the need for the MS to support frequency full duplex operation.

When the MS switches out of traffic mode, it shall attempt to receive and decode all allocated slots for downlink ACCH signalling (within the constraints of the napping procedures and the cell reselection procedures, and linearization and transmission requirements). Similarly, any of the allocated slots may be used for uplink signalling in accordance with the MAC random access and reserved access procedures.

In the case of a downlink FACCH, the ACCESS-ASSIGN PDU in frames 1 to 17 shall contain a header value of 01_2 , 10_2 or 11_2 and "field 1" shall be equal to UMa (000001₂). In the case of an uplink FACCH, the ACCESS-ASSIGN PDU in frames 1 to 17 shall contain a header value of 01_2 or 10_2 depending on whether the uplink is also to be shared with common control uplink accesses.

In the case of a bidirectional FACCH, the ACCESS-ASSIGN PDU in frames 1 to 17 shall contain a header value of 01_2 or 10_2 depending on whether the uplink is also to be shared with common control uplink accesses.

The ACCH in frame 18 may be used for any combination of common or assigned control signalling on the downlink and the ACCESS-ASSIGN PDU shall indicate the uplink access restrictions.

The BS shall always transmit in the downlink slots of an ACCH except during a BLCH. This applies even while there is no signalling information to send. (The BS may send broadcast PDUs (except the SYNC PDU) or Null PDUs during these times.) This is required in order for the MS to carry out correctly its channel maintenance procedures for an assigned channel.

23.3.1.4 Monitoring pattern during multi-timeslot traffic operation

The BS may allocate a multi-slot traffic channel for circuit mode data calls. Monitoring pattern information shall be given by the BS along with the channel allocation at call set-up. A transmitting MS shall attempt to receive and decode downlink slots according to the assigned monitoring pattern(s). This allows the BS to send signalling, for example using the STCH, to a transmitting MS. The MS shall only be expected to adhere to the assigned monitoring pattern(s) within its duplex and switching capability. A BS should take this into account when attempting to transmit downlink signalling to a transmitting MS on a multi-slot channel. An MS transmitting on multiple slots per TDMA frame without a duplex or fast switching capability shall not be expected to receive signalling on the downlink in between transmitted bursts on the uplink; therefore the BS should only use frame 18 (or the lowest numbered slot in frame 1 - see note 1) for signalling to that MS during transmission.

NOTE 1: The MS will not always be able to receive the lowest numbered downlink slot in the frame 1's indicated by the assigned monitoring pattern(s) e.g. when the MS linearizes or transmits in the highest numbered uplink slot in frame 18.

The following requirements apply to reception in frames 1 to 17 by an MS with a duplex or fast switching capability:

- when an MS with frequency full duplex capability is transmitting in traffic mode on a multi-slot channel, it shall attempt to receive and decode all the downlink slots of the assigned channel, in those frames required by the monitoring pattern(s);
- when an MS with fast switching capability is transmitting in traffic mode on a multi-slot channel, it shall attempt to receive and decode any downlink slots of the assigned channel that it is capable of receiving, in those frames required by the monitoring pattern(s).

In frame 18, the MS shall attempt to receive and decode at least the highest numbered downlink slot of the assigned channel, in those frames required by the monitoring pattern(s) (see clause 23.3.1.3).

NOTE 2: Fast switching capability on a phase-modulated channel and frequency full duplex capability are indicated in the "class of MS" element (see clause 16).

23.3.2 Discontinuous transmission for CA

23.3.2.0 General

In the continuous mode of operation, the BS shall transmit continuously on the CA main carrier except during a BLCH. (If there is no signalling information to send, the BS may send broadcast PDUs or Null PDUs.) On the other carriers:

- for phase modulation carriers (i.e. carriers currently carrying $\pi/4$ -DQPSK and/or D8PSK channel(s)), the BS may ramp down and up during slots on the unused physical channels; however, the inter-slot training sequence (i.e. normal training sequence 3) shall always be present and so this ramping down and up is transparent to the MS operation;
- for QAM carriers (i.e. carriers currently carrying QAM channel(s)), the BS shall transmit continuously except during a BLCH-Q.

The BS shall indicate continuous or discontinuous operation on phase modulation carriers by setting appropriately the "sharing mode" field broadcast in the SYNC PDU on the BSCH. Three modes of discontinuous transmission are defined:

- carrier sharing;
- MCCH sharing; and
- traffic carrier sharing.

These modes are described in the following clauses.

Discontinuous operation on a CA main carrier may be used for the purposes of sharing the channel resources between a number of cells. It may be desired to allocate different slots on the main carrier to different cells for $\pi/4$ -DQPSK or D8PSK channels. This is known as carrier sharing operation. Alternatively, it may be desired to share slot 1 of the main carrier between a number of cells. This is known as MCCH sharing.

Discontinuous operation on phase modulation carriers other than the main carrier may be used for the purposes of sharing traffic resources between a number of cells for $\pi/4$ -DQPSK and D8PSK channels. This may apply if the BS uses either mode of discontinuous operation on the main carrier. Otherwise it may apply only to the phase modulation carriers other than the main carrier. This is known as traffic carrier sharing.

NOTE: Irrespective of the value of the "sharing mode" field, the BS should transmit continuously on irregular phase modulation carriers (except during a BLCH), in order to allow MSs to perform irregular channel monitoring.

QAM carriers shall not be shared between cells using traffic carrier sharing, irrespective of the value of the "sharing mode" field: when the BS is using a carrier for QAM, it shall transmit continuously on that carrier (except during a BLCH-Q).

It is optional for the MS to implement the methods for operating with a BS that uses any of the discontinuous modes. The MS shall not attempt to obtain service from a BS that uses a discontinuous mode unless that MS is capable of performing the appropriate procedures.

23.3.2.1 Carrier sharing operation for CA

Carrier sharing operation allows the four slots of a CA main carrier to be shared between up to four adjacent cells. For example, each of four CA cells may be allocated one of the four timeslots on the main carrier, or each of two CA cells may be allocated two timeslots each. Interference is avoided by ensuring that only one of the cells sharing the carrier transmits on the downlink at any one time. This implies that the BSs sharing the main carrier need to be synchronized in time.

If the slot allocated to a BS is for use as a common control channel (i.e. MCCH or common SCCH), the BS shall transmit on the downlink in all frames for that slot (except during a BLCH). If the slot is for use as a traffic channel or assigned SCCH, the BS need not transmit on the downlink for that slot while it is not assigned. Indeed, a slot may be shared between a number of BSs for allocation as a traffic channel or as a $\pi/4$ -DQPSK or D8PSK assigned SCCH.

The slot, frame and multiframe numbering may be independent between the cells sharing the main carrier. This means that all cells sharing a carrier can have a slot 1 for use as the MCCH for that cell.

Phase modulation carriers other than the main carrier may also be shared between adjacent cells for $\pi/4$ -DQPSK and D8PSK channels. Therefore the MS designer should note that the BS may use discontinuous bursts on any of the phase modulation carriers of a carrier sharing cell.

23.3.2.2 MCCH sharing operation for CA

MCCH sharing allows a number of adjacent CA cells to share slot 1 of the main carrier for MCCH signalling. Up to 36 cells may share the same MCCH. Each cell has a number of reserved frames during which only the BS for that cell may transmit on the downlink MCCH. The remaining frames which are not reserved by any of the BSs sharing the MCCH may be used as common frames during which any of the BSs may transmit. However the network shall schedule downlink transmissions on common frames to ensure that two BSs do not transmit during the same common frame.

If the SYNC PDU indicates "MCCH sharing", the SYNC PDU shall also indicate the number of reserved frames for this BS using the "TS reserved frames" field. The "TS reserved frames" field shall indicate the number of frames reserved over two multiframe periods as defined in clause 9. The BS shall transmit on the downlink during these reserved frames.

During this mode of operation, the BSs shall also broadcast the location of the common frames by using the "TS_COMMON_FRAMES" field in the SYSINFO PDU sent on the BNCH. This field shall contain a bit map of the common frames for either the even-numbered or odd-numbered multiframes as indicated by the "Optional field flag".

In order for this mode of operation to work successfully, the transmission of downlink bursts shall be synchronized in time between the BSs sharing the MCCH. In addition, slot numbering shall be synchronized between the BSs to ensure that they all have a common view of when downlink slot 1 is transmitted. However, frame and multiframe numbering shall be offset in order to avoid collision of bursts transmitted during reserved downlink slots.

The remaining slots on the main carrier may be allocated as common SCCHs in which case the rules for reserved and common frames apply not only to slot 1 but also to those slots allocated as common SCCHs. Then the remaining slots not allocated for main or common secondary control may be shared between the BSs for use as traffic channels or as $\pi/4$ -DQPSK or D8PSK assigned SCCHs. This sharing is performed on a carrier sharing basis; the rules for reserved and common frames do not apply to assigned channels. A BS need not transmit during these slots if they are not assigned.

On a shared MCCH or common SCCH, the MS shall attempt to receive and decode the relevant slot during reserved frames for this BS and during those frames marked as common. It shall use the colour code received in the SYNC PDU on choosing a cell on which to camp in order to de-scramble the PDUs. This ensures that the MS cannot decode those transmissions during common frames on adjacent cells. In addition, the MS shall only use SYNC PDUs which contain the correct value of the "colour code" element for this cell, since SYNC is not scrambled using the colour code meaning that an MS could receive SYNC from an adjacent cell; to prevent incorrect operation, only those with the correct value of the "colour code" element shall be interpreted by the MS.

Phase modulation carriers other than the main carrier may be shared between adjacent cells for $\pi/4$ -DQPSK and D8PSK channels (on a carrier sharing basis). Therefore the MS designer should note that the BS may use discontinuous bursts on any of the phase modulation carriers of an MCCH sharing cell.

23.3.2.3 Traffic carrier sharing operation for CA

Traffic carrier sharing allows the four slots of phase modulation carriers other than the main carrier to be shared between adjacent cells for $\pi/4$ -DQPSK and D8PSK channels. The BS shall transmit continuously on the main carrier (except during a BLCH). However, it may use discontinuous bursts on the other phase modulation carriers.

23.3.2a Discontinuous transmission for DA

For all QAM carriers (i.e. carriers currently carrying QAM channel(s)), the BS shall transmit continuously except during a BLCH-Q.

Therefore the equivalent of carrier sharing operation and MCCH sharing operation do not apply for DA cells.

However there are two possible modes of operation for any phase modulation carriers used by the BS:

- If phase modulation carrier sharing operation is used, this allows the four slots of phase modulation carriers to be shared between a number of adjacent cells for $\pi/4$ -DQPSK and D8PSK channels. If the BS indicates that it may use phase modulation carrier sharing, the MS designer should note that the BS may use discontinuous bursts on phase modulation channels.
- If phase modulation carrier sharing operation is not used, the BS may still ramp down and up during slots on the unused physical channels on phase modulation carriers; however, the inter-slot training sequence (i.e. normal training sequence 3) shall always be present and so this ramping down and up is transparent to the MS operation.

In order for phase modulation carrier sharing operation to work successfully, the BSs sharing a phase modulation carrier need to be synchronized in slot timing (though the slot, frame and multiframe numbering may be independent between the cells).

The BS indicates whether it may use phase modulation carrier sharing by setting appropriately the one-bit "phase modulation carrier sharing mode" field broadcast in the SYSINFO-DA PDU.

QAM carriers shall not be shared between cells, irrespective of the value of the "phase modulation carrier sharing mode" field. When the BS is using a carrier for QAM, it shall transmit continuously on that carrier (except during a BLCH-Q).

NOTE: The BS should also transmit continuously on irregular phase modulation carriers (except during a BLCH), in order to allow MSs to perform irregular channel monitoring.

23.3.3 Minimum mode operation

23.3.3.0 General

Minimum mode operation allows a BS to allocate all four timeslots of a CA main carrier for traffic or assigned control purposes. Therefore, only frame 18 is available for common control. The following clauses describe the procedures for minimum mode operation which shall apply only to CA MSs that are in common control mode and receiving the MCCH. They do not apply to MSs on an assigned channel (traffic or assigned secondary control).

NOTE: Minimum mode is not supported for DA.

The BS should not allocate downlink slot 1 of a CA main carrier as a D8PSK channel. The BS should not allocate any timeslot of a CA main carrier as a QAM channel.

23.3.3.1 Beginning of minimum mode or no service mode

In the normal mode of operation, a CA MS shall receive the downlink of the MCCH and shall decode the AACH information (ACCESS-ASSIGN PDU). In the normal mode of operation, the MCCH is mapped to slot 1 of the main carrier frequency. The AACH in frames 1 to 17 shall indicate that downlink slot 1 is allocated for common control signalling, with the header set to 00_2 or "Field 1" set to $UMc (000010_2)$.

The BS may choose to enter minimum mode by allocating slot 1 of the main carrier for some other $\pi/4$ -DQPSK purpose. The AACH shall indicate that downlink slot 1 is no longer allocated for common control.

If the AACH has header value = 11_2 and "field 1" = $UMx (000000_2)$ and "field 2" = $UMx (000000_2)$ then the BS is entering no service mode, and not entering minimum mode.

NOTE 1: Minimum mode is not supported for DA. However, no service mode may apply for DA; see clause 23.3.1.1.3 and clause 23.5.7.

All CA MSs in idle mode and currently receiving downlink slot 1 shall recognize when the system has entered minimum mode and should recognize when the system has entered no service mode.

Minimum mode during frame 18 shall be assumed by an MS if the AACH indicates that downlink slot 1 in frame 17 is allocated for some purpose other than common control signalling unless the AACH is indicating UMx for no service mode. If the AACH cannot be decoded in frame 17, then the MS shall assume that the BS is in the mode indicated by the last correctly decoded AACH in a downlink slot 1. The BS shall not enter minimum mode in frame 18 but may only indicate the beginning of minimum mode in the AACH of frames 1 to 17.

NOTE 2: In order to ensure robust operation, a BS may choose to enter minimum mode several frames before frame 18. This would ensure that all MSs have an increased probability of correctly decoding the AACH and taking the proper action during frame 18.

The BS shall not enter minimum mode while there is future capacity already granted for reserved access on the MCCH. Thus the BS shall wait until any granted slots or subslots on the MCCH have been used (or released by the Null PDU) before entering minimum mode.

23.3.3.2 MS operation during frames 1 to 17

During minimum mode, an MS shall receive slot 1 in frames 2 to 17 so that the BS may send signalling to an MS using the stealing channel or fast associated control channel. An MS shall decode the full contents of the slot to check whether the information is addressed to that MS. An MS shall decode the AACH in downlink slot 1 of frames 1 to 17 so that it can detect the end of minimum mode. If the end of minimum mode is detected, the MS shall also decode the full contents of that slot to check whether the signalling message contained is addressed to that MS (except if minimum mode ends in frame 1 in which case the BS should not assume that every MS is able to receive the full contents of the slot). An MS assigned to slot 1 during frame 18 in minimum mode shall decode the full contents of slot 1 in frame 1. All other MSs need only decode the AACH during slot 1 in frame 1.

The BS should not assume that every MS is able to decode slot 1 of frame 1 since an MS assigned to slot 4 in frame 18 may not be able to decode the following slot in frame 1.

23.3.3.3 MS operation during frame 18

During minimum mode, an MS shall receive one of the four downlink slots in frame 18 as allocated to that MS at registration or subscription. An MS is allocated a minimum mode frame 18 slot at registration or subscription and shall receive that assigned downlink slot in frame 18 if the BS has entered minimum mode. The BS, therefore, may sub-divide the MS population at registration between the frame 18 slots for minimum mode operation according to whatever criteria it chooses to apply, or the sub-division may be applied at subscription of the MS population. If an MS has been assigned a minimum mode slot at subscription and then also receives a minimum mode slot at registration, the one received at registration shall be used.

If the MS does not have a minimum mode slot on this network, and has no minimum mode slot from subscription, it shall use downlink slot 1 in frame 18 by default.

NOTE 1: Subscription is applicable only for the MS's home network.

NOTE 2: A BS may choose not to sub-divide the MS population in minimum mode, but instead may assign downlink slot 1 as the minimum mode frame 18 slot for all MSs.

Frame 18 slots shall be shared between idle MSs for common control channel signalling and MSs on assigned channels which use frame 18 for associated control signalling. The BS may send downlink signalling messages on a downlink slot intended either for an idle MS receiving that slot or for an MS on the assigned channel using that slot for associated signalling. The BS shall indicate the destination for signalling messages with an address in the MAC header.

NOTE 3: When an MS obeys a channel allocation command for an assigned channel, it may be permitted to continue to use the MCCH if it is capable of doing so (see clause 23.5.4). If the BS is in minimum mode, and if the assigned channel happens to correspond to the MS's minimum mode frame 18 slot, then there is a possible ambiguity of usage of the downlink slot in frame 18. If this occurs then the MS should not attempt concurrent random access on both the MCCH in minimum mode and the assigned channel. Also the BS should avoid sending ambiguous fragmented signalling in frame 18.

Frame 18 downlink slots shall also be used for broadcast control signalling. The normal mapping of frame 18 downlink slots for BNCH and BSCH as specified in clause 9 shall apply.

23.3.3.4 MS operation in energy economy or dual watch mode

During minimum mode, an MS in energy economy or dual watch mode shall not modify its reception behaviour. An MS waking up to find that the system is in minimum mode shall not modify its reception behaviour. The BS may page an MS in energy economy or dual watch mode even during minimum mode by using the STCH or FACCH in the MS's "awake" frames.

NOTE: If an MS in energy economy or dual watch mode on the MCCH perceives that the system is in minimum mode then, when it is required by clauses 23.7.6 or 23.7.7 to receive in frame 18, it receives and decodes slot 1. This applies even if the MS's nominal minimum mode frame 18 slot (as received at subscription or registration) is not slot 1.

23.3.3.5 End of minimum mode

During minimum mode, an MS shall continue to receive the AACH on downlink slot 1 of frames 1 to 17. If the AACH indicates that downlink slot 1 is allocated for common control purposes once again, the MS shall recognize that the BS is no longer in minimum mode and that normal mode operation has resumed.

The BS shall not leave minimum mode while there is minimum mode capacity already granted for reserved access in slot 2, 3 or 4 of frame 18. Thus the BS shall wait until any slots or subslots granted in slot 2, 3 or 4 of frame 18 for MSs in common control mode have been used before leaving minimum mode.

23.3.3.6 Restrictions on usage of minimum mode

The minimum mode procedures are not applicable for a BS that uses MCCH sharing.

The minimum mode procedures may apply for a BS that uses main carrier sharing. However, in this case, the MS shall always use downlink slot 1 in frame 18 as its minimum mode frame 18 slot, irrespective of any value received at subscription or registration.

The minimum mode procedures apply only to CA MSs that are in common control mode and receiving the MCCH. They do not apply to MSs on an assigned channel. Also, they do not apply to an MS that is receiving a common SCCH. If the AACH information indicates that the downlink slot is not being used for common control purposes, the MS should remain on its common SCCH unless the "number of common secondary control channels in use on CA main carrier" field changes in the SYSINFO PDU (BNCH).

The minimum mode procedures do not apply to MSs that are operating in DA mode.

It is optional for an MS to be capable of performing the minimum mode procedures. If the BS enters minimum mode, and the MS is not capable of performing the minimum mode procedures, then that MS will not receive service during minimum mode. The MS shall not attempt random access and need not decode slot 1 for signalling messages. A CA MS shall at least be able to recognize the beginning and end of minimum mode.

23.3.4 Independent allocation of uplink and downlink

A BS may allocate uplink and downlink channels for different purposes. This can apply to channels which are assigned for use as a traffic channel or control channel. For example, a traffic channel may be allocated in the downlink direction when there are only receiving mobiles for that cell and the corresponding uplink channel may be allocated for a call which only requires an uplink channel. The BS shall not allocate different modulation modes for the downlink channel and the corresponding uplink channel.

NOTE 1: The above requirement restricts the BS from allocating different modulation modes for the downlink channel and the corresponding uplink channel. Note, however, that the D8PSK modulation mode refers to a channel on which signalling and data messages may be sent using either $\pi/4$ -DQPSK or $\pi/8$ -D8PSK bursts. Therefore, on a D8PSK channel, both $\pi/4$ -DQPSK and $\pi/8$ -D8PSK bursts may be used on both uplink and downlink.

NOTE 2: In the present document, the only usage of D8PSK and QAM assigned channels is for assigned SCCH, so independent allocation of uplink and downlink applies only for $\pi/4$ -DQPSK channels. However, in future editions of the present document, the BS may be permitted to allocate a D8PSK or QAM assigned SCCH in only one direction. Therefore the MS should expect that a D8PSK or QAM assigned SCCH may be allocated in only one direction.

Some examples are listed below:

- a) circuit mode call X on downlink channel;
circuit mode call Y on uplink channel;
- b) circuit mode call on downlink channel;
assigned SCCH on uplink channel;
- c) assigned SCCH on downlink channel;
circuit mode call on uplink channel;
- d) common control on downlink MCCH (slot 1);
uplink slot 1 of main carrier allocated for a circuit mode call;
- e) downlink slot 1 of main carrier allocated for a circuit mode call;
uplink slot 1 of main carrier available for common control.

The allocation of uplink and downlink slots is indicated by the contents of the ACCESS-ASSIGN PDU, which is broadcast by the BS in every downlink slot on a $\pi/4$ -DQPSK or D8PSK channel and may be broadcast in downlink slots on a QAM channel. All of the above examples can be accommodated with the available combinations of the header in the ACCESS-ASSIGN PDU (see clause 21 for more details). Also, when a channel is allocated, the "up/downlink assigned" or "up/downlink assigned for augmented channel allocation" element in the channel allocation shall inform the MS of any restrictions.

However, for the application of the general procedures for transmission and reception of signalling messages, each control channel (ACCH or SCCH) shall be assumed to occupy any control slots on both the uplink and downlink directions, as indicated by the "timeslot assigned" element in the channel allocation.

Therefore, for example, in case a), any ACCH in each direction shall be shared by the two unidirectional circuit mode calls. Similarly, in cases b) and c), the ACCH and SCCH shall be shared. In cases d) and e), the MSs in the circuit mode call shall share the common control channel.

NOTE 3: In case a), the two calls X and Y generally involve different MSs. However, it is possible that they may be concurrent calls involving the same MS.

23.3.5 Usage of a multi-slot channel

A "channel" or "MAC channel", as used in the MAC protocol, means a common control channel or assigned channel.

- For CA, a common control channel comprises one timeslot per TDMA frame on a pair of radio carrier frequencies (downlink and uplink) so it equates with a physical channel; see clause 9.4.1.
- For DA, the MCCH-Q may comprise more than one timeslot per TDMA frame on a pair of radio carrier frequencies. It then corresponds to a combination of up to four physical channels. Any common SCCHs comprise one timeslot per TDMA frame on the pair of radio carrier frequencies.
- An assigned channel may comprise more than one timeslot per TDMA frame on a pair of radio carrier frequencies. It then corresponds to a combination of up to four physical channels, as indicated by the "timeslot assigned" element in the MAC-RESOURCE or MAC-END PDU that sent the MS to the channel.

NOTE 1: A common control channel is a $\pi/4$ -DQPSK channel for CA or a QAM channel for DA. An assigned channel (either single-slot or multi-slot) may be a $\pi/4$ -DQPSK, D8PSK or QAM channel.

For the purposes of the procedures for transmission and reception of signalling messages on an assigned SCCH or an ACCH or the MCCH-Q, all the slots comprising a multi-slot channel are equivalent. Downlink signalling messages (including continuation fragments and final fragments) may be sent on any downlink slot appropriate to that channel. Also, when the MS is counting slots on the channel (e.g. for the granting delay or for a reserved access allocation), all the slots appropriate to that channel shall be counted continuously.

This contrasts with the method for a multi-slot circuit mode data service with interleaving depth $N = 4$ or 8 . In this case, when the assigned channel is in traffic mode, multiple single-slot data TCHs (TCH/2,4 or TCH/4,8) shall be operated in parallel in order to obtain the multi-slot TCH transmission. The N -slot interleaving shall be performed within each single-slot TCH, such that interleaved blocks are separated by three timeslots.

NOTE 2: The use of multiple single-slot data TCHs for the interleaving ensures that the performance of multi-slot circuit mode data is the same as that for single-slot circuit mode data with the same interleaving depth. This method applies only when the assigned channel is in traffic mode. When the channel is not being used for TCH, the channel reverts to FACCH and the normal signalling methods apply.

23.3.6 Usage of a 50 kHz, 100 kHz or 150 kHz channel

In the case of a $\pi/4$ -DQPSK or D8PSK channel, the bandwidth of the channel is 25 kHz.

In the case of a QAM channel, the bandwidth of the channel is 25 kHz, 50 kHz, 100 kHz or 150 kHz:

- for both CA and DA, the bandwidth of a QAM assigned channel is indicated by the "channel allocation" element in the MAC-RESOURCE or MAC-END PDU;
- for DA, the bandwidth of the DA main carrier is indicated by the "DA main carrier bandwidth" element in the SYNC-DA and SYSINFO-DA PDUs.

For a wide-bandwidth channel, the SCH MAC blocks are larger than for a narrower channel. Apart from the SCH MAC blocks being larger: for the purposes of the transmission and reception of signalling messages, the bandwidth does not generally affect the MAC procedures with the following exceptions:

- Random access messages are always sent using a 25 kHz bandwidth. (When an MS has chosen a subslot in an access frame and counted subslots to its chosen subslot in time using the same procedures as for a 25 kHz channel, it then makes a further random choice of which 25 kHz frequency block to use within the wider bandwidth; see clause 23.5.1.)

- The normal advanced link data segment size depends on the bandwidth of the channel. (The MS-MAC informs the LLC of the normal advanced link data segment size when it issues the MAC-READY signal.)

A wide-bandwidth channel may comprise more than one timeslot per TDMA frame, in which case clause 23.3.5 also applies.

23.4 General MAC procedures

23.4.1 PDU header analysis for signalling messages

23.4.1.1 MAC PDU types

The header of each MAC PDU enables the receiving MAC to interpret its contents correctly (see clause 21 for a full description of the PDUs).

23.4.1.2 Addressing at the TMA-SAP

23.4.1.2.0 General

The TMA-SAP MAC headers generally contain an "Address" element and an element specifying the type of address. This layer 2 address is the source address for an uplink PDU, or the destination address for a downlink PDU.

Another address (when needed) may be contained within the layer 3 part of the message e.g. the called address for an uplink PDU, or the calling address for a downlink PDU. The infrastructure makes the required address conversion between the uplink and downlink PDUs as appropriate.

The usage of TETRA addresses and identities is described in ETSI EN 300 392-1 [6], clause 7.

The address in the MAC header shall be a Short Subscriber Identity (SSI/USSI), a Short Management Identity (SMI) or an event label. An SSI/USSI is a 24-bit address specific to a particular TETRA network and is part of the complete TETRA Subscriber Identity (TSI). The 24-bit SMI is part of the TETRA Management Identity (TMI). An event label is a 10-bit MAC address that may be used to replace an SSI or SMI.

The MS procedures throughout clause 23 apply to the requirements for a single TSI family. If an MS contains more than one TSI family (see ETSI EN 300 392-1 [6], clause 7), then each family shall meet the MAC protocol requirements independently of other families.

23.4.1.2.1 Downlink message

When the BS transmits a downlink MAC-RESOURCE PDU, it shall use one of the following addresses as appropriate as the destination address:

- an Individual Short Subscriber Identity (ISSI);
- an Alias Short Subscriber Identity (ASSI);
- an Un-exchanged Short Subscriber Identity (USSI), used only until a migrating MS has been assigned a valid address on this network;
- a Group Short Subscriber Identity (GSSI);
- a Short Management Identity (SMI);
- a valid event label (see clause 23.4.1.2.3).

The "address type" element in the MAC header shall indicate whether the address is an SSI (ISSI/ASSI/GSSI), event label, USSI or SMI; and may be used to assign an event label (or a usage marker).

When the BS transmits a MAC-D-BLCK PDU, it shall use a valid event label as the destination address.

The receiving MS-MAC shall use the contents of a MAC-RESOURCE or MAC-D-BLCK PDU only if it recognizes the address as one of its own valid addresses or event labels. The one exception is that the MS-MAC shall process the MAC header in all received PDUs sufficiently to deduce the length of the PDU, in order to perform dissociation of multiple PDUs sent within a MAC block.

If the MS-MAC receives a PDU with one of its valid addresses or event labels, it shall pass the TM-SDU to the LLC using the TMA-UNITDATA indication primitive. It shall indicate the received address and address type, unless the received address is an event label in which case the MS-MAC shall translate the event label into the corresponding SSI or SMI before passing the information to the LLC.

NOTE 1: The other downlink TMA-SAP PDUs are used for continuations and end of a fragmented TM-SDU, and do not contain addressing information.

NOTE 2: There is no distinction between an ISSI, ASSI or GSSI in the PDU. There is no distinction between an ISSI and an ASSI in the MAC. However, it is assumed that the MS-MAC knows which of its addresses are group addresses. The MS-MAC also knows which of its addresses is the SMI, and it knows whether an address is an USSI.

NOTE 3: The predefined broadcast group address ("all ones" address), as described in ETSI EN 300 392-1 [6], clause 7, defines a group to which all MS belong. For example, it may be used as the destination address for CMCE or packet data calls, or it may be used by the BS for sending broadcast signalling messages using the services provided at the TLA-SAP and TMA-SAP.

NOTE 4: After an ASSI has been allocated to the MS, the ISSI remains available and may still be used by the BS if required. The MS therefore continues to recognize its ISSI on the downlink. This applies only on a home network, and not in the case of migration when the MS does not have a valid ISSI for the network.

23.4.1.2.2 Uplink message

When the MS-MAC is required to send a C-plane message, it receives a TMA-UNITDATA request primitive from the LLC. This primitive shall contain the appropriate layer 2 address (the main address) and the address type.

The main address in the request primitive shall be one of the following:

- the MS's ISSI or ASSI for the network;
- an USSI, used only by a migrating MS for the initial registration request;
- a GSSI;
- the SMI for the MS.

When the MS-MAC forms a MAC-ACCESS or MAC-DATA PDU, it shall use the main address from the TMA-UNITDATA request primitive in the PDU "Address" element, unless an event label has been assigned for this address (see clause 23.4.1.2.3) in which case it may use the event label when appropriate. The "Address type" element in the MAC header shall indicate whether the "Address" element contains an SSI (ISSI/ASSI/GSSI), event label, USSI or SMI.

If an event label has been assigned for the main address, and fragmentation is not needed, the MS-MAC may optionally use a MAC-U-BLCK PDU instead of a MAC-DATA PDU - if the pre-defined length is appropriate (see clause 21.4.2.6) and the BS supports the MAC-U-BLCK PDU.

NOTE 1: The other uplink TMA-SAP PDUs are used for continuations and end of a fragmented TM-SDU, and do not contain addressing information.

NOTE 2: A group address in the MAC header is used on the uplink for the low level group presence indication (see clauses 22.2.1.3 and 22.3.1.2). This is the only case for which a group address is used in the MAC header on the uplink.

NOTE 3: After an ASSI has been allocated to the MS, and while it is still valid, that ASSI should be used in uplink messages in preference to the ISSI.

23.4.1.2.3 Event labels

23.4.1.2.3.0 General

An "event label" is a temporary shortened form of address which replaces a specified SSI (ISSI, ASSI or GSSI) or a specified SMI in the MAC PDUs, and is visible only at the MAC layer. It is valid only on one MAC channel. Its usage is illustrated in figure 23.6.

Event label 000000000₂ (all zeros) may be used by the BS for withdrawing an event label assignment (using "address type" 101₂ or 111₂). It is not valid for normal use.

Event label 111111111₂ (all ones) may be used by the BS (with "address type" 101₂ or 111₂) to indicate that current event labels remain valid after a channel change. It is not valid for normal use.

23.4.1.2.3.1 General usage of event labels

When the BS wishes to assign an event label, it shall use the MAC-RESOURCE PDU, which shall contain both the SSI (or SMI) and the assigned event label.

- a) If the BS includes an event label assignment in a MAC-RESOURCE PDU containing a non-fragmented message then:
 - if the BS includes a "channel allocation" element in the MAC-RESOURCE PDU then the event label shall apply on the allocated channel (see note 1);
 - otherwise the event label shall apply on the current channel.
- b) If the BS includes an event label assignment in the MAC-RESOURCE PDU of a fragmented message then the event label shall not apply until the associated MAC-END PDU has been received. Then:
 - if the BS includes a "channel allocation" element in the MAC-END PDU then the event label shall apply on the allocated channel (see note 1);
 - otherwise the event label shall apply on the current channel.

If the MS discards the partially reconstructed TM-SDU (as described in clause 23.4.3.1.1) then it shall ignore the event label assignment.

NOTE 1: If the MS does not obey the channel allocation, it ignores the event label assignment.

NOTE 2: For a channel allocation with "allocation type" = 11₂ (Replace + CSS channel), the event label applies only on the assigned channel, not on the CSS channel. (See clause 23.5.4 for a description of the allocation types.)

The MS-MAC may then use the event label (if neither all zeros nor all ones) instead of the corresponding SSI (respectively SMI) as the source address in uplink PDUs sent on this channel; see figure 23.6. While the event label is valid, it may be used for both basic link and advanced link messages, and for random access, reserved access and STCH.

NOTE 3: Thus, while the event label is valid, it may replace the SSI or SMI in any uplink PDUs sent on this channel. As defined in clause 23.3.5, all the slots comprising a multi-slot channel (i.e. a multi-slot assigned channel or multi-slot MCCH-Q) are equivalent for the purposes of the general signalling procedures. Therefore an assigned event label applies to all slots of a multi-slot channel.

The BS may use the event label as the destination address in downlink PDUs (though the corresponding SSI or SMI may still be used). If the MS-MAC receives a downlink PDU containing a valid event label then it shall process the information contained in that PDU. The MS-MAC shall translate the event label into the corresponding SSI (respectively SMI) before passing the TM-SDU to the LLC.

The event label has a limited lifetime. The MS-MAC shall consider that an assigned event label is no longer valid in the following cases:

- 1) A time T.201 has elapsed since the MS last received a downlink PDU containing that event label. Then the MS-MAC shall revert to using the SSI (respectively SMI).

- 2) The MS receives another event label assignment (other than event label 11111111₂) on this channel, for the same SSI (respectively SMI). Then, if the received event label is non-zero, the MS-MAC shall accept that new event label; if the received event label = 0, the MS-MAC shall revert to using the SSI (respectively SMI).
- 3) The MS moves to another channel (unless the MS is leaving the channel as a result of a channel allocation message sent with "address type" 101₂ or 111₂ and containing event label 11111111₂). Then the MS-MAC shall revert to using the SSI (respectively SMI), unless a new event label was assigned with the channel allocation.

NOTE 4: In case 3), the MS discards an event label if it leaves the physical resource for which the event label was assigned i.e. the timeslot or timeslots on the appropriate carrier on this cell. The MS also discards an event label if the width of the channel (i.e. the number of timeslots allocated for the channel) is increased or decreased. As defined in clause 23.4.1.2.3.3, an exception to this definition occurs if the MS obeys a channel allocation command sent with "address type" 101₂ or 111₂ and containing event label 11111111₂.

An event label is retained if a single-slot channel changes from common to assigned or from assigned to common.

An event label is retained if a DA MS changes from common mode to assigned mode, or from assigned mode to common mode, on the same timeslot of the DA main carrier - or on the same timeslots of the DA main carrier for multi-slot MCCH-Q.

If the BS changes the number of common SCCHs then an event label is retained if the MS continues to use the same timeslot on the main carrier, but is discarded if the MS moves to a different timeslot.

An event label is retained when the BS enters and leaves minimum mode even if the MS's minimum mode frame 18 slot is not slot 1.

The BS is responsible for ensuring that it does not re-use an event label for another MS until the valid lifetime has expired.

If the BS establishes or accepts an advanced link for the acknowledged service to carry TL-SDUs with a maximum length of 4 096 octets then, in the case of a 25 kHz QAM channel, the BS shall assign an event label for that MS address for use on that channel. Similarly, if the BS establishes an advanced link for the unacknowledged service to carry TL-SDUs with a maximum length of 4 096 octets then, in the case of a 25 kHz QAM channel, the BS shall assign an event label for that address for use on that channel.

NOTE 5: Event label assignment is intended primarily for when an advanced link (or advanced links) have been set up for the appropriate address. However, its use is not precluded when there is only a basic link.

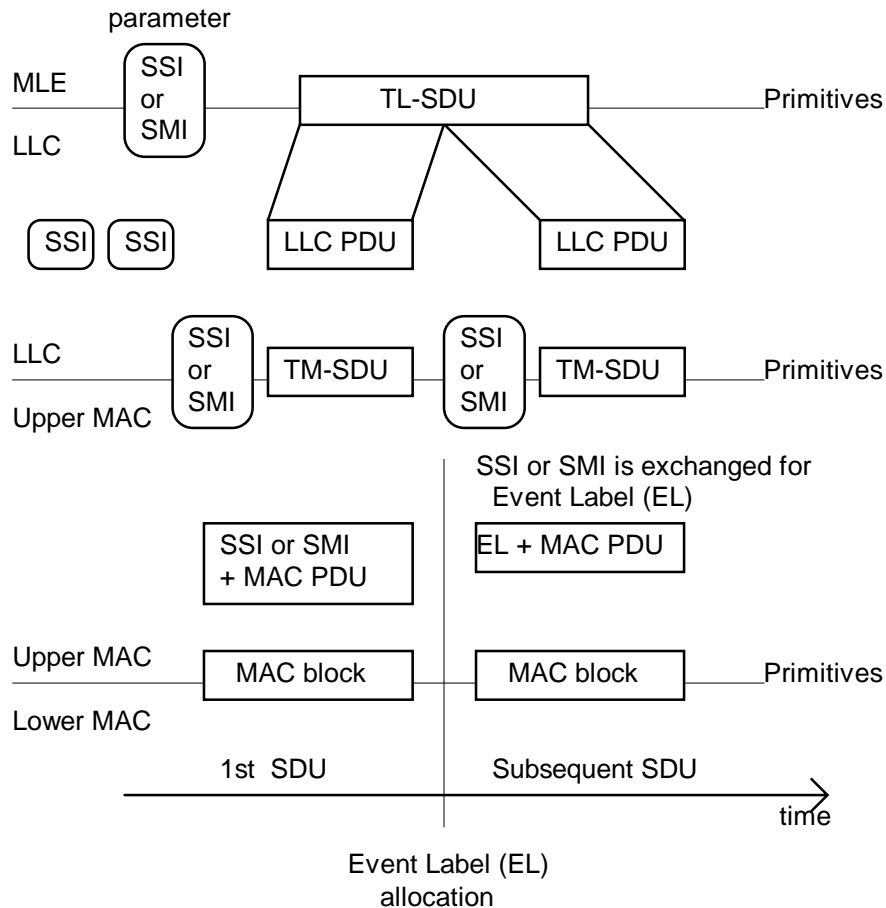

Figure 23.6: V+D air interface addressing

23.4.1.2.3.2 Usage of event label all zeros

As defined above, the BS may use event label 0 to withdraw an event label assignment (using "address type" 101_2 or 111_2 i.e. SSI/SMI + Event Label). Event label 0 is not valid for use at other times. Thus it is not valid for use in downlink PDUs with "address type" 010_2 or in uplink PDUs with "address type" 01_2 , or in MAC-D-BLCK or MAC-U-BLCK PDUs. If an MS receives a MAC-RESOURCE PDU with "address type" 010_2 and event label = 0, or a MAC-D-BLCK PDU with event label = 0, it shall ignore the PDU; or, if the BS receives a MAC-ACCESS or MAC-DATA PDU with "address type" 01_2 and event label = 0, or a MAC-U-BLCK PDU with event label = 0, it shall ignore the PDU.

23.4.1.2.3.3 Usage of event label all ones

When the BS sends a channel allocation, it may use "address type" 101_2 or 111_2 (i.e. SSI/SMI + Event Label) with the event label set to 11111111_2 to indicate to those MS or MSs addressed by the SSI or SMI that their event labels from the current channel shall be valid on the allocated channel. For an MS addressed by the SSI/SMI, this indicates that all its event labels (for all its addresses) from the current channel shall be valid on the allocated channel - not only the event label corresponding to the SSI/SMI.

NOTE 1: For a channel allocation with "allocation type" = 01_2 (Add), the event labels from the current channel are then valid on both the current channel and the allocated channel.

For a channel allocation with "allocation type" = 11_2 (Replace + CSS channel), the retention of event labels from the current channel applies only on the assigned channel, not on the CSS channel.

NOTE 2: As an example: the BS could use "address type" 101_2 or 111_2 with event label 111111111_2 if it wishes to replace an assigned channel ("allocation type" = 00_2) without invalidating the current event labels. This could apply if the BS wishes to change the width of the assigned channel (e.g. for a packet data channel PDCH) or if it wishes to replace the channel for any other reason. If the BS chooses to use the predefined broadcast group address (all ones SSI) then the replacement would apply to all the MSs on the current channel and would allow all the event labels from the current channel to remain valid on the new channel.

If the BS uses "address type" 101_2 or 111_2 with event label 111111111_2 in a MAC-RESOURCE PDU containing a non-fragmented message then the event labels from the current channel shall apply on the channel allocated by the "channel allocation" element in the MAC-RESOURCE PDU. If the BS uses "address type" 101_2 or 111_2 with event label 111111111_2 in a MAC-RESOURCE PDU containing a fragmented message then the event labels from the current channel shall apply on the channel allocated by the "channel allocation" element in the associated MAC-END PDU.

If the MS either:

- does not have any event labels on the current channel; or
- does not obey the channel allocation;

then it shall ignore the event label part of the MAC-RESOURCE PDU - obeying the other procedures within clause 23 as if the PDU had been sent with "address type" 001_2 or 100_2 .

Event label 111111111_2 is not valid for use at other times. Thus it is not valid for use in downlink PDUs unless there is an associated channel allocation. If an MS receives a MAC-RESOURCE PDU with "address type" 101_2 or 111_2 and event label 111111111_2 without receiving an associated channel allocation, it shall ignore the event label part of the PDU (obeying other procedures within clause 23 as if the PDU had been sent with "address type" 001_2 or 100_2). Also event label 111111111_2 is not valid for use in downlink PDUs with "address type" 010_2 or in uplink PDUs with "address type" 01_2 , or in MAC-D-BLCK or MAC-U-BLCK PDUs. If an MS receives a MAC-RESOURCE PDU with "address type" 010_2 and event label = 111111111_2 , or a MAC-D-BLCK PDU with event label = 111111111_2 , it shall ignore the PDU; or, if the BS receives a MAC-ACCESS or MAC-DATA PDU with "address type" 01_2 and event label = 111111111_2 , or a MAC-U-BLCK PDU with event label = 111111111_2 , it shall ignore the PDU.

23.4.1.2.4 Usage of SMI

The SMI is an address specific to a particular TETRA network and is part of the complete TMI. The management identity can be used to address a particular piece of equipment independently from the subscriber identity.

NOTE: The subscriber identities may be transferable, and may be removed from the equipment by the user.

The SMI enables management functions to be performed over the air interface. Alternatively, if the infrastructure knows the correspondence between the equipment and the SSI, it may use the SSI for the management functions, since the management messages can be recognized by the MLE (see clause 18).

The SMI may be numerically equal to an SSI attached either to that MS or to another MS. The SSI and SMI remain distinct because they can be distinguished by the address type in the MAC PDUs.

23.4.1.2.5 Usage of USSI

An USSI is the SSI of an MS from a foreign ITSI. It shall only be used in case of migration, when the MS does not have a valid ISSI or ASSI for the network, and shall only be used for the registration procedure. The USSI shall be equal to the ISSI used by the MS in its home network.

When migrating into a network, the first message sent by an MS shall be a registration request, with the USSI as the layer 2 source address. The home MCC and MNC are included within the layer 3 part of the message.

The USSI is then used on the downlink, in the BS response, as the layer 2 destination address. Also, if the layer 3 reply from the BS is not sent with the MAC response, the USSI will be used again as the layer 2 address when the BS sends the layer 3 reply.

The layer 3 reply to the registration request carries an ASSI for the visiting MS; that new SSI shall then be used by the MS inside the visited network. The allocated ASSI may be (by chance) equal to the USSI, but usually is not.

Sometimes, the USSI may be numerically equal to an SSI or SMI already in use by another MS on the visited network. The signalling messages remain distinct because they can be distinguished by the address type in the MAC PDUs.

Sometimes, the USSI may be numerically equal to the USSI of another migrating MS that is trying to register at the same time. In this case, the downlink signalling messages are not distinct at layer 2. However, the layer 3 reply from the BS contains the MS's home MCC and MNC, and the MM in the MS will discard a received reply if it has incorrect MCC or MNC (see clause 16).

As stated above, there are cases when downlink signalling messages containing the USSI are not distinct at layer 2, so reserved capacity granted before the BS sends a layer 3 reply could occasionally be accepted by more than one migrating MS. Thus, if a migrating MS's first registration request exceeds the capacity of the random access message and the MS uses fragmentation, there is a possibility that the BS might reconstruct a TM-SDU from fragments sent by two different migrating MSs. Therefore, if a migrating MS's first registration request exceeds the capacity of the random access message, the MS shall either:

- a) include the optional FCS when sending the first registration request (in which case it may use fragmentation); or
- b) choose not to include a first fragment of TM-SDU in the random access message - instead just requesting reserved capacity in the random access message and then sending the TM-SDU without fragmentation in the granted slot or subslot.

NOTE: In the case of migration to a CA cell, the MS's first registration request normally fits within the random access message. However, in the case of migration to a DA cell, the MS's first registration request does not fit within the random access message, so the MS needs to use method a) or b) above.

After the MS has received an ASSI, and has sent the LLC response if appropriate, usage of the USSI becomes invalid on this network for as long as the MS has a valid ASSI (see clause 16.4.7); the MS shall not use the USSI in uplink messages and shall not recognize the USSI in downlink messages.

23.4.1.3 Addressing at the TMB-SAP

The characteristic of this SAP is that the broadcast information (system information) is implicitly addressed to every MS and, in order to keep the overhead as low as possible, does not contain an address field. The MAC PDU type under the TMB-SAP is distinct from those used under the TMA-SAP (see clause 21). The LLC shall be transparent for system broadcasts. No address is reported by the MAC to the MLE.

NOTE: Broadcast messages under the TMB-SAP comprise only the SYNC PDU (contained in the BSCH), SYSINFO PDU (contained in the BNCH), SYSINFO-Q PDU (contained in the BNCH-Q), SYNC-DA PDU (contained in the BSCH-Q), SYSINFO-DA PDU (generally contained in the BNCH-Q) and ACCESS-DEFINE PDU. They should not be confused with signalling messages addressed to a group of MSs in the downlink using a specific group address at the TLA-SAP and TMA-SAP. Broadcast to all MSs in a cell or wider area may use the predefined broadcast group address ("all ones" address) and the services provided at the TLA-SAP and TMA-SAP (see clause 23.4.1.2.1).

23.4.1.4 Addressing at the TMD-SAP

There is no addressing at the TMD-SAP. There may be multiple endpoints in the TMD-SAP which shall be associated with the corresponding CC instance and address used in the set-up phase in the user application.

If the MAC steals from the circuit mode capacity to send C-plane signalling, it shall use TMA-SAP PDUs and addressing.

23.4.2 PDU composition for signalling messages

23.4.2.0 General

This clause describes the mechanisms whereby PDUs may be transmitted in the SCH MAC blocks. Three general mechanisms are provided:

- a) Fragmentation:
 - This is the subdivision procedure that shall be used by an MS-MAC or BS in the case that a TM-SDU received from the LLC exceeds the available capacity in a MAC block. The transmission of the TM-SDU is then subdivided between two or more MAC blocks.
- b) Fill bit addition:
 - The length of a MAC PDU is generally represented as a number of octets. In other cases the MAC PDU has an implicit length. "Fill bits" shall be used when the PDU does not fully occupy the indicated or implicit PDU length. They are used to make up the difference between the actual PDU content and the indicated or implicit length, and they also show the exact end of the TM-SDU.
- c) Association:
 - This is the procedure that may be used by an MS or BS for sending two or more PDUs within a single MAC block.

The reverse procedures (called reconstruction, fill bit deletion and dissociation respectively) are described in clause 23.4.3.

23.4.2.1 Fragmentation (TMA-SAP only)

23.4.2.1.0 General

Fragmentation is the procedure that shall be used by an MS-MAC or BS in the case that a TM-SDU received from the LLC exceeds the available capacity in the MAC block. The MAC subdivides the TM-SDU into a number of fragments, where each fragment is sent within one MAC PDU. The whole TM-SDU contains only a single LLC header. This procedure is illustrated in figure 23.7. Fragments are not numbered, and so they shall be sent in sequence. If an error occurs during transmission then the MAC procedure fails (and the LLC has to request a re-transmission of the whole TM-SDU). From the point of view of the higher layers, the process is the same as if the TM-SDU had been transmitted in a single MAC block.

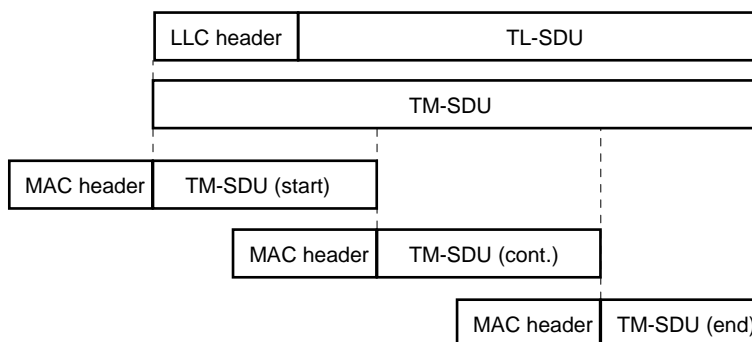

Figure 23.7: MAC fragmentation of a long TM-SDU

The first fragment of a TM-SDU shall be sent with a full MAC header (MAC-RESOURCE PDU on the downlink, MAC-ACCESS or MAC-DATA PDU on the uplink). Whereas continuation fragments (MAC-FRAG PDU) and the final fragment (MAC-END or MAC-END-HU PDU) shall be sent with a reduced MAC header (see clause 21). In particular, only the full MAC header contains addressing information.

Fragmentation applies only to subdivision of the actual TM-SDU. The MAC header cannot be subdivided between MAC blocks.

On the downlink, the BS may temporarily interrupt a fragmented message to send other signalling whereas, on the uplink, the MS-MAC shall not interleave any other signalling with a fragmented TM-SDU.

NOTE 1: The fragmentation procedure is intended primarily for use for basic link messages, if a TM-SDU exceeds the capacity of the MAC block. It is recommended that the MS/BS does not normally fragment advanced link messages. However fragmentation is needed on a D8PSK channel when an advanced link segment first sent using $\pi/8$ -D8PSK modulation is re-transmitted using $\pi/4$ -DQPSK modulation. Fragmentation may also be needed for re-transmissions of advanced link segments after a reduction of bandwidth (for example, if the bandwidth of a QAM channel changes from 150 kHz to 50 kHz).

NOTE 2: The fragmentation procedure is not intended for very long messages:

- a) It is recommended that fragmentation is not used for TL-SDUs that cannot be carried within a MAC-ACCESS PDU + four full slots.

The capacity of MAC blocks depends on the modulation, and also the bandwidth and coding rate for QAM. The longest recommended size of TM-SDU and TL-SDU for use of fragmentation is shown in table 23.7 (in which it is assumed that the MAC-ACCESS PDU is sent by random access using an SSI and the full slots are sent using the indicated transmission method). For example, on a $\pi/4$ -DQPSK channel, it is recommended that fragmentation is not used for TM-SDUs exceeding 1 106 bits; this corresponds to a TL-SDU of approximately 133 octets (if using FCS) or 137 octets (if not using FCS).

- b) The maximum permitted TM-SDU size is 2 632 bits (N.202), so fragmentation cannot be used for TL-SDUs exceeding approximately 324 octets (if using FCS) or 328 octets (if not using FCS).

Instead, the MLE should set up an advanced link (or use an existing advanced link).

It is recommended that the MLE uses the optional FCS if it sends long messages on the basic link (particularly if fragmentation is needed), but not when it sends short signalling messages.

NOTE 3: There is no MAC acknowledgement or MAC re-transmission of a fragmented TM-SDU. Acknowledgements and retransmissions are under the control of the LLC.

Table 23.7: Longest recommended size of TM-SDU / TL-SDU for fragmentation

Modulation and QAM coding rate and bandwidth for reserved access	Longest recommended size of TM-SDU for fragmentation [bits]	Approximate longest recommended size of TL-SDU for fragmentation [octets] if using FCS	Approximate longest recommended size of TL-SDU for fragmentation [octets] if not using FCS
$\pi/4$ -DQPSK	1 106	133	137
$\pi/8$ -D8PSK	1 682	205	209
4-QAM rate=1/2, 25 kHz	731	86	90
16-QAM rate=1/2, 25 kHz	1 531	186	190
16-QAM rate=1, 25 kHz	2 632 (see note)	324 (see note)	328 (see note)
64-QAM rate=1/2, 25 kHz	2 331	286	290
64-QAM rate=2/3, 25 kHz	2 632 (see note)	324 (see note)	328 (see note)
64-QAM rate=1, 25 kHz	2 632 (see note)	324 (see note)	328 (see note)
4-QAM rate=1/2, 50 kHz	1 563	190	194
16-QAM rate=1/2, 50 kHz	2 632 (see note)	324 (see note)	328 (see note)
16-QAM rate=1, 50 kHz	2 632 (see note)	324 (see note)	328 (see note)
64-QAM rate=1/2, 50 kHz	2 632 (see note)	324 (see note)	328 (see note)
64-QAM rate=2/3, 50 kHz	2 632 (see note)	324 (see note)	328 (see note)
64-QAM rate=1, 50 kHz	2 632 (see note)	324 (see note)	328 (see note)
QAM, 100 kHz (any modulation level and rate)	2 632 (see note)	324 (see note)	328 (see note)
QAM, 150 kHz (any modulation level and rate)	2 632 (see note)	324 (see note)	328 (see note)
NOTE: This corresponds to the maximum permitted size of TM-SDU (N.202).			

23.4.2.1.1 Fragmentation of downlink TM-SDU

When the BS wishes to send a TM-SDU that does not require fragmentation, it shall send the entire TM-SDU within the MAC-RESOURCE PDU, or within the MAC-D-BLCK PDU (if the pre-defined length is appropriate and the MAC-D-BLCK PDU is supported by the addressed MS(s); see "class of MS" element in clause 16).

NOTE 1: A single bit in the "class of MS" element indicates whether the MS supports reception of the MAC-D-BLCK PDU and augmented channel allocations. MSs that support D8PSK and/or QAM operation need to support augmented channel allocations in order to be allocated to a D8PSK or QAM channel; they therefore need to support reception of the MAC-D-BLCK PDU. It is optional whether an MS that only supports $\pi/4$ -DQPSK operation supports reception of the MAC-D-BLCK PDU and augmented channel allocations.

When the BS wishes to send a TM-SDU that exceeds the available capacity within a MAC block, it may subdivide the TM-SDU into fragments, which shall be sent on this control channel, in the following sequence:

- a) the first fragment shall be sent using the MAC-RESOURCE PDU;
- b) any continuation fragments shall be sent using $n \times$ MAC-FRAG PDUs (where $n \geq 0$);
- c) the final fragment shall be sent using the MAC-END PDU.

Since the MAC-END PDU header is longer than the MAC-FRAG PDU header, there may be some cases when the remainder of the TM-SDU fits within MAC-FRAG but would not fit within MAC-END. In these cases, the BS should send the remaining data within MAC-FRAG (with fill bits if necessary) and then send an empty MAC-END PDU to complete the message.

When the BS has sent one or more fragments of a fragmented message, it may temporarily interrupt the transmission if necessary to send a TMB-SAP broadcast message or a non-fragmented TMA-SAP message (but not a fragmented message). However the following points may be noted:

- The MS-MAC receiving the fragmented message will discard a partially received TM-SDU if it does not receive a fragment in at least every $N \cdot 203^{\text{th}}$ slot on this downlink control channel; see reconstruction by MS given in clause 23.4.3.1.1.
- The MS-MAC receiving the fragmented message will discard a partially received TM-SDU if it fails to decode an SCH MAC block on this control channel; see reconstruction by MS given in clause 23.4.3.1.1. Therefore, on a D8PSK channel, if the BS interrupts the transmission of a $\pi/4$ -DQPSK fragmented message to send a non-fragmented message using $\pi/8$ -D8PSK modulation, this may cause the reconstruction of the fragmented message to fail (i.e. if the MS cannot currently receive SCH at the higher bit rate). Similarly, on a QAM channel, if the BS interrupts the transmission of a fragmented message to send a non-fragmented message using a higher modulation level and/or less coding, this may cause the reconstruction of the fragmented message to fail (i.e. if the MS cannot currently receive SCH at the higher bit rate).
- The MS-MAC receiving a fragmented message on a QAM channel will discard a partially received TM-SDU if it does not understand the value of the "slot format" element in the downlink QAM-SLOTINFO PDU in a slot on this downlink control channel; see reconstruction by MS given in clause 23.4.3.1.1. Some CA MSs may not understand the value of the "slot format" element that indicates a QAM FCB. Therefore, if the BS interrupts the transmission of a fragmented message to a CA MS to send a SYNC-DA PDU (in either a predefined or non-predefined position), this may cause the reconstruction of the fragmented message to fail.

NOTE 2: Similarly, some CA MSs may not understand the SYSINFO-DA PDU and therefore will not know the length of the SYSINFO-DA PDU - so cannot process associated PDUs following the SYSINFO-DA PDU in a downlink MAC block. Also such MSs may decide to discard a partially received TM-SDU if the BS sends a SYSINFO-DA PDU. Thus, if the BS interrupts the transmission of a fragmented message to a CA MS to send a SYSINFO-DA PDU (in either a predefined or non-predefined position), this may cause the reconstruction of the fragmented message to fail.

The MAC PDU structure allows only one first fragment or continuation fragment to be sent per MAC block. This shall be sent as the last PDU in the MAC block. In the MAC-RESOURCE PDU that contains the first fragment, the "Length indication" element shall be set to 11111_2 .

The BS may abort a fragmented transmission at any time before transmission of MAC-END by sending no more fragments of the message.

If the BS wishes to send slot granting information with a fragmented message, the grant may be included in either the MAC-RESOURCE or the MAC-END PDU.

If the BS wishes to send channel allocation information with a fragmented message, then this information shall be included within the MAC-END PDU and shall not be included within the MAC-RESOURCE PDU.

NOTE 3: For a multi-slot control channel, all the downlink slots comprising that control channel are equivalent. In particular, the continuation and final fragments may be transmitted on any downlink slot appropriate to that channel (as indicated by the "Timeslot Assigned" element from the MAC-RESOURCE or MAC-END PDU that allocated an assigned channel or as indicated by the SYSINFO-DA PDU for a multi-slot MCCH-Q); they are not restricted to the same timeslot number as the first fragment.

23.4.2.1.2 Fragmentation of uplink TM-SDU

When the MS-MAC wishes to send a TM-SDU that does not require fragmentation, it shall send the entire TM-SDU within the MAC-ACCESS PDU or the MAC-DATA PDU or the MAC-U-BLCK PDU (if supported by the BS). The MAC-ACCESS PDU applies if the MS-MAC is using random access or a subslot granted by the BS; the MAC-DATA or MAC-U-BLCK PDU applies if the MS-MAC is using a full slot granted by the BS. After transmission in a granted subslot or slot, the MS-MAC shall inform the LLC that the TM-SDU has been sent (using the TMA-REPORT indication primitive).

For CA, the BS indicates whether it supports the MAC-U-BLCK PDU using the "extended services broadcast" element in the SYSINFO and SYSINFO-Q PDUs. For DA, the BS shall support the MAC-U-BLCK PDU.

The MS-MAC may perform fragmentation of a TM-SDU using any of the following transmission forms:

- i) MAC-ACCESS + MAC-END-HU;
- ii) MAC-ACCESS + $n \times$ MAC-FRAG + MAC-END $0 \leq n \leq n_{\max}$;
- iii) MAC-DATA + MAC-END-HU;
- iv) MAC-DATA + $n \times$ MAC-FRAG + MAC-END $0 \leq n \leq n_{\max}$.

Form i) or ii) shall apply if the MS-MAC is using random access to start the process or if the MS-MAC is granted a subslot by the BS. Form iii) or iv) shall apply if the transmission starts in a full slot granted by the BS.

NOTE 1: The value of parameter n_{\max} depends on the modulation, and also the bandwidth and coding rate for QAM, to be used for the reserved access slot(s) containing the MAC-FRAG and MAC-END PDUs; see table 23.8.

When the MS-MAC wishes to send a TM-SDU, it shall first determine whether fragmentation is required and, if so, the required capacity to carry the TM-SDU.

For MAC-ACCESS, fragmentation is required for a TM-SDU exceeding:

- 62 bits if sent by random access on a $\pi/4$ -DQPSK or D8PSK channel; or
- 35 bits if sent by random access on a QAM channel; or
- B_{ACCESS} bits if sent by reserved access (see note 2).

If fragmentation is required, the MAC-ACCESS PDU can carry a first fragment of:

- 56 bits of TM-SDU if sent by random access on a $\pi/4$ -DQPSK or D8PSK channel; or
- 29 bits of TM-SDU if sent by random access on a QAM channel; or
- $(B_{\text{ACCESS}} - 6)$ bits of TM-SDU if sent by reserved access (see note 2).

NOTE 2: The value of parameter B_{ACCESS} depends on the modulation, and also the bandwidth and coding rate for QAM, to be used for the reserved access subslot containing the MAC-ACCESS PDU; see table 23.8.

NOTE 3: If the MS is on a QAM channel and is using random access to start the process of sending a TM-SDU exceeding 35 bits, but not exceeding B_{ACCESS} bits for the modulation, bandwidth and coding to be used in a reserved access subslot, the MS may choose not to include a first fragment of TM-SDU in the random access message - instead just requesting a reserved subslot in the random access message and then sending the TM-SDU without fragmentation in the granted subslot. This may sometimes be more efficient for channels with high bandwidth.

If the MS is on a D8PSK channel, and is using random access to start the process of sending a TM-SDU exceeding 62 bits, but not exceeding B_{ACCESS} bits for $\pi/8$ -D8PSK, and if the MS intends to use $\pi/8$ -D8PSK modulation in a reserved access subslot, the MS may choose not to include a first fragment of TM-SDU in the random access message - instead just requesting a reserved subslot in the random access message and then sending the TM-SDU without fragmentation in the granted subslot.

For MAC-DATA, fragmentation is required for a TM-SDU exceeding B_{DATA} bits (and the MAC-DATA PDU can carry a first fragment of B_{DATA} bits of TM-SDU).

NOTE 4: The value of parameter B_{DATA} depends on the modulation, and also the bandwidth and coding rate for QAM, to be used for the reserved access slot containing the MAC-DATA PDU; see table 23.8.

NOTE 5: The above numbers and the numbers in table 23.8 assume that the first fragment is the only PDU within the MAC block. If association has occurred within the subslot or slot, the available size is reduced correspondingly. Fragmentation can only be used after association if the complete MAC header, plus at least one bit of TM-SDU, can be sent within the MAC block.

NOTE 6: The above numbers and the numbers in table 23.8 assume the use of an SSI or SMI in the MAC header. If an event label is used, then the available sizes are increased by 14 bits.

If the remainder of the TM-SDU does not exceed $B_{\text{END-HU}}$ bits, then the transmission can be completed with a single subslot (MAC-END-HU PDU).

NOTE 7: The value of parameter $B_{\text{END-HU}}$ depends on the modulation, and also the bandwidth and coding rate for QAM, to be used for the reserved access subslot containing the MAC-END-HU PDU; see table 23.8.

Otherwise, the MS-MAC shall determine the required number ($N = n + 1$) of full slots to send the remainder (R bits) of the TM-SDU:

- if $R \leq B_{\text{END}}$, $N = 1$;
- if $R > B_{\text{END}}$, $N = 2 + (R - B_{\text{END}} - 1) \text{ DIV } B_{\text{FRAG}}$;

where DIV represents integer division, rounded down.

NOTE 8: The values of parameters B_{FRAG} and B_{END} depend on the modulation, and also the bandwidth and coding rate for QAM, to be used for the reserved access slot(s) containing the MAC-FRAG and MAC-END PDUs; see table 23.8.

It is not possible to indicate a reservation requirement in a MAC-FRAG PDU, so it will not normally be possible for the MS to change its decision about modulation and coding rate during transmission of the reserved slots containing the MAC-FRAG and MAC-END PDUs. Therefore, when performing fragmentation on a D8PSK or QAM channel, the MS-MAC first needs to decide on the modulation and coding rate that it will use for the transmission of the MAC-FRAG and MAC-END PDUs. It then calculates the required number of slots (N) based on that decision.

The MS-MAC shall use the following procedure for sending a fragmented TM-SDU:

- The MS-MAC shall send the first fragment in the MAC-ACCESS or MAC-DATA PDU, setting the "fill bit indication" to indicate that no fill bits are present and the optional elements to include the "Capacity request" indicating:
 - start of fragmentation;
 - the reservation requirement for the remainder of the TM-SDU (and for any other messages which the MS has ready to send for this address on this control channel).

- If the MS-MAC requested only a subslot then it shall send the final fragment in the first subslot or full slot granted for this address on this control channel (using MAC-END-HU or MAC-END respectively). The "fill bit indication" shall be used to indicate whether or not fill bits are used within the PDU.
- If the MS-MAC requested one or more full slots then it shall send further fragments in full slots on this control channel, using n MAC-FRAG PDUs and then one MAC-END PDU. It shall send fragments in any slots already granted for this address, and in slots as they are granted by the BS for this address (in one or more slot grants).

NOTE 9: The BS is permitted to use more than one slot grant when granting the requested slots for the further fragments, in which case the granted slots need not be continuous on this uplink control channel. However, see timer T.202 in procedure b) below.

- For the first $n-1$ MAC-FRAG PDUs, the MS-MAC shall include fragments of B_{FRAG} bits of the TM-SDU (with no fill bits). For the last MAC-FRAG, the MS-MAC shall include the next B_{FRAG} bits of the TM-SDU, or the remainder of the TM-SDU if this is less than B_{FRAG} bits (with the "fill bit indication" used to indicate the end of the user data).
- The MS-MAC shall include the remaining part (if any) of the TM-SDU in the MAC-END PDU. The "fill bit indication" shall be used to indicate whether or not fill bits are used within the PDU.

NOTE 10: The ISSI and its associated ASSI are equivalent for the purposes of the slot granting procedure (so the MS should use any subslot or slot(s) granted on its ISSI for a TM-SDU being sent with its ASSI, or vice versa). Similarly, an event label and its corresponding address are equivalent for the purposes of the slot granting procedure. Also, a newly assigned ASSI is equivalent to the replaced ASSI or USSI for the purposes of the slot granting procedure.

The transmission process described above shall be continued until one of the following cases a) to d) occurs:

- a) The MS-MAC sends the MAC-END-HU or MAC-END PDU.

The MS-MAC shall then inform the LLC that the TM-SDU has been sent by reserved access (using the TMA-REPORT indication primitive).

The remainder (if any) of the MAC block shall be completed either by a Null PDU (plus fill bits) or by a MAC-ACCESS or a MAC-DATA or MAC-U-BLCK PDU by association as appropriate.

If the MS has further signalling to send for this address on this control channel, then the MS-MAC shall include the reservation requirement in the MAC-END-HU/MAC-END PDU (or in the last PDU in the MAC block if association is performed).

- b) The MS-MAC does not have any capacity granted for this address on this control channel and a time T.202 has elapsed since:

- it last transmitted a fragment; or
- it last received a "basic slot granting" element for this address on this control channel containing the instruction to "Wait for another Slot Grant",

whichever is the later.

The MS-MAC shall then inform the LLC that the transmission has failed (using the TMA-REPORT indication primitive), and shall discard the TM-SDU.

NOTE 11: After a fragmentation failure, the LLC is responsible for sending a re-transmission if appropriate.

- c) The MS-MAC asked for full slot reservation, and it receives a subslot grant for this address.

The MS-MAC shall then inform the LLC that the transmission has failed (using the TMA-REPORT indication primitive), and shall discard the TM-SDU. The MS-MAC may use the granted subslot to send another TM-SDU.

- d) The MS-MAC receives a TMA-CANCEL request primitive from the LLC, cancelling transmission of this message. In this case, the MS-MAC shall discard the TM-SDU (reporting to the LLC that the message was not completely sent).

If the MS-MAC is granted any further subslots or slots, it may send another TM-SDU.

NOTE 12: Where procedures a), b) and c) use the expression "for this address", the ISSI and its associated ASSI are equivalent for the purposes of this procedure. Similarly, an event label and its corresponding address are equivalent for the purposes of this procedure. Also, a newly assigned ASSI is equivalent to the replaced ASSI or USSI for the purposes of this procedure.

Table 23.8: Value of parameters in uplink fragmentation procedure

Modulation and QAM coding rate and bandwidth for reserved access	n_{\max}	B_{ACCESS}	B_{DATA}	$B_{\text{END-HU}}$	B_{FRAG}	B_{END}
$\pi/4$ -DQPSK	9	62	231	85	264	258
$\pi/8$ -D8PSK	6	118	375	141	408	402
4-QAM rate=1/2, 25 kHz	14	27	144	50	177	171
16-QAM rate=1/2, 25 kHz	6	103	344	126	377	371
16-QAM rate=1, 25 kHz	3	258	747	281	780	774
64-QAM rate=1/2, 25 kHz	4	179	544	202	577	571
64-QAM rate=2/3, 25 kHz	3	255	744	278	777	771
64-QAM rate=1, 25 kHz	2	410	1 147	433	1 180	1 174
4-QAM rate=1/2, 50 kHz	6	111	352	134	385	379
16-QAM rate=1/2, 50 kHz	3	271	760	294	793	787
16-QAM rate=1, 50 kHz	1	594	1 579	617	1 612	1 606
64-QAM rate=1/2, 50 kHz	2	431	1 168	454	1 201	1 195
64-QAM rate=2/3, 50 kHz	1	591	1 576	614	1 609	1 603
64-QAM rate=1, 50 kHz	1	914	2 395	937	2 428	2 422
4-QAM rate=1/2, 100 kHz	3	279	768	302	801	795
16-QAM rate=1/2, 100 kHz	1	607	1 592	630	1 625	1 619
16-QAM rate=1, 100 kHz	0	1 266	3 243 (see note 1)	1 289	n/a (see note 2)	3 270
64-QAM rate=1/2, 100 kHz	1	935	2 416	958	2 449	2 443
64-QAM rate=2/3, 100 kHz	0	1 263	3 240 (see note 1)	1 286	n/a (see note 2)	3 267
64-QAM rate=1, 100 kHz	0	1 922	4 891 (see note 1)	1 945	n/a (see note 2)	4 918
4-QAM rate=1/2, 150 kHz	2	447	1 184	470	1 217	1 211
16-QAM rate=1/2, 150 kHz	1	943	2 424	966	2 457	2 451
16-QAM rate=1, 150 kHz	0	1 938	4 907 (see note 1)	1 961	n/a (see note 2)	4 934
64-QAM rate=1/2, 150 kHz	0	1 439	3 664 (see note 1)	1 462	n/a (see note 2)	3 691
64-QAM rate=2/3, 150 kHz	0	1 935	4 904 (see note 1)	1 958	n/a (see note 2)	4 931
64-QAM rate=1, 150 kHz	0	2 930 (see note 1)	7 387 (see note 1)	2 953	n/a (see note 2)	7 414
NOTE 1: In these cases, the complete subslot or slot can carry the maximum permitted size of TM-SDU. Therefore fragmentation will not be needed unless association has occurred within the subslot or slot, in which case the available size may have been reduced sufficiently for fragmentation to be appropriate.						
NOTE 2: In the cases of B_{FRAG} for which "n/a" is indicated, a MAC-END PDU can always carry the remainder of the TM-SDU after the initial MAC-ACCESS or MAC-DATA, so use of MAC-FRAG is not appropriate.						

23.4.2.1.3 Fragmentation in minimum mode

Fragmentation is possible in minimum mode. However, long delays may be introduced, particularly for fragmentation over more than two MAC blocks. Therefore, an MS or BS may choose not to perform fragmentation during minimum mode, and the BS may (as always) choose not to grant slots to an MS for continuation of a fragmented message.

When in minimum mode, the BS should not attempt fragmentation (other than within one slot on stealing channel STCH) of a message addressed to an MS that is in energy economy or dual watch mode.

a) Downlink TM-SDU

The general procedure for downlink fragmentation, described in clause 23.4.2.1.1, applies during minimum mode except that, when sending a fragmented message to an MS, the only MAC blocks that the BS may use for MAC-FRAG or MAC-END are those in the MS's designated minimum mode frame 18 slot. The MS-MAC receiving the fragmented message will discard a partially received TM-SDU if it does not receive a fragment in at least every N.203'th frame 18.

NOTE 1: Not all MSs will receive all AACH blocks, so there is some uncertainty about exactly when a particular MS enters and leaves minimum mode. Therefore, if the BS is in process of sending a fragmented message when it enters or leaves minimum mode, it may prefer to abort the transmission.

NOTE 2: The fragmentation procedure defined above applies only when the MAC-RESOURCE PDU is sent on SCH/F or SCH/HD (in slot 1 of frames 2 to 17 if the downlink is in FACCH or assigned SCCH, or in the MS's minimum mode frame 18 slot). If the MAC-RESOURCE PDU is sent on STCH then the fragmentation procedure defined in clause 23.4.2.1.7 applies.

b) Uplink TM-SDU

During minimum mode, the MS-MAC shall follow the defined minimum mode rules for receiving and decoding the downlink for signalling messages (e.g. for receiving slot grants from the BS).

The general procedure for uplink fragmentation, described in clause 23.4.2.1.2, applies (although, since time T.202 is counted in downlink signalling opportunities (as defined in annex B), in minimum mode the absolute time is 18 times its usual value).

23.4.2.1.4 Fragmentation on time-shared control channel**a) Downlink TM-SDU**

The general procedure for downlink fragmentation, described in clause 23.4.2.1.1, applies on a time-shared MCCH except that, when sending a fragmented message to an MS, the only MAC blocks that the BS may use for MAC-FRAG or MAC-END are those in the reserved frames for this BS, not the common frames. The MS-MAC receiving the fragmented message will discard a partially received TM-SDU if it does not receive a fragment in at least every N.203'th reserved frame.

b) Uplink TM-SDU

On a time-shared MCCH, the MS-MAC shall follow the defined rules for receiving and decoding the downlink for signalling messages (e.g. for receiving slot grants from the BS). The normal procedure for uplink fragmentation, described in clause 23.4.2.1.2, applies (although, since time T.202 is counted in downlink signalling opportunities (as defined in annex B), on a time-shared control channel the absolute time is greater than on a non-time-shared channel).

23.4.2.1.5 Fragmentation on assigned channel if downlink is in SACCH**a) Downlink TM-SDU**

In frames 1 to 17, fragmentation may be performed on the stealing channel within one slot (see clause 23.4.2.1.7). Fragmentation may also be performed on the SACCH in frame 18.

NOTE 1: Long delays may be introduced for fragmentation over more than two frame 18s. Also, transmission of a fragmented message on SACCH should be aborted if the BS needs to send a fragmented message on the STCH of that assigned channel. Therefore, the BS may choose not to perform fragmentation on the SACCH in frame 18.

The general procedure for downlink fragmentation, described in clause 23.4.2.1.1, applies on the SACCH in frame 18 with the following differences:

- 1) When sending a fragmented message on SACCH to an individual MS that is currently transmitting traffic on the uplink, the only MAC blocks that the BS may use for the message are those in the highest numbered downlink slot of the assigned channel, in those frame 18s that the MS is required to receive according to the assigned monitoring pattern(s). The MS-MAC receiving the fragmented message will discard a partially received TM-SDU if it does not receive a fragment in at least every N.203'th frame 18 where it is required to receive.

NOTE 2: The above procedure applies only for an individually addressed message. If the BS needs to send a group addressed fragmented message when the downlink is in traffic and an MS is transmitting traffic on the uplink then the BS follows procedure 2).

NOTE 3: If the BS wishes to abort a fragmented transmission on SACCH to an individual MS that is currently transmitting traffic on the uplink, it should either wait for the appropriate number of multiframes (e.g. $N.203 \times 3$ / number of monitoring patterns) before sending another fragmented message on SACCH or otherwise send a MAC-RESOURCE PDU indicating start of fragmentation in the highest numbered downlink slot of the assigned channel in a frame 18 where the MS is required to receive.

- 2) When sending a fragmented message on SACCH to other MSs, the only MAC blocks that the BS may use for MAC-FRAG or MAC-END are those in the lowest numbered downlink slot of the assigned channel in frame 18. The MS-MAC receiving the fragmented message will discard a partially received TM-SDU if it does not receive a fragment in at least every N.203'th frame 18.

NOTE 4: As defined in clause 23.3.1.3, an MS receiving in traffic mode on a multi-slot channel is normally required to receive only the lowest numbered slot in frame 18. Therefore, when sending a fragmented message on SACCH to MS(s) that are receiving in traffic mode on a multi-slot channel, the BS should send the first fragment in the lowest numbered slot of the assigned channel in frame 18. Continuation and final fragments sent on SACCH to any MS that is not transmitting traffic on the uplink may be sent only in the lowest numbered slot of the assigned channel in frame 18.

NOTE 5: The BS should note the procedures used by an MS for reconstruction if the MS switches in or out of traffic transmit mode or sees the downlink leave SACCH (see clause 23.4.3.1.5, paragraph before note 1 and paragraph before note 4).

NOTE 6: In case of propagation errors, there is some uncertainty about exactly when a particular MS sees the channel enter or leave SACCH. Therefore, if the BS is in process of sending a fragmented message when it enters or leaves SACCH, it may prefer to abort the transmission.

b) Uplink TM-SDU

In frames 1 to 17, if an MS is transmitting traffic on the uplink then it may perform fragmentation on the stealing channel within one slot (see clause 23.4.2.1.7).

Fragmentation may be performed by any MS on the uplink SACCH or FACCH. The general procedure for uplink fragmentation, described in clause 23.4.2.1.2, applies although, since time T.202 is counted in downlink signalling opportunities (as defined in annex B), the absolute time is 18 times its usual value. If a fragmentation on uplink SACCH is being performed by an MS that is transmitting traffic on the uplink then the absolute time of T.202 is also modified by the monitoring pattern(s).

NOTE 7: Time T.202 is counted in downlink signalling opportunities (as defined in annex B). However, the BS may choose to send a slot grant by stealing from the downlink TCH.

23.4.2.1.6 Fragmentation on assigned channel if downlink is in FACCH or assigned SCCH

a) Downlink TM-SDU

The general procedure for downlink fragmentation, described in clause 23.4.2.1.1, applies when an assigned channel is not in downlink traffic with the following difference:

- When sending a fragmented message to an individual MS that is currently transmitting traffic on the uplink, the only MAC blocks that the BS may use for MAC-FRAG or MAC-END are those in the downlink slots where the MS is required to look for further fragments (as defined in clause 23.4.3.1.6 procedure a). The MS-MAC receiving the fragmented message will discard a partially received TM-SDU if it does not receive a fragment in at least every N.203th slot where it is required to look for further fragments.

NOTE: The above procedure applies only for a message individually addressed to an MS that is currently transmitting traffic on the uplink. If the BS needs to send other fragmented messages when the downlink is not in traffic then the BS follows the general procedure for downlink fragmentation (so continuation and final fragments may be transmitted on any downlink slot appropriate to the assigned channel). This applies even if the uplink is in traffic.

b) Uplink TM-SDU

In frames 1 to 17, if an MS is transmitting traffic on the uplink then it may perform fragmentation on the stealing channel within one slot (see clause 23.4.2.1.7).

Fragmentation may be performed by any MS on the uplink SACCH or FACCH. The general procedure for uplink fragmentation, described in clause 23.4.2.1.2, applies (although, if a fragmentation on uplink SACCH is being performed by an MS that is transmitting traffic on the uplink then the absolute time of T.202 is modified by the monitoring pattern(s)).

23.4.2.1.7 Fragmentation on stealing channel

On the stealing channel STCH, fragmentation is only permitted within one slot. Neither the MS nor the BS shall attempt to perform fragmentation over more than one stolen slot.

The procedure for transmission on STCH (including fragmentation) is described in clause 23.8.4.

23.4.2.2 Fill bit addition

Fill bits shall be added when the actual size of the MAC PDU is:

- for a MAC-U-BLCK or MAC-D-BLCK PDU: less than the implicit length of the PDU, or less than the available capacity of the MAC block;
- for the other TMA-SAP PDUs: less than the PDU length indicated in the MAC header, or less than the available capacity of the MAC block.

Fill bit addition applies only to TMA-SAP PDUs.

If fill bits are added, the MAC shall set the "fill bit indication" in the MAC header to 1. In order to add fill bits within a PDU, the MAC shall:

- add a bit "1" immediately following the last bit of the TM-SDU data;
- complete as appropriate with bits set to "0":
 - in the case of a MAC-U-BLCK or MAC-D-BLCK PDU, complete with the required number (≥ 0) of bits set to "0" until the size of the PDU corresponds to the implicit length or the available capacity of the MAC block (if that is less than the implicit length);
 - in the case of the other TMA-SAP PDUs:
 - if a length indication is included in the MAC header, then complete with the required number (≥ 0) of bits set to "0" until the size of the PDU corresponds to the indicated length or the available capacity of the MAC block (if that is less than the indicated length);

- if a length indication is not included in the MAC header (or if the length indication is set to 111110₂), then complete with the required number (≥ 0) of zeros to fill the MAC block.

Fill bits inserted after a Null PDU to complete the MAC block shall be set to "0", except for the first bit after the Null PDU which shall be set to "1".

When there is not enough space to insert a Null PDU in the remainder of a MAC block, the MAC block shall be completed such that the first bit after the user data shall be set to "1" and the following bits shall be set to "0".

NOTE: In this procedure (i.e. when there is not enough space to insert a Null PDU), the MAC uses the normal method for indicating whether there are fill bits inserted within the last indicated or implicit PDU length. Thus, if the actual size of the last MAC PDU in the MAC block is less than the indicated or implicit PDU length then the MAC sets the "fill bit indication" to 1; if the actual size of the last MAC PDU in the MAC block is equal to the indicated or implicit PDU length then the MAC sets the "fill bit indication" to 0. In either case, the recipient discards the bits added following the end of the indicated or implicit length of the last MAC PDU.

The procedure for fill bit addition is valid for both MS and BS.

23.4.2.3 PDU association

PDU association may be used when several small PDUs can be fitted into a single MAC block for transfer across the air interface. The PDUs are independent. And the BS may associate PDUs addressed to different MSs within one MAC block. However, the MS shall not associate PDUs sent using different addresses within one MAC block.

NOTE 1: The MS's ISSI and its associated ASSI are equivalent for the purposes of PDU association by an MS (so the MS is not precluded from performing PDU association for PDUs sent using its ISSI and ASSI). Similarly, an event label and its corresponding address are equivalent for the purposes of PDU association by an MS. Also the MS is not precluded from performing PDU association of PDUs sent using a newly assigned ASSI with PDUs sent using the replaced ASSI or USSI.

However, an MS is not permitted to associate PDUs sent using its SMI with PDUs sent using an SSI within a single MAC block; also an MS is not permitted to associate PDUs from multiple TSI families within a single MAC block. These restrictions may possibly be relaxed in future editions of the present document in the case of the final slot of an MS's requested reserved capacity.

The MS is not permitted to associate PDUs sent using a GSSI with PDUs sent using another address.

The association procedure is illustrated in figure 23.8.

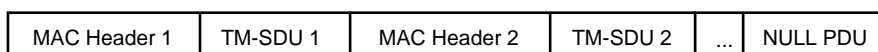

Figure 23.8: Association of several MAC PDUs in one MAC block

Each PDU shall contain its own MAC header and each TMA-SAP PDU, except possibly the last in the MAC block, shall indicate the length of the PDU either explicitly or implicitly:

- in the case of a MAC-U-BLCK or MAC-D-BLCK PDU, the length of the PDU is defined implicitly for each modulation type and bandwidth (see clauses 21.4.2.6 and 21.4.3.4);
- for the other TMA-SAP PDUs, the length of the PDU is indicated explicitly, except possibly for the last PDU in the MAC block.

The MAC header of the next PDU shall immediately follow the end of the current PDU. (Within a PDU, fill bits shall be inserted as required.) If there are no more PDUs to follow, a special message (the Null PDU) may be used if it fits within the remaining space in the MAC block. If there are unused bits, they shall follow the rules for fill bit addition.

This procedure is valid for both MS and BS.

In order to associate, the MAC shall:

- a) prepare a PDU:
 - for a MAC-U-BLCK or MAC-D-BLCK PDU, the MAC shall place the relevant MAC header in front of the TM-SDU; the length of the PDU is defined implicitly;
 - for the other TMA-SAP PDUs, the MAC shall place the relevant MAC header in front of the TM-SDU, including the PDU length (except in the cases indicated below); in cases where the PDU length cannot be represented exactly by the defined values of the length indication, the MAC shall round up to the next higher valid value of the length indication (including fill bits to make up the difference between the actual PDU content and the indicated PDU length);
 - for a TMB-SAP PDU, the size of the PDU is implicit from the MAC header and modulation;
- b) if the PDU does not completely fill the MAC block then:
 - if the size of the remainder of the MAC block < appropriate Null PDU size (see below) then the MAC shall complete the MAC block such that the first bit after the user data shall be set to "1" and the following bits shall be set to "0"; or
 - if the size of the remainder of the MAC block \geq appropriate Null PDU size (see below) then the MAC shall either:
 - repeat step a) with another PDU; or
 - use the Null PDU and complete the remainder (if any) with fill bits.

For the downlink, the Null PDU size to be used for the comparison in b) shall be 16 bits. For the uplink, the comparison in b) shall be performed using the Null PDU size that corresponds to an address length of 24 bits. This is 36 bits in a subslot, or 37 bits in a full slot or on STCH. This rule shall apply even if the MS has been assigned an event label.

Association shall not be performed if the remainder of the MAC block is less than the size of the appropriate Null PDU, even if the MAC has a PDU to send that is shorter than the Null PDU.

NOTE 2: The "length indication" element in the MAC header refers to the size of the complete MAC PDU (rounded up to the next higher valid value of length indication), not to the length of the TM-SDU. The length of the TM-SDU is then known, since the TM-SDU follows immediately after the MAC header.

NOTE 3: The definition of the "length indication" element uses two units Y and Z where, for length indication values up to division point D, the length of the MAC PDU is given in units of Y octets. For length indication values above division point D, the incremental unit of the length indication is Z octets (where $Z \geq Y$). In cases where $Z > Y$ this definition allows a lower overhead for shorter PDUs.

NOTE 4: Length indications 11111_2 (for MAC-ACCESS PDUs) and 111101_2 (for MAC-DATA and MAC-RESOURCE PDUs) define a specific length in bits - set to correspond to the normal size of an advanced link data segment on a QAM channel. If this specific length is not appropriate then the required value V of the "length indication" element is as follows:

- if $\text{BITS} \leq 8 \times Y \times D$ then $V = 1 + ((\text{BITS} - 1) \text{DIV} (8 \times Y))$
- if $\text{BITS} > 8 \times Y \times D$ then $V = 1 + D + ((\text{BITS} - (8 \times Y \times D) - 1) \text{DIV} (8 \times Z))$

where:

- BITS is the PDU size in bits;
- $D = 14$, $Y = Y_1$ and $Z = Z_1$ when sending a MAC-ACCESS PDU;
- $D = 0$, $Y = Y_1$ and $Z = Z_1$ when sending a MAC-END-HU PDU;
- $D = 18$, $Y = Y_2$ and $Z = Z_2$ when sending a MAC-DATA, MAC-RESOURCE or downlink MAC-END PDU;
- $D = 6$, $Y = Y_2$ and $Z = Z_2$ when sending an uplink MAC-END PDU; and

- DIV represents integer division, rounded down.

The values of Y_1 , Y_2 , Z_1 and Z_2 depend on the modulation and the QAM coding rate and the bandwidth of the burst in which the PDU is sent. They are given in clause 21.6.

NOTE 5: There will be some cases when the PDU only just fits within the MAC block so that, after rounding up to the next higher valid value of length indication, the "length indication" element may indicate a value which exceeds the available capacity of the MAC block. Similarly the implicit length may indicate a value which exceeds the available capacity of the MAC block.

NOTE 6: In the present document, the only TMB-SAP PDUs for which association may apply are:

- the ACCESS-DEFINE PDU; and
- the SYSINFO PDU when it is sent using $\pi/8$ -D8PSK modulation;
- the SYSINFO-Q PDU; and
- the SYSINFO-DA PDU.

The following points apply for TMA-SAP PDUs other than MAC-U-BLCK and MAC-D-BLCK:

- When a BS performs fragmentation, it shall send the first fragment and continuation fragments as the last PDU in a MAC block. Or, when an MS has further signalling to send, it shall include the reservation requirement in the MAC header of the last (non-Null) PDU in a MAC block. In both these cases, the PDU length cannot be indicated in the MAC header. Also, when an MS-MAC does not require to perform association within an uplink subslot, it should not include the "length indication" element in the MAC-ACCESS PDU except when it needs to send the Null PDU in a subslot.
- In all three cases, the PDU shall be deemed to fill the remainder of the MAC block, and the length of the TM-SDU, or TM-SDU fragment, shall be indicated by use of the "fill bit indication" and any fill bits.

For MAC-U-BLCK and MAC-D-BLCK, the length of the PDU is defined implicitly for each modulation type and bandwidth:

- When the PDU is sent using $\pi/4$ -DQPSK or $\pi/8$ -D8PSK modulation, the implicit length is equal to the size of the MAC block, so the MAC-U-BLCK or MAC-D-BLCK PDU is always the last PDU in the MAC block; the PDU size (before removal of fill bits) is equal to:
 - the size of the MAC block if this is the only PDU in the MAC block; or
 - the available capacity of the MAC block if this is not the first PDU in the MAC block.
- When the PDU is sent using QAM modulation with modulation level higher than 4-QAM or for bandwidths of 100 kHz or more, the implicit length is less than the size of the MAC block, so association may apply following the PDU.

23.4.3 PDU decomposition for signalling messages

23.4.3.1 Reconstruction (TMA-SAP only)

23.4.3.1.0 General

This procedure is the opposite to fragmentation which is performed by the sender as described in clause 23.4.2.1.

23.4.3.1.1 Reconstruction of downlink TM-SDU

The MS-MAC shall attempt to receive and decode the downlink slots appropriate to the relevant control channel (within the constraints of the energy economy or dual watch or part-time reception regime or the napping procedures, and the cell reselection procedures, and linearization and transmission requirements).

On receipt of a MAC-D-BLCK PDU containing one of its valid event labels, the MS-MAC shall deliver the TM-SDU to the LLC using the TMA-UNITDATA indication primitive. Other actions may be performed relating to other elements in the MAC header.

On receipt of a MAC-RESOURCE PDU containing one of its valid addresses or event labels, the MS-MAC shall perform the following actions relating to the TM-SDU. Other actions may be performed relating to other elements in the MAC header.

- a) If the MAC-RESOURCE PDU contains "Length indication" $\neq 11111_2$, indicating no fragmentation, then the MS-MAC shall deliver the TM-SDU (if any) to the LLC using the TMA-UNITDATA indication primitive.
- b) If the MAC-RESOURCE PDU contains "Length indication" $= 11111_2$, indicating the start of fragmentation, then the MS-MAC shall store the TM-SDU fragment. (The length of the first fragment is indicated only by the "fill bit indication" and any fill bits.)

The MS-MAC shall then receive all the downlink slots on this control channel, looking for continuation fragments or for the end of the fragmented data i.e. MAC-FRAG or MAC-END PDU respectively.

On receipt of a MAC-FRAG PDU, the MS-MAC shall append the TM-SDU fragment to the already received fragment(s). (The length of a continuation fragment is indicated only by the "fill bit indication" and any fill bits.) The MS-MAC shall then continue to receive the control channel, looking for further MAC-FRAG PDUs or for the MAC-END PDU.

On receipt of a MAC-END PDU, the MS-MAC shall append the TM-SDU fragment to the already received fragment(s). (The length of the final fragment is indicated by the combination of the "Length indication", the "fill bit indication" and any fill bits.) The MS-MAC shall then deliver the reconstructed TM-SDU to the LLC using the TMA-UNITDATA indication primitive.

NOTE: Occasionally the MAC-END PDU will contain no user data, in which case the already assembled fragments comprise the complete TM-SDU. On receipt of MAC-END, the MS-MAC delivers the TM-SDU to the LLC.

The MS-MAC shall continue this process until it receives the MAC-END PDU, or until one of the following occurs:

- i) it receives any MAC-RESOURCE PDU on this control channel containing "Length indication" $= 11111_2$ (for any address, not only one of its own addresses or event labels);
- ii) it fails to decode an SCH MAC block on this control channel (see below);
- iii) it has received N.203 consecutive slots on this control channel without receiving a fragment of its TM-SDU.

In all three cases, the MS-MAC shall discard the partially reconstructed TM-SDU. In case i), if the MAC-RESOURCE PDU contains one of its own addresses or event labels, the MS-MAC shall then continue to process that new PDU.

The MS shall provide adequate buffering to store a fragmented TM-SDU which may be up to N.202 bits in length. The MS-MAC does not deliver any part of the TM-SDU to the LLC until the complete TM-SDU has been received.

The appropriate types of SCH MAC block in criterion ii) shall be:

- an SCH/HD or SCH/F MAC block if the MS is on a $\pi/4$ -DQPSK channel;
- an SCH/HD, SCH/F, SCH-P8/HD or SCH-P8/F MAC block if the MS is on a D8PSK channel; or
- any SCH-Q/D MAC block or an SCH-Q/B MAC block if the MS is on a QAM channel.

For the purposes of the reconstruction procedure, an MS on a QAM channel shall also regard it as failure to decode an SCH MAC block on this control channel if the MS does not attempt to decode the main part of the slot because it fails to decode the downlink QAM-SLOTINFO PDU or does not understand the value of the "slot format" element in the downlink QAM-SLOTINFO PDU or is not capable of processing slots with the indicated format.

23.4.3.1.2 Reconstruction of uplink TM-SDU

On receipt of a MAC-U-BLCK PDU, the BS shall assume that the received TM-SDU is complete.

On receipt of a MAC-ACCESS or MAC-DATA PDU, the BS shall perform the following actions relating to the TM-SDU.

If the received PDU does not indicate start of fragmentation then the BS shall assume that the received TM-SDU is complete.

If the received PDU indicates start of fragmentation, and if the BS decides to grant capacity for the fragmented message, then the BS shall store the TM-SDU fragment. It shall also attempt to receive any subslot or slots granted to the MS for this address on this control channel (either granted already or granted in subsequent MAC-RESOURCE, MAC-END or MAC-D-BLCK PDUs), looking for further fragments of the TM-SDU.

NOTE 1: The MS ISSI and its associated ASSI are equivalent for the purposes of usage of granted slots (so the MS will use any capacity granted on its ISSI for a fragmented message being sent with its ASSI, or vice versa). Similarly, an event label and its corresponding address are equivalent for the purposes of usage of granted slots. Also, a newly assigned ASSI is equivalent to the replaced ASSI or USSI for the purposes of usage of granted slots.

- a) If the MS requested a single subslot, and the BS grants a subslot for a final fragment, then the BS shall inspect the first PDU in that subslot.

If the BS receives the MAC-END-HU PDU, it shall append the TM-SDU fragment to the first fragment, and shall assume that the received TM-SDU is complete.

If the BS receives the MAC-ACCESS PDU, it shall discard the old fragment and shall continue to process the new PDU.

If the BS fails to decode the uplink subslot, it shall discard the old fragment.

- b) If the BS grants full slots to the MS, then it shall attempt to receive those granted slots, looking for the MAC-FRAG or MAC-END PDU.

On receipt of a MAC-FRAG PDU, the BS shall append the TM-SDU fragment to the already received fragment(s). It shall then continue to attempt to receive the granted slots, looking for further MAC-FRAG PDUs or for the MAC-END PDU.

On receipt of a MAC-END PDU, the BS shall append the TM-SDU fragment to the already received fragment(s), and shall assume that the received TM-SDU is complete.

NOTE 2: Occasionally the MAC-END PDU will contain no user data, in which case the already assembled fragments comprise the complete TM-SDU.

The BS may continue this process (granting more slots if appropriate) until it receives the MAC-END PDU, or until one of the following occurs:

- i) it receives a MAC-DATA or MAC-U-BLCK PDU in one of the granted slots;
- ii) it fails to decode a MAC block in one of the granted slots;
- iii) it has not granted slots to the MS nor sent the instruction to "Wait for another Slot Grant", and a time T.202 has elapsed since the last slot granted to the MS on this control channel (see clause 23.4.2.1.2).

In all three cases, the BS shall discard the partially reconstructed TM-SDU. In case i), the BS shall continue to process the new PDU. In case ii), the BS shall discard any MAC-FRAG or MAC-END PDUs received in any further slots granted to this MS for this address (until receipt of the next MAC-ACCESS, MAC-DATA or MAC-U-BLCK PDU from the MS).

If, at any time, the BS receives a MAC-FRAG, MAC-END or MAC-END-HU PDU in a granted slot or subslot, without a corresponding start of fragmentation from this MS (on this control channel), the BS shall discard the PDU.

NOTE 3: After receiving a fragmented TM-SDU containing a BL-DATA or BL-ADATA message, the BS may choose to send the LLC acknowledgement more than once (for reliability).

23.4.3.1.3 Reconstruction in minimum mode

a) Downlink TM-SDU

During minimum mode, the MS-MAC shall follow the defined minimum mode rules for receiving and decoding the downlink for signalling messages in frames 1 to 17 and in frame 18.

The normal procedure for reconstruction of a downlink TM-SDU, described in clause 23.4.3.1.1, generally applies except that, after the MS-MAC receives a MAC-RESOURCE PDU addressed to itself and containing a start of fragmentation, the procedure b) of clause 23.4.3.1.1 for looking for continuation fragments (MAC-FRAG) or for the end of the fragmented data (MAC-END) shall apply only to the MS's designated minimum mode frame 18 slot.

Also, the normal criteria ii) and iii) of clause 23.4.3.1.1 for discarding a partially reconstructed TM-SDU shall be replaced by the following criteria ii) and iii):

- ii) it fails to decode an SCH MAC block in its designated minimum mode frame 18 slot;
- iii) it has received its designated minimum mode slot in N.203 consecutive frame 18s without receiving a fragment of its TM-SDU.

On leaving minimum mode, the MS-MAC shall return to the normal method of reconstruction (i.e. looking for fragments in all downlink slots on the MCCH).

NOTE 1: The above minimum mode procedure applies only to those MSs that are in common control mode and receiving the MCCH. It does not apply to MSs on an assigned channel.

NOTE 2: While receiving a fragmented message during minimum mode, the MS-MAC is still required to receive slot 1 of frames 2 to 17, e.g. it may be sent a non-fragmented message. As defined in criterion i) of clause 23.4.3.1.1, the MS discards the partially reconstructed message if it receives any MAC-RESOURCE PDU on this channel containing "Length indication" = 111111₂ (i.e. start of fragmentation).

NOTE 3: The reconstruction procedure defined above applies only when the MAC-RESOURCE PDU was sent on SCH/F or SCH/HD (in slot 1 of frames 2 to 17 if the downlink is in FACCH or assigned SCCH, or in the MS's minimum mode frame 18 slot). If the MAC-RESOURCE PDU was sent on STCH then the reconstruction procedure defined in clause 23.4.3.1.7 applies.

b) Uplink TM-SDU

The normal procedure for reconstruction of an uplink TM-SDU, described in clause 23.4.3.1.2, applies during minimum mode.

23.4.3.1.4 Reconstruction on time-shared control channel

a) Downlink TM-SDU

On a time-shared MCCH, the MS-MAC shall follow the defined rules for receiving and decoding the downlink for signalling messages.

The normal procedure for reconstruction of a downlink TM-SDU, described in clause 23.4.3.1.1, generally applies except that, after the MS-MAC receives a MAC-RESOURCE PDU addressed to itself and containing a start of fragmentation, the procedure b) of clause 23.4.3.1.1 for looking for continuation fragments (MAC-FRAG) or for the end of the fragmented data (MAC-END) shall apply only to slot 1 of the reserved frames for this BS, not to the common frames.

Also, the normal criteria ii) and iii) of clause 23.4.3.1.1 for discarding a partially reconstructed TM-SDU shall be replaced by the following criteria ii) and iii):

- ii) it fails to decode an SCH MAC block in slot 1 of one of the reserved frames for this BS;
- iii) it has received slot 1 of N.203 consecutive reserved frames for this BS without receiving a fragment of its TM-SDU.

NOTE: While receiving a fragmented message, the MS-MAC is still required to attempt to receive and decode slot 1 of the common frames, e.g. it may be sent a non-fragmented message.

For a time-shared common SCCH, "slot 1" in the above shall be replaced by the appropriate slot number on the main carrier.

b) Uplink TM-SDU

The normal procedure for reconstruction of an uplink TM-SDU applies.

23.4.3.1.5 Reconstruction on assigned channel if downlink is in SACCH

a) Downlink TM-SDU

In frames 1 to 17, reconstruction of downlink STCH may apply (see clause 23.4.3.1.7).

The normal procedure for reconstruction of a downlink TM-SDU, described in clause 23.4.3.1.1, generally applies for a message sent on the SACCH in frame 18 with the following differences:

- 1) If an MS that is transmitting traffic on the uplink receives a MAC-RESOURCE PDU in frame 18 of the assigned channel, individually addressed to itself and containing a start of fragmentation, the procedure b) of clause 23.4.3.1.1 for looking for continuation fragments (MAC-FRAG) or for the end of the fragmented data (MAC-END) shall apply only to the highest numbered downlink slot of the assigned channel in those frame 18s indicated by the assigned monitoring pattern(s).

Also, the normal criteria ii) and iii) of clause 23.4.3.1.1 for discarding a partially reconstructed TM-SDU shall be replaced by the following criteria ii) and iii):

- ii) it fails to decode an SCH MAC block in the highest numbered downlink slot of the assigned channel in a frame 18 indicated by the assigned monitoring pattern(s);
- iii) it has received the highest numbered downlink slot of the assigned channel in N.203 consecutive frame 18s indicated by the assigned monitoring pattern(s) without receiving a fragment of its TM-SDU.

If the MS switches out of traffic transmit mode, it reverts to procedure 2). Or, if the downlink leaves SACCH, the MS reverts to the procedure for reconstruction when the downlink is in FACCH.

NOTE 1: For a single-slot channel, the highest numbered downlink slot of the assigned channel is implicitly the one slot of the assigned channel, as defined by element "timeslot assigned".

NOTE 2: For a simplex call, the transmitting MS recognizes that the downlink is in SACCH by using the ACCESS-ASSIGN PDU as defined in clause 23.5.6.3. For a duplex call, the duplex traffic transmit permission included traffic receive permission and thus indicated that the downlink is in SACCH.

NOTE 3: The reconstruction procedure defined above applies only for a message individually addressed to an MS that is transmitting traffic on the uplink. If the MS receives the start of a group addressed fragmented message then it should either discard the TM-SDU fragment or continue the reconstruction using procedure 2).

- 2) If an MS that is not transmitting traffic on the uplink receives a MAC-RESOURCE PDU in frame 18 of the assigned channel, addressed to itself and containing a start of fragmentation, the procedure b) of clause 23.4.3.1.1 for looking for continuation fragments (MAC-FRAG) or for the end of the fragmented data (MAC-END) shall apply only to the lowest numbered downlink slot of the assigned channel in frame 18.

Also, the normal criteria ii) and iii) of clause 23.4.3.1.1 for discarding a partially reconstructed TM-SDU shall be replaced by the following criteria ii) and iii):

- ii) it fails to decode an SCH MAC block in the lowest numbered downlink slot of the assigned channel in frame 18;
- iii) it has received the lowest numbered downlink slot of the assigned channel in N.203 consecutive frame 18s without receiving a fragment of its TM-SDU.

If the MS switches into traffic transmit mode, it reverts to procedure 1). Or, if the downlink leaves SACCH, the MS reverts to the procedure for reconstruction when the downlink is in FACCH.

NOTE 4: Procedure 2) applies both to MSs receiving traffic on the channel in a simplex call and to any MSs not in traffic mode. The use of only the lowest numbered downlink slot in frame 18 for MAC-FRAG and MAC-END means that an MS receiving in traffic mode on a multi-slot channel is not required to modify its reception pattern during the reconstruction.

For a single-slot channel, the lowest numbered downlink slot of the assigned channel is implicitly the one slot of the assigned channel, as defined by element "timeslot assigned".

NOTE 5: If the MS is receiving traffic on the channel then the traffic receive permission informed it that the downlink is in SACCH. If the MS is not in traffic mode on the channel then it recognizes that the downlink is in SACCH (i.e. carrying traffic for other MSs) by using the ACCESS-ASSIGN PDU as defined in clause 23.5.6.3.

NOTE 6: In procedure 1), while receiving a fragmented message on SACCH, the MS-MAC also receives in frames 1 to 17 when appropriate. In procedure 2), while receiving a fragmented message on SACCH, the MS-MAC also receives in frames 1 to 17. In either case, the MS may be sent a non-fragmented message on STCH. And, as defined in criterion i) of clause 23.4.3.1.1, the MS discards the partially reconstructed message if it receives any MAC-RESOURCE PDU on this assigned channel containing "Length indication" = 111111_2 (i.e. start of fragmentation).

b) Uplink TM-SDU

If the uplink is in traffic then, in frames 1 to 17, reconstruction of uplink STCH may apply (see clause 23.4.3.1.7).

The normal procedure for reconstruction of an uplink TM-SDU, described in clause 23.4.3.1.2, applies on uplink SACCH or FACCH.

23.4.3.1.6 Reconstruction on assigned channel if downlink is in FACCH or assigned SCCH

a) Downlink TM-SDU

The normal procedure for reconstruction of a downlink TM-SDU, described in clause 23.4.3.1.1, generally applies when an assigned channel is not in downlink traffic with the following differences for an MS that is transmitting traffic on the uplink:

- If an MS that is transmitting traffic on the uplink receives a MAC-RESOURCE PDU individually addressed to itself and containing a start of fragmentation, the procedure b) of clause 23.4.3.1.1 for looking for continuation fragments (MAC-FRAG) or for the end of the fragmented data (MAC-END) shall apply only to those slots where the MS is required to look for further fragments (as defined below).

Also, the normal criteria ii) and iii) of clause 23.4.3.1.1 for discarding a partially reconstructed TM-SDU shall be replaced by the following criteria ii) and iii):

- ii) it fails to decode an SCH MAC block in one of the slots where it is required to look for further fragments;
- iii) it has received N.203 consecutive slots where it is required to look for further fragments without receiving a fragment of its TM-SDU.

For a single-slot channel, the "slots where the MS is required to look for further fragments" (as used above) shall comprise the downlink slot, as defined by element "timeslot assigned", in those frames indicated by the assigned monitoring pattern(s).

For a frequency half duplex MS transmitting traffic on a multi-slot channel, the "slots where the MS is required to look for further fragments" (as used above) shall comprise:

- in frames 1 to 17: no slots; and
- in frame 18: the highest numbered downlink slot of the assigned channel, in those frame 18s indicated by the assigned monitoring pattern(s).

For a frequency full duplex MS transmitting traffic on a multi-slot channel, the "slots where the MS is required to look for further fragments" (as used above) shall comprise:

- in frames 1 to 17: all slots of the downlink assigned channel, as defined by element "timeslot assigned", in those frames indicated by the assigned monitoring pattern(s); and
- in frame 18: the highest numbered downlink slot of the assigned channel, in those frame 18s indicated by the assigned monitoring pattern(s).

NOTE 1: The reconstruction procedure defined above for a frequency half duplex MS transmitting traffic on a multi-slot channel applies even if the MS has fast switching capability.

NOTE 2: The reconstruction procedure defined above applies only for a message individually addressed to an MS that is transmitting traffic on the uplink. If the MS receives the start of a group addressed fragmented message then it should either discard the TM-SDU fragment or continue the reconstruction using the normal procedure defined in clause 23.4.3.1.1 (i.e. overriding the monitoring pattern information and assuming that continuation and final fragments may be transmitted on any downlink slot appropriate to the assigned channel).

NOTE 3: The normal reconstruction procedure defined in clause 23.4.3.1.1 applies for MSs that are not currently transmitting traffic on the uplink. So continuation and final fragments may be transmitted on any downlink slot appropriate to the assigned channel.

b) Uplink TM-SDU

If the uplink is in traffic then, in frames 1 to 17, reconstruction of uplink STCH may apply (see clause 23.4.3.1.7).

The normal procedure for reconstruction of an uplink TM-SDU, described in clause 23.4.3.1.2, applies on uplink SACCH or FACCH.

23.4.3.1.7 Reconstruction on stealing channel

On the stealing channel STCH, fragmentation is only permitted within one timeslot. The procedure for reception of STCH (including reconstruction within the two half slots of one stolen timeslot) is described in clause 23.8.4.

23.4.3.2 Fill bit deletion

On receipt of a TMA-SAP PDU, the MAC shall check whether fill bits are present ("fill bit indication" set to 1 in the PDU header). If fill bits are present, the MAC shall:

- inspect the last bit of the PDU;
- if the last bit is "1", remove this bit; then the rest of the data is the true PDU content;
- if the last bit is "0", remove this bit and all preceding zeros until a bit "1" is found; remove this bit "1"; then the rest of the data is the true PDU content.

NOTE: The maximum number of fill bits to remove is normally $(8Z_1 - 1)$ bits for a PDU in a subslot, or $(8Z_2 - 1)$ bits for a PDU in a slot, if a specific length indication is given in the MAC header. (The values of Z_1 and Z_2 are given in clause 21.6.) It may be a larger number in the case of an implicit length indication (i.e. for MAC-U-BLCK or MAC-D-BLCK) or, for the other TMA-SAP PDUs, if there is no length indication or if the length indication is set to 11111_2 or 111101_2 or 111110_2 .

Fill bits used for completing a MAC block after the Null PDU, or if there is not enough space for a Null PDU, shall be discarded.

The procedure for fill bit deletion is valid for both MS and BS.

23.4.3.3 PDU dissociation

PDU dissociation shall be used when several small PDUs have been fitted into a single MAC block by the association procedure.

Each TMA-SAP PDU (except possibly the last in the MAC block) indicates the length of the PDU - either explicitly or, in the case of a MAC-U-BLCK or MAC-D-BLCK PDU, implicitly. The MAC header of the next PDU immediately follows the end of the current PDU as indicated by the "length indication" element or the implicit length. So separation of PDUs from each other relies on the "length indication" contained in the first MAC header or the implicit length of the first MAC PDU, then the "length indication" contained in the second MAC header or the implicit length of the second MAC PDU, and so on. The Null PDU indicates that there is no more useful data in this MAC block; after receipt of the Null PDU, the MAC shall not look for further information in the block. If the remaining size in the MAC block is less than the length of the Null PDU, the MAC shall discard the remaining bits.

This procedure is valid for both MS and BS.

In order to dissociate, the MAC shall:

- decode the first MAC header and determine the length of the PDU:
 - for a MAC-U-BLCK or MAC-D-BLCK PDU, the length of the PDU is defined implicitly;
 - for the other TMA-SAP PDUs, the MAC shall extract the PDU length indication (if included); if there is no length indication, the PDU size shall be deemed to be the remainder of the MAC block;
 - for a TMB-SAP PDU, the exact size of the PDU is implicit from the MAC header and modulation (see note 1);
- remove any fill bits contained in the PDU, if indicated by the "fill bit indication";
- repeat the above steps until a Null PDU is found or the remaining space in the block is less than the size of the appropriate Null PDU (see note 2).

Each separate PDU shall then be further processed by the MAC.

There will be some cases when the "length indication" or implicit length will indicate a value which exceeds the available capacity of the MAC block. The recipient MAC shall regard the length of the PDU as either the available capacity of the MAC block or the indicated or implicit length, whichever is the lesser. In either case, fill bits shall be removed if the "fill bit indication" is set to 1.

NOTE 1: Some CA MSs may not understand the SYSINFO-DA PDU and therefore will not know the length of the SYSINFO-DA PDU - so cannot process associated PDUs following the SYSINFO-DA PDU in a downlink MAC block.

NOTE 2: The size of the appropriate Null PDU (as used above) is 16 bits for the downlink, 36 bits for an uplink subslot, or 37 bits for an uplink full slot or uplink STCH.

23.4.3.4 PDU error detection

The purpose of the CRC added to a MAC block by the lower MAC is to enable the MAC at the receiving side of the air interface to detect whether errors have been introduced into the message during transmission. Therefore, the receiving lower MAC shall extract the decoded CRC and shall calculate a CRC on the remainder of the data as in the transmitting case. The two CRCs shall be compared. If they are not identical, the CRC fail parameter in the TMV-UNITDATA indication primitive shall inform the receiving upper MAC that an error has occurred.

Upon reception of a MAC block as indicated with the CRC fail parameter in the TMV-UNITDATA indication primitive, the upper MAC shall discard the incoming data. However, the upper MAC may use the CRC fail information to update its statistics on error measurement.

Upon reception of a MAC block as indicated with the CRC pass parameter in the TMV-UNITDATA indication primitive, the upper MAC shall further check that the incoming PDU or PDUs are valid by inspecting the MAC headers.

The lower MAC also performs error detection on the AACH and AACH-Q MAC blocks.

Upon reception of an AACH or AACH-Q MAC block as indicated with the CRC fail parameter in the TMV-UNITDATA indication primitive, the upper MAC shall discard the data in that AACH or AACH-Q MAC block. However, the upper MAC in a CA MS uses the AACH or AACH-Q failure information to update its RDC, RDC-NC or RDC-Q statistics; the upper MAC in a DA MS uses the AACH or AACH-Q failure information to update its RDC-DA, RDC-DA-Q or RDC-DA-P statistics; see clause 23.7.3.1.1.

Upon reception of an AACH or AACH-Q MAC block as indicated with the CRC pass parameter in the TMV-UNITDATA indication primitive, the upper MAC shall process the data in that AACH or AACH-Q MAC block. The upper MAC in a CA MS also uses the AACH or AACH-Q success information to update its RDC, RDC-NC or RDC-Q statistics; the upper MAC in a DA MS uses the AACH or AACH-Q success information to update its RDC-DA, RDC-DA-Q or RDC-DA-P statistics; see clause 23.7.3.1.1.

23.4.4 Power control

23.4.4.1 Overall process

Adaptive RF power control shall be used by the MS. It allows the system to minimize the transmit power required by the MS whilst maintaining the quality of the radio uplink. By minimizing the transmit power levels, interference to co-channel and adjacent channel users is reduced and MS power consumption could be reduced.

Two methods of adaptive RF power control may be used:

- The first method, known as open loop power control, shall be implemented in the MS. Using this method, the MS shall adjust its transmit power based on the power level or equivalent signal quality being received by the MS on the downlink from the BS.
- The second method, known as closed loop power control, shall be supported by the MS if it supports circuit mode traffic transmission (i.e. $\pi/4$ -DQPSK circuit mode voice calls and/or $\pi/4$ -DQPSK circuit mode data calls) and may be implemented in the BS. Using this method, the MS shall adjust its transmit power as instructed by the BS. The BS shall calculate the optimal MS transmit power, for example based upon the power level being received on the uplink from that MS. The exact method of measurement and calculation in the BS are outside of the scope of the present document.

These methods are described in more detail in the following clauses. Adaptive RF power control shall not be used to control the BS transmit power.

23.4.4.2 MS open loop power control

23.4.4.2.1 Obtaining values of MS_TXPWR_MAX_CELL and ACCESS_PARAMETER

The MS open loop power control procedure uses two parameters: MS_TXPWR_MAX_CELL and ACCESS_PARAMETER (see clause 23.4.4.2.2). These parameters are broadcast by the BS:

- in the SYSINFO PDU broadcast by the BS on a $\pi/4$ -DQPSK or D8PSK channel;
- in the SYSINFO-Q PDU broadcast by the BS to CA MSs on a QAM channel;
- in the SYSINFO-DA PDU broadcast by the BS to DA MSs on a QAM channel.

Also, MS_TXPWR_MAX_CELL for the DA main carrier is included in the SYNC-DA PDU broadcast by the BS to DA MSs on a QAM channel.

The values of these parameters may vary according to the modulation mode and bandwidth of the channel (and according to whether the channel is conforming, non-conforming concentric, sectored, super-sectored or eccentric):

- when an MS first acquires a CA main carrier or receives a channel allocation for a $\pi/4$ -DQPSK channel on a CA new cell, or when a CA MS is sent to a new $\pi/4$ -DQPSK channel within the cell or returns to the MCCH or to a $\pi/4$ -DQPSK common SCCH, it shall make the assumptions specified in clause 23.6.6.1 about the values of these parameters until updated by receiving SYSINFO PDUs on that channel;
- when a CA MS is sent to a D8PSK channel, it shall make the assumptions specified in clause 23.6.6.2 about the values of these parameters until updated by receiving SYSINFO PDUs on that channel;

- when a CA MS is sent to a QAM channel, it shall make the assumptions specified in clause 23.6.6.3 about the values of these parameters until updated by receiving SYSINFO-Q PDUs on that channel;
- when an MS first acquires a DA main carrier or receives a channel allocation for a QAM channel on a DA new cell, or when a DA MS is sent to a new QAM channel within the cell or returns to the MCCH-Q or to a QAM common SCCH, it shall make the assumptions specified in clause 23.6.11.1 about the values of these parameters until updated by receiving SYSINFO-DA (or SYNC-DA) PDUs on that channel;
- when a DA MS is sent to a $\pi/4$ -DQPSK channel, it shall make the assumptions specified in clause 23.6.11.2 about the values of these parameters until updated by receiving SYSINFO PDUs on that channel;
- when a DA MS is sent to a D8PSK channel, it shall make the assumptions specified in clause 23.6.11.3 about the values of these parameters until updated by receiving SYSINFO PDUs on that channel.

23.4.4.2.2 MS open loop power control procedure

Open loop power control shall be implemented in the MS. The power level shall be controlled for all transmitted bursts except random access messages for which power level control may be based only on the MS_TXPWR_MAX_CELL parameter (and the bandwidth when on a QAM channel).

An MS, when camped on a cell, shall obtain the appropriate values of the MS_TXPWR_MAX_CELL and ACCESS_PARAMETER parameters for the current channel as specified in clause 23.6.6.

For any reserved access or traffic transmissions, the MS shall use the transmit power level supported by the MS that is the closest to P_{MS} , where P_{MS} is defined by:

$$P_{MS} = \text{MIN} (\text{MS_TXPWR_MAX_CELL}, \text{ACCESS_PARAMETER} - \text{RSSI}) \quad (23.1)$$

where: MS_TXPWR_MAX_CELL = Maximum MS transmit power allowed on that channel;

ACCESS_PARAMETER = Parameter for transmit power calculation on that channel;

RSSI = Averaged signal level received by the MS or an equivalent signal quality measurement.

All values are expressed in dBm. The nominal MS power control level shall not exceed the maximum MS transmit power indicated in the MS_TXPWR_MAX_CELL parameter for that channel.

NOTE: ACCESS_PARAMETER is based on BS power and configuration and on the required mean power level received at the BS. On a D8PSK channel, it is expected that the BS will set the ACCESS_PARAMETER so that the MS power is not reduced below a level that would allow the MS to use $\pi/8$ -D8PSK modulation for some data categories. On a QAM channel, it is expected that the BS will set the ACCESS_PARAMETER so that the MS power is not reduced below a level that would allow the MS to use the highest permitted uplink bit rate (with the possible exception of coding rate $r = 1$) for some data categories.

The MS, while receiving traffic or signalling, shall update P_{MS} for the current channel at least every 30 s and, in case of modification, may linearize on a subslot provided for common linearization (CLCH or CLCH-Q).

The MS, while transmitting, shall update P_{MS} at least every 3 s based upon its RSSI measurements. The MS shall adjust its transmit power to the level supported by the MS that is the closest to P_{MS} , at the latest, immediately following the next common linearization opportunity on that channel.

In the case of a random access transmission:

- when on a 25 kHz channel, the MS may increase its nominal transmit power to a level supported by the MS that does not exceed the MS_TXPWR_MAX_CELL parameter for this channel in order to increase the probability of the random access transmission reaching the BS without being corrupted;
- when on a QAM channel with bandwidth greater than 25 kHz, the nominal MS transmit power for a random access transmission shall not exceed $\text{MS_TXPWR_MAX_CELL} - 10 \log_{10} (B / 25)$, where:

MS_TXPWR_MAX_CELL = Maximum MS transmit power allowed on that channel;

B = bandwidth of the QAM channel in kHz.

23.4.4.3 MS closed loop power control

Closed loop power control may be employed by a BS in order to control the power of an MS transmitting in circuit mode on a traffic channel.

NOTE 1: Closed loop power control therefore applies only on a $\pi/4$ -DQPSK channel.

The MS shall obey power control messages from the BS while the MS-MAC is transmitting in U-plane mode. Such power control instructions shall be obeyed only for the duration of that U-plane transmission after which the MS shall revert to open loop power control for subsequent transmissions.

When the MS-MAC switches from C-plane to U-plane transmission mode, or at any time during the U-plane transmission, the BS may control the MS transmit power by sending a MAC-RESOURCE PDU which includes the optional "power control" element, to instruct the MS to increase or decrease its transmit power by the appropriate number of steps (or remain at its current power level, see note 2). A step is equal to 5 dB except that, if an MS with a power class "L" is currently transmitting at its maximum transmit power, then the first step is 2,5 dB; see clause 6.4.1.2.

NOTE 2: The step size is always 5 dB for an MS that is not using a power class "L". It is also 5 dB for an MS with a power class "L" for steps other than the first step down from its maximum transmit power. The 2,5 dB first step for an MS with a power class "L" enables the MS to step down onto one of the nominal MS power control levels defined in clause 6.4.1.2.

The MS shall obey these power control instructions. If the MS is instructed to increase its power above the maximum transmit power of that MS then it shall set its power to the maximum transmit power. Similarly, if it is instructed by the BS to set its power below the minimum power control level of 15 dBm, then it shall set its power to 15 dBm. The MS shall adjust its power after receiving a power control message, at the latest, immediately following the next common linearization opportunity. This power level shall take precedence over open loop power control and shall be used for all subsequent traffic and signalling transmissions, including any transmissions in frame 18, for the duration of the U-plane transmission until one of the following events occurs:

- a) the MS ends its transmission and switches out of U-plane mode; or
- b) the MS receives a MAC-RESOURCE PDU with the "power control" element set to "Revert to open loop power control".

Then the MS shall revert to using the rules defined for open loop power control as defined in clause 23.4.4.2. During closed loop power control operation, the MS shall continue to maintain its RSSI estimate for the downlink so that P_{MS} is always up to date.

NOTE 3: A power control message may instruct the MS to increase or decrease its transmit power. Alternatively, a "power control" element set to "No change in power" (value 0000₂) instructs the MS to remain at its current power level, with that power level taking precedence over open loop power control until event a) or b) occurs.

23.4.5 MS linearization

23.4.5.1 MS linearization on $\pi/4$ -DQPSK or D8PSK channel

The ACCESS-ASSIGN PDU on the AACH shall indicate those uplink subslots that are available for common use for linearization. The MS may linearize its transmitter using any subslot that is indicated as a "CLCH(-Q) subslot", without regard to the access code or common/assigned designation, and even on another physical channel.

NOTE 1: If the ACCESS-ASSIGN PDU contains only one access field, and that access field indicates "CLCH(-Q) subslot", the MS assumes that subslot 1 may be used for linearization and that subslot 2 is reserved; see clause 23.5.1.4.2.

In addition, during frame 18, the MS may linearize on the first subslot of the uplink slot defined by (in accordance with clause 9):

CLCH mapped if:

$$FN = 18 \text{ and } (MN + TN) \bmod 4 = 3 \quad (23.2)$$

This provides a linearization opportunity at least every four multiframe periods on each of the four physical channels of a carrier. The MS may linearize during these subslots without checking the ACCESS-ASSIGN PDU contents but the BS should set the ACCESS-ASSIGN PDU appropriately to indicate a CLCH opportunity.

If the BS is using discontinuous operation then the usage of this mapping is restricted for CA MSs as follows:

- if the BS is using carrier sharing then the MS may linearize using this mapping without checking the ACCESS-ASSIGN PDU contents only on an assigned channel or on a common control channel that it is receiving;
- if the BS is using MCCH sharing then the MS may linearize using this mapping without checking the ACCESS-ASSIGN PDU contents only on an assigned channel, or on a common control channel that it is receiving but restricted to those frame 18s that are reserved frames for this BS;
- if the BS is using traffic carrier sharing then the MS may linearize using this mapping without checking the ACCESS-ASSIGN PDU contents only on the main carrier or on an assigned channel.

For DA, if the BS is using phase modulation carrier sharing, DA MSs on a $\pi/4$ -DQPSK or D8PSK assigned channel may linearize using this mapping without checking the ACCESS-ASSIGN PDU contents only on that assigned channel.

The MS shall keep adequately linearized, so that it is ready at any time to send a message on the current uplink RF carrier (for example, a response to a BS paging message) without first needing to use a CLCH subslot. This rule shall apply even while the MS is in energy economy or napping mode.

However, an exception is in the case of a dual watching MS which sometimes may not be able to maintain adequate V+D linearization during a Direct Mode call (see ETSI EN 300 396-3 [22], clause 8.4.7.10). Then the MS may, if necessary, use the first subslot of an individually addressed slot grant for linearization. If it does this then it shall maintain adequate V+D linearization on that carrier for at least the next 4 multiframe periods in order to be able to send a message by reserved access if required.

NOTE 2: If the dual watching MS uses the first subslot of an individually addressed slot grant for linearization then, for a single-slot grant, it should not transmit in the second subslot of that slot; for a grant of more than one slot, it should not transmit in the second subslot of the first granted slot but then should send a V+D message in at least the second granted slot.

23.4.5.2 MS linearization on QAM channel

The ACCESS-ASSIGN PDU on the AACH-Q shall indicate those uplink subslots that are available for common use for linearization. The MS may linearize its transmitter using any subslot that is indicated as a "CLCH(-Q) subslot", without regard to the access code or common/assigned designation, and even on another QAM physical channel.

NOTE 1: If the ACCESS-ASSIGN PDU contains one access field, and that access field indicates "CLCH(-Q) subslot", the MS assumes that subslot 1 may be used for linearization and that subslot 2 is reserved; see clause 23.5.1.4.2.

If the ACCESS-ASSIGN PDU is not present within the AACH-Q, the MS shall regard the corresponding uplink subslots as not available for common use for linearization.

In addition, during frame 18, the MS may linearize on the first subslot of the uplink slot defined by (in accordance with clause 9):

For MSs in assigned mode on a single-slot QAM channel (both CA MSs and DA MSs), CLCH-Q mapped if:

$$FN = 18 \text{ and } (MN + TN) \bmod 4 = 3 \text{ and } TN \text{ is the allocated timeslot} \quad (23.3)$$

For MSs in assigned mode on a multi-slot QAM channel (both CA MSs and DA MSs), CLCH-Q mapped if:

$$FN = 18 \text{ and } (MN + TN) \bmod 4 = 3 \text{ and } TN \text{ is the lowest numbered timeslot of the allocated channel} \quad (23.4)$$

For DA MSs in common mode on a one-slot common control channel, CLCH-Q mapped if:

$$FN = 18 \text{ and } (MN + TN) \bmod 4 = 3 \text{ and } TN \text{ is the common control timeslot} \quad (23.5)$$

For DA MSs in common mode on a multi-slot MCCH-Q, CLCH-Q mapped if:

$$FN = 18 \text{ and } (MN + 1) \bmod 4 = 3 \text{ and } TN = 1 \quad (23.6)$$

This provides a linearization opportunity at least every four multiframe periods on the QAM channel. The MS may linearize during these subslots without checking the ACCESS-ASSIGN PDU presence and contents but the BS should set the ACCESS-ASSIGN PDU appropriately to indicate a CLCH-Q opportunity.

NOTE 2: If the channel is a multi-slot QAM assigned channel, and $FN = 18$ and $(MN + TN) \bmod 4 = 3$ and TN is not the lowest numbered timeslot of the allocated channel, then CLCH-Q is not mapped.

Similarly, if the channel is a multi-slot MCCH-Q, and $FN = 18$ and $(MN + TN) \bmod 4 = 3$ and TN is not equal to 1, then CLCH-Q is not mapped.

The MS shall keep adequately linearized, so that it is ready at any time to send a message on the uplink QAM channel without first needing to use a CLCH-Q subslot. This rule shall apply even when the MS is in energy economy or part-time reception or napping mode.

However, if necessary, the MS may occasionally use a reserved slot or subslot for linearization purposes provided that:

- the slot or subslot has been granted to the MS by an individually addressed slot grant; and
- the MS's emission for linearization purposes conforms to the spectrum mask defined in clause 6.4.9.2.1 for emission during the useful part of the burst.

NOTE 3: For example, the MS may occasionally use this form of linearization in a reserved slot or subslot if it has been granted a large number of reserved slots on a multi-slot channel and is not able to maintain adequate linearization between the mapped CLCH-Q opportunities. Or this form of linearization could be used by a dual watching MS.

23.4.6 BS synchronization

When an MS moves from one carrier to another within a cell, it shall assume that the old frame and slot synchronization apply also on the new carrier. For example, at call set-up, it may immediately linearize and use granted slots or subslots using the timing of the old carrier.

Therefore, the BS shall synchronize the slot, frame and multiframe timing on all its carriers within a cell.

NOTE: This applies for all carriers within the cell. Thus the slot, frame and multiframe timing on both phase modulation carriers and QAM carriers within the cell needs to be synchronized with the slot, frame and multiframe timing on the main carrier. See clause 7 for details of the synchronization of phase modulation carriers and QAM carriers.

When the MS obeys a channel allocation for an eccentric channel, the MS may perceive a larger timing difference on the new channel relative to the old channel than when moving to a non-eccentric channel; see clauses 7.7 and 7.8. The same applies when the MS moves from an eccentric channel to another channel (for example, when the MS returns to its common control channel).

23.4.7 Data priority

23.4.7.0 Introduction

Clauses 23.4.7.1, 23.4.7.2, 23.4.7.3, 23.4.7.4, 23.4.7.5 and 23.4.7.6 shall be applicable only to MSs and BSs which support data priority.

23.4.7.1 General

Data priority enables the MS to indicate a priority for obtaining reserved slots when it is sending packet data. For example, this permits the BS to grant slots to an MS with high data-priority PDUs to send ahead of other MSs with lower data-priority PDUs to send on the same channel.

NOTE 1: Data priority is distinct from PDU priority. PDU priority affects the MS's queue re-ordering in the LLC and the MS's random access procedure. Data priority principally affects the BS's criteria for slot granting on a shared packet data channel, but is also used for queue re-ordering in the LLC.

The SNDCP in an MS that uses data priority either regards the "MS default data priority" as being the "network default data priority" indicated by the SwMI or may negotiate a specific MS default data priority with the SwMI (see clause 28.3.5.5). In either case, the MS default data priority is a data priority which the BS applies by default to all reservation requirements indicated by that MS on a packet data channel unless temporarily overridden by a short-term data priority requested by the MS-MAC. The higher layers inform the MS-MAC about the current MS default data priority using the TMC-CONFIGURE request primitive.

NOTE 2: The MS default data priority in the TMC-CONFIGURE request primitive may be set to one of the eight defined values of data priority (0 to 7) or may be set to "not applicable". The value "not applicable" applies if the SNDCP is not aware of the network default data priority and has not negotiated a specific MS default data priority (or if the current BS does not support data priority); it applies also when the SNDCP is not in the READY state.

Also, when the SNDCP sends each packet data PDU, it includes the data priority for that PDU within the primitive issued to the lower layers. The LLC collates the information on the data priorities for the data in its queue and issues it to the MS-MAC in the DATA-IN-BUFFER signal, indicating:

- the maximum value of the data priority for the data in the LLC queue for the specified address and endpoint identifier (set either to one of the eight defined values of data priority (0 to 7) or to value "undefined" if there is only data of undefined data priority in the LLC queue); and
- if the endpoint identifier corresponds to a $\pi/4$ -DQPSK channel: the subdivision of that data into data priorities;
- if the endpoint identifier corresponds to a D8PSK or QAM channel: the subdivision of that data into data categories and data priorities.

NOTE 3: The LLC also indicates (using the DATA-IN-BUFFER signal) whether or not it currently expects that the next PDU to be sent with the specified address and endpoint identifier will contain packet data.

The MS-MAC sends an L2-DATA-PRIORITY message when it wishes to indicate a short-term variation on that channel which temporarily overrides the default data priority. (The MS-MAC does not send the L2-DATA-PRIORITY message until the LLC wishes to send a PDU whose data priority differs from the MS default data priority.)

The L2-DATA-PRIORITY message is a layer 2 signalling message, so the MS-MAC sends it using the data transfer service provided by the LLC at the TLE-SAP; see clause 23.1.4.

23.4.7.2 Content of L2-DATA-PRIORITY message

23.4.7.2.1 Formats of L2-DATA-PRIORITY message

The MAC sends an L2-DATA-PRIORITY message when it wishes to indicate a short-term variation to the default data priority (see clause 23.4.7.4 for criteria for sending the L2-DATA-PRIORITY message). The L2-DATA-PRIORITY message applies to the address with which it is sent and the channel on which it is sent. It may contain either:

- 1) a single short-term data priority (the "residual data priority"); or

- 2) up to 7 data priority blocks each containing:
- a data priority (the "temporary data priority"); and
 - the expected number of slots needed to send the currently queued data at that data priority for this address and channel (as indicated in the DATA-IN-BUFFER signal from the LLC),
- followed by the "residual data priority", which applies to slots following those included in the data priority block(s).

See clause 21.2.4.1 for the description of the L2-DATA-PRIORITY PDU.

If the MS uses format 2, the data priority blocks shall be included in decreasing order of data priority.

The MS may use either format 1) or format 2) as appropriate to its capabilities or to the information in the DATA-IN-BUFFER signal.

NOTE: When the MS indicates its data priority requirements, it indicates only the data priority requirements for the address with which the L2-DATA-PRIORITY PDU will be sent. The ISSI and its associated ASSI are regarded as equivalent for the purposes of this procedure. Similarly, an event label and its corresponding address are regarded as equivalent for the purposes of this procedure. However, an MS is not permitted to combine any data priority requirements for its SMI with requirements for an SSI (or vice versa), and it is not permitted to combine the data priority requirements for multiple TSI families.

23.4.7.2.2 Content of L2-DATA-PRIORITY message if using format 1)

If the MS-MAC uses format 1), it shall set the "residual data priority" to the maximum data priority indicated by the LLC for the appropriate address and endpoint identifier (unless the MS-MAC is sending the L2-DATA-PRIORITY message when there is only data of undefined data priority in the LLC queue, in which case the MS-MAC may set the "residual data priority" to the MS default data priority).

NOTE: The "residual data priority" indicates the data priority information for the data in the LLC queue (for this address on this channel), irrespective of whether the MS has already been granted some future slots.

23.4.7.2.3 Content of L2-DATA-PRIORITY message if using format 2)

If the MS-MAC uses format 2) then:

- if the MS is on a $\pi/4$ -DQPSK channel, the appropriate number of slots in each data priority block is known from the information about the amount of queued data per data priority, provided in the DATA-IN-BUFFER signal received from the LLC;
- if the MS is on a D8PSK or QAM channel, the appropriate number of slots in each data priority block shall be estimated from the information about the amount of queued data per data category and per data priority, provided in the DATA-IN-BUFFER signal received from the LLC. The expected number of slots to send the data for a particular data priority depends on both the amount of data and the modulation level (and coding rate for QAM) with which the MS-MAC currently expects to send the data. If there is data for more than one data category for this data priority, the expected modulation level (and coding rate for QAM) may be different for the different data categories; in this case, the MS-MAC shall estimate the number of slots required at each modulation level (and coding rate for QAM) and shall indicate the total in the "number of slots" element for that data priority; see also clause 23.4.9.

NOTE 1: The "number of slots" element indicates the number of slots that the MS needs to send the data for this data priority (for this address on this channel), irrespective of whether the MS has already been granted some future slots.

The MS-MAC may indicate a data priority requirement of one subslot, or one or more full slots (as shown in clause 21.2.4.1). The required number of slots is coded in a non-linear format. If the MS's requirement cannot be represented exactly within the defined format:

- the MS-MAC should round up to the next higher valid number of slots for data priorities above the MS default data priority;
- the MS-MAC may round down to the next lower valid number of slots for data priorities below the MS default data priority.

In most cases, the MS-MAC should choose the number of data priority blocks such that fragmentation of the message will not be needed. For example:

- if the message will be sent by random access on a $\pi/4$ -DQPSK or D8PSK channel then:
 - if the MS has an event label, there is space for the maximum number (i.e. 7) of data priority blocks;
 - if the MS does not have an event label, there is space for up to 6 data priority blocks before fragmentation becomes necessary;
- if the message will be sent by random access on a QAM channel then:
 - if the MS has an event label, there is space for up to 4 data priority blocks before fragmentation becomes necessary;
 - if the MS does not have an event label, there is space for up to 2 data priority blocks before fragmentation becomes necessary.

EXAMPLE: If the MS is on a QAM channel and does not have an event label, and the LLC indicates data at data priority levels 6, 5, 4 and 3, the MAC may include data priority blocks for data priorities 6 and 5, and then set the "residual data priority" to 4 in the L2-DATA-PRIORITY message.

If the LLC is currently indicating data for N data priorities (with $1 \leq N \leq 7$) and there would be space for the MS to send data priority blocks for all N data priorities without fragmentation, the MS-MAC may either:

- i) include N - 1 data priority blocks (one for each data priority except the lowest data priority in the LLC queue) and then set the "residual data priority" to the lowest of the data priorities in the LLC queue; or
- ii) include N data priority blocks (one for each data priority in the LLC queue) and then set the "residual data priority" to the MS default data priority.

NOTE 2: The MS designer should choose an appropriate method. (The choice of method may depend on the pattern of data and/or on whether the lowest of the data priorities in the LLC queue is more than, or less than, the MS default data priority.)

NOTE 3: The maximum number of data priority blocks is 7. Therefore, if the LLC is currently indicating data for all 8 data priorities, the MAC cannot use method ii).

If the MS requires more than 68 slots for a data priority, the MS-MAC may send more than one data priority block for that data priority. Otherwise it may set the "residual data priority" to the highest data priority for which more than 68 slots is required, in which case it should not include any data priority blocks for any lower data priorities.

23.4.7.2.4 Sending L2-DATA-PRIORITY message

When the MS-MAC sends an L2-DATA-PRIORITY message, it shall issue the message to the LLC in a TLE-UNITDATA request primitive. The MS-MAC shall set the PDU priority level in the request primitive to the PDU priority of the highest priority message in the LLC buffer for this address and channel, as indicated in the DATA-IN-BUFFER signal from the LLC.

NOTE 1: Therefore the LLC will normally send the L2-DATA-PRIORITY PDU on reception of the next MAC-READY signal (delivering the PDU to the MAC using a TMA-UNITDATA request primitive).

It is recommended that the number of repetitions of the layer 2 signalling message is normally set to 0.

NOTE 2: In some cases the MS-MAC may choose to set the number of repetitions to more than 0; for example, it could choose to do so if the required data priority has increased and the MS has a large quantity of data to send with that increased data priority. However the MS designer should note that excessive repetition of the L2-DATA-PRIORITY message may reduce the MS's overall data throughput.

If the MS-MAC sends an L2-DATA-PRIORITY message, and there is a significant change in the data priority requirements before the MS-MAC receives a TLE-REPORT indication primitive reporting completion of the transfer (either successful or failed transfer), the MS-MAC may cancel the ongoing transfer using the TLE-CANCEL request primitive and then send a revised L2-DATA-PRIORITY message.

After sending an L2-DATA-PRIORITY message and receiving a TLE-REPORT indication primitive reporting first complete transmission of the message, the MS-MAC shall record the "residual data priority" in the L2-DATA-PRIORITY message and the highest "temporary data priority" in any data priority blocks. Also, if the L2-DATA-PRIORITY message contained data priority block(s), the MS-MAC shall maintain the current value of the "derived data priority". The "derived data priority" is the data priority that the MS-MAC regards as applying at the current moment for this address and channel. It is calculated by counting the number of reserved slots and subslots used for this address on this channel since the first transmission of the L2-DATA-PRIORITY message and comparing this with the numbers of slots and subslots given in the data priority block(s) as follows:

- after the first complete transmission of the L2-DATA-PRIORITY message, the MS-MAC shall set the "derived data priority" to the "temporary data priority" in the first data priority block;
- then, after each reserved slot or subslot until the "derived data priority" is set to the "residual data priority", the MS-MAC shall perform the following or equivalent check:
 - if the reserved capacity used for this address on this channel since the first complete transmission of the L2-DATA-PRIORITY message \geq capacity requested for the "derived data priority" and for any higher temporary data priorities then:
 - if there are more data priority blocks, the MS-MAC shall set the "derived data priority" to the "temporary data priority" in the next data priority block;
 - otherwise the MS-MAC shall set the "derived data priority" to the "residual data priority".

EXAMPLE: For example, if the MS included one data priority block with temporary data priority DPRI requiring 6 slots then the "derived data priority" is set to DPRI until 6 reserved slots have been used and then reverts to the residual data priority. If the MS included two data priority blocks with temporary data priorities DPRIa and DPRIb, requiring 4 slots and 6 slots respectively, then the "derived data priority" is set to DPRIa until 4 reserved slots have been used, is then set to DPRIb until a further 6 reserved slots have been used, and then reverts to the residual data priority.

23.4.7.3 Expiry of short-term data priority information

The data priority information included in the L2-DATA-PRIORITY message is only temporary. The SNDCP in the MS receives the value of the layer 2 data priority lifetime timer from the SwMI when it receives the network default data priority or negotiates a specific MS default data priority. The SNDCP also receives the value of the layer 2 data priority signalling delay (and the data priority random access delay factor). The higher layers inform the MS-MAC about the values of the layer 2 data priority lifetime and layer 2 data priority signalling delay timers (and the data priority random access delay factor) using the TMC-CONFIGURE request primitive.

After sending an L2-DATA-PRIORITY message and receiving a TLE-REPORT indication primitive reporting first complete transmission of the message, the MS-MAC shall start the layer 2 data priority lifetime timer T.222. It shall also start the layer 2 data priority signalling delay timer T.223.

NOTE 1: Timer T.223 is used in the criteria for sending an L2-DATA-PRIORITY message (see clause 23.4.7.4).

The MS-MAC shall assume that the information sent in the L2-DATA-PRIORITY message applies until one of the following occurs:

- a) a time T.222 has elapsed since the MS-MAC received the TLE-REPORT indication primitive reporting first complete transmission of the message; or
- b) the MS-MAC initiates the random access procedure for this address on this channel and has transmitted a first random access request; or
- c) the MS-MAC sends another L2-DATA-PRIORITY message for this address on this channel and has received a TLE-REPORT indication primitive reporting that the message has been completely transmitted once.

In case a), the MS-MAC shall assume that the MS's current data priority for this address and channel is the MS default data priority.

In case b), after transmitting the first random access request, the MS-MAC shall assume that its current data priority for this address and channel is the MS default data priority. (If the random access request carried an L2-DATA-PRIORITY message then the data priority information in that L2-DATA-PRIORITY message shall apply, and timers T.222 and T.223 shall be started, when the MS-MAC receives the TLE-REPORT indication primitive from the LLC reporting first complete transmission of the message as in case c).)

In case c), when the MS-MAC receives the TLE-REPORT indication primitive reporting first complete transmission of the new L2-DATA-PRIORITY message, it shall assume that the information sent in the new L2-DATA-PRIORITY message applies and shall start the layer 2 data priority lifetime timer T.222 and the layer 2 data priority signalling delay timer T.223.

NOTE 2: If the message is not completely transmitted at least once, the MS-MAC assumes that the information sent in the previous L2-DATA-PRIORITY message applies until one of criteria a), b) or c) occurs.

23.4.7.4 Criteria for sending L2-DATA-PRIORITY message

The MS-MAC shall not send the L2-DATA-PRIORITY message if:

- it has not received a SYSINFO, SYSINFO-Q or SYSINFO-DA PDU from the BS indicating that the BS supports data priority (using the "extended services broadcast" element in the SYSINFO or SYSINFO-Q PDU or the "extended DA services broadcast" element in the SYSINFO-DA PDU); or
- the MS default data priority last provided by the higher layers in the TMC-CONFIGURE request primitive was set to "not applicable".

The MS-MAC should not send the L2-DATA-PRIORITY message if it has already been granted capacity sufficient and suitable for its current reserved access requirements for this address on this channel.

NOTE 1: On a $\pi/4$ -DQPSK or D8PSK channel, or if the MS does not currently have any schedules in operation, the MS-MAC should not send the L2-DATA-PRIORITY message if it has already been granted capacity sufficient for its current reserved access requirements for this address on this channel. On a QAM channel, if the MS has schedule(s) in operation and also has unscheduled data to send, and has been granted capacity by multiple slot granting, then it may choose to send the L2-DATA-PRIORITY message if the granted capacity matches only its expected future scheduled access requirements.

Also, if the DATA-IN-BUFFER signal indicates that the next PDU that the LLC expects to send for this address on this channel does not contain packet data, the MS-MAC should not send the L2-DATA-PRIORITY message at this time (see note 2) unless:

- the maximum data priority indicated in the DATA-IN-BUFFER signal for this address and channel is data priority 7; and
- the amount of data indicated in the DATA-IN-BUFFER signal for data priority 7 would not fit within the next MAC block that the MS will be transmitting on this channel (either within the next granted slot or subslot, or within the random access request if appropriate); and
- the MS has not already been granted capacity sufficient and suitable for the amount of data with data priority 7.

NOTE 2: The MS-MAC may send the L2-DATA-PRIORITY message if both PDUs would fit within the next MAC block that the MS will be transmitting on this channel. Also, if the MS-MAC has issued an L2-LINK-FEEDBACK-INFO message to the LLC, and the MS supports the combined L2-LINK-FEEDBACK-INFO-AND-RESIDUAL-DATA-PRIORITY PDU (see clause 22.3.1.7.3), the MS-MAC may send an L2-DATA-PRIORITY message containing only a "residual data priority".

Subject to the above constraints, the MS-MAC may send the L2-DATA-PRIORITY message if any of the following criteria are satisfied:

- the MS default data priority currently applies for this address on this channel (i.e. the MS-MAC has not sent an L2-DATA-PRIORITY message or timer T.222 has expired or the MS-MAC has transmitted a random access request since the last L2-DATA-PRIORITY message), or the MS is initiating the random access procedure, and:
 - the maximum data priority indicated in the DATA-IN-BUFFER signal for this address and channel is a defined value and is not equal to the MS default data priority (see note 3); or
 - if the MS supports format 2): the DATA-IN-BUFFER signal indicates data for this address and channel with a defined data priority not equal to the MS default data priority (see note 4);

NOTE 3: When the maximum data priority indicated in the DATA-IN-BUFFER signal is a defined value less than the MS default data priority, the MS-MAC may decide not to send the L2-DATA-PRIORITY message if there is only a small amount of data to send at less than the MS default data priority; this may be preferable particularly if the MS is not initiating the random access procedure.

NOTE 4: In the case indicated, transmission of the L2-DATA-PRIORITY message is permitted if the maximum data priority indicated in the DATA-IN-BUFFER signal is equal to the MS default data priority but there is data with data priority lower than the MS default data priority. Alternatively, the MS may wait until the maximum data priority indicated in the DATA-IN-BUFFER signal is not equal to the MS default data priority before sending the L2-DATA-PRIORITY message; this may be preferable particularly if the MS is not initiating the random access procedure.

- information sent in the last L2-DATA-PRIORITY message for this address on this channel still applies and any of the following criteria a), b) or c) are satisfied:
 - a) the last L2-DATA-PRIORITY message contained only a "residual data priority" and the maximum data priority indicated in the DATA-IN-BUFFER signal for this address and channel is a defined value and is greater than the "residual data priority"; or
 - b) the last L2-DATA-PRIORITY message contained data priority block(s) and:
 - i) the maximum data priority indicated in the DATA-IN-BUFFER signal for this address and channel is a defined value and is greater than the highest "temporary data priority" in the data priority block(s) in the last L2-DATA-PRIORITY message and is greater than the current "derived data priority"; or
 - ii) the maximum data priority indicated in the DATA-IN-BUFFER signal for this address and channel is a defined value and is greater than the current "derived data priority"; or
 - iii) as an alternative option to ii), the maximum data priority indicated in the DATA-IN-BUFFER signal for this address and channel will be greater than the "derived data priority" that will apply after use of the next reserved slot or subslot;
 - c) a time T.223 has elapsed since the MS-MAC received the TLE-REPORT indication primitive reporting first complete transmission of the message and either:
 - there has been a change in the data priority information since the last L2-DATA-PRIORITY message (see below); or
 - the last L2-DATA-PRIORITY message was not sent by successful random access; however, the MS-MAC shall not send the same or equivalent information more than a total of N.223 times (see note 7).

NOTE 5: In cases a) and b), the MS-MAC should not send the L2-DATA-PRIORITY message if it has already been granted capacity sufficient and suitable for its reserved access requirements for the data with data priority greater than the "residual data priority" or highest "temporary data priority" or "derived data priority" as appropriate in the specified criteria.

NOTE 6: The MS may send the L2-DATA-PRIORITY message immediately if criterion a) or criterion b) i) is satisfied. The MS is also permitted to send the L2-DATA-PRIORITY message immediately if criterion b)ii) or b)iii) is satisfied. However the MS designer should note that care needs to be taken to avoid excessive use of the L2-DATA-PRIORITY message. Excessive use of the L2-DATA-PRIORITY message (in an attempt to track fluctuating data priority requirements too closely) may reduce the MS's overall data throughput.

NOTE 7: If an L2-DATA-PRIORITY message was sent by stealing or reserved access, or if the transfer failed, the MS-MAC may send another L2-DATA-PRIORITY message after expiry of timer T.223 (and possibly again after the next expiry of timer T.223 if the L2-DATA-PRIORITY message was again sent by stealing or reserved access) - within the limit defined by N.223; see point c) above. This may apply particularly if the number of repetitions of the layer 2 signalling message was 0. However, the MS-MAC should not continually send the same or equivalent information after each expiry of timer T.223 since this may reduce the MS's overall data throughput. Also, if the number of repetitions of the layer 2 signalling message was not 0, the MS-MAC should reduce the value of N.223 accordingly.

In case c) above, the MS designer should choose criteria for the MS-MAC to send the L2-DATA-PRIORITY message after expiry of the layer 2 data priority signalling delay timer T.223. As always, the MS-MAC may send the L2-DATA-PRIORITY message if criterion a) or b) is satisfied. Additionally, the MS-MAC may regard the following or equivalent cases as constituting a change in the data priority information since the last L2-DATA-PRIORITY message such that an L2-DATA-PRIORITY message may be sent after expiry of timer T.223:

- the last L2-DATA-PRIORITY message contained data priority block(s) and the MS-MAC deduces from the information in the DATA-IN-BUFFER signal for this address and channel that the LLC now has a significant amount of new data to send for the data priorities appropriate to those data priority block(s); or
- the maximum data priority indicated in the DATA-IN-BUFFER signal for this address and channel is a defined value and is less than:
 - the "residual data priority", if the last L2-DATA-PRIORITY message contained only a "residual data priority"; or
 - the current "derived data priority", if the last L2-DATA-PRIORITY message contained data priority block(s).

In the second two cases, the MS-MAC may decide not to send the L2-DATA-PRIORITY message if there is only a small amount of data to be sent with the lower data priority.

NOTE 8: The MS designer should note that care needs to be taken to avoid excessive use of the L2-DATA-PRIORITY message, while at the same time avoiding delays in receiving high data-priority capacity when it is required and avoiding receiving too much capacity with higher data priority than needed. Excessive use of the L2-DATA-PRIORITY message (in an attempt to track fluctuating data priority requirements too closely) may reduce the MS's overall data throughput; this applies particularly if the MS will send the L2-DATA-PRIORITY message using reserved access.

23.4.7.5 Reverting to random access if MS supports data priority

23.4.7.5.1 General

As defined in clause 23.5.1.4.3, the MS-MAC may initiate the random access procedure immediately if the MS has individually addressed unscheduled signalling messages to send, and the MS-MAC does not currently have any capacity granted for this address on this control channel, and either:

- a) it has not already sent a PDU indicating a reservation requirement for this address on this control channel; or
- b) the DATA-IN-BUFFER signal from the LLC indicates that a new emergency unscheduled message has been received from layer 3.

Also, the MS-MAC may initiate the random access procedure if the MS has unscheduled signalling messages to send, and the MS-MAC has sent a PDU indicating a reservation requirement for this address on this control channel and does not currently have any capacity granted for this address on this control channel, and the timing criteria in clause 23.5.2.4.1 are satisfied.

NOTE 1: The MS-MAC may also initiate the random access procedure if the MS has scheduled signalling messages to send for this address on this control channel and the criteria in clause 23.5.2.4.2 are satisfied.

The procedure in clause 23.5.2.4.1 requires the MS-MAC to continue to wait when it receives a "basic slot granting" element for this address on this channel containing the instruction to "Wait for another slot grant" (except in case of emergency); the BS may send the instruction to "Wait for another slot grant" repeatedly to the MS, in which case the MS-MAC continues to wait. This procedure generally applies also when the MS is sending packet data. However, if the MS supports data priority (and the SNDCP is in the READY state), the MS-MAC is permitted to initiate the random access procedure if the criteria in clause 23.4.7.5.2 or 23.4.7.5.3 are satisfied - even though the criteria in clause 23.5.2.4.1 may not be satisfied.

NOTE 2: If the criteria in clause 23.5.2.4.1 are satisfied before the criteria in clause 23.4.7.5.2 or 23.4.7.5.3 are satisfied, the MS-MAC may initiate the random access procedure in the usual way.

The procedure in clause 23.4.7.5.2 gives criteria based on an increase in the MS's data priority requirements. This procedure may allow the MS-MAC to initiate the random access procedure earlier than in clause 23.5.2.4.1 in order to indicate its increased data priority requirements (for example, when the BS has sent the instruction to "Wait for another slot grant" because it is granting slots to other MS(s) with higher data priority than the MS indicated in its last L2-DATA-PRIORITY message).

The procedure in clause 23.4.7.5.3 gives criteria if the next message that the MS expects to send does not contain packet data, for example, if the next message is an acknowledged basic link message or link adaptation feedback message. An uplink message that does not contain packet data has undefined data priority (except optionally for PDU priority 7), so it takes the data priority of any packet data behind it in the LLC queue by default. However, the procedure in clause 23.4.7.5.3 may allow the MS-MAC to initiate the random access procedure earlier than in clause 23.5.2.4.1 in order to send the non-packet-data message (for example, when the BS has sent the instruction to "Wait for another slot grant" because it is granting slots to other MS(s) with higher data priority than the MS indicated in its last L2-DATA-PRIORITY message).

23.4.7.5.2 Reverting to random access to send L2-DATA-PRIORITY message

If the following criteria are all satisfied then the MS-MAC may initiate the random access procedure (see clause 23.5.1):

- a) the MS-MAC has received a SYSINFO, SYSINFO-Q or SYSINFO-DA PDU from the BS indicating that the BS supports data priority;
- b) the MS default data priority last provided by the higher layers in the TMC-CONFIGURE request primitive was set to a defined value (i.e. was not set to "not applicable");
- c) the MS-MAC has sent a PDU (MAC-ACCESS, MAC-DATA, MAC-U-BLCK, MAC-END-HU or MAC-END) indicating a reservation requirement for this address on this control channel;
- d) the MS-MAC does not currently have any capacity granted for this address on this control channel;
- e) the MS default data priority currently applies for this address on this channel and the maximum data priority indicated in the DATA-IN-BUFFER signal for this address and channel is a defined value and is greater than the MS default data priority; or

information sent in the last L2-DATA-PRIORITY message for this address on this channel still applies and either:

- i) the last L2-DATA-PRIORITY message contained only a "residual data priority" and the maximum data priority indicated in the DATA-IN-BUFFER signal for this address and channel is a defined value and is greater than the "residual data priority"; or

- ii) the last L2-DATA-PRIORITY message contained data priority block(s) and:
- the maximum data priority indicated in the DATA-IN-BUFFER signal for this address and channel is a defined value and is greater than the highest "temporary data priority" in the data priority block(s) in the last L2-DATA-PRIORITY message and is greater than the current "derived data priority"; or
 - the maximum data priority indicated in the DATA-IN-BUFFER signal for this address and channel is a defined value and is greater than the current "derived data priority";
- f) a time T has elapsed since the MS-MAC last sent a PDU on this control channel for this address (i.e. either a MAC-ACCESS, MAC-DATA or MAC-U-BLCK PDU with this address or a MAC-FRAG, MAC-END or MAC-END-HU PDU relating to this address), where T is defined as follows:
- if $DF = 0$ then $T = T.206$;
 - if $DF > 0$ then $T = (8 - MDP) \times DF \times T.206$,

where:

- MDP is the maximum data priority indicated in the DATA-IN-BUFFER signal for this address and channel;
- DF is the current value of the data priority random access delay factor (received from the SwMI at SMDCP level and provided to the MS-MAC using the TMC-CONFIGURE request primitive);
- T.206 is the value of the reserved access waiting time-out (see annex B); and
- T is measured in terms of downlink signalling frames for this control channel (as for timer T.206).

NOTE 1: When appropriate, this procedure allows the MS to revert to random access after time T has elapsed even if the MS-MAC has received a "basic slot granting" element for this address on this control channel containing the instruction to "Wait for another slot grant". Therefore, in the cases listed in criterion e), this procedure may permit the MS to revert to random access in order to send an L2-DATA-PRIORITY message even though the criteria in clause 23.5.2.4.1 may not be satisfied.

NOTE 2: The MS is permitted to revert to random access to send the L2-DATA-PRIORITY message after time T has elapsed if any of the criteria in e) are satisfied. However the MS designer should note that excessive sending of the L2-DATA-PRIORITY message by random access (in an attempt to track fluctuating data priority requirements too closely) may reduce the performance of the random access channel.

If the MS-MAC decides to initiate the random access procedure and wishes to send an L2-DATA-PRIORITY message, it should issue the L2-DATA-PRIORITY message to the LLC in a TLE-UNITDATA request primitive and then issue the MAC-READY signal.

NOTE 3: In an implementation, the MAC should not issue the MAC-READY signal until the LLC has had time to process the TLE-UNITDATA request primitive.

If the MS-MAC decides to initiate the random access procedure based on the above criteria being satisfied, but it does not wish to send an L2-DATA-PRIORITY message, it should issue the MAC-READY signal to the LLC since there may be a PDU in the LLC queue that can be sent within the MAC-ACCESS PDU. For example, this may apply if the maximum data priority indicated in the DATA-IN-BUFFER signal for this address and channel is the MS default data priority - since the action of sending a random access request implicitly sets the MS's current data priority for this address and channel to the MS default data priority (see clause 23.4.7.3). Or the MS-MAC may decide not to send the L2-DATA-PRIORITY message at this time if the amount of data indicated in the DATA-IN-BUFFER signal for the maximum data priority for this address and channel could be sent within the random access request.

The random access request shall be sent on SCH/HU (for a $\pi/4$ -DQPSK or D8PSK channel) or on SCH-Q/RA (for a QAM channel) using the MAC-ACCESS PDU, containing a TM-SDU if appropriate. If the MS has any further signalling ready to send for this address on this control channel, the MS-MAC shall include a request for reserved capacity ("reservation requirement" element) in the MAC-ACCESS PDU.

NOTE 4: If the MS was in the process of sending a fragmented message at the time when it decides to initiate the random access procedure, it should discard the partially sent TM-SDU. (Alternatively the MS may choose not to initiate the random access procedure in this case.)

23.4.7.5.3 Reverting to random access to send non-packet-data message

If the following criteria are all satisfied then the MS-MAC may initiate the random access procedure (see clause 23.5.1):

- a) the MS-MAC has received a SYSINFO, SYSINFO-Q or SYSINFO-DA PDU from the BS indicating that the BS supports data priority;
- b) the MS default data priority last provided by the higher layers in the TMC-CONFIGURE request primitive was set to a defined value (i.e. was not set to "not applicable");
- c) the MS-MAC has sent a PDU (MAC-ACCESS, MAC-DATA, MAC-U-BLCK, MAC-END-HU or MAC-END) indicating a reservation requirement for this address on this control channel;
- d) the MS-MAC does not currently have any capacity granted for this address on this control channel;
- e) the DATA-IN-BUFFER signal indicates that the next PDU that the LLC expects to send for this address on this control channel does not contain packet data;
- f) a time T has elapsed since the MS-MAC last sent a PDU on this control channel for this address (i.e. either a MAC-ACCESS, MAC-DATA or MAC-U-BLCK PDU with this address or a MAC-FRAG, MAC-END or MAC-END-HU PDU relating to this address), where T is defined as follows:
 - if $DF = 0$ then $T = T.206$;
 - if $DF > 0$ then $T = 2 \times DF \times T.206$,

where:

- DF is the current value of the data priority random access delay factor (received from the SwMI at SNDCP level and provided to the MS-MAC using the TMC-CONFIGURE request primitive);
- T.206 is the value of the reserved access waiting time-out (see annex B); and
- T is measured in terms of downlink signalling frames for this control channel (as for timer T.206).

If the MS-MAC decides to initiate the random access procedure based on the above criteria being satisfied, it should not send an L2-DATA-PRIORITY message at this time (unless the maximum data priority indicated in the DATA-IN-BUFFER signal for this address and channel is data priority 7 and the amount of data indicated in the DATA-IN-BUFFER signal for data priority 7 would not fit within the random access request).

NOTE 1: If the MS-MAC has issued an L2-LINK-FEEDBACK-INFO message to the LLC, and the MS supports the combined L2-LINK-FEEDBACK-INFO-AND-RESIDUAL-DATA-PRIORITY PDU (see clause 22.3.1.7.3), the MS-MAC may send an L2-DATA-PRIORITY message containing only a "residual data priority".

The random access request shall be sent on SCH/HU (for a $\pi/4$ -DQPSK or D8PSK channel) or on SCH-Q/RA (for a QAM channel) using the MAC-ACCESS PDU, containing a TM-SDU if appropriate. If the MS has any further signalling ready to send for this address on this control channel, the MS-MAC shall include a request for reserved capacity ("reservation requirement" element) in the MAC-ACCESS PDU.

NOTE 2: If the MS was in the process of sending a fragmented message at the time when it decides to initiate the random access procedure, it should discard the partially sent TM-SDU. (Alternatively the MS may choose not to initiate the random access procedure in this case.)

23.4.7.6 BS procedures for data priority

23.4.7.6.1 Packet data on uplink

If the BS supports data priority, it should use any:

- information about the default data priority; and
- short-term data priority information received in L2-DATA-PRIORITY messages,

for the MSs on a shared channel used for packet data in deciding when to grant slots to those MSs. The BS may also use uplink fragmentation as a criterion in deciding when to grant slots to MSs (see note). The methods used by the BS for scheduling of the uplink channel are outside the scope of the present document.

NOTE: If an MS on a packet data channel has a message to send that does not contain packet data (for example, an acknowledged basic link message), it may be permitted to use random access to send the message; see clauses 23.4.7.5.3 and 23.5.1.4.3. An uplink message that does not contain packet data has undefined data priority (except optionally for PDU priority 7) and may require fragmentation. The BS may choose to give high priority to fragmented messages when granting slots.

The BS should assume that the default data priority applies for an MS unless it has received an L2-DATA-PRIORITY message from that MS.

After receiving an L2-DATA-PRIORITY message from an MS, the BS should assume that the information sent in the L2-DATA-PRIORITY message applies while that MS is sending packet data on that channel, until one of the following occurs:

- a) a time corresponding to the layer 2 data priority lifetime timer for that MS has elapsed since receipt of the L2-DATA-PRIORITY message; or
- b) the BS receives a MAC-ACCESS PDU from that MS, sent by random access on that channel; or
- c) the BS receives another L2-DATA-PRIORITY message from that MS on that channel.

In case a), the BS should assume that the default data priority applies for that MS until it receives another L2-DATA-PRIORITY message from that MS.

In case b), if the MAC-ACCESS PDU contained an L2-DATA-PRIORITY message, the BS should assume that the information sent in the L2-DATA-PRIORITY message applies as in case c); otherwise the BS should assume that the default data priority applies for that MS until it receives another L2-DATA-PRIORITY message from that MS.

In case c), the BS should assume that the information sent in the new L2-DATA-PRIORITY message applies until one of cases a), b) or c) occurs as above.

The "data priority details" element sent by the BS's SNDCP entity in some SNDCP PDUs contains the values of the layer 2 data priority lifetime (timer T.222) and the layer 2 data priority signalling delay (timer T.223) to be used by the addressed MS(s). The "data priority details" element also allows control of how soon the MS(s) may revert to random access to send the L2-DATA-PRIORITY message or a message that does not contain packet data, by using the data priority random access delay factor (see clause 23.4.7.5). The methods used by the BS to choose the values of these parameters are outside the scope of the present document.

23.4.7.6.2 Packet data on downlink

The methods used by the BS for scheduling of data packets on the downlink channel are outside the scope of the present document.

23.4.8 Napping

23.4.8.1 General

As described in clause 23.7.6, the MS may use energy economy mode when on its common control channel (i.e. the MCCH or MCCH-Q, or the appropriate $\pi/4$ -DQPSK or QAM common SCCH) if it has negotiated an energy economy group by an MM message exchange. Or, as described in clause 23.7.8, a DA MS may use the part-time reception procedure (if permitted by the BS) when on a multi-slot MCCH-Q.

The napping procedure is an independent procedure which may apply when the MS is on an assigned channel. It may provide the MS with some opportunities for neighbour cell monitoring, irregular channel monitoring, main carrier monitoring and/or background scanning, even when the MS is on a multi-slot assigned channel; also it may allow some battery economy in the MS. However it generally requires more reception than when the MS is using energy economy mode.

NOTE 1: The napping procedure does not apply when the MS is in common mode on its common control channel.

NOTE 2: The napping procedure applies for MSs that are in assigned mode, having accepted a channel allocation for an assigned channel. In some cases other MSs may be in common mode on the same physical channel(s), in which case energy economy mode (or dual watch mode or part-time reception mode) may apply for those other MSs. For example, for DA, this may occur if the BS assigns the physical channel(s) used for the MCCH-Q as a QAM assigned SCCH while still maintaining the MCCH-Q for MSs in common control mode.

When the BS sends an augmented channel allocation for an assigned channel, it indicates whether use of the napping procedure is permitted on the assigned channel. If use of the napping procedure is permitted, the BS normally includes the appropriate napping information for use on the assigned channel. The napping information comprises:

- the "napping reception timeslots" i.e. a timeslot bit map indicating the downlink slot or slots that the MS is required to receive in the napping reception frames when the MS is in napping mode (but limited to the slots appropriate to the downlink assigned channel);
- the "napping reception frames" when in napping mode, specified as either:
 - all downlink TDMA frames; or
 - every two TDMA frames (so that the MS is only required to receive in either odd-numbered or even-numbered TDMA frames); or
 - every three TDMA frames (so that the MS is only required to receive in every third TDMA frame);
- the value of the napping timer T.226; and
- a flag indicating whether the MS may use reduced reception in frame 18 when not in napping mode.

Alternatively, the BS may indicate that any napping information for the current channel (i.e. the channel on which the channel allocation was received) may be used on the assigned channel. For example, this may apply in the case of a channel replacement on a group address.

The napping method allows the MS to use napping mode when it has not sent or received a message recently i.e. during long gaps between transmissions (based on inactivity timer T.226).

Also the BS may instruct the MS dynamically that the MS may return to napping mode immediately (see note 3). This dynamic instruction may be used to allow the MS to use napping mode temporarily during short gaps in transmission. It may also be used to allow a fast return to napping mode at the end of the current data. The BS informs the MS that it may return to napping mode immediately by setting the "immediate napping permission flag" element to 1 (see note 3). This element is included in:

- MAC-RESOURCE and MAC-END PDUs sent using $\pi/8$ -D8PSK or QAM modulation; and
- MAC-D-BLCK PDUs.

When the MS receives a MAC-RESOURCE or MAC-END PDU sent using $\pi/4$ -DQPSK modulation, it regards the PDU as not giving immediate napping permission.

NOTE 3: The MS does not return to napping mode on receipt of a PDU with the "immediate napping permission flag" set to 1 if it has received a PDU on a different address not giving immediate napping permission.

23.4.8.2 MS criteria for napping

If the MS supports napping, and is on an assigned channel on which use of the napping procedure is permitted (i.e. if the channel was allocated with an augmented channel allocation with "napping status" element set to 01₂ or 10₂), the MS-MAC shall maintain a record of whether it is currently either:

- required to be in full reception mode; or
- permitted to be in napping mode;

on that assigned channel. This is specified in terms of whether each of its valid addresses (individual and group addresses) are currently "eligible for napping" or "ineligible for napping" on the assigned channel. As defined below, the MS-MAC is not permitted to use napping mode unless all its valid addresses are currently "eligible for napping" on this channel (plus some additional criteria).

EXAMPLE: On receipt of a PDU for any of the MS's valid addresses, and that does not give immediate napping permission (i.e. that either does not contain the "immediate napping permission flag" or contains the "immediate napping permission flag" set to 0), the MS is required to use full reception mode. A PDU giving immediate napping permission overrides a previous instruction not to nap received on the same address; however it does not override a previous instruction not to nap received on a different address.

NOTE 1: The ISSI and its associated ASSI are regarded as equivalent for the purposes of this procedure. Similarly, an event label and its corresponding address are regarded as equivalent for the purposes of this procedure.

The MS-MAC shall regard all its addresses as "ineligible for napping" on the assigned channel when it first moves to the assigned channel. The MS-MAC shall then maintain a record of whether an address is currently "eligible for napping" or "ineligible for napping" on the assigned channel as follows:

- a) If the MS-MAC receives a MAC-RESOURCE PDU on this channel and containing that address then:
 - if the MAC-RESOURCE PDU either does not contain the "immediate napping permission flag" or contains the "immediate napping permission flag" set to 0, the MS-MAC shall regard that address as currently "ineligible for napping";
 - if the MAC-RESOURCE PDU contains the "immediate napping permission flag" set to 1, the MS-MAC may regard that address as currently "eligible for napping".
- b) If the MS-MAC receives a MAC-END PDU on this channel and relating to that address then:
 - if the MAC-END PDU either does not contain the "immediate napping permission flag" or contains the "immediate napping permission flag" set to 0, the MS-MAC shall regard that address as currently "ineligible for napping";
 - if the MAC-END PDU contains the "immediate napping permission flag" set to 1, the MS-MAC may regard that address as currently "eligible for napping".
- c) If the MS-MAC receives a MAC-D-BLCK PDU on this channel and containing that address then:
 - if the MAC-D-BLCK PDU contains the "immediate napping permission flag" set to 0, the MS-MAC shall regard that address as currently "ineligible for napping";
 - if the MAC-D-BLCK PDU contains the "immediate napping permission flag" set to 1, the MS-MAC may regard that address as currently "eligible for napping".
- d) If a time T.226 has elapsed since the MS moved to the channel and the MS-MAC has not sent or received a PDU on this channel using that address, and the MS does not have any reserved capacity on this channel granted for that address, then the MS-MAC may regard that address as currently "eligible for napping".
- e) If a time T.226 has elapsed since the MS-MAC last sent or received a PDU on this channel using that address or relating to that address, and the MS does not have any reserved capacity on this channel granted for that address, then the MS-MAC may regard that address as currently "eligible for napping".

NOTE 2: In cases a), b) and c), if the "immediate napping permission flag" is set to 1, the MS-MAC may regard the address as "eligible for napping" irrespective of whether the MS has been granted reserved capacity for that address.

The MS-MAC shall enter full reception mode when it first moves to the assigned channel.

The MS-MAC shall enter (or remain in) full reception mode on the assigned channel when any of the following events occurs:

- any of its valid addresses become "ineligible for napping" on this channel; or
- it initiates the random access procedure on this channel; or
- it receives a MAC-RESOURCE PDU on this channel containing one of its addresses or event labels, and containing "Length indication" set to 111111₂ (indicating the start of fragmentation); or
- it enters traffic mode on this channel for transmission and/or reception (see clause 23.8).

When the MS-MAC is in full reception mode on the assigned channel, it may enter napping mode on the assigned channel if:

- all its valid addresses are currently "eligible for napping" on this channel; and
- it is not currently making a random access attempt on this channel (see note 3); and
- it is not currently performing reconstruction on this channel of a downlink TM-SDU for any of its addresses or event labels (see note 4); and
- it is not in traffic mode for transmission or reception on this channel (see note 5).

NOTE 3: At the end of a random access attempt (i.e. when the MS receives a response from the BS or abandons the random access attempt), the MS may check whether it may enter napping mode based on the other criteria. For example, if the BS response message gives immediate napping permission, the response message makes that address currently eligible for napping; if the BS response message does not give immediate napping permission, that address is currently ineligible for napping.

NOTE 4: At the end of a reconstruction (i.e. when the MS receives the MAC-END PDU or the reconstruction procedure fails), the MS may check whether it may enter napping mode based on the other criteria.

NOTE 5: The MS may check whether it may enter napping mode based on the other criteria when it goes out of traffic mode.

NOTE 6: If the MS is in napping mode on a channel assigned for a circuit mode call, and it receives an ACCESS-ASSIGN PDU in frames 1 to 17 in a slot appropriate to the downlink assigned channel, containing Header $\neq 00_2$ and containing the correct downlink traffic usage marker for this MS, the MS may choose to revert to full reception mode temporarily if it wishes to use "N.213 permission method" criterion for entering traffic mode for reception of traffic (see clause 23.8.2.3.2).

23.4.8.3 MS reception requirements

23.4.8.3.1 Generation of napping reception pattern

The "napping reception timeslots" element is a four-bit bit map, even when the allocated channel is a one-slot, two-slot or three-slot channel. In order to allow the BS flexibility to instruct the MS that the current napping information may be used on another allocated channel (for example, in the case of a channel replacement), the "napping reception timeslots" bit map may contain a bit set to 1 for timeslot(s) that are not appropriate to the downlink assigned channel as defined by element "timeslot assigned". This does not indicate that the MS is required to receive those slots.

Therefore, when the MS moves to a assigned channel on which use of the napping procedure is permitted (i.e. when it obeys an augmented channel allocation with "napping status" element set to 01₂ or 10₂), the MS-MAC shall derive a "napping reception pattern" for that channel i.e. a four-bit timeslot bit map indicating the downlink slot or slots that the MS-MAC is required to receive in the napping reception frames when it is in napping mode. The MS-MAC shall derive the "napping reception pattern" from the "timeslot assigned" element for the assigned channel and from the appropriate "napping reception timeslots" element; the latter is:

- for "napping status" = 01₂, the "napping reception timeslots" element in the "napping information" element in the channel allocation; or
- for "napping status" = 10₂, the "napping reception timeslots" element appropriate on the channel on which the channel allocation was received.

For each of the four bits in the "timeslot assigned" and "napping reception timeslots" bit maps:

- if that bit is set to 1 in both the "timeslot assigned" and "napping reception timeslots" bit maps, then the MS-MAC shall set the corresponding bit in the "napping reception pattern" bit map to 1;
- otherwise the MS-MAC shall set the corresponding bit in the "napping reception pattern" bit map to 0.

If the resulting "napping reception pattern" is 0000₂ (i.e. no match between the "timeslot assigned" and "napping reception timeslots" bit maps), the MS-MAC shall set the "napping reception pattern" to the value of the "timeslot assigned" element.

23.4.8.3.2 Reception requirements when MS is in napping mode

When the MS-MAC is in napping mode on an assigned channel, it shall attempt to receive and decode at least the downlink slots indicated by the "napping reception pattern" in at least the TDMA frames indicated by the "napping reception frames" element for that assigned channel (within the constraints of the cell reselection procedures, and linearization and transmission requirements). If the MS is not able to attempt to receive and decode at least one of the downlink slots indicated by the "napping reception pattern" in a TDMA frame indicated by the "napping reception frames" element because of linearization or transmission requirements then, in that TDMA frame, the MS shall attempt to receive and decode any downlink slots of the assigned channel that it is capable of receiving.

Additionally, when the MS-MAC is in napping mode on an assigned channel and:

- MAC timer T.202 is running on this channel; and/or
- MAC timer T.206 is running on this channel; and/or
- the LLC has indicated (using the "LLC timer status" parameter in the TMC-CONFIGURE request primitive) that any of its timers measured in downlink signalling frames are currently running on this channel;

the MS shall attempt to receive and decode at least the downlink slots indicated by the "napping reception pattern" in all TDMA frames (within the constraints of the cell reselection procedures, and linearization and transmission requirements). If the MS is not able to attempt to receive and decode at least one of the downlink slots indicated by the "napping reception pattern" in a TDMA frame because of linearization or transmission requirements then, in that TDMA frame, the MS shall attempt to receive and decode any downlink slots of the assigned channel that it is capable of receiving.

NOTE 1: The LLC timers that are measured in downlink signalling frames are timers T.251, T.252, T.261, T.263 and T.265; see annex A.

NOTE 2: The procedure requiring reception in all TDMA frames (not just in the napping reception frames) when T.202 or T.206 or one of these LLC timers is running is defined so that the MS and BS should count the downlink signalling frames in the same way, even if the BS perceives that the MS may be napping when the MS is actually in full reception mode (for example, because another address is ineligible for napping or because the MS was not able to decode a PDU giving immediate napping permission).

NOTE 3: In an implementation, the MS may choose to regard the "napping reception frames" as always requiring reception in all TDMA frames. This reduces the napping opportunities when the BS has permitted reception every two or three TDMA frames in napping mode, but would mean that the same procedure applies in napping mode irrespective of whether T.202 or T.206 or the LLC timers are running.

NOTE 4: The setting of the "reduced reception in frame 18 flag" for the assigned channel affects the reception requirements when the MS is in full reception mode. It does not affect the reception requirements when the MS is in napping mode.

23.4.8.3.3 Reception requirements when MS is in full reception mode

When the MS-MAC is in full reception mode on an assigned channel on which use of the napping procedure is permitted, the MS reception requirements may vary depending on the value of the "reduced reception in frame 18 flag" for that assigned channel. If the "reduced reception in frame 18 flag" was set to 1, the MS is usually permitted to use the "napping reception pattern" in frame 18 instead of receiving all downlink slots of the assigned channel (as indicated by the "timeslot assigned" element in the channel allocation).

If the MS is in full reception mode on an assigned channel and is not in traffic mode for transmission or reception on this channel then:

- the MS shall attempt to receive and decode all downlink slots of the assigned channel in frames 1 to 17 (within the constraints of the cell reselection procedures, and linearization and transmission requirements);
- if the "reduced reception in frame 18 flag" was set to 0 indicating that reduced reception in frame 18 is not permitted, or the MS-MAC is currently performing reconstruction on this channel of a downlink TM-SDU for any of its addresses or event labels, then the MS shall attempt to receive and decode all downlink slots of the assigned channel in frame 18 (within the constraints of the cell reselection procedures, and linearization and transmission requirements);
- if the "reduced reception in frame 18 flag" was set to 1 indicating that reduced reception in frame 18 is permitted, and the MS-MAC is not currently performing reconstruction on this channel of a downlink TM-SDU for any of its addresses or event labels, then the MS shall attempt to receive and decode at least the downlink slots indicated by the "napping reception pattern" in frame 18 (within the constraints of the cell reselection procedures, and linearization and transmission requirements); if the MS is not able to attempt to receive and decode at least one of the downlink slots indicated by the "napping reception pattern" in a frame 18 because of linearization or transmission requirements then, in that frame 18, the MS shall attempt to receive and decode any downlink slots of the assigned channel that it is capable of receiving.

If the MS is in traffic mode for transmission or reception on this channel, the requirements for reception of the downlink channel shall be as specified in clauses 23.3.1.3 and 23.3.1.4.

23.4.8.4 MS use of napping status element

When the MS moves to an assigned channel allocated with an augmented channel allocation, the "napping status" element indicates whether use of the napping procedure is permitted on the allocated channel. If "napping status" = 00₂ (or for a non-augmented channel allocation), the MS shall assume that use of the napping procedure is not permitted on the allocated channel. If "napping status" = 01₂ or 10₂, the MS may assume that use of the napping procedure is permitted on the allocated channel.

If "napping status" = 01₂, the appropriate napping information for use on the allocated channel is included in the channel allocation.

Alternatively, the "napping status" element may be set to 10₂, indicating that the MS may regard any napping information appropriate on the current channel (i.e. the channel on which the channel allocation was received) as being appropriate also on the allocated channel. Thus:

- the MS may regard the "napping reception frames", "napping timer T.226" and "reduced reception in frame 18 flag" from the current napping information as being appropriate on the allocated channel;
- the MS may also regard the "napping reception timeslots" from the current napping information as being appropriate on the allocated channel, in which case it shall use that information, together with the "timeslot assigned" element for the allocated channel, in order to derive the "napping reception pattern" for the allocated channel (see clause 23.4.8.3.1).

23.4.8.5 Independent allocation of uplink and downlink

When a channel is allocated, if the "up/downlink assigned" or "up/downlink assigned for augmented channel allocation" element in the channel allocation indicates that the MS has only been allocated either the uplink or the downlink then (as specified in clause 23.3.4), for the application of the general procedures for transmission and reception of signalling messages, the control channel shall be assumed to occupy any control slots on both the uplink and downlink directions, as indicated by the "timeslot assigned" element in the channel allocation. This applies also to the napping procedure if the MS has been assigned only one direction, so the normal napping procedure applies.

It is possible that the MS may receive concurrent independent channel allocations for the uplink and downlink of the same channel (e.g. both on the MS's individual address, or one on the MS's individual address and the other on one of the MS's group addresses):

- If the napping information is the same for both directions, the MS may assume that the normal napping procedure applies.
- If the napping information is different for the two directions, the MS shall regard the two sets of napping procedures as applying independently. Then:
 - The MS shall attempt to receive and decode downlink slots of the assigned channel if required by either set of napping procedures (within the constraints of the cell reselection procedures, and linearization and transmission requirements).
 - If the BS sends a "replace" or "replace + CSS channel" channel allocation on that channel, it should include a higher layer message, thus enabling the MS to deduce which of the current channel allocations is being replaced (see clause 23.5.4.2.3) - and thereby also enabling the MS to deduce which set of napping information applies on the allocated channel if "napping status" = 10₂; this applies also for a "quit command". If the MS is unable to deduce which set of napping information applies on the allocated channel then it shall regard both sets of napping information as still applying on the current channel and shall regard napping as not being permitted on the allocated channel.
 - If the BS sends an "add" channel allocation on that channel with "napping status" = 10₂, the MS shall regard both sets of napping information as applying on the allocated channel.

Alternatively the MS may regard napping as not being applicable.

23.4.8.6 BS procedures for supporting MS napping

If the BS supports the use of the napping procedure by MSs, it may include napping information in channel allocations sent to MSs that support the augmented channel allocation (as indicated in the "class of MS" element in the U-LOCATION UPDATE DEMAND PDU).

NOTE 1: MSs that support D8PSK and/or QAM operation need to support the augmented channel allocation in order to be allocated to a D8PSK or QAM channel. It is optional whether an MS that only supports $\pi/4$ -DQPSK operation supports the augmented channel allocation. The BS designer should note that an MS that does not support the augmented channel allocation will discard augmented channel allocations addressed to itself.

The napping procedure is intended principally for multi-slot channels. However it may be used to enable some battery economy on a single-slot channel if the "napping reception frames" element specifies reception in every two or three TDMA frames.

The methods used by the BS for choosing the napping information are outside the scope of the present document. The choice may be based on a compromise between allowing flexibility of scheduling of the downlink channel and giving opportunities for MS neighbour cell monitoring, irregular channel monitoring, main carrier monitoring, background scanning and/or battery economy. The choice may also depend on whether the BS makes use of the immediate napping permission facility, since the same napping information applies during short gaps in transmission (using the immediate napping permission facility) and during longer gaps (e.g. based on inactivity timer T.226).

NOTE 2: The "immediate napping permission flag" is included in MAC-RESOURCE, MAC-END and MAC-D-BLCK PDUs sent using $\pi/8$ -D8PSK or QAM modulation, and in MAC-D-BLCK PDUs sent using $\pi/4$ -DQPSK modulation; however, it is not included in MAC-RESOURCE and MAC-END PDUs sent using $\pi/4$ -DQPSK modulation. Therefore use of the immediate napping permission facility is restricted on $\pi/4$ -DQPSK channels and when using $\pi/4$ -DQPSK modulation on D8PSK channels.

If the BS makes use of the immediate napping permission facility, the methods used by the BS for choosing when to give immediate napping permission are outside the scope of the present document. The methods of use may depend on the type of data being sent by the BS or the MS. For example:

- When the BS is sending background class data to an MS, the BS may choose usually to set the "immediate napping permission flag" to 0 until the end of the data - except when there are intervals when the BS knows that it will be transmitting to other MSs for the next few slots or frames. Thus the MS may be required to receive most of the downlink assigned slots during the data transfer. The MS returns to napping mode at the end of the data, either immediately or after time $T.226$, depending on the setting of the "immediate napping permission flag".
- When the MS is sending background class data to the BS, the BS may choose whether to set the "immediate napping permission flag" to 0 or 1 - depending on whether it needs to have flexibility to send acknowledgements and slot grants in any slot of the downlink assigned channel.
- When the BS is sending data involving periodic transmissions of short packets (such as real-time class data or telemetry class data), the BS may choose to set the "immediate napping permission flag" to 1 in most or all downlink MAC PDUs sent to the MS. (For packets that require more than one slot, the flag would be set to 1 only in the last of the slots sent to this MS.)
- When the MS is sending data involving periodic transmissions of short packets, the BS may choose to set the "immediate napping permission flag" to 1 in most or all downlink MAC PDUs sent to the MS e.g. the downlink MAC PDUs containing the slot grants and/or link adaptation feedback messages.

If the BS sends a channel allocation on an assigned channel, allocating another assigned channel, it may set the "napping status" element to 00_2 to indicate that use of the napping procedure is not permitted on the allocated channel, or it may set the "napping status" element to 01_2 and provide napping information for use on the allocated channel. Alternatively it may set the "napping status" element to 10_2 to indicate that current napping information may be used on the allocated channel; for example, this may be used if the BS wishes MSs to retain their current individual napping information after a channel replacement on a group address - particularly if performing the channel replacement using the predefined broadcast group address. (The BS should choose an appropriate method if it wishes to send a channel replacement on a $\pi/4$ -DQPSK channel using a group address if some MSs in the group support the augmented channel allocation and other MSs do not - for example, sending the augmented channel allocation first.)

23.4.9 Link adaptation on D8PSK or QAM channel

23.4.9.1 General

On a D8PSK channel, signalling and data messages may generally be sent using either $\pi/4$ -DQPSK or $\pi/8$ -D8PSK bursts:

- for downlink transmissions in the assigned slots in frames 1 to 17, and in the assigned slots in frame 18 for which $(MN + TN) \bmod 4 = 2$ or 4, the BS shall choose whether to use a $\pi/4$ -DQPSK or $\pi/8$ -D8PSK burst on a slot-by-slot basis;

NOTE 1: The BS always uses $\pi/4$ -DQPSK modulation on a D8PSK channel in downlink slots in frame 18 for which $(MN + TN) \bmod 4 = 1$ or 3.

- for reserved slots and subslots on the uplink, the transmitting MS shall choose whether to use a $\pi/4$ -DQPSK or $\pi/8$ -D8PSK burst in each slot or subslot.

On a QAM channel, signalling and data messages may generally be sent using any valid combination of modulation and coding rate:

- for downlink transmissions on a DA main carrier in frames 1 to 17, and in the slots in frame 18 for which $(MN + TN) \bmod 4 = 1, 2$ or 4, the BS shall choose which modulation level and coding rate to use for the SCH-Q/D on a slot-by-slot basis;

NOTE 2: The BS sends the QAM Frequency Correction Burst (FCB) on the DA main carrier in downlink slots in frame 18 for which $(MN + TN) \bmod 4 = 3$. The FCB always uses 4-QAM, coding rate = $1/2$.

- for downlink transmissions on other QAM carriers, the BS shall choose which modulation level and coding rate to use for the SCH-Q/D on a slot-by-slot basis;
- for reserved uplink slots and subslots on the uplink, the transmitting MS shall choose which modulation level and coding rate to use for the SCH-Q/U in each slot or SCH-Q/HU in each subslot - subject to the maximum uplink modulation level permitted by the BS.

In the link adaptation algorithm, the MAC may evaluate the current state of the link; then, when sending a TM-SDU, the MAC adaptively selects the appropriate modulation level (and coding rate for QAM) to use, based on:

- a) the link conditions; and
- b) the data category parameter in the TMA-UNITDATA request primitive.

NOTE 3: It is not expected that the MS or BS would attempt to follow changes in the link conditions over a period shorter than about half a second.

Alternatively, the MAC may use a predefined choice of modulation levels (and coding rates for QAM) for each of the data categories (or for some of the data categories). Then, when sending a TM-SDU, the MAC selects the appropriate modulation level (and coding rate for QAM) based solely on the data category parameter in the TMA-UNITDATA request primitive.

The data category parameter provides information about the type of data in the TM-SDU and the required reliability level for the transmission. The MS designer should choose an appropriate definition of the data category parameter for the chosen link adaptation algorithm. For example, the data category parameter may indicate whether the data is:

- background class data - reliability level 1; or
- background class data - reliability level 2; or
- background class data - reliability level 3; or
- telemetry class data - reliability level 1; or
- telemetry class data - reliability level 2; or
- telemetry class data - reliability level 3; or
- real-time class data; or
- non-classified data (i.e. TM-SDU does not contain packet data) - reliability level 1; or
- non-classified data (i.e. TM-SDU does not contain packet data) - reliability level 2; or
- non-classified data (i.e. TM-SDU does not contain packet data) - reliability level 3.

NOTE 4: In this example of possible data categories, it is intended that reliability level 3 refers to better (i.e. higher) reliability than reliability level 2, and reliability level 2 refers to better (i.e. higher) reliability than reliability level 1. See also clause 22.3.1.10.

NOTE 5: In this example of possible data categories, three reliability levels are used for background class data, telemetry class data and non-classified data. In an implementation, fewer than three reliability levels could be used if preferred. For instance, if preferred, two reliability levels could be used for background class data and/or telemetry class data and/or non-classified data.

NOTE 6: The MAC uses both the data class and the reliability level when it selects the appropriate modulation level (and coding rate for QAM). For example, the appropriate modulation level (and/or coding rate for QAM) for "telemetry class data - reliability level 1" may be different from that for "background class data - reliability level 1".

The data category parameter is also used in the buffering process between the LLC and the MAC. It is used in the DATA-IN-BUFFER signal, so that the MS-MAC can estimate the reservation requirement from the amount of data in the LLC buffer per data category; see clause 23.5.2.1. It is also used in the MAC-READY signal; see clause 23.1.2.1.2.

Two layer 2 signalling messages may be used in the link adaptation process:

- the L2-LINK-FEEDBACK-CONTROL message may be used by the BS either:
 - to request link adaptation feedback from the MS on a D8PSK or QAM channel; or
 - to terminate link adaptation feedback from the MS;
- the L2-LINK-FEEDBACK-INFO message may be used by the BS or MS to send link adaptation feedback information on a D8PSK or QAM channel.

The MAC sends and receives layer 2 signalling messages using the data transfer service provided by the LLC at the TLE-SAP; see clause 23.1.4.

23.4.9.2 MS choice of bit rate

23.4.9.2.1 General on MS choice of bit rate

When on a D8PSK or QAM channel, the MS-MAC shall maintain assessments of the current appropriate bit rate for use for reserved access transmission for each of the data categories i.e.:

- on a D8PSK channel, the appropriate modulation ($\pi/4$ -DQPSK or $\pi/8$ -D8PSK) for each data category; or
- on a QAM channel, the appropriate modulation level and coding rate for each data category.

These assessments are used when the MS-MAC has a reserved slot (or subslot) individually granted to it by the BS, as described in clause 23.1.2.1.3. As indicated below, the assessments of the appropriate bit rate for each of the data categories may be adaptive estimates, varying with the current channel conditions, or may be predefined choices.

The MS designer should choose suitable criteria for the MS-MAC to decide on the current appropriate bit rate for each of the data categories. The criteria may be based on various types of information, including the following:

- a) Any L2-LINK-FEEDBACK-INFO messages received from the BS.

The feedback information may indicate the preferred bit rate for a specified data class; alternatively it may provide the BS's estimate of the E_s/N_0 received on the uplink and (optionally) the BS's estimate of the channel model and speed; see clause 21. If the feedback information indicates a preferred bit rate for background class data or telemetry class data, the MS should regard this as applying to the lowest reliability level for that class of data (and the MS should regard lower (or equal) bit rates as applying to the other reliability levels for that class of data).

- b) Link performance information in the TMC-CONFIGURE request primitive.

This parameter may be provided by the LLC, indicating information about the current advanced link performance. For example, the LLC may provide information derived from the acknowledgement bit maps in received AL-ACK, AL-RNR, AL-X-ACK and AL-X-RNR PDUs.

NOTE 1: The method for derivation of this link performance information is outside the scope of the present document. However the following points may be noted:

- If multiple advanced link segments are sent in a single slot, then those segments will all either be successfully received or fail together. This may need to be taken into account if the MS is using a link adaptation algorithm based on estimating slot error rates.
- If the MS has used a mixture of different bit rates to send the segments, it may need to keep a record of the bit rate used to send those segments, for comparison with the information derived from the acknowledgement bit maps - if the MS is using a link adaptation algorithm based on estimating slot error rates at particular bit rate(s).
- If the MS's link adaptation algorithm gives more weighting to the success or failure of segments that were sent recently, the MS may need to keep a record of when segments were sent, for comparison with the information derived from the acknowledgement bit maps.

c) Measurements of the downlink channel, such as:

- 1) measurements of slot error rates on the downlink channel for different bit rates; and/or
- 2) other measurements of the downlink channel e.g. E_s/N_0 or RSSI or symbol quality measurements.

Use of this information, together with knowledge of the BS link imbalance and an MS correction factor (see clause 21.5.2a), may enable the MS to make an approximate estimate of the uplink slot error rates.

NOTE 2: When making measurements of the downlink channel, the MS may use information from any downlink slots on the channel, not only those slots containing information addressed to itself. In case c1):

- on a D8PSK channel, the MS determines whether a downlink slot contains a $\pi/4$ -DQPSK normal downlink burst or a $\pi/8$ -D8PSK normal downlink burst by inspecting the training sequence;
- on a QAM channel, the MS first attempts to decode the QAM-SLOTINFO PDU in the SICH-Q/D in order to determine the bit rate used in the remainder of the slot; it may record the decode failure rate for any slots on the downlink channel for which it can decode the QAM-SLOTINFO PDU. (It may not be appropriate for the MS to use the decode failure rate for slots for which the QAM-SLOTINFO PDU indicates that the burst is an FCB.)

d) Choice of predefined bit rates for each of the data categories.

This choice of predefined bit rates may be made by the MS designer.

Predefined bit rates may be used in different ways; for example:

- 1) predefined bit rates may be used temporarily as a default in the absence of preferred information;
- 2) alternatively, the MS designer may choose to use suitable predefined bit rates for each of the data categories in general (or for some of the data categories), in order to provide a simple link adaptation algorithm; see also clause 23.4.9.2.2.

The information used may depend on the data category; for example, use of method b) is not appropriate when the MS is sending real-time class data. Also, use of method b) may not be appropriate for infrequent telemetry class data.

The information used may also depend on whether the MS is starting to send data (or a significant time has elapsed since the MS last transmitted data) or whether the MS has been transmitting data for some time. For example:

- use of method b) is not appropriate when the MS is starting to send advanced link data or if a significant time has elapsed since the MS last transmitted advanced link data;
- when the MS is starting to send advanced link data or if a significant time has elapsed since the MS last transmitted advanced link data, the MS could use method c) or use a predefined choice of bit rate;
- when the MS is starting to send real-time data, the MS could use method c) or use a predefined bit rate.

NOTE 3: For a DA MS, the information used may also depend on whether the MS is on its common control channel or on an assigned channel. For example, when a DA MS is idle on its common control channel, the MS might use a simpler method than when it is on an assigned channel.

NOTE 4: If an MS is not frequency full duplex and is operating on a multi-slot channel (e.g. a multi-slot assigned channel), it may not be able to receive the downlink channel during the elapse time corresponding to one granted capacity allocation, depending on the MS's fast switching capability and the timeslots belonging to the channel. (For multiple slot granting, the MS can receive the downlink channel between each instance of capacity allocation for appropriate values of the granting delay.) If the MS cannot receive the downlink channel during the elapse time corresponding to a capacity allocation, it cannot receive L2-FEEDBACK-INFO messages or acknowledgement bit maps from the BS, or make measurements of the downlink channel, during the elapse time corresponding to that capacity allocation. In this case, the BS may choose to limit the size of each instance of the capacity allocation. This may apply particularly when the BS perceives that the quality of the link is currently variable such that the MS may wish to adapt its bit rate more frequently than the maximum length of capacity allocation.

If the MS maintains an adaptive estimate of the appropriate bit rate for each of the data categories (varying with the current channel conditions) then:

- In the absence of feedback information from the BS indicating a preferred bit rate, the MS may use the chosen information in order to choose a bit rate such that the actual uplink slot error rate for each data category is intended to lie within a target range. The target range would generally be different for the different data categories. The choice involves a trade-off between throughput and reliability of a single transmission: if the uplink slot error rate exceeds the maximum acceptable then a lower bit rate may be appropriate in order to achieve more reliability; whereas, if the uplink slot error rate is less than the minimum in the target range then a higher bit rate may be appropriate in order to achieve higher throughput.
- When choosing an algorithm for making an adaptive estimate of the appropriate bit rate:
 - it is expected that the MS designer may choose an algorithm which allows relatively high slot error rates to be used for "background class data - reliability level 1", thereby enabling choice of higher bit rates and therefore higher throughput, and relying on the advanced link retransmission protocol in the case of failed segments; then more moderate slot error rates may apply for "background class data - reliability level 2"; and lower slot error rates should apply for "background class data - reliability level 3" (which may be used when the maximum number of segment retransmissions will soon be exceeded);
 - it is expected that the MS designer would choose an algorithm with relatively low slot error rates for "real-time class data";
 - it is expected that the MS designer would choose an algorithm with relatively low slot error rates for "non-classified data - reliability level 3";
 - it is expected that the MS designer may choose an algorithm which allows intermediate slot error rates to be used for "telemetry class data - reliability level 1" (i.e. lower than for "background class data - reliability level 1"); then reduced slot error rates may apply for "telemetry class data - reliability level 2"; and lower slot error rates should apply for "telemetry class data - reliability level 3" (which may be used when the maximum number of segment retransmissions will soon be exceeded).

NOTE 5: Use of a predefined choice of bit rates may be more appropriate for infrequent telemetry class data.

NOTE 6: If fewer than three reliability levels are used then appropriate target ranges for slot error rates may still apply. For example, if using two reliability levels for background class data, the MS designer may choose an algorithm which allows relatively high slot error rates to be used for "background class data - reliability level 1"; then lower slot error rates should apply for "background class data - reliability level 2" (which is used when the maximum number of segment retransmissions will soon be exceeded).

The following additional points may be noted relating to transmission on a QAM channel:

- when the MS transmits in a slot or subslot, it shall not exceed the maximum uplink QAM modulation level permitted by the BS;
- if the MS is capable of using 64-QAM, and the BS permits use of 64-QAM on the uplink, the MS should use 64-QAM in preference to using 16-QAM with coding rate $r = 1$.

23.4.9.2.2 Suggested predefined bit rates for background class and telemetry class data

23.4.9.2.2.1 General

Clause 23.4.9.2.1 gives general information on MS choice of bit rate. The MS designer should choose suitable criteria for the MS to decide on the current appropriate bit rate for each of the data categories. The assessments of the appropriate bit rate for each of the data categories may be adaptive estimates, varying with the current channel conditions, or may be predefined choices.

Clauses 23.4.9.2.2.2 and 23.4.9.2.2.3 suggest possible choices of predefined bit rates for background class data and telemetry class data. The MS should use appropriate bit rates for each of the data categories for background class data and telemetry class data to provide performance equal to or better than use of these suggested predefined bit rates.

NOTE: The suggested predefined bit rates in clauses 23.4.9.2.2.2 and 23.4.9.2.2.3 provide a simple link adaptation algorithm for background class data and telemetry class data. It is expected that a simple link adaptation algorithm using a predefined choice of bit rates may be the most appropriate for telemetry class data because link performance information may be out-of-date. However, it is expected that, at least for background class data, MS designers may prefer to use adaptive estimates of the appropriate bit rates in such a way as to provide better performance.

23.4.9.2.2.2 Suggested predefined bit rates on D8PSK channel

For background class data and telemetry class data, if the maximum number of segment retransmissions (LLC parameter N.274) is at least three, the MS should use appropriate bit rates for each of the data categories to provide performance equal to or better than use of the following predefined choices:

- one transmission of each segment at reliability level 1, using $\pi/8$ -D8PSK modulation;
- if retransmission of a segment is needed:
 - one transmission of that segment at reliability level 2, using $\pi/8$ -D8PSK modulation;
- then, if retransmission of the segment is still needed:
 - further transmission(s) of that segment at reliability level 3, using $\pi/4$ -DQPSK modulation.

As indicated in clause 22.3.1.10, the maximum number of segment transmissions using reliability level 1 (and/or reliability level 2) may depend on the maximum number of segment retransmissions N.274 for that advanced link.

Also, in an implementation, there may be some variations according to the current channel conditions (without necessarily using full adaptive estimates); for example:

- a) the maximum number of segment transmissions using reliability level 1 (and/or reliability level 2) may vary according to the current channel conditions, based on information provided by the MAC to the LLC;
- b) when appropriate, the MS may revert to using fewer than three reliability levels;
- c) when the channel conditions are perceived as poor, the MS could decide adaptively not to attempt any segment transmissions using $\pi/8$ -D8PSK modulation until the channel conditions are perceived to have improved.

NOTE: On a D8PSK channel, fragmentation is generally needed when a segment first sent using $\pi/8$ -D8PSK modulation is retransmitted using $\pi/4$ -DQPSK modulation (because the segment is cut to match the size of a $\pi/8$ -D8PSK MAC block). This impairs the performance of the $\pi/4$ -DQPSK retransmission compared with the performance if the segment had been first sent using $\pi/4$ -DQPSK modulation (in which case the segment would have been cut to match the size of a $\pi/4$ -DQPSK MAC block). Therefore, as indicated in point c), the MS may choose not to attempt any segment transmissions using $\pi/8$ -D8PSK modulation when the MS perceives that a $\pi/8$ -D8PSK transmission would be unlikely to be successfully received.

23.4.9.2.2.3 Suggested predefined bit rates on QAM channel

For background class data and telemetry class data, if the maximum number of segment retransmissions (LLC parameter N.274) is at least three, the MS should use appropriate bit rates for each of the data categories to provide performance equal to or better than use of the following predefined choices:

- one transmission of each segment at reliability level 1:
 - using 64-QAM rate = 2/3 if the BS permits use of 64-QAM on the uplink; else
 - using 16-QAM rate = 1/2;
- if retransmission of a segment is needed:
 - one transmission of that segment at reliability level 2, using 16-QAM rate = 1/2;
- then, if retransmission of the segment is still needed:
 - further transmission(s) of that segment at reliability level 3, using 4-QAM rate = 1/2.

As indicated in clause 22.3.1.10, the maximum number of segment transmissions using reliability level 1 (and/or reliability level 2) may depend on the maximum number of segment retransmissions N_{274} for that advanced link.

Also, in an implementation, there may be some variations according to the current channel conditions (without necessarily using full adaptive estimates); for example:

- a) the maximum number of segment transmissions using reliability level 1 (and/or reliability level 2) may vary according to the current channel conditions, based on information provided by the MAC to the LLC;
- b) when appropriate, the MS may revert to using fewer than three reliability levels;
- c) when the channel conditions are perceived as poor, the MS could decide adaptively not to attempt any segment transmissions using 64-QAM until the channel conditions are perceived to have improved.

NOTE: Fragmentation is not generally needed when a segment first sent using 64-QAM is retransmitted using 16-QAM or 4-QAM, or when a segment first sent using 16-QAM is retransmitted using 4-QAM.

23.4.9.3 BS choice of bit rate

The BS designer should choose suitable criteria for the MAC in the BS to decide on the appropriate bit rate in each downlink slot. The criteria for the BS to decide on an appropriate bit rate to use when sending data of a particular category to an MS may be based on various types of information, including the following:

- a) any L2-LINK-FEEDBACK-INFO messages received from that MS; and/or
- b) link performance information relating to current advanced link performance (such as information derived from the acknowledgement bit maps in received AL-ACK, AL-RNR, AL-X-ACK and AL-X-RNR PDUs); and/or
- c) measurements of the uplink slots and subslots used by that MS; and/or
- d) choice of predefined bit rates for each of the data categories (or for some of the data categories), for example:
 - for temporary use as a default in the absence of preferred information; or
 - for use in general, in order to provide a simple link adaptation algorithm.

The information used may depend on whether the BS is starting to send data to the MS (or a significant time has elapsed since the BS last transmitted data to the MS) or whether the BS has been transmitting data to the MS for some time.

The BS may include signalling or data messages for more than one MS within one downlink slot. The BS should take account of the appropriate bit rate for transmission to each MS when deciding which messages to associate within a slot and when choosing the bit rate to use in the slot.

NOTE: It is recommended that PDUs containing slot grants are sent using a high reliability.

The following additional points may be noted relating to transmission on a QAM channel:

- the BS should not exceed the maximum QAM modulation level supported by that MS for reception;
- if the BS and MS are both capable of using 64-QAM, the BS should use 64-QAM in preference to using 16-QAM with coding rate $r = 1$.

23.4.9.4 Link adaptation feedback control by BS

The BS may send the L2-LINK-FEEDBACK-CONTROL message either:

- to request link adaptation feedback from the MS on a D8PSK or QAM channel; or
- to terminate link adaptation feedback from the MS.

The request for link adaptation feedback may solicit a single feedback message from the MS, or it may also invite feedback from the MS, following a change in channel conditions, for a specified feedback duration. When the BS sends a request for link adaptation feedback, it may include a slot grant (e.g. granting a subslot) for the solicited feedback message from the MS.

The request for link adaptation feedback indicates a preferred channel metric type (and the appropriate data class in the case of a request for bit rate feedback). However the BS should note that the MS may send feedback with a different channel metric type if it does not support the preferred channel metric type.

It is recommended that the BS requests link adaptation feedback during transmission of real-time class data to an individual MS if the BS wishes to use link adaptation for that data.

The BS may request link adaptation feedback during transmission of telemetry class data and/or background class data.

The termination of link adaptation feedback message indicates the channel metric type (and the data class in the case of bit rate feedback) to which the termination applies.

23.4.9.5 Link adaptation feedback by MS

23.4.9.5.1 Sending link adaptation feedback

On receipt of an L2-LINK-FEEDBACK-CONTROL message (delivered by the LLC in a TLE-UNITDATA indication primitive), the MS-MAC shall inspect the "link feedback control type" element.

If the "link feedback control type" element is set to 000₂, indicating a request for feedback, the MS-MAC shall send an L2-LINK-FEEDBACK-INFO message. The L2-LINK-FEEDBACK-CONTROL message indicates the preferred channel metric type for the feedback (and the appropriate data class in the case of a request for bit rate feedback). If the MS supports the preferred channel metric type, it shall send the information corresponding to that channel metric type (and that data class in the case of bit rate feedback) in the L2-LINK-FEEDBACK-INFO message; otherwise it shall send information corresponding to a channel metric type that it supports.

If the L2-LINK-FEEDBACK-CONTROL feedback request message contains "feedback duration T.230" element set to 000000₂, the MS-MAC shall not send any further L2-LINK-FEEDBACK-INFO messages relating to this feedback request.

If the L2-LINK-FEEDBACK-CONTROL feedback request message contains "feedback duration T.230" element not equal to 000000₂, the MS-MAC may send further L2-LINK-FEEDBACK-INFO messages relating to this feedback request (designated "unsolicited" feedback messages) - when there has been a significant change in the perceived channel conditions and within the T.231 constraints defined below - until either:

- a) the MS-MAC receives a further L2-LINK-FEEDBACK-CONTROL feedback request message containing the same channel metric type (and data class in the case of a request for bit rate feedback); or
- b) the MS-MAC receives an L2-LINK-FEEDBACK-CONTROL feedback termination message containing the same channel metric type (and data class in the case of bit rate feedback) as in the L2-LINK-FEEDBACK-CONTROL feedback request message; or
- c) a time T.230 has elapsed since receipt of the L2-LINK-FEEDBACK-CONTROL feedback request message; or
- d) the MS leaves the current channel (or changes from assigned mode to common mode), unless the MS is leaving the channel as a result of obeying an augmented channel allocation within the current cell and with:
 - i) "allocation type" element set to 00₂ (Replace) or 11₂ (Replace + CSS channel); and
 - ii) "modulation mode of allocated channel" element indicating that the allocated channel is a D8PSK or QAM channel; and
 - iii) "timeslot assigned" element not set to 0000₂.

NOTE 1: For the purposes of criterion d), the MS should regard changing from assigned mode to common mode on the same physical channel(s) as leaving the current channel.

NOTE 2: If the MS leaves the current channel as a result of obeying an augmented channel allocation within the current cell and satisfying criteria i), ii) and iii), it may send further L2-LINK-FEEDBACK-INFO messages on the allocated channel (when there has been a significant change in the perceived channel conditions and within the T.231 constraints defined below) until one of criteria a), b), c) or d) applies.

In case a), the MS shall process the L2-LINK-FEEDBACK-CONTROL feedback request message as described above (responding with an L2-LINK-FEEDBACK-INFO message and then, if the "feedback duration T.230" element is not 000000₂, optionally sending further L2-LINK-FEEDBACK-INFO messages - subject to the constraints below).

During the time when unsolicited feedback is permitted:

- 1) the MS-MAC shall not send an L2-LINK-FEEDBACK-INFO message relating to this feedback request unless the minimum time interval T.231 has elapsed since the MS-MAC last sent an L2-LINK-FEEDBACK-INFO message relating to this feedback request;
- 2) the MS-MAC should send an L2-LINK-FEEDBACK-INFO message if:
 - there has been a significant change in the perceived channel conditions since the last feedback relating to this feedback request, such as a change in the preferred bit rate for this data class or a significant change in the E_s/N_0 feedback information; and
 - the minimum time interval T.231 has elapsed since the MS-MAC last sent an L2-LINK-FEEDBACK-INFO message relating to this feedback request;
- 3) the MS-MAC may send an L2-LINK-FEEDBACK-INFO message if:
 - there has been a significant change in the perceived channel conditions since the last feedback relating to this feedback request sent either as the immediate response to the L2-LINK-FEEDBACK-CONTROL feedback request message or by successful random access; and
 - the minimum time interval T.231 has elapsed since the MS-MAC last sent an L2-LINK-FEEDBACK-INFO message relating to this feedback request;

however, the MS-MAC shall not send the same or similar information more than a total of N.231 times.

NOTE 3: If a feedback message was sent as the immediate response to a feedback request message, it is the BS's responsibility to send the feedback request message again if the response was not received.

NOTE 4: If a feedback message was successfully sent by random access, the MS-MAC can deduce that the message was received by the BS.

NOTE 5: If a feedback message indicating a significant change in the perceived channel conditions was sent by reserved access, and not as the immediate response to a feedback request message, or if the transfer failed, the MS-MAC may send another feedback message after expiry of timer T.231 (and possibly again after the next expiry of timer T.231 if the feedback message was again sent by reserved access) - within the limit defined by N.231; see point 3) above. This may apply particularly if the number of repetitions of the layer 2 signalling message was 0. However, the MS-MAC should not continually send the same information after each expiry of timer T.231 unless there is another significant change in the perceived channel conditions. Also, if the number of repetitions of the layer 2 signalling message was not 0, the MS-MAC should reduce the value of N.231 accordingly

The MS may receive L2-LINK-FEEDBACK-CONTROL feedback request messages from the BS inviting unsolicited feedback messages relating to different channel metric types or different data class linkage. Then the above procedures for unsolicited feedback messages generally apply independently to each of the feedback request messages. However, if the MS is unable to support the preferred channel metric type and so sends information corresponding to the same channel metric type (and data class) in response to more than one feedback request then, when there is a significant change in the perceived channel conditions, the MS should only send the L2-LINK-FEEDBACK-INFO message according to the procedures for one of those feedback requests (e.g. when first permitted by one of the T.231 timers).

When the MS-MAC sends an L2-LINK-FEEDBACK-INFO message, it shall issue the message to the LLC in a TLE-UNITDATA request primitive. The MS-MAC should set PDU priority level = 6 in the request primitive. When the message is sent as the immediate response to an L2-LINK-FEEDBACK-CONTROL feedback request, the number of repetitions of the layer 2 signalling message shall be set to 0. For an unsolicited feedback message, it is recommended that the number of repetitions of the layer 2 signalling message is normally set to 0.

If the MS-MAC sends an L2-LINK-FEEDBACK-INFO message, and there is a significant change in the perceived channel conditions before the MS-MAC receives a TLE-REPORT indication primitive reporting completion of the transfer (either successful or failed transfer), the MS-MAC may cancel the ongoing transfer using the TLE-CANCEL request primitive and then send a revised L2-LINK-FEEDBACK-INFO message.

23.4.9.5.2 MS feedback information

When the MS-MAC sends an L2-LINK-FEEDBACK-INFO message, as defined in clause 23.4.9.5.1, it may indicate:

- the preferred bit rate for reception of data for a specified data class; or
- the MS's estimate of the E_s/N_0 received on the downlink and (optionally) the MS's estimate of the channel model and speed.

If the feedback information indicates a preferred bit rate for background class data or telemetry class data, this refers to the preferred bit rate for the lowest reliability level for that class of data.

The MS designer should choose suitable methods for the MS to derive the preferred bit rate or to estimate the E_s/N_0 received on the downlink and the channel model and speed.

In order to derive or estimate this information, the MS needs to make measurements of the downlink channel, such as:

- 1) measurements of slot error rates on the downlink channel for different bit rates; and/or
- 2) other measurements of the downlink channel e.g. E_s/N_0 or RSSI or symbol quality measurements.

NOTE: When making measurements of the downlink channel, the MS may use information from any downlink slots on the channel, not only those slots containing information addressed to itself.

If the MS indicates the preferred bit rate for reception of data for a specified data class, it may use the measurements in order to choose that preferred bit rate such that the actual downlink slot error rate for the data is intended to lie within a target range. The target range may be different for the different data classes, since it involves a trade-off between throughput and reliability of a single transmission; for example, when choosing the preferred bit rate:

- for background class data, the MS may select a preferred bit rate corresponding to a relatively high slot error rate, thereby enabling a higher bit rate and therefore higher throughput (relying on the advanced link retransmission protocol in the case of failed segments);
- for real-time class data, the MS may select a preferred bit rate corresponding to a relatively low slot error rate;
- for telemetry class data, an intermediate choice may be appropriate.

On a QAM channel, if the MS indicates the preferred bit rate, the MS shall not indicate a QAM modulation level exceeding the maximum uplink QAM modulation level permitted by the BS. If the BS does not support transmission at the indicated QAM modulation level, it may use a lower modulation level that it supports (with an appropriate coding rate). Similarly, if the indicated coding rate is coding rate $r = 1$, and the BS does not support transmission using coding rate $r = 1$, the BS should use a coding rate that it supports.

23.4.9.6 Link adaptation feedback by BS

The BS may send the L2-LINK-FEEDBACK-INFO message to an MS at any time in order to provide link adaptation information. When the BS sends a link adaptation feedback message, it may include a slot grant for the MS's data.

It is recommended that the BS sends link adaptation feedback when the MS is transmitting real-time class data if it wishes to enable the MS to use link adaptation for that data.

The BS may send link adaptation feedback when the MS is transmitting background class data and/or telemetry class data. (This may not be useful for infrequent uplink telemetry class data.)

The feedback information may indicate the preferred bit rate for a specified data class; alternatively it may provide the BS's estimate of the E_s/N_0 received on the uplink and (optionally) the BS's estimate of the channel model and speed.

The BS designer should choose suitable methods for the BS to derive the preferred bit rate or to estimate the E_s/N_0 received on the uplink and the channel model and speed.

On a QAM channel, if the BS indicates the preferred bit rate, the BS shall not indicate a QAM modulation level exceeding the maximum QAM modulation level supported by that MS for reception. If the MS does not support transmission at the indicated QAM modulation level, it should use a lower modulation level that it supports (with an appropriate coding rate). Similarly, if the indicated coding rate is coding rate $r = 1$, and the MS does not support transmission using coding rate $r = 1$, the MS should use a coding rate that it supports.

EXAMPLE: If the MS supports reception but not transmission using 64-QAM then:

- if the BS indicates 64-QAM rate = 1/2 as the preferred bit rate, the MS should use 16-QAM rate = 1/2;
- if the BS indicates 64-QAM rate = 2/3 as the preferred bit rate, the MS may choose to use either 16-QAM rate = 1/2 or 16-QAM rate = 1;
- if the BS indicates 64-QAM rate = 1 as the preferred bit rate, the MS should use 16-QAM rate = 1 if supported for transmission or else should use 16-QAM rate = 1/2.

23.4.10 MAC aspects of assigned channel replacement on serving cell

23.4.10.1 MS-MAC advice to MLE on assigned channel replacement

The MLE in the MS may request the SwMI to replace an assigned channel on the serving cell; see clause 18. The criteria used by the MLE to decide whether to request assigned channel replacement may include use of information provided by the MS-MAC about whether the MS-MAC considers that:

- a) channel replacement is advisable (for example, if an RF bandwidth reduction or a change of sector or eccentric channel may be advisable because reliability performance on the current channel may not be acceptable); or
- b) channel replacement may be beneficial (for example, because performance on the current channel is good and a bandwidth increase might have a beneficial effect on data throughput); or
- c) performance on the current channel is acceptable.

When the MS-MAC provides this information to the MLE, it shall use a TMC-REPORT indication primitive.

NOTE 1: The MLE also uses path loss parameters (C1, C2, C4 and C5) provided by the MS-MAC in its criteria for requesting assigned channel replacement. See clause 23.7 for the definition of the path loss parameters.

The MS designer should choose suitable criteria for the MS-MAC to issue the TMC-REPORT indication primitive to provide information relating to assigned channel replacement. The criteria may be similar in principle to those used in link adaptation if the MS maintains an adaptive estimate of the appropriate bit rate for each of the data categories, varying with the current channel conditions (see clause 23.4.9.2), or when the MS sends a preferred bit rate for reception of data (see clause 23.4.9.5.2). However, in the case of assigned channel replacement, the criteria may be based on the most demanding data class for currently active PDP context(s) using the current channel; the information about the most demanding data class is provided to the MS-MAC using the TMC-CONFIGURE request primitive ("data class activity information" parameter).

NOTE 2: The real-time data class is more demanding than the telemetry data class, and the telemetry data class is more demanding than the background data class. The term "more demanding" here refers to reliability of transmission at the MAC layer.

For link adaptation, if the MS maintains an adaptive estimate of the appropriate bit rate for each of the data categories (varying with the current channel conditions), the MS may attempt to choose a bit rate such that the actual slot error rate for each data category or data class is intended to lie within a target range, where the target range may be different for the different data categories or data classes since it involves a trade-off between throughput and reliability of a single transmission; see clauses 23.4.9.2 and 23.4.9.5.2. Then, for example, for assigned channel replacement, the MS-MAC criteria for issuing the TMC-REPORT indication primitive might include the following or similar criteria:

- i) the MS-MAC might choose to indicate that channel replacement is advisable if the measured or estimated downlink slot error rate for the lowest modulation level, or the estimated uplink slot error rate (if available) for the lowest modulation level, exceeds either:
 - the maximum acceptable slot error rate for the most demanding data class (see note 3); or
 - the maximum acceptable slot error rate for non-classified data i.e. messages not containing packet data (see note 4);
- ii) the MS-MAC might choose to indicate that channel replacement may be beneficial if:
 - the MS is capable of using a higher bandwidth channel; and
 - the measured or estimated downlink slot error rate for the highest bit rate on the current channel and the estimated uplink slot error rate (if available) for the highest bit rate on the current channel are both less than the minimum slot error rate in the target range for the most demanding data class (see note 5 and note 6).

NOTE 3: In case i), if the most demanding data class is the background data class or the telemetry data class, it may be preferable for the MS-MAC to advise channel replacement based on the maximum acceptable slot error rate for reliability level 3 rather than reliability level 1 or reliability level 2 (if using three reliability levels). If the most demanding data class is the real-time data class, it may be appropriate for the MS-MAC to advise channel replacement if the lost N-PDU probability for real-time class data is greater than (or equal to) 2,5 %; see also clause 28.

NOTE 4: In case i), it may be preferable for the MS-MAC to advise channel replacement based on the maximum acceptable slot error rate for non-classified data with reliability level 3 rather than reliability level 1 or reliability level 2 (if using three reliability levels).

NOTE 5: In case ii), when the MS-MAC is checking whether downlink and uplink slot error rates for the highest bit rate on the current channel are less than the minimum slot error rate in the target range for the most demanding data class, it may be preferable for the MS-MAC to exclude coding rate $r = 1$ (even if it supports transmission at coding rate $r = 1$). Then, for the purposes of the procedure in case ii), the MS-MAC would treat the highest bit rate on the current channel as being either 16-QAM rate = 1/2 or 64-QAM rate = 2/3 as appropriate.

NOTE 6: The MS-MAC's criteria for indicating that channel replacement may be beneficial may be affected by whether the MS is currently limiting its power as a result of the MS open loop power control procedure (see clause 23.4.4.2.2).

23.4.10.2 Assigned channel replacement by BS

When an MS is on an assigned channel, the BS may choose to move the MS to a different channel at any time (for example, from one QAM channel to another QAM channel with a different bandwidth) - based on its observations of the performance of the current channel and the MS's capabilities. It may also move the MS to a different channel as a result of any assigned channel replacement requests received from the MS at MLE level.

NOTE: If the BS accepts an assigned channel replacement request from the MS, the channel allocation need not be to an irregular channel or channel class requested by the MS. For example, in some cases, it may be appropriate for the BS to allocate a channel whose existence has not been broadcast to MSs because the channel fully covers the area covered by the main carrier.

The BS shall not send a channel allocation to an MS that is using an eccentric channel allocating the MS to another eccentric channel on the same cell where the separation between the transmitter sites of the two eccentric channels is more than 4 km; see clause 7.

23.5 PDU transfer for signalling messages (TMA-SAP)

23.5.1 Random access protocol

23.5.1.1 Introduction

The MS-MAC layer uses the random access protocol to initiate information transfer to the BS. The random access protocol is generally used for unsolicited MS messages, whereas messages solicited by the BS are sent using reserved access.

The random access protocol is based on slotted ALOHA procedures, with a superimposed access framing structure. By a suitable choice of access parameters, it is possible for the BS to:

- control the collision of access requests from different MSs;
- minimize access delay and traffic loss for a particular traffic loading;
- maintain peak throughput for a particular traffic loading;
- avoid protocol instability;
- dynamically restrict random access to different access priorities, and to selected groups and subscriber classes;
- provide simultaneously, independent access grades of service for different groups and subscriber classes.

The random access procedures defined in clauses 23.5.1.2, 23.5.1.3 and 23.5.1.4 are suitable for use on all types of control channel.

23.5.1.2 Overview

23.5.1.2.1 General

This clause provides a general overview of the random access protocol. The precise protocol definition is contained in clauses 23.5.1.3 and 23.5.1.4.

The BS may offer random access opportunities to different sets of MSs in turn by using "Access Codes". There is a maximum of four possible access codes (denoted A, B, C and D), and the BS marks each access opportunity with the appropriate access code. Alternatively, the BS may use a single access code.

The binding of MSs to access codes is dynamic. The binding defines the minimum valid PDU priority for an access code. It may also restrict use of the access code to a set of subscriber classes, or to a group of MSs. An MS may use a subslot designated for a particular access code only if the PDU priority (as supplied by layer 3), and the subscriber class parameter or MS identity, conform to the current binding.

For a particular access code, requests from MSs are invited within "access frames" consisting of a number of access opportunities (uplink subslots).

The random access procedures are based on two types of PDU broadcast by the BS. The PDUs are:

i) The ACCESS-DEFINE PDU

This PDU is transmitted at intervals, how often being an operator option. It contains fairly slowly changing information about the random access parameters for an access code:

- the PDU priority and MS binding to the access code;
- a parameter (IMM) defining when immediate access is permitted for the first transmission;
- the waiting time (WT) before deciding to re-try;
- the permitted number of random access retries;

- a frame-length multiplying factor;
- the uplink random access channel configuration.

ii) The ACCESS-ASSIGN PDU

This PDU:

- is transmitted in every downlink slot of a $\pi/4$ -DQPSK or D8PSK channel, on the AACH;
- may be transmitted in downlink slots of a QAM channel (except slots containing BLCH-Q), on the AACH-Q.

NOTE 1: The BS always includes the ACCESS-ASSIGN PDU within the AACH. In the present document, the BS should include the ACCESS-ASSIGN PDU within the AACH-Q. However, in future editions of the present document, the BS may choose not to include the ACCESS-ASSIGN PDU in the AACH-Q in some downlink slots on a QAM channel (see clause 21.4.7.1). Therefore the MS should expect that the ACCESS-ASSIGN PDU may not be present in the AACH-Q.

The ACCESS-ASSIGN PDU conveys information about the usage of the downlink slot in which it appears, and also access rights for the corresponding (same-numbered) uplink timeslot of that TDMA frame.

When the uplink is in use for control signalling, the ACCESS-ASSIGN PDU may contain two "Access Fields" which convey independent access rights for each of the two uplink subslots in the uplink slot.

The access field defines the allowed access code for the uplink subslot. It also may include a frame-length parameter. Otherwise, it may indicate that the uplink subslot is reserved for use by one MS and is therefore not available for random access; or it may assign the subslot for common linearization.

In other cases (for example, in frames 1 to 17 on an assigned SCCH), the ACCESS-ASSIGN PDU contains only one access field, which conveys access rights for both uplink subslots in the uplink slot.

When the uplink is in use for traffic, the ACCESS-ASSIGN PDU contains no access field, in which case the uplink slot is not available for random access or common linearization.

NOTE 2: If the AACH or AACH-Q is not decodeable or, on a QAM channel, if the ACCESS-ASSIGN PDU is not present within the AACH-Q, the MS regards the corresponding uplink slot as not available for random access or common linearization.

Also, the SYSINFO PDU, SYSINFO-Q PDU and SYSINFO-DA PDU may include some default parameters to be assumed, for access code A, by MSs that have acquired the main carrier (until receipt of ACCESS-DEFINE PDUs). For BSs that do not need multiple access codes, the facilities provided by the SYSINFO, SYSINFO-Q and SYSINFO-DA PDU may be adequate, so that the ACCESS-DEFINE PDU is not used.

The BS may optimize the system performance by varying the access code bindings, the frame-length and the other access parameters. The choice of parameters will depend on the type of system and the traffic mix.

23.5.1.2.2 Overview of random access channel on a 25 kHz channel

The basic format of the random access channel is illustrated in figures 23.9 to 23.12 inclusive.

NOTE: In these representations, the detailed TDMA frame structure (e.g. with a control timeslot and three traffic timeslots per TDMA frame) is not shown. The uplink control subslots (half timeslots) for this control channel are shown as if they were contiguous.

Figure 23.9 illustrates an example of designation of uplink subslots on a common control channel, showing multiple access codes and reserved subslots. The designation is performed using the ACCESS-ASSIGN PDU, with two access fields in the ACCESS-ASSIGN PDU defining the use of the two corresponding uplink subslots.

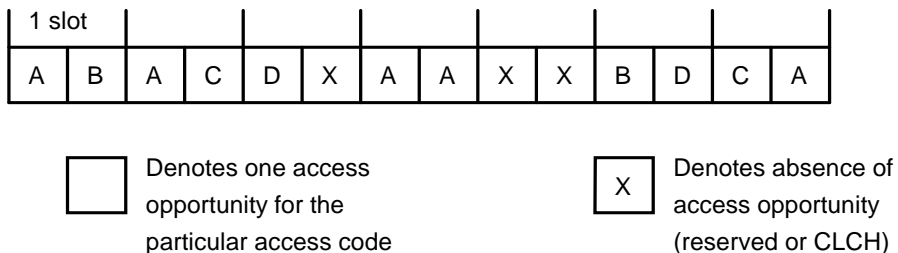

Figure 23.9: Example of subslot structure on common control channel

Figure 23.10 illustrates an example of designation of uplink subslots on an assigned SCCH, showing multiple access codes and reserved subslots. The designation is performed using the ACCESS-ASSIGN PDU, with a single access field in the ACCESS-ASSIGN PDU defining the use of the two corresponding uplink subslots.

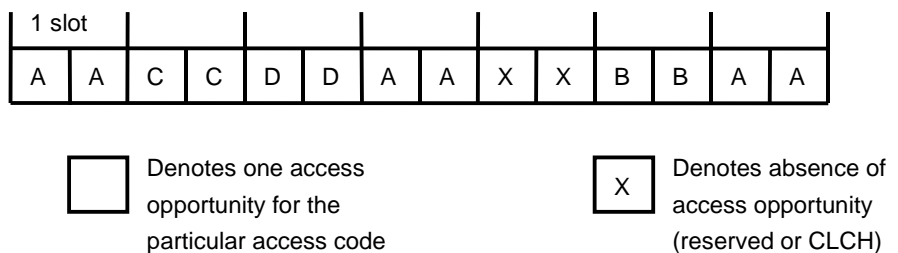

Figure 23.10: Example of subslot structure on assigned SCCH

Now consider only those subslots relevant to a particular access code. For these subslots, requests from MSs are invited within access frames. The access field in the ACCESS-ASSIGN PDU indicates the number of following uplink subslots, for this access code, that constitute an access frame. A special value ("ongoing frame") is used when the field does not mark the start of a new access frame.

When a user request is initiated, for example valid for access code A, the MS-MAC is permitted to send a first random access request in the next access code A subslot, provided that this occurs within a designated time. Otherwise the MS-MAC waits for an ACCESS-ASSIGN PDU containing a frame marker for access code A, and then chooses a subslot randomly from this access frame for its random access request. An MS-MAC wishing to send a repeat transmission after an unsuccessful access request waits for a new frame marker before choosing another subslot randomly from that access frame.

This procedure is illustrated in figures 23.11 and 23.12, in which the subslots shown are only those control subslots marked for random access by access code A. WT is the re-try time when the MS-MAC decides that its access request has failed.

In figure 23.11, the BS chooses to mark rolling access frames, with a new access frame marked in every subslot so that the access frames clearly overlap. In figure 23.12, the BS chooses to mark discrete access frames, by using the "ongoing frame" value (here denoted by *) to indicate continuation. The MS procedures operate independently of this BS choice.

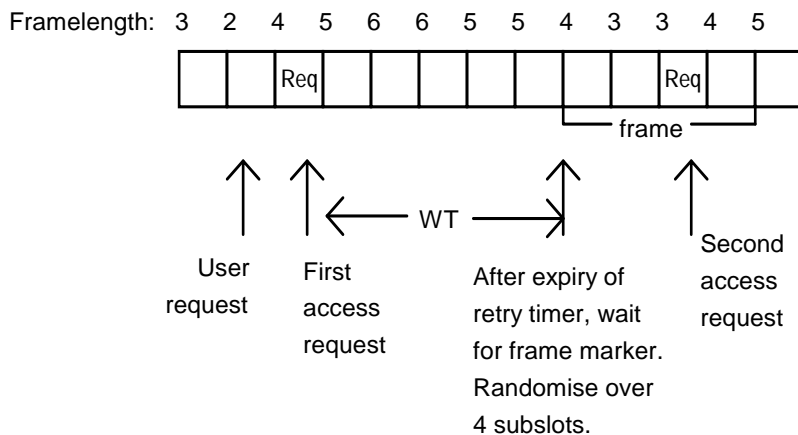

Figure 23.11: Example of random access procedure (BS using rolling access frames)

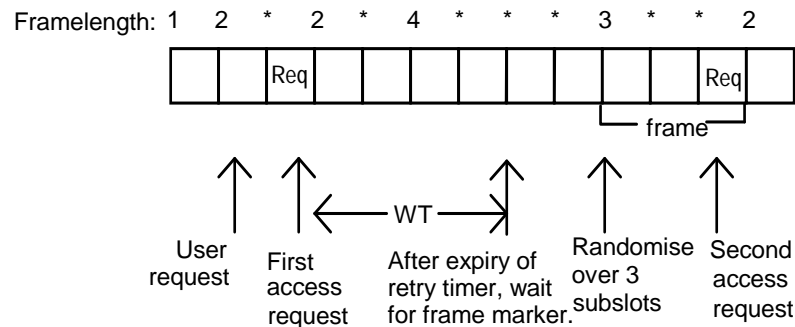

Figure 23.12: Example of random access procedure (BS using discrete access frames)

In either case, the BS may assess activity on the uplink channel in the subslots assigned to the access code, and may vary the frame-length to prevent excessive collision and to minimize access delays. Under normal conditions, the frame-length can be short. Then, when collision is detected, the BS may increase the frame-length dynamically according to its estimate of the backlogged traffic. This allows rapid smoothing of traffic transients.

23.5.1.2.3 Overview of random access channel on a 50 kHz, 100 kHz or 150 kHz QAM channel

There is an additional step in the procedure for random access on 50 kHz, 100 kHz and 150 kHz QAM channels as follows.

Access requests are sent within a 25 kHz bandwidth for all QAM channels. Each subslot (i.e. half timeslot) that is available for random access is divided into 25 kHz frequency blocks - called random access uplink RF channel subslots - so that each subslot provides:

- 2 random access uplink RF channel subslots on a 50 kHz channel;
- 4 random access uplink RF channel subslots on a 100 kHz channel; or
- 6 random access uplink RF channel subslots on a 150 kHz channel.

The MS uses the normal procedures for choosing a subslot randomly from an access frame and then counting the subslots to its chosen subslot. Thus, for the purposes of counting subslots in an access frame, the parallel random access uplink RF channel subslots are regarded as a single subslot. However, when the MS reaches its chosen subslot, there is then an additional procedure whereby the MS makes a random choice of one of the 2, 4 or 6 random access uplink RF channel subslots corresponding to its chosen subslot. The MS then transmits its access request in the selected random access uplink RF channel subslot.

23.5.1.3 Access control facilities for BS

23.5.1.3.0 General

See also the MS random access protocol (clause 23.5.1.4).

23.5.1.3.1 Transmission of ACCESS-DEFINE and ACCESS-ASSIGN PDU

The BS may transmit ACCESS-DEFINE PDUs at intervals decided by the operator. The BS shall transmit the ACCESS-ASSIGN PDU in every downlink timeslot on a $\pi/4$ -DQPSK or D8PSK channel, and should transmit the ACCESS-ASSIGN PDU in every downlink timeslot on a QAM channel (except slots containing BLCH-Q). The formats of the ACCESS-DEFINE and ACCESS-ASSIGN PDUs are defined in clause 21. Between them, these PDUs shall indicate:

- the configuration of the random access channel for this control channel;
- the valid priorities and the MSs eligible for each uplink subslot;
- the frame-lengths to be used; and

- other ALOHA re-try parameters.

Also:

- the BS may include in the SYSINFO PDU some default random access parameters to be assumed by MSs on phase modulation channels, for access code A, until receipt of ACCESS-DEFINE PDUs;
- the BS may include in the SYSINFO-Q PDU some default random access parameters to be assumed by CA MSs on QAM channels, for access code A, until receipt of ACCESS-DEFINE PDUs;
- the BS may include in the SYSINFO-DA PDU some default random access parameters to be assumed by DA MSs on QAM channels, for access code A, until receipt of ACCESS-DEFINE PDUs.

The following points may be noted:

- MSs that have missed ACCESS-DEFINE PDU broadcasts will be unaware of some of the current access restrictions and will be applying the limitations of the last received ACCESS-DEFINE PDU (or SYSINFO, SYSINFO-Q or SYSINFO-DA information).
- MSs count subslots in access frames using only the ACCESS-ASSIGN PDUs that they receive. Therefore, in case of un-decodeable ACCESS-ASSIGN PDUs, not all MSs will count the subslots in exactly the same way.
- Use of the ACCESS-DEFINE PDU is not required if the facilities provided within the SYSINFO, SYSINFO-Q and SYSINFO-DA PDU are adequate for a particular BS.
- The "Timeslot Pointer" element in the ACCESS-DEFINE PDU (and in the SYSINFO, SYSINFO-Q and SYSINFO-DA PDU) allows the BS to define those timeslots per TDMA frame that can be used for random access by MSs on this control channel, independently of the downlink channel configuration. For example, the BS may define an extended random access channel, allowing additional random access opportunities. The BS may define an extended random access channel for a common control channel (i.e. MCCH or MCCH-Q or common SCCH) or for an assigned channel.

The ACCESS-ASSIGN PDU then indicates (on a slot-by-slot basis) whether each uplink random access slot is available for common use or only for MSs on an assigned channel. This allows flexible use of the uplink e.g. in the case of an extended random access channel or in the case of minimum mode or if a QAM channel is shared by MSs in common mode and MSs in assigned mode.

- The BS designer should note the default assumptions for an MS when it acquires the main carrier or changes channel within the cell.

23.5.1.3.2 BS response to access request

After receiving an MS random access request, the BS should respond with a MAC-RESOURCE PDU indicating successful random access. The response may be sent in the corresponding downlink timeslot in the next TDMA frame (if that slot is appropriate to the downlink control channel). Alternatively the response may be delayed. The WT parameter in the ACCESS-DEFINE PDU defines the time the MS-MAC will wait before deciding to retransmit; see clause 23.5.1.4.

The BS should return the response in a timeslot on the MS's downlink control channel. In the case of a multi-slot downlink control channel, the BS may return the response in any slot of that downlink control channel.

If there is any possible ambiguity about the requesting MS's downlink configuration, the BS may return the response in more than one downlink slot.

If the BS is ready to return an LLC response or a layer 3 message (e.g. D-CALL PROCEEDING or D-CONNECT ACKNOWLEDGE) to the requesting MS at the time when it sends the MAC-RESOURCE response PDU, then it may include a TM-SDU in the MAC-RESOURCE PDU. Otherwise it should send a dedicated MAC response PDU.

23.5.1.3.3 Reserving subslots on uplink

During an access frame, the BS may transmit PDUs that demand a response from a specific MS (e.g. the D-SETUP PDU). To allow the MS to respond without making a random access, the BS may reserve a subslot or slot(s) for the response. The ACCESS-ASSIGN PDU indicates which subslots are reserved and therefore not available for random access. The MS for which a subslot or slot(s) are reserved shall be informed in the downlink signalling channel (see clause 23.5.2).

The ACCESS-ASSIGN PDU also indicates subslots that are available for common use for linearization (and therefore not available for random access).

23.5.1.4 MS-MAC random access protocol

23.5.1.4.0 General

The general random access procedure is described in clauses 23.5.1.4.1 to 23.5.1.4.9; this procedure covers normal operation on one $\pi/4$ -DQPSK control channel (common, assigned or multi-slot). Then any variations in operation for different channel configurations are described in clauses 23.5.1.4.10 to 23.5.1.4.18. For example, random access operation on a QAM control channel is described in clause 23.5.1.4.18.

23.5.1.4.1 Reception of ACCESS-DEFINE PDU

The MS-MAC shall continuously receive the downlink control channel, looking for ACCESS-DEFINE PDUs (within the constraints of the energy economy or dual watch regime or the napping procedures, and the cell reselection procedures, and linearization and transmission requirements). The downlink slot(s) appropriate to this control channel are known from the SYSINFO PDU (BNCH) or from the "Timeslot Assigned" element in the MAC-RESOURCE or MAC-END PDU that sent the MS to the channel. An ACCESS-DEFINE PDU defines access restrictions and access parameters for one access code.

On receipt of an ACCESS-DEFINE PDU, the MS-MAC shall note the minimum valid PDU priority for the access code; also, if included, the MS-MAC shall note the eligible subscriber classes or group address. If the ACCESS-DEFINE PDU does not include a "subscriber class bit map" element, the MS-MAC shall assume that there is no subscriber class restriction. If the ACCESS-DEFINE PDU does not include a "GSSI" element, the MS-MAC shall assume that there is no address restriction.

The MS-MAC shall note the ALOHA parameters (IMM, WT, Nu, frame-length factor). It shall also note from element "Timeslot Pointer" which uplink slots are potentially available for random access on this control channel i.e. the valid pattern for attempting to receive and decode the AACH for access invitations. If Nu is set to 0 in the ACCESS-DEFINE PDU, this indicates that the access code is not available for use.

The MS-MAC shall comply with the received ACCESS-DEFINE parameters for random access attempts on this access code and control channel. Each parameter set shall remain valid until updated by a subsequent ACCESS-DEFINE PDU for this access code and with the same setting of the "Common or assigned control channel flag", received on this downlink control channel.

NOTE 1: A subsequent ACCESS-DEFINE PDU for this access code overwrites the previous definition even if the addressing mechanism (i.e. subscriber class bit map, GSSI or neither) is not the same.

An MS on its common control channel shall ignore any received ACCESS-DEFINE PDUs containing "Common or assigned control channel flag" = 1 (i.e. assigned). Similarly, an MS on a channel assigned for SCCH or for a circuit mode call shall ignore any received ACCESS-DEFINE PDUs containing "Common or assigned control channel flag" = 0 (i.e. common).

NOTE 2: A $\pi/4$ -DQPSK common control channel is the MCCH or a $\pi/4$ -DQPSK common SCCH.

NOTE 3: The "Timeslot Pointer" element may give a bit map of the appropriate timeslots for the random access channel for this control channel, or it may be set to 0000₂ (i.e. same as downlink slot assignment). The latter means:

- slot 1 if the MS is on the MCCH;
- the appropriate slot for this MS when common SCCHs are in use; or

- the same timeslot number(s) as for the "Timeslot Assigned" element from the MAC-RESOURCE or MAC-END PDU in the case of an assigned channel.

23.5.1.4.2 Reception of ACCESS-ASSIGN PDU

If the MS-MAC wishes to send a random access message, and knows a valid access code for the message, it shall attempt to decode the appropriate downlink AACH which contains the ACCESS-ASSIGN PDU. The MS should look for the AACH in all the slots defined by element "Timeslot Pointer" from the ACCESS-DEFINE PDU (or the default value from the SYSINFO PDU), in all frames 1 to 18.

If an ACCESS-ASSIGN PDU contains two access field elements then "Access field 1" conveys access rights to subslot 1 in the corresponding uplink slot, i.e. the same-numbered uplink timeslot of that TDMA frame. "Access field 2" conveys independent access rights to subslot 2 in the uplink slot.

If an ACCESS-ASSIGN PDU contains only one access field, this conveys access rights to both subslots of the corresponding uplink slot as follows:

- a) the same access code shall be assumed for both subslots;
- b) when the access field indicates "Reserved subslot", it shall be assumed that both subslots are reserved;
- c) when the access field indicates "CLCH(-Q) subslot", it shall be assumed that subslot 1 may be used for linearization, and that subslot 2 is reserved;
- d) when the access field indicates "Ongoing frame", it shall be assumed that ongoing frame applies to both subslots;
- e) when the access field indicates a frame marker base frame-length of ≥ 1 subslots, it shall be assumed that the frame marker base frame-length applies to subslot 1, and that "Ongoing frame" applies to subslot 2.

If an ACCESS-ASSIGN PDU contains no access field (i.e. traffic on uplink) then both the corresponding uplink subslots shall be regarded as reserved.

If an MS on its common control channel receives an ACCESS-ASSIGN PDU indicating that the uplink slot is designated as "Assigned only", then both the corresponding uplink subslots shall be regarded as reserved.

If an MS on an assigned channel (assigned for SCCH or for a circuit mode call) receives an ACCESS-ASSIGN PDU indicating that the uplink slot is designated as "Common only", then both the corresponding uplink subslots shall be regarded as reserved.

If the AACH is un-decodeable then both the corresponding uplink subslots shall be regarded as reserved.

NOTE: As defined in clause 9, the start of the TDMA frame (and multiframe and hyperframe) on the uplink is delayed by a fixed period of two timeslots from the start of the TDMA frame (or multiframe or hyperframe) on the downlink. So the ACCESS-ASSIGN PDU in a downlink slot conveys access rights to the corresponding uplink slot, which is two slots later.

23.5.1.4.3 Initiating a random access

The MS shall only make one random access attempt at a time, per control channel. A random access attempt refers to the period from initiation of the random access procedure until a response is received or the procedure is abandoned.

When the MS has individually addressed unscheduled signalling messages to send, as indicated by the DATA-IN-BUFFER signal from the LLC, the MS-MAC may initiate the random access procedure if it:

- a) does not have a reserved subslot or slot(s) already granted for this address on this control channel; and
- b) has not already indicated to the BS that it has a signalling requirement for this address on this control channel (by asking for a reserved subslot or slot(s)).

NOTE 1: The ISSI and its associated ASSI are equivalent for the purposes of the slot granting procedure (so the MS should use any subslot or slot(s) granted on its ISSI for messages sent with its ASSI, or vice versa). Similarly, an event label and its corresponding address are equivalent for the purposes of the slot granting procedure. Also, a newly assigned ASSI is equivalent to the replaced ASSI or USSI for the purposes of the slot granting procedure.

NOTE 2: As defined above, the MS is permitted to initiate the random access procedure if the MS has individually addressed unscheduled signalling messages to send and criteria a) and b) are satisfied. This applies either if the MS has only unscheduled signalling messages to send or if it has both unscheduled and fully scheduled signalling messages to send. However, in the latter case, the MS may choose to delay initiation of the random access procedure in some cases. For example, it could decide to delay initiation of the random access procedure if the lowest value of the maximum schedule interval for the fully scheduled data (as indicated by the DATA-IN-BUFFER signal from the LLC) is small.

NOTE 3: If the MS has only fully scheduled signalling messages to send, it is not permitted to initiate the random access procedure unless the criteria in clause 23.5.2.4.2 are satisfied.

Also, the MS-MAC may initiate the random access procedure if it does not have a reserved subslot or slot(s) already granted for this address on this control channel, and the LLC indicates that a new emergency unscheduled message has just been received from layer 3, as indicated by the PDU priority parameter set to 7 in the DATA-IN-BUFFER signal.

NOTE 4: This exception allows the MS-MAC to cut short the reserved access waiting time-out T.206 in case of emergency; see clause 23.5.2.4.1. The MS may then send the emergency message by random access.

If the MS-MAC was in the process of sending a fragmented message at the time when it decides to cut short the reserved access waiting time-out T.206, it should discard the partially sent TM-SDU.

When the MS has individually addressed unscheduled signalling messages to send, and has indicated a signalling requirement for this address on this control channel, and does not have a reserved subslot or slot(s) granted for this address on this control channel, the MS-MAC may initiate the random access procedure if the criteria in clause 23.5.2.4.1 are satisfied.

Also, if the MS supports data priority, and has individually addressed signalling messages to send, and has indicated a signalling requirement for this address on this control channel, and does not have a reserved subslot or slot(s) granted for this address on this control channel, the MS-MAC may initiate the random access procedure if the criteria in clause 23.4.7.5.2 or clause 23.4.7.5.3 are satisfied.

When the MS has fully scheduled signalling messages to send, the MS-MAC may initiate the random access procedure if the criteria in clause 23.5.2.4.2 are satisfied.

The random access request shall be sent using the MAC-ACCESS PDU, fitting within a single subslot on the uplink (SCH/HU) and containing a TM-SDU or first fragment if appropriate. Any TM-SDU to be sent, or TM-SDUs if using association, are received from the LLC in the TMA-UNITDATA request primitive.

If the MS has any further signalling to send for this address on this control channel, the MS-MAC shall include a request for reserved capacity in the MAC-ACCESS PDU.

When the MS-MAC is required to initiate a random access, it shall comply with the access parameters. If the access request is not valid for any of the current access codes (as specified in clauses 23.5.1.4.1 and 23.5.1.4.4), the MS-MAC may immediately abandon the random access attempt, reporting the failure to the LLC using the TMA-REPORT indication primitive.

23.5.1.4.4 Checking for appropriate access code

When the MS-MAC wishes to send a non-emergency message, it shall not use a subslot designated for a particular access code unless the following criteria are all satisfied:

- a) the PDU priority, as supplied in the TMA-UNITDATA request primitive, is equal to or higher than the minimum PDU priority for this access code;
- b) if subscriber class is restricted for this access code: the subscriber class information, as supplied in the TMA-UNITDATA request primitive, is eligible for this access code;
- c) if address is restricted for this access code: the designated GSSI is one of the MS's valid group addresses.

For an emergency message, the same criteria shall apply for access codes B, C and D. However, the MS may use access code A for an emergency message without checking the above criteria.

For a message sent when the MS does not have subscriber class information for this network, criterion b) need not be checked.

NOTE 1: In criterion b), the eligibility for subscriber class requires that, for at least one class, the class is invited by the ACCESS-DEFINE PDU (i.e. there is a "1" in the appropriate position) and the MS belongs to that class.

NOTE 2: The message is an "emergency message" if the PDU priority parameter in the TMA-UNITDATA request primitive indicated the highest priority, i.e. 7.

NOTE 3: The exemption from checking criterion b) when the MS does not have subscriber class information for this network applies during migration. It applies also on the MS's home network if the MS does not have subscriber class information on this network and did not receive subscriber class information at subscription.

23.5.1.4.5 First try procedure

There is a special procedure for the first random access transmission.

The MS-MAC shall transmit its random access request in the first uplink slot in which one or both subslots are valid access opportunities (i.e. slot corresponds to element "Timeslot Pointer" and has an appropriate common/assigned designation, and subslot has an appropriate access code and is not reserved nor assigned for linearization) if:

- a) it is an emergency message; or
- b) parameter IMM = 15; or
- c) $1 \leq \text{IMM} \leq 14$, and the valid access opportunity occurs within the IMM TDMA frames following the initiation of the random access procedure.

If both the subslots in the uplink slot are valid access opportunities, the MS-MAC shall choose one of the two subslots randomly. This rule applies only to this first try procedure.

If the above conditions are not met, then the MS-MAC shall choose a subslot from a new access frame (see clause 23.5.1.4.6).

If a complete TM-SDU is contained within the MAC-ACCESS PDU, then the MS-MAC shall report to the LLC when the first random access transmission has been sent using the TMA-REPORT indication primitive.

23.5.1.4.6 Choosing from a new access frame

An MS-MAC that requires to select a subslot from a new access frame shall wait for a suitable access frame marker i.e. an ACCESS-ASSIGN PDU in a slot corresponding to element "Timeslot Pointer" with an access field that contains:

- a frame marker ("Base Frame-length" of ≥ 1 subslots); and
- an appropriate uplink slot designation (common/assigned); and
- an appropriate access code (as defined in clause 23.5.1.4.4),

with the most recently received access code parameters enforced at this time.

The MS-MAC shall then select a subslot randomly from the specified access frame. That is, it shall choose a subslot randomly between 1 and "Frame-length" using a uniform distribution, where:

```
if the "frame-length factor" for this access code = 0
then Frame-length = 1 × Base Frame-length
else Frame-length = 4 × Base Frame-length.
```

The MS-MAC shall transmit its access request in the chosen subslot, unless the random access attempt is abandoned (see clause 23.5.1.4.9).

23.5.1.4.7 Counting subslots in an access frame

The uplink subslot corresponding to the frame marker access field is defined as the first subslot in the access frame.

When counting further access subslots to its chosen subslot in the access frame, the MS-MAC shall count a subslot only if:

- a) it was indicated by element "Timeslot Pointer" in the ACCESS-DEFINE PDU (or, for access code A, in the SYSINFO PDU if the default definition is still valid); and
- b) the corresponding ACCESS-ASSIGN PDU is received; and
- c) the uplink slot designation (common/assigned) is appropriate for this control channel; and
- d) the subslot is marked with the appropriate access code, i.e. the access code used when choosing from the access frame; and
- e) the subslot is not designated as reserved or assigned for linearization.

NOTE: Subslots for this code designated as "ongoing frame" are counted, and also subslots starting new access frames; a new access frame marker does not alter a subslot choice already made.

23.5.1.4.8 Re-try procedure

After sending an access request, the MS-MAC shall wait for a response from the BS, i.e. a MAC-RESOURCE PDU on the downlink control channel, containing the same address as in the access request and with the "random access flag" indicating successful random access. If a complete TM-SDU was contained within the MAC-ACCESS PDU, the MS-MAC shall report the success to the LLC using the TMA-REPORT indication primitive. Then, if the received MAC-RESOURCE PDU contains a TM-SDU, the MS-MAC shall deliver that TM-SDU to the LLC using the TMA-UNITDATA indication primitive.

The MS-MAC shall look for the response in all downlink slots appropriate to this downlink control channel, as indicated by the SYSINFO PDU or by the MAC-RESOURCE or MAC-END PDU that sent the MS to the channel. The first potential slot in which the response may be received is the corresponding downlink slot in the next TDMA frame, i.e. the same timeslot number as the request slot, if that slot is appropriate to the downlink control channel. This allows the MS approximately one timeslot duration for switching from transmission to reception.

If a response is not received within the WT downlink signalling opportunities after transmission of its access request, the MS-MAC shall assume that the transmission has failed. Then it shall either:

- a) abandon its random access attempt (see clause 23.5.1.4.9 point a); or
- b) select a further subslot randomly from a new access frame, as in clause 23.5.1.4.6, and using a frame marker ACCESS-ASSIGN PDU received in or after the WTth downlink signalling opportunity following the unsuccessful access request. However, if the MS-MAC receives a response before sending a repeat message, it shall accept the response and not retransmit.

When counting slots (i.e. downlink signalling opportunities) for time-out WT, the MS-MAC shall count only one slot per TDMA frame, namely the downlink slot with the same timeslot number as the request slot or, if that slot is not appropriate to the downlink control channel, then the next slot that is appropriate to the downlink control channel.

On an assigned channel, the MS-MAC shall count the downlink slot only if it is available for control. Downlink slots in frames 1 to 17 for which the ACCESS-ASSIGN PDU (or last received ACCESS-ASSIGN PDU in frames 1 to 17) indicates downlink user traffic should not be counted in the time-out WT. However, the BS may choose to send the response by stealing from the downlink TCH.

NOTE 1: Downlink user traffic in frames 1 to 17 is indicated by Header $\neq 00_2$ and downlink usage marker $\geq 000100_2$.

NOTE 2: The above procedure allows for possible cases of independent allocation of uplink and downlink.

NOTE 3: As defined above, the MS looks for a response in all downlink slots appropriate to that channel. However a maximum of one slot per TDMA frame is counted for time-out WT. This is equivalent to the method for timers T.202 and T.206, and some LLC timers. It contrasts with the method for counting uplink opportunities for the granting delay for reserved access, when all slots on a multi-slot channel are counted; and with the method for counting access subslots in an access frame, when all appropriate subslots are counted.

23.5.1.4.9 Abandoning random access attempt

The MS-MAC shall cease attempting random access if it receives a response from the BS, as described in clause 23.5.1.4.8, or if any of the following occurs:

- a) The MS-MAC has sent the current maximum permitted number of random access transmissions without receiving a response; the maximum number of transmissions is N_u for a message with PDU priority 0 to 6, or $2 \times N_u$ for a message with PDU priority 7. The failure shall be reported to the LLC using the TMA-REPORT indication primitive.
- b) A time T.205 has elapsed since initiation of the random access procedure. The failure shall be reported to the LLC.
- c) The MS-MAC receives a TMA-CANCEL request primitive from the LLC, cancelling transmission of this message. The MS-MAC shall abandon the random access attempt whether or not it has sent any transmissions, reporting the state of transmission to the LLC.
- d) The MS-MAC receives a MAC-RESOURCE (or MAC-END or MAC-D-BLCK) PDU that does not indicate successful random access but grants a reserved subslot or slot(s) for this address. The MS-MAC shall send a PDU (or PDUs) in the reserved capacity, e.g. its own request and/or the message demanded by the BS. If the MS has any further signalling ready to send for this address on this control channel, the MS-MAC shall include the "reservation requirement" element in its transmission.

If a complete TM-SDU is transmitted, the MS-MAC shall report to the LLC that the message has been sent by reserved access.

Also, if the access request becomes ineligible for the current definition of the access codes, the MS-MAC may abandon the random access attempt, reporting the failure to the LLC.

If the MS-MAC abandons a random access attempt without having received a response from the BS, it shall not initiate any new random access attempt until any ongoing WT timer from the last request has expired.

23.5.1.4.10 Random access operation after acquiring main carrier

The MS-MAC shall make the following assumptions about the random access parameters on first acquiring a CA main carrier or receiving a channel allocation for a CA new cell.

If the MS-MAC has received the "default definition for access code A" element in the SYSINFO PDU then it shall assume the most recently received SYSINFO parameters for access code A, and with no MAC subscriber class restriction or address restriction, until it receives an ACCESS-DEFINE PDU for access code A. Otherwise it shall not use access code A until it receives either the SYSINFO default definition for access code A or an ACCESS-DEFINE PDU for access code A.

The MS-MAC shall not use access code B, C or D until it receives the appropriate ACCESS-DEFINE PDU.

NOTE 1: These parameters apply both to the MCCH and to a $\pi/4$ -DQPSK common SCCH.

There is no time limit on the validity of use of the SYSINFO parameters, since some BSs may choose never to send the ACCESS-DEFINE PDU, relying solely on the SYSINFO default definition for access code A. Until receipt of a "common" ACCESS-DEFINE PDU for access code A, the MS shall assume the most recently received SYSINFO parameters. After receipt of a "common" ACCESS-DEFINE PDU for access code A, the MS shall ignore any access parameters received in SYSINFO PDUs, reverting to the procedure in clause 23.5.1.4.1.

NOTE 2: The validity of use of the SYSINFO parameters on the MCCH or a $\pi/4$ -DQPSK common SCCH is not affected by receipt of an ACCESS-DEFINE PDU with "Common or assigned control channel flag" = 1 (i.e. assigned). Receipt of an "assigned" ACCESS-DEFINE PDU for access code A while the MS is on the MCCH or a $\pi/4$ -DQPSK common SCCH does not affect the validity of the SYSINFO parameters. Receipt of an "assigned" ACCESS-DEFINE PDU for access code A while the MS is on an assigned channel over-rides the SYSINFO definition while the MS is on that assigned channel, but does not affect operation when the MS returns to the MCCH or to a $\pi/4$ -DQPSK common SCCH.

NOTE 3: If the MS receives a channel allocation for an assigned channel on a CA new cell, it should apply a combination of the procedures for random access operation after acquiring a CA main carrier and then random access operation on a new channel. So, for the purposes of the random access parameters, the MS should treat the channel allocation for the type 1 announced cell reselection (actually received on an assigned channel on the old cell) as if it had been received on the main carrier of the new cell.

EXAMPLE: If the MS receives a channel allocation for a $\pi/4$ -DQPSK assigned channel on a CA new cell then, when clause 23.5.1.4.11 b) says that the MS-MAC assumes that "the other parameters are equal to those on the old channel except that ..." the MS-MAC should actually assume that "the other parameters are equal to those on the main carrier of the CA new cell except that ...".

23.5.1.4.11 Random access operation on a new channel

When an MS is sent to a new channel within the cell, it shall make the following assumptions about the random access parameters, until updated by ACCESS-DEFINE PDUs or the SYSINFO definition.

- a) When changing channel to the MCCH or to a $\pi/4$ -DQPSK common SCCH, a CA MS-MAC shall assume that all random access parameters except the "Timeslot Pointer" are equal to those used when the MS-MAC last received either the MCCH or a $\pi/4$ -DQPSK common SCCH (parameters as received in SYSINFO and/or ACCESS-DEFINE PDUs). This rule applies both when the BS has changed the number of common SCCHs in use and when the MS-MAC returns from an assigned channel.

The MS-MAC shall assume that the random access channel uses the same timeslot as the current downlink assignment.

- b) For an assigned channel (either for SCCH or for a circuit mode call):
- For the "Timeslot Pointer", the MS-MAC shall assume the same timeslot number(s) as for the "Timeslot Assigned" from the MAC-RESOURCE or MAC-END PDU.
 - The MS-MAC shall assume that the other parameters are equal to those on the old channel except that, for access code A, the MS-MAC shall assume "Frame-length Factor" = 0, "Minimum PDU Priority" = 000₂ and no subscriber class restriction or address restriction.

The MS-MAC may continue an ongoing random access attempt on the new channel, but shall choose a subslot from a new access frame using an appropriate frame marker received on the new channel.

The random access parameters shall all be updated on receipt of an appropriate ACCESS-DEFINE PDU on that channel. If the MS is on the MCCH or a $\pi/4$ -DQPSK common SCCH, and is still using the SYSINFO default definition, then the MS shall update the parameters on receipt of a new SYSINFO definition on that channel. If the MS is on an assigned channel, and is still using the SYSINFO default definition on that channel, then the MS shall update the parameters on receipt of a new SYSINFO definition on that channel, except for parameters "Timeslot Pointer", "Frame-length Factor" and "Minimum PDU Priority" for which it shall retain the values given in b) above.

NOTE: Random access information is not included in the SYSINFO-DA PDU when the PDU is sent on a phase modulation channel. Therefore, if a DA MS on a phase modulation channel receives a SYSINFO-DA PDU on that channel, it does not update its random access parameters. (As described above, if a DA MS (or CA MS) is on a phase modulation assigned channel, and is still using the SYSINFO default definition on that channel, it updates its random access parameters on receipt of a new SYSINFO definition on that channel - except for parameters "Timeslot Pointer", "Frame-length Factor" and "Minimum PDU Priority".)

23.5.1.4.12 Random access operation on ACCH

If the MS-MAC wishes to send a random access message on a channel allocated for a circuit mode call, it shall obey the normal procedures but with the following differences.

If the MS is transmitting traffic in frames 1 to 17 and sends a random access request in frame 18 then, when counting downlink slots for waiting time WT, the MS shall count only those slots that it is required to attempt to receive and decode, according to the assigned monitoring pattern(s), and are available for control (see clause 23.5.1.4.8).

NOTE 1: As in clause 23.5.1.4.8, the MS counts a maximum of one slot per TDMA frame for waiting time WT.

NOTE 2: For a multi-slot channel, if the MS is not frequency full duplex, and if the BS assigns monitoring pattern(s) that the MS is not capable of following, then, when counting for waiting time WT, the MS counts only those downlink TDMA frames containing at least one slot that it is able to attempt to receive and decode and that is available for control.

For a multi-slot channel, if the MS is not frequency full duplex, and if there is currently traffic on the downlink, then the MS is not required to transmit a random access request if it would thereby miss downlink traffic. The MS may regard unsuitable uplink subslots as reserved.

Similarly, for a multi-slot channel, if the MS is not frequency full duplex, and if the MS is currently performing a reconstruction of a downlink TM-SDU, then the MS is not required to transmit a random access request if it would thereby cause the reconstruction to fail. The MS may regard unsuitable uplink subslots as reserved. This applies for any multi-slot assigned channel i.e. assigned either for SCCH or for a circuit mode call.

23.5.1.4.13 Random access operation in minimum mode

During minimum mode, the MS-MAC shall follow the defined minimum mode rules for receiving and decoding the downlink for signalling messages - in slot 1 of frames 1 to 17 and in its designated minimum mode slot in frame 18.

When an MS-MAC enters minimum mode, the most recently received access definitions shall apply. If the MS-MAC then receives ACCESS-DEFINE PDUs in the downlink slots that it is required to receive, it shall obey the ACCESS-DEFINE definition for PDUs containing "Common or assigned control channel flag" = 0 (i.e. common); but shall ignore ACCESS-DEFINE PDUs containing "Common or assigned control channel flag" = 1 (i.e. assigned).

If an MS-MAC in minimum mode wishes to send a random access message, the valid pattern for attempting to receive and decode the AACH for access invitations and for counting subslots in an access frame is:

- in frames 1 to 17: the slot(s) defined by the current setting of "timeslot pointer";
- in frame 18: all four slots.

Only those uplink slots marked in the ACCESS-ASSIGN PDU as available for common access are applicable.

The procedures defined in preceding clauses for choosing a subslot for the first and subsequent random access transmissions shall apply. When counting downlink slots for waiting time WT, the MS shall count only its designated minimum mode frame 18 slot. However, the BS may choose to send the response in slot 1 of the assigned channel during frames 2 to 17, either by stealing or within the assigned channel's FACCH (as described in clause 23.3).

NOTE: The above minimum mode procedure applies only to those MSs that are in common control mode and receiving the MCCH. It does not apply to MSs on an assigned channel.

23.5.1.4.14 Random access operation on time-shared control channel

On a time-shared MCCH, the MS-MAC shall follow the defined rules for receiving and decoding the downlink for signalling messages.

If the MS-MAC wishes to send a random access message, it shall obey the normal procedures but with the following differences:

- The rules for attempting to receive and decode the AACH for access invitations and for counting subslots in an access frame (according to element "Timeslot Pointer") shall apply only to the frames reserved for this BS and the common frames.

- For $1 \leq IMM \leq 14$, IMM shall be replaced by:
 - IMM \times 12 / TS-RES, for TS-RES = 1, 2, 3, 4, 6;
 - IMM \times 36 / TS-RES, for TS-RES = 9, 12, 18;
 where TS-RES is the number of reserved frames per two multiframes for this BS.
- When counting downlink slots for waiting time WT, the MS shall count only slot 1 of the frames reserved for this BS. However, the BS may choose to send the response in slot 1 of one of the common frames.

For a time-shared common SCCH, "slot 1" in the above shall be replaced by the appropriate slot number on the main carrier.

23.5.1.4.15 Random access operation on CSS channel

On a CSS channel, the MS-MAC shall generally apply the random access procedures defined in the earlier clauses within clause 23.5.1.4 as if the CSS channel were an independent single-slot $\pi/4$ -DQPSK assigned channel allocated by a specific MAC-RESOURCE or MAC-END PDU with "Timeslot Assigned" = 1000_2 (see clause 23.5.4.2.1 d)). So, for example:

- a) The ALOHA parameters (e.g. IMM, WT, Nu, frame-length factor) received on the CSS downlink channel apply to the CSS random access channel.
- b) An uplink slot has an appropriate common/assigned designation only if it is designated as "common and assigned" or "assigned only".

However, the following differences shall apply:

- 1) As defined in clause 23.5.4.2.1 d), the MS is only required to receive the CSS channel within the capabilities of that MS.
- 2) If the MS is not frequency full duplex then it is not required to transmit a random access request on the CSS channel if it would thereby miss downlink traffic on an assigned channel or cause a reconstruction on an assigned channel to fail. The MS may regard unsuitable uplink subslots on the CSS channel as reserved.
- 3) After sending a random access request on the CSS channel and not receiving a response within the waiting time WT, the MS may send a retry either on the CSS channel or alternatively on the appropriate assigned channel. Conversely, after sending a random access request on an assigned channel and not receiving a response within the waiting time WT, the MS may send a retry either on the same assigned channel or alternatively on the CSS channel. When the MS wishes to send a retry on a channel, it shall choose a subslot from a new access frame using an appropriate frame marker received on that channel.

When a CA MS obeys a channel allocation with "allocation type" = 11_2 (i.e. Replace + CSS channel) where the specified carrier is the MS's main carrier, the MS may, if capable, use the MCCH or the appropriate common SCCH for that MS in addition to the assigned channel (see clause 23.5.4.2.1 d)). Then the same random access procedures shall apply on the MCCH or common SCCH as defined above for a CSS channel except that the MS shall regard the MCCH or common SCCH as a common control channel and therefore an uplink slot has an appropriate common/assigned designation only if it is designated as "common only" or "common and assigned".

23.5.1.4.16 Random access operation with extended random access channel

When an extended random access channel has been defined by the BS, the MS-MAC shall obey the procedures defined in the earlier clauses within clause 23.5.1.4. So, for example:

- a) The ALOHA parameters (e.g. IMM, WT, Nu, frame-length factor) received on the downlink control channel apply to the extended random access channel defined by element "Timeslot Pointer".
- b) A subslot is a valid access opportunity if the slot corresponds to element "Timeslot Pointer" for this control channel and has an appropriate common/assigned designation (as defined in c)), and the subslot has an appropriate access code and is not reserved nor assigned for linearization.
- c) If the MS is on its common control channel then the slot has an appropriate common/assigned designation only if the uplink slot is designated as "common only" or "common and assigned".

If the MS is on an assigned channel then the slot has an appropriate common/assigned designation only if the uplink slot is designated as "common and assigned" or "assigned only".

NOTE 1: Thus the MS applies the same check on the common/assigned designation to all slots of the random access channel defined by element "Timeslot Pointer", irrespective of whether the same-numbered downlink slot is part of the downlink control channel.

- d) When the MS chooses a subslot from a new access frame, it may use a frame marker from any slot corresponding to element "Timeslot Pointer" for this control channel if the slot has an appropriate common/assigned designation (as defined in c)), and the subslot has an appropriate access code.
- e) When counting access subslots to its chosen slot in an access frame, the MS counts all valid access subslots (as defined in b)) i.e. it counts all subslots corresponding to element "Timeslot Pointer" if they have an appropriate common/assigned designation and access code and are not reserved nor assigned for linearization.

Thus all the access subslots corresponding to element "Timeslot Pointer" are equivalent for the purposes of the random access procedure.

When waiting for a response from the BS, the MS looks for the response in the downlink slots appropriate to the downlink control channel (as indicated by the SYSINFO PDU or by the "Timeslot Assigned" element in the MAC-RESOURCE or MAC-END PDU that sent the MS to the channel).

NOTE 2: As in clause 23.5.1.4.8, the MS counts a maximum of one slot per TDMA frame for waiting time WT. See also clauses 23.5.1.4.12, 23.5.1.4.13 and 23.5.1.4.14.

NOTE 3: In the first sentence of clause 23.5.1.4.3 (i.e. where it is specified that the MS makes only one random access attempt at a time, per control channel), the expression "per control channel" refers to the combination of the downlink control channel and the extended random access channel.

23.5.1.4.17 Random access operation on D8PSK channel

If an MS-MAC on a D8PSK channel wishes to send a random access message, it shall obey the procedures defined in the earlier clauses within clause 23.5.1.4.

The following points may be noted:

- a) The BS sends the ACCESS-ASSIGN PDU using $\pi/4$ -DQPSK modulation, on the AACH.
- b) The MS shall send the random access request using $\pi/4$ -DQPSK modulation, on SCH/HU.
- c) The BS may send the response MAC-RESOURCE PDU using either a $\pi/4$ -DQPSK burst or a $\pi/8$ -D8PSK burst.
- d) If the MS is attempting random access and receives a MAC-RESOURCE (or MAC-END or MAC-D-BLCK) PDU that does not indicate successful random access but grants a reserved subslot or slot(s) for this address (see clause 23.5.1.4.9d), the MS may use either $\pi/4$ -DQPSK or $\pi/8$ -D8PSK burst(s) when it transmits in the reserved capacity.
- e) In the present document, the only usage of D8PSK channels is for assigned SCCH. Therefore the MS obeys the procedures for an MS on an assigned channel as defined in the earlier clauses within clause 23.5.1.4.

23.5.1.4.18 Random access operation on QAM channel

If an MS-MAC on a QAM channel wishes to send a random access message, it shall obey the procedures defined in the earlier clauses within clause 23.5.1.4, with the following differences:

- 1) The BS sends the ACCESS-ASSIGN PDU on AACH-Q. Therefore, where clauses 23.5.1.4.1 and 23.5.1.4.2 refer to the MS attempting to decode the AACH, the MS shall attempt to decode the AACH-Q instead.
- 2) On a QAM channel, the ACCESS-ASSIGN PDU may not be present within the AACH-Q in some downlink slots; see clause 21.4.7.1. Therefore, for the procedure for reception of the ACCESS-ASSIGN PDU (clause 23.5.1.4.2), there is an additional procedure for the MS:
 - If the ACCESS-ASSIGN PDU is not present within the AACH-Q then both the corresponding uplink subslots shall be regarded as reserved.

NOTE 1: Thus the MS regards both the corresponding uplink subslots as reserved whenever it does not receive the ACCESS-ASSIGN PDU in a downlink slot - either because the AACH-Q is not decodeable or because the ACCESS-ASSIGN PDU is not present within the AACH-Q.

- 3) The MS shall send the random access request using the MAC-ACCESS PDU on SCH-Q/RA (instead of SCH/HU).
- 4) For the first try procedure (clause 23.5.1.4.5) and when counting subslots in an access frame (clause 23.5.1.4.7), the MS shall use the defined procedures for choosing a transmission slot and subslot in time (i.e. subslot 1 or subslot 2). The MS shall then decide which 25 kHz random access uplink RF channel subslot SSN-Q to use for the access request as follows:
 - for a 25 kHz channel:
 - if the defined procedures indicate transmission in subslot 1, the MS shall select SSN-Q = 11;
 - if the defined procedures indicate transmission in subslot 2, the MS shall select SSN-Q = 21;
 - for a 50 kHz channel:
 - if the defined procedures indicate transmission in subslot 1, the MS shall choose SSN-Q randomly from the range 11 to 12 using a uniform distribution;
 - if the defined procedures indicate transmission in subslot 2, the MS shall choose SSN-Q randomly from the range 21 to 22 using a uniform distribution;
 - for a 100 kHz channel:
 - if the defined procedures indicate transmission in subslot 1, the MS shall choose SSN-Q randomly from the range 11 to 14 using a uniform distribution;
 - if the defined procedures indicate transmission in subslot 2, the MS shall choose SSN-Q randomly from the range 21 to 24 using a uniform distribution;
 - for a 150 kHz channel:
 - if the defined procedures indicate transmission in subslot 1, the MS shall choose SSN-Q randomly from the range 11 to 16 using a uniform distribution;
 - if the defined procedures indicate transmission in subslot 2, the MS shall choose SSN-Q randomly from the range 21 to 26 using a uniform distribution.

The MS shall transmit its access request in the selected random access uplink RF channel subslot SSN-Q, unless the random access attempt is abandoned. (See also clauses 9.3.2b and 9.3.6a.)

- 5) On a QAM channel, the BS sends the SYSINFO-Q PDU and/or the SYSINFO-DA PDU on BNCH-Q (instead of sending the SYSINFO PDU on BNCH). The SYSINFO-Q and SYSINFO-DA PDUs contain the "default definition for access code A" element (with the same element structure as in the SYSINFO PDU), though the element is always present in the SYSINFO-Q and SYSINFO-DA PDUs instead of being conditional.

When on a QAM channel:

- CA MSs shall use the information in the SYSINFO-Q PDU;
- DA MSs shall use the information in the SYSINFO-DA PDU.

NOTE 2: When a channel is shared by CA and DA MSs, the values of the "default definition for access code A" element in the SYSINFO-Q and SYSINFO-DA PDUs do not need to be the same.

NOTE 3: The BS should not send the SYSINFO-DA PDU on an assigned channel that is shared by MSs from different DA cells.

- 6) Where clause 23.5.1.4.11 refers to the MS updating the random access parameters on receipt of a new SYSINFO definition on that channel (if it is still using the SYSINFO default definition on that channel), a CA MS on a QAM assigned channel shall instead update the random access parameters on receipt of a new SYSINFO-Q definition on that channel (if it is still using the SYSINFO-Q default definition on that channel). However, the CA MS shall update all the random access parameters on receipt of the new SYSINFO-Q definition (if it is still using the SYSINFO-Q default definition on that channel) - including parameters "Timeslot Pointer", "Frame-length Factor" and "Minimum PDU Priority".

NOTE 4: This contrasts with the procedure in clause 23.5.1.4.11, in which an MS on a $\pi/4$ -DQPSK (or D8PSK) assigned channel does not update parameters "Timeslot Pointer", "Frame-length Factor" and "Minimum PDU Priority" on receipt of a new SYSINFO definition on that channel.

- 7) The common control channel for a DA MS is the MCCH-Q or a QAM common SCCH. The downlink slot(s) appropriate to a DA MS's common control channel are known from the SYSINFO-DA PDU.
- 8) A DA MS-MAC shall make the following assumptions about the random access parameters on first acquiring a DA main carrier or receiving a channel allocation for a DA new cell.

The MS-MAC shall assume the parameters for the "default definition for access code A" from the most recently received SYSINFO-DA PDU, and with no MAC subscriber class restriction or address restriction, until it receives an ACCESS-DEFINE PDU for access code A.

The MS-MAC shall not use access code B, C or D until it receives the appropriate ACCESS-DEFINE PDU.

NOTE 5: These parameters apply both to the MCCH-Q and to a QAM common SCCH.

There is no time limit on the validity of use of the SYSINFO-DA parameters, since some BSs may choose never to send the ACCESS-DEFINE PDU, relying solely on the SYSINFO-DA default definition for access code A. Until receipt of a "common" ACCESS-DEFINE PDU for access code A, the MS shall assume the most recently received SYSINFO-DA parameters. After receipt of a "common" ACCESS-DEFINE PDU for access code A, the MS shall ignore any access parameters received in SYSINFO-DA PDUs, reverting to the procedure in clause 23.5.1.4.1.

NOTE 6: The validity of use of the SYSINFO-DA parameters on the MCCH-Q or a QAM common SCCH is not affected by receipt of an ACCESS-DEFINE PDU with "Common or assigned control channel flag" = 1 (i.e. assigned). Receipt of an "assigned" ACCESS-DEFINE PDU for access code A while the MS is on the MCCH-Q or a QAM common SCCH does not affect the validity of the SYSINFO-DA parameters. Receipt of an "assigned" ACCESS-DEFINE PDU for access code A while the MS is on an assigned channel over-rides the SYSINFO-DA definition while the MS is on that assigned channel, but does not affect operation when the MS returns to the MCCH-Q or to a QAM common SCCH.

NOTE 7: If the MS receives a channel allocation for an assigned channel on a DA new cell, it should apply a combination of the procedures for random access operation after acquiring a DA main carrier and then random access operation on a new channel. So, for the purposes of the random access parameters, the MS should treat the channel allocation for the type 1 announced cell reselection (actually received on an assigned channel on the old cell) as if it had been received on the main carrier of the DA new cell.

EXAMPLE: If the MS receives a channel allocation for a $\pi/4$ -DQPSK assigned channel on a DA new cell then, when clause 23.5.1.4.11 b) says that the MS-MAC assumes that "the other parameters are equal to those on the old channel except that ..." the MS-MAC should actually assume that "the other parameters are equal to those on the main carrier of the DA new cell except that ...".

- 9) When a DA MS is sent to a new QAM channel within the cell, it shall make the following assumptions about the random access parameters, until updated by ACCESS-DEFINE PDUs or the SYSINFO-DA definition.
- a) When changing channel to the MCCH-Q or to a QAM common SCCH, a DA MS-MAC shall assume that all random access parameters except the "Timeslot Pointer" are equal to those used when the MS-MAC last received either the MCCH-Q or a QAM common SCCH (parameters as received in SYSINFO-DA and/or ACCESS-DEFINE PDUs). This rule applies both when the BS has changed the number of QAM common SCCHs in use and when the MS-MAC returns from an assigned channel.

The MS-MAC shall assume that the random access channel uses the same timeslot or timeslots as the current downlink assignment.

- b) For an assigned channel:
- For the "Timeslot Pointer", the MS-MAC shall assume the same timeslot number(s) as for the "Timeslot Assigned" from the MAC-RESOURCE or MAC-END PDU.
 - The MS-MAC shall assume that the other parameters are equal to those on the old channel except that, for access code A, the MS-MAC shall assume "Frame-length Factor" = 0, "Minimum PDU Priority" = 000₂ and no subscriber class restriction or address restriction.

The MS-MAC may continue an ongoing random access attempt on the new channel, but shall choose a subslot from a new access frame using an appropriate frame marker received on the new channel.

The random access parameters shall all be updated on receipt of an appropriate ACCESS-DEFINE PDU on that channel. If the DA MS is on the MCCH-Q or a QAM common SCCH, and is still using the SYSINFO-DA default definition, then the MS shall update the parameters on receipt of a new SYSINFO-DA definition on that channel. If the DA MS is on a QAM assigned channel, and is still using the SYSINFO-DA default definition on that channel, then the MS shall update the parameters on receipt of a new SYSINFO-DA definition on that channel (including parameters "Timeslot Pointer", "Frame-length Factor" and "Minimum PDU Priority").

NOTE 8: This contrasts with the procedure in clause 23.5.1.4.11, in which an MS on a $\pi/4$ -DQPSK (or D8PSK) assigned channel does not update parameters "Timeslot Pointer", "Frame-length Factor" and "Minimum PDU Priority" on receipt of a new SYSINFO definition on that channel.

- 10) For DA, when the "Timeslot Pointer" element is set to 0000₂ (i.e. same as downlink slot assignment) on a QAM common control channel, this means:
- slot 1 if the MS is on a one-slot MCCH-Q;
 - slots 1 and 2 if the MS is on a two-slot MCCH-Q;
 - slots 1, 2 and 3 if the MS is on a three-slot MCCH-Q;
 - all four slots if the MS is on a four-slot MCCH-Q;
 - the appropriate slot for this MS when QAM common SCCHs are in use.

NOTE 9: When the "Timeslot Pointer" element is set to 0000₂ on a QAM assigned channel, this has the usual meaning i.e. it means the same timeslot number(s) as for the "Timeslot Assigned" element from the MAC-RESOURCE or MAC-END PDU that sent the MS to the channel.

- 11) For a multi-slot MCCH-Q, if a DA MS is not frequency full duplex, and if the MS is currently performing a reconstruction of a downlink TM-SDU, then the MS is not required to transmit a random access request if it would thereby cause the reconstruction to fail. The MS may regard unsuitable uplink subslots as reserved.

The following points may be noted:

- i) The BS may send the response MAC-RESOURCE PDU using any valid combination of modulation level and coding rate.
- ii) If the MS is attempting random access and receives a MAC-RESOURCE (or MAC-END or MAC-D-BLCK) PDU that does not indicate successful random access but grants a reserved subslot or slot(s) for this address (see clause 23.5.1.4.9d):
 - in the case of a reserved subslot, the MS may use any SCH-Q/HU logical channel appropriate to the bandwidth of the channel when it transmits in a reserved capacity; the MS shall not use SCH-Q/RA in the reserved subslot;
 - in the case of reserved slot(s), the MS may use any SCH-Q/U logical channel appropriate to the bandwidth of the channel when it transmits in the reserved capacity.
- iii) In the present document, the only usage of QAM channels for CA MSs is for assigned SCCH. Therefore a CA MS obeys the procedures for an MS on an assigned channel as defined in the earlier clauses within clause 23.5.1.4, subject to the differences given above.

A DA MS uses QAM channels for assigned SCCH and also for common control. When a DA MS is in assigned mode (having accepted a channel allocation for an assigned channel), it obeys the procedures for an MS on an assigned channel as defined in the earlier clauses within clause 23.5.1.4, subject to the differences given above. When a DA MS is in common mode on its common control channel, it obeys the procedures for an MS on a common control channel as defined in the earlier clauses within clause 23.5.1.4, subject to the differences given above.

23.5.2 Reserved access

23.5.2.0 General

The random access protocol is generally needed when the MS-MAC wishes to initiate a transaction. However, when an MS-MAC is required to send a solicited message or when it has further signalling to send after the initial access, the BS may reserve slots for that particular MS. Also the MS at SMDCP level may negotiate that the BS will grant reserved capacity with a specified repetition period (and specified accuracy), in order to support an application which requires regular transmissions of bursts of data; this is called scheduled access. When the schedule becomes active, the BS may reserve slots for that MS without the MS needing to use random access (see clauses 23.5.2.6 and 28).

The ACCESS-ASSIGN PDU (on the AACH or AACH-Q) indicates which subslots are reserved and therefore not available for random access by other MSs. The MS-MAC for which a subslot or slot(s) are reserved is informed on the downlink signalling channel, using the MAC-RESOURCE or MAC-END or MAC-D-BLCK PDU.

This clause describes the MS procedures for requesting reserved slots, and the procedures for granting and using reserved slots.

23.5.2.1 Reservation requirement

The MAC-ACCESS, MAC-DATA, MAC-U-BLCK, MAC-END-HU and MAC-END PDUs on the uplink all allow the MS-MAC to indicate its reservation requirement on this control channel:

- The "reservation requirement" element is an optional element in the MAC-ACCESS, MAC-DATA, MAC-END-HU and MAC-END PDUs, and shall not be included unless the MS has further signalling ready to send.
- The "reservation requirement" element is always included in the MAC-U-BLCK PDU. A specific value is used in the MAC-U-BLCK PDU when the MS has no further signalling to send.

If the MS has further signalling to send for this address on this control channel, the MS-MAC shall include the "reservation requirement" element whenever it transmits an SCH MAC block (i.e. SCH/HU, SCH-P8/HU, SCH-Q/HU, SCH-Q/RA, SCH/F, SCH-P8/F or SCH-Q/U) containing a MAC-ACCESS, MAC-DATA, MAC-U-BLCK, MAC-END-HU or MAC-END PDU. If PDU association is used within the MAC block then the "reservation requirement" element shall be included in the last (non-null) PDU in the MAC block.

All MAC-U-BLCK PDUs contain the "reservation requirement" element, irrespective of whether the PDU is sent as the last PDU in the MAC block. (The "reservation requirement" element in a MAC-U-BLCK PDU may indicate "no reservation requirement".) On a QAM channel, the MAC-U-BLCK PDU is shorter than the MAC block in many cases i.e. when using modulation levels higher than 4-QAM or for bandwidths of 100 kHz or more; therefore the "reservation requirement" element may be sent more than once in a MAC block. If the "reservation requirement" element is sent more than once in a MAC block, each instance of the element shall contain the same information.

The "reservation requirement" element shall indicate the MS's estimate of the total capacity required for any further signalling messages (basic link or advanced link, fully scheduled or unscheduled) that it currently has ready to send for this individual address on this control channel:

- The method for the MS-MAC to calculate the required capacity for a fragmented message is described in clause 23.4.2.1.2. The required number of slots depends on the modulation, and the bandwidth and coding rate for QAM, to be used for sending the fragmented message.
- The required capacity for other signalling ready to send on a $\pi/4$ -DQPSK channel is known from the "amount of data in LLC buffer" parameter in the DATA-IN-BUFFER signal received from the LLC.

- The required capacity for other signalling ready to send on a D8PSK or QAM channel shall be estimated from the information about the amount of data in the LLC buffer per data category, provided in the DATA-IN-BUFFER signal received from the LLC. The required number of slots to send the data depends on both the amount of data and the modulation level (and coding rate for QAM) with which the MS-MAC currently expects to send the data. If there is data for more than one data category, the expected modulation level (and coding rate for QAM) may be different for the different data categories; in this case, the MS-MAC shall estimate the number of slots required at each modulation level (and coding rate for QAM) and shall indicate the total in the "reservation requirement"; see also clause 23.4.9.

NOTE 1: The reservation requirement indicates the total amount of C-plane signalling that the MS wishes to send for this address, irrespective of whether or not the MS has already been granted some future slots.

NOTE 2: The reservation requirement procedure applies only to signalling messages to be sent with an individual address, i.e. the MS's ISSI/ASSI, USSI, SMI or corresponding event label. The BS grants a subslot or slot(s) for the group address when it invokes a low level group presence indication, so the reservation requirement procedure does not apply to group addresses.

NOTE 3: When the MS indicates its reservation requirement, it indicates only the required capacity for the address with which the reservation requirement is sent. The ISSI and its associated ASSI are regarded as equivalent for the purposes of this procedure. Similarly, an event label and its corresponding address are regarded as equivalent for the purposes of this procedure. However, an MS is not permitted to combine any reservation requirements for its SMI with requirements for an SSI (or vice versa), and it is not permitted to combine the reservation requirements for multiple TSI families.

The MS-MAC may indicate a reservation requirement of one subslot, or one or more full slots (as shown in clause 21). The required number of slots is coded in a non-linear format. If the MS's requirement cannot be represented exactly within the defined format, the MS-MAC shall round down to the next lower valid number of slots, except possibly in the case of a MAC-ACCESS or MAC-DATA PDU containing the start of fragmentation. In the case of the start of fragmentation, the reservation requirement shall cover at least the capacity needed for the remainder of the fragmented message.

NOTE 4: The above exception is needed for fragmented messages because the MAC-FRAG PDU cannot include a "reservation requirement" element. Therefore:

- a) if the MS needs 7 slots to send the rest of the TM-SDU, it asks for 8 slots (or more if it has other signalling to send); or
- b) if it needs 9 slots to send the rest of the TM-SDU, it asks for 10 slots (or more); or
- c) if it needs 11 or 12 slots to send the rest of the TM-SDU, it asks for 13 slots (or more); or
- d) if it needs 14 or 15 slots to send the rest of the TM-SDU, it asks for 17 slots (or more).

In all other cases, the "rounding down" rule applies.

Case a) may apply when using $\pi/4$ -DQPSK or $\pi/8$ -D8PSK modulation, or 4-QAM rate=1/2 on a 25 or 50 kHz channel, or 16-QAM rate=1/2 on a 25 kHz channel; case b) may apply when using $\pi/4$ -DQPSK, or 4-QAM rate=1/2 on a 25 kHz channel; cases c) and d) may apply when using 4-QAM rate=1/2 on a 25 kHz channel; see clause 23.4.2.1.2.

23.5.2.2 Slot granting

23.5.2.2.1 General

The BS may allocate reserved slots to an MS either:

- a) after receiving a request for reserved capacity from the MS; or
- b) when the BS sends the MS a message that requires a response; or
- c) as a result of an active schedule negotiated by the SNDPCP (see clause 23.5.2.6 and clause 28).

The BS shall perform the allocation by including either the "basic slot granting" element or the "multiple slot granting" element in a MAC-RESOURCE or MAC-END PDU sent to the MS, or by including the "basic slot granting" element in a MAC-D-BLCK PDU sent to the MS. The "basic slot granting" and "multiple slot granting" elements are optional elements, included only when required.

In case b), the "basic slot granting" or "multiple slot granting" element will generally be included in the same downlink PDU as the invoking message. For a fragmented downlink TM-SDU, the grant may be included in either the MAC-RESOURCE or the MAC-END PDU.

For the MAC-RESOURCE or MAC-D-BLCK PDU, the slot grant shall refer to the MS addressed in the MAC header. For the MAC-END PDU, the slot grant shall refer to the MS receiving the fragmented message (addressed in the MAC-RESOURCE PDU that contained the first fragment).

There are two forms of the slot granting mechanism: basic slot granting and multiple slot granting:

- Basic slot granting may be used on a $\pi/4$ -DQPSK, D8PSK or QAM channel. It allows the BS to grant a single subslot, or a single slot, or several slots occupying successive slots on this uplink control channel (except that the MS shall jump over those slots in frame 18 that contain predefined common linearization opportunities).
- Multiple slot granting is available only on a QAM channel. It allows the BS to grant disjoint resources with one slot grant by including multiple explicit instances of the "basic slot granting" element and/or by implicit repetition of the "basic slot granting" element.

23.5.2.2.2 Basic slot granting

The "basic slot granting" element shall be sent by the BS, and understood by the receiving MS-MAC, in the format shown in clause 21. It shall consist of two sub-elements:

1) Capacity allocation:

This element shall indicate the amount of reserved capacity that is granted on the uplink channel. It may indicate either a single subslot or one or more full slots. For a subslot grant, the "capacity allocation" element shall indicate whether the MS shall use the first or second subslot.

2) Granting delay:

This element shall indicate the time of the start of the reservation. It shall have one of the following forms:

- Start in the next uplink slot on this channel (granting delay = 0000₂). For both single-slot and multi-slot channels, this shall refer to the same-numbered uplink timeslot as the slot containing the slot grant, in the same TDMA frame.
- Delay for the specified number of delay opportunities on this uplink channel (granting delay = 0001₂ to 1101₂). When counting delay opportunities, the MS shall count successive slots on this uplink channel (including those slots in frame 18 that contain predefined common linearization opportunities). So, for a single-slot channel, the granting delay indicates the delay in TDMA frames; whereas, for a multi-slot channel, there are two or more delay opportunities per TDMA frame (as indicated by the "Timeslot Assigned" element from the MAC-RESOURCE or MAC-END PDU that allocated the channel for a multi-slot assigned channel or as indicated by the SYSINFO-DA PDU for a multi-slot MCCH-Q).
- Start in the first uplink opportunity in the next frame 18 (granting delay = 1110₂). For a slot grant sent in frame 18, this shall refer to the following frame 18 (after this one).
- Wait for another slot grant (granting delay = 1111₂). This form does not actually grant slots at this time, but shall serve to restart the MS's timer T.206, thereby preventing the MS-MAC from reverting to random access.

After any granting delay, a grant for one subslot or slot shall apply to the next slot on this uplink channel. For a subslot grant, the "capacity allocation" element shall indicate whether the MS shall use the first or second subslot.

NOTE: For a grant of a first subslot or a full slot, it is the responsibility of the BS not to send a granting delay which indicates that the granted capacity is in an uplink slot in frame 18 corresponding to one of the predefined common linearization opportunities. This applies also to the first slot of a grant of more than one slot. If an MS receives a slot granting PDU that does not conform to this limitation then it should ignore the slot grant.

However, the BS may grant the second subslot for reserved access in an uplink slot in frame 18 corresponding to one of the predefined common linearization opportunities.

When several slots are granted, these shall occupy successive slots on this uplink channel (after any granting delay) except that the MS shall jump over those slots in frame 18 that contain predefined common linearization opportunities. As defined in clause 9 and clause 23.4.5, predefined common linearization opportunities in frame 18 occur:

- on a $\pi/4$ -DQPSK or D8PSK channel: when $(MN + TN) \bmod 4 = 3$;
- on a QAM assigned channel: when $(MN + TN) \bmod 4 = 3$ and TN is the lowest numbered timeslot of the allocated channel;
- on a one-slot QAM common control channel: when $(MN + TN) \bmod 4 = 3$ and TN is the common control timeslot;
- on a multi-slot MCCH-Q: when $(MN + 1) \bmod 4 = 3$ and $TN = 1$.

If the MS-MAC receives more than one slot grant for an individual address or valid event label, it shall assume that its current allocation is the combination (i.e. union) of slot grants on this control channel.

Capacity that has been granted cannot be withdrawn by the BS. However, if the MS indicates that it has no further signalling to send then, in some cases, the BS may re-use any remaining granted capacity for another MS (see clause 23.5.2.3.1 for details of when the MS does not use the remainder of the allocation).

23.5.2.2.3 Multiple slot granting

Multiple slot granting is available only on a QAM channel. It allows the BS to grant disjoint resources with one slot grant by including multiple explicit instances of the "basic slot granting" element and/or by implicit repetition of the "basic slot granting" element:

- it allows multiple instances of the "basic slot granting" element to be included in one slot grant;
- it also provides an implicit repeat mechanism for each instance of the "basic slot granting" element, to allow a patterned repetition of resources to be granted with one "basic slot granting" element.

The "multiple slot granting" element shall be sent by the BS, and understood by the receiving MS-MAC, in the format shown in clause 21. The "multiple slot granting" element contains a number (1 to 7) of slot granting sets where each set comprises:

- an 8-bit "basic slot granting" element; and
- a 4-bit implicit repeat count (IRC) for this "basic slot granting" element.

The receiving MS-MAC shall regard each slot granting set as if it had received $(IRC + 1)$ instances of the 8-bit "basic slot granting" element.

EXAMPLE: For a multiple slot grant comprising two slot granting sets, where the first slot granting set included an implicit repeat count of 3 and the second slot granting set included an implicit repeat count of 2, the MS regards the multiple slot grant as if it had received 7 basic slot granting elements in the following order:

- first basic slot granting element;
- implicit repetition of first basic slot granting element;
- implicit repetition of first basic slot granting element;
- implicit repetition of first basic slot granting element;

- second basic slot granting element;
- implicit repetition of second basic slot granting element;
- implicit repetition of second basic slot granting element.

The MS-MAC shall process each of the basic slot granting elements (either included explicitly or implied by the implicit repeat count). As in clause 23.5.2.2.2, the basic slot granting element shall consist of two sub-elements:

1) Capacity allocation:

This element shall indicate the amount of reserved capacity that is granted on the uplink channel. It may indicate either a single subslot or one or more full slots. For a subslot grant, the "capacity allocation" element shall indicate whether the MS shall use the first or second subslot.

2) Granting delay:

This element shall indicate the time of the start of the reservation.

Use of granting delay = 1111₂ is not valid in a multiple slot grant.

The granting delay in the first basic slot granting element shall be counted from the downlink slot containing the slot grant, as defined in clause 23.5.2.2.2.

The granting delay in the second and subsequent implicit or explicit basic slot granting elements (including implicit repetitions of the first basic slot granting element) shall be counted from the end of the grant defined by the previous implicit or explicit basic slot granting element. The granting delay shall have one of the following forms:

- a) Start in the next uplink slot on this channel (granting delay = 0000₂). For both single-slot and multi-slot channels, this shall refer to the next uplink timeslot on this uplink channel following the end of the previous slot grant.
- b) Delay for the specified number of delay opportunities on this uplink channel (granting delay = 0001₂ to 1101₂). When counting delay opportunities, the MS shall count successive slots on this uplink channel (including those slots in frame 18 that contain predefined common linearization opportunities).
- c) Start in the first uplink opportunity in the next frame 18 (granting delay = 1110₂). If last slot or subslot of the previous slot grant was in frame 18, this shall refer to the following frame 18 (after this one).

After any granting delay, the start of the grant shall apply to the defined slot on this uplink channel with the following exceptions in cases a), b) and c). For a grant of a first subslot or a full slot, if the granting delay nominally indicates that the granted capacity is in an uplink slot in frame 18 corresponding to one of the predefined common linearization opportunities, the MS shall regard the slot grant as being in the following slot on this uplink channel. Similarly, for a grant of more than one slot, if the granting delay nominally indicates that the granted capacity starts in an uplink slot in frame 18 corresponding to one of the predefined common linearization opportunities, the MS shall regard the slot grant as starting in the following slot on this uplink channel.

NOTE 1: This exception does not apply for a grant of the second subslot in a slot for reserved access.

NOTE 2: This exception applies only for second and subsequent implicit or explicit basic slot granting elements (including implicit repetitions of the first slot granting element). For the granting delay in the first basic slot granting element, if granting a first subslot or a full slot, it is the responsibility of the BS not to send a granting delay which indicates that the granted capacity is in an uplink slot in frame 18 corresponding to one of the predefined common linearization opportunities. This applies also to the first slot of a grant of more than one slot. If an MS receives a slot granting PDU that does not conform to this limitation then it should ignore the entire multiple slot grant.

When several slots are granted, these shall occupy successive slots on this uplink channel (after any granting delay) except that the MS shall jump over those slots in frame 18 that contain predefined common linearization opportunities.

If the MS-MAC receives more than one slot grant for an individual address or valid event label, it shall assume that its current allocation is the combination (i.e. union) of slot grants - either basic slot grants or multiple slot grants - on this control channel.

Capacity that has been granted cannot be withdrawn by the BS. However, if the MS indicates that it has no further signalling to send then, in some cases, the BS may re-use any remaining granted capacity for another MS (see clause 23.5.2.3.1 for details of when the MS does not use the remainder of the allocation).

23.5.2.2.4 Slot granting in normal mode

On the MCCH or on a single-slot MCCH-Q, the uplink for reserved access shall occupy only slot 1 of the main carrier. For a capacity allocation of more than one slot, this refers to the use of successive slot 1's except that the MS shall jump over those slots in frame 18 that contain predefined common linearization opportunities.

EXAMPLE 1: A three-slot granted allocation on the MCCH or on a single-slot MCCH-Q starting in slot 1 of frame 8 occupies also slot 1 of frames 9 and 10; a four-slot granted allocation starting in slot 1 of frame 16 of multiframe 2 occupies also slot 1 of frames 17, 1 and 2.

For a common SCCH (either a $\pi/4$ -DQPSK common SCCH or a QAM common SCCH), the same rule shall apply, except with the appropriate slot number on the main carrier.

For a multi-slot MCCH-Q, the uplink for reserved access shall occupy the number of timeslots per TDMA frame indicated by the SYSINFO-DA PDU except that the MS shall jump over those slots in frame 18 that contain predefined common linearization opportunities.

EXAMPLE 2: An eight-slot granted allocation on a four-slot MCCH-Q starting in slot 2 of frame 17 of multiframe 5 occupies also slots 3 and 4 of frame 17, slots 1, 2, 3 and 4 of frame 18 and slot 1 of frame 1. An eight-slot granted allocation on a four-slot MCCH-Q starting in slot 2 of frame 17 of multiframe 6 occupies also slots 3 and 4 of frame 17, slots 2, 3 and 4 of frame 18 and slots 1 and 2 of frame 1.

For an assigned SCCH or for an ACCH, the uplink for reserved access shall occupy the timeslot(s) per TDMA frame indicated in the "Timeslot Assigned" element from the MAC-RESOURCE or MAC-END PDU that allocated the channel except that the MS shall jump over those slots in frame 18 that contain predefined common linearization opportunities.

EXAMPLE 3: For an assigned SCCH using timeslots 3 and 4:

- a four-slot granted allocation starting in slot 4 of frame 10 occupies also slots 3 and 4 of frame 11 and slot 3 of frame 12;
- on a $\pi/4$ -DQPSK or D8PSK channel, a six-slot granted allocation starting in slot 3 of frame 17 of multiframe 3 occupies also slot 4 of frame 17, slot 3 of frame 18, slots 3 and 4 of frame 1 and slot 3 of frame 2;
- on a QAM channel, a six-slot granted allocation starting in slot 3 of frame 17 of multiframe 3 occupies also slot 4 of frame 17, slots 3 and 4 of frame 18 and slots 3 and 4 of frame 1;
- on a QAM channel, a six-slot granted allocation starting in slot 3 of frame 17 of multiframe 4 occupies also slot 4 of frame 17, slot 4 of frame 18, slots 3 and 4 of frame 1 and slot 3 of frame 2.

The granting delay is given in terms of the number of opportunities for reserved access on this channel except that, when counting slots for the granting delay, the MS shall include those slots in frame 18 that contain predefined common linearization opportunities. So, for a single-slot channel, the granting delay indicates the delay in TDMA frames; whereas, for a multi-slot channel, there are two or more opportunities per TDMA frame.

EXAMPLE 4: On the MCCH or on a single-slot MCCH-Q, for a slot grant sent in frame 15 with a granting delay of 0100_2 (i.e. 4 opportunities delay), the granted capacity starts in slot 1 of frame 1 irrespective of the multiframe number. On an assigned SCCH using timeslots 1 and 2, for a slot grant sent in slot 2 of frame 4 with a granting delay of 0101_2 (i.e. 5 opportunities delay), the granted capacity starts in slot 1 of frame 7.

NOTE 1: The width of the uplink channel for reserved access is the same as the width of the downlink channel. It is defined independently of any extension of the uplink channel for random access.

NOTE 2: The counting of slots for the granting delay is defined in absolute terms given the known number of timeslots per TDMA frame for this channel (and the predefined mapping of common linearization opportunities in frame 18 for a multiple slot grant after the first granting delay). The use of granted slots by the MS is defined in absolute terms given the known number of timeslots per TDMA frame for this channel and the predefined mapping of common linearization opportunities in frame 18. The MS transmits in the granted slots without needing to check the ACCESS-ASSIGN PDU.

For example, on a channel assigned for traffic, the MS should follow the normal methods for counting slots for the granting delay and for using reserved slots. It is the responsibility of the BS to avoid granting slots where another MS may be transmitting traffic. Therefore, when the uplink is in SACCH so that only frame 18 is available for reserved access, the BS should grant only one reserved subslot or slot at a time. (The BS should use either granting delay = 0000_2 or 1110_2 when sending the slot grant in downlink frame 18 since, for example, if it were to use granting delay = 0001_2 , the MS would regard this as an instruction to transmit in frame 1.)

For a basic slot grant or the first basic slot grant in a multiple slot grant, the BS should not grant the first subslot or a first full slot in a frame 18 slot that corresponds to one of the predefined common linearization opportunities. It is also the responsibility of the BS to avoid assigning common linearization subslots in frames 1 to 17 in positions that coincide with granted slots.

Multiple slot granting may be used on a QAM channel (as described in clause 23.5.2.2.3).

EXAMPLE 5: On a QAM assigned channel using timeslots 2, 3 and 4: for a multiple slot grant sent in slot 4 of frame 11 of multiframe 9 and comprising two slot granting sets, where:

- the first slot granting set granted a capacity allocation of two slots with a granting delay of 0001_2 (i.e. 1 opportunity delay) and an implicit repeat count of 3; and
- the second slot granting set granted a capacity allocation of five slots with a granting delay of 0100_2 (i.e. 4 opportunities delay) and an implicit repeat count of 0;

the granted allocation comprises slots 2 and 3 of frames 12, 13, 14 and 15, slots 2, 3 and 4 of frame 17 and slots 3 and 4 of frame 18 of the current multiframe.

EXAMPLE 6: On a 4-slot QAM channel: for a multiple slot grant sent in slot 2 of frame 3 of any multiframe and comprising three slot granting sets, where:

- the first slot granting set granted a capacity allocation of one slot with a granting delay of 0000_2 and an implicit repeat count of 0; and
- the second and third slot granting sets each granted a capacity allocation of one slot with a granting delay of 0011_2 (i.e. 3 opportunities delay) and an implicit repeat count of 10;

the granted allocation comprises slot 2 of frames 3 to 18 of the current multiframe and slot 2 of frames 1 to 7 of the next multiframe.

EXAMPLE 7: On a 4-slot QAM channel: for a multiple slot grant sent in slot 2 of frame 11 of multiframe 6 and comprising one slot granting set granting a capacity allocation of one slot with a granting delay of 0011_2 (i.e. 3 opportunities delay) and an implicit repeat count of 9, the granted allocation comprises slot 1 of frames 12 to 17 of multiframe 6, slot 2 of frame 18 of multiframe 6 and slot 2 of frames 1 to 3 of multiframe 7. (If the BS wishes the MS to revert back to use of slot 1 after the predefined linearization opportunity, it would need to use more slot granting sets.)

23.5.2.2.5 Slot granting in minimum mode

During minimum mode, if the BS sends a slot granting PDU in an MS's designated minimum mode frame 18 slot, and if that slot is slot 2, 3 or 4, then the BS shall grant only one reserved subslot or slot in that PDU. The reserved subslot or slot shall be granted either in the corresponding uplink slot of that frame 18 (Granting delay = 0000_2) or in the corresponding uplink slot of the following frame 18 (Granting delay = 1110_2).

If an MS in minimum mode receives a slot granting PDU in slot 2, 3 or 4 of frame 18 that does not conform to the above limitations, then it shall ignore the slot grant.

NOTE 1: The above limitations apply only to those MSs that are in common control mode, having been receiving the MCCH. They do not apply to MSs on an assigned channel that are using slot 2, 3 or 4 of frame 18 within their ACCH.

NOTE 2: The BS should not grant the first subslot or a full slot in a frame 18 slot that corresponds to one of the predefined common linearization opportunities.

For a slot grant sent in slot 1 of frames 1 to 17, or in slot 1 of frame 18, the BS may make a capacity allocation of more than one slot; this shall then refer to the use of successive uplink slot 1's except that the MS shall jump over those slots in frame 18 that contain predefined common linearization opportunities (i.e. the normal method).

NOTE 3: Multiple slot granting does not apply on a $\pi/4$ -DQPSK channel. Therefore only basic slot granting is appropriate in minimum mode.

23.5.2.2.6 Slot granting on time-shared control channel

On a time-shared MCCH, the BS may send a slot granting PDU either in one of its own reserved frames or in a common frame. It may grant single subslots, or one or more full slots.

The delay opportunities for counting the granting delay comprise the combination of:

- a) slot 1 of the reserved frames for this BS; and
- b) slot 1 of the common frames.

So the MS shall count successive slot 1's, except that it shall jump over frames that are neither reserved for this BS nor common.

The opportunities for reserved access for using a grant of more than one slot comprise the combination of:

- a) slot 1 of the reserved frames for this BS; and
- b) slot 1 of the common frames,

except that the MS shall jump over those slots in frame 18 for which $(MN + TN) \bmod 4 = 3$. So the MS shall use successive slot 1's, except that it shall jump over frames that are neither reserved for this BS nor common and shall jump over those slots in frame 18 for which $(MN + TN) \bmod 4 = 3$.

For a time-shared common SCCH, "slot 1" in the above procedure shall be replaced by the appropriate slot number on the main carrier.

NOTE 1: The network is responsible for co-ordinating the use of the uplink on time-sharing cells, to avoid collisions in granted slots.

NOTE 2: Multiple slot granting does not apply on a $\pi/4$ -DQPSK channel. Therefore only basic slot granting is appropriate on a time-shared control channel.

23.5.2.2.7 BS slot granting operation

The BS may use the facilities for slot granting defined above.

After granting a subslot or slots, the BS should mark the equivalent uplink subslots as "reserved" in the ACCESS-ASSIGN PDU, thereby preventing other MS from sending random accesses. For example, after granting one slot, the BS should mark the two equivalent uplink subslots as "reserved".

If the BS does not receive a message in an individually granted subslot or slot, this may be either because the MS did not receive the downlink message or because the uplink message was corrupted during propagation. The BS may decide to send another slot granting PDU to the MS. In particular, if the BS does not receive a message in the first slot of a grant of several slots, or for a multiple slot grant, it is recommended that the BS sends another slot granting PDU re-granting the remainder of the slots to the same MS (and further slots if appropriate).

For slot granting PDUs, as for all downlink PDUs, the BS should take account of any energy economy or napping or dual watch or part-time reception operation in the MS, sending the PDU in a slot where the MS should be listening.

If the BS wishes to send data to a group, with a low level presence indication from recipient MSs, the BS shall include the group address and a basic slot grant in the MAC PDU that contains the invoking BL-DATA message. The slot grant may be for one subslot, or optionally for one or more full slots, though each MS in the group will use only one subslot; see clause 23.5.2.3.2. The methods whereby the BS detects transmission in the granted subslot (or slots) are left open for choice by system designers, e.g. measurement of received signal strength.

NOTE: Multiple slot granting is not appropriate for the low level presence indication.

The BS may use basic slot granting on a $\pi/4$ -DQPSK, D8PSK or QAM channel. This allows the BS to grant a single subslot, or a single slot, or several slots occupying successive slots on this uplink control channel (except that the MS jumps over those slots in frame 18 that contain predefined common linearization opportunities).

The BS may use multiple slot granting on a QAM channel. As described in clause 23.5.2.2.3, this allows the BS to grant disjoint resources with one slot grant by including multiple explicit instances of the "basic slot granting" element and/or by using an implicit repeat mechanism for each instance of the "basic slot granting" element.

The implicit repeat mechanism allows a patterned repetition of resources to be granted with one "basic slot granting" element. For example, this may be useful for allocating resources to an MS using scheduled access with a fairly short schedule repetition period (i.e. within the range of the "granting delay" element), or for allocating resources to other MSs sharing the channel with an MS that is using scheduled access.

Use of multiple explicit instances of the "basic slot granting" element may be useful for providing disjoint slot grants that are not based on a patterned repetition of resources.

Use of multiple explicit instances of the "basic slot granting" element in combination with the implicit repeat mechanism may be useful in some cases, for example: at the beginning of a patterned repetition of resources in order to be able to specify a different granting delay for the first capacity allocation, or to extend the effective length of the patterned repetition. It may also be useful if the BS wishes to regain the exact synchronization of a patterned repetition of resources after a predefined common linearization opportunity.

If the MS is not frequency full duplex and does not have fast switching capability, and is operating on a multi-slot channel, it cannot receive the downlink of that multi-slot channel during the elapse time corresponding to one capacity allocation. Similarly, if the MS is not frequency full duplex but does have fast switching capability, and is operating on a four-slot channel or a two-slot channel with alternating timeslots (i.e. slots 1 and 3 or slots 2 and 4), it cannot receive the downlink of the channel during the elapse time corresponding to one capacity allocation. (For multiple slot granting, the MS can receive the downlink of the channel between each instance of capacity allocation for appropriate values of the granting delay.) If the MS cannot receive the downlink of the channel during the elapse time corresponding to a capacity allocation, it cannot receive L2-LINK-FEEDBACK-INFO messages or acknowledgement bit maps from the BS, or make measurements of the downlink channel, during the elapse time corresponding to that capacity allocation; this may affect the MS's link adaptation procedures on a D8PSK or QAM channel (see clause 23.4.9.2). When appropriate, the BS may choose to limit the size of each instance of the capacity allocation on a multi-slot D8PSK or QAM channel. This may apply particularly when the BS perceives that the quality of the link is currently variable such that the MS may wish to adapt its bit rate more frequently than the maximum length of capacity allocation.

23.5.2.3 Use of reserved slots

23.5.2.3.1 Individual address or event label

If an MS receives a MAC-RESOURCE PDU or MAC-END PDU containing a "basic slot granting" or "multiple slot granting" element for one of its individual addresses (i.e. its ISSI, ASSI, USSI or SMI) or for a valid individual event label for this control channel, the MS-MAC shall perform the following actions relating to the "basic slot granting" or "multiple slot granting" element; if an MS receives a MAC-D-BLCK PDU containing a "basic slot granting" element for one of its individual addresses or for a valid individual event label for this control channel, the MS-MAC shall perform the following actions relating to the "basic slot granting" element. Other actions may be performed relating to other elements in the MAC header.

For a basic slot grant, the MS-MAC shall inspect the "capacity allocation" and "granting delay" elements and shall record which subslot or slot(s) are allocated to it, as described in clause 23.5.2.2. For a multiple slot grant, the MS-MAC shall inspect the "number of slot granting sets" element, the "capacity allocation" and "granting delay" elements in each "basic slot granting" element and the "implicit repeat count" element(s) and shall record which subslots and/or slots are allocated to it, as described in clause 23.5.2.2.

If the MS has signalling messages to send for this address on this control channel, as known from the DATA-IN-BUFFER signal, then the following procedure applies for each allocated subslot or slot:

- For an allocated subslot, the MS-MAC shall use the appropriate logical channel (SCH/HU on a $\pi/4$ -DQPSK channel, SCH/HU or SCH-P8/HU on a D8PSK channel, SCH-Q/HU on a QAM channel); it shall send the final fragment of a fragmented TM-SDU, or otherwise a message from the LLC (or messages by association), except in the following case. If the MS has signalling to send but cannot use a subslot, e.g. if it has only full-slot advanced link messages to send, then the MS-MAC shall send a MAC-ACCESS PDU containing the "reservation requirement" element and no TM-SDU.
- For an allocated slot, the MS-MAC shall use the appropriate logical channel (SCH/F on a $\pi/4$ -DQPSK channel, SCH/F or SCH-P8/F on a D8PSK channel, SCH-Q/U on a QAM channel); it shall send the next fragment of a fragmented TM-SDU, or otherwise a message from the LLC (or messages by association).

After transmitting a complete TM-SDU, or a final fragment, the MS-MAC shall report to the LLC that the message has been sent by reserved access (using the TMA-REPORT indication primitive).

If the MS has no signalling message to send for this address on this control channel then:

- if the MS is on a $\pi/4$ -DQPSK or D8PSK channel, the MS-MAC should send the Null PDU in the allocated subslot or slot;
- if the MS is on a QAM channel, the MS-MAC shall send either:
 - a) the Null PDU in the allocated subslot or slot; or
 - b) a dummy MAC-ACCESS or MAC-DATA PDU in the allocated subslot or slot i.e. a PDU containing no TM-SDU; the dummy PDU shall be followed by a Null PDU sent by association (except in the case of logical channel SCH-Q/HU25-4H).

On a $\pi/4$ -DQPSK or D8PSK channel, after sending:

- the Null PDU in an SCH/HU, SCH-P8/HU, SCH/F or SCH-P8/F MAC block; or
- any SCH/HU or SCH-P8/HU MAC block that does not include a "reservation requirement" element; or
- any SCH/F or SCH-P8/F MAC block that contains:
 - a MAC-DATA or MAC-END PDU, and does not include a "reservation requirement" element; or
 - a MAC-U-BLCK PDU indicating no reservation requirement,

the MS shall not use any other capacity that has already been granted for this address on this control channel (whether in one slot granting PDU, or more than one). If the MS receives a further slot granting PDU, and if it still has no signalling messages to send for this address, then it shall send the Null PDU in the first allocated slot or in the allocated subslot, and shall not use the remainder of the allocation.

On a QAM channel, after sending the Null PDU as the only PDU in an SCH-Q/HU or SCH-Q/F MAC block, the MS shall not use any other capacity that has already been granted for this address on this control channel (whether in one slot granting PDU, or more than one, and by either basic slot granting or multiple slot granting). If the MS receives a further slot granting PDU, and if it still has no signalling messages to send for this address, then it may send the Null PDU as the only PDU in the first allocated slot or subslot; if it transmits the Null PDU as the only PDU in the MAC block then it shall not use the remainder of the allocation.

NOTE 1: Therefore, in case a) above, the MS is not permitted to use any other capacity that has already been granted for this address on this control channel. In case b), the MS may use any other capacity that has already been granted for this address on this control channel.

NOTE 2: The ISSI and its associated ASSI are equivalent for the purposes of use of reserved slots (so the MS may use any subslot or slot(s) granted on its ISSI for messages sent with its ASSI, or vice versa). Similarly, an event label and its corresponding address are equivalent for the purposes of use of reserved slots.

Also, a newly assigned ASSI is equivalent to the replaced ASSI or USSI for the purposes of use of reserved slots. Thus, if an MS receives a slot grant on its ASSI then it may use the subslot or slot(s) for messages sent using a new ASSI which replaces that ASSI; and, if a migrating MS receives a slot grant on its USSI while that USSI is still valid then it may use the subslot or slot(s) for messages sent with its ASSI.

However, an MS is not permitted to use a subslot or slot(s) granted on an SSI for messages to be sent with its SMI, or vice versa; also, it is not permitted to use a subslot or slot(s) granted on one SSI for an SSI from another TSI family. These restrictions may possibly be relaxed in future editions of the present document in the case of the final slot of an MS's requested reserved capacity.

NOTE 3: As defined above, a migrating MS that receives a slot grant on its USSI while that USSI is still valid may use the subslot or slot(s) for messages sent with its ASSI. However, there is possible contention on capacity granted on the USSI if multiple migrating MSs with the same USSI are trying to register at the same time. Therefore, when assigning the ASSI, the BS may prefer not to allocate more than one reserved slot on the USSI. This is because any continuation or final fragments of an uplink message sent with the ASSI do not contain addressing information.

23.5.2.3.2 Group address

If an MS receives a MAC-RESOURCE PDU or MAC-END PDU or MAC-D-BLCK PDU containing a "basic slot granting" element for one of its valid group addresses, the MS-MAC shall perform the following actions relating to the "basic slot granting" element. Other actions may be performed relating to other elements in the MAC header.

The MS-MAC shall inspect the "capacity allocation" and "granting delay" elements and shall note which subslot or slot(s) are allocated, as described in clause 23.5.2.2. If the MS has a signalling message with this group address to send on this control channel then it shall transmit the message in an uplink subslot using the MAC-ACCESS PDU:

- a) for a subslot grant, it shall use the allocated subslot;
- b) for a grant of one or more slots (G slots), it shall choose one subslot randomly from the grant, i.e. random choice between 1 and $2 \times G$ using a uniform distribution.

Otherwise, the MS shall not transmit.

NOTE: This procedure is used only for the low level group presence indication (see clauses 22.2.1.3 and 22.3.1.2).

23.5.2.4 Reverting to random access

23.5.2.4.1 Reverting to random access for unscheduled signalling messages

If the following criteria are all satisfied then the MS-MAC may initiate the random access procedure (see clause 23.5.1):

- a) the MS-MAC has sent a PDU (MAC-ACCESS, MAC-DATA, MAC-U-BLCK, MAC-END-HU or MAC-END) indicating a reservation requirement for this address on this control channel; and
- b) the MS-MAC does not currently have any capacity granted for this address on this control channel; and
- c) a time T.206 has elapsed since:
 - the MS-MAC last sent a PDU on this control channel for this address (i.e. either a MAC-ACCESS, MAC-DATA or MAC-U-BLCK PDU with this address or a MAC-FRAG, MAC-END or MAC-END-HU PDU relating to this address); or
 - the MS-MAC last received a basic slot granting element for this address on this control channel containing the instruction to "Wait for another Slot Grant";

whichever is the later; and

- d) the MS still has unscheduled signalling messages to send for this address on this control channel (as indicated by the DATA-IN-BUFFER signal).

The random access request shall be sent on SCH/HU (for a $\pi/4$ -DQPSK or D8PSK channel) or on SCH-Q/RA (for a QAM channel) using the MAC-ACCESS PDU, containing a TM-SDU if appropriate. If the MS has any further signalling ready to send for this address on this control channel, the MS-MAC shall include a request for reserved capacity ("reservation requirement" element) in the MAC-ACCESS PDU.

NOTE 1: T.206 is greater than, or equal to, the fragmentation time-out constant T.202. Then, at the time of reverting to random access, the MS-MAC will not be in the process of an uplink fragmentation.

NOTE 2: Time T.206 is counted in downlink signalling opportunities (as defined in annex B). So, for example, in minimum mode the absolute time is 18 times its normal value.

23.5.2.4.2 Reverting to random access for fully scheduled signalling messages

When the MS has fully scheduled signalling messages to send, as indicated by the DATA-IN-BUFFER signal from the LLC, the MS-MAC may initiate the random access procedure if it:

- a) does not currently have any capacity granted for this address on this control channel; and
- b) a time T has elapsed since the MS-MAC last sent a PDU on this control channel for this address (i.e. either a MAC-ACCESS, MAC-DATA or MAC-U-BLCK PDU with this address or a MAC-FRAG, MAC-END or MAC-END-HU PDU relating to this address), where T is defined by:

$$T = \text{Max} (\text{LMSI}, T.227)$$

where:

- LMSI is the lowest value of the maximum schedule interval for the fully scheduled data to be sent for this address on this channel (as indicated by the DATA-IN-BUFFER signal from the LLC); and
- T.227 is the value of the minimum scheduled access waiting time-out (see annex B).

The random access request shall be sent on SCH/HU (for a $\pi/4$ -DQPSK or D8PSK channel) or on SCH-Q/RA (for a QAM channel) using the MAC-ACCESS PDU, containing a TM-SDU if appropriate. If the MS has any further signalling ready to send for this address on this control channel, the MS-MAC shall include a request for reserved capacity ("reservation requirement" element) in the MAC-ACCESS PDU.

NOTE 1: If the MS has both fully scheduled and unscheduled signalling messages to send, it may initiate the random access procedure if the criteria in either this clause or clause 23.5.2.4.1 are satisfied.

NOTE 2: If the MS was in the process of sending a fragmented message at the time when it decides to initiate the random access procedure, it should discard the partially sent TM-SDU. (Alternatively the MS may choose not to initiate the random access procedure in this case.)

23.5.2.5 Example of reservation process

This clause gives an example of the reservation process on a $\pi/4$ -DQPSK channel.

The MS-MAC has received a TMA-UNITDATA request primitive from the LLC, containing a long TM-SDU (length 512 bits). It uses a MAC-ACCESS PDU for the random access, including the first 56 bits of the TM-SDU and indicating a "reservation requirement" of two slots. The BS sends a MAC-RESOURCE PDU to acknowledge the random access request. The MAC-RESOURCE PDU also includes a "basic slot granting" element, granting the two required slots. The MS-MAC then sends the remainder of the TM-SDU in one MAC-FRAG PDU (264 bits of TM-SDU) and the MAC-END PDU (final 192 bits). The MS has no further signalling to send for this address, so the MAC-END PDU does not contain the "reservation requirement" element, and the MAC block is completed with the Null PDU and fill bits.

23.5.2.6 Scheduled access

23.5.2.6.1 General

The scheduled access mechanism is provided to support applications which require regular transmissions of bursts of data, such as some types of real-time class and telemetry class data.

The MS at SNDCP level negotiates that the BS will grant a number of reserved slots with the specified schedule repetition period (with the specified accuracy). The number of slots is the BS's estimate of the number of slots needed to send the specified quantity of data.

NOTE: On a D8PSK or QAM channel, the BS's estimate will not always be correct because of the MS's link adaptation procedures. It is the MS's responsibility to request any additional slots needed.

The scheduled access mechanism avoids the need for the MS to make frequent random access attempts in order to request reserved slot(s) for each TL-SDU.

The MAC is responsible for the schedule timing. On request from the SNDCP (via the MLE-CONFIGURE, TL-CONFIGURE and TMC-CONFIGURE request primitives), the MAC in the MS provides a schedule timing service to the higher layers, issuing schedule timing prompts (using the TMC-REPORT indication primitive) at intervals equal to the schedule repetition period. The synchronization of these prompts is initially based on the timing of the TMC-CONFIGURE request primitive. However, the BS may send the L2-SCHEDULE-SYNC message to define the schedule synchronization, in which case the MS-MAC bases the timing of further prompts on that synchronization.

23.5.2.6.2 MS operation for sending scheduled messages

When the SNDCP in the MS issues packet data to the lower layers, the "scheduled data status" parameter in the request primitive indicates whether the data should be treated as "not scheduled data", "initial scheduled data" or "scheduled data". When the SNDCP starts sending data using a context for which a schedule has been arranged, and after a substantial gap in the arrival of scheduled data from the service user, the SNDCP instructs the lower layers to treat the first TL-SDU as "initial scheduled data" (see clause 28); further TL-SDUs are then labelled as "scheduled data".

In the DATA-IN-BUFFER signal, the LLC in the MS indicates whether the data in its sending buffer is "fully scheduled" or "unscheduled" or a mixture (see clause 22.3.1.9). For this purpose:

- initial scheduled data is treated as "unscheduled" so that, for example, the MS-MAC may immediately use random access in order to send the data (if it does not have reserved capacity granted for this address on this control channel and has not already indicated a signalling requirement for this address on this control channel);
- scheduled data is treated as "fully scheduled" (except for segment retransmissions), so that the MS-MAC generally waits for a slot grant instead of attempting random access;
- all other types of data and signalling are treated as "unscheduled".

The LLC also indicates the lowest value of the "maximum schedule interval" for all fully scheduled data in the buffer.

NOTE 1: The maximum schedule interval is the sum of the agreed schedule repetition period plus the schedule timing error. It therefore indicates the longest expected time between the granted slots for a particular schedule.

The MS-MAC procedures for fully scheduled messages are similar to the procedures for unscheduled messages except that, if the DATA-IN-BUFFER signal indicates that all the data in the buffer is fully scheduled, the MS-MAC does not attempt random access unless it considers that the schedule agreement has not been honoured (see clauses 23.5.1.4.3 and 23.5.2.4.2).

Otherwise the procedures are similar to the procedures for unscheduled messages; therefore, for example:

- When the MS-MAC transmits a MAC block containing a MAC-ACCESS, MAC-DATA, MAC-U-BLCK, MAC-END-HU or MAC-END PDU, the "reservation requirement" shall include the MS's estimate of the total capacity required for any further signalling messages that it has ready to send for this individual address on this control channel, including fully scheduled messages; see clause 23.5.2.1.

The "reservation requirement" therefore includes the capacity required for the remainder of the agreed quantity of data - including any additional slots needed because the MS may use a lower bit rate on a D8PSK or QAM channel than the BS's estimate assumed. It also covers additional slots needed, for example, if some scheduled SDUs are larger than the size agreed in the schedule, or if the MS has failed to receive slot grant(s) so that it has a backlog of scheduled messages to send, or if the MS also has unscheduled messages ready to send.

- When the MS has been granted a slot or subslot for one of its individual addresses, the MS may use the slot or subslot for any signalling messages (basic link or advanced link, fully scheduled or unscheduled) to be sent for this address on this control channel; see clause 23.5.2.3.1.

When the MS is on a QAM channel, and may have a schedule or schedules in operation (e.g. if the MS has sent scheduled data recently), it should not send the Null PDU as the only PDU in an SCH-Q/HU or SCH-Q/F MAC block if it has already been granted further capacity for this address on this control channel (whether in one slot granting PDU, or more than one, and by either basic slot granting or multiple slot granting).

NOTE 2: This is because the further capacity may be intended for the schedule(s), for data not yet issued by the SNDPCP. If the MS sends the Null PDU as the only PDU in the SCH-Q/HU or SCH-Q/F MAC block, it is not permitted to use that further capacity; see clause 23.5.2.3.1.

23.5.2.6.3 Schedule timing in MS

The higher layers may issue a TMC-CONFIGURE request primitive containing the "schedule repetition information" parameter. The "schedule repetition information" parameter contains the following subparameters:

- NSAPI;
- start-stop flag (start or stop);
- schedule repetition period (as a number of timeslot durations).

If the MS-MAC receives a TMC-CONFIGURE request primitive containing the "schedule repetition information" parameter with the "start-stop" flag indicating "start" then it shall start to issue schedule timing prompts at intervals corresponding to the specified schedule repetition period. According to the protocol model, the schedule timing prompt is performed by issuing the TMC-REPORT indication primitive with the "Report" parameter set to "schedule timing prompt". The TMC-REPORT indication primitive shall indicate the NSAPI to which the schedule timing prompt applies.

The MS-MAC shall continue issuing schedule timing prompts for that NSAPI at intervals corresponding to the specified schedule repetition period until:

- it receives a TMC-CONFIGURE request primitive containing schedule repetition information for that NSAPI, with the "start-stop" flag indicating "start" and containing a different value of the schedule repetition period; or
- it receives a TMC-CONFIGURE request primitive containing schedule repetition information for that NSAPI, with the "start-stop" flag indicating "stop".

In the first case, the MS-MAC shall stop issuing schedule timing prompts at intervals corresponding to the old schedule repetition period and shall start issuing schedule timing prompts for that NSAPI at intervals corresponding to the new schedule repetition period. In the second case, the MS-MAC shall stop issuing schedule timing prompts for that NSAPI.

The BS may send the L2-SCHEDULE-SYNC message to define the schedule synchronization. The L2-SCHEDULE-SYNC message contains the NSAPI to which the message applies and a "schedule synchronization point" expressed as a timeslot number, frame number and multiframe number. The MS-MAC shall regard the specified schedule synchronization point as being the uplink slot corresponding to the next occurring instance of that timeslot number, frame number and multiframe number.

If the MS-MAC receives an L2-SCHEDULE-SYNC message while it is issuing schedule timing prompts for that NSAPI then:

- a) if appropriate, the MS-MAC shall continue to issue schedule timing prompts for that NSAPI using its current schedule synchronization until just before the schedule synchronization point specified in the L2-SCHEDULE-SYNC message;

- b) the MS-MAC shall then set its "schedule timing point" for that NSAPI to the schedule synchronization point specified in the L2-SCHEDULE-SYNC message;
- c) the MS-MAC shall then issue a schedule timing prompt for that NSAPI using a timing such that the following criteria 1 and 2 are both satisfied:
 - 1) scheduled data appropriate to this schedule timing prompt shall not be included in the "reservation requirement" or any "data priority blocks" in slots more than one slot before the uplink slot corresponding to the schedule timing point, if the MS transmits in those slots (see note 2); and
 - 2) the MS shall be capable of sending scheduled data appropriate to this schedule timing prompt in the uplink slot corresponding to the schedule timing point, if granted capacity is available at that time for that address on that control channel;
- d) the MS-MAC shall then increment the schedule timing point by the schedule repetition period for that NSAPI.

The MS-MAC shall then continue to perform actions c) and d) (i.e. issuing a schedule timing prompt for that NSAPI, using a timing such that criteria 1 and 2 are both satisfied for the schedule timing point, and then incrementing the schedule timing point by the current schedule repetition period for that NSAPI), until:

- it receives a TMC-CONFIGURE request primitive from the higher layers instructing it to stop issuing schedule timing prompts for that NSAPI; or
- it receives another L2-SCHEDULE-SYNC message for that NSAPI, in which case it shall obey the procedure above for the new schedule synchronization.

NOTE 1: The implementation methods in the MS for achieving the requirements in criteria 1 and 2 are outside the scope of the present document. For example, in an implementation, the MS could choose to hold the scheduled data appropriate to the schedule timing point in a separate buffer in the LLC until just before the schedule timing point instead of holding the scheduled data in the SNDPCP.

NOTE 2: In criterion 1, it is preferable that the MS does not include the scheduled data appropriate to this schedule timing prompt in the "reservation requirement" or "data priority blocks" in any slots before the uplink slot corresponding to the schedule timing point. However, for flexibility of implementation on a multi-slot channel, the MS is not precluded from including the scheduled data in the "reservation requirement" or any "data priority blocks" in the slot immediately preceding the uplink slot corresponding to the schedule timing point (if that slot is appropriate to this uplink control channel and the MS transmits in that slot).

NOTE 3: After receiving an L2-SCHEDULE-SYNC message then, as specified above, the MS-MAC should base the timing of further prompts on that synchronization until it receives a TMC-CONFIGURE request primitive instructing it to stop issuing prompts or it receives another L2-SCHEDULE-SYNC message for that NSAPI. This continues to apply if the MS changes channel and even if it changes cell.

NOTE 4: The procedures in this clause apply to a single address. If the MS has schedules on more than one address then the procedures in this clause apply independently for each address and the L2-SCHEDULE-SYNC message applies only to the schedule for the address on which the message was received.

23.5.2.6.4 BS operation for granting slots for schedule

The BS should start granting scheduled capacity to the MS when its SNDPCP entity receives an SN-DATA or SN-UNITDATA PDU with NSAPI corresponding to an agreed schedule. The BS should then proceed to send slot grants appropriate to the schedule.

The BS designer should choose criteria for when the BS stops sending slot grants appropriate to the schedule, for example, if the PDP context containing the schedule is deactivated, or if the SwMI suspends or cancels the schedule, or if the MS indicates that it is pausing use of the schedule or context, or if the BS repeatedly perceives that the slot grants are not used. In the last two cases, the BS should re-start the slot grants if its SNDPCP entity receives an SN-DATA or SN-UNITDATA PDU with NSAPI corresponding to an agreed schedule.

When the schedule is negotiated at the SNDCP level, the agreement is that the BS will grant a number of slots with the specified schedule repetition period (and with the specified accuracy). The number of slots is the BS's estimate of the number of slots needed to send the specified quantity of data. On a D8PSK or QAM channel, the BS does not know which bit rate the MS will use to send the data. Therefore the BS should estimate the bit rate that the MS will use and then estimate the number of slots for that bit rate. (When the MS uses the slot(s), it will include any reservation requirement for the remainder of the scheduled data and for any other data.)

The "granting delay" element allows a basic slot grant to be delayed by up to 13 delay opportunities:

- On a $\pi/4$ -DQPSK or D8PSK channel, the BS should not attempt to use the granting delay facility to grant multiple disjoint resources in advance to an MS with a schedule whose period corresponds to less than 13 delay opportunities. This is because, when the MS sends any SCH/HU or SCH-P8/HU MAC block that does not include a "reservation requirement" element or any SCH/F or SCH-P8/F MAC block that contains a MAC-DATA or MAC-END PDU and does not include a "reservation requirement" element or a MAC-U-BLCK PDU indicating no reservation requirement, the MS is not permitted to use any other capacity that has already been granted for this address on this control channel. If the MS used one of the disjoint resources for a scheduled message, it would usually have no further reservation requirement at that time and therefore would not be able to use the other disjoint resources.
- The BS may use multiple slot granting on a QAM channel. As described in clause 23.5.2.2.3, this allows the BS to grant disjoint resources with one slot grant by including multiple explicit instances of the "basic slot granting" element and/or by using an implicit repeat mechanism for each instance of the "basic slot granting" element. Multiple slot granting may be useful for allocating resources to an MS using scheduled access with a fairly short schedule repetition period (i.e. within the range of the "granting delay" element), or for allocating resources to other MSs sharing the channel with an MS that is using scheduled access; see clause 23.5.2.2.7.

23.5.2.6.5 Schedule synchronization by BS

The BS may send the L2-SCHEDULE-SYNC message to an MS in order to synchronize the times at which the SNDCP in the MS issues the scheduled data to the lower layers with the earliest times that the BS intends for the scheduled reserved slots.

NOTE 1: If the BS does not use the L2-SCHEDULE-SYNC message then, for some schedule repetition periods, if the MS also has other data to send while the schedule is running, there are cases when the MS may send its scheduled data with the other data before the reserved slots intended for the scheduled data. If this occurs, the MS may then have no data to send in the reserved slots intended for the scheduled data.

NOTE 2: If the BS uses the L2-SCHEDULE-SYNC message, the BS designer should note that, for flexibility of MS implementation on a multi-slot channel, the MS may include the scheduled data in the "reservation requirement" (and any "data priority blocks") if it transmits in the slot immediately preceding the uplink slot corresponding to the schedule timing point; see clause 23.5.2.6.3.

The BS may send a slot grant with the L2-SCHEDULE-SYNC message, in order to obtain an implicit acknowledgement that the message was received by the MS.

The BS includes a timeslot number, frame number and multiframe number in the L2-SCHEDULE-SYNC message, defining a schedule synchronization point for that NSAPI in the addressed MS. This refers to the next occurring instance of the uplink slot corresponding to that timeslot number, frame number and multiframe number. The BS should send the L2-SCHEDULE-SYNC message at least two TDMA frames before the time corresponding to the intended schedule synchronization point in order to allow for processing delays in the MS (thereby avoiding a possible difference of perception about which hyperframe is intended).

The BS may update the schedule synchronization information for an NSAPI at any time by sending a further L2-SCHEDULE-SYNC message for that NSAPI to the same MS address.

It should be noted that the MS may discard the information received in an L2-SCHEDULE-SYNC message when:

- the PDP context containing the schedule is deactivated; or
- the SwMI suspends or cancels the schedule; or
- the SNDCP in the MS goes into the STANDBY state (see clause 28).

Therefore, in these cases, the BS should send a new L2-SCHEDULE-SYNC message if use of the schedule re-starts and the BS wishes to synchronize the schedule.

23.5.3 Cancel request

The LLC may use the TMA-CANCEL request primitive to stop the MAC activities relating to a particular TMA-UNITDATA request primitive. The "handle to the request" references the service request that is to be aborted.

On reception of a TMA-CANCEL request primitive from the LLC, the MS-MAC shall cease all activities related to the service request as identified by its handle. The MS-MAC shall report to the LLC that MAC transmission activities have been aborted, indicating whether:

- a) the TM-SDU has not been completely sent; or
- b) the complete TM-SDU has been sent at least once,

using the TMA-REPORT indication primitive.

NOTE 1: This procedure can be used by the LLC to abort transmission of a message until:

- the complete TM-SDU, or final fragment of a fragmented TM-SDU, has been sent by reserved access or by stealing; or
- the complete TM-SDU has been sent and acknowledged by random access.

After a first transmission of a random access message, the TMA-CANCEL request primitive stops the MS-MAC from sending further random access retries. However, it should be noted that the BS may have received the message.

NOTE 2: The primitive TMA-CANCEL request is used for modelling purposes only.

23.5.4 Channel allocation

23.5.4.1 Transmission of channel allocation

The BS may send a channel allocation command either:

- a) to instruct an addressed MS (or MSs) to move from the current channel to another channel; or
- b) to allocate an additional channel for the addressed MS (or MSs). If the MS does not support concurrent MAC services (i.e. if it is not capable of operating on multiple channels) then it may either remain on the current channel and reject the new service or move from the current channel to the new channel and accept the new service.

The BS shall perform the allocation by including the "channel allocation" element in a MAC-RESOURCE or MAC-END PDU. The "channel allocation" element is an optional element, included only when required.

The channel allocation is generally sent in a MAC-RESOURCE PDU. However, if the BS wishes to send channel allocation information with a fragmented message then that information shall be included within the MAC-END PDU and shall not be included within the MAC-RESOURCE PDU.

For the MAC-RESOURCE PDU, the channel allocation shall refer to the MS or MSs addressed in the MAC header. For the MAC-END PDU, the channel allocation shall refer to the MS or MSs receiving the fragmented message (addressed in the MAC-RESOURCE PDU that contained the first fragment).

The channel allocation command may be used to allocate a different channel (timeslot or timeslots) on the current RF carrier or to change both the carrier and timeslot(s) (see clause 21).

When the BS directs the MS to an assigned channel, it shall set element "timeslot assigned" to indicate the appropriate timeslot(s), as a bit map.

If the BS wishes a CA MS to return to the appropriate common control channel (i.e. the MCCH or a $\pi/4$ -DQPSK common SCCH), it shall set "timeslot assigned" = 0000₂ and indicate the CA main carrier number.

If the BS wishes a DA MS to return to the appropriate common control channel (i.e. the MCCH-Q or a QAM common SCCH), it shall set "timeslot assigned" = 0000₂. The BS may use an augmented QAM channel allocation, in which case it shall indicate the DA main carrier number. Alternatively, if the BS uses a non-augmented channel allocation, any addressed DA MSs ignore the carrier number and go to the DA main carrier indicated by the last received SYSINFO-DA or SYNC-DA PDU.

The channel allocation command is used to allocate a $\pi/4$ -DQPSK channel. Alternatively, the channel allocation command may indicate that the allocated channel is a D8PSK channel or a QAM channel. In the case of a QAM channel, the BS indicates whether the bandwidth of the allocated channel is 25 kHz, 50 kHz, 100 kHz or 150 kHz.

The channel allocation command may be used to allocate a channel on the current cell. It may also be used to allocate a channel on another cell e.g. in case of announced cell reselection type 1. The "cell change flag" shall indicate whether the channel allocation is for another cell. For a channel allocation directing an MS to another cell, the bit map in element "timeslot assigned" shall refer to the timeslot numbering on the new cell.

NOTE 1: The channel allocation method is used for directing addressed MSs to a specified channel. In addition, the broadcast message SYSINFO PDU or SYSINFO-DA PDU may cause an MS to move from one common control channel to another, e.g. when the number of common SCCHs is changed (see clause 23.3). For such a move, the same endpoint identifier applies, and the same service to the LLC is maintained for basic link and for any advanced link(s).

NOTE 2: When the BS assigns a channel for a circuit mode call, the resource allocation should correspond to that required for the network layer basic service information for the call (see clause 14). For example, the assigned channel should be a $\pi/4$ -DQPSK channel, and the number of slots per TDMA frame allocated by element "timeslot assigned" should match the basic service information.

When the BS assigns a channel for packet data, it should allocate a channel within the MS's declared capabilities, with a modulation mode and number of slots per TDMA frame and RF bandwidth appropriate to the MS's PDP context(s) that are in active use.

NOTE 3: It is optional for a CA MS to be capable of using a multi-slot channel, or of supporting concurrent channels on one carrier, or of supporting concurrent multi-carrier operation, or of supporting D8PSK channels, or of supporting QAM channels, or of supporting bandwidths greater than 25 kHz. It is optional for a DA MS to be capable of supporting concurrent channels on one carrier, or of supporting concurrent multi-carrier operation, or of supporting more than one QAM bandwidth, or of supporting $\pi/4$ -DQPSK channels, or of supporting D8PSK channels. The BS should use the information on MS capabilities provided in the "class of MS" and "extended capabilities" elements (see clause 16) when allocating resources; also, when the BS assigns a $\pi/4$ -DQPSK or D8PSK channel for packet data, it should use the capability information provided in the "resource request" element (if the MS included the "resource request" element in the SMDCP signalling; see clause 28).

NOTE 4: In many cases, the MS may choose whether to move to an allocated channel (see clause 23.5.4.2). This applies for both individually addressed and group addressed channel allocations. BS designers should take account of this in their BS algorithms.

23.5.4.2 Reception of channel allocation

23.5.4.2.1 Channel allocation types

The "channel allocation" element includes a two-bit element "allocation type", which is intended to aid interpretation of the allocation. The precise procedures are defined in clauses 23.5.4.2.2, 23.5.4.2.3 and 23.5.4.2.4.

The values for the "allocation type" are as follows:

- a) 00₂: Replace current channel with specified channel.

This indicates that the allocated channel is intended to replace the current channel (i.e. the channel on which the command was received). This replacement applies only to the channel on which the command was received, not to any other concurrent channels that the MS may be using on that carrier. If the current channel is a multi-slot channel, the replacement applies to all the timeslots comprising that channel.

The "Replace" mechanism may be used to move the MS to a different resource allocation. Otherwise it may be used if the BS wishes to increase or decrease the number of slots allocated to a particular assigned channel; the BS sends a "Replace" channel allocation on the assigned channel indicating the revised slot allocation.

- b) 01₂: Additional channel allocation.

This indicates the allocation of an additional independent channel for an independent service e.g. a concurrent service. It cannot be used for changing the configuration of the current channel (see above).

- c) 10₂: Quit current channel and go to specified channel.

This allows the BS to replace the current channel but without maintaining full service. This means that the physical layer service is no longer available for the higher layers to use, though the higher layer service is not necessarily disconnected. Any current traffic transmit/receive authorization does not apply on the new channel (see clause 23.8.2).

- d) 11₂: Replace current channel with specified channel, plus MCCH/SCCH or additional $\pi/4$ -DQPSK carrier specific signalling channel (CSS channel) in timeslot 1.

This indicates that the specified channel is intended to replace the current channel (i.e. the channel on which the command was received). If the specified carrier is the CA main carrier, it indicates that a CA MS may, if capable, use also the MCCH or the appropriate common SCCH for that MS. If the specified carrier is not the MS's main carrier, it indicates that the MS (either CA MS or DA MS) may, if capable, use timeslot 1 as an additional channel - referred to as a CSS channel - to increase signalling capacity between the MS and BS. If the MS is not capable of receiving both the specified channel and the MCCH/SCCH or CSS channel then the specified channel shall take precedence.

If the specified carrier is the CA main carrier and a CA MS chooses to use the MCCH or the appropriate common SCCH then it shall regard that channel as a common control channel (in the usual way), within the capabilities of that MS.

If the specified carrier is not the MS's main carrier and the MS (either CA MS or DA MS) chooses to use the CSS channel then it shall regard that CSS channel as an independent single-slot $\pi/4$ -DQPSK channel. For the purposes of the general procedures for transmission and reception of signalling messages, the MS shall apply those procedures as if the CSS channel were a $\pi/4$ -DQPSK assigned channel, allocated by a specific MAC-RESOURCE or MAC-END PDU with "timeslot assigned" = 1000₂, i.e. allocation of timeslot 1.

However, the MS is only required to receive the CSS channel within the capabilities of that MS. Also, reduced channel maintenance procedures shall apply on the CSS channel, and the CSS channel becomes invalid when the MS has no other assigned channel on that carrier (see clause 23.5.6.2).

EXAMPLE: The BS might decide to allocate a CSS channel to provide information to MSs on that carrier about new calls, e.g. late entry signalling, without disturbing the operation of the assigned SCCHs and traffic channels on the other timeslots. The CSS channel could also be used for other signalling purposes such as status messages or packet data.

NOTE 1: The BS may allocate the CSS channel to all MSs using that carrier, by setting the "allocation type" to 11₂ in all the channel allocations. Slot 1 could also be an assigned channel for some MSs e.g. for advanced links with low data transfer throughput. The channel is then shared between the MSs.

An MS in a circuit mode call may, for example, send the U-TX DEMAND PDU on the CSS channel, e.g. with a high priority request. However, if FACCH is available on the assigned channel, then the MS should use this in preference to the CSS channel.

NOTE 2: The MS only receives the common channel (i.e. MCCH or common SCCH) or CSS channel within the capabilities of that MS. For example, a frequency half duplex MS in a simplex circuit mode call is permitted to receive the common or CSS channel while it is receiving traffic on the assigned channel even if it is not capable of receiving the common or CSS channel while it is transmitting traffic.

NOTE 3: In the present document, use of "allocation type" 11₂ is not appropriate when the BS is allocating a QAM channel.

Use of "allocation type" 11₂ is valid when the BS is allocating a $\pi/4$ -DQPSK or D8PSK channel; in both cases, the CSS channel is a $\pi/4$ -DQPSK channel.

NOTE 4: In the present document, if an MS receives "allocation type" 11₂ when the BS is allocating a QAM channel, the MS should regard the allocation as "allocation type" 00₂ (replace current channel with specified channel).

NOTE 5: "Allocation type" 11₂ is valid for both CA MSs and DA MSs when the BS is allocating a $\pi/4$ -DQPSK or D8PSK channel.

- For a CA MS, "allocation type" 11₂ indicates that the CA MS may use also the MCCH (or the appropriate common SCCH for that MS) or the CSS channel in timeslot 1 - depending on whether the specified carrier is the CA MS's main carrier (as described above).
- A DA MS may receive "allocation type" 11₂ when the BS is allocating a $\pi/4$ -DQPSK or D8PSK channel. The specified carrier is a phase modulation carrier, which is therefore not the DA MS's main carrier. Therefore, as described above, the DA MS may then, if capable, use timeslot 1 as a CSS channel, applying the general procedures for transmission and reception of signalling messages (within the capabilities of the MS) as if the CSS channel were an independent single-slot $\pi/4$ -DQPSK assigned channel. This applies even if that carrier is being used as the main carrier for a CA cell.

As usual for a CSS channel, reduced channel maintenance procedures apply on the CSS channel (see clause 23.5.6.2). For example, the MS does not check validity of the AACH for channel maintenance purposes. Therefore the MS does not leave the CSS channel as a result of receiving AACH indicating common control usage. However the CSS channel becomes invalid for the MS when the MS has no other assigned channel on that carrier (see clause 23.5.6.2).

MSs on a CSS channel check the common/assigned designation of uplink slots when performing random access (see clause 23.5.1.4.15). Therefore, if DA MS(s) are using slot 1 of a CA main carrier as a CSS channel, the BS should designate some random access opportunities as "common and assigned" or "assigned only".

In many cases, the MS may choose whether to obey a channel allocation e.g. if the channel allocation is received on its common control channel, or for an additional channel allocation. The MS-MAC refers to the higher layers for a decision. For a group addressed channel allocation, the higher layers may either make an immediate decision on whether to accept the channel allocation or may delay the decision. However, for an individually addressed channel allocation, the MS needs to make an immediate decision on whether to accept a particular channel allocation.

NOTE 6: For a group call, especially on a (quasi-)transmission trunked system, the MS may sometimes receive a channel allocation on the group address and sometimes on its individual address.

When the higher layers respond with their decision on whether to accept a channel allocation, they may indicate "accept" or "reject" or, in some cases, they may indicate "ignore". The MAC actions for "reject" and "ignore" are the same except when a "replace" or "replace + CSS channel" or "quit" channel allocation is received on an assigned channel or when a "quit" channel allocation is received on a CSS channel (see clauses 23.5.4.2.3 and 23.5.4.2.4).

The "reject" instruction is used when the higher layers may choose not to accept the channel allocation. The "ignore" instruction applies only in specific protocol cases when the higher layers are required by the protocol to ignore specific PDUs and to instruct the MAC to ignore any channel allocation received with those PDUs e.g. when the MS is transmitting traffic and the CMCE receives a group addressed D-TX GRANTED or D-TX INTERRUPT PDU, or in some instances of receipt of a group addressed D-SETUP PDU when the MS is trying to make a call to that group (see clause 14.5.2), or if the SNDCP receives a group addressed SN-END OF DATA PDU while the READY timer is active (see clause 28.2.4.7).

The following procedures for reception of a channel allocation indicate the physical layer service provided by the channel to the higher layers.

The MS-MAC generally uses the TMC-CONFIGURE indication primitive to inform the higher layers when it has lost physical resources. There are also some error conditions (as defined in clause 23.5.4.2.3 procedure a1, or if the MS leaves the channel as a result of channel maintenance procedures) for which the MS-MAC may either issue a TMC-CONFIGURE indication primitive indicating loss of the physical resource or alternatively may issue the TMA-RELEASE indication primitive to indicate loss of the connection.

NOTE 7: When the LLC receives a TMC-CONFIGURE indication primitive indicating loss of the physical resource, it may retain any advanced links on that resource for potential continuation (see clause 22.3.5). When the LLC receives the TMA-RELEASE indication primitive, it locally disconnects any advanced links on that resource (see clause 22.3.3.4).

23.5.4.2.2 Reception of channel allocation on MS's common control channel

A CA MS's common control channel is the MCCH or a $\pi/4$ -DQPSK common SCCH. A DA MS's common control channel is the MCCH-Q or a QAM common SCCH. This clause applies to MSs that are in common mode on their common control channel. In some cases other MSs may be in assigned mode on that channel, in which case those other MSs obey the procedures in clause 23.5.4.2.3 (or clause 23.5.4.2.4).

If the MS receives a channel allocation on its common control channel for one of its valid addresses or for a corresponding event label, then the "allocation type" may be 00_2 (Replace current channel) or 01_2 (Additional channel) or 11_2 (Replace current channel, and add CSS channel).

If a TM-SDU was included within the PDU that allocated the channel then the MS-MAC shall set the "channel change response required" parameter to "true" in the TMA-UNITDATA indication primitive, to indicate that a response is required to instruct the MS-MAC whether it should obey the allocation; the MS-MAC may also include information about the channel allocation, using the "channel information" parameter. The MS-MAC shall generate a local identifier for the channel allocation, referred to as the "channel change handle", and shall include it in the TMA-UNITDATA indication primitive, enabling unique identification of the related response from the higher layers. If a TM-SDU was not included within the PDU that allocated the channel then the MS-MAC shall issue a TMA-UNITDATA indication primitive containing the "channel change response required" parameter set to "true" (and a channel change handle and, optionally, the channel information parameter) and with no TM-SDU.

NOTE 1: It is optional for the MS to obey a channel allocation received on its common control channel. According to the protocol model, the MS-MAC refers to the higher layers so that, for example, for a circuit mode group call, the MS-MAC does not move to the channel if the CMCE does not accept the associated message. However, in an implementation, the MS is permitted to obey all individually addressed channel allocations in which case the primitive exchange is unnecessary in practice.

When the BS sends a channel allocation on a common control channel, it is recommended that the BS includes a higher layer message indicating the intended usage of the channel allocation. Even if only an LLC acknowledgement is included with the channel allocation, this may enable the MS to deduce the intended usage (e.g. in the case of medium channel assignment to a called MS).

If "allocation type" = 01_2 and the MS is capable of operating with concurrent channels and the MS is not already receiving the indicated channel then the MS-MAC shall allocate an endpoint identifier for the new channel. The MS-MAC shall include both the endpoint identifier of the current channel (i.e. the channel on which the channel allocation PDU was received) and the endpoint identifier of the newly allocated channel (parameter "new endpoint identifier") in the TMA-UNITDATA indication primitive.

NOTE 2: A new endpoint identifier will usually be required. However, for example, in the case of independent allocation of uplink and downlink for concurrent calls involving the same MS, that MS may receive independent channel allocations with the same carrier number and same element "timeslot assigned" but with a different up/downlink assigned designation.

NOTE 3: The new endpoint identifier enables the higher layers to make the intended usage of the new channel if the MS-MAC obeys the channel allocation. For example, for an AL-SETUP PDU for a new advanced link, sent with the additional channel allocation, the new advanced link is intended to be on the allocated channel.

If "allocation type" = 11_2 and the MS is capable of using the common or CSS channel then the MS-MAC shall allocate an endpoint identifier for the common or CSS channel. The MS-MAC shall include both the endpoint identifier of the current channel and the endpoint identifier of the common or CSS channel (parameter "CSS endpoint identifier") in the TMA-UNITDATA indication primitive.

NOTE 4: The CSS endpoint identifier enables the higher layers to make correct usage of the common or CSS channel if the MS-MAC obeys the channel allocation.

The MS-MAC should then receive a response (TMC-CONFIGURE request primitive) from the higher layers indicating whether it should obey the allocation. For an individually addressed channel allocation, the MS-MAC should expect that the response from the higher layers will be immediate. However, for a group addressed channel allocation, the response from the higher layers may be immediate or may be delayed, in which case the MS-MAC continues to obey the normal MAC procedures on the common control channel in the interim time.

NOTE 5: For the purposes of the protocol description, it is assumed that, in the case of an immediate decision by the higher layers, the process of the MAC issuing the TMA-UNITDATA indication primitive and then receiving the corresponding TMC-CONFIGURE request primitive is effectively instantaneous.

If the higher layers return a TMC-CONFIGURE request primitive containing the "channel change accepted" parameter set to "reject" or "ignore" then the MS-MAC shall ignore the channel allocation corresponding to the channel change handle. The MS may use any subslot or slot(s) that are granted on the current channel but shall ignore a slot grant if element "position of grant" in the channel allocation PDU indicated the allocated channel.

If the higher layers return a TMC-CONFIGURE request primitive containing the "channel change accepted" parameter set to "accept" then the MS-MAC shall obey the channel allocation command corresponding to the channel change handle, using the appropriate procedure a) or b):

- a) If "allocation type" = 00₂ (Replace) or 11₂ (Replace + CSS channel) in the "channel allocation" element then the MS shall move from the current channel (i.e. the channel on which the channel allocation PDU was received) to the specified channel. It shall assume that the allocated channel will provide the same service to the LLC as the current channel, corresponding to the same endpoint identifier (see note 6).

If the MS was receiving other channels on the main carrier, and it is not capable of receiving those other channels as well as the newly allocated channel, then the MS-MAC shall issue a TMC-CONFIGURE indication primitive to the higher layers for any channels that it can no longer receive in order to indicate that the physical resource on those channels is lost. Otherwise, if the MS is capable of continuing to receive its other channels, then those other channels are not affected.

If "allocation type" = 00₂ then the MS shall not continue to use the common control channel.

If "allocation type" = 11₂ and the assigned carrier is the CA main carrier then a CA MS may, if capable, use also the MCCH or the appropriate common SCCH for that MS. If the assigned carrier is not the MS's main carrier then the MS (either CA MS or DA MS) may, if capable, use slot 1 of the assigned carrier as a CSS channel. If the MS is not capable of receiving both the assigned channel and the common or CSS channel then the MS shall ignore the common/CSS part of the allocation.

NOTE 6: For a "replace" or "replace + CSS channel" command within the cell, the service provided to the LLC is maintained both for the basic link and for any advanced link(s) on the current channel. This applies even if the number of allocated timeslots or modulation mode or bandwidth changes. (Though, for $\pi/4$ -DQPSK operation, in the case of a change of the number of allocated timeslots, the MS is not precluded from performing an LLC reset if the AL-SETUP PDU contained radio resource information; also, in the case of a change of modulation mode or bandwidth, the MS is not precluded from performing an LLC reset in order to avoid use of fragmentation for re-transmissions of segments cut for transmission on the old channel.) In the case of a cell reselection, the MLE decides whether to release current advanced links or attempt reconnection. If the MLE does not attempt reconnection then any current advanced links are released when the MS obeys a channel allocation indicating a cell change.

NOTE 7: A "replace" or "replace + CSS channel" command applies only to the channel on which the message was received, and so cannot be used to simultaneously replace other concurrent channels on that carrier when allocating a channel on another carrier. However, if the channel allocation PDU includes a slot grant on the current channel with "granting delay" > 0000₂ then the MS does not change channel immediately (see clause 23.5.4.3.1). During the interim time, the MS should continue to receive its other concurrent channels, since the BS may also send a "replace" or "replace + CSS channel" command on one of those channels, enabling both services to be maintained on the new carrier. Then, in the timing procedure for the carrier change, the MS may use the later (or latest) of the specified times.

- b) If "allocation type" = 01₂ (Add) in the "channel allocation" element then the MS shall obey the command to receive the allocated channel.

If the MS is not capable of receiving all concurrent channels as well as the newly allocated channel, then the MS-MAC shall issue a TMC-CONFIGURE indication primitive to the higher layers for those channels that it can no longer receive in order to indicate that the physical resource on those channels is lost. Otherwise the MS shall continue to receive all concurrent channels, including the channel on which the channel allocation PDU was received, as well as the newly allocated channel.

After a channel change, the MS-MAC shall inform the higher layers about the channel now in use using the TMC-SELECT indication primitive.

NOTE 8: For DA, the BS may allocate the MCCH-Q physical channel(s) as a QAM assigned channel for some MSs that are camped on the cell. Then the MSs in common mode and the MSs in assigned mode share the channel. Similarly, the BS may allocate a physical channel used as a QAM common SCCH also as a QAM assigned channel for some MSs, with the channel shared between the MSs in common mode and the MSs in assigned mode. As indicated above, it is optional for an MS to obey a channel allocation received on the common control channel; this applies for both individually addressed and group addressed channel allocations. However, MSs in assigned mode may use some slightly different procedures from MSs in common mode. (For example, napping may apply when the MS is in assigned mode, whereas energy economy or part-time reception mode may apply when the MS is in common mode; and the MS may use a different value of the event label inactivity time-out.) BS designers should take account of this in their BS algorithms.

23.5.4.2.3 Reception of channel allocation on assigned channel

This clause applies to MSs that are in assigned mode, having accepted a channel allocation for an assigned channel. In some cases other MSs may be in common mode on that channel, in which case those other MSs obey the procedures in clause 23.5.4.2.2.

If the MS receives a channel allocation on an assigned channel for one of its valid addresses or for a corresponding event label, then the "allocation type" may take any of the following four values:

- 00₂ (Replace current channel), in which case the MS shall assume that the allocated channel will provide the current service.
- 01₂ (Additional channel), in which case the MS shall assume that the channel is intended for the purpose indicated in the higher layer message.
- 10₂ (Quit current channel), in which case the MS should assume that the current service on that channel is not fully maintained. This means that the physical layer service is no longer available for the higher layers to use, though the higher layer service is not necessarily disconnected. Any current traffic transmit/receive authorization does not apply on the new channel.
- 11₂ (Replace current channel, and add CSS channel), in which case the MS shall assume that the allocated channel will provide the current service, and that timeslot 1 (or the MCCH or common SCCH) may be used for additional signalling.

NOTE 1: For a "replace" or "replace + CSS channel" command received while the MS is in a circuit mode call, current traffic transmit and/or receive authorization may apply on the allocated channel; refer to clause 23.8.2.

The MS-MAC shall follow the appropriate procedure a), b) or c):

- a) For allocation type 00₂ (Replace) or 11₂ (Replace + CSS channel), the appropriate procedure shall apply as follows:
- 1) If a TM-SDU was not included within the PDU that allocated the channel, and:
 - the MS does not have a concurrent assigned channel; or
 - the MS would still be able to receive any concurrent assigned channels after moving to the allocated channel,

then the MS-MAC shall decide whether to obey the channel allocation as follows:

- If the MS is capable of using the allocated channel then the MS-MAC shall obey the channel allocation. The MS shall cease to receive the current channel (unless it has a concurrent independent allocation on that channel, see note 7) and shall move to the allocated channel.
- Otherwise, if the MS is not capable of using the allocated channel (e.g. the replacement channel has a larger number of slots than the current channel and the MS cannot support the channel, or the MS cannot support the indicated modulation mode or bandwidth) then the MS-MAC shall reject the channel allocation. The MS-MAC shall cease to receive the current channel and shall issue either a TMA-RELEASE indication primitive to indicate loss of the connection or a TMC-CONFIGURE indication primitive indicating loss of the physical resource (unless it has a concurrent independent allocation on that channel, see note 7). The MS may use any subslot or slot(s) that are granted on the current channel but shall ignore a slot grant if element "position of grant" in the channel allocation PDU indicated the allocated channel. If the MS does not have a concurrent assigned channel, it shall return to its common control channel.

NOTE 2: For allocation type 11₂: when the above procedure refers to the MS not being capable of using the allocated channel, this refers only to the allocated channel as indicated by element "timeslot assigned", not to the CSS channel.

- 2) If a TM-SDU was included within the PDU that allocated the channel, or the MS has a concurrent assigned channel that it would be unable to receive as a result of moving to the allocated channel, then the MS-MAC shall set the "channel change response required" parameter in the TMA-UNITDATA indication primitive to "true" (and shall include a channel change handle and may include the channel information parameter). The MS-MAC shall then wait for a response from the higher layers:
 - If the higher layers return a TMC-CONFIGURE request primitive containing the "channel change accepted" parameter set to "accept" then the MS-MAC shall obey the channel allocation corresponding to the channel change handle. The MS shall cease to receive the current channel (unless it has a concurrent independent allocation on that channel, see note 7) and shall move to the allocated channel.
 - If the higher layers return a TMC-CONFIGURE request primitive containing the "channel change accepted" parameter set to "reject" then the MS shall cease to receive the current channel (unless it has a concurrent independent allocation on that channel, see note 7). The MS may use any subslot or slot(s) that are granted on the current channel but shall ignore a slot grant if element "position of grant" in the channel allocation PDU indicated the allocated channel. If the MS does not have a concurrent assigned channel, it shall return to its common control channel.
 - If the higher layers return a TMC-CONFIGURE request primitive containing the "channel change accepted" parameter set to "ignore" then the MS-MAC shall ignore the channel allocation corresponding to the channel change handle and continue to use the current channel. The MS may use any subslot or slot(s) that are granted on the current channel but shall ignore a slot grant if element "position of grant" in the channel allocation PDU indicated the allocated channel.
 - If the higher layers do not return a TMC-CONFIGURE request primitive containing the "channel change accepted" parameter within a time T.216 following receipt of the channel allocation then the MS shall cease to receive the current channel (unless it has a concurrent independent allocation on that channel, see note 7). If the MS does not have a concurrent assigned channel, it shall return to its common control channel. If the higher layers later return a TMC-CONFIGURE request primitive containing the "channel change accepted" parameter set to "accept" then the MS should move to the allocated channel.

NOTE 3: Thus, when the higher layers wish the MS-MAC to ignore a replacement channel allocation on an assigned channel, they return the "channel change accepted" parameter set to "ignore" within a time T.216 in order for the MS-MAC to act on it.

NOTE 4: In the case of a channel allocation with a slot grant on the current channel, when the above procedures 1) and 2) refer to the MS ceasing to receive the current channel, the MS should not leave the channel until after the end of the last uplink slot granted by that PDU (or the end of the slot containing a granted subslot). Similarly, if the current channel is a multi-slot channel, and the next immediate uplink slot following the channel allocation is part of the current channel, and the MS is transmitting traffic in that slot or was previously granted that slot (or a subslot in that slot) for reserved access, the MS should not leave until after the end of that next immediate uplink slot.

NOTE 5: A "replace" or "replace + CSS channel" command applies only to the channel on which the message was received, and so cannot be used to simultaneously replace other concurrent channels on that carrier when allocating a channel on another carrier. However, if the channel allocation PDU includes a slot grant on the current channel with "granting delay" > 0000₂ then the MS does not change channel immediately (see clause 23.5.4.3.1). During the interim time, the MS should continue to receive its other concurrent channels, since the BS may also send a "replace" or "replace + CSS channel" command on one of those channels, enabling both services to be maintained on the new carrier. Then, in the timing procedure for the carrier change, the MS may use the later (or latest) of the specified times.

- b) For allocation type 01₂ (Add), the MS-MAC shall set the "channel change response required" parameter in the TMA-UNITDATA indication primitive to "true" to indicate that a response is required to instruct the MAC whether it should accept the allocation (and shall include a channel change handle and may include the channel information parameter). If the decision is delayed for a group addressed channel allocation then the MS-MAC may continue to use the current channel in the interim time.

If the higher layers return a TMC-CONFIGURE request primitive containing the "channel change accepted" parameter set to "accept" then the MS-MAC shall obey the channel allocation command corresponding to the channel change handle. It may also continue to use the current channel if it is capable of doing so.

If the higher layers return a TMC-CONFIGURE request primitive containing the "channel change accepted" parameter set to "reject" or "ignore" then the MS-MAC shall ignore the channel allocation corresponding to the channel change handle and continue to use the current channel. The MS may use any subslot or slot(s) that are granted on the current channel but shall ignore a slot grant if element "position of grant" in the channel allocation PDU indicated the allocated channel.

- c) For allocation type 10₂ (Quit), the MS-MAC shall obey the procedure defined in procedure a) above for allocation type 00₂ (Replace) except that, if the MS ceases to receive the current channel, the MS-MAC shall issue a TMC-CONFIGURE indication primitive for the current channel in order to indicate that the physical resource has been lost.

If the MS is already receiving the allocated channel then any services on that channel are not affected and the endpoint identifier is unchanged.

After obeying a channel allocation command then, if the MS is not capable of receiving all concurrent channels as well as the newly allocated channel, the MS-MAC shall issue a TMC-CONFIGURE indication primitive to the higher layers for those channels that it can no longer receive in order to indicate that the physical resource on those channels is lost.

After a channel change, the MS-MAC shall inform the higher layers about the channel now in use using the TMC-SELECT indication primitive.

NOTE 6: For allocation type 01₂ (Add) or 11₂ (Replace + CSS channel), the MS-MAC may need to allocate additional endpoint identifiers, in a similar manner to that described in clause 23.5.4.2.2.

NOTE 7: As indicated in clause 23.3.4, it is possible that an MS may receive concurrent independent channel allocations for the uplink and downlink of the same channel. If the BS has sent channel allocations that have assigned the uplink and downlink independently to the same MS (e.g. both on the MS's individual address, or one on the MS's individual address and the other on one of the MS's valid group addresses) then the BS should include a higher layer message when it sends a "replace" or "replace + CSS channel" command on that channel, thus enabling the MS to deduce which channel allocation is being replaced. This applies also for a "quit" command.

NOTE 8: When the BS sends an additional channel allocation (allocation type 01₂) on an assigned channel, it should include a higher layer message indicating the intended usage of the channel allocation; even if only an LLC acknowledgement is included with the channel allocation, this may enable the MS to deduce the intended usage.

23.5.4.2.4 Reception of channel allocation on CSS channel

This clause applies to MSs that are using a CSS channel, having accepted the CSS part of a channel allocation with allocation type 11₂ (Replace + CSS channel) where the allocated carrier is not the MS's main carrier.

If the MS receives a channel allocation on a CSS channel for one of its valid addresses or for a corresponding event label, then the "allocation type" may take any of the four values:

- a) For allocation type 00₂ (Replace) or 11₂ (Replace + CSS channel), the MS-MAC shall set the "channel change response required" parameter in the TMA-UNITDATA indication primitive to "true" (and shall include a channel change handle and may include the channel information parameter). If the decision is delayed for a group addressed channel allocation then the MS-MAC may continue to use the CSS channel in the interim time.

If the higher layers return a TMC-CONFIGURE request primitive containing the "channel change accepted" parameter set to "reject" or "ignore" then the MS-MAC shall ignore the channel allocation and may continue to use the CSS channel. The MS may use any subslot or slot(s) that are granted on the CSS channel but shall ignore a slot grant if element "position of grant" in the channel allocation PDU indicated the allocated channel.

If the higher layers return a TMC-CONFIGURE request primitive containing the "channel change accepted" parameter set to "accept" then the MS-MAC shall obey the channel allocation command. If "allocation type" = 11₂ in a channel allocation indicating the current carrier then the MS may continue to use the CSS channel. However, if either:

- 1) "allocation type" = 00₂; or
- 2) "allocation type" = 11₂ in a channel allocation directing the MS to another carrier;

then the MS shall not continue to use the CSS channel on the current carrier though, in case 2), it may use the common or CSS channel on the new carrier.

- b) For allocation type 01₂ (Add), the MS-MAC shall set the "channel change response required" parameter in the TMA-UNITDATA indication primitive to "true" (and shall include a channel change handle and may include the channel information parameter). If the decision is delayed for a group addressed channel allocation then the MS-MAC may continue to use the CSS channel in the interim time.

If the higher layers return a TMC-CONFIGURE request primitive containing the "channel change accepted" parameter set to "reject" or "ignore" then the MS-MAC shall ignore the channel allocation and may continue to use the CSS channel. The MS may use any subslot or slot(s) that are granted on the CSS channel but shall ignore a slot grant if element "position of grant" in the channel allocation PDU indicated the allocated channel.

If the higher layers return a TMC-CONFIGURE request primitive containing the "channel change accepted" parameter set to "accept" then the MS-MAC shall obey the channel allocation command. It may also continue to use the CSS channel if it is capable of doing so.

- c) For allocation type 10₂ (Quit), the appropriate procedure shall apply as follows:
 - 1) If a TM-SDU was not included within the PDU that allocated the channel and the MS would still be able to receive its current assigned channel(s) after moving to the allocated channel and the MS is capable of using the allocated channel then the MS-MAC shall obey the channel allocation. It shall cease to receive the CSS channel using the timing for an immediate decision and shall move to the allocated channel.
 - 2) If a TM-SDU was not included within the PDU that allocated the channel, and either the MS would be unable to receive its current assigned channel(s) after moving to the allocated channel (e.g. if the channel allocation is directing the MS to the common control channel and the MS is not capable of concurrent multi-carrier operation) or the MS is not capable of using the allocated channel, then the MS-MAC shall cease to receive the CSS channel using the timing for an immediate decision but shall not move to the allocated channel.

- 3) If a TM-SDU was included within the PDU that allocated the channel then the MS-MAC shall set the "channel change response required" parameter in the TMA-UNITDATA indication primitive to "true" (and shall include a channel change handle and may include the channel information parameter). The MS-MAC shall then wait for a response from the higher layers:
- If the higher layers return a TMC-CONFIGURE request primitive containing the "channel change accepted" parameter set to "accept" then the MS-MAC shall obey the channel allocation. The MS shall cease to receive the CSS channel and shall move to the allocated channel.
 - If the higher layers return a TMC-CONFIGURE request primitive containing the "channel change accepted" parameter set to "reject" then the MS shall cease to receive the CSS channel. The MS may use any subslot or slot(s) that are granted on the CSS channel but shall ignore a slot grant if element "position of grant" in the channel allocation PDU indicated the allocated channel.
 - If the higher layers return a TMC-CONFIGURE request primitive containing the "channel change accepted" parameter set to "ignore" then the MS-MAC shall ignore the channel allocation and may continue to use the CSS channel. The MS may use any subslot or slot(s) that are granted on the CSS channel but shall ignore a slot grant if element "position of grant" in the channel allocation PDU indicated the allocated channel.
 - If the higher layers do not return a TMC-CONFIGURE request primitive containing the "channel change accepted" parameter within a time T.216 following receipt of the channel allocation then the MS shall cease to receive the CSS channel. If the higher layers later return a TMC-CONFIGURE request primitive containing the "channel change accepted" parameter set to "accept" then the MS should start to receive the allocated channel.

If the MS ceases to receive the CSS channel, the MS-MAC shall issue a TMC-CONFIGURE indication primitive for the CSS channel in order to indicate that the physical resource has been lost.

If the MS is already receiving the allocated channel then any services on that channel are not affected and the endpoint identifier is unchanged.

NOTE 1: In the case of a channel allocation with a slot grant on the CSS channel, when the above procedures refer to the MS ceasing to receive the CSS channel, the MS should not leave the channel until after the end of the last uplink slot granted by that PDU (or the end of the slot containing a granted subslot).

After obeying a channel allocation command then, if the MS is not capable of receiving all concurrent channels as well as the newly allocated channel, the MS-MAC shall issue a TMC-CONFIGURE indication primitive to the higher layers for those channels that it can no longer receive in order to indicate that the physical resource on those channels is lost.

After a channel change, the MS-MAC shall inform the higher layers about the channel now in use using the TMC-SELECT indication primitive.

NOTE 2: For allocation type 01₂ (Add) or 11₂ (Replace + CSS channel), the MS-MAC may need to allocate additional endpoint identifiers, in a similar manner to that described in clause 23.5.4.2.2.

NOTE 3: When the BS sends a channel allocation on a CSS channel, it should include a higher layer message indicating the intended usage of the channel allocation except in some cases of allocation type 10₂ (Quit). Even if only an LLC acknowledgement is included with the channel allocation, this may enable the MS to deduce the intended usage.

23.5.4.3 Channel change

23.5.4.3.1 Timing of channel change

When the MS-MAC obeys a channel allocation command, it shall inform the lower layers of any change of RF carrier and/or timeslot(s) and/or bandwidth and/or modulation mode - using the TMV-CONFIGURE request primitive. The carrier information is contained in the "channel allocation" element (see clause 21).

For a change of carrier within the cell, the MS shall assume that the current frame and slot synchronization apply also on the new carrier.

NOTE 1: When the MS obeys a channel allocation command for an eccentric channel, the MS may perceive a larger timing difference on the new channel relative to the old channel than when moving to a non-eccentric channel; see clauses 7.7 and 7.8. The same applies when the MS moves from an eccentric channel to another channel (for example, when the MS returns to its common control channel).

When directed to a CA new cell, the MS-MAC shall assume the frame and slot synchronization from the SYNC and SYSINFO PDUs most recently received while scanning the main carrier of that cell (see clause 23.7); when directed to a DA new cell, the MS-MAC shall assume the frame and slot synchronization from the SYNC-DA and SYSINFO-DA PDUs most recently received while scanning the main carrier of that cell and when reading the SYSINFO-DA PDU on that cell (see clause 23.7). On receiving the TL-SELECT indication primitive for a cell change channel allocation, the MLE returns a TL-SELECT response primitive indicating the main carrier of the new cell; the LLC passes the response primitive to the MAC as a TMC-SELECT response primitive, enabling the MAC to reference the correct information.

NOTE 2: When the MS obeys a channel allocation command for an eccentric channel on a new cell, the MS may perceive a larger timing difference on the eccentric channel relative to the main carrier of the new cell than when moving to a non-eccentric channel on the new cell; see clause 7.7.

If a "basic slot granting" or "multiple slot granting" element is included in the same PDU as the "channel allocation" element then:

- if element "position of grant" in the PDU indicates "Current Channel", the MS shall obey the procedure for use of reserved slots (see clause 23.5.2) on the current channel;
- otherwise the MS shall assume that the slot grant is on the allocated channel.

NOTE 3: If the MS does not obey the channel allocation, it may use any subslot or slot(s) that are granted on the current channel but ignores a slot grant if element "position of grant" in the PDU indicates the allocated channel.

The timing of the move to an allocated channel shall be as follows:

- 1) If the MS obeys an individually addressed channel allocation, or if it makes an immediate decision to obey a group addressed channel allocation, then the first uplink (respectively downlink) slot on the allocated channel shall be defined relative to either:
 - a) the end of the downlink slot containing the channel allocation; or
 - b) in the case of a channel allocation with a slot grant on the current channel (with "granting delay" $\neq 1111_2$):
 - the end of the last uplink slot granted by that PDU (or the end of the slot containing a granted subslot or, for a multiple slot grant, the end of the last slot containing a granted subslot); or
 - c) if the current channel is a multi-slot channel, and the next immediate uplink slot following the channel allocation is part of the current channel, and the MS is transmitting traffic in that slot or was previously granted that slot (or a subslot in that slot) for reserved access:
 - the end of that next immediate uplink slot;

whichever is the later; see note 4. Then, after one timeslot duration, the first uplink (respectively downlink) slot on the allocated channel shall be defined as the next uplink (respectively downlink) slot that corresponds to one of the timeslots indicated by element "timeslot assigned". This timing rule shall apply both for allocation within the same cell and for a different cell.

NOTE 4: For the purposes of this procedure, the time of the end of the slot is defined as being just less than one timeslot duration after the start of that slot (i.e. the time of the end of the slot is regarded as occurring an instant before the start of the next slot), where the start of the slot is as specified in clauses 7, 9.4.3.4 and 9.4.7.4. This applies even though, in case a), the MS may need to receive the downlink beyond the "end of the downlink slot" in order to decode that downlink slot. Also, after switching, the MS may need to start receiving the downlink before the start of the first slot on the allocated channel in order to decode that slot.

For a slot grant on the allocated channel, granting delay = 0000₂ in the "basic slot granting" element (or in the first "basic slot granting" element in a "multiple slot granting" element) shall refer to the use of the first uplink slot on the allocated channel. Granting delay > 0000₂ shall then refer to delaying by the specified number of delay opportunities on the allocated channel as defined by element "timeslot assigned".

NOTE 5: Condition b) may apply for a channel allocation with either a basic slot grant or a multiple slot grant on the current channel. In either case, condition b) refers to the end of the last uplink slot in which either the whole slot or a subslot is granted by that PDU.

NOTE 6: Condition c) above applies only to a frequency full duplex or fast switching MS. It assumes that the MS cannot stop transmission immediately and should not stop in the middle of a full slot. For example, if the MS is transmitting traffic and receives a channel allocation sent in downlink slot 1, the MS should continue to transmit in the immediately following uplink slot 4 (if that is a valid traffic slot), before moving to the allocated channel.

NOTE 7: The following are examples of the channel timing, for allocation within the same cell.

- i) For a channel allocation sent in slot 1, assigning timeslot 1, e.g. on another RF carrier:
 - the first uplink slot on the allocated channel is the uplink slot 1 of the same TDMA frame;
 - the first downlink slot on the allocated channel is the downlink slot 1 of the next TDMA frame.
- ii) For a channel allocation sent in slot 1, assigning timeslot 2:
 - the first uplink slot on the allocated channel is the uplink slot 2 of the same TDMA frame;
 - the first downlink slot on the allocated channel is the downlink slot 2 of the next TDMA frame.
- iii) For a channel allocation sent in slot 1, assigning timeslot 4:
 - the first downlink (respectively uplink) slot on the allocated channel is the downlink (respectively uplink) slot 4 of the same TDMA frame (i.e. frame number X where the channel allocation was sent in slot 1 of frame X).
- iv) For a channel allocation sent in slot 1, with a single subslot grant on the current channel in that TDMA frame, and assigning timeslot 1:
 - the first downlink (respectively uplink) slot on the allocated channel is the downlink (respectively uplink) slot 1 of the next TDMA frame.
- v) For a channel allocation sent in slot 1, with a single subslot grant on the current channel in that TDMA frame, and assigning timeslot 2:
 - the first downlink (respectively uplink) slot on the allocated channel is the downlink (respectively uplink) slot 2 of the next TDMA frame.
- vi) For a channel allocation sent in slot 1, with a single subslot grant on the current channel in that TDMA frame, and assigning timeslot 3:
 - the first uplink slot on the allocated channel is the uplink slot 3 of the same TDMA frame;
 - the first downlink slot on the allocated channel is the downlink slot 3 of the next TDMA frame.
- vii) For a channel allocation sent in slot 1, with a single subslot grant on the current channel in that TDMA frame, and assigning timeslots 1 and 4:
 - the first uplink slot on the allocated channel is the uplink slot 4 of the same TDMA frame;
 - the first downlink slot on the allocated channel is the downlink slot 1 of the next TDMA frame.

- viii) If a frequency full duplex or fast switching MS is transmitting traffic on a multi-slot channel comprising timeslots 1, 2 and 3, and receives a channel allocation sent in slot 2 of a frame in the range 1 to 17, replacing the current channel with timeslots 2, 3 and 4, then the MS continues to transmit traffic in uplink slot 1 before it switches channel. Then:
 - the first uplink slot on the allocated channel is the uplink slot 3 of the same TDMA frame;
 - the first downlink slot on the allocated channel is the downlink slot 2 of the next TDMA frame.
- ix) If the MS is on a two-slot channel comprising timeslots 2 and 3, and receives a channel allocation sent in slot 2 of frame X, with a multiple slot grant for slot 2 of the current TDMA frame (frame X) and slot 3 of the next TDMA frame but one (frame X + 2), and assigning timeslots 2, 3 and 4:
 - the first downlink slot on the allocated channel is the downlink slot 3 of frame X + 3;
 - the first uplink slot on the allocated channel is the uplink slot 2 of frame X + 3.

For allocation on a different cell, the MS still allows one timeslot duration (approximately 14,167 ms). Then the first uplink (respectively downlink) slot on the allocated channel on the new cell is the next uplink (respectively downlink) slot that corresponds to one of the timeslots indicated by element "timeslot assigned" - using the new cell synchronization. This timing applies whether the new cell is synchronized to the current cell or not. The normal rules for slot grants and CLCH(-Q) permission then apply on the allocated channel.

NOTE 8: Element "position of grant" is included to allow flexibility of channel scheduling by the BS. For example, if there is already traffic on the uplink of the allocated channel, the BS may wish to grant a subslot on the current channel for a layer 2 acknowledgement from an MS that is to receive traffic, e.g. in case of independent allocation of uplink and downlink. In other cases, granting on the allocated channel may often be more appropriate.

When using the layer 2 acknowledged service, the BS should grant a subslot on the current channel for the layer 2 acknowledgement from the MS when sending a channel allocation that the MS may choose to "reject". This is because, if the BS granted a subslot on the allocated channel and the MS did not move to the allocated channel, then the MS could not use the granted subslot on the allocated channel for the layer 2 acknowledgement.

- 2) If the MS decides to obey a group addressed channel allocation after a delay then the first uplink (respectively downlink) slot on the allocated channel shall be defined either relative to the time when the MS-MAC receives the TMC-CONFIGURE request primitive accepting the channel allocation or relative to the end of the slot in which the MS-MAC received the TMC-CONFIGURE request primitive. Then, after one timeslot duration, the first uplink (respectively downlink) slot on the allocated channel shall be defined as the next uplink (respectively downlink) slot that corresponds to one of the timeslots indicated by element "timeslot assigned". This timing rule shall apply both for allocation within the same cell and for a different cell.

For a slot grant on the allocated channel, the granting delay is defined relative to the first uplink slot on the allocated channel for an immediate decision (as specified in procedure 1) above). Therefore, in the case of a delayed decision, the MS-MAC shall not use the granted capacity unless it is capable of calculating the intended time of the granted capacity based on an immediate decision and the higher layers accept the channel allocation before that time occurs. If the MS-MAC does not use the granted capacity then, since uplink messages with a group address in the MAC header are only ever sent by reserved access, the MS should discard the uplink message intended to be sent in the granted capacity.

EXAMPLE: In an implementation, the MS-MAC could issue a MAC-READY signal for the group address and receive the TMA-UNITDATA request primitive but then report failure to send the message.

NOTE 9: Uplink messages with the group address in the MAC header are used only for the low-level group presence indication.

Slot granting is valid only on the channel on which the grant was made, except in the case of slots granted in the same PDU as a channel allocation and with element "position of grant" indicating the allocated channel. Therefore, after an MS has obeyed a channel allocation command then, if it is no longer using the channel on which the channel allocation was received, any slot grants received on the old channel before the channel allocation shall cease to be valid.

As defined in clauses 23.4.2.1 and 23.4.3.1, fragmentation and reconstruction apply to a specific control channel. Therefore, after an MS has obeyed a channel allocation command then, if it is no longer using the channel on which the channel allocation was received, it shall discontinue any ongoing uplink fragmentation on the old channel (reporting to the LLC that the transmission has failed) and shall also discard any partially reconstructed downlink TM-SDU.

23.5.4.3.2 Use of "timeslot assigned"

If the "timeslot assigned" element $\neq 0000_2$, the MS-MAC shall note that the channel is an assigned channel, assigned for SCCH or for a circuit mode call.

If the "timeslot assigned" element = 0000_2 , a CA MS shall go to the appropriate common control channel as indicated by the last received SYSINFO or SYSINFO-Q PDU.

If the "timeslot assigned" element = 0000_2 , a DA MS shall go to the appropriate common control channel as indicated by the last received SYSINFO-DA PDU. The channel allocation may be augmented or non-augmented.

- a) If the channel allocation containing the "timeslot assigned" element set to 0000_2 is augmented, and the modulation mode indicates QAM, a DA MS shall use the other information provided in the channel allocation.
- b) If the channel allocation containing the "timeslot assigned" element set to 0000_2 is not augmented, or is augmented but the modulation mode does not indicate QAM, a DA MS shall:
 - go to the main carrier indicated by the last received SYSINFO-DA or SYNC-DA PDU (ignoring the carrier information in the channel allocation);
 - assume the bandwidth indicated by the last received SYSINFO-DA or SYNC-DA PDU;
 - assume QAM modulation mode;
 - assume the values of the maximum uplink QAM modulation level and BS link imbalance indicated by the last received SYSINFO-DA PDU;
 - assume that the conforming channel status is conforming;
 - assume a BS transmit power relative to the main carrier of 0 dB;
 - assume that CLCH(-Q) permission is as indicated by the "CLCH(-Q) permission" flag in the channel allocation.

NOTE 1: If a slot grant is included in the same PDU as the channel allocation and element "position of grant" indicates that the slot grant is on the allocated channel, the same procedure for the slot grant applies in method b) as for all other cases of a channel allocation; so, in this case, the MS regards the slot grant as applying on the appropriate common control channel on the main carrier indicated by the last received SYSINFO-DA or SYNC-DA PDU. Thus the MS follows the usual procedure as defined in clause 23.5.4.3.1.

Similarly, if an event label assignment is associated with the channel allocation, the same procedure for the event label assignment applies in method b) as for all other cases of a channel allocation; so, in this case, the MS regards the event label assignment as applying on the appropriate common control channel on the main carrier indicated by the last received SYSINFO-DA or SYNC-DA PDU. Thus the MS follows the usual procedure as defined in clauses 23.4.1.2.3.1 and 23.4.1.2.3.3.

NOTE 2: Method b) allows for cases such as when the BS is sending a group-addressed instruction to return to the appropriate common control channel to a group that includes both CA MSs and DA MSs and/or that includes DA MSs from more than one DA cell sharing the assigned channel.

EXAMPLE: If the BS is sending a group-addressed instruction to return to the appropriate common control channel to a group that includes both CA MSs and DA MSs sharing the assigned channel, it should use a non-augmented channel allocation (including the CA main carrier number).

If the BS is sending a group-addressed instruction to return to the appropriate common control channel to a group that includes DA MSs from more than one DA cell sharing the assigned channel, it should use a non-augmented channel allocation (and should set the carrier number to zero).

NOTE 3: The BS is also permitted to use a non-augmented channel allocation (setting the carrier number to zero) when it is sending an individually-addressed instruction to return to the appropriate common control channel to a DA MS.

NOTE 4: If the BS is sending an instruction to return to the appropriate common control channel to a DA MS (or DA MSs), and the DA main carrier has moved while the MS (or MSs) have been on the assigned channel, the BS should use an augmented QAM channel allocation if possible.

An assigned channel may comprise one or more timeslots per TDMA frame, as indicated by the bit map in element "timeslot assigned".

For "allocation type" = 11₂ (i.e. Replace + CSS channel), the "timeslot assigned" element shall indicate only those slots belonging to the assigned channel. Thus, if the specified carrier is not the MS's main carrier, the first bit in the bit map shall be 0 (bit map = 0xxx₂); the use of slot 1 for the CSS channel is implicit. For CA, if the specified carrier is the MS's main carrier, the bit corresponding to the MS's common channel shall be 0.

NOTE 5: The designation of whether the MS-MAC regards the channel as "assigned" or "common" affects the random access and channel maintenance procedures, and whether energy economy (or part-time reception) mode or napping mode may be appropriate.

If the BS assigns slot 1 of a CA main carrier for a circuit mode call, it should send a channel allocation command to those users. This may not cause a change of carrier or timeslot; but it is needed to change the MAC mode from "common" to "assigned", and also to define monitoring pattern information and a traffic usage marker. A similar procedure applies if the BS wishes to allow an MS that is receiving a CSS channel to use slot 1 of that carrier for a circuit mode call or as a fully assigned SCCH.

If the BS assigns the timeslot or timeslots used for the MCCH-Q (or the timeslot used for a QAM common SCCH) as an assigned SCCH for an MS or MSs, it should send a channel allocation command to those users. This may not cause a change of carrier or timeslot; but it is needed to change the MAC mode from "common" to "assigned". There will usually also be other MSs still in common mode on the MCCH-Q or common SCCH.

23.5.4.3.3 Use of "up/downlink assigned" and "Up/downlink assigned for augmented channel allocation"

The "Up/downlink assigned" element in the channel allocation is used in two ways:

- values 01₂, 10₂ and 11₂ indicate whether either or both directions on the allocated channel have been assigned exclusively for the usage required by the MS;
- value 00₂ indicates that this is an augmented channel allocation; then conditional element "Up/downlink assigned for augmented channel allocation" indicates whether either or both directions on the allocated channel have been assigned exclusively for the usage required by the MS.

The MS-MAC shall note, from element "Up/downlink assigned" or "Up/downlink assigned for augmented channel allocation", whether either or both directions on the allocated channel have been assigned exclusively for the usage required by the MS.

This information generally affects only the channel maintenance procedure. In the case of independent allocation of uplink and downlink for different purposes, reduced procedures shall apply; see clause 23.5.6.

However, for the application of the general procedures for transmission and reception of signalling messages, each control channel (ACCH or SCCH) shall be assumed to occupy any control slots on both the downlink and uplink directions, as indicated by element "timeslot assigned".

EXAMPLE: The MS attempts to receive and decode the downlink channel according to the normal procedures for an assigned channel, even if only the uplink was allocated by element "Up/downlink assigned" or "Up/downlink assigned for augmented channel allocation". Similarly, the normal procedures for random access and reserved access on an assigned channel apply, even if only the downlink was allocated by element "Up/downlink assigned" or "Up/downlink assigned for augmented channel allocation".

NOTE 1: The up/downlink assigned designation (from either element) is included to allow the BS to use independent allocation of uplink and downlink i.e. allocating the uplink and downlink channels for different purposes (as described in clause 23.3.4).

NOTE 2: For "allocation type" = 11₂, the up/downlink assigned designation applies only to the assigned channel. Allocation of only one direction of a CSS channel does not apply.

MSs that support D8PSK and/or QAM operation need to support the augmented channel allocation in order to be allocated to a D8PSK or QAM channel. It is optional whether an MS that only supports $\pi/4$ -DQPSK operation supports the augmented channel allocation (see "class of MS" element in clause 16). If an MS that does not support augmented channel allocations receives a channel allocation with the "Up/downlink assigned" element set to 00₂, the MS-MAC shall discard the channel allocation and any TM-SDU carried in the MAC-RESOURCE or MAC-END PDU that contained the channel allocation.

The currently defined values of the "Up/downlink assigned for augmented channel allocation" element are values 01₂, 10₂ and 11₂; value 00₂ is reserved in the present document. If the MS-MAC receives an augmented channel allocation with the "Up/downlink assigned for augmented channel allocation" element set to 00₂, it shall discard the channel allocation and any TM-SDU carried in the MAC-RESOURCE or MAC-END PDU that contained the channel allocation.

23.5.4.3.4 CLCH(-Q) permission

If the "CLCH(-Q) permission" flag indicates "Immediate CLCH(-Q) permission" and the MS makes an immediate decision to accept the channel allocation then the MS may use the first subslot of the first uplink slot on the allocated channel for linearization, without needing to receive the corresponding ACCESS-ASSIGN PDU. The first uplink slot on the allocated channel is as defined in procedure 1) of clause 23.5.4.3.1 i.e. as defined for an immediate decision. The MS uses CLCH if the allocated channel is a $\pi/4$ -DQPSK or D8PSK channel, or CLCH-Q if the allocated channel is a QAM channel.

Otherwise, if the MS requires to use CLCH or CLCH-Q for linearization, it shall wait for an appropriate frame 18 or for an ACCESS-ASSIGN PDU indicating a linearization subslot.

NOTE 1: The "CLCH(-Q) permission" flag is included to allow for fast call set-up with a change of RF carrier while still allowing flexibility for the BS, e.g. in cases of independent allocation of uplink and downlink or repeat set-up signalling for a group call. The BS should at least give CLCH(-Q) permission to any MSs that have indicated that they need to use:

- CLCH for linearization, if the allocated channel is a $\pi/4$ -DQPSK or D8PSK channel; or
- CLCH-Q for linearization, if the allocated channel is a QAM channel,

and that are granted slots and/or given transmit permission on a new carrier. The CLCH(-Q) permission applies to any MS that obeys the channel allocation message without delay, whether or not it has been granted slots and/or transmit permission.

The MS indicates whether it needs to use CLCH for linearization on carrier change in the "class of MS" element; see clause 16. The MS indicates whether it needs to use CLCH-Q for linearization on carrier change in the "QAM capabilities" element; see clause 16.

NOTE 2: For "allocation type" = 11₂, the CLCH(-Q) permission applies only to the assigned channel, not to the CSS channel.

NOTE 3: In the case of a delayed decision to accept a group addressed channel allocation, the MS may use the CLCH(-Q) permission if it is capable of calculating the time of the first uplink slot of the allocated channel based on an immediate decision and the higher layers accept the channel allocation before that time occurs.

23.5.4.3.5 Monitoring pattern information

The MS shall note the monitoring pattern information in case it is required to transmit user traffic on this channel. This requirement to store the monitoring pattern information applies to any MS that obeys the channel allocation message, whether or not it has been given permission to transmit user traffic at this time.

The monitoring pattern information indicates in which downlink frames the MS is required to receive downlink slots and attempt to decode any signalling messages (within the capabilities of that MS) while it is transmitting traffic. This enables the BS to send signalling messages to that MS during its traffic transmission. See clause 9 for the definition of the usage of the monitoring pattern numbers; see also clause 21.5.2.

In the case that no monitoring pattern is assigned, an additional field defines the multiframe(s) in which the MS shall receive and attempt to decode the downlink assigned slot in frame 18 (or, for a multi-slot channel, at least the highest numbered downlink slot of the assigned channel in frame 18).

The requirements for the MS to adhere to the assigned monitoring pattern(s) are only within the capabilities of that MS. The BS should note those capabilities when sending signalling messages to an MS that is transmitting traffic on a multi-slot channel (see clauses 23.3.1.3 and 23.3.1.4).

- NOTE 1: When the BS allocates a multi-slot channel to a frequency half duplex MS, it is not precluded from assigning monitoring pattern(s) that the MS cannot observe. For example, this may be convenient if the BS assigns the monitoring pattern information in a group addressed channel allocation, where the group contains both frequency full duplex and frequency half duplex MSs. However the BS should be aware that a frequency half duplex MS without fast switching capability is not able to receive signalling on the downlink between transmitted bursts on the uplink.
- NOTE 2: The monitoring pattern information refers to the requirements on an MS that is transmitting traffic to receive the downlink of the current channel. This is not the same as the "monitoring procedure" defined in clause 23.7.4, in which the MS measures the signal strength of adjacent cells or irregular channels (or the main carrier of the serving cell) and calculates C2.
- NOTE 3: The BS designer should note that the assignment of all three monitoring patterns to a frequency half duplex MS in a simplex call may reduce that MS's ability to perform cell reselection measurements on adjacent cells while it is transmitting traffic. The BS designer should also note that the assignment of all three monitoring patterns to a frequency half duplex dual watching MS may reduce that MS's ability to perform dual watch on the Direct Mode RF carrier during V+D calls.
- NOTE 4: For "allocation type" = 11₂, the monitoring pattern information applies only to the assigned channel, not to the CSS channel.

23.5.4.3.6 Bandwidth, modulation mode and related parameters

The "channel allocation" element allows the BS to make an augmented channel allocation. An augmented channel allocation is indicated by setting the "Up/downlink assigned" element to 00₂.

If the channel allocation is not augmented (i.e. element "Up/downlink assigned" ≠ 00₂):

- a CA MS shall assume that the allocated channel is a 25 kHz $\pi/4$ -DQPSK conforming channel and that the BS transmit power on the allocated channel relative to the CA main carrier is 0 dB;
- if element "timeslot assigned" ≠ 0000₂, a DA MS shall assume that the allocated channel is a 25 kHz $\pi/4$ -DQPSK conforming channel and that the BS transmit power on the allocated channel relative to the DA main carrier is 0 dB;
- if element "timeslot assigned" = 0000₂, a DA MS shall make the assumptions specified in clause 23.5.4.3.2.

If the channel allocation is augmented (i.e. element "Up/downlink assigned" = 00₂), elements "bandwidth of allocated channel" and "modulation mode of allocated channel" shall indicate the bandwidth of the allocated channel and whether the allocated channel is a $\pi/4$ -DQPSK, D8PSK or QAM channel; see note 10.

- NOTE 1: In the case of a $\pi/4$ -DQPSK or D8PSK channel, the bandwidth of the allocated channel is 25 kHz. In the case of a QAM channel, the bandwidth of the allocated channel is 25 kHz, 50 kHz, 100 kHz or 150 kHz.

If the allocated channel is a QAM channel, the "maximum uplink QAM modulation level" element shall indicate the maximum modulation level that the MS is permitted to use on the uplink. If the MS does not understand the value of the "maximum uplink QAM modulation level" element, it shall regard the value as indicating the maximum QAM modulation level supported by that MS.

NOTE 2: If the allocated channel is an assigned channel, the MS continues to use the value of the "maximum uplink QAM modulation level" element from the channel allocation while on that assigned channel.

The SYSINFO-DA PDU indicates the maximum uplink QAM modulation level to be used on common control channels on the DA main carrier. Therefore, if the allocated channel is the common control channel, a DA MS updates the maximum uplink QAM modulation level when it receives the SYSINFO-DA PDU on the common control channel.

Then the "conforming channel status" element shall indicate whether the allocated channel is a conforming channel, non-conforming concentric channel, sectored channel, super-sectored channel or eccentric channel; see note 5 and note 10.

NOTE 3: As described in clause 23.7, a "concentric channel" has essentially the same azimuthal radiation pattern as the main carrier and is radiated from the same site as the main carrier. A "conforming channel" is a concentric channel that has essentially the same range as the main carrier. A "non-conforming concentric channel" is a concentric channel that has a larger or smaller range than the main carrier. A "sectored channel" has an azimuthal extent that is smaller than, and contained entirely within, the azimuthal extent of the main carrier, and is radiated from the same site as the main carrier; it is a non-conforming channel and is not a concentric channel. A "super-sectored channel" has an azimuthal extent that exceeds the azimuthal extent of the main carrier in at least one azimuthal direction, and is radiated from the same site as the main carrier; it is a non-conforming channel and is not a concentric or sectored channel. An "eccentric channel" is a channel that is not radiated from the same site as the main carrier; it is a non-conforming channel and is not a concentric, sectored or super-sectored channel.

NOTE 4: When the MS receives a channel allocation directing it to a channel on a new cell, it should regard the "conforming channel status" as being defined relative to the main carrier of the new cell.

NOTE 5: If element "conditional element A" is included in the channel allocation, a DA MS uses the "DA conforming channel status" element from element "conditional element A" instead of using the "conforming channel status" element; see clause 23.5.4.3.8 and clause 23.5.4.3.9.

If the MS does not understand the value of the "conforming channel status" element and the MS accepts the channel allocation:

- i) the MS cannot perform assessment of the main carrier based on measurements made on the allocated channel; therefore the MS shall perform monitoring of the main carrier (path loss parameter C2) instead of performing assessment of the main carrier (path loss parameter C3); see clause 23.7;
- ii) similarly the MS cannot perform assessment of channel classes based on measurements made on the allocated channel; therefore, if the MS wishes to perform assessment of channel classes, it shall perform main carrier monitoring with assessment of channel classes (path loss parameter C5) instead of performing serving cell channel class assessment (path loss parameter C4).

DA MSs shall be capable of performing the additional monitoring described in i) and ii) above, whereas it is optional for CA MSs to be capable of performing this additional monitoring. If a CA MS does not understand the value of the "conforming channel status" element and is not capable of performing this additional monitoring, the MS is not capable of using the allocated channel and shall not accept the channel allocation. (Therefore, for example, for a channel replacement received on an assigned channel, the MS normally returns to its common control channel; see clause 23.5.4.2.3.)

NOTE 6: Thus, if the "conforming channel status" element is set to one of the reserved values, the MS may accept the channel allocation provided that the MS performs the additional monitoring described in i) and ii) above.

The MS shall also perform the additional monitoring described in i) and ii) above if it accepts a channel allocation for which the "conforming channel status" indicates that the allocated channel is a super-sectored or eccentric channel; see clause 23.7. DA MSs shall be capable of performing this additional monitoring, whereas it is optional for CA MSs to be capable of performing this additional monitoring. If a CA MS is not capable of performing this additional monitoring, the MS is not capable of using the allocated channel and shall not accept the channel allocation.

The "BS link imbalance" element contains information that may be used by the MS in its link adaptation algorithm if the allocated channel is a D8PSK or QAM channel (see clause 23.4.9); see note 7 and note 10.

NOTE 7: If the allocated channel is an assigned channel, the MS continues to use the value of the "BS link imbalance" element from the channel allocation while on that assigned channel.

The SYSINFO-DA PDU indicates the BS link imbalance value to be used on common control channels on the DA main carrier. Therefore, if the allocated channel is the common control channel, a DA MS updates the BS link imbalance value when it receives SYSINFO-DA on the common control channel.

The "BS transmit power relative to main carrier" element shall indicate the BS transmit power (ERP) on the allocated channel; see note 8, note 9 and note 10.

NOTE 8: When the MS receives a channel allocation directing it to a channel on a new cell, it should regard the "BS transmit power relative to main carrier" as being defined relative to the main carrier of the new cell.

NOTE 9: If element "conditional element A" is included in the channel allocation, a DA MS calculates the BS transmit power on the allocated channel using the "BS transmit power relative to current carrier" element from element "conditional element A" instead of using the "BS transmit power relative to main carrier" element; see clause 23.5.4.3.8 and clause 23.5.4.3.9.

NOTE 10: If element "timeslot assigned" = 0000₂, and the channel allocation is augmented but the modulation mode does not indicate QAM, a DA MS makes the assumptions specified in clause 23.5.4.3.2.

NOTE 11: For "allocation type" = 11₂, the "modulation mode of allocated channel" information applies only to the assigned channel, not to the CSS channel; a CSS channel is always a $\pi/4$ -DQPSK channel. In the present document, use of "allocation type" 11₂ is not appropriate when the BS is allocating a QAM channel.

NOTE 12: In the present document, if an MS receives "allocation type" 11₂ when the BS is allocating a QAM channel, the MS should regard the allocation as "allocation type" 00₂ (replace current channel with specified channel).

23.5.4.3.7 Napping status and napping information

If the channel allocation is augmented (i.e. element "Up/downlink assigned" = 00₂), the "napping status" element shall indicate whether napping is permitted on the allocated channel:

- if "napping status" = 00₂, the MS shall assume that use of the napping procedure is not permitted on the allocated channel;
- if "napping status" = 01₂, the MS shall assume that use of the napping procedure is permitted on the allocated channel, using the napping parameters specified in the "napping information" element;
- if "napping status" = 10₂, the MS shall assume that use of the napping procedure is permitted on the allocated channel, using the napping parameters for the current channel (i.e. the channel on which the channel allocation was received).

If the channel allocation is not augmented (i.e. element "Up/downlink assigned" \neq 00₂), the MS shall assume that use of the napping procedure is not permitted on the allocated channel.

NOTE 1: Napping may apply only when the MS has accepted a channel allocation for an assigned channel. It does not apply to MSs that are in common mode.

In some cases some MSs may be in assigned mode on a physical channel (or physical channels) while other MSs may be in common mode on that physical channel (or physical channels). Napping may apply only to those MSs that are in assigned mode.

NOTE 2: For "allocation type" = 11₂, the "napping status" and "napping information" apply only to the assigned channel, not to the CSS channel. Use of the napping procedure does not apply on a CSS channel.

23.5.4.3.8 Elements following napping status and napping information

If the channel allocation is augmented (i.e. element "Up/downlink assigned" = 00₂), the channel allocation includes the following elements following the "napping status" or "napping information" element:

- a four-bit reserved element (set to zero in the present document);
- a flag (named "conditional element A flag") indicating whether a first 16-bit conditional element is present, and the conditional element (named element "conditional element A") if appropriate; if present, element "conditional element A" contains:
 - element "DA conforming channel status" (see clause 23.5.4.3.9);
 - element "BS transmit power relative to current carrier" (see clause 23.5.4.3.9); and
 - an eight-bit reserved element (set to zero in the present document);
- a flag (named "conditional element B flag") indicating whether a second 16-bit conditional element is present; this flag shall be set to 0 in the present document, to indicate that element "conditional element B" is not present;
- a flag indicating further augmentation of the channel allocation (allowing for future further extension).

The reserved elements allow for inclusion of future information in the channel allocation, while still allowing MSs that do not understand that information to process and obey the channel allocation. The reserved elements (when present) are set to zero in the present document. However the MS may continue to process the channel allocation and any TM-SDU carried in the MAC-RESOURCE or MAC-END PDU, and may obey the channel allocation, if these elements are not set to zero.

"Conditional element B" also allows for inclusion of future information in the channel allocation, while still allowing MSs that do not understand that information to process and obey the channel allocation. The "conditional element B flag" shall be set to 0 in the present document, indicating that element "conditional element B" is not present. However, if the MS receives a channel allocation with "conditional element B flag" set to 1, it shall assume that a 16-bit element is included following the "conditional element B flag"; the MS may then continue to process the channel allocation and any TM-SDU carried in the MAC-RESOURCE or MAC-END PDU, and may obey the channel allocation.

The further augmentation flag allows for inclusion of future additional information whose size is not defined in the present document. The further augmentation flag shall be set to 0 in the present document. If the MS receives a channel allocation with the further augmentation flag set to 1, it shall discard the channel allocation and any TM-SDU carried in the MAC-RESOURCE or MAC-END PDU that contained the channel allocation.

23.5.4.3.9 DA conforming channel status and BS transmit power relative to current carrier

If the channel allocation is augmented (i.e. element "Up/downlink assigned" = 00₂), the channel allocation includes the "conforming channel status" element and "BS transmit power relative to main carrier" element (see clause 23.5.4.3.6). These elements are used by all CA MSs. They are also used by DA MSs if element "conditional element A" is not present in the channel allocation (see clause 23.5.4.3.8).

However, if element "conditional element A" is included in the channel allocation, a DA MS:

- a) shall use the "DA conforming channel status" element from element "conditional element A" as the conforming channel status of the allocated channel instead of using the "conforming channel status" element; and
- b) shall calculate the BS transmit power on the allocated channel using the "BS transmit power relative to current carrier" element from element "conditional element A" instead of using the "BS transmit power relative to main carrier" element.

The MS already knows the BS transmit power of the current channel relative to its main carrier. It shall then calculate the BS transmit power of the allocated channel relative to its main carrier as:

$$\begin{aligned} & \text{BS transmit power (of the allocated channel) relative to the current carrier} \\ & + \text{BS transmit power (of the current channel) relative to the main carrier} \end{aligned} \quad (23.7)$$

NOTE 1: The BS should not include "conditional element A" when it is sending a channel allocation directing an MS to a channel on a new cell.

If a DA MS does not understand the value of the "DA conforming channel status" element and the DA MS accepts the channel allocation:

- i) the MS cannot perform assessment of the main carrier based on measurements made on the allocated channel; therefore the MS shall perform monitoring of the main carrier (path loss parameter C2) instead of performing assessment of the main carrier (path loss parameter C3); see clause 23.7;
- ii) similarly the MS cannot perform assessment of channel classes based on measurements made on the allocated channel; therefore, if the MS wishes to perform assessment of channel classes, it shall perform main carrier monitoring with assessment of channel classes (path loss parameter C5) instead of performing serving cell channel class assessment (path loss parameter C4).

The MS shall also perform the additional monitoring described in i) and ii) above if it accepts a channel allocation for which the "DA conforming channel status" indicates that the allocated channel is a super-sectored or eccentric channel; see clause 23.7.

DA MSs shall be capable of performing the additional monitoring described in i) and ii) above.

EXAMPLE: The BS may need to include element "conditional element A" (therefore including elements "DA conforming channel status" and "BS transmit power relative to current carrier") if it wishes to replace an assigned channel using a group-addressed channel allocation sent to a group that includes MSs from more than one cell (CA cell or DA cell(s)) sharing the assigned channel. (If the group does not include MSs from more than one cell sharing the assigned channel, the BS does not need to include element "conditional element A".)

Use of a group address (possibly the predefined broadcast group address) might be useful, for example, if the BS needs to move the assigned channel or if it wishes to change the number of slots comprising the assigned channel.

NOTE 2: If the BS includes element "conditional element A", and it is sending a group-addressed channel allocation to a group that includes MSs from more than one DA cell sharing the assigned channel, the BS should set the "DA conforming channel status" to the most pessimistic value of conforming channel status appropriate for any of the DA MSs in the group. (For this purpose, eccentric is more pessimistic than super-sectored; super-sectored is more pessimistic than sectored; sectored is more pessimistic than concentric; and non-conforming concentric is more pessimistic than conforming. Thus, in the present document, if the allocated channel is eccentric relative to the DA main carrier for any of the DA MSs in the group, the "DA conforming channel status" is set to "eccentric".)

NOTE 3: In future editions of the present document, the most pessimistic value of conforming channel status may be a value that is currently reserved. MS designers should consider this possibility when deciding whether to implement the monitoring procedure used if the MS accepts a channel allocation containing a value of "DA conforming channel status" that it does not understand.

23.5.5 Usage marker assignment

A traffic usage marker is a 6-bit MAC label used during circuit mode calls for transmitter pre-emption, for prevention of crossed calls and for channel maintenance purposes. The BS shall assign a traffic usage marker before any traffic transmission takes place on an assigned channel.

It shall assign the usage marker with a message that contains also a channel allocation command directing MS(s) to an assigned channel. The usage marker assignment shall be valid for that MS (or those MSs) only on that assigned channel. So, for example, for message trunking, one traffic usage marker generally applies for the complete call and the same usage marker should be assigned for all participants in that call on that assigned channel; whereas, for transmission trunking, the BS should assign a traffic usage marker for each "over".

NOTE 1: If the BS wishes to assign a traffic usage marker on an already assigned channel, then it may use the "replace channel" command indicating the current channel. However, when the BS uses a group addressed message to allocate a channel for a circuit mode call, it is recommended that, if possible, it assigns the traffic usage marker when it sends the channel allocation; otherwise the usage marker may not be received by those MSs that do not make an immediate decision to accept the channel allocation.

NOTE 2: For "allocation type" = 11₂, the usage marker applies only to the assigned channel, not to the CSS channel.

When there is traffic (TCH or STCH) on either the uplink or the downlink, the BS shall use the appropriate traffic usage marker in the ACCESS-ASSIGN PDU sent on the AACH in frames 1 to 17 on the downlink assigned channel to confirm permission to transmit and/or receive traffic. For uplink traffic, Header 11₂ shall be used, with "Field 2" set to the uplink traffic usage marker. For downlink traffic, Header 01₂, 10₂ or 11₂ shall be used, with "Field 1" set to the downlink traffic usage marker.

A traffic usage marker may also be sent in the ACCESS-ASSIGN PDU in frame 18, though frame 18 is never used for TCH or STCH. Then the frame 18 Header shall be set to 11₂ and the usage marker in "Field 1" may be set to either the uplink or downlink traffic usage marker as appropriate. This can be useful for channel maintenance purposes. And, during uplink traffic, it should be used with the traffic usage marker of the transmitting MS if the BS has not assigned a monitoring pattern for frames 1 to 17 (or, for a multi-slot channel, if the BS has assigned monitoring pattern(s) that the MS may not be capable of following in any slots in frames 2 to 17).

The procedures for channel maintenance by the MS-MAC, and the criteria for MS transmission and reception of traffic, are described in clauses 23.5.6 and 23.8.2 respectively.

When the BS wishes to assign a traffic usage marker, it shall use the MAC-RESOURCE PDU, which shall contain "Address Type" = 110₂ and the assigned traffic usage marker. The "channel allocation" element shall be included in that MAC-RESOURCE PDU or in the associated MAC-END PDU. If the MS-MAC receives a usage marker assignment without the corresponding channel allocation (e.g. in the case of fragmentation if the MS does not receive the MAC-END PDU), or if it does not obey the channel allocation, then it shall ignore the usage marker assignment.

A traffic usage marker shall apply for the direction(s) specified in the channel allocation, i.e. the appropriate direction for element "Up/downlink assigned" or "Up/downlink assigned for augmented channel allocation" = 01₂ or 10₂, or both directions for element "Up/downlink assigned" or "Up/downlink assigned for augmented channel allocation" = 11₂. If the BS uses independent allocation of the uplink and downlink for two circuit mode calls then the traffic usage marker should be different for the two directions.

In the case of independent allocation of the uplink and downlink of a channel for concurrent calls involving the same MS, the MS-MAC may receive independent channel allocations of uplink and downlink, each with a usage marker assignment. Each usage marker shall apply independently for the specified direction. (However, the same endpoint identifier applies for both allocations when the allocations are for the same assigned channel.)

The MS-MAC shall consider that an assigned traffic usage marker is valid until:

- i) it leaves the assigned channel (or returns to common mode on this channel); or
- ii) it receives another traffic usage marker with a channel allocation for the same direction(s) or for both directions on the same assigned channel; or
- iii) it receives a channel allocation for the same direction(s) or for both directions on the same assigned channel, but without a usage marker assignment.

The BS is responsible for deciding when a traffic usage marker may safely be re-used for a subsequent call on the same physical channel.

23.5.6 Maintenance of assigned channel

23.5.6.0 General

The MS shall receive its common control channel (i.e. the MCCH or MCCH-Q, or the appropriate $\pi/4$ -DQPSK or QAM common SCCH) unless directed by the BS to an assigned channel. An assigned channel may be intended for secondary control purposes or for a circuit mode call. The MS shall assume that the assigned channel is intended for secondary control unless it has received a traffic usage marker for use on the channel.

The ACCH is the control channel associated with an assigned traffic channel. When ACCH is present, its usage is similar to the usage of assigned SCCH, and there is no distinction in the pre-set usage marker designation in the ACCESS-ASSIGN PDU. Both types of control channel shall be regarded as assigned control channel. The traffic usage marker is generally used only while the channel is carrying user traffic TCH or STCH.

The procedures for channel maintenance defined in clause 23.5.6.1 apply on either type of assigned channel, unless specified otherwise.

The procedures for maintenance of a CSS channel are reduced compared with those for a normal assigned channel. They are defined in clause 23.5.6.2.

23.5.6.1 Criteria for leaving assigned channel

23.5.6.1.0 General

NOTE: This clause applies to MSs that are in assigned mode, having accepted a channel allocation for an assigned channel. In some cases other MSs may be in common mode on that channel, in which case those other MSs obey the maintenance procedures for a common channel; see clause 23.5.7.

The MS-MAC shall continue to receive and attempt to decode signalling on the downlink assigned channel as defined by element "timeslot assigned" (within the constraints of the napping procedures and the cell reselection procedures, and monitoring pattern requirements, and linearization and transmission requirements) until one of the following occurs:

- the MS-MAC obeys a channel allocation command from the BS, directing it elsewhere (see clause 23.5.4); or
- the MS is required to leave the channel by one of the channel maintenance procedures in clauses 23.5.6.1.1 and 23.5.6.1.2; or
- the MS-MAC receives a TMC-SELECT request primitive from the higher layers instructing it to leave the assigned channel; or
- the MS-MAC receives a TMC-CONFIGURE request primitive from the higher layers indicating call release for this channel, e.g. the user wishes to leave a group call.

In the last case, the MS should not leave the channel if it has been assigned both directions of the channel in two independent allocations of uplink and downlink, and if the service on the other direction is still ongoing.

23.5.6.1.1 Checking of AACH or AACH-Q

The MS shall attempt to decode:

- the AACH, on a $\pi/4$ -DQPSK or D8PSK channel; or
- the AACH-Q, on a QAM channel;

in slots appropriate to the downlink assigned channel as defined by element "timeslot assigned" (within the constraints of the napping procedures and the cell reselection procedures, and monitoring pattern requirements, and linearization and transmission requirements).

The AACH always contains the ACCESS-ASSIGN PDU. The AACH-Q may contain the ACCESS-ASSIGN PDU (depending on the value of the "AACH-Q mode" element - see clause 21.4.7.1).

If N.208 successive ACCESS-ASSIGN PDUs received in frames 1 to 17 in the AACH or AACH-Q of slots appropriate to the downlink assigned channel indicate that:

- a) the downlink is unallocated, i.e. Header $\neq 00_2$ and downlink usage marker = UMx (000000₂); or
- b) the channel has returned to exclusively common control use, i.e. Header = 00₂; or
- c) the relevant direction(s) have been assigned for another purpose (see below);

then the MS shall regard the assigned channel as no longer valid for transmission or reception. Then, if the MS does not have a concurrent assigned channel, it shall return to its common control channel. The MS-MAC shall inform the higher layers of the de-allocation using either:

- the TMA-RELEASE indication primitive to indicate loss of the connection; or
- a TMC-CONFIGURE indication primitive indicating loss of the physical resource;

and shall inform the higher layers of any change of channel using the TMC-SELECT indication primitive.

NOTE 1: When the LLC receives the TMA-RELEASE indication primitive, it locally disconnects any advanced links on that resource (see clause 22.3.3.4). When the LLC receives the TMC-CONFIGURE indication primitive indicating loss of the physical resource, it may retain any advanced links on that resource for potential continuation (see clause 22.3.5).

For criterion c), the MS shall check as follows:

- If the downlink was assigned for this MS (element "Up/downlink assigned" or "Up/downlink assigned for augmented channel allocation" = 01_2 or 11_2), the MS shall regard the assigned channel as no longer valid if:
 - for a $\pi/4$ -DQPSK or D8PSK assigned SCCH:

the downlink is not in assigned control i.e. the channel is no longer valid if Header = 00_2 or if the downlink usage marker $\neq 000001_2$;
 - for a QAM assigned SCCH:

the downlink is not in assigned control nor in common and assigned control i.e. the channel is no longer valid if Header = 00_2 or if the downlink usage marker is neither 000001_2 nor 000011_2 (see note 8);
 - for a circuit mode call:

the downlink is not in assigned control nor in traffic with the MS's usage marker i.e. the channel is no longer valid if Header = 00_2 or if the downlink usage marker is neither 000001_2 nor the MS's downlink traffic usage marker.
- If the uplink was assigned for this MS (element "Up/downlink assigned" or "Up/downlink assigned for augmented channel allocation" = 10_2 or 11_2), the MS shall regard the assigned channel as no longer valid if:
 - for assigned SCCH:

the uplink is unallocated or is being used for traffic i.e. the channel is no longer valid if Header = 11_2 and the uplink usage marker = 000000_2 or is $\geq 000100_2$;
 - for a circuit mode call:

the uplink is unallocated or is being used for traffic by other users i.e. the channel is no longer valid if Header = 11_2 and the uplink usage marker = 000000_2 or is $\geq 000100_2$ and is not the MS's uplink traffic usage marker.

If the MS has been assigned both directions of the channel in two independent channel allocations then it shall not leave the channel on criterion c) unless both directions are no longer valid according to the above definition. Whereas, if the MS has been assigned both directions of the channel in a single channel allocation (i.e. with element "Up/downlink assigned" or "Up/downlink assigned for augmented channel allocation" = 11_2) then it shall leave the channel on criterion c) if either direction is no longer valid.

NOTE 2: The MS should not react to reception of only one adverse ACCESS-ASSIGN PDU, because of the possibility of incorrectly decoding the AACH or AACH-Q. So $N.208 \geq 2$.

NOTE 3: The value of N.208 may be different on a QAM channel from the value on a $\pi/4$ -DQPSK or D8PSK channel.

NOTE 4: The N.208 procedure refers to a check on those ACCESS-ASSIGN PDUs that are received by the MS, irrespective of whether or not these are in successive slots on the assigned channel. On a $\pi/4$ -DQPSK or D8PSK channel, the MS does not receive the ACCESS-ASSIGN PDU in a downlink slot if the AACH is not decodeable. On a QAM channel, the MS does not receive the ACCESS-ASSIGN PDU in a downlink slot if either the AACH-Q is not decodeable or the ACCESS-ASSIGN PDU is not present within the AACH-Q.

NOTE 5: For this procedure, the MS checks only the designation of slots belonging to the downlink assigned channel (although, in the case of an extended random access channel, the MS may be decoding other ACCESS-ASSIGN PDUs).

NOTE 6: As a result of de-allocation on criterion b) or c), the MS may actually remain on the same physical channel. However, its designation has changed from "assigned" to "common".

NOTE 7: If the BS has assigned only the uplink in a channel allocation, and the downlink is not used for another purpose, the BS should mark the downlink as "assigned control" in the ACCESS-ASSIGN PDU, not "unallocated". Similarly, the BS should not use Header 00₂ unless the channel is entirely dedicated to common control usage.

NOTE 8: Downlink usage marker 000001₂ may be used on $\pi/4$ -DQPSK, D8PSK and QAM channels; it indicates "assigned control". Downlink usage marker 000011₂ may be used on QAM channels; it indicates "common and assigned control". Therefore the MS regards both values 000001₂ and 000011₂ as valid downlink usage markers on a QAM assigned SCCH.

23.5.6.1.2 Inactivity time-out

If the MS is on a channel assigned for SCCH, and a time T.208 elapses without either:

- transmission by the MS by reserved access; or
- receipt of a downlink message on this channel containing one of its valid addresses or event labels, other than the predefined broadcast group address (all ones),

then the MS shall regard the channel as no longer valid for transmission or reception.

If the MS is on a channel assigned for a circuit mode call, and a time T.209 elapses without either:

- transmission by the MS, for traffic (TCH or STCH) or by reserved access; or
- receipt of a downlink message on this channel containing one of its valid addresses or event labels, other than the predefined broadcast group address (all ones); or
- receipt of an ACCESS-ASSIGN PDU containing the MS's traffic usage marker (either as the downlink or the uplink usage marker in the ACCESS-ASSIGN PDU, and in any frame 1 to 18),

then the MS shall regard the channel as no longer valid for transmission or reception.

In case of time-out on either T.208 or T.209 then, if the MS does not have a concurrent assigned channel, it shall return to its common control channel. The MS-MAC shall inform the higher layers of the de-allocation using either:

- the TMA-RELEASE indication primitive to indicate loss of the connection; or
- a TMC-CONFIGURE indication primitive indicating loss of the physical resource,

and shall inform the higher layers of any change of channel using the TMC-SELECT indication primitive.

NOTE 1: In order to keep MSs on the channel during long periods of FACCH, e.g. for an open channel, the BS may send occasional slots in frames 1 to 17 containing the traffic usage marker as the uplink usage marker (with Header 11₂); or it may use the traffic usage marker as the usage marker in frame 18 (frame 18 Header 11₂). Also, use of the traffic usage marker as the downlink usage marker in occasional slots in frames 1 to 17 (with STCH + STCH) is not precluded though it is not recommended. Otherwise the BS could send dummy messages addressed to the MS(s) on the channel.

NOTE 2: If the MS decides to obey a group addressed channel allocation after a delay then it may choose to decrease its value of T.208 or T.209 until it has received signalling confirming that the expected service is still ongoing on the assigned channel i.e. until it has received an appropriate downlink message addressed to itself or ACCESS-ASSIGN PDU(s) containing its traffic usage marker. Similarly, in clause 23.5.6.1.1, the MS is not precluded from reducing its value of N.208 though it should not reduce N.208 to below 2.

23.5.6.2 Criteria for leaving carrier specific signalling channel

This clause applies to MSs that are on a CSS channel, having accepted the CSS part of a channel allocation with allocation type 11₂ (Replace + CSS channel) where the allocated carrier is not the MS's main carrier.

After assignment of a CSS channel, the MS-MAC may continue to use the CSS channel on that carrier until one of the following occurs:

- a) it obeys a channel allocation command received on that CSS channel, directing it elsewhere (see clause 23.5.4.2.4); or
- b) it has no assigned channel on that carrier, assigned either for SCCH or for a circuit mode call; or
- c) it obeys a channel allocation command allocating slot 1 of that carrier as an assigned channel.

The MS-MAC should inform the higher layers of the de-allocation of the CSS channel and of any change of channel.

EXAMPLE: In criterion a), the MS leaves the CSS channel if it obeys a "replace" channel allocation received on the CSS channel, or if it obeys a "replace + CSS channel" allocation received on the CSS channel and assigning a different carrier, or if it receives and does not ignore a "quit" channel allocation received on the CSS channel.

Criterion b) requires the MS to leave the CSS channel when it no longer has an assigned channel (other than the CSS channel) on that carrier.

If criterion c) occurs, the MS remains on the same physical channel (i.e. slot 1 of the carrier). However, its usage of the physical channel has changed from CSS channel to assigned channel.

NOTE 1: Criterion a) only requires the MS to leave the CSS channel. It does not require the MS to leave the assigned channel that was allocated in the same channel allocation as the CSS channel (unless the MS is no longer capable of receiving that assigned channel as a result of obeying the channel allocation command).

NOTE 2: Criterion b) requires the MS to leave the CSS channel when it has no assigned channel on that carrier. Thus the permission to use the CSS channel is not specifically linked to the assigned channel that was allocated in the same channel allocation as the CSS channel. If the MS leaves that assigned channel then it may continue to use the CSS channel if it has another assigned channel on the carrier.

23.5.6.3 Traffic on downlink for other users

When the MS is receiving a $\pi/4$ -DQPSK assigned channel, the downlink may be used for traffic independently of any usage of the uplink for signalling or traffic. For example:

- uplink assigned for SCCH, but with downlink not dedicated to SCCH;
- inter-site circuit mode call.

An MS is specifically instructed when it may process received user traffic TCH for transfer to its U-plane application, as described in clause 23.8.2.

An MS that has not received such authorization shall interpret the downlink slots as follows.

The MS shall assume that a downlink slot in frames 1 to 17 is in traffic mode carrying traffic for other MSs if the ACCESS-ASSIGN PDU contains a downlink traffic usage marker (i.e. Header \neq 00₂ and downlink usage marker \geq 000100₂). Otherwise it shall assume that the downlink is in signalling mode. If the ACCESS-ASSIGN PDU is not received then the MS shall assume that the downlink is in the mode indicated by the last ACCESS-ASSIGN PDU received in frames 1 to 17 in a slot appropriate to the downlink assigned channel. (See clause 19 for the configuration in signalling and traffic mode.)

In both signalling and traffic mode, full ($SF = 0$) or half slot ($SF = 1$) downlink transmissions may be used. The slot flag (SF) shall correspond to a change between two training sequences, as described in clause 9.

In the case of signalling mode on a $\pi/4$ -DQPSK channel:

- a) The MS shall interpret slots with $SF = 0$ as SCH/F.
- b) The MS shall interpret slots with $SF = 1$ as SCH/HD + SCH/HD.

In the case of traffic mode on a $\pi/4$ -DQPSK channel:

- a) The MS shall interpret slots with $SF = 0$ as TCH, and shall ignore that TCH.
- b) For $SF = 1$, the MS shall interpret the slot as STCH + TCH or STCH + STCH, depending on the content of the first STCH.

For STCH, the MS shall inspect the MAC header of each PDU in order to:

- discover whether the second half slot is stolen;
- perform PDU dissociation (in the case of C-plane stealing);
- process any C-plane messages addressed to itself.

See clause 23.8.4.2.2 for the method for reception of STCH.

The MS shall ignore the TM-SDU in any MAC-U-SIGNAL PDUs, and the TCH.

Slots containing the synchronization training sequence shall always be interpreted as BSCH + SCH/HD.

Traffic mode applies only to frames 1 to 17. Both MS and BS shall always be in signalling mode on frame 18.

NOTE 1: The above procedure applies to any MS that does not have authorization or "N.213 permission" (see clause 23.8.2.3.2) to receive TCH with this traffic usage marker. This includes an MS that is transmitting traffic in simplex mode, or an MS with a different traffic usage marker, or an MS on assigned SCCH.

NOTE 2: When the BS changes the designation of the downlink channel, it may choose to send a few slots using normal training sequence 2 (i.e. $SF = 1$), to allow for poor reception of the ACCESS-ASSIGN PDU. MS interpretation of SCH/HD and two-half-slot STCH is very similar. At other times, use of SCH/F (with PDU association) is recommended for most C-plane signalling on the downlink, since it is generally more flexible.

23.5.7 Maintenance of common channel

The MS shall attempt to decode the AACH or AACH-Q in slots appropriate to the downlink common channel (within the constraints of the cell reselection procedures, and linearization and transmission requirements, and energy economy or dual watch or part-time reception mode).

If N.215 successive ACCESS-ASSIGN PDUs received in frames 1 to 17 in the AACH or AACH-Q of slots appropriate to the downlink common channel indicate that:

- the downlink is unallocated, i.e. header value = 11_2 and "field 1" = $UMx (000000_2)$ and "field 2" = $UMx (000000_2)$,

then the MS should regard the common channel as no longer valid for transmission or reception. The MS-MAC should inform the higher layers of the de-allocation using the "common channel deallocated" TMC-REPORT indication primitive (indicating a downlink failure) in order to initiate the MLE cell reselection procedures (as indicated in clause 18.3.4.5.3).

NOTE 1: This procedure applies to MSs that are in common mode on their common control channel. In some cases other MSs may be in assigned mode on that channel, in which case those other MSs obey the maintenance procedures for an assigned channel.

NOTE 2: The value of N.215 may be different on a QAM common channel from the value on a $\pi/4$ -DQPSK common channel.

NOTE 3: The N.215 procedure refers to a check on those ACCESS-ASSIGN PDUs that are received by the MS, irrespective of whether or not these are in successive slots on the downlink common channel. On a $\pi/4$ -DQPSK channel, the MS does not receive the ACCESS-ASSIGN PDU in a downlink slot if the AACH is not decodeable. On a QAM channel, the MS does not receive the ACCESS-ASSIGN PDU in a downlink slot if either the AACH-Q is not decodeable or the ACCESS-ASSIGN PDU is not present within the AACH-Q.

23.6 PDU transfer for broadcast messages (TMB-SAP)

23.6.1 Broadcast logical channels

23.6.1.1 General

The BS shall transmit broadcast system information on phase modulation carriers (i.e. carriers currently carrying $\pi/4$ -DQPSK and/or D8PSK channel(s)) using the SYNC PDU transmitted on the BSCH and the SYSINFO PDU transmitted on the BNCH.

NOTE 1: The ACCESS-DEFINE PDU also contains broadcast information relating to random access and is described within clause 23.5.1.

NOTE 2: CA MSs use all the information in the SYNC and SYSINFO PDUs. DA MSs on a $\pi/4$ -DQPSK or D8PSK channel receive and decode the SYNC and SYSINFO PDUs. However they use only the information appropriate to their operation on the current channel; see clause 23.6.9.

On a phase modulation traffic or control channel, the BSCH and BNCH shall be transmitted in frame 18 using a fixed mapping. The BNCH may also be transmitted during frames 1 to 17 of a control channel, and both BSCH and BNCH may be transmitted on unallocated channels. The precise rules for BSCH and BNCH transmission are described in clause 9.

The BS may send broadcast system information to CA MSs on QAM carriers using the SYSINFO-Q PDU transmitted on the BNCH-Q.

The BS shall transmit DA broadcast system information on DA main carriers using the SYNC-DA PDU transmitted on the BSCH-Q and the SYSINFO-DA PDU transmitted on the BNCH-Q. The SYNC-DA and SYSINFO-DA PDUs are used by DA MSs.

The BS may send DA broadcast system information on QAM carriers other than the DA main carrier using the SYNC-DA PDU transmitted on the BSCH-Q and the SYSINFO-DA PDU transmitted on the BNCH-Q.

On a DA main carrier, the BSCH-Q and BNCH-Q (containing SYSINFO-DA) shall be transmitted in frame 18 using a fixed mapping. The BSCH-Q and BNCH-Q (containing either SYSINFO-DA or SYSINFO-Q) may also be transmitted during frames 1 to 18 of any QAM channel (on both the DA main carrier and QAM carriers other than the DA main carrier); and both BSCH-Q and BNCH-Q may be transmitted on unallocated QAM channels. The precise rules for BSCH-Q and BNCH-Q transmission are described in clause 9.

The BS may send DA broadcast system information to DA MSs on phase modulation carriers using the SYSINFO-DA PDU transmitted on the SCH/F, SCH-P8/HD or SCH-P8/F.

23.6.1.2 CA broadcast logical channels

BSCH and BNCH shall be received and decoded by all MSs wishing to camp or camped on a CA cell. These broadcast PDUs contain essential system information required by an MS to synchronize with and use the facilities of a CA cell.

A CA MS, on receiving and correctly decoding broadcast information, shall remove the MAC header and shall store the parameters contained therein as the serving cell broadcast parameters. (While scanning CA adjacent cells, the MAC may also be required to store the broadcast parameters for those adjacent cells for use in the cell reselection procedures.) The MAC shall then pass the TM-SDU to the MLE. Upon receiving subsequent SYNC or SYSINFO PDUs, the MAC shall update its stored serving cell parameters before passing the MLE data contained in the TM-SDU to the LLC which shall then pass the MLE data transparently to the MLE.

The appropriate MAC primitives for the MAC to pass the MLE data to the LLC are the TMB-SYNC indication and TMB-SYSINFO indication.

NOTE 1: In addition to the TM-SDU, the TMB-SYSINFO indication primitive may include extended services information from the MAC PDU. For example, any information in the SYSINFO PDU about support of data priority by the BS is used by the MAC but is also used by the higher layers (e.g. SNDCP).

The broadcast information in both of these PDUs relates to the system configuration for that CA cell. Therefore, the BSCH and BNCH information transmitted on all carriers belonging to a single CA cell shall be identical (with the exception of the items in note 2). This means that a CA MS may receive the system information on any phase modulation carrier belonging to a CA cell. This includes slot, frame and multiframe number implying that all carriers belonging to a BS shall be synchronized in time (see also clause 7).

NOTE 2: The power control and cell/channel (re-)selection parameters may be different for different channels; see clause 23.6.6. Also the random access parameters may be different on different channels.

NOTE 3: The carriers belonging to a BS are synchronized in time as defined in clause 7.7. However the MS may perceive a larger timing difference between an eccentric carrier and the main carrier than between a non-eccentric carrier and the main carrier, because the timing difference depends additionally on the difference between the MS's distance from the eccentric carrier's transmitter site and the MS's distance from the main carrier's transmitter site; see also clause 7.8.

The BS may transmit broadcast system information to CA MSs on QAM carriers (i.e. carriers currently carrying QAM channel(s)) using the SYSINFO-Q PDU transmitted on the BNCH-Q using SCH-Q/D; see clause 23.6.5. The BNCH-Q may be transmitted in any slot in frames 1 to 18: in the present document, there is no fixed mapping of the SYSINFO-Q PDU on a QAM channel.

Further information about the usage of broadcast messages by CA MSs is contained in clauses 23.6.2, 23.6.3, 23.6.4, 23.6.5 and 23.6.6.

23.6.1.3 DA broadcast logical channels

BSCH-Q containing the SYNC-DA PDU and BNCH-Q containing the SYSINFO-DA PDU shall be received and decoded by all MSs wishing to camp on a DA cell. These broadcast PDUs contain essential system information required by an MS to synchronize with and use the facilities of a DA cell.

The information in the SYNC-DA PDU is intended primarily for MSs that are attempting to synchronize with and obtain initial information about the DA cell; the SYNC-DA PDU enables the MS to synchronize with and decide whether it wishes to use a DA cell.

The SYSINFO-DA PDU contains further information needed before the MS can actually use the cell. The SYSINFO-DA PDU also duplicates some of the information from the SYNC-DA PDU so that it contains all the TMB-SAP information needed by DA MSs that are already camped on the DA cell.

Therefore all DA MSs camped on a DA cell shall continue to receive and attempt to decode the SYSINFO-DA PDU. However it is optional whether DA MSs camped on a DA cell continue to decode the BSCH-Q to receive the SYNC-DA PDU.

NOTE 1: The SYSINFO-DA PDU does not contain the colour code (or MCC or MNC), timeslot number, frame number or multiframe number. Therefore the MS uses the colour code and derives its timeslot, frame and multiframe numbering from that last received in a SYNC-DA PDU within that cell.

A DA MS, on receiving and correctly decoding DA broadcast information, shall remove the MAC header and shall store the parameters contained therein as the serving cell broadcast parameters. (While scanning DA adjacent cells, the MAC may also be required to store the broadcast parameters for those adjacent cells for use in the cell reselection procedures.) The MAC shall then pass the TM-SDU to the MLE. Upon receiving subsequent SYSINFO-DA PDUs (and optionally SYNC-DA PDUs), the MAC shall update its stored serving cell parameters before passing the MLE data contained in the TM-SDU to the LLC which shall then pass the MLE data transparently to the MLE.

The appropriate MAC primitives for the MAC to pass the MLE data to the LLC are the TMB-SYNC-DA indication and TMB-SYSINFO-DA indication.

NOTE 2: In addition to the TM-SDU, the TMB-SYNC-DA and TMB-SYSINFO-DA indication primitives may include extended services information from the MAC PDU; also the TMB-SYNC-DA indication primitive may include Location Area (LA) information from the MAC PDU.

The broadcast information in both of these PDUs relates to the system configuration for that DA cell. Therefore, the SYNC-DA and SYSINFO-DA information transmitted on all carriers used by a single DA cell shall be identical (with the exception of the items in notes 3 and 4). This means that a DA MS may receive the system information on any QAM carrier used by a DA cell (see note 5). This includes slot, frame and multiframe number implying that all carriers used by a BS shall be synchronized in time (see also clause 7).

NOTE 3: The power control and cell/channel (re-)selection parameters may be different for different channels; see clause 23.6.11. Also the random access parameters may be different on different channels.

NOTE 4: The full information about the DA downlink main carrier is included in the SYNC-DA PDU when the PDU is sent on a QAM carrier other than the DA main carrier; however it is not included (except the DA main carrier bandwidth) when the PDU is sent on the DA main carrier.

The Location Area (LA) is included in the SYNC-DA PDU when the PDU is sent on the DA main carrier; however it is not included when the PDU is sent on a QAM carrier other than the DA main carrier.

NOTE 5: If an assigned channel is shared by MSs from different DA cells, the BS should not send the SYNC-DA or SYSINFO-DA PDU on that assigned channel.

NOTE 6: The carriers belonging to a BS are synchronized in time as defined in clause 7.7. However the MS may perceive a larger timing difference between an eccentric carrier and the main carrier than between a non-eccentric carrier and the main carrier, because the timing difference depends additionally on the difference between the MS's distance from the eccentric carrier's transmitter site and the MS's distance from the main carrier's transmitter site; see also clause 7.8.

The BS may also transmit broadcast system information to DA MSs on phase modulation carriers using the SYSINFO-DA PDU transmitted on the SCH/F, SCH-P8/HD or SCH-P8/F in any slot in frames 1 to 18; see clause 23.6.10.

Further information about the usage of broadcast messages by DA MSs is contained in clauses 23.6.7, 23.6.8, 23.6.9, 23.6.10 and 23.6.11.

23.6.2 Acquiring cell synchronization on a CA cell

An MS synchronizes with a CA cell by first attempting to synchronize with the synchronization training sequence contained in the synchronization burst (BSCH). On acquiring synchronization, the MS shall then decode the contents of the SYNC PDU also contained in the synchronization burst. The SYNC PDU contains the colour code, which shall be used by the MS to de-scramble the contents of all other bursts transmitted by that BS, and the system code, which indicates whether the system is a TETRA V+D system (or whether this is a Direct Mode transmission). The SYNC PDU also contains the slot, frame and multiframe number for this downlink slot giving the MS full synchronization with this BS. The SYNC PDU also contains some information about the discontinuous mode of operation of the BS for phase modulation carriers.

The MS may acquire cell synchronization on any phase modulation downlink carrier being transmitted by the BS for that CA cell. The BSCH information shall be the same for all carriers within the cell, and the slot, frame and multiframe synchronization shall be the same.

Having synchronized with a CA cell, the MS shall continue to decode subsequent SYNC PDUs transmitted by that BS but shall only use those with the correct value of the "colour code" element to prevent an MS from using the BSCH transmitted by an adjacent cell.

NOTE: There is no other co-channel interference protection on the BSCH.

The MS shall store the information received in the SYNC PDU and shall update this stored information on receiving subsequent SYNC PDUs.

23.6.3 Acquiring network information on a CA cell

An MS, having acquired synchronization with a CA cell by receiving and decoding the BSCH information (SYNC PDU), is able to decode all $\pi/4$ -DQPSK downlink bursts transmitted by the BS. First of all, the MS shall search for the BNCH in order to receive and decode the SYSINFO PDU containing system information for this cell. The SYSINFO PDU contains information about the frequency of the main carrier of this CA cell, the number of common secondary control channels in operation on the main carrier, information used for power control and cell (re-)selection (parameters MS_TXPWR_MAX_CELL, RXLEV_ACCESS_MIN, ACCESS_PARAMETER and RADIO_DOWNLINK_TIMEOUT) and some random access parameters (see clause 21 for full description). The MAC shall decode the SYSINFO PDU and store the MAC parameters. On receiving subsequent SYSINFO PDUs, the MAC shall update the stored parameters accordingly.

Having decoded the SYNC and SYSINFO PDUs, the MS may locate the MCCH (i.e. slot 1 of the main carrier) or the relevant common SCCH. The MS has all of the information needed to communicate with the BS and may now receive downlink PDUs and transmit uplink PDUs using the procedures defined elsewhere within the MAC protocol.

23.6.4 Receiving SYNC and SYSINFO PDUs on D8PSK channel - CA MS

On a D8PSK channel, the BS shall transmit the BSCH (containing the SYNC PDU) and BNCH (containing the SYSINFO PDU) in frame 18 according to the mapping described in clause 9, and using $\pi/4$ -DQPSK bursts. The SYSINFO PDU may also be transmitted in other slots in frame 18 and in frames 1 to 17, in which case the BS may use either a $\pi/4$ -DQPSK burst or a $\pi/8$ -D8PSK burst.

The SYNC and SYSINFO PDUs shall be received and decoded by all CA MSs using a D8PSK channel. The MS shall use the same procedures as described in clauses 23.6.1, 23.6.2 and 23.6.3 with the following exception:

- parameters MS_TXPWR_MAX_CELL, RXLEV_ACCESS_MIN, ACCESS_PARAMETER and RADIO_DOWNLINK_TIMEOUT are specific to that D8PSK channel (see clause 23.6.6); therefore, on receipt of the SYSINFO PDU on a D8PSK channel, the MS shall not overwrite the equivalent stored parameters received on a $\pi/4$ -DQPSK or QAM channel (or received on a concurrent D8PSK channel).

NOTE: When an MS first acquires cell synchronization and network information on a CA cell (using the procedure described in clauses 23.6.2 and 23.6.3), if the BNCH was received on a D8PSK channel then the MS's first stored values of parameters MS_TXPWR_MAX_CELL, RXLEV_ACCESS_MIN, ACCESS_PARAMETER and RADIO_DOWNLINK_TIMEOUT will be the values for the D8PSK channel - which may be different from the values for a conforming $\pi/4$ -DQPSK channel. However, when the MS moves to the MCCH or the relevant common SCCH, it will receive the values for a conforming $\pi/4$ -DQPSK channel when it receives the SYSINFO PDU on that channel and will update the stored parameters accordingly.

23.6.5 Receiving SYSINFO-Q PDU on QAM channel - CA MS

There is a QAM broadcast network logical channel BNCH-Q (containing the SYSINFO-Q or SYSINFO-DA PDU), which the BS may transmit on SCH-Q/D in any slot in frames 1 to 18 of a QAM channel. The SYSINFO-Q PDU is used by CA MSs, whereas the SYSINFO-DA PDU is used by DA MSs.

In the present document, there is no fixed mapping of the SYSINFO-Q PDU on a QAM channel.

NOTE 1: There is also a QAM broadcast synchronization logical channel BSCH-Q (containing the SYNC-DA PDU), which the BS may transmit on QAM channels. The SYNC-DA PDU is used by DA MSs.

The SYSINFO-Q PDU shall be received and decoded by all CA MSs using a QAM channel. A CA MS, on receiving and correctly decoding the SYSINFO-Q PDU, shall remove the MAC header and shall store the parameters contained therein. The MAC shall then pass the TM-SDU to the MLE. Upon receiving subsequent SYSINFO-Q PDUs on that channel, the MAC shall update its stored parameters before passing the MLE data contained in the TM-SDU to the LLC which shall then pass the MLE data transparently to the MLE. The appropriate MAC primitive for the MAC to pass the MLE data to the LLC is the TMB-SYSINFO-Q indication.

NOTE 2: In addition to the TM-SDU, the TMB-SYSINFO-Q indication primitive may include extended services information from the MAC PDU.

The SYSINFO-Q PDU contains information about the frequency of the main carrier of this CA cell, the number of common secondary control channels in operation on the main carrier, information used for power control and cell (re-)selection or assigned channel replacement, an encryption parameter, some random access parameters and the "extended services broadcast" element (see clause 21 for full description).

The information about the frequency of the main carrier of this CA cell, the number of common secondary control channels in operation on the main carrier, encryption and extended services transmitted within the SYSINFO-Q PDU shall be identical to the equivalent information in the SYSINFO PDU transmitted on phase modulation carriers within that cell. Therefore the MS shall update these stored parameters whenever it receives either a SYSINFO or SYSINFO-Q PDU.

However, parameters MS_TXPWR_MAX_CELL, RXLEV_ACCESS_MIN, ACCESS_PARAMETER and RADIO_DOWNLINK_TIMEOUT are specific to that QAM channel (see clause 23.6.6). Therefore, on receipt of the SYSINFO-Q PDU, the MS shall not overwrite the equivalent stored parameters received on a $\pi/4$ -DQPSK or D8PSK channel (or received on a concurrent QAM channel).

The BS does not send the colour code, timeslot number, frame number, multiframe number or hyperframe number to CA MSs on a QAM channel. Therefore, when a CA MS is on a QAM channel, it shall use the colour code last received in a SYNC PDU on a phase modulation channel within that cell. Also it shall derive its timeslot, frame, multiframe and hyperframe numbering from that last received in SYNC and SYSINFO PDUs on a phase modulation channel within that cell. This implies that all QAM carriers used by a CA cell shall be synchronized in time with the phase modulation carrier(s) used by that cell; see clause 7 for details of the synchronization of phase modulation carriers and QAM carriers.

NOTE 3: The carriers belonging to a BS are synchronized in time as defined in clause 7.7. However the MS may perceive a larger timing difference between an eccentric carrier and the main carrier than between a non-eccentric carrier and the main carrier; see also clause 7.8.

Also the BS does not send any information about the discontinuous mode of operation (or U-plane DTX or frame 18 extension) to CA MSs on a QAM channel; therefore, when a CA MS is on a QAM channel, it shall assume that the last information received in SYNC and SYSINFO PDUs within that cell still applies on phase modulation carriers.

23.6.6 Power control and cell/channel reselection parameters for CA

23.6.6.0 General

The power control and cell (re-)selection or assigned channel replacement parameters MS_TXPWR_MAX_CELL, RXLEV_ACCESS_MIN, ACCESS_PARAMETER and RADIO_DOWNLINK_TIMEOUT are broadcast by the BS:

- in the SYSINFO PDU broadcast by the BS to all MSs on a $\pi/4$ -DQPSK or D8PSK channel;
- in the SYSINFO-Q PDU broadcast by the BS to CA MSs on a QAM channel.

NOTE: If DA MSs are also present on a QAM channel, the BS may send the SYSINFO-DA and SYNC-DA PDUs to those MSs; see clause 23.6.11. Also, if DA MSs are present on a $\pi/4$ -DQPSK or D8PSK channel, the BS may send the SYSINFO-DA PDU to those MSs; see clause 23.6.10.

Parameters MS_TXPWR_MAX_CELL and ACCESS_PARAMETER are used in the open loop power control procedure (see clause 23.4.4.2). Parameters MS_TXPWR_MAX_CELL and RXLEV_ACCESS_MIN are used in the calculation of the path loss parameter for the current channel on the serving cell, and for adjacent cells by scanning, and for the main carrier of the serving cell by monitoring (see clause 23.7). RADIO_DOWNLINK_TIMEOUT is used for assessing the quality of the downlink of the current channel on the serving cell (see clause 23.7.3).

The values of parameters MS_TXPWR_MAX_CELL, RXLEV_ACCESS_MIN, ACCESS_PARAMETER and RADIO_DOWNLINK_TIMEOUT may vary according to the modulation mode and bandwidth of the channel and according to whether the channel is conforming, non-conforming concentric, sectored, super-sectored or eccentric (see clause 23.7 for the definition of conforming, concentric, sectored, super-sectored and eccentric channels).

23.6.6.1 $\pi/4$ -DQPSK channel

When an MS first acquires a CA main carrier or receives a channel allocation for a $\pi/4$ -DQPSK channel on a CA new cell, the MS-MAC shall use the values of MS_TXPWR_MAX_CELL, RXLEV_ACCESS_MIN, ACCESS_PARAMETER and RADIO_DOWNLINK_TIMEOUT obtained when it acquired network information by receiving the SYSINFO PDU on that cell (see clause 23.6.3).

When a CA MS is sent to a new $\pi/4$ -DQPSK channel within the cell, or when it returns to the MCCH or to a $\pi/4$ -DQPSK common SCCH, the MS-MAC shall use the values of MS_TXPWR_MAX_CELL, RXLEV_ACCESS_MIN, ACCESS_PARAMETER and RADIO_DOWNLINK_TIMEOUT last received on a conforming $\pi/4$ -DQPSK channel in that cell.

In either case, on receiving subsequent SYSINFO PDUs on the $\pi/4$ -DQPSK channel, the MS-MAC shall update the MS_TXPWR_MAX_CELL, RXLEV_ACCESS_MIN, ACCESS_PARAMETER and RADIO_DOWNLINK_TIMEOUT parameters for that channel accordingly.

23.6.6.2 D8PSK channel

When a CA MS is sent to a D8PSK channel, the MS-MAC shall make the following assumptions about the values of MS_TXPWR_MAX_CELL, RXLEV_ACCESS_MIN, ACCESS_PARAMETER and RADIO_DOWNLINK_TIMEOUT until updated by receiving SYSINFO PDUs on that channel:

- If the MS-MAC has previously received the SYSINFO PDU on a D8PSK channel in that cell, it shall assume that the values of MS_TXPWR_MAX_CELL, RXLEV_ACCESS_MIN, ACCESS_PARAMETER and RADIO_DOWNLINK_TIMEOUT are equal to those last received on a D8PSK channel in that cell.
- Otherwise (i.e. if the MS-MAC has not previously received the SYSINFO PDU on a D8PSK channel in that cell) the MS-MAC shall use the values of MS_TXPWR_MAX_CELL, RXLEV_ACCESS_MIN, ACCESS_PARAMETER and RADIO_DOWNLINK_TIMEOUT last received on a conforming $\pi/4$ -DQPSK channel in that cell.

In either case, on receiving a SYSINFO PDU on the D8PSK channel, the MS-MAC shall update the MS_TXPWR_MAX_CELL, RXLEV_ACCESS_MIN, ACCESS_PARAMETER and RADIO_DOWNLINK_TIMEOUT parameters for that channel accordingly.

23.6.6.3 QAM channel

When a CA MS is sent to a QAM channel with RF bandwidth B, the MS-MAC shall make the following assumptions about the values of MS_TXPWR_MAX_CELL, RXLEV_ACCESS_MIN, ACCESS_PARAMETER and RADIO_DOWNLINK_TIMEOUT until updated by receiving SYSINFO-Q PDUs on that channel:

- If the MS-MAC has previously received the SYSINFO-Q PDU on a QAM channel in that cell with the same bandwidth B, it shall assume that the values of MS_TXPWR_MAX_CELL, RXLEV_ACCESS_MIN, ACCESS_PARAMETER and RADIO_DOWNLINK_TIMEOUT are equal to those last received on a QAM channel in that cell with bandwidth B.
- Otherwise (i.e. if the MS-MAC has not previously received the SYSINFO-Q PDU on a QAM channel in that cell with the same bandwidth B):
 - a) the MS-MAC shall use the values of MS_TXPWR_MAX_CELL, ACCESS_PARAMETER and RADIO_DOWNLINK_TIMEOUT last received on a conforming $\pi/4$ -DQPSK channel in that cell;

- b) the MS-MAC shall use a value of `RXLEV_ACCESS_MIN` equal to:

$$\text{RXLEV_ACCESS_MIN}(\text{main}) + \text{CONVERSION_FACTOR} \quad (23.8)$$

where `RXLEV_ACCESS_MIN(main)` is the value of `RXLEV_ACCESS_MIN` last received on a conforming $\pi/4$ -DQPSK channel in that cell and:

- `CONVERSION_FACTOR` = -3 dB if the bandwidth B of the QAM channel is 25 kHz;
- `CONVERSION_FACTOR` = 0 dB if the bandwidth B of the QAM channel is 50 kHz;
- `CONVERSION_FACTOR` = 3 dB if the bandwidth B of the QAM channel is 100 kHz;
- `CONVERSION_FACTOR` = 5 dB if the bandwidth B of the QAM channel is 150 kHz.

In either case, on receiving a `SYSINFO-Q` PDU on the QAM channel, the MS-MAC shall update the `MS_TXPWR_MAX_CELL`, `RXLEV_ACCESS_MIN`, `ACCESS_PARAMETER` and `RADIO_DOWNLINK_TIMEOUT` parameters for that channel accordingly.

23.6.7 Acquiring cell synchronization on a DA cell

An MS synchronizes with a DA cell by first attempting to find and synchronize with the QAM Frequency Correction downlink Burst (FCB). The MS shall then decode the contents of the `SYNC-DA` PDU in the logical channel `BSCH-Q`, which is contained within the FCB. The `SYNC-DA` PDU contains:

- a) the system code;
- b) information about the bandwidth of the downlink main carrier of this DA cell;
- c) information about the frequency of the downlink main carrier of this DA cell (included when the PDU is sent on a QAM carrier other than the DA main carrier);
- d) the Location Area (LA) in which this DA cell is located (included when the PDU is sent on the DA main carrier);
- e) essential information about the security and services provided by this BS;
- f) the cell selection parameters `RXLEV_ACCESS_MIN` and `MS_TXPWR_MAX_CELL` for the main carrier of this DA cell;
- g) the colour code, which shall be used by the MS to de-scramble the contents of all other logical channels transmitted by this BS;
- h) the slot, frame and multiframe number for this downlink slot, giving the MS full synchronization with the BS.

This information enables the MS to synchronize, to locate the downlink main carrier of this DA cell and to decide whether it wishes to use the cell. It also enables the MS to receive other bursts transmitted by the BS on the downlink main carrier of this DA cell.

NOTE 1: The `SYNC-DA` PDU contains essential information for the MS to decide whether it wishes to use the cell. However the `SYSINFO-DA` PDU contains some additional information about the cell, so the MS may prefer to receive the `SYSINFO-DA` PDU on a likely cell before confirming its decision.

It is optional for the BS to transmit the `SYNC-DA` PDU on carriers other than the DA main carrier. The `SYNC-DA` information shall be the same for all carriers on which it is transmitted within the cell (except see items c) and d) above); and the slot, frame and multiframe synchronization shall be the same.

The MS may acquire cell synchronization on any QAM downlink carrier for that DA cell on which the BS chooses to transmit the `SYNC-DA` PDU. However the MS needs to locate the DA main carrier in order to perform path loss measurements and to receive other bursts transmitted by the BS.

Having synchronized with a DA cell, the MS may continue to decode subsequent `SYNC-DA` PDUs transmitted by the BS. If the MS continues to decode subsequent `SYNC-DA` PDUs transmitted by the BS, it shall only use those with the correct value of the "colour code" element to prevent the MS from using the `BSCH-Q` transmitted by an adjacent cell.

NOTE 2: There is no other co-channel interference protection on the `BSCH-Q`.

If the MS continues to decode subsequent SYNC-DA PDUs transmitted by the BS, it shall update its stored information on receiving SYNC-DA PDUs.

23.6.8 Acquiring network information on a DA cell

An MS, having acquired synchronization with a DA cell by receiving and decoding the BSCH-Q information (SYNC-DA PDU), is able to locate the downlink main carrier of the DA cell and to decide whether it wishes to use the cell. It is also able to receive other bursts transmitted by the BS on the downlink main carrier.

If the MS wishes to use the cell, it also needs to receive and decode the SYSINFO-DA PDU. This PDU duplicates some of the information from the SYNC-DA PDU and also contains further system information for this cell. The further information includes the duplex spacing of the DA main carrier, the number of slots comprising the MCCH-Q or the number of QAM common secondary control channels in operation on the main carrier, further information used for power control and cell (re-)selection, the hyperframe number, some random access and other radio parameters and some further details about the security and services provided by this BS. (See clause 21 for full description.) The MAC shall decode the SYSINFO-DA PDU and store all the MAC parameters.

Having decoded the SYNC-DA and SYSINFO-DA PDUs, the MS may locate the MCCH-Q or the relevant QAM common SCCH. The MS has all of the information needed to communicate with the BS and may now receive other downlink PDUs and transmit uplink PDUs using the procedures defined elsewhere within the MAC protocol.

While camped on the cell, the MS shall continue to decode subsequent SYSINFO-DA PDUs transmitted by the BS. On receiving subsequent SYSINFO-DA PDUs, the MAC shall update its stored parameters accordingly.

23.6.9 Receiving SYNC and SYSINFO PDUs on $\pi/4$ -DQPSK or D8PSK channel - DA MS

On a $\pi/4$ -DQPSK channel, the BS shall transmit the BSCH (containing the SYNC PDU) and BNCH (containing the SYSINFO PDU) in frame 18 according to the mapping described in clause 9, using $\pi/4$ -DQPSK bursts. The SYSINFO PDU may also be transmitted in other slots in frame 18 and in frames 1 to 17, using a $\pi/4$ -DQPSK burst.

Similarly, on a D8PSK channel, the BS shall transmit the BSCH (containing the SYNC PDU) and BNCH (containing the SYSINFO PDU) in frame 18 according to the mapping described in clause 9, using $\pi/4$ -DQPSK bursts. The SYSINFO PDU may also be transmitted in other slots in frame 18 and in frames 1 to 17, in which case the BS may use either a $\pi/4$ -DQPSK burst or a $\pi/8$ -D8PSK burst.

The SYNC and SYSINFO PDUs shall be received and decoded by all MSs using a $\pi/4$ -DQPSK or D8PSK channel, including DA MSs.

A DA MS shall decode all SYNC PDUs it receives but shall only use those with the correct value of the "colour code" element for its DA operation - to prevent an MS from using the BSCH transmitted by an adjacent cell.

NOTE 1: There is no other co-channel interference protection on the BSCH.

DA MSs shall use the information in the SYNC and SYSINFO PDUs that is appropriate to its operation on the current channel, for example:

- timeslot, frame, multiframe and hyperframe numbering;
- the power control and cell (re-)selection or assigned channel replacement parameters MS_TXPWR_MAX_CELL, RXLEV_ACCESS_MIN, ACCESS_PARAMETER and RADIO_DOWNLINK_TIMEOUT;
- the default definition for access code A;
- information about frame 18 extension;
- information about discontinuous operation and U-plane DTX;
- encryption and security parameters;
- information about whether data priority is supported; and

- information about whether extended advanced links and MAC-U-BLCK are supported.

However, a DA MS does not need to process information specific to CA operation such as information about the (if any) CA main carrier, other services provided by the (if any) associated CA cell, the Location Area LA of the (if any) associated CA cell and the subscriber classes allowed to use the (if any) associated CA cell.

NOTE 2: As indicated above, a DA MS does not need to process the information about the subscriber classes allowed to use the (if any) associated CA cell, as included in the SYSINFO PDU at the MLE level. However, if a DA MS on a $\pi/4$ -DQPSK or D8PSK channel receives an ACCESS-DEFINE PDU containing the "subscriber class bit map" element, it uses that element in the usual way when following the random access procedures on that channel (as defined in clause 23.5.1.4).

The MS shall store the appropriate information received in the SYNC and SYSINFO PDUs and shall update this stored information on receiving subsequent SYNC and SYSINFO PDUs on this channel.

Parameters MS_TXPWR_MAX_CELL, RXLEV_ACCESS_MIN, ACCESS_PARAMETER and RADIO_DOWNLINK_TIMEOUT are specific to the current $\pi/4$ -DQPSK or D8PSK channel (see clause 23.6.11). Therefore, on receipt of the SYSINFO PDU on a $\pi/4$ -DQPSK channel, the MS shall not overwrite the equivalent stored parameters received on a D8PSK or QAM channel (or received on a concurrent $\pi/4$ -DQPSK channel). Similarly, on receipt of the SYSINFO PDU on a D8PSK channel, the MS shall not overwrite the equivalent stored parameters received on a $\pi/4$ -DQPSK or QAM channel (or received on a concurrent D8PSK channel).

23.6.10 Receiving SYSINFO-DA PDU on $\pi/4$ -DQPSK or D8PSK channel - DA MS

The BS may transmit the SYSINFO-DA PDU on a $\pi/4$ -DQPSK or D8PSK channel. On a $\pi/4$ -DQPSK channel, it uses a $\pi/4$ -DQPSK burst (logical channel SCH/F); or, on a D8PSK channel, it uses either a $\pi/4$ -DQPSK burst (logical channel SCH/F) or a $\pi/8$ -D8PSK burst (logical channel SCH-P8/HD or SCH-P8/F). For example, the BS may choose to transmit the SYSINFO-DA PDU on a $\pi/4$ -DQPSK or D8PSK channel if there are DA MSs on the channel and the BS needs to move the DA main carrier or change its configuration.

NOTE: If an $\pi/4$ -DQPSK or D8PSK channel is shared by MSs from different DA cells, the BS should not send the SYSINFO-DA PDU on that $\pi/4$ -DQPSK or D8PSK channel.

The power control and cell (re-)selection or assigned channel replacement parameters MS_TXPWR_MAX_CELL, RXLEV_ACCESS_MIN, ACCESS_PARAMETER and RADIO_DOWNLINK_TIMEOUT are not present in the SYSINFO-DA PDU if the PDU is sent on a $\pi/4$ -DQPSK or D8PSK channel. Therefore, if a DA MS on a $\pi/4$ -DQPSK or D8PSK channel receives a SYSINFO-DA PDU on that channel, it shall not update its power control and cell (re-)selection or assigned channel replacement parameters.

Similarly, the random access parameters (default definition for access code A) are not present in the SYSINFO-DA PDU if the PDU is sent on a $\pi/4$ -DQPSK or D8PSK channel. Therefore, if a DA MS on a $\pi/4$ -DQPSK or D8PSK channel receives a SYSINFO-DA PDU on that channel, it shall not update its random access parameters.

The MS shall store the other information received in the SYSINFO-DA PDU and shall update this stored information on receiving subsequent SYSINFO-DA PDUs on this channel.

23.6.11 Power control and cell/channel reselection parameters for DA

23.6.11.0 General

The power control and cell (re-)selection or assigned channel replacement parameters MS_TXPWR_MAX_CELL, RXLEV_ACCESS_MIN, ACCESS_PARAMETER and RADIO_DOWNLINK_TIMEOUT are broadcast by the BS:

- in the SYSINFO-DA PDU broadcast by the BS to DA MSs on a QAM channel;
- in the SYNC-DA PDU broadcast by the BS to DA MSs on a QAM channel (contains MS_TXPWR_MAX_CELL and RXLEV_ACCESS_MIN for the DA main carrier);
- in the SYSINFO PDU broadcast by the BS on a $\pi/4$ -DQPSK or D8PSK channel.

NOTE 1: The power control and cell (re-)selection or assigned channel replacement parameters are not present in the SYSINFO-DA PDU if the PDU is sent on a $\pi/4$ -DQPSK or D8PSK channel.

NOTE 2: If there are also CA MSs on a QAM channel, the BS may send the SYSINFO-Q PDU to those MSs.

Parameters `MS_TXPWR_MAX_CELL` and `ACCESS_PARAMETER` are used in the open loop power control procedure (see clause 23.4.4.2). Parameters `MS_TXPWR_MAX_CELL` and `RXLEV_ACCESS_MIN` are used in the calculation of the path loss parameter for the current channel on the serving cell, and for adjacent cells by scanning, and for the main carrier of the serving cell by monitoring (see clause 23.7). `RADIO_DOWNLINK_TIMEOUT` is used for assessing the quality of the downlink of the current channel on the serving cell (see clause 23.7.3).

The values of parameters `MS_TXPWR_MAX_CELL`, `RXLEV_ACCESS_MIN`, `ACCESS_PARAMETER` and `RADIO_DOWNLINK_TIMEOUT` may vary according to the modulation mode and bandwidth of the channel and according to whether the channel is conforming, non-conforming concentric, sectored, super-sectored or eccentric (see clause 23.7 for the definition of conforming, concentric, sectored, super-sectored and eccentric channels).

23.6.11.1 QAM channel

When an MS first acquires a DA main carrier or receives a channel allocation for a QAM channel on a DA new cell, the MS-MAC shall use the values of `MS_TXPWR_MAX_CELL`, `RXLEV_ACCESS_MIN`, `ACCESS_PARAMETER` and `RADIO_DOWNLINK_TIMEOUT` obtained when it acquired network information by receiving the SYSINFO-DA PDU on that cell (see clause 23.6.8).

When a DA MS returns to the MCCH-Q or to a QAM common SCCH, the MS-MAC shall use the values of `MS_TXPWR_MAX_CELL`, `RXLEV_ACCESS_MIN`, `ACCESS_PARAMETER` and `RADIO_DOWNLINK_TIMEOUT` last received on a conforming QAM channel in that cell with the same bandwidth as the DA main carrier (i.e. either the MCCH-Q or a QAM common SCCH or a conforming QAM assigned channel with the same bandwidth as the DA main carrier).

When a DA MS is sent to a new QAM channel, with RF bandwidth B , the MS-MAC shall make the following assumptions about the values of `MS_TXPWR_MAX_CELL`, `RXLEV_ACCESS_MIN`, `ACCESS_PARAMETER` and `RADIO_DOWNLINK_TIMEOUT` until updated by receiving SYSINFO-DA PDUs on that channel:

- If the MS-MAC has previously received the SYSINFO-DA PDU on a QAM channel in that cell with the same bandwidth B , it shall assume that the values of `MS_TXPWR_MAX_CELL`, `RXLEV_ACCESS_MIN`, `ACCESS_PARAMETER` and `RADIO_DOWNLINK_TIMEOUT` are equal to those last received on a QAM channel in that cell with bandwidth B .
- Otherwise (i.e. if the MS-MAC has not previously received the SYSINFO-DA PDU on a QAM channel in that cell with the same bandwidth B):
 - a) the MS-MAC shall use the values of `MS_TXPWR_MAX_CELL`, `ACCESS_PARAMETER` and `RADIO_DOWNLINK_TIMEOUT` last received on a conforming QAM channel in that cell with the same bandwidth B_m as the DA main carrier;
 - b) the MS-MAC shall use a value of `RXLEV_ACCESS_MIN` equal to:

$$\text{RXLEV_ACCESS_MIN}(\text{main}) + 10 \log_{10} (B / B_m) \quad (23.9)$$

where `RXLEV_ACCESS_MIN(main)` is the value of `RXLEV_ACCESS_MIN` last received on a conforming QAM channel in that cell with the same bandwidth B_m as the DA main carrier.

In all cases, on receiving subsequent SYSINFO-DA PDUs on the QAM channel, the MS-MAC shall update the `MS_TXPWR_MAX_CELL`, `RXLEV_ACCESS_MIN`, `ACCESS_PARAMETER` and `RADIO_DOWNLINK_TIMEOUT` parameters for that channel accordingly. Also, when on the QAM common control channel, the MS-MAC may update the `MS_TXPWR_MAX_CELL` and `RXLEV_ACCESS_MIN` parameters when it receives SYNC-DA PDUs.

23.6.11.2 $\pi/4$ -DQPSK channel

When a DA MS is sent to a $\pi/4$ -DQPSK channel, the MS-MAC shall make the following assumptions about the values of MS_TXPWR_MAX_CELL, RXLEV_ACCESS_MIN, ACCESS_PARAMETER and RADIO_DOWNLINK_TIMEOUT until updated by receiving SYSINFO PDUs on that channel:

- If the MS-MAC has previously received the SYSINFO PDU on a $\pi/4$ -DQPSK channel in that cell, it shall assume that the values of MS_TXPWR_MAX_CELL, RXLEV_ACCESS_MIN, ACCESS_PARAMETER and RADIO_DOWNLINK_TIMEOUT are equal to those last received on a $\pi/4$ -DQPSK channel in that cell.
- Otherwise, if the MS-MAC has previously received the SYSINFO PDU on a D8PSK channel in that cell, it shall assume that the values of MS_TXPWR_MAX_CELL, RXLEV_ACCESS_MIN, ACCESS_PARAMETER and RADIO_DOWNLINK_TIMEOUT are equal to those last received on a D8PSK channel in that cell.
- Otherwise (i.e. if the MS-MAC has not previously received the SYSINFO PDU in that cell):
 - a) the MS-MAC shall use the values of MS_TXPWR_MAX_CELL, ACCESS_PARAMETER and RADIO_DOWNLINK_TIMEOUT last received on a conforming QAM channel in that cell with the same bandwidth B_m as the DA main carrier;
 - b) the MS-MAC shall use a value of RXLEV_ACCESS_MIN equal to:

$$\text{RXLEV_ACCESS_MIN}(\text{main}) - \text{CONVERSION_FACTOR} \quad (23.10)$$

where RXLEV_ACCESS_MIN(main) is the value of RXLEV_ACCESS_MIN last received on a conforming QAM channel in that cell with the same bandwidth B_m as the DA main carrier and:

- CONVERSION_FACTOR = -3 dB if the bandwidth B_m of the QAM channel was 25 kHz;
- CONVERSION_FACTOR = 0 dB if the bandwidth B_m of the QAM channel was 50 kHz;
- CONVERSION_FACTOR = 3 dB if the bandwidth B_m of the QAM channel was 100 kHz;
- CONVERSION_FACTOR = 5 dB if the bandwidth B_m of the QAM channel was 150 kHz.

In all cases, on receiving a SYSINFO PDU on the $\pi/4$ -DQPSK channel, the MS-MAC shall update the MS_TXPWR_MAX_CELL, RXLEV_ACCESS_MIN, ACCESS_PARAMETER and RADIO_DOWNLINK_TIMEOUT parameters for that channel accordingly.

NOTE: This clause applies when an MS that is camped on a DA cell is sent to a $\pi/4$ -DQPSK channel within the cell. It also applies during type 1 announced cell reselection if the MS receives a channel allocation for a $\pi/4$ -DQPSK channel on a DA new cell (so the MS-MAC uses or derives the values as described above from the parameters received on the DA new cell).

23.6.11.3 D8PSK channel

When a DA MS is sent to a D8PSK channel, the MS-MAC shall make the following assumptions about the values of MS_TXPWR_MAX_CELL, RXLEV_ACCESS_MIN, ACCESS_PARAMETER and RADIO_DOWNLINK_TIMEOUT until updated by receiving SYSINFO PDUs on that channel:

- If the MS-MAC has previously received the SYSINFO PDU on a D8PSK channel in that cell, it shall assume that the values of MS_TXPWR_MAX_CELL, RXLEV_ACCESS_MIN, ACCESS_PARAMETER and RADIO_DOWNLINK_TIMEOUT are equal to those last received on a D8PSK channel in that cell.
- Otherwise, if the MS-MAC has previously received the SYSINFO PDU on a $\pi/4$ -DQPSK channel in that cell, it shall assume that the values of MS_TXPWR_MAX_CELL, RXLEV_ACCESS_MIN, ACCESS_PARAMETER and RADIO_DOWNLINK_TIMEOUT are equal to those last received on a $\pi/4$ -DQPSK channel in that cell.
- Otherwise (i.e. if the MS-MAC has not previously received the SYSINFO PDU in that cell):
 - a) the MS-MAC shall use the values of MS_TXPWR_MAX_CELL, ACCESS_PARAMETER and RADIO_DOWNLINK_TIMEOUT last received on a conforming QAM channel in that cell with the same bandwidth B_m as the DA main carrier;

- b) the MS-MAC shall use a value of `RXLEV_ACCESS_MIN` equal to:

$$\text{RXLEV_ACCESS_MIN}(\text{main}) - \text{CONVERSION_FACTOR} \quad (23.11)$$

where `RXLEV_ACCESS_MIN(main)` is the value of `RXLEV_ACCESS_MIN` last received on a conforming QAM channel in that cell with the same bandwidth B_m as the DA main carrier and:

- `CONVERSION_FACTOR` = -3 dB if the bandwidth B_m of the QAM channel was 25 kHz;
- `CONVERSION_FACTOR` = 0 dB if the bandwidth B_m of the QAM channel was 50 kHz;
- `CONVERSION_FACTOR` = 3 dB if the bandwidth B_m of the QAM channel was 100 kHz;
- `CONVERSION_FACTOR` = 5 dB if the bandwidth B_m of the QAM channel was 150 kHz.

In all cases, on receiving a `SYSINFO` PDU on the D8PSK channel, the MS-MAC shall update the `MS_TXPWR_MAX_CELL`, `RXLEV_ACCESS_MIN`, `ACCESS_PARAMETER` and `RADIO_DOWNLINK_TIMEOUT` parameters for that channel accordingly.

23.7 Layer management communication (TMC-SAP)

23.7.0 General

Clauses 23.7.1 to 23.7.5 describe procedures that the MAC performs as a service to the MLE for:

- estimation of the radio path loss on the current channel(s) on the serving cell;
- measurements of the quality of the link on the current channel(s) on the serving cell;
- if the MS is not currently receiving a conforming channel, and the current channel is a non-conforming concentric or sectored channel: assessment of the path loss on the main carrier of the serving cell (based on the measurements made on the current channel);
- on request of the MLE:
 - a) assessment of the path loss for channel classes on the serving cell based on the measurements made on the current channel;
 - b) neighbour cell monitoring i.e. monitoring of the main carrier on adjacent cells;
 - c) irregular channel monitoring i.e. monitoring of irregular carriers on the serving cell or on adjacent cells;
 - d) scanning of the main carrier on adjacent cells;
 - e) reception of the `SYSINFO-DA` PDU on the main carrier of a DA adjacent cell;
 - f) main carrier monitoring i.e. monitoring of the main carrier on the serving cell.

In cases b) and d), the MLE may also request assessment of the path loss for channel classes on the adjacent cell (based on the measurements made on the monitored or scanned main carrier on the adjacent cell). In case f), the MLE may also request assessment of the path loss for channel classes on the serving cell (based on the measurements made on the main carrier).

Then clause 23.7.6 defines procedures for energy economy mode, clause 23.7.7 defines procedures for selection of dual watch mode with energy economy group, and clause 23.7.8 defines procedures for part-time reception on a multi-slot MCCH-Q.

The following points may be noted (see clause 18):

- A "concentric channel" has essentially the same azimuthal radiation pattern as the main carrier and is radiated from the same site as the main carrier. It may have a larger or smaller range and coverage area than the main carrier (i.e. it may be a non-conforming channel); and it may use a different modulation mode, RF bandwidth and RF power from the main carrier. Where the BS offers multiple concentric channels with different RF characteristics, a concentric channel with a higher RF bandwidth will generally have a shorter range.

- A "channel class" is defined as a set of values indicating the general RF characteristics of a concentric channel or fully super-sectored channel. The MS predicts the performance of channel(s) corresponding to a channel class from measurements made on another carrier on that cell (i.e. the current channel or the main carrier on the serving cell, or the main carrier on an adjacent cell), together with the characteristics of that channel class. A cell may offer more than one channel or carrier belonging to the same channel class.
- A "conforming channel" is a special case of a concentric channel. It has essentially the same azimuthal radiation pattern as the main carrier, is radiated from the same site as the main carrier and has essentially the same range (as measured by the C1 path loss parameter) as the main carrier. A channel that is not a conforming channel is called a non-conforming channel.
- A "sectored channel" has an azimuthal extent that is smaller than, and contained entirely within, the azimuthal extent of the main carrier, and is radiated from the same site as the main carrier. It is a non-conforming channel and is not a concentric channel. The MS cannot predict the performance of a sectored channel by measurements made on any other channel; it discovers which sectored channels it can use by monitoring each sectored carrier.
- A "super-sectored channel" has an azimuthal extent that exceeds the azimuthal extent of the main carrier in at least one azimuthal direction, and is radiated from the same site as the main carrier; it is a non-conforming channel and is not a concentric or sectored channel. A super-sectored channel may be either a semi-super-sectored channel or a fully super-sectored channel:
 - A "semi-super-sectored channel" is radiated from the same site as the main carrier, and has an azimuthal extent that exceeds the azimuthal extent of the main carrier in one azimuthal direction and is less than the azimuthal extent of the main carrier in the other azimuthal direction. Since the azimuthal extent of a semi-super-sectored channel is less than the azimuthal extent of the main carrier in one azimuthal direction, the MS cannot predict the performance of a semi-super-sectored channel by measurements made on any other channel; it discovers which semi-super-sectored channels it can use by monitoring each semi-super-sectored carrier.
 - A "fully super-sectored channel" is radiated from the same site as the main carrier, and has an azimuthal extent that is greater than, and entirely contains, the azimuthal extent of the main carrier. The BS may choose whether to broadcast information about fully super-sectored channels individually or as a channel class. (Broadcast is not needed if the channel fully covers the area covered by the main carrier i.e. if the radial range of the channel is the same as, or larger than, the radial range of the main carrier; see note 2.)
- An "eccentric channel" is a channel that is not radiated from the same site as the main carrier; it is a non-conforming channel and is not a concentric, sectored or super-sectored channel. The MS cannot predict the performance of an eccentric channel by measurements made on any other channel; it discovers which eccentric channels it can use by monitoring each eccentric carrier (if the BS broadcasts information about the channel, for example, if the channel does not fully cover the area covered by the main carrier). The present document supports up to a maximum separation of 4 km between the eccentric channel's transmitter site and the main carrier's transmitter site; see clauses 7.7 and 7.8.

NOTE 1: The present document does not support use of carriers for which there is a greater separation than 4 km between the carrier's transmitter site and the main carrier's transmitter site.

- An "irregular channel" is a non-conforming channel that needs to be monitored by the MS in order for the MS to discover whether the channel would be usable as an assigned channel. Sectored channels and semi-super-sectored channels are irregular channels. An eccentric channel is an irregular channel (if it does not fully cover the area covered by the main carrier). The BS may broadcast information about a fully super-sectored channel as either a channel class or an irregular channel (if broadcast is needed, for example, if the channel does not fully cover the area covered by the main carrier i.e. if the radial range of the channel is less than the radial range of the main carrier).

NOTE 2: The BS does not need to broadcast information about conforming channels or those non-conforming channels that fully cover the area covered by the main carrier, since the MS does not normally need to assess or monitor these channels or inform the BS that these channels would be usable as an assigned channel. Nevertheless, the BS may choose to broadcast information about channels that fully cover the area covered by the main carrier; for example, in some cases, this may aid MSs that are sending or receiving real-time class data. (An MS that is sending or receiving real-time class data might prefer a channel that is more reliable than conforming when it is near the edge of the service area of the cell.)

- If the MS is not receiving a conforming channel, and the current channel is a non-conforming concentric or sectored channel, the MAC estimates the performance of the main carrier on the serving cell from measurements made on the current channel. Additionally the MLE may request that the MAC performs main carrier monitoring; this may apply particularly if the MS is receiving only sectored channel(s), but is also permitted when the MS is receiving a non-conforming concentric channel (see clause 18).

If the MS is on a super-sectored or eccentric assigned channel, or if the MS did not understand the conforming channel status for the assigned channel, it cannot estimate the performance of the main carrier on the serving cell from measurements made on that assigned channel. Therefore, when the MS is not receiving a concentric or sectored channel, the MLE needs to request that the MAC performs main carrier monitoring.

- When assessment of channel classes on the serving cell is required:
 - if the MS is on a concentric or sectored channel, the MLE may request assessment of the path loss for those channel classes based on the measurements made on the current channel; this process is referred to as serving cell channel class assessment;
 - alternatively (or additionally), the MLE may request main carrier monitoring with assessment of the path loss for those channel classes based on the measurements made on the main carrier; this process is referred to as main carrier monitoring with assessment of channel classes.

Main carrier monitoring with assessment of channel classes may apply particularly if the MS is receiving only sectored channel(s), but is not precluded when the MS is receiving a concentric channel (see clause 18).

If the MS is on a super-sectored or eccentric assigned channel, or if the MS did not understand the conforming channel status for the assigned channel, it cannot perform assessment of channel classes based on measurements made on that assigned channel. Therefore main carrier monitoring with assessment of channel classes is needed if the MS is receiving only super-sectored channel(s) and/or eccentric channel(s) (or if the MS did not understand the conforming channel status).

- When assessment of channel classes on an adjacent cell is required, the MLE requests neighbour cell monitoring or scanning of the adjacent cell main carrier with assessment of the path loss for those channel classes (based on the measurements made on the monitored or scanned adjacent cell main carrier); this process is referred to as neighbour cell channel class assessment.

The main carrier is a phase modulation carrier for a Conventional Access cell or a QAM carrier for a Direct Access cell. Where there are differences in the procedures, these are indicated in the following clauses.

23.7.1 Path loss calculation

23.7.1.0 General

The MAC layer makes signal strength measurements both autonomously on the current channel(s) on the serving cell and, under the control of the MLE layer, on selected neighbouring cells and on selected other carriers on the serving cell. The signal strength measurements shall be passed to the MLE as an approximation of radio path loss using the path loss parameters, C1 and C2, which are defined in clauses 23.7.1.1 and 23.7.1.2.

When the MS is not receiving a conforming channel, and the current channel is a non-conforming concentric or sectored channel, the MAC layer autonomously estimates the path loss C3 on the main carrier of the serving cell (based on the measurements made on the current channel) and passes it to the MLE.

Also, under control of the MLE layer, the MAC layer estimates the path loss as follows and passes it to the MLE:

- it estimates the path loss C4 for selected channel classes on the serving cell (based on the measurements made on the current channel);
- it estimates the path loss C5 for selected channel classes on the serving cell (based on measurements made on the main carrier of the serving cell);
- it estimates the path loss C5 for selected channel classes on adjacent cells (based on measurements made on the main carrier of the adjacent cell).

The path loss parameters C3, C4 and C5 are defined in clauses 23.7.1.3, 23.7.1.4 and 23.7.1.5.

The process of estimating the path loss of the serving cell main carrier or of a channel class (on the serving cell or an adjacent cell), based on measurements made on another channel or carrier radiated from the same site, is referred to as "assessment".

NOTE: If the MS is on a super-sectored or eccentric assigned channel, or if the MS did not understand the conforming channel status for the assigned channel, it cannot perform assessment of the serving cell main carrier or assessment of channel classes based on measurements made on that assigned channel.

23.7.1.1 Path loss parameter C1

The MS shall calculate the path loss parameter, C1, according to the following formula:

$$C1 = \text{RSSI} - \text{RXLEV_ACCESS_MIN} - \text{Max} (0, \text{MS_TXPWR_MAX_CELL} - P_{\text{MSMAX}}) \quad (23.12)$$

where:

- RSSI = averaged received signal level at MS or equivalent signal quality measurement;
- RXLEV_ACCESS_MIN = the sum of the minimum power level at which the BS wishes to receive MSs and the link imbalance for an MS transmitting at MS_TXPWR_MAX_CELL on this channel;
- MS_TXPWR_MAX_CELL = maximum MS transmit power permissible on this channel;
- P_{MSMAX} = maximum transmit power of the MS for the modulation mode on this channel.

C1 is expressed in dB and all the other parameters in dBm.

C1 is calculated for the current channel(s) on the serving cell, and for adjacent cell main carriers by scanning. RSSI, therefore, is defined in the relevant clauses for serving cell measurement (see clause 23.7.3) and scanning (see clause 23.7.5).

The cell selection or assigned channel replacement parameters, RXLEV_ACCESS_MIN and MS_TXPWR_MAX_CELL, shall be transmitted on CA cells using the Broadcast Network Channel (BNCH) containing the SYSINFO PDU. They shall be decoded for C1 calculation by MSs that are scanning CA cells. They shall also be decoded by CA MSs for C1 calculation on the serving cell. CA MSs on a QAM channel shall use the values of RXLEV_ACCESS_MIN and MS_TXPWR_MAX_CELL in the QAM Broadcast Network Channel (BNCH-Q) containing the SYSINFO-Q PDU for C1 calculation on that channel.

The values of RXLEV_ACCESS_MIN and MS_TXPWR_MAX_CELL for the DA main carrier shall be transmitted on all DA cells using the QAM Broadcast System Channel (BSCH-Q) containing the SYNC-DA PDU, and shall be decoded for C1 calculation by MSs that are scanning DA cells.

The cell selection or assigned channel replacement parameters, RXLEV_ACCESS_MIN and MS_TXPWR_MAX_CELL, shall be transmitted on DA cells using the QAM Broadcast Network Channel (BNCH-Q) containing the SYSINFO-DA PDU, and shall be decoded by DA MSs for C1 calculation on the serving cell. DA MSs on a $\pi/4$ -DQPSK or D8PSK channel shall use the values of RXLEV_ACCESS_MIN and MS_TXPWR_MAX_CELL in the BNCH (SYSINFO PDU) for C1 calculation on that channel.

After synchronization has been acquired, the serving cell measurement procedure requires that C1 shall be calculated using the values of RXLEV_ACCESS_MIN and MS_TXPWR_MAX_CELL transmitted on the current channel. The values of parameters RXLEV_ACCESS_MIN and MS_TXPWR_MAX_CELL may vary according to the modulation mode and bandwidth of the channel (and according to whether the channel is conforming, non-conforming concentric, sectored, super-sectored or eccentric):

- when an MS first acquires a CA main carrier or receives a channel allocation for a $\pi/4$ -DQPSK channel on a CA new cell, or when a CA MS is sent to a new $\pi/4$ -DQPSK channel within the cell or returns to the MCCH or to a $\pi/4$ -DQPSK common SCCH, it shall make the assumptions specified in clause 23.6.6.1 about the values of these parameters until updated by receiving SYSINFO PDUs on that channel;
- when a CA MS is sent to a D8PSK channel, it shall make the assumptions specified in clause 23.6.6.2 about the values of these parameters until updated by receiving SYSINFO PDUs on that channel;

- when a CA MS is sent to a QAM channel, it shall make the assumptions specified in clause 23.6.6.3 about the values of these parameters until updated by receiving SYSINFO-Q PDUs on that channel;
- when an MS first acquires a DA main carrier or receives a channel allocation for a QAM channel on a DA new cell, or when a DA MS is sent to a new QAM channel within the cell or returns to the MCCH-Q or to a QAM common SCCH, it shall make the assumptions specified in clause 23.6.11.1 about the values of these parameters until updated by receiving SYSINFO-DA (or SYNC-DA) PDUs on that channel;
- when a DA MS is sent to a $\pi/4$ -DQPSK channel, it shall make the assumptions specified in clause 23.6.11.2 about the values of these parameters until updated by receiving SYSINFO PDUs on that channel;
- when a DA MS is sent to a D8PSK channel, it shall make the assumptions specified in clause 23.6.11.3 about the values of these parameters until updated by receiving SYSINFO PDUs on that channel.

The scanning procedures also require a calculation of C1 on adjacent cells; in this case, the MS shall be synchronized to the adjacent cell and shall use the values of RXLEV_ACCESS_MIN and MS_TXPWR_MAX_CELL transmitted on the main carrier of that adjacent cell in the above C1 calculation. If the adjacent cell is a CA cell, the values of RXLEV_ACCESS_MIN and MS_TXPWR_MAX_CELL are contained in the SYSINFO PDU transmitted on the main carrier of that adjacent cell. If the adjacent cell is a DA cell, the values of RXLEV_ACCESS_MIN and MS_TXPWR_MAX_CELL are contained in SYNC-DA and SYSINFO-DA PDUs transmitted on the main carrier of that adjacent cell.

23.7.1.2 Path loss parameter C2

The MS shall calculate the path loss parameter, C2, according to the following formula:

$$C2(n) = \text{RSSI}(n) - \text{RXLEV_ACCESS_MIN_MCELL}(n) - \text{Max} (0, \text{MS_TXPWR_MAX_MCELL}(n) - P_{\text{MSMAX}}(n)) \quad (23.13)$$

where:

- RSSI(n) = averaged received signal level at MS or equivalent signal quality measurement on the monitored carrier;
- RXLEV_ACCESS_MIN_MCELL(n) = the sum of the minimum power level at which the BS wishes to receive MSs and the link imbalance for an MS transmitting at MS_TXPWR_MAX_MCELL(n) on the monitored carrier;
- MS_TXPWR_MAX_MCELL(n) = maximum MS transmit power allowed on the monitored carrier;
- $P_{\text{MSMAX}}(n)$ = maximum transmit power of the MS for the modulation mode on the monitored carrier.

C2 is expressed in dB and all the other parameters in dBm. (n) indicates the nth monitored carrier.

C2 is calculated for the main carrier on adjacent cells, by monitoring. C2 is also calculated for irregular carriers on both the serving cell and adjacent cells, by monitoring. C2 may be calculated for the main carrier on the serving cell, by monitoring. RSSI, therefore, is defined in the relevant clause for monitoring (see clause 23.7.4).

The cell selection parameters, RXLEV_ACCESS_MIN_MCELL(n) and MS_TXPWR_MAX_MCELL(n), for the main carrier on adjacent cells may be transmitted in the serving cell using an MLE broadcast message on the relevant common control channel (main and/or secondary). The MLE broadcast message for transmitting the cell selection parameters for the main carrier on CA adjacent cells is the D-NWRK-BROADCAST PDU (or D-NWRK-BROADCAST-DA PDU, see note). The MLE broadcast message for transmitting the cell selection parameters (and RF bandwidth B) for the main carrier on DA adjacent cells is the D-NWRK-BROADCAST-DA PDU.

NOTE: MSs generally obtain information about the main carrier on CA adjacent cells from the D-NWRK-BROADCAST PDU. However DA MSs may obtain information about the main carrier of the (if any) local CA cell from the D-NWRK-BROADCAST-DA PDU. (DA MSs obtain information about the channel classes and/or irregular channels on the local CA cell from the D-NWRK-BROADCAST-EXTENSION PDU.)

In the case where these parameters are not known by the serving cell or where the MS has not received them on the serving cell:

- For a CA MS monitoring a CA adjacent cell, the MS shall use the cell selection parameters `RXLEV_ACCESS_MIN` and `MS_TXPWR_MAX_CELL` last received on a conforming $\pi/4$ -DQPSK channel on the serving cell as default values. These are broadcast on the serving cell BNCH in the SYSINFO PDU.
- For a DA MS monitoring a DA adjacent cell:
 - If the MS has received the SYSINFO-DA PDU on a QAM channel on the serving cell with the same bandwidth B as the main carrier of the adjacent cell, it shall use as default values the parameters `RXLEV_ACCESS_MIN` and `MS_TXPWR_MAX_CELL` last received on a QAM channel on the serving cell with bandwidth B .
 - Otherwise (i.e. if the MS has not received the SYSINFO-DA PDU on a QAM channel on the serving cell with the same bandwidth B as the main carrier of the adjacent cell):
 - a) the MS shall use as a default value the parameter `MS_TXPWR_MAX_CELL` last received on a conforming QAM channel on the serving cell with the same bandwidth B_m as the main carrier of the serving cell;
 - b) the MS shall use a default value of `RXLEV_ACCESS_MIN` equal to:

$$\text{RXLEV_ACCESS_MIN}(\text{main}) + 10 \log_{10} (B / B_m) \quad (23.14)$$

where `RXLEV_ACCESS_MIN(main)` is the value of `RXLEV_ACCESS_MIN` last received on a conforming QAM channel on the serving cell with the same bandwidth B_m as the main carrier of the serving cell.

- For a CA MS monitoring a DA adjacent cell:
 - If the MS has received the SYSINFO-Q PDU on a QAM channel on the serving cell with the same bandwidth B as the main carrier of the DA adjacent cell, it shall use as default values the parameters `RXLEV_ACCESS_MIN` and `MS_TXPWR_MAX_CELL` last received on a QAM channel on the serving cell with bandwidth B .
 - Otherwise (i.e. if the MS has not received the SYSINFO-Q PDU on a QAM channel on the serving cell with the same bandwidth B as the main carrier of the DA adjacent cell):
 - a) the MS shall use as a default value the parameter `MS_TXPWR_MAX_CELL` last received on a conforming $\pi/4$ -DQPSK channel on the serving cell;
 - b) the MS shall use a default value of `RXLEV_ACCESS_MIN` equal to:

$$\text{RXLEV_ACCESS_MIN}(\text{main}) + \text{CONVERSION_FACTOR} \quad (23.15)$$

where `RXLEV_ACCESS_MIN(main)` is the value of `RXLEV_ACCESS_MIN` last received on a conforming $\pi/4$ -DQPSK channel on the serving cell and:

- `CONVERSION_FACTOR` = -3 dB if the bandwidth B of the DA main carrier is 25 kHz;
 - `CONVERSION_FACTOR` = 0 dB if the bandwidth B of the DA main carrier is 50 kHz;
 - `CONVERSION_FACTOR` = 3 dB if the bandwidth B of the DA main carrier is 100 kHz;
 - `CONVERSION_FACTOR` = 5 dB if the bandwidth B of the DA main carrier is 150 kHz.
- For a DA MS monitoring a CA adjacent cell:
 - If the MS has received the SYSINFO PDU on a $\pi/4$ -DQPSK channel on the serving cell, it shall use as default values the parameters `RXLEV_ACCESS_MIN` and `MS_TXPWR_MAX_CELL` last received on a $\pi/4$ -DQPSK channel on the serving cell.
 - Otherwise, if the MS has received the SYSINFO PDU on a D8PSK channel on the serving cell, it shall use as default values the parameters `RXLEV_ACCESS_MIN` and `MS_TXPWR_MAX_CELL` last received on a D8PSK channel on the serving cell.

- Otherwise (i.e. if the MS has not received the SYSINFO PDU on the serving cell):
 - a) the MS shall use as a default value the parameter `MS_TXPWR_MAX_CELL` last received on a conforming QAM channel on the serving cell with the same bandwidth B_m as the main carrier of the serving cell;
 - b) the MS shall use a default value of `RXLEV_ACCESS_MIN` equal to:

$$\text{RXLEV_ACCESS_MIN(main)} - \text{CONVERSION_FACTOR} \quad (23.16)$$

where `RXLEV_ACCESS_MIN(main)` is the value of `RXLEV_ACCESS_MIN` last received on a conforming QAM channel on the serving cell with the same bandwidth B_m as the main carrier of the serving cell and:

- `CONVERSION_FACTOR` = -3 dB if the bandwidth B_m of the DA main carrier is 25 kHz;
- `CONVERSION_FACTOR` = 0 dB if the bandwidth B_m of the DA main carrier is 50 kHz;
- `CONVERSION_FACTOR` = 3 dB if the bandwidth B_m of the DA main carrier is 100 kHz;
- `CONVERSION_FACTOR` = 5 dB if the bandwidth B_m of the DA main carrier is 150 kHz.

The parameters `RXLEV_ACCESS_MIN_MCELL(n)` and `MS_TXPWR_MAX_MCELL(n)`, and the modulation mode and RF bandwidth, for irregular carriers on the serving cell or adjacent cells shall be transmitted in the serving cell using an MLE broadcast message (D-NWRK-BROADCAST-EXTENSION or D-NWRK-BROADCAST-DA PDU).

When performing monitoring of the main carrier of the serving cell:

- a CA MS shall use the parameters `RXLEV_ACCESS_MIN` and `MS_TXPWR_MAX_CELL` last received on a conforming $\pi/4$ -DQPSK channel on the serving cell for the C2 calculation; these parameters are broadcast on the serving cell BNCH in the SYSINFO PDU;
- a DA MS shall use the parameters `RXLEV_ACCESS_MIN` and `MS_TXPWR_MAX_CELL` last received on a conforming QAM channel on the serving cell with the same bandwidth as the main carrier for the C2 calculation; these parameters are broadcast on the serving cell BNCH-Q in the SYSINFO-DA PDU.

23.7.1.3 Path loss parameter C3

The MAC layer autonomously calculates the path loss parameter C1 for the current channel (see clause 23.7.1.1) and passes it to the MLE. Also, when the MS is not receiving a conforming channel, and the current channel is a non-conforming concentric or sectored channel, the MAC layer autonomously estimates the path loss C3 on the main carrier of the serving cell, based on the measurements made on the current channel, and passes it to the MLE. This process is referred to as assessment of the main carrier.

NOTE 1: The main carrier is a phase modulation carrier for CA or a QAM carrier for DA.

NOTE 2: Additionally, if the MLE prefers the MAC to make direct measurements of the path loss on the main carrier, the MLE may request main carrier monitoring on the serving cell.

NOTE 3: If the MS is on a super-sectored or eccentric assigned channel, or if the MS did not understand the conforming channel status for the assigned channel, it cannot perform assessment of the main carrier based on the measurements made on that assigned channel. Therefore, if the MS is currently receiving only super-sectored and/or eccentric channel(s) and/or channel(s) for which it does not understand the conforming channel status, it needs to perform main carrier monitoring on the serving cell (path loss parameter C2) instead of performing assessment of the main carrier (path loss parameter C3). Thus, when the MS is not currently receiving a concentric or sectored channel, the MLE requests that the MAC performs main carrier monitoring, by including the main carrier of the serving cell in the TMC-MONITOR-LIST request primitive (see clause 18).

The MS shall calculate the path loss parameter, C3, according to the following formula:

$$C3 = \text{RSSI} - \text{RXLEV_ACCESS_MIN}(\text{main}) - \text{Max} (0, \text{MS_TXPWR_MAX_CELL}(\text{main}) - P_{\text{MSMAX}}(\text{main})) - \text{BS_TXPWR_RATIO_CHANNEL} \quad (23.17)$$

where:

- RSSI = averaged received signal level at MS or equivalent signal quality measurement on the current channel;
- RXLEV_ACCESS_MIN(main) = the sum of the minimum power level at which the BS wishes to receive MSs and the link imbalance for an MS transmitting at MS_TXPWR_MAX_CELL(main) on the common control channel;
- MS_TXPWR_MAX_CELL(main) = maximum MS transmit power allowed on the common control channel;
- P_{MSMAX}(main) = maximum transmit power of the MS:
 - for $\pi/4$ -DQPSK modulation for a CA MS; or
 - for QAM modulation for a DA MS;
- BS_TXPWR_RATIO_CHANNEL is the BS transmit power (ERP) relative to the main carrier for the current channel.

C3 and BS_TXPWR_RATIO_CHANNEL are expressed in dB and all the other parameters in dBm.

C3 is calculated when the MS is on a non-conforming concentric or sectored channel and is performing serving cell measurements. RSSI, therefore, is defined in the relevant clause for serving cell measurement (see clause 23.7.3).

In most cases, the MS received the value of BS_TXPWR_RATIO_CHANNEL in the channel allocation that sent the MS to the current channel. However, if element "conditional element A" was included in the channel allocation that sent the MS to the current channel, a DA MS calculates the value of BS_TXPWR_RATIO_CHANNEL as described in clause 23.5.4.3.9.

For CA, the parameters RXLEV_ACCESS_MIN(main) and MS_TXPWR_MAX_CELL(main) shall be the values of RXLEV_ACCESS_MIN and MS_TXPWR_MAX_CELL last received in the SYSINFO PDU on a conforming $\pi/4$ -DQPSK channel in this cell.

For DA, the parameters RXLEV_ACCESS_MIN(main) and MS_TXPWR_MAX_CELL(main) shall be the values of RXLEV_ACCESS_MIN and MS_TXPWR_MAX_CELL last received in the SYSINFO-DA PDU on a conforming QAM channel in this cell with the same bandwidth as the main carrier or (optionally) in the SYNC-DA PDU.

23.7.1.4 Path loss parameter C4

Under control of the MLE layer, the MAC estimates the values of the path loss C4 for selected channel classes on the serving cell, based on the measurements made on the current channel (together with the characteristics of the channel classes to be assessed), and passes the values of C4 to the MLE. This process is referred to as serving cell channel class assessment. Serving cell channel class assessment is applicable only when the current channel is a concentric or sectored channel.

NOTE 1: Alternatively (or additionally), when assessment of channel classes on the serving cell is required, the MLE may request main carrier monitoring with assessment of channel classes (see clause 23.7.1.5).

NOTE 2: If the MS is on a super-sectored or eccentric assigned channel, or if the MS did not understand the conforming channel status for the assigned channel, it cannot perform serving cell channel class assessment based on the measurements made on that assigned channel. Therefore, if the MS is currently receiving only super-sectored and/or eccentric channel(s) and/or channel(s) for which it does not understand the conforming channel status, and it wishes to perform assessment of channel classes, it needs to perform main carrier monitoring with assessment of channel classes (see clause 23.7.1.5) instead of performing serving cell channel class assessment.

The MS shall calculate the path loss parameter, C4, according to the following formula:

$$C4(m) = \text{RSSI} - \text{RXLEV_ACCESS_MIN_MCELL}(m) - \text{Max} (0, \text{MS_TXPWR_MAX_MCELL}(m) - P_{\text{MSMAX}}(m)) - (\text{BS_TXPWR_RATIO_CHANNEL} - \text{BS_TXPWR_RATIO_CHANNEL}(m)) \quad (23.18)$$

where:

- RSSI = averaged received signal level at MS or equivalent signal quality measurement on the current channel;
- RXLEV_ACCESS_MIN_MCELL(m) = the sum of the minimum power level at which the BS wishes to receive MSs and the link imbalance for an MS transmitting at MS_TXPWR_MAX_MCELL(m) for the assessed channel class;
- MS_TXPWR_MAX_MCELL(m) = maximum MS transmit power allowed for the assessed channel class;
- P_{MSMAX}(m) = maximum transmit power of the MS for the modulation mode of the assessed channel class;
- BS_TXPWR_RATIO_CHANNEL is the BS transmit power (ERP) relative to the main carrier for the current channel;
- BS_TXPWR_RATIO_CHANNEL(m) is the BS transmit power (ERP) relative to the main carrier for the assessed channel class.

C4, BS_TXPWR_RATIO_CHANNEL and BS_TXPWR_RATIO_CHANNEL(m) are expressed in dB and all the other parameters in dBm. (m) indicates the mth assessed channel class.

C4 is calculated for the appropriate channel classes when the MS is performing serving cell measurements. RSSI, therefore, is defined in the relevant clause for serving cell measurement (see clause 23.7.3).

If the channel allocation that sent the MS to the current channel was an augmented channel allocation:

- in most cases, the MS received the value of BS_TXPWR_RATIO_CHANNEL in the channel allocation;
- however, if element "conditional element A" was included in the channel allocation, a DA MS calculates the value of BS_TXPWR_RATIO_CHANNEL as described in clause 23.5.4.3.9.

If the channel allocation that sent the MS to the current channel was not an augmented channel allocation, or if the current channel is a common control channel, the value of BS_TXPWR_RATIO_CHANNEL is 0 dB.

The parameters RXLEV_ACCESS_MIN_MCELL(m), MS_TXPWR_MAX_MCELL(m) and BS_TXPWR_RATIO_CHANNEL(m) and the modulation mode for the assessed channel classes shall be transmitted in the serving cell using an MLE broadcast message (D-NWRK-BROADCAST-EXTENSION or D-NWRK-BROADCAST-DA PDU).

23.7.1.5 Path loss parameter C5

When the MLE requests that the MAC performs monitoring or scanning of the main carrier on an adjacent cell, it may also request that the MAC estimates the values of the path loss C5 for selected channel classes on that adjacent cell, based on the measurements made on the main carrier of the adjacent cell (together with the characteristics of the channel classes to be assessed). This process is referred to as neighbour cell channel class assessment.

When the MLE requests that the MAC performs monitoring of the main carrier on the serving cell, it may also request that the MAC estimates the values of the path loss C5 for selected channel classes on the serving cell, based on the measurements made on the main carrier of the serving cell (together with the characteristics of the channel classes to be assessed). This process is referred to as main carrier monitoring with assessment of channel classes.

The MS shall calculate the path loss parameter, C5, according to the following formula:

$$C5(m,n) = \text{RSSI}(n) - \text{RXLEV_ACCESS_MIN_MCELL}(m) - \text{Max} (0, \text{MS_TXPWR_MAX_MCELL}(m) - P_{\text{MSMAX}}(m)) + \text{BS_TXPWR_RATIO_CHANNEL}(m) \quad (23.19)$$

where:

- $\text{RSSI}(n)$ = averaged received signal level at MS or equivalent signal quality measurement on the monitored or scanned main carrier;
- $\text{RXLEV_ACCESS_MIN_MCELL}(m)$ = the sum of minimum power level at which the BS wishes to receive MSs and the link imbalance for an MS transmitting at $\text{MS_TXPWR_MAX_MCELL}(m)$ for the assessed channel class;
- $\text{MS_TXPWR_MAX_MCELL}(m)$ = maximum MS transmit power allowed for the assessed channel class;
- $P_{\text{MSMAX}}(m)$ = maximum transmit power of the MS for the modulation mode of the assessed channel class;
- $\text{BS_TXPWR_RATIO_CHANNEL}(m)$ is the BS transmit power (ERP) relative to the appropriate main carrier for the assessed channel class (see note 1).

NOTE 1: For assessment of a channel class on an adjacent cell, the appropriate main carrier is the main carrier of that adjacent cell; for assessment of a channel class on the serving cell, the appropriate main carrier is the main carrier of the serving cell.

C5 and $\text{BS_TXPWR_RATIO_CHANNEL}(m)$ are expressed in dB and all the other parameters in dBm. (m) indicates the mth assessed channel class on the nth monitored or scanned main carrier.

NOTE 2: The TMC-SCAN request primitive requests scanning of a single main carrier; therefore, for scanning, n is always 1. The TMC-MONITOR-LIST request primitive may request monitoring of a list of main carriers.

C5 is calculated for the appropriate channel classes when the MS is performing neighbour cell monitoring or scanning, or main carrier monitoring. RSSI, therefore, is defined in the relevant clauses for monitoring (see clause 23.7.4) and scanning (see clause 23.7.5).

The parameters $\text{RXLEV_ACCESS_MIN_MCELL}(m)$, $\text{MS_TXPWR_MAX_MCELL}(m)$ and $\text{BS_TXPWR_RATIO_CHANNEL}(m)$ and the modulation mode for the assessed channel classes shall be transmitted in the serving cell using an MLE broadcast message (D-NWRK-BROADCAST-EXTENSION or D-NWRK-BROADCAST-DA PDU).

23.7.2 Cell selection

The MLE may instruct the MAC to select a cell, as shown in figure 23.13, using the TMC-SELECT request primitive which shall contain a channel number parameter corresponding to the frequency of the main carrier and may contain the modulation mode and RF bandwidth of the main carrier. The MAC shall then instruct the physical layer to tune to that frequency for reception. As soon as the MS MAC has acquired synchronization on that carrier and decoded:

- for CA, the SYNC PDU and SYSINFO PDU for that cell; or
- for DA, the SYNC-DA PDU and SYSINFO-DA PDU for that cell,

it shall confirm the cell selection, by sending a TMC-SELECT confirm primitive to the MLE, and begin the serving cell measurements described in the following clause. If the TMC-SELECT request primitive is to inform the MAC of a change to a CA cell which the MAC has previously been scanning, the MS MAC may already have acquired synchronization on the new cell and decoded the SYNC and SYSINFO PDUs, in which case it may respond with a TMC-SELECT confirm primitive as soon as the physical layer has changed frequency. If the TMC-SELECT request primitive is to inform the MAC of a change to a DA cell which the MAC has previously been scanning, the MS MAC may already have acquired synchronization on the new cell and decoded the SYNC-DA PDU; the MS MAC may also have received a recent SYSINFO-DA PDU on the new cell (see notes 2 and 3), in which case it may respond with a TMC-SELECT confirm primitive as soon as the physical layer has changed frequency.

NOTE 1: When scanning a CA cell, the MS needs to receive both the SYNC PDU and the SYSINFO PDU; see clause 23.7.5.

NOTE 2: When scanning a DA cell, the MS is only required to receive the SYNC-DA PDU; see clause 23.7.5. However the MS needs to receive the SYSINFO-DA PDU before it can use a DA cell.

The SYNC-DA PDU contains all the essential information needed for the MS to decide whether it wishes to use the cell. However the SYSINFO-DA PDU contains some additional details about the cell and information needed for transmission, and the MS needs to receive the SYSINFO-DA PDU before it can use a DA cell, so the MS may prefer to receive the SYSINFO-DA PDU on a likely DA cell before confirming its decision to use that cell. The MLE instructs the MAC to attempt to receive the SYSINFO-DA PDU on a DA adjacent cell by using the TMC-CELL-READ request primitive; see clause 23.7.5.4.

NOTE 3: Some contents of the SYSINFO-DA PDU may change quite frequently. If the MS has not received a SYSINFO-DA PDU since a change in the contents then, in the case of some changes (e.g. if the CCK identifier has changed), the MS may initially miss signalling addressed to itself on the new cell.

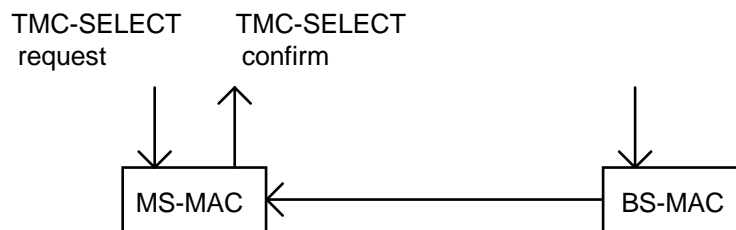

Figure 23.13: Cell selection

This procedure is identical in the MAC for initial cell selection and cell reselection.

23.7.3 Serving cell measurement

23.7.3.0 General

Having selected and acquired synchronization on a cell as described in the previous clause, the MAC shall begin measurement of the downlink RSSI on the current channel(s) on the serving cell, as defined in clause 23.7.3.1, and use this to calculate C1 for the current channel(s) (see clause 23.7.1.1). It shall then periodically report C1 to the MLE using a TMC-MEASUREMENT indication primitive as illustrated in figures 23.14 and 23.15. This measurement of the downlink RSSI and calculation of C1 is known as surveillance and shall be based upon the cell selection or assigned channel replacement parameters (RXLEV_ACCESS_MIN and MS_TXPWR_MAX_CELL) decoded on the current channel.

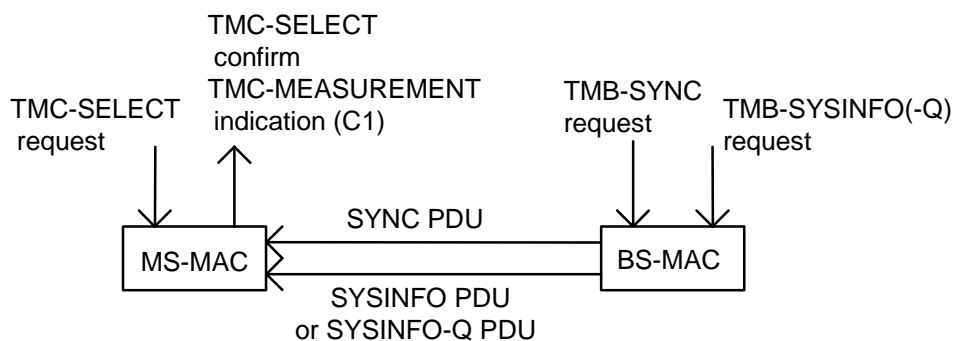

Figure 23.14: Cell selection and surveillance scenario for CA MS

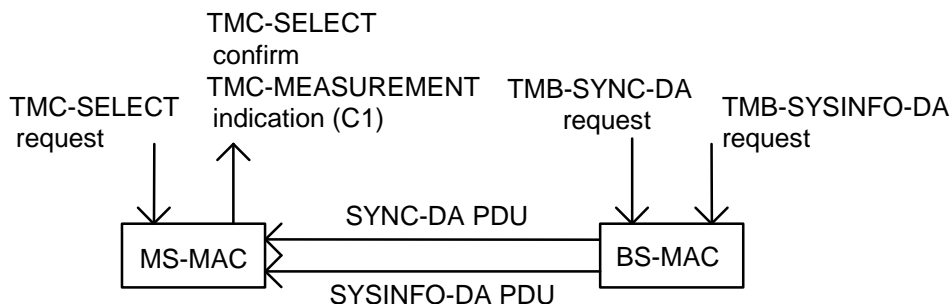

Figure 23.15: Cell selection and surveillance scenario for DA MS on QAM channel

The MAC also performs other measurements and/or calculations relating to the performance of the serving cell:

- If the MS is not currently receiving a conforming channel, and the current channel is a non-conforming concentric or sectored channel, the MAC estimates the path loss C3 on the main carrier of the serving cell (based on the measurements made on the current channel); see notes 1 and 2. This calculation is regarded as being part of the serving cell surveillance procedure. It is described in clause 23.7.3.1.2.
- On request of the MLE, the MAC estimates the path loss C4 for a list of channel classes on the serving cell (based on the measurements made on the current channel). This is described in clause 23.7.3.1.3.
- On request of the MLE, the MAC performs monitoring of irregular carriers on the serving cell, making measurements on those irregular carriers and calculating the path loss C2. This is described in clause 23.7.4 with the other monitoring functions.
- On request of the MLE, the MAC performs monitoring of the main carrier on the serving cell, making measurements on the main carrier and calculating the path loss C2. This monitoring is regarded as being part of the serving cell surveillance procedure. It is described in clause 23.7.4 with the other monitoring functions.
- When the MAC performs monitoring of the main carrier on the serving cell: on request of the MLE, the MAC also estimates the path loss C5 for a list of channel classes on the serving cell (based on the measurements made on the main carrier). This is described in clause 23.7.4.5.

NOTE 1: If the MS is currently receiving a conforming channel, the MLE uses the value of C1 for that channel as a criterion for serving cell radio link failure (see clause 18). If the MS is receiving a non-conforming channel, the MLE uses the value of C1 for that channel as a criterion for current channel radio link failure. If the MS is not currently receiving a conforming channel, but is receiving non-conforming concentric or sectored channel(s), the MAC estimates a path loss parameter C3 for the main carrier. In this case, if the MLE has not currently requested main carrier monitoring, the MLE uses the value of C3 as a criterion for serving cell radio link failure; if the MLE has currently requested main carrier monitoring, the MLE uses the value of C2 for the main carrier as a criterion for serving cell radio link failure.

NOTE 2: If the MS is on a super-sectored or eccentric assigned channel, or if the MS did not understand the conforming channel status for the assigned channel, it cannot estimate a path loss parameter C3 for the main carrier based on the measurements made on that assigned channel. Therefore, if the MS is currently receiving only super-sectored and/or eccentric channel(s) and/or channel(s) for which it does not understand the conforming channel status, it needs to monitor the main carrier on the serving cell (path loss parameter C2) instead of performing assessment of the main carrier (path loss parameter C3); see clause 23.7.3.1.2.

Similarly, if the MS is on a super-sectored or eccentric assigned channel, or if the MS did not understand the conforming channel status for the assigned channel, it cannot estimate the path loss parameter C4 for channel classes on the serving cell based on the measurements made on that assigned channel.

23.7.3.1 Downlink measurements

23.7.3.1.1 Downlink measurements on current channel

23.7.3.1.1.1 Signal strength measurements

The MAC shall continuously perform the measurements described in this clause on the physical channel(s) to which the MS is attached on the serving cell. Measurements shall be made on all downlink timeslots which the MAC attempts to receive within the constraints of its energy economy or dual watch or part-time reception mode or the napping procedures, and linearization and transmission requirements, or according to the monitoring pattern requirements for traffic transmission on an assigned channel.

The MAC shall measure the received RF signal strength or make an equivalent signal quality measurement and calculate a running average of at least 5 measurement samples.

These samples shall be taken during at least the last 5 s and at most the last 60 s. If less than 5 measurements were collected during this period, for example due to the constraints of an energy economy or dual watch mode, then the last 5 measurements may be used. The measurement sample duration shall be at least SD1 (see clause 10). For CA, if the BS operates in MCCCH sharing then, when the MS is on the MCCCH or a common SCCH, the measurements shall be performed only on the frames reserved for the BS, and not on the common frames (see clause 9).

Based upon these measurements, the path loss parameter C1 shall be calculated by the MAC at least every 5 s for the current channel.

23.7.3.1.1.2 Radio Downlink Counter

The quality of the radio downlink shall be estimated from the success rate of decoding:

- the AACH when the MS is receiving a $\pi/4$ -DQPSK or D8PSK channel; or
- the AACH-Q when the MS is receiving a QAM channel.

The MAC in a CA MS shall perform the measurements described in clause 23.7.3.1.1.3, 23.7.3.1.1.4 or 23.7.3.1.1.5 to ensure that:

- the quality on the serving cell is acceptable, in the case of measurements on a conforming $\pi/4$ -DQPSK or D8PSK channel; or
- the quality on the current channel is acceptable, in the case of measurements on a QAM channel or on a non-conforming $\pi/4$ -DQPSK or D8PSK channel.

For a CA MS, the criterion for relinquishing the radio downlink is based on the Radio Downlink Counter RDC, RDC-NC or RDC-Q.

The MAC in a DA MS shall perform the measurements described in clause 23.7.3.1.1.6, 23.7.3.1.1.7 or 23.7.3.1.1.8 to ensure that:

- the quality on the serving cell is acceptable, in the case of measurements on a QAM channel on the DA main carrier; or
- the quality on the current channel is acceptable, in the case of measurements on a $\pi/4$ -DQPSK or D8PSK channel or on a QAM channel that is not on the DA main carrier.

For a DA MS, the criterion for relinquishing the radio downlink is based on the Radio Downlink Counter RDC-DA, RDC-DA-Q or RDC-DA-P.

23.7.3.1.1.3 RDC on conforming $\pi/4$ -DQPSK and D8PSK channels - CA MS

When the MAC first acquires cell synchronization and begins to receive the downlink of a common control channel on a CA cell, RDC shall be initialized to a value equal to RADIO_DOWNLINK_TIMEOUT. The RADIO_DOWNLINK_TIMEOUT parameter is broadcast in the SYSINFO PDU.

If the MAC is unable to decode an AACH, RDC shall be decreased by $N \times N.210$. ($N.210$ is a constant which defines the quality threshold for the MS on a $\pi/4$ -DQPSK or D8PSK channel.) In the case of a successful reception of an AACH, RDC shall be increased by N but shall not be increased above the value of RADIO_DOWNLINK_TIMEOUT.

The parameter N is equal to the number of timeslots between successive downlink slots which the MS is attempting to receive and decode (except if the BS operates in MCCH sharing, see note 5); therefore, N is dependent on the MS mode of operation. Some examples are listed below.

NOTE 1: The parameter N includes the downlink slot that the MS is attempting to receive and decode, in addition to the gap between downlink slots that the MS attempts to receive and decode.

a) MS in normal mode:

In this mode, the MS is receiving the MCCH or a $\pi/4$ -DQPSK common SCCH and so listens to one slot per TDMA frame. Therefore, in this case, $N = 4$.

b) MS in an energy economy or dual watch mode:

In this mode, the MS is not receiving all downlink slots of the common control channel.

EXAMPLE 1: For example, an MS operating with an energy group, EG5, may only be attempting to receive and decode one downlink slot per multiframe. In this case, $N = 72$.

c) MS receiving on an assigned channel:

In this mode, the MS is receiving one or more timeslots per TDMA frame depending upon the number of slots assigned to that channel. In this case, $N = 4 / \text{number of timeslots per TDMA frame assigned to that channel on the downlink}$.

d) MS in napping mode on an assigned channel:

In this mode, the MS is not receiving all downlink slots of the assigned channel.

EXAMPLE 2: For example, if an MS on a multi-slot assigned channel is only required to attempt to receive and decode one slot per TDMA frame when in napping mode then $N = 4$ when in napping mode.

e) MS transmitting traffic on a single-slot assigned channel:

In this mode, the MS is transmitting on the uplink and is receiving the downlink according to the monitoring pattern(s) given at channel assignment. In this case, $N = 12 / \text{number of monitoring patterns allocated to the MS}$. This applies when 1, 2 or 3 monitoring patterns are assigned.

When the mode of operation of the MS is changed, the corresponding value of N shall be calculated by the MAC and used for updating RDC.

A single RDC is valid for all conforming $\pi/4$ -DQPSK and D8PSK channels on a CA cell, whatever the RF channel on which the MS decodes the AACH. Thus, if the MS moves to another conforming $\pi/4$ -DQPSK or D8PSK channel, the RDC shall continue to run without re-initialization. If the MS moves to a non-conforming $\pi/4$ -DQPSK or D8PSK channel, or to a QAM channel, the MAC shall store the current value of RDC; then, when the MS returns to reception of a conforming $\pi/4$ -DQPSK or D8PSK channel, the MAC should resume updating of that RDC (using the usual value of N i.e. it shall not re-calculate the value of N taking account of the additional time since the last reception on a conforming $\pi/4$ -DQPSK or D8PSK channel).

NOTE 2: If the MS returns to reception of a conforming $\pi/4$ -DQPSK or D8PSK channel after a long period of receiving only non-conforming $\pi/4$ -DQPSK or D8PSK channel(s), or QAM channel(s), the MS may choose to re-initialize the RDC to a value equal to RADIO_DOWNLINK_TIMEOUT.

NOTE 3: The BS should indicate the same value of the RADIO_DOWNLINK_TIMEOUT parameter on all conforming $\pi/4$ -DQPSK and D8PSK channels on a CA cell.

Radio downlink failure shall be declared when the RDC falls below 0. If this happens, the MAC shall inform the MLE that radio downlink failure has occurred using a TMC-REPORT indication primitive.

NOTE 4: N.210 controls the AACH message error rate threshold at which radio downlink failure occurs on a $\pi/4$ -DQPSK or D8PSK channel. For example, if $N.210 = 4$, the ratio 4 to 1 between failure and success counting gives a decreasing RDC when the message error rate exceeds 20 %. Therefore, a continuing message error rate greater than 20 % will cause radio downlink failure in this case.

NOTE 5: If the BS operates in MCCH sharing, the MS uses only the frames reserved for the BS to update RDC (though it attempts to receive and decode the relevant slot also in the common frames). Therefore, in this case, for an MS in normal mode, $N = 144 / \text{number of reserved frames per two multiframe for the BS}$.

23.7.3.1.1.4 RDC-NC on non-conforming $\pi/4$ -DQPSK and D8PSK channels - CA MS

When a CA MS moves to a non-conforming $\pi/4$ -DQPSK or D8PSK channel (or if the MS did not understand the conforming channel status of a $\pi/4$ -DQPSK or D8PSK channel), the MAC shall use an independent radio downlink counter RDC-NC for that channel (except possibly in the case of concurrent channels; see clause 23.7.3.1.4). The MAC shall initialize the RDC-NC to a value equal to the assumed value of RADIO_DOWNLINK_TIMEOUT for that channel (see clauses 23.6.6.1 and 23.6.6.2), and shall start to decrease or increase RDC-NC according to failure to decode or successful reception of the AACH as described below. On receiving a SYSINFO PDU on that channel, if the value of the RADIO_DOWNLINK_TIMEOUT parameter in the SYSINFO PDU is different from the assumed value, the MAC shall make a correction by adding the difference between the true value and the assumed value of the RADIO_DOWNLINK_TIMEOUT to the current value of RDC-NC.

As in clause 23.7.3.1.1.3:

- If the MAC is unable to decode an AACH, RDC-NC shall be decreased by $N \times N.210$. In the case of a successful reception of an AACH, RDC-NC shall be increased by N but shall not be increased above the value of RADIO_DOWNLINK_TIMEOUT for that channel.
- The parameter N is equal to the number of timeslots between successive downlink slots which the MS is attempting to receive and decode; therefore, N is dependent on the MS mode of operation. Examples c), d) and e) in clause 23.7.3.1.1.3 apply. When the mode of operation of the MS is changed, the corresponding value of N shall be calculated by the MAC and used for updating RDC-NC.

NOTE: The parameter N includes the downlink slot that the MS is attempting to receive and decode, in addition to the gap between downlink slots that the MS attempts to receive and decode.

RDC-NC is valid only for the current channel (except possibly in the case of concurrent channels; see clause 23.7.3.1.4).

Radio downlink failure for the current channel shall be declared when the RDC-NC falls below 0. If this happens, the MAC shall inform the MLE that radio downlink failure has occurred on that channel using a TMC-REPORT indication primitive.

23.7.3.1.1.5 RDC-Q on QAM channels - CA MS

When a CA MS moves to a QAM channel, the MAC shall use an independent radio downlink counter RDC-Q for that channel (except possibly in the case of concurrent channels; see clause 23.7.3.1.4).

If the MS is moving from one conforming QAM channel to another conforming QAM channel with the same carrier frequency, RF bandwidth and BS transmit power relative to the main carrier, the MS may continue use of the previous RDC-Q without re-initialization. Otherwise the MAC shall initialize the RDC-Q to a value equal to the assumed value of RADIO_DOWNLINK_TIMEOUT for that channel (see clause 23.6.6.3), and shall start to decrease or increase RDC-Q according to failure to decode or successful reception of the AACH-Q as described below. On receiving a SYSINFO-Q PDU on that channel, if the value of the RADIO_DOWNLINK_TIMEOUT parameter in the SYSINFO-Q PDU is different from the assumed value, the MAC shall make a correction by adding the difference between the true value and the assumed value of the RADIO_DOWNLINK_TIMEOUT to the current value of RDC-Q.

If the MAC is unable to decode an AACH-Q, RDC-Q shall be decreased by $N \times N.209$. (N.209 is a constant which defines the quality threshold for the MS on a QAM channel.) In the case of a successful reception of an AACH-Q, RDC-Q shall be increased by N but shall not be increased above the value of RADIO_DOWNLINK_TIMEOUT for that channel.

The parameter N is equal to the number of timeslots between successive downlink slots which the MS is attempting to receive and decode; therefore, N is dependent on the MS mode of operation. Examples c) and d) in clause 23.7.3.1.1.3 apply. When the mode of operation of the MS is changed, the corresponding value of N shall be calculated by the MAC and used for updating RDC-Q.

NOTE 1: The parameter N includes the downlink slot that the MS is attempting to receive and decode, in addition to the gap between downlink slots that the MS attempts to receive and decode.

RDC-Q is valid only for the current channel (except possibly in the case of concurrent channels; see clause 23.7.3.1.4).

Radio downlink failure for the current channel shall be declared when the RDC-Q falls below 0. If this happens, the MAC shall inform the MLE that radio downlink failure has occurred on that channel using a TMC-REPORT indication primitive.

NOTE 2: $N_{.209}$ on a QAM channel is equivalent to $N_{.210}$ on a $\pi/4$ -DQPSK or D8PSK channel. It controls the AACH-Q message error rate threshold at which radio downlink failure occurs on a QAM channel. The value of $N_{.209}$ may be different from the value of $N_{.210}$.

23.7.3.1.1.6 RDC-DA on QAM channels on the DA main carrier - DA MS

When the MAC first acquires cell synchronization and begins to receive the downlink of a common control channel on a DA cell, RDC-DA shall be initialized to a value equal to RADIO_DOWNLINK_TIMEOUT. The RADIO_DOWNLINK_TIMEOUT parameter is broadcast in the SYSINFO-DA PDU.

If the MAC is unable to decode an AACH-Q, RDC-DA shall be decreased by $N \times N_{.209}$. ($N_{.209}$ is a constant which defines the quality threshold for the MS on a QAM channel.) In the case of a successful reception of an AACH-Q, RDC-DA shall be increased by N but shall not be increased above the value of RADIO_DOWNLINK_TIMEOUT.

The parameter N is equal to the number of timeslots between successive downlink slots which the MS is attempting to receive and decode; therefore, N is dependent on the MS mode of operation. Some examples are listed below.

NOTE 1: The parameter N includes the downlink slot that the MS is attempting to receive and decode, in addition to the gap between downlink slots that the MS attempts to receive and decode.

a) MS in normal mode on a single-slot common control channel:

In this mode, the MS is receiving a single-slot MCCH-Q or a QAM common SCCH and so listens to one slot per TDMA frame. Therefore, in this case, $N = 4$.

b) MS in normal mode on a multi-slot common control channel:

In this mode, the MS is receiving a multi-slot MCCH-Q and so listens to more than one slot per TDMA frame. In this case, $N = 4 / \text{number of timeslots per TDMA frame comprising the MCCH-Q}$.

c) MS in part-time reception mode on a multi-slot common control channel:

In this mode, the MS may only be attempting to receive one slot of the multi-slot MCCH-Q per TDMA frame. In this case, $N = 4$ when the MS is using part-time reception.

d) MS in an energy economy or dual watch mode:

In this mode, the MS is not receiving all downlink slots of the common control channel.

EXAMPLE 1: For example, an MS operating with an energy group, EG5, on a single-slot common control channel (or on a multi-slot MCCH-Q if enhanced energy economy is available) may only be attempting to receive and decode one downlink slot per multiframe. In this case, $N = 72$.

e) MS receiving on an assigned channel:

In this mode, the MS is receiving one or more timeslots per TDMA frame depending upon the number of slots assigned to that channel. In this case, $N = 4 / \text{number of timeslots per TDMA frame assigned to that channel on the downlink}$.

- f) MS in napping mode on an assigned channel:

In this mode, the MS is not receiving all downlink slots of the assigned channel.

EXAMPLE 2: For example, if an MS on a multi-slot assigned channel is only required to attempt to receive and decode one slot per TDMA frame when in napping mode then $N = 4$ when in napping mode.

When the mode of operation of the MS is changed, the corresponding value of N shall be calculated by the MAC and used for updating RDC-DA.

A single RDC-DA is valid for all QAM channels on the DA main carrier i.e. for QAM common control channels and for conforming assigned QAM channels with the same carrier frequency and RF bandwidth as the DA main carrier and with BS transmit power relative to the main carrier of 0 dB. Thus, if the MS moves to another QAM channel on the DA main carrier, the RDC-DA shall continue to run without re-initialization. If the MS moves to a QAM channel that is not on the DA main carrier, or to a $\pi/4$ -DQPSK or D8PSK channel, the MAC shall store the current value of RDC-DA; then, when the MS returns to reception of a QAM channel on the DA main carrier, the MAC should resume updating of that RDC-DA (using the usual value of N i.e. it shall not re-calculate the value of N taking account of the additional time since the last reception on a QAM channel on the DA main carrier).

NOTE 2: If the MS returns to reception of a QAM channel on the DA main carrier after a long period of receiving only QAM channel(s) not on the DA main carrier, or $\pi/4$ -DQPSK or D8PSK channel(s), the MS may choose to re-initialize the RDC-DA to a value equal to RADIO_DOWNLINK_TIMEOUT.

NOTE 3: The BS should indicate the same value of the RADIO_DOWNLINK_TIMEOUT parameter on all QAM channels on the DA main carrier.

Radio downlink failure shall be declared when the RDC-DA falls below 0. If this happens, the MAC shall inform the MLE that radio downlink failure has occurred using a TMC-REPORT indication primitive.

NOTE 4: $N_{.209}$ controls the AACH-Q message error rate threshold at which radio downlink failure occurs on a QAM channel. For example, if $N_{.209} = 4$, the ratio 4 to 1 between failure and success counting gives a decreasing RDC-DA when the message error rate exceeds 20 %. Therefore, a continuing message error rate greater than 20 % will cause radio downlink failure in this case.

23.7.3.1.1.7 RDC-DA-Q on QAM channels not on the DA main carrier - DA MS

When a DA MS moves to a QAM channel that is not on the DA main carrier, the MAC shall use an independent radio downlink counter RDC-DA-Q for that channel (except possibly in the case of concurrent channels; see clause 23.7.3.1.4).

If the MS is moving from one conforming QAM channel to another conforming QAM channel with the same carrier frequency, RF bandwidth and BS transmit power relative to the main carrier, the MS may continue use of the previous RDC-DA-Q without re-initialization. Otherwise the MAC shall initialize the RDC-DA-Q to a value equal to the assumed value of RADIO_DOWNLINK_TIMEOUT for that channel (see clause 23.6.11.1), and shall start to decrease or increase RDC-DA-Q according to failure to decode or successful reception of the AACH-Q as described below. On receiving a SYSINFO-DA PDU on that channel, if the value of the RADIO_DOWNLINK_TIMEOUT parameter in the SYSINFO-DA PDU is different from the assumed value, the MAC shall make a correction by adding the difference between the true value and the assumed value of the RADIO_DOWNLINK_TIMEOUT to the current value of RDC-DA-Q.

As in clause 23.7.3.1.1.6:

- If the MAC is unable to decode an AACH-Q, RDC-DA-Q shall be decreased by $N \times N_{.209}$. In the case of a successful reception of an AACH-Q, RDC-DA-Q shall be increased by N but shall not be increased above the value of RADIO_DOWNLINK_TIMEOUT for that channel.
- The parameter N is equal to the number of timeslots between successive downlink slots which the MS is attempting to receive and decode; therefore, N is dependent on the MS mode of operation. Examples e) and f) in clause 23.7.3.1.1.6 apply. When the mode of operation of the MS is changed, the corresponding value of N shall be calculated by the MAC and used for updating RDC-DA-Q.

NOTE: The parameter N includes the downlink slot that the MS is attempting to receive and decode, in addition to the gap between downlink slots that the MS attempts to receive and decode.

RDC-DA-Q is valid only for the current channel (except possibly in the case of concurrent channels; see clause 23.7.3.1.4).

Radio downlink failure for the current channel shall be declared when the RDC-DA-Q falls below 0. If this happens, the MAC shall inform the MLE that radio downlink failure has occurred on that channel using a TMC-REPORT indication primitive.

23.7.3.1.1.8 RDC-DA-P on $\pi/4$ -DQPSK and D8PSK channels - DA MS

When a DA MS moves to a $\pi/4$ -DQPSK or D8PSK channel, the MAC shall use an independent radio downlink counter RDC-DA-P for that channel (except possibly in the case of concurrent channels; see clause 23.7.3.1.4).

If the MS is moving from one conforming $\pi/4$ -DQPSK or D8PSK channel to another conforming $\pi/4$ -DQPSK or D8PSK channel with the same carrier frequency and BS transmit power relative to the main carrier, the MS may continue use of the previous RDC-DA-P without re-initialization. Otherwise the MAC shall initialize the RDC-DA-P to a value equal to the assumed value of RADIO_DOWNLINK_TIMEOUT for that channel (see clauses 23.6.11.2 and 23.6.11.3), and shall start to decrease or increase RDC-DA-P according to failure to decode or successful reception of the AACH as described below. On receiving a SYSINFO PDU on that channel, if the value of the RADIO_DOWNLINK_TIMEOUT parameter in the SYSINFO PDU is different from the assumed value, the MAC shall make a correction by adding the difference between the true value and the assumed value of the RADIO_DOWNLINK_TIMEOUT to the current value of RDC-DA-P.

If the MAC is unable to decode an AACH, RDC-DA-P shall be decreased by $N \times N.210$. ($N.210$ is a constant which defines the quality threshold for the MS on a $\pi/4$ -DQPSK or D8PSK channel.) In the case of a successful reception of an AACH, RDC-DA-P shall be increased by N but shall not be increased above the value of RADIO_DOWNLINK_TIMEOUT for that channel.

The parameter N is equal to the number of timeslots between successive downlink slots which the MS is attempting to receive and decode; therefore, N is dependent on the MS mode of operation. Examples e) and f) in clause 23.7.3.1.1.6 apply. Another example is as follows:

- MS transmitting traffic on a single-slot assigned channel:

In this mode, the MS is transmitting on the uplink and is receiving the downlink according to the monitoring pattern(s) given at channel assignment. In this case, $N = 12 / \text{number of monitoring patterns allocated to the MS}$. This applies when 1, 2 or 3 monitoring patterns are assigned.

When the mode of operation of the MS is changed, the corresponding value of N shall be calculated by the MAC and used for updating RDC-DA-P.

NOTE 1: The parameter N includes the downlink slot that the MS is attempting to receive and decode, in addition to the gap between downlink slots that the MS attempts to receive and decode.

RDC-DA-P is valid only for the current channel (except possibly in the case of concurrent channels; see clause 23.7.3.1.4).

Radio downlink failure for the current channel shall be declared when the RDC-DA-P falls below 0. If this happens, the MAC shall inform the MLE that radio downlink failure has occurred on that channel using a TMC-REPORT indication primitive.

NOTE 2: $N.210$ on a $\pi/4$ -DQPSK or D8PSK channel is equivalent to $N.209$ on a QAM channel. It controls the AACH message error rate threshold at which radio downlink failure occurs on a $\pi/4$ -DQPSK or D8PSK channel. The value of $N.210$ may be different from the value of $N.209$.

23.7.3.1.2 Assessment of the main carrier from a non-conforming assigned channel

As defined in clause 23.7.3.1.1.1, having selected and acquired synchronization on a cell, the MAC begins measurement of the downlink RSSI on the current channel(s) on the serving cell, and uses this to calculate $C1$ for the current channel(s). It then periodically reports each $C1$ to the MLE using a TMC-MEASUREMENT indication primitive.

When the MS is not currently receiving a conforming channel, and the current channel is a non-conforming concentric or sectorized channel, the following additional procedure shall apply.

When the MAC calculates C1 for the current channel on the serving cell, it shall also estimate the path loss C3 on the main carrier of the serving cell - based on the RF signal strength or equivalent measurements made on the current channel (see clause 23.7.1.3). The MAC shall include the C3 result in the TMC-MEASUREMENT indication primitive whenever it reports C1 to the MLE.

When the MAC calculates C3:

- for CA, it shall use the cell selection parameters (RXLEV_ACCESS_MIN and MS_TXPWR_MAX_CELL) last received in the SYSINFO PDU on a conforming $\pi/4$ -DQPSK channel in this cell;
- for DA, it shall use the cell selection parameters (RXLEV_ACCESS_MIN and MS_TXPWR_MAX_CELL) last received in the SYSINFO-DA PDU on a conforming QAM channel in this cell with the same bandwidth as the main carrier or (optionally) in the SYNC-DA PDU;
- it shall use the BS transmit power relative to the main carrier for the current channel, as received in the channel allocation (or as calculated from element "conditional element A" in the channel allocation).

NOTE: Additionally, if the MLE prefers the MAC to make direct measurements of the path loss on the main carrier, the MLE may request monitoring of the main carrier on the serving cell (see clause 23.7.4).

If the MS is on a super-sectored or eccentric assigned channel, or if the MS did not understand the conforming channel status for the assigned channel, it cannot perform assessment of the main carrier based on the measurements made on that assigned channel. Therefore the MS needs to perform monitoring of the main carrier on the serving cell (path loss parameter C2) instead of performing assessment of the main carrier (path loss parameter C3). Thus, when the MS is not currently receiving a concentric or sectored channel, the MLE requests that the MAC performs monitoring of the main carrier on the serving cell, by including the main carrier of the serving cell in the TMC-MONITOR-LIST request primitive (see clause 18 and clause 23.7.4).

23.7.3.1.3 Serving cell channel class assessment

Serving cell channel class assessment is an MS function which uses measurements made on the current channel to estimate the path loss C4 for selected channel classes. The current channel may be either a conforming channel or a non-conforming concentric or sectored channel (see note 3).

Figure 23.16 illustrates how the MLE initiates the procedure for serving cell channel class assessment. The MLE sends a TMC-ASSESSMENT-LIST request primitive including a list of channel classes to be assessed, together with the characteristics of each channel class to be assessed.

NOTE 1: The characteristics of each channel class to be assessed include the modulation mode for that channel class, the maximum MS transmit power for that channel class, the minimum RX access level for that channel class and the BS transmit power relative to the main carrier of the serving cell.

The MAC shall measure the received RF signal strength or equivalent on the current channel as described in clause 23.7.3.1.1.1. Based on these measurements, the MAC shall estimate the path loss C4 for each of the channel classes (see clause 23.7.1.4). The MAC shall estimate the path loss C4 for each channel class at least every 5 s.

The result of the TMC-ASSESSMENT-LIST request primitive shall be contained in the TMC-ASSESSMENT indication primitive. The MAC shall estimate C4 for each channel class and shall periodically pass the results to the MLE using the TMC-ASSESSMENT indication primitive.

When the MAC calculates C4 for a channel class, it shall use the values of the channel class characteristics parameters provided by the MLE (received by the MLE in the D-NWRK-BROADCAST-EXTENSION or D-NWRK-BROADCAST-DA PDU). It shall also use the BS transmit power relative to the main carrier for the current channel. (This is assumed to be 0 dB unless the current channel is an assigned channel allocated with an augmented channel allocation.)

A TMC-ASSESSMENT-LIST request primitive with an empty channel class list shall inform the MAC to cease serving cell channel class assessment.

NOTE 2: Alternatively (or additionally) to requesting serving cell channel class assessment, if the MLE wishes the channel classes on the serving cell to be assessed using measurements made on the main carrier, the MLE may request main carrier monitoring with assessment of channel classes (see clause 23.7.4.5).

NOTE 3: If the MS is on a super-sectored or eccentric assigned channel, or if the MS did not understand the conforming channel status for the assigned channel, it cannot perform serving cell channel class assessment based on the measurements made on that assigned channel. Therefore, if the MS is currently receiving only super-sectored and/or eccentric channel(s) and/or channel(s) for which it does not understand the conforming channel status, and it wishes to perform assessment of channel classes, it needs to perform main carrier monitoring with assessment of channel classes (see clause 23.7.4.5).

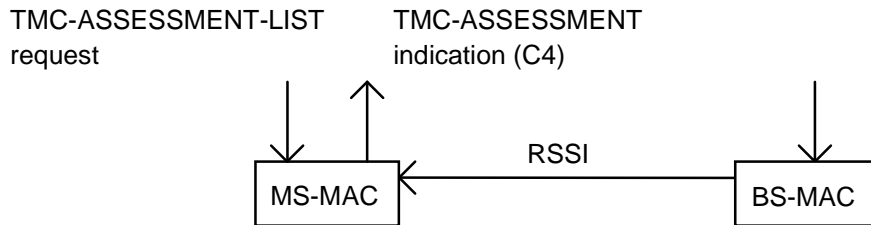

Figure 23.16: Scenario for serving cell channel class assessment

23.7.3.1.4 Concurrent channels on the serving cell

If the MAC is using concurrent channels on the serving cell, it shall perform the measurements and fulfil the requirements of providing the C1 parameter to the MLE (and C3 when appropriate), and information about the channel quality, in a way which is equivalent to or better than the method described below.

If the MAC is using concurrent channels, it may measure and report C1 independently for each individual channel.

Alternatively, if two or more of the concurrent channels are conforming channels with the same RF parameters, the MAC may make a single C1 calculation for those channels, based on measurements made on the combination of those channels. For the purposes of this procedure, the channels may be regarded as having the same RF parameters if they have the same value of P_{MSMAX} , $RXLEV_ACCESS_MIN$, $MS_TXPWR_MAX_CELL$, BS transmit power relative to the main carrier, carrier frequency and RF bandwidth.

If none of the concurrent channels is a conforming channel, and the MS is receiving one or more non-conforming concentric or sectored channels, the MAC is required to provide an estimate of the path loss C3 to the MLE (see clause 23.7.3.1.2). The MAC shall provide C3 to the MLE when it provides C1, for at least one of the non-conforming concentric or sectored channels (see note 1).

NOTE 1: If any of the concurrent channels are super-sectored or eccentric, or if the MS did not understand the conforming channel status for any of the concurrent channels, the MS cannot perform assessment of the main carrier based on the measurements made on those channels.

If the MLE initiates the procedure for serving cell channel class assessment, the MAC may use the measurements made on any of the current concentric or sectored channels to estimate the path loss C4 for the selected channel classes; however, if the MS is currently using both concentric and sectored channel(s), the MS should use the measurements made on a concentric channel in preference to measurements made on a sectored channel. If two or more of the concurrent channels are conforming channels with the same RF parameters (as defined above), the MAC may estimate the path loss C4 based on measurements made on the combination of those channels.

NOTE 2: If the MS is on a super-sectored or eccentric assigned channel, or if the MS did not understand the conforming channel status for the assigned channel, it cannot perform serving cell channel class assessment based on the measurements made on that assigned channel.

For a CA MS:

- If the MS is using concurrent conforming $\pi/4$ -DQPSK and/or D8PSK channels, the MAC shall use a single radio downlink counter RDC for those channels, as defined in clause 23.7.3.1.1.3.

NOTE 3: The BS should indicate the same value of the `RADIO_DOWNLINK_TIMEOUT` parameter on all conforming $\pi/4$ -DQPSK and D8PSK channels on the cell.

- If the MS is using concurrent non-conforming $\pi/4$ -DQPSK and/or D8PSK channels with the same carrier frequency, BS transmit power relative to the main carrier and value of `RADIO_DOWNLINK_TIMEOUT`, the MAC may use a single radio downlink counter RDC-NC for those channels.

- If the MS is using concurrent conforming QAM channels with the same carrier frequency, RF bandwidth, BS transmit power relative to the main carrier and value of RADIO_DOWNLINK_TIMEOUT, the MAC may use a single radio downlink counter RDC-Q for those channels.
- If the MS is using concurrent non-conforming QAM channels with the same carrier frequency, RF bandwidth, BS transmit power relative to the main carrier and value of RADIO_DOWNLINK_TIMEOUT, the MAC may use a single radio downlink counter RDC-Q for those channels.
- Otherwise the MAC shall use separate radio downlink counters for concurrent channels.

For a DA MS:

- If the MS is using concurrent QAM channels on the DA main carrier, the MAC shall use a single radio downlink counter RDC-DA for those channels.

NOTE 4: The BS should indicate the same value of the RADIO_DOWNLINK_TIMEOUT parameter on all channels on the DA main carrier.

- For QAM channels not on the DA main carrier:
 - If the MS is using concurrent conforming QAM channels with the same carrier frequency, RF bandwidth, BS transmit power relative to the main carrier and value of RADIO_DOWNLINK_TIMEOUT, the MAC may use a single radio downlink counter RDC-DA-Q for those channels.
 - If the MS is using concurrent non-conforming QAM channels with the same carrier frequency, RF bandwidth, BS transmit power relative to the main carrier and value of RADIO_DOWNLINK_TIMEOUT, the MAC may use a single radio downlink counter RDC-DA-Q for those channels.
- If the MS is using concurrent conforming $\pi/4$ -DQPSK and/or D8PSK channels with the same carrier frequency, BS transmit power relative to the main carrier and value of RADIO_DOWNLINK_TIMEOUT, the MAC may use a single radio downlink counter RDC-DA-P for those channels.
- If the MS is using concurrent non-conforming $\pi/4$ -DQPSK and/or D8PSK channels with the same carrier frequency, BS transmit power relative to the main carrier and value of RADIO_DOWNLINK_TIMEOUT, the MAC may use a single radio downlink counter RDC-DA-P for those channels.
- Otherwise the MAC shall use separate radio downlink counters for concurrent channels.

23.7.3.2 Uplink measurements

The criterion for determining the relinquishment of the radio uplink in the BS may be based upon uplink received signal strength measurement or an equivalent signal quality measurement and a measurement of the path delay from MS to BS derived from the time at which uplink slots are received at the BS.

The measurement of uplink received signal strength or quality may be used by the BS as a criterion to relinquish the radio link. The BS may inform the MS if this happens by sending a MAC-RESOURCE PDU which includes the optional "Power control" element with a value set to "Radio uplink failure". On receiving this, the MS MAC shall inform the MLE using a TMC-REPORT indication primitive. (The MLE action on receipt of this report depends on whether the current channel is a conforming channel; see clause 18.)

The measurement of uplink path delay may also be used by the BS as a criterion to relinquish the radio link. This allows the BS to limit the MS-BS distance and prevent the MS grossly exceeding the planned cell boundaries. The BS may inform the MS if this happens by sending a MAC-RESOURCE PDU which includes the optional "Power control" element with a value set to "maximum path delay exceeded" or "maximum path delay almost exceeded" (see note). On receiving either of these, the MS MAC shall inform the MLE using a TMC-REPORT indication primitive in order to initiate the MLE cell reselection procedures.

NOTE: The interpretation "maximum path delay almost exceeded" is applicable only to MSs that support the AGA service (see annex O).

23.7.4 Monitoring

23.7.4.0 General

The monitoring procedure is an MS function which measures the signal strength of carriers other than the carrier of the current channel and calculates C2. The monitoring procedure may be used for neighbour cell monitoring, irregular channel monitoring and main carrier monitoring.

Neighbour cell monitoring is an MS function which measures the signal strength of the main carrier on adjacent cells and calculates C2. The cell selection parameters for the adjacent cell may be broadcast on the serving cell for the C2 calculation. Monitoring is used when the MS is not synchronized to the adjacent cells and so cannot decode the adjacent cell BNCH (for a CA adjacent cell) or BSCH-Q (for a DA adjacent cell).

For neighbour cell monitoring, when the MLE initiates the monitoring procedure in the MAC, the MLE may also request assessment of the path loss (C5) for a number of channel classes on an adjacent cell (using the measurements made on the main carrier of that adjacent cell).

Irregular channel monitoring is an MS function which measures the signal strength of irregular carriers on the serving cell or on adjacent cells. The parameters for the irregular carrier are broadcast on the serving cell for the C2 calculation.

Main carrier monitoring is an MS function which measures the signal strength of the main carrier of the serving cell and calculates C2. The parameters for the main carrier are broadcast on the serving cell.

For main carrier monitoring, when the MLE initiates the monitoring procedure in the MAC, the MLE may also request assessment of the path loss (C5) for a number of channel classes on the serving cell (using the measurements made on the main carrier of the serving cell).

The following clauses describe the monitoring procedure. The MS MAC shall perform the measurements and fulfil the requirements of providing the C2 parameter to the MLE in a way which is equivalent to or better than the method described.

23.7.4.1 Monitoring scenario

Figure 23.17 illustrates how the MLE initiates the monitoring procedure in the MAC by sending TMC-MONITOR-LIST request primitive along with a list of channel numbers which correspond to the frequencies of the RF channels (carriers) to be monitored. The channel numbers in the list may correspond to a combination of adjacent cell main carriers, serving cell irregular carriers and/or adjacent cell irregular carriers, and may include the main carrier of the serving cell.

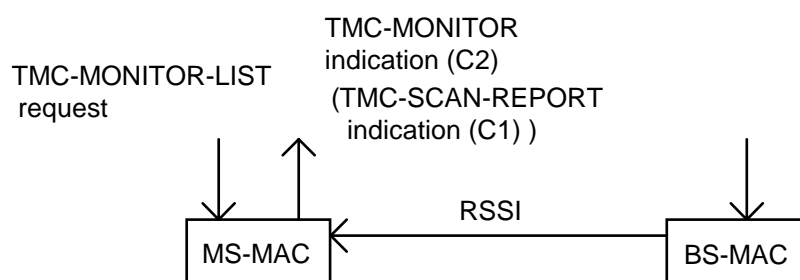

Figure 23.17: Monitoring scenario

The result of the TMC-MONITOR-LIST request primitive shall be contained in the TMC-MONITOR indication primitive. The MAC shall make the measurements needed to calculate C2 for each RF channel and shall periodically pass the result for each one using the TMC-MONITOR indication primitive.

NOTE 1: It is possible that the MLE may request neighbour cell monitoring of a channel that the MAC is currently receiving, for example, if a CA MS is currently receiving an assigned channel on a DA main carrier, or if a DA MS is currently receiving an assigned channel on the (if any) local CA main carrier.

The following points apply for neighbour cell monitoring:

- When monitoring a CA adjacent cell, the MAC shall use the adjacent cell parameters provided by the MLE for the C2 calculation (if they have been received on the serving cell by the MLE in the D-NWRK-BROADCAST PDU (or D-NWRK-BROADCAST-DA PDU, see note 2)). If the MS has not received these, the MAC shall use cell selection parameters as specified in clause 23.7.1.2 to calculate C2 instead.

NOTE 2: MSs generally obtain information about the main carrier on CA adjacent cells from the D-NWRK-BROADCAST PDU. However DA MSs may obtain information about the main carrier of the (if any) local CA cell from the D-NWRK-BROADCAST-DA PDU. (They obtain information about the channel classes and/or irregular channels on the local CA cell from the D-NWRK-BROADCAST-EXTENSION PDU.)

- When monitoring a DA adjacent cell:
 - the TMC-MONITOR-LIST request primitive indicates the RF bandwidth of the adjacent cell main carrier (received on the serving cell by the MLE in the D-NWRK-BROADCAST-DA PDU);
 - the MAC shall use the adjacent cell parameters provided by the MLE for the C2 calculation (if they have been received on the serving cell by the MLE in the D-NWRK-BROADCAST-DA PDU). If the MS has not received these, the MAC shall use cell selection parameters as specified in clause 23.7.1.2 to calculate C2 instead.

NOTE 3: For bandwidths greater than 25 kHz, the carrier number in the D-NWRK-BROADCAST-DA PDU refers to the centre frequency of the lowest 25 kHz comprising the carrier (as for a channel allocation, see clause 21.5.2).

- If the MS has already acquired synchronization on an adjacent cell and it has decoded the broadcast parameters needed to calculate C1, the MAC shall report the updated value of C1 for the adjacent cell using the TMC-SCAN-REPORT indication primitive instead of reporting C2 for that cell.

The following points apply for irregular channel monitoring:

- For each irregular carrier to be monitored, the TMC-MONITOR-LIST request primitive indicates the modulation mode and the RF bandwidth (received on the serving cell by the MLE in the D-NWRK-BROADCAST-EXTENSION or D-NWRK-BROADCAST-DA PDU).
- The MLE provides the parameters for the C2 calculation (received on the serving cell by the MLE in the D-NWRK-BROADCAST-EXTENSION or D-NWRK-BROADCAST-DA PDU).

NOTE 4: For bandwidths greater than 25 kHz, the carrier number in the D-NWRK-BROADCAST-EXTENSION or D-NWRK-BROADCAST-DA PDU refers to the centre frequency of the lowest 25 kHz comprising the carrier (as for a channel allocation, see clause 21.5.2).

The following points apply for main carrier monitoring:

- A CA MS shall use the parameters RXLEV_ACCESS_MIN and MS_TXPWR_MAX_CELL last received on a conforming $\pi/4$ -DQPSK channel on the serving cell for the C2 calculation.
- A DA MS shall use the parameters RXLEV_ACCESS_MIN and MS_TXPWR_MAX_CELL last received on a conforming QAM channel on the serving cell with the same bandwidth as the main carrier for the C2 calculation.

A TMC-MONITOR-LIST request primitive with an empty channel list shall inform the MAC to cease monitoring.

23.7.4.2 Monitoring measurements

The MAC shall measure the received RF signal strength or equivalent signal quality for all RF channels (carriers) of the monitor list.

As far as possible the same number of measurement samples shall be taken for all RF channels and the measurement samples shall be uniformly distributed over the averaging period.

The MAC shall measure the received RF signal strength or make an equivalent signal quality measurement for all RF channels of the monitor list. For each RF channel, it shall calculate a running average of at least 5 measurement samples. These samples shall be taken during at least the last 5 s and at most the last 60 s. If less than 5 measurements were collected during this period, for example due to the constraints of an energy economy or dual watch mode, then the last 5 measurements may be used. The measurement sample duration shall be at least SD1 (refer to clause 10). Using the average of these measurements, the MAC shall calculate the parameter C2 at least every 5 s. In the case of neighbour cell monitoring, the MAC may in addition calculate the parameter C1 for all RF channels of the monitoring list with which it has already synchronized and decoded the BNCH (for a CA cell) or BSCH-Q (for a DA cell).

23.7.4.3 Signal strength measurement

The RSSI measurements or equivalent signal quality measurements shall be made during the non-assigned or non-used timeslots of the physical channel(s) to which the MS is attached.

- EXAMPLE:
- for a receiving or idle MS, during the uplink slots of the physical channel;
 - for a transmitting MS, during the downlink slots not already assigned to serving cell reception as defined by the monitoring pattern(s) allocated to the MS;
 - for an MS in full duplex, during the unused uplink slot of the control frame;
 - when the MS is not transmitting, during the downlink slots in which the MS is not required to receive, as a result of the napping or energy economy or part-time reception procedures.

The measurements shall be made whenever possible, taking into account the mode of operation and the frequency switching capability of the MS. However, the overall frequency of measurement, taking into account all RF channels, need not exceed the following rate:

- | | |
|----------------------------------|--|
| MS in half duplex RX or TX mode: | 6 measurements per multiframe period; |
| MS in idle mode: | 1 measurement per 3 downlink TDMA frames of the MCCH or single-slot MCCH-Q or common SCCH; |
| | 6 measurements per multiframe period of a multi-slot MCCH-Q. |

If the RF channel does not operate in timesharing mode, the measurement sample duration shall be at least SD2 as defined in clause 10.

If the RF channel operates in timesharing mode and if the MS has knowledge of the timesharing synchronization, the MS shall perform the measurements only during the timeslots exclusively reserved to the monitored channel. If no active timeslots can be found that coincide with the monitoring periods, the measurement shall not be performed on this RF channel. If some can be found, the measurement sample duration shall be at least SD1.

If the RF channel operates in timesharing mode and if the MS does not have knowledge of the timesharing synchronization, the measurement sample duration shall be at least SD1 and several measurements are allowed on the same RF channel during one monitoring period. The MS shall calculate the average of the 5 samples showing the highest RF signal strength during the preceding 10 s, these samples being separated by at least 50 ms.

- NOTE: Timesharing mode may apply for neighbour cell monitoring on a CA adjacent cell (indicated by the MLE in the TMC-MONITOR-LIST request primitive); timesharing mode may apply for main carrier monitoring on a CA serving cell (indicated by the SYNC PDU on the serving cell); timesharing mode does not apply for irregular channel monitoring or for neighbour cell monitoring on a DA adjacent cell or for main carrier monitoring on a DA serving cell.

23.7.4.4 Neighbour cell monitoring with assessment of channel classes

When the MLE initiates the monitoring procedure for the main carrier on an adjacent cell, it may also request assessment of the path loss (C5) for a number of channel classes on that adjacent cell.

Figure 23.18 illustrates how the MLE initiates the neighbour cell monitoring procedure with assessment of channel classes on the adjacent cell(s). The MLE sends a TMC-MONITOR-LIST request primitive including one or more channel numbers, of which at least one corresponds to the frequency of an adjacent cell main carrier to be monitored. For each adjacent cell main carrier to be monitored, the MLE may include a list of channel classes to be assessed (together with the characteristics of each channel class to be assessed).

NOTE 1: The characteristics of each channel class to be assessed include the modulation mode for that channel class, the maximum MS transmit power for that channel class, the minimum RX access level for that channel class and the BS transmit power relative to the main carrier of that adjacent cell.

NOTE 2: For monitoring of a DA adjacent cell, the TMC-MONITOR-LIST request primitive also indicates the RF bandwidth of the main carrier of that adjacent cell.

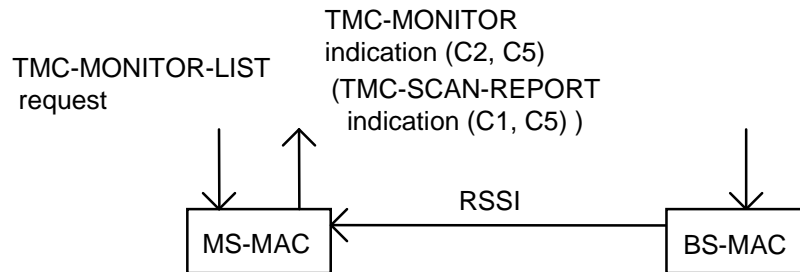

Figure 23.18: Neighbour cell monitoring scenario with assessment of channel classes

The MAC shall make the measurements needed to calculate C2 for the adjacent cell main carrier (as defined in clauses 23.7.4.2 and 23.7.4.3), and shall then estimate the path loss (C5) for each of the channel classes to be assessed - based on the RSSI or equivalent measurements made on the monitored main carrier. The MAC shall then pass the C2 result and the C5 results to the MLE using the TMC-MONITOR indication primitive.

The MAC shall make the measurements needed to calculate C2 for each adjacent cell main carrier and shall periodically pass the result for each one, and also the corresponding C5 results for each one, using the TMC-MONITOR indication primitive.

The MAC shall use the adjacent cell parameters provided by the MLE for the C2 calculation (if they have been received on the serving cell by the MLE in the D-NWRK-BROADCAST or D-NWRK-BROADCAST-DA PDU). If the MS has not received these, the MAC shall use cell selection parameters as specified in clause 23.7.1.2 to calculate C2 instead. The MAC shall use the values of the channel class characteristics parameters provided by the MLE for the C5 calculation (received on the serving cell by the MLE in the D-NWRK-BROADCAST-EXTENSION or D-NWRK-BROADCAST-DA PDU).

If the MS has already acquired synchronization on an adjacent cell and it has decoded the broadcast parameters needed to calculate C1, the MAC shall report the updated value of C1 for the adjacent cell using the TMC-SCAN-REPORT indication primitive instead of reporting C2 for that cell. In this case the MAC shall include the C5 results in the TMC-SCAN-REPORT indication primitive.

23.7.4.5 Main carrier monitoring with assessment of channel classes

When the MLE initiates the monitoring procedure for the main carrier on the serving cell, it may also request assessment of the path loss (C5) for a number of channel classes on the serving cell.

Figure 23.19 illustrates how the MLE initiates the main carrier monitoring procedure with assessment of channel classes on the serving cell. The MLE sends a TMC-MONITOR-LIST request primitive including one or more channel numbers, one of which corresponds to the frequency of the main carrier on the serving cell. The MLE also includes a list of channel classes to be assessed (together with the characteristics of each channel class to be assessed).

NOTE: The characteristics of each channel class to be assessed include the modulation mode for that channel class, the maximum MS transmit power for that channel class, the minimum RX access level for that channel class and the BS transmit power relative to the main carrier of the serving cell.

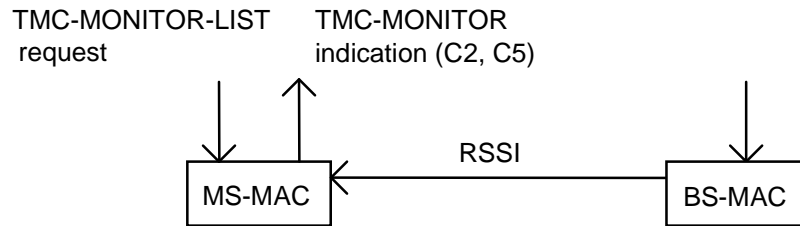

Figure 23.19: Main carrier monitoring scenario with assessment of channel classes

The MAC shall make the measurements needed to calculate C2 for the main carrier (as defined in clauses 23.7.4.2 and 23.7.4.3), and shall then estimate the path loss (C5) for each of the channel classes to be assessed - based on the RSSI or equivalent measurements made on the main carrier. The MAC shall then pass the C2 result and the C5 results to the MLE using the TMC-MONITOR indication primitive.

The MAC shall make the measurements needed to calculate C2 for the main carrier and shall periodically pass the result, and also the corresponding C5 results, using the TMC-MONITOR indication primitive.

The MAC in a CA MS shall use the parameters RXLEV_ACCESS_MIN and MS_TXPWR_MAX_CELL last received on a conforming $\pi/4$ -DQPSK channel on the serving cell for the C2 calculation. The MAC shall use the values of the channel class characteristics parameters provided by the MLE for the C5 calculation (received by the MLE in the D-NWRK-BROADCAST-EXTENSION PDU).

The MAC in a DA MS shall use the parameters RXLEV_ACCESS_MIN and MS_TXPWR_MAX_CELL last received on a conforming QAM channel on the serving cell with the same bandwidth as the main carrier for the C2 calculation. The MAC shall use the values of the channel class characteristics parameters provided by the MLE for the C5 calculation (received by the MLE in the D-NWRK-BROADCAST-DA PDU).

23.7.5 Scanning

23.7.5.0 General

Scanning is an MS function which measures the signal strength on the main carrier of the adjacent cells and calculates C1 using the adjacent cell parameters broadcast on the relevant adjacent cell. It is used when the MS obtains synchronization to the adjacent cell and is able to decode:

- the adjacent cell BSCH and BNCH for a CA adjacent cell; or
- the adjacent cell BSCH-Q for a DA adjacent cell.

When the MLE initiates the scanning procedure in the MAC, it may also request assessment of the path loss (C5) for a number of channel classes on that adjacent cell (using the measurements made on the main carrier of the adjacent cell).

The following clauses describe the scanning procedure. The MS MAC shall perform the measurements and fulfil the requirements of providing the C1 parameter to the MLE in a way which is equivalent to or better than the method described.

23.7.5.1 Scanning scenario

Figures 23.20 and 23.21 illustrate how the MLE initiates the scanning procedure in the MAC by sending TMC-SCAN request primitive along with a channel number which corresponds to the frequency of the adjacent cell main carrier to be scanned, the modulation mode and RF bandwidth of the adjacent cell main carrier to be scanned, and a scanning measurement method to indicate whether foreground, background or interrupted scanning is to be used.

The MAC shall make the measurements needed to calculate C1 for the adjacent cell RF channel (carrier) and shall pass the result using TMC-SCAN confirm primitive. The MS shall use the cell selection parameters broadcast on the adjacent cell for the C1 calculation.

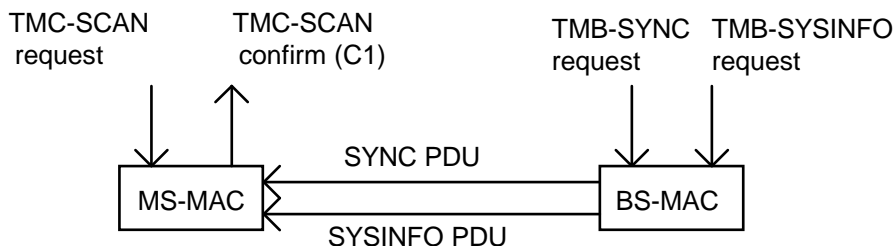

Figure 23.20: Scanning scenario for CA adjacent cell

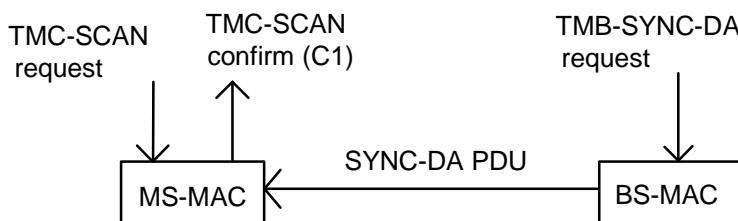

Figure 23.21: Scanning scenario for DA adjacent cell

23.7.5.2 Scanning measurement

23.7.5.2.0 General

Scanning shall comprise of achieving synchronization with an adjacent cell, measuring the received signal strength or an equivalent signal quality and decoding:

- the BSCH and BNCH broadcast on the adjacent cell for a CA adjacent cell; or
- the BSCH-Q broadcast on the adjacent cell for a DA adjacent cell (see note).

NOTE: When scanning a DA cell, the SYNC-DA PDU (carried in the BSCH-Q) contains all the essential information needed for the MS to decide whether it wishes to use the cell. However the SYSINFO-DA PDU contains some additional details about the cell and information needed for transmission, and the MS needs to receive the SYSINFO-DA PDU before it can use a DA cell (see clause 23.7.2), so the MS may prefer to receive the SYSINFO-DA PDU on a likely DA cell before confirming its decision to use that cell. The MLE instructs the MAC to attempt to receive the SYSINFO-DA PDU on a DA adjacent cell by using the TMC-CELL-READ request primitive; see clause 23.7.5.4.

Scanning shall be performed on one RF channel at a time. Three different methods of scanning are defined:

- foreground, where scanning is the only activity;
- background, where communications with the current serving cell are maintained in parallel with the scanning, and the scanning causes no interruption to that service;
- interrupting, where communications with the current serving cell are maintained in parallel with the scanning, but the scanning causes limited interruptions to that service.

23.7.5.2.1 Foreground scanning

Foreground scanning is used when the MS is in idle mode on the serving cell and wishes to scan an adjacent cell. The MS switches from the serving cell main carrier to the adjacent cell main carrier. The MS then acquires synchronization and makes the adjacent cell measurements before returning to the serving cell main carrier.

The MS MAC shall carry out the following in response to an MLE instruction to perform foreground scanning:

- Change frequency to the RF channel to be scanned in the adjacent cell.
- Attempt to acquire synchronization on the RF channel to be scanned and:
 - for a CA adjacent cell, decode the cell selection parameters in BNCH; if the BNCH cannot be decoded within 5 s, the scanning shall be stopped;
 - for a DA adjacent cell, decode the cell selection parameters in BSCH-Q; if the BSCH-Q cannot be decoded within 5 s, the scanning shall be stopped.
- Measure the received RF signal strength or equivalent received signal quality. These measurements shall be used for calculating C1. The averaging shall be calculated using at least 5 measurement samples, each sample having a duration of at least SD2 (as defined in clause 10). As far as possible, these samples should be evenly spread over at least 300 ms.
- Calculate C1 for the scanned RF channel.
- Return to the serving cell main carrier.

The MAC may decode the cell selection parameters at the same time as making the RSSI or equivalent measurements. Any measurements made within the 5 s before the start of scanning may also be used to calculate C1.

In the case where the BS is operating in timesharing mode on a CA cell, the measurements shall be made during the timeslots exclusively reserved to the scanned channel and the number of periods may be reduced to the number of active timeslots over a period of two multiframe.

23.7.5.2.2 Background scanning

Background scanning is used when the MS wishes to scan an adjacent cell and maintain any current service on the serving cell, whether that is receiving the downlink control channel or transmitting or receiving as part of a call. The MS switches from the serving cell carrier to the adjacent cell main carrier in between any transmissions or receptions on the serving cell. The MS attempts to acquire synchronization on the adjacent cell during those times.

NOTE: It is possible that the MLE may request scanning of a channel that the MAC is currently receiving, for example, if a CA MS is currently receiving an assigned channel on a DA main carrier, or if a DA MS is currently receiving an assigned channel on the (if any) local CA main carrier.

The signal strength measurements shall be identical to those performed during monitoring (see clause 23.7.4.3).

When scanning a CA adjacent cell, the MAC shall attempt to synchronize and read the BSCH and BNCH for the scanned RF channel. The MAC shall devote all its monitoring capability to these operations. The parameters decoded on the BNCH shall be used to calculate the path loss parameter C1.

When scanning a DA adjacent cell, the MAC shall attempt to synchronize and read the BSCH-Q for the scanned RF channel. The MAC shall devote all its monitoring capability to these operations. The parameters decoded on the BSCH-Q shall be used to calculate the path loss parameter C1.

The MAC shall keep the information concerning the time synchronization for the RF channels of the list. This information may be used to schedule the subsequent decoding of cell selection parameters and shall be used when accessing a re-selected cell.

When a new RF channel for which the MAC does not have synchronization has to be scanned, the MAC shall devote all its monitoring capability to synchronize on this RF channel and read the cell selection parameters contained in the BNCH (for a CA cell) or BSCH-Q (for a DA cell), in priority over signal strength measurements on all other RF channels. If the cell selection parameters cannot be read within 15 s, a re-attempt shall not take place before $\text{Attempt_number} \times 15$ s after the end of the last attempt period, Attempt_number being the number of attempts already performed.

The MAC shall attempt to read the cell selection parameters of each of the RF channels of the list at least every minute, to confirm that it is monitoring the same cell and update the value of these parameters. If a change of identity is detected then the RF channel shall be treated as a new RF channel in the list. If the BSCH or BSCH-Q cannot be decoded, a re-attempt shall be made at the next available opportunity.

For initial and subsequent cell selection parameters decoding, if the cell selection parameters cannot be decoded after 5 attempts, its RF channel shall be discarded from the list and any existing signal strength measurements shall be discarded.

The MAC shall re-calculate the parameter C1 at least every 10 s for the RF channels of the list based on the updated measurement done by monitoring (C2).

23.7.5.2.3 Interrupting scanning

Interrupting scanning is similar to foreground scanning except that the MS is participating in a call on the serving cell and temporarily suspends service in order to scan an adjacent cell.

NOTE: It is possible that the MLE may request scanning of a channel that the MAC is currently receiving, for example, if a CA MS is currently receiving an assigned channel on a DA main carrier, or if a DA MS is currently receiving an assigned channel on the (if any) local CA main carrier.

The signal strength measurements shall be identical to those performed during monitoring (see clause 23.7.4.3).

The MAC shall attempt to synchronize, read the cell selection parameters and calculate the path loss parameter C1 for all RF channels as instructed by the MLE.

The MAC shall devote all its resources to these operations. If the cell selection parameters cannot be read within 5 s for an RF channel, all signal strength measurements on this RF channel shall be discarded.

The MAC shall keep the information concerning the time synchronization for the RF channels. This information may be used to schedule the subsequent decoding of cell selection parameters and when accessing a re-selected cell. Whenever the MAC re-calculates the parameter C2 for one of these RF channels, it shall re-calculate the parameter C1 for this RF channel. The MAC may periodically attempt to read the cell selection parameters for these RF channels, to confirm that it is monitoring the same cells and update the value of these parameters.

In the case where the radio link is relinquished before the link is declared relinquishable, the MAC shall first check all RF channels for which it has kept the time synchronization according to the indication given by the MLE. If none of the RF channels meets this criterion, the MAC shall perform the cell selection parameters measurement as for unprepared cell selection.

23.7.5.3 Scanning with assessment of channel classes on adjacent cell

When the MLE initiates the scanning procedure in the MAC, it may also request assessment of the path loss (C5) for a number of channel classes on that adjacent cell.

Figure 23.22 illustrates how the MLE initiates the scanning procedure with assessment of channel classes on the adjacent cell. The MLE sends a TMC-SCAN request primitive along with a channel number which corresponds to the frequency of the adjacent cell main carrier to be scanned, the modulation mode and RF bandwidth of the adjacent cell main carrier to be scanned, a scanning measurement method to indicate whether foreground, background or interrupted scanning is to be used, and a list of channel classes to be assessed (together with the characteristics of each channel class to be assessed).

NOTE: The characteristics of each channel class to be assessed include the modulation mode for that channel class, the maximum MS transmit power for that channel class, the minimum RX access level for that channel class and the BS transmit power relative to the main carrier of the adjacent cell.

The MAC shall make the measurements needed to calculate C1 for the adjacent cell (as defined in clause 23.7.5.2), and shall estimate the path loss (C5) for each of the channel classes to be assessed - based on the RSSI or equivalent measurements made on the scanned main carrier. The MAC shall then pass the C1 result and the C5 results to the MLE using TMC-SCAN confirm primitive. The MS shall use the cell selection parameters broadcast on the adjacent cell for the C1 calculation. The MAC shall use the values of the channel class characteristics parameters provided by the MLE for the C5 calculation (received on the serving cell by the MLE in the D-NWRK-BROADCAST-EXTENSION or D-NWRK-BROADCAST-DA PDU).

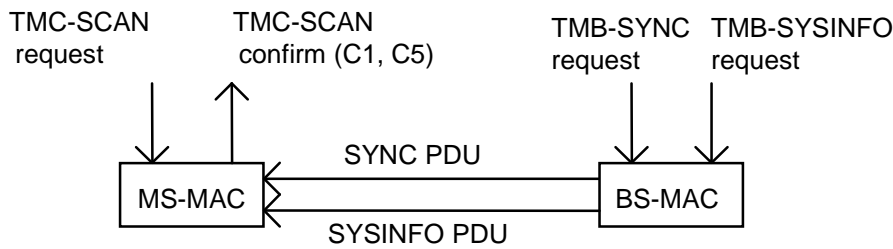

Figure 23.22: Scanning scenario for CA adjacent cell with assessment of channel classes

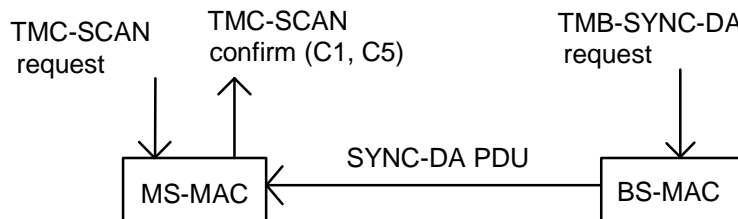

Figure 23.23: Scanning scenario for DA adjacent cell with assessment of channel classes

23.7.5.4 Reading SYSINFO-DA PDU on DA adjacent cell

When scanning a DA cell, the MS is only required to receive the SYNC-DA PDU; see clause 23.7.5.2. However the MS needs to receive the SYSINFO-DA PDU before it can use a DA cell. Therefore the MS may prefer to receive the SYSINFO-DA PDU on a likely DA cell before confirming its decision to use that cell.

Figure 23.24 illustrates how the MLE instructs the MAC to attempt to receive the SYSINFO-DA PDU on a DA adjacent cell by sending the TMC-CELL-READ request primitive along with a channel number which corresponds to the frequency of the DA adjacent cell main carrier (and the RF bandwidth of the DA adjacent cell main carrier).

The MAC shall attempt to receive the SYSINFO-DA PDU on the specified DA adjacent cell main carrier and shall pass the result to the MLE using the TMC-CELL-READ confirm primitive. If the MAC receives the SYSINFO-DA PDU on the adjacent cell, it shall store the broadcast parameters from the PDU; it shall also pass the TM-SDU and other appropriate parameters to the MLE e.g. using the TMB-SYSINFO-DA indication primitive (see clause 23.6.1.3).

NOTE: The MAC needs to refer to information from the SYNC-DA PDU received when scanning that DA adjacent cell e.g. in order to obtain the synchronization of the DA adjacent cell main carrier and the scrambling code to be used for reception of the SYSINFO-DA PDU.

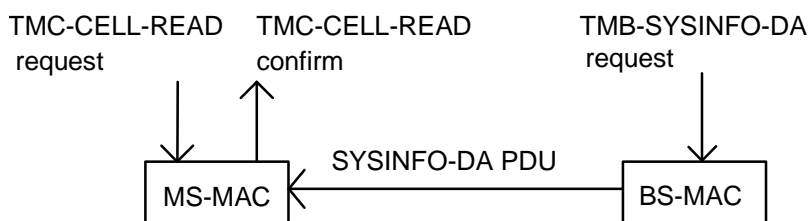

Figure 23.24: Scenario for reading SYSINFO-DA PDU on DA adjacent cell

23.7.6 Selection of energy economy mode

An MS may enter energy economy mode by negotiating with the BS. This negotiation shall be performed by an MM message exchange (see clause 16.7.1). Once MM has negotiated a particular energy economy group, the MAC shall be informed through the protocol stack using MLE-INFO request, TL-CONFIGURE request and TMC-CONFIGURE request primitives. These primitives shall include two parameters:

- "Energy economy group"; and
- "Energy economy start point".

"Energy economy group" shall specify how long the MS may sleep between receiving downlink slots on the control channel and shall have one of the values shown in table 23.9. "Energy economy start point" shall specify the frame and multiframe number at which energy economy operation shall begin.

Table 23.9: Definition of the Economy Groups and duration

Economy Group	TDMA frames to sleep
EG1	1
EG2	2
EG3	5
EG4	8
EG5	17
EG6	71
EG7	359

An MS shall only request to enter energy economy mode while on its common control channel. A CA MS's common control channel is the MCCH or a $\pi/4$ -DQPSK common SCCH. A DA MS's common control channel is the MCCH-Q or a QAM common SCCH.

If the common control channel is a single-slot channel (i.e. the MCCH or a single-slot MCCH-Q or a common SCCH), the MS shall attempt to receive and decode the relevant slot on the main carrier in all the TDMA frames up until and including the frame and multiframe given by the "Energy economy start point". The MS may then sleep for the number of TDMA frames indicated by the "Energy economy group". After this number of TDMA frames has elapsed, the MS shall then attempt to receive and decode the relevant downlink slot in the next TDMA frame. This operation (i.e. the regular cycle of sleeping for N TDMA frames and then receiving the relevant downlink slot in one TDMA frame) shall continue while the MS remains in energy economy mode using this energy economy group.

If the common control channel is a multi-slot MCCH-Q, there are two possible methods:

- a) If the BS indicates in the SYSINFO-DA PDU that enhanced energy economy is available then, when in the sleeping cycle, the DA MS is only required to receive one downlink slot in the reception TDMA frames. That slot is derived from the parameter MS_SCCH which the MS received on registration or subscription (also used to indicate to the MS which one of the downlink slots on the main carrier shall be used when common SCCHs are in operation). If an MS has received this value at subscription and then also is assigned a value at registration, the value given at registration shall be used. The following rule shall then be applied by the MS to derive its reception slot when in the sleeping cycle:

Reception slot on multi-slot MCCH-Q when in sleeping cycle:

$$= 1 + (\text{MS_SCCH mod (Number of slots comprising the MCCH-Q)})$$

If the MS does not have a value of MS_SCCH on this network, and has no value from subscription, it shall assume that its required reception slot on a multi-slot MCCH-Q when in the sleeping cycle is slot 1.

- b) If the BS indicates in the SYSINFO-DA PDU that enhanced energy economy is not available then, when in the sleeping cycle, the DA MS is required to receive all slots comprising the multi-slot MCCH-Q in the reception TDMA frames.

NOTE 1: If the MS does not support enhanced energy economy (or does not wish to use enhanced energy economy) then, even if the BS indicates in the SYSINFO-DA PDU that enhanced energy economy is available, the MS when in the sleeping cycle receives all slots comprising the multi-slot MCCH-Q in the reception TDMA frames. The MS indicates whether it may use enhanced energy economy (if permitted by the BS) using the "part-time reception" sub-element in the "extended capabilities" element in the U-LOCATION UPDATE DEMAND PDU; see clause 16.

For either method on a multi-slot MCCH-Q, the MS shall attempt to receive and decode all downlink slots comprising the multi-slot MCCH-Q in all the TDMA frames up until and including the frame and multiframe given by the "Energy economy start point". The MS may then sleep for the number of TDMA frames indicated by the "Energy economy group". After this number of TDMA frames has elapsed the MS shall perform the appropriate procedure as follows:

- a) If enhanced energy economy is available, the MS shall attempt to receive and decode the relevant downlink slot (as specified above) in the next TDMA frame. This operation (i.e. the regular cycle of sleeping for N TDMA frames and then receiving the relevant downlink slot in one TDMA frame) shall continue while the MS remains in energy economy mode using this energy economy group.
- b) If enhanced energy economy is not available (or the MS is not using enhanced energy economy), the MS shall attempt to receive and decode all downlink slots comprising the multi-slot MCCH-Q in the next TDMA frame. This operation (i.e. the regular cycle of sleeping for N TDMA frames and then receiving all downlink slots comprising the multi-slot MCCH-Q in one TDMA frame) shall continue while the MS remains in energy economy mode using this energy economy group.

An energy economy mode shall be valid in all cells within a Registered Area (RA). If an MS changes cell within the RA, it may maintain the same energy economy mode and follow the same energy economy pattern after acquiring slot and frame synchronization on the new cell (but using the frame and multiframe numbering of the new cell). All energy economy groups have a cyclic energy economy pattern within a hyperframe and so, given a start point and energy economy group, the MS may calculate the absolute frame and multiframe numbers in which it shall attempt to receive and decode the relevant downlink slot (or relevant downlink slots if appropriate for a multi-slot MCCH-Q). Therefore, even although adjacent cells need not be synchronized, an MS may apply the same energy economy pattern on the new cell within the RA.

NOTE 2: At the time of the cell change, the MS may need to sleep for a shorter time if there is a different synchronization on the new cell. The MS then reverts to the negotiated cycle.

During energy economy mode, the MAC shall temporarily suspend the sleeping cycle if:

- it obeys a channel allocation command allocating an assigned channel; or
- the MS becomes active in an advanced link (see clause 18.3.5.3.3), as indicated by the MLE activity indicator parameter in the TMC-CONFIGURE request primitive; or
- the MS becomes active in a call (see clause 18.3.5.3.3), as indicated by the MLE activity indicator parameter in the TMC-CONFIGURE request primitive; or
- the MS has signalling messages to send; or
- it receives a TMA-SAP signalling message from the BS for any of its valid addresses or event labels, other than the predefined broadcast group address (all ones).

NOTE 3: If the MS is using enhanced energy economy operation on a multi-slot MCCH-Q, and then needs to suspend the sleeping cycle on the multi-slot MCCH-Q, the MS also reverts to multi-slot reception i.e. attempting to receive and decode all downlink slots comprising the multi-slot MCCH-Q.

However, if the MS suspends the sleeping cycle as the result of receiving a downlink signalling message from the BS, and the next immediate downlink slot is part of the MCCH-Q, the MS is not required to receive that next immediate downlink slot.

The MAC shall return to the sleeping cycle when it is on its common control channel and a time T.210 has elapsed since:

- the higher layers indicated no activity using the TMC-CONFIGURE request primitive; or
- it sent its last signalling message; or
- it last received a TMA-SAP signalling message from the BS for one of its valid addresses or event labels, other than the predefined broadcast group address (all ones),

whichever is the most recent. During this time-out period, the MS shall continue to receive the downlink MCCH or common SCCH slot or MCCH-Q slots for any further signalling from the BS.

NOTE 4: The MS may sleep only on its common control channel, not on an assigned channel.

An MS shall end energy economy mode via an exchange of MM messages with the BS. MM instructs the MAC via the MLE-INFO, TL-CONFIGURE and TMC-CONFIGURE request primitives and the "Energy economy group" set to "Stay alive" to return to receiving the common control channel during all TDMA frames. The MAC shall begin this immediately and so the "Energy economy start point" parameter shall have no meaning in this case.

An MS in energy economy mode may request to change its energy economy group via an exchange of MM messages with the BS. From the perception of the MAC, this function is seen only as receiving an instruction from MM to end energy economy mode and then receiving another instruction to enter energy economy mode.

NOTE 5: Thus, as defined for ending energy economy mode, the MAC obeys the instruction to "Stay alive" immediately so the "Energy economy start point" parameter has no meaning in this case. On receiving the instruction to enter energy economy mode, the MS continues to receive the control channel in all TDMA frames up until and including the frame and multiframe given by the new "Energy economy start point". The MS may then sleep for the number of TDMA frames indicated by the new "Energy economy group". After this number of TDMA frames has elapsed, the MS then receives and decodes the relevant downlink slot (or slots) in the next TDMA frame. Operation with the new sleeping cycle (i.e. the regular cycle of sleeping for N' TDMA frames and then receiving in one TDMA frame) continues while the MS remains in energy economy mode using this energy economy group.

If the MS is in energy economy mode and the MAC receives an instruction from MM to enter energy economy mode then it shall attempt to receive and decode the relevant slot (or slots) on the main carrier in all TDMA frames up until and including the frame and multiframe given by the new "Energy economy start point". It shall then use the sleeping cycle defined by the new "Energy economy group".

NOTE 6: This case may occur if the BS changes the MS's energy economy parameters.

The MS shall end energy economy mode if it leaves the RA (or if it is required to re-register when it moves between a DA cell and a CA cell irrespective of LA).

23.7.7 Selection of dual watch mode with energy economy group

An MS may enter dual watch mode by negotiating with the BS. This negotiation is performed by an MM message exchange (see clause 16.7.2). The procedures in this clause relate to dual watch mode when the MS is using an energy economy group.

NOTE 1: A full dual watch MS is capable of periodically receiving the V+D common control channel while it is in a Direct Mode call (when practicable). It is also capable of periodically receiving the Direct Mode RF carrier while it is in a V+D call and, when idle, it periodically receives both the Direct Mode RF carrier and the V+D common control channel. In order for the MS to periodically receive the V+D common control channel while in a Direct Mode call, the MS needs to request to use an appropriate energy economy group when it requests to perform the full dual watching procedure.

An MS may, alternatively, request to perform an idle dual watching procedure in which the MS may not be capable of receiving the V+D common control channel while it is in a Direct Mode call and may not be capable of receiving the Direct Mode RF carrier while it is in a V+D call. It is optional for the MS to request to use an energy economy group when it is performing the idle dual watching procedure.

The procedures defined in this clause relate to the full dual watching procedure. They apply also to the idle dual watching procedure in the case that the MS is using an energy economy group.

Once MM has negotiated dual watch mode with a particular energy economy group, the MAC shall be informed through the protocol stack using MLE-INFO request, TL-CONFIGURE request and TMC-CONFIGURE request primitives. These primitives shall include two parameters:

- "Dual watch energy economy group"; and
- "Dual watch start point".

"Dual watch energy economy group" shall specify how long the MS may be unreachable (transmitting and/or receiving in Direct Mode, and/or sleeping) between receiving downlink slots on the V+D control channel and shall have one of the values shown in table 23.9. "Dual watch start point" shall specify the V+D frame and multiframe number at which dual watch mode using the agreed energy economy group shall begin.

An MS shall only request to enter dual watch mode while on its common control channel. A CA MS's common control channel is the MCCH or a $\pi/4$ -DQPSK common SCCH. A DA MS's common control channel is the MCCH-Q or a QAM common SCCH.

If the common control channel is a single-slot channel (i.e. the MCCH or a single-slot MCCH-Q or a common SCCH), the MS shall attempt to receive and decode the relevant slot on the main carrier if practicable (i.e. unless Direct Mode requirements take precedence), in all the TDMA frames up until and including the frame and multiframe given by the "Dual watch start point". The MS may then be unreachable (transmitting and/or receiving in Direct Mode, and/or sleeping) for the number of TDMA frames indicated by the "Dual watch energy economy group". After this number of TDMA frames has elapsed, the MS shall then attempt to receive and decode the relevant downlink slot in the next V+D TDMA frame if practicable. This operation (i.e. the regular cycle of being unreachable for N TDMA frames and then receiving the relevant downlink slot in one V+D TDMA frame when practicable) shall continue while the MS remains in dual watch mode using this energy economy group.

If the common control channel is a multi-slot MCCH-Q, there are two possible methods:

- a) If the BS indicates in the SYSINFO-DA PDU that enhanced energy economy is available then, when in the dual watch reception cycle, the DA MS is only required to receive one downlink slot in the reception TDMA frames (when practicable). That slot is derived from the parameter MS_SCCH which the MS received on registration or subscription (or when it negotiated dual watch). (The parameter MS_SCCH is also used to indicate to the MS which one of the downlink slots on the main carrier shall be used when common SCCHs are in operation.) If an MS has received this value at subscription and then also is assigned a value at registration (or dual watch negotiation), the value given at registration (or dual watch negotiation) shall be used. The following rule shall then be applied by the MS to derive its reception slot when in the dual watch reception cycle:

Reception slot on multi-slot MCCH-Q when in dual watch reception cycle

$$= 1 + (\text{MS_SCCH mod (Number of slots comprising the MCCH-Q)})$$

If the MS does not have a value of MS_SCCH on this network, and has no value from subscription, it shall assume that its required reception slot (when practicable) on a multi-slot MCCH-Q when in the dual watch reception cycle is slot 1.

- b) If the BS indicates in the SYSINFO-DA PDU that enhanced energy economy is not available then, when in the dual watch reception cycle, the DA MS is required to receive all slots comprising the multi-slot MCCH-Q in the reception TDMA frames when practicable.

NOTE 2: If the MS does not support enhanced energy economy (or does not wish to use enhanced energy economy) then, even if the BS indicates in the SYSINFO-DA PDU that enhanced energy economy is available, the MS when in the dual watch reception cycle receives all slots comprising the multi-slot MCCH-Q in the reception TDMA frames when practicable. The MS indicates whether it may use enhanced energy economy (if permitted by the BS) using the "part-time reception" sub-element in the "extended capabilities" element in the U-LOCATION UPDATE DEMAND PDU; see clause 16.

For either method on a multi-slot MCCH-Q, the MS shall attempt to receive and decode all downlink slots comprising the multi-slot MCCH-Q if practicable, in all the TDMA frames up until and including the frame and multiframe given by the "Dual watch start point". The MS may then be unreachable for the number of TDMA frames indicated by the "Dual watch energy economy group". After this number of TDMA frames has elapsed the MS shall perform the appropriate procedure as follows:

- a) If enhanced energy economy is available, the MS shall attempt to receive and decode the relevant downlink slot (as specified above) in the next V+D TDMA frame if practicable. This operation (i.e. the regular cycle of being unreachable for N TDMA frames and then receiving the relevant downlink slot in one V+D TDMA frame when practicable) shall continue while the MS remains in dual watch mode using this energy economy group.
- b) If enhanced energy economy is not available (or the MS is not using enhanced energy economy), the MS shall attempt to receive and decode all downlink slots comprising the multi-slot MCCH-Q in the next V+D TDMA frame if practicable. This operation (i.e. the regular cycle of being unreachable for N TDMA frames and then receiving all downlink slots comprising the multi-slot MCCH-Q in one V+D TDMA frame when practicable) shall continue while the MS remains in dual watch mode using this energy economy group.

NOTE 3: For both single-slot and multi-slot common control channels, the MS is required to attempt to receive and decode the V+D downlink slots defined in this clause only when practicable i.e. when Direct Mode requirements do not take precedence. When a full dual watching MS is a calling or called party in a Direct Mode call, Direct Mode requirements sometimes take precedence over V+D dual watch requirements (see ETSI EN 300 396-3 [22], clause 8.4.7.10). When an idle dual watching MS is a calling or called party in a Direct Mode call, the MS may not be capable of receiving the V+D control channel for the duration of the Direct Mode call. Even when a dual watching MS is not in a Direct Mode call, if the V+D common control channel is a multi-slot MCCH-Q and the BS does not support enhanced energy economy, in some cases the MS may not be able to receive all slots comprising the MCCH-Q if it needs to maintain its Direct Mode surveillance.

Therefore the BS should be aware that a dual watching MS will not always be able to receive in the agreed slots. (This applies also in the case of an MS that is performing idle dual watch without an energy economy group.)

This may apply for all V+D common control channels. However, in particular, if the V+D common control channel is a multi-slot MCCH-Q and the BS does not support enhanced energy economy, there may be many cases when the MS may not be able to receive all slots comprising the MCCH-Q.

Also the BS should be aware that, even if the MS receives a V+D message, it may not always be able to send a response - even a layer 2 acknowledgement e.g. if the MS is currently in an emergency Direct Mode call or if the MS is in a non-emergency Direct Mode call and the BS does not grant a subslot or slot(s) on the current V+D channel. The BS should also be aware that, if it grants a subslot or slot(s) on the current V+D channel, the MS may sometimes need to use the first granted subslot for linearization (see clause 23.4.5). For a subslot or single-slot grant the MS should then send a response in the next granted subslot or slot (if this occurs within 4 multiframes). For a grant of more than one slot, the MS sends a response in the second granted slot.

Dual watch mode shall be valid in all cells within an RA. If an MS changes cell within the RA, it may maintain the same dual watch energy economy group and follow the same reception pattern after acquiring slot and frame synchronization on the new cell (but using the frame and multiframe numbering of the new cell). All energy economy groups have a cyclic reception pattern within a hyperframe and so, given a start point and energy economy group, the MS may calculate the absolute frame and multiframe numbers in which it shall attempt to receive and decode the relevant downlink slot when practicable (or relevant downlink slots if appropriate for a multi-slot MCCH-Q). Therefore, even although adjacent cells need not be synchronized, an MS may apply the same reception pattern on the new cell within the RA.

NOTE 4: At the time of the cell change, the MS may need to be unreachable for a shorter time if there is a different synchronization on the new cell. The MS then reverts to the negotiated reception cycle.

A dual watching MS shall temporarily revert to receiving the V+D channel in all TDMA frames if:

- it obeys a channel allocation command allocating an assigned channel; or
- it becomes active in a V+D advanced link (see clause 18.3.5.3.3), as indicated by the MLE activity indicator parameter in the TMC-CONFIGURE request primitive; or
- it becomes active in a V+D call (see clause 18.3.5.3.3), as indicated by the MLE activity indicator parameter in the TMC-CONFIGURE request primitive.

NOTE 5: While on an assigned channel, or when active in a V+D advanced link or call, a full dual watching MS should still periodically receive the Direct Mode RF carrier if practicable, in order to look for calls addressed to itself. However, this may not always be practicable e.g. for a three-slot or four-slot V+D call or for the transmitting party in a circuit mode V+D call if the BS has assigned monitoring pattern 11₂ (i.e. three monitoring patterns).

While on an assigned channel, or when active in a V+D advanced link or call, an idle dual watching MS need not attempt to receive the Direct Mode RF carrier.

If practicable (i.e. unless Direct Mode requirements take precedence), a dual watching MS shall temporarily revert to receiving the V+D channel in all TDMA frames if:

- it has V+D signalling messages to send; or
- it receives a TMA-SAP signalling message from the BS for any of its valid addresses or event labels, other than the predefined broadcast group address (all ones).

NOTE 6: When the MS is in a Direct Mode call, it need not revert to receiving the V+D channel in all TDMA frames when it has V+D signalling messages to send or has received a signalling message from the BS (see ETSI EN 300 396-3 [22], clause 8.4.7.10).

NOTE 7: If the MS is using dual watch with enhanced energy economy operation on a multi-slot MCCH-Q, and then reverts to receiving the V+D channel in all TDMA frames (when practicable), the MS also reverts to multi-slot reception i.e. attempting to receive and decode all downlink slots comprising the multi-slot MCCH-Q (when practicable).

However, if the MS reverts to receiving the V+D channel in all TDMA frames as the result of receiving a downlink signalling message from the BS, and the next immediate downlink slot is part of the MCCH-Q, the MS is not required to receive that next immediate downlink slot.

The MS shall return to the dual watch reception cycle when it is on its common control channel and a time T.220 has elapsed since:

- the higher layers indicated no V+D activity using the TMC-CONFIGURE request primitive; or
- it sent its last V+D signalling message; or
- it last received a TMA-SAP signalling message from the BS for one of its valid addresses or event labels, other than the predefined broadcast group address (all ones),

whichever is the most recent. During this time-out period, the MS shall continue to receive the downlink MCCH or common SCCH slot or MCCH-Q slots in all TDMA frames if practicable (i.e. unless Direct Mode requirements take precedence), for any further signalling from the BS.

NOTE 8: The BS should be aware that it will not always be practicable for the MS to receive the V+D channel in all TDMA frames during the T.220 time-out period e.g. if the MS is currently in a Direct Mode call or if the MS user decides to initiate or receive a Direct Mode call.

NOTE 9: The dual watch reception cycle applies only on the MS's common control channel, not on an assigned channel.

An MS ends dual watch mode via an exchange of MM messages with the BS. MM instructs the MAC via the MLE-INFO, TL-CONFIGURE and TMC-CONFIGURE request primitives and the "Dual watch energy economy group" set to "Stay alive" to return to receiving the common control channel during all TDMA frames. The MAC shall begin this immediately and so the "Dual watch start point" parameter shall have no meaning in this case.

An MS in dual watch mode may request to change its energy economy group via an exchange of MM messages with the BS. From the perception of the MAC, this function is seen only as receiving an instruction from MM to "Stay alive" and then receiving another instruction to enter dual watch mode with the specified energy economy group.

If the MS is in dual watch mode and the MAC receives an instruction from MM to enter dual watch mode with a specified energy economy group then it shall attempt to receive and decode the relevant slot (or slots) on the main carrier if practicable (i.e. unless Direct Mode requirements take precedence), in all TDMA frames up until and including the frame and multiframe given by the new "Dual watch start point". It shall then use the reception cycle defined by the new "Dual watch energy economy group".

NOTE 10: This case may occur if the BS changes the MS's dual watch energy economy group.

The MS cannot operate in both normal energy economy mode and dual watch mode at one time. An MS in energy economy mode may request to change to dual watch mode via an exchange of MM messages with the BS. Conversely, an MS in dual watch mode may request to change to energy economy mode via an exchange of MM messages with the BS. From the perception of the MAC, this function is seen only as receiving an instruction from MM to "Stay alive" and then receiving another instruction to enter the other mode with the specified energy economy group.

The MS shall end dual watch mode if it leaves the RA (or if it is required to re-register when it moves between a DA cell and a CA cell irrespective of LA).

23.7.8 Part-time reception for DA MS on multi-slot MCCH-Q

As described in clause 23.7.6, the MS may use energy economy mode when on its common control channel if it has negotiated an energy economy group by an MM message exchange.

The part-time reception procedure is an alternative procedure which may apply when a DA MS is on a multi-slot MCCH-Q. If part-time reception is permitted by the BS, this allows DA MSs in common mode on a multi-slot MCCH-Q to receive and decode just one downlink slot per TDMA frame when they have not sent or received a message recently (based on inactivity timer T.234). When an MS is active on the multi-slot MCCH-Q, it reverts to multi-slot operation.

The part-time reception procedure may provide DA MSs in common mode on a multi-slot MCCH-Q with some opportunities for battery economy, neighbour cell monitoring, irregular channel monitoring and/or background scanning. However it generally requires more reception than when the MS is using energy economy mode.

The BS indicates whether part-time reception by DA MSs on a multi-slot MCCH-Q is permitted using the "part-time reception" element in the SYSINFO-DA PDU.

NOTE 1: MS support of part-time reception on a multi-slot MCCH-Q is indicated in the "extended capabilities" element in the U-LOCATION UPDATE DEMAND PDU; see clause 16.

If the BS indicates in the SYSINFO-DA PDU that part-time reception on a multi-slot MCCH-Q is permitted then, when using part-time reception, the DA MS is only required to receive one downlink slot per TDMA frame. That slot is derived from the parameter MS_SCCH which the MS received on registration or subscription (also used to indicate to the MS which one of the downlink slots on the main carrier shall be used when common SCCHs are in operation). If an MS has received this value at subscription and then also is assigned a value at registration, the value given at registration shall be used. The following rule shall then be applied by the MS to derive its reception slot when using part-time reception:

$$\begin{aligned} &\text{Reception slot on multi-slot MCCH-Q when using part-time reception} \\ &= 1 + (\text{MS_SCCH mod (Number of slots comprising the MCCH-Q)}) \end{aligned}$$

If the MS does not have a value of MS_SCCH on this network, and has no value from subscription, it shall assume that its required reception slot on a multi-slot MCCH-Q when using part-time reception is slot 1.

The MAC shall temporarily suspend part-time reception if:

- it obeys a channel allocation command allocating an assigned channel; or
- the MS becomes active in an advanced link (see clause 18.3.5.3.3), as indicated by the MLE activity indicator parameter in the TMC-CONFIGURE request primitive; or
- the MS becomes active in a call (see clause 18.3.5.3.3), as indicated by the MLE activity indicator parameter in the TMC-CONFIGURE request primitive; or
- the MS has signalling messages to send; or
- it receives a TMA-SAP signalling message from the BS for any of its valid addresses or event labels, other than the predefined broadcast group address (all ones).

NOTE 2: If the MS needs to suspend part-time reception while on a multi-slot MCCH-Q, it reverts to multi-slot reception i.e. attempting to receive and decode all downlink slots comprising the multi-slot MCCH-Q.

However, if the MS suspends part-time reception on a multi-slot MCCH-Q as the result of receiving a downlink signalling message from the BS, and the next immediate downlink slot is part of the MCCH-Q, the MS is not required to receive that next immediate downlink slot.

The MAC may return to part-time reception when it is on the multi-slot MCCH-Q and a time T_{234} has elapsed since:

- the higher layers indicated no activity using the TMC-CONFIGURE request primitive; or
- it sent its last signalling message; or
- it last received a TMA-SAP signalling message from the BS for one of its valid addresses or event labels, other than the predefined broadcast group address (all ones),

whichever is the most recent. During this time-out period, the MS shall continue to receive all slots of the downlink multi-slot MCCH-Q for any further signalling from the BS.

NOTE 3: The part-time reception procedure applies only when the MS is in common mode on a multi-slot MCCH-Q. It does not apply when the MS is on an assigned channel.

An MS may end part-time reception on a multi-slot MCCH-Q at any time if it wishes. The MS shall end part-time reception on a multi-slot MCCH-Q if the BS indicates in the SYSINFO-DA PDU that part-time reception on a multi-slot MCCH-Q is not permitted; the MS shall then revert to receiving all slots of the downlink multi-slot MCCH-Q (within the constraints of the cell reselection procedures, and linearization and transmission requirements).

23.8 PDU transfer for traffic (TMD-SAP)

23.8.0 General

Circuit mode traffic transmission applies only on $\pi/4$ -DQPSK channels.

23.8.1 Introduction

For a message trunked system, a complete circuit mode call generally takes place on one $\pi/4$ -DQPSK assigned channel. Before any traffic transmission, the BS allocates a traffic usage marker for the call.

For a transmission trunked system, each traffic transmission (i.e. "over") takes place on a $\pi/4$ -DQPSK assigned channel. Between "overs", the MS is directed to its common control channel or to an assigned SCCH. Before each traffic transmission, the BS allocates a traffic usage marker for use on the assigned channel.

For a quasi-transmission trunked system, each traffic transmission takes place on a $\pi/4$ -DQPSK assigned channel. At the end of an "over", the MS(s) remain on the assigned channel for a short period (i.e. the channel hang-time). If another traffic transmission for the call is requested within the hang-time then the same channel is used for that traffic transmission. Otherwise, after the hang-time, the BS directs the MS(s) to their common control channel, or to an assigned SCCH, until the next traffic transmission is requested; the BS then assigns a channel for that traffic transmission (either the previous assigned channel or a different channel). Before any traffic transmission on an assigned channel, the BS allocates a traffic usage marker for use on that channel.

The choice between these modes is made by the BS. The MS procedures operate independently of this BS choice.

During a call, ACCH is always available in frame 18. When frames 1 to 17 are not being used for traffic, the fast ACCH is available in frames 1 to 18 (see clause 23.3.1.3). In the case of independent allocation of uplink and downlink, or for an inter-site call, the availability of FACCH at any time may be independent on uplink and downlink.

The usage of both uplink and downlink is indicated, independently, in the ACCESS-ASSIGN PDU on the AACH. A traffic usage marker is used when the corresponding direction is in use for traffic (i.e. TCH or STCH). During FACCH, the uplink is controlled by the access field, and the downlink is marked with the assigned control or common control pre-set usage marker as appropriate.

In traffic mode, on frames 1 to 17, capacity may be stolen from the circuit for signalling purposes, without changing the current mode of operation. Use of normal training sequence 2 (i.e. SF = 1) indicates when stealing has occurred and the MAC header in the first half slot indicates whether the second half slot is also stolen. This mechanism applies to both uplink and downlink.

See clause 19 for the configuration of the lower MAC in signalling and traffic mode. The default mode is signalling mode.

NOTE: The STCH mechanism applies only when the channel is in traffic mode, allowing signalling messages to be sent within an "over", and without waiting for frame 18. For example: U-plane signalling (i.e. user-to-user signalling and/or encryption synchronization) is sent on STCH; Call Control (CC) PDU U-TX CEASED should normally be sent on STCH; and D-TX CEASED may be sent on STCH. C-plane signalling messages unrelated to the call may also be sent on STCH.

Between "overs" on a message trunked (or quasi-transmission) trunked system, the assigned channel will normally return to signalling mode (FACCH). The SCH procedures then apply.

23.8.2 Criteria for transmission and reception of traffic

23.8.2.0 General

During a circuit mode call:

- a sending MS needs to be instructed when to start sending traffic (and when to stop);
- a receiving MS needs to know when to process any received TCH (and when to stop).

This process shall be performed by CC messages sent by the BS to the appropriate MS(s). The CMCE in the MS shall then instruct the MS-MAC using the TMC-CONFIGURE request primitive. There are also some back-up mechanisms using the ACCESS-ASSIGN PDU.

23.8.2.1 Use of TMC-CONFIGURE primitive

For the purposes of the protocol description, it is assumed that the instruction from the CMCE for changing the operating mode in the MS-MAC comprises the following sub-parameters:

- switch U-plane on/off;
- Tx-grant flag;
- simplex/duplex flag;
- type of circuit (i.e. TCH/S, TCH/2,4, TCH/4,8, TCH/7,2);
- interleaving depth N;
- end-to-end encryption flag;
- user device;
- endpoint identifier.

The possible combinations of the first three sub-parameters may be:

- | | | |
|----|---|--|
| a) | Switch U-plane on, Tx-grant, Simplex: | MS is authorized to transmit TCH; |
| b) | Switch U-plane on, Not Tx-grant, Simplex: | MS is authorized to receive TCH; |
| c) | Switch U-plane on, Tx-grant, Duplex: | MS is authorized to transmit and receive TCH; |
| d) | Switch U-plane off: | Withdraws previous authorization to transmit and/or receive TCH. |

The upper MAC shall inform the lower MAC of the appropriate type of TCH logical channel for transmission and/or reception, since this affects the coding/decoding method.

For the purposes of the protocol description, it is assumed that the process of the MAC issuing a TMA-UNITDATA indication primitive containing a CC message and then receiving the corresponding TMC-CONFIGURE request primitive is effectively instantaneous except in the case when the MS decides to obey a group addressed channel allocation after a delay.

If the MS decides to obey a group addressed channel allocation after a delay then the CMCE may indicate TCH receive authorization when it accepts the channel allocation. However, the MS-MAC shall not use this authorization if the decision to move to the allocated channel has been delayed by more than a time $T_{.215}$ (see clause 23.8.2.2). If the decision has been delayed by more than a time $T_{.215}$ then, after moving to the allocated channel, the MS shall not process received TCH until the "N.213 permission method" criterion applies (see clause 23.8.2.3.2) or until authorization by another CC message.

NOTE 1: In case a) above, the MS continues to receive the downlink in the normal manner (subject to the defined monitoring pattern(s)) and using the procedures in clause 23.5.6.3 for interpretation of the downlink. The downlink may be either in signalling or traffic mode.

NOTE 2: If the MS has independent circuit mode calls in progress on the uplink and downlink of the channel, it should use appropriate means to distinguish between the operating mode instructions from the CMCE.

NOTE 3: The MAC may receive changes to the operating mode for the same call, with consecutive changes both containing the instruction to "Switch U-plane on". For example, this may occur if the next traffic transmission has already been requested so that there is no need to return to signalling mode. The most recent instruction for the call over-writes previous instructions, e.g. case b) after case a) withdraws the TCH transmit authorization and gives TCH receive authorization; case a) after case b) withdraws the TCH receive authorization and gives TCH transmit authorization.

23.8.2.2 Timing of change of mode

For a switch to U-plane transmission, the MS shall use the following timings:

- If the downlink slot containing the transmit permission (or the final fragment) contained no channel change and no slot grant, then:
 - if in frames 1 to 17, the MS shall start sending traffic in the corresponding uplink slot in that TDMA frame;
 - if in frame 18, the MS shall start sending traffic in frame 1.

NOTE 1: If the MS with transmit permission has received previous slot grants on the assigned channel then that MS should assume that any granted slots in frames 1 to 17 are withdrawn whereas any granted slots in frame 18 are still valid.

- If the downlink slot containing the transmit permission (or the final fragment) contained a slot grant, either with no channel change or with a grant on the allocated channel, then the MS shall start sending traffic in the next full uplink slot on the assigned channel in frames 1 to 17, following the end of the grant. This rule applies even if the grant exceeds the MS's requirement to send signalling messages. When the MS starts sending traffic, note 1 applies to any previous slot grants on the assigned channel.
- If the downlink slot containing the transmit permission (or the final fragment) contained a channel change and no slot grant on the allocated channel, then:
 - if CLCH(-Q) permission is given then the MS shall start sending traffic in the next uplink slot on the assigned channel in frames 1 to 17; this is the next valid full uplink traffic slot following the slot containing the potential CLCH subslot, even if the MS does not need to use CLCH;
 - if CLCH(-Q) permission is not given, e.g. no change of RF carrier, then the MS shall start sending traffic in the first uplink slot on the allocated channel (as defined in clause 23.5.4.3.1) if that slot is in frames 1 to 17, or else in frame 1.

In the first traffic slot, and if the DATA-IN-BUFFER signal from the LLC indicates that there is a message in the buffer for this channel with the stealing permission parameter set to "steal within time $T_{.214}$ " or "steal immediately", then the MS-MAC shall issue a MAC-READY signal to the LLC offering stolen capacity, e.g. for a layer 2 acknowledgement to the layer 3 transmit permission message.

NOTE 2: For the purposes of the above procedures for timing a switch to U-plane transmission, a "slot grant" refers to a grant with "granting delay" $\neq 1111_2$. So the MS should regard a "basic slot granting" element with "granting delay" = 1111_2 as not being a slot grant.

For a switch to U-plane reception, with no channel change:

- for a single-slot channel, or for a multi-slot channel in which the next downlink slot is not part of that channel, the MS shall switch to U-plane reception at the end of the downlink slot containing the receive permission;
- for a multi-slot channel, and if the next downlink slot is part of that channel, the MS shall delay the switch to U-plane reception by one timeslot duration.

EXAMPLE 1: For a multi-slot channel comprising timeslots 2, 3 and 4, with a switch instruction in downlink slot 2, the MS assumes SCH for downlink slot 3 and then switches to U-plane reception for downlink slot 4. Whereas, if the switch instruction is in downlink slot 4 then the MS switches to U-plane reception for downlink slot 2 in the next TDMA frame.

For a switch to U-plane reception, with a channel change, the MS shall switch to U-plane mode when it moves to the allocated channel, for reception of the first downlink slot on the allocated channel (as defined in clause 23.5.4.3.1). The MS shall use this procedure for an individually addressed channel allocation or if the MS makes an immediate decision to obey a group addressed channel allocation. Also, the MS may use this procedure when it decides to obey a group addressed channel allocation after a delay, provided that the MS-MAC receives the TMC-CONFIGURE request primitive accepting the channel allocation within a time T.215 after receipt of the channel allocation.

In the case of a group addressed channel allocation, if the MS-MAC receives the TMC-CONFIGURE request primitive accepting the channel allocation more than a time T.215 after receipt of the channel allocation then, after moving to the allocated channel, the MS shall not process received traffic until the "N.213 permission method" criterion applies (see clause 23.8.2.3.2) or until authorization by another CC message.

For a switch out of U-plane transmission:

- for a single-slot channel, or for a multi-slot channel in which the next uplink slot is not part of that channel, the MS shall switch mode immediately, i.e. as soon as the downlink message has been processed;
- for a multi-slot channel, and if the next uplink slot is part of that channel, the MS shall delay the switch by one timeslot duration.

EXAMPLE 2: For a multi-slot channel comprising timeslots 2, 3 and 4, with a switch instruction in downlink slot 3, e.g. in frame 10, the MS continues to transmit TCH or STCH in uplink slot 2 before switching. Whereas, if the switch instruction is in downlink slot 2 then the MS stops U-plane transmission at the end of the coinciding uplink slot 4.

For a switch out of U-plane reception:

- for a single-slot channel, or for a multi-slot channel in which the next downlink slot is not part of that channel, the MS shall switch mode at the end of the downlink slot containing the switch instruction;
- for a multi-slot channel, and if the next downlink slot is part of that channel, the MS shall delay the switch by one timeslot duration.

EXAMPLE 3: For a multi-slot channel comprising timeslots 2, 3 and 4, with a switch instruction in downlink slot 2, the MS assumes TCH or STCH for downlink slot 3 and SCH for downlink slot 4.

NOTE 3: If the BS does not receive an expected layer 2 acknowledgement to a downlink message giving or withdrawing authorization to receive traffic on the downlink, it cannot know whether the MS actually received the message; therefore, it cannot know whether the MS is in signalling or traffic mode for reception. In either case, if the BS wishes to send a re-transmission, it is necessary that the MS is able to interpret the downlink channel correctly. At this time, it is recommended that the BS uses only normal training sequence 2, sending either STCH + STCH or SCH/HD + SCH/HD. Interpretation of these forms by MSs is very similar, provided that the BS uses only "length indication" 111110_2 or 111111_2 in the last PDU in a first half slot, even if that half slot actually contains SCH/HD.

NOTE 4: After being authorized to receive traffic, the MS may switch to traffic mode almost immediately. If TCH from the source is not ready at this time, the BS should send C-plane STCH + STCH on the downlink, e.g. containing Null PDUs.

NOTE 5: As specified above, the switch out of U-plane mode is almost immediate after the CMCE has received the command from the BS. Therefore, for a circuit mode data call with an interleaving depth of $N = 4$ or 8 , the CMCE in the transmitting MS should ensure that the MS has been able to issue $N - 1$ slots containing tail bits (zeros) to the lower MAC at the end of the required data transmission (on each allocated slot in the case of a multi-slot channel) before sending the U-TX CEASED PDU to the BS. These tail bits are needed to complete the interleaving of the circuit mode data.

23.8.2.3 AACH mechanisms

23.8.2.3.0 General

The following procedures specify criteria for stopping transmitting or receiving traffic. There are also criteria for leaving an assigned traffic channel, based on received ACCESS-ASSIGN PDUs. (See clause 23.5.6 for maintenance of an assigned channel.)

23.8.2.3.1 MS transmitting traffic

The MS shall not transmit traffic unless it has been authorized by a CC message and has a traffic usage marker applicable to the uplink channel (i.e. assigned with element "Up/downlink assigned" or "Up/downlink assigned for augmented channel allocation" = 10_2 or 11_2).

During traffic transmission, the MS shall receive and attempt to decode the downlink assigned channel for at least those frames defined by the monitoring pattern information, within the capabilities of that MS.

After starting to transmit traffic, and if the BS does not allow U-plane DTX (i.e. discontinuous traffic transmission by the MS), then the MS shall transmit traffic (TCH and/or STCH) in frames 1 to 17, in successive slots on the uplink assigned channel, as defined by element "Timeslot Assigned", until any one of the following criteria a), b), c) or d) occurs.

NOTE 1: The "U-plane DTX" element in the SYNC PDU, and in the SYSINFO-DA PDU, indicates whether or not the BS supports discontinuous traffic transmission by the MS.

After starting to transmit traffic, and if the BS allows U-plane DTX, then the MS may transmit traffic (TCH and/or STCH) in frames 1 to 17 on the uplink assigned channel, and shall transmit in at least one traffic slot every T_{213} TDMA frames, until any one of the following criteria a), b), c) or d) occurs.

- a) Authorization to transmit traffic is withdrawn (either by an instruction to switch the U-plane off or by a switch from transmit to receive for this call).
- b) If one or more monitoring patterns were assigned, i.e. element "Monitoring Pattern" $\neq 00_2$:
 - N_{211} successive ACCESS-ASSIGN PDUs received in frames 1 to 17 on the downlink assigned channel contain "Header" $\neq 11_2$ or do not contain the correct uplink traffic usage marker.

If no monitoring pattern was assigned, i.e. element "Monitoring Pattern" = 00_2 :

- N_{211} successive ACCESS-ASSIGN PDUs received in any TDMA frame on the downlink assigned channel contain "Header" $\neq 11_2$ or do not contain the correct uplink traffic usage marker.

- c) If one or more monitoring patterns were assigned, i.e. element "Monitoring Pattern" $\neq 00_2$:

- a time T_{211} elapses without receipt of an ACCESS-ASSIGN PDU in frames 1 to 17 on the downlink assigned channel, containing "Header" = 11_2 and containing the correct uplink traffic usage marker.

If no monitoring pattern was assigned, i.e. element "Monitoring Pattern" = 00_2 :

- a time $18 \times T_{211}$ elapses without receipt of an ACCESS-ASSIGN PDU in any TDMA frame on the downlink assigned channel, containing "Header" = 11_2 and containing the correct uplink traffic usage marker (as "Field 2" in frames 1 to 17 or "Field 1" in frame 18).

- d) The MS leaves the assigned channel (see clause 23.5.6.1).

NOTE 2: For a multi-slot channel, if the MS is not frequency full duplex, and if the BS assigns monitoring pattern(s) that the MS is not capable of following in any slots in frames 2 to 17, then, in criteria b) and c), the MS should use the method specified for element "Monitoring Pattern" = 00₂.

In all cases a), b), c) and d), the MS shall stop transmitting traffic (TCH and STCH) and shall revert to the normal C-plane methods of random access and reserved access in all frames 1 to 18.

In cases b) or c), the MS-MAC shall report the change of mode to the higher layers using the TMC-REPORT indication primitive.

In case d), the interruption may be only temporary. If the MS is changing channel on instruction from the BS and if:

- the "Allocation Type" = 00₂ or 11₂ ("Replace" or "Replace + CSS channel"); and
- the MS is being directed to an assigned channel (i.e. element "Timeslot Assigned" ≠ 0000₂); and
- the uplink is assigned (i.e. element "Up/downlink assigned" or "Up/downlink assigned for augmented channel allocation" = 10₂ or 11₂); and
- the MS receives a traffic usage marker assignment with the channel allocation; and
- the MS does not receive a CC message withdrawing authorization to transmit traffic; and
- this is an individually addressed channel allocation or, for a group addressed channel allocation, the MS decides within a time T.216 to obey the channel allocation,

then, on receipt of the channel allocation, the MS-MAC shall stop transmitting traffic on the current channel. For a single-slot channel, or for a multi-slot channel in which the next uplink slot is not part of that channel, the MS shall stop transmitting traffic immediately. For a multi-slot channel, and if the next uplink slot is part of that channel, the MS shall delay the switch by one timeslot duration. After changing channel, the MS shall continue traffic transmission as follows:

```

if the MS has a slot grant on the assigned channel
then the MS shall continue traffic transmission in the next uplink slot on the
      assigned channel (in frames 1 to 17), following the end of the slot grant
else
if "Immediate CLCH(Q) permission" is given
  then the MS shall continue traffic transmission in the next full uplink slot on the
        assigned channel (in frames 1 to 17), following the slot containing the potential
        CLCH subslot
  else the MS shall continue traffic transmission in the first uplink slot on the
        allocated channel (as defined in clause 23.5.4.3.1) if that slot is in
        frames 1 to 17 or otherwise in frame 1.

```

This rule shall apply both for allocation within the same cell and for a different cell (seamless handover i.e. type 1 announced cell reselection).

For a channel change that does not conform to the above, or if the MS decides not to move to the allocated channel, the MS-MAC shall stop transmitting traffic and shall report the change of mode to the higher layers.

If, after starting to transmit traffic and at any time other than during a temporary interruption for channel change, the MS receives a slot grant addressed to itself, and granting a reserved uplink subslot or slot(s) in frames 1 to 17 (i.e. where it expected to transmit traffic), then the MS-MAC shall stop transmitting traffic, reporting the change of mode to the higher layers.

NOTE 3: The scenario above should not occur except in case of transmission errors. It is not intended for use by the BS as a normal method for ending U-plane transmission.

NOTE 4: Criterion b) refers to a check on those ACCESS-ASSIGN PDUs that are received by the MS, irrespective of whether or not these are in successive slots on the assigned channel. Then criterion c) covers the case when the ACCESS-ASSIGN PDU is not received during the specified time.

If no monitoring pattern is assigned, the BS should use "Header" 11₂ in ACCESS-ASSIGN PDUs in frame 18 on the downlink assigned channel, including the traffic usage marker of the transmitting MS. This applies also for a multi-slot channel if the BS assigns monitoring pattern(s) that the MS may not be capable of following in any slots in frames 2 to 17.

NOTE 5: The "channel replace" mechanism without withdrawal of transmit authorization may be used within the cell, for convenience of BS resource allocation, or between cells e.g. for seamless handover (type 1 announced cell reselection). Before continuing U-plane transmission, the MS may be required to transmit a C-plane reply, in a reserved slot on either the current or allocated channel, or by stealing.

Alternatively, the BS may prefer to interrupt the traffic transmission by sending the CC PDU D-TX WAIT (temporarily withdrawing transmit permission).

23.8.2.3.2 MS receiving traffic

The MS should process received traffic after authorization by a CC message, except that it shall not process received TCH if it does not have a traffic usage marker applicable to the downlink channel (i.e. assigned with element "Up/downlink Assigned" or "Up/downlink assigned for augmented channel allocation" = 01_2 or 11_2). Also, if a group addressed channel allocation was sent with the CC message and the decision to accept the channel allocation was delayed by more than time T.215 then the MS shall not process received TCH on the allocated channel until the "N.213 permission method" criterion applies or until authorization by another CC message.

The MS may process received traffic, without specific authorization, if N.213 ACCESS-ASSIGN PDUs received in frames 1 to 17 in successive slots appropriate to the downlink assigned channel contain Header $\neq 00_2$ and contain the correct downlink traffic usage marker for this MS. The MS-MAC should report the change of mode to the higher layers using the TMC-REPORT indication primitive.

NOTE 1: If the CMCE indicates traffic receive permission when it accepts a group addressed channel allocation after a delay of more than time T.215 then the MS-MAC is not precluded from reducing its value of N.213 provided that the reduced value of N.213 ≥ 2 . This applies also for a channel replacement without withdrawal of receive authorization if the MS accepts a group addressed channel allocation after a delay of more than time T.215 (see below). The reduced value of N.213 may apply until the MS next receives a CC message indicating authorization or withdrawal of authorization to transmit or receive traffic on the allocated channel.

The MS shall process any received traffic (TCH and STCH) in frames 1 to 17 in slots on the downlink assigned channel until any one of the following occurs:

- a) authorization to receive traffic is withdrawn (either by an instruction to switch the U-plane off or by a switch from receive to transmit for this call);
- b) N.212 successive ACCESS-ASSIGN PDUs received in frames 1 to 17 on the downlink assigned channel contain "Header" = 00_2 or do not contain the correct downlink traffic usage marker;
- c) a time T.212 elapses without receipt of an ACCESS-ASSIGN PDU in frames 1 to 17 on the downlink assigned channel, containing "Header" $\neq 00_2$ and containing the correct downlink traffic usage marker;
- d) the MS leaves the assigned channel (see clause 23.5.6.1), unless the criteria described below are satisfied.

In all cases, the MS shall stop processing received traffic.

In cases b), c) or d), the MS-MAC shall report the change of mode to the higher layers using the TMC-REPORT indication primitive.

In all cases, the MS may again process received traffic either after authorization by a CC message or by using the "N.213 permission method" described above.

The exception to case d) is that, if the MS changes channel on instruction from the BS and if:

- the "Allocation Type" = 00_2 or 11_2 ("Replace" or "Replace + CSS channel");
- the MS is being directed to an assigned channel (i.e. element "Timeslot Assigned" $\neq 0000_2$);
- the downlink is assigned (i.e. element "Up/downlink Assigned" or "Up/downlink assigned for augmented channel allocation" = 01_2 or 11_2);
- the MS receives a traffic usage marker assignment with the channel allocation;
- the MS does not receive a CC message withdrawing authorization to receive traffic; and

- this is an individually addressed channel allocation or, for a group addressed channel allocation, the MS decides within a time T.215 to obey the channel allocation,

then the MS-MAC shall switch out of U-plane reception at the end of the downlink slot containing the channel allocation; or, for a multi-slot channel, and if the next downlink slot is part of that channel and the MS is still on the current channel to receive that slot (see note 2), the MS shall delay the switch by one timeslot duration. The MS shall switch back to U-plane reception when it moves to the allocated channel, using the newly assigned usage marker, for reception of the first downlink slot on the allocated channel (as defined in clause 23.5.4.3.1).

This rule shall apply both for allocation within the same cell and for a different cell.

NOTE 2: For the purposes of this procedure it is assumed that, for a multi-slot channel, and if the next downlink slot is part of that channel, then the MS is "still on the current channel to receive that slot" only in the cases defined in condition b) of procedure 1) in clause 23.5.4.3.1 and, for a frequency full duplex MS, condition c) of procedure 1) in clause 23.5.4.3.1 i.e. in the cases of a channel allocation with a slot grant on the current channel and, for a frequency full duplex MS, if the next immediate uplink slot following the channel allocation is part of the current channel and the MS is transmitting traffic in that slot or was previously granted that slot (or a subslot in that slot) for reserved access. So, for the purposes of this procedure, it is assumed that the MS is not "still on the current channel to receive that slot" if the timing of the channel change is based on condition a) of procedure 1) in clause 23.5.4.3.1.

NOTE 3: Criterion b) refers to a check on those ACCESS-ASSIGN PDUs that are received by the MS, irrespective of whether these are in successive slots on the assigned channel. Whereas the "N.213 permission method" applies only if ACCESS-ASSIGN PDUs are received in successive traffic slots on the assigned channel.

NOTE 4: The permission method based on parameter N.213 should not be used by an MS that is transmitting in simplex mode and that has only one circuit mode call on this channel i.e. the MS should not attempt to transmit and receive simultaneously in a simplex call.

NOTE 5: The "channel replace" mechanism without withdrawal of receive authorization may be used within the cell, for convenience of BS resource allocation, or between cells e.g. for seamless handover (type 1 announced cell reselection).

If an MS that is receiving traffic is sent to a different timeslot during an end-to-end encrypted call, the BS may choose to interrupt the transmitting station with the D-TX WAIT PDU, thereby causing the transmitting station to re-send encryption synchronization when the transmission starts again.

NOTE 6: In the case of circuit mode data, in order to avoid corrupting downlink data transmission, the BS designer may prefer (when possible) to send any channel allocation commands or D-TX WAIT PDUs in frame 18.

NOTE 7: The MS is not permitted to maintain traffic receive authorization if it accepts a group addressed channel allocation after a delay of more than time T.215; after moving to the new channel, it cannot process received TCH until the "N.213 permission method" criterion applies (using the traffic usage marker for the new channel) or until authorization by a CC message.

23.8.2.3.3 Multi-slot interleaving with interruption

If a circuit mode data transmission is interrupted, either by use of the CMCE's D-TX WAIT mechanism or by a "channel replace", as defined in the above two clauses, then the MS shall continue with the transmission or reception of the data as if the intervening time out of U-plane mode had not been present. This rule includes the interleaving/de-interleaving of the data for interleaving depth $N = 4$ or 8 .

For a single-slot channel with $N = 4$ or 8 , the MS shall continue to process the U-plane data after the interruption, performing interleaving/de-interleaving of the old data with the new data as traffic blocks are transmitted/received.

For a multi-slot channel with $N = 4$ or 8 , multiple single-slot data TCHs are operated in parallel in order to obtain the multi-slot TCH transmission, as defined in clause 23.3.5. After an interruption, the order of presentation of the data at the receiving side shall be maintained. Therefore, across the interruption, the single-slot TCHs may be linked between different timeslot numbers according to the next occurring traffic slot.

EXAMPLE: For a multi-slot channel comprising timeslots 1, 2 and 3, where a slot 1 is the last traffic slot before interruption and a slot 3 is the next traffic slot:

- the old interleaving process corresponding to slot 2 continues in slot 3;
- the old interleaving process corresponding to slot 3 continues in slot 1;
- the old interleaving process corresponding to slot 1 continues in slot 2.

Similarly, for a multi-slot channel comprising timeslots 1, 2 and 3, with a new channel allocation comprising timeslots 1, 3 and 4, where a slot 2 contained the last traffic on the old channel and a slot 3 contains the first traffic on the new channel:

- the old interleaving process corresponding to slot 3 continues in slot 3;
- the old interleaving process corresponding to slot 1 continues in slot 4;
- the old interleaving process corresponding to slot 2 continues in slot 1.

This second example could be caused either by use of the channel replace without withdrawal of U-plane authorization, or by use of the D-TX WAIT mechanism with a channel replacement during the pause.

NOTE: The procedures defined in this clause do not apply for a group addressed channel replacement if the MS decides to obey the channel allocation after a delay.

23.8.3 Exchange of information at the TMD-SAP

23.8.3.0 General

In the protocol model, the actual user traffic is transferred between the U-plane application (e.g. the speech CODEC) and the MS-MAC via the TMD-SAP. The TMD-SAP is used for the transfer of speech frames or circuit mode data. It is also used if the U-plane application steals from the traffic capacity to send U-plane signalling.

For the purposes of the protocol description, the following services primitives are used. However, this does not imply any specific implementation. The word "shall" is used with the primitives and their parameters for traceability reasons in the protocol model, but the primitives are not testable.

- The TMD-UNITDATA request primitive shall be used when the U-plane application wishes to send information to the peer entity.
- The TMD-UNITDATA indication primitive shall be used for the MS-MAC to deliver information from the peer entity.
- The TMD-REPORT indication primitive shall be used by the sending MAC to issue reports to the U-plane application e.g. at the start and stop of traffic transmission, and when the MS changes channel within an "over", and when the MAC has stolen from the traffic capacity. It shall also be used by the receiving MAC at the start of a call.

The parameters specific to the TMD-UNITDATA primitive are as follows (see clause 20):

a) Half slot content:

The unit of information in the TMD-UNITDATA primitive is one half slot. The U-plane application shall provide a TM-SDU of the correct size for the appropriate logical channel, so that the MS-MAC does not have to insert filler bits to complete the MAC block nor have to remove filler bits on reception.

In particular, when the U-plane application steals from the traffic capacity for U-plane signalling, the TM-SDU shall always be 121 bits. The upper MAC shall then add a 3-bit MAC header, making the MAC block up to the 124 bits required for STCH. The U-plane signalling may be for user-to-user signalling or for encryption synchronization. However, the MAC is not aware of the intended purpose of the U-plane signalling. (Any necessary discrimination shall be included within the TM-SDU.)

User traffic TCH does not have a MAC header.

b) Half slot position:

Each transferred half slot (in either direction) should be accompanied by a marker identifying it as the first or second half slot of a timeslot.

At all points in the system, half slots should be grouped in pairs, equivalent to the data transmitted over the air interface in one slot. The binding between these pairs shall remain intact and the correct timing/ordering relationships with adjacent half slots preserved, even when a half slot is stolen and the half slots are processed separately by the MAC.

c) Stolen indication:

At the transmitting side, this parameter shall indicate whether the half slot is stolen for U-plane signalling or not stolen.

At the receiving side, this parameter shall indicate whether the half slot was stolen for C-plane signalling, stolen for U-plane signalling or not stolen.

d) Half slot importance:

This parameter may be used only in the TMD-UNITDATA request primitive. It indicates the importance of the U-plane information, enabling the sending MS-MAC to decide when and whether to steal from the traffic capacity and to decide whether to use U-plane DTX (discontinuous traffic transmission). Four levels of importance may be used: no importance, and low, medium and high importance.

e) Half slot condition:

This parameter may be used only in the TMD-UNITDATA indication primitive. It indicates to the receiving U-plane application whether a half traffic slot was received successfully. It may take the following values:

- "Good" if the half slot was decodeable;
- "Bad" if a valid training sequence was detected but the CRC check failed;
- "Null" if no valid training sequence was detected.

The distinction between "Good" and "Bad" is not appropriate for TCH/7,2.

f) User device:

The user device parameter shall identify the appropriate circuit.

NOTE 1: For the purposes of the protocol description, channel encoding and decoding are performed in the lower MAC. However, this does not imply any particular implementation. If, for example, the implementers were to choose to perform the channel coding of TCH directly in the CODEC, then the descriptions of half slot transfer generally still apply (though the distinction between "Good" and "Bad" in the "half slot condition" parameter is no longer relevant).

NOTE 2: For the purposes of the protocol description, the unit of exchange at the TMD-SAP is always a half slot (corresponding to one speech frame). However, this does not imply any particular implementation. For example, implementers may prefer to use a full slot of data as the unit of exchange for circuit mode data TCH.

NOTE 3: It is assumed that the U-plane application provides valid data in the "half slot content" parameter even if the "half slot importance" is set to "no importance".

23.8.3.1 Interface at transmitting MS

At the start of a call (or before each "over"), or if the basic service information changes, the MS-MAC shall issue a report to the U-plane application to supply the traffic type, the interleaving depth, the number of slots per TDMA frame, a flag indicating whether end-to-end encryption applies and the user device parameter.

When the MS has been authorized to transmit TCH, and has established whether it will steal the first half slot for C-plane signalling (e.g. a layer 2 acknowledgement), the MS-MAC shall issue a report to the U-plane application. This report shall indicate the initial half slot synchronization i.e. whether the first valid U-plane half slot is a first or second half slot; that half slot may then be used either for TCH or for U-plane signalling.

A report should be issued to the U-plane application if there is any interruption (e.g. a channel change) so that, for an end-to-end encrypted call, the U-plane application can send encryption synchronization again.

A report should also be issued to the U-plane application when traffic transmission is no longer permitted.

When transmitting a slot in traffic mode, the sending MS-MAC is generally given the first half slot by the U-plane application, in a TMD-UNITDATA request primitive. That half slot may be either TCH, or U-plane signalling in the case of stealing by the U-plane application.

If the MS-MAC decides to steal the first half slot for C-plane signalling then the MAC should issue a TMD-REPORT indication primitive, enabling the U-plane application to revise the intended use of the second half slot.

The MS-MAC is then given the second half slot in another TMD-UNITDATA request primitive. Again, if the MS-MAC decides to steal the half slot for C-plane signalling then the MAC should issue a TMD-REPORT indication primitive.

In the case of circuit mode data with low or high protection: if the U-plane application steals the first half slot but not the second half slot then it should issue two TMD-UNITDATA request primitives for the first half slot (one containing the U-plane signalling data and the other containing TCH) and one TMD-UNITDATA request primitive for the second half slot (containing TCH). In the case of circuit mode data with interleaving depth $N = 4$ or 8 : if the U-plane application steals both half slots then it should issue two TMD-UNITDATA request primitives for each half slot (one containing the U-plane signalling data and the other containing TCH).

At this time, the MS-MAC has the contents of one slot. Permitted combinations for the two half slots are as follows:

- a) Not stolen i.e. TCH / Not stolen i.e. TCH;
- b) Stolen for C-plane / Not stolen i.e. TCH;
- c) Stolen for U-plane / Not stolen i.e. TCH;
- d) Stolen for C-plane / Stolen for C-plane;
- e) Stolen for C-plane / Stolen for U-plane;
- f) Stolen for U-plane / Stolen for C-plane;
- g) Stolen for U-plane / Stolen for U-plane.

In case a), and if the BS allows U-plane DTX, the MS may decide not to transmit in the slot, based on the "half slot importance" of the two half slots. If the MS transmits in the slot then normal training sequence 1 shall be used, with a full slot of TCH (MAC-TRAFFIC PDU). In all the other cases, normal training sequence 2 shall be used and the stealing procedure described in clause 23.8.4 shall apply.

In cases b) and c), for a speech call or unprotected data, the upper MAC shall issue a half slot of STCH and a half slot of TCH to the lower MAC. In cases d), e), f) and g), for a speech call or unprotected data, the upper MAC shall issue two half slots of STCH to the lower MAC.

In cases b) and c), for a circuit mode data call with low or high protection, the upper MAC shall issue both a half slot of STCH and a full slot of TCH to the lower MAC. In cases d), e), f) and g), for a circuit mode data call with $N = 1$, the upper MAC shall issue two half slots of STCH to the lower MAC. In cases d), e), f) and g), for a circuit mode data call with $N = 4$ or 8 , the upper MAC shall issue two half slots of STCH and also a full slot of TCH to the lower MAC.

NOTE 1: Not stolen + Stolen for C-plane is not a permitted combination.

If the MAC receives Not stolen + Stolen for U-plane from the U-plane application, it could use case e), replacing the traffic with a dummy C-plane message (containing no TM-SDU). However, this would make inefficient use of the channel. It is recommended that the U-plane application does not request this form.

NOTE 2: In an implementation, it may be preferred that (when practicable) the MAC informs the U-plane application as soon as it knows that it will perform C-plane stealing. For example, for a high priority C-plane message, the MAC may intend to steal irrespective of the U-plane half slot importance.

NOTE 3: The above procedure specifies that, for protected circuit mode data with stealing in a slot, the upper MAC may issue both the STCH and a full slot of TCH to the lower MAC. This is because, for protected circuit mode data, the lower MAC replaces traffic bits with STCH bits after normal coding and interleaving of the TCH (see clause 8). This contrasts with the method for speech, where the second half slot is half-slot interleaved if the first half slot is stolen.

23.8.3.2 Interface at receiving MS

At the start of a call, or if the basic service information changes, the receiving MS-MAC shall issue a report to the U-plane application to supply the traffic type, the interleaving depth, the number of slots per TDMA frame, a flag indicating whether end-to-end encryption applies and the user device parameter.

The following procedures in this clause shall apply for reception in frames 1 to 17 by an MS that is authorized to receive TCH.

TCH shall be passed to the U-plane application.

U-plane signalling shall be passed to the U-plane application after removal of the 3-bit MAC header.

C-plane STCH shall be processed by the MAC, and any suitably addressed TM-SDUs shall be passed to the LLC.

In all cases, for each half slot, the MS-MAC shall issue the TMD-UNITDATA indication primitive to the U-plane application containing any U-plane information (TCH or STCH) and indicating whether the half slot was stolen for C-plane signalling, stolen for U-plane signalling or not stolen.

For protected circuit mode data, in the case of a slot in which only the first half slot was stolen, the upper MAC should receive a half slot of STCH and a full slot of TCH from the lower MAC. The upper MAC shall issue a TMD-UNITDATA indication primitive to the U-plane application containing the U-plane signalling data (if the first half slot was stolen for U-plane signalling) and shall issue two TMD-UNITDATA indication primitives containing TCH, one for each half slot. For circuit mode data with $N = 4$ or 8 , in the case that both half slots are stolen, the upper MAC should receive two half slots of STCH and a full slot of TCH from the lower MAC. The upper MAC shall issue the appropriate TMD-UNITDATA indication primitive(s) to the U-plane application containing U-plane signalling data (if either half slot was stolen for U-plane signalling) and shall issue two TMD-UNITDATA indication primitives containing TCH.

NOTE 1: For the purposes of the protocol description, in the case of U-plane stealing from circuit mode data with $N = 1$: when the U-plane signalling data is delivered to the U-plane application, it is associated with the same half slot as the circuit mode data delivered for that half slot. In any instances for which it is necessary to define the relative order of the two types of data associated with a half slot, it is recommended that the U-plane application considers the U-plane signalling data associated with the half slot to be available before the circuit mode data associated with that half slot.

The same principle applies to circuit mode data with $N = 4$ or 8 . However, the $N - 1$ traffic frame delay procedure for U-plane signalling also applies, as described below.

For the purposes of the protocol description (see note 3): in the case of U-plane stealing from circuit mode data with $N = 4$ or 8 , the receiving upper MAC shall delay the issuing of the TMD-UNITDATA indication primitive(s) containing the U-plane signalling data by $N - 1$ traffic frames.

NOTE 2: This procedure for delaying the delivery of signalling data for $N = 4$ and 8 applies only to U-plane stealing (not to C-plane stealing).

The procedure is defined so that the U-plane signalling is delivered to the U-plane application with the same U-plane circuit mode data as when it was given by the sending U-plane application to the sending upper MAC. The need for the procedure arises because the multi-slot interleaving causes the circuit mode data to be delayed by $N - 1$ traffic frames across a link of the air interface, whereas the U-plane signalling is not delayed.

NOTE 3: For the purposes of the protocol description, the U-plane signalling is delayed in the upper MAC. However, in an implementation, it may be preferred that the upper MAC delivers the U-plane signalling to the U-plane application as soon as it is received. In this case, it is a task of the U-plane application to delay position-sensitive signalling (such as end-to-end encryption synchronization) before use.

In the case of un-decodeable TCH, the MS-MAC may pass the received data to the U-plane application, but shall set the "half slot condition" parameter appropriately in the TMD-UNITDATA indication primitive.

23.8.4 Stealing from circuit mode capacity

23.8.4.1 Uplink stealing

23.8.4.1.1 Transmission on uplink STCH

Transmission on STCH shall only be used by an MS that has been authorized to transmit traffic.

The appropriate PDUs for C-plane STCH on the uplink shall be:

- MAC-DATA PDU: first or second half slot;
- MAC-END PDU: second half slot only (final fragment).

The appropriate PDU for U-plane STCH shall be:

- MAC-U-SIGNAL PDU: first or second half slot.

The MAC header of a MAC-U-SIGNAL PDU sent in a first half slot shall indicate whether the second half slot is also stolen, using the second half slot stolen flag. If the second half slot is stolen, it may contain either U-plane or C-plane signalling (as indicated by the first MAC header in the second half slot).

For C-plane stealing within the first half slot, PDU association may be used. The "Length indication" in the last MAC-DATA PDU, or in the only MAC-DATA PDU, in the first half slot shall indicate whether the second half slot is also stolen.

- i) "Length indication" $\leq 010000_2$: second half slot not stolen.

Then the second half slot shall contain TCH (MAC-TRAFFIC PDU).

- ii) "Length indication" = 111110_2 : second half slot stolen, no fragmentation.

Then the second half slot may contain either U-plane or C-plane signalling (as indicated by the first MAC header in the second half slot). For C-plane signalling, PDU association may be used within the second half slot.

- iii) "Length indication" = 111111_2 : second half slot stolen, start of fragmentation.

Then the final fragment shall be sent in the second half slot (except in case of cancellation), using the MAC-END PDU. If PDU association is used within the second half slot, then the fragment shall be sent as the first PDU in the MAC block.

After transmitting a C-plane TM-SDU, the MS-MAC shall report to the LLC that the message has been sent by stealing (using the TMA-REPORT indication primitive).

23.8.4.1.2 Criteria for uplink stealing

When an MS is authorized to transmit traffic, the MS-MAC may steal from the traffic capacity to send C-plane signalling. The MS then sends C-plane signalling instead of the data received from the U-plane application. The MS-MAC shall not move the replaced U-plane data (neither traffic nor signalling) to a different half slot or slot.

The MS-MAC should report C-plane stealing to the U-plane application, enabling the application to revise the intended use of subsequent half slots, or to retransmit any U-plane signalling that has been overwritten by the MAC.

The following procedures shall apply for the different settings of the stealing permission parameter for the C-plane message.

a) Steal immediately

The MS-MAC shall send the C-plane message at the first opportunity on the uplink assigned channel, without regard to the half slot importance. This rule shall apply to both one- and two-half-slot messages.

For this setting of the stealing permission parameter, and if the MS is authorized to transmit traffic, the MS-MAC shall use stealing in preference to using random access or reserved access on frame 18.

b) Steal within time T.214

If the MS has not been granted a reserved subslot or slot in frame 18 (i.e. in the uplink SACCH for this channel) then the MS-MAC shall send the message within the next T.214 traffic slots on the uplink assigned channel (i.e. within the next T.214 TDMA frames 1 to 17 for a single-slot channel). This rule shall apply to both one- and two-half-slot messages.

The MS-MAC should send the message in the first slot for which the half slot importance is not "high". Or, if this does not occur within T.214 - 1 slots, the MS-MAC shall send the message in the T.214th traffic slot on the uplink assigned channel, without regard to the half slot importance.

c) Steal when convenient

The MS designer should choose suitable criteria for deciding when the MS-MAC may steal, based on the priority of the C-plane message, the half slot importance and the time since the last stealing occurrence. It is recommended that the MS-MAC does not re-steal over U-plane signalling.

d) Stealing not required

The MS-MAC should not use stealing to send the message (unless the half slot importance of the traffic is set to "no importance").

The MS designer should note that frequent stealing would degrade the quality of the circuit.

NOTE 1: The stealing permission parameter should be set to "steal immediately" for U-TX CEASED (and U-DISCONNECT if currently transmitting traffic). The stealing permission parameter should be set to "steal within time T.214" for the reply to a BS message received while the MS is transmitting traffic, e.g. for a layer 2 acknowledgement.

NOTE 2: For "steal within time T.214", the MS-MAC may plan when to steal based on the stealing permission parameter in the DATA-IN-BUFFER signal from the LLC. The MAC should not issue the MAC-READY signal until it is actually ready to send the message, thereby allowing the maximum time if the layer 3 in the MS is preparing a response to the BS message.

23.8.4.1.3 Stealing repeats mechanism

When the MS-MAC has used stealing to transmit a C-plane PDU with stealing permission parameter = "steal immediately", it shall check the setting of the "stealing repeats flag" in the TMA-UNITDATA request primitive. For a message with stealing permission parameter \neq "steal immediately", or if this flag is not set, the MS-MAC shall regard the requested procedure as complete and shall discard the TM-SDU, i.e. it shall use the normal procedure.

A special procedure shall apply for a message with "steal immediately" if the stealing repeats flag is set.

Then the MS-MAC shall repeat the message on STCH, sending the message once per frame in successive traffic frames (i.e. frames 1 to 17) on the assigned uplink channel, until either:

- a) it has sent the message N.214 times (including the first transmission); or
- b) it has stopped transmitting traffic, e.g. as a result of a higher layer message or after checks on the ACCESS-ASSIGN PDU; or
- c) it receives a TMA-CANCEL request primitive from the higher layers instructing it to abort transmission of the message.

In cases a) and b), the MS-MAC shall regard the requested procedure as complete and shall discard the TM-SDU. In case c), the MS-MAC shall cease attempting to send the message and shall discard the TM-SDU (see also clause 23.5.3).

While the MS-MAC is performing the "stealing repeats" mechanism described above, it shall over-ride the normal monitoring pattern information, and shall attempt to receive and decode the downlink assigned channel in every TDMA frame. For a multi-slot channel, and if the MS is not frequency full duplex, the MS shall transmit only in the lowest numbered uplink slot appropriate to the assigned channel, sending its message in that slot. It shall attempt to receive and decode at least the lowest numbered downlink slot appropriate to the assigned channel in all frames 1 to 17, and all slots appropriate to the assigned channel in frame 18 (within the constraints of linearization and transmission requirements).

If the MS-MAC stops the requested procedure on criterion a) or c) above then it shall continue to use the modified rules for receiving and decoding the downlink channel for the T.251 TDMA frames following the N.214th transmission of the message.

NOTE 1: The stealing repeats flag may be used by the higher layers to trigger this special stealing method in the MAC. This method is intended for signalling at the end of an uplink traffic transmission, for U-TX CEASED or possibly U-DISCONNECT. It provides a faster procedure for signalling the end of traffic transmission in case of propagation errors. Firstly, it allows more frequent repeats of the message. Also, the method of modifying the normal monitoring pattern and the structure of a multi-slot channel enables a faster response from the BS.

NOTE 2: This special procedure affects MAC operation only; the LLC re-transmission protocol is unchanged. The MAC should issue the TMA-REPORT indication primitive to the LLC only after the first transmission of the message.

23.8.4.1.4 Reception on uplink STCH

This clause describes the procedure for BS reception on uplink slots that have been assigned for traffic.

The training sequence in each slot shall indicate whether stealing has occurred.

For normal training sequence 1 (i.e. SF = 0), the receiving BS shall assume that the slot contains only TCH.

For normal training sequence 2 (i.e. SF = 1), the first half slot shall be assumed to be STCH. Then the MAC PDU type shall indicate whether the first half slot was stolen for C-plane signalling (MAC-DATA PDU) or for U-plane signalling (MAC-U-SIGNAL PDU). The receiving BS shall inspect the MAC header(s) to discover whether the second half slot is also stolen.

- For U-plane signalling, the "second half slot stolen flag" shall indicate whether the second half slot is stolen.
- For C-plane signalling, PDU dissociation may be necessary within the first half slot.
- If the last PDU (or only PDU) in the first half slot is a MAC-DATA PDU containing "Length indication" not equal to 111110_2 nor 111111_2 , then the BS shall assume that the second half slot is not stolen.
- If the last PDU (or only PDU) in the first half slot is a MAC-DATA PDU containing "Length indication" = 111110_2 or 111111_2 , the BS shall assume that the second half slot is stolen. Also, for "Length indication" = 111111_2 , the BS shall assume the start of fragmentation and shall store the TM-SDU fragment.

If the second half slot is not stolen, the BS shall interpret the second half slot as TCH.

If the second half slot is stolen, the BS shall interpret the second half slot as STCH. Then the MAC PDU type shall indicate whether the second half slot was stolen for C-plane signalling (MAC-DATA or MAC-END PDU) or for U-plane signalling (MAC-U-SIGNAL PDU). For C-plane signalling, PDU dissociation may be necessary within the second half slot.

In the case of fragmentation: If the second half slot is not decodeable, or if the second half slot does not include a MAC-END PDU, then the BS should discard the first fragment. Otherwise, it shall append the fragment from the MAC-END PDU to the already received fragment and shall assume that the received TM-SDU is complete.

23.8.4.2 Downlink stealing

23.8.4.2.1 Transmission on downlink STCH

The BS may steal from a traffic circuit to send C-plane signalling messages on the downlink, either to the MS(s) receiving the traffic or to other MSs on the channel. However, the BS designer should note that frequent stealing would degrade the quality of the circuit, especially for circuit mode data calls. Also, it is recommended that, when the BS requires to steal, it steals from TCH in preference to overwriting U-plane signalling. This recommendation applies particularly to end-to-end encrypted calls.

Valid PDUs for C-plane STCH on the downlink are:

- MAC-RESOURCE PDU: first or second half slot;
- SYSINFO PDU: first or second half slot;
- ACCESS-DEFINE PDU: first or second half slot;
- MAC-END PDU: second half slot only (final fragment).

The appropriate PDU for U-plane STCH is:

- MAC-U-SIGNAL PDU: first or second half slot.

The downlink MAC-U-SIGNAL PDU should be identical to that received from the transmitting station, except that the setting of the "second half slot stolen flag" may be changed when appropriate.

The MAC header of a MAC-U-SIGNAL PDU sent in a first half slot shall indicate whether the second half slot is also stolen, using the second half slot stolen flag. If the second half slot is stolen, it may contain either U-plane or C-plane signalling (as indicated by the first MAC header in the second half slot).

For C-plane stealing within the first half slot, PDU association may be used. The PDU type or "Length indication" in the last PDU (or only PDU) in the first half slot shall indicate whether the second half slot is also stolen.

- i) TMB-SAP PDU (SYSINFO or ACCESS-DEFINE): second half slot not stolen.

Then the second half slot shall contain TCH (MAC-TRAFFIC PDU).

- ii) MAC-RESOURCE PDU with "Length indication" $\leq 010000_2$: second half slot not stolen.

Then the second half slot shall contain TCH (MAC-TRAFFIC PDU).

- iii) MAC-RESOURCE PDU with "Length indication" = 111110_2 : second half slot stolen, no fragmentation.

Then the second half slot may contain either U-plane or C-plane signalling (as indicated by the first MAC header in the second half slot). For C-plane signalling, PDU association may be used within the second half slot.

- iv) MAC-RESOURCE PDU with "Length indication" = 111111_2 : second half slot stolen, start of fragmentation.

Then the final fragment should be sent in the second half slot, using the MAC-END PDU. PDU association may be used within the second half slot.

NOTE 1: The BS may use the Null PDU as a dummy C-plane message on STCH, in either the first half slot, second half slot or both. As always, "Address type" 000_2 in the MAC-RESOURCE PDU indicates a downlink Null PDU. In the first half slot, the "Length indication" indicates whether or not the second half slot is stolen.

NOTE 2: The SYSINFO PDU cannot be sent in the first half slot if the second half slot is also to be stolen.

If the second half slot is to be stolen, the ACCESS-DEFINE PDU can be included in the first half slot if required, but not as the last PDU (or only PDU) in the first half slot.

23.8.4.2.2 Reception on downlink STCH

This procedure shall be used by all MSs that are receiving the downlink channel.

All MSs that are receiving the channel shall check whether C-plane messages are addressed to itself and, if so, shall process the message and deliver any TM-SDU to the LLC. Only MSs that are currently permitted to process received traffic shall pass the TCH, and the TM-SDU in U-plane signalling (MAC-U-SIGNAL PDU), to the U-plane application.

The training sequence in each slot shall indicate whether stealing has occurred.

For normal training sequence 1 (i.e. SF = 0), the receiving MS shall assume that the slot contains only TCH.

For normal training sequence 2 (i.e. SF = 1), the first half slot shall be assumed to be STCH. Then the MAC PDU type shall indicate whether the first half slot was stolen for C-plane (TMA-SAP/TMB-SAP) or for U-plane (TMD-SAP) signalling. The receiving MAC shall inspect the MAC header(s) to discover whether the second half slot is also stolen.

- For U-plane signalling, the "second half slot stolen flag" shall indicate whether the second half slot is stolen.
- For C-plane signalling, PDU dissociation may be necessary within the first half slot.
- If the last PDU (or only PDU) in the first half slot is a TMB-SAP PDU, or a MAC-RESOURCE PDU (or Null PDU) containing "Length indication" not equal to 111110₂ nor 111111₂, then the MS shall assume that the second half slot is not stolen.
- If the last PDU (or only PDU) in the first half slot is a MAC-RESOURCE PDU (or Null PDU) containing "Length indication" = 111110₂ or 111111₂, the MS shall assume that the second half slot is stolen. Also, for "Length indication" = 111111₂, the addressed MS(s) shall assume the start of fragmentation and shall store the TM-SDU fragment.

If the first half slot is not decodeable, the MS designer should choose an appropriate method for processing the second half of the slot.

EXAMPLE: The MS might make a first assumption that the second half slot is stolen, but revise that decision if the CRC fails. (This method could be particularly useful at the start of an encrypted transmission when encryption synchronization might be sent in both halves of the slot.) Otherwise the MS could treat the second half slot as "CRC fail" TCH.

If the second half slot is not stolen, the receiving MS shall interpret the second half slot as TCH.

If the second half slot is stolen, the MS shall interpret the second half slot as STCH. Then the MAC PDU type shall indicate whether the second half slot was stolen for C-plane (TMA-SAP/TMB-SAP) or U-plane (TMD-SAP) signalling. If the second half slot is not decodeable, the MS should regard the MAC block as C-plane signalling with CRC failure.

In the case of C-plane signalling, PDU dissociation may be necessary within the second half slot.

If the second half slot is not decodeable, or if the second half slot does not include a MAC-END PDU, an MS-MAC that stored a first fragment in the first half slot shall discard that fragment. Otherwise, it shall append the fragment from the MAC-END PDU to the already received fragment, and shall deliver the complete TM-SDU to the LLC.

23.8.5 BS operation

For traffic slots received on the uplink:

- a) for normal training sequence 1, channel decoding (and re-encoding) may be performed at the BS, allowing error correction for multiple hops;
- b) channel decoding (and re-encoding) should be performed at the BS in the case of normal training sequence 2, in order that the BS can recognize C-plane stealing;
- c) when a half slot has been stolen on the uplink for C-plane signalling, the BS should replace the stolen half slot (e.g. with another C-plane message or with the Null PDU or with substitution traffic) before transmission on the downlink.

The BS should pass the U-plane signalling and TCH on towards the destination. The timing and ordering and half-slot pairing of the U-plane information (signalling and TCH) shall be preserved. The BS may replace (i.e. overwrite) U-plane information when performing C-plane stealing, but shall not move the replaced U-plane information to a different position.

If the BS does not receive data from the sending MS, e.g. in the case of U-plane DTX, it should still transmit on the downlink channel to the receiving MS(s). For example, it could fill the slot with two stolen half slots each containing the C-plane Null PDU, or it could fill the slot with substitution traffic.

If the BS is decoding and re-encoding the traffic for a circuit mode data call with an interleaving depth of $N = 4$ or 8 then:

- i) the BS should delay U-plane signalling by $N - 1$ traffic frames before transmission on the downlink;

NOTE 1: This procedure for $N = 4$ or 8 means that the BS transmits the U-plane data stream with the U-plane signalling in the same position as when the MS transmitted it. This position may be important if the U-plane signalling is carrying end-to-end encryption synchronization.

The need for the procedure arises because the de-interleaving process causes the circuit mode data to be delayed by $N - 1$ traffic frames relative to the U-plane signalling. The receiving MS's procedure (see clause 23.8.3.2) takes account of the relative delay over the air interface if the BS does not de-interleave the traffic before transmission on the downlink. The BS needs to compensate for the additional relative delay introduced by its de-interleaving and re-interleaving of the traffic.

- ii) after a U-TX CEASED or U-DISCONNECT PDU has been received from the transmitting MS, the BS should ensure that it has been able to issue $N - 1$ slots containing tail bits to the lower MAC at the end of the data transmission (on each allocated slot in the case of a multi-slot channel) before sending the D-TX CEASED, D-RELEASE or D-DISCONNECT PDU to receiving MS(s).

NOTE 2: These tail bits are needed to complete the interleaving of the circuit mode data that has been received from the transmitting MS.

Some examples of scenarios for call set-up and channel usage for circuit mode calls are illustrated in annex D.

24 Void

25 Void

26 Void

27 Void

28 TETRA Packet Data Protocol

28.0 General

Clause 28 defines the TETRA Packet Data Protocol (PDP) for packet data operation. The TETRA packet data service is built on top of the Mobile Link Entity (MLE) defined in clauses 17 and 18 of the present document.

NOTE 1: The TETRA packet data service is separate from the Connection Oriented Network Service (CONS) and the Specific Connectionless Network Service (SCLNS) which were defined in clauses 24 to 27 of the ETSI ETS 300 392-2, edition 1.

The TETRA packet data service provides mechanisms to convey different higher layer protocols. The present document supports the following network layer protocols:

- Internet Protocol (IP), versions 4 and 6.

TETRA packet data extends TETRA to act as an IP subnet. This enables application programmers to build their applications in a well-standardized environment.

At the MS side the IP and the higher layers on top of it may be located at:

- MT0;
- TE2 where the protocol used between TE2 and MT2 is defined in ETSI EN 300 392-5 [7];
- TE where the protocol used between TE and MT0 is outside the scope of the present document and ETSI EN 300 392-5 [7];
- MEX layer (clause 30).

The implementation of the SwMI's IP routing and relaying as well as the connection to external networks is outside the scope of the present document.

Figure 28.1 illustrates the usage of TETRA packet data when the application is located in MT0.

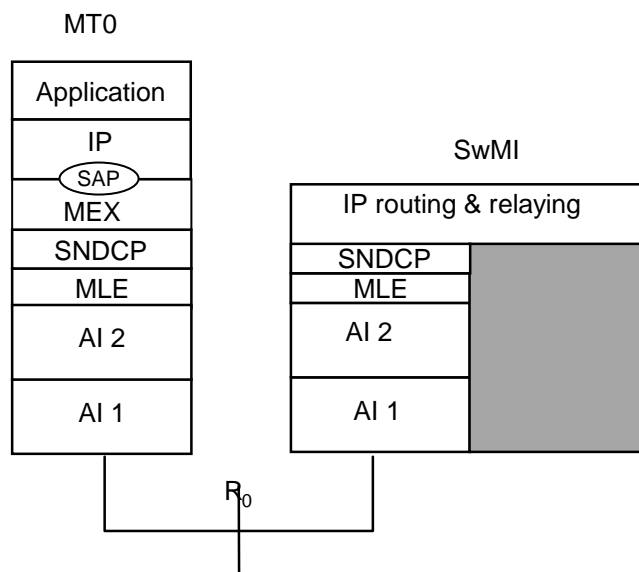

Figure 28.1: Usage of TETRA packet data for MT0 IP application

Figure 28.2 illustrates the usage of TETRA packet data when the applications use IP protocol and are located in TE2. Mapping between PEI DLL (MT2) and MEX is via the TNMXPI-SAP (see clause 30).

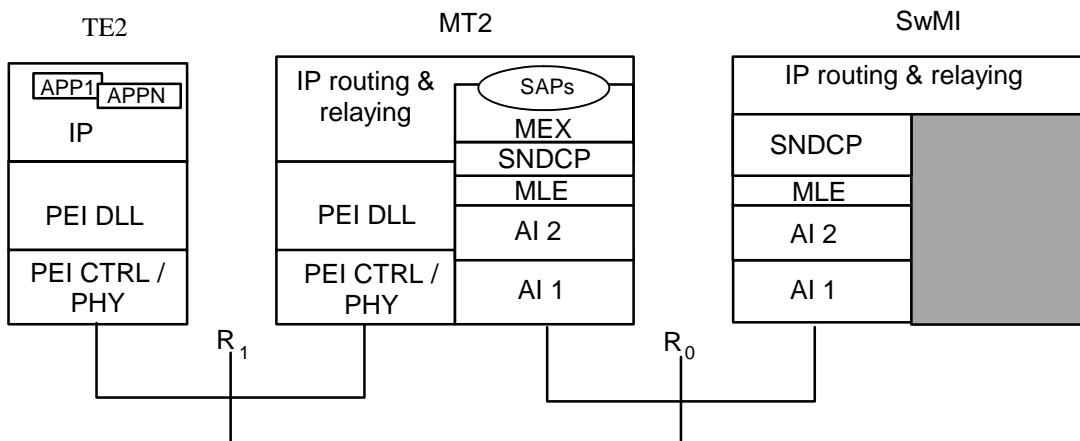

Figure 28.2: Usage of TETRA packet data for TE2 IP application

The Wireless Application Protocol (WAP) architecture, see WAP2.0 [i.9], defines a framework to meet the challenges of the advanced services, differentiation and fast/flexible service creation in wireless networks. The WAP defines a set of protocols in transport, session and application layers.

The upper layers of WAP will be independent of the underlying wireless network, while the transport layer should be adapted to specific features of underlying services. This adaptation to TETRA packet data is, however, outside of the scope of the present document. When used in conjunction with the TETRA packet data service, it is recommended that WAP be located on top of UDP/IP. Figure 28.3 illustrates the recommended usage of TETRA packet data when the application is a WAP application and it is located in MT0.

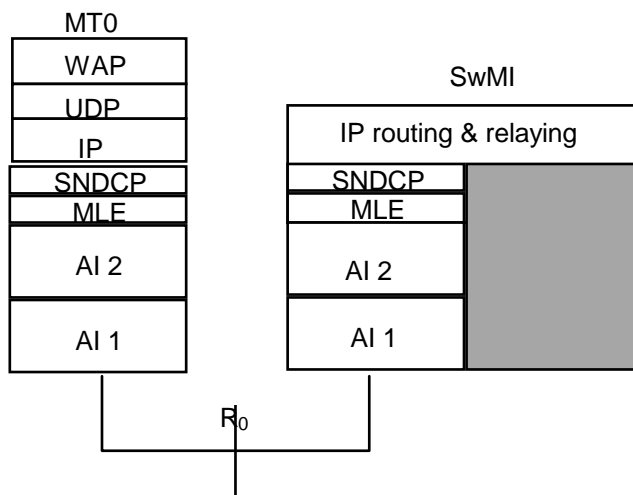

Figure 28.3: Usage of TETRA packet data for MT0 WAP application

NOTE 2: The MEX layer, defined in clause 30 of the present document, may be used to enhance the interface between SNDSCP and its user applications.

28.1 Subnetwork Dependent Convergence Protocol (SNDCP) overview

The Subnetwork Dependent Convergence Protocol (SNDCP) is a TETRA specific network layer protocol that has two main functions:

- 1) to negotiate and maintain PDP contexts between an MS and the SwMI. A unique primary PDP context is established for each PDP address active (i.e. which requires packets to be routed to it) on the network. The primary PDP context activation procedure involves the binding of a PDP address to a TETRA ITSI and also the optional negotiation of compression algorithms and QoS parameters to be used during data transfer. Secondary PDP context activation involves binding the secondary PDP context to the PDP address of a primary PDP context and also the optional negotiation of compression algorithms and QoS parameters to be used during data transfer;
- 2) to control PDP data transfer between MS and SwMI. Data transfer is unacknowledged (i.e. SNDCP does not perform retransmissions); however, SNDCP allows the service user to select the acknowledged or unacknowledged layer 2 services for data transfer over the air interface. SNDCP provides mechanisms by which data may be compressed before being transmitted over the air interface.

Figure 28.4 describes the protocol model for TETRA packet data and the SNDCP position in it.

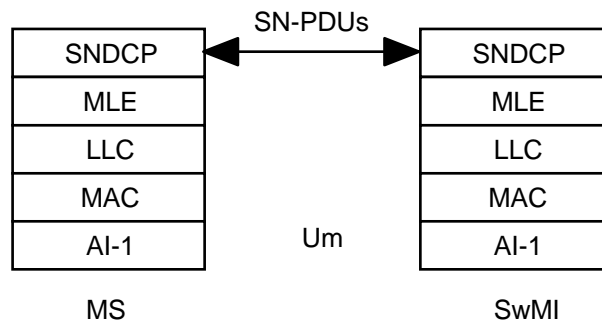

NOTE: Legend:

Subnetwork Dependent Convergence Protocol (SNDCP): TETRA specific Network layer protocol that shall be used to negotiate and maintain PDP contexts between MS and SwMI

Mobile Link Entity (MLE): MLE protocol discriminator entity (data transfer) routes TETRA Packet data signalling and data to corresponding TETRA Packet data SAP at the peer entity (SwMI/MS).

Logical Link Control (LLC): This layer provides a logical link.

Medium Access Control (MAC): This controls the access signalling (request and grant) procedures for the radio channel, and the mapping of LLC frames onto the TETRA physical channel.

Air Interface layer 1 (AI-1): As defined in the present document.

Figure 28.4: Subnetwork Dependent Convergence Protocol (SNDCP)

Before a MS may gain access to any SNDCP services, it firstly goes through a packet data registration procedure, called PDP context activation. PDP context activation is initiated by the MS. The MS may activate primary PDP contexts and secondary PDP contexts. Activation of a primary PDP context involves the negotiation of a PDP address (e.g. an IPv4 address) and other parameters to be used during data transfer. Each primary PDP context should have a different PDP address. When the MS has established one or more primary PDP contexts, it may request establishment of secondary PDP contexts. A secondary PDP context derives its PDP address from a primary PDP context and is used by the SwMI to differentiate the QoS given to different types of packets being sent to the same PDP address. The SwMI uses a QoS filter to determine if a downlink packet should use a secondary PDP context. If a downlink packet does not match the PDP address and the QoS filter of any secondary PDP context, the SwMI should instead send the packet via the primary PDP context for the relevant PDP address. The MS SNDCP may also specify a differentiated services field ("diffserv") filter for a secondary PDP context. The SwMI may inspect the lower 5 bits (4 to 0) of the 6-bit Differentiated Services Code Point (DSCP) in downlink IP packet headers and route the packets through a secondary PDP context with a matching diffserv filter.

If the MS does not specify a QoS filter during activation of a secondary PDP context, the SwMI should generate an automatic QoS filter.

EXAMPLE: The SwMI may generate an automatic QoS filter by recording the source port numbers and NSAPIs of uplink TCP/IP and UDP/IP packets received via secondary PDP contexts and use this to filter downlink packets on the basis of the downlink packets' destination IP addresses and destination ports.

PDP data transfer normally takes place over an assigned secondary control channel (assigned SCCH), termed in this specification a Packet Data CHannel (PDCH). An advanced link is set up before data transfer may begin on the PDCH using the acknowledged layer 2 service. When a MS has data to transfer, it implicitly requests permission to switch to the PDCH. If accepted, the SwMI normally responds with a channel allocation, directing the MS to a PDCH.

NOTE: The SwMI may allow the MS to use the MCCH or MCCH-Q (or common SCCH) for the exchange of packet data.

The protocol for SNDCP is described in terms of a state machine. There are three main states which are defined for both the MS and SwMI, namely READY, STANDBY and IDLE.

READY state typically implies a MS is located on a PDCH and is currently engaged in data transfer or has recently (defined by a timer) been engaged in packet data transfer.

STANDBY state implies a MS is no longer on a PDCH i.e. the MS has not recently (defined by a timer) been engaged in data transfer.

IDLE state implies that a MS has no PDP contexts activated.

A more complete description of SNDCP is given in the following clauses.

28.2 SNDCP service description

28.2.1 Introduction

This clause describes the services offered by the Subnetwork Dependent Convergence Protocol (SNDCP) entity for the voice plus data TETRA layer 3 air interface.

28.2.2 Services offered

SNDCP shall be a service provider for packet data users. The services shall be made available through the SNDCP Service Access Point (SN-SAP). The SNDCP procedures and protocol description are defined in clauses 28.3 and 28.4.

The services offered shall be:

- PDP context activation and PDP context deactivation;
- PDP context modification;
- Negotiation and modification of QoS requirements;
- Packet Data CHannel (PDCH) handling;
- Multiplexing of N-PDUs from one or several higher protocol entities onto a single layer 2 connection;
- Mapping of SN primitives received from the network layer into corresponding MLE-UNITDATA request primitives to be passed to the MLE;
- If data priority is not supported:
 - management of the delivery sequence according to the PDU priority of SN-UNITDATA request and SN-DATA request primitives;

- If data priority is supported:
 - management of the delivery sequence according to the PDU priority and data priority of SN-UNITDATA request and SN-DATA request primitives;
 - mapping of N-PDU data priorities into a priority for reserved access;
- Compression and recovery of redundant protocol control information (e.g. TCP/IP header). Header compression is performed independently for each NSAPI;
- Compression and recovery of redundant user data. Data compression is performed independently for each NSAPI;
- Interface to MEX mediated applications and applications which bypass MEX (see clause 30).

The SwMI indicates support for the SNDSCP service on conventional access cells in the D-MLE-SYSINFO and D-MLE-SYSINFO-Q PDUs (in the "BS service details" information element). A direct access cell always supports the SNDSCP service while the "system wide services" information element in the D-MLE-SYSINFO-DA (and the D-MLE-SYNC-DA) PDU is indicating "normal mode" (system wide services supported). It is optional for the DA cell to support the SNDSCP service while the "system wide services" information element in the D-MLE-SYSINFO-DA (and the D-MLE-SYNC-DA) PDU is indicating "system wide services temporarily not supported".

The MS SNDSCP shall not attempt to use the SNDSCP service on a conventional access cell that indicates no support for the SNDSCP service. If the MS SNDSCP possesses activated PDP contexts at the time that the SwMI indicates that the present cell does not support the SNDSCP service, the MS SNDSCP shall cease use of its activated PDP contexts, but may attempt to continue using the activated PDP contexts if the SwMI later indicates that the present cell does support the SNDSCP service or if the MS performs a cell reselection to a DA cell or to a CA cell that indicates support for the SNDSCP service.

The MS SNDSCP shall not attempt to use the SNDSCP services on a cell where a subscriber class mismatch exists (see clause 16.4.9) or on a not-permitted cell (see clause 18.3.5.1.5).

28.2.3 Service Primitives

28.2.3.0 General

The services shall be provided through primitives at the service access point SN-SAP. This clause describes the primitives and their parameters.

Mapping of various protocols to the SNDSCP operation is defined with respect to an abstract underlying service. The underlying service consists of the following primitives:

- SN-DATA {Request, Indication};
- SN-DELIVERY {Indication};
- SN-NSAPI ALLOC {Request, Indication, Confirm};
- SN-NSAPI CONFIGURE {Request, Confirm};
- SN-NSAPI DEALLOC {Request, Indication};
- SN-NSAPI MODIFY {Request, Indication, Confirm};
- SN-QOS {Request, Indication};
- SN-UNITDATA {Request, Indication};
- SN-PAGE { Request, Indication, Response, Confirm}.

28.2.3.1 Primitive descriptions

In parameter descriptions:

- M = Mandatory:
- O = Optional:
- - = Not allowed.

SN-DATA request/indication: SN-DATA primitive is used for acknowledged data transfer service at the LLC. The receipt of data shall be confirmed by the LLC layer.

Parameters of the primitive shall be as shown in table 28.1.

Table 28.1: Parameters for the primitive SN-DATA

Parameter	Request	Indication
NSAPI	M	M
Handle	M	-
PDU priority	O (see note 1)	-
Data priority	O (see note 2)	-
Data importance	O (see note 3)	-
Schedule surplus flag	O (see note 4)	-
N-PDU	M	M
NOTE 1: If PDU priority is not given in the primitive, then the value assigned by the SwMI during context activation is used.		
NOTE 2: If the data priority is not given in the primitive, then the value "undefined" should be assumed by SNDCCP.		
NOTE 3: If the data importance is not given in the primitive, then the value "low" should be assumed by SNDCCP.		
NOTE 4: If the schedule surplus flag is not given in the primitive then the value "not surplus to schedule" should be assumed by SNDCCP.		

SN-DELIVERY indication: SN-DELIVERY primitive is used to indicate that SNDCCP has completed its transmission of the N-PDU in a SN-DATA request primitive (success/failure/deleted or cancelled by SNDCCP) or SN-UNITDATA request primitive (failure/deleted or cancelled by SNDCCP).

Parameters of the primitive shall be as shown in table 28.2.

Table 28.2: Parameters for the primitive SN-DELIVERY

Parameter	Indication
Handle	M
Delivery report	M

SN-NSAPI ALLOC request/indication/confirm: SN-NSAPI ALLOC primitive is used to set NSAPI into use.

Parameters of the primitive shall be as shown in table 28.3.

Table 28.3: Parameters for the primitive SN-NSAPI ALLOC

Parameter	Request (MS only)	Indication (SwMI only)	Confirm (MS only)
NSAPI	M	M	M
NSAPI alloc report	-	-	M
PDP type	M	M	C (see note 3)
PDP address	C (see note 1)	M	C (see notes 2 and 3)
DCOMP negotiation	O	O	O (see note 3)
PCOMP negotiation	O	O	O (see note 3)
NSAPI alloc reject cause	-	-	C (see note 4)
PDU priority max	-	-	C (see note 3)
NSAPI data priority	O (see note 6)	-	-
Maximum transmission unit	-	-	M
Mobile IPv4 information	-	-	C (see notes 3 and 5)
NSAPI QoS negotiation	O	O	O (see note 3)
NOTE 1: Conditional on PDP type. PDP address not present in case of IPv4 dynamic address negotiation or IPv6.			
NOTE 2: Conditional on PDP type. PDP address not present in case of IPv6 or Mobile IPv4 FA care of address requested.			
NOTE 3: Conditional on NSAPI alloc report. Not present in case of NSAPI alloc report set to "Failure".			
NOTE 4: Conditional on NSAPI alloc report. Present in case of NSAPI alloc report set to "Failure".			
NOTE 5: Conditional on PDP type. Present if PDP type set to Mobile IPv4.			
NOTE 6: If the "NSAPI data priority" is not given in the primitive, then the value "undefined" should be assumed by SMDCP.			

SN-NSAPI CONFIGURE request/confirm: SN-NSAPI CONFIGURE primitive is used to make local modifications to the characteristics of an activated NSAPI.

Parameters of the primitive shall be as shown in table 28.4.

Table 28.4: Parameters for the primitive SN-NSAPI CONFIGURE

Parameter	Request	Confirm
NSAPI	M	M
NSAPI data priority	M	M

SN-NSAPI DEALLOC request/indication: SN-NSAPI DEALLOC primitive is used to withdraw NSAPI from use.

Parameters of the primitive shall be as shown in table 28.5.

Table 28.5: Parameters for the primitive SN-NSAPI DEALLOC

Parameter	Request	Indication
Deactivation type	M	M
NSAPI	C (see note)	C (see note)
NOTE: Not present if Deactivation Type is set to "Deactivate All NSAPIs".		

SN-NSAPI MODIFY request/indication/confirm: SN-NSAPI MODIFY primitive is used to modify the characteristics of an activated NSAPI which have been agreed with the SwMI.

Parameters of the primitive shall be as shown in table 28.6.

Table 28.6: Parameters for the primitive SN-NSAPI MODIFY

Parameter	Request	Indication	Confirm
NSAPI	M	M	M
NSAPI modify report	-	-	M
NSAPI modify reject cause	-	-	C (see note 1)
NSAPI QoS negotiation (see note 3)	O	O	O (see note 2)
Schedule availability	-	O	-
NSAPI usage (see note 3)	O	-	-
NOTE 1: Conditional on NSAPI modify report. Present only in case of NSAPI modify report set to "failure".			
NOTE 2: Conditional on NSAPI modify report. Not present in case of NSAPI modify report set to "failure".			
NOTE 3: Only one of "NSAPI QoS negotiation" and "NSAPI usage" should be included in a single primitive, not both.			

SN-QOS request/indication: SN-QOS primitive is used to negotiate about QoS to the peer entity.

Parameters of the primitive shall be as shown in table 28.7.

Table 28.7: Parameters for the primitive SN-QOS

Parameter	Request	Indication
QoS requested	M	M
QoS minimum	M	-
QoS negotiated	-	M
QoS negotiation result	-	M
NOTE: It is recommended that this primitive is used only to set parameters within the MS SNDPCP entity, to be used at a later stage during advanced link setup negotiation. This primitive should not in itself trigger the establishment or resetting of the advanced link.		

NOTE: The SN-QOS request primitive is retained for backward compatibility with previous versions of this document, and is applicable only to $\pi/4$ -DQPSK modulation. The optional NSAPI QoS negotiation parameter included in the SN-NSAPI ALLOC and SN-NSAPI MODIFY primitives has more general applicability, and should be used instead of the SN-QOS request primitive.

SN-UNITDATA request/indication: SN-UNITDATA primitive is used for unacknowledged data transfer service at the LLC. The receipt of data is not confirmed by the SNDCP or lower layers.

Parameters of the primitive shall be as shown in table 28.8.

Table 28.8: Parameters for the primitive SN-UNITDATA

Parameter	Request	Indication
NSAPI	M	M
Handle	M	-
PDU priority	O (see note 1)	-
Data priority	O (see note 2)	
Data importance	O (see note 3)	
Schedule surplus flag	O (see note 4)	
N-PDU	M	M
NOTE 1: If PDU priority is not given in the primitive, then the value assigned during context activation is used.		
NOTE 2: If the data priority is not given in the primitive, then the value "undefined" should be assumed by SNDCP.		
NOTE 3: If the data importance is not given in the primitive, then the value "low" should be assumed by SNDCP.		
NOTE 4: If the schedule surplus flag is not given in the primitive then the value "not surplus to schedule" should be assumed by SNDCP.		

SN-PAGE request/indication/response/confirm: SN-PAGE primitive is used as part of the TETRA packet data paging mechanism.

Parameters of the primitive shall be as shown in table 28.9.

Table 28.9: Parameters for the primitive SN-PAGE

Parameter	Request (SwMI only)	Indication (MS only)	Response (MS only)	Confirm (SwMI only)
NSAPI	M	M	M	M
Reply requested	M	M	-	-
PD service status	-	-	M	M

28.2.3.2 Parameter descriptions

CONTEXT_READY time =

- track READY timer;
- 200 ms;
- 500 ms;
- 700 ms;
- 1 s;
- 2 s;
- 3 s;
- 5 s;
- 10 s;
- 20 s;
- 30 s;

- 60 s;
- 120 s;
- 180 s;
- 300 s.

Data class =

- Real-time class - layer 2 link optimized for data which cannot tolerate delivery delay (late packets discarded by the receiving application);
- Telemetry class - layer 2 link optimized for intermittent data which can tolerate moderate delivery delay and packet loss;
- Background class - layer 2 link optimized for data which are intolerant of packet loss.

Data importance =

- Low;
- Medium;
- High.

NOTE 0: In circumstances where the MS SNDCP decides to delete or cancel untransmitted N-PDUs, "data importance" allows the MS SNDCP to preferentially delete or cancel N-PDUs containing lower-importance data. Data importance is not transmitted over the air interface.

Data priority =

- 0 Lowest data priority;
etc.;
- 7 Highest data priority.

DCOMP negotiation =

- This parameter may contain several different data compression methods, such as Recommendation ITU-T V.42bis [27], and their parameters negotiated with the peer entity.

Deactivation type =

- Deactivate all NSAPIs;
- Deactivate NSAPI given in the primitive.

Delay class =

- Low;
- Moderate;
- High;
- Unpredictable.

Table 28.10 defines the meaning of the delay class values.

Table 28.10: Packet delays for different delay classes

Delay Class	N-PDU size ≤ 128 octets		128 < N-PDU size ≤ 1 024 octets		1 024 < N-PDU size ≤ 2 002 octets	
	Mean transfer delay (s)	95 percentile delay (s)	Mean transfer delay (s)	95 percentile delay (s)	Mean transfer delay (s)	95 percentile delay (s)
Low	< 1	< 3	< 3	< 7	< 5	< 10
Moderate	< 5	< 25	< 15	< 75	< 30	< 150
High	< 50	< 250	< 75	< 375	< 110	< 560
Unpredictable	Undefined	Undefined	undefined	undefined	undefined	undefined

NOTE 1: For packets sizes up to 1 024 octets, the delays for moderate and high classes match those for GPRS, see ETSI TS 122 060 [i.10].

NOTE 2: Real-time class data requires the low delay class; if real-time class data is specified, the low delay class should be assumed by default.

NOTE 3: The delay values are for MS to MS communication in a single network (SwMI) including random access delay.

Delivery report =

- Success;
- Failure;
- Deleted or cancelled by SNDSCP.

DSCP =

- differentiated services code point.

Handle =

- Defines the handle used to generate a mapping between SN-DATA or SN-UNITDATA request primitives and SN-DELIVERY indication primitives.

Maximum transmission unit =

- This is the maximum size of N-PDU which may be presented by the MS service user to SNDSCP for transport over the air interface. This typically represents the maximum size of IP packet (prior to adding SNDSCP header and performing compression) which may be carried over the air-interface.

Mean active throughput =

- This is the mean throughput of N-PDUs expected by the SNDSCP service user while the PDP context is actively transmitting or receiving data (i.e. while the PDP context's CONTEXT_READY timer is active, if supported, or while the READY timer is active if CONTEXT_READY timers are not supported).
- The values are as for minimum peak throughput.

Mean throughput =

- This is the mean throughput of N-PDUs expected by the SNDSCP service user, averaged over the expected lifetime of the PDP context. It is given in units of octets/hour.
 - 100 (~0,22 bits/s);
 - 200 (~0,44 bits/s);
 - 500 (~1,11 bits/s);
 - 1 000 (~2,2 bits/s);

- 2 000 (~4,4 bits/s);
- 5 000 (~11,1 bits/s);
- 10 000 (~22 bits/s);
- 20 000 (~44 bits/s);
- 50 000 (~111 bits/s);
- 100 000 (~0,22 kbit/s);
- 200 000 (~0,44 kbit/s);
- 500 000 (~1,11 kbit/s);
- 1 000 000 (~2,2 kbit/s);
- 2 000 000 (~4,4 kbit/s);
- 5 000 000 (~11,1 kbit/s);
- 10 000 000 (~22 kbit/s);
- 20 000 000 (~44 kbit/s);
- 50 000 000 (~111 kbit/s);
- Best effort.

NOTE 4: These values follow those given for GPRS, see ETSI EN 301 344 [i.11].

Minimum peak throughput =

- This is the minimum peak throughput of N-PDUs in units of octets/s requested or offered for a particular PDP context. This is the minimum throughput required when the PDP context is at its most active; if the peak rate available is lower than this, the application may not be usable (though the application may be capable of using a higher rate than this).
 - < 1 000;
 - $\geq 1\ 000$;
 - $\geq 2\ 000$;
 - $\geq 4\ 000$;
 - $\geq 8\ 000$;
 - $\geq 16\ 000$;
 - $\geq 32\ 000$;
 - $\geq 64\ 000$.

NOTE 5: The following examples show methods of providing the requested peak throughput in a reliable channel:

- a peak throughput less than 1 000 octets/s can be provided by any PDCH;
- a peak throughput $\geq 1\ 000$ octets/s requires 4-QAM 25 kHz (3-, 4-slot), $\pi/4$ -DQPSK (2-, 3-slot), etc.;
- a peak throughput $\geq 2\ 000$ octets/s requires 4-QAM 50 kHz (3-, 4-slot), $\pi/4$ -DQPSK (4-slot), etc.;
- a peak throughput $\geq 4\ 000$ octets/s requires 4-QAM 100 kHz (3-, 4-slot), 4-QAM 150 kHz (2-slot), etc.;
- a peak throughput $\geq 8\ 000$ octets/s requires 4-QAM 150 kHz (3-, 4-slot);

- a peak throughput $\geq 16\ 000$ octets/s requires 16-QAM 150 kHz (4-slot), etc.;
- a peak throughput $\geq 32\ 000$ octets/s requires 64-QAM $r = \frac{1}{2}$, 150 kHz (4-slot), etc.;
- a peak throughput $\geq 64\ 000$ octets/s requires 64-QAM $r = 1$, 150 kHz (4-slot).

Mobile IPv4 Information =

- Information specific to Mobile IPv4 operation.

N-PDU =

- Any number of bits needed to carry a Network layer protocol PDU.

NSAPI =

- 0 Reserved;
- 1 Free;
- etc.;
- 14 Free;
- 15 Reserved.

NSAPI alloc reject cause =

- Undefined;
- MS not provisioned for Packet Data;
- IPv4 not supported;
- IPv6 not supported;
- IPv4 dynamic address negotiation not supported;
- IPv6 stateful address autoconfiguration not supported;
- IPv6 stateless address autoconfiguration not supported;
- Dynamic address pool empty;
- Static address not correct;
- Static address in use;
- Static address not allowed;
- Static IP address congestion;
- TETRA Packet Data not supported on this location area;
- TETRA Packet Data not supported on this network;
- Temporary rejection;
- Packet Data MS Type not supported;
- SNDCCP version not supported;
- Mobile IPv4 not supported;
- Mobile IPv4 Co-located Care of Addresses not supported;
- Maximum allowed PDP contexts per ITSI exceeded;

- User authentication failed;
- Activation rejected by external PDN;
- Access point name index not correct;
- No response from network;
- Bad response from network;
- NSAPI not available;
- NSAPI already allocated;
- Requested minimum peak throughput not available;
- Scheduled access not supported;
- Requested schedule not available;
- Requested QoS not available;
- Secondary PDP contexts not supported;
- Primary PDP context does not exist;
- Asymmetric QoS not supported;
- Automatic QoS filter not supported;
- Specified QoS filter not supported;
- QoS filter type not supported;
- QoS filter not available for primary PDP context;
- SMDCP service temporarily not available.

NSAPI alloc report =

- Failure;
- Success (Note that DCOMP negotiation, PCOMP negotiation and NSAPI QoS negotiation values might be changed).

NSAPI data priority =

- As data priority.

NSAPI modify reject cause =

- Undefined;
- Temporary rejection;
- No response from network;
- Bad response from network;
- NSAPI not activated;
- Requested minimum peak throughput not available;
- Scheduled access not supported;
- Requested schedule not supported;
- Requested QoS not available;
- Secondary PDP contexts not supported;
- Primary PDP context does not exist;
- Asymmetric QoS not supported;
- Automatic QoS filter not supported;
- Specified QoS filter not supported;
- QoS filter type not supported;
- QoS filter not available for primary PDP context;
- SNDCP service temporarily not available.

NSAPI modify report =

- Failure (the NSAPI QoS negotiation parameter was not changed from its previous value);
- Success (one or more of the items in the NSAPI QoS negotiation parameter were changed from their previous values).

NSAPI QoS negotiation =

- A set of: QoS for uplink and downlink or for uplink only, QoS for downlink, CONTEXT_READY time, QoS filter (only when a secondary PDP context is requested) and scheduled access.

NSAPI Usage =

- Schedule paused;
- PDP context paused.

PCOMP negotiation =

- This parameter may contain several different protocol compression methods. They may be one or more of: TCP/IP header compression (not available for unacknowledged layer 2 service or real-time class data) and IP header compression.

PD service status =

- Available for packet data service;
- Temporarily unavailable for packet data service.

PDP address =

- IPv4 address (only when a primary PDP context is being requested); or
- NSAPI (only when a secondary PDP context is being requested).

PDP type =

- IPv4 (static address);
- IPv4 (dynamic address negotiation);
- IPv6;
- Mobile IPv4 - Foreign Agent care of address requested;
- Mobile IPv4 - Co-located care of address requested;
- Primary NSAPI (secondary PDP context requested).

PDU priority =

- 0 Lowest PDU priority;
etc.;
- 7 Highest PDU priority.

PDU priority max =

- As PDU priority.

Port =

- A port number (0 to 65 535).

Port range =

- Lower limit of a range of port numbers (0 to 65 535);
- Upper limit of a range of port numbers (0 to 65 535).

QoS filter =

- A set of: QoS filter operation, QoS filter type and one of: port, port range or DSCP (port, port range and DSCP not required when QoS filter type = automatic QoS filter).

QoS filter operation =

- Add to any existing QoS filter for the specified PDP context;
- Replace any existing QoS filter for the specified PDP context;
- Remove from any existing QoS filter for the specified PDP context.

QoS filter type =

- Automatic QoS filter;
- All types of ports;
- UDP ports;
- TCP ports;
- Diffserv.

QoS for downlink =

- A set of: data class, minimum peak throughput, mean throughput, mean active throughput, delay class and reliability class.

QoS for uplink and downlink or for uplink only =

- A set of: data class, minimum peak throughput, mean throughput, mean active throughput, delay class and reliability class.

QoS minimum =

- As QoS requested.

QoS negotiated =

- As QoS requested.

QoS negotiation result =

- Success;
- Failure;
- Failure, try again.

NOTE 6: The QoS requested, QoS minimum and QoS negotiated and QoS negotiation result parameters are retained for compatibility with previous versions of this document. The NSAPI QoS negotiation parameter in the SN-NSAPI ALLOC and SN-NSAPI MODIFY request primitives should be used instead, if supported. SNDCP requires the information they contain to request any QoS other than background class operation with unspecified throughput, reliability and delay. For example, the NSAPI QoS negotiation parameter needs to be used if the application wishes to use scheduled access.

QoS requested =

- A set of:
 - Advanced link service (unacknowledged, acknowledged);
 - Maximum length of N-PDU;
 - Number of timeslots used per TDMA frame (1-4); and
 - Data transfer throughput (network dependent minimum, 1/32, 1/16, 1/8, 1/4, 1/2, maximum).

Reliability class =

- High (uses an acknowledged link with FCS enabled);
- Moderate (uses an acknowledged link with FCS disabled);
- Low (uses the unacknowledged basic link, normally with FCS disabled and no retransmissions).

Table 28.11 defines the reliability classes.

Table 28.11: Definition of reliability classes

Reliability class	Lost N-PDU Probability	Duplicate N-PDU Probability	Out of Sequence N-PDU Probability	Corrupt N-PDU Probability
High	$< 10^{-9}$	$< 10^{-9}$	$< 10^{-9}$	$< 10^{-9}$
Moderate	$< 10^{-4}$	$< 10^{-9}$	$< 10^{-5}$	$< 10^{-4}$
Low (see note 1)	Undefined	0 (see note 2)	0 (see note 2)	$< 10^{-4}$

NOTE 1: Uses an unacknowledged link.
NOTE 2: Applies only if each N-PDU is transmitted once.

NOTE 7: Real-time class data uses the low reliability class.

The lost N-PDU probability for the low reliability class is shown in table 28.11 as "undefined". However, for example, some applications may need the lost N-PDU probability for real-time class data to be less than $2,5 \times 10^{-2}$.

Reply requested =

- SNDCP response required;
- SNDCP response not required.

Schedule availability =

- Available;
- Cancelled;
- Suspended.

Schedule repetition period =

- 4 slot durations;
- 5 slot durations;
- etc.;
- 706 slot durations (10 s).

NOTE 8: A slot has a duration of $85/6$ ms.

Schedule surplus flag =

- Not surplus to schedule;
- Surplus to schedule.

Schedule timing error =

- ≤ 1 slot duration;
- ≤ 2 slot durations;
- ≤ 4 slot durations;
- ≤ 8 slot durations;
- ≤ 16 slot durations;
- ≤ 32 slot durations;
- ≤ 64 slot durations;
- ≤ 128 slot durations.

NOTE 9: A slot has a duration of $85/6$ ms.

NOTE 10: The SwMI sets the earliest timing of successive scheduled slot grants relative to the time of the first slot grant. The schedule timing error is the maximum acceptable delay of a scheduled slot grant beyond the earliest time of a scheduled slot grant. The SNDCP application should not propose a schedule timing error which is greater than the schedule repetition period.

Scheduled Access =

- A set of:
 - schedule repetition period;
 - schedule timing error;
 - scheduled number of N-PDUs per grant;
 - scheduled N-PDU size.

NOTE 11: The scheduled N-PDU size parameter should be repeated as many times as necessary to indicate a size for each scheduled N-PDU per grant.

Scheduled N-PDU size =

- 1 octet;
- 2 octets;
- etc.;
- 2 002 octets.

Scheduled number of N-PDUs per grant =

- 1;
- 2;
- etc.;
- 7.

28.2.4 Definition of SNDCP states and state transitions

28.2.4.0 General

The SNDCP activities related to a TETRA MS are characterized by one of eight different SNDCP states: CLOSED, IDLE, IDLE-Temporary Break, STANDBY, STANDBY-Temporary Break, RESPONSE-WAITING, READY and READY-Temporary Break. The SNDCP activities related to a TETRA SwMI are characterized by one of three different SNDCP states: IDLE, STANDBY and READY.

Each state describes a certain level of functionality and information allocated to the involved entities. The SNDCP state relates only to SNDCP activities of a subscriber represented by the ITSI. It is independent of number of PDP contexts for that subscriber.

It is optional for a MS to support multiple PDP contexts. It is also optional for a SwMI to support multiple PDP contexts for a single ITSI.

NOTE: If multiple PDP contexts are used by a single ITSI, then the MS will release all its PDP contexts at the same time when entering to state IDLE from state STANDBY. The SwMI may use SwMI originated PDP Deactivation procedure in order to control PDP context lifetimes separately.

28.2.4.1 CLOSED

CLOSED state is valid for a MS only. In CLOSED state access to the communication resources is unavailable (e.g. due to MS not being registered or being temporarily disabled) and SNDCP is not permitted to communicate with its peer entity.

In CLOSED state, the MS does not have any PDP contexts active.

When entering state CLOSED, the READY, CONTEXT_READY, RESPONSE_WAIT and STANDBY timers are stopped. If the MS supports data priority, the MS SNDCP shall inform MLE that the MS default data priority is "not applicable" using the MLE-CONFIGURE request primitive. If the MS supports the use of non-conforming PDCHs (see clause 18.3.4.9.1), the MS SNDCP should inform MLE that the SNDCP status is "idle" using the MLE-CONFIGURE request primitive.

On reception of an indication that access to the communication resources has become available (on reception of MLE-OPEN indication primitive from MLE), if the MS is not temporarily disabled, the MS SNDCP entity shall enter IDLE state. If SNDCP is temporarily disabled, the MS SNDCP shall remain in the CLOSED state.

If SNDCP receives an MLE-ENABLE indication primitive, the MS SNDCP shall record that it is no longer temporarily disabled. Then, if SNDCP has previously received an MLE-OPEN indication primitive while in the CLOSED state, the MS SNDCP entity shall enter IDLE. If SNDCP has not received an MLE-OPEN indication primitive since it entered the CLOSED state, it shall remain in the CLOSED state.

28.2.4.2 IDLE

In IDLE state the MS and SwMI shall not have PDP contexts. When entering to state IDLE, the STANDBY, RESPONSE_WAIT, READY, and CONTEXT_READY timers are stopped. If the MS supports the use of non-conforming PDCHs (see clause 18.3.4.9.1), MLE should be informed that the SNDCP status is "idle" (using the MLE-CONFIGURE request primitive).

Data transfer to and from the mobile subscriber is not possible. The MS is seen as not reachable in this case for TETRA Packet data.

In order to establish SNDCP contexts in the MS and the SwMI, the MS shall perform the PDP context activation procedure. After successful PDP context activation the MS shall start STANDBY timer and enter to state STANDBY.

On reception of an MLE-BREAK indication primitive from the MLE, the MS SNDCP entity shall enter IDLE-Temporary Break state.

28.2.4.3 IDLE-temporary break

IDLE-Temporary Break state is only valid for the MS. This state is only entered while access to the communication resources has become temporarily unavailable (e.g. due to cell reselection). A temporary break in access to the communication resources is signalled to SNDCP by reception of the MLE-BREAK indication primitive from the MLE.

Network selection and initial cell selection and reselection processes are performed by the MS based on V+D procedures. The criteria to select a new cell should also contain weight for advanced link support in the cell.

This state shall be entered from IDLE state on reception of an MLE-BREAK indication primitive. This state shall also be entered from STANDBY-Temporary Break state when the STANDBY timer expires. On entering this state from STANDBY-Temporary Break, all PDP contexts shall be locally deactivated.

In IDLE-Temporary Break state the MS and SwMI shall not have PDP contexts.

Communication between the MS and SwMI SNDCP entities is not possible in this state.

On reception of an MLE-RESUME indication primitive from the MLE, the MS SNDCP entity shall enter IDLE state.

28.2.4.4 STANDBY

In STANDBY state, the subscriber has at least one PDP context activated.

The MS may receive and respond to SN-PAGE REQUEST PDUs while in this state.

The MS may initiate activation of a new PDP context while in STANDBY state.

The MS and SwMI may initiate modification of PDP contexts while in STANDBY state.

The MS may initiate activation of an already-activated PDP context while in STANDBY state as an alternative method of modifying the PDP context; however if the reactivation fails, the PDP context is deactivated and no longer available for use until a successful activation has been performed.

If SNDCP is in the STANDBY state and the MS supports the use of non-conforming PDCHs (see clause 18.4.4.9.1) the MS SNDCP should inform the MLE that the SNDCP status is "standing-by" (using the MLE-CONFIGURE request primitive) in advance of transmitting an SN-DATA TRANSMIT REQUEST PDU requesting channel advice (see clause 28.2.5a). The MS MLE uses this information to start searching for suitable non-conforming PDCHs. The method by which the MS SNDCP gives the MS MLE time to locate a suitable non-conforming PDCH before transmitting a SN-DATA TRANSMIT REQUEST PDU requesting channel advice (see clause 18.3.4.9.11) is outside the scope of the present document.

The MS may initiate deactivation of PDP contexts while in STANDBY state. Before deactivation of the last PDP context assigned by the MS to a particular layer 2 logical link, the MS SNDCP entity shall disconnect that logical link using the method described in clause 28.3.4.3. After deactivation of the last PDP context the STANDBY timer is stopped and SNDCP state is changed to IDLE.

If the MS SNDCP has previously informed the MLE that the SNDCP status is "standing-by" or "ready" and the MS no longer expects to transmit or receive packet data in the foreseeable future, the MS SNDCP should inform the MLE that its SNDCP status is now "idle" (using the MLE-CONFIGURE request primitive). The MS MLE may use this information to stop assessing channel classes and monitoring irregular channels. The information should be sent to the MS MLE when SNDCP returns to the IDLE state, but may be sent sooner.

On reception of a SN-DATA request or SN-UNITDATA request primitive from the service user when the SERVICE_CHANGE timer is inactive, the MS SNDCP entity shall transmit a SN-DATA TRANSMIT REQUEST PDU.

During an alternating voice and data communication, an MS SNDCP that has returned from READY to STANDBY because of READY timer expiry and now wishes to resume transmitting N-PDUs may transmit a SN-DATA TRANSMIT REQUEST PDU if the SERVICE_CHANGE timer is inactive (see clause 28.3.4.2 item e).

On transmission of a SN-DATA TRANSMIT REQUEST PDU, the MS SNDCP entity shall send an MLE-ACTIVITY request primitive with sleep mode set to "stay alive", start the RESPONSE_WAIT timer and enter RESPONSE-WAITING state. The STANDBY timer is not stopped on entering RESPONSE-WAITING state. On reception (MS only) or transmission (SwMI only) of a SN-ACTIVATE PDP CONTEXT ACCEPT PDU or a SN-MODIFY PDP CONTEXT RESPONSE PDU the SNDCP entity shall restart the STANDBY timer.

The STANDBY timer is stopped and the SNDCP state is changed to READY on transmission of (SwMI only) or reception of (MS only) SN-DATA TRANSMIT REQUEST PDU. Upon moving to the READY state the MS SNDCP shall issue an MLE-ACTIVITY request primitive with sleep mode set to "stay alive". If the PDU was individually addressed, the MS and SwMI SNDCPs shall each start the READY timer and the MS SNDCP shall, if supported (see clause 28.2.6.2), start a CONTEXT_READY timer for each PDP context whose NSAPI was given in the SN-DATA TRANSMIT REQUEST PDU. The SwMI SNDCP may also start CONTEXT_READY timers (see clause 28.2.6.2). Where the MS receives a group addressed SN-DATA TRANSMIT REQUEST PDU, on moving to READY state the MS shall not start the READY timer or a CONTEXT_READY timer. (The READY timer and the CONTEXT_READY timer are not activated when a MS enters READY state for reception of point to multipoint packet data) If data priority is supported by both MS and SwMI on the current cell, and the MS SNDCP wishes to make use of data priority (see clause 28.3.5.5), the MS SNDCP should inform MLE of the MS default data priority when it enters READY state using the MLE-CONFIGURE request primitive. If the MS supports the use of non-conforming PDCHs (see clause 18.3.4.9.1), the MS SNDCP should inform MLE that the SNDCP status is "ready" using the MLE-CONFIGURE request primitive, and should inform MLE of the most demanding data class of those NSAPIs in active use using the MLE-CONFIGURE request primitive, so that MLE can use the MS's currently most demanding data class when determining any reliability adjustment to the present assigned channel replacement threshold (see clause 18.3.4.9.9.1).

On transmission of a SN-DATA TRANSMIT RESPONSE PDU with Accept/Reject = 1 (i.e. Request accepted), the SwMI SNDCP entity shall stop the STANDBY timer, start the READY timer and enter READY state.

On transmission of a SN-DATA TRANSMIT RESPONSE PDU with Accept/Reject = 0 (i.e. Request rejected), the SwMI SNDCP entity shall remain in STANDBY state.

On reception of an SN-UNITDATA PDU, the MS SNDCP shall enter the READY state and, if the PDU was individually addressed, shall start the READY timer and, if supported, a CONTEXT_READY timer. (The SwMI SNDCP starts READY timer and, if used, the CONTEXT_READY timer on transmission of the PDU.) If the PDU was group addressed, the MS SNDCP shall not start the READY timer or a CONTEXT_READY timer on entering the READY state. In either case, the MS SNDCP shall issue an MLE-ACTIVITY request primitive with sleep mode set to "stay alive".

During an alternating voice and data communication, an MS that returns from READY to STANDBY because of READY timer expiry during the voice call and now wishes to resume the interrupted PDCH communication but has no data to send may transmit an SN-RECONNECT PDU with "Data to Send" = 0 and remain in the STANDBY state (see clause 28.3.4.2 item e).

If the STANDBY timer expires, the PDP contexts in the SwMI and in the MS are deleted independently and the SNDCP state is changed to IDLE. The SNDCP entity shall issue a SN-NSAPI DEALLOC indication primitive to the service user having "Deactivation type" parameter set to value "Deactivate all NSAPIs". If the MS supports the use of non-conforming PDCHs, the MS SNDCP informs MLE that the SNDCP status is now "idle" (using the MLE-CONFIGURE request primitive).

Where there is a temporary break in access to the radio communication resources as indicated by the reception of an MLE-BREAK indication primitive from the MLE, the MS SNDCP entity shall issue MLE-RELEASE request primitives asking MLE to locally disconnect the advanced links and shall enter STANDBY-Temporary Break state.

If the MS SNDCP entity has an active SERVICE_CHANGE timer and it receives a SN-DATA request or SN-UNITDATA request primitive from the service user, it shall delay the transmission of a SN-DATA TRANSMIT REQUEST PDU and keep the SN-DATA request or SN-UNITDATA request primitive in its buffers. If the SERVICE_CHANGE timer expires, the MS SNDCP entity may continue normal operation and transmit a SN-DATA TRANSMIT REQUEST PDU if necessary.

NOTE: The MS SNDCP entity should handle other service requests normally regardless of active SERVICE_CHANGE timer.

28.2.4.5 STANDBY-temporary break

STANDBY-Temporary Break state is only valid for the MS. This state is only entered while access to the communication resources has become temporarily unavailable (e.g. due to cell reselection). A temporary break in access to the communication resources is signalled to SNDCP by reception of the MLE-BREAK indication primitive from the MLE.

Network selection and initial cell selection and reselection processes are performed by the MS based on V+D procedures. The criteria to select a new cell should also contain weight for advanced link support in the cell.

This state shall be entered from STANDBY state and RESPONSE-WAITING state on reception of an MLE-BREAK indication primitive. This state shall also be entered from READY-Temporary Break state when the READY timer expires.

Communication between the MS and SwMI SNDCP entities is not possible in this state.

On reception of an MLE-RESUME indication primitive from the MLE, the MS SNDCP entity shall enter STANDBY state. In case the MNI values in the MLE-RESUME indication primitive do not match with ones in the MLE-OPEN indication primitive, the MS knows that it has changed the network. Therefore it shall enter the IDLE state and may attempt to reactivate the existing PDP contexts by sending SN-ACTIVATE PDP CONTEXT DEMAND PDUs to the SwMI after state transition, otherwise all contexts shall be deactivated locally. After successful PDP context activation the MS shall start the STANDBY timer and enter to state STANDBY.

If the STANDBY timer expires, the PDP contexts are deleted locally and the SNDCP state is changed to IDLE-Temporary Break. The SNDCP entity shall issue a SN-NSAPI DEALLOC indication primitive to the service user having "Deactivation type" parameter set to value "Deactivate all NSAPIs". If the MS supports the use of non-conforming PDCHs (see clause 18.3.4.9.1), the MS SNDCP should inform MLE that the SNDCP status is now "idle" (using the MLE-CONFIGURE request primitive).

28.2.4.6 RESPONSE-WAITING

RESPONSE-WAITING state is only valid for the MS. In RESPONSE-WAITING state, the MS has at least one PDP context activated.

The MS SNDCP entity shall enter RESPONSE-WAITING state from STANDBY state on transmission of a SN-DATA TRANSMIT REQUEST PDU. On entering RESPONSE-WAITING state the STANDBY timer remains active and the RESPONSE_WAIT timer is started.

The MS SNDCP entity shall also enter RESPONSE-WAITING state from READY-Temporary Break state on reception of an MLE-RESUME indication primitive from the MLE if pending SN-DATA request or SN-UNITDATA request primitives from the service user cause the MS to transmit an SN-RECONNECT PDU containing "Data to Send" = 1. In this case the MS stops the READY timer and starts the RESPONSE_WAIT and STANDBY timers.

The MS shall not initiate the activation or modification of PDP contexts while in RESPONSE-WAITING state. The MS shall not initiate the deactivation of PDP contexts while in RESPONSE-WAITING state. The MS may respond to a SN-PAGE REQUEST while in RESPONSE-WAITING state.

On reception of a SN-DATA request or SN-UNITDATA request primitive from the service user, the MS SNDCP entity shall store the request. If the primitive includes a data priority parameter with higher value than the data priority which the MS indicated to MLE with the SN-DATA TRANSMIT REQUEST PDU for which a response is awaited, the MS SNDCP may transmit a new SN-DATA TRANSMIT REQUEST PDU including the new data priority in the MLE-UNITDATA request primitive. In this case, the RESPONSE_WAIT timer is restarted.

On reception of a SN-DATA TRANSMIT REQUEST PDU, the MS SNDCP shall stop the STANDBY and RESPONSE_WAIT timers, start the READY timer and, if supported, the CONTEXT_READY timers for the indicated PDP contexts, and enter READY state. (The SwMI SNDCP may start CONTEXT_READY timers on transmission of the PDU - see clause 28.2.6.2.) Where the MS receives a group addressed SN-DATA TRANSMIT REQUEST PDU, on moving to READY state the MS shall not start the READY timer or a CONTEXT-READY timer. Neither the READY timer nor a CONTEXT-READY timer is activated when a MS enters READY state for reception of point to multipoint packet data.

On reception of a SN-DATA TRANSMIT RESPONSE PDU with Accept/Reject = 1, the MS SNDCP shall stop the STANDBY and RESPONSE_WAIT timers, start the READY timer and enter READY state. The MS shall also, if supported, start the CONTEXT_READY timers for the PDP contexts whose NSAPIs were given in the SN-DATA TRANSMIT RESPONSE PDU. (The SwMI SNDCP may start CONTEXT_READY timers on transmission of this PDU.)

If data priority is supported by both MS and SwMI on the current cell (see clause 28.3.5.5), the MS SNDCP shall inform MLE of the MS default data priority when it enters READY state if it wishes to use data priority, using the MLE-CONFIGURE request primitive.

If the MS supports the use of non-conforming PDCHs (see clause 18.3.4.9.1), the MS SNDCP should inform the MLE that the SNDCP status is "ready" (using the MLE-CONFIGURE request primitive) when it enters the READY state, and should inform MLE of the most demanding data class of the NSAPIs given in the SN-DATA TRANSMIT RESPONSE PDU using the MLE-CONFIGURE request primitive, so that MLE can use the MS's currently most demanding data class when determining any reliability adjustment to the present assigned channel replacement threshold (see clause 18.3.4.9.1).

On reception of a SN-DATA TRANSMIT RESPONSE PDU with Accept/Reject = 0, the MS SNDCP shall:

- send an MLE-ACTIVITY request primitive with sleep mode set to "sleep permitted";
- stop the RESPONSE_WAIT timer;
- if the MS SNDCP was awaiting a response to an SN-RECONNECT PDU: issue MLE-RELEASE request primitives instructing MLE to locally disconnect the advanced links;
- enter STANDBY state.

Where the RESPONSE_WAIT timer expires, the MS SNDCP shall:

- send an MLE-ACTIVITY request primitive with sleep mode set to "sleep permitted";
- if the MS SNDCP was awaiting a response to an SN-RECONNECT PDU: issue MLE-RELEASE request primitives instructing MLE to locally disconnect the advanced links;
- enter STANDBY state.

Where the STANDBY timer expires, the RESPONSE_WAIT timer is stopped, all PDP contexts are deleted locally and the SNDSCP state is changed to IDLE. The SNDSCP entity shall send an MLE-ACTIVITY request primitive with sleep mode set to "sleep permitted", issue a SN-NSAPI DEALLOC indication primitive to the service user having "Deactivation type" parameter set to value "Deactivate all NSAPIs". If the MS supports the use of non-conforming PDCHs, the MS SNDSCP should inform MLE that the SNDSCP status is now "idle" (using the MLE-CONFIGURE request primitive).

Where there is a temporary break in access to the radio communication resources as indicated by the reception of an MLE-BREAK indication primitive from the MLE, the MS SNDSCP entity shall send an MLE-ACTIVITY request primitive with sleep mode set to "sleep permitted", stop the RESPONSE_WAIT timer and enter STANDBY-Temporary Break state.

Prior to entering states STANDBY, STANDBY-Temporary Break, CLOSED or IDLE from state RESPONSE-WAITING, the MS SNDSCP entity shall ensure that all stored SN-DATA request and SN-UNITDATA request primitives are deleted. For each SN-DATA request or SN-UNITDATA request primitive deleted, a corresponding notification of failure shall be sent to the service user in the form of a SN-DELIVERY indication primitive.

28.2.4.7 READY

In READY state, the subscriber has at least one PDP context activated.

The MS may receive and transmit N-PDUs while in this state.

The MS SNDSCP shall enter READY state on reception of a SN-DATA TRANSMIT REQUEST PDU or of a SN-DATA TRANSMIT RESPONSE PDU (with Accept/Reject = 1) and the MS SNDSCP shall send an MLE-ACTIVITY request primitive with sleep mode set to "stay alive". On entering the READY state, the MS SNDSCP shall stop the RESPONSE_WAIT and STANDBY timers. If the SN-DATA TRANSMIT REQUEST PDU was individually addressed (but not if it was group addressed), the MS SNDSCP shall start the READY timer and, if supported (see clause 28.2.6.2), CONTEXT_READY timers for the relevant PDP contexts (i.e. the PDP contexts whose NSAPIs were included in the SN-DATA TRANSMIT REQUEST PDU or SN-DATA TRANSMIT RESPONSE PDU).

The SwMI SNDSCP shall enter READY state on transmission of a SN-DATA TRANSMIT RESPONSE PDU (with Accept/Reject = 1) or of a SN-DATA TRANSMIT REQUEST PDU. On entering READY state, the RESPONSE_WAIT and STANDBY timers are stopped and the READY timer. The SwMI SNDSCP may start the appropriate CONTEXT_READY timers on transmission of the PDU (see clause 28.2.6.2).

In the case where the MS enters READY state after reception of a group addressed SN-DATA TRANSMIT REQUEST PDU, the MS shall not start the READY timer or a CONTEXT_READY timer. Neither the READY timer nor a CONTEXT_READY timer is activated when a MS enters READY state for reception of point to multipoint packet data.

If data priority is supported by both MS and SwMI on the current cell (see clause 28.3.5.5), the MS SNDSCP should inform layer 2 of the MS default data priority when it enters READY state if it wishes to use data priority, using the MLE-CONFIGURE request primitive. If the MS supports the use of non-conforming PDCHs (see clause 18.3.4.9.1) the MS SNDSCP should inform MLE that the SNDSCP status is "ready" using the MLE-CONFIGURE request primitive.

The READY timer is re-started when a SN-DATA PDU (point-to-point) is successfully transmitted as indicated by the reception of a MLE-REPORT indication primitive and accordingly, the READY timer is re-started when an N-PDU is received. The READY timer is also re-started when a SN-UNITDATA (point-to-point) is sent to the MLE for transmission in an MLE-UNITDATA request primitive. In the case of reception of point to multipoint N-PDUs, the READY timer and CONTEXT-READY timer are not (re)started in the MS.

In addition the SwMI should have some other mechanisms to optimize the usage of the PDCH. Because the transfer delay on the LLC can vary substantially as a function of message length, radio link quality, and other traffic on the PDCH, and because only full N-PDUs are delivered to the SNDSCP, the READY timer does not provide tight control of the stay on the PDCH.

The SwMI may therefore further refine the state transition handling by using the MLE-RECEIVE indication primitive and/or other methods to ensure a timely exit from the READY state (by sending an SN-END OF DATA PDU to the MS). The SwMI may use this indication to optimize the length of the stay on the PDCH and should use this indication to prevent sending SN-END OF DATA PDU while data reception is in progress on the LLC. The optimal procedures for this will depend on SwMI design as well as application behaviour, and is therefore outside the scope of the present document.

If the MS possesses more than one activated PDP context and supports the use of CONTEXT_READY timers, the MS SNDPCP shall maintain a separate CONTEXT_READY timer for each activated PDP context. Whenever a SN-DATA PDU or SN-UNITDATA PDU is successfully transmitted (as indicated by the reception of a MLE-REPORT indication primitive), whenever a SN-DATA PDU is received and whenever an individually addressed SN-UNITDATA PDU is received, the CONTEXT_READY timer for the PDP context addressed by the NSAPI in the PDU shall, if supported, be restarted.

If the MS SNDPCP in the READY state receives SN-DATA request primitives or SN-UNITDATA request primitives referencing PDP contexts with inactive or expired CONTEXT_READY timers, the MS SNDPCP entity shall, if supported, transmit a SN-DATA TRANSMIT REQUEST PDU containing the NSAPIs of the relevant PDP contexts. This warns the SwMI to expect an increase in data throughput, and gives the SwMI an opportunity to reassign the MS to a more suitable PDCH. The MS SNDPCP should use the MLE-CONFIGURE request primitive to inform MLE of the most demanding data class of those PDP contexts with active CONTEXT_READY timers and the PDP context indicated in the SN-DATA TRANSMIT REQUEST PDU.

NOTE 1: The real-time data class is more demanding than the telemetry data class, and the telemetry data class is more demanding than the background data class.

After transmitting an SN-DATA TRANSMIT REQUEST PDU in the READY state, the MS SNDPCP shall send an MLE-ACTIVITY request primitive with sleep mode set to "stay alive", shall start (or restart) the RESPONSE_WAIT timer and remain in the READY state. It shall not transmit any SN-DATA or SN-UNITDATA PDUs referencing an NSAPI included in the SN-DATA TRANSMIT REQUEST PDU until it receives an SN-DATA TRANSMIT RESPONSE PDU referencing that NSAPI with Accept/Reject = 1.

On receiving an SN-DATA TRANSMIT RESPONSE PDU with Accept/Reject = 1 referencing waiting NSAPIs, the MS SNDPCP shall stop the RESPONSE_WAIT timer, shall set up new advanced links if required, and shall commence transmitting SN-DATA PDUs or SN-UNITDATA PDUs for those NSAPIs. (The MS SNDPCP should support the ability to maintain multiple RESPONSE_WAIT timers in the READY state if it supports sending parallel SN-DATA TRANSMIT REQUEST PDUs for different PDP contexts.)

On reception of an SN-DATA TRANSMIT RESPONSE PDU with Accept/Reject = 0, or if the RESPONSE_WAIT timer expires, the MS SNDPCP shall stop the RESPONSE_WAIT timer and remain in the READY state. The MS SNDPCP entity shall ensure that all stored SN-DATA request and SN-UNITDATA request primitives relating to the relevant PDP context are deleted. For each SN-DATA request and SN-UNITDATA request primitive deleted, a corresponding notification of failure shall be sent to the service user in the form of a SN-DELIVERY indication primitive.

The MS shall not deactivate PDP contexts while in READY state. To initiate the deactivation of one or more PDP contexts, a MS returns to STANDBY state. On reception of the SN-NSAPI-DEALLOC request primitive from the SNDPCP service user requesting deactivation of all NSAPIs with active CONTEXT-READY timers, the MS SNDPCP entity may attempt to return to STANDBY state prior to the expiry of the READY timer by sending a SN-END OF DATA PDU to the SwMI. The SwMI shall respond to the SN-END OF DATA PDU with a SN-END OF DATA PDU (unless the MS included an "immediate service change" indication, in which case the MS shall return to the STANDBY state immediately after sending the SN-END OF DATA PDU). See clause 28.3.4.

NOTE 2: If the MS does not get any response to the SN-END OF DATA PDU from the SwMI after a number of retransmissions and restarts of READY timer, it may return independently to the STANDBY state even before inactivity time-out on assigned SCCH. The number of used retransmissions is an implementation dependent issue and is out of the scope of the present document.

NOTE 3: The MS may also return independently to the STANDBY state without any SN-END OF DATA PDU response if the packet data service is overridden by some other service and the channel change to other channel is needed to do immediately (e.g. in case of emergency service). However, the MS should then send a SN-END OF DATA PDU to the SwMI before the state transition and use the "immediate service change" information element to indicate that an immediate service change has occurred and therefore the MS has left the PDCH. An SN-END OF DATA PDU indicating "immediate service change" may be sent on the PDCH, some other allocated channel or a common control channel.

The MS may initiate activation of a new PDP context while in READY state. The MS may also initiate modification of PDP contexts while in this state. Should either happen, the MS shall remain in the state READY.

The MS may initiate activation of an already-activated PDP context while in READY state as an alternative method of modifying the PDP context; however if the reactivation fails, the PDP context is deactivated and no longer available for use until a successful activation has been performed.

Except during cell change or following loss of radio resources, the MS SNDCP remains in the READY state while the READY timer is active even when there is no data being communicated.

When a CONTEXT_READY timer expires, the MS SNDCP should inform MLE of the most demanding data class of any remaining PDP contexts with active CONTEXT_READY timers, using the data class information parameter of MLE-CONFIGURE request primitive.

If the READY timer expires in the MS when the MS SNDCP is in the READY state, the MS shall send SN-END OF DATA PDU to the SwMI and shall restart the READY timer.

When the READY timer expires in the SwMI, the SwMI shall send an SN-END OF DATA PDU to the MS. The SwMI shall also send an SN-END OF DATA PDU in response to reception of an SN-END OF DATA PDU from the MS that does not indicate "immediate service change". The SwMI should not send an SN-END OF DATA PDU in response to reception of an SN-END OF DATA PDU that indicates "immediate service change".

The MS SNDCP shall stop the READY timer, stop all active CONTEXT_READY timers, send an MLE-ACTIVITY request primitive with sleep mode set to "sleep permitted", start the STANDBY timer and enter to state STANDBY on receiving an SN-END OF DATA PDU, unless the SN-END OF DATA PDU is group addressed and the READY timer is active. The SwMI SNDCP shall enter to state STANDBY when sending an individually addressed SN-END OF DATA PDU.

In the case where an MS with an active READY timer receives a group addressed SN-END OF DATA PDU, the MS shall remain in the READY state with the READY timer still active; if, in this same case, the SN-END OF DATA PDU is accompanied by a "channel change response required" parameter set to "true", the MS shall issue an MLE-CONFIGURE request primitive containing a "channel change accepted" parameter set to "ignore".

If the MS supports data priority, the MS SNDCP shall inform MLE that the MS default data priority is "not applicable" when it exits the READY state, using the MLE-CONFIGURE request primitive. The MS should inform MLE that the SNDCP status is "standing by" when it exits the READY state if the MS supports the use of non-conforming PDCHs.

NOTE 4: An active READY timer normally implies that the MS is on the PDCH and involved in point to point packet data exchanges. Hence the MS in such a case may not wish to leave the READY state.

An MS SNDCP that is in the READY state with an inactive READY timer (i.e. waiting to receive group addressed SN-UNITDATA PDUs) should have a means of returning to the STANDBY state after at least 120 s have elapsed without reception of an SN-UNITDATA PDU or an SN-END OF DATA PDU.

When a SwMI is required by this specification to respond to a SN-END OF DATA PDU received from a MS by sending another SN-END OF DATA PDU to the MS, the SwMI may delay sending the SN-END OF DATA PDU until any outstanding data being prepared for transmission on the downlink, has been transmitted if the MS has not indicated immediate service change in the SN-END OF DATA PDU.

NOTE 5: This delay is required due to the MS SNDCP entity having no knowledge of the status of the LLC entity i.e. if it is currently receiving advanced link segments from the SwMI. Hence the MS SNDCP entity may be unaware that the lower layers are currently receiving packet data.

If the MS indicates "immediate service change" in an SN-END OF DATA PDU (see clause 28.3.4), the SwMI shall cancel the downlink data transmission immediately and enter to state STANDBY.

NOTE 6: If "immediate service change" is indicated by the MS, it does not have to wait for an SN-END OF DATA PDU response from the SwMI before entering to state STANDBY. However, the layer 2 acknowledgement to the SN-END OF DATA PDU sending should be expected before any state transition.

If the SwMI indicates "immediate service change" in an SN-END OF DATA PDU, the MS SNDCP entity should stop the READY timer and any CONTEXT_READY timers, start the STANDBY timer and SERVICE_CHANGE timer and enter to state STANDBY and, if data priority is supported by the MS, the MS SNDCP shall inform MLE that the MS default data priority is "not applicable" using the MLE-CONFIGURE request primitive. If the MS supports the use of non-conforming PDCHs, the MS SNDCP should inform the MLE that the SNDCP status is "standing-by" (using the MLE-CONFIGURE request primitive) when it exits the READY state.

NOTE 7: The SwMI should indicate "immediate service change" only if it is going to send a request to another service to the MS which is capable to handle only one active service at the time. When new service is accepted in this case, the exact SNDCP functioning is outside the scope of the present document.

Where there is a temporary break in access to the radio communication resources as indicated by the reception of an MLE-BREAK indication primitive from the MLE, the MS SNDCP entity shall enter READY-temporary break state and, if data priority is supported by the MS, the MS SNDCP shall inform MLE that the MS default data priority is "not applicable" using the MLE-CONFIGURE request primitive. If the MS supports the use of non-conforming PDCHs, the MS SNDCP shall inform the MLE that the SNDCP status is "standing-by" (using the MLE-CONFIGURE request primitive).

Where there is a failure of the PDCH as indicated by reception of an MLE-CONFIGURE indication primitive from the MS MLE indicating "loss of radio resources", the MS SNDCP shall respond as described in clause 28.3.4.7.

The SwMI SNDCP entity shall stop the READY timer and any CONTEXT_READY timers, start the STANDBY timer and enter STANDBY state on reception of the SN-RECONNECT PDU.

Upon moving to the STANDBY state the MS SNDCP shall send an MLE-ACTIVITY request primitive with sleep mode set to "sleep permitted".

28.2.4.8 READY-temporary break

READY-Temporary Break state is only valid for the MS. This state shall be entered only from the READY state and only when access to the communication resources has become temporarily unavailable (e.g. due to cell reselection or loss of radio resource). A temporary break in access to the communication resources is signalled to SNDCP by reception of the MLE-BREAK indication primitive or MLE-CONFIGURE indication primitive indicating "loss of radio resources" from the MLE.

Communication between the MS and SwMI SNDCP entities may not be possible in this state.

While in the READY-temporary break state, the MS SNDCP shall not attempt to transmit SN-DATA or SN-UNITDATA PDUs.

NOTE 1: When the MS SNDCP is in the READY-temporary break state, the MS should suspend transmission of N-PDUs, including any partially sent or unacknowledged N-PDUs in the LLC buffers, until the MS SNDCP returns to the READY state.

On reception of an MLE-RESUME indication primitive from the MLE, the MS SNDCP entity shall first check if it has a pending SN-DATA request or SN-UNITDATA request primitive. If there is data awaiting transmission, or if the MS wishes to be on a PDCH because it expects imminent reception of data on the downlink or imminent arrival of data for transmission on the uplink, then the MS SNDCP entity shall send to the SwMI a SN-RECONNECT PDU with the field "Data to Send" set to 1 for each NSAPI with data to send or for which downlink or uplink data is imminently expected. The PDU should include the NSAPIs of all PDP contexts for which the MS has active CONTEXT_READY timers. Where the MS supports advanced link roaming (see clause 28.3.4.4) and where the SNDCP entity is aware that a partially transmitted TL-SDU is in the LLC buffers (i.e. one which has not yet been fully transmitted or one for which an acknowledgement has not yet been received from the peer entity), then the MS shall also set the field "Data to Send" to 1. It shall then stop the READY timer and any CONTEXT_READY timers, shall start the STANDBY and RESPONSE_WAIT timers and enter RESPONSE-WAITING state.

If there is no data awaiting transmission, then MS SNDCP entity shall send to the SwMI a SN-RECONNECT PDU with the field "Data to Send" set to 0. It shall then stop the READY timer, start the STANDBY timer and enter STANDBY state.

If the MNI values in the MLE-RESUME indication primitive do not match with the ones in the MLE-OPEN indication primitive, the MS knows that it has changed the network and it shall enter the IDLE state. If the MS supports the use of non-conforming PDCHs, the MS SNDCP should inform MLE that the SNDCP status is "idle" using the ML-CONFIGURE request primitive. The MS shall stop the READY timer and any CONTEXT_READY timers and may attempt to reactivate the existing PDP contexts by sending SN-ACTIVATE PDP CONTEXT DEMAND PDUs to the SwMI after state transition, otherwise it shall deactivate all contexts locally. After successful PDP context activation the MS shall start the STANDBY timer and enter STANDBY state.

On reception of a SN-DATA TRANSMIT RESPONSE PDU with Accept/Reject = 1, the MS SNDCP shall stop the RESPONSE_WAIT timer, start the READY timer and, if supported, the CONTEXT_READY timers for the indicated PDP contexts and shall enter the READY state. If data priority is supported by both MS and SwMI on the current cell (see clause 28.3.5.5), the MS SNDCP should inform MLE of the MS default data priority when it enters the READY state if it wishes to use data priority, using the MLE-CONFIGURE request primitive.

On reception of an SN-DATA TRANSMIT RESPONSE PDU with Accept/Reject = 0, the MS SNDCP shall send an MLE-ACTIVITY request primitive with sleep mode set to "sleep permitted", stop the RESPONSE_WAIT timer, the READY timer and any CONTEXT_READY timers, start the STANDBY timer and shall enter the STANDBY state.

On reception of an SN-DATA TRANSMIT REQUEST PDU, the MS SNDCP shall stop the RESPONSE_WAIT timer, start the READY timer and, if supported, the CONTEXT-READY timers for the indicated PDP contexts, and shall enter the READY state. Where the MS receives a group addressed SN-DATA TRANSMIT REQUEST PDU, on moving to READY state the MS shall not start the READY timer or a CONTEXT-READY timer. Neither the READY timer nor a CONTEXT-READY timer is activated when a MS enters READY state for reception of point to multipoint packet data.

Where the RESPONSE_WAIT timer expires, the MS SNDCP shall send an MLE-ACTIVITY request primitive with sleep mode set to "sleep permitted", start the STANDBY timer, shall stop the READY timer and any CONTEXT_READY timers and shall enter the STANDBY state.

On reception of an MLE-BREAK indication primitive, the MS SNDCP shall stop the RESPONSE_WAIT timer.

When the READY timer expires, the MS SNDCP entity shall enter STANDBY-Temporary Break state and shall start the STANDBY timer.

NOTE 2: The READY timer does not expire while the RESPONSE_WAIT timer is active.

Upon moving to the STANDBY, STANDBY-temporary break or IDLE states the MS SNDCP shall send an MLE-ACTIVITY request primitive with sleep mode set to "sleep permitted".

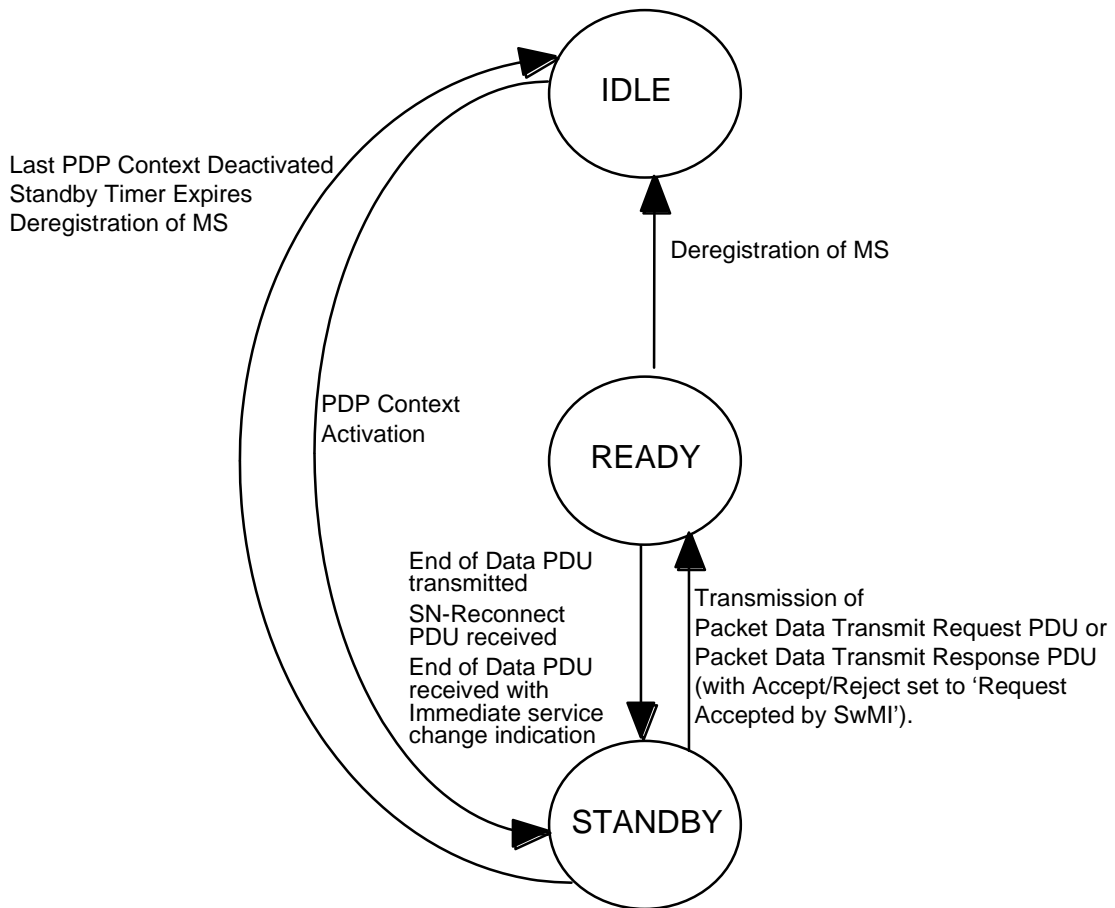

Figure 28.6: Functional SNDCP State Transition Model for SwMI

Tables 28.12 and 28.13 provide a summary of the triggers which shall result in a state transition, the principle actions which are performed and the new state which is entered.

Table 28.12: MS State Transition Table

Current State	Event	Principle Actions	New State
Any State	MLE-CLOSE indication primitive or MLE-DISABLE indication primitive received	Stop STANDBY, READY, CONTEXT_READY and RESPONSE_WAIT timers. Fail all pending SN-DATA and SN-UNITDATA request primitives Delete all PDP contexts If sleep is permitted send MLE-ACTIVITY request primitive "sleep permitted". If MLE-DISABLE received, SMDCP records that it is temporarily disabled.	CLOSED
CLOSED	MLE-OPEN indication primitive received when SMDCP is not temporarily disabled.		IDLE
IDLE	MLE-BREAK indication primitive received		IDLE Temp Break
	First PDP Context Activation	Start STANDBY timer	STANDBY
IDLE-Temp Break	MLE-RESUME indication primitive received		IDLE
STANDBY	Last PDP Context Deactivated	Stop STANDBY timer	IDLE
	STANDBY timer expires	Delete all PDP contexts	IDLE
	Receive SN-DATA TRANSMIT REQUEST PDU	Stop STANDBY timer Start READY and CONTEXT_READY timers Send MLE-ACTIVITY request primitive "stay alive"	READY
	Receive SN-DATA or SN-UNITDATA request primitive and SERVICE_CHANGE timer is inactive.	Transmit SN-DATA TRANSMIT REQUEST PDU Start RESPONSE_WAIT timer Send MLE-ACTIVITY request primitive "stay alive"	RESPONSE-WAITING
	SERVICE_CHANGE timer expires, and an SN-DATA request primitive or an SN-UNITDATA request primitive is buffered.	Transmit SN-DATA TRANSMIT REQUEST PDU Start RESPONSE_WAIT timer Send MLE-ACTIVITY request primitive "stay alive"	RESPONSE-WAITING
	MLE-BREAK indication primitive received		STANDBY Temp Break
STANDBY-temp break	MLE-RESUME indication primitive received		STANDBY
	MLE-RESUME indication primitive received and according to MNI values the MS has changed the network	Stop STANDBY timer Delete all PDP contexts	IDLE
	STANDBY timer expires	Delete all PDP contexts	IDLE Temp Break

Current State	Event	Principle Actions	New State
RESPONSE-WAITING	Receive SN-DATA TRANSMIT RESPONSE PDU (Accept/Reject = 1)	Stop STANDBY timer Stop RESPONSE_WAIT timer Start READY and CONTEXT_READY timers	READY
	Receive SN-DATA TRANSMIT RESPONSE PDU (Accept/Reject = 0)	Stop RESPONSE_WAIT timer Send MLE-ACTIVITY request primitive "sleep permitted" Fail all pending SN-DATA and SN-UNITDATA request primitives	STANDBY
	Receive SN-DATA TRANSMIT REQUEST PDU	Stop STANDBY timer Stop RESPONSE_WAIT timer Start READY and CONTEXT_READY timers	READY
	RESPONSE_WAIT timer expires	Fail all pending SN-DATA and SN-UNITDATA request primitives Send MLE-ACTIVITY request primitive "sleep permitted"	STANDBY
	STANDBY timer expires	Stop RESPONSE_WAIT timer Send MLE-ACTIVITY request primitive "sleep permitted" Fail all pending SN-DATA and SN-UNITDATA request primitives Delete all PDP contexts	IDLE
	MLE-BREAK indication primitive received	Stop RESPONSE_WAIT timer Fail all pending SN-DATA or SN-UNITDATA request primitives Send MLE-ACTIVITY request primitive "sleep permitted"	STANDBY temp break
READY	Receive SN-END OF DATA PDU	Stop READY timer Start STANDBY timer Send MLE-ACTIVITY request primitive "sleep permitted"	STANDBY
	Number of SN-END OF DATA PDU retransmissions exceeded	Stop READY timer Start STANDBY timer Send MLE-ACTIVITY request primitive "sleep permitted"	STANDBY
	Immediate service change indicated	Stop READY timer Stop CONTEXT_READY timers Send MLE-ACTIVITY request primitive "sleep permitted" Start STANDBY timer	STANDBY
	MLE-BREAK indication primitive received		READY temp break
	MLE-CONFIGURE indication primitive received (loss of radio resources) and there is data to send	Transmit SN-RECONNECT PDU (Data to Send = 1) Start RESPONSE_WAIT timer	READY Temp Break
	MLE-CONFIGURE indication primitive received (loss of radio resources) and there is no data to send	Transmit SN-RECONNECT PDU (Data to Send = 0) Send MLE-ACTIVITY request primitive "sleep permitted" Stop READY timer Start STANDBY timer	STANDBY

Current State	Event	Principle Actions	New State
READY-temp break	MLE-RESUME indication primitive received and there is data to send.	Transmit SN-RECONNECT PDU (Data to Send = 1) Stop READY timer Stop CONTEXT_READY timers Start STANDBY timer Start RESPONSE_WAIT timer	RESPONSE-WAITING
	MLE-RESUME indication primitive received and there is no data to send.	Transmit SN-RECONNECT PDU (Data to Send = 0) Send MLE-ACTIVITY req "sleep permitted" Stop READY timer Stop CONTEXT_READY timers Start STANDBY timer	STANDBY
	MLE-RESUME indication primitive received and according to MNI values the MS has changed the network. PDP context activation after migration.	Stop READY timer Stop CONTEXT_READY timers Delete all PDP contexts Send MLE-ACTIVITY request primitive "sleep permitted"	IDLE
	Receive SN-DATA TRANSMIT RESPONSE PDU (Accept/Reject = 1)	Stop RESPONSE_WAIT timer Start READY and CONTEXT_READY timers	READY
	Receive SN-DATA TRANSMIT RESPONSE PDU (Accept/Reject = 0)	Stop RESPONSE_WAIT timer Stop READY timer Send MLE-ACTIVITY request primitive "sleep permitted" Fail all pending SN-DATA req	STANDBY
	Receive SN-DATA TRANSMIT REQUEST PDU	Stop RESPONSE_WAIT timer Start READY timer	READY
	RESPONSE_WAIT timer expires	Fail all pending SN-DATA request primitives Send MLE-ACTIVITY request primitive "sleep permitted " Stop READY timer Start STANDBY timer	STANDBY
	READY timer expires	Send MLE-ACTIVITY request primitive "sleep permitted" Start STANDBY timer	STANDBY Temp Break

Table 28.13: SwMI State Transition table

Current State	Event	Principle Actions	New State
IDLE	First PDP Context Activation	Start STANDBY timer	STANDBY
STANDBY	Last PDP Context Deactivated	Stop STANDBY timer	IDLE
	STANDBY timer expires	Delete all PDP contexts	IDLE
	Deregistration of MS	Delete all PDP contexts	IDLE
	Receive SN-DATA or SN-UNITDATA request primitive	Transmit SN-DATA TRANSMIT REQUEST PDU Stop STANDBY timer Start READY and CONTEXT_READY timers	READY
READY	Receive SN-DATA TRANSMIT REQUEST PDU	Transmit SN-DATA TRANSMIT RESPONSE PDU (Accept/Reject = 1) Stop STANDBY timer Start READY and CONTEXT_READY timers	READY
	READY timer expires	Transmit SN-END OF DATA PDU Stop READY timer Start STANDBY timer and CONTEXT_READY timers	STANDBY
	SN-END OF DATA PDU received without indication of immediate service change, and SwMI not transmitting TL-SDU to MS.	Transmit SN-END OF DATA PDU Stop READY timer and CONTEXT_READY timers Start STANDBY timer	STANDBY
	Deregistration of MS	Stop READY timer and CONTEXT_READY timers Delete all PDP contexts	IDLE
	SN-END OF DATA PDU received with an indication of immediate service change	Stop READY timer and CONTEXT_READY timers Start STANDBY timer	STANDBY
	SN-RECONNECT PDU received	Stop READY timer Start STANDBY timer	STANDBY

28.2.5a MLE-UNITDATA request primitive

If the MS supports the use of non-conforming PDCHs and the MS SNDCP is transmitting an SN-DATA TRANSMIT REQUEST, an SN-PAGE-RESPONSE or an SN-RECONNECT PDU, the MS SNDCP should set the channel advice flag in the MLE-UNITDATA request primitive containing the PDU to "channel advice requested". For all other PDUs, the MS SNDCP shall set the channel advice flag in the MLE-UNITDATA request primitive to "channel advice not requested".

28.2.5b Other MLE primitives

This clause describes other MLE primitives at the LTPD-SAP which are more or less separate from normal SNDCP state transition model.

On reception of an MLE-INFO indication primitive, which indicates that the subscriber class being broadcasted by the SwMI and the subscriber class of the MS do not match in the current cell, the MS SNDCP shall stop the communication with the peer entity totally. However, the SwMI should not offer packet data service to the MS, which subscriber class parameter does not match. This information is relevant also in other SNDCP states where the MS is seen as reachable in this case for TETRA Packet data.

On reception of an MLE-INFO indication primitive which indicates that a subscriber class mismatch exists (see clause 16.4.9) or that the present cell is a not-permitted cell (see clause 18.3.5.1.5) the MS SNDCP shall cease communication with the peer entity.

On reception of an MLE-BUSY indication primitive, the MS SNDCP entity knows that an MM protocol exchange is in progress. Then the MS SNDCP shall stop the communication with the peer entity and cannot continue it until it receives an MLE-IDLE indication primitive.

On reception of an MLE-IDLE indication primitive, the MS SNDCP entity knows that an MM protocol exchange has completed and it may continue its normal function.

On reception of an MLE-CLOSED indication primitive, the MS SNDCP shall enter the CLOSED state.

On reception of an MLE-DISABLE indication primitive, the MS SNDCP shall record that the MS is now temporarily disabled and shall enter the CLOSED state. SNDCP shall remain temporarily disabled through power cycles and through cycles of loss and gain of radio resources until it receives an MLE-ENABLE indication primitive from MLE.

28.2.6 STANDBY, READY, CONTEXT_READY and RESPONSE_WAIT timer functions

28.2.6.1 STANDBY timer function

The purpose of the STANDBY Timer is to work as a fallback timer to delete the PDP contexts when they remain unintentionally undeleted.

The STANDBY timer function maintains the STANDBY timer in the MS and SwMI. When the STANDBY timer expires, the MS and SwMI return to IDLE state (or for the MS only, where the previous state was STANDBY-Temporary Break, then the MS shall enter IDLE-Temporary Break), and the PDP contexts are deleted locally.

The duration of the STANDBY timer is the same in the MS and SwMI. Normally, the length of the STANDBY timer is defined by a default value. The SwMI, and only the SwMI, may change this value dynamically by transmitting a new value in the header part of a PDP context activation PDU (accept).

In the present document, the STANDBY timer shall not be set to 0. If the STANDBY timer is set to all 1s (binary), then the STANDBY timer function is deactivated (i.e. the timer no longer runs and the MS and SwMI remain in STANDBY state).

The STANDBY timer is reset and begins running in the MS in the following circumstances:

- on entering STANDBY state from IDLE state;
- on entering STANDBY state from RESPONSE-WAITING state after reception of a SN-DATA TRANSMIT RESPONSE PDU with Accept/Reject = 0;
- on entering STANDBY state from READY state after reception of a SN-END OF DATA PDU;
- on entering STANDBY state from READY-Temporary Break state after transmission of a SN-RECONNECT PDU with "Data to Send" = 0;
- on entering RESPONSE-WAITING state from READY-Temporary Break state after transmission of a SN-RECONNECT PDU with "Data to Send" = 1;
- on entering STANDBY-Temporary break state from READY-Temporary Break state.

The STANDBY timer is stopped in the MS in the following circumstances:

- on entering CLOSED state;
- on entering IDLE state from STANDBY state;
- on entering READY state from STANDBY state after reception of a SN-DATA TRANSMIT REQUEST PDU;
- on entering READY state from RESPONSE-WAITING state after reception of a SN-DATA TRANSMIT REQUEST PDU;
- on entering READY state from RESPONSE-WAITING state after reception of a SN-DATA TRANSMIT RESPONSE PDU with Accept/Reject = 1.

The STANDBY timer is reset and begins running in the SwMI in the following circumstances:

- on entering STANDBY state from IDLE state;
- after transmission of a SN-DATA TRANSMIT RESPONSE PDU with Accept/Reject = 0;
- on entering STANDBY state from READY state after transmission of a SN-END OF DATA PDU;
- on entering STANDBY state from READY state after reception of a SN-RECONNECT PDU.

The STANDBY timer is stopped in the SwMI in the following circumstances:

- on entering IDLE state from STANDBY state;
- on entering READY state from STANDBY state after transmission of a SN-DATA TRANSMIT REQUEST PDU;
- on entering READY state from STANDBY state after transmission of a SN-DATA TRANSMIT RESPONSE PDU with Accept/Reject = 1.

28.2.6.2 READY timer and CONTEXT_READY timer functions

The READY timer function maintains the READY timer in the MS and SwMI. The READY timer may be defined for each MS separately. The READY timer controls, with the help of other potential timers, the time an MS and SwMI remains in READY state after either a SN-DATA, SN-UNITDATA, SN-DATA TRANSMIT REQUEST PDU (SwMI to MS) or SN-DATA TRANSMIT RESPONSE PDU (SwMI to MS) has been transmitted between the MS and SwMI. When the READY timer expires in the MS, the MS shall send SN-END OF DATA PDU to the SwMI and restart READY timer. The MS shall stop the READY timer, start the STANDBY timer and enter to the STANDBY state on receiving SN-END OF DATA PDU. When the READY timer expires in the SwMI, the SwMI shall send a SN-END OF DATA PDU to the MS and enter to the STANDBY state. The SwMI may also send a SN-END OF DATA PDU to the MS for its own reasons.

NOTE 1: It is recommended that Packet Data CHannel (PDCH) releasing is done by the SwMI and the MS PDCH release is used as a fallback method. This means that the SwMI should set its own READY timer to a shorter value than the one sent to the MS in the SN-ACTIVATE PDP CONTEXT ACCEPT PDU.

In the present document, the READY timer shall not be set to 0.

The READY timer is reset and begins running in the MS and SwMI in the following cases:

- every time an SN-DATA PDU has been transmitted successfully (as indicated by reception of a MLE-REPORT indication primitive from the MLE) or received by the MS or SwMI;
- every time an SN-UNITDATA PDU is sent to the MLE in an MLE-UNITDATA request primitive;
- when a SN-DATA TRANSMIT RESPONSE PDU with Accept/Reject = 1 is transmitted (SwMI only) or received (MS only);
- when a SN-DATA TRANSMIT REQUEST PDU is transmitted (SwMI only) or received (MS only);
- when an MLE-CONNECT confirm or an MLE-CONNECT indication primitive is received from the MLE; and
- when an MLE-RECONNECT confirm or an MLE-RECONNECT indication primitive is received from the MLE.

NOTE 2: In the case where a MS receives a group addressed SN-DATA TRANSMIT REQUEST the MS SNDCP entity does not start the READY timer when entering READY state. The READY timer is not activated when a MS enters READY state for reception of point to multipoint packet data.

NOTE 3: In the case of the SN-DATA TRANSMIT RESPONSE and SN-DATA TRANSMIT REQUEST PDUs, transmitted here means that it has been transmitted over the air interface. Acknowledgement from the peer entity is not required nor awaited.

The READY timer should not expire while the MS is actively transmitting an N-PDU at layer 2. The READY timer shall not expire while the RESPONSE_WAIT timer or any CONTEXT_READY timer is active.

NOTE 4: If the READY time runs out while the MS is actively transmitting an N-PDU at layer 2 or while any CONTEXT_READY timer is active, the READY timer should not announce the timer expiry event to SNDCP until the MS has finished transmitting an N-PDU at layer 2 and the RESPONSE_WAIT timer and the last CONTEXT_READY timer has expired. The READY timer should not announce the expiry event at all if the READY timer is reset before it has announced the expiry event.

The CONTEXT_READY timer function allows the MS SNDCP to advise the SwMI when the MS is in the READY state, but wishes to start transmitting N-PDUs for a quiescent PDP context. (A quiescent PDP context is one which has not transmitted or received N-PDUs since it was activated, or for a period of time greater than the duration of its CONTEXT_READY timer). This gives the SwMI an opportunity to adjust the radio resources available to the MS to suit the MS's total QoS requirement.

MSs which support the transmission or reception of data through more than one PDP context at the same time shall support the use of CONTEXT_READY timers.

A SwMI that supports the use of QoS negotiation during PDP context activation may make local use of CONTEXT_READY timers to track the state of the MS's CONTEXT_READY timers. A SwMI that uses CONTEXT_READY timers shall follow the same rules as the MS for management of the READY timer and the CONTEXT_READY timers.

The SNDCP service user may propose a CONTEXT_READY timer value to the MS SNDCP in the NSAPI-QoS negotiation parameter of the SN-NSAPI ALLOC request and SN-NSAPI MODIFY request primitives. The MS should then propose this CONTEXT_READY timer value to the SwMI in the QoS information element during PDP context activation or modification, if QoS negotiation is supported by the MS and the current cell (SwMI support for QoS negotiation is indicated in the MLE-INFO indication primitive). If no value was specified in the SN-NSAPI ALLOC or SN-NSAPI MODIFY request primitive, and QoS negotiation is supported by the MS and the current cell, or if the MS does not support the use of CONTEXT_READY timers, the MS SNDCP should propose to the SwMI that the value of the CONTEXT_READY timer should be set to track the READY timer value.

If the MS proposes that the CONTEXT_READY timer should be set to track the READY timer value, the SwMI shall accept that proposal. If the MS proposes a CONTEXT_READY timer that does not track the READY timer value and the SwMI uses CONTEXT_READY timers, the SwMI may accept the proposal (possibly with a modified time period). If the MS proposes a CONTEXT_READY timer that is longer than the READY timer and the SwMI does not use CONTEXT_READY timers, the SwMI shall propose a CONTEXT_READY timer that is less than or equal to the READY timer or that shall track the READY timer.

The CONTEXT_READY timers shall obtain their values either from the QoS information element of the SN-ACTIVATE PDP CONTEXT ACCEPT and SN-MODIFY PDP CONTEXT RESPONSE PDUs for the relevant PDP context, if included, or shall track the value of the READY timer if the QoS information element was not included.

If a CONTEXT_READY timer is set to track the READY timer value, it shall be set to the READY timer value included in the SN-ACTIVATE-PDP-CONTEXT ACCEPT PDU most recently sent to that MS (irrespective of the NSAPI in the PDU) each time it is restarted.

NOTE 5: A PDP context to be used for transmission or reception of intermittent data (such as for telemetry class data) may benefit from using a longer CONTEXT_READY timer than would be required by a PDP context used for background class data.

The CONTEXT_READY timers for the appropriate PDP contexts, if supported, shall be started or re-started whenever an SN-DATA, SN-DATA TRANSMIT REQUEST PDU (SwMI to MS only) or SN-DATA TRANSMIT RESPONSE PDU (with Accept/Reject = 1) has been transmitted successfully (as indicated by MLE-REPORT indication primitive) or has been received for a non-group address, or when an SN-UNITDATA PDU has been sent to MLE for transmission. The CONTEXT_READY timer shall not be started or re-started by group-addressed PDUs.

If SNDCP is in the READY state, but a CONTEXT-READY timer is inactive or has expired when the MS SNDCP receives an SN-DATA request or SN-UNITDATA request primitive for that PDP context, the MS SNDCP shall transmit an SN-DATA TRANSMIT REQUEST PDU to the SwMI as an indication that its immediate QoS requirement has changed, start the RESPONSE_WAIT timer and wait for an SN-DATA TRANSMIT RESPONSE PDU (with Accept/Reject = 1) for the relevant PDP context before transmitting an SN-DATA PDU or SN-UNITDATA PDU for that PDP context.

If the MS SNDCP is in the READY state when it receives an SN-NSAPI MODIFY request primitive from the MS SNDCP service user requesting a PDP context to be paused, the MS SNDCP shall stop the CONTEXT_READY timer and, if the current cell supports QoS negotiation during PDP context activation, shall notify the SwMI SNDCP that it is pausing use of the PDP context by transmitting an SN-MODIFY PDP CONTEXT USAGE PDU. The SwMI shall stop any CONTEXT_READY timer for the relevant PDP context when it receives this notification.

All CONTEXT_READY timers shall be stopped when SNDCP exits the READY state or the MS SNDCP exits the READY temporary break state into some state other than these.

28.2.6.3 RESPONSE_WAIT Timer Function

The RESPONSE_WAIT timer function maintains the RESPONSE_WAIT timer in the MS. The duration of the RESPONSE_WAIT timer is assigned by the SwMI at PDP context activation. The value received from the SwMI in the most recent PDP context activation shall apply to all PDP contexts. The RESPONSE_WAIT timer controls the time an MS shall await a response from the SwMI to a SN-DATA TRANSMIT REQUEST or SN-RECONNECT PDU and hence the time the MS SNDCP remains in RESPONSE-WAITING state. If a response (in the form of a SN-DATA TRANSMIT RESPONSE) is received before the RESPONSE_WAIT timer expires, then the MS SNDCP shall leave RESPONSE-WAITING state (if it is in that state) and shall stop the RESPONSE_WAIT timer. If the MS is in the RESPONSE_WAITING or READY temporary break state when the RESPONSE_WAIT timer expires before a response is received, then the MS shall go to the STANDBY state. If the MS is in the READY state when the response is received or when the RESPONSE_WAIT timer expires, it shall remain in the READY state (this can occur when the MS is attempting to transmit N-PDUs for a quiescent PDP context when busy transmitting or receiving N-PDUs for a different PDP context).

The RESPONSE_WAIT timer is reset and begins running in the MS when entering RESPONSE-WAITING state.

The RESPONSE_WAIT timer is stopped in the MS when leaving RESPONSE-WAITING state.

NOTE: The MS SNDCP may support concurrent RESPONSE_WAIT timers (one per PDP context) in the READY state.

28.2.6.4 SERVICE_CHANGE Timer Function

The SERVICE_CHANGE timer shall be started by the MS SNDCP when it receives an individually addressed SN-END OF DATA PDU indicating immediate service change. The MS shall then enter the STANDBY state. While the SERVICE_CHANGE timer remains active the MS shall defer sending the SwMI an SN-DATA TRANSMIT REQUEST PDU (in respect of any pending N-PDUs).

When the SERVICE_CHANGE timer expires, if the MS SNDCP has any pending N-PDUs it shall send the SwMI an SN-DATA TRANSMIT REQUEST PDU in the normal way, preparatory to sending the pending N-PDUs.

The SERVICE_CHANGE timer function enables the SwMI to keep the MS SNDCP in the STANDBY state on the common control channel (MCCH or MCCH-Q or common SCCH) for the SERVICE_CHANGE period of time, even though the MS SNDCP may have pending N-PDUs ready for transmission. This allows the SwMI to complete an exchange of signalling with the MS on the common control channel concerning some other service.

28.3 SNDCP Procedures

28.3.1 Services provided by the protocol

SNDCP performs the following functions (see figures 28.7 and 28.8):

- PDP context activation and PDP context deactivation;
- assignment of layer 2 logical links to activated PDP contexts;
- Packet Data CHannel (PDCH) handling;
- multiplexing of N-PDUs from one or several higher protocol entities onto one or more layer 2 connections;
- mapping of SN primitives received from the network layer into corresponding MLE-UNITDATA request primitives to be passed to the MLE;
- if data priority is not supported by the MS, management of the delivery sequence according to the PDU priority of SN-UNITDATA and SN-DATA request primitives;
- if data priority is supported by the MS:
 - management of the delivery sequence according to the PDU priority and data priority of SN-UNITDATA and SN-DATA request primitives;
 - management of the data priority of N-PDUs;
- compression and recovery of redundant protocol control information (e.g. TCP/IP header). Header compression is performed independently for each NSAPI;
- compression and recovery of redundant user data. Data compression is performed independently for each NSAPI;
- management of application-level QoS requirements.

MEX (optional)

- Parameters:
 - NSAPI
 - PDU priority (optional)
 - data priority (optional)
 - data importance (optional)
 - schedule surplus flag (optional)

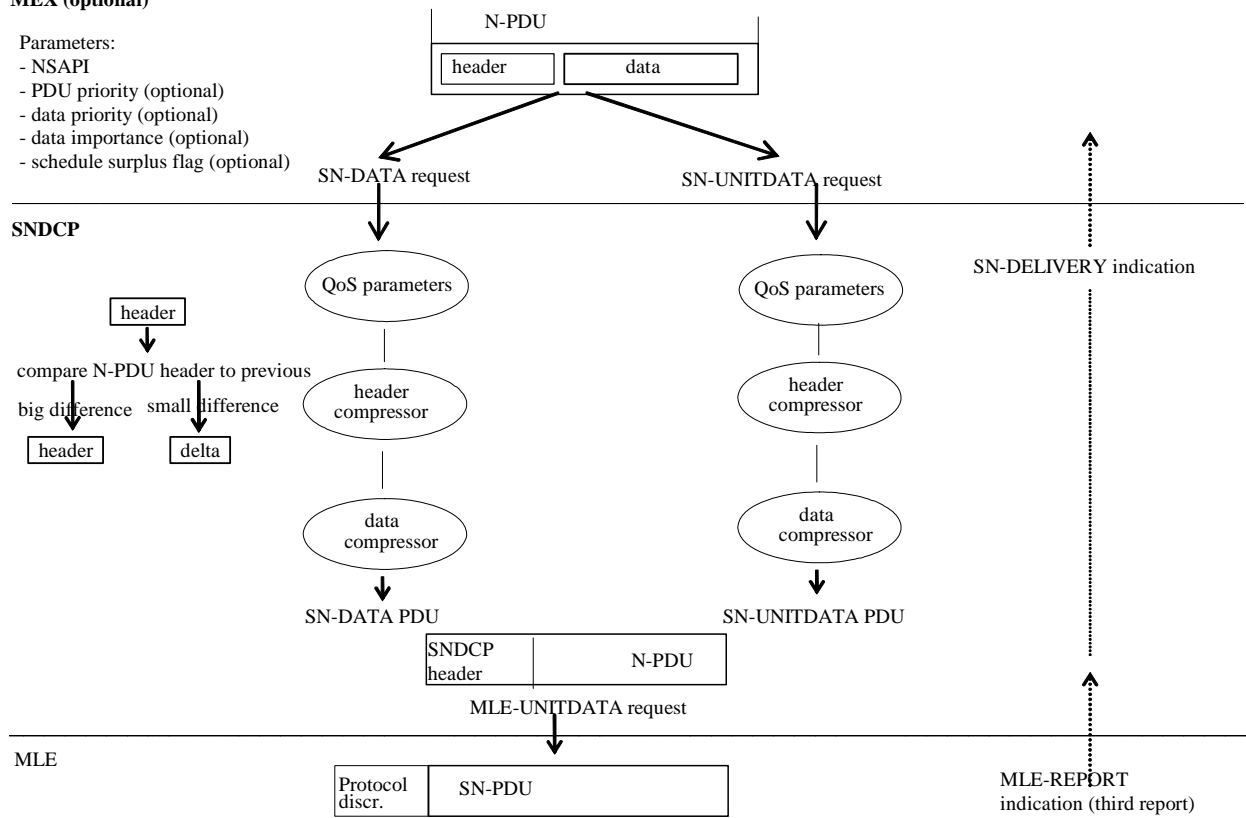

Figure 28.7: SNDCP model for transmitting end

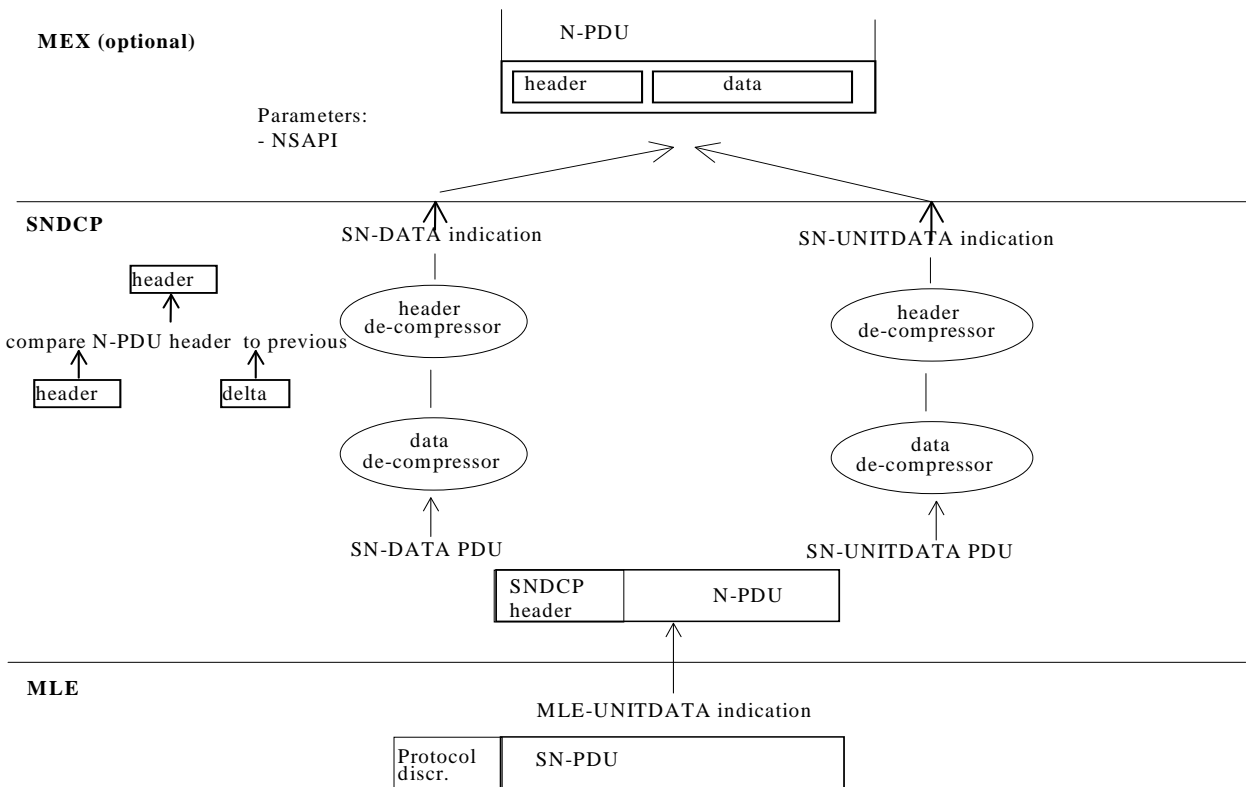

Figure 28.8: SNDCP model for receiver end

28.3.2 Underlying services assumed by the protocol

The following services are expected to be provided by the MLE through the LTPD-SAP:

- acknowledged (MS -> SwMI and SwMI -> MS) and unacknowledged (MS -> SwMI and SwMI -> MS) data transfer; point-to-point (MS -> SwMI and SwMI -> MS) and point-to-multipoint data transfer (SwMI -> MS);
- high reliability data transfer (FCS on, acknowledged), moderate reliability data transfer (FCS off, acknowledged) and low delay (low reliability) data transfer (FCS on or off and unacknowledged);
- PDU priority based transfer of SN-PDUs (eight PDU priority levels);
- if the MS does not support data priority:
 - in-order delivery of SN-PDUs per PDU priority (i.e. SN-PDUs with the same PDU priority have to appear at the receiving end in the same order as transmitted between SNDCCP entities). This is required only for acknowledged service;
- if the MS does support data priority:
 - data-priority based N-PDU access to radio resources (8 data priority levels);
 - in-order delivery of SN-PDUs not containing an N-PDU per PDU priority (i.e. SN-PDUs not containing an N-PDU and having the same PDU priority have to appear at the receiving end in the same order as transmitted between SNDCCP entities). This is required only for acknowledged service;
 - in-order delivery of SN-DATA PDUs per PDU priority and data priority (i.e. SN-DATA PDUs with the same PDU priority and data priority have to appear at the receiving end in the same order as transmitted between SNDCCP entities);
 - in-order transmission of SN-UNITDATA PDUs per PDU priority and data priority (i.e. SN-UNITDATA PDUs with the same PDU priority and data priority have to be transmitted a first time in the same order as sent to MLE by the MS SNDCCP);
- support for variable length SN-PDUs;
- indications about radio link condition (CLOSE, OPEN, BREAK);
- indications about LLC connections (establishment, re-connection, release);
- access to disconnect LLC connections;
- support for regularly scheduled slot grants (scheduled access), including provision of schedule timing indications to the MS SNDCCP.

28.3.3 Context activation, modification and deactivation procedures

28.3.3.0 General

An MS in IDLE, STANDBY or READY states can initiate PDP context activation functions to establish a virtual data channel i.e. PDP context between the MS and the SwMI. An MS in STANDBY state can initiate PDP context deactivation functions. An MS or SwMI in the STANDBY or READY states can initiate PDP context modification. An MS in the STANDBY or READY state may initiate activation of an already-activated PDP context as an alternative method of modifying the PDP context; however if a reactivation fails, the PDP context is deactivated and is no longer available for use until a successful activation has been performed.

Upon receiving an SN-ACTIVATE PDP CONTEXT DEMAND PDU, the SwMI shall initiate procedures to set up the PDP context.

Upon receiving an SN-MODIFY PDP CONTEXT REQUEST PDU, the SwMI shall, if supported, initiate procedures to modify the PDP context.

Upon receiving an SN-MODIFY PDP CONTEXT REQUEST PDU, the MS shall, if supported, confirm to the SwMI the modification of the PDP context and advise affected applications.

Upon receiving a SN-DEACTIVATE PDP CONTEXT DEMAND PDU, the SwMI shall initiate procedures to delete the PDP context.

Upon receiving a SN-DEACTIVATE PDP CONTEXT DEMAND PDU, the MS shall initiate procedures to delete the PDP context.

A conventional access MS shall not attempt to activate or modify a PDP context while the D-MLE SYSINFO or D-MLE SYSINFO-Q PDUs are indicating "SNDCCP service is not available on this cell".

A MS may only attempt to activate one PDP context at a time. Hence a MS after transmitting a SN-ACTIVATE PDP CONTEXT DEMAND PDU shall await the occurrence of one of the following events, before sending a new SN-ACTIVATE PDP CONTEXT DEMAND PDU:

- reception of a SN-ACTIVATE PDP CONTEXT ACCEPT PDU;
- reception of a SN-ACTIVATE PDP CONTEXT REJECT PDU;
- expiration of the PDP_ACTIVATE_WAIT timer.

A MS may only have one PDP context modification request outstanding at a time. Hence a MS, after transmitting a SN-MODIFY PDP CONTEXT REQUEST PDU shall await the occurrence of one of the following events before sending a new SN-MODIFY PDP CONTEXT REQUEST PDU:

- reception of a SN-MODIFY PDP CONTEXT RESPONSE PDU with modify type = response;
- expiration of the PDP_MODIFY_WAIT timer.

A MS may only have one PDP context deactivation request outstanding at a time. Hence a MS after transmitting a SN-DEACTIVATE PDP CONTEXT DEMAND PDU shall await the occurrence of one of the following events, before sending a new SN-DEACTIVATE PDP CONTEXT DEMAND PDU:

- reception of a SN-DEACTIVATE PDP CONTEXT ACCEPT PDU;
- expiration of the PDP_DEACTIVATE_WAIT timer.

An MS shall activate a primary PDP context before it attempts to activate a secondary PDP context linked to that primary PDP context. Primary and secondary PDP context activation requests are indicated by the "address type identifier in demand" information element.

An MS should not request a secondary PDP context unless QoS negotiation is supported by the SwMI.

When a primary PDP context is deactivated, all secondary PDP contexts linked to that primary PDP context shall be locally deactivated.

The SwMI shall not accept a primary PDP context activation request specifying a PDP address already in use by some other PDP context.

A SwMI that supports QoS negotiation during PDP context activation but does not support the use of secondary PDP contexts shall refuse an MS's request for activation of a secondary PDP context with reject cause "Secondary PDP contexts not supported".

28.3.3.0a SNDCCP QoS requests

The MS can request two types of QoS. QoS that is requested during advanced link setup is called advanced link QoS. The present clause concerns QoS that is requested during PDP context activation and modification.

The MS requests a particular type of QoS by including the QoS information element in the SN-ACTIVATE PDP CONTEXT DEMAND or SN-MODIFY PDP CONTEXT REQUEST PDU.

The MS shall not send the SwMI a QoS information element unless it knows that the present BS supports QoS negotiation e.g. because the MS has received an indication in a SYSINFO PDU that the present cell supports QoS negotiation or QAM (in an extended services broadcast information element), or because the present cell is a DA cell.

The MS shall not include the QoS information element in its response to an SN-MODIFY PDP CONTEXT REQUEST PDU received from the SwMI.

If the MS does not include a QoS information element in an SN-ACTIVATE PDP CONTEXT DEMAND or SN-MODIFY PDP CONTEXT REQUEST PDU and the SwMI accepts the MS's PDP context activation or modification request, the SwMI shall not include a QoS information element in its response and the MS shall assume that it has been granted a background class QoS with unspecified throughput, reliability and delay.

If the MS sends a QoS information element and the SwMI accepts the MS's PDP context activation or modification request and QoS request, the SwMI may either include the same QoS information element or may omit the the QoS information element in the response accepting the MS's PDP context activation or modification request. If the SwMI does not include a QoS information element in its response, the MS shall assume that its QoS request has been granted in full.

If the SwMI decides to grant a QoS that is different to the QoS requested by the MS, the SwMI shall include a QoS information element in its response.

If the SwMI includes a QoS information element in its response, the MS shall assume that it has been granted exactly the QoS specified by the SwMI's QoS information element. If any QoS item that the MS requested is omitted from the SwMI's QoS information element, the MS shall assume it has not been granted that QoS item. If the SwMI sends a one-bit QoS element in its response, the MS shall assume that it has been granted a background class QoS with unspecified throughput, reliability and delay but no other items that were requested by the MS.

If the MS sends a one-bit QoS information element, the SwMI shall not include a full QoS information element in its response.

If an MS sends a full QoS information element to a SwMI that does not support full QoS information elements and the SwMI accepts the MS's context activation request, the SwMI shall include a one-bit QoS information element in its response.

If the MS requests use or modification of scheduled access and the SwMI is unable to provide the proposed schedule, the SwMI shall respond with an SN-ACTIVATE-PDP CONTEXT REJECT PDU or an SN-MODIFY PDP CONTEXT RESPONSE PDU indicating "modification rejected".

The MS shall not include a QoS filter specification in the QoS element of any PDU relating to a primary PDP context. The SwMI shall reject any PDP context activation or modification request for a primary PDP context that includes a QoS filter specification, using reject cause "QoS filter not available for primary PDP context". See clause 28.3.9 for a description of QoS filters.

28.3.3.1 Internet Protocol addressing support

28.3.3.1.1 IPv4 - Static and dynamic IP addresses

A TETRA system can be viewed as a single or multiple IP subnets. A TE which is attached to a MT on a TETRA network, can be viewed as a host on an IP subnet.

In order for IP packets from an external IP network, to reach a data TE which is attached to a MT on a TETRA network, it is necessary for the destination address used in the IP packets to be topologically correct i.e. packets, using standard internet routing procedures, can be forwarded to the TETRA network. The forwarding of packets within the TETRA network is outside of the scope of the present document.

IP addresses can be allocated to an MS in two different ways:

- an IP address is assigned permanently to the MS. The IP address shall be sent to the SwMI when activating PDP context;
- the SwMI assigns a dynamic IP address to the MS when PDP context is activated.

It is the operator that defines in the subscription whether a dynamic IP address can be used.

When dynamic addressing is used, it is the responsibility of the SwMI to allocate and release the dynamic IP address.

28.3.3.1.2 Mobile IPv4

Mobile IP allows nodes to move from one IP subnet to another without changing their IP address. A brief overview of Mobile IP is given below so as to help illustrate the addressing concept, however the reader is referred to IETF RFC 5944 [39] for a more complete description of the protocol.

In the description below, the following definitions apply:

- **Mobile Node:** An IP host or router that changes its point of attachment to the internet from one subnet to another.
- **Home address:** Internet protocol address, that is assigned to a Mobile Node for an extended period of time. This address is used by all other nodes when attempting to send IP packets to the Mobile Node. This address remains constant irrespective of the Mobile Nodes point of attachment to the internet.
- **Home network:** A network, having a network prefix matching that of the Mobile Node's home address. Standard IP routing mechanisms ensure that IP packets destined for the Mobile Node's home address are routed via the Mobile Node's home network.
- **Foreign network:** Any network, other than the Mobile Node's home network, i.e. a network which has a network prefix different to that of the Mobile Node's home IP address.
- **Visited Network:** A foreign network to which the Mobile Node is currently connected.
- **Home Agent:** A router on a Mobile Node's home network which tunnels IP packets for delivery to the Mobile Node when it is away from its home network. The Home Agent has similar functionality to the Home Location Register (HLR) in GSM.
- **Foreign Agent:** A router on the Mobile Node's visited network which detunnels and delivers IP packets to the Mobile Node, that were tunneled by the Home Agent.
- **Care-of Address:** The termination point of a tunnel towards a Mobile Node, for IP packets forwarded to the Mobile Node while it is away from its home network. The protocol can use two different types of care-of address: a "foreign agent care-of address" is an address of a foreign agent with which the mobile node is registered, and a "co-located care-of address" is an externally obtained local address which the mobile node has associated with one of its own network interfaces.

A Mobile Node is given a long term IP address on a home network. This IP address is administered in the same way as a "permanent" IP address is provided to a stationary host. When the Mobile Node detects that it is located on its home network, it operates without mobility services.

When a Mobile Node detects that it has moved to a foreign network, it obtains a care-of address on the foreign network. The mobile node then registers its new care-of address with its Home Agent.

IP packets sent to the Mobile Node's home address are intercepted by its Home Agent, tunneled by the Home Agent to the Mobile Node's care-of address, received at the tunnel endpoint (typically the foreign agent), and finally delivered to the mobile node.

In the reverse direction, IP packets sent by the mobile node are generally delivered to their destination using standard IP routing mechanisms, not necessarily passing through the home agent.

The TETRA packet data specification extends a TETRA network to act as one or more IP subnets. A TETRA network may offer Mobile IP services by including Home Agent and/or Foreign Agent functionality. The TETRA packet data specification provides a mechanism by which a Mobile Node may use Mobile IP services where they are available.

As an example, where a TETRA SwMI includes Mobile IP Foreign Agent functionality, a Mobile Node may perform Mobile IP Registration as described in IETF RFC 5944 [39] with its Home Agent (which may be located on a fixed IP subnet) via the SwMI based Foreign Agent. This Foreign Agent shall then act as the tunnel end point for those IP packets forwarded by the Home Agent. The Mobile Node may learn the Foreign Agent Care of Address through the PDP Context Activation procedure.

In TETRA Packet data, a MS shall indicate if it wishes to avail of Mobile IP services in the SN-ACTIVATE PDP CONTEXT DEMAND PDU by setting "Address Type Identifier in Demand" to "Mobile IPv4 Foreign Agent Care-of Address" or "Mobile IPv4 Co-located Care-of Address". A SwMI which offers support for Mobile IP services may respond with a "Mobile IPv4 Care-of Address" plus further information within the information element "SwMI Mobile IPv4 Information" of the SN-ACTIVATE PDP CONTEXT ACCEPT PDU.

28.3.3.1.3 IPv6

IPv6 will support two methods for a host to obtain a global IPv6 address. Stateful address autoconfiguration shall enable a host to be dynamically allocated an IP address through the use of a protocol such as Dynamic Host Configuration Protocol (DHCPv6). This will operate in a similar way to dynamic address allocation in IPv4. Stateless address autoconfiguration enables a host to generate its own IP address through information broadcast on the network where it is camped. The IPv6 address is 128 bits compared to 32 bits in IPv4. The address is broken into two parts, the Link Prefix and the Interface Identifier as shown in figure 28.9.

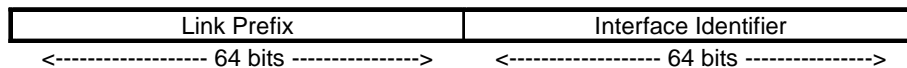

Figure 28.9: Ipv6 address

In the case of both address autoconfiguration methods, the IPv6 node first generates a link local IPv6 address. A link-local IPv6 address may only be used on the link or subnet to which the node is connected. To generate a link local address, an IPv6 node combines an Interface-Identifier with the Link Prefix which has been reserved for link local addresses. The IPv6 node will then use this link local IPv6 address to obtain a global IPv6 address. Typically this will involve sending a Router Solicitation and receiving a Router Advertisement.

In TETRA Packet data, a MS indicates in the SN-ACTIVATE PDP CONTEXT DEMAND PDU whether it wishes to use IPv6 services by setting "Address Type Identifier in Demand" appropriately.

Where the SwMI indicates in a SN-ACTIVATE PDP CONTEXT ACCEPT PDU that IPv6 is supported, the MS may then use a link local IPv6 address to perform stateful or stateless address autoconfiguration.

It is recommended that when generating a link local IPv6 address, the MS shall use its ITSI as the 48 least significant bits of the Interface Identifier thus ensuring that the Interface Identifier is unique on the link or subnet. A further requirement for Interface Identifier, is for the 6th most significant bit to be set to zero. All other bits of the Interface Identifier may be set to zero or may be used to support multiple link local addresses per ITSI.

This version of the packet data specification does not specify how IPv6 service is provided by a SwMI or the actions which a MS takes in order to obtain a global IPv6 address. Where a SwMI sends a SN-ACTIVATE PDP CONTEXT ACCEPT PDU indicating that it supports IPv6 services, it is recommended that the SwMI then prepares to receive a Router Solicitation and respond with a Router Advertisement.

28.3.3.2 NSAPI usage

The set of protocol entities above SNDCP uses the same SNDCP entity, which then performs multiplexing of data coming from different sources to be sent across a single LLC connection. Sharing a single LLC connection requires that different addresses can be identified. The NSAPI field of four bits is used for this purpose, defining the end user PDP type and PDP address pair that the MS is using. Following values are reserved for special use:

- 0 is reserved;
- 15 is reserved.

NOTE 1: The user application should start from NSAPI value 1 when allocating the first PDP context.

Other values are allocated dynamically. The allocation of the dynamic NSAPIs can be e.g. following:

- IPv4: 133.12.75.111 => NSAPI = 2
- IPv4: 133.12.75.222 => NSAPI = 3

NOTE 2: NSAPI may be used also for routing between MT and TE, e.g. NSAPI = 2 is activated by the TE2 and NSAPI = 3 is activated by the MT (actually MT0 to be exact i.e. the MS may act as MT0 and MT2 at the same time). The MEX layer may be used to provide this routing service (see clause 30.3.7).

NOTE 3: Data arriving in SNDTCP via a secondary PDP context should be routed according to the NSAPI of the primary PDP context.

Since the adaptation of different higher layer protocol to SNDTCP is implementation dependent, it is not defined in the present document.

28.3.3.3 SNDTCP network endpoint identifier

Within the SwMI, there may be a requirement for multiple SNDTCP entities in order to provide load balancing or to provide packet data service for different geographical regions. In order to support the existence of multiple such SNDTCP entities within the SwMI, a SNDTCP Network Endpoint Identifier (SNEI) may be assigned to each MS at PDP Context Activation. The SNEI information element shall only be present in uplink communication when the SwMI has assigned a SNEI value to the MS during context activation. Where the MS has been assigned a SNEI value during PDP context activation, then there are four occasions where the MS shall include the SNEI as part of uplink communication:

- 1) When in READY state and after performing a cell change, the MS SNDTCP entity shall include the SNEI as part of the Reconnect message (see clause 28.3.4.2 c) if the BS does not support QAM modulation - the SNEI does not need to be included if the BS supports QAM modulation.
- 2) When requesting permission to transmit data to a BS which does not support QAM modulation, the MS SNDTCP entity shall include the SNEI - the SNEI does not need to be included if the BS supports QAM modulation.
- 3) When responding to a page from the SwMI, the MS SNDTCP entity shall include the SNEI if the BS does not support QAM modulation - the SNEI does not need to be included if the BS supports QAM modulation.
- 4) When deactivating a PDP context, the MS SNDTCP entity shall include the SNEI if BS does not support QAM modulation - the SNEI does not need to be included if the BS supports QAM modulation.

A BS which supports QAM modulation shall have an alternative method of discovering an MS's SNEI.

The SwMI may assign a new SNEI to a MS in any of the following circumstances:

- 1) When activating a new PDP context.
- 2) When responding to a request from a MS to transmit data.
- 3) When paging a MS.

On reception of a new SNEI value, the MS SNDTCP entity should store this value for later use. The value of SNEI which the MS shall send to the SwMI during uplink communication shall be the most recently received SNEI. The SwMI shall only assign one SNEI per ITSI. The most recently received SNEI shall apply to all PDP contexts for a given ITSI.

The usage of the SNEI within the SwMI is outside the scope of the present document.

28.3.3.4 Definition of Packet data MS Types

28.3.3.4.0 General

The following clauses 28.3.3.4.1 to 28.3.3.4.4 describe the service interactions between circuit mode, messaging and packet data services as defined by the value of the Packet data MS Type information element. The types have meaning only in the context of TETRA Packet data. It is used by the MS to indicate to the SwMI its service interaction capabilities between packet data and individual circuit mode speech and data calls. The Packet data MS Type is sent to the SwMI when activating PDP context. If the Packet data MS Type is changed after the first PDP context activation, then the SwMI shall use the Packet data MS Type value, as received in the latest PDP activation.

NOTE 1: If the SwMI rejects a PDP context activation with the Activation reject cause set as "Packet Data MS type not supported" the MS may retry the PDP context activation with a lower Packet Data MS type e.g. if the SwMI rejects a Packet Data MS type of A the MS may try to activate a context as a Packet Data MS type of B, C or D. How the MS determines which Packet Data MS type to choose following a PDP context activation rejection is outside the scope of the present document.

The SwMI may use the Packet data MS type value to assist in optimizing air interface signalling when offering packet data services to an MS. For example the SwMI may choose not to offer (because the MS will probably not accept):

- TETRA Packet data to type D and C MS which is engaged in a circuit mode speech/data;
- Circuit mode speech/data to type D and C MS which is engaged in TETRA Packet data.

NOTE 2: If the MS is offered a circuit mode service, it may choose to ignore, reject or accept the service. The criteria for the MS to ignore, reject or accept the service are outside the scope of the present document.

In addition SwMI should be aware that type B MS shall abandon TETRA Packet data temporarily if it accepts or initiates circuit mode speech/data and vice versa. Type A MS may preserve both services parallel.

NOTE 3: SN-NSAPI ALLOC request primitive does not contain MS TETRA Packet data Type as a parameter. This is because the type may be constrained by the capabilities of the MS.

NOTE 4: An MS should always be capable of making an emergency call set up irrespective of the packet data MS Type and packet data state.

NOTE 5: How the SwMI determines the circuit mode status of an MS is outside the scope of the present document.

NOTE 6: The SwMI can only optimize the air interface signalling when interacting with individual calls. Interaction with group calls and Supplementary Services is outside the scope of the present document.

The different types for TETRA Packet data MSs and their capabilities to handle other services in addition to TETRA Packet data are summarized in table 28.14.

Table 28.14: Packet data MS types and other services

Service	Type A	Type B	Type C	Type D
Circuit mode speech/data conducted in READY state	X			
Circuit mode speech/data set up in READY state	X	X		
SDS in READY state	X	X	X	
Circuit mode speech/data conducted in STANDBY state	X	X	X	X
TETRA Packet Data	X	X	X	X

28.3.3.4.1 Type A - Parallel

All services (SDS, Circuit mode speech/data) may be conducted parallel with TETRA Packet data. MS has the capability to receive/send both circuit mode speech/data and TETRA Packet data at the same time. This means that circuit mode speech/data may be set up, accepted and conducted while the MS is in READY state. SDS may be conducted while the MS is in READY state.

NOTE: This MS can only support concurrent Packet data and circuit mode if the appropriate resources matching the "Class of MS" (refer to clause 16.10.5) can be allocated by the SwMI.

28.3.3.4.2 Type B - Alternating

Other services (SDS, Circuit mode speech/data) may be conducted alternating with TETRA Packet data, i.e. if MS is engaged in TETRA Packet data it may accept circuit mode speech/data and vice versa but only one service (TETRA Packet data or circuit mode speech/data) can be active at any time. SDS can be conducted parallel both with TETRA Packet data and circuit mode speech/data. This means that circuit mode speech/data may be set up but not conducted while the MS is in READY state. Circuit mode speech/data may be only conducted in STANDBY state.

28.3.3.4.3 Type C - IP single mode

The MS is engaged to one service at a time; if MS is engaged in TETRA Packet data it does not accept circuit mode speech/data and vice versa:

- 1) While the MS is in the READY state i.e. engaged in TETRA Packet Data, no circuit mode speech/data calls may be set up, accepted or conducted. However, SDS may be conducted while the MS is in the READY state.
- 2) While the MS has an ongoing circuit mode speech/data call or is in the call set up phase, TETRA Packet data is not allowed (accepted or initiated). This means that circuit mode speech/data may be set up, accepted or conducted while the MS is in STANDBY state. SDS may also be conducted while the MS is in the STANDBY state.

NOTE: Circuit mode calls in the STANDBY state are only permitted if allowed by the "Class of MS" (refer to clause 16.10.5).

28.3.3.4.4 Type D - Restricted IP single mode

The MS is engaged to one service at a time; if MS is engaged in TETRA Packet data it does not accept circuit mode speech/data and does not support SDS and vice versa:

- 1) While the MS is in the READY state i.e. engaged in TETRA Packet Data, no circuit mode speech/data may calls be set up, accepted or conducted. SDS should not be conducted while the MS is in READY state.
- 2) While the MS has an ongoing circuit mode speech/data call or is in the call set up phase, TETRA Packet data is not allowed (accepted or initiated). This means that circuit mode speech/data may be set up, accepted or conducted while the MS is in STANDBY state. SDS may also be conducted while the MS is in the STANDBY state.

28.3.3.5 PDP Context Activation Procedure

Successful PDP Context Activation procedure is illustrated in figure 28.10. Each numbered step is explained in the following list.

NOTE 1: In figures 28.10 to 28.13 the PDU names are presented without an "SN-" preamble.

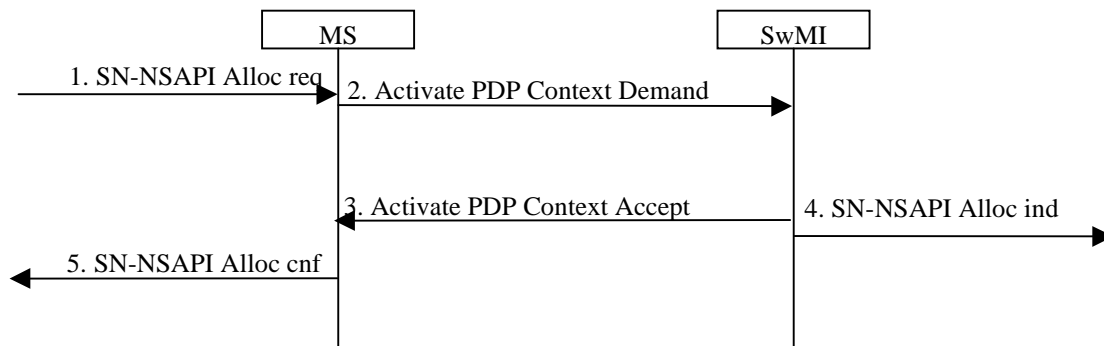

Figure 28.10: PDP Context activation procedure - activation accepted

1. The SN-SAP user triggers PDP context activation by issuing a SN-NSAPI ALLOC request primitive.
2. The MS sends an SN-ACTIVATE PDP CONTEXT DEMAND PDU to the SwMI. The MS indicates the form of IP address it wishes to use in the information element "Address Type Identifier in Demand". If supported, the MS shall request the QoS it requires in the "QoS" information element. The requested QoS shall be derived from information in the NSAPI QoS negotiation parameter of the SN-NSAPI ALLOC request primitive. The MS shall start PDP_ACTIVATE_WAIT timer.
3. SwMI inserts the NSAPIs in its PDP Contexts. The SwMI returns an SN-ACTIVATE PDP CONTEXT ACCEPT PDU to the MS. The SwMI is now able to route PDP PDUs to and from MS. If the MS indicated a QoS requirement, and the SwMI decides to grant a different QoS to that requested by the MS, the SwMI indicates the QoS it expects to provide for this PDP context in the "QoS" information element (see clause 28.3.3.0). The MS shall stop PDP_ACTIVATE_WAIT timer.
4. The SwMI SN-SAP user is informed about PDP context activation by the SwMI SNDSCP issuing SN-NSAPI ALLOC indication primitive.
5. The MS SN-SAP user is informed about successful PDP context activation and any negotiated QoS by the MS SNDSCP issuing SN-NSAPI ALLOC confirm primitive.

Unsuccessful PDP Context Activation procedure due to SwMI rejection is illustrated in figure 28.11. Each numbered step is explained in the following list.

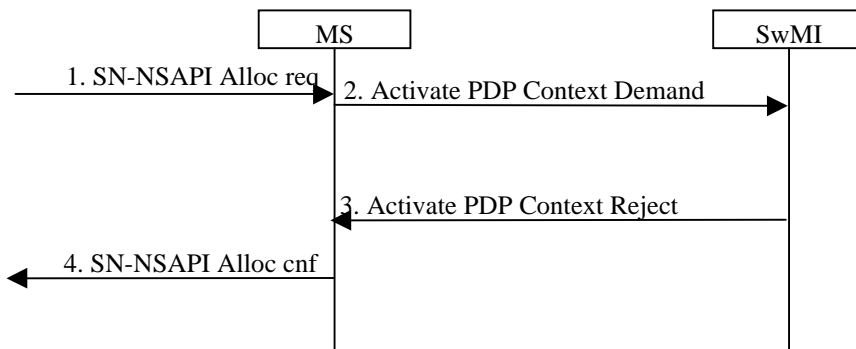

Figure 28.11: PDP context activation procedure - activation rejected

1. The SN-SAP user triggers PDP context activation by issuing SN-NSAPI ALLOC request primitive.
2. The MS sends an SN-ACTIVATE PDP CONTEXT DEMAND PDU to the SwMI. The MS shall start PDP_ACTIVATE_WAIT timer.
3. SwMI rejects activation by returning a SN-ACTIVATE PDP CONTEXT REJECT PDU to the MS. The MS shall stop PDP_ACTIVATE_WAIT timer.
4. The MS SN-SAP user is informed about unsuccessful PDP context activation by the MS SNDSCP issuing SN-NSAPI ALLOC confirm primitive.

NOTE 2: For direct access, the BS always supports the SNDSCP service when the "system wide services" information element in the D-MLE-SYSINFO-DA (and the D-MLE-SYNC-DA) PDU indicates "normal mode" (system wide services supported); see clause 18. The MS SNDSCP may send the SwMI an SN-ACTIVATE PDP CONTEXT DEMAND PDU while the "system wide services" information element in the D-MLE-SYSINFO-DA (or the D-MLE-SYNC-DA) PDU is indicating "system wide services temporarily not supported"; however the BS in this mode may temporarily not support the SNDSCP service, in which case the BS may send the SN-ACTIVATE PDP CONTEXT REJECT PDU with reject cause "SNDSCP service temporarily not available". If the MS receives an SN-ACTIVATE PDP CONTEXT REJECT PDU with reject cause "SNDSCP service temporarily not available", the MS should not continue to send the SN-ACTIVATE PDP CONTEXT DEMAND PDU while the "system wide services" information element in the D-MLE-SYSINFO-DA or D-MLE-SYNC-DA PDUs is indicating "system wide services temporarily not supported" (though the MS is not precluded from occasionally sending the SN-ACTIVATE PDP CONTEXT DEMAND PDU).

A conventional access MS is not permitted to send the SN-ACTIVATE PDP CONTEXT DEMAND PDU while the D-MLE SYSINFO or D-MLE SYSINFO-Q PDUs are indicating "SNDCCP service is not available on this cell".

NOTE 3: The MS is not permitted to send the SN-ACTIVATE PDP CONTEXT DEMAND PDU on a cell where a subscriber class mismatch exists (see clause 16.4.9) or on a not-permitted cell (see clause 18.3.5.1.5).

Unsuccessful PDP Context Activation procedure due to expiry of PDP_ACTIVATE_WAIT timer is illustrated in the figure 28.12. Each numbered step is explained in the following list.

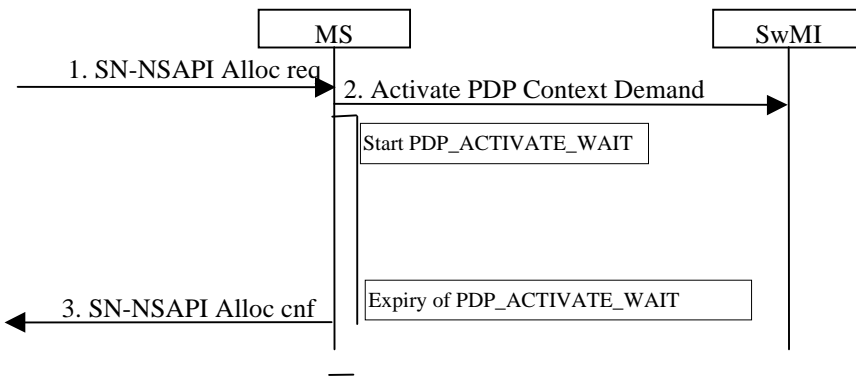

Figure 28.12: PDP context activation procedure - no response to activation

1. The SN-SAP user triggers PDP context activation by issuing SN-NSAPI ALLOC request primitive.
2. The MS sends an SN-ACTIVATE PDP CONTEXT DEMAND PDU to the SwMI. The MS shall start PDP_ACTIVATE_WAIT timer.
3. Timer PDP_ACTIVATE_WAIT timer expires. The MS SN-SAP user is informed about unsuccessful PDP context activation by the MS SNDCCP issuing SN-NSAPI ALLOC confirm primitive.

Unsuccessful PDP Context Activation procedure due to wrong NSAPI in the SwMI's response is illustrated in the figure 28.13. Each numbered step is explained in the following list.

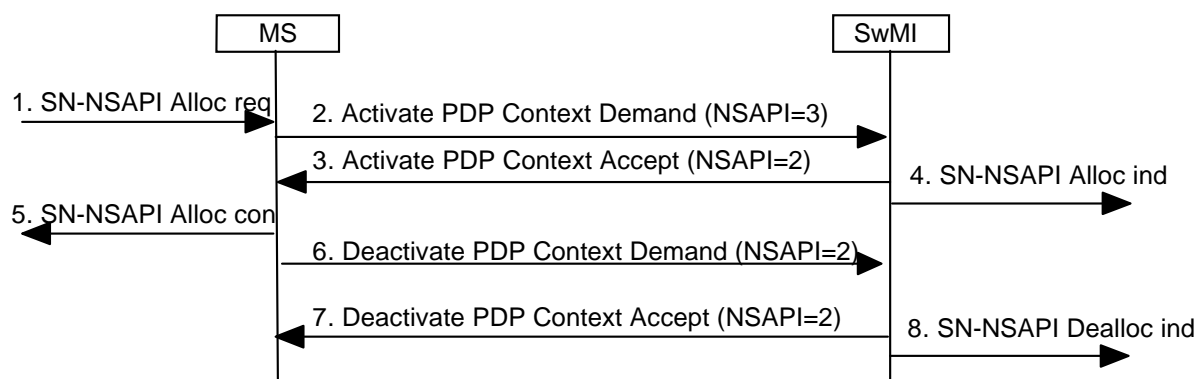

Figure 28.13: PDP context activation procedure - wrong NSAPI

1. The SN-SAP user triggers PDP context activation by issuing SN-NSAPI ALLOC request primitive.
2. The MS sends an SN-ACTIVATE PDP CONTEXT DEMAND PDU to the SwMI. The MS shall start PDP_ACTIVATE_WAIT timer.
3. SwMI inserts the NSAPIs in its PDP Contexts. The SwMI returns an SN-ACTIVATE PDP CONTEXT ACCEPT PDU to the MS. The MS shall stop the PDP_ACTIVATE_WAIT timer.
4. The SwMI SN-SAP user is informed about PDP context activation by the SwMI SNDSCP issuing SN-NSAPI ALLOC indication primitive.
5. The NSAPI in the Demand and Accept differ, and hence the MS SN-SAP user is informed about the failed PDP context activation by the MS SNDSCP issuing SN-NSAPI ALLOC confirm primitive.
6. The MS deactivates the NSAPI issued by the SwMI by sending a SN-DEACTIVATE PDP CONTEXT DEMAND PDU to the SwMI. The MS shall start the PDP_DEACTIVATE_WAIT timer.
7. The SwMI shall respond by sending a SN-DEACTIVATE PDP CONTEXT ACCEPT PDU to the MS. On reception of the SN-DEACTIVATE PDP CONTEXT ACCEPT PDU, the MS shall stop the PDP_DEACTIVATE_WAIT timer.
8. The SwMI SN-SAP user is informed about PDP context deactivation by the SwMI SNDSCP issuing SN-NSAPI DEALLOC indication primitive.

If the PDP context activation procedure fails, then the MS SNDSCP service user may attempt another activation to the same PDP address up to a maximum number RETRY_ACTIVATION of attempts.

28.3.3.5a PDP context modification procedure

It is optional for an MS and SwMI to support PDP context modification.

Normally, MSs should be responsible for initiating PDP context modification, either because the application's QoS requirements have changed, or because the MS has observed that the SwMI is no longer able to provide the previously agreed QoS.

A conventional access MS shall not attempt PDP context modification while the D-MLE SYSINFO or D-MLE SYSINFO-Q PDUs are indicating "SNDSCP service is not available on this cell".

The SwMI shall not use the PDP context modification procedure to increase an already agreed QoS above the highest value requested by the MS during activation and modification of the present PDP context. The SwMI is not required to modify PDP contexts every time the available QoS changes. The SwMI may initiate modification of a PDP context if it becomes unable to support a previously agreed schedule for slot grants on that PDP context. See also clause 28.3.5.6.

The MS shall not reject a SwMI-initiated PDP context modification.

Successful PDP Context modification procedure initiated by the MS is illustrated in the figure 28.14. Each numbered step is explained in the following list.

NOTE 1: In figures 28.14 to 28.18 the PDU names are presented without an "SN-" preamble.

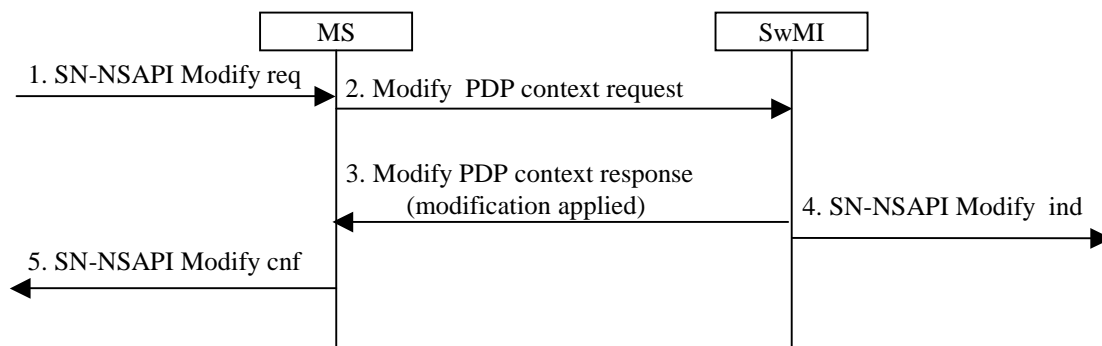

Figure 28.14: MS-initiated PDP Context modification procedure - modification accepted

1. The MS's SN-SAP user triggers PDP context modification by issuing a SN-NSAPI MODIFY request primitive.
2. The MS sends an SN-MODIFY PDP CONTEXT REQUEST PDU containing a proposed QoS to the SwMI. The MS shall start PDP_MODIFY_WAIT timer.
3. SwMI modifies its recorded QoS information for the PDP context and returns an SN-MODIFY PDP CONTEXT RESPONSE PDU (modification result = modification applied) to the MS. If the SwMI decides to grant a modified QoS that differs from the QoS requested by the MS, the SwMI includes a QoS information element indicating the QoS offered by the SwMI (see clause 28.3.3.0). (The modified QoS offered by the SwMI should differ from the previously agreed QoS). SN-DATA and SN-UNITDATA PDUs for this PDP context should now experience the modified QoS. The MS shall stop the PDP_MODIFY_WAIT timer.
4. The SwMI SN-SAP user is informed about the PDP context modification by the SwMI SNDSCP issuing a SN-NSAPI MODIFY indication primitive.
5. The MS SN-SAP user is informed about the PDP context modification by the MS SNDSCP issuing a SN-NSAPI MODIFY confirm primitive.

The SwMI may initiate PDP context modification when it needs to reduce the level of the presently agreed QoS and when it wishes to advise the MS that it is now increasing the level of QoS to more closely match the MS's request. Successful PDP Context modification procedure initiated by the SwMI is illustrated in the figure 28.15. Each numbered step is explained in the following list.

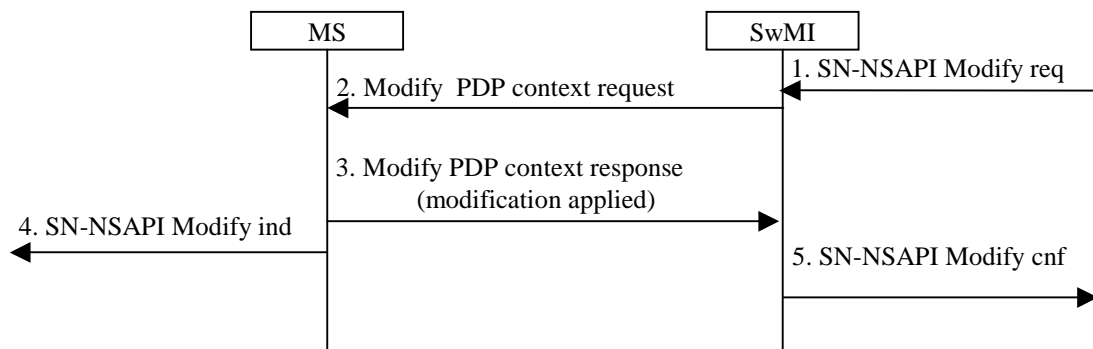

Figure 28.15: SwMI-initiated PDP Context modification procedure - modification accepted

1. The SwMI SN-SAP user triggers PDP context modification by issuing a SN-NSAPI MODIFY request primitive.
2. The SwMI sends an SN-MODIFY PDP CONTEXT REQUEST PDU containing a modified QoS to the MS.
3. The MS modifies its recorded QoS information for the PDP context and returns an SN-MODIFY PDP CONTEXT RESPONSE PDU (modification result = modification applied) to the SwMI. PDP PDUs for this PDP context should now experience the modified QoS.
4. The MS SN-SAP user is informed about PDP context modification by the SwMI SNDSCP issuing SN-NSAPI MODIFY indication primitive.
5. The SwMI SN-SAP user is informed about the PDP context modification by the MS SNDSCP issuing SN-NSAPI MODIFY confirm primitive.

NOTE 2: The SwMI may also initiate PDP context modification as a result of SwMI layer 2 changes, without first receiving a SN-NSAPI MODIFY request primitive. In this case, the SwMI informs the SwMI SN-SAP user of the change in QoS by issuing a SN-NSAPI MODIFY indication primitive (and not a SN-NSAPI MODIFY confirm primitive).

The MS shall not reject a PDP context modification initiated by the SwMI (but it may subsequently deactivate the modified PDP context or may attempt to modify it).

Unsuccessful PDP context modification procedure due to SwMI rejection is illustrated in the figure 28.16. Each numbered step is explained in the following list.

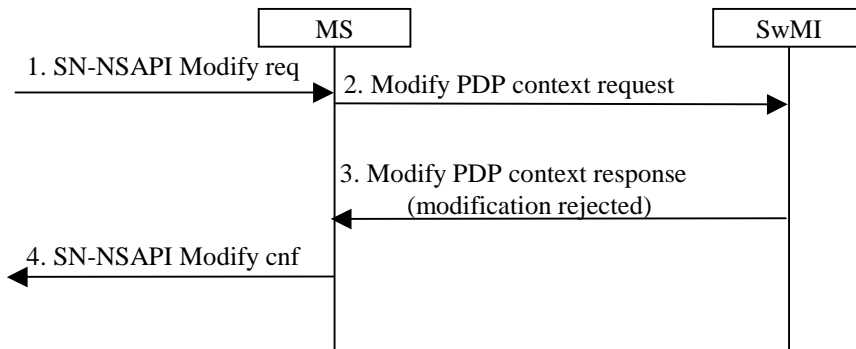

Figure 28.16: MS-initiated PDP context modification procedure - modification rejected by SwMI

1. The SN-SAP user triggers PDP context modification by issuing a SN-NSAPI MODIFY request primitive.
2. The MS sends an SN-MODIFY PDP CONTEXT REQUEST PDU containing a proposed QoS to the SwMI. The MS shall start PDP_MODIFY_WAIT timer.
3. SwMI rejects modification by returning a SN-MODIFY PDP CONTEXT RESPONSE PDU (modification result = modification rejected) to the MS. The QoS previously agreed for the PDP context remains unchanged. The MS shall stop PDP_MODIFY_WAIT timer.
4. The MS SN-SAP user is informed about unsuccessful PDP context modification by the MS SNDSCP issuing a SN-NSAPI MODIFY confirm primitive.

NOTE 3: For direct access, the BS always supports the SNDSCP service when the "system wide services" information element in the D-MLE-SYSINFO-DA (and D-MLE-SYNC-DA) PDU indicates "normal mode" (system wide services supported); see clause 18. The MS SNDSCP may send the SwMI an SN-MODIFY PDP CONTEXT REQUEST PDU while the "system wide services" information element in the D-MLE-SYSINFO-DA (or D-MLE-SYNC-DA) PDU is indicating "system wide services temporarily not supported"; however the BS in this mode may temporarily not support the SNDSCP service, in which case the BS may send the SN-MODIFY PDP CONTEXT RESPONSE PDU with reject cause "SNDSCP service temporarily not available". If the MS receives an SN-MODIFY PDP CONTEXT RESPONSE PDU with reject cause "SNDSCP service temporarily not available", the MS should not continue to send the SN-MODIFY PDP CONTEXT REQUEST PDU while the "system wide services" information element in the D-MLE-SYSINFO-DA (or D-MLE-SYNC-DA) PDU is indicating "system wide services temporarily not supported" (though the MS is not precluded from occasionally sending the SN-MODIFY PDP CONTEXT REQUEST PDU).

A conventional access MS is not permitted to send the SN-MODIFY PDP CONTEXT REQUEST PDU while the D-MLE SYSINFO or D-MLE SYSINFO-Q PDUs are indicating "SNDSCP service is not available on this cell".

Unsuccessful PDP Context Modification procedure due to expiry of PDP_MODIFY_WAIT timer is illustrated in the figure 28.17. Each numbered step is explained in the following list.

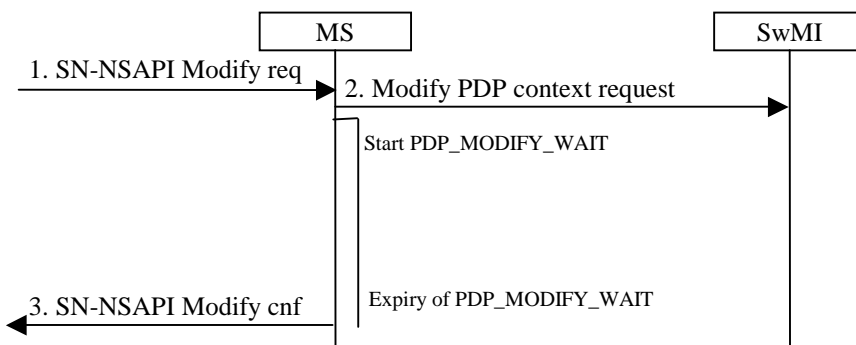

Figure 28.17: MS-initiated PDP context modification procedure - no response to modification request

1. The SN-SAP user triggers PDP context modification by issuing a SN-NSAPI ALLOC request primitive.
2. The MS sends an SN-MODIFY PDP CONTEXT REQUEST PDU to the SwMI. The MS shall start PDP_MODIFY_WAIT timer.
3. Timer PDP_MODIFY_WAIT timer expires. The MS SN-SAP user is informed about unsuccessful PDP context modification by the MS SNDSCP issuing a SN-NSAPI MODIFY confirm primitive.

Unsuccessful MS-initiated PDP context modification procedure due to MS receiving a SN-MODIFY PDP CONTEXT REQUEST PDU from the SwMI while the PDP_MODIFY_WAIT timer is active is illustrated in the figure 28.18. Each numbered step is explained in the following list.

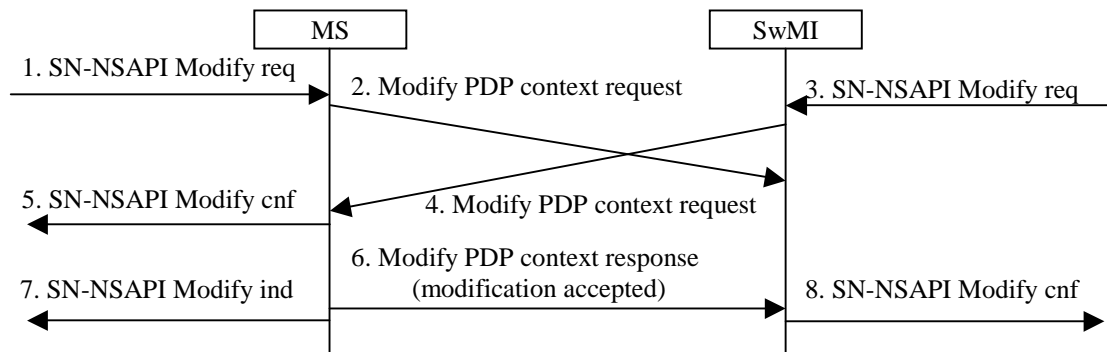

Figure 28.18: MS-initiated PDP context modification procedure - SwMI also initiating modification of the same PDP context

1. The SN-SAP user triggers PDP context modification by issuing a SN-NSAPI MODIFY request primitive.
2. The MS sends an SN-MODIFY PDP CONTEXT REQUEST PDU. The MS shall start PDP_MODIFY_WAIT timer.
3. The SwMI SN-SAP user triggers PDP context activation by issuing SN-NSAPI MODIFY request primitive.
4. The SwMI SNDSCP sends an SN-MODIFY PDP CONTEXT REQUEST PDU containing a proposed QoS to the MS before it receives the SN-MODIFY PDP CONTEXT RESPONSE PDU from the MS. The SwMI shall now discard any SN-MODIFY PDP CONTEXT REQUEST PDU received from the MS until after it receives SN-MODIFY PDP CONTEXT RESPONSE PDU (modification result = modification applied) from the MS.
5. On receipt of SN-MODIFY PDP CONTEXT REQUEST PDU while the PDP_MODIFY_WAIT timer is active, the MS SNDSCP informs the MS SN-SAP user about unsuccessful PDP context modification by issuing SN-NSAPI MODIFY confirm primitive. The MS shall stop PDP_MODIFY_WAIT timer.
6. The MS SNDSCP sends receives SN-MODIFY PDP CONTEXT RESPONSE PDU (modification result = modification applied) to the SwMI.
7. The MS SN-SAP user is informed about PDP context modification by the MS SNDSCP issuing SN-NSAPI MODIFY indication primitive.
8. The SwMI SN-SAP user is informed about the PDP context modification by the SwMI SNDSCP issuing SN-NSAPI MODIFY confirm primitive.

In general, if MS-initiated PDP context modification procedure fails, then the MS SNDSCP service user may attempt an identical modification of that PDP context up to a maximum number RETRY_MODIFICATION of attempts before deactivation of the PDP context.

28.3.3.6 PDP context deactivation procedure

28.3.3.6.0 General

Either a MS or the SwMI may initiate the deactivation procedure.

28.3.3.6.1 MS originated PDP context deactivation procedure

MS originated PDP Context Deactivation procedure is illustrated in figure 28.19. Each numbered step is explained in the following list.

NOTE: In figures 28.19 to 28.21 the PDU names are presented without an "SN-" preamble.

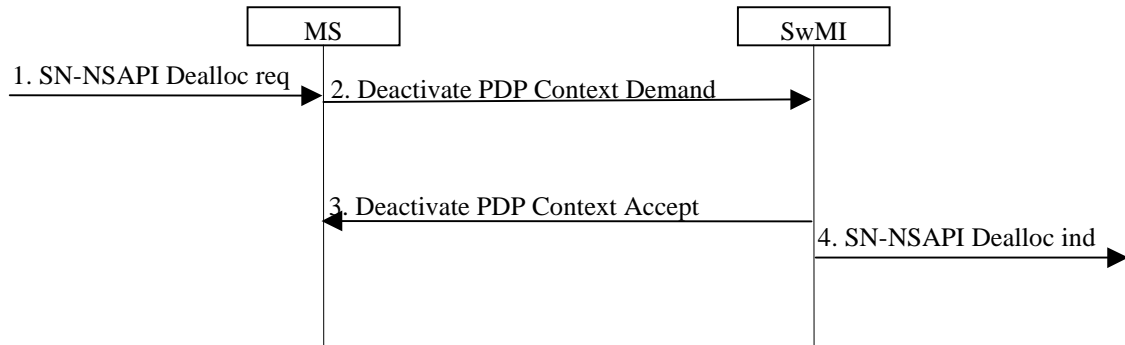

Figure 28.19: PDP context deactivation procedure

1. The SN-SAP user triggers PDP context deactivation by issuing SN-NSAPI DEALLOC request primitive.
2. The MS sends a SN-DEACTIVATE PDP CONTEXT DEMAND PDU to the SwMI. The MS shall start PDP_DEACTIVATE_WAIT timer.
3. The SwMI returns a SN-DEACTIVATE PDP CONTEXT ACCEPT PDU to the MS. The MS shall stop PDP_DEACTIVATE_WAIT timer.
4. The SwMI SN-SAP user is informed about PDP context deactivation by the SwMI SNDSCP issuing SN-NSAPI DEALLOC indication primitive.
5. The MS SN-SAP user is informed about PDP context deactivation by the MS SNDSCP issuing an SN-NSAPI DEALLOC confirm primitive.

MS originated PDP Context Deactivation unsuccessful procedure due to expiry of PDP_DEACTIVATE_WAIT timer is illustrated in figure 28.20. Each numbered step is explained in the following list.

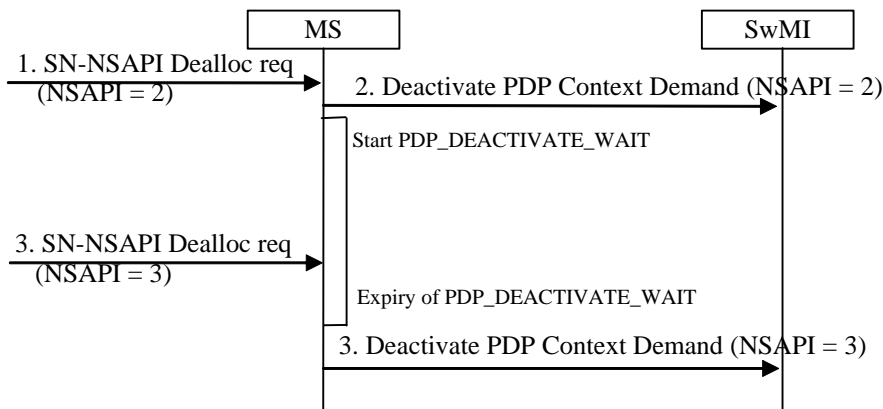

Figure 28.20: PDP context deactivation procedure - no response to deactivation

1. The SN-SAP user triggers PDP context deactivation by issuing SN-NSAPI DEALLOC request primitive (NSAPI = 2 in this scenario).

2. The MS sends a SN-DEACTIVATE PDP CONTEXT DEMAND PDU (NSAPI = 2 in this scenario) message to the SwMI. The MS shall start PDP_DEACTIVATE_WAIT timer.
3. The SN-SAP user triggers PDP context deactivation by issuing SN-NSAPI DEALLOC request primitive (NSAPI = 3 in this scenario).
4. Timer PDP_DEACTIVATE_WAIT timer expires. The MS shall not retry de-activation procedure for that NSAPI= 2. The PDP context is deactivated locally.
5. The MS sends a Deactivate PDP Context Demand (NSAPI = 3 in this scenario) message to the SwMI. The MS shall start PDP_DEACTIVATE_WAIT timer.

The MS may use Deactivation type parameter value "Deactivation of all NSAPIs" when sending the SN-DEACTIVATE PDP CONTEXT DEMAND PDU. Should this happen the MS shall deactivate all its active PDP Contexts locally. The SwMI shall respond to the Demand by sending a SN-DEACTIVATE PDP CONTEXT ACCEPT PDU having Deactivation type parameter value "Deactivation of all NSAPIs" and deactivate all NSAPIs for that MS.

28.3.3.6.2 SwMI originated context deactivation procedure

SwMI originated PDP Context Deactivation procedure is illustrated in the figure 28.21. Each numbered step is explained in the following list.

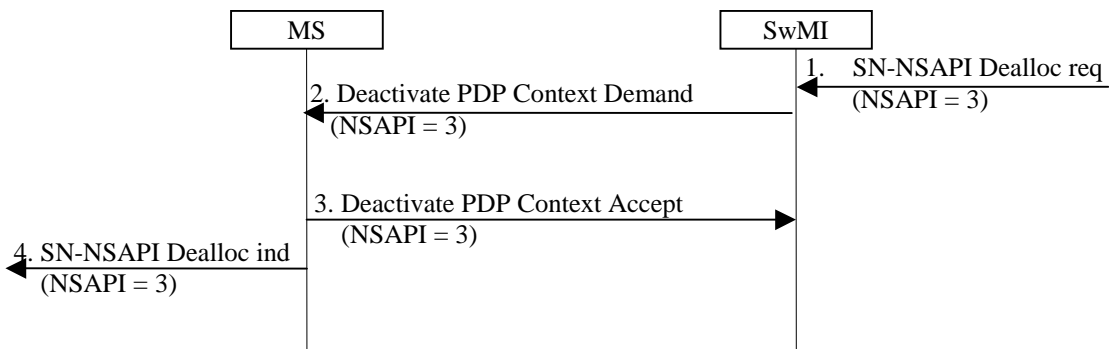

Figure 28.21: SwMI originated PDP context deactivation procedure

1. The SN-SAP user triggers PDP context deactivation by issuing SN-NSAPI DEALLOC request primitive (NSAPI = 3 in this scenario).
2. The SwMI sends a SN-DEACTIVATE PDP CONTEXT DEMAND PDU to the MS.
3. The MS sends a SN-DEACTIVATE PDP CONTEXT ACCEPT PDU to the SwMI.
4. The MS SN-SAP user is informed about PDP context deactivation by the MS SNDSCP issuing SN-NSAPI DEALLOC indication primitive

In a case of failed PDP Context deactivation the SwMI may retry deactivation.

The SwMI may use Deactivation type parameter value "Deactivation of all NSAPIs" when sending the SN-DEACTIVATE PDP CONTEXT DEMAND PDU. Should this happen, the MS shall respond to the demand by sending a SN-DEACTIVATE PDP CONTEXT ACCEPT PDU having Deactivation type parameter value "Deactivation of all NSAPIs" and deactivate all NSAPIs locally.

28.3.3a Assignment of layer 2 logical links to PDP contexts

Four different types of layer 2 logical links are available for transmission of N-PDUs. These are:

- original acknowledged advanced link;
- extended acknowledged advanced link;
- unacknowledged advanced link; and

- unacknowledged basic link.

The MS may support up to four acknowledged advanced links. One of these may be an original advanced link or an extended advanced link. The other three shall be extended advanced links. Extended advanced links may use a larger transmission window size than the original advanced link, and this may be beneficial where multiple applications are using the same link. However, extended advanced links have slightly less capacity than the original advanced link.

Information about the support by a conventional access cell for the original advanced link is broadcast in the "BS service details" information element of the D-MLE-SYSINFO and D-MLE-SYSINFO-Q PDUs. Information about the support by a conventional access cell for extended advanced links is broadcast in section 1 of the "extended services broadcast" information element of the MAC SYSINFO PDU and the MAC SYSINFO-Q PDU. Broadcast parameters are passed to the MS SMDCP in the MLE-INFO primitive.

A direct access cell always supports original and extended advanced links when the "system wide services" information element in the D-MLE-SYSINFO-DA (and D-MLE-SYNC-DA) PDU indicates "normal mode" (system wide services supported). When the "system wide services" information element in the D-MLE-SYSINFO-DA (and D-MLE-SYNC-DA) PDU indicates "system wide services temporarily not supported", it is optional for the direct access cell to support original and extended advanced links.

NOTE: If an MS on a direct access cell receives an AL-DISC PDU with a report "service temporarily unavailable" the MS should not continue to attempt to establish advanced links while the "system wide services" information element indicates "system wide services temporarily not supported" (though the MS is not precluded from occasionally attempting to establish advanced links).

The MS may also support up to four unacknowledged advanced links per address and a single unacknowledged basic link.

The MS SMDCP shall assign a layer 2 link to a PDP context before transmitting or receiving SN-DATA or SN-UNITDATA PDUs for that PDP context.

The MS SMDCP shall request the MS LLC to set up acknowledged advanced links when required, and the SwMI shall set up unacknowledged advanced links when required (see clause 28.3.4.2). The unacknowledged basic link does not require setting up.

If the MS and SwMI negotiated QoS during activation of the PDP context, the MS's choice of layer 2 logical link type shall be based on the data class information element included in the QoS information element of the most recently exchanged SN-ACTIVATE PDP CONTEXT ACCEPT PDU or SN-MODIFY PDP CONTEXT RESPONSE PDU for that PDP context. If the MS and SwMI did not negotiate QoS during PDP context activation, the MS SMDCP shall assign an acknowledged advanced link to the PDP context. Table 28.15 specifies how the MS's choice of logical link type depends on negotiated data class and use of QoS negotiation.

Table 28.15: Assignment of layer 2 logical link type to PDP context

Data class	Link type
Background	Acknowledged advanced link
Telemetry	Acknowledged advanced link
Real-time	Unacknowledged basic link (see note)
QoS not negotiated	Acknowledged advanced link
NOTE:	It is expected that a real-time class PDP context might be used only for unacknowledged streamed data. If any associated control signalling needs to be sent using an acknowledged service then a telemetry or background class PDP context using an acknowledged advanced link with small window size may be appropriate for the control signalling.

The MS SMDCP shall assign one of the available advanced links to a PDP context before the MS or SwMI commences transmitting SN-DATA PDUs for that PDP context. The MS SMDCP may use the contents of the QoS parameter in the most recently exchanged SN-ACTIVATE PDP CONTEXT ACCEPT PDU or SN-MODIFY PDP CONTEXT RESPONSE PDU (containing modify type = "response") for that PDP context, if available, to assist in its choice of acknowledged advanced link identifier and type (original or extended). If the MS and SwMI did not negotiate QoS during PDP context activation, the MS should choose an acknowledged advanced link suitable for background class data (see clause 28.3.3b).

When assigning particular acknowledged advanced links to PDP contexts, the MS may choose to group PDP contexts requiring the same data class and reliability class on the same acknowledged advanced link. When an advanced link is required, the MS SNDCP may request LLC to set up the acknowledged advanced link with a TL-SDU window size, maximum number of TL-SDU transmissions and maximum number of segment retransmissions suited to the QoS requirements of the PDP contexts assigned to that link (see clause 28.3.3b).

When the SwMI transmits an SN-DATA PDU, it should use the most suitable existing acknowledged advanced link.

If the MS receives an individually addressed SN-DATA TRANSMIT REQUEST for a PDP context whose assigned acknowledged advanced link has not been set up, the MS should set up the assigned acknowledged advanced link as soon as the MS reaches the PDCH. If the SwMI has already started using a different acknowledged advanced link, the SwMI should change to the new, more suitable link when it has delivered all the SN-DATA PDUs already being sent on the previous acknowledged advanced link for that PDP context, if it thinks the new advanced link is more suitable.

When the SwMI wishes to transmit unacknowledged packet data to one or more MSs, it may use the unacknowledged basic link (e.g. for real-time class data) or it shall set up and use an unacknowledged advanced link.

28.3.3b Choice of layer 2 logical link parameters

When setting up an acknowledged advanced link, the MS should attempt to set the parameters to suit the QoS requirements of the PDP contexts assigned to use that link.

An advanced link assigned for telemetry class data may be given a window size greater than 1 to help the transmitter to catch up with the schedule after a scheduled grant is missed or a transmission fails, but kept small (e.g. N.272 = 2 or 3) to limit the loss of partially delivered TL-SDUs if the link has to be reset. The maximum number of TL-SDU retransmissions (N.273) and the maximum number of segment retransmissions (N.274) may be set to a small number (e.g. 2 or 3), so that the transmitter can abandon an undelivered TL-SDU, reset the advanced link and move on to the new TL-SDU before too much delay is incurred.

An advanced link assigned for use by background class data may be given a large window size (e.g. N.272 = 15), a large maximum number of TL-SDU retransmissions (e.g. N.273 = 7) and a large maximum number of segment retransmissions (e.g. N.274 = 15) to maximize the chance of ultimately delivering the TL-SDU. However, if a low delay is required, it may be preferable to use a small window size.

SNDCP should set the FCS flag in the MLE-UNITDATA request primitive to instruct the LLC to use the FCS when transmitting an SN-DATA PDU containing best effort class data or telemetry class data requiring high reliability. SNDCP should set the FCS flag to instruct the LLC not to use an FCS when transmitting an SN-UNITDATA PDU containing real-time class data.

28.3.4 Packet Data Channel (PDCH) handling procedures

28.3.4.0 General

The control channel procedures specified in the present document apply for TETRA packet data. The control channel used for TETRA packet data SN-PDU transfer is called the Packet Data Channel (PDCH). The SwMI may add channel allocation to SN-DATA TRANSMIT REQUEST PDU (Data from SwMI to MS). The SwMI may add channel allocation to SN-DATA TRANSMIT RESPONSE PDU (data from MS to SwMI) if the MS's request to transmit is accepted by the SwMI.

Clause 28.3.4.8 describes how the SwMI should select an appropriate PDCH.

The channel is released by the SwMI by issuing SN-END OF DATA PDU when SwMI's READY timer expires. Where the MS was directed to the PDCH using a channel allocation, then the SN-END OF DATA PDU shall include channel allocation to common control channel. If the READY timer expires in the MS, then the MS shall issue SN-END OF DATA PDU and await a corresponding SN-END OF DATA PDU from the SwMI.

If the packet data service in the MS is overridden by some other service requiring an immediate channel change, the MS may release the channel without waiting to receive an SN-END OF DATA PDU by sending the SwMI an SN-END OF DATA PDU indicating "immediate service change" and then immediately entering the STANDBY state.

If the MS receives an SN-NSAPI-DEALLOC request primitive from the SNDCP service user requesting deactivation of a PDP context with an active CONTEXT_READY timer at a time when no other PDP contexts have active CONTEXT_READY timers, or if the SN-NSAPI-DEALLOC request primitive requested deactivation of all PDP contexts, the MS may attempt to return to the STANDBY state prior to the expiry of the READY timer by sending an SN-END OF DATA PDU that does not indicate "immediate service change". The MS shall then await a corresponding SN-END OF DATA PDU from the SwMI before entering the STANDBY state. (However, if the packet data service in the MS is at the same time overridden by some other service requiring an immediate channel change, the MS may indicate "immediate service change" in the SN-END OF DATA PDU as described above.) If the SN-NSAPI-DEALLOC request primitive did not request deactivation of all PDP contexts with active CONTEXT-READY timers, the MS should not send an SN-END OF DATA PDU in response to the primitive (except in the case where an immediate service change is required). When the MS returns to the STANDBY state it shall deactivate the indicated PDP contexts as described in clause 28.3.3.

An SN-END OF DATA PDU indicating "immediate service change" may be sent on the PDCH, some other allocated channel or a common control channel.

NOTE 1: The case where the READY timer expires in the MS prior to reception of a SN-END OF DATA PDU should be viewed as an exceptional case. To ensure the MS receives a SN-END OF DATA PDU from the SwMI before its READY timer expires, the SwMI should set its own READY timer to a shorter value than the one sent to the MS in the SN-ACTIVATE PDP CONTEXT ACCEPT PDU.

NOTE 2: The packet channel is defined from a single MS point of view (except when the SwMI uses multicast address). Thus here releasing the PDCH means releasing the channel for a single MS. In the same control channel there may be also more than one MS at the same time.

NOTE 3: The MS may choose to adjust its value of T.208 against READY timer on a PDCH to ensure that the use of SN-END OF DATA will be the normal way of leaving a PDCH.

28.3.4.1 Logical link handling

Table 28.16 defines the division between basic link and advanced link based on SN-PDU type.

Table 28.16: Logical link usage by SN-PDUs

SN-PDU	Basic link	Advanced links
SN-ACTIVATE PDP CONTEXT DEMAND	x	
SN-DEACTIVATE PDP CONTEXT DEMAND	x	
SN-ACTIVATE PDP CONTEXT ACCEPT	x	
SN-ACTIVATE PDP CONTEXT REJECT	x	
SN-DEACTIVATE PDP CONTEXT ACCEPT	x	
SN-DATA-PRIORITY ACKNOWLEDGEMENT	x	
SN-DATA-PRIORITY INFORMATION	x	
SN-DATA-PRIORITY REQUEST	x	
SN-MODIFY PDP CONTEXT REQUEST	x	
SN-MODIFY PDP CONTEXT RESPONSE	x	
SN-MODIFY PDP CONTEXT AVAILABILITY	x	
SN-MODIFY PDP CONTEXT USAGE	x	
SN-UNITDATA	x (see note)	x (see note)
SN-DATA		x
SN-DATA TRANSMIT REQUEST	x	
SN-DATA TRANSMIT RESPONSE	x	
SN-NOT SUPPORTED	x	
SN-RECONNECT	x	
SN-PAGE REQUEST	x	
SN-PAGE RESPONSE	x	
SN-END OF DATA	x	
NOTE:	The SwMI and MS use the unacknowledged basic link service for real-time class data. The SwMI uses the unacknowledged advanced link service for point-to-multipoint telemetry class and background class data.	

The basic link's unacknowledged and acknowledged services are used by the MS and SwMI according to table 28.17.

Table 28.17: Usage of basic link unacknowledged and acknowledged services

SN-PDU	Unacknowledged	Acknowledged
SN-ACTIVATE PDP CONTEXT DEMAND		x
SN-DEACTIVATE PDP CONTEXT DEMAND		x
SN-ACTIVATE PDP CONTEXT ACCEPT		x
SN-ACTIVATE PDP CONTEXT REJECT		x
SN-DEACTIVATE PDP CONTEXT ACCEPT		x
SN-DATA-PRIORITY ACKNOWLEDGEMENT		x
SN-DATA-PRIORITY INFORMATION		x
SN-DATA-PRIORITY REQUEST		x
SN-MODIFY PDP CONTEXT REQUEST		x
SN-MODIFY PDP CONTEXT RESPONSE		x
SN-MODIFY PDP CONTEXT AVAILABILITY		x
SN-MODIFY PDP CONTEXT USAGE		x
SN-DATA TRANSMIT REQUEST	x (see note 1)	x (see note 1)
SN-DATA TRANSMIT RESPONSE	x	x (see note 2)
SN-NOT SUPPORTED	x (see note 1)	x (see note 1)
SN-RECONNECT		x
SN-PAGE REQUEST	x (see note 2)	x (see note 2)
SN-PAGE RESPONSE		x
SN-END OF DATA	x (see note 1)	x (see note 1)
SN-UNITDATA	x (see note 3)	
NOTE 1: The SwMI may use either unacknowledged or acknowledged basic link service and the MS shall use acknowledged service.		
NOTE 2: The SwMI may use either acknowledged or unacknowledged basic link service.		
NOTE 3: The SwMI and MS use the unacknowledged basic link service for real-time class data.		

The lower layer service selection is informed in the protocol model to the lower layers in the corresponding MLE service request primitive as the "layer 2 service" parameter.

28.3.4.2 Logical link setup

See also clause 28.3.4.8 on selection of physical channels and clause 28.3.5.2a on usage of the "resource request" information element.

N-PDUs may be sent on acknowledged advanced links, unacknowledged advanced links, and on the unacknowledged basic link. Clause 28.3.3a describes how SMDCP assigns particular logical links to PDP contexts. Clause 28.3.3b suggests how the MS SMDCP may choose appropriate link parameters.

The MS shall take the active part in establishing acknowledged advanced links. Up to four advanced links may be used by the SMDCP per MS for acknowledged service. The MS shall not establish an advanced link for packet data if there are no PDP contexts active. Furthermore the SMDCP entity tracks whether each underlying advanced link is established or not.

The SwMI shall take the active part in establishing unacknowledged advanced links. Up to four advanced links may be used by the SMDCP per address for the unacknowledged service, and shall be established when required by the SwMI.

The unacknowledged basic link does not need to be set up.

The advanced links are established on the PDCH under the control of SMDCP. Once established, the advanced links stay established even when the MS resides on the common control channel (MCCH or MCCH-Q or common SCCH) but still the MS SMDCP shall not use an advanced link without requesting the SwMI for permission.

NOTE 1: The MS may be involved in circuit mode speech/data in between accessing a PDCH. Then the advanced links remain established.

The MS shall not attempt to establish an acknowledged advanced link on a cell where a subscriber class mismatch exists (see clause 16.4.9) or on a not-permitted cell (see clause 18.3.5.1.5).

There are four scenarios listed below where a MS may establish or reset the acknowledged advanced link.

a) Inbound or outbound data pending - no active advanced link

A MS shall establish an acknowledged advanced link if the MS has assigned an acknowledged advanced link to the relevant PDP context and the assigned acknowledged advanced link is not already active either if the MS has data to send or if the MS is notified by an individually-addressed SN-DATA TRANSMIT REQUEST PDU from the SwMI that there is outbound data pending. This scenario is the typical scenario where a MS, after successfully activating a PDP context, wishes to send data. An example of the establishment of an advanced link in this scenario is presented in figures 28.22 to 28.25.

NOTE 2: The examples described below assume a channel allocation is required to direct a MS from its current channel to the PDCH. There may however be occasions where the SwMI decides to allow packet data transfer on a common control channel and therefore a channel allocation may not be required.

NOTE 3: The examples described below shows the MLE as the entity in the SwMI negotiating the establishment of advanced links. This is due to there being no information contained within the AL-SETUP PDUs to indicate the layer 3 entity in the MS (e.g. SNDCP, SDS, SS etc) which initiated the advanced link establishment, thus the SwMI MLE entity would be expected to negotiate on behalf of all SwMI layer 3 entities. The present document does not define how the establishment of advanced links is negotiated within the SwMI.

In figure 28.22 the establishment of an acknowledged advanced link is initiated by the arrival at the MS SNDCP entity of a SN-DATA request primitive. While on a common control channel (MCCH or MCCH-Q or common SCCH), the MS will send a SN-DATA TRANSMIT REQUEST PDU on the uplink using the acknowledged basic link service. The SwMI will respond by sending a SN-DATA TRANSMIT RESPONSE PDU to the MS. The MAC-RESOURCE PDU which contains this PDU includes a "Channel Allocation" information element. As no advanced link exists, the SwMI shall direct the MS to a suitable PDCH (unless the current channel is suitable). Clause 28.3.4.8 describes the procedure which the SwMI should use to choose a suitable PDCH.

Once on the PDCH, the MS shall establish an advanced link if the advanced link assigned to the PDP context referenced in the SN-DATA request or SN-UNITDATA request primitive is not already established. This is achieved through the sending of a MLE-CONNECT request primitive to the MLE.

NOTE 4: If SNDCP did not send a "resource request" information element (see clause 28.3.5.2a), SNDCP should provide no information about throughput in the MLE-CONNECT request primitive's "quality of service (QoS) for layer 2" parameter.

Within the MAC-ACCESS PDU used to carry the AL-SETUP PDU on the uplink, the MS may include a "Reservation Requirement" for the total number of slots needed to transfer the N-PDU. The MAC-RESOURCE PDU used to carry the AL-SETUP PDU response on the downlink may include a "Slot Granting" information element to reserve the required number of slots for the MS on the uplink.

Also, the SwMI may alter the capacity of the PDCH by including in the MAC-RESOURCE PDU used to carry the AL-SETUP PDU response on the downlink a "Channel Allocation" information element with "allocation type" = 00 - see clause 23.5.4.2.1 and its clauses of the present document. (For example, the SwMI could decide to alter the number of timeslots per TDMA frame of a phase modulation PDCH depending on the number of $\pi/4$ -DQPSK timeslots per TDMA frame requested by the MS in an AL-SETUP PDU. Or the SwMI could move the MS from a QAM PDCH to a phase modulation PDCH within the MS's declared capabilities if the MS requests a phase modulation connection in an AL-SETUP PDU sent on the QAM PDCH). Once the advanced link has been successfully established, the SNDCP service users in the MS and SwMI shall be notified using the SN-QoS indication primitive. With the advanced link successfully established, the MS may then begin sending the SN-DATA PDU.

Refer clause 28.3.4.6 on the channel change protocol.

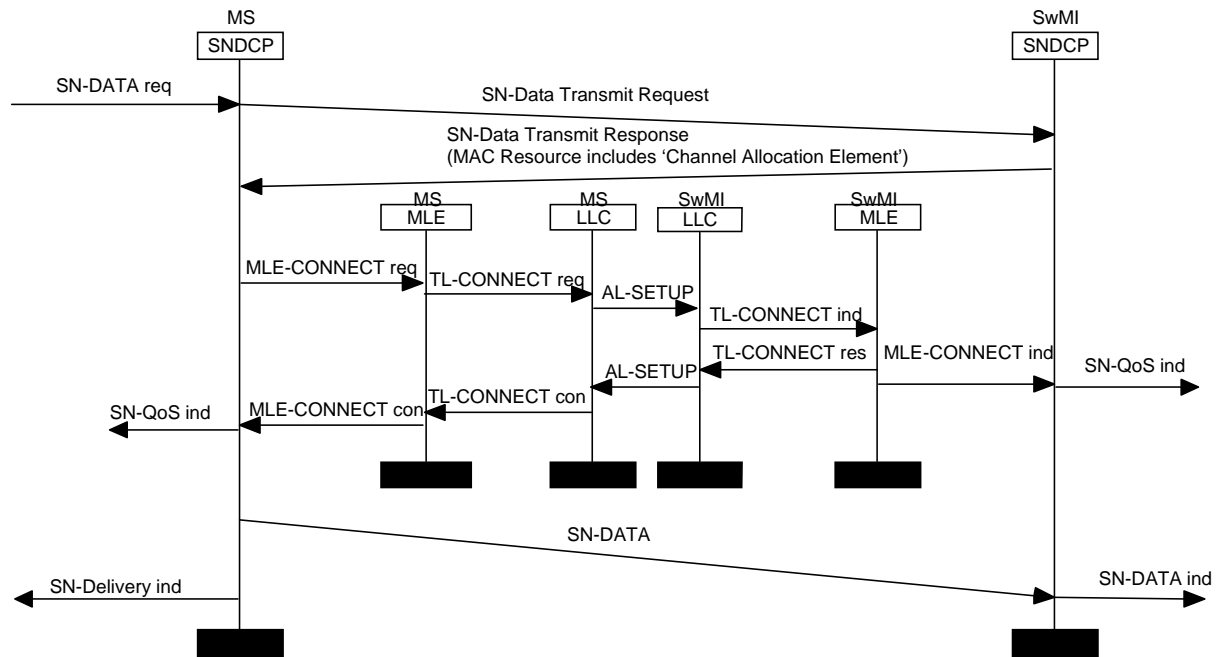

Figure 28.22: Successful advanced link set up, initiated by pending inbound data transfer

In figure 28.23 the establishment of an acknowledged advanced link is initiated by the arrival at the SwMI Sndcp entity of a SN-DATA (or SN-UNITDATA) request primitive. The SwMI shall send a SN-DATA TRANSMIT REQUEST PDU on the downlink using the unacknowledged basic link service. The basic link message shall be transported using a MAC-RESOURCE PDU which, in this example, contains a "Channel Allocation" information element sending the MS to a suitable PDCH. (The procedure for choosing a PDCH is given in clause 28.3.4.)

Once on the PDCH, if the SN-DATA TRANSMIT REQUEST PDU is individually addressed, the MS shall establish an acknowledged advanced link. This is achieved through the sending of a MLE-CONNECT request primitive to the MLE. The SwMI may alter the capacity of the PDCH by including in the MAC-RESOURCE PDU used to carry the AL-SETUP PDU response on the downlink a "Channel Allocation" information element with "allocation type"= 00 - see clause 23.5.4.2.1 of the present document. (For example, the SwMI could decide to alter the number of timeslots per TDMA frame of a phase modulation PDCH depending on the number of $\pi/4$ -DQPSK timeslots per TDMA frame requested by the MS in an AL-SETUP PDU. Or the SwMI could decide to move the MS from a QAM PDCH to a phase modulation PDCH within the MS's declared capabilities if the MS requests a phase modulation connection in an AL-SETUP PDU sent on the QAM PDCH.) Once an advanced link has been successfully established, the Sndcp service users in the MS and SwMI shall be notified using the SN-QoS indication primitive. With an advanced link successfully established, the SwMI may then begin sending the SN-DATA PDU.

Refer to clause 28.3.4.6 on the channel change protocol.

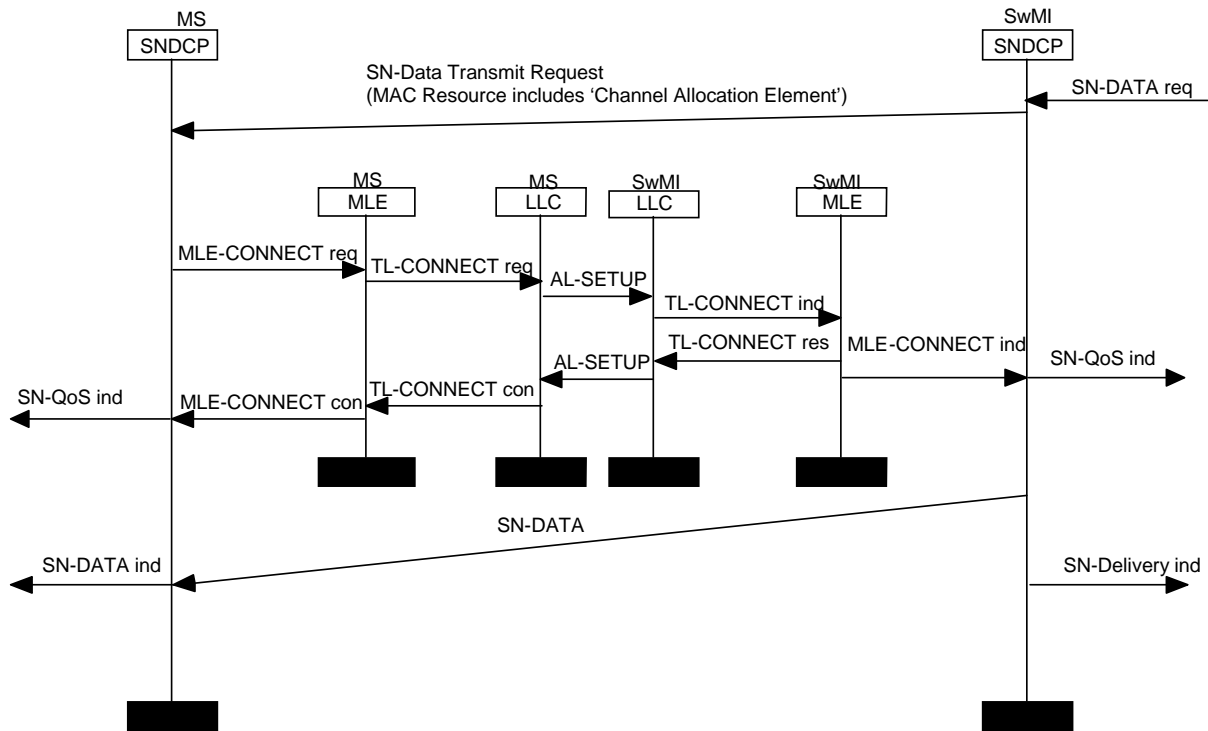

Figure 28.23: Successful advanced link set up, initiated by pending outbound data transfer

Figure 28.24 shows the case where the establishment of the advanced link fails due to the advanced link QoS being offered by the SwMI, being lower than the minimum advanced link QoS which the MS is willing to accept.

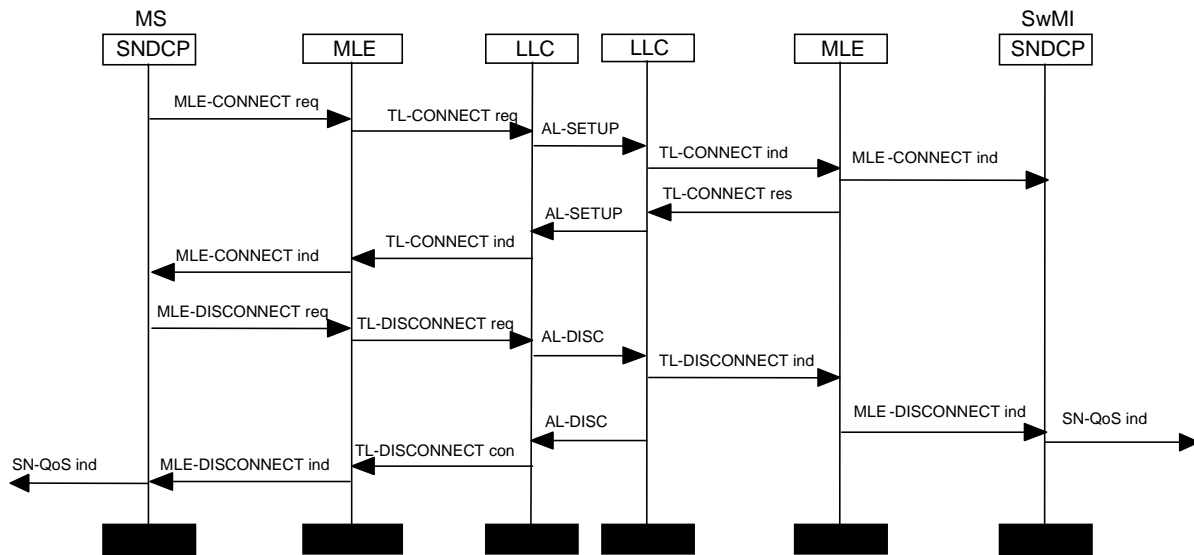

Figure 28.24: Failed advanced link setup - too low advanced link QoS offered by SwMI

Figure 28.25 shows the case where the establishment of the advanced link succeeds, after the MS accepts a lower advanced link QoS than that originally requested.

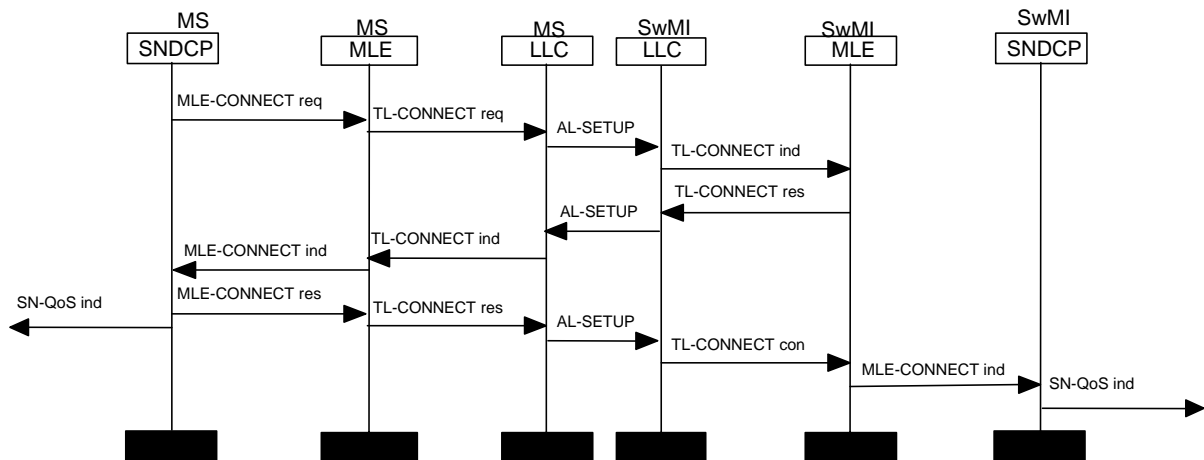

Figure 28.25: Successful advanced link setup - lower advanced link QoS accepted

b) Resetting an active advanced link

At any time both peer entities, MS and SwMI, may reset an advanced link in order to change the advanced link QoS parameters.

NOTE 5: The SwMI should not reset the advanced link QoS number of $\pi/4$ -DQPSK timeslots per TDMA frame to a higher value than the last received advanced link setup initiated by the MS i.e. the upwards advanced link QoS negotiation should be limited to the value indicated by the MS.

NOTE 6: If the MS is on a phase modulation PDCH, the SwMI may temporarily provide fewer or more timeslots per TDMA frame than were negotiated in the advanced link setup. This is indicated in the channel allocation information element and does not thus need advanced link reset. This is, however, against the advanced link QoS negotiation and should be used only because the SwMI temporarily does not have suitable resources for matching the advanced link QoS demand. The SwMI should provide the number of phase modulation timeslots per TDMA frame that was negotiated as soon as conditions permit. If there is a permanent lack of resources, the advanced link may be reset to fewer timeslots per TDMA frame. If the MS is not using a phase modulation PDCH at the time that the SwMI resets the advanced link, the SwMI is not required to take account of any resources that were negotiated in the preceding advanced link setup.

NOTE 7: If QoS was negotiated during PDP context activation, the MS or SwMI should change the QoS by modifying the PDP context (see clause 28.3.3.5a).

c) MS returns from READY Temporary Break state after recovering from cell reselection

The MS SNDCP entity shall re-establish the acknowledged advanced links if the following three conditions are true:

- 1) The MS SNDCP entity is in READY Temporary Break state and receives a MLE-RESUME indication primitive from the MLE.
- 2) There are SN-DATA PDUs pending for transmission.
- 3) The MS does not support advanced link roaming (see clause 28.3.4.4).

Where a MS SNDCP entity, which is in READY Temporary Break state, receives a MLE-RESUME indication primitive from the MLE, it is the responsibility of the MS SNDCP entity to firstly notify the SwMI SNDCP entity that it has regained access to the underlying resources (e.g. cell reselection has completed). This notification is carried out by sending a SN-RECONNECT PDU on the uplink.

NOTE 8: This SN-RECONNECT PDU is of most use when a SwMI is engaged in data transfer on the downlink to a MS and the MS switches cell. The SN-RECONNECT PDU is an efficient means by which the SwMI SNDCP entity can discover the cell change and re-route data accordingly.

If the MS has pending SN-DATA or SN-UNITDATA PDUs for a single NSAPI, the MS shall include that NSAPI in the "NSAPI" information element of the SN-RECONNECT PDU and shall set the "data to send" information element to indicate "SN-DATA PDU or SN-UNITDATA PDU awaiting transmission on uplink".

If the MS has pending SN-DATA or SN-UNITDATA PDUs for more than one NSAPI, the MS shall include an NSAPI with pending SN-DATA or SN-UNITDATA PDUs in the "NSAPI" information element of the SN-RECONNECT PDU and shall set the main "data to send" information element to indicate "SN-DATA PDU or SN-UNITDATA PDU awaiting transmission on uplink". (Note that there are supplementary "data to send" information elements in the "NSAPI for reconnection" information element.) The MS may include the NSAPIs of the remaining PDP contexts with active CONTEXT_READY timers in the "NSAPI for reconnection" information element. The SwMI should regard the NSAPI in the "NSAPI" information element as having higher priority than the NSAPIs in the "NSAPI for reconnection" information element. The SwMI should regard the NSAPIs in the "NSAPI for reconnection" element as having been sent in order of priority, most important first.

NOTE 9: In both the above cases, the MS is not precluded from including the same NSAPI in both the "NSAPI" information element and the "NSAPI for reconnection" information element (though there is no purpose for this in the present document). If this occurs, the SwMI should ignore the second instance of the same NSAPI. (It is intended that in a future version of the present document the SwMI should use the additional information about the NSAPI in the "NSAPI for reconnection" information element when the same NSAPI is included in both information elements.)

The SN-RECONNECT PDU shall be transmitted using the acknowledged basic link service. The SN-RECONNECT PDU includes a main "data to send" information element which indicates if the MS has SN-DATA or SN-UNITDATA PDUs awaiting transmission and includes further "data to send" information elements in the "NSAPI for reconnection" information element (if present). Upon successful transmission of the SN-RECONNECT PDU with the main "Data to Send" = 0 (thus indicating that the MS has no data to send), the MS shall stop the READY timer, shall stop any CONTEXT_READY timers, shall start the STANDBY timer and shall enter state STANDBY. Upon successful transmission of the SN-RECONNECT PDU with the main "data to send" = 1 (thus indicating that the MS has data to send), the MS shall stop the READY timer, shall stop any CONTEXT_READY timers, shall start the STANDBY and RESPONSE_WAIT timers and shall enter state RESPONSE-WAITING. On reception of the SN-RECONNECT PDU, the SwMI SMDCP entity shall stop the READY timer and any CONTEXT_READY timers, start the STANDBY timer and enter state STANDBY. The SwMI SMDCP entity shall check if the MS has indicated within the SN-RECONNECT PDU that it has a pending SN-DATA or SN-UNITDATA PDU for transfer on the uplink. The SwMI SMDCP shall also check to see if there is a pending SN-DATA PDU or SN-UNITDATA PDU for transfer on the downlink. The message (if any), sent on the downlink by the SMDCP entity is shown in table 28.18.

Table 28.18: Message sent by SwMI in response to SN-RECONNECT from MS

MS has SN-DATA PDU or SN-UNITDATA PDU pending	SwMI has SN-DATA or SN-UNITDATA PDU pending	SwMI response
No	No	no response
Yes	No	SN-DATA TRANSMIT RESPONSE
No	Yes	SN-DATA TRANSMIT REQUEST
Yes	Yes	SN-DATA TRANSMIT RESPONSE

NOTE 10: The MS is not precluded from setting "data to send" if it wishes to be on a PDCH because it expects imminent reception of data on the downlink or imminent arrival of data for transmission on the uplink.

The SwMI may include a channel allocation in the SN-DATA TRANSMIT REQUEST or SN-DATA TRANSMIT RESPONSE PDU, sending the MS to the PDCH. The SN-DATA TRANSMIT REQUEST or SN-DATA TRANSMIT RESPONSE PDU shall include the NSAPI or NSAPIs that the SwMI has successfully reconnected.

NOTE 11: The SwMI is not precluded from including the same NSAPI in both the "NSAPI" information element and the "NSAPI additional" information element (though there is no purpose for this in the present document). If this occurs, the MS should ignore the second instance of the same NSAPI. (It is intended that in a future version of the present document the MS should use the additional information about the NSAPI in the "NSAPI additional" information element when the same NSAPI is included in both information elements.)

The MS shall start the READY timer and shall (if supported) start the CONTEXT_READY timers of those PDP contexts included in the SN-DATA-TRANSMIT REQUEST or SN-DATA-TRANSMIT RESPONSE PDU. Once on the PDCH, the MS shall re-establish the advanced links that it has assigned to the PDP contexts identified by the NSAPIs included in the SN-DATA TRANSMIT REQUEST or SN-DATA TRANSMIT RESPONSE PDU.

If, while awaiting a response to an SN-RECONNECT PDU, the MS SNDCP receives an SN-DATA TRANSMIT RESPONSE PDU with Accept/Reject = 0 or the RESPONSE_WAIT timer expires, the MS SNDCP shall stop the RESPONSE_WAIT timer, issue MLE-RELEASE request primitives asking MLE to locally disconnect the advanced links and shall enter STANDBY state.

NOTE 12: For direct access, the BS always supports the SNDCP service when the "system wide services" information element in the D-MLE-SYSINFO-DA (and D-MLE-SYNC-DA) PDU indicates "normal mode" (system wide services supported); see clause 18. A direct access MS may send an SN-RECONNECT PDU to the SwMI while the "system wide services" information element in the D-MLE-SYSINFO-DA (or D-MLE-SYNC-DA) PDUs is indicating "system wide services temporarily not supported"; however the BS in this mode may temporarily not support the SNDCP service, in which case the BS may send the SN-DATA TRANSMIT RESPONSE PDU with reject cause "SNDCP service temporarily not available".

A conventional access MS is not permitted to send the SN-RECONNECT PDU while the D-MLE SYSINFO or D-MLE SYSINFO-Q PDUs are indicating "SNDCP service is not available on this cell".

NOTE 13: The MS is not permitted to send the SN-RECONNECT PDU on a cell where a subscriber class mismatch exists (see clause 16.4.9) or on a not-permitted cell (see clause 18.3.5.1.5).

Figure 28.26 presents the case where the MS has data to send and re-establishes the advanced link once on the PDCH.

In this case, the MS SNDCP entity is in state READY Temporary Break and receives a MLE-RESUME indication primitive from the MLE, thus indicating that access to the communication resources has become available again. It sends a SN-RECONNECT PDU to the SwMI SNDCP entity, stops the READY timer, stops all CONTEXT_READY timers, starts the STANDBY and RESPONSE_WAIT timers and enters RESPONSE-WAITING state. On reception of the SN-RECONNECT PDU, the SwMI stops the READY timer and any CONTEXT_READY timers, starts the STANDBY timer and enters STANDBY state. The SwMI on seeing that the MS has indicated in the SN-RECONNECT PDU that it has a SN-DATA or SN-UNITDATA PDU awaiting transfer on the uplink, shall respond with a SN-DATA TRANSMIT RESPONSE PDU.

The SN-DATA TRANSMIT RESPONSE PDU may be sent using the acknowledged basic link service or the unacknowledged basic link service. Where the MS (after recovering from the radio downlink failure) is on a common control channel (MCCH or MCCH-Q or common SCCH), the MAC-RESOURCE PDU which contains this message shall (unless the current channel is suitable) either include a "Channel Allocation" information element which directs the MS to a PDCH chosen by the SwMI (taking into account the MS's declared capabilities and negotiated or default QoS requirements), or, if requested by the "resource request" information element in the SN-RECONNECT PDU, shall include a "Channel Allocation" information element which should direct the MS to a single-slot or multi-slot phase modulation PDCH within the MS's declared capabilities (see clause 28.3.4.8). On transmission of the SN-DATA TRANSMIT RESPONSE PDU, the SwMI shall stop the STANDBY timer, start the READY timer and enter READY state. The SwMI may start CONTEXT_READY timers (see clause 28.2.6.2). On reception of the SN-DATA TRANSMIT RESPONSE PDU, the MS shall stop the STANDBY and RESPONSE_WAIT timers, start the READY timer, shall, if supported, start CONTEXT-READY timers for the indicated PDP contexts, and shall enter READY state.

NOTE 14: The MS's default QoS requirements are for background class data with unspecified throughput, delay and reliability.

On the PDCH, the MS shall re-establish the advanced links assigned to the PDP contexts which have data waiting to be sent. This is achieved through the sending of MLE-CONNECT request primitives to the MLE. Within the MAC-ACCESS PDU used to carry the AL-SETUP PDU on the uplink, the MS may include a "Reservation Requirement" information element for the total number of timeslots needed to transfer any pending data. The MAC-RESOURCE PDU used to carry the AL-SETUP PDU response on the downlink may include a "Slot Granting" information element to reserve timeslots for the MS on the uplink. Also, the SwMI may alter the capacity of the PDCH by including in the MAC-RESOURCE PDU a "Channel Allocation" information element with "allocation type" = 00 - see clause 23.5.4.2.1 and its clauses of the present document. (For example, the SwMI could decide to alter the number of timeslots per TDMA frame of a phase modulation PDCH depending on the number of $\pi/4$ -DQPSK timeslots per TDMA frame requested by the MS in an AL-SETUP PDU. Or the SwMI could move the MS from a QAM PDCH to a phase modulation PDCH within the MS's declared capabilities if the MS requests a phase modulation connection in an AL-SETUP PDU sent on the QAM PDCH).

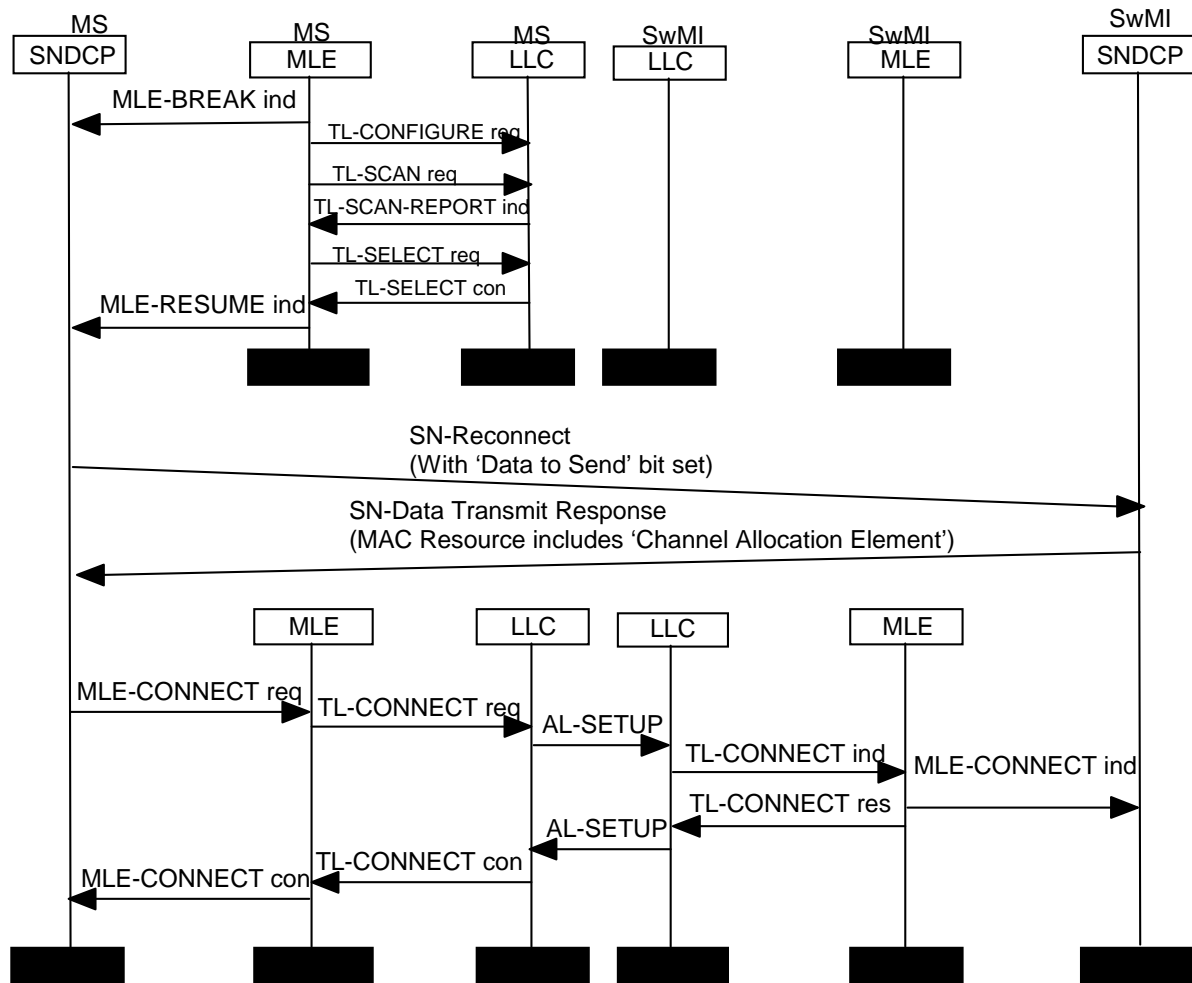

Figure 28.26: Advanced link set up after a radio downlink failure, with MS in READY state

d) Failure to send a N-PDU

After receiving an MLE-REPORT indication primitive indicating failure sending a N-PDU the MS or SwMI shall reset the relevant advanced link. This reset is required by the SNDSCP user application and compression mechanisms expecting a reliable link. This link reset is required when even a single N-PDU is lost. This applies for both the MS and SwMI i.e. the SwMI should reset the relevant advanced link when it recognizes failure sending a N-PDU.

Where the MS SNDSCP entity receives a SN-END OF DATA PDU from the SwMI (effectively moving the MS off the PDCH), prior to reception of a MLE-REPORT indicating whether the transmission of a SN-DATA or SN-UNITDATA PDU was successful or not, then the MS shall reset the assigned advanced link (SN-DATA PDU only) and notify the service user, with a SN-DELIVERY indication primitive, of the failure to send the SN-DATA or SN-UNITDATA PDU. This scenario is shown in figure 28.27.

In the example, a MS passes a SN-DATA PDU to the lower layers. It then receives a SN-END OF DATA from the peer SNDSCP entity in the SwMI. As the MS SNDSCP has not yet had confirmation (in the form of a MLE-REPORT indication primitive) that the previous SN-DATA was successfully transmitted, it resets the assigned advanced link. Before sending the AL-SETUP PDU with a reason "Reset", the MS sends SN-DATA TRANSMIT REQUEST PDU to the SwMI in order to get to the PDCH where it can re-establish the assigned advanced link.

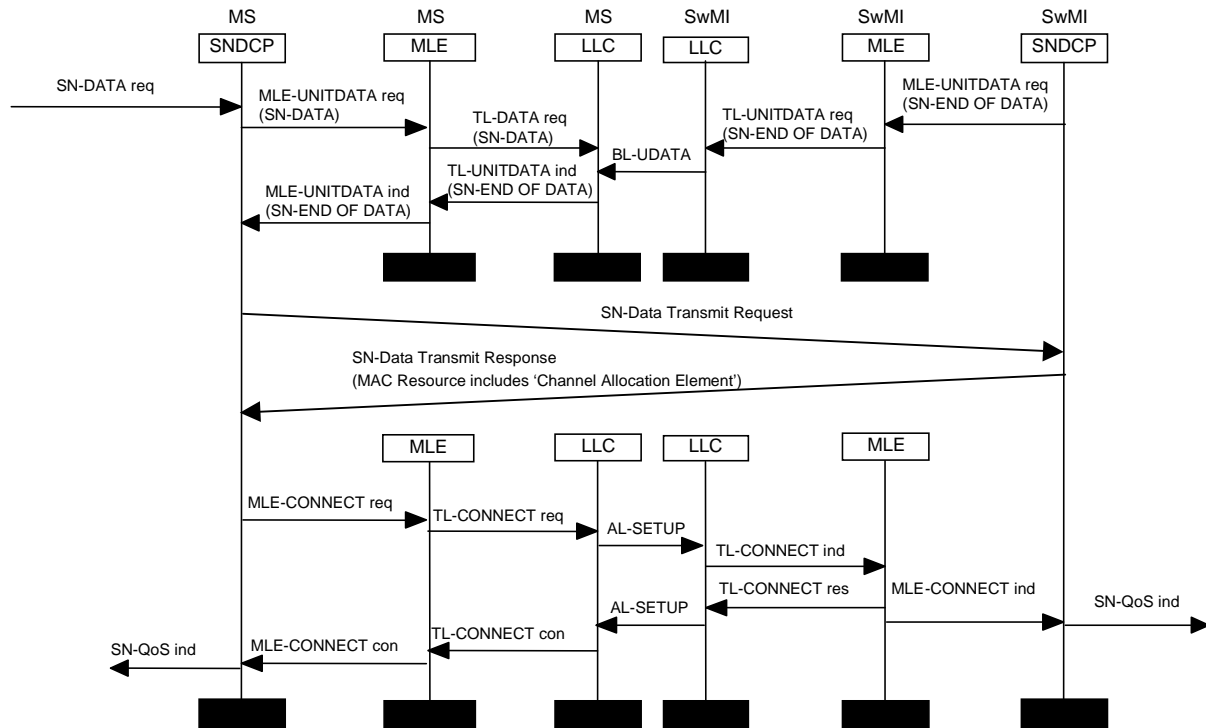

Figure 28.27: Resetting advanced link after reception of SN-END OF DATA PDU prior to completing transfer of previous SN-DATA PDU

e) Return from circuit mode call

In an alternating voice and data communication a MS can be offered a group call on the PDCH and the MS may accept the group call. The MS may want to return to the interrupted PDCH communication and the MS SNDSCP entity may notify the SwMI SNDSCP entity that it is again available. In case the MS has no data to send this notification is carried out by sending a SN-RECONNECT PDU on the uplink; if the MS has data to send then it is done with SN-TRANSMIT REQUEST PDU when the SERVICE_CHANGE timer is inactive.

If the MS supports and needs to reconnect advanced link after return from the voice call, then clause 28.3.4.4 is applicable.

28.3.4.3 Logical Link disconnection

An acknowledged advanced link is disconnected before the deactivation of the last PDP context assigned to that advanced link, as shown in figure 28.28. The disconnection is triggered by the MS. In case of MS originated PDP context deactivation procedure (e.g. the SN-SAP user has triggered PDP context deactivation by issuing SN-NSAPI DEALLOC request primitive), the MS shall first disconnect the advanced link explicitly and after advanced link disconnection start the actual PDP context deactivation procedure as defined in clause 28.3.3.6.1. In case of SwMI originated PDP context deactivation procedure, the MS shall trigger advanced link disconnection in reception of a SN-DEACTIVATE PDP CONTEXT DEMAND PDU from the SwMI and shall not respond by a SN-DEACTIVATE PDP CONTEXT ACCEPT PDU until advanced link is explicitly disconnected.

NOTE 1: If the MS has initiated the advanced link disconnection, it should not accept packet data service any more for PDP contexts assigned to that link.

NOTE 2: In case the STANDBY timer expires, the advanced links may be exceptionally released implicitly without sending AL-DISC PDUs.

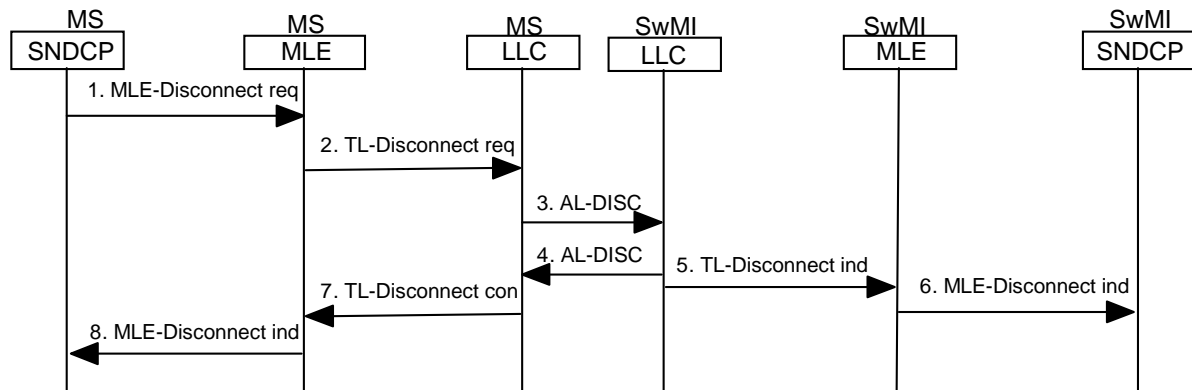

Figure 28.28: Disconnecting advanced link before the last PDP context deactivation

28.3.4.4 Advanced link reconnection

In an attempt to improve the performance of packet data transfer during cell reselection, a SwMI may allow a MS to maintain its advanced link as it roams between cells. The ability for a MS to continue using an advanced link on a new cell with all parameters, variables and timers carried from the previous cell is called advanced link roaming. It is optional for a MS or SwMI to support advanced link roaming. Advanced link roaming is initiated by the MS, by requesting the reconnection of an advanced link on the new cell. The SwMI shall respond to this request by indicating if the request has been accepted or rejected. The reconnection of an advanced link shall only be initiated by the MS. The MS SNDCP entity shall only attempt to reconnect an advanced link if the following two events have occurred:

- 1) The MS SNDCP entity has transmitted a SN-RECONNECT PDU after successful cell handover.
- 2) The MS has received a SN-DATA TRANSMIT RESPONSE PDU accepting the request or a SN-DATA TRANSMIT REQUEST PDU in response to the SN-RECONNECT PDU and moved to the PDCH.

If both the above are true and the MS supports advanced link roaming, then the MS SNDCP entity may issue a MLE-RECONNECT request primitive to the MLE which shall be forwarded to the LLC as a TL-RECONNECT request primitive. The LLC shall build an AL-RECONNECT PDU with reconnect report value "propose" and send it to the SwMI. If the SwMI recognizes the AL-RECONNECT PDU it shall respond with an AL-RECONNECT PDU. In this PDU the SwMI shall indicate if it supports advanced link roaming or not by the reconnect report value "accept" or "reject" respectively. Reception of the AL-RECONNECT PDU from the SwMI shall result in the MS LLC passing a TL-RECONNECT confirm primitive to the MLE and in turn a MLE-RECONNECT confirm primitive being passed to the SNDCP entity. Based on the response from the SwMI, the MS SNDCP entity at this point will know if the advanced link has been successfully reconnected or not. Where multiple acknowledged advanced links are in use, the MS SNDCP may attempt to reconnect each by issuing successive MLE-RECONNECT request primitives to the MLE. The MS SNDCP does not need to await the arrival of a MLE-RECONNECT confirm primitive for one advanced link before sending an MLE-RECONNECT request primitive for another advanced link.

Refer to clause 28.3.4.6 on the channel change protocol.

Figure 28.29 presents the case where both the MS and SwMI support advanced link roaming and where the MS is in ready state with data to transmit when the the cell reselection procedures begin.

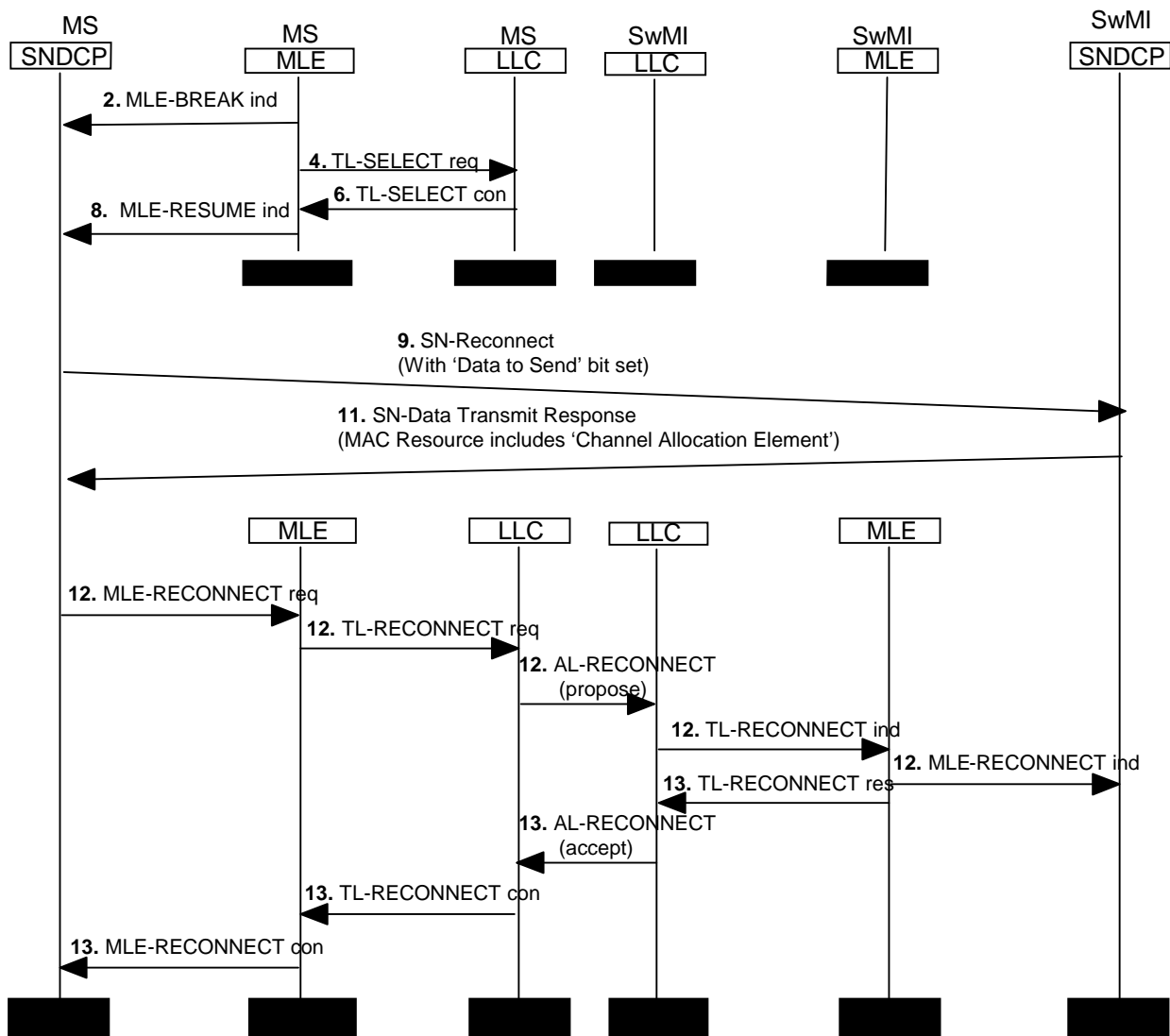

NOTE: Each message number in the figure above has a number associated with it which corresponds to the numbers of the bullet points in the description below.

Figure 28.29: Successfully reconnecting an advanced link after cell reselection. Both MS and SwMI support advanced link roaming

1. Signal quality begins to fall -> MLE decides to switch cell.
2. MLE sends MLE-BREAK indication primitive to Sndcp.
3. As the MS supports advanced link roaming, the MLE will not disconnect the advanced links (i.e. a TL-RELEASE request primitive is not sent to the LLC). The MS Sndcp enters the READY-temporary break state from the READY state.
4. MLE sends TL-SELECT request primitive to the LLC requesting the MAC to switch to the main carrier of the new cell.
5. LLC forwards this as a TMC-SELECT request primitive to the MAC (not shown).
6. The MAC switches to the MCCH or MCCH-Q (or common SCCH) of the new cell and issues a TMC-SELECT confirm primitive to the LLC which is then passed to the MLE as a TL-SELECT confirm primitive.
7. MM performs registration (V+D) and authentication if required (not shown).

8. MLE sends MLE-RESUME indication primitive to SNDCP.
9. SNDCP sends a SN-RECONNECT PDU to the SwMI. If there is data awaiting transmission in the SNDCP buffer, or if the SNDCP entity is aware that a partially transmitted TL-SDU is in the LLC buffers (i.e. one which has not yet been fully transmitted or one for which an acknowledgement has not yet been received from the peer entity), then the "Data to Send" field in the SN-RECONNECT PDU will be set to True else the "Data to Send" field will be set to False. In this case the Data to Send field is set to True.
10. The MS SNDCP entity enters RESPONSE-WAITING state, stops the READY timer, stops all CONTEXT_READY timers and starts the STANDBY and RESPONSE-WAIT timers.
11. On reception of a SN-DATA TRANSMIT RESPONSE PDU from the SwMI, the MS shall switch to the PDCH and enter READY state.

NOTE 1: If for some reason the MS does not receive a SN-DATA TRANSMIT RESPONSE PDU prior to the RESPONSE_WAITING timer expires or if a SN-DATA TRANSMIT RESPONSE PDU is received with Accept/Reject = 0 (i.e. requested is rejected), then SNDCP should attempt to initiate local disconnection of the advanced links.

12. SNDCP requests that an acknowledged advanced link is reconnected by passing MLE-RECONNECT request primitive to the MLE which in turn passes a TL-RECONNECT request primitive to the LLC. The LLC sends an AL-RECONNECT PDU with the reconnect report set to "propose" to the SwMI.
13. The SwMI responds with an AL-RECONNECT PDU, indicating that advanced link roaming is supported by setting the reconnect report set to "accept". The MS may now continue transmitting or receiving LLC segments for that advanced link from where it left off on the previous cell. If SNDCP possesses activated PDP contexts assigned to other acknowledged advanced links, the MS SNDCP may attempt to reconnect those links by issuing further MLE-RECONNECT request primitives (not shown in figure 28.29).

Figure 28.30 presents the case where the MS attempts to reconnect an advanced link on the new cell, but the SwMI rejects this request.

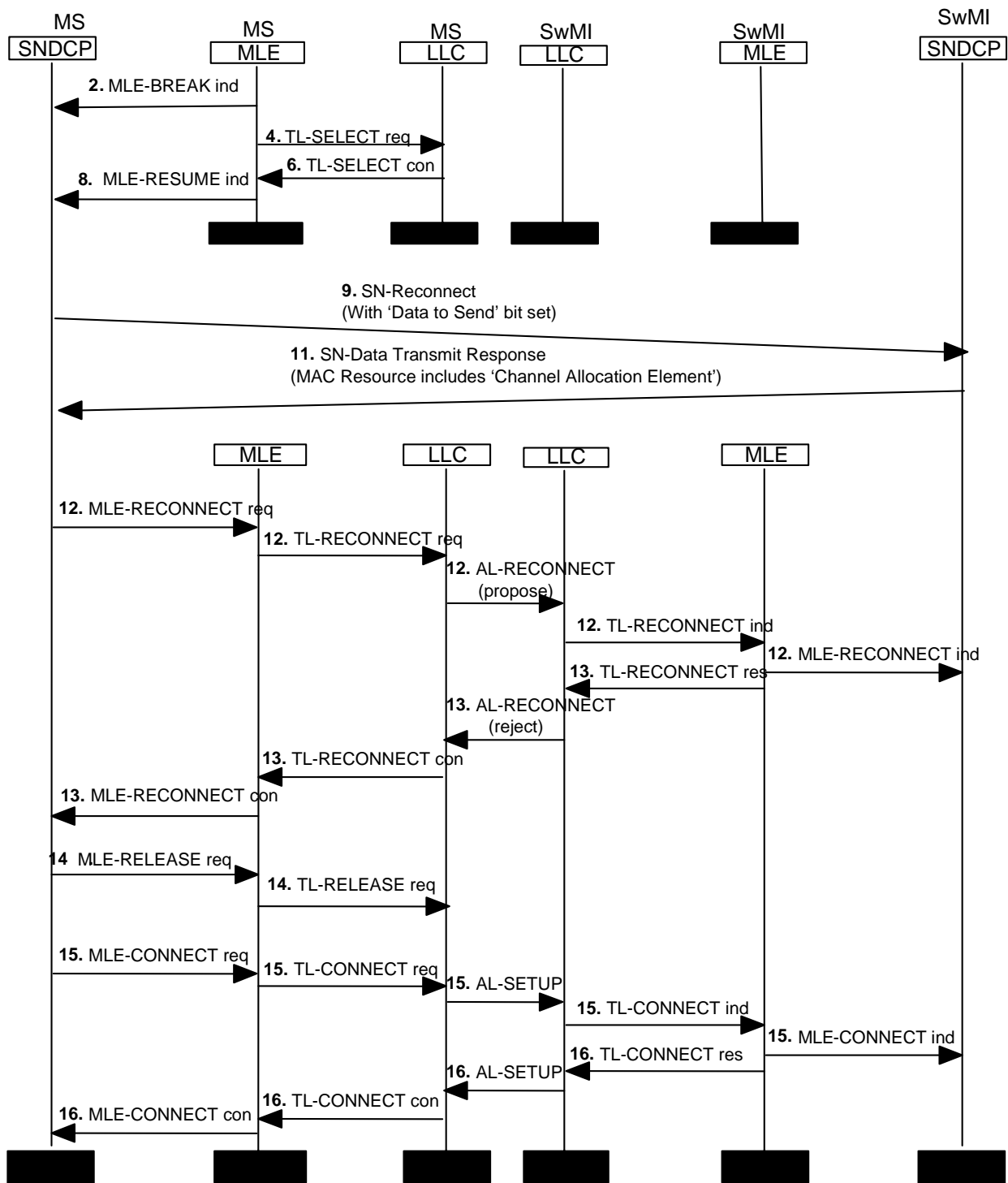

Figure 28.30: Failure to reconnect the advanced link after cell reselection. SwMI does not support advanced link roaming

1. Signal quality begins to fall -> MLE decides to switch cell.
2. MLE sends MLE-BREAK indication primitive to SNDCP.
3. As the MS supports advanced link roaming, the MLE will not disconnect the advanced links (i.e. no TL-RELEASE request primitives are sent to the LLC). The MS SNDCP enters the READY-temporary break state from the READY state.

4. MLE sends TL-SELECT request primitive to the LLC requesting the MAC to switch to the main carrier of the new cell.
5. LLC forwards this as a TMC-SELECT request primitive to the MAC (not shown).
6. The MAC switches to the MCCH or MCCH-Q (or common SCCH) of the new cell and issues TMC-SELECT confirm primitive to the LLC which is then passed to the MLE as a TL-SELECT confirm primitive.
7. MM performs registration (V+D) and authentication if required (not shown).
8. MLE sends MLE-RESUME indication primitive to SNDCP.
9. SNDCP shall send a SN-RECONNECT PDU to the SwMI. If there is data awaiting transmission in the SNDCP buffer, or if the SNDCP entity is aware that a partially transmitted TL-SDU is in the LLC buffers (i.e. one which has not yet been fully transmitted or one for which an acknowledgement has not yet been received from the peer entity), then the "Data to Send" field in the SN-RECONNECT PDU will be set to True. Else the "Data to Send" field will be set to False. In this case it is assumed the Data to Send field is set to True.
10. The MS SNDCP entity enters RESPONSE-WAITING state, stops the READY timer, stops all CONTEXT_READY timers and starts the STANDBY and RESPONSE-WAIT timers.
11. On reception of a SN-DATA TRANSMIT RESPONSE PDU from the SwMI, the MS shall switch to the PDCH and enter READY state.

NOTE 2: If for some reason the MS does not receive a SN-DATA TRANSMIT RESPONSE PDU prior to the RESPONSE_WAITING timer expires or if a SN-DATA TRANSMIT RESPONSE PDU is received with Accept/Reject = 0 (i.e. requested is rejected), then SNDCP should attempt to initiate local disconnection of the advanced link.

12. SNDCP requests that the advanced link is reconnected by passing MLE-RECONNECT request primitive to the MLE which in turn passes a TL-RECONNECT request primitive to the LLC. The LLC sends an AL-RECONNECT PDU to the SwMI with the reconnect report set to "propose". If SNDCP possesses PDP contexts assigned to other acknowledged advanced links, the MS may also attempt to reconnect each of those links by issuing further MLE-RECONNECT request primitives (not shown in figure 28.30).
13. The SwMI responds with an AL-RECONNECT PDU, indicating that advanced link roaming is not supported for the indicated link by setting the reconnect report to "reject".
14. In order to reset the LLC advanced link state machine, the SNDCP entity shall pass a MLE-RELEASE request primitive to the MLE which in turn passes a TL-RELEASE request primitive to the LLC.
15. The SNDCP entity now requests that the advanced link is reset by passing MLE-CONNECT request primitive to the MLE which in turn passes a TL-CONNECT request primitive to the LLC. The LLC sends an AL-SETUP PDU to the SwMI.
16. The SwMI responds with an AL-SETUP PDU indicating the resetting of the advanced link. The MS may now begin transmitting or receiving packet data.

28.3.4.5 Releasing the advanced link

Where a MS does support advanced link roaming, and where the SNDCP entity receives a MLE-BREAK indication primitive while in standby state, then on reception of a corresponding MLE-RESUME indication primitive, the SNDCP entity shall locally disconnect all existing advanced links by issuing MLE-DISCONNECT request primitives to the MLE.

28.3.4.6 Physical channel handling

In the TETRA protocol model MAC layer may request upper layers to decide whether a physical channel change is performed as proposed by BS to support a network layer service. This allows application layers to negotiate which service is selected when there is a conflict between various services e.g. ongoing speech service and packet data service. The details of the negotiation are outside the scope of the present document. The MLE layer provides the channel change request to the SNDCP as a "channel change response required" parameter set to "true" in conjunction with a "Channel change handle" parameter, refer to clause 17.3.5.

If the channel change is acceptable on all services point of view the SNDCP shall respond to that request by issuing an MLE-CONFIGURE request primitive containing a "channel change accepted" parameter set to "accept". In the SNDCP protocol descriptions this is implied by requirements such as "the MS shall switch to the PDCH".

In the special case that the "channel change response required" parameter set to "true" is delivered to the MS SNDCP in an MLE-UNITDATA indication primitive that contains a group addressed SN-END OF DATA PDU when the READY timer is active, the MS SNDCP shall respond by issuing an MLE-CONFIGURE request primitive containing a "channel change accepted" parameter set to "ignore".

In all other cases where the channel change is not acceptable, the MS SNDCP shall respond to an MLE primitive containing a "channel change response required" parameter set to "true" by issuing an MLE-CONFIGURE request primitive with the "channel change accepted" parameter set to "reject".

28.3.4.7 Loss of Radio Resource

On reception of an MLE-CONFIGURE indication primitive advising "loss of radio resources":

- if data priority is supported by the MS, the MS SNDCP shall inform MLE that the MS default data priority is "not applicable" using the MLE-CONFIGURE request primitive;
- if there is data awaiting transmission, including where the MS SNDCP entity is aware that a partially transmitted N-PDU is in the LLC buffers (i.e. one which has not yet been fully transmitted or one for which an acknowledgement has not yet been received from the peer entity), then the MS SNDCP entity shall send to the SwMI a SN-RECONNECT PDU with the field "Data to Send" set to 1, shall start the RESPONSE_WAIT timer and shall enter the READY-temporary break state;
- if there is no data awaiting transmission, the MS SNDCP entity shall send to the SwMI a SN-RECONNECT PDU with the field "Data to Send" set to 0, shall stop the READY timer and any CONTEXT_READY timers, start the STANDBY timer and enter STANDBY state.

NOTE: The "loss of radio resources" indication means that the PDCH has failed, and that the MS has been moved back to the common control channel (MCCH or MCCH-Q or common SCCH). The MS attempts to transmit the SN-RECONNECT PDU on the common control channel.

28.3.4.8 Selection of physical channel

See also clause 28.3.4.2 on logical link setup and clause 28.3.5.2a on usage of the "resource request" information element.

When an MS indicates to the SwMI that it wishes to transmit or receive SN-DATA or SN-UNITDATA PDUs by sending an SN-DATA TRANSMIT REQUEST, SN-PAGE RESPONSE or SN-RECONNECT PDU on the uplink, or if the SwMI wishes to transmit SN-DATA or SN-UNITDATA PDUs to an MS, the SwMI should assign the MS to a suitable PDCH within the MS's declared capabilities (see note 1) if the current physical channel is not suitable. This also applies if the MS-MLE requests a change to a new assigned channel when the MS is already using a PDCH (see clause 18.3.4.9). The SwMI may also assign the MS to a new PDCH following advanced link negotiation on an existing PDCH (see clause 28.3.5.2a), following successful modification of a PDP context, or following successful reactivation of an already-activated PDP context.

NOTE 1: The MS's declared capabilities comprise the information the MS sent to the SwMI in a recent successful registration request that included a "class of MS" and, optionally, an "extended capabilities" information element (see clauses 16.4.1.1 to 16.4.3). The relevant information concerns single-slot or multi-slot capabilities, and supported modulation types and RF bandwidths. If the MS included a "resource request" information element in the SN-DATA TRANSMIT REQUEST, SN-PAGE RESPONSE or SN-RECONNECT PDU, the MS's declared capabilities also include the contents of the "full phase modulation capability" information element in the "resource request" information element. If the SwMI wishes to allocate a phase modulation channel with more timeslots than the requested number of timeslots per TDMA frame, the SwMI should use the capabilities information in the "resource request" information element to determine the maximum number of phase modulation timeslots per TDMA frame that the MS can use on $\pi/4$ -DQPSK channels, and on D8PSK channels if the MS supports the D8PSK modulation mode.

The SwMI chooses a suitable physical channel as follows:

- if QoS was not negotiated for a PDP context, the SwMI should assume by default that this PDP context is required for background class data with unspecified throughput, delay and reliability;
- if a $\pi/4$ -DQPSK single-slot channel was indicated in the "resource request" information element of an SN-DATA TRANSMIT REQUEST, SN-PAGE RESPONSE or SN-RECONNECT PDU, the SwMI should choose a single slot phase modulation PDCH within the MS's declared capabilities. If a suitable single-slot phase modulation PDCH is not available, the SwMI should choose a multi-slot phase modulation PDCH within the MS's declared capabilities. If a phase modulation channel is not available and the MS is QAM-capable, the BS may choose a QAM PDCH within the MS's declared capabilities; or
- if a specific $\pi/4$ -DQPSK multi-slot channel was indicated in the "resource request" information element of an SN-DATA TRANSMIT REQUEST, SN-PAGE RESPONSE or SN-RECONNECT PDU, the SwMI should choose a multi-slot phase modulation PDCH within the MS's declared capabilities with the number of timeslots per TDMA frame requested in the "resource request" information element. If a suitable multi-slot phase modulation PDCH with the requested number of timeslots per TDMA frame is not available, the SwMI should choose some other phase modulation PDCH within the MS's declared capabilities. If a phase modulation channel is not available and the MS is QAM-capable, the BS may choose a QAM PDCH within the MS's declared capabilities; or
- if an unspecified phase modulation resource was indicated in the "resource request" information element of an SN-DATA TRANSMIT REQUEST, SN-PAGE RESPONSE or SN-RECONNECT PDU, the SwMI should choose a phase modulation PDCH within the MS's declared capabilities. If a phase modulation channel is not available and the MS is QAM-capable, the BS may choose a QAM PDCH within the MS's declared capabilities;
- if a "resource request" was not included in the SN-DATA-TRANSMIT REQUEST, SN-PAGE RESPONSE or SN-RECONNECT PDU, or if SMDCP is in the READY state, the SwMI should choose a physical channel within the MS's declared capabilities which can satisfy the negotiated or default QoS requirements of the PDP contexts named in the SN-DATA TRANSMIT REQUEST, SN-PAGE RESPONSE or SN-RECONNECT PDU and the QoS requirements of all the MS's PDP contexts with active CONTEXT_READY timers. The SwMI should take into account any advice from the MLE about which channels the MS can currently use that is included in the U-IRREGULAR CHANNEL ADVICE or U-CHANNEL CLASS ADVICE PDU (which may accompany the SN-DATA TRANSMIT REQUEST, SN-PAGE RESPONSE or SN-RECONNECT PDU) or in a U-CHANNEL REQUEST PDU.

NOTE 2: If an MS that supports phase modulation is unable to use the phase modulation channel it is allocated, the MS SMDCP may send the SwMI an SN-END OF DATA PDU indicating immediate service change followed by an SN-DATA-TRANSMIT REQUEST PDU that includes a resource request. Then it should start the RESPONSE_WAIT timer and enter the RESPONSE-WAITING state. (This could occur if, for example, an MS that indicates it supports multi-slot phase modulation but is unable to use a four-slot phase modulation channel and does not send a "resource request" information element is allocated to a four-slot phase modulation channel.) Between sending the SN-END OF DATA PDU and receiving an acceptable response to its SN-DATA TRANSMIT REQUEST PDU (or receiving an SN-DATA TRANSMIT REQUEST PDU with an acceptable channel allocation) or receiving an SN-DATA TRANSMIT RESPONSE PDU that rejects the MS's request, or expiry of the RESPONSE_WAIT timer, the MS should ignore any further SN-DATA TRANSMIT RESPONSE PDUs containing unusable channel allocations and should ignore any SN-END OF DATA PDUs that it may receive. (The window size is 1 for the acknowledged basic link, so the MS's SN-DATA TRANSMIT REQUEST PDU will not be transmitted until the MS has finished waiting for a layer 2 acknowledgement of the SN-END OF DATA PDU.)

NOTE 3: The SwMI should regard a resource request received on a QAM PDCH as a request for the MS to be moved to a phase modulation PDCH.

NOTE 4: In version 3.4.1 (and in earlier versions) [i.16] of the present document, an MS that did not negotiate QoS and did not include a "resource request" information element was assigned to a single-slot $\pi/4$ -DQPSK PDCH. In this version of the present document, if the MS did not negotiate QoS during activation of a PDP context and does not include a "resource request" information element when commencing use of this PDP context, the SwMI chooses a PDCH based on the MS's declared capabilities and the default assumption that this PDP context is required for background class data with unspecified throughput, delay and reliability. Thus, an MS designed according to the present document that does not negotiate QoS will be unable to access D8PSK and QAM channels when using a SwMI that operates in accordance with version 3.4.1 (and earlier) [i.16] of the present document. An MS designed according to version 3.4.1 (or earlier) [i.16] that expects to be granted a single-slot $\pi/4$ -DQPSK PDCH when it does not include a "resource request" information element may be sent to some other type of PDCH within its declared capabilities when using a SwMI that operates in accordance with the present document.

28.3.5 Packet Data transmission and reception procedures

28.3.5.0 General

This clause describes the procedures within SNDCP for transmitting and receiving packet data. Acknowledged and unacknowledged services are available for packet data transfer. This clause also defines compression techniques which may be used during data transfer as a way of improving efficiency.

28.3.5.1 Acknowledged data service

The basic setting for sending N-PDUs between MS and SwMI is to use acknowledged service.

A scenario illustrating acknowledged data sending from SwMI to MS is shown in figure 28.31 (window size 1). Each numbered step is explained in the following list.

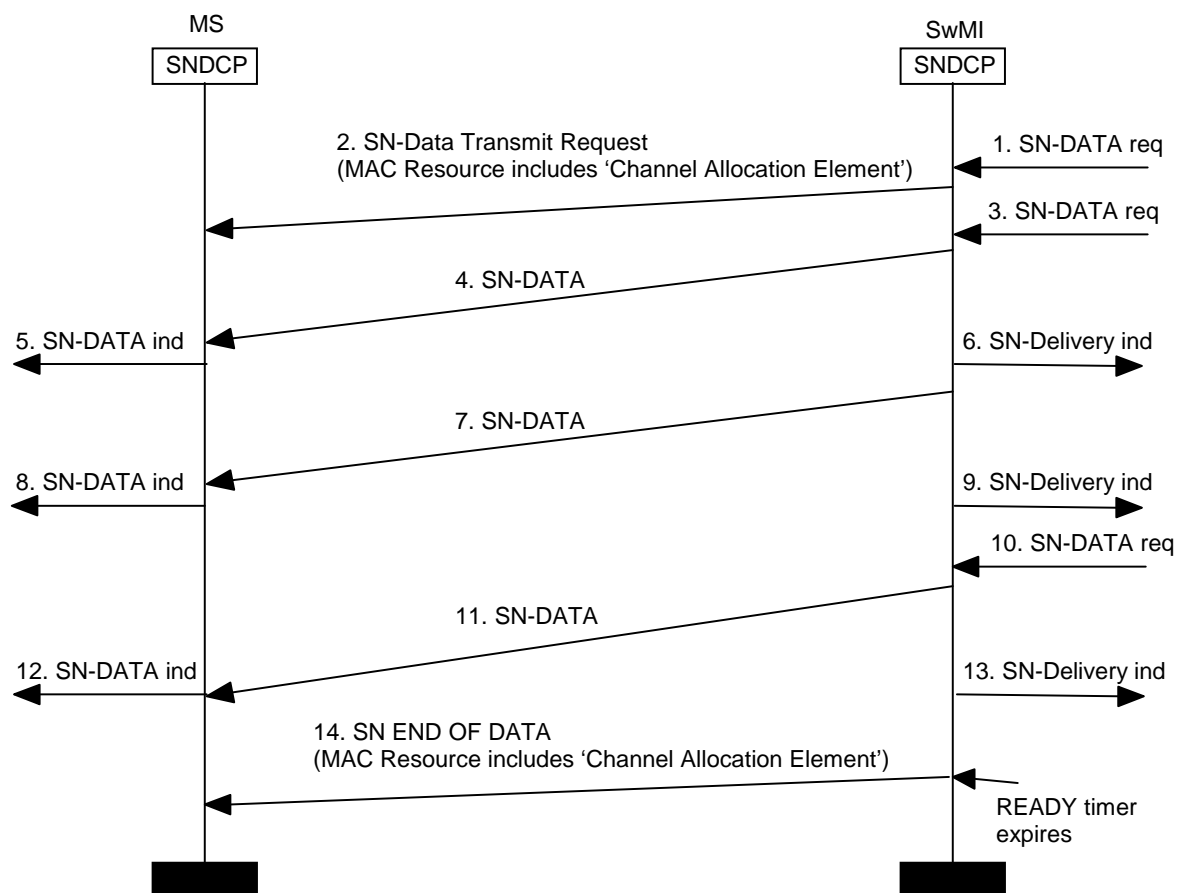

Figure 28.31: Acknowledged service, data from SwMI to MS

1. The SwMI SNDCP receives the first SN-DATA request primitive.
2. The SwMI SNDCP sends SN-DATA TRANSMIT REQUEST PDU. The request is sent by using the acknowledged or unacknowledged service (basic link) and the MAC-RESOURCE PDU contains a "Channel Allocation" information element sending the MS to a PDCH (the method of choosing the PDCH is given in clause 28.3.4.8). On transmission of the SN-DATA TRANSMIT REQUEST PDU, the SwMI stops the STANDBY timer, starts the READY timer, may start a CONTEXT_READY timer (see clause 28.2.6.2) and enters state READY. On reception of the SN-DATA TRANSMIT REQUEST PDU, the MS stops the STANDBY timer, starts the READY timer, starts the CONTEXT_READY timer for the PDP context referenced by the NSAPI parameter in the SN-DATA request primitive, and enters state READY.
3. The SwMI SNDCP receives the second SN-DATA request primitive.
4. The first N-PDU is sent to the MS by issuing SN-DATA PDU. On reception of an indication from the MLE, in the form of an MLE-REPORT indication primitive, that the SN-DATA PDU was successfully transmitted by the lower layers, the SwMI SNDCP entity shall restart the READY timer and the CONTEXT_READY timer (if used). At the MS the reception of the SN-DATA PDU shall result in the READY timer and, if supported, the CONTEXT_READY timer being restarted.
5. After receiving the first SN-DATA PDU the MS SNDCP passes the N-PDU to the higher layer by issuing a SN-DATA indication primitive.
6. After receiving acknowledgement that the first SN-DATA PDU was successfully sent to the MS the SwMI sends SN-DELIVERY indication primitive to the higher layer.
7. The second N-PDU is sent to the MS by issuing SN-DATA PDU. The READY timer is restarted in the SwMI SNDCP and in the MS SNDCP. The relevant CONTEXT_READY timer is restarted in the MS SNDCP and, if used, in the SwMI SNDCP.
8. After receiving the second SN-DATA PDU the MS SNDCP passes the N-PDU to the higher layer by issuing a SN-DATA indication primitive.
9. After receiving acknowledgement that the second SN-DATA PDU was successfully sent to the MS the SwMI sends SN-DELIVERY indication primitive to the higher layer.
10. The SwMI SNDCP receives the third SN-DATA request primitive.
11. The third N-PDU is sent to the MS by issuing SN-DATA PDU. The READY timer is re-started in the SwMI SNDCP and in the MS SNDCP. The relevant CONTEXT_READY timer is restarted in the MS SNDCP and, if used, in the SwMI SNDCP.
12. After receiving the third SN-DATA PDU the MS SNDCP passes the N-PDU to the higher layer by issuing SN-DATA indication primitive.
13. After receiving acknowledgement that the third SN-DATA PDU was successfully sent to the MS the SwMI sends SN-DELIVERY indication primitive to the higher layer.
14. The READY timer expires in the SwMI SNDCP and it issues SN-END OF DATA PDU, including channel allocation, to the MS, starts the STANDBY timer and enters STANDBY state. The MS SNDCP receives SN-END OF DATA PDU, stops its READY timer and any CONTEXT_READY timers, starts the STANDBY timer and enters STANDBY state on the indicated channel.

NOTE 1: If the existing advanced links do not include the advanced link which the MS has assigned to this PDP context, the MS may setup the assigned advanced link following receipt of the SN-DATA TRANSMIT REQUEST PDU from the SwMI. The SwMI may then switch to using this new advanced link if it thinks this is the most suitable for carrying data for this PDP context.

A scenario illustrating acknowledged data sending from the SwMI to MS over an advanced link having TL-SDU window size of 3 is shown in figure 28.32. Each numbered step is explained in the following list.

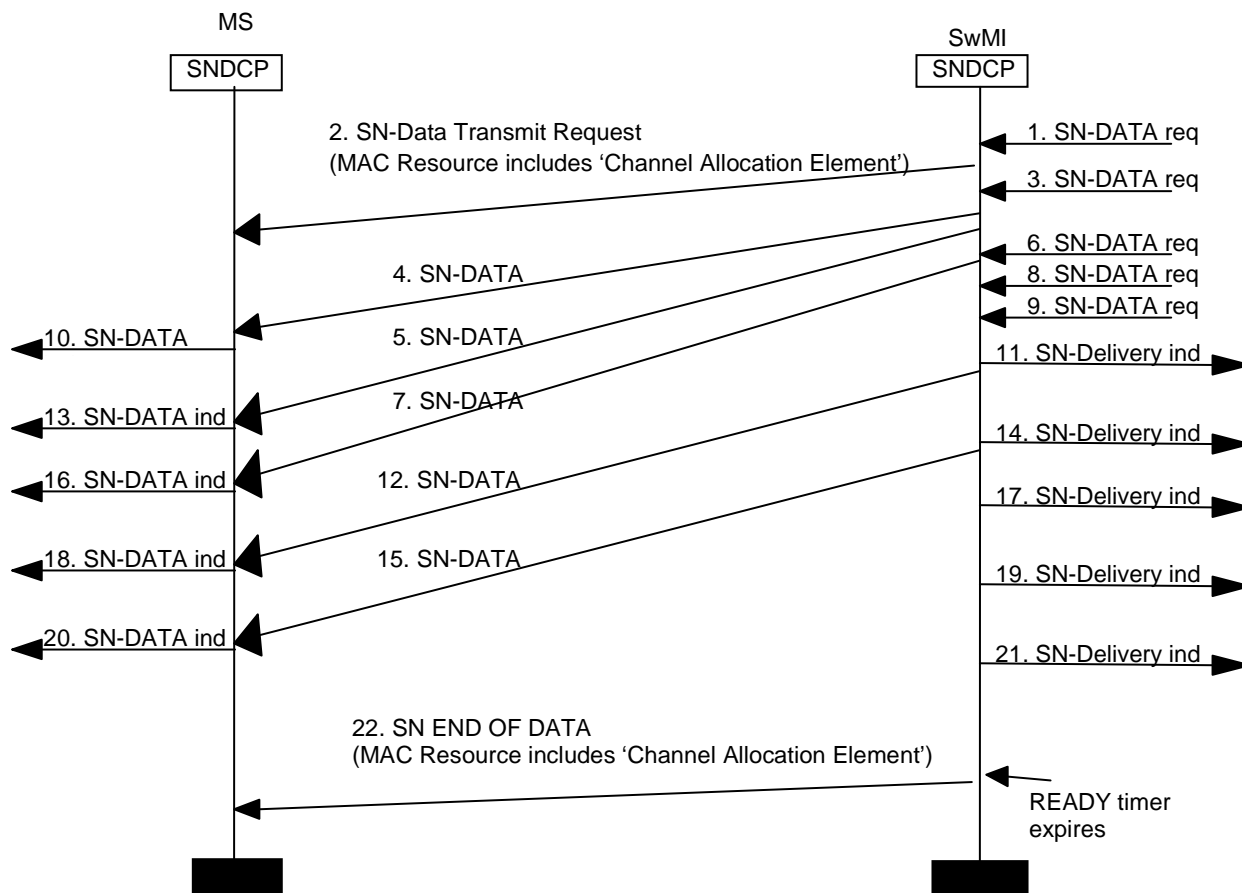

Figure 28.32: Acknowledged service on advanced link having TL-SDU window size 3, data from SwMI to MS

1. The SwMI SNDSCP receives the first SN-DATA request primitive.
2. The SwMI SNDSCP sends SN-DATA TRANSMIT REQUEST PDU. The request is sent by using the acknowledged or unacknowledged service (basic link) and the MAC-RESOURCE PDU contains a "Channel Allocation" information element sending the MS to a PDCH (the method of choosing the PDCH is given in clause 28.3.4.8). On transmission of the SN-DATA TRANSMIT REQUEST PDU, the SwMI stops the STANDBY timer, starts the READY timer and enters state READY. On reception of the SN-DATA TRANSMIT REQUEST PDU, the MS stops the STANDBY timer, starts the READY timer, starts the CONTEXT_READY timer for the PDP context referenced by the NSAPI parameter in the SN-DATA request primitive, and enters state READY.
3. The SwMI SNDSCP receives the second SN-DATA request primitive.
4. The first N-PDU is sent to the MS by issuing SN-DATA PDU. On reception of an indication from the MLE, in the form of an MLE-REPORT indication primitive, that the SN-DATA PDU was successfully transmitted by the lower layers, the SwMI SNDSCP entity shall restart the READY timer. At the MS the reception of the SN-DATA PDU shall result in the READY timer and, if supported, the CONTEXT_READY timer being restarted.
5. The second N-PDU is sent (immediately after the first one) to the MS by issuing SN-DATA PDU as the sliding TL-SDU window allows it.
6. The SwMI SNDSCP receives the third SN-DATA request primitive.
7. The third N-PDU is sent to the MS by issuing SN-DATA PDU as the sliding TL-SDU window allows it.

8. The SwMI SNDCP receives the fourth SN-DATA request primitive. The N-PDU cannot be sent to the MS yet as the sliding window is full.
9. The SwMI SNDCP receives the fifth SN-DATA request primitive. The N-PDU cannot be sent to the MS yet as the sliding window is full.
10. After receiving the first SN-DATA PDU the MS SNDCP passes the N-PDU to the higher layer by issuing a SN-DATA indication primitive.
11. After receiving acknowledgement that the first SN-DATA PDU was successfully sent to the MS the SwMI sends SN-DELIVERY indication primitive to the higher layer.
12. The fourth N-PDU is sent to the MS by issuing SN-DATA PDU as the TL-SDU window now allows it (since the first N-PDU was transmitted correctly and thus the sliding TL-SDU window may advance).
13. After receiving the second SN-DATA PDU the MS SNDCP passes the N-PDU to the higher layer by issuing a SN-DATA indication primitive.
14. After receiving acknowledgement that the second SN-DATA PDU was successfully sent to the MS the SwMI sends SN-DELIVERY indication primitive to the higher layer.
15. The fifth N-PDU is sent to the MS by issuing SN-DATA PDU as the TL-SDU window now allows it (since the second N-PDU was transmitted correctly and thus the sliding TL-SDU window may advance).
16. After receiving the third SN-DATA PDU the MS SNDCP passes the N-PDU to the higher layer by issuing a SN-DATA indication primitive.
17. After receiving acknowledgement that the third SN-DATA PDU was successfully sent to the MS the SwMI sends SN-DELIVERY indication primitive to the higher layer. If the SNDCP had more N-PDUs for the MS one PDU could be sent now since the sliding window would allow it. However, in this example there is no more data to send.
18. After receiving the fourth SN-DATA PDU the MS SNDCP passes the N-PDU to the higher layer by issuing a SN-DATA indication primitive.
19. After receiving acknowledgement that the fourth SN-DATA PDU was successfully sent to the MS the SwMI sends SN-DELIVERY indication primitive to the higher layer.
20. After receiving the fifth SN-DATA PDU the MS SNDCP passes the N-PDU to the higher layer by issuing a SN-DATA indication primitive.
21. After receiving acknowledgement that the fifth SN-DATA PDU was successfully sent to the MS the SwMI sends SN-DELIVERY indication primitive to the higher layer.
22. The READY timer expires in the SwMI SNDCP and it issues SN-END OF DATA PDU, including channel allocation, to the MS, starts the STANDBY timer and enters STANDBY state. The MS SNDCP receives SN-END OF DATA PDU, stops its READY timer, starts the STANDBY timer and enters STANDBY state on the indicated channel.

A scenario illustrating acknowledged data sending from MS to SwMI is shown in figure 28.33. Each numbered step is explained in the following list.

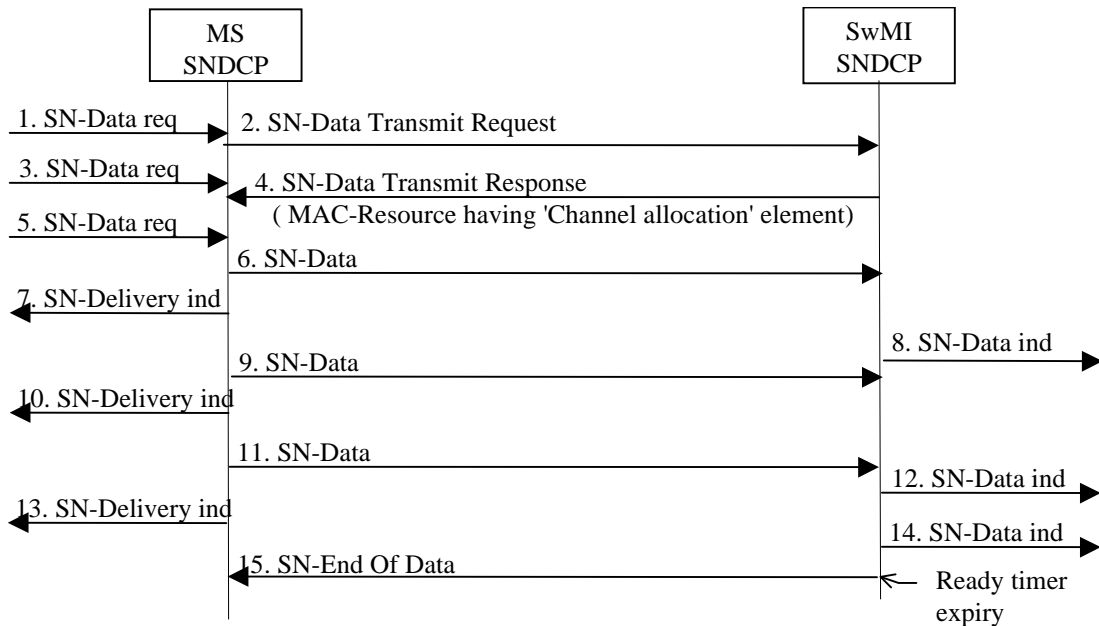

Figure 28.33: Acknowledged service, data from MS to SwMI

1. The MS SNDCP receives the first SN-DATA request primitive.
2. The MS SNDCP sends SN-DATA TRANSMIT REQUEST PDU. The request is sent by using acknowledged service (basic link). On sending the SN-DATA TRANSMIT REQUEST PDU, the MS SNDCP entity, starts the RESPONSE_WAIT timer and enters RESPONSE-WAITING state.
3. The MS SNDCP receives the second SN-DATA request primitive.
4. The SwMI SNDCP sends SN-DATA TRANSMIT RESPONSE PDU. The response is sent by using the acknowledged or unacknowledged service (basic link) and the MAC-level MAC-RESOURCE PDU contains channel allocation information element commanding the MS to PDCH. On transmission of the SN-DATA TRANSMIT RESPONSE PDU, the SwMI stops the STANDBY timer, starts the READY timer, may start a CONTEXT_READY timer (see clause 28.2.6.2) and enters state READY. On reception of the SN-DATA TRANSMIT RESPONSE PDU, the MS stops the STANDBY and RESPONSE_WAIT timers, starts the READY timer and the relevant CONTEXT_READY timer, and enters state READY.
5. The MS SNDCP receives the third SN-DATA request primitive.
6. The first N-PDU is sent to the SwMI by issuing SN-DATA PDU. On reception of an indication from the MLE, in the form of an MLE-REPORT indication primitive, that the SN_DATA PDU was successfully transmitted by the lower layers, the MS SNDCP entity shall restart the READY timer and shall, if supported, restart the relevant CONTEXT_READY timer. At the SwMI the reception of the SN-DATA PDU shall result in the READY timer being restarted and, if used, the CONTEXT_READY timer is restarted.
7. After receiving acknowledgement that the first SN-DATA PDU was successfully sent to the SwMI, the MS sends SN-DELIVERY indication primitive to the higher layer.
8. After receiving the first SN-DATA PDU, the SwMI SNDCP passes the N-PDU to the higher layer by issuing SN-DATA indication primitive.

9. The second N-PDU is sent to the SwMI by issuing SN-DATA PDU. The READY timer is restarted in the MS SNDCP and in the SwMI SNDCP. The relevant CONTEXT_READY timer is restarted in the MS SNDCP and, if used, in the SwMI SNDCP. If scheduled access was agreed with the SwMI for this PDP context during PDP context activation, the MS SNDCP indicates that the SN-PDU is scheduled and includes the value of the maximum schedule period for this PDP context in the MLE-UNITDATA request primitives carrying this and all subsequent SN-DATA PDUs for this PDP context.
10. After receiving acknowledgement that the second SN-DATA PDU was successfully sent to the SwMI, the MS sends SN-DELIVERY indication primitive to the higher layer.
11. The third N-PDU is sent to the SwMI by issuing SN-DATA PDU. The READY timer is re-started in the MS SNDCP and in the SwMI SNDCP. The relevant CONTEXT_READY timer is restarted in the MS SNDCP and, if used, in the SwMI SNDCP.
12. After receiving the second SN-DATA PDU, the SwMI SNDCP passes the N-PDU to the higher layer by issuing SN-DATA indication primitive.
13. After receiving acknowledgement that the third SN-DATA PDU was successfully sent to the SwMI, the MS sends SN-DELIVERY indication primitive to the higher layer.
14. After receiving the third SN-DATA PDU the SwMI SNDCP passes the N-PDU to the higher layer by issuing SN-DATA indication primitive.
15. The READY timer expires in the SwMI SNDCP and it issues SN-END OF DATA PDU, including channel allocation, to the MS, starts the STANDBY timer and enters STANDBY state. The MS SNDCP receives SN-END OF DATA PDU, stops its READY timer and any CONTEXT_READY timers, starts the STANDBY timer and enters STANDBY state in the allocated channel.

A scenario illustrating acknowledged data sending from MS to SwMI and from SwMI to MS is shown in figure 28.34. Each numbered step is explained in the following list.

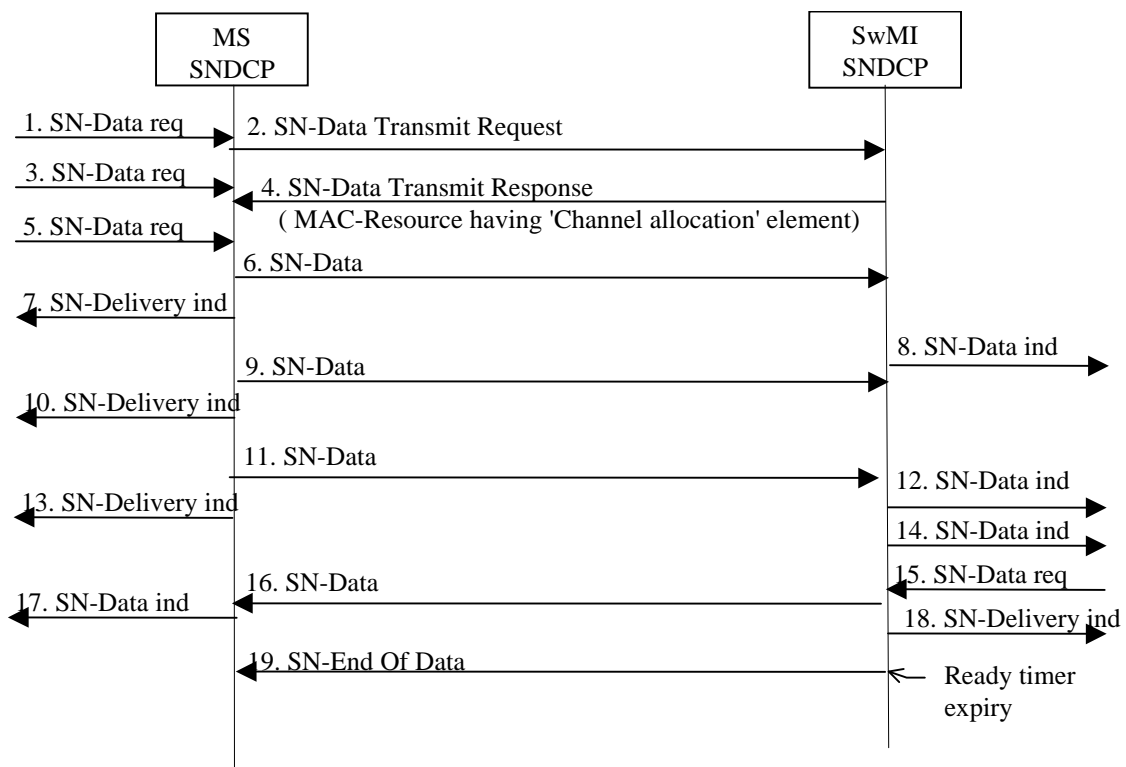

Figure 28.34: Acknowledged service, data from MS to SwMI and from SwMI to MS

1. to 14. These steps as in figure 28.33 "acknowledged service, data from MS to SwMI".
15. The SwMI SNDCP receives the first (and only one in this scenario) SN-DATA request primitive.

16. The first N-PDU is sent to the MS by issuing SN-DATA PDU. On reception of an indication from the MLE, in the form of an MLE-REPORT indication primitive, that the SN_DATA PDU was successfully transmitted by the lower layers, the SwMI SNDSCP entity shall restart the READY timer and, if used, the CONTEXT_READY timer. At the MS, the reception of the SN-DATA PDU shall result in the READY timer being restarted. The MS SNDSCP also starts the CONTEXT_READY timer referenced by the NSAPI in the SN-DATA PDU.
17. After receiving the first SN-DATA PDU, the MS SNDSCP passes the N-PDU to the higher layer by issuing SN-DATA indication primitive.
18. After receiving acknowledgement that the first SN-DATA PDU was successfully sent to the MS, the SwMI sends SN-DELIVERY indication primitive to the higher layer.
19. The READY timer expires in the SwMI SNDSCP and it issues SN-END OF DATA PDU, including channel allocation, to the MS, starts the STANDBY timer and enters STANDBY state. The MS SNDSCP receives SN-END OF DATA PDU, stops its READY timer, stops all CONTEXT_READY timers, starts the STANDBY timer and enters STANDBY state on the allocated channel.

A scenario illustrating Ready timer expiry in the MS is shown in figure 28.35. Each numbered step is explained in the following list.

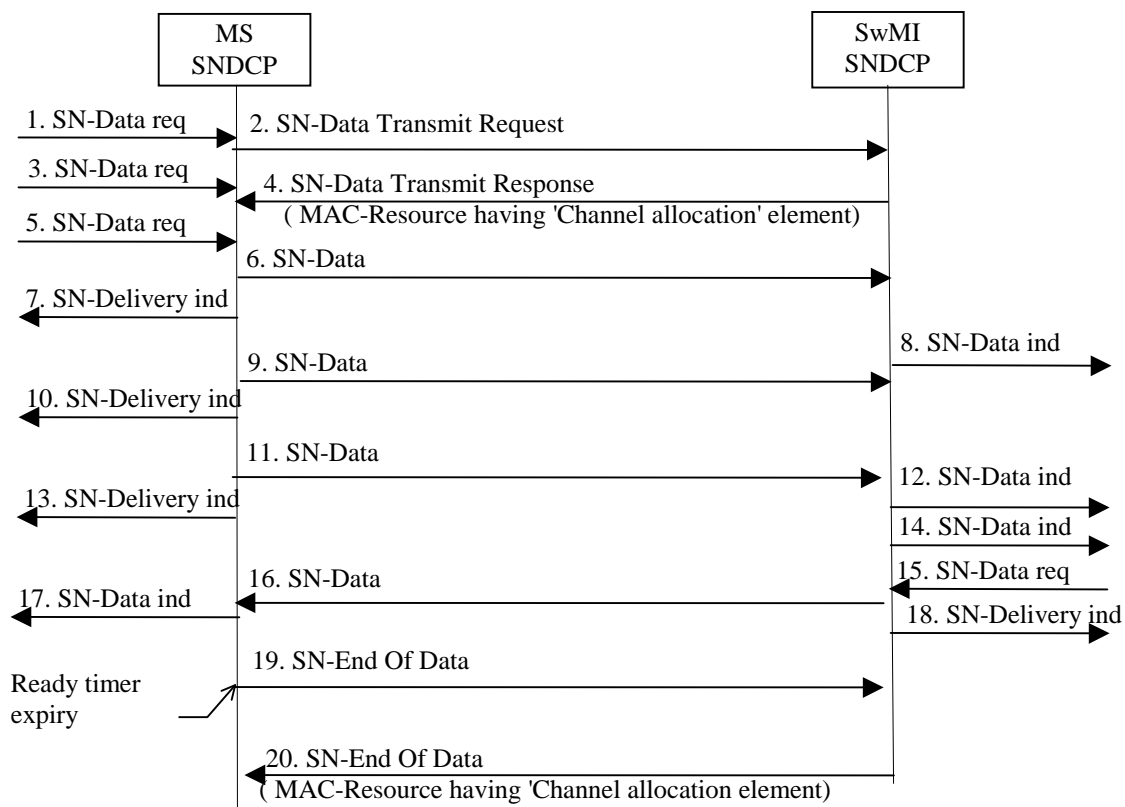
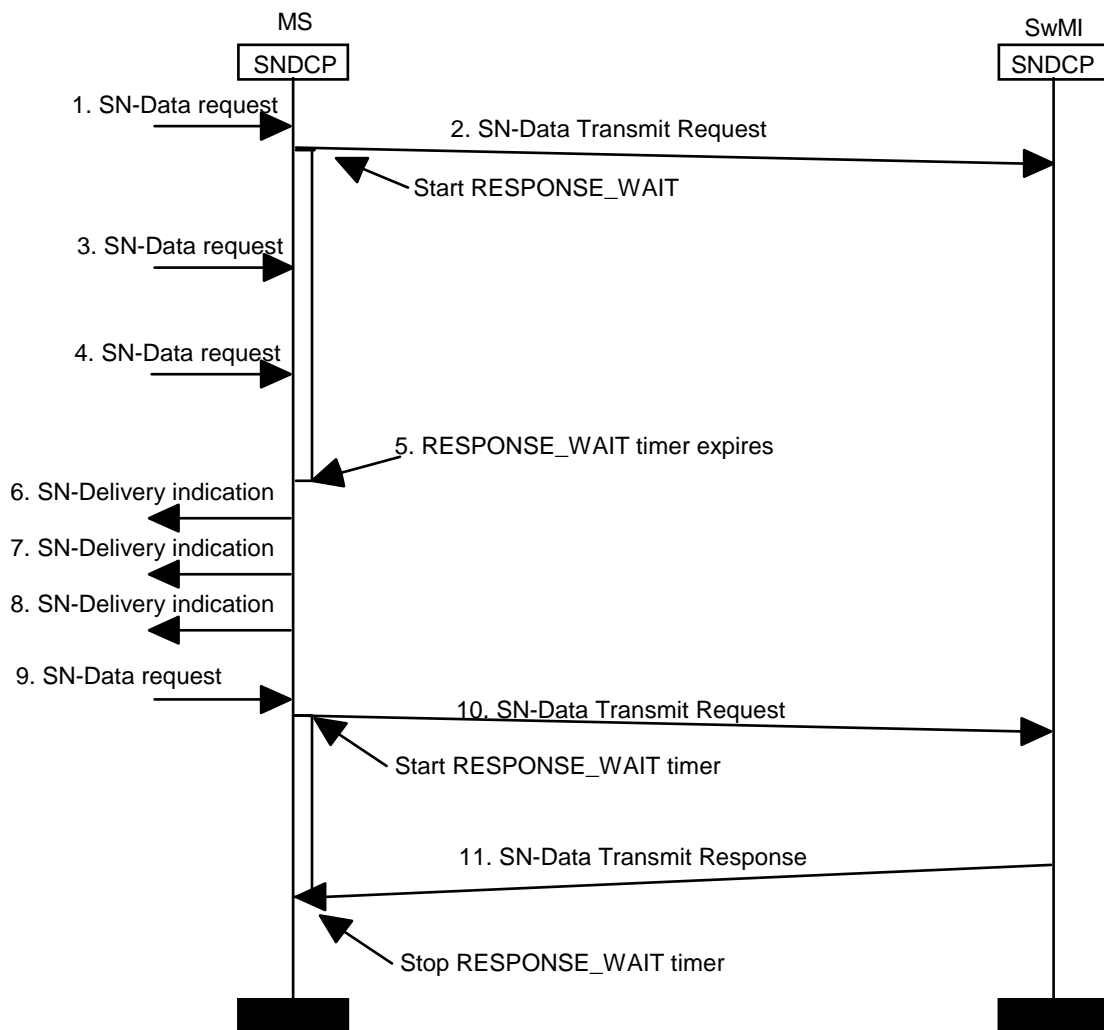

Figure 28.35: Acknowledged service, READY timer expiry in the MS

1. to 14. These steps are the same as in figure 28.33 "acknowledged service, data from MS to SwMI".
15. The SwMI SNDSCP receives the first (and only one in this scenario) SN-DATA request primitive.
16. The first N-PDU is sent to the MS by issuing SN-DATA PDU. The READY timer and, if used, the CONTEXT_READY timer are started in the SwMI SNDSCP (when the SN-DATA PDU is successfully sent) and in the MS SNDSCP (when the SN-DATA PDU is received). The relevant CONTEXT_READY timer is also started in the MS SNDSCP when the SN-DATA PDU is received.
17. After receiving the first SN-DATA PDU the MS SNDSCP passes N-PDU to the higher layer by issuing SN-DATA indication primitive.

18. After receiving acknowledgement that the first SN-DATA PDU was successfully sent to the MS the SwMI sends SN-Delivery indication primitive to the higher layer.
19. The READY timer expires in the MS SNDCP and it issues SN-END OF DATA PDU to the SwMI. The MS restarts the READY timer.
20. After receiving SN-END OF DATA PDU from the MS SNDCP the SwMI SNDCP issues SN-END OF DATA PDU, including channel allocation, to the MS, starts the STANDBY timer and enters STANDBY state. The MS SNDCP receives SN-END OF DATA PDU, stops its READY timer, starts the STANDBY timer and enters STANDBY state on the allocated channel.

A scenario illustrating RESPONSE_WAIT timer expiry in the MS is shown in figure 28.36. Each numbered step is explained in the following list.



NOTE: The present document does not define the number of SN-DATA and SN-UNITDATA request primitives which may be buffered in the MS while the RESPONSE_WAIT timer is active.

Figure 28.36: Acknowledged service, RESPONSE_WAIT timer expiry in the MS

1. The service user issues a SN-DATA request primitive to the MS SNDCP entity.
2. The MS SNDCP entity transmits a SN-DATA TRANSMIT REQUEST PDU, starts the RESPONSE_WAIT timer and enters RESPONSE-WAITING state.
3. The service user issues a second SN-DATA request primitive to the MS SNDCP entity.
4. The service user issues a third SN-DATA request primitive to the MS SNDCP entity.

5. The RESPONSE_WAIT timer expires. The MS SNDCP entity enters STANDBY state.
6. The MS SNDCP entity issues a SN-DELIVERY indication primitive to the service user, giving notification that the SN-DATA request primitive received in 1) has failed.
7. The MS SNDCP entity issues a SN-DELIVERY indication primitive to the service user, giving notification that the SN-DATA request primitive received in 3) has failed.
8. The MS SNDCP entity issues a SN-DELIVERY indication primitive to the service user, giving notification that the SN-DATA request primitive received in 4) has failed.
9. The service user issues a new SN-DATA request primitive to the MS SNDCP entity.
10. The MS SNDCP entity transmits a SN-DATA TRANSMIT REQUEST PDU, starts the RESPONSE_WAIT timer and enters RESPONSE-WAITING state.
11. The MS SNDCP entity receives a SN-DATA TRANSMIT RESPONSE PDU (with Accept/Reject = 1). The RESPONSE_WAIT and STANDBY timers are stopped and the READY state is entered. The MS may now send the N-PDUs received from the service user, using SN-DATA PDUs as described in the previous examples.

A scenario illustrating SwMI rejecting a request from the MS is shown in figure 28.37. Each numbered step is explained in the following list.

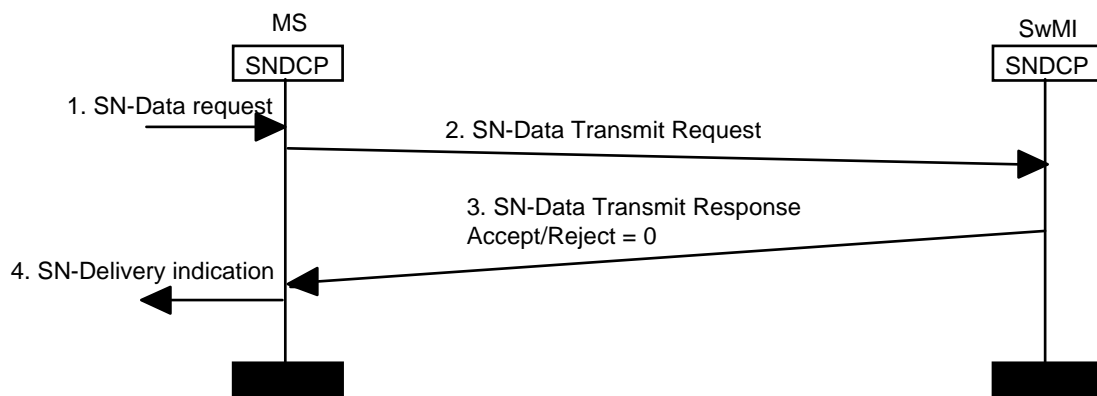

Figure 28.37: Acknowledged service, SwMI rejects request

1. The service user issues a SN-DATA request primitive to the MS SNDCP entity.
2. The MS SNDCP entity transmits a SN-DATA TRANSMIT REQUEST PDU, starts the RESPONSE_WAIT timer and enters RESPONSE-WAITING state.
3. Due to heavy system loading the SwMI rejects the request. The SwMI delivers a SN-DATA TRANSMIT RESPONSE PDU to the MS, with Accept/Reject set to "Request rejected by the SwMI", and "Transmit Response Reject Cause" set to "System resources not available". The MS stops its RESPONSE_WAIT timer, restarts the STANDBY timer and enters STANDBY state.
4. The MS SNDCP entity issues a SN-DELIVERY indication primitive to the service user, giving notification that the SN-DATA request primitive received in 1) has failed.

NOTE 2: For direct access, the BS always supports the Sndcp service while the "system wide services" information element in the D-MLE-SYSINFO-DA (and D-MLE-SYNC-DA) PDU is indicating "normal mode" (system wide services supported); see clause 18. The MS Sndcp may send the SwMI an SN-DATA TRANSMIT REQUEST PDU while the "system wide services" information element in the D-MLE-SYSINFO-DA (or D-MLE-SYNC-DA) PDU is indicating "system wide services temporarily not supported"; however the BS in this mode may temporarily not support the Sndcp service, in which case the BS may send the SN-DATA TRANSMIT RESPONSE PDU with reject cause "Sndcp service temporarily not available". If the MS receives an SN-DATA TRANSMIT RESPONSE PDU with reject cause "Sndcp service temporarily not available", the MS should not continue to send the SN-DATA TRANSMIT REQUEST PDU while the "system wide services" information element in the D-MLE-SYSINFO-DA (or D-MLE-SYNC-DA) PDU is indicating "system wide services temporarily not supported" (though the MS is not precluded from occasionally sending the SN-DATA TRANSMIT REQUEST PDU).

A conventional access MS is not permitted to send SN-DATA TRANSMIT REQUEST or SN-DATA PDUs while the D-MLE SYSINFO or D-MLE SYSINFO-Q PDUs are indicating "Sndcp service is not available on this cell".

NOTE 3: The MS is not permitted to send SN-DATA TRANSMIT REQUEST or SN-DATA PDUs on a cell where a subscriber class mismatch exists (see clause 16.4.9) or on a not-permitted cell (see clause 18.3.5.1.5).

28.3.5.2 Unacknowledged data service (advanced link)

The SwMI may use also unacknowledged service (advanced link) to send N-PDUs. The procedures for unacknowledged data transfer differ from those of acknowledged data transfer when the destination is a group address. The READY timer is not activated when an MS enters READY state for reception of point to multipoint packet data. Also the reception of a point to multipoint N-PDU does not effect any of the Sndcp timers.

A scenario illustrating unacknowledged data sending from SwMI to MS using an advanced link is shown in figure 28.38. Each numbered step is explained in the following list.

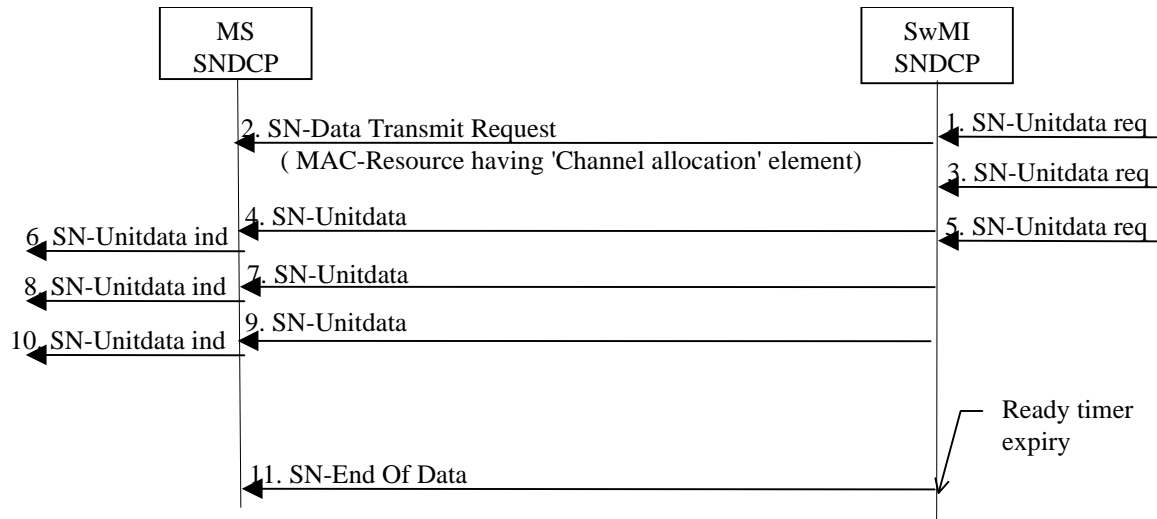

Figure 28.38: Unacknowledged service, data from SwMI to MS

1. The SwMI Sndcp receives the first SN-UNITDATA request primitive.
2. The SwMI Sndcp sends SN-DATA TRANSMIT REQUEST PDU. The request is sent by using unacknowledged service (basic link) and the MAC-RESOURCE PDU contains channel allocation information element commanding the MS to PDCH. The STANDBY timer is stopped and the READY timer is started in the SwMI Sndcp (when the SN-DATA TRANSMIT REQUEST PDU is sent). The STANDBY timer is stopped in the MS Sndcp (when the SN-DATA TRANSMIT REQUEST PDU is received).
3. The SwMI Sndcp receives the second SN-UNITDATA request primitive.

4. The first N-PDU is sent to the MS by issuing SN-UNITDATA PDU. On reception of an indication from the MLE, in the form of an MLE-REPORT indication primitive, that the SN-UNITDATA PDU was transmitted by the lower layers, the SwMI SNDCP entity shall restart the READY timer.
5. The SwMI SNDCP receives the third SN-UNITDATA request primitive.
6. After receiving the first SN-UNITDATA PDU, the MS SNDCP passes the N-PDU to the higher layer by issuing SN-UNITDATA indication primitive.
7. The second N-PDU is sent to the MS by issuing SN-UNITDATA PDU. The READY timer is re-started in the SwMI SNDCP.
8. After receiving the second SN-UNITDATA PDU, the MS SNDCP passes the N-PDU to the higher layer by issuing SN-UNITDATA indication primitive.
9. The third N-PDU is sent to the MS by issuing SN-UNITDATA PDU. The READY timer is re-started in the SwMI SNDCP.
10. After receiving the third SN-UNITDATA PDU, the MS SNDCP passes N-PDU to the higher layer by issuing SN-UNITDATA indication primitive.
11. The READY timer expires in the SwMI SNDCP and it issues SN-END OF DATA PDU, including channel allocation, to the MS, starts the STANDBY timer and enters STANDBY state. The MS SNDCP receives SN-END OF DATA PDU, starts the STANDBY timer and enters STANDBY state on the allocated channel.

28.3.5.2a Usage of Resource request

See also clause 28.3.4.8 on selection of physical channels and clause 28.3.4.2 on logical link setup.

The MS SNDCP entity should normally set "enhanced $\pi/4$ -DQPSK service" information element to indicate "enhanced $\pi/4$ -DQPSK service not requested" when transmitting an SN-DATA TRANSMIT REQUEST PDU, SN-PAGE RESPONSE or SN-RECONNECT PDU. The MS should not include the conditional "resource request" information element unless the MS advised the SwMI during registration that it supports QAM modulation but now specifically requires a phase modulation PDCH or unless the MS wishes to request a specific number of phase modulation timeslots per TDMA frame.

By default, if the MS did not negotiate QoS for a particular PDP context and the MS does not include a "resource request" information element in the SN-DATA TRANSMIT REQUEST PDU, SN-PAGE RESPONSE or SN-RECONNECT PDU, the SwMI chooses the connection based on the MS's declared capabilities and the default assumption that the MS requires a background class QoS with unspecified throughput, delay and reliability.

NOTE 1: In version 3.4.1 (and in earlier versions) [i.16] of the present document, an MS that did not negotiate QoS was assigned to a single-slot $\pi/4$ -DQPSK PDCH if it did not include a "resource request" information element.

The MS SNDCP entity may request a phase modulation single or multi-slot service (within its declared capabilities) in PDCH access signalling. That may be indicated by setting the "enhanced $\pi/4$ -DQPSK service" information element to "enhanced $\pi/4$ -DQPSK service requested" in the SN-DATA TRANSMIT REQUEST (data from MS to SwMI), SN-PAGE RESPONSE (data from MS to SwMI) or SN-RECONNECT PDU transmitted to the peer entity. If enhanced $\pi/4$ -DQPSK service is indicated in the PDU, the PDU shall also contain a conditional "resource request" information element, which shall either inform the SwMI of the desired number of timeslots per TDMA frame in the PDCH or shall inform the SwMI that an unspecified phase modulation resource is required. If a specific phase modulation resource is required, the required number of phase modulation timeslots per TDMA frame shall be informed to the SwMI before the MS has already been directed to a PDCH. In consequence this shall aid the SwMI in directing the MSs to the proper channels, and access to resources, where the actual data transfer occurs, is immediate.

EXAMPLE: A QAM-capable MS sending or receiving limited quantities of data over an extended period of time may prefer to use any available phase modulation PDCH for reasons of battery economy.

If no advanced link exists, the MS establishes an advanced link when it arrives on the PDCH.

If the MS requires a single or multi-slot phase modulation connection and the "resource request" information element is not used, the MS may be directed to a QAM channel (if it supports QAM), or may be directed to a phase modulation channel (within its declared capabilities) with the wrong number of timeslots per TDMA frame to do the advanced link set up. If the MS was directed to the wrong type of channel, advanced link negotiation may cause the SwMI to direct the MS to the actual single or multi-slot phase modulation channel to do the data transfer. In this case the MS visits completely uselessly on the wrong type of channel for a short time. If the requirement for single or multi-slot phase modulation packet data is indicated earlier by using the "resource request" information element, the MS can be moved directly to the desired phase modulation channel, and latency time to the resource access can be reduced.

If the MS uses the "resource request" information element:

- If no advanced link exists when the MS has been sent to a PDCH and the MS used the "resource request" information element, the MS SNDCP entity shall use the data transfer throughput and number of $\pi/4$ -DQPSK timeslots per TDMA frame parameters which were indicated in the "resource request" information element during the advanced link set up negotiation on the PDCH. This applies on all types of PDCH (i.e. not just on a phase modulation PDCH).
- If an advanced link has already been established for the packet data service when the MS enters from STANDBY state to READY state (i.e. MS has visited on the PDCH at least once before), the MS's AL-SETUP PDU that initiated the establishment of the advanced link did not indicate "no information about radio resources" and the MS requires a phase modulation PDCH, the MS shall adapt the requested width of the PDCH in PDCH access signalling with the already negotiated advanced link parameters.

When MSs requiring phase modulation PDCHs indicate their requested data transfer throughput values in the "resource request" information element before being directed to the PDCH, the BS may be able to optimize its resource allocations between several MSs on the same channel and direct them to the proper channels right away. The "connection symmetry" information element indicates whether the same number of timeslots per TDMA frame shall be used both on uplink and downlink. In the case of symmetric connection, the next information element, "number of $\pi/4$ -DQPSK timeslots on uplink", shall indicate the number of requested timeslots both on uplink and downlink. In that case the "number of $\pi/4$ -DQPSK timeslots on downlink" information element is not needed at all.

Instead if asymmetric connection is indicated by the "connection symmetry" information element, the information element "number of $\pi/4$ -DQPSK timeslots on downlink" is also present. Then the number of $\pi/4$ -DQPSK timeslots requested on uplink and downlink shall be indicated by different information elements.

NOTE 2: The actual protocol part of asymmetric connection is outside the scope of the present document, i.e. different timeslot requests on uplink and downlink are not used in the present version of this document.

The "full phase modulation capability" information element shall indicate the MS's capability to handle physical resources. Any resource granting over this capability limit by the SwMI is useless, because the MS does not have physical capabilities to handle more timeslots in one TDMA frame than indicated by this information element.

NOTE 3: How the SwMI should handle the situation where more resources have been negotiated than indicated by the capability limit is outside the scope of the present document.

28.3.5.2b Unacknowledged data service (basic link)

The unacknowledged data service (basic link) shall be used by the MS to transmit data from a PDP context for which real-time class data was agreed during QoS negotiation. It may also be used by the SwMI.

When the MS SNDCP receives a SN-UNITDATA request primitive for a real-time class PDP context, it shall follow the normal rules for transmitting an SN-DATA TRANSMIT REQUEST PDU. When the MS receives a SN-DATA TRANSMIT REQUEST PDU or a SN-DATA TRANSMIT RESPONSE PDU for a real-time class PDP context, the MS shall follow any included channel allocation, and may then transmit any waiting SN-UNITDATA PDUs on the unacknowledged basic link immediately (the unacknowledged basic link does not need to be set up).

Each SN-UNITDATA PDU shall be passed to the MLE layer in a MLE-UNITDATA request primitive, accompanied by an indication that the unacknowledged basic link is to be used, and an indication of the number of retransmissions of the SN-UNITDATA PDU and an indication of whether an FCS is required. In the case of real-time class data, the number of retransmissions will normally be zero.

A scenario illustrating unacknowledged basic link data sending from MS to SwMI is shown in figure 28.39. Each numbered step is explained in the following list.

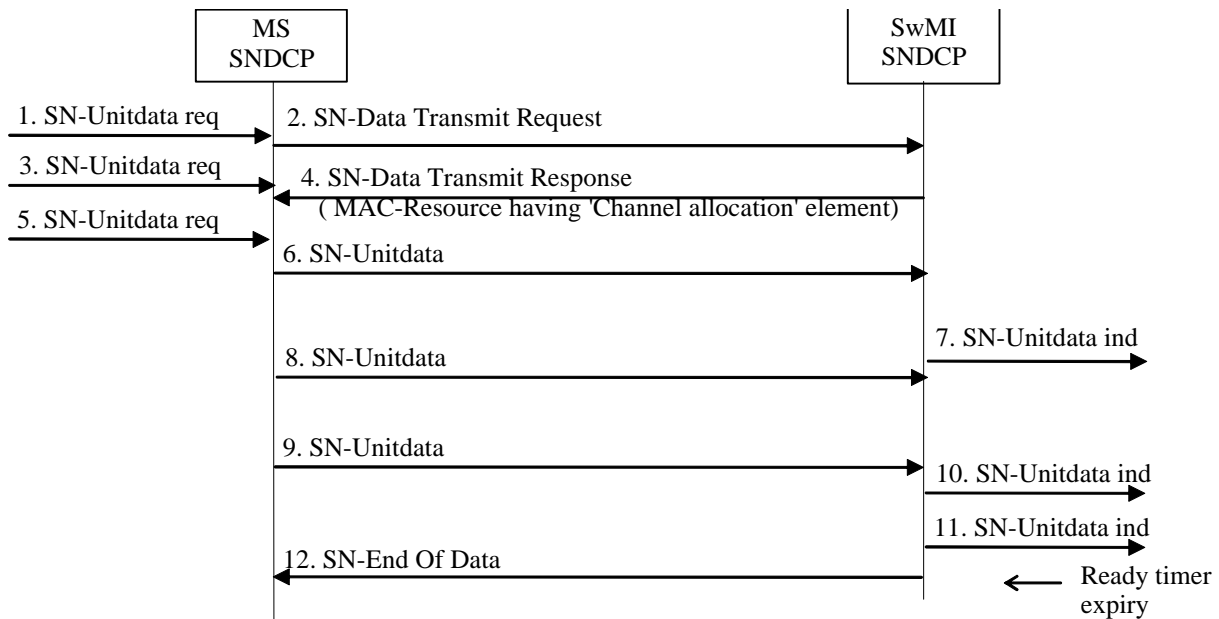

Figure 28.39: Unacknowledged basic link service, data from MS to SwMI

1. The MS SNDPCP receives the first SN-UNITDATA request primitive.
2. The MS SNDPCP sends SN-DATA TRANSMIT REQUEST PDU. The request is sent by using acknowledged service (basic link). On sending the SN-DATA TRANSMIT REQUEST PDU, the MS SNDPCP entity starts the RESPONSE_WAIT timer and enters RESPONSE-WAITING state.
3. The MS SNDPCP receives the second SN-UNITDATA request primitive.
4. The SwMI SNDPCP sends SN-DATA TRANSMIT RESPONSE PDU. The response may be sent by using the acknowledged basic link service of the unacknowledged basic link service and the MAC-level MAC-RESOURCE PDU contains a channel allocation information element commanding the MS to a PDCH. On transmission of the SN-DATA TRANSMIT RESPONSE PDU, the SwMI stops the STANDBY timer, starts the READY timer, may start a CONTEXT_READY timer (see clause 28.2.6.2) and enters state READY. On reception of the SN-DATA TRANSMIT RESPONSE PDU, the MS stops the STANDBY and RESPONSE_WAIT timers, starts the READY timer and the relevant CONTEXT_READY timer, and enters state READY.
5. The MS SNDPCP receives the third SN-UNITDATA request primitive.
6. The first N-PDU is sent to the SwMI by issuing an SN-UNITDATA PDU. On reception of an indication from the MLE, in the form of an MLE-REPORT indication primitive, that the SN-UNITDATA PDU was transmitted by the lower layers, the MS SNDPCP entity shall restart the READY timer and shall, if supported, restart the relevant CONTEXT_READY timer. At the SwMI the reception of the SN-UNITDATA PDU shall result in the READY timer and, if used, the CONTEXT_READY timer being restarted.
7. After receiving the first SN-UNITDATA PDU, the SwMI SNDPCP passes the N-PDU to the higher layer by issuing SN-UNITDATA indication primitive.
8. The second N-PDU is sent to the SwMI by issuing SN-UNITDATA PDU. If scheduled access was agreed with the SwMI for this PDP context during PDP context activation, the MS SNDPCP indicates that this SN-PDU is scheduled and indicates the value of the maximum schedule period for this PDP context in the MLE-UNITDATA request primitives carrying this and all subsequent SN-UNITDATA PDUs for this PDP context. The READY timer is re-started in the MS SNDPCP and in the SwMI SNDPCP. If supported, the relevant CONTEXT_READY timer is restarted in the MS and SwMI SNDPCP.
9. The third N-PDU is sent to the SwMI by issuing SN-UNITDATA PDU. If scheduled access was agreed with the SwMI for this PDP context during PDP context activation, the MS SNDPCP indicates that this SN-PDU is scheduled. The READY timer is re-started in the MS SNDPCP. If supported, the relevant CONTEXT_READY timer is restarted in the MS and SwMI SNDPCP.

10. After receiving the second SN-UNITDATA PDU, the SwMI SNDCP re-starts the READY timer and, if used, the CONTEXT_READY timer and passes the N-PDU to the higher layer by issuing SN-UNITDATA indication primitive.
11. After receiving the third SN-UNITDATA PDU the SwMI SNDCP re-starts the READY timer and, if used, the CONTEXT_READY timer and passes the N-PDU to the higher layer by issuing SN-UNITDATA indication primitive.
12. The READY timer expires in the SwMI SNDCP and it issues SN-END OF DATA PDU, including channel allocation, to the MS, starts the STANDBY timer and enters STANDBY state. The MS SNDCP receives SN-END OF DATA PDU, stops its READY timer and any CONTEXT_READY timers, starts the STANDBY timer and enters STANDBY state in the allocated channel.

NOTE 1: For direct access, the BS always supports the SNDCP service while the "system wide services" information element in the D-MLC-SYSINFO-DA (and D-MLC-SYNC-DA) PDUs is indicating "normal mode" (system wide services supported); see clause 18. The MS SNDCP may send the SwMI an SN-DATA TRANSMIT REQUEST PDU while the "system wide services" information element in the D-MLC-SYSINFO-DA (or D-MLC-SYNC-DA) PDUs is indicating "system wide services temporarily not supported"; however the BS in this mode may temporarily not support the SNDCP service, in which case the BS may send the SN-DATA TRANSMIT RESPONSE PDU with reject cause "SNDCP service temporarily not available". If the MS receives an SN-DATA TRANSMIT RESPONSE PDU with reject cause "SNDCP service temporarily not available", the MS should not continue to send the SN-DATA TRANSMIT PDU while the "system wide services" information element in the D-MLC-SYSINFO-DA or D-MLC-SYNC-DA PDUs is indicating "system wide services temporarily not supported" (though the MS is not precluded from occasionally sending the SN-ACTIVATE PDP CONTEXT DEMAND PDU).

A conventional access MS should not send SN-DATA TRANSMIT REQUEST or SN-UNITDATA PDUs while the D-MLC SYSINFO or D-MLC SYSINFO-Q PDUs are indicating "SNDCP service is not available on this cell".

NOTE 2: If the BS becomes unable to support the SNDCP service while a direct access MS is sending real time class data to the SwMI, the BS may send the MS an SN-END OF DATA PDU to stop the MS from sending further SN-UNITDATA PDUs.

NOTE 3: The MS is not permitted to send SN-DATA TRANSMIT REQUEST or SN-UNITDATA PDUs on a cell where a subscriber class mismatch exists (see clause 16.4.9) or on a not-permitted cell (see clause 18.3.5.1.5).

28.3.5.3 Protocol header compression

28.3.5.3.1 Header compression types

Header compression attempts to remove redundant protocol header information of transmitted PDUs between source and destination addresses. The used compression method is specific for each network layer protocol type. TCP/IP (IPv4) and IP (IPv4 and IPv6) header compression are introduced in the present document.

Multiple types of header compression are supported. Negotiation of supported algorithms is carried out between MS and SwMI in Activate PDP Context procedure, if necessary. The negotiation uses the PCOMP negotiation information element (8 bits bitmap) in SN-ACTIVATE PDP CONTEXT PDUs whereas the control of the compression process is done by using the PCOMP information element (4 bits) in SN-DATA and SN-UNITDATA PDUs.

If the receiving SNDCP entity does not recognize the value of the PCOMP information element included in the SN-DATA PDU or SN-UNITDATA PDU it shall discard the PDU.

28.3.5.3.2 TCP/IP header compression

IETF RFC 1144 [29] defines an encoding method and protocol for compressing the standard 40-octet TCP/IP (IPv4) protocol header down to 3 octets at minimum. The standard TCP/IP header comprises 20 octets of IP part and 20 octets of TCP part. The idea is to replace the IP header with a one octet connection number, and the TCP header with delta information (only differences are sent).

TCP/IP header compression modes that require a reliable link should not be used with the unacknowledged layer 2 service.

The protocol requires that the underlying service should be able to distinguish three types of IP frames. The frame type information is conveyed in the PCOMP field of the SNDCP header.

When compression is used, a TCP/IP header is replaced with a compressed header of length varying from 3 to 16 octets. Octet one carries a change mask that identifies which of the consequent fields has changed per packet. A mask bit is set if the associated field is changed and present in the header. The corresponding bit is clear if there are no changes, and the delta field is absent. The unmodified TCP checksum field, however, is always included in the compressed header. The format of the header is shown in table 28.19.

Table 28.19: Compressed header format

Bit	8	7	6	5	4	3	2	1
Octet 1	0	C	I	P	S	A	W	U
2	Connection number (C)							
3	TCP checksum							
4								
..	Urgent pointer (U)							
..	delta (Window) (W)							
	delta (Ack) (A)							
	delta (Sequence) (S)							
N	delta (IP ID) (I)							

The connection information table in each connection entity shall be initialized upon occurrence of:

- initial LLC connection establishment/release; or
- at any time when the SNDCP entity concludes that the peer entity has lost TCP/IP header compression synchronization.

NOTE: Where an MS moves to a new cell and establishes an advanced link, there should not be a need for the connection information table to be re-initialized.

In TETRA packet data, each SNDCP entity maintains two connection state tables per PDP context, one for N-PDUs sent (compressor state table) and one for N-PDUs received (decompressor state table). Within each table there may be up to 256 state slots, thus allowing the compression of up to 256 simultaneous TCP connections per PDP context. The exact number of state slots supported by SNDCP entities is negotiated at context activation. The MS shall specify in the SN-ACTIVATE PDP CONTEXT DEMAND PDU the number of state slots which it can support for this context. The SwMI shall respond in the SN-ACTIVATE PDP CONTEXT ACCEPT PDU with either the same value or a lower value. The lower of the values specified in the SN-ACTIVATE PDP CONTEXT DEMAND PDU and SN-ACTIVATE PDP CONTEXT ACCEPT PDU shall be used by both SNDCP entities. It is recommended at least 16 state slots are supported per PDP context. It is also recommended that implementations should avoid specifying one slot during PDP context activation if possible.

28.3.5.3.3 IP header compression

IETF RFC 2507 [35] and IETF RFC 2508 [36] define an encoding method and protocol for compressing multiple types of IPv4 or IPv6 protocol header(s). This includes UDP/IP headers, which can be compressed down to 3 octets at minimum. The idea is as for the TCP/IP header compression described in clause 28.3.5.3.2 to replace the IP header(s) with a one or two octet context number, and required delta information (only differences are sent).

The protocol requires that the underlying service should be able to distinguish nine types of IP frames. The frame type information is conveyed in the PCOMP field of the SNDCP header.

In TETRA packet data, each SNDCP entity maintains two context state tables per PDP context, one for N-PDUs sent (compressor context state table) and one for N-PDUs received (decompressor context state table). Within each table there may be up to 256 + 65 536 context state slots, thus allowing the compression of up to 256 simultaneous TCP connections and 65 536 simultaneous non-TCP "contexts" per PDP context. The exact number of state slots supported by SNDCP entities is negotiated at PDP context activation. The MS shall specify in the SN-ACTIVATE PDP CONTEXT DEMAND PDU the number of state slots which it can support for this context. The SwMI shall respond in the SN-ACTIVATE PDP CONTEXT ACCEPT PDU with either the same value or a lower value. The lower of the values specified in the SN-ACTIVATE PDP CONTEXT DEMAND PDU and SN-ACTIVATE PDP CONTEXT ACCEPT PDU shall be used by both SNDCP entities. It is recommended at least 16 state slots be supported per PDP context. It is also recommended that implementations should avoid specifying one slot during PDP context activation if possible.

The context information table in each entity shall be initialized upon occurrence of:

- initial LLC connection establishment/release; or
- at any time when the SNDCP entity concludes that the peer entity has lost IP header compression synchronization.

NOTE: Where an MS moves to a new cell and establishes an advanced link, there should not be a need for the context information table to be re-initialized.

IP header compression modes that require a reliable link should not be used with the unacknowledged layer 2 service.

28.3.5.4 Data compression

28.3.5.4.0 General

Data compression in TETRA Packet data shall primarily be done according to the Recommendation ITU-T V.42bis [27]. It is also possible to use alternative compression methods, if required.

The supported alternative data compression methods introduced in the present document are:

- BSD Compression (IETF RFC 1977 [32]);
- Predictor Compression (IETF RFC 1978 [33]).

28.3.5.4.1 Support of multiple compression types

Each SNDCP entity shall be equipped with the ability to handle several compression types. Then, the means have to be arranged between the peer SNDCP entities to negotiate and switch on the selected algorithm.

The negotiation of the supported algorithms needs to be done prior to data transfer, and it is done between the MS and SwMI in Activate PDP Context procedure. The MS sends a list of algorithms that it can support. The SwMI responds by picking up those algorithms on the list, which it accepts, and then returns a list of the permitted algorithms back to the MS. The format of the negotiation information element is similar for both directions.

Any permitted compression algorithm can be switched on during data transfer period. The selected compression type is identified with DCOMP parameter, which is carried in SN-DATA or SN-UNITDATA PDU frames.

If the receiving SNDCP entity does not recognize the value of the DCOMP information element included in the SN-DATA PDU or SN-UNITDATA PDU it shall discard the PDU.

28.3.5.4.2 Management of V.42bis data compression

According to the present document the use of data compression function and associated parameters shall be negotiated at initial connection establishment. The negotiated parameters, P0, P1 and P2 shall be transferred between MS and SwMI.

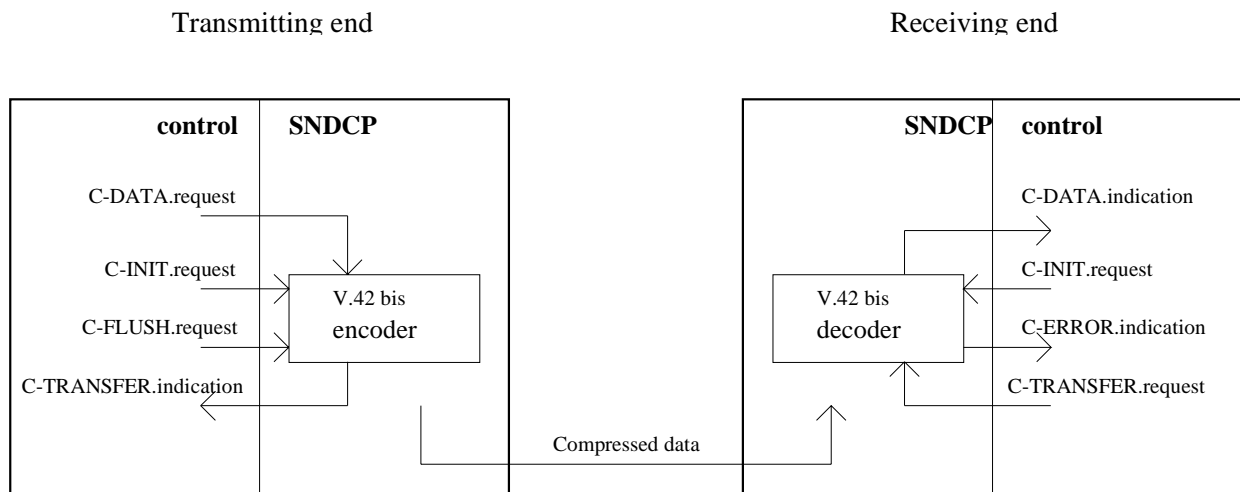

Figure 28.40: Recommendation ITU-T V.42bis [27] data compression function

The service interface of the Recommendation ITU-T V.42bis [27] data compression function is modelled as a set of abstract service primitives, figure 28.40. The control function at each end of data transfer shall issue a C-INIT request primitive to the data compression function after a successful negotiation of compression parameters and after completion of LLC link establishment.

To encode data, the SND CP control function shall issue a C-DATA request primitive to the data compression function, indicating the data to be encoded. The encoder indicates with C-TRANSFER indication primitive that the compressed data is ready to be delivered.

At the receiver end the encoded data block is delivered to the decoder unit using C-TRANSFER request primitive. After this the decoder indicates by C-DATA indication primitive that the decoded data block is ready to be moved further.

The C-FLUSH request primitive shall be used to preserve boundaries between network protocol data blocks (PDUs). The control function shall issue a C-FLUSH request primitive immediately after encoding of each PDU.

The C-ERROR indication primitive informs the control function that an error has been detected by the decoder. The error situation is recovered by re-establishing the LLC connection.

Any subsequent PDP context activation, which requests, and is granted, Recommendation ITU-T V.42bis [27] compression support with different Recommendation ITU-T V.42bis [27] compression parameters, shall cause the Recommendation ITU-T V.42bis [27] compression dictionaries to be cleared.

28.3.5.4.3 Management of BSD data compression

The BSD data compression algorithm is described in IETF RFC 1977 [32]. IETF RFC 1977 [32] describes the compression algorithm and defines the encapsulation header. The encapsulation is shown in table 28.20.

Table 28.20: BSD compressed data format

Bit	8	7	6	5	4	3	2	1
Octet 1	Sequence							
2	Sequence (continued)							
3	Compressed data							
etc.	etc.							
N	Compressed data							

The compressed data information element is the output of the BSD algorithm when applied to the original N-PDU content.

In TETRA packet data, each SNDPCP entity maintains two BSD compression dictionaries, one for N-PDUs sent (compressor dictionary) and one for N-PDUs received (decompressor dictionary). All BSD dictionaries shall be cleared at context activation.

If the decoder has detected an error, the error situation is recovered by re-establishing the LLC connection. According to the specification, the use of the BSD data compression function and associated parameters shall be negotiated at initial connection establishment. The negotiated parameters, version and dictionary size shall be transferred between MS and SwMI.

Any subsequent PDP context activation, which requests, and is granted, BSD compression support with different BSD compression parameters shall cause the BSD compression dictionaries to be cleared.

28.3.5.4.4 Management of Predictor data compression

The predictor data compression algorithm is described in IETF RFC 1978 [33]. IETF RFC 1978 [33] describes the compression algorithm and defines two types of encapsulation headers. However, only type 1 encapsulation is allowed within the present document. The encapsulation is shown in table 28.21.

Table 28.21: Predictor compressed data format

Bit	8	7	6	5	4	3	2	1
Octet 1	Uncompressed length (octets)							
Octet 2	Uncompressed length (continued)							
Octet 3	Compressed data							
etc.	etc.							
etc.	etc.							
Octet N	Compressed data							

The compressed data information element is the output of the predictor algorithm when applied to the original N-PDU content with an appended 16 bit CRC. This CRC shall be calculated as defined in IETF RFC 1662 [31].

In TETRA Packet data, each SNDPCP entity maintains two predictor compression dictionaries, one for N-PDUs sent (compressor dictionary) and one for N-PDUs received (decompressor dictionary). All predictor dictionaries shall be cleared at context activation. If the decoder has detected an error, the error situation is recovered by re-establishing the LLC connection.

According to the specification, the use of the predictor data compression function shall be negotiated at initial connection establishment. There are no negotiated parameters for the predictor data compression.

28.3.5.5 Data Priority

28.3.5.5.1 General

Except where stated otherwise, this clause shall be applicable only to MSs and SwMIs which support data priority.

SNDPCP may provide support for data priority. Eight levels of data priority are available. Data priority allows an MS to transmit high data-priority N-PDUs ahead of lower data-priority N-PDUs from the same MS and other MSs.

The SwMI indicates support for data priority in the "Extended services broadcast" information element of the MAC SYSINFO PDU. The MS SNDPCP is informed of this by the broadcast parameters in the MLE-INFO indication primitive.

The data priority of N-PDUs may be defined by the SNDPCP service user by two different methods. The first provides a data priority for each PDP context and the second allows the SNDPCP service user to set a data priority for individual N-PDUs.

The MS has three different methods for requesting data priority from the SwMI. The first method is conducted within SNDCP, and is a method of requesting a change to the data priority which the SwMI applies by default to all SN-DATA and SN-UNITDATA PDUs transmitted by the MS. The second method is applied at layer 2 in response to information from the MS SNDCP, and is a method of requesting short-term variations to the default data priority. This allows the SwMI to respond quickly to a priority increase while minimizing the amount of signalling required to track rapidly changing data priorities. The third method is applied by the MLE in response to information from the MS SNDCP and is a method of indicating that the MS needs high priority access to a PDCH so that it can be sent to the PDCH ahead of other waiting MSs with lower data priority.

N-PDUs from an MS which does not support data priority will experience the network default data priority. When an MS supporting data priority uses a SwMI which does not support data priority, its N-PDUs and PDCH access requests are given the same data priority as all other MSs' requests.

NOTE: Data priority is distinct from PDU priority (see clause 28.6). PDU priority affects LLC queue reordering and the MS's permission to use random access opportunities. Data priority affects LLC queue reordering, slot granting delays and the speed of the MS's access to the PDCH.

28.3.5.5.2 Network default data priority and initial MS default data priority

Unless otherwise stated, this clause shall be applicable only to MSs and SwMIs that support data priority.

The SwMI should set a "network default data priority". It should apply the network default data priority to reservation requirements from MSs that do not support data priority or have not requested a change in "MS default data priority". An MS may discover the value of the network default data priority in the following ways described in figure 28.41.

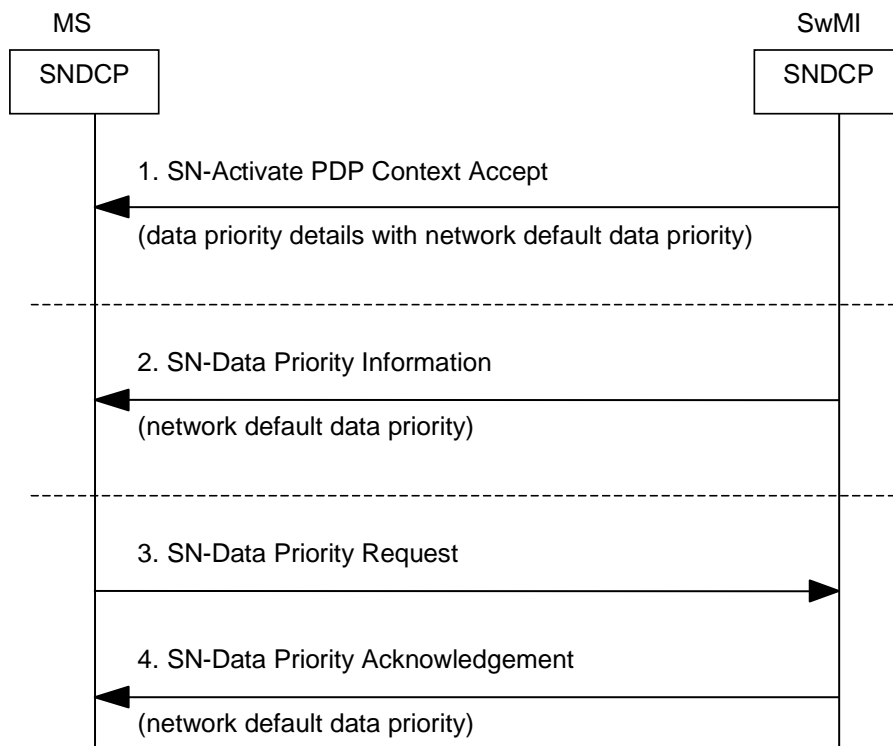

Figure 28.41: Method by which the MS SNDCP discovers the network default priority

1. A SwMI that supports data priority should send MSs the value of the network default data priority in the "data priority details" information element in the SN-ACTIVATE PDP CONTEXT ACCEPT PDU.
2. The SwMI may inform all MSs of the network default data priority by transmitting broadcast-addressed SN-DATA-PRIORITY INFORMATION PDUs from time to time. If the SwMI changes the network default data priority it should inform all MSs of the new network default data priority by transmitting broadcast-addressed SN-DATA-PRIORITY INFORMATION PDUs.

3. An MS SNDCP that has activated packet data context and received MLE INFO indication primitive advising that data priority is supported on the current cell may request the value of the network default data priority by sending an SN-DATA-PRIORITY REQUEST PDU to the SwMI.
4. The SwMI shall then notify the MS of the value of the network default data priority in an SN-DATA-PRIORITY ACKNOWLEDGEMENT PDU.

The SwMI should set and record an initial "MS default data priority" when an MS activates a first PDP context. (This includes MSs which do not support data priority.) The SwMI should set the initial value of "MS default data priority" to the value of the "network default data priority".

When an MS is powered-up, and when it deactivates its last PDP context, the MS SNDCP shall set its recorded value of "MS default data priority" to "undefined" and shall inform MLE that the MS default data priority is "not applicable" using the MLE-CONFIGURE request primitive.

When the MS SNDCP receives a value of network default data priority, then:

- if MS default data priority is "undefined", the MS SNDCP shall set MS default data priority to the value of network default data priority. If in the READY state and the MS wishes to use data priority, MS SNDCP shall then inform MLE of the MS default data priority using the MLE-CONFIGURE request primitive; or
- if MS default data priority has been set from a previous value of network default data priority, the MS SNDCP shall set MS default data priority to the new value of network default data priority. If in the READY state and the MS wishes to use data priority, the MS SNDCP shall then inform MLE of the new MS default data priority using the MLE-CONFIGURE request primitive; or
- if MS default data priority has been set by negotiation with the SwMI, the MS SNDCP shall not set MS default data priority to the value of network default data priority.

If the MS SNDCP wishes to revert a negotiated MS data priority back to the network default data priority, so that it tracks future values of the network default data priority, the MS SNDCP should send the SwMI a SN-DATA-PRIORITY REQUEST PDU with the "data priority request type" set to "set MS default data priority to track network default data priority". If the resulting SN-DATA-PRIORITY ACKNOWLEDGEMENT PDU from the SwMI indicates that MS default data priority has been set to the network default data priority, the MS SNDCP shall set its local value of MS default data priority to the value of network default data priority included in the same PDU. If in the READY state, the MS SNDCP shall then inform MLE of the new MS default data priority using the MLE-CONFIGURE request primitive.

Similarly, if the MS SNDCP receives an SN-DATA-PRIORITY INFORMATION PDU from the SwMI indicating that MS default data priority has been set to the network default data priority, the MS SNDCP shall set its local value of MS default data priority to the value of network default data priority included in the same PDU. If in the READY state, the MS SNDCP shall then inform MLE of the new MS default data priority using the MLE-CONFIGURE request primitive.

When the MS SNDCP enters the READY state and wishes to use data priority and the MS default data priority has a defined value (i.e. not equal to "undefined"), it should send the value of the MS default data priority to MLE in the MS default data priority parameter of the MLE-CONFIGURE request primitive. When the MS SNDCP leaves the READY state, it shall inform MLE that the MS default data priority is "not applicable".

28.3.5.5.3 NSAPI data priority

This clause shall be applicable only to MSs which support data priority.

When an SNDCP service user requests activation of a PDP context (using the SN-NSAPI ALLOC request primitive), the SNDCP service user may include a default data priority for N-PDUs using that PDP context in the "NSAPI data priority" parameter. The MS SNDCP shall record a value for this parameter for each activated PDP context. It shall record the value "undefined" for any PDP context where an NSAPI data priority parameter was not provided.

The SNDCP service user may ask the MS SNDCP to modify the NSAPI data priority of a particular PDP context at any time by use of the SN-NSAPI CONFIGURE request primitive. When the MS SNDCP receives this primitive, it shall replace the previously recorded value with the new value and confirm its arrival by issuing the SN-NSAPI CONFIGURE confirm primitive.

If the SNDCP service user is making a long-term change to the data priority of all its N-PDUs for a particular PDP context, it should alter the NSAPI data priority.

NOTE: The NSAPI data priority is intended to aid the MS in adjusting a long-term default data priority, and the SNDCP service user should not attempt to use the SN-NSAPI CONFIGURE request primitive to follow short-term changes in data priority.

28.3.5.5.4 Changing the MS default data priority

This clause shall be applicable only to MSs and SwMIs which support data priority.

When the MS SNDCP needs to transmit an SN-DATA TRANSMIT REQUEST PDU, when the SNDCP service user requests a change in an NSAPI data priority, or when a CONTEXT_READY timer expires or is stopped, the MS SNDCP should compute a preferred default data priority.

The MS SNDCP should compute the preferred default data priority by examination of the recorded "NSAPI data priority" for each PDP context that is actively sending or receiving data (i.e. for each PDP context with an active CONTEXT_READY timer, or, if CONTEXT_READY timers are not supported, for the PDP context that is presently keeping the READY timer active). The MS SNDCP may include in its computation the "mean active throughput" values of those PDP contexts which are actively attempting to transmit N-PDUs. The MS's preferred default data priority should be an estimate of the modal value of the data priority of the SN-DATA or SN-UNITDATA PDUs that the MS currently expects to transmit.

If the MS's preferred default data priority is different from the current "MS default data priority", the MS SNDCP may request a change to MS default data priority by sending an SN-DATA-PRIORITY REQUEST PDU to the SwMI (it should first transmit any pending SN-DATA TRANSMIT REQUEST PDU). The SwMI shall respond to the SN-DATA-PRIORITY REQUEST PDU with an SN-DATA-PRIORITY ACKNOWLEDGEMENT PDU accepting or rejecting the request, refer to figure 28.42. The MS SNDCP shall not change its value of MS default data priority if the request is rejected. If the request is accepted, the MS SNDCP shall set its value of MS default data priority to the value included with the SN-DATA-PRIORITY ACKNOWLEDGEMENT PDU. (The SwMI need not set this to the value requested by the MS). If the request is accepted and SNDCP is in the READY state, the MS SNDCP shall inform MLE of the new value of MS default data priority using the MLE-CONFIGURE request primitive.

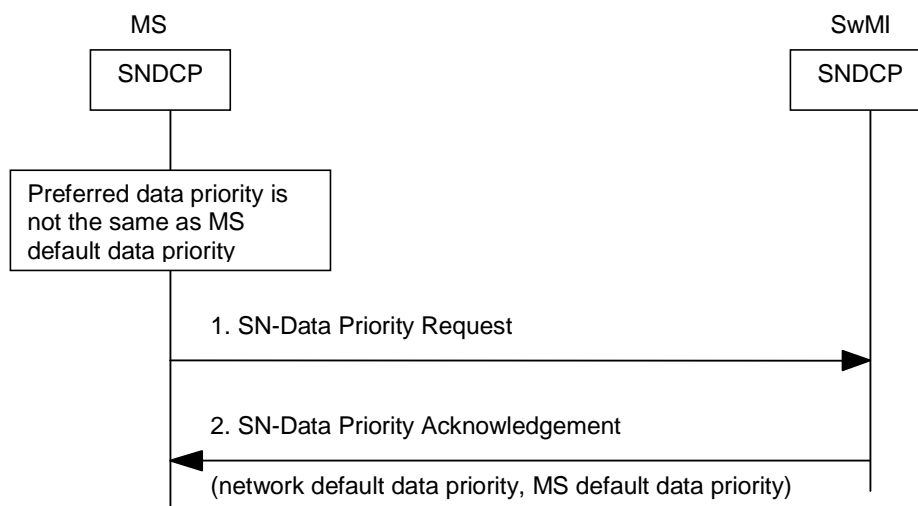

Figure 28.42: SNDCP changes MS default priority

The MS shall not transmit an SN-DATA-PRIORITY REQUEST PDU containing the same information as a previously-transmitted SN-DATA-PRIORITY REQUEST PDU or requesting the same or lower MS default data priority than a previously-transmitted SN-DATA-PRIORITY REQUEST PDU until time DATA_PRIORITY_REQUEST_WAIT has elapsed since the previous transmission of the SN-DATA-PRIORITY REQUEST PDU.

The SwMI may decide to change the MS default data priority for its own reasons. If it changes the MS default data priority it should inform the MS concerned using an individually-addressed SN-DATA-PRIORITY INFORMATION PDU. If the MS default data priority is changed and SNDCP is in the READY state and has informed MLE that the MS default data priority has a value other than "not applicable", the MS SNDCP shall inform MLE using the "MS default data priority" parameter in the MLE-CONFIGURE request primitive.

28.3.5.5.5 Short-term data priorities

This clause shall be applicable only to MSs which support data priority.

SN-DATA and SN-UNITDATA request primitives from the SNDCP service users may include a data priority parameter.

When the MS SNDCP sends an SN-DATA PDU or SN-UNITDATA PDU to the MLE in an MLE-UNITDATA request primitive, the MS SNDCP shall include a data priority parameter in the MLE-UNITDATA request primitive. This data priority parameter shall be set as follows:

- if the SN-DATA PDU or SN-UNITDATA PDU is scheduled (see clause 28.3.5.6) then the data priority parameter shall be set to "undefined" (this includes data which is surplus to the schedule);
- if the SN-DATA PDU or SN-UNITDATA PDU is "initial scheduled data" (see clause 28.3.5.6) then the data priority parameter may be set to "undefined" or may be set using the following methods for data which is not scheduled;
- if the SN-DATA PDU or SN-UNITDATA PDU is not scheduled and there was no data priority parameter in the matching SN-SAP primitive, then:
 - if the "NSAPI data priority" is "undefined" and the MS default data priority is "undefined" then the data priority parameter in the MLE-UNITDATA request primitive shall not take the value "undefined" but should be set to the value "2";
 - if the "NSAPI data priority" is "undefined" and the MS default data priority is not "undefined" then the data priority parameter in the MLE-UNITDATA request primitive shall take the value of the MS default data priority;
 - if the "NSAPI data priority" is not "undefined" then the data priority parameter in the MLE-UNITDATA request primitive shall take its value from the "NSAPI data priority";
- if the SN-DATA PDU or SN-UNITDATA PDU is not scheduled and there was a data priority parameter in the matching SN-SAP primitive then the data priority parameter in the MLE-UNITDATA request primitive shall take its value from the data priority parameter in the matching SN-SAP primitive.

When sending an SN-DATA or SN-UNITDATA PDU, the MS SNDCP shall set the packet data flag in the MLE-UNITDATA request primitive to indicate that the PDU contains packet data. (For all other PDUs, the MS SNDCP shall set the flag to indicate that the PDU does not contain packet data.)

28.3.5.5.6 Short term data priority control

This clause shall be applicable only to MSs which support data priority.

The "Layer 2 data priority lifetime" and "Layer 2 data priority signalling delay" timer values and the "Data priority random access delay factor" are used by layer 2 for control of the short term data priority.

Whenever these items are received by the MS SNDCP in the "data priority details" information element of a SN-ACTIVATE PDP CONTEXT ACCEPT, SN-DATA-PRIORITY INFORMATION or SN-DATA-PRIORITY ACKNOWLEDGEMENT PDU, the MS SNDCP shall inform MLE of their values using the MLE-CONFIGURE request primitive.

The SwMI should transmit broadcast-addressed SN-DATA-PRIORITY INFORMATION PDUs if it wishes to change or update MSs' recorded values of any of the items in the "data priority details" information element.

28.3.5.5.7 Data priority of SN-DATA TRANSMIT REQUEST and SN-RECONNECT PDUs

This clause shall be applicable only to MSs which support data priority.

If the current cell supports data priority, the MS SNDCP may ask the MLE to include data priority with an SN-DATA TRANSMIT REQUEST PDU or SN-RECONNECT PDU by setting the MLE data priority flag parameter to "MLE data priority signalling required" in the MLE-UNITDATA request primitive carrying the SNDCP PDU, and including a data priority parameter with a defined value (i.e. shall not be set to "undefined"). The data priority parameter should be set to the highest data priority of those SN-DATA PDUs which are waiting to be transmitted using the NSAPI or NSAPIs included in the SN-DATA TRANSMIT REQUEST or SN-RECONNECT PDU.

NOTE: This causes the MS MLE to inform the SwMI that the PDCH request implicit in the SNDCP PDU should be given an appropriate data priority by the SwMI, with the objective of reducing the MS's waiting time for access to the PDCH.

The MLE data priority flag shall be set to "MLE data priority signalling not required" for all PDUs other than SN-DATA TRANSMIT REQUEST and SN-RECONNECT, and for all PDUs when the current cell does not support data priority.

28.3.5.6 Scheduled Access

SNDCP provides a scheduled data service known as scheduled access. Scheduled access is available on the uplink for the acknowledged data service and the unacknowledged data service (basic link). It is intended for use by real-time class data and telemetry class data generated by an MS SNDCP service user at regular intervals. Use of a schedule reduces the need for the MS to make random access requests to send its scheduled data, and therefore increases channel efficiency. Scheduled access is available only when SNDCP supports QoS negotiation during PDP context activation.

If an MS SNDCP service user specifies a schedule in an SN-NSAPI ALLOC request primitive, if the MS and SwMI support QoS negotiation during PDP context activation and if the MS supports scheduled access, the MS SNDCP shall request a schedule in the QoS information element of the SN-ACTIVATE PDP CONTEXT DEMAND PDU.

When requesting a schedule, the MS SNDCP shall convert the N-PDU sizes specified by the MS SNDCP service user into SN-DATA or SN-UNITDATA PDU sizes, taking into account the SNDCP header and the effects of IP header compression and data compression, and, in the case of real-time class data, the number of transmission repetitions it requires for each SN-UNITDATA PDU.

If the schedule is agreed by the SwMI, when the SwMI receives a SN-DATA or SN-UNITDATA PDU from the MS for that PDP context, the SwMI shall commence or continue sending regular slot grants to the MS with the repetition period and timing accuracy agreed during the PDP context negotiation.

When the MS SNDCP sends an SN-DATA or SN-UNITDATA PDU to MLE from a PDP context with a schedule for the first time after activation of that PDP context, it shall inform MLE that it requires schedule timing prompts to be started for the relevant NSAPI (using the schedule repetition information parameter in an MLE-CONFIGURE request primitive).

The MS SNDCP may inform MLE that the schedule timing prompts for a particular PDP context can be stopped (using the schedule repetition information parameter in the MLE-CONFIGURE request primitive) when the PDP context containing the schedule is deactivated or when SNDCP returns to the STANDBY state or if the MS SNDCP is informed that the SwMI has suspended or cancelled the schedule.

If MS SNDCP decides to resume use of a schedule after it has informed MLE that the schedule timing prompts may be stopped, it shall inform MLE that it requires schedule timing prompts to be started for the relevant NSAPI when it sends to MLE the next SN-DATA or SN-UNITDATA PDU for that PDP context.

If a schedule has been agreed for a PDP context, the MLE-UNITDATA request primitive carrying the first SN-DATA or SN-UNITDATA PDU from that PDP context following activation of the PDP context shall indicate in the "scheduled data status" parameter that the SN-DATA or SN-UNITDATA PDU is "initial scheduled data". The "scheduled data status" of subsequent SN-DATA or SN-UNITDATA PDUs for that PDP context shall be set to "scheduled data" and the MLE-UNITDATA request primitives shall include the "maximum schedule interval" for the PDP context. (The maximum schedule interval is sum of the schedule repetition period and the schedule timing error.)

If there is a substantial gap in the arrival of N-PDUs from the SNDCP service user, such that the MS SNDCP has no data to transmit for a particular schedule for several schedule periods (for example, when SNDCP returns to the STANDBY state) the MS SNDCP may indicate to the MLE that the first SN-DATA or SN-UNITDATA PDU after the gap is "initial scheduled data". The subsequent SN-DATA or SN-UNITDATA PDUs shall be marked as "scheduled data".

NOTE 1: The indication that an SN-DATA or SN-UNITDATA PDU is "initial scheduled data" allows layer 2 to speed up the re-establishment of a schedule in the event that the SwMI has paused the scheduled slot grants during a gap in the MS's use of the scheduled slot grants.

"Initial scheduled data" SN-DATA and SN-UNITDATA PDUs may be sent to the MLE immediately. "Scheduled data" SN-DATA and SN-UNITDATA PDUs shall be buffered by the MS SNDCP until receipt of an MLE-INFO indication request primitive containing a "schedule timing prompt" parameter for the relevant NSAPI.

SN-DATA request and SN-UNITDATA request primitives containing an N-PDU for a PDP context with a schedule may be labelled "not surplus to schedule" or "surplus to schedule" by the SNDCP service user. N-PDUs which are surplus to schedule are N-PDUs in excess of the number of N-PDUs per schedule interval which the MS agreed with the SwMI during the PDP context activation. The MS SNDCP limits transmission of "not surplus to schedule" N-PDUs to the agreed number of N-PDUs per schedule period. If the application delivers these N-PDUs irregularly (e.g. more than one schedule period early), the MS SNDCP buffers them and delivers them at the agreed schedule intervals and numbers. The MS SNDCP does not limit the number of N-PDUs labeled "surplus to schedule", apart from delaying them until arrival of the next schedule timing signal from MLE.

When the relevant schedule timing prompt is received, the MS SNDCP shall start sending its buffered N-PDUs to the MLE in order of receipt. It shall count the number of those N-PDUs that arrive for this PDP context since the last scheduled transmission having no label or having the label "not surplus to schedule", and shall stop sending buffered N-PDUs for this PDP context if transmission of the next N-PDU would cause the count to exceed the agreed number of N-PDUs per schedule for this schedule.

New N-PDUs arriving after this time shall be buffered until arrival of the next schedule timing prompt.

NOTE 2: This permits the MS SNDCP to transmit "surplus to schedule" N-PDUs on the current schedule timing prompt without delaying following N-PDUs scheduled to be sent on the next schedule timing prompt.

If SNDCP re-negotiates the period of a schedule, the MS SNDCP shall inform MLE that it requires the schedule timing prompts for the relevant NSAPI to be re-started by issuing the new schedule repetition information in an MLE-CONFIGURE request primitive.

The data priority of a "scheduled data" SN-DATA or SN-UNITDATA PDU shall be set to "undefined". "Initial scheduled data" SN-DATA or SN-UNITDATA PDUs may be given a data priority.

If the lower layers fail to provide an MLE-REPORT indication primitive indicating transmission or failure of an SN-UNITDATA PDU containing a scheduled real-time class N-PDU by the time the MS is due to send the next N-PDU in the schedule, the MS SNDCP may attempt to cancel the previous unsent SN-UNITDATA PDU for that PDP context by issuing an MLE-CANCEL request primitive.

If SNDCP decides to cancel N-PDUs, it should preferentially cancel N-PDUs with low "data importance" (as indicated in the SN-DATA or SN-UNITDATA request primitives).

When an MS SNDCP service user stops using a PDP context temporarily it may notify the MS SNDCP in a SN-NSAPI MODIFY request primitive advising that it is pausing use of the schedule or of the entire PDP context. In either case, if the current cell supports QoS negotiation during PDP context activation, the MS SNDCP shall notify the SwMI SNDCP by sending an SN-MODIFY PDP CONTEXT USAGE PDU to the SwMI.

The SwMI may pause a schedule if the MS SNDCP notifies it that it is pausing use of the schedule or PDP context.

The SwMI may also pause a schedule if the MS stops using the scheduled resource for a sufficient period of time (the time is not specified in this document).

The SwMI pauses a schedule by ceasing to provide scheduled slot grants for that PDP context. The SwMI shall resume provision of slot grants for a paused schedule when it next receives an SN-DATA or SN-UNITDATA PDU for that PDP context.

The SwMI may suspend a schedule for a particular PDP context:

- if the SwMI needs to grant resource to an MS wishing to transmit N-PDUs with data priority 7; or
- if the SwMI can no longer provide sufficient resource to support the agreed schedule.

On a cell supporting QoS negotiation during PDP context activation, the SwMI shall suspend a schedule by sending an SN-MODIFY PDP CONTEXT AVAILABILITY PDU to the MS with the "PDP context availability" information element set to "schedule suspended". When the MS SNDCP receives this message, it shall notify the SNDCP service user that the schedule is suspended by issuing an SN-NSAPI MODIFY indication primitive. The MS SNDCP may attempt to renegotiate the schedule when this occurs. SNDCP may delete or cancel N-PDUs received for this PDP context from the SNDCP service user while the schedule is suspended (in which case it shall inform the SNDCP service user by issuing SN-DELIVERY indication primitives).

When the SwMI is able to support a suspended schedule again and the PDP context is still activated, the SwMI shall inform the MS by sending an SN-MODIFY PDP CONTEXT AVAILABILITY PDU with the "PDP context availability" information element set to "PDP context available for use". When the MS SNDCP receives this message it shall notify the SNDCP service user that the PDP context is available by issuing the SN-NSAPI MODIFY indication primitive.

When an MS with an agreed schedule reselects a cell which does not support QoS negotiation during PDP context activation, the MS shall regard the schedule as suspended, shall stop the relevant CONTEXT-READY timer, and shall notify the SNDCP service user that the PDP context is suspended by issuing an SN-NSAPI MODIFY indication primitive. SNDCP may delete or cancel N-PDUs received from the SNDCP service user for this PDP context while the schedule is suspended, in which case it shall inform the SNDCP service user by issuing SN-DELIVERY indication primitives. When the MS returns to a cell supporting QoS negotiation during PDP context activation, the MS should regard the schedule as available and may notify the SNDCP service user that the PDP context is available by issuing the SN-NSAPI MODIFY indication primitive.

The SwMI may cancel a schedule if it wishes to permanently reallocate the scheduled resource.

The SwMI shall cancel a schedule by sending the MS a SN-MODIFY PDP CONTEXT REQUEST PDU whose QoS information element does not include the schedule (e.g. the SwMI could send a one-bit QoS information element if it is now only providing a background class QoS with unspecified throughput, reliability and delay). The MS SNDCP shall reply to this with a SN-MODIFY PDP CONTEXT RESPONSE PDU and shall notify the SNDCP service user that the schedule has been cancelled by issuing a SN-NSAPI MODIFY indication primitive. After the schedule has been cancelled, the MS SNDCP may cancel or delete N-PDUs queued or received for this PDP context from the SNDCP service user (in which case it shall inform the SNDCP service user by issuing SN-DELIVERY indication primitives). On a cell not supporting PDP context modification, the SwMI cannot cancel the schedule but may choose to deactivate the PDP context.

28.3.6 Packet data paging mechanism

A paging mechanism has been defined within SNDCP to provide the following three functions:

- to allow a SwMI to determine the current location of a MS which is in state STANDBY (or state RESPONSE-WAITING), in order to deliver data;
- to provide a method for the SwMI to discover which channels the MS can use in advance of delivering data to the MS (the MS-MLE adds advice about usable channels to the paging response from the MS SNDCP);
- to provide a mechanism by which a SwMI may indicate that there is outbound data awaiting delivery to this MS and allow the MS to indicate whether it is available to accept this data.

There are three main scenarios where the paging mechanism may be used. Firstly where data arrives in the SwMI for a MS which is in STANDBY (or RESPONSE-WAITING) state, and if the SwMI is unsure of the exact location of the MS (e.g. due to there being multiple cells per registration area), then the SwMI may page the MS. Secondly where data arrives in the SwMI for a MS which is presently in STANDBY (or RESPONSE-WAITING) state and the SwMI wishes to discover which (if any) non-conforming channels the MS is presently able to use for receiving the data, then the SwMI may page the MS. Thirdly where data arrives in the SwMI for a MS which is in STANDBY state, and the SwMI wishes to first check to see if the MS is available for packet data service, then the SwMI may page the MS. This third scenario may be useful when considering service interaction with Type B, C and D of MS. This paging mechanism allows a MS to decide whether it wishes to drop its current service in order to switch to the packet data service.

Upon reception of a page request from the SwMI, the MS SNDCP entity may act in one of the following ways:

- 1) Where the SwMI indicates that no SNDCP response is requested, then the MS SNDCP entity shall take no further action. In this case the page request shall be carried using the basic link acknowledged service.

NOTE 1: As the page request is carried using the basic link acknowledged service, hence by acknowledging this basic link message, the MS is implicitly responding to the page.

- 2) Where the SwMI indicates that a SNDCP response is requested, the MS SNDCP entity may respond indicating whether it is available or temporarily unavailable for packet data service. The MS may set the "Stealing Permission" parameter in the MLE-UNITDATA request primitive used to pass the SN-PAGE RESPONSE PDU to the MLE, to "steal immediately".

NOTE 2: If the MS is on a cell where a subscriber class mismatch exists (see clause 16.4.9) or on a not-permitted cell (see clause 18.3.5.1.5), the MS SNDCP should send no response to a page request.

- 3) Where the MS does not have an active PDP context, the MS SNDCP entity may respond by the SN-DEACTIVATE PDP CONTEXT DEMAND PDU initiating the MS originated PDP context deactivation procedure (see clause 28.3.3.6.1).

NOTE 3: The MS may respond with the "Deactivation type" set to "Deactivate all NSAPIs" if no active PDP context exist. If PDP contexts do exist at the MS, the MS may respond with the "Deactivation type" set to "Deactivate NSAPI given in the PDU" if the NSAPI identified in the SN-PAGE REQUEST PDU is not recognized by the MS.

Figure 28.43 shows the scenario where the MS SNDCP entity responds to a page received from the SwMI.

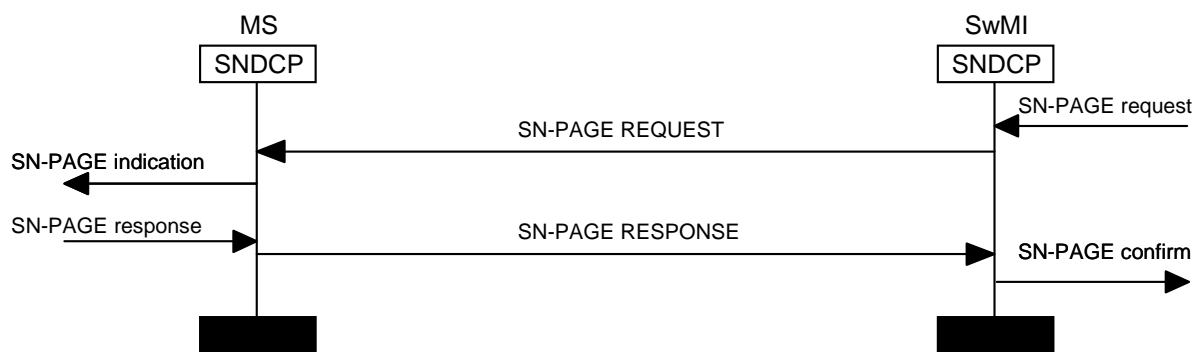

Figure 28.43: SwMI Pages MS, MS SNDCP entity responds

28.3.7 TETRA IP user authentication

Figure 28.44 illustrates the reference model of IP user authentication when using PPP and RADIUS protocols, refer to IETF RFC 1661 [30] and IETF RFC 2865 [37]. In the model an AAA server and the RADIUS protocol are used to verify the user access. Other alternatives for the model are also possible. For instance inside the SwMI there could be a user authentication entity to provide the same functionality as the external AAA server.

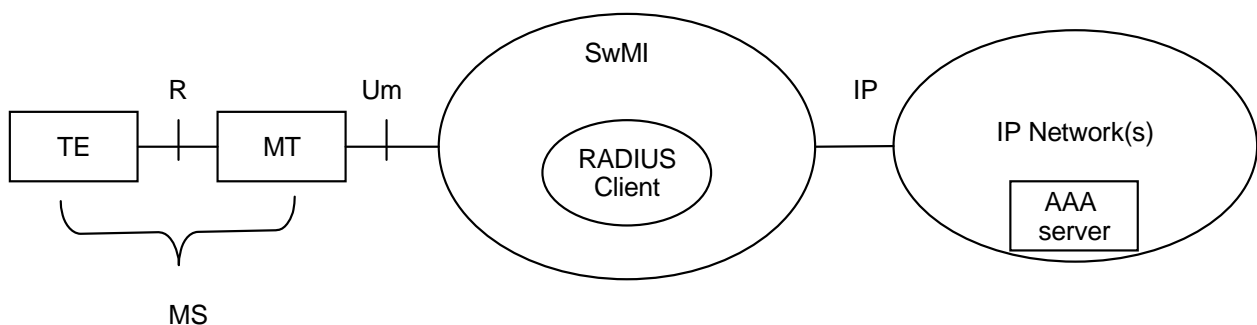

Figure 28.44: IP user authentication model

Following assumptions are made:

- PPP is the link layer protocol used between a TETRA Terminal Equipment (TE) and a TETRA Mobile Termination (MT);
- there is a requirement to authenticate the TE using PAP or CHAP, refer to IETF RFC 1994 [34];
- the TE is the peer that shall be authenticated, and the MT is the authenticator, using the terminology defined in ISO/IEC 8348 [i.7];
- there is a requirement to support the PPP authentication with a centralized AAA server which is accessed by RADIUS protocol as defined in IETF RFC 2865 [37];
- the PAP or CHAP authentication information collected in the MT is forwarded over the TETRA Air Interface to the TETRA SwMI;
- inside the TETRA SwMI is a RADIUS client entity which forwards the authentication information to the external AAA server.

Figure 28.45 illustrates the phases of a packet data context setup upon a successful authentication with CHAP. Corresponding signalling using PAP authentication would be slightly more straightforward.

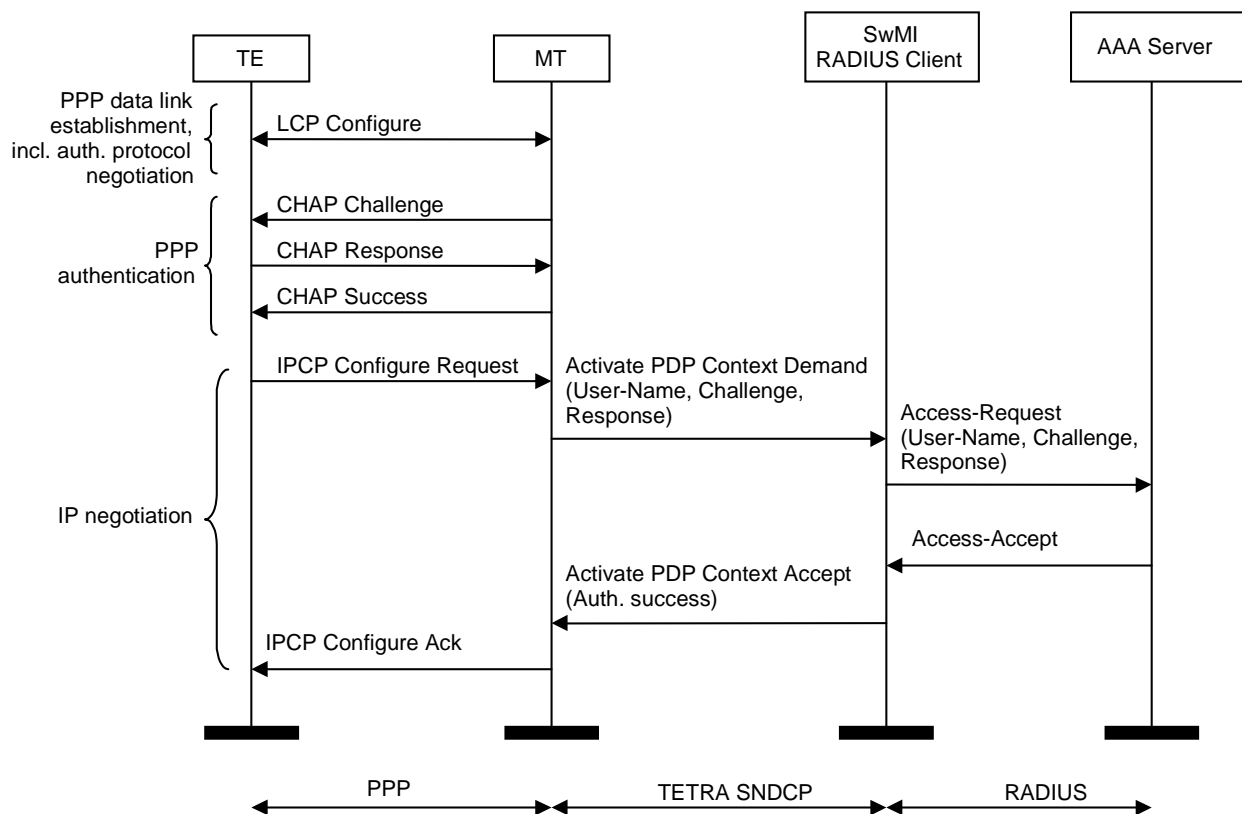

Figure 28.45: A successful authentication with CHAP

Following steps clarifies the figure above:

1. PPP/LCP negotiates the Maximum-Receive-Unit and authentication options;
2. When using CHAP (or PAP), the TE authenticates itself to the MT, which stores the information (username, challenge and response, or password when using PAP) and sends an accept to TE;
3. TE requests IP configuration from the MT using PPP/PCP, either defining a static address, or requesting an address from the network;
4. MT sends an ACTIVATE PDP CONTEXT DEMAND PDU to SwMI, containing in the Protocol configuration option information element the authentication and configuration information it has collected;
5. RADIUS client in SwMI sends an Access-Request to AAA Server using RADIUS protocol;
6. AAA Server sends an Access-Accept to RADIUS Client;
7. SwMI sends an ACTIVATE PDP CONTEXT ACCEPT PDU to MT;
8. MT sends an IPCP Configure Ack to TE and the link is open (or dropped if negotiation failed).

28.3.8 TETRA Packet data over the air provisioning

As indicated in figure 28.44, the TETRA reference model in many ways resembles the reference model used by many IP service providers. Here, the PPP establishment mechanisms are used as a flexible, easily expandable way to provision essential information to the dial up client at connection establishment. Similar information is required at the TE/MT in the TETRA environment, and the TETRA standard therefore allows for such parameters to be provisioned to the TE/MT at context activation.

This information should be transferred to the TE/MT contained in an IPCP Configuration-Ack within the Protocol configuration options information element in the SN-ACTIVATE PDP CONTEXT ACCEPT PDU. The SwMI may include IPCP configuration options specifying (but not limited to):

- Primary and secondary DNS servers.
- Primary and secondary NBNS servers.

The MT shall be prepared to receive Protocol configuration options information elements with Protocol identity set to IPCP (8021H). The MT may ignore the IPCP protocol or IPCP configuration options.

NOTE: Ignoring received information is dissimilar to normal PPP behaviour but required here as the MT can not reject received information.

28.3.9 QoS filters

The MS shall not include a QoS filter specification in the QoS information element when requesting activation of a primary PDP context.

When the MS requests activation of a secondary PDP context it may include a QoS filter specification in the QoS information element. If the SwMI does not support the proposed QoS filter, either the SwMI shall accept the activation request and propose an alternative QoS filter specification or the SwMI shall reject the activation request (e.g. with reject cause "QoS filter type not supported" or "Specified QoS filter not supported").

If the MS does not include a QoS filter specification in the activation request for a secondary PDP context, either the SwMI shall accept the activation request and shall generate an automatic QoS filter for that PDP context (see clause 28.1), or the SwMI shall reject the activation request with reject cause "Automatic QoS filter not supported".

After a secondary PDP context has been activated, the MS may ask the SwMI to modify the QoS filter by sending the SwMI an SN-MODIFY PDP CONTEXT REQUEST PDU. The MS may ask the SwMI to:

- add additional items to the existing the QoS filter;
- remove items from the existing QoS filter; or

- replace the existing QoS filter with a different QoS filter.

Depending on the value of the QoS filter operation information element in the QoS filter information element, the SwMI shall add the QoS filter in the SN-MODIFY PDP CONTEXT REQUEST PDU to the existing QoS filter, or replace any existing QoS filter for the specified PDP context with the new QoS filter, or remove the QoS filter from the specified PDP context. An MS should not attempt removal of a QoS filter that it has not previously established.

If the SwMI is using an automatic QoS filter for a particular PDP context when it receives a request from the MS to replace the QoS filter for that same PDP context, the SwMI shall stop using that automatic QoS filter. If the SwMI is using an automatic QoS filter for a particular PDP context when it receives a request from the MS to add a QoS filter to that same PDP context, the SwMI shall, if it accepts the request, combine the newly requested QoS filter with the automatic QoS filter and use the new combined QoS filter with that PDP context until the MS replaces the existing QoS filter for that PDP context with a new QoS filter.

Where a downlink data packet matches more than one automatic QoS filter, the SwMI shall use the PDP context whose automatic QoS filter was most recently updated with the matching item.

Where a downlink data packet matches more than one explicitly-defined QoS filter, the SwMI shall use the PDP context whose explicitly-defined QoS filter was most recently updated with the matching item.

Where a downlink data packet matches an automatic QoS filter and an explicitly-defined QoS filter, the SwMI shall use the PDP context with the explicitly-defined QoS filter.

EXAMPLE: A SwMI has automatic QoS filters for NSAPIs 2 and 3 that presently accept data packets for downlink destination ports 1005 and 1006 respectively. The SwMI also has an explicitly defined QoS filter for NSAPI 4 that accepts data packets for downlink destination port 1007. The SwMI now receives some uplink packets via NSAPI 3 from source ports 1005 and 1007, so the SwMI updates NSAPI 3's QoS filter to accept packets for downlink destination ports 1005, 1006 and 1007. Shortly afterwards, the SwMI receives a downlink packet for destination port 1007. The SwMI sends this packet to the MS via NSAPI 4 because NSAPI 4's explicitly-defined QoS filter takes precedence over the automatic QoS filter of NSAPI 3. Then the SwMI receives a downlink packet for destination port 1005. The SwMI sends this packet to the MS via NSAPI 3 because port 1005 was added to NSAPI 3 more recently than to NSAPI 2. When the filter on NSAPI 3 is subsequently removed, the SwMI sends packets for downlink destination port 1005 via NSAPI 2.

If the MS includes a QoS filter specification in a secondary PDP context activation or modification request and the SwMI accepts the activation or modification request but includes no QoS filter specification in its response, the MS shall assume that the requested QoS filter has been applied by the SwMI.

If the MS does not include a QoS filter specification in a secondary PDP context activation request and the SwMI accepts the activation request but includes no QoS filter specification in its response, the MS shall assume that an automatic QoS filter has been applied by the SwMI.

If the MS includes a QoS filter specification in a PDP context activation or modification request and the SwMI accepts the activation or modification request, but includes in its response a QoS filter specification which differs from the QoS filter requested by the MS, the MS shall assume that the QoS filter specified by the SwMI has been applied.

28.4 SN-PDU formats

28.4.0 General

The general format of the PDU encoding is as defined in annex E of the present document.

The information elements shall be transmitted in the order specified by the table with the top information element being transmitted first. The content of an information element is represented by a binary value and the most significant bit of that binary value shall be transmitted first.

The information contained in the PDU description tables which follow corresponds to the following key:

- Length: length of the information element in bits;
- Type: information element type (1, 2 or 3) as defined in annex E;

- C/O/M: conditional/optional/mandatory information in the PDU;
- Remark: comment.

28.4.1 PDU priority

At the transmitting end the message PDU priority management at SNDCP level is done before any other operations. Each PDU priority has its own queue that is mapped to the corresponding queue in LLC (MLE passes messages without changing their order). By doing so, for instance, a long file transfer PDU can be quickly bypassed by any other message that has a higher PDU priority. Eight PDU priority levels are used, number 7 representing the highest PDU priority. The PDU priorities for SN-PDUs shall be set according to table 28.22.

Table 28.22: PDU priority for SN-PDUs

SN-PDU	PDU priority
SN-ACTIVATE PDP CONTEXT DEMAND	4
SN-DEACTIVATE PDP CONTEXT DEMAND	4
SN-ACTIVATE PDP CONTEXT ACCEPT	4
SN-ACTIVATE PDP CONTEXT REJECT	4
SN-DEACTIVATE PDP CONTEXT ACCEPT	4
SN-DATA-PRIORITY REQUEST	4
SN-DATA-PRIORITY ACKNOWLEDGEMENT	4
SN-DATA-PRIORITY INFORMATION	4
SN-MODIFY PDP CONTEXT DEMAND	4
SN-MODIFY PDP CONTEXT RESPONSE	4
SN-MODIFY PDP CONTEXT AVAILABILITY	4
SN-MODIFY PDP CONTEXT USAGE	4
SN-UNITDATA	see note
SN-DATA	see note
SN-DATA TRANSMIT REQUEST	see note
SN-DATA TRANSMIT RESPONSE	see note
SN-RECONNECT	4
SN-PAGE REQUEST	4
SN-PAGE RESPONSE	4
SN-END OF DATA	4
SN-NOT SUPPORTED	4
NOTE: The maximum value for PDU priority is defined in SN-ACTIVATE PDP CONTEXT ACCEPT PDU "PDU priority max" information element for each NSAPI. The value used in the MLE-UNITDATA request primitive is given in the SN-DATA/UNITDATA request primitive. If the value given by the higher layer is higher than the "PDU priority max" information element indicates, then the PDU priority is decreased by the SNDCP to the value indicated in the "PDU priority max" information element. If the value is not given in the SN-DATA/UNITDATA request primitive, then the SNDCP uses value indicated in the "PDU priority max" information element.	

At the receiver end there is no need for queuing mechanism.

28.4.2 Maximum N-PDU size

The maximum N-PDU size is assigned by the SwMI at context activation using the parameter "Maximum transmission unit". This value represents the maximum N-PDU size which is allowed. This size refers to the maximum size of a N-PDU prior to the addition of the SNDCP header and the application of any compression.

The Maximum transmission unit should always be less than the Maximum size of a TL-SDU, which is negotiated during advanced link setup. Hence where the SwMI sets Maximum transmission unit to 1 500 octets at context activation, then the negotiated maximum size of TL-SDU at advanced link setup should be 2 048 octets.

28.4.3 PDU not supported

In case the receiving MS or SwMI SNDCP entity receives an unknown SN PDU, the receiving entity should send the SN-NOT SUPPORTED PDU. The behaviour of the requesting party when receiving SN-NOT SUPPORTED PDU is outside the scope of the present document. The meaning of this functionality is only to maintain backward compatibility of the systems.

28.4.4 SN PDU description tables

28.4.4.1 SN-ACTIVATE PDP CONTEXT ACCEPT

SN-ACTIVATE PDP CONTEXT ACCEPT PDU shall contain information elements as defined in table 28.23.

- Message: SN-ACTIVATE PDP CONTEXT ACCEPT PDU
- Response to: SN-ACTIVATE PDP CONTEXT DEMAND PDU
- Response expected: -
- Short description:

Table 28.23: SN-ACTIVATE PDP CONTEXT ACCEPT PDU contents

Information element	Length	Type	C/O/M	Remark
SN PDU type	4	1	M	SN-ACTIVATE PDP CONTEXT ACCEPT
NSAPI	4	1	M	
PDU priority max	3	1	M	
READY timer	4	1	M	
STANDBY timer	4	1	M	
RESPONSE_WAIT timer	4	1	M	
Type identifier in accept	3	1	M	
IP Address IPv4	32		C	see note 1
PCOMP negotiation	8	1	M	
Number of Van Jacobson compression state slots	8		C	see note 2
Number of compression state slots, TCP	8		C	see note 3
Number of compression state slots, non-TCP	16		C	see note 3
Maximum interval between full headers	8		C	see note 3
Maximum time interval between full headers	8		C	see note 3
Largest header size in octets that may be compressed	8		C	see note 3
Maximum transmission unit	3	1	M	
SNDCP network endpoint identifier	16	2	O	see note 4
SwMI IPv6 information	98	2	O	
SwMI Mobile IPv4 information	71	2	O	
DCOMP negotiation	varies	3	O	see note 5
Protocol configuration options	varies	3	O	see note 6
Data priority details	24	3	O	
QoS	varies	3	O	
<p>NOTE 1: Shall be conditional on the value of Type Identifier in Accept (TIA):</p> <ul style="list-style-type: none"> - when TIA = 1 or 2 the information element shall be present; - for all other values of TIA the information element shall not be present. <p>NOTE 2: Shall be conditional on the value of bit 1 (LSB) of PCOMP negotiation:</p> <ul style="list-style-type: none"> - when bit 1 of PCOMP negotiation = 0 the information element shall not be present; - when bit 1 of PCOMP negotiation = 1 the information element shall be present. <p>NOTE 3: Shall be conditional on the value of second LSB of PCOMP negotiation:</p> <ul style="list-style-type: none"> - when bit 2 of PCOMP negotiation = 0 the information element shall not be present; - when bit 2 of PCOMP negotiation = 1 the information element shall be present. <p>NOTE 4: For usage, refer to clause 28.3.3.3.</p> <p>NOTE 5: There may be more than one DCOMP negotiation information element if more than one compression mechanism is assigned for a single NSAPI.</p> <p>NOTE 6: The maximum length shall be 128 octets.</p>				

28.4.4.2 SN-ACTIVATE PDP CONTEXT DEMAND

SN-ACTIVATE PDP CONTEXT DEMAND PDU shall contain information elements as defined in table 28.24.

- Message: SN-ACTIVATE PDP CONTEXT DEMAND PDU
- Response to: -
- Response expected: SN-ACTIVATE PDP CONTEXT ACCEPT PDU
/SN-ACTIVATE PDP CONTEXT REJECT PDU
- Short description:

Table 28.24: SN-ACTIVATE PDP CONTEXT DEMAND PDU contents

Information element	Length	Type	C/O/M	Remark
SN PDU type	4	1	M	SN-ACTIVATE PDP CONTEXT DEMAND
SNDCP version	4	1	M	
NSAPI	4	1	M	see notes 1 and 2
Address type identifier in demand	3	1	M	see note 3
IP Address IPv4	32		C	see note 4
NSAPI	4		C	see notes 5 and 6
Packet data MS Type	4	1	M	
PCOMP negotiation	8	1	M	
Number of Van Jacobson compression state slots	8		C	see note 7
Number of compression state slots, TCP	8		C	see note 8
Number of compression state slots, non-TCP	16		C	see note 8
Maximum interval between full headers	8		C	see note 8
Maximum time interval between full headers	8		C	see note 8
Largest header size in octets that may be compressed	8		C	see note 8
Access point name index	16	2	O	see note 9
DCOMP negotiation	varies	3	O	
Protocol configuration options	varies	3	O	see note 10
QoS	varies	3	O	
<p>NOTE 1: The MS shall not use value 0.</p> <p>NOTE 2: Shall contain the NSAPI for the requested PDP context.</p> <p>NOTE 3: If the SwMI supports use of the QoS information element but does not support the use of secondary PDP contexts, and it receives an ATID value 101₂ it shall discard the remainder of this PDU and shall reject the MS's request with reject cause "Secondary PDP contexts not supported" (value 00011011₂).</p> <p>NOTE 4: Shall be conditional on the value of Address Type Identifier in Demand (ATID):</p> <ul style="list-style-type: none"> - when ATID = 0 the information element shall be present; - for any other value of the ATID the information element shall not be present. <p>NOTE 5: Shall be conditional on the value of Address Type Identifier in Demand (ATID):</p> <ul style="list-style-type: none"> - when ATID = 5 (Primary NSAPI (secondary PDP context requested)) the information element shall be present; - for any other value of the ATID the information element shall not be present. <p>NOTE 6: Shall contain the NSAPI of the primary PDP context from which the requested secondary PDP context derives its PDP address.</p> <p>NOTE 7: Shall be conditional on the value of bit 1 (LSB) of PCOMP negotiation:</p> <ul style="list-style-type: none"> - when bit 1 of PCOMP negotiation = 0 the information element shall not be present; - when bit 1 of PCOMP negotiation = 1 the information element shall be present. <p>NOTE 8: Shall be conditional on the value bit 2 of PCOMP negotiation:</p> <ul style="list-style-type: none"> - when bit 2 of PCOMP negotiation = 0 the information element shall not be present; - when bit 2 of PCOMP negotiation = 1 the information element shall be present. <p>NOTE 9: The default value shall be "0000hex".</p> <p>NOTE 10: The maximum length shall be 128 octets.</p>				

NOTE: Some combinations of the SN-ACTIVATE PDP CONTEXT DEMAND PDU that include the QoS information element may be transmitted without fragmentation in SCH/HU. For example:

- requesting a primary PDP context with no conditional information elements, with no optional information elements apart from the 1-bit version of the QoS information element, with a layer 2 reservation requirement and with an SSI (one unused SCH/HU bit);

- requesting a secondary PDP context with no conditional information elements, with no optional information elements apart from the 48-bit version of the QoS information element with asymmetric QoS and no QoS filter, with no layer 2 reservation requirement and with an event label (two unused SCH/HU bits);
- requesting a primary PDP context, with no conditional information elements apart from the number of Van Jacobson compression state slots, with no optional information elements apart from the 1-bit version of the optional QoS information element, with a layer 2 reservation requirement and with an event label (seven unused SCH/HU bits).

28.4.4.3 SN-ACTIVATE PDP CONTEXT REJECT

SN-ACTIVATE PDP CONTEXT REJECT PDU shall contain information elements as defined in table 28.25.

- Message: SN-ACTIVATE PDP CONTEXT REJECT PDU
- Response to: SN-ACTIVATE PDP CONTEXT DEMAND PDU
- Response expected: -
- Short description: -

Table 28.25: SN-ACTIVATE PDP CONTEXT REJECT PDU contents

Information element	Length	Type	C/O/M	Remark
SN PDU type	4	1	M	SN-ACTIVATE PDP CONTEXT REJECT
NSAPI	4	1	M	
Activation reject cause	8	1	M	
Protocol configuration options	varies	3	O	see note

NOTE: The maximum length shall be 128 octets.

28.4.4.4 SN-DATA

SN-DATA PDU shall contain information elements as defined in table 28.26.

- Message: SN-DATA PDU
- Response to: -
- Response expected: -
- Short description: SN-DATA PDU is used for acknowledged service.

Table 28.26: SN-DATA PDU contents

Information element	Length	Type	C/O/M	Remark
SN PDU type	4	1	M	SN-DATA
NSAPI	4	1	M	
PCOMP	4	1	M	
DCOMP	4	1	M	
N-PDU	varies	1	M	

NOTE: The N-PDU length is defined by the length of the lower layer PDU. There shall be no O-bit after the N-PDU.

28.4.4.4a SN-DATA-PRIORITY ACKNOWLEDGEMENT

SN-DATA-PRIORITY ACKNOWLEDGEMENT PDU shall contain information elements as defined in table 28.27.

- Message: SN-DATA-PRIORITY ACKNOWLEDGEMENT PDU
- Response to: SN-DATA-PRIORITY REQUEST PDU
- Response expected: -
- Short description: Used by SwMI in reply to request from the MS concerning data priority.

Table 28.27: SN-DATA-PRIORITY ACKNOWLEDGEMENT PDU contents

Information element	Length	Type	C/O/M	Remark
SN PDU type	4	1	M	SN-DATA-PRIORITY
Data priority sub-type	4	1	M	SN-DATA-PRIORITY ACKNOWLEDGEMENT
Data priority request result	1	1	M	
Data priority details	24	1	M	
MS default data priority	4		C	See note
NOTE: This information element shall be present only if the data priority request result information element indicates "Request accepted". The value of the MS default data priority information element may differ from that requested by the MS in the SN-DATA-PRIORITY REQUEST PDU.				

28.4.4.4b SN-DATA-PRIORITY INFORMATION

SN-DATA-PRIORITY INFORMATION PDU shall contain information elements as defined in table 28.28.

- Message: SN-DATA-PRIORITY INFORMATION PDU
- Response to: -
- Response expected: -
- Short description: Used by SwMI to send MS information about data priority.

Table 28.28: SN-DATA-PRIORITY INFORMATION PDU contents

Information element	Length	Type	C/O/M	Remark
SN PDU type	4	1	M	SN-DATA-PRIORITY
Data priority sub-type	4	1	M	SN-DATA-PRIORITY INFORMATION
Data priority details	24	1	M	
MS default data priority flag	1	1	M	See note 1
MS default data priority	4		C	See note 2
NOTE 1: This information element should be set to "0" if this PDU is sent to a group or broadcast address.				
NOTE 2: This information element shall be present only if "MS default data priority flag" = 1.				

28.4.4.4c SN-DATA-PRIORITY REQUEST

SN-DATA-PRIORITY REQUEST PDU shall contain information elements as defined in table 28.29.

- Message: SN-DATA-PRIORITY REQUEST PDU
- Response to: -
- Response expected: SN-DATA-PRIORITY ACKNOWLEDGEMENT PDU
- Short description: Used by MS to request data priority change or information.

Table 28.29: SN-DATA-PRIORITY REQUEST PDU contents

Information element	Length	Type	C/O/M	Remark
SN PDU type	4	1	M	SN-DATA-PRIORITY
Data priority sub-type	4	1	M	SN-DATA-PRIORITY REQUEST
Data priority request type	4	1	M	

28.4.4.5 SN-DATA TRANSMIT REQUEST

SN-DATA TRANSMIT REQUEST PDU shall contain information elements as defined in table 28.30.

- Message: SN-DATA TRANSMIT REQUEST PDU
- Response to: -
- Response expected: SN-DATA TRANSMIT RESPONSE PDU (when SN-DATA TRANSMIT REQUEST PDU is sent by the MS)
- Short description:

Table 28.30: SN-DATA TRANSMIT REQUEST PDU contents

Information element	Length	Type	C/O/M	Remark
SN PDU type	4	1	M	SN-DATA TRANSMIT REQUEST
NSAPI	4	1	M	
Logical link status	1	1	M	see note 1
Enhanced $\pi/4$ -DQPSK service (see note 5)	1	1	M	see note 1
Resource request	varies		C	see note 2
SNDCP network endpoint identifier	16	2	O	see note 3
Reserved	20	2	O	see note 4
NSAPI additional	varies	4	O	see notes 6 and 7
NOTE 1: This information element has meaning only on uplink. The information element value shall be "0" on downlink in the present document.				
NOTE 2: For usage refer to clause 28.3.5.2a. Shall be conditional on the value of Enhanced $\pi/4$ -DQPSK service information element: <ul style="list-style-type: none"> - when the Enhanced $\pi/4$-DQPSK service = 1 the Resource request information element shall be present; - when the Enhanced $\pi/4$-DQPSK service = 0 the Resource request information element shall not be present. 				
NOTE 3: For usage refer to clause 28.3.3.3.				
NOTE 4: Shall not be used in protocol defined in the present document.				
NOTE 5: This was formerly known as the "enhanced service" information element.				
NOTE 6: This information element may be included if the MS wishes to transmit data for more than one NSAPI. In combination with the "NSAPI" information element, it indicates to the SwMI those NSAPIs for which the MS wishes to transmit data.				
NOTE 7: The sender of this PDU is not precluded from including the same NSAPI value in both the "NSAPI" information element and the "NSAPI for reconnection" information element. In the present document, the receiver shall ignore a second incidence of the same NSAPI.				

If MS supports the use of non-conforming PDCHs, the "channel advice flag" parameter in the MLE-UNITDATA request primitive containing this PDU should be set to "channel advice requested".

NOTE: Fragmentation will occur if this PDU is sent in SCH-Q/RA with an SSI and SNEI.

28.4.4.6 SN-DATA TRANSMIT RESPONSE

SN-DATA TRANSMIT RESPONSE PDU shall contain information elements as defined in table 28.31.

- Message: SN-DATA TRANSMIT RESPONSE PDU
- Response to: SN-DATA TRANSMIT REQUEST PDU (MS to SwMI), SN-RECONNECT PDU
- Response expected: -
- Short description:

Table 28.31: SN-DATA TRANSMIT RESPONSE PDU contents

Information element	Length	Type	C/O/M	Remark
SN PDU type	4	1	M	SN-DATA TRANSMIT RESPONSE
NSAPI	4	1	M	
Accept/Reject	1	1	M	
Transmit response reject cause	8		C	see note 1
SNDCP network endpoint identifier	16	2	O	see note 2
NSAPI additional	varies	4	O	see notes 3 and 4
NOTE 1: Shall be conditional on the value of the Accept/Reject information element: <ul style="list-style-type: none"> - when the Accept/Reject = 0 the transmit response reject cause information element shall be present; - when the Accept/Reject = 1 the transmit response reject cause information element shall not be present. 				
NOTE 2: For usage refer to clause 28.3.3.3.				
NOTE 3: This information element may be included in response to an SN-DATA TRANSMIT REQUEST or SN-RECONNECT PDU that contained more than one NSAPI. In combination with the "NSAPI" information element, it indicates to the MS those NSAPIs for which the MS's request has been accepted.				
NOTE 4: The SwMI is not precluded from including the same NSAPI value in both the "NSAPI" information element and the "NSAPI for reconnection" information element. In the present document, the MS shall ignore a second incidence of the same NSAPI.				

28.4.4.7 SN-DEACTIVATE PDP CONTEXT DEMAND

SN-DEACTIVATE PDP CONTEXT DEMAND PDU shall contain information elements as defined in table 28.32.

- Message: SN-DEACTIVATE PDP CONTEXT DEMAND PDU
- Response to: -
- Response expected: SN-DEACTIVATE PDP CONTEXT ACCEPT PDU
- Short description:

Table 28.32: SN-DEACTIVATE PDP CONTEXT DEMAND PDU contents

Information element	Length	Type	C/O/M	Remark
SN PDU type	4	1	M	SN-DEACTIVATE PDP CONTEXT DEMAND
Deactivation type	8	1	M	
NSAPI	4		C	see note 1
SNDCP network endpoint identifier	16	2	O	see note 2
Reserved	12	2	O	see note 3
NOTE 1: Shall be conditional on the value of the Deactivation type information element: <ul style="list-style-type: none"> - when the value of the Deactivation type = 0 the NSAPI information element shall not be present; - when the value of the Deactivation type = 1 the NSAPI information element shall be present; - for all other values of the Deactivation type information element the NSAPI shall be present. 				
NOTE 2: For usage, refer to clause 28.3.3.3.				
NOTE 3: Shall not be used in protocol defined in the present document.				

28.4.4.8 SN-DEACTIVATE PDP CONTEXT ACCEPT

SN-DEACTIVATE PDP CONTEXT ACCEPT PDU shall contain information elements as defined in table 28.33.

- Message: SN-DEACTIVATE PDP CONTEXT ACCEPT PDU
- Response to: SN-DEACTIVATE PDP CONTEXT DEMAND PDU
- Response expected: -
- Short description: -

Table 28.33: SN-DEACTIVATE PDP CONTEXT ACCEPT PDU contents

Information element	Length	Type	C/O/M	Remark
SN PDU type	4	1	M	SN-DEACTIVATE PDP CONTEXT ACCEPT
Deactivation type	8	1	M	
NSAPI	4		C	see note 1
SND CP network endpoint identifier	16	2	O	see note 2
Reserved	11	2	O	see note 3
NOTE 1: Shall be conditional on the value of Deactivation type information element: <ul style="list-style-type: none"> - when the Deactivation Type = 0 the NSAPI information element shall not be present; - when the value of the Deactivation type = 1 the NSAPI information element shall be present; - for all other values of the Deactivation type information element the NSAPI shall be present. 				
NOTE 2: For usage, refer to clause 28.3.3.3.				
NOTE 3: Shall not be used in protocol defined in the present document.				

28.4.4.9 SN-END OF DATA

SN-END OF DATA PDU shall contain information elements as defined in table 28.34.

- Message: SN-END OF DATA PDU
- Response to: -/SN-END OF DATA PDU
- Response expected: -/SN-END OF DATA PDU
- Short description: -

Table 28.34: SN-END OF DATA PDU contents

Information element	Length	Type	C/O/M	Remark
SN PDU type	4	1	M	SN-END OF DATA
Immediate service change	1	1	M	
Reserved	41	2	O	see note
NOTE: Shall not be used in protocol defined in the present document.				

28.4.4.9a SN-MODIFY PDP CONTEXT REQUEST

SN-MODIFY PDP CONTEXT REQUEST PDU shall contain information elements as defined in table 28.35.

- Message: SN-MODIFY PDP CONTEXT REQUEST PDU
- Response to: -
- Response expected: SN-MODIFY PDP CONTEXT RESPONSE PDU
- Short description: -

Table 28.35: SN-MODIFY PDP CONTEXT REQUEST PDU contents

Information element	Length	Type	C/O/M	Remark
SN PDU type	4	1	M	SN-MODIFY
Modify sub-type	4	1	M	SN-MODIFY PDP CONTEXT REQUEST
NSAPI	4	1	M	
QoS	varies	1	M	

28.4.4.9b SN-MODIFY PDP CONTEXT RESPONSE

SN-MODIFY PDP CONTEXT RESPONSE PDU shall contain information elements as defined in table 28.36.

- Message: SN-MODIFY PDP CONTEXT RESPONSE PDU
- Response to: SN-MODIFY PDP CONTEXT REQUEST PDU
- Response expected: -
- Short description: -

Table 28.36: SN-MODIFY PDP CONTEXT RESPONSE PDU contents

Information element	Length	Type	C/O/M	Remark
SN PDU type	4	1	M	SN-MODIFY
Modify sub-type	4	1	M	SN-MODIFY PDP CONTEXT RESPONSE.
NSAPI	4	1	M	
Modification result	1	1	M	see note 1
Modification reject cause	8		C	see note 2
PDU priority max	3		C	see note 3
QoS	varies		C	see note 3
NOTE 1: "Modification rejected" means the PDP context remains unaltered.				
NOTE 2: Shall be present only if "modification result" has value "1" (modification rejected).				
NOTE 3: Shall be present only if "modification result" has value "0" (modification applied).				

28.4.4.9c SN-MODIFY PDP CONTEXT AVAILABILITY

SN-MODIFY PDP CONTEXT AVAILABILITY PDU shall contain information elements as defined in table 28.37.

- Message: SN-MODIFY PDP CONTEXT AVAILABILITY PDU
- Response to: -
- Response expected: -
- Short description: -

Table 28.37: SN-MODIFY PDP CONTEXT AVAILABILITY PDU contents

Information element	Length	Type	C/O/M	Remark
SN PDU type	4	1	M	SN-MODIFY
Modify sub-type	4	1	M	SN-MODIFY PDP CONTEXT AVAILABILITY
NSAPI	4	1	M	
PDP context availability	3	1	M	

28.4.4.9d SN-MODIFY PDP CONTEXT USAGE

SN-MODIFY PDP CONTEXT USAGE PDU shall contain information elements as defined in table 28.38.

- Message: SN-MODIFY PDP CONTEXT USAGE PDU
- Response to: -
- Response expected: -
- Short description: -

Table 28.38: SN-MODIFY PDP CONTEXT USAGE PDU contents

Information element	Length	Type	C/O/M	Remark
SN PDU type	4	1	M	SN-MODIFY
Modify sub-type	4	1	M	SN-MODIFY PDP CONTEXT USAGE.
NSAPI	4	1	M	
PDP context usage	3	1	M	
Reserved	9	2	O	Shall not be used in the present document.

NOTE: This PDU is an exact fit in SCH-Q/RA when the reserved type 2 information element is included with an SSI and without a layer 2 reservation requirement.

28.4.4.10 SN-NOT SUPPORTED

SN-NOT SUPPORTED PDU shall contain information elements as defined in table 28.39.

- Message: SN-NOT SUPPORTED PDU
- Response to: Any individually addressed SN PDU
- Response expected: -
- Short description: This PDU may be sent by the MS or the SwMI to indicate that the received SN PDU or the function indicated in the PDU is not supported by the peer entity.

Table 28.39: SN-NOT SUPPORTED PDU contents

Information element	Length	Type	C/O/M	Remark
SN PDU type	4	1	M	SN-NOT SUPPORTED
Not supported SN PDU type	4	1	M	

28.4.4.11 SN-PAGE REQUEST

SN-PAGE REQUEST PDU shall contain information elements as defined in table 28.40.

- Message: SN-PAGE REQUEST PDU
- Response to: -
- Response expected: No response or SN-PAGE RESPONSE PDU
- Short description: -

Table 28.40: SN-PAGE REQUEST PDU contents

Information element	Length	Type	C/O/M	Remark
SN PDU type	4	1	M	SN-PAGE REQUEST
NSAPI	4	1	M	
Reply requested	1	1	M	
SNDCP network endpoint identifier	16	2	O	see note
NOTE: For usage, refer to clause 28.3.3.3.				

28.4.4.12 SN-PAGE RESPONSE

SN-PAGE RESPONSE PDU shall contain information elements as defined in table 28.41.

- Message: SN-PAGE RESPONSE PDU
- Response to: SN-PAGE REQUEST PDU
- Response expected: -
- Short description: -

Table 28.41: SN-PAGE RESPONSE PDU contents

Information element	Length	Type	C/O/M	Remark
SN PDU type	4	1	M	SN-PAGE RESPONSE
NSAPI	4	1	M	
PD service status	1	1	M	
Logical link status	1	1	M	
Enhanced $\pi/4$ -DQPSK service (see note 4)	1	1	M	
Resource request	varies		C	See note 1
SNDCP network endpoint identifier	16	2	O	See note 2
Reserved	18	2	O	See note 3
NOTE 1: For usage, refer to clause 28.3.5.2a. Shall be conditional on the value of Enhanced $\pi/4$ -DQPSK service information element: <ul style="list-style-type: none"> - when the Enhanced $\pi/4$-DQPSK service = 1 the Resource request information element shall be present; - when the Enhanced $\pi/4$-DQPSK service = 0 the Resource request information element shall not be present. 				
NOTE 2: For usage, refer to clause 28.3.3.3.				
NOTE 3: Shall not be used in protocol defined in the present document.				
NOTE 4: This was formerly known as the "enhanced service" information element.				

If the MS supports the use of non-conforming PDCHs, the "channel advice flag" parameter in the MLE-UNITDATA request primitive containing this PDU should be set to "channel advice requested".

28.4.4.13 SN-RECONNECT

SN-RECONNECT PDU shall contain information elements as defined in table 28.42.

- Message: SN-RECONNECT PDU
- Response to: -
- Response expected: No response, SN-DATA TRANSMIT RESPONSE PDU or SN-DATA TRANSMIT REQUEST PDU
- Short description: -

Table 28.42: SN-RECONNECT PDU contents

Information element	Length	Type	C/O/M	Remark
SN PDU type	4	1	M	SN-RECONNECT
Data to send	1	1	M	See note 8
NSAPI	4		C	See note 1
Enhanced $\pi/4$ -DQPSK service (see note 5)	1	1	M	
Resource request	varies		C	See note 2
SNDCP network endpoint identifier	16	2	O	See note 3
Reserved	19	2	O	See note 4
NSAPI for reconnection	varies	4	O	See notes 6 and 7
<p>NOTE 1: Shall be conditional on the value of the Data to send information element:</p> <ul style="list-style-type: none"> - when Data to send = 1 the NSAPI information element shall be present; - when Data to send = 0 the NSAPI information element shall not be present. <p>NOTE 2: For usage, refer to clause 28.3.5.2a. Shall be conditional on the value of the Enhanced $\pi/4$-DQPSK service information element:</p> <ul style="list-style-type: none"> - when the Enhanced $\pi/4$-DQPSK service = 1 the Resource request information element shall be present; - when the Enhanced $\pi/4$-DQPSK service = 0 the Resource request information element shall not be present. <p>NOTE 3: For usage, refer to clause 28.3.3.3.</p> <p>NOTE 4: Shall not be used in protocol defined in the present document.</p> <p>NOTE 5: This was formerly known as the "enhanced service" information element.</p> <p>NOTE 6: This information element may be included if the MS wishes to request reconnection for more than one NSAPI. In combination with the "NSAPI" information element, it indicates to the SwMI those NSAPIs for which the MS wishes reconnection.</p> <p>NOTE 7: The MS is not precluded from including the same NSAPI in both the "NSAPI" information element and the "NSAPI for reconnection" information element. In the present document, the SwMI shall ignore a second incidence of the same NSAPI.</p> <p>NOTE 8: The MS is not precluded from setting "data to send" if it wishes to be on a PDCH because it expects imminent reception of data on the downlink or imminent arrival of data for transmission on the uplink.</p>				

If the MS supports the use of non-conforming PDCHs, the "channel advice flag" parameter in the MLE-UNITDATA request primitive containing this PDU should be set to "channel advice requested".

28.4.4.14 SN-UNITDATA

SN-UNITDATA PDU shall contain information elements as defined in table 28.43.

- Message: SN-UNITDATA PDU
- Response to: -
- Response expected: -
- Short description: SN-UNITDATA PDU is used for unacknowledged service.

Table 28.43: SN-UNITDATA PDU contents

Information element	Length	Type	C/O/M	Remark
SN PDU type	4	1	M	SN-UNITDATA
NSAPI	4	1	M	
PCOMP	4	1	M	
DCOMP	4	1	M	
N-PDU	varies	1	M	
NOTE:	The N-PDU length is defined by the length of the lower layer PDU. There shall be no O-bit after the N-PDU.			

28.4.5 SNDCP information elements coding

28.4.5.1 Accept/Reject

The Accept/Reject information element shall be encoded as defined in table 28.44.

Table 28.44: Accept/Reject information element contents

Information element	Length	Value	Remark
Accept/Reject	1	0	Request rejected by the SwMI
		1	Request accepted by the SwMI

28.4.5.2 Access point name index

The Access point name index information element shall be encoded as defined in table 28.45.

Table 28.45: Access point name index information element contents

Information element	Length	Value	Remark
Access point name index	16	any	

28.4.5.3 Activation reject cause

The Activation reject cause information element shall be encoded as defined in table 28.46.

Table 28.46: Activation reject cause information element contents

Information element	Length	Value	Remark
Reject cause	8	0	Undefined
		1	MS not provisioned for Packet Data
		2	IPv4 not supported
		3	IPv6 not supported
		4	IPv4 dynamic address negotiation not supported
		5	IPv6 stateful address autoconfiguration not supported
		6	IPv6 stateless address autoconfiguration not supported
		7	Dynamic address pool empty
		8	Static address not correct
		9	Static address in use
		10	Static address not allowed
		11	Static IP address congestion
		12	TETRA Packet data not supported on this location area
		13	TETRA Packet data not supported on this network.
		14	Temporary rejection
		15	Packet Data MS Type not supported
		16	SNDTCP version not supported
		17	Mobile IPv4 not supported
		18	Mobile IPv4 Co-located care of address not supported
		19	Maximum number of PDP Contexts per ITSI exceeded
		20	User authentication failed
		21	Activation rejected by external PDN
		22	Access point name index not correct
		23	Requested minimum peak throughput not available
		24	Scheduled access not supported
		25	Requested schedule not available
		26	Requested QoS not available
		27	Secondary PDP contexts not supported
		28	Primary PDP context does not exist
		29	Asymmetric QoS not supported
		30	Automatic QoS filter not supported
		31	Specified QoS filter not supported
		32	QoS filter type not supported
		33	QoS filter not available for primary PDP context
		34	SNDTCP service temporarily not available
others	Reserved		

28.4.5.3a Additional QoS information A

The "additional QoS information A" information element shall be encoded as defined in table 28.47.

Table 28.47: Additional QoS information A information element contents

Information element	Length	Value	Remark
Additional QoS information A	16	any	Reserved

28.4.5.3b Additional QoS information A included

The "additional QoS information A included" information element shall be encoded as defined in table 28.48.

Table 28.48: Additional QoS information A included information element contents

Information element	Length	Value	Remark
Additional QoS information A included	1	0	Not included
		1	Included

28.4.5.3c Additional QoS information B

The "additional QoS information B" information element shall be encoded as defined in table 28.49.

Table 28.49: Additional QoS information B information element contents

Information element	Length	Value	Remark
Additional QoS information B	16	any	Reserved

28.4.5.3d Additional QoS information B included

The "additional QoS information B included" information element shall be encoded as defined in table 28.50.

Table 28.50: Additional QoS information B included information element contents

Information element	Length	Value	Remark
Additional QoS information B included	1	0	Not included
		1	Included

28.4.5.4 Address Type Identifier in Demand

The Address Type Identifier in Demand information element shall be encoded as defined in table 28.51.

Table 28.51: Address Type Identifier in Demand information element contents

Information element	Length	Value	Remark
Address Type Identifier in Demand	3	0	IPv4 Static Address
		1	IPv4 Dynamic Address Negotiation
		2	IPv6
		3	Mobile IPv4 Foreign Agent care of address requested
		4	Mobile IPv4 Co-located care-of address requested
		5	Primary NSAPI (secondary PDP context requested)
		others	Reserved

28.4.5.4a Asymmetrical QoS

The asymmetrical QoS information element shall be encoded as defined in table 28.52.

Table 28.52: Asymmetrical QoS information element contents

Information element	Length	Value	Remark
Asymmetrical QoS	1	0	Symmetrical QoS
		1	Asymmetrical QoS (separate uplink QoS and downlink QoS included)

28.4.5.4b Background class request

The background class request information element shall be encoded as defined in table 28.53.

Table 28.53: Background class request information element contents

Information element	Length	Value	Remark
Background class request	1	0	Background class
		1	Any data class

28.4.5.5 BSD data compression parameters

The BSD data compression parameters information element shall be encoded as defined in table 28.54.

Table 28.54: BSD data compression parameters information element contents

Information element	Length	Type	C/O/M	Remark
BSD compression version	3	1	M	
BSD dictionary size	5	1	M	

28.4.5.6 BSD compression version

The BSD compression version information element shall be encoded as defined in table 28.55.

Table 28.55: BSD compression version information element contents

Information element	Length	Value	Remark
BSD compression version	3	0	Reserved
		1	Version 1
		2 to 7	Reserved

28.4.5.7 BSD dictionary size

The BSD dictionary size information element shall be encoded as defined in table 28.56.

Table 28.56: BSD dictionary size information element contents

Information element	Length	Value	Remark
BSD dictionary size	5	0 to 8	Reserved
		9 to 16	Length of largest code in bits
		17 to 31	Reserved

28.4.5.7a CONTEXT_READY timer

The CONTEXT_READY timer information element shall be encoded as defined in table 28.57.

Table 28.57: CONTEXT_READY timer information element contents

Information element	Length	Value	Remark
CONTEXT_READY timer	4	0	Track the READY timer
		1	200 ms
		2	500 ms
		3	700 ms
		4	1 s
		5	2 s
		6	3 s
		7	5 s
		8	10 s
		9	20 s
		10	30 s
		11	60 s
		12	120 s
		13	180 s
		14	300 s
15	Reserved		

28.4.5.7b Data class

The Data class information element shall be encoded as defined in table 28.58.

Table 28.58: Data class information element contents

Information element	Length	Value	Remark
Data class	3	0	Background
		1	Telemetry
		2	Real-time
		3	Reserved
		4	Reserved
		5	Reserved
		6	Reserved
		7	Reserved

28.4.5.7c Data priority details

The Data priority details information element shall be encoded as defined in table 28.59.

Table 28.59: Data priority details information element contents

Information element	Length	Type	C/O/M	Remark
Network default data priority	3	1	M	
Layer 2 data priority lifetime	6	1	M	
Layer 2 data priority signalling delay	3	1	M	
Data priority random access delay factor	3	1	M	
Reserved	9	1	M	Shall be set to "0".

NOTE: The layer 2 data priority lifetime should normally be set to a greater time than the layer 2 data priority signalling delay.

28.4.5.7d Data priority random access delay factor

The Data priority random access delay factor information element shall be encoded as defined in table 28.60.

Table 28.60: Data priority random access delay factor information element contents

Information element	Length	Value	Remark
Data priority random access delay factor	3	0	Data priority random access delay factor = 0
		1	Data priority random access delay factor = 1
		etc.	etc.
		7	Data priority random access delay factor = 7

NOTE: The use of the data priority random access delay factor is defined in clauses 23.4.7.5.2 and 23.4.7.5.3.

28.4.5.7e Data priority request result

The Data priority request result information element shall be encoded as defined in table 28.61.

Table 28.61: Data priority request result information element contents

Information element	Length	Value	Remark
Data priority request result	1	0	Request accepted (see note)
		1	Request rejected
NOTE: This means that the MS default data priority has been changed, but it need not be changed to the value requested by the MS.			

28.4.5.7f Data priority request type

The Data priority request type information element shall be encoded as defined in table 28.62.

Table 28.62: Data priority request type information element contents

Information element	Length	Value	Remark
Data priority request type	4	0	Set MS default data priority 0
		1	Set MS default data priority 1
		etc.	etc.
		7	Set MS default data priority 7
		8	Set MS default data priority to track network default data priority
		9	Report Network and MS default data priorities
		10	Reserved
		etc.	etc.
		15	Reserved

28.4.5.7g Data priority sub-type

The data priority sub-type information element shall be encoded as defined in table 28.63.

Table 28.63: Data priority sub-type information element contents

Information element	Length	Value	Remark
Data priority sub-type	4	0	SN-DATA-PRIORITY ACKNOWLEDGEMENT
		1	SN-DATA-PRIORITY INFORMATION
		2	SN-DATA-PRIORITY REQUEST
		3	Reserved
		etc.	etc.
		15	Reserved

28.4.5.8 Data to send

The Data to send information element shall be encoded as defined in table 28.64.

Table 28.64: Data to Send information element contents

Information element	Length	Value	Remark
Data to send	1	0	No data to send
		1	SN-DATA PDU or SN-UNITDATA PDU awaiting transmission on uplink

28.4.5.8a Delay class

The Delay class information element shall be encoded as defined in table 28.65.

Table 28.65: Delay class information element contents

Information element	Length	Value	Remark
Delay class (see note)	2	0	Low
		1	Moderate
		2	High
		3	Unpredictable
NOTE: Delay classes are defined in table 28.10.			

28.4.5.9 DCOMP

The DCOMP information element shall be encoded as defined in table 28.66.

Table 28.66: DCOMP information element contents

Information element	Length	Value	Remark
DCOMP	4	0	No compression
		1	Recommendation ITU-T V.42bis [27]
		2	BSD compression
		3	Predictor compression
		4	BSD uncompressible packet
		Others	Reserved for further compression algorithms(a list of fixed or negotiated algorithms e.g. pzip, fax, MPEG)

28.4.5.10 DCOMP negotiation

The DCOMP negotiation information element shall be encoded as defined in table 28.67.

Table 28.67: DCOMP negotiation information element contents

Information element	Length	Type	C/O/M	Remark
DCOMP	4	1	M	
Data compression parameters	varies		C	see note
NOTE: Shall be conditional on the value of DCOMP:				
- when DCOMP = 0, 3 or 4 no data compression parameters are present;				
- when DCOMP = 1, "Recommendation ITU-T 4.2bis data compression request parameters" shall be present;				
- when DCOMP = 2, "BSD data compression parameters" shall be present.				

28.4.5.11 Deactivation type

The Deactivation type information element shall be encoded as defined in table 28.68.

Table 28.68: Deactivation type information element contents

Information element	Length	Value	Remark
Deactivation type	8	0	Deactivate all NSAPIs
		1	Deactivate NSAPI given in the PDU
		others	Reserved

28.4.5.11a Diffserv filter

The Diffserv filter information element shall be encoded as defined in table 28.69.

Table 28.69: Diffserv filter information element contents

Information element	Length	Type	C/O/M	Remark
DSCP	8		M	See note 1
Reserved	8		M	See note 2
NOTE 1: Contains a differentiated services code point value (see IETF RFC 2474 [43] and IETF RFC 2475 [44]).				
NOTE 2: Shall be set to zero in the present document.				

28.4.5.12 Enhanced $\pi/4$ -DQPSK service

The Enhanced $\pi/4$ -DQPSK service information element shall be encoded as defined in table 28.70.

Table 28.70: Enhanced $\pi/4$ -DQPSK service information element contents

Information element	Length	Value	Remark
Enhanced $\pi/4$ -DQPSK service	1	0	Enhanced $\pi/4$ -DQPSK service not requested
		1	Enhanced $\pi/4$ -DQPSK service requested

NOTE: This was formerly known as the "enhanced service" information element.

28.4.5.13 Immediate service change

The Immediate service change information element shall be encoded in table 28.71.

Table 28.71: Immediate service change information element contents

Information element	Length	Value	Remark
Immediate service change	1	0	Not indicated
		1	Indicated

28.4.5.14 IP address ipv4

The IP address ipv4 information element shall be encoded as defined in table 28.72.

Table 28.72: IP address IPv4 information element contents

Information element	Length	Value	Remark
IP address ipv4	32	any	

28.4.5.15 Largest header size in octets that may be compressed

The Largest header size in octets that may be compressed information element shall be encoded as defined in table 28.73.

Table 28.73: Largest header size in octets that may be compressed information element contents

Information element	Length	Value	Remark
Largest header in octets that may be compressed	8	0 to 255	The size of the largest header in octets.

28.4.5.15a Layer 2 data priority lifetime

The Layer 2 data priority lifetime information element shall be encoded as defined in table 28.74.

Table 28.74: Layer 2 data priority lifetime information element contents

Information element	Length	Value	Remark
Layer 2 data priority lifetime	6	0	Reserved
		1	2 multiframe
		2	4 multiframe
		etc.	etc.
		63	126 multiframe

28.4.5.15b Layer 2 data priority signalling delay

The Layer 2 data priority signalling delay information element shall be encoded as defined in table 28.75.

Table 28.75: Layer 2 data priority signalling delay information element contents

Information element	Length	Value	Remark
Layer 2 data priority signalling delay	3	0	6 TDMA frames
		1	9 TDMA frames
		2	12 TDMA frames
		3	18 TDMA frames
		4	27 TDMA frames
		5	36 TDMA frames
		6	54 TDMA frames
7	90 TDMA frames		

28.4.5.16 Logical link status

The Logical link status information element shall be encoded as defined in table 28.76.

Table 28.76: Logical link status information element contents

Information element	Length	Value	Remark
Logical link status	1	0	Advanced link not connected
		1	Advanced link connected

28.4.5.17 Maximum interval between full headers

The Maximum interval between full headers indicates the maximum number of compressed non-TCP headers that can be sent between full headers. The information element shall be encoded as defined in table 28.77.

Table 28.77: Maximum interval between full headers information element contents

Information element	Length	Value	Remark
Maximum interval between full headers	8	0	There is no limit to the number of consecutive compressed headers.
		1 to 255	Maximum 16 × value consecutive compressed headers.

28.4.5.18 Maximum time interval between full headers

The Maximum time interval between full headers indicates the maximum interval between full headers. The information element shall be encoded as defined in table 28.78.

Table 28.78: Maximum time interval between full headers information element contents

Information element	Length	Value	Remark
Maximum time interval between full headers	8	0	Infinity.
		1 to 255	Compressed headers may not be sent more than 5 × value s after sending the last full header.

28.4.5.19 Maximum transmission unit

The Maximum transmission unit information element shall be encoded as defined in table 28.79.

Table 28.79: Maximum Transmission Unit information element contents

Information element	Length	Value	Remark
Maximum transmission unit	3	0	Reserved
		1	296 octets
		2	576 octets
		3	1 006 octets
		4	1 500 octets
		5	2 002 octets
		6	Reserved
		7	Reserved

28.4.5.19a Mean active throughput

The Mean active throughput information element shall be encoded as defined in table 28.80.

Table 28.80: Mean active throughput information element contents

Information element	Length	Value	Remark
Mean active throughput	4	0	No value given
		1	< 1 000 octets s ⁻¹
		2	≥ 1 000 octets s ⁻¹
		3	≥ 2 000 octets s ⁻¹
		4	≥ 4 000 octets s ⁻¹
		5	≥ 8 000 octets s ⁻¹
		6	≥ 16 000 octets s ⁻¹
		7	≥ 32 000 octets s ⁻¹
		8	≥ 64 000 octets s ⁻¹
		9	Reserved
		etc.	etc.
		15	Reserved

28.4.5.19b Mean throughput

The Mean throughput information element shall be encoded as defined in table 28.81.

Table 28.81: Mean throughput information element contents

Information element	Length	Value	Remark
Mean throughput	5	0	No value given
		1	100 octets h ⁻¹
		2	200 octets h ⁻¹
		3	500 octets h ⁻¹
		4	1 000 octets h ⁻¹
		5	2 000 octets h ⁻¹
		6	5 000 octets h ⁻¹
		7	10 000 octets h ⁻¹
		8	20 000 octets h ⁻¹
		9	50 000 octets h ⁻¹
		10	100 000 octets h ⁻¹
		11	200 000 octets h ⁻¹
		12	500 000 octets h ⁻¹
		13	1 000 000 octets h ⁻¹
		14	2 000 000 octets h ⁻¹
		15	5 000 000 octets h ⁻¹
		16	10 000 000 octets h ⁻¹
		17	20 000 000 octets h ⁻¹
		18	50 000 000 octets h ⁻¹
		19	Reserved
etc.	etc.		
30	Reserved		
31	Best effort.		

28.4.5.19c Minimum peak throughput

The Minimum peak throughput information element shall be encoded as defined in table 28.82.

Table 28.82: Minimum peak throughput information element contents

Information element	Length	Value	Remark
Minimum peak throughput	4	0	No value given
		1	< 1 000 octets s ⁻¹
		2	≥ 1 000 octets s ⁻¹
		3	≥ 2 000 octets s ⁻¹
		4	≥ 4 000 octets s ⁻¹
		5	≥ 8 000 octets s ⁻¹
		6	≥ 16 000 octets s ⁻¹
		7	≥ 32 000 octets s ⁻¹
		8	≥ 64 000 octets s ⁻¹
		9	Reserved
		etc.	etc.
	15	Reserved	

28.4.5.19d Modification reject cause

The modification reject cause information element shall be encoded as defined in table 28.83.

Table 28.83: Modification reject cause information element contents

Information element	Length	Value	Remark
Modification reject cause	8	0	Undefined
		14	Temporary rejection
		23	Requested minimum peak throughput not available
		24	Scheduled access not supported
		25	Requested schedule not available
		26	Requested QoS not available
		27	Secondary PDP contexts not supported
		28	Primary PDP context does not exist
		29	Asymmetric QoS not supported
		30	Automatic QoS filter not supported
		31	Specified QoS filter not supported
		32	QoS filter type not supported
		33	QoS filter not available for primary PDP context
		34	SNDP service temporarily not available
		others	Reserved

28.4.5.19e Modification result

The modification result information element shall be encoded as defined in table 28.84.

Table 28.84: Modification result information element contents

Information element	Length	Value	Remark
Modification result	1	0	Modification applied
		1	Modification rejected (PDP context remains unmodified)

28.4.5.19f Modify sub-type

The modify sub-type information element shall be encoded as defined in table 28.85.

Table 28.85: Modify sub-type information element contents

Information element	Length	Value	Remark
Modify sub-type	4	0	SN-MODIFY PDP CONTEXT REQUEST
		1	SN-MODIFY PDP CONTEXT RESPONSE
		3	SN-MODIFY PDP CONTEXT AVAILABILITY
		4	SN-MODIFY PDP CONTEXT USAGE
		etc.	etc.
		15	Reserved

28.4.5.19g MS default data priority

The MS default data priority information element shall be encoded as defined in table 28.86.

Table 28.86: MS default data priority information element contents

Information element	Length	Value	Remark
MS default data priority	4	0	MS default data priority = 0
		1	MS default data priority = 1
		etc.	etc.
		7	MS default data priority = 7
		8	MS default data priority = Network default data priority (see note)
		9	Reserved
		etc.	etc.
		15	Reserved

NOTE: When this value is set, the MS default data priority tracks the value of the network default data priority.

28.4.5.19h MS default data priority flag

The MS default data priority flag information element shall be encoded as defined in table 28.87.

Table 28.87: MS default data priority flag information element contents

Information element	Length	Value	Remark
MS default data priority flag	1	0	MS default data priority not included
		1	MS default data priority included

28.4.5.19i Network default data priority

The Network default data priority information element shall be encoded as defined in table 28.88.

Table 28.88: Network default data priority information element contents

Information element	Length	Value	Remark
Network default data priority	3	0	Network default data priority = 0
		1	Network default data priority = 1
		etc.	etc.
		7	Network default data priority = 7

28.4.5.20 Not supported SN PDU type

The Not supported SN PDU type information element shall be encoded as defined in table 28.89.

Table 28.89: Not supported SN PDU type information element contents

Information element	Length	Value	Remark
SN PDU type	4	0	SN-ACTIVATE PDP CONTEXT DEMAND SN-ACTIVATE PDP CONTEXT ACCEPT
		1	SN-DEACTIVATE PDP CONTEXT ACCEPT
		2	SN-DEACTIVATE PDP CONTEXT DEMAND
		3	SN-ACTIVATE PDP CONTEXT REJECT
		4	SN-UNITDATA
		5	SN-DATA
		6	SN-DATA TRANSMIT REQUEST
		7	SN-DATA TRANSMIT RESPONSE
		8	SN-END OF DATA
		9	SN-RECONNECT
		10	SN-PAGE REQUEST (SwMI to MS) SN-PAGE RESPONSE (MS to SwMI)
		11	Reserved
		12	SN-DATA PRIORITY
		13	SN-MODIFY
others	Reserved		

28.4.5.21 N-PDU

The N-PDU information element shall be encoded as defined in table 28.90.

Table 28.90: N-PDU information element contents

Information element	Length	Value	Remark
N-PDU	varies	any	The length of a N-PDU may range from 0 bits up to the Maximum transmission unit size, which is set at context activation.

28.4.5.22 NSAPI

The NSAPI information element shall be encoded as defined in table 28.91.

Table 28.91: NSAPI information element contents

Information element	Length	Value	Remark
NSAPI	4	0	Reserved
		1 to 14	Dynamically allocated
		15	Reserved

28.4.5.22a NSAPI additional

The NSAPI additional information element shall be encoded as defined in table 28.92.

Table 28.92: NSAPI additional information element contents

Information element	Length	Value	Remark
NSAPI	4	0	Reserved
		1 to 14	Dynamically allocated
		15	Reserved
Reserved	2	0	Shall be set to zero in the present document

28.4.5.22b NSAPI for reconnection

The NSAPI for reconnection information element shall be encoded as defined in table 28.93.

Table 28.93: NSAPI for reconnection information element contents

Information element	Length	Value	Remark
NSAPI	4	0	Reserved
		1 to 14	Dynamically allocated
		15	Reserved
Data to send	1	0	No data to send for this NSAPI
		1	SN-DATA PDU or SN-UNITDATA PDU awaiting transmission
Reserved	1	0	Shall be set to zero in the present document

NOTE: The MS is not precluded from setting "data to send" if it wishes to be on a PDCH because it expects imminent reception of data on the downlink or imminent arrival of data for transmission on the uplink.

28.4.5.23 Number of compression state slots, TCP

The Number of compression state slots, TCP indicates the maximum value of a context identifier in the space of context identifiers allocated for TCP. The information element shall be encoded as defined in table 28.94.

Table 28.94: Number of compression state slots, TCP information element contents

Information element	Length	Value	Remark
Number of compression state slots, TCP	8	0 to 255	The value 0 implies having one context. It is recommended that value 0 is not used.

28.4.5.24 Number of compression state slots, non-TCP

The Number of compression state slots, non-TCP indicates the maximum value of a context identifier in the space of context identifiers allocated for non-TCP. The information element shall be encoded as defined in table 28.95.

Table 28.95: Number of compression state slots, non-TCP information element contents

Information element	Length	Value	Remark
Number of compression state slots, non-TCP	16	0 to 65 535	The value 0 implies having one context. It is recommended that value 0 is not used.

28.4.5.25 Number of Van Jacobson compression state slots

The number of Van Jacobson compression state slots information element shall be encoded as defined in table 28.96.

Table 28.96: Number of Van Jacobson compression state slots information element contents

Information element	Length	Value	Remark
Number of Van Jacobson compression state slots	8	2 to 255	It is recommended that values 0 and 1 are not used.

28.4.5.26 Packet data MS Type

The Packet data MS Type information element shall be encoded as defined in table 28.97.

Table 28.97: Packet data MS Type information element contents

Information element	Length	Value	Remark
Packet data MS type	4	0	Type A
		1	Type B
		2	Type C
		3	Type D
		others	Reserved

28.4.5.27 PCOMP

The PCOMP information element shall be encoded as defined in table 28.98.

Table 28.98: PCOMP information element contents

Information element	Length	Value	Remark
PCOMP	4	0	No compression
		1	Van Jacobson compressed TCP/IP
		2	Van Jacobson non-compressed TCP/IP
		3	FULL_HEADER
		4	COMPRESSED_TCP
		5	COMPRESSED_TCP_NODELTA
		6	COMPRESSED_NON_TCP
		7	COMPRESSED_RTP_8
		8	COMPRESSED_RTP_16
		9	COMPRESSED_UDP_8
		10	COMPRESSED_UDP_16
		11	CONTEXT_STATE
others	For further standardization (a list of fixed or negotiated algorithms e.g. IPv6)		

28.4.5.28 PCOMP negotiation

The PCOMP negotiation information element shall be encoded as defined in table 28.99.

Table 28.99: PCOMP negotiation information element contents

Information element	Length	Value	Remark
PCOMP negotiation	8	bit 1 (LSB)	Van Jacobson TCP/IP header compression (IETF RFC 1144 [29])
		bit 2	IP header compression (IETF RFC 2507 [35]) Enable use of PCOMP values: FULL_HEADER, COMPRESSED_TCP, COMPRESSED_TCP_NODELTA, COMPRESSED_NON_TCP, CONTEXT_STATE (see note 1)
		bit 3	Enable use of PCOMP values: COMPRESSED_RTP_8, COMPRESSED_RTP_16, COMPRESSED_UDP_8, COMPRESSED_UDP_16 and CONTEXT_STATE (IETF RFC 2508 [36]) (see notes 1 and 2)
		bit 4	Reserved
		bit 5	Reserved
		bit 6	Reserved
		bit 7	Reserved
		bit 8 (MSB)	Reserved
NOTE 1: Bit 3 not set - "CONTEXT_STATE" shall only be used to synchronize TCP context identities - clause 10.2 IETF RFC 2507 [35]; Bit 3 set - "CONTEXT_STATE" may also be used to synchronize UDP_8 and UDP_16 context identities - clause 3.3.5 IETF RFC 2508 [36].			
NOTE 2: This bit shall be conditional on bit 2 and shall only be set to 1 if bit 2 is also set to 1.			

28.4.5.29 PD service status

The PD service status information element shall be encoded as defined in table 28.100.

Table 28.100: PD service status information element contents

Information element	Length	Value	Remark
PD service status	1	0	Temporarily unavailable for PD service
		1	Available for PD service

28.4.5.29a PDP context availability

The PDP context availability information element shall be encoded as defined in table 28.101.

Table 28.101: PDP context availability information element contents

Information element	Length	Value	Remark
PDP context availability	3	0	PDP context available for use
		1	Schedule suspended
		2	Reserved
		etc.	etc.
		7	Reserved

28.4.5.29b PDP context usage

The PDP context usage information element shall be encoded as defined in table 28.102.

Table 28.102: PDP context usage information element contents

Information element	Length	Value	Remark
PDP context usage	3	0	Use of schedule paused
		1	Use of PDP context paused
		2	Reserved
		etc.	etc.
		7	Reserved

28.4.5.30 PDU priority max

The PDU priority max information element shall be encoded as defined in table 28.103.

Table 28.103: PDU priority max information element contents

Information element	Length	Value	Remark
PDU priority max	3	0	Lowest PDU priority
		etc.	etc.
		7	Highest PDU priority

28.4.5.30a Port

The port information element shall be encoded as defined in table 28.104.

Table 28.104: Port information element contents

Information element	Length	Value	Remark
Port	16	Any	See note
NOTE: Shall contain a port number in the range 0 to 65 535.			

28.4.5.31 Protocol configuration options

The Protocol configuration options information element shall be encoded as defined in table 28.105.

Table 28.105: Protocol configuration options information element contents

Information element	Length	C/O/M	Value	Remark
Configuration protocol	4	M	0000 ₂	PPP All other values are interpreted as PPP in this version of the protocol
Protocol identity	16	M		see notes 1 and 3
Length of protocol identity contents	8	M		see notes 3 and 4
Protocol identity contents	varies	M		see notes 2 and 3
<p>NOTE 1: Contains the hexadecimal coding of the configuration protocol identifier as defined in IETF RFC 3232 [38]. Bit 8 of the first octet of the protocol identifier information element shall contain the most significant bit and bit 1 of the second octet of the protocol identifier information element shall contain the least significant bit. At least the following protocol identifiers shall be supported in this version of the protocol:</p> <ul style="list-style-type: none"> - C023H = (PAP); and - C223H (CHAP). <p>The support of other protocol identifiers is implementation dependent and outside the scope of the present document. If the configuration protocol options list contains a protocol identifier that is not supported by the receiving entity the corresponding unit shall be discarded.</p> <p>NOTE 2: The protocol identifier contents information element of each set corresponds to a "Packet" as defined in IETF RFC 1661 [30] that is stripped off the "Protocol field" and the "Padding" octets (i.e. the protocol identifier contents field is constructed from fields "Code", "Identifier", "Length" and "Data" as described in IETF RFC 1661 [30]). The detailed coding of the protocol identifier contents field is specified in the RFC that is associated with the protocol identifier of that unit.</p> <p>NOTE 3: These information elements shall be repeated as a set for each protocol.</p> <p>NOTE 4: The "length of protocol identity contents" information element shall indicate the length of the "protocol identity contents" in octets.</p>				

28.4.5.31a QoS

The QoS information element shall be encoded as defined in table 28.106.

Table 28.106: QoS information element contents

Information element	Length	Type	C/O/M	Remark
Background class request	1	1	M	
CONTEXT_READY timer	4		C	See note 1
Asymmetrical QoS	1		C	See note 1
QoS set	20		C	See notes 1 and 2
QoS set	20		C	See note 3
QoS filter included	1		C	See notes 1 and 4
QoS filter	Varies		C	See notes 1 and 5
Scheduled access information included	1		C	See notes 1 and 6
Scheduled access	Varies		C	See note 7
Additional QoS information A included	1		C	See note 1
Additional QoS information A	16		C	See notes 8 and 9
Additional QoS information B included	1		C	See note 1
Additional QoS information B	16		C	See notes 8 and 10
NOTE 1: This information element shall be present only if "background class request" value is equal to "any data class".				
NOTE 2: If "asymmetrical QoS" value is equal to "symmetrical QoS" this information element specifies a common uplink and downlink QoS; if "asymmetrical QoS" value is equal to "asymmetrical QoS" it specifies only the uplink QoS.				
NOTE 3: This information element shall be present only if "asymmetrical QoS" value is equal to "asymmetrical QoS" and specifies the downlink QoS.				
NOTE 4: This information element shall be set to "QoS filter not included" if the QoS information element relates to a primary PDP context.				
NOTE 5: This information element shall be present only if "QoS filter included" value is equal to "QoS filter included". See clause 28.3.9 for usage.				
NOTE 6: If the SwMI does not support a schedule on this PDP context, it shall set "scheduled access information included" value to "not included".				
NOTE 7: This information element shall be present only if "scheduled access information included" value is equal to "included".				
NOTE 8: This information element shall not be used in the protocol defined in the present document. The contents of this element, if present, shall be ignored.				
NOTE 9: This information element shall be present only if "additional QoS information A included" value is equal to "included".				
NOTE 10: This information element shall be present only if "additional QoS information B included" value is equal to "included".				

28.4.5.31b QoS filter

The QoS filter information element shall be encoded as defined in table 28.107.

Table 28.107: QoS filter information element contents

Information element	Length	Type	C/O/M	Remark
QoS filter operation	2	1	M	
QoS filter type	4	1	M	
Port	16		C	See notes 1 and 2
Port	16		C	See notes 3 and 4
Diffserv filter	16		C	See note 5
Reserved	16		C	See note 6
Reserved	16		C	See note 7
NOTE 1: This information element shall be present only if "QoS filter type" has a value in the range 1 to 6.				
NOTE 2: If "QoS filter type " has a value in the range 1 to 3 this information element shall contain a port number. If the "QoS filter type" has a value in the range 4 to 6, this information element shall contain the lower limit of a range of port numbers.				
NOTE 3: This information element shall be present only if "QoS filter type" has a value in the range 4 to 6.				
NOTE 4: This information element shall contain the upper limit of a range of port numbers.				
NOTE 5: This information element shall be present only if "QoS filter type" has value 7.				
NOTE 6: This information element shall be present only if "QoS filter type" has a value in the range 8 to 15.				
NOTE 7: This information element shall be present only if "QoS filter type" has a value in the range 12 to 15.				

28.4.5.31c QoS filter included

The QoS filter included information element shall be encoded as defined in table 28.108.

Table 28.108: QoS filter included information element contents

Information element	Length	Value	Remark
QoS filter included	1	0	QoS filter not included
		1	QoS filter included

28.4.5.31d QoS filter operation

The QoS filter operation information element shall be encoded as defined in table 28.109.

Table 28.109: QoS filter operation information element contents

Information element	Length	Value	Remark
QoS filter operation	2	0	Add this QoS filter to any existing QoS filter for this PDP context
		1	Replace any existing QoS filter for this PDP context by this QoS filter
		2	Remove this QoS filter from this PDP context
		3	Reserved

28.4.5.31e QoS filter type

The port type information element shall be encoded as defined in table 28.110.

Table 28.110: Port type information element contents

Information element	Length	Value	Remark
Port type	4	0	Use automatic QoS filter for this PDP context until the QoS filter for this PDP context is replaced
		1	All types of port
		2	UDP ports
		3	TCP ports
		4	Range of all types of port
		5	Range of UDP ports
		6	Range of TCP ports
		7	Diffserv filter
		8 to 15	Reserved

28.4.5.31f QoS set

The QoS set information element shall be encoded as defined in table 28.111.

Table 28.111: QoS set information element contents

Information element	Length	Type	C/O/M	Remark
Data class	3	1	M	
Minimum peak throughput	4	1	M	
Mean throughput	5	1	M	
Mean active throughput	4	1	M	
Delay class	2	1	M	
Reliability class	2	1	M	

28.4.5.32 READY timer

The READY timer information element shall be encoded as defined in table 28.112.

Table 28.112: READY timer information element contents

Information element	Length	Value	Remark
READY timer	4	0	Reserved
		1	200 ms
		2	500 ms
		3	700 ms
		4	1 s
		5	2 s
		6	3 s
		7	5 s
		8	10 s
		9	20 s
		10	30 s
		11	60 s
		12	120 s
		13	180 s
		14	300 s
15	Reserved		

28.4.5.32a Reliability class

The Reliability class information element shall be encoded as defined in table 28.113.

Table 28.113: Reliability class information element contents

Information element	Length	Value	Remark
Reliability class (see note)	2	0	Low
		1	Moderate
		2	High
		3	Reserved
NOTE: Reliability classes are defined in table 28.11.			

28.4.5.33 Reply requested

The Reply requested information element shall be encoded as defined in table 28.114.

Table 28.114: Reply requested information element contents

Information element	Length	Value	Remark
Reply requested	1	0	SNDCP response not requested
		1	SNDCP response requested

28.4.5.34 Resource request

The resource request information element shall be coded as defined in table 28.115. This information element refers only to phase modulation resources.

Table 28.115: Resource request information element contents

Information element	Length	C/O/M	Value	Remark
Connection symmetry (see note 8)	1	M	0	Symmetric phase modulation connection
			1	Asymmetric phase modulation connection
Data transfer throughput (mean value) (see notes 1 and 5)	3	M	000 ₂	Network dependent minimum
			001 ₂	1/32 of maximum
			010 ₂	1/16 of maximum
			011 ₂	1/8 of maximum
			100 ₂	1/4 of maximum
			101 ₂	1/2 of maximum
			110 ₂	Unspecified phase modulation resource (see notes 7 and 8)
111 ₂	Maximum			
Number of $\pi/4$ -DQPSK timeslots on uplink or on uplink and downlink (see notes 2 and 8)	2	M	00 ₂	1 timeslot
			01 ₂	2 timeslots
			10 ₂	3 timeslots
			11 ₂	4 timeslots
Number of $\pi/4$ -DQPSK timeslots on downlink (see notes 3 and 8)	2	C	00 ₂	1 timeslot
			01 ₂	2 timeslots
			10 ₂	3 timeslots
			11 ₂	4 timeslots
Full phase modulation capability (see notes 4 and 6)	2	M	00 ₂	1 timeslot
			01 ₂	2 timeslots
			10 ₂	3 timeslots
			11 ₂	4 timeslots
Reserved	2	M	00 ₂	Reserved
			01 ₂	Reserved
			10 ₂	Reserved
			11 ₂	Shall be set to 11 ₂ in the present document
NOTE 1: The BS may use a control channel as a general packet data channel, supporting advanced links for many MSs, where each MS may be offering/receiving data packets at a low rate or intermittently. This parameter gives the BS the necessary information for planning its resource allocations.				
NOTE 2: In case of symmetric connection (i.e. Connection symmetry information element set to "0") the "number of $\pi/4$ -DQPSK timeslots on uplink or on uplink and downlink" information element indicates the number of phase modulation timeslots per TDMA frame requested both on uplink and downlink direction.				
NOTE 3: Shall be conditional on the value of the Connection symmetry information element. The information element is present only for asymmetric connection (i.e. Connection symmetry information element set to "1"). If present, it indicates the number of phase modulation timeslots per TDMA frame requested on the downlink.				
NOTE 4: This information element indicates the MS's maximum capability to handle phase modulation physical resources. It applies to $\pi/4$ -DQPSK channels and, if supported, to D8PSK channels.				
NOTE 5: The data transfer throughput shall be specified relative to the number of $\pi/4$ -DQPSK timeslots requested.				
NOTE 6: The BS shall not allocate the MS more phase modulation timeslots per TDMA frame than indicated by the "full phase modulation capability" information element.				
NOTE 7: An MS that cannot use a multi-slot phase modulation channel shall not set the "Data transfer throughput (mean value)" information element to "110 ₂ " (unspecified phase modulation resource).				
NOTE 8: If the "Data transfer throughput (mean value)" information element is set to value "110 ₂ " (unspecified phase modulation resource), the "connection symmetry" information element shall be set to "0" (symmetric phase modulation connection) and the "number of $\pi/4$ -DQPSK timeslots on uplink or on uplink and downlink" information element shall be set equal to the "full phase modulation capability" information element.				

28.4.5.35 RESPONSE_WAIT timer

The RESPONSE_WAIT timer information element shall be encoded as defined in table 28.116.

Table 28.116: RESPONSE_WAIT timer information element contents

Information element	Length	Value	Remark
RESPONSE_WAIT timer	4	0	400 ms
		1	600 ms
		2	800 ms
		3	1 s
		4	2 s
		5	3 s
		6	4 s
		7	5 s
		8	10 s
		9	15 s
		10	20 s
		11	30 s
		12	40 s
		13	50 s
		14	60 s
15	Reserved		

28.4.5.35a Scheduled access

The scheduled access information element shall be encoded as defined in table 28.117.

Table 28.117: Scheduled access information element contents

Information element	Length	C/O/M	Value	Remark
Schedule repetition period	10	M	0	Reserved
			1	Reserved
			etc.	etc.
			3	Reserved
			4	4 slot durations (see note 1)
			5	5 slot durations
			etc.	etc.
			706	706 slot durations (10,00 s)
			707	Reserved
			etc.	etc.
			1 023	Reserved
Schedule timing error	3	M	0	≤ 1 slot duration (see note 1)
			1	≤ 2 slot durations
			2	≤ 4 slot durations
			3	≤ 8 slot durations
			4	≤ 16 slot durations
			5	≤ 32 slot durations
			6	≤ 64 slot durations
			7	≤ 128 slot durations
Scheduled number of SN-DATA or SN-UNITDATA PDUs per grant	3	M	0	Reserved
			1	1
			2	2
			etc.	etc.
			7	7
Scheduled SN-DATA or SN-UNITDATA PDU size (see note 2)	12	C	0	Reserved
			1	1 octet
			2	2 octets
			etc.	etc.
			2 002	2 002 octets
			2 003	Reserved
			etc.	etc.
			4 095	Reserved
NOTE 1: One slot has a duration of 85/6 ms.				
NOTE 2: This information element shall be present as many times as indicated by the "Scheduled number of SN-DATA or SN-UNITDATA PDUs per grant" information element.				

28.4.5.35b Scheduled access information included

The "Scheduled access information included" information element shall be encoded as defined in table 28.118.

Table 28.118: Scheduled access information included information element contents

Information element	Length	Value	Remark
Scheduled access information included	1	0	Not included
		1	Included

28.4.5.36 SNDCP version

The SNDCP version information element shall be encoded as defined in table 28.119.

Table 28.119: SNDCP version information element contents

Information element	Length	Value	Remark
SNDCP version	4	0	Reserved
		1	The first version of the TETRA Packet Data specification
		others	Reserved

28.4.5.37 SNDCP network endpoint identifier

The SNDCP network endpoint identifier information element shall be encoded as defined in table 28.120.

Table 28.120: SNDCP endpoint identifier information element contents

Information element	Length	Value	Remark
SNDCP endpoint identifier	16		

28.4.5.38 SN PDU type

The PDU type information element shall be encoded as defined in table 28.121.

Table 28.121: SN PDU type information element contents

Information element	Length	Value	Remark
SN PDU type	4	0	SN-ACTIVATE PDP CONTEXT DEMAND (MS to SwMI) SN-ACTIVATE PDP CONTEXT ACCEPT (SwMI to MS)
		1	SN-DEACTIVATE PDP CONTEXT ACCEPT
		2	SN-DEACTIVATE PDP CONTEXT DEMAND
		3	SN-ACTIVATE PDP CONTEXT REJECT
		4	SN-UNITDATA
		5	SN-DATA
		6	SN-DATA TRANSMIT REQUEST
		7	SN-DATA TRANSMIT RESPONSE
		8	SN-END OF DATA
		9	SN-RECONNECT
		10	SN-PAGE REQUEST (SwMI to MS) SN-PAGE RESPONSE (MS to SwMI)
		11	SN-NOT SUPPORTED
		12	SN-DATA PRIORITY, see "Data priority sub-type" (clause 28.4.5.7g) for definition of SN PDU sub-type.
		13	SN-MODIFY, see "Modify sub-type" (clause 28.4.5.19f) for definition of SN PDU sub-type
Others	Reserved		

28.4.5.39 STANDBY timer

The STANDBY timer information element shall be encoded as defined in table 28.122.

Table 28.122: STANDBY timer information element contents

Information element	Length	Value	Remark
STANDBY timer	4	0	Reserved
		1	10 s
		2	30 s
		3	1 min
		4	5 min
		5	10 min
		6	30 min
		7	1 hour
		8	2 hours
		9	3 hours
		10	6 hours
		11	12 hours
		12	24 hours
		13	48 hours
		14	72 hours
15	Forever		

28.4.5.40 SwMI IPv6 Information

The "SwMI IPv6 information" information element shall be encoded as defined in table 28.123.

Table 28.123: SwMI IPv6 Information information element contents

Information element	Length	C/O/M	Value	Remark
IPv6 Network Prefix	64	M		
Prefix Valid Lifetime	32	M		
On-Link Flag	1	M		
Autonomous Address Configuration	1	M	0	Not Supported
			1	Supported

28.4.5.41 SwMI Mobile IPv4 Information

The "SwMI Mobile IPv4 information" information element shall be encoded as defined in table 28.124.

Table 28.124: SwMI Mobile IPv4 Information information element contents

Information element	Length	C/O/M	Value	Remark
FA Care of Address	32	M		
Sequence Number	16	M		
FA Registration Lifetime	16	M		
Register via FA (R)	1	M	0	Registration via FA not required
			1	Registration via FA required
FA Busy (B)	1	M	0	Accepting Registrations
			1	Accepting no Registrations
Home Agent (H)	1	M	0	Offers no HA Services
			1	Offers HA Services
Foreign Agent (F)	1	M	0	Offers no HA Services
			1	Offers HA Services
Minimal Encapsulation (M)	1	M	0	Not Supported
			1	Supported
GRE Encapsulation (G)	1	M	0	Not Supported
			1	Supported
Van Jacobsen Compression (V)	1	M	0	Not Supported
			1	Supported

28.4.5.42 Transmit response reject cause

The Transmit response reject cause information element shall be encoded as defined in table 28.125.

Table 28.125: Transmit response reject cause information element contents

Information element	Length	Value	Remark
Transmit Response Reject Cause	8	0	Undefined
		1	Unknown NSAPI
		2	System resources not available
		23	Requested minimum peak throughput not available
		25	Requested schedule not available
		34	SNDCP service temporarily not available
		others	Reserved

28.4.5.43 Type identifier in accept

The Type identifier in accept information element shall be encoded as defined in table 28.126.

Table 28.126: Type Identifier in Accept information element contents

Information element	Length	Value	Remark
Type identifier in accept	3	0	No address
		1	IPv4 Static Address
		2	IPv4 Dynamic Address
		3 to 7	Reserved

28.4.5.44 Type 3/4 element identifier

The Type 3/4 element identifier information element shall be encoded as defined in table 28.127.

Table 28.127: Type 3/4 element identifier information element contents

Information element	Length	Value	Remark
Type 3/4 element identifier	4	0	DCOMP negotiation
		1	Protocol configuration options
		2	Data priority details
		3	QoS
		4	NSAPI additional
		5	NSAPI for reconnection
		others	Reserved

28.4.5.45 V.42bis compression request, P₀

The Recommendation ITU-T V.42bis [27] compression request, P₀ information element shall be encoded as defined in table 28.128.

Table 28.128: Recommendation ITU-T V.42bis data compression request parameters information element contents

Information element	Length	Value	Remark
V.42bis [27] data compression request	2	0	compress neither direction
		1	compress initiator-to-responder direction only
		2	compress responder-to-initiator direction only
		3	compress both directions

28.4.5.46 V.42bis data compression parameters

The Recommendation ITU-T V.42bis [27] data compression parameters information element shall be encoded as defined in table 28.129.

Table 28.129: Recommendation ITU-T V.42bis data compression parameters information element contents

Information element	Length	Type	C/O/M	Remark
Recommendation ITU-T V.42bis [27] compression request	2	1	M	
Recommendation ITU-T V.42bis [27] number of codewords	16	1	M	
Recommendation ITU-T V.42bis [27] maximum string length	8	1	M	

28.4.5.47 V.42bis maximum string length, P₂

The Recommendation ITU-T V.42bis [27] maximum string length, P₂ information element shall be encoded as defined in table 28.130.

Table 28.130: Recommendation ITU-T V.42bis maximum string length information element contents

Information element	Length	Value	Remark
Recommendation ITU-T V.42bis [27] maximum string length, P ₂	8	0 to 5	Reserved
		6 to 250	Maximum number of characters in an uncompressed data string that is accepted to be encoded
		251 to 255	Reserved

28.4.5.48 V.42bis number of codewords, P_1

The Recommendation ITU-T V.42bis [27] number of codewords, P_1 information element shall be encoded as defined in table 28.131.

Table 28.131: Recommendation ITU-T V.42bis number of codewords information element contents

Information element	Length	Value	Remark
Recommendation ITU-T V.42bis [27] number of codewords, P_1	16	0 to 511	Reserved
		512 to 65 535	Maximum number of codewords in the compressor dictionary. Suitable default value for TETRA packet data TBD

28.5 Timers and constants

28.5.1 Timers

28.5.1.1 PDP_ACTIVATE_WAIT

PDP_ACTIVATE_WAIT timer has a fixed value of 30 s. The timer is valid for MS SNDTCP only.

28.5.1.2 PDP_DEACTIVATE_WAIT

PDP_DEACTIVATE_WAIT timer has a fixed value of 180 s. The timer is valid for MS SNDTCP only.

28.5.1.2a PDP_MODIFY_WAIT

PDP_MODIFY_WAIT timer has a fixed value of 30 s. The timer is valid for MS SNDTCP only.

28.5.1.3 READY

READY timer value is always given in SN-ACTIVATE PDP CONTEXT ACCEPT PDU. The latest received SN-ACTIVATE PDP CONTEXT ACCEPT PDU values shall be used.

28.5.1.4 STANDBY

STANDBY timer value is always given in SN-ACTIVATE PDP CONTEXT ACCEPT PDU. The latest received SN-ACTIVATE PDP CONTEXT ACCEPT PDU values shall be used.

28.5.1.5 DATA_PRIORITY_REQUEST_WAIT

DATA_PRIORITY_REQUEST_WAIT timer has a fixed value of 30 s. The timer is valid for MS SNDTCP only.

28.5.1.6 RESPONSE_WAIT

RESPONSE_WAIT timer value is always given in SN-ACTIVATE PDP CONTEXT ACCEPT PDU. The latest received SN-ACTIVATE PDP CONTEXT ACCEPT PDU values shall be used.

28.5.1.7 SERVICE_CHANGE

SERVICE_CHANGE timer has a fixed value of 3 s. The timer is valid for MS SNDTCP only.

28.5.1.8 CONTEXT_READY

CONTEXT_READY timer value obtains its value from the READY timer value or the QoS information element (if present) of the SN-ACTIVATE PDP CONTEXT ACCEPT and the SN-MODIFY PDP CONTEXT RESPONSE PDUs.

28.5.2 Constants

RETRY_ACTIVATION has a fixed value 3 times. The constant is valid for MS SMDCP only.

RETRY_MODIFICATION has a fixed value 3 times. The constant is valid for MS SMDCP only.

29 SDS-TL service and protocol

29.0 General

The Short Data Service (SDS) as defined in clauses 13 and 14 consists of a pre-coded message service and a user-defined message service. The user-defined message service provides a bearer service for 16 bits, 32 bits, 64 bits or up to 2 047 bits of application-defined data. This bearer service and the underlying protocol ensure reliable delivery of user-defined data over the air interface. However, in order to ensure inter-operability of different applications using SDS service, an additional header information is defined to support Short Data Service Transport Layer (SDS-TL) data transfer service.

This clause defines a layer 4 protocol for the SDS user defined data type 4 (this is carried within the 2 047 bits of application defined data).

This additional protocol layer, hereafter called the SDS Transport Layer (SDS-TL), defines means which enhances the service provided by the layer 3 Short Data Service protocol to provide protocol mechanisms for end-to-end acknowledgement, forwarding, storing and forwarding and to ensure that applications using this service interpret the user data in the same way. Because of the additional header, this protocol is only for use with SDS type 4. In order to guarantee that the basic SDS user data type-4 service and the SDS-TL data transfer service do not disturb each other a protocol header is also added into the basic SDS user data type-4 service, refer to clauses 13.3 and 29.3.2.1.

This clause specifies:

- the services provided by the SDS-TL;
- the functional requirements for the SDS-TL;
- SDS-TL procedures for specific transmission and reception of SDS user-defined data messages;
- the encoding of the Protocol Data Units (PDUs) defined by SDS-TL.

The SDS-TL protocol provides the following services:

- point-to-point message transfer;
- point-to-multipoint message transfer;
- broadcast message transfer;
- end-to-end acknowledgement of message receipt and consumption by application;
- support for multiple application protocols;
- transfer of long messages by dissection into individual SDS-TL messages for transmission and reconstruction by the receiver.

The SDS-TL supports the following types of application which use the SDS bearer service:

- standard applications which use the SDS-TL services;
- non-standard applications which use the SDS-TL services;
- standard applications which do not use the SDS-TL services;
- non-standard applications which do not use the SDS-TL services.

29.1 Overview of SDS-TL

29.1.1 Protocol architecture

The SDS-TL data transfer service enhances the SDS type 4 data service and in effect replaces SDS type 4 data service to the user application. Figure 29.1 shows the position of the SDS-TL protocol in the MS protocol stack. The SDS-TL entity access the same layer control information as CMCE. The layer control and related primitives are not presented in figure 29.1 The present document does not define a base station protocol architecture or user application SAPs for SDS-TL within the SwMI or in a storing/forwarding entity (service centre).

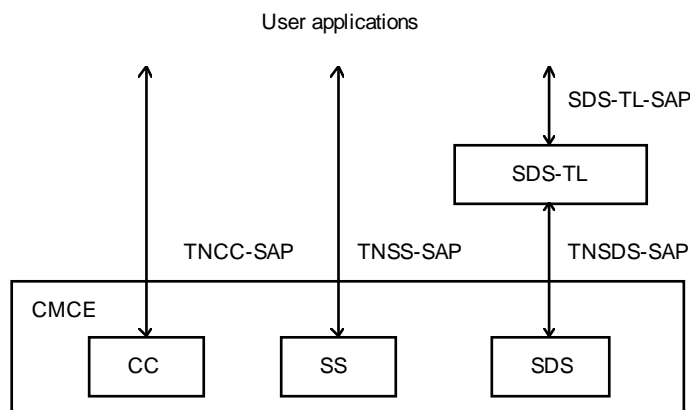

Figure 29.1: SDS-TL position in TETRA protocol stack

SDS-TL adds a layer of protocol functionality to the SDS user-defined type 4 message protocol which is accessed using the TNSDS-UNITDATA request/indication primitives as defined in clause 13 through the TNSDS-SAP. Note that the pre-coded message service and type 1, 2 and 3 short data message service, also provided by the SDS protocol entity within CMCE, shall still be accessed from a user application using the TNSDS-STATUS and TNSDS-UNITDATA request/indication primitives; there is no other SDS-TL protocol functionality for these services except that the SDS-TL protocol uses a range of STATUS PDUs for acknowledgement purposes.

The present document defines in clause 29.5 standardized protocols, which use services of the TNSDS-SAP via SDS-TL-SAP. Those protocols shall run parallel to each other and other protocols utilizing SDS-TL without any interactions.

- NOTE 1: In clause 29 terminology "SDS DATA PDU" is used to indicate either U-SDS DATA or D-SDS DATA PDU or an information element of it as defined in clause 14. SDS-TL PDUs refer to the PDUs defined in clause 29 and transported inside in the User-defined data-4 information element of the SDS DATA PDU.
- NOTE 2: The term "message" is used in service descriptions when the actual PDU name is not relevant.
- NOTE 3: The external subscriber number (information element) may be present both as a part of the SDS DATA PDU and as a part of the SDS-TL PDU inside the forward address information element. The position of the external subscriber number defines its meaning and is indicated when necessary.
- NOTE 4: The layer control includes information that is provided by MLE-BREAK and MLE-DISABLE primitives such as "Permitted services in graceful service degradation mode" and "Permitted services in temporary disabled mode".

29.1.2 Addressing

The SDS-TL layer modifies network layer addressing of the SDS, when storing/forwarding entity capability is used. The storing/forwarding entity capabilities can be used to deliver store and forward functionality. The sending entity will always indicate at the U/D-SDS DATA PDU the address of the next node. When the next node is a storing/forwarding entity, then the final address will be inside the SDS-TL PDU as a forward address. When the sending entity is the storing/forwarding entity then its address is as the source address in the SDS-DATA PDU and the real source address is in the SDS-TL PDU in the forward address information element. Refer to clause 29.3.1 for further details.

In the protocol model, the external subscriber number (MS-ISDN number) of the sending user is known in the SwMI based on the ITSI of the subscriber and the sending MS does not send it. It is also assumed that the MS user application knows its MS-ISDN number from its ITSI and does not receive it as an additional external subscriber number. MS may use an MS-ISDN number as a destination address in the external subscriber number information element either in the SDS DATA PDU or in the forward address information element and may receive it as a source address in the external subscriber number information element either in the SDS DATA PDU or in the forward address information element.

When MS uses the external subscriber number as a destination address with storing/forwarding entity there is no gateway address inside the forward address information element for the external subscriber or MS-ISDN user and it is assumed that the SwMI or the storing/forwarding entity can route the message to a proper gateway or destination.

NOTE 1: The service primitives and protocol PDUs use the same parameter and information element names, which may give a wrong impression of the usage of those parameters and information elements in a storing/forwarding entity case, refer to relevant notes in the definition tables.

NOTE 2: The storing/forwarding entity can be either:

- storing/forwarding entity with basic function to deliver messages to MSs that are not available at the moment the message is received in the storing/forwarding entity, there may also server functionalities that are outside the scope of the present document;
- forwarding entity with a basic function other than storing and forwarding such as server functionalities, normally forwarding entity should not store the message for a later delivery. The forwarding entity functions other than delivering messages to the indicated destinations are outside the scope of the present document.

29.1.3 SDS-TL Requirement to SDS and STATUS services

29.1.3.1 Requirements to MS

In order to support SDS-TL data transport service the MS shall support SDS type 4 data service at TNSDS-SAP as defined in clause 13 and transportation a range of status values, refer to clause 29.4.2.3.

29.1.3.2 Requirements to the SwMI

In order to support SDS-TL data transport service the SwMI shall support SDS type 4 data and status services as defined in clause 13.

29.2 SDS-TL Service Descriptions

29.2.0 General

The following service descriptions describe the SDS-TL services provided to the higher layers in the MS protocol stack.

29.2.1 Services available at the SDS-TL-SAP

The SDS-TL data transfer service shall provide the means whereby SDU are transmitted from a source to a destination in a reliable manner. The source can request confirmation of reception and consumption from the destination. The reception and consumption confirmation can also be transferred in a reliable manner.

The reliable aspect of the transfer can either be achieved transparently through the SwMI or by utilizing storing/forwarding entity capability of the SwMI. The implementation of the storing/forwarding entity (service centre) is outside the scope of the present document.

29.2.2 Service primitives at the SDS-TL-SAP

TLSDS-TRANSFER request: the primitive shall be used by the SDS-TL entity to send data to a peer entity. Parameters indicate whether reporting is requested.

TLSDS-TRANSFER indication: the primitive shall be used by the SDS-TL to pass to the SDS-TL entity data which has been received from a peer entity.

Table 29.1 gives parameters for the TLSDS-TRANSFER primitives, when no storing/forwarding entity is used.

Table 29.1: Parameters for the TLSDS-TRANSFER primitive without storing/forwarding addressing

Parameter	Request	Indication
Access priority	O	-
Traffic stealing	O	-
Area selection	O	-
Called party	(see note 1)	(see note 5)
Called party SNA	O (see note 2)	-
Called party SSI	M (see note 2)	M
Called party extension	O (see note 2)	M
External subscriber number (called party)	O	-
Received address type	-	O
Calling party	- (see note 3)	(see note 6)
Calling party SSI	-	M
Calling party extension	-	M
External subscriber number (calling party)	-	O
Protocol identifier	M	M
Delivery report request	M	M
Service selection	M	-
Short form report	-	M
Storage/forward control	O	O
Validity period	O	O
Message reference handle	M	-
Message reference	-	M
Time stamp	O (see note 7)	O (see note 7)
User data	O	O
NOTE 1: This parameter shall indicate the address of the destination entity.		
NOTE 2: This parameter shall be present as defined by the called party type identifier parameter.		
NOTE 3: Lower protocol layers will add the calling party identity.		
NOTE 4: Void.		
NOTE 5: This parameter value shall indicate "Called party SSI" and "Called party extension".		
NOTE 6: This parameter value shall indicate "Calling party SSI" and "Calling party extension".		
NOTE 7: Availability of this parameter is protocol dependent refer to clauses 29.3.2.9 and 29.5.3.3. Normally the SwMI will add the timestamp to the message and the timestamp in the request is to support those cases where that service is not available in the SwMI.		

Table 29.2 gives parameters for the TLSDS-TRANSFER primitives, when a storing/forwarding entity is used.

Table 29.2: Parameters for the TLSDS-TRANSFER primitive with storing/forwarding addressing

Parameter	Request	Indication
Access priority	O	-
Traffic stealing	O	-
Area selection	O	-
Called party:	(see note 1)	(see note 7)
Called party SNA	C (see note 2)	-
Called party SSI	C (see note 2)	M
Called party extension	C (see note 2)	M
External subscriber number	O (see note 1)	-
Received address type	-	O
Calling party:	- (see note 3)	(see note 9)
Calling party SSI	-	C (see note 8)
Calling party extension	-	C (see note 8)
External subscriber number (calling party)	-	O (see note 9)
Protocol identifier	M	M
Delivery report request	M	M
Service selection	M	-
Short form report	-	M
Storage/forward control	M (see note 4)	M (see note 4)
Message reference handle	M	-
Message reference	-	M
Validity period	M	O
Forward address:	(see note 5)	(see note 10)
Forward address SNA	C (see note 6)	
Forward address SSI	C (see note 6)	C (see note 11)
Forward address extension	C (see note 6)	C (see note 11)
External subscriber number	C (see note 6)	C (see note 11)
Time stamp	O (see note 12)	O (see note 12)
User data	O	O
NOTE 1: This parameter shall indicate the address of the storing/forwarding entity to which the message is going for delivery to the destination entity.		
NOTE 2: This parameter shall be present as defined by the called party type identifier parameter.		
NOTE 3: Lower protocol layers will add the calling party identity.		
NOTE 4: This parameter shall indicate, if storage/forward control information is available.		
NOTE 5: This information element shall indicate the address of the final destination entity.		
NOTE 6: This parameter shall be present as defined by the forward address type identifier parameter.		
NOTE 7: This parameter value shall indicate "Called party SSI" and "Called party extension". This identity shall indicate the destination entity.		
NOTE 8: This parameter shall be present as defined by the calling party type identifier parameter.		
NOTE 9: This parameter shall indicate the address of the storing/forwarding entity to which sent the message on behalf of the original source entity.		
NOTE 10: This parameter shall indicate the address of the original source entity.		
NOTE 11: This parameter shall be present as defined by the forward address type identifier parameter.		
NOTE 12: Availability of this parameter is protocol dependent refer to clauses 29.3.2.9 and 29.5.3.3. Normally the SwMI will add the timestamp to the message and the timestamp in the request is to support those cases where that service is not available in the SwMI.		

TLSDS-REPORT request: the primitive shall be used by the SDS-TL entity to send reports to a peer entity. Parameters indicate whether reporting is requested.

TLSDS-REPORT indication: the primitive shall be used by the SDS-TL to pass to the SDS-TL entity reports which have been received from a peer entity or generated by the SwMI or a storing/forwarding entity.

NOTE: A TLSDS-TNSDS-REPORT indication is used to convey local LLC generated reports about the PDU transfer result.

Table 29.3 gives parameters for the TLSDS TLSDS-REPORT primitives when no storing/forwarding entity is used.

Table 29.3: Parameters for the TLSDS-REPORT primitive (no storing/forwarding)

Parameter	Request	Indication
Access priority	O	-
Traffic stealing	O	-
Area selection	O	-
Called party:	See note 1	See note 4
Called party SNA	C (see note 2)	-
Called party SSI	C (see note 2)	M
Called party extension	C (see notes 2 and 7)	M
External subscriber number (called party)	O (see note 7)	-
Calling party:	See note 3	See notes 5 and 6
Calling party SSI	-	M
Calling party extension	-	M
External subscriber number (calling party)	-	O (see notes 6 and 7)
Protocol identifier	M (see note 7)	M (see note 7)
Acknowledgement required	M (see note 8)	M (see note 8)
Delivery status	M (see note 8)	M (see note 8)
Message reference handle	-	O (see note 9)
Message reference	M	M
Time stamp	O (see note 10)	O (see note 10)
User data	O (see note 7)	O (see note 7)
<p>NOTE 1: This parameter shall indicate the address of the destination entity.</p> <p>NOTE 2: This parameter shall be present as defined by the called party type identifier parameter.</p> <p>NOTE 3: Lower protocol layers will add the calling party identity.</p> <p>NOTE 4: This parameter value shall indicate "Called party SSI" and "Called party extension". This parameter shall indicate the address of the destination entity.</p> <p>NOTE 5: This parameter shall value indicate "Calling party SSI" and "Calling party extension".</p> <p>NOTE 6: This parameter shall indicate the address of the source entity.</p> <p>NOTE 7: Not applicable for short reports.</p> <p>NOTE 8: For short reports these parameters are set to default values locally or may have a limited range of values.</p> <p>NOTE 9: This parameter shall be used in the first TLSDS-REPORT indication to a TLSDS-TRANSFER request.</p> <p>NOTE 10: Availability of this parameter is protocol dependent refer to clauses 29.3.2.9 and 29.5.3.3. Normally the SwMI will add the timestamp to the message and the timestamp in the request is to support those cases where that service is not available in the SwMI.</p>		

Table 29.4 gives parameters for the TLSDS-REPORT primitives, when a storing/forwarding entity is used.

Table 29.4: Parameters for the TLSDS-REPORT primitive (storing/forwarding)

Parameter	Request	Indication
Access priority	O	-
Traffic stealing	O	-
Area selection	O	-
Called party	See note 1	See note 4
Called party SNA	C (see note 2)	-
Called party SSI	C (see note 2)	M
Called party extension	C (see note 2)	M
External subscriber number	O (see note 1)	-
Calling party	See note 3	See notes 5 and 6
Calling party SSI	-	M
Calling party extension	-	M
External subscriber number (calling party)	-	O (see note 6)
Protocol identifier	M	M
Acknowledgement required	M	M
Delivery status	M	M
Storage/forward control	M (see note 13)	M (see note 13)
Message reference handle	-	O (see note 7)
Message reference	M	M
Validity period	M	O
Forward address:	See note 8	See note 10
Forward address SNA	C (see note 9)	
Forward address SSI	C (see note 9)	C (see note 11)
Forward address extension	C (see note 9)	C (see note 11)
External subscriber number	C (see note 9)	C (see note 11)
Time stamp	O (see note 12)	O (see note 12)
User data	O	O
NOTE 1: This parameter shall indicate the address of the storing/forwarding entity which sent the reported message on behalf of the original source entity.		
NOTE 2: This parameter shall be present as defined by the called party type identifier parameter.		
NOTE 3: Lower protocol layers will add the calling party identity.		
NOTE 4: This parameter value shall indicate "Called party SSI" and "Called party extension". This identity shall indicate the destination entity.		
NOTE 5: This parameter value shall indicate "Calling party SSI" and "Calling party extension".		
NOTE 6: This parameter shall indicate the address of the storing/forwarding entity which sent the TLSDS-REPORT indication on behalf of the original destination entity.		
NOTE 7: This parameter shall be used in the first TLSDS-REPORT indication to a TLSDS-TRANSFER request.		
NOTE 8: This information element shall indicate the address of the final destination entity.		
NOTE 9: This parameter shall be present as defined by the forward address type identifier parameter.		
NOTE 10: This parameter shall indicate the address of the original source entity.		
NOTE 11: This parameter shall be present as defined by the forward address type identifier parameter.		
NOTE 12: Availability of this parameter is protocol dependent refer to clauses 29.3.2.9 and 29.5.3.3. Normally the SwMI will add the timestamp to the message and the timestamp in the request is to support those cases where that service is not available in the SwMI.		
NOTE 13: This parameter shall indicate storing/forwarding.		

TLSDS-ACK request: the primitive shall be used by the SDS-TL entity to acknowledge reports from a peer entity to the next SDS-TL aware node. The TLSDS-ACK request is used to acknowledge unsolicited reports (consumed message) or reports which may have been stored in the SwMI or at a storing/forwarding entity.

TLSDS- ACK indication: the primitive shall be used by the SDS-TL to pass to the SDS-TL entity report acknowledgements which have been received from a peer entity or generated by the SwMI or a storing/forwarding entity.

Table 29.55 gives parameters for the TLSDS-ACK primitives when no storing/forwarding entity is used.

Table 29.5: Parameters for the TLSDS-ACK primitive (no storing/forwarding)

Parameter	Request	Indication
Access priority	O	-
Traffic stealing	O	-
Area selection	O	-
Called party	See note 1	See note 4
Called party SNA	C (see note 2)	-
Called party SSI	C (see note 2)	M
Called party extension	C (see note 2)	M
External subscriber number (called party)	O	-
Calling party	See note 3	See notes 5 and 6
Calling party SSI	-	M
Calling party extension	-	M
External subscriber number (calling party)	-	O (see note 6)
Protocol identifier	M	M
Delivery status	M	M
Message reference	M	M
NOTE 1: This parameter shall indicate the address of the destination entity.		
NOTE 2: This parameter shall be present as defined by the called party type identifier parameter.		
NOTE 3: Lower protocol layers will add the calling party identity.		
NOTE 4: This parameter value shall indicate "Called party SSI" and "Called party extension". This parameter shall indicate the address of the destination entity.		
NOTE 5: This parameter value shall indicate "Calling party SSI" and "Calling party extension".		
NOTE 6: This parameter shall indicate the address of the source entity.		

Table 29.56 gives parameters for the TLSDS-ACK primitives, when a storing/forwarding entity is used.

Table 29.6: Parameters for the TLSDS-ACK primitive (storing/forwarding)

Parameter	Request	Indication
Access priority	O	-
Traffic stealing	O	-
Area selection	O	-
Called party:	See note 1	See note 4
Called party SNA	C (see note 2)	-
Called party SSI	C (see note 2)	M
Called party extension	C (see note 2)	M
External subscriber number	O (see note 1)	-
Calling party:	See note 3	See notes 5 and 6
Calling party SSI	-	M
Calling party extension	-	M
External subscriber number (calling party)	-	O (see note 6)
Protocol identifier	M	M
Delivery status	M	M
Message reference	M	M
NOTE 1: This parameter shall indicate the address of the storing/forwarding entity from which the acknowledged report message was received.		
NOTE 2: This parameter shall be present as defined by the called party type identifier parameter.		
NOTE 3: Lower protocol layers will add the calling party identity.		
NOTE 4: This parameter value shall indicate "Called party SSI" and "Called party extension". This identity shall indicate the destination entity.		
NOTE 5: This parameter value shall indicate "Calling party SSI" and "Calling party extension".		
NOTE 6: This parameter shall indicate the address of the storing/forwarding entity to which the acknowledged report message was originally sent.		

TLSDS-TNSDS-REPORT indication: the primitive shall be used to indicate whether a TLSDS-ACK request, a TLSDS-TRANSFER request, a TLSDS-REPORT request, or a TLSDS-UNITDATA request has been either transmitted successfully or the transmission has failed. Refer to clause 13.3.2.2 for primitive contents.

TLSDS-UNITDATA request: the primitive shall be used to send user defined data-4 to a peer entity, when not using the SDS-TL data transfer services. Refer to clause 13.3.2.2 for primitive contents. The user defined data-4 parameter shall contain the protocol identifier parameter and the actual user data.

TLSDS-UNITDATA indication: the primitive shall be used to receive user defined data-4 from a peer entity, when not using the SDS-TL data transfer services. Refer to clause 13.3.2.2 for primitive contents. The user defined data-4 parameter shall contain the protocol identifier parameter and the actual user data.

29.2.3 SDS-TL primitives' parameters

Parameter values shall be as defined in this clause and in clause 13.3.3 for the basic SDS.

Acknowledgement required =

- no further acknowledgements required for this message; or
- acknowledgement required for this message.

Delivery report request =

- no delivery report requested;
- message received report requested;
- message consumed report requested; or
- message received and consumed report requested.

Delivery status =

- Refer to clause 29.4.3.2 for further details.

Forward address =

- SNA;
- SSI;
- SSI and address extension; or
- external subscriber number.

Message reference =

- 0 to 255.

Message reference handle =

- 0 to 255, a local handle to the actual message reference. The mapping between a message reference and a message reference handle is a local issue and outside the scope of the present document.

Protocol identifier =

- Protocol which is invoked by the primitive, refer to clause 29.4.3.9.

Service selection =

- individual service; or
- group or individual service.

Short form report =

- Use of short form report is recommended (during the validity period of the message);
- Only standard report allowed.

Storage/forward control =

- Storage/forward control information not available; or
- Storage/forward control information available.

Validity period =

- one try, no extended validity period i.e. any other value indicates that storage is allowed;
- 10 s to 2 weeks; or
- network determined.

29.2.4 State description

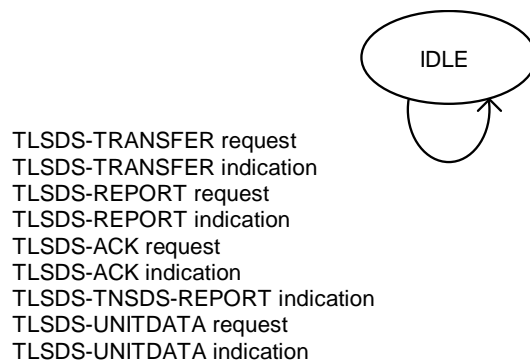

Figure 29.2: State transition diagram

The IDLE state represents the initial and final state of all the primitive sequences as defined in figure 29.2. Note that this state transition diagram represents the state transfer of the SDS-TL entity, not the application using SDS-TL. The state diagram of such applications is outside the scope of the present document.

29.3 Protocol description

29.3.1 Addressing mechanism

When sending an SDS-TL message, the addressing to the final destination is achieved in a number of different ways depending whether or not a storing/forwarding entity function is used. Following destination addresses are specified in an SDS-TL message from MS to SwMI:

- Called party address (destination or next node) in U-SDS-DATA PDU part;
- External subscriber number (destination or next node) in U-SDS-DATA PDU part;

NOTE 1: The previous addresses can be used for all of the SDS-TL PDUs.

- Forward address (destination) in SDS-TRANSFER PDU part;
- Forward address (original source) in the SDS-REPORT PDU; and
- The used MAC layer address implies the source address.

The following source addresses are specified in an SDS-TL message from SwMI to MS:

- calling party address (source or previous node) in D-SDS-DATA PDU part;
- external subscriber number (source or previous node) in D-SDS-DATA PDU part;

NOTE 2: The previous addresses can be used for all of the SDS-TL PDUs.

- forward address (source) in SDS-TRANSFER PDU part;
- forward address (original destination) in the SDS-REPORT PDU; and
- the used MAC layer address implies the destination address.

The called party address is always present and always indicates the next node address (final destination, storing/forwarding entity or gateway and external subscriber number).

The external subscriber number is an optional information element that allows sending of up to 24 digits in e.g. an ISDN address. When used in the U-SDS-DATA PDU it amends the called party address (PDU next destination). When used in the D-SDS-DATA PDU it amends the calling party address (PDU latest source). When used in the forward address it is the final destination or original source address.

The forward address is an optional information element that indicates the final destination or original source TETRA address. It may be an SSI, SSI and address extension (TSI) or external subscriber number.

The calling party address is always present and always indicates the previous node address (final destination, storing/forwarding entity or gateway and external subscriber number). In case no forward address is used, the called party address (optionally amended by the external subscriber number) indicates the final destination and the calling party address (optionally amended by the external subscriber number) indicates the source. The use of the addresses in this case is shown in table 29.7. The addressing of having the final destination/original source in external subscriber number information element of the U-SDS DATA PDU and gateway address in the called party address information element is supported by this addressing scenario.

In case the forward address is used, this address indicates the true destination or original source, and the called or calling party address in the SDS-DATA PDU (optionally amended by the external subscriber number in U-SDS DATA or D-SDS DATA PDU) indicates the next or previous node address. The use of the addresses in this case for MS to MS communication is shown in table 29.8.

The use of the addresses in the case of communication via a gateway to a user addressed by the external subscriber number is shown in table 29.9. In that table, user 2 is addressed by the external subscriber number in the forward address field or in the U-SDS-DATA. A target MS (using an MS-ISDN) may be addressed using any of the following combinations:

- via a gateway by indicating the gateway SSI in the called party address and the target in the external subscriber number of the U-SDS-DATA with no forward address (the SSI is the gateway address); or
- via a gateway by indicating the gateway SSI in the called party address and an external subscriber number in U-SDS-DATA (in which case the external subscriber number identifies some gateway), with the final target in the external subscriber number of the forward address field.

The SwMI may control usage of the forward address for storing/forwarding entity purpose in case of CA by the "extended services broadcast" information element in SYSINFO and SYSINFO-Q broadcasts, refer to clause 21.4.4.1 and 21.4.4.1a or in case of DA by the "extended DA services broadcast" information element in SYSINFO-DA broadcast, refer to clause 21.4.4.1b. The SDS-TL addressing method information element values has the meaning, when using the storing/forwarding entity functionality:

- "Service centre addressing preferred" defines that the MS shall address the SDS-TL transport service PDUs so it contains the destination of the PDU in the forward address information element and the address of the storing/forwarding entity in the called party or in the called party and external subscriber number information element of the SDS DATA PDU. Exceptions to that rule are:
 - MS does not know the storing/forwarding entity (service centre) address in which case MS may attempt to send the PDU without the forward address directly to the destination. In this scenario, the SwMI may either support the addressing types as defined by "Never use service centre addressing" or the SwMI may reject the message;

NOTE 3: The SwMI may support SDS-TL transport services and use a default storing/forwarding entity or may not support SDS-TL transport services but behave as a transparent SwMI.

- MS is sending the message to a user of another SwMI in which case it may or may not use a forward address. How MS knows whether the other SwMI supports forwards addressing and how it knows the storing/forwarding entity address of the other SwMI and the behaviour of the other SwMI are outside the scope of the present document.
- "Never use service centre addressing" defines that the MS shall address the SDS-TL transport service PDUs directly to the destination of the PDU. The message should be addressed directly to the destination, and the forward address shall not be used. If storage is required (a SwMI may support storage without requiring a storing/forwarding entity (service centre) to be addressed), the "storage/forward control" bit shall set to "storage/forward control information available" and the forward address type shall be set to "no forward address present". Otherwise, the "storage/forward control" bit shall be set to "storage/forward control information not available". Exception to the forward addressing rule is:
 - MS is sending the message to a user of another SwMI in which case it may or may not use a forward address. How MS knows whether the other SwMI supports forwards addressing and how it knows the storing/forwarding address of the other SwMI and the behaviour of the other SwMI are outside the scope of the present document.

NOTE 4: The broadcast value "never use service centre addressing" normally indicates that the SwMI does not support storing/forwarding entity functionality.

- "MS choice to use service centre addressing" defines that the MS may select the addressing it applies. The SwMI supports both addressing with and without a storing/forwarding entity (service centre). MS should use PDUs without a forward address when it is not using the transport services (storing/forwarding entity) of the SwMI.

The SYSINFO, SYSINFO-Q and SYSINFO-DA broadcast information shall control the addressing of the SDS-TRANSFER PDU. The addressing of the SDS-REPORT PDU shall be the same as used in the corresponding SDS-TRANSFER PDU and the SDS-REPORT PDU should use the same storing/forwarding entity (service centre) as used in the original received SDS-TRANSFER PDU so that also the storing/forwarding entity knows that the SDS-TRANSFER PDU has been received. This also implies that the SDS-SHORT-REPORT shall be send to the storing/forwarding entity, if it is allowed to send a SDS-SHORT-REPORT. It shall be emphasized that a storing/forwarding entity shall only request a short report, if it can differentiate between the replies.

Table 29.7: MS1 to MS2 transparent

PDU and hop	Source address in the SDS DATA PDU	Destination address in the SDS DATA PDU	Forward address	Remark
SDS-TRANSFER MS1 → MS2	MS1	MS2	-	No forward address
SDS-REPORT MS2 → MS1 (received)	MS2	MS1	-	No forward address
SDS-REPORT MS2 → MS1 (consumed)	MS2	MS1	-	No forward address
SDS-ACK MS1 → MS2 (consumed-ack)	MS1	MS2	N/A	
NOTE: The destination address can be any addressing type of the SDS-DATA PDU.				

Table 29.8: MS1 to MS2 using forward address

PDU and hop	Source address in the SDS DATA PDU	Destination address in the SDS DATA PDU	Forward address	Remark
SDS-TRANSFER MS1 → SwMI	MS1	SwMI	MS2, (see note 1)	Forward address indicates the true destination
SDS-REPORT SwMI → MS1 (delivered/stored)	SwMI	MS1	MS2, (see note 3)	If present, forward address indicates the destination of the original SDS-TRANSFER PDU
SDS-TRANSFER SwMI → MS2	SwMI	MS2	MS1	Forward address indicates the true source
SDS-REPORT MS2 → SwMI (received)	MS2	SwMI	MS1, (see note 2)	Forward address indicates the original source of the reported SDS-TRANSFER PDU
SDS-REPORT SwMI → MS1 (received)	SwMI	MS1	MS2, (see note 3)	If present, forward address indicates the destination of the original SDS-TRANSFER PDU
SDS-ACK MS1 → SwMI (received-ack)	MS1	SwMI	N/A	
SDS-REPORT MS2 → SwMI (consumed)	MS2	SwMI	MS1, (see note 2)	Forward address indicates the original source of the reported SDS-TRANSFER PDU
SDS-ACK SwMI → MS2 (consumed-ack)	SwMI	MS2	N/A	
SDS-REPORT SwMI → MS1 (consumed)	SwMI	MS1	MS2, (see note 3)	If present, forward address indicates the destination of the original SDS-TRANSFER PDU
SDS-ACK MS1 → SwMI (consumed-ack)	MS1	SwMI	N/A	
NOTE 1: The use of the Forward address for the storing/forwarding entity functionality is controlled by the "extended services broadcast" information element in SYSINFO and SYSINFO-Q broadcasts, refer to clauses 21.4.4.1 and 21.4.4.1a and by the "extended DA services broadcast" information element in SYSINFO-DA broadcast, refer to clause 21.4.4.1b.				
NOTE 2: The forward address is used because the original SDS-TRANSFER PDU to MS2 contained a forward address.				
NOTE 3: The forward address is optional.				

Table 29.9: MS1 to MS2/user 2 using forward address via a gateway

PDU and hop	Source address in the SDS DATA PDU	Destination address in the SDS DATA PDU	Forward address	Remark
SDS-TRANSFER MS1 → SwMI	MS1	SwMI/SwMI with User 2 in external subscriber number	user 2/N/A, (see note 1)	Forward address may indicate the true destination or the true destination may be in the external subscriber number field
SDS-REPORT SwMI → MS1 (delivered/stored)	SwMI	MS1	MS2, (see note 3)	If present, forward address indicates the destination of the original SDS-TRANSFER PDU
SDS-TRANSFER SwMI → MS2/user 2	SwMI	MS2/user 2	MS1	Forward address indicates the true source
SDS-REPORT MS2/user 2 → SwMI (received)	MS2/user 2	SwMI	MS1, (see note 2)	Forward address indicates the source of the reported SDS-TRANSFER PDU
SDS-REPORT SwMI → MS1 (received)	SwMI	MS1	MS2/user 2, (see note 3)	If present, forward address indicates the destination of the original SDS-TRANSFER PDU
SDS-ACK MS1 → SwMI (received-ack)	MS1	SwMI	N/A	
SDS-REPORT MS2/user 2 → SwMI (consumed)	MS2/user 2	SwMI	MS1, (see note 2)	Forward address indicates the source of the reported SDS-TRANSFER PDU
SDS-ACK SwMI → MS2/user 2 (consumed-ack)	SwMI	MS2/user 2	N/A	
SDS-REPORT SwMI → MS1 (consumed)	SwMI	MS1	MS2/user 2, (see note 3)	If present, forward address indicates the destination of the original SDS-TRANSFER PDU
SDS-ACK MS1 → SwMI (consumed-ack)	MS1	SwMI	N/A	
NOTE 1: The use of the Forward address for the storing/forwarding entity functionality is controlled by the "extended services broadcast" information element in SYSINFO and SYSINFO-Q broadcasts, refer to clauses 21.4.4.1 and 21.4.4.1a and by the "extended DA services broadcast" information element in SYSINFO-DA broadcast, refer to clause 21.4.4.1b.				
NOTE 2: The forward address is used because the original SDS-TRANSFER PDU to MS2/user 2 gateway contained a forward address. In the case of a TETRA gateway, the PDU exchange is internal to SwMI and may not be explicit.				
NOTE 3: The forward address is optional.				

"MS1", "MS2", and "SwMI" here denotes the address of the originating and destination MS, and the address of the storing/forwarding entity. The "SwMI" address may comprise a gateway address or a gateway address and an external subscriber address.

29.3.2 Description of protocol elements

29.3.2.0 General

The clauses 29.3.2.1 to 29.3.2.10 describe the key aspects of the SDS-TL protocol information elements.

29.3.2.1 Protocol identifier

Each SDS-DATA type 4 PDU which is sent shall contain a protocol identifier. The protocol identifier shall indicate to the addressed entity application which type of application protocol is using the SDS service. The present document currently defines a number of protocol identifiers to provide e.g. OTAK, text messaging, location system, WAP, WCMP, end-to-end encrypted message, immediate text messaging, M-DMO, PIN-authentication, LIP and message with user data header application services. A number of reserved protocol identifiers allow additional standard data services to be added in the future. There is also a range of protocol identifiers available for user definition. The value of the protocol identifier determines whether the SDS-TL (data transfer service) protocol elements and the protocol defined in the present document shall be used (see table 29.21).

29.3.2.2 End-to-end acknowledgement types

The main objective of the SDS-TL protocol, as well as providing a mechanism to indicate the type of application using the service, is to provide a means for end-to-end acknowledgement of messages; this mechanism is not provided by the TETRA SDS service as defined in clause 14. SDS-TL provides two types of end-to-end acknowledgement which are distinct from the layer 2 acknowledgement procedures already provided by the LLC. The type of end-to-end acknowledgement which shall apply to a message transfer is set by the originator using the "Delivery report request" information element. These end-to-end acknowledgement types are described below:

- Layer 2 acknowledgement only i.e. no end-to-end acknowledgement.
- The LLC provides an acknowledged service for PDUs transferred point-to-point over a single hop i.e. MS to SwMI or SwMI to MS. This acknowledgement confirms to the sender that the layer 3 PDU was received correctly by the receiver. However, the LLC acknowledgement does not imply that the receiving end has yet examined the contents of the PDU. Figure 29.3 illustrates the layer 2 acknowledgement.

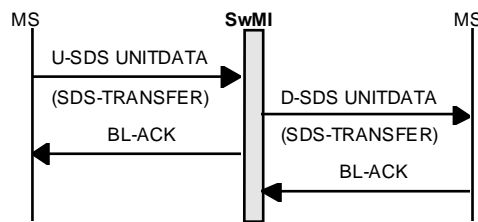

Figure 29.3: Layer 2 Acknowledgement

- Message received:
 - The "message received" acknowledgement is sent using the SDS-TL layer to indicate that a message sent by an MS has been successfully received by the destination. This acknowledgement message is an SDS-TL PDU which is generated by the MS after it has decoded the SDS-TL PDU received from the originator. (This is in contrast to a layer 2 acknowledgement which is sent before the incoming PDU has been decoded.) Therefore, this acknowledgement is sent by the destination back to the originator and simply relayed by the SwMI. This type of acknowledgement may be used for point-to-point and point-to-multipoint transfer although care should be used for point-to-multipoint transfer where large group sizes may result in large amounts of air interface traffic for acknowledgements. Figure 29.4 illustrates the "message received" end-to-end acknowledgement.

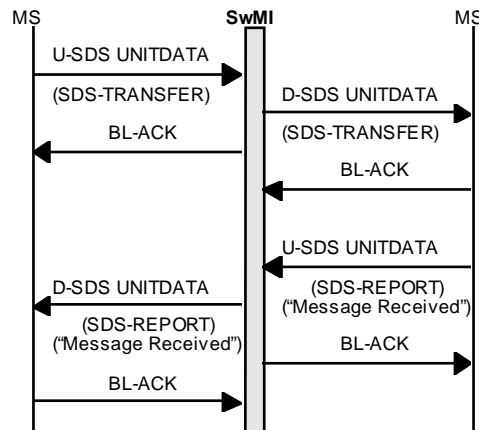

Figure 29.4: "Message received" end-to-end acknowledgement

- Message consumed:
 - The "message consumed" acknowledgement is sent using the SDS-TL layer to indicate that a message sent by an MS has been consumed by the destination. Message consumption occurs after the SDS-TL PDU has been received and decoded by the destination application and refers to the point where the message is actually used by the application. Message consumption is application dependent and is specified in clause 29.3.2.2 for each of the standard applications covered by the present document. Once an application has consumed a message, it may use the SDS-TL protocol to convey this back to the originator. Figure 29.5 illustrates the "message consumed" end-to-end acknowledgement. Note that this figure does not show any "message received" acknowledgement which may be sent in between the message transfer and the "message consumed" acknowledgement.

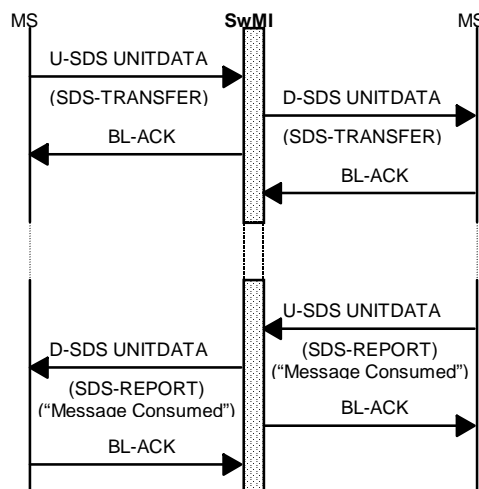

Figure 29.5: "Message consumed" end-to-end acknowledgement

For the acknowledgement types "message received" and "message consumed", the SDS-TL protocol shall allow the originator of a message to specify which type of acknowledgement is desired from the destination. An application shall then make this choice depending on the type of data being delivered and whether the transfer is point-to-point or multipoint. SDS-TL simply provides an application with a standardized mechanism to convey these acknowledgement reports.

The criteria of message consumption depend on the application. Message consumption criteria for each of the applications covered by the present document are defined below:

- Text Messaging:
 - Message consumption for the text messaging application shall be when the application displays the text message to the user. Usually, this requires an action by the user to read the message which has been received and stored in the MS.

- Location system:
 - The location system protocol does not have a clear concept of message consumption. Whether message consumption is applicable or not depends on the application using the protocol.
- Simple Text Messaging:
 - The simple text messaging protocol does not use the SDS-TL data transfer protocol. This means that no end-to-end acknowledgement is available in simple text messaging.
- Simple location system:
 - The simple location system protocol does not use the SDS-TL data transfer protocol. This means that no end-to-end acknowledgement is available in simple location systems.
- AGNSS:
 - The AGNSS protocol does not have a clear concept of message consumption. Whether message consumption is applicable or not depends on the application using the protocol. The sending of broadcast messages using SDS TL is defined in clause 29.3.3.8.2, explicitly defining that no acknowledgements shall be used when using SDS-TL for system broadcast messages
- Simple AGNSS:
 - The simple AGNSS protocol does not use the SDS-TL data transfer protocol. This means that no end-to-end acknowledgement is available in simple GNSS.
- Other standardized protocols using SDS:
 - The other standardized protocols using SDS may or may not use the SDS-TL data transfer protocol. Other SDS-TL protocols may be standardized in the future and the meaning of message consumption defined in the present document. Alternatively, user applications may use SDS-TL where the meaning of message consumption is specific to that application.

29.3.2.3 Service selection/short form report

Each uplink SDS-TRANSFER PDU that is sent shall contain a service selection information element. The service selection information element is used to indicate whether the message is allowed to be sent to a group address or not. This is useful in a text messaging application where the user may be allowed to enter the destination address manually. In this case, the sending MS has no way of informing the user that this message will be sent to multiple targets. This could lead to substantial resource waste if, by accident, a message with non-zero delivery report requests is sent to a large group of MSs.

To prevent this, the service selection information element forces the originating user to make an explicit choice that the message is allowed to be sent to a group. The network is then able to reject messages addressed to a group, but with the service selection information element set to "Individual service".

The short form report information element on downlink SDS-TRANSFER PDUs inform the destination user whether it should use or is not allowed to use short form reporting mechanism.

29.3.2.4 Storage/forward control

Each SDS-TRANSFER PDU that is sent shall contain a "storage/forward control" information element. The "storage/forward control" information element is used to indicate whether the SwMI is allowed to store the message longer than needed for ordinary processing and whether a storing/forwarding entity is specified. If indicated by this information element, the SwMI or a storing/forwarding entity, may store the message for later delivery attempts if the destination is not available.

The criterion for attempting to deliver the message again is outside the scope of the present document.

29.3.2.5 Message reference

Each SDS-TL data transfer service PDU that is sent shall contain a message reference information element. This message reference shall be used in the end-to-end acknowledgement back from the destination, or in reports from the SwMI or storing/forwarding entity, to indicate to the originator which message is being acknowledged. The message reference shall also be used in negative acknowledgements.

The originator should choose a different message reference for each new message sent regardless of the destination, if it requests a report. If an acknowledgement is outstanding, regardless of the destination, the corresponding message reference should not be re-used. In the source entity, the validity of the message reference of a message after an extended time after sending the message and expiry of the selected validity period, if any, but without receiving requested reports is outside the scope of the present document.

By following this use of the message reference, the combination of the message reference, and source address (ITSI) shall uniquely identify each message being transported by a TETRA network.

The storing/forwarding entity or SwMI shall not modify the value of the message reference.

NOTE 1: SwMI may not include the forward address into all reports notably error reports in which case the storing/forwarding entity (service centre) address may be the only destination related address in the report. Consequently, the message reference with the storing/forwarding entity address is the only linkage to the sent message and SDS-TRANSFER PDU source entity should choose to use different message reference for each message independently of the destination address.

NOTE 2: In the case of a gateway to another telecommunication network the source or destination address as appropriate is the TETRA address of that gateway.

In the case of short report the message reference may be the only valid identifier of the acknowledgement.

29.3.2.6 Validity period

If storage of the message is allowed, each SDS-TRANSFER or SDS-REPORT PDU which is sent by an MS shall contain a "validity period" information element. This information element indicates how long the message should be held by the SwMI in the event that the message cannot be delivered to the destination. A destination MS may be unavailable due to being out of coverage or switched off. If the SwMI holds a message, it should attempt to deliver the message until the validity period expires after which the message is discarded and an error report may be sent back to the originating MS.

Note that the SwMI may not support a storage mechanism or it may limit the duration of the validity period in which case it should return an error report indicating either that the message has not been delivered and that the SwMI will not store the message or that the validity period has terminated.

If the validity period is set to "0" or the element is missing then the SwMI should not store the message for an extended period, if it cannot be delivered.

29.3.2.7 Forward address

If storage/forward control information is available, each SDS-TRANSFER which is sent by an MS may contain a "forward address" information element. The MS uses "forward address" information element when the layer 3 destination address points to a network service entity (e.g., a service centre) instead of the final destination. The use of such a network service entity can be many. The network service entity can:

- identify the storing/forwarding entity for a message in a store and forward service;
- identify some other value adding network device.

The "forward address" is somewhat similar to the layer 3 information element "external subscriber number" but is totally independent of it.

When used in the context of providing an addressed storing/forwarding entity for text messages, the forward address is used on the uplink is to inform the network service entity of the true destination, and used on the downlink is to inform the destination of the true source. If no forward address is present, the true source and destination are the addresses present in the CMCE SDS PDU information elements except in certain error cases, refer to clause 29.3.3.

29.3.2.8 Data coding scheme

The data coding scheme information element shall indicate to the destination application which type of data coding is being used by the application according to the type of protocol identifier. For example, the text messaging application may use a 7-bit character coding alphabet or a 16-bit alphabet depending on the needs of the particular application. The text coding scheme defines some standard alphabets with some reserved values available for user definition and future standard coding schemes. The location system coding scheme does the same for location information.

This information element is present in protocols where data coding scheme is of importance. The information element is thus not part of the SDS-TL protocol, but rather a higher layer addition for specific protocol identifiers (see table 29.21 and clause 29.5).

29.3.2.9 Time stamp

The time stamp information element shall indicate the approximate creation time of the message. The information element is added to a message by the SwMI to allow the destination to evaluate the age of the message. The SwMI decides whether to add the time stamp or not. How this decision is made is outside the scope of the present document, but can e.g. be based on the capabilities of the SwMI or on provisioning arrangements.

In some situations the addition of the time stamp can cause the maximum allowed message length to be exceeded. The SwMI should not add the time stamp in these circumstances, regardless of provisioning arrangements or other aspects.

NOTE: The time stamps added by the SwMI(s) are not guaranteed to be monotonically increasing.

This information element is present in protocols where storing/forwarding entity is used and where time stamping is of importance. The information element is thus not part of the layer 4 SDS-TL protocol, but rather a higher layer addition for specific protocol identifiers (see clauses 29.4.3.9 and 29.5).

Table 29.40 defines possibilities for timeframes of the time stamp. The time stamp should use Universal Time Co-ordinated (UTC time) as the time frame. That is in line with the TETRA network time usage, refer to clause 18.5.24 although the time encoding is different.

Applications may convert the UTC time to the local time and take into account summer time as applicable for presentation to the human users.

29.3.2.10 User data length

The length of the "User data" information element (the payload) is derived from the length field in the SDS DATA PDU header. This field indicates the number of bits in the SDS payload, including the (known) length of the SDS-TL header.

For applications, such as simple text messaging, the number of bits in the "User data" information element together with the "Text coding scheme" information element can then be used to derive the number of characters in a message. For example, if the layer 3 SDS type 4 header specifies a length of 86 bits and the coding scheme is 7-bit ASCII, then the "User data" information element contains 70 bits of characters of 7 bits after removal of the SDS-TL header (protocol identifier and text coding scheme), indicating that there are 10 characters present.

29.3.3 Procedures

29.3.3.1 General description

Figure 29.6 shows the protocol sequence for a message transfer from an MS to a destination MS (or group of MSs), where both the received and consumed end-to-end acknowledgements are requested. The SDS-TRANSFER is carried by U/D-SDS-DATA PDUs with an end-to-end acknowledgement being sent by the application of the destination MS on receipt of the message. The acknowledgement is conveyed using SDS-REPORT which is also carried by U/D-SDS-DATA PDUs. On consumption of the message by the application e.g. the user reading a text message, a second end-to-end acknowledgement (SDS-REPORT PDU) is sent by the destination back to the originating MS. This second acknowledgement can almost be considered a second service invocation: the linkage to the original transfer is the message reference and the addresses of the MSs, refer to table 29.7. Because of this, application may request the SDS-REPORT PDU be acknowledged as well. This acknowledgement shall be conveyed using SDS-ACK PDU. The SDS-ACK PDU is not an end-to-end acknowledgement, but an acknowledgement to the next SDS-TL aware node. This next node may or may not be the final destination.

NOTE 1: If the destination consumes the message before the message received report is sent the destination may only send back the consumed report.

If the end-to-end mechanisms are used without a storing/forwarding entity, the application should define procedures for handling of retries in case of missing acknowledgements. These procedures are application specific and outside the scope of the present document.

The protocol used without a storing/forwarding entity is used transparently to the SwMI, which only acts as a layer 3 network. This means that part of this protocol sequence can be left out by the application: the SwMI need not to be aware of this. In particular, the SDS-TL protocol allows the application to specify which kind of acknowledgement is requested by the message source. If storage is not allowed, the SwMI should normally act transparently. The SwMI may though for example inject a forwarding entity, if the SwMI wants to exercise further control over, how a service is provided.

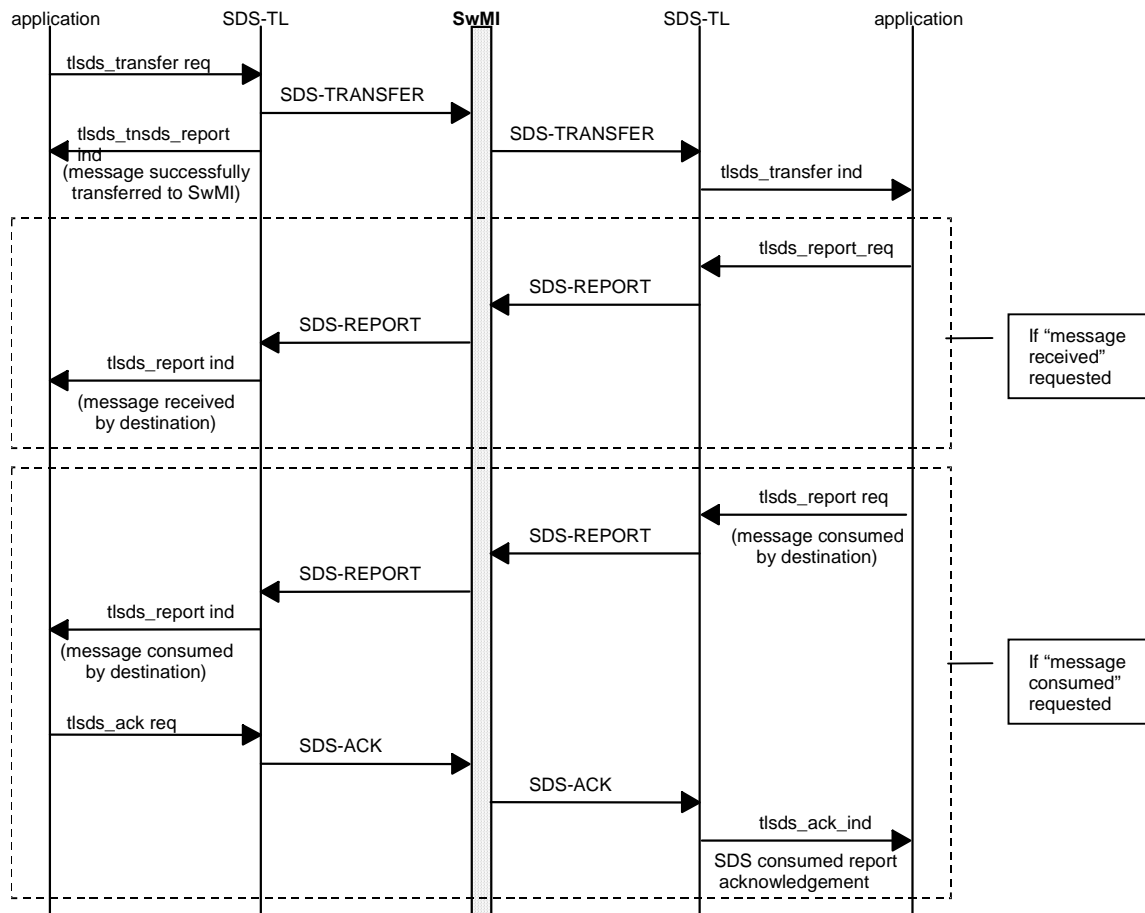

NOTE: The `tlsds_tnsds` report (message successfully transferred to SwMI) as the first response to the `tlsds` transfer req is an example of lower layer reports (BL-ACK PDU) and is not repeated for all requests.

Figure 29.6: SDS message transfer with end-to-end acknowledgement, SwMI transparent

If the SwMI stores the message for later delivery, the SwMI storing/forwarding entity may inform the originating MS by sending an SDS-REPORT PDU. This is shown in figure 29.7. This informs the originating MS that the message has been received by the storing/forwarding entity service: note that this message should be sent if either the "message received" or "message consumed" delivery reports are requested. On consumption of the message by the application e.g. the user reading a text message, a second end-to-end acknowledgement is sent by the destination back to the originating MS, again through the storing/forwarding entity service.

NOTE 2: In figures 29.6 to 29.8 texts in brackets next to service primitives indicate a completion of an action not a service primitive parameter value.

Note that the protocol sequence changes when the SwMI supports storing/forwarding entity. First, the sequence of messages changes because of the "intelligent" part resident in the SwMI. Secondly, one additional layer 4 acknowledgement may be needed: the "message received" acknowledge back to source shall, if requested, be acknowledged. However, even if storing/forwarding entity is supported in the SwMI and allowed by the message source, the protocol sequence can be the same as in the transparent case: if the SwMI delivers the message immediately, the "message stored by SwMI" may not be sent. Note that the SwMI now plays an active role, and leaving out part of this protocol sequence does require that the SwMI is aware of it.

If the "forward address" information element is used to provide storing/forwarding entity service via an addressed network service entity, the true destination address is only visible inside the initial SDS-TRANSFER PDU on the source (left) side of the SwMI (see figure 29.7). The same applies for the true source address on the destination (right) side. Seen from the SwMI perspective, the source and the destination will no longer communicate with each other, but both will communicate with the storing/forwarding entity.

When using store and forward the SwMI storing/forwarding entity may choose to modify the SDS-REPORT PDU to the source to get an additional SDS-ACK as shown in figure 29.7.

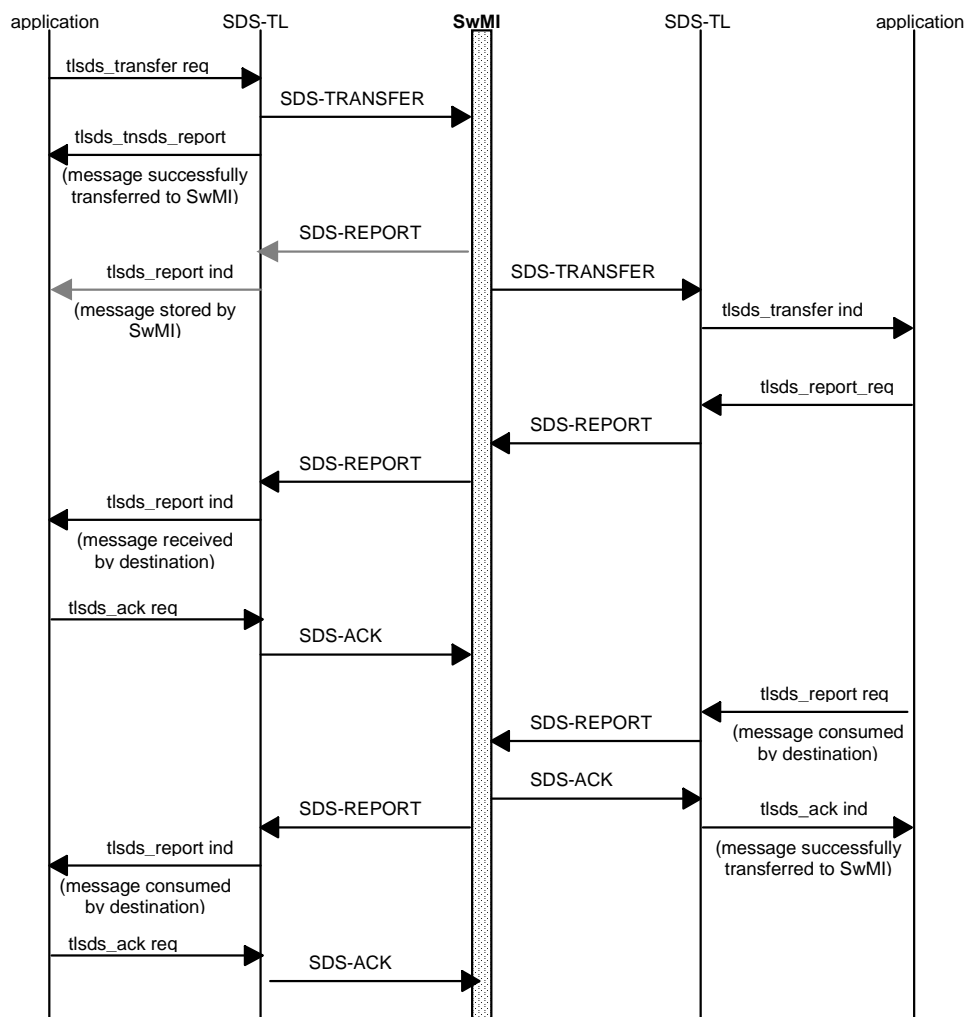

NOTE: The `tlsds_tnsds report` (message successfully transferred to SwMI) as the first response to the `tlsds transfer req` is an example of lower layer reports (BL-ACK PDU) and is not repeated for all requests.

Figure 29.7: SDS message transfer with end-to-end acknowledgement, SwMI does storing/forwarding

When using storing/forwarding entity and requesting "message consumed" report but not "message received", the SwMI may choose to modify the SDS-TRANSFER PDU to the destination, as shown in figure 29.8. This will enable the SwMI to stop trying to deliver the message once it has reached the destination application.

NOTE 3: The SDS-ACK PDU is not an end-to-end acknowledgement, but an acknowledgement from the next node. This next node may or may not be the final destination.

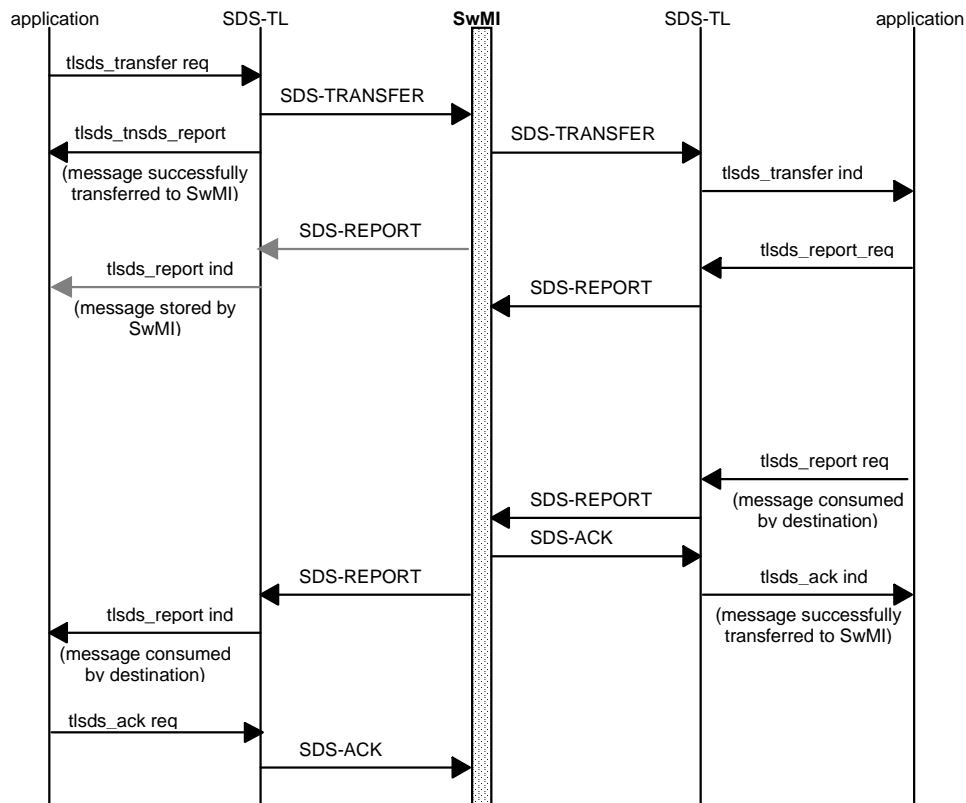

NOTE: The tlds tnsds report (message successfully transferred to SwMI) as the first response to the tlds transfer req is an example of lower layer reports (BL-ACK PDU) and is not repeated for all requests.

Figure 29.8: SDS message transfer with consumed acknowledge, SwMI modifies requested reports

NOTE 4: In this content the MS is the entity which may also be a fixed entity having a TETRA identity and addressed in the same manner as MSs.

29.3.3.2 MS sending a message

An MS sends a message using SDS-TRANSFER PDU which is conveyed to the SwMI in U-SDS-DATA PDU and to another MS using D-SDS-DATA PDU. SDS procedures for sending U-SDS-DATA PDU and D-SDS-DATA PDU are described in clause 14. The SDS-TRANSFER PDU uses user-defined data type 4 which allows up to 2 047 bits of user data to be transferred (including SDS-TL headers).

SDS-TRANSFER PDU shall contain the information elements defined in clause 29.4.2.4, table 29.14.

The protocol identifier indicates the user application protocol that is using the short data transfer service.

The message reference shall be set by the SDS-TL entity of the sending party (original source) to identify reports sent back from the destination or next node. The sending user application shall use a local message reference handle in the TLSDS-TRANSFER request primitive and the SDS-TL entity shall allocate the actual message reference and shall inform it the user application in the first report. The sending MS SDS-TL entity shall select a new value to the message reference each time it sends a new message in the SDS-TRANSFER PDU whether to the same destination or to a different destination. The sending MS shall not select a message reference value used in a received SDS-TRANSFER PDU from the same source to which MS is sending a SDS-TRANSFER PDU as long as there is a pending report request to the received SDS-TRANSFER PDU. The combination of the identities of the source address and the message reference shall uniquely identify the sent message.

The short form report does not contain the Protocol identifier information element, and therefore SDS-TL entity shall not allocate the same message reference value for multiple applications in the same originating MS when there is a pending report on that message reference value. The usage of the SDS-SHORT REPORT PDU is application independent.

The delivery report request indicates to the SwMI and the destination for the short message the type of reports which are required. These may be an acknowledgement from the destination when it receives the message or an acknowledgement from the destination when the message is consumed or both. For a text messaging application, message consumption would correspond to the user reading the received text message.

If message storage is allowed the validity period shall inform the SwMI how long the message is valid. The SwMI may use this information to store the message in the situation where the destination is not available. If the message cannot be delivered before the validity period expires, the SwMI shall discard the message and may report back to the sending MS that the message delivery was unsuccessful. The SwMI may modify the validity period for its own purposes when it send the message to the destination.

The destination MS may refer to the message also after the validity period by using the message reference. The message validity time in that sense is application dependent and is outside the scope of the present document.

The SwMI may control whether the destination may use short form report or not by the short form report information element in the SDS-TRANSFER PDU, refer to clause 29.4.3.10.

29.3.3.3 MS receiving a message

An incoming message is received as an SDS-TRANSFER PDU which is carried to an MS in D-SDS-DATA PDU. The information elements of SDS-TRANSFER PDU are as described in clause 29.4.2.4, table 29.14. The validity period information element may have been modified by the SwMI and may use the indicated value when choosing the report type or addressing, refer to clause 29.3.3.4.4.

When an MS SDS-TL entity receives an incoming message, it shall deliver it to the user application or interpret the message according to the protocol identifier and, if present, the data coding scheme. The delivery report request shall indicate to the MS or user application whether or not an acknowledgement for the message needs to be sent back to the SwMI. The procedures for sending an acknowledgement as a report are covered in clause 29.3.3.4. The report may also contain user data.

29.3.3.4 Sending an acknowledgement from the destination MS

29.3.3.4.1 General

An MS receiving a message shall send an acknowledgement back to the SwMI according to the value of the "Delivery report request" information element. Note that the use of the term, "acknowledgement" in this sub-clause refers to an SDS-TL data transfer report and not to the layer 2 acknowledgements which may also be sent as part of the underlying SDS and LLC transport mechanism which are being used by SDS-TL. Also, the generator of the report should be the final destination: if the final destination is a host located on the PEI, then the report should be generated by the host connected to the PEI.

The SDS-REPORT PDU shall be used to send an acknowledgement back to the sender of the message. The "Message reference" information element shall be set to be equal to the message reference of the original received message to which the acknowledgement refers. The message reference and original source (destination of the SDS-REPORT PDU) address uniquely identifies a message so that the report can be matched to the SDS-TRANSFER PDU, which is acknowledged, in the SwMI. The message reference may be the only matching element to the SDS-TRANSFER PDU, which is acknowledged, in the originator entity as the use of the original destination address is optional. Refer to clause 29.3.1 on addressing and clause 29.3.2.5 on message reference.

Upon receiving an SDS-REPORT PDU, the SwMI should relay this PDU back to the originator of the SDS-TRANSFER PDU without other modification than required for addressing and validity period, which SwMI may modify. When storing/forwarding entity is supported, the SwMI may temporarily shield the originator from negative acknowledgements or modify the report (see clause 29.3.3.6.3); for example, if a memory capacity exceeded delivery status is returned from the target, the storing/forwarding entity may shield this report from the originator and retry sending the message at a later time within the validity period. The validity period in the SDS-REPORT PDU has no meaning to the destination of the SDS-REPORT PDU. The SwMI may use storing/forwarding entity service, if it is allowed in the SDS-REPORT PDU. Note that, as shown in figures 29.6 to 29.8, the application is responsible for sending acknowledgements using the TLSDS-REPORT request primitive in accordance with the parameters of the TLSDS-TRANSFER indication. The SDS-TL layer simply provides a transport mechanism and PDU definition for sending acknowledgements.

End-to-end acknowledgements may be requested for both point-to-point and point-to-multipoint message transfers; in the case of multipoint transfers an acknowledged service should be used with care due to the amount of air interface traffic which could be generated by a large group of MS sending acknowledgements back to the originator. It is recommended that point-to-multipoint transfer does not request end-to-end acknowledgement. In fact, the SwMI may modify a multi-point transfer (by modifying the "Delivery report request" information element to "No delivery report requested" and returning a report to the originator indicating "SDS sent to group, acknowledgements prevented") to prevent the destination MS group sending acknowledgements.

If an acknowledgement is requested for a point-to-multipoint transfer, the SDS message carrying the acknowledgement shall contain the individual address of each destination MS (not the group address) and the message reference of the original SDS-TRANSFER PDU. It is then the responsibility of the originating application to match the acknowledgements to the original sent message using the message reference.

The sender of the SDS-REPORT PDU may request the recipient to send an SDS-ACK PDU to acknowledge the reception of the SDS-REPORT PDU, refer to clauses 29.3.3.5 and 29.3.3.7.

NOTE: When the destination MS wishes to receive an SDS-ACK PDU to its SDS-REPORT PDU and the next node is (non-transparent) SwMI, it may have received other SDS-TRANSFER PDU (from another MS) for which it has sent an SDS-REPORT PDU waiting for an SDS-ACK PDU and the message reference values of the SDS-TRANSFER PDUs happen to be the same. This can happen as each MS allocates independently message references to the SDS-TRANSFER PDUs. In the case of conflict the MS may delay the sending of the SDS-REPORT PDU until it receives an SDS-ACK PDU for the previous one.

29.3.3.4.2 Positive acknowledgement from an MS

If the "Delivery report request" information element in the original SDS-TRANSFER PDU indicates the following acknowledgement type:

- no delivery report requested;

then the destination application shall simply consume the message and shall not send any acknowledgement back to the SwMI.

If the "Delivery report request" information element in the original SDS-TRANSFER PDU indicates:

- message receipt report requested;

and the message is received and successfully decoded, then the destination application shall initiate sending of an acknowledgement to the SwMI using the SDS-REPORT PDU. If the SwMI fails to receive this report, it may retry the delivery. The mechanism determining when to retry the delivery is outside the scope of the present document.

When receiving the acknowledgement, the SwMI should relay this back to the original sending MS. In this case the "Delivery status" information element shall have the following value:

- SDS receipt acknowledged by destination.

If the "Delivery report request" information element in the original SDS-TRANSFER PDU indicates:

- message consumed report requested;

and the message is received and successfully decoded, then the destination application shall initiate sending of an acknowledgement to the SwMI using the SDS-REPORT PDU when the message is consumed. Determining when a message is consumed shall depend on the application which is using the SDS-TL protocol and which is indicated by the protocol identifier (see clause 29.4.3.9). In this case the "Delivery status" information element shall have the following value:

- SDS consumed by destination.

The originator may also request both reports.

The SwMI may control addressing type of the SDS-REPORT PDU by the broadcast information element SDS-TL addressing method, refer to clause 29.3.1.

29.3.3.4.3 Negative acknowledgement from an MS

If a destination receives an individually addressed SDS-TL data transfer service PDU and the MS does not support the specific SDS-TL protocol, or the message cannot be delivered to the peer application, or the destination does not support the application, or the destination cannot receive more messages, then the destination shall issue a negative acknowledgement using the SDS-REPORT PDU. Also the peer application may generate some negative acknowledgements. These error situations are indicated with the "Delivery status" information element set to one of the values outlined in table 29.16 depending on the nature of the error condition (in this table, the MS may return values that indicate a "report source" as "destination").

Note that, if an error occurs when receiving an individually addressed SDS-TL message, the destination shall send a negative acknowledgement regardless of whether or not the originator requested an acknowledgement. If an error occurs when receiving a broadcast or group addressed message, the message shall be silently discarded.

The SwMI may control addressing type by the broadcast information element SDS-TL addressing method, refer to clause 29.3.1.

29.3.3.4.4 Short form acknowledge

A short form acknowledgement SDS-SHORT REPORT PDU is defined and transferred using SDS STATUS PDUs to provide an alternative to using the SDS-REPORT PDU (when using SSI addressing, the short form acknowledgement will fit into a single $\pi/4$ -QPSK random access burst on the air interface). The SDS-SHORT REPORT PDU may be used to send an acknowledgement from a MS, as described in clauses 29.3.3.4.2 and 29.3.3.4.3 instead of SDS-REPORT PDU.

The SDS-SHORT REPORT PDU may be used when the report is a response to SDS-TRANSFER PDU which contains short form report value "Use of short form report recommended during the validity period of the message" and the validity period has not expired, refer to clause 29.4.3.10. In this case, the destination MS may choose between the SDS-SHORT REPORT PDU and the SDS-REPORT PDU in the cases where the report types available in the short form will suffice. In a transparent transfer mode the SDS-SHORT REPORT PDU may be used even though the validity period is not included into the reported SDS-TRANSFER PDU. The implied validity time is application dependent and outside the scope of the present document.

The short form acknowledgement should be treated by the SwMI and MS equivalent to the corresponding full SDS-REPORT PDU. The SwMI may modify a short report to a standard report for transmission to the original originator of the SDS-TRANSFER which is being reported.

The usage of the SDS-SHORT REPORT PDU is application independent.

The short form report does not contain the Acknowledgement required information element. The implied value of this information element shall be "No further acknowledgements required for this message".

29.3.3.5 Sending an acknowledgement from the source MS

An MS receiving an acknowledgement shall if requested send a delivery report back to the SwMI. Note that the use of the term, "acknowledgement" in this clause refers to an SDS-TL reports and not to the layer 2 acknowledgements which may also be sent as part of the underlying SDS and LLC transport mechanism which are being used by SDS-TL. Also, the generator of the acknowledgement should be the final destination of the report: if the final destination is a host located on the PEI, then the acknowledgement should be generated by the host connected to the PEI.

The SDS-ACK PDU shall, when required, be used to send an acknowledgement back to the sender of the acknowledgement (report). The "Message reference" information element shall be set to be equal to the message reference of the original received message to which the acknowledgement refers. The message reference and source address (of the SDS-ACK PDU) uniquely identifies the message so that the acknowledgement can be matched to the SDS-REPORT PDU in the next node. In the case of transparent SwMI the next node on this protocol point of view is the destination MS.

If the "Delivery report" information element in the SDS-REPORT PDU indicates:

- SDS receipt acknowledged by destination;

and if the "Acknowledgement required" information element indicates that further acknowledgement is needed, then the source application shall initiate sending of an acknowledgement to the SwMI using the SDS-ACK PDU. In this case the "Delivery status" information element shall have the following value:

- SDS receipt report acknowledgement.

If the "Delivery report" information element in the SDS-REPORT PDU indicates:

- SDS consumed by destination;

and if the "Acknowledgement required" information element indicates that further acknowledgement is needed, then the source application shall initiate sending of an acknowledgement to the SwMI using the SDS-ACK PDU. In this case the "Delivery status" information element shall have the following value:

- SDS consumed report acknowledgement.

For all negative "Delivery report" information values in the SDS-REPORT PDU and if the "Acknowledgement required" information element indicates that further acknowledgement is needed, then the source application shall initiate sending of an acknowledgement to the SwMI using the SDS-ACK PDU. In this case the "Delivery status" information element shall have the following value:

- Negative report acknowledgement.

If the requester fails to receive any of these SDS-ACKs, it may retry the delivery of the SDS-REPORT PDU. The mechanism determining when to retry the delivery is outside the scope of the present document.

29.3.3.6 Sending an acknowledgement from the SwMI

29.3.3.6.1 General

In most cases, the SwMI is simply a relay for messages and acknowledgements (reports) sent between an originator and destination. An exception to this is the case of an SDS-TRANSFER PDU that cannot be delivered. Note that the use of the term, "acknowledgement" in this sub-clause refers to an SDS-TL report and not to the layer 2 acknowledgements which may also be sent as part of the underlying SDS and LLC transport mechanism which are being used by SDS-TL.

The SDS-REPORT PDU shall be used to send an acknowledgement back to the sender of the message. The "Message reference" information element shall be set to be equal to the message reference of the SDS-TRANSFER PDU to which the acknowledgement refers. The message reference and original source address of the SDS-TRANSFER PDU (i.e. the destination of the SDS-REPORT PDU) uniquely identify a message so that the acknowledgement can be matched to an SDS-TRANSFER PDU in the next node. The message reference may be the only matching element to the SDS-TRANSFER PDU, which is acknowledged, in the originator entity as the use of the original destination address is optional. Refer to clause 29.3.1 on addressing and clause 29.3.2.5 on message reference.

The SDS-ACK PDU shall be used to send an acknowledgement back to the sender of the report, if requested. The "Message reference" information element shall be set to be equal to the message reference of the SDS-REPORT PDU to which the acknowledgement refers. The message reference and source address uniquely identify the message so that the acknowledgement can be matched to the SDS-REPORT PDU.

NOTE: In this content the SwMI is the entity which is addressed in the basic SDS PDU such as a store and forward entity, forwarding entity, gateway or a service centre.

29.3.3.6.2 Positive acknowledgement from the SwMI

If the SwMI, a gateway or a storing/forwarding entity (service centre) forward an SDS-TL message to an external network that does not support the SDS-TL services requested by the originator, the SwMI may acknowledge the forwarding of the message. This acknowledgement only acknowledges the fact that the message has been forwarded and is not a guarantee for either delivery or consumption of the message.

In this case the "Delivery report" information element in the SDS-REPORT PDU indicates:

- SDS message forwarded to external network.

The originator will not receive any further acknowledgements for the message.

29.3.3.6.3 Negative acknowledgement from the SwMI

If the SwMI receives an SDS-TL message and the message cannot be delivered to the destination or SwMI detects some error condition (for example, source/destination not authorized for SDS or the network is overloaded) or the message transfer fails for some reason, then the SwMI should issue a negative acknowledgement to the originator using the SDS-REPORT PDU. The "Delivery status" information element is set to one of the values outlined in table 29.16 depending on the nature of the error condition (in this table, the SwMI may return values that indicate a "report source" as "SwMI").

In networks that support storing/forwarding entity, once the validity period has expired, the storing/forwarding entity or SwMI should return an SDS-REPORT with "Delivery status" indicating "validity period expired". The storing/forwarding entity or SwMI should not attempt any further deliveries, and the originating MS should not expect to receive any further reports, for a given message transmission, once "validity period" has expired.

Note that, if an error occurs in the message transfer to the destination, the SwMI should send a negative acknowledgement regardless of whether or not the originator requested an acknowledgement.

29.3.3.6.4 Temporary negative acknowledgement from the SwMI

If the SwMI receives an SDS-TL message and the message cannot be delivered to the destination for a temporary reason (for example, destination is not immediately reachable or the network is overloaded), then the SwMI should issue a temporary negative acknowledgement to the originator using the SDS-REPORT PDU. The "Delivery status" information element is set to one of the values outlined in table 29.16 depending on the nature of the error condition.

The "Delivery status" information element value "Message stored by SwMI" may be used instead of a specific value.

On the reception of these reasons MS should expect that the message will be delivered later and should not resend it before a further failure indication.

29.3.3.7 Sending an acknowledgement from the SwMI to destination MS

An SwMI receiving a report shall if requested send an acknowledgement back to the MS. Note that the use of the term, "acknowledgement" in this clause refers to an SDS-TL ACK PDU and not to the layer 2 acknowledgements which may also be sent as part of the underlying LLC transport mechanism. For the scenario refer to figures 29.7 and 29.8.

The SDS-ACK PDU shall, when required, be used to send an acknowledgement back to the sender of the report. The "Message reference" information element shall be set to be equal to the message reference of the report to which the acknowledgement refers. Only the message reference uniquely identifies the message so that the acknowledgement can be matched to the SDS-REPORT PDU in the MS receiving the SDS-ACK PDU. Refer to clause 29.3.1 on addressing and clause 29.3.2.5 on message reference.

If the "Delivery report" information element in the SDS-REPORT PDU indicates:

- SDS receipt acknowledged by destination

and if the "Acknowledgement required" information element indicates that an acknowledgement is needed, then the SwMI shall initiate sending of an acknowledgement to the MS using the SDS-ACK PDU. In this case the "Delivery status" information element shall have the following value:

- SDS receipt report acknowledgement.

If the "Delivery report" information element in the SDS-REPORT PDU indicates:

- SDS consumed by destination;

and if the "Acknowledgement required" information element indicates that an acknowledgement is needed, then the SwMI shall initiate sending of an acknowledgement to the MS using the SDS-ACK PDU. In this case the "Delivery status" information element shall have the following value:

- SDS consumed report acknowledgement.

For all negative "Delivery report" information values in the SDS-REPORT PDU and if the "Acknowledgement required" information element indicates that an acknowledgement is needed, then the SwMI shall initiate sending of an acknowledgement to the SwMI using the SDS-ACK PDU. In this case the "Delivery status" information element shall have the following value:

- Negative report acknowledgement.

If the requester fails to receive any of these SDS-ACKs, it may retry the delivery of the SDS-REPORT PDU. The mechanism determining when to retry the delivery is outside the scope of the present document.

29.3.3.8 Using SDS-TL for system broadcast messages

29.3.3.8.1 General

The SwMI may use SDS-TL to generate messages which contain broadcast information for TETRA MS. This service may provide something similar to the GSM cell broadcast service, refer to ETSI TS 144 012 [i.2].

29.3.3.8.2 Sending a broadcast message

The SwMI may send a broadcast message at any time using the SDS-TRANSFER PDU and the SDS bearer service. The SwMI may send such a message to the broadcast address (0xFFFFFFFF hexadecimal) or to a group address and it may repeat the message at intervals dependent on the application using this service. The SwMI should indicate the broadcast address (0xFFFFFFFF hexadecimal) as the source address of the message to allow MSs to react on, or ignore system broadcast messages.

When the SwMI sends a broadcast message, it shall set the protocol identifier to indicate the type of system broadcast information. The system broadcast is thus not limited to text messages, but can be used to transmit other kinds of information, e.g. differential GPS information.

The SwMI shall also set the "Delivery report request" information element to indicate that no delivery report is requested since there shall be no acknowledgement associated with this service.

The "Message reference" information element may be used to indicate different system broadcast messages or it may be changed to indicate that the message has changed.

The "User data" field shall be used in the same way as for point-point and point-to-multipoint transfer described in clause 29.3.3.2.

29.3.3.8.3 Receiving a broadcast message

The MS shall attempt to decode the message according to the protocol identifier and data coding scheme indicated in the header. If the message is a text message and the MS is configured to receive system broadcast messages, then the message may be displayed to the user as it is received.

29.4 Coding requirements

29.4.1 PDU general structure

The PDUs detailed in clauses 29.4.2.1 to 29.4.2.4 and in clause 29.5 are sub-PDUs of SDS type 4, embedded in the "User defined data-4", refer to clause 14.8.52. The first information element within the "User defined data-4" shall be a protocol identifier. This information element shall identify the application using SDS and the protocol used. The applications using protocol identifiers in the range 10000000_2 to 11111111_2 shall use the PDUs described in this clause. Applications using protocol identifiers in the range from 00000000_2 to 01111111_2 shall not use the SDS-TL data transport service protocol (see table 29.21). The PDU descriptions for some of these protocol identifiers are defined in clause 29.5 and the others are outside the scope of the present document.

The general format of the SDS-TL PDU inside the "User defined data-4" information element is defined according to the annex E.

The information elements shall be transmitted in the order specified by the table with the top information element being transmitted first (before interleaving). The content of an information element is represented by a binary value and the most significant bit of that binary value shall be transmitted first (before interleaving).

Table 29.10: PDU layout

Information element	Length	Value	Remark
Protocol identifier	8		Refer clause 29.4.3.9
Type 1 information element (1)	variable		See definitions in annex E
Type 1 information element (2)	variable		See definitions in annex E
etc.	etc.		etc.
Type 1 information element (n)	variable		See definitions in annex E

The SDS-TL PDUs are intended to be byte-aligned for easier handling by the application. The information elements may be a part of a byte or combination of multiple bytes. There shall be no O-bits or P-bits in the SDS-TL PDUs and the SDS-TL PDU shall fill the whole user data type 4 information element in the D-SDS DATA and U-SDS DATA PDUs.

Information element lengths, values and contents are specified in clause 29.4.2.

The information contained in the following PDU description tables corresponds to the following key:

- Length: length of the information element in bits;
- Type: information element type as defined above;
- C/O/M: conditional/optional/mandatory information in the PDU;
- Remark: comment.

29.4.2 PDU Descriptions

29.4.2.0 General

The PDU described in this clause all have mandatory and conditional information elements. However, it should be noted that the entire SDS-TL is not used for some protocol identifiers but only the protocol identifier, refer to clause 29.4.3.9. The mandatory elements are thus only mandatory in the case where the SDS-TL is used.

29.4.2.1 SDS-ACK

- Response to: SDS-REPORT PDU
- Response expected: -
- Short description: This PDU shall be used to acknowledge previously received SDS delivery report
- PDU carrier: U/D-SDS DATA PDU User defined data-4 information element.

Table 29.11: SDS-ACK PDU contents

Information element	Length	Type	C/O/M	Remark
Protocol identifier	8	1	M	
Message type	4	1	M	SDS-ACK
Reserved	4	1	M	See note
Delivery status	8	1	M	
Message reference	8	1	M	
NOTE: This field is inserted to ensure that the following information elements are aligned to octet boundaries. In this edition of the present document the field shall be set to "0000 ₂ ".				

29.4.2.2 SDS-REPORT

- Response to: -/SDS-TRANSFER PDU
- Response expected: -/SDS-ACK PDU
- Short description: This PDU shall be used to report on the progress of previously received SDS data.
- PDU carrier: U/D-SDS DATA PDU User defined data-4 information element.

Table 29.12: SDS-REPORT PDU contents

Information element	Length	Type	C/O/M	Remark
Protocol identifier	8	1	M	
Message type	4	1	M	SDS-REPORT
Acknowledgement required	1	1	M	
Reserved	2	1	M	See note 1
Storage/forward control	1	1	M	
Delivery status	8	1	M	
Message reference	8	1	M	See note 2
Validity period	5	1	C	See note 3
Forward address type	3	1	C	See note 3
Forward address short number address	8	1	C	See note 4
Forward address SSI	24	1	C	See note 4
Forward address extension	24	1	C	See note 4
Number of external subscriber number digits	8	1	C	See notes 4 and 5
External subscriber number digit	4	1	C	See note 6
User data	variable	1	O	See note 7

NOTE 1: This field is inserted to ensure that the following information elements are aligned to octet boundaries. The field shall be set to "00₂" by default.

NOTE 2: The value shall be the same as defined by the original source of the PDU.

NOTE 3: This information element shall be present in the PDU only when the "Storage/forward control" information element indicates storage/forward control information available.

NOTE 4: This information element shall be present only when the Forward address type information element is present and indicates an address type that requires presence of the information element.

NOTE 5: The number of external subscriber number digits shall be between 1 and 24 digits.

NOTE 6: This information element shall be present only when the number of external subscriber digits information element is present and it shall contain as many digits as defined in that information element. When the Number of external subscriber number digits information element indicates an odd value the last digit of the external subscriber number shall be followed by an additional digit set to "0" and that additional digit shall not be a part of the external subscriber number.

NOTE 7: This information element is marked to be type 1 and optional on purpose so that there is no O-bit or P-bit before it but the user data length may be zero.

29.4.2.3 SDS-SHORT REPORT

- Response to: -/SDS-TRANSFER PDU
- Response expected: -
- Short description: This PDU shall be used to report on the progress of previously received SDS data
- PDU carrier: U/D-STATUS PDU Pre-coded status information element

Table 29.13: SDS-SHORT REPORT PDU contents

Information element	Length	Value	Remark
SDS-TL PDU	6	011111 ₂	This status message belongs to the SDS-TL protocol
Short report type	2	any	
Message reference	8	any	The same value as in the corresponding request PDU

NOTE: The short form acknowledgement does not contain the Acknowledgement required information element. The implied value of this information element defaults to "No further acknowledgements required for this message".

29.4.2.4 SDS-TRANSFER

- Response to: -
- Response expected: -/SDS-REPORT
- Short description: This PDU shall be used to send SDS data
- PDU carrier: U/D-SDS DATA PDU User defined data-4 information element.

Table 29.14: SDS-TRANSFER PDU contents

Information element	Length	Type	C/O/M	Remark
Protocol identifier	8	1	M	
Message type	4	1	M	SDS-TRANSFER
Delivery report request	2	1	M	
Service selection/Short form report	1	1	M	
Storage/forward control	1	1	M	
Message reference	8	1	M	See note 1
Validity period	5	1	C	See note 2
Forward address type	3	1	C	See note 2
Forward address short number address	8	1	C	See note 3
Forward address SSI	24	1	C	See note 3
Forward address extension	24	1	C	See note 3
Number of external subscriber number digits	8	1	C	See notes 3 and 4
External subscriber number digit	4	1	C	Repeatable, see note 5
Dummy digit	4		C	See note 6
User data	variable	1	M	
NOTE 1: The value shall be defined by the original source of the PDU.				
NOTE 2: This information element shall be present only, when "Storage/forward control" information element indicates storage/forward control information available.				
NOTE 3: This information element shall be present only, when Forward address type information element is present and indicates address type that requires presence of the information element.				
NOTE 4: The length shall be between 1 and 24, refer to clause 14.8.20.				
NOTE 5: This information element shall be present only, when the number of external subscriber number digits information element is present and it shall be present as many times as defined by the number of external subscriber number digits information element.				
NOTE 6: This information element shall be present only when the Number of external subscriber number digits information element indicates an odd value. When present the Dummy digit shall be set to "0". The Dummy digit shall not be a part of the external subscriber number. For encoding of each digit refer to clause 14.8.20.				

29.4.3 Information elements coding

29.4.3.1 Acknowledgement required

The Acknowledgement required information element shall indicate as defined in table 29.15 if an SDS-REPORT PDU needs further acknowledgement by an SDS-ACK PDU. This may be requested by either the originator or by the SwMI or the storing/forwarding entity (service centre) if needed.

Table 29.15: Acknowledgement required information element contents

Information element	Length	Value	Remark
Acknowledgement required	1	0 ₂	No further acknowledgements required for this message
		1 ₂	Acknowledgement required for this message

29.4.3.2 Delivery status

The Delivery status information element in SDS-REPORT and SDS-ACK PDUs shall indicate as defined in table 29.16 the status of a previously sent SDS-TRANSFER PDU for which a delivery report has been requested. This information element is also used to communicate error information to an MS when SDS data transfer fails. The "Report source" column in table 29.16 shall indicate whether the status value can be used in a status report sourced by the SwMI or the destination for the message transfer or both. Note that a status report generated by the destination may be relayed back to the originator by the SwMI but this report is still classified as being sourced by the destination. The Service Centre remark indicates how the Service Centre (storing/forwarding entity) or any entity outside the SwMI should interpret the delivery status. A temporary error indicates that the condition is only expected to exist for a limited amount of time. A Service Centre should normally not relay these errors message, but instead send a message indicating that the message have been stored, if such a message have not already been sent. In this way the originator will know that the message have been received by the Service Centre. The Service Centre should therefore re-send the message later. A permanent error is not expected to change, so the Service Centre should not re-send the message later. A Service Centre may though return a delivery status with a Service Centre remark indicating temporary or permanent error when the validity period has expired.

Table 29.16: Delivery status information element contents

Information element	Length	Value	Remark	Report source	Service Centre remark
Delivery status	8	000XXXXX ₂	SDS data transfer success	-	SDS data transfer success
		00000000 ₂	SDS receipt acknowledged by destination	Destination	Success
		00000001 ₂	SDS receipt report acknowledgement	SwMI/Source	Success
		00000010 ₂	SDS consumed by destination	Destination	Success
		00000011 ₂	SDS consumed report acknowledgement	SwMI/Source	Success
		00000100 ₂	SDS message forwarded to external network	SwMI	Success
		00000101 ₂	SDS sent to group, acknowledgements prevented	SwMI	Success
		00000110 ₂	Concatenation-part receipt acknowledged by destination	Destination	Success
		00000111 ₂ to 00011111 ₂	Reserved	-	Success
		001XXXXX ₂	Temporary error, SwMI still trying to transfer SDS data	-	SC still trying to transfer SDS data
		00100000 ₂	Congestion, message stored by SwMI	SwMI	-
		00100001 ₂	message stored by SwMI	SwMI	-
		00100010 ₂	Destination not reachable, message stored by SwMI	SwMI	-
		00100011 ₂ to 00111111 ₂	Reserved	-	See note 2
		010XXXXX ₂	SDS data transfer failed, SwMI is not making any more transfer attempts	-	SDS data transfer failed, Service Centre will not make any more transfer attempts
		01000000 ₂	Network overload	SwMI	Temporary
		01000001 ₂	Service permanently not available on BS	SwMI	Permanent
		01000010 ₂	Service temporary not available on BS	SwMI	Temporary
		01000011 ₂	Source is not authorized for SDS	SwMI	Temporary
		01000100 ₂	Destination is not authorized for SDS	SwMI	Temporary
01000101 ₂	Unknown destination, gateway, or service centre address	SwMI	Permanent		
01000110 ₂	Unknown forward address	SwMI	Permanent		
01000111 ₂	Group address with individual service	SwMI	Permanent		
01001000 ₂	Validity period expired, message not received by far end	SwMI	Permanent		

Information element	Length	Value	Remark	Report source	Service Centre remark
		01001001 ₂	Validity period expired, message not consumed by far end	SwMI	Permanent
		01001010 ₂	Delivery failed	SwMI/Destination	Permanent
		01001011 ₂	Destination not registered on system	SwMI	Temporary
		01001100 ₂	Destination queue full	SwMI	Temporary
		01001101 ₂	Message too long for destination or gateway	SwMI	Permanent
		01001110 ₂	Destination does not support SDS-TL data transfer service PDUs	SwMI/Destination	Permanent
		01001111 ₂	Destination host not connected, message discarded	Destination	Temporary
		01010000 ₂	Protocol not supported	Destination	Permanent
		01010001 ₂	Data coding scheme not supported	Destination	Permanent
		01010010 ₂	Destination memory full, message discarded	Destination	Temporary
		01010011 ₂	Destination not accepting SDS messages	SwMI	Permanent
		01010100 ₂	Concatenated message too long	Local/SwMI/Destination	Permanent
		01010101 ₂	Reserved	-	Permanent, see note 2
		01010110 ₂	Destination address administratively prohibited	SwMI	Permanent
		01010111 ₂	Can not route to external network	SwMI	Permanent
		01011000 ₂	Unknown external subscriber number	SwMI	Permanent
		01011001 ₂	Negative report acknowledgement	Source	Permanent
		01011010 ₂	Destination not reachable, message delivery failed	SwMI	Temporary
		01011011 ₂	Text distribution error, message discarded	Destination	Permanent
		01011100 ₂	Corrupt information element, message discarded	Destination	Permanent
		01011101 ₂	Concatenation entity has not received some of the concatenation parts, message discarded, see note 3	Destination	Permanent
		01011110 ₂	Destination engaged in another service, message discarded	Destination	Temporary
		01011111 ₂	Destination engaged in another service, message discarded	SwMI	Temporary
		011XXXXX ₂	Flow control messages	-	
		01100000 ₂	Destination memory full	Destination	N/A
		01100001 ₂	Destination memory available	Destination	N/A
		01100010 ₂	Start pending messages	Destination	N/A
		01100011 ₂	No pending messages	SwMI	N/A
		01100100 ₂ to 01111111 ₂	Reserved	-	N/A, see note 2
		100XXXXX ₂	End to end control messages	-	
		10000000 ₂	Stop sending	Destination	N/A
		10000001 ₂	Start sending	Destination	N/A
		10000010 ₂ to 10011111 ₂	Available for user application definition, (see note 1)	Destination	See note 2
		101XXXXX ₂ to 111XXXXX ₂	Reserved for future use	-	See note 2

NOTE 1: These values may be co-ordinated outside the scope of the present document in order to prevent clashes.

NOTE 2: These values may change in future versions of the present document.

NOTE 3: Message transfer has failed on the reporting entity point of view.

29.4.3.3 Delivery report request

The Delivery report request information element shall indicate as defined in table 29.17 the type of delivery report which is being requested by the sender of SDS-TRANSFER PDU. This delivery report may be generated either by the SwMI or the destination for the message depending on the type of report. Note that this information element is a bitmap to allow multiple combinations of the types of report (end-to-end acknowledgement) to be requested.

Table 29.17: Delivery report request information element contents

Information element	Length	Value	Remark
Delivery report request	2	00 ₂	No delivery report requested
		01 ₂	Message received report requested (see note 1)
		10 ₂	Message consumed report requested (see note 2)
		11 ₂	Message received and consumed report requested
NOTE 1: This delivery report type shall indicate that the sender of the message is requesting a report when the message has been received by the destination.			
NOTE 2: This delivery report type shall indicate that the sender of the message is requesting a report when the message has been consumed by the destination. A message is consumed when the application processes the message. For example, in the case of text messaging, a message is consumed when the user reads the message.			

29.4.3.4 Dummy digit

The Dummy digit information element shall fill unused 4 bits in the case of an odd number of digits in the address information element in order to keep octet boundaries. The only applicable value of the digit shall be "0000₂" and all other values shall be reserved.

29.4.3.5 Forward address type

The Forward address type information element shall indicate as defined in table 29.18 the type of address in the "Forward address" information element.

NOTE: The usage of a short number address as a forward address requires that the SwMI (storing/forwarding entity or service centre) to which MS addresses the U-SDS-DATA PDU supports supplementary service SS-SNA for the sending MS, refer to ETSI EN 300 392-10-7 [i.4], ETSI EN 300 392-11-7 [i.5] and ETSI EN 300 392-12-7 [13].

Table 29.18: Forward address type information element contents

Information element	Length	Value	Remark
Forward address type	3	000 ₂	Short Number Address (SNA) (see note 1)
		001 ₂	Short Subscriber Identity (SSI)
		010 ₂	TETRA Subscriber Identity (TSI)
		011 ₂	External subscriber number
		100 ₂	Reserved
		101 ₂	Reserved
		110 ₂	Reserved
		111 ₂	No forward address present (see note 2).
NOTE 1: The short number addressing is applicable only in messages from an MS to SwMI direction.			
NOTE 2: Refer to clause 29.3.1 for usage of this value.			

29.4.3.6 Forward address

The Forward address information element, if present, is one of SNA, SSI or TSI as defined in ETSI EN 300 392-1 [6], clause 7 or an External subscriber number. The forward address may be used to convey the true source/destination address to a network service point or service user.

29.4.3.7 Message reference

The message reference information element shall give as defined in table 29.19 an integer representation of a reference number of an SDS-TRANSFER PDU submitted to the SwMI by an MS.

Table 29.19: Message reference information elements contents

Information element	Length	Value	Remark
Message reference	8	00000000 ₂ to 11111111 ₂	0 to 255

29.4.3.8 Message type

The Message type information element shall identify as defined in table 29.20 the SDS-TL message type being conveyed by the SDS user defined data service.

Table 29.20: Message type information element contents

Information element	Length	Value	Remark
Message type	4	0XXX ₂	Message transfer protocol is defined by SDS-TL
		0000 ₂	SDS-TRANSFER
		0001 ₂	SDS-REPORT
		0010 ₂	SDS-ACK
		0011 ₂ to 0111 ₂	Reserved for additional message types
		1XXX ₂	Defined by application (see note)
NOTE: In this case, the format of the SDS user data shall be defined by the application and not necessarily conforming to this transport protocol standard.			

29.4.3.9 Protocol identifier

The Protocol identifier information element shall refer to the user application utilizing the SDS-TL protocol as defined in table 29.21.

Table 29.21: Protocol identifier information element contents

Information element	Length	Value	Remark	Clause
Protocol identifier	8	00000000 ₂	Reserved, (see notes 1 and 2)	-
		00000001 ₂	OTAK (Over The Air re-Keying for end to end encryption), refer to ETSI EN 300 392-7 [8] V2.1.1 clause 7.6 or ETSI ES 202 109 [3] clause 4.6, (see notes 2 and 3)	29.5.1
		00000010 ₂	Simple Text Messaging, (see note 2)	29.5.2
		00000011 ₂	Simple location system, (see note 2)	29.5.5
		00000100 ₂	Wireless Datagram Protocol WAP, (see note 2)	29.5.8
		00000101 ₂	Wireless Control Message Protocol WCMP, (see note 2)	29.5.8
		00000110 ₂	M-DMO (Managed DMO), refer to ETSI EN 300 396-10 [26], (see note 2)	29.5.1
		00000111 ₂	PIN authentication, (see note 2)	29.5.1
		00001000 ₂	End-to-end encrypted message, (see notes 2 and 6)	-
		00001001 ₂	Simple immediate text messaging, (see note 2)	29.5.2
		00001010 ₂	Location information protocol, (see note 2)	29.5.12
		00001011 ₂	Net Assist Protocol 2 (NAP2), (see notes 2 and 9)	29.5.13
		00001100 ₂	Concatenated SDS message, (see note 2)	29.5.14
		00001101 ₂	DOTAM, refer to ETSI TS 100 392-18-3 [48], (see note 2)	29.5.1
		00001110 ₂	Simple AGNSS service, (see notes 2 and 9)	29.5.15
		00001111 ₂ to 00111111 ₂	Reserved for future standard definition, (see note 2)	29.5.1
		01000000 ₂ to 01111110 ₂	Available for user application definition, (see notes 2 and 4)	29.5.1
		01111111 ₂	Reserved for extension, (see notes 2 and 7)	-
		10000000 ₂ to 10000001 ₂	Reserved, (see note 5)	-
		10000010 ₂	Text Messaging, (see note 5)	29.5.3
		10000011 ₂	Location system, (see note 5)	29.5.6
		10000100 ₂	Wireless Datagram Protocol WAP, (see note 5)	29.5.8
		10000101 ₂	Wireless Control Message Protocol WCMP, (see note 5)	29.5.8
		10000110 ₂	M-DMO (Managed DMO), refer to ETSI EN 300 396-10 [26], (see note 5)	29.5.1
		10000111 ₂	Reserved for future standard definition, (see note 5)	-
		10001000 ₂	End-to-end encrypted message, (see notes 5 and 6)	-
		10001001 ₂	Immediate text messaging, (see note 5)	29.5.3
		10001010 ₂	Message with User Data Header	29.5.9
		10001011 ₂	Reserved for future standard definition (see note 5)	-
		10001100 ₂	Concatenated SDS message, (see notes 5 and 8)	29.5.14
		10001101 ₂	AGNSS service (see note 9)	29.5.16
		10001110 ₂ to 10111111 ₂	Reserved for future standard definition, (see note 5)	-
11000000 ₂ to 11111110 ₂	Available for user application definition, (see notes 4 and 5)	-		
11111111 ₂	Reserved for extension, (see notes 5 and 7)	-		

Information element	Length	Value	Remark	Clause
NOTE 1:			This protocol identifier value should not be used as it is not allocated for a pre-defined application.	
NOTE 2:			The SDS-TL data transfer service shall not be used for these protocol identifiers, refer to clause 29.4.1.	
NOTE 3:			In the ETSI EN 300 392-7 [8] clause 7.6 or ETSI ES 202 109 [3] clause 4.6 the protocol identifier is identified as "SDS type 4 header".	
NOTE 4:			The assignment of these protocol identifiers will be co-ordinated in order to prevent clashes, refer to annex J.	
NOTE 5:			The SDS-TL data transfer service shall be used for these protocol identifiers.	
NOTE 6:			Refer to TETRA MoU SFPG recommendation 07 for information.	
NOTE 7:			This value shall indicate that the next 8 bits long value is the protocol identifier and the 16 bits replaces the eight bits of the protocol identifier in the PDUs using this extension method.	
NOTE 8:			The specific usage for concatenation layer is defined in clause 29.5.14.	
NOTE 9:			An AGNSS PID is added that is different from NAP2 PID, as AGNSS is a separate broadcast service, while NAP2 is a more general service for requesting ondemand some specific AGNSS data.	

29.4.3.10 Service selection/short form report

The Service selection information element shall indicate as defined in table 29.22 on the uplink if the message is allowed to be sent to a group address and on the downlink whether a short form report is allowed for this message. If the value of this information element is set to "individual service" when the destination address is a group address, the SwMI may reject the message.

Table 29.22: Service selection/ short form report information element contents

Information element	Length	Value	Remark
Service selection/short form report	1	0 ₂	Uplink: Individual service Downlink: Use of short form report recommended during the validity period of the message
		1 ₂	Uplink: Group or individual service Downlink: Only standard report allowed

29.4.3.11 Short report type

The Short report type information element shall indicate the reason for report as defined in table 29.23.

Table 29.23: Short report type information element contents

Information element	Length	Value	Remark
Short report type	2	00 ₂	Protocol/encoding not supported
		01 ₂	Destination memory full
		10 ₂	Message received
		11 ₂	Message consumed

29.4.3.12 Storage/forward control

The Storage/forward control information element shall indicate as defined in table 29.24 if the SwMI is allowed to store the message longer than needed for ordinary processing and whether a storing/forwarding entity is specified. If storage/forward control information is available, the "Validity period" and "Forward address" information elements are present.

Table 29.24: Storage/forward control information element contents

Information element	Length	Value	Remark
Storage/forward control	1	0 ₂	Storage/forward control information not available
		1 ₂	Storage/forward control information is available

29.4.3.13 User data

The User data information element contains the application data which is coded according to the protocol identified by the Protocol identifier and, if present, the data coding scheme information elements.

29.4.3.14 Validity period

The Validity period information element shall indicate the length of time after receiving an SDS-TRANSFER PDU that the SwMI should attempt to deliver the message. If this time expires, the SwMI shall stop delivery attempts and may report message failure to the sending MS. The values shall be as defined in table 29.25. The applied validity period in the SwMI should not be less than the requested validity period and should not be longer than the requested validity period plus one hour or a network dependent value.

Table 29.25: Validity period information element contents

Information element	Length	Value	Remark
Validity period (VP)	5	0	No validity period, (see note 1)
		1 to 6	VP x 10 seconds, (see note 2)
		7 to 10	(VP - 5) x 1 minute, (see note 3)
		11 to 16	(VP - 10) x 10 minutes, (see note 4)
		17 to 21	(VP - 15) x 1 hour, (see note 5)
		22 to 24	(VP - 20) x 6 hours, (see note 6)
		25 to 30	(VP - 24) x 2 days, (see note 7)
		31	Infinite validity period, (see note 8)
NOTE 1: In this case, the SwMI should attempt to deliver the message. If unsuccessful, the message is dropped.			
NOTE 2: 10 second intervals up to 60 seconds.			
NOTE 3: 1 minute intervals up to 5 minutes.			
NOTE 4: 10 minute intervals up to 1 hour.			
NOTE 5: 1 hour intervals up to 6 hours.			
NOTE 6: 6 hour intervals up to 24 hours.			
NOTE 7: 2 day intervals up to 12 days.			
NOTE 8: In this case, the SwMI should attempt to deliver the message until expiry of a network dependant maximum time.			

29.5 Protocol specific definitions

29.5.0 General

This clause defines information elements specific to the some of the standardized protocol identifiers.

29.5.1 Standardized protocols using SDS Type 4 without SDS-TL

29.5.1.0 General

For TETRA some services use SDS type 4 without SDS-TL data transport service as information carrier. Some of these protocols will be defined in other TETRA standards such as OTAR for the end-to-end encryption key management mechanism.

29.5.1.1 Protocol sequences

These protocols shall not use the SDS-TL acknowledgement and storing/forwarding entity services. For protocol sequences refer to references in table 29.21.

29.5.1.2 PDU Description tables

The minimum standardized information element of these "simple" protocols defined in clause 29 is the protocol identifier. For all other aspects refer to the specific protocol as indicated in the table 29.21. The standardized simple protocol PDUs shall be constructed as defined for the User Defined Data-4 information element in clause 14.8.52. Thus the minimum information elements shall be as defined in table 29.26 unless more elements are defined in the specific protocol description.

Table 29.26: Standardized "simple" protocol PDU contents

Information element	Length	Type	C/O/M	Remark
Protocol identifier	8	1	M	Refer to table 29.21
Protocol information	variable	1	M	

29.5.2 Simple text messaging

29.5.2.0 General

The Simple text message protocol is intended to be a very basic text messaging application defined to a degree where interoperability can be expected. Mechanisms how Simple text messages are presented to the user is outside the scope of the present document.

When a mobile terminated text message is indicated to be a Simple immediate text message and the MS has the capability of displaying short messages, the MS shall display the message immediately. Otherwise the protocol for Simple immediate text messaging is the same as in case of normal simple text messaging. If the MS is incapable of displaying Simple immediate text messages, they can be handled as a normal simple text message.

29.5.2.1 Protocol sequences

Simple text message protocol does not use any end-to-end acknowledgement or storing/forwarding entity mechanisms. The only delivery acknowledgement mechanisms offered is the layer 2 acknowledge independently on each hop.

29.5.2.2 PDU description tables

Simple text messaging does not use the SDS-TL data transfer service PDUs, but defines a protocol specific field to specify the data format, refer to 29.5.4.1. The basic SDS type-4 information element shall contain elements as defined in clause 29.5.2.3, refer to clause 14.8.52.

29.5.2.3 Simple text messaging

- Response to: -
- Response expected: -
- Short description: This PDU shall be used to send simple text messaging SDS data
- PDU carrier:

Table 29.27: Simple text messaging PDU contents

Information element	Length	Type	C/O/M	Remark
Protocol identifier	8	1	M	Refer to table 29.21
Reserved	1	1	M	See note 1
Text coding scheme	7	1	M	As defined in table 29.29
Text	variable	1	M	See note 2
NOTE 1: This information element is added in order to keep octet boundaries and to align encoding with the text messaging, refer to clause 29.5.3.3 where the timestamp used information element is in the position. The value of this information element shall be set to "0".				
NOTE 2: The text shall be encoded as defined in the text coding scheme information element.				

29.5.3 Text messaging using SDS-TL

29.5.3.0 General

The text message protocol offers either a store and forward mechanism in the SwMI or acknowledgements (reports) from destination or both as selected by the originating MS. Mechanisms how normal text messages are presented to the user is outside the scope of the present document.

When a mobile terminated text message is indicated to be an Immediate text message and the MS has the capability of displaying short messages, the MS shall display the message immediately. Otherwise the protocol functionality for Immediate text messaging is the same as in case of normal text messaging. If the MS is incapable of displaying Immediate text messages, they can be handled as a normal text message. For Immediate text messages a message consumed report shall be sent only after the user has performed an action that can be taken as an indication that the Immediate text message is read. The related man machine actions are outside the scope of the present document.

29.5.3.1 Protocol sequences

The protocol sequences of text messaging shall be the unmodified protocol sequences defined in clause 29.3.3.

29.5.3.2 PDU description tables

The text messaging protocol uses the full SDS-TL data transport service protocol. The text messaging protocol defines additional information elements which are transported in the SDS-TRANSFER PDU.

29.5.3.3 Text message transfer SDU

The text message transfer is done by use of an SDS-TRANSFER PDU with additional information elements embedded in the user data portion of the SDS-TRANSFER PDU. The SDU part as defined in table 29.28 shall be the user data in the SDS-TRANSFER PDU, refer to table 29.14.

Table 29.28: Text message transfer SDU contents

Information element	Length	Type	C/O/M	Remark
Time stamp used	1	1	M	As defined in table 29.41 (see note 1)
Text coding scheme	7	1	M	As defined in table 29.29 (see note 1)
Time stamp	24	1	C	As defined in table 29.40 (see note 2)
Text	variable	1	M	See note 3
NOTE 1: These two elements can be processed together in order to keep byte alignment.				
NOTE 2: This information element shall be present only, when the Time stamp used indicates the presence of timestamp.				
NOTE 3: The text shall be encoded as defined in the text coding scheme information element.				

29.5.3.4 Text message short form acknowledgement

The text messaging may use the SDS-SHORT REPORT PDU as defined in clause 29.4.4.4.

The destination MS can choose between the SDS-SHORT REPORT PDU and the SDS-REPORT PDU in the cases where the report types available in the short form will suffice, refer to clause 29.3.3.4.4.

29.5.4 Text messaging information elements

29.5.4.1 Text coding scheme

The text coding of the user data in an SDS message shall be specified by the Text coding scheme information element. The text coding schemes defined in the present document are:

- 7-bit alphabet;
- 8-bit alphabets;

- UCS-2 with the UTF-16BE extension.

The 7-bit alphabet is identical to the GSM default alphabet, refer to ETSI TS 100 900 [1] and this is the 7-bit alphabet which shall be used by the TETRA SDS-TL service defined in the present document.

The 8-bit alphabets defined in the present document are a broad range of available alphabets produced by ISO/IEC 8859 [40], PC code pages and IETF RFCs, supporting character sets for multiple languages.

The UCS2 alphabet is coded according to the 16-bit UCS2 standard produced by ISO, refer to ISO/IEC 10646 [41] and the Unicode Standard in the annex L Bibliography. This alphabet supports an enhanced selection of characters to support non-Latin languages and is set to become the basic coding form for all 16 bit and 32-bit computer systems during 1997. This alphabet is also supported by GSM.

The text coding scheme shall be as defined in table 29.29.

NOTE: The timestamp used, refer table 29.41, and the text coding scheme information elements could be processed together in order to keep byte alignment in the protocol.

Table 29.29: Text coding scheme information element contents

Information element	Length	Value	Remark
Text coding scheme	7	000000 ₂	7-bit alphabet, see clause 29.5.4.3, see note 1
		0000001 ₂	ISO/IEC 8859-1 Latin 1 (8-bit) alphabet [40], see note 1
		0000010 ₂	ISO/IEC 8859-2 Latin 2 (8-bit) alphabet [40]
		0000011 ₂	ISO/IEC 8859-3 Latin 3 (8-bit) alphabet [40]
		0000100 ₂	ISO/IEC 8859-4 Latin 4 (8-bit) alphabet [40]
		0000101 ₂	ISO/IEC 8859-5 Latin/Cyrillic (8-bit) alphabet [40]
		0000110 ₂	ISO/IEC 8859-6 Latin/Arabic (8-bit) alphabet [40]
		0000111 ₂	ISO/IEC 8859-7 Latin/Greek (8-bit) alphabet [40]
		0001000 ₂	ISO/IEC 8859-8 Latin/Hebrew (8-bit) alphabet [40]
		0001001 ₂	ISO/IEC 8859-9 Latin 5 (8-bit) alphabet [40]
		0001010 ₂	ISO/IEC 8859-10 Latin 6 (8-bit) alphabet [40]
		0001011 ₂	ISO/IEC 8859-13 Latin 7 (8-bit) alphabet [40]
		0001100 ₂	ISO/IEC 8859-14 Latin 8 (8-bit) alphabet [40]
		0001101 ₂	ISO/IEC 8859-15 Latin 0 (8-bit) alphabet [40]
		0001110 ₂	PC code page 437 (United States)
		0001111 ₂	PC code page 737 (Greek II)
		0010000 ₂	PC code page 850 (Latin I)
		0010001 ₂	PC code page 852 (Eastern Europe/Latin II)
		0010010 ₂	PC code page 855 (Cyrillic I)
		0010011 ₂	PC code page 857 (Turkish)
		0010100 ₂	PC code page 860 (Portuguese)
		0010101 ₂	PC code page 861 (Icelandic)
		0010110 ₂	PC code page 863 (Canadian/French)
		0010111 ₂	PC code page 865 (Nordic)
		0011000 ₂	PC code page 866 (Russian/Cyrillic II)
		0011001 ₂	PC code page 869 (Greek)
		0011010 ₂	ISO/IEC 10646-1 [41] UCS-2/UTF-16BE (16-bit) alphabet, see note 1
		0011011 ₂	IETF RFC 1456 [47] VISCII (Vietnamese)
		0011100 ₂	Reserved
		etc.	etc.
		0011111 ₂	Reserved
		0100000 ₂	Available for user application definition, see note 2
etc.	etc.		
1111110 ₂	Available for user application definition, see note 2		
1111111 ₂	Reserved for text coding scheme extension, see note 3		
NOTE 1: These are the recommended character sets.			
NOTE 2: Identities of these text coding schemes should be allocated by a central body in order to support interoperability.			
NOTE 3: Extension definition is outside the scope of the present document.			

The "7-bit alphabet" shall indicate that the user data is coded using the 7-bit alphabet given in clause 29.5.4.3. When this alphabet is used, the characters of the message are packed into octets so that 285 characters can be transported in 250 bytes of user data. The support of the 7-bit alphabet is optional for MS equipment supporting the SDS-TL service.

Several 8-bit alphabets are listed as well, however, the list is very long and it is unlikely that an MS will support all 8-bit coding schemes. In case the MS receives a message in an unknown alphabet, the MS may reject the message using Delivery status value "Data coding scheme not supported" or map the unsupported alphabet to an alphabet supported by the MS.

The UCS-2 alphabet indicates that the user data is coded according to the UCS-2 coding scheme, employing the UTF-16 extension of ISO/IEC 10646 [41] using the "BE" (Big Endian) form. While using SDS-TL the Byte Order Mark (BOM) shall not be used as "BE" format shall be the only format defined.

UTF-16BE uses two consecutive values to represent a character beyond the Basic Multilingual Plane (i.e. Plane 00). As the "BE" form is stated, the "value" for the high-half zone (D800-DCFF) shall precede the "value" for the low-half zone (DB00-DFFF), refer to ISO/IEC 10646 [41].

29.5.4.2 Character packing

A 7-bit character number α is represented as shown in table 29.30.

Table 29.30: 7-bit character presentation

b7	b6	b5	b4	b3	b2	b1
αa	αb	αc	αd	αe	αf	αg

A 7-bit character number α has bit "a" as the most significant bit "b7" and bit "g" as the least significant bit "b1".

For the 7-bit alphabet, characters shall first be packed into octets according to ETSI TS 100 900 [1] and then inserted octet-by-octet into the user data information element. The unused part of the last octet shall be padded by zeros, if needed.

Tables 29.31 to 29.33 present examples of the 7-bit character packing into octets, refer to ETSI TS 100 900 [1] clause 6.1.2.1.1 for further examples.

Table 29.31: One 7-bit character in one octet

	Bits number							
	7	6	5	4	3	2	1	0
Octet 1	0	1a	1b	1c	1d	1e	1f	1g

Table 29.32: Two 7-bit characters in two octets

	Bits number							
	7	6	5	4	3	2	1	0
Octet 1	2g	1a	1b	1c	1d	1e	1f	1g
Octet 2	0	0	2a	2b	2c	2d	2e	2f

Table 29.33: Seven 7-bit characters in seven octets

	Bits number							
	7	6	5	4	3	2	1	0
Octet 1	2g	1a	1b	1c	1d	1e	1f	1g
Octet 2	3f	3g	2a	2b	2c	2d	2e	2f
Octet 3	4e	4f	4g	3a	3b	3c	3d	3e
Octet 4	5d	5e	5f	5g	4a	4b	4c	4d
Octet 5	6c	6d	6e	6f	6g	5a	5b	5c
Octet 6	7b	7c	7d	7e	7f	7g	6a	6b
Octet 7	0	0	0	0	0	0	0	7a

NOTE 1: If the last octet contains 7 padding zeros those can be misinterpreted as an "@" character, refer to table 29.33. In that case use of Carriage Return character instead of zero padding will prevent presentation of the "@" character.

The octets containing 7-bit characters shall be set into the user data information element as shown in table 29.34 for the case of four 7-bit characters.

Table 29.34: Character packing for 7-bit alphabet

	Octet 1								Octet 2							
Bit position	n	n-1	n-2	n-3	n-4	n-5	n-6	n-7	n-8	n-9	n-10	n-11	n-12	n-13	n-14	n-15
Character bit	2g	1a	1b	1c	1d	1e	1f	1g	3f	3g	2a	2b	2c	2d	2e	2f
	Octet 3								Octet 4							
Bit position	n-16	n-17	n-18	n-19	n-20	n-21	n-22	n-23	n-24	n-25	n-26	n-27	n-28	n-29	n-30	n-31
Character bit	4e	4f	4g	3a	3b	3c	3d	3e	0	0	0	0	4a	4b	4c	4d

NOTE 2: In GSM, the LSB of each octet is transmitted first. However, in TETRA, the PDUs are packed such that the MSB of each octet is transmitted first as indicated in tables 29.34, 29.36 and 29.38.

An 8-bit character number α is represented as shown in table 29.35.

Table 29.35: 8-bit character presentation

b8	b7	b6	b5	b4	b3	b2	b1
αa	αb	αc	αd	αe	αf	αg	αh

An 8-bit character number α has bit "a" as the most significant bit "b8" and bit "h" as the least significant bit "b1".

The 8-bit characters shall be set into the user data information element as shown in table 29.36 for the case of four 8-bit characters.

Table 29.36: Character packing for 8-bit alphabet

	Octet 1								Octet 2							
Bit position	n	n-1	n-2	n-3	n-4	n-5	n-6	n-7	n-8	n-9	n-10	n-11	n-12	n-13	n-14	n-15
Character bit	1a	1b	1c	1d	1e	1f	1g	1h	2a	2b	2c	2d	2e	2f	2g	2h
	Octet 3								Octet 4							
Bit position	n-16	n-17	n-18	n-19	n-20	n-21	n-22	n-23	n-24	n-25	n-26	n-27	n-28	n-29	n-30	n-31
Character bit	3a	3b	3c	3d	3e	3f	3g	3h	4a	4b	4c	4d	4e	4f	4g	4h

A 16-bit character number α is represented as shown in table 29.37.

Table 29.37: 16-bit character presentation

b16	b15	b14	b13	b12	b11	b10	b9	b8	b7	b6	b5	b4	b3	b2	b1
αa	αb	αc	αd	αe	αf	αg	αh	αi	αj	αk	αl	αm	αn	αo	αp

A 16-bit character number α has bit "a" as the most significant bit "b16" and bit "p" as the least significant bit "b1".

The 16-bit characters shall be set into the user data information element as shown in table 29.38 for the case of two 16-bit characters.

Table 29.38: Character packing for 16-bit alphabet

	Octet 1								Octet 2							
Bit position	n	n-1	n-2	n-3	n-4	n-5	n-6	n-7	n-8	n-9	n-10	n-11	n-12	n-13	n-14	n-15
Character bit	1a	1b	1c	1d	1e	1f	1g	1h	1i	1j	1k	1l	1m	1n	1o	1p
	Octet 3								Octet 4							
Bit position	n-16	n-17	n-18	n-19	n-20	n-21	n-22	n-23	n-24	n-25	n-26	n-27	n-28	n-29	n-30	n-31
Character bit	2a	2b	2c	2d	2e	2f	2g	2h	2i	2j	2k	2l	2m	2n	2o	2p

29.5.4.3 7-bit alphabet table

The 7-bit alphabet shall be exactly the same as that specified by the GSM standard. This alphabet should be supported by all MSs which support the SDS-TL protocol. Additional alphabets (including UCS2) may also be supported as options.

The 7-bit alphabet shall be as shown in table 29.39.

Table 29.39: Alphabet table for GSM 7-bit alphabet

				b7	0	0	0	0	1	1	1	1
				b6	0	0	1	1	0	0	1	1
				b5	0	1	0	1	0	1	0	1
b4	b3	b2	b1		0	1	2	3	4	5	6	7
0	0	0	0	0	@	Δ	SP	0	i	P	ı	p
0	0	0	1	1	£	_	!	1	A	Q	a	q
0	0	1	0	2	\$	Φ	"	2	B	R	b	r
0	0	1	1	3	¥	Γ	#	3	C	S	c	s
0	1	0	0	4	è	Λ	α	4	D	T	d	t
0	1	0	1	5	é	Ω	%	5	E	U	e	u
0	1	1	0	6	ù	Π	and	6	F	V	f	v
0	1	1	1	7	ì	Ψ	'	7	G	W	g	w
1	0	0	0	8	ò	Σ	(8	H	X	h	x
1	0	0	1	9	Ç	Θ)	9	I	Y	i	y
1	0	1	0	10	LF	Ξ	*	:	J	Z	j	z
1	0	1	1	11	Ø	1)	+	;	K	Ä	k	ä
1	1	0	0	12	ø	Æ	,	<	L	Ö	l	ö
1	1	0	1	13	CR	æ	-	=	M	Ñ	m	ñ
1	1	1	0	14	À	ß	.	>	N	Ü	n	ü
1	1	1	1	15	à	É	/	?	O	Ş	o	ş

The following rules shall apply to the use of this alphabet:

- Control characters shall have the following meaning:

Code Meaning

LF Line Feed: Any characters following LF which are to be displayed shall be presented as the next line of the text message, commencing with the first character position;

CR Carriage Return: Any characters following CR which are to be displayed shall be presented as the current line of the text message, commencing with the first character position;

SP Space Character.

- If these characters are to be displayed within a message, each character shall be taken in turn and be placed in the next available space from left to right and from top to bottom.

29.5.4.4 Time stamp

The Time stamp information element shall indicate as defined in table 29.40 the (approximate) creation time of the message. The information element is added to a message by the SwMI to allow the destination to evaluate the age of the message.

Table 29.40: Time stamp information element contents

Information element	Length	Type	C/O/M	Value	Remark
Timeframe type	2	1	M	0	Undefined, application dependent
				1	UTC
				2	Local time, normal time
				3	Local time, daylight saving time
Reserved	2	1	M	0	See note
Month	4	1	M	1 to 12	
Day	5	1	M	1 to 31	
Hour	5	1	M	0 to 23	
Minute	6	1	M	0 to 59	
NOTE: This field is inserted to ensure that the following information elements are aligned to octet boundaries and so ease processing by the application. In the present document the field shall be set to "00 ₂ ".					

29.5.4.5 Timestamp used

The Timestamp used information element shall indicate as defined in table 29.41 if a timestamp is used in the PDU.

Table 29.41: Timestamp used information element contents

Information element	Length	Value	Remark
Timestamp used	1	0 ₂	Timestamp not present
		1 ₂	Timestamp present

29.5.5 Simple location system

29.5.5.0 General

The simple location system protocol is intended to be a location system application, which does not require any transport mechanism to ensure delivery.

29.5.5.1 Protocol sequences

Simple location system does not use any end-to-end acknowledgement (reporting) signalling. The only delivery mechanisms offered is the layer 2 acknowledge.

29.5.5.2 PDU description tables

Simple location system does not use the SDS-TL data transfer service PDUs, but defines a protocol specific field to specify the data format, refer to clause 29.5.7. The basic SDS type-4 information element shall contain elements as defined in clause 29.5.5.3.

29.5.5.3 Simple location system PDU

- Response to: -
- Response expected: -
- Short description: This PDU shall be used to send location system SDS data.

Table 29.42: Simple location system PDU contents

Information element	Length	Type	C/O/M	Remark
Protocol identifier	8	1	M	Value 00000011 ₂
Location system coding scheme	8	1	M	As defined in table 29.44
Location system data	variable	1	M	

29.5.6 Location system using SDS-TL data transfer services

29.5.6.0 General

This location system protocol set offers end-to-end acknowledgement and/or storing/forwarding entity services in the SwMI.

29.5.6.1 Protocol sequences

The protocol sequences of location system messaging shall be the protocol sequences defined in clause 29.3.3.

29.5.6.2 PDU description tables

The location system protocol uses the full TL protocol. Additional information elements are present in the SDS-TRANSFER PDU.

29.5.6.3 Location system transfer SDU

The location system message transfer is done by use of an SDS-TRANSFER with additional information elements embedded in the user data portion of the SDS-TRANSFER. The location system SDU shall be encoded as defined in table 29.43.

Table 29.43: Location system SDU contents

Information element	Length	Type	C/O/M	Remark
Location system coding scheme	8	1	M	As defined in table 29.44
Location system data	variable	1	M	

29.5.7 Location system coding scheme

For protocols carrying location system data, the location system coding scheme information element shall be as defined in table 29.44.

Table 29.44: Location system coding scheme information element contents

Information element	Length	Value	Remark
Location system coding scheme	8	0000000 ₂	National Marine Electronics Association, see annex L
		0000001 ₂	RTCM SC-104, see annex L
		0000010 ₂ to 0111111 ₂	Reserved
		1000000 ₂ to 1111110 ₂	Available for user application definition (see note)
		1111111 ₂	Reserved
NOTE: Identities of these applications should be allocated by a central body in order to support interoperability.			

NOTE 1: This list only defines a subset of the available data coding schemes for location systems. The list should be expected to expand as more data coding schemes are adopted.

NOTE 2: TETRA defines a standardized location information transport protocol (LIP) that uses another protocol identifier than the "simple location system" or the "location system", refer to clauses 29.4.3.9, 29.5.12 and ETSI TS 100 392-18-1 [19].

29.5.8 Wireless Application Protocol (WAP)

29.5.8.0 General

Wireless Application Protocol (WAP) is a result of continuous work to define an industry wide standard for developing applications over wireless communication networks. The scope for the WAP working group is to define a set of standards to be used by service applications, refer to IETF RFC 1994 [34]. The upper layers of WAP will be independent of the underlying wireless network, while the data link layer might be adapted to specific features of underlying bearers. However, by keeping the data link layer interface, as well as the basic features, consistent global interoperability can be achieved using mediating gateways.

29.5.8.1 Protocol sequences

WAP need not use the SDS-TL data transfer services as those will only add overhead over the normal WAP operation. For WAP protocol sequences, the reader is referred to WAP 2.0 [i.9].

29.5.8.2 PDU description tables

WAP need not use the SDS-TL data transfer service PDUs as those will only add overhead, refer to clause 29.5.1.2. The minimum standardized information element of WAP is the Protocol Identifier. For all other aspects of WAP the reader is referred to WAP 2.0 [i.9].

29.5.9 Message with user data header (UDH)

29.5.9.0 General

The UDH protocol is based on (TP-UD) field defined in GSM specification for SMS (ETSI TS 123 040 [2]). This protocol is terminated in the application layer and uses SDS-TL transport service. The UDH is carried with the User Data parameter of the SDS-TRANSFER PDU as defined in table 29.14.

NOTE: "Field" in GSM specifications means same as "information element" in the present document.

29.5.9.1 Protocol sequences

The protocol sequences of UDH messaging shall be the unmodified protocol sequences defined in clause 29.3.3.

29.5.9.2 PDU description tables

The UDH protocol uses the full SDS-TL data transport service protocol. The UDH protocol defines additional information elements, which are transported in the SDS-TRANSFER PDU.

29.5.9.3 User Data Header transfer SDU

The text message transfer is done by use of an SDS-TRANSFER PDU with additional information elements embedded in the user data portion of the SDS-TRANSFER PDU. The SDU part as defined in table 29.45 shall be the user data in the SDS-TRANSFER PDU, refer to table 29.14.

Table 29.45: UDH transfer SDU contents

Information element	Length	Type	C/O/M	Remark
Time stamp used	1	1	M	As defined in table 29.41, see note 1.
Text coding scheme	7	1	M	As defined in table 29.29, see note 1.
Time stamp	24		C	As defined in table 29.40, see note 2.
User Data Header length	8	1	M	See note 3.
User Data Header information element	Variable		C	Repeatable, see note 4.
Network layer user data	Variable		C	See note 5.
NOTE 1: These two elements can be processed together in order to keep byte alignment.				
NOTE 2: This information element shall be present only, when the Time stamp used indicates the presence of timestamp.				
NOTE 3: The User Data Header length information element shall indicate the number of octets within the User Data Header information element information elements, which follow and shall not include itself in its count.				
NOTE 4: The User Data Header length indirectly defines how many User Data Header information element information elements are present as each User Data Header information element contains its length.				
NOTE 5: The Network layer user data information element may be present and the content depends on UDH information element ID meaning. The end of the Network layer user data information element is defined by the end of the SDS-TRANSFER PDU.				

29.5.9.4 UDH transfer SDU information elements

29.5.9.4.1 User Data Header Information Element

The User Data Header information element information element shall be encoded as defined in table 29.46.

Table 29.46: User Data Header information element information element contents

Information element	Length	Type	C/O/M	Remark
UDH information element ID (1)	8	1	M	See note 1.
UDH information element length (1)	8	1	M	See note 2.
UDH information element data (1)	Variable		C	See note 3.
NOTE 1: See table 29.47.				
NOTE 2: The UDH information element length information element shall indicate the number of octets within its associated UDH information element data information element, which follows and shall not include itself in its count value.				
NOTE 3: The content depends on UDH information element ID meaning.				

The UDH information element ID information element shall be encoded as presented in table 29.47.

Table 29.47: UDH information element ID information element contents

Information element	Length	Value	Remark	Clause
UDH information element ID	8	00000000 ₂	Concatenated text message (8-Bit reference number)	29.5.10
		00000001 ₂ to 00000111 ₂	Reserved (see note)	-
		00001000 ₂	Concatenated text message (16-Bit reference number)	29.5.10
		00001001 ₂ to 11111111 ₂	Reserved (see note)	-
NOTE: Defined in GSM specification for SMS (ETSI TS 123 040 [2]).				

29.5.10 Concatenated text messaging

29.5.10.0 General

Concatenated text messaging uses the UDH protocol. It allows an application to concatenate several single SDS text messages to transfer one long text message. Each single message is a segment of the long text message. Segmentation and recombination of long text messages is done in the application layer.

29.5.10.1 Protocol sequences

The protocol sequences of concatenated text messaging shall be the unmodified protocol sequences defined in clause 29.3.3.

29.5.10.2 PDU description tables

The UDH protocol uses the full SDS-TL data transport service protocol. The UDH protocol defines additional information elements, which are transported in the SDS-TRANSFER PDU.

29.5.10.3 Concatenated text message transfer SDU

The concatenated text message transfer is done by use of an SDS-TRANSFER PDU with additional information elements embedded in the user data portion of the SDS-TRANSFER PDU. The SDU part as defined in table 29.48 shall be the user data in the SDS-TRANSFER PDU, refer to table 29.46.

NOTE: In the table 29.48 the User Data Header information element as defined in table 29.46 is presented as information elements of the Concatenated text message transfer SDU.

Table 29.48: Concatenated text message transfer SDU contents

Information element	Length	Type	C/O/M	Remark
Time stamp used	1	1	M	As defined in table 29.41 (see note 1)
Text coding scheme	7	1	M	As defined in table 29.29 (see note 1)
Time stamp	24		C	As defined in table 29.40 (see note 2)
User Data Header length	8	1	M	
UDH information element ID	8	1	M	
UDH information element length	8	1	M	
Message reference number	8/16		C	(see note 3)
Maximum number of messages	8	1	M	
Sequence number of current message	8	1	M	
User text (Text segment)	Variable	1	M	(see note 4)
NOTE 1: These two elements can be processed together in order to keep byte alignment.				
NOTE 2: This information element shall be present only, when the Time stamp used indicates the presence of timestamp.				
NOTE 3: The length and value depends on the UDH information element ID see table 29.47 and clause 29.5.11.7.				
NOTE 4: The length of the User text is determined by the end of the User data in the SDS-TRANSFER PDU.				

29.5.10.4 Concatenated text message short form acknowledgement

The concatenated text messaging may use the SDS-SHORT REPORT PDU as defined in clause 29.4.4.4.

The destination MS can choose between the SDS-SHORT REPORT PDU and the SDS-REPORT PDU in the cases where the report types available in the short form will suffice, refer to clause 29.3.3.4.4.

If the receiving entity receives "delivery report request" information element value "message consumed report requested" or "message received and consumed report requested" in one or more of the SDS text messages within the concatenated SDS text message, the receiving entity should send only one SDS-SHORT-REPORT or SDS-REPORT PDU to report consumption of the concatenated text message. The receiving entity should not send separate consumption reports for the individual SDS text messages comprising the concatenated SDS text message.

NOTE 1: If the receiving entity receives the "delivery report request" information element value "message received and consumed report requested" in individual SDS text messages comprising the concatenated SDS text message, the receiving entity should acknowledge reception of the individual SDS text messages with separate PDUs and should report consumption of the concatenated SDS message with a further single PDU.

NOTE 2: The sending entity should include the same value of the "delivery report request" information element in each individual SDS text message comprising the concatenated SDS text message.

29.5.11 Concatenated text messaging information elements

29.5.11.1 Text coding scheme

See clause 29.5.4.1.

29.5.11.2 Time stamp

See clause 29.5.4.4.

29.5.11.3 Time stamp used

See clause 29.5.4.5.

29.5.11.4 User data header length

See clause 29.5.9.3.

29.5.11.5 UDH information element ID

The value shall be "Concatenated SDS text message (8 bit reference number)" or "Concatenated SDS text message (16 bit reference number)" as defined in table 29.47.

29.5.11.6 UDH information element length

The value depends on the UDH information element ID. If the UDH information element ID is "Concatenated Text Message (8 bit reference number)" the value is 3 bytes. If the UDH information element ID is "Concatenated Text Message (16 bit reference number)" the value is 4 bytes.

29.5.11.7 Message reference number

The length depends on UDH information element ID. It shall contain modulo 256 counter for 8 bit length or modulo 65 536 for 16 bit indicating the reference number for a particular concatenated short message. This reference number shall remain constant for every short message, which makes up a particular concatenated short message.

29.5.11.8 Maximum number of messages

Maximum number of SDS text messages in the concatenated SDS text message. This octet shall contain a value in the range 0 to 255 indicating the total number of SDS text messages within the concatenated SDS text message. The value shall start at 1 and remain constant for every SDS text message, which makes up the concatenated SDS text message. If the value is zero then the receiving entity shall ignore the whole UDH information element.

29.5.11.9 Sequence number of current message

The Sequence number of current message shall contain a value in the range 0 to 255 indicating the sequence number of a particular SDS text message within the concatenated SDS text message. The value shall start at 1 and increment by one for every SDS text message sent within the concatenated SDS text message. If the value is zero or the value is greater than the value in octet 2 then the receiving entity shall ignore the whole UDH information element.

29.5.11.10 User text (Text segment)

The sender application is responsible for dividing a text message into a concatenated SDS text message. The receiver application is responsible for re-constructing the concatenated SDS text message.

29.5.12 Location information transport

29.5.12.1 General

The Location Information Protocol (LIP) is defined in ETSI TS 100 392-18-1 [19] and clauses 29.5.12.2 to 29.5.12.6 define how SDS-TL shall be used as a transportation mechanism for it. The location information protocol is described as an application using SDS-TL service at SDS-TL SAP, refer to 29.1.1. The location information protocol can use packet data at SND CP SAP as defined in clause 28. The use of packet data is outside the scope of the clauses 29.5.12.2 to 29.5.12.6 of the present document.

29.5.12.2 Protocol sequences at SDS-TL

The location information protocol does not use any end-to-end acknowledgement (reporting) signalling of the SDS-TL protocol. The only delivery mechanism at the transportation level is the layer 2 acknowledgement.

29.5.12.3 Location information protocol architecture

29.5.12.3.1 System architecture

System architecture is described in ETSI TS 100 392-18-1 [19].

29.5.12.3.2 MS architecture

When the location information protocol (LIP) uses SDS-TL data transfer service figure 29.9 shows the position of the location information transport protocol in the MS protocol stack. The physical location of the location transport protocol and LIP-SAP may be imbedding into the user applications and is outside the the scope of the present document. A physical access to the LIP-SAP is outside the scope of the present document.

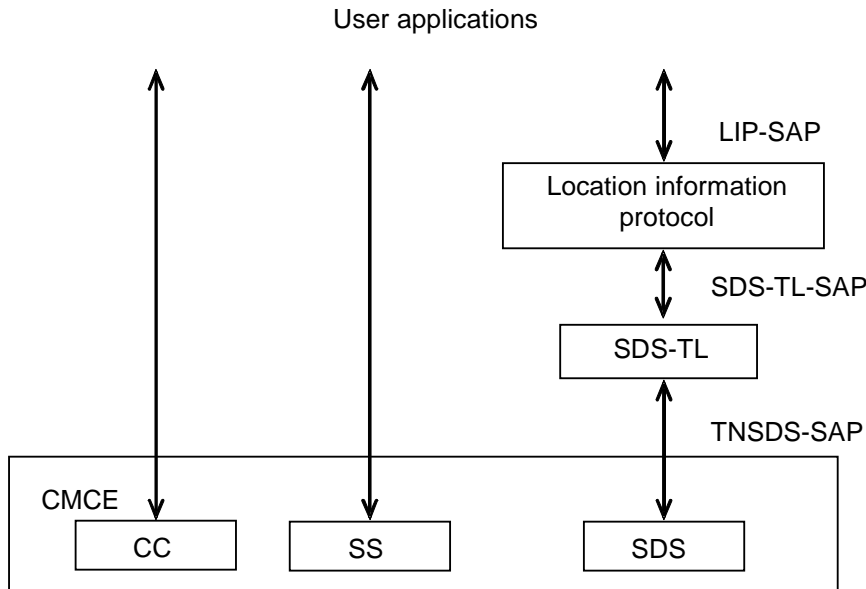

Figure 29.9: LIP position in TETRA protocol stack

Location information protocol adds a layer of protocol functionality that utilizes the SDS-TL.

The location information protocol can use services of the TNSDS-SAP via SDS-TL-SAP. The location information protocol shall run parallel to any other protocols utilizing SDS-TL without any interactions.

29.5.12.4 Addressing at SDS-TL

The addressing for the LIP shall use the basic SDS addressing without storing/forwarding entity addresses.

29.5.12.5 Location information transport protocol

ETSI TS 100 392-18-1 [19] defines the location information protocol.

29.5.12.6 SDS-TL overhead

The location information transport PDUs in the LIP shall use a PID value that is not utilizing SDS-TL transport service. The general content of the SDS type 4 user data part shall be as shown in table 29.49.

Table 29.49: SDS type 4 user data contents for LIP protocol

Information element	Length	Type	C/O/M	Value	Remark
Protocol identifier	8	1	M		Location information protocol
Location information transport protocol PDU	variable	1	M		See note.
NOTE: Content of this information element is defined in ETSI TS 100 392-18-1 [19].					

29.5.13 Net assist protocol

29.5.13.1 General

The Net Assist Protocol (NAP) is defined in ETSI TS 100 392-18-2 [20] and clauses 29.5.9.2 to 29.5.9.6 define how SDS-TL shall be used as a transportation mechanism for it. The Net Assist Protocol is described as an application using SDS-TL service at SDS-TL SAP, refer to clause 29.1.1.

29.5.13.2 Protocol sequences at SDS-TL

The location information protocol does not use any end-to-end acknowledgement (reporting) signalling of the SDS-TL protocol. The only delivery mechanism at the transportation level is the layer 2 acknowledgement.

29.5.13.3 Location information protocol architecture

29.5.13.3.1 System architecture

System architecture is described in ETSI TS 100 392-18-2 [20].

29.5.13.3.2 MS architecture

When the Net Assist Protocol (NAP) uses SDS-TL data transfer service figure 29.10 shows the position of the location information transport protocol in the MS protocol stack. The physical location of the location transport protocol and NAP-SAP may be imbedding into the user applications and is outside the the scope of the present document. A physical access to the NAP-SAP is outside the scope of the present document.

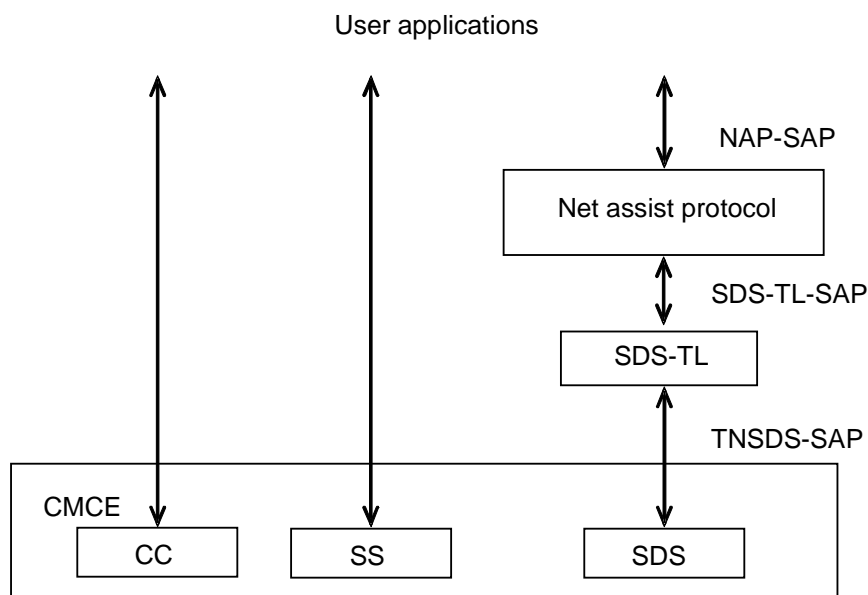

Figure 29.10: NAP position in TETRA protocol stack

The Net Assist Protocol adds a layer of protocol functionality that utilizes the SDS-TL.

The Net Assist Protocol can use services of the TNSDS-SAP via SDS-TL-SAP. The Net Assist Protocol shall run parallel to any other protocols utilizing SDS-TL without any interactions.

29.5.13.4 Addressing at SDS-TL

The addressing for the Net Assist Protocol shall use the basic SDS addressing without storing/forwarding entity addresses.

29.5.13.5 Net Assist Protocol

ETSI TS 100 392-18-2 [20] defines the Net Assist Protocol.

29.5.13.6 SDS-TL overhead

The Net Assist Protocol PDUs in the NAP shall use a PID value that is not utilizing SDS-TL transport service. The general content of the SDS type 4 user data part shall be as shown in table 29.50.

Table 29.50: SDS type 4 user data contents for NAP protocol

Information element	Length	Type	C/O/M	Value	Remark
Protocol identifier	8	1	M		Net Assist Protocol
Net assist protocol PDU	variable	1	M		See note.
NOTE: Content of this information element shall be as defined in ETSI TS 100 392-18-2 [20].					

29.5.14 Concatenation of SDS-TL messages protocol

29.5.14.1 Introduction

The concatenation of SDS-TL messages provides a means for delivering long messages using the SDS mechanism. As with UDH it concatenates several single SDS messages to transfer one long message, refer to clause 29.5.10. Each single message is a concatenation-part of the long message. The "parting" and recombination of long messages is done in a protocol layer above SDS-TL.

The concatenation protocol defined in clause 29.5.14 has the advantage over UDH that it can transfer messages of any PID, and so is not restricted to carrying solely text messages.

29.5.14.2 MS protocol stack

For the concatenation service presentation purpose a protocol stack is defined in figure 29.11.

The concatenation is done at the concatenation layer i.e. the PIDs indicating a concatenation are used to route SDS messages to the concatenation layer that performs the re-assembly of the long message. The re-assembled long SDS message is routed to the proper application indicated by the PID of the user information. It is outside the scope of the present document whether the concatenation layer is a part of the MS or TE.

Concatenated SDS messages may be end to end encrypted, however the method of the encryption is outside the scope of the present document.

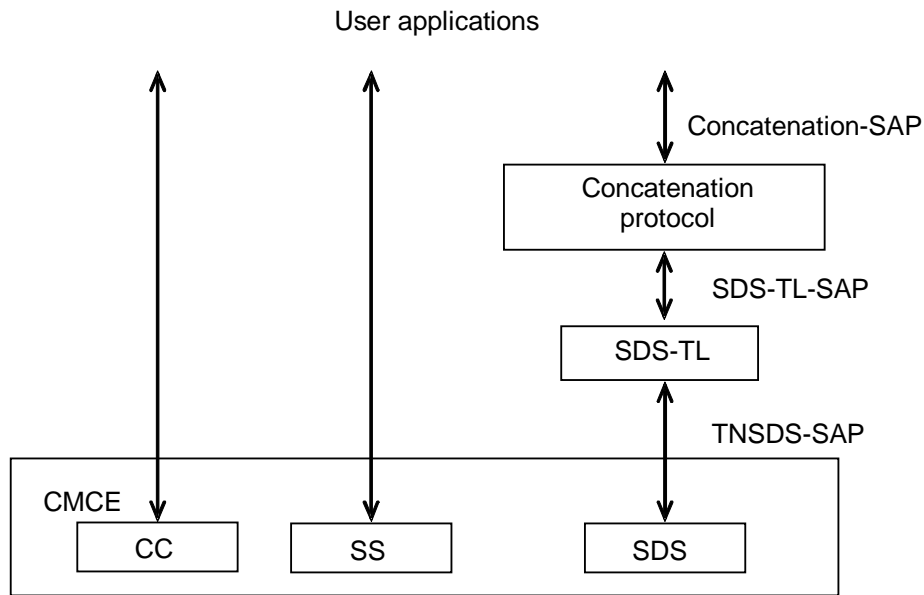

Figure 29.11: Concatenation protocol stack

29.5.14.3 Concatenation service

29.5.14.3.1 General overview

Concatenation service as defined in clause 29.5.14 accepts a long user message from upper protocol layers as a single message. The concatenation layer forms multiple SDS-TL messages from that single message and sends those using the same SDS-TL service as defined in the long user message. The receiving entity re-assembles the multiple SDS-TL messages into a single long message and passes that to the upper protocol layers for user.

On the network point of view those multiple SDS-TL messages are normal SDS-TL messages and the network transports those without any concatenation specific actions.

The present concatenation service provides a minor limitation compared to the SDS-TL service and does not support user data in report messages.

29.5.14.3.2 Concatenation service primitives

The concatenation layer provides almost the same service primitives as the SDS-TL layer modified so that a Concatenation reference is used instead of the Message reference. For the presentation purposes new service primitives are defined for the concatenation service although the basic services are the same as for the SDS-TL.

Services at the Concatenation-SAP are:

Concatenation-TRANSFER request: the primitive shall be used by the Concatenation entity to send data to a peer entity.

Concatenation-TRANSFER indication: the primitive shall be used by the Concatenation entity to pass data, which has been received from a peer entity.

Table 29.51 gives parameters for the Concatenation-TRANSFER primitives, when no forwarding entity is used.

Table 29.51: Parameters for the Concatenation-TRANSFER primitive without forwarding addressing

Parameter	Request	Indication
Access priority	O	-
Traffic stealing	O	-
Area selection	O	-
Called party	(see note 1)	(see note 5)
Called party SNA	C (see note 2)	-
Called party SSI	C (see note 2)	M
Called party extension	C (see note 2)	M
External subscriber number (called party)	O	-
Received address type	-	O
Calling party	- (see note 3)	(see note 6)
Calling party SSI	-	M
Calling party extension	-	M
External subscriber number (calling party)	-	O
Protocol identifier (P PID)	M	M
Delivery report request	M	M
Service selection	M	-
Short form report	-	M
Forward control	O	O
Validity period	O	O
Concatenation reference handle	M	-
Concatenation reference	-	M
User data (see notes 7 and 8)	O	O
User data is not complete (see note 8)	-	O
NOTE 1: This parameter shall indicate the destination entity address.		
NOTE 2: This parameter shall be present as defined by the called party type identifier parameter.		
NOTE 3: Lower protocol layers will add the calling party identity.		
NOTE 4: Void.		
NOTE 5: This parameter value shall indicate "Called party SSI" and "Called party extension".		
NOTE 6: This parameter value shall indicate "Calling party SSI" and "Calling party extension".		
NOTE 7: User data (payload) may contain for some payload protocols a timestamp as a part of the SDS-TL protocol.		
NOTE 8: The user data parameter may be organized to indicate the presence and location of missing parts of the concatenated message, refer to clauses 29.5.14.7.2 and 29.5.14.7.3.		

Table 29.52 gives parameters for the Concatenation-TRANSFER primitives, when a forwarding entity is used.

Table 29.52: Parameters for the Concatenation-TRANSFER primitive with forwarding addressing

Parameter	Request	Indication
Access priority	O	-
Traffic stealing	O	-
Area selection	O	-
Called party:	(see note 1)	(see note 6)
Called party SNA	C (see note 2)	-
Called party SSI	C (see note 2)	M
Called party extension	C (see note 2)	M
External subscriber number	O (see note 1)	-
Received address type	-	O
Calling party:	- (see note 3)	(see note 7)
Calling party SSI	-	C (see note 8)
Calling party extension	-	C (see note 8)
External subscriber number (calling party)	-	O (see note 9)
Protocol identifier (P PID)	M	M
Delivery report request	M	M
Service selection	M	-
Short form report	-	M
Forward control	M	M
Validity period	M	O
Forward address:	(see note 4)	(see note 10)
Forward address SNA	C (see note 5)	
Forward address SSI	C (see note 5)	C (see note 11)
Forward address extension	C (see note 5)	C (see note 11)
External subscriber number	C (see note 5)	C (see note 11)
Concatenation reference handle	M	-
Concatenation reference	-	M
User data (see notes 12 and 13)	O	O
User data is not complete (see note 13)	-	O
NOTE 1: This parameter shall indicate the forwarding entity address to which the message is going for delivery to the destination.		
NOTE 2: This parameter shall be present as defined by the called party type identifier parameter.		
NOTE 3: Lower protocol layers will add the calling party identity.		
NOTE 4: This information element shall indicate the final destination entity address.		
NOTE 5: This parameter shall be present as defined by the forward address type identifier parameter.		
NOTE 6: This parameter value shall indicate "Called party SSI" and "Called party extension". This identity shall indicate the destination.		
NOTE 7: This parameter shall indicate the forwarding entity address to which sent the message on behalf of the original source.		
NOTE 8: This parameter shall be present as defined by the calling party type identifier parameter.		
NOTE 9: This parameter shall indicate the storing/forwarding entity address to which sent the message on behalf of the original source.		
NOTE 10: This parameter shall indicate the original source entity address.		
NOTE 11: This parameter shall be present as defined by the forward address type identifier parameter.		
NOTE 12: User data (payload) may contain for some payload protocols a timestamp as a part of the SDS-TL protocol.		
NOTE 13: The user data parameter may be organized to indicate the presence and location of missing parts of the concatenated message, refer to clauses 29.5.14.7.2 and 29.5.14.7.3.		

Concatenation-REPORT request: the primitive shall be used by the Concatenation entity to send reports to a peer entity.

Concatenation-REPORT indication: the primitive shall be used by the Concatenation entity to pass reports, which has been received from a peer entity.

Table 29.53 gives parameters for the Concatenation-REPORT primitives, when no forwarding entity is used.

Table 29.53: Parameters for the Concatenation-REPORT primitive (no forwarding)

Parameter	Request	Indication
Access priority	O	-
Traffic stealing	O	-
Area selection	O	-
Called party:	See note 1	See note 4
Called party SNA	C (see note 2)	-
Called party SSI	C (see note 2)	M
Called party extension	C (see note 2)	M
External subscriber number (called party)	O	-
Calling party:	See note 3	See notes 5 and 6
Calling party SSI	-	M
Calling party extension	-	M
External subscriber number (calling party)	-	O (see note 6)
Protocol identifier (P PID)	M	M
Acknowledgement required	M	M
Delivery status	M	M
Concatenation reference handle	-	O (see note 7)
Concatenation reference	M	M
User data	- (see note 8)	- (see note 8)
NOTE 1: This parameter shall indicate the destination entity address.		
NOTE 2: This parameter shall be present as defined by the called party type identifier parameter.		
NOTE 3: Lower protocol layers will add the calling party identity.		
NOTE 4: This parameter value shall indicate "Called party SSI" and "Called party extension". This parameter shall indicate the destination entity address.		
NOTE 5: This parameter shall value indicate "Calling party SSI" and "Calling party extension".		
NOTE 6: This parameter shall indicate the source entity address.		
NOTE 7: This parameter shall be used in the first Concatenation-REPORT indication to a Concatenation-TRANSFER request, unless provided in a Concatenation-TNSDS-REPORT indication.		
NOTE 8: The present concatenation service does not support user data.		

Table 29.54 gives parameters for the Concatenation-REPORT primitives, when a forwarding entity is used.

Table 29.54: Parameters for the Concatenation-REPORT primitive (forwarding)

Parameter	Request	Indication
Access priority	O	-
Traffic stealing	O	-
Area selection	O	-
Called party	See note 1	See note 4
Called party SNA	C (see note 2)	-
Called party SSI	C (see note 2)	M
Called party extension	C (see note 2)	M
External subscriber number	O (see note 1)	-
Calling party	See note 3	See notes 5 and 6
Calling party SSI	-	M
Calling party extension	-	M
External subscriber number (calling party)	-	O (see note 6)
Protocol identifier (P PID)	M	M
Acknowledgement required	M	M
Delivery status	M	M
Storage/forward control	M	M
Validity period	M	O
Forward address:	See note 8	See note 10
Forward address SNA	C (see note 9)	
Forward address SSI	C (see note 9)	C (see note 11)
Forward address extension	C (see note 9)	C (see note 11)
External subscriber number	C (see note 9)	C (see note 11)
Concatenation reference handle	-	O (see note 7)
Concatenation reference	M	M
User data	- (see note 12)	- (see note 12)
<p>NOTE 1: This parameter shall indicate the address of the forwarding entity which sent the reported message on behalf of the original source.</p> <p>NOTE 2: This parameter shall be present as defined by the called party type identifier parameter.</p> <p>NOTE 3: Lower protocol layers will add the calling party identity.</p> <p>NOTE 4: This parameter value shall indicate "Called party SSI" and "Called party extension". This identity shall indicate the destination.</p> <p>NOTE 5: This parameter value shall indicate "Calling party SSI" and "Calling party extension".</p> <p>NOTE 6: This parameter shall indicate the address of the forwarding entity which sent the Concatenation-REPORT indication on behalf of the original destination.</p> <p>NOTE 7: This parameter shall be used in the first Concatenation-REPORT indication to a Concatenation-TRANSFER request, unless provided in a Concatenation-TNSDS-REPORT indication.</p> <p>NOTE 8: This information element shall indicate the address of the final destination entity.</p> <p>NOTE 9: This parameter shall be present as defined by the forward address type identifier parameter.</p> <p>NOTE 10: This parameter shall indicate the address of the original source entity.</p> <p>NOTE 11: This parameter shall be present as defined by the forward address type identifier parameter.</p> <p>NOTE 12: The present concatenation service does not support user data.</p>		

Concatenation-ACK request: the primitive may be used by the concatenation entity to acknowledge reports from a peer entity. The Concatenation-ACK request is used to acknowledge unsolicited reports (consumed message) or reports which may have been stored in the SwMI or at a storing/forwarding entity.

Concatenation-ACK indication: the primitive may be used by the concatenation entity to pass to the concatenation entity report acknowledgements, which has been received from a peer entity or generated by the SwMI or a storing/forwarding entity.

NOTE 1: The Concatenation-ACK request and Concatenation-ACK indication service primitives may be hidden from user application.

Table 29.55 gives parameters for the Concatenation-ACK primitives, when no forwarding entity is used.

Table 29.55: Parameters for the Concatenation-ACK primitive (no forwarding)

Parameter	Request	Indication
Access priority	O	-
Traffic stealing	O	-
Area selection	O	-
Called party	See note 1	See note 4
Called party SNA	C (see note 2)	-
Called party SSI	C (see note 2)	M
Called party extension	C (see note 2)	M
External subscriber number (called party)	O	-
Calling party	See note 3	See notes 5 and 6
Calling party SSI	-	M
Calling party extension	-	M
External subscriber number (calling party)	-	O (see note 6)
Protocol identifier (P PID)	M	M
Delivery status	M	M
Concatenation reference	M	M
NOTE 1: This parameter shall indicate the destination entity address.		
NOTE 2: This parameter shall be present as defined by the called party type identifier parameter.		
NOTE 3: Lower protocol layers will add the calling party identity.		
NOTE 4: This parameter value shall indicate "Called party SSI" and "Called party extension". This parameter shall indicate the destination entity address.		
NOTE 5: This parameter value shall indicate "Calling party SSI" and "Calling party extension".		
NOTE 6: This parameter shall indicate the source entity address.		

Table 29.56 gives parameters for the Concatenation-ACK primitives, when a storing/forwarding entity is used.

Table 29.56: Parameters for the Concatenation-ACK primitive (storing/forwarding)

Parameter	Request	Indication
Access priority	O	-
Traffic stealing	O	-
Area selection	O	-
Called party:	See note 1	See note 4
Called party SNA	C (see note 2)	-
Called party SSI	C (see note 2)	M
Called party extension	C (see note 2)	M
External subscriber number	O (see note 1)	-
Calling party:	See note 3	See notes 5 and 6
Calling party SSI	-	M
Calling party extension	-	M
External subscriber number (calling party)	-	O (see note 6)
Protocol identifier (P PID)	M	M
Delivery status	M	M
Concatenation reference	M	M
NOTE 1: This parameter shall indicate the storing/forwarding entity address from which the acknowledged report message was received.		
NOTE 2: This parameter shall be present as defined by the called party type identifier parameter.		
NOTE 3: Lower protocol layers will add the calling party identity.		
NOTE 4: This parameter value shall indicate "Called party SSI" and "Called party extension". This identity shall indicate the destination.		
NOTE 5: This parameter value shall indicate "Calling party SSI" and "Calling party extension".		
NOTE 6: This parameter shall indicate the storing/forwarding entity address to which the acknowledged report message was originally sent.		

Concatenation-TNSDS-REPORT indication: the primitive shall be used to indicate whether a Concatenation-ACK request, a Concatenation-TRANSFER request, a Concatenation-REPORT request, or a Concatenation-UNITDATA request has been either transmitted successfully or transmission have failed. The parameters are defined in table 29.57.

NOTE 2: This is a local information that is based on the LLC acknowledgements.

Table 29.57: Parameters for the Concatenation-TNSDS-REPORT primitive

Parameter	Indication
Transfer result	M
Concatenation reference handle	M
Concatenation reference	O

Concatenation-UNITDATA request: the primitive shall be used to send user defined data-4 to a peer entity, when the SDS-TL data transfer services are not used.

Concatenation-UNITDATA indication: the primitive shall be used to receive user defined data-4 from a peer entity, when the SDS-TL data transfer services are not used.

The parameters are defined in table 29.58.

Table 29.58: Parameters for the Concatenation-UNITDATA primitive

Parameter	Request	Indication
Access priority	O	-
Traffic stealing	O	-
Area selection	O (see note 4)	-
Called party type identifier	M	-
Called party SNA	C (see note 1)	-
Called party SSI	C (see note 1)	M
Called party extension	C (see note 1)	O (see note 2)
Called party address type	-	O
External subscriber number (called)	O	-
Calling party:		
Calling party SSI	-	M
Calling party extension	-	O (see note 2)
External subscriber number (calling)	-	O
Protocol identifier (P PID)	M	M
Concatenation handle	M	-
Concatenation reference	-	M
User defined data-4	M (see note 3)	C (see note 3)
User data is not complete	-	O
NOTE 1: Depending on the value of called party type identifier.		
NOTE 2: If not present, the user application shall assume that the address extension is the MNI of the current network.		
NOTE 3: This parameter is modified by the Concatenation and SDS-TL protocols and it contains always concatenation control and a user data protocol identifier, and is available via the Concatenation-SAP, refer to clause 29.5.14.2.		
NOTE 4: Usage of this parameter is defined in ETSI EN 300 392-12-8 [14].		

Concatenation-MANAGEMENT request: the primitive shall be used to set concatenation specific service parameters.

Concatenation-MANAGEMENT indication: the service shall be used to inform user application on the concatenation specific service parameters.

Table 29.59: Parameters for the Concatenation-MANAGEMENT primitive

Parameter	Request	Indication
Maximum concatenated message length	O	O
Concatenation part size	O	O
Maximum number of concatenation parts	O	O
Timeout for concatenation message reception	O	O
Acknowledgement control	O	O
Re-sending control	O	O

29.5.14.3.3 Concatenation service primitive parameters

Parameters defined in clause 29.2.3 are applicable for the concatenation service primitive parameters. In addition following parameters are defined.

Acknowledgement control =

- Direct sending
 - No acknowledgement of concatenation parts
 - All concatenation parts acknowledged
 - Only last concatenation part acknowledged
- Store and forward sending
 - No acknowledgement of concatenation parts
 - All concatenation parts acknowledged
 - Only last concatenation part acknowledged

NOTE 1: The acknowledgement in the last concatenation part is a request for whole concatenated message acknowledgement, refer to clause 29.5.14.8.1.

Concatenation reference =

- Short concatenation reference 0 to 15;
- Extended concatenation reference 16 to 4 095.

NOTE 2: The short concatenation reference values can be considered to be a part of the extended concatenation references i.e. belong to a single numbering resource.

Concatenation reference handle =

- 0 to 4 095, a local handle to the actual concatenation reference. The mapping between a concatenation reference and a concatenation reference handle is a local issue and outside the scope of the present document.

Concatenation part size =

- Size of individual concatenation parts;

NOTE 3: Concatenation part size may be used in the calculation of the total message size, if the concatenation parts are of the same size.

- Use air interface optimized concatenation part size.

NOTE 4: How air interface optimized concatenation part size is defined is outside the scope of the present document.

NOTE 5: The concatenation part size sets indirectly how many timeslots will be used in fragmentation of the basic link service at the MAC layer.

Maximum concatenated message length =

- Network or application dependent.

Maximum number of concatenation-parts =

- Network dependent number (more than one);

NOTE 6: How MS or user application knows the network dependent number is outside the scope of the present document.

NOTE 7: The maximum number of concatenation-parts may be defined depend on the sizes of the concatenation parts and/or on the maximum length of the concatenated message.

Protocol identifier (P PID) =

- Payload protocol (P PID)

NOTE 8: This parameter is not used by the concatenation protocol, but is presented to remind that it is not the C PID that is not presented in any of the concatenation service primitives. It is the P PID of the payload, refer to clause 29.5.14.5 and for the value, refer to clause 29.4.3.9.

Re-sending control =

- No re-sending of failed concatenation parts
- Use application dependent re-sending algorithm

NOTE 9: Re-sending control may be applicable only, if acknowledgements are requested for individual concatenation parts, refer to clause 29.5.14.8.1.

Timeout for concatenation message reception =

NOTE 10: The value is outside the scope of the present document, could be 30 s to 10 min.

Transfer result =

- Success
- Failure, some concatenation parts are sent successfully
- Failure, transmission of all concatenation parts has failed

29.5.14.4 Concatenation protocol

The present document defines the concatenation of the user SDS message containing user data. No protocol or PDUs (SDS messages) are defined for retransmission requests of missing concatenation-parts.

NOTE 1: The protocol can be enhanced in a later version of the present document to include acknowledgements and retransmission of missed concatenation-parts in the concatenation protocol.

NOTE 2: The protocol description assumes that the user application is using SDS-TL messages in the same manner as without concatenation i.e. on the user's point of view a concatenated message is a single message and the concatenation layer hides actions inside the SDS-TL layer. In real implementations application and concatenation may be combined together.

The concatenation can be used with or without SDS-TL data transport service protocol as defined by the PID value of the concatenation indication. The PID value of the concatenation indication shall define whether SDS-TL service is used or not and shall indicate the same SDS-TL service as the original SDS message.

29.5.14.5 Concatenated message structures

The concatenated messages are divided into concatenation parts. The first concatenation part shall contain the PID of the user payload message.

Figure 29.12 presents how a long SDS message without SDS-TL service shall be divided into concatenation parts. The concatenation PID (C PID) of each SDS-TL message containing a concatenation part shall indicate that SDS-TL service is not used.

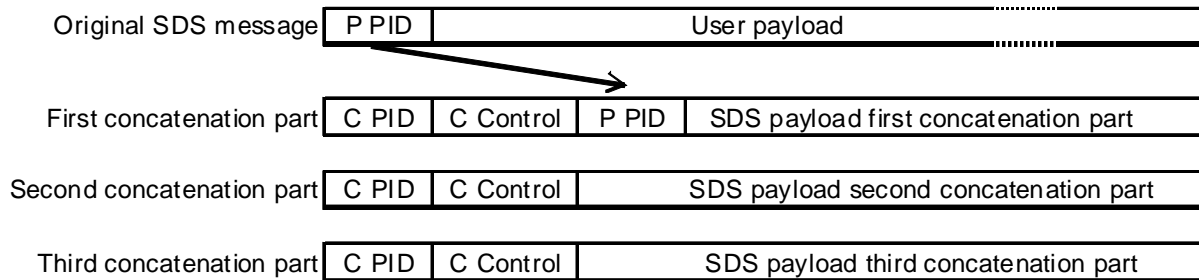

Figure 29.12: Concatenation of SDS-TL message without SDS-TL service

Figure 29.13 presents how a long SDS message with SDS-TL service is divided into concatenation parts. The PID of the user payload (indicating usage of SDS-TL service) shall be in the first concatenation part (P PID). The PID (C PID) of each SDS-TL message containing a concatenation part shall indicate that SDS-TL service is used and shall be followed by a SDS-TL header. Each SDS-TL header shall contain a different Message reference value for each concatenation part.

The underlying SDS-TL layer will consider the C Control and the P PID in the first concatenation part to be user payload in the SDS-TL messages and will not study those information elements.

NOTE 1: Although the payload PID (P PID) in a concatenated message indicates usage of SDS-TL service the user payload follows directly the P PID and the SDS-TL header is not repeated after the P PID as the concatenation protocol places that P PID into the user payload of the SDS-TL service.

NOTE 2: If the SDS-TRANSFER PDU Message reference value were the same in multiple SDS-TRANSFER PDUs, then the receiving entity would use all but one of the SDS-TRANSFER PDUs as repetitions. Also optional acknowledgements require unique values of the Message reference.

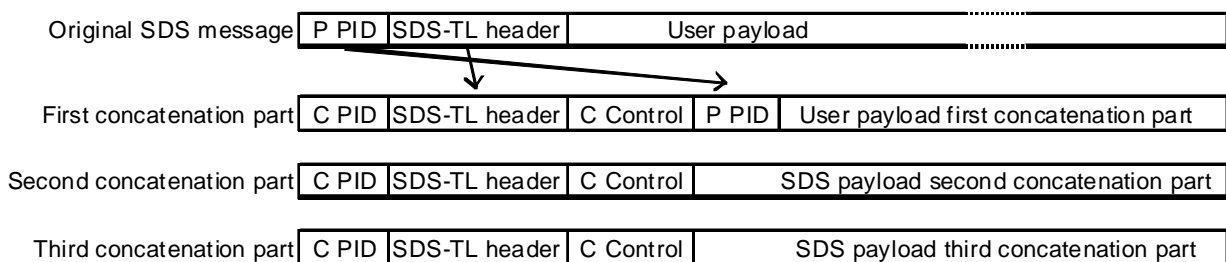

Figure 29.13: Concatenation of SDS-TL message with SDS-TL service

29.5.14.6 General on concatenated messages transport

The sending entity shall divide each user message into concatenation-parts, add to each concatenation-part a concatenation PID indicating whether the SDS-TL service is used or not, copy SDS-TL header and add Concatenation control information element, refer to clause 29.5.14.5.

The **concatenation control** information elements mark and identify SDS-TL messages that form a concatenated message, refer to table 29.60.

The **concatenation message reference** that is a combination of the Short concatenation reference information element and the Concatenation reference extension information element providing either four bits or 12 bits long reference number. That number shall be the same in all concatenation parts of a single user message. The sending entity shall manage concatenation reference numbers so that at least the combination of the concatenation reference number, sender's address and recipient's address is unique over a time that prevents mixing concatenation parts of different messages.

NOTE 1: Where the numbering scheme makes use of the long concatenation reference for higher numbered parts of the message, the lowest values (0 to 15) may be sent using either short or long concatenation references.

NOTE 2: The Message reference information element value in the SDS-TL data transfer service part of the SDS-TRANSFER PDU is independent of the Concatenation reference, refer to clause 29.5.14.4.

The **Number of concatenation-parts** shall indicate how many concatenation-parts form a single user message.

The **Sequence number of the current concatenation-part** shall define the position of the concatenation-part in the user message.

The concatenation-parts shall be sent in the numerical order of the concatenation-part numbers. The receiving entity shall not assume that the concatenation-part will arrive in the concatenation-part number order as some of the network elements may not keep them in order due to various reasons. The network elements need not to study the concatenation control information elements of the concatenation-parts.

The radio interface protocol may generate multiple copies of concatenation-parts and the receiving entity shall suppress extra concatenation-parts at the re-assembly.

A maximum of 5 to 10 concatenation-parts is recommended (to assist with reliability of message delivery, when using basic link). Whether a network sets a limit to the number of concatenation parts or total length of the user message and how many long messages a user may send is outside the scope of the present protocol.

The sending entity should divide each user message into suitably sized concatenation-parts to fit into available MAC layer PDUs and timeslot sizes. It is outside of the present document how SDS-TL layer knows which concatenation-part sizes are optimum in each situation.

NOTE 3: This will vary according to the type of channel and modulation employed on the channel.

29.5.14.7 Concatenated messages transport without SDS-TL service

29.5.14.7.1 Sending concatenated SDS-TL messages without SDS-TL service

The sending entity shall divide each user message into concatenation-parts, refer to clause 29.5.14.6 and send concatenation-parts as independent SDS messages.

29.5.14.7.2 Receiving concatenated SDS-TL messages without SDS-TL service

When all concatenation-parts have been received the receiving entity shall remove the concatenation PID and the Concatenation control information elements and shall re-assemble the concatenation-parts into a SDS message and pass it to the higher layer application. It is outside the scope of the present document whether or when a partially received concatenated message is forwarded to a higher layer application.

The radio interface protocol may generate multiple copies of concatenation-parts and the receiving entity shall suppress extra concatenation-parts at the re-assembly.

29.5.14.7.3 Acknowledgement of concatenated SDS-TL messages without SDS-TL service

Concatenation layer does not add any acknowledgements to the SDS-TL (Type 4 SDS).

29.5.14.7.4 Concatenated message lifetime

The concatenation protocol does not contain any control of message lifetime. It is recommended that lifetime of concatenated messages sent without an SDS-TL service is considered to be quite limited. Exact lifetime is outside the scope of the present document.

29.5.14.7.5 Exceptional conditions

The present concatenation protocol does not define any protocol for exceptional situations for transport without SDS-TL service.

NOTE: Future versions of the present protocol may add acknowledgements or failure indications into the concatenation protocol as a part of the concatenation control.

29.5.14.8 Concatenated messages transport with SDS-TL transport service

29.5.14.8.1 Acknowledgements in transport of concatenated SDS-TL messages

The SDS-TL provides forwarding, storage and acknowledgement services. The concatenation protocol can use the SDS-TL transport acknowledgement services for its internal purposes and for the service user purposes.

The concatenation layer may use SDS-TL acknowledgements to acknowledge individual concatenation-parts. In order to differentiate concatenation-part acknowledgement and whole concatenated message acknowledgements a new value of the Delivery status information element "Concatenation-part receipt acknowledged by destination" is defined.

The Delivery report request information element value "Message received report requested" in the SDS-TRANSFER PDU has a double function in the concatenation protocol:

- in any other than in the last concatenation-part it requests report of reception of that concatenation part; and
- in the last concatenation-part it in addition requests a report of reception of the whole concatenated message.

The Message consumed report request is used for concatenation service at the same manner as in SDS-TL service modified so that a consumption of the whole concatenated message will be reported.

29.5.14.8.2 Sending concatenated SDS-TL messages with SDS-TL service

The sending entity shall divide each user message into concatenation-parts, refer to clause 29.5.14.6 and send concatenation-parts as independent SDS-TRANSFER PDUs. Each SDS-TRANSFER PDU shall have a different Message reference value within a single concatenated message.

NOTE 1: A unique value of the SDS-TL Message reference is required with a single concatenated message as otherwise the receiving entity keeps only one of the colliding concatenation-parts. The SDS-TL Message reference needs also be unique between multiple concatenated messages, if reports are requested and multiple concatenated messages are in transit at the same time, because as the reports do not contain any concatenation message reference.

When the sending entity asks for a whole concatenated message received report, then it shall use in all but the last concatenation-part Delivery report request information element value "No delivery report requested" and in the last concatenation-part value "Message received report requested". In the last concatenation part the sending entity may also use Delivery report request information element values "Message consumed report requested" and "Message received and consumed report requested". By this the Concatenation reference and the SDS-TL Message reference are linked together inside the concatenation layer and the SDS-TL Message reference is used for acknowledgement purposes.

When the sending entity asks reception reports of individual concatenation parts, then it shall use in all concatenation parts Delivery report request information element value "Message received report requested". In the last concatenation part the sending entity may also use Delivery report request information element value "Message received and consumed report requested".

NOTE 2: When a message received report is requested in the last concatenation-part, then the whole concatenated message reception report is requested instead of reception of the last concatenation part due to the limitations of the possible request values.

NOTE 3: The usage of the "Message received and consumed report requested" in the last concatenation-part may be advantageous as a loss of at least the last concatenation-part may be identified faster than using only "Message consumed report request". It also may save some air interface resources as fewer reports will be used.

When the sending entity receives SDS-REPORT PDU to the last concatenation part acknowledging the whole concatenated message the sending entity shall pass it to the user application using the corresponding Concatenation reference.

If an SDS-TL delivery report is requested for each concatenation-part by "Message received report requested" and sending entity has not received a report with Delivery status value "SDS receipt acknowledged by destination" or "SDS consumed by destination" the sending entity may re-send the concatenation-part or parts for which it has not received a report with Delivery status value "Concatenation-part receipt acknowledged by destination". The re-sending strategy may depend on the served application, and is instructed by the re-sending control parameter, refer to clause 29.5.14.3.3.

29.5.14.8.3 Receiving concatenated SDS-TL messages with SDS-TL service

When all concatenation-parts have been received the receiving entity shall remove the concatenation PID and the Concatenation control information elements and shall re-assemble the concatenation-parts into a concatenation message and pass it to the higher layer application using Concatenation-TRANSFER indication. It is outside the scope of the present document whether or when a partially received concatenated message is forwarded to a higher layer application.

The following clauses define how concatenation layer reacts to the individual SDS-TRANSFER PDUs.

Upon receiving a concatenation-part with Delivery report request with value "Message received report requested" or "Message received and consumed report requested" the concatenation entity acts:

- If the whole concatenated message is received, but the message is not yet consumed or consumption report is not requested, then it shall send a report with Delivery status value "SDS receipt acknowledged by destination".

NOTE 1: The concatenation layer may wait for consumption indication before sending a reception report and save some air interface resources as only a consumption report will be sent. The waiting time is outside the scope of the present document.

- If the whole concatenated message is received and has been consumed and consumption report is requested, then it shall send a report with Delivery status value "SDS consumed by destination" and shall not send another report to indicate reception.
- If the whole concatenated message is not received, then it shall send a report with Delivery status value "Concatenation-part receipt acknowledged by destination".

Upon receiving a concatenation-part with Delivery report request with value "Message consumed report requested" the concatenation entity acts:

- If the whole concatenated message is received and has been consumed, then it shall send an SDS-REPORT PDU with Delivery status value "SDS consumed by destination".

NOTE 2: The SDS-REPORT PDU refers to the SDS-TL message reference that was in the concatenation part that contained the Delivery report request with value "Message consumed report requested". That SDS-TL message reference value may be numerically less than some other SDS-TL message reference value in a concatenated message.

- If the whole concatenated message is not received, then it shall not send a consumption report, refer to clause 29.5.14.8.2.

Upon receiving a concatenation-part with Delivery report request with value "No delivery report requested" the receiving concatenation entity acts:

- if the whole concatenated message is not received, then the receiving concatenation entity shall not send any report to that concatenation part to the sending concatenation entity;
- if the whole concatenated message is received and passed to the upper layers then receiving concatenation entity shall not send any report to the sending concatenation entity;
- if an error is detected in an individually addressed concatenation part or in the whole concatenated message, then a SDS-REPORT PDU shall be sent to the sending concatenation entity. If an error occurs when receiving a broadcast or group addressed message, the MS shall not send an SDS-REPORT PDU to the sending party the message shall be silently discarded.

NOTE 3: The present document does not define how the receiving entity could request retransmission of a specific concatenation-part, refer to clause 29.5.14.8.5.

29.5.14.8.4 Acknowledgements of SDS-REPORT PDUs

The concatenation layer should not normally ask request acknowledgements to the individual SDS-REPORT PDUs. For the whole concatenated message a higher layer application may request acknowledgement in a Concatenation-REPORT request. The concatenation layer may ask request the acknowledgement in the last concatenation-part of a concatenated message. The higher layer application will then use Concatenation-ACK request primitive with concatenation reference and the concatenation layer shall send SDS-ACK PDU with the corresponding Message reference, refer to clause 29.3.3.5. It is recommended that user application asks acknowledgement to a Concatenation-REPORT request only in direct transport without a forwarding entity.

NOTE: As the Concatenation layer uses SDS-TL service SDS-ACK PDU the acknowledgements are between SDS-TL aware nodes and are end to end only, when no forwarding service is used, refer to clause 29.3.3.1.

If SwMI or a forwarding entity asks requests acknowledgements in SDS-REPORT PDUs, then the concatenation layer shall send SDS-ACK PDUs to those and shall not inform service user about the requests.

29.5.14.8.5 Exceptional conditions

While sending a concatenated message the sending entity may receive an SDS-REPORT PDU with a Delivery status value "Concatenated message too long" as a response for a SDS-TRANSFER PDU independently whether one or more or all concatenation parts have been sent and the sending entity shall stop sending the corresponding concatenated message and pass the failure indication to the upper layer application in a Concatenation-REPORT indication. Receiver does not continue to receive the message.

The receiving concatenation entity may apply a timeout between receptions of concatenation-parts. The same timeout may be applied also, when the last concatenation part is received, but one or more concatenation-part is not received. At the timeout the receiving concatenation entity may send an SDS-REPORT PDU with "Concatenation entity has not received some of the concatenation parts, message discarded". Receiver does not continue to receive the message. How the sending entity may use this information and the timeout value is outside the scope of the present document.

29.5.14.9 Concatenation management

An upper layer application may want to control parameters of concatenation by using a Concatenation-MANAGEMENT request primitive. The concatenation entity may inform recommended concatenation parameters to the upper layer application using a Concatenation-MANAGEMENT indication primitive.

The Concatenation-MANAGEMENT request primitive is used before a Concatenation-TRANSFER request primitive and will define how the concatenated message should be sent. MS may also apply some default values, if a Concatenation-MANAGEMENT request is not used to set the transfer parameters. The default values are outside the scope of the present document.

MS may provide a Concatenation-MANAGEMENT indication primitive to inform user application about the concatenation parameters.

29.5.14.10 Timestamp usage

If a timestamp is used as defined in clause 29.3.2.9, then SwMI will add it only to the concatenation part that contains the payload PID. So if SwMI adds a timestamp, then it identifies the approximate time of the start of the sending of the concatenated message.

29.5.14.11 Concatenation coding requirements

29.5.14.11.1 Concatenation control

The concatenation control information elements shall be coded as presented in table 29.60.

Table 29.60: Concatenation control information elements for concatenation transfer contents

Information element	Length	Type	C/O/M	Value	Remark
Concatenation control PDU type	3	1	M		Concatenation transfer
Concatenation reference type	1	1	M	0	Concatenation reference extension not present
				1	Concatenation reference extension present
Concatenation reference extension	8		C		See notes 1 and 2
Short concatenation reference	4	1	M		See note 2
Number of concatenation-parts	8	1	M	2 to 255	
Sequence number of the current concatenation-part	8	1	M	1 to 255	
NOTE 1: This information element shall be present as indicated by the concatenation reference type.					
NOTE 2: When the Concatenation reference extension information element is present, then it shall contain the most significant bits of the concatenation reference and the Short concatenation reference information element shall contain the least significant bits of the 12 bits long concatenation reference value.					

29.5.14.11.2 Concatenation control PDU type

The concatenation control PDU type information elements shall be coded as presented in table 29.61.

Table 29.61: Concatenation control PDU type contents

Information element	Length	Value	Remark
Concatenation control PDU type	3	000 ₂	Concatenation transfer
		001 ₂	Reserved
		etc.	etc.
		111 ₂	Reserved

29.5.14.12 Concatenation message examples

29.5.14.12.1 Concatenation of SDS messages without SDS-TL data transport service

When SDS-TL data transfer service is not used the PID that defines a concatenated SDS shall be followed by concatenation control information element, refer to clause 29.5.14.5.

The format of SDS-TL message without SDS-TL data transport service shall be as defined in table 29.62.

Table 29.62: Concatenation-part message without SDS-TL data transfer service

Information element	Length	Type	C/O/M	Remark
Protocol identifier	8	1	M	Concatenated SDS without SDS-TL data transport service
Concatenation control	variable	1	M	Refer to table 29.60
PID of the user payload message	8		C	See notes 1 and 2
User data	variable	1	M	
NOTE 1: That information element shall be present only when the Sequence number of current concatenation-part information element value is "1".				
NOTE 2: The PID of the user data payload message can be any other than a concatenation indication PID of the table 29.21.				

29.5.14.12.2 Concatenation of SDS messages with SDS-TL data transport service

When SDS-TL data transfer service is used the set of concatenation control information elements shall be after the SDS-TL data transfer service information elements, refer to clause 29.5.14.5 and table 29.63.

Although the PID of the user data can indicate that SDS-TL data transfer service shall be used, refer to note 5 in table 29.21, the Protocol identifier of the concatenated SDS in the first information element shall define whether the SDS-TL data transfer service is used or not and there shall be no SDS-TL data transfer service related information elements after the PID of the user payload message information element.

Table 29.63: Concatenation-part message with SDS-TL data transfer service

Information element	Length	Type	C/O/M	Remark
Protocol identifier	8	1	M	Concatenated SDS with SDS-TL data transfer service
Message type	4	1	M	SDS-TRANSFER
Delivery report request	2	1	M	
Service selection/Short form report	1	1	M	
Storage/forward control	1	1	M	
Message reference	8	1	M	Refer to table 29.14
Validity period	5		C	Refer to table 29.14
Forward address type	3		C	Refer to table 29.14
Forward address short number address	8		C	Refer to table 29.14
Forward address SSI	24		C	Refer to table 29.14
Forward address extension	24		C	Refer to table 29.14
Number of external subscriber number digits	8		C	Refer to table 29.14
External subscriber number digit	4		C	Refer to table 29.14
Dummy digit	4		C	Refer to table 29.14
Concatenation control	variable	1	M	Refer to table 29.60, note 1
PID of the user payload message	8	1	M	See notes 1, 2 and 3
User data	variable	1	M	
NOTE 1: SDS-TL shall consider these information elements to be a part of User data.				
NOTE 2: That information element shall be present only when the Sequence number of current concatenation-part information element value is "1".				
NOTE 3: The PID of the user data payload message can be any other than a concatenation indication PID of the table 29.21.				

29.5.15 Simple AGNSS

29.5.15.1 General

The Simple AGNSS protocol is intended to be a very basic AGNSS application, which does not require any transport mechanism to ensure delivery.

29.5.15.2 Protocol sequences

Simple AGNSS does not use any end-to-end acknowledgement (reporting) signaling. The only delivery mechanisms offered is the layer 2 acknowledge.

29.5.15.3 PDU description tables

Simple AGNSS does not use the SDS-TL data transfer service PDUs, but defines a protocol specific field to specify the data format, refer to clauses 29.5.16.5 and 29.5.16.6. The basic SDS type-4 information element shall contain elements as defined in clause 29.5.15.4.

29.5.15.4 Simple AGNSS unitdata

Response to: -

Response expected: -

Short description: This PDU shall be used to send AGNSS SDS data

Table 29.64: Simple AGNSS PDU contents

Information element	Length	Type	C/O/M	Remark
Protocol identifier	8	1	M	"00001110" (decimal value 14)
AGNSS constellation	4	1	M	As defined in table 29.66
AGNSS coding scheme	4	1	M	As defined in table 29.67
AGNSS data	Variable	1	M	

29.5.16 AGNSS using SDS-TL data transfer services

29.5.16.1 General

This AGNSS protocol set offers end-to-end acknowledgement and/or store and forward in the SwMI.

29.5.16.2 Protocol sequences

The protocol sequences of AGNSS messaging shall be the protocol sequences defined in clause 29.3.3.

29.5.16.3 PDU description tables

The AGNSS protocol uses the full TL protocol. Additional information elements are present in the SDS-TRANSFER PDU.

29.5.16.4 AGNSS transfer SDU

The AGNSS transfer is done by use of an SDS-TRANSFER with additional information elements embedded in the user data portion of the SDS-TRANSFER. The AGNSS SDU shall be encoded as defined in table 29.65.

Table 29.65: AGNSS SDU contents

Information element	Length	Type	C/O/M	Remark
AGNSS constellation	4	1	M	As defined in table 29.66
AGNSS coding scheme	4	1	M	As defined in table 29.67
AGNSS data	Variable	1	M	

29.5.16.5 AGNSS constellation

For protocols carrying AGNSS data, the 'AGNSS constellation' information element shall be as defined in table 29.66.

Table 29.66: AGNSS constellation information element contents

Information element	Length	Value	Remark
AGNSS constellation	4	0000 to 1111	0000: GPS 0001: GALILEO 0010: GLONASS 0011: BEIDOU 0100: WAAS 0101: EGNOS 0110: MSAS 0111: IRNSS 1000: QZSS 1001 to 1111: available to future constellations
NOTE: Identities of these applications should be allocated by a central body in order to support interoperability.			

NOTE: The AGNSS Constellation Identifier is coded over 4 bits as NAP2 is specified to support 16 constellations.

29.5.16.6 AGNSS coding scheme

For protocols carrying AGNSS data, the 'AGNSS coding scheme' information element shall be as defined in table 29.67.

Table 29.67: AGNSS coding scheme information element contents

Information element	Length	Value	Remark
AGNSS coding scheme	4	0000 to 1111	0000 : TETRA NET ASSIST Protocol 2, NAP2 ETSI TS 100 392-18-4 [49] 0001 to 1111: available to future coding schemes.
NOTE: Identities of these applications should be allocated by a central body in order to support interoperability.			

NOTE: This list only defines a subset of the available data coding schemes for AGNSS. The list should be expected to expand as more data coding schemes are adopted.

30 Multimedia Exchange Layer

30.1 General

Clause 30 describes the structure and the functionality of the TETRA Multimedia Exchange (MEX) Layer. The TETRA MEX layer resides above the SNDCP defined in clause 28.

The MEX layer supports the Internet Protocol (IP) and at the MS side the IP and the higher layers on top of it may be located at the MT and the TE. Support of the full MEX layer functionality is optional.

Figure 30.1 illustrates the usage of TETRA MEX layer with the applications in MT.

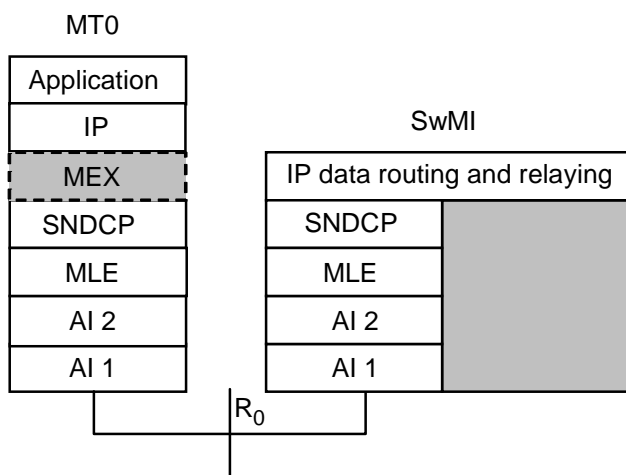

Figure 30.1: Usage of TETRA packet data with MEX Layer with an MT0 application

Figure 30.2 illustrates the usage of TETRA packet data with the MEX layer when the application uses IP protocol. Applications are illustrated with co-existence within both the TE2 and MT2 allowing them to independently access TETRA packet data services and associated QoS management.

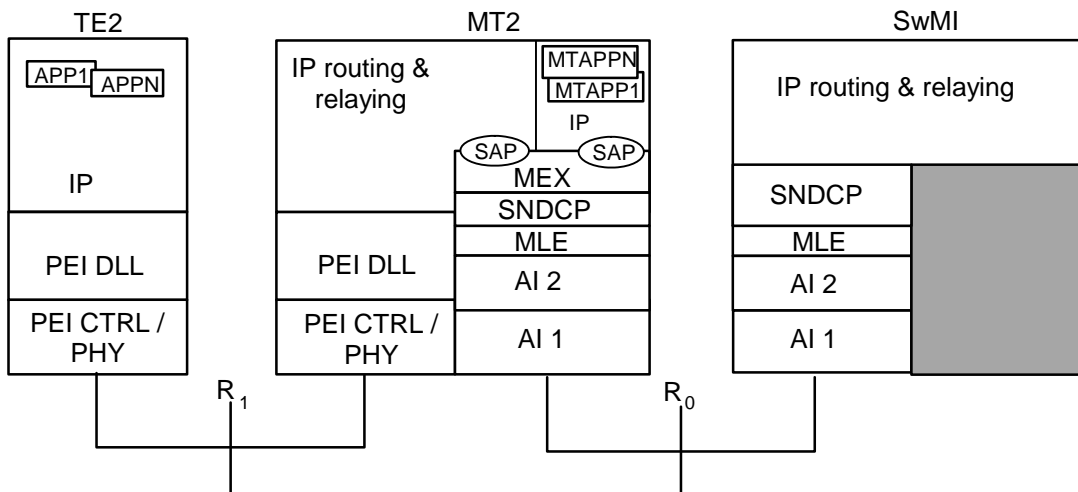

Figure 30.2: Usage of TETRA packet data with MEX for TE2 and MT2 IP applications

The IP traffic from the TE and MT applications go through the MEX layer. The MEX layer handles three types of IP traffic:

Type 1 - Control traffic between the applications and the MEX layer.

Type 2 - Data traffic between the applications and the SNDSCP layer via the MEX layer.

Type 3 - Data traffic between the applications and the SNDSCP layer (bypassing the MEX layer).

In addition, the MEX layer handles the communication with the SNDSCP layer using the SNDSCP primitives, which will be discussed as part of this clause in the later sections. First, the details of the MEX layer interface will be described.

Figure 30.3 illustrates a typical deployment example showing the full set of components involved, namely:

- PEI Ctrl/Phy - The peripheral equipment interface.
- PCON - A logical connection associated with the PEI physical connection. Where a modern high speed connectivity technology is implemented, several logical PCONs may be available. In a legacy implementation only one PCON is available utilizing a V.24/V.28 physical interface.
- DLL (PEI) - The link layer protocol for carrying data across the Peripheral Equipment Interface (PEI). Most commonly, Point to point protocol (PPP) is employed.
- NCON - A network connection consisting of an IP address, Subnet mask, Gateway address and other applicable parameters for support of carrying IP packets to and from the MT2. Where multiple PDP contexts are supported, both the TE2 and internal application environment of the MT2 can host multiple NCONs and hence, multiple IP addresses. An NCON can typically be a connected PPP connection over a PCON.
- IP - The section of the IP stack related to an applicable NCON.
- Applications - Applications requiring both uplink and downlink packet data services.
- QoS Manager - An agent which often resides close to the IP stack which can negotiate QoS services and capabilities in IP networks. In TETRA, the QoS Manager may use either AT commands or TNPI protocol to negotiate QoS enabled packet data services. Applications, themselves, may also implement QoS management functionality.

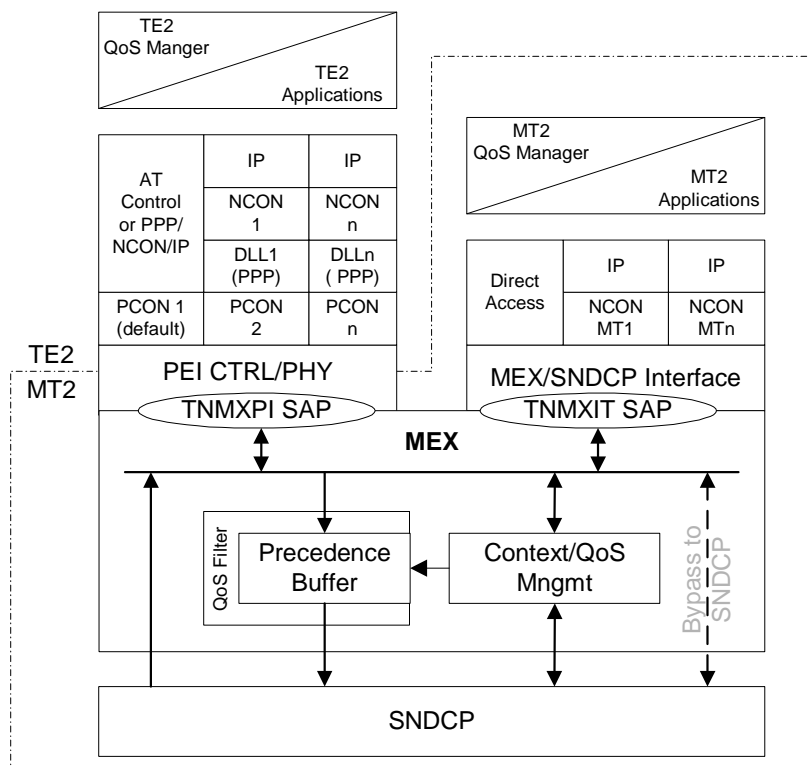

Figure 30.3: MEX Peripheral Interfaces

Access to MEX services is available via 2 possible SAPs:

- TNMXPI SAP - Service Access Point to carry data and configuration via the Peripheral Equipment Interface (PEI). For clarity, the PEI section of Figure 30.3 illustrates multiple logical PEI connections (PCON) over which applications may communicate through TNMXPI. Note that applications may have either a dedicated PCON or may share a PCON (PCON_n). Furthermore, these relations, by definition, bear no specific mapping to a particular PDP context at the SNDSCP.
- TNMXIT_SAP - Service Access Point to carry data and configuration related to applications housed internally to the MT.

The MEX layer incorporates the following functionality some of which is mandatory or optional as denoted by (M) or (O):

- QoS Filter (M) - To assist in routing of application data having different QoS requirements to appropriately predefined PDP contexts.
- Precedence Buffer (O) - To manage flow of IP packets to SNDSCP according to precedence requirements.
- Context/QoS Management (M)- To provide an abstracted interface to PDP context creation and modification, QoS negotiation and Uplink data routing via the QoS Filter.

Each application using the MEX layer transfers data through the IP transport layers via NCONs. The application or associated QoS Manager on the MS may, if MEX is supported, request its QoS via the MEX-CONNECT primitive together with the QoS filter information. Upon success, a PDP context exists and the MEX and SwMI are prepared to route data with the appropriate QoS on both the uplink and downlink.

MEX supports three forms of QoS filtering:

- 1) Port Filtering - The MEX inspects the destination port and protocol (port type) fields of the uplink IP transport packet header and ensures that the packet is routed via SNDSCP SN-DATA primitive to the NSAPI with the previously accepted QoS. The use of a port filter requires that the application is using a port oriented transport protocol (e.g. UDP, TCP, SCTP and DCCP).
- 2) Port and Peer IP Address Filtering - The destination IP Address is inspected in addition to the destination port and protocol fields of the uplink IP transport packet header and ensures that the packet is routed via SNDSCP SN-DATA primitive to the NSAPI with the previously accepted QoS. This method allows differentiation of QoS for similar applications residing on different peer nodes in the packet network.
- 3) Diffserv - The lower 5 bits (4 to 0) of the 6 bit Differentiated services Code Point (DSCP) is inspected in the IP packet header and ensures that the packet is routed via SNDSCP SN-DATA primitive to the NSAPI with the previously accepted QoS. The application should appropriately utilize the "Per Hop Behaviour (PHB)" classes which are defined by IETF RFC 2474 [43], IETF RFC 2475 [44], IETF RFC 2597 [45] and IETF RFC 3246 [46]. Bit 5 of DSCP is used to allow the application to utilize the escalated priority functionality which is defined within the MEX.

MEX itself can perform QoS filtering only on the uplink. However, interfaces are provided to allow requests to be forwarded via SNDSCP in order to set QoS filtering at the SwMI to facilitate filtering on the downlink also.

Four QoS filter transaction types are defined:

- 1) Uplink Filter - The application on the MS sends IP packets to a peer on the IP network. IP packets are routed to a PDP context on the Uplink by the MEX QoS filter based upon either:
 - the destination port and protocol field;
 - destination port and protocol field plus destination IP address; or
 - DSCP of the transmitted IP transport packets.

- 2) Downlink Filter - The application on the MS awaits receipt of IP packets on the downlink from the IP network. Downlink IP transport packets may be routed to a PDP context at the SwMI based upon either:
- the destination port and protocol field;
 - destination port and protocol field plus source IP address; or
 - DSCP of the IP packet.
- 3) Downlink Automatic Filter - The application on the MS sends IP packets to a peer on the IP network. Uplink IP packets are routed to a PDP context on the uplink by the MEX QoS Filter based upon either:
- destination port and protocol field;
 - destination port and protocol field plus destination IP address; or
 - DSCP of the IP packet.

Either the:

- source port and protocol field;
- source port and protocol field plus destination IP; or
- DSCP of the uplink IP packet;

may be recorded at the SwMI to allow for automatic downlink filtering. Automatic filtering at the SwMI on the downlink may use the recorded information to filter downlink packets by either:

- destination port and protocol field;
- destination port and protocol field plus source IP address; or
- DSCP to the appropriate PDP context.

- 4) Uplink Automatic Filter - The application on the MS awaits receipt of IP transport packets on the downlink from the IP network. Downlink IP transport packets are routed to PDP context at the SwMI based upon either:
- destination port and protocol field;
 - destination port and protocol field plus source address; or
 - DSCP of the IP packet.

Either the:

- source port and protocol field;
- source port and protocol field plus source IP address; or
- DSCP of the downlink IP packet;

is recorded at the MEX QoS Filter to allow for automatic uplink filtering. Automatic filtering at the MEX QoS Filter uses recorded information to filter uplink packets by:

- destination port and protocol field;
- destination port and protocol field plus destination IP address; or
- DSCP.

Automatic filters are defined to support the client/server connection oriented nature of the IP protocol.

Where multiple filters are specified, there may be the occasion where an Uplink or Downlink Filter may conflict with a filter automatically determined by an automatic filter. In this state, the explicitly defined Uplink or Downlink filter shall take precedence and override that automatically defined filter.

The usage of DSCP is outside the scope of the present document.

The method of transferring peer IP address or Diffserv QoS Filter information to the SwMI for the purpose of downlink filtering is outside the scope of the present document. Therefore QoS Filtering including the peer IP address or Diffserv may be only supported on the uplink.

30.2 MEX Layer Overview

30.2.1 General

MEX is a TETRA specific network layer with the primary objective to provide a simplified interface to allow the development of applications which can take advantage of the advanced QoS capabilities made available by the packet data service of TETRA.

MEX can offer 3 levels of abstraction to the application or QoS Manager with respect to the negotiation of QoS:

- 1) Legacy context - An application initiates a packet data transfer (equivalent to ATD*99#). The MEX initiates creation of a PDP context via SNDTCP using a default set of QoS settings (see clause 3.2.2.4; MEX QoS Class entry 0).
- 2) MEX QoS - An application or QoS Manager initiates creation of a PDP context by specifying a range of QoS by specifying 2 of 256 QoS abstract classes; one indicating an upper QoS requirement and one indicating a lower QoS requirement and a QoS filter specification. The MEX then automates the creation of the PDP context, and negotiates the QoS within the specified limits. The full range of QoS classes and attributes together with MEX QoS filtering on the uplink is available in this mode.
- 3) SNDTCP QoS - An application or QoS Manager may initiate direct creation of a PDP context and data transfer using the full SNDTCP QoS primitives. Automatic negotiation using MEX QoS class, MEX Precedence, MEX QoS filtering on the uplink are not supported in this mode.

NOTE: SNDTCP QoS is negotiated between SwMI and MS or the default background class QoS is applied (see clause 28.3.4.8).

Applications residing on both TE2 and MT2 the can utilize any of the three options above and can coexist at any time, limited only by the services available at the SNDTCP.

30.2.2 QoS Classes

30.2.2.1 Data Class

Each TE2 and MT2 application that requires access to the MEX layer can belong to one of three classes. MEX layer offers QoS to the following multimedia service classes:

- | | |
|------------------|---|
| Real-time class | layer 2 link optimized for data which cannot tolerate delivery delay (late packets discarded by the receiving application); |
| Telemetry class | layer 2 link optimized for intermittent data which can tolerate moderate delivery delay and packet loss; |
| Background class | layer 2 link optimized for data which are intolerant of packet loss. |

Real-time class applications require regular access to the radio resources, and have low delay tolerance. Although data reliability is important for such applications, it can be compromised for low transmission delays. Typical examples of applications which would utilize this class are video conferencing and packet speech transmission.

The telemetry class applications may also require regular access to the radio resources, and have moderate delay tolerance (higher than real-time class). Reliability can be compromised for short transmission delays. Depending on the update rate of the application data, even unacknowledged transmission may be used. Typical examples include location update, medical telemetry and data logging applications.

The background class is the most delay tolerant among all the multimedia classes. In most cases, the objective is to transmit the packets correctly despite long delays. Although high data throughput is a desirable feature, its absence does not dramatically affect the usability of the application. Web browsing, file transmission and control applications belong to this class.

If QoS is not negotiated, then the background class is provided as default (see clause 28.3.4.8).

30.2.2.2 Delay Class

Maximum packet delay refers to the delay within a single SwMI TETRA network from MS to MS.

The reader should refer to clause 28.2.3.2 for details of achievable maximum packets delays for each of the delay Classes:

- Low;
- Moderate;
- High; and
- Unpredictable.

30.2.2.3 Reliability Class

Packet reliability is specified for the local MS - SwMI air interface for a single link and it is not associated with the end-to-end reliability.

The reader should refer to clause 28.2.3.2 for details of N-PDU reliability for each of the reliability classes:

- High;
- Moderate; and
- Low.

30.2.2.4 MEX QoS abstract class

The MEX QoS Abstract class is defined for the ease of setting the multitude of QoS parameters by the application. The MEX shall implement a table (MEX_QOS_CLASS_TBL) of up to 256 MEX QoS abstract classes which can be chosen or modified by the TE2 application via MEX-QOSCLASS. A default QoS class 0 is used to support legacy applications which do not request any QoS via the PEI. MEX QoS Classes 0-8 are defined in this specification and shall be implemented in all MT2. These are shown in table 30.3 MEX QoS Classes 9 to 32 are reserved for addition of manufacturer specific values. For entries in MEX_QOS_CLASS_TBL which are accessible for modification (33 to 255), a lock feature is available to prevent applications from modifying each others' entries in the MEX_QOS_CLASS_TBL.

Two entries in the MEX QoS Class table can be used to define a range of acceptable QoS during MEX-CONNECT to allow MEX the flexibility to automatically negotiate QoS with SMDCP and, hence, the network. Where a range (Upper and Lower) is used the following table 30.2 clarifies the upper and lower values for each QoS Class / Parameter.

Table 30.1: Void

Table 30.2: Full Range of operation for QoS Classes and Attributes

Class / Attribute	Upper	Lower	Note
Minimum Peak Throughput	≥ 64 000	< 1 000	Octets/s
Mean Throughput	Best effort	100	Octets/h
Mean Active Throughput	Best effort	100	Octets/h
Data Class	Real time	Background	
Delay Class	High	Unpredictable	
Reliability Class	High	Low	
CONTEXT_READY time	300 s	200 ms	Where track READY timer is required, this should be entered for both upper and lower
Scheduled Repetition Period	706	4	Slot durations (85/6 ms)
Scheduled Timing Error	1	128	Slot durations (85/6 ms)
Scheduled Number of N-PDUs per grant	7	1	
Scheduled N-PDU size	2 002	1	Octets
MEX Precedence	14	1	
MEX Data Priority	7	0	
MEX PDU Priority Max	7	0	
MEX Data Importance	High	Low	

Applications which do not have a preference for a particular class or parameter should specify the extreme range as given in the table 30.3. Applications which have a direct need should specify the specific range as tightly as appropriate for the specific requirement or specify identical values in both the upper and lower request.

Table 30.3: Fixed values for MEX QoS Class

QoS parameter	MEX QoS class									Remarks
	0 (default)	1	2	3	4	5	6	7	8	
Minimum peak throughput	< 1 000	< 1 000	< 1 000	≥ 1 000	≥ 2 000	≥ 4 000	≥ 1 000	≥ 8 000	≥ 32 000	Octets/s
Mean throughput	Best effort	100 000	10 000	500 000	2 000 000	10 000 000	Best effort	Best effort	Best effort	Octets/h
Mean active throughput	< 1 000	< 1 000	< 1 000	≥ 1 000	≥ 2 000	≥ 4 000	50 000 000	50 000 000	50 000 000	Octets/h
Data class	Background	Background	Background	Telemetry	Telemetry	Telemetry	Real time	Real time	Real time	
Delay class	Unpredictable	Unpredictable	Unpredictable	Low	Moderate	High	Low (default)	Low (default)	Low (default)	Unpredictable, High, Moderate, Low
Reliability class	Moderate	Moderate	High	High	Moderate	Low	Low (default)	Low (default)	Low (default)	High, Moderate, Low
CONTEXT_READY time	track READY	track READY	track READY	500 ms	1 s	2 s	3 s	2 s	500 ms	
Schedule repetition time	N/A (Background class)	N/A (Background class)	N/A (Background class)	20	50	70	150	100	20	4 to 706 slot durations (85/6 ms)
Schedule timing error	N/A (Background class)	N/A (Background class)	N/A (Background class)	2	5	10	3	2	1	≤ 1 to ≤ 128 slot durations
Scheduled number of N-PDUs per grant	N/A (Background class)	N/A (Background class)	N/A (Background class)	1	1	1	5	6	7	1 to 7 N-PDUs per grant
Scheduled N-PDU size	N/A (Background class)	N/A (Background class)	N/A (Background class)	150	500	1 000	500	2 000	1 300	Octets
MEX precedence	1	1	1	2	2	2	10	12	14	1 to 14
MEX data priority	0	0	0	6	4	0	6	4	0	0 - Low, 7 - High
MEX PDU priority max	0	0	0	6	4	0	6	4	0	0 - Low, 7 - High
MEX data importance	High	Medium	Low	High	Medium	Low	High	Medium	Low	Low, Medium, High

30.2.3 QoS Attributes

30.2.3.1 General

In addition to the QoS classes described above, the MEX layer supports the following QoS attributes which shall be as defined in the clauses 30.2.3.2 to 30.2.3:

- Data throughput;
- MEX precedence;
- Data Priority;
- PDU Priority;
- Data importance;
- Scheduled access; and
- CONTEXT_READY time.

30.2.3.2 Data Throughput

An MT or TE application always requests the following parameters as different throughput measures:

- **Minimum Peak Throughput:** The expected minimum peak throughput, measured in octets per second. This indicates to the lower layers how allocate channel bandwidth, coding and modulation in order to achieve the minimum peak throughput require by the application. This is the minimum peak throughput of N-PDUs in units of octets per second requested or offered for a particular PDP context. This is the minimum throughput required when the PDP context is at its most active; if the peak rate available is lower than this, the application may not be usable (though the application may be capable of using a higher rate than this). Valid values are:
 - < 1 000;
 - $\geq 1\ 000$;
 - $\geq 2\ 000$;
 - $\geq 4\ 000$;
 - $\geq 8\ 000$;
 - $\geq 16\ 000$;
 - $\geq 32\ 000$; and
 - $\geq 64\ 000$.
- **Mean Throughput:** The expected mean throughput, measured in octets per hour is averaged over the expected lifetime of the associated PDP context. This is the mean throughput of N-PDUs expected by the SNDSCP service user, averaged over the expected lifetime of the PDP context. It is given in units of octets per hour. Valid values are:
 - 100 (~0,22 bits/s);
 - 200 (~0,44 bits/s);
 - 500 (~1,11 bits/s);
 - 1 000 (~2,2 bits/s);
 - 2 000 (~4,4 bits/s);
 - 5 000 (~11,1 bits/s);

- 10 000 (~22 bits/s);
- 20 000 (~44 bits/s);
- 50 000 (~111 bits/s);
- 100 000 (~0,22 kbits/s);
- 200 000 (~0,44 kbits/s);
- 500 000 (~1,11 kbits/s);
- 1 000 000 (~2,2 kbits/s);
- 2 000 000 (~4,4 kbits/s);
- 5 000 000 (~11,1 kbits/s);
- 10 000 000 (~22 kbits/s);
- 20 000 000 (~44 kbits/s);
- 50 000 000 (~111 kbits/s); and
- Best effort.

NOTE: These values follow those given for GPRS (see ETSI EN 301 344 [i.11]).

- **Mean Active Throughput:** The mean active throughput, measured in octets per hours, is averaged over the period defined by the CONTEXT_READY time. Values shall be as for the Mean throughput.

30.2.3.3 MEX Precedence

MEX precedence defines how frequently application data is transferred to the SNDSCP for transmission, which is achieved by a queuing mechanism at the MEX layer. The MEX layer provides data precedence internally, which can manage an unlimited number of applications simultaneously. Each application can choose one of 14 precedence levels (1 to 14). Note that if an application does not specify a precedence level, it is assigned to precedence level 1.

The MEX precedence mechanism consists of an application list, multiple buffers and a precedence switch as shown in figure 30.4. MEX Precedence is a round robin mechanism which processes and transfers packets to the SNDSCP as follows:

- up to 14 packets from each application which has specified precedence level 14;
- up to 13 packets from each application which has specified precedence level 13;
- and so on for each precedence level; until
- one packet is processed for each application which has requested precedence level 1.

The round robin then continues again at precedence level 14.

During PDP context activation, the application chooses the MEX precedence level using MEX-CONNECT, and the MEX layer places that application to its precedence list. Each precedence level is associated with an internal buffer. Therefore, after an application chooses its MEX precedence, its MEX-DATA payload is routed to a corresponding buffer. Each buffer output is connected to a precedence switch, which allocates the available MEX output bandwidth dynamically. In other words, high precedence data is transferred more frequently than the low precedence one.

A precedence rank figure is defined to allow an application to understand its real placement within the precedence buffer where there may be other application operating for which the requesting application is not directly aware. Equation 1 describes how precedence rank is derived. This provides a figure relating to the ratio of full precedence bandwidth that the application is actually given. An application may then choose to modify its MEX Precedence or other QoS parameter should its actual placement not be sufficient.

$$PR = \frac{RP}{\sum_{n=1}^{14} n * NAP} \quad (30.1)$$

where:

PR = Precedence Rank.

RP = Requested Precedence level.

NAP = Number of applications which are operational at that precedence.

If the MEX precedence functionality is not supported, Precedence Rank will always equal 0.

Two examples of usage are given in order to explain the functionality offered by the MEX precedence buffer.

EXAMPLE 1: In simple terms, application A requests precedence 14 and application B requests precedence 7. Where both applications provide a sensible matched throughput to the requested MEX precedence, the precedence switch transfers 14 packets (MEX-DATA primitives) as SN-DATA to the SNDPCP. Once 14 packets of application A are transferred, 7 packets of application B are then transferred. Application A therefore has twice the precedence of application B. A similar precedence is achieved using precedence 2 and 1 respectively effectively operating in a different precedence dimension. However, the application may wish to request an appropriate precedence dimension to assist in matching an equivalent Scheduled access (i.e. Scheduled N-PDUs per grant).

Precedence Rank for both cases is therefore:

- Application A - 0,667 (66,7 %);
- Application B - 0,333 (33,3 %).

EXAMPLE 2: Figure 30.4 illustrates 4 applications populating the precedence list. Where all applications provide a sensible matched throughput to the requested MEX precedence, the follow packet transfer occurs:

- 14 packets of application 1;
- 11 packets of application 2;
- 11 packets of application 3; and
- 1 packet of application 4.

Precedence Rank is therefore:

- Application 1 has PR=0,378 (37,8 %);
- Application 2 has PR=0,297 (29,7 %);
- Application 3 has PR=0,297 (29,7 %); and
- Application 4 has PR=0,027 (2,7 %).

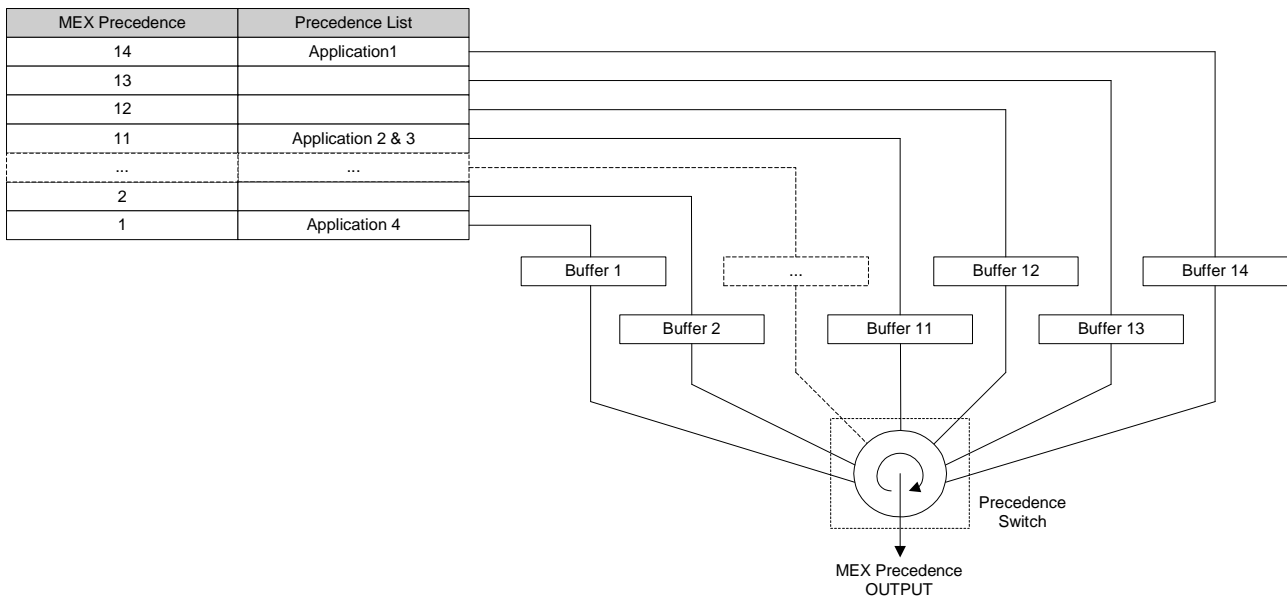

Figure 30.4: MEX Precedence

30.2.3.4 Data Priority

Data priority allows an MS to transmit high data-priority N-PDUs (IP packets) ahead of lower data-priority N-PDUs from the same MS and other MSs. 8 levels of data priority are defined where 0 is the lowest and 7 is the highest.

30.2.3.5 PDU Priority

PDU priority affects LLC queue reordering and the MS's permission to use random access opportunities. 8 levels of PDU priority are defined where 0 is the lowest and 7 is the highest priority.

30.2.3.6 Data Importance

Data Importance allows the SNDCP the option to delete or cancel untransmitted lower importance N-PDUs in circumstances where buffer overflow might otherwise occur. Data Importance has three levels, Low, Medium and High.

30.2.3.7 Scheduled Access Option

Scheduled access allows the application to reserve a periodic schedule of bandwidth appropriate to the application's requirements. Only the real-time and telemetry service classes may request regular access from the network.

Four attributes are defined to allow specification of the required schedule. Figure 30.5 illustrates the relationship between these attributes. Timing is always described with respect to the slot duration of 65/6 ms:

- Schedule Repetition Period - the number of slot durations between each schedule grant. Valid values are 4 (56,67 ms) to 706 (10 s).
- Scheduled number of IP Packets (N-PDUs) per grant - Each grant can consist from 1 up to 7 IP packets.
- Scheduled IP Packet (N-PDU) size - the size of the IP packet (N-PDU). This may be from 1 to 2 002 octets and may be specified separately for each IP packet within the grant.
- Schedule Timing Error - This allows the specification of a tolerated delay relative to the scheduled slot granting time. This is measured in slot durations and can be specified to be ≤ 1 to ≤ 128 slot durations. Note that the Scheduled Repetition Period is maintained and that Schedule Timing Error does not accumulate on each schedule grant.

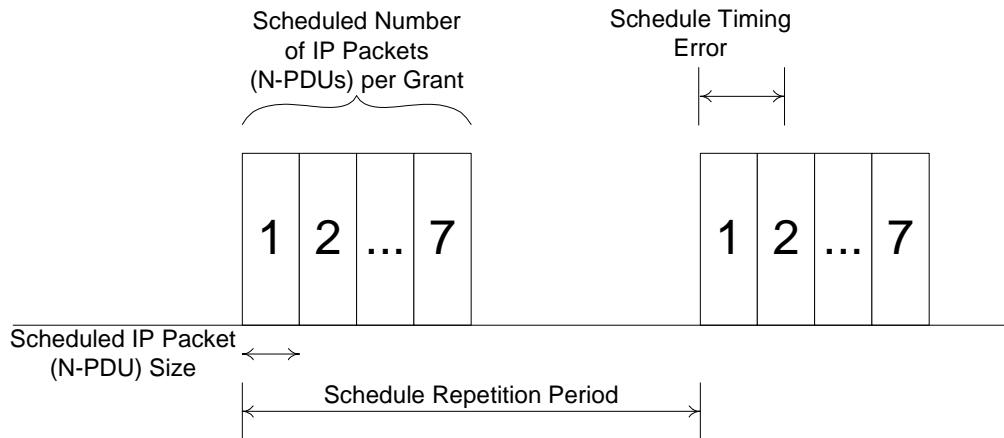

Figure 30.5: Scheduled Access

30.2.3.8 CONTEXT_READY timer

For a PDP context, the CONTEXT_READY time is the duration for which the PDP context is actively transferring data. Upon the expiration of the CONTEXT_READY time the SwMI is free to reallocate resources to other active PDP contexts. Valid values are:

- track READY timer;
- 200 ms;
- 500 ms;
- 700 ms;
- 1 s;
- 2 s;
- 3 s;
- 5 s;
- 10 s;
- 20 s;
- 30 s;
- 60 s;
- 120 s;
- 180 s; and
- 300 s.

30.2.3.9 Escalated Priority

Where an application may require to send temporary higher priority data, the MEX provides a means for the application to specify this. This is commonly used in the TCP header where the URG flag is utilized to indicate the highest urgency in transferring the packet.

A mechanism is also provided for the application to mark escalated priority within the IP header to allow the use of other transport protocols such as UDP. Bit 5 of the Differentiated Services Code Point field (DSCP) is utilized (according to the Local Use definition given by IETF RFC 2474 [43]).

The following two options are available for the application to mark a packet for escalated priority:

- Bit 5 of DSCP in the IP Header is set; and
- A TCP protocol is used and the URG flag is set.

The MEX QoS Filter shall inspect the packet protocol field. If the packet protocol field is TCP then the URG flag is inspected. The MEX shall also inspect bit 5 of the DSCP IP Header field.

The PDU Priority, Data Priority and Data Importance added to the SN-DATA/SN-UNITDATA primitive is derived as follows for each IP packet to be transmitted on the uplink. Note that MEX_SNDATA_QOS_TBL is not affected by this operation:

- a) Protocol field is not TCP and DSCP bit 5 is not set - use the PDU Priority, Data priority and Data Importance from MEX_SNDATA_QOS_TBL.
- b) Protocol field is not TCP and DSCP bit 5 is set - increase PDU Priority and Data priority by 2 from the appropriate values stored in MEX_SNDATA_QOS_TBL. Increase Data Importance by one point higher over the value stored in MEX_SNDATA_QOS_TBL.
- c) Protocol field is TCP, DSCP bit 5 is not set and URG flag is not set - use the PDU Priority, Data priority and Data Importance from MEX_SNDATA_QOS_TBL.
- d) Protocol field is TCP, DSCP bit 5 is not set and URG flag is set - increase PDU Priority and Data priority by 1 from MEX_SNDATA_QOS_TBL. Increase Data Importance by one point higher over the value stored in MEX_SNDATA_QOS_TBL.
- e) Protocol field is TCP, DSCP bit 5 is set and URG is not set - increase PDU and Data priority by 1 from MEX_SNDATA_QOS_TBL. Increase Data Importance by one point higher over the value stored in MEX_SNDATA_QOS_TBL.
- f) Protocol field is TCP, DSCP bit 5 is set and URG flag is set - increase PDU and Data priority by 2 from MEX_SNDATA_QOS_TBL. Increase Data Importance by one point higher over the value stored in MEX_SNDATA_QOS_TBL.

Where it is not possible to increase PDU Priority, Data Priority or Data Importance, the highest value will be used. PDU Priority shall not exceed the returned PDU Priority max as specified by the SN-NSAPI Alloc Cnf when the PDP context was created.

Whilst this escalation is only appropriate for the TETRA air interface, the MEX shall optionally reset bit 5 of the DSCP before forwarding the packet on to any further hops in the IP network. If this option is active, MEX should reset bit 5 of DSCP before transferring the packet to the SNDSCP on the uplink and also before forwarding any downlink packets to the application. This option, by default, shall not reset bit 5 of DSCP. The option to enable the reset of bit 5 of DSCP is given during PDP context creation and is provided to avoid any limitation in the wider usage of Diffserv in an end to end communication.

By default the use of Bit 5 of DSCP for escalated priority shall be disabled. Usage can be enabled by the application during the MEX_CONNECT procedure.

The SwMI may also provide escalated priority functionality in order to maintain escalated priority on both air interfaces of an MS to MS communication.

30.2.4 Definition of MEX states and state transitions

30.2.4.1 General

At the highest level each transaction flow with the MEX layer has two major states as shown in figure 30.6. Each transaction flow is identified by "MEX Handle" which can represent the specific "MEX mode" by request. This allows multiple control and data streams to the MEX allowing the ability to transact across multiple logical PEI connections (PCONs) and to allow the instantiation and representation of multiple MS IP addresses in the TE2.

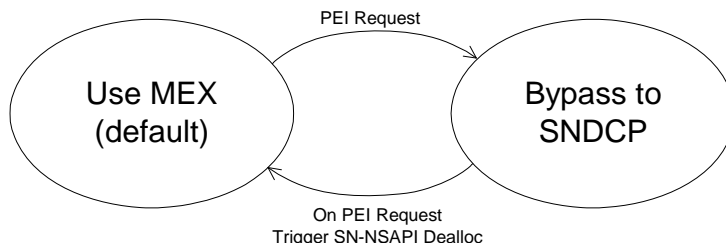

Figure 30.6: Activating, Bypassing MEX QoS features using MEX Handle

Individual states are described as follows:

- Use MEX - All QoS functionality, including PDP service negotiation is managed by the MEX Layer; and
- Bypass to SNDCP - All SNDCP services are directly accessible to the user application via the PEI.

Within the Use MEX state, the following state machine given in figure 30.7 elaborates the use of the default background context for the support of legacy applications.

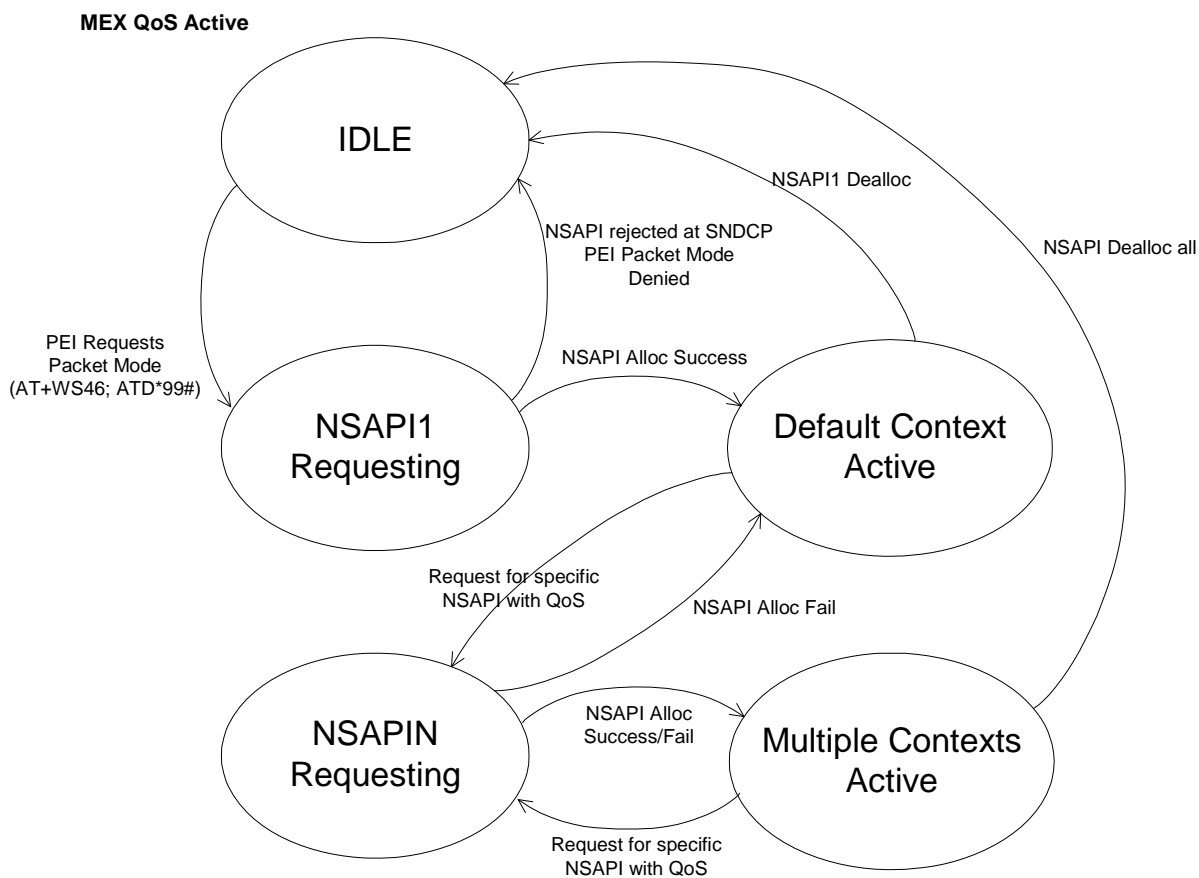

Figure 30.7: PDP context creation state machine

Individual states are described as follows:

- IDLE - No NSAPIs are active, PEI only has one PCON in AT mode only;
- NSAPI1 Requesting - A Default, background class NSAPI is requested (MEX QoS Class = 0);
- Default Context Active - Equivalent Legacy Context. All data is routed through this basic NSAPI;
- NSAPIN Requesting - The application has requested another PDP context; and
- Multiple contexts active - Data is routed appropriately via the requested PDP contexts.

30.2.4.2 Secondary PDP contexts

The concept of secondary PDP contexts is defined at the SMDCP to allow for different applications with different QoS requirements to operate over a PDP context with the same MS IP address. The MEX-CONNECT primitive has provision to request either a new MS IP address or attach a new application with differing QoS requirements to an existing IP address. It is the MEX responsibility to ensure that the appropriate SMDCP transactions occur to request either the primary or secondary NSAPI appropriately.

30.2.4.3 MEX QoS Filter and Address/NSAPI mapping tables

Four tables, internal to MEX, are defined in order to facilitate operation of the MEX QoS Filter, the use of NSAPI and IP addresses and parameters for compilation of the SN-DATA/SN-UNITDATA primitives.

Table 30.4 illustrates MEX_CONTEXT_TBL table. MEX_CONTEXT_TBL is used to identify relationships between active PDP contexts. MEX_CONTEXT_TBL is used initially to store the unique MEX_Handle, when a particular MEX_Handle successfully initiates a PDP context, the MS IP address and associated NSAPI is stored. As the applications are only aware of IP Addresses and do not concern with NSAPI numbers, the MEX uses the mapping between MS IP Address and Primary NSAPI in order to facilitate the correct formulation of SN NSAPI Alloc requests for secondary PDP contexts. Successful creation of secondary PDP contexts are entered into the MEX_CONTEXT_TBL table 30.4.

Table 30.4: MEX_CONTEXT_TBL

MEX Handle	MS IP Address	Primary NSAPI	Secondary NSAPI
....
....

Table 30.5 illustrates the MEX_QOS_FILTER_TBL table. Upon successful creation of a PDP context, MEX_QOS_FILTER_TBL is updated with the Uplink Destination Port Range and filter type (with optional Peer Destination IP Address), or DSCP, Filter Type as specified by MEX QoS Filter in MEX-CONNECT. The Upper and Lower MEX QoS Class for Uplink and Downlink are also stored to allow MEX to renegotiate QoS parameters upon a network initiated SN NSAPI Modify as described in clause 30.3.4.

Table 30.5: MEX_QOS_FILTER_TBL

NSAPI	Uplink Destination Port Range	Peer Destination IP Address	DSCP	DSCP Priority Escalate Option	Filter Type	QoS Class Uplink Lower	QoS Class Uplink Upper	QoS Class Downlink Lower	QoS Class Downlink Upper
....
....

Table 30.6 illustrates the MEX_QOS_AUTOFILTER_TBL table. When "MEX Transaction Type" is specified in MEX-CONNECT or MEX-MODIFY as "Uplink Automatic Filter", MEX_QOS_AUTOFILTER_TBL stores the details required to automatically generate entries into MEX_QOS_FILTER_TBL from downlink packets. For each NSAPI, a destination Port Range and filter type is specified (with optional downlink Source IP address). Entries in MEX_QOS_FILTER_TBL are updated based upon the following mappings:

- uplink packet Destination port - from the source port of the downlink packet; and

- uplink Peer Destination IP Address - from the source IP address of the downlink packet.

Table 30.6: MEX_QOS_AUTOFILTER_TBL

NSAPI	Downlink Destination Port Range	Downlink Source (Peer) IP address	Filter Type
....
....

Table 30.7 illustrates MEX_SNDATA_QOS_TBL table. During MEX-CONNECT and MEX-MODIFY, MEX PDU priority, MEX Data Priority and Data Importance are specified through entries of MEX QoS Class. These figures are stored in MEX_SNDATA_QOS_TBL to allow MEX to automatically fill the optional fields within the SN-DATA primitive for uplink packets.

Table 30.7: MEX_SNDATA_QOS_TBL

NSAPI	MEX PDU Priority	MEX Data Priority	MEX Data Importance
....
....

30.3 MEX Procedures

30.3.1 Services provided by the protocol and QoS negotiations

MEX performs the following functions:

- processing PDP context activation, modification and PDP context deactivation requests;
- MEX precedence handling;
- handling the QoS modification requests originating from the SMDCP layer and the MT and TE applications;
- mapping of SN primitives received from the network layer into corresponding MEX messages to be passed to the MT and TE applications via the saps; and
- routing TE2 and internal MT2 application data, to and from the SMDCP layer.

30.3.2 MEX access procedure

MEX-HANDLE is used to request and deallocate a handle from MEX and to also indicate whether any subsequent MEX communication should be dealt with by the MEX or routed direct to the SMDCP.

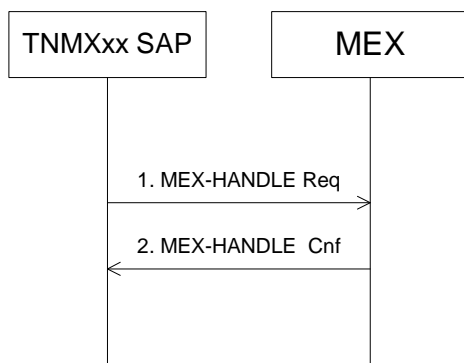

Figure 30.8: Obtaining a handle for use with MEX procedures

Each numbered step in figure 30.8 is explained in the following list:

- 1) MEX-HANDLE Req is sent to the MEX requesting a "MEX Mode".
- 2) MEX-HANDLE Cnf returns the "MEX Handle" which is to be used in subsequent MEX primitives. "MEX Handle" may also be returned as 0xFF which is used to indicate a failure to supply a valid Handle.

MEX primitives used without first using MEX-HANDLE can only originate from the default PCON and shall set a default handle of 0 and shall be handled by the MEX layer for provisioning of the Legacy context (ATD*99# equivalent).

MEX-HANDLE used where "MEX Mode" is "Deallocate Handle", shall tear down all associated PDP contexts.

A MEX Handle is Deallocated only upon request or if the MS is powered off.

30.3.3 MEX-CONNECT Procedure

MEX-CONNECT is used to initiate a PDP context with a set of QoS parameters.

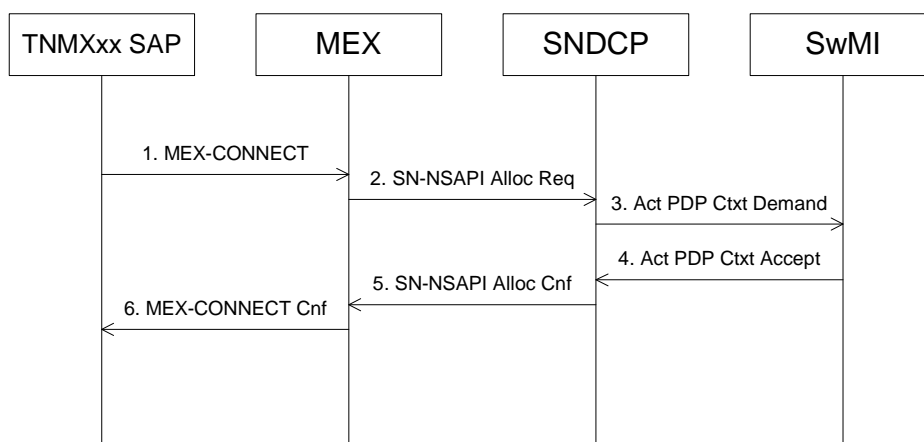

Figure 30.9: MEX-CONNECT procedure

Each numbered step in figure 30.9 is explained in the following lists with respect to whether MEX is utilized or bypassed based upon the MEX Mode associated with the "MEX Handle" which is used.

MEX Mode is "Use MEX":

1. MEX-CONNECT Req is sent to MEX with a MEX Handle, Port Range, transaction type and MEX QoS Class range and MEX PDP Type.
2. MEX looks up the QoS parameters from the internal MEX QoS Class table using parameter MEX QoS Class Upper. Firstly, the QoS parameters of currently active PDP contexts which have been initiated by MEX are investigated to assess the possibility to use a currently active PDP context. Step 2.1 shall be followed if a currently active PDP context is to be used:
 - 2.1. The procedures described in clause 30.3.4 are followed (without the originating MEX-MODIFY) taking into account the combined QoS of all applications currently using the PDP context including the application which has made the MEX-CONNECT request. This shall ensure that all applications using the chosen PDP context can remain within their requested MEX QoS Class range. Throughput parameters shall always be modified.
 - 2.2. If the current MEX-CONNECT cannot use an existing PDP context the MEX sends a full SN-NSAPI Alloc Req to SNDCP. If the QoS Manager or application requires a new IP address (MEX PDP Type), parameter NSAPI is automatically chosen numerically from the unallocated pool of NSAPI 1 to 14. If PDP address is present, PDP Type is set to IPv4 (static address). If PDP Type is specified as Primary NSAPI (secondary PDP context requested), the MEX shall lookup the NSAPI from MEX_CONTEXT_TBL table and supply the primary NSAPI appropriately in SN-NSAPI Alloc. If MEX Handle is 0, the default MEX QoS Class 0 shall be used. If MEX Data Priority Flag Reset is present then the QoS filter is enabled to reset bit 5 of DSCP upon data transfer.

3. SNDTCP demands the PDP context from SwMI.
4. The SwMI may set its Downlink QoS filter as requested. SwMI replies with a success or failure.
5. SNDTCP notifies MEX via SN-NSAPI Alloc Cnf. MEX inspects the returned QoS parameters and compares with the values of the MEX QoS Class table pointed to by "MEX QoS Class Lower". If one or more of the returned QoS parameters are returned specifying a lower QoS capability than those specified by "MEX QoS Class Lower" then the MEX-MODIFY procedure is subsequently used with parameters of "MEX QoS Class Lower". Step 6 is then returned accordingly.
6. Upon successful creation or attachment to an existing PDP context, MEX returns MEX-CONNECT Cnf with details of the final QoS parameters in operation. If an existing PDP context is modified as described in step 2.1 then all applications originally using the modified PDP context shall receive a MEX-MODIFY Ind as for the Network initiated MEX-MODIFY described by step 8 of figure 30.13 (clause 30.3.4). MEX updates MEX_CONTEXT_TBL table. If MEX transaction type is "Uplink Filter" MEX updates MEX_QOS_FILTER_TBL table. If MEX transaction type is "Uplink Automatic Filter", MEX updates MEX_QOS_AUTOFILTER_TBL table. If a subsequent MEX-MODIFY is attempted in step 5 and returns QoS parameters specifying a lower QoS capability than those specified by "MEX QoS Class Lower" MEX-CONNECT Cnf, MEX Connect Report shall equal Failure and MEX Connect reject Cause shall equal Requested QoS not available. An additional SN-NSAPI Dealloc req shall be sent to the SNDTCP to deactivate the corresponding PDP context.

MEX mode is "Bypass to SNDTCP":

- 1) MEX-CONNECT is sent to MEX with all PDP Context creation and QoS parameters except "MEX Precedence". MEX Transaction types "uplink filter" and "Automatic uplink filter" are not available.
- 2) MEX directly forwards, or if necessary, reformats and forwards the request as SN NSAPI Alloc Req to SNDTCP.
- 3) SNDTCP demands the PDP context from SwMI.
- 4) SwMI replies with a success or failure.
- 5) SNDTCP notifies MEX via SN-NSAPI Alloc Cnf.
- 6) MEX directly forwards or, if necessary, reformats and forwards SN NSAPI Alloc Cnf as MEX-CONNECT Cnf.

30.3.4 MEX-MODIFY Procedure

MEX-MODIFY can be either MS or Network initiated. For an MS initiated MEX-MODIFY, depending upon which QoS parameters are required to change, there are three different procedures which may be followed as shown in figures 30.10, 30.11 and 30.12. Depending upon the combination of QoS parameters which are required to change the functionality of figures 30.10, 30.11 and 30.12 will be combined.

By default, the description below assumes that MEX-HANDLE represents MEX Mode as "Use MEX". Exceptions are described throughout.

The following sequence charts illustrate all distinct combinations of transactions required to achieve MEX-MODIFY functionality. In many cases, combinations of these transactions are required. Where this is necessary, only one MEX-MODIFY Cnf should be returned for each MEX-MODIFY Req.

Where a PDP context is shared by several applications, a MEX-MODIFY Req from a single application should not infer a lower QoS on to the sharing applications.

Figure 30.10 illustrates the transactions required with MEX where MEX Precedence, PDU Priority, Data Importance and/or MEX QoS Filter, has changed or MEX Filter Operation is present.

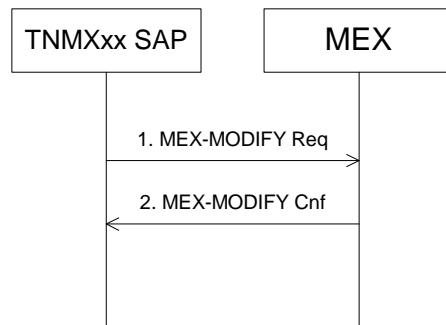

Figure 30.10: MEX-MODIFY where MEX Precedence, PDU Priority, Data Importance and/or MEX QoS Filter, has changed or MEX Filter Operation is present

Each numbered step in figure 30.10 is explained in the following list:

1. MEX-MODIFY Req is sent to MEX where MEX Precedence, PDU Priority and/or Data Importance, uplink MEX QoS Filter has changed or MEX Filter Operation is present. MEX internally modifies its MEX_QOS_FILTER_TBL, MEX_QOS_AUTOFILTER_TBL and MEX_SNDATA_QOS_TBL and MEX Precedence buffers.
2. MEX-MODIFY Cnf is returned.

This transaction is not appropriate where MEX-HANDLE represents MEX Mode as "Bypass to SNDCP".

Figure 30.11 illustrates the transactions required with MEX when only "MEX Data Priority" has changed.

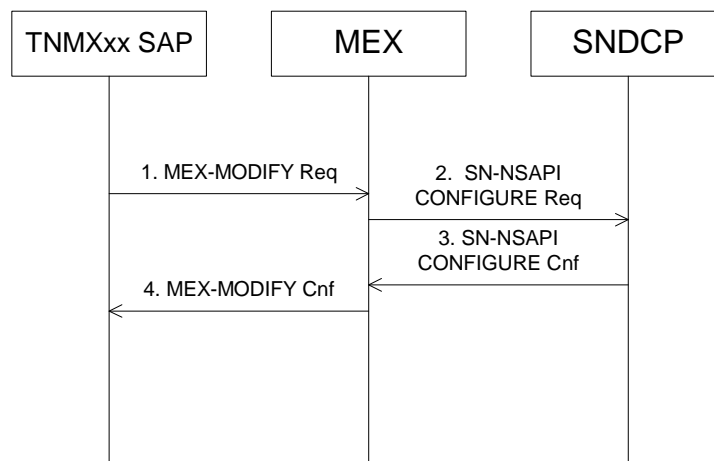

Figure 30.11: MEX-MODIFY where Data Priority has changed

Each numbered step in figure 30.11 is explained in the following list:

1. MEX-MODIFY Req is sent to MEX where Data Priority has changed.
2. SN-NSAPI CONFIGURE Req is sent to SNDCP with the requested default Data Priority.
3. SNDCP agrees a change in default Data Priority with the SwMI. SN-NSAPI CONFIGURE Cnf is then returned to MEX. Where "NSAPI Modify Report" is returned with Success, MEX updates MEX_SNDATA_QOS_TBL.
4. MEX-MODIFY Cnf is returned.

Where MEX-HANDLE represents MEX Mode as "Bypass to SNDCP", this transaction is only applicable where ONLY Data Priority has changed.

Figure 30.12 illustrates the transactions required with MEX where other QoS parameters have changed or "MEX NSAPI Usage" is requested.

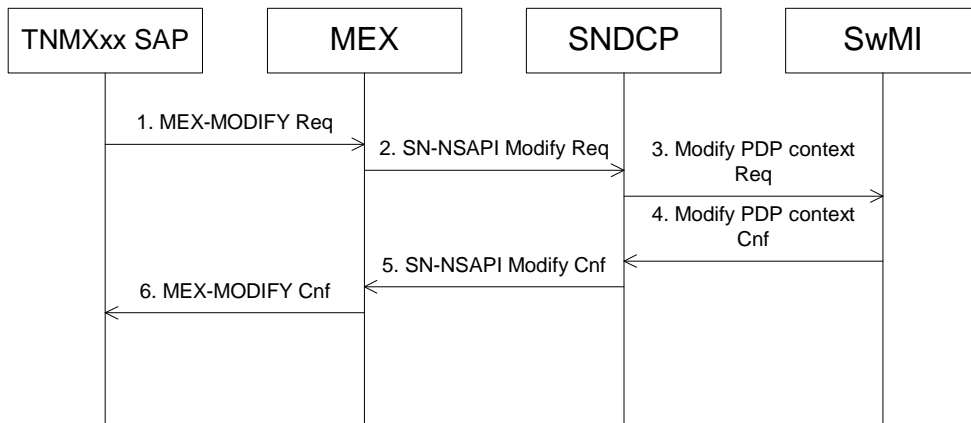

Figure 30.12: MS initiated MEX-MODIFY

Each numbered step in figure 30.12 is explained in the following list:

1. MEX-MODIFY Req is sent to MEX. If "MEX Data Priority" has changed, the SN-NSAPI CONFIGURE procedure shall be carried out according to Figure 30.11 above in advance of the following steps except for MEX MODIFY Cnf which shall be sent as a single instance in step 6 below. This extra step is not applicable where MEX-HANDLE represents MEX Mode as "Bypass to SNDCP".
2. SN-NSAPI MODIFY Req is sent to SNDCP with the requested modifications to NSAPI QoS Negotiation.
3. SNDCP requests modifications from SwMI.
4. SwMI may update its QoS Filter based upon any new downlink filter parameters. SwMI confirms modifications to SNDCP.
5. SN-NSAPI MODIFY Cnf is returned to MEX. On success, MEX updates its internal tables and/or MEX precedence buffers appropriately.
6. MEX-MODIFY Cnf is returned.

Figure 30.13 illustrates a network initiated MEX-MODIFY.

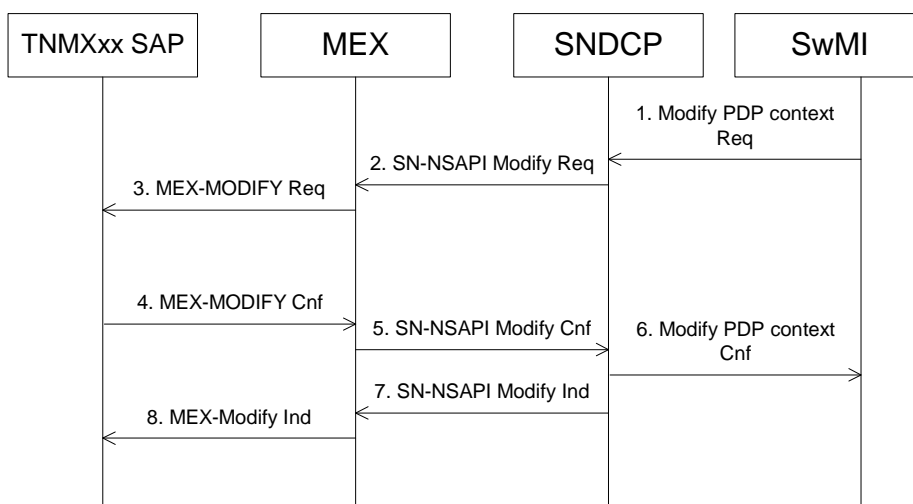

Figure 30.13: Network initiated MEX-MODIFY

Each numbered step in figure 30.13 is explained in the following list:

1. SwMI Requests a modification to the PDP context.
2. SNDTCP forwards appropriately to MEX using SN-NSAPI Modify Req. MEX may lookup the requested QoS modification to check if this specifies a higher QoS capability than the appropriate "MEX QoS Class Lower" entry for the NSAPI. Should this be true, steps 3 and 4 are bypassed. Where MEX-HANDLE represents MEX Mode as "Bypass to SNDTCP", SN-NSAPI Modify Req is forwarded directly using MEX-MODIFY Req in step 3.
3. The application is notified of the requested modification using MEX-MODIFY Req.
4. The application replies using MEX-MODIFY Cnf. Where MEX-HANDLE represents MEX Mode as "Bypass to SNDTCP", SN-NSAPI Modify Cnf is forwarded directly.
5. MEX forwards the confirmation to SNDTCP using SN Modify Cnf.
6. SNDTCP forward confirmation to SwMI.
7. Upon a successful modification SN NSAPI Modify Ind is send to the MEX. MEX shall update its tables accordingly. Where MEX-HANDLE represents MEX Mode as "Bypass to SNDTCP", SN-NSAPI Modify Ind is forwarded directly using MEX-MODIFY Ind in step 8.
8. Application is notified of the new QoS modification using MEX-MODIFY Ind. Note that this may the first indication to the application of any QoS modification should the new QoS parameters exceed the originally requested "MEX QoS Class Lower" as described in step 2.

Where a PDP context modification is initiated by the network and the PDP context is shared by multiple applications, each application shall receive a MEX-MODIFY Req with an appropriate proportion of the full PDP context throughput to the originating request. Each application shall reply with a MEX-MODIFY Cnf before step 5 can continue. Each application using the shared PDP context shall also receive the MEX-MODIFY Ind as described in step 8.

MEX-MODIFY Ind is also sent, unsolicited, direct from the MEX upon a change of the overall MEX Precedence ranking as described in clause 30.2.3.3.

30.3.5 MEX connection termination procedure

The following describes the procedure for terminating a PDP context. Termination can be either MS or Network initiated, both of which are described below.

Figure 30.14 illustrates an MS initiated PDP Context Deactivation.

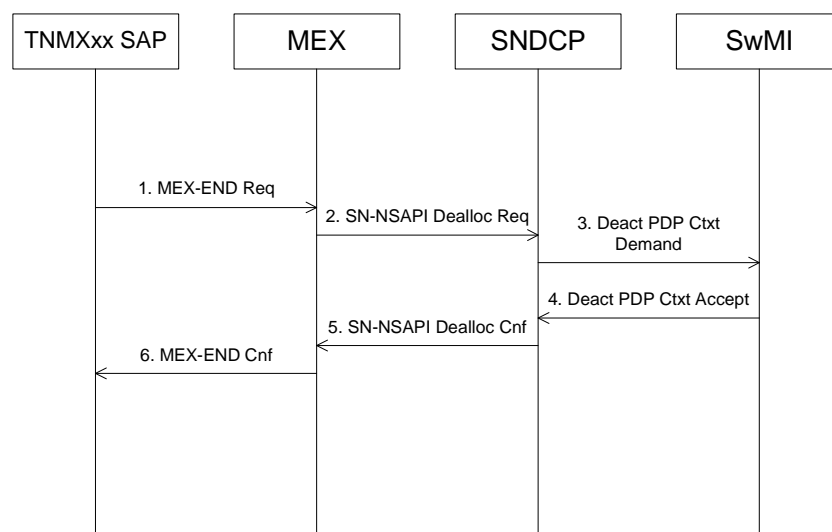

Figure 30.14: MS initiated PDP Context Deactivation

Each numbered step in figure 30.14 is explained in the following list:

1. The application on the MS initiates a MEX-END Request. If Deactivation type is "Deactivate all MEX Contexts" then steps 2 to 5 shall be carried out for each active PDP context which has been created by the MEX layer.
2. SN-NSAPI Dealloc Req is sent to SNDPCP.
3. Deactivate PDP Context Demand is sent to SwMI.
4. SwMI replies with acceptance.
5. SN-NSAPI Dealloc Cnf Confirms to MEX. MEX removes all appropriate entries from internal tables.
6. MEX informs the application of successful deactivation.

Figure 30.15 illustrates a Network initiated PDP Context Deactivation.

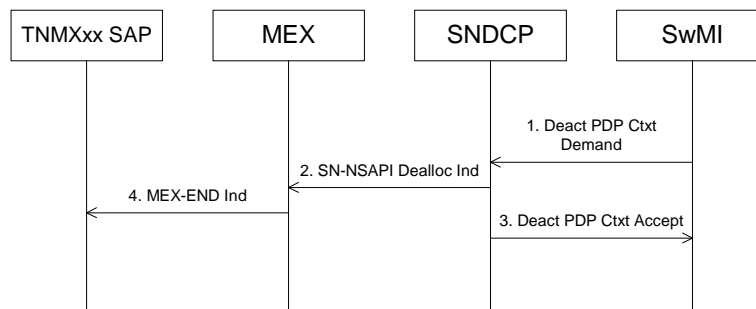

Figure 30.15: Network initiated PDP Context Deactivation

Each numbered step in figure 30.15 is explained in the following list:

1. SwMI Demands PDP Context Deactivation.
2. SNDPCP forwards the Deactivation using SN-NSAPI Dealloc Ind.
3. MEX determines all active MEX Contexts for the Deactivation of the requested NSAPI and removes all appropriate entries from internal tables.
4. MEX-END Ind notifies the application of the deactivation of either a single or all PDP contexts. Where a single NSAPI deactivation is given by SN-NSAPI Dealloc and multiple MEX Contexts are active on the single NSAPI, a MEX-END Ind shall be sent for each appropriate MEX Context.

30.3.6 MEX QoS Abstract Class Table Management

Figure 30.16 describes the procedure for accessing the MEX QoS Class table.

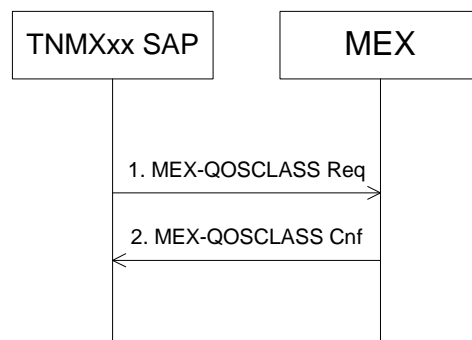

Figure 30.16: Managing the MEX QoS Abstract Class table

Each numbered step in figure 30.16 is explained in the following list:

1. The application requests indication, update and or locking of a MEX QoS Class entry. MEX QoS Class Access is used to request the read, write and lock functionality. If MEX QoS Class Access is "Write and Lock" the specified MEX QoS class entry shall only be writeable when the specified MEX Handle is stated. MEX QoS Class Access "Unlock" shall be used to release the entry for subsequent access using any MEX Handle.
2. MEX returns confirmation that the entry has been updated (if applicable) together with the full list of QoS parameters in the requested class.

A lock on a MEX QoS Class entry shall be automatically released upon the termination of all contexts which use the MEX QoS Class entry. All locks shall be released upon power off of the MS.

30.3.7 MEX data routing procedure

30.3.7.1 Uplink Data Service

The following describes the procedure for data routing in the uplink service.

When using MEX services and an acknowledged service is utilized, the MEX shall allocate and keep track of SN-DATA handles paired with SN-DELIVERY returns. Where SN-DELIVERY returns with either Failure or Deletion by SNDCP report, or no SN-DELIVERY is received then the MEX shall return the full IP header together with the first 64 bytes of data back to the application through the PEI to allow for implementation of ICMP signalling support in the TE2 or MT2 IP stack.

Note that in the following description, the SNDCP primitive SN-DATA is described. Where an unacknowledged service is used, the treatment of SN-DATA should be replaced by SN-UNITDATA.

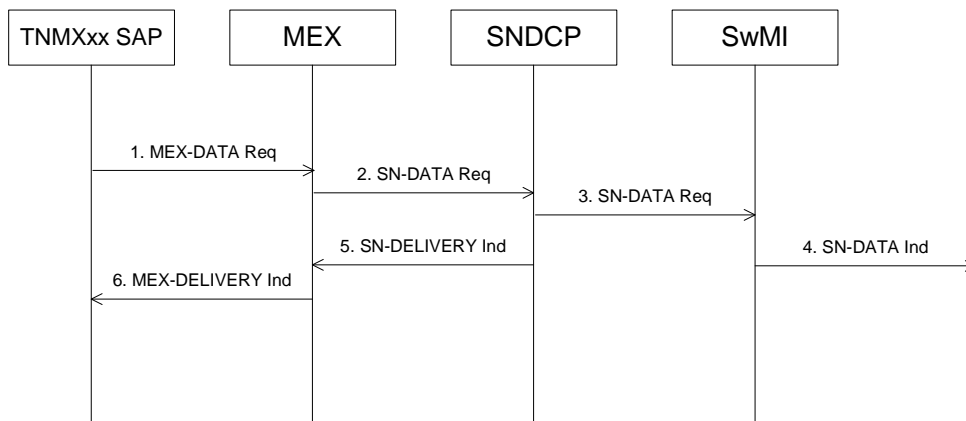

Figure 30.17: MS initiated Data Routing

Each numbered step in figure 30.17 is explained in the following list:

1. MEX-DATA Req is either an IP packet to be transferred to the network or a MEX-BYPASS DATA Req encapsulating a full SNDCP SN-DATA Req primitive.
2. MEX prepares and sends an SN-DATA Req to SNDCP. The MEX inspects the Destination port, Destination Address and DSCP of the IP packet and decides which NSAPI should be used, by using MEX_QOS_FILTER_TBL. SN-DATA Handle is assigned and recorded ready for checking of a receipt of SN-DELIVERY. PDU Priority, Data Priority, Data Importance of SN-DATA are set according the appropriate entry in MEX_SNDATA_QOS_TBL. The IP packet is inspected and priority escalated appropriately according to clause 30.2.3.9. If the MEX recognizes an excess of data over and above any accepted schedule, the MEX sets the Schedule Surplus flag. (see clause 28.3.5.6). Where MEX-HANDLE represents MEX Mode as "Bypass to SNDCP", MEX-DATA Req is forwarded, with any necessary reformatting, directly to SNDCP.
3. SN-DATA Req is sent across the air interface to the SwMI.
4. SwMI forwards SN-DATA Ind to the IP network.

5. If an acknowledged service is utilized, SN-DELIVERY is sent to MEX. MEX checks the SN-DELIVERY Handle against those recorded at step 2.
6. If SN-DELIVERY Delivery Report is "Failure" or "Deleted or Cancelled by SNDCP" then MEX DELIVERY is sent to the application.

30.3.7.2 Downlink Data Service

The following describes the procedure for data routing in the downlink service.

Note that in the following description, the SNDCP primitive SN-DATA is described. Where an unacknowledged service is used, the treatment of SN-DATA should be replaced by SN-UNITDATA.

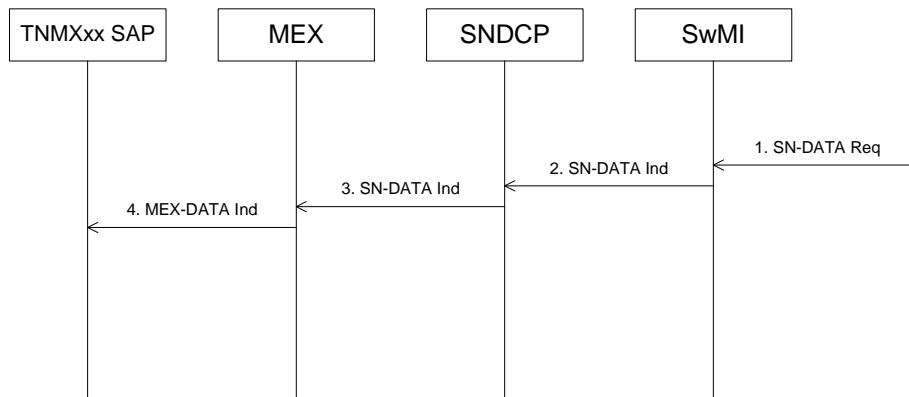

Figure 30.18: SwMI initiated Data Routing

Each numbered step in figure 30.18 is explained in the following list:

1. SwMI receives SN-DATA Req from the network.
2. SN-DATA Ind is received over the air interface by SNDCP.
3. SN-DATA Ind is sent to MEX. The IP packet is inspected for Destination port and source IP address. MEX_QOS_AUTOFILTER_TBL is compared and MEX_QOS_FILTER_TBL is updated accordingly as described in clause 30.2.4.3. If the option MEX Escalate Flag Reset was present at MEX-CONNECT for the NSAPI, the MEX shall reset bit 5 of DSCP prior to forwarding the packet (clause 30.2.3.9).
4. MEX forwards the data to the appropriate SAP using MEX-DATA Ind containing either an IP packet or MEX-BYPASS DATA Ind primitive.

30.3.7.3 Maximum Transmission Unit

Where MEX-DATA on the uplink represents an IP packet which exceeds the state Maximum Transmission Unit, a MEX-DELIVERY Ind shall be returned to the application to allow the possibility to utilize the ICMP Destination unreachable Message (IETF RFC 792 [i.14]) to indicate through the MT2 or TE2 IP stack. Path MTU discovery (PMTUD) (IETF RFC 1191 [i.15]) can therefore be utilized by the TE2 IP stack to determine the appropriate MTU to use.

30.3.7.4 Scheduled access

The MEX shall remain aware of any uplink MEX-DATA request primitives which are intended to make use of the scheduled access service. The MEX shall keep a count and detect any increase in the quantity of data exceeding the requested schedule. In such case where the schedule is exceeded, the MEX shall send extra SN-DATA with the Schedule Surplus Flag set, as appropriate, so as not to loose any data.

30.3.7.5 MEX-QOS

The MEX-QOS request primitive is a direct mapping to SN-QoS in the SNDCP and is retained for backward compatibility with previous versions of SNDCP, and is applicable only to $\pi/4$ -DQPSK modulation. The optional MEX NSAPI QoS negotiation parameter included in the MEX-CONNECT and MEX-MODIFY primitives has more general applicability, and should be used instead of the MEX-QOS request primitive.

MEX-QOS is only available at TNMXIT_SAP and not available through the PEI via TNMXPI SAP.

30.3.7.6 Packet mode Paging

The MEX-PAGE primitive is a direct mapping to SN-PAGE in the SNDCP.

MEX-PAGE is only available at TNMXIT_SAP and not available through the PEI via TNMXPI SAP.

30.4 MEX service description

30.4.1 Introduction

Clause 30.4 describes the services offered by the Multimedia Exchange (MEX) entity for the voice plus data TETRA layer 3 air interface.

30.4.2 Services offered

MEX shall be a service provider for packet data users.

The services offered shall be:

- receiving MEX access requests from the MT and TE applications;
- filtering TE and MT application data to the appropriate PDP context and QoS by monitoring the port numbers, IP addresses and DSCP encapsulated within IP datagrams;
- receiving the QoS requirements from the MT and TE applications;
- negotiating application QoS requirements with the SNDCP layer;
- management of MEX precedence specified by the MT and TE applications using internal buffering and a switching function; and
- providing feedback on the changing QoS values to the MT and TE applications.

30.4.3 Service Primitives

30.4.3.1 General on service primitives

The services shall be provided using MEX messages to the PEI via TNMXPI SAP and MT2 internal applications via TNMXIT SAP. Access to the SNDCP primitives is via the SN-SAP. This clause describes the primitives and their parameters.

The MEX services consist of the following messages:

- MEX-CAPABILITY;
- MEX-CONNECT;
- MEX-DATA;
- MEX-DELIVERY;
- MEX-END;

- MEX-HANDLE;
- MEX-MODIFY; and
- MEX-QOSCLASS.

In parameter descriptions:

- C = Conditional;
- M = Mandatory; and
- O = Optional.

30.4.3.2 MEX-CAPABILITY

The parameters for the primitive MEX-CAPABILITY shall be as defined in table 30.8.

Table 30.8: Parameters for the primitive MEX-CAPABILITY

Parameter	Req	Ind
MEX Handle	M	M
MEX Capability	M	M

30.4.3.3 MEX-CONNECT

The parameters for the primitive MEX-CONNECT shall be as defined in table 30.9.

Table 30.9: Parameters for the primitive MEX-CONNECT

Parameter	Req	Cnf
MEX Handle	M	M
MEX QoS Filter	O	-
MEX QoS Class Uplink Upper	C (see note 2)	-
MEX QoS Class Uplink Lower	C (see note 2)	-
MEX QoS Class Downlink Upper	O	-
MEX QoS Class Downlink Lower	O	-
MEX Escalate DSCP5 Flag Enable	O	-
MEX Escalate DSCP5 Flag Reset	O	-
MEX Connect Report	-	M
MEX Connect Reject Cause	-	C (see note 6)
Maximum Transmission Unit	-	M
MEX PDP Type	M	C (see note 5)
MEX PDP Address	C (see note 5)	C (see note 5)
NSAPI	C (see note 3)	-
DCOMP	O (see notes 3 and 4)	O (see note 3)
PCOMP	O (see notes 3 and 4)	O (see note 3)
NSAPI QoS Negotiation	O (see notes 3 and 4)	O (see note 3)
NSAPI Data Priority	O (see notes 3 and 4)	-
PDU Priority Max	-	C (see note 5)
Mobile IPv4 Information	-	C (see note 5)
MEX Precedence	-	C (see notes 2 and 8)
NOTE 1: Provided if mapping of data is filtered by both IP address and Port.		
NOTE 2: Only used if the "MEX Handle" was returned with MEX mode as "Use MEX".		
NOTE 3: Only used if the "MEX Handle" was returned with MEX mode as "Bypass to SNDSCP" and the values has changed. Refer to SN-NSAPI Alloc, refer to clause 28.2.3.1.		
NOTE 4: Optional, refer to SN-NSAPI Alloc, refer to clause 28.2.3.1.		
NOTE 5: Shall be present, if MEX connect report is "Success (QoS parameter changed)". Refer to SN-NSAPI Alloc, refer to clause 28.2.3.1.		
NOTE 6: Present if MEX Report is "Failure".		
NOTE 7: Not present if MEX Report is "Failure".		
NOTE 8: MEX Precedence for Cnf will return the overall ranking of MEX precedence rather than the requested MEX Precedence as described in clause 30.2.3.3.		

30.4.3.4 MEX-BYPASS DATA

The parameters for the primitive MEX-BYPASS DATA shall be as defined in table 30.10.

Table 30.10: Parameters for the primitive MEX-BYPASS DATA

Parameter	Req	Ind
MEX Handle	M (see note 1)	M (see note 1)
NSAPI	C (see note 2)	C (see note 2)
Data Handle	C (see note 2)	-
PDU Priority	C (see note 2)	-
Data Priority	C (see note 2)	-
Data Importance	C (see note 2)	-
Schedule Surplus Flag	C (see note 2)	-
MEX N-PDU	M	M
NOTE 1: The MEX Handle shall be set to "Bypass to SNDSCP".		
NOTE 2: The parameter shall be present if MEX Handle represents "Bypass to SNDSCP".		

30.4.3.5 MEX-DELIVERY

The parameters for the primitive MEX-DELIVERY shall be as defined in table 30.11.

Table 30.11: Parameters for the primitive MEX-DELIVERY

Parameter	Ind
MEX Handle	M
Data Handle	C (see note 1)
MEX Delivery Report	M
MEX Delivery Header	C (see note 2)
NOTE 1: Only present if MEX Handle represents "Bypass to SNDCP".	
NOTE 2: Only present if MEX Handle represents "Use MEX".	

30.4.3.6 MEX-END

The parameters for the primitive MEX-END shall be as defined in table 30.12.

Table 30.12: Parameters for the primitive MEX-END

Parameter	Req	Ind	Cnf
MEX Handle	M	M	M
NSAPI	C (see note)	C (see note)	C (see note)
MEX Deactivation Type	M	M	M
NOTE: Only present if MEX Handle represents "Bypass to SNDCP".			

30.4.3.7 MEX-HANDLE

The parameters for the primitive MEX-HANDLE shall be as defined in table 30.13.

Table 30.13: Parameters for the primitive MEX-HANDLE

Parameter	Req	Ind
MEX Handle	M	M
MEX Mode	M	M

30.4.3.8 MEX-MODIFY

The parameters for the primitive MEX-MODIFY shall be as defined in table 30.14.

Table 30.14: Parameters for the primitive MEX-MODIFY

Parameter	Req	Ind	Cnf
MEX Handle	M	M	M
MEX QoS Filter	O	-	-
MEX Filter Operation	O	-	-
MEX QoS Class Uplink Upper	C (see note 1)	-	-
MEX QoS Class Uplink Lower	C (see note 1)	-	-
MEX QoS Class Downlink Upper	C (see notes 1 and 7)	-	-
MEX QoS Class Downlink Lower	C (see notes 1 and 7)	-	-
MEX Modify Report	-	-	M
MEX Modify Reject Cause	-	-	C (see note 4)
MEX NSAPI Usage	O	-	-
NSAPI QoS Negotiation	C (see notes 2 and 3)	C (see notes 2 and 3)	C (see notes 1 and 2)
Schedule Availability	-	O	-
MEX Precedence	-	C (see notes 1 and 6)	C (see notes 1 and 6)

NOTE 1: Only used if the "MEX Handle" was returned with MEX mode as "Use MEX".
 NOTE 2: Only used if the "MEX Handle" was returned with MEX mode as "Bypass to SNDCP".
 NOTE 3: Optional as for SN-NSAPI Modify.
 NOTE 4: Present if MEX Report is "Failure".
 NOTE 5: Not present if MEX Report is "Failure".
 NOTE 6: MEX Precedence for Ind and Cnf will return the overall ranking of MEX precedence rather than the requested MEX Precedence as described in clause 30.2.3.3.
 NOTE 7: Only if SNDCP supports Asymmetric QoS.

30.4.3.9 MEX-PAGE

The parameters for the primitive MEX-PAGE shall be as defined in table 30.15.

Table 30.15: Parameters for the primitive MEX-PAGE

Parameter	Indication	Response
NSAPI	M	M
Reply requested	M	-
PD service status	-	M

30.4.3.10 MEX-QOS

The parameters for the primitive MEX-QOS shall be as defined in table 30.16.

Table 30.16: Parameters for the primitive MEX-QOS

Parameter	Request	Indication
QoS requested	M	M
QoS minimum	M	-
QoS negotiated	-	M
QoS negotiation result	-	M

NOTE: It is recommended that this primitive is used only to set parameters within the MS SNDCP entity, to be used at a later stage during advanced link setup negotiation. This primitive should not in itself trigger the establishment or resetting of the advanced link.

30.4.3.11 MEX-QOSCLASS

The parameters for the primitive MEX-QOSCLASS shall be as defined in table 30.17.

Table 30.17: Parameters for the primitive MEX-QOSCLASS

Parameter	Req	Cnf
MEX Handle	M	M
MEX QoS Class	M	M
MEX QoS Class Access	M	M (see note 2)
MEX QoS	C (see note 1)	M
MEX Precedence	C (see note 1)	M
MEX Data Priority	C (see note 1)	M
MEX PDU Priority Max	C (see note 1)	M
MEX Data Importance	C (see note 1)	M
NOTE 1: Not present is MEX QoS Class Access is "Read".		
NOTE 2: "Read" is indicated if the MEX QoS Class is Read Only. "Write" is indicated if the "MEX QoS Class" entry has been updated.		

30.4.4 MEX Parameters

30.4.4.0 General

MEX Parameters are described in detail in the following list. Note that many parameters are derived directly from their original definition within clause 28. Some of these parameters have been modified for appropriate operation with the MEX layer primitives described above. Those which have modifications with respect to those defined in clause 28 are prefixed with "MEX". Those which are identical to the SNDTCP parameters do not have this prefix.

30.4.4.1 Data Handle

This parameter is only used in "Bypass to SNDTCP" mode and mimics the SNDTCP Data Handle parameter. See clause 28.1 for a full definition as applied to SN-DATA and SN-UNITDATA.

30.4.4.2 Data Importance

This parameter is only used in "Bypass to SNDTCP" mode and mimics the SNDTCP Data Importance parameter. See clause 28.1 for a full definition as applied to SN-DATA and SN-UNITDATA.

30.4.4.3 Data Priority

This parameter is only used in "Bypass to SNDTCP" mode and mimics the SNDTCP Data Priority parameter. See clause 28.1 for a full definition as applied to SN-DATA and SN-UNITDATA.

30.4.4.4 DCOMP

This parameter may contain several different data compression methods, such as Recommendation ITU-T V.42bis [27], and their parameters negotiated with the peer entity.

30.4.4.5 Maximum Transmission Unit

This is the maximum size of N PDU which may be presented by the MS service user to SNDTCP for transport over the air interface. This typically represents the maximum size of IP packet (prior to adding SNDTCP header and performing compression) which may be carried over the air interface.

30.4.4.6 MEX Capability

- MEX Precedence is supported; or
- MEX Precedence is not supported.

30.4.4.7 MEX Connect Reject Cause

- undefined;
- MS not provisioned for Packet Data;
- IPv4 not supported;
- IPv6 not supported;
- IPv4 dynamic address negotiation not supported;
- IPv6 stateful address autoconfiguration not supported;
- IPv6 stateless address autoconfiguration not supported;
- dynamic address pool empty;
- static address not correct;
- static address in use;
- static address not allowed;
- static IP address congestion;
- TETRA Packet Data not supported on this location area;
- TETRA Packet Data not supported on this network;
- temporary rejection;
- packet Data MS Type not supported;
- SNDCP version not supported;
- mobile IPv4 not supported;
- mobile IPv4 Co-located Care of Addresses not supported;
- maximum allowed PDP contexts per ITSI exceeded;
- user authentication failed;
- activation rejected by external PDN;
- access point name index not correct;
- no response from network;
- bad response from network;
- NSAPI not available;
- NSAPI already allocated;
- requested minimum peak throughput not available;
- scheduled access not supported;
- requested schedule not available;
- requested QoS not available;
- secondary PDP contexts not supported;
- primary PDP context does not exist;

- asymmetric QoS not supported;
- automatic QoS filter not supported;
- specified QoS filter not supported; or
- QoS filter type not supported; or
- QoS filter not available for primary PDP context; or
- SNDCP service temporarily not available.

30.4.4.8 MEX Connect Report

- failure;
- success (not used in "Bypass to SNDCP" mode); or
- success QoS Parameters changed.

30.4.4.9 MEX Deactivation Type

- deactivate all NSAPIs;
- deactivate all MEX Contexts (NOTE: only in Use MEX mode); or
- deactivate all contexts associated with the MEX Handle given in the primitive.

30.4.4.10 MEX Delay Class

- Low;
- Moderate;
- High; or
- Unpredictable.

30.4.4.11 MEX Delivery Header

This parameter consists of the full IP header plus the first 64 bytes of data of the IP packet for delivery failed. The intended provision of this data is to allow the possibility to utilize the ICMP Destination Unreachable Message (IETF RFC 792 [i.14]) to indicate through the TE2 or MT2 IP stack.

30.4.4.12 MEX Delivery Report

- Success;
- Failure;
- Deleted or cancelled by SNDCP;
- Packet exceeds MTU (Only used if MEX Handle represents "Use MEX"); or
- Packet was Surplus to Schedule (Only used if MEX Handle represents "Use MEX").

30.4.4.13 MEX Escalate DSCP5 Flag Enable

Parameter is present in MEX-CONNECT to specify that the Diffserv bit 5 shall be used for priority escalation as described in clause 30.2.3.9.

30.4.4.14 MEX Escalate DSCP5 Flag Reset

Parameter is present in MEX-CONNECT to specify that the Diffserv bit 5 shall be reset before an IP packet is forwarded from the MEX.

30.4.4.15 MEX Filter

- a range of IP Ports; or
- a DSCP.

30.4.4.16 MEX Filter Operation

- add this QoS filter to any existing QoS filter for this PDP context;
- replace any existing QoS filter for this PDP context by this QoS filter; or
- remove this QoS filter from the existing QoS filter for this PDP context.

30.4.4.17 MEX Filter Type

- Automatic;
- All types of ports;
- UDP Only;
- TCP Only; or
- Diffserv.

NOTE: Diffserv is not applicable to either the "Automatic Uplink Filter" or "Automatic Downlink Filter" MEX Transaction types.

30.4.4.18 MEX Handle

- 0 Use to indicate no Handle. Used to support legacy applications requiring a simply defined PDP context.
- 1 to 254 Valid Handle identifiers.
- 255 Used to indicate failure to generate a valid handle. Only used in confirmation or indication primitives.

30.4.4.19 MEX IP Request

Used only in "Bypass to SNDCCP" mode.

30.4.4.20 MEX Mode

- Use MEX;
- Bypass to SNDCCP; or
- Deallocate Handle.

30.4.4.21 MEX Modify Report

Where an application is working with "Bypass to SND CP" MEX handle, MEX Modify Report shall mimic SND CP NSAPI Modify Report (see clause 28.2.3.2):

- Failure (No parameters are changed from their previous values).
- Success Local (One or more of MEX Precedence, PDU Priority, Data Importance, Data Priority have changed from their previous values).
- Success (One or more of the MEX NSAPI QoS parameters were changed from their previous values).
- Full Success (All requested parameter changes have been made).

30.4.4.22 MEX Modify Reject Cause

- Undefined;
- Temporary rejection;
- No response from network;
- Bad response from network;
- NSAPI not activated;
- Requested minimum peak throughput not available;
- Scheduled access not supported;
- Requested schedule not supported;
- Requested QoS not available;
- Secondary PDP contexts not supported;
- Primary PDP context does not exist;
- Asymmetric QoS not supported;
- Automatic QoS filter not supported;
- Specified QoS filter not supported; or
- QoS filter type not supported; or
- QoS filter not available for primary PDP context; or
- SND CP service temporarily not available.

30.4.4.23 MEX N-PDU

Any number of bits needed to carry a Network layer protocol PDU. This is typically the full IP packet.

30.4.4.24 MEX NSAPI Usage

- Schedule paused; or
- PDP context paused.

30.4.4.25 MEX PDP Address

- IPv4 address (only when a primary PDP context is being requested); or
- NSAPI (only when a secondary PDP context is being requested).

30.4.4.26 MEX PDP Type

- IPv4 (static address);
- IPv4 (dynamic address negotiation);
- IPv6;
- Mobile IPv4 - Foreign Agent care of address requested;
- Mobile IPv4 - Co-located care of address requested; or
- Primary NSAPI (secondary PDP context requested).

30.4.4.27 MEX Peer IP Filter

An IP address of a network node for which the MS is intended to communicate with.

30.4.4.28 MEX Precedence

See clause 30.2.3.3 for full description of the MEX Precedence.

30.4.4.29 MEX QoS

- A set of:
 - Data Class (see clause 30.2.2.1);
 - Delay Class (see clause 30.2.2.2);
 - Reliability Class (see clause 30.2.2.3);
 - Minimum Peak Throughput (see clause 30.2.3.2);
 - Mean Throughput (see clause 30.2.3.2);
 - Mean Active Throughput (see clause 30.2.3.2);
 - MEX Precedence (see clause 30.2.3.3);
 - Data Priority (see clause 30.2.3.4);
 - PDU Priority (see clause 30.2.3.5);
 - Data Importance (see clause 30.2.3.6);
 - Schedule Repetition Period (see clause 30.2.3.7);
 - Scheduled Number of IP Packets (N-PDUs) per grant (see clause 30.2.3.7);
 - Scheduled IP Packet (N-PDU) size (see clause 30.2.3.7);
 - Schedule Timing Error (see clause 30.2.3.7); and
 - CONTEXT Ready Timer (see clause 30.2.3.8).

30.4.4.30 MEX QoS Class

- 0 Identifier of the default QoS settings for a legacy PDP context creation;
- 1 to 8 Identifiers of Specified QoS Class parameters;
- 9 to 32 Identifiers of Manufacturer set Read Only QoS Class parameters; or
- 33 to 255 Identifiers of User writable QoS Class parameters.

30.4.4.31 MEX QoS Class Uplink/Downlink Upper/Lower

Values as for MEX QoS Class.

30.4.4.32 MEX QoS Class Access

- Read;
- Write;
- Write and Lock;
- Unlock; or
- Locked (Used only in MEX-QOSCLASS Cnf where a MEX QoS Class is locked).

30.4.4.33 MEX QoS Filter

- A set of:
 - MEX Filter;
 - MEX Peer IP Filter (optional);
 - MEX Transaction Type; and
 - MEX Filter Type.

30.4.4.34 MEX Scheduled Access

- A set of:
 - schedule repetition period;
 - schedule timing error;
 - scheduled number of N-PDUs per grant; and
 - scheduled N-PDU size.

NOTE: The scheduled N PDU size parameter should be repeated as many times as necessary to indicate a size for each scheduled N PDU per grant.

30.4.4.35 MEX Transaction Type

- Uplink Filter (Not available when using "Bypass to SNDCCP" mode);
- Downlink Filter;
- Uplink Automatic Filter (Not available when using "Bypass to SNDCCP" mode); or
- Downlink Automatic Filter.

NOTE 1: Uplink Filter and Uplink Automatic Filter are not available when using "Bypass to SNDCCP" mode.

NOTE 2: Uplink Automatic Filter and Downlink Automatic filter are not applicable when MEX Filter Type is "Diffserv".

30.4.4.36 Mobile IPv4 Information

This parameter is only used in "Bypass to SNDCP" mode and mimics the SNDCP Mobile IPv4 Information parameter. See clause 28.1 for a full definition as applied to SN-NSAPI Alloc.

30.4.4.37 NSAPI

This parameter is only used in "Bypass to SNDCP" mode and mimics the SNDCP NSAPI parameter. See clause 28.1 for a full definition as applied to SN-DATA, SN-NSAPI Alloc, SN-NSAPI Configure, SN-NSAPI Dealloc, SN-NSAPI Modify.

30.4.4.38 NSAPI Data Priority

This parameter is only used in "Bypass to SNDCP" mode and mimics the SNDCP NSAPI Data Priority parameter. See clause 28.1 for a full definition as applied to SN-NSAPI Alloc and SN-NSAPI CONFIGURE.

30.4.4.39 NSAPI QoS Negotiation

This parameter is only used in "Bypass to SNDCP" mode and mimics the SNDCP NSAPI QoS Negotiation parameter. See clause 28.1 for a full definition as applied to SN-NSAPI Alloc and SN-NSAPI Modify.

30.4.4.40 PCOMP

This parameter may contain several different protocol compression methods. They may be one or more of: TCP/IP header compression (not available for unacknowledged layer 2 service or real time class data) and IP header compression.

30.4.4.41 PDU Priority

This parameter is only used in "Bypass to SNDCP" mode and mimics the SNDCP PDU Priority parameter. See clause 28.1 for a full definition as applied to SN-DATA and SN-UNITDATA.

30.4.4.42 PDU Priority Max

This parameter is only used in "Bypass to SNDCP" mode and mimics the SNDCP PDU Priority Max parameter. See clause 28.1 for a full definition as applied to SN-NSAPI Alloc.

30.4.4.43 Schelude availability

This parameter indicates availability of scheduled access, see clause 28.3.5.6.

30.4.4.44 Schedule Surplus Flag

This parameter is only used in "Bypass to SNDCP" mode and mimics the SNDCP Schedule Surplus Flag parameter. See clause 28.1 for a full definition as applied to SN-DATA and SN-UNITDATA.

Annex A (normative): LLC timers and constants

A.0 General

This annex lists the LLC timers and constants in the MS.

Where indicated, a value should be chosen by the MS designer from within a given range. For other timers and constants, a default value is given. The default value shall be used by the MS unless it received a different value when it subscribed to that network.

A.1 LLC timers

Timers T.251, T.252, T.261, T.263 and T.265 are defined in terms of downlink signalling frames for the control channel on which the downlink message is expected. When counting downlink signalling frames, the MS should normally count all frames, except that:

- on an assigned channel, the MS shall count only those downlink frames that are available for control signalling on that channel; note, however, that the BS may choose to send a PDU to the MS by stealing from the downlink TCH;
- when the MS transmits using reserved access on a multi-slot channel, if the MS is not frequency full duplex, then, when counting downlink frames, the MS shall count only those frames containing at least one slot that it is able to attempt to receive and decode and that is available for control signalling;
- if the MS is transmitting traffic then:
 - for timer T.251, and if the stealing repeats flag is set for the PDU being sent, the MS shall count all downlink frames (irrespective of whether they are available for control signalling);
 - otherwise, the MS shall count only those downlink frames that it is required to monitor (according to the assigned monitoring pattern(s)) and that are available for control signalling; note, however, that the BS may choose to send a PDU to the MS by stealing from the downlink TCH in one of the monitored slots;

NOTE 1: For a multi-slot channel, if the MS is not frequency full duplex, and if the BS assigns monitoring pattern(s) that the MS is not capable of following, then, when counting downlink frames, the MS counts only those frames containing at least one slot that it is able to monitor and that is available for control signalling.

- if the MS is in minimum mode, the MS shall count only frame 18; note, however, that the BS may choose to send a PDU to the MS in slot 1 during frames 2 to 17;
- on a time-shared MCCH, the MS shall count only frames reserved for this BS; note, however, that the BS may choose to send a PDU to the MS in one of the common frames.

T.251 Sender re-try timer:

- Default value = 4 signalling frames.

T.252 Acknowledgement waiting timer:

- Default value = 9 signalling frames.

T.261 Set-up waiting timer:

- Default value = 4 signalling frames.

T.263 Disconnection waiting timer:

- Default value = 4 signalling frames.

T.265 Reconnection waiting timer:

- Default value = 4 signalling frames.

T.271 Receiver not ready validity timer for the data sending entity:

- Default value = 36 TDMA frames.

NOTE 2: The value of this timer should exceed the value for the data receiving entity T.272.

T.272 Receiver not ready validity timer for the data receiving entity:

- Default value = 18 TDMA frames.

A.2 LLC constants

Constants N.252, N.253, N.262, N.263, N.265, N.273, N.274, N.282 and N.293 define the maximum number of retransmissions or repetitions. The maximum number of transmissions (including the first transmission) is therefore the specified value + 1.

N.251 Maximum length of TL-SDU (basic link):

- This is the maximum length of one TL-SDU if the optional Frame Check Sequence (FCS) is used.
- Default value = 2 595 bits (i.e. approximately 324 octets).
- The FCS is optional. If the FCS is not used, the TL-SDU part may be larger by four octets.

N.252 Maximum number of TL-SDU retransmissions for acknowledged basic link service:

- MS designer choice from range 3 to 5 if the stealing repeats flag is set;
- MS designer choice from range 1 to 5 if the stealing repeats flag is not set.

N.253 Number of TL-SDU repetitions in unacknowledged basic link service:

- MS designer choice from range 0 to 5.

NOTE 1: The service user may indicate the required number of TL-SDU repetitions for a particular TL-SDU in the unacknowledged basic link service. The value of N.253 chosen by the MS designer applies when the service user does not indicate the required number of repetitions.

N.261 Advanced link number:

- This value is defined during the set-up of the advanced link (see AL-SETUP PDU definition). Range: (1; 4).

N.262 Maximum number of connection set-up retries:

- MS designer choice from range 1 to 5.

N.263 Maximum number of disconnection retries:

- MS designer choice from range 3 to 5.

N.264 Number of $\pi/4$ -DQPSK timeslots used per TDMA frame:

- This value may be defined during the set-up of the advanced link (see AL-SETUP definition). Range: 1 to 4.

N.265 Reconnection retries:

- MS designer choice from range 0 to 5.

N.271 Maximum length of TL-SDU (advanced link):

- This is the maximum length of one TL-SDU including the FCS, it is defined during the set-up of the advanced link (see AL-SETUP PDU definition), Range: (32, 4 096) octets.

N.272 Window size for TL-SDU in acknowledged service:

- This value is defined during the set-up of the advanced link, (see AL-SETUP definition).
 - Range: (1;3) for the original advanced link.
 - Range: (1;15) for an extended advanced link.

N.273 Maximum number of TL-SDU retransmissions:

- This value is defined during the set-up of the advanced link (see AL-SETUP definition). Range: (0;7).

N.274 Maximum number of segment retransmissions:

- This value is defined during the set-up of the advanced link, (see AL-SETUP definition). Range: (0;15).

N.281 Window size for TL-SDU in unacknowledged service:

- This value is defined during the set-up of the advanced link (see AL-SETUP definition).
 - Range: (1;3) for the original advanced link.
 - Range: (1;15) for an extended advanced link.

N.282 Number of repetitions for unacknowledged information:

- This value is defined during the set-up of the advanced link (see AL-SETUP definition). Range: (0;7).

N.293 Number of repetitions of layer 2 signalling PDU:

- MS designer choice from range 0 to 5.

NOTE 2: The MAC may indicate the required number of repetitions of a particular layer 2 signalling PDU. The value of N.293 chosen by the MS designer applies when the MAC does not indicate the required number of repetitions.

NOTE 3: It is recommended that N.293 is set to 0 in most cases.

Annex B (normative): MAC timers and constants

B.0 General

This annex lists the MAC timers and constants in the MS.

Where indicated, a value should be chosen by the MS designer from within a given range. For other timers and constants, a default value is given. The default value shall be used by the MS unless it received a different value when it subscribed to that network.

B.1 MAC timers

Timers T.202 and T.206 are defined in terms of downlink signalling frames for the control channel on which the downlink message is expected. When counting downlink signalling frames, the MS should normally count all frames, except that:

- on an assigned channel, the MS shall count only those downlink frames that are available for control signalling on that channel; note, however, that the BS may choose to send a PDU to the MS by stealing from the downlink TCH;
- if the MS is transmitting traffic then the MS shall count only those downlink frames that it is required to monitor (according to the assigned monitoring pattern(s)) and that are available for control signalling; note, however, that the BS may choose to send a PDU to the MS by stealing from the downlink TCH in one of the monitored slots;

NOTE 1: For a multi-slot channel, if the MS is not frequency full duplex, and if the BS assigns monitoring pattern(s) that the MS is not capable of following, then, when counting downlink frames, the MS counts only those frames containing at least one slot that it is able to monitor and that is available for control signalling.

- if the MS is in minimum mode, the MS shall count only frame 18; note, however, that the BS may choose to send a PDU to the MS in slot 1 during frames 2 to 17;
- on a time-shared MCCH, the MS shall count only frames reserved for this BS; note, however, that the BS may choose to send a PDU to the MS in one of the common frames.

T.201 Event label inactivity time-out:

- On the MCCH or MCCCH-Q or on a common SCCH, default value = 30 multiframe.
- On any assigned channel, no default upper limit.

T.202 Fragmentation time-out:

- Default value = 9 downlink signalling frames.

T.205 Random access time-out:

- MS designer choice from 5 multiframe to 60 multiframe.

T.206 Reserved access waiting time-out:

- Default value = 18 downlink signalling frames.

NOTE 2: For correct operation of the procedures, $T.206 \geq T.202$.

T.208 Inactivity time-out on assigned SCCH:

- Default value = 30 multiframes.

T.209 Inactivity time-out on traffic channel:

- Default value = 18 multiframes.

T.210 Timer for returning to energy economy mode:

- Default value = 18 TDMA frames.

T.211 ACCESS-ASSIGN time-out for transmission of TCH:

- Default value = 36 TDMA frames.

T.212 ACCESS-ASSIGN time-out for reception of TCH:

- Default value = 18 TDMA frames.

T.213 DTX timer:

- Default value = 18 TDMA frames.

T.214 Stealing timer:

- Default value = 6 uplink opportunities.

T.215 Timer for traffic receive authorization if obeying channel allocation after delay:

Default value = 18 TDMA frames.

T.216 Timer for leaving assigned channel after channel replacement:

- Default value = 2 TDMA frames.

T.220 Timer for returning to dual watch reception cycle:

- Default value = 18 TDMA frames.

T.222 Layer 2 data priority lifetime timer:

- This value is defined by SNDCP signalling and given to the MAC in the TMC-CONFIGURE request primitive.

T.223 Layer 2 data priority signalling delay timer:

- This value is defined by SNDCP signalling and given to the MAC in the TMC-CONFIGURE request primitive.

T.226 Napping timer:

- This value is defined in the channel allocation (see channel allocation information element definition).

T.227 Minimum scheduled access waiting time-out:

- Default value = 9 TDMA frames.

T.230 Link adaptation feedback time-out:

- This value is defined when feedback is invited (see L2-LINK-FEEDBACK-CONTROL definition).

T.231 Minimum feedback interval:

- This value may be defined when feedback is invited (see L2-LINK-FEEDBACK-CONTROL definition).
- Otherwise, MS designer choice with $T.231 \geq 9$ TDMA frames.

T.234 Timer for returning to part-time reception on multi-slot MCCH-Q:

- Default value = 18 TDMA frames.

B.2 MAC constants

N.202 Maximum size of TM-SDU:

- 2 632 bits (i.e. 329 octets).

N.203 Number of timeslots without a fragment before MAC will discard an uncompleted TM-SDU:

- Default value greater than or equal to 4.

N.208 Number of invalid ACCESS-ASSIGN PDUs to leave assigned channel:

- Default value = 3.

NOTE 1: The value of N.208 may be different on a QAM channel from the value on a $\pi/4$ -DQPSK or D8PSK channel.

N.209 Quality threshold on a QAM channel:

Assumed default value = 4.

NOTE 2: The values of N.209 and N.210 need not be integers.

N.210 Quality threshold on a $\pi/4$ -DQPSK or D8PSK channel:

- Default value = 4.

N.211 Number of invalid ACCESS-ASSIGN PDUs to stop transmission of TCH:

- Default value = 3.

N.212 Number of invalid ACCESS-ASSIGN PDUs to stop reception of TCH:

- Default value = 3.

N.213 Number of valid ACCESS-ASSIGN PDUs to allow reception of TCH:

- Default value = 3.

N.214 Number of transmissions if stealing repeats flag is set:

- Default value = 4.

N.215 Number of unallocated ACCESS-ASSIGN PDUs to deallocate common channel.

- Default value = 3.

NOTE 3: The value of N.215 may be different on a QAM common channel from the value on a $\pi/4$ -DQPSK common channel.

N.223 Maximum number of transmissions of same or equivalent L2-DATA-PRIORITY message:

- MS designer choice from range 1 to 5.

N.231 Maximum number of transmissions of same or similar L2-LINK-FEEDBACK-INFO message:

- MS designer choice from range 1 to 5.

Annex C (normative): Mathematical definition of Frame Check Sequence (FCS)

The FCS value corresponding to a given frame is defined by the following procedure:

- 1) the first 4 octets (first 32 bits) of the frame are complemented. If there are less than 32 bits, then those bits will be complemented;
- 2) the n bits of the frame are then considered to be the co-efficients of a polynomial $M(x)$ of degree $n - 1$;
- 3) $M(x)$ is multiplied by x^{32} and divided by $G(x)$, producing a remainder $R(x)$ of degree less than 32;
- 4) the co-efficients of $R(x)$ are considered to be a 32-bit sequence;
- 5) the 32-bit sequence is complemented and the result is the FCS.

The generator polynomial is defined as:

$$G(x) = 1 + X + X^2 + X^4 + X^5 + X^7 + X^8 + X^{10} + X^{11} + X^{12} + X^{16} + X^{22} + X^{23} + X^{26} + X^{32} \quad (\text{C.1})$$

NOTE: There is a minor difference in the rule 1 compared to ISO/IEC 13239 [i.8] in the case when the frame length is less than 32 bits.

Annex D (informative): MAC scenarios for use of traffic channel

This annex shows some examples of scenarios for use of an assigned channel for a circuit mode call. It demonstrates methods for using the MAC TMD-SAP procedures described in clause 23.8 and shows some possible CMCE signalling scenarios.

The BS may use the protocol facilities provided for call set-up and channel usage for circuit mode calls in many different ways. For example:

- early, medium or late assignment;
- transmission, quasi-transmission or message trunking;
- simplex or duplex calls;
- different strategies in case of transmission errors.

Figure D.1 to figure D.10 illustrate a few examples of signalling related to circuit mode calls. It should be noted that there are many other possible scenarios depending on the BS's methods for allocating resources. It should also be noted that some of the features represented here are optional.

In the figures, * beside a BS PDU represents a channel change command. In all the examples shown, the position of any slot grant is on the allocated channel.

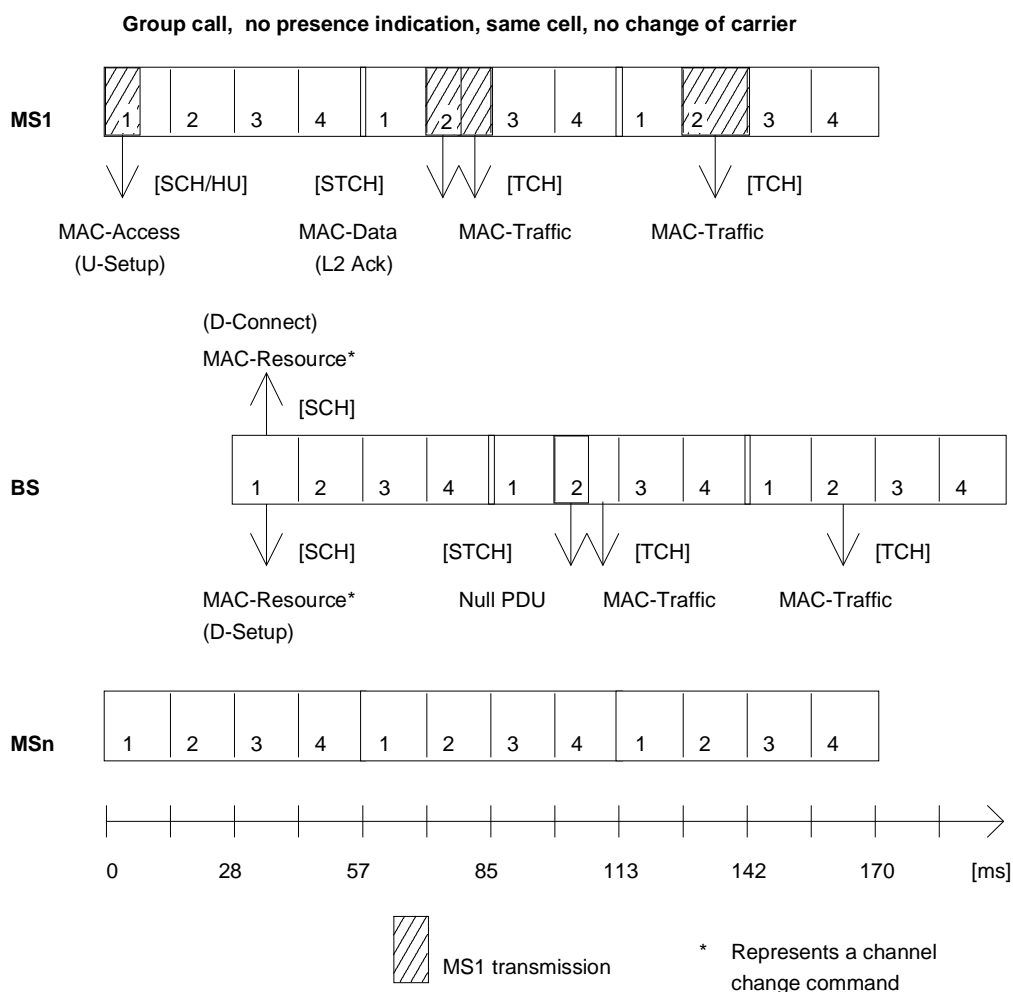

Figure D.1: Initial access message exchange in group call set-up procedure

Figure D.1 illustrates a call set-up of a group call on a single CA cell (without presence indication). The assigned channel is on the main carrier, so no CLCH is needed. The D-CONNECT PDU authorizes the calling MS to start transmitting traffic on the assigned channel and the D-SETUP PDU authorizes the called members of the group to receive traffic. In this example, the BS does not grant a subslot for the calling MS's layer 2 acknowledgement to the D-CONNECT PDU, so the MS steals from the first traffic slot. On the downlink, the BS replaces the half slot with the Null PDU on STCH. The BS may send back-up D-SETUP PDUs (not shown) to the called group.

NOTE 1: In this example, the channel assigned for the circuit mode call is on the main carrier. Circuit mode traffic transmission applies only on $\pi/4$ -DQPSK channels. Therefore this case is not applicable on a DA cell (since the main carrier on a DA cell is a QAM carrier).

In figure D.1, the BS instructs the calling MS to send a layer 2 acknowledgement to the D-CONNECT PDU. This is an optional feature. For example, the BS may choose instead to send the D-CONNECT PDU several times without demanding the layer 2 acknowledgement and so allowing TCH to start one half slot earlier. This general principle applies also to other figures in this annex.

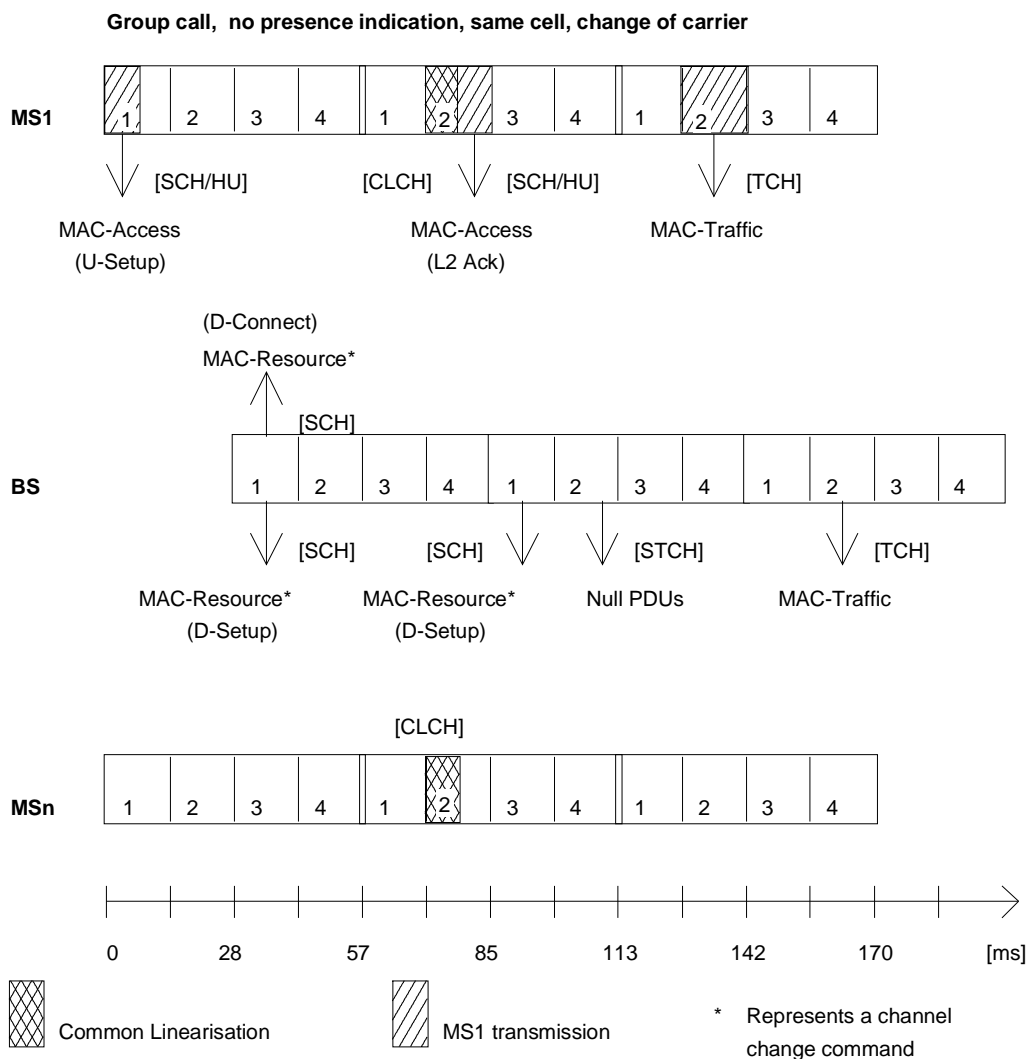

Figure D.2: Initial access message exchange in group call set-up procedure

Figure D.2 illustrates another call set-up of a group call on a single CA cell (without presence indication). The assigned channel is not on the main carrier, so the BS gives "Immediate CLCH Permission" to the calling MS with the channel allocation. In this example, the BS grants the second subslot (after the CLCH) for the calling MS's layer 2 acknowledgement; the MS can then start full-slot TCH in the next slot 2. The BS also gives "Immediate CLCH permission" with the first D-SETUP PDU to the group members. In the example, the BS sends a back-up D-SETUP message on the MCCH. There is "No Immediate CLCH Permission" in the back-up message, because the calling MS has already started traffic transmission.

In figure D.2, traffic from the source is not available for transmission in the first downlink slot on the allocated channel. The BS therefore sends C-plane STCH + STCH on the downlink, in this case containing null C-plane signalling, until traffic from the source is available.

NOTE 2: Figures D.2 and D.3 illustrate group call set-up on a CA cell. In these examples, the channel assigned for the circuit mode call is not on the main carrier. Therefore these cases are also generally applicable on a DA cell, except that:

- the U-SETUP PDU exceeds the available capacity within the QAM random access burst (SCH-Q/RA) sent on the DA main carrier, so the calling MS uses fragmentation and the BS needs to grant a subslot (SCH-Q/HU) for the final fragment;
- for a 25 kHz DA main carrier, the BS may prefer to send the D-CONNECT and D-SETUP PDUs in separate slots (e.g. if it wishes to use 4-QAM coding rate = 1/2).

Group encrypted call, no presence indication, same cell, change of carrier

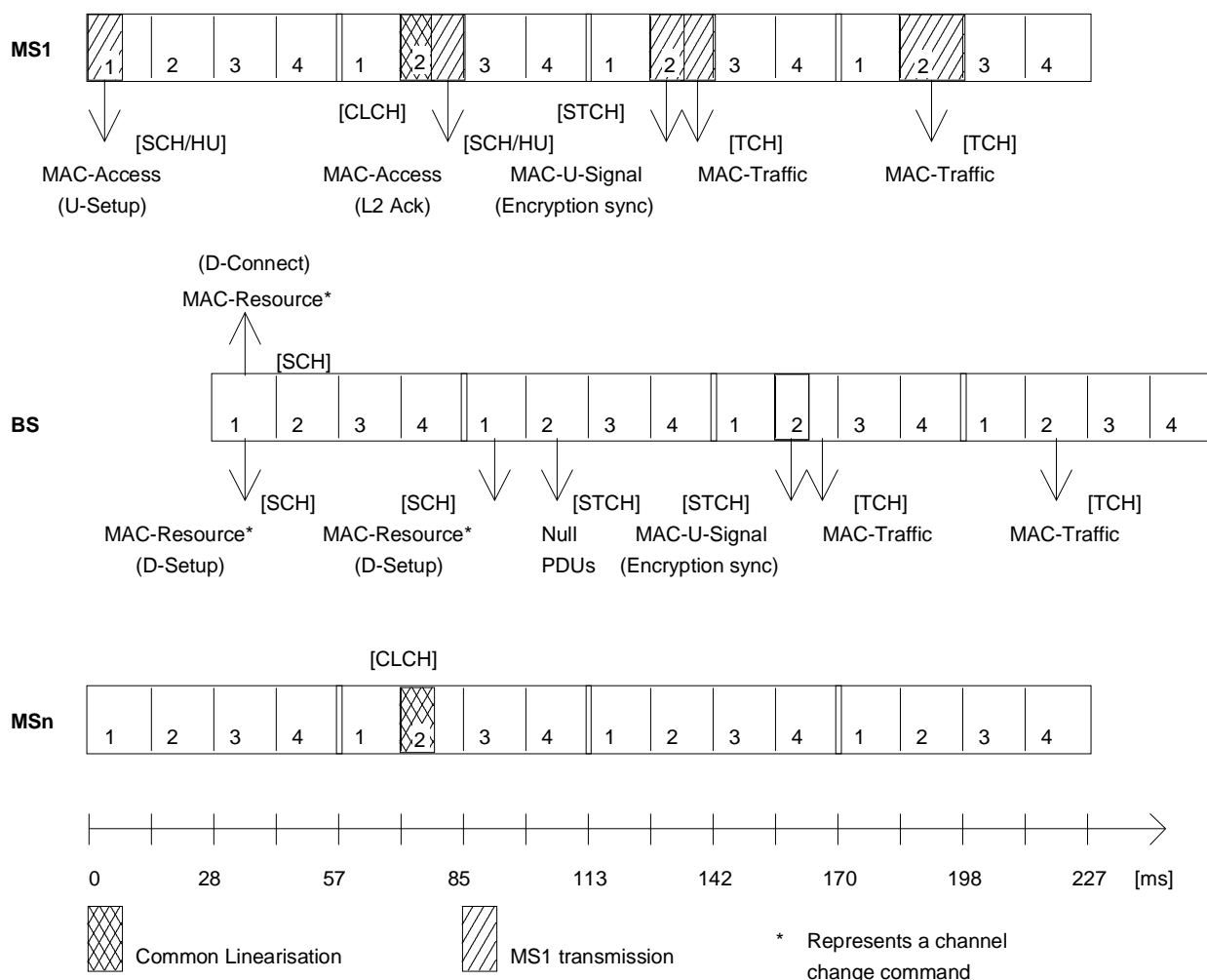

Figure D.3: End-to-end signalling for starting encryption of speech (group call)

Figure D.3 is similar to figure D.2 except that this call uses end-to-end encryption, so the calling MS steals from the first traffic slot to send U-plane signalling. This message is passed on to the receiving group.

Figure D.4 illustrates a call set-up of an individual call on a single CA cell (with direct call set-up). The BS checks the availability of the called MS before allocating a traffic channel. The assigned channel is on the main carrier, so no CLCH is needed. In this example, the BS sends D-CONNECT ACK with the channel allocation to the called MS, authorizing it to receive traffic. However, it waits for the called MS to respond before authorizing the calling MS to start transmitting traffic (D-CONNECT PDU).

NOTE 3: In this example, the channel assigned for the circuit mode call is on the main carrier. Circuit mode traffic transmission applies only on $\pi/4$ -DQPSK channels. Therefore this case is not applicable on a DA cell.

In the example shown, the BS receives a layer 2 acknowledgement from the called MS in the granted subslot. If it had not received a PDU in the granted subslot, then it cannot know whether it was the downlink message that failed or only the uplink response. So it does not know whether the MS is still receiving the MCCH or whether it has moved to slot 2. Using the method illustrated, the BS can repeat the D-CONNECT ACK on the MCCH and also page the MS on slot 2 until it receives a layer 2 acknowledgement on slot 2. The BS can then authorize the calling MS to transmit.

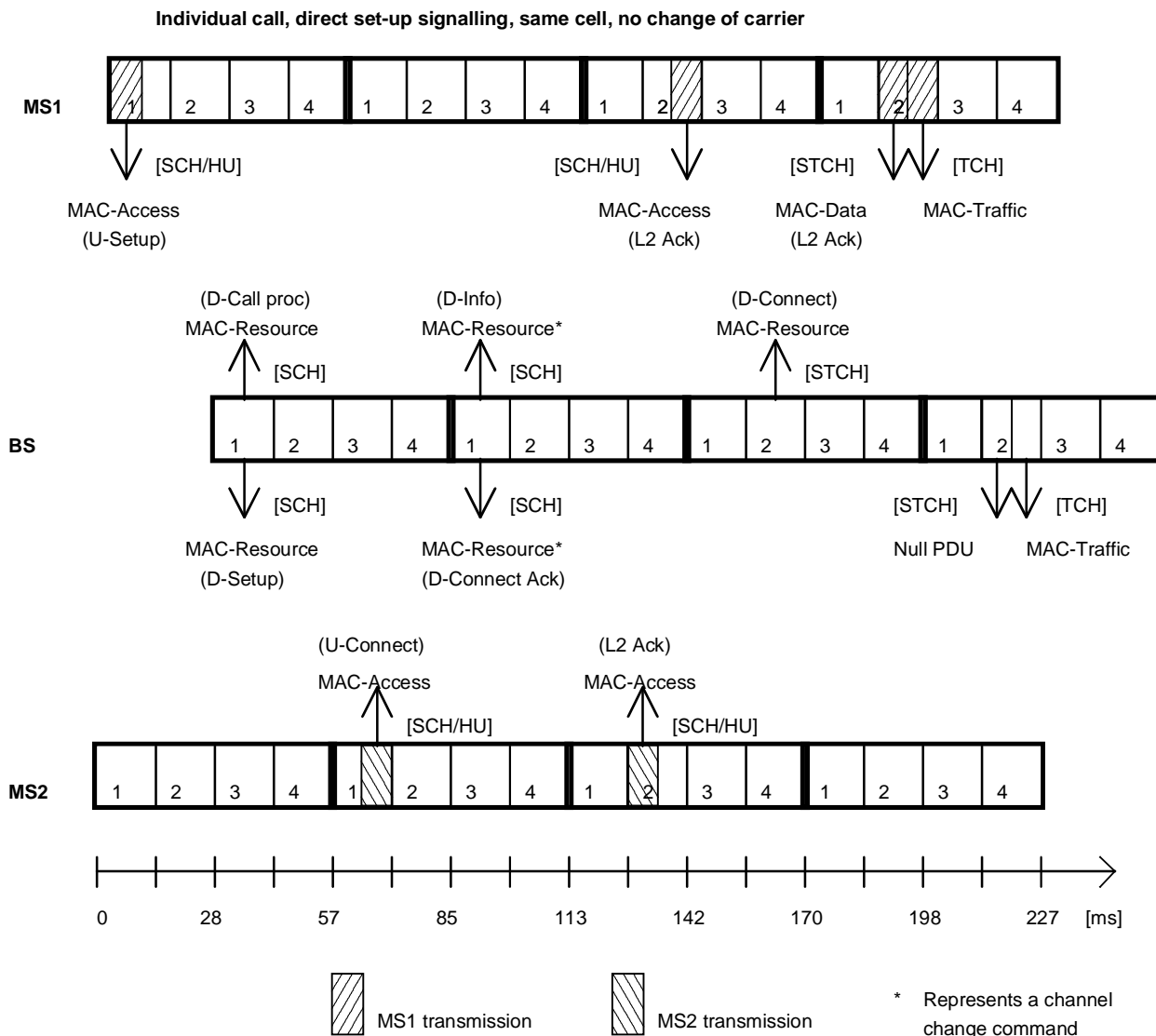

Figure D.4: Initial access message exchange in individual call set-up procedure

The signalling method shown in figure D.4 can be used more generally when there may be a queuing delay between D-CALL PROCEEDING and channel allocation. Whereas, in the case illustrated, with no queuing delay, the BS could have delayed the D-CALL PROCEEDING until channel allocation (replacing D-INFO).

Alternatively to the method shown in figure D.4, the BS may send D-CONNECT to the calling MS with the channel allocation (instead of D-INFO). This method is illustrated in figure D.5. It can be seen that this allows TCH to start one half slot earlier. However, if the called MS misses the D-CONNECT ACK PDU, it will not receive the first part of the traffic. Also, for repeat signalling, the BS should either use the unacknowledged service or grant a subslot on the MCCH (i.e. before the channel change) or delay the layer 2 acknowledgement until frame 18.

NOTE 4: In this example, the channel assigned for the circuit mode call is on the main carrier. Circuit mode traffic transmission applies only on $\pi/4$ -DQPSK channels. Therefore this case is not applicable on a DA cell.

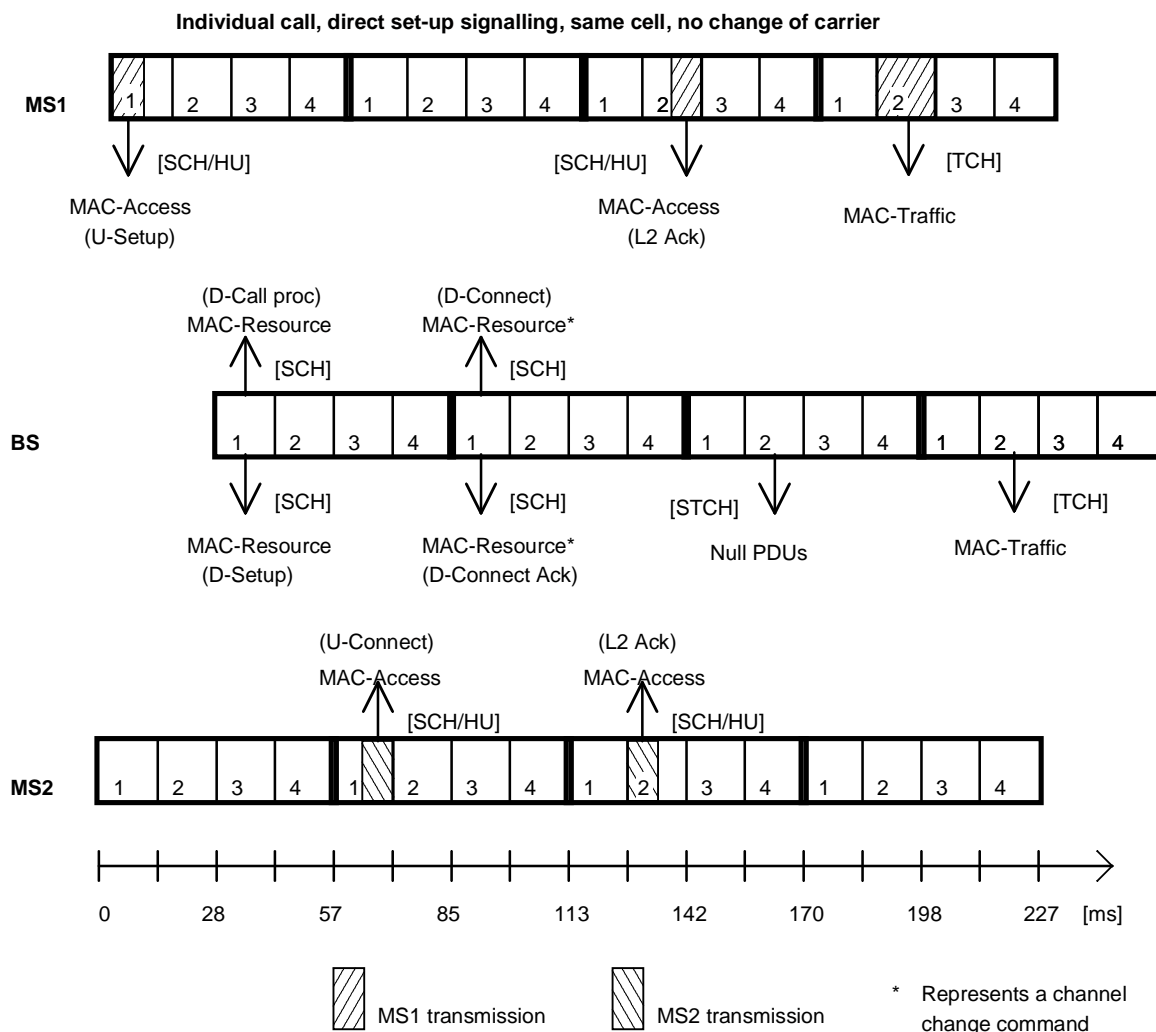

Figure D.5: Initial access message exchange in individual call set-up procedure

Figure D.6 is similar to figure D.4, but with a change of carrier.

NOTE 5: Figures D.6 and D.7 illustrate individual call set-up on a CA cell. In these examples, the channel assigned for the circuit mode call is not on the main carrier. Therefore these cases are also generally applicable on a DA cell, except that:

- the U-SETUP PDU exceeds the available capacity within the QAM random access uplink burst (logical channel SCH-Q/RA) sent on the DA main carrier, so the calling MS uses fragmentation and the BS needs to grant a subslot (logical channel SCH-Q/HU) for the final fragment;
- for a 25 kHz DA main carrier, the BS may prefer to grant a full slot (logical channel SCH-Q/U) for the U-CONNECT PDU; for a 50 kHz, 100 kHz or 150 kHz DA main carrier, the U-CONNECT PDU from the called MS can generally be carried in a subslot;
- for a 25 kHz DA main carrier, the BS may prefer to send the downlink PDUs to the calling MS and called MS in separate slots (this may apply particularly if the BS wishes to use 4-QAM coding rate = 1/2 when it is sending the D-INFO and D-CONNECT ACK PDUs).

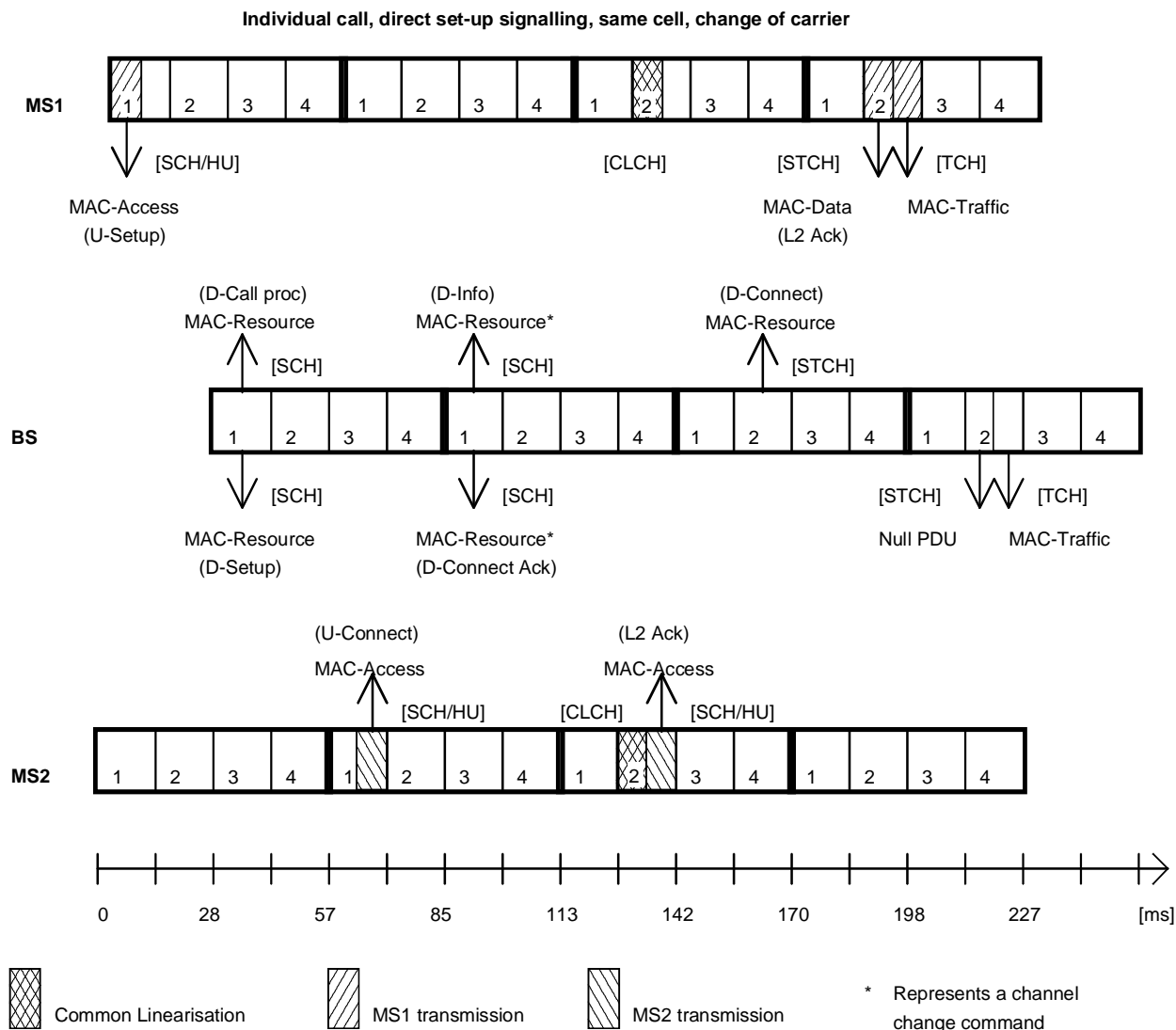

Figure D.6: Initial access message exchange in individual call set-up procedure

Figure D.8 shows an example of signalling at the end of an "over" in an individual call. In this example, the BS requires confirmation of receipt of D-TX CEASED from both MSs.

NOTE 6: Figures D.8, D.9 and D.10 show examples of signalling on the channel assigned for the circuit mode call. These examples may apply for circuit mode calls on both CA cells and DA cells.

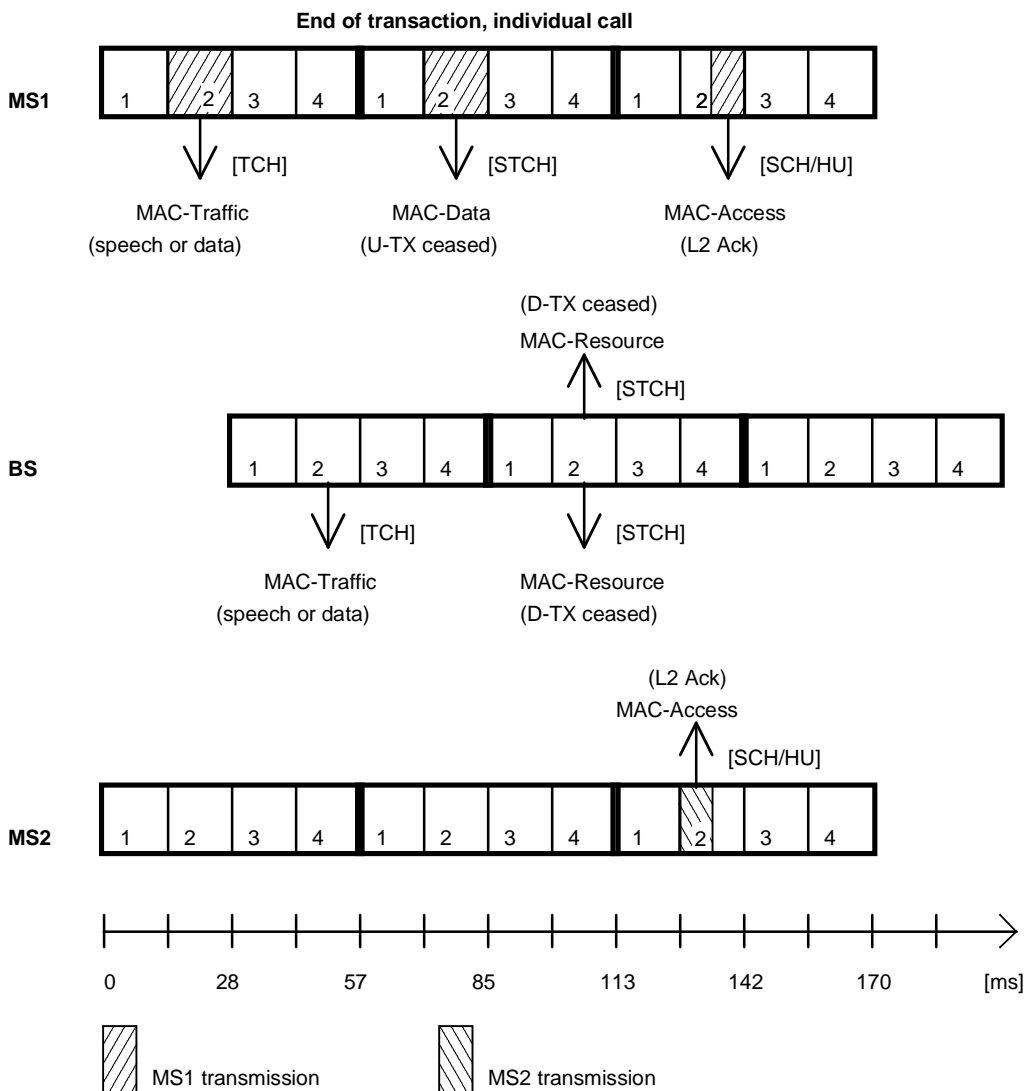

Figure D.8: End of transaction sequence in circuit mode

Figures D.9 and D.10 show options for signalling at the start of subsequent "over" for a message trunked call. The BS may prefer to wait for an acknowledgement from the receiving party before giving transmit permission, as in figure D.9. Or it may give transmit and receive permission at the same time, as in figure D.10 (risking some loss of traffic by the recipient).

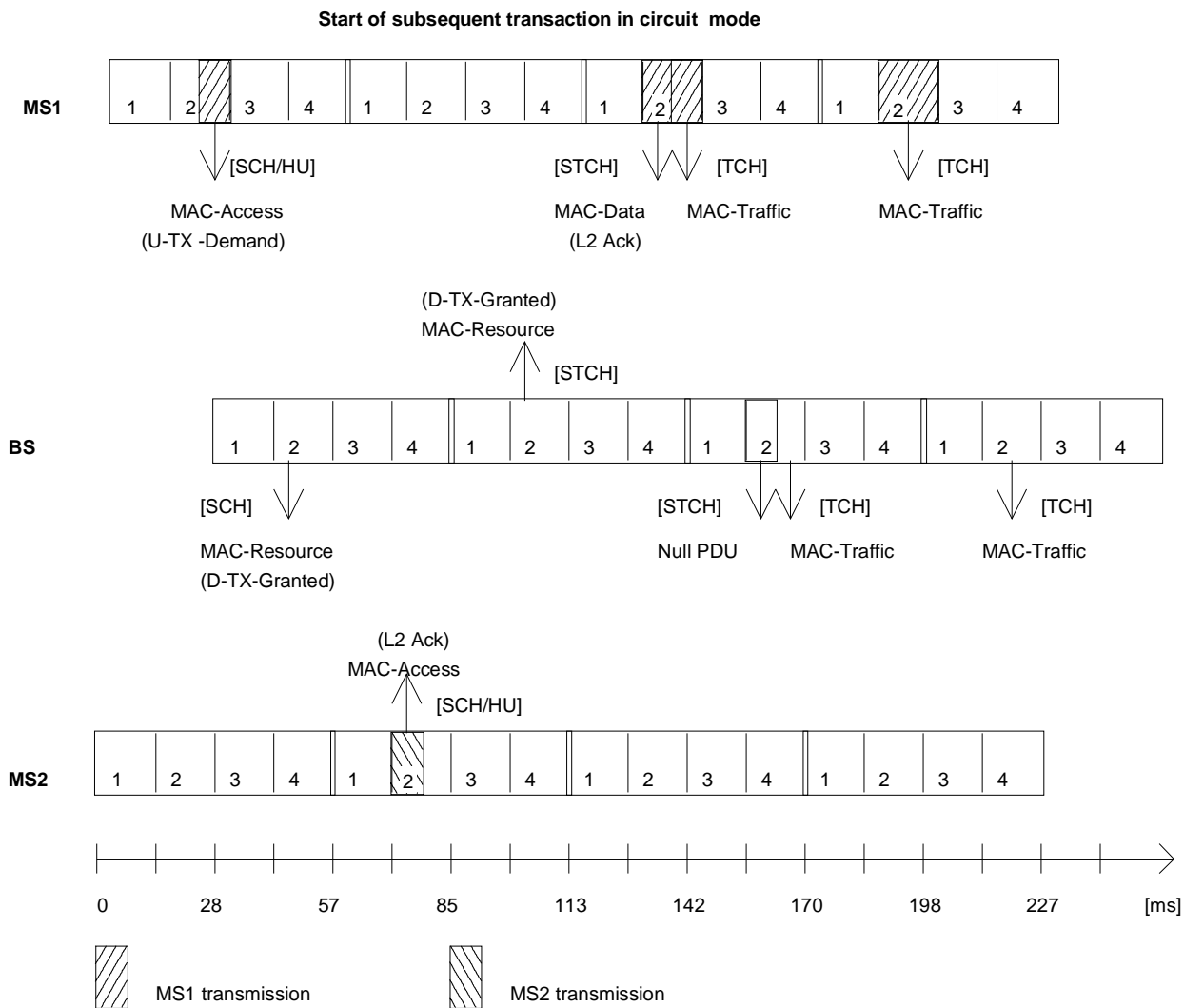

Figure D.9: Start of subsequent transaction in circuit mode

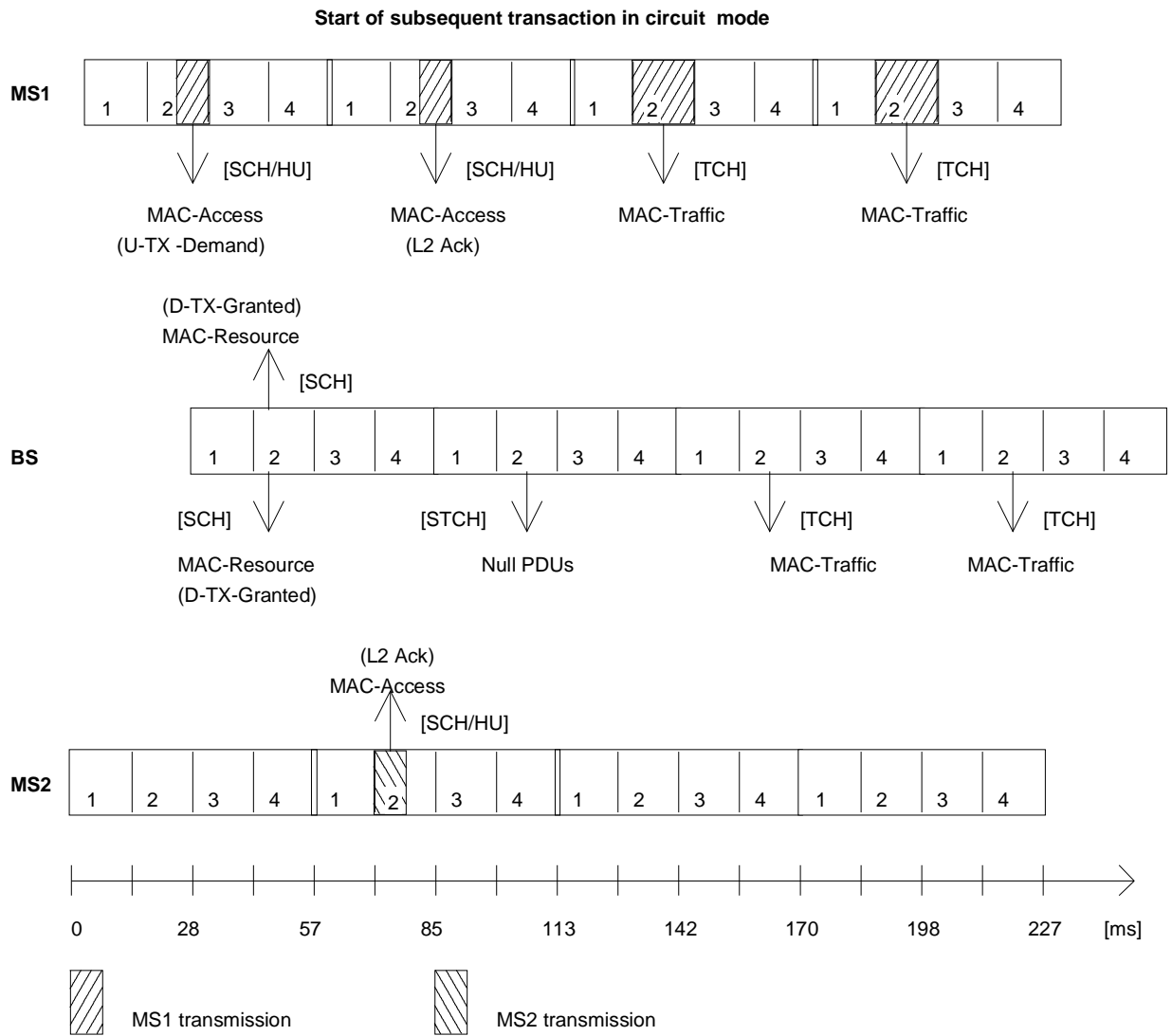

Figure D.10: Start of subsequent transaction in circuit mode

Annex E (normative): PDU encoding rules and examples

E.0 General

This annex defines general PDU encoding rules and examples for some PDUs, which may require further clarification.

E.1 PDU encoding rules for CMCE, MM and SND CP PDUs

E.1.1 General PDU encoding rules for CMCE, MM and SND CP PDUs

The general format of the PDUs are defined in table E.1. The information element Protocol identifier is present for each PDU before the PDU type element although not shown in the PDU descriptions. The MLE sub-layer shall add/remove Protocol identifier element before sending the PDU to lower layers or passing the PDU to other layer 3 entities.

The elements shall be transmitted in the order specified by the table with the top element being transmitted first (before interleaving). The content of an information element is represented by a binary value and the most significant bit of that binary value shall be transmitted first (before interleaving).

Table E.1: CMCE, MM and SND CP PDU layout

Information element	Length	Value	Remark
PDU type	variable		Dependent on the protocol entity
Type 1 element (1)	variable		See definitions below
Type 1 element (2)	variable		See definitions below
etc.	etc.		Etc.
Type 1 element (m)	variable		See definitions below
Conditional element to previous element	variable		See definitions below
etc.	etc.		Etc.
Type 1 element (m+1)	variable		See definitions below
etc.	etc.		Etc.
Type 1 element (n)	variable		See definitions below
Optional bit (O-bit)	1	0	No optional type 2 or type 3/4 elements follow
		1	Optional type 2 or type 3/4 elements follow
Presence bit (P-bit) (1)	1	0	The type 2 element (1) is not present
		1	The type 2 element (1) is present
Type 2 element (1)	variable		See definitions below
Presence bit (P-bit) (2)	1	0	The type 2 element (2) is not present
		1	The type 2 element (2) is present
Type 2 element (2)	variable		See definitions below
etc.	etc.		Etc.
Presence bit (P-bit) (m)	1	0	The type 2 element (m) is not present
		1	The type 2 element (m) is present
Type 2 element (m)	variable		See definitions below
Conditional element to previous element	variable		See definitions below
etc.	etc.		Etc.
Presence bit (P-bit) (m+1)	1	0	The type 2 element (m+1) is not present
		1	The type 2 element (m+1) is present
Type 2 element (m+1)	variable		See definitions below
etc.	etc.		Etc.

Information element	Length	Value	Remark
Presence bit (P-bit) (n)	1	0	The type 2 element (n) is not present
		1	The type 2 element (n) is present
Type 2 element (n)	variable		See definitions below
More bit (M-bit) (1)	1	0	No type 3/4 elements follow
		1	Type 3/4 elements follow
Type 3 element identifier (1)	4		See definitions below
Length indicator (1)	11	0	Reserved
		1 to 2 047	Length of the following type 3 Element in bits
Type 3 element (1)	variable		See definitions below
More bit (M-bit) (2)	1	0	No more type 3/4 elements follow
		1	More type 3/4 elements follow
Type 3 element identifier (2)	4		See definitions below
Length indicator (2)	11		See length indicator (1)
Type 3 element (2)	variable		See definitions below
More bit (M-bit) (3)	1	0	No more type 3/4 elements follow
		1	More type 3/4 elements follow
Type 4 element identifier (3)	4		See definitions below
Length indicator (3)	11		Total length of the following type 4 Elements in bits (including the Number of repeated elements)
Number of repeated elements (3)	6	0	Reserved
		1 to 63	Indicates the number of repeated type 4 elements
Type 4 sub-element (3.1)	variable		See definitions below
Type 4 sub-element (3.2)	variable		See definitions below
etc.	etc.		Etc.
Type 4 sub-element (3.n)	variable		See definitions below
More bit (M-bit) (4)	1	0	No more type 3/4 elements follow
		1	More type 3/4 elements follow
etc.	etc.		Etc.
More bit (M-bit) (n)	1	0	No more type 3/4 elements follow
		1	More type 3/4 elements follow
Type 3 element identifier (n)	4		See definitions below
Length indicator (n)	11		See length indicator (1)
Type 3 element (n)	variable		See definitions below
More bit (M-bit) (n+1) = 0	1	0	Last M-bit (Least Significant Bit (LSB) in the PDU) = 0

Presence of O-bit, P-bit and M-bit:

The O-bit is always present straight after last type 1 element or element conditional to the last type 1 element unless stated otherwise in the PDU description. In case O-bit has value "0", the PDU contains no more elements; no P-bits for type 2 elements, no type 2 elements, no M-bits nor type 3 or type 4 elements.

In case the O-bit has value 1, then at least one type 2, type 3 or type 4 element follows. In this case there is P-bit for each type 2 element which is defined for the PDU; if the type 2 element is present in the PDU then the corresponding P-bit has value 1, if the type 2 element is not present, then the corresponding P-bit has value 0.

NOTE 1: There is no P-bit before an element that is conditional to type 2 element.

In case the O-bit has value 1, then after the last type 2 element or element that is conditional to the last type 2 element, or after the P-bit indicating that the last type 2 element is not present, there is always an M-bit telling whether there are any type 3 or type 4 elements present in the PDU. For each type 3 or type 4 element present in the PDU there is preceding M-bit having value 1. After the last type 3 or type 4 element, there is always one M-bit (the last bit in the PDU) having value 0.

NOTE 2: If there are type 2 element(s) present in the PDU and no type 3/4 elements are specified for the PDU, the M bit is present and set to "0" unless stated otherwise in the PDU description.

NOTE 3: In case the PDU definition does not contain any type 2 elements and the PDU contains type 3 or type 4 elements, then there is the O-bit having value 1 after the last type 1 element or element conditional to the last type 1 element, followed by M-bit having value 1 and then the first type 3 or type 4 element.

NOTE 4: If there is no type 2 nor type 3 nor type 4 elements specified for the PDU the O-bit is present and set to "0" unless stated otherwise in the PDU description.

Length of the elements:

The length of a type 1 or type 2 element or element conditional to type 1 or type 2 element is either fixed as indicated in the "Length" column in the PDU or the length may be indicated by the value of a preceding element to which this element is conditional, or it shall be possible for the receiver to determine the length of the element by the examination of the element and its sub-elements.

NOTE 5: A conditional element may also be present in the PDU varying times as indicated by the value of a preceding element to which this element is conditional. In such case the element is marked as "Repeatable" in the PDU.

The length of a type 3 and type 4 element is indicated by the preceding "Length indicator" element.

NOTE 6: Because of these PDU encoding rules, only adding of a type 3 or type 4 element can be done without causing backward incompatibility problems, as the decoding entity can pass unknown type 3 and type 4 elements because their length is indicated in the PDU whereas the length of type 1 or type 2 element are known beforehand.

Encoding rules for PDU:

The element type defines the encoding rule applied to an element as follows:

- Type 1 elements are mandatory and shall be placed within the PDU in a fixed order as specified in the PDU description tables. Type 1 elements shall be placed before any type 2 or type 3 elements in the PDU encoding. In addition the PDU may contain elements that are conditional to type 1 elements; they are present only if the corresponding type 1 element has specified value. These conditional elements are placed after the type 1 elements to which they are conditional;
- Type 2 elements are optional and shall be placed within the PDU in a fixed order as specified in the PDU description tables. Type 2 elements shall be placed after all type 1 elements and elements conditional to type 1 elements, and before any type 3 elements in the PDU encoding. In addition the PDU may contain elements that are conditional to type 2 elements; they are present only if the corresponding type 2 element has specified value. These conditional elements are placed after the type 2 elements to which they are conditional;
- Type 3 and type 4 elements are optional and shall be placed within the PDU in numerical order as specified within the "type 3/4 Element Identifier" element. Type 3/4 Elements shall be placed after any type 1 and type 2 elements in the PDU encoding. Each type 3 and type 4 element shall be preceded by a "type 3/4 Element Identifier" element and a "Length Indicator" element in that order. In addition for each type 4 element a length indicator shall be followed by the "Number of repeated elements" information element.

NOTE 7: For presentation purposes a set of information elements can be defined as an information element. The set of information sub-elements may contain also optional or conditional elements and also elements consisting of set of sub-elements. The set is encoded into the PDU as if it were a single information element of the indicated type.

The following rules shall apply for decoding of the PDU:

```

DO for all Type 1 elements
  DECODE Type 1 element
    WHILE conditional elements to the type 1 element
      DECODE conditional element
    END WHILE
END DO
DECODE O-bit
IF O-bit set to 'No Optional Elements present'
  THEN END of PDU decoding
ELSE
  DO for all possible Type 2 elements
    DECODE P-bit
    IF P-bit set to 'Present'
      THEN DECODE Type 2 element AND
        WHILE conditional elements to the type 2 element
          DECODE conditional element
        END WHILE
    END DO
  WHILE M-bit set to 'More Type 3/4 elements follows'
    IF element is a Type 4 element
      THEN DECODE Number of repeated elements
        WHILE more type 4 sub-elements
          DECODE Type 4 sub-element
        END WHILE
    ELSE
      DECODE Type 3 element
    END IF
  END WHILE
END of PDU decoding.

```

The encoding rules for elements and sub-elements:

- in case the PDU information element or sub-element definition contains no "Type" column, the sub-elements of the element/sub-element shall be all considered to be of type 1;
- type 1 element or type 1 sub-element can contain only type 1 or type 2 sub-elements and conditional elements to type 1 or type 2 element/sub-element;
- type 2 element or type 2 sub-element can contain only type 1 or type 2 sub-elements and conditional elements to type 1 or type 2 element/sub-element;
- element conditional to type 1 or type 2 element or sub-element can contain only type 1 or type 2 sub-elements and conditional elements to type 1 or type 2 element/sub-element;
- in case the type 1 element definition does not contain optional sub-elements, there is no O-bit after the type 1 sub-elements;
- in case the type 1 element definition contains optional sub-elements, there shall be an O-bit after the last type 1 sub-element. There shall be no M-bit after the last type 2 element or conditional element or the P-bit indicating that the last type 2 element is not present;
- type 3 or type 4 element or sub-element can contain sub-elements which can be one of type 1, 2, 3 and 4. In case the type 3 or type 4 element/sub-element definition does not contain optional elements, there is no O-bit after the type 1 sub-elements;

NOTE 8: Any supplementary service PDU may contain optional type 3/4 information elements unless the supplementary service PDU definition states otherwise. For that purpose those supplementary service PDUs contain O-bit as the last bit also when all the PDU information elements are of type 1 independent of whether it is carried in a facility information element or in U/D-FACILITY PDU, refer to clause E.1.2 for examples.

- in case type 3 or type 4 element/sub-element definition contains optional type 2 or type 3 elements, there shall be an O-bit indicating whether the type 3/4 element/sub-element contains any optional elements:
 - in case the type 3 or type 4 element/sub-element contains no optional elements, the O-bit is set to value "no optional elements follow" and no other information shall be included to the type 3 or type 4 element/sub-element;

- in case the type 3 or type 4 element/sub-element contains optional elements (either type 2 or type 3 or type 4) the O-bit is set to value "optional elements follow" and a P-bit shall be set for each type 2 optional element (if any defined) indicating presence of that element. The P-bit shall indicate either "type 2 element present" or "type 2 element not present":
 - in case the element/sub-element definition does not contain any type 3 or type 4 elements there shall be no M-bit after the last type 2 element or conditional element or the P-bit indicating that the last type 2 element is not present;
 - in case the type 3/4 element/sub-element definition contains type 3/4 elements, there shall be a M-bit after the last type 2 element or conditional element or P-bit indicating that last optional type 2 element is not present, indicating whether the element/sub-element contains any type 3/4 elements. The type 3 and type 4 sub-elements are coded similarly as type 3 and type 4 PDU information elements, i.e. type 3 and type 4 sub-element shall be preceded by a "type 3/4 Element Identifier" element and a "Length Indicator" element in that order. In addition in the type 4 sub-element a length indicator shall be followed by the "Number of repeated elements" information element. A further M-bit shall follow each Type 3/4 sub-element to indicate either "type 3/4 element to follow" or "no type 3/4 element to follow". After the last type 3/4 sub-element included the M-bit shall be set to "0" to indicate "no type 3/4 element to follow" in this sub-element:
 - in case the information element/sub-element contains one or more type 3 elements but no type 2 elements are specified for the element/sub-element, an M-bit (having value "type 3/4 elements to follow") shall follow the O-bit (having value "optional elements to follow") placed after the last type 1 element;
 - in case the element/sub-element contains no type 3/4 elements but contains type 2 elements there shall be one M-bit bit indicating "no type 3/4 elements to follow" after the last type 2 element or P-bit indicating that last optional type 2 element is not present as the last bit in the type 3/4 element.

The C/O/M column indicates how the presence of an information element is controlled in the PDU or element/sub-element:

- M: Mandatory information element is always present (mandatory) in the main PDU level and is always present in a sub-element, when the sub-element itself is present. The type of mandatory element is type 1;
- O: Optional information element may be present in the PDU. The protocol state or an implementation choice defines when it is present or not. The type of optional element is either type 2 or type 3 or type 4;
- C: Conditional information element is present as defined in the PDU or element/sub-element description. The presence depends on the value of another preceding information element. If the information element on which the conditional information element is conditional is not present then also the conditional information element is not present. The conditional information element may be also repeated as many times as indicated by a preceding information element.

E.1.2 PDU encoding examples for CMCE PDUs

Tables E.2 to E.8 present examples of proper CMCE PDU encoding in specific cases.

Table E.2: D-FACILITY PDU with two SS-PDUs

Information Element	Length	Type	C/O/M	Value
Protocol discriminator	3	1	M	CMCE
PDU Type	5	1	M	D-FACILITY
Number of SS PDUs	4	1	M	2
Length indicator	11	1	M	variable
SS-PDU contents	variable	1	C	variable
Length indicator	11	1	M	variable
SS-PDU contents	variable	1	C	variable
Optional elements present?	1	O-bit		0 ("not present" for D-FACILITY PDU)
NOTE: When the U/D-FACILITY PDU contains more than a single SS-PDU it is a collection of SS-PDUs which are encoded independently of each other. Each SS-PDU may contain any type of information elements as defined for the SS-PDU.				

Table E.3: D-FACILITY PDU with "SS not supported" acknowledgement

Information Element	Length	Type	C/O/M	Value
Protocol discriminator	3	1	M	CMCE
PDU Type	5	1	M	D-FACILITY
Number of SS PDUs	4	1	M	1
Length indicator	11	1	M	12
SS-PDU contents	12			<i>See next 3 elements</i>
SS-Type	6	1	M	SS-DGNA
SS-PDU Type	5	1	M	SS not supported
Optional elements present?	1	O-bit		0 ("not present" for SS not supported PDU)
Optional elements present?	1	O-bit		0 ("not present" for D-FACILITY PDU)

Table E.4: D-FACILITY with SS-DGNA ASSIGN PDU

Information Element	Length	Type	C/O/M	Value
Protocol discriminator	3	1	M	CMCE
PDU Type	5	1	M	D-FACILITY
Number of SS PDUs	4	1	M	1
Length indicator	11	1	M	147
<i>SS-PDU contents</i>	<i>147</i>			<i>See next 20 rows</i>
SS type	6	1	M	SS-DGNA
SS-DGNA PDU type	5	1	M	ASSIGN
Number of groups	5	1	M	2 (Group assignments)
<i>Group assignment (first)</i>	<i>82</i>			<i>See next 15 rows</i>
1 Group SSI	24	1	M	Any
Group extension present	1	1	M	Group extension present
Group extension	24		C	Any
Group identity attachment mode	3	1	M	Any
Optional elements present?	1	O-bit		1 (present)
P-bit for Class of usage element	1	P-bit		1 (present)
Class of usage	3	2	O	Any
P-bit for Mnemonic group name element	1	P-bit		1 (present)
Mnemonic group name	39			<i>See next three elements.</i>
Text coding scheme	7	1	M	Latin-1 (8-bit characters)
Length of mnemonic group name character string	8	1	M	24
Mnemonic group name character string	24		C	"EPT" (= 3 × 8)
P-bit for Length of security related information element	1	P-bit		0 (not present)
Length of additional group information element	1	P-bit		0 (not present)
P-bit for (V)GSSI	1	P-bit		0 (not present)
<i>Group assignment (second)</i>	<i>29</i>			<i>See next 4 rows</i>
2 Group SSI	24	1	M	Any
Group extension present	1	1	M	0 (not present)
Group identity attachment mode	3	1	M	Any
Optional elements present?	1	O-bit		0 ("not present" for this Group assignment)
Acknowledgement requested from affected user(s)	1	1	M	Any
Optional elements present?	1	O-bit		0 ("not present" for SS-DGNA ASSIGN PDU)
Optional elements present?	1	O-bit		0 ("not present" for D-FACILITY PDU)
NOTE: The Mnemonic name encoding requires that the receiving entity is capable to understand the Length of mnemonic group name character string information element. The decoding of the mnemonic name is optional as the length allows to by-pass the name.				

Table E.5: U-INFO PDU with DTMF element

Information Element	Length	Type	C/O/M	Value
Protocol discriminator	3	1	M	CMCE
PDU Type	5	1	M	U-INFO
Poll response	1	1	M	0
Optional elements present?	1	O-bit		1 (present)
P-bit for Modify element	1	P-bit		0
Type 3 / 4 elements to follow	1	M-bit		1 (present)
Type 3/4 element identifier	4	1	M	DTMF
Length indicator	11	1	M	11
DTMF type	3	1	M	DTMF tone start
DTMF digit	4	1	M	1st digit
DTMF digit	4	1	M	2nd digit
Type 3/4 elements to follow	1	M-bit		0 (not present)

Table E.6: U-STATUS PDU with External subscriber number element

Information Element	Length	Type	C/O/M	Value
Protocol discriminator	3	1	M	CMCE
PDU Type	5	1	M	U-STATUS
Area selection	4	1	M	Any
Called party type identifier	2	1	M	SSI
Called party SSI	24		C	Any gateway
Pre-coded status	16	1	M	Any
Optional elements present?	1	O-bit		1 (present)
Type 3/4 elements to follow	1	M-bit		1 (present)
Type 3/4 element identifier	4	1	M	External subscriber number
Length indicator	11	1	M	28
<i>External subscriber number</i>	28			<i>See next seven rows</i>
External subscriber number digit	4	1	M	1st digit
External subscriber number digit	4	1	M	2nd digit
External subscriber number digit	4	1	M	3rd digit
External subscriber number digit	4	1	M	4th digit
External subscriber number digit	4	1	M	5th digit
External subscriber number digit	4	1	M	6th digit
External subscriber number digit	4	1	M	7th digit
Type 3/4 elements to follow	1	M-bit		0 (not present)

Table E.7: U-SETUP with SS-AL INVOKE1 PDU

Information Element	Length	Type	C/O/M	Value
Protocol discriminator	3	1	M	CMCE
PDU Type	5	1	M	U-SETUP
Area selection	4	1	M	Any
Hook method selection	1	1	M	0
Simplex/duplex selection	1	1	M	0
Basic service information	8	1	M	0
Request to transmit/send data	1	1	M	0
Call priority	4	1	M	Any
CLIR control	2	1	M	Any
Called party type identifier	1	1	M	SSI
Called party SSI	24		C	Any
Optional elements present?	1	O-bit		1 (present)
Type 3/4 elements to follow	1	M-bit		1 (present)
Type 3 element identifier	4	1	M	Facility
Length indicator	11	1	M	12
<i>SS-PDU contents</i>	12			<i>See next 3 rows</i>
SS type	6	1	M	SS-AL
SS-AL PDU type	5	1	M	INVOKE1
Optional elements present?	1	O-bit		0 ("not present" for INVOKE1 PDU)
Type 3/4 elements to follow	1	M-bit		0 ("not present" for U-SETUP PDU)

Table E.8: D-CONNECT with SS-AL INVOKE1 ACK PDU

Information Element	Length	Type	C/O/M	Value
Protocol discriminator	3	1	M	CMCE
PDU Type	5	1	M	D-CONNECT
Call identifier	14	1	M	Any
Call time-out	4	1	M	Any
Hook method	1	1	M	0 (not present)
Simplex/duplex selection	1	1	M	0 (not present)
Transmission grant	2	1	M	1 (present)
Transmission request permission	1	1	M	0 (not present)
Call ownership	1	1	M	0 (not present)
Optional elements present?	1	O-bit		1 (present)
Call priority	1	P-bit		0 (not present)
Basic service information	1	P-bit		0 (not present)
Temporary address	1	P-bit		0 (not present)
Notification indicator	1	P-bit		0 (not present)
More optional elements present?	1	M-bit		1 (present)
Type 3 element identifier	4	1	M	Facility
Length indicator	11	1	M	42
SS-PDU contents	42			See next 6 rows
SS type	6	1	M	SS-AL
SS-AL PDU type	5	1	M	INVOKE1 ACK
Affected party type identifier	2	1	M	SSI
Affected party SSI	24		C	Any
Result for invocation	4	1	M	Any
Optional elements present?	1	O-bit		0 ("not present" for INVOKE1 ACK PDU)
More optional elements present?	1	M-bit		0 ("not present" for D-CONNECT PDU)

E.1.3 PDU encoding examples for MM PDUs

Tables E.9 to E.14 present examples of proper MM PDU encoding in specific cases.

Table E.9: D-ATTACH/DETACH GROUP IDENTITY PDU

Information Element	Length	Type	C/O/M	Value
Protocol discriminator	3	1	M	MM
PDU Type	4	1	M	D-ATTACH / DETACH GROUP IDENTITY
Group identity report	1	1	M	No report request
Group identity acknowledgement request	1	1	M	Any
Group identity attach/detach mode	1	1	M	Any
Optional elements present?	1	O-bit		1
Type 3 / 4 elements to follow	1	M-bit		1
Type 3/4 element identifier	4	1	M	Group identity downlink
Length indicator	11	1	M	67
Number of repeated elements	6	1	M	2
1 Group identity attach/detach type identifier	1	1	M	Attachment
Group identity attachment	5		C	See next 2 rows
Group identity attachment lifetime	2	1	M	Any
Class of usage	3	1	M	Any
Group identity address type	2	1	M	GSSI
GSSI	24		C	Any
2 Group identity attach/detach type identifier	1	1	M	Detachment
Group identity detachment downlink	2		C	Any
Group identity address type	2	1	M	GSSI
GSSI	24		C	Any
Type 3/4 elements to follow?	1	M-bit		0

Table E.10: D-LOCATION UPDATE ACCEPT PDU without optional elements

Information Element	Length	Type	C/O/M	Value
Protocol discriminator	3	1	M	MM
PDU Type	4	1	M	D-LOCATION UPDATE ACCEPT
Location update accept type	3	1	M	Any
Optional elements present?	1	O-bit		0

Table E.11: D-LOCATION UPDATE ACCEPT PDU with optional Type 4 elements

Information Element	Length	Type	C/O/M	Value
Protocol discriminator	3	1	M	MM
PDU Type	4	1	M	D-LOCATION UPDATE ACCEPT
Location update accept type	3	1	M	Any
Optional elements present?	1	O-bit		1
P-bit for SSI element	1	P-bit		0
P-bit for Address extension element	1	P-bit		0
P-bit for Subscriber class element	1	P-bit		1
Subscriber class	16	2	O	Any
P-bit for Energy saving information element	1	P-bit		0
P-bit for SCCH information and distribution on 18th frame element	1	P-bit		0
Type 3 / 4 elements to follow	1	M-bit		1
Type 3/4 element identifier	4	1	M	New registered area
Length indicator	11	1	M	42
Number of repeated elements	6	1	M	2
1 LA timer	3	1	M	Any
LA	14	1	M	Any
Optional elements present?	1	O-bit		0
2 LA timer	3	1	M	Any
LA	14	1	M	Any
Optional elements present?	1	O-bit		0
Type 3/4 elements to follow	1	M-bit		1
Type 3/4 element identifier	4	1	M	Group identity location accept
Length indicator	11	1	M	55
Group identity accept/reject	1	1	M	Any
Reserved	1	1	M	Any
Optional elements present?	1	O-bit		1
Type 3/4 elements to follow	1	M-bit		1
Type 3/4 element identifier	4	1	M	Group identity downlink
Length indicator	11	1	M	35
Number of repeated elements	6	1	M	1
1 Group identity attach/detach type identifier	1	1	M	Detachment
Group identity detachment downlink	2		C	Any
Group identity address type	2	1	M	GSSI
GSSI	24		C	Any
Type 3/4 elements to follow?	1	M-bit		0 (no more elements inside Group identity location accept element)
Type 3/4 elements to follow?	1	m-bit		0 (no more elements in the D-LOCATION UPDATE ACCEPT PDU)

Table E.12: U-LOCATION UPDATE DEMAND PDU without optional elements

Information Element	Length	Type	C/O/M	Value
Protocol discriminator	3	1	M	MM
PDU Type	4	1	M	U-LOCATION UPDATE DEMAND
Location update type	3	1	M	Any
Request to append LA	1	1	M	Any
Cipher control	1	1	M	1
Ciphering parameters	10		C	Any
Optional elements present?	1	O-bit		0

Table E.13: U-LOCATION UPDATE DEMAND PDU with optional Type 2 elements

Information Element	Length	Type	C/O/M	Value
Protocol discriminator	3	1	M	MM
PDU Type	4	1	M	U-LOCATION UPDATE DEMAND
Location update type	3	1	M	Any
Request to append LA	1	1	M	Any
Cipher control	1	1	M	0
Optional elements present?	1	O-bit		1
P-bit for Class of MS	1	P-bit		1
Class of MS	24	2	O	Any
P-bit for Energy saving mode	1	P-bit		1
Energy saving mode	3	2	O	Any
P-bit for LA information	1	P-bit		1
Location Area (LA)	14	1		Any
Zero-bit	1	1		0
P-bit for SSI	1	P-bit		0
P-bit for Address extension	1	P-bit		0
Type 3/4 elements present?	1	M-bit		0

Table E.14: U-LOCATION UPDATE DEMAND PDU with optional Type 4 element

Information Element	Length	Type	C/O/M	Value
Protocol discriminator	3	1	M	MM
PDU Type	4	1	M	U-LOCATION UPDATE DEMAND
Location update type	3	1	M	Any
Request to append LA	1	1	M	Any
Cipher control	1	1	M	0
Optional elements present?	1	O-bit		1
P-bit for Class of MS	1	P-bit		0
P-bit for Energy saving mode	1	P-bit		0
P-bit for LA information	1	P-bit		0
P-bit for SSI	1	P-bit		0
P-bit for Address extension	1	P-bit		0
Type 3/4 elements present?	1	M-bit		1
Type 3/4 element identifier	4	1	M	Group identity location demand
Length indicator	11	1	M	86
Reserved	1	1	M	Any
Group identity attach/detach mode	1	1	M	Any
Optional elements present?	1	O-bit		1
Type 3/4 elements present	1	M-bit		1
Type 3/4 element identifier	4	1	M	Group identity uplink
Length indicator	11	1	M	66
Number of repeated elements	6	1	M	2
1	1	1	M	Attachment
Group identity attach/detach type identifier				
Class of usage	3		C	Any
Group identity address type	2	1	M	GSSI
GSSI	24		C	Any
2	1	1	M	Attachment
Group identity attach/detach type identifier				
Class of usage	3		C	Any
Group identity address type	2	1	M	GSSI
GSSI	24		C	Any
Type 3/4 elements to follow?	1	M-bit		0 (no more elements inside Group identity uplink element)
Type 3/4 elements to follow?	1	M-bit		0 (no more elements in the U-LOCATION UPDATE DEMAND PDU)

E.2 PDU encoding rules for MLE PDUs

E.2.1 General PDU encoding rules for MLE PDUs

The general format of the MLE protocol PDU is defined according to table E.15.

The elements shall be transmitted in the order specified by the table with the top element being transmitted first (before interleaving). The content of an information element is represented by a binary value and the most significant bit of that binary value shall be transmitted first (before interleaving).

Table E.15: MLE protocol PDU layout

Information element	Length	Value	Remark
Protocol discriminator	3	101 ₂	Specifies an MLE protocol PDU
PDU type	3		Specifies the particular MLE protocol PDU
Type 1 element (1)	variable		See element definition for length and values
Type 1 element (2)	variable		See element definition for length and values
etc.	etc.		Etc.
Type 1 element (m)	variable		See element definition for length and values
Conditional element to previous element	variable		See element definition for length and values
Type 1 element (m+1)	variable		See element definition for length and values
etc.	etc.		Etc.
Type 1 element (n)	variable		See element definition for length and values
Optional bit (O-bit)	1	0	No type 2 elements follow
		1	Type 2 elements follow
Presence bit (P-bit) (1)	1	0	The type 2 element (1) is not present
		1	The type 2 element (1) is present
Type 2 element (1)	variable		See element definition for length and values
Presence bit (P-bit) (2)	1	0	The type 2 element (2) is not present
		1	The type 2 element (2) is present
Type 2 element (2)	variable		See element definition for length and values
etc.	etc.		Etc.
Presence bit (P-bit) (n)	1	0	The type 2 element (n) is not present
		1	The type 2 element (n) is present
Type 2 element (n)	variable		See element definition for length and values
Conditional element to previous element	variable		See element definition for length and values
etc.	etc.		Etc.
SDU	variable	variable	Encoded as nominated CMCE or MM PDU except protocol discriminator element is not present

NOTE: The optional SDU information element is not preceded by a P-bit for the SDU.

Presence of O-bit and P-bit:

The O-bit is always present straight after last type 1 element unless stated otherwise in the PDU description. Also when the no type 2 elements are defined for the PDU, the O-bit shall be present and set equal to "0", unless stated otherwise in the PDU description.

In case O-bit has value "0", the PDU contains no type 2 elements; no P-bits for type 2 elements and no type 2 elements.

In case the O-bit has value 1, then at least one type 2 element follows. In this case there is P-bit for each type 2 element which is defined for the PDU; if the type 2 element is present in the PDU then the corresponding P-bit has value 1, if the type 2 element is not present, then the corresponding P-bit has value 0.

NOTE 1: There is no P-bit before an element that is conditional to another element.

NOTE 2: The PDU can contain further information after O-bit even when it is set to value "0"; the PDU can contain an SDU also in case the PDU does not contain any type 2 elements (the O-bit is set to "0").

Length of the elements:

The length of a type 1 or type 2 element is either fixed as indicated in the "Length" column in the PDU or variable, refer to note 4. The length of an element conditional to type 1 or type 2 element is either fixed as indicated in the "Length" column in the PDU or the length may be indicated by the value of a preceding element to which this element is conditional.

NOTE 3: A conditional element may also be present in the PDU varying times as indicated by the value of a preceding element to which this element is conditional. In such case the element is marked as "Repeatable" in the PDU.

Encoding rules for PDU:

- elements of type 1 are mandatory and shall be placed within the PDU in fixed order as specified in the PDU description tables. The type 1 elements shall be placed before any type 2 elements in the PDU encoding. In addition the PDU may contain elements that are conditional to type 1 elements; they are present only if the corresponding type 1 element has specified value. These conditional elements are placed after the type 1 elements to which they are conditional;
- elements of type 2 are optional and shall be placed within the PDU in fixed order as specified in the PDU description tables. In addition the PDU may contain elements that are conditional to type 2 elements; they are present only if the corresponding type 2 element is present and has specified value. These conditional elements are placed after the type 2 element to which they are conditional;
- elements of type SDU are placed as the last element at the end of the PDU. There is no preceding bit for the SDU element, the length of the whole PDU as indicated in the MAC header defines whether the element is present in the PDU or not.

NOTE 4: For presentation purposes a set of information elements can be defined as an information element. The set of information sub-elements may contain also optional or conditional elements and also elements consisting of set of sub-elements. The set is encoded into the PDU as if it were a single information element of the indicated type. If the information element is a set of information elements that contain either a variable number of conditional elements or optional elements then the length is marked to be variable.

The following rules shall apply for decoding of an MLE PDU:

```
DO for all Type 1 elements
  DECODE Type 1 Element
    WHILE conditional elements to the type 1 element
      DECODE conditional element
    END WHILE;
END DO;
IF explicitly defined that the PDU shall not contain an O-bit
THEN END of PDU encoding;
ELSE
  DECODE O-bit
    IF O-bit set to "Type 2 elements follow"
      DO for all possible type 2 elements
        DECODE P-bit
          IF P-bit set to "Present", decode type 2 element
            WHILE conditional element to the type 2 element
              DECODE indicated conditional element
            END WHILE;
          END IF;
        END DO;
      END IF;
    IF SDU present, decode SDU
  END ELSE.
```

The encoding rules for elements and sub-elements:

- in case the PDU information element or sub-element definition contains no "Type" column, the element/sub-element is considered to be of type 1;
- an element or sub-element may contain a set of information elements, and any individual information element in that set may be followed immediately by conditional elements to that individual information element;

NOTE 5: When no optional elements are specified for the type 1 or type 2 elements/sub-element, there is no O-bit after the last type 1 sub-element.

- a conditional information element may contain type 1 and type 2 sub-elements. In the case that at least one type 2 element is specified for the conditional element, there shall be an O-bit indicating whether the element contains any optional type 2 elements:
 - in case no optional type 2 elements are present in the element, the O-bit shall be set to value "no optional elements follow";
 - in case at least one optional type 2 element is present in the element, the O-bit shall be set to value "optional elements follow" and a P-bit shall be set for each type 2 sub-element specified for the conditional element to indicate presence of that element. The P-bit shall indicate either "type 2 element present" or "type 2 element not present".

NOTE 6: As no type 3 or type 4 sub-elements are specified for the conditional elements, there is no M-bit after the last type 2 element or P-bit indicating that the last optional type 2 element is not present.

The following rules shall apply for decoding of information element containing a set of information elements:

```

DO for all Type 1 elements
  DECODE Type 1 Element
    WHILE conditional elements to the type 1 element
      DECODE conditional element
    END WHILE;
END DO;
IF no optional information element is defined for the set of information elements
THEN END of the set of information element encoding;
ELSE
  DECODE O-bit
  IF O-bit set to "Type 2 elements follow"
    DO for all possible type 2 elements
      DECODE P-bit
      IF P-bit set to "Present", decode type 2 element
        WHILE conditional element to the type 2 element
          DECODE indicated conditional element
        END WHILE;
      END IF;
    END DO;
  END IF;
END ELSE;
END

```

The C/O/M column indicates how the presence of an information element is controlled in the PDU or element/sub-element:

- M: Mandatory information element is always present (mandatory) in the main PDU level and is always present in a sub-element, when the sub-element itself is present. The type of mandatory element is type 1;
- O: Optional information element may be present in the PDU. The protocol state or an implementation choice defines when it is present or not. The type of optional element is type 2;
- C: Conditional information element is present as defined in the PDU description. The presence depends on the value of another preceding information element. If the information element on which the conditional information element is conditional is not present then also the conditional information element is not present. The conditional information element may be also repeated as many times as indicated by a preceding information element.

E.2.2 PDU encoding examples for MLE PDUs

Tables E.16 to E.29 present examples of proper MLE PDU encoding in specific cases.

Table E.16: D-NWRK-BROADCAST PDU with no neighbour cell information elements

Information Element	Length	Type	C/O/M	Value
Protocol discriminator	3	1	M	MLE
PDU Type	3	1	M	D-NWRK-BROADCAST
Cell re-select parameters	16	1	M	Any
Cell load CA	2	1	M	Any
Optional elements present?	1	O-bit		0

Table E.17: D-NWRK-BROADCAST PDU with "No neighbour cell information available" indication

Information Element	Length	Type	C/O/M	Value
Protocol discriminator	3	1	M	MLE
PDU Type	3	1	M	D-NWRK-BROADCAST
Cell re-select parameters	16	1	M	Any
Cell load CA	2	1	M	Any
Optional elements present?	1	O-bit		1
P-bit for TETRA network time element	1	P-bit		0
P-bit for Number of neighbour cells	1	P-bit		1
Number of Neighbour cells element	3	2	O	"No neighbour cell information available"

Table E.18: D-NWRK-BROADCAST PDU with 2 neighbour cell information elements

Information Element	Length	Type	C/O/M	Value
Protocol discriminator	3	1	M	MLE
PDU Type	3	1	M	D-NWRK-BROADCAST
Cell re-select parameters	16	1	M	Any
Cell load CA	2	1	M	Any
Optional elements present?	1	O-bit		1
P-bit for TETRA network time element	1	P-bit		0
P-bit for Number of neighbour cells	1	P-bit		1
Number of Neighbour cells element	3	2	O	2
Neighbour cell information (first)	23		C	See next 6 rows
1 Cell identifier	5	1	M	Any except 0
Announced cell reselection types supported	2	1	M	Any
Neighbour cell synchronized	1	1	M	Any
Cell load CA	2	1	M	Any
Main carrier number	12	1	M	Any
Optional elements present?	1	O-bit		0
Neighbour cell information (second)	47		C	See next 17 rows.
2 Cell identifier	5	1	M	Any except 0
Announced cell reselection types supported	2	1	M	Any
Neighbour cell synchronized	1	1	M	Any
Cell load CA	2	1	M	Any
Main carrier number	12	1	M	Any
Optional elements present?	1	O-bit		1
P-bit for Main carrier number extension element	1	P-bit		0
P-bit for MCC element	1	P-bit		0
P-bit for MNC element	1	P-bit		0
P-bit for LA element	1	P-bit		1
LA element	14	2	O	Any
P-bit for Maximum MS transmit power	1	P-bit		0
P-bit for Minimum RX access level	1	P-bit		0
P-bit for Subscriber class	1	P-bit		0
P-bit for BS Service details	1	P-bit		0
P-bit for Timeshare cell information	1	P-bit		0
P-bit for TDMA frame offset	1	P-bit		0

Table E.19: D-NEW CELL PDU without SDU element

Information Element	Length	Type	C/O/M	Value
Protocol discriminator	3	1	M	MLE
PDU Type	3	1	M	D-NEW CELL
Channel command valid	2	1	M	Any
Optional elements present?	1	O-bit		0

Table E.20: D-NEW CELL PDU with SDU (D-LOCATION UPDATE ACCEPT PDU) element

Information Element	Length	Type	C/O/M	Value
Protocol discriminator	3	1	M	MLE
PDU Type	3	1	M	D-NEW CELL
Channel command valid	2	1	M	Any
Optional elements present?	1	O-bit		0
PDU Type	4	1	M	D-LOCATION UPDATE ACCEPT
Location update accept type	3	1	M	Any
Optional elements present?	1	O-bit		0

Table E.21: D-PREPARE FAIL PDU without SDU element

Information Element	Length	Type	C/O/M	Value
Protocol discriminator	3	1	M	MLE
PDU Type	3	1	M	D-PREPARE FAIL
Fail cause	2	1	M	Any
Optional elements present?	1	O-bit		0

Table E.22: D-PREPARE FAIL PDU with SDU (D-LOCATION UPDATE REJECT PDU) element

Information Element	Length	Type	C/O/M	Value
Protocol discriminator	3	1	M	MLE
PDU Type	3	1	M	D-PREPARE FAIL
Fail cause	2	1	M	Any
Optional elements present?	1	O-bit		0
PDU Type	4	1	M	D-LOCATION UPDATE REJECT
Location update type	3	1	M	Any
Reject cause	5	1	M	Any
Cipher control	1	1	M	0
Optional elements present?	1	O-bit		0

Table E.23: D-RESTORE ACK PDU with SDU (D-CALL RESTORE PDU) element

Information Element	Length	Type	C/O/M	Value
Protocol discriminator	3	1	M	MLE
PDU Type	3	1	M	D-RESTORE ACK
Optional elements present?	1	O-bit		0
PDU Type	5	1	M	D-CALL RESTORE
Call identifier	14	1	M	Any
Transmission grant	2	1	M	Any
Transmission request permission	1	1	M	Any
Reset call time-out timer (T310)	1	1	M	Any
Optional elements present?	1	O-bit		0

Table E.24: D-RESTORE FAIL PDU

Information Element	Length	Type	C/O/M	Value
Protocol discriminator	3	1	M	MLE
PDU Type	3	1	M	D-RESTORE FAIL
Fail cause	2	1	M	Any
Optional elements present?	1	O-bit		0

Table E.25: U-PREPARE PDU without Cell identifier element and without SDU element

Information Element	Length	Type	C/O/M	Value
Protocol discriminator	3	1	M	MLE
PDU Type	3	1	M	U-PREPARE
Optional elements present?	1	O-bit		0

Table E.26: U-PREPARE PDU with Cell identifier element and without SDU element

Information Element	Length	Type	C/O/M	Value
Protocol discriminator	3	1	M	MLE
PDU Type	3	1	M	U-PREPARE
Optional elements present?	1	O-bit		1
P-bit for Cell identifier element	1	P-bit		1
Cell identifier	5	2	M	Any

Table E.27: U-PREPARE PDU with SDU (U-LOCATION UPDATE DEMAND PDU) element

Information Element	Length	Type	C/O/M	Value
Protocol discriminator	3	1	M	MLE
PDU Type	3	1	M	U-PREPARE
Optional elements present?	1	O-bit		1
P-bit for Cell identifier element	1	P-bit		1
Cell identifier	5	2	M	Any
PDU Type	4	1	M	U-LOCATION UPDATE DEMAND
Location update type	3	1	M	Call restoration roaming location updating
Request to append LA	1	1	M	Any
Cipher control	1	1	M	0
Optional elements present?	1	O-bit		1
P-bit for Class of MS	1	P-bit		0
P-bit for Energy saving mode	1	P-bit		1
Energy saving mode	3	2	O	Any
P-bit for LA information	1	P-bit		1
Location area (LA)	14	1	M	Any
Optional elements present?	1	O-bit		0
P-bit for SSI	1	P-bit		0
P-bit for Address extension	1	P-bit		0
M-bit for Type 3 elements	1	M-bit		0

Table E.28: U-RESTORE PDU with optional LA element, U-CALL RESTORE PDU does not contain type 3 elements

Information Element	Length	Type	C/O/M	Value
Protocol discriminator	3	1	M	MLE
PDU Type	3	1	M	U-RESTORE
Optional elements present?	1	O-bit		1
P-bit for MCC element	1	P-bit		1
P-bit for MNC element	1	P-bit		1
P-bit for LA element	1	P-bit		1
LA element	14	2	O	Any
PDU Type	5	1	M	U-CALL RESTORE
Call identifier	14	1	M	Any
Request to transmit/send data	1	1	M	Any
Other party type identifier	2	1	M	SSI
Other party SSI	24		C	Any
Optional elements present?	1	O-bit		1
P-bit for Basic service information element	1	P-bit		1
Basic service information element	8	2	M	Any
M-bit (for Type 3 elements)	1	M-bit		0

**Table E.29: U-RESTORE PDU without optional element,
U-CALL RESTORE PDU contains type 3 element**

Information Element	Length	Type	C/O/M	Value
Protocol discriminator	3	1	M	MLE
PDU Type	3	1	M	U-RESTORE
Optional elements present?	1	O-bit		0
PDU Type	5	1	M	U-CALL RESTORE
Call identifier	14	1	M	Any
Request to transmit/send data	1	1	M	Any
Other party type identifier	2	1	M	SSI
Other party SSI	24		C	Any
Optional elements present?	1	O-bit		1
P-bit for Basic service information element	1	P-bit		1
Basic service information element	8	2	M	Any
M-bit (for Type 3 elements)	1	M-bit		1
Type 3 element identifier	4	1	M	Facility or Proprietary
Length indicator	11	1	M	N
Type 3 element	n	1	M	Any
M-bit (for Type 3 elements)	1	M-bit		0

Annex F (normative): TETRA frequency bands, duplex spacings and channel numbering

The usage of the TETRA frequency bands, duplex spacings and channel numbering shall be as defined in ETSI TS 100 392-15 [18].

Annex G (normative): TETRA group management scenarios

G.0 Introduction

TETRA group management scenarios define how group management PDUs shall be encoded in the presented scenarios.

G.1 General requirements

The requirements are presented as a list to facilitate an easier referencing.

- 1) The structure of the D/U-ATTACH DETACH GROUP IDENTITY PDUs and U/D-ATTACH DETACH GROUP IDENTITY ACK PDUs is defined in clause 16.9 and the PDU encoding in annex E.
 - The Group identity uplink element as defined in clause 16.10.15 should have the values as defined in table G.1.

Table G.1: Group identity uplink information values

Location scenario	MS location	Group identity address type
1a)	On home system	00 ₂
1b)	On foreign system and SwMI has not previously allocated VGSSI	01 ₂
1c)	On foreign system and SwMI has previously allocated VGSSI (for example, if the MS wishes to detach a group)	10 ₂

- The Group identity downlink element as defined in clause 16.10.15 should have the values as defined in table G.2.

Table G.2: Group identity downlink information values

Location scenario	MS location	Group identity address type
2a	On home system	00 ₂
2b)	On foreign system (SwMI initiated attachment)	11 ₂
2c) i	On foreign system (response to 1b) above - acceptance of attachment)	11 ₂
2c) ii	On foreign system (response to 1b) above - rejection of attachment)	01 ₂
2d)	On foreign system (response to 1c) above, same VGSSI)	10 ₂
2e)	On foreign system and the foreign SwMI wishes to allocate a new VGSSI to an existing GTSI which has been allocated a VGSSI (i.e. the new VGSSI replaces the existing VGSSI)	11 ₂
2f)	On foreign system (response to group report, SwMI has previously allocated VGSSI to MS)	11 ₂

- 2) New group attachments/detachments cannot be mixed with the acknowledgements to requested group attachments/detachments contained in the "Group identity location accept" element of the D-LOCATION UPDATE ACCEPT PDU or the D/U-ATTACH / DETACH GROUP IDENTITY ACK PDUs. If the acknowledgement to the group attachment/ detachment request contains a group or a number of groups, those groups shall be the complete set or a subset of the group(s) in the request.
- 3) The "Group identity attach/detach mode" element of the D-ATTACH/DETACH GROUP IDENTITY ACK PDU and the "Group identity attach/detach mode" element of the "Group identity location accept" element of the D-LOCATION UPDATE ACCEPT PDU are to be marked "Reserved".

- 4) The MS shall not reject a SwMI-requested detachment; the SwMI may reject a MS-requested detachment, refer to scenario 5 (7).
- 5) Rejection of attachment is equivalent to acceptance of detachment: the group is detached. Rejection of detachment is equivalent to acceptance of attachment (subject to the restriction described in requirement 4): the group is attached.
 - In the following set of rules, "requester" refers to the sender of the D/U-ATTACH DETACH GROUP IDENTITY PDU and "responder" refers to the sender of the U/D-ATTACH DETACH GROUP IDENTITY ACK PDU.
- 6) A value of "0" (Attachment/detachment accepted) in the "Group identity accept/reject" element (D-ATTACH DETACH GROUP IDENTITY ACK PDU) or "Group identity acknowledgement type" element (U-ATTACH DETACH GROUP IDENTITY ACK PDU) indicates to the requester that all the requested attachments and/or detachments have been accepted. All or some of the accepted groups may be present in the Group identity uplink/downlink element of the acknowledgement.

Examples are:

- 6a) Request contains only attachments: all attachments are accepted and the Group identity uplink/downlink element is not present in the acknowledgement.
- 6b) Request contains only attachments: all attachments are accepted, but the Group identity uplink/downlink element in the acknowledgement contains attachment (of some/all groups) indicating a different CoU than the request.
- 6c) Request contains only attachments: all attachments are accepted, but the Group identity uplink/downlink element in the acknowledgement contains attachment (of some/all groups) indicating the attachment lifetime of the group (if different than the default attachment lifetime).
- 6d) Request contains only detachments: all detachments are accepted and the Group identity uplink/downlink element is not present in the acknowledgement.
- 6e) Several attachments and/or detachments in the request: all accepted, Group identity uplink/downlink element is not present in the acknowledgement.
- 6f) Several attachments and/or detachments in the request: all accepted but the Group identity uplink/downlink element in the acknowledgement contains attachment(s) of one or several groups that were requested to be attached, indicating different CoU than the request and/or indicating the attachment lifetime of the group (if different than the default attachment lifetime).

NOTE 1: If a detachment request is accepted, the Group identity uplink/downlink element should not be included in the acknowledgement because it gives the requester no useful information; in fact, the difference in detachment reasons between the request and response may be confusing to the requester.

- 7) A value of 1 (Attachment/detachment rejected) in the "Group identity accept/reject" element (D-ATTACH DETACH GROUP IDENTITY ACK PDU) or "Group identity acknowledgement type" element (U-ATTACH DETACH GROUP IDENTITY ACK PDU) indicates to the requester that at least one of the requested attachments and/or detachments have been rejected. All rejected groups are present in the Group identity uplink/downlink element of the acknowledgement. All or some of the accepted groups may be present in the Group identity uplink/downlink element of the acknowledgement.

Examples are (see proposal 6 for examples of acceptance of attachment/detachment):

- 7a) Request contains only attachments: one or several (maybe even all) attachments are rejected, the Group identity uplink/downlink element is included in the acknowledgement containing the rejected groups and a reject reason for each rejected group.
- 7b) Request contains only detachments: one or several (maybe even all) detachments are rejected, the Group identity uplink/downlink element is included in the acknowledgement containing the rejected groups and attachment information for each rejected group.
- 7c) Request contains attachments and detachments: at least one attachment and/or detachment is rejected, the Group identity uplink/downlink element is included in the acknowledgement containing the rejected group(s) and reject reason/attachment information for each rejected group.

- 8) If the responder accepts a group attachment or detachment request but does not include the group in the response, the responder is said to be implicitly accepting the attachment/detachment request. If the responder accepts or rejects a group attachment or detachment request and does include the group in the response, the responder is said to be explicitly accepting or rejecting the attachment/detachment request:
- 8a) To explicitly accept an attachment, the responder sets the "Group identity attach/detach type identifier" element of the "Group identity uplink" or "Group identity downlink" element to "0" (Attachment).
 - 8b) To explicitly reject an attachment, the responder sets the "Group identity attach/detach type identifier" element of the "Group identity uplink" or "Group identity downlink" element to "1" (Detachment).
 - 8c) To explicitly reject a detachment, the responder sets the "Group identity attach/detach type identifier" element of the "Group identity uplink" or "Group identity downlink" element to "0" (Attachment).
 - 8d) Detachment should not be explicitly accepted - see note 1.

NOTE 2: Implicit rejection of a group attachment or detachment request is not permitted - see requirement 7.

- 9) A MS or a SwMI may request detachment of all groups by sending a group attach/detach request without any groups. For all requests of this nature, with the exception of one solicited by a group report request, the "Group identity attach/detach mode" element shall be set to "1". ("Detach all currently active group identities and attach group identities..."); for a group report request, the "Group identity attach/detach mode" element shall be set to "0" (Amendment).
- 10) If a D/U-ATTACH DETACH GROUP IDENTITY PDU contains at least one detachment request and the "Group identity attach/detach mode" element is set to "1" (Detach all currently active group identities and attach group identities defined in the group identity downlink/uplink element), the responder shall ignore the detachment request(s).

The scenarios in clauses G.2 and G.3 define contents of the group attachment/detachment related information elements of PDUs.

In the scenarios the information contained in the PDU description tables corresponds to the following key:

- [C] denotes element upon which other elements are conditional (note that this is not a reference to annex C); and
- CoU = Class of usage.

G.2 MS-INITIATED GROUP ATTACHMENT/DETACHMENT

G.2.1 SCENARIO 1

MS requests attachment of one group; SwMI accepts attachment, ACK contains group.

U-ATTACH DETACH GROUP IDENTITY

- Group identity report = 0 (Not report requested).
- Group identity attach/detach mode = X (Either value).
- Group identity uplink:
 - Group identity attach/detach type identifier = 0 (Attach) [C];
 - CoU = XXX (Any value);
 - Group identity address type = XX (Any value) [C];
 - GSSI/GTSSI/(V)GSSI/GTSSI-(V)GSSI.

D-ATTACH DETACH GROUP IDENTITY ACK

- Group identity accept/reject = 0 (Attachment/detachment accepted).
- Group identity attach/detach mode = 0 (Reserved).
- Group identity downlink:
 - Group identity attach/detach type identifier = 0 (Attach) [C];
 - Group identity attachment lifetime = XX (Any value);
 - CoU = XXX (Any value), see note;
 - Group identity address type = see table G.2;
 - GSSI/GTSI/(V)GSSI/GTSI-(V)GSSI = see table G.2.

NOTE: The SwMI may send a different CoU value to that requested by the MS; if the MS does not accept the SwMI CoU, it may send a separate U-ATTACH/DETACH GROUP IDENTITY PDU requesting detachment of the group.

G.2.2 SCENARIO 2

MS requests attachment of one group; SwMI accepts attachment, ACK does not contain group, see note.

U-ATTACH DETACH GROUP IDENTITY

- Group identity report = 0 (Not report requested).
- Group identity attach/detach mode = X (Either value).
- Group identity uplink:
 - Group identity attach/detach type identifier = 0 (Attach) [C];
 - CoU = XXX (Any value);
 - Group identity address type = XX (Any value) [C];
 - GSSI/GTSI/(V)GSSI/GTSI-(V)GSSI.

D-ATTACH DETACH GROUP IDENTITY ACK

- Group identity accept/reject = 0 (Attachment/detachment accepted).
- Group identity attach/detach mode = 0 (Reserved).

NOTE: Attachment lifetime of the group is the "default group attachment lifetime"; if the attachment lifetime of the group is different to the default, the group will be present in the ACK PDU, see scenario 1. MS assumes the CoU of the group is the CoU contained in the uplink request.

G.2.3 SCENARIO 3

MS requests attachment of one group; SwMI rejects attachment, ACK contains group.

U-ATTACH DETACH GROUP IDENTITY

- Group identity report = 0 (Not report requested).
- Group identity attach/detach mode = X (Either value).
- Group identity uplink:
 - Group identity attach/detach type identifier = 0 (Attach) [C];
 - CoU = XXX (Any value);
 - Group identity address type = XX (Any value) [C];
 - GSSI/GTSSI/(V)GSSI/GTSSI-(V)GSSI.

D-ATTACH DETACH GROUP IDENTITY ACK

- Group identity accept/reject = 1 (Attachment/detachment rejected).
- Group identity attach/detach mode = 0 (Reserved).
- Group identity downlink:
 - Group identity attach/detach type identifier = 1 (Detach) [C];
 - Group identity detachment downlink = XX (Any value);
 - Group identity address type = see table G.2;
 - GSSI/GTSSI/(V)GSSI/GTSSI-(V)GSSI = see table G.2.

G.2.4 SCENARIO 4

MS requests detachment of one group; SwMI accepts detachment, ACK does not contain group.

U-ATTACH DETACH GROUP IDENTITY

- Group identity report = 0 (Not report requested).
- Group identity attach/detach mode = 0.
- Group identity uplink:
 - Group identity attach/detach type identifier = 1 (Detach) [C];
 - Group identity detachment uplink = XX (Any value);
 - Group identity address type = XX (Any value) [C];
 - GSSI/GTSSI/(V)GSSI/GTSSI-(V)GSSI.

D-ATTACH DETACH GROUP IDENTITY ACK

- Group identity accept/reject = 0 (Attachment/detachment accepted).
- Group identity attach/detach mode = 0 (Reserved).

G.2.5 SCENARIO 5

MS requests detachment of one group; SwMI rejects detachment, ACK contains group.

U-ATTACH DETACH GROUP IDENTITY

- Group identity report = 0 (Not report requested).
- Group identity attach/detach mode = 0.
- Group identity uplink:
 - Group identity attach/detach type identifier = 1 (Detach) [C];
 - Group identity detachment uplink = XX (Any value);
 - Group identity address type = XX (Any value) [C];
 - GSSI/GTSI/(V)GSSI/GTSI-(V)GSSI.

D-ATTACH DETACH GROUP IDENTITY ACK

- Group identity accept/reject = 1 (Attachment/detachment rejected).
- Group identity attach/detach mode = 0 (Reserved).
- Group identity downlink:
 - Group identity attach/detach type identifier = 0 (Attach) [C];
 - Group identity attachment lifetime = XX (Any value);
 - CoU = XXX (Any value but probably the value held by the SwMI for this MS/Group combination);
 - Group identity address type = see table G.2;
 - GSSI/GTSI/(V)GSSI/GTSI-(V)GSSI = see table G.2.

G.2.6 SCENARIO 6

MS requests attachment of multiple groups; SwMI accepts all the attachments, ACK contains all the groups in the uplink request, see note 1.

U-ATTACH DETACH GROUP IDENTITY

- Group identity report = 0 (Not report requested).
- Group identity attach/detach mode = X (Either value).
- Group identity uplink {FOR GROUP 1}:
 - Group identity attach/detach type identifier = 0 (Attach) [C];
 - CoU = XXX (Any value);
 - Group identity address type = XX (Any value) [C];
 - GSSI/GTSI/(V)GSSI/GTSI-(V)GSSI.

- Group identity uplink {FOR GROUP 2}:
 - Group identity attach/detach type identifier = 0 (Attach) [C];
 - CoU = XXX (Any value);
 - Group identity address type = XX (Any value) [C];
 - GSSI/GTSI/(V)GSSI/GTSI-(V)GSSI.
- Group identity uplink {FOR GROUP 3}:
 - Group identity attach/detach type identifier = 0 (Attach) [C];
 - CoU = XXX (Any value);
 - Group identity address type = XX (Any value) [C];
 - GSSI/GTSI/(V)GSSI/GTSI-(V)GSSI.

D-ATTACH DETACH GROUP IDENTITY ACK

- Group identity accept/reject = 0 (Attachment/detachment accepted).
- Group identity attach/detach mode = 0 (Reserved).
- Group identity downlink {FOR GROUP 1}:
 - Group identity attach/detach type identifier = 0 (Attach) [C];
 - Group identity attachment lifetime = XX (Any value);
 - CoU = XXX (Any value) (see note 2);
 - Group identity address type = see table G.2;
 - GSSI/GTSI/(V)GSSI/GTSI-(V)GSSI = see table G.2.
- Group identity downlink {FOR GROUP 2}:
 - Group identity attach/detach type identifier = 0 (Attach) [C];
 - Group identity attachment lifetime = XX (Any value);
 - CoU = XXX (Any value) (see note 2);
 - Group identity address type = see table G.2;
 - GSSI/GTSI/(V)GSSI/GTSI-(V)GSSI = see table G.2.
- Group identity downlink {FOR GROUP 3}:
 - Group identity attach/detach type identifier = 0 (Attach) [C];
 - Group identity attachment lifetime = XX (Any value);
 - CoU = XXX (Any value) (see note 2);
 - Group identity address type = see table G.2;
 - GSSI/GTSI/(V)GSSI/GTSI-(V)GSSI = see table G.2.

NOTE 1: The order of groups in the downlink response does not have to match the order of groups in the uplink request. For example, GROUP 2 followed by GROUP 1 followed by GROUP 3 would be a valid order in the ACK PDU above.

NOTE 2: The SwMI may send a different CoU value to that requested by the MS; if the MS does not accept the SwMI CoU, it may send a separate D-ATTACH DETACH GROUP IDENTITY requesting detachment of the group.

G.2.7 SCENARIO 7

MS requests attachment of multiple groups; SwMI accepts all the attachments, ACK contains a subset of the groups in the uplink request (see note 1).

U-ATTACH DETACH GROUP IDENTITY

- Group identity report = 0 (Not report requested).
- Group identity attach/detach mode = X (Either value).
- Group identity uplink {FOR GROUP 1}:
 - Group identity attach/detach type identifier = 0 (Attach) [C];
 - CoU = XXX (Any value);
 - Group identity address type = XX (Any value) [C];
 - GSSI/GTSSI/(V)GSSI/GTSSI-(V)GSSI.
- Group identity uplink {FOR GROUP 2}:
 - Group identity attach/detach type identifier = 0 (Attach) [C];
 - CoU = XXX (Any value);
 - Group identity address type = XX (Any value) [C];
 - GSSI/GTSSI/(V)GSSI/GTSSI-(V)GSSI.
- Group identity uplink {FOR GROUP 3}:
 - Group identity attach/detach type identifier = 0 (Attach) [C];
 - CoU = XXX (Any value);
 - Group identity address type = XX (Any value) [C];
 - GSSI/GTSSI/(V)GSSI/GTSSI-(V)GSSI.

D-ATTACH DETACH GROUP IDENTITY ACK

- Group identity accept/reject = 0 (Attachment/detachment accepted).
- Group identity attach/detach mode = 0 (Reserved).
- Group identity downlink {FOR GROUP 1}:
 - Group identity attach/detach type identifier = 0 (Attach) [C];
 - Group identity attachment lifetime = XX (Any value);
 - CoU = XXX (Any value) (see note 2);
 - Group identity address type = see table G.2;
 - GSSI/GTSSI/(V)GSSI/GTSSI-(V)GSSI = see table G.2.

- Group identity downlink {FOR GROUP 3}:
 - Group identity attach/detach type identifier = 0 (Attach) [C];
 - Group identity attachment lifetime = XX (Any value);
 - CoU = XXX (Any value) (see note 2);
 - Group identity address type = see table G.2;
 - GSSI/GTSI/(V)GSSI/GTSI-(V)GSSI = see table G.2.

NOTE 1: Any group contained in the uplink request but not contained in the downlink response (GROUP 2 in this example) is implicitly attached. The attachment lifetime of the group is the "default group attachment lifetime", the MS assumes the CoU of the group is the CoU contained in the uplink request.

NOTE 2: The SwMI may send a different CoU value to that requested by the MS; if the MS does not accept the SwMI CoU, it may send a separate D-ATTACH/DETACH GROUP IDENTITY requesting detachment of the group.

G.2.8 SCENARIO 8

MS requests attachment of multiple groups; SwMI accepts all the attachments, ACK contains no groups (see note).

U-ATTACH DETACH GROUP IDENTITY

- Group identity report = 0 (Not report requested).
- Group identity attach/detach mode = X (Either value).
- Group identity uplink {FOR GROUP 1}:
 - Group identity attach/detach type identifier = 0 (Attach) [C];
 - CoU = XXX (Any value);
 - Group identity address type = XX (Any value) [C];
 - GSSI/GTSI/(V)GSSI/GTSI-(V)GSSI.
- Group identity uplink {FOR GROUP 2}:
 - Group identity attach/detach type identifier = 0 (Attach) [C];
 - CoU = XXX (Any value);
 - Group identity address type = XX (Any value) [C];
 - GSSI/GTSI/(V)GSSI/GTSI-(V)GSSI.
- Group identity uplink {FOR GROUP 3}:
 - Group identity attach/detach type identifier = 0 (Attach) [C];
 - CoU = XXX (Any value);
 - Group identity address type = XX (Any value) [C];
 - GSSI/GTSI/(V)GSSI/GTSI-(V)GSSI.

D-ATTACH DETACH GROUP IDENTITY ACK

- Group identity accept/reject = 0 (Attachment/detachment accepted).
- Group identity attach/detach mode = 0 (Reserved).

NOTE: Attachment lifetime of the groups is the "default group attachment lifetime"; if the attachment lifetime of the group is different to the default, the group will be present in the ACK PDU, see scenario 6 (9). MS assumes the CoU of the group is the CoU contained in the uplink request.

G.2.9 SCENARIO 9

MS requests attachment of multiple groups; SwMI rejects one of the attachments, ACK contains all the groups in the uplink request (see note).

U-ATTACH DETACH GROUP IDENTITY

- Group identity report = 0 (Not report requested).
- Group identity attach/detach mode = X (Either value).
- Group identity uplink {FOR GROUP 1}:
 - Group identity attach/detach type identifier = 0 (Attach) [C];
 - CoU = XXX (Any value);
 - Group identity address type = XX (Any value) [C];
 - GSSI/GTSI/(V)GSSI/GTSI-(V)GSSI.
- Group identity uplink {FOR GROUP 2}:
 - Group identity attach/detach type identifier = 0 (Attach) [C];
 - CoU = XXX (Any value);
 - Group identity address type = XX (Any value) [C];
 - GSSI/GTSI/(V)GSSI/GTSI-(V)GSSI.
- Group identity uplink {FOR GROUP 3}:
 - Group identity attach/detach type identifier = 0 (Attach) [C];
 - CoU = XXX (Any value);
 - Group identity address type = XX (Any value) [C];
 - GSSI/GTSI/(V)GSSI/GTSI-(V)GSSI.

D-ATTACH DETACH GROUP IDENTITY ACK

- Group identity accept/reject = 1 (Attachment/detachment rejected).
- Group identity attach/detach mode = 0 (Reserved).
- Group identity downlink {FOR GROUP 1}:
 - Group identity attach/detach type identifier = 0 (Attach) [C];
 - Group identity attachment lifetime = XX (Any value);
 - CoU = XXX (Any value);
 - Group identity address type = see table G.2;
 - GSSI/GTSI/(V)GSSI/GTSI-(V)GSSI = see table G.2.
- Group identity downlink {FOR GROUP 2}:
 - Group identity attach/detach type identifier = 1 (Detach) [C];
 - Group identity detachment downlink = XX (Any value);
 - Group identity address type = see table G.2;
 - GSSI/GTSI/(V)GSSI/GTSI-(V)GSSI = see table G.2.
- Group identity downlink {FOR GROUP 3}:
 - Group identity attach/detach type identifier = 0 (Attach) [C];
 - Group identity attachment lifetime = XX (Any value);
 - CoU = XXX (Any value);
 - Group identity address type = see table G.2;
 - GSSI/GTSI/(V)GSSI/GTSI-(V)GSSI = see table G.2.

NOTE: Attachment of GROUP 1 and GROUP 3 is explicitly accepted. Attachment of GROUP 2 is explicitly rejected.

G.2.10 SCENARIO 10

MS requests attachment of multiple groups; SwMI rejects one of the attachments, ACK contains only the rejected group (see note).

U-ATTACH DETACH GROUP IDENTITY

- Group identity report = 0 (Not report requested).
- Group identity attach/detach mode = X (Either value).
- Group identity uplink {FOR GROUP 1}:
 - Group identity attach/detach type identifier = 0 (Attach) [C];
 - CoU = XXX (Any value);
 - Group identity address type = XX (Any value) [C];
 - GSSI/GTSI/(V)GSSI/GTSI-(V)GSSI.

- Group identity uplink {FOR GROUP 2}:
 - Group identity attach/detach type identifier = 0 (Attach) [C];
 - CoU = XXX (Any value);
 - Group identity address type = XX (Any value) [C];
 - GSSI/GTSSI/(V)GSSI/GTSSI-(V)GSSI.
- Group identity uplink {FOR GROUP 3}:
 - Group identity attach/detach type identifier = 0 (Attach) [C];
 - CoU = XXX (Any value);
 - Group identity address type = XX (Any value) [C];
 - GSSI/GTSSI/(V)GSSI/GTSSI-(V)GSSI.

D-ATTACH DETACH GROUP IDENTITY ACK

- Group identity accept/reject = 1 (Attachment/detachment rejected).
- Group identity attach/detach mode = 0 (Reserved).
- Group identity downlink {FOR GROUP 2}:
 - Group identity attach/detach type identifier = 1 (Detach) [C];
 - Group identity detachment downlink = XX (Any value);
 - Group identity address type = see table G.2;
 - GSSI/GTSSI/(V)GSSI/GTSSI-(V)GSSI = see table G.2.

NOTE: Attachment of GROUP 1 and GROUP 3 is implicitly accepted. Attachment of GROUP 2 is explicitly rejected.

G.2.11 SCENARIO 11

MS requests attachment of multiple groups; SwMI rejects all the attachments, ACK contains all the groups in the uplink request (see note).

U-ATTACH DETACH GROUP IDENTITY

- Group identity report = 0 (Not report requested).
- Group identity attach/detach mode = X (Either value).
- Group identity uplink {FOR GROUP 1}:
 - Group identity attach/detach type identifier = 0 (Attach) [C];
 - CoU = XXX (Any value);
 - Group identity address type = XX (Any value) [C];
 - GSSI/GTSSI/(V)GSSI/GTSSI-(V)GSSI.

- Group identity uplink {FOR GROUP 2}:
 - Group identity attach/detach type identifier = 0 (Attach) [C];
 - CoU = XXX (Any value);
 - Group identity address type = XX (Any value) [C];
 - GSSI/GTSI/(V)GSSI/GTSI-(V)GSSI.
- Group identity uplink {FOR GROUP 3}:
 - Group identity attach/detach type identifier = 0 (Attach) [C];
 - CoU = XXX (Any value);
 - Group identity address type = XX (Any value) [C];
 - GSSI/GTSI/(V)GSSI/GTSI-(V)GSSI.

D-ATTACH DETACH GROUP IDENTITY ACK

- Group identity accept/reject = 1 (Attachment/detachment rejected).
- Group identity attach/detach mode = 0 (Reserved).
- Group identity downlink {FOR GROUP 1}:
 - Group identity attach/detach type identifier = 1 (Detach) [C];
 - Group identity detachment downlink = XX (Any value);
 - Group identity address type see table G.2;
 - GSSI/GTSI/(V)GSSI/GTSI-(V)GSSI = see table G.2.
- Group identity downlink {FOR GROUP 2}:
 - Group identity attach/detach type identifier = 1 (Detach) [C];
 - Group identity detachment downlink = XX (Any value);
 - Group identity address type = see table G.2;
 - GSSI/GTSI/(V)GSSI/GTSI-(V)GSSI = see table G.2.
- Group identity downlink {FOR GROUP 3}:
 - Group identity attach/detach type identifier = 1 (Detach) [C];
 - Group identity detachment downlink = XX (Any value);
 - Group identity address type = see table G.2;
 - GSSI/GTSI/(V)GSSI/GTSI-(V)GSSI = see table G.2.

NOTE: Attachment of all groups is explicitly rejected.

G.2.12 SCENARIO 12

MS requests attachment of two groups and detachment of one group; SwMI accepts one of the attachments and rejects the detachment and the other attachment, ACK contains all the groups in the uplink request (see note).

U-ATTACH DETACH GROUP IDENTITY

- Group identity report = 0 (Not report requested).
- Group identity attach/detach mode = 0.
- Group identity uplink {FOR GROUP 1}:
 - Group identity attach/detach type identifier = 0 (Attach) [C];
 - CoU = XXX (Any value);
 - Group identity address type = XX (Any value) [C];
 - GSSI/GTTSI/(V)GSSI/GTTSI-(V)GSSI.
- Group identity uplink {FOR GROUP 2}:
 - Group identity attach/detach type identifier = 1 (Detach) [C];
 - Group identity detachment uplink = XX (Any value);
 - Group identity address type = XX (Any value) [C];
 - GSSI/GTTSI/(V)GSSI/GTTSI-(V)GSSI.
- Group identity uplink {FOR GROUP 3}:
 - Group identity attach/detach type identifier = 0 (Attach) [C];
 - CoU = XXX (Any value);
 - Group identity address type = XX (Any value) [C];
 - GSSI/GTTSI/(V)GSSI/GTTSI-(V)GSSI.

D-ATTACH DETACH GROUP IDENTITY ACK

- Group identity accept/reject = 1 (Attachment/detachment rejected).
- Group identity attach/detach mode = 0 (Reserved).
- Group identity downlink {FOR GROUP 1}:
 - Group identity attach/detach type identifier = 0 (Attach) [C];
 - Group identity attachment lifetime = XX (Any value);
 - CoU = XXX (Any value);
 - Group identity address type = see table G.2;
 - GSSI/GTTSI/(V)GSSI/GTTSI-(V)GSSI = see table G.2.

- Group identity downlink {FOR GROUP 2}:
 - Group identity attach/detach type identifier = 0 (Attach) [C];
 - Group identity attachment lifetime = XX (Any value);
 - CoU = XXX (Any value);
 - Group identity address type = see table G.2;
 - GSSI/GTSI/(V)GSSI/GTSI-(V)GSSI = see table G.2.
- Group identity downlink {FOR GROUP 3}:
 - Group identity attach/detach type identifier = 1 (Detach) [C];
 - Group identity detachment downlink = XX (Any value);
 - Group identity address type = see table G.2;
 - GSSI/GTSI/(V)GSSI/GTSI-(V)GSSI = see table G.2.

NOTE: Attachment of GROUP 1 is explicitly accepted. Detachment of GROUP 2 is explicitly rejected. Attachment of GROUP 3 is explicitly rejected.

G.2.13 SCENARIO 13

MS requests attachment of two groups and detachment of one group; SwMI accepts one of the attachments and rejects the detachment and the other attachment, ACK contains a subset of the groups in the uplink request (see note).

U-ATTACH DETACH GROUP IDENTITY

- Group identity report = 0 (Not report requested).
- Group identity attach/detach mode = 0.
- Group identity uplink {FOR GROUP 1}:
 - Group identity attach/detach type identifier = 0 (Attach) [C];
 - CoU = XXX (Any value);
 - Group identity address type = XX (Any value) [C];
 - GSSI/GTSI/(V)GSSI/GTSI-(V)GSSI.
- Group identity uplink {FOR GROUP 2}:
 - Group identity attach/detach type identifier = 1 (Detach) [C];
 - Group identity detachment uplink = XX (Any value);
 - Group identity address type = XX (Any value) [C];
 - GSSI/GTSI/(V)GSSI/GTSI-(V)GSSI.
- Group identity uplink {FOR GROUP 3}:
 - Group identity attach/detach type identifier = 0 (Attach) [C];
 - CoU = XXX (Any value);
 - Group identity address type = XX (Any value) [C];
 - GSSI/GTSI/(V)GSSI/GTSI-(V)GSSI.

D-ATTACH DETACH GROUP IDENTITY ACK

- Group identity accept/reject = 1 (Attachment/detachment rejected).
- Group identity attach/detach mode = 0 (Reserved).
- Group identity downlink {FOR GROUP 2}:
 - Group identity attach/detach type identifier = 0 (Attach) [C];
 - Group identity attachment lifetime = XX (Any value);
 - CoU = XXX (Any value);
 - Group identity address type = see table G.2;
 - GSSI/GTSI/(V)GSSI/GTSI-(V)GSSI = see table G.2.
- Group identity downlink {FOR GROUP 3}:
 - Group identity attach/detach type identifier = 1 (Detach) [C];
 - Group identity detachment downlink = XX (Any value);
 - Group identity address type = see table G.2;
 - GSSI/GTSI/(V)GSSI/GTSI-(V)GSSI = see table G.2.

NOTE: Attachment of GROUP 1 is implicitly accepted. Detachment of GROUP 2 is explicitly rejected. Attachment of GROUP 3 is explicitly rejected.

G.3 SwMI-INITIATED GROUP ATTACHMENT/DETACHMENT

The principles of SwMI-initiated group attachment/detachment are the same as those for MS-initiated group attachment/detachment with the following exceptions:

- 1) The PDU exchange is D-ATTACH DETACH GROUP IDENTITY / U-ATTACH DETACH GROUP IDENTITY ACK.
- 2) The "Group identity accept/reject" element in the SwMI ACK becomes a "Group identity acknowledgement type" element in the MS ACK (the bit orientation and the meaning of the bit values is identical between the two elements).
- 3) The SwMI may request that the MS does not send an ACK (via "Group identity acknowledgement request" element in the D-ATTACH DETACH GROUP IDENTITY PDU). If the MS wishes to reject a SwMI-initiated attachment or detachment but is prevented from sending an ACK by the SwMI, the MS may initiate a separate U-ATTACH DETACH GROUP IDENTITY / D-ATTACH DETACH GROUP IDENTITY ACK PDUs transaction with the SwMI.
- 4) The U-ATTACH DETACH GROUP IDENTITY ACK PDU does not contain a "Group identity attach/detach mode" element (refer to proposal 3).
- 5) SwMI requests attachment/detachment with the "Group identity downlink" element; MS requests attachment / detachment with the "Group identity uplink" element. SwMI ACKs attachment / detachment with the "Group identity downlink" element; MS ACKs attachment / detachment with the "Group identity uplink" element.
- 6) The MS may send a different CoU value in the ACK to that requested by the SwMI. If the SwMI does not accept the MS CoU, it may send a separate D-ATTACH / DETACH GROUP IDENTITY PDU enforcing detachment of the group, refer to note 1 of scenario 1.
- 7) The MS cannot reject a SwMI-requested group detachment (refer to proposal 4).

Annex H (normative): TETRA proprietary information element owner

H.0 General

This annex defines TETRA proprietary information element owner.

H.1 Proprietary information element

TETRA protocols for CMCE and MM contain optional proprietary information elements. In order to identify and differentiate various implementations of the proprietary elements a proprietary element owner is defined as the first information element of the proprietary element, refer to clauses 14.8.35 and 16.10.41.

The proprietary element owner information element shall contain elements as defined in table H.1.

Table H.1: Proprietary element owner contents

Information element	Length	Type	C/O/M	Value	Remark
Proprietary element owner	8	1	M	00000000 ₂	Extension indicator, (see note 1)
				00000001 ₂	Owner 1
				etc.	etc.
				11111111 ₂	Owner 255
Proprietary element owner extension	Reserved	1	C	All values reserved	See note 2
NOTE 1: This value shall indicate that the proprietary element owner is indicated by the proprietary element owner extension information element. This value is not used in V2.1.1 of the present document.					
NOTE 2: This information element shall be present only when the proprietary element owner information element has the value 00000000 ₂ . This information element is not used in V2.1.1 of the present document.					

The proprietary element owner values are managed by a central body.

Each manufacture should have only a single value of the proprietary element owner information element. The manufacture should design his proprietary information element contents so that he can use the same proprietary element owner value for various purposes. It is recommended that the proprietary information part is coded so that it contains in the beginning a protocol identifier, a PDU type or an information element type managed by that manufacturer so that the usage of the single proprietary element owner value can be continued as long as possible.

It is allowed that multiple manufacturers use the same proprietary element owner value under responsibility of the registered owner.

H.2 Application for the proprietary element owner value

This application form is provided under assumption that ETSI will be the central body for the management of the proprietary element owner values of V2.1.1 of the present document. The application and allocation may be implemented by other means such as a World Wide Web server application.

PROVISION OF AND RESTRICTED USAGE UNDERTAKING

relating to

a **proprietary element owner** information element value, to be used in mobile and line stations and in TETRA SwMIs for Terrestrial Trunked Radio (TETRA) systems.

Between

(COMPANY NAME)

(COMPANY ADDRESS)

hereinafter called: the **BENEFICIARY**;

and

(COMPANY NAME).....European Telecommunications Standards Institute

(COMPANY ADDRESS).....06921 Sophia Antipolis CEDEX, France

hereinafter called: the **PROVIDER**.

- Whereas

The **BENEFICIARY** has alleged that he fulfils the following criteria:

- He is a manufacturer of TETRA equipment.

The **PROVIDER** undertakes to give to the **BENEFICIARY**:

- One globally unique **proprietary element owner** information element value, registered by the **PROVIDER**.

The provided **proprietary element owner** information element value is filled in below by the **PROVIDER** when he has received and approved two signed originals of this agreement.

Proprietary element owner: =
 Decimal number Binary number

The code above is given as a decimal (1 to 255) number, and as a 8 bit binary number (00000001₂ to 11111111₂). The most significant digit and bit are positioned to the left.

The BENEFICIARY undertakes:

1. To apply and use the **proprietary element owner** value in accordance with rules in annex H of the present document.
2. To return the **proprietary element owner** value to the PROVIDER, within 5 years, if these has not been used.

ETSI EN 300 392-2: "Terrestrial Trunked Radio (TETRA); Voice plus Data (V+D); Part 2: Air Interface (AI)", annex H.

In case the BENEFICIARY violates any of the obligations incurred on him by the present undertaking, he shall be liable of indemnifying ETSI for all losses suffered directly or through claims from legitimate TETRA users.

All disputes which derive from the present undertaking or its interpretation shall be settled by the Court of Arbitration of the International Chamber of Commerce situated in Paris, in accordance with the procedures of this Court of Arbitration and with the application of French Law regarding questions of interpretation.

Made in two originals, one of which is for the PROVIDER, the other for the BENEFICIARY; both originals signed by a legal representative of his company/organization.

For the PROVIDER

For the BENEFICIARY

(signed)

(Name, Title (typed))

.....

(signed)

(Name, Title (typed))

.....

Director General

(Date)

(Date)

Annex I (normative): TETRA SDS-TL Location system coding scheme information element owner

I.0 General

This annex defines TETRA SDS-TL Location system coding scheme information element owner.

I.1 Location system coding scheme information element

TETRA SDS-TL in clause 29.5.7 defines Location system coding scheme identifiers for various location information transport protocols. Some of the potential protocols are defined in the SDS-TL standard in clause 29 and some protocol will be defined independently of the clause 29. In order to identify the manufacturer specific protocols the Location system coding scheme identifiers are allocated by a central body. The manufacturer means in this context the owner of the Location system coding scheme such as a TETRA equipment manufacturer, a TETRA application designer or TETRA operator.

NOTE 1: Location system coding scheme identifiers is a generic name for location information transport protocols and is not limited to GPS only although the earlier name of the information element (GPS coding scheme) may imply that limitation.

NOTE 2: In addition to the "Location system" TETRA SDS-TL Protocol Identifier (PID) TETRA standard contains another PID for a standardized location information transport protocol, refer to ETSI TS 100 392-18-1 [19].

There is a range on the Location system coding scheme identifiers available for the manufacturer specific protocols as defined in the clause 29.5.7.

The Location system coding scheme identifier values are managed by a central body.

Each manufacture may have multiple values of the Location system coding scheme identifier information element. The manufacture may design his proprietary information element contents so that he can use the same Location system coding scheme identifier value for all purposes of location information transport protocol. The manufacturer specific Location system coding scheme information part may be coded so that it contains in the beginning a PDU type or an information element type managed by that manufacturer so that the usage of the single protocol identifier value can be used for all purposes for that protocol. The same Location system coding scheme identifier value may be used for various protocols if suitable on the manufacturers point of view.

It is allowed that multiple manufacturers, operators or application designers use the same Location system coding scheme identifier value under responsibility of the registered owner.

I.2 Application for the Location system coding scheme identifier value

This application form is provided under assumption that ETSI will be the central body for the management of the SDS-TL Location system coding scheme identifier owner values of the present document. The application and allocation may be implemented by other means such as a World Wide Web server application.

The BENEFICIARY undertakes:

1. To apply and use the SDS-TL **Location system coding scheme** value in accordance with rules in annex I of the present document.
2. To return the SDS-TL **Location system coding scheme** value to the PROVIDER, within 5 years, if these has not been used.

ETSI EN 300 392-2: "Terrestrial Trunked Radio (TETRA); Voice plus Data (V+D); Part 2: Air Interface (AI)", annex I.

In case the BENEFICIARY violates any of the obligations incurred on him by the present undertaking, he shall be liable of indemnifying ETSI for all losses suffered directly or through claims from legitimate TETRA users.

All disputes which derive from the present undertaking or its interpretation shall be settled by the Court of Arbitration of the International Chamber of Commerce situated in Paris, in accordance with the procedures of this Court of Arbitration and with the application of French Law regarding questions of interpretation.

Made in two originals, one of which is for the PROVIDER, the other for the BENEFICIARY; both originals signed by a legal representative of his company/organization.

For the PROVIDER

For the BENEFICIARY

(signed)

(Name, Title (typed))

.....

(signed)

Director General

(Name, Title (typed))

.....

(Date)

(Date)

Annex J (normative): TETRA SDS-TL protocol identifier information element owner

J.0 General

This annex defines TETRA SDS-TL protocol identifier information element owner.

J.1 Protocol identifier information element

TETRA SDS-TL in clause 29.4.3.9 defines protocol identifiers for various SDS-TL protocols. Some of the potential protocols are defined in the SDS-TL standard in clause 29 and some protocol will be defined independently of the clause 29. In order to identify the manufacturer specific protocols the protocol identifiers are allocated by a central body. The manufacturer means in this context either a TETRA equipment manufacturer, or a TETRA application designer or TETRA application protocol owner.

There are two ranges on protocol identifiers available for the manufacturer specific protocols as defined in the clause 29.4.3.9 and copied in a short form into table J.1.

Table J.1: SDS-TL protocol identifier information element contents

Information element	Length	Type	C/O/M	Value	Remark
Protocol identifier	8	1	M	01000000 ₂ to 01111110 ₂	The SDS-TL protocol PDUs are not used (see note 1).
				11000000 ₂ to 11111110 ₂	The SDS-TL protocol PDUs are used (see note 2).
				All other values	These values are outside the scope of this annex.
NOTE 1: For these values each SDS type 4 user data information element contains as the standardized part the protocol identifier as the first 8 bits. The rest of the user data information is outside the scope of the present document. In the application form this is indicated as "no SDS-TL service".					
NOTE 2: For these values each SDS type 4 user data information element contains as the standardized part one of the SDS-TL PDUs as defined in clause 29.4.2. The SDS-TL PDUs contain as the first information element the protocol identifier. In the application form this is indicated as "SDS-TL service".					

The protocol identifier values are managed by a central body.

Each manufacture may have multiple values of the protocol identifier information element. The manufacture should design his proprietary information element contents so that he can use the same protocol identifier value for all purposes of a protocol. It is recommended that the manufacturer specific protocol information part is coded so that it contains in the beginning a PDU type or an information element type managed by that manufacturer so that the usage of the single protocol identifier value can be used for all purposes for that protocol. The same protocol identifier value may be used for various protocols if suitable on the manufacturers' point of view.

It is allowed that multiple manufacturers or application designers use the same protocol identifier value under responsibility of the registered owner.

J.2 Application for the protocol identifier value

This application form is provided under assumption that ETSI will be the central body for the management of the SDS-TL protocol identifier owner values of the present document. The application and allocation may be implemented by other means such as a World Wide Web server application. The applicant shall indicate the range on which the SDS-TL Protocol Identifier is applied. Only a single range can be present in each application form.

PROVISION OF AND RESTRICTED USAGE UNDERTAKING

relating to

a SDS-TL **protocol identifier** information element value, to be used in mobile and line stations, in application using TETRA equipment and in TETRA SwMIs for Terrestrial Trunked Radio (TETRA) systems.

Between

(COMPANY NAME)

(COMPANY ADDRESS)

hereinafter called: the BENEFICIARY;

and

(COMPANY NAME).....European Telecommunications Standards Institute

(COMPANY ADDRESS).....06921 Sophia Antipolis CEDEX, France

hereinafter called: the PROVIDER.

- Whereas

The BENEFICIARY has alleged that he fulfils the following criteria:

- He is a manufacturer of TETRA equipment, or a TETRA application designer or TETRA application protocol owner.

The PROVIDER undertakes to give to the BENEFICIARY:

- One globally unique SDS-TL **protocol identifier** information element value, registered by the PROVIDER.

The BENEFICIARY applies for an SDS-TL **protocol identifier**

for no SDS-TL service: decimal number value in range 64 to 126
 for SDS-TL service: decimal number value in range 192 to 254

The provided SDS-TL **protocol identifier** information element value is filled in below by the PROVIDER when he has received and approved two signed originals of this agreement.

SDS-TL **protocol identifier**: =
 Decimal number Binary number

The code above is given as a decimal (64 to 126 or 192 to 254) number, and as a 8 bit binary number (01000000₂ to 01111110₂.or 11000000₂ to 11111110₂). The most significant digit and bit are positioned to the left.

The BENEFCIARY undertakes:

- 1. To apply and use the SDS-TL **protocol identifier** value in accordance with rules in annex J of the present document.
- 2. To return the SDS-TL **protocol identifier** value to the PROVIDER, within 5 years, if these has not been used.

ETSI EN 300 392-2: "Terrestrial Trunked Radio (TETRA); Voice plus Data (V+D); Part 2: Air Interface (AI)", annex J.

In case the BENEFCIARY violates any of the obligations incurred on him by the present undertaking, he shall be liable of indemnifying ETSI for all losses suffered directly or through claims from legitimate TETRA users.

All disputes which derive from the present undertaking or its interpretation shall be settled by the Court of Arbitration of the International Chamber of Commerce situated in Paris, in accordance with the procedures of this Court of Arbitration and with the application of French Law regarding questions of interpretation.

Made in two originals, one of which is for the PROVIDER, the other for the BENEFCIARY; both originals signed by a legal representative of his company/organization.

For the PROVIDER

For the BENEFCIARY

(signed)

(Name, Title (typed))

.....

(signed)

K H Rosenbrock, Director General

(Name, Title (typed))

.....

(Date)

(Date)

Annex K (informative): TETRA Mobile Country Code information element values

K.1 Management of TETRA Mobile Country Codes

ITU-T manages TETRA Mobile Country Codes in contrary what is defined in V2.1.1 of ETSI EN 300 392-1 [6] clause 7.2.5, refer to <http://www.itu.int/>.

K.2 TETRA Mobile Country Code information element values

Refer to Recommendation ITU-T E.218 [42], <http://www.itu.int/>.

Annex L (informative): Bibliography

- National Marine Electronics Association: "NMEA 0183 Interface Standard".
- TETRA MoU SFPG Recommendation 07: "End-to-End Encrypted Short Data Service", <http://www.tetramou.com/>.
- CEPT Recommendation T/CS 46-02 E: "Multifrequency Signalling System to be Used for Push-Button Telephones".
- Digital Land Mobile Radiocommunications, M. Failli (Ed.): Final Report 14.3.1984-13.9.1988, published by European Commission, Directorate of General Telecommunication, Information Industries and Innovation. Luxembourg. ISBN 92-825-9946-9 (1989).
- ETSI ETS 300 392-2 (Edition 1): "Terrestrial Trunked Radio (TETRA); Voice plus Data (V+D); Part 2: Air Interface (AI)".
- ETSI EN 300 392-2 (V2.3.2): "Terrestrial Trunked Radio (TETRA); Voice plus Data (V+D); Part 2: Air Interface (AI)".
- RTCM Paper 136-2001/SC104-STD: "RTCM Recommended Standards for **Differential GNSS** (Global Navigation Satellite Systems) Service, version 2.3".
- RTCM Paper 137-2001/SC104-STD: "RTCM Recommended Standards for **Differential Navstar GPS Reference Stations** and Integrity Monitors (RSIM), Version 1.1".
- The Unicode Consortium. The Unicode Standard, Version 4.0.0, defined by: The Unicode Standard, Version 4.0 (Boston, MA, Addison-Wesley, 2003. ISBN 0-321-18578-1).
- ETSI TS 122 060: "Digital cellular telecommunications system (Phase 2+) (GSM); Universal Mobile Telecommunications System (UMTS); General Packet Radio Service (GPRS); Service description; Stage 1".
- ETSI EN 301 344: "Digital cellular telecommunications system (Phase 2+); General Packet Radio Service (GPRS); Service description; Stage 2".
- WAP Forum WAP-210: "Wireless Application Protocol Architecture Specification".
- ETSI TR 102 021-8: "Terrestrial Trunked Radio (TETRA); User Requirement Specification TETRA Release 2; Part 8: Air - Ground - Air services".

Annex M (informative): Table and figure numbering

Table M.1 compares table numbers of ETSI EN 300 392-2 versions up to V2.4.2 and table numbers of ETSI TS 100 392-2 and ETSI EN 300 392-2 V2.5.1, V2.5.2 and V2.6.1. In the later versions than ETSI TS 100 392-2 and ETSI EN 300 392-2 V2.5.1, V2.5.2 and V2.6.1 the table numbers may be different than those in the table M.1. Table M.1 identifies by bold font table numbers that are referenced to from other clauses than those in each editorial sub-part of ETSI EN 300 392-2 or from other TETRA specifications or standards at the time of drafting the present document. That marking may not be complete.

Table M.1: Table numbering

Versions V2.4.2 and V2.4.1		Versions V2.5.1, V2.5.2 and V2.6.1	Name
Figure	Clause	Clause.figure	
1	5.4	5.1	Phase transitions
2	6.4.1.1	6.1	Nominal power of BS transmitters
3	6.4.1.2	6.2	Nominal power of MS transmitters
4	6.4.1.2	6.3	Nominal MS power control levels
5a	6.4.2.2.1	6.4	Maximum adjacent power levels for frequencies below 700 MHz
5b	6.4.2.2.1	6.5	Maximum adjacent power levels for frequencies above 700 MHz
6a	6.4.2.3	6.6	Wideband noise limits for frequencies below 700 MHz
6b	6.4.2.3	6.7	Wideband noise limits for frequencies above 700 MHz
7	6.4.5	6.8	Transmit level versus time mask symbol durations (re figure 6.3)
8	6.5.1.2	6.9	Blocking levels of the receiver
9	6.6.2.1	6.10	Nominal error rates
10	6.6.2.2.1	6.11	Maximum permissible BS receiver MER or BER at dynamic reference sensitivity level
11	6.6.2.2.2	6.12	Maximum permissible MS receiver MER or BER at dynamic reference sensitivity level
12	6.6.2.3.1	6.13	Maximum permissible BS receiver MER or BER at reference interference level
13	6.6.2.3.2	6.14	Maximum permissible MS receiver MER or BER at reference interference level
14	6.6.2.4.1	6.15	Maximum permissible BS receiver MER or BER at static reference sensitivity level
15	6.6.2.4.2	6.16	Maximum permissible MS receiver MER or BER at static reference sensitivity level
16	6.6.2.5	6.17	MS receiver performance for synchronization burst acquisition
17	6.6.3.3	6.18	Propagation models
18	9.4.4.1	9.1	Burst types
19	9.4.4.2.1	9.2	Control uplink Burst (CB)
20	9.4.4.2.4	9.3	Normal Uplink Burst (NUB)
21	9.4.4.2.5	9.4	Normal continuous downlink burst
22	9.4.4.2.6	9.5	Synchronization continuous downlink burst
23	9.4.4.2.7	9.6	Normal discontinuous downlink burst
24	9.4.4.2.8	9.7	Synchronization discontinuous downlink burst
25	9.4.4.3.2	9.8	Training sequence mapping to logical channels
26	9.4.4.3.6	9.9	Phase adjustment bits
27	9.4.5.1	9.10	Start burst
28	9.4.5.1	9.11	Stop burst
29	9.4.5.2	9.12	Bits following the burst
30	9.4.5.2	9.13	Bits preceding the burst
31	9.4.5.3	9.14	Bits following the burst
32	9.4.5.3	9.15	Bits preceding the burst
33	9.5.1	9.16	Mapping of logical channel into physical channels
34	9.5.1	9.17	TDMA frame mapping on TP channel
35	9.5.1	9.18	TDMA frame mapping on CP channel

Versions V2.4.2 and V2.4.1 Figure Clause		Versions V2.5.1, V2.5.2 and V2.6.1 Clause.figure	Name
36	9.5.1	9.19	TDMA frame mapping on unallocated physical channel
37	9.5.2	9.20	Mapping of the BCCH onto the control frame
38	9.6	9.21	Monitoring patterns for transmitting MSs
39	9.8.2	9.22	Reserved frames in BS timing
40	9.8.2	-	Void
41	11.3.3.1	11.1	Parameters for the primitive TNCC-ALERT
42	11.3.3.2	11.2	Parameters for the primitive TNCC-COMplete
43	11.3.3.3	11.3	Parameters for the primitive TNCC-DTMF
44	11.3.3.4	11.4	Parameters for the primitive TNCC-MODIFY
45	11.3.3.5	11.5	Parameters for the primitive TNCC-NOTIFY
46	11.3.3.6	11.6	Parameters for the primitive TNCC-PROCEED
47	11.3.3.7	11.7	Parameters for the primitive TNCC-RELEASE
48	11.3.3.8	11.8	Parameters for the primitive TNCC-SETUP
49	11.3.3.9	11.9	Parameters for the primitive TNCC-TX
50	11.3.4	-	Void
51	12.3.1	12.1	Parameters for the supplementary service primitives
52	12.3.2	-	Void
53	13.3.2.1	13.1	Parameters for the TNSDS-STATUS primitive
54	13.3.2.2	13.2	Parameters for the TNSDS-REPORT primitive
55	13.3.2.3	13.3	Parameters for the TNSDS-UNITDATA primitive
56	14.5.3.1	14.1	Traffic channel assignment
57	14.5.6.2	14.2	Low/high/emergency PDU priority default values
58	14.6	14.3	Timers
59	14.7	-	Void
60	14.7.1.1	14.4	D-ALERT PDU contents
61	14.7.1.2	14.5	D-CALL PROCEEDING PDU contents
62	14.7.1.3	14.6	D-CALL RESTORE PDU contents
63	14.7.1.4	14.7	D-CONNECT PDU contents
64	14.7.1.5	14.8	D-CONNECT ACKNOWLEDGE PDU contents
65	14.7.1.6	14.9	D-DISCONNECT PDU contents
66	14.7.1.7	14.10	D-FACILITY PDU contents
67	14.7.1.8	14.11	D-INFO PDU contents
68	14.7.1.9	14.12	D-RELEASE PDU contents
69	14.7.1.10	14.13	D-SDS-DATA PDU contents
70	14.7.1.11	14.14	D-STATUS PDU contents
71	14.7.1.12	14.15	D-SETUP PDU contents
72	14.7.1.13	14.16	D-TX CEASED PDU contents
73	14.7.1.14	14.17	D-TX CONTINUE PDU contents
74	14.7.1.15	14.18	D-TX GRANTED PDU contents
75	14.7.1.16	14.19	D-TX INTERRUPT PDU contents
76	14.7.1.17	14.20	D-TX WAIT PDU contents
77	14.7.2.1	14.21	U-ALERT PDU contents
78	14.7.2.2	14.22	U-CALL RESTORE PDU contents
79	14.7.2.3	14.23	U-CONNECT PDU contents
80	14.7.2.4	14.24	U-DISCONNECT PDU contents
81	14.7.2.5	14.25	U-FACILITY PDU contents
82	14.7.2.6	14.26	U-INFO PDU contents
83	14.7.2.7	14.27	U-STATUS PDU contents
84	14.7.2.8	14.28	U-SDS-DATA PDU contents
85	14.7.2.9	14.29	U-RELEASE PDU contents
86	14.7.2.10	14.30	U-SETUP PDU contents
87	14.7.2.11	14.31	U-TX CEASED PDU contents
88	14.7.2.12	14.32	U-TX DEMAND PDU contents
88a	14.7.3.2	14.33	CMCE FUNCTION NOT SUPPORTED PDU contents
89	14.8.1	14.34	Area selection information element contents
90	14.8.2	14.35	Basic service information element contents
91	14.8.3	14.36	Call identifier information element contents
91a	14.8.3a	14.37	Call identifier present information element contents
92	14.8.4	14.38	Call ownership information element contents
93	14.8.5	14.39	Called party type identifier information element contents
94	14.8.6	14.40	Called party SNA information element contents

Versions V2.4.2 and V2.4.1 Figure Clause		Versions V2.5.1, V2.5.2 and V2.6.1 Clause.figure	Name
95	14.8.7	14.41	Called party extension information element contents
96	14.8.8	14.42	Called party SSI information element contents
97	14.8.9	14.43	Calling party type identifier information element contents
98	14.8.10	14.44	Calling party extension information element contents
99	14.8.11	14.45	Calling party SSI information element contents
100	14.8.12	14.46	Call priority information element contents
101	14.8.13	14.47	Call status information element contents
102	14.8.14	14.48	Call queued information element contents
103	14.8.15	14.49	Continue information element contents
104	14.8.16	14.50	Call time-out information element contents
105	14.8.17	14.51	Call time-out, set-up phase information element contents
105a	14.8.17a	14.52	Circuit mode type information element contents
105b	14.8.17b	14.53	CLIR control information element contents
105c	14.8.17c	14.54	Communication type information element contents
106	14.8.18	14.55	Disconnect cause information element contents
107	14.8.19	14.56	DTMF information element contents
107a	14.8.19a	14.57	DTMF digit information element contents
107b	14.8.19b	14.58	DTMF type information element contents
108	14.8.20	14.59	Encoding of the digits in the external subscriber number information element
109	14.8.21	14.60	Encryption control information element contents
109a	14.8.21a	14.61	Encryption flag information element contents
110	14.8.23	14.62	Hook method selection information element contents
111	14.8.24	14.63	Length indicator information element contents
112	14.8.26	14.64	Modify information element contents
113	14.8.27	14.65	Notification indicator information element contents
114	14.8.28	14.66	PDU type information element contents
115	14.8.29	14.67	Poll request information element contents
116	14.8.30	14.68	Poll response information element contents
117	14.8.31	14.69	Poll response addresses information element contents
118	14.8.32	14.70	Poll response number information element contents
119	14.8.33	14.71	Poll response percentage information element contents
120	14.8.34	14.72	Pre-coded status information element contents
120a	14.8.35	14.73	Proprietary information element contents
121	14.8.36	14.74	Request to transmit/send data information element contents
122	14.8.37	14.75	Reset call time-out timer information element contents
123	14.8.38	14.76	Short data type identifier information element contents
124	14.8.39	14.77	Simplex/duplex selection information element contents
124a	14.8.39a	14.78	Slots per frame information element contents
125	14.8.40	14.79	Speech service information element contents
126	14.8.42	14.80	Transmission grant information element contents
127	14.8.43	14.81	Transmission request permission information element contents
128	14.8.44	14.82	Transmitting party type identifier information element contents
129	14.8.45	14.83	Transmitting party extension information element contents
130	14.8.46	14.84	Transmitting party SSI information element contents
131	14.8.47	14.85	Tx demand priority information element contents
132	14.8.48	14.86	Type 3 element identifier information element contents
133	14.8.49	14.87	User Defined Data-1 information element contents
134	14.8.50	14.88	User Defined Data-2 information element contents
135	14.8.51	14.89	User Defined Data-3 information element contents
136	14.8.52	14.90	User Defined Data-4 information element contents
137	15.3.3.1	15.1	Parameters for the primitive TNMM-ATTACH DETACH GROUP IDENTITY
138	15.3.3.2	15.2	Parameters for the primitive TNMM-DEREGISTRATION
139	15.3.3.3	-	Void
140	15.3.3.4	-	Void
141	15.3.3.5	15.3	Parameters for the primitive TNMM-ENERGY SAVING
142	15.3.3.6	15.4	Parameters for the primitive TNMM-ENERGY SAVING
143	15.3.3.7	15.5	Parameters for the primitive TNMM-REGISTRATION
144	15.3.3.8	15.6	Parameters for the primitive TNMM-SERVICE
144a	15.3.3.9	15.7	Parameters for the primitive TNMM-STATUS
145	15.3.4	15.8	Group identities parameter

Versions V2.4.2 and V2.4.1 Figure Clause		Versions V2.5.1, V2.5.2 and V2.6.1 Clause.figure	Name
146	15.3.4	15.9	Group identity request parameter
147	16.9.1	-	Void
148	16.9.2.1	16.1	D-ATTACH/DETACH GROUP IDENTITY PDU contents
149	16.9.2.2	16.2	D-ATTACH/DETACH GROUP IDENTITY ACKNOWLEDGEMENT PDU contents
150	16.9.2.3	-	Void
151	16.9.2.4	-	Void
152	16.9.2.5.1	16.3	D-MM STATUS PDU generic contents
152a	16.9.2.5.2	16.4	D-CHANGE OF ENERGY SAVING MODE REQUEST PDU contents
152B	16.9.2.5.3	16.5	D-CHANGE OF ENERGY SAVING MODE RESPONSE PDU contents
152C	16.9.2.5.4	16.6	D-DUAL WATCH MODE RESPONSE PDU contents
152D	16.9.2.5.5	16.7	D-TERMINATING DUAL WATCH MODE RESPONSE PDU contents
152E	16.9.2.5.6	16.8	D-CHANGE OF DUAL WATCH MODE REQUEST PDU contents
152F	16.9.2.5.8	16.9	D-MS FREQUENCY BANDS REQUEST PDU contents
152G	16.9.2.5.9	16.10	D-DISTANCE REPORTING REQUEST PDU contents
153	16.9.2.6	-	Void
154	16.9.2.7	16.11	D-LOCATION UPDATE ACCEPT contents
155	16.9.2.8	16.12	D-LOCATION UPDATE COMMAND contents
156	16.9.2.9	16.13	D-LOCATION UPDATE REJECT contents
157	16.9.2.10	16.14	D-LOCATION UPDATE PROCEEDING contents
158	16.9.3.1	16.15	U-ATTACH/DETACH GROUP IDENTITY contents
159	16.9.3.2	16.16	U-ATTACH/DETACH GROUP IDENTITY ACKNOWLEDGEMENT contents
160	16.9.3.3	16.17	U-ITSI DETACH contents
161	16.9.3.4	16.18	U-LOCATION UPDATE DEMAND contents
162	16.9.3.5.1	16.19	U-MM STATUS PDU generic contents
162a	16.9.3.5.2	16.20	U-CHANGE OF ENERGY SAVING MODE REQUEST PDU contents
162B	16.9.3.5.3	16.21	U-CHANGE OF ENERGY SAVING MODE RESPONSE PDU contents
162C	16.9.3.5.4	16.22	U-DUAL WATCH MODE REQUEST PDU contents
162D	16.9.3.5.5	16.23	U-TERMINATING DUAL WATCH MODE REQUEST PDU contents
162E	16.9.3.5.6	16.24	U-CHANGE OF DUAL WATCH MODE RESPONSE PDU contents
162F	16.9.3.5.7	16.25	U-START OF DIRECT MODE OPERATION PDU contents
162Fb	16.9.3.5.9	16.26	U-MS FREQUENCY BANDS PDU contents
162G	16.9.4.1	16.27	MM FUNCTION NOT SUPPORTED PDU contents
163	16.10.1	16.28	Address extension information element contents
164	16.10.2	16.29	Cipher control information element contents
165	16.10.3	-	Void
166	16.10.4	-	Void
167	16.10.5	16.30	Class of MS information element contents
168	16.10.6	16.31	Class of Usage information element contents
169	16.10.7	-	Void
169a	16.10.7a	16.32	Default group attachment lifetime information element contents
169B	16.10.7b	16.33	Distance reporting timer information element contents
169C	16.10.7c	16.34	Distance reporting validity information element contents
170	16.10.8	16.35	Distribution on 18th frame
170A	16.10.8a	16.36	DMO carrier
170B	16.10.8b	16.37	Dual watch mode information element contents
171	16.10.9	16.38	Energy saving mode information element contents
172	16.10.10	16.39	Energy saving information element contents
173	16.10.11	16.40	Frame number information element contents
173a	16.10.11a	16.41	Frequency band definition information element contents
174	16.10.12	16.42	Group identity accept/reject information element contents
175	16.10.13	16.43	Group identity acknowledgement request information element contents

Versions V2.4.2 and V2.4.1 Figure Clause		Versions V2.5.1, V2.5.2 and V2.6.1 Clause.figure	Name
176	16.10.14	16.44	Group identity acknowledgement type information element contents
177	16.10.15	16.45	Group identity address type information element contents
178	16.10.16	16.46	Group identity attachment lifetime information element contents
179	16.10.17	16.47	Group identity attach/detach mode information element contents
180	16.10.18	16.48	Group identity attach/detach type identifier information element contents
181	16.10.19	16.49	Group identity attachment information element contents
182	16.10.20	16.50	Group identity detachment downlink information element contents
183	16.10.21	16.51	Group identity detachment uplink information element contents
184	16.10.22	16.52	Group identity downlink information element contents
185	16.10.23	16.53	Group identity location accept information element contents
186	16.10.24	16.54	Group identity location demand information element contents
187	16.10.25	-	Void
188	16.10.26	16.55	Group identity report information element contents
189	16.10.27	16.56	Group identity uplink information element contents
189a	16.10.27a	16.57	Group report response information element contents
190	16.10.28	16.58	GSSI information element contents
191	16.10.29	-	Void
192	16.10.30	16.59	LA information element contents
193	16.10.31	16.60	Location Area Country Code information element contents
194	16.10.32	16.61	LANC information element contents
195	16.10.33	16.62	LA timer information element contents
196	16.10.34	16.63	LA information element contents
196A	16.10.34a	16.64	Length of the copied PDU information element contents
197	16.10.35	16.65	Location update type information element contents
197a	16.10.35a	16.66	Location update accept type information element contents
198	16.10.36	16.67	MCC information element contents
199	16.10.37	16.68	MNC information element contents
199a	16.10.37a	16.69	Mode change information element contents
199b	16.10.37b	16.70	MS operating with type 2 repeater information element contents
200	16.10.38	16.71	Multiframe number information element contents
200A	16.10.38b	16.72	Number of the frequency band definitions information element contents
201	16.10.39	16.73	PDU type information element contents
202	16.10.40	16.74	New registered area information element contents
202a	16.10.41a	16.75	Reason for dual watch change by SwMI information element contents
203	16.10.42	16.76	Reject cause information element contents
204	16.10.43	16.77	Request to Append LA information element contents
204a	16.10.43a	16.78	Re-send interval information element contents
204B	16.10.43b	16.79	Result of dual watch request information element contents
205	16.10.44	16.80	SSI information element content
206	16.10.45	16.81	SCCH information element contents
207	16.10.46	16.82	SCCH information and distribution on 18th frame information element contents
208	16.10.47	-	Void
208a	16.10.47a	16.83	Start of direct mode operation cause information element contents
209	16.10.48	16.84	Status downlink information element content
209a	16.10.48a	16.85	Status uplink information element content
210	16.10.49	16.86	Subscriber class information element
211	16.10.50	-	Void
212	16.10.51	16.87	Type 3/4 element identifier information element contents
213	16.10.52	16.88	(V)GSSI information element contents
213a	16.10.53	16.89	Zero bit information element contents
214	17.2	17.1	MLE SAPs
215	17.3.1	17.2	Primitives and parameters at the LMM-SAP

Versions V2.4.2 and V2.4.1 Figure Clause		Versions V2.5.1, V2.5.2 and V2.6.1 Clause.figure	Name
216	17.3.3	17.3	Primitives and parameters at the LCMC-SAP
217	17.3.5	17.4	Primitives and parameters at the LTPD-SAP
218	17.3.7	-	Void
219	17.3.7	-	Void
220	18.4.1.3	18.1	MLE service PDU layout
221	18.4.1.3	-	Void
222	18.4.1.4.1	18.2	D-NWRK-BROADCAST PDU
223	18.4.1.4.2	18.3	D-NEW-CELL PDU
224	18.4.1.4.3	18.4	D-PREPARE-FAIL PDU
225	18.4.1.4.4	18.5	D-RESTORE-ACK PDU
226	18.4.1.4.5	18.6	D-RESTORE-FAIL PDU
227	18.4.1.4.6	18.7	U-PREPARE PDU
228	18.4.1.4.7	18.8	U-RESTORE PDU
229	18.4.2.1	18.9	D-MLE-SYNC PDU
230	18.4.2.2	18.10	D-MLE-SYSINFO PDU
231	18.5.1	18.11	Cell reselection types supported information element
232	18.5.2	18.12	BS Service details information element
233	18.5.3	18.13	Cell identifier information element
234	18.5.4	18.14	Cell re-select parameters information element
235	18.5.5	18.15	Cell service level information element
236	18.5.6	18.16	Channel command valid element
237	18.5.7	18.17	Fail cause information element
238	18.5.8	18.18	Late entry supported information element
239	18.5.9	18.19	LA information element
240	18.5.10	18.20	Main carrier number information element
241	18.5.11	18.21	Main carrier number extension information element
242	18.5.12	18.22	Minimum RX access level information element
243	18.5.13	18.23	Maximum MS transmit power information element
244	18.5.14	18.24	MCC information element
245	18.5.15	18.25	MNC information element
246	18.5.16	18.26	Neighbour cell broadcast information element
247	18.5.17	18.27	Neighbour cell information information element
248	18.5.18	18.28	Neighbour cell synchronized information element
249	18.5.19	18.29	Number of neighbour cells information element
250	18.5.20	18.30	PDU type information element
251	18.5.21	18.31	Protocol discriminator information element
252	18.5.22	18.32	Subscriber class information element
253	18.5.23	18.33	TDMA frame offset information element
254	18.5.24	18.34	TETRA network time information element
255	18.5.25	18.35	Timeshare cell information information element
256	19.2.4.4	19.1	Mapping between TMx-SAP and MAC logical channels
257	19.2.4.4	19.2	Mapping between MAC logical channels and physical layer bursts
258	20.2.4.19	20.1	Definition of half slot importance
259	20.2.4.31	20.2	Throughput for constant delay services
260	20.2.4.31	20.3	Throughput for variable delay services
261	20.2.4.31	20.4	Residual error rate
262	20.2.4.31	20.5	Transfer failure probability
263	20.2.4.31	20.6	NC Release failure probability
264	20.2.4.33	20.7	Reports at TMA-, TMC-, TLA- and TLC-SAPs
265	20.3.1	20.8	Services provided at the TLA-SAP
266	20.3.1	20.9	Data transfer relationships available in the LLC
267	20.3.2	20.10	Services provided at the TLB-SAP
268	20.3.3	20.11	Services provided at the TLC-SAP
-	20.3.3a	20.12	Services provided at the TLE-SAP
-	20.3.4	20.13	TLE-SAP service primitives
269	20.3.4	20.14	TLA-SAP service primitives
270	20.3.4	20.15	TLB-SAP service primitives
271	20.3.4	20.16	TLC-SAP service primitives
272	20.3.5.1.1	20.17	Parameters used in the TL-CANCEL primitive
273	20.3.5.1.2	20.18	Parameters used in the TL-CONNECT primitive

Versions V2.4.2 and V2.4.1 Figure Clause		Versions V2.5.1, V2.5.2 and V2.6.1 Clause.figure	Name
274	20.3.5.1.3	20.19	Parameters used in the TL-DATA primitive for advanced link
275	20.3.5.1.4	20.20	Parameters used in the TL-DATA primitive for basic link
276	20.3.5.1.5	20.21	Parameters used in the TL-DISCONNECT primitive
276A	20.3.5.1.5a	20.22	Parameters used in the TL-RECEIVE primitive (TLA-SAP)
276A	20.3.5.1.6	20.23	Parameters used in the TL-RECONNECT primitive
277	20.3.5.1.7	20.24	Parameters used in the TL-RELEASE primitive
278	20.3.5.1.8	20.25	Parameters used in the TL-REPORT primitive (TLA-SAP)
279	20.3.5.1.9	20.26	Parameters used in the TL-UNITDATA primitive in basic link
280	20.3.5.1.9	20.27	Parameters used in the TL-UNITDATA primitive in advanced link
281	20.3.5.3.1	20.28	Parameters used in the TL-SYNC primitive
282	20.3.5.3.2	20.29	Parameters used in the TL-SYSINFO primitive
283	20.3.5.4.1	20.30	Parameters used in the TL-CONFIGURE primitive
284	20.3.5.4.2	20.31	Parameters used in the TL-MEASUREMENT primitive
285	20.3.5.4.3	20.32	Parameters used in the TL-MONITOR primitive
286	20.3.5.4.4	20.33	Parameters used in the TL-MONITOR-LIST primitive
287	20.3.5.4.5	20.34	Parameters used in the TL-REPORT primitive (TLC-SAP)
288	20.3.5.4.6	20.35	Parameters used in the TL-SCAN primitive
289	20.3.5.4.7	20.36	Parameters used in the TL-SCAN-REPORT primitive
290	20.3.5.4.8	20.37	Parameters used in the TL-SELECT primitive
-	20.3.5.5.1	20.38	Parameters used in the TLE-CANCEL primitive
-	20.3.5.5.2	20.39	Parameters used in the TLE-REPORT primitive
-	20.3.5.5.3	20.40	Parameters used in the TLE-UNITDATA primitive
291	20.4	20.41	TMA-SAP service primitives
292	20.4	20.42	TMB-SAP service primitives
293	20.4	20.43	TMC-SAP service primitives
294	20.4	20.44	TMD-SAP service primitives
295	20.4.1.1.1	20.45	Parameters used in the TMA-CANCEL primitive
296	20.4.1.1.2	20.46	Parameters used in the TMA-RELEASE primitive
297	20.4.1.1.3	20.47	Parameters used in the TMA-REPORT primitive
298	20.4.1.1.4	20.48	Parameters used in the TMA-UNITDATA primitive
299	20.4.1.3	20.49	Correspondence between MAC and LLC at the TMA-SAP and TLA-SAP
300	20.4.2	20.50	Correspondence between MAC and LLC at the TMB-SAP and TLB-SAP
300A	20.4.3	20.51	Parameters used in the TMC-CONFIGURE request primitive
301	20.4.3	20.52	Correspondence between MAC and LLC at the TMC-SAP and TLC-SAP
302	20.4.4.1.1	20.53	Parameters used in the TMD-REPORT primitive
303	20.4.4.1.2	20.54	Parameters used in the TMD-UNITDATA primitive
304	21.2.1	21.1	Definition of LLC PDU types
-	21.2.1	21.2	Definition of layer 2 signalling PDU subtypes for LLC PDU type 1110 ₂
305	21.2.2.1	21.3	BL-ACK PDU without FCS contents
306	21.2.2.1	21.4	BL-ACK PDU with FCS contents
307	21.2.2.2	21.5	BL-ADATA PDU without FCS contents
308	21.2.2.2	21.6	BL-ADATA PDU with FCS contents
309	21.2.2.3	21.7	BL-DATA PDU without FCS contents
310	21.2.2.3	21.8	BL-DATA PDU with FCS contents
311	21.2.2.4	21.9	BL-UDATA PDU without FCS contents
312	21.2.2.4	21.10	BL-UDATA PDU with FCS contents
313	21.2.3.1	21.11	AL-ACK and AL-RNR PDUs contents
314	21.2.3.1	21.12	Acknowledgement block information element contents
315	21.2.3.2	21.13	AL-FINAL and AL-FINAL-AR PDUs contents
316	21.2.3.3	21.14	AL-DATA and AL-DATA-AR PDUs contents
317	21.2.3.4	21.15	AL-DISC PDU contents
317a	21.2.3.4a	21.16	AL-RECONNECT PDU contents
318	21.2.3.5	21.17	AL-SETUP PDU contents
319	21.2.3.6	21.18	AL-UDATA PDU contents
320	21.2.3.7	21.19	AL-UFINAL PDU contents
-	21.2.4.1	21.20	L2-DATA-PRIORITY PDU contents
-	21.2.4.1	21.21	Data priority block information element contents

Figure	Versions V2.4.2 and V2.4.1 Clause	Versions V2.5.1, V2.5.2 and V2.6.1 Clause.figure	Name
			in L2-DATA-PRIORITY PDU
321	21.4.1	21.22	MAC PDU types for SCH/F, SCH/HD and STCH
322	21.4.1	21.23	MAC PDU Types for SCH/HU
323	21.4.2.1	21.24	MAC-ACCESS PDU contents
324	21.4.2.1	21.25	Length of MAC-ACCESS PDU header and SDU
325	21.4.2.2	21.26	MAC-END-HU PDU contents
326	21.4.2.3	21.27	MAC-DATA PDU contents
327	21.4.2.4	21.28	MAC-FRAG (uplink) PDU contents
328	21.4.2.5	21.29	MAC-END (uplink) PDU contents
329	21.4.3.1	21.30	MAC-RESOURCE PDU contents
330	21.4.3.2	21.31	MAC-FRAG (downlink) PDU contents
331	21.4.3.3	21.32	MAC-END (downlink) PDU contents
332	21.4.4	21.33	Broadcast PDU contents
333	21.4.4.1	21.34	Broadcast PDU contents
334	21.4.4.1	21.35	Default definition for access code A information element contents
334a	21.4.4.1	21.36	Extended services broadcast information element
-	21.4.4.1	21.37	Extended services broadcast section 1 information element
-	21.4.4.1	21.38	Extended services broadcast section 2 information element
-	21.4.4.1	21.39	Extended services broadcast section 3 information element
-	21.4.4.1	21.40	Extended services broadcast section 4 information element
335	21.4.4.2	21.41	SYNC PDU contents
336	21.4.4.3	21.42	Access define PDU contents
337	21.4.5	21.43	MAC-U-SIGNAL PDU contents
338	21.4.7	21.44	ACCESS-ASSIGN PDU contents for frames 1 to 17
339	21.4.7	21.45	ACCESS-ASSIGN PDU contents for frame 18
340	21.5.1	21.46	Access field information element contents
341	21.5.2	21.47	Channel allocation information element contents
342	21.5.3	21.48	Power control information element contents
343	21.5.4	21.49	Reservation requirement information element contents
344	21.5.5	21.50	TS_COMMON_FRAMES information element contents
345	21.5.6	21.51	Slot granting information element contents
346	23.2.1	23.1	Correspondence between the upper and lower MAC at the TMV-SAP
347	23.2.1	23.2	Parameters used in the TMV-UNITDATA primitive
348	23.2.2	23.3	Mapping of the MAC PDU onto the logical channels
349	23.7.6	23.4	Definition of the Economy Groups and duration
350	Void	-	Void
351	Void	-	Void
352	Void	-	Void
353	Void	-	Void
354	Void	-	Void
355	Void	-	Void
356	Void	-	Void
357	Void	-	Void
358	28.2.3.1	28.1	Parameters for the primitive SN-DATA
359	28.2.3.1	28.2	Parameters for the primitive SN-DELIVERY
360	28.2.3.1	28.3	Parameters for the primitive SN-NSAPI ALLOC
361	28.2.3.1	28.4	Parameters for the primitive SN-NSAPI DEALLOC
362	28.2.3.1	28.5	Parameters for the primitive SN-QOS
363	28.2.3.1	28.6	Parameters for the primitive SN-UNITDATA
364	28.2.3.1	28.7	Parameters for the primitive SN-PAGE
365	28.2.5	28.8	MS State Transition Table
366	28.2.5	28.9	SwMI State Transition table
366A	28.3.3.4	28.10	Packet data MS types and other services
367	28.3.4.1	28.11	Logical link usage by SN-PDUs
368	28.3.4.1	28.12	Usage of basic link unacknowledged and acknowledged services
369	28.3.4.2	28.13	Message sent by SwMI in response to SN-RECONNECT from MS
370	28.3.5.3.2	28.14	Compressed header format
370A	28.3.5.4.3	28.15	BSD compressed data format

Versions V2.4.2 and V2.4.1 Figure Clause		Versions V2.5.1, V2.5.2 and V2.6.1 Clause.figure	Name
370B	28.3.5.4.4	28.16	Predictor compressed data format
371	28.4.1	28.17	PDU priority for SN-PDUs
372	28.4.4.1	28.18	SN-ACTIVATE PDP CONTEXT ACCEPT PDU contents
373	28.4.4.2	28.19	SN-ACTIVATE PDP CONTEXT DEMAND PDU contents
374	28.4.4.3	28.20	SN-ACTIVATE PDP CONTEXT REJECT PDU contents
375	28.4.4.4	28.21	SN-DATA PDU contents
376	28.4.4.5	28.22	SN-DATA TRANSMIT REQUEST PDU contents
377	28.4.4.6	28.23	SN-DATA TRANSMIT RESPONSE PDU contents
378	28.4.4.7	28.24	SN-DEACTIVATE PDP CONTEXT DEMAND PDU contents
379	28.4.4.8	28.25	SN-DEACTIVATE PDP CONTEXT ACCEPT PDU contents
380	28.4.4.9	28.26	SN-END OF DATA PDU contents
380A	28.4.4.10	28.27	SN-NOT SUPPORTED PDU contents
381	28.4.4.11	28.28	SN-PAGE REQUEST PDU contents
382	28.4.4.12	28.29	SN-PAGE RESPONSE PDU contents
383	28.4.4.13	28.30	SN-RECONNECT PDU contents
384	28.4.4.14	28.31	SN-UNITDATA PDU contents
385	28.4.5.1	28.32	Accept/Reject information element contents
385a	28.4.5.2	28.33	Access point name index information element contents
386	28.4.5.3	28.34	Activation reject cause information element contents
387	28.4.5.4	28.35	Address Type Identifier in Demand information element contents
387a	28.4.5.5	28.36	BSD data compression parameters information element contents
387b	28.4.5.6	28.37	BSD compression version information element contents
387c	28.4.5.7	28.38	BSD dictionary size information element contents
388	28.4.5.8	28.39	Data to Send information element contents
389	28.4.5.9	28.40	DCOMP information element contents
390	28.4.5.10	28.41	DCOMP negotiation information element contents
391	28.4.5.11	28.42	Deactivation type information element contents
391a	28.4.5.11	-	
391B	28.4.5.12	28.43	Enhanced service information element contents
391C	28.4.5.13	28.44	Immediate service change information element contents
392	28.4.5.14	28.45	IP address IPv4 information element contents
392a	28.4.5.15	28.46	Largest header size in octets that may be compressed information element contents
392B	28.4.5.16	28.47	Logical link status information element contents
392C	28.4.5.16	-	
392D	28.4.5.17	28.48	Maximum interval between full headers information element contents
392E	28.4.5.18	28.49	Maximum time interval between full headers information element contents
393	28.4.5.19	28.50	Maximum Transmission Unit information element contents
393a	29.4.5.20	28.51	Not supported SN PDU type information element contents
394	29.4.5.21	28.52	N-PDU information element contents
395	29.4.5.22	28.53	NSAPI information element contents
395a	29.4.5.23	28.54	Number of compression state slots, TCP information element contents
395B	29.4.5.24	28.55	Number of compression state slots, non-TCP information element contents
396	29.4.5.25	28.56	Number of VJ compression state slots information element contents
397	29.4.5.26	28.57	Packet data MS Type information element contents
398	29.4.5.27	28.58	PCOMP information element contents
399	29.4.5.28	28.59	PCOMP negotiation information element contents
400	29.4.5.29	28.60	PD service status information element contents
401	29.4.5.30	28.61	PDU priority information element contents
402	29.4.5.31	28.62	Protocol configuration options information element contents
403	29.4.5.32	28.63	READY timer information element contents
404	29.4.5.33	28.64	Reply requested information element contents
404a	29.4.5.34	28.65	Resource request information element contents
405	29.4.5.35	28.66	RESPONSE_WAIT timer information element contents
406	29.4.5.36	28.67	SNDCP version information element contents

Versions V2.4.2 and V2.4.1 Figure Clause		Versions V2.5.1, V2.5.2 and V2.6.1 Clause.figure	Name
407	29.4.5.37	28.68	SNDCP endpoint identifier information element contents
408	29.4.5.38	28.69	SN PDU type information element contents
409	29.4.5.39	28.70	STANDBY timer information element contents
410	29.4.5.40	28.71	SwMI IPv6 Information information element contents
411	29.4.5.41	28.72	SwMI Mobile IPv4 Information information element contents
412	29.4.5.42	28.73	Transmit reject cause information element contents
413	29.4.5.43	28.74	Type Identifier in Accept information element contents
414	29.4.5.44	28.75	Type 3 element identifier information element contents
415	29.4.5.45	28.76	ITU-T Recommendation V.42bis data compression request parameters information element contents
416	29.4.5.46	28.77	ITU-T Recommendation V.42bis data compression parameters element contents
417	29.4.5.47	28.78	ITU-T Recommendation V.42bis maximum string length element contents
418	29.4.5.48	28.79	ITU-T Recommendation V.42bis number of codewords element contents
419	29.2.2	29.1	Parameters for the TLSDS-TRANSFER primitive without store and forward addressing
420	29.2.2	29.2	Parameters for the TLSDS-TRANSFER primitive with store and forward addressing
421	29.2.2	29.3	Parameters for the TLSDS-REPORT primitive (no store and forward)
422	29.2.2	29.4	Parameters for the TLSDS-REPORT primitive (store and forward)
423	29.2.2	29.5	Parameters for the TLSDS-ACK primitive (no store and forward)
424	29.2.2	29.6	Parameters for the TLSDS-ACK primitive (store and forward)
425	29.3.1	29.7	MS1 to MS2 transparent
426	29.3.1	29.8	MS1 to MS2 using forward address
427	29.3.1	29.9	MS1 to MS2/user 2 using forward address via a gateway
428	29.4.1	29.10	PDU layout
429	29.4.2.1	29.11	SDS-ACK PDU contents
430	29.4.2.2	29.12	SDS-REPORT PDU contents
431	29.4.2.3	29.13	SDS-SHORT REPORT PDU contents
432	29.4.2.4	29.14	SDS-TRANSFER PDU contents
433	29.4.3.1	29.15	Acknowledgement required information element contents
434	29.4.3.2	29.16	Delivery status information element contents
435	29.4.3.3	29.17	Delivery report request information element contents
436	29.4.3.5	29.18	Forward address type information element contents
437	29.4.3.7	29.19	Message reference information elements contents
438	29.4.3.8	29.20	Message type information element contents
439	29.4.3.9	29.21	Protocol identifier information element contents
440	29.4.3.10	29.22	Service selection/ short form report information element contents
441	29.4.3.11	29.23	Short report type information element contents
442	29.4.3.12	29.24	Storage information element contents
443	29.4.3.14	29.25	Validity period information element contents
444	29.5.1.2	29.26	Standardized "simple" protocol PDU contents
445	29.5.2.3	29.27	Simple text messaging PDU contents
446	29.5.3.3	29.28	Text message transfer SDU contents
447	29.5.4.1	29.29	Text coding scheme information element contents
448	29.5.4.2	29.30	7-bit character presentation
448a	29.5.4.2	29.31	One 7-bit character in one octet
448b	29.5.4.2	29.32	Two 7-bit characters in two octets
448c	29.5.4.2	29.33	Seven 7-bit characters in seven octets
449	29.5.4.2	29.34	Character packing for 7-bit alphabet
449a	29.5.4.2	29.35	8-bit character presentation
449B	29.5.4.2	29.36	Character packing for 8-bit alphabet
449C	29.5.4.2	29.37	16-bit character presentation
449D	29.5.4.2	29.38	Character packing for 16-bit alphabet
450	29.5.4.3	29.39	Alphabet table for GSM 7-bit alphabet
451	29.5.4.4	29.40	Time stamp information element contents

Versions V2.4.2 and V2.4.1 Figure Clause		Versions V2.5.1, V2.5.2 and V2.6.1 Clause.figure	Name
452	29.5.4.5	29.41	Timestamp used information element contents
453	29.5.5.3	29.42	Simple GPS PDU contents
454	29.5.6.3	29.43	GPS SDU contents
455	29.5.7	29.44	GPS coding scheme information element contents
-	29.5.9.3	29.45	UDH transfer SDU contents
-	29.5.9.4.1	29.46	User Data Header information element information element contents
-	29.5.9.4.1	29.47	UDH information element ID contents
-	29.5.10.3	29.48	Concatenated text message transfer SDU contents
-	29.5.12.6	29.49	SDS type 4 user data contents

Table M.2 compares figure numbers of ETSI EN 300 392-2 versions up to V2.4.2 and figure numbers of ETSI TS 100 392-2 and ETSI EN 300 392-2 V2.5.1, V2.5.2 and V2.6.1. In the later versions than ETSI TS 100 392-2 and ETSI EN 300 392-2 V2.5.1, V2.5.2 and V2.6.1 the figure numbers may be different than those in the table M.2. Table M.2 identifies by bold font figure numbers that are referenced to from other clauses than those in each editorial sub-part of ETSI EN 300 392-2 or from other TETRA specifications or standards at the time of drafting the present document. That marking may not be complete.

Table M.2: Figure numbering

Versions V2.4.2 and V2.4.1 Figure Clause		Versions V2.5.1, V2.5.2 and V2.6.1 Clause.figure	Name
1	4.3	4.1	Reference configuration
2	4.5.1	4.2	V+D TDMA structure
3	5.4	5.1	Modulation symbol constellation and possible transitions
4	5.7	5.2	Block diagram of the modulation process
5	6.3	6.1	Reference interconnection of transmitters and receivers at BS
6	6.4.2.1	6.2	Schematic presentation of transmitter states
7	6.4.5	6.3	Transmit level versus time mask
8	8.2.1	8.1	Interfaces in the error control structure
9	8.3	8.2	Error control structure for V+D logical channels (part 1)
10	8.3	8.3	Error control structure for V+D logical channels (part 2)
11	9.3.2	9.1	TDMA structure
12	9.4.4.1	9.2	Types of bursts
13	11.3.1	11.1	CC services provided at TNCC-SAP MS-side
14	11.4	11.2	State transition diagram for one instance at the CC SAP
15	12.3.1	-	Void
16	13.3.1	13.1	SDS provided at TNSDS-SAP (MS-side)
17	13.3.5	13.2	Service state diagram for the mobile terminated short data message
18	14.2	14.1	System view
19	14.2.1	14.2	Block view of CMCE-MS
20	14.4.1	14.3	State transition diagram for the PC sub-entity
21	14.4.2	14.4	State transition diagram for the CC sub-entity
22	14.4.2	14.5	Sub state transition diagram for the CALL-ACTIVE state
23	14.4.2	14.6	Sub state transition diagram for the MT-CALL-SETUP state
24	14.4.3	14.7	State transition diagram for the SS sub-entity
25	14.4.4	14.8	State transition diagram for the SDS
26	14.5.1.1	14.9	Individual call set-up scenario using on/off hook signalling
27	14.5.1.1	14.10	Individual call set-up scenario using direct set-up signalling
28	14.5.1.1.5	14.11	Individual call set-up phase - called user application rejects the call
29	14.5.1.2.1	14.12	Individual call request-to-transmit
30	14.5.1.2.4	14.13	Individual call - successful call restoration
31	14.5.1.2.4	14.14	Individual call - unsuccessful call restoration
32	14.5.1.3	14.15	Individual call request-to-disconnect
33	14.5.2.1	14.16	Group call - set-up phase
34	14.5.2.1	14.17	Acknowledged group call - set-up phase

Versions V2.4.2 and V2.4.1 Figure Clause		Versions V2.5.1, V2.5.2 and V2.6.1 Clause.figure	Name
35	14.5.2.2.1	14.18	Group call - request-to-transmit
36	14.5.2.2.4	14.19	Group call - successful call restoration
37	14.5.2.2.4	14.20	Group call - unsuccessful call restoration
38	14.5.2.3	14.21	Group call - request-to-disconnect
39	14.5.2.3	14.22	Group call - group member leaves ongoing group call
40	14.5.4	14.23	Internal view of SS sub-entity
41	15.3.1	15.1	Services provided at TNMM-SAP/MS-side
42	15.3.6	15.2	MM service state diagram (sheet 1 of 4)
42	15.3.6	15.3	MM service state diagram (sheet 2 of 4)
42	15.3.6	15.4	MM service state diagram (sheet 3 of 4)
42	15.3.6	15.5	MM service state diagram (sheet 4 of 4)
43	15.3.6	-	Void
44	15.3.6	-	Void
45	15.3.6	-	Void
46	16.3	16.1	MM main functions on the MS
47	16.3.1.1	16.2	MM Activation procedure, successful cell selection
48	16.4.1.1	16.3	MLE initiated registration in cases a), b) and d)
49	16.4.1.2	16.4	MLE initiated forward registration
50	16.4.2	16.5	User application initiated registration in cases a) and b)
51	16.4.3	16.6	Infrastructure initiated registration
52	16.4.3	-	Void
53	16.4.3	-	Void
54	16.6.1	16.7	De-registration of MS (detach)
55	16.7.1	16.8	Change energy economy mode
56	16.8.1	16.9	SwMI initiated attachment/detachment of group identities
57	16.8.2	16.10	MS initiated attachment/detachment of group identities, acknowledgement requested
58	16.8.3	16.11	SwMI initiated group report
59a	16.8.4	16.12	MS initiated group report
59B	17.2	17.1	Relationship between a service user and a service provider
60	17.2	17.2	Services relationships offered by the MLE in the air interface
61	17.3.1	17.3	LMM-SAP state transition diagram
62	17.3.3	17.4	State transition diagram of LCMC-SAP
63	17.3.5	17.5	State transition diagram of LTPD-SAP
64	17.3.7	-	Void
65	18.2.1	18.1	The MLE (sub-layer 3.1) in the MS protocol stack
66	18.2.8	18.2	Primitive time sequence at the LTPD-SAP
67	18.2.8	18.3	Primitive time sequence at the LMM-SAP
68	18.2.8	18.4	Primitive time sequence at the LCMC-SAP
69	18.3.1	18.5	MLE functional model
70	18.3.4.7.1	18.6	Decision tree to choose reselection type
71	18.3.4.7.3	18.7	Unannounced cell reselection procedure
72	18.3.4.7.4	18.8	Announced type 3 cell reselection procedure
73	18.3.4.7.5	18.9	Announced type 2 cell reselection procedure
74	18.3.4.7.6	18.10	Announced type 1 cell reselection procedure
75	19.2.1	19.1	Layer 2 reference architecture
76	19.2.2	19.2	Layer 2 data structure for basic link (typically layer 3 signalling messages)
77	19.2.2	19.3	Layer 2 data structure for advanced link (e.g. packet data)
78	19.2.2.3	19.4	Segmentation and fragmentation in the DLL
79	19.2.2.3	19.5	Fragmentation of long SDU in the MAC layer
80	19.2.3	19.6	DLL protocol illustration for the MS side
81	19.2.4.4	19.7	MAC sub-layers and logical channels for MS uplink transmission
82	19.2.4.4	19.8	MAC sub-layers and logical channels for MS downlink reception
83	19.4.2.4	19.9	Configuration in signalling and packet mode
84	19.4.2.4	19.10	Configuration in traffic mode for frames 1 to 17
85	19.4.4	19.11	Selection of the configuration for the current mode of operation

Figure	Versions V2.4.2 and V2.4.1 Clause	Versions V2.5.1, V2.5.2 and V2.6.1 Clause.figure	Name
86	19.5	19.12	Primitives and PDUs on the calling MS air interface for an individual call with direct set-up signalling - Calling MS side
87	19.5	19.13	Primitives and PDUs on the calling MS air interface for an individual call with direct set-up signalling - SwMI side
88	19.5	19.14	Primitives and PDUs on the called MS air interface for an individual call with direct set-up signalling - SwMI side
89	19.5	19.15	Primitives and PDUs on the called MS air interface for an individual call with direct set-up signalling - Called MS side
90	20.2.1	20.1	SAPs at the MLE-LLC boundary
91	20.3.6	20.2	State transition diagram in basic link at TL-SAP
92	20.3.7	20.3	State transition in connection mode at MLE-LLC SAP (advanced link)
93	21.1.2	21.1	Construction of an LLC PDU (shown with optional FCS)
94	21.1.2.2	21.2	General format of an LLC header before the TL-SDU content
95	21.1.3.1	21.3	General format of the MAC PDU
96	21.1.3.2	21.4	General format of a MAC header
97	21.1.3.2	21.5	Association of several MAC PDU in one MAC block
98	21.1.4.1	21.6	Building of DLL PDU (with no fragmentation)
99	21.1.4.1	21.7	MAC fragmentation of a long TM-SDU
100	21.1.4.2	21.8	Segmentation provided by the advanced link
101	22.1.2	22.1	LLC relations
102	22.1.2	22.2	LLC protocol structure
103	22.2.1.1	22.3	Basic link PDU exchange with acknowledgement carrying a layer 3 message
104	22.2.1.1	22.4	Basic link data transfer and acknowledgement with a layer 3 message
105	22.2.1.1	22.5	Basic link PDU exchange with LLC acknowledgement with a delayed response
106	22.2.1.1	22.6	Basic link data transfer and acknowledgement with a delayed layer 3 response
107	22.2.1.1	22.7	Concurrent independent message exchange in both directions
108	22.2.1.1	22.8	Concurrent independent message exchange in both directions
109	22.2.1.2	22.9	PDU exchange in unacknowledged mode
110	22.2.1.2	22.10	Basic link data transfer in unacknowledged mode
111	22.2.1.3	22.11	Basic link data transfer with presence indication
112	22.2.1.3	22.12	Basic link data transfer with presence indication
113	22.2.2.1	22.13	PDU setting up the advanced link
114	22.2.2.1	22.14	Advanced link set-up
115	22.2.2.1	22.15	Advanced link set-up to a lower quality of service
116	22.2.2.1	22.16	Simultaneous advanced link set-up
117	22.2.2.1	22.17	Simultaneous advanced link set-up with different QoS
118	22.2.2.1	22.18	Simultaneous advanced link set-up with different QoS
119	22.2.2.1	22.19	Unsupported service indication
120	22.2.2.2	22.20	Unacknowledged transfer mode set-up of the advanced link
121	22.2.2.2	22.21	Unacknowledged transfer mode set-up of the advanced link
122	22.2.2.3	22.22	PDU exchange in a unidirectional transfer
123	22.2.2.3	22.23	PDU exchange in a unidirectional transfer
124	22.2.2.3	22.24	A longer PDU transfer
125	22.2.2.3	22.25	Bi-directional data transfer
126	22.2.2.3	22.26	Bi-directional PDU transfer
127	22.2.2.4	22.27	PDU sending in a unidirectional transfer
128	22.2.2.4	22.28	PDU sending in a unidirectional transfer
129	22.2.2.5	22.29	PDU exchange for forced acknowledgement
130	22.2.2.5	22.30	Forced acknowledgement
131	22.2.2.6	22.31	Selective re-transmission example
132	22.2.2.7	22.32	Flow control PDU exchange
133	22.2.2.7	22.33	Flow control
133a	22.2.2.8a	22.34	PDU exchange for reconnection the advanced link
133b	22.2.2.8a	22.35	Reconnection of an advanced link
134	22.2.2.9	22.36	PDU exchange for releasing the advanced link
135	22.2.2.9	22.37	Disconnection of an advanced link

Versions V2.4.2 and V2.4.1 Figure	Clause	Versions V2.5.1, V2.5.2 and V2.6.1 Clause.figure	Name
136	22.2.2.10	22.38	PDU exchange for releasing the unacknowledged advanced link
137	22.2.2.10	22.39	Disconnection of an unacknowledged advanced link
138	23.1.2.1	23.1	Scenario for exchange of two LLC messages
139	23.1.3.1.1	23.2	Frequency half duplex operation
139a	23.1.3.1.2	23.3	Frequency half duplex operation with fast switching capability
140	23.1.3.2	23.4	Frequency full duplex operation
141	23.2.1	23.5	Mapping of scrambling code to extended colour code
142	23.4.1.2.3.1	23.6	V+D air interface addressing
143	23.5.1.2	23.7	Example of subslot structure
144	23.5.1.2	23.8	Example of random access procedure (BS using rolling access frames)
145	23.5.1.2	23.9	Example of random access procedure (BS using discrete access frames)
146	23.7.2	23.10	Cell selection
147	23.7.3	23.11	Cell selection and surveillance scenario
148	23.7.4.1	23.12	Monitoring scenario
149	23.7.5.1	23.13	Scanning scenario
150 to 179	Void	-	Void
180	28	28.1	Usage of TETRA packet data for MT0 IP application
181	28	28.2	Usage of TETRA packet data for TE2 IP application
182	28	28.3	Usage of TETRA packet data for MT0 WAP application
183	28.1	28.4	Subnetwork Dependent Convergence Protocol (SNDTCP)
184	28.2.5	28.5	Functional SNDTCP State Transition Model for MS
185	28.2.5	28.6	Functional SNDTCP State Transition Model for SwMI
186	28.3.1	28.7	SNDTCP model for transmitting end
187	28.3.1	28.8	SNDTCP model for receiver end
188	28.3.3.1.3	28.9	Ipv6 address
189	28.3.3.5	28.10	PDP Context activation procedure - activation accepted
190	28.3.3.5	28.11	PDP context activation procedure - activation rejected
191	28.3.3.5	28.12	PDP context activation procedure - no response to activation
192	28.3.3.5	28.13	PDP context activation procedure - wrong NSAPI
193	28.3.3.6.1	28.14	PDP context deactivation procedure
194	28.3.3.6.1	28.15	PDP context deactivation procedure - no response to deactivation
195	28.3.3.6.1	28.16	SwMI originated PDP context deactivation procedure
196	28.3.4.2	28.17	Successful advanced link set-up, initiated by pending inbound data transfer
197	28.3.4.2	28.18	Successful advanced link set-up, initiated by pending outbound data transfer
198	28.3.4.2	28.19	Failed advanced link setup - too low QoS offered by SwMI
199	28.3.4.2	28.20	Successful advanced link setup - lower QoS accepted
200	28.3.4.2	28.21	Advanced link set-up after a radio downlink failure, with MS in READY state
201	28.3.4.2	28.22	Resetting advanced link after reception of SN-END OF DATA prior to completing transfer of previous SN-DATA
202	28.3.4.3	28.23	Disconnecting advanced link before the last PDP context deactivation
203	28.3.4.4	28.24	Successfully reconnecting the advanced link after cell reselection. Both MS and SwMI support advanced link roaming
204	28.3.4.4	28.25	Failure to reconnect the advanced link after cell reselection. SwMI does not support advanced link roaming
205	28.3.5.1	28.26	Acknowledged service, data from SwMI to MS
206	28.3.5.1	28.27	Acknowledged service, data from MS to SwMI
207	28.3.5.1	28.28	Acknowledged service, data from MS to SwMI and from SwMI to MS
208	28.3.5.1	28.29	Acknowledged service, READY timer expiry in the MS
209	28.3.5.1	28.30	Acknowledged service, RESPONSE_WAIT timer expiry in the MS
210	28.3.5.1	28.31	Acknowledged service, SwMI rejects request

Versions V2.4.2 and V2.4.1 Figure Clause		Versions V2.5.1, V2.5.2 and V2.6.1 Clause.figure	Name
211	28.3.5.2	28.32	Unacknowledged service, data from SwMI to MS
212	28.3.5.4.2	28.33	Recommendation ITU-T V.42bis [27] data compression function
213	28.3.6	28.34	SwMI Pages MS, MS SMDCP entity responds
214	28.3.7	28.35	IP user authentication model
215	28.3.7	28.36	A successful authentication with CHAP
216	29.1.1	29.1	SDS-TL position in TETRA protocol stack
217	29.2.4	29.2	State transition diagram
218	29.3.2.2	29.3	Layer 2 Acknowledgement
219	29.3.2.2	29.4	"Message received" end-to-end acknowledgement
220	29.3.2.2	29.5	"Message consumed" end-to-end acknowledgement
221	29.3.3.1	29.6	SDS message transfer with end-to-end acknowledgement, SwMI transparent
222	29.3.3.1	29.7	SDS message transfer with end-to-end acknowledgement, SwMI does store and forward
223	29.3.3.1	29.8	SDS message transfer with consumed acknowledge, SwMI modifies requested reports
-	29.5.12.3.2	29.9	LIP position in TETRA protocol stack

Annex N (informative): Example for coding of SDS Transfer SDU with UDH information elements

N.0 General

This annex lists an example for using the UDH information elements within a SDS Transfer SDU. It shows the basic procedure to decode UDH information.

N.1 Multiple Information Elements with Network Layer User Data (Text Message)

This example shows how to send information for 3 different fictive user applications and a text message using one SDU. The following is assumed:

- 1) Three dimensional location information shall be sent including x, y, z coordinates. UDH information element ID value shall be 0xE1. The definition for the data of that protocol shall be 2 bytes for each x, y and z coordinates value.
- 2) Star time information shall be sent including standard star time format. UDH information element ID value shall be 0xE2. The definition for the data of that protocol shall be 3 bytes star time value and 4 bytes universe ID.
- 3) Speed information shall be sent including speed over ground. UDH information element ID value shall be 0xE3. The definition for the data of that protocol shall be 2 bytes for speed value.
- 4) Text message shall be sent including 11 bytes Latin-1 coded characters.

The resulting SDU would look as presented in table N.1.

Table N.1: Example transfer SDU for multiple UDH information elements with text message

Information element	Length	Value	Remark
Time stamp used	1	0x00	No time stamp used
Text coding scheme	7	0x01	Latin-1 coding for text message
User data header length	8	0x15	21 byte UDH
UDH information element ID	8	0xE1	Three dimensional location information
UDH information element length	8	0x06	6 bytes (2 x, 2 y, 2 z)
X-Coordinate	16	0x0010	16 cm
Y-Coordinate	16	0x0020	32 cm
Z-Coordinate	16	0x0030	48 cm
UDH information element ID	8	0xE2	Star time information
UDH information element length	8	0x07	7 bytes (3 time, 4 universe. ID)
Star Time	24	0xD91122	217.17.34 units
Universe ID	32	0x00112233	Andromeda
UDH information element ID	8	0xE3	Speed information
UDH information element length	8	0x02	2 bytes speed
Speed	16	0x0011	17 km/h
Text Message	88	"The is text"	11 bytes Latin-1 coded text

All these information elements or information element sets respectively are independent from each other. Since this SDU will be sent using the PI Message with User Data Header the receiving application would have to support all these information elements. That means the application will proceed the following steps:

- 1) Get transfer SDU length from lower layer (34 bytes).
- 2) Decode Time stamp used and Text coding information elements. Subtract length of both information elements (1 byte) from transfer SDU length ($34 - 1 = 33$).
- 3) Get the UDH information element length value to determine the length of the UDH information element. Subtract length of UDH information element length information element (1 byte) from remaining transfer SDU length ($33 - 1 = 32$). If the result is equal to the UDH information element length value (21) the SDU does not contain Network layer user data and the Text coding IE can be ignored.
- 4) Decode the first UDH information element IE ID information element and get the UDH information element IE length value (6 bytes). Process the UDH information element U IE Data (x,y,z) information element. Subtract complete length of this UDH information element set (2 + 6 bytes) from UDH information element length ($21 - 8 = 13$). Use the UDH information element IE length to find the next UDH information element IE ID.
- 5) Decode the next UDH information element ID and UDH information element length (7 bytes) information elements. Process the UDH information element Data (Star time, Universe ID). Subtract complete length of this UDH information element set (2 + 7 bytes) from remaining UDH information element length ($13 - 9 = 4$). Use the UDH information element length to find the next UDH information element ID.
- 6) Decode the next UDH information element ID and UDH information element length (2 bytes) information elements. Process the UDH information element IE Data (Speed) information element. Subtract complete length of this UDH information element IE set (2 + 2 bytes) from remaining UDH information element length ($4 - 4 = 0$). The remainder is now 0 and that means the end of UDH information element is reached.
- 7) Subtract the remainder of UDH information element length value from the remaining transfer SDU length ($32 - 21 = 11$). The result is the length of the text message. Use the Text coding IE to decode the text message.

Annex O (normative): Air - Ground - Air service

O.1 Introduction

Air - Ground - Air service describes the method of operation for Air - Ground - Air service (AGA) in TETRA systems. It serves as a specification for TETRA MSs and SwMI manufacturers to enable them to configure their MSs and systems for operation with respect to AGA functionality.

O.2 Air - Ground - Air service overview

The AGA service enables TETRA MSs to operate in special situations, where access to the base station is restricted and the cell radius is controlled by round trip delay rather than by RF path loss. Examples of large cells are air cells and sea cells. These cases also exemplify the restricted use, since the capacity of these cells is usually small and ordinary MSs would not normally have access to them. This solution uses subscriber class 1 or 2 value "Highly preferred cell for subscriber class" as indication of the air cell, see clause O.4.

NOTE 1: There are also alternative ways to prefer air cells e.g. air cells with value "preferred location areas" may be stored in the MS at subscription. That method may not support migration between different networks.

Because of the low signal attenuation due to the almost line of sight propagation, the geographical size of an air cell can be much larger than that of a normal terrestrial cell. So one air cell may cover several terrestrial cells, and air cells may need to use specially designated radio channels. Refer to ETSI TR 102 021-8 [i.12].

The path delay due to the air cell size may exceed normal system capabilities and clause O.5 defines optional modifications to the air BSs and MSs to support longer path delays allowing distances at least to 80 km on phase modulation channels and on QAM channels.

NOTE 2: Based on the specifications in clause 6.4.5 the maximum allowable path delay for a normal TETRA $\pi/4$ -DQPSK burst structure is 7 phase modulation symbols (i.e. 14 $\pi/4$ -DQPSK bits equivalent to the guard period at the end of uplink timeslot). Each symbol represents a distance of 8,33 km giving a total maximum cell radius of 58 km. Based on the specifications in clause 6.4.10 the maximum allowable path delay for a normal TETRA QAM burst structure is 1,0 QAM symbols giving a total maximum cell radius of 63 km.

Path delay on the air cells may cause the uplink slots from a far and a near MS to partly overlap, refer to clause O.5.1. So the base station shall measure the path delay and tell the MS to select a new cell before the delayed signal starts to interfere with the next slot. BS may command MS to send periodic signalling or BS may poll the MS to allow BS to detect if path delay has been exceeded.

When air MS loses air cell coverage, it is allowed to use the terrestrial cells, but it should return to an air cell as soon as possible. This is achieved by broadcasting AGA subscriber class support (either one of the "highly preferred subscriber classes", see clause O.4.7) on the air cells. If terrestrial MS are not allowed to use air cells, then they will not have a matching subscriber class profile. Additionally the SwMI may reject registrations from terrestrial MSs on air cells.

An air MS should not use a terrestrial cell, unless the aircraft is on or close to the ground.

An MS supporting AGA service with range extension may also register as a terrestrial service only MS i.e. without AGA service subscriber class, but should not try to use air cells in that case.

Clause O.3 summarizes system requirements for Air - Ground - Air services.

Clauses O.4 to O.7 define how the system requirements are implemented for AGA services.

O.3 System requirements regarding AGA

Table O.1 describes what the various elements need to do in order to have a working AGA solution.

Table O.1: AGA solution system requirements

Solution	Air MS	Terrestrial MS	Air BS	Terrestrial BS
Target: keep terrestrial MS away from air cell and move interfering air MS to air cell ASAP				
Allocation of subscriber class (off-line or over the air)	Yes	Yes	Yes, if over the air is used	Yes, if over the air is used
Subscriber class aspects in roaming	Prefer air cells based on highly preferred subscriber class	Stay out of air cells	Subscriber class broadcast with highly preferred subscriber class	Subscriber class broadcast without highly preferred subscriber class
Air cell preference	Shall register as soon as an air cell becomes radio usable	-	-	-
Neighbour cells	Continuous monitoring of neighbour cells	-	Broadcast up to 31 neighbours	Broadcast of neighbour air cells
Registration rejection	Remember LA rejection	Remember LA rejection	Should reject terrestrial MS	-
Target: air MS shall not drag beyond maximum cell size				
Path delay measurement	Distance reporting and response to polling; only one may be used by each BS	-	Distance reporting or polling	-
Path delay	Cell reselection if maximum path delay exceeded or almost exceeded	-	Path delay measurement and notification to MS	-
Target: extend cell size to 83 km				
A longer guard time between bursts	Reduce ramp-up and ramp-down times	-	Look for training sequence corresponding to the longer delay	-

O.4 Signalling protocol

O.4.1 General

Clauses O.4.2 to O.4.7 describe mechanisms that are used to support AGA.

O.4.2 Distance reporting

The SwMI shall implement one of the following methods of distance reporting (distance reporting or polling) to detect if the path delay of the air MS exceeds the allowable path delay.

The SwMI may order the MS to send some information during a distance reporting interval. In this case if the MS has nothing else to send the Null PDU shall be sent, see clause 16.4.11. SwMI may calculate the path delay and hence the distance of the MS from the serving base station.

The SwMI may use a variant of D-MM STATUS PDU to start the MS's distance reporting timer, refer to clause 16.10.48. The air MS shall support the D-MM STATUS PDU for distance reporting. The D-MM STATUS PDU may be sent any time, but typically it is sent immediately after the MS has registered on the air cell. While the MS is starting transmission for any reason it shall stop the reporting timer and upon ceasing the transmission MS shall start the reporting timer. Upon expiry of the reporting timer the MS shall send a Null PDU unless the MS has something else to send.

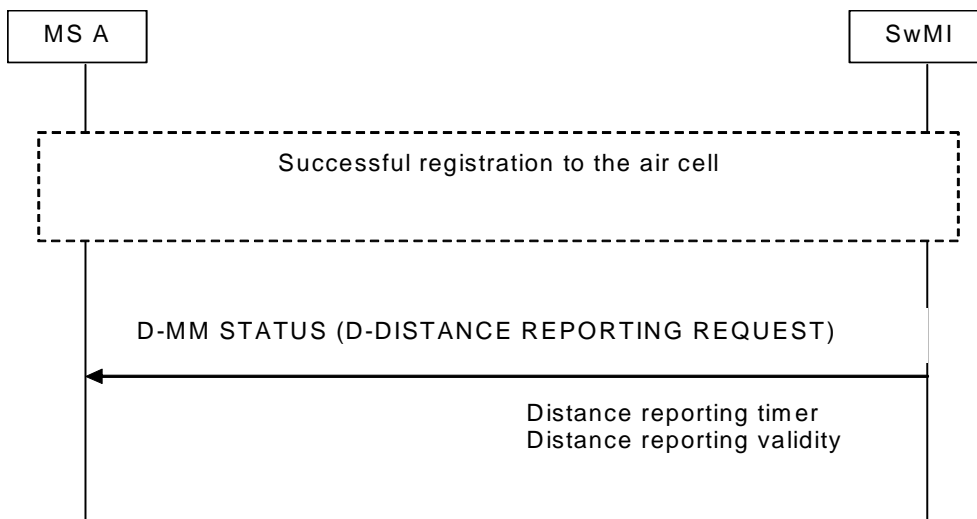

Figure O.1: Starting distance reporting

NOTE: Location Information Protocol may be also used to initiate periodic reporting, refer to ETSI TS 100 392-18-1 [19].

Alternatively, the SwMI may grant a slot (i.e. poll the MS) in order to make the MS transmit BL-DATA with an SDU (if ready) or a NULL PDU.

The related transmissions from the MS shall be used on traffic channels as well as control channels (MCCH/SCCH and PDCH). This applies also to the polling of MSs by the SwMI.

O.4.3 Excessive path delay

The SwMI (base station) shall measure all transmissions from the air MS in air cells. If the path delay exceeds the limit set in the SwMI, the SwMI shall order the air MS to perform cell re-selection to another cell. This is done by including the power control element with value "maximum path delay exceeded" into any PDU addressed to the MS, see figure O.2. If the SwMI has nothing to send to the MS, it may send an empty MAC-RESOURCE PDU (without a TM-SDU).

SwMI may also indicate when the path delay is almost exceeded using the same mechanism as for the maximum path delay exceeded with the power control element value "maximum path delay almost exceeded". The actual path delay that invokes the sending information of the maximum path delay almost exceeded is outside the scope of the present document. The action of the MS on receiving this value is defined in clause 18.3.5.4.

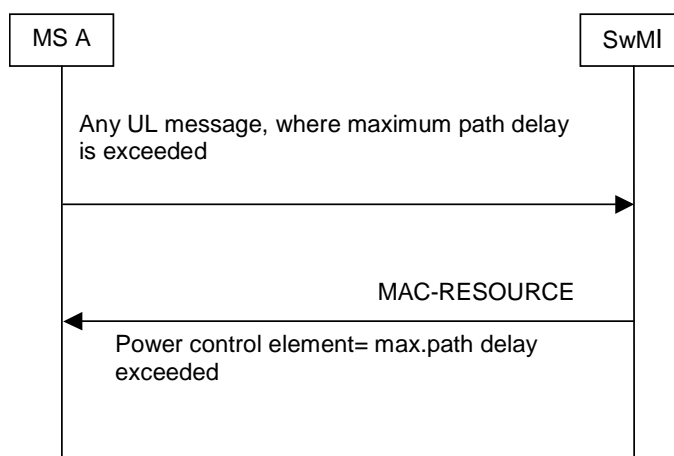

Figure O.2: Maximum path delay has been exceeded

O.4.4 Cell re-selection

An air MS shall be able to differentiate between air and terrestrial cells.

Air cell is identified using the generic subscriber class mechanisms- by the fact that it broadcasts support of the highly preferred subscriber class reserved for AGA operation. An air MS prefers this cell over a terrestrial cell due to the fact that it is a highly preferred subscriber class cell.

NOTE: Another solution is to store air cell identities into the air MS at subscription (preferred location area). Use of the highly preferred subscriber class mechanism for air cell preference is the recommended solution as it provides an easier global service access.

Terrestrial cell is identified as any cell that is not an air cell.

The air MS may be allowed to use terrestrial cells of the network, when the air cell coverage is missing (e.g. on the ground). If the MS stays registered to a terrestrial cell while it is high above ground, this could produce interference at distant terrestrial base stations on the same frequency. To avoid interference the air MS shall select the air cell as soon as it becomes radio usable, provided that the air cell supports the required services. See clause O.4.7 for preferred subscriber classes and cell re-selection.

A terrestrial MS should normally only use the air cells if it cannot find another cell that supports its subscriber class and is making an emergency call, refer to clause 14.5.7, for mobility purposes MS is allowed to use a limited set of actions refer to clause 16.4.9.

If terrestrial MSs are not allowed to use air cells then they shall not have a matching subscriber class profile. In that case SwMI shall apply subscriber class procedures, refer to clause 16.4.9 to prevent terrestrial MSs from using air cells.

The SwMI should reject registrations from terrestrial MSs on air cells with reject cause "LA not allowed (LA rejection)". The terrestrial MS shall remember that it was rejected from the (air) cell, so that it shall not try to register on the cell again, even if the cell is ranked highest in the ranking list in terms of RSSI. Refer to clause O.7.1.3.

O.4.5 Neighbour cells

If air MSs are also to be allowed to use terrestrial cells, information for neighbouring terrestrial cells shall be included in the D-NWRK-BROADCAST, D-NWRK-BROADCAST-EXTENSION and D-NWRK-BROADCAST-DAPDU's broadcast on air cells. The maximum number of neighbouring cells shall be supported by the air MSs and the air cells. The terrestrial BSs close to expected landing sites should broadcast air cell neighbour information so that the air MSs can go to the air cell as soon as possible, refer to table O.1.

The neighbour cell information and neighbour cell information for DA information elements shall include the subscriber class element unless the neighbour and the serving cell support an identical set of subscriber classes, refer to clauses 18.5.17 and 8.5.17a, note 2 in the tables in those clauses.

When an air MS is camped on a terrestrial cell, it shall perform constant monitoring of neighbouring cells, regardless of the serving cell's RSSI, with the intention of moving to an air cell as soon as the air cell becomes usable.

O.4.6 Base station fallback

The air MS shall favour a normal mode terrestrial base station over an air cell in fallback, if no other air cell is radio usable.

NOTE: This requirement is in contradiction with the recommendation in ETSI TR 102 021-8 [i.12], clause 4.7. The possibilities to communicate were deemed more important than possible interference prevention. In most cases an air MS user may be the only one using an air cell and base station fallback is not operationally viable. Therefore base station fallback should not be used for air cells.

O.4.7 Subscriber class

The SwMI may assign a new subscriber class to an MS at any registration. The new subscriber class shall be effective immediately until a) the MS is assigned a new one, b) the MS is powered down or c) the MS migrates to another network, refer to clauses 16.4.9 and O.6.

Clause O.8 gives a guideline for subscriber class allocation in a network with air cells.

O.5 Range extension

O.5.1 Background for phase modulated channels

The phase modulation air interface bursts are defined in figure 9.3 in clause 9.4.4.1. The figure 9.3 copied as figure O.3 presents the TDMA frame and bursts. The related phase modulation RF output power time mask is shown in the figure 6.3 in clause 6.4.5 and is copied as figure O.4 for easier reference.

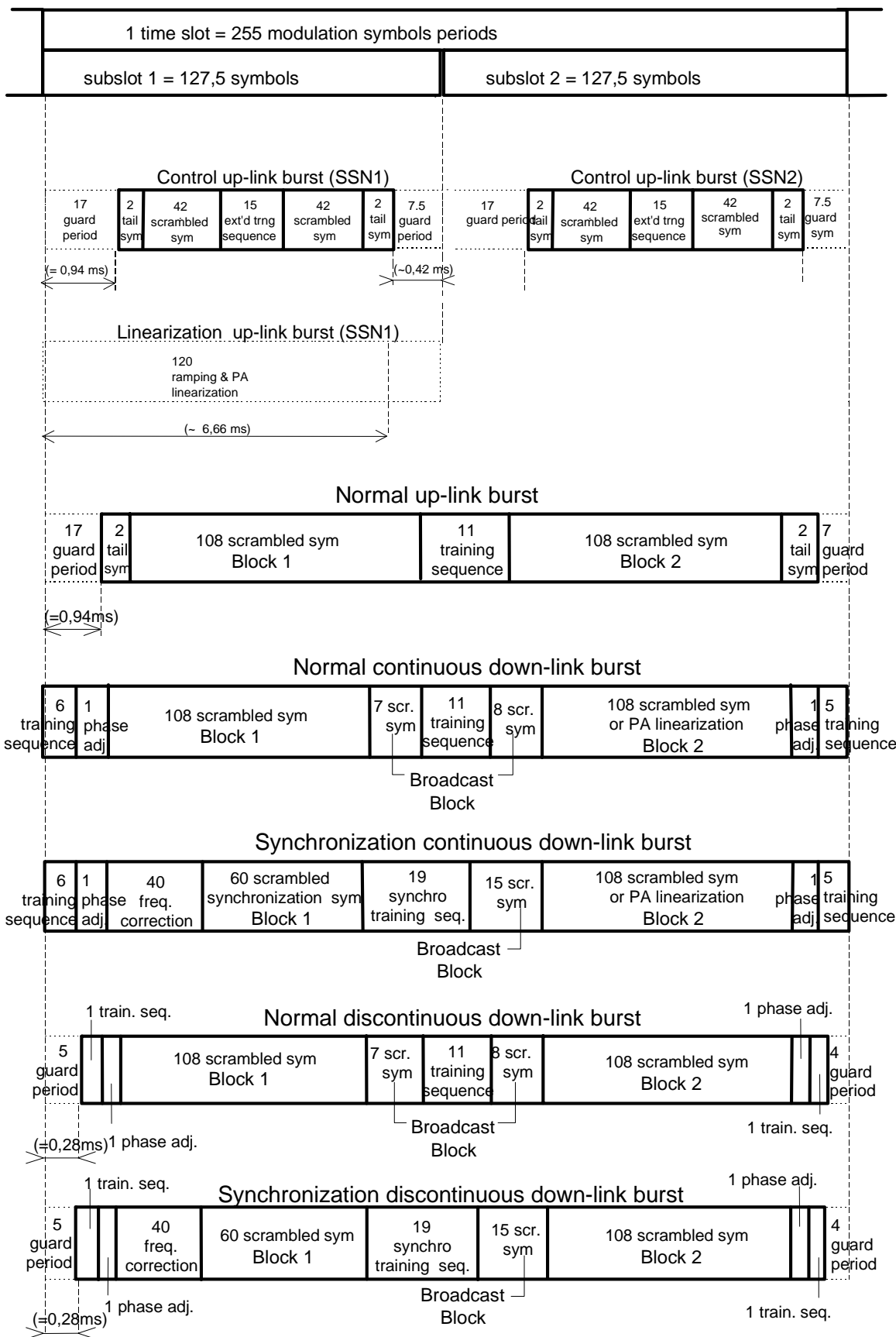

Figure O.3: TETRA uplink bursts for phase modulation

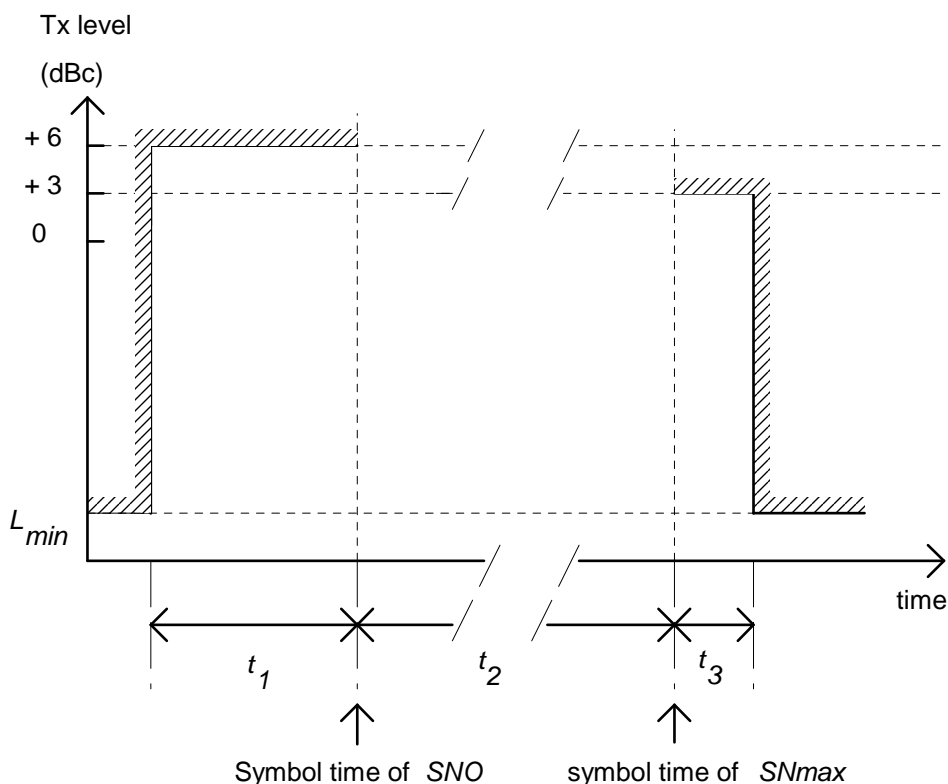

Figure O.4: TETRA phase modulation RF output power time mask

In the figure O.4 times t_1 , t_2 and t_3 are defined as in the table 6.8 of clause 6.4.5. Table O.2 presents the resulting delay tolerance when the useful part of an uplink burst (i.e. the period t_2), transmitted on the timeslot $TN = n$ by a far MS is not interfered by the ramp up (period t_1) of an uplink burst from a near MS.

Table O.2: Ramp-up and ramp-down times for terrestrial services in phase modulation symbol periods

Burst Type	t_1	t_2	t_3	Total time	Delay tolerance
Control uplink	16	103	15	134	7,5
Normal uplink	16	231	15	262	7
Linearization burst, see note	119	0	15	134	7,5

NOTE: By that definition of t_1 the timing of the linearization burst is referencing to the symbol time of SN_{max} instead of symbol time of SN_0 .

NOTE 1: Although the t_1 and t_3 values in the table O.2 are given as a number of phase modulation symbol periods the nature of ramp-up and ramp-down time does not require an alignment to a number of symbol periods.

NOTE 2: The t_1 and t_3 values in the table O.2 are maximum times and an implementation may use any shorter values as long as the adjacent channel requirements are fulfilled.

The delay tolerance values in the table O.2 are calculated with equation O.1:

$$\text{Delay tolerance} = \text{Timeslot length} - (\text{Information length} + \text{Max}(\text{Ramp-up time}, \text{Ramp-down time}) + \text{Filter implementation}) \quad (\text{O.1})$$

where $\text{Max}(\text{Ramp-up time}, \text{Ramp-down time})$ means the maximum of these two times.

EXAMPLE: As the length of the normal burst is 231 symbols and there are 231 phase modulation symbol periods needed for the information transmission and ramp-up time is 16 phase modulation symbol periods and one additional phase modulation symbol period is allocated for the receiver filter implementation, then the delay tolerance for the normal uplink burst is:

$$\text{Delay tolerance}_{\text{Terrestrial}} = T_d = 7 \text{ phase modulation symbol periods} \quad (\text{O.2})$$

The corresponding maximum cell radius of a TETRA terrestrial cell is:

$$R_{\text{Terrestrial_max}} = 0,5 \times T_d \times T_s \times c = 58,3 \text{ km} \quad (\text{O.3})$$

where:

$T_d = 7$ = number of phase modulation symbol periods of delay tolerance.

T_s = phase modulation symbol period = $500/9 \mu\text{s} = 55,6 \mu\text{s}$.

c = electromagnetic wave propagation speed = 299 792 km/s.

In practice, the useful part of a phase modulation uplink burst (i.e. the period t_2), transmitted on slot $TN = n$ by a far MS at 58 km from the BS, is not interfered by the ramp up (period t_1) of an uplink burst from a near MS, where the uplink burst from the near MS is transmitted on slot $TN = (n + 1)$ (i.e. an MS at zero propagation time from the BS).

This scenario (with reference to BS receiver input) is described in the figure O.5. The time is calculated in symbol periods in the figure O.5. The figure O.5 also contains the applied solution as defined in clause O.5.2.

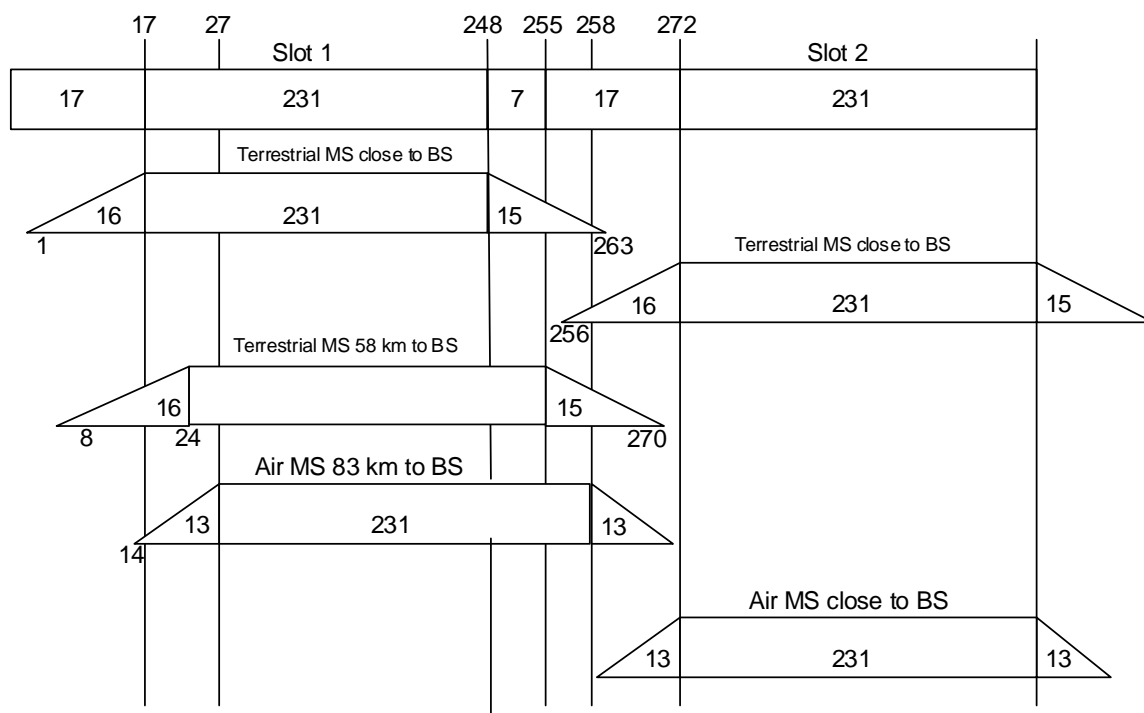

Figure O.5: TETRA maximum phase modulation round-trip delay

If the round-trip delay of the far MS exceeds 7 phase modulation symbol periods, then the near MS ramp up interferes with the last useful symbols of the far MS.

In addition to the information carrying bursts the phase modulation linearization burst as defined in clause 6.4.5 may cause interference, if it uses the whole allowed time in the time-mask.

O.5.2 Extended range requirements for phase modulation

The range extension is implemented by shortening phase modulation ramp-up and ramp-down times in the guard period between phase modulation uplink bursts. The same adjacent channel requirements are applied as for terrestrial TETRA MSs, refer to clause 6.4, especially clauses 6.4.2.2.2 and 6.4.2.4. The air MS shall use shortened t_1 and t_3 values as defined in table O.3. The information part of the burst shall be in the same location as in the terrestrial service.

Table O.3: Ramp-up and ramp-down times for AGA services in phase modulation symbol periods

Burst Type	t_1	t_2	t_3	Total time	Delay tolerance
Control uplink	13	103	13	125	10,5
Normal uplink	13	231	13	255	10
Linearization burst, see note	116	0	13	128	10,5
NOTE: By that definition of t_1 the timing of the linearization burst is referencing to the symbol time of SN_{\max} instead of symbol time of SN_0 .					

NOTE 1: Although the t_1 and t_3 values in the table O.3 are given as number of phase modulation symbol periods the ramp-up and ramp-down times need not be exact number of symbol periods.

EXAMPLE: Using t_1 value in table O.3 for the normal uplink burst and other values as in equation O.2 the air MS delay tolerance is:

$$\text{Delay tolerance}_{\text{AGA}} = T_d = 10 \text{ phase modulation symbol periods} \quad (\text{O.4})$$

The corresponding maximum cell radius of a TETRA air cell using equation O.2 is:

$$R_{\text{AGA}_{\max}} = 0.5 \times T_d \times T_s \times c = 83,3 \text{ km} \quad (\text{O.5})$$

NOTE 2: Terrestrial MS using an air cell may reduce the maximum cell radius due to its longer ramp-up time especially, when it is close to the BS. Network operators should consider whether they allow terrestrial MSs to use air cells.

BS can control the actual maximum range using the power control information element values "maximum path delay exceeded" and "maximum path delay almost exceeded", as defined in clause 23.7.3.2.

O.5.3 Background for QAM channels

The QAM air interface bursts are defined in figure 9.6 in clause 9.4.8.1. The figure 9.6 copied as figure O.6 presents the TDMA frame and bursts. The related QAM RF output power time mask is shown in the figure 6.4 in clause 6.4.10 and is copied as figure O.7 for easier reference.

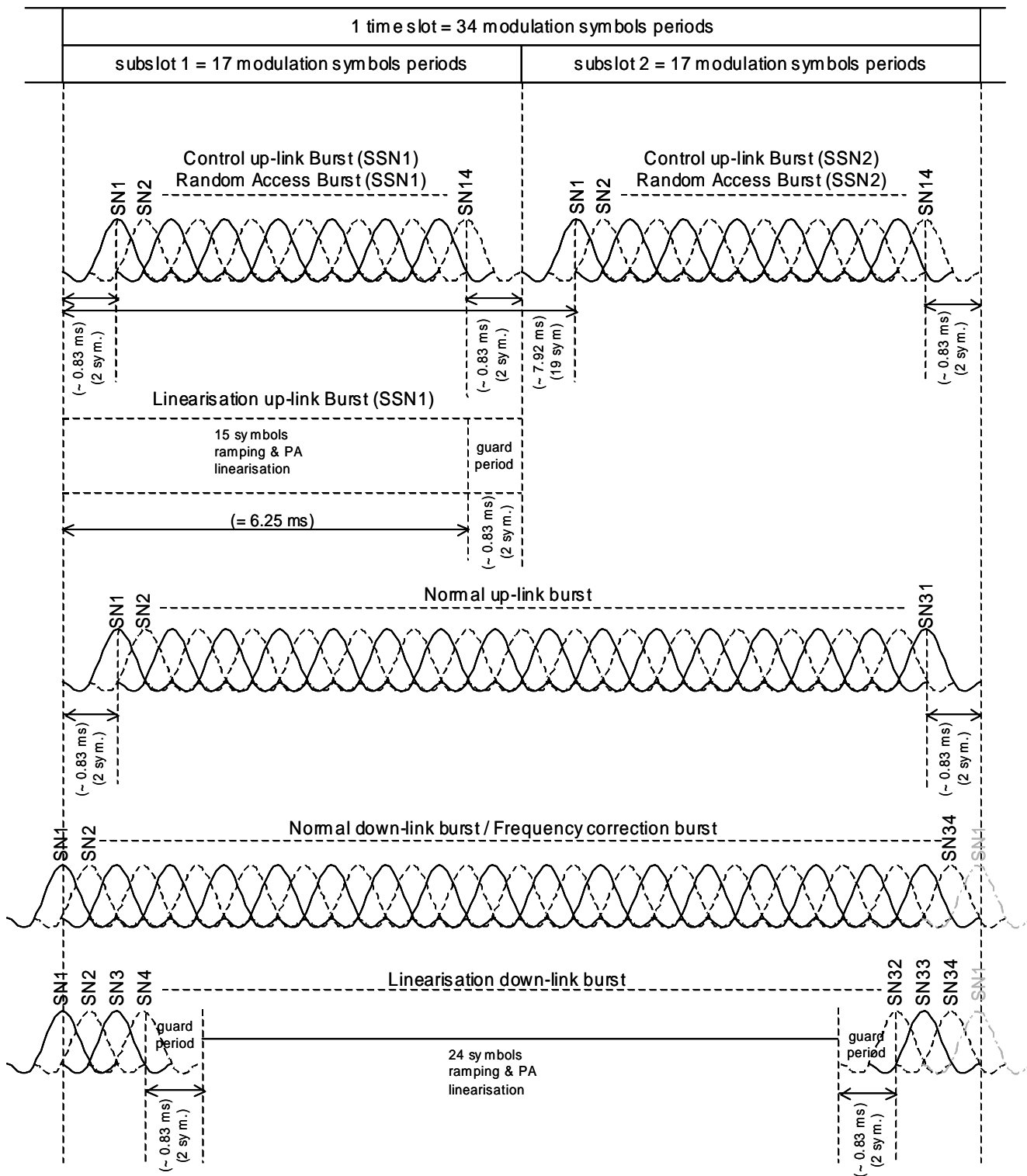

Figure O.6: TETRA uplink bursts for QAM

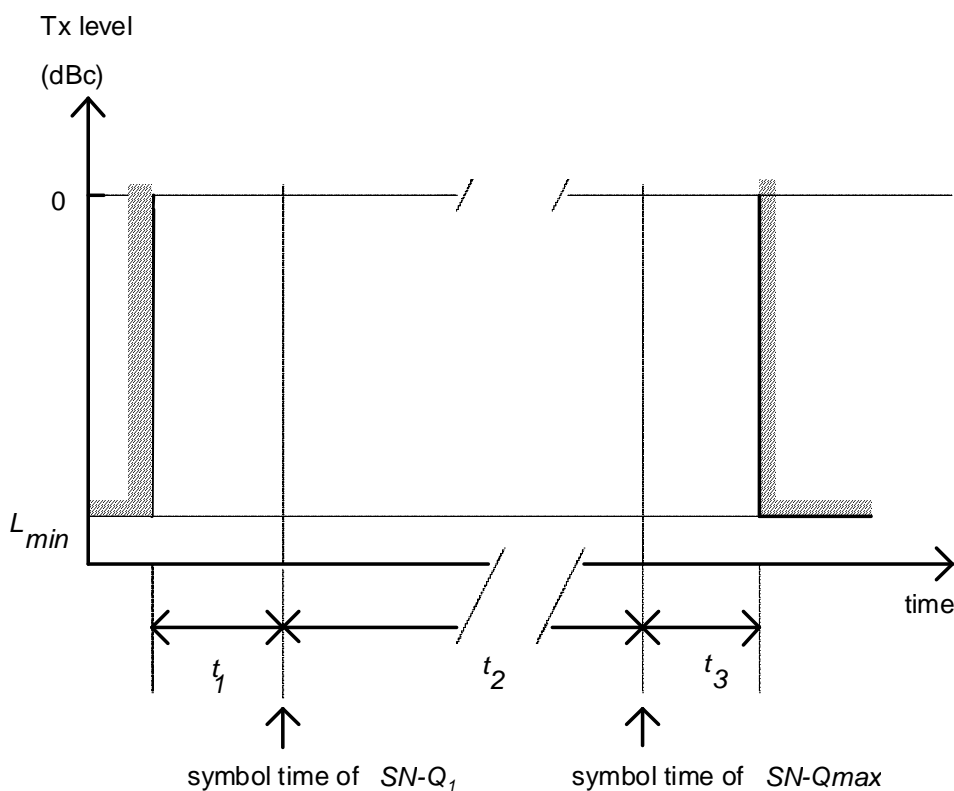

Figure O.7: TETRA QAM RF output power time mask

In the figure O.7 times t_1 , t_2 and t_3 are defined as in the table 6.20 of clause 6.4.10. Table O.4 presents the resulting delay tolerance when the useful part of an uplink burst (i.e. the period t_2), transmitted on the timeslot $TN = n$ by a far MS is not interfered by the ramp up (period t_1) of an uplink burst from a near MS.

Table O.4: Ramp-up and ramp-down times for terrestrial services in QAM symbol periods

Burst Type	t_1	t_2	t_3	Total time	Delay tolerance
Control uplink	2,0	13	2,5	17,5	
Normal uplink	2,0	30 (see note 1)	2,5	34,5	1,0
Linearization burst, see note 2	15,0	0	2,5	17,5	

NOTE 1: In the case of single slot transmission.
 NOTE 2: By that definition of t_1 the timing of the linearization burst is referencing to the symbol time of $SN-Q_{max}$ instead of symbol time of $SN-Q_1$.
 NOTE 3: Symbol synchronization time is included in t_1 and t_3 .

NOTE 1: Although the t_1 and t_3 values in the table O.4 are given as a number of QAM symbol periods the nature of ramp-up and ramp-down time does not require an alignment to a number of symbol periods.

NOTE 2: The t_1 and t_3 values in the table O.4 are maximum times and an implementation may use any shorter values as long as the adjacent channel requirements are fulfilled.

The delay tolerance values in the table O.4 are calculated with equation O.6:

$$\text{Delay tolerance} = \text{Timeslot length} - (\text{Information length} + \text{Max (Ramp-up time, Ramp-down time)} + \text{Symbol synchronization time} + \text{Filter implementation}) \quad (\text{O.6})$$

where Max (Ramp-up time, Ramp-down time) means the maximum of these two times.

EXAMPLE: As the timeslot length is 34 QAM symbol periods and there are 30 QAM symbol periods needed for the information transmission and ramp-down time is 2,5 QAM symbol periods and an additional 0,5 QAM symbol time is allocated for the symbol synchronization and no QAM symbol periods are allocated for receiver filter implementation (included in the ramp-down time), then the delay tolerance for the normal uplink burst is:

$$\text{Delay tolerance}_{\text{Terrestrial}} = T_d = 1,0 \text{ QAM symbol periods} \quad (\text{O.7})$$

The corresponding maximum cell radius of a TETRA terrestrial cell is:

$$R_{\text{Terrestrial_max}} = 0,5 \times T_d \times T_s \times c = 62,5 \text{ km} \quad (\text{O.8})$$

where:

$T_d = 1,0$ = number of QAM symbol periods of delay tolerance.

T_s = QAM symbol period = $1/2 \text{ 400 s} = 417 \text{ }\mu\text{s}$.

c = electromagnetic wave propagation speed = 299 792 km/s .

In practice, the useful part of a QAM uplink burst (i.e. the period t_2), transmitted on slot $TN = n$ by a far MS at 62,5 km from the BS, is not interfered by the ramp up (period t_1) of an uplink burst from a near MS, where the uplink burst from the near MS is transmitted on slot $TN = (n + 1)$ (i.e. an MS at zero propagation time to the BS).

This scenario (with reference to BS receiver input) is described in the figure O.8. The time is calculated in QAM symbol periods in the figure O.8. Figure O.8 also contains the applied solution as defined in clause O.5.3.

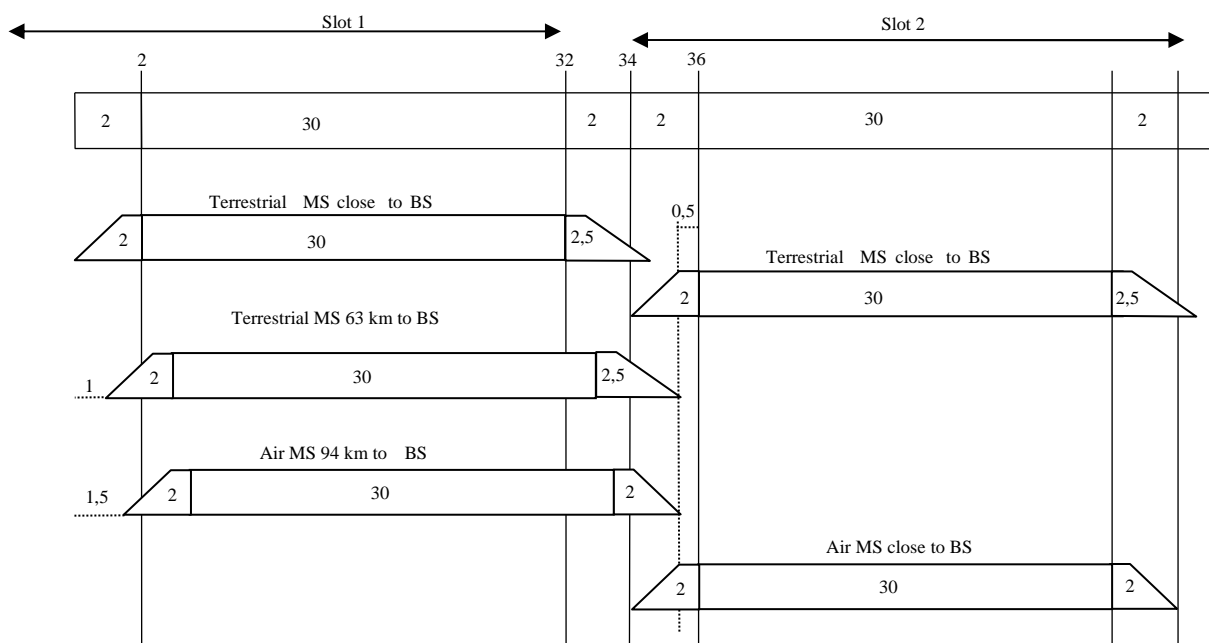

NOTE: Symbol synchronization time is included in ramp-up and ramp-down times.

Figure O.8: TETRA maximum QAM round-trip delay

If the round-trip delay of the far MS exceeds one QAM symbol period, then the near MS ramp up interferes with the last useful symbols of the far MS.

In addition to the information carrying bursts the QAM linearization burst as defined in clause 6.4.5 may cause interference, if it uses the whole allowed time in the time-mask.

O.5.4 Extended range requirements for QAM

The range extension is implemented by shortening QAM ramp-down times in the guard period between QAM uplink bursts. The same adjacent channel requirements are applied as for terrestrial TETRA MSs, refer to clause 6.4, especially clauses 6.4.9.2.2 and 6.4.9.4. The air MS shall use shortened t_3 values as defined in table O.5. The information part of the burst shall be in the same location as in the terrestrial service.

Table O.5: Ramp-up and ramp-down times for AGA services in QAM symbol periods

Burst Type	t_1	t_2	t_3	Total time	Delay tolerance
Control uplink	2,0	13	2,0	17,0	
Normal uplink	2,0	30 (see note 1)	2,0	34,0	1,5
Linearization burst, see note 2	15,0	0	2,0	17,0	

NOTE 1: In the case of single slot transmission.
 NOTE 2: By that definition of t_1 the timing of the linearization burst is referencing to the symbol time of SN-Q_{max} instead of symbol time of SN-Q₀.
 NOTE 3: Symbol synchronization time is included in t_1 and t_3 .

NOTE 1: Although the t_1 and t_3 values in the table O.5 are given as number of QAM symbol periods the ramp-up and ramp-down times need not be exact number of symbol periods.

EXAMPLE: Using t_3 value in table O.5 for the normal uplink burst and other values as in equation O.6 the air MS delay tolerance is:

$$\text{Delay tolerance}_{\text{AGA}} = T_d = 1,5 \text{ QAM symbol periods} \quad (\text{O.9})$$

The corresponding maximum cell radius of a TETRA air cell using equation O.8 is:

$$R_{\text{AGA_max}} = 0.5 \times T_d \times T_s \times c = 93,7 \text{ km} \quad (\text{O.10})$$

NOTE 2: Terrestrial MS using an air cell may reduce the maximum cell radius due to its longer ramp time(s). Network operators should consider whether they allow terrestrial MSs to use air cells.

BS can control the actual maximum range using the power control information element values "maximum path delay exceeded" and "maximum path delay almost exceeded", as defined in clause 23.7.3.2.

O.6 Subscriber class procedures

O.6.1 Purpose of the subscriber class

AGA service requires that SwMI applies subscriber class procedures to prevent terrestrial MSs to use air cells, refer to clauses 14.5.7, O.4.7 and O.7.1.2.

The SwMI may include the subscriber class element in all cases of location update signalling. If the SwMI sends the optional subscriber class element then the MS shall use the new subscriber class profile as defined in clause 16.4.9.

O.6.2 Preferred subscriber classes

The values for the subscriber class information elements in amended clauses 16.10.49 and 18.5.22 to support AGA service and to allow a more flexible control of cell re-selection in some other cases are defined in clauses O.7.1.2 and O.7.1.3.

The subscriber class element shall be broadcasted by the SwMI to indicate which subscriber classes are supported on the cell as defined in the table O.7. The first two subscriber classes are the highly preferred subscriber classes. Refer to clause O.8 how those are used for the AGA service.

O.7 Amendments and modifications due to the AGA service

O.7.1 Modified information elements

O.7.1.1 General

In order to support protocol defined in clauses O.4 to O.6 some of the air interface protocol PDU information elements shall be modified as presented in clauses O.7.1.2 to O.7.1.4.

O.7.1.2 Amendment to clause 16.10.49 Subscriber class

The subscriber class information element shall subdivide the MS population in up to 16 classes (see definition) represented as a bit map as defined in table O.6.

Table O.6: Subscriber class information element

Information element	Length	Value	Remark
Class 1	1	0	Not a member of highly preferred cell subscriber class 1
		1	Member of highly preferred cell subscriber class 1
Class 2	1	0	Not a member of highly preferred cell subscriber class 2
		1	Member of highly preferred cell subscriber class 2
Class 3	1	0	Not a member of subscriber class 3
		1	Member of subscriber class 3
Class 4	1	0	Not a member of subscriber class 4
		1	Member of subscriber class 4
Class 5	1	0	Not a member of subscriber class 5
		1	Member of subscriber class 5
etc.	1	0	Not a member of subscriber class n
		1	Member of subscriber class n
Class 16	1	0	Not a member of subscriber class 16
		1	Member of subscriber class 16

O.7.1.3 Amendment to clause 18.5.22 Subscriber class

The subscriber class information element shall be used by the SwMI to indicate which subscriber classes are allowed to use this cell as defined in table O.7.

Table O.7: Subscriber class information element

Information element	Length	Value	Remark
Class 1	1	0	Subscriber class not supported on cell
		1	Highly preferred cell for subscriber class
Class 2	1	0	Subscriber class not supported on cell
		1	Highly preferred cell for subscriber class
Class 3	1	0	Subscriber class not supported on cell
		1	Subscriber class supported on cell
Class 4	1	0	Subscriber class not supported on cell
		1	Subscriber class supported on cell
Class 5	1	0	Subscriber class not supported on cell
		1	Subscriber class supported on cell
etc.	1	0	Subscriber class not supported on cell
		1	Subscriber class supported on cell
Class 16	1	0	Subscriber class not supported on cell
		1	Subscriber class supported on cell

O.7.1.4 Modification of clause 21.5.3 Power control

For the BSs supporting AGA service the power control information element shall be modified as presented in the table O.8.

Table O.8: Power control information element contents

Information element	Length	Type	Value	Remark
Power control	4	M	0000 ₂	No change in power
			0001 ₂	Increase power by 1 step
			0010 ₂	Increase power by 2 steps
			0011 ₂	Increase power by 3 steps
			0100 ₂	Increase power by 4 steps
			0101 ₂	Increase power by 5 steps
			0110 ₂	Increase power by 6 steps or maximum path delay almost exceeded, see note
			0111 ₂	Maximum path delay exceeded
			1000 ₂	Revert to open loop power control
			1001 ₂	Decrease power by 1 step
			1010 ₂	Decrease power by 2 steps
			1011 ₂	Decrease power by 3 steps
			1100 ₂	Decrease power by 4 steps
			1101 ₂	Decrease power by 5 steps
			1110 ₂	Decrease power by 6 steps
1111 ₂	Radio uplink failure			
NOTE:	The interpretation of the value 0110 ₂ depends on whether or not it is received by an air MS using an air cell. If the value 0110 ₂ is received by an MS that has indicated it supports the air to ground service (see clause 16.10.10a) and is currently using an air cell as defined in clause O.4.4, the value 0110 ₂ shall be interpreted as indicating "maximum path delay almost exceeded". In all other cases, the value 0110 ₂ shall be interpreted as "increase power by 6 steps".			

O.7.2 Modified protocols

O.7.2.1 General

In order to support AGA service protocol defined in clauses O.4 to O.6 the air interface protocol shall be modified as defined in clauses O.7.2.2 to O.7.2.4.

O.7.2.2 Monitoring modification of clauses 18.3.4.2 and 18.3.4.5.1

While attached to a terrestrial cell the air MS shall monitor neighbour cells continuously and the MLE shall not issue a TL-MONITOR-LIST request parameter with an empty list of neighbour cell channels as parameter. Refer to clause O.4.4.

While attached to an air cell the air MS may monitor neighbour cells continuously in order to better support all requirements in clause O.7.2.3.

O.7.2.3 MS cell selection modification of clause 18.3.4.5.7

In order to force air MS to use air cells also at low altitudes the air MS cell selection protocol as defined in clause 18.3.4.5.7 shall be modified as presented in the following paragraphs of the present clause.

If the air MS supports highly preferred bits, the highest-ranked highly preferred cell (i.e. where the cell broadcast and the subscriber class profile have a match in this bit position) shall be selected as soon as it becomes:

- radio usable;

- offers adequate service; and
- the current serving cell is not a highly preferred cell.

Preferred cells are used for subscriber based cell precedence (priority cell in "BS service details" element of SYSINFO broadcast and priority cell in "BS service details DA" element of SYSINFO-DA broadcast affect all MSs). Preferred cell affects only those MSs that have a matching subscriber class profile, the MS shall combine the match with other services to order the cells in the ranking list.

The criteria in clause 18.3.4.5.7 "Criteria for initiating the cell re-selection procedures" shall be appended with the following conditions that shall cause the air MS to rate a neighbour cell to have better service than the current serving cell:

- The neighbour cell is a highly preferred cell for the MS's subscriber class but the serving cell is not. This condition shall also override the postponement of cell re-selection due to ongoing circuit mode call.

In addition to those ranking reasons air MS may use the criteria defined in clause 18.3.4.5.7:

- the MS subscriber class is supported on the neighbour cell but not on the serving cell;
- the neighbour cell supports system-wide services and the serving cell does not;
- the neighbour cell is a priority cell and the serving cell is not a priority cell;
- the neighbour cell supports a service (i.e. TETRA voice, circuit mode data or TETRA packet data (SNDP) services) which is not supported by the serving cell and the air MS prefers that service to be available;
- the neighbour cell supports a modulation mode (e.g. $\pi/4$ -DQPSK, D8PSK, QAM) which is not supported by the serving cell and the MS prefers that modulation mode to be available;
- the neighbour cell supports a higher bandwidth matching the MS's capabilities than does the serving cell, and the MS prefers the ability to use that higher bandwidth;
- the neighbour cell supports QoS negotiation during PDP context activation and the serving cell does not, and the MS prefers the use of services accessed via QoS negotiation (e.g. scheduled access or any QoS other than background class with unspecified throughput, reliability and delay);
- the neighbour cell supports air interface encryption, the serving cell does not and the air MS prefers that air interface encryption is available;
- the cell load indicates that the neighbour cell is more lightly loaded than the serving cell;
- the neighbour cell is a preferred cell (or "home cell") or belongs to a preferred LA;
- the neighbour cell is a CA cell, the present cell is a DA cell and the MS prefers to use a CA cell;
- the neighbour cell is a DA cell, the present cell is a CA cell and the MS prefers to use a DA cell;
- the neighbour cell is a wide-area cell, the present cell is not a wide-area cell, and the MS prefers to use a wide-area cell (see note); and
- the neighbour cell is not a wide-area cell, the present cell is a wide-area cell, and the MS prefers not to use a wide-area cell (see note).

NOTE: An MS may be configured to prefer using wide-area cells or to prefer not using wide-area cells. Or it may have no particular preference. Or its preference may depend on its present activities.

The MS supporting AGA service should choose to initiate cell re-selection as soon as the neighbour cell becomes radio usable as defined in clause 18.3.4.5.6. If there is more than one neighbour cell which is radio usable, the air MS should choose the one which has the highest ranking in the ranking list and which best satisfies the service requirements for the air MS.

O.7.2.4 Modification of clause 23.4.4.3

The air MS closed loop power control shall be modified on the Power control information element so that an MS that has indicated it supports the air to ground service (see clause 16.10.10a) and is currently using an air cell as defined in clause O.4.4 shall interpret the information element value "0110₂" as "Maximum path delay almost exceeded" and upon reception of that value should start cell re-selection and not to increase output power, refer to clause O.4.3.

O.8 Example of subscriber class values used by operators and users in some networks

In order to promote interoperability, some values of subscriber class are defined and used by operators, users and manufacturers and presented in the table O.9. This definition facilitates inter-operability and supports very wide-area roaming and migration of air MSs, subject to operator and user subscription agreement.

Table O.9: Subscriber class information element values for AGA service

Information element	Length	Value	Remark
Class 1	1	any	Not defined by the present annex
Class 2	1	1	Highly preferred cell for subscriber class
Class 3	1	any	Not defined by the present annex
Class 4	1	any	Not defined by the present annex
Class 5	1	any	Not defined by the present annex
Class 6	1	any	Not defined by the present annex
Class 7	1	any	Not defined by the present annex
Class 8	1	any	Not defined by the present annex
Class 9	1	any	Not defined by the present annex
Class 10	1	any	Not defined by the present annex
Class 11	1	any	Not defined by the present annex
Class 12	1	any	Not defined by the present annex
Class 12	1	any	Not defined by the present annex
Class 14	1	any	Not defined by the present annex
Class 15	1	any	Not defined by the present annex
Class 16	1	any	Not defined by the present annex

O.9 Requirements for air MSs

On transmitter characteristics air phase modulated MSs shall conform to requirements in clause 6.4 with additional requirements as defined in clause O.5.2 and air QAM MSs shall conform to requirements in clause 6.4 with additional requirements as defined in clause O.5.3.

On signalling protocol air MSs shall behave as defined in clauses O.4, O.6 and O.7.2.

Air MSs shall utilize amended information elements as defined in clause O.7.1.

O.10 Requirements for AGA BSs

Based on specifications in clause O.5.2 the maximum allowable path delay for phase modulation is 10,5 phase modulation symbol periods. The air BS receiver shall apply at least that large synchronization search window in order to receive bursts from near-by and distant air MSs, when range extension is supported for phase modulation.

Based on specifications in clause O.5.3 the maximum allowable path delay for QAM is 1,5 QAM symbol periods. The air BS receiver shall apply at least that large synchronization search window in order to receive bursts from near-by and distant air MSs, when range extension is supported for QAM.

NOTE: The air MSs may use a shorter ramp-up period on phase modulation and a shorter ramp-down period on QAM than the ones normally used for terrestrial services and that may affect to the design of the AGC mechanism of BSs.

AGA BSs should use signalling protocol as defined in clauses O.4, O.6 and O.7.2.

AGA BS shall use the signalling protocol information elements as defined in clause O.7.1.

In order to reduce interference from air MSs the BS may use closed loop power control (where applicable) and/or use a suitable low value for the MS_TXPWR_MAX_CELL in the SYSINFO, SYSINFO-Q and SYSINFO-DA PDU broadcasts, refer to clause 23.4.4.2.

Annex P (normative): QAM modulation symbol allocations and symbol set definitions

P.1 QAM modulation symbol sub-carrier allocation

P.1.0 General

Clause 9.4.8.2 describes the sub-carrier symbol sets. Clauses P.1.1 to P.1.7 define how symbol sets are allocated within bursts.

P.1.1 Control uplink Burst (CB)

The allocation of the sub-carrier symbols in the CB shall be in accordance with tables P.1 to P.4.

Table P.1: Allocation of sub-carrier symbols in CB for 8 sub-carriers (25 kHz) case

	1	2	3	4	5	6	7	8	9	10	11	12	13	14	←i
0	S1	S9	D1	D7	D15	P1	D25	D33	D41	P5	D51	D59	D67	P9	
1	S2	S10	H1	D8	D16	H3	D26	D34	D42	H5	D52	D60	D68	H7	
2	S3	S11	D2	D9	D17	P2	D27	D35	D43	P6	D53	D61	D69	P10	
3	S4	S12	D3	D10	D18	D23	D28	D36	D44	D49	D54	D62	D70	D75	
4	S5	S13	D4	D11	D19	D24	D29	D37	D45	D50	D55	D63	D71	D76	
5	S6	S14	D5	D12	D20	P3	D30	D38	D46	P7	D56	D64	D72	P11	
6	S7	S15	H2	D13	D21	H4	D31	D39	D47	H6	D57	D65	D73	H8	
7	S8	S16	D6	D14	D22	P4	D32	D40	D48	P8	D58	D66	D74	P12	

↑j

Table P.2: Allocation of sub-carrier symbols in CB for 16 sub-carriers (50 kHz) case

	1	2	3	4	5	6	7	8	9	10	11	12	13	14	←i
0	S1	S17	D1	D15	D31	P1	D53	D69	D85	P9	D107	D123	D139	P17	
1	S2	S18	D2	D16	D32	D47	D54	D70	D86	D101	D108	D124	D140	D155	
2	S3	S19	D3	D17	D33	P2	D55	D71	D87	P10	D109	D125	D141	P18	
3	S4	S20	D4	D18	D34	D48	D56	D72	D88	D102	D110	D126	D142	D156	
4	S5	S21	D5	D19	D35	P3	D57	D73	D89	P11	D111	D127	D143	P19	
5	S6	S22	H1	D20	D36	H3	D58	D74	D90	H5	D112	D128	D144	H7	
6	S7	S23	D6	D21	D37	P4	D59	D75	D91	P12	D113	D129	D145	P20	
7	S8	S24	D7	D22	D38	D49	D60	D76	D92	D103	D114	D130	D146	D157	
8	S9	S25	D8	D23	D39	D50	D61	D77	D93	D104	D115	D131	D147	D158	
9	S10	S26	D9	D24	D40	P5	D62	D78	D94	P13	D116	D132	D148	P21	
10	S11	S27	H2	D25	D41	H4	D63	D79	D95	H6	D117	D133	D149	H8	
11	S12	S28	D10	D26	D42	P6	D64	D80	D96	P14	D118	D134	D150	P22	
12	S13	S29	D11	D27	D43	D51	D65	D81	D97	D105	D119	D135	D151	D159	
13	S14	S30	D12	D28	D44	P7	D66	D82	D98	P15	D120	D136	D152	P23	
14	S15	S31	D13	D29	D45	D52	D67	D83	D99	D106	D121	D137	D153	D160	
15	S16	S32	D14	D30	D46	P8	D68	D84	D100	P16	D122	D138	D154	P24	

↑j

Table P.3: Allocation of sub-carrier symbols in CB for 32 sub-carriers (100 kHz) case

	1	2	3	4	5	6	7	8	9	10	11	12	13	14	←i
0	S1	S33	D1	D31	D63	P1	D109	D141	D173	P17	D219	D251	D283	P33	
1	S2	S34	D2	D32	D64	D95	D110	D142	D174	D205	D220	D252	D284	D315	
2	S3	S35	D3	D33	D65	P2	D111	D143	D175	P18	D221	D253	D285	P34	
3	S4	S36	D4	D34	D66	D96	D112	D144	D176	D206	D222	D254	D286	D316	
4	S5	S37	D5	D35	D67	P3	D113	D145	D177	P19	D223	D255	D287	P35	
5	S6	S38	D6	D36	D68	D97	D114	D146	D178	D207	D224	D256	D288	D317	
6	S7	S39	D7	D37	D69	P4	D115	D147	D179	P20	D225	D257	D289	P36	
7	S8	S40	D8	D38	D70	D98	D116	D148	D180	D208	D226	D258	D290	D318	
8	S9	S41	D9	D39	D71	P5	D117	D149	D181	P21	D227	D259	D291	P37	
9	S10	S42	D10	D40	D72	D99	D118	D150	D182	D209	D228	D260	D292	D319	
10	S11	S43	D11	D41	D73	P6	D119	D151	D183	P22	D229	D261	D293	P38	
11	S12	S44	D12	D42	D74	D100	D120	D152	D184	D210	D230	D262	D294	D320	
12	S13	S45	D13	D43	D75	P7	D121	D153	D185	P23	D231	D263	D295	P39	
13	S14	S46	H1	D44	D76	H3	D122	D154	D186	H5	D232	D264	D296	H7	
14	S15	S47	D14	D45	D77	P8	D123	D155	D187	P24	D233	D265	D297	P40	
15	S16	S48	D15	D46	D78	D101	D124	D156	D188	D211	D234	D266	D298	D321	
16	S17	S49	D16	D47	D79	D102	D125	D157	D189	D212	D235	D267	D299	D322	
17	S18	S50	D17	D48	D80	P9	D126	D158	D190	P25	D236	D268	D300	P41	
18	S19	S51	H2	D49	D81	H4	D127	D159	D191	H6	D237	D269	D301	H8	
19	S20	S52	D18	D50	D82	P10	D128	D160	D192	P26	D238	D270	D302	P42	
20	S21	S53	D19	D51	D83	D103	D129	D161	D193	D213	D239	D271	D303	D323	
21	S22	S54	D20	D52	D84	P11	D130	D162	D194	P27	D240	D272	D304	P43	
22	S23	S55	D21	D53	D85	D104	D131	D163	D195	D214	D241	D273	D305	D324	
23	S24	S56	D22	D54	D86	P12	D132	D164	D196	P28	D242	D274	D306	P44	
24	S25	S57	D23	D55	D87	D105	D133	D165	D197	D215	D243	D275	D307	D325	
25	S26	S58	D24	D56	D88	P13	D134	D166	D198	P29	D244	D276	D308	P45	
26	S27	S59	D25	D57	D89	D106	D135	D167	D199	D216	D245	D277	D309	D326	
27	S28	S60	D26	D58	D90	P14	D136	D168	D200	P30	D246	D278	D310	P46	
28	S29	S61	D27	D59	D91	D107	D137	D169	D201	D217	D247	D279	D311	D327	
29	S30	S62	D28	D60	D92	P15	D138	D170	D202	P31	D248	D280	D312	P47	
30	S31	S63	D29	D61	D93	D108	D139	D171	D203	D218	D249	D281	D313	D328	
31	S32	S64	D30	D62	D94	P16	D140	D172	D204	P32	D250	D282	D314	P48	

↑j

Table P.4: Allocation of sub-carrier symbols in CB 48 sub-carriers (150 kHz) case

	1	2	3	4	5	6	7	8	9	10	11	12	13	14	←i
0	S1	S49	D1	D47	D95	P1	D165	D213	D261	P25	D331	D379	D427	P49	
1	S2	S50	D2	D48	D96	D143	D166	D214	D262	D309	D332	D380	D428	D475	
2	S3	S51	D3	D49	D97	P2	D167	D215	D263	P26	D333	D381	D429	P50	
3	S4	S52	D4	D50	D98	D144	D168	D216	D264	D310	D334	D382	D430	D476	
4	S5	S53	D5	D51	D99	P3	D169	D217	D265	P27	D335	D383	D431	P51	
5	S6	S54	D6	D52	D100	D145	D170	D218	D266	D311	D336	D384	D432	D477	
6	S7	S55	D7	D53	D101	P4	D171	D219	D267	P28	D337	D385	D433	P52	
7	S8	S56	D8	D54	D102	D146	D172	D220	D268	D312	D338	D386	D434	D478	
8	S9	S57	D9	D55	D103	P5	D173	D221	D269	P29	D339	D387	D435	P53	
9	S10	S58	D10	D56	D104	D147	D174	D222	D270	D313	D340	D388	D436	D479	
10	S11	S59	D11	D57	D105	P6	D175	D223	D271	P30	D341	D389	D437	P54	
11	S12	S60	D12	D58	D106	D148	D176	D224	D272	D314	D342	D390	D438	D480	
12	S13	S61	D13	D59	D107	P7	D177	D225	D273	P31	D343	D391	D439	P55	
13	S14	S62	D14	D60	D108	D149	D178	D226	D274	D315	D344	D392	D440	D481	
14	S15	S63	D15	D61	D109	P8	D179	D227	D275	P32	D345	D393	D441	P56	
15	S16	S64	D16	D62	D110	D150	D180	D228	D276	D316	D346	D394	D442	D482	
16	S17	S65	D17	D63	D111	P9	D181	D229	D277	P33	D347	D395	D443	P57	
17	S18	S66	D18	D64	D112	D151	D182	D230	D278	D317	D348	D396	D444	D483	
18	S19	S67	D19	D65	D113	P10	D183	D231	D279	P34	D349	D397	D445	P58	
19	S20	S68	D20	D66	D114	D152	D184	D232	D280	D318	D350	D398	D446	D484	
20	S21	S69	D21	D67	D115	P11	D185	D233	D281	P35	D351	D399	D447	P59	
21	S22	S70	H1	D68	D116	H3	D186	D234	D282	H5	D352	D400	D448	H7	
22	S23	S71	D22	D69	D117	P12	D187	D235	D283	P36	D353	D401	D449	P60	
23	S24	S72	D23	D70	D118	D153	D188	D236	D284	D319	D354	D402	D450	D485	
24	S25	S73	D24	D71	D119	D154	D189	D237	D285	D320	D355	D403	D451	D486	
25	S26	S74	D25	D72	D120	P13	D190	D238	D286	P37	D356	D404	D452	P61	
26	S27	S75	H2	D73	D121	H4	D191	D239	D287	H6	D357	D405	D453	H8	
27	S28	S76	D26	D74	D122	P14	D192	D240	D288	P38	D358	D406	D454	P62	
28	S29	S77	D27	D75	D123	D155	D193	D241	D289	D321	D359	D407	D455	D487	
29	S30	S78	D28	D76	D124	P15	D194	D242	D290	P39	D360	D408	D456	P63	
30	S31	S79	D29	D77	D125	D156	D195	D243	D291	D322	D361	D409	D457	D488	
31	S32	S80	D30	D78	D126	P16	D196	D244	D292	P40	D362	D410	D458	P64	
32	S33	S81	D31	D79	D127	D157	D197	D245	D293	D323	D363	D411	D459	D489	
33	S34	S82	D32	D80	D128	P17	D198	D246	D294	P41	D364	D412	D460	P65	
34	S35	S83	D33	D81	D129	D158	D199	D247	D295	D324	D365	D413	D461	D490	
35	S36	S84	D34	D82	D130	P18	D200	D248	D296	P42	D366	D414	D462	P66	
36	S37	S85	D35	D83	D131	D159	D201	D249	D297	D325	D367	D415	D463	D491	
37	S38	S86	D36	D84	D132	P19	D202	D250	D298	P43	D368	D416	D464	P67	
38	S39	S87	D37	D85	D133	D160	D203	D251	D299	D326	D369	D417	D465	D492	
39	S40	S88	D38	D86	D134	P20	D204	D252	D300	P44	D370	D418	D466	P68	
40	S41	S89	D39	D87	D135	D161	D205	D253	D301	D327	D371	D419	D467	D493	
41	S42	S90	D40	D88	D136	P21	D206	D254	D302	P45	D372	D420	D468	P69	
42	S43	S91	D41	D89	D137	D162	D207	D255	D303	D328	D373	D421	D469	D494	
43	S44	S92	D42	D90	D138	P22	D208	D256	D304	P46	D374	D422	D470	P70	
44	S45	S93	D43	D91	D139	D163	D209	D257	D305	D329	D375	D423	D471	D495	
45	S46	S94	D44	D92	D140	P23	D210	D258	D306	P47	D376	D424	D472	P71	
46	S47	S95	D45	D93	D141	D164	D211	D259	D307	D330	D377	D425	D473	D496	
47	S48	S96	D46	D94	D142	P24	D212	D260	D308	P48	D378	D426	D474	P72	

↑j

The allocation of the sub-carrier symbols and their content are presented in table P.5.

Table P.5: Control Uplink Burst (CB) for QAM

Channel Bandwidth	SS Set (see note)	Number of SS symbols	Set content	BNmax			Definition
				4Q	16Q	64Q	
All	H1 to H8	8	Uplink slot header set	16			See clause 8
25 kHz	S1 to S16	16	Uplink sync sequence set	not applicable			See clause 9.4.8.3.2
	P1 to P12	12	Half-slot uplink pilots set	not applicable			See clause 9.4.8.3.4
	D1 to D76	76	Half-slot uplink data set	152	304	456	See clause 8
50 kHz	S1 to S32	32	Uplink sync sequence set	not applicable			See clause 9.4.8.3.2
	P1 to P24	24	Half-slot uplink pilots set	not applicable			See clause 9.4.8.3.4
	D1 to D160	160	Half-slot uplink data set	320	640	960	See clause 8
100 kHz	S1 to S64	64	Uplink sync sequence set	not applicable			See clause 9.4.8.3.2
	P1 to P48	48	Half-slot uplink pilots set	not applicable			See clause 9.4.8.3.4
	D1 to D328	328	Half-slot uplink data set	656	1312	1968	See clause 8
150 kHz	S1 to S96	96	Uplink sync sequence set	not applicable			See clause 9.4.8.3.2
	P1 to P72	72	Half-slot uplink pilots set	not applicable			See clause 9.4.8.3.4
	D1 to D496	496	Half-slot uplink data set	992	1984	2976	See clause 8

NOTE: SS is an abbreviation of sub-carrier symbol.

P.1.2 Random Access uplink Burst (RAB)

The allocation of the sub-carrier symbols in the RAB shall be in accordance with table P.6.

Table P.6: Allocation of sub-carrier symbols in RAB

	1	2	3	4	5	6	7	8	9	10	11	12	13	14	←i
0	S1	S9	D1	D9	D17	P1	D29	D37	D45	P5	D57	D65	D73	P9	
1	S2	S10	D2	D10	D18	D25	D30	D38	D46	D53	D58	D66	D74	D81	
2	S3	S11	D3	D11	D19	P2	D31	D39	D47	P6	D59	D67	D75	P10	
3	S4	S12	D4	D12	D20	D26	D32	D40	D48	D54	D60	D68	D76	D82	
4	S5	S13	D5	D13	D21	D27	D33	D41	D49	D55	D61	D69	D77	D83	
5	S6	S14	D6	D14	D22	P3	D34	D42	D50	P7	D62	D70	D78	P11	
6	S7	S15	D7	D15	D23	D28	D35	D43	D51	D56	D63	D71	D79	D84	
7	S8	S16	D8	D16	D24	P4	D36	D44	D52	P8	D64	D72	D80	P12	
tj															

The allocation of the sub-carrier symbols and their content are presented in table P.7.

Table P.7: Random Access Uplink Burst (CB)

SS Set (see note)	Number of SS symbols	Set content	BNmax	Definition
S1 to S16	16	Uplink sync sequence set	not applicable	See clause 9.4.8.3.2
P1 to P12	12	Half-slot uplink pilots set	not applicable	See clause 9.4.8.3.4
D1 to D84	84	Random access data set	168	See clause 8

NOTE: SS is an abbreviation of sub-carrier symbol.

P.1.3 Linearization uplink Burst (LB)

The LB may be used by the MSs to linearize their transmitters. The LB contains no useful symbols and its timing shall only be determined by the time mask (see clause 6.4.10).

P.1.4 Normal Uplink Burst (NUB)

The allocation of the sub-carrier symbols in the NUB shall be in accordance with tables P.8 to P.11. The NUB shall be used by MS to transmit control messages to the BS.

Table P.8: Allocation of sub-carrier symbols in NUB for 8 sub-carriers (25 kHz) case

	1	2	3	4	5	6	7	8	9	10	11	12	13	14	15	16	17	18	19	20	21	22	23	24	25	26	27	28	29	30	31	←i
0	S1	S9	D1	D7	D15	D23	P1	D33	D41	D49	D57	P5	D67	D75	D83	D91	P9	D101	D109	D117	D125	P13	D137	D145	D153	D161	P17	D173	D181	D189	P21	
1	S2	S10	H1	D8	D16	D24	H3	D34	D42	D50	D58	H5	D68	D76	D84	D92	H7	D102	D110	D118	D126	D133	D138	D146	D154	D162	D169	D174	D182	D190	D197	
2	S3	S11	D2	D9	D17	D25	P2	D35	D43	D51	D59	P6	D69	D77	D85	D93	P10	D103	D111	D119	D127	P14	D139	D147	D155	D163	P18	D175	D183	D191	P22	
3	S4	S12	D3	D10	D18	D26	D31	D36	D44	D52	D60	D65	D70	D78	D86	D94	D99	D104	D112	D120	D128	D134	D140	D148	D156	D164	D170	D176	D184	D192	D198	
4	S5	S13	D4	D11	D19	D27	D32	D37	D45	D53	D61	D66	D71	D79	D87	D95	D100	D105	D113	D121	D129	D135	D141	D149	D157	D165	D171	D177	D185	D193	D199	
5	S6	S14	D5	D12	D20	D28	P3	D38	D46	D54	D62	P7	D72	D80	D88	D96	P11	D106	D114	D122	D130	P15	D142	D150	D158	D166	P19	D178	D186	D194	P23	
6	S7	S15	H2	D13	D21	D29	H4	D39	D47	D55	D63	H6	D73	D81	D89	D97	H8	D107	D115	D123	D131	D136	D143	D151	D159	D167	D172	D179	D187	D195	D200	
7	S8	S16	D6	D14	D22	D30	P4	D40	D48	D56	D64	P8	D74	D82	D90	D98	P12	D108	D116	D124	D132	P16	D144	D152	D160	D168	P20	D180	D188	D196	P24	

↑j

Table P.9: Allocation of sub-carrier symbols in NUB for 16 sub-carriers (50 kHz) case

	1	2	3	4	5	6	7	8	9	10	11	12	13	14	15	16	17	18	19	20	21	22	23	24	25	26	27	28	29	30	31	←i
0	S1	S17	D1	D15	D31	D47	P1	D69	D85	D101	D117	P9	D139	D155	D171	D187	P17	D209	D225	D241	D257	P25	D281	D297	D313	D329	P33	D353	D369	D385	P41	
1	S2	S18	D2	D16	D32	D48	D63	D70	D86	D102	D118	D133	D140	D156	D172	D188	D203	D210	D226	D242	D258	D273	D282	D298	D314	D330	D345	D354	D370	D386	D401	
2	S3	S19	D3	D17	D33	D49	P2	D71	D87	D103	D119	P10	D141	D157	D173	D189	P18	D211	D227	D243	D259	P26	D283	D299	D315	D331	P34	D355	D371	D387	P42	
3	S4	S20	D4	D18	D34	D50	D64	D72	D88	D104	D120	D134	D142	D158	D174	D190	D204	D212	D228	D244	D260	D274	D284	D300	D316	D332	D346	D356	D372	D388	D402	
4	S5	S21	D5	D19	D35	D51	P3	D73	D89	D105	D121	P11	D143	D159	D175	D191	P19	D213	D229	D245	D261	P27	D285	D301	D317	D333	P35	D357	D373	D389	P43	
5	S6	S22	H1	D20	D36	D52	H3	D74	D90	D106	D122	H5	D144	D160	D176	D192	H7	D214	D230	D246	D262	D275	D286	D302	D318	D334	D347	D358	D374	D390	D403	
6	S7	S23	D6	D21	D37	D53	P4	D75	D91	D107	D123	P12	D145	D161	D177	D193	P20	D215	D231	D247	D263	P28	D287	D303	D319	D335	P36	D359	D375	D391	P44	
7	S8	S24	D7	D22	D38	D54	D65	D76	D92	D108	D124	D135	D146	D162	D178	D194	D205	D216	D232	D248	D264	D276	D288	D304	D320	D336	D348	D360	D376	D392	D404	
8	S9	S25	D8	D23	D39	D55	D66	D77	D93	D109	D125	D136	D147	D163	D179	D195	D206	D217	D233	D249	D265	D277	D289	D305	D321	D337	D349	D361	D377	D393	D405	
9	S10	S26	D9	D24	D40	D56	P5	D78	D94	D110	D126	P13	D148	D164	D180	D196	P21	D218	D234	D250	D266	P29	D290	D306	D322	D338	P37	D362	D378	D394	P45	
10	S11	S27	H2	D25	D41	D57	H4	D79	D95	D111	D127	H6	D149	D165	D181	D197	H8	D219	D235	D251	D267	D278	D291	D307	D323	D339	D350	D363	D379	D395	D406	
11	S12	S28	D10	D26	D42	D58	P6	D80	D96	D112	D128	P14	D150	D166	D182	D198	P22	D220	D236	D252	D268	P30	D292	D308	D324	D340	P38	D364	D380	D396	P46	
12	S13	S29	D11	D27	D43	D59	D67	D81	D97	D113	D129	D137	D151	D167	D183	D199	D207	D221	D237	D253	D269	D279	D293	D309	D325	D341	D351	D365	D381	D397	D407	
13	S14	S30	D12	D28	D44	D60	P7	D82	D98	D114	D130	P15	D152	D168	D184	D200	P23	D222	D238	D254	D270	P31	D294	D310	D326	D342	P39	D366	D382	D398	P47	
14	S15	S31	D13	D29	D45	D61	D68	D83	D99	D115	D131	D138	D153	D169	D185	D201	D208	D223	D239	D255	D271	D280	D295	D311	D327	D343	D352	D367	D383	D399	D408	
15	S16	S32	D14	D30	D46	D62	P8	D84	D100	D116	D132	P16	D154	D170	D186	D202	P24	D224	D240	D256	D272	P32	D296	D312	D328	D344	P40	D368	D384	D400	P48	

↑j

Table P.10: Allocation of sub-carrier symbols in NUB for 32 sub-carriers (100 kHz) case

	1	2	3	4	5	6	7	8	9	10	11	12	13	14	15	16	17	18	19	20	21	22	23	24	25	26	27	28	29	30	31	←i
0	S1	S33	D1	D31	D63	D95	P1	D141	D173	D205	D237	P17	D283	D315	D347	D379	P33	D425	D457	D489	D521	P49	D569	D601	D633	D665	P65	D713	D745	D777	P81	
1	S2	S34	D2	D32	D64	D96	D127	D142	D174	D206	D238	D269	D284	D316	D348	D380	D411	D426	D458	D490	D522	D553	D570	D602	D634	D666	D697	D714	D746	D778	D809	
2	S3	S35	D3	D33	D65	D97	P2	D143	D175	D207	D239	P18	D285	D317	D349	D381	P34	D427	D459	D491	D523	P50	D571	D603	D635	D667	P66	D715	D747	D779	P82	
3	S4	S36	D4	D34	D66	D98	D128	D144	D176	D208	D240	D270	D286	D318	D350	D382	D412	D428	D460	D492	D524	D554	D572	D604	D636	D668	D698	D716	D748	D780	D810	
4	S5	S37	D5	D35	D67	D99	P3	D145	D177	D209	D241	P19	D287	D319	D351	D383	P35	D429	D461	D493	D525	P51	D573	D605	D637	D669	P67	D717	D749	D781	P83	
5	S6	S38	D6	D36	D68	D100	D129	D146	D178	D210	D242	D271	D288	D320	D352	D384	D413	D430	D462	D494	D526	D555	D574	D606	D638	D670	D699	D718	D750	D782	D811	
6	S7	S39	D7	D37	D69	D101	P4	D147	D179	D211	D243	P20	D289	D321	D353	D385	P36	D431	D463	D495	D527	P52	D575	D607	D639	D671	P68	D719	D751	D783	P84	
7	S8	S40	D8	D38	D70	D102	D130	D148	D180	D212	D244	D272	D290	D322	D354	D386	D414	D432	D464	D496	D528	D556	D576	D608	D640	D672	D700	D720	D752	D784	D812	
8	S9	S41	D9	D39	D71	D103	P5	D149	D181	D213	D245	P21	D291	D323	D355	D387	P37	D433	D465	D497	D529	P53	D577	D609	D641	D673	P69	D721	D753	D785	P85	
9	S10	S42	D10	D40	D72	D104	D131	D150	D182	D214	D246	D273	D292	D324	D356	D388	D415	D434	D466	D498	D530	D557	D578	D610	D642	D674	D701	D722	D754	D786	D813	
10	S11	S43	D11	D41	D73	D105	P6	D151	D183	D215	D247	P22	D293	D325	D357	D389	P38	D435	D467	D499	D531	P54	D579	D611	D643	D675	P70	D723	D755	D787	P86	
11	S12	S44	D12	D42	D74	D106	D132	D152	D184	D216	D248	D274	D294	D326	D358	D390	D416	D436	D468	D500	D532	D558	D580	D612	D644	D676	D702	D724	D756	D788	D814	
12	S13	S45	D13	D43	D75	D107	P7	D153	D185	D217	D249	P23	D295	D327	D359	D391	P39	D437	D469	D501	D533	P55	D581	D613	D645	D677	P71	D725	D757	D789	P87	
13	S14	S46	H1	D44	D76	D108	H3	D154	D186	D218	D250	H5	D296	D328	D360	D392	H7	D438	D470	D502	D534	D559	D582	D614	D646	D678	D703	D726	D758	D790	D815	
14	S15	S47	D14	D45	D77	D109	P8	D155	D187	D219	D251	P24	D297	D329	D361	D393	P40	D439	D471	D503	D535	P56	D583	D615	D647	D679	P72	D727	D759	D791	P88	
15	S16	S48	D15	D46	D78	D110	D133	D156	D188	D220	D252	D275	D298	D330	D362	D394	D417	D440	D472	D504	D536	D560	D584	D616	D648	D680	D704	D728	D760	D792	D816	
16	S17	S49	D16	D47	D79	D111	D134	D157	D189	D221	D253	D276	D299	D331	D363	D395	D418	D441	D473	D505	D537	D561	D585	D617	D649	D681	D705	D729	D761	D793	D817	
17	S18	S50	D17	D48	D80	D112	P9	D158	D190	D222	D254	P25	D300	D332	D364	D396	P41	D442	D474	D506	D538	P57	D586	D618	D650	D682	P73	D730	D762	D794	P89	
18	S19	S51	H2	D49	D81	D113	H4	D159	D191	D223	D255	H6	D301	D333	D365	D397	H8	D443	D475	D507	D539	D562	D587	D619	D651	D683	D706	D731	D763	D795	D818	
19	S20	S52	D18	D50	D82	D114	P10	D160	D192	D224	D256	P26	D302	D334	D366	D398	P42	D444	D476	D508	D540	P58	D588	D620	D652	D684	P74	D732	D764	D796	P90	
20	S21	S53	D19	D51	D83	D115	D135	D161	D193	D225	D257	D277	D303	D335	D367	D399	D419	D445	D477	D509	D541	D563	D589	D621	D653	D685	D707	D733	D765	D797	D819	
21	S22	S54	D20	D52	D84	D116	P11	D162	D194	D226	D258	P27	D304	D336	D368	D400	P43	D446	D478	D510	D542	P59	D590	D622	D654	D686	P75	D734	D766	D798	P91	
22	S23	S55	D21	D53	D85	D117	D136	D163	D195	D227	D259	D278	D305	D337	D369	D401	D420	D447	D479	D511	D543	D564	D591	D623	D655	D687	D708	D735	D767	D799	D820	
23	S24	S56	D22	D54	D86	D118	P12	D164	D196	D228	D260	P28	D306	D338	D370	D402	P44	D448	D480	D512	D544	P60	D592	D624	D656	D688	P76	D736	D768	D800	P92	
24	S25	S57	D23	D55	D87	D119	D137	D165	D197	D229	D261	D279	D307	D339	D371	D403	D421	D449	D481	D513	D545	D565	D593	D625	D657	D689	D709	D737	D769	D801	D821	
25	S26	S58	D24	D56	D88	D120	P13	D166	D198	D230	D262	P29	D308	D340	D372	D404	P45	D450	D482	D514	D546	P61	D594	D626	D658	D690	P77	D738	D770	D802	P93	
26	S27	S59	D25	D57	D89	D121	D138	D167	D199	D231	D263	D280	D309	D341	D373	D405	D422	D451	D483	D515	D547	D566	D595	D627	D659	D691	D710	D739	D771	D803	D822	
27	S28	S60	D26	D58	D90	D122	P14	D168	D200	D232	D264	P30	D310	D342	D374	D406	P46	D452	D484	D516	D548	P62	D596	D628	D660	D692	P78	D740	D772	D804	P94	
28	S29	S61	D27	D59	D91	D123	D139	D169	D201	D233	D265	D281	D311	D343	D375	D407	D423	D453	D485	D517	D549	D567	D597	D629	D661	D693	D711	D741	D773	D805	D823	
29	S30	S62	D28	D60	D92	D124	P15	D170	D202	D234	D266	P31	D312	D344	D376	D408	P47	D454	D486	D518	D550	P63	D598	D630	D662	D694	P79	D742	D774	D806	P95	
30	S31	S63	D29	D61	D93	D125	D140	D171	D203	D235	D267	D282	D313	D345	D377	D409	D424	D455	D487	D519	D551	D568	D599	D631	D663	D695	D712	D743	D775	D807	D824	
31	S32	S64	D30	D62	D94	D126	P16	D172	D204	D236	D268	P32	D314	D346	D378	D410	P48	D456	D488	D520	D552	P64	D600	D632	D664	D696	P80	D744	D776	D808	P96	

†j

Table P.11: Allocation of sub-carrier symbols in NUB for 48 sub-carriers (150 kHz) case

	1	2	3	4	5	6	7	8	9	10	11	12	13	14	15	16	17	18	19	20	21	22	23	24	25	26	27	28	29	30	31	←i
0	S1	S49	D1	D47	D95	D143	P1	D213	D261	D309	D357	P25	D427	D475	D523	D571	P49	D641	D689	D737	D785	P73	D857	D905	D953	D1001	P97	D1073	D1121	D1169	P121	
1	S2	S50	D2	D48	D96	D144	D191	D214	D262	D310	D358	D405	D428	D476	D524	D572	D619	D642	D690	D738	D786	D833	D858	D906	D954	D1002	D1049	D1074	D1122	D1170	D1217	
2	S3	S51	D3	D49	D97	D145	P2	D215	D263	D311	D359	P26	D429	D477	D525	D573	P50	D643	D691	D739	D787	P74	D859	D907	D955	D1003	P98	D1075	D1123	D1171	P122	
3	S4	S52	D4	D50	D98	D146	D192	D216	D264	D312	D360	D406	D430	D478	D526	D574	D620	D644	D692	D740	D788	D834	D860	D908	D956	D1004	D1050	D1076	D1124	D1172	D1218	
4	S5	S53	D5	D51	D99	D147	P3	D217	D265	D313	D361	P27	D431	D479	D527	D575	P51	D645	D693	D741	D789	P75	D861	D909	D957	D1005	P99	D1077	D1125	D1173	P123	
5	S6	S54	D6	D52	D100	D148	D193	D218	D266	D314	D362	D407	D432	D480	D528	D576	D621	D646	D694	D742	D790	D835	D862	D910	D958	D1006	D1051	D1078	D1126	D1174	D1219	
6	S7	S55	D7	D53	D101	D149	P4	D219	D267	D315	D363	P28	D433	D481	D529	D577	P52	D647	D695	D743	D791	P76	D863	D911	D959	D1007	P100	D1079	D1127	D1175	P124	
7	S8	S56	D8	D54	D102	D150	D194	D220	D268	D316	D364	D408	D434	D482	D530	D578	D622	D648	D696	D744	D792	D836	D864	D912	D960	D1008	D1052	D1080	D1128	D1176	D1220	
8	S9	S57	D9	D55	D103	D151	P5	D221	D269	D317	D365	P29	D435	D483	D531	D579	P53	D649	D697	D745	D793	P77	D865	D913	D961	D1009	P101	D1081	D1129	D1177	P125	
9	S10	S58	D10	D56	D104	D152	D195	D222	D270	D318	D366	D409	D436	D484	D532	D580	D623	D650	D698	D746	D794	D837	D866	D914	D962	D1010	D1053	D1082	D1130	D1178	D1221	
10	S11	S59	D11	D57	D105	D153	P6	D223	D271	D319	D367	P30	D437	D485	D533	D581	P54	D651	D699	D747	D795	P78	D867	D915	D963	D1011	P102	D1083	D1131	D1179	P126	
11	S12	S60	D12	D58	D106	D154	D196	D224	D272	D320	D368	D410	D438	D486	D534	D582	D624	D652	D700	D748	D796	D838	D868	D916	D964	D1012	D1054	D1084	D1132	D1180	D1222	
12	S13	S61	D13	D59	D107	D155	P7	D225	D273	D321	D369	P31	D439	D487	D535	D583	P55	D653	D701	D749	D797	P79	D869	D917	D965	D1013	P103	D1085	D1133	D1181	P127	
13	S14	S62	D14	D60	D108	D156	D197	D226	D274	D322	D370	D411	D440	D488	D536	D584	D625	D654	D702	D750	D798	D839	D870	D918	D966	D1014	D1055	D1086	D1134	D1182	D1223	
14	S15	S63	D15	D61	D109	D157	P8	D227	D275	D323	D371	P32	D441	D489	D537	D585	P56	D655	D703	D751	D799	P80	D871	D919	D967	D1015	P104	D1087	D1135	D1183	P128	
15	S16	S64	D16	D62	D110	D158	D198	D228	D276	D324	D372	D412	D442	D490	D538	D586	D626	D656	D704	D752	D800	D840	D872	D920	D968	D1016	D1056	D1088	D1136	D1184	D1224	
16	S17	S65	D17	D63	D111	D159	P9	D229	D277	D325	D373	P33	D443	D491	D539	D587	P57	D657	D705	D753	D801	P81	D873	D921	D969	D1017	P105	D1089	D1137	D1185	P129	
17	S18	S66	D18	D64	D112	D160	D199	D230	D278	D326	D374	D413	D444	D492	D540	D588	D627	D658	D706	D754	D802	D841	D874	D922	D970	D1018	D1057	D1090	D1138	D1186	D1225	
18	S19	S67	D19	D65	D113	D161	P10	D231	D279	D327	D375	P34	D445	D493	D541	D589	P58	D659	D707	D755	D803	P82	D875	D923	D971	D1019	P106	D1091	D1139	D1187	P130	
19	S20	S68	D20	D66	D114	D162	D200	D232	D280	D328	D376	D414	D446	D494	D542	D590	D628	D660	D708	D756	D804	D842	D876	D924	D972	D1020	D1058	D1092	D1140	D1188	D1226	
20	S21	S69	D21	D67	D115	D163	P11	D233	D281	D329	D377	P35	D447	D495	D543	D591	P59	D661	D709	D757	D805	P83	D877	D925	D973	D1021	P107	D1093	D1141	D1189	P131	
21	S22	S70	H1	D68	D116	D164	H3	D234	D282	D330	D378	H5	D448	D496	D544	D592	H7	D662	D710	D758	D806	D843	D878	D926	D974	D1022	D1059	D1094	D1142	D1190	D1227	
22	S23	S71	D22	D69	D117	D165	P12	D235	D283	D331	D379	P36	D449	D497	D545	D593	P60	D663	D711	D759	D807	P84	D879	D927	D975	D1023	P108	D1095	D1143	D1191	P132	
23	S24	S72	D23	D70	D118	D166	D201	D236	D284	D332	D380	D415	D450	D498	D546	D594	D629	D664	D712	D760	D808	D844	D880	D928	D976	D1024	D1060	D1096	D1144	D1192	D1228	
24	S25	S73	D24	D71	D119	D167	D202	D237	D285	D333	D381	D416	D451	D499	D547	D595	D630	D665	D713	D761	D809	D845	D881	D929	D977	D1025	D1061	D1097	D1145	D1193	D1229	
25	S26	S74	D25	D72	D120	D168	P13	D238	D286	D334	D382	P37	D452	D500	D548	D596	P61	D666	D714	D762	D810	P85	D882	D930	D978	D1026	P109	D1098	D1146	D1194	P133	
26	S27	S75	H2	D73	D121	D169	H4	D239	D287	D335	D383	H6	D453	D501	D549	D597	H8	D667	D715	D763	D811	D846	D883	D931	D979	D1027	D1062	D1099	D1147	D1195	D1230	
27	S28	S76	D26	D74	D122	D170	P14	D240	D288	D336	D384	P38	D454	D502	D550	D598	P62	D668	D716	D764	D812	P86	D884	D932	D980	D1028	P110	D1100	D1148	D1196	P134	
28	S29	S77	D27	D75	D123	D171	D203	D241	D289	D337	D385	D417	D455	D503	D551	D599	D631	D669	D717	D765	D813	D847	D885	D933	D981	D1029	D1063	D1101	D1149	D1197	D1231	
29	S30	S78	D28	D76	D124	D172	P15	D242	D290	D338	D386	P39	D456	D504	D552	D600	P63	D670	D718	D766	D814	P87	D886	D934	D982	D1030	P111	D1102	D1150	D1198	P135	
30	S31	S79	D29	D77	D125	D173	D204	D243	D291	D339	D387	D418	D457	D505	D553	D601	D632	D671	D719	D767	D815	D848	D887	D935	D983	D1031	D1064	D1103	D1151	D1199	D1232	
31	S32	S80	D30	D78	D126	D174	P16	D244	D292	D340	D388	P40	D458	D506	D554	D602	P64	D672	D720	D768	D816	P88	D888	D936	D984	D1032	P112	D1104	D1152	D1200	P136	
32	S33	S81	D31	D79	D127	D175	D205	D245	D293	D341	D389	D419	D459	D507	D555	D603	D633	D673	D721	D769	D817	D849	D889	D937	D985	D1033	D1065	D1105	D1153	D1201	D1233	
33	S34	S82	D32	D80	D128	D176	P17	D246	D294	D342	D390	P41	D460	D508	D556	D604	P65	D674	D722	D770	D818	P89	D890	D938	D986	D1034	P113	D1106	D1154	D1202	P137	

	1	2	3	4	5	6	7	8	9	10	11	12	13	14	15	16	17	18	19	20	21	22	23	24	25	26	27	28	29	30	31	←i
34	S35	S83	D33	D81	D129	D177	D206	D247	D295	D343	D391	D420	D461	D509	D557	D605	D634	D675	D723	D771	D819	D850	D891	D939	D987	D1035	D1066	D1107	D1155	D1203	D1234	
35	S36	S84	D34	D82	D130	D178	P18	D248	D296	D344	D392	P42	D462	D510	D558	D606	P66	D676	D724	D772	D820	P90	D892	D940	D988	D1036	P114	D1108	D1156	D1204	P138	
36	S37	S85	D35	D83	D131	D179	D207	D249	D297	D345	D393	D421	D463	D511	D559	D607	D635	D677	D725	D773	D821	D851	D893	D941	D989	D1037	D1067	D1109	D1157	D1205	D1235	
37	S38	S86	D36	D84	D132	D180	P19	D250	D298	D346	D394	P43	D464	D512	D560	D608	P67	D678	D726	D774	D822	P91	D894	D942	D990	D1038	P115	D1110	D1158	D1206	P139	
38	S39	S87	D37	D85	D133	D181	D208	D251	D299	D347	D395	D422	D465	D513	D561	D609	D636	D679	D727	D775	D823	D852	D895	D943	D991	D1039	D1068	D1111	D1159	D1207	D1236	
39	S40	S88	D38	D86	D134	D182	P20	D252	D300	D348	D396	P44	D466	D514	D562	D610	P68	D680	D728	D776	D824	P92	D896	D944	D992	D1040	P116	D1112	D1160	D1208	P140	
40	S41	S89	D39	D87	D135	D183	D209	D253	D301	D349	D397	D423	D467	D515	D563	D611	D637	D681	D729	D777	D825	D853	D897	D945	D993	D1041	D1069	D1113	D1161	D1209	D1237	
41	S42	S90	D40	D88	D136	D184	P21	D254	D302	D350	D398	P45	D468	D516	D564	D612	P69	D682	D730	D778	D826	P93	D898	D946	D994	D1042	P117	D1114	D1162	D1210	P141	
42	S43	S91	D41	D89	D137	D185	D210	D255	D303	D351	D399	D424	D469	D517	D565	D613	D638	D683	D731	D779	D827	D854	D899	D947	D995	D1043	D1070	D1115	D1163	D1211	D1238	
43	S44	S92	D42	D90	D138	D186	P22	D256	D304	D352	D400	P46	D470	D518	D566	D614	P70	D684	D732	D780	D828	P94	D900	D948	D996	D1044	P118	D1116	D1164	D1212	P142	
44	S45	S93	D43	D91	D139	D187	D211	D257	D305	D353	D401	D425	D471	D519	D567	D615	D639	D685	D733	D781	D829	D855	D901	D949	D997	D1045	D1071	D1117	D1165	D1213	D1239	
45	S46	S94	D44	D92	D140	D188	P23	D258	D306	D354	D402	P47	D472	D520	D568	D616	P71	D686	D734	D782	D830	P95	D902	D950	D998	D1046	P119	D1118	D1166	D1214	P143	
46	S47	S95	D45	D93	D141	D189	D212	D259	D307	D355	D403	D426	D473	D521	D569	D617	D640	D687	D735	D783	D831	D856	D903	D951	D999	D1047	D1072	D1119	D1167	D1215	D1240	
47	S48	S96	D46	D94	D142	D190	P24	D260	D308	D356	D404	P48	D474	D522	D570	D618	P72	D688	D736	D784	D832	P96	D904	D952	D1000	D1048	P120	D1120	D1168	D1216	P144	

tj

The allocation of the sub-carrier symbols and their content are presented in table P.12.

Table P.12: Normal Uplink Burst (NUB) for QAM

Channel Bandwidth	SS Set (see note)	Number of SS symbols	Set content	BNmax			Definition
				4Q	16Q	64Q	
All	H1 to H8	8	Uplink slot header set	16			See clause 8
25 KHz	S1 to S16	16	Uplink sync sequence set	not applicable			See clause 9.4.8.3.2
	P1 to P24	24	Full-slot uplink pilots set	not applicable			See clause 9.4.8.3.5
	D1 to D200	200	Full-slot uplink data set	400	800	1 200	See clause 8
50 kHz	S1 to S32	32	Uplink sync sequence set	not applicable			See clause 9.4.8.3.2
	P1 to P48	48	Full-slot uplink pilots set	not applicable			See clause 9.4.8.3.5
	D1 to D408	408	Full-slot uplink data set	816	1 632	2 448	See clause 8
100 kHz	S1 to S64	64	Uplink sync sequence set	not applicable			See clause 9.4.8.3.2
	P1 to P96	96	Full-slot uplink pilots set	not applicable			See clause 9.4.8.3.5
	D1 to D824	824	Full-slot uplink data set	1648	3 296	4 944	See clause 8
150 kHz	S1 to S96	96	Uplink sync sequence set	not applicable			See clause 9.4.8.3.2
	P1 to P144	144	Full-slot uplink pilots set	not applicable			See clause 9.4.8.3.5
	D1 to D1240	1 240	Full-slot uplink data set	2480	4 960	7 440	See clause 8

NOTE: SS is an abbreviation of sub-carrier symbol.

P.1.5 Normal Downlink Burst (NDB)

The allocation of the sub-carrier symbols in the NDB shall be in accordance with tables P.13 to P.16. The NDB shall be used by the BS to transmit control messages to the MS.

Table P.13: Allocation of sub-carrier symbols in NDB for 8 sub-carriers (25 kHz) case

	1	2	3	4	5	6	7	8	9	10	11	12	13	14	15	16	17	18	19	20	21	22	23	24	25	26	27	28	29	30	31	32	33	34	←i
0	S1	S9	D1	D9	D17	P1	D29	D37	D45	D53	P5	D61	D69	D77	D85	P9	D93	D99	D107	D115	P13	D123	D129	D137	D145	P17	D153	D161	D169	D177	P21	D185	D193	D201	
1	S2	H1	D2	D10	D18	D25	D30	D38	D46	D54	H5	D62	D70	D78	D86	H9	D94	D100	D108	D116	H15	D124	D130	D138	D146	H21	D154	D162	D170	D178	H25	D186	D194	H29	
2	S3	S10	D3	D11	D19	P2	D31	D39	D47	D55	P6	D63	D71	D79	D87	P10	H13	D101	D109	D117	P14	H19	D131	D139	D147	P18	D155	D163	D171	D179	P22	D187	D195	D202	
3	S4	H2	D4	D12	D20	D26	D32	D40	D48	D56	H6	D64	D72	D80	D88	H10	D95	D102	D110	D118	H16	D125	D132	D140	D148	H22	D156	D164	D172	D180	H26	D188	D196	H30	
4	S5	H3	D5	D13	D21	D27	D33	D41	D49	D57	H7	D65	D73	D81	D89	H11	D96	D103	D111	D119	H17	D126	D133	D141	D149	H23	D157	D165	D173	D181	H27	D189	D197	H31	
5	S6	S11	D6	D14	D22	P3	D34	D42	D50	D58	P7	D66	D74	D82	D90	P11	H14	D104	D112	D120	P15	H20	D134	D142	D150	P19	D158	D166	D174	D182	P23	D190	D198	D203	
6	S7	H4	D7	D15	D23	D28	D35	D43	D51	D59	H8	D67	D75	D83	D91	H12	D97	D105	D113	D121	H18	D127	D135	D143	D151	H24	D159	D167	D175	D183	H28	D191	D199	H32	
7	S8	S12	D8	D16	D24	P4	D36	D44	D52	D60	P8	D68	D76	D84	D92	P12	D98	D106	D114	D122	P16	D128	D136	D144	D152	P20	D160	D168	D176	D184	P24	D192	D200	D204	

tj

Table P.14: Allocation of sub-carrier symbols in NDB for 16 sub-carriers (50 kHz) case

	1	2	3	4	5	6	7	8	9	10	11	12	13	14	15	16	17	18	19	20	21	22	23	24	25	26	27	28	29	30	31	32	33	34	
0	S1	S17	D5	D21	D37	P1	D61	D77	D93	D109	P9	D129	D145	D161	D177	P17	D197	D211	D227	D243	P25	D263	D277	D293	D309	P33	D329	D345	D361	D377	P41	D397	D413	D429	
1	S2	D1	D6	D22	D38	D53	D62	D78	D94	D110	D125	D130	D146	D162	D178	D193	D198	D212	D228	D244	D259	D264	D278	D294	D310	D325	D330	D346	D362	D378	D393	D398	D414	D430	
2	S3	S18	D7	D23	D39	P2	D63	D79	D95	D111	P10	D131	D147	D163	D179	P18	D199	D213	D229	D245	P26	D265	D279	D295	D311	P34	D331	D347	D363	D379	P42	D399	D415	D431	
3	S4	D2	D8	D24	D40	D54	D64	D80	D96	D112	D126	D132	D148	D164	D180	D194	D200	D214	D230	D246	D260	D266	D280	D296	D312	D326	D332	D348	D364	D380	D394	D400	D416	D432	
4	S5	S19	D9	D25	D41	P3	D65	D81	D97	D113	P11	D133	D149	D165	D181	P19	D201	D215	D231	D247	P27	D267	D281	D297	D313	P35	D333	D349	D365	D381	P43	D401	D417	D433	
5	S6	H1	D10	D26	D42	D55	D66	D82	D98	D114	H5	D134	D150	D166	D182	H9	D202	D216	D232	D248	H15	D268	D282	D298	D314	H21	D334	D350	D366	D382	H25	D402	D418	H29	
6	S7	S20	D11	D27	D43	P4	D67	D83	D99	D115	P12	D135	D151	D167	D183	P20	H13	D217	D233	D249	P28	H19	D283	D299	D315	P36	D335	D351	D367	D383	P44	D403	D419	D434	
7	S8	H2	D12	D28	D44	D56	D68	D84	D100	D116	H6	D136	D152	D168	D184	H10	D203	D218	D234	D250	H16	D269	D284	D300	D316	H22	D336	D352	D368	D384	H26	D404	D420	H30	
8	S9	H3	D13	D29	D45	D57	D69	D85	D101	D117	H7	D137	D153	D169	D185	H11	D204	D219	D235	D251	H17	D270	D285	D301	D317	H23	D337	D353	D369	D385	H27	D405	D421	H31	
9	S10	S21	D14	D30	D46	P5	D70	D86	D102	D118	P13	D138	D154	D170	D186	P21	H14	D220	D236	D252	P29	H20	D286	D302	D318	P37	D338	D354	D370	D386	P45	D406	D422	D435	
10	S11	H4	D15	D31	D47	D58	D71	D87	D103	D119	H8	D139	D155	D171	D187	H12	D205	D221	D237	D253	H18	D271	D287	D303	D319	H24	D339	D355	D371	D387	H28	D407	D423	H32	
11	S12	S22	D16	D32	D48	P6	D72	D88	D104	D120	P14	D140	D156	D172	D188	P22	D206	D222	D238	D254	P30	D272	D288	D304	D320	P38	D340	D356	D372	D388	P46	D408	D424	D436	
12	S13	D3	D17	D33	D49	D59	D73	D89	D105	D121	D127	D141	D157	D173	D189	D195	D207	D223	D239	D255	D261	D273	D289	D305	D321	D327	D341	D357	D373	D389	D395	D409	D425	D437	
13	S14	S23	D18	D34	D50	P7	D74	D90	D106	D122	P15	D142	D158	D174	D190	P23	D208	D224	D240	D256	P31	D274	D290	D306	D322	P39	D342	D358	D374	D390	P47	D410	D426	D438	
14	S15	D4	D19	D35	D51	D60	D75	D91	D107	D123	D128	D143	D159	D175	D191	D196	D209	D225	D241	D257	D262	D275	D291	D307	D323	D328	D343	D359	D375	D391	D396	D411	D427	D439	
15	S16	S24	D20	D36	D52	P8	D76	D92	D108	D124	P16	D144	D160	D176	D192	P24	D210	D226	D242	D258	P32	D276	D292	D308	D324	P40	D344	D360	D376	D392	P48	D412	D428	D440	

tj

Table P.15: Allocation of sub-carrier symbols in NDB for 32 sub-carriers (100 kHz) case

	1	2	3	4	5	6	7	8	9	10	11	12	13	14	15	16	17	18	19	20	21	22	23	24	25	26	27	28	29	30	31	32	33	34
0	S1	S33	D13	D45	D77	P1	D125	D157	D189	D221	P17	D265	D297	D329	D361	P33	D405	D435	D467	D499	P49	D543	D573	D605	D637	P65	D681	D713	D745	D777	P81	D821	D853	D885
1	S2	D1	D14	D46	D78	D109	D126	D158	D190	D222	D253	D266	D298	D330	D362	D393	D406	D436	D468	D500	D531	D544	D574	D606	D638	D669	D682	D714	D746	D778	D809	D822	D854	D886
2	S3	S34	D15	D47	D79	P2	D127	D159	D191	D223	P18	D267	D299	D331	D363	P34	D407	D437	D469	D501	P50	D545	D575	D607	D639	P66	D683	D715	D747	D779	P82	D823	D855	D887
3	S4	D2	D16	D48	D80	D110	D128	D160	D192	D224	D254	D268	D300	D332	D364	D394	D408	D438	D470	D502	D532	D546	D576	D608	D640	D670	D684	D716	D748	D780	D810	D824	D856	D888
4	S5	S35	D17	D49	D81	P3	D129	D161	D193	D225	P19	D269	D301	D333	D365	P35	D409	D439	D471	D503	P51	D547	D577	D609	D641	P67	D685	D717	D749	D781	P83	D825	D857	D889
5	S6	D3	D18	D50	D82	D111	D130	D162	D194	D226	D255	D270	D302	D334	D366	D395	D410	D440	D472	D504	D533	D548	D578	D610	D642	D671	D686	D718	D750	D782	D811	D826	D858	D890
6	S7	S36	D19	D51	D83	P4	D131	D163	D195	D227	P20	D271	D303	D335	D367	P36	D411	D441	D473	D505	P52	D549	D579	D611	D643	P68	D687	D719	D751	D783	P84	D827	D859	D891
7	S8	D4	D20	D52	D84	D112	D132	D164	D196	D228	D256	D272	D304	D336	D368	D396	D412	D442	D474	D506	D534	D550	D580	D612	D644	D672	D688	D720	D752	D784	D812	D828	D860	D892
8	S9	S37	D21	D53	D85	P5	D133	D165	D197	D229	P21	D273	D305	D337	D369	P37	D413	D443	D475	D507	P53	D551	D581	D613	D645	P69	D689	D721	D753	D785	P85	D829	D861	D893
9	S10	D5	D22	D54	D86	D113	D134	D166	D198	D230	D257	D274	D306	D338	D370	D397	D414	D444	D476	D508	D535	D552	D582	D614	D646	D673	D690	D722	D754	D786	D813	D830	D862	D894
10	S11	S38	D23	D55	D87	P6	D135	D167	D199	D231	P22	D275	D307	D339	D371	P38	D415	D445	D477	D509	P54	D553	D583	D615	D647	P70	D691	D723	D755	D787	P86	D831	D863	D895
11	S12	D6	D24	D56	D88	D114	D136	D168	D200	D232	D258	D276	D308	D340	D372	D398	D416	D446	D478	D510	D536	D554	D584	D616	D648	D674	D692	D724	D756	D788	D814	D832	D864	D896
12	S13	S39	D25	D57	D89	P7	D137	D169	D201	D233	P23	D277	D309	D341	D373	P39	D417	D447	D479	D511	P55	D555	D585	D617	D649	P71	D693	D725	D757	D789	P87	D833	D865	D897
13	S14	H1	D26	D58	D90	D115	D138	D170	D202	D234	H5	D278	D310	D342	D374	H9	D418	D448	D480	D512	H15	D556	D586	D618	D650	H21	D694	D726	D758	D790	H25	D834	D866	H29
14	S15	S40	D27	D59	D91	P8	D139	D171	D203	D235	P24	D279	D311	D343	D375	P40	H13	D449	D481	D513	P56	H19	D587	D619	D651	P72	D695	D727	D759	D791	P88	D835	D867	D898
15	S16	H2	D28	D60	D92	D116	D140	D172	D204	D236	H6	D280	D312	D344	D376	H10	D419	D450	D482	D514	H16	D557	D588	D620	D652	H22	D696	D728	D760	D792	H26	D836	D868	H30
16	S17	H3	D29	D61	D93	D117	D141	D173	D205	D237	H7	D281	D313	D345	D377	H11	D420	D451	D483	D515	H17	D558	D589	D621	D653	H23	D697	D729	D761	D793	H27	D837	D869	H31
17	S18	S41	D30	D62	D94	P9	D142	D174	D206	D238	P25	D282	D314	D346	D378	P41	H14	D452	D484	D516	P57	H20	D590	D622	D654	P73	D698	D730	D762	D794	P89	D838	D870	D899
18	S19	H4	D31	D63	D95	D118	D143	D175	D207	D239	H8	D283	D315	D347	D379	H12	D421	D453	D485	D517	H18	D559	D591	D623	D655	H24	D699	D731	D763	D795	H28	D839	D871	H32
19	S20	S42	D32	D64	D96	P10	D144	D176	D208	D240	P26	D284	D316	D348	D380	P42	D422	D454	D486	D518	P58	D560	D592	D624	D656	P74	D700	D732	D764	D796	P90	D840	D872	D900
20	S21	D7	D33	D65	D97	D119	D145	D177	D209	D241	D259	D285	D317	D349	D381	D399	D423	D455	D487	D519	D537	D561	D593	D625	D657	D675	D701	D733	D765	D797	D815	D841	D873	D901
21	S22	S43	D34	D66	D98	P11	D146	D178	D210	D242	P27	D286	D318	D350	D382	P43	D424	D456	D488	D520	P59	D562	D594	D626	D658	P75	D702	D734	D766	D798	P91	D842	D874	D902
22	S23	D8	D35	D67	D99	D120	D147	D179	D211	D243	D260	D287	D319	D351	D383	D400	D425	D457	D489	D521	D538	D563	D595	D627	D659	D676	D703	D735	D767	D799	D816	D843	D875	D903
23	S24	S44	D36	D68	D100	P12	D148	D180	D212	D244	P28	D288	D320	D352	D384	P44	D426	D458	D490	D522	P60	D564	D596	D628	D660	P76	D704	D736	D768	D800	P92	D844	D876	D904
24	S25	D9	D37	D69	D101	D121	D149	D181	D213	D245	D261	D289	D321	D353	D385	D401	D427	D459	D491	D523	D539	D565	D597	D629	D661	D677	D705	D737	D769	D801	D817	D845	D877	D905
25	S26	S45	D38	D70	D102	P13	D150	D182	D214	D246	P29	D290	D322	D354	D386	P45	D428	D460	D492	D524	P61	D566	D598	D630	D662	P77	D706	D738	D770	D802	P93	D846	D878	D906
26	S27	D10	D39	D71	D103	D122	D151	D183	D215	D247	D262	D291	D323	D355	D387	D402	D429	D461	D493	D525	D540	D567	D599	D631	D663	D678	D707	D739	D771	D803	D818	D847	D879	D907
27	S28	S46	D40	D72	D104	P14	D152	D184	D216	D248	P30	D292	D324	D356	D388	P46	D430	D462	D494	D526	P62	D568	D600	D632	D664	P78	D708	D740	D772	D804	P94	D848	D880	D908
28	S29	D11	D41	D73	D105	D123	D153	D185	D217	D249	D263	D293	D325	D357	D389	D403	D431	D463	D495	D527	D541	D569	D601	D633	D665	D679	D709	D741	D773	D805	D819	D849	D881	D909
29	S30	S47	D42	D74	D106	P15	D154	D186	D218	D250	P31	D294	D326	D358	D390	P47	D432	D464	D496	D528	P63	D570	D602	D634	D666	P79	D710	D742	D774	D806	P95	D850	D882	D910
30	S31	D12	D43	D75	D107	D124	D155	D187	D219	D251	D264	D295	D327	D359	D391	D404	D433	D465	D497	D529	D542	D571	D603	D635	D667	D680	D711	D743	D775	D807	D820	D851	D883	D911
31	S32	S48	D44	D76	D108	P16	D156	D188	D220	D252	P32	D296	D328	D360	D392	P48	D434	D466	D498	D530	P64	D572	D604	D636	D668	P80	D712	D744	D776	D808	P96	D852	D884	D912

ij

Table P.16: Allocation of sub-carrier symbols in NDB for 48 sub-carriers (150 kHz) case

	1	2	3	4	5	6	7	8	9	10	11	12	13	14	15	16	17	18	19	20	21	22	23	24	25	26	27	28	29	30	31	32	33	34
0	S1	S49	D21	D69	D117	P1	D189	D237	D285	D333	P25	D401	D449	D497	D545	P49	D613	D659	D707	D755	P73	D823	D869	D917	D965	P97	D1033	D1081	D1129	D1177	P121	D1245	D1293	D1341
1	S2	D1	D22	D70	D118	D165	D190	D238	D286	D334	D381	D402	D450	D498	D546	D593	D614	D660	D708	D756	D803	D824	D870	D918	D966	D1013	D1034	D1082	D1130	D1178	D1225	D1246	D1294	D1342
2	S3	S50	D23	D71	D119	P2	D191	D239	D287	D335	P26	D403	D451	D499	D547	P50	D615	D661	D709	D757	P74	D825	D871	D919	D967	P98	D1035	D1083	D1131	D1179	P122	D1247	D1295	D1343
3	S4	D2	D24	D72	D120	D166	D192	D240	D288	D336	D382	D404	D452	D500	D548	D594	D616	D662	D710	D758	D804	D826	D872	D920	D968	D1014	D1036	D1084	D1132	D1180	D1226	D1248	D1296	D1344
4	S5	S51	D25	D73	D121	P3	D193	D241	D289	D337	P27	D405	D453	D501	D549	P51	D617	D663	D711	D759	P75	D827	D873	D921	D969	P99	D1037	D1085	D1133	D1181	P123	D1249	D1297	D1345

	1	2	3	4	5	6	7	8	9	10	11	12	13	14	15	16	17	18	19	20	21	22	23	24	25	26	27	28	29	30	31	32	33	34	←
5	S6	D3	D26	D74	D122	D167	D194	D242	D290	D338	D383	D406	D454	D502	D550	D595	D618	D664	D712	D760	D805	D828	D874	D922	D970	D1015	D1038	D1086	D1134	D1182	D1227	D1250	D1298	D1346	
6	S7	S52	D27	D75	D123	P4	D195	D243	D291	D339	P28	D407	D455	D503	D551	P52	D619	D665	D713	D761	P76	D829	D875	D923	D971	P100	D1039	D1087	D1135	D1183	P124	D1251	D1299	D1347	
7	S8	D4	D28	D76	D124	D168	D196	D244	D292	D340	D384	D408	D456	D504	D552	D596	D620	D666	D714	D762	D806	D830	D876	D924	D972	D1016	D1040	D1088	D1136	D1184	D1228	D1252	D1300	D1348	
8	S9	S53	D29	D77	D125	P5	D197	D245	D293	D341	P29	D409	D457	D505	D553	P53	D621	D667	D715	D763	P77	D831	D877	D925	D973	P101	D1041	D1089	D1137	D1185	P125	D1253	D1301	D1349	
9	S10	D5	D30	D78	D126	D169	D198	D246	D294	D342	D385	D410	D458	D506	D554	D597	D622	D668	D716	D764	D807	D832	D878	D926	D974	D1017	D1042	D1090	D1138	D1186	D1229	D1254	D1302	D1350	
10	S11	S54	D31	D79	D127	P6	D199	D247	D295	D343	P30	D411	D459	D507	D555	P54	D623	D669	D717	D765	P78	D833	D879	D927	D975	P102	D1043	D1091	D1139	D1187	P126	D1255	D1303	D1351	
11	S12	D6	D32	D80	D128	D170	D200	D248	D296	D344	D386	D412	D460	D508	D556	D598	D624	D670	D718	D766	D808	D834	D880	D928	D976	D1018	D1044	D1092	D1140	D1188	D1230	D1256	D1304	D1352	
12	S13	S55	D33	D81	D129	P7	D201	D249	D297	D345	P31	D413	D461	D509	D557	P55	D625	D671	D719	D767	P79	D835	D881	D929	D977	P103	D1045	D1093	D1141	D1189	P127	D1257	D1305	D1353	
13	S14	D7	D34	D82	D130	D171	D202	D250	D298	D346	D387	D414	D462	D510	D558	D599	D626	D672	D720	D768	D809	D836	D882	D930	D978	D1019	D1046	D1094	D1142	D1190	D1231	D1258	D1306	D1354	
14	S15	S56	D35	D83	D131	P8	D203	D251	D299	D347	P32	D415	D463	D511	D559	P56	D627	D673	D721	D769	P80	D837	D883	D931	D979	P104	D1047	D1095	D1143	D1191	P128	D1259	D1307	D1355	
15	S16	D8	D36	D84	D132	D172	D204	D252	D300	D348	D388	D416	D464	D512	D560	D600	D628	D674	D722	D770	D810	D838	D884	D932	D980	D1020	D1048	D1096	D1144	D1192	D1232	D1260	D1308	D1356	
16	S17	S57	D37	D85	D133	P9	D205	D253	D301	D349	P33	D417	D465	D513	D561	P57	D629	D675	D723	D771	P81	D839	D885	D933	D981	P105	D1049	D1097	D1145	D1193	P129	D1261	D1309	D1357	
17	S18	D9	D38	D86	D134	D173	D206	D254	D302	D350	D389	D418	D466	D514	D562	D601	D630	D676	D724	D772	D811	D840	D886	D934	D982	D1021	D1050	D1098	D1146	D1194	D1233	D1262	D1310	D1358	
18	S19	S58	D39	D87	D135	P10	D207	D255	D303	D351	P34	D419	D467	D515	D563	P58	D631	D677	D725	D773	P82	D841	D887	D935	D983	P106	D1051	D1099	D1147	D1195	P130	D1263	D1311	D1359	
19	S20	D10	D40	D88	D136	D174	D208	D256	D304	D352	D390	D420	D468	D516	D564	D602	D632	D678	D726	D774	D812	D842	D888	D936	D984	D1022	D1052	D1100	D1148	D1196	D1234	D1264	D1312	D1360	
20	S21	S59	D41	D89	D137	P11	D209	D257	D305	D353	P35	D421	D469	D517	D565	P59	D633	D679	D727	D775	P83	D843	D889	D937	D985	P107	D1053	D1101	D1149	D1197	P131	D1265	D1313	D1361	
21	S22	H1	D42	D90	D138	D175	D210	D258	D306	D354	H5	D422	D470	D518	D566	H9	D634	D680	D728	D776	H15	D844	D890	D938	D986	H21	D1054	D1102	D1150	D1198	H25	D1266	D1314	H29	
22	S23	S60	D43	D91	D139	P12	D211	D259	D307	D355	P36	D423	D471	D519	D567	P60	H13	D681	D729	D777	P84	H19	D891	D939	D987	P108	D1055	D1103	D1151	D1199	P132	D1267	D1315	D1362	
23	S24	H2	D44	D92	D140	D176	D212	D260	D308	D356	H6	D424	D472	D520	D568	H10	D635	D682	D730	D778	H16	D845	D892	D940	D988	H22	D1056	D1104	D1152	D1200	H26	D1268	D1316	H30	
24	S25	H3	D45	D93	D141	D177	D213	D261	D309	D357	H7	D425	D473	D521	D569	H11	D636	D683	D731	D779	H17	D846	D893	D941	D989	H23	D1057	D1105	D1153	D1201	H27	D1269	D1317	H31	
25	S26	S61	D46	D94	D142	P13	D214	D262	D310	D358	P37	D426	D474	D522	D570	P61	H14	D684	D732	D780	P85	H20	D894	D942	D990	P109	D1058	D1106	D1154	D1202	P133	D1270	D1318	D1363	
26	S27	H4	D47	D95	D143	D178	D215	D263	D311	D359	H8	D427	D475	D523	D571	H12	D637	D685	D733	D781	H18	D847	D895	D943	D991	H24	D1059	D1107	D1155	D1203	H28	D1271	D1319	H32	
27	S28	S62	D48	D96	D144	P14	D216	D264	D312	D360	P38	D428	D476	D524	D572	P62	D638	D686	D734	D782	P86	D848	D896	D944	D992	P110	D1060	D1108	D1156	D1204	P134	D1272	D1320	D1364	
28	S29	D11	D49	D97	D145	D179	D217	D265	D313	D361	D391	D429	D477	D525	D573	D603	D639	D687	D735	D783	D813	D849	D897	D945	D993	D1023	D1061	D1109	D1157	D1205	D1235	D1273	D1321	D1365	
29	S30	S63	D50	D98	D146	P15	D218	D266	D314	D362	P39	D430	D478	D526	D574	P63	D640	D688	D736	D784	P87	D850	D898	D946	D994	P111	D1062	D1110	D1158	D1206	P135	D1274	D1322	D1366	
30	S31	D12	D51	D99	D147	D180	D219	D267	D315	D363	D392	D431	D479	D527	D575	D604	D641	D689	D737	D785	D814	D851	D899	D947	D995	D1024	D1063	D1111	D1159	D1207	D1236	D1275	D1323	D1367	
31	S32	S64	D52	D100	D148	P16	D220	D268	D316	D364	P40	D432	D480	D528	D576	P64	D642	D690	D738	D786	P88	D852	D900	D948	D996	P112	D1064	D1112	D1160	D1208	P136	D1276	D1324	D1368	
32	S33	D13	D53	D101	D149	D181	D221	D269	D317	D365	D393	D433	D481	D529	D577	D605	D643	D691	D739	D787	D815	D853	D901	D949	D997	D1025	D1065	D1113	D1161	D1209	D1237	D1277	D1325	D1369	
33	S34	S65	D54	D102	D150	P17	D222	D270	D318	D366	P41	D434	D482	D530	D578	P65	D644	D692	D740	D788	P89	D854	D902	D950	D998	P113	D1066	D1114	D1162	D1210	P137	D1278	D1326	D1370	
34	S35	D14	D55	D103	D151	D182	D223	D271	D319	D367	D394	D435	D483	D531	D579	D606	D645	D693	D741	D789	D816	D855	D903	D951	D999	D1026	D1067	D1115	D1163	D1211	D1238	D1279	D1327	D1371	
35	S36	S66	D56	D104	D152	P18	D224	D272	D320	D368	P42	D436	D484	D532	D580	P66	D646	D694	D742	D790	P90	D856	D904	D952	D1000	P114	D1068	D1116	D1164	D1212	P138	D1280	D1328	D1372	
36	S37	D15	D57	D105	D153	D183	D225	D273	D321	D369	D395	D437	D485	D533	D581	D607	D647	D695	D743	D791	D817	D857	D905	D953	D1001	D1027	D1069	D1117	D1165	D1213	D1239	D1281	D1329	D1373	
37	S38	S67	D58	D106	D154	P19	D226	D274	D322	D370	P43	D438	D486	D534	D582	P67	D648	D696	D744	D792	P91	D858	D906	D954	D1002	P115	D1070	D1118	D1166	D1214	P139	D1282	D1330	D1374	
38	S39	D16	D59	D107	D155	D184	D227	D275	D323	D371	D396	D439	D487	D535	D583	D608	D649	D697	D745	D793	D818	D859	D907	D955	D1003	D1028	D1071	D1119	D1167	D1215	D1240	D1283	D1331	D1375	
39	S40	S68	D60	D108	D156	P20	D228	D276	D324	D372	P44	D440	D488	D536	D584	P68	D650	D698	D746	D794	P92	D860	D908	D956	D1004	P116	D1072	D1120	D1168	D1216	P140	D1284	D1332	D1376	
40	S41	D17	D61	D109	D157	D185	D229	D277	D325	D373	D397	D441	D489	D537	D585	D609	D651	D699	D747	D795	D819	D861	D909	D957	D1005	D1029	D1073	D1121	D1169	D1217	D1241	D1285	D1333	D1377	
41	S42	S69	D62	D110	D158	P21	D230	D278	D326	D374	P45	D442	D490	D538	D586	P69	D652	D700	D748	D796	P93	D862	D910	D958	D1006	P117	D1074	D1122	D1170	D1218	P141	D1286	D1334	D1378	
42	S43	D18	D63	D111	D159	D186	D231	D279	D327	D375	D398	D443	D491	D539	D587	D610	D653	D701	D749	D797	D820	D863	D911	D959	D1007	D1030	D1075	D1123	D1171	D1219	D1242	D1287	D1335	D1379	
43	S44	S70	D64	D112	D160	P22	D232	D280	D328	D376	P46	D444	D492	D540	D588	P70	D654	D702	D750	D798	P94	D864	D912	D960	D1008	P118	D1076	D1124	D1172	D1220	P142	D1288	D1336	D1380	
44	S45	D19	D65	D113	D161	D187	D233	D281	D329	D377	D399	D445	D493	D541	D589	D611	D655	D703	D751	D799	D821	D865	D913	D961	D1009	D1031	D1077	D1125	D1173	D1221	D1243	D1289	D1337	D1381	

	1	2	3	4	5	6	7	8	9	10	11	12	13	14	15	16	17	18	19	20	21	22	23	24	25	26	27	28	29	30	31	32	33	34	←i
45	S46	S71	D66	D114	D162	P23	D234	D282	D330	D378	P47	D446	D494	D542	D590	P71	D656	D704	D752	D800	P95	D866	D914	D962	D1010	P119	D1078	D1126	D1174	D1222	P143	D1290	D1338	D1382	
46	S47	D20	D67	D115	D163	D188	D235	D283	D331	D379	D400	D447	D495	D543	D591	D612	D657	D705	D753	D801	D822	D867	D915	D963	D1011	D1032	D1079	D1127	D1175	D1223	D1244	D1291	D1339	D1383	
47	S48	S72	D68	D116	D164	P24	D236	D284	D332	D380	P48	D448	D496	D544	D592	P72	D658	D706	D754	D802	P96	D868	D916	D964	D1012	P120	D1080	D1128	D1176	D1224	P144	D1292	D1340	D1384	

ij

The allocation of the sub-carrier symbols and their content are presented in table P.17.

Table P.17: Normal Downlink Burst (NDB) for QAM

Channel Bandwidth	SS Set (see note)	Number of SS symbols	Set content	BNmax			Definition
				4Q	16Q	64Q	
All	H1 to H32	32	Downlink slot header set	64			See clause 8
25 kHz	S1 to S12	12	Downlink sync sequence set	not applicable			See clause 9.4.8.3.3
	P1 to P24	24	Full-slot downlink pilots set	not applicable			See clause 9.4.8.3.6
	D1 to D204	204	Full-slot downlink data set	408	816	1 224	See clause 8
50 kHz	S1 to S24	24	Downlink sync sequence set	not applicable			See clause 9.4.8.3.3
	P1 to P48	48	Full-slot downlink pilots set	not applicable			See clause 9.4.8.3.6
	D1 to D440	440	Full-slot downlink data set	880	1 760	2 640	See clause 8
100 kHz	S1 to S48	48	Downlink sync sequence set	not applicable			See clause 9.4.8.3.3
	P1 to P96	96	Full-slot downlink pilots set	not applicable			See clause 9.4.8.3.6
	D1 to D912	912	Full-slot downlink data set	1 824	3 648	5 472	See clause 8
150 kHz	S1 to S72	72	Downlink sync sequence set	not applicable			See clause 9.4.8.3.3
	P1 to P144	144	Full-slot downlink pilots set	not applicable			See clause 9.4.8.3.6
	D1 to D1384	1 384	Full-slot downlink data set	2 768	5 536	8 304	See clause 8

NOTE: SS is an abbreviation of sub-carrier symbol.

P.1.6 Linearization downlink burst (LDB)

The linearization downlink burst may be used by the BS to linearize its transmitter. Part of the linearization downlink burst contains non useful symbols and its timing during the linearization portion shall be determined only by the time mask (see clause 6.4.10).

The allocation of the sub-carrier symbols in the LDB shall be in accordance with tables P.18 to P.21.

Table P.18: Allocation of sub-carrier symbols in LDB for 8 sub-carriers (25 kHz) case

	1	2	3	4	5	6	7	8	9	10	11	12	13	14	15	16	17	18	19	20	21	22	23	24	25	26	27	28	29	30	31	32	33	34	←i																							
0	S1	S9	Z5	Z13	Linearization portion of the burst																						FiA1	FiA9	FiA17																													
1	S2	Z1	Z6	Z14																							FiA2	FiA10	FiA18																													
2	S3	S10	Z7	Z15																							FiA3	FiA11	FiA19																													
3	S4	Z2	Z8	Z16																							FiA4	FiA12	FiA20																													
4	S5	Z3	Z9	Z17																							FiA5	FiA13	FiA21																													
5	S6	S11	Z10	Z18																							FiA6	FiA14	FiA22																													
6	S7	Z4	Z11	Z19																							FiA7	FiA15	FiA23																													
7	S8	S12	Z12	Z20																							FiA8	FiA16	FiA24																													

↑j

Table P.19: Allocation of sub-carrier symbols in LDB for 16 sub-carriers (50 kHz) case

	1	2	3	4	5	6	7	8	9	10	11	12	13	14	15	16	17	18	19	20	21	22	23	24	25	26	27	28	29	30	31	32	33	34	←i																								
0	S1	S17	Z9	Z25	Linearization portion of the burst																						FiA1	FiA17	FiA33																														
1	S2	Z1	Z10	Z26																							FiA2	FiA18	FiA34																														
2	S3	S18	Z11	Z27																							FiA3	FiA19	FiA35																														
3	S4	Z2	Z12	Z28																							FiA4	FiA20	FiA36																														
4	S5	S19	Z13	Z29																							FiA5	FiA21	FiA37																														
5	S6	Z3	Z14	Z30																							FiA6	FiA22	FiA38																														
6	S7	S20	Z15	Z31																							FiA7	FiA23	FiA39																														
7	S8	Z4	Z16	Z32																							FiA8	FiA24	FiA40																														
8	S9	Z5	Z17	Z33																							FiA9	FiA25	FiA41																														
9	S10	S21	Z18	Z34																							FiA10	FiA26	FiA42																														
10	S11	Z6	Z19	Z35																							FiA11	FiA27	FiA43																														
11	S12	S22	Z20	Z36																							FiA12	FiA28	FiA44																														
12	S13	Z7	Z21	Z37																							FiA13	FiA29	FiA45																														
13	S14	S23	Z22	Z38																							FiA14	FiA30	FiA46																														
14	S15	Z8	Z23	Z39																							FiA15	FiA31	FiA47																														
15	S16	S24	Z24	Z40																							FiA16	FiA32	FiA48																														

↑j

Table P.20: Allocation of sub-carrier symbols in LDB for 32 sub-carriers (100 kHz) case

	1	2	3	4	5	6	7	8	9	10	11	12	13	14	15	16	17	18	19	20	21	22	23	24	25	26	27	28	29	30	31	32	33	34	←i
0	S1	S33	Z17	Z49																												FiA1	FiA33	FiA65	
1	S2	Z1	Z18	Z50																												FiA2	FiA34	FiA66	
2	S3	S34	Z19	Z51																												FiA3	FiA35	FiA67	
3	S4	Z2	Z20	Z52																												FiA4	FiA36	FiA68	
4	S5	S35	Z21	Z53																												FiA5	FiA37	FiA69	
5	S6	Z3	Z22	Z54																												FiA6	FiA38	FiA70	
6	S7	S36	Z23	Z55																												FiA7	FiA39	FiA71	
7	S8	Z4	Z24	Z56																												FiA8	FiA40	FiA72	
8	S9	S37	Z25	Z57																												FiA9	FiA41	FiA73	
9	S10	Z5	Z26	Z58																												FiA10	FiA42	FiA74	
10	S11	S38	Z27	Z59																												FiA11	FiA43	FiA75	
11	S12	Z6	Z28	Z60																												FiA12	FiA44	FiA76	
12	S13	S39	Z29	Z61																												FiA13	FiA45	FiA77	
13	S14	Z7	Z30	Z62																												FiA14	FiA46	FiA78	
14	S15	S40	Z31	Z63																												FiA15	FiA47	FiA79	
15	S16	Z8	Z32	Z64																												FiA16	FiA48	FiA80	
16	S17	Z9	Z33	Z65																												FiA17	FiA49	FiA81	
17	S18	S41	Z34	Z66																												FiA18	FiA50	FiA82	
18	S19	Z10	Z35	Z67																												FiA19	FiA51	FiA83	
19	S20	S42	Z36	Z68																												FiA20	FiA52	FiA84	
20	S21	Z11	Z37	Z69																												FiA21	FiA53	FiA85	
21	S22	S43	Z38	Z70																												FiA22	FiA54	FiA86	
22	S23	Z12	Z39	Z71																												FiA23	FiA55	FiA87	
23	S24	S44	Z40	Z72																												FiA24	FiA56	FiA88	
24	S25	Z13	Z41	Z73																												FiA25	FiA57	FiA89	
25	S26	S45	Z42	Z74																												FiA26	FiA58	FiA90	
26	S27	Z14	Z43	Z75																												FiA27	FiA59	FiA91	
27	S28	S46	Z44	Z76																												FiA28	FiA60	FiA92	
28	S29	Z15	Z45	Z77																												FiA29	FiA61	FiA93	
29	S30	S47	Z46	Z78																												FiA30	FiA62	FiA94	
30	S31	Z16	Z47	Z79																												FiA31	FiA63	FiA95	
31	S32	S48	Z48	Z80																												FiA32	FiA64	FiA96	

Linearization portion of the burst

↑j

Table P.21: Allocation of sub-carrier symbols in LDB for 48 sub-carriers (150 kHz) case

	1	2	3	4	5	6	7	8	9	10	11	12	13	14	15	16	17	18	19	20	21	22	23	24	25	26	27	28	29	30	31	32	33	34	←i
0	S1	S49	Z25	Z73																												FiA1	FiA49	FiA97	
1	S2	Z1	Z26	Z74																												FiA2	FiA50	FiA98	
2	S3	S50	Z27	Z75																												FiA3	FiA51	FiA99	
3	S4	Z2	Z28	Z76																												FiA4	FiA52	FiA100	
4	S5	S51	Z29	Z77																												FiA5	FiA53	FiA101	
5	S6	Z3	Z30	Z78																												FiA6	FiA54	FiA102	
6	S7	S52	Z31	Z79																												FiA7	FiA55	FiA103	
7	S8	Z4	Z32	Z80																												FiA8	FiA56	FiA104	
8	S9	S53	Z33	Z81																												FiA9	FiA57	FiA105	
9	S10	Z5	Z34	Z82																												FiA10	FiA58	FiA106	
10	S11	S54	Z35	Z83																												FiA11	FiA59	FiA107	
11	S12	Z6	Z36	Z84																												FiA12	FiA60	FiA108	
12	S13	S55	Z37	Z85																												FiA13	FiA61	FiA109	
13	S14	Z7	Z38	Z86																												FiA14	FiA62	FiA110	
14	S15	S56	Z39	Z87																												FiA15	FiA63	FiA111	
15	S16	Z8	Z40	Z88																												FiA16	FiA64	FiA112	
16	S17	S57	Z41	Z89																												FiA17	FiA65	FiA113	
17	S18	Z9	Z42	Z90																												FiA18	FiA66	FiA114	
18	S19	S58	Z43	Z91																												FiA19	FiA67	FiA115	
19	S20	Z10	Z44	Z92																												FiA20	FiA68	FiA116	
20	S21	S59	Z45	Z93																												FiA21	FiA69	FiA117	
21	S22	Z11	Z46	Z94																												FiA22	FiA70	FiA118	
22	S23	S60	Z47	Z95																												FiA23	FiA71	FiA119	
23	S24	Z12	Z48	Z96																												FiA24	FiA72	FiA120	
24	S25	S61	Z49	Z97																												FiA25	FiA73	FiA121	
25	S26	Z13	Z50	Z98																												FiA26	FiA74	FiA122	
26	S27	S62	Z51	Z99																												FiA27	FiA75	FiA123	
27	S28	Z14	Z52	Z100																												FiA28	FiA76	FiA124	
28	S29	S63	Z53	Z101																												FiA29	FiA77	FiA125	
29	S30	Z15	Z54	Z102																												FiA30	FiA78	FiA126	
30	S31	S64	Z55	Z103																												FiA31	FiA79	FiA127	
31	S32	Z16	Z56	Z104																												FiA32	FiA80	FiA128	
32	S33	S65	Z57	Z105																												FiA33	FiA81	FiA129	
33	S34	Z17	Z58	Z106																												FiA34	FiA82	FiA130	

Linearization portion of the burst

The allocation of the sub-carrier symbols and their content are presented in table P.22.

Table P.22: Linearization Downlink Burst (LDB) for QAM

Channel Bandwidth	SS Set (see note)	Number of SS symbols	Set content	Definition
25 kHz	S1 to S12	12	Downlink sync sequence set	See clause 9.4.8.3.3
	Z1 to Z20	20	Linearization downlink zeroed set	See clause 9.4.8.3.8
	FiA1 to FiA24	24	Filler set A	See clause 9.4.8.3.7
50 kHz	S1 to S24	24	Downlink sync sequence set	See clause 9.4.8.3.3
	Z1 to Z40	40	Linearization downlink zeroed set	See clause 9.4.8.3.8
	FiA1 to FiA48	48	Filler set A	See clause 9.4.8.3.7
100 kHz	S1 to S48	48	Downlink sync sequence set	See clause 9.4.8.3.3
	Z1 to Z80	80	Linearization downlink zeroed set	See clause 9.4.8.3.8
	FiA1 to FiA96	96	Filler set A	See clause 9.4.8.3.7
150 kHz	S1 to S72	72	Downlink sync sequence set	See clause 9.4.8.3.3
	Z1 to Z120	120	Linearization downlink zeroed set	See clause 9.4.8.3.8
	FiA1 to FiA144	144	Filler set A	See clause 9.4.8.3.7
NOTE: SS is an abbreviation of sub-carrier symbol.				

P.1.7 Frequency Correction downlink burst (FCB)

The allocation of the modulation symbols in the frequency correction downlink burst shall be in accordance with tables P.23 to P.26. The frequency correction downlink burst shall be used by BSs to aid the MSs adjust their frequency and to broadcast synchronization messages to the MSs.

Table P.23: Allocation of sub-carrier symbols in FCB for 8 sub-carriers (25 kHz) case

	1	2	3	4	5	6	7	8	9	10	11	12	13	14	15	16	17	18	19	20	21	22	23	24	25	26	27	28	29	30	31	32	33	34	←i
0	S1	S9	F1	F9	F17	P1	F29	F37	F45	F53	P5	S'1	DA1	DA9	DA17	P9	DA25	DA31	DA39	DA47	P13	DA55	DA61	DA69	DA77	P17	DA85	DA93	DA101	DA109	P21	DA117	DA125	DA133	
1	S2	H1	F2	F10	F18	F25	F30	F38	F46	F54	H5	S'2	DA2	DA10	DA18	H9	DA26	DA32	DA40	DA48	H15	DA56	DA62	DA70	DA78	H21	DA86	DA94	DA102	DA110	H25	DA118	DA126	H29	
2	S3	S10	F3	F11	F19	P2	F31	F39	F47	F55	P6	S'3	DA3	DA11	DA19	P10	H13	DA33	DA41	DA49	P14	H19	DA63	DA71	DA79	P18	DA87	DA95	DA103	DA111	P22	DA119	DA127	DA134	
3	S4	H2	F4	F12	F20	F26	F32	F40	F48	F56	H6	S'4	DA4	DA12	DA20	H10	DA27	DA34	DA42	DA50	H16	DA57	DA64	DA72	DA80	H22	DA88	DA96	DA104	DA112	H26	DA120	DA128	H30	
4	S5	H3	F5	F13	F21	F27	F33	F41	F49	F57	H7	S'5	DA5	DA13	DA21	H11	DA28	DA35	DA43	DA51	H17	DA58	DA65	DA73	DA81	H23	DA89	DA97	DA105	DA113	H27	DA121	DA129	H31	
5	S6	S11	F6	F14	F22	P3	F34	F42	F50	F58	P7	S'6	DA6	DA14	DA22	P11	H14	DA36	DA44	DA52	P15	H20	DA66	DA74	DA82	P19	DA90	DA98	DA106	DA114	P23	DA122	DA130	DA135	
6	S7	H4	F7	F15	F23	F28	F35	F43	F51	F59	H8	S'7	DA7	DA15	DA23	H12	DA29	DA37	DA45	DA53	H18	DA59	DA67	DA75	DA83	H24	DA91	DA99	DA107	DA115	H28	DA123	DA131	H32	
7	S8	S12	F8	F16	F24	P4	F36	F44	F52	F60	P8	S'8	DA8	DA16	DA24	P12	DA30	DA38	DA46	DA54	P16	DA60	DA68	DA76	DA84	P20	DA92	DA100	DA108	DA116	P24	DA124	DA132	DA136	

↑j

Table P.24: Allocation of sub-carrier symbols in FCB for 16 sub-carriers (50 kHz) case

	1	2	3	4	5	6	7	8	9	10	11	12	13	14	15	16	17	18	19	20	21	22	23	24	25	26	27	28	29	30	31	32	33	34	←i
0	S1	S17	DB5	DB13	DB21	P1	DB33	DB41	DB49	DB57	P9	DB69	DB77	DB85	DB93	P17	DB105	DB113	DB121	DB129	P25	DB141	DB149	DB157	DB165	P33	DB177	DB185	DB193	DB201	P41	DB213	DB221	DB229	
1	S2	DB1	DB6	DB14	DB22	DB29	DB34	DB42	DB50	DB58	DB65	DB70	DB78	DB86	DB94	DB101	DB106	DB114	DB122	DB130	DB137	DB142	DB150	DB158	DB166	DB173	DB178	DB186	DB194	DB202	DB209	DB214	DB222	DB230	
2	S3	S18	DB7	DB15	DB23	P2	DB35	DB43	DB51	DB59	P10	DB71	DB79	DB87	DB95	P18	DB107	DB115	DB123	DB131	P26	DB143	DB151	DB159	DB167	P34	DB179	DB187	DB195	DB203	P42	DB215	DB223	DB231	
3	S4	DB2	DB8	DB16	DB24	DB30	DB36	DB44	DB52	DB60	DB66	DB72	DB80	DB88	DB96	DB102	DB108	DB116	DB124	DB132	DB138	DB144	DB152	DB160	DB168	DB174	DB180	DB188	DB196	DB204	DB210	DB216	DB224	DB232	
4	S5	S19	F1	F9	F17	P3	F29	F37	F45	F53	P11	S'1	DA1	DA9	DA17	P19	DA25	DA31	DA39	DA47	P27	DA55	DA61	DA69	DA77	P35	DA85	DA93	DA101	DA109	P43	DA117	DA125	DA133	
5	S6	H1	F2	F10	F18	F25	F30	F38	F46	F54	H5	S'2	DA2	DA10	DA18	H9	DA26	DA32	DA40	DA48	H15	DA56	DA62	DA70	DA78	H21	DA86	DA94	DA102	DA110	H25	DA118	DA126	H29	
6	S7	S20	F3	F11	F19	P4	F31	F39	F47	F55	P12	S'3	DA3	DA11	DA19	P20	H13	DA33	DA41	DA49	P28	H19	DA63	DA71	DA79	P36	DA87	DA95	DA103	DA111	P44	DA119	DA127	DA134	
7	S8	H2	F4	F12	F20	F26	F32	F40	F48	F56	H6	S'4	DA4	DA12	DA20	H10	DA27	DA34	DA42	DA50	H16	DA57	DA64	DA72	DA80	H22	DA88	DA96	DA104	DA112	H26	DA120	DA128	H30	
8	S9	H3	F5	F13	F21	F27	F33	F41	F49	F57	H7	S'5	DA5	DA13	DA21	H11	DA28	DA35	DA43	DA51	H17	DA58	DA65	DA73	DA81	H23	DA89	DA97	DA105	DA113	H27	DA121	DA129	H31	
9	S10	S21	F6	F14	F22	P5	F34	F42	F50	F58	P13	S'6	DA6	DA14	DA22	P21	H14	DA36	DA44	DA52	P29	H20	DA66	DA74	DA82	P37	DA90	DA98	DA106	DA114	P45	DA122	DA130	DA135	
10	S11	H4	F7	F15	F23	F28	F35	F43	F51	F59	H8	S'7	DA7	DA15	DA23	H12	DA29	DA37	DA45	DA53	H18	DA59	DA67	DA75	DA83	H24	DA91	DA99	DA107	DA115	H28	DA123	DA131	H32	
11	S12	S22	F8	F16	F24	P6	F36	F44	F52	F60	P14	S'8	DA8	DA16	DA24	P22	DA30	DA38	DA46	DA54	P30	DA60	DA68	DA76	DA84	P38	DA92	DA100	DA108	DA116	P46	DA124	DA132	DA136	
12	S13	DB3	DB9	DB17	DB25	DB31	DB37	DB45	DB53	DB61	DB67	DB73	DB81	DB89	DB97	DB103	DB109	DB117	DB125	DB133	DB139	DB145	DB153	DB161	DB169	DB175	DB181	DB189	DB197	DB205	DB211	DB217	DB225	DB233	
13	S14	S23	DB10	DB18	DB26	P7	DB38	DB46	DB54	DB62	P15	DB74	DB82	DB90	DB98	P23	DB110	DB118	DB126	DB134	P31	DB146	DB154	DB162	DB170	P39	DB182	DB190	DB198	DB206	P47	DB218	DB226	DB234	
14	S15	DB4	DB11	DB19	DB27	DB32	DB39	DB47	DB55	DB63	DB68	DB75	DB83	DB91	DB99	DB104	DB111	DB119	DB127	DB135	DB140	DB147	DB155	DB163	DB171	DB176	DB183	DB191	DB199	DB207	DB212	DB219	DB227	DB235	
15	S16	S24	DB12	DB20	DB28	P8	DB40	DB48	DB56	DB64	P16	DB76	DB84	DB92	DB100	P24	DB112	DB120	DB128	DB136	P32	DB148	DB156	DB164	DB172	P40	DB184	DB192	DB200	DB208	P48	DB220	DB228	DB236	

↑j

Table P.25: Allocation of sub-carrier symbols in FCB for 32 sub-carriers (100 kHz) case

	1	2	3	4	5	6	7	8	9	10	11	12	13	14	15	16	17	18	19	20	21	22	23	24	25	26	27	28	29	30	31	32	33	34	←i
0	S1	S33	DB13	DB37	DB61	P1	DB97	DB121	DB145	DB169	P17	DB205	DB229	DB253	DB277	P33	DB313	DB337	DB361	DB385	P49	DB421	DB445	DB469	DB493	P65	DB529	DB553	DB577	DB601	P81	DB637	DB661	DB685	
1	S2	DB1	DB14	DB38	DB62	DB85	DB98	DB122	DB146	DB170	DB193	DB206	DB230	DB254	DB278	DB301	DB314	DB338	DB362	DB386	DB409	DB422	DB446	DB470	DB494	DB517	DB530	DB554	DB578	DB602	DB625	DB638	DB662	DB686	
2	S3	S34	DB15	DB39	DB63	P2	DB99	DB123	DB147	DB171	P18	DB207	DB231	DB255	DB279	P34	DB315	DB339	DB363	DB387	P50	DB423	DB447	DB471	DB495	P66	DB531	DB555	DB579	DB603	P82	DB639	DB663	DB687	
3	S4	DB2	DB16	DB40	DB64	DB86	DB100	DB124	DB148	DB172	DB194	DB208	DB232	DB256	DB280	DB302	DB316	DB340	DB364	DB388	DB410	DB424	DB448	DB472	DB496	DB518	DB532	DB556	DB580	DB604	DB626	DB640	DB664	DB688	
4	S5	S35	DB17	DB41	DB65	P3	DB101	DB125	DB149	DB173	P19	DB209	DB233	DB257	DB281	P35	DB317	DB341	DB365	DB389	P51	DB425	DB449	DB473	DB497	P67	DB533	DB557	DB581	DB605	P83	DB641	DB665	DB689	
5	S6	DB3	DB18	DB42	DB66	DB87	DB102	DB126	DB150	DB174	DB195	DB210	DB234	DB258	DB282	DB303	DB318	DB342	DB366	DB390	DB411	DB426	DB450	DB474	DB498	DB519	DB534	DB558	DB582	DB606	DB627	DB642	DB666	DB690	
6	S7	S36	DB19	DB43	DB67	P4	DB103	DB127	DB151	DB175	P20	DB211	DB235	DB259	DB283	P36	DB319	DB343	DB367	DB391	P52	DB427	DB451	DB475	DB499	P68	DB535	DB559	DB583	DB607	P84	DB643	DB667	DB691	
7	S8	DB4	DB20	DB44	DB68	DB88	DB104	DB128	DB152	DB176	DB196	DB212	DB236	DB260	DB284	DB304	DB320	DB344	DB368	DB392	DB412	DB428	DB452	DB476	DB500	DB520	DB536	DB560	DB584	DB608	DB628	DB644	DB668	DB692	
8	S9	S37	DB21	DB45	DB69	P5	DB105	DB129	DB153	DB177	P21	DB213	DB237	DB261	DB285	P37	DB321	DB345	DB369	DB393	P53	DB429	DB453	DB477	DB501	P69	DB537	DB561	DB585	DB609	P85	DB645	DB669	DB693	
9	S10	DB5	DB22	DB46	DB70	DB89	DB106	DB130	DB154	DB178	DB197	DB214	DB238	DB262	DB286	DB305	DB322	DB346	DB370	DB394	DB413	DB430	DB454	DB478	DB502	DB521	DB538	DB562	DB586	DB610	DB629	DB646	DB670	DB694	
10	S11	S38	DB23	DB47	DB71	P6	DB107	DB131	DB155	DB179	P22	DB215	DB239	DB263	DB287	P38	DB323	DB347	DB371	DB395	P54	DB431	DB455	DB479	DB503	P70	DB539	DB563	DB587	DB611	P86	DB647	DB671	DB695	
11	S12	DB6	DB24	DB48	DB72	DB90	DB108	DB132	DB156	DB180	DB198	DB216	DB240	DB264	DB288	DB306	DB324	DB348	DB372	DB396	DB414	DB432	DB456	DB480	DB504	DB522	DB540	DB564	DB588	DB612	DB630	DB648	DB672	DB696	
12	S13	S39	F1	F9	F17	P7	F29	F37	F45	F53	P23	S'1	DA1	DA9	DA17	P39	DA25	DA31	DA39	DA47	P55	DA55	DA61	DA69	DA77	P71	DA85	DA93	DA101	DA109	P87	DA117	DA125	DA133	
13	S14	H1	F2	F10	F18	F25	F30	F38	F46	F54	H5	S'2	DA2	DA10	DA18	H9	DA26	DA32	DA40	DA48	H15	DA56	DA62	DA70	DA78	H21	DA86	DA94	DA102	DA110	H25	DA118	DA126	H29	
14	S15	S40	F3	F11	F19	P8	F31	F39	F47	F55	P24	S'3	DA3	DA11	DA19	P40	H13	DA33	DA41	DA49	P56	H19	DA63	DA71	DA79	P72	DA87	DA95	DA103	DA111	P88	DA119	DA127	DA134	
15	S16	H2	F4	F12	F20	F26	F32	F40	F48	F56	H6	S'4	DA4	DA12	DA20	H10	DA27	DA34	DA42	DA50	H16	DA57	DA64	DA72	DA80	H22	DA88	DA96	DA104	DA112	H26	DA120	DA128	H30	
16	S17	H3	F5	F13	F21	F27	F33	F41	F49	F57	H7	S'5	DA5	DA13	DA21	H11	DA28	DA35	DA43	DA51	H17	DA58	DA65	DA73	DA81	H23	DA89	DA97	DA105	DA113	H27	DA121	DA129	H31	
17	S18	S41	F6	F14	F22	P9	F34	F42	F50	F58	P25	S'6	DA6	DA14	DA22	P41	H14	DA36	DA44	DA52	P57	H20	DA66	DA74	DA82	P73	DA90	DA98	DA106	DA114	P89	DA122	DA130	DA135	
18	S19	H4	F7	F15	F23	F28	F35	F43	F51	F59	H8	S'7	DA7	DA15	DA23	H12	DA29	DA37	DA45	DA53	H18	DA59	DA67	DA75	DA83	H24	DA91	DA99	DA107	DA115	H28	DA123	DA131	H32	
19	S20	S42	F8	F16	F24	P10	F36	F44	F52	F60	P26	S'8	DA8	DA16	DA24	P42	DA30	DA38	DA46	DA54	P58	DA60	DA68	DA76	DA84	P74	DA92	DA100	DA108	DA116	P90	DA124	DA132	DA136	
20	S21	DB7	DB25	DB49	DB73	DB91	DB109	DB133	DB157	DB181	DB199	DB217	DB241	DB265	DB289	DB307	DB325	DB349	DB373	DB397	DB415	DB433	DB457	DB481	DB505	DB523	DB541	DB565	DB589	DB613	DB631	DB649	DB673	DB697	
21	S22	S43	DB26	DB50	DB74	P11	DB110	DB134	DB158	DB182	P27	DB218	DB242	DB266	DB290	P43	DB326	DB350	DB374	DB398	P59	DB434	DB458	DB482	DB506	P75	DB542	DB566	DB590	DB614	P91	DB650	DB674	DB698	
22	S23	DB8	DB27	DB51	DB75	DB92	DB111	DB135	DB159	DB183	DB200	DB219	DB243	DB267	DB291	DB308	DB327	DB351	DB375	DB399	DB416	DB435	DB459	DB483	DB507	DB524	DB543	DB567	DB591	DB615	DB632	DB651	DB675	DB699	
23	S24	S44	DB28	DB52	DB76	P12	DB112	DB136	DB160	DB184	P28	DB220	DB244	DB268	DB292	P44	DB328	DB352	DB376	DB400	P60	DB436	DB460	DB484	DB508	P76	DB544	DB568	DB592	DB616	P92	DB652	DB676	DB700	
24	S25	DB9	DB29	DB53	DB77	DB93	DB113	DB137	DB161	DB185	DB201	DB221	DB245	DB269	DB293	DB309	DB329	DB353	DB377	DB401	DB417	DB437	DB461	DB485	DB509	DB525	DB545	DB569	DB593	DB617	DB633	DB653	DB677	DB701	
25	S26	S45	DB30	DB54	DB78	P13	DB114	DB138	DB162	DB186	P29	DB222	DB246	DB270	DB294	P45	DB330	DB354	DB378	DB402	P61	DB438	DB462	DB486	DB510	P77	DB546	DB570	DB594	DB618	P93	DB654	DB678	DB702	
26	S27	DB10	DB31	DB55	DB79	DB94	DB115	DB139	DB163	DB187	DB202	DB223	DB247	DB271	DB295	DB310	DB331	DB355	DB379	DB403	DB418	DB439	DB463	DB487	DB511	DB526	DB547	DB571	DB595	DB619	DB634	DB655	DB679	DB703	
27	S28	S46	DB32	DB56	DB80	P14	DB116	DB140	DB164	DB188	P30	DB224	DB248	DB272	DB296	P46	DB332	DB356	DB380	DB404	P62	DB440	DB464	DB488	DB512	P78	DB548	DB572	DB596	DB620	P94	DB656	DB680	DB704	
28	S29	DB11	DB33	DB57	DB81	DB95	DB117	DB141	DB165	DB189	DB203	DB225	DB249	DB273	DB297	DB311	DB333	DB357	DB381	DB405	DB419	DB441	DB465	DB489	DB513	DB527	DB549	DB573	DB597	DB621	DB635	DB657	DB681	DB705	
29	S30	S47	DB34	DB58	DB82	P15	DB118	DB142	DB166	DB190	P31	DB226	DB250	DB274	DB298	P47	DB334	DB358	DB382	DB406	P63	DB442	DB466	DB490	DB514	P79	DB550	DB574	DB598	DB622	P95	DB658	DB682	DB706	
30	S31	DB12	DB35	DB59	DB83	DB96	DB119	DB143	DB167	DB191	DB204	DB227	DB251	DB275	DB299	DB312	DB335	DB359	DB383	DB407	DB420	DB443	DB467	DB491	DB515	DB528	DB551	DB575	DB599	DB623	DB636	DB659	DB683	DB707	
31	S32	S48	DB36	DB60	DB84	P16	DB120	DB144	DB168	DB192	P32	DB228	DB252	DB276	DB300	P48	DB336	DB360	DB384	DB408	P64	DB444	DB468	DB492	DB516	P80	DB552	DB576	DB600	DB624	P96	DB660	DB684	DB708	

†j

Table P.26: Allocation of sub-carrier symbols in FCB for 48 sub-carriers (150 kHz) case

	1	2	3	4	5	6	7	8	9	10	11	12	13	14	15	16	17	18	19	20	21	22	23	24	25	26	27	28	29	30	31	32	33	34	←i
0	S1	S49	DB21	DB61	DB101	P1	DB161	DB201	DB241	DB281	P25	DB341	DB381	DB421	DB461	P49	DB521	DB561	DB601	DB641	P73	DB701	DB741	DB781	DB821	P97	DB881	DB921	DB961	DB1001	P121	DB1061	DB1101	DB1141	
1	S2	DB1	DB22	DB62	DB102	DB141	DB162	DB202	DB242	DB282	DB321	DB342	DB382	DB422	DB462	DB501	DB522	DB562	DB602	DB642	DB681	DB702	DB742	DB782	DB822	DB861	DB882	DB922	DB962	DB1002	DB1041	DB1062	DB1102	DB1142	
2	S3	S50	DB23	DB63	DB103	P2	DB163	DB203	DB243	DB283	P26	DB343	DB383	DB423	DB463	P50	DB523	DB563	DB603	DB643	P74	DB703	DB743	DB783	DB823	P98	DB883	DB923	DB963	DB1003	P122	DB1063	DB1103	DB1143	
3	S4	DB2	DB24	DB64	DB104	DB142	DB164	DB204	DB244	DB284	DB322	DB344	DB384	DB424	DB464	DB502	DB524	DB564	DB604	DB644	DB682	DB704	DB744	DB784	DB824	DB862	DB884	DB924	DB964	DB1004	DB1042	DB1064	DB1104	DB1144	
4	S5	S51	DB25	DB65	DB105	P3	DB165	DB205	DB245	DB285	P27	DB345	DB385	DB425	DB465	P51	DB525	DB565	DB605	DB645	P75	DB705	DB745	DB785	DB825	P99	DB885	DB925	DB965	DB1005	P123	DB1065	DB1105	DB1145	
5	S6	DB3	DB26	DB66	DB106	DB143	DB166	DB206	DB246	DB286	DB323	DB346	DB386	DB426	DB466	DB503	DB526	DB566	DB606	DB646	DB683	DB706	DB746	DB786	DB826	DB863	DB886	DB926	DB966	DB1006	DB1043	DB1066	DB1106	DB1146	
6	S7	S52	DB27	DB67	DB107	P4	DB167	DB207	DB247	DB287	P28	DB347	DB387	DB427	DB467	P52	DB527	DB567	DB607	DB647	P76	DB707	DB747	DB787	DB827	P100	DB887	DB927	DB967	DB1007	P124	DB1067	DB1107	DB1147	
7	S8	DB4	DB28	DB68	DB108	DB144	DB168	DB208	DB248	DB288	DB324	DB348	DB388	DB428	DB468	DB504	DB528	DB568	DB608	DB648	DB684	DB708	DB748	DB788	DB828	DB864	DB888	DB928	DB968	DB1008	DB1044	DB1068	DB1108	DB1148	
8	S9	S53	DB29	DB69	DB109	P5	DB169	DB209	DB249	DB289	P29	DB349	DB389	DB429	DB469	P53	DB529	DB569	DB609	DB649	P77	DB709	DB749	DB789	DB829	P101	DB889	DB929	DB969	DB1009	P125	DB1069	DB1109	DB1149	
9	S10	DB5	DB30	DB70	DB110	DB145	DB170	DB210	DB250	DB290	DB325	DB350	DB390	DB430	DB470	DB505	DB530	DB570	DB610	DB650	DB685	DB710	DB750	DB790	DB830	DB865	DB890	DB930	DB970	DB1010	DB1045	DB1070	DB1110	DB1150	
10	S11	S54	DB31	DB71	DB111	P6	DB171	DB211	DB251	DB291	P30	DB351	DB391	DB431	DB471	P54	DB531	DB571	DB611	DB651	P78	DB711	DB751	DB791	DB831	P102	DB891	DB931	DB971	DB1011	P126	DB1071	DB1111	DB1151	
11	S12	DB6	DB32	DB72	DB112	DB146	DB172	DB212	DB252	DB292	DB326	DB352	DB392	DB432	DB472	DB506	DB532	DB572	DB612	DB652	DB686	DB712	DB752	DB792	DB832	DB866	DB892	DB932	DB972	DB1012	DB1046	DB1072	DB1112	DB1152	
12	S13	S55	DB33	DB73	DB113	P7	DB173	DB213	DB253	DB293	P31	DB353	DB393	DB433	DB473	P55	DB533	DB573	DB613	DB653	P79	DB713	DB753	DB793	DB833	P103	DB893	DB933	DB973	DB1013	P127	DB1073	DB1113	DB1153	
13	S14	DB7	DB34	DB74	DB114	DB147	DB174	DB214	DB254	DB294	DB327	DB354	DB394	DB434	DB474	DB507	DB534	DB574	DB614	DB654	DB687	DB714	DB754	DB794	DB834	DB867	DB894	DB934	DB974	DB1014	DB1047	DB1074	DB1114	DB1154	
14	S15	S56	DB35	DB75	DB115	P8	DB175	DB215	DB255	DB295	P32	DB355	DB395	DB435	DB475	P56	DB535	DB575	DB615	DB655	P80	DB715	DB755	DB795	DB835	P104	DB895	DB935	DB975	DB1015	P128	DB1075	DB1115	DB1155	
15	S16	DB8	DB36	DB76	DB116	DB148	DB176	DB216	DB256	DB296	DB328	DB356	DB396	DB436	DB476	DB508	DB536	DB576	DB616	DB656	DB688	DB716	DB756	DB796	DB836	DB868	DB896	DB936	DB976	DB1016	DB1048	DB1076	DB1116	DB1156	
16	S17	S57	DB37	DB77	DB117	P9	DB177	DB217	DB257	DB297	P33	DB357	DB397	DB437	DB477	P57	DB537	DB577	DB617	DB657	P81	DB717	DB757	DB797	DB837	P105	DB897	DB937	DB977	DB1017	P129	DB1077	DB1117	DB1157	
17	S18	DB9	DB38	DB78	DB118	DB149	DB178	DB218	DB258	DB298	DB329	DB358	DB398	DB438	DB478	DB509	DB538	DB578	DB618	DB658	DB689	DB718	DB758	DB798	DB838	DB869	DB898	DB938	DB978	DB1018	DB1049	DB1078	DB1118	DB1158	
18	S19	S58	DB39	DB79	DB119	P10	DB179	DB219	DB259	DB299	P34	DB359	DB399	DB439	DB479	P58	DB539	DB579	DB619	DB659	P82	DB719	DB759	DB799	DB839	P106	DB899	DB939	DB979	DB1019	P130	DB1079	DB1119	DB1159	
19	S20	DB10	DB40	DB80	DB120	DB150	DB180	DB220	DB260	DB300	DB330	DB360	DB400	DB440	DB480	DB510	DB540	DB580	DB620	DB660	DB690	DB720	DB760	DB800	DB840	DB870	DB900	DB940	DB980	DB1020	DB1050	DB1080	DB1120	DB1160	
20	S21	S59	F1	F9	F17	P11	F29	F37	F45	F53	P35	S'1	DA1	DA9	DA17	P59	DA25	DA31	DA39	DA47	P83	DA55	DA61	DA69	DA77	P107	DA85	DA93	DA101	DA109	P131	DA117	DA125	DA133	
21	S22	H1	F2	F10	F18	F25	F30	F38	F46	F54	H5	S'2	DA2	DA10	DA18	H9	DA26	DA32	DA40	DA48	H15	DA56	DA62	DA70	DA78	H21	DA86	DA94	DA102	DA110	H25	DA118	DA126	H29	
22	S23	S60	F3	F11	F19	P12	F31	F39	F47	F55	P36	S'3	DA3	DA11	DA19	P60	H13	DA33	DA41	DA49	P84	H19	DA63	DA71	DA79	P108	DA87	DA95	DA103	DA111	P132	DA119	DA127	DA134	
23	S24	H2	F4	F12	F20	F26	F32	F40	F48	F56	H6	S'4	DA4	DA12	DA20	H10	DA27	DA34	DA42	DA50	H16	DA57	DA64	DA72	DA80	H22	DA88	DA96	DA104	DA112	H26	DA120	DA128	H30	
24	S25	H3	F5	F13	F21	F27	F33	F41	F49	F57	H7	S'5	DA5	DA13	DA21	H11	DA28	DA35	DA43	DA51	H17	DA58	DA65	DA73	DA81	H23	DA89	DA97	DA105	DA113	H27	DA121	DA129	H31	
25	S26	S61	F6	F14	F22	P13	F34	F42	F50	F58	P37	S'6	DA6	DA14	DA22	P61	H14	DA36	DA44	DA52	P85	H20	DA66	DA74	DA82	P109	DA90	DA98	DA106	DA114	P133	DA122	DA130	DA135	
26	S27	H4	F7	F15	F23	F28	F35	F43	F51	F59	H8	S'7	DA7	DA15	DA23	H12	DA29	DA37	DA45	DA53	H18	DA59	DA67	DA75	DA83	H24	DA91	DA99	DA107	DA115	H28	DA123	DA131	H32	
27	S28	S62	F8	F16	F24	P14	F36	F44	F52	F60	P38	S'8	DA8	DA16	DA24	P62	DA30	DA38	DA46	DA54	P86	DA60	DA68	DA76	DA84	P110	DA92	DA100	DA108	DA116	P134	DA124	DA132	DA136	
28	S29	DB11	DB41	DB81	DB121	DB151	DB181	DB221	DB261	DB301	DB331	DB361	DB401	DB441	DB481	DB511	DB541	DB581	DB621	DB661	DB691	DB721	DB761	DB801	DB841	DB871	DB901	DB941	DB981	DB1021	DB1051	DB1081	DB1121	DB1161	
29	S30	S63	DB42	DB82	DB122	P15	DB182	DB222	DB262	DB302	P39	DB362	DB402	DB442	DB482	P63	DB542	DB582	DB622	DB662	P87	DB722	DB762	DB802	DB842	P111	DB902	DB942	DB982	DB1022	P135	DB1082	DB1122	DB1162	
30	S31	DB12	DB43	DB83	DB123	DB152	DB183	DB223	DB263	DB303	DB332	DB363	DB403	DB443	DB483	DB512	DB543	DB583	DB623	DB663	DB692	DB723	DB763	DB803	DB843	DB872	DB903	DB943	DB983	DB1023	DB1052	DB1083	DB1123	DB1163	
31	S32	S64	DB44	DB84	DB124	P16	DB184	DB224	DB264	DB304	P40	DB364	DB404	DB444	DB484	P64	DB544	DB584	DB624	DB664	P88	DB724	DB764	DB804	DB844	P112	DB904	DB944	DB984	DB1024	P136	DB1084	DB1124	DB1164	
32	S33	DB13	DB45	DB85	DB125	DB153	DB185	DB225	DB265	DB305	DB333	DB365	DB405	DB445	DB485	DB513	DB545	DB585	DB625	DB665	DB693	DB725	DB765	DB805	DB845	DB873	DB905	DB945	DB985	DB1025	DB1053	DB1085	DB1125	DB1165	
33	S34	S65	DB46	DB86	DB126	P17	DB186	DB226	DB266	DB306	P41	DB366	DB406	DB446	DB486	P65	DB546	DB586	DB626	DB666	P89	DB726	DB766	DB806	DB846	P113	DB906	DB946	DB986	DB1026	P137	DB1086	DB1126	DB1166	

	1	2	3	4	5	6	7	8	9	10	11	12	13	14	15	16	17	18	19	20	21	22	23	24	25	26	27	28	29	30	31	32	33	34	←i
34	S35	DB14	DB47	DB87	DB127	DB154	DB187	DB227	DB267	DB307	DB334	DB367	DB407	DB447	DB487	DB514	DB547	DB587	DB627	DB667	DB694	DB727	DB767	DB807	DB847	DB874	DB907	DB947	DB987	DB1027	DB1054	DB1087	DB1127	DB1167	
35	S36	S66	DB48	DB88	DB128	P18	DB188	DB228	DB268	DB308	P42	DB368	DB408	DB448	DB488	P66	DB548	DB588	DB628	DB668	P90	DB728	DB768	DB808	DB848	P114	DB908	DB948	DB988	DB1028	P138	DB1088	DB1128	DB1168	
36	S37	DB15	DB49	DB89	DB129	DB155	DB189	DB229	DB269	DB309	DB335	DB369	DB409	DB449	DB489	DB515	DB549	DB589	DB629	DB669	DB695	DB729	DB769	DB809	DB849	DB875	DB909	DB949	DB989	DB1029	DB1055	DB1089	DB1129	DB1169	
37	S38	S67	DB50	DB90	DB130	P19	DB190	DB230	DB270	DB310	P43	DB370	DB410	DB450	DB490	P67	DB550	DB590	DB630	DB670	P91	DB730	DB770	DB810	DB850	P115	DB910	DB950	DB990	DB1030	P139	DB1090	DB1130	DB1170	
38	S39	DB16	DB51	DB91	DB131	DB156	DB191	DB231	DB271	DB311	DB336	DB371	DB411	DB451	DB491	DB516	DB551	DB591	DB631	DB671	DB696	DB731	DB771	DB811	DB851	DB876	DB911	DB951	DB991	DB1031	DB1056	DB1091	DB1131	DB1171	
39	S40	S68	DB52	DB92	DB132	P20	DB192	DB232	DB272	DB312	P44	DB372	DB412	DB452	DB492	P68	DB552	DB592	DB632	DB672	P92	DB732	DB772	DB812	DB852	P116	DB912	DB952	DB992	DB1032	P140	DB1092	DB1132	DB1172	
40	S41	DB17	DB53	DB93	DB133	DB157	DB193	DB233	DB273	DB313	DB337	DB373	DB413	DB453	DB493	DB517	DB553	DB593	DB633	DB673	DB697	DB733	DB773	DB813	DB853	DB877	DB913	DB953	DB993	DB1033	DB1057	DB1093	DB1133	DB1173	
41	S42	S69	DB54	DB94	DB134	P21	DB194	DB234	DB274	DB314	P45	DB374	DB414	DB454	DB494	P69	DB554	DB594	DB634	DB674	P93	DB734	DB774	DB814	DB854	P117	DB914	DB954	DB994	DB1034	P141	DB1094	DB1134	DB1174	
42	S43	DB18	DB55	DB95	DB135	DB158	DB195	DB235	DB275	DB315	DB338	DB375	DB415	DB455	DB495	DB518	DB555	DB595	DB635	DB675	DB698	DB735	DB775	DB815	DB855	DB878	DB915	DB955	DB995	DB1035	DB1058	DB1095	DB1135	DB1175	
43	S44	S70	DB56	DB96	DB136	P22	DB196	DB236	DB276	DB316	P46	DB376	DB416	DB456	DB496	P70	DB556	DB596	DB636	DB676	P94	DB736	DB776	DB816	DB856	P118	DB916	DB956	DB996	DB1036	P142	DB1096	DB1136	DB1176	
44	S45	DB19	DB57	DB97	DB137	DB159	DB197	DB237	DB277	DB317	DB339	DB377	DB417	DB457	DB497	DB519	DB557	DB597	DB637	DB677	DB699	DB737	DB777	DB817	DB857	DB879	DB917	DB957	DB997	DB1037	DB1059	DB1097	DB1137	DB1177	
45	S46	S71	DB58	DB98	DB138	P23	DB198	DB238	DB278	DB318	P47	DB378	DB418	DB458	DB498	P71	DB558	DB598	DB638	DB678	P95	DB738	DB778	DB818	DB858	P119	DB918	DB958	DB998	DB1038	P143	DB1098	DB1138	DB1178	
46	S47	DB20	DB59	DB99	DB139	DB160	DB199	DB239	DB279	DB319	DB340	DB379	DB419	DB459	DB499	DB520	DB559	DB599	DB639	DB679	DB700	DB739	DB779	DB819	DB859	DB880	DB919	DB959	DB999	DB1039	DB1060	DB1099	DB1139	DB1179	
47	S48	S72	DB60	DB100	DB140	P24	DB200	DB240	DB280	DB320	P48	DB380	DB420	DB460	DB500	P72	DB560	DB600	DB640	DB680	P96	DB740	DB780	DB820	DB860	P120	DB920	DB960	DB1000	DB1040	P144	DB1100	DB1140	DB1180	

ij

The allocation of the sub-carrier symbols and their content are presented in Table P.27. For this type of burst, the data set uses only 4-QAM modulation sub-carrier symbols.

Table P.27: Frequency Correction Burst (FCB) for QAM

Channel Bandwidth	SS Set	Number of SS symbols	Set content	Bnmax	Definition
All	H1 to H32	32	Downlink slot header set	64	See clause 9.4.8.3.9
	F1 to F60	60	Frequency correction set	not applicable	See clause 9.4.8.3.9
	DA1 to DA136	136	Frequency correction data set A	272	See clause 9.4.8.3.10
	S'1 to S'8	8	Secondary sync sequence set	not applicable	See clause 9.4.8.3.3A
25 KHz	S1 to S12	12	Downlink sync sequence set	not applicable	See clause 9.4.8.3.3
	P1 to P24	24	Full-slot downlink pilots set	not applicable	See clause 9.4.8.3.6
50 KHz	S1 to S24	24	Downlink sync sequence set	not applicable	See clause 9.4.8.3.3
	P1 to P48	48	Full-slot downlink pilots set	not applicable	See clause 9.4.8.3.6
	DB1 to DB236	236	Frequency correction data set B	472	See clause 9.4.8.3.11
100 KHz	S1 to S48	48	Downlink sync sequence set	not applicable	See clause 9.4.8.3.3
	P1 to P96	96	Full-slot downlink pilots set	not applicable	See clause 9.4.8.3.6
	DB1 to DB708	708	Frequency correction data set B	1 416	See clause 9.4.8.3.11
150 KHz	S1 to S72	72	Downlink sync sequence set	not applicable	See clause 9.4.8.3.3
	P1 to P144	144	Full-slot downlink pilots set	not applicable	See clause 9.4.8.3.6
	DB1 to DB1180	1 180	Frequency correction data set B	2 360	See clause 9.4.8.3.11

P.2 Burst sub-carrier symbol sets

P.2.1 Uplink sync sequence set

The numbering and use of this symbol set is defined in clause 9.4.8.3.2. The amplitude of the symbols is as described in clause 5.13. The symbol waveform filter independent phases are defined as a multiple of π radians. The values of the phases shall be as expressed in tables P.28 to P.31.

Table P.28: Uplink sync sequence set USS8 phase values as a multiple of π radians

USS8	
S1	0,67190
S2	-0,83201
S3	0,69601
S4	-0,07206
S5	0,07206
S6	-0,69601
S7	0,83201
S8	-0,67190
S9	0,20310
S10	-0,54299
S11	-0,32101
S12	0,19706
S13	-0,19706
S14	0,32101
S15	0,54299
S16	-0,20310

Table P.29: Uplink sync sequence set USS16 phase values as a multiple of π radians

<i>USS16</i>			
S1	0,50431	S17	-0,62931
S2	-0,23747	S18	-0,13753
S3	0,41092	S19	0,96408
S4	-0,36690	S20	-0,50810
S5	-0,14414	S21	-0,98086
S6	0,21904	S22	0,40596
S7	-0,23052	S23	0,60552
S8	-0,78060	S24	0,90560
S9	0,78060	S25	-0,90560
S10	0,23052	S26	-0,60552
S11	-0,21904	S27	-0,40596
S12	0,14414	S28	0,98086
S13	0,36690	S29	0,50810
S14	-0,41092	S30	-0,96408
S15	0,23747	S31	0,13753
S16	-0,50431	S32	0,62931

Table P.30: Uplink sync sequence set USS32 phase values as a multiple of π radians

<i>USS32</i>							
S1	-0,43253	S17	0,14760	S33	0,30753	S49	-0,27260
S2	-0,57262	S18	0,86183	S34	0,19762	S50	0,76317
S3	0,91410	S19	-0,25480	S35	0,46090	S51	-0,37020
S4	0,77733	S20	-0,89652	S36	0,34767	S52	0,02152
S5	0,63921	S21	0,08524	S37	0,23579	S53	0,78976
S6	-0,48052	S22	-0,44834	S38	-0,89448	S54	-0,92666
S7	0,38733	S23	0,97904	S39	-0,01233	S55	-0,60404
S8	0,81992	S24	0,35346	S40	-0,69492	S56	-0,22846
S9	-0,35346	S25	-0,81992	S41	0,22846	S57	0,69492
S10	-0,97904	S26	-0,38733	S42	0,60404	S58	0,01233
S11	0,44834	S27	0,48052	S43	0,92666	S59	0,89448
S12	-0,08524	S28	-0,63921	S44	-0,78976	S60	-0,23579
S13	0,89652	S29	-0,77733	S45	-0,02152	S61	-0,34767
S14	0,25480	S30	-0,91410	S46	0,37020	S62	-0,46090
S15	-0,86183	S31	0,57262	S47	-0,76317	S63	-0,19762
S16	-0,14760	S32	0,43253	S48	0,27260	S64	-0,30753

Table P.31: Uplink sync sequence set USS48 phase values as a multiple of π radians

<i>USS48</i>											
S1	0,03434	S17	0,30684	S33	-0,73860	S49	-0,15934	S65	-0,43184	S81	0,61360
S2	-0,74665	S18	0,45957	S34	0,16353	S50	0,37165	S66	-0,83457	S82	-0,53853
S3	0,64037	S19	0,42437	S35	-0,71507	S51	0,73463	S67	0,95063	S83	0,09007
S4	-0,24758	S20	-0,65456	S36	0,66230	S52	-0,62742	S68	-0,22044	S84	0,46270
S5	-0,11663	S21	0,49251	S37	-0,46788	S53	0,99163	S69	0,38249	S85	-0,65712
S6	0,81293	S22	0,86560	S38	0,02273	S54	-0,18793	S70	-0,24060	S86	0,60227
S7	0,24810	S23	0,22977	S39	-0,49450	S55	0,12690	S71	0,14523	S87	0,86950
S8	0,92339	S24	-0,20342	S40	-0,60400	S56	-0,79839	S72	0,32842	S88	0,72900
S9	0,60400	S25	0,20342	S41	-0,92339	S57	-0,72900	S73	-0,32842	S89	0,79839
S10	0,49450	S26	-0,22977	S42	-0,24810	S58	-0,86950	S74	-0,14523	S90	-0,12690
S11	-0,02273	S27	-0,86560	S43	-0,81293	S59	-0,60227	S75	0,24060	S91	0,18793
S12	0,46788	S28	-0,49251	S44	0,11663	S60	0,65712	S76	-0,38249	S92	-0,99163
S13	-0,66230	S29	0,65456	S45	0,24758	S61	-0,46270	S77	0,22044	S93	0,62742
S14	0,71507	S30	-0,42437	S46	-0,64037	S62	-0,09007	S78	-0,95063	S94	-0,73463
S15	-0,16353	S31	-0,45957	S47	0,74665	S63	0,53853	S79	0,83457	S95	-0,37165
S16	0,73860	S32	-0,30684	S48	-0,03434	S64	-0,61360	S80	0,43184	S96	0,15934

P.2.2 Downlink sync sequence set

The numbering and use of this symbol set is defined in clause 9.4.8.3.3. The amplitude of the symbols is as described in clause 5.13. The symbol waveform filter independent phases are defined as a multiple of π radians. The values of the phases shall be as expressed in tables P.32 to P.35.

Table P.32: Downlink sync sequence set DSS8 phase values as a multiple of π radians

<i>DSS8</i>	
S1	0,98180
S2	0,80687
S3	-0,83599
S4	0,22390
S5	-0,22390
S6	0,83599
S7	-0,80687
S8	-0,98180
S9	-0,10680
S10	-0,78901
S11	0,78901
S12	0,10680

Table P.33: Downlink sync sequence set DSS16 phase values as a multiple of π radians

<i>DSS16</i>			
S1	0,69624	S13	-0,74070
S2	-0,42021	S14	0,59028
S3	-0,59028	S15	0,42021
S4	0,74070	S16	-0,69624
S5	0,98180	S17	-0,82124
S6	0,80687	S18	-0,03472
S7	-0,83599	S19	-0,10680
S8	0,22390	S20	-0,78901
S9	-0,22390	S21	0,78901
S10	0,83599	S22	0,10680
S11	-0,80687	S23	0,03472
S12	-0,98180	S24	0,82124

Table P.34: Downlink sync sequence set DSS32 phase values as a multiple of π radians

<i>DSS32</i>							
S1	-0,69081	S13	0,98180	S25	-0,45675	S37	-0,07171
S2	0,95190	S14	0,80687	S26	0,97464	S38	0,14912
S3	0,17230	S15	-0,83599	S27	-0,50153	S39	-0,10680
S4	0,99091	S16	0,22390	S28	0,78198	S40	-0,78901
S5	-0,78198	S17	-0,22390	S29	-0,99091	S41	0,78901
S6	0,50153	S18	0,83599	S30	-0,17230	S42	0,10680
S7	-0,97464	S19	-0,80687	S31	-0,95190	S43	-0,14912
S8	0,45675	S20	-0,98180	S32	0,69081	S44	0,07171
S9	-0,05329	S21	0,34018	S33	0,56581	S45	0,65036
S10	-0,55326	S22	0,77412	S34	-0,79730	S46	0,34302
S11	-0,77412	S23	0,55326	S35	-0,34302	S47	0,79730
S12	-0,34018	S24	0,05329	S36	-0,65036	S48	-0,56581

Table P.35: Downlink sync sequence set DSS48 phase values as a multiple of π radians

<i>DSS48</i>											
S1	-0,42160	S13	0,58812	S25	-0,22390	S37	0,49694	S49	0,29660	S61	0,78901
S2	0,99986	S14	0,49850	S26	0,83599	S38	-0,77020	S50	-0,54658	S62	0,10680
S3	-0,07842	S15	0,79337	S27	-0,80687	S39	0,30147	S51	-0,12701	S63	0,77546
S4	0,81763	S16	0,55757	S28	-0,98180	S40	-0,09935	S52	-0,19551	S64	-0,06962
S5	-0,99799	S17	-0,19462	S29	-0,22270	S41	0,85311	S53	-0,22435	S65	0,41837
S6	0,45136	S18	0,78269	S30	-0,15046	S42	-0,57051	S54	0,60480	S66	-0,28688
S7	0,57051	S19	0,15046	S31	-0,78269	S43	-0,45136	S55	0,28688	S67	-0,60480
S8	-0,85311	S20	0,22270	S32	0,19462	S44	0,99799	S56	-0,41837	S68	0,22435
S9	0,09935	S21	0,98180	S33	-0,55757	S45	-0,81763	S57	0,06962	S69	0,19551
S10	-0,30147	S22	0,80687	S34	-0,79337	S46	0,07842	S58	-0,77546	S70	0,12701
S11	0,77020	S23	-0,83599	S35	-0,49850	S47	-0,99986	S59	-0,10680	S71	0,54658
S12	-0,49694	S24	0,22390	S36	-0,58812	S48	0,42160	S60	-0,78901	S72	-0,29660

P.2.3 Half-slot uplink pilots set

The numbering and use of this symbol set is defined in clause 9.4.8.3.4. The amplitude of the symbols is as described in clause 5.13. The symbol waveform filter independent phases are defined as a multiple of π radians. The values of the phases shall be as expressed in tables P.36 to P.39.

Table P.36: Half-slot Uplink Pilots Set HUPS8 phase values as a multiple of π radians

<i>HUPS8</i>	
P1	-0,77675
P2	-0,99415
P3	0,02270
P4	0,85321
P5	-0,77675
P6	-0,99415
P7	-0,97730
P8	-0,14679
P9	0,22325
P10	0,00585
P11	-0,97730
P12	-0,14679

Table P.37: Half-slot Uplink Pilots Set HUPS16 phase values as a multiple of π radians

<i>HUPS16</i>			
P1	-0,61834	P13	-0,97730
P2	0,32487	P14	-0,14679
P3	-0,77675	P15	-0,24886
P4	-0,99415	P16	-0,57485
P5	0,02270	P17	0,38166
P6	0,85321	P18	-0,67513
P7	0,75114	P19	0,22325
P8	0,42515	P20	0,00585
P9	-0,61834	P21	-0,97730
P10	0,32487	P22	-0,14679
P11	-0,77675	P23	-0,24886
P12	-0,99415	P24	-0,57485

Table P.38: Half-slot Uplink Pilots Set HUPS32 phase values as a multiple of π radians

<i>HUPS32</i>							
P1	-0,68802	P13	0,96016	P25	-0,97730	P37	0,40752
P2	0,76268	P14	0,02775	P26	-0,14679	P38	0,63007
P3	0,74075	P15	0,76268	P27	0,98120	P39	0,22325
P4	0,95335	P16	-0,52905	P28	0,48894	P40	0,00585
P5	-0,59248	P17	-0,68802	P29	-0,03984	P41	-0,97730
P6	-0,36993	P18	0,76268	P30	-0,97225	P42	-0,14679
P7	-0,77675	P19	0,74075	P31	-0,23732	P43	0,98120
P8	-0,99415	P20	0,95335	P32	0,47095	P44	0,48894
P9	0,02270	P21	-0,59248	P33	0,31198	P45	-0,03984
P10	0,85321	P22	-0,36993	P34	-0,23732	P46	-0,97225
P11	-0,01880	P23	-0,77675	P35	-0,25925	P47	-0,23732
P12	-0,51106	P24	-0,99415	P36	-0,04665	P48	0,47095

Table P.39: Half-slot Uplink Pilots Set HUPS48 phase values as a multiple of π radians

<i>HUPS48</i>											
P1	0,40869	P13	0,02270	P25	0,40869	P37	-0,97730	P49	-0,59131	P61	-0,97730
P2	-0,95949	P14	0,85321	P26	-0,95949	P38	-0,14679	P50	0,04051	P62	-0,14679
P3	0,19009	P15	0,36990	P27	0,19009	P39	-0,63010	P51	-0,80991	P63	-0,63010
P4	0,43550	P16	0,93643	P28	0,43550	P40	-0,06357	P52	-0,56450	P64	-0,06357
P5	0,32821	P17	-0,97339	P29	0,32821	P41	0,02661	P53	-0,67179	P65	0,02661
P6	0,55944	P18	-0,65544	P30	0,55944	P42	0,34456	P54	-0,44056	P66	0,34456
P7	0,62331	P19	-0,24319	P31	0,62331	P43	0,75681	P55	-0,37669	P67	0,75681
P8	0,17103	P20	0,23268	P32	0,17103	P44	-0,76732	P56	-0,82897	P68	-0,76732
P9	0,50730	P21	-0,25551	P33	0,50730	P45	0,74449	P57	-0,49270	P69	0,74449
P10	0,05567	P22	-0,80672	P34	0,05567	P46	0,19328	P58	-0,94433	P70	0,19328
P11	-0,77675	P23	0,56451	P35	-0,77675	P47	-0,43549	P59	0,22325	P71	-0,43549
P12	-0,99415	P24	-0,97755	P36	-0,99415	P48	0,02245	P60	0,00585	P72	0,02245

P.2.4 Full-slot uplink pilots set

The numbering and use of this symbol set is defined in clause 9.4.8.3.5. The amplitude of the symbols is as described in clause 5.13. The symbol waveform filter independent phases are defined as a multiple of π radians. The values of the phases shall be as expressed in tables P.40 to P.43.

**Table P.40: Full-slot Uplink Pilots Set FUPS8 phase values
as a multiple of π radians**

<i>FUPS8</i>	
P1	-0,90175
P2	0,38085
P3	0,64770
P4	0,97821
P5	0,97325
P6	-0,24415
P7	0,27270
P8	0,10321
P9	-0,15175
P10	0,13085
P11	0,89770
P12	0,22821
P13	-0,77675
P14	-0,99415
P15	0,02270
P16	0,85321
P17	-0,40175
P18	0,88085
P19	0,14770
P20	0,47821
P21	0,09825
P22	-0,61915
P23	-0,35230
P24	-0,02179

**Table P.41: Full-slot Uplink Pilots Set FUPS16 phase values
as a multiple of π radians**

FUPS16			
P1	0,25666	P25	-0,61834
P2	0,69987	P26	0,32487
P3	-0,90175	P27	-0,77675
P4	0,38085	P28	-0,99415
P5	0,64770	P29	0,02270
P6	0,97821	P30	0,85321
P7	0,37614	P31	0,75114
P8	-0,44985	P32	0,42515
P9	-0,86834	P33	0,75666
P10	-0,92513	P34	-0,80013
P11	0,97325	P35	-0,40175
P12	-0,24415	P36	0,88085
P13	0,27270	P37	0,14770
P14	0,10321	P38	0,47821
P15	-0,99886	P39	-0,12386
P16	-0,32485	P40	-0,94985
P17	-0,99334	P41	-0,74334
P18	0,44987	P42	-0,30013
P19	-0,15175	P43	0,09825
P20	0,13085	P44	-0,61915
P21	0,89770	P45	-0,35230
P22	0,22821	P46	-0,02179
P23	0,62614	P47	-0,62386
P24	0,80015	P48	0,55015

Table P.42: Full-slot Uplink Pilots Set FUPS32 phase values as a multiple of π radians

<i>FUPS32</i>							
P1	0,18698	P25	0,27270	P49	-0,68802	P73	0,14770
P2	-0,86232	P26	0,10321	P50	0,76268	P74	0,47821
P3	0,61575	P27	0,23120	P51	0,74075	P75	-0,89380
P4	0,32835	P28	0,73894	P52	0,95335	P76	0,11394
P5	0,28252	P29	-0,78984	P53	-0,59248	P77	-0,91484
P6	0,00507	P30	-0,72225	P54	-0,36993	P78	-0,34725
P7	-0,90175	P31	-0,98732	P55	-0,77675	P79	-0,11232
P8	0,38085	P32	0,72095	P56	-0,99415	P80	0,09595
P9	0,64770	P33	0,93698	P57	0,02270	P81	-0,81302
P10	0,97821	P34	0,88768	P58	0,85321	P82	0,13768
P11	-0,39380	P35	-0,63425	P59	-0,01880	P83	-0,38425
P12	0,61394	P36	0,07835	P60	-0,51106	P84	-0,67165
P13	-0,41484	P37	-0,96748	P61	0,96016	P85	-0,71748
P14	0,15275	P38	-0,24493	P62	0,02775	P86	-0,99493
P15	0,38768	P39	-0,15175	P63	0,76268	P87	0,09825
P16	0,59595	P40	0,13085	P64	-0,52905	P88	-0,61915
P17	-0,93802	P41	0,89770	P65	0,68698	P89	-0,35230
P18	-0,48732	P42	0,22821	P66	-0,36232	P90	-0,02179
P19	0,49075	P43	-0,14380	P67	-0,88425	P91	0,60620
P20	-0,29665	P44	-0,13606	P68	0,82835	P92	-0,38606
P21	-0,84248	P45	-0,16484	P69	0,78252	P93	0,58516
P22	0,38007	P46	-0,59725	P70	0,50507	P94	-0,84725
P23	0,97325	P47	0,63768	P71	-0,40175	P95	-0,61232
P24	-0,24415	P48	-0,15405	P72	0,88085	P96	-0,40405

Table P.43: Full-slot Uplink Pilots Set FUPS48 phase values as a multiple of π radians

<i>FUPS48</i>											
P1	-0,71631	P25	0,15869	P49	0,03369	P73	0,40869	P97	-0,21631	P121	0,28369
P2	-0,58449	P26	-0,20949	P50	-0,83449	P74	-0,95949	P98	-0,08449	P122	0,41551
P3	0,06509	P27	-0,05991	P51	0,81509	P75	0,19009	P99	0,56509	P123	-0,93491
P4	-0,18950	P28	-0,81450	P52	-0,43950	P76	0,43550	P100	0,31050	P124	0,81050
P5	-0,79679	P29	0,07821	P53	-0,04679	P77	0,32821	P101	-0,29679	P125	0,20321
P6	0,93444	P30	-0,69056	P54	0,68444	P78	0,55944	P102	-0,56556	P126	-0,06556
P7	0,49831	P31	0,37331	P55	-0,75169	P79	0,62331	P103	0,99831	P127	-0,50169
P8	-0,45397	P32	0,92103	P56	-0,70397	P80	0,17103	P104	0,04603	P128	0,54603
P9	-0,61770	P33	0,25730	P57	0,13230	P81	0,50730	P105	-0,11770	P129	0,38230
P10	0,43067	P34	0,80567	P58	0,18067	P82	0,05567	P106	0,93067	P130	-0,56933
P11	-0,90175	P35	0,97325	P59	-0,15175	P83	-0,77675	P107	-0,40175	P131	0,09825
P12	0,38085	P36	-0,24415	P60	0,13085	P84	-0,99415	P108	0,88085	P132	-0,61915
P13	0,64770	P37	0,27270	P61	0,89770	P85	0,02270	P109	0,14770	P133	-0,35230
P14	0,97821	P38	0,10321	P62	0,22821	P86	0,85321	P110	0,47821	P134	-0,02179
P15	-0,00510	P39	0,61990	P63	0,24490	P87	0,36990	P111	-0,50510	P135	0,99490
P16	0,06143	P40	0,18643	P64	-0,68857	P88	0,93643	P112	-0,43857	P136	-0,93857
P17	-0,34839	P41	-0,72339	P65	-0,09839	P89	-0,97339	P113	-0,84839	P137	0,65161
P18	-0,53044	P42	0,59456	P66	0,71956	P90	-0,65544	P114	0,96956	P138	0,46956
P19	-0,61819	P43	0,00681	P67	-0,36819	P91	-0,24319	P115	0,88181	P139	0,38181
P20	-0,64232	P44	-0,51732	P68	0,60768	P92	0,23268	P116	0,85768	P140	0,35768
P21	0,36949	P45	-0,00551	P69	0,61949	P93	-0,25551	P117	-0,13051	P141	-0,63051
P22	-0,68172	P46	0,44328	P70	0,56828	P94	-0,80672	P118	0,81828	P142	0,31828
P23	0,18951	P47	0,81451	P71	0,43951	P95	0,56451	P119	-0,31049	P143	-0,81049
P24	0,14745	P48	0,27245	P72	-0,60255	P96	-0,97755	P120	-0,35255	P144	-0,85255

P.2.5 Full-slot downlink pilots set

The numbering and use of this symbol set is defined in clause 9.4.8.3.5. The amplitude of the symbols is as described in clause 5.13. The symbol waveform filter independent phases are defined as a multiple of π radians. The values of the phases shall be as expressed in tables P.44 to P.47.

Table P.44: Downlink Pilots Set FDPS8 phase values as a multiple of π radians

<i>FDPS8</i>	
P1	-0,77675
P2	-0,99415
P3	0,02270
P4	0,85321
P5	0,96985
P6	-0,57733
P7	0,57733
P8	-0,96985
P9	-0,02675
P10	0,75585
P11	0,27270
P12	0,10321
P13	-0,65175
P14	-0,36915
P15	-0,60230
P16	0,72821
P17	-0,27675
P18	-0,49415
P19	-0,47730
P20	0,35321
P21	0,09825
P22	-0,61915
P23	-0,35230
P24	-0,02179

**Table P.45: Downlink Pilots Set FDPS16 phase values
as a multiple of π radians**

<i>FDPS16</i>			
P1	-0,61834	P25	0,50666
P2	0,32487	P26	-0,05013
P3	-0,77675	P27	-0,65175
P4	-0,99415	P28	-0,36915
P5	0,02270	P29	-0,60230
P6	0,85321	P30	0,72821
P7	0,75114	P31	-0,87386
P8	0,42515	P32	-0,69985
P9	-0,31839	P33	-0,11834
P10	-0,64267	P34	0,82487
P11	0,96985	P35	-0,27675
P12	-0,57733	P36	-0,49415
P13	0,57733	P37	-0,47730
P14	-0,96985	P38	0,35321
P15	-0,22663	P39	0,25114
P16	-0,93193	P40	-0,07485
P17	0,13166	P41	-0,74334
P18	0,07487	P42	-0,30013
P19	-0,02675	P43	0,09825
P20	0,75585	P44	-0,61915
P21	0,27270	P45	-0,35230
P22	0,10321	P46	-0,02179
P23	-0,99886	P47	-0,62386
P24	-0,32485	P48	0,55015

Table P.46: Downlink Pilots Set FDPS32 phase values as a multiple of π radians

FDPS32							
P1	-0,68802	P25	0,57733	P49	0,43698	P73	-0,47730
P2	0,76268	P26	-0,96985	P50	0,38768	P74	0,35321
P3	0,74075	P27	0,71089	P51	0,86575	P75	-0,51880
P4	0,95335	P28	0,78770	P52	-0,42165	P76	0,98894
P5	-0,59248	P29	-0,39755	P53	0,53252	P77	0,46016
P6	-0,36993	P30	-0,56099	P54	-0,74493	P78	-0,47225
P7	-0,77675	P31	0,80111	P55	-0,65175	P79	0,26268
P8	-0,99415	P32	0,35060	P56	-0,36915	P80	0,97095
P9	0,02270	P33	0,06198	P57	-0,60230	P81	-0,81302
P10	0,85321	P34	0,51268	P58	0,72821	P82	0,13768
P11	-0,01880	P35	-0,50925	P59	0,35620	P83	-0,38425
P12	-0,51106	P36	0,70335	P60	0,36394	P84	-0,67165
P13	0,96016	P37	0,15752	P61	0,33516	P85	-0,71748
P14	0,02775	P38	-0,61993	P62	-0,09725	P86	-0,99493
P15	0,76268	P39	-0,02675	P63	-0,86232	P87	0,09825
P16	-0,52905	P40	0,75585	P64	0,34595	P88	-0,61915
P17	-0,36875	P41	0,27270	P65	-0,18802	P89	-0,35230
P18	0,69641	P42	0,10321	P66	-0,73732	P90	-0,02179
P19	-0,76835	P43	0,23120	P67	-0,75925	P91	0,60620
P20	-0,45208	P44	0,73894	P68	-0,54665	P92	-0,38606
P21	0,45770	P45	-0,78984	P69	-0,09248	P93	0,58516
P22	-0,43225	P46	-0,72225	P70	0,13007	P94	-0,84725
P23	0,96985	P47	-0,98732	P71	-0,27675	P95	-0,61232
P24	-0,57733	P48	0,72095	P72	-0,49415	P96	-0,40405

Table P.47: Downlink Pilots Set FDPS48 phase values as a multiple of π radians

FDPS48											
P1	0,40869	P25	-0,95923	P49	-0,84131	P73	-0,46631	P97	0,90869	P121	0,28369
P2	-0,95949	P26	-0,19966	P50	0,79051	P74	0,66551	P98	-0,45949	P122	0,41551
P3	0,19009	P27	0,72691	P51	0,94009	P75	0,31509	P99	0,69009	P123	-0,93491
P4	0,43550	P28	0,00502	P52	0,18550	P76	-0,93950	P100	0,93550	P124	0,81050
P5	0,32821	P29	-0,54264	P53	-0,92179	P77	-0,54679	P101	0,82821	P125	0,20321
P6	0,55944	P30	0,71870	P54	0,30944	P78	0,18444	P102	-0,94056	P126	-0,06556
P7	0,62331	P31	0,80411	P55	-0,62669	P79	0,74831	P103	-0,87669	P127	-0,50169
P8	0,17103	P32	-0,13019	P56	-0,07897	P80	0,79603	P104	0,67103	P128	0,54603
P9	0,50730	P33	0,75959	P57	-0,74270	P81	-0,36770	P105	-0,99270	P129	0,38230
P10	0,05567	P34	-0,51745	P58	-0,19433	P82	-0,31933	P106	0,55567	P130	-0,56933
P11	-0,77675	P35	0,96985	P59	-0,02675	P83	-0,65175	P107	-0,27675	P131	0,09825
P12	-0,99415	P36	-0,57733	P60	0,75585	P84	-0,36915	P108	-0,49415	P132	-0,61915
P13	0,02270	P37	0,57733	P61	0,27270	P85	-0,60230	P109	-0,47730	P133	-0,35230
P14	0,85321	P38	-0,96985	P62	0,10321	P86	0,72821	P110	0,35321	P134	-0,02179
P15	0,36990	P39	-0,70486	P63	0,61990	P87	0,74490	P111	-0,13010	P135	0,99490
P16	0,93643	P40	-0,17845	P64	0,18643	P88	-0,18857	P112	0,43643	P136	-0,93857
P17	-0,97339	P41	0,97135	P65	-0,72339	P89	0,40161	P113	0,52661	P137	0,65161
P18	-0,65544	P42	-0,00409	P66	0,59456	P90	-0,78044	P114	0,84456	P138	0,46956
P19	-0,24319	P43	-0,12898	P67	0,00681	P91	0,13181	P115	-0,74319	P139	0,38181
P20	0,23268	P44	-0,46624	P68	-0,51732	P92	-0,89232	P116	-0,26732	P140	0,35768
P21	-0,25551	P45	-0,86440	P69	-0,00551	P93	-0,88051	P117	-0,75551	P141	-0,63051
P22	-0,80672	P46	-0,68654	P70	0,44328	P94	-0,93172	P118	0,69328	P142	0,31828
P23	0,56451	P47	-0,46720	P71	0,81451	P95	0,93951	P119	0,06451	P143	-0,81049
P24	-0,97755	P48	0,83510	P72	0,27245	P96	-0,10255	P120	0,52245	P144	-0,85255

P.2.6 Filler sets

The numbering and use of these symbol sets are defined in clause 9.4.8.3.7. The amplitude of the symbols is as described in clause 5.13. The symbol waveform filter independent phases are defined as a multiple of π radians. The values of the phases shall be as expressed in tables P.48 to P.55.

Table P.48: Filler Set A FiSA8 phase values as a multiple of π radians

<i>FiSA8</i>	
FiA1	0,75204
FiA2	-0,58430
FiA3	0,95743
FiA4	0,49625
FiA5	0,50375
FiA6	0,04257
FiA7	-0,41570
FiA8	0,24796
FiA9	-0,50000
FiA10	0,50000
FiA11	-0,50000
FiA12	-0,50000
FiA13	-0,50000
FiA14	-0,50000
FiA15	0,50000
FiA16	-0,50000
FiA17	0,24796
FiA18	-0,41570
FiA19	0,04257
FiA20	0,50375
FiA21	0,49625
FiA22	0,95743
FiA23	-0,58430
FiA24	0,75204

Table P.49: Filler Set A FiSA16 phase values as a multiple of π radians

FiSA16			
FiA1	-0,75639	FiA25	0,50000
FiA2	-0,36021	FiA26	-0,50000
FiA3	0,82607	FiA27	-0,50000
FiA4	0,50316	FiA28	0,50000
FiA5	-0,73390	FiA29	-0,50000
FiA6	0,77596	FiA30	0,50000
FiA7	-0,77875	FiA31	0,50000
FiA8	0,08003	FiA32	0,50000
FiA9	0,91997	FiA33	-0,24361
FiA10	-0,22125	FiA34	-0,63979
FiA11	0,22404	FiA35	0,17393
FiA12	-0,26610	FiA36	0,49684
FiA13	0,49684	FiA37	-0,26610
FiA14	0,17393	FiA38	0,22404
FiA15	-0,63979	FiA39	-0,22125
FiA16	-0,24361	FiA40	0,91997
FiA17	0,50000	FiA41	0,08003
FiA18	0,50000	FiA42	-0,77875
FiA19	0,50000	FiA43	0,77596
FiA20	-0,50000	FiA44	-0,73390
FiA21	0,50000	FiA45	0,50316
FiA22	-0,50000	FiA46	0,82607
FiA23	-0,50000	FiA47	-0,36021
FiA24	0,50000	FiA48	-0,75639

Table P.50: Filler Set A FiSA32 phase values as a multiple of π radians

FiSA32							
FiA1	0,01334	FiA25	0,60533	FiA49	-0,50000	FiA73	-0,47455
FiA2	0,55821	FiA26	0,48932	FiA50	-0,50000	FiA74	0,91276
FiA3	0,42374	FiA27	-0,44554	FiA51	0,50000	FiA75	-0,45073
FiA4	-0,05004	FiA28	-0,08948	FiA52	0,50000	FiA76	-0,69412
FiA5	-0,91052	FiA29	-0,94996	FiA53	-0,50000	FiA77	-0,66409
FiA6	-0,55446	FiA30	0,57626	FiA54	-0,50000	FiA78	-0,16860
FiA7	0,51068	FiA31	0,44179	FiA55	-0,50000	FiA79	0,36719
FiA8	0,39467	FiA32	0,98666	FiA56	-0,50000	FiA80	-0,80037
FiA9	-0,52545	FiA33	0,50000	FiA57	-0,50000	FiA81	-0,19963
FiA10	0,08724	FiA34	0,50000	FiA58	-0,50000	FiA82	0,63281
FiA11	-0,54927	FiA35	-0,50000	FiA59	0,50000	FiA83	-0,83140
FiA12	-0,30588	FiA36	0,50000	FiA60	-0,50000	FiA84	-0,33591
FiA13	-0,33591	FiA37	-0,50000	FiA61	0,50000	FiA85	-0,30588
FiA14	-0,83140	FiA38	0,50000	FiA62	-0,50000	FiA86	-0,54927
FiA15	0,63281	FiA39	-0,50000	FiA63	0,50000	FiA87	0,08724
FiA16	-0,19963	FiA40	-0,50000	FiA64	0,50000	FiA88	-0,52545
FiA17	-0,80037	FiA41	-0,50000	FiA65	0,98666	FiA89	0,39467
FiA18	0,36719	FiA42	-0,50000	FiA66	0,44179	FiA90	0,51068
FiA19	-0,16860	FiA43	-0,50000	FiA67	0,57626	FiA91	-0,55446
FiA20	-0,66409	FiA44	-0,50000	FiA68	-0,94996	FiA92	-0,91052
FiA21	-0,69412	FiA45	0,50000	FiA69	-0,08948	FiA93	-0,05004
FiA22	-0,45073	FiA46	0,50000	FiA70	-0,44554	FiA94	0,42374
FiA23	0,91276	FiA47	-0,50000	FiA71	0,48932	FiA95	0,55821
FiA24	-0,47455	FiA48	-0,50000	FiA72	0,60533	FiA96	0,01334

Table P.51: Filler Set A FiSA48 phase values as a multiple of π radians

<i>FiSA48</i>											
FiA1	0,12836	FiA25	0,19698	FiA49	-0,50000	FiA73	-0,50000	FiA97	0,87164	FiA121	0,80302
FiA2	-0,84195	FiA26	-0,26635	FiA50	-0,50000	FiA74	0,50000	FiA98	-0,15805	FiA122	-0,73365
FiA3	0,91084	FiA27	-0,19250	FiA51	-0,50000	FiA75	-0,50000	FiA99	0,08916	FiA123	-0,80750
FiA4	-0,14609	FiA28	0,15926	FiA52	0,50000	FiA76	0,50000	FiA100	-0,85391	FiA124	0,84074
FiA5	0,15839	FiA29	-0,19669	FiA53	-0,50000	FiA77	0,50000	FiA101	0,84161	FiA125	-0,80331
FiA6	0,06634	FiA30	-0,75652	FiA54	-0,50000	FiA78	0,50000	FiA102	0,93366	FiA126	-0,24348
FiA7	-0,82586	FiA31	-0,17711	FiA55	-0,50000	FiA79	-0,50000	FiA103	-0,17414	FiA127	-0,82289
FiA8	-0,34694	FiA32	-0,13511	FiA56	0,50000	FiA80	0,50000	FiA104	-0,65306	FiA128	-0,86489
FiA9	0,22480	FiA33	-0,17785	FiA57	0,50000	FiA81	0,50000	FiA105	0,77520	FiA129	-0,82215
FiA10	-0,41949	FiA34	-0,29517	FiA58	-0,50000	FiA82	0,50000	FiA106	-0,58051	FiA130	-0,70483
FiA11	-0,25113	FiA35	0,60773	FiA59	0,50000	FiA83	0,50000	FiA107	-0,74887	FiA131	0,39227
FiA12	0,63543	FiA36	-0,11453	FiA60	-0,50000	FiA84	-0,50000	FiA108	0,36457	FiA132	-0,88547
FiA13	-0,88547	FiA37	0,36457	FiA61	-0,50000	FiA85	-0,50000	FiA109	-0,11453	FiA133	0,63543
FiA14	0,39227	FiA38	-0,74887	FiA62	0,50000	FiA86	0,50000	FiA110	0,60773	FiA134	-0,25113
FiA15	-0,70483	FiA39	-0,58051	FiA63	0,50000	FiA87	-0,50000	FiA111	-0,29517	FiA135	-0,41949
FiA16	-0,82215	FiA40	0,77520	FiA64	0,50000	FiA88	0,50000	FiA112	-0,17785	FiA136	0,22480
FiA17	-0,86489	FiA41	-0,65306	FiA65	0,50000	FiA89	0,50000	FiA113	-0,13511	FiA137	-0,34694
FiA18	-0,82289	FiA42	-0,17414	FiA66	-0,50000	FiA90	-0,50000	FiA114	-0,17711	FiA138	-0,82586
FiA19	-0,24348	FiA43	0,93366	FiA67	0,50000	FiA91	-0,50000	FiA115	-0,75652	FiA139	0,06634
FiA20	-0,80331	FiA44	0,84161	FiA68	0,50000	FiA92	-0,50000	FiA116	-0,19669	FiA140	0,15839
FiA21	0,84074	FiA45	-0,85391	FiA69	0,50000	FiA93	0,50000	FiA117	0,15926	FiA141	-0,14609
FiA22	-0,80750	FiA46	0,08916	FiA70	-0,50000	FiA94	-0,50000	FiA118	-0,19250	FiA142	0,91084
FiA23	-0,73365	FiA47	-0,15805	FiA71	0,50000	FiA95	-0,50000	FiA119	-0,26635	FiA143	-0,84195
FiA24	0,80302	FiA48	0,87164	FiA72	-0,50000	FiA96	-0,50000	FiA120	0,19698	FiA144	0,12836

**Table P.52: Filler Set B FiSB8 phase values
as a multiple of π radians**

<i>FiSB8</i>	
FiB1	0,87704
FiB2	-0,20930
FiB3	-0,41757
FiB4	-0,62875
FiB5	-0,37125
FiB6	-0,58243
FiB7	-0,79070
FiB8	0,12296
FiB9	-0,37500
FiB10	0,87500
FiB11	0,12500
FiB12	0,37500
FiB13	0,62500
FiB14	0,87500
FiB15	0,12500
FiB16	-0,62500
FiB17	0,37296
FiB18	-0,04070
FiB19	0,66757
FiB20	-0,62125
FiB21	-0,37875
FiB22	0,33243
FiB23	-0,95930
FiB24	0,62704

**Table P.53: Filler Set B FiSB16 phase values
as a multiple of π radians**

<i>FiSB16</i>			
FiB1	0,36861	FiB25	-0,37500
FiB2	-0,98521	FiB26	0,87500
FiB3	0,45107	FiB27	-0,87500
FiB4	0,37816	FiB28	0,37500
FiB5	-0,60890	FiB29	-0,37500
FiB6	-0,84904	FiB30	0,87500
FiB7	-0,15375	FiB31	-0,87500
FiB8	0,95503	FiB32	-0,62500
FiB9	0,04497	FiB33	0,88139
FiB10	-0,84625	FiB34	0,73521
FiB11	-0,15096	FiB35	-0,20107
FiB12	-0,39110	FiB36	0,37184
FiB13	0,62184	FiB37	-0,14110
FiB14	0,54893	FiB38	0,59904
FiB15	-0,01479	FiB39	0,40375
FiB16	0,63139	FiB40	-0,20503
FiB17	-0,37500	FiB41	-0,79497
FiB18	-0,12500	FiB42	0,59625
FiB19	0,12500	FiB43	0,40096
FiB20	-0,62500	FiB44	-0,85890
FiB21	0,62500	FiB45	0,62816
FiB22	-0,12500	FiB46	-0,79893
FiB23	0,12500	FiB47	0,26479
FiB24	-0,62500	FiB48	0,11861

Table P.54: Filler Set B FiSB32 phase values as a multiple of π radians

<i>FiSB32</i>							
FiB1	-0,86166	FiB25	-0,26967	FiB49	0,62500	FiB73	0,65045
FiB2	-0,06679	FiB26	-0,13568	FiB50	0,87500	FiB74	0,28776
FiB3	0,04874	FiB27	-0,82054	FiB51	0,12500	FiB75	-0,82573
FiB4	-0,17504	FiB28	-0,21448	FiB52	0,37500	FiB76	-0,81912
FiB5	-0,78552	FiB29	-0,82496	FiB53	-0,37500	FiB77	-0,53909
FiB6	-0,17946	FiB30	0,95126	FiB54	-0,12500	FiB78	0,20640
FiB7	-0,86432	FiB31	-0,93321	FiB55	0,12500	FiB79	0,99219
FiB8	-0,73033	FiB32	-0,13834	FiB56	0,37500	FiB80	0,07463
FiB9	0,59955	FiB33	-0,37500	FiB57	0,62500	FiB81	0,92537
FiB10	-0,53776	FiB34	-0,12500	FiB58	0,87500	FiB82	0,00781
FiB11	-0,92427	FiB35	-0,87500	FiB59	0,12500	FiB83	0,79360
FiB12	-0,43088	FiB36	0,37500	FiB60	-0,62500	FiB84	-0,46091
FiB13	-0,21091	FiB37	-0,37500	FiB61	0,62500	FiB85	-0,18088
FiB14	-0,45640	FiB38	0,87500	FiB62	-0,12500	FiB86	-0,17427
FiB15	-0,74219	FiB39	0,12500	FiB63	-0,87500	FiB87	0,71224
FiB16	0,67537	FiB40	0,37500	FiB64	-0,62500	FiB88	0,34955
FiB17	0,32463	FiB41	0,62500	FiB65	0,11166	FiB89	-0,48033
FiB18	-0,25781	FiB42	0,87500	FiB66	-0,18321	FiB90	-0,11432
FiB19	-0,54360	FiB43	-0,87500	FiB67	0,20126	FiB91	-0,92946
FiB20	-0,78909	FiB44	-0,62500	FiB68	0,92504	FiB92	0,96448
FiB21	-0,56912	FiB45	0,62500	FiB69	0,03552	FiB93	0,07496
FiB22	-0,07573	FiB46	0,87500	FiB70	-0,07054	FiB94	0,79874
FiB23	-0,46224	FiB47	0,12500	FiB71	-0,88568	FiB95	-0,81679
FiB24	0,40045	FiB48	0,37500	FiB72	-0,51967	FiB96	0,88834

Table P.55: Filler Set B FiSB48 phase values as a multiple of π radians

<i>FiSB48</i>											
FiB1	-0,74664	FiB25	-0,67802	FiB49	0,62500	FiB73	0,62500	FiB97	-0,00336	FiB121	-0,07198
FiB2	0,53305	FiB26	-0,89135	FiB50	0,87500	FiB74	-0,12500	FiB98	-0,78305	FiB122	0,64135
FiB3	0,53584	FiB27	-0,56750	FiB51	-0,87500	FiB75	-0,87500	FiB99	-0,28584	FiB123	0,81750
FiB4	-0,27109	FiB28	0,03426	FiB52	0,37500	FiB76	0,37500	FiB100	-0,97891	FiB124	0,71574
FiB5	0,28339	FiB29	-0,07169	FiB53	-0,37500	FiB77	0,62500	FiB101	0,96661	FiB125	-0,67831
FiB6	0,44134	FiB30	-0,38152	FiB54	-0,12500	FiB78	0,87500	FiB102	-0,69134	FiB126	0,13152
FiB7	-0,20086	FiB31	0,44789	FiB55	0,12500	FiB79	0,12500	FiB103	0,45086	FiB127	-0,19789
FiB8	0,52806	FiB32	0,73989	FiB56	-0,62500	FiB80	-0,62500	FiB104	0,22194	FiB128	0,01011
FiB9	-0,65020	FiB33	0,94715	FiB57	-0,37500	FiB81	-0,37500	FiB105	-0,09980	FiB129	0,30285
FiB10	0,95551	FiB34	-0,92017	FiB58	0,87500	FiB82	-0,12500	FiB106	0,79449	FiB130	0,67017
FiB11	-0,62613	FiB35	0,23273	FiB59	0,12500	FiB83	0,12500	FiB107	0,87613	FiB131	0,01727
FiB12	0,51043	FiB36	-0,23953	FiB60	-0,62500	FiB84	-0,62500	FiB108	0,23957	FiB132	0,98953
FiB13	-0,76047	FiB37	0,48957	FiB61	-0,37500	FiB85	-0,37500	FiB109	0,01047	FiB133	0,76043
FiB14	0,76727	FiB38	-0,37387	FiB62	0,87500	FiB86	0,87500	FiB110	0,98273	FiB134	0,12387
FiB15	-0,07983	FiB39	0,04449	FiB63	-0,87500	FiB87	0,12500	FiB111	0,32983	FiB135	0,20551
FiB16	0,05285	FiB40	-0,34980	FiB64	-0,62500	FiB88	-0,62500	FiB112	0,69715	FiB136	-0,90020
FiB17	0,26011	FiB41	0,47194	FiB65	-0,37500	FiB89	-0,37500	FiB113	0,98989	FiB137	0,77806
FiB18	0,55211	FiB42	-0,79914	FiB66	0,87500	FiB90	0,87500	FiB114	-0,80211	FiB138	0,54914
FiB19	-0,61848	FiB43	0,55866	FiB67	0,12500	FiB91	-0,87500	FiB115	0,86848	FiB139	-0,30866
FiB20	-0,92831	FiB44	0,71661	FiB68	0,37500	FiB92	-0,62500	FiB116	-0,32169	FiB140	0,03339
FiB21	0,96574	FiB45	-0,72891	FiB69	0,62500	FiB93	0,62500	FiB117	0,28426	FiB141	-0,02109
FiB22	-0,43250	FiB46	0,46416	FiB70	-0,12500	FiB94	-0,12500	FiB118	0,18250	FiB142	-0,71416
FiB23	-0,10865	FiB47	0,46695	FiB71	-0,87500	FiB95	0,12500	FiB119	0,35865	FiB143	-0,21695
FiB24	-0,32198	FiB48	-0,25336	FiB72	0,37500	FiB96	0,37500	FiB120	-0,92802	FiB144	-0,99664

P.2.7 Linearization downlink zeroed set

The numbering and use of this symbol set is defined in clauses 9.4.8.3.8 and P.1.6. The linearization downlink zeroed set is a set of sub-carrier symbols whose magnitude is equal to zero.

P.2.8 Frequency correction set

The numbering and use of these symbol sets are defined in clauses 9.4.8.3.9 and P.1.7. The Frequency Correction Set contains 60 sub-carrier symbols independent of the number of sub-carriers used. They are denoted FrCS. The amplitude of the non-zero symbols is as described in clause 5.13 for pilots. The rest have zero amplitude.

The values of the phases shall be as expressed in table P.56. For the non-zero sub-channel symbols, the symbol waveform filter independent phases are defined as a multiple of π radians. Those marked 0 in the table shall have zero amplitude.

Table P.56: Frequency Correction Set phase values as a multiple of π radians (0 indicate zero amplitude)

FrCS									
F1	-0,40175	F13	0	F25	0,57364	F37	0,97325	F49	0
F2	-0,30136	F14	0,77270	F26	0	F38	-0,17636	F50	-0,10230
F3	0,88085	F15	0,17344	F27	0	F39	-0,24415	F51	0,04844
F4	0	F16	0,60321	F28	0,92344	F40	0	F52	-0,77179
F5	0	F17	-0,65175	F29	-0,90175	F41	0	F53	0,72325
F6	0,14770	F18	0,94864	F30	0,19864	F42	-0,72730	F54	-0,92636
F7	-0,20156	F19	-0,36915	F31	0,38085	F43	-0,32656	F55	0,50585
F8	0,47821	F20	0	F32	0	F44	-0,89679	F56	0
F9	-0,52675	F21	0	F33	0	F45	0,84825	F57	0
F10	-0,67636	F22	-0,60230	F34	0,64770	F46	-0,55136	F58	0,52270
F11	0,25585	F23	0,54844	F35	-0,70156	F47	-0,86915	F59	0,42344
F12	0	F24	0,72821	F36	0,97821	F48	0	F60	-0,64679

The FrCS is used in all frequency correction bursts.

The disposition of the phases of the non-zero symbols is such that, together with the intervening sub-carrier pilot symbols (see tables P.23 ... P.26), they generate discrete tones ± 4 800 Hz, ± 7 200 Hz and ± 9 600 Hz away from the transmitter carrier frequency.

P.2.9 Secondary sync sequence set

The numbering and use of these symbol sets are defined in clauses 9.4.8.3.9 and P.1.7. The Secondary sync Sequence Set contains 8 sub-carrier symbols independent of the number of sub-carriers used. They are denoted SSS.

The SSS are used in all frequency correction bursts and help the MS, together with its surrounding pilots, time synchronize to the symbol, following successful frequency correction.

The values of the phases shall be as expressed in table P.57. For the non-zero sub-channel symbols, the symbol waveform filter independent phases are defined as a multiple of π radians.

**Table P.57: Secondary sync Sequence Set phase values
as a multiple of π radians**

SSS	
S'1	-0,59485
S'2	-0,67411
S'3	0,45233
S'4	-0,97982
S'5	0,97982
S'6	-0,45233
S'7	0,67411
S'8	0,59485

Annex Q (normative): Graceful service degradation mode

Q.1 General

The graceful service degradation mode is intended to provide best effort SDS and status message (short message) services, when an MS has entered into a weak signal situation, where normal speech or data circuit operation in MS traffic mode is no longer available, refer to clause Q.2.

It is outside the scope of the present annex to define which short message services and applications may use the graceful service degradation mode. One example for using the graceful service degradation mode is a callout service that uses the SDS-TL transport service without store and forward functionality.

NOTE 1: The TETRA Association has specified a Callout service.

The present document does not preclude the use of graceful service degradation mode for other services (i.e. circuit mode speech, circuit mode data, and packet data) and applications based on those services. It is outside the scope of the present document to define how to support them.

In the protocol model MLE layer controls entering and leaving the graceful service degradation mode.

NOTE 2: MLE is chosen as the controlling point as it could dynamically control which services are allowed in the graceful service degradation mode, if a network broadcast will be defined in a later version of the present document.

Network layer service entity may indicate which messages are eligible for graceful service degradation mode even in the normal mode and lower layers may apply separate buffers for the graceful service degradation mode messages so that those can by-pass other messages, when MS enters graceful service degradation mode.

Q.2 Procedures

Q.2.1 Entering graceful service degradation mode

An MS may enter graceful service degradation mode, if serving cell radio link failure occurs as defined in clause 18.3.4.5.3 and if the MS is unable to reselect any neighbour cell in the ranking list whose main carrier path loss parameter, C1 or C2, is greater than zero. The indications "maximum path delay exceeded" and "common channel deallocated" in MLE-REPORT indication shall not invoke graceful service degradation mode.

Upon entering graceful service degradation mode MLE tells to network layer entities in the MLE-BREAK(GSDM) indication which services are allowed during the graceful service degradation mode. MLE shall keep the communication for those services and command lower layer by TL-CONFIGURE request.

Q.2.2 Operating in graceful service degradation mode

When operating in graceful service degradation mode, an MS shall provide only the specific services that are allowed to use the graceful service degradation mode to the MS user as informed in MLE-BREAK(GSDM) indication primitive.

NOTE 1: It is outside the scope of the present document to define how the MLE knows which services it is permitted to use when MS has entered into the graceful service degradation mode.

When operating in graceful service degradation mode, an MS may not be able to successfully transmit a short message on the uplink. In this case, transmission failure should be indicated to the short message service or application:

- at the TNSDS-SAP with the help of the TNSDS-REPORT primitive as defined in clause 13.3.2.2;
- at the SDS-TL-SAP with the help of the TLSDS-TNSDS-REPORT primitive as defined in clause 29.2.2; and

- at the Concatenation-SAP with the help of the Concatenation-TNSDS-REPORT primitive as defined in clause 29.5.14.3.2.

If transmission failure is detected in graceful service degradation mode, the MS should try to retransmit the uplink short message up to the maximum number of retransmissions (N400). The MS should apply a retransmission algorithm, e.g. wait:

- after initial transmission, the waiting time before first retransmission (T400);
- after first retransmission, the waiting time before second retransmission (T401);
- after second and subsequent retransmissions, the waiting time before other retransmissions (T402).

If an MS finally fails to retransmit an uplink short message in graceful service degradation mode, the MS should locally store the uplink short message as long as it is valid. It is outside the scope of the present document if the storage period of a stored uplink short message:

- is locally defined by a storage timer;
- can be extended by another uplink short message;
- can be defined by other means that are application specific.

NOTE 2: It is an implementation option of the short message service or application to define the storage period, the type and the maximum number of uplink short messages to be stored in graceful service degradation mode.

An MS should try to retransmit an uplink short message in graceful service degradation mode, even if the MS previously failed to retransmit another uplink short message, i.e. an MS should separately apply the retransmission procedure to all uplink short messages.

If an MS is waiting for expiry of timer T400, T401, or T402 in order to retransmit an uplink short message, if the pathloss parameter C1 for the serving cell becomes greater than zero for a short period of time, e.g. less than five seconds, and if the MS has not yet decided to leave graceful service degradation mode as indicated by MLE-BREAK(GSDM) indication, then the MS should stop timer T400, T401, or T402, should instantaneously retransmit the uplink short message and may send some or all valid short messages on the uplink which are either stored or awaiting transmission.

NOTE 3: Implementations may use a modified or different retransmission strategy during graceful service degradation mode than outlined in this clause. The retransmission strategy should prevent overloading of the signalling channel.

Q.2.3 Criterion for temporary break of service in graceful service degradation mode

When an MS operates in graceful service degradation mode and if the MS is no longer able to reliably decode downlink data for a short period of time for graceful service degradation mode purposes MLE shall indicate that with a MLE-BREAK indication, the MS may remain ready for graceful service degradation mode. During this temporary break of service, the MS shall not send any uplink messages related to the graceful service degradation mode and should suspend timer T400, T401, or T402. When the MS is again able to reliably decode downlink data for graceful service degradation mode purposes as indicated by MLE-BREAK(GSDM) indication, the MS should continue timer T400, T401, or T402 and should continue transmitting or retransmitting uplink short messages. When the MS is permanently unable to reliably decode downlink data for graceful service degradation mode purposes, then the MS shall follow the procedure as defined in clause Q.2.5.

NOTE: It is outside the scope of the present document to define the duration of a temporary break of service in graceful service degradation mode.

Q.2.4 Criterion for leaving graceful service degradation mode due to service aggradation

An MS shall leave graceful service degradation mode in order to regain full service:

- if the pathloss parameter C1 for the serving cell becomes greater than zero for normal service;
- if the MS selects a neighbour cell the pathloss parameter C1 of which is greater than zero and greater than the pathloss parameter C1 of the serving cell plus FAST_RESELECT_HYSTERESIS;
- if the MS selects a cell not contained in the neighbour cell list the pathloss parameter C1 of which is greater than zero and greater than the pathloss parameter C1 of the serving cell plus FAST_RESELECT_HYSTERESIS.

When an MS has left graceful service degradation mode and if the MS has regained service as indicated by MLE-RESUME indication, the MS should send all valid short messages on the uplink which are either stored or awaiting transmission or retransmission.

Q.2.5 Criterion for leaving graceful service degradation mode due to catastrophic service degradation

An MS shall leave graceful service degradation mode due to permanent service unavailability, if the MS is no longer able to reliably decode downlink data for an extended period of time for graceful service degradation mode purposes or if the BS of the serving cell has entered no service mode as defined in clause 19.3.6. MLE indicates that situation to the upper layers with a MLE-CLOSE indication. Thus, the MS invokes the initial cell selection procedure as defined in clause 18.3.4.6.

Q.2.6 Criterion for starting scanning of neighbour cells in graceful service degradation mode

When operating in graceful service degradation mode, an MS shall continue scanning of neighbour cells as defined in clause 18.3.4.5.2.

Q.2.7 Criterion for starting scanning of non-neighbour cells in graceful service degradation mode

When operating in graceful service degradation mode for an extended period of time, an MS may start scanning cells not contained in the neighbour cell list. Actual details are out of the scope of the present document.

Q.3 Constants and Timers

This clause lists the graceful service degradation mode constants and timers in the MS. The MS designer shall choose a value from within a given range which shall be used by the MS unless it received a different value when it subscribed to a network.

N400 Maximum number of retransmissions =

- Retransmission not allowed 0;
- Retransmissions allowed: 1 to 10, default = 3.

T400 Waiting time before first retransmission =

- 10 s to 180 s, default = 30 s.

T401 Waiting time before second retransmission =

- 10 s to 180 s, default = 60 s.

T402 Waiting time before other retransmissions =

- 10 s to 180 s, default = 90 s.

Annex R (normative): Subscriber Class Preference levels

R.1 Introduction

Subscriber class preference levels can be used by operators to create different network layers, e.g.:

- air cells to be used by MSs installed in helicopters and fixed wing airplanes at flying altitude, thus avoiding RF interference on "normal" cells;
- terrestrial cells intended for indoor coverage, providing dedicated coverage (and often small capacity) in a specific building or area;
- "normal" terrestrial cells intended for outdoor coverage;
- underground cells intended to provide (low capacity) services into Underground Transit networks.

R.2 Subscriber Class preference levels

There are four preference levels for subscriber classes:

- 1) Highly Preferred Subscriber Class (HPSC).
- 2) Preferred Subscriber Class (PSC).
- 3) (Basic) Subscriber Class (BSC).
- 4) Unpreferred Subscriber Class (USC).

Subscriber classes 1 and 2 are reserved for HPSC and one of them is used for A2G service as described in annex O. The allocation of the remaining subscriber classes 3-16 (see clauses 16.10.49 and 18.5.22) to the preference levels is out of scope of the present document.

Annex S (informative): Multiple CA cells sharing a channel - interim method

This version of the present document supports sharing of an assigned channel by MSs from multiple DA cells, or by MSs from one DA cell and one CA cell, or by MSs from multiple DA cells and one CA cell. However it does not provide a general method for sharing of an assigned channel by MSs from multiple CA cells. In general, if this facility is supported in a future version of the present document, the CA MSs on the shared channel would need to use some different procedures to support this function fully (for example, when processing SYSINFO PDUs received on a shared channel and when receiving the channel allocation at the end of the call). However, it may be possible for SwMIs to use the following restricted method in the interim without the MSs being aware of the usage.

NOTE 1: It is possible that some MS implementations may include checks that are not compatible with this restricted method.

This is the case of CA cells that have the same MCC, MNC, LA and colour code (and the same static cipher key or common cipher key), and where one of the CA cells is an umbrella cell i.e. a cell whose coverage area fully covers the coverage areas of the other CA cells; this could occur, for example, if there are CA cells that have a sectored coverage area within a CA cell that is nominally circular (and whose radial range is the same as or greater than the radial range of the sectored cells). Then the CA MSs on those cells could be assigned to a phase modulation channel that is conforming relative to the umbrella CA cell's main carrier, with a channel allocation to the umbrella CA cell's main carrier at the end of the call. Thus those CA MSs from the smaller CA cells that have accepted the call on the umbrella channel undergo a forced cell change onto the umbrella CA cell. This cell change is likely to be un-noticed by the CA MSs, since the LA is the same.

NOTE 2: It is possible that some MS implementations may include checks that are not compatible with this method.

Since the umbrella channel is conforming relative to the new CA cell, a non-augmented channel allocation could be used when allocating the umbrella channel to the CA MSs, including the MSs from the smaller CA cells. Therefore this method may be usable for all CA MSs, including those that do not support the augmented channel allocation.

SYSINFO PDUs sent on the umbrella channel would indicate the main carrier of the umbrella CA cell.

The umbrella CA cell and the smaller CA cells would need to use the same "cell identifier CA" values to identify the same CA neighbour cells (including the other CA cells that may send MSs to the umbrella channel) and would need to use the same "cell identifier DA" values to identify the same DA neighbour cells.

When a CA MS has undergone a forced and un-noticed cell change as a result of accepting a channel allocation for the umbrella channel, it will not have its old CA cell on its neighbour cell list but will probably have the new CA cell on its neighbour cell list.

- The MS is likely to receive neighbour cell information for its old CA cell in due course.
- However the MS could continue to monitor or scan its new CA cell, regarding it as a neighbour cell, and could decide to re-select to it if the umbrella CA cell's main carrier happens to have a better RSSI than the assigned umbrella channel. If the SwMI wishes to avoid this, it could send revised "neighbour cell information" on the assigned umbrella channel for the "cell identifier CA" used by the smaller CA cells for the umbrella CA cell, to overwrite the MS's record of the umbrella CA cell as a neighbour and, for example, indicating a carrier number not used locally. (If there are also DA MSs sharing the umbrella channel and using the same cell identifier CA for the umbrella CA cell, the SwMI could then send genuine information about the umbrella CA cell as the local CA cell in the "neighbour cell information for CA" element in the D-NWRK-BROADCAST-DA PDU.)

It is expected that whatever preference caused the MS to select the smaller CA cell in the first place would cause the MS to return to a smaller cell in due course at the end of the call.

Annex T (informative): Change Requests

The present document includes Change Requests as presented in table T.1.

NOTE: The version number column indicates the version that is used as the baseline for the CR and the next version of the standard is modified as indicated in the CR.

Table T.1: List of Change Requests

No	CR vers.	Version (see note)	Clauses affected	Title	CR Status
001	APP	V2.1.1	28.4.4.1, 28.4.4.2, 28.4.4.3, 28.4.5.2	Access point name index size	EPT Approved 2000
002	APPi	V2.3.2	17.3.5, 17.3.6, 17.3.9, 18.2.4, 18.2.8, 20.2.4, 20.3.4, 20.3.5.1, 22.1.2, 22.2.2.3, 22.2.2.5, 22.2.2.7, 22.3.3.2.2, 22.3.3.2.7, 28.2.4.7, 28.2.6.2 and clause A.1	READY timer enhancement	EPT approved 011121
003	APP	V2.3.1	29.5.4.2	Text Character Encoding and Packing for 7, 8 and 16-bit Alphabet	EPT approved 010305
004	APP	V2.3.1	29.4.3.9	Error in see note reference	EPT approved 010305
005	APP	V2.3.1	16.10.5 Table 167	Clarification of Concurrent Channel in Class of MS	EPT approved 010419
006	APP	V2.3.1	14.4.2 Figure 22	Acceptance of D_INFO in CC WAIT state	EPT approved 010305
007	APP	V2.3.1	21.4.4.1	Additional bit required for Security Information ("GCK Supported") for use in 392-7	EPT approved 010419
008	APP	V2.3.1	28.2.4.5, 28.2.4.8, Figure 184 and Table 365	Migration of Packet Data Mobile	EPT approved 010419
009	REJ	V2.3.1	28.2.5a	Mismatch of subscriber class	Rejected
010	APPi2	V2.3.1	28.3.6, 28.4.1, 28.4.4.3, 28.4.5.10, 28.4.5.38 and 28.4.5.45	Correction of typographical errors and minor omissions	EPT approved 010419
011	APPi	V2.3.2	28.2.4.4, 28.2.4.7, 28.4.4.9, 28.5	Use of Immediate service change element on downlink	EPT approved 011121
012	REJ	V2.3.1	16.4, 16.9, 16.10	SwMI Capabilities	Withdrawn
013	REJ	V2.3.1	21.4.4.1	Additional bit required for Security Information ("Short GCK-VN") for use in 392-7	Rejected
014	REJ	V2.3.1	14.5.6.2	PDU Priority for U-INFO	Rejected
015	Comb	V2.3.1	11.3.4, 14.8.18	New additional disconnect cause	Combined with CR021
016	APP	V2.3.1	28.3.3.4	Clarification to Packet Data MS type	EPT approved 010629
017	APP	V2.3.1	annex C	Correction to CRC calculation algorithm	EPT approved 010629
018		V2.3.1			Not used
019	Comb	V2.3.1	11.3.4, 14.8.18	New additional disconnect cause	Combined with CR021
020	APP	V2.3.2	28.4.4.1 and 28.4.4.3	Access point name index element on downlink	EPT approved 011121
021	APP	V2.3.1	14.8.18	New disconnect causes	EPT approved 011121
022	REJ	V2.3.1	14.8.18	New disconnect cause; Unknown number	Withdrawn
023	REJ	V2.3.2	16	Subscriber class	Rejected

No	CR vers.	Version (see note)	Clauses affected	Title	CR Status
024	APPi2	V2.3.2	11.3.4, 14.5.1.1.5, 14.8.18	DCOMP negotiation element	EPT approved 011121
025	APP	V2.3.2	29.4.3.9	SDS-TL Protocol IDs for encryption	EPT approved 020130
026	APP	V2.3.2	18.5.17	Note on Timeshare cell and AI encryption element	EPT approved 011121
027	APP	V2.3.2	16.4.11, 16.9.2.5.9, 16.10.7b, 16.10.7c, 17.3.1, 17.3.2, 17.3.9, 20.3.5.4.1, 20.4.1.1.4, 20.2.4.29a	Periodic distance reporting MM-STATUS PDU	EPT approved 020130
028	APP	V2.3.2	28.3.3.4	Packet data MS type	EPT approved 030307
029	APP	V2.3.2	16.11.1.1	Registration timer T351	EPT approved 030307
030	APP	V2.3.2	14.6	Call restoration timer T307 (P2MP)	EPT approved 030307
031	APP	V2.3.2	29.5.2, 29.5.3 and 29.4.3.9	Reservation of Protocol Identifiers for Immediate Text messaging	EPT approved 030307
032	APP	V2.3.2	16.10.5 (Table 167)	Errors in references to ETSI ETS 300 392-2 and ETSI EN 300 392-2	EPT approved 030307
033	APP	V2.3.2	21.4.4.2 (Table 335)	Errors in references to ETSI EN 300 392-2 and ETSI ETS/EN 300 392-7	EPT approved 030307
034	APP	V2.3.2	29.4.3.9	SDS-TL PID for OTAR should be for OTAK for End to End Encryption Key Delivery	EPT approved 030307
035	APP	V2.3.2	29.5.4.1	Mistake in the referred clause number 29.5.4.3	EPT approved 030307
036	APP	V2.3.2	9.4.4.3.6	Phase adjustment bits and n2 value	EPT approved 030307
037	APP	V2.3.2	23.3.1.2.1	Expand description of common SCCH configuration changes on BNCH	EPT approved 030307
038	APP	V2.3.2	14.5.6b, 17.3.1, 17.3.2, 17.3.5, 17.3.6, 17.3.9, 23.7.6, 28.2.4.4, 28.2.4.6, 28.2.4.7, 28.2.4.8	Improve call set-up phase response for mobiles using Energy Economy Group	EPT approved 030307
039	APP	V2.3.2	29.4.3.2	Correction of the report source	EPT approved 030307
040	APP	V2.3.2	29.3.3.6.3, 29.4.3.2	Modification of the report reason "Destination not reachable, message stored by SwMI"	EPT approved 030307
041	APP	V2.3.2	28.4.5.28	Update to PCOMP negotiation table	EPT approved 030307
042	APP	V2.3.2	28.4.5.9	BSD compression and uncompressed data	EPT approved 030307
043	APP	V2.3.2	28.3.5.4.2, 28.3.5.4.3, 28.3.5.4.4	Clarification over data compression	EPT approved 030307
044	APP	V2.3.2	14.8.34	Typo in 14.8.34 Pre-coded status	EPT approved 030307
045	APP	V2.3.2	6.6.2.3	Change in 6.6.2.3 Receiver performance at reference interference ratios	EPT approved 030704
046	APP	V2.3.2	21.4.4.2	Change of System Code in V+D to give 1 bit to DMO for 2 additional values	EPT approved 030708
047	REJ	V2.3.2	23.7.1.1	<i>Path loss parameter C1</i>	<i>Withdrawn</i>
048	APP	V2.3.2	18.3.4.7.5	Error in reference to ETSI EN 300 392-7	EPT approved 030708
049	APP	V2.3.2	clause K.2	Change of Hong Kong country code	EPT approved 030708
050	APP	V2.3.2	18.5.24	TETRA System Time bits	EPT approved 030708
051	APP	V2.3.2	3.1	Further editorial corrections	EPT approved 030708
052	APP	V2.3.2	29.4.3.9	SDS-TL PID extension	EPT approved 030708
053	REJ	V2.3.2	16.9.2.7, 16.10.51, 16.10.41	<i>Addition to the Air Interface in order to support Radio User Assignment (RUA)</i>	<i>Withdrawn</i>
054	APP	V2.3.2	16.10.5, 21.4.4.2	TETRA standard version number	EPT approved 030708
101	APP2	V2.4.2	18.3.4.6, 18.3.4.7, 19.3, 23.3.1.1, 23.3.1.2.1,	Addition of a new system (BS) mode of operation	EPT approved 050429

No	CR vers.	Version (see note)	Clauses affected	Title	CR Status
			23.5.6.1.1, clause B.2		
102	APP	V2.4.2	3.2, 29.5.4.1, Annex L	Definition of how characters beyond that available with UCS-2 encoding is to be supported	EPT approved 040901
103	APP	V2.4.2	29.5.1.2	Clarification of 29.5.1.2	EPT approved 040901
104	APP	V2.4.2	23.5.4.2.2, 23.5.4.2.3	Movement of event labels	EPT approved 040901
105	APP	V2.4.2	22.1.1	Need for multiple advanced links	EPT approved 050429
106	APP	V2.4.2	16.3.1.3.4, 17.3.6, 18.3.5.3.3, 20.2.4.24, 22.3.6, 23.7.6, 23.7.7	Energy economy mode inconsistencies between layers	EPT approved 050429
107	APP	V2.4.2	16.10.48	Periodic distance reporting "status downlink" value	EPT approved 040901
108	APP	V2.4.2	16.10.5, 21.4.4.2	Erroneous implementation of CR054	EPT approved 040901
109	APP	V2.4.2	29.5.7, Annex I	GPS coding scheme information element value application	EPT approved 050429
110	APP	V2.4.2	18.5.24	TETRA Network Time	EPT approved 040901
111	APP	V2.4.2	2, 3.1, 3.2, 29.4.3.2, 29.4.3.9, 29.5.9 (new), 29.5.10 (new), 29.5.11 (new), Annex N (new)	Message with User Data Header	EPT approved 040901
112	APP	V2.4.2	9.4.4.3.6, 14, 16, 18, 21, 28, 29	Indication of PDU type in the PDU definition tables	EPT approved 040901
113	REJ	V2.4.2	16.10.30, 18.5.9	<i>LA range limitation due to ETSI EN 300 392-7</i>	<i>Part 7 modified</i>
114	APP	V2.4.2	11.3.3.5, 14.5.1.2.2	Notice of imminent call disconnection	EPT approved 040901
115	APP	V2.4.2	16.11.1.3	T353 value editorial correction	EPT approved 040901
116	APP	V2.4.2	14.6	T310 value range alignment	EPT approved 040901
117	APP	V2.4.2	clause B.1	T201 value on the assigned channel	EPT approved 040901
118	APP	V2.4.2	annex J	Improvement of SDS-TL PID application form	EPT approved 040901
119	REJ	V2.4.2	18.3.4.5.4, 18.3.4.5.5	<i>Cell dragging</i>	<i>Withdrawn</i>
120	APP	V2.4.2	8.2.3.2	Typo in RM definition equation	EPT approved 050429
121	APP	V2.4.2	2, 3, 29.4.3.9, 29.5.12	Location information transport protocol - additions to SDS-TL	EPT approved 050429
122	SUB	V2.4.2	<i>annex (new)</i>	<i>Location information transport protocol - transport method independent part</i>	<i>Refer to TS 300 392-18-1</i>
123	APP	V2.4.2	2, annex K	Annex K update due to publication of ITU-T E.218	EPT approved 050429
124	APP	V2.4.2	23.5.2.3.1	Slot granting and not sending null PDU	EPT approved 050429
125	APP	V2.4.2	5.4	Missing part of equation (4)	EPT approved 050429
126	APP	V2.4.2	23.5.2.3.2	Wrong range	EPT approved 050429
127	APP	V2.4.2	many clauses in 17 to 23 and 28 to 29	Addition of data priority feature for packet data	EPT approved 050429
128	APP	V2.4.2	annex J	Overlapping allocation of PID values	EPT approved 050429
129	APP	V2.4.2	28.4.5.31	Length of protocol identity contents - clarification	EPT approved 050429
130	APP	V2.4.2	clause A.1	Counting downlink frames during reserved access on a multi-slot channel	EPT approved 050429
131	APP	V2.4.2	21.5.2, 23.5.4.3.3	Channel allocation with "Up/downlink assigned" element set to 00 ₂	EPT approved 050429
132	APP	V2.4.2	28.3.4.2	Editorial correction in clause 28.3.4.2	EPT approved 050429
133	APP	V2.4.2	20.3.1	Unacknowledged advance link on uplink	EPT approved 050429
134	APP	V2.4.2	28.3.4.2	Additional clarification in the use of the SN-RECONNECT PDU	EPT approved 050429
135	APP	V2.4.2	28.2.4.4, 28.2.4.6, 28.2.4.7, 28.2.4.8	Sleeping due to SNDCP state	EPT approved 050429
136	APP	V2.4.2	22.3.4.2	Unnecessary repetition of TL-CONNECT indication	EPT approved 050429
137	APP	V2.4.2	23.5.4.2.1, 28.2.4.7, 28.3.4.6	Correction of MS behaviour on receipt of a group-addressed	EPT approved 050429

No	CR vers.	Version (see note)	Clauses affected	Title	CR Status
				SN-END OF DATA PDU when the READY timer is active	
138	APP	V2.4.2	15.3.1	TNMM-STATUS response	EPT approved 050429
139	APP	V2.4.2	18.3.4.7, 18.3.4.7.1	Conditions affecting the cell reselection method.	EPT approved 050429
140	APP	V2.4.2	18.2.6, 18.3.5.4, 20.3.5.1.7, 28.3.4.7	Incorrect use of TL-RELEASE indication primitive	EPT approved 050429
141	APP	V2.4.2	28.3.4.2	Clarification in the use of the SN RECONNECT PDU	EPT approved 050429
142	REJ	V2.4.2	16.10.5	GCK encryption support in Class of MS element	Refer to ETSI EN 300 392-7
143	APP	V2.4.2	28.2.4.4, 28.2.4.7	MS SNDPCP can get stuck in READY state.	EPT approved 050429
144	APP	V2.4.2	28.3.5.3.1, 28.3.5.3.2, 28.5.3.3.3, 28.3.5.4.1, 28.4.4.14	Inclusion of the PCOMP information element in SN-UNITDATA PDUs	EPT approved 050429
145	APP	V2.4.2	E.2.1	Conditional information elements in type 2 information element	EPT approved 050429
146	APP	V2.4.2	29.3.2.1, 29.3.2.2, 29.3.2.8, 29.4.3.9, 29.5.5, 29.5.6, 29.5.7, Annex I	GPS and generic location information systems	EPT approved 050429
147	10	V2.4.2	foreword, 1	Contents of the scope	TETRA approved 050615
201	11	V2.5.2	18.3.4.7.2, 28.2.4.4, 28.2.4.6, 28.3.4.2	Clarification of Advanced Link Connection Status	TETRA approved 060712
202	10	V2.5.2	16.9.2.1, 16.9.2.2, 16.9.2.7	Definition of Security Related Information and Group Identity Security Related Information element	TETRA approved 060712
203	10	V2.5.2	28.2.4.7, 28.2.5, 28.2.5a, 28.3.4.7	Actions following receipt by the MS SNDPCP of an MLE CONFIGURE indication announcing "loss of radio resources".	TETRA approved 060712
204	10	V2.5.2	16.4.1.1, 16.10.42, 16.11.2, 16.11.2.1	Actions following authentication failure	TETRA approved 060712
205	10	V2.5.1	21.4.7, 29.5.7, 29.5.12.1, I.1	Identified editorial errors	TETRA approved 060712
206	10	V2.5.1	annex M	Errors in table numbering mapping for clause 18	TETRA approved 060712
207	REJ	V2.5.2		LIP usage during temporary disable	Withdrawn
208	10	V2.5.2	28.2.4.4, 28.2.6.4, 28.3.4.4	Use of SN-RECONNECT and SERVICE_CHANGE timer	TETRA approved 060712
209	10	V2.5.2	16.10.5, 21.4.4.2	Version number	TETRA approved 060712
210	10	V2.5.2	18.3.4.5.1, 18.3.4.5.6b, 18.3.4.5.7, 18.3.4.7, 18.3.4.7.1	Quick handover in tunnels and similar conditions	TETRA approved 060712
211	10	V2.5.2	18.3.5.3.3, 23.7.6, 23.7.7	Additional clarification of the use of Energy Economy Groups during call set-up phase	TETRA approved 060712
212	10	V2.5.2	annex O CR requests	Alignment of TS 100 392-2 version with EN 300 392-7 version V2.3.1	For information
213	10	V2.5.2	29.5.9.3, 29.5.10.3, 29.5.11.3 new, 29.5.11.4 to 29.5.11.10	Time stamp used and Text encoding method information element lengths	TETRA approved 060712
216	10	V2.5.2	6.4.2.2.1, 6.4.2.2.2, 6.4.6.2, 6.4.7	-36 dBm requirement clarification	TETRA approved 060712
217	10	V2.5.2	14.5.6.6, 16.3.1.1, 16.4, 16.4.1.1, 16.4.1.2, 16.4.2, 17.3.1, 17.3.2, 17.3.3, 17.3.4, 17.3.5, 17.3.6, 17.3.9, 18.2.2, 18.2.3, 18.3.5.4, 28.2.4.1, 28.2.5, 28.2.5b	Protocol model for temporary disabling	TETRA approved 060712
218	02	V2.5.2	new annex "O" (not included 16.5.2006)	Addition of air - ground - air service	TETRA approved 060712
-	-	V2.5.2	many	Additions due to High Speed Data	TETRA approved
301	11	V3.1.1	18.3.4.7 (including 18.3.4.7.0 (new heading), 18.3.4.7.1, 18.3.4.7.4, 18.3.4.7.5(renamed) and 18.3.4.7.6(renamed))	Clarification to type 1 and type 2 cell reselection	WG3 approved 070423

No	CR vers.	Version (see note)	Clauses affected	Title	CR Status
302	11	V3.1.1	6.7.1.1	Modulation accuracy for QAM	WG3 approved 070109
303	10	V3.1.1	16.4.1.1, 16.4.1.2, 16.4.2, 16.4.3	MS response to unexpected D-LOCATION UPDATE REJECT PDU	WG3 approved 070320
304	01	V3.2.0	30	Updated MEX layer	WG3 approved 070821
305	10	V3.2.1	16.10.5, 21.4.4.2	Version number update	WG3 approved 071004
306	10	V3.2.1	6.4.9.3	Correction of the wideband noise limits 50 kHz QAM	WG3 approved 071004
307	10	V3.2.1	8.2.3.4.2	Clarification to the turbo interleaving	WG3 approved 071004
308	10	V3.2.1	18.3.4.5.7	Use of cells with reserved system code	WG3 approved 071127
309	20	V3.2.1	2, 3, 28, 28.1, 28.2.3.2, 28.2.4.7, 28.3.3, 28.3.3.2, 28.3.4.2, 28.3.5.5.4, 28.3.6, 28.4.4.2, 28.4.5.3, 28.4.5.11a, 28.4.5.30b, 28.4.5.31a, 28.4.5.31b, 28.4.5.31d, 28.4.5.31e, 28.4.5.35c, 30.1, 30.4.4	SNDCP updates	WG3 approved 080624
310	10	V3.2.1	14.2.7.6, 14.5.5.2, 17.3.9, 18.3.5.3.1	Concerning the use of advanced links for SDSs	WG3 approved 080408
311	10	V3.2.1	2, 3, 29.4.3.9, 29.5.13	PID for NAP	WG3 approved 080226
312	10	V3.2.1	29.4.3.2	Too long SDS messages	WG3 approved 080310
313	REJ	V3.2.1	21.4.3.1	NULL-PDU and change of cipher key	
314	10	V3.2.1	11.2, 11.3.3.1, 11.3.3.2, 11.3.3.4, 11.3.3.5, 11.3.3.6, 11.3.3.7, 11.3.3.8, 11.3.3.9, 11.3.4, 14.5.1.2.2, 14.5.2.2.2	Limited group coverage	WG3 approved 080408
315	10	V3.2.1	29.5.4.1	Recommended character sets and names of those	WG3 approved 080226
316	10	V3.2.1	28.3.5.1	Effect of the TL-SDU windowing mechanism to the SNDCP behavior.	WG3 approved 080624
317	01	V3.2.2	3.2, 4.10, 5.12, 6.4.1.2, 6.7.2.1, 9.4.9.2, 14.2.3, 16.4.7.3, 16.10.10a, 18.3.4.7.3, 18.2.4.7.5, 18.3.4.9.5, 18.4.1.4.6, 20.2.4.50, 21.5.2b, 22.2.2.1, 22.2.2.8a, 23.1.2.1.3, 23.5.2.4.1, 23.5.4.2.3, 23.8.3.2, 28.2.3.2, 28.2.4.4, 28.3.3, 28.3.3.3, 28.3.6, 28.3.9, 28.4.5.3, 28.4.5.11a, 28.4.5.19d, 28.4.5.31a, 30.2.3.2, 30.4.4.7, 30.4.4.22, 30.3.7.3, E.1.1, E.2.1, O.2	Editorial corrections	For information
318	10	V3.2.1	16.10.10a	Air to ground support indication	WG3 approved 080624
401	10	V3.3.1	22.3.3.2.5	Clarifications to the repetitions, when RNR is received.	WG3 approved 090703
402	11	V3.3.1	29.2.2, 29.3.1, 29.4.3.2	Use of SDS Service Centres	WG3 approved 081107
403	21	V3.3.1	3.1, 29.4.3.2, 29.4.3.9, 29.5.14	Introduction of 'multipart SDS'	WG3 approved 090825
404	10	V3.3.1	21.2.3.5	Islands of TEDS – LLC notification	WG3 approved 090401 WG4 approved 090305
405	10	V3.3.1	16.10.3, 18.5.17, 18.5.25	Correction of editorial errors concerning ciphering parameters	WG3 approved 090507
406	REJ	V3.3.1	11.3.4, 14.5.2.3.1, 14.8.18	Emergency group call disconnection by non-call owner	See CR411
407	REJ	V3.3.1	11.3.3.9, 11.3.4, 14.5.2.2.1, 14.7.2.12, 14.8	Enable a non-call owner MS to take control of a group call	WG3 rejected 090226
408	10	V3.3.1	2.1, 29.5.4.1	Support for Vietnamese text coding "VISCII".	WG3 approved 090507
409	10	V3.3.1	9.4.8.1	Burst types for QAM	WG3 approved 090401
410	11	V3.3.1	29.1.2, 29.2.1, 29.2.2, 29.2.3, 29.3.1, 29.3.2.4,	Flexible use of SDS Service Centres	WG3 approved 090525

No	CR vers.	Version (see note)	Clauses affected	Title	CR Status
			293.2.5, 29.3.2.7, 29.3.3.1, 29.3.3.4.1, 29.3.3.4.3, 29.3.3.6.1, 29.4.2.2, 29.4.2.4, 29.4.3.2, 29.4.3.12		
411	10	V3.3.1	11.3.4, 14.5.2.3.1, 14.8.18	Group call disconnection by non-call owner	WG3 approved 090507
412	10	V3.3.1	29.3.2.9	SDS timestamp definition	WG3 approved 090624
413	02	V3.3.1	8.2.3.4, 8.2.3.4.2, 8.2.3.4.3, 8.2.3.7	Correction of an error in the turbocoding	WG3 approved 090507
414	10	V3.3.1	29.2.2, 29.3.3.1	Clarification of the ACK message	WG3 approved 090624
415	11	V3.3.1	6.7.3.2.1	ACR requirement modification	WG3 approved 090624
416	10	V3.3.1	14.5.2.2.6	Key associations for temporary group addresses	WG3 approved 090903
417	10	V3.3.1	18.4.1.4.9, 18.4.1.4.10, 18.5.6a, 18.5.21b	Increase in the size of the channel identifier information element	WG3 approved 091013
418	10	V3.3.1	23.5.4.2.1, 23.5.4.3.6	On not rejecting QAM channel allocations including CSS channels	WG3 approved 091023
419	01	V3.3.1	28.4.5.26	Packet data MS types	For information
420	10	V3.3.1	21.5.2	Clarification of cell change channel allocation when extended carrier numbering is not included	WG3 approved 091023
421	-	-	-	-	See CR501
422	10	V3.3.1	6.7.1.2	Vector error for 64-QAM	WG3 approved 091028
423	12	V3.4.0	2.1, 29.4.3.9	PID value for DOTAM	WG3 approved 091112
424	10	V3.3.1	29.4.3.9	SDS lost due to host un-availability	WG3 approved 091127
425	10	V3.3.1	clauses E.1.1, E.1.2	Supplementary Service PDU encoding	WG3 approved 091127
426	10	V3.3.1	18.3.4.7.6	Unsuccessful cell reselection	WG3 approved 091127
427	10	V3.3.1	16.10.5, 21.4.4.2	Version number update	WG3 approved 091127
501	10	V3.4.1	18.3.4.5.4, 18.3.4.7.0, 18.3.4.7.1, 18.3.6.5, 18.5.2, 18.6.3	Some correction to MLE	WG3 approved 100615
502	11	V3.4.1	23.3.1.2.1	MS SCCH usage at registration	WG3 approved 100426
503	10	V3.4.1	18.3.4.7.6	Correction to CR426 on Unsuccessful cell reselection	WG3 approved 100614
504	30	V3.4.1	13.1, 13.3.2.1, 13.3.2.3, 13.3.3, 14.2.2, 14.2.6, 14.2.7.6, 14.2.7.7.1, 15.3.4, 17.3.1, 17.3.2, 17.3.3, 17.3.4, 17.3.5, 17.3.9, 20.2.4.25a, 20.2.4.25b, 20.3.5.1.3, 20.3.5.1.4, 20.3.5.4.1c, 20.4.3, 29.1.1, annex Q	Graceful service degradation mode	WG3 approved 110812
505	10	V3.4.1	18.3.4.7.2	Correction to undeclared cell reselection	WG3 approved 100609
506	10	V3.4.1	17.3.1, 21.1.3.2, 21.4.2.1, 21.4.2.3	Addressing in null PDU	WG3 approved 100917
507	03	V3.4.0	8.2.3.4.5, 16.10.8a	Editorial errors in clauses 8.2.3.4.5 and 16.10.8a	For information
508	10	V3.4.1	18.3.4.5.1	Expedited cell reselection clarification	WG3 approved 100917
509	11	V3.4.1	28.2.4.7, 28.2.4.8, 28.3.4.2, 28.4.4.6, 28.4.4.13, 28.4.5.22a, 28.4.5.44	Improved handling of multiple NSAPIs	WG3 approved 101022
510	11	V3.4.1	28.3.4.2, 28.3.4.8, 28.3.5.2a	Changes to the method of default QoS	WG3 approved 101022
511	10	V3.4.1	7.7	BS timing	WG3 approved 110208
512	10	V3.4.1	29.5.12.1	Reference correction in clause 29.5.12.1	WG3 approved 101008
513	10	V3.4.1	18.3.4.5.7	Correction to user application initiated registration request	WG3 approved 101214
514	10	V3.4.1	6.7.2.2	Relaxed MER for AACH-Q	WG3 approved 101214
515	10	V3.4.1	18.3.4.7.6	Additional clarification of Unsuccessful cell reselection	WG3 approved 101214

No	CR vers.	Version (see note)	Clauses affected	Title	CR Status
516	10	V.3.4.1	21.2.3.1, 21.2.3.1a, 22.3.1.4, 22.3.3.2.3, 22.3.3.2.7, 22.3.3.2a	Advanced link clarifications	WG3 approved 110107
517	24	V3.4.1	18.3.4.5.7	Subscriber mismatch	WG3 approved 110510
518	10	V3.4.1	30.2.1, 30.2.2.1, 30.2.2.4, 30.2.3.2, 30.3.3, 30.3.4, 30.3.5, 30.3.7.1, 30.4.4.13, 30.4.4.19, 30.4.4.21 and 30.4.4.35	MEX corrections	WG3 approved 110125
519	10	V3.4.1	20.2.4.55, 21.2.3.5, 22.2.2.1	LLC changes for a revised default QoS	WG3 approved 110208
520	10	V3.4.1	15.3.3.7	Removal of note 4	WG3 approved 110301
521	10	V3.4.1	18.3.5.3.1 item e)	Keeping SNDTCP open when the present cell does not support SNDTCP	WG3 approved 110518
522	02	V3.4.1	9.5.1b	Lost channel allocation / D-RELEASE PDU	WG3 approved 110908
523	02	V3.4.1	15.3.3.9, 15.3.4, 16.4.12	Cell load information	WG3 approved 110908
524	12	V3.5.1	21.2.3.1, 21.2.3.1a, 22.3.3.2.2, 22.3.3.2.7	LLC optimizations	WG3 approved 121220
525	01	V3.4.1	29.5.10.4	Sending a single consumption report for a UDH concatenated text message	WG3 approved 110628
526	10	V3.4.1	18.3.4.7.2, 18.3.4.7.3, 18.3.4.7.4, 18.3.7.5	Clarification of "cell rejection" actions	WG3 approved 110628
527	10	V3.4.1	28.2.4.4, 28.2.4.7, 28.3.3	Reactivating existing PDP contexts	WG3 approved 110628
528	REJ			SCADA system application	Rejected
529	02	V3.4.1	3, 4, 6, 7, 8, 9, 15, 16, 17, 18, 19, 20, 21, 22, 23, 28, 29, 30, annexes B, D, O, P	Changes due to Direct Access	For information
530	10	V3.5.1	29.4.3.14	SDS-TL validity period	WG3 approved 111024
531	10	V3.4.1	18.3.4.1, 18.5.17a, 18.5.11a	Addition of a hook for space-frequency coding	TETRA approved 110913
532	20	V3.5.1	18.5.12, 23.7.1.1, 23.7.1.2, 23.7.1.3, 23.7.1.4, 23.7.1.5, 23.7.3.1.4	Correction to Minimum RX access level	WG3 approved 130308
533	10	V3.5.1	16.4.1.1, 16.4.2, 16.4.3, 18.3.4.7.2, 18.3.4.7.3, 18.3.4.7.4, 18.3.7.5	Further clarification of "cell rejection" actions	WG3 approved 120309
534	10	V3.5.1	16.4.2	Clarification of In Service state terminology	WG3 approved 120309
535	10	V3.5.1	17.3.3	GTSI in the called address	WG3 approved 120309
536	11	V3.5.1	16.4.8, 16.4.11, 16.10.49, 17.3.1, 17.3.9, 18.3.4.7.0, 18.3.4.5.4, 18.5.22, 18.6.6, 20.2.4.57, 21.5.3, 23.7.3.2, O.3, O.4.3, O.5.2, O.5.4, O.7.1.4, O.7.2.4	Maximum path delay almost exceeded	WG3 approved 120529
537	10	V3.5.1	14.5.9, 15.3.4, 16.3, 17.3.3, 17.3.4, 17.3.5, 17.3.6, 17.3.9, 18.3.4.5.7, 18.3.4.7.0, 18.3.4.7.1, 18.3.4.7.2, 18.3.4.7.3, 18.3.4.7.4, 18.3.4.7.5, 18.3.5.1.5, 28.2.2, 28.2.5b, 28.3.3.5, 28.3.4.2, 28.3.5.1, 28.3.5.2b, 28.3.6	Preferred cells, preferred LAs and home cells	WG3 approved 130319
538	10	V3.5.1	18.3.4.5.7	Essential services clarifications	WG3 approved 120419
359	10	V3.5.1	14.5.7, 16.4.9	Subscriber class mismatch clarifications	WG3 approved 120615
540	01	V3.5.1	clause E.2.2	Cell service level to cell load CA	For information
541	11	V3.5.1	16.4, 18.3.4.4, 18.3.4.7.1a	On returning to the previous cell	WG3 approved 121128

No	CR vers.	Version (see note)	Clauses affected	Title	CR Status
542	10	V3.5.1	28.3.3.5a	SwMI increasing negotiated QoS	WG3 approved 120829
543	10	V3.5.1	16.4.12	Cell type preference or requirement	WG3 approved 121010
544	10	V3.5.1	18.5.2a	Editorial correction to reserved value	WG3 approved 120829
545	10	V3.5.1	16.4.1.2	Forward Registration to new SwMI	WG3 approved 121010
546	10	V3.5.1	17.3.4, 17.3.6, 18.3.5.3.1	TL-REPORT and TL-DATA confirm primitives	WG3 approved 130212
547		V3.5.1		<i>mSDS</i>	<i>Postponed</i>
548	10	V3.5.1	14.5.1.2.4, 14.5.2.2.4	Signalling when MS starts roaming with permission to talk	WG3 approved 130212
549	10	V3.5.1	16.10.5, 16.10.41a, 23.1.2.5	Clarification of multislot capability	WG3 approved 121128
550	10	V3.5.1	17.3.3, 17.3.5, 17.3.9, 18.3.5.3.1, 28.2.4.7, 28.3.4, 28.3.4.2, 28.3.4.8, 28.3.5.2a, 28.4.5.34.	Layer 3 Resource request and AL-SETUP coordination, and value 110 ₂ redefinition	WG3 approved 121128
551	10	V3.5.1	20.2.4.55, 21.2.3.5, 22.2.2.1, 23.5.4.1	Layer 2 resource request and AL-SETUP coordination, and value 110 ₂ redefinition	WG3 approved 121128
552	10	V3.5.1	introduction, 6.1, 6.6.2.2.1, 6.6.2.2.2, 6.6.2.3.1, 6.6.2.3.2, 6.7.2	Addition of 138 MHz support	WG3 approved 130212
553	10	V3.6.1	Q.2.4	GSDM hysteresis	WG3 approved 131107
554	10	V3.5.1	4.2.3, O.10.	Two missing DA changes	WG3 approved 121220
555	01	V3.5.1	3.2	Editorial amendments	For information
556	10	V3.5.1	18.3.4.0.4	Note about multiple CA local cells	WG3 approved 130314
557	10	V3.5.1	21.5.7	Multiple slot granting	WG3 approved 130314
558	10	V3.5.1	28.4.5.3a, 28.4.5.3b, 28.4.5.3c, 28.4.5.3d, 28.4.5.31a	Addition of reserved values in the QoS element	WG3 approved 130314
559	10	V3.6.1	14.5.1.2.4, 14.5.2.2.4	Sending D-CALL RESTORE PDUs	WG3 approved 130618
560	10	V3.6.1	14.5.2.2.1	Stop transmission order in group call is not fully defined.	WG3 Approved 130903
561	10	V3.6.1	23.5.2.2.7	Deletion of a paragraph in BS slot granting	WG3 Approved 130618
562	10	V3.6.1	18.3.4.5.7	MS behaviour when system wide services are not supported	WG3 Approved 140801
563	REJ.				CR rejected
564	10	V3.6.1	3.1	Definition of 'attached'	WG3 Approved 130904
565	10	V3.6.1	14.2.3, 14.5.1.2.2, 14.5.2.2.2, 16.4, 18.3.4.7.1a, 18.3.4.7.5	Clarification and correction of some incomplete protocol	WG3 Approved 140211
566	10	V3.6.1	18.3.4.5.6a (new), 18.3.4.5.7, O.6.2, O.7.1.2, O.7.1.3, O.7.1.4, annex R (new)	Unpreferred Subscriber Class	WG3 Approved 141208
567	10	V3.6.1	18.3.4.5.7, 18.4.2.1a, 18.5.17a, 18.5.26, O.7.2.3	Change of name of "umbrella cell" to "wide-area cell"	WG3 Approved 131107
568	10	V3.6.1	3.1	Definitions of LA, RA, migration and roaming	WG3 Approved 140123
569	10	V3.6.1	18.5.14	Correction of MCC reference	WG3 approved 130906
570	10	V3.6.1	16.10.35a	Correction in Location update accept type information element	WG3 Approved 140312
571	10	V3.6.1	16.4.7.3	Correction in ASSI/V-ASSI invalidation rules	WG3 Approved 150410
572	10	V3.6.1	29, 29.3.2.9	Removal of layer 6 reference	WG3 Approved 140123
573	20	V3.6.1	18.3.4.0.4, 19.3.2.1.3, 23.3.1.1.1 and annex S (new)	Multiple CA cells sharing a channel - interim method	WG3 Approved 140319
574	10	V3.6.1	22.2.2.1, 22.3.3.1	AL QoS negotiation	WG3 Approved 140211

No	CR vers.	Version (see note)	Clauses affected	Title	CR Status
575	10	V3.6.1	28.3.3, 28.3.3.0, 28.3.3.5, 28.3.3.5a, 28.3.4.1, 28.3.4.8, 28.3.5.6	Correction of QoS negotiation response	WG3 Approved 140211
576	10	V3.6.1	28.3.3a	Note about real-time class data	WG3 Approved 140109
577	10	V3.6.1	5.17	QAM symbol timing	WG3 Approved 140116
578					Proposal
579	10	V3.6.1	16.10.51, 16.10.51a	Type 3 / 4 element identifier restructuring	WG3 Approved 140124
580	20	V3.6.1	3.2, 29.4.3.9, 29.3.2.2, 29.5.15 (new), 29.5.16 (new)	PID, coding scheme and predefined GSSI values for AGNSS	WG3 Approved 150205
581	10	V3.6.1	6.6.2.2.2	Missed 138 MHz MS performance table	WG3 Approved 140319
582	10	V3.6.1	16.4.1.2, 16.11.1.4, 18.3.4.7.6	Clarifications concerning timer T354	WG3 Approved 140204
583	10	V3.6.1	16.9.2.7, 16.10.39, 16.10.51	New UL PDU and DL element for hardware/software version provision	WG3 Approved 150327
584	20	V3.6.1	16.9.2.1, 16.9.2.2, 16.9.2.7	MM Type 3 and 4 IE order	WG3 Approved 141003
585	10	V3.6.1	18.3.5.3.1, 18.4.1.4.8, 18.4.1.4.10, 18.5.6f (new)	Inclusion of a source protocol identifier in certain MLE PDUs	WG3 Approved 141124
586	10	V3.6.1	E.1.1.	Encoding rules for optional subelements in type 1 and type 2 elements	WG3 Approved 150616
587	10	V3.6.1	3	Clarifications to definitions	WG3 Approved 150311
588	10	V3.6.1	3.1, 7.7, 7.8, 19.3.2.1.3, 20.2.4.8, 20.2.4.9, 20.2.4.11, 20.2.4.51, 20.3.5.4.1a, 20.3.5.4.2, 20.3.5.4.4, 21.5.2, 21.5.2d, 23.1.1, 23.3.1.1.1, 23.3.2, 23.3.2a, 23.4.4.2.1, 23.4.6, 23.4.8.1, 23.4.8.6, 23.4.10.1, 23.4.10.2, 23.5.4.3.1, 23.5.4.3.5, 23.5.4.3.6, 23.5.4.3.9, 23.6.1.2, 23.6.1.3, 23.6.5, 23.6.6, 23.6.11, 23.7, 23.7.1, 23.7.1.1, 23.7.1.2, 23.7.1.3, 23.7.1.4, 23.7.3, 23.7.3.1.2, 23.7.3.1.3, 23.7.3.1.4, 23.7.4, 23.7.4.1, 23.7.4.3, 23.7.8	Layer 2 changes to allow super-sectorized channels, eccentric channels and umbrella channels	WG3 Approved 150612
589	10	V3.6.1	18.3.1, 18.3.4.0.4, 18.3.4.0.6, 18.3.4.3, 18.3.4.5.7, 18.3.4.9.1 (now 18.3.4.9.1.1 and 18.3.4.9.1.2), 18.3.4.9.2, 18.3.4.9.6, 18.3.4.9.7, 18.3.4.9.8, 18.3.4.9.9.2, 18.3.4.9.9.3, 18.3.4.9.9.4, 18.3.4.9.9.5, 18.3.4.9.10, 18.3.4.9.11, 18.3.5.3.1, 18.3.6.2, 18.3.6.5, 18.3.6.6, 18.3.6.7, 18.4.1.4.1a, 18.4.1.4.1b, 18.4.1.4.8, 18.4.1.4.10, 18.4.2.1a, 18.5.2a, 18.5.6f, 18.5.13, 18.5.15a, 18.5.17a, 18.5.17b, 18.5.17c, 18.5.18d, 18.5.19c, 18.5.19f, 18.5.20, 18.5.21i, 18.5.26, 28.2.3.2, 28.2.4.4, 28.3.4.8, O.7.2.3	Layer 3 changes to allow super-sectorized channels, eccentric channels and umbrella channels	WG3 approved 12.6.2015
590	10	V3.6.1	9.1, 9.4.3.4, 9.4.7.4	Reference corrections in cl. 9.	WG3 approved 23.6.2015
591	10	V3.6.1	21.2.3.1a, 22.3.3.2a	AL-X-ACK formatting rules	WG3 approved 29.6.2015
592	10	V3.6.1	29.4.3.2	Allowing MS to send "Delivery Failure"	WG3 approved 31.7.2015
593	10	V3.6.1	16.4	Note about hardware and software version numbers	WG3 approved 10.8.2015

No	CR vers.	Version (see note)	Clauses affected	Title	CR Status
594	10	V3.7.1	28.3.4.2	Incorrect reference to "Reservation request" in MAC-ACCESS	WG3 approved 21.10.2015
595	10	V3.8.1	O.5.4	Corrections in clause O.5.4.	WG3 approved 30.9.2016 WG4 approved 6.9.2016
596	10	V3.8.1	23.5.2.2.4	Corrections in clause 23.5.2.2.4.	WG3 approved 30.9.2016 WG4 approved 6.9.2016
597	10	V3.8.1	21.4.4.2a	Correction in clause 21.4.4.2a	WG3 approved 30.9.2016 WG4 approved 6.9.2016
598	10	V3.8.1	16.4.0, 16.4.1.1, 16.4.1.2, 16.4.2, 16.4.3	Migrating while temporarily disabled	WG3 approved 9.5.2018
599	10	V3.8.1	13.3.3, 14.8.34	Status code reservation for international co-operation	WG3 Approved 18.1.2018
600	10	V3.8.1	16.4.9	Subscriber Class for migrating MS	WG3 approved 4 April 2018

History

Document history		
Edition 1	March 1996	Publication as ETSI ETS 300 392-2 (Historical)
V2.1.1	September 2000	Publication
V2.1.1	December 2000	Publication as ETSI EN 300 392-2
V2.2.1	September 2000	Publication (Withdrawn)
V2.3.1	November 2000	Publication
V2.3.2	March 2001	Publication as ETSI EN 300 392-2
V2.4.1	October 2003	Publication
V2.4.2	February 2004	Publication as ETSI EN 300 392-2
V2.5.1	July 2005	Publication
V2.5.2	November 2005	Publication as ETSI EN 300 392-2
V2.6.1	May 2006	Publication
V3.1.1	September 2006	Publication
V3.2.1	September 2007	Publication as ETSI EN 300 392-2
V3.3.1	October 2008	Publication
V3.4.1	August 2010	Publication as ETSI EN 300 392-2
V3.5.1	October 2011	Publication
V3.6.1	May 2013	Publication
V3.7.1	January 2016	Publication
V3.8.1	August 2016	Publication as ETSI EN 300 392-2
V3.9.1	January 2019	Publication
V3.9.2	June 2020	Publication