

# ETSI TS 100 392-18-1 V1.3.1 (2007-04)

---

*Technical Specification*

**Terrestrial Trunked Radio (TETRA);  
Voice plus Data (V+D) and Direct Mode Operation (DMO);  
Part 18: Air interface optimized applications;  
Sub-part 1: Location Information Protocol (LIP)**

---



---

Reference

RTS/TETRA-03179

---

Keywords

air interface, location, TETRA, V+D

**ETSI**

650 Route des Lucioles  
F-06921 Sophia Antipolis Cedex - FRANCE

Tel.: +33 4 92 94 42 00 Fax: +33 4 93 65 47 16

Siret N° 348 623 562 00017 - NAF 742 C  
Association à but non lucratif enregistrée à la  
Sous-Préfecture de Grasse (06) N° 7803/88

---

**Important notice**

Individual copies of the present document can be downloaded from:

<http://www.etsi.org>

The present document may be made available in more than one electronic version or in print. In any case of existing or perceived difference in contents between such versions, the reference version is the Portable Document Format (PDF). In case of dispute, the reference shall be the printing on ETSI printers of the PDF version kept on a specific network drive within ETSI Secretariat.

Users of the present document should be aware that the document may be subject to revision or change of status. Information on the current status of this and other ETSI documents is available at

<http://portal.etsi.org/tb/status/status.asp>

If you find errors in the present document, please send your comment to one of the following services:

[http://portal.etsi.org/chaicor/ETSI\\_support.asp](http://portal.etsi.org/chaicor/ETSI_support.asp)

---

**Copyright Notification**

No part may be reproduced except as authorized by written permission.  
The copyright and the foregoing restriction extend to reproduction in all media.

© European Telecommunications Standards Institute 2007.  
All rights reserved.

**DECT**<sup>TM</sup>, **PLUGTESTS**<sup>TM</sup> and **UMTS**<sup>TM</sup> are Trade Marks of ETSI registered for the benefit of its Members.  
**TIPHON**<sup>TM</sup> and the **TIPHON logo** are Trade Marks currently being registered by ETSI for the benefit of its Members.  
**3GPP**<sup>TM</sup> is a Trade Mark of ETSI registered for the benefit of its Members and of the 3GPP Organizational Partners.

# Contents

Intellectual Property Rights .....	7
Foreword.....	7
1 Scope .....	8
2 References .....	8
3 Definitions, symbols and abbreviations .....	8
3.1 Definitions .....	8
3.2 Symbols.....	9
3.3 Abbreviations .....	9
4 Location information protocol.....	10
4.1 General .....	10
4.2 Location information protocol system architecture.....	10
4.3 Location information protocol service description.....	13
4.3.1 General on services.....	13
4.3.2 Services available at the LIP-SAP .....	14
4.3.3 Service primitives at the LIP-SAP.....	14
4.3.4 Service primitive parameters at the LIP-SAP .....	15
4.5.5 State description.....	15
5 Location information protocol description.....	15
5.1 Description of information elements .....	15
5.1.1 General on accuracies and uncertainties .....	15
5.1.2 Acknowledgement request.....	15
5.1.3 Basic parameters.....	16
5.1.4 Confidence level .....	16
5.1.5 Direction of travel and direction of travel accuracy.....	16
5.1.6 Horizontal position and horizontal position accuracy.....	16
5.1.7 Horizontal velocity and horizontal velocity accuracy.....	16
5.1.8 Location altitude and location altitude accuracy.....	17
5.1.9 Location information destination .....	17
5.1.10 Location message reference .....	17
5.1.11 Location shape .....	17
5.1.12 Maximum information age .....	17
5.1.13 Maximum reporting distance .....	17
5.1.14 Maximum reporting interval .....	17
5.1.15 Maximum response time.....	18
5.1.16 Minimum reporting interval.....	18
5.1.17 Reason for sending.....	18
5.1.18 Report type.....	18
5.1.19 Request priority .....	18
5.1.20 Requested/required .....	18
5.1.21 Start time.....	19
5.1.22 Stop time.....	19
5.1.23 Terminal or location identification .....	19
5.1.24 Trigger definition.....	19
5.1.25 Trigger type .....	19
5.1.26 Velocity type.....	20
5.1.27 Vertical velocity and vertical velocity accuracy .....	20
5.2 Information flows.....	20
5.2.1 General on information flows .....	20
5.2.2 Pre-programmed MS sending reports .....	20
5.2.3 Pre-programmed MS sending reports and receiving acknowledgement.....	21
5.2.4 MS receiving basic parameters .....	21
5.2.5 MS receiving basic parameters and sending response .....	22
5.2.6 MS reporting basic parameters .....	23
5.2.7 MS receiving immediate report request and sending response .....	23

5.2.8	MS receiving immediate report request and asking acknowledgement .....	24
5.2.9	MS receiving trigger definitions and sending reports .....	24
5.2.10	MS receiving trigger definitions and sending reports and asking acknowledgements.....	25
5.2.11	MS receiving trigger definitions and sending modification.....	26
5.2.12	MS receiving trigger definitions and rejecting triggers .....	26
5.2.13	MS receiving trigger definitions and sending reports to other location information destination.....	27
5.2.14	MS receiving trigger definitions via location server and sending reports to another location information destination .....	28
5.2.15	Trigger removal .....	29
5.2.16	Trigger reporting.....	29
5.2.17	Location reporting enabling.....	30
5.2.18	Location reporting disabling.....	30
5.2.19	Location reporting temporary control.....	31
5.2.20	Allocation of entities.....	32
5.3	Procedures .....	32
5.3.1	Relations to flow charts .....	32
5.3.2	General on control messages .....	32
5.3.3	Accuracy control in control messages .....	33
5.3.4	General on location report sending.....	33
5.3.5	General on location report reception.....	34
5.3.6	MS sending unsolicited reports.....	34
5.3.7	MS receiving basic parameters .....	34
5.3.8	MS reporting basic parameters .....	34
5.3.9	MS sending immediate reports .....	34
5.3.10	MS sending immediate report request .....	35
5.3.11	Triggered report request sending .....	35
5.3.12	MS receiving triggered reports requests .....	36
5.3.13	MS sending triggered reports.....	36
5.3.14	MS receiving triggered reports .....	36
5.3.15	Triggered report reception in location server.....	36
5.3.16	Trigger removal .....	36
5.3.17	Report trigger request .....	36
5.3.18	Location report enable/disable request .....	37
5.3.19	Trigger configuration request .....	38
5.3.20	Trigger and report type interactions.....	38
5.3.21	Location message reference usage.....	38
5.3.22	Triggers for Lost and Regained ability to determine location.....	38
5.3.23	Trigger for Ambience Listening call.....	39
5.3.24	Temporary control of location reporting.....	39
6	Location information protocol coding requirements.....	40
6.1	General on coding requirements.....	40
6.2	Location information protocol PDU description tables.....	41
6.2.1	SHORT LOCATION REPORT PDU.....	41
6.2.2	LONG LOCATION REPORT PDU.....	41
6.2.3	LOCATION REPORT ACKNOWLEDGEMENT PDU.....	42
6.2.4	BASIC LOCATION PARAMETERS REQUEST PDU .....	42
6.2.5	BASIC LOCATION PARAMETERS RESPONSE PDU .....	43
6.2.6	REPORT BASIC LOCATION PARAMETERS REQUEST PDU .....	44
6.2.7	REPORT BASIC LOCATION PARAMETERS RESPONSE PDU .....	44
6.2.8	ADD/MODIFY TRIGGER REQUEST PDU.....	45
6.2.9	ADD/MODIFY TRIGGER RESPONSE PDU.....	46
6.2.10	REMOVE TRIGGER REQUEST PDU .....	47
6.2.11	REMOVE TRIGGER RESPONSE PDU .....	47
6.2.12	REPORT TRIGGERS REQUEST PDU.....	47
6.2.13	REPORT TRIGGER RESPONSE PDU .....	48
6.2.14	LOCATION REPORTING ENABLE/DISABLE REQUEST PDU .....	49
6.2.15	LOCATION REPORTING ENABLE/DISABLE RESPONSE PDU .....	49
6.2.16	IMMEDIATE LOCATION REPORT REQUEST PDU .....	50
6.2.17	LOCATION REPORTING TEMPORARY CONTROL REQUEST PDU.....	50
6.2.18	LOCATION REPORTING TEMPORARY CONTROL RESPONSE PDU.....	51
6.3	Location information protocol PDU information elements.....	51

6.3.1	Acknowledgement request.....	51
6.3.2	Address or identification type.....	51
6.3.3	Angle.....	52
6.3.4	Confidence level.....	52
6.3.4a	Default enable/disable lifetime.....	52
6.3.5	Direction of travel.....	53
6.3.6	Direction of travel extended.....	53
6.3.7	Direction of travel accuracy.....	53
6.3.8	Direction of travel and direction of travel accuracy.....	54
6.3.9	Direction of travel uncertainty.....	54
6.3.10	Extended user defined data.....	54
6.3.11	External subscriber number.....	54
6.3.12	Half of major axis.....	54
6.3.13	Half of minor axis.....	54
6.3.14	Horizontal position accuracy.....	55
6.3.15	Horizontal position and horizontal position accuracy.....	55
6.3.16	Horizontal position uncertainty.....	55
6.3.17	Horizontal velocity.....	56
6.3.18	Horizontal velocity accuracy.....	57
6.3.19	Horizontal velocity and horizontal velocity accuracy.....	57
6.3.20	Horizontal velocity and vertical velocity.....	57
6.3.21	Horizontal velocity and vertical velocity with uncertainty.....	57
6.3.22	Horizontal velocity and vertical velocity with direction of travel extended and uncertainty.....	58
6.3.23	Horizontal velocity uncertainty.....	58
6.3.24	Horizontal velocity with direction of travel extended.....	58
6.3.25	Horizontal velocity with direction of travel extended and uncertainty.....	58
6.3.26	Horizontal velocity with uncertainty.....	59
6.3.27	Inner radius.....	59
6.3.28	IPv4 address.....	59
6.3.29	IPv6 address.....	59
6.3.30	Latitude.....	59
6.3.31	Location altitude.....	59
6.3.32	Location altitude accuracy.....	60
6.3.33	Location altitude and location altitude accuracy.....	60
6.3.34	Location altitude uncertainty.....	60
6.3.35	Location arc.....	61
6.3.36	Location circle.....	61
6.3.37	Location circle with altitude.....	61
6.3.38	Location circle with altitude and uncertainty.....	61
6.3.39	Location data.....	62
6.3.40	Location ellipse.....	62
6.3.41	Location ellipse with altitude.....	62
6.3.42	Location ellipse with altitude and uncertainty.....	63
6.3.43	Location information destination.....	63
6.3.44	Location message reference.....	63
6.3.45	Location point.....	64
6.3.46	Location point and position error.....	64
6.3.47	Location point with altitude.....	64
6.3.48	Location reporting enable flags.....	64
6.3.49	Location shape.....	65
6.3.50	Longitude.....	65
6.3.51	Maximum information age.....	65
6.3.52	Maximum reporting distance.....	66
6.3.53	Maximum reporting interval.....	66
6.3.54	Maximum response time.....	66
6.3.54a	Minimum detection interval.....	67
6.3.55	Minimum reporting interval.....	67
6.3.56	MNI + SSI.....	67
6.3.57	MNI + SSI + external subscriber number.....	68
6.3.58	Name of location.....	68
6.3.59	Name server type.....	68
6.3.60	Outer radius.....	68

6.3.61	PDU type .....	69
6.3.62	PDU type extension .....	69
6.3.63	Position error .....	69
6.3.64	Reason for sending.....	70
6.3.65	Report type.....	71
6.3.66	Requested or required .....	71
6.3.67	Request priority .....	71
6.3.68	Result code.....	72
6.3.69	SDS type-1 value .....	73
6.3.70	SSI .....	73
6.3.71	SSI + external subscriber number.....	73
6.3.72	Start angle .....	73
6.3.73	Start time.....	74
6.3.74	Status value .....	74
6.3.75	Stop angle .....	74
6.3.76	Stop time.....	74
6.3.76a	Temporary control parameter definition .....	75
6.3.76b	Temporary control parameter type.....	75
6.3.76c	Temporary control validity .....	76
6.3.76d	Temporary maximum reporting distance - relative.....	76
6.3.76e	Temporary minimum reporting distance.....	76
6.3.76f	Temporary minimum reporting interval - absolute.....	77
6.3.76g	Temporary minimum reporting interval - relative .....	77
6.3.76h	Temporary report type .....	77
6.3.77	Terminal or location identification .....	77
6.3.78	Time elapsed.....	78
6.3.79	Time of position.....	78
6.3.80	Time data .....	78
6.3.81	Time type .....	79
6.3.82	Trigger definition (one-shot/recurring).....	79
6.3.83	Trigger removal .....	79
6.3.84	Trigger type (one-shot/recurring) .....	80
6.3.85	Trigger type (recurring) .....	81
6.3.86	Type 5 element identifier .....	81
6.3.87	Type of additional data .....	82
6.3.88	User defined data .....	82
6.3.89	Velocity data .....	82
6.3.90	Velocity type.....	82
6.3.91	Vertical velocity.....	83
6.3.92	Vertical velocity accuracy .....	83
6.3.93	Vertical velocity and vertical velocity accuracy .....	84
6.3.94	Vertical velocity uncertainty.....	84
6.4	Type 5 information element description.....	84
6.4.1	Type 5 information element definition .....	84
6.4.2	Type 5 element length.....	84
6.4.3	Type 5 element length extension .....	85
6.4.4	Type 5 information element.....	85
6.5	Geographical shape descriptions .....	85
7	Implementation requirements.....	85
<b>Annex A (informative):</b>	<b>Example of trigger priorities .....</b>	<b>86</b>
A.1	Trigger priority setting .....	86
<b>Annex B (informative):</b>	<b>Use of location message reference .....</b>	<b>88</b>
B.1	Potential usage of location message reference .....	88
<b>Annex C (informative):</b>	<b>Change Requests.....</b>	<b>89</b>
<b>Annex D (informative):</b>	<b>Bibliography.....</b>	<b>90</b>
History .....		91

---

# Intellectual Property Rights

IPRs essential or potentially essential to the present document may have been declared to ETSI. The information pertaining to these essential IPRs, if any, is publicly available for **ETSI members and non-members**, and can be found in ETSI SR 000 314: "*Intellectual Property Rights (IPRs); Essential, or potentially Essential, IPRs notified to ETSI in respect of ETSI standards*", which is available from the ETSI Secretariat. Latest updates are available on the ETSI Web server (<http://webapp.etsi.org/IPR/home.asp>).

Pursuant to the ETSI IPR Policy, no investigation, including IPR searches, has been carried out by ETSI. No guarantee can be given as to the existence of other IPRs not referenced in ETSI SR 000 314 (or the updates on the ETSI Web server) which are, or may be, or may become, essential to the present document.

---

## Foreword

This Technical Specification (TS) has been produced by ETSI Technical Committee Terrestrial Trunked Radio (TETRA).

The present document is part 18, sub-part 1 of a multi-part deliverable covering the Terrestrial Trunked Radio (TETRA); the Voice plus Data (V+D), as identified below:

EN 300 392-1: "General network design";

TS 100 392-2: "Air Interface (AI)";

TS 100 392-3: "Interworking at the Inter-System Interface (ISI)";

ETS 300 392-4: "Gateways basic operation";

TS 100 392-5: "Peripheral Equipment Interface (PEI)";

TS 100 392-7: "Security";

EN 300 392-9: "General requirements for supplementary services";

EN 300 392-10: "Supplementary services stage 1";

TS 100 392-11: "Supplementary services stage 2";

TS 100 392-12: "Supplementary services stage 3";

ETS 300 392-13: "SDL model of the Air Interface (AI)";

ETS 300 392-14: "Protocol Implementation Conformance Statement (PICS) proforma specification";

TS 100 392-15: "TETRA frequency bands, duplex spacings and channel numbering";

TS 100 392-16: "Network Performance Metrics";

TR 100 392-17: "TETRA V+D and DMO specifications";

**TS 100 392-18: "Air interface optimized applications".**

**Sub-part 1: "Location Information Protocol (LIP)";**

Sub-part 2: "Air interface optimized applications".

NOTE: Part 10, sub-part 15 (Transfer of control), part 13 (SDL) and part 14 (PICS) of this multi-part deliverable are of status "historical" and are not maintained.

---

# 1 Scope

The present document defines Location Information Protocol that is optimized for TETRA air interface. It defines services:

- Unsolicited location information reporting.
- Immediate location information reporting.
- Triggered location information reporting.

---

# 2 References

The following documents contain provisions which, through reference in this text, constitute provisions of the present document.

- References are either specific (identified by date of publication and/or edition number or version number) or non-specific.
- For a specific reference, subsequent revisions do not apply.
- For a non-specific reference, the latest version applies.

Referenced documents which are not found to be publicly available in the expected location might be found at <http://docbox.etsi.org/Reference>.

NOTE: While any hyperlinks included in this clause were valid at the time of publication ETSI cannot guarantee their long term validity.

- [1] ETSI EN 300 392-1: "Terrestrial Trunked Radio (TETRA); Voice plus Data (V+D); Part 1: General network design".
- [2] ETSI EN 300 392-2: "Terrestrial Trunked Radio (TETRA); Voice plus Data (V+D); Part 2: Air Interface (AI)".
- [3] Void.
- [4] IETF RFC 791: "Internet Protocol; DARPA internet program; Protocol specification".
- [5] IETF RFC 3513: "Internet Protocol Version 6 (IPv6) Addressing Architecture".
- [6] ETSI TS 123 032: "Digital cellular telecommunications system (Phase 2+); Universal Mobile Telecommunications System (UMTS); Universal Geographical Area Description (GAD) (3GPP TS 23.032)".

---

# 3 Definitions, symbols and abbreviations

## 3.1 Definitions

For the purposes of the present document, the terms and definitions given in EN 300 392-2 [2] and the following apply:

**accuracy:** requirement on error of location information in location information requests

**location server:** entity that collects and optionally stores location information and sends location information reports to its clients



**TETRA domain:** all entities that are addressed using TETRA defined addresses and understand the binary format of the Location Information Protocol

NOTE: This definition may cover entities that are not controlled by TETRA security features.

**uncertainty:** error estimation of location information in location information reports

## 3.2 Symbols

For the purposes of the present document, the following symbols apply:

ra	relationship between original location information source and location information controlling entity
rb	relationship between original location information source and location information destination
rc	relationship between original location information source and location server
rd	relationship between location server and location information controlling entity
re	relationship between location server and location information destination
rf	relationship between the location server in the TETRA domain to the location information controlling entity outside the TETRA domain
rg	relationship between the location server in the TETRA domain to the location information destination entity outside the TETRA domain
rh	relationship between the location server in the TETRA domain to the location information source outside the TETRA domain

## 3.3 Abbreviations

For the purposes of the present document, the following abbreviations apply:

C	Conditional
DMO	Direct Mode Operation
ENE	East North East
ESE	East South East
FE	Functional Entity
GSSI	Group Short Subscriber Identity
GTSI	Group TETRA Subscriber Identity
IPv4	Internet Protocol version 4
IPv6	Internet Protocol version 6
ISSI	Individual Short Subscriber Identity
ITSI	Individual TETRA Subscriber Identity
LIP	Location Information Protocol
M	Mandatory
M-bit	More-bit
MNI	Mobile Network Identity
MS	Mobile Station
NE	North East
NNE	North North East
NNW	North North West
NW	North West
O	Optional
O-bit	Optional-bit
PDU	Protocol Data Unit
SAP	Service Access Point
SDS	Short Data Service
SDS-TL	Short Data Service - Transport Layer
SE	South East
SNDCP SAP	SubNetwork Dependent Convergence Protocol Service Access Point
SSE	South South East
SSI	Short Subscriber Identity
SSW	South South West
SU	Subscriber Unit
SW	South West

TMO	Trunked Mode Operation
URL	Universal Resource Locator
WGS84	World Geodetic System 1984

NOTE: See <http://www.geoconcept.com/?498/WGS84>

WNW	West North West
WSW	West South West
TxI	Transmit Inhibit
TSI	TETRA Subscriber Identity

## 4 Location information protocol

### 4.1 General

The Location Information Protocol (LIP) is a TETRA air interface optimized, application layer protocol that can utilize various transport mechanisms.

The location information protocol may use SDS-TL service at SDS-TL SAP, refer to EN 300 392-2 [2], clauses 29.1.1 to 29.5.12 in the case of TETRA MS, though it does not use SDS-TL transport mechanisms to ensure delivery. The same protocol can use packet data at SndCP SAP as defined in EN 300 392-2 [2], clause 28 in the case of TETRA MS.

The location information protocol is location determination technology independent, supports a wide variety of location applications and at the same time optimizes usage of air interface resources. The resource optimization considers both message size and the number of messages, particularly for location reporting. The message size optimization is a compromise between the number bits available and user needs, refer to TR 102 021-4 (see bibliography), clause 4.4. As a result the present document defines two basic location reports:

- short location report; and
- long location report.

The first is a general report with restricted information elements and with restricted resolution for some of them. The second provides more flexibility and resolution.

In addition to the location reports the present document defines "control messages" to set and modify MS behaviour and initiate sending of location reports.

The location information protocol can be used in various system configurations including:

- MS to MS communication.
- MS to location server communication.
- Location server to MS communication.

NOTE: Although LIP supports direct MS to individual MS communication; the use of it is discouraged as the optimized air interface usage may be compromised. One possibility to maintain air interface optimization is the use of a group address as the destination address.

### 4.2 Location information protocol system architecture

Location information may be needed in various entities of the TETRA network or outside the TETRA domain. Physical entities identified for the purpose of the present document are:

- Mobile Station (MS) and location accessory providing or using location information.
- Location server inside the TETRA domain collecting location information and providing it to clients.
- Location information transmission controller.

- Location server outside the TETRA domain.
- Entity outside the TETRA domain providing or using location information.

The functions and services that a location server provides to its clients are outside the scope of the present document and any configuration may be used e.g. a dispatcher station can act as a location server.

A location server outside the TETRA domain may communicate with entities in the TETRA domain using the protocol defined in the present document or e.g. a location server inside the TETRA domain may act as a protocol converter and communicate with the location server or client entities outside the TETRA domain using other protocols. The other protocols are outside the scope of the present document.

The location information exchange contains scenarios:

- MS to MS location information exchange without any action in any other entities.
- MS to location server inside the TETRA domain, where MS is the source of location information and the location server may send requests for it.
- Location server to MS, where the location server has location information of a third party, and MS asks for that location information or the location server distributes the third party location information to MS.
- Location server to MS, where the location server has location information of the requesting MS due a network based location determination, and MS asks for that location information.
- Location server sends location information to any entity outside the TETRA domain.
- Any entity outside the TETRA domain sends location information to location server.
- Location server or MS may control location information sending triggers and define location information destination.
- Location information transmission controller may control location information sending rate.

Some of the scenarios contain security and privacy risks and may not be supported in all systems. Security and privacy issues are outside the scope of the present document.

For the purposes of the present document, the TETRA domain consists of entities that are addressable using TETRA addressing and understand the location information protocol LIP in the binary format of the protocol.

For the purposes of the present document, entities are considered to be outside the TETRA domain when they use and provide location information, but do not support the binary format used in the TETRA location information protocol LIP. They may use any other location information protocol. Any converters between LIP and any other location information protocol are outside the scope of the present document.

For the purposes of the present document protocol Functional Entities (FE) are used in some clauses instead of physical entities:

- FE1: Location information source.
- FE2: Location server.
- FE3: Location requester.
- FE4: Location information destination.
- FE5: Location information transmission controller.

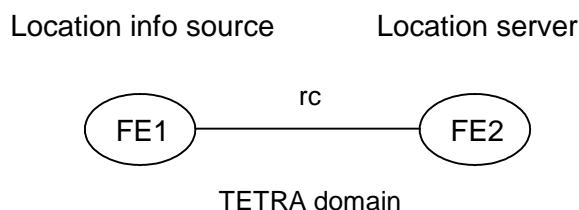
The following relationships exist between these FEs:

- ra: Relationship between original location information source and location information controlling entity (also referred to as location requester).
- rb: Relationship between original location information source and location information destination.
- rc: Relationship between original location information source and location server.

- rd: Relationship between location server and location information controlling entity.
- re: Relationship between location server and location information destination.
- rf: Relationship between the location server in the TETRA domain to the location information controlling entity outside the TETRA domain.
- rg: Relationship between the location server in the TETRA domain to the location information destination entity outside the TETRA domain.
- rh: Relationship between the location server in the TETRA domain to the location information source outside the TETRA domain.
- ri: Relationship between location information transmission controller and original location information source.
- rj: Relationship between location information transmission controller and location information destination.
- rk: Relationship between location information transmission controller and location server.

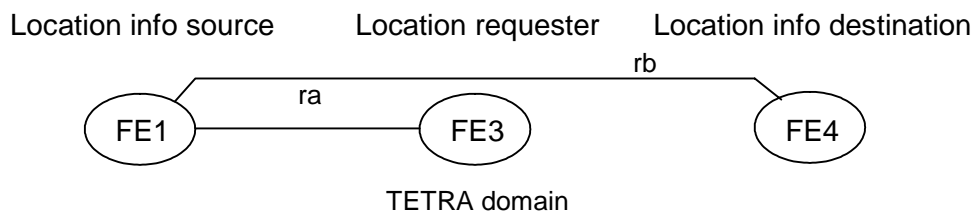
Figures 4.1 to 4.6 define typical scenarios for the location information protocol usage.

In figure 4.1 the location server FE2 acts as location information controlling entity (FE3) and as location information destination (FE4).

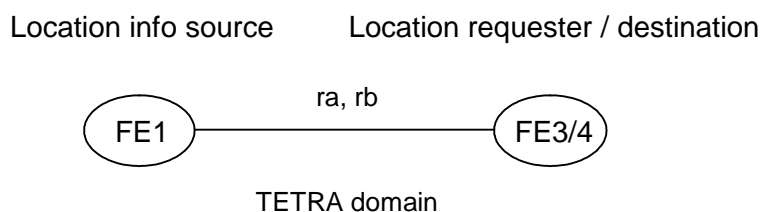


**Figure 4.1: Simple system with location server in TETRA domain**

In figure 4.2 location requester FE3 controls location information source directly and location information reports are sent directly to the location information destination FE4. In figure 4.3 location requester FE3 and location information destination FE4 use the same TETRA address.

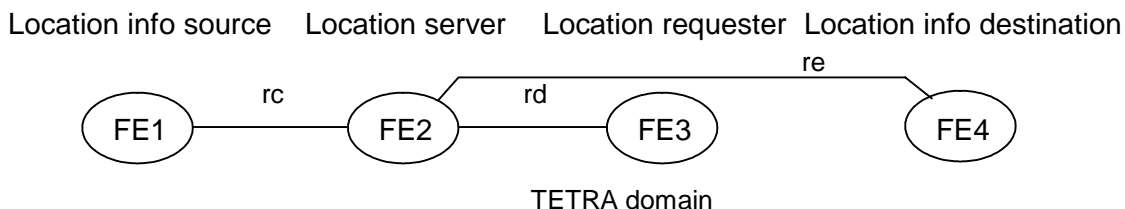


**Figure 4.2: System where FE3 and FE4 are different in TETRA domain**



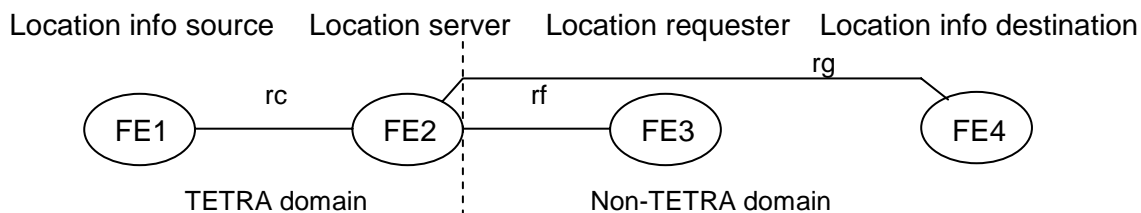
**Figure 4.3: System where FE3 and FE4 are the same in TETRA domain**

In figure 4.4 location server FE2 controls access to the location information source FE1 and distributes location information. In this scenario location server FE2 acts as controller of the location information source on behalf of location requester FE3 and the location information destination on behalf of FE4. There can be multiple location requesters and location information destinations with relationship to the location server. In this case the number of messages is optimized on relationship rc but is not necessarily optimized on the relationships rd and re. The mediation between multiple FE3s and FE4s is responsibility of the location server FE2 and is outside the scope of the present document.



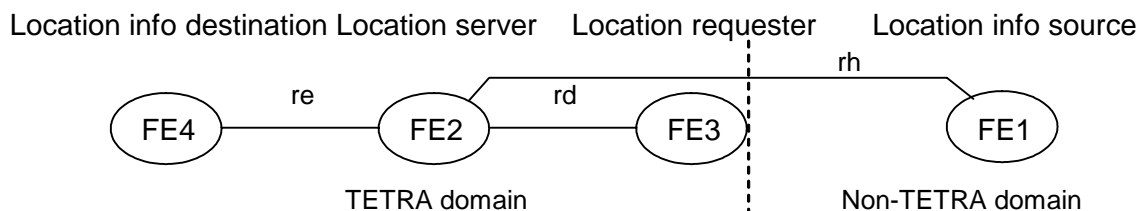
**Figure 4.4: System with location server and identified requester and information destination**

In figure 4.5 both location requester FE3 and location information destination FE4 are outside the TETRA domain. In this case the protocols for relationships rf and rg are outside the scope of the present document and location server FE2 performs the necessary conversions.



**Figure 4.5: System with a Location server accessed from outside TETRA Domain**

In figure 4.6 location source FE1 is outside TETRA domain and the protocol for relationship rh is outside the scope of the present document.



**Figure 4.6: System with location source outside TETRA domain**

## 4.3 Location information protocol service description

### 4.3.1 General on services

The location information protocol can support multiple services. Typical services are:

- Unsolicited reporting, location information source sends location reports as defined by pre-programming, without any request.
- Immediate reporting, location information requester asks for a location report from the location information source or from a location server and the source or location server sends one report "immediately".
- Triggered reporting, location information requester sends trigger definitions to the information source or to a location server, and the source or location server sends location information reports as invoked by the defined triggers.

NOTE: Some triggers may interact and limit which reports are sent.

The location information protocol optimizes the use of location reports sent by the information source over the air interface. As a result these location information reports are location service independent, and all services use the same location reports. It is possible to indicate the report type.

### 4.3.2 Services available at the LIP-SAP

FE1 may support unsolicited reporting of its location by sending location information reports as defined by pre-programming. FE1 may ask for and receive acknowledgements to the reports.

FE1 may support immediate reporting of its location by receiving immediate report requests and responding with location information reports. FE1 may ask for and receive acknowledgements to the location information reports. FE1 may reject or ignore immediate report requests from some requesting entities.

FE1 may support triggered reporting of its location by receiving trigger definitions and sending location information reports when trigger conditions are met. FE1 may confirm and modify e.g. accuracy requirements of the received trigger setting by sending an acknowledgement. FE1 may ask for and receive acknowledgements to the location information reports. For triggered reporting FE1 may support one or more trigger setting entities, but always sends location information reports to the defined single address. FE1 may combine triggers set by various trigger setting entities or may reject or ignore trigger settings from some entities. The method of combining triggers is outside the scope of the present document.

FE3 may support sending of immediate report requests and FE4 may support reception of location information reports.

FE3 may support sending of triggered report requests and FE4 may support reception of location information reports.

FE2 may support reception of unsolicited location information reports from any number of FE1s and sending of acknowledgements if requested.

FE2 may support sending of immediate report requests to FE1s, reception of resulting location information report and sending of acknowledgements.

FE2 may support sending of triggered report requests to FE1s, reception of resulting location information reports and sending of acknowledgements.

FE2 may support unsolicited reporting of the location of an FE1 to any number of FE4s and may ask for and receive acknowledgements.

FE2 may support immediate reporting of the location of an FE1 to an FE4 and may ask for and receive an acknowledgement.

FE2 may support triggered reporting of the location of an FE1 by receiving trigger definitions from FE3s and sending location information reports to FE4s when trigger conditions are met. FE2 may confirm and modify e.g. accuracy requirements of the received trigger setting by sending an acknowledgement. FE2 may ask for and receive acknowledgements to the location information reports. FE2 may support multiple trigger setting entities FE3 and may send location reports to multiple FE4. FE2 should combine the triggers set by multiple FE3s for the same FE1 before passing on to FE1.

In typical TETRA systems FE1 will be an MS. In some systems an MS may be FE3 and/or FE4. Although FE2 could be an MS, it is more likely to be a line connected device.

### 4.3.3 Service primitives at the LIP-SAP

Service primitives at the LIP-SAP define service access. This service primitive definition assumes that the entity using these service primitives gets all trigger invocations by other means and those are outside the scope of the present document.

**LIP-Report request:** this primitive is used to send unsolicited, immediate and triggered location information reports.

**LIP-Report indication:** this primitive is used to receive location information reports.

**LIP-Report response:** this primitive is used to send acknowledgements.

**LIP-Report confirmation:** this primitive is used to receive acknowledgements to location information reports.

**LIP-Immediate report request:** this primitive is used to send immediate location report requests.

**LIP-Immediate report indication:** this primitive is used to receive immediate location information report requests.

**LIP-Configure request:** this primitive is used to send location information configuration.

**LIP-Configure indication:** this primitive is used to receive location information configuration.

**LIP-Configure response:** this primitive is used to send response to the location information configuration.

**LIP-Configure confirmation:** this primitive is used to receive response to the location information configuration.

**LIP-Trigger request:** this primitive is used to send trigger settings.

**LIP-Trigger indication:** this primitive is used to receive location trigger settings.

**LIP-Trigger response:** this primitive is used to acknowledge location trigger settings.

**LIP-Trigger confirmation:** this primitive is used to receive trigger settings acknowledgements.

#### 4.3.4 Service primitive parameters at the LIP-SAP

As the present document does not define a physical access to the LIP-SAP, the description of the conceptual service primitives is minimized and the service primitive parameters are implied by the information elements in the PDUs, refer to clause 6.3.

#### 4.5.5 State description

The location information protocol uses a single state at the FE that does not link request and response together. At that state LIP sends and receives all the service primitives and PDUs. If it is important for an application to get e.g. response to a specific request or receive an acknowledgement before proceeding, then the application should use a suitable state machine or other means to make that possible.

---

## 5 Location information protocol description

### 5.1 Description of information elements

#### 5.1.1 General on accuracies and uncertainties

Related to accuracies and uncertainties there is a probability that the actual value is within the indicated value range. Confidence level can explicitly define that probability in some cases. In all other cases a certain confidence level is assumed. For the purposes of the present document the assumed confidence level is set to be one sigma probability (68 %), refer to clause 5.1.4. An application including the location determination equipment may define another value. Management of those values is outside the scope of the present document.

NOTE: Typical TETRA applications should behave properly with one sigma confidence level; on the other hand e.g. in land surveying three sigma probability is often used as the required confidence level.

#### 5.1.2 Acknowledgement request

Acknowledgement request shall define whether a confirmation is expected for the message.

NOTE 1: Acknowledgement request in a "request" control message means that confirmation of receipt is requested using the corresponding "response" control message. Acknowledgement request in a long location report means that confirmation of receipt is requested using a location report acknowledgement. Immediate location report request does not support acknowledgement request as receipt is confirmed by the related location report.

NOTE 2: Behaviour on failure to receive a requested confirmation is not defined.

### 5.1.3 Basic parameters

Basic parameters shall define which information elements will be included in location reports as a minimum. The basic parameters may also define accuracy requirements and whether uncertainty information will be included in the location reports. The basic parameters may be defined by MS personalization and over the air interface. The defined basic parameters are valid until replaced by another definition, and are not reset during power off/on cycle.

### 5.1.4 Confidence level

Confidence level shall define the probability that the actual value is within the indicated value range e.g. within the ellipse defined in the Location ellipse information element in a location information report.

### 5.1.5 Direction of travel and direction of travel accuracy

The direction of travel and direction of travel accuracy information element defines reporting requirements for direction of travel and direction of travel uncertainty, and defines accuracy requirements for the direction of travel determination. Presence of this information element implies that horizontal velocity and direction of travel information elements shall be included in related location reports. Return value indicates whether horizontal velocity uncertainty and direction of travel uncertainty information elements shall also be included in related location reports, containing the achieved values at the defined confidence level. Optionally requested and/or required direction of travel accuracy values may be included and if present shall define the accuracy requirement for direction of travel determination.

### 5.1.6 Horizontal position and horizontal position accuracy

The horizontal position and horizontal position accuracy information element defines reporting requirements for horizontal position uncertainty and defines accuracy requirements for horizontal position determination. Return value indicates whether horizontal position uncertainty shall be included in related location reports in addition to horizontal position. Preferred shape indicates whether reporting horizontal position uncertainty as a circle is preferred, or reporting as an ellipse or other shape is allowed.

NOTE: By default, each location report contains longitude and latitude (horizontal position) independently of this information element.

Optionally requested and/or required horizontal position accuracy values may be included and, if present, shall define the accuracy requirement for horizontal position determination.

In the case that a location information report contains an ellipse uncertainty definition, the horizontal position accuracy defines half of the major axis value instead of the circle radius. In the case that a position report contains an arc uncertainty definition, the horizontal position accuracy defines half of the maximum uncertainty dimension measured from the centre of the uncertainty area (defined as mean of the inner and outer radius and mean angle).

### 5.1.7 Horizontal velocity and horizontal velocity accuracy

The horizontal velocity and horizontal velocity accuracy information element defines reporting requirements for horizontal velocity and horizontal velocity uncertainty, and defines accuracy requirements for the horizontal velocity determination. Presence of this information element implies that horizontal velocity information element shall be included in related location reports. Return value indicates whether horizontal velocity uncertainty information element shall also be included in related location reports, containing the achieved value at the defined confidence level. Optionally requested and/or required horizontal velocity accuracy values may be included and if present shall define the accuracy requirement for horizontal velocity determination.



### 5.1.8 Location altitude and location altitude accuracy

The location altitude and location altitude accuracy information element defines reporting requirements for location altitude and location altitude uncertainty, and defines accuracy requirements for the altitude determination. Presence of this information element implies that location altitude information element shall be included in related location reports. Return value indicates whether location altitude uncertainty information element shall also be included in related location reports, containing the achieved value at the defined confidence level. Location altitude type shall indicate the altitude reference. Optionally requested and/or required location altitude accuracy values may be included and if present shall define the accuracy requirement for altitude determination.

### 5.1.9 Location information destination

Location information destination shall define the address to which MS shall send location report or reports. The address can be one of:

- ITSI or ISSI.
- GTSI or GSSI.
- IPv4 or IPv6.
- External subscriber number.
- ITSI or ISSI and external subscriber number.
- URL supported by name servers.

### 5.1.10 Location message reference

Location message reference shall define a reference for the location information defined by application. It may be a sequential message numbering or other reference. User requirements define it as a consecutive numbering of location reports, refer to TR 102 021-4 (see bibliography), clause 4.4.8, table 2 and to annex B of the present document.

### 5.1.11 Location shape

Location shape shall define pre-defined combination of location information parameters and their uncertainties.

### 5.1.12 Maximum information age

Maximum information age shall define how old the location information may be in related location reports. If the location information is older than defined by the maximum information age, then a new location determination should be performed.

### 5.1.13 Maximum reporting distance

Maximum reporting distance shall define how far from the previous reported location the MS can travel before it should send another location information report. If there is another location information report under preparation e.g. location determination takes a long time due to requested accuracy, then the MS should wait until that report is ready and send only the one that was under preparation.

NOTE: Sending of any location report to the concerned location information destination will reset maximum reporting distance counting (i.e. this location becomes the previously reported location).

### 5.1.14 Maximum reporting interval

The maximum reporting interval shall define that the MS should send a location report when the time elapsed since previous location report exceeds the maximum reporting interval. If there is another location report under preparation e.g. location determination takes a long time due to requested accuracy, then the MS should wait until that report is ready and send only the one that was under preparation.

NOTE: Sending of any location report to the concerned location information destination will reset maximum reporting interval counting (i.e. restart the time since previous location report).

### 5.1.15 Maximum response time

Maximum response time shall define how long the MS is allowed to spend making the location determination before sending a location information report. In the case that the accuracy to the required confidence level is achieved before the maximum response time, then the location report should be sent at that time. Otherwise if the maximum time is reached without achieving the accuracy and/or confidence level, then the location report should be sent including an indication of the achieved accuracy and/or confidence level. Refer to requested/required interaction clause 5.1.20.

### 5.1.16 Minimum reporting interval

The minimum reporting interval controls how often MS normally can send location information reports, to try to avoid overloading the air interface. It defines how much time needs to elapse after a location information report before the next report may be sent. In order to manage special situations, such as emergency, certain exceptions are defined, refer to clause 5.3.20.

### 5.1.17 Reason for sending

Reason for sending shall define why MS is sending a location report, refer to clause 6.3.64.

### 5.1.18 Report type

Report type shall define preferred report contents at general level including time.

### 5.1.19 Request priority

Request priority shall define the priority of the related location report compared to other reports when the reporting event occurs when a position determination is already being made or before the minimum reporting period has elapsed.

### 5.1.20 Requested/required

This information element with the corresponding accuracy values shall define how much effort the MS should use in the location determination and how the MS should behave if the defined accuracy is not achieved within maximum response time, refer to clause 5.1.15.

When the requested and/or required accuracy is achieved, the corresponding return info information element indicates whether the achieved uncertainty shall be included in the location information report.

When the requested and/or required accuracy is not achieved on one or more parameters, the MS shall include those uncertainty information elements in the location information report, even if those were not requested by the return info setting. In the required case MS shall also include result code "required accuracy not achieved". The result code indicates to the receiving applications that they should check the relevant uncertainty information element values, if the achieved accuracy is important to them.

If one or more requested positioning or velocity parameter is not available at all, then the MS shall send a location information report containing available information without result code.

If one or more required positioning or velocity parameter is not available at all, then the MS shall send a location information report containing available information with a result code.

NOTE: This requested/required (best effort/assured, must-be-satisfied) functionality may be different to other location information reporting standards, as the location information, if available at all, is included in the error message.

### 5.1.21 Start time

Start time shall define when triggered location reporting should start. If not present, then the triggers should be active immediately.

In the start and stop time definitions "day" is the day of the month as presented in regular calendar i.e. in February "day" can have value 1 to 28 in normal years or 29 in leap years. The time is intended to point to a value that is between current time and "one month" from current time. If the value of the "day" and the other parts of the time is less than the current date, then the "day" refers to the same value "day" of the next month. Due to the different number of days in various months and leap years the time range is limited to the end of the next month. E.g. if the "day" is set at the 31st of January in normal years to "29" or "30", then the day shall be considered to be "28".

If stop time occurs before start time, then the start time shall be set to the current time.

NOTE: This can happen when start time has already passed, so it looks as if it is in the next month.

### 5.1.22 Stop time

Stop time shall define when triggered location reporting should end and all trigger information related to that stop time should be invalidated. If not present, then reporting should continue until further information. Refer to clause 5.1.21 on the possible time span.

### 5.1.23 Terminal or location identification

Terminal or location identification shall define the target of control messages and location information source in location report or reports. The address can be one of:

- ITSI or ISSI.
- GTSI or GSSI.
- IPv4 or IPv6.
- External subscriber number.
- ITSI or ISSI and external subscriber number.
- Name of location.

### 5.1.24 Trigger definition

Trigger definition shall define a trigger and whether it is one-shot or recurrent. Some of the triggers may be either one-shot or recurrent. One-shot report means that reporting due to that trigger is stopped after sending the location report due to the first trigger event. Recurrent report means that a location information report is sent for each trigger event until stop time is reached.

### 5.1.25 Trigger type

Trigger type parameter shall define events when location reports should be sent. Some of the trigger types have parameters that define value or values the trigger e.g.:

- Status value (for trigger type Status).
- Location circle (for trigger type Approaching point).
- Location point (for trigger type Arrival at point).
- SDS type 1 value (for trigger type SDS type 1 entered).

Refer to clause 6.3.84.

## 5.1.26 Velocity type

Velocity type shall define pre-defined combination of velocity information parameters and their uncertainties, refer to clause 6.3.90.

## 5.1.27 Vertical velocity and vertical velocity accuracy

The vertical velocity and vertical velocity accuracy information element defines reporting requirements for vertical velocity and vertical velocity uncertainty, and defines accuracy requirements for the vertical velocity determination. Presence of this information element implies that vertical velocity information elements shall be included in related location reports. Return value indicates whether vertical velocity uncertainty information element shall also be included in related location reports, containing the achieved values at the defined confidence level. Optionally requested and/or required vertical velocity accuracy values may be included and if present shall define the accuracy requirement for vertical velocity determination.

**NOTE:** Use of the vertical velocity and vertical velocity accuracy information element implies that horizontal velocity and horizontal velocity uncertainty will be included in the location information report due to the available velocity types, refer to clause 6.3.90. In order to define horizontal velocity accuracy the Horizontal velocity and horizontal velocity accuracy information element is required.

## 5.2 Information flows

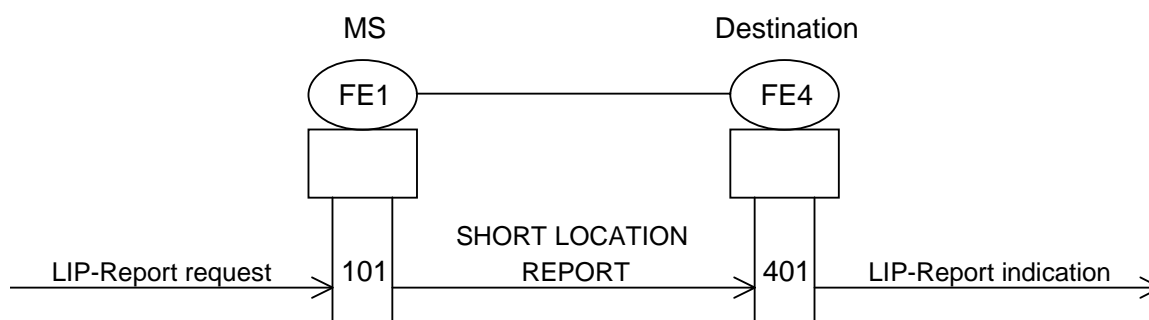
### 5.2.1 General on information flows

The information flows in clauses 5.2.2 to 5.2.18 present typical implementations of location information protocol services. The service primitives are defined in clause 4.3. The information flows use the PDU names as defined in clause 6.2 or descriptive names, if no PDU is defined in the present protocol.

The trigger events may originate from different sources. Some may originate from the communication device such as change of serving cell or loss of communication. Some are due to user action such as typing status value. Some may be generated in the protocol entity or in the location determination device such as maximum reporting distance. Some are based on timers inside the LIP entity such as maximum reporting interval. The present document identifies those instances and actions due to those in the protocol, but the trigger information collection and transport to the protocol entity is outside the scope of the present document and are not presented in the information flow charts.

### 5.2.2 Pre-programmed MS sending reports

MS may support unsolicited reporting by sending location information reports as defined by pre-programming, refer to figure 5.1.

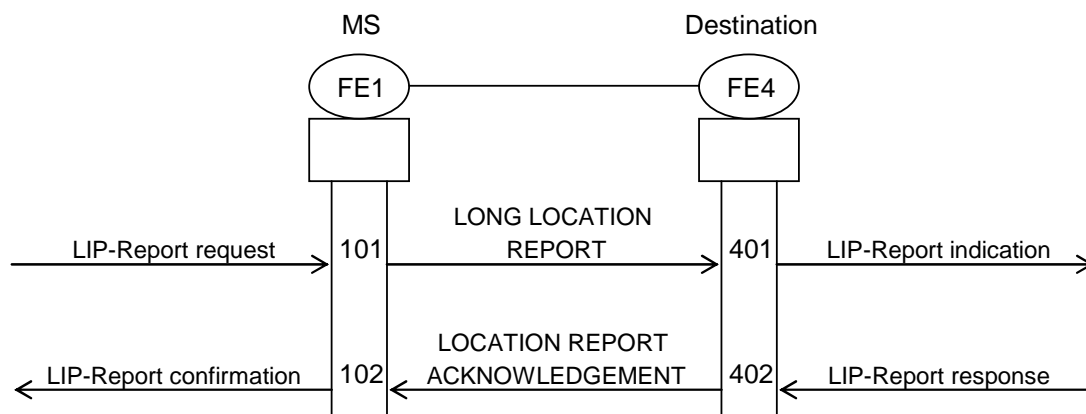


**NOTE:** Pre-programmed MS may send also LONG LOCATION REPORT PDUs.

**Figure 5.1: Pre-programmed MS sending reports**

### 5.2.3 Pre-programmed MS sending reports and receiving acknowledgement

MS may support unsolicited reporting by sending location information reports as defined by pre-programming and MS may ask and receive acknowledgements to the reports, refer to figure 5.2. When SHORT LOCATION REPORT PDU is used, then the sending of the LOCATION REPORT ACKNOWLEDGEMENT PDU is controlled by the service user at the location information destination and is outside the scope of the present document.

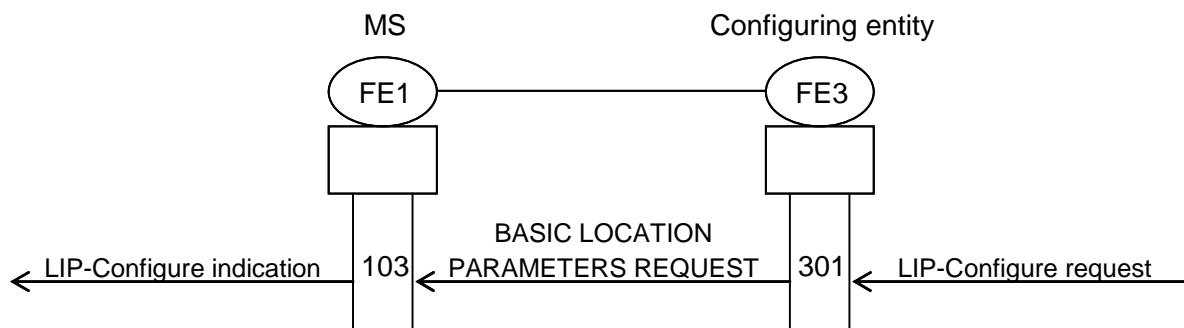


NOTE: Pre-programmed MS may send also SHORT LOCATION REPORT PDUs.

**Figure 5.2: Pre-programmed MS sending reports and receiving acknowledgement**

### 5.2.4 MS receiving basic parameters

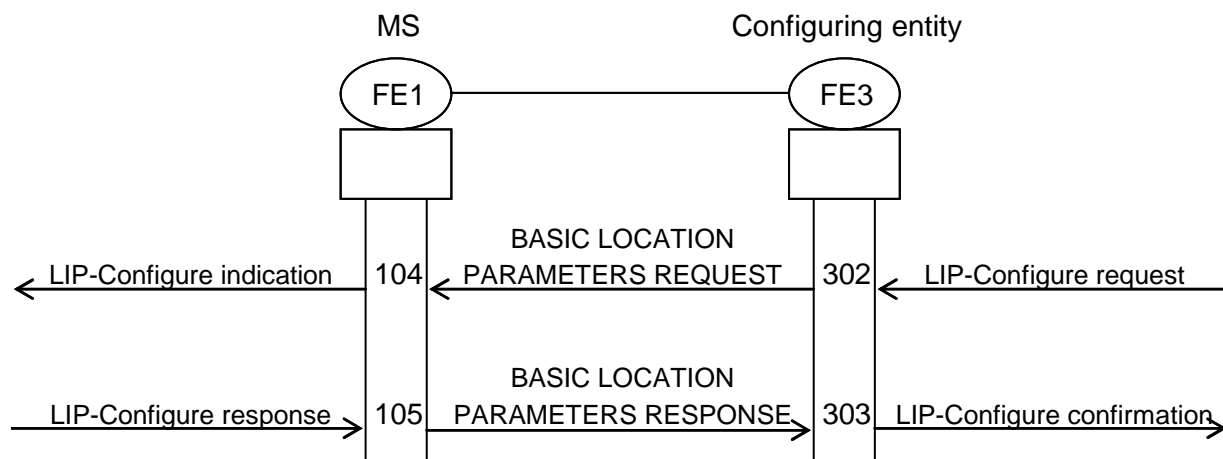
MS may receive basic configuration as presented in figure 5.3. LIP entity stores the parameters for further usage.



**Figure 5.3: MS receiving basic parameters**

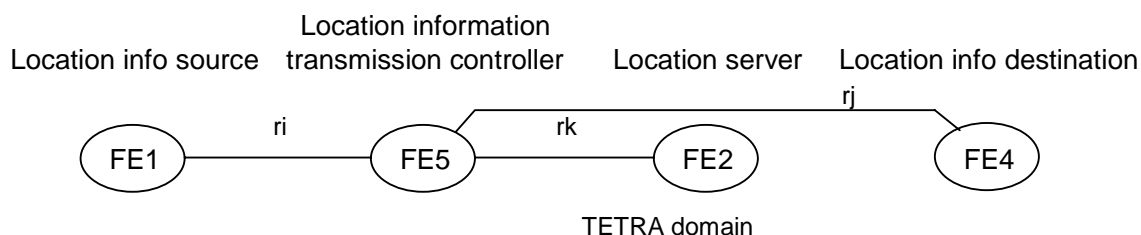
## 5.2.5 MS receiving basic parameters and sending response

MS may receive basic configuration and send acknowledgement to it as presented in figure 5.4. MS may indicate in the LIP-Configure response changes to the basic parameters. The LIP-Configure response may reject or modify the basic parameters. LIP entity may also ignore the LIP-Configure indication especially, when it originates from an unauthorized source.



**Figure 5.4: MS receiving basic parameters and sending response to it**

In figure 5.5a, a location information transmission controller FE5 commands the location information source FE1 and informs location server FE2 and location information destinations FE4.



**Figure 5.5a: Location information transmission control**

## 5.2.6 MS reporting basic parameters

MS may receive a request to report basic configuration parameters at any time and respond to it as presented in figure 5.5b.

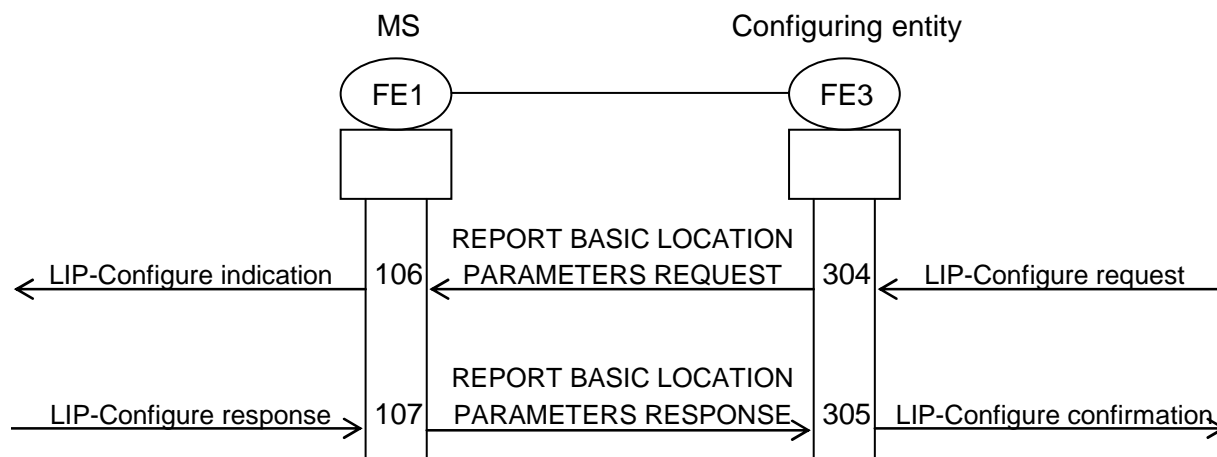
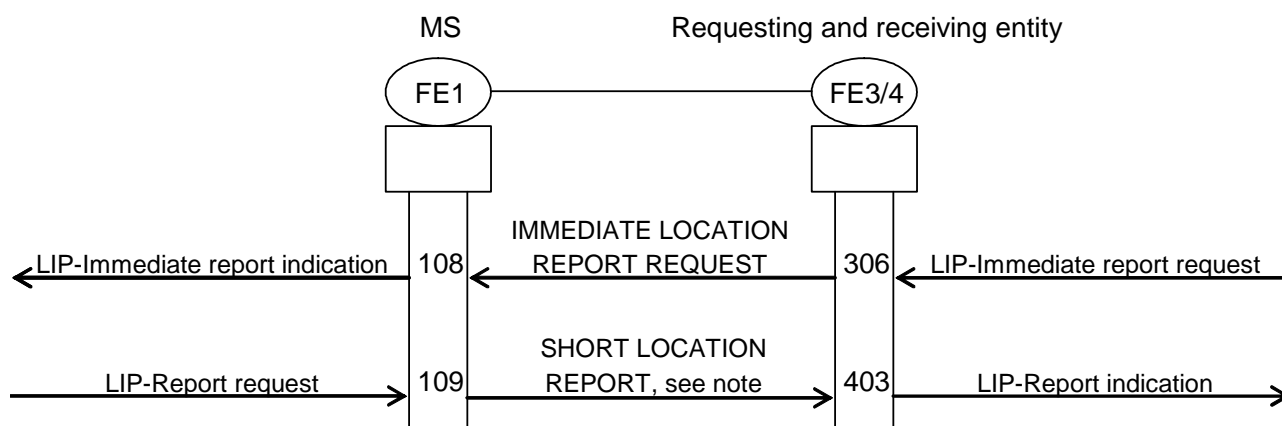


Figure 5.5b: Basic configuration parameters reporting

## 5.2.7 MS receiving immediate report request and sending response

MS may receive immediate location report request and answer to it as presented in figure 5.6. The report type and contents depend on the basic parameters and specific parameters in the LIP-Immediate report indication.



NOTE: MS may send LONG LOCATION REPORT instead, depending on the basic parameters and what information is requested in the LIP-Immediate report indication.

Figure 5.6: MS receiving and sending reports due to an immediate location report request

## 5.2.8 MS receiving immediate report request and asking acknowledgement

MS may support immediate reporting by receiving immediate report requests and responding with location information reports. MS may ask for and receive acknowledgements to the location information reports. Refer to figure 5.7. The location information report acknowledgement requests can be sent in long location information reports.

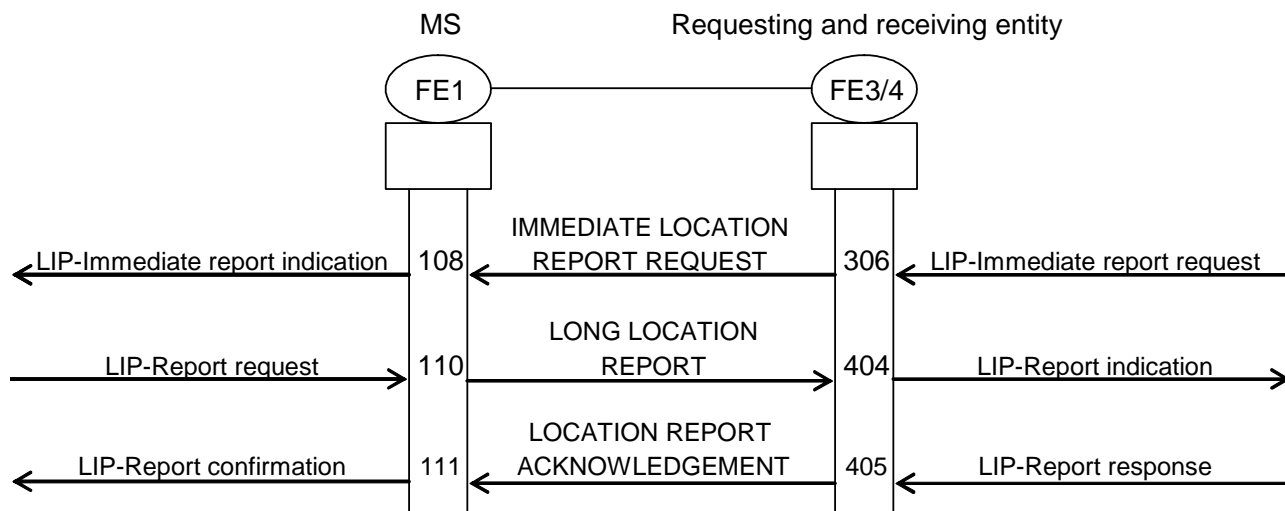
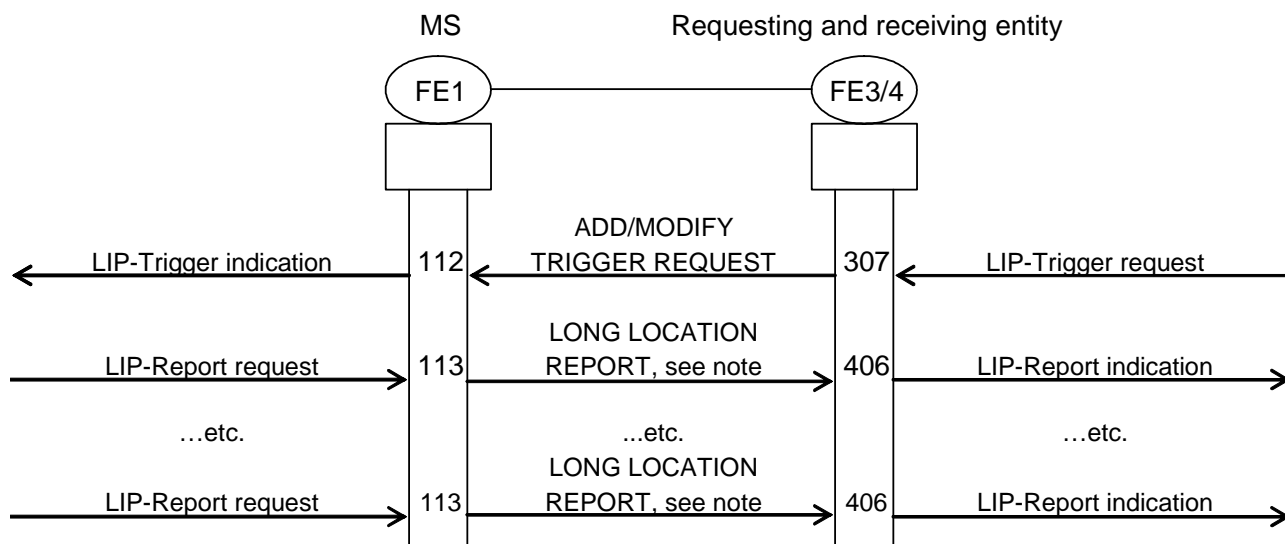


Figure 5.7: MS receiving immediate report request and asking acknowledgement

## 5.2.9 MS receiving trigger definitions and sending reports

MS may support triggered reporting by receiving trigger definitions and sending location information reports when trigger conditions are met, refer to figure 5.8.



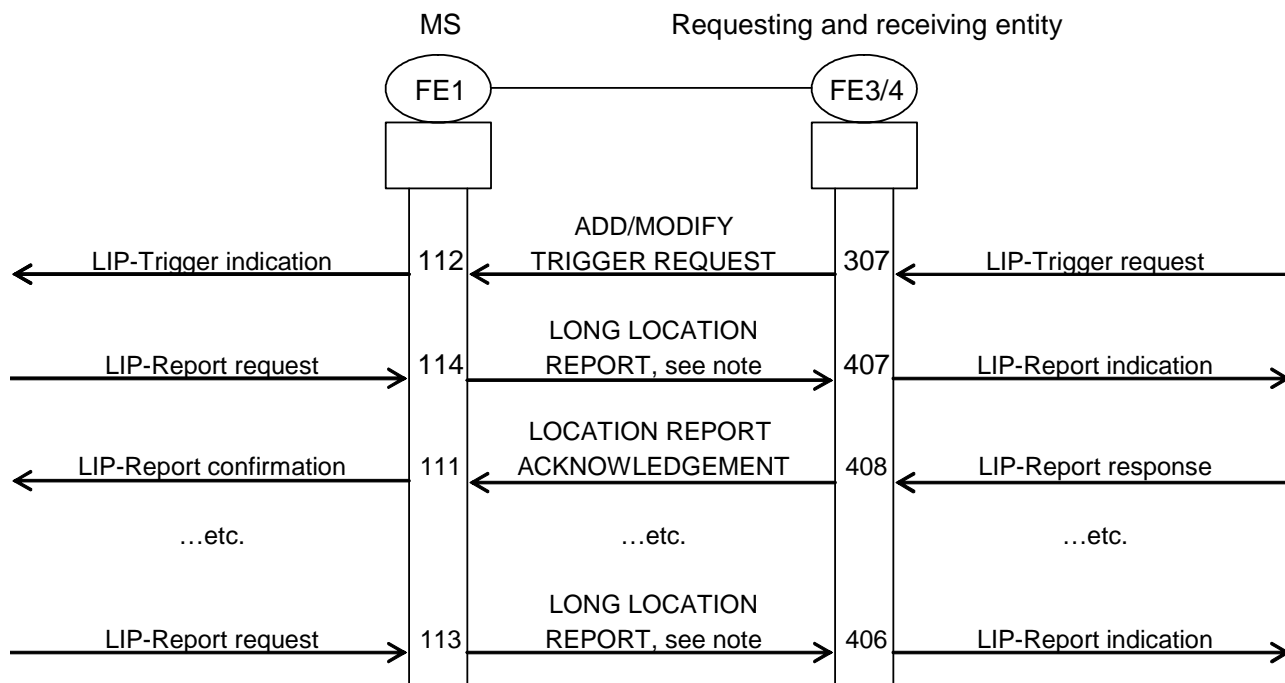
NOTE: MS may send SHORT LOCATION REPORT instead, depending on the basic parameters and what information is requested in the LIP-Trigger indication.

Figure 5.8: MS receiving trigger definitions and sending reports



## 5.2.10 MS receiving trigger definitions and sending reports and asking acknowledgements

MS may support triggered reporting by receiving trigger definitions and sending location information reports when trigger conditions are met. MS may ask and receive acknowledgements to the location information reports, refer to figure 5.9.

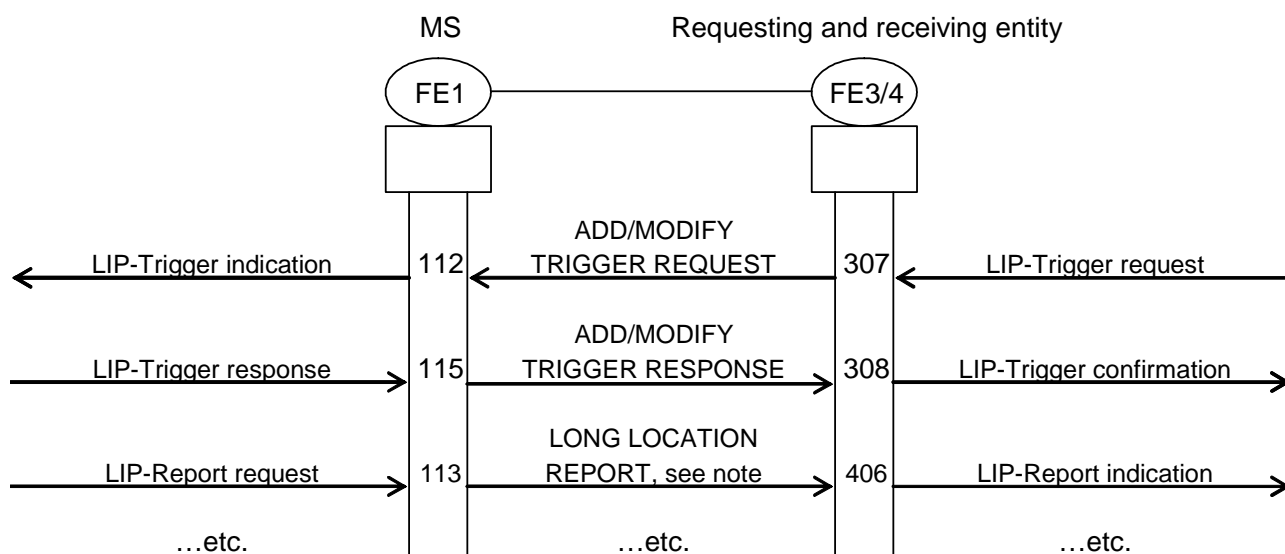


NOTE: MS may ask the location report acknowledgements in the LONG LOCATION REPORT independently for each report.

**Figure 5.9: MS receiving trigger definitions and sending reports and asking acknowledgements**

### 5.2.11 MS receiving trigger definitions and sending modification

Requesting entity ask MS to confirm the triggers or MS may confirm and modify the received trigger setting by sending acknowledgement as presented in figure 5.10.



NOTE: MS may send SHORT LOCATION REPORT instead, depending on the basic parameters and what information is requested in the LIP-Trigger indication.

Figure 5.10: MS receiving trigger definitions and sending modification and reports

### 5.2.12 MS receiving trigger definitions and rejecting triggers

LIP may reject the received trigger setting by sending acknowledgement as presented in figure 5.11. The LIP may also ignore the LIP-Trigger indication without sending any LIP-Trigger response especially, when the LIP-Trigger indication originates from an unauthorized source.

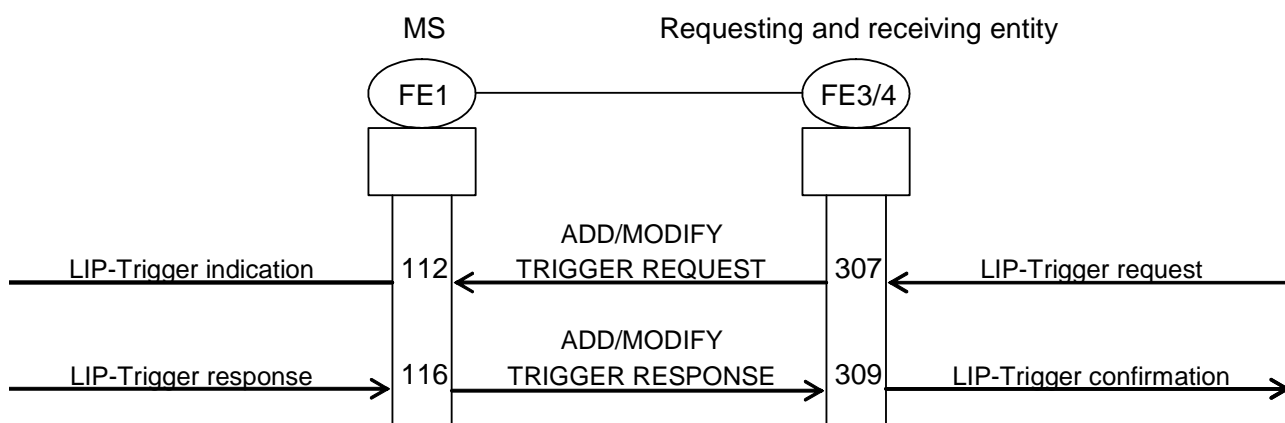
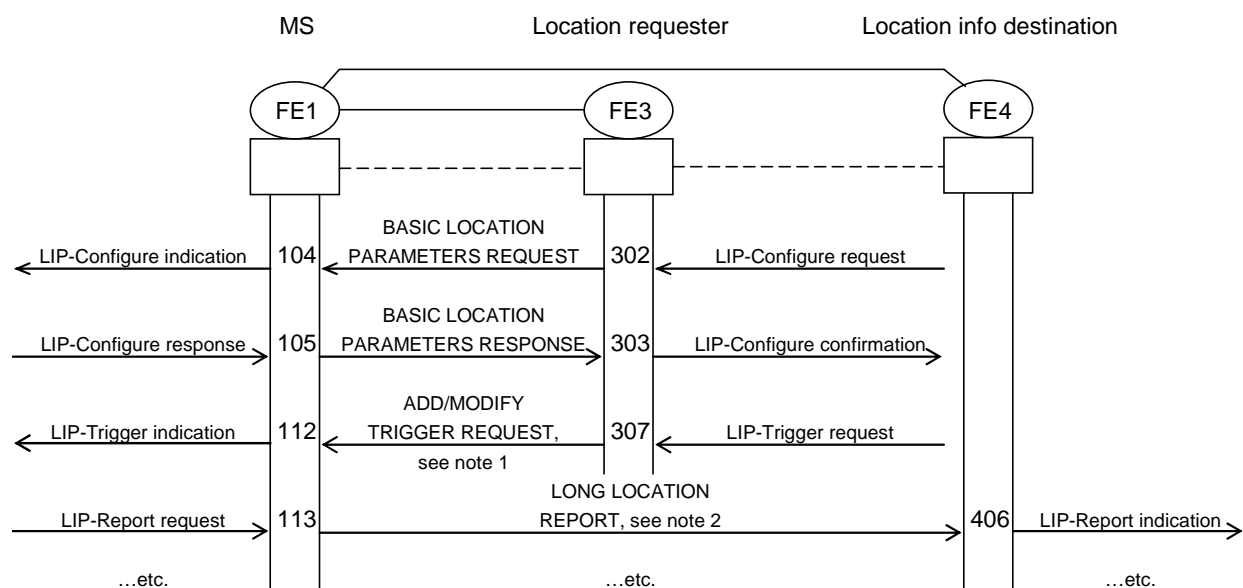


Figure 5.11: MS receiving trigger definitions and rejecting triggers

### 5.2.13 MS receiving trigger definitions and sending reports to other location information destination

The location requester and location information destination may be different entities as presented in figure 5.12.



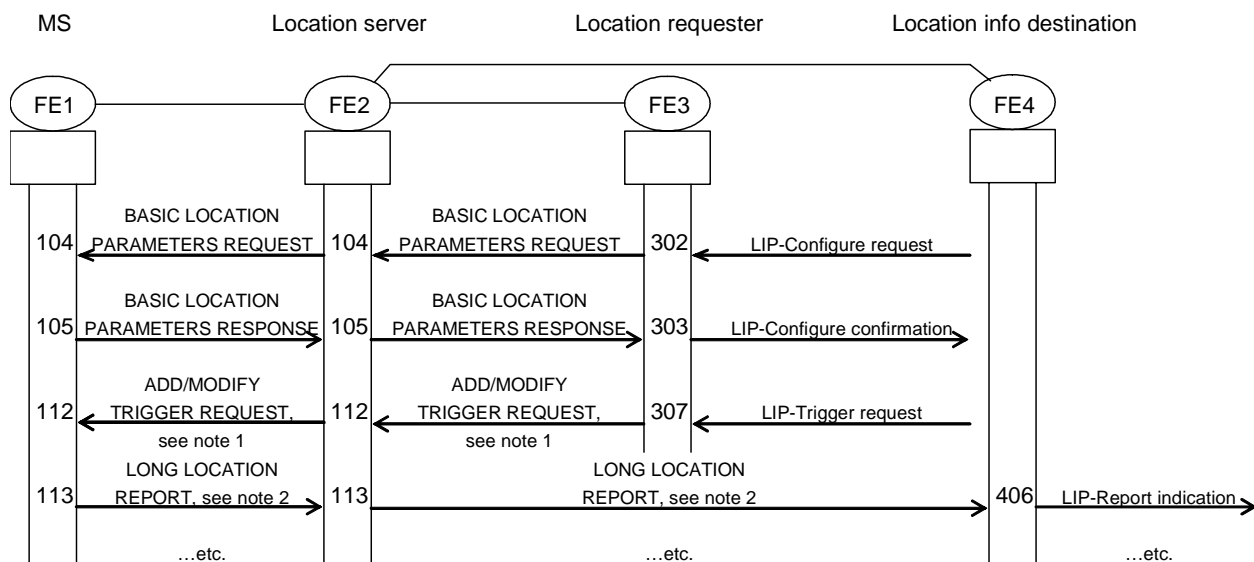
NOTE 1: The location requester may also ask for ADD/MODIFY TRIGGER RESPONSE PDU in the ADD/MODIFY TRIGGER PDUs, refer to figure 5.10.

NOTE 2: MS may ask from the location information destination a location report acknowledgement in the LONG LOCATION REPORT PDU independently for each report, refer to figure 5.9.

**Figure 5.12: MS receiving trigger definitions and sending reports to another location information destination**

## 5.2.14 MS receiving trigger definitions via location server and sending reports to another location information destination

The location requester and location information destination may be different entities and there may be a server as presented in figure 5.13.



NOTE 1: The location requester may also ask for ADD/MODIFY TRIGGER RESPONSE PDU in the ADD/MODIFY TRIGGER PDUs, refer to figure 5.10.

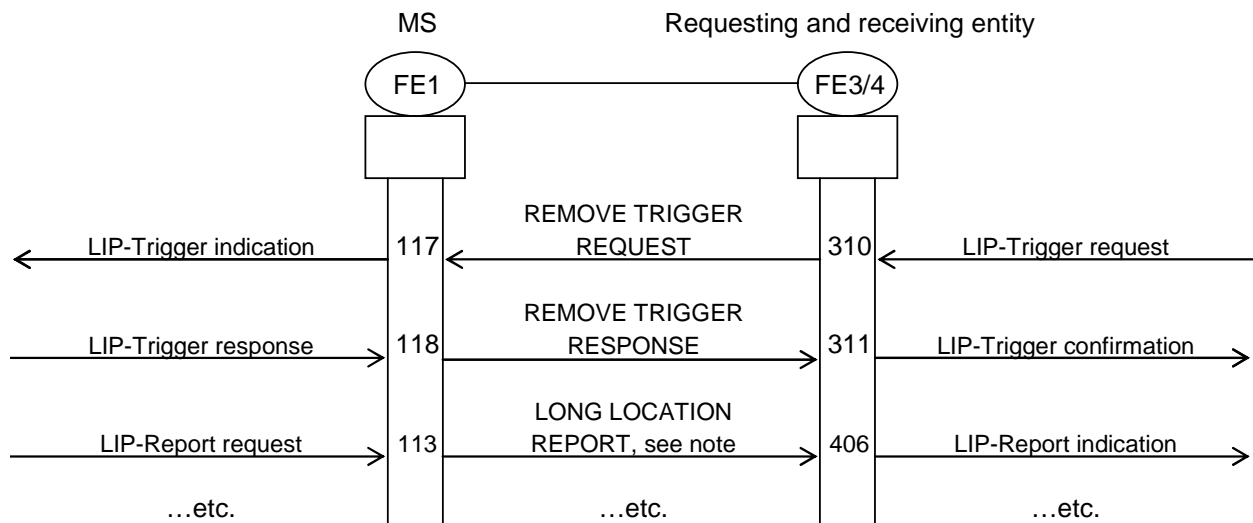
NOTE 2: MS may ask from the location server a location report acknowledgement in the LONG LOCATION REPORT PDU independently for each report, refer to figure 5.9. The location server may ask from the location information destination a location report acknowledgement in the LONG LOCATION REPORT PDU independently for each report. Whether the location server returns a LOCATION REPORT ACKNOWLEDGEMENT PDU to the MS immediately or waits for an acknowledgement from the location destination is outside the scope of the present document.

NOTE 3: Service primitives to the left of FE1 are the same as in figure 5.12.

**Figure 5.13: MS receiving trigger definitions via location server and sending reports to another location information destination**

## 5.2.15 Trigger removal

Controlling entity may remove a trigger or triggers at any time as presented in figure 5.14. MS continues sending triggered location reports, if there are any remaining triggers.

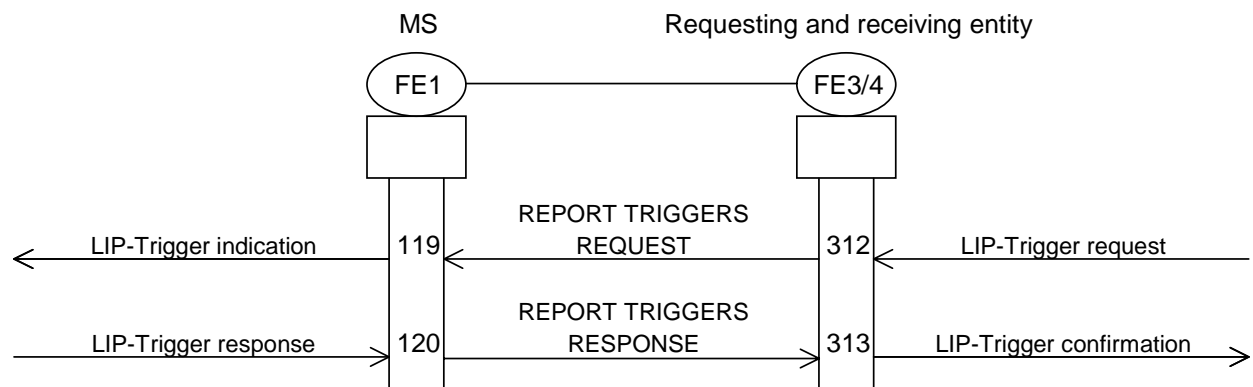


NOTE: MS may send SHORT LOCATION REPORT depending on the basic parameters and what information is requested in the LIP-Report request.

**Figure 5.14: Trigger removal**

## 5.2.16 Trigger reporting

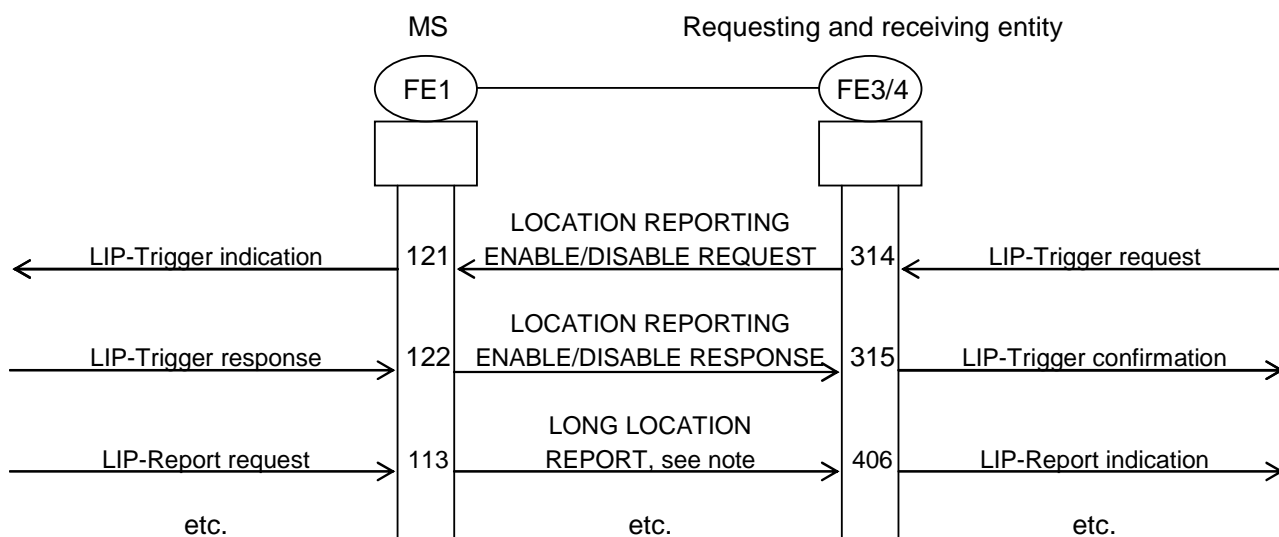
Controlling entity may request triggers from the MS at any time as presented in figure 5.15.



**Figure 5.15: Trigger reporting**

## 5.2.17 Location reporting enabling

Controlling entity may enable triggered location reporting at any time as presented in figure 5.16.

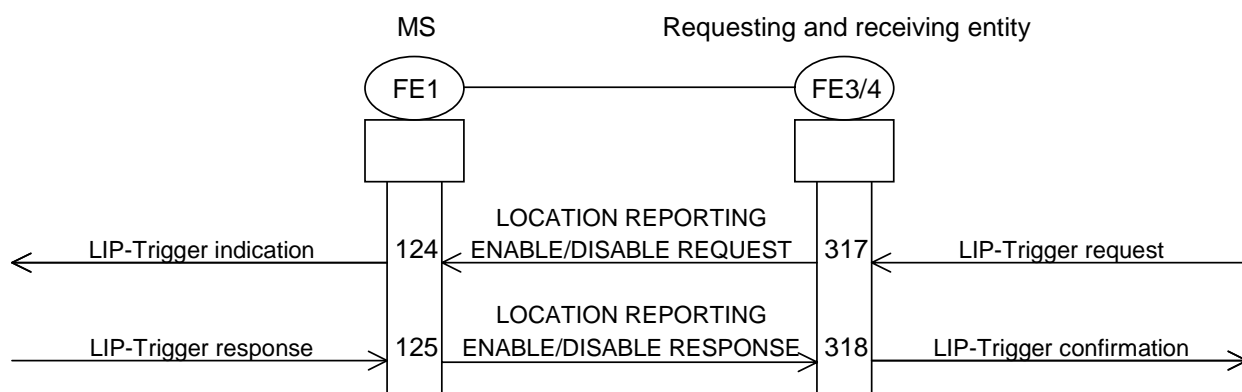


NOTE: MS may send SHORT LOCATION REPORT depending on the basic parameters and what information is requested in the LIP-Report request.

**Figure 5.16: Location reporting enabling**

## 5.2.18 Location reporting disabling

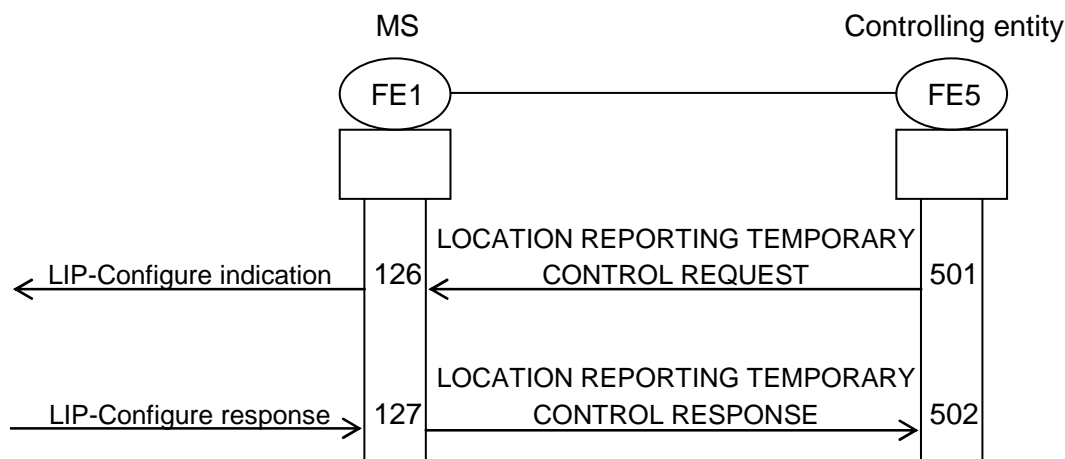
Controlling entity may disable triggered location reporting at any time as presented in figure 5.17. MS stops sending triggered location reports.



**Figure 5.17: Location reporting disabling**

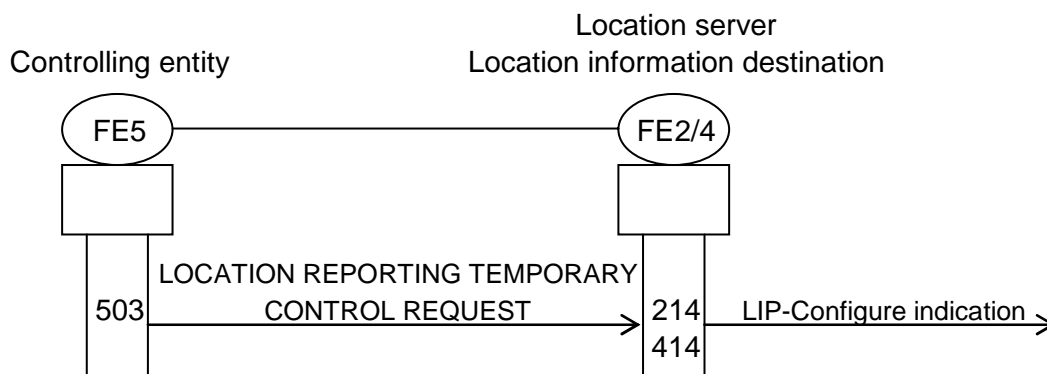
## 5.2.19 Location reporting temporary control

Controlling entity may modify triggered location reporting at any time as presented in figure 5.18. MS modifies sending of triggered location reports and if requested sends response to the controlling entity.



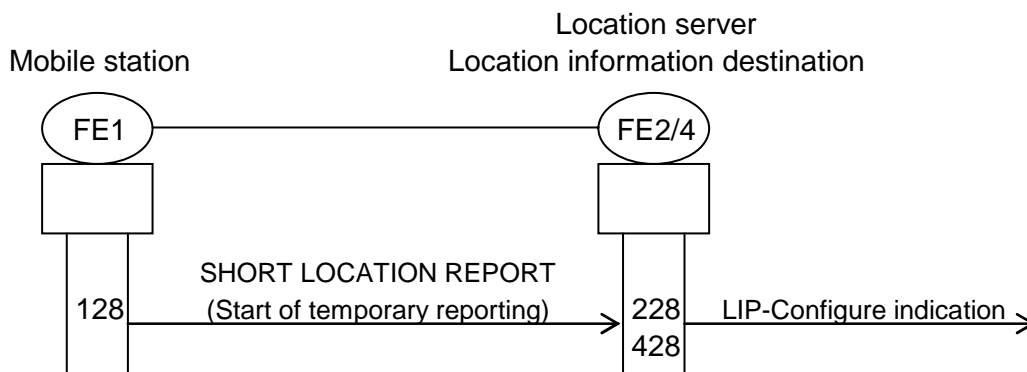
**Figure 5.18: Location reporting temporary control**

Controlling entity may inform location server and/or location information destination about temporary reporting parameters as presented in figure 5.19.



**Figure 5.19: Location reporting temporary control information**

Location information source entity may inform location server and/or location information destination about temporary reporting as presented in figure 5.20.



**Figure 5.20: Location reporting temporary control information sent by MS**

## 5.2.20 Allocation of entities

In the flow charts in figures 5.1 to 5.20 "MS" was used as a physical allocation to FE1. The location information source from the requesting FE3 and receiving entity FE4 point of view can also be a location information server FE2.

The location information server may also be in the role of the requesting FE3 and receiving FE4 entities.

MS may also be in any other role of the entities presented in figures 5.1 to 5.20. E.g. in figure 5.6 MS as FE3/4 may support sending of immediate report requests and reception of location reports. MS may support sending of triggered report requests and reception of location reports as entity FE3/4 in figure 5.8.

In systems extending to domain outside TETRA domain the roles of information entities are in principle the same as in figures 5.1 to 5.17, but the information flows to and from the external entities may use other PDUs than shown in the information flows.

The location information transmission controller may be independent of other entities or may be combined with one or more of entities FE2 and FE3.

In a system there may be any number of any entities allocated to any number of physical entities.

## 5.3 Procedures

### 5.3.1 Relations to flow charts

The procedures refer to the flow chart action numbers as needed. Some of the actions in the flow charts are not described as those should be self-evident and do not contain any requirements.

### 5.3.2 General on control messages

The controlling entity may define how MS (or any other physical allocation to FE1) should report its location. The report request functionality may contain two steps. The first one sets basic parameter values that are applicable to all reports. The second step is in the form of report requests containing the immediate or trigger definition, but may also contain specific parameter values for this request or trigger. Some or all of the basic parameters may be pre-programmed into MS in which case immediate and triggered requests can be sent without a previous basic parameters setting.

Basic parameters and trigger parameters interact as follows:

- Trigger parameters are inherited from the basic parameters i.e. if a trigger definition does not contain any parameters, then the basic parameters are used:
  - If the basic parameters are modified during lifetime of the trigger definition, then the changes shall be immediately valid for the inherited trigger parameter as well.
  - If the basic parameter is removed (by new definition of basic parameters) during lifetime of the trigger definition, then the inherited parameter shall also be removed from the trigger definition.
- If the trigger definition contains a parameter that is also defined in the basic parameters, then the parameter's value in the trigger definition shall be used for the lifetime of that trigger:
  - The basic parameter shall not be affected due to the trigger definition.
  - If the basic parameter definition is modified or removed during lifetime of the trigger definition, then the trigger definition shall not be changed.
- If trigger definition contains a parameter that is not in the basic parameters, then that parameter shall be valid for the lifetime of the trigger definition:
  - The basic parameter shall not be defined due to this trigger definition.
  - If that basic parameter is defined or later modified during lifetime of the trigger definition, then the trigger definition shall not be changed.



The basic parameters shall be inherited with the same rules used for the immediate location reports.

All location information reports should by default contain a "point" i.e. longitude and latitude information and therefore control messages do not contain information elements to request a point.

**EXAMPLE:** When no location related parameter is defined in the basic parameters, then location point with altitude is requested by including only altitude in the request.

**NOTE:** Although location information report can be without longitude and latitude information elements, the present document does not define any method to ask for a location information report without longitude and latitude information.

### 5.3.3 Accuracy control in control messages

There are two accuracy related control issues in the control messages:

- which accuracy is requested/required in the location or velocity determination; and
- whether the achieved accuracy i.e. measurement uncertainty shall be included in the location information report or not.

**NOTE:** Requester's independent control of the requested/required accuracy and whether uncertainty information will be included in the report is specific to TETRA. That capability allows a better control of uplink air interface resource usage.

Uncertainty of a location point (on the WGS84 reference ellipsoid) is defined as the horizontal distance from that point. In the report request a single number defines the horizontal accuracy requirement. In the reports the achieved accuracy i.e. uncertainty can be expressed as a single number in the "circle" shape and with a set of numbers in the "ellipse" and "arc" shapes.

Accuracy requirement can be defined in the basic parameters, in the trigger definition or in the immediate location report request. The same inheritance rules apply as defined in clause 5.3.2.

If no accuracy is defined then "best effort" is used as default value.

In the report requests a (requested/required) accuracy shall be defined explicitly, if it replaces existing accuracy requirement.

In the PDU information element encoding the request for inclusion of location parameter and its uncertainty parameter is combined with the accuracy information into a single information element that also includes requested/required control. Presence of that combined information element indicates firstly that the main parameter whose accuracy is defined is requested, secondly what accuracy should be used in the parameter value measurement and thirdly whether the uncertainty information element is requested to be included in the location information report.

It is under further study how MS should behave, when the same location information parameter have at the same time different accuracy values for requested and required accuracies.

### 5.3.4 General on location report sending

The reporting entity should generate location reports as set by the parameters defined in the requesting PDU, in the basic parameters and in the parameters for triggers and immediate reports, refer to clause 5.3.2. The reporting entity may use existing location information or may need to request location information from the location determination entity before it can construct the location report. The actions for acquiring the location information are outside scope of the present document.

Refer to clause 5.1.20 for accuracy requirements and maximum response time interactions.

The reporting entity may ignore report requests due to security or privacy reasons. Alternatively the reporting entity may send a LONG LOCATION REPORT PDU without location information but containing an applicable result code.

### 5.3.5 General on location report reception

Upon reception of a location report the receiving entity should check whether the report matches with the request, if any. The checking may be necessary especially when the request contained e.g. accuracy requirements. If the report sending entity has failed to achieve the required accuracy, then the report sending entity normally sends the achieved accuracy information and that will indicate that the requested accuracy requirement was not met, refer to clause 5.3.4.

The receiving entity may receive more location reports than it is requesting. The related application may use the location information as is suitable to it. The application should tolerate the reception of extra location reports.

The receiving entity may receive less location reports than it is requesting. E.g. instead of receiving a report based on the maximum reporting distance it may receive emergency condition location report. Application should tolerate and use, when possible, location reports that are sent for other reasons than those requested by that application.

NOTE: Triggered reporting restrictions do not normally affect the sending of immediate reports and an application may use that feature to get location reports remembering that air interface resource may be limited.

### 5.3.6 MS sending unsolicited reports

MS may be programmed to send location reports SHORT LOCATION REPORT PDU or LONG LOCATION REPORT PDU without any request from other entities as described in action 101 in figures 5.1 and 5.2. The MS may ask for acknowledgement of the report reception as needed and get back LOCATION REPORT ACKNOWLEDGEMENT PDU as shown in action 102.

### 5.3.7 MS receiving basic parameters

MS may receive a BASIC LOCATION PARAMETERS REQUEST PDU at any time as shown in action 103 in figure 5.3 and action 104 in figure 5.4. The parameters in the received PDU shall replace all the existing basic parameters and non-included parameters shall be set to "not applicable" values.

If the MS received the BASIC LOCATION PARAMETERS REQUEST PDU individually addressed to it and cannot support some of the requested triggers, parameters or accuracies the MS should send BASIC LOCATION PARAMETERS RESPONSE PDU with result "Accepted, but some of the triggers or accuracies are modified or not supported", and containing supported triggers and parameters and accuracies to be used in report sending process in the BASIC LOCATION PARAMETERS RESPONSE PDU. The non-support of a parameter shall be indicated by non-presence of that parameter, refer to action 105 in figures 5.4 and 5.12. Otherwise if acknowledgement request is indicated in the received PDU MS shall send as acknowledgement a BASIC LOCATION PARAMETERS RESPONSE PDU with value "success".

The basic parameters that MS received and accepted or modified shall be valid until replaced by a new BASIC LOCATION PARAMETERS REQUEST PDU or when stop time is reached.

### 5.3.8 MS reporting basic parameters

MS may receive a REPORT BASIC LOCATION PARAMETERS REQUEST PDU at any time as described in action 106 in figure 5.5b. If MS support the reporting, then it shall response by a REPORT BASIC LOCATION PARAMETERS RESPONSE PDU, refer action 107.

### 5.3.9 MS sending immediate reports

Upon reception of an IMMEDIATE LOCATION REPORT REQUEST PDU the location information protocol entity shall acquire location information as requested, refer to action 108 in figure 5.6 and clause 5.3.2. The MS shall send a SHORT LOCATION REPORT or LONG LOCATION REPORT PDU as requested.

In the case the requested or required accuracy was not achieved during the applicable maximum response time, see requirements in clause 5.3.4.

MS may request acknowledgement to the location report in the LONG LOCATION REPORT PDU as shown in action 110 in figure 5.7 and should receive a LOCATION REPORT ACKNOWLEDGEMENT PDU as a response, as in action 111.

### 5.3.10 MS sending immediate report request

MS may also act as the location information requester (FE3) and location report receiving entity (FE4). Refer to action 306 in figure 5.6 and clause 5.3.2 for an IMMEDIATE LOCATION REPORT REQUEST PDU and reception of a SHORT LOCATION REPORT PDU or a LONG LOCATION REPORT PDU refer to action 403.

The reporting entity may ask for an acknowledgement to the report as shown in action 404 in figure 5.7 and the MS (as FE4) should send a LOCATION REPORT ACKNOWLEDGEMENT as in action 405.

The reporting entity may ignore the IMMEDIATE LOCATION REPORT REQUEST PDU due to security or privacy reasons. Reporting entity may in that case send a LONG LOCATION REPORT PDU containing an applicable result code.

### 5.3.11 Triggered report request sending

The controlling entity requests triggered location reports using an ADD/MODIFY TRIGGER REQUEST PDU as presented in action 307 in figure 5.8.

In the request a start time, a stop time, and trigger conditions may be specified. If a start time is specified, it indicates when reporting should begin. The reporting should occur based on the specified trigger events. If a start time is not specified, the current time is implied (i.e. the reports should begin as soon as possible, based on the trigger events).

If a stop time is specified, it indicates when reporting should end. No specified stop time in this case means the reports should continue until the trigger condition (if one was specified) ends, or the reporting is explicitly stopped either by the controlling entity (through sending a REMOVE TRIGGER REQUEST PDU), or by the reporting entity (through sending location report with result code "user disabled location report sending").

If no other trigger than "maximum reporting interval" trigger is specified, it specifies the interval between successive reports after the first report takes place. If no other trigger than "maximum reporting distance" trigger is specified, it specifies that after the first report, future reports should be sent when the location of the original location information source has changed by at least the specified distance from the previously reported location. However, the minimum amount of time between successive reports after the first report takes place must be at least the value specified by the "minimum reporting interval" parameter.

If no other trigger than "maximum reporting interval" and "maximum reporting distance" trigger is specified, after the first report, location information reports should be sent when either the location of the original location information source has changed by at least the specified distance from the previously reported location or the interval time is passed since the previous location report. However, the minimum amount of time between successive reports after the first report takes place must be at least the value specified by the "minimum reporting interval" parameter.

Other triggers are based on particular trigger events occurring. If a time or distance based location report is under preparation when another trigger event occurs, e.g. due to location determination taking a long time, then the MS should wait until that report is ready and send only that report for the other trigger event. Similarly, if a time or distance based location report becomes due when a report is under preparation due to another trigger, then again only a single location report should be sent (due to the other trigger).

If the trigger is specified to be a one-shot trigger, then the trigger shall be removed after sending the location information report resulting from that trigger, regardless of whether a stop time was defined.

In addition to trigger definitions the ADD/MODIFY TRIGGER REQUEST PDU may define which location and velocity parameters and their related uncertainties location reports should contain, refer to clause 5.3.3. When the ADD/MODIFY TRIGGER REQUEST PDU contains accuracy parameter that is different than the one in the existing basic parameter, then the accuracy defined in the ADD/MODIFY TRIGGER REQUEST PDU shall be applied for that trigger and only for that trigger, refer to clause 5.3.4.

The controlling entity may ask for trigger definition confirmation and/or MS may send modifications to the triggers in an ADD/MODIFY TRIGGER RESPONSE PDU shown as actions 307 and 113 in figure 5.10. The reporting MS may have received basic parameters as described in clause 5.3.7.

The ADD/MODIFY TRIGGER REQUEST PDU may contain multiple trigger definitions and trigger parameter may have different values for different trigger.

### 5.3.12 MS receiving triggered reports requests

MS supporting triggered location report sending may at any time receive ADD/MODIFY TRIGGER REQUEST PDU and shall store the trigger information for use, and if requested in the "Acknowledgement" information element it shall send an ADD/MODIFY TRIGGER RESPONSE PDU with result "Accepted", if MS accepted trigger information.

If the MS received the ADD/MODIFY TRIGGER REQUEST PDU individually addressed to it and cannot support some of the requested triggers, parameters or accuracies the MS should send ADD/MODIFY TRIGGER RESPONSE PDU with result "Accepted, but some of the triggers or accuracies are modified or not supported", and containing supported triggers and parameters and accuracies to be used in report sending process in the ADD/MODIFY TRIGGER RESPONSE PDU. The non-support of a parameter shall be indicated by non-presence of that parameter, refer to action 115 in figure 5.10.

If the MS received the ADD/MODIFY TRIGGER REQUEST PDU individually addressed to it and does not support any of the triggers in the ADD/MODIFY TRIGGER REQUEST PDU, then MS should send ADD/MODIFY TRIGGER RESPONSE PDU with result "Triggers not supported" as presented in figure 5.11 action 116.

### 5.3.13 MS sending triggered reports

After reception of an ADD/MODIFY TRIGGER REQUEST PDU the MS shall start sending location reports as defined by the triggers and shall take into account trigger interactions as defined in clause 5.3.20, see action 113 in figure 5.8 and in figure 5.9. MS may ask for confirmation as presented in action 114 in figure 5.9. For the interaction between basic parameters and trigger definitions refer to clause 5.3.2.

MS may be asked to send reports to a different address than the requesting address as shown figure 5.12. The communication for the trigger setting is between FE1 and FE3, MS actions 104, 105 and 112. The reports are from FE1 to FE4, MS action 113. Also in this case MS may ask acknowledgements from the location information destination as in figure 5.9, actions 114 and 111.

### 5.3.14 MS receiving triggered reports

When MS is in the role of FE3/4, as defined in clause 5.2.19, and it has sent request for a triggered report request as defined in clause 5.3.11 it should receive triggered reports. Upon reception of a triggered report, SHORT LOCATION REPORT or LONG LOCATION REPORT PDU, the location information protocol entity in MS passes contents of it via the LIP-SAP to the requesting entity, refer to action 406 in figure 5.8. The sending entity may ask for confirmation as presented in action 407 in figure 5.9 and the MS should return a LOCATION REPORT ACKNOWLEDGEMENT PDU as presented in action 408.

### 5.3.15 Triggered report reception in location server

Upon reception of a triggered report, SHORT LOCATION REPORT or LONG LOCATION REPORT PDU, the location information protocol entity FE4 passes contents of it to the location information destination entity or entities or stores it for a later use, refer to action 406 in figure 5.8. The sending entity may ask for confirmation as presented in action 407 in figure 5.9 and the location server should return a LOCATION REPORT ACKNOWLEDGEMENT PDU as presented in action 408. The actions in a location server are outside the scope of the present document.

### 5.3.16 Trigger removal

MS may receive at any time a REMOVE TRIGGER REQUEST PDU as presented as action 117 in figure 5.14 and if requested in the "Acknowledgement" information element it shall send a REMOVE TRIGGER RESPONSE PDU as shown as action 118. If the acknowledgement is not requested, then MS shall not send any response, but remove the trigger silently.

### 5.3.17 Report trigger request

MS may receive at any time a REPORT TRIGGERS REQUEST PDU as presented as action 119 in figure 5.15 and shall send a REPORT TRIGGERS RESPONSE PDU or PDUs to report all triggers as presented in action 120.

If the MS is able to send the REPORT TRIGGERS RESPONSE PDU successfully, it shall set the Result code in the REPORT TRIGGER RESPONSE PDU to "Report complete" instead of "Success" to indicate successful transmission of the full report.

If the MS decides to send multiple PDUs and is able to send the PDUs successfully, it shall set the Result code to "Report complete" in the last REPORT TRIGGER RESPONSE PDU and to "Success" in the other PDUs.

If the MS has no triggers to report, it shall send the REPORT TRIGGERS RESPONSE PDU with the Result code set to "Report complete" and without any optional element in the PDU other than the "Terminal or location identification" element which may be present in the PDU.

This allows the Location server to determine if it received successfully the full report as the MS might not be able to complete the report e.g. due to entering DMO, TxI, or failing Layer 2 transmissions while sending the report.

If the location server does not receive a REPORT TRIGGERS RESPONSE PDU with "Report complete" as Result code, it may take no further action, request the full report again, or remove all triggers and re-define them again.

### 5.3.18 Location report enable/disable request

MS may receive at any time a LOCATION REPORTING ENABLE/DISABLE REQUEST PDU as presented as action 121 in figure 5.16 for location information reporting enabling and shall start/continue triggered location information reporting as defined by triggers. If the LOCATION REPORTING ENABLE/DISABLE REQUEST PDU is for location information reporting disabling as presented as action 124 in figure 5.17, then MS shall stop triggered location information reporting, but keep trigger definitions.

An MS capable of and wishing to location report shall request explicit authorization from the location server by sending an "initialization request" which consists of a SHORT LOCATION REPORT PDU with reason for sending set to "Subscriber unit asks for transfer initialization configuration":

- If the MS receives LOCATION REPORTING ENABLE/DISABLE REQUEST PDU with Location reporting enable flag 1 set to 1 (*Location reporting globally enabled*), it shall consider itself enabled until the default enable/disable lifetime expires.
- If the MS receives LOCATION REPORTING ENABLE/DISABLE REQUEST PDU with Location reporting enable flag 1 set to 0 (*Location reporting globally disabled*), it shall consider itself disabled until the default enable/disable lifetime expires.
- If the MS does not receive any PDU response, it shall consider itself disabled until the next ITSI attach registration.

NOTE 1: The MS may send the SHORT LOCATION REPORT PDU to a globally defined address, to a predefined address or to the last known address.

NOTE 2: In case the MS does not receive any PDU response, it may make one more attempt (to the same address or to another address).

When the default enable/disable lifetime expires, the MS shall consider itself disabled and send an initialization request as described earlier.

The MS may receive at any time a LOCATION REPORTING ENABLE/DISABLE REQUEST PDU which shall override the current enable/disable status of the MS.

The last received default enable/disable lifetime overrides previously received values.

In case the default enable/disable lifetime is equal to "Until migration", the MS needs to remember its enable/disable status through power cycles and switches to and from DMO.

In case the default enable/disable lifetime is equal to "Until next ITSI attach registration", the MS does not need to remember its enable/disable status through ITSI attach registration.

### 5.3.19 Trigger configuration request

At power-on or for any other reason MS may not have a valid set of basic parameters or trigger definitions. In that situation MS may send to a default address a SHORT LOCATION REPORT PDU containing as the reason for sending "Subscriber unit asks for transfer initialization configuration". The MS should then receiver basic parameters and/or trigger definitions as presented in clauses 5.3.7 and 5.3.12.

### 5.3.20 Trigger and report type interactions

The location information reporting protocol is designed to minimize number of location reports sent over the air interface. That causes trigger interactions and less important instances will be combined with more important triggers. There are also three trigger kind of events:

- maximum reporting interval;
- maximum reporting distance; and
- minimum reporting interval.

The first two define the minimum amount of location information reports, when there are no other trigger instances. The minimum reporting interval on the other hand limits the amount of radio resource usage for location information reports by suppressing low priority location information reports.

The location information reports due to the maximum reporting interval and the maximum reporting distance instances may contain another report reason, if the other reason is valid at that time.

Each location information report sending should re-start interval and distance calculations for triggered reports.

The triggered location information reports delayed/suppressed due to the minimum reporting interval instance may contain a lower priority reason that was delayed/suppressed due to the preventive action of the minimum reporting interval. The location information may either be the current one, or the one that was applicable at the trigger instance. If time information is included into the report, it should be the actual location determination time (time of the trigger event).

Immediate location information report will be sent independently of the triggered reports. The sending of an immediate location information report to group addresses or a location server address should re-start interval and distance calculations for triggered reports. The immediate location information report may contain more location information than requested, if the triggered location information reports would contain some information that was not requested in the immediate location information report request. That would minimize number of situations where a triggered location information report would be sent after minimum reporting interval to honour all information elements for triggered location information reports.

NOTE: It is outside the present document how MS know which addresses are group and location server addresses, except the destination address defined in the basic parameters.

There may be cases were the MS may not have to wait to the end of the minimum reporting interval. For example MS may send location information report before power off, when entering TxI mode, when entering to emergency mode. Whether MS sends location information reports on those instances is outside the scope of the present document, refer to annex A that present potential priorities of triggers.

### 5.3.21 Location message reference usage

The use of location message reference is optional. Annex B defines a possible usage.

### 5.3.22 Triggers for Lost and Regained ability to determine location

When the MS loses its ability to determine its location for longer than the minimum detection interval, it may send a location report with reason for sending set to "Lost ability to determine location".

When the MS is in a state where it has lost its ability to determine location for longer than the minimum detection interval, and it regains this ability for longer than the minimum detection interval, it may send a location report with reason for sending set to "Regained ability to determine location".

If the MS loses and regains its ability to determine location before expiry of the minimum reporting interval, both of these location reports shall be suppressed.

Likewise, if the MS regains and loses its ability to determine location before expiry of the minimum reporting interval, both of these location reports shall be suppressed as well.

### 5.3.23 Trigger for Ambience Listening call

When the MS receives an Ambience listening call, it may send a location report using reason for sending set to "Ambience Listening call detected", but it shall not provide any user indication about the location report.

The minimum reporting interval should not apply to this trigger type.

NOTE 1: Knowledge of the Ambience Listening of a user may be sensitive information and the location server could provide a location information for general usage without indication of the Ambience Listening using instead a suitable reason e.g. "Response to an immediate location request".

NOTE 2: Transmit inhibit and Ambience listening interaction may complicate the security issue a bit more as a location report from a transmit inhibited MS as such indicate unexpected transmission e.g. due to Ambience Listening.

### 5.3.24 Temporary control of location reporting

Temporary control of location reporting allows an entity to control locally LIP signalling load of a cell. MS may receive at any time a LOCATION REPORTING TEMPORARY CONTROL REQUEST PDU on its individual, one of its group addresses or on the broadcast address from a controlling entity. The MS shall obey the control defined in the LOCATION REPORTING TEMPORARY CONTROL REQUEST PDU upon reception of the PDU from its normal control entity or from a SwMI address. If the new control value results in an increase in the normal location reporting rate, then the MS should retain its normal value. If MS receives multiple LOCATION REPORTING TEMPORARY CONTROL REQUEST PDUs with different control values the MS shall use the lowest requested reporting rate.

If the LOCATION REPORTING TEMPORARY CONTROL REQUEST PDU contains both relative and absolute control parameters, then MS shall not use a minimum reporting interval that is less than the requested minimum reporting interval

MS should update the validity time counter each time it receives a LOCATION REPORTING TEMPORARY CONTROL REQUEST PDU to the indicated validity time.

If MS receives during validity time a ADD/MODIFY TRIGGER REQUEST PDU as described in clause 5.3.12, then it shall apply the control defined in the LOCATION REPORTING TEMPORARY CONTROL REQUEST PDU to the new values defined in the ADD/MODIFY TRIGGER REQUEST PDU.

MS shall return to normal reporting at the reception of a LOCATION REPORTING TEMPORARY CONTROL REQUEST PDU from any of the control entities containing "Return to normal reporting", or when the validity time of the temporary location reporting expires, or at the defined return to the normal reporting instance, refer to table 6.85. By default MS shall return to normal reporting at cell change and should return to normal reporting at power cycle.

If the LOCATION REPORTING TEMPORARY CONTROL REQUEST PDU contains an acknowledgement request MS shall send a LOCATION REPORTING TEMPORARY CONTROL RESPONSE PDU to requestor. MS may send instead of the LOCATION REPORTING TEMPORARY CONTROL RESPONSE PDU a location report with the Reason for sending information element set to "Start of temporary reporting" or "Return to normal reporting" as appropriate.

The controlling entity should inform location information servers or users when the reporting rate will be reduced and when the controlling is returned to normal by sending the LOCATION REPORTING TEMPORARY CONTROL REQUEST PDU also to servers and users. If the location information user is outside TETRA domain, then the protocol is outside the scope of the present document.

---

## 6 Location information protocol coding requirements

### 6.1 General on coding requirements

The location information protocol sets strict requirements on the PDU encoding so that the maximum amount of information can be fitted into short messages. As a result mandatory information elements are used in cases where it is expected that the information is not needed by all applications that receive the PDU. In order to let location information generating entity use such PDUs when they do not have data for all the mandatory information elements, some information element values are used to indicate that situation.

The location information protocol uses many optional information elements in its PDUs and may require additional new ones in the future. The TETRA air interface protocol optional information elements encoding is optimized for a limited number of optional information elements (type 2) that are known at the design time of the protocol. Additional new information elements can be added later (type 3 or type 4), but the overhead for each new information element is quite large. As a result a new type of optional information elements was designed for the location information protocol called type 5. The use of that type removes use of type 2 and so no O-bit or M-bit is used in the PDU encoding. Refer to clause 6.4.

Due to many optional information elements there are a large number of possible combinations of information elements. Some of the allowed combinations are defined in the PDU description tables. Application designers should be aware that some combinations of optional information elements are not sensible.

In clauses 6.2 and 6.3 PDU encoding and information element encoding tables use the following key:

- Length: length of the element in bits;
- Type: element type (1, 2, or 5) as defined above;
- C/O/M: conditional/optional/mandatory information in the PDU;
- Value: value of the information element;
- Remark: comment.



## 6.2 Location information protocol PDU description tables

### 6.2.1 SHORT LOCATION REPORT PDU

The SHORT LOCATION REPORT PDU shall be encoded as defined in table 6.1.

NOTE: This PDU is optimized for the case, where SDS-TL uses random access and a half slot of air interface in the TETRA release 1.

**Table 6.1: SHORT LOCATION REPORT PDU contents**

Information element	Length	Type	C/O/M	Value	Remark
PDU type	2	1	M	0	Short location report
Time elapsed	2	1	M		
Longitude	25	1	M		
Latitude	24	1	M		
Position error	3	1	M		See note 4
Horizontal velocity	7	1	M		
Direction of travel	4	1	M		
Type of additional data	1	1	M		
Reason for sending	8		C		See note 1
User defined data	8		C		See notes 1 and 2
NOTE 1: This information element shall be present as defined by the Type of additional data information element.					
NOTE 2: The contents of this information element is outside the scope of the present document.					
NOTE 3: This PDU shall not include any O-bit in the coding as there will never be any optional information elements.					
NOTE 4: The MS may set the Position error to "Position error not known" to indicate that it failed to acquire valid location data.					

### 6.2.2 LONG LOCATION REPORT PDU

The LONG LOCATION REPORT PDU shall be encoded as defined in table 6.2.

The encoding of the LONG LOCATION REPORT PDU allows more flexibility than is needed for all combinations of information elements. For that reason the shapes based encoding shall be used, when applicable, as it provides a better bit usage efficiency.

**Table 6.2: LONG LOCATION REPORT PDU contents**

Information element	Length	Type	C/O/M	Value	Remark
PDU type	2	1	M	1	Long location message
PDU type extension	4	1	M		Long location report
Time data	Variable	1	M		
Location data	Variable	1	M		
Velocity data	Variable	1	M		
Acknowledgement request	1	1	M		
Type of additional data	1	1	M		
Reason for sending	8		C		See note 1
User defined data	8		C		See notes 1 and 2
Extended user defined data	Variable	5	O		See note 2
Location message reference	8	5	O		
Result code	8	5	O		
SDS type-1 value	16	5	O		
Status value	16	5	O		
Terminal or location identification	Variable	5	O		
NOTE 1: This information element shall be present as defined by the Type of additional data information element.					
NOTE 2: The contents of this information element is outside the scope of the present document.					
NOTE 3: This PDU shall not include any O-bit or M-bit in the coding as type 5 optional information elements do not use that feature and the total length of the underlying transport protocol shall indicate whether any or any more optional information elements follow, refer to clause 6.4.					

## 6.2.3 LOCATION REPORT ACKNOWLEDGEMENT PDU

The LOCATION REPORT ACKNOWLEDGEMENT PDU is used to acknowledge reception of location report and shall be encoded as presented in table 6.3.

**Table 6.3: LOCATION REPORT ACKNOWLEDGEMENT PDU contents**

Information element	Length	Type	C/O/M	Value	Remark
PDU type	2	1	M	1	Long location message
PDU type extension	4	1	M		Location report acknowledgement
Reserved	8	1	M	0	Reserved for result reasons
Extended user defined data	Variable	5	O		See note 1

NOTE 1: The contents of this information element is outside the scope of the present document.  
 NOTE 2: This PDU shall not include any O-bit or M-bit in the coding as type 5 optional information elements do not use that feature and the total length of the underlying transport protocol shall indicate whether any or any more optional information elements follow, refer to clause 6.4.

## 6.2.4 BASIC LOCATION PARAMETERS REQUEST PDU

The BASIC LOCATION PARAMETERS REQUEST PDU is used to configure basic parameters in an MS related to the location reporting service and shall be encoded as presented in table 6.4.

**Table 6.4: BASIC LOCATION PARAMETERS REQUEST PDU contents**

Information element	Length	Type	C/O/M	Value	Remark
PDU type	2	1	M	1	Long location message
PDU type extension	4	1	M		Basic location parameters
Request/response	1	1	M	0	Request
Acknowledgement request	1	1	M		
Minimum reporting interval	7	1	M		
Report type	2	1	M		
Terminal or location identification	Variable	5	O		See note 1
Direction of travel and direction of travel accuracy	Variable	5	O		See note 2
Horizontal position and horizontal position accuracy	Variable	5	O		
Horizontal velocity and horizontal velocity accuracy	Variable	5	O		See note 3
Location information destination	Variable	5	O		See note 4
Location altitude and location altitude accuracy	Variable	5	O		See note 5
Maximum information age	7	5	O		
Maximum response time	7	5	O		
Start time	22	5	O		
Stop time	22	5	O		
Vertical velocity and vertical velocity accuracy	Variable	5	O		See note 5

NOTE 1: Original location information source or identifier in the case this PDU is sent to another address e.g. location server address.  
 NOTE 2: If report type value is "Short location report preferred", then the accuracy definition of this information element has a limited usage due to the resolution of the Direction of travel information element.  
 NOTE 3: If report type value is "Short location report preferred", then the horizontal velocity without horizontal velocity uncertainty indication is implied and this information element may not be used.  
 NOTE 4: This information element shall be included if the location information destination is other than the address of the requesting entity.  
 NOTE 5: If report type value is "Short location report preferred", then this information element should not be used.  
 NOTE 6: This PDU shall not include any O-bit or M-bit in the coding as type 5 optional information elements do not use that feature and the total length of the underlying transport protocol shall indicate whether any or any more optional information elements follow, refer to clause 6.4.

## 6.2.5 BASIC LOCATION PARAMETERS RESPONSE PDU

The BASIC LOCATION PARAMETERS RESPONSE PDU is the response to the BASIC LOCATION PARAMETERS REQUEST PDU generated by the MS and shall be encoded as presented in table 6.5.

**Table 6.5: BASIC LOCATION PARAMETERS RESPONSE PDU contents**

Information element	Length	Type	C/O/M	Value	Remark
PDU type	2	1	M	1	Long location message
PDU type extension	4	1	M		Basic location parameters
Request/response	1	1	M	1	Response
Result code	8	1	M		Success or failure code, see note 1
Location reporting enable flags	8	1	M		
Minimum reporting interval	7	1	M		
Report type	2	1	M		
Terminal or location identification	Variable	5	O		See note 2
Direction of travel and direction of travel accuracy	Variable	5	O		See note 3
Horizontal position and horizontal position accuracy	Variable	5	O		
Horizontal velocity and horizontal velocity accuracy	Variable	5	O		See note 4
Location information destination	Variable	5	O		
Location altitude and location altitude accuracy	Variable	5	O		See note 5
Maximum information age	7	5	O		
Maximum response time	7	5	O		In relation to accuracies
Start time	22	5	O		Should be included only, when in future
Stop time	22	5	O		
Vertical velocity and vertical velocity accuracy	Variable	5	O		See note 5
NOTE 1: Result code value "Accepted" shall indicate that all basic parameters were accepted as in the request and implies that no optional information elements should be in this PDU.					
NOTE 2: Original location information source or identifier in the case this PDU is sent from another address e.g. location server address.					
NOTE 3: If report type value is "Short location report preferred", then the accuracy definition of this information element has a limited usage due to the resolution of the Direction of travel information element.					
NOTE 4: If report type value is "Short location report preferred", then the horizontal velocity without horizontal velocity uncertainty indication is implied and this information element may not be used.					
NOTE 5: If report type value is "Short location report preferred", then this information element should not be used.					
NOTE 6: This PDU should not contain parameters that were not asked for. The not supported parameters shall be left out. All requested are reported unless all accepted as is, see note 1.					
NOTE 7: This PDU shall not include any O-bit or M-bit in the coding as type 5 optional information elements do not use that feature and the total length of the underlying transport protocol shall indicate whether any or any more optional information elements follow, refer to clause 6.4.					

## 6.2.6 REPORT BASIC LOCATION PARAMETERS REQUEST PDU

The REPORT BASIC LOCATION PARAMETERS REQUEST PDU is used to request that the MS reports its current basic configuration and shall be encoded as presented in table 6.6.

**Table 6.6: REPORT BASIC LOCATION PARAMETERS REQUEST PDU contents**

Information element	Length	Type	C/O/M	Value	Remark
PDU type	2	1	M	1	Long location message
PDU type extension	4	1	M		Report basic location parameters request
Request/response	1	1	M	0	Request
Terminal or location identification	Variable	5	O		See note 1
NOTE 1: Original location information source or identifier in the case this PDU is sent to another address e.g. location server address.					
NOTE 2: This PDU shall not include any O-bit or M-bit in the coding as type 5 optional information elements do not use that feature and the total length of the underlying transport protocol shall indicate whether any or any more optional information elements follow, refer to clause 6.4.					

## 6.2.7 REPORT BASIC LOCATION PARAMETERS RESPONSE PDU

The REPORT BASIC LOCATION PARAMETERS RESPONSE PDU reports the values of basic parameters in the MS and shall be encoded as presented in table 6.7.

**Table 6.7: REPORT BASIC LOCATION PARAMETERS RESPONSE PDU contents**

Information element	Length	Type	C/O/M	Value	Remark
PDU type	2	1	M	1	Long location message
PDU type extension	4	1	M		Report basic location parameters
Request/response	1	1	M	1	Response
Result code	8	1	M		See note 1
Location reporting enable flags	8	1	M		
Minimum reporting interval	7	1	M		
Report type	2	1	M		
Terminal or location identification	Variable	5	O		See note 2
Direction of travel and direction of travel accuracy	Variable	5	O		See note 3
Horizontal position and horizontal position accuracy	Variable	5	O		
Horizontal velocity and horizontal velocity accuracy	Variable	5	O		See note 4
Location information destination	Variable	5	O		See note 5
Location altitude and location altitude accuracy	Variable	5	O		See note 6
Maximum information age	7	5	O		
Maximum response time	7	5	O		
Start time	22	5	O		Should be included only, when in future
Stop time	22	5	O		
Vertical velocity and vertical velocity accuracy	Variable	5	O		See note 6
NOTE 1: Result code value "Accepted" is not applicable for this PDU and "Success" shall be used instead.					
NOTE 2: Original location information source or identifier in the case this PDU is sent from another address e.g. location server address.					
NOTE 3: If report type value is "Short location report preferred", then the accuracy definition of this information element has a limited usage due to the resolution of the Direction of travel information element and use of this information element is optional.					
NOTE 4: If report type value is "Short location report preferred", then the horizontal velocity without horizontal velocity uncertainty indication is implied and this information element may not be used.					
NOTE 5: Currently configured location information destination, shall be included if different to source of request.					
NOTE 6: If report type value is "Short location report preferred", then this information element should not be used.					
NOTE 7: This PDU shall not include any O-bit or M-bit in the coding as type 5 optional information elements do not use that feature and the total length of the underlying transport protocol shall indicate whether any or any more optional information elements follow, refer to clause 6.4.					

## 6.2.8 ADD/MODIFY TRIGGER REQUEST PDU

The ADD/MODIFY TRIGGER REQUEST PDU is used to configure a new trigger in an MS or to change the configuration of an existing trigger and shall be encoded as presented in table 6.8.

**Table 6.8: ADD/MODIFY TRIGGER REQUEST PDU contents**

Information element	Length	Type	C/O/M	Value	Remark
PDU type	2	1	M	1	Long location message
PDU type extension	4	1	M		Add/modify trigger
Request/response	1	1	M	0	Request
Acknowledgement request	1	1	M		
Report type	2	1	M		
Terminal or location identification	Variable	5	O		See note 1
Direction of travel and direction of travel accuracy	Variable	5	O		See notes 2 and 3
Horizontal position and horizontal position accuracy	Variable	5	O		See note 2
Horizontal velocity and horizontal velocity accuracy	Variable	5	O		See notes 2 and 4
Location altitude and location altitude accuracy	Variable	5	O		See notes 2 and 5
Maximum information age	7	5	O		See note 2
Maximum response time	7	5	O		See note 2
Request priority	2	5	O		See notes 2 and 6
Start time	22	5	O		See note 2
Stop time	22	5	O		See note 2
Vertical velocity and vertical velocity accuracy	Variable	5	O		See notes 2 and 5
Trigger definition	Variable	5	O		Repeatable, see note 7
Direction of travel and direction of travel accuracy	Variable	5	O		See notes 3 and 8
Horizontal position and horizontal position accuracy	Variable	5	O		See note 8
Horizontal velocity and horizontal velocity accuracy	Variable	5	O		See notes 4 and 8
Location altitude and location altitude accuracy	Variable	5	O		See notes 5 and 8
Maximum information age	7	5	O		See note 8
Maximum response time	7	5	O		See note 8
Request priority	2	5	O		See note 6 and 8
Start time	22	5	O		See note 8
Stop time	22	5	O		See note 8
Vertical velocity and vertical velocity accuracy	Variable	5	O		See notes 5 and 8
NOTE 1: Original location information source or identifier in the case this PDU is sent to another address e.g. location server address.					
NOTE 2: This information element shall be applicable to all trigger definitions unless superseded by a specific definition, see notes 7 and 8. There may be none of these information elements, if the trigger definitions do not have any common information elements or there is only one trigger definition.					
NOTE 3: If report type value is "Short location report preferred", then the accuracy definition of this information element has a limited usage due to the resolution of the Direction of travel information element.					
NOTE 4: If report type value is "Short location report preferred", then the horizontal velocity without horizontal velocity uncertainty indication is implied and this information element may not be used.					
NOTE 5: If report type value is "Short location report preferred", then this information element should not be used.					
NOTE 6: The request priority may be used to set trigger priority, refer to annex A.					
NOTE 7: Trigger definition and information elements up to next trigger definition information element (not including) belong together. The new set of parameters, if present, only applies to the last preceding trigger definition.					
NOTE 8: This information element shall apply only to the last trigger definition above it and shall supersede common information element, if any, see note 2.					
NOTE 9: This PDU shall not include any O-bit or M-bit in the coding as type 5 optional information elements do not use that feature and the total length of the underlying transport protocol shall indicate whether any or any more optional information elements follow, refer to clause 6.4.					

## 6.2.9 ADD/MODIFY TRIGGER RESPONSE PDU

The ADD/MODIFY TRIGGER RESPONSE PDU is the response from the MS to the ADD/MODIFY TRIGGER REQUEST PDU and shall be encoded as presented in table 6.9.

**Table 6.9: ADD/MODIFY TRIGGER RESPONSE PDU contents**

Information element	Length	Type	C/O/M	Value	Remark
PDU type	2	1	M	1	Long location message
PDU type extension	4	1	M		Add/modify trigger
Request/response	1	1	M	1	Response
Result code	8	1	M		Success or failure code
Report type	2	1	M		
Terminal or location identification	Variable	5	O		See note 1
Direction of travel and direction of travel accuracy	Variable	5	O		See notes 2 and 3
Horizontal position and horizontal position accuracy	Variable	5	O		See note 2
Horizontal velocity and horizontal velocity accuracy	Variable	5	O		See notes 2 and 4
Location altitude and location altitude accuracy	Variable	5	O		See notes 2 and 5
Maximum information age	7	5	O		See note 2
Maximum response time	7	5	O		See note 2
Request priority	2	5	O		See notes 2 and 6
Start time	22	5	O		See note 2
Stop time	22	5	O		See note 2
Vertical velocity and vertical velocity accuracy	Variable	5	O		See notes 2 and 5
Trigger definition	Variable	5	O		Repeatable, supported triggers, see clause 6.3.82. See note 7
Direction of travel and direction of travel accuracy	Variable	5	O		See notes 3 and 8
Horizontal position and horizontal position accuracy	Variable	5	O		See note 8
Horizontal velocity and horizontal velocity accuracy	Variable	5	O		See notes 4 and 8
Location altitude and location altitude accuracy	Variable	5	O		See notes 5 and 8
Maximum information age	7	5	O		See note 8
Maximum response time	7	5	O		See note 8
Request priority	2	5	O		See notes 6 and 8
Start time	22	5	O		See note 8
Stop time	22	5	O		See note 8
Vertical velocity and vertical velocity accuracy	Variable	5	O		See notes 5 and 8

NOTE 1: Original location information source or identifier in the case this PDU is sent to another address e.g. location server address.

NOTE 2: This information element shall be applicable to all trigger definitions unless superseded by a specific definition, see note 7. There may be none of these information elements, if the trigger definitions do not have any common information elements or there is only one trigger definition.

NOTE 3: If report type value is "Short location report preferred", then the accuracy definition of this information element has a limited usage due to the resolution of the Direction of travel information element.

NOTE 4: If report type value is "Short location report preferred", then the horizontal velocity without horizontal velocity uncertainty indication is implied and this information element may not be used.

NOTE 5: If report type value is "Short location report preferred", then this information element should not be used.

NOTE 6: The request priority may be used to set trigger priority, refer to annex A.

NOTE 7: Trigger definition and information elements up to next trigger definition information element (not including) belong together. The new set of parameters, if present, only applies to the last preceding trigger definition.

NOTE 8: This information element shall apply only to the last trigger definition above it and shall supersede common information element, if any, see note 2.

NOTE 9: This PDU shall not include any O-bit or M-bit in the coding as type 5 optional information elements do not use that feature and the total length of the underlying transport protocol shall indicate whether any or any more optional information elements follow, refer to clause 6.4.

## 6.2.10 REMOVE TRIGGER REQUEST PDU

The REMOVE TRIGGER REQUEST PDUs are used to remove triggers that are configured in an MS and shall be encoded as presented in table 6.10.

**Table 6.10: REMOVE TRIGGER REQUEST PDU contents**

Information element	Length	Type	C/O/M	Value	Remark
PDU type	2	1	M	1	Long location message
PDU type extension	4	1	M		Remove trigger
Request/response	1	1	M	0	Request
Acknowledgement request	1	1	M		
Terminal or location identification	Variable	5	O		See note 1
Trigger removal	Variable	5	O		Requested triggers, see clause 6.3.83
NOTE 1: Original location information source or identifier in the case this PDU is sent to another address e.g. location server address.					
NOTE 2: This PDU shall not include any O-bit or M-bit in the coding as type 5 optional information elements do not use that feature and the total length of the underlying transport protocol shall indicate whether any or any more optional information elements follow, refer to clause 6.4.					

## 6.2.11 REMOVE TRIGGER RESPONSE PDU

The REMOVE TRIGGER RESPONSE PDU is used to confirm removal of one or more triggers and shall be encoded as presented in table 6.11.

**Table 6.11: REMOVE TRIGGER RESPONSE PDU contents**

Information element	Length	Type	C/O/M	Value	Remark
PDU type	2	1	M	1	Long location message
PDU type extension	4	1	M		Remove trigger
Request/response	1	1	M	1	Response
Result code	8	1	M		Success or failure code
Terminal or location identification	Variable	5	O		See note 1
Trigger removal	Variable	5	O		Requested triggers that cannot be removed, see clause 6.3.83
NOTE 1: Original location information source or identifier in the case this PDU is sent from another address e.g. location server address.					
NOTE 2: This PDU shall not include any O-bit or M-bit in the coding as type 5 optional information elements do not use that feature and the total length of the underlying transport protocol shall indicate whether any or any more optional information elements follow, refer to clause 6.4.					

## 6.2.12 REPORT TRIGGERS REQUEST PDU

The REPORT TRIGGERS REQUEST PDUs are used to enquire the triggers that are currently configured in an MS and shall be encoded as presented in table 6.12.

**Table 6.12: REPORT TRIGGER REQUEST PDU contents**

Information element	Length	Type	C/O/M	Value	Remark
PDU type	2	1	M	1	Long location message
PDU type extension	4	1	M		Report trigger
Request/response	1	1	M	0	Request
Terminal or location identification	Variable	5	O		See note 1
NOTE 1: Original location information source or identifier in the case this PDU is sent to another address e.g. location server address.					
NOTE 2: This PDU shall not include any O-bit or M-bit in the coding as type 5 optional information elements do not use that feature and the total length of the underlying transport protocol shall indicate whether any or any more optional information elements follow, refer to clause 6.4.					

## 6.2.13 REPORT TRIGGER RESPONSE PDU

The Report Trigger Response PDU is used to report triggers and shall be encoded as defined in table 6.13.

NOTE: The response may be divided into multiple PDUs.

**Table 6.13: REPORT TRIGGER RESPONSE PDU contents**

Information element	Length	Type	C/O/M	Value	Remark
PDU type	2	1	M	1	Long location message
PDU type extension	4	1	M		Report trigger
Request/response	1	1	M	1	Response
Result code	8	1	M		Success or failure code
Location reporting enable flags	8	1	M		
Report type	2	1	M		
Terminal or location identification	Variable	5	O		See note 1
Trigger definition	Variable	5	O		Repeatable, configured trigger, see clause 6.3.82. See note 2
Direction of travel and direction of travel accuracy	Variable	5	O		See note 3
Horizontal position and horizontal position accuracy	Variable	5	O		
Horizontal velocity and horizontal velocity accuracy	Variable	5	O		See note 4
Location altitude and location altitude accuracy	Variable	5	O		See note 5
Maximum information age	7	5	O		
Maximum response time	7	5	O		
Request priority	2	5	O		See note 6
Start time	22	5	O		
Stop time	22	5	O		
Vertical velocity and vertical velocity accuracy	Variable	5	O		See note 5
NOTE 1: Original location information source or identifier in the case this PDU is sent from another address e.g. location server address.					
NOTE 2: This trigger and information elements up to next trigger definition information element belong together. Each Trigger definition shall start a new set of parameters, if those parameters are needed.					
NOTE 3: If report type value is "Short location report preferred", then the accuracy definition of this information element has a limited usage due to the resolution of the Direction of travel information element.					
NOTE 4: If report type value is "Short location report preferred", then the horizontal velocity without horizontal velocity uncertainty indication is implied and this information element may not be used.					
NOTE 5: If report type value is "Short location report preferred", then this information element should not be used.					
NOTE 6: The request priority should be included only if it was in the ADD/MODIFY TRIGGER REQUEST PDU.					
NOTE 7: This PDU shall not include any O-bit or M-bit in the coding as type 5 optional information elements do not use that feature and the total length of the underlying transport protocol shall indicate whether any or any more optional information elements follow, refer to clause 6.4.					



## 6.2.14 LOCATION REPORTING ENABLE/DISABLE REQUEST PDU

The LOCATION REPORTING ENABLE/DISABLE REQUEST PDU shall be encoded as presented in table 6.14.

NOTE: The enabling and disabling controls only triggered reporting. It does not affect or modify basic parameters for immediate reporting.

**Table 6.14: LOCATION REPORTING ENABLE/DISABLE REQUEST PDU contents**

Information element	Length	Type	C/O/M	Value	Remark
PDU type	2	1	M	1	Long location message
PDU type extension	4	1	M		Location reporting enable/disable
Request/response	1	1	M	0	Request
Acknowledgement request	1	1	M		
Location reporting enable flags	8	1	M		
Terminal or location identification	Variable	5	O		See note 1
Default enable/disable lifetime	2	5	O		See note 2
NOTE 1: Original location information source or identifier in the case this PDU is sent to another address e.g. location server address.					
NOTE 2: If the information element is not present, it shall be assumed to have value "Until migration".					
NOTE 3: This PDU shall not include any O-bit or M-bit in the coding as type 5 optional information elements do not use that feature and the total length of the underlying transport protocol shall indicate whether any or any more optional information elements follow, refer to clause 6.4.					

## 6.2.15 LOCATION REPORTING ENABLE/DISABLE RESPONSE PDU

The LOCATION REPORTING ENABLE/DISABLE RESPONSE PDU shall be encoded as presented in table 6.15.

NOTE: The enabling and disabling is controlling only triggered reporting. It does not affect or modify basic parameters for immediate reporting.

**Table 6.15: LOCATION REPORTING ENABLE/DISABLE RESPONSE PDU contents**

Information element	Length	Type	C/O/M	Value	Remark
PDU type	2	1	M	1	Long location message
PDU type extension	4	1	M		Location reporting enable/disable
Request/response	1	1	M	0	Response
Location reporting enable flags	8	1	M		
Terminal or location identification	Variable	5	O		See note 1
NOTE 1: Original location information source or identifier in the case this PDU is sent from another address e.g. location server address.					
NOTE 2: This PDU shall not include any O-bit or M-bit in the coding as type 5 optional information elements do not use that feature and the total length of the underlying transport protocol shall indicate whether any or any more optional information elements follow, refer to clause 6.4.					

## 6.2.16 IMMEDIATE LOCATION REPORT REQUEST PDU

The IMMEDIATE LOCATION REPORT REQUEST PDU is use to request an immediate location report and it shall be encoded as presented in table 6.16.

**Table 6.16: IMMEDIATE LOCATION REPORT REQUEST PDU contents**

Information element	Length	Type	C/O/M	Value	Remark
PDU type	2	1	M	1	Long location message
PDU type extension	4	1	M		Immediate location report
Request/response	1	1	M	0	Request
Report type	2	1	M		
Location information destination	Variable	5	O		See note 1
Terminal or location identification	Variable	5	O		See note 2
Direction of travel and direction of travel accuracy	Variable	5	O		See note 3
Horizontal position and horizontal position accuracy	Variable	5	O		
Horizontal velocity and horizontal velocity accuracy	Variable	5	O		See note 4
Location altitude and location altitude accuracy	Variable	5	O		See note 5
Maximum information age	7	5	O		
Maximum response time	7	5	O		
Vertical velocity and vertical velocity accuracy	Variable	5	O		See note 5
NOTE 1: Shall be included if location information destination is different than the source address of this PDU.					
NOTE 2: Original location information source or identifier in the case this PDU is sent to another address e.g. location server address.					
NOTE 3: If report type value is "Short location report preferred", then the accuracy definition of this information element has a limited usage due to the resolution of the Direction of travel information element.					
NOTE 4: If report type value is "Short location report preferred", then the horizontal velocity without horizontal velocity uncertainty indication is implied and this information element may not be used.					
NOTE 5: If report type value is "Short location report preferred", then this information element should not be used.					
NOTE 6: This PDU shall not include any O-bit or M-bit in the coding as type 5 optional information elements do not use that feature and the total length of the underlying transport protocol shall indicate whether any or any more optional information elements follow, refer to clause 6.4.					

## 6.2.17 LOCATION REPORTING TEMPORARY CONTROL REQUEST PDU

The LOCATION REPORTING TEMPORARY CONTROL REQUEST PDU shall be encoded as presented in table 6.17. The LOCATION REPORTING TEMPORARY CONTROL REQUEST PDU may be also used as an indication PDU.

**Table 6.17: LOCATION REPORTING TEMPORARY CONTROL REQUEST PDU contents**

Information element	Length	Type	C/O/M	Value	Remark
PDU type	2	1	M	1	Long location message
PDU type extension	4	1	M		Location reporting temporary control
Request/response	1	1	M	0	Request, see note 2
Acknowledgement request	1	1	M		
Temporary control validity	4	1	M		See note 3
Temporary control parameter definition	Variable	5	O		PDU can include several temporary control parameters, see note 3
NOTE 1: This PDU shall not include any O-bit or M-bit in the coding as type 5 optional information elements do not use that feature and the total length of the underlying transport protocol shall indicate whether any or any more optional information elements follow, refer to clause 6.4.					
NOTE 2: Value "Request" is also used, when this PDU is sent as information to location server and/or location information destination.					
NOTE 3: When the Location reporting temporary control value is "Return to normal reporting" there shall be no Temporary control parameter definitions.					

## 6.2.18 LOCATION REPORTING TEMPORARY CONTROL RESPONSE PDU

The LOCATION REPORTING TEMPORARY CONTROL RESPONSE PDU shall be encoded as presented in table 6.18.

**Table 6.18: LOCATION REPORTING TEMPORARY CONTROL RESPONSE PDU contents**

Information element	Length	Type	C/O/M	Value	Remark
PDU type	2	1	M	1	Long location message
PDU type extension	4	1	M		Location reporting temporary control
Request/response	1	1	M	1	Response
Location reporting temporary control	1	1	M	0	Return to normal reporting
				1	Start of temporary control

## 6.3 Location information protocol PDU information elements

### 6.3.1 Acknowledgement request

The acknowledgement request information element shall be encoded as defined in table 6.19.

**Table 6.19: Acknowledgement request information element contents**

Information element	Length	Value	Remark
Acknowledgement request	1	0	No acknowledgement requested
		1	Acknowledgement requested

### 6.3.2 Address or identification type

The information element shall be encoded as defined in table 6.20.

**Table 6.20: Address or identification type information element contents**

Information element	Length	Value	Remark
Address or identification type	4	0000 <sub>2</sub>	No terminal or location identification available
		0001 <sub>2</sub>	SSI
		0010 <sub>2</sub>	SSI and MNI
		0011 <sub>2</sub>	IP address (Version 4) RFC 791 [4]
		0100 <sub>2</sub>	IP address (Version 6) RFC 3513 [5]
		0101 <sub>2</sub>	Reserved
		0110 <sub>2</sub>	Reserved
		0111 <sub>2</sub>	Reserved
		1000 <sub>2</sub>	External subscriber number
		1001 <sub>2</sub>	SSI and External subscriber number
		1010 <sub>2</sub>	SSI and MNI and External subscriber number
		1011 <sub>2</sub>	Name server type name
		1100 <sub>2</sub>	Name, free format
		1101 <sub>2</sub>	Reserved
		1110 <sub>2</sub>	Reserved
1111 <sub>2</sub>	Reserved		

### 6.3.3 Angle

The angle information element shall be encoded as defined by formula:

- $\text{Angle} = K \times 360 / 256$ , where
- $K = \text{information element value}$ .

Some values are presented without rounding in table 6.21. Angle shall be measured in degrees (in 0 to 360 scale) clockwise from north.

**Table 6.21: Angle information element contents**

Information element	Length	Value	Direction in degrees	Remark
Angle	8	0	0	
		1	1,40625	
		2	2,8125	
		etc.	etc.	
		16	22,5	
		etc.	etc.	
		32	45	
		etc.	etc.	
		64	90	
		etc.	etc.	
		127	178,59375	
		128	180	
		etc.	etc.	
		192	270	
		etc.	etc.	
255	358,59375			

### 6.3.4 Confidence level

Confidence level information element shall indicate the probability that the actual location is inside the indicated uncertainty area. It shall be coded as presented in table 6.22.

**Table 6.22: Confidence level information element contents**

Information element	Length	Value	Remark
Confidence level	3	0	50 %
		1	68 %
		2	80 %
		3	90 %
		4	95 %
		5	99 %
		6	99,9 %
		7	Confidence level not known.

#### 6.3.4a Default enable/disable lifetime

The default enable/disable lifetime information element shall be encoded as presented in table 6.23.

**Table 6.23: Default enable/disable lifetime information element contents**

Information element	Length	Type	C/O/M	Value	Remark
Default enable/disable lifetime	2	1	M	0	Until migration
				1	Until next ITSI attach registration
				2	Reserved
				3	Reserved

### 6.3.5 Direction of travel

The direction of travel information element shall be encoded as defined in table 6.24.

NOTE: Table 6.24 definition can be expressed also by equation:  
 Direction of travel value =  $\text{trunc}((\text{direction} + 11,25)/22,5)$ , when direction is given in degrees.

**Table 6.24: Direction of travel information element contents**

Information element	Length	Value	Direction in degrees	Remark
Direction of travel	4	0000 <sub>2</sub>	0	North (N)
		0001 <sub>2</sub>	22,5	NNE
		0010 <sub>2</sub>	45	NE
		0011 <sub>2</sub>	67,5	ENE
		0100 <sub>2</sub>	90	East (E)
		0101 <sub>2</sub>	112,5	ESE
		0110 <sub>2</sub>	135	SE
		0111 <sub>2</sub>	157,5	SSE
		1000 <sub>2</sub>	180	South (S)
		1001 <sub>2</sub>	202,5	SSW
		1010 <sub>2</sub>	225	SW
		1011 <sub>2</sub>	247,5	WSW
		1100 <sub>2</sub>	270	West (W)
		1101 <sub>2</sub>	292,5	WNW
		1110 <sub>2</sub>	315	NW
1111 <sub>2</sub>	337,5 or direction of travel is not known	NNW		

### 6.3.6 Direction of travel extended

The direction of travel extended information element shall be encoded as defined for the Angle information element in table 6.21.

### 6.3.7 Direction of travel accuracy

The direction of travel accuracy information element shall be encoded as defined in table 6.25.

**Table 6.25: Direction of travel accuracy information element contents**

Information element	Length	Value	Direction in degrees
Direction of travel accuracy	3	0	Less than 1,5 degrees
		1	Less than 3 degrees
		2	Less than 6 degrees
		3	Less than 12 degrees
		4	Less than 24 degrees
		5	Less than 48 degrees
		6	Less than 96 degrees
		7	Best effort or uncertainty not known.

### 6.3.8 Direction of travel and direction of travel accuracy

The direction of travel and direction of travel accuracy information element shall be encoded as defined in table 6.26.

**Table 6.26: Direction of travel and direction of travel accuracy information element contents**

Information element	Length	Type	C/O/M	Value	Remark
Return value	1	1	M	0	Direction of travel value required
				1	Direction of travel and direction of travel uncertainty value required
Requested or required	2	1	M		
Direction of travel accuracy (requested)	3		C		Shall be present if requested
Direction of travel accuracy (required)	3		C		Shall be present if required

### 6.3.9 Direction of travel uncertainty

The direction of travel uncertainty information element shall be encoded as defined in table 6.25 for direction of travel accuracy.

### 6.3.10 Extended user defined data

Free format information element. The length is defined by the type 5 definition and is limited by its capability unless other reasons set a tighter limit.

### 6.3.11 External subscriber number

The external subscriber number information element shall be encoded as presented in table 6.27.

**Table 6.27: External subscriber number information element contents**

Information element	Length	Type	C/O/M	Remark
External subscriber number digit	4	1	M	Repeatable, see note
NOTE: The length and so the number of the External subscriber number digits of this information element is defined by the total length of the address information element. If the length resolution cannot indicate exact length so that there are unused bits at the end of this information element, then the fill bit shall be set to "1". That convention means that the External subscriber number digit cannot be "1111".				

### 6.3.12 Half of major axis

Half of major axis value shall indicate half of the total length of the major axis of the ellipse shape. For coding purposes half of the major axis value shall be used in the shapes. Half of major axis shall be encoded as defined for the Horizontal position uncertainty in clause 6.3.16. The value of the major axis shall be larger or equal to the value of the minor axis.

NOTE: The use of the half of the major and minor axis in the ellipse shapes results in the same numerical value for the major and minor axis presentation in the PDU as for the horizontal position accuracy in the circle shape in the case of circular ellipse.

### 6.3.13 Half of minor axis

Half of minor axis value shall indicate half of the total length of the minor axis of the ellipse shape. For coding purposes half of the minor axis value shall be used in the shapes. Half of minor axis shall be encoded as defined for the Horizontal position uncertainty in clause 6.3.16.

### 6.3.14 Horizontal position accuracy

The horizontal position accuracy information elements shall be encoded as defined in table 6.28. The horizontal position accuracy part is defined by equation:

- Horizontal position accuracy =  $A \times (1 + x)^{(K + B)} + C$ , where:
- $A = 2$ ;
- $x = 0,2$ ;
- $K =$  information element value;
- $B = 5$ ;
- $C = -4$ .

**Table 6.28: Horizontal position accuracy information element contents**

Information element	Length	Type	C/O/M	Value	Remark
Horizontal position accuracy	6	1	M	0	Less than 1 m
				1	Less than 2 m
				2	Less than 3,2 m
				etc.	etc.
				10	Less than 27 m
				etc.	etc.
				20	Less than 187 m
				etc.	etc.
				30	Less than 1,18 km
				etc.	etc.
				40	Less than 7,31 km
				etc.	etc.
				50	Less than 45,3 km
				etc.	etc.
60	Less than 280 km				
61	Less than 337 km				
62	Less than 404 km				
63	Best effort				

### 6.3.15 Horizontal position and horizontal position accuracy

The horizontal position and horizontal position accuracy information elements shall be encoded as defined in table 6.29.

**Table 6.29: Horizontal position and horizontal position accuracy information element contents**

Information element	Length	Type	C/O/M	Value	Remark
Return value	1	1	M	0	Horizontal position value required
				1	Horizontal position and horizontal position uncertainty value required
Preferred shape	1	1	M	0	Circle shape preferred
				1	Ellipse or another shape allowed
Requested or required	2	1	M		
Horizontal position accuracy (requested)	6		C		Shall be present if requested
Horizontal position accuracy (required)	6		C		Shall be present if required

### 6.3.16 Horizontal position uncertainty

The horizontal position uncertainty information elements shall be encoded as defined in table 6.28 for horizontal position accuracy.

### 6.3.17 Horizontal velocity

Horizontal velocity shall be encoded for speeds 0 to 28 km/h in 1 km/h steps and from 28 km/h onwards using equation:

- $v = C \times (1 + x)^{(K-A)} + B$  where:
- $C = 16$
- $x = 0,038$
- $A = 13$
- $K =$  Horizontal velocity information element value
- $B = 0$

Table 6.30 gives examples of velocity values for various K values.

**Table 6.30: Examples of horizontal velocity information element contents**

Information element	Length	Value	Speed	Remark
Horizontal velocity	7	0	0 km/h	Steps 1 km/h
		1	1 km/h	
		2	2 km/h	
		etc.	etc.	
		28	28 km/h	
		29	29,1 km/h	3,8 % steps
		30	30,2 km/h	
		31	31,3 km/h	
		etc.	etc.	
		38	40,6 km/h	
		etc.	etc.	
		44	50,8 km/h	
		etc.	etc.	
		56	79,5 km/h	
		etc.	etc.	
		62	99,5 km/h	
		etc.	etc.	
		67	120 km/h	
		etc.	etc.	
		81	202 km/h	
		etc.	etc.	
		92	305 km/h	
etc.	etc.			
105	495km/h			
etc.	etc.			
114	692km/h			
etc.	etc.			
124	1 005 km/h			
125	1 043 km/h	3,8 % steps		
126	More than 1 043 km/h			
127	Horizontal speed is not known	See note		

NOTE: Included as the horizontal velocity information element is mandatory in the short location report.



### 6.3.18 Horizontal velocity accuracy

The horizontal velocity accuracy information element shall be encoded as defined in table 6.31.

**Table 6.31: Horizontal velocity accuracy information element contents**

Information element	Length	Type	C/O/M	Value	Remark
Horizontal velocity accuracy	3	1	M	0	Less than 1,5 km/h
				1	Less than 3 km/h
				2	Less than 6 km/h
				3	Less than 12 km/h
				4	Less than 24 km/h
				5	Less than 48 km/h
				6	Less than 96 km/h
				7	Best effort

### 6.3.19 Horizontal velocity and horizontal velocity accuracy

The horizontal velocity and horizontal velocity accuracy information element shall be encoded as defined in table 6.32.

NOTE: In a request PDU horizontal velocity accuracy information element implies that horizontal speed is requested.

**Table 6.32: Horizontal velocity accuracy information element contents**

Information element	Length	Type	C/O/M	Value	Remark
Return value	1	1	M	0	Horizontal velocity value required
				1	Horizontal velocity and horizontal velocity uncertainty values required
Requested or required	2	1	M		
Horizontal velocity accuracy (requested)	3		C		Shall be present if requested
Horizontal velocity accuracy (required)	3		C		Shall be present if required

### 6.3.20 Horizontal velocity and vertical velocity

The horizontal velocity and vertical velocity information element shall be encoded as presented in table 6.33.

**Table 6.33: Horizontal velocity and vertical velocity information element contents**

Information element	Length	Type	C/O/M	Remark
Horizontal velocity	7	1	M	
Vertical velocity	8	1	M	

### 6.3.21 Horizontal velocity and vertical velocity with uncertainty

The horizontal velocity and vertical velocity with uncertainty information element shall be encoded as presented in table 6.34.

**Table 6.34: Horizontal velocity and vertical velocity with uncertainty information element contents**

Information element	Length	Type	C/O/M	Remark
Horizontal velocity	7	1	M	
Horizontal velocity uncertainty	3	1	M	
Vertical velocity	8	1	M	
Vertical velocity uncertainty	3	1	M	

### 6.3.22 Horizontal velocity and vertical velocity with direction of travel extended and uncertainty

The horizontal velocity and vertical velocity with direction of travel extended and uncertainty information element shall be encoded as presented in table 6.35.

**Table 6.35: Horizontal velocity and vertical velocity with direction of travel extended and uncertainty information element contents**

Information element	Length	Type	C/O/M	Remark
Horizontal velocity	7	1	M	
Horizontal velocity uncertainty	3	1	M	
Vertical velocity	8	1	M	
Vertical velocity uncertainty	3	1	M	
Direction of travel extended	8	1	M	
Direction of travel uncertainty	3	1	M	

### 6.3.23 Horizontal velocity uncertainty

The horizontal velocity uncertainty information element shall be encoded as defined in table 6.36.

**Table 6.36: Horizontal velocity uncertainty information element contents**

Information element	Length	Type	C/O/M	Value	Remark
Horizontal velocity uncertainty	3	1	M	0	Less than 1,5 km/h
				1	Less than 3 km/h
				2	Less than 6 km/h
				3	Less than 12 km/h
				4	Less than 24 km/h
				5	Less than 48 km/h
				6	Less than 96 km/h
7	Reserved				

### 6.3.24 Horizontal velocity with direction of travel extended

The horizontal velocity with direction of travel extended information element shall be encoded as presented in table 6.37.

**Table 6.37: Horizontal velocity with direction of travel extended information element contents**

Information element	Length	Type	C/O/M	Remark
Horizontal velocity	7	1	M	
Direction of travel extended	8	1	M	

### 6.3.25 Horizontal velocity with direction of travel extended and uncertainty

The horizontal velocity with direction of travel extended and uncertainty information element shall be encoded as presented in table 6.38.

**Table 6.38: Horizontal velocity with direction of travel extended and uncertainty information element contents**

Information element	Length	Type	C/O/M	Remark
Horizontal velocity	7	1	M	
Horizontal velocity uncertainty	3	1	M	
Direction of travel extended	8	1	M	
Direction of travel uncertainty	3	1	M	

### 6.3.26 Horizontal velocity with uncertainty

The horizontal velocity with uncertainty information element shall be encoded as presented in table 6.39.

**Table 6.39: Horizontal velocity with uncertainty information element contents**

Information element	Length	Type	C/O/M	Remark
Horizontal velocity	7	1	M	
Horizontal velocity uncertainty	3	1	M	

### 6.3.27 Inner radius

The inner radius shall be encoded as presented in table 6.40.

**Table 6.40: Inner radius information element contents**

Information element	Length	Type	C/O/M	Value	Remark
Inner radius	16	1	M	0	0 m
				1	2 m
				2	4 m
				etc.	etc.
				65 536	13 1072 m

### 6.3.28 IPv4 address

Shall be encoded as 4 octets, refer to RFC 791 [4].

### 6.3.29 IPv6 address

Shall be encoded as 16 octets, refer to RFC 3513 [5].

### 6.3.30 Latitude

Latitude information element shall indicate latitude of the location point in units of  $180/2^{24}$  degrees in range -90 degrees to  $+(90 - 180 / 2^{24})$  degrees using two's complement presentation. Negative values shall be south of equator and positive values shall be north of equator.

NOTE: The information element values indicate the centre of resolution range in contrary to GSM presentation where the resolution boundaries are indicated.

### 6.3.31 Location altitude

The location altitude information element shall be encoded as presented in table 6.41.

NOTE 1: The reference level of the location altitude is defined by the Location altitude type information element.

NOTE 2: The 75 m resolution is selected to match will civil aviation flight levels.

**Table 6.41: Location altitude information element contents**

Information element	Length	Value	Remark	Remark
Location altitude type	1	0	Altitude above WGS84 ellipsoid, see note 1	
		1	User defined altitude reference, see note 2	
Altitude	11	0	Reserved	
		1	-200 m	
		2	-199 m	Step 1 m
		etc.	etc.	
		1 201	1 000 m	
		1 202	1 002 m	Step 2 m
		etc.	etc.	
		1 926	2 450 m	
		1 927	2 525 m	Step 75 m
		etc.	etc.	
		2 045	11 375 m	
		2 046	11 450 m	
2 047	11 525 m or more			
NOTE 1: Altitude is the height above WGS84 reference system. In order to get actual altitude above see level application need to make adjustment based on the longitude and latitude.				
NOTE 2: User defined altitude may be an altitude determined on a map, flight height or any other means. It is assumed that the involved applications know the meaning of the user defined altitude reference.				

### 6.3.32 Location altitude accuracy

The location altitude accuracy information element shall be encoded as presented in table 6.42.

**Table 6.42: Location altitude accuracy information element contents**

Information element	Length	Value	Height	Remark
Location altitude accuracy	3	0	Less than 1 m	
		1	Less than 2 m	
		2	Less than 5 m	
		3	Less than 15 m	
		4	Less than 50 m	
		5	Less than 150 m	
		6	Less than 300 m	
		7	Best effort or not supported	

### 6.3.33 Location altitude and location altitude accuracy

The location altitude and location altitude accuracy information elements shall be encoded as defined in table 6.43.

**Table 6.43: Location altitude and location altitude accuracy information element contents**

Information element	Length	Type	C/O/M	Value	Remark
Return value	1	1	M	0	Altitude value required
				1	Altitude and altitude uncertainty values required
Location altitude type	1	1	M	0	WGS84
				1	User defined
Requested or required	2		C		
Location altitude accuracy (requested)	3		C		Shall be present if requested
Location altitude accuracy (required)	3		C		Shall be present if required

### 6.3.34 Location altitude uncertainty

The location altitude uncertainty information element shall be encoded as presented in table 6.42 for location altitude accuracy.

### 6.3.35 Location arc

The location arc information element shall be encoded as presented in table 6.44.

The area shall be from start angle to stop angle in clockwise direction.

**Table 6.44: Location arc information element contents**

Information element	Length	Type	C/O/M	Remark
Longitude	25	1	M	
Latitude	24	1	M	
Inner radius	16	1	M	
Outer radius	16	1	M	
Start angle	8	1	M	
Stop angle	8	1	M	
Confidence level	3	1	M	

NOTE: The total size of this information element is 100.

### 6.3.36 Location circle

The location circle information element shall be encoded as presented in table 6.45.

**Table 6.45: Location circle information element contents**

Information element	Length	Type	C/O/M	Remark
Longitude	25	1	M	
Latitude	24	1	M	
Horizontal position uncertainty	6	1	M	

NOTE: The total size of this information element is 55.

### 6.3.37 Location circle with altitude

The location circle with altitude information element shall be encoded as presented in table 6.46.

**Table 6.46: Location circle with altitude information element contents**

Information element	Length	Type	C/O/M	Remark
Longitude	25	1	M	
Latitude	24	1	M	
Horizontal position uncertainty	6	1	M	
Location altitude	12	1	M	

NOTE: The total size of this information element is 67.

### 6.3.38 Location circle with altitude and uncertainty

The location circle with altitude and uncertainty information element shall be encoded as presented in table 6.47.

**Table 6.47: Location circle with altitude and uncertainty information element contents**

Information element	Length	Type	C/O/M	Remark
Longitude	25	1	M	
Latitude	24	1	M	
Horizontal position uncertainty	6	1	M	
Location altitude	12	1	M	
Location altitude uncertainty	3	1	M	

NOTE: The total size of this information element is 70.

### 6.3.39 Location data

The location data information element shall be encoded as presented in table 6.48.

**Table 6.48: Location data information element contents**

Information element	Length	Type	C/O/M	Remark
Location shape	4	1	M	
No shape	0		C	See note 1
Location point	49		C	See note 1
Location circle	55		C	See note 1
Location ellipse	72		C	See note 1
Location point with altitude	61		C	See note 1
Location circle with altitude	67		C	See note 1
Location ellipse with altitude	84		C	See note 1
Location circle with altitude and uncertainty	70		C	See note 1
Location ellipse with altitude and uncertainty	87		C	See note 1
Location arc	100		C	See note 1
Location point and position error	52		C	See notes 1 and 2
NOTE 1: Presence of this information element is conditional on the location shape information element.				
NOTE 2: Use of Location circle is recommended in LONG LOCATION REPORT PDUs instead of this information element.				

### 6.3.40 Location ellipse

The location ellipse information element shall be encoded as presented in table 6.49.

**Table 6.49: Location ellipse information element contents**

Information element	Length	Type	C/O/M	Remark
Longitude	25	1	M	
Latitude	24	1	M	
Half of the major axis	6	1	M	
Half of the minor axis	6	1	M	
Angle, see note 1	8	1	M	
Confidence level	3	1	M	
NOTE 1: Angle should be in range 0 to 180 degrees (in 360 degrees scale).				
NOTE 2: The total size of this information element is 72.				

### 6.3.41 Location ellipse with altitude

The location ellipse with altitude and uncertainty information element shall be encoded as presented in table 6.50.

**Table 6.50: Location ellipse with altitude and uncertainty information element contents**

Information element	Length	Type	C/O/M	Remark
Longitude	25	1	M	
Latitude	24	1	M	
Half of the major axis	6	1	M	
Half of the minor axis	6	1	M	
Angle, see note 1	8	1	M	
Location altitude	12	1	M	
Confidence level	3	1	M	
NOTE 1: Angle should be in range 0 to 180 degrees (in 360 degrees scale).				
NOTE 2: The total size of this information element is 84.				

### 6.3.42 Location ellipse with altitude and uncertainty

The location ellipse with altitude and uncertainty information element shall be encoded as presented in table 6.51.

NOTE: The confidence level is the confidence level of the horizontal position uncertainty.

**Table 6.51: Location ellipse with altitude and uncertainty information element contents**

Information element	Length	Type	C/O/M	Remark
Longitude	25	1	M	
Latitude	24	1	M	
Half of the major axis	6	1	M	
Half of the minor axis	6	1	M	
Angle, see note 1	8	1	M	
Location altitude	12	1	M	
Location altitude accuracy	3	1	M	
Confidence level	3	1	M	
NOTE 1: Angle should be in range 0 to 180 degrees (in 360 degrees scale).				
NOTE 2: The total size of this information element is 87.				

### 6.3.43 Location information destination

The location information destination information element shall be encoded as defined in table 6.52.

**Table 6.52: Location information destination information element contents**

Information element	Length	Type	C/O/M	Remark
Address or identification type	4	1	M	
No address	0		C	See note 1
SSI	24		C	See note 1
MNI + SSI	48		C	See note 1
External subscriber number	Variable		C	See notes 1 and 2
SSI + external subscriber number	Variable		C	See notes 1 and 2
MNI + SSI + external subscriber number	Variable		C	See notes 1 and 2
IP address (Version 4) RFC 791 [4]	32		C	See note 1
IP address (Version 6) RFC 3513 [5]	128		C	See note 1
Name server type	Variable		C	See notes 1 and 2
NOTE 1: This information element is conditional on the address or identification type.				
NOTE 2: The length of this information element is defined by the total length of the combined information element.				

### 6.3.44 Location message reference

The location message reference shall be encoded as presented in table 6.53.

**Table 6.53: Location message reference information element contents**

Information element	Length	Type	C/O/M	Remark
Location message reference	8	1	M	Any value 0 to 255.

### 6.3.45 Location point

The location point information element shall be encoded as presented in table 6.54.

**Table 6.54: Location point information element contents**

Information element	Length	Type	C/O/M	Remark
Longitude	25	1	M	
Latitude	24	1	M	
NOTE: The total size of this information element is 49.				

### 6.3.46 Location point and position error

The location point and position error information element shall be encoded as presented in table 6.55.

**Table 6.55: Location point and position error information element contents**

Information element	Length	Type	C/O/M	Remark
Longitude	25	1	M	
Latitude	24	1	M	
Position error	3	1	M	
NOTE: The total size of this information element is 52.				

### 6.3.47 Location point with altitude

The location point with altitude information element shall be encoded as presented in table 6.56.

**Table 6.56: Location point with altitude information element contents**

Information element	Length	Type	C/O/M	Remark
Longitude	25	1	M	
Latitude	24	1	M	
Location altitude	12	1	M	
NOTE: The total size of this information element is 61.				

### 6.3.48 Location reporting enable flags

The location reporting enable flags information element shall be encoded as defined in table 6.57.

**Table 6.57: Location reporting enable flags information element contents**

Information element	Length	Value	Remark
Location reporting enable flag 1	1	0	Location reporting globally disabled
		1	Location reporting globally enabled
Location reporting enable flag 2	1	0	Default value
		1	Reserved
Location reporting enable flag 3	1	0	Default value
		1	Reserved
Location reporting enable flag 4	1	0	Default value
		1	Reserved
Location reporting enable flag 5	1	0	Default value
		1	Reserved
Location reporting enable flag 6	1	0	Default value
		1	Reserved
Location reporting enable flag 7	1	0	Default value
		1	Reserved
Location reporting enable flag 8	1	0	Default value
		1	Reserved



### 6.3.49 Location shape

Location shape information element shall be encoded as presented in table 6.58.

**Table 6.58: Location shape information element contents**

Information element	Length	Value	Remark
Location shape	4	0	No shape
		1	Location point
		2	Location circle
		3	Location ellipse
		4	Location point with altitude
		5	Location circle with altitude
		6	Location ellipse with altitude
		7	Location circle with altitude and altitude uncertainty
		8	Location ellipse with altitude and altitude uncertainty
		9	Location arc
		10	Location point and position error
		11	Reserved
		12	Reserved
		13	Reserved
		14	Reserved
15	Location shape extension, see note		
NOTE: For this value the Location shape information element shall be followed by the Location shape extension information element of 4 bits. The Location shape extension is outside the scope of the present document.			

### 6.3.50 Longitude

Longitude information element shall indicate longitude of the location point in steps of  $360/2^{25}$  degrees in range -180 degrees to  $+(180 - 360/2^{25})$  degrees using two's complement presentation. Negative values shall be west of zero meridian and positive values shall be east of zero meridian.

NOTE: The information element value indicates the centre of resolution range in contrary to GSM presentation where the resolution boundary is indicated. That may introduce a systematic displacement in conversions.

### 6.3.51 Maximum information age

The maximum information age information element shall be encoded as defined in table 6.59.

NOTE: The actual age of the information in the response is defined by the time information element.

**Table 6.59: Maximum information age information element contents**

Information element	Length	Type	C/O/M	Value	Remark
Maximum information age	7	1	M	0	1 s
				1	2 s
				etc.	etc.
				29	30 s
				30	35 s
				etc.	etc.
				59	3 min
				60	3,5 min
				etc.	etc.
				73	10 min
				74	11 min
				etc.	etc.
				126	1 h 3 min
				127	Best effort

### 6.3.52 Maximum reporting distance

The maximum reporting distance information element shall be encoded as defined in table 6.60.

**Table 6.60: Maximum reporting distance information element contents**

Information element	Length	Type	C/O/M	Value	Remark
Maximum reporting distance	7	1	M	0	100 m
				1	200 m
				etc.	etc.
				99	10 km
				100	10,5 km
				etc.	etc.
				127	24 km

### 6.3.53 Maximum reporting interval

The maximum reporting interval shall be encoded as presented in table 6.61.

**Table 6.61: Maximum reporting interval information element contents**

Information element	Length	Type	C/O/M	Value	Remark
Maximum reporting interval	7	1	M	0	30 s
				1	1 min, 30 s steps
				etc.	etc.
				19	10 min, 1 min steps
				20	11 min
				etc.	etc.
				39	30 min
				40	40 min, 10 min steps
				etc.	etc.
				93	9,5 h
				94	10 h, 30 min steps
				etc.	etc.
				126	26 h
127	26,5 h				

### 6.3.54 Maximum response time

The maximum response time information element shall be encoded as defined in table 6.62.

**Table 6.62: Maximum response time information element contents**

Information element	Length	Type	C/O/M	Value	Remark
Maximum response time	7	1	M	0	Immediate
				1	2 s
				2	4 s
				etc.	etc.
				127	254 s (4 min 14 s)

### 6.3.54a Minimum detection interval

The minimum detection interval information element shall be encoded as presented in table 6.63.

**Table 6.63: Minimum detection interval information element contents**

Information element	Length	Type	C/O/M	Value	Remark
Minimum detection interval	7	1	M	0	0 s
				1	10 s
				etc.	etc.
				30	5 min
				31	5,5 min
				etc.	etc.
				60	20 min
				61	21 min
				etc.	etc.
				127	87 min

### 6.3.55 Minimum reporting interval

The minimum reporting interval information element shall be encoded as presented in table 6.64.

**Table 6.64: Minimum reporting interval information element contents**

Information element	Length	Type	C/O/M	Value	Remark
Minimum reporting interval	7	1	M	0	10 s
				1	20 s
				etc.	etc.
				29	5 min
				30	5,5 min
				etc.	etc.
				59	20 min
				60	21 min
				etc.	etc.
				127	88 min

### 6.3.56 MNI + SSI

The MNI + SSI information element shall indicate the TSI address as defined in table 6.87.

**Table 6.65: MNI + SSI + external subscriber number information element contents**

Information sub-element	Length	C/O/M	Remark
Short Subscriber Identity (SSI)	24	M	See EN 300 392-1 [1], clause 7
Country Code	10	M	See EN 300 392-1 [1], clause 7
Network Code	14	M	See EN 300 392-1 [1], clause 7

### 6.3.57 MNI + SSI + external subscriber number

The MNI + SSI + external subscriber number information element shall indicate the TSI address as defined in table 6.66.

**Table 6.66: MNI + SSI + external subscriber number information element contents**

Information sub-element	Length	C/O/M	Remark
Short Subscriber Identity (SSI)	24	M	See EN 300 392-1 [1], clause 7
Country Code	10	M	See EN 300 392-1 [1], clause 7
Network Code	14	M	See EN 300 392-1 [1], clause 7
External subscriber number digit	4	M	Repeatable, see note
NOTE: The length and so the number of the External subscriber number digits of this information element is defined by the total length of the combined address information element. If the length resolution cannot indicate exact length so that there are unused bits at the end of this information element, then the fill bit shall be set to "1". That convention means that the External subscriber number digit cannot be "1111".			

### 6.3.58 Name of location

The name of location information element shall be encoded as presented in table 6.67.

**Table 6.67: Name of location information element contents**

Information element	Length	Type	C/O/M	Remark
Text encoding scheme	7	1	M	Refer to EN 300 392-2 [2], clause 29.5.4.1.
Character string	Variable		C	

### 6.3.59 Name server type

The name server type information element shall be encoded as presented in table 6.68.

**Table 6.68: Name server type information element contents**

Information element	Length	Type	C/O/M	Remark
Text encoding scheme	7	1	M	Refer to EN 300 392-2 [2], clause 29.5.4.1.
Character string	Variable		C	

### 6.3.60 Outer radius

The outer radius shall be encoded as presented in table 6.69.

**Table 6.69: Outer radius information element contents**

Information element	Length	Type	C/O/M	Value	Remark
Outer radius	16	1	M	0	0 m
				1	2 m
				2	4 m
				etc.	etc.
				65 536	13 1072 m

### 6.3.61 PDU type

The PDU type information element shall be encoded as presented in table 6.70.

**Table 6.70: PDU type information element contents**

Information element	Length	Value	Remark
PDU type	2	0	Short location report
		1	Location protocol PDU with extension, see note 1
		2	Reserved, see note 2
		3	Reserved, see note 2
NOTE 1: A PDU type extension will follow this PDU type to identify the actual PDU type.			
NOTE 2: Reserved for further extension, will not be used in phase 1.			

### 6.3.62 PDU type extension

The PDU type extension information element shall be encoded as presented in table 6.71.

**Table 6.71: PDU type extension information element contents**

Information element	Length	Value	Remark
PDU type extension	4	0000 <sub>2</sub>	Reserved for further extension, see note
		0001 <sub>2</sub>	Immediate location report request
		0010 <sub>2</sub>	Reserved
		0011 <sub>2</sub>	Long location report
		0100 <sub>2</sub>	Location report acknowledgement
		0101 <sub>2</sub>	Basic location parameters request/response
		0110 <sub>2</sub>	Add/modify trigger request/response
		0111 <sub>2</sub>	Remove trigger request/response
		1000 <sub>2</sub>	Report trigger request/response
		1001 <sub>2</sub>	Report basic location parameters request/response
		1010 <sub>2</sub>	Location reporting enable/disable request/response
		1011 <sub>2</sub>	Location reporting temporary control request/response
		1100 <sub>2</sub>	Reserved
		1101 <sub>2</sub>	Reserved
1110 <sub>2</sub>	Reserved		
1111 <sub>2</sub>	Reserved, see note		
NOTE: An extension method will be defined in the case a PDU extension will be needed.			

### 6.3.63 Position error

The position error information element shall be encoded as presented in table 6.72.

**Table 6.72: Position error information element contents**

Information element	Length	Value	Remark
Position error	3	000 <sub>2</sub>	less than 2 m
		001 <sub>2</sub>	less than 20 m
		010 <sub>2</sub>	less than 200 m
		011 <sub>2</sub>	less than 2 km
		100 <sub>2</sub>	less than 20 km
		101 <sub>2</sub>	less than or equal to 200 km
		110 <sub>2</sub>	more than 200 km
		111 <sub>2</sub>	Position error not known

### 6.3.64 Reason for sending

The reason for sending shall indicate the reason why location information was sent from the location determination entity and shall be encoded as defined in the table 6.73.

**Table 6.73: Reason for sending information element contents**

Information element	Length	Value	Reason	Remark
Reason for sending	8	0	Subscriber unit is powered ON	
		1	Subscriber unit is powered OFF, see note 1	
		2	Emergency condition is detected	
		3	Push-to-talk condition is detected	
		4	Status, see note 2	
		5	Transmit inhibit mode ON, see note 3	
		6	Transmit inhibit mode OFF	
		7	System access (TMO ON)	
		8	DMO ON, see note 4	
		9	Enter service (after being out of service)	
		10	Service loss, see note 5	
		11	Cell reselection or change of serving cell, see note 6	
		12	Low battery	
		13	Subscriber unit is connected to a car kit	
		14	Subscriber unit is disconnected from a car kit	
		15	Subscriber unit asks for transfer initialization configuration	
		16	Arrival at destination	Destination definition is outside the scope of the present document
		17	Arrival at a defined location	
		18	Approaching a defined location	
		19	SDS type-1 entered	
		20	User application initiated	
		21	Lost ability to determine location	See clause 5.3.22
		22	Regained ability to determine location	See clause 5.3.22
		23	Leaving point	
		24	Ambience Listening call is detected	
		25	Start of temporary reporting	
		26	Return to normal reporting	
		27	Reserved	
		etc.	etc.	
		31	Reserved	
32	Response to an immediate location request			
33	Reserved			
etc.	etc.			
128	Reserved			
129	Maximum reporting interval exceeded since the last location information report			
130	Maximum reporting distance limit travelled since last location information report			
131	Reserved			
etc.	etc.			
255	Reserved			

NOTE 1: The location and time information shall be those at the power OFF.

NOTE 2: The status value shall be as defined in clause 14.8.34 of EN 300 392-2 [2] as Pre-coded status. Applicable only for long location reports.

NOTE 3: If the location information report is sent, when the Transmit inhibit mode is turned back OFF, then the location and time information shall be those at the Transmit inhibit mode ON. Location information report should be sent just before going into Transmit inhibit mode ON.

NOTE 4: If the location information report is sent, when returning back in TMO, then the location and time information shall be those at the DMO ON. Location information report should be sent just before going into DMO.

NOTE 5: Could be sent when retuning back in service.

NOTE 6: Use of this reason may require careful considerations as it may generate lot of reports.

### 6.3.65 Report type

The report type information element shall be encoded as presented in table 6.74.

**Table 6.74: Report type information element contents**

Information element	Length	Value	Remark
Report type	2	0	Long location report preferred with no time information
		1	Long location report preferred with time type "Time elapsed"
		2	Long location report preferred with time type "Time of position"
		3	Short location report preferred, see note
NOTE: If for any reason a long location report is returned instead, then time type should be "Time elapsed".			

### 6.3.66 Requested or required

The requested or required information element shall be encoded as presented in table 6.75.

**Table 6.75: Requested or required information element contents**

Information element	Length	Type	C/O/M	Value	Remark
Requested or required	2	1	M	0	Use basic parameter value or default value, if basic parameter value is not defined
				1	Requested
				2	Required
				3	Requested and required

### 6.3.67 Request priority

The request priority information element shall be encoded as presented in table 6.76.

**Table 6.76: Request priority information element contents**

Information element	Length	Type	C/O/M	Value	Remark
Request priority	2	1	M	0	Low request priority
				1	Normal request priority
				2	High request priority
				3	Highest request priority

### 6.3.68 Result code

The result code shall be encoded as presented in table 6.77.

**Table 6.77: Result codes and their meaning**

Information element	Length	Value	Definition	Description
Result code	8	0	Success	No error occurred while processing the request, see note.
		1	System failure	The provider is unable to provide the required information due to a general problem in the server or the underlying network.
		2	Unspecified error	The unspecified error is used in case none of the other errors applies. This result code can also be used in cases where privacy issues prevent certain errors from being presented.
		3	Unauthorized application	The requesting application/user is not authorized to obtain the information for the specified terminal or location identification.
		4	Unknown subscriber	Unknown terminal or location identification.
		5	Absent subscriber	The terminal or location identification is currently not reachable.
		6	Congestion in provider	The provider is unable to provide the required information because of congestion in the provider or an entity invoked by the Provider.
		7	Congestion in mobile network	The provider is unable to provide the required information because of congestion in the mobile network.
		8	Unsupported version	The version number is not supported by the provider, not used in the protocol of the present document.
		9	Insufficient resource	The provider was unable to complete a request due to insufficient resources, e.g. lack of memory, etc.
		10	Syntax error	The information request has a syntax error, e.g. invalid values in some information elements, missing required elements, etc.
		11	Protocol element not supported	The provider does not support a protocol information element specified in the request.
		12	Service not supported	The provider does not support the specified service, e.g. triggered request.
		13	Protocol element value not supported	The provider does not support a specific value of a protocol information element.
		14	Type of information not currently available	A required type of information is temporarily unavailable, e.g. due to some temporary problem.
		15	Required accuracy not achieved	A required accuracy was not achieved and report contains achieved uncertainty.
		16	Reserved	
		17	Reporting will stop	A triggered request has been cancelled, and no further reports will be produced.
		18	Time expired	The start time or stop time of a triggered request has expired.
		19	Disallowed by local regulations	The request is disallowed by local regulatory requirements.
		20	Reserved	Reserved.
		21	No such request	No pending request identifiers match the request identifier specified for a triggered location stop request message.
		22	User disabled location information report sending	User has prevented sending of location information reports.
		23	Parameter values modified	One or more parameter is modified or not supported.
		24	Accepted	All definitions accepted without modifications.
		25	Accepted, but some of the triggers or accuracies are modified or are not supported	Accepted, but some of the triggers or accuracies are modified or are not supported.
		26	Triggers not supported	The requested triggers are not supported.
27	Report complete	Indicates the end of the report.		



Information element	Length	Value	Definition	Description
		28	Reserved	
		etc.	etc.	
		80	Reserved	
		81	Position method failure	Position method failure, resulting in the provider not being able to obtain the position of the terminal or location point.
		82	Reserved	
		etc.	etc.	
		199	Reserved	
		200	Insufficient GPS satellites	Insufficient number of GPS satellites to determine a position.
		201	Bad GPS geometry	Invalid GPS satellite geometry information.
		202		Reserved.
		..etc.		etc.
		255		Reserved.

NOTE: This result can only be returned by a response PDU.

### 6.3.69 SDS type-1 value

The SDS type-1 value information element shall be encoded as defined in table 6.78.

**Table 6.78: SSI information element contents**

Information element	Length	Value	Remark
SDS type-1 value	16		See EN 300 392-2 [2], clause 14.8.49 User defined data-1

### 6.3.70 SSI

The SSI information element shall indicate the Short Subscriber Identity address as defined in table 6.79.

**Table 6.79: SSI information element contents**

Information element	Length	Value	Remark
Short Subscriber Identity (SSI)	24		See EN 300 392-1 [1], clause 7

### 6.3.71 SSI + external subscriber number

The SSI + external subscriber number information element shall indicate the Short Subscriber Identity address as defined in table 6.80.

**Table 6.80: SSI + external subscriber number information element contents**

Information sub-element	Length	C/O/M	Remark
Short Subscriber Identity (SSI)	24	M	See EN 300 392-1 [1], clause 7
External subscriber number digit	4	M	Repeatable, see note

NOTE: The length and so the number of the External subscriber number digits of this information element is defined by the total length of the combined address information element. If the length resolution cannot indicate exact length so that there are unused bits at the end of this information element, then the fill bit shall be set to "1". That convention means that the External subscriber number digit cannot be "1111".

### 6.3.72 Start angle

Start angle shall be encoded as defined in table 6.21.

### 6.3.73 Start time

The start time information element shall be encoded as presented in table 6.81.

**Table 6.81: Start time information element contents**

Information element	Length	Type	C/O/M	Value	Remark
Day, note	5	1	M	0	Reserved
				1	Day number
				etc.	etc.
				31	Day number
Hour	5	1	M	0	Hour number
				etc.	etc.
				23	Hour number
				25	Reserved
				etc.	etc.
				31	Reserved
Minute	6	1	M	0	Minute number
				etc.	etc.
				59	Minute number
				60	Reserved
				etc.	etc.
				63	Reserved
Second	6	1	M	0	Second number
				etc.	etc.
				59	Second number
				60	Reserved
				etc.	etc.
				63	Reserved

NOTE: The day shall indicate day of month, refer to clause 5.1.21.

### 6.3.74 Status value

The status value information element shall be encoded as defined in table 6.82.

**Table 6.82: Status value information element contents**

Information element	Length	Value	Remark
Status value	16		See EN 300 392-2 [2], clause 14.8.34 pre-coded status

### 6.3.75 Stop angle

Stop angle shall be encoded as defined in table 6.21.

### 6.3.76 Stop time

The stop time information element shall be encoded as presented in table 6.81 for start time.

### 6.3.76a Temporary control parameter definition

The temporary control parameter definition information element shall be encoded as defined in table 6.83.

**Table 6.83: Temporary control parameter definition information element contents**

Information element	Length	Type	C/O/M	Value	Remark
Temporary control parameter type	3	1	M		
Temporary minimum reporting distance	7		C		Included if temporary control parameter type is Temporary minimum reporting distance
Temporary maximum reporting distance	7		C		Included if temporary control parameter type is Temporary maximum reporting distance
Temporary minimum reporting interval - absolute	7		C		Included if temporary control parameter type is Temporary minimum reporting interval - absolute
Temporary minimum reporting interval - relative	3		C		Included if temporary control parameter type is Temporary minimum reporting interval - relative
Temporary report type	2		C		Included if temporary control parameter type is Temporary report type

### 6.3.76b Temporary control parameter type

The temporary control parameter type information shall be encoded as defined in table 6.84.

**Table 6.84: Temporary control parameter type information element contents**

Information element	Length	Value	Remark
Temporary control parameter type	3	000 <sub>2</sub>	Temporary minimum reporting distance
		001 <sub>2</sub>	Temporary maximum reporting distance
		010 <sub>2</sub>	Temporary minimum reporting interval - absolute
		011 <sub>2</sub>	Temporary minimum reporting interval - relative
		100 <sub>2</sub>	Temporary short location report
		101 <sub>2</sub>	Reserved
		110 <sub>2</sub>	Reserved
		111 <sub>2</sub>	Reserved

### 6.3.76c Temporary control validity

The temporary control validity information element shall be encoded as defined in table 6.85.

**Table 6.85: Temporary control parameter validity information element contents**

Information element	Length	Value	Remark
Temporary control validity	4	0000 <sub>2</sub>	Return to normal reporting
		0001 <sub>2</sub>	Until next location update, see note 1
		0010 <sub>2</sub>	Until next ITSI attach, see note 1
		0011 <sub>2</sub>	Until normal reporting notification, see note 1
		0100 <sub>2</sub>	Reserved
		etc.	etc.
		0111 <sub>2</sub>	Reserved
		1000 <sub>2</sub>	10 min
		1001 <sub>2</sub>	20 min
		1010 <sub>2</sub>	30 min
		1011 <sub>2</sub>	40 min
		1100 <sub>2</sub>	50 min
		1101 <sub>2</sub>	60 min
		1110 <sub>2</sub>	70 min
		1111 <sub>2</sub>	No time-out, see note 2
NOTE 1: Instance related return to normal reporting without time limit.			
NOTE 2: No system defined time limit.			

### 6.3.76d Temporary maximum reporting distance - relative

The Temporary maximum reporting distance - relative information shall be encoded as defined in table 6.86.

**Table 6.86: Temporary maximum reporting distance - relative information element contents**

Information element	Length	Value	Remark
Temporary maximum reporting interval - relative	3	000 <sub>2</sub>	1,4 times normal maximum reporting distance
		001 <sub>2</sub>	Two times normal maximum reporting distance
		010 <sub>2</sub>	Three times normal maximum reporting distance
		011 <sub>2</sub>	Four times normal maximum reporting distance
		100 <sub>2</sub>	Six times normal maximum reporting distance
		101 <sub>2</sub>	Eight times normal maximum reporting distance
		110 <sub>2</sub>	Reserved
		111 <sub>2</sub>	Reserved

### 6.3.76e Temporary minimum reporting distance

The Temporary minimum reporting distance information element shall be encoded as defined in table 6.87.

**Table 6.87: Temporary minimum reporting distance information element contents**

Information element	Length	Type	C/O/M	Value	Remark
Temporary minimum reporting distance	7	1	M	0	10 m
				1	20 m, step 10 m
				etc.	etc.
				99	1 km
				100	1,05 km, step 50 m
				etc.	etc.
				127	2,4 km

### 6.3.76f Temporary minimum reporting interval - absolute

The Temporary minimum reporting interval - absolute information element shall be encoded as the Minimum reporting interval presented in table 6.64.

### 6.3.76g Temporary minimum reporting interval - relative

The Temporary minimum reporting interval - relative information shall be encoded as defined in table 6.88.

**Table 6.88: Temporary minimum reporting interval - relative information element contents**

Information element	Length	Value	Remark
Temporary minimum reporting interval - relative	3	000 <sub>2</sub>	1,4 times normal minimum reporting interval
		001 <sub>2</sub>	Two times normal minimum reporting interval
		010 <sub>2</sub>	Three times normal minimum reporting interval
		011 <sub>2</sub>	Four times normal minimum reporting interval
		100 <sub>2</sub>	Six times normal minimum reporting interval
		101 <sub>2</sub>	Eight times normal minimum reporting interval
		110 <sub>2</sub>	Reserved
		111 <sub>2</sub>	Reserved

### 6.3.76h Temporary report type

The temporary report type information shall be encoded as defined in table 6.89.

**Table 6.89: Temporary report type information element contents**

Information element	Length	Value	Remark
Temporary report type	2	00 <sub>2</sub>	Only Short location reports allowed, refer to clause 6.3.2.1
		01 <sub>2</sub>	Short location reports recommended, refer to clause 6.3.2.1
		10 <sub>2</sub>	Reserved
		11 <sub>2</sub>	Reserved

### 6.3.77 Terminal or location identification

The terminal or location identification information element shall be encoded as presented in table 6.90.

**Table 6.90: Terminal or location identification type information element contents**

Information element	Length	Type	C/O/M	Remark
Address or identification type	4	1	M	
No address	0		C	See note 1
SSI	24		C	See note 1
MNI + SSI	48		C	See note 1
External subscriber number	Variable		C	See notes 1 and 2
SSI + external subscriber number	Variable		C	See notes 1 and 2
MNI + SSI + external subscriber number	Variable		C	See notes 1 and 2
IP address (Version 4) RFC 791 [4]	32		C	See note 1
IP address (Version 6) RFC 3513 [5]	128		C	See note 1
Name of location	Variable		C	See notes 1 and 2
NOTE 1: This information element is conditional on the address or identification type.				
NOTE 2: The length of this information element is defined by the total length of the combined information element.				

### 6.3.78 Time elapsed

The time elapsed information element shall indicate approximate time since location determination as defined in table 6.91.

**Table 6.91: Time elapsed information element contents**

Information element	Length	Value	Remark
Time elapsed	2	0	less than 5 s
		1	less than 5 min
		2	less than 30 min
		3	Time elapsed not known or not applicable

### 6.3.79 Time of position

The time of position information element shall be encoded as presented in table 6.92.

**Table 6.92: Time of position information element contents**

Information element	Length	Type	C/O/M	Value	Remark
Day	5	1	M	0	Reserved
				1	Day number
				etc.	etc.
				31	Day number, see note.
Hour	5	1	M	0	Hour number
				etc.	etc.
				23	Hour number
				25	Reserved
				etc.	etc.
				29	Reserved
				30	Reserved
Minute	6	1	M	0	Minute number
				etc.	etc.
				59	Minute number
				60	Reserved
				etc.	etc.
Second	6	1	M	0	Second number
				etc.	etc.
				59	Second number
				60	Reserved
				etc.	etc.
				63	Reserved

NOTE: The day of month can have values as in normal calendar i.e. in February is can be 1 to 28 on normal years and 29 on leap years.

### 6.3.80 Time data

The time data information element shall be encoded as presented in table 6.93.

**Table 6.93: Time data information element contents**

Information element	Length	Type	C/O/M	Remark
Time type	2	1	M	
None	0		C	Shall be present, when time type value is 0
Time elapsed	2		C	Shall be present, when time type value is 1
Time of position	22		C	Shall be present, when time type value is 2
Reserved	N/A		C	Time type value 3 is not applicable in the present document

### 6.3.81 Time type

The time type information element shall be encoded as presented in table 6.94.

**Table 6.94: Time type information element contents**

Information element	Length	Value	Remark
Time type	2	0	None
		1	Time elapsed
		2	Time of position
		3	Reserved

### 6.3.82 Trigger definition (one-shot/recurring)

The trigger definition information element shall contain a trigger and related parameter and shall be encoded as defined in table 6.95.

**Table 6.95: Trigger definition information element contents**

Information element	Length	Type	C/O/M	Value	Remark
Trigger type (one-shot/recurring)	8	1	M		
One-shot/recurring	1	1	M	0	One-shot
				1	Recurring
Status value	16		C		Included if Trigger type is Status
Location circle	55		C		Included if Trigger type is Approaching point or Leaving point, see note 1
Location point	49		C		Included if Trigger type is Arrival at point, see note 2
SDS type-1 value	16		C		Included if Trigger type is SDS type-1 entered
Maximum reporting interval	7		C		Included if Trigger type is Maximum reporting interval
Maximum reporting distance	7		C		Included if Trigger type is Maximum reporting distance
Minimum detection interval	7		C		Included if Trigger type is Lost ability to determine location, or Regained ability to determine location
NOTE 1: The horizontal position uncertainty information element value shall indicate the distance at which this trigger is activated.					
NOTE 2: "Arrival at point" means that the defined point is within measurement uncertainty of the current location or some other application dependent uncertainty. The application dependent uncertainty and how it is defined is outside the scope of the present document.					

### 6.3.83 Trigger removal

The trigger removal information element shall contain a trigger and related parameter and shall be encoded as defined in table 6.96.

**Table 6.96: Trigger removal information element contents**

Information element	Length	Type	C/O/M	Value	Remark
Removal type	1	1	M	0	Remove all triggers
				1	Remove listed triggers
Trigger type (one-shot/recurring)	8		C		Repeatable, see note 1
Status value	16		C		Included if Trigger type is "Status"
Location point	49		C		Included if Trigger type is "Arrival at point", "Approaching point" or "Leaving point", see note 2
SDS type-1 value	16		C		Included if Trigger type is "SDS type-1 entered"
NOTE 1: Shall be present only if the removal type value is "Remove listed triggers".					
NOTE 2: Differentiation between removal of "Arrival at point", "Approaching point" and "Leaving point" triggers shall be indicated by the trigger type information element. It is assumed that only one "approaching point" and one "Leaving point" trigger distance is used for each location point.					

### 6.3.84 Trigger type (one-shot/recurring)

The trigger type information element shall be encoded as presented in table 6.97.

**Table 6.97: Trigger type information element contents**

Information element	Length	Value	Reason	Remark
Trigger type	8	0	Subscriber unit is powered ON	
		1	Subscriber unit is powered OFF, note 1	
		2	Emergency condition is detected	
		3	Push-to-Talk condition is detected	
		4	Status entered	Parameter, see table 6.95
		5	Transmit Inhibit Mode ON	
		6	Transmit Inhibit Mode OFF	
		7	System access (TMO ON)	
		8	DMO ON	
		9	Enter service (after being out of service)	
		10	Loss of service	
		11	Change of serving cell	
		12	Low battery	
		13	Subscriber unit is connected to a car kit	
		14	Subscriber unit is disconnected from a car kit	
		15	Reserved	
		16	Arrival at destination	Destination definition is outside the scope of the present document
		17	Arrival at point, note 2	Parameter, see table 6.95 for location point
		18	Approaching point	Parameter, see table 6.95 for location circle
		19	SDS type-1 entered	Parameter, see table 6.95
		20	Reserved	
		21	Lost ability to determine location	See note 3
		22	Regained ability to determine location	
		23	Leaving point	Parameter, see table 6.95 for location circle
		24	Ambience Listening call is detected	
		25	Reserved	
		etc.	etc.	
127	Reserved			
128	Not applicable	See table 6.98		
etc.		etc.		
131	Not applicable	See table 6.98		
132	Reserved or not applicable			
etc.	etc.			
255	Reserved or not applicable			

NOTE 1: Could be sent when the SU is powered back ON, but should not generate additional sending of a location report "SU is powered ON".

NOTE 2: "Arrival at point" means that the defined point is within measurement uncertainty of the current location or some other application dependent uncertainty. The application dependent uncertainty and how it is defined is outside the scope of the present document.

NOTE 3: "Lost ability to determine location" should be sent only if MS cannot determine location for longer than the Maximum Information Age.



### 6.3.85 Trigger type (recurring)

The trigger type information element shall be encoded as presented in table 6.98.

**Table 6.98: Trigger type information element contents**

Information element	Length	Value	Reason	Remark
Trigger type	8	0	Not applicable	See table 6.97
		etc.	etc.	etc.
		127	Not applicable	See table 6.97
		128	Reserved	
		129	Maximum reporting interval	
		130	Maximum reporting distance	
		131	Reserved or not applicable	
		etc.	etc.	
		255	Reserved or not applicable	

### 6.3.86 Type 5 element identifier

Type 5 element identifier shall define information contents of the information element as presented in table 6.99.

**Table 6.99: Type 5 element identifier information element contents**

Information element	Length	Value	Remark
Type 5 element identifier	5	0	Direction of travel and direction of travel accuracy
		1	Extended user defined data
		2	Horizontal position and horizontal position accuracy
		3	Horizontal velocity and horizontal velocity accuracy
		4	Location information destination
		5	Location altitude and location altitude accuracy
		6	Location message reference
		7	Maximum information age
		8	Maximum response time
		9	Default enable/disable lifetime
		10	Reserved
		11	Request priority
		12	Result code
		13	SDS type-1 value
		14	Start time
		15	Status value
		16	Stop time
		17	Terminal or location identification
		18	Reserved
		19	Trigger definition
		20	Trigger removal
		21	Vertical velocity and vertical velocity accuracy
		22	Temporary control parameter definition
		23	Reserved
		24	Reserved
		25	Reserved
		26	Reserved
		27	Reserved
		28	Reserved
		29	Reserved
		30	Reserved
		31	Extended type 5 information element, see note

NOTE: Extension encoding is outside the scope of the present document. The extended type 5 information element shall be ignored, if the extension is not supported.

### 6.3.87 Type of additional data

The type of additional data information element shall be encoded as defined in table 6.100.

**Table 6.100: Type of additional data information element contents**

Information element	Length	Value	Remark
Type of additional data	1	0	Reason for sending
		1	User defined data

### 6.3.88 User defined data

The user defined data information element shall be encoded as presented in table 6.101. The information content is outside the scope of the present document.

**Table 6.101: User defined data information element contents**

Information element	Length	Type	C/O/M	Remark
User defined data	8	1	M	Any value 0 to 255

### 6.3.89 Velocity data

The velocity data shall be encoded as presented in table 6.102.

**Table 6.102: Velocity data information element contents**

Information element	Length	Type	C/O/M	Remark
Velocity type	3	1	M	
No velocity information	0		C	See note
Horizontal velocity	7		C	See note
Horizontal velocity with uncertainty	10		C	See note
Horizontal velocity and vertical velocity	15		C	See note
Horizontal velocity and vertical velocity with uncertainty	21		C	See note
Horizontal velocity with direction of travel extended	15		C	See note
Horizontal velocity with direction of travel extended and uncertainty	21		C	See note
Horizontal velocity and vertical velocity with direction of travel extended and uncertainty	32		C	See note

NOTE: This information element is conditional on the velocity type information element.

### 6.3.90 Velocity type

The velocity type information element shall be encoded as presented in table 6.103.

**Table 6.103: Velocity type information element contents**

Information element	Length	Value	Remark
Velocity type	3	0	No velocity information
		1	Horizontal velocity
		2	Horizontal velocity with uncertainty
		3	Horizontal velocity and vertical velocity
		4	Horizontal velocity and vertical velocity with uncertainty
		5	Horizontal velocity with direction of travel extended
		6	Horizontal velocity with direction of travel extended and uncertainty
7	Horizontal velocity and vertical velocity with direction of travel extended and uncertainty		

### 6.3.91 Vertical velocity

The vertical velocity shall be encoded as described in table 6.104.

**Table 6.104: Vertical velocity information element contents**

Vertical velocity sign	1	0	Velocity upwards	
		1	Velocity downwards	
Vertical velocity	7	0	0 km/h	Steps 1 km/h
		1	1 km/h	
		2	2 km/h	
		etc.	etc.	
		28	28 km/h	
		29	29,1 km/h	3,8 % steps
		30	30,2 km/h	
		31	31,3 km/h	
		etc.	etc.	
		38	40,6 km/h	
		etc.	etc.	
		44	50,8 km/h	
		etc.	etc.	
		56	79,5 km/h	
		etc.	etc.	
		62	99,5 km/h	
		etc.	etc.	
		67	120 km/h	
		etc.	etc.	
		81	202 km/h	
etc.	etc.			
92	305 km/h			
etc.	etc.			
105	495km/h			
etc.	etc.			
114	692km/h			
etc.	etc.			
124	1 005 km/h			
125	1 043 km/h	3,8 % steps		
126	More than 1 043 km/h			
127	Horizontal velocity is not known			

### 6.3.92 Vertical velocity accuracy

The vertical velocity accuracy information element shall be encoded as defined in table 6.105.

**Table 6.105: Vertical velocity accuracy information element contents**

Information element	Length	Type	C/O/M	Value	Remark
Vertical velocity accuracy	3	1	M	0	Less than 1,5 km/h
				1	Less than 3 km/h
				2	Less than 6 km/h
				3	Less than 12 km/h
				4	Less than 24 km/h
				5	Less than 48 km/h
				6	Less than 96 km/h
				7	Best effort

### 6.3.93 Vertical velocity and vertical velocity accuracy

The vertical velocity and vertical velocity accuracy information element shall be encoded as defined in table 6.106.

**Table 6.106: Vertical velocity and vertical velocity accuracy information element contents**

Information element	Length	Type	C/O/M	Value	Remark
Return value	1	1	M	0	Vertical velocity value required
				1	Vertical velocity and vertical velocity uncertainty values required
Requested or required	2	1			
Vertical velocity accuracy (requested)	3		C		Shall be present if requested
Vertical velocity accuracy (required)	3		C		Shall be present if required

### 6.3.94 Vertical velocity uncertainty

The vertical velocity uncertainty information element shall be encoded as defined in table 6.105 for vertical velocity accuracy.

## 6.4 Type 5 information element description

### 6.4.1 Type 5 information element definition

Type 5 information element coding modifies PDU encoding principles so that the type 5 information element replaces both type 2 and type 3/4 information elements. In a PDU using type 5 information elements there cannot be any type 2 or type 3/4 information elements and so no O-bit nor M-bit is needed. PDU end is indicated by length information element.

Type 5 information element length can be from 1 bit to 63 bits in one bit steps and from 64 bits to 1 080 bits in 8 bits (octet) steps.

### 6.4.2 Type 5 element length

The type 5 element length information element shall be encoded as presented in table 6.107.

**Table 6.107: Type 5 element length information element contents**

Information element	Length	Value	Remark
Type 5 element length	6	000000 <sub>2</sub>	Type 5 length extension
		000001 <sub>2</sub>	Element data length is one bit
		000010 <sub>2</sub>	Element data length is two bits
		etc.	etc.
		111111 <sub>2</sub>	Element data length is 63 bits

### 6.4.3 Type 5 element length extension

The type 5 element length extension information element shall be encoded as presented in table 6.108.

**Table 6.108: Type 5 element length extension information element contents**

Information element	Length	Value	Remark
Type 5 element length extension	7	0000000 <sub>2</sub>	Reserved
		00000001 <sub>2</sub>	Element data length is eight octets
		0000010 <sub>2</sub>	Element data length is nine octets
		etc.	etc.
		1111111 <sub>2</sub>	Element data length is 135 octets

### 6.4.4 Type 5 information element

The type 5 information elements shall be encoded as presented in table 6.109.

**Table 6.109: Type 5 information element**

Information element	Length	Type	C/O/M	Remark
Type 5 element identifier	5	1	M	Shall be unique per SDS-TL Protocol ID
Type 5 element length	6	1	M	
Type 5 element length extension	7		C	Shall be present, if and only if type 5 element length has value "000000"
Extended type 5 information element	See note 1		C	Shall be present, if and only if type 5 element identifier value is "11111"
Element data	variable	1	M	See note 2
NOTE 1: The length of the Extended type 5 information element will be defined in a later version of the present document.				
NOTE 2: In the case the type 5 element length extension is used and the length of the actual element data is not octet bounded the element data shall contain fill bits at the end, the fill bits shall have value "1". Fill bit value one allows Binary Coded Decimal presentation of numbers, refer to clause 6.3.11.				

## 6.5 Geographical shape descriptions

Geographical shapes are described in TS 123 032 [6].

---

## 7 Implementation requirements

MSs supporting LIP protocol shall in minimum support:

- SHORT LOCATION REPORT PDU as defined in clause 6.2.1.
- LOCATION REPORTING ENABLE/DISABLE REQUEST PDU as defined in clause 6.2.14 and the associated location reporting enable/disable service as defined in clause 5.3.18.
- LOCATION REPORTING ENABLE/DISABLE RESPONSE PDU as defined in clause 6.2.15 and the associated location reporting enable/disable service as defined in clause 5.3.18.
- LOCATION REPORTING TEMPORARY CONTROL REQUEST PDU as defined in clause 6.2.17 and the associated location reporting temporary control service as defined in clause 5.3.24.
- LOCATION REPORTING TEMPORARY CONTROL RESPONSE PDU as defined in clause 6.2.18 and the associated location reporting temporary control service as defined in clause 5.3.24.

## Annex A (informative): Example of trigger priorities

### A.1 Trigger priority setting

This annex gives a potential preference order of trigger reason presentation in the report in the case of "colliding" trigger instances, refer to table A.1. Network operator may modify the priorities according to the needs of users.

The main division is as foreground and background triggers.

**Table A.1: Trigger priorities**

Trigger	Priority	Remark
SU is powered ON	Foreground 3	
SU is powered OFF	Background	
Emergency condition is detected	Foreground 1	Should override any other
Ambience Listening call is detected	Foreground 1	Should override any other, except Emergency condition
Push-to-Talk condition is detected	Background	
Status entered	Foreground 3 or background	
Transmit Inhibit Mode ON	Foreground 2	
Transmit Inhibit Mode OFF	Foreground 2	
System access (TMO ON)	Background	
DMO ON	Foreground 2	
Enter service (after being out of service)	Background	
Leave service	Foreground	
Change of serving cell	Background	
Low battery	Background	
SU is connected to a car kit	Background	
SU is disconnected from a car kit	Background	
Maximum reporting interval	Background	
Maximum reporting distance	Background	
Arrival to destination	Foreground 2	
Arrival at point	Foreground 2	Overrides minimum time for single shot reports
Leaving at point	Foreground 2	Overrides minimum time for single shot reports
Approaching point	Foreground 3	Does not override minimum time
SDS Type-1 entered	Foreground 3 or background	
Minimum reporting interval, see note	Foreground 2	Minimum time between location information reports
Lost ability to determine location	Background	
Regained ability to determine location	Background	
NOTE: The minimum reporting interval is not a real trigger as its function is to prevent location report sending, but it is listed in the table for priority definition purposes.		

The "Minimum reporting interval" is a tool to minimize sending of location reports. In order to allow important (high priority) events to override the minimum reporting interval limit their priority will be set to a higher value than the priority of the minimum reporting interval.

If two or more triggers invoke report potentiality then normally only the highest priority trigger invokes sending of location information report, and that report shall contain the trigger reason of the highest priority trigger and should use at least quality of positioning as required for that trigger. If higher quality of positioning is required for the lower priority trigger, and this information is available at the time of sending, it should be included.

The principle of priority is:

- 1) Foreground 1 priority shall override foreground 2 priority and foreground 3 and background priority location information reports. Foreground 2 shall override foreground 3 and background priority.
- 2) Background priority report is sent only if no foreground priority trigger invokes location information report sending.
- 3) The minimum reporting interval timer is re-started and also distance based reporting is re-started each time MS sends a location report for any reason including immediate and unsolicited location information reports to the same location information destination.
- 4) If a foreground triggered location information report is sent, then the suppressed background one may be sent once the minimum reporting interval is passed (the delayed background report time information may be the original event time or one applicable to the time when it is sent).

NOTE: The target is to minimize number of sent location information report even if that "destroys" event reporting capability.

This sets requirements to applications as especially background location information reports may be "lost" (or delayed) as some foreground one is sent instead.

---

## Annex B (informative): Use of location message reference

### B.1 Potential usage of location message reference

The location message reference may be included into the basic parameters or into a location report request, then it can be used to control location message numbering:

- if its value is zero, then the location information report numbering should continue from the current value stored into the location information source;
- if its value is not zero, then the next location information report should start counting from the defined value and each of the following location information reports after that should increase the number by one; and
- SHORT LOCATION REPORT PDUs are not included into the location information report counting.

If the basic parameters or triggered report requests do not define a location message number, then use of the location message reference is outside the scope of the present document.

If the location reporting entity does not support location message reference numbering, then it shall ignore the value in the basic parameters and triggered report requests and shall not include location message reference into location reports.



## Annex C (informative): Change Requests

The Change Requests defined in the table C.1 have been included into the present version of the present document.

**Table C.1: Change Requests**

No	CR vers.	Standard Version	Clauses affected	Title	CR Status
001	10	V1.1.1	6.3.53	Correction of the Maximum reporting interval value scale presentation	TC TETRA approved 0512
002	REJ	V1.1.1	6.3.82	Update of LIP	WG3 rejected 050704
003	10	V1.1.1	6.3.48	Presentation of the Location reporting enable flags information element	TC TETRA approved 0512
101	10	V1.2.1	5.3.22 (new), 6.2.1, 6.3.54a (new), 6.3.64, 6.3.82, 6.3.84, Appendix A.1	Loss of GPS	TC TETRA approved 0703
102	20	V1.2.1	5.3.18, 6.2.14, 6.3.4a, 7	Location reporting enable/disable	TC TETRA approved 0703
103	10	V1.2.1	6.3.64, 6.3.82, 6.3.83, 6.3.84	Leaving point	TC TETRA approved 0703
104	10	V1.2.1	5.3.23 (new), 6.3.64, 6.3.84, clause A.1	Ambience listening	TC TETRA approved 0703
106	12	V1.2.1	4.2, 5.2.6, 5.2.17, 5.2.19, 5.2.20, 5.3.24, 6.2.17, 6.2.18, 6.3.62, 6.3.64, 6.3.76a, 6.3.76b, 6.3.76c, 6.3.76d, 6.3.76e, 6.3.76f, 6.3.76g, 6.3.76h	Temporary reporting	TC TETRA approved 0703
107	11	V1.2.1	5.3.17, 6.3.68	Completion report for REPORT TRIGGER RESPONSE PDU	TC TETRA approved 0703
108	10	V1.2.1	5.3.11, 6.2.8, 6.2.9	Optimization of ADD/MODIFY TRIGGER REQUEST for triggers using the same generic parameters	TC TETRA approved 0703
109	10	V1.2.1	7, A.1	Issues identified during finalisation	TC TETRA approved 0703
110	10	V1.2.1	6.3.15	Requested or required information element coding	WG3 approved 070320

---

## Annex D (informative): Bibliography

- ETSI TR 102 021-4: "Terrestrial Trunked Radio (TETRA); User Requirement Specification TETRA Release 2; Part 4: Air Interface Enhancements".

---

## History

<b>Document history</b>		
V1.1.1	February 2005	Publication
V1.2.1	December 2005	Publication
V1.3.1	April 2007	Publication