

ETSI TS 100 500 V6.2.0 (1999-08)

Technical Specification

**Digital cellular telecommunications system (Phase 2+);
Principles of telecommunication services supported by a GSM
Public Land Mobile Network (PLMN)
(GSM 02.01 version 6.2.0 Release 1997)**



GSM®
GLOBAL SYSTEM FOR
MOBILE COMMUNICATIONS

ETSI 

Reference

RTS/SMG-010201Q6R2 (4mo030o3.PDF)

Keywords

Digital cellular telecommunications system,
Global System for Mobile communications (GSM)

ETSI

Postal address

F-06921 Sophia Antipolis Cedex - FRANCE

Office address

650 Route des Lucioles - Sophia Antipolis
Valbonne - FRANCE
Tel.: +33 4 92 94 42 00 Fax: +33 4 93 65 47 16
Siret N° 348 623 562 00017 - NAF 742 C
Association à but non lucratif enregistrée à la
Sous-Préfecture de Grasse (06) N° 7803/88

Internet

secretariat@etsi.fr
Individual copies of this ETSI deliverable
can be downloaded from
<http://www.etsi.org>
If you find errors in the present document, send your
comment to: editor@etsi.fr

Copyright Notification

No part may be reproduced except as authorized by written permission.
The copyright and the foregoing restriction extend to reproduction in all media.

© European Telecommunications Standards Institute 1999.
All rights reserved.

Contents

Intellectual Property Rights.....	5
Foreword	5
0 Scope.....	6
0.1 References.....	6
0.2 Abbreviations.....	12
1 Framework for the description of telecommunication services.....	12
1.1 General.....	12
1.2 The attribute method of characterization of telecommunication services	12
2 Description of telecommunication services by the attribute method.....	12
2.1 General.....	12
2.2 Bearer services and teleservices.....	13
2.3 Supplementary services.....	13
2.4 Categorisation of telecommunication services	13
3 Customer access to telecommunication services supported by a GSM PLMN	14
3.1 Reference configuration and access points	14
3.2 Access points and telecommunication services.....	15
3.3 Terminal equipment	15
4 Capabilities to support a telecommunication service.....	15
4.1 General.....	15
4.2 Network capabilities	15
4.3 Terminal capabilities.....	16
4.4 Operational capabilities	16
5 Characterization of telecommunication services	16
5.1 General.....	16
5.2 Bearer services supported by a GSM PLMN.....	16
5.3 Teleservices supported by a GSM PLMN	17
6 Provision of telecommunication services	17
6.1 Subscription checking for Basic Services	18
6.2 Subscription checking for Supplementary Services	20
Annex A (normative): List of definition of attributes and values used for bearer services.....	21
A.1 Information transfer attributes	21
A.1.1 Information transfer capability.....	21
A.1.2 Information transfer mode.....	21
A.1.3 Information transfer rate	21
A.1.4 Structure.....	21
A.1.5 Establishment of communication	22
A.1.6 Communication configuration.....	22
A.1.7 Symmetry.....	22
A.1.8 Data compression.....	23
A.2 Attributes describing the access at the mobile station	23
A.2.1 Signalling access.....	23
A.2.2 Information access	23
A.2.2.1 Rate	23
A.2.2.2 Interface	23
A.3 Interworking attribute.....	24
A.3.1 Type of terminating network.....	24
A.3.2 Terminal to terminating network interface.....	24
A.4 General attributes	24
A.4.1 Supplementary services provided	24

A.4.2	Quality of service	24
A.4.3	Commercial and operational	25
A.4.4	Service interworking	25
Annex B (normative): List of definitions of attributes and values used for teleservices		26
B.1	High layer attributes	26
B.1.1	Type of user information	26
B.1.2	Layer 4 protocol functions	26
B.1.3	Layer 5 protocol functions	26
B.1.4	Layer 6 protocol functions	26
B.1.5	Layer 7 protocol functions	26
B.2	Low layer attribute (bearer capabilities)	26
B.3	General attributes	26
Annex C (normative): Definition of "busy" in a GSM PLMN		27
C.1	Scope	27
C.2	Network Determined User Busy (NDUB) condition	27
C.3	User Determined User Busy (UDUB) condition	27
C.4	Mobile subscriber busy	27
Annex D (normative): Call setup procedures		28
D.1	Scope	28
D.2	Mobile Originated Call Setup	28
D.2.1	Called Party Address	28
D.2.2	Calling/Called Party Sub-address	28
D.2.3	Type of Number	28
D.2.4	Number Plan Indicator	28
D.2.5	Bearer Capability	29
D.2.6	Calling Line Indication Restriction Override	29
D.2.7	Action of the Network on Call Setup	29
D.3	Mobile Terminated Call Setup	29
D.3.1	Bearer Type	30
D.3.2	Response of the MS	30
D.3.3	Description of Call Re-establishment	30
Annex E (Informative): Change Request History		31
	History	32

Intellectual Property Rights

IPRs essential or potentially essential to the present document may have been declared to ETSI. The information pertaining to these essential IPRs, if any, is publicly available for **ETSI members and non-members**, and can be found in SR 000 314: "*Intellectual Property Rights (IPRs); Essential, or potentially Essential, IPRs notified to ETSI in respect of ETSI standards*", which is available **free of charge** from the ETSI Secretariat. Latest updates are available on the ETSI Web server (<http://www.etsi.org/ipr>).

Pursuant to the ETSI IPR Policy, no investigation, including IPR searches, has been carried out by ETSI. No guarantee can be given as to the existence of other IPRs not referenced in SR 000 314 (or the updates on the ETSI Web server) which are, or may be, or may become, essential to the present document.

Foreword

This Technical Specification (TS) has been produced by the Special Mobile Group (SMG).

The present document defines the telecommunication services supported by a GSM PLMN within the digital cellular telecommunications system (Phase 2+).

The contents of the present document is subject to continuing work within SMG and may change following formal SMG approval. Should SMG modify the contents of the present document, it will be re-released with an identifying change of release date and an increase in version number as follows:

Version 6.x.y

where:

- 6 indicates Release 1997 of GSM Phase 2+
- x the second digit is incremented for all changes of substance, i.e. technical enhancements, corrections, updates, etc.
- y the third digit is incremented when editorial only changes have been incorporated in the specification.

The specification from which the present document has been derived was originally based on CEPT documentation, hence the presentation of the present document may not be entirely in accordance with the ETSI rules.

0 Scope

The GSM 02 series cover the definition of the telecommunication services supported by a GSM PLMN. The purpose of the present document is to provide a method for the characterization and the description of these telecommunication services.

0.1 References

The following documents contain provisions which, through reference in this text, constitute provisions of the present document.

- References are either specific (identified by date of publication, edition number, version number, etc.) or non-specific.
- For a specific reference, subsequent revisions do not apply.
- For a non-specific reference, the latest version applies.
- A non-specific reference to an ETS shall also be taken to refer to later versions published as an EN with the same number.
- For this Release 1997 document, references to GSM documents are for Release 1997 versions (version 6.x.y).

[1] GSM 01.04: "Digital cellular telecommunications system (Phase 2+); Abbreviations and acronyms"

[2] GSM 04.02: "Digital cellular telecommunication systems (Phase 2+); GSM Public Land Mobile Network (PLMN) access reference configuration".

[3] CCITT Recommendation I.221: "Common specific characteristics of services".

[4] CCITT Recommendation X.200: "Reference model of open systems interconnection for CCITT applications".

[GSM 02 Series] GSM 02.02: "Digital cellular telecommunications system (Phase 2+); Bearer Services (BS) supported by a GSM Public Land Mobile Network (PLMN)".

GSM 02.03: "Digital cellular telecommunications system (Phase 2+); Teleservices supported by a GSM Public Land Mobile Network (PLMN)".

GSM 02.04: "Digital cellular telecommunications system (Phase 2+); General on supplementary services".

GSM 02.06: "Digital cellular telecommunications system (Phase 2+); Types of Mobile Stations (MS)".

GSM 02.07: "Digital cellular telecommunications system (Phase 2+); Mobile Stations (MS) features".

GSM 02.09: "Digital cellular telecommunications system (Phase 2+); Security aspects".

GSM 02.11: "Digital cellular telecommunications system (Phase 2+); Service accessibility".

GSM 02.16: "Digital cellular telecommunication system (Phase 2+); International Mobile station Equipment Identities (IMEI)".

GSM 02.17: "Digital cellular telecommunications system (Phase 2+); Subscriber Identity Modules (SIM) Functional characteristics".

GSM 02.22: "Digital cellular telecommunication system (Phase 2+); Personalization of GSM Mobile Equipment (ME) Mobile functionality specification".

GSM 02.24: "Digital cellular telecommunications system (Phase 2+); Description of Charge Advice Information (CAI)".

GSM 02.30: "Digital cellular telecommunications system (Phase 2+); Man-Machine Interface (MMI) of the Mobile Station (MS)".

GSM 02.33: "Digital cellular telecommunication system (Phase 2+); "Lawful Interception - stage 1".

GSM 02.34: "Digital cellular telecommunication system (Phase 2+); "High Speed Circuit Switched Data (HSCSD) - stage 1".

GSM 02.40: "Digital cellular telecommunication system (Phase 2+); Procedures for call progress indications".

GSM 02.41: "Digital cellular telecommunication system (Phase 2+); "Operator determined barring".

GSM 02.42: "Digital cellular telecommunication system (Phase 2+); "Network Identity and Timezone (NITZ) Service Description, Stage 1".

GSM 02.63: "Digital cellular telecommunication system (Phase 2+); "Packet Data on Signalling channels Service (PDS) - Stage 1".

GSM 02.67: "Digital cellular telecommunication system (Phase 2+); enhanced Multi-Level Precedence and Pre-emption service (eMLPP) - Stage 1".

GSM 02.68: "Digital cellular telecommunication system (Phase 2+); "Voice Group Call Service (VGCS) - Stage 1".

GSM 02.69: "Digital cellular telecommunication system (Phase 2+); "Voice Broadcast Service (VBS) - Stage 1".

GSM 02.72: "Digital cellular telecommunication system (Phase 2+); "Call deflection - stage 1".

GSM 02.78: "Digital cellular telecommunication system (Phase 2+); "Customized Applications for Mobile network Enhanced Logic (CAMEL); Service definition (Stage 1)".

GSM 02.79: "Digital cellular telecommunication system (Phase 2+); "Support of Optimal Routing (SOR); Service definition (Stage 1)".

GSM 02.81: "Digital cellular telecommunication system (Phase 2+); Line identification supplementary services - Stage 1".

GSM 02.82: "Digital cellular telecommunication system (Phase 2+); Call Forwarding (CF) supplementary services - Stage 1".

GSM 02.83: "Digital cellular telecommunication system (Phase 2+); Call Waiting (CW) and Call Hold (HOLD) supplementary services - Stage 1".

GSM 02.84: "Digital cellular telecommunication system (Phase 2+); MultiParty (MPTY) supplementary services - Stage 1".

GSM 02.85: "Digital cellular telecommunication system (Phase 2+); Closed User Group (CUG) supplementary services - Stage 1".

GSM 02.86: "Digital cellular telecommunication system (Phase 2+); Advice of charge (AoC) supplementary services - Stage 1".

GSM 02.88: "Digital cellular telecommunication system (Phase 2+); Call Barring (CB) supplementary services - Stage 1".

GSM 02.90: "Digital cellular telecommunication system (Phase 2+); "Stage 1 description of Unstructured Supplementary Service Data (USSD)".

GSM 02.91: "Digital cellular telecommunication system (Phase 2+); "Explicit Call Transfer (ECT)".

GSM 02.93: "Digital cellular telecommunication system (Phase 2+); "Completion of Calls to Busy Subscriber (CCBS); Service description, Stage 1".

GSM 02.95: "Digital cellular telecommunication system (Phase 2+); "Support of Private Numbering Plan (SPNP); Service description - Stage 1".

GSM 02.97: "Digital cellular telecommunication system (Phase 2+); "Multiple Subscriber Profile (MSP) Service description, Stage 1".

[GSM 03 Series] GSM 03.01: "Digital cellular telecommunication system (Phase 2+); Network functions".

GSM 03.02: "Digital cellular telecommunication system (Phase 2+); Network architecture".

GSM 03.03: "Digital cellular telecommunications system (Phase 2+); Numbering, addressing and identification".

GSM 03.04: "Digital cellular telecommunication system (Phase 2+); Signalling requirements relating to routing of calls to mobile subscribers".

GSM 03.05: "Digital cellular telecommunication system Technical performance objectives".

GSM 03.07: "Digital cellular telecommunication system (Phase 2+); Restoration procedures".

GSM 03.08: "Digital cellular telecommunication system (Phase 2+); Organization of subscriber data".

GSM 03.09: "Digital cellular telecommunication system (Phase 2+); Handover procedures".

GSM 03.10: "Digital cellular telecommunication system (Phase 2+); GSM Public Land Mobile Network (PLMN) connection types".

GSM 03.11: "Digital cellular telecommunication system (Phase 2+); Technical realization of supplementary services".

GSM 03.12: "Digital cellular telecommunication system (Phase 2+); Location registration procedures".

GSM 03.13: "Digital cellular telecommunication system (Phase 2+); Discontinuous Reception (DRX) in the GSM system".

GSM 03.14: "Digital cellular telecommunication system (Phase 2+); Support of Dual Tone Multi-Frequency signalling (DTMF) via the GSM system".

GSM 03.15: "Digital cellular telecommunication system (Phase 2+); Technical realization of operator determined barring".

GSM 03.16: "Digital cellular telecommunication system (Phase 2+); "Subscriber data management - Stage 2".

GSM 03.20: "Digital cellular telecommunication system ; Security related network functions".

GSM 03.22: "Digital cellular telecommunications system (Phase 2+); Functions related to Mobile Station (MS) in idle mode and group receive mode".

GSM 03.26: "Digital cellular telecommunication system (Phase 2+); Radio network planning aspects".

GSM 03.3: "Digital cellular telecommunication system (Phase 2+); Radio network planning aspects".

GSM 03.38: "Digital cellular telecommunications system (Phase 2+); "Alphabets and language-specific information".

- GSM 03.39: "Digital cellular telecommunication system ;".
- GSM 03.40: "Digital cellular telecommunications system (Phase 2+); Technical realization of the Short Message Service (SMS) Point-to-Point (PP)".
- GSM 03.41: "Digital cellular telecommunications system (Phase 2+); Technical realization of Short Message Service Cell Broadcast (SMSCB)".
- GSM 03.43: "Digital cellular telecommunication system (Phase 2+); Support of Videotex".
- GSM 03.44: "Digital cellular telecommunication system (Phase 2+); Support of teletex in a GSM Public Land Mobile Network (PLMN)".
- GSM 03.45: "Digital cellular telecommunications system (Phase 2+); Technical realization of facsimile group 3 transparent".
- GSM 03.46: "Digital cellular telecommunication system (Phase 2+); Technical realization of facsimile group 3 non-transparent".
- GSM 03.47: "Digital cellular telecommunication system (Phase 2+); Example protocol stacks for interconnecting Service Centre(s) (SC) and Mobile-services Switching Centre(s) (MSC)".
- GSM 03.49: "Digital cellular telecommunication system (Phase 2+); Example protocol stacks for interconnecting Cell Broadcast Centre (CBC) and Mobile-services Switching Centre (MSC)".
- GSM 03.50: "Digital cellular telecommunications system (Phase 2+); Transmission planning aspects of the speech service in the GSM Public Land Mobile Network (PLMN) system".
- GSM 03.63: "Digital cellular telecommunication system (Phase 2+); Packet Data on Signalling channels service (PDS); Service description - Stage 2".
- GSM 03.67: "Digital cellular telecommunication system (Phase 2+); enhanced Multi-Level Precedence and Pre-emption service (eMLPP) - Stage 2".
- GSM 03.68: "Digital cellular telecommunication system (Phase 2+); Voice Group Call Service (VGCS) - Stage 2".
- GSM 03.69: "Digital cellular telecommunication system (Phase 2+); Voice Broadcast Service (VBS) - Stage 2".
- GSM 03.70: "Digital cellular telecommunication system (Phase 2+); Routing of calls to/from Public Data Networks (PDN)".
- GSM 03.81: "Digital cellular telecommunication system (Phase 2+); Line identification supplementary services - Stage 2".
- GSM 03.82: "Digital cellular telecommunication system (Phase 2+); Call Forwarding (CF) supplementary services - Stage 2".
- GSM 03.83: "Digital cellular telecommunication system (Phase 2+); Call Waiting (CW) and Call Hold (HOLD) supplementary services - Stage 2".
- GSM 03.84: "Digital cellular telecommunication system (Phase 2+); MultiParty (MPTY) supplementary services - Stage 2".
- GSM 03.85: "Digital cellular telecommunication system (Phase 2+); Closed User Group (CUG) supplementary services - Stage 2".
- GSM 03.86: "Digital cellular telecommunication system Advice of Charge (AoC) supplementary services - Stage 2".
- GSM 03.88: "Digital cellular telecommunication system (Phase 2+); Call Barring (CB) supplementary services - Stage 2".

GSM 03.90: "Digital cellular telecommunication system (Phase 2+); Unstructured supplementary services operation - Stage 2".

GSM 03.91: "Digital cellular telecommunication system (Phase 2+); "Explicit Call Transfer (ECT) supplementary service - Stage 2".

[GSM 06 Series] GSM 06.01: "Digital cellular telecommunication system (Phase 2+); Full rate speech; Processing functions".

GSM 06.02: "Digital cellular telecommunications system (Phase 2+); Half rate speech; Half rate speech processing functions".

GSM 06.06: "Digital cellular telecommunications system (Phase 2+); Half rate speech; ANSI-C code for the GSM half rate speech codec".

GSM 06.07: "Digital cellular telecommunications system (Phase 2+); Half rate speech; Test sequences for the GSM half rate speech codec".

GSM 06.10: "Digital cellular telecommunication system (Phase 2+); Full rate speech; Transcoding".

GSM 06.11: "Digital cellular telecommunication system (Phase 2+); Full rate speech; Substitution and muting of lost frames for full rate speech channels".

GSM 06.12: "Digital cellular telecommunication system (Phase 2+); Full rate speech; Comfort noise aspect for full rate speech traffic channels".

GSM 06.20: "Digital cellular telecommunications system (Phase 2+); Half rate speech; Half rate speech transcoding".

GSM 06.21: "Digital cellular telecommunications system (Phase 2+); Half rate speech; Substitution and muting of lost frames for half rate speech traffic channels".

GSM 06.22: "Digital cellular telecommunications system (Phase 2+); Half rate speech; Comfort noise aspects for half rate speech traffic channels".

GSM 06.31: "Digital cellular telecommunication system (Phase 2+); Full rate speech; Discontinuous Transmission (DTX) for full rate speech traffic channel".

GSM 06.32: "Digital cellular telecommunication system (Phase 2+); Full rate speech; Voice Activity Detector (VAD)".

GSM 06.41: "Digital cellular telecommunications system (Phase 2+); Half rate speech; Discontinuous Transmission (DTX) for half rate speech traffic channels".

GSM 06.42: "Digital cellular telecommunications system (Phase 2+); Half rate speech; Voice Activity Detector (VAD) for half rate speech traffic channels".

GSM 06.51: "Digital cellular telecommunications system (Phase 2+); Enhanced Full Rate (EFR) speech processing functions; General description".

GSM 06.53: "Digital cellular telecommunications system (Phase 2+); ANSI-C code for the GSM Enhanced Full Rate (EFR) speech codec".

GSM 06.54: "Digital cellular telecommunications system (Phase 2+); Test sequences for the GSM Enhanced Full Rate (EFR) speech codec".

GSM 06.60: "Digital cellular telecommunications system (Phase 2+); Enhanced Full Rate (EFR) speech transcoding".

GSM 06.61: "Digital cellular telecommunications system (Phase 2+); Substitution and muting of lost frames for Enhanced Full Rate (EFR) speech traffic channels".

GSM 06.62: "Digital cellular telecommunications system (Phase 2+); Comfort noise aspects for Enhanced Full Rate (EFR) speech traffic channels".

GSM 06.81: "Digital cellular telecommunications system (Phase 2+); Discontinuous transmission (DTX) for Enhanced Full Rate (EFR) speech traffic channels".

GSM 06.82: "Digital cellular telecommunications system (Phase 2+); Voice Activity Detector (VAD) for Enhanced Full Rate (EFR) speech traffic channels".

[GSM 07 Series] GSM 07.01: "Digital cellular telecommunications system (Phase 2+); General on Terminal Adaptation Functions (TAF) for Mobile Stations (MS)".

GSM 07.02: "Digital cellular telecommunications system (Phase 2+); Terminal Adaptation Functions (TAF) for services using asynchronous bearer capabilities".

GSM 07.03: "Digital cellular telecommunications system (Phase 2+); Terminal Adaptation Functions (TAF) for services using synchronous bearer capabilities".

GSM 07.05: "Digital cellular telecommunication system (Phase 2+); Use of Data Terminal Equipment - Data Circuit terminating Equipment (DTE - DCE) interface for Short Message Service (SMS) and Cell Broadcast Service (CBS)".

GSM 07.07: "Digital cellular telecommunications system (Phase 2+); "AT command set for GSM Mobile Equipment (ME)".

GSM 07.08: "Digital cellular telecommunications system (Phase 2+); GSM Application Programming Interface (GSM-API)".

[GSM 09 Series] GSM 09.01: "Digital cellular telecommunication system (Phase 2+); General network interworking scenarios".

GSM 09.02: "Digital cellular telecommunications system (Phase 2+); Mobile Application Part (MAP) specification".

GSM 09.03: "Digital cellular telecommunication system (Phase 2+); Signalling requirements on interworking between the Integrated Services Digital Network (ISDN) or Public Switched Telephone Network (PSTN) and the Public Land Mobile Network (PLMN)".

GSM 09.04: "Digital cellular telecommunication system (Phase 2+); Interworking between the Public Land Mobile Network (PLMN) and the Circuit Switched Public Data Network (CSPDN)".

GSM 09.05: "Digital cellular telecommunication system (Phase 2+); Interworking between the Public Land Mobile Network (PLMN) and the Packet Switched Public Data Network (PSPDN) for Packet Assembly/Disassembly facility (PAD) access".

GSM 09.06: "Digital cellular telecommunications system (Phase 2+); Interworking between a Public Land Mobile Network (PLMN) and a Packet Switched Public Data Network/Integrated Services Digital Network (PSPDN/ISDN) for the support of packet switched data transmission services".

GSM 09.07: "Digital cellular telecommunications system (Phase 2+); General requirements on interworking between the Public Land Mobile Network (PLMN) and the Integrated Services Digital Network (ISDN) or Public Switched Telephone Network (PSTN)".

GSM 09.08: "Digital cellular telecommunications system (Phase 2+); Application of the Base Station System Application Part (BSSAP) on the E-interface".

GSM 09.10: "Digital cellular telecommunication system (Phase 2+); Information element mapping between Mobile Station - Base Station System and BSS - Mobile-services Switching Centre (MS - BSS - MSC) Signalling procedures and the Mobile Application Part (MAP)"

GSM 09.11: "Digital cellular telecommunication system (Phase 2+); Signalling interworking for supplementary services".

GSM 09.90: "Digital cellular telecommunication system (Phase 2+); Interworking between Phase 1 infrastructure and Phase 2+ Mobile Stations (MS)".

GSM 09.91: "Digital cellular telecommunications system (Phase 2+); Interworking aspects of the Subscriber Identity Module - Mobile Equipment (SIM - ME) interface between Phase 1 and Phase 2".

GSM 09.94: "Digital cellular telecommunications system (Phase 2+); Recommended infrastructure measures to overcome specific Phase 1 Mobile Station (MS) faults".

0.2 Abbreviations

Abbreviations used in the present document are listed in GSM 01.04.

1 Framework for the description of telecommunication services

1.1 General

Telecommunication services supported by a GSM PLMN are the communication capabilities made available to customers by network operators. A GSM PLMN provides, in cooperation with other networks, a set of network capabilities which are defined by standardized protocols and functions and enable telecommunication services to be offered to customers.

A service provision by a network operator (e.g. an Administration or an RPOA) to a subscriber of a GSM PLMN may cover the whole or only part of the means required to fully support the service. The operational and commercial features associated with the provision of the service are included in the service concept.

The service classification and description which follow are independent of different possible arrangements for the ownership and provision to the customer of the means required to support a service.

1.2 The attribute method of characterization of telecommunication services

This characterization is made by using a set of attributes. A telecommunication service attribute is a specific characteristic of that service whose values distinguish it from other telecommunication services. Particular values are assigned to each attribute when a given telecommunication service is described and defined.

A list of definitions of attributes and values used for bearer services and teleservices is contained in, respectively, annex A and annex B.

2 Description of telecommunication services by the attribute method

2.1 General

Telecommunication services are described by attributes which define service characteristics as they apply at a given reference point where the customer accesses the service. The description of a telecommunication service by the method of attributes is composed of:

- technical attributes as seen by the customer, and;
- other attributes associated with the service provision, e.g. operational and commercial attributes.

2.2 Bearer services and teleservices

Telecommunication services are divided in two broad categories:

- bearer services, which are telecommunication services providing the capability of transmission of signals between access points (called user-network interfaces in ISDN);
- teleservices, which are telecommunication services providing the complete capability, including terminal equipment functions, for communication between users according to protocols established by agreement between network operators.

Figure 1 illustrates these definitions.

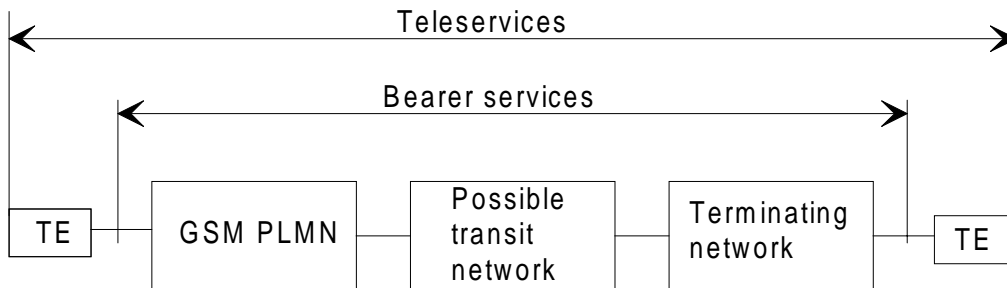

TE: Terminal Equipment

Figure 1: Bearer services and Teleservices supported by a GSM PLMN

NOTE 1: In the majority of cases, at least two networks of different types are involved in the support of a telecommunication service.

NOTE 2: Figure 1 does not preclude any routing possibility.

NOTE 3: In order to limit the complexity of the figure, only one transit network is shown.

NOTE 4: The terminating network type may include a GSM PLMN, either the originating one or another one.

2.3 Supplementary services

A supplementary service modifies or supplements a basic telecommunication service. Consequently, it cannot be offered to a customer as a stand alone service. It must be offered together or in association with a basic telecommunication service. The same supplementary service may be applicable to a number of telecommunication services.

NOTE: Supplementary services are not currently characterized by the attribute method (see Specification GSM 02.04).

2.4 Categorisation of telecommunication services

The concepts introduced in the present document are illustrated in table 1.

Table 1: Categorisation of telecommunication services

TELECOMMUNICATION SERVICES			
BEARER SERVICE		TELESERVICE	
Basic Bearer Service	Basic Bearer service + supplementary services	Basic Teleservice	Basic Teleservice + supplementary service

3 Customer access to telecommunication services supported by a GSM PLMN

3.1 Reference configuration and access points

Considering the reference configuration defined in Specification GSM 04.02, customers can access various telecommunication services at different access points. Figure 2 shows an example of these access points. The reference configuration shows the MS to consist of mobile termination and terminal equipment.

Figure 2 takes into account that service provision by the network operator to a customer accessing a GSM PLMN may cover the whole or part of the means required to fully support the service.

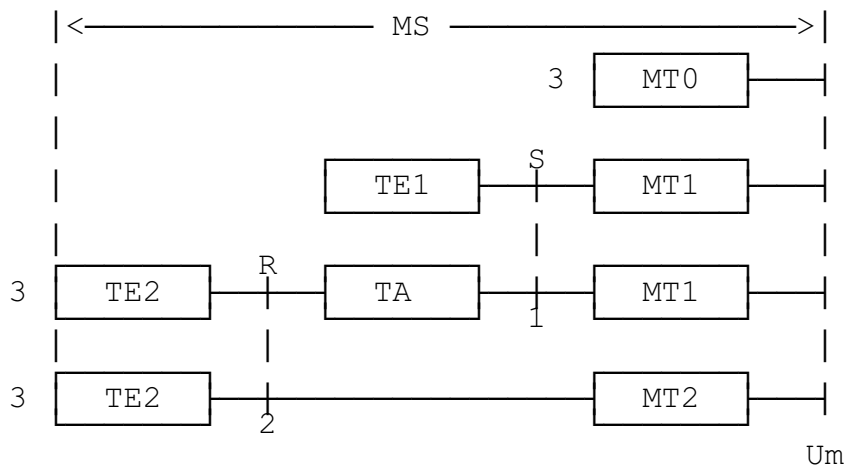

Figure 2: Example of customer access to services supported by a GSM PLMN

- MS: Mobile Station
- MT: Mobile Termination: supports function specific to management of the radio interface (Um) and adapting information flows at Um to those required by terminal functions at access points 1 or 2. For further descriptions of functions and types (e.g. MTO, MT1 and MT2) see GSM 04.02.
- TE: Terminal Equipment: supports man-machine (access point 3) to the user and may support a physical interface at access point 1 or 2.
- TE1: TE presenting an ISDN interface.
- TE2: TE presenting a non-ISDN (e.g. a CCITT V or X series) interface [84,85].
- TA: ISDN Terminal Adapting functions: may be used to adapt between access points 1 and 2.
- Um: Radio interface.

3.2 Access points and telecommunication services

The definition of the access points introduced in Figure 2/GSM 02.01 are as follows:

- 1) at access point 1 and 2, bearer services may be accessed;
- 2) at access point 3 (user to terminal interface), teleservices are accessed - note that the teleservice concept includes the terminal capabilities.

3.3 Terminal equipment

It should be noted that a Terminal Equipment (TE) may consist of one or more pieces of equipment and may include the following entities:

- telephone set;
- customer terminals, e.g. Data Terminal Equipments, Teletex terminals;
- customer systems.

NOTE: The whole mobile station, customer terminals and systems may be privately owned or provided by network operators.

All terminal equipment accessing a GSM PLMN interface at one of the access points defined in section 3.2 must meet the specifications of the protocols at that interface for all the layers that are included in the definition of the telecommunication service used.

For some telecommunication services, the service definition also covers some terminal functions and characteristics in addition to those specified by the protocols at the interface.

4 Capabilities to support a telecommunication service

4.1 General

The capabilities to fully support a telecommunication service for a customer accessing a GSM PLMN include:

- network capabilities (in the GSM PLMN and in most cases in another network);
- terminal capabilities, when required;
- other service providing capabilities, when required;
- operational and commercial features associated with the service provision.

4.2 Network capabilities

Network capabilities are described in detail in the GSM 03 series of specifications. Two different levels of GSM PLMN network capabilities are introduced:

- low layer capabilities, which relate to bearer services;
- high layer capabilities, which together with low layer capabilities relate to teleservices.

4.3 Terminal capabilities

Terminal capabilities are also described in terms of low layer and high layer capabilities. In the description of teleservices, the terminal capabilities, both low layer and high layer, are included in the service definition. In the case of bearer service definition, the terminal capabilities are not included but the terminal equipment must conform to the low layer capabilities of the bearer service.

4.4 Operational capabilities

The operational capabilities associated with a service offering may include capabilities for maintenance, charging, user control of service features, etc.

The use of such capabilities may involve terminal-network communication and may therefore be viewed as specific applications.

5 Characterization of telecommunication services

5.1 General

A telecommunication service supported by a GSM PLMN is characterized and described by service attributes.

There are two groups of service attributes applicable to user information flow:

- low layer attributes;
- high layer attributes.

Bearer services are characterized only by low layer attributes. Teleservices are characterized by both low layer attributes and high layer attributes.

The basic characteristics of a telecommunication service are described by the basic service attributes.

The additional characteristics associated with a supplementary service which modify or supplement a basic telecommunication service are described in Specification GSM 02.04.

5.2 Bearer services supported by a GSM PLMN

Bearer services supported by a GSM PLMN provide the capability for information transfer between a GSM PLMN access point 1 or 2 and an appropriate access point in a terminating network and involve only low layer functions (i.e. relating to layers 1-3 of the OSI Reference Model).

The customer may choose any set of high layer (at least 4-7) protocols for his communication, but a GSM PLMN will not ensure compatibility at these high layers between customers.

Bearer services are characterized by a set of low layer attributes in Specification GSM 02.02. These attributes are classified into four categories:

- information transfer attributes;
- access attributes;
- interworking attributes;
- general attributes, including operational and commercial attributes.

The bearer capability defines the technical features of a bearer service as they appear to the user at the appropriate access point. For the time being, the bearer capability is characterized by information transfer, access and interworking attributes. A bearer capability is associated with every bearer service.

The bearer service provides the user with the possibility of gaining access to various forms of communication, covering for example:

- information transfer between a user in a GSM PLMN and a user in a terminating network, including the same GSM PLMN, another GSM PLMN and other types of PLMNs;
- information transfer between a user in a GSM PLMN and separate resource providing high layer functions.

5.3 Teleservices supported by a GSM PLMN

Teleservices provide the full capacity for communication by means of terminals and network functions and possibly functions provided by dedicated centres.

A teleservice supported by a GSM PLMN should use only one (or a small number of) bearer capability recommended by GSM. GSM teleservices are specified in GSM 02.03. Teleservices are characterized by a set of low layer attributes, a set of high layer attributes and operational and commercial attributes.

Low layer attributes are those used to characterize the bearer capability (see subclause 5.2). High layer attributes are used in Specification GSM 02.03 to describe high layer (i.e. layer 4-7) information transfer related characteristics. They refer to functions and protocols of layers 4-7 in the CCITT Recommendation X.200 framework which are concerned with the transfer, storage and processing of user messages (provided by a subscriber's terminal, a retrieval centre or a network service centre).

Therefore, not all attributes can be applied directly at the user to terminal interface (access point 3) as they represent two kinds of features, the bearer capability and the terminal features, that are not directly perceived by the user.

A teleservice provides the user with the possibility of gaining access to various forms of applications (or teleservice APPLICATIONS) covering for example:

- teleservice application involving two terminals providing compatible or identical teleservice attributes at an access point in a GSM PLMN and an access point in a terminating network;
- teleservice application involving a terminal at one access point in a GSM PLMN and a system providing high layer functions (e.g. speech storage system, message handling system) located either within the GSM PLMN or in a terminating network.

6 Provision of telecommunication services

Specifications GSM 02.10 and 02.11 define some aspects of the provisions of telecommunication services by a GSM PLMN.

The provision of telecommunication services implies:

- subscription of basic services and possibly subscription to supplementary services;
- registration into a service directory;
- compatibility between terminals;
- interworking capabilities (see GSM 09 series of specifications).

The user's subscription to a Basic or Supplementary service is normally verified by the network prior to completion of Call Establishment and/or Supplementary Service operation. This subscription checking shall be performed in accordance with the following sections.

6.1 Subscription checking for Basic Services

General

Subscription checking is the function/process to ascertaining whether a subscriber has the authorization to use the particular Basic Service deduced from the call set-up parameters. It is the responsibility of the HPLMN to transfer, to the VPLMN, only the subscription data corresponding to those services a given subscriber is entitled to use in that VPLMN.

For mobile originated calls, subscription checking is performed in the VLR, whilst for mobile terminated calls it is performed in either the HLR or the VLR (determined as described below). The prerequisite for executing the subscription check is a successful deduction of a Basic Service from the Compatibility Information contained in the call set up, i.e. Bearer Capability Information Element and, in some cases, also the Low Layer and High Layer Compatibility Information elements.

For mobile originated calls an MS shall indicate the requested service by appropriate compatibility information elements according to GSM 07.01. This information is mapped to an individual Basic Service code (i.e. the MAP representation) by the MSC in order to be compared with the subscriber data available in the VLR.

An equivalent process is required in the HLR for mobile terminated calls, where the caller's requested service is indicated to the HLR (by the ISDN) by exhaustive compatibility information consisting of ISDN Bearer Capability Information Elements and in some cases - depending on the service requested - also of Low Layer and High layer Compatibility information elements. In case the compatibility information is not exhaustive, e.g. when the call is originated/transited by a PSTN, no GSM Basic Service can be deduced and subscription checking cannot be performed in the "normal" way. Instead, rules for the Single and Multi Numbering Schemes apply.

In the Multi Numbering Scheme the Basic Service can be deduced by information stored in the HLR against the called number and hence an implicit subscription check is performed. In the Single Numbering Scheme, the Basic Service cannot be deduced until the MS has responded to the set up and therefore the HLR cannot perform subscription check. Instead, the VLR/MSC will perform the subscription check or calls are passed "unfiltered" (as regards subscription check), at the network operators' discretion.

Bearer Services

GSM 02.02 lists the Bearer Services, each of them with a specific "BS number" constituting either a single or a dual (Alternate... or Followed by...) service. Single services defined independent of the fixed network user rate are called General Bearer Services. These distinct [numbered] services may individually be provided to a subscriber, e.g. an operator may offer a subscription called "Synchronous Data 1200 bps" and another subscription "Synchronous Data 2400 bps". Operators may also, or instead, offer their subscribers a subscription to groups and/or combinations of the Bearer Services as packages, e.g. "All Synchronous Data services". A subscription to a General Bearer Service comprises the subscription to all individual single services of its group, e.g. "Asynchronous General Bearer Service" is equivalent to "All Asynchronous Data Services". A subscriber shall not have a simultaneous subscription to a General Bearer Service and any of the individual single services covered by this General Bearer Service.

Whichever the subscription arrangements are, all PLMNs (MSCs, VLRs and HLRs) shall be able to allow - as regards subscription checking - the use of individually subscribed-to Basic Services, within the range of services supported by the PLMN. That is, whenever it is possible to deduce the Basic Service from a call set up, subscription check shall be performed at the granularity of that particular Basic Service or the group to which it belongs. This is obvious for "single" services, but "dual" services require attention due to its virtual composition of two single services. I.e. a subscription to an Alternate Service (e.g. Speech and data) does not on its own entitle the use of the Telephony service, however a speech call may be set up, but by use of - or rather as a part of - the Alternate Service.

In case a PLMN supports the "Alternate" and/or "Followed by" functionality but does not support all the data services comprised in those services, it shall still offer the "Alternate" and/or "Followed by" services in its reduced form, i.e. for those data rates it supports.

Explanatory examples:

- An operator offers individual services only, hence transfers to the VLR (for a roaming subscriber) subscriber data consisting of a number of single basic service codes, e.g. the MAP representation of Bearer Services 21, 22 and 61. This entitles the use (subject to support in the VPLMN) of Asynchronous bearer services with 300 and 1200 bps, and the use of "Alternate Speech/Data Asynch/Synch with 300-9600 bps", but not the use of a single (i.e. non-dual) synch/asynch service with e.g. 9600 bps (though it may be used in "Alternate mode").
- An operator offers combinations (or groups) of single Bearer Services e.g. the group All single Asynchronous services (BS 2x). The subscription entitles the usage of any of the Bearer Services comprised in the group, but not the use of an "Alternate" or "Followed by" service.

TeleServices

GSM 02.03 lists the TeleServices, each of them with a specific "TS number". These may be provided to subscribers individually or combined, to the operators' discretion, however TS 12 (E-calls) and 23 (CB) are not subscribable. But, as for Bearer Services, networks shall be able to handle subscription checking at the granularity of individual TeleServices.

Table 2 summarizes the basis on which a successful subscription checking will result. It also describes on which basis Supplementary Service handling for a given call set-up should be performed.

Table 2

Set Up	Subscription Check	SS handling
BS 20	BS 20	BS Group 2x
BS 21	BS 21, BS20, BS Group 2x or BS Group All	BS Group 2x
BS 22	BS 22, BS20, BS Group 2x or BS Group All	BS Group 2x
BS 23	BS 23, BS20, BS Group 2x or BS Group All	BS Group 2x
BS 24	BS 24, BS20, BS Group 2x or BS Group All	BS Group 2x
BS 25	BS 25, BS20, BS Group 2x or BS Group All	BS Group 2x
BS 26	BS 26, BS20, BS Group 2x or BS Group All	BS Group 2x
BS 30	BS 30	BS Group 3x
BS 31	BS 31, BS30, BS Group 3x or BS Group All	BS Group 3x
BS 32	BS 32, BS30, BS Group 3x or BS Group All	BS Group 3x
BS 33	BS 33, BS30, BS Group 3x or BS Group All	BS Group 3x
BS 34	BS 34, BS30, BS Group 3x or BS Group All	BS Group 3x
BS 40	BS 40	BS Group 4x
BS 41	BS 41, BS 40, BS Group 4x or BS Group All	BS Group 4x
BS 42	BS 42, BS 40, BS Group 4x or BS Group All	BS Group 4x
BS 43	BS 43, BS 40, BS Group 4x or BS Group All	BS Group 4x
BS 44	BS 44, BS 40, BS Group 4x or BS Group All	BS Group 4x
BS 45	BS 45, BS 40, BS Group 4x or BS Group All	BS Group 4x
BS 46	BS 46, BS 40, BS Group 4x or BS Group All	BS Group 4x
BS 50	BS 50	BS Group 5x
BS 51	BS 51, BS 50, BS Group 5x or BS Group All	BS Group 5x
BS 52	BS 52, BS 50, BS Group 5x or BS Group All	BS Group 5x
BS 53	BS 53, BS 50, BS Group 5x or BS Group All	BS Group 5x
BS 61	BS 61, BS Group 6x or BS Group All	BS Group 2x or BS Group 3x
BS 70	BS 70	N.A.
BS 81	BS 81, BS Group 8x or BS Group All	BS Group 2x or BS Group 3x
TS 11	TS 11, TS Group 1x or TS Group All	TS Group 1x
TS 12	N.A.	
TS 21	TS 21, TS Group 2x or TS Group All	TS Group 2x
TS 22	TS 22, TS Group 2x or TS Group All	TS Group 2x
TS 23	N.A.	
TS 61	TS 61, TS Group 6x or TS Group All	TS Group 6x
TS 62	TS 61, 62, Group 6x or TS Group All	TS Group 6x
TS 91	TS 91, TS Group 9x or TS Group All	TS Group 9x
TS 92	TS 92, TS Group 9x or TS Group All	TS Group 9x

Legend:

Set up: The Basic Service which is set up for the call.

Subscription check: Required VLR or HLR data for successful subscription check.

SS handling: Against which VLR or HLR data SS handling should be performed. For example; a call set-up indicating BS61 and Asynchronous mode should be treated for SS purposes in accordance with the SS-data stored against BS group 2x.

Example: A Call set up for BS 81 Synchronous should be permitted if the subscription data in the VLR/HLR says "BS81", "BS Group 8x" or "All BS". Furthermore, it should be handled for SS purposes in accordance with those SS which are Active (and Operative) for BS Group 3x.

When TS61 is requested in a call set-up and the subscription check for TS61 is negative, but a subscription check for TS62 is positive, then the call shall proceed according to the GSM 02.03 and GSM 07.01. If a subscription check for both TS61 and TS62 is negative, then the call shall be released.

6.2 Subscription checking for Supplementary Services

This is described in GSM 02.04 and the GSM 03.8x series of specifications.

Annex A (normative): List of definition of attributes and values used for bearer services

A.1 Information transfer attributes

A.1.1 Information transfer capability

This attribute describes the capability associated with the transfer of different types of information through a GSM PLMN and another network or through a GSM PLMN.

Values:

- unrestricted digital information;
transfer of information sequence of bits at its specified bit rate without alteration; this implies bit sequence independence, digit sequence integrity and bit integrity.
- speech;
digital representation of speech information and audible signalling tones of the PSTN coded according to the encoding rule defined in the GSM 06 series of specifications.
- 3.1 kHz Ex PLMN;
unrestricted digital information transfer within the PLMN and 3.1 kHz audio restricted within the ISDN.
- Group 3 Fax;
transfer of Group 3 Fax information.

A.1.2 Information transfer mode

This attribute describes the operational mode of transferring (transportation and switching) through a GSM PLMN.

Values:

- circuit;
- packet.

A.1.3 Information transfer rate

This attribute describes the bit rate (circuit mode) or the throughput (packet mode). It refers to the transfer of digital information between two access points or reference points.

Values:

- appropriate bit rate, throughput rate.

A.1.4 Structure

This attribute refers to the capability of the GSM PLMN and if involved other networks to deliver information to the destination access point or reference point in a structure.

NOTE: This attribute has not been utilised in GSM 02.02 or GSM 02.03.

Values:

- Not applicable.

A.1.5 Establishment of communication

This attribute associated with a telecommunication service describes the mode of establishment used to establish and a given communication.

In every telecommunication service communication may be between users within the GSM PLMN or between a user in the GSM PLMN and a user in another network.

Values:

- demand Mobile Originated (MO) only;
- demand Mobile Terminated (MT) only;
- demand Mobile Originated or Terminated (MO, MT).

A.1.6 Communication configuration

This attribute describes the spatial arrangement for transferring information between two or more access points. It completes the structure associated to a telecommunication services as it associates the relationship between the access points involved and the flow of information between these access points.

Values:

- point-to-point communication;
this value applies when there are only two access points.
- multipoint communication;
this value applies when more than two access points (1) are provided by the service. The exact characteristics of the information flows must be specified separately based on functions provided by the GSM PLMN.

NOTE 1: The number of access points can be undefined.

- broadcast communication;
this value applies when more than two access points (2) are provided by the service. The information flows are from a unique point (source) to the others (destination) in only one direction.

NOTE 2: The number of destination access points can be undefined.

A.1.7 Symmetry

This attribute describes the relationship of information flow between two (or more) access points or reference points involved in a communication.

It characterizes the structure associated to a communication service.

Values:

- unidirectional;
this value applies when the information flow is provided only in one direction.
- bidirectional symmetric;
this value applies when the information flow characteristics provided by the service are the same between two (or more) access points or reference points in the forward and backward directions.
- bidirectional asymmetric;
this value applies when the information flow characteristics provided by the service are different in the two directions.

A.1.8 Data compression

This attribute indicates whether use of a data compression function is desired (and accepted) between an MT and IWF.

Values:

- use of data compression requested/not requested;
- use of data compression accepted/not accepted.

A.2 Attributes describing the access at the mobile station

A.2.1 Signalling access

This attribute characterizes the protocol on the signalling channel at a given access point or reference point (access point 1 or 2 at the MS in figure 2/GSM 02.01).

Values:

- manual;
- appropriate V-series protocol;
- appropriate X-series protocol;
- I-series stack of signalling protocols.

A.2.2 Information access

A.2.2.1 Rate

This attribute describes either the bit rate (circuit mode including transparent access to a PSPDN) or variable bit rate (packet mode) used to transfer the user information at a given access point or reference point (access point 1 or 2 at the MS in figure 2/GSM 02.01).

Values:

- appropriate bit rate;
- variable bit rate.

A.2.2.2 Interface

This attribute describes the interface according to the protocol used to transfer user information at a given access point or reference point (access point 1 or 2 at the MS in figure 2/GSM 02.01).

Values:

- appropriate V-series DTE/DCE interface;
- appropriate X-series interface;
- S interface;
- analogue 4-Wire interface.

A.3 Interworking attribute

A.3.1 Type of terminating network

Communication can be established between a MS in a GSM PLMN (originating network) and a terminal in a network (terminating network) including the same GSM PLMN or another GSM PLMN. The attribute designates the terminating network.

NOTE 1: The terms "originating" and "terminating" do not indicate the direction of communication establishment.

NOTE 2: This attribute does not reflect whether there is none, one or several transit networks between the originating and terminating networks.

Values:

- PSTN;
- ISDN;
- CSPDN;
- PSPDN;
- PDN
- GSM PLMN;
- Direct access networks.

A.3.2 Terminal to terminating network interface

This attribute describes the interface between a terminal equipment and the terminating network.

Values:

- appropriate V-series (DTE/DCE) interface;
- appropriate X-series interface;
- analogue 2 resp. 4 wire interface;
- S interface (D+B+B).

A.4 General attributes

A.4.1 Supplementary services provided

This attribute refers to the supplementary services to a given telecommunication service.

Values:

- appropriate supplementary services.

A.4.2 Quality of service

The Bearer Services use the Quality of Service attribute to indicate one of the following values:

- transparent;
service characterized by constant throughput, constant transit delay and variable error rate.
- non-transparent;
service characterized by an improved error rate with variable transit delay and throughput.

A.4.3 Commercial and operational

A.4.4 Service interworking

Annex B (normative): List of definitions of attributes and values used for teleservices

B.1 High layer attributes

B.1.1 Type of user information

This attribute describes the type of information which the communication offered to the user by the teleservice is based on.

Values:

- speech;
- short message;
- facsimile.

B.1.2 Layer 4 protocol functions

B.1.3 Layer 5 protocol functions

B.1.4 Layer 6 protocol functions

B.1.5 Layer 7 protocol functions

B.2 Low layer attribute (bearer capabilities)

The low layer attributes describe the bearer capabilities which support the teleservice. These low layer attributes and their values are the same as presented in Annex A: List of definitions of attributes and values used for bearer services.

B.3 General attributes

The general attributes are the same as presented in Annex A: List of definitions and values used for bearer services.

Annex C (normative): Definition of "busy" in a GSM PLMN

C.1 Scope

This annex describes the conditions under which a given mobile subscriber (station) is considered as "busy". In general, this occurs whenever the resources associated with that MS (and needed to successfully complete the call) exist but are not available for that call. The description is based on the busy definition in the ISDN (CCITT Recommendation I.221).

In addition, the operation of some Supplementary Services occurs when certain of these resources are busy. Therefore, these "resources busy" are also described herein.

This annex does not cover the cases, when network resources not associated with a given destination are unavailable, or when such resources are out-of-service or otherwise non-functional.

C.2 Network Determined User Busy (NDUB) condition

This condition occurs, when a call is about to be offered, if the information (i.e. traffic) channel (Bm or Lm) is busy and the maximum number of total calls has been reached (see NOTE).

This condition also occurs, when a call is about to be offered and an already on-going call attempt (incoming or outgoing) is in the establishing phase, i.e. not yet active.

When NDUB condition occurs, the PLMN will clear the call and indicate "busy" back towards the calling subscriber (see also section 4).

NOTE: The value of the maximum number of calls is 1 for the basic call. When the supplementary service "Call Waiting" is applicable the value is $n+1$ where n is the maximum number of calls that can be waiting.

C.3 User Determined User Busy (UDUB) condition

This condition occurs when a call is offered to a Mobile Station and the MS responds "user busy" because the subscribers resources (terminal or person using them) are busy. Then the PLMN will clear the call with the indication "busy" back towards the calling subscriber (see also section 4).

C.4 Mobile subscriber busy

A mobile subscriber is considered to be busy if either a "Network Determined User Busy" or a "User Determined User Busy" condition occurs.

Some supplementary services (e.g. Call Forwarding on Busy) may cause the call not to be cleared when a busy condition occurs.

Annex D (normative): Call setup procedures

D.1 Scope

This annex specifies the service requirements for call setup, both Mobile originated and mobile terminated, in a GSM network, including the establishment of radio contact.

For GPRS see GSM 02.60.

D.2 Mobile Originated Call Setup

When an MS wishes to start a call and there is no existing radio connection, it requests a signalling channel. When such a signalling channel has been allocated to the MS, the MS can transfer the call setup information.

A traffic channel may be allocated at any time before the network informs the MS that the remote user has answered.

For a call to be set up, certain information needs to be sent by the MS to the network, defining the call. This information may be provided as default by the MS, it may be derived from the SIM or be entered by the user either directly into the MS or from a DTE by using the DTE/DCE Interface as described in the GSM 07 series.

The following information is sent. Where necessary, default values will generally be inserted by the MS if not directly specified by the user. The GSM Teleservice Emergency Calls are set up using a special procedure not using the fields described in this section (except for the Bearer Capability).

D.2.1 Called Party Address

This is the address of the called party, generally as defined in GSM 03.03, using the TON/NPI specified below. In the case of Dedicated PAD or Packet Access, if NPI is set to PNP, the called party address field may be used to specify the profile to be used. In that case, the address of the called DTE will be given in-band as the second part of two-stage call set-up.

D.2.2 Calling/Called Party Sub-address

This is the sub-address of the calling/called party, as defined in GSM 03.03, in order to provide interworking with ISDN. This is described in more detail in ETS 300 059. Support and use of these fields are optional.

D.2.3 Type of Number

This indicates the format of the called party address. The selection procedure is given in GSM 02.30. The following Types of Number are commonly used:

- International Format;
- Open Format ("Unknown");
- Dedicated PAD/Packet Access.

D.2.4 Number Plan Indicator

This indicates the number plan of the called party address. Either of the following number plans may be the "default", depending on the contents of the Called Party Address (see GSM 02.30):

- ISDN/Telephony E.164;

- Unknown.

Alternatively, one of these number plans may be specified if appropriate:

- Data network X.121;
- Telex network F.69;
- National Numbering Plan;
- Private Numbering Plan.

D.2.5 Bearer Capability

This is used to define the type of call to be set up (telephony, data, rate etc.) For most applications, the MS will use a set of default conditions, generally on the assumption of a telephony call, unless otherwise set. These may be overridden by the user (or DTE via the DTE/DCE Interface) if desired except for the determination of the channel mode (full or half rate, speech codec conversion).

The MS shall indicate to the network its channel mode capability in terms of the data channels and the speech codec versions supported.

The network decides which mode to use on the basis of the requested bearer or teleservice, the available network resources and the channel mode capability of the MS:

For the “alternate” and “followed-by” services, the same principle applies (with the exception of TS61, where a Full Rate or an Enhanced Full Rate channel shall be provided).

For the full set of parameters and values, refer to GSM 04.08.

For data services see the GSM 07 series.

Lower Layer Compatibility and Higher Layer Compatibility Information Elements may also be included.

D.2.6 Calling Line Indication Restriction Override

If the user wishes to override the calling line identification restriction, he may indicate this on a per-call basis as described in GSM 02.30 and 02.81.

D.2.7 Action of the Network on Call Setup

On receipt of the call setup message, the network shall attempt to connect the call. However, if insufficient information has been provided by the MS to indicate the exact Bearer Capability requirements (e.g. due to missing or optional values or for rate adaptation for data), the network may insert the missing information, if this is possible, and the call setup shall proceed using the new information. If the call setup is unsuccessful, the network shall notify the MS of the cause.

D.3 Mobile Terminated Call Setup

Using the procedures described in GSM 02.11, the network knows the location area where the MS is positioned. If the MS is not already in two way radio communication with the network, the network pages the MS. Upon receiving its page message, the MS establishes communication with the selected cell (see GSM 03.22). The network then allocates a channel which is used for signalling and sends call setup information to the MS.

A traffic channel may be allocated at any instant until just after the call is answered by the MS.

The network indicates to the MS that it wishes to offer the MS a call. This notification includes the proposed bearer capability information, where available (see section D.2.5 above).

D.3.1 Bearer Type

If the calling party specifies the required bearer capability this shall be used for the call setup attempt. If the calling party does not specify the required bearer capability (e.g. because the call originated in the PSTN), the network shall attempt to determine the bearer capability to be used as described below.

The network may use a multi-numbering scheme to define the bearer capability by the MSISDN. In a multi-numbering scheme several MSISDNs are associated with one IMSI. Each MSISDN is used for a different bearer capability. If the network uses a multi-numbering scheme and the calling party has not specified the required bearer capability then the network shall use the bearer capability associated with the called party MSISDN.

The network may use a single-numbering scheme, in which one MSISDN is associated with each IMSI. If the network uses a single-numbering scheme and the calling party has not specified the required service then the network shall omit the bearer capability information.

D.3.2 Response of the MS

On receipt of the call setup request from the network, the MS shall check that it is able to support the type of call requested and that it is not User Determined User Busy (see annex C). The MS then alerts the user.

If the MS is unable to support the type of call requested, or the information is incomplete, the MS shall, if possible and not restricted by requirements in other ETSs, reply to the network proposing an alternative set of parameters, indicating those that are different from those proposed by the network. The network then either accepts this new proposal or terminates the call attempt.

D.3.3 Description of Call Re-establishment

Call re-establishment allows the mobile station to attempt to reconnect a call following the loss of radio coverage between the MS and the network while a call is in progress. Call re-establishment may be initiated by the MS when it detects this situation, if supported in the network.

Call re-establishment is mandatory in the ME and optional in the network.

Annex E (Informative): Change Request History

Change history					
SMG No.	TDoc. No.	CR. No.	Section affected	New version	Subject/Comments
SMG#16	605/95	A003	A.1.8	5.0.0	Data compression
SMG#17	52/96	A004r1	Table 2	5.1.0	Addition of handling for VBS and VCGS
SMG#20	577/96 609/96	A005 A006	D.2, D.2.5 6.1, Table 2	5.2.0	Updating to account for EFR codec channels General Bearer Services
SMG#24		A007	Table 2	5.3.0	Correct Table to reflect text in 6.1 i.e. the subscription of a General Bearer Service comprises the subscription to all individual single services of its group.
SMG#24		A008	2.2 and Table 2	5.3.0	Editorial clean-up of the spec
SMG#26	98-0316	A009	Table 2	5.4.0	Subscriptions to the Phase 2 bearer services All_data_CDA & Bearer Service XX should not include subscription to the phase 2+ bearer services.
SMG#27>				6.0.0	Specification upgrade to Release 1997 version 6.0.0
SMG#28	99-031	A010	6, Annex A, D	6.1.0	Addition of Supplementary Code for GPRS.
SMG#29	P-99-373	A017	5, 6, A, B	6.2.0	Miscellaneous editorial changes: This CR contains editorial updates for all releases

History

Document history		
V6.0.0	January 1999	Publication
V6.1.0	March 1999	Publication
V6.2.0	August 1999	Publication