

ETSI TS 100 595 V7.0.0 (1999-08)

Technical Specification

**Digital cellular telecommunications system (Phase 2+);
Base Station Controller - Base Transceiver Station
(BSC - BTS) interface;
Layer 2 specification
(GSM 08.56 version 7.0.0 Release 1998)**

GSM®

GLOBAL SYSTEM FOR
MOBILE COMMUNICATIONS



Reference

RTS/SMG-030856Q7 (5ic03i03.PDF)

Keywords

Digital cellular telecommunications system,
Global System for Mobile communications (GSM)

ETSI

Postal address

F-06921 Sophia Antipolis Cedex - FRANCE

Office address

650 Route des Lucioles - Sophia Antipolis
Valbonne - FRANCE
Tel.: +33 4 92 94 42 00 Fax: +33 4 93 65 47 16
Siret N° 348 623 562 00017 - NAF 742 C
Association à but non lucratif enregistrée à la
Sous-Préfecture de Grasse (06) N° 7803/88

Internet

secretariat@etsi.fr
Individual copies of this ETSI deliverable
can be downloaded from
<http://www.etsi.org>
If you find errors in the present document, send your
comment to: editor@etsi.fr

Copyright Notification

No part may be reproduced except as authorized by written permission.
The copyright and the foregoing restriction extend to reproduction in all media.

© European Telecommunications Standards Institute 1999.
All rights reserved.

Contents

Intellectual Property Rights	4
Foreword	4
1 Scope.....	5
2 References.....	5
3 Definitions and abbreviations	6
4 General description.....	7
5 Functional contents.....	8
6 LAPD functions	8
6.1 Exceptions and modifications	8
6.1.2 Command/Response field bit (C/R)	8
6.1.3 Service Access Point Identifier (SAPI)	8
6.1.4 TEI for point-to-point data link connection.....	9
6.1.5 Commands and responses.....	9
6.1.6 Exchange identification (XID) command/response.....	9
6.1.7 MDL-XID	9
6.1.8 PH-DATA, PH DEACTIVATE and PH-ACTIVATE	9
6.1.9 MPH-ACTIVATE, MPH-DEACTIVATE an MPH-INFORMATION	10
6.1.10 Priority indicator	10
6.1.11 Terminal Endpoint Identifier (TEI) management procedures	10
6.1.11.1 General	10
6.1.11.2 TEI assignment procedure	10
6.1.11.3 TEI identity verify procedure	12
6.1.11.4 Formats and codes	12
6.1.12 Automatic negotiation of data link layer parameters	12
6.1.13 Establishment procedures	12
6.1.14 N(S) sequence error.....	12
6.1.15 List of system parameters	13
6.1.15.1 Timer T200.....	13
6.1.15.2 Maximum number of retransmissions (N200)	13
6.1.15.3 Maximum number of octets in an information field (N201)	13
6.1.15.4 Maximum number of transmission of the TEI identity request message (N202).....	13
6.1.15.5 Maximum number of outstanding frames (K).....	13
6.1.15.6 Timer T201	13
6.1.15.7 Timer T202.....	13
6.1.15.8 Timer T203.....	13
6.1.16 Data link layer monitor function	14
6.1.17 Miscellaneous.....	14
Annex A (informative): Change Request History	15
History.....	16

Intellectual Property Rights

IPRs essential or potentially essential to the present document may have been declared to ETSI. The information pertaining to these essential IPRs, if any, is publicly available for **ETSI members and non-members**, and can be found in SR 000 314: "*Intellectual Property Rights (IPRs); Essential, or potentially Essential, IPRs notified to ETSI in respect of ETSI standards*", which is available **free of charge** from the ETSI Secretariat. Latest updates are available on the ETSI Web server (<http://www.etsi.org/ipr>).

Pursuant to the ETSI IPR Policy, no investigation, including IPR searches, has been carried out by ETSI. No guarantee can be given as to the existence of other IPRs not referenced in SR 000 314 (or the updates on the ETSI Web server) which are, or may be, or may become, essential to the present document.

Foreword

This Technical Specification (TS) has been produced by the Special Mobile Group (SMG).

The present document defines the link layer used for signalling on the A-bis interface between the Base Station Controller (BSC) and the Base Transceiver Station (BTS) within the digital cellular telecommunications system (Phase 2/Phase 2+).

The contents of the present document is subject to continuing work within SMG and may change following formal SMG approval. Should SMG modify the contents of the present document it will be re-released with an identifying change of release date and an increase in version number as follows:

Version 7.x.y

where:

- 7 indicates Release 1998 of GSM Phase 2+
- x the second digit is incremented for all changes of substance, i.e. technical enhancements, corrections, updates, etc.
- y the third digit is incremented when editorial only changes have been incorporated in the specification.

1 Scope

The present document specifies the link layer used for signalling on the A-bis interface between BSC and BTS. The use and general aspects of the A-bis interface are described in GSM 08.51 and the interface aspects in GSM 08.52.

The Link Access Procedure on the D-channel (LAPD) specification used on the A-bis interface in the GSM PLMN is a subset of the ETS 300 125 which in turn has less options than the CCITT Recommendation Q.921.

This description contains first the protocol definitions and second the services provided by the layer 2 to the layer 3.

2 References

The following documents contain provisions which, through reference in this text, constitute provisions of the present document.

- References are either specific (identified by date of publication, edition number, version number, etc.) or non-specific.
- For a specific reference, subsequent revisions do not apply.
- For a non-specific reference, the latest version applies.
- A non-specific reference to an ETS shall also be taken to refer to later versions published as an EN with the same number.
- For this Release 1998 document, references to GSM documents are for Release 1998 versions (version 7.x.y).

- [1] GSM 01.04: "Digital cellular telecommunications system (Phase 2+); Abbreviations and acronyms".
- [2] GSM 08.51: "Digital cellular telecommunications system (Phase 2+); Base Station Controller (BSC) to Base Transceiver Station (BTS) interface General aspects".
- [3] GSM 08.52: "Digital cellular telecommunications system (Phase 2+); Base Station Controller (BSC) to Base Transceiver Station (BTS) Interface principles".
- [4] GSM 12.00: "Digital cellular telecommunications system (Phase 2+); Objectives and structure of Network Management (NM)".
- [5] GSM 12.01: "Digital cellular telecommunications system (Phase 2+); Common aspects of GSM Network Management (NM)".
- [6] GSM 12.07: "Digital cellular telecommunications system (Phase 2+); Operations and performance management".
- [7] GSM 12.02: "Digital cellular telecommunications system (Phase 2+); Subscriber, Mobile Equipment (ME) and services data administration".
- [8] GSM 12.03: "Digital cellular telecommunications system (Phase 2+); Security management".
- [9] GSM 12.04: "Digital cellular telecommunications system (Phase 2+); Performance data measurements".
- [10] GSM 12.05: "Digital cellular telecommunications system (Phase 2+); Subscriber related event and call data".
- [11] GSM 12.06: "Digital cellular telecommunications system (Phase 2+); GSM Network change control".
- [12] GSM 12.10: "Digital cellular telecommunications system (Phase 2+); Maintenance provisions for operational integrity of Mobile Stations (MS)".

- [13] GSM 12.11: "Digital cellular telecommunications system (Phase 2+); Maintenance of the Base Station System (BSS)".
- [14] GSM 12.13: "Digital cellular telecommunications system (Phase 2+); Maintenance of the Mobile-services Switching Centre (MSC)".
- [15] GSM 12.14: "Digital cellular telecommunications system (Phase 2+); Maintenance of location registers".
- [16] GSM 12.20: "Digital cellular telecommunications system (Phase 2+); Network Management (NM) procedures and messages".
- [17] GSM 12.21: "Digital cellular telecommunications system (Phase 2+); Network Management (NM) procedures and message on the A-bis interface".
- [18] GSM 12.22: "Digital cellular telecommunications system (Phase 2+); Interworking of GSM Network Management (NM) procedures and messages at the Base Station Controller (BSC)".
- [19] CCITT Recommendation Q.921: "Integrated services digital network (ISDN) user-network interface - Data link layer specification".
- [20] ETS 300 125: "Integrated Services Digital Network (ISDN); User-network interface data link layer specification Application of CCITT Recommendations Q.920/I.440 and Q.921/I.441".

3 Definitions and abbreviations

The following abbreviations and acronyms are used in the present document.

Ai	Action indicator
BCF	Base Station Control Function
BSC	Base Station Controller
BTS	Base Transceiver Station
C/R	Command/Response field bit
GSM	Global System for Mobile communication
L2ML	Layer 2 Management Link
LAPD	Link Access Procedure on the D-Channel
MPH-	Communication between Management and PHysical layer
MS	Mobile Station
N(S)	Send sequence variable
O&M	Operation and Maintenance
OML	Operation and Maintenance Link
PH-	Communication between data link layer and PHysical layer
PLMN	Public Land Mobile Network
Ri	Reference number
RSL	Radio Signalling Link
SAP	Service Access Point
SAPI	Service Access Point Identifier
SMS	Short Message Service
TEI	Terminal Endpoint Identifier
TRX	Transceiver
XID	EXchange IDentification

4 General description

The following information categories are supported by the procedures of this layer 2 Recommendation:

- signalling (including Short Message Service (SMS) information);
- operation and maintenance;
- layer 2 management.

For each of these categories the BSC may have one or more layer 2 links to every TRX and BCF.

The signalling links over the A-bis interface are addressed to the different units by Terminal Endpoint Identifiers (TEI).

The same unit will normally have more than one functional entity. The logical links between different functional entities are identified by functional addresses, the Service Access Points Identifier (SAPI).

Figure 1 shows the architectural model with different layer 2 links.

A number of logical links may be multiplexed on each physical link. The same layer 2 logical link may not be distributed over more than one physical link.

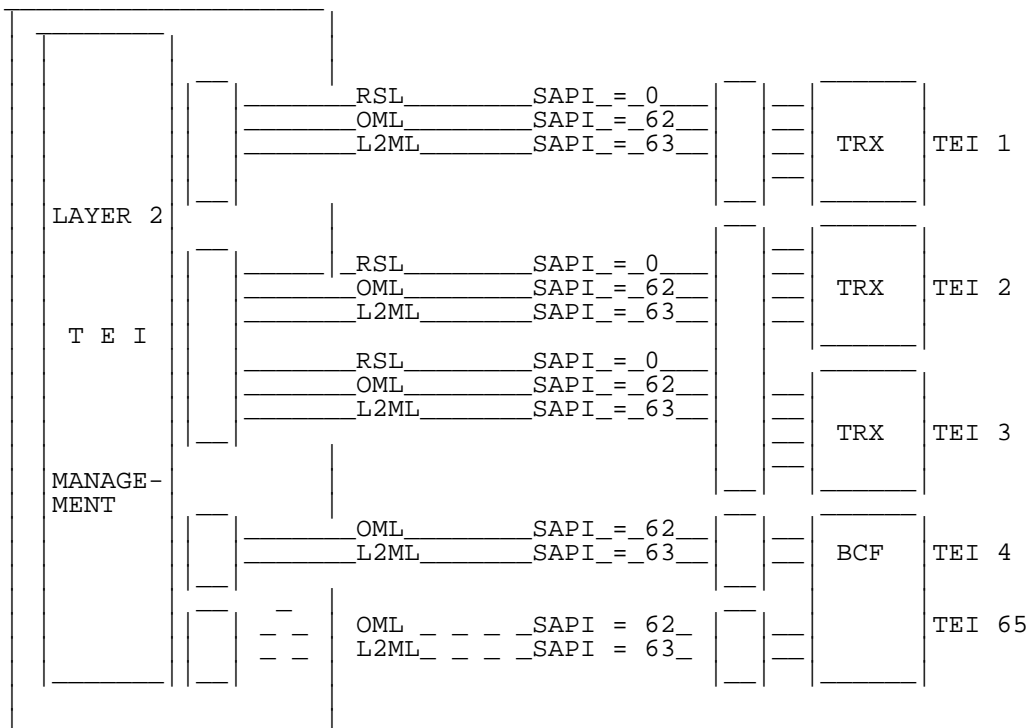

Figure 1:
An example of Logical Layer 2 links supported by three permanent and one semipermanent links

5 Functional contents

The basic functional content of the layer 2 protocol is:

- transparent layer 2 links and time fill;
- point-to-point dedicated layer 2 links addressing both physical entities and functional entities;
- point-to-multipoint addressed links used for layer 2 management;
- basic functions for TEI assignment and management;
- basic priority functions;
- basic supervision of links when not carrying traffic;
- sequence control;
- transmission error control;
- control of errors not recoverable by retransmission.

6 LAPD functions

The LAPD functions as specified in ETS 300 125 are applicable. However, the exceptions and modifications specified in the remainder of the present document shall be used.

6.1 Exceptions and modifications

In the following headlines from ETS 300 125 are kept and references are made to the corresponding subclause of ETS 300 125.

6.1.2 Command/Response field bit (C/R)

(Refer to ETS 300 125, part 2, subclause 3.3.2)

In GSM PLMN's BSC represents the network side and TRX/BCF the user side of the interface.

6.1.3 Service Access Point Identifier (SAPI)

(Refer to ETS 300 125, part 2, subclause 3.3.3)

The SAPI values for the A-bis interface are as listed in table 1.

Table 1: Allocation of SAPI values and priority classes

SAPI value	Related layer 3 or layer management entity	Priority
0	Radio signalling procedures	2
1	Reserved for packet mode communications using Q.931 call control procedures (Not used in GSM PLMN)	-
16	Reserved for packet communication conforming to X.25 level 3 procedures (Not used in GSM PLMN)	-
62	Operation and maintenance procedures	1
63	Layer 2 management procedures	1
All others	Reserved for future standardization	-

6.1.4 TEI for point-to-point data link connection

(Refer to ETS 300 125, part 2, subclause 3.3.4.2)

The remaining Terminal Endpoint Identifier (TEI) values are used for the point-to-point data link connections associated with the addressed Service Access Point (SAP). The range of TEI values shall be allocated as shown in table 2.

Table 2: Allocation of TEI values

TEI value	User type
0 - 63	TEI assignment for fixed TRX and BCF addresses.
64 - 126	TEI assignment for additional, TRX or BCF addresses.

NOTE: A BCF is given a separate layer 2 link only if it is not integrated with a TRX.

6.1.5 Commands and responses

(Refer to ETS 300 125, part 2, subclause 3.6.1)

The XID command and response are not used.

6.1.6 Exchange identification (XID) command/response

(Refer to ETS 300 125, part 2, subclause 3.6.12)

This functionality is not used.

6.1.7 MDL-XID

(Refer to ETS 300 125, part 2, subclause 4.1.1.9)

This functionality is not used.

6.1.8 PH-DATA, PH DEACTIVATE and PH-ACTIVATE

(Refer to ETS 300 125, part 2, subclauses 4.1.1.10 - 4.1.1.12)

This functionality is not relevant.

6.1.9 MPH-ACTIVATE, MPH-DEACTIVATE and MPH-INFORMATION

(Refer to ETS 300 125, part 2, subclauses 4.1.1.13 - 4.1.1.15)

This functionality is not relevant.

6.1.10 Priority indicator

(Refer to ETS 300 125, part 2, subclause 4.1.3.1)

The different SAPIs are given the priority classes as listed in table 1 when contending (with priority one as the highest).

6.1.11 Terminal Endpoint Identifier (TEI) management procedures

(Refer to ETS 300 125, part 2, subclause 5.3)

Due to the special assignment functions needed on the A-bis interface there are modifications and additions to the assignment procedures. The rest of subclause 5.3 in ETS 300 125, part 2, is kept if not stated otherwise.

6.1.11.1 General

(Refer to ETS 300 125, part 2, subclause 5.3.1)

TEI management for A-bis interface is based on the following procedural means:

- a Subset of the TEI assignment procedures;
- the TEI check procedures;
- the TEI remove procedures;
- an additional TEI assignment procedure.

The TEI management needs procedures to check the used TEI values and procedures for reaction in situation where more than one TRX equipment uses the same TEI value. In addition to the fixed values it shall be possible to use additional TEI value to the same TRX equipment and thus increase the signalling capacity.

6.1.11.2 TEI assignment procedure

(Refer to ETS 300 125, part 2, subclause 5.3.2)

The TEI assignment procedure used on the A-bis interface has some additions to the automatic TEI assignment procedure specified in ETS 300 125, part 2.

To facilitate the configuration control in the BSC each TRX will have a fixed TEI and possibly get access to one or more additional TEIs assigning physical channels/layer 2 links.

The layer 2 links may all be turned on and off according to the normal automatic TEI assignment scheme but the TRX may only request identified TEI values which is (semi-) permanently programmed or programmed by operation and maintenance messages.

In GSM the reference number R_i is not used. It is only misoperation situations resulting from double failures that could be prevented/solved faster by this parameter. The marginal advantage is not supposed to motivate the application of a random generator and the checking procedure.

The subset of the automatic assignment procedure applicable for the first layer 2 link to a TRX shall have the following modifications to ETS 300 125, part 2:

- the identity request shall have an A_i value in the range 0-63 identifying the TEI value which is requested for activation;
- on reception of the identity request message the BSC will check that the requested TEI may be used from the configurations aspects and then perform a normal TEI check procedure to prevent a double assignment;
- if the TEI request is accepted an identity assigned message with the requested TEI number is received by TRX before the expiry of timer T202;

- a successful assignment procedure is shown in figure 2.

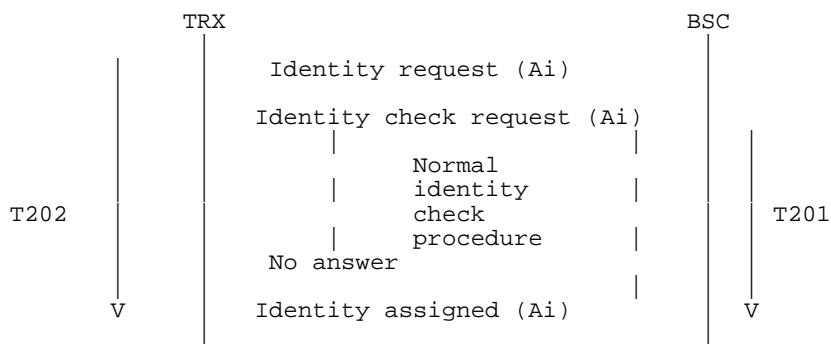

If timer T201 expires the request shall be repeated once and timer T201 restarted

Figure 2: A successful assignment procedure

If timer T202 expires the assignment procedure did not succeed, and the TRX will take further actions in accordance with the procedures as specified in ETS 300 125, part 2.

If within the assignment procedure an identity check response is received, then the requested TEI value is already in use. There shall be no answer to the requesting TRX and an error indication shall be sent to O&M.

An example of a non-successful assignment procedure is shown in figure 3.

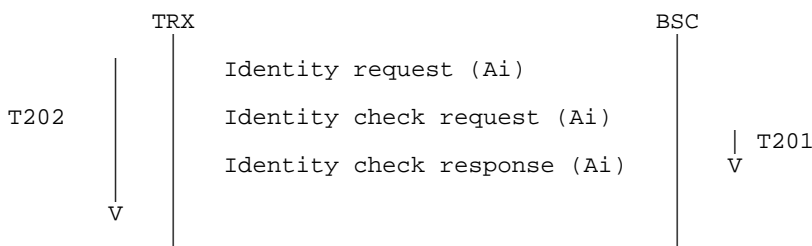

If timer T201 expires the request shall be repeated once and timer T201 restarted

Figure 3: An example of assignment in error case (TEI value already in use)

The additional TEI assignment procedure is equivalent to the normal one with two exceptions:

- the TEI value is in the range: 64-126;
- the TEI value and the identification of which physical link it shall operate on is transmitted to the TRX from BSC in an operation and maintenance message. This layer 3 O&M message is transferred on an already assigned layer 2 link. (See 12-series of GSM Technical Specifications).

The successful additional assignment procedure is shown in figure 4.

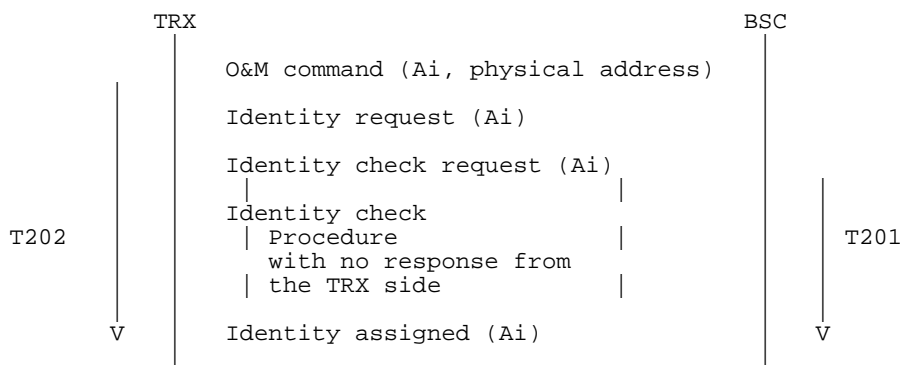

If timer T201 expires the request shall be repeated once and timer T201 restarted

Figure 4: The procedure for assigning an additional TEI to a TRX or BCF

6.1.11.3 TEI identity verify procedure

(Refer to ETS 300 125, part 2, subclause 5.3.5)
 This procedure is not used.

6.1.11.4 Formats and codes.

(Refer to ETS 300 125, part 2, subclause 5.3.6)
 All messages except Identity verify and Identity denied are used. The Ai is used as described in subclause 6.1.11.2, the modification to ETS 300 125, part 2, subclause 5.3.2. The Ri parameter is not used and will always be coded 0000 0000.

The coding of each field of the various messages is specified in table 3.

Table 3: Codes for messages concerning TEI management procedures

Message name	Layer management entity identifier	Reference number Ri	Message type	Action indicator Ai
Identity request (user to network)	0000 1111	Not used (coded 0)	0000 0001	Ai = 0-126
Identity assigned (network to user)	0000 1111	Not used (coded 0)	0000 0010	Ai = 0-126 Assigned TEI value
Identity check request (network to user)	0000 1111	Not used (coded 0)	0000 0100	Ai = 127 Check all TEI values ----- Ai = 0-126 TEI value to be checked
Identity check response (user to network)	0000 1111	Not used (coded 0)	0000 0101	Ai = 0-126 TEI value in use
Identity remove (network to user)	0000 1111	Not used (coded 0)	0000 0110	Ai = 127 Request for removal of all TEI values ----- Ai = 0-126 TEI value to be removed

6.1.12 Automatic negotiation of data link layer parameters

(Refer to ETS 300 125, part 2, subclause 5.4 and annex IV)
 The procedures are not supported.

6.1.13 Establishment procedures

(Refer to ETS 300 125, part 2, subclause 5.5.1.2)
 The timer T203 shall be implemented in the equipment on both sides of interface A-bis.

6.1.14 N(S) sequence error

(Refer to ETS 300 125, part 2, subclause 5.8.1 and appendix I)
 As it is the case in ETS 300 125, the optional procedure for retransmission as described in Appendix I is not supported.

6.1.15 List of system parameters

(Refer to ETS 300 125, part 2, subclause 5.9)

All the default values are given in the following subclauses.

6.1.15.1 Timer T200

(Refer to ETS 300 125, part 2, subclause 5.9.1)

The default value of timer T200 is 240 ms starting from the end of a transmitted frame.

NOTE: This timer depends on the timer values used for supervising the message flow between the Mobile Station (MS) and the network. The proper operation of the procedure requires timer T200 to be greater than the maximum time between transmission of command frames and the reception of their corresponding response or acknowledgement frames and shorter than the shortest layer 3 timer used for supervising this message flow.

6.1.15.2 Maximum number of retransmissions (N200)

(Refer to ETS 300 125, part 2, subclause 5.9.2)

The default value of (N200) is 3.

6.1.15.3 Maximum number of octets in an information field (N201)

(Refer to ETS 300 125, part 2, subclause 5.9.3)

The default and maximum value of (N201) is 260 octets for all SAPI values.

6.1.15.4 Maximum number of transmission of the TEI identity request message (N202)

(Refer to ETS 300 125, part 2, subclause 5.9.4)

Not used (i.e. equivalent to infinity).

6.1.15.5 Maximum number of outstanding frames (K)

(Refer to ETS 300 125, part 2, subclause 5.9.5)

For the SAPI value 0 identifying radio signalling the default (K) value shall be 2. For all other SAPIs the value shall be set to the fixed value of 1.

NOTE: The value of K for SAPI value 0 shall always be greater than the k value for the other SAPIs.

6.1.15.6 Timer T201

(Refer to ETS 300 125, part 2, subclause 5.9.6)

Timer T201 shall have the default value 1 second.

6.1.15.7 Timer T202

(Refer to ETS 300 125, part 2, subclause 5.9.7)

The minimum time between the transmission of TEI Identity request messages is a system parameter (T202) which shall be set to 15 seconds.

6.1.15.8 Timer T203

(Refer to ETS 300 125, part 2, subclause 5.9.8)

The timer T203 represents the maximum time allowed without frames being exchanged for each TEI. The value of timer T203 shall be 10 seconds.

6.1.16 Data link layer monitor function

(Refer to ETS 300 125, part 2, subclause 5.10)

The supervisory function will be used in the equipment on both sides of the A-bis interface.

6.1.17 Miscellaneous

(Refer to ETS 300 125, part 2, appendix I-IV)

The functionalities specified in appendix I-IV of ETS 300 125, part 2, is not used.

Annex A (informative): Change Request History

Change history					
SMG No.	TDoc. No.	CR. No.	Section affected	New version	Subject/Comments
SMG#08				4.0.2	ETSI Publication
SMG#20				5.0.0	Release 1996 version
SMG#27				6.0.0	Release 1997 version
SMG#29				7.0.0	Release 1998 version

History

Document history		
V7.0.0	August 1999	Publication