

# ETSI TS 100 607-3 V4.30.0 (2000-11)

---

*Technical Specification*

**Digital cellular telecommunications system (Phase 2);  
Mobile Station (MS) conformance specification;  
Part 3: Layer 3 (L3) Abstract Test Suite (ATS)  
(3GPP TS 11.10-3 version 4.30.0 GSM Phase 2)**

---



GLOBAL SYSTEM FOR  
MOBILE COMMUNICATIONS



---

**Reference**

RTS/TSGG-041110PRE-3

---

**Keywords**

GSM

**ETSI**

650 Route des Lucioles  
F-06921 Sophia Antipolis Cedex - FRANCE

---

Tel.: +33 4 92 94 42 00 Fax: +33 4 93 65 47 16

Siret N° 348 623 562 00017 - NAF 742 C  
Association à but non lucratif enregistrée à la  
Sous-Préfecture de Grasse (06) N° 7803/88

---

**Important notice**

---

Individual copies of the present document can be downloaded from:

<http://www.etsi.org>

The present document may be made available in more than one electronic version or in print. In any case of existing or perceived difference in contents between such versions, the reference version is the Portable Document Format (PDF). In case of dispute, the reference shall be the printing on ETSI printers of the PDF version kept on a specific network drive within ETSI Secretariat.

Users of the present document should be aware that the document may be subject to revision or change of status. Information on the current status of this and other ETSI documents is available at <http://www.etsi.org/tb/status/>

If you find errors in the present document, send your comment to:  
editor@etsi.fr

---

**Copyright Notification**

---

No part may be reproduced except as authorized by written permission.  
The copyright and the foregoing restriction extend to reproduction in all media.

© European Telecommunications Standards Institute 2000.

All rights reserved.

---

## Intellectual Property Rights

IPRs essential or potentially essential to the present document may have been declared to ETSI. The information pertaining to these essential IPRs, if any, is publicly available for **ETSI members and non-members**, and can be found in ETSI SR 000 314: "*Intellectual Property Rights (IPRs); Essential, or potentially Essential, IPRs notified to ETSI in respect of ETSI standards*", which is available from the ETSI Secretariat. Latest updates are available on the ETSI Web server (<http://www.etsi.org/ipr>).

Pursuant to the ETSI IPR Policy, no investigation, including IPR searches, has been carried out by ETSI. No guarantee can be given as to the existence of other IPRs not referenced in ETSI SR 000 314 (or the updates on the ETSI Web server) which are, or may be, or may become, essential to the present document.

---

## Foreword

This Technical Specification (TS) has been produced by the ETSI 3<sup>rd</sup> Generation Partnership Project (3GPP).

The present document may refer to technical specifications or reports using their 3GPP identities, UMTS identities or GSM identities. These should be interpreted as being references to the corresponding ETSI deliverables.

The cross reference between GSM, UMTS, 3GPP and ETSI identities can be found under [www.etsi.org/key](http://www.etsi.org/key).

# Contents

Foreword.....	5
1 Scope .....	6
2 References .....	6
3 Definitions and abbreviations.....	9
3.1 Definitions.....	9
3.2 Abbreviations.....	9
4 Test Suite Structure (TSS).....	9
4.1 Test suite naming convention.....	9
4.2 Suite Overview.....	11
4.3 Test groups.....	11
4.3.1 Valid Behaviour tests (BV).....	11
4.3.2 Invalid Behaviour/Inopportune Behaviour tests (BI-BO).....	11
4.4 Test Step Structure .....	12
4.4.1 Preambles .....	12
4.4.2 Postambles.....	12
5 Test Purposes (TP) .....	12
5.1 TP and test case naming convention .....	12
6 Abstract test method and test configurations.....	12
6.1 Test system model.....	12
6.2 Test Method .....	13
<b>Annex A (normative): Layer 3 Abstract Test Suite.....</b>	<b>14</b>
A.1 The TTCN Graphical form (TTCN.GR) .....	14
A.2 The TTCN Machine Processable form (TTCN.MP) .....	14
<b>Annex B (normative): Partial IXIT proforma.....</b>	<b>15</b>
Introduction.....	15
B.1 Identification Summary .....	16
B.2 Abstract Test Suite Summary .....	16
B.3 Test Laboratory .....	16
B.3.1 Test Laboratory Identification .....	16
B.3.2 Accreditation status of the test service .....	18
B.3.3 Manager of Test Laboratory .....	18
B.3.4 Contact person of Test Laboratory .....	18
B.3.5 Means of Testing .....	19
B.3.6 Instructions for Completion.....	20
B.4 Client .....	21
B.4.1 Client Identification.....	21
B.4.2 Client Test Manager .....	21
B.4.3 Client Contact person .....	21
B.4.4 Test Facilities Required.....	22
B.5 System Under Test .....	23
B.5.1 SUT Information .....	23
B.5.2 Limitations of the SUT .....	24
B.5.3 Environmental Conditions.....	25
B.6 Ancillary Protocols .....	26
B.6.1 Ancillary Protocols 1.....	26
B.6.2 Ancillary Protocols 2.....	26

B.7	Protocol Layer Information for L3 of Mobile Station .....	26
B.7.1	Information provided for test purposes by the MS supplier .....	26
B.7.2	MMI information.....	43
B.7.3	Test house specified parameters .....	47
<b>Annex C (normative):</b>	<b>PCTR Proforma .....</b>	<b>81</b>
<b>Annex D (normative):</b>	<b>Enhanced Full Rate Abstract Test Suite.....</b>	<b>82</b>
D.1	The TTCN Graphical form (TTCN.GR) .....	82
D.2	The TTCN Machine Processable form (TTCN.MP) .....	82
<b>Annex E (informative):</b>	<b>Cell Selection Abstract Test Suite.....</b>	<b>83</b>
E.1	The TTCN Graphical form (TTCN.GR) .....	83
E.2	The TTCN Machine Processable form (TTCN.MP) .....	83
<b>Annex F (informative):</b>	<b>Dual band Abstract Test Suite.....</b>	<b>84</b>
F.1	The TTCN Graphical form (TTCN.GR) .....	84
F.2	The TTCN Machine Processable form (TTCN.MP) .....	84
<b>Annex G (informative):</b>	<b>Change history .....</b>	<b>85</b>

---

# Foreword

This Technical Specification has been produced by the 3<sup>rd</sup> Generation Partnership Project (3GPP).

The contents of the present document are subject to continuing work within the TSG and may change following formal TSG approval. Should the TSG modify the contents of the present document, it will be re-released by the TSG with an identifying change of release date and an increase in version number as follows:

Version x.y.z

where:

- x the first digit:
  - 1 presented to TSG for information;
  - 2 presented to TSG for approval;
  - 3 or greater indicates TSG approved document under change control.
- y the second digit is incremented for all changes of substance, i.e. technical enhancements, corrections, updates, etc.
- z the third digit is incremented when editorial only changes have been incorporated in the document.

---

# 1 Scope

The present document specifies the Abstract Test Suite (ATS) and partial IXIT proforma for the Network Layer (Layer 3) at the mobile radio interface of the GSM or DCS (Phase 2) mobile stations (MS) conforming to the TSs for the Radio Resource management, the Mobility Management, the circuit-switched Call Control, the Supplementary Services and Short Message Services for the digital cellular telecommunications systems (Phase 2).

The ISO standards for the methodology of conformance testing are used as the basis for the test specifications.

---

# 2 References

The following documents contain provisions which, through reference in this text, constitute provisions of the present document.

- References are either specific (identified by date of publication, edition number, version number, etc.) or non-specific.
- For a specific reference, subsequent revisions do not apply.
- For a non-specific reference, the latest version applies.

- [1] ISO/IEC 9646-1: "Information Technology-OSI- Conformance Testing Methodology and Framework, Part 1: General Concepts".
- [2] ISO/IEC 9646-2: "Information Technology-OSI- Conformance Testing Methodology and Framework, Part 2: Abstract Test Suite Specification".
- [3] ISO/IEC 9646-3: "Information Technology-OSI- Conformance Testing Methodology and Framework, Part 3: The Tree and Tabular Combined Notation".
- [4] ISO/IEC 9646-5: "Information Technology-OSI- Conformance Testing Methodology and Framework, Part 5: Requirements on test laboratories and clients for the conformance assessment process".
- [5] ISO/IEC 8824: "Information Technology-OSI- Specification of Abstract Syntax Notation One (ASN.1)".
- [6] ISO/IEC 8825: "Information Technology-OSI- Specification of Basic Encoding Rules for Abstract Syntax Notation One (ASN.1)".
- [7] ITU-T Recommendation Q.773: "Specifications of Signalling System No.7; Transaction capabilities formats and encoding".
- [8] ETS 300 287: "Integrated Services Digital Network (ISDN); Signalling System No.7, Transaction Capabilities Application Part (TCAP) version 2".
- [9] ETS 300 406 (January 1995): "Methods for Testing and Specification (MTS); Protocol and profile conformance testing specifications; Standardization methodology".
- [10] GSM 02.02 Version 4.2.2: "Digital cellular telecommunication system (Phase 2); Bearer Services (BS) supported by a GSM Public Land Mobile Network (PLMN)".
- [11] GSM 02.03 Version 4.3.1: "Digital cellular telecommunication system (Phase 2); Teleservices supported by a GSM Public Land Mobile Network (PLMN)".
- [12] GSM 02.06 Version 4.5.2: "Digital cellular telecommunication system (Phase 2); Types of Mobile Stations (MS)".
- [13] GSM 02.07 Version 4.8.2: "Digital cellular telecommunication system (Phase 2); Mobile Station (MS) features".

- [14] GSM 02.30 Version 4.13.0: "Digital cellular telecommunication system (Phase 2); Man-Machine Interface (MMI) of the Mobile Station (MS)".
- [15] GSM 03.03 Version 4.9.0: "Digital cellular telecommunication system (Phase 2); Numbering, addressing and identification".
- [16] GSM 03.09 Version 4.6.0: "Digital cellular telecommunications system (Phase 2); Handover procedures".
- [17] GSM 03.10 Version 4.3.1: "Digital cellular telecommunications system (Phase 2); GSM Public Land Mobile Network (PLMN) connection types".
- [18] GSM 03.11 Version 4.10.1: "Digital cellular telecommunication system (Phase 2); Technical realization of supplementary services".
- [19] GSM 03.12 Version 4.4.2: "Digital cellular telecommunications system (Phase 2); Location registration procedures".
- [20] GSM 03.14 Version 4.1.1: "Digital cellular telecommunications system (Phase 2); Support of Dual Tone Multi-Frequency signalling (DTMF) via the GSM system".
- [21] GSM 03.22 Version 4.11.0: "Digital cellular telecommunication system (Phase 2); Functions related to Mobile Station (MS) in idle mode".
- [22] GSM 03.40 Version 4.13.0: "Digital cellular telecommunication system (Phase 2); Technical realization of the Short Message Service (SMS) Point to Point (PP)".
- [23] GSM 03.41 Version 4.11.0: "Digital cellular telecommunication system (Phase 2); Technical realization of Short Message Service Cell Broadcast (SMSCB)".
- [24] GSM 04.01 Version 4.0.4: "Digital cellular telecommunications system (Phase 2); Mobile Station - Base Station System (MS - BSS) interface General aspects and principles".
- [25] GSM 04.03 Version 4.1.1: "Digital cellular telecommunications system (Phase 2); Mobile Station - Base Station System (MS - BSS) interface Channel structures and access capabilities".
- [26] GSM 04.04 Version 4.0.4: "Digital cellular telecommunication system (Phase 2); layer 1 General requirements".
- [27] GSM 04.05 Version 4.0.3: "Digital cellular telecommunication system (Phase 2); Data Link (DL) layer General aspects".
- [28] GSM 04.06 Version 4.4.0: "Digital cellular telecommunication system (Phase 2); Mobile Station - Base Station System (MS - BSS) interface Data Link (DL) layer specification".
- [29] GSM 04.07 Version 4.3.1: "Digital cellular telecommunication system (Phase 2); Mobile radio interface signalling layer 3 General aspects".
- [30] GSM 04.08 Version 4.23.1: "Digital cellular telecommunication system (Phase 2); Mobile radio interface layer 3 specification".
- [31] GSM 04.10 Version 4.10.1: "Digital cellular telecommunication system (Phase 2); Mobile radio interface layer 3 Supplementary services specification General aspects".
- [32] GSM 04.11 Version 4.10.0: "Digital cellular telecommunication system (Phase 2); Point-to-Point (PP) Short Message Service (SMS) support on mobile radio interface".
- [33] GSM 04.12 Version 4.6.0: "Digital cellular telecommunication system (Phase 2); Short Message Service Cell Broadcast (SMSCB) support on the mobile radio interface".
- [34] GSM 04.80 Version 4.11.1: "Digital cellular telecommunication system (Phase 2); Mobile radio interface layer 3 supplementary services specification; Formats and coding".
- [35] GSM 04.81 Version 4.4.1: "Digital cellular telecommunication system (Phase 2); Line identification supplementary services - Stage 3".



- [36] GSM 04.82 Version 4.9.1: "Digital cellular telecommunication system (Phase 2); Call Forwarding (CF) supplementary services - Stage 3".
- [37] GSM 04.83 Version 4.6.1: "Digital cellular telecommunication system (Phase 2); Call Waiting (CW) and Call Hold (HOLD) supplementary services - Stage 3".
- [38] GSM 04.84 Version 4.3.2: "Digital cellular telecommunication system (Phase 2); MultiParty (MPTY) supplementary services - Stage 3".
- [39] GSM 04.85 Version 4.1.1: "Digital cellular telecommunications system (Phase 2); Closed User Group (CUG) supplementary services - Stage 3".
- [40] GSM 04.86 Version 4.5.2: "Digital cellular telecommunication system (Phase 2); Advice of Charge (AoC) supplementary services - Stage 3".
- [41] GSM 04.88 Version 4.7.1: "Digital cellular telecommunication system (Phase 2); Call Barring (CB) supplementary services - Stage 3".
- [42] GSM 04.90 Version 4.1.1: "Digital cellular telecommunication system (Phase 2); Unstructured supplementary services operation - Stage 3".
- [43] GSM 05.01 Version 4.6.0: "Digital cellular telecommunications system (Phase 2); Physical layer on the radio path General description".
- [44] GSM 05.02 Version 4.10.0: "Digital cellular telecommunication system (Phase 2); Multiplexing and multiple access on the radio path".
- [45] GSM 05.03 Version 4.5.1: "Digital cellular telecommunication system (Phase 2); Channel coding".
- [46] GSM 05.04 Version 4.0.3: "Digital cellular telecommunication system (Phase 2); Modulation".
- [47] GSM 05.05 Version 4.22.1: "Digital cellular telecommunication system (Phase 2); Radio transmission and reception".
- [48] GSM 05.08 Version 4.22.1: "Digital cellular telecommunication system (Phase 2); Radio subsystem link control".
- [49] GSM 05.10 Version 4.9.0: "Digital cellular telecommunication system (Phase 2); Radio subsystem synchronisation".
- [50] GSM 07.01 Version 4.10.0: "Digital cellular telecommunication system (Phase 2); General on Terminal Adaptation Functions (TAF) for Mobile Stations (MS)".
- [51] GSM 08.08 Version 4.12.1: "Digital cellular telecommunications system (Phase 2); Mobile-services Switching Centre - Base Station System (MSC - BSS) interface Layer 3 specification".
- [52] GSM 08.58 Version 4.9.0: "Digital cellular telecommunications system (Phase 2); Base Station Controller - Base Transceiver Station (BSC - BTS) interface Layer 3 specification".
- [53] GSM 09.02 Version 4.18.0: "Digital cellular telecommunication system (Phase 2); Mobile Application Part (MAP) specification".
- [54] 3GPP TS 51.010-1 Version 4.1.0: "Digital cellular telecommunications system; Mobile Station (MS) conformance specification; Part 1: Conformance specification".
- [55] GSM 11.10-2 Version 4.15.0: "Digital cellular telecommunications system (Phase 2); Mobile Station (MS) conformance specification; Part 2: Protocol Implementation Conformance Statement (PICS) Proforma specification".

---

## 3 Definitions and abbreviations

### 3.1 Definitions

For the purposes of the present document, the following terms and definitions apply.

**Abstract Test Suite (ATS):** refer to ISO/IEC 9646-1 [1].

**Implementation Under Test (IUT):** refer to ISO/IEC 9646-1 [1].

**Partial Protocol Implementation eXtra Information for Testing (IXIT):** refer to ISO/IEC 9646-1 [1].

**Point of Controls and Observations (PCO):** refer to ISO/IEC 9646-1 [1].

**Protocol Implementation Conformance Statement (ICS):** refer to ISO/IEC 9646-1 [1].

**System Under Test (SUT):** refer to ISO/IEC 9646-1 [1].

### 3.2 Abbreviations

For the purposes of the present document, the following abbreviations apply:

ATS	Abstract Test Suite
BI	Invalid Behaviour tests
BO	Inopportune Behaviour tests
BV	Valid Behaviour tests
CA	CApability tests
EDP-N	Event Detection Point - Notification
EDP-R	Event Detection Point - Request
ETS	European Telecommunication Standard
FE	Functional Entity
FSM	Finite State Machine
ICS	Implementation Conformance Statement
IUT	Implementation Under Test
IXIT	Implementation eXtra Information for Testing
PDU	Protocol Data Unit
SUT	System Under Test
TP	Test Purpose
TS	Technical Specification
TSS	Test Suite Structure

Further abbreviations used within GSM related document may be found in ETR 100.

Abbreviations for test case group names may be found in figure 1 and 2.

---

## 4 Test Suite Structure (TSS)

### 4.1 Test suite naming convention

The test group identifier for each group and subgroup is built according to the scheme in figure 1.

Identifier: L3<c><s><g0><g1><g2><nn>
--------------------------------------

<c> = category: BIT BIT, Basic Interconnection tests (not used) CACA, Capability tests (not used) BVBV, Valid Behaviour tests BI-BOBI and BO, Invalid and Inopportune Behaviour tests
--

<g0> = group: IN Initial tests  
ID Idle mode tests  
RR Radio Resource management  
MM Mobility Management  
CC Call Control  
SP Structured Procedures  
SS Supplementary services  
LLF Lower Layer Failures  
UUE Unknown, Unforeseen or erroneous Elements

<g1> = group: CR Channel Request  
AT IMSI detach and IMSI attach  
SMT Sequenced MM / CC message transfer  
EC Establishment Cause  
IA Immediate assignment  
PG Test of paging  
MR Test of measurement report  
ASS Test of the channel  
HO Test of handover  
FR Test of frequency redefinition  
CMM Test of the channel mode modify procedure  
CY Test of ciphering mode setting  
CM Test of classmark  
CHR Test of channel release  
START Test of starting time  
IDAU Identification and authentication  
LU Location updating  
CON MM connection  
CCSMO State Machine Verification, Mobile Originating Call  
CCSMT State Machine Verification, Mobile Terminating Call  
SMICF State machine verification, In Call Functions  
CRE Call Re-establishment  
UUS User to user signalling  
UPD Unknown protocol discriminator  
TIS TI and skip indicator  
UMT Undefined or unexpected message type  
UIE Unforeseen information elements in the non-imperative  
NMIE Non-semantic mandatory IE errors  
CNR Unknown IE, comprehension not required  
SB Spare bits

<g2> = group:	ACHandover / successful / active call
	CUE Handover / successful / call under establishment
	FSY Handover / successful / active call / finely synchronized
	PRS Pre-synchronized handovers
	PRF Protocol failures
	ACC Location updating / accepted
	REJ Location updating / rejected
	ABN Location updating / abnormal cases
	REL Location updating / release
	PER Location updating / periodic
	HPER Location updating / periodic HPLMN search
	IWAT Location updating / interworking of attach and periodic
	EST MM connection / establishment
	EXP MM connection / expiry
	NWAB MM connection / abortion by the network
	FRQP MM connection / follow-on request pending
	U0 Mobile Originating Call U0 State
	U0.1 Mobile Originating Call U0.1 MM Connection pending
	U1 Mobile Originating Call U1 State
	U3 Mobile Originating Call U3 State
	U4 Mobile Originating Call U4 State
	U10 Mobile Originating Call U10 State
	U11 Mobile Originating Call U11 State
	U12 Mobile Originating Call U12 State
	U19 Mobile Originating Call U19 State
	U0 Mobile Terminating Call U0 State
	U6 Mobile Terminating Call U6 State
	U9 Mobile Terminating Call U9 State
	U7 Mobile Terminating Call U7 State
	U8 Mobile Terminating Call U8 State
	DTMFState machine verification, In Call Functions / transfer
	CHC State machine verification, In Call Functions /
	TICM State machine verification, In Call Functions / in-
	OICM State machine verification, In Call Functions / in-

Figure 1: Test group identifier naming convention scheme

## 4.2 Suite Overview

Figure 2 shows the structure of the test suites for L3.

L3 ATS									
BV								BI/O	
IN	ID	RR	MM	CC	SP	SS	SMS	LLF	UUE

Figure 2: Test suite structure of the L3 tests

## 4.3 Test groups

### 4.3.1 Valid Behaviour tests (BV)

Predefined state transitions are considered as valid. The test purposes in the valid behaviour test subgroup cover the verification of the normal and exceptional procedures of the various Finite State Machines (FSMs), i.e. a valid behaviour test is a test where the message sequence and the message contents are considered as valid.

### 4.3.2 Invalid Behaviour/Inopportune Behaviour tests (BI-BO)

This test sub group verifies that the Implementation Under Test (IUT) is able to react properly having received an invalid Protocol Data Unit (PDU) or in the case an inopportune protocol event occurs. An invalid PDU is defined as a

syntactically incorrect message. An inopportune event is syntactically correct but occurs when it is not expected, e.g. a correctly coded operation is received in a wrong state (the IUT may respond Error UnexpectedComponentSequence).

## 4.4 Test Step Structure

### 4.4.1 Preambles

The preamble is defined for each test purpose.

### 4.4.2 Postambles

After each test case the IUT shall be brought to the state as defined in the postamble for each test purpose.

---

## 5 Test Purposes (TP)

For each conformance requirement a Test Purpose (TP) is defined. The test purposes are specified in the ATS Dynamic part (annex A).

### 5.1 TP and test case naming convention

In order clearly to map the conformance requirements specified in the TS 51.010-1 and TTCN test cases in the ATS, the section numbers in the TS 51.010-1 are used as test case names.

The identifier of each TP is identical to the name of the implemented TTCN test case.

"Test Purpose Identifier" = "Test Case Name" = TPI = TC\_NN\_A\_B\_C\_D\_E, where NN, A, B, C, D and E are digits used in the corresponding section numbers of TS 51.010-1. For example, the test case name TC\_26\_5\_6\_2 is the TTCN specification corresponding to the conformance requirements in the section 26.5.6.1.2 in the TS 51.010-1. In case where the section has been implemented in more than one test case sub numbering has been introduced. For example, the section 26.7.4.2.4 of TS 51.010-1, Location updating/rejected/national roaming testing is split into 5 test cases. The corresponding TCs are identified as TC\_26\_7\_4\_2\_4\_1, TC\_26\_7\_4\_2\_4\_2, TC\_26\_7\_4\_2\_4\_3, TC\_26\_7\_4\_2\_4\_4 and TC\_26\_7\_4\_2\_4\_5, respectively.

---

## 6 Abstract test method and test configurations

The distributed test method applies to the L3 MS testing. The test method uses a lower tester and a Man-Machine Interface (MMI) as an upper tester at the SUT.

### 6.1 Test system model

The model of the L3 test system is based on the original protocol architecture at the air interface. The test system consists conceptually of a lower tester LT, the L3 test programme (executable test suite), a L2 radio link emulator, a management functional unit, the L1 service provider and a TRx set (see figure 1).

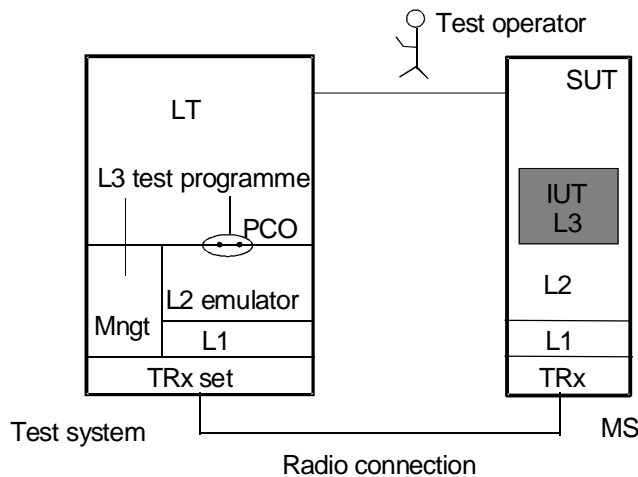

**Figure 3: Test system and distributed test method**

The LT provides the test environment and for test execution and the means of control and observation at the L3 lower service boundary within the test system.

The L3 TTCN test specification uses the three LT interfaces to communicate with the MS, the system under test, and with the other parts of the test system:

- Interface to the L2 emulator via the PCO;
- Interface to the management functional unit via TTCN test suite operations;
- Interface to the MS Man-Machine Interface (MMI) via a test operator.

## 6.2 Test Method

The PCO in the LT is defined as L2 SAP (SAP 0 + 3). The PCO has two FIFO queues (data buffers) to store all sending and receiving test events. The L2 primitives in the ATS which constitute mainly the interface to the L2 emulator are specified via the L2 primitives. In order to simulate multicell testing as required in some test cases, the defined primitives are able to address individual cells of the test system and the logic channels of each cell for the L3 message exchanges. The L2 emulator together with the underlying L1 and the TRx set support all message exchanges via correct radio links.

The management function unit has three management functions:

- L2 and L1 management.
- Channel management.
- TRx management.

The interface to the management function unit is presented in the ATS via a set of test suite operations. The major functions of the test suite management operations are:

- To load configuration parameters necessary for the test system.
- To control and get the necessary values of radio resources/ channels for tests.

The SUT (MS) has a more or less standardized MMI, such as keys, digital display, tones, etc. The ATS uses such kind of functions to provoke some procedures or to observe simple results at the SUT side. A human operator is needed during the test. The test system shall have an interface to the human operator to enable the test co-ordination.

---

## Annex A (normative): Layer 3 Abstract Test Suite

This ATS has been produced using the Tree and Tabular Combined Notation (TTCN) according to ISO/IEC 9646-3 [3].

The ATS was developed on a separate TTCN software tool and therefore the TTCN tables are not completely referenced in the table of contents. The ATS itself contains a test suite overview part which provides additional information and references.

---

### A.1 The TTCN Graphical form (TTCN.GR)

The TTCN.GR representation of this ATS for Layer 3 is contained in an Adobe Portable Document Format™ file (l3-4u0.PDF contained in archive 1110c4u0ATS.zip) (Layer 3) which accompanies this TS.

---

### A.2 The TTCN Machine Processable form (TTCN.MP)

The TTCN.MP representation corresponding to this ATS for Layer 3 is contained in an ASCII file (l3-4u0.MP contained in archive 1110c4u0ATS.zip) (Layer 3) which accompanies this TS.

---

## Annex B (normative): Partial IXIT proforma

Notwithstanding the provisions of the copyright clause related to the text of this TS, 3GPP grants that users of this TS may freely reproduce the PIXIT proforma in this annex so that it can be used for its intended purposes and may further publish the completed PIXIT.
--

---

### Introduction

This partial IXIT proforma contained in the present document, after augmented by the Test Realizer, is proposed to be provided to the client for completion, when the related Abstract Test Suite is to be used against client's Implementation Under Test (IUT).

Text in *italics* is comments for guidance for the production of a IXIT, and is not to be included in the actual IXIT.

The completed IXIT will normally be used in conjunction with the completed ICS, as it adds precision to the information provided by the ICS.



---

## B.1 Identification Summary

*This table is completed by the test laboratory. The item "Contract References" is optional.*

**Table 1: Identification Summary**

<b>IXIT Reference Number</b>	
<b>Test Laboratory Name</b>	
<b>Date of Issue</b>	
<b>Issued to (name of client)</b>	
<b>Contract References</b>	

---

## B.2 Abstract Test Suite Summary

*In the following table the test laboratory provides the version number of the protocol specification and the version number of ATS which are used in the conformance testing.*

**Table 2: ATS Summary**

<b>Protocol Specification</b>	<b>ETS 300 557</b>
<b>Version of Protocol Specification</b>	
<b>TSS &amp; TP Specification</b>	<b>3G TS 51.010-1</b>
<b>Version of TSS &amp; TP Specification</b>	
<b>ATS Specification</b>	<b>GSM 11.10-3</b>
<b>Version of ATS Specification</b>	
<b>Abstract Test Method</b>	<b>Remote Test Method</b>

---

## B.3 Test Laboratory

### B.3.1 Test Laboratory Identification

*The test laboratory provides the following information.*

**Table 3: Test Laboratory Identification**

<b>Name of Test Laboratory</b>	
<b>Postal Address</b>	
<b>Office address</b>	
<b>Telephone Number</b>	
<b>FAX Number</b>	

## B.3.2 Accreditation status of the test service

*The test laboratory provides the following information.*

**Table 4: Accreditation status of the test service**

<b>Accreditation status</b>	
<b>Accreditation Reference</b>	

## B.3.3 Manager of Test Laboratory

*The test laboratory provides the information about the manager of test laboratory in the following table.*

**Table 5: Manager of Test Laboratory**

<b>Name of Manager of Test Laboratory</b>	
<b>Telephone Number</b>	
<b>FAX Number</b>	
<b>E-mail Address</b>	

## B.3.4 Contact person of Test Laboratory

*The test laboratory provides the information about the contact person of test laboratory in the following table.*

**Table 6: Contact person of Test Laboratory**

<b>Name of Contact of Test Laboratory</b>	
<b>Telephone Number</b>	
<b>FAX Number</b>	
<b>E-mail Address</b>	

## B.3.5 Means of Testing

*In the table below, the test laboratory provides a statement of conformance of the Means Of Testing (MOT) to the reference standardized ATS, and identifies all restrictions for the test execution required by the MOT beyond those stated in the reference standardized ATS.*

**Table 7: Means of Testing**

Means of Testing
------------------

## B.3.6 Instructions for Completion

*In this table, the test laboratory provides any specific instructions necessary for completion and return of the proforma from the client.*

**Table 8: Instruction for Completion**

Instructions for Completion

## B.4 Client

### B.4.1 Client Identification

*The client provides the identification in the following table.*

**Table 9: Client Identification**

<b>Name of Client</b>	
<b>Postal Address</b>	
<b>Office Address</b>	
<b>Telephone Number</b>	
<b>FAX Number</b>	

### B.4.2 Client Test Manager

*In this table the client provides information about the test manager.*

**Table 10: Client Test Manager**

<b>Name of Client Test Manager</b>	
<b>Telephone Number</b>	
<b>FAX Number</b>	
<b>E-mail Address</b>	

### B.4.3 Client Contact person

*In this table the client provides information about the test contact person.*

**Table 11: Client Contact person**

<b>Name of Client contact person</b>	
<b>Telephone Number</b>	
<b>FAX Number</b>	
<b>E-mail Address</b>	

## B.4.4 Test Facilities Required

*In the following table, the client records the particular facilities required for testing, if a range of facilities is provided by the test laboratory.*

**Table 12: Test Facilities Required**

Test Facilities Required

---

## B.5 System Under Test

### B.5.1 SUT Information

*The client provides information about the SUT in the table below.*

**Table 13: SUT Information**

<b>System Name</b>	
<b>System Version</b>	
<b>SCS Reference</b>	
<b>Machine Configuration</b>	
<b>Operating System Identification</b>	
<b>IUT Identification</b>	
<b>ICS Reference for the IUT</b>	



## B.5.2 Limitations of the SUT

*In the table below, the client provides information explaining if any of the abstract tests cannot be executed.*

**Table 14: Limitation of the SUT**

Limitations of the SUT
------------------------

## B.5.3 Environmental Conditions

*In the table below the client provides information about any tighter environmental conditions for the correct operation of the SUT.*

**Table 15: Environmental Conditions**

Environmental Conditions

## B.6 Ancillary Protocols

*This clause is completed by the client in conjunction with the test laboratory.*

*In the following tables, the client identifies relevant information concerning each ancillary protocol in the SUT other than the IUT itself. One table for one ancillary protocol.*

*Based on the MOT the test laboratory should create question proforma for each ancillary protocol in the blank space following each table. The information required is dependent on the MOT and the SUT, and covers all the addressing, parameter values, timer values and facilities (relevant to TSs) as defined by the ICS for the ancillary protocol.*

### B.6.1 Ancillary Protocols 1

**Table 16: Ancillary Protocol 1**

<b>Protocol Name</b>	<b>ETS 300</b>
<b>Version number</b>	
<b>ICS Reference (optional)</b>	
<b>IXIT Reference (optional)</b>	
<b>PCTR Reference (optional)</b>	

### B.6.2 Ancillary Protocols 2

**Table 17: Ancillary Protocol 2**

<b>Protocol Name</b>	<b>ETS 300</b>
<b>Version number</b>	
<b>ICS Reference (optional)</b>	
<b>IXIT Reference (optional)</b>	
<b>PCTR Reference (optional)</b>	

## B.7 Protocol Layer Information for L3 of Mobile Station

### B.7.1 Information provided for test purposes by the MS supplier

<b>Item</b>	<b>Description</b>	<b>Type/Allowed values</b>	<b>Supported Value</b>
TSPC_24DataF	2.4 k full rate data mode supported – must be TRUE if TSPC_24DataH = TRUE	BOOLEAN	
TSPC_24DataH	2.4 k half rate data mode supported	BOOLEAN	

Item	Description	Type/Allowed values	Supported Value
TSPC_48DataF	4.8 k full rate data mode supported – must be TRUE if TSPC_48DataH = TRUE	BOOLEAN	
TSPC_48DataH	4.8 k half rate data mode supported	BOOLEAN	
TSPC_96Data	9.6 k full rate data mode supported	BOOLEAN	
TSPC_Feat_A51	ciphering algorithm A5/1 supported	BOOLEAN	
TSPC_Feat_A52	ciphering algorithm A5/2 supported	BOOLEAN	
TSPC_AddCharSet	A, B, C, D chars supported	BOOLEAN	
TSPC_AddInfo_PseudoSynch	Pseudo synchronised supported	BOOLEAN	
TSPC_AlertInd	alerting indication to the user supported	BOOLEAN	
TSPC_SvcOnTCH	at least one service on traffic channel supported	BOOLEAN	
TSPC_SMS	at least one short message service supported	BOOLEAN	
TSPC_SS	at least one supplementary service supported	BOOLEAN	
TSPC_AutoAutoMode	automatically enter automatic selection of PLMN mode supported	BOOLEAN	
TSPC_BasCharSet	Chars 0-9, *, # supported	BOOLEAN	
TSPC_CalledNumDisp	called number display supported	BOOLEAN	
TSPC_DCS	testing DCS1 800	BOOLEAN	
TSPC_DetachOnPwrDn	detach on power down supported	BOOLEAN	
TSPC_DetachOnSIMRmv	detach on SIM remove supported	BOOLEAN	
TSPC_DisprcvSMS	display of received SMS supported	BOOLEAN	
TSPC_DualRate	dual rate channel types supported	BOOLEAN	
TSPC_EGSM	both standard (PGSM) and extended GSM band supported	BOOLEAN	
TSPC_EmgOnly	the only circuit switched basic service is emergency call	BOOLEAN	
TSPC_followOnReq	follow-on request procedure supported	BOOLEAN	
TSPC_HalfRateData	at least one half rate data supported	BOOLEAN	
TSPC_HalfRateSpeech	half rate speech mode supported	BOOLEAN	
TSPC_InCallMod	In-Call modification supported	BOOLEAN	
TSPC_NoimmConn	at least one service not support immediate connection	BOOLEAN	

Item	Description	Type/Allowed values	Supported Value
TSPC_Feat_FND	FND feature supported	BOOLEAN	
TSPC_NonCallSS	non call related supplementary service supported	BOOLEAN	
TSPC_MTsvc	at least one MT circuit switched basic service supported	BOOLEAN	
TSPC_MOsvc	at least one MO circuit switched basic service supported	BOOLEAN	
TSPC_PGSM	only standard GSM band supported	BOOLEAN	
TSPC_RefusalCall	refusal of call supported	BOOLEAN	
TSPC_ReplaceSMS	replace SMS supported	BOOLEAN	
TSPC_ReplyProc	(SMS) reply procedures supported	BOOLEAN	
TSPC_RFAmp	RF amplification supported	BOOLEAN	
TSPC_SDCCHOnly	only SDCCH supported	BOOLEAN	
TSPC_Serv_SS_AoCC	Advice of Charge (Charging) SS supported	BOOLEAN	
TSPC_Serv_SS_BAIC	Barring of All Incoming Calls SS supported	BOOLEAN	
TSPC_Serv_SS_BI	BI SS supported	BOOLEAN	
TSPC_Serv_SS_BICRoam	Barring of Incoming Calls when Roaming Outside the Home PLMN Country SS supported	BOOLEAN	
TSPC_Serv_SS_BAOC	Barring of all Outgoing Calls SS supported	BOOLEAN	
TSPC_Serv_SS_BOIC	Barring of Outgoing International Calls SS supported	BOOLEAN	
TSPC_Serv_SS_BOICexHC	Barring of Outgoing International Calls except those directed to the Home PLMN Country SS supported	BOOLEAN	
TSPC_Serv_SS_CFB	Call Forwarding on Mobile Subscriber Busy SS supported	BOOLEAN	
TSPC_Serv_SS_CFNry	Call Forwarding on No Reply SS supported	BOOLEAN	
TSPC_Serv_SS_CFNrc	Call Forwarding on Mobile Subscriber Not Reachable SS supported	BOOLEAN	
TSPC_Serv_SS_CFU	Call Forwarding Unconditional SS supported	BOOLEAN	
TSPC_Serv_SS_HOLD	Call Hold SS supported	BOOLEAN	
TSPC_Serv_SS_MPTY	multiparty SS supported	BOOLEAN	
TSPC_Serv_SS_unstruct	USSD supported	BOOLEAN	
TSPC_Serv_TS11	telephony supported	BOOLEAN	
TSPC_Serv_TS12	emergency call supported	BOOLEAN	

Item	Description	Type/Allowed values	Supported Value
TSPC_Serv_TS21	SMS MT/PP supported	BOOLEAN	
TSPC_Serv_TS22	SMS MO/PP supported	BOOLEAN	
TSPC_Serv_TS23	SMS cell broadcast supported	BOOLEAN	
TSPC_Serv_TS61	alternate speech and G3 fax (TS61) supported	BOOLEAN	
TSPC_Serv_TS62	automatic G3 fax (TS62) supported	BOOLEAN	
TSPC_Serv_BS21	data circuit duplex async 300 bit/s supported	BOOLEAN	
TSPC_Serv_BS22	data circuit duplex async 1 200 bit/s supported	BOOLEAN	
TSPC_Serv_BS23	data circuit duplex async 1 200/75 bit/s supported	BOOLEAN	
TSPC_Serv_BS24	data circuit duplex async 2 400 bit/s supported	BOOLEAN	
TSPC_Serv_BS25	data circuit duplex async 4 800 bit/s supported	BOOLEAN	
TSPC_Serv_BS26	data circuit duplex async 9 600 bit/s supported	BOOLEAN	
TSPC_Serv_BS31	data circuit duplex sync 1 200 bit/s supported	BOOLEAN	
TSPC_Serv_BS32	data circuit duplex sync 2 400 bit/s supported	BOOLEAN	
TSPC_Serv_BS33	data circuit duplex sync 4 800 bit/s supported	BOOLEAN	
TSPC_Serv_BS34	data circuit duplex sync 9 600 bit/s supported	BOOLEAN	
TSPC_Serv_BS41	PAD access 300 bit/s supported	BOOLEAN	
TSPC_Serv_BS42	PAD access 1 200 bit/s supported	BOOLEAN	
TSPC_Serv_BS43	PAD access 1 200/75 bit/s supported	BOOLEAN	
TSPC_Serv_BS44	PAD access 2 400 bit/s supported	BOOLEAN	
TSPC_Serv_BS45	PAD access 4 800 bit/s supported	BOOLEAN	
TSPC_Serv_BS46	PAD access 9 600 bit/s supported	BOOLEAN	
TSPC_Serv_BS51	packet access 2 400 bit/s supported	BOOLEAN	
TSPC_Serv_BS52	packet access 4 800 bit/s supported	BOOLEAN	
TSPC_Serv_BS53	packet access 9 600 bit/s supported	BOOLEAN	
TSPC_Serv_BS61	alternate speech/data (BS61) supported	BOOLEAN	
TSPC_Serv_BS81	speech followed data (BS81) supported	BOOLEAN	
TSPC_SMSStatusRepCap	SMS status report capabilities supported	BOOLEAN	

Item	Description	Type/Allowed values	Supported Value
TSPC_StoreRcvSMSME	Storage of received SMS in ME supported	BOOLEAN	
TSPC_StoreRcvSMSSIM	Storage of received SMS in SIM supported	BOOLEAN	
TSPC_SIMRmv	SIM removable without power down supported	BOOLEAN	
TSPC_SwitchOnOff	switch on/off supported	BOOLEAN	
TSPC_TranspDataOnly	only transparent data service supported	BOOLEAN	
TSPC_CC	CC protocol for at least one BC supported	BOOLEAN	
TSPC_TeleSvc	at least one teleservice supported	BOOLEAN	
TSPC_EFR	Set to TRUE for EFR MS which supports any EFR features and FALSE otherwise	BOOLEAN	
TSPC_EFR_Speech_v2	Set to TRUE for EFR MS which supports EFR Speech Version 2 and FALSE otherwise	BOOLEAN	
TSPC_EFR_Speech_v3	Set to TRUE for EFR MS which supports EFR Speech Version 3 and FALSE otherwise	BOOLEAN	
TSPC_EFR_EmgCallBcap	Set to TRUE if received ESETUP message contains bearer capability IE, otherwise FALSE	BOOLEAN	
TSPC_FullRateSpeech	full rate speech mode supported – must be TRUE if TSPC_HalfRateSpeech = TRUE	BOOLEAN	
TSPC_FullRateOnly	only full rate channel type supported	BOOLEAN	
TSPC_StoredListCellSel	Stored List Cell Selection supported	BOOLEAN	
TSPX_TE_stopbit	Terminal Equipment configuration number stop bits. default value : '0'B, 1 bit	BITSTRING[1]	
TSPX_TE_databit	Terminal Equipment configuration number data bits. '0'B, 7bits, '1'B, 8bits - default value : '1'B, 8 bits	BITSTRING[1]	
TSPX_TE_FLCT	Terminal Equipment flow control. Type of flow control. 0-outband flow control, 1-inband flow control, 2-no flow control. default : 0, outband flow control	0, 1, 2	
TSPX_TE_parity	Terminal Equipment configuration parity. 000=odd, 010=even, 011=none, 100=forced to 0, 101=forced to 1. default : '001'B, no parity	BITSTRING[3]	
TSPX_BS_21_itc1	Information Transfer Capability value supported for BS21(async data 300bit/s). default value : '001'B, Unrestricted Digital Information	BITSTRING[3]	

Item	Description	Type/Allowed values	Supported Value
TSPX_BS_21_more_etc	more than one Information Transfer Capability value supported by BS21(async data 300bit/s). default value : FALSE, only one etc	BOOLEAN	
TSPX_BS_21_T_NT	both Transparent and Non-Transparent supported by BS21(async data 300bit/s). default value : FALSE, not support both transparent and non transparent modes	BOOLEAN	
TSPX_BS_21_ce	BS21(async data 300bit/s). Connection Element value used in MO call and if the answer to TSPX_BS_21_T_NT is FALSE, the manufacturer must precise which mode is supported by the MS. default value : '00'B, transparent mode	BITSTRING[2]	
TSPX_BS_21_sacp	BS21(async data 300bit/s). Signalling Access Protocol value used in MO call. default value : '001'B, I440/450	BITSTRING[3]	
TSPX_BS_21_etc2	other Information Transfer Capability value supported by BS21(async data 300bit/s), it shall be different from the previous one if the answer to TSPX_BS_21_more_etc is TRUE. default value : '001'B, Unrestricted Digital Information	BITSTRING[3]	
TSPX_BS_22_etc1	Information Transfer Capability value supported by BS22(async data 1200bit/s). default value : '010'B, 3.1kHz audio, exPLMN	BITSTRING[3]	
TSPX_BS_22_more_etc	more than one Information Transfer Capability value supported by BS22(async data 1200bit/s). default value : FALSE, only one etc	BOOLEAN	
TSPX_BS_22_T_NT	both Transparent and Non-Transparent supported by BS22(async data 1200bit/s). default value : FALSE, not support both transparent and non transparent modes	BOOLEAN	
TSPX_BS_22_ce	BS22(async data 1200bit/s) Connection Element value used in MO call and if the answer to TSPX_BS_22_T_NT is FALSE, the manufacturer must precise which mode is supported by the MS. default value : '01'B, non transparent	BITSTRING[2]	
TSPX_BS_22_sacp	BS22(async data 1200bit/s) Signalling Access Protocol value used in MO call. default value : '001'B, I440/450	BITSTRING[3]	



Item	Description	Type/Allowed values	Supported Value
TSPX_BS_22_itc2	other Information Transfer Capability value supported by BS22(async data 1200bit/s), it shall be different from the previous one if the answer to TSPX_BS_22_more_itc is TRUE. default value : '010'B, 3.1kHz audio, exPLMN	BITSTRING[3]	
TSPX_BS_23_itc	Information Transfer Capability value supported by BS23(async 1200/75 bit/s). default value : '010'B, 3.1kHz audio, exPLMN	BITSTRING[3]	
TSPX_BS_23_T_NT	both Transparent and Non-Transparent supported for BS23(async 1200/75 bit/s). default value : FALSE, not support both transparent and non transparent modes	BOOLEAN	
TSPX_BS_23_ce	BS23(async 1200/75 bit/s) Connection Element value used in MO call. default value : '00'B, transparent	BITSTRING[2]	
TSPX_BS_23_sacp	BS23(async 1200/75 bit/s) Signalling Access Protocol value used in MO call. default value : '001'B, 1440/450	BITSTRING[3]	
TSPX_BS_24_itc1	Information Transfer Capability value supported by BS24(async 2400 bit/s). default value : '010'B, 3.1kHz audio, exPLMN	BITSTRING[3]	
TSPX_BS_24_more_itc	more than one Information Transfer Capability value supported by BS24(async 2400 bit/s). default value : FALSE, only one itc	BOOLEAN	
TSPX_BS_24_T_NT	both Transparent and Non-Transparent supported by BS24(async 2400 bit/s). default value : FALSE, not support both transparent and non transparent modes	BOOLEAN	
TSPX_BS_24_ce	BS24(async 2400 bit/s) Connection Element value used in MO call and if the answer to TSPX_BS_24_T_NT is FALSE, the manufacturer must precise which mode is supported by the MS. default value : '00'B, transparent	BITSTRING[2]	
TSPX_BS_24_sacp	BS24(async 2400 bit/s) Signalling Access Protocol value used in MO call. default value : '001'B, 1440/450	BITSTRING[3]	

Item	Description	Type/Allowed values	Supported Value
TSPX_BS_24_itc2	other Information Transfer Capability value supported by BS24(async 2400 bit/s), it shall be different from the previous one if the answer to TSPX_BS_24_more_itc is TRUE. default value : '010'B, 3.1kHz audio, exPLMN	BITSTRING[3]	
TSPX_BS_25_itc1	Information Transfer Capability value supported by BS25(async 4800 bit/s). default value : '001'B, Unrestricted Digital Information	BITSTRING[3]	
TSPX_BS_25_more_itc	more than one Information Transfer Capability value supported by BS25(async 4800 bit/s). default value : FALSE, only one itc	BOOLEAN	
TSPX_BS_25_T_NT	both Transparent and Non-Transparent supported by BS25(async 4800 bit/s). default value : FALSE, not support both transparent and non transparent modes	BOOLEAN	
TSPX_BS_25_ce	BS25(async 4800 bit/s) Connection Element value used in MO call and if the answer to TSPX_BS_25_T_NT is FALSE, the manufacturer must precise which mode is supported by the MS. default value : '00'B, transparent	BITSTRING[2]	
TSPX_BS_25_sacp	BS25(async 4800 bit/s) Signalling Access Protocol value used in MO call. default value : '001'B, I440/450	BITSTRING[3]	
TSPX_BS_25_itc2	other Information Transfer Capability value supported by BS25(async 4800 bit/s), it shall be different from the previous one if the answer to TSPX_BS_25_more_itc is TRUE. default value : '001'B, Unrestricted Digital Information	BITSTRING[3]	
TSPX_BS_26_itc1	Information Transfer Capability value supported by BS26(async 9600 bit/s). default value : '010'B, 3.1kHz audio, exPLMN	BITSTRING[3]	
TSPX_BS_26_more_itc	more than one Information Transfer Capability value supported by BS26(async 9600 bit/s). default value : FALSE, only one itc	BOOLEAN	
TSPX_BS_26_T_NT	both Transparent and Non-Transparent supported by BS26(async 9600 bit/s). default value : FALSE, not support both transparent and non transparent modes	BOOLEAN	

Item	Description	Type/Allowed values	Supported Value
TSPX_BS_26_ce	BS26(async 9600 bit/s) Connection Element value used in MO call and if the answer to TSPX_BS_26_T_NT is FALSE, the manufacturer must precise which mode is supported by the MS. default value : '00'B, transparent	BITSTRING[2]	
TSPX_BS_26_sacp	BS26(async 9600 bit/s) Signalling Access Protocol value used in MO call. default value : '001'B, I440/450	BITSTRING[3]	
TSPX_BS_26_itc2	other Information Transfer Capability value supported by BS26, it shall be different from the previous one if the answer to TSPX_BS_26_more_itc is TRUE. default value : '010'B, 3.1kHz audio, exPLMN	BITSTRING[3]	
TSPX_BS_31_more_itc	more than one Information Transfer Capability value supported by BS31(sync data 1200 bit/s). default value : FALSE, only one itc	BOOLEAN	
TSPX_BS_31_more_sacp	more than one Signalling Access Protocol value supported by BS31(sync data 1200 bit/s). default value : FALSE, only one sacp	BOOLEAN	
TSPX_BS_31_itc1	Information Transfer Capability value supported by BS31(sync data 1200 bit/s). default value : '001'B, Unrestricted Digital Information	BITSTRING[3]	
TSPX_BS_31_sacp1	Signalling Access Protocol value supported by BS31(sync data 1200 bit/s). default value : '001'B, I440/450	BITSTRING[3]	
TSPX_BS_31_itc2	other Information Transfer Capability value supported by BS31(sync data 1200 bit/s), it shall be different from the previous one if the answer to TSPX_BS_31_more_itc is TRUE. default value : '001'B, Unrestricted Digital Information	BITSTRING[3]	
TSPX_BS_31_sacp2	other Signalling Access Protocol value supported by BS31(sync data 1200 bit/s), it shall be different from the previous one if the answer to TSPX_BS_31_more_Signalling Access Protocol is TRUE. default value : '001'B, I440/450	BITSTRING[3]	
TSPX_BS_32_itc1	Information Transfer Capability value supported by BS32(sync data 2400 bit/s). default value : '010'B, 3.1kHz audio, exPLMN	BITSTRING[3]	

Item	Description	Type/Allowed values	Supported Value
TSPX_BS_32_more_its	more than one Information Transfer Capability value supported by BS32(sync data 2400 bit/s). default value : FALSE, only one its	BOOLEAN	
TSPX_BS_32_more_sacp	more than one Signalling Access Protocol value supported by BS32(sync data 2400 bit/s). default value : FALSE, only one sacp	BOOLEAN	
TSPX_BS_32_sacp1	Signalling Access Protocol value supported by BS32(sync data 2400 bit/s). default value : '110'B, X.32	BITSTRING[3]	
TSPX_BS_32_X32_T_NT	BS 32(sync data 2400 bit/s) both Transparent and Non-Transparent supported for X32 3.1kHz. default value : FALSE, not support both transparent and non transparent modes	BOOLEAN	
TSPX_BS_32_X32_ce	BS32(sync data 2400 bit/s). If the answer to TSPX_BS_32_X32_T_NT is FALSE, the manufacturer must precise which mode is supported by the MS. Connection Element default value : '01'B, non transparent	BITSTRING[2]	
TSPX_BS_32_its2	other Information Transfer Capability value supported by BS32(sync data 2400 bit/s), it shall be different from the previous one if the answer to TSPX_BS_32_more_its is TRUE. default value : '010'B, 3.1kHz audio, exPLMN	BITSTRING[3]	
TSPX_BS_32_sacp2	other Signalling Access Protocol value supported by BS32(sync data 2400 bit/s), it shall be different from the previous one if the answer to TSPX_BS_32_more_sacp is TRUE. default value : '110'B, X.32	BITSTRING[3]	
TSPX_BS_33_its1	Information Transfer Capability value supported by BS33 (sync data 4800 bit/s). default value : '001'B, Unrestricted Digital Information	BITSTRING[3]	
TSPX_BS_33_more_its	more than one Information Transfer Capability value supported by BS33(sync data 4800 bit/s). default value : FALSE, only one its	BOOLEAN	
TSPX_BS_33_more_sacp	more than one Signalling Access Protocol value supported by BS33(sync data 4800 bit/s). default value : FALSE, only one sacp	BOOLEAN	

Item	Description	Type/Allowed values	Supported Value
TSPX_BS_33_sacp1	Signalling Access Protocol value supported by BS33(sync data 4800 bit/s). default value : '010'B, X.21	BITSTRING[3]	
TSPX_BS_33_X32_T_NT	BS 33(sync data 4800 bit/s) both Transparent and Non-Transparent supported for X32 3.1kHz. default value : FALSE, not support both transparent and non transparent modes	BOOLEAN	
TSPX_BS_33_X32_ce	BS33(sync data 4800 bit/s). If the answer to TSPX_BS_33_X32_T_NT is FALSE, the manufacturer must precise which mode is supported by the MS. Connection Element default value : '00'B, transparent	BITSTRING[2]	
TSPX_BS_33_itc2	other Information Transfer Capability value supported by BS33(sync data 4800 bit/s), it shall be different from the previous one if the answer to TSPX_BS_33_more_itc is TRUE. default value : '001'B, Unrestricted Digital Information	BITSTRING[3]	
TSPX_BS_33_sacp2	other Signalling Access Protocol value supported by BS33(sync data 4800 bit/s), it shall be different from the previous one if the answer to TSPX_BS_33_more_sacp is TRUE. default value : '010'B, X.21	BITSTRING[3]	
TSPX_BS_34_itc1	Information Transfer Capability value supported by BS34(sync data 9600 bit/s). default value : '010'B, 3.1kHz audio, exPLMN	BITSTRING[3]	
TSPX_BS_34_more_itc	more than one Information Transfer Capability value supported by BS34(sync data 9600 bit/s). default value : FALSE, only one itc	BOOLEAN	
TSPX_BS_34_more_sacp	more than one Signalling Access Protocol value supported by BS34(sync data 9600 bit/s). default value : FALSE, only one sacp	BOOLEAN	
TSPX_BS_34_sacp1	Signalling Access Protocol value supported by BS34(sync data 9600 bit/s). default value : '001'B, I440/450	BITSTRING[3]	
TSPX_BS_34_X32_T_NT	BS 34(sync data 9600 bit/s) both Transparent and Non-Transparent supported for X32 3.1kHz. default value : FALSE, not support both transparent and non transparent modes	BOOLEAN	

Item	Description	Type/Allowed values	Supported Value
TSPX_BS_34_X32_ce	BS34(sync data 9600 bit/s). If the answer to TSPX_BS_34_X32_T_NT is FALSE, the manufacturer must precise which mode is supported by the MS. Connection Element default value : '00'B, transparent	BITSTRING[2]	
TSPX_BS_34_itc2	other Information Transfer Capability value supported by BS34(sync data 9600 bit/s), it shall be different from the previous one if the answer to TSPX_BS_34_more_itc is TRUE. default value : '010'B, 3.1kHz audio, exPLMN	BITSTRING[3]	
TSPX_BS_34_sacp2	other Signalling Access Protocol value supported by BS34(sync data 9600 bit/s), it shall be different from the previous one if the answer to TSPX_BS_34_more_sacp is TRUE. default value : '001'B, I440/450	BITSTRING[3]	
TSPX_BS_41_T_NT	BS41(PAD access 300 bit/s) both Transparent and Non-Transparent supported . default value : FALSE, not support both	BOOLEAN	
TSPX_BS_41_ce	Connection Element value used in BS41(PAD access 300 bit/s) MO call. default value : '00'B, transparent	BITSTRING[2]	
TSPX_BS_42_T_NT	BS42(PAD access 1200 bit/s) both Transparent and Non-Transparent supported . default value : FALSE, not support both transparent and non transparent modes	BOOLEAN	
TSPX_BS_42_ce	Connection Element value used in BS42(PAD access 1200 bit/s) MO call. default value : '00'B, transparent	BITSTRING[2]	
TSPX_BS_43_T_NT	BS43(PAD access 1200/75 bit/s) both Transparent and Non-Transparent supported . default value : FALSE, not support both transparent and non transparent modes	BOOLEAN	
TSPX_BS_43_ce	Connection Element value used in BS43(PAD access 1200/75 bit/s) MO call. default value : '00'B, transparent	BITSTRING[2]	
TSPX_BS_44_T_NT	BS44(PAD access 2400 bit/s) both Transparent and Non-Transparent supported . default value : FALSE, not support both transparent and non transparent modes	BOOLEAN	

Item	Description	Type/Allowed values	Supported Value
TSPX_BS_44_ce	Connection Element value used in BS44(PAD access 2400 bit/s) MO call. default value : '00'B, transparent	BITSTRING[2]	
TSPX_BS_45_T_NT	BS45(PAD access 4800 bit/s) both Transparent and Non-Transparent supported . default value : FALSE, not support both transparent and non transparent modes	BOOLEAN	
TSPX_BS_45_ce	Connection Element value used in BS45(PAD access 4800 bit/s) MO call. default value : '00'B, transparent	BITSTRING[2]	
TSPX_BS_46_T_NT	BS46(PAD access 9600 bit/s) both Transparent and Non-Transparent supported . default value : FALSE, not support both transparent and non transparent modes	BOOLEAN	
TSPX_BS_46_ce	Connection Element value used in BS46(PAD access 9600 bit/s) MO call. default value : '00'B, transparent	BITSTRING[2]	
TSPX_BS_61_S	synchronous data supported by BS 61(alternate speech/data) . default value : TRUE, synchronous mode	BOOLEAN	
TSPX_BS_61_S_more_ur	more than one user rate for synchronous data service supported by BS61(alternate speech/data). default value : FALSE, only one user rate	BOOLEAN	
TSPX_BS_61_S_ur1	user rate value supported for synchronous data service of BS61(alternate speech/data). default value : '0100'B, 4.8 kbit/s	BITSTRING[4]	
TSPX_BS_61_S_ur2	another user rate value supported for synchronous data service of BS61(alternate speech/data). it shall be different from the previous one if the answer to TSPX_BS_61_S_more_ur is TRUE. default value : '0100'B, 4.8 kbit/s	BITSTRING[4]	
TSPX_BS_61_A	asynchronous data service supported by BS61(alternate speech/data) . default value : TRUE, asynchronous	BOOLEAN	
TSPX_BS_61_A_ur1	user rate value supported for asynchronous data service of BS61(alternate speech/data). default value : '0101'B, 9.6 kbit/s	BITSTRING[4]	

Item	Description	Type/Allowed values	Supported Value
TSPX_BS_61_A_ur1_T_NT	both Transparent and Non-Transparent supported for the rate TSPX_BS_61_A_ur1 of BS61(alternate speech/data). default value : FALSE, not support both transparent and non transparent modes	BOOLEAN	
TSPX_BS_61_A_ur1_ce	BS61(alternate speech/data). If the answer to TSPX_BS_61_A_ur1_T_NT is FALSE, the manufacturer must precise which mode is supported by the MS. Connection Element default value : '00'B, transparent	BITSTRING[2]	
TSPX_BS_61_A_more_ur	more than one user rate for asynchronous data service supported by BS61(alternate speech/data). default value : FALSE, only one user rate	BOOLEAN	
TSPX_BS_61_A_ur2	another user rate value supported for asynchronous data service of BS61(alternate speech/data).. it shall be different from the previous one if the answer to TSPX_BS_61_A_more_ur is TRUE. default value : '0101'B, 9.6 kbit/s	BITSTRING[4]	
TSPX_BS_61_A_ur2_T_NT	BS61(alternate speech/data). both Transparent and Non-Transparent supported for the rate TSPX_BS_61_A_ur2 of BS61. default value : FALSE, not support both transparent and non transparent modes	BOOLEAN	
TSPX_BS_81_S	synchronous data supported by BS 81(speech followed by data). default value : TRUE, synchronous mode	BOOLEAN	
TSPX_BS_81_S_more_ur	more than one user rate for synchronous data service supported by BS81(speech followed by data). default value : FALSE, only one user rate	BOOLEAN	
TSPX_BS_81_S_ur1	user rate value supported for synchronous data service of BS81(speech followed by data). default value : '0101'B, 9.6 kbit/s	BITSTRING[4]	
TSPX_BS_81_S_ur2	another user rate value supported for synchronous data service of BS81(speech followed by data). it shall be different from the previous one if the answer to TSPX_BS_81_S_more_ur is TRUE. default value : '0101'B, 9.6 kbit/s	BITSTRING[4]	
TSPX_BS_81_A	asynchronous data service supported by BS81 (speech followed by data). default value : TRUE, asynchronous mode	BOOLEAN	



Item	Description	Type/Allowed values	Supported Value
TSPX_BS_81_A_ur1	user rate value supported for asynchronous data service of BS81 (speech followed by data).. default value : '0100'B, 4.8 kbit/s	BITSTRING[4]	
TSPX_BS_81_A_ur1_T_NT	both Transparent and Non-Transparent supported for the rate TSPX_BS_81_A_ur1 of BS81(speech followed by data). default value : FALSE, not support both transparent and non transparent modes	BOOLEAN	
TSPX_BS_81_A_ur1_ce	BS81(speech followed by data). if the answer to TSPX_BS_81_A_ur1_T_NT is FALSE, the manufacturer must precise which mode is supported by the MS. Connection Element default value : '01'B, non transparent	BITSTRING[2]	
TSPX_BS_81_A_more_ur	more than one user rate for asynchronous data service supported by BS81(speech followed by data). default value : FALSE, only one user rate	BOOLEAN	
TSPX_BS_81_A_ur2	another user rate value supported for asynchronous data service of BS81(speech followed by data). it shall be different from the previous one if the answer to TSPX_BS_81_A_more_ur is TRUE. default value : '0100'B, 4.8 kbit/s	BITSTRING[4]	
TSPX_BS_81_A_ur2_T_NT	both Transparent and Non-Transparent supported for the rate TSPX_BS_81_A_ur2 of BS81(speech followed by data). default value : FALSE, not support both transparent and non transparent modes	BOOLEAN	
TSPX_TS_61_T_NT	both Transparent and Non-Transparent supported for TS61(alternate speech and G3 fax). default value : FALSE, not support both transparent and non transparent modes	BOOLEAN	
TSPX_TS_61_ce	TS61(alternate speech and G3 fax). if the answer to TSPX_TS_61_T_NT is FALSE, the manufacturer must precise which mode is supported by the MS. Connection Element default value : '01'B, non transparent	BITSTRING[2]	
TSPX_TS_61_ur1	user rate for TS61(alternate speech and G3 fax). default value : '0101'B, 9.6 kbit/s	BITSTRING[4]	
TSPX_TS_61_more_ur	more than one user rate supported for TS61(alternate speech and G3 fax). default value : FALSE, only one user rate	BOOLEAN	

Item	Description	Type/Allowed values	Supported Value
TSPX_TS_61_ur2	another user rate for TS61(alternate speech and G3 fax), it shall be different from the previous one if the answer to TSPX_TS_61_more_ur is TRUE. default value : '0101'B, 9.6 kbit/s	BITSTRING[4]	
TSPX_TS_62_T_NT	both Transparent and Non-Transparent supported for TS62(automatic G3 fax). default value : FALSE, not support both transparent and non transparent modes	BOOLEAN	
TSPX_TS_62_ce	TS62(automatic G3 fax). if the answer to TSPX_TS_62_T_NT is FALSE, the manufacturer must precise which mode is supported by the MS. Connection Element default value : '00'B, transparent	BITSTRING[2]	
TSPX_TS_62_ur1	user rate for TS62(automatic G3 fax). default value : '0100'B, 4.8 kbit/s	BITSTRING[4]	
TSPX_TS_62_more_ur	more than one user rate supported by TS62(automatic G3 fax). default value : FALSE, only one user rate	BOOLEAN	
TSPX_TS_62_ur2	another user rate for TS62(automatic G3 fax), it shall be different from the previous one if the answer to TSPX_TS_62_more_ur is TRUE. default value : '0100'B, 4.8 kbit/s	BITSTRING[4]	
TSPX_DTMF	call control capabilities: value '1'B means MS supports DTMF	BITSTRING[1]	
TSPX_modF	any non signalling full rate channel mode for TC_26_6_4_1	BITSTRING[8]	
TSPX_modH	any non signalling half channel mode for TC_26_6_4_1	BITSTRING[8]	
TSPX_anymod	Any supported channel mode value except signalling and Full rate speech.	BITSTRING[8]	
TSPX_CKSNA	cipher key sequence number GSM 04.08, 10.5.1.2	BITSTRING[3]	
TSPX_CKSNB	cipher key sequence number GSM 04.08, 10.5.1.2	BITSTRING[3]	
TSPX_CKSNC	cipher key sequence number GSM 04.08, 10.5.1.2	BITSTRING[3]	
TSPX_CKSNDf	default cipher key sequence number GSM 04.08, 10.5.1.2	BITSTRING[3]	
TSPX_RfPwrCap	RF power capability GSM: '000'B Class1 to '100'B Class 5 DCS: '000'B Class1 to '010'B Class 3	BITSTRING[3]	
TSPX_RevLevel	Revision level of classmark 1 – '00'B Phase 1, '01'B Phase 2	BITSTRING[2]	
TSPX_CiphAlgA5_1	Default Algorithm - A5/1 algorithm: NB '0'B : available, '1'B: not available	BITSTRING[1]	

Item	Description	Type/Allowed values	Supported Value
TSPX_CiphAlgA5_2	A5/2 algorithm: '1'B : available, '0'B: not available	BITSTRING[1]	
TSPX_CiphAlgA5_3	A5/3 algorithm: '1'B : available, '0'B: not available	BITSTRING[1]	
TSPX_CiphAlgA5_4	A5/4 algorithm: '1'B : available, '0'B: not available	BITSTRING[1]	
TSPX_CiphAlgA5_5	A5/5 algorithm: '1'B : available, '0'B: not available	BITSTRING[1]	
TSPX_CiphAlgA5_6	A5/6 algorithm: '1'B : available, '0'B: not available	BITSTRING[1]	
TSPX_CiphAlgA5_7	A5/7 algorithm: '1'B : available, '0'B: not available	BITSTRING[1]	
TSPX_pSyncCap	pseudo synchronisation capability, '0'B: not present '1'B: present	BITSTRING[1]	
TSPX_SSscrnInd	SS screen indicator – GSM 04.80	BITSTRING[2]	
TSPX_SMCap	Support of mobile terminated point to point short messages , '0'B: not present '1'B: present	BITSTRING[1]	
TSPX_frqCap	EGSM frequency capability. DCS: reserved, GSM: '0'B not support extension band, '1'B support extension band	BITSTRING[1]	
TSPX_ClsMk3	classmark 3 indicator, '0'B no addition capability info, '1'B additional capability info in class mark 3	BITSTRING[1]	
TSPX_ESIND	Controlled Early Classmark Sending option implementation – default =0, not implemented	BITSTRING[1]	
TSPX_RfPwrCapAmp	RF power capability with external RF amplifier GSM: '000'B Class1 to '100'B Class 5 DCS: '000'B Class1 to '010'B Class 3	BITSTRING[3]	
TSPX_DTMFInd	DTMF indication to user supported	BOOLEAN	
TSPX_IMEI	IMEI of the MS.	HEXSTRING	
TSPX_IMEISV	IMEISV of the MS. Used in: TC_26_6_8_5, TC_26_7_3_1	HEXSTRING	
TSPX_TC1M	timer value for GSM timer TC1M (for SMS)	INTEGER	
TSPX_MaxCPDataRetx	max. number of CP data retransmissions for SMS	INTEGER	
TSPX_Immconn	Immediate connect for telephony supported ?	BOOLEAN	
TSPX_Uupd	user-user protocol discriminator for TC_26_8_3	BITSTRING[8]	
TSPX_UuInfo	user-user information for TC_26_8_3	OCTETSTRING	

## B.7.2 MMI information

<p>How is the Accumulated Call Meter (ACM) on the SIM read ?</p> <p>NOTE: Used in Operation OO_ACMIncCHK and OO_ACMReading.</p>
<p>How is the ACM on the SIM reset to zero, and ACMmax set to 2 units?</p> <p>NOTE: Used in Operation OO_ACMSetting.</p>
<p>How is power amplification added to the mobile and removed?</p> <p>NOTE: Used in Operation OO_AddPwrAmp and OO_RemvPwrAmp.</p>
<p>What alerting indication is given by the mobile?</p> <p>NOTE: Used in Operation OO_AltIndCHK.</p>
<p>How is the called party number displayed on the mobile?</p> <p>NOTE: Used in Operation OO_CalledNumCHK and OO_CalledPtyNumCHK.</p>
<p>How is a call placed on Hold?</p> <p>NOTE: Used in Operation OO_CallHold.</p>
<p>How is the presence of short messages checked in the mobile and how are they displayed?</p> <p>NOTE: Used in Operation OO_CheckAllSMPresentBut4th and OO_CheckMessageDisplayed and OO_DisplaySMAndSendReplySM and OO_ReadSMAndRemove and OO_RecallAndDisplaySM.</p>
<p>How is the presence of Cell Broadcast short messages in the mobile checked?</p> <p>NOTE: Used in Operation OO_CheckCBSMReceived.</p>

<p>How is it checked whether the memory capacity of the SIM has been exceeded?</p> <p>NOTE: Used in Operation OO_CheckMCEFOOnSIM and OO_CheckMCEFOOnSIMUnset.</p>
<p>How and where is the SIM inserted and removed?</p> <p>NOTE: Used in Operation OO_ConnectSIMSimulator and OO_SIMIns and OO_SIM2Ins and OO_SIM3Ins and OO_SIMRmv.</p>
<p>Does the MS have an 'END' key? If not, what method is used to replace its function?</p> <p>NOTE: Used in Operation OO_DepressEndKey.</p>
<p>How is a number entered in order to make an outgoing call?</p> <p>NOTE: Used in Operation OO_DiallCalledNum.</p>
<p>How is a reply to a received short message sent?</p> <p>NOTE: Used in Operation OO_DisplaySMAndSendReplySM.</p>
<p>How is it checked which DTMF character has been sent?</p> <p>NOTE: Used in Operation OO_DTMFIndCHK.</p>
<p>How is the message store of the MS emptied?</p> <p>NOTE: Used in OO_EmptyMessageStorage.</p>
<p>How is a password on the MS entered?</p> <p>NOTE: Used in Operation OO_EnterPswd.</p>

<p>How is an incoming call answered?</p> <p>NOTE: Used in Operation OO_HookOff.</p>
<p>For each service on the MS which requires the MS to be connected to an interface on other equipment (e.g. a computer), how is that interface set up for the purpose?</p> <p>NOTE: Used in Operation OO_IFsetup.</p>
<p>How is an In-Call modification initiated on the MS?</p> <p>NOTE: Used in Operation OO_InCallMod.</p>
<p>For each mobile originating basic service supported by the MS, how is the MS configured to make an outgoing call on that service?</p> <p>NOTE: Used in Operation OO_InitCall.</p>
<p>How is the MS to configured accept standard MMI sequences for the initiation of supplementary services?</p> <p>NOTE: Used in Operation OO_InitSS</p>
<p>How is the MS checked whether it is in the normal service state (idle, updated).</p> <p>NOTE: Used in Operation OO_InServiceCHK and OO_PressKeyWhenInService.</p>
<p>How is a Multi-Party call initiated on the MS.</p> <p>NOTE: Used in Operation OO_MptyCall</p>
<p>How is the MS configured to store received Class 1 short messages in the mobile equipment (rather than in the SIM)?</p> <p>NOTE: Used in Operation OO_MSSetupStoreClass1SMInMEMemory.</p>

<p>How is the list of available PLMNs checked?</p> <p>NOTE: Used in Operation OO_PLMNsCHK.</p>
<p>How is the PLMN selection mode switched to automatic selection.</p> <p>NOTE: Used in operation OO_PLMNselModeAuto.</p>
<p>How is the PLMN selection mode switched to manual selection.</p> <p>NOTE: Used in operation OO_PLMNselModeMan.</p>
<p>How is the power source for the MS removed and replaced. (Note, this is not the same as switching the Mobile on and off using the on/off switch.)</p> <p>NOTE: Used in operation OO_PowerUp and OO_PowerDown.</p>
<p>How is a short message removed from the message store?</p> <p>NOTE: Used in operation OO_ReadSMAndRemove.</p>
<p>When in manual PLMN selection mode, how is a PLMN selected?</p> <p>NOTE: Used in OperationOO_SelPLMN</p>
<p>How is a short message sent from the MS?</p> <p>NOTE: Used in operation OO_SendMOShortMessage.</p>
<p>How is an SMS COMMAND message sent to delete the last short message sent?</p> <p>NOTE: Used in OO_SendSMSCOMMANDDe.</p>

<p>How is an SMS COMMAND message sent enquiring about the last short message sent?</p> <p>NOTE: Used in OO_SendSMS_COMMANDEnq</p>
<p>How is Call Refusal set on the MS?</p> <p>NOTE: Used in Operation OO_SetRefuseCall.</p>
<p>How is a DTMF digit sent?</p> <p>NOTE: Used in operation OO_ShortKeyDepr.</p>
<p>How is it checked whether a supplementary service result is correct?</p> <p>NOTE: Used in Operation OO_SSresultCHK</p>
<p>How is the MS switched on and off?</p> <p>NOTE: Used in operation OO_SwitchOn and OO_SwitchOff.</p>
<p>How is a call cleared?</p> <p>NOTE: Used in operation OO_TermCall.</p>

### B.7.3 Test house specified parameters

Item	Description	Type/Allowed values	Value chosen
TSPX_AltNb	use alternative neighbour cells description. default : FALSE	BOOLEAN	
TSPX_CphAlgA	ciphering algorithm identifier – ‘000’ A5/1 to ‘110’ A5/7	OCTETSTRING [1]	
TSPX_CphAlgB	ciphering algorithm identifier – ‘000’ A5/1 to ‘110’ A5/7	OCTETSTRING [1]	
TSPX_CphAlgC	ciphering algorithm identifier – ‘000’ A5/1 to ‘110’ A5/7	OCTETSTRING [1]	



Item	Description	Type/Allowed values	Value chosen
TSPX_CphAlgD	ciphering algorithm identifier – ‘000’ A5/1 to ‘110’ A5/7	OCTETSTRING [1]	
TSPX_CphAlgE	ciphering algorithm identifier – ‘000’ A5/1 to ‘110’ A5/7	OCTETSTRING [1]	
TSPX_CphAlgDef	default ciphering algorithm identifier – ‘000’ A5/1 to ‘110’ A5/7	OCTETSTRING [1]	
TSPX_NoOfHoAccA	number of handover access bursts, value range 10 - 20 TC_26_6_5_1(M=1, 8) TC_26_6_5_2(M=1,8) TC_26_6_5_4_1 TC_26_10_2_4_1 TC_26_10_2_4_2 TC_26_12_2_1(M=1,4,7,11) TC_26_12_2_2(M=1,4,7,8,11) TC_26_11_2_2_1 TC_26_11_5_1 TC_26_11_5_2	INTEGER	
TSPX_NoOfHoAccB	number of handover access bursts, value range 10 - 20 TC_26_6_5_1(M=2) TC_26_6_5_2(M=6,9) TC_26_12_2_1(M=2,5,8,13) TC_26_12_2_2(M=2,5,9) TC_26_11_2_2_1	INTEGER	
TSPX_NoOfHoAccC	number of handover access bursts, value range 10 - 20 TC_26_6_5_1(M=3) TC_26_6_5_2(M=7) TC_26_12_2_1(M=3,6,9,15) TC_26_12_2_2(M=3,6,10) TC_26_11_2_2_1	INTEGER	
TSPX_NoOfHoAccD	number of handover access bursts, value range 5 - 10 TC_26_6_5_1(M=4, 7) TC_26_6_5_2(M=2) TC_26_12_2_1(M=10)	INTEGER	
TSPX_NoOfHoAccE	number of handover access bursts, value range 5 - 10 TC_26_6_5_1(M=5) TC_26_6_5_2(M=5) TC_26_12_2_2(M=12)	INTEGER	
TSPX_NoOfHoAccF	number of handover access bursts, value range 5 - 10 TC_26_6_5_1(M=6) TC_26_6_5_2(M=10) TC_26_12_2_1(M=14)	INTEGER	
TSPX_NoOfHoAccG	number of handover access bursts, value range 2 – 5 TC_26_6_5_2_3	INTEGER	
TSPX_NoOfHoAccH	number of handover access bursts, value range 2 - 5 TC_26_6_5_2_4	INTEGER	
TSPX_NoOfHoAccI	number of handover access bursts, value range 2 - 5 TC_26_10_2_4_1	INTEGER	

Item	Description	Type/Allowed values	Value chosen
TSPX_HoRefA	Hand over reference, GSM 04.08, 10.5.2.15 TC_26_6_5_1(M=1) TC_26_6_5_2(M=1) TC_26_6_5_4_1 TC_26_10_2_4_2 TC_26_12_2_1(M=1,11) TC_26_12_2_2(M=1) TC_26_11_5_1 TC_26_11_5_2	BITSTRING [8]	
TSPX_HoRefB	Hand over reference, GSM 04.08, 10.5.2.15 TC_26_6_5_1(M=2, 8) TC_26_6_5_2(M=2) TC_26_12_2_1(M=2,12) TC_26_11_2_2_1	BITSTRING [8]	
TSPX_HoRefC	Hand over reference, GSM 04.08, 10.5.2.15 TC_26_6_5_1(M=3) TC_26_6_5_2(M=3) TC_26_12_2_1(M=3,13) TC_26_12_2_2(M=3,6,10) TC_26_11_2_2_1	BITSTRING [8]	
TSPX_HoRefD	Hand over reference, GSM 04.08, 10.5.2.15 TC_26_6_5_1(M=4) TC_26_6_5_2(M=4) TC_26_12_2_1(M=4,14)	BITSTRING [8]	
TSPX_HoRefE	Hand over reference, GSM 04.08, 10.5.2.15 TC_26_6_5_1(M=5) TC_26_6_5_2(M=5) TC_26_12_2_1(M=5,15)	BITSTRING [8]	
TSPX_HoRefF	Hand over reference, GSM 04.08, 10.5.2.15 TC_26_6_5_1(M=6) TC_26_6_5_2(M=6) TC_26_12_2_1(M=6)	BITSTRING [8]	
TSPX_HoRefG	Hand over reference, GSM 04.08, 10.5.2.15 TC_26_6_5_1(M=7) TC_26_6_5_2(M=7) TC_26_12_2_1(M=7)	BITSTRING [8]	
TSPX_HoRefH	Hand over reference, GSM 04.08, 10.5.2.15 TC_26_6_5_2(M=8) TC_26_12_2_1(M=8)	BITSTRING [8]	
TSPX_HoRefI	Hand over reference, GSM 04.08, 10.5.2.15 TC_26_6_5_2(M=9) TC_26_12_2_1(M=9)	BITSTRING [8]	
TSPX_HoRefJ	Hand over reference, GSM 04.08, 10.5.2.15 TC_26_6_5_2(M=10) TC_26_12_2_1(M=10)	BITSTRING [8]	
TSPX_HSN	Hopping sequence number value range: 0 – 63 (0=Cyclic Hopping)	INTEGER	
TSPX_IMSI	IMSI of the MS – Phase 2 Test SIM value - 001010123456063	HEXSTRING	

Item	Description	Type/Allowed values	Value chosen
TSPX_Ki	default authentication key used in testing	BITSTRING	
TSPX_MAIO	mobile allocation index offset, value range: 0 - 63	INTEGER	
TSPX_MaxRetrans	Max-Retrans –Maximum number of re-transmissions of Channel Requests as defined in System Information (values 1, 2, 4 or 7 re-transmissions)	INTEGER	
TSPX_MSTxpwrMax	maximum output power from MS GSM 05.05, 4.1.1	0..31	
TSPX_PwrlvlA	MS power level, value between 2 to 15 GSM 05.05, 4.1.1	INTEGER	
TSPX_PwrlvlB	MS power level, value between 2 to 15 GSM 05.05, 4.1.1	INTEGER	
TSPX_PwrlvlC	MS power level, value between 2 to 15 GSM 05.05, 4.1.1	INTEGER	
TSPX_PwrlvlD	MS power level, value between 2 to 15 GSM 05.05, 4.1.1	INTEGER	
TSPX_RANDA	challenge RAND	BITSTRING [128]	
TSPX_RANDB	challenge RAND	BITSTRING [128]	
TSPX_RANDC	challenge RAND	BITSTRING [128]	
TSPX_RANDDef	default challenge RAND	BITSTRING [128]	
TSPX_SDCCH4SubA	TDMA offset of SDCCH/4 subchannel	BITSTRING[2]	
TSPX_SDCCH4SubB	TDMA offset of SDCCH/4 subchannel	BITSTRING[2]	
TSPX_SDCCH4SubC	TDMA offset of SDCCH/4 subchannel	BITSTRING[2]	
TSPX_SDCCH4SubDef	TDMA offset of default SDCCH/4 subchannel	BITSTRING[2]	
TSPX_SDCCH8SubA	TDMA offset of SDCCH/8 subchannel	BITSTRING[3]	
TSPX_SDCCH8SubB	TDMA offset of SDCCH/8 subchannel	BITSTRING[3]	
TSPX_SDCCH8SubC	TDMA offset of SDCCH/8 subchannel	BITSTRING[3]	
TSPX_SDCCH8SubD	TDMA offset of SDCCH/8 subchannel	BITSTRING[3]	
TSPX_SDCCH8SubE	TDMA offset of SDCCH/8 subchannel	BITSTRING[3]	
TSPX_SDCCH8SubF	TDMA offset of SDCCH/8 subchannel	BITSTRING[3]	
TSPX_SDCCH8SubG	TDMA offset of SDCCH/8 subchannel	BITSTRING[3]	
TSPX_SDCCH8SubDef	TDMA offset of default SDCCH/8 subchannel	BITSTRING[3]	
TSPX_TimadvA	timing advance in bit periods	INTEGER	
TSPX_TimadvB	timing advance in bit periods	INTEGER	

Item	Description	Type/Allowed values	Value chosen
TSPX_TimadvC	timing advance in bit periods	INTEGER	
TSPX_TmSltA	time slot, GSM 04.08 10.5.2.5	BITSTRING [3]	
TSPX_TmSltB	time slot, GSM 04.08 10.5.2.5	BITSTRING [3]	
TSPX_TmSltC	time slot, GSM 04.08 10.5.2.5	BITSTRING [3]	
TSPX_TmSltD	time slot, GSM 04.08 10.5.2.5	BITSTRING [3]	
TSPX_TmSltE	time slot, GSM 04.08 10.5.2.5	BITSTRING [3]	
TSPX_TmSltF	time slot, GSM 04.08 10.5.2.5	BITSTRING [3]	
TSPX_TmSltG	time slot, GSM 04.08 10.5.2.5	BITSTRING [3]	
TSPX_TmSltDef	default time slot, GSM 04.08 10.5.2.5	BITSTRING [3]	
TSPX_TmSltNotZero	time slot, arbitrarily value, but not zero.	BITSTRING [3]	
TSPX_TmSltNotZero1	time slot, arbitrarily value, but not zero and not TSPX_TmSltNotZero	BITSTRING [3]	
TSPX_Txint	Tx-Integer, no of slots to spread transmission (values 3,4,5,6,7,8,9,10,11,12,14,16, 20,25,32 or 50)	INTEGER	
TSPX_TscA	training sequence code, GSM 04.08 10.5.2.5	BITSTRING [3]	
TSPX_TscB	training sequence code, GSM 04.08 10.5.2.5	BITSTRING [3]	
TSPX_TscC	training sequence code, GSM 04.08 10.5.2.5	BITSTRING [3]	
TSPX_TscD	training sequence code, GSM 04.08 10.5.2.5	BITSTRING [3]	
TSPX_TscE	training sequence code, GSM 04.08 10.5.2.5	BITSTRING [3]	
TSPX_TscF	training sequence code, GSM 04.08 10.5.2.5	BITSTRING [3]	
TSPX_TscG	training sequence code, GSM 04.08 10.5.2.5	BITSTRING [3]	
TSPX_TscDef	default training sequence code, GSM 04.08 10.5.2.5	BITSTRING [3]	
TSPX_T3122	value of timer T3122, HEXSTRING[2]	HEXSTRING [2]	
TSPX_TCHcarrierA_ho	the value can be chosen arbitrarily from cell allocation of cell A (GSM), but not BCCH carrier .possible value is : 10, 17, 26, 34, 42, 45, 46, 52, 59, 66, 73, 74, 75, 76, 108, 114	INTEGER	

Item	Description	Type/Allowed values	Value chosen
TSPX_TCHcarrierA_hod	the value can be chosen arbitrarily from cell allocation of cell A (DCS), but not BCCH carrier . possible value is : 734,741,754,759,762,766,767,773,775,779,782,791,798,829,832,844	INTEGER	
TSPX_TCHcarrierB	TCH and SDCCH channel frequency number of cell B (GSM)	INTEGER	
TSPX_TCHcarrierBd	TCH and SDCCH channel frequency number of cell B (DCS)	INTEGER	
TSPX_TCHcarrierB_ho	the value can be chosen arbitrarily from cell allocation of cell B (GSM), but not BCCH carrier . possibles value is : 14,18,22,24,30,31,38,60,66,73,74,75,76,108,114	INTEGER	
TSPX_TCHcarrierB_hod	not BCCH carrier of cell B. the value can be chosen arbitrarily from cell allocation of cell B (DCS), which is (739,743,746,749,756,758,761,771,779,782,791,798,829,832,844)	INTEGER	
TSPX_TCHcarrierB2_ho	Chosen arbitrarily from cell allocation B for GSM HO cases, but not BCCH carrier!	INTEGER	
TSPX_TCHcarrierB2_hod	Chosen arbitrarily from cell allocation B for DCS HO cases, but not BCCH carrier!	INTEGER	
TSPX_TCHHSubA	TDMA offset of half rate subchannel	BITSTRING[1]	
TSPX_TCHHSubDef	TDMA offset of default half rate subchannel	BITSTRING[1]	
TSPX_TMSI	TMSI of the MS used in test	OCTETSTRING[4]	
TSPX_TMSI1	another TMSI used in test which shall differ from TSPX_TMSI, TSPX_TMSI + '01' TSPX_TMSI + '02' TSPX_TMSI + '03'	OCTETSTRING[4]	
TSPX_k	timing of cell A before cell B k bit periods for TC_26_6_5_1_?, TC_26_6_5_2_?, TC_26_6_5_4_?, TC_26_6_5_3_?.	INTEGER	
TSPX_y	timing advance for TC_26_6_5_4_?, TC_26_6_5_3_? TC_26_6_5_5_?.,. the values of TSPX_k (or TSPX_k1) and TSPX_y shall be $0 < (2 * TSPX_k + TSPX_y) \text{ MOD } 256 < 60$ .	INTEGER	
TSPX_k1	timing of cell A before cell B k bit periods for TC_26_6_5_5	INTEGER	
TSPX_k2	timing of cell A before cell B k bit periods for TC_26_6_5_6	INTEGER	

Item	Description	Type/Allowed values	Value chosen
TSPX_y2	timing advance for TC_26_6_5_6, value range : 11 - 62.	INTEGER	
TSPX_k3	timing of cell A before cell B k bit periods for TC_26_6_5_7	INTEGER	
TSPX_y3	timing advance for TC_26_6_5_7	INTEGER	
TSPX_nPara	the n'th ChReq for TC_26_6_1_2, shall be choose to [1..8], MAXRETRANS for TC_26_6_1_2 is 7 (See 11.10 for more explanation).	INTEGER	
TSPX_kPara	the k'th ChReq for TC_26_6_1_2 (range 4...8)	INTEGER	
TSPX_rPara	the r'th ChReq for TC_26_6_1_2 (range 4...8)	INTEGER	
TSPX_i1Para	for TC_26_1_2(TSPX_nPara-3) < TSPX_i1Para <= TSPX_nPara	INTEGER	
TSPX_i2Para	for TC_26_1_2 0 < TSPX_i2Para <= (TSPX_kPara-3)	INTEGER	
TSPX_i3Para	for TC_26_1_2(TSPX_rPara-3) < TSPX_i3Para <= TSPX_rPara	INTEGER	
TSPX_n1Para	the n'th ChReq for TC_26_6_1_3 (range 1...8)	INTEGER	
TSPX_i4Para	for TC_26_6_1_3 (TSPX_n1Para-3) < TSPX_i4Para <= TSPX_n1Para	INTEGER	
TSPX_xPara	t3122 for TC_26_6_1_3 (range 5...255)	INTEGER	
TSPX_AGBLKS1	BS-AG-BLKS-RES for TC_26_6_2_3_1, TC_26_6_2_1_1	INTEGER	
TSPX_PAMFRMS1	BS-PA-MFRMS for TC_26_6_2_3_1 (shall not be set to 9), TC_26_6_2_1_1	INTEGER	
TSPX_CcchConf1	CCCH configuration for TC_26_6_2_3_1, TC_26_6_2_1_1	BITSTRING[3]	
TSPX_PgSubch	paging subchannel for TC_26_6_2_3_1	INTEGER	
TSPX_AGBLKS2	BS-AG-BLKS-RES for TC_26_6_2_3_2 (range 0...2), TC_26_6_2_1_2	INTEGER	
TSPX_PAMFRMS2	BS-PA-MFRMS for TC_26_6_2_3_2, TC_26_6_2_1_2	INTEGER	
TSPX_CcchConf2	CCCH configuration for TC_26_6_2_3_2, TC_26_6_2_1_2	BITSTRING[3]	
TSPX_AGBLKS3	BS-AG-BLKS-RES for TC_26_6_2_4, TC_26_6_2_2, TC_26_6_2_1_3	INTEGER	
TSPX_PAMFRMS3	BS-PA-MFRMS for TC_26_6_2_4, TC_26_6_2_2, TC_26_6_2_1_3	INTEGER	

Item	Description	Type/Allowed values	Value chosen
TSPX_CcchConf3	CCCH configuration for TC_26_6_2_4, TC_26_6_2_2, TC_26_6_2_1_3	BITSTRING[3]	
TSPX_AGBLKS4	BS-AG-BLKS-RES for TC_26_6_2_5	INTEGER	
TSPX_PAMFRMS4	BS-PA-MFRMS for TC_26_6_2_5	INTEGER	
TSPX_CcchConf4	CCCH configuration for TC_26_6_2_5 (shall be in the set ('010', '100', '110'))	BITSTRING[3]	
TSPX_Chtp1	channel type and TDMA offset for TC_26_6_13_1, any value supported by the MS	BITSTRING[5]	
TSPX_ChMod1	channel mode for TC_26_6_13_1, any value for the channel type of TSPX_Chtp1	BITSTRING[8]	
TSPX_Maio1	Mobile allocation index offset hopping parameter for TC_26_6_13_1, its value between 0 and (the number of frequencies) -1, which is defined in TSPX_Ma1, default : 2	INTEGER	
TSPX_Ma1	mobile allocation (GSM 04.08 10.5.2.21) for TC_26_6_13_1, its value shall indicate number of frequencies between 1 and 17. default : '010101'0	OCTETSTRING[3]	
TSPX_Hsn1	hopping sequence number for TC_26_6_13_1. default: 1	INTEGER	
TSPX_Maio2	Mobile allocation index offset hopping parameter for TC_26_6_13_1, its value between 0 and (the number of frequencies) -1, which is defined in TSPX_Ma2, default : 8	INTEGER	
TSPX_Ma2	mobile allocation for TC_26_6_13_1, its value shall indicate number of frequencies between 1 and 17. default : '01362A5'0	OCTETSTRING[3]	
TSPX_Hsn2	hopping sequence number for TC_26_6_13_1, default : 6	INTEGER	
TSPX_Maio3	Mobile allocation index offset hopping parameter for TC_26_6_13_1, its value between 0 and (the number of frequencies) -1, which is defined in TSPX_Ma3, default : 14	INTEGER	
TSPX_Ma3	mobile allocation for TC_26_6_13_1, its value shall indicate number of frequencies between 1 and 17. default : '01FFFA'0	OCTETSTRING[3]	
TSPX_Hsn3	hopping sequence number for TC_26_6_13_1, default : 0	INTEGER	
TSPX_Chtp2	channel type for TC_26_6_13_2, any value supported by the MS	BITSTRING[5]	

Item	Description	Type/Allowed values	Value chosen
TSPX_ChMod2	channel mode for TC_26_6_13_2	BITSTRING[8]	
TSPX_Maio4	Mobile allocation index offset hopping parameter for TC_26_6_13_2, its value between 0 and (the number of frequencies) -1, which is defined in TSPX_Ma4, default : 3	INTEGER	
TSPX_Ma4	mobile allocation for TC_26_6_13_2, its value shall indicate number of frequencies between 1 and 17. default : 001141'O	OCTETSTRING[3]	
TSPX_Hsn4	hopping sequence number for TC_26_6_13_2, default : 0	INTEGER	
TSPX_Maio5	Mobile allocation index offset hopping parameter for TC_26_6_13_2, its value between 0 and (the number of frequencies) -1, which is defined in TSPX_Ma5, default : 9	INTEGER	
TSPX_Ma5	mobile allocation for TC_26_6_13_2, its value shall indicate number of frequencies between 1 and 17. default : 01ABCB'O	OCTETSTRING[3]	
TSPX_Hsn5	hopping sequence number for TC_26_6_13_2, default : 16	INTEGER	
TSPX_Chtp3	channel type for TC_26_6_13_3, any value supported by the MS	BITSTRING[5]	
TSPX_Maio6	Mobile allocation index offset hopping parameter for TC_26_6_13_3, its value between 0 and (the number of frequencies) -1, which is defined in TSPX_Ma6, default : 4	INTEGER	
TSPX_Ma6	mobile allocation for TC_26_6_13_3, its value shall indicate number of frequencies between 1 and 17. default : 006248'O	OCTETSTRING[3]	
TSPX_Hsn6	hopping sequence number for TC_26_6_13_3, default : 4	INTEGER	
TSPX_Maio7	Mobile allocation index offset hopping parameter for TC_26_6_13_3, its value between 0 and (the number of frequencies) -1, which is defined in TSPX_Ma7, default : 10	INTEGER	
TSPX_Ma7	mobile allocation for TC_26_6_13_3, its value shall indicate number of frequencies between 2 and 17. default : 009AFB'O	OCTETSTRING[3]	
TSPX_Chtp4	channel type for TC_26_6_13_3, any value supported by the MS	BITSTRING[5]	



Item	Description	Type/Allowed values	Value chosen
TSPX_Maio8	Mobile allocation index offset hopping parameter for TC_26_6_13_3, its value between 0 and (the number of frequencies) -1, which is defined in TSPX_Ma8, default : 1	INTEGER	
TSPX_Ma8	mobile allocation for TC_26_6_13_3, its value shall indicate number of frequencies between 2 and 17. default : 002800'O	OCTETSTRING[3]	
TSPX_Hsn8	hopping sequence number for TC_26_6_13_3, default : 40	INTEGER	
TSPX_Maio9	Mobile allocation index offset hopping parameter for TC_26_6_13_3, its value between 0 and (the number of frequencies) -1, which is defined in TSPX_Ma9, default : 15	INTEGER	
TSPX_Ma9	mobile allocation for TC_26_6_13_3, its value shall indicate number of frequencies between 2 and 17. default : 01FFFB'O	OCTETSTRING[3]	
TSPX_Hsn9	hopping sequence number for TC_26_6_13_3, default : 8	INTEGER	
TSPX_Chtp5	SDDCH8 subchannel immediately assigned in TC_26_6_13_4	BITSTRING[5]	
TSPX_Maio10	Mobile allocation index offset hopping parameter for TC_26_6_13_4, its value between 0 and (the number of frequencies) -1, which is defined in TSPX_Ma10, default : 5	INTEGER	
TSPX_Ma10	mobile allocation for TC_26_6_13_4, its value shall indicate number of frequencies between 1 and 17. default : 01D082'O	OCTETSTRING[3]	
TSPX_Hsn10	hopping sequence number for TC_26_6_13_4, default: 0	INTEGER	
TSPX_Maio11	Mobile allocation index offset hopping parameter for TC_26_6_13_4, its value between 0 and (the number of frequencies) -1, which is defined in TSPX_Ma11, default : 11	INTEGER	
TSPX_Ma11	mobile allocation for TC_26_6_13_4, its value shall indicate number of frequencies between 2 and 17. default : 00CFF3'O	OCTETSTRING[3]	
TSPX_Chtp6	channel type of a non existing channel in the Assignment Command for TC_26_6_13_4	BITSTRING[5]	

Item	Description	Type/Allowed values	Value chosen
TSPX_Maio12	Mobile allocation index offset hopping parameter for TC_26_6_13_4, its value between 0 and (the number of frequencies) -1, which is defined in TSPX_Ma12, default : 1	INTEGER	
TSPX_Ma12	mobile allocation for TC_26_6_13_4, its value shall indicate number of frequencies between 1 and 17. default : 0101000	OCTETSTRING[3]	
TSPX_Hsn12	hopping sequence number for TC_26_6_13_4, default : 39	INTEGER	
TSPX_Maio13	Mobile allocation index offset hopping parameter for TC_26_6_13_4, its value between 0 and (the number of frequencies) -1, which is defined in TSPX_Ma13, default : 6	INTEGER	
TSPX_Ma13	mobile allocation for TC_26_6_13_4, its value shall indicate number of frequencies between 1 and 17. default : 00E6900	OCTETSTRING[3]	
TSPX_Hsn13	hopping sequence number for TC_26_6_13_4, default: 42	INTEGER	
TSPX_Chtp7	channel type for TC_26_6_13_5	BITSTRING[5]	
TSPX_ChMod4	channel mode for TC_26_6_13_5	BITSTRING[8]	
TSPX_Maio14	Mobile allocation index offset hopping parameter for TC_26_6_13_5, its value between 0 and (the number of frequencies) -1, which is defined in TSPX_Ma14, default : 4	INTEGER	
TSPX_Ma14	mobile allocation for TC_26_6_13_5, its value shall indicate number of frequencies between 1 and 17. default : 004A280	OCTETSTRING[3]	
TSPX_Hsn14	hopping sequence number for TC_26_6_13_5, default : 50	INTEGER	
TSPX_Maio15	Mobile allocation index offset hopping parameter for TC_26_6_13_5, its value between 0 and (the number of frequencies) -1, which is defined in TSPX_Ma15, default : 12	INTEGER	
TSPX_Ma15	mobile allocation for TC_26_6_13_5, its value shall indicate number of frequencies between 1 and 16. default : 00FF790	OCTETSTRING[3]	
TSPX_Hsn15	hopping sequence number for TC_26_6_13_5, default : 33	INTEGER	

Item	Description	Type/Allowed values	Value chosen
TSPX_Maio16	Mobile allocation index offset hopping parameter for TC_26_6_13_5, its value between 0 and (the number of frequencies) -1, which is defined in TSPX_Ma16, default : 2	INTEGER	
TSPX_Ma16	mobile allocation for TC_26_6_13_5, its value shall indicate number of frequencies between 1 and 16. default : 001110'O	OCTETSTRING[3]	
TSPX_Hsn16	hopping sequence number for TC_26_6_13_5, default : 21	INTEGER	
TSPX_Chtp8	channel type for TC_26_6_13_6	BITSTRING[5]	
TSPX_ChMod5	channel mode for TC_26_6_13_6	BITSTRING[8]	
TSPX_Maio17	Mobile allocation index offset hopping parameter for TC_26_6_13_6, its value between 0 and (the number of frequencies) -1, which is defined in TSPX_Ma17, default : 7	INTEGER	
TSPX_Ma17	mobile allocation for TC_26_6_13_6, its value shall indicate number of frequencies between 1 and 17. default : 00E6A1'O	OCTETSTRING[3]	
TSPX_Hsn17	hopping sequence number for TC_26_6_13_6, default : 22	INTEGER	
TSPX_Maio18	Mobile allocation index offset hopping parameter for TC_26_6_13_6, its value between 0 and (the number of frequencies) -1, which is defined in TSPX_Ma18, default : 13	INTEGER	
TSPX_Ma18	mobile allocation for TC_26_6_13_6, its value shall indicate number of frequencies between 1 and 16. default : 00FFF9'O	OCTETSTRING[3]	
TSPX_Hsn18	hopping sequence number for TC_26_6_13_6, default : 9	INTEGER	
TSPX_Maio19	Mobile allocation index offset hopping parameter for TC_26_6_13_6, its value between 0 and (the number of frequencies) -1, which is defined in TSPX_Ma19, default : 3	INTEGER	
TSPX_Ma19	mobile allocation for TC_26_6_13_6, its value shall indicate number of frequencies between 1 and 16. default : 001111'O	OCTETSTRING[3]	
TSPX_Hsn19	hopping sequence number for TC_26_6_13_6, default : 44	INTEGER	
TSPX_Chtp9	channel type for TC_26_6_13_7	BITSTRING[5]	

Item	Description	Type/Allowed values	Value chosen
TSPX_ChMod6	channel mode for TC_26_6_13_7	BITSTRING[8]	
TSPX_Maio20	Mobile allocation index offset hopping parameter for TC_26_6_13_7, its value between 0 and (the number of frequencies) -1, which is defined in TSPX_Ma20, default : 8	INTEGER	
TSPX_Ma20	mobile allocation for TC_26_6_13_7, its value shall indicate number of frequencies between 1 and 17. default : 0166990	OCTETSTRING[3]	
TSPX_Hsn20	hopping sequence number for TC_26_6_13_7, default : 30	INTEGER	
TSPX_Maio21	Mobile allocation index offset hopping parameter for TC_26_6_13_7, its value between 0 and (the number of frequencies) -1, which is defined in TSPX_Ma21, default : 14	INTEGER	
TSPX_Ma21	mobile allocation for TC_26_6_13_7, its value shall indicate number of frequencies between 1 and 17. default : 01FEFB0	OCTETSTRING[3]	
TSPX_Chtp10	channel type for TC_26_6_13_7	BITSTRING[5]	
TSPX_Maio22	Mobile allocation index offset hopping parameter for TC_26_6_13_7, its value between 0 and (the number of frequencies) -1, which is defined in TSPX_Ma22, default : 4	INTEGER	
TSPX_Ma22	mobile allocation for TC_26_6_13_7, its value shall indicate number of frequencies between 1 and 16. default : 0062410	OCTETSTRING[3]	
TSPX_Hsn22	hopping sequence number for TC_26_6_13_7, default : 11	INTEGER	
TSPX_Maio23	Mobile allocation index offset hopping parameter for TC_26_6_13_7, its value between 0 and (the number of frequencies) -1, which is defined in TSPX_Ma23, default : 11	INTEGER	
TSPX_Ma23	mobile allocation for TC_26_6_13_7, its value shall indicate number of frequencies between 1 and 16. default : 00FF1B0	OCTETSTRING[3]	
TSPX_Hsn23	hopping sequence number for TC_26_6_13_7, default : 60	INTEGER	
TSPX_Chtp11	SDCCH8 subchannel immediately assigned, TC_26_6_13_8	BITSTRING[5]	

Item	Description	Type/Allowed values	Value chosen
TSPX_ChMod7	channel mode for TC_26_6_13_8	BITSTRING[8]	
TSPX_Maio24	Mobile allocation index offset hopping parameter for TC_26_6_13_8, its value between 0 and (the number of frequencies) -1, which is defined in TSPX_Ma24, default : 9	INTEGER	
TSPX_Ma24	mobile allocation for TC_26_6_13_8, its value shall indicate number of frequencies between 1 and 17. default : 00E6E90	OCTETSTRING[3]	
TSPX_Hsn24	hopping sequence number for TC_26_6_13_8, default : 7	INTEGER	
TSPX_Maio25	Mobile allocation index offset hopping parameter for TC_26_6_13_8, its value between 0 and (the number of frequencies) -1, which is defined in TSPX_Ma25, default : 15	INTEGER	
TSPX_Ma25	mobile allocation for TC_26_6_13_8, its value shall indicate number of frequencies between 1 and 17. default : 01FFFB0	OCTETSTRING[3]	
TSPX_Chtp12	channel type of a non-existing channel in the Assignment Command for TC_26_6_13_8	BITSTRING[5]	
TSPX_Maio26	Mobile allocation index offset hopping parameter for TC_26_6_13_8, its value between 0 and (the number of frequencies) -1, which is defined in TSPX_Ma26, default : 5	INTEGER	
TSPX_Ma26	mobile allocation for TC_26_6_13_8, its value shall indicate number of frequencies between 1 and 16. default : 0091680	OCTETSTRING[3]	
TSPX_Hsn26	hopping sequence number for TC_26_6_13_8, default : 9	INTEGER	
TSPX_Maio27	Mobile allocation index offset hopping parameter for TC_26_6_13_8, its value between 0 and (the number of frequencies) -1, which is defined in TSPX_Ma27, default : 1	INTEGER	
TSPX_Ma27	mobile allocation for TC_26_6_13_8, its value shall indicate number of frequencies between 1 and 16. default : 0040800	OCTETSTRING[3]	
TSPX_Hsn27	hopping sequence number for TC_26_6_13_8, default : 38	INTEGER	
TSPX_Chtp13	channel type for TC_26_6_13_9	BITSTRING[5]	

Item	Description	Type/Allowed values	Value chosen
TSPX_Tm3	Timer for TC_26_6_13_9, value between 60 -100	INTEGER	
TSPX_Maio28	Mobile allocation index offset hopping parameter for TC_26_6_13_9, its value between 0 and (the number of frequencies) -1, which is defined in TSPX_Ma28, default : 10	INTEGER	
TSPX_Ma28	mobile allocation for TC_26_6_13_9, its value shall indicate number of frequencies between 1 and 17. default : 00EE7A0	OCTETSTRING[3]	
TSPX_Hsn28	hopping sequence number for TC_26_6_13_9, default : 11	INTEGER	
TSPX_Maio29	Mobile allocation index offset hopping parameter for TC_26_6_13_9, its value between 0 and (the number of frequencies) -1, which is defined in TSPX_Ma29, default : 6	INTEGER	
TSPX_Ma29	mobile allocation for TC_26_6_13_9, its value shall indicate number of frequencies between 1 and 17. default : 00F0700	OCTETSTRING[3]	
TSPX_Chtp14	channel type for TC_26_6_13_10	BITSTRING[5]	
TSPX_Maio30	Mobile allocation index offset hopping parameter for TC_26_6_13_10, its value between 0 and (the number of frequencies) -1, which is defined in TSPX_Ma30, default : 11	INTEGER	
TSPX_Ma30	mobile allocation for TC_26_6_13_10, its value shall indicate number of frequencies between 1 and 17. default : 017F690	OCTETSTRING[3]	
TSPX_Hsn30	hopping sequence number for TC_26_6_13_10, default : 62	INTEGER	
TSPX_Maio31	Mobile allocation index offset hopping parameter for TC_26_6_13_10, its value between 0 and (the number of frequencies) -1, which is defined in TSPX_Ma31, default : 1	INTEGER	
TSPX_Ma31	mobile allocation for TC_26_6_13_10, its value shall indicate number of frequencies between 1 and 17. default : 0001010	OCTETSTRING[3]	

Item	Description	Type/Allowed values	Value chosen
TSPX_MOBscSvcA	any supported MO basic service	"C_Telephony", "C_EmgCallSRV", "C_AltSpchG3", "C_AutoG3", "C_300cda", "C_1200cda", "C_120075cda", "C_2400cda", "C_4800cda", "C_2400cda", "C_4800cda", "C_2400cda", "C_4800cda", "C_2400cda", "C_4800cda", "C_PAD300", "C_PAD1200", "C_PAD120075", "C_PAD2400", "C_PAD4800", "C_PAD9600", "C_Pkt2400", "C_Pkt4800", "C_Pkt9600", "C_AltSpchData", "C_SpchData"	
TSPX_MOBscSvcB	any supported MO basic service	"C_Telephony", "C_EmgCallSRV", "C_AltSpchG3", "C_AutoG3", "C_300cda", "C_1200cda", "C_120075cda", "C_2400cda", "C_4800cda", "C_2400cda", "C_4800cda", "C_2400cda", "C_4800cda", "C_PAD300", "C_PAD1200", "C_PAD120075", "C_PAD2400", "C_PAD4800", "C_PAD9600", "C_Pkt2400", "C_Pkt4800", "C_Pkt9600", "C_AltSpchData", "C_SpchData"	

Item	Description	Type/Allowed values	Value chosen
TSPX_MOBscSvcC	any supported MO basic service	"C_Telephony", "C_EmgCallSRV", "C_AltSpchG3", "C_AutoG3", "C_300cda", "C_1200cda", "C_120075cda", "C_2400cda", "C_4800cda", "C_2400cda", "C_4800cda", "C_2400cda", "C_4800cda", "C_2400cda", "C_4800cda", "C_PAD300", "C_PAD1200", "C_PAD120075", "C_PAD2400", "C_PAD4800", "C_PAD9600", "C_Pkt2400", "C_Pkt4800", "C_Pkt9600", "C_AltSpchData", "C_SpchData"	
TSPX_MOBscSvcD	any supported MO basic service	"C_Telephony", "C_EmgCallSRV", "C_AltSpchG3", "C_AutoG3", "C_300cda", "C_1200cda", "C_120075cda", "C_2400cda", "C_4800cda", "C_2400cda", "C_4800cda", "C_2400cda", "C_4800cda", "C_PAD300", "C_PAD1200", "C_PAD120075", "C_PAD2400", "C_PAD4800", "C_PAD9600", "C_Pkt2400", "C_Pkt4800", "C_Pkt9600", "C_AltSpchData", "C_SpchData"	































Item	Description	Type/Allowed values	Value chosen
TSPX_MTNIC_BscSvcI	any supported MT basic service without immediate connection	"C_Telephony", "C_EmgCallSRV", "C_AltSpchG3", "C_AutoG3", "C_300cda", "C_1200cda", "C_120075cda", "C_2400cda", "C_4800cda", "C_2400cda", "C_4800cda", "C_2400cda", "C_4800cda", "C_PAD300", "C_PAD1200", "C_PAD120075", "C_PAD2400", "C_PAD4800", "C_PAD9600", "C_Pkt2400", "C_Pkt4800", "C_Pkt9600", "C_AltSpchData", "C_SpchData"	
TSPX_MTNIC_BscSvcJ	any supported MT basic service without immediate connection	"C_Telephony", "C_EmgCallSRV", "C_AltSpchG3", "C_AutoG3", "C_300cda", "C_1200cda", "C_120075cda", "C_2400cda", "C_4800cda", "C_2400cda", "C_4800cda", "C_2400cda", "C_4800cda", "C_PAD300", "C_PAD1200", "C_PAD120075", "C_PAD2400", "C_PAD4800", "C_PAD9600", "C_Pkt2400", "C_Pkt4800", "C_Pkt9600", "C_AltSpchData", "C_SpchData"	
TSPX_Telephony_Rate	channel rate for TS11 (telephony), default value : "F"	"F", "H"	
TSPX_MOChRateA	channel rate for TSPX_MOBscSvcA, default value : "F"	"F", "H"	
TSPX_MOChRateB	channel rate for TSPX_MOBscSvcB, default value : "F"	"F", "H"	
TSPX_MOChRateC	channel rate for TSPX_MOBscSvcC, default value : "F"	"F", "H"	
TSPX_MOChRateD	channel rate for TSPX_MOBscSvcD, default value : "F"	"F", "H"	

Item	Description	Type/Allowed values	Value chosen
TSPX_MOChRateE	channel rate for TSPX_MOBscSvcE, default value : "F"	"F", "H"	
TSPX_MOChRateF	channel rate for TSPX_MOBscSvcF, default value : "F"	"F", "H"	
TSPX_MOChRateG	channel rate for TSPX_MOBscSvcG, default value : "F"	"F", "H"	
TSPX_MOChRateH	channel rate for TSPX_MOBscSvcH, default value : "F"	"F", "H"	
TSPX_MOChRateI	channel rate for TSPX_MOBscSvcI, default value : "F"	"F", "H"	
TSPX_MOChRateJ	channel rate for TSPX_MOBscSvcJ, default value : "F"	"F", "H"	
TSPX_MTChRateA	channel rate for TSPX_MTBscSvcA, default value : "F"	"F", "H"	
TSPX_MTChRateB	channel rate for TSPX_MTBscSvcB, default value : "F"	"F", "H"	
TSPX_MTChRateC	channel rate for TSPX_MTBscSvcC, default value : "F"	"F", "H"	
TSPX_MTChRateD	channel rate for TSPX_MTBscSvcD, default value : "F"	"F", "H"	
TSPX_MTChRateE	channel rate for TSPX_MTBscSvcE, default value : "F"	"F", "H"	
TSPX_MTChRateF	channel rate for TSPX_MTBscSvcF, default value : "F"	"F", "H"	
TSPX_MTChRateG	channel rate for TSPX_MTBscSvcG, default value : "F"	"F", "H"	
TSPX_MTChRateH	channel rate for TSPX_MTBscSvcH, default value : "F"	"F", "H"	
TSPX_MTChRateI	channel rate for TSPX_MTBscSvcI, default value : "F"	"F", "H"	
TSPX_MTChRateJ	channel rate for TSPX_MTBscSvcJ, default value : "F"	"F", "H"	
TSPX_MTNIC_ChRateA	channel rate for TSPX_MTNIC_BscSvcA, default value : "F"	"F", "H"	
TSPX_MTNIC_ChRateB	channel rate for TSPX_MTNIC_BscSvcB, default value : "F"	"F", "H"	
TSPX_MTNIC_ChRateC	channel rate for TSPX_MTNIC_BscSvcC, default value : "F"	"F", "H"	

Item	Description	Type/Allowed values	Value chosen
TSPX_MTNIC_ChRateD	channel rate for TSPX_MTNIC_BscSvcD, default value : "F"	"F", "H"	
TSPX_MTNIC_ChRateE	channel rate for TSPX_MTNIC_BscSvcE, default value : "F"	"F", "H"	
TSPX_MTNIC_ChRateF	channel rate for TSPX_MTNIC_BscSvcF, default value : "F"	"F", "H"	
TSPX_MTNIC_ChRateG	channel rate for TSPX_MTNIC_BscSvcG, default value : "F"	"F", "H"	
TSPX_MTNIC_ChRateH	channel rate for TSPX_MTNIC_BscSvcH, default value : "F"	"F", "H"	
TSPX_MTNIC_ChRateI	channel rate for TSPX_MTNIC_BscSvcI, default value : "F"	"F", "H"	
TSPX_MTNIC_ChRateJ	channel rate for TSPX_MTNIC_BscSvcJ, default value : "F"	"F", "H"	
TSPX_EmgCallRate	Rate for the basic service supported for MO emergency calls	"F", "H"	
TSPX_MO_NonCallSS	any supported MO non-call related supplementary service	"C_Telephony", "C_EmgCallSRV", "C_AltSpchG3", "C_AutoG3", "C_300cda", "C_1200cda", "C_120075cda", "C_2400cda", "C_4800cda", "C_2400cda", "C_4800cda", "C_2400cda", "C_4800cda", "C_PAD300", "C_PAD1200", "C_PAD120075", "C_PAD2400", "C_PAD4800", "C_PAD9600", "C_Pkt2400", "C_Pkt4800", "C_Pkt9600", "C_AltSpchData", "C_SpchData"	





## Annex C (normative):PCTR Proforma

Notwithstanding the provisions of the copyright clause related to the text of this TS, 3GPP grants that users of this TS may freely reproduce the PCTR proforma in this annex so that it can be used for its intended purposes and may further publish the completed PCTR.

### Global System for Mobile Communication, GSM, User-Network Access

Test Candidate	
Name :	SUT name
Model :	model
H/W version :	hw
S/W version :	sw
Serial No. :	serienr

Client	
Name :	
Street / No. :	
Postal Code / City:	
Country :	

## Layer 3 Signalling Functions

## PROTOCOL Conformance Test Report (PCTR)

*This Test Report shall not be reproduced except in full without the written permission of TEST LAB REFERENCE, and shall not be quoted out of context.*

---

## Annex D (normative): Enhanced Full Rate Abstract Test Suite

This ATS has been produced using the Tree and Tabular Combined Notation (TTCN) according to ISO/IEC 9646-3 [3].

The ATS was developed on a separate TTCN software tool and therefore the TTCN tables are not completely referenced in the contents table. The ATS itself contains a test suite overview part which provides additional information and references.

---

### D.1 The TTCN Graphical form (TTCN.GR)

The TTCN.GR representation of this ATS for Layer 3 is contained in an Adobe Portable Document Format™ file (ef-4u0.PDF, contained in archive 1110c4u0ATS.zip) (EFR) which accompanies this TS (Part 3).

---

### D.2 The TTCN Machine Processable form (TTCN.MP)

The TTCN.MP representation corresponding to this ATS for Layer 3 is contained in an ASCII file (ef-4u0.MP, contained in archive 1110c4u0ATS.zip) (EFR) which accompanies this TS (Part 3).

---

## Annex E (informative): Cell Selection Abstract Test Suite

This ATS has been produced using the Tree and Tabular Combined Notation (TTCN) according to ISO/IEC 9646-3 [3].

The ATS was developed on a separate TTCN software tool and therefore the TTCN tables are not completely referenced in the contents table. The ATS itself contains a test suite overview part which provides additional information and references.

---

### E.1 The TTCN Graphical form (TTCN.GR)

The TTCN.GR representation of this ATS for Layer 3 is contained in an Adobe Portable Document Format™ file (cs-4u0.PDF, contained in archive 1110c4u0ATS.zip) (Cell Selection) which accompanies this TS (Part 3).

---

### E.2 The TTCN Machine Processable form (TTCN.MP)

The TTCN.MP representation corresponding to this ATS for Layer 3 is contained in an ASCII file (cs-4u0.MP, contained in archive 1110c4u0ATS.zip) (Cell Selection) which accompanies this TS (Part 3).

---

## Annex F (informative): Dual band Abstract Test Suite

This ATS has been produced using the Tree and Tabular Combined Notation (TTCN) according to ISO/IEC 9646-3 [3].

The ATS was developed on a separate TTCN software tool and therefore the TTCN tables are not completely referenced in the contents table. The ATS itself contains a test suite overview part which provides additional information and references.

---

### F.1 The TTCN Graphical form (TTCN.GR)

The TTCN.GR representation of this ATS for Layer 3 is contained in an Adobe Portable Document Format™ file (db-4u0.PDF, contained in archive 1110c4u0ATS.zip) (Dual Band) which accompanies this TS (Part 3).

---

### F.2 The TTCN Machine Processable form (TTCN.MP)

The TTCN.MP representation corresponding to this ATS for Layer 3 is contained in an ASCII file (db-4u0.MP, contained in archive 1110c4u0ATS.zip) (Dual Band) which accompanies this TS (Part 3).

## Annex G (informative): Change history

Change history							
Date	TSG #	TSG Doc.	CR	Rev	Subject/Comment	Old	New
10/11/00	GP-02	--	--	--	Conversion to 3GPP layout and number	4.29.0	4.30.0
10/11/00	GP-02	GP-000493	C471		Changes to TC_26_6_4_1	4.29.0	4.30.0
10/11/00	GP-02	GP-000493	C472		Correction to TC_26_5_6_3	4.29.0	4.30.0
10/11/00	GP-02	GP-000493	C473		PIXIT change to TC_26_8_1_4_3_1	4.29.0	4.30.0
10/11/00	GP-02	GP-000493	C474		Addition of Test Case 33.6 to Layer 3 ATS	4.29.0	4.30.0
10/11/00	GP-02	GP-000493	C475		PIXIT change to TC_26_6_12_4	4.29.0	4.30.0
10/11/00	GP-02	GP-000493	C476		Training sequence code PIXIT changes to TC_26_11_2_1 and TC_26_11_2_2_1	4.29.0	4.30.0
10/11/00	GP-02	GP-000493	C477		Addition of Test Case 20.19 to Cell Selection ATS	4.29.0	4.30.0
10/11/00	GP-02	GP-000493	C478		PIXIT change in test step 'Varlnit_fix_Dual' for test cases 20.20.1, 20.20.2 and 20.11.2.1	4.29.0	4.30.0
10/11/00	GP-02	GP-000493	C471		Correction to TC_26_5_6_3	4.29.0	4.30.0
10/11/00	GP-02	GP-000493	C472		PIXIT change to TC_26_8_1_4_3_1	4.29.0	4.30.0
10/11/00	GP-02	GP-000493	C473		Addition of Test Case 33.6 to Layer 3 ATS	4.29.0	4.30.0

## History

Document history				
Edition 1	December 1995	Public Enquiry	PE 97:	1995-12-04 to 1995-04-12
Edition 1	May 1996	Vote	V 103:	1996-05-20 to 1996-08-23
Edition 2	August 1996	Unified Approval Procedure	UAP 52:	1996-08-19 to 1996-12-13
Edition 1	September 1996	Publication as ETS 300 607-3		
Edition 3	November 1996	Unified Approval Procedure	UAP 58:	1996-11-18 to 1997-03-14
Edition 2	January 1997	Publication as ETS 300 607-3		
Edition 4	April 1997	One-step Approval Procedure	OAP 9731:	1997-04-04 to 1997-08-01
Edition 3	May 1997	Publication as ETS 300 607-3		
Edition 4	August 1997	Publication as ETS 300 607-3		
Edition 5	August 1997	One-step Approval Procedure	OAP 9750:	1997-08-15 to 1997-12-12
Edition 6	November 1997	One-step Approval Procedure	OAP 9813:	1997-11-28 to 1998-03-27
Edition 5	January 1998	Publication as ETS 300 607-3		
Edition 7	March 1998	One-step Approval Procedure	OAP 9829:	1998-03-20 to 17-07-1998
Edition 6	April 1998	Publication as ETS 300 607-3		
Edition 8	May 1998	One-step Approval Procedure	OAP 9841:	1998-05-20 to 1998-10-16
Edition 7	August 1998	Publication as ETS 300 607-3		
Edition 9	August 1998	One-step Approval Procedure	OAP 9850:	1998-08-14 to 1998-12-11
Edition 8	October 1998	Publication as ETS 300 607-3		
Edition 9	December 1998	Publication as ETS 300 607-3		
Edition 10	December 1998	One-step Approval Procedure	OAP 9914:	1998-12-04 to 1999-04-02
Edition 10	April 1999	Publication as ETS 300 607-3		
Edition 11	April 1999	One-step Approval Procedure	OAP 9934:	1999-04-23 to 1999-08-20
Edition 12	July 1999	One-step Approval Procedure	OAP 9952:	1999-07-28 to 1999-11-26
Edition 11	August 1999	Publication as ETS 300 607-3		
Edition 12	December 1999	Publication as ETS 300 607-3		
Edition 13	January 2000	One-step Approval Procedure	OAP 200019:	2000-01-12 to 2000-05-12
Edition 14	May 2000	One-step Approval Procedure	OAP 20000901:	2000-05-03 to 2000-09-01
Edition 13	June 2000	Publication as ETS 300 607-3		
Edition 14	October 2000	Publication as ETS 300 607-3		
V4.29.0	November 2000	Publication		
V4.30.0	November 2000	Publication		