

ETSI TS 100 812-2 V2.3.1 (2003-10)

Technical Specification

Terrestrial Trunked Radio (TETRA); Subscriber Identity Module to Mobile Equipment (SIM-ME) interface; Part 2: Universal Integrated Circuit Card (UICC); Characteristics of the TSIM application



Reference

RES/TETRA-03103

Keywords

card, security, SIM, TETRA, radio

ETSI

650 Route des Lucioles
F-06921 Sophia Antipolis Cedex - FRANCE

Tel.: +33 4 92 94 42 00 Fax: +33 4 93 65 47 16

Siret N° 348 623 562 00017 - NAF 742 C
Association à but non lucratif enregistrée à la
Sous-Préfecture de Grasse (06) N° 7803/88

Important notice

Individual copies of the present document can be downloaded from:

<http://www.etsi.org>

The present document may be made available in more than one electronic version or in print. In any case of existing or perceived difference in contents between such versions, the reference version is the Portable Document Format (PDF). In case of dispute, the reference shall be the printing on ETSI printers of the PDF version kept on a specific network drive within ETSI Secretariat.

Users of the present document should be aware that the document may be subject to revision or change of status. Information on the current status of this and other ETSI documents is available at

<http://portal.etsi.org/tb/status/status.asp>

If you find errors in the present document, send your comment to:

editor@etsi.org

Copyright Notification

No part may be reproduced except as authorized by written permission.
The copyright and the foregoing restriction extend to reproduction in all media.

© European Telecommunications Standards Institute 2003.
All rights reserved.

DECT™, **PLUGTESTS™** and **UMTS™** are Trade Marks of ETSI registered for the benefit of its Members.
TIPHON™ and the **TIPHON logo** are Trade Marks currently being registered by ETSI for the benefit of its Members.
3GPP™ is a Trade Mark of ETSI registered for the benefit of its Members and of the 3GPP Organizational Partners.

Content

Intellectual Property Rights	7
Foreword.....	7
Introduction	7
1 Scope	8
2 References	8
3 Definitions, symbols and abbreviations	9
3.1 Definitions	9
3.2 Symbols.....	10
3.3 Abbreviations	10
4 Void.....	11
5 Void.....	11
6 Void.....	11
7 Security features	12
7.1 General on security.....	12
7.2 Authentication and cipher key generation procedure	12
7.3 Support of Over The Air Re-keying (OTAR) distribution of cipher keys.....	12
7.4 Support of SIM-ME enhanced security	13
7.5 Storage of DCK.....	13
7.6 User verification and file access conditions	13
8 Void.....	14
9 TETRA Commands	14
9.1 AUTHENTICATE	14
9.1.1 Command description	14
9.1.1.1 TETRA TA11/TA12 ALGORITHM	15
9.1.1.2 TETRA TA21/TA22 ALGORITHM	15
9.1.1.3 TB4/TE ALGORITHM.....	15
9.1.1.4 TA32 ALGORITHM	15
9.1.1.5 TA41/TA82 ALGORITHM	16
9.1.1.6 TA41/TA52 ALGORITHM	16
9.1.1.7 TA71/TE ALGORITHM	16
9.1.1.8 TB7/TA52 ALGORITHM	16
9.1.1.9 TA41/TA92 ALGORITHM.....	17
9.1.1.10 TB7/TA52 ALGORITHM	17
9.2 Coding of the commands.....	17
9.3 Definitions and coding	20
9.4 Status conditions returned by the card.....	22
9.4.1 Security management.....	22
9.4.2 Commands versus possible status responses	22
10 Contents of the EFs	22
10.1 General on EFs	22
10.2 Contents of the EFs at the MF level	23
10.3 Contents of the EFs at the TETRA application level	23
10.3.1 EF _{SST} (SIM Service Table)	23
10.3.2 EF _{ITSI} (Individual Tetra Subscriber Identity)	26
10.3.3 EF _{ITSIDIS} (ITSI Disabled).....	28
10.3.4 EF _{UNAME} (Username)	28
10.3.5 EF _{SCT} (Subscriber Class Table).....	29
10.3.6 EF _{PHASE} (Phase identification)	30
10.3.7 EF _{CCK} (Common Cipher Key)	31
10.3.8 EF _{CCKLOC} (CCK location areas)	32

10.3.9	EF _{SCK} (Static Cipher Keys).....	37
10.3.10	EF _{GSSIS} (Static GSSIs).....	38
10.3.11	EF _{GRDS} (Group related data for static GSSIs)	40
10.3.12	EF _{GSSID} (Dynamic GSSIs).....	41
10.3.13	EF _{GRDD} (Group related data for dynamic GSSIs).....	41
10.3.14	EF _{GCK} (Group Cipher Keys)	42
10.3.15	Void	44
10.3.16	EF _{GINFO} (User's group information)	44
10.3.17	EF _{SEC} (Security settings).....	47
10.3.18	EF _{FORBID} (Forbidden networks).....	47
10.3.19	EF _{PREF} (Preferred networks)	49
10.3.20	EF _{SPN} (Service Provider Name)	50
10.3.21	Void	51
10.3.22	EF _{DNWRK} (Broadcast network information).....	51
10.3.23	EF _{NWT} (Network table)	52
10.3.24	EF _{GW} (Gateway table)	55
10.3.25	EF _{CMT} (Call Modifier Table).....	57
10.3.26	EF _{ADNGWT} (Abbreviated Dialling Number with Gateways)	59
10.3.27	EF _{GWTEXT1} (Gateway Extension1).....	61
10.3.28	EF _{ADNTETRA} (Abbreviated dialling numbers for TETRA network)	61
10.3.29	EF _{EXTA} (Extension A)	63
10.3.30	EF _{FDNGWT} (Fixed dialling numbers with Gateways)	63
10.3.31	EF _{GWTEXT2} (Gateway Extension2).....	64
10.3.32	EF _{FDNTETRA} (Fixed dialling numbers for TETRA network)	65
10.3.33	EF _{EXTB} (Extension B).....	65
10.3.34	EF _{LNDGWT} (Last number dialled with Gateways)	66
10.3.35	EF _{LNDTETRA} (Last numbers dialled for TETRA network).....	66
10.3.36	EF _{SDNGWT} (Service Dialling Numbers with gateway)	67
10.3.37	EF _{GWTEXT3} (Gateway Extension3).....	67
10.3.38	EF _{SDNTETRA} (Service Dialling Numbers for TETRA network).....	68
10.3.39	EF _{STXT} (Status message texts).....	68
10.3.40	EF _{MSGTXT} (SDS-1 message texts).....	69
10.3.41	EF _{SDS123} (Status and SDS type 1, 2 and 3 message storage)	71
10.3.42	EF _{SDS4} (SDS type 4 message storage).....	73
10.3.43	EF _{MSGEXT} (Message Extension).....	81
10.3.44	EF _{EADDR} (Emergency addresses).....	81
10.3.45	EF _{EINFO} (Emergency call information).....	83
10.3.46	EF _{DMOCh} (DMO radio channel information)	84
10.3.47	EF _{MSCh} (MS allocation of DMO channels)	85
10.3.48	EF _{KH} (List of Key Holders).....	86
10.3.49	EF _{REPGATE} (DMO repeater and gateway list)	87
10.3.50	EF _{AD} (Administrative data).....	88
10.3.51	EF _{PREF_LA} (Preferred location areas)	88
10.3.52	EF _{LNDComp} (Composite LND file).....	89
10.3.53	EF _{DFLTSTSGT} (Status Default Target).....	90
10.3.54	EF _{SDSMEM_STATUS} (SDS Memory Status)	94
10.3.55	EF _{WELCOME} (Welcome Message).....	95
10.3.56	EF _{SDSR} (SDS delivery report).....	95
10.3.57	EF _{SDSP} (SDS parameters)	96
10.3.58	EF _{DIALSC} (Dialling schemes for TETRA network).....	97
10.3.59	EF _{APN} (APN table)	99
10.3.60	EF _{ARR} (Access Rule Reference).....	99
10.3.61	EF _{PNI} (Private Number Information).....	100
10.3.62	EF _{SCAN} (Scan list files).....	101
10.3.63	EF _{SCAND} (Scan list data)	102
10.3.64	EF _{DMO_GSSIS} (DMO pre-programmed group numbers).....	103
10.3.65	EF _{DMO_GRDS} (Group related data for DMO static GSSIs).....	103
10.3.66	EF _{GTMO_GDMO} (TMO - DMO selected group association)	104
10.3.67	EF _{GDMO_GTMO} (DMO - TMO selected group association)	105
10.3.68	EF _{DMO_DEF} (Default encryption parameters)	105
10.3.69	EF _{GSKO} (Group Session Key).....	107
10.4	Contents of the EFs at the Telecom level	108

10.4.1	EF _{ADN} (Abbreviated dialling numbers).....	108
10.4.2	EF _{FDN} (Fixed dialling numbers).....	108
10.4.3	EF _{MSISDN} (MSISDN).....	108
10.4.4	EF _{LND} (Last number dialled).....	109
10.4.5	EF _{SDN} (Service Dialling Numbers).....	109
10.4.6	EF _{EXT1} (Extension1).....	109
10.4.7	EF _{EXT2} (Extension2).....	109
10.4.8	EF _{EXT3} (Extension3).....	109
10.5	Files of TETRA.....	109
11	Application protocol.....	111
11.1	General procedures.....	112
11.1.1	Reading an EF.....	112
11.1.2	Updating an EF.....	112
11.1.3	Invalidating an EF.....	113
11.2	SIM management procedures.....	113
11.2.1	SIM initialization.....	113
11.2.2	TETRA session initialization.....	113
11.2.3	TETRA session termination.....	113
11.2.4	Language preference request.....	114
11.2.5	Administrative information request.....	114
11.2.6	SIM service table request.....	114
11.2.7	SIM phase request.....	114
11.2.8	SIM presence detection.....	114
11.2.9	SIM card number request.....	114
11.2.10	Common Cipher Key request.....	114
11.3	PIN related procedures.....	114
11.3.1	PIN verification.....	115
11.3.2	PIN value substitution.....	115
11.3.3	PIN disabling.....	115
11.3.4	PIN enabling.....	115
11.3.5	PIN unblocking.....	116
11.4	TETRA security related procedures.....	116
11.4.1	Authentication procedures and generation of DCK.....	116
11.4.1.1	Mutual authentication requirement request.....	116
11.4.1.2	SIM authentication.....	116
11.4.1.3	SwMI authentication.....	116
11.4.2	TETRA OTAR key computation (CCK, GCK, SCK).....	117
11.4.2.1	CCK distribution.....	117
11.4.2.2	CCK changeover.....	117
11.4.2.3	GCK distribution.....	117
11.4.2.4	SCK distribution.....	117
11.4.3	ITSI request.....	117
11.4.4	ITSI disabling/re-enabling.....	117
11.5	Subscription related procedures.....	118
11.5.1	Username request.....	118
11.5.2	ITSI temporarily disabled enquiry.....	118
11.5.3	Subscriber class request.....	118
11.5.4	Void.....	118
11.5.5	Group identity information.....	118
11.5.5.1	Static Group identity information.....	118
11.5.5.2	Dynamic Group identity information.....	119
11.5.6	Group related data.....	119
11.5.7	User's group information.....	119
11.5.8	Call modifiers.....	119
11.5.9	Service Provider Name.....	119
11.5.10	DMO channel procedures.....	119
11.5.11	Emergency addresses.....	120
11.5.12	Interrupted emergency call request.....	120
11.6	Network related procedures.....	120
11.6.1	Forbidden networks.....	120
11.6.2	Preferred networks.....	120

11.7	Dialling number related procedures	121
11.7.1	Dialling numbers under DF _{TETRA}	121
11.7.2	Dialling numbers under DF _{TELECOM}	122
11.7.3	FDNGWT specific procedures	123
11.7.3.1	FDNGWT capability request	123
11.7.3.2	FDNGWT disabling	124
11.7.3.3	FDNGWT enabling	124
11.8	Status and short data message procedures.....	124
11.8.1	Display of status message texts.....	124
11.8.2	Display of SDS1 message texts	124
11.8.3	Storage of status and SDS messages types 1, 2 and 3.....	124
11.8.4	Storage of SDS messages type 4.....	125
11.8.5	SDS delivery report	125
11.8.6	Default Status Target	126
Annex A: Void		127
Annex B (informative): FDN Procedures		128
Annex C (informative): Suggested contents of EFs at pre-personalization.....		129
C.1	Contents of the EFs at the MF level	129
C.2	Contents of the EFs at the TETRA application level	129
C.3	Contents of the EFs at the Telecom Level.....	131
Annex D (normative): Database structure for group IDs and phone books		132
Annex E (informative): Emergency call facilities and procedures.....		134
Annex F (informative): Composite List of Last Dialed Numbers		136
Annex G (informative): Bibliography.....		138
Annex H (informative): Change requests.....		139
History		141

Intellectual Property Rights

IPRs essential or potentially essential to the present document may have been declared to ETSI. The information pertaining to these essential IPRs, if any, is publicly available for **ETSI members and non-members**, and can be found in ETSI SR 000 314: "*Intellectual Property Rights (IPRs); Essential, or potentially Essential, IPRs notified to ETSI in respect of ETSI standards*", which is available from the ETSI Secretariat. Latest updates are available on the ETSI Web server (<http://webapp.etsi.org/IPR/home.asp>).

Pursuant to the ETSI IPR Policy, no investigation, including IPR searches, has been carried out by ETSI. No guarantee can be given as to the existence of other IPRs not referenced in ETSI SR 000 314 (or the updates on the ETSI Web server) which are, or may be, or may become, essential to the present document.

Foreword

This Technical Specification (TS) has been produced by ETSI Project Terrestrial Trunked Radio (TETRA).

The present document is part 2 of a multi-part deliverable covering the Subscriber Identity Module to Mobile Equipment (SIM-ME) interface, as identified below:

TS 100 812-1: "Universal Integrated Circuit Card (UICC); Physical and logical characteristics";

TS 100 812-2: "Universal Integrated Circuit Card (UICC); Characteristics of the TSIM application";

EN 300 812-3: "Integrated Circuit (IC); Physical, logical and TSIM application characteristics".

NOTE: Part 3 was originally published as EN 300 812 and defines different technology than part 1 and part 2.

Introduction

The present document defines TETRA SIM application to be used with the generic terminal/Integrated Circuit Card (ICC) interface.

1 Scope

The present document defines the TETRA SIM ("TSIM") application for TETRA mobile radio network operation.

The present document specifies:

- specific command parameters;
- file structures;
- contents of EFs (Elementary Files);
- security functions;
- application protocol to be used on the interface between UICC and ME.

This is to ensure interoperability between a TSIM/UICC combination and an ME in accordance with the requirements laid down in ETR 295 [1].

Common files and commands are specified in TS 102 221 [14] to which reference should be made.

The present document does not define any aspects related to the administrative management phase of the TSIM. Any internal technical realization of either the TSIM or the ME is only specified where this is reflected over the ME-TSIM interface.

2 References

The following documents contain provisions which, through reference in this text, constitute provisions of the present document.

- References are either specific (identified by date of publication and/or edition number or version number) or non-specific.
- For a specific reference, subsequent revisions do not apply.
- For a non-specific reference, the latest version applies.

Referenced documents which are not found to be publicly available in the expected location might be found at <http://docbox.etsi.org/Reference>.

- [1] ETSI ETR 295: "Terrestrial Trunked Radio (TETRA); User requirements for Subscriber Identity Module (SIM)".
- [2] ETSI EN 300 392-1: "Terrestrial Trunked Radio (TETRA); Voice plus Data (V+D); Part 1: General network design".
- [3] ETSI EN 300 392-2: "Terrestrial Trunked Radio (TETRA); Voice plus Data (V+D); Part 2: Air Interface (AI)".
- [4] ETSI EN 300 392-7: "Terrestrial Trunked Radio (TETRA); Voice plus Data (V+D); Part 7: Security".
- [5] ETSI TS 100 977: "Digital cellular telecommunications system (Phase 2+); Specification of the Subscriber Identity Module - Mobile Equipment (SIM-ME) interface (3GPP TS 11.11 version 8.6.0 Release 1999)".
- [6] ITU-T Recommendation T.50: "International Reference Alphabet (IRA) (Formerly International Alphabet No. 5 or IA5) - Information technology - 7-bit coded character set for information interchange".
- [7] ETSI ETS 300 396-6: "Terrestrial Trunked Radio (TETRA); Direct Mode Operation (DMO); Part 6: Security".

- [8] ETSI ETS 300 392-12-22: "Terrestrial Trunked Radio (TETRA); Voice plus Data (V+D); Part 12: Supplementary services stage 3; Sub-part 22: Dynamic Group Number Assignment (DGNA)".
- [9] ISO/IEC 8859-1: "Information technology - 8-bit single-byte coded graphic character sets - Part 1: Latin alphabet No. 1".
- [10] ETSI ETS 300 394-2 (Edition 1) (all sub-parts): "Terrestrial Trunked Radio (TETRA); Conformance testing specification; Part 2: Protocol testing specification for Voice plus Data (V+D)".
- [11] ETSI TS 100 940: "Digital cellular telecommunications system (Phase 2+); Mobile radio interface layer 3 specification (3GPP TS 04.08 version 7.17.0 Release 1998)".
- [12] ETSI TS 100 927: "Digital cellular telecommunications system (Phase 2+); Numbering, Addressing and Identification (3GPP TS 03.03 version 7.6.0 Release 1998)".
- [13] ISO/IEC 7816-9: "Identification cards - Integrated circuit(s) cards with contacts - Part 9: Additional interindustry commands and security attributes".
- [14] ETSI TS 102 221: "Smart cards; UICC-Terminal interface; Physical and logical characteristics (Release 5)".

3 Definitions, symbols and abbreviations

3.1 Definitions

For the purposes of the present document, the terms and definitions given in TS 102 221 [14], EN 300 392-1 [2] and the following apply:

access conditions: set of security attributes associated with access to an Elementary File (EF)

NOTE: ADM (administrative):

indicates an access condition defined by the card issuer. Before issue of the card ADM serves as a placeholder for an access condition to be defined by the card issuer. Any access condition may be assigned. The assigned access condition is used during the usage phase of the SIM;

PIN_n (personal identification number):

defines the access condition to an EF which requires verification of the user identity (n = 1 or n = 2);

NEV (never):

access to the EF is never allowed across the SIM-ME interface.

administrative phase: part of the card life between the manufacturing phase and the usage phase

card holder verification: authentication of the user to the SIM card

key generator: secure system entity authorized to generate Static Cipher Keys (SCKs) for Direct Mode Operation (DMO)

key holder: secure system entity authorized to distribute SCKs for DMO

key user: standard Direct Mode (DM) terminal which uses SCKs provided by an authorized key holder

Mobile Equipment (ME): part of the MS which interfaces to the SIM card

Mobile Station (MS): entirety of the equipment needed to communicate with the infrastructure (in trunked mode of operation) or direct with another MS (in direct mode of operation)

personalization: addition of subscriber and end user data to the appropriate EFs in the SIM during the administrative phase of a card's life cycle

pre-personalization: assignment of EF values at the manufacturing phase of a card's life cycle

TETRA application: set of security mechanisms, files, data and protocols required by TETRA

TETRA session: part of the card session dedicated to the TETRA operation

TETRA SIM: subscriber identity module used in a TETRA MS

TSIM: TETRA SIM application supported by the UICC

usage phase: part of the card life, after the administrative phase, when the card is being used for operational purposes

3.2 Symbols

For the purposes of the present document, the following symbols apply:

"0" to "9" and "A" to "F" The sixteen hexadecimal digits

3.3 Abbreviations

For the purposes of the present document, the following abbreviations apply:

ADF	Application Dedicated File
ADM	ADMInistrative (see definitions)
ADN	Abbreviated Dialling Number
ALW	ALWays
APN	Access Point Name
BCD	Binary Coded Decimal
CCK	Common Cipher Key
CCK-id	CCK-identifier
CLA	CLAss
DCK	Derived Cipher Key
DCK1	Part 1 of the DCK
DCK2	Part 2 of the DCK
DF	Dedicated File
DGNA	Dynamic Group Number Assignment
DMO	Direct Mode Operation
EF	Elementary File
FCP	File Control Parameters
FDN	Fixed Dialling Number
FSSN	Fleet Specific Short Number
GCK	Group Cipher Key
GCK-VN	GCK-Version Number
GGSN	Gateway GPRS Support Node
GPRS	General Packet Radio Service
GSSI	Group Short Subscriber Identity
GTSI	Group Tetra Subscriber Identity
IC	Integrated Circuit
ID	IDentifier
IP	Internet Protocol
ISSI	Individual Short Subscriber Identity
ITSI	Individual TETRA Subscriber Identity
K	individual subscriber authentication Key
KE	Enhanced security Key
LND	Last Number Dialed
LSB	Least Significant Bit
MCC	Mobile Country Code
ME	Mobile Equipment

MF	Master File
MGCK	Modified Group Cipher Key
MMI	Man Machine Interface
MNC	Mobile Network Code
MS	Mobile Station
MSB	Most Significant Bit
NET	NETwork
NEV	NEVer (see definitions)
OTAR	Over The Air Re-keying
PABX	Private Automatic Branch eXchange
PIN	Personal Identification Number
PS_DO	PIN Status Data Object
PSTN	Public Switched Telephone Network
RAND1	RANDom challenge 1
RAND2	RANDom challenge 2
RES1	RESponse 1
RES2	RESponse 2
RFU	Reserved for Future Use
RS	Random Seed
RSO	Random Seed for OTAR
SCCK	Sealed CCK
SCK	Static Cipher Key
SCKN	SCK Number
SCK-VN	SCK-Version Number
SDN	Service Dialling Number
SDS	Short Data Service
SEID	Security Environment ID
SGCK	Sealed GCK
SIM	Subscriber Identity Module
SSC	Supplementary Service Control string
SSCK	Sealed SCK
SSI	Short Subscriber Identity
SwMI	Switching and Management Infrastructure
TE	TETRA algorithm for enhanced security on SIM-ME interface
TLV	Tag, Length, Value
TON	Type Of Number
TP	Transfer layer Protocol
UICC	Universal Integrated Circuit Card
XRES2	eXpected RESponse 2

4 Void

5 Void

6 Void

7 Security features

7.1 General on security

The security aspects of TETRA are described in EN 300 392-7 [4] and ETS 300 396-6 [7]. This clause gives information related to security features supported by the SIM to enable the following:

- authentication of the subscriber identity to the network;
- data confidentiality over the air interface;
- confidentiality of air interface keys when passed over the SIM-ME interface;
- file access conditions.

The security of an MS is defined by security class (see EN 300 392-7 [4]). Table 1 indicates for which class the SIM has to provide security functions and key storage.

Table 1: Security functions and key storage

Class	Authentication	Key store	OTAR SCK	OTAR GCK	OTAR CCK
1	O	n/a	n/a	n/a	n/a
2	O	SCK	O	n/a	n/a
3	M	DCK, CCK, GCK, MGCK	O	O	M

NOTE 1: Where authentication is provided the SIM shall also store K (not in an accessible EF).
NOTE 2: M = Mandatory, O = Optional and n/a = not applicable.

7.2 Authentication and cipher key generation procedure

This clause describes the authentication mechanism and cipher key generation which are invoked by the network and the SIM.

The names and parameters of the authentication algorithms supported by the SIM are defined in EN 300 392-7 [4]. These are:

- algorithms TA11/TA12 to authenticate the SIM to the SwMI;
- algorithms TA21/TA22 to authenticate the SwMI to the SIM.

The cipher key generation algorithm supported by the SIM is defined in EN 300 392-7 [4] and is required only for a SIM-ME pair supporting Class 3 security. This is:

- algorithm TB4 to generate the Derived Cipher Key (DCK).

These algorithms may exist either discretely or combined within the SIM.

7.3 Support of Over The Air Re-keying (OTAR) distribution of cipher keys

The names and parameters of the OTAR algorithms supported by the SIM are defined in EN 300 392-7 [4] and ETS 300 396-6 [7]. These are:

- algorithm TA32 to obtain the Common Cipher Key (CCK) from the Sealed CCK (SCCK);
- algorithm TA41/TA82 to obtain the Group Cipher Key (GCK) from the Sealed Group Cipher Key (SGCK);
- algorithm TA41/TA52 to obtain the Static Cipher Key (SCK) from the Sealed SCK (SSCK);

- algorithm TA71/TE to obtain the Modified Group Cipher Key (MGCK) from the GCK. Reino: is it so that the TE is not applicable in ES 200 812-2 but is applicable in EN 300 812-3;
- algorithm TA41/TA92 to obtain the Group Sealing Key GSKO from the sealed SGSKO;
- algorithm TB7/TA52 to obtain the SCK from the SSCK distributed by OTAR in case of group address delivery;
- algorithm TB7/TA82 to obtain the Group Cipher Key (GCK) from the Sealed Group Cipher Key (SGCK) in case of group address delivery.

These algorithms may exist either discretely or combined within the SIM.

7.4 Support of SIM-ME enhanced security

Enhanced security for DCK, CCK, SCK and MGCK on the SIM-ME interface in SIM-ME pairs supporting security Class 2 and 3 is supported by use of the TETRA algorithm for enhanced security on SIM-ME interface (TE) algorithm. When enhanced SIM-ME security is required (SIM Service 20 set):

- algorithm immediately following TB4 algorithm;
- CCK, SCK and MGCK are sealed by the TE algorithm as part of the "Read EF" command.

7.5 Storage of DCK

After successful authentication DCK shall be stored on the SIM for further use to unseal cipher keys for the duration of the authentication session, refer to EN 300 392-7 [4], clause 3.1 for the authentication session.

7.6 User verification and file access conditions

The TETRA application uses 2 PINs for user verification, PIN and PIN2. PIN2 is used only in the ADF. The PIN and PIN2 are mapped into key references as defined in TS 102 221 [14]. Each key reference is associated with a usage qualifier as defined in ISO/IEC 7816-9 [13]. The PIN status is indicated in the PS_DO, which is part of the FCP response when an ADF/DF is selected. The coding of the PS_DO is defined in TS 102 221 [14].

PIN and PIN2 are coded on 8 bytes. Only (decimal) digits (0 to 9) shall be used, coded in ITU-T Recommendation T.50 [6] with bit 8 set to zero. The minimum number of digits is 4. If the number of digits presented by the user is less than 8 then the ME shall pad the presented PIN with "FF" before sending it to the SIM.

The coding of the UNBLOCK PINs is identical to the coding of the PINs. However, the number of (decimal) digits is always 8.

The security architecture as defined in TS 102 221 [14] applies to the TETRA application with the following definitions and additions:

- the TETRA application shall use key reference "01" as PIN and key reference "81" as PIN2. For access to DF_{Telecom} the PIN shall be verified. Access with PIN2 is limited to the TETRA application;
- the only valid usage qualifier is "08" which means user authentication knowledge based (PIN) as defined in ISO/IEC 7816-9 [13]. The terminal shall support the multi-application capabilities as defined in TS 102 221 [14];
- every file in the TETRA application shall have a reference to an access rule stored in EF_{ARR};
- every file under DF_{Telecom} shall have a reference to an access rule stored in EF_{ARR} under DF_{Telecom};
- a multi-application capability UICC (from the security context point of view) shall support the referenced format using SEID as defined in TS 102 221 [14];

- a multi-application capability UICC (from the security context point of view) shall support the replacement of a TETRA application PIN with the Universal PIN, key reference "01", as defined in TS 102 221 [14]. Only the Universal PIN is allowed as a replacement;
- a terminal shall support the use of level 1 and level 2 user verification requirements as defined in TS 102 221 [14];
- a terminal shall support the replacement of a TETRA application PIN with the Universal PIN, key reference "01", as defined in TS 102 221 [14];
- a terminal shall support the security attributes defined using tag's "8C", "AB" and "8B" as defined in TS 102 221 [14]. In addition both the referencing methods indicated by tag "8B" shall be supported as defined in TS 102 221 [14].

The access rule is referenced in the FCP using tag "8B". The TLV object contains the file ID (the file ID of EF_{ARR}) and record number, or file ID (the file ID of EF_{ARR}), SEID and record number, pointer to the record in EF_{ARR} where the access rule is stored. Each SEID refers to a record number in EF_{ARR}. EFs having the same access rule use the same record reference in EF_{ARR}. For an example EF_{ARR}, see TS 102 221 [14].

8 Void

9 TETRA Commands

9.1 AUTHENTICATE

9.1.1 Command description

The function is used during the procedure for authenticating the SIM to its SwMI and vice versa and key management.

The function is related to a particular TETRA-application and shall not be executable unless the TETRA or any sub-directory has been selected as the Current Directory and a successful PIN verification procedure has been performed.

The function can be used in following contexts:

- TETRA TA11/TA12 ALGORITHM;
- TETRA TA21/TA22 ALGORITHM;
- TETRA TB4/TE ALGORITHM;
- TETRA TA32 ALGORITHM;
- TETRA TA41/TA82 ALGORITHM;
- TETRA TA41/TA52 ALGORITHM;
- TETRA TA71/TE ALGORITHM;
- TETRA TA41/TA92 ALGORITHM;
- TETRA TB7/TA52 ALGORITHM;
- TETRA TB7/TA82 ALGORITHM.

9.1.1.1 TETRA TA11/TA12 ALGORITHM

This function, initiated by the SwMI, is used for authenticating the SIM to the TETRA network (SwMI).

- Input from ME: RANDom challenge 1 (RAND1), Random Seed (RS).
- Input from SIM: K.
- Output to SIM: DCK1.
- Output to ME: Response 1 (RES1).

RES1 shall be obtained from the SIM by use of the GET RESPONSE command.

9.1.1.2 TETRA TA21/TA22 ALGORITHM

This function, initiated by the SIM, is used for authenticating the TETRA network (SwMI) to the SIM.

- Input from ME: Response 2 (RES2), RS.
- Input from SIM: K, RAND2.
- Output to SIM: DCK2.
- Output to ME: XRES2.

XRES2 shall be obtained from the SIM by use of the GET RESPONSE command.

Before running TA21/TA22 ME shall run the GET CHALLENGE command. The result random challenge shall be stored internally on the SIM and used as input RAND2.

NOTE: The ME is informed about the success of the operation via the status condition [R2] returned by the SIM.

9.1.1.3 TB4/TE ALGORITHM

This function is used to obtain the DCK from its two parts DCK1 and DCK2 by use of the specified algorithm TB4. If SIM Service 20 is set (enhanced SIM-ME security) the enhanced security algorithm TE is automatically run by the SIM to seal DCK with KE before sending it to the ME.

- Input from SIM: DCK1, DCK2, optionally KE (if SIM Service 20 is set).
- Output to SIM: DCK.
- Output to ME: DCK (sealed by KE if service 20 is set).

In the case of mutual authentication between SIM and SwMI (authentication in both directions) the inputs DCK1 and DCK2 shall be obtained internally from the TA11/TA12 and TA21/TA22 algorithms respectively. In the case of unilateral authentication, either DCK1 or DCK2 shall be set to zero; for SIM authentication DCK2 = 0; for SwMI authentication DCK1 = 0.

9.1.1.4 TA32 ALGORITHM

This function is used to obtain the CCK from the SCCK by use of the specified algorithm TA32. The SCCK can be delivered to the ME in sealed format by an OTAR procedure. The SCCK shall be unsealed on the SIM and the CCK stored on the SIM for subsequent use in the ME.

- Input from ME: SCCK, CCK-id, Record number (to be updated).
- Input from SIM: DCK.
- Output to EF: CCK, CCK-id.
- Output to ME: None.

NOTE: The ME is informed about the success of the operation via the status condition (manipulation flag) returned by the SIM.

9.1.1.5 TA41/TA82 ALGORITHM

This function shall be used to compute GCK and GCKN from SGCK, GCK Version Number (GCK-VN) and KSO.

- Input from ME: SGCK, GCK-VN, Random Seed for OTAR (RSO).
- Input from SIM: K.
- Output to EF: GCK (to EFGCK), GCKN.
- Output to ME: None.

NOTE 1: GCKs are not accessible over the SIM-ME interface.

NOTE 2: The ME is informed about the success of the operation via the status condition (manipulation flag) returned by the SIM.

9.1.1.6 TA41/TA52 ALGORITHM

This function is used to obtain the SCK from the SSCK which may be distributed by OTAR. The SSCKs shall be unsealed on the SIM and the SCK stored on the SIM for subsequent use in the ME.

- Input from ME: SSCK, SCK-VN, Random Seed for OTAR (RSO).
- Input from SIM: K.
- Output to EF: SCK, SCKN.
- Output to ME: None.

NOTE: The ME is informed about the success of the operation via the status condition (manipulation flag) returned by the SIM.

Algorithm TA52 shall output SCKN which shall be used as an index to the record in EF_{SCK}. The record number shall be updated only if the Manipulation flag is TRUE.

9.1.1.7 TA71/TE ALGORITHM

This function shall be used to obtain the MGCK from the GCK and the CCK by use of the specified algorithm TA71. The algorithm shall be run whenever a new GCK is distributed or when a new CCK is issued (for instance caused by entering a new location area).

- Input from ME: record number in EF_{CCK} to be used, GCKN, GCK-VN.
- Input from EF: GCK, CCK.
- Output to EF: None.
- Output to ME: MGCK (encrypted using TE algorithm in case SIM enhanced service is enabled).

9.1.1.8 TB7/TA52 ALGORITHM

This function is used to obtain the SCK from the SSCK which may be distributed by OTAR in case of group address delivery. The SSCKs shall be unsealed on the SIM and the SCK stored on the SIM for subsequent use in the ME.

- Input from ME: SSCK, SCK-VN.
- Input from SIM: GSKO.
- Output to EF: SCK, SCKN.

- Output to ME: None.

NOTE: The ME is informed about the success of the operation via the status condition (manipulation flag) returned by the SIM.

9.1.1.9 TA41/TA92 ALGORITHM

This function is used to obtain the GSKO. See EN 300 392-7 [4] clause 4.2.5.

- Input from ME: SGSKO, GSKO-VN, RSO.
- Input from SIM: K.
- Output to EF: GSKO.
- Output to ME: None.

NOTE: The ME is informed about the success of the operation via the status condition (manipulation flag) returned by the SIM.

9.1.1.10 TB7/TA52 ALGORITHM

This function is used to obtain the GCK from the SGCK which may be distributed by OTAR in case of group address delivery. The SGCKs shall be unsealed on the SIM and the GCK stored on the SIM for subsequent use in the ME.

- Input from ME: SGCK, GCK-VN.
- Input from SIM: GSKO.
- Output to EF: GCK, GCKN.
- Output to ME: None.

NOTE: The ME is informed about the success of the operation via the status condition (manipulation flag) returned by the SIM).

9.2 Coding of the commands

The AUTHENTICATE command contents shall be as defined in table 2.

Table 2: Contents of the AUTHENTICATE command

Code	Value
CLA	As specified in TS 102 221 [14]
INS	"88"
P1	"00"
P2	See table 3
Lc	
Data	
Le	"00", or maximum length of data expected in response

Parameter P2 shall specify the authentication context as defined in table 3.

Table 3: Coding of the reference control P2

Coding b8-b1	Meaning
"1-----"	Specific reference data (e.g. DF specific/application dependant key)
"-XX-----"	"00"
"-xxxxx"	Authentication context: 00000 RFU 00001 TA11/TA12 ALGORITHM 00010 TA21/TA22 ALGORITHM 00011 TB4/TE ALGORITHM 00100 TA32 ALGORITHM 00101 TA41/TA82 ALGORITHM 00110 TA41/TA52 ALGORITHM 00111 TA71/TE ALGORITHM 01000 TA41/TA92 ALGORITHM 01001 TB7/TA52 ALGORITHM 01010 TB7/TA82 ALGORITHM

All other codings shall be RFU.

Command parameters/data, case 1 TA11/TA12 ALGORITHM contents shall be as defined in table 4.

Table 4: Contents of the case 1 TA11/TA12 ALGORITHM command

Byte(s)	Description	Length
1 to 10	RAND1	10
11 to 20	RS	10

See EN 300 392-7 [4] for use of RES1 and for size of the cryptographic parameters.

Command parameters/data, case 2 TA21/TA22 ALGORITHM contents shall be as defined in table 5.

Table 5: Contents of the case 2 TA21/TA22 ALGORITHM command

Byte(s)	Description	Length
1 to 4	RES2	4
5 to 14	RS	10

Command parameters/data, case 4 TA32 ALGORITHM contents shall be as defined in table 6.

Table 6: Contents of the case 4 TA32 ALGORITHM command

Byte(s)	Description	Length
1 to 15	SCCK	15
16 to 17	CCK-id	2
18	Record number	1

Command parameters/data, case 5 TA41/TA82 ALGORITHM contents shall be as defined in table 7.

Table 7: Contents of the case 5 TA41/TA82 ALGORITHM command

Byte(s)	Description	Length
1 to 15	SGCK	15
16 to 17	GCK-VN	2
18 to 27	RSO	10

Command parameters/data, case 6 TA41/TA52 ALGORITHM contents shall be as defined in table 8.

Table 8: Contents of the case 6 TA41/TA52 ALGORITHM command

Byte(s)	Description	Length
1 to 15	SCK	15
16 to 17	SCK-VN	2
18 to 27	RSO	10

Command parameters/data, case 7 TA71/TE ALGORITHM contents shall be as defined in table 9.

Table 9: Contents of the case 7 TA71 ALGORITHM command

Byte(s)	Description	Length
1	Target record in EF _{MGCK}	1
2	Input record from EF _{CCK}	1

Table 10: Contents of the case 7 TA71/TE ALGORITHM command

Byte(s)	Description	Length
1	Input record from EF _{CCK}	1 (see note)
2 to 3	GCKN	2
4 to 5	GCK-VN	2
NOTE: The input record from EF _{CCK} specifies the record number (1 or 2) in EF _{CCK} from which the CCK shall be retrieved.		

Command parameters/data, case 8, TA41/TA92 ALGORITHM contents shall be as defined in table 9?

Table 9: Contents of the case 8 TA41/TA92 ALGORITHM command

Byte(s)	Description	Length
1 to 15	SGSKO	15
16 to 17	GSKO-VN	2
18 to 27	RSO	10

Command parameters/data, case 9, TB7/TA52 ALGORITHM contents shall be as defined in table 10.

Table 10: Contents of the case 9 TA41/TA92 ALGORITHM command

Byte(s)	Description	Length
1	Record Number for GSKO	1
2 to 16	SCK	15
17 to 18	SCK-VN	2

Command parameters/data, case 10, TB7/TA82 ALGORITHM contents shall be as defined in table 12.

Table 11: Contents of the case 10 TB7/TA82 ALGORITHM command

Byte(s)	Description	Length
1	Record Number for GSKO	1
2 to 16	SGCK	15
17 to 18	GCK-VN	2

Response parameters/data, case 1, TA11/TA12 ALGORITHM contents shall be as defined in table 11.

Table 11: Contents of the case 1, TA11/TA12 ALGORITHM response

Byte(s)	Description	Length
1 to 4	RES1	4

See EN 300 392-7 [4] for use of RES1 and for size of the cryptographic parameters.

Response parameters/data, case 2, TA21/TA22 ALGORITHM contents shall be as defined in table 12.

Table 12: Contents of the case 2, TA21/TA22 ALGORITHM response

Byte(s)	Description	Length
1 to 4	XRES2	4

Response parameters/data, case 3, TB4/TE ALGORITHM contents shall be as defined in table 13.

Table 13: Contents of the case 3, TB4/TE ALGORITHM response

Byte(s)	Description	Length
1 to 10	DCK	10

Response parameters/data, case 7 TA71/TE ALGORITHM contents shall be as defined in table 14

Table 14: Contents of the case 7 TA71/TE ALGORITHM response

Response parameters/data:

Byte(s)	Description	Length
1 to 10	MGCK	10

9.3 Definitions and coding

The following definitions and coding are used in the response parameters/data of the commands.

Coding: each byte is represented by bits b8 to b1, where b8 is the Most Significant Bit (MSB) and b1 is the Least Significant Bit (LSB). In each representation the leftmost bit is the MSB.

RFU: in a TETRA specific card all bytes which are RFU shall be set to "00" and RFU bits to 0. Where the TETRA application exists on a multi-application card or is built on a generic telecommunications card (e.g. TE9) then other values may apply. The values will be defined in the appropriate specifications for such cards. These bytes and bits shall not be interpreted by an ME in a TETRA session.

File status: refer to figure 1.

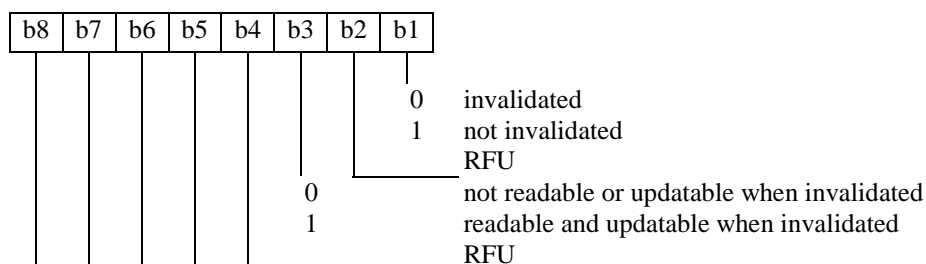
**Figure 1: File status**

Bit b3 may be set to 1 in special circumstances when it is required that the EF can be read and updated even if the EF is invalidated, e.g. reading and updating the EF_{ADN} when the Fixed Dialling Number (FDN) feature is enabled.

Structure of file:

- "00" transparent;
- "01" linear fixed;
- "03" cyclic;
- "11" key.

Type of File:

- "00" RFU;
- "01" MF;
- "02" DF;
- "04" EF.

Coding of PINs and UNBLOCK PINs:

A PIN is coded on 8 bytes. Only (decimal) digits (0 to 9) shall be used, coded in ITU-T Recommendation T.50 [6] with bit 8 set to zero. The minimum number of digits is 4. If the number of digits presented by the user is less than 8 then the ME shall pad the presented PIN with "FF" before sending it to the SIM.

The coding of the UNBLOCK PINs is identical to the coding of the PINs. However, the number of (decimal) digits is always 8.

Coding of access conditions:

The access conditions for the commands are coded on bytes 9,10 and 11 of the response data of the SELECT command. Each condition is coded on 4 bits as shown in figure 2.

Byte 9:

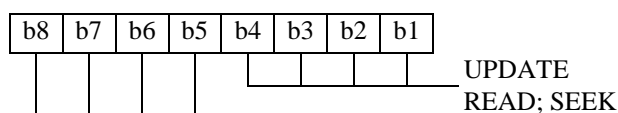

Byte 10:

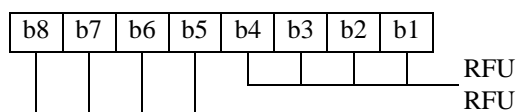

Byte 11:

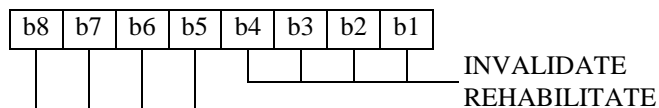

Figure 2: Access conditions

9.4 Status conditions returned by the card

This clause specifies the coding of the status words SW1 and SW2.

9.4.1 Security management

Security management contents shall be as defined in table 15.

Table 15: Contents of the security management

SW1	SW2	Error description
"98"	"60"	manipulation flag set
"98"	"70"	SwMI authentication unsuccessful

9.4.2 Commands versus possible status responses

Table 16 shows for each command the possible status conditions returned (marked by an asterisk *).

Table 16: Commands and status words

	OK		Mem Status		Refer. Status				Security status						Application Independent Errors					
	9	9	9	9	9	9	9	9	9	9	9	9	9	9	9	6	6	6	6	6
Commands	0	F	2	2	4	4	4	4	8	8	8	8	8	8	8	7	B	D	E	F
	0	X	0	4	0	0	0	0	0	0	0	1	4	6	7	X	X	X	X	X
	0	X	X	0	0	2	4	8	2	4	8	0	0	0	0	X	X	X	X	X
TA11/TA12 Algorithm		*		*					*						*	*			*	*
TA21/TA22 Algorithm	*			*					*					*	*	*			*	*
TB4/TE Algorithm	*			*					*					*	*	*			*	*
TA32 Algorithm	*			*					*				*		*	*			*	*
TA41/TA82 Algorithm	*			*					*				*		*	*			*	*
TA41/TA52 Algorithm	*			*					*				*		*	*			*	*
TA71/TE Algorithm	*			*					*				*		*	*			*	*

10 Contents of the EFs

10.1 General on EFs

This clause specifies the EFs for the TETRA session defining access conditions, data items and coding. A data item is a part of an EF which represents a complete logical entity, e.g. the alpha tag in an EF_{ADN} record.

EFs or data items having an unassigned value, or, which during the TETRA session, are cleared by the ME, shall have their bytes set to "FF". After the administrative phase all data items shall have a defined value or have their bytes set to "FF". If a data item is "deleted" during a TETRA session by the allocation of a value specified in another TETRA TS, then this value shall be used, and the data item is not unassigned.

EFs are mandatory (M) or optional (O). The file size of an optional EF may be zero. All implemented EFs with a file size greater than zero shall contain all mandatory data items. Optional data items may either be filled with "F", or, if located at the end of an EF, need not exist.

Using the command GET RESPONSE the ME can determine the length of variable length records (e.g. 1 to X).

NOTE: The field "Update activity" has only meaning to the card manufacturer to help choosing proper memory management for EFs. If an EF is updated very seldom, e.g. once during the administrative phase, it is set to "low". If an EF is updated or may be updated in every TETRA session it is set to "high". The actual update activity of certain EFs also depends on the system. Therefore the update activity of an EF is set to high if it may be updated frequently in some systems. For example, high security systems may want to update cipher keys frequently, but less secure systems may update keys only when a particular reason to do it arises.

10.2 Contents of the EFs at the MF level

Contents of application independent files at the MF level shall be as specified in TS 102 221 [14].

10.3 Contents of the EFs at the TETRA application level

10.3.1 EF_{SST} (SIM Service Table)

This EF shall indicate which of the optional services and EFs are available as defined in table 17.

NOTE: Having the presence of optional services indicated simplifies their handling for the ME.

Table 17: Contents of the SIM service table EF

Identifier: "6F01"		Structure: transparent		Mandatory
File size: X bytes, X ≥ 4		Update activity: low		
Access Conditions:				
READ		PIN1		
UPDATE		ADM		
INVALIDATE		ADM		
REHABILITATE		ADM		
Bytes	Description	M/O	Length	
1	Services no. 1 to no. 8	M	1	
2	Services no. 9 to no. 16	M	1	
3	Services no. 17 to no. 24	M	1	
4	Services no. 25 to no. 32	M	1	
5	Services no. 33 to no. 40	M	1	
6	Services no. 41 to no. 48	M	1	
etc.	etc.			
X	Service (8X-7) to (8X)	O	1	

- Services:

Contents:

- Service no.1: PIN1 disable function;
- Service no.2: ADNTETRA (Internal TETRA Phone Book) and Extension A;
- Service no.3: ADNGWT (External phones), Gateway Extension1 and Gateway table;
- Service no.4: FDNTETRA and Extension B;
- Service no.5: FDNGWT, Gateway Extension2 and Gateway table;
- Service no.6: SDNTETRA;
- Service no.7: SDNGWT, Gateway Extension3 and Gateway table;
- Service no.8: LNDTETRA and Extension A;
- Service no.9: LNDGWT, Gateway Extension1 and Gateway table;

Service no.10:	RFU;
Service no.11:	CCK and CCK location areas;
Service no.12:	SCK;
Service no.13:	GCK and MGCK;
Service no.14:	Service Provider Name;
Service no.15:	Preferred Networks;
Service no.16:	Username;
Service no.17:	Authentication;
Service no.18:	OTAR;
Service no.19:	RFU;
Service no.20:	Enhanced SIM-ME security;
Service no.21:	RFU;
Service no.22:	Status message texts;
Service no.23:	SDS1 message texts;
Service no.24:	SDS 123 Storage;
Service no.25:	SDS 4 Storage (including the SDS 4 message storage status);
Service no.26:	Call Modifiers;
Service no.27:	DMO channel information, MS allocation of DMO channels, DMO groups, DMO-TMO associations;
Service no.28:	List of key holders;
Service no.29:	DMO repeater and gateway list;
Service no.30:	SDS Parameters;
Service no.31:	Default Status Target;
Service no.32:	SDS Delivery Report;
Service no.33:	RFU
Service no.34:	Preferred Location Area;
Service no.35:	Welcome Message;
Service no.36:	ADN (External phones), Extension1 and Gateway table;
Service no.37:	FDN, Extension2 and Gateway table;
Service no.38:	SDN, Extension3 and Gateway table;
Service no.39:	LND, Extension1 and Gateway table;
Service no.40:	LNDCComp;
Service no.41:	Private Number information;
Service no.42:	APN table;
Service no.43:	Multi-Group feature.

NOTE: Other services are possible in the future and will be coded on further bytes in the EF.

The coding falls under the responsibility of ETSI.

Coding shall be as defined in figure 3.

1 bit is used to code each service:

bit = 1: service available

bit = 0: service not available

Byte 1:

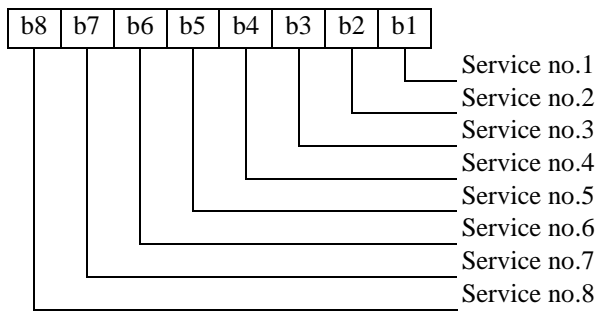

Byte 2:

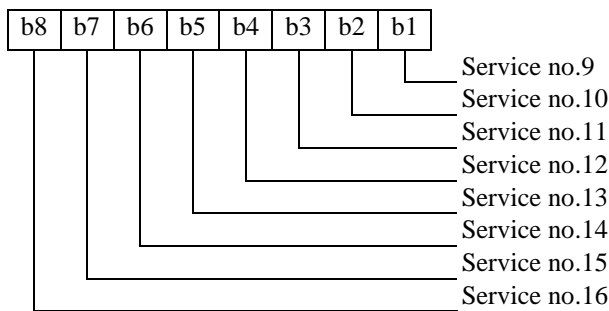

Byte 3:

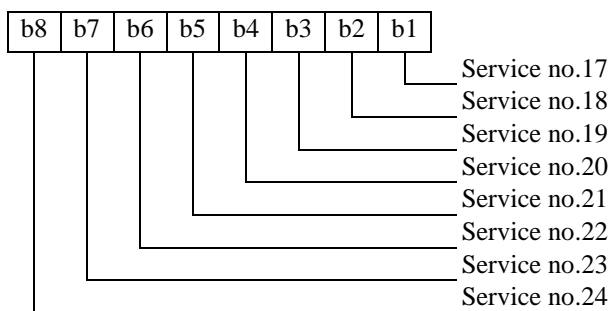

etc.

Figure 3: Coding of the SIM service table parameters

EXAMPLE: Figure 4 shows example of coding for the first byte indicating that service no.1 "PIN1-Disabling" is available.

Byte 1:

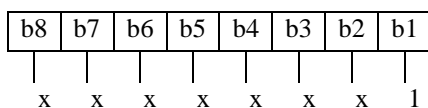

Figure 4: Example of service coding

10.3.2 EF_{ITSI} (Individual Tetra Subscriber Identity)

This EF shall contain the Individual Tetra Subscriber Identity number (ITSI) as defined in table 18. This EF shall not be readable or updateable when invalidated.

Table 18: Contents of Individual Tetra Subscriber Identity EF

Identifier: "6F02"		Structure: transparent		Mandatory	
File size: 6 bytes			Update activity: low		
Access Conditions:					
READ		PIN1			
UPDATE		ADM			
INVALIDATE		ADM			
REHABILITATE		NEV			
Bytes	Description			M/O	Length
1 to 6	ITSI			M	6

- ITSI:

Contents: ITSI consists of Mobile Country Code (MCC), Mobile Network Code (MNC) and Individual Short Subscriber Identity (ISSI).

Coding shall be as defined in figure 5.

Byte 1:

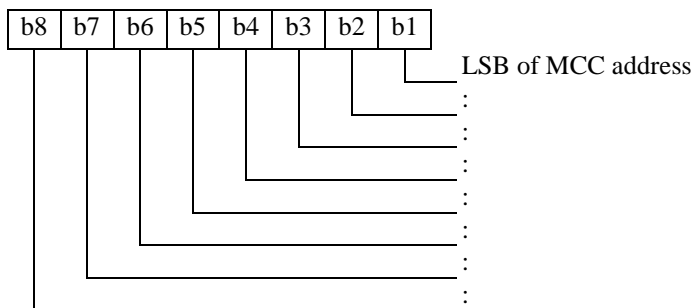

Byte 2:

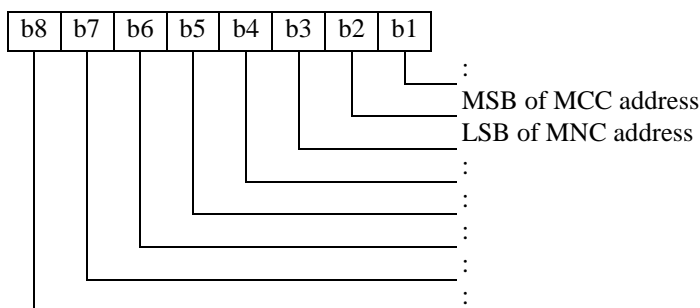

Byte 3:

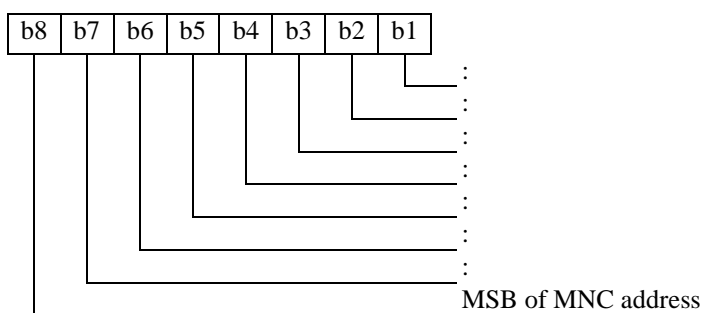

Byte 4:

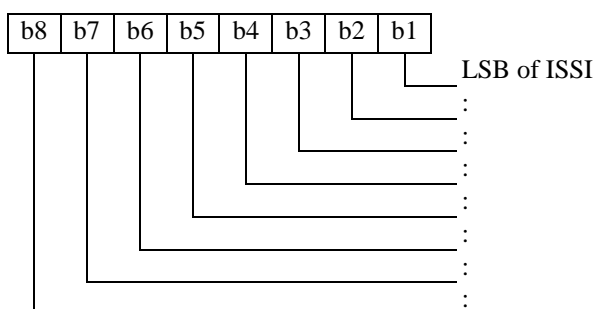

Byte 5:

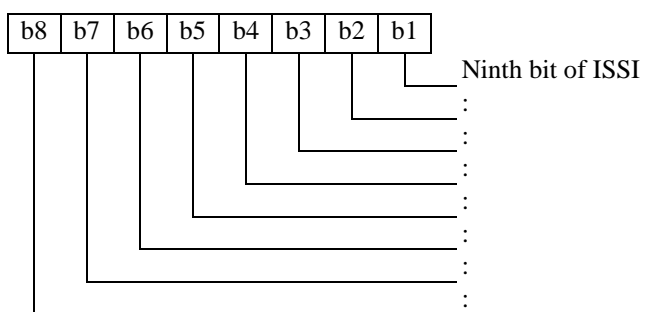

Byte 6:

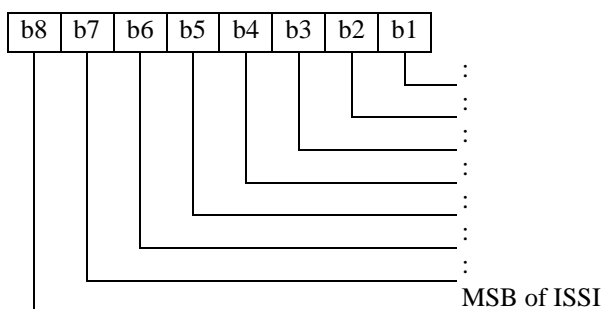

Figure 5: Coding of ITSI

The network address of the ITSI shall be used as the preferred network address.

10.3.3 EF_{ITSIDIS} (ITSI Disabled)

This EF shall indicate if the ITSI is temporarily disabled as defined in table 19.

Table 19: Contents of ITSI Disabled EF

Identifier: "6F03"		Structure: transparent		Mandatory
File size: 1 byte		Update activity: low		
Access Conditions:				
READ		PIN1		
UPDATE		ADM		
INVALIDATE		ADM		
REHABILITATE		ADM		
Bytes	Description	M/O	Length	
1	Status	M	1	

- Status:

Contents: The status bit indicates the temporary disable status of ITSI.

Coding shall be as defined in figure 6.

Byte 1:

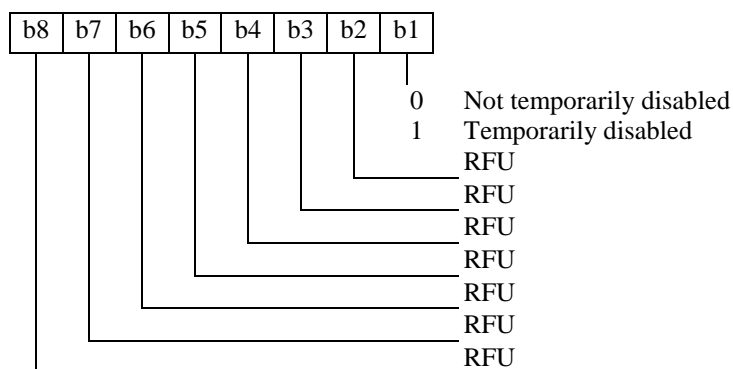

Figure 6: Coding of status

10.3.4 EF_{UNAME} (Username)

This EF may contain the alphanumeric name corresponding to the ITSI as defined in table 20.

Table 20: Contents of Username EF

Identifier: "6F04"		Structure: transparent		Optional
File size: 20 bytes		Update activity: low		
Access Conditions:				
READ		PIN1		
UPDATE		ADM		
INVALIDATE		ADM		
REHABILITATE		ADM		
Bytes	Description	M/O	Length	
1 to 20	Name	M	20	

- Name:

Contents: The common name of the card holder to be displayed.

Coding: According to the default 8-bit alphabet ISO/IEC 8859-1 [9]. Unused bytes shall be set as "FF".

10.3.5 EF_{SCT} (Subscriber Class Table)

This EF shall record the subscriber class membership of the ITSI subscription as defined in table 21. The subscriber class membership shall be defined at subscription. The subscriber class element is used to subdivide the MS population in up to 16 classes.

The ITSI subscriber class may only be changed via the MMI by an authorized administrator or via the SwMI by the Network Operator or authorized system manager.

Table 21: Contents of Subscriber Class Table EF

Identifier: "6F05"		Structure: transparent		Mandatory	
File size: 4 bytes			Update activity: low		
Access Conditions:					
READ		PIN1			
UPDATE		ADM			
INVALIDATE		ADM			
REHABILITATE		ADM			
Bytes	Description	M/O	Length		
1	Classes from 1 to 8	M	1		
2	Classes from 9 to 16	M	1		
3 to 4	Energy saving information	O	2		

- Classes from 1 to 16:

Coding shall be coded as defined in figure 7.

Bit value 1 means that user is a member, value 0 that user is not a member.

Byte 1:

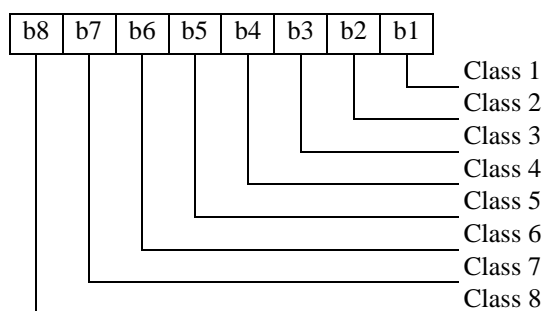

Byte 2:

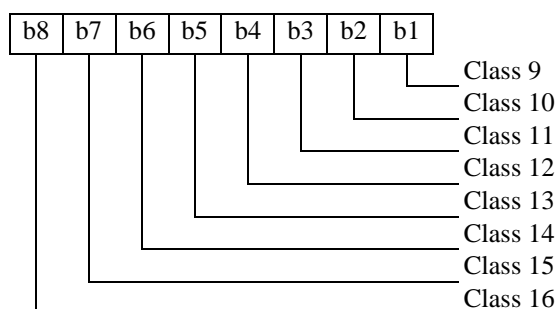

Figure 7: Coding of subscriber classes

- Energy Saving Information:

Contents: Indicates which energy saving scheme (if any) is in operation and the starting point of the energy economy mode.

Coding: As per EN 300 392-2 [3] (14 bits) with b8 and b7 of first byte RFU.

10.3.6 EF_{PHASE} (Phase identification)

This EF contains information concerning the phase of the SIM as defined in table 22.

Table 22: Contents of the Phase identification EF

Identifier: "6F06"		Structure: transparent		Mandatory	
File size: 1 byte			Update activity: low		
Access Conditions:					
READ		ALW			
UPDATE		ADM			
INVALIDATE		ADM			
REHABILITATE		ADM			
Bytes	Description			M/O	Length
1	SIM Phase			M	1 byte

- SIM Phase shall be indicated as defined in figure 8.

Coding:

Byte 1:

b8	b7	b6	b5	b4	b3	b2	b1	
					0	0	0	Indicates support of ETS 300 812 Edition 1
					0	0	1	Indicates support of EN 300 812 V2.1.1
					0	1	0	Indicates support of TS 100 812-2 V2.2.1 and ES 200 812-2 V2.2.2
					0	1	1	EN 300 812-3 the present version
					1	0	0	TS 100 812-2 and ES 200 812-2 present version
					1	0	1	RFU
					1	1	0	RFU
					1	1	1	RFU
								RFU

Figure 8: Coding of SIM phase

All other codings are reserved for specification by ETSI.

10.3.7 EF_{CCK} (Common Cipher Key)

This EF shall contain common cipher key as defined in table 23. This EF shall contain 2 records.

Table 23: Contents of Common Cipher Key EF

Identifier: "6F07"		Structure: linear fixed		Optional
Record size: 12 bytes		Update activity: high		
Access Conditions:				
READ		PIN1		
UPDATE		NEV (see note)		
INVALIDATE		NEV		
REHABILITATE		NEV		
Bytes	Description	M/O	Length	
1 to 2	CCK-id	M	2	
3 to 12	Common cipher key CCK	M	10	

NOTE: This EF is updated using the TA32 algorithm on the SIM.

If SIM Service 20 is set (Enhanced SIM-ME security) the enhanced security algorithm TE shall be automatically run by the SIM to seal the record with Enhanced Security Key (KE) before sending it to the ME.

- CCK-id:

Contents: Common cipher key identity.

Coding shall be as defined in figure 9:

Byte 1:

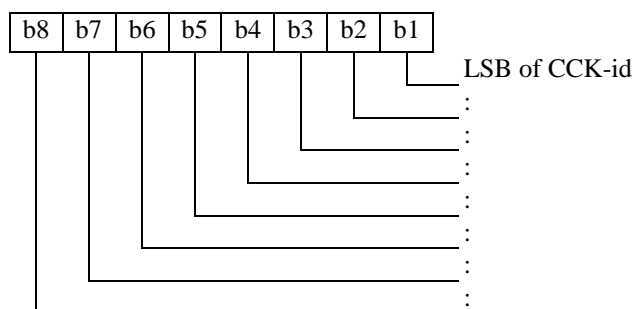

Byte 2:

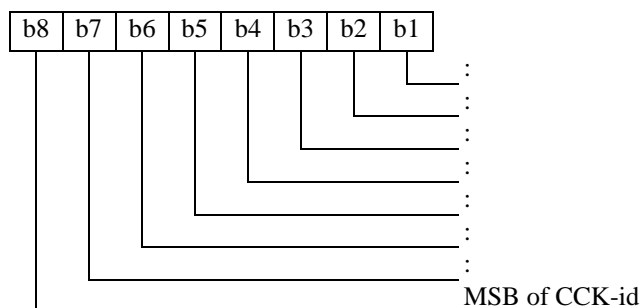

Figure 9: Coding of CCK-id

- Common Cipher Key (CCK):

Contents: CCK.

Coding: CCK shall be coded in 10 bytes according to figure 10.

Byte 3:

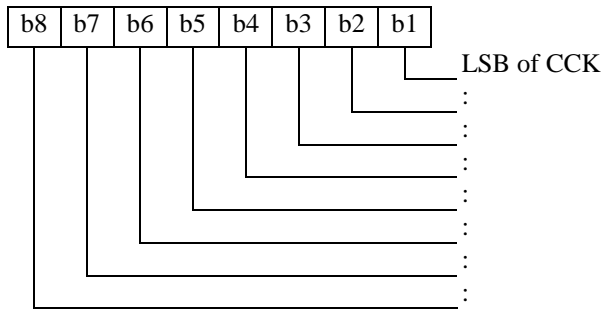

etc.

Byte 12:

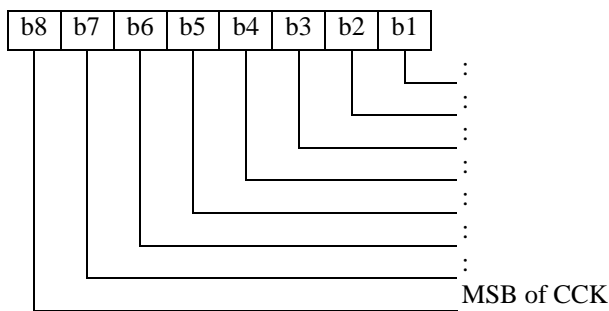

Figure 10: Coding of CCK

10.3.8 EF_{CCKLOC} (CCK location areas)

This EF shall contain the location area(s) the CCK is valid as defined in table 24.

Table 24: Contents of CCK location areas EF

Identifier: "6F08"		Structure: transparent		Optional
File size: 32 bytes		Update activity: high		
Access Conditions:				
READ		PIN1		
UPDATE		PIN1		
INVALIDATE		ADM		
REHABILITATE		ADM		
Bytes	Description	M/O	Length	
1	Type	M	1	
2 to 32	Location area information	O	31	

- **Type:**

Contents: defines the structure of the location area information.

Coding: shall be binary coded from 0 to 4 as defined in figure 11. (See also EN 300 392-7 [4]).

Byte 1:

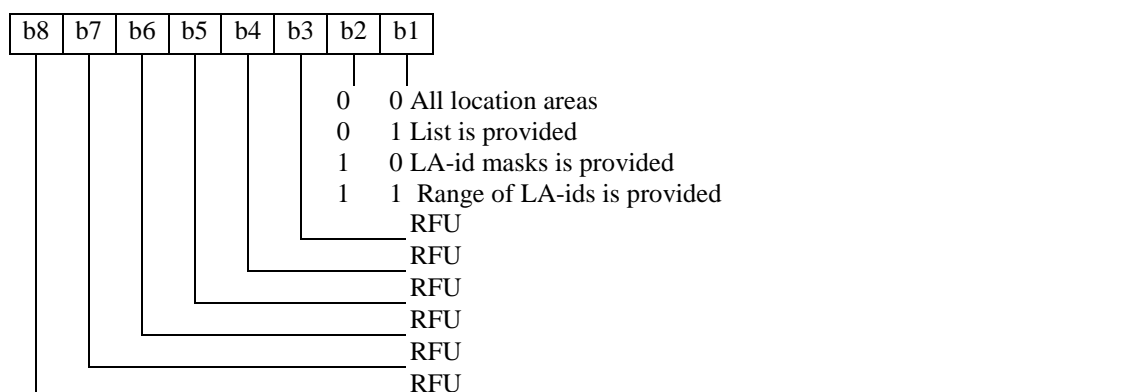

Figure 11: Location type

- **Location area Information**

Contents : defines the LA-ID where the CCK-ID is valid

Coding: the coding is binary coded, where the structure is dependent on the type.

1 Type 00:

CCK-ID is valid for all location area, so no more information. Bytes 2 to 32 are RFU.

2 Type 01:

In that case a list of LA-ID is provided. The structure is as following:

- Byte 2: indicates number of location areas (1 to 15) shall be binary coded; and
- Bytes 3 to 32: Location areas Contents: a list of location areas where CCKs are valid.

Coding: Each element is coded in 2 bytes, 14 bits. The first element (bytes 2 and 3) shall be as defined in figure 12. See also EN 300 392-7 [4].

Byte 3:

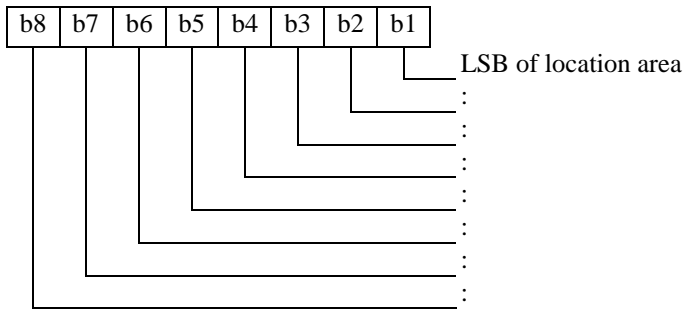

Byte 4:

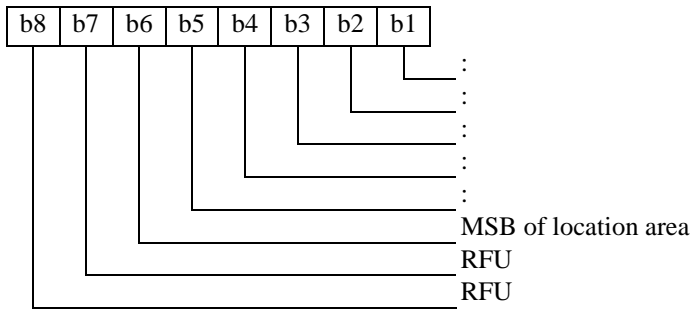

Figure 12: Coding of location area

3 Type 10:

In that case the LA selector and mask mechanism is intended to find if the CCK applies to the current LA.

Coding:

Bytes 2 to 3: Location area bit mask shall be coded as defined in figure 13.

Byte 2:

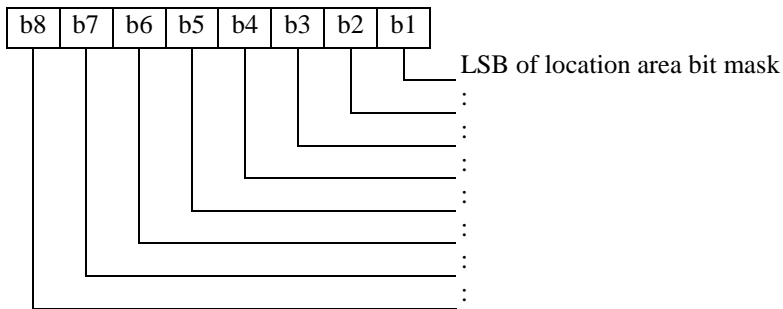

Byte 3:

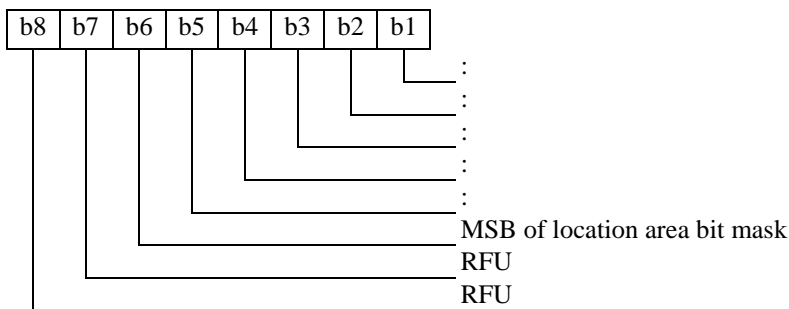
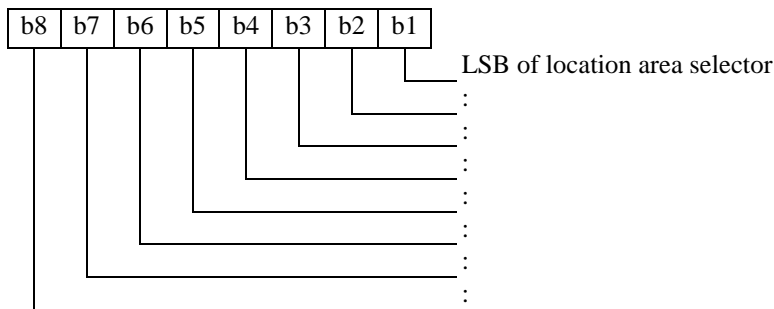

Figure 13: Location area bit mask

Bytes 4 to 5: Location area selector shall be coded as defined in figure 14.

Byte 4:



Byte 5:

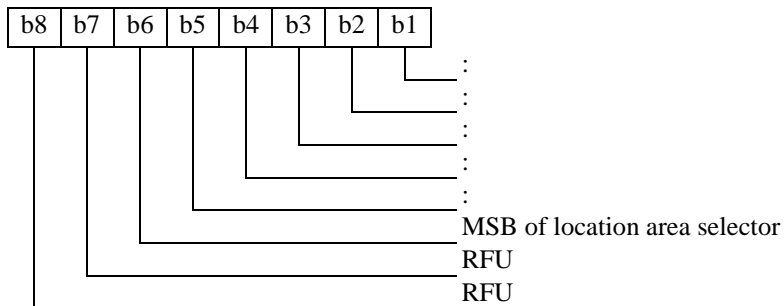

Figure 14: Location area selector

Bytes 6 to 32 are RFU.

4 Type 11:

In that case a range of LA identities is defined according to the following:

Bytes 2 to 3: Low location area value shall be coded as defined in figure 15.

Byte 2:

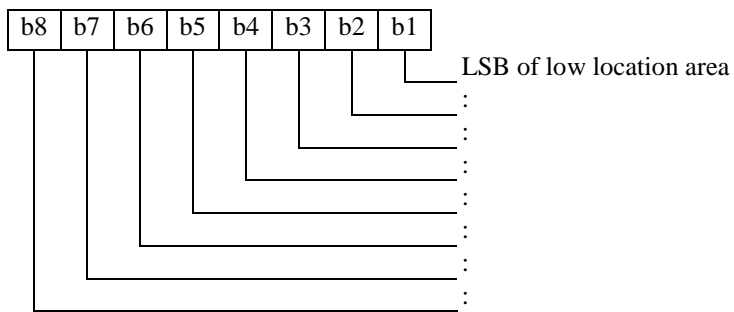

Byte 3:

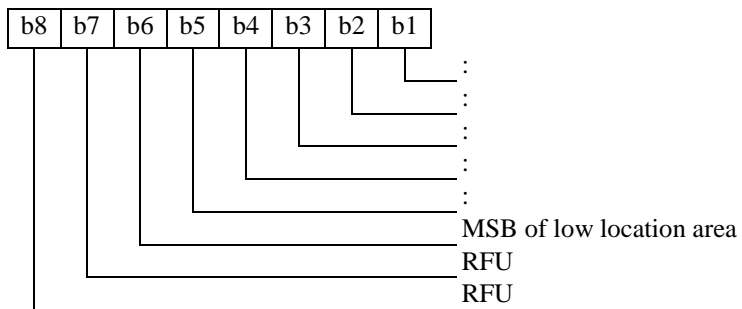
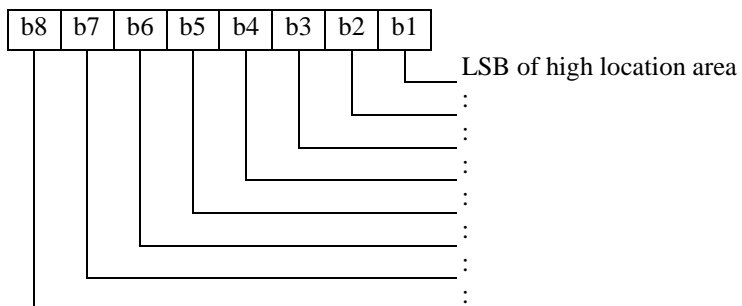

Figure 15: Low location area

Bytes 4 to 5: High location area value shall be encoded as defined in figure 16.

Byte 4:



Byte 5:

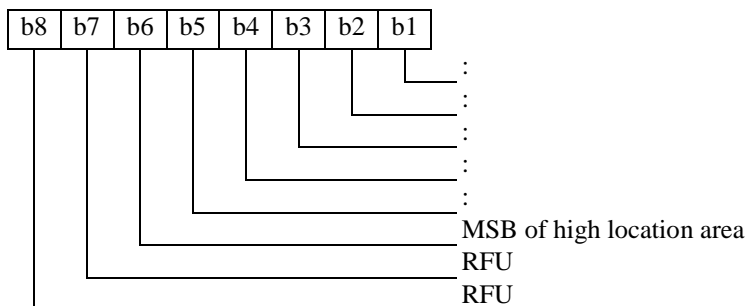

Figure 16: High location area

10.3.9 EF_{SCK} (Static Cipher Keys)

This EF shall contain information as defined in table 25 and can contain up to 32 records.

Table 25: Contents of Static Cipher Keys EF

Identifier: "6F09"		Structure: linear fixed		Optional	
Record length: 12 bytes			Update activity: high		
Access Conditions:					
READ		PIN1			
UPDATE		NEV (see note)			
INVALIDATE		NEV			
REHABILITATE		NEV			
Bytes	Description			M/O	Length
1 to 2	Static Cipher Key Version Number			M	2
3 to 12	Static Cipher Key			M	10

NOTE: This EF is updated using the TA41/52 algorithms on the SIM.

If SIM Service 20 is set (Enhanced SIM-ME security) the enhanced security algorithm TE shall be automatically run by the SIM to seal the record with Enhanced Security Key (KE) before sending it to the ME.

- Static Cipher Key Version Number:

Contents: The Static Cipher Key Version Number.

Coding: The Static Cipher Key Version Number shall be coded according to figure 17.

Byte 1:

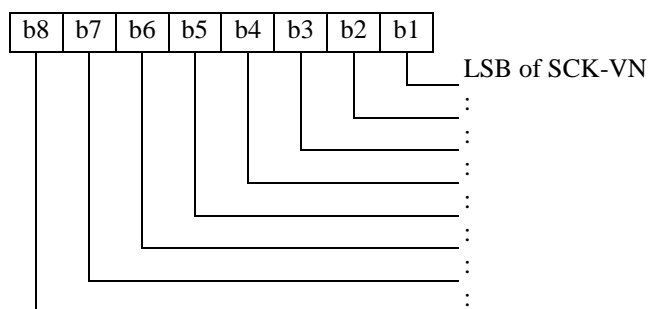

Byte 2:

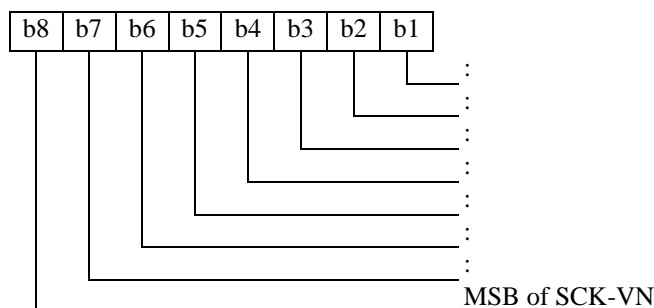

Figure 17: Coding of Static Cipher Key Version Number

- Static Cipher Key:

Contents: The Static Cipher Key.

Coding: The Static Cipher Key is coded in 10 bytes according to figure 18.

Byte 3:

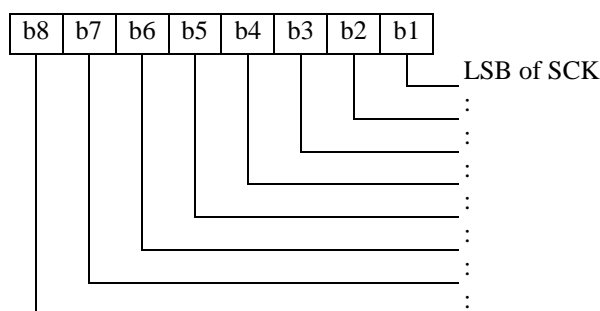

etc.

Byte 12:

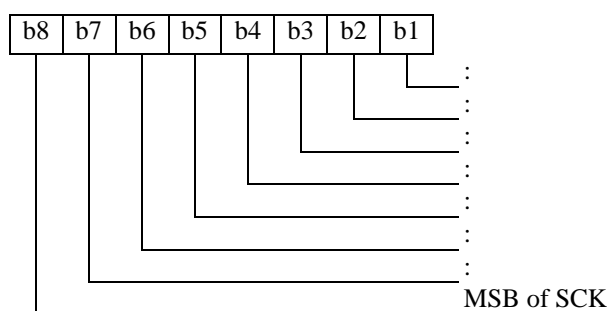

Figure 18: Coding of Static Cipher Key

10.3.10 EF_{GSSIS} (Static GSSIs)

This EF shall contain the pre-programmed (by the operator or organization) group identities as defined in table 26.

Table 26: Contents of Static GSSIs EF

Identifier: "6F0A"		Structure: linear fixed		Mandatory
Record length: X + 6 bytes		Update activity: low		
Access Conditions:				
READ		PIN1		
UPDATE		ADM		
INVALIDATE		ADM		
REHABILITATE		ADM		
Bytes	Description	M/O	Length	
1 to X	Group name	M	X	
X + 1	Network address record number	M	1	
X + 2 to X + 4	Group Identity (GSSI)	M	3	
X + 5	Parent Flag	M	1	
X + 6	Parent Talk Group Index	M	1	

- Group name:

Contents: Alphanumeric names for the static groups stored on the SIM.

Coding: The value of X may range from zero to 251.

- Network address record number:

Contents: Record number of the corresponding network address. Network addresses are stored in EF_{NWT}.

Coding: binary. Free records are indicated by NULL value ("00").

- Group Identity (GSSI):

Contents: The short subscriber identity for the group.

Coding: Length of the GSSI shall be 24 bits as defined in figure 19.

Byte X + 2:

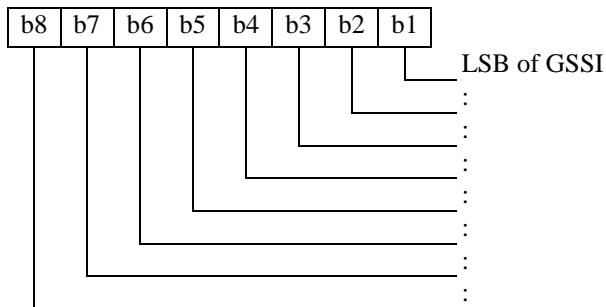

Byte X + 3:

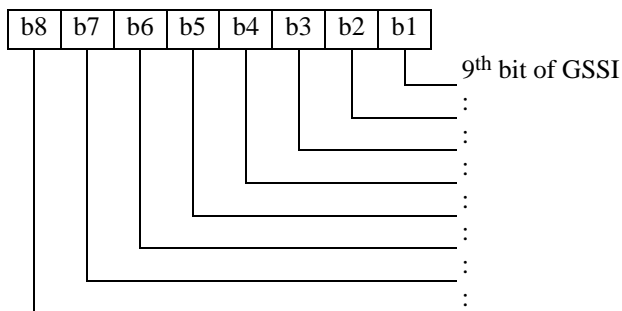

Byte X + 4:

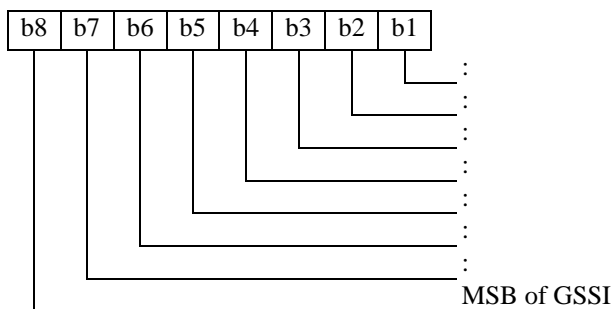

Figure 19: Coding of Group Identity

- Parent Flag:

Contents: Flag indicating if the group has a parent group.

Coding:

0 - no parent.

1 - has a parent.

- Parent Talk Group Index:

Contents: The index of the parent group (the record number in the EF_{GSSIS} file).

Coding: shall be binary.

10.3.11 EF_{GRDS} (Group related data for static GSSIs)

This EF shall contain information related to each static GSSI as defined in table 27. There shall be a 1:1 relationship between each record in EF_{GRDS} and the corresponding record in EF_{GSSIS}.

Table 27: Contents of Group related data for static GSSIs EF

Identifier: "6F0B"		Structure: linear fixed		Mandatory
Record size: 2 bytes		Update activity: low		
Access Conditions:				
READ		PIN1		
UPDATE		PIN1		
INVALIDATE		ADM		
REHABILITATE		ADM		
Bytes	Description	M/O	Length	
1	Key record number	M	1	
2	Group related data	M	1	

- Key record number:

Contents: Class 2 systems record number of the corresponding SCK in the EF_{SCK}-file.

Contents: Class 3 systems record number of the corresponding GCK in the EF_{GCK}-file.

Coding: binary. In class 2 systems if there is no SCK defined for this group, key record number shall be NULL value ("00").

Coding: binary. In class 3 systems if there is no GCK defined for this group, key record number shall be NULL value ("00").

- Group related data:

Contents:

Group Identity lifetime (2 bits): Shall indicate the attachment lifetime of the group identity as defined in table 28 copied from EN 300 392-2 [3], clause 16.10.16.

Class of usage (3 bits). Shall indicate the importance of the group for the user and define the participation rules for the groups defined with Class of usage. (EN 300 392-2 [3] and ETS 300 392-12-22 [8]).

Permanent Detachment Flag (1 bit). Shall indicate that whether a group identity was permanent detached by the SwMI.

MS user is allowed to request an attachment (1 bit): Shall indicate whether MS user is allowed to request an attachment.

Table 28: Group identity attachment lifetime

Information element	Length	Value	Remark
Group Identity Lifetime	2	00	attachment not needed
		01	attachment for next ITSI attach required
		10	attachment not allowed for next ITSI attach
		11	attachment for next location update required

Coding: shall be as defined in figure 15.

Byte 2:

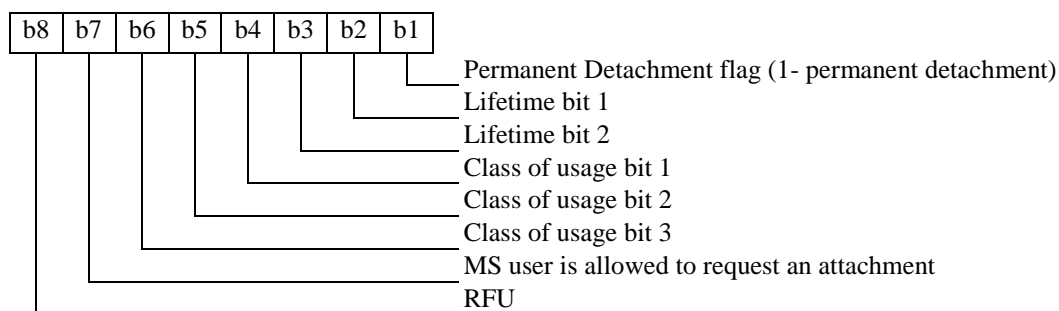

Figure 20: Coding of Group related data

10.3.12 EF_{GSSID} (Dynamic GSSIs)

This EF shall contain the dynamic group identities as defined in table 29.

Table 29: Content of Dynamic GSSIs EF

Identifier: "6F0C"		Structure: linear fixed		Mandatory
Record length: X + 4 bytes			Update activity: low	
Access Conditions:				
READ		PIN1		
UPDATE		ADM		
INVALIDATE		ADM		
REHABILITATE		NEV		
Bytes	Description	M/O	Length	
1 to X	Group name	M	X	
X + 1	Network address record number	M	1	
X + 2 to X + 4	Group Identity (GSSI)	M	3	

- See EF_{GSSIS} (Static GSSIs) for contents and coding.

10.3.13 EF_{GRDD} (Group related data for dynamic GSSIs)

This EF shall contain information related to each dynamic GSSI as defined in table 30. There shall be a 1:1 relationship between each record in EF_{GRDD} and the corresponding record in EF_{GSSID}.

Table 30: Contents of Group related data for dynamic GSSIs EF

Identifier: "6F0D"		Structure: linear fixed		Mandatory
Record size: 3 bytes			Update activity: low	
Access Conditions:				
READ		PIN1		
UPDATE		PIN1		
INVALIDATE		ADM		
REHABILITATE		ADM		
Bytes	Description	M/O	Length	
1	Key record number	M	1	
2 to 3	Group related data	M	2	

- See EF_{GRDS} for contents and coding.

10.3.14 EF_{GCK} (Group Cipher Keys)

This EF shall contain the group cipher keys associated with the group identities as defined in table 31. There shall be a 1:1 relationship between each MGCK in EF_{MGCK} and the corresponding record of GCK in EF_{GCK}.

Table 31: Contents of Group Cipher Keys EF

Identifier: "6F0E"		Structure: linear fixed		Optional
Record length: 26 bytes		Update activity: high		
Access Conditions:				
READ		NEV (see note 1)		
UPDATE		NEV (see note 2)		
INVALIDATE		ADM		
REHABILITATE		ADM		
Bytes	Description	M/O	Length	
1 to 2	GCKN	M	2	
3 to 4	GCK-VN	M	2	
5 to 14	GCK	M	10	
15 to 16	GCK-VN	M	2	
17 to 26	GCK	M	10	
NOTE 1: There is no access to this EF over the SIM-ME interface.				
NOTE 2: GCK and GCKN are updated on the SIM by use of the TA41/TA82 algorithm.				
NOTE 3: A record is free if no (static or dynamic) GSSI points to it.				

- GCKN:

Contents: The Group Cipher Key Number is the identifier for a GCK used to associate it to one or more groups.

Coding: shall be coded as defined in figure 21.

Byte 1:

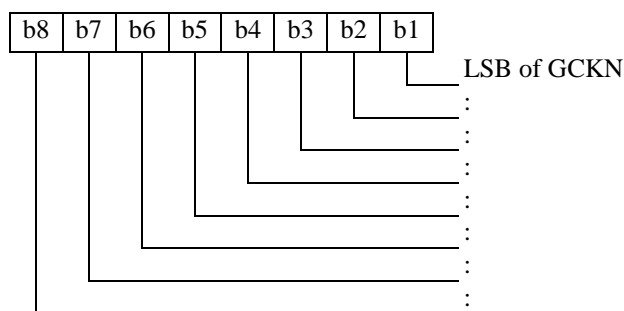

Byte 2:

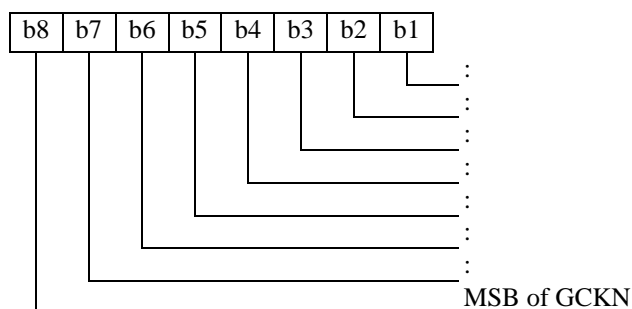

Figure 21: Coding of GCKN

- GCK-VN:

Contents: Group Cipher key Version Number.

Coding:

Bytes 3 and 15:

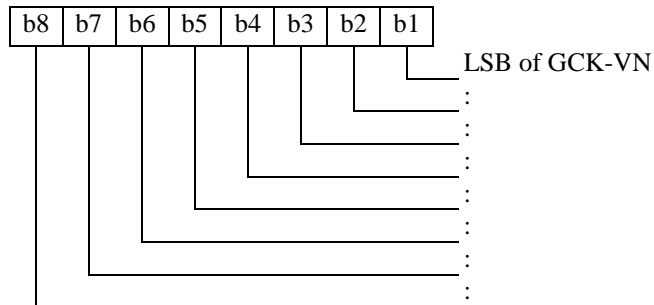

Bytes 4 and 16:

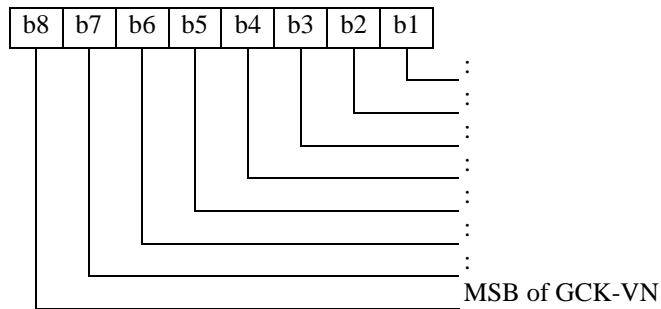

- GCK:

Contents: The Group Cipher Keys.

Coding: The key shall be stored in 10 bytes according to figure 22.

Bytes 5 and 17:

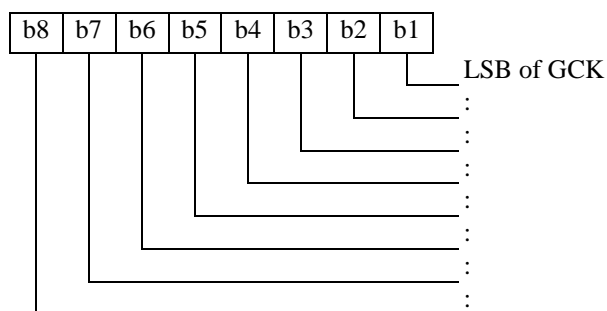

etc.

Bytes 14 and 26:

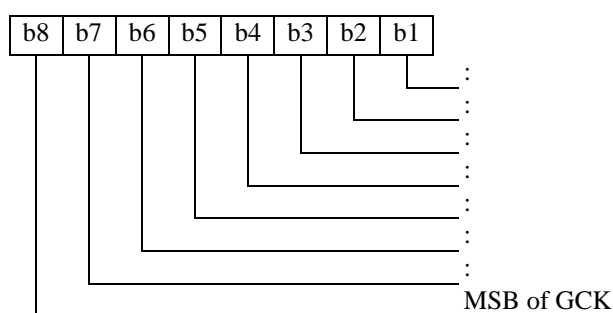

Figure 22: Coding of GCK

10.3.15 Void

10.3.16 EF_{GINFO} (User's group information)

This EF shall contain the user's last active group, user's preferred group and information about using these group addresses as defined in table 32.

Table 32: Contents of User's group information EF

Identifier: "6F10"		Structure: transparent		Mandatory	
File size: 9 bytes			Update activity: high		
Access Conditions:					
READ		PIN1			
UPDATE		PIN1			
INVALIDATE		ADM			
REHABILITATE		ADM			
Bytes	Description	M/O	Length		
1	Usage information	M	1		
2 to 3	Last TMO active group	M	2		
4	Last DMO active Group	M	1		
5 to 6	TMO user's preferred group	M	2		
7	DMO user's preferred group	M	1		
8	Last selected scan list	M	1		
9	Scan on/off	M	1		

- Usage information: indicate the use of addresses. It is common to TMO and DMO.

Coding: shall be coded as defined in figure 23.

Byte 1:

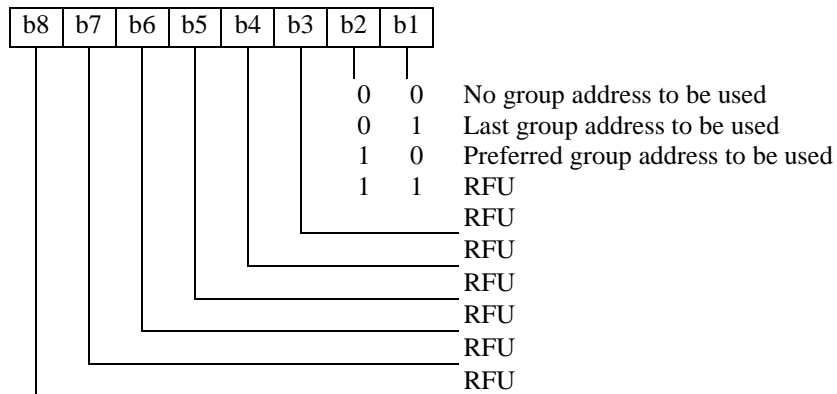

Figure 23: Coding of Usage information

- Last TMO active group: Shall indicate the record number of the corresponding TMO group in EF_{GSSIS} or EF_{GSSID} .

Coding:

Byte 2:

GSSIS_GSSID_flag: 1 – from EF_{GSSIS} .

0 – from EF_{GSSID} .

Byte 3: Coded binary – Indicate the record number of the corresponding TMO group in EF_{GSSIS} or EF_{GSSID} .

- Last DMO active group : Shall indicate the record number of the corresponding DMO group in EF_{DMO_GSSIS} .

Coding:

Byte 4: Coded binary – Indicate the record number of the corresponding DMO Group in EF_{DMO_GSSIS} .

- TMO user's preferred group: Shall indicate the record number of the corresponding TMO group in EF_{GSSIS} or EF_{GSSID} .

Coding: the TMO user's preferred group shall be coded as presented in figure 24.

Byte 5:

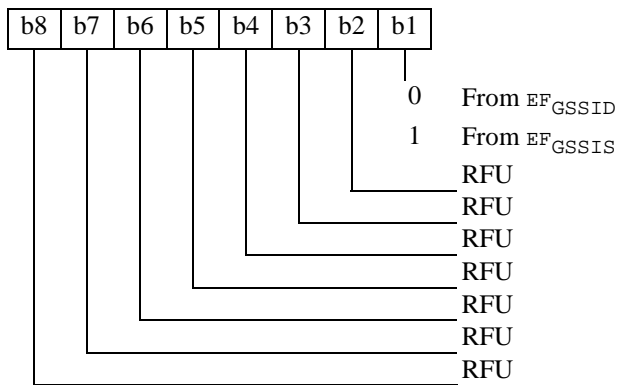

Byte 6: Coded binary – Indicate the record number of the corresponding TMO group in EF_{GSSIS} or EF_{GSSID} .

Figure 24: TMO user's preferred group

- DMO user's preferred group : Shall indicate the record number of the corresponding DMO group in EF_{DMO_GSSIS} .

Coding:

Byte 7: Coded binary – Indicate the record number of the corresponding DMO Group in EF_{DMO_GSSIS} .

- Last Selected Scan List: Shall indicate the record number of the scan list in EF_{SCAN} .

Coding:

Byte 8: Coded binary – Indicate the record number of the corresponding Scan list in EF_{SCAN} .

- Scan on/off: Shall indicated scanning state.

Coding: the scan on/off shall be coded as presented in table 25.

Byte 9:

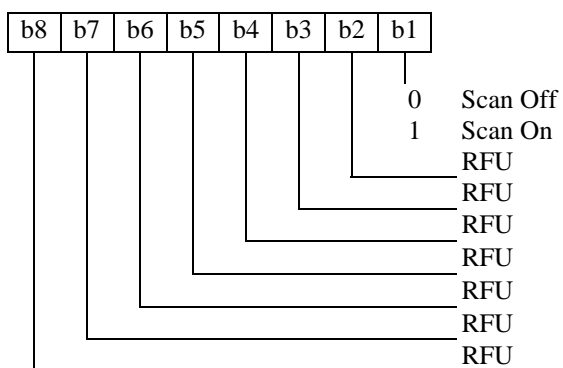

Figure 25: Scanning on/off

10.3.17 EF_{SEC} (Security settings)

This EF shall indicate the values for the security settings as defined in table 33.

Table 33: Contents of Security settings EF

Identifier: "6F11"		Structure: transparent		Mandatory	
File size: 1 byte			Update activity: low		
Access Conditions:					
READ		PIN1			
UPDATE		ADM			
INVALIDATE		ADM			
REHABILITATE		ADM			
Bytes	Description			M/O	Length
1	Security settings			M	1

- Security settings:

Contents: indicates whether the SIM requests a mutual authentication when it is authenticated by the SwMI, or whether the SIM requests authentication and the security class.

Coding: shall be coded as defined in figure 26.

Byte 1:

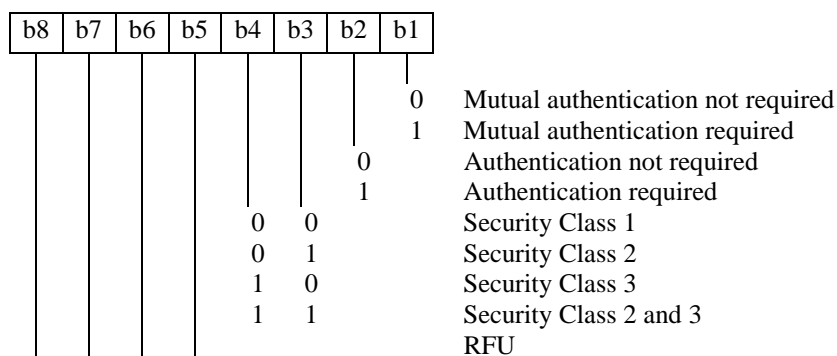

Figure 26: Coding of Security settings

10.3.18 EF_{FORBID} (Forbidden networks)

This EF shall contain the Forbidden networks as defined in table 34. It is read by the ME as part of the SIM initialization procedure and indicates networks which the MS shall not automatically attempt to access.

A network address is written to the EF if a network rejects a Location Update with the following causes "Illegal MS" and "Migration not supported" as in EN 300 392-2 [3]. The ME shall update the list by using the "next" mode of the update record command.

NOTE 1: By using the "next" mode in update operations the oldest record will be overwritten in the case the file is full.

NOTE 2: This EF should have at least as many records as is the expected amount of forbidden networks. Otherwise the ME may find the same forbidden networks in the beginning of every TETRA session and rewrite them to the list.

Table 34: Contents of Forbidden networks EF

Identifier: "6F12"		Structure: cyclic		Mandatory	
Record length: 3 bytes			Update activity: low		
Access Conditions:					
READ		PIN1			
UPDATE		PIN1			
INVALIDATE		ADM			
REHABILITATE		ADM			
Bytes	Description			M/O	Length
1 to 3	Network address			M	3

- Network address:

Contents: The address consists of MCC and MNC addresses, 10 and 14 bits respectively.

Coding: shall be coded as defined in figure 27. Empty records shall be set to "FF".

Byte 1:

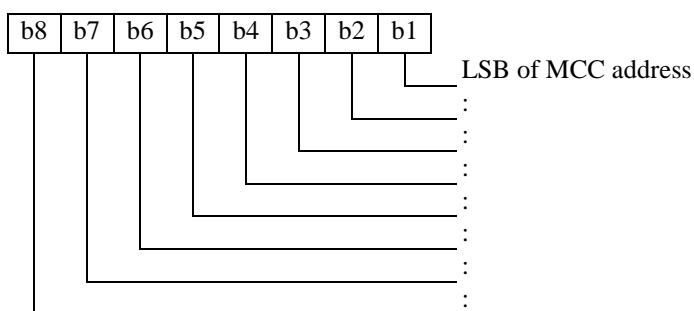

Byte 2:

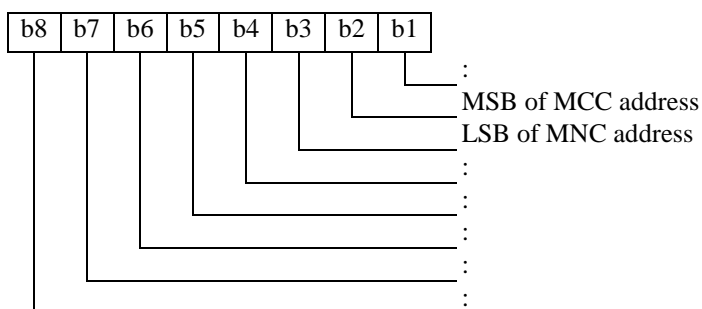

Byte 3:

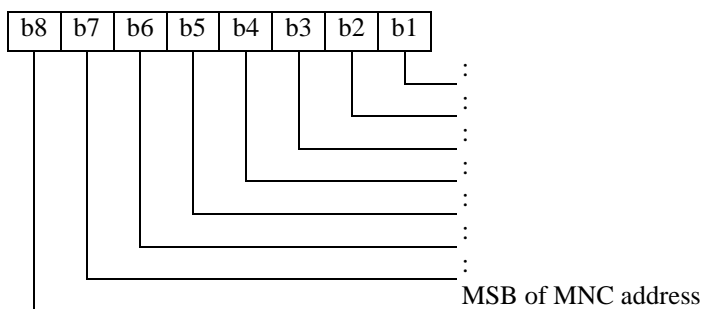
**Figure 27: Coding of Network address**

10.3.19 EF_{PREF} (Preferred networks)

This EF shall contain a list of preferred network addresses as defined in table 35. The networks are listed in the order of preference. The first record corresponds to the highest preference.

Table 35: Contents of Preferred networks EF

Identifier: "6F13"		Structure: linear fixed		Optional
Record length: 3 bytes		Update activity: low		
Access Conditions:				
READ		PIN1		
UPDATE		ADM		
INVALIDATE		ADM		
REHABILITATE		ADM		
Bytes	Description	M/O	Length	
1 to 3	Network address	M	3	

- Network address:

Contents: The address consists of MCC and MNC addresses, 10 and 14 bits respectively.

Coding: shall be coded as defined in figure 28. Empty records shall be set to "FF".

Byte 1:

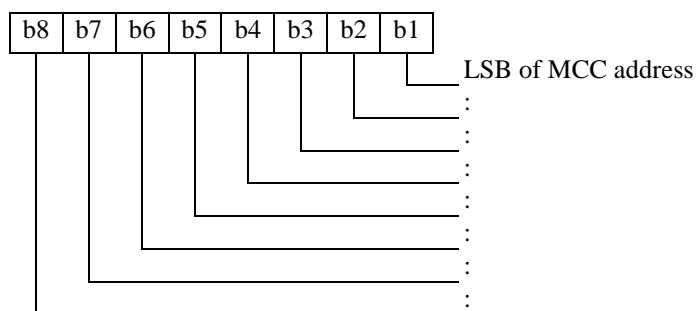

Byte 2:

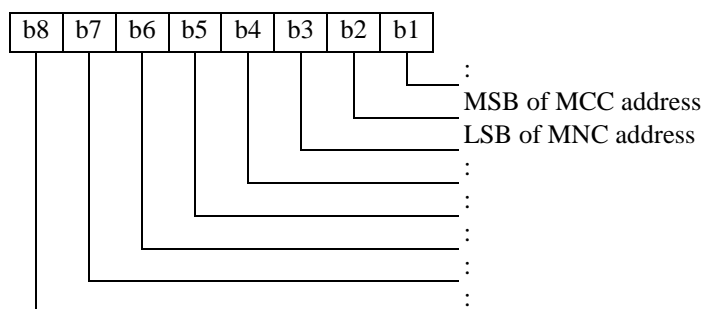

Byte 3:

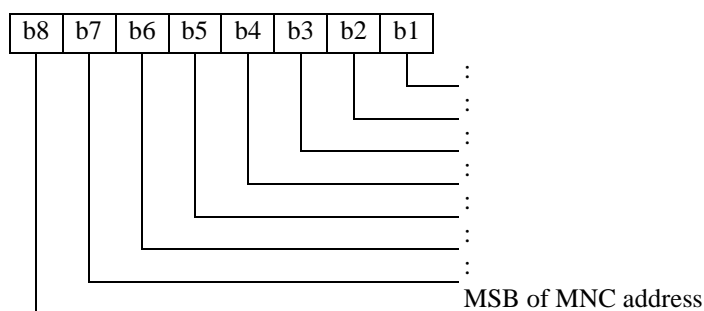

Figure 28: Coding of network address

10.3.20 EF_{SPN} (Service Provider Name)

This EF shall contain the service provider name and appropriate requirements for the display by the ME as defined in table 36.

Table 36: Contents of Service Provider Name EF

Identifier: "6F14"		Structure: transparent		Optional	
File size: 17 bytes			Update activity: low		
Access Conditions:					
READ		ALW			
UPDATE		ADM			
INVALIDATE		ADM			
REHABILITATE		ADM			
Bytes	Description	M/O	Length		
1	Display Condition	M	1		
2 to 17	Service Provider Name	M	16		

- Display condition:

Contents: Display condition for the service provider name in respect to the network.

Coding: shall be as defined in figure 29.

Byte1:

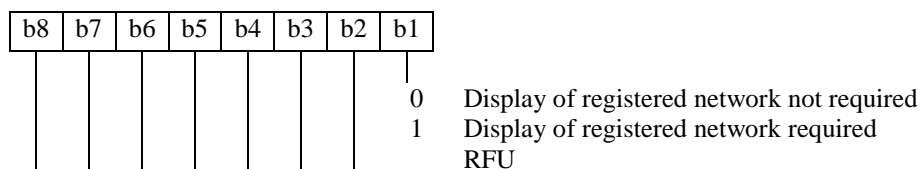

Figure 29: Coding of Display condition

- Service provider name:

Contents: Service provider string to be displayed.

Coding: The string shall use the default 8-bit alphabet ISO/IEC 8859-1 [9]. The string shall be left justified. Unused bytes shall be set to "FF".

10.3.21 Void

10.3.22 EF_{DNWRK} (Broadcast network information)

This EF shall contain information concerning the D-NWRK-BROADCAST according to EN 300 392-2 [3] as defined in table 37. It shall contain 32 records (see EN 300 392-2 [3]).

Storage of neighbour cell information may reduce the extent of a MS's search for MCCH carriers when selecting a cell.

Table 37: Contents of Broadcast network information EF

Identifier: "6F16"		Structure: linear fixed		Mandatory
Record size: 3 bytes		Update activity: high		
Access Conditions:				
READ		PIN1		
UPDATE		PIN1		
INVALIDATE		ADM		
REHABILITATE		ADM		
Bytes	Description	M/O	Length	
1 to 3	MCCH information	M	3 bytes	

- MCCH information:

Coding: The information shall be coded as defined in EN 300 392-2 [3] and presented in figure 30. Free record shall be indicated in bit 7 of byte 3.

Byte 1:

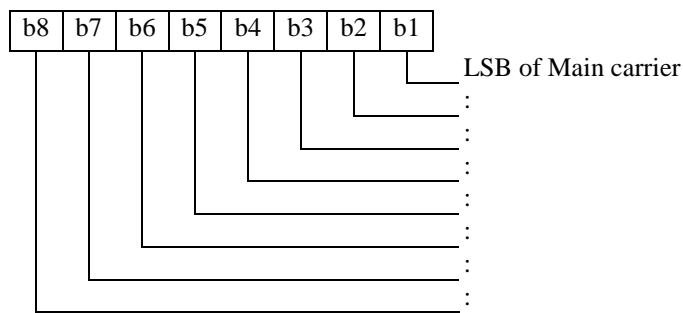

Byte 2:

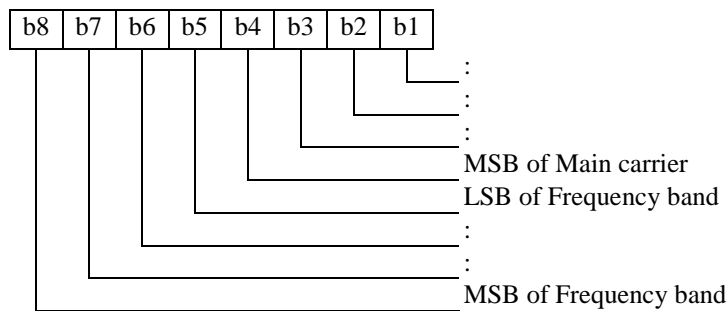

Byte 3:

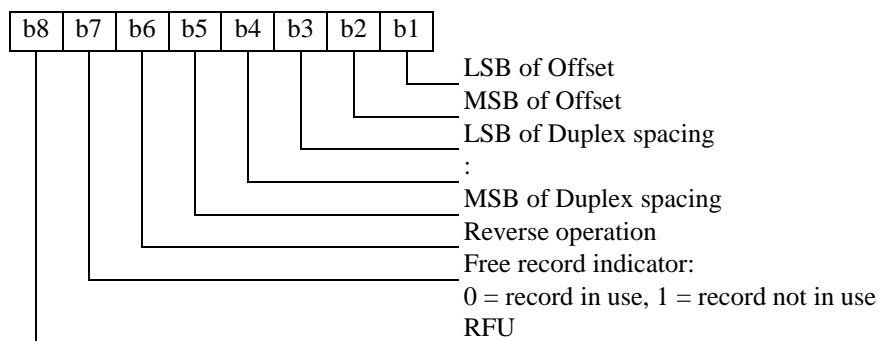

Figure 30: Coding of MCCH information

10.3.23 EF_{NWT} (Network table)

This EF shall contain the network part of the TETRA addresses as defined in table 38. These addresses are used and updated by several EFs (EF_{GSSIS}, EF_{GSSID}, EF_{GINFO}, EF_{GWT}, EF_{ADNTETRA}, EF_{SDNTETRA}, EF_{FDNTETRA}, and EF_{LNDTETRA}). The records in these files make reference to particular network address records in this file using the record number of the network address.

Table 38: Contents of Network table EF

Identifier: "6F17"		Structure: linear fixed		Mandatory
Record size: 5 bytes		Update activity: high		
Access Conditions:				
READ		PIN1		
UPDATE		PIN1		
INVALIDATE		ADM		
REHABILITATE		ADM		
Bytes	Description	M/O	Length	
1 to 3	Network address (MCC and MNC)	M	3	
4 to 5	Record pointer counter	M	2	

- Network address:

Contents: The address consists of MCC and MNC addresses, 10 and 14 bits respectively. The user's home address (from ITSI) is stored as the first record of the file.

Coding: shall be as defined in figure 31.

Byte 1:

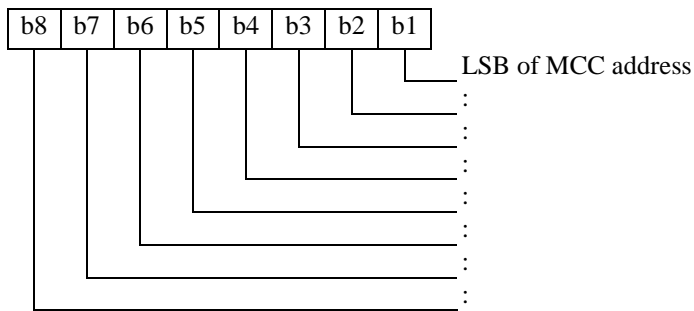

Byte 2:

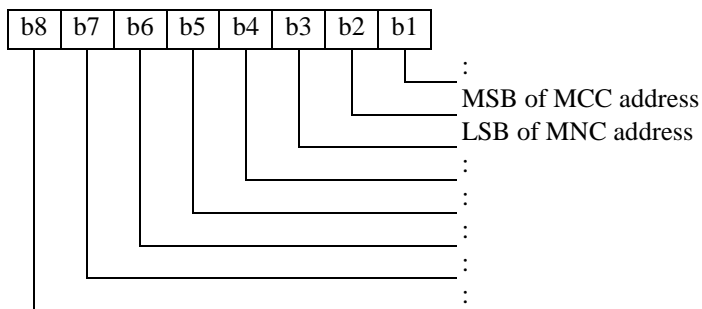

Byte 3:

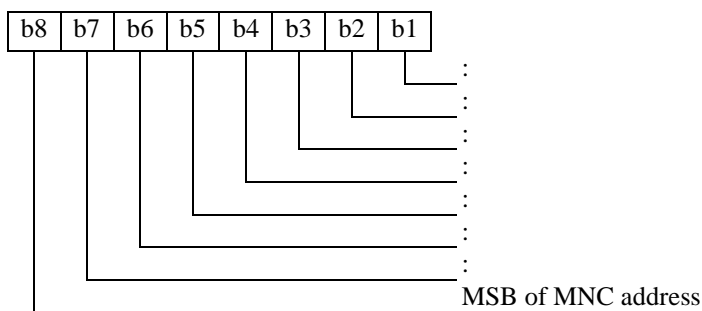

Figure 31: Network address

- Record pointer counter:

Contents: The records in this file can be referenced from several other files. This counter is incremented each time a new reference to a record is created. Also when the reference is deleted, this counter should be decremented.

Coding: Binary. NULL value ("00") indicates a free record.

NOTE: This file is updated by the ME when updating EFs which reference this file.

10.3.24 EF_{GWT} (Gateway table)

This EF shall contain the names and addresses for gateways in a TETRA network e.g. Private Automatic Branch Exchange (PABX) as defined in table 38 and Public Switched Telephone Network (PSTN). This file is referenced by EF_{ADNGWT}, EF_{FDNGWT}, EF_{LNDGWT}, EF_{SDNGWT}, EF_{ADN}, EF_{FDN}, EF_{LND} and EF_{SDN}. The files reference to this file using the record number of gateway names and addresses on this file.

NOTE: This implementation requires that there is one universally acknowledged TETRA address for PSTN gateways in all different networks.

Table 39: Contents of Gateway table EF

Identifier: "6F18"		Structure: linear fixed		Optional
Record size: 14 bytes			Update activity: high	
Access Conditions:				
READ		PIN1		
UPDATE		ADM		
INVALIDATE		ADM		
REHABILITATE		ADM		
Bytes	Description	M/O	Length	
1 to 8	Name	M	8	
9	Network address record number	M	1	
10 to 12	SSI of the gateway	M	3	
13	Type	M	1	
14	RFU	M	1	

The name and address of the PSTN gateway is stored as the first record of the file.

- Name:

Contents: The alphanumeric name for the corresponding gateway.

Coding: The string shall use the default 8-bit alphabet, refer to ISO/IEC 8859-1 [9]. The string shall be left justified. Unused bytes shall be set to "FF".

- Network address record number:

Contents: Record number of the corresponding network address in EF_{NWT}.

Coding: binary.

- SSI of the Gateway:

Contents: The short subscriber identity of the gateway used.

Coding: Length of the SSI shall be 24 bits and coded as defined in figure 32.

Byte 10:

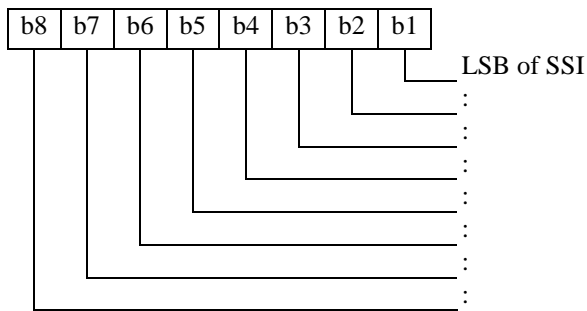

Byte 11:

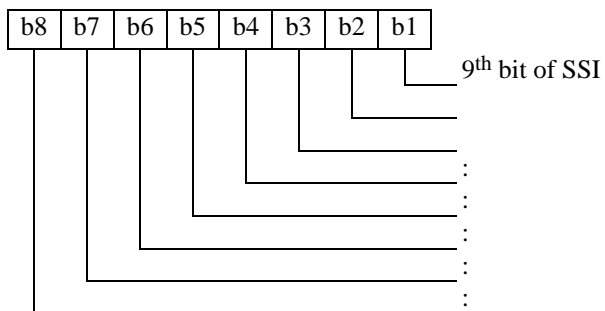

Byte 12:

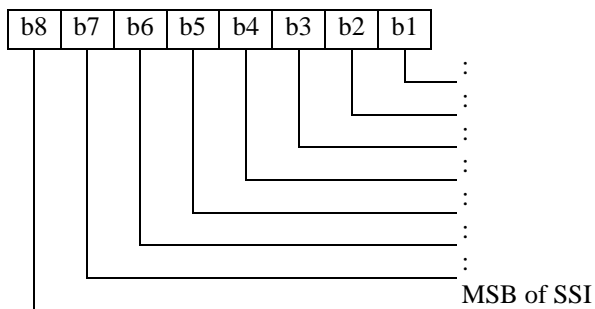

Figure 32: Coding of gateway SSI

Type:

Contents: The type of gateway.

Coding: shall be coded as defined in figure 33.

Byte 13:

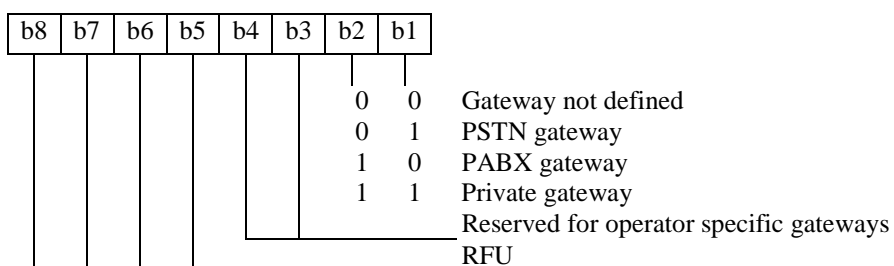

Figure 33: Coding of type of gateway

- RFU:

Contents: RFU.

Coding: "FF".

10.3.25 EF_{CMT} (Call Modifier Table)

This EF shall indicate the values for the call modifiers required by the ME on a per call basis as defined in table 40. These are intended to provide a sensible set of call modifiers for use where the user does not, or cannot, enter them during call set-up. It is proposed that there are different sets of modifiers for different types of calls and that these sets are selected by the ME according to the call type. Alternatively, the ME may allow the user to select a set of call modifiers via the MMI. The alphanumeric field is intended to assist the user in selecting a proper call modifier.

To allow default values to be defined on subscription for each of the call types, the first 12 entries in the table are designated for particular call types in fixed positions. The user may add more call modifiers after the first 12 entries.

Each record in phonebooks may refer to a call modifier in this EF.

Table 40: Contents of Call Modifier Table

Identifier: "6F19"		Structure: linear fixed		Optional
Record length: X + 4 bytes			Update activity: low	
Access Conditions:				
READ		PIN1		
UPDATE		PIN1/PIN2 (see note)		
INVALIDATE		ADM		
REHABILITATE		ADM		
Bytes	Description	M/O	Length	
1 to X	Name	M	X	
X + 1 to X + 4	Call modifiers	M	4	
NOTE: Card issuer will choose between PIN1 or PIN2 protection.				

- Name:

Contents: An alphanumeric identifier for the set of call modifier values.

Coding: According to the default 8-bit alphabet ISO/IEC 8859-1 [9]. A free record is indicated by filling this field with "FF".

- Call modifiers:

Contents: The file consists of the following pieces of information:

- Area selection 4 bits;
- Call priority 4 bits;
- Hook method selection 1 bit;
- Simplex/duplex selection 1 bit;
- End-to-end encryption 1 bit;
- Basic service information 16 bits.

Coding: The first 11 bits shall be coded into four bytes as defined in figure 34.

Byte 1:

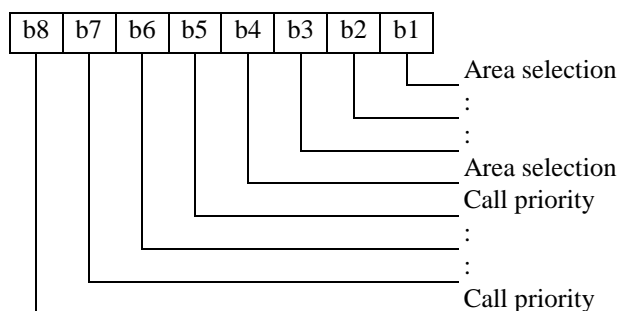

Byte 2:

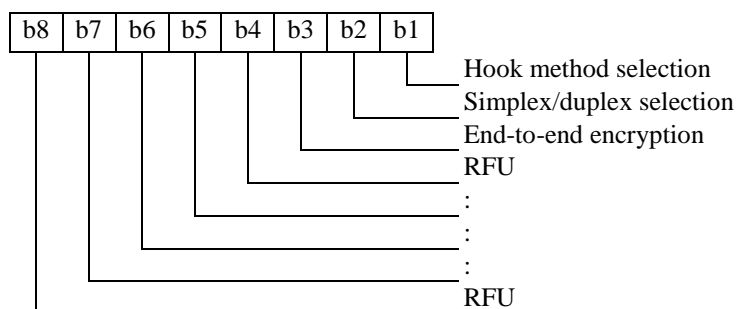

Figure 34: Coding of call modifier bytes 1 and 2

Bytes 3 and 4 shall be coded as "basic service information" in EN 300 392-2 [3].

- Fixed call modifier sets:

the default call modifier sets shall be placed in EF_{CMT} in a standard order as defined in table 41 to allow selection of the set by call type.

Table 41: Contents of fixed call modifier set

Record in EF_{CMT}	Call Type	Call features
Record 1	Voice call	Intra-TETRA, individual call
Record 2	Voice call	Intra-TETRA, group call
Record 3	Voice call	Intra-TETRA, acknowledged group call
Record 4	Voice call	Intra-TETRA, broadcast call
Record 5	Voice call	PABX call
Record 6	Voice call	PSTN call
Record 7	Circuit mode data call	Intra-TETRA, individual call
Record 8	Circuit mode data call	Intra-TETRA, group call
Record 9	Circuit mode data call	Intra-TETRA, acknowledged group call
Record 10	Circuit mode data call	Intra-TETRA, broadcast call
Record 11	Circuit mode data call	PABX call
Record 12	Circuit mode data call	PSTN call

NOTE: This EF references EN 300 392-2 [3].

10.3.26 EF_{ADNGWT} (Abbreviated Dialling Number with Gateways)

This EF shall contain ADNs as defined in table 42. In addition it contains record numbers of the associated gateway, call modifier and gateway extension records.

NOTE: When calling to phone numbers contained in this EF from within a TETRA network, the gateway address is sent with the dialled number.

Table 42: Contents of Abbreviated Dialling Number with Gateways EF

Identifier: "6F1A"		Structure: linear fixed		Optional
Record length: X + 12 bytes		Update activity: low		
Access Conditions:				
READ		PIN1		
UPDATE		PIN1		
INVALIDATE		PIN2		
REHABILITATE		PIN2		
Bytes	Description	M/O	Length	
1 to X	Name	O	X	
X + 1	Length of number contents	M	1	
X + 2 to X + 9	Dialling number	M	8	
X + 10	Gateway address record number	M	1	
X + 11	Call modifier record number	M	1	
X + 12	Gateway Extension1 record number	M	1	

- Name:

Contents: The alphanumeric name the user has assigned for corresponding dialling number.

Coding: According to the default 8-bit alphabet ISO/IEC 8859-1 [9].

- Length of number contents:

Contents: this field gives the number of digits of the following "number" field containing an actual BCD number. This means that the maximum value is 16, even when the actual ADN length is greater than 16 digits. When an ADN requires more than 16 digits it is indicated by the Gateway Extension1 record number being unequal to "FF". The remainder is stored in the EF_{GWTEXT1} with the remaining length of the overflow data being coded in the appropriate overflow record itself (see clause 10.3.27).

Coding: binary. NULL ("00") value indicates a free record.

- Dialling number:

Contents: up to 16 digits of the number.

Coding: shall be according to EN 300 392-2 [3] and as defined in figure 35. If the dialling number is longer than 16 digits, the first 16 digits are stored in this data item and the overflow data is stored in an associated record in the EF_{GWTEXT1}. The record is identified by the Gateway Extension1 record number. If ADN requires less than 16 digits, excess nibbles at the end of the data item shall be ignored.

Byte X + 2:

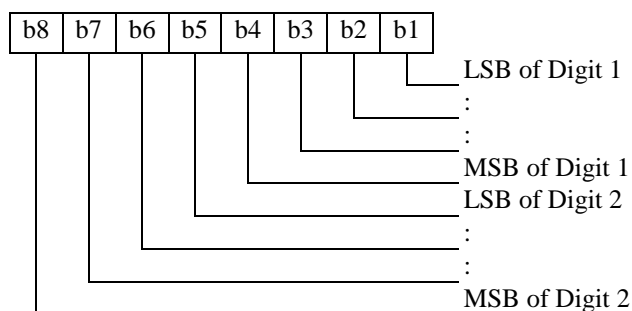

Byte X + 3:

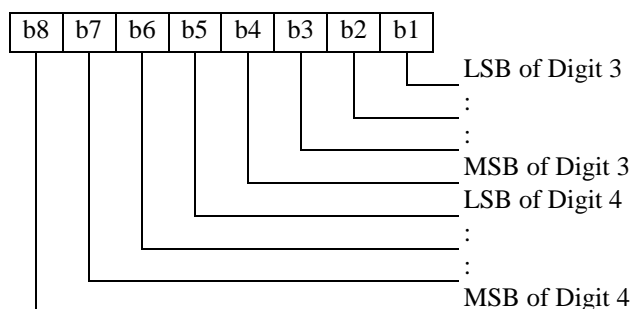

etc.

Figure 35: Coding of dialled number

- Gateway address record number:

Contents: This byte identifies the number of a record in the EF_{GWT} containing an associated gateway address. The use of this byte is optional. If it is not used it shall be set to "FF".

Coding: binary.

- Call modifier record number:

Contents: This byte identifies the number of a record in the EF_{CMT} containing an associated call modifier information. The use of this byte is optional. If it is not used it shall be set to "FF".

Coding: binary.

- Gateway Extension1 record number:

Contents: This byte identifies the number of a record in the $EF_{GWTEXT1}$ containing an associated ADN overflow. The use of this byte is optional. If it is not used it shall be set to "FF".

Coding: binary.

10.3.27 EF_{GWTEXT1} (Gateway Extension1)

This EF shall contain extension data of an ADNGWT or Last Number Dialed with gateway (LNDGWT) as defined in table 43. Extension data is caused by an ADNGWT or LNDGWT which is greater than the 16 digit capacity of the ADNGWT or LNDGWT EF. The remainder is stored in this EF as a record, which is identified by a specified identification byte inside the ADNGWT or LNDGWT EF.

Table 43: Contents of Gateway Extension1 EF

Identifier: "6F1B"		Structure: linear fixed		Optional
Record length: 13 bytes		Update activity: low		
Access Conditions:				
READ		PIN1		
UPDATE		PIN1		
INVALIDATE		ADM		
REHABILITATE		ADM		
Bytes	Description	M/O	Length	
1	Record Type	M	1	
2 to 12	Extension data	M	11	
13	Identifier	M	1	

- For contents and coding as defined in TS 100 977 [5].

10.3.28 EF_{ADNTETRA} (Abbreviated dialling numbers for TETRA network)

This EF shall contain the phone numbers that are used when calling to a TETRA phone as defined in table 44. The access strings for Supplementary services are stored in the same file.

Table 44: Contents of Abbreviated dialling numbers for TETRA network EF

Identifier: "6F1C"		Structure: linear fixed		Optional
Record length: X + 7 bytes		Update activity: low		
Access Conditions:				
READ		PIN1		
UPDATE		PIN1		
INVALIDATE		PIN2		
REHABILITATE		PIN2		
Bytes	Description	M/O	Length	
1	Type	M	1	
2 to X + 1	Name	M	X	
X + 2	Network address record number	M	1	
X + 3 to X + 5	TETRA address or Supplementary service access string	M	3	
X + 6	Call modifier record number	M	1	
X + 7	Extension A record number	M	1	

- Type:

Contents: One byte indicator to identify the entry type TETRA address or Supplementary service access string field.

Coding: shall be as defined in figure 36.

Byte 1:

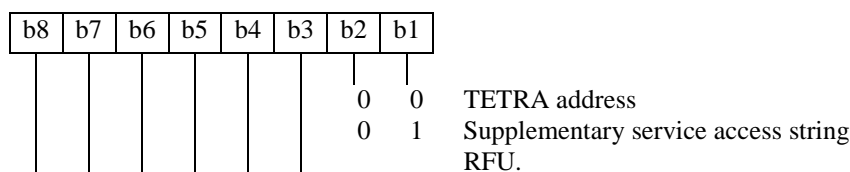

Figure 36: Coding of type

- Name:

Contents: The alphanumeric name the user has assigned for corresponding phone number or Supplementary services access string.

Coding: According to the default 8-bit alphabet ISO/IEC 8859-1 [9].

- Network address record number:

Contents: Record number of the corresponding network address. Network addresses are stored in EF_{NWT} .

Coding: Binary. NULL ("00") value indicates a free record. When storing the Supplementary service access strings to the TETRA address, this field is set to "FF".

- Call modifier record number:

Contents: This byte identifies the number of a record in the EF_{CMT} containing an associated call modifier information. The use of this byte is optional. If it is not used it shall be set to "FF".

Coding: Binary.

- TETRA address or Supplementary service access string:

Contents: The identity that is used when calling to a TETRA phone or Supplementary service strings to be stored.

Coding: When the field contains a TETRA address the field is binary-coded. When storing Supplementary service strings on this field, the digits and characters are BCD-coded according to EN 300 392-2 [3].

- Extension A record number:

Contents: This byte identifies the number of a record in the EF_{EXTA} containing an associated supplementary services access string overflow. The use of this byte is optional. If it is not used, it shall be set to "FF".

Coding: Binary.

10.3.29 EF_{EXTA} (Extension A)

This EF shall contain the overflow of a Supplementary service access string as defined in table 45.

Table 45: Contents of Extension A EF

Identifier: "6F1D"		Structure: linear fixed		Optional	
Record length: 20 bytes			Update activity: low		
Access Conditions:					
READ		PIN1			
UPDATE		PIN1			
INVALIDATE		ADM			
REHABILITATE		ADM			
Bytes	Description	M/O	Length		
1	Length of extension data	M	1		
2 to 19	Overflow data	M	18		
20	Next record number	M	1		

- Length of extension data:

Contents: This field gives the number of digits of the following "Overflow data" field containing an actual BCD number.

Coding: Binary. NULL ("00") value indicates a free record.

- Overflow data:

Contents: Overflow data of a Supplementary services access string.

Coding: BCD according to EN 300 392-2 [3].

- Next record number:

Contents: record number of the next extension record to enable storage of information longer than 18 bytes.

Coding: record number of next record. "FF" identifies the end of the chain.

10.3.30 EF_{FDNGWT} (Fixed dialling numbers with Gateways)

This EF shall contain FDN as defined in table 46. In addition it contains record numbers of associated gateway, call modifier and gateway extension records.

NOTE 1: When calling to phone numbers contained in this EF from within a TETRA network, the gateway address is sent with the dialled number.

NOTE 2: Fixed dialling numbers are used for example in a situation when a supervisor in an organization fixes the numbers on a SIM card so that a worker of the organization may only call to work related numbers.

Table 46: Contents of Fixed dialling numbers with Gateways EF

Identifier: "6F1E"		Structure: linear fixed		Optional
Record length: X + 12 bytes		Update activity: low		
Access Conditions:				
READ	PIN1			
UPDATE	PIN2			
INVALIDATE	ADM			
REHABILITATE	ADM			
Bytes	Description	M/O	Length	
1 to X	Name	O	X	
X + 1	Length of dialling number contents	M	1	
X + 2 to X + 9	Dialling number	M	8	
X + 10	Gateway address record number	M	1	
X + 11	Call modifier record number	M	1	
X + 12	Gateway Extension2 record number	M	1	

- For contents and coding of all data items see the respective data items of the EF_{ADNGWT}, with the exception that gateway extension records are stored in the EF_{GWTEXT2}.

10.3.31 EF_{GWTEXT2} (Gateway Extension2)

This EF shall contain gateway extension data of an FDN (see Gateway Extension2 record number in clause 10.3.30) as defined in table 47. Gateway Extension data is caused by an FDN which is greater than the 16 digit capacity of the EF_{FDNGWT}. The remainder is stored in this EF as a record, which is identified by a specified identification byte inside the EF_{FDNGWT}.

Table 47: Contents of Gateway Extension2 EF

Identifier: "6F1F"		Structure: linear fixed		Optional
Record length: 13 bytes		Update activity: low		
Access Conditions:				
READ	PIN1			
UPDATE	PIN2			
INVALIDATE	ADM			
REHABILITATE	ADM			
Bytes	Description	M/O	Length	
1	Record Type	M	1	
2 to 12	Extension data	M	11	
13	Identifier	M	1	

- Contents and coding shall be as defined in TS 100 977 [5].

10.3.32 EF_{FDNTETRA} (Fixed dialling numbers for TETRA network)

This EF shall contain the Fixed Dialling Numbers (FDN) to be used within TETRA network as defined in table 48.

Table 48: Coding of Fixed dialling numbers for TETRA network EF

Identifier: "6F20"		Structure: linear fixed		Optional
Record length: X + 7 bytes		Update activity: low		
Access Conditions:				
READ		PIN1		
UPDATE		PIN2		
INVALIDATE		ADM		
REHABILITATE		ADM		
Bytes	Description		M/O	Length
1	Type		M	1
2 to X + 1	Name		M	X
X + 2	Network address record number		M	1
X + 3 to X + 5	SSI of TETRA address		M	3
X + 6	Call modifier record number		M	1
X + 7	Extension B record number		M	1

- For contents and coding of all data items see the respective data items of the EF_{ADNTETRA}.

10.3.33 EF_{EXTB} (Extension B)

This EF shall contain the overflow of a Supplementary service access string as defined in table 49.

Table 49: Contents of Extension B EF

Identifier: "6F21"		Structure: linear fixed		Optional
Record length: 20 bytes		Update activity: low		
Access Conditions:				
READ		PIN1		
UPDATE		PIN2		
INVALIDATE		ADM		
REHABILITATE		ADM		
Bytes	Description		M/O	Length
1	Length of extension data		M	1
2 to 19	Overflow data		M	18
20	Next record number		M	1

- For contents and coding of all data items see the respective data items of the EF_{EXTA}.

10.3.34 EF_{LNDGWT} (Last number dialled with Gateways)

This EF shall contain the last numbers dialled (LND) as defined in table 50. In addition it contains record numbers of associated gateway, call modifier and gateway extension records.

NOTE: When calling to phone numbers contained in this EF from within a TETRA network, the gateway address is sent with the dialled number.

Table 50: Contents of Last number dialled with Gateway EF

Identifier: "6F22"		Structure: cyclic		Optional
Record length: X + 12 bytes		Update activity: high		
Access Conditions:				
READ	PIN1			
UPDATE	PIN1			
INVALIDATE	ADM			
REHABILITATE	ADM			
Bytes	Description	M/O	Length	
1 to X	Name	O	X	
X + 1	Length of dialling number contents	M	1	
X + 2 to X + 9	Dialling number	M	8	
X + 10	Gateway address record number	M	1	
X + 11	Call modifier record number	M	1	
X + 12	Gateway Extension1 record number	M	1	

- Contents and coding: see EF_{ADNGWT}.

10.3.35 EF_{LNDTETRA} (Last numbers dialled for TETRA network)

This EF shall contain the last numbers dialled to TETRA phones within TETRA network as defined in table 51.

Table 51: Contents of Last numbers dialled for TETRA network EF

Identifier: "6F23"		Structure: cyclic		Optional
Record length: X + 7 bytes		Update activity: high		
Access Conditions:				
READ	PIN1			
UPDATE	PIN1			
INVALIDATE	ADM			
REHABILITATE	ADM			
Bytes	Description	M/O	Length	
1	Type	M	1	
2 to X	Name	M	X	
X + 2	Network address record number	M	1	
X + 3 to X + 5	SSI of TETRA address or Supplementary service access string	M	3	
X + 6	Call modifier record number	M	1	
X + 7	Extension A record number	M	1	

- For contents and coding of all data items see the respective data items of the EF_{ADNTETRA}.

10.3.36 EF_{SDNGWT} (Service Dialling Numbers with gateway)

This EF shall contain the special user-non-modifiable Service Dialling Numbers (SDN) that are used when calling to a phone outside the TETRA network as defined in table 52. In addition it contains record numbers of associated gateway, call modifier and gateway extension records.

NOTE: When calling to numbers contained in this EF from within a TETRA network, the gateway address is sent with the dialled number.

Table 52: Contents of Service Dialling Numbers with gateway EF

Identifier: "6F24"		Structure: linear fixed		Optional
Record length: X + 12 bytes		Update activity: low		
Access Conditions:				
READ	PIN1			
UPDATE	ADM			
INVALIDATE	ADM			
REHABILITATE	ADM			
Bytes	Description	M/O	Length	
1 to X	Name	O	X	
X + 1	Length of dialling number contents	M	1	
X + 2 to X + 9	Dialling number	M	8	
X + 10	Gateway address record number	M	1	
X + 11	Call modifier record number	M	1	
X + 12	Gateway Extension3 record number	M	1	

- For contents and coding of all data items see the respective data items of the EF_{ADNGWT} (see clause 10.3.25), with the exception that gateway extension records are stored in the EF_{GWTEXT3}.

10.3.37 EF_{GWTEXT3} (Gateway Extension3)

This EF shall contain gateway extension data of an SDN (see Extension3 record number in clause 10.3.36) as defined in table 53. Gateway Extension data is caused by an SDN which is greater than the 16 digit capacity of the EF_{SDNGWT}. The remainder is stored in this EF as a record, which is identified by a specified identification byte inside the EF_{SDNGWT}.

Table 53: Contents of Gateway Extension3 EF

Identifier: "6F25"		Structure: linear fixed		Optional
Record length: 13 bytes		Update activity: low		
Access Conditions:				
READ	PIN1			
UPDATE	ADM			
INVALIDATE	ADM			
REHABILITATE	ADM			
Bytes	Description	M/O	Length	
1	Record Type	M	1	
2 to 12	Extension data	M	11	
13	Identifier	M	1	

- Contents and coding shall be as defined in TS 100 977 [5].

10.3.38 EF_{SDNTETRA} (Service Dialling Numbers for TETRA network)

This EF shall contain the user-non-modifiable phone numbers that are used when calling to a TETRA phone as defined in table 53.

Table 54: Contents of Service Dialling Numbers for TETRA network EF

Identifier: "6F26"		Structure: linear fixed		Optional
Record length: X + 6 bytes		Update activity: low		
Access Conditions:				
READ		PIN1		
UPDATE		ADM		
INVALIDATE		ADM		
REHABILITATE		ADM		
Bytes	Description		M/O	Length
1	Type		M	1
2 to X + 1	Name		M	X
X + 2	Network address record number		M	1
X + 3 to X + 5	SSI of TETRA address		M	3
X + 6	Call modifier record number		M	1

- For contents and coding of all data items see the respective data items of the EF_{ADNTETRA}.

10.3.39 EF_{STXT} (Status message texts)

This EF shall contain text strings to be displayed upon receipt of precoded status message as defined in table 55.

Table 55: Contents of Status message texts EF

Identifier: "6F27"		Structure: linear fixed		Optional
Record length: X + 2 bytes		Update activity: low		
Access Conditions:				
READ		PIN1		
UPDATE		ADM		
INVALIDATE		ADM		
REHABILITATE		ADM		
Bytes	Description		M/O	Length
1 to 2	Message value		M	2
3 to X + 2	Message text		M	X

- Message value:

Contents: The message value identifies the actual message.

Coding: The message value is coded with two bytes as defined in EN 300 392-2 [3] A reserved ("0001"- "7FFF") value indicates an empty record.

- Message text:

Contents: The message text contains the text string corresponding to the message value and it is shown to the user instead of or with the message value.

Coding: The string shall use the default 8-bit alphabet ISO/IEC 8859-1 [9] and coded as defined in figure 37. The message text is coded with X bytes. If the text is shorter than X bytes, the remaining bytes shall be filled with FF.

Byte 3:

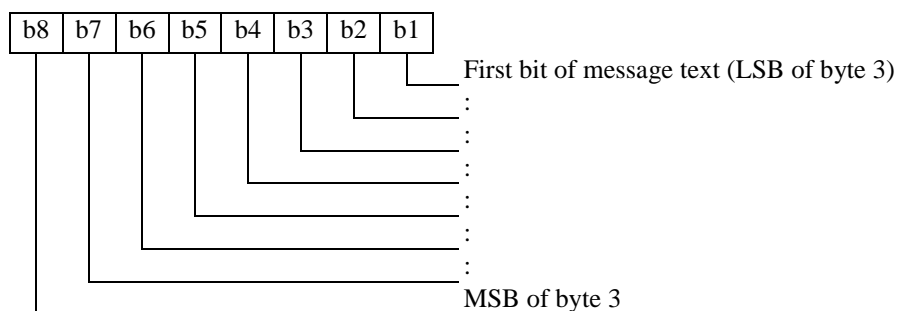

etc.

Byte X + 2:

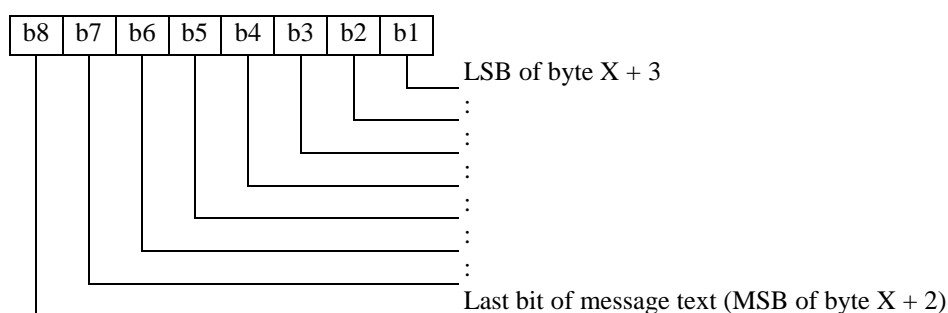

Figure 37: Coding of message text

NOTE: Of the precoded status messages only messages above and including the value of 32 768 are stored in this EF.

10.3.40 EF_{MSGTXT} (SDS-1 message texts)

This EF shall contain text strings to be displayed upon receipt of an SDS-1 (user defined data 1) message as defined in table 56.

Table 56: Contents of SDS-1 message texts EF

Identifier: "6F28"		Structure: linear fixed		Optional
Record length: X + 2 bytes			Update activity: low	
Access Conditions:				
READ		PIN1		
UPDATE		ADM		
INVALIDATE		ADM		
REHABILITATE		ADM		
Bytes	Description	M/O	Length	
1 to 2	Message value	M	2	
3 to X + 2	Message text	M	X	

- Message value:

Contents: The message value identifies the actual message.

Coding: The message value is coded with two bytes as defined in EN 300 392-2 [3].

NOTE: User application knows which Message values are valid, because all values have been reserved for user application. Therefore the user application also knows which records contain valid data.

- Message text:

Contents: The message text contains the text string corresponding to the message value and it is shown to the user instead of or with the message value.

Coding: The string shall use the default 8-bit alphabet ISO/IEC 8859-1 [9] and coded as defined in figure 38. The message text is coded with X bytes. If the text is shorter than X bytes, the remaining bytes shall be filled with FF.

Byte 3:

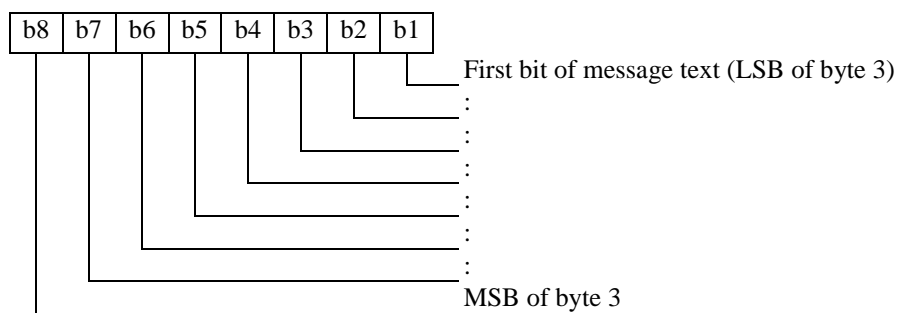

etc.

Byte X + 2:

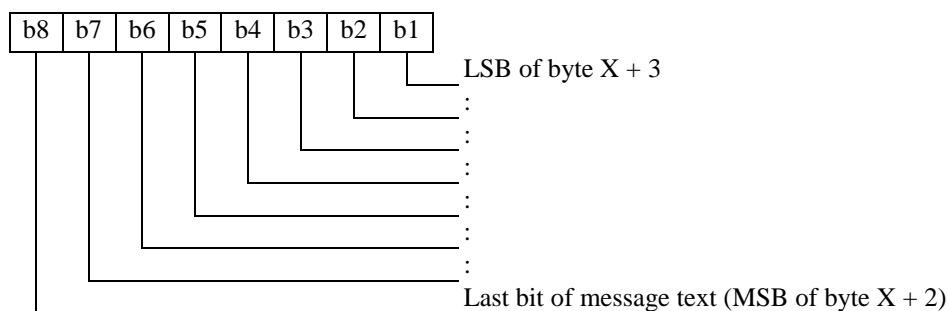

Figure 38: Coding of SDS-1 message text

NOTE: The SDS-1 message text definitions are applicable to the user's home network only.

10.3.41 EF_{SDS123} (Status and SDS type 1, 2 and 3 message storage)

This EF shall contain the numerical values of Status messages and SDS type 1, 2 or 3 messages (and associated parameters) which have either been received by the MS from the network, or are to be used as MS originated messages as defined in table 57.

Table 57: Contents of Status and SDS type 1, 2 and 3 message storage EF

Identifier: "6F29"		Structure: linear fixed		Optional
Record length: 46 bytes		Update activity: high		
Access Conditions:				
READ	PIN1			
UPDATE	PIN1			
INVALIDATE	ADM			
REHABILITATE	ADM			
Bytes	Description	M/O	Length	
1	Message status and area selection	M	1	
2 to 32	Message destination and source identifier	M	31	
33 to 34	Message Index	M	2	
35 to 37	Network Time	M	3	
38 to 46	Message header and message	M	9	

- Message status and area selection:

Contents: Status of the message stored.

The area selection used in the MS originated SDS as defined in EN 300 392-2 [3].

Coding: shall be as defined in figure 39.

Byte 1:

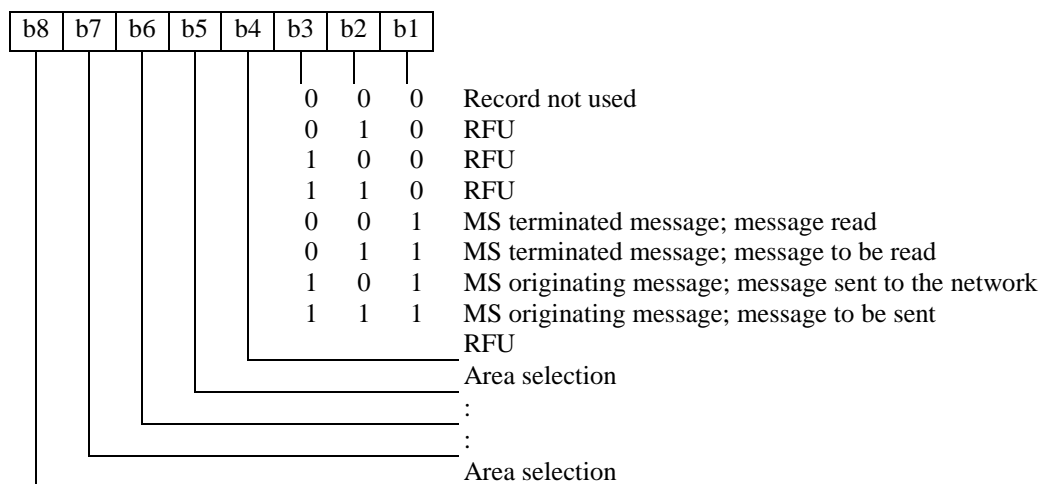

Figure 39: Coding of message status and area selection

- Message destination and source identifier:

For contents and coding see clause 10.3.42.

- Message index:

Contents: Message index of the message stored. The Message Index will be incremented each time a new message is stored in this file. In case of an overflow the Message Index will be reset to 0.

Coding: 16 bits, binary.

- Network time:

Contents: It indicates approximate reception time of the SDS message.

Coding: 24 bits binary as defined in EN 300 392-2 [3].

- Message header and message:

Contents: Contains information on transmitted or received messages.

Coding: The first byte is the short data type identifier as defined in EN 300 392-2 [3] and shall be coded as defined in figure 40.

NOTE: The User defined data 4 is not included as the EF_{SDS4} contains that.

Byte 38:

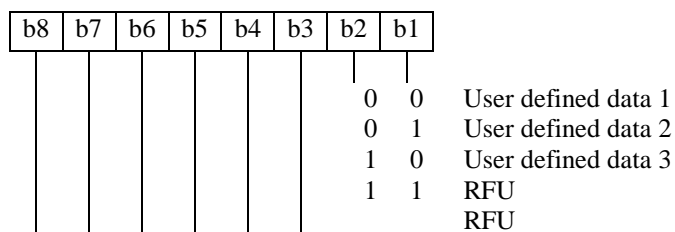

Figure 40: Message header

- The bytes 39 to 46 are the user data 1,2,3 (left aligned) as defined in EN 300 392-2 [3].

10.3.42 EF_{SDS4} (SDS type 4 message storage)

This EF shall contain text strings (and associated parameters) which have either been received by the MS from the network, or are to be used as an MS originated message as defined in table 58.

Table 58: Contents of SDS type 4 message storage EF

Identifier: "6F2A"		Structure: linear fixed		Optional
Record length: 255 bytes		Update activity: high		
Access Conditions:				
READ		PIN1		
UPDATE		PIN1		
INVALIDATE		ADM		
REHABILITATE		ADM		
Bytes	Description	M/O	Length	
1 to 2	Message status and area selection	M	2	
3 to 33	Message destination and source identifier (see note 1)	M	31	
34	Protocol Identifier	M	1	
35 to 35 + X - 1	Message header (see note 2)	O	X	
35 + X to 36 + X	Message Index	M	2	
37 + X to 39 + X	Network Time	M	3	
40 + X to 41 + X	Length Indicator	M	2	
42 + X to 254	User Data	M		
255	Message extension record number	O	1	
NOTE 1: The address length shall be according to the address type (first byte in the message destination/source).				
NOTE 2: For protocol identifier less than 128 there is no message header.				

- Message status and area selection:

Contents: It contains the status of the message stored and information if a delivery report of MS originating message is stored in the EF_{SDSR}.

The area selection used in the MS originated SDS as defined in EN 300 392-2 [3].

Coding: Shall be coded as defined in figure 41.

Byte 1:

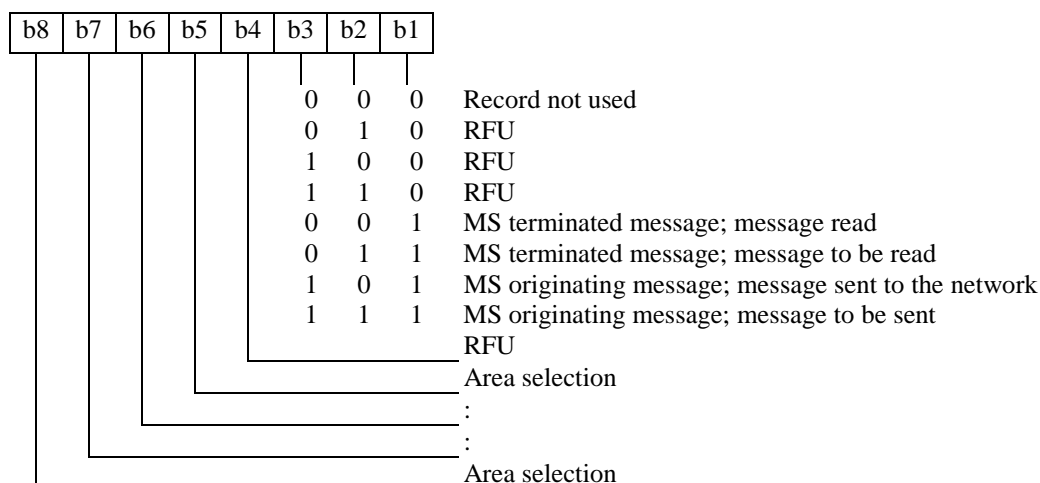

Byte 2:

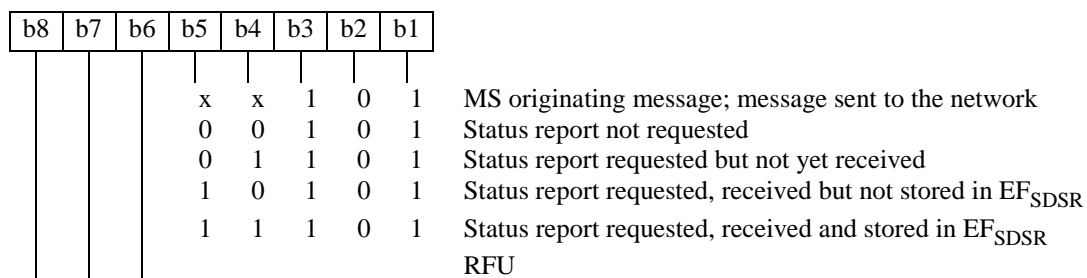

Figure 41: Coding of message status and area selection

- Message destination and source identifier:

Contents: This data item shall contain:

For received message:

- The called party address (Address type identifier and the actual address).
- Communication type.
- The calling party address.

For transmitted message:

- The called party address.

The calling and called address can be an SNA, SSI, TSI or external subscriber.

NOTE: The present document does not define how calling address SNA is known to the SIM.

Coding:

- The called party address:

The address type identifier shall be coded as defined in figure 42 and it shall define the type of the following address.

Byte 3:

b8	b7	b6	b5	b4	b3	b2	b1	
					0	0	0	Short number address (SNA)
					0	0	1	Short subscriber identity (SSI)
					0	1	0	TETRA subscriber identity (TSI)
					0	1	1	External subscriber number
					1	0	0	RFU
					1	0	1	RFU
					1	1	0	RFU
					1	1	1	RFU
								RFU

Figure 42: Coding of address type identifier

- Called party short number address (SNA):

Contents: The called party short number address consists of the SNA of the called user as defined in EN 300 392-2 [3] - byte 4: Address, bytes 5 to 17 set to "FF".

- Called party short subscriber identity (SSI):

Contents: The called party short subscriber identity address consists of the SSI of the called user as defined in EN 300 392-2 [3] - bytes 4 to 6: Address, bytes 7 to 17 set to "FF" as defined in figure 43.

Byte 4:

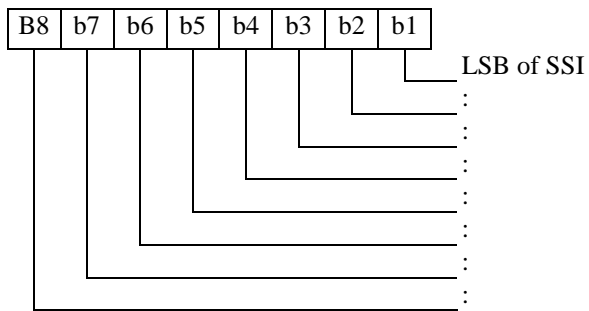

Byte 5:

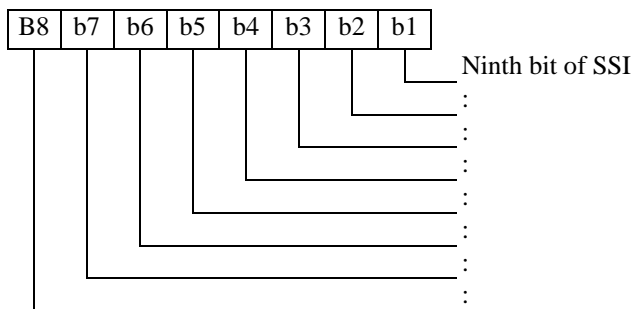

Byte 6:

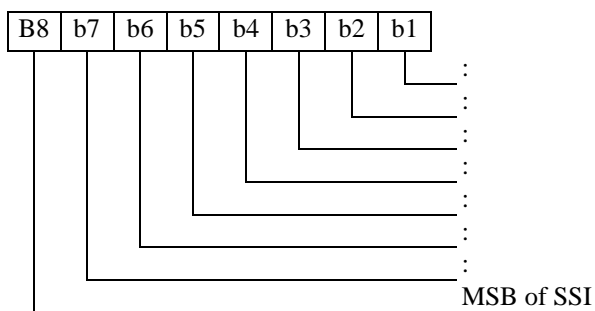
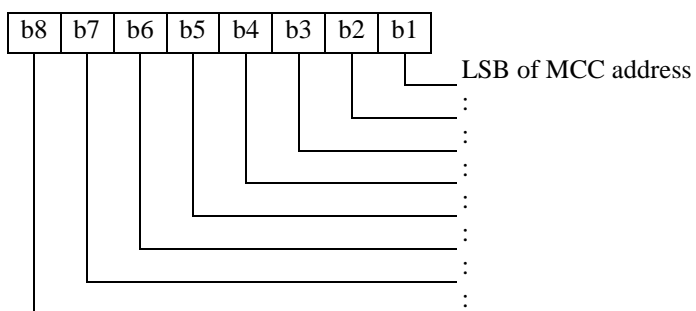

Figure 43: Coding of SSI

- Called party TETRA subscriber identity:

Contents: The TETRA subscriber identity as defined in EN 300 392-1 [2], consists of Country Code (MCC), Network Code (MNC) and Short Subscriber Identity (SSI) - bytes 4 to 9: address, bytes 10 to 17 set to "FF" shall be coded as defined in figure 44.

Byte 4:



Byte 5:

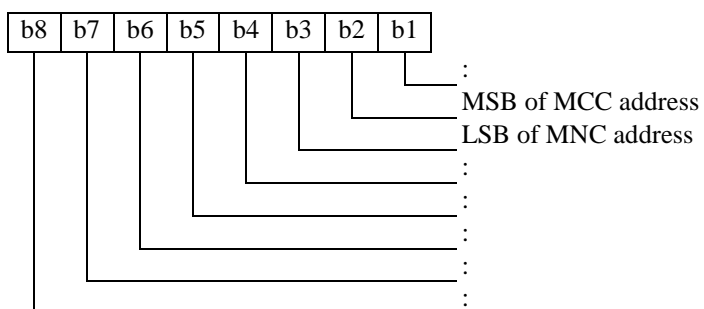

Byte 6:

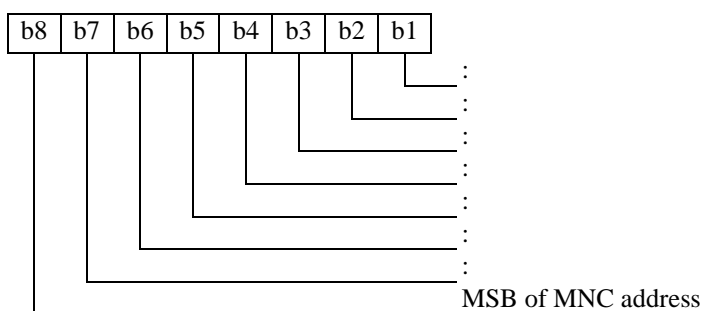

Byte 7:

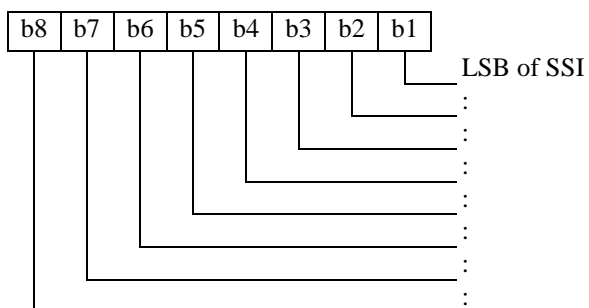

Byte 8:

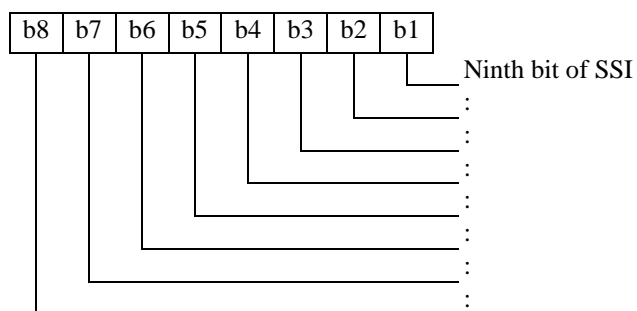

Byte 9:

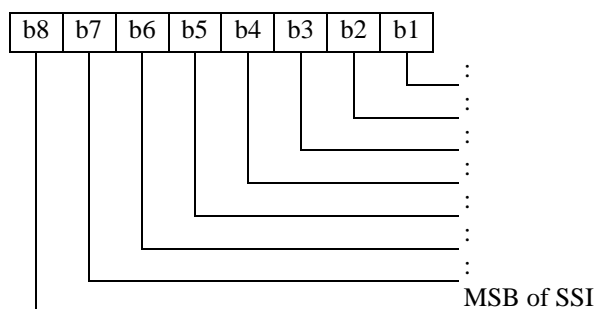

Figure 44: Coding of ITSI/GTSI

- Called party external subscriber number:

Contents: It consists of the gateway address record number, number of digits in the subscriber number and the subscriber number.

Coding:

Byte 4: The gateway address record number identifies the number of a record in the EF_{GWT} containing an associated gateway address.

Byte 5: The number of digits (n) in the subscriber number.

Bytes 6 to $6+n/2-1$: The subscriber number digits (less or equal to 24). Each digit shall be encoded as defined in EN 300 392-2 [3], clause 14.8.20. The potentially unused half byte shall be set to "F" and unused bytes to "FF" for bytes up to and including byte 17.

- Communication type:

Content: It consists of the communication type of the received message.

Coding: Shall be as defined in figure 45.

Byte 18:

b8	B7	b6	b5	b4	B3	B2	b1	
						0	0	RFU
						0	1	Individual
						1	0	Group
						1	1	RFU
								RFU

Unused bits shall be set to "1".

Figure 45: Coding of communication type

- The calling party address:
 - Coding: Bytes 19-33. Same format as the called party address (address type and address).
- Protocol Identifier:
 - Content: It shall indicate to the addressed entity application which type of application protocol is using the SDS service. See definition in EN 300 392-2 [3].
 - Coding: 1 byte as defined in EN 300 392-2 [3].
- Message Header:
 - Content:
 - For originating message it contains: the message reference, delivery report request, storage, validity period, service selection, forward address (only in case of storage).
 - For terminating message, it contains: the message reference, delivery report request, storage, validity period, short form report, and forward address.
 - Coding:
 - For originating message:
 - Message reference:
 - Each SDS-TL message carrying a SDS-TL data transfer service PDU shall contain a message reference. See definition in EN 300 392-2 [3]: 1 byte - "FF" - message to be sent, otherwise the message reference used in the message sent to the network.
 - Delivery report request:
 - 2 bits as defined in EN 300 392-2 [3] (b1-b2 of byte 2 of message header).
 - Storage:
 - 1 bit as defined in EN 300 392-2 [3] (b8 of byte2 of message header).
 - Validity Period:
 - 5 bits as defined in EN 300 392-2 [3] (b1-b5 of byte 3 of message header).
 - Service Selection:
 - 1 bit as defined in EN 300 392-2 [3] (b8 of byte 3 of message header).
 - Forward Address:
 - Same definition as the Message destination and source - only in case of storage.

For terminating message:

- Message reference:

Each SDS-TL message carrying a SDS-TL data transfer service PDU shall contain a message reference. See definition in EN 300 392-2 [3]: 1 byte - "FF" - message to be sent, otherwise the message reference used in the message sent to the network.
- Delivery report request:

2 bits as defined in EN 300 392-2 [3] (b1-b2 of byte 2 of message header).
- Storage:

1 bit as defined in EN 300 392-2 [3] (b8 of byte 2 of message header).
- Validity Period:

5 bits as defined in EN 300 392-2 [3] (b1-b5 of byte 3 of message header).
- Short form report:

2 bits as defined in EN 300 392-2 [3] (b7-b8 of byte 3 of message header).
- Forward Address:

Same definition as the Message destination and source - only in case of storage.
- Message index:

Content: It contains a message index .The Message Index will be incremented each time a new message is stored in this file. In case of an overflow the Message Index will be reset to 0.

Coding: 16 bits, binary.
- Network time:

Content: It indicates approximate reception time of the SDS message.

Coding: 24 bits binary as defined in EN 300 392-2 [3].
- Length Indicator:

Content: It contains the length in bits of the user data.

Coding: 11 bits, binary.
- User Data:

Content: It contains the user data, as defined in EN 300 392-2 [3].
- Message Extension record number:

Contents: This byte identifies the number of a record in the EF_{MSGEXT} containing an associated message overflow. The use of this byte is optional. If it is not used, it shall be set to "FF".

Coding: Binary.

10.3.43 EF_{MSGEXT} (Message Extension)

This EF shall contain the overflow of an SDS-4 message which is longer than the space reserved for it in EF_{SDS4} as defined in table 59.

Table 59: Contents of Message extension EF

Identifier: "6F2B"		Structure: linear fixed		Optional
Record length: 16 bytes		Update activity: high		
Access Conditions:				
READ		PIN1		
UPDATE		PIN1		
INVALIDATE		ADM		
REHABILITATE		ADM		
Bytes	Description	M/O	Length	
1 to 16	Overflow message	M	16	

- Overflow message:

Contents: Overflow data of a SDS-4 message exceeding the length reserved for it in EF_{SDS4}.

Coding: As defined in EN 300 392-2 [3]. All bytes following the PDUs shall be filled with "FF".

NOTE: A free record is not pointed to by any record in EF_{SDS4}.

10.3.44 EF_{EADDR} (Emergency addresses)

The user (or the organization) can determine the address to which an emergency call is initiated; to a predetermined address or to the group last used by the user. The selection is controlled by the addresses stored in EF_{EADDR}. The EF shall contain information as defined in table 60.

Where a data call type is selected, the ESource field indicates the preferred source of the data to be included in the message for status, SDS-1, SDS-2, SDS-3 and SDS-4 messages. In each case the data content can be a pre-defined value stored in EF_{SDS123} or EF_{SDS4} (or a data field obtained from an application running in the terminal).

Table 60: Contents of Emergency addresses EF

Identifier: "6F2C"		Structure: linear fixed		Mandatory
Record size: 17 bytes		Update activity: low		
Access Conditions:				
READ		ALW		
UPDATE		PIN1/PIN2 (see note)		
INVALIDATE		ADM		
REHABILITATE		ADM		
Bytes	Description	M/O	Length	
1	Emergency call definition	M	1	
2 to 17	Emergency address	M	16	
NOTE: Card issuer will choose between PIN1 or PIN2 protection.				

- Emergency call definition:

Contents: One byte indicating the call type and the emergency address type coded on the Emergency address field, and the source of the message content for status and data calls.

Coding: shall be as defined in figure 46.

- b1-b4: Emergency call type.
- b5-b8: Call setup parameters.

- b5: Source of the data to be transmitted in the emergency data message.
- b6-b7: Emergency call type.
- b8: Simplex/Duplex.

NOTE: An empty record is indicated by NULL ("F") value in bits b1-b4.

b8	b7	b6	b5	b4	b3	b2	b1	
				0	0	0	0	TETRA address
				0	0	0	1	DMO address
				0	0	1	0	PABX address (gateway and External subscriber number)
				0	0	1	1	PSTN number (gateway and External subscriber number)
				0	1	0	0	Last active group address
				0	1	0	1	RFU
				0	1	1	0	RFU
				0	1	1	1	RFU
				1	0	0	0	Status/SDS123 msg record number
				1	0	0	1	SDS4 message record number
				1	0	1	0	RFU
				1	0	1	1	RFU
				1	1	0	0	RFU
				1	1	0	1	RFU
				1	1	1	0	RFU
				1	1	1	1	Record contains no valid data
			0					Predefined and stored in EF_{EADDR}
			1					From an application in the terminal
	0	0						Point-to-Point
	0	1						Point to Multipoint
	1	0						Point-to-Multipoint acknowledged
	1	1						Broadcast
0								Simplex
1								Duplex

Figure 46: Coding of Emergency call definition

- Emergency address:

Contents: The address that can be used when the user initiates an emergency call. The type of call is determined by byte 1.

In the case of a TETRA address the emergency address consists of the ITSI (or GTSI) of the called party.

In the case of a DMO address the emergency address consists of the ITSI (or GTSI) of the called party and the DMO channel number.

In the case of a PABX address the emergency address consists of the PABX Gateway and the External Subscriber number. (See coding.)

In the case of a PSTN address the emergency address consists of the PSTN Gateway and the external subscriber number. (See coding.)

In the case of the last active group address, the address field in EF_{EADDR} is unused - the address for the emergency call should be obtained from EF_{GINFO} .

In the case of status, SDS-1, SDS-2, SDS-3 and SDS-4 messages the content of this data item consists of the message record number in SDS123 or SDS4 as appropriate.

Coding:

In the case of a TETRA address, according to EF_{ITSI} .

In the case of a DMO address, according to EF_{ITSI} followed by the 24 bit DMO channel number, coded according to EF_{DMOCh} .

In the case of a PABX number, the Gateway ITSI is coded according to EF_{ITSI} and the External Subscriber number is BCD coded as defined in EN 300 392-2 [3].

The structure shall be as following:

Byte 2: Length of BCD encoded number.

Byte 3: Gateway address record number.

Byte 4 to 16: Dialling Number.

Byte 17: Gateway Extension1 record number.

In the case of a PSTN number, the Gateway ITSI is coded according to EF_{ITSI} and the external PSTN address is BCD coded according to EN 300 392-2 [3].

The structure shall be as following:

Byte 2: Length of BCD number.

Byte 3: Gateway address record number.

Byte 4 to 16: Dialling Number.

Byte 17: Extension1 record number.

In the case of the last used group address, this field is unused - the address for the call to be obtained from EF_{GINFO} .

NOTE: The emergency addresses are stored in order of precedence.

10.3.45 EF_{EINFO} (Emergency call information)

This EF shall contain information about setting up and continuing an emergency call as defined in table 61.

Table 61: Contents of Emergency call information EF

Identifier: "6F2D"		Structure: transparent		Mandatory
File size: 2 bytes		Update activity: low		
Access Conditions:				
READ		ALW		
UPDATE		PIN1		
INVALIDATE		ADM		
REHABILITATE		ADM		
Bytes	Description	M/O	Length	
1	Emergency call continuation	M	1	
2	Current emergency call record number	M	1	

- Emergency call continuation:

Contents: A flag indicating whether an interrupted emergency call should continue at power-on.

Coding: shall be as defined in figure 47.

Byte 1:

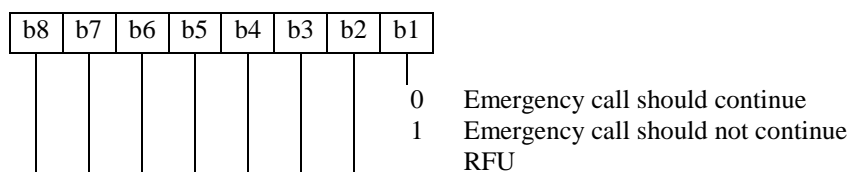

Figure 47: Coding of emergency call continuation

- Current emergency call record number:

Contents: One byte field available to the emergency application to store on the SIM information pertaining to an emergency call in progress, typically to cater for the possibility of unexpected power-down. It may be the record number of the record in EF_{EADDR} used to set up the emergency call currently in progress. A zero value indicates that no call is in progress.

Coding: Binary.

10.3.46 EF_{DMOCh} (DMO radio channel information)

This EF shall contain a selection of DMO radio channels as defined in table 62.

Table 62: Contents of DMO radio channel information EF

Identifier: "6F2E"		Structure: linear fixed		Optional
Record size: 4 bytes		Update activity: low		
Access Conditions:				
READ		PIN1		
UPDATE		ADM		
INVALIDATE		ADM		
REHABILITATE		ADM		
Bytes	Description	M/O	Length	
1	DMO radio channel type	M	1	
2 to 4	DMO radio channel number	M	3	

- DMO radio channel type:

Contents: This field contains the DMO radio channel type information.

Coding: shall be as defined in figure 48.

Byte 1:

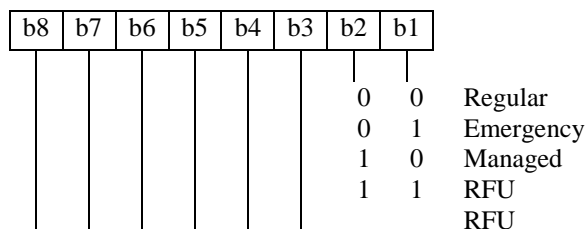

NULL ("FF") value indicates an empty record. All other values are reserved.

Figure 48: Coding of radio channel type

NOTE: Emergency calls are not restricted to emergency channels. Emergency calls may also be made on regular DMO radio channels and managed DMO radio channels.

- DMO radio channel number:

Contents: This field contains the DMO radio channel definition.

Coding: shall be as in table 63.

Table 63: Contents of DMO radio channel number

Information sub-element	Length	Type	C/O/M	Value	Remark
Carrier number	12	1	M		Carrier frequency number (see note 1)
Frequency band	4	1	M		Provision for different frequency bands (see note 1)
Offset	2	1	M		Provision for different offsets, (see note 2)
Duplex spacing	3	1	M		Provision for different duplex spacing (see notes 1 and 3)
DMO normal/reverse operation	1	1	M	0	DMO uplink frequency = DMO downlink frequency + duplex spacing (see note 3)
				1	DMO uplink frequency = DMO downlink frequency - duplex spacing (see note 3)
Reserved	2	1	M	00 ₂	Default value = 00 ₂
NOTE 1: Refer to annex F in EN 300 392-2 [3] for meaning of the values.					
NOTE 2: Refer to clause 21.4.4.1 in EN 300 392-2 [3], table 333 for the meaning of the offset values.					
NOTE 3: A DMO radio channel may comprise either one or two radio frequencies. 0,0 MHz value of duplex spacing indicates single frequency operation. For two frequency operation the carrier number indicates the direct mode RF carrier where the MS should receive (i.e. the downlink RF carrier). Then the duplex spacing information element together with the DMO normal/reverse operation information element indicate the direct mode RF carrier where the MS should transmit (i.e. the uplink RF carrier).					

10.3.47 EF_{MSCh} (MS allocation of DMO channels)

This EF shall contain a bitmap which allocates a subset of the DMO channels in EF_{DMOCh} as defined in table 64. There shall be one bit corresponding to each record in EF_{DMOCh}.

NOTE 1: The information in the following EF may not be accurate with respect to ETS 300 396 series. This EF will be updated accordingly when necessary.

Table 64: Contents of MS allocation of DMO channels EF

Identifier: "6F2F "		Structure: transparent		Optional	
File size: X bytes			Update activity: low		
Access Conditions:					
READ		PIN1			
UPDATE		ADM			
INVALIDATE		ADM			
REHABILITATE		ADM			
Bytes	Description			M/O	Length
1	Allocation flag 1 to 8			M	1
etc.	etc.				
X	Allocation flag 8*X-7 to 8*X			M	1

NOTE 2: The value of X should be sufficiently large to accommodate all the records in EF_{DMOCh}.

- Allocation flag:

Coding: Channel is allocated = 1, channel is not allocated = 0. Allocation flags shall be coded as defined in figure 49.

Byte 1:

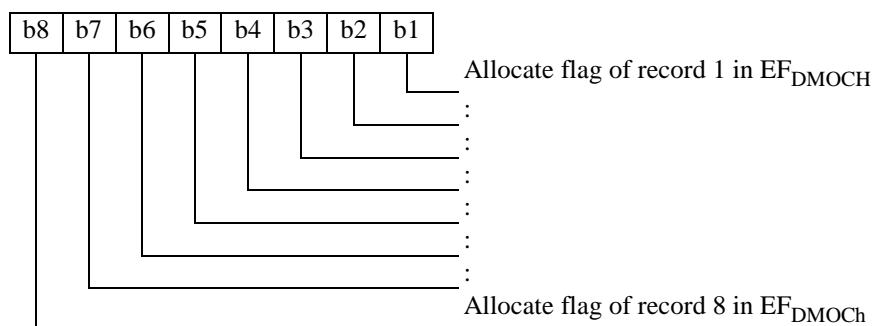

etc.

Byte X:

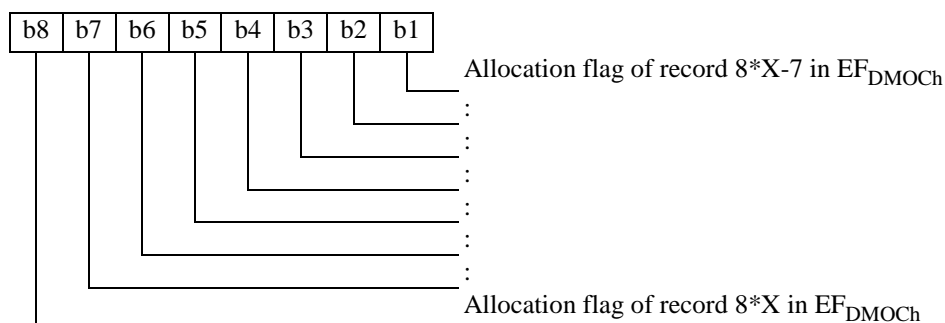

Figure 49: Coding of allocation flags

10.3.48 EF_{KH} (List of Key Holders)

This EF shall contain a list of those ITSI numbers that can act as a key holder for this subscriber's ITSI as defined in table 65.

Table 65: Contents of List of Key Holders EF

Identifier: "6F30"	Structure: transparent	Optional	
Record size: 6 bytes		Update activity: low	
Access Conditions:			
READ	PIN1		
UPDATE	ADM		
INVALIDATE	ADM		
REHABILITATE	ADM		
Bytes	Description	M/O	Length
1 to 6	Key holder ITSI	M	6

- Key holder ITSI;

Contents: Key holder ITSI consists of MCC, MNC and ISSI.

Coding: As in EF_{ITSI}. Record filled with NULL ("FF") value indicates no ITSI is stored.

10.3.49 EF_{REPGATE} (DMO repeater and gateway list)

This EF shall contain a list of those DMO repeaters, gateways and REP/GATEs that this subscriber is allowed to use as defined in table 66. Each address is 10 bits long. DMO equipment type is also identified.

Table 66: Contents of DMO repeater and gateway list EF

Identifier: "6F31"		Structure: linear fixed		Optional	
Record size: 2 bytes			Update activity: low		
Access Conditions:					
READ		PIN1			
UPDATE		ADM			
INVALIDATE		ADM			
REHABILITATE		ADM			
Bytes	Description			M/O	Length
1 to 2	DMO equipment type and identity			M	2

- DMO equipment type and identity:

Contents: This field contains the DMO equipment type and the first part of its identity.

Coding: shall be as defined in figure 50.

Byte 1:

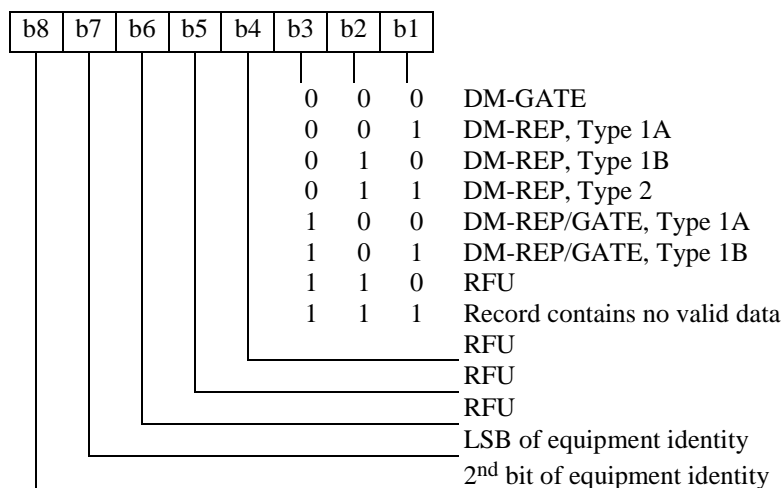

Byte 2:

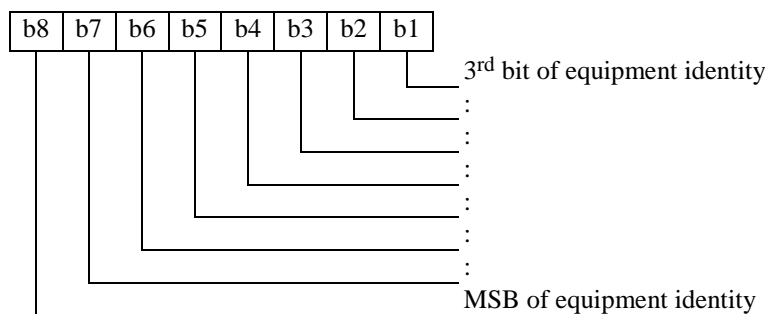

Figure 50: Coding of DMO equipment type and identity

10.3.50 EF_{AD} (Administrative data)

This EF shall contain information concerning the mode of operation according to the type of SIM, such as normal operation, type approval (to allow specific use of the ME during type approval procedures of e.g. the radio equipment) or others as defined in table 67.

Table 67: Contents of Administrative data EF

Identifier: "6F32"		Structure: transparent		Mandatory
File size: 1 byte		Update activity: low		
Access Conditions:				
READ		ALW		
UPDATE		ADM		
INVALIDATE		ADM		
REHABILITATE		ADM		
Bytes	Description	M/O	Length	
1	MS operation mode	M	1 byte	

- MS operation mode:

Contents: mode of operation for the MS.

Coding: shall be as defined in figure 51.

Byte 1:

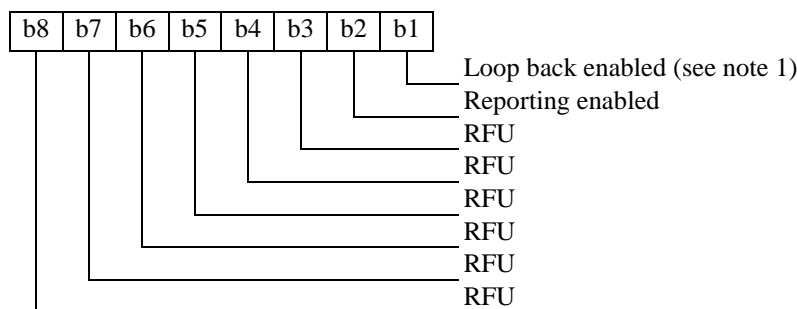

NOTE 1: Loop back enabled and security/authentication disabled (see ETS 300 394-2 [10]).

NOTE 2: The coding "00" means normal operation.

Figure 51: Coding of MS operation mode

10.3.51 EF_{PREF_LA} (Preferred location areas)

This EF shall contain the preferred location area as defined in table 68.

Table 68: Contents of Preferred location areas EF

Identifier: "6F33"		Structure: Transparent		Optional
File size: 2 bytes		Update activity: low		
Access Conditions:				
READ		PIN1		
UPDATE		ADM		
INVALIDATE		ADM		
REHABILITATE		ADM		
Bytes	Description	M/O	Length	
1 to 2	Preferred location area	M	2	

- Preferred location area:

Contents: a list of preferred location areas.

Coding: Each element is coded in 2 bytes with the 2 highest order bits of the 2nd byte RFU as defined in figure 52. The first element (bytes 2 and 3) is shown in figure 52. See also EN 300 392-7 [4].

Byte 1:

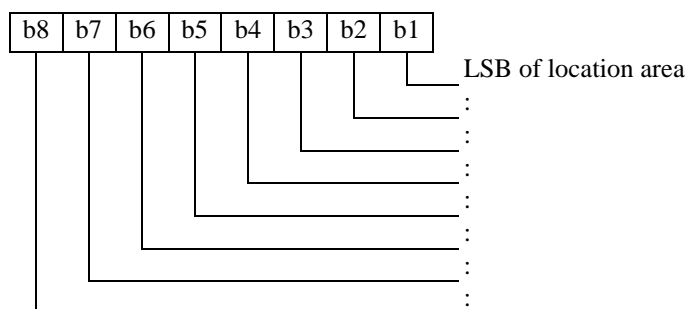

Byte 2:

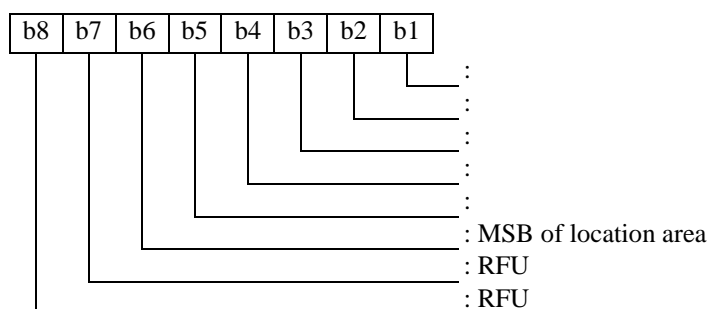

NOTE: This LA is intended to be used during cell re-selection, the procedures are outside the scope of the present document. See EN 300 392-2 [3].

Figure 52: Coding of preferred location area

10.3.52 EF_{LNDComp} (Composite LND file)

This EF shall contain a pointer to the LND entries in EF_{LND}, EF_{LNDGWT} and EF_{LNDTETRA} as defined in table 69.

Table 69: Contents of Composite LND file EF

Identifier: "6F34"		Structure: cyclic		Optional	
Record length: 3 bytes			Update activity: high		
Access Conditions:					
READ		PIN1			
UPDATE		PIN1			
INVALIDATE		ADM			
REHABILITATE		ADM			
Bytes	Description			M/O	Length
1 to 2	Elementary File ID			M	2
3	Record No. in corresponding LND EF			M	1

- Elementary File ID:

Contents: The ID of the file in which the LND record is stored.

Coding: shall be as defined in figure 53.

Byte 1:

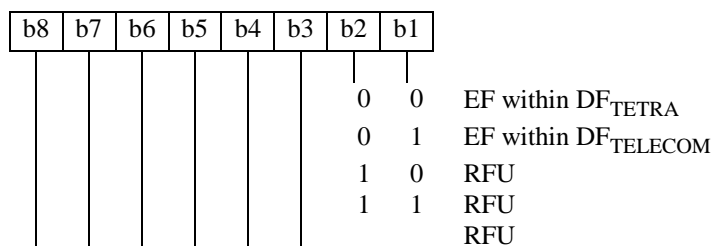

Byte 2:

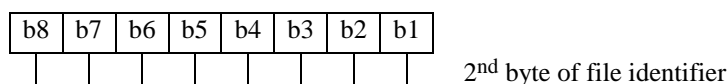

Figure 53: Coding of elementary file ID

- Record No. in corresponding LND Elementary File:

Contents: The record number of the LND.

Coding: Binary.

NOTE: This file shall be updated when any of the files EF_{LND}, EF_{LNDGWT} or EF_{LNDTETRA} is updated.

10.3.53 EF_{DFLTSTSGT} (Status Default Target)

This EF shall contain information concerning the default target for status message texts as defined in table 70.

Table 70: Contents of Status Default Target EF

Identifier: "6F35"		Structure: transparent		Optional
File size: 16 bytes		Update activity: low		
Access Conditions:				
READ		PIN1		
UPDATE		PIN1		
INVALIDATE		ADM		
REHABILITATE		ADM		
Bytes	Description	M/O	Length	
1	Acknowledgement required	M	1 byte	
2	Address Type	M	1 byte	
3 to 16	Address (see note)	M	14 bytes	
NOTE: The address length shall be according to the address type. The unused bytes shall be set to "FF".				

- Acknowledgement required:

Contents: Indicates if an acknowledgement is required.

Coding: shall be as defined in figure 54.

Byte 1:

b8	b7	b6	b5	b4	b3	b2	b1	
x	x	x	x	x	x	x	0	acknowledgement required
x	x	x	x	x	x	x	1	no acknowledgement required

Figure 54: Coding of acknowledgement required

- Address Type:

Contents: This data item contains the target address type.

Coding: shall be as defined in figure 55.

Byte 2:

b8	b7	b6	b5	b4	b3	b2	b1	
					0	0	0	No address defined
					0	0	1	Short number address (SNA)
					0	1	0	Short subscriber identity (SSI)
					0	1	1	TETRA subscriber identity (TSI)
					1	0	0	External subscriber identity
					1	0	1	RFU
					1	1	0	RFU
					1	1	1	RFU
								RFU

Figure 55: Coding of address type

- Address:

Contents: The address could be: a short number address, or an SSI, or a TETRA subscriber identity or an external subscriber identity.

Called party short number address.

Coding: the called party short number address consists of the SNA of the called user as defined in EN 300 392-2 [3] - byte 3 = Address, bytes 4 to 16 set to "FF".

Called party SSI.

Coding: the SSI address of the called user as defined in EN 300 392-2 [3] - bytes 3 to 5 = Address, bytes 6 to 16 set to "FF".

TETRA subscriber identity:

Coding: the TETRA subscriber identity as defined in EN 300 392-1 [2], consists of Country Code (MCC), Network Code (MNC) and Short Subscriber Identity (SSI): byte 3 to 8 = address, bytes 9 to 16 set to "FF": The coding shall be as defined in figure 56.

Byte 3:

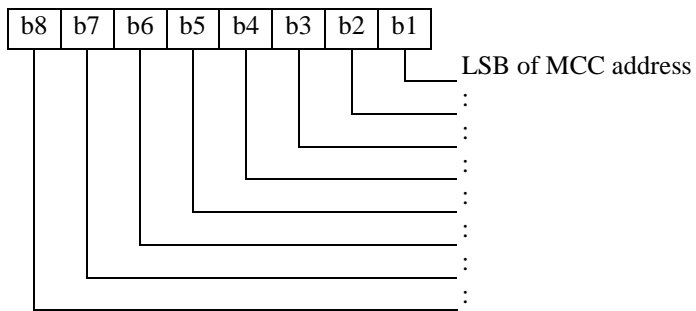

Byte 4:

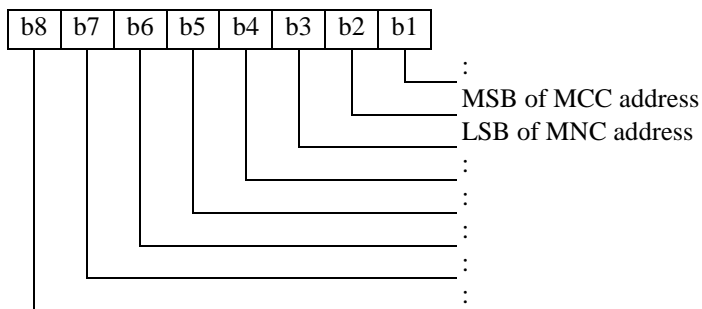

Byte 5:

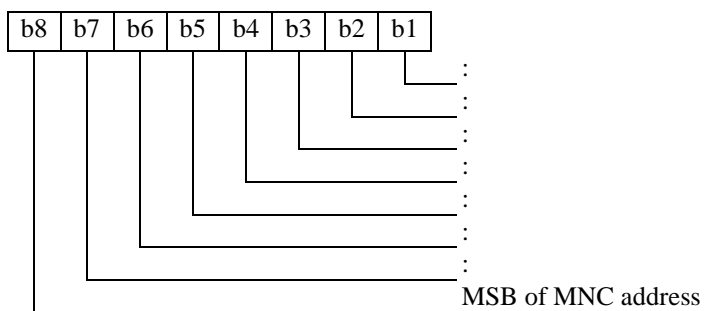

Byte 6:

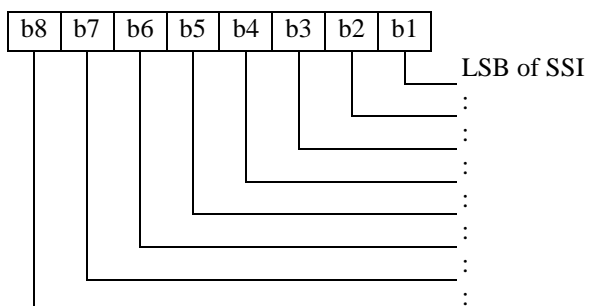

Byte 7:

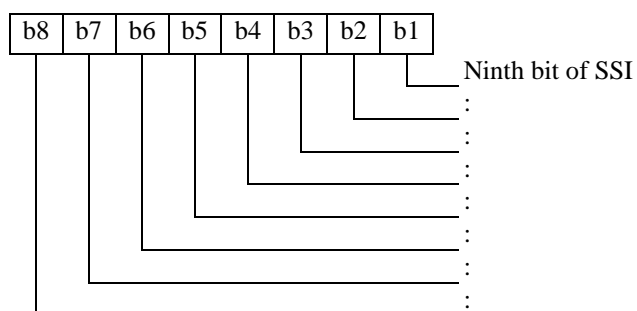

Byte 8:

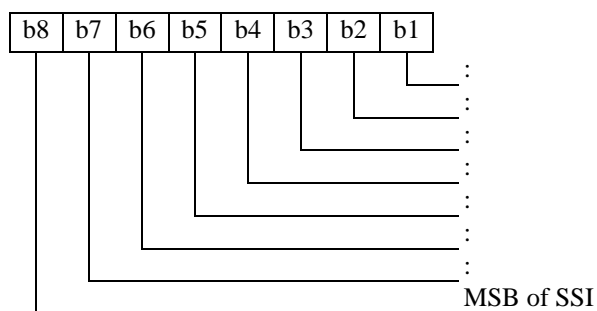

Figure 56: Coding of ITS/I/GTSI

- External subscriber identity:

Contents: It consists of the external subscriber number and the gateway address record number.

The gateway address record number identifies the number of a record in the EF_{GWT} containing an associated gateway address - byte 3 is the number of the record in the EF_{GWT} .

The external subscriber number consists of the number of digits (less or equal to 24) and the digits. Each digit is as defined in EN 300 392-2 [3] - byte 4 - the number of digits, byte 5 to 5+n-1 the digits, all unused set to "FF".

10.3.54 EF_{SDSMEM_STATUS} (SDS Memory Status)

This EF shall contain storage information relating to the SDS4 service as defined in table 71.

The provision of this EF is associated with EF_{SDS123} and/or EF_{SDS4}. The files shall be present together, or both absent from the SIM.

Table 71: Contents of SDS Memory Status EF

Identifier: "6F36"		Structure: transparent		Optional
File size: 7 bytes			Update activity: low	
Access Conditions:				
READ		PIN1		
UPDATE		PIN1		
INVALIDATE		ADM		
REHABILITATE		ADM		
Bytes	Description	M/O	Length	
1	Last used TP-Message Reference	M	1 byte	
2	SDS4 "Memory capacity exceeded" notification flag	M	1 byte	
3	SDS123 memory capacity exceeded notification flag	M	1 byte	
4 to 5	SDS4 last used message index	M	2 bytes	
6 to 7	SDS123 last used message index	M	2 bytes	

- Last used Transport Protocol (TP)-Message Reference:

Contents:

The value of the TP-Message Reference parameter in the last mobile originated short message, as defined in EN 300 392-2 [3].

Coding:

As defined in EN 300 392-2 [3].

- SDS4 "Memory capacity exceeded" notification flag:

Contents:

This flag is required to allow a process of flow control, so that as memory capacity becomes available, the network service centre can be informed.

Coding: shall be as defined in figure 57.

Byte 2:

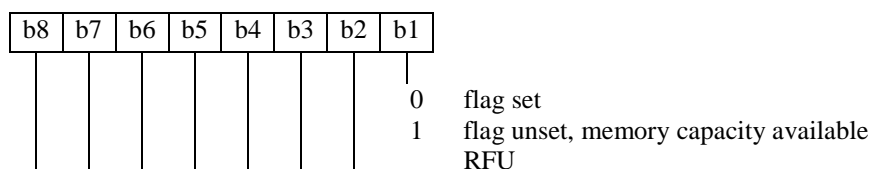

Figure 57: Coding of memory capacity exceeded notification flag

- SDS123 "memory capacity exceeded notification flag":

Same as SDS4 "memory capacity exceeded".

- SDS4 last used message index:
 - Contents: The value of the last message index used for the SDS4 message.
 - Coding: binary in two bytes.
- SDS123 last used message index:
 - Contents: The value of the last message index used for the SDS123 message.
 - Coding: binary in two bytes.

10.3.55 EF_{WELCOME} (Welcome Message)

This EF shall contain an alpha-numeric message displayed during the ME boot sequence as defined in table 72.

Table 72: Contents of Welcome Message EF

Identifier: "6F37"		Structure: transparent		Optional	
File size: 32 bytes			Update activity: low		
Access Conditions:					
READ		PIN1			
UPDATE		ADM			
INVALIDATE		ADM			
REHABILITATE		ADM			
Bytes	Description			M/O	Length
1 to 32	Message string			M	32 bytes

- Message string
 - Contents:
 - A string defined by the network operator.
 - Coding:
 - According to the default 8-bit alphabet ISO/IEC 8859-1 [9] (Latin-1). Unused bytes shall be set as "FF".

10.3.56 EF_{SDSR} (SDS delivery report)

This EF shall contain information in accordance with EN 300 392-2 [3] comprising delivery report messages which have been received by the MS from the network as defined in table 73.

Each record is used to store the delivery report of a short data service message. The first byte of each record is the link between the delivery report and the corresponding SDS in EF_{SDS4}.

Table 73: Contents of SDS delivery report EF

Identifier: "6F38"		Structure: linear fixed		Optional	
Record length: 2 bytes			Update activity: low		
Access Conditions:					
READ		PIN1			
UPDATE		PIN1			
INVALIDATE		ADM			
REHABILITATE		ADM			
Bytes	Description			M/O	Length
1	SDS record identifier			M	1
2	SDS delivery status			M	1

- SDS record identifier

Contents:

This data item identifies the corresponding SDS record in EF_{SDS4} , e.g. if this byte is coded "05" then this delivery report corresponds to the SDS record #5 of EF_{SDS4} .

Coding:

"00" empty record.

"01" to "FF" record number of the corresponding SDS in EF_{SDS4}

- SDS delivery status:

This data item contains the delivery status as defined in EN 300 392-2 [3].

10.3.57 EF_{SDSP} (SDS parameters)

This EF shall contain values for short data service header parameters, which can be used by the ME for user assistance in preparation of mobile originated SDS, as defined in table 74.

The EF consists of one or more records, with each record able to hold a set of SDS parameters. The first record in the EF shall be used as a default set of parameters, if no other record is selected.

To distinguish between records, an alpha identifier is included within each record, coded on X bytes.

Table 74: Contents of SDS parameters EF

Identifier: "6F39"		Structure: linear fixed		Optional
Record length: 1 to X + 19 bytes		Update activity: low		
Access Conditions:				
READ		PIN1		
UPDATE		PIN1		
INVALIDATE		ADM		
REHABILITATE		ADM		
Bytes	Description	M/O	Length	
1 to X	Alpha identifier	M	X bytes	
X + 1	Parameter indicators	M	1 byte	
X + 2 to X + 16	Service centre address	M	15 bytes	
X + 17	Protocol identifier	M	1 byte	
X + 18	Data coding scheme	M	1 byte	
X + 19	Validity period	M	1 byte	

Storage is allocated for all the possible SDS parameters, regardless of whether they are present or absent. Any unused bytes, due to parameters not requiring all of the bytes, or due to absent parameters, shall be set to "FF".

- Alpha identifier

Contents:

Alpha tag of the associated SDS - parameter.

Coding:

As defined in clause 10.4.1.

- Parameter Indicators

Contents:

Each of the default SDS parameters which can be stored in the remainder of the record are marked absent or present by individual bits within this byte.

Coding: shall be as defined in figure 58.

Byte X + 1:

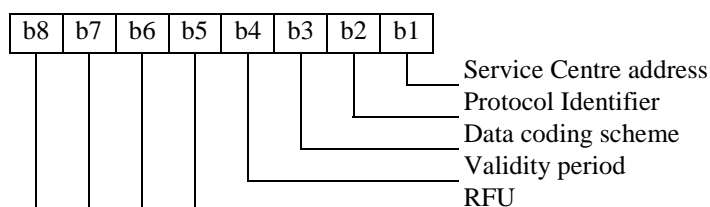

Bit value:

0 - parameter present

1 - parameter absent

Figure 58: Coding of parameter indicators

- Service centre address:

Contents:

Service centre address.

Coding:

As defined for the message destination/source identifier in clause 10.3.42.

- Protocol Identifier:

As defined for the protocol identifier in clause 10.3.42.

- Data coding scheme:

As defined in EN 300 392-2 [3].

- Validity period:

As defined in EN 300 392-2 [3].

10.3.58 EF_{DIALSC} (Dialling schemes for TETRA network)

This EF shall contain the information indicating the dialling scheme as defined in table 75.

Table 75: Contents of Dialling schemes for TERA network EF

Identifier: "6F46"		Structure: transparent		Mandatory	
File size: 5 bytes			Update activity: low		
Access Conditions:					
READ		PIN1			
UPDATE		ADM			
INVALIDATE		ADM			
REHABILITATE		ADM			
Bytes	Description			M/O	Length
1	Type of dialling			M	1
2	Number of digits			M	1
3 to 5	Base address			M	3

- Type of dialling:

Contents: the type of dialling scheme to be selected.

Coding: shall be as defined in figure 59.

Byte 1:

b8	b7	b6	b5	b4	b3	b2	b1	
						0	0	ISSI or ITSI dialling
						0	1	FSSN Dialling
						1	0	RFU
						1	1	RFU
								RFU

Figure 59: Coding of type of dialling

- Number of digits

Contents:

In case of FSSN dialling, up to this number of digits, the number dialled has to be added to the base address. Else the dialling is as ISSI/ITSI dialling.

Coding: 1 byte

"FF" in case of ISSI/ITSI dialling, else number of digits.

- Base Address

Contents: It contains the base address to which the dialled number has to be added.

Coding: 3 bytes - used in case of FSSN dialling else set to "FF FF FF".

10.3.59 EF_{APN} (APN table)

This EF shall contain a list of APNs (IP access point names) which the ME can use to match the access point name string to the corresponding index which is used in the air interface (EN 300 392-2 [3]) as defined in table 76.

Table 76: Contents of ANP table EF

Identifier: "6F3E"		Structure: linear fixed		Optional
Record size: 65 bytes		Update activity: high		
Access Conditions:				
READ		PIN1		
UPDATE		PIN1		
INVALIDATE		ADM		
REHABILITATE		ADM		
Bytes	Description	M/O	Length	
1 to 2	Access point name index	M	2	
3 to 65	Access point name	M	63	

- Access point name index:

Contents: The Access point name index is used over the air interface.

Coding: The message value is coded with two bytes as defined in EN 300 392-2 [3].

- Access point name:

Contents: The alphanumeric name the user has assigned for the corresponding access point name index.

Coding: According to the default 8-bit alphabet ISO/IEC 8859-1 [9].

NOTE: The access point name stored in this EF does not have to be the same as the access point name sent by TETRA SwMI towards the IP gateway. This is because only the access point name index is sent over the air interface. The SwMI maps the index to the real APN Network Identifier that is sent to the GGSN network element (TS 100 927 [12]).

10.3.60 EF_{ARR} (Access Rule Reference)

This EF shall contain the access rules for files located under the TETRA ADF in the UICC. If the security attribute tag "8B" is indicated in the FCP it contains a reference to a record in this file as defined in table 77.

Table 77: Structure of EF_{ARR} at ADF-level

Identifier: "6F47"		Structure: Linear fixed		Mandatory
Record Length: X bytes		Update activity: low		
Access Conditions:				
READ		ALW		
UPDATE		ADM		
DEACTIVATE		ADM		
ACTIVATE		ADM		
Bytes	Description	M/O	Length	
1 to X	Access Rule TLV data objects	M	X bytes	

This EF contains one or more records containing access rule information according to the reference to expanded format as defined in ISO/IEC 7816-9 [13]. Each record represents an access rule. Unused bytes in the record are set to "FF".

10.3.61 EF_{PNI} (Private Number Information)

Each record of this EF shall contain a number structure definition and stores the user's own private number as defined in table 77. The number structure definition allows the MS to understand the structure of different Private Number Plans that may be in use. This enables the MS to display the user's own private number correctly.

The first record contains the default private number information, the other records are in descending order of priority.

The selection of which type of Private Number Plan to use is outside the scope of the present document.

Table 78: Contents of Private Number Information EF

Identifier: "6F C0"		Structure: linear fixed		Optional
Record length: 14 bytes		Update activity: low		
Access Conditions:				
READ		PIN1		
UPDATE		PIN1/PIN2		
INVALIDATE		ADM		
REHABILITATE		ADM		
Bytes	Description	M/O	Length	
1 to 2	Tier Details	M	2	
3 to 14	Private Number	M	12	

- Tier Details

Contents: This field of each record defines the hierarchical structure of the private number, allowing up to four variable length tiers in descending order of significance.

Coding: shall be as defined in figure 60.

The tier lengths are binary encoded nibbles.

The number of tiers in the hierarchy is N, where N may take the value 1 to 4.

There is no absolute hierarchy, the structure is relative. For example if there are two tiers in the hierarchy the first two tier fields (N and N - 1) are set to the length of digits in each, the remaining two tiers (N - 2 and N - 3) will be set to "0".

"00 00" - No Private Number Stored.

"01 mn" signifies that what follows is concatenation of m digit leading number + n digit second number + [remainder] with unused digits padded with "F".

EXAMPLE 1: The full coding for an FSSN number "ab cdef" with 2 + 4 structure might be:

"01 02 ab cd ef FF FF FF FF FF FF FF FF".

EXAMPLE 2: The full coding for a private number "ab cdefg hijk" with 2 + 5 + 4 structure might be:

"01 25 ab cd ef gh ij kF FF FF FF FF FF FF FF".

"01 FF" - 1 to 24 digit private number with no tier structure defined.

"XX XX" - 1 to 4 tier Private number stored (where X takes the range "1" to "F" hex and the sum of digits does not exceed 24).

"FF FF" - No valid number follows.

Byte 1:

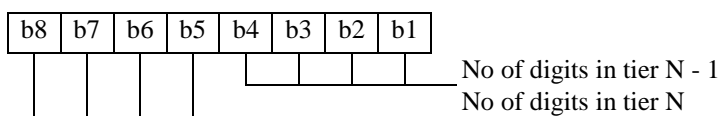

Byte 2:

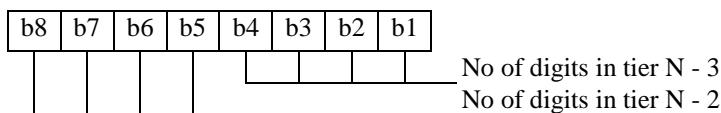

Figure 60: Coding of tier details

- Private Number

Contents: This field of each record allows storage of a private number.

Coding: A contiguous string of left-justified BCD encoded digits, starting with the most significant digit. Where the number is shorter than 24 digits the remaining digits shall be padded with "F".

10.3.62 EF_{SCAN} (Scan list files)

This EF shall contain information concerning all the multi-group lists as defined in table 79.

Table 79: Contents of Scan list files EF

Identifier: "6F4D"	Structure: linear fixed	Optional	
Record size: X byte	Update activity: low		
Access Conditions:			
READ	PIN1		
UPDATE	PIN1		
INVALIDATE	ADM		
REHABILITATE	ADM		
Bytes	Description	M/O	Length
1 to X	Scan list name	M	X

- Scan list name:

Contents: Alphanumeric name for the scan list stored on the SIM.

Coding: The value of X may range from zero to 241. Coding according to the default 8-bit alphabet ISO/IEC 8859-1 [9].

10.3.63 EF_{SCAND} (Scan list data)

This EF shall contain information related to each scan list as defined in table 80. There shall be a 1:1 relationship between each record in EF_{SCAND} and the corresponding record in EF_{SCANL}.

Table 80: Contents of Scan list data EF

Identifier: "6F4E"	Structure: linear fixed	Optional	
Record size: $2 \times (X + 1)$ bytes	Update activity: high		
Access Conditions:			
READ	PIN1		
UPDATE	PIN1		
INVALIDATE	ADM		
REHABILITATE	ADM		
Bytes	Description	M/O	Length
1	Number of groups in list	M	1
2 to $2 \times (X + 1)$	Group indexes for first group to N th group	M	$2 \times X$

- Number of groups in list:

Contents:

The number of groups in the scan list.

Coding:

Byte 1: Number of groups in list (X)- coded binary.

- Group indexes for first group to Nth group:

Contents:

Shall indicate for each group in the scan list, the record number of the corresponding TMO group in EF_{GSSIS} or EF_{GSSID}.

Coding: For each group number N in the scan list:

- Byte $N \times 2$:

GSSIS_GSSID_flag:

1 - from EF_{GSSIS}.

0 - from EF_{GSSID}.

- Byte $N \times 2 + 1$: Coded binary - shall indicate the record number of the corresponding TMO group in EF_{GSSIS} or EF_{GSSID}.

Unused bytes shall be set to "FF".

10.3.64 EF_{DMO_GSSIS} (DMO pre-programmed group numbers)

This EF shall contain the pre-programmed (by the operator or organization) group identities for DMO as defined in table 81.

Table 81: Coding of DMO pre-Programmed group numbers EF

Identifier: "6F49"		Structure: linear fixed		Optional
Record length: X + 4 bytes		Update activity: low		
Access Conditions:				
READ		PIN1		
UPDATE		ADM		
INVALIDATE		ADM		
REHABILITATE		ADM		
Bytes	Description	M/O	Length	
1 to X	Group name	M	X	
X + 1	Network address record number	M	1	
X + 2 to X + 4	Group Identity (GSSI)	M	3	

- Group name: See definition in EF_{GSSIS}.
- Network address record number: See definition in EF_{GSSIS}.
- Group Identity (GSSI): See definition in EF_{GSSIS}.

10.3.65 EF_{DMO_GRDS} (Group related data for DMO static GSSIs)

This EF shall contain information related to each static DMO GSSI as defined in table 82. There shall be a 1:1 relationship between each record in EF_{DMO-GRDS} and the corresponding record in EF_{DMO_GSSIS}.

Table 82: Contents of Group related data for DMO static GSSIs EF

Identifier: "6F4A"		Structure: linear fixed		Optional
Record size: 4 + N bytes		Update activity: low		
Access Conditions:				
READ		PIN1		
UPDATE		PIN1		
INVALIDATE		ADM		
REHABILITATE		ADM		
Bytes	Description	M/O	Length	
1	Key record number	M	1	
2 to 4 + N	Group related data	M	3	

- Key record number: See definition in EF_{GRDS} file:
- Group related data:

Class of usage (3 bits). Shall indicate the importance of the group for the user and define the participation rules for the groups defined with Class of usage.

NOTE: Class of usage may be used to support scanning (multi-group) in DMO.

Preferred DMO Air Encryption Class (2 bits): Shall indicate the preferred encryption class (EN 300 396-6 [7]) to be used for communication with this address.

Minimum DMO Air Encryption Class (2 bits): Shall indicate which encryption classes (EN 300 396-6 [7]) may be used for communication with this address.

Number of DMO radio channels for this group: Shall indicate the number of radio channels this group point to.

DMO radio channel index: Shall indicate record number of the corresponding DMO channel in the EF_{DMOCH} file (repeated according to Number of DMO radio channels).

Coding: shall be as defined in figure 61.

Byte 2:

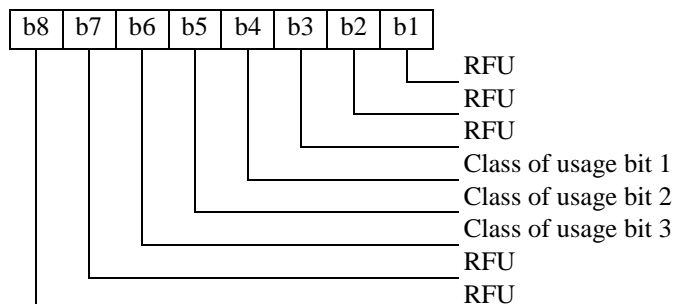

Byte 3:

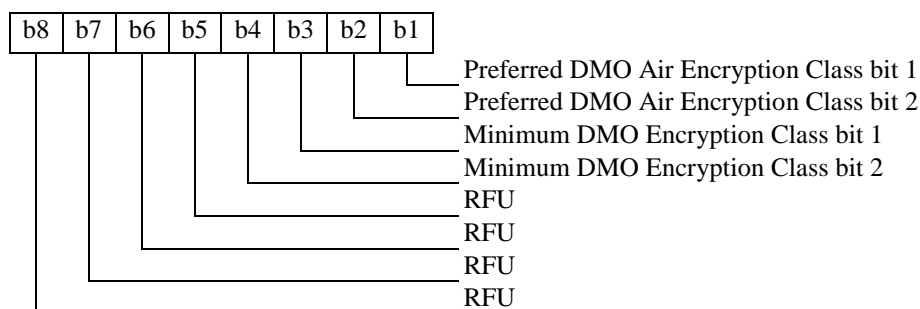

Where:

- Preferred Air Encryption Class: coded as defined in EN 300 396-6 [7].
The Preferred Air Encryption Class shall not be set to a lower priority level than the Minimum Air Encryption class. The order of priority is defined in EN 300 396-6 [7].
- Minimum Air Encryption Class: coded as shown in EN 300 396-6 [7].
- Byte 4: binary coded - Number of DMO radio channels (N).
- Byte 5 to byte 5+N-1: binary coded - record number of the corresponding DMO radio channel.

NOTE: The managed DMO may override the radio channel information.

Figure 61: Coding of group related data

10.3.66 EF_{GTMO_GDMO} (TMO - DMO selected group association)

This EF shall contain information related group association from TMO selected groups to DMO selected groups as defined in table 83.

There shall be a 1:1 relationship between each record in EF_{GTMO_GDMO} and the corresponding record in EF_{GSSIS} .

NOTE: Table 83 is used only for manual switch from TMO to DMO.

Table 83: Contents of TMO - DMO selected group association EF

Identifier: "6F4B"		Structure: linear fixed		Optional	
Record size: 1 byte			Update activity: low		
Access Conditions:					
READ		PIN1			
UPDATE		PIN1			
INVALIDATE		ADM			
REHABILITATE		ADM			
Bytes	Description			M/O	Length
1	DMO Group index			M	1

- DMO Group Index:

Contents: DMO Group Index: Shall indicate record number of the corresponding DMO Group in EF_{DMO_GSSIS} .

Coding:

Byte 1: binary coded.

10.3.67 EF_{GDMO_GTMO} (DMO - TMO selected group association)

This EF shall contain information related group association from DMO selected groups to TMO selected groups as defined in table 84.

There shall be a 1:1 relationship between each record in EF_{GDMO_GTMO} and the corresponding record in EF_{DMO_GSSIS} .

NOTE: Table 84 is used only for manual switch from DMO to TMO.

Table 84: Contents of DMO - TMO selected group association EF

Identifier: "6F4C"		Structure: linear fixed		Optional	
Record size: 1 byte			Update activity: low		
Access Conditions:					
READ		PIN1			
UPDATE		PIN1			
INVALIDATE		ADM			
REHABILITATE		ADM			
Bytes	Description			M/O	Length
1	TMO Group index			M	1

- TMO Group Index:

Contents: TMO Group Index: Shall indicate record number of the corresponding TMO Group in EF_{GSSIS} .

Coding:

Byte 1: binary coded.

10.3.68 EF_{DMO_DEP} (Default encryption parameters)

This EF shall contain information showing air-interface encryption parameters to be used for communication with DMO addresses which are not specified in EF_{DMO_GRDS} (Group related data for DMO static GSSIs) as defined in table 85.

NOTE: Pre-emption requests need not use these parameters.

Table 85: Contents of Group related data for DMO static GSSIs EF

Identifier: "6F4F"		Structure: Transparent		Optional	
Record size: 2 bytes			Update activity: low		
Access Conditions:					
READ		PIN1			
UPDATE		PIN1			
INVALIDATE		ADM			
REHABILITATE		ADM			
Bytes	Description	M/O	Length		
1	Key record number	M	1		
2	Encryption related default data	M	1		

- Key record number: see definition in EF_{GRDS} file.

This defines the key to be used for encrypted communication with DMO addresses which are not specified in EF_{DMO_GRDS} (Group related data for DMO static GSSIs). It has no meaning for an MS which never uses encryption for communicating with these addresses.

- Encryption related default data:

Preferred DMO Air Encryption Class (2 bits): shall indicate the preferred encryption class (EN 300 396-6) to be used for communication with DMO addresses, which are not specified in EF_{DMO_GRDS} (Group related data for DMO static GSSIs).

Minimum DMO Air Encryption Class (2 bits): shall indicate which encryption classes (EN 300 396-6) may be used for communication with DMO addresses, which are not specified in EF_{DMO_GRDS} (Group related data for DMO static GSSIs).

Coding: shall be as defined in figure 62.

Byte 2:

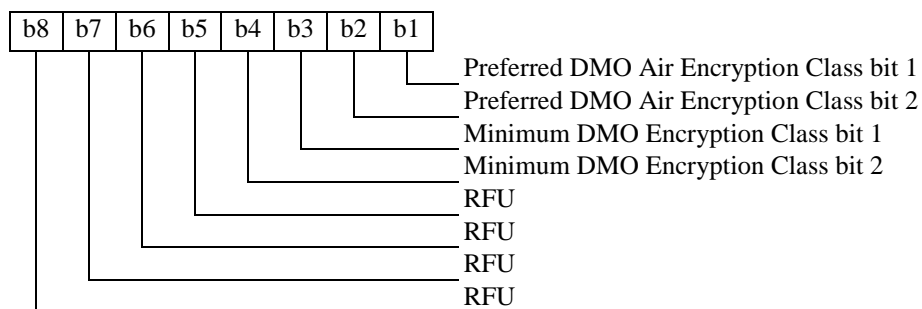

Where:

- Preferred Air Encryption Class: coded as shown in EN 300 396-6 [7].

The Preferred Air Encryption Class shall not be set to a lower priority level than the Minimum Air Encryption Class. The order of priority is defined in EN 300 396-6 [7].

- Minimum Air Encryption Class: coded as shown in EN 300 396-6 [7].

Figure 62: Coding of encryption related default data

10.3.69 EF_{GSKO} (Group Session Key)

This EF shall contain the group sealing key for OTAR (see [3] clause 4.2.5) as defined in table 86.

Table 86: Contents of the Group Session Key EF_{GSKO}

Identifier: "6F50 "		Structure: linear fixed		Optional
Record length: 14 bytes		Update activity: low		
Access Conditions: READ NEV (see note 1) UPDATE NEV (see note 2) INVALIDATE ADM REHABILITATE ADM				
Bytes	Description	M/O	Length	
1-2	GSKO-VN	M	2	
3-14	GSKO	M	12	
NOTE 1: There is no access to this EF over the SIM-ME interface.				
NOTE 2: GSKO and GSKO-VN are updated on the SIM by use of the TA41/TA92 algorithm.				

- GSKO-VN:

Contents: The version number of GSKO.

Coding: The key shall be stored in 2 bytes according to figure 63.

Byte 1:

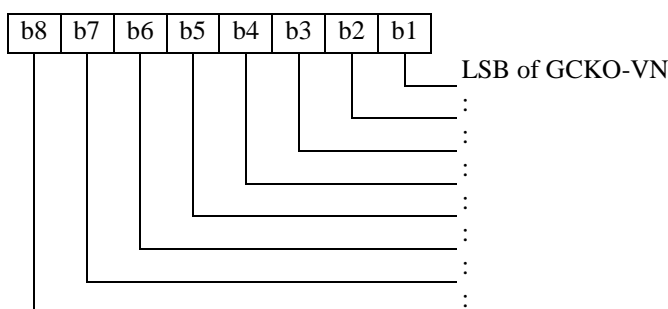

Byte 2:

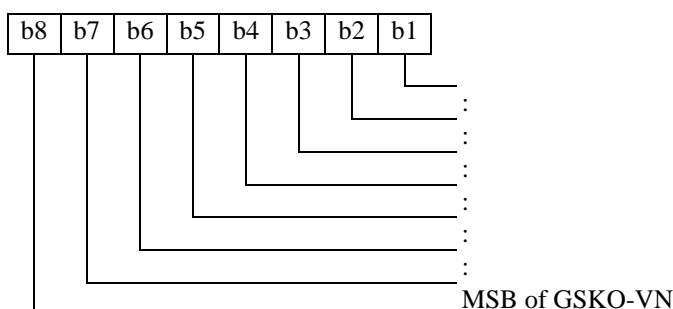

Figure 63: Coding of GSKO-VN

- GSKO:

Contents: The Group sealing key for OTAR.

Coding: The key shall be stored in 12 bytes according to figure 64.

Byte 3:

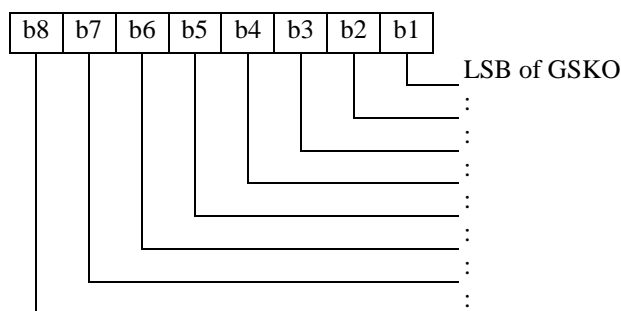

...etc.

Byte 14:

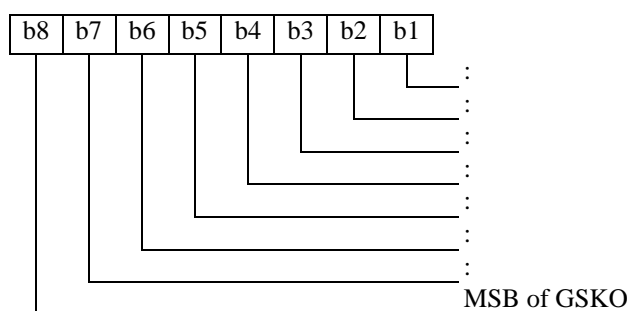

Figure 64: Coding of GSKO

10.4 Contents of the EFs at the Telecom level

10.4.1 EF_{ADN} (Abbreviated dialling numbers)

This EF shall contain Abbreviated Dialling Numbers (ADN) and/or Supplementary Service Control strings (SSC). In addition it contains identifiers of associated network/bearer capabilities and identifiers of extension records. It may also contain an associated alpha-tagging.

For contents and coding see TS 100 977 [5].

10.4.2 EF_{FDN} (Fixed dialling numbers)

This EF shall contain Fixed Dialling Numbers (FDN) and/or Supplementary Service Control strings (SSC). In addition it contains identifiers of associated network/bearer capabilities and identifiers of extension records. It may also contain an associated alpha-tagging.

For contents and coding see TS 100 977 [5].

10.4.3 EF_{MSISDN} (MSISDN)

This EF shall contain MSISDN(s) related to the subscriber. In addition it contains identifiers of associated network/bearer capabilities and identifiers of extension records. It may also contain an associated alpha-tagging.

For contents and coding see TS 100 977 [5].

10.4.4 EF_{LND} (Last number dialled)

This EF shall contain the last numbers dialled (LND) and/or the respective supplementary service control strings (SSC). In addition it contains identifiers of associated network/bearer capabilities and identifiers of extension records. It may also contain associated alpha-tagging.

For contents and coding see TS 100 977 [5].

10.4.5 EF_{SDN} (Service Dialling Numbers)

This EF shall contain special service numbers (SDN) and/or the respective supplementary service control strings (SSC). In addition it contains identifiers of associated network/bearer capabilities and identifiers of extension records. It may also contain associated alpha-tagging.

For contents and coding see TS 100 977 [5].

10.4.6 EF_{EXT1} (Extension1)

This EF shall contain extension data of an ADN/SSC, an MSISDN, or an LND. Extension data is caused by:

- an ADN/SSC (MSISDN, LND) which is greater than the 20 digit capacity of the ADN/SSC (MSISDN, LND) Elementary File or where common digits are required to follow an ADN/SSC string of less than 20 digits. The remainder is stored in this EF as a record, which is identified by a specified identification byte inside the ADN/SSC (MSISDN, LND) Elementary File. The EXT1 record in this case is specified as additional data;
- an associated called party subaddress. The EXT1 record in this case is specified as subaddress data.

For contents and coding see TS 100 977 [5].

10.4.7 EF_{EXT2} (Extension2)

This EF shall contain extension data of an FDN/SSC (see EXT2 in clause 10.4.2).

For contents and coding see TS 100 977 [5].

10.4.8 EF_{EXT3} (Extension3)

This EF shall contain extension data of an SDN (see EXT3 in clause 10.4.5).

For contents and coding see TS 100 977 [5].

10.5 Files of TETRA

This clause contains a figure depicting the file structure of the SIM. DF_{TETRA} shall be selected by using the identifier "7F90".

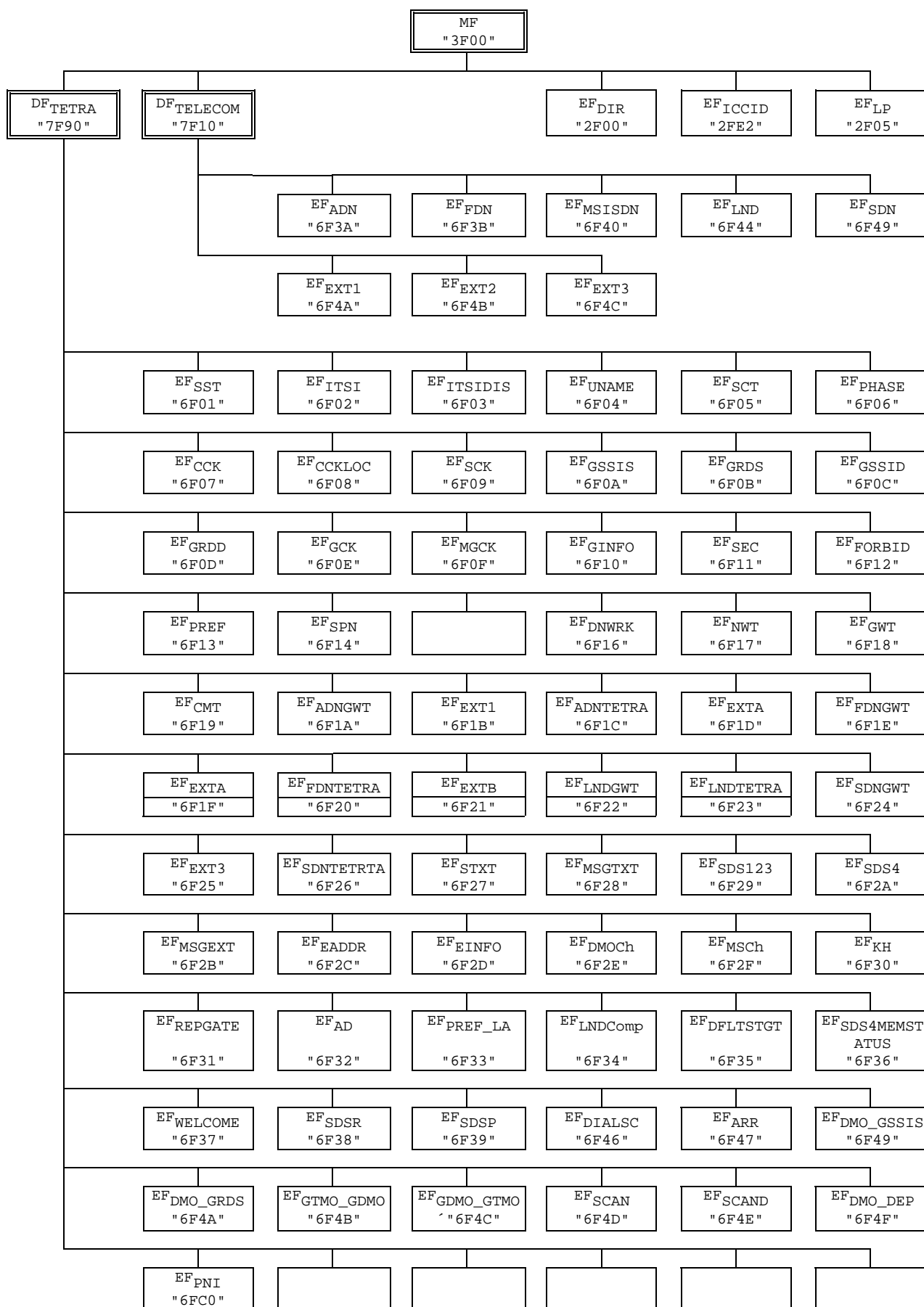

Figure 65: File identifiers and directory structures of TETRA

11 Application protocol

The SIM interfaces with appropriate terminal equipment (ME) when in TETRA administrative mode. These operations are outside the scope of the present document.

During TETRA network operations the SIM exchanges messages with the ME via the SIM/ME interface. A message can be a command or a response as follows:

- a TETRA command/response pair is a sequence consisting of a command and the associated response;
- a TETRA procedure consists of one or more TETRA command/response pairs which are used to perform all or part of an application-oriented task. A procedure shall be considered as a whole, that is to say that the corresponding task is achieved if and only if the procedure is completed. The ME shall ensure that, when operated according to the manufacturer's manual, any unspecified interruption of the sequence of command/response pairs which realize the procedure, leads to the abortion of the procedure itself;
- a TETRA session of the SIM in the TETRA application is the interval of time starting at the completion of the SIM initialization procedure and ending either with the start of the TETRA session termination procedure, or at the first instant the link between the SIM and the ME is interrupted.

During the TETRA network operation phase, the ME plays the role of the master and the SIM plays the role of the slave.

The list of procedures at the SIM/ME interface in TETRA network operation are listed in the following table:

The ME automatically initiates some procedures. They are marked "ME".

NOTE 1: Some procedures at the SIM/ME interface require MMI interactions. The following descriptions do not intend to infer any specific implementation of the corresponding MMI. When MMI interaction is required, it is marked "MMI".

NOTE 2: Some procedures are not clearly user dependent. They are directly caused by the interaction of the MS and the network. Such procedures are marked NETwork "(NET)".

General Procedures:

- Reading an EF ME;
- Updating an EF ME.

SIM management procedures:

- SIM initialization ME;
- TETRA session initialization ME;
- TETRA session termination ME;
- Language preference request ME;
- Administrative information request ME;
- SIM service table request ME;
- SIM phase request ME;
- SIM presence detection ME.

PIN related procedures:

- PIN verification MMI;
- PIN value substitution MMI;
- PIN disabling MMI;

- PIN enabling MMI;
- PIN unblocking MMI.

TETRA security related procedures:

- TETRA algorithms computation NET;
- TETRA key computation (SCK, DCK, MGCK, GCK)NET;
- ITSI request NET;
- ITSI disabling NET;
- Location Information NET;
- Broadcast network information NET;
- Forbidden networks information NET.

Subscription related procedures:

- Username MMI;
- Subscriber class request ME;
- Group information MMI/NET;
- User's group information ME/NET;
- Call modifiers NET/ME;
- Network information ME;
- Dialling Numbers (ADN, ADNTETRA, ADNGWT, FDN, FDNTETRA, FDNGWT, LND, LNDTETRA, LNDGWT, SDN, SDNTETRA, SDNGWT LNDComp) MMI/ME;
- SDS messages (Message texts, SDS123 and SDS4) MMI;
- Preferred networks MMI;
- Service Provider Name (SPN) ME;
- ICCID ME;
- Emergency addresses ME/MMI.

11.1 General procedures

11.1.1 Reading an EF

The ME selects the EF and sends a READ command. This contains the location of the data to be read. If the access condition for READ is fulfilled, the SIM sends the requested data contained in the EF to the ME. If the access condition is not fulfilled, no data will be sent and an error code will be returned.

11.1.2 Updating an EF

The ME selects the EF and sends an UPDATE command. This contains the location of the data to be updated and the new data to be stored. If the access condition for UPDATE is fulfilled, the SIM updates the selected EF by replacing the existing data in the EF with that contained in the command. If the access condition is not fulfilled, the data existing in the EF will be unchanged, the new data will not be stored, and an error code will be returned.

In some cases, files are updated by running an algorithm resident on the SIM.

11.1.3 Invalidating an EF

The ME selects the EF and sends an INVALIDATE command. If the access conditions of INVALIDATE are fulfilled the EF is invalidated.

11.2 SIM management procedures

The procedures listed in this clause are required for execution of the procedures in clauses 11.3, 11.4 and 11.5.

11.2.1 SIM initialization

The ME runs the language request procedure. If none of the indicated languages are available, the ME selects a default language (e.g. English).

11.2.2 TETRA session initialization

Following the SIM initialization, the ME selects DF_{TETRA} by using the identifier or by the path given in EF_{DIR} . The ME then selects EF_{ITSI} to obtain its INVALIDATION status. If the ITSI is invalidated the ME informs the user and the TETRA session initialization fails.

The ME runs the PIN verification procedure for PIN1 as defined in clause 11.3.1. If the PIN verification is unsuccessful, the TETRA session initialization fails.

If the PIN verification procedure is performed successfully, the ME then runs the following procedures:

- Administrative information request;
- SIM Phase request;
- SIM Service Table request;
- ITSI request;
- ITSI temporarily disabled enquiry;
- Subscriber class request;
- Preferred networks request;
- Location Information request;
- Mutual authentication requirement request;
- Forbidden networks request;
- Interrupted emergency call request.

After the SIM initialization has been completed successfully, the MS is ready for a TETRA session.

NOTE: If the ITSI is "Temporary disabled by SwMI", the ME enters a TETRA session with a restricted mode of operation. The restricted TETRA session usually consists of the MS simply listening to the SwMI to eventually detect a re-enabling of the ITSI by the network (see EN 300 392-7 [4]).

11.2.3 TETRA session termination

The ME terminates the TETRA session as follows:

The ME runs all the procedures that are necessary to transfer the following subscriber related information to the SIM:

As soon as the SIM indicates that these procedures are completed, the ME/SIM link may be deactivated.

Finally, the ME deletes all these subscriber related information elements from its memory.

NOTE 1: This procedure is not to be confused with the deactivation procedure.

NOTE 2: If the ME has already updated any of the subscriber related information during the TETRA Session, and the value has not changed until TETRA session termination, the ME may omit the respective update procedure.

11.2.4 Language preference request

- Request: The ME performs the reading procedure with EF_{LP}.
- Update: The ME performs the updating procedure with EF_{LP}.

11.2.5 Administrative information request

- Request: The ME performs the reading procedure with EF_{AD}.
- Update: The ME performs the updating procedure with EF_{AD}.

11.2.6 SIM service table request

The ME performs the reading procedure with EF_{SST}.

11.2.7 SIM phase request

The ME performs the reading procedure with EF_{PHASE}.

11.2.8 SIM presence detection

As an additional mechanism, to ensure that the SIM has not been removed during a card session, the ME sends, at frequent intervals, a STATUS command during each call. A STATUS command shall be issued within all 30 second periods of inactivity on the SIM-ME interface during a call. Inactivity in this case is defined as starting at the end of the last communication or the last issued STATUS command. If no response data is received to this STATUS command, then the call shall be terminated as soon as possible but at least within 5 seconds after the STATUS command has been sent. If the DF indicated in response to a STATUS command is not the same as that which was indicated in the previous response, or accessed by the previous command, then the call shall be terminated as soon as possible but at least within 5 seconds after the response data has been received. This procedure shall be used in addition to a mechanical or other device used to detect the removal of a SIM.

11.2.9 SIM card number request

The ME performs the reading procedure with EF_{ICCID}.

11.2.10 Common Cipher Key request

The ME performs the read procedure with EF_{CCK} to obtain the current record in this EF.

11.3 PIN related procedures

The procedures listed in this clause are mandatory.

A successful completion of one of the following procedures grants the access right of the corresponding PIN for the TETRA session. This right is valid for all files within the application(s) protected by this PIN.

After a third consecutive presentation of a wrong PIN to the SIM, not necessarily in the same TETRA session, the PIN status becomes "blocked" and the access right previously granted by this PIN is lost immediately.

An access right is not granted if any of the following procedures are unsuccessfully completed or aborted.

11.3.1 PIN verification

The ME checks the PIN status.

In the case of PIN1 the following procedures applies:

- If the PIN1 status is "blocked", and PIN1 is "enabled" the procedure ends and is finished unsuccessfully.
- If the PIN1 status is "blocked" but PIN1 is "disabled", the procedure ends and is finished successfully. The ME shall, however, accept SIMs which do not grant access rights when PIN1 is "blocked" and "disabled". In that case ME shall consider those SIMs as "blocked";
- If the PIN status is not "blocked", but PIN1 is "disabled", the procedure is finished successfully.
- If the PIN1 status is not "blocked" and PIN1 is "enabled", the ME uses the VERIFY PIN1 function. If the PIN1 presented by the ME is equal to the corresponding PIN1 stored in the SIM, the procedure is finished successfully. If the PIN1 presented by the ME is not equal to the corresponding PIN1 stored in the SIM, the procedure ends and is finished unsuccessfully.

In the case of PIN2 the following procedure applies:

- if the PIN2 status is "blocked", the procedure ends and is finished unsuccessfully;
- if the PIN2 status is not "blocked", the ME uses the VERIFY PIN function. If the PIN2 presented by the ME is equal to the corresponding PIN2 stored in the SIM, the procedure is finished successfully. If the PIN2 presented by the ME is not equal to the corresponding PIN2 stored in the SIM, the procedure ends and is finished unsuccessfully.

11.3.2 PIN value substitution

The ME checks the PIN status. If the PIN status is "blocked" or "disabled", the procedure ends and is finished unsuccessfully.

If the PIN status is not "blocked" and the enabled/disabled indicator is set "enabled", the ME uses the CHANGE PIN function. If the old PIN presented by the ME is equal to the corresponding PIN stored in the SIM, the new PIN presented by the ME is stored in the SIM and the procedure is finished successfully.

If the old PIN and the PIN in memory are not identical, the procedure ends and is finished unsuccessfully.

11.3.3 PIN disabling

Requirement: Service no.1 "available".

The ME checks the PIN1 status. If the PIN1 status is "blocked", the procedure ends and is finished unsuccessfully.

If the PIN1 status is not "blocked", the ME reads the PIN1 enabled/disabled indicator. If this is set "disabled", the procedure ends and is finished unsuccessfully.

If the PIN1 status is not "blocked" and the enabled/disabled indicator is set "enabled", the ME uses the DISABLE PIN function. If the PIN1 presented by the ME is equal to the PIN1 stored in the SIM, the status of PIN1 is set "disabled" and the procedure is finished successfully. If the PIN1 presented by the ME is not equal to the PIN1 stored in the SIM, the procedure ends and is finished unsuccessfully.

This requirement applies to the PIN1 at the TETRA application level. For the PIN1 at the master file level, it only applies in the case of a TETRA only card.

11.3.4 PIN enabling

The ME checks the PIN1 status. If the PIN1 status is "blocked", the procedure ends and is finished unsuccessfully.

If the PIN1 status is not "blocked", the ME reads the PIN1 enabled/disabled indicator. If this is set "enabled", the procedure ends and is finished unsuccessfully.

If the PIN1 status is not "blocked" and the enabled/disabled indicator is set "disabled", the ME uses the ENABLE PIN function. If the PIN1 presented by the ME is equal to the PIN1 stored in the SIM, the status of PIN1 is set "enabled" and the procedure is finished successfully. If the PIN presented by the ME is not equal to the PIN1 stored in the SIM, the procedure ends and is finished unsuccessfully.

11.3.5 PIN unblocking

The execution of the PIN unblocking procedure is independent of the corresponding PIN status, i.e. being blocked or not.

The ME checks the UNBLOCK PIN status. If the UNBLOCK PIN status is "blocked", the procedure ends and is finished unsuccessfully.

If the UNBLOCK PIN status is not "blocked", the ME uses the UNBLOCK PIN function. If the UNBLOCK PIN presented by the ME is equal to the corresponding UNBLOCK PIN stored in the SIM, the relevant PIN status becomes "unblocked" and the procedure is finished successfully. If the UNBLOCK PIN presented by the ME is not equal to the corresponding UNBLOCK PIN stored in the SIM, the procedure ends and is finished unsuccessfully.

11.4 TETRA security related procedures

The procedures listed in this clause are only executable if the associated services, which are optional, are provided in the SIM. However, if the procedures are implemented, they shall be in accordance with the requirement stated in this clause. If a procedure is related to a specific service indicated in the SIM service table, it shall only be executed if the corresponding bit denoting this service as "available" (see EF_{SSP}). In all other cases this procedure shall not start.

The SIM security procedures are associated with the air interface message exchange protocol procedures for authenticating the SIM to a TETRA network and the TETRA network to the SIM. During these SIM security procedures the card runs the specified algorithms TA11/12 and TA21/22 to calculate respectively the expected response from the SIM, (X)RES1 with its associated derived cipher key DCK1 and the expected response from the SwMI, (X)RES2 with its associated derived cipher key DCK2.

On successful authentication the derived cipher key DCK, used for encrypting air interface signalling and traffic channels, shall be derived from its two parts DCK1 and DCK2 by running the TB4 algorithm.

All the algorithms shall not be executable unless DF_{TETRA} has been selected as the Current Directory and a successful PIN verification procedure has been performed (see clause 11.3.1).

The procedures are either initiated by the ME (internal applications or MMI) or interfaced from the SwMI via the ME. In the latter case the ME provides only a delivery service with no other functionality than to interpret the PDUs if necessary.

11.4.1 Authentication procedures and generation of DCK

11.4.1.1 Mutual authentication requirement request

The SIM performs the read procedure with EF_{SEC} to determine whether a mutual authentication is requested by the SIM in case of a SIM authentication request from the SwMI.

11.4.1.2 SIM authentication

The ME runs the TA11/12 ALGORITHM, followed by a GET RESPONSE to obtain the RES1. If and only if the SIM requests a mutual authentication (see clause 11.4.1.1), the ME runs then the GET CHALLENGE, followed by the TA21/22 ALGORITHM. If the authentication was successful, it finally runs the TB4 ALGORITHM to obtain DCK.

11.4.1.3 SwMI authentication

The ME runs the GET CHALLENGE function, followed by the TA21/22 ALGORITHM. If and only if the SwMI requests a mutual authentication, the ME runs the TA11/12 ALGORITHM, followed by a GET RESPONSE to obtain the RES1. If the authentication was successful, it finally runs the TB4 ALGORITHM to obtain DCK.

11.4.2 TETRA OTAR key computation (CCK, GCK, SCK)

The CCK, GCK and SCK cipher keys can be updated by OTAR. They are sent over the air interface in sealed format and need to be unsealed on receipt by algorithms on the SIM.

SCK and CCK are accessible from the SIM-ME interface but GCK is accessible only in modified format (MGCK).

11.4.2.1 CCK distribution

On receipt of a new SCCK from the SwMI, the ME checks the validity of the CCK-ID received from the SwMI, calculates the record number to be updated and then runs the TA32 ALGORITHM to update EF_{CCK} .

11.4.2.2 CCK changeover

When the ME detects a new CCK-ID in use it determines the record number in EF_{CCK} which contains the new CCK-ID.

11.4.2.3 GCK distribution

The ME analyses EF_{GSSIS} and EF_{GSSID} to locate the required GTSI. If the GTSI is not already present, the ME allocates a free record number in the EF_{GSSID} and there places the new GTSI.

The ME checks whether there is a GCK (and MGCK) associated with the GTSI by accessing the appropriate GCK record number data element in EF_{GRDS} or EF_{GRDD} . If there is no such associated GCK, then a free record in EF_{GCK} is allocated (see note below), and the corresponding target record number in EF_{GRDS} or EF_{GRDD} is updated accordingly.

In the case where there was already a GCK (and MGCK) present, the ME identifies whether the new GCK-VN is valid by comparing it to the GCK-VN being stored currently in the appropriate record of EF_{MGCK} . If it is not valid the procedure is aborted.

The ME then runs the TA82 ALGORITHM to update the respective GCK. After this, the ME runs the TA71 ALGORITHM on this particular GCK to obtain the corresponding MGCK. For this operation, the current CCK (the one being indicated on the broadcast channel) is used.

NOTE: To allocate a free record in EF_{GCK} the ME reads EF_{GRDS} and EF_{GRDD} and works out if there is a record in EF_{GCK} which is not presently pointed to by any GCK record pointer.

11.4.2.4 SCK distribution

On receipt of a new SSCK from the SwMI, the ME identifies whether the new SCK-VN is valid by comparing it to the one being stored currently. If it is not valid the procedure is aborted. Then the ME runs the TA41/52 ALGORITHM in order to unseal the SCK and store it in that record of EF_{SCK} , which is indicated by the SCKN.

11.4.3 ITSI request

The ME performs the reading procedure with EF_{ITSI} .

11.4.4 ITSI disabling/re-enabling

See also EN 300 392-7 [4].

Permanent disabling:

On receiving the ITSI permanent disable command the ME selects EF_{ITSI} and shall then immediately run the SwMI authentication procedure defined in clause 11.4.1.3. If the SwMI is successfully authenticated then the invalidate procedure is performed on EF_{ITSI} . The TETRA session is immediately terminated (see note).

Temporary disabling:

On receiving the ITSI temporary disable command the ME selects $EF_{ITSIDIS}$ and shall then immediately run the SwMI authentication procedure defined in clause 11.4.1.3. If the SwMI is successfully authenticated then the ME performs the update procedure with $EF_{ITSIDIS}$ to set the flag to "temporarily disabled" (see note).

Re-enabling:

On receiving the ITSI enable command the ME selects $EF_{ITSIDIS}$ and shall then immediately run the SwMI authentication procedure defined in clause 11.4.1.3. If the SwMI is successfully authenticated then the updating procedure is performed on $EF_{ITSIDIS}$ to set the flag to "not disabled".

NOTE: It is an implementation issue for the SIM to deny access to further sensitive EFs (such as group identities and air interface encryption keys) if the ITSI is temporarily or permanently disabled.

11.5 Subscription related procedures

The procedures listed in this clause are only executable if the associated services, which are optional, are provided in the SIM. However, if the procedures are implemented, it shall be in accordance with the requirement stated in this clause. If a procedure is related to a specific service indicated in the SIM service table, it shall only be executed if the corresponding bit denoting this service as "available" (see EF_{SST}). In all other cases this procedure shall not start.

11.5.1 Username request

- Requirement: Service no.16 "available".
- Request: The ME performs the reading procedure with EF_{UNAME} .
- Update: The ME performs the updating procedure with EF_{UNAME} .

11.5.2 ITSI temporarily disabled enquiry

- Request: The ME performs the reading procedure with $EF_{ITSIDIS}$.
- Update: The ME performs the updating procedure with $EF_{ITSIDIS}$.

11.5.3 Subscriber class request

- Request: The ME performs the reading procedure with EF_{SCT} .
- Update: The ME performs the updating procedure with EF_{SCT} .

11.5.4 Void

11.5.5 Group identity information

The following procedures apply to both static (EF_{GSSIS}) and dynamic (EF_{GSSID}) groups with the exceptions mentioned in the following clauses.

11.5.5.1 Static Group identity information

- Request: The ME performs the reading procedure with EF_{GSSIS} .

11.5.5.2 Dynamic Group identity information

- Request: The ME performs the reading procedure with EF_{GSSID}.
- Erasure: The ME identifies the record in EF_{GSSID} containing the GSSID to be erased and marks it as free.

Update/invalidate:

The ME selects EF_{GSSID} and shall then immediately run the SwMI authentication procedure defined in clause 11.4.1.3. If the SwMI is successfully authenticated then the update or invalidate procedure is performed on EF_{GSSID}.

The update and erasure of EF_{GSSID} requires the updating of the network table. The handling procedures of the network table (EF_{NWT}) are defined under clause 11.6.

11.5.6 Group related data

The following procedures apply to both static and dynamic group related data (EF_{GRDS} and EF_{GRDD}).

- Request: The ME performs the reading procedure with EF_{GRDS} or EF_{GRDD}.
- Update: The ME performs the updating procedure with EF_{GRDS} or EF_{GRDD}.

NOTE: A record in EF_{GRDS} or EF_{GRDD} is free when the associated record in EF_{GSSIS} or EF_{GSSID} is marked free.

11.5.7 User's group information

- Request: The ME performs the reading procedure with EF_{GINFO}.
- Update: The ME performs the updating procedure with EF_{GINFO}.

The update of the file is performed in the beginning of a group call.

The update of this file requires the updating of the network table. The handling procedures of the network table (EF_{NWT}) are defined under clause 11.6.

11.5.8 Call modifiers

- Requirement: Service no.26 "available".
- Request: The ME performs the reading procedure with EF_{CMT}.
- Update: The ME performs the updating procedure with EF_{CMT}.

11.5.9 Service Provider Name

- Requirement: Service no.14 "available".
- Request: The ME performs the reading procedure with EF_{SPN}.

11.5.10 DMO channel procedures

- Requirement: Service no.27 "available".
- Request: The ME performs the reading procedure with EF_{DMOCh}.
- Update: The ME performs the updating procedure with EF_{DMOCh}.

- Erasure: The ME erases the contents of the record in EF_{DMOCh} by filling the record with 'FF'.

11.5.11 Emergency addresses

- Request: The ME performs the reading procedure with EF_{EADDR}.
- Update: The ME performs the updating procedure with EF_{EADDR}.
- Erasure: The ME erases the contents of the record in EF_{EADDR} by filling the b1 to b4 in the record with 1.

11.5.12 Interrupted emergency call request

- Request: The ME performs the reading procedure with EF_{EINFO}.
- Update: The ME performs the update procedure with EF_{EINFO}.

NOTE: If an emergency call was in progress when the ME was powered down the current emergency call record number, if non-zero, indicates that an emergency call procedure was in progress when the ME was powered down. The ME should recognize the non-zero value as an indication to take action as necessary to restart the emergency call after authentication.

11.6 Network related procedures

- Request: The ME performs the reading procedure with EF_{NWT}.
- Update: The ME checks whether the network address to be stored is already present. If so, the record pointer counter of the found network address record is increased by one.

If the address is not found on the network table, a new record is added to the network table and the corresponding record pointer counter is set to one.
- Erasure: The record on the network table is deleted (indicated as free by filling it with "FF"s).

11.6.1 Forbidden networks

- Request: The ME performs the reading procedure with EF_{FORBID}.
- Update: The ME performs the updating procedure with EF_{FORBID}.
- Erasure: The ME can erase the whole contents of the Forbidden networks. The action can either be initiated by the ME or the MMI. In case of erasure, the whole table of Forbidden addresses will be erased i.e. marked free by filling them with "FF"s.

11.6.2 Preferred networks

- Requirement: Service no.15 "available".
- Request: The ME performs the reading procedure with EF_{PREF}.
- Update: The ME performs the updating procedure with EF_{PREF}.

11.7 Dialling number related procedures

The procedures listed in this clause are only executable if the associated services, which are optional, are provided in the SIM. However, if the procedures are implemented, it shall be in accordance with the requirement stated in this clause. If a procedure is related to a specific service indicated in the SIM service table, it shall only be executed if the corresponding bit denoting this service as "available" (see EF_{SS}T). In all other cases this procedure shall not start.

11.7.1 Dialling numbers under DF_{TETRA}

The following procedures may be applied to EF_{ADNGWT} and its associated extension file EF_{GWTEXT1} as described in the procedures below. The procedures also refer to EF_{FDNGWT}, EF_{LNDGWT}, EF_{SDNGWT}, EF_{ADNTETRA}, EF_{FDNTETRA}, EF_{LNDTETRA} and EF_{SDNTETRA} and their associated extension files. If these files are not available, as denoted in the SIM service table, the current procedure shall be aborted and the appropriate EFs shall remain unchanged.

As an example, the following procedures are described as applied to ADNGWT.

- Requirement: Service no.3 "available".
- Request: The ME sends the identification of the information to be read. The ME shall analyse the data of EF_{ADNGWT} (see clause 10.3.26) to ascertain whether additional data is associated in EF_{GWTEXT1}. If necessary, the ME performs the reading procedure on EF_{GWTEXT1} and EF_{GW}T to assemble the complete ADNGWT.
- Update: The ME analyses and assembles the information to be stored as follows:
 - i) the ME identifies the record containing the Name to be updated;
 - ii) the dialling number (and/or Supplementary service access string in case of ADNTETRA) shall be allocated to the bytes of the EF as follows:
 - If the dialling number contains 16 or less "digits", it shall be stored in "number".
 - If the dialling number contains more than 16 "digits", the procedure shall be as follows:

The ME seeks for a free record in EF_{GWTEXT1}. If no Extension1 record is marked as "free", the procedure is aborted.

When a free Gateway Extension1 record is found, the first 16 "digits" are stored in the "number". The value of the "Length of number contents" is set to the maximum value, which is 16. The Gateway Extension1 record number in EF_{ADNGWT} is coded with the associated record number in the EF_{GWTEXT1}. The remaining digits are stored in the selected Gateway Extension1 record. The first byte of the Gateway Extension1 record is set with the number of digits of the remaining data. Further gateway extension records can be added up to the full length of the dialling string by chaining records in Gateway Extension1. The total number of digits is the sum of the "Length of number contents" of EF_{ADNGWT} and byte 2 of all associated chained Gateway Extension1 records containing data;

Example of a chain of gateway extension records being associated to an ADNGWT or LNDGWT is presented in figure 66. The Gateway Extension1 record number of ADNGWT or LNDGWT is set to 3.

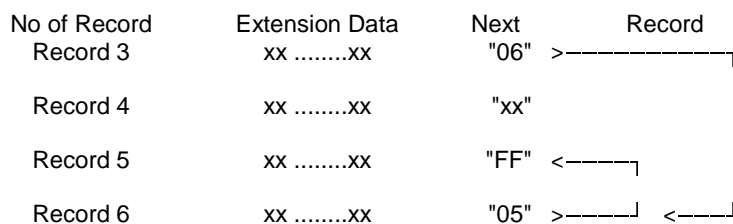

Figure 66: Gateway extension chain

- iii) the ME seeks the gateway address in EF_{GWT}. If it is not already in the table a new entry is created. If a new entry cannot be created, the procedure is aborted. When the entry is available the ME updates the Gateway address record number in EF_{ADNGWT} to the associated record in EF_{GWT};
- iv) the ME chooses a proper call modifier in EF_{CMT}.

When i), ii), iii) and iv) have been successfully executed the ME performs the updating procedure with EF_{ADNGWT}.

NOTE: If the SIM does not have available empty space to store the received ADN, or if the procedure has been aborted, the ME advises the user.

Erasure: The ME sends the identification of the information to be erased. The content of the identified record in EF_{ADNGWT} is marked as "free". Furthermore, the associated records in EF_{GWT} and EF_{GWTEXT1} are updated accordingly.

11.7.2 Dialling numbers under DF_{TELECOM}

The following procedures may be applied to EF_{ADN} and its associated extension file EF_{EXT1} as described in the procedures below, and also to EF_{FDN}, EF_{LND}, EF_{SDN} and their associated extension files. If these files are not available, as denoted in the SIM service table, the current procedure shall be aborted and the appropriate EFs shall remain unchanged.

As an example, the following procedures are described as applied to ADN.

- **Requirement:** Service no. 36 "available".
- **Request:** The ME sends the identification of the information to be read. The ME shall analyse the data of EF_{ADN} (see clause 10.4.1) to ascertain whether additional data is associated in EF_{EXT1}. If necessary, the ME performs the reading procedure on EF_{EXT1} and reading of default gateway SSI from EF_{GWT} to assemble the complete ADN.
- **Update:** The ME analyses and assembles the information to be stored as follows (subscriber has chosen to store ADN to the general EF_{ADN} under DF_{TELECOM}):
 - i) the ME identifies the record containing the Name to be updated;
 - ii) the dialling number shall be allocated to the bytes of the EF as follows:
 - if a "+" is found, the TON identifier is set to "International";
 - if the dialling number contains 20 or less "digits", it shall be stored in "Dialling Number/SSC String";
 - if the dialling number contains more than 20 "digits", the procedure shall be as follows:

The ME seeks for a free record in EF_{EXT1}. If no Extension1 record is marked as "free", the procedure is aborted.

When a free Extension1 record is found, the first 20 "digits" are stored in the Dialling Number/SSC String. The value of the "Length of BCD number/SSC contents" is set to the maximum value, which is 11. The Extension1 record number in EF_{ADN} is coded with the associated record number in the EF_{EXT1}. The remaining digits are stored in the selected Extension1 record. The first byte of the extension data in EF_{EXT1} (second byte of Extension1 record) is set with the number of digits of the remaining data. Further extension records can be added up to the full length of the dialling string by chaining records in Extension1. The total number of digits is the sum of the "Length of BCD number/SSC contents" of EF_{ADN} and byte 2 of all associated chained extension data records containing data;

iii) If a called party subaddress is associated to the ADN/SSC the procedure shall proceed as follows:

If the length of the called party subaddress is less than or equal to 11 bytes (see TS 100 940 [11] for coding):

- the ME seeks for a free record in EF_{EXT1}. If an Extension1 record is not marked as "free", the ME runs the Purge procedure. If an Extension1 record is still unavailable, the procedure is aborted;
- the ME stores the called party subaddress in the Extension1 record, and sets the Extension1 record type to "called party subaddress".

If the length of the called party subaddress is greater than 11 bytes (see TS 100 940 [11] for coding):

- the ME seeks for two free records in EF_{EXT1}. If no such two records are found, the ME runs the Purge procedure. If two Extension1 records are still unavailable, the procedure is aborted;
- the ME stores the called party subaddress in the two Extension1 records. The identifier field in the Extension1 record containing the first part of the subaddress data is coded with the associated EF_{EXT1} record number containing the second part of the subaddress data. Both Extension1 record types are set to "called party subaddress".

Once i), ii), and iii) have been considered the ME performs the updating procedure with EF_{ADN}. If the SIM has no available empty space to store the received ADN/SSC, or if the procedure has been aborted, the ME advises the user.

- Erasure: The ME sends the identification of the information to be erased. The content of the identified record in EF_{ADN} is marked as "free". Furthermore, the associated records in EF_{EXT1} are updated accordingly.
- Purge: The ME shall access each EF which references EF_{EXT1} (EF_{EXT2}) for storage and shall identify records in these files using extension data (additional data or called party subaddress). Note that existing chains have to be followed to the end. All referred Extension1 (Extension2) records are noted by the ME. All Extension1 (Extension2) records not noted are then marked by the ME as "free".

11.7.3 FDNGWT specific procedures

Requirement: Service no. 5 "available".

If FDN is enabled (i.e. EF_{ADNGWT} is invalidated or not present) the ME shall operate in a restricted mode where only those phone numbers contained in EF_{FDN} and EF_{FDNGWT} are used.

If FDNTETRA is enabled (i.e. EF_{ADNTETRA} is invalidated or not present) the ME shall operate in a restricted mode where only those phone numbers contained in EF_{FDNTETRA} are used.

Both modes FDN and FDNTETRA can be enabled independently of each other.

ADNGWT and FDNGWT are mutually exclusive of each other and independent of the state of ADNTETRA and FDNTETRA. Likewise, ADNTETRA and FDNTETRA are mutually exclusive of each other and independent of the state of ADNGWT and FDNGWT. This means that there may be restricted ADNGWT phonebook operation or restricted TETRA phonebook operation and these are independent of each other.

The following three procedures are only applicable to service no.4 (FDNTETRA) no.5 (FDNGWT). As an example, the following procedures are described as applied to FDNGWT.

11.7.3.1 FDNGWT capability request

To ascertain the state of FDNGWT, the ME checks in EF_{SSST} whether or not ADNGWT is activated. If ADNGWT is not activated, service no.5 is enabled. If ADNGWT is activated, the ME checks the response data EF_{ADNGWT}. If EF_{ADNGWT} are invalidated, service no.5 is enabled. In all other cases service no.5 is disabled.

11.7.3.2 FDNGWT disabling

The FDNGWT disabling procedure requires that PIN2 verification procedure has been performed successfully and that ADNGWT is activated. If not, FDNGWT disabling procedure will not be executed successfully. To disable FDNGWT capability, the ME rehabilitates EF_{ADNGWT} . The invalidate/rehabilitate flag of EF_{ADNGWT} , which are set by the REHABILITATE command, is at the same time the indicator for the state of the service no.5. If ADNGWT is not activated, disabling of FDNGWT is not possible and thus service no.5 is always enabled (see FDNGWT capability request).

11.7.3.3 FDNGWT enabling

The FDNGWT enabling procedure requires that PIN2 verification procedure has been performed successfully. If not, FDNGWT enabling procedure will not be executed successfully. To enable FDNGWT capability, the ME invalidates EF_{ADNGWT} . The invalidate/rehabilitate flag of EF_{ADNGWT} , which is set by the INVALIDATE command, is at the same time the indicator for the state of the service no.5 (see FDNGWT capability request). If ADNGWT is not activated, service no.5 is always enabled.

Invalidated ADNGWTs may optionally still be readable and updatable depending on the file status (see clause 9.4).

11.8 Status and short data message procedures

The procedures listed in this clause are only executable if the associated services, which are optional, are provided in the SIM. However, if the procedures are implemented, it shall be in accordance with the requirement stated in this clause. If a procedure is related to a specific service indicated in the SIM service table, it shall only be executed if the corresponding bit denoting this service as "available" (see EF_{SST}). In all other cases this procedure shall not start.

11.8.1 Display of status message texts

- Requirement: Service no.22 "available".
- Request: The SIM selects EF_{STXT} and searches for the identified status message value. If the message value is found it performs the reading procedure with EF_{STXT} .

11.8.2 Display of SDS1 message texts

- Requirement: Service no.23 "available".
- Request: The SIM selects EF_{MSGTXT} and searches for the identified status message value. If the message value is found it performs the reading procedure with EF_{MSGTXT} .

11.8.3 Storage of status and SDS messages types 1, 2 and 3

- Requirement: Service no.24 "available".
- Request: The SIM selects EF_{SDS123} and searches for the identified status or SDS message. If this message is found, the ME performs the reading procedure with EF_{SDS123} .
- Update: The ME looks for the next available area to store the status or SDS message in EF_{SDS123} . If such an area is available, it performs the updating procedure with EF_{SDS123} .

If there is no available empty space in the SIM to store the received short message, the ME advises the user.
- Erasure: The ME selects EF_{SDS123} and identifies the records to be erased. Then it performs the update procedure to mark them as free.

NOTE: Depending on the ME, the message may be read before the record is marked as "free". After performing the updating procedure with EF_{SDS123} , the memory allocated to this short message in the SIM is made available for a new incoming message. The memory of the SIM may still contain the old message until a new message is stored in that area.

11.8.4 Storage of SDS messages type 4

- Requirement: Service no.25 "available".
- Request: The SIM selects EF_{SDS4} and searches for the identified short message. If this message is found, the ME performs the reading procedure.
- Update: The ME looks for the next available area to store the short message in EF_{SDS4} . If such an area is available, it performs the updating procedure with EF_{SDS4} .

If there is no available empty space in the SIM to store the received short message, the ME advises the user.
- Erasure: The ME selects EF_{SDS4} and identifies the records to be erased. Then it performs the update procedure to mark them as free.

NOTE: Depending on the ME, the message may be read before the record is marked as "free". After performing the updating procedure with EF_{SDS123} , the memory allocated to this short message in the SIM is made available for a new incoming message. The memory of the SIM may still contain the old message until a new message is stored in that area.

11.8.5 SDS delivery report

- Requirement: Service number 32 "available".
- Request: If the status of a stored short message indicates that there is a corresponding status report, the ME performs the seek function with EF_{SDSR} to identify the record containing the appropriate status report. The ME performs the reading procedure with EF_{SDSR} .
- Update: If the status report is received, the ME first seeks within the SDS record identifiers of EF_{SDSR} for the same record number it used for the short message in EF_{SDS4} . If such a record identifier is found in EF_{SDSR} , it is used for storage. If such a record identifier is not found, then the ME seeks for a free entry in EF_{SDSR} for storage. If no free entry is found, the ME runs the Purge procedure with EF_{SDSR} . If there is still no free entry, the status report is not stored.

If the ME found an appropriate record in EF_{SDSR} for storage, it updates the record with the status report setting the record identifier in EF_{SDSR} to the appropriate record number of the short message in EF_{SDS4} .

The status in EF_{SDS4} is updated accordingly (see clause 10.3.42) by performing update procedure with EF_{SDS4} .
- Erasure: The ME runs the update procedure with EF_{SDSR} by storing "00" in the first byte of the record.
- Purge: The ME shall read the SDS record identifier (byte 1) of each record of EF_{SDSR} . With each record the ME checks the corresponding SDS message in EF_{SDS4} . If the status of the corresponding SDS is not equal to "status report requested, received and stored in EF_{SDSR} " the ME shall perform the erasure procedure with the appropriate record in EF_{SDSR} .

11.8.6 Default Status Target

- Requirement: Service number 31 "available".
- Request: The ME checks whether a destination address has been specified if not then the ME performs the read procedure with $EF_{DFLTSTSTGT}$.
- Update: The ME runs the update procedure with $EF_{DFLTSTSTGT}$.

Annex A:
Void

Annex B (informative): FDN Procedures

The FDN facility allows operation of the TETRA terminal in a restricted state whereby it can only initiate calls to a pre-determined destination or list of destinations.

A TETRA SIM may be personalized so that the terminal can be operated in only the restricted state, only the unrestricted state or to allow the operation mode to be switched between states through the MMI.

FDN services:

Two FDN services are provided for the TETRA SIM. Service number 4 allows fixed dialling to other TETRA addresses while service number 5 allows fixed dialling to destinations on a PABX or the PSTN. These services may be individually or jointly enabled as indicated in the SIM service table.

The SIM service table provides an enable/disable indicator for each of the two FDN services to indicate to the ME the capabilities of the SIM. Where the SIM service table indicates that the SIM is capable of both ADN and FDN services, the operating state can be switched as described below.

FDN operation:

When the ME is operating in the restricted FDN state, the user may only call destinations listed in the FDN directories EF_{FDN} (service no 5) and/or EF_{FDNTETRA} (service no 4). Attempts to call other destinations shall be rejected by the ME, other than those initiated by activation of the emergency call procedures.

FDN initialization:

When a TETRA session is initialized, the ME should check the SIM service table for the state of the FDN services. If neither service is enabled, the ME should enter the unrestricted operation state, offering facilities as otherwise indicated in the SIM service table.

If either of the FDN services are enabled in the SIM service table, the ME should further check the entries for ADN (service no 2) and ADNTETRA (service no. 3). If neither ADN service is enabled the ME should enter the restricted FDN operation state.

If both ADN and FDN services are enabled in the SIM service table, the operation mode may be determined by the validity of EF_{ADN} . If EF_{ADN} is invalidated, the ME should enter the restricted FDN operation state. If EF_{ADN} is not invalidated, the ME should enter the unrestricted state.

Change of FDN operation mode:

Where the SIM Service Table indicates that a SIM supports both FDN and unrestricted modes of operation, the validity of the file EF_{ADN} provides the indicator as to the current operating state as described above.

The ME may provide an MMI operation to allow toggling of the operation state by performing invalidation or rehabilitation of EF_{ADN} . This procedure can only be performed after successful completion of the PIN2 verification procedure to satisfy the access rights for EF_{ADN} .

Change of FDN access details:

The ME may provide a method on the MMI to change entries in the FDN directories, thereby changing the list of call destination when the ME is operating in the restricted state. This procedure can only be performed after successful completion of the PIN2 verification procedure to satisfy the access rights for update to EF_{FDN} .

Annex C (informative): Suggested contents of EFs at pre-personalization

If EFs have an unassigned value, it may not be clear from the main text what this value should be after conclusion of the manufacturing phase and prior to personalization of initial usage. This annex suggests values in these cases in tables C.1 to C.3.

The values stored in EF_{CCK}, EF_{SCK}, EF_{GCK} and EF_{MGCK} may only be changed using the appropriate OTAR algorithms in the TAA1 set. The initial values to be stored may be assigned by the network operator and loaded during the manufacturing phase. If particular values are not assigned it is suggested that these files are populated with a null value, "00 ... 00".

C.1 Contents of the EFs at the MF level

Table C.1: Contents of the EFs at the MF level after pre-personalization

File Identification	Description	Value
EF _{ICCID}	Card identification	Operator dependent (see clause 10.2.1)
EF _{DIR}	Application directory	"FF...FF"
EF _{LP}	Language preference	Operator dependent (see clause 10.2.3)

C.2 Contents of the EFs at the TETRA application level

Table C.2: Contents of the EFs at the TETRA application level after pre-personalization

File Identification	Description	Value
EF _{AD}	Administrative Data	See clause 10.3.50
EF _{ADNGWT}	Abbreviated Dialling Number with Gateway	"FF...FF"
EF _{ADNTETRA}	Abbreviated Dialling Numbers for TETRA network	"FF...FF"
EF _{ARR}	Access Rule Reference	
EF _{CCK}	Common Cipher Key	Operator dependent (see clause 10.3.7)
EF _{CCKLOC}	CCK Location Areas	Operator dependent (see clause 10.3.8)
EF _{CMT}	Call modifier table	"FF...FF"
EF _{DFLTSTSTGT}	Default Status Target	"FF...FF"
EF _{DIALSC}	Dialling schemes for TETRA network	"FF...FF"
EF _{DMOCH}	DMO Channel Information	"FF...FF"
EF _{DMO_DEP}	Default encryption parameters	"FF...FF"
EF _{DMO_GRDS}	Group related data for DMO static GSSIs	Operator dependent (see clause 10.3.65), else "FF...FF"
EF _{DMO_GSSIS}	DMO pre-programmed group numbers	Operator dependent (see clause 10.3.64), else "FF...FF"
EF _{DNWRK}	Broadcast network information	"00...00"
EF _{EADDR}	Emergency address	"FF...FF"
EF _{EINFO}	Emergency call information	"00"
EF _{EXTA}	Extension A	"FF...FF"
EF _{FDNGWT}	Fixed Dialling Number with Gateway	"FF...FF"
EF _{FDNTETRA}	Fixed Dialling Numbers for TETRA network	"FF...FF"
EF _{FORBID}	Forbidden networks table	Operator dependent (see clause 10.3.18), else "FF...FF"

File Identification	Description	Value
EF _{GCK}	Group Cipher Keys	Operator dependent (see clause 10.2.14)
EF _{GINFO}	User's group information	Operator dependent (see clause 10.3.16), else "00 00FF...FF FF 00 FF FF FF"
EF _{GRDD}	Group related data for Dynamic GSSIs	"FF...FF"
EF _{GRDS}	Group related data for Static GSSIs	Operator dependent (see clause 10.3.11), else "FF...FF"
EF _{GSKO}	Group Session Key	"FF...FF"
EF _{GSSID}	Dynamic GSSIs	"FF...FF"
EF _{GSSIS}	Pre-programmed GSSIs	Operator dependent (see clause 10.2.10)
EF _{GDMO_GTMO}	DMO - TMO selected group association	"FF...FF"
EF _{GTMO_GDMO}	TMO - DMO selected group association	"FF...FF"
EF _{GWT}	Gateway Table	Operator dependent (see clause 10.3.24), else "FF...FF"
EF _{GWTEXT1}	Gateway Extension1	"FF...FF"
EF _{GWTEXT2}	Gateway Extension2	"FF...FF"
EF _{GWTEXT3}	Gateway Extension3	"FF...FF"
EF _{ITSI}	ITSI	Operator dependent (see clause 10.3.2)
EF _{ITSIDIS}	ITSI Disabled	"00"
EF _{KH}	List of Key Holders	See clause 10.3.48
EF _{LNDCOMP}	Composite LND file	"FF...FF"
EF _{LNDGWT}	Last Number Dialed with Gateway	"FF...FF"
EF _{LNDTETRA}	Last Number Dialed for TETRA network	"FF...FF"
EF _{MGCK}	Modified Group Cipher Keys	Operator dependent (see clause 10.3.15)
EF _{MSCH}	MS allocation of DMO channels	"FF...FF"
EF _{MSGEXT}	Message Extension	"FF...FF"
EF _{MSGTXT}	SDS-1 message texts	"FF...FF"
EF _{NWT}	Network table	1 st record operator dependent (see clause 10.3.24), else "FF...FF"
EF _{PHASE}	Phase identification	"01"
EF _{PNI}	Private Number Information	"FF...FF"
EF _{PREF}	Preferred networks table	Operator dependent (see clause 10.3.19), else "FF...FF"
EF _{PREF_LA}	Preferred Location Areas	"FF...FF"
EF _{REPGATE}	DMO repeater and gateway list	"FF...FF"
EF _{SCAN}	Scan list files	
EF _{SCAND}	Scan list data	
EF _{SCK}	Static Cipher Key	Operator dependent (see clause 10.3.9)
EF _{SCT}	Subscriber class table	Operator dependent (see clause 10.3.5)
EF _{SDNGWT}	Service Dialling Numbers with Gateway	"FF...FF"
EF _{SDNTETRA}	Service Dialling Numbers for TETRA network	"FF...FF"
EF _{SDS123}	Status and SDS type 1, 2 and 3 message storage	"FF...FF"
EF _{SDS4}	SDS type 4 message storage	"FF...FF"
EF _{SDSMEM_STATUS}	SDS Memory Status	
EF _{SDSP}	SDS Parameters	"FF...FF"
EF _{SDSR}	SDS delivery report	"00...00"
EF _{SPN}	Service Provider Name	"FF...FF"

File Identification	Description	Value
EF _{SST}	SIM Service Table	Operator dependent (see clause 10.3.1), else "00...00"
EF _{STXT}	Status message texts	Operator dependent (see clause 10.3.39)
EF _{UNAME}	Username	"FF...FF"
EF _{WELCOME}	Welcome message	Operator dependent (see clause 10.3.55), else "FF...FF"

C.3 Contents of the EFs at the Telecom Level

Table C.3: Contents of the EFs at the Telecom level after pre-personalization

File Identification	Description	Value
EF _{ADN}	Abbreviated Dialling Numbers	"FF...FF"
EF _{FDN}	Fixed Dialling Numbers	"FF...FF"
EF _{MSISDN}	MSISDN	"FF...FF"
EF _{LND}	Last Number Dialed	"FF...FF"
EF _{SDN}	Service Dialling Numbers	"FF...FF"
EF _{EXT1}	Extension1	"FF...FF"
EF _{EXT2}	Extension2	"FF...FF"
EF _{EXT3}	Extension3	"FF...FF"

Annex D (normative): Database structure for group IDs and phone books

Use of the network table:

Relational database mechanisms are used to save a significant amount of memory. Several EFs (e.g. EF_{GSSIS} and EF_{GSSID}) refer to the Network table for network address instead of saving it with each group short subscriber identity. However, since a network address can be referenced from more than one place, a record pointer counter is needed to keep track of how many times a network address is referenced. When the record pointer counter of a network address is one, it is referenced from only one place. When that address is removed, the corresponding network address can be removed also, since it was the only one using it. This housekeeping method is used to remove unnecessary network addresses from the network table. Refer to figure D.1.

The network table is thus handled using the following procedures:

- When a network address needs to be stored with a record, the network table (EF_{NWT} see clause 10.3.23) needs to be read. If the address (MCC and MNC) is already found on the network table, the Record pointer counter of the found network address record needs to be increased by one. Only the record number of the network address on the network table is stored with the record that needs the network address.
- If the address is not found on the network table, a new record needs to be added to the network table. On the network table the new network address (MCC and MNC) is stored along with a record pointer counter, which is set to one. Only the record number of the network address on the network table is stored with the record that needs the network address.
- If the desired network address is not found in the network table, and it cannot be added because of the file being full, the new network address cannot be stored on the SIM.
- If a record that uses a network address in the network table needs to be deleted, the network table also needs to be updated. The record that needs to be updated can be found using the record number. The record number is stored with the record that is to be deleted. When the record in the network table is found, the record pointer counter is read. If the value of the counter is 2 or higher, the counter is decreased by one and the record that referenced it can be deleted.
- If the record pointer counter is 1, the whole record on the network table can be deleted (indicated as free by filling it with "FF"s) along with the record that pointed to that record.

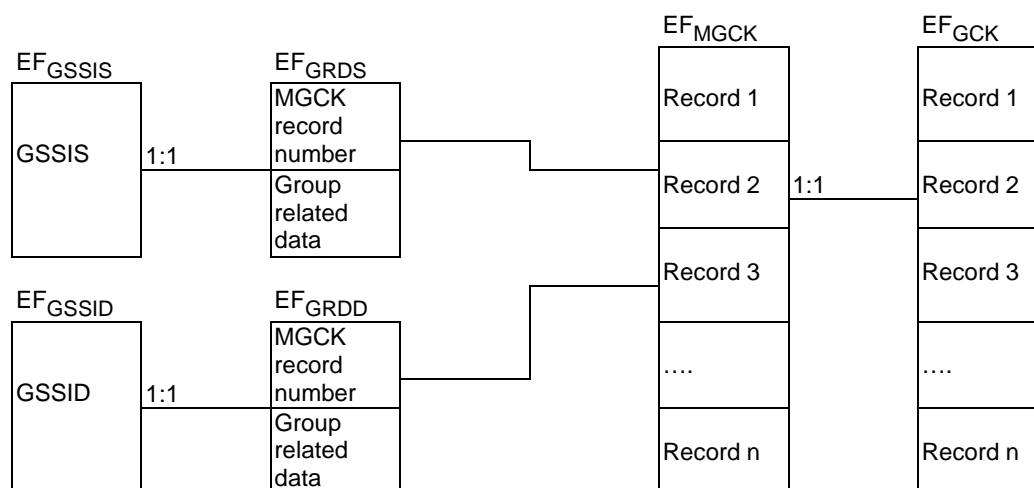

Figure D.1: Graphical presentation of group data related EF structures

Figure D.2 shows how records in phonebook related EFs can point to records in other phonebook related EFs.

NOTE: Each of the 8 phonebooks (ADNGWT, LNDGWT, FDNGWT, SDNGWT, ADNTETRA, LNDTETRA, FDNTETRA and SDNTETRA) may point to EF_{CMT}, which is not shown on the diagram.

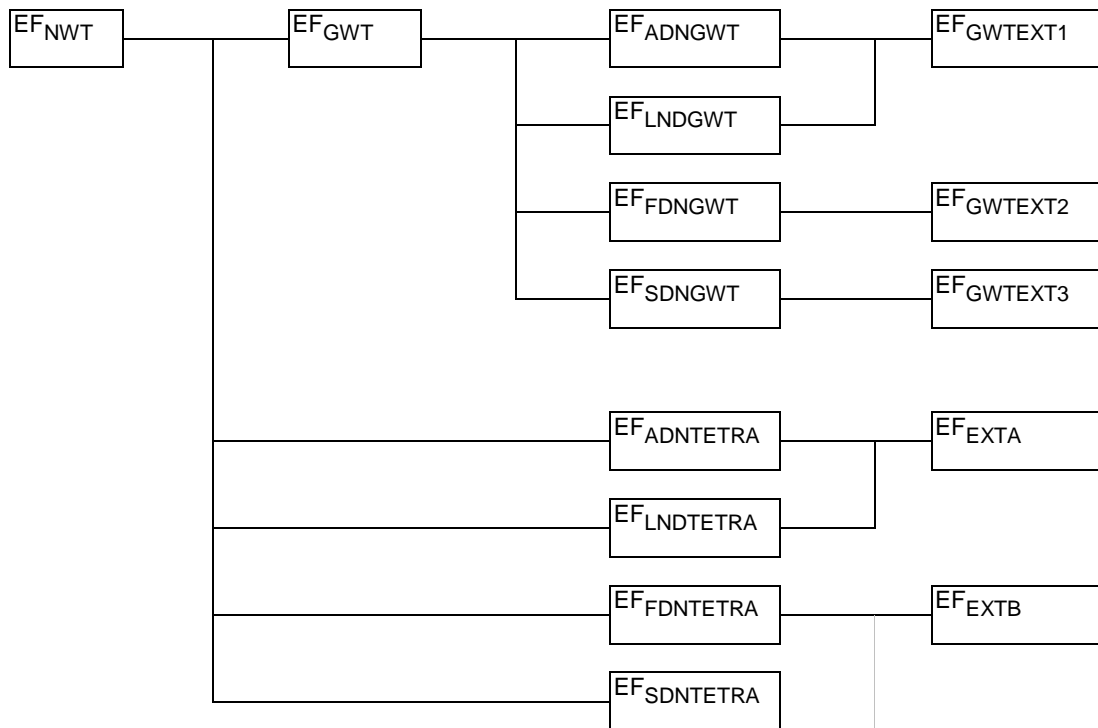

Figure D.2: Graphical presentation of phonebook related EF structures

Annex E (informative): Emergency call facilities and procedures

The TETRA standards provide a wide variety of call types and facilities which may be used in an emergency situation. The activation of an emergency facility is implementation-specific and so the file content defined for the TETRA SIM card is intended to offer flexibility in handling emergency situations. This annex offers further explanation of the information available to the ME in handling an emergency situation.

Emergency call control:

The EF_{EINFO} contains a control flag to indicate to the whether or not emergency calls are enabled for this particular card.

Emergency call addresses:

The EF_{EADDR} contains a list of call destinations for use in an emergency call. Entries in the file can require that the call be placed to either the last group in which the ME took part or to a pre-defined destination. When the file contains more than one address, it is suggested that the order of the records in the file should indicate the order of preference for the call, starting with the highest preference.

Each record in EF_{EADDR} also contains a number of flags providing an indication as to the type of the call address, allowing a mix of call types to be indicated. The call type can be one of a selection of 10 variants, including all of the common speech calls and short data transactions. For circuit mode calls, a data field indicates the nature of the required call i.e. individual, group, acknowledged group or broadcast.

When the emergency call type is a status or short data transaction, an additional option is selected by a flag which may be used to indicate a preference as to the source of the data to be transferred in an emergency message. When the pre-defined value stored in the card is selected, a record number pointer indicates EF_{SDS123} or EF_{SDS4} which contain both the destination and message content. When the "application" source is selected, it is suggested that the contents of the data field would be obtained by an application running in the ME.

Protection for interrupted emergency calls:

The EF_{EINFO} contains a flag indicating the action to be taken on power-on after an interrupted emergency call - to optionally resume the emergency call without further operator intervention.

Where EF_{EINFO} indicates that an interrupted emergency call should be continued next time the ME is powered up, the ME should maintain the current emergency call index in EF_{EINFO} during any emergency call procedure. In particular, the index should be set by the ME to a value to be understood by the restarting ME as the call is initiated and zeroed on normal termination. The index allows the restarting ME to establish that an emergency transaction was in progress and, from the index, which of the available call options to restart. The coding of the index is implementation-dependant but is dimensioned so that it can be used as a pointer to a record number in EF_{EADDR} if required.

Successful connection of an emergency call:

It is suggested above that the ME should attempt to set up the emergency call to each of the destinations prescribed in EF_{EADDR} until a successful connection is achieved.

It should, however, be noted that not all call types provide a definite indication of success. An unacknowledged group call, for example, may succeed in establishing a "call" but it is possible that no other member of the group could be available and so the result would be no exchange of useful information. For PABX or PSTN voice calls, call routing beyond the TETRA infrastructure may not be able to return a definite indication of a successful exchange to the originating terminal and so a call to an unanswered or engaged number could result. The implementation of the emergency facility may take account of this possibility in controlling the emergency call.

Emergency calls in Direct Mode:

When an emergency call record in EF_{EADDR} requires the use of direct mode, the implementation may handle the possibility of the required party being on one of a multiplicity of DMO channels. The record in EF_{EADDR} includes a field to indicate a channel number explicitly. It is suggested that a zero channel number could cause the ME to use the flags provided in EF_{DMOCh} which designate a channel for emergency use in attempting to set up the call.

Emergency calls when the SIM card is not fitted:

Where the ME is not equipped with a SIM interface, or the SIM is absent, it must still be possible, for some applications, to make an emergency call.

Annex F (informative): Composite List of Last Dialed Numbers

Each phonebook has a distinct file holding a list of Last Numbers Dialed (LND). When a subscriber initiates a call in a particular mode, the called number is written to the corresponding LND file. Table F.1 summarizes the link between the handset mode, phonebook elementary file and the LND elementary file.

Table F.1

Mode	Phonebook	Last Number Dialed
PSTN	EF _{ADN}	EF _{LND}
PABX	EF _{ADNGWT}	EF _{LNDGWT}
PRIVATE	EF _{ADNTETRA}	EF _{LNDTETRA}
GROUP	EF _{GSSIS} /EF _{GSSID}	Non-existent

The navigation of the MMI may be simplified for the user if only one (composite) list of Last Dialed Numbers is maintained to permit the user to review the Last Numbers Dialed in reverse chronological order. The composite LND file enables this functionality to be offered because each mode (except GROUP) has a distinct LND file and entries in these files are not timestamped and therefore cannot be sorted in time.

Operation of EF_{LNDComp}:

The composite LND file is updated with a pointer to the relevant individual LND file when a call is originated. The pointer includes the file identifier and record number for the relevant LND file.

The relationship between the files is shown in figure F.1.

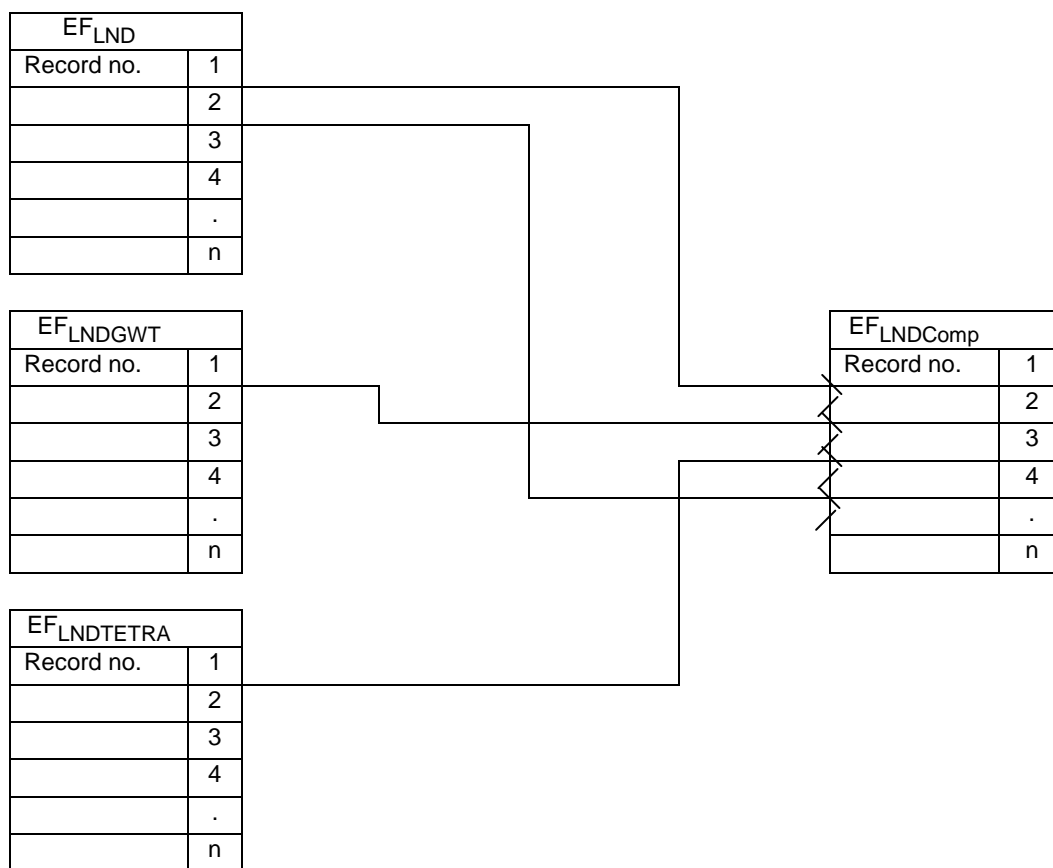

Figure F.1: Graphical representation of relationship between the LND files

It is recommended that a maximum file length equal to the length of one of the individual LND files is used. The reasoning is that if $EF_{LNDComp}$ is longer than one of the individual LND files it will be quicker to find the original dialling number in the phone books.

Annex G (informative): Bibliography

- CEN EN 726-3: "Terminal Equipment (TE); Requirements for IC cards and terminals for telecommunication use - Part 3: Application independent card requirements".
- CEN EN 726-4: "Terminal Equipment (TE); Requirements for IC cards and terminals for telecommunication use - Part 4: Application independent card related terminal requirements".

Annex H (informative): Change requests

The present document contains Change Requests as described in the table H.1.

NOTE 1: The Change Requests CR201 to CR214 are originally drafted for EN 300 812 and for that reason "CHV1" in the Change Requests are in the present document "PIN1".

NOTE 2: Many of the clause numbers in the EN 300 812 are one less than in present version of the ES 200 812-2. The clause numbers of the Change Requests are adapted to ones of the present document.

Table H.1: Change Requests

CR No	CR vers	Version	Remarks	Clauses affected	Title	CR Status
201	10	V2.2.2	Already in version V2.2.2. Only reference to ISO/IEC 8859-1 added.	10.3.24	Elementary file EF_GWT, Gateway Table. [CR149 note]	WG7 approved 021112
202	10	V2.2.2	Already in version V2.2.2	10.3.2, 10.3.3 and 10.3.12	CR150 change to ADCH questioned, new solution	WG3 approved 030227
203	20	V2.2.2	Already in version V2.2.2	10.3.17	Change to EF_SEC file in order to support class 2 and class 3	WG7 approved 021112
204	10	V2.2.2	<i>Superseded by CR214.</i>	10.3.1, 10.3.63, 10.3.64, 10.3.65, 10.3.66, 10.5	Add support of DMO group call feature	WG7 approved 021112
205	10	V2.2.2	Already in version V2.2.2	10.3.10, 10.3.12	Add support of group hierarchy	WG7 Approved
206	10	V2.2.2	Already in version V2.2.2	10.3.1, 10.3.61, 10.3.62, 10.5	Add support of multiple group attachments feature as specified in the TETRA standard	WG7 approved
207	11	V2.2.2	Figure titles and references to new figures added	10.3.8	CCK Location areas (EF _{CCKLOC})	WG7 approved 021112
208	10	V2.2.2	Included	7.5	DCK storage	WG3 approved 030227
209	11	V2.2.2	Included (with corrections to version 1.0)	10.3.14	EF _{GCK} expanded to multiple groups	WG7 approved 021112
210	10	V2.2.2	Included as 10.3.69, table and figure headings added with references to those	New clause 10.3.68	Add GSKO definition to SIM	WG7 approved 021112
211	10	V2.2.2	-	7.3, 9.1.15, 9.1.1.7, 9.1.1.8, 9.1.1.9, 9.1.1.10, 9.2.1, 9.4.2, 10.3.15, 11.4.2.2 (clauses in EN 300 812: 7.2, 8.17.2, 9.2, 11.4.2.2)	Addition and updates of algorithms in SIM. Delete also EF _{MGCK}	WG3 approved 030613
212	10	V2.2.2	-	9.1.14, 9.2, 11.4.2.1	Update algorithm TA32	WG7 approved 021112 for EN 300 812, Modified applicable to ES 200 812-2 030606
213	10	V2.2.2	Included editorially modified.	10.3.16	Add some fields in EF_GINFO	WG7 approved 030127
214	REJ	V2.2.2	Substituted by CR215	(10.3.63, 10.3.64, 10.3.65, 10.3.66) Update of clause 10.3.1, 10.5	To add support of DMO Group call feature according to TETRA standard. Change to CR 204 – editorial errors	Approval expected
215	10	V2.2.2	-	10.3.65, 10.3.66, 10.3.67, 10.3.68	Changes due to CR214 for EN 300 812-3	WG3 approved 030603
216	10	V2.2.2	-	Annex C.1, C.2, C.3	Addition of missing files	WG3 approved 030603
217	10	V2.2.2	-	11.7.1	Typo in EFADNGWT in clause 11.7.1	WG3 approved 030613
218	10	V2.2.2	-	10.3.6	SIM phase coding	WG3 approved 030613
219	10	V2.2.2	-	11.2.1, 11.2.2	Remove reference to EFchv	WG3 approved 030620
220	REJ	V2.2.2	-	11.2.3	Updates on the SIM by the terminal upon Session termination	WG3 rejected 030620

History

Document history		
V2.2.1	April 2002	Publication
V2.2.2	September 2002	Publication as ES 200 812-2
V2.3.1	October 2003	Membership Approval Procedure MV 20031212: 2003-10-14 to 2003-12-12
V2.3.1	October 2003	Publication