

TS 101 113 V5.2.0 (1998-01)

Technical Specification

**Digital cellular telecommunications system (Phase 2+);
General Packet Radio Service (GPRS);
Service description;
Stage 1
(GSM 02.60 version 5.2.0)**

GSM®

GLOBAL SYSTEM FOR
MOBILE COMMUNICATIONS



European Telecommunications Standards Institute

Reference

RTS/SMG-010260QR1 (ab002io3.PDF)

Keywords

Digital cellular telecommunications system,
Global System for Mobile communications
(GSM), GPRS***ETSI Secretariat***

Postal address

F-06921 Sophia Antipolis Cedex - FRANCE

Office address

650 Route des Lucioles - Sophia Antipolis
Valbonne - FRANCE
Tel.: +33 4 92 94 42 00 Fax: +33 4 93 65 47 16
Siret N° 348 623 562 00017 - NAF 742 C
Association à but non lucratif enregistrée à la
Sous-Préfecture de Grasse (06) N° 7803/88

X.400

c= fr; a=atlas; p=etsi; s=secretariat

Internet

secretariat@etsi.fr
<http://www.etsi.fr>

Copyright Notification

No part may be reproduced except as authorized by written permission.
The copyright and the foregoing restriction extend to reproduction in all media.

Contents

Intellectual Property Rights.....	5
Foreword	5
1 Scope.....	6
2 Normative references	7
3 Definitions and abbreviations	8
3.1 Definitions.....	8
3.2 Abbreviations	14
4 Applicability.....	14
5 Description	14
5.1 GPRS reference model	15
5.1.1 Bearer services.....	16
5.1.2 Teleservices	16
5.1.3 GPRS Access Points	17
5.2 GPRS service description.....	17
5.2.1 Point-To-Point Connectionless Network Service (PTP-CLNS).....	18
5.2.2 Point-To-Point Connection Orientated Network Service (PTP-CONS)	18
5.2.3 Point-To-Multipoint (PTM) service overview	19
5.2.3.1 Identification of subscribers and subscriber groups in PTM	19
5.2.3.2 PTM Multicast (PTM-M) Description	20
5.2.3.3 PTM Group Call (PTM-G) Description.....	20
5.2.3.4 Geographical Area Definition	21
5.2.4 PTM-Multicast Operations and User Interface	21
5.2.4.1 PTM-M data transfer operation.....	21
5.2.4.2 PTM-M data cancel operation.....	22
5.2.4.3 PTM-M data status operation.....	23
5.2.5 PTM-Group-Call Operations and User Interface.....	24
5.2.5.1 PTM Group Administration	24
5.2.5.2 PTM Group Call service description.....	25
5.2.5.3 PTM-G call initiate operation	26
5.2.5.4 PTM-G call terminate operation	28
5.2.5.5 PTM-G call status operation	28
5.2.5.6 PTM-G join call operation	30
5.2.5.7 PTM-G leave call operation.....	30
5.2.5.8 PTM-G data transfer operation	32
5.3 Transfer Characteristics.....	32
5.4 Service characteristics	33
5.4.1 Subscriber profile	33
5.4.2 Quality of Service (QoS)	33
5.4.2.1 QoS parameter definitions.....	34
5.4.2.1.1 Service precedence (priority)	34
5.4.2.1.2 Reliability.....	34
5.4.2.1.3 Delay.....	34
5.4.2.1.4 Throughput.....	35
5.4.2.1.5 Scheduled repeated transmission.....	35
5.4.2.2 QoS profile - PTP and PTM-G	35
5.4.2.3 QoS profile - PTM-M	35
5.4.2.4 Monitor	36
5.4.3 Security services	36
5.4.4 Packet size	37
5.4.5 Capabilities of GPRS MS Classes	37
5.4.6 Subscriber roaming.....	38
5.4.7 Construction of GPRS subscriber numbers.....	38
5.4.8 Battery life extension	38

5.4.9	Format Of Message User Data.....	38
5.4.10	Charging aspects.....	38
5.4.10.1	PTP and IP-M charging information.....	38
5.4.10.2	PTM-M charging information.....	39
5.4.10.3	PTM-G charging information.....	39
5.4.10.4	Reverse Charging.....	39
5.4.11	Message Screening.....	39
5.4.11.1	Network controlled screening.....	39
5.4.11.2	Subscription controlled screening.....	39
5.4.11.3	User controlled screening.....	40
6	Normal procedures with successful outcome.....	40
6.1	Provision.....	40
6.2	Withdrawal.....	40
6.3	GPRS-Attach, GPRS-Detach.....	41
6.4	Registration.....	41
6.5	Erasure.....	42
6.6	Interrogation.....	42
6.7	Activation.....	42
6.8	De-activation.....	42
6.9	Invocation and operation.....	42
6.10	PIN and Password Management.....	43
7	Exceptional procedures.....	43
7.1	Provision.....	43
7.2	Withdrawal.....	43
7.3	Registration.....	43
7.4	Erasure.....	43
7.5	Interrogation.....	43
7.6	Activation.....	44
7.7	De-activation.....	44
7.8	Invocation and operation.....	44
7.9	PIN and Password management.....	44
8	Addressing.....	44
8.1	Point to Point services.....	44
8.2	Point to Multipoint services.....	44
8.3	Overview.....	44
9	Supplementary Services.....	45
9.1	GSM Phase 2 Supplementary Services.....	45
9.2	GPRS specific supplementary services.....	46
9.2.1	Barring of GPRS interworking profile(s) (BGIWP).....	46
10	Service interworking.....	46
11	Network interworking.....	46
11.1	Interworking with other data networks and other PLMNs.....	46
11.1.1	QoS when Interworking.....	47
11.1.2	Supplementary Services when interworking.....	47
11.2	GPRS Numbering Plan.....	47
11.3	Addressing and routing requirements.....	47
11.3.1	PTP network layer services.....	47
11.3.2	PTM services.....	47
11.4	Interworking for subscriber roaming.....	47
Annex A (Informative): Change history.....		48
History.....		49

Intellectual Property Rights

IPRs essential or potentially essential to the present document may have been declared to ETSI. The information pertaining to these essential IPRs, if any, is publicly available for **ETSI members and non-members**, and can be found in ETR 314: "*Intellectual Property Rights (IPRs); Essential, or potentially Essential, IPRs notified to ETSI in respect of ETSI standards*", which is available **free of charge** from the ETSI Secretariat. Latest updates are available on the ETSI Web server (<http://www.etsi.fr/ipr>).

Pursuant to the ETSI Interim IPR Policy, no investigation, including IPR searches, has been carried out by ETSI. No guarantee can be given as to the existence of other IPRs not referenced in ETR 314 (or the updates on <http://www.etsi.fr/ipr>) which are, or may be, or may become, essential to the present document.

Foreword

This ETSI Technical Specification has been produced by ETSI Special Mobile Group (SMG) of the European Telecommunications Standard Institute (ETSI).

In analogy with CCITT Recommendations I.130, the first stage of the following three level structure is used to describe the telecommunications services as provided by European public telecommunications operators:

- | | |
|---------|---|
| Stage 1 | is an overall service description, from the service subscriber's and user's standpoint; |
| Stage 2 | identifies the functional capabilities and information flows needed to support the service described in stage 1; and |
| Stage 3 | defines the signalling system protocols and switching functions needed to implement the service described in stage 1. |

This TS details the stage 1 aspects (overall service description) for the General Packet Radio Service (GPRS) on Global System for Mobile communications (GSM) networks.

1 Scope

This ETSI Technical Specification defines the stage one description of the General Packet Radio Service (GPRS) on Global System for Mobile communications (GSM) networks. Stage one is an overall service description, primarily from the service subscriber's and user's points of view, but does not deal with the details of the human interface itself. This TS includes information applicable to network operators, service providers and terminal, switch and data base manufacturers.

This TS contains the core requirements for the GPRS on GSM, which are sufficient to provide a complete service.

This TS also documents some additional requirements which may be implemented (but do not have to be implemented).

In addition, additional functionalities not documented in this TS may be implemented. The requirements of which are considered outside the scope of this TS and consequently outside the scope of the corresponding stage 2 and stage 3 TSs. This additional functionality may be on a network-wide basis, or particular to one or a group of users. Such additional functionality shall not compromise conformance to the core requirements of the service.

The interface between the Mobile Station (MS) and any external applications are outside the scope of this TS.

Charging principles are outside the scope of this TS, unless specific service requirements are stated. These requirements deal with the allocation of certain call charges to particular users.

A later phase of GPRS may include interworking with circuit switched networks (e.g. PSTN, ISDN) and may emulate certain circuit switched services. These aspects are outside the scope of this version of this TS.

NOTE: This specification includes requirements for GPRS phase 1 (Rel '97) and phase 2. The first phase of standards specified will provide a basic functional GPRS service. The second phase will complete the standardisation to meet all the GPRS requirements.

Phase 1 GPRS supports:

- PTP
- User Interworking for PTP TCP/IP.
- X.28 from MS to GGSN; X.25 from GGSN to external PDNs.

Internal Network Interfaces:

- **Gn** - GSN backbone network
- **Gb** - BSS to SGSN
- **Gr** - SGSN to HLR
- **Gp** - PLMN to PLMN (ie roaming)
- **Gs** - SGSN to MSC
- External Reference point **Gi** for connecting via **TCP/IP** and **X.25**
- Identities
- Security Issues - for PTP and roaming
- Charging Issues
- Operator Call Barring and Termination, Operator Call Screening
- PTM radio interface in preparation for phase 2.
- Anonymous access
- Support of SMS-MO and -MT via GPRS (note: SMS-CB not supported in phase 1).

2 Normative references

References may be made to:

- a) specific versions of publications (identified by date of publication, edition number, version number, etc.), in which case, subsequent revisions to the referenced document do not apply; or
- b) all versions up to and including the identified version (identified by "up to and including" before the version identity); or
- c) all versions subsequent to and including the identified version (identified by "onwards" following the version identity); or
- d) publications without mention of a specific version, in which case the latest version applies.

A non-specific reference to an ETS shall also be taken to refer to later versions published as an EN with the same number.

- [1] GSM 02.01: "Digital cellular telecommunications system (Phase 2+); Principles of telecommunication services supported by a GSM Public Land Mobile Network (PLMN)".
- [2] GSM 04.02: "Digital cellular telecommunications system (Phase 2+); GSM Public Land Mobile Network (PLMN) access reference configuration".
- [3] ITU-T Recommendation X.25: "Interface between data terminal equipment (DTE) and data circuit-terminating equipment (DCE) for terminals operating in the packet mode and connected to public data networks by dedicated circuit".
- [4] ISO 8208: "Information processing systems - data communications - X.25 packet level protocol for data terminal equipment".
- [5] ISO 8348: "Information processing systems - data communications - network service definition".
- [6] ISO 8473: "Information technology - protocol for providing the connectionless mode network service".
- [7] ISO 8878: "Information processing systems - data communications - use of X.25 to provide the OSI connection-mode network service".
- [8] Internet STD 5:RFC 791: Internet protocol, RFC 950: "Internet standard subnetting procedure", RFC 919: "Broadcasting internet datagrams", RFC 922: "Broadcasting internet datagrams in the presence of subnets", RFC 792: "Internet control message protocol", RFC 1112: "Host extensions for IP multicasting" RFC 1122:" Requirements for Internet hosts - communication layers". RFC 1920:" Internet official protocol standards", RFC 1458: "Requirements for multicast protocols", RFC 1301: "Multicast transport protocol".
- [9] ITU-T Recommendation X.3: "Packet Assembly/Disassembly facility (PAD) in a public data network".
- [10] ITU-T Recommendation X.28: "DTE/DCE interface for a start-stop mode Data Terminal Equipment accessing the Packet Assembly/Disassembly facility (PAD) in a public data network situated in the same country".
X.28 Add. 1 (7/94) Addendum 1 to Recommendation X.28 to enable MAP support in accordance with Recommendation X.8.
- [11] ITU-T Recommendation X.29: "Procedures for the exchange of control information and user data between a Packet Assembly/Disassembly (PAD) facility and a packet mode DTE or another PAD".
- [12] ITU-T Recommendation X.75: "Packet-switched signalling system between public networks providing data transmission services".
- [13] ITU-T Recommendation X.121: "International numbering plan for public data networks".

- [14] ITU-T Recommendation X.136: "Accuracy and dependability performance values for public data networks when providing international packet-switched services".
- [15] ITU-T Recommendation X.137: "Availability performance values for public data networks when providing international packet-switched services".
- [16] GSM 02.68 (ETS 300 925): "Digital cellular telecommunications system (Phase 2+); Voice Group Call Service (VGCS) - Stage 1".
- [17] GSM 02.06 (ETS 300 919): "Digital cellular telecommunications system; Types of Mobile Stations (MS)".
- [18] GSM 02.04 (ETS 300 918): "Digital cellular telecommunications system (Phase 2+); General on supplementary services".
- [19] GSM 02.30 (ETS 300 907): "Digital cellular telecommunications system (Phase 2+); Man-Machine Interface (MMI) of the Mobile Station (MS)".
- [20] GSM 02.17 (ETS 300 922): "Digital cellular telecommunications system; Subscriber Identity Modules (SIM) Functional characteristics".
- [21] GSM 03.68 (ETS 300 933): "Digital cellular telecommunications system (Phase 2+); Voice Group Call Service (VGCS) - Stage 2".
- [22] GSM 04.68 (ETS 300 948): "Digital cellular telecommunications system (Phase 2+); Group Call Control (GCC) protocol".

3 Definitions and abbreviations

3.1 Definitions

For the purposes of this TS the following definitions apply:

A

access delay: The value of elapsed time between an access request and a successful access (source: ITU-T X.140).

access protocol: a defined set of procedures that is adopted at an interface at a specified reference point between a user and a network to enable the user to employ the services and/or facilities of that network (source: ITU-T I.112).

accuracy: A performance criterion that describes the degree of correctness with which a function is performed. (The function may or may not be performed with the desired speed.) (source: ITU-T I.350).

B

basic service: The telecommunication services excluding the supplementary services (source: GSM 01.04).

bearer service: A type of telecommunication service that provides the capability for the transmission of signals between user-network interfaces (source: GSM 01.04, ITU-T I.112).

best effort service: A service model which provides minimal performance guarantees, allowing an unspecified variance in the measured performance criteria.

broadcast: A value of the service attribute "communication configuration", which denotes unidirectional distribution to all users (source: ITU-T I.113).

C

calling user: Entity which originates a call to the General Packet Radio Service (GPRS).

closed group: A group with a pre-defined set of members. Only defined members may participate in a closed group.

connectionless service: A service which allows the transfer of information among service users without the need for end-to-end call establishment procedures (source: ITU-T I.113).

connectionless-mode transfer:

"The terms 'message', 'datagram', 'transaction mode' and 'connection-free' have been used in the literature to describe variations on the same basic theme: the transmission of a unit of data in a single, self-contained operation without establishing, maintaining, and releasing a connection."

"(Connectionless-mode transmission) is the transmission of a single unit of data from a source service-access-point to one or more destination service-access-point(s) without establishing a connection. A connectionless-mode service allows an entity to initiate such a transmission by the performance of a single service access.

In contrast to a connection, an instance of the use of a connectionless-mode service does not have a clearly distinguishable lifetime. In addition, the connectionless-mode service, unless otherwise explicitly determined, has the following fundamental characteristics:

- a) no dynamic peer-to-peer agreement is involved in an instance of the service;
- b) all of the information required to deliver a unit of data (destination address, quality of service selection, options, etc.) is presented to the layer providing the connectionless-mode service, together with the user data to be transmitted, in a single service access. The layer providing the connectionless-mode service is not required to relate this access to any other service access.

As a result of these fundamental characteristics it may also be true that

- c) each unit of data transmitted is entirely self-contained and can be routed independently;
- d) copies of a unit of data can be transmitted to a number of destination addresses."

NOTE: **Connectionless-mode transfer** normally implies that the service a) does not provide confirmed delivery of SDUs, b) does not guarantee delivery of SDUs, c) does not guarantee maintenance of SDU sequencing and d) does not guarantee elimination of SDUs.

connection-mode transfer:

"A connection is an association established for the transfer of data between two or more peer-entities. This association is established between the peer-entities themselves and between each entity and the next lower layer. The ability to establish a connection and to transfer data over it is provided to the entities in a given layer by the next lower layer as a connection-mode service. An instance of the use of a connection-mode service by peer-entities proceeds through three distinct phases of operation:

- a) connection establishment;
- b) data transfer; and
- c) connection release."

NOTE: **Connection-mode transfer** normally implies that the service a) provides confirmed delivery of SDUs, b) provides ordered, in-sequence delivery of SDUs and c) will not duplicate SDUs.

conversational service: An interactive service which provides for bi-directional communication by means of real-time (no store-and-forward) end-to-end information transfer from user to user (source: ITU-T I.113).

D

demand service: A type of telecommunication service in which the communication path is established almost immediately, in response to a user request effected by means of user-network signalling (source: GSM 01.04, ITU-T I.112).

dependability: A performance criterion that describes the degree of certainty (or surety) with which a function is performed regardless of speed or accuracy, but within a given observational interval (source: ITU-T I.350).

destination user: Entity to which calls to the General Packet Radio Service (GPRS) are directed.

distribution service: Service characterised by the unidirectional flow of information from a given point in the network to other (multiple) locations (source: ITU-T I.113).

E

extra SDU delivery probability: The ratio of total (unrequested) extra service data units (SDUs) to total service data units received by a destination user in a specified sample (source: ITU-T X.140).

NOTE: the term "user information unit" has been replaced by the term "service data unit".

F

functional group: A set of functions that may be performed by a single equipment (source: ITU-T I.112).

G

geographical routing: The conversion of the PDU's geographical area definition, which specifies the area in which the PDU will be broadcast, into an equivalent radio coverage map.

group: A set of members allowed to participate in the group call service. The group is defined by a set of rules that identifies a collection of members implicitly or explicitly. These rules may associate members for the purpose of participating in a group call, or may associate members who do not participate in data transfer but do participate in management, security, control, or accounting for the group.

group call: The relationship that exists between the members of a group for the purpose of transferring data. More than one group call may exist in a group. A group call establishes an active group.

group call initiator: A member (or third party) authorised to initiate a group call. More than one member may initiate group calls.

group call participant: A member of a group participating in a particular group call at a given time.

group call server: A logical entity that provides the group call service to the members.

group call service: A PTM service in which a relationship exists between participants of the group, and in which a single data unit transmitted by a source participant is received by multiple destination participants; it is a one-in, many-out service.

group controller: The member (or third party) responsible for the group creation and membership control.

guaranteed service: A service model which provides highly reliable performance, with little or no variance in the measured performance criteria.

I

interactive service: A service which provides the means for bi-directional exchange of information between users. Interactive services are divided into three classes of services: conversational services, messaging services and retrieval services (source: ITU-T I.113).

interface: The common boundary between two associated systems (source: GSM 01.04, ITU-T I.112).

M

mean bit rate: A measure of throughput. The average (mean) bit rate available to the user for the given period of time (source: ITU-T I.210).

mean transit delay: The average transit delay experienced by a (typically) large sample of PDUs within the same service category.

messaging service: An interactive service which offers user-to-user communication between individual users via storage units with store-and-forward, mailbox and/or message handling, (e.g., information editing, processing and conversion) functions (source: ITU-T I.113).

mobile station: Equipment intended to access a set of GSM PLMN telecommunication services. Services may be accessed while the equipment capable of surface movement within the GSM system area is in motion or during halts at unspecified points (source: GSM 01.04).

mobile termination: The part of the mobile station which terminates the radio transmission to and from the network and adapts terminal equipment capabilities to those of the radio transmission (source GSM 01.04).

multicast service: A unidirectional PTM service in which a message is transmitted from a single source entity to all subscribers currently located within a geographical area. The message contains a group identifier indicating whether the message is of interest to all subscribers or to only the subset of subscribers belonging to a specific multicast group.

multipoint: A value of the service attribute "communication configuration", which denotes that the communication involves more than two network terminations (source: ITU-T I.113).

N

network connection: An association established by a network layer between two users for the transfer of data, which provides explicit identification of a set of network data transmissions and agreement concerning the services to be provided by the set (source: ITU-T X.213 / ISO-IEC 8348).

network operator: Entity which provides the network operating elements and resources for the execution of the General Packet Radio Service (GPRS).

network service data unit (NSDU): A unit of data passed between the user and the GPRS network across a Network Service Access Point (NSAP).

network termination: A functional group on the network side of a user-network interface (source: ITU-T I.112).

O

open group: A group that does not have a pre-defined set of members. Any user may participate in an open group.

P

packet: An information unit identified by a label at layer 3 of the OSI reference model (source: ITU-T I.113). A network protocol data unit (NPDU).

packet data protocol (PDP): Any protocol which transmits data as discrete units known as packets, e.g., IP, or X.25.

packet transfer mode: Also known as packet mode. A transfer mode in which the transmission and switching functions are achieved by packet oriented techniques, so as to dynamically share network transmission and switching resources between a multiplicity of connections (source: ITU-T I.113).

peak bit rate: A measure of throughput. The maximum bit rate offered to the user for a given time period (to be defined) for the transfer of a bursty signal (source: ITU-T I.210). (The maximum user information transfer rate achievable by a user for a single service data unit transfer.)

PLMN Operator: Public Land Mobile Network operator. The entity which offers a GPRS.

point-to-multipoint (PTM) service: A service type in which data is sent to "all service subscribers or a pre-defined subset of all subscribers" within an area defined by the Service Requester.

point-to-point (PTP): A value of the service attribute "communication configuration", which denotes that the communication involves only two network terminations.

point-to-point (PTP) service: A service type in which data is sent from a single network termination to another network termination.

predictive service: A service model which provides reliable performance, but allowing a specified variance in the measured performance criteria.

protocol: A formal set of procedures that are adopted to ensure communication between two or more functions within the within the same layer of a hierarchy of functions (source: ITU-T I.112).

protocol data unit (PDU): In the reference model for OSI, a unit of data specified in an (N)-protocol layer and consisting of (N)-protocol control information and possibly (N)-user data (source: ITU-T X.200 / ISO-IEC 7498-1).

Q

quality of service: The collective effect of service performances which determine the degree of satisfaction of a user of the service (ITU-T E.800). The set of performance parameters that can be directly observed and measured at the point at which the service is accessed by the user. There are three criteria by which performance is measured: speed, accuracy and dependability (source: ITU-T I.350).

R

reference configuration: A combination of functional groups and reference points that shows possible network arrangements (source: GSM 01.04, ITU-T I.112).

reference point: A conceptual point at the conjunction of two non-overlapping functional groups (source: GSM 01.04, ITU-T I.112).

residual error rate: A parameter describing service accuracy. The frequency of lost SDUs, and of corrupted or duplicated network SDUs delivered at the user-network interface.

retrieval service: An interactive service which provides the capability of accessing information stored in data base centres. The information will be sent to the user on demand only. The information is retrieved on an individual basis, i.e., the time at which an information sequence is to start is under the control of the user (source ITU-T I.113).

S

SDU error probability: The ratio of total incorrect service data units (SDUs) to total successfully transferred service data units plus incorrect service data units in a specified sample (source: ITU-T X.140).

NOTE: the source document term "user information unit" has been replaced by the term "service data unit".

SDU loss probability: The ratio of total lost service data units (SDUs) to total transmitted service data units in a specified sample (source: ITU-T X.140).

NOTE: the source document term "user information unit" has been replaced by the term "service data unit".

SDU misdelivery probability: The ratio of total misdelivered service data units (SDUs) to total service data units transferred between a specified source and destination user in a specified sample (source: ITU-T X.140).

NOTE: the source document term "user information unit" has been replaced by the term "service data unit".

SDU transfer delay: The value of elapsed time between the start of transfer and successful transfer of a specified service data unit (SDU) (source: ITU-T X.140).

NOTE: the source document term "user information unit" has been replaced by the term "service data unit".

SDU transfer rate: The total number of successfully transferred service data units (SDUs) in a transfer sample divided by the input/output time for that sample. The input/output time is the larger of the input time or the output time for the sample (source: ITU-T X.140).

NOTE: the source document term "user information unit" has been replaced by the term "service data unit".

service access point (SAP): In the reference model for OSI, the points through which services are offered to an adjacent higher layer (source: GSM 01.04, ITU-T X.200 / ISO-IEC 7498-1).

service attribute: A specified characteristic of a telecommunication service (source: ITU-T I.112).

NOTE: the value(s) assigned to one or more service attributes may be used to distinguish that telecommunications service from others.

service bit rate: The bit rate that is available to a user for the transfer of user information (source: ITU-T I.113).

service category or **service class:** A service offered to the users described by a set of performance parameters and their specified values, limits or ranges. The set of parameters provides a comprehensive description of the service capability.

service data unit (SDU): In the reference model for OSI, an amount of information whose identity is preserved when transferred between peer (N+1)-layer entities and which is not interpreted by the supporting (N)-layer entities (source: ITU-T X.200 / ISO-IEC 7498-1).

service delay: The time elapsed from the invocation of the service request, to the corresponding service request indication at the Service Receiver, indicating the arrival of application data.

service model: A general characterisation of services based upon a QoS paradigm, without specifying the actual performance targets.

service provider: Entity which offers the General Packet Radio Service (GPRS) for subscription. The network operator may be the service provider.

service receiver: The entity which receives the service request indication primitive, containing the SDU.

service request: This is defined as being one invocation of the service through a service request primitive.

service requester: The entity which requests the initiation of a GPRS operation, through a service request.

service subscriber: Entity which subscribes to the General Packet Radio Service (GPRS) service.

signalling: The exchange of information specifically concerned with the establishment and control of connections, and with management, in a telecommunications network (source: ITU-T I.112).

simultaneous use of services: The concurrent use of a GSM circuit-mode service (voice or data) and GSM packet-mode services (GPRS) by a single mobile station.

speed: A performance criterion that describes the time interval required to perform a function or the rate at which the function is performed. (The function may or may not be performed with the desired accuracy.) (source: ITU-T I.350).

supplementary service: A service that modifies or supplements a basic telecommunication service (as defined in GSM 01.04). It cannot be offered to a customer as a stand-alone service. It must be offered together or in association with a basic telecommunication service (bearer or teleservice). The same supplementary service may be common to a number of telecommunication services (source: ITU-T I.210).

T

teleaction service: A type of telecommunication service that uses short messages, requiring a low transmission rate, between the user and the network (source: ITU-T I.112).

telecommunication service: That which is offered by a PLMN operator or service provider to its customers in order to satisfy a specific telecommunication requirement. (source: GSM 01.04, ITU-T I.112). Telecommunication services are divided into two broad families: bearer services and teleservices (source: ITU-T I.210).

teleservice: A type of telecommunication service that provides the complete capability, including terminal equipment functions, for communication between users according to protocols established by agreement between Administrations (source: GSM 01.04, ITU-T I.112).

terminal equipment: Equipment that provides the functions necessary for the operation of the access protocols by the user (source: GSM 01.04). A functional group on the user side of a user-network interface (source: ITU-T I.112).

throughput: A parameter describing service speed. The number of data bits successfully transferred in one direction between specified reference points per unit time (source: ITU-T I.113).

transit delay: A parameter describing service speed. The time difference between the instant at which the first bit of a protocol data unit (PDU) crosses one designated boundary (reference point), and the instant at which the last bit of the PDU crosses a second designated boundary (source: ITU-T I.113).

U

user access or user network access: The means by which a user is connected to a telecommunication network in order to use the services and/or facilities of that network (source: GSM 01.04, ITU-T I.112).

user-network interface: The interface between the terminal equipment and a network termination at which interface the access protocols apply (source: ITU-T I.112).

user-user protocol: A protocol that is adopted between two or more users in order to ensure communication between them (source: ITU-T I.112).

V

variable bit rate service: A type of telecommunication service characterised by a service bit rate specified by statistically expressed parameters which allow the bit rate to vary within defined limits (source: ITU-T I.113).

3.2 Abbreviations

For the purposes of this TS the following definitions apply:

CLNP	Connectionless network protocol
CLNS	Connectionless network service
CONS	Connection-oriented network service
FFS	For further study
GPRS	General packet radio service
GSN	GPRS support node
IMGI	International mobile group identity
IP	Internet protocol
IP-M	Internet protocol multicast
NSDU	Network service data unit
PDP	Packet data protocol
PDU	Protocol data unit
PLMN	Public land mobile network
PTM	Point to multipoint
PTM-M	Point to multipoint – multicast
PTM-G	Point to multipoint – group call
PTP	Point to point
QoS	Quality of service
SAP	Service access point
SVC	Switched virtual circuit
SDU	Service data unit
TBD	To be defined
TLLI	Temporary link level identity

Additional GSM related abbreviations can be found in GSM 01.04 (ETR 350) [1].

4 Applicability

The GPRS is a set of new GSM bearer services that provides packet mode transmission within the PLMN and interworks with external networks. It is not a requirement that the GPRS be an extension of or an emulation of one or any of these non-GSM services or networks.

The GPRS shall not prevent the user's operation of other GSM services.

5 Description

The GPRS allows the service subscriber to send and receive data in an end-to-end packet transfer mode, without utilizing network resources in circuit switched mode.

GPRS enables the cost effective and efficient use of network resources for packet mode data applications e.g. for applications that exhibit one or more of the following characteristics:

- intermittent, non-periodic (i.e., bursty) data transmissions, where the time between successive transmissions greatly exceeds the average transfer delay;
- frequent transmissions of small volumes of data, for example transactions consisting of less than 500 octets of data occurring at a rate of up to several transactions per minute;

- infrequent transmission of larger volumes of data, for example transactions consisting of several kilobytes of data occurring at a rate of up to several transactions per hour.

Within the GPRS, two different bearer service types are defined. These are:

- Point-To-Point (PTP);
- Point-To-Multipoint (PTM).

Based on standardized network protocols supported by the GPRS bearer services, a GPRS network administration may offer (or support) a set of additional services. This is outside the scope of this specification, however, a number of possible PTP interactive teleservices include:

- retrieval services which provide the capability of accessing information stored in data base centres. The information is sent to the user on demand only. An example of one such service in the Internet's World Wide Web (WWW);
- messaging services which offer user-to-user communication between individual users via storage units with store-and-forward mailbox, and/or message handling (e.g., information editing, processing and conversion) functions;
- conversational services which provide bi-directional communication by means of real-time (no store-and-forward) end-to-end information transfer from user to user. An example of such a service is the Internet's Telnet application;
- tele-action services which are characterized by low data-volume (short) transactions, for example credit card validations, lottery transactions, utility meter readings and electronic monitoring and surveillance systems.

Some examples of teleservices which may be supported by a PTM bearer service include:

- distribution services which are characterized by the unidirectional flow of information from a given point in the network to other (multiple) locations. Examples may include news, weather and traffic reports, as well as product or service advertisements;
- dispatching services which are characterized by the bi-directional flow of information from a given point in the network (dispatcher) and other (multiple) users. Examples include taxi and public utility fleet services;
- conferencing services which provide multi-directional communication by means of real-time (no store-and-forward) information transfer between multiple users.

Capabilities that may be offered together with the PTM bearer services include:

- geographical routeing capability, which provides the ability to restrict message distribution to a specified geographical area;
- scheduled delivery capability, allowing store-and-forward type services to specify a future delivery time and a repetition rate.

It is possible to include these capabilities as part of the service request (i.e., as part of the packet). Some operators may offer PTM services only together with these capabilities.

5.1 GPRS reference model

The GPRS can be described using the simplified reference model in figure 1.

GPRS provides data transfer capabilities between a sending entity and one or more receiving entities. These entities may be an MS or a Terminal Equipment, the latter being attached either to a GPRS network or to an external data network. The base station provides radio channel access for MSs to the GPRS network. User data may be transferred between four types of MSs as described in GSM 02.01 [1] and GSM 04.02 [2]:

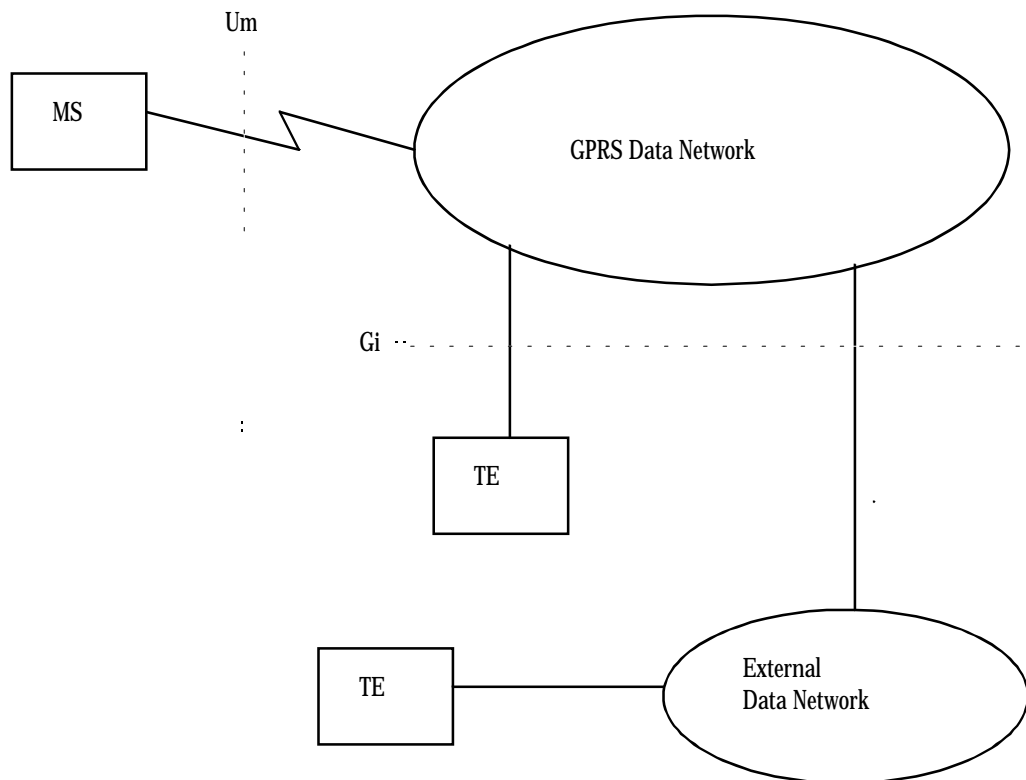

Figure 1: GPRS simplified reference model

5.1.1 Bearer services

The GPRS bearer services support the capability to transmit data between user-network access points (2, 4 and 7 in figure 2).

5.1.2 Teleservices

GPRS supports teleservices to provide complete communication service capabilities including the terminal equipment functions necessary for communication between network customers using the user-user protocols supported by the GPRS service provider(s) (see also GSM 02.01 [1]).

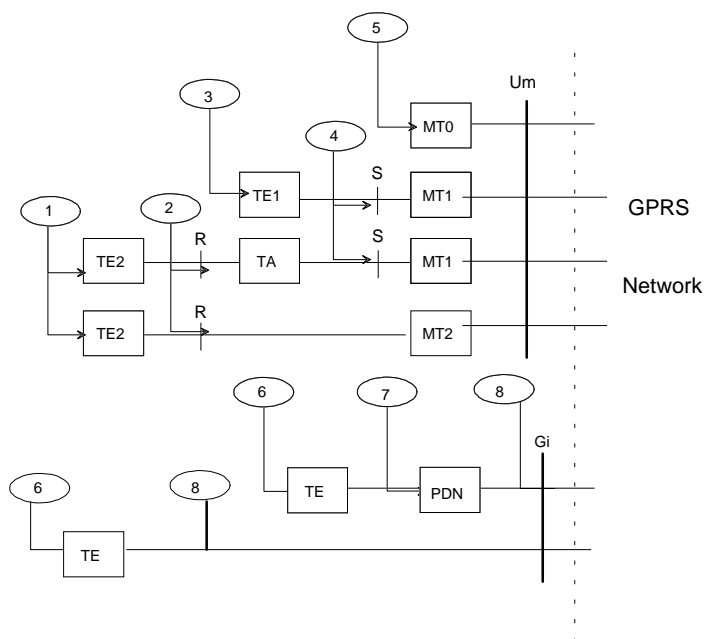

Figure 2: Telecommunication services access points

5.1.3 GPRS Access Points

Considering the reference configuration in figure 1, users can access various telecommunication services at different access points as shown in figure 2:

- at access points 1, 3, 5, and 6 (user-to-terminal interfaces), teleservices are accessed - the teleservice concept includes the terminal capabilities;
- at access point 2 (the R reference point), non-ISDN bearer services may be accessed, for example ITU-T X- and V-Series Recommendations;
- at access point 4 (the S reference point), ISDN compatible bearer services may be accessed;
- at access point 7 external data network bearer services may be accessed;
- access point 8 (the Gi reference point, which may not be identical for direct access and external data network access) provides bearer service access for direct access for a data terminal and/or for external data networks, for example X.25 networks.

5.2 GPRS service description

There are two categories of GPRS services:

- Point to Point (PTP) services,
- Point to Multipoint (PTM) services.

The PTP service provides a transmission of one or more packets between two users, initiated by a service requester and received by a receiver.

There are two PTP services:

- PTP Connectionless Network Service (PTP-CLNS);
- PTP Connection Orientated Network Service (PTP-CONS).

The PTM service provides a transmission of packets between a service requester and a receiver group.

There are three PTM services:

- PTM Multicast (PTM-M);
- PTM Group Call (PTM-G);
- IP Multicast (IP-M).

For PTM-M and PTM-G the data transmission is restricted to the members of a receiver group currently located within a geographical area. Both the receiver group and the geographical area are specified by the service requester.

The geographical area addressing mechanism is not applicable to IP-M.

An invocation of the service request by a service requester is possible from the fixed and mobile access points. Invocation and operation procedures (i.e., parallel sessions) are described in subclause 6.9.

Table 1 presents the relationship between service requests and the Service Requester/Receiver.

Table 1: Relationship of service request and service requester/receiver

Service requester/receiver AP = Access Point (see note 1)	Types of service request			
	PTP-CONS and PTP-CLNS	PTM-M	PTM-G	IP-M
From fixed AP to mobile AP	Supported	Supported	Supported	Supported
From mobile AP to mobile AP (see note 3)	Supported	Supported	Supported	Supported
From mobile AP to fixed AP	Supported	Not applicable	Supported (limited, see note 2)	Supported
NOTE 1: Mobile bearer services access points are 2 and 4 from figure 2. Fixed bearer service access points are 7 and 8.				
NOTE 2: All PTM-G features may not be supported for fixed AP, e.g., paging.				
NOTE 3: It shall be possible to transfer data between two mobiles of the same operator without the use of non-GSM external data networks.				

5.2.1 Point-To-Point Connectionless Network Service (PTP-CLNS)

Point-To-Point Connectionless Network Service (PTP-CLNS) is a service in which one (or more) single packet(s) is (are) sent from a single service subscriber "A" to a single destination user "B". Each packet is independent of the preceding and succeeding packet. This service is of the datagram type and is intended to support bursty applications. On the radio interface PTP-CLNS supports the acknowledged transfer mode for reliable delivery.

GPRS provides data communications services consistent with the connectionless network layer service definition ISO 8348 [5]. Specifically, GPRS shall be able to support applications based on the following network layer protocol:

- Internet Protocol (IP);
- IP is the network layer protocol of the Internet TCP/IP protocol suite defined by Internet STD 5 [8].

5.2.2 Point-To-Point Connection Orientated Network Service (PTP-CONS)

Point-To-Point Connection Orientated Network Service (PTP-CONS) is a service in which multiple packets are sent between a single service subscriber "A" and a single destination user "B". This service provides a logical relation between the users which may last between seconds to hours. The service is intended to support bursty transactive or interactive applications. On the radio interface PTP-CONS utilises the acknowledged transfer mode for reliable delivery.

GPRS provides data communications services consistent with the connection orientated network layer service definition ISO 8348 [5] and ISO 8878 [7]. This means that GPRS shall be able to support applications based on the following network layer protocol:

- Connection Orientated Network Protocol (CONP).

- CONP is the standard OSI connection orientated network protocol defined in ISO 8208 [4], i.e., the X.25 Packet Level Protocol for Data Terminal Equipment.

GPRS should provide the ability to maintain a connection orientated virtual circuit upon change of cell within a PLMN but not when transiting from one PLMN to another PLMN.

Any established SVC shall be released on irrecoverable failure of the radio data link.

5.2.3 Point-To-Multipoint (PTM) service overview

A PTM service is the transmission of a single message to multiple subscribers. The GPRS PTM services provide the capability for a subscriber to send data to multiple destinations with a single service request. Transmission shall be performed within the specified service delay, over one or more, geographical areas as defined by the service requester. Repeated transmission shall be performed where applicable according to the schedule as defined/negotiated by the service requester.

There are three PTM services:

- PTM - Multicast (PTM-M) in which messages are transmitted throughout the geographical area(s) as defined by the service requester. The message may be targeted to a specific receiver group or to "all subscribers" within the area. No knowledge of the instantaneous, actual receiver group members present within the given area at any point in time is required.
- PTM - Group Call (PTM-G) in which messages are transmitted to a specified receiver group within the geographical area(s) as defined by the service requester. The messages are transmitted only within cells which are known to contain participants of the specific receiver group. The network has knowledge of the instantaneous, actual group call participants present within the given area.
- IP Multicast (IP-M), which is a service defined as a part of the IP protocol suite. In IP-M messages are sent between participants of an IP-M group. An IP-M group can be internal to the PLMN or distributed across the Internet. Participation and data transfer in the IP-M service shall be compliant with the Internet protocols. See RFC 1920 [8], RFC 1458 [8], RFC 1301 [8] and RFC 1112 [8].

The Service Receiver of a point-to-multipoint service request shall be able to filter out packets at a network level, through use of the Packet Identities, which are of no interest either because they are for a service for which no subscription is held, or the packet belongs to a sub-group within the offered application service which is of no interest. It is required that the MS-Application resources shall not be utilized for this function.

Table 2: PTM Service Characteristics

Characteristics	PTM-M	PTM-G	IP-M
Primary addressing mechanism	specified geographical area	specified group of subscribers	specified group of subscribers
Secondary addressing mechanism	specified group of recipients	specified geographical area	no
Present subscribers known	no, recipients of messages are anonymous	yes, group members shall join the PTM-G call to become participants	yes, group members shall join the IP-M call to become participants.
Delivery time	according to specified scheduling	real time	real time
Direction of transmission	uni-directional	uni-directional bi-directional multi-directional	multi-directional
Reliable delivery	no	optional	acknowledged as normal IP PTP packets
Ciphering	no	yes	yes

5.2.3.1 Identification of subscribers and subscriber groups in PTM

For reasons of privacy and service management, the service requester shall be able to route PTM messages to a subset of all GPRS subscribers. This enables, for example, service providers to distinguish their application messages from the messages of other service providers using the same shared resource. A PTM group is identified by the International

Mobile Group Identity IMGID (see clause 8) which shall support two levels of identification: a service provider level and an application level. It shall be possible to store the IMGID on the SIM and in addition as an option in the ME. Adequate protection of the storage on the SIM and for the transmission over the radio interface is required. A SIM storage capacity of 50 (or more) IMGIDs and the capability to securely modify the IMGID via the SIM-Toolkit is required. The IMSI shall be used for authentication of the individual subscriber.

Similarly, the service receiver shall only receive, and use its resources to process messages from the underlying GPRS application to which it has subscribed.

In the following subclauses describing the PTM services references are made to "calling ID" and "called ID". Each of these terms indicate different forms of the same identity depending on "who" the receiver of the information is. For example a "calling ID" given to the network is the IMSI but the "calling ID" given to the called party is the MSISDN.

5.2.3.2 PTM Multicast (PTM-M) Description

PTM Multicast is a service in which the message is transmitted to all subscribers currently located within a geographical area. The message contains a group identifier (IMGID) indicating whether the message is of interest to all subscribers or to only the subset of subscribers belonging to a specific PTM group. The following characteristics define the PTM-M service:

- message distribution is to a specified geographical area defined by the service requester (messages may optionally be distributed throughout the entire PLMN);
- messages are addressed to a specified subscriber group (messages may optionally be addressed to all subscribers within the PLMN);
- message reception is anonymous, that is the network has no knowledge of which subscribers have received the message;
- the network has no knowledge of which subscribers (group members) are present within the geographical area;
- message scheduling options may be specified by the service requester, including a specific delivery time, a message repetition rate or a message repetition count, and quality of service parameters. Obsolete messages may be deactivated;
- service negotiation between the service requester and the PLMN operator shall be possible;
- adverse network conditions (e.g., congestion) may be notified to the service requester if necessary;
- message transfer is one-way (unidirectional), from a single service requester to multiple destination subscribers (receivers);
- message reception is unreliable, in that a particular subscriber is not guaranteed to correctly receive all PTM-M transmissions;
- increased message reliability may be provided as a QoS option and achieved by repeated transmission;
- the PTM-M service does not provide ciphering. Messages are transmitted without confidentiality. Data ciphering may be performed by the user or application prior to transmission, this is, however, outside the scope of this specification.

5.2.3.3 PTM Group Call (PTM-G) Description

PTM Group Call is a service in which the message is transmitted to a specific subset of subscribers (PTM group participants) currently located within a geographical area. The message may be transmitted only within cells known to contain PTM group participants. The following characteristics define the PTM Group Call service:

- Message distribution is to a specified geographical area defined by the sender (messages may optionally be distributed throughout the entire PLMN).
- Messages are addressed to a specified group.
- The network may not have knowledge of which participants have received the message.

- The network has knowledge of which participants are present within the geographical area.
- Message delivery is in real-time, that is messages are transmitted by the network as soon as possible following the receipt of a service request.
- Message transfer is by default one-way (unidirectional), but may optionally be two-way (bi-directional), or n-way (multi-directional). Two-way data transfer enables the group controller or initiator to send messages to the entire group (one to many), while other participants may send messages only to the group controller or initiator (many to one). N-way data transfer allows all participants to send and receive messages (many to many), as in a (voice) multiparty call.
- Message reception may be unreliable, in that a particular participant is not guaranteed to correctly receive all PTM-G transmissions. Reliable delivery may be optionally provided per group call, whereby individual participants are able to request the retransmission of lost or incorrectly received messages.
- Messages are transmitted or received only by group members which have explicitly joined the call by registering with the network.
- Messages are transmitted with confidentiality, that is data ciphering is performed prior to transmission, and only group members which have joined the call are able to cipher and decipher the transmitted data.

5.2.3.4 Geographical Area Definition

The PTM-M and PTM-G services allow a user to specify a geographical area within which data transfer will occur between the network and mobile subscribers. For PTM-G data transfers, the geographical area is specified by the group call initiator at call initiation. Optionally the sender of PTM-G data is able to specify a geographical area sub-set with a request for data transfer. For PTM-M data transfers, the geographical area is specified by the sender with each data transfer request. It shall be possible for the network operator and/or service provider to assign logical names to geographical areas, thus enabling a simplified service request in which the geographical area is described by the logical name. A logical name assigned by a PLMN operator is valid only within that operator's PLMN unless suitable roaming agreements exist.

The method used to specify and define the boundaries of a geographical area shall be based on geographical/terrestrial co-ordinates which are independent of the PLMN network infrastructure. The GPRS network maps the geographical area description onto a set of GSM cells to be used for transmission. Due to the nature of radio transmissions it is possible that some subscribers outside the defined geographical area boundaries may receive PTM data transmissions.

5.2.4 PTM-Multicast Operations and User Interface

Three operations shall be possible in the PTM-M services. These are:

- data transfer operation;
- data cancel operation;
- status operation.

5.2.4.1 PTM-M data transfer operation

The service user initiates the data transfer operation with a PTM-M-Data-Transfer-Request transmitted to the network. The request contains the following information:

- the calling identity;
- the subscriber group to whom the data is addressed;
- the geographical area over which the data is to be transmitted;
- the scheduling of repeated user data transmissions;
- the QoS associated with user data transmissions;
- the user data to be transmitted.

The network shall respond by either acknowledging the acceptance of the request or by rejecting the request. If the request is accepted the network shall provide a unique PTM transaction ID and may provide a logical name for the geographical area, these may be used in subsequent PTM operations related to this or further requests.

The network transmits the user data according to the request parameters.

The receiver receives the user data, calling ID and called group ID. No acknowledge is required.

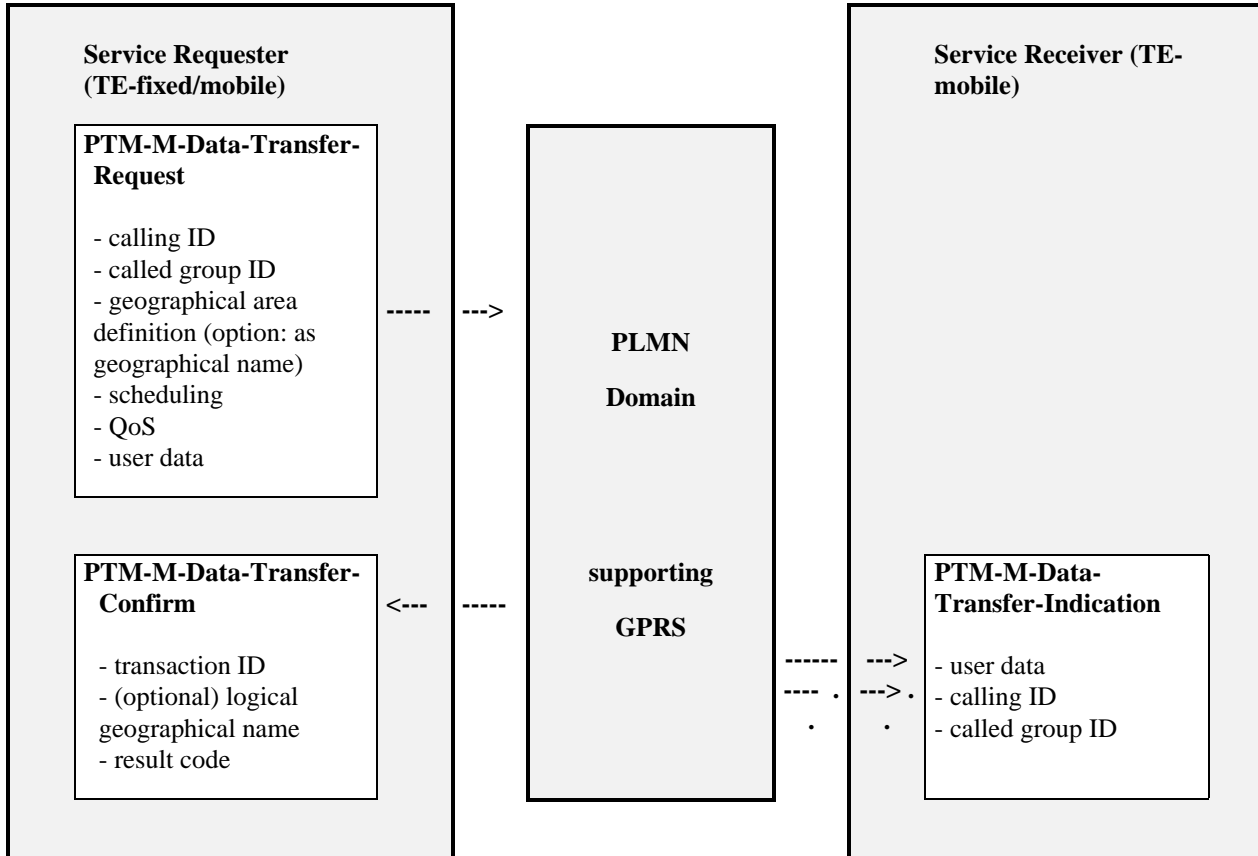

Figure 3: PTM-M data transfer operation

5.2.4.2 PTM-M data cancel operation

The service user performs this operation to prematurely stop a PTM data transfer operation before it has reached its scheduled completion. The PTM-M transaction ID shall be used to identify the initial data request operation. A cancel request shall also include the initiating user's ID for security reasons.

The network shall respond by either acknowledging the acceptance of the cancel-request or by rejecting the cancel-request. If the request is accepted the network shall provide a confirmation which contains the unique PTM-M transaction ID related to the data transfer request. All previously negotiated, scheduled, future transmissions associated with the initial data transfer request are not performed. All data within the network associated with the initial data request, except call and/or charging record information, shall be deleted. The inherent delay associated with performing the cancellation throughout the whole geographical area concerned may result in the transmission of a limited number of "unwanted" messages.

The receiver (of the data transfer operation) is not involved in the cancel operation.

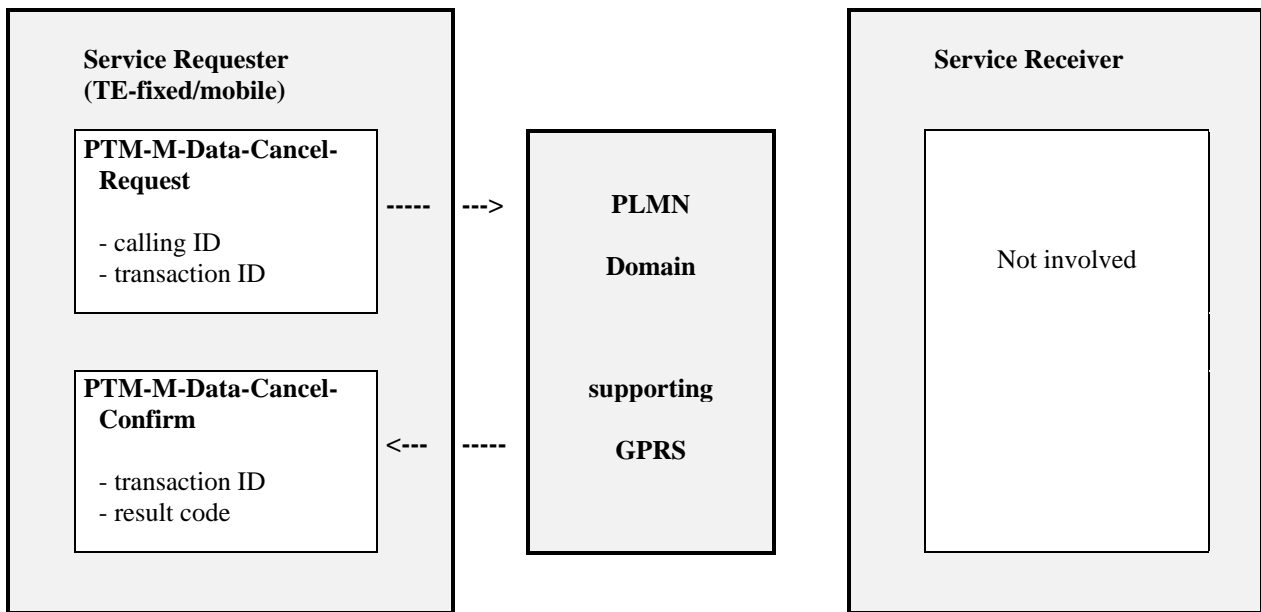

Figure 4: PTM-M data cancel operation

5.2.4.3 PTM-M data status operation

The service user performs the PTM-M-Data-Status-Request operation to obtain the progress of a PTM-M data transfer operation. The PTM-M transaction ID shall be used to identify the initial data request operation. The status request shall also include the initiating user's identity for security purposes.

The network shall respond by either acknowledging the acceptance of the status-request or by rejecting the status-request. If the request is accepted the network shall provide a confirmation which contains the unique PTM-M transaction ID related to the data transfer request and the present status information. The status information is returned within the PTM-M-Data-Status-Confirm response. Any previously negotiated scheduled transmissions associated with the initial data transfer request are not affected by a status request.

The receiver (of the data transfer operation) is not involved in the status operation.

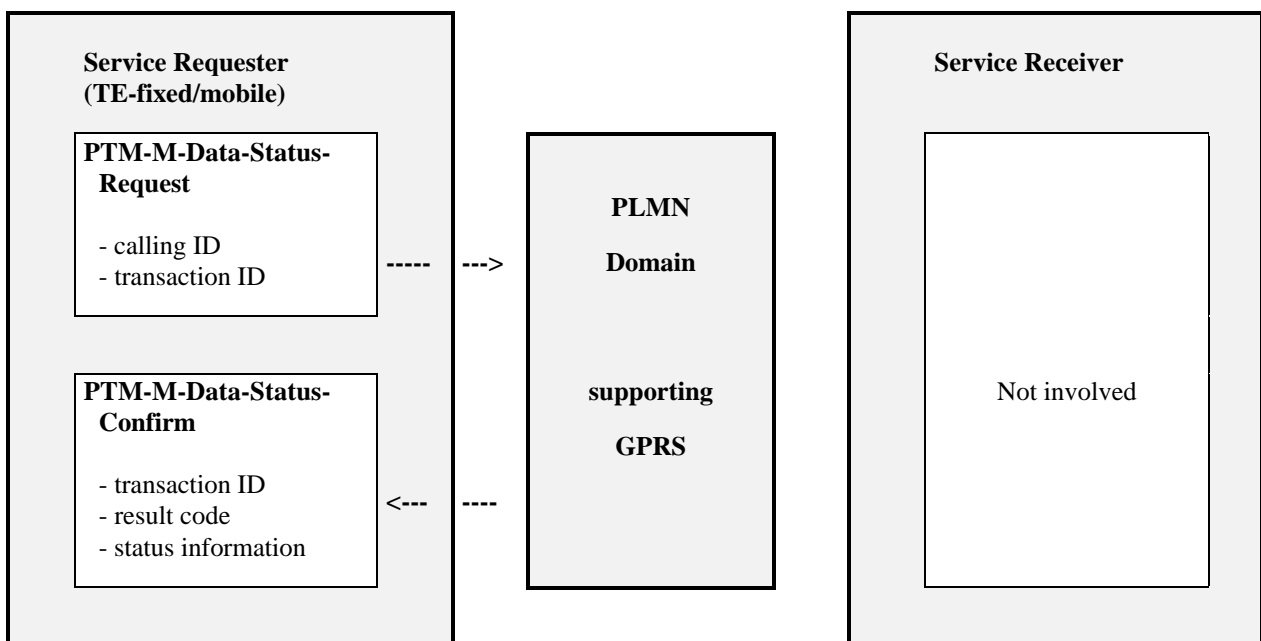

Figure 5: PTM-M data status operation

The network may also initiate this operation (without a status request from the user) by using the PTM-M-Data-Status-Indication. This shall be used to inform the initiating service user of a significant change in the status of an on-going data-transfer-operation (e.g., the network has "aborted" the data-transfer-operation due to adverse network conditions).

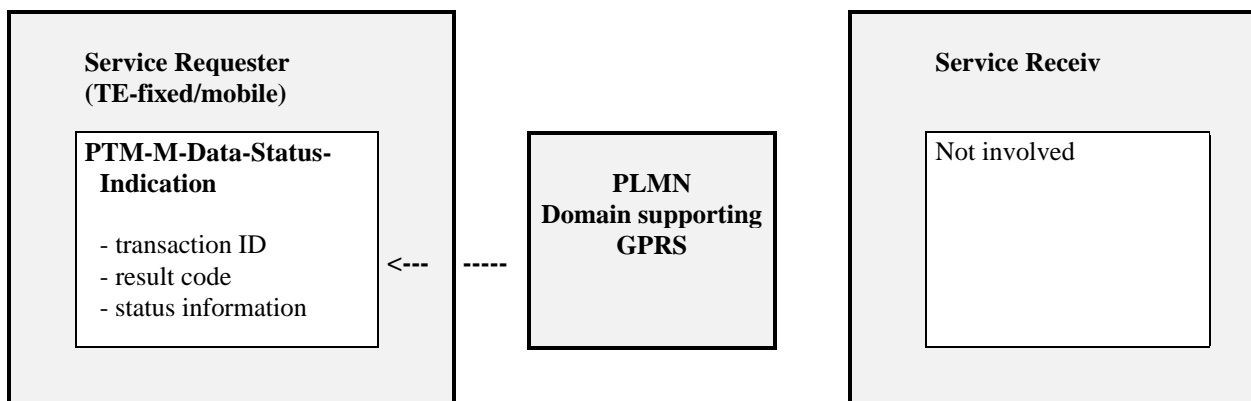

Figure 6: PTM-M network invoked data status operation

5.2.5 PTM-Group-Call Operations and User Interface

The PTM-G service allows members of a PTM-G group to establish a logical relationship within the group for the purposes of transferring data; this relationship is known as a group call. Not all members of the PTM-G group need to participate in a group call. The group membership defines those users which are permitted to participate in the group call. Individual group members may join or leave the call at their discretion. A group call may be restricted to a specific geographical area, determined at the call initiation. Group members are only permitted to join a group call and receive data if they are within the defined geographical area. There may be several simultaneous group calls in-progress within a single group covering multiple geographical areas which may overlap. A group member may participate simultaneously in multiple group calls of any group to which the member has a subscription.

The network maintains location information on group members participating in the group call, and may direct data transmissions only to specific GSM cells containing participants.

5.2.5.1 PTM Group Administration

A PTM-G group is identified by an IMGI. The PTM-G group database defines the group capabilities and the set of GPRS subscribers belonging to the group. A PTM-G group is created by administrative procedures specific to the individual PLMNs. PTM-G group membership is modified by administrative procedures.

Individual group members (subscribers) may be assigned different subscription options within the group. A group member shall have one or more of the following capabilities:

- as a controller, authorized to create and delete the group and to control the membership;
- as an initiator, authorized to initiate and terminate group calls, and to send and receive data to other group members;
- as a participant, authorized to send or receive data to other group members.

PTM-G groups may be classified as either open or closed:

- a closed group is a PTM-G group which has a set of members pre-defined by subscription. Only the pre-defined group members are authorized to join and participate in PTM-G communications with other participants;
- an open group is a PTM-G group which does not have a pre-defined set of members. Any subscriber may attempt to participate in an open group call.

An initiator initiates a group call. Group members which have joined a group call including the initiator are termed participants.

In general, group membership consists primarily of mobile subscribers. However each GPRS group may contain one or more fixed network users, communicating with the network across the Gi reference point.

For each PTM group, the following group attributes may be configured within the network:

group call notification:	active or not-active
group call notification repetition period:	n deci-minutes, where the range of n is 0 (no repetition, sent once only) to 14400 (daily repetition)
join/leave call indication:	active or not-active
group data transfer mode:	one-way, two-way or n-way
group membership class:	open or closed
group restrictions:	geographical area, time-of-day, data transfer limits, quality of service class, or other network-specific restrictions.

For each PTM group, the following individual member attributes may be configured within the network:

member privileges:	controller, initiator, participant
member type:	mobile subscriber or fixed subscriber
member restrictions:	geographical area, time-of-day, data transfer limits, send or receive only, quality of service class, or other network-specific restrictions.

5.2.5.2 PTM Group Call service description

The following six operations are supported by the PTM-G service:

- call initiate operation;
- call terminate operation;
- call status operation;
- join call operation;
- leave call operation;
- data transfer operation.

A group call initiator initiates a group call by means of a call initiate operation. The network assigns a call ID and confirms to the initiator that the call has been created and optionally transmits a group-call-notification to all the group members within the designated geographical area. The periodic re-transmission of the notification may be negotiated during the call initiate operation.

A group member may choose to join a group call and thereby become a group call participant, by informing the network using the join call operation. A participant may leave a group call at any time by informing the network using the leave call operation. A mobile participant automatically leaves the call (with an optional delay) when that participant leaves the geographical area designated for this group call.

Data transfer operations may occur at any time following group call initiation. Data transfers for the group call are restricted to the geographical area designated during the group call initiate operation or optionally restricted to a sub-set of this area as designated during the data transfer operation. Data transfers are distributed only to the participants including the initiator.

The initiator may terminate a group call by means of the call terminate operation. The network notifies participants of the group call termination.

Group members may query the status of a group call at any time using the call status operation.

5.2.5.3 PTM-G call initiate operation

This operation is used by a group call initiator to initiate a PTM-G call and establish the call characteristics.

Call attributes shall include:

- the PTM-G IMGI;
- the initiator's member ID;
- the data transfer mode (one-way, two-way, n-way);
- the QoS associated with data transfers.

Call attributes may include:

- the (optional) geographical area (definition or logical name) over which the call is to be supported;
- the (optional) join/leave call indication of the participants ID to the initiator;
- the (optional) group call notification and its repetition rate.

The network shall respond by confirming the operation. If successful, the network shall provide a unique call ID which shall be used in subsequent PTM-G operations. If the initiator has selected the corresponding option(s) the network shall transmit the group-call-notification to those group members currently located within the designated geographical area for the group call and re-transmit according to the designated repetition rate. The network optionally assigns a unique group cipher key to each group call which shall be used for data transfer operations. If a group cipher key is not assigned the cipher key of each individual group member shall be used. It shall be possible for a group call initiator to initiate or participate in more than one group call simultaneously.

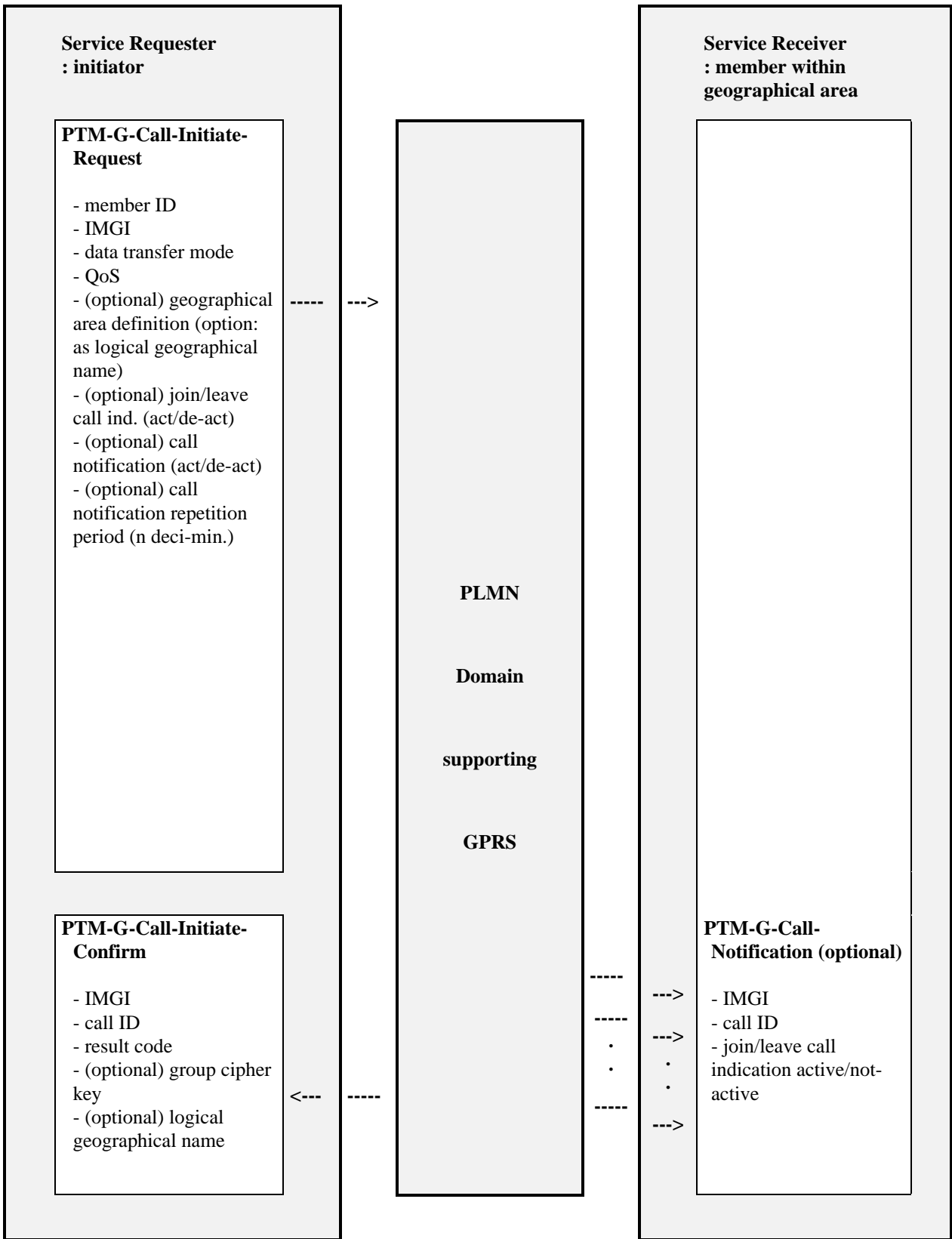

Figure 7: PTM-G call initiate operation

5.2.5.4 PTM-G call terminate operation

This operation is used by a group call initiator to terminate a group call. The network shall respond by confirming the operation. The network shall inform participants of the termination.

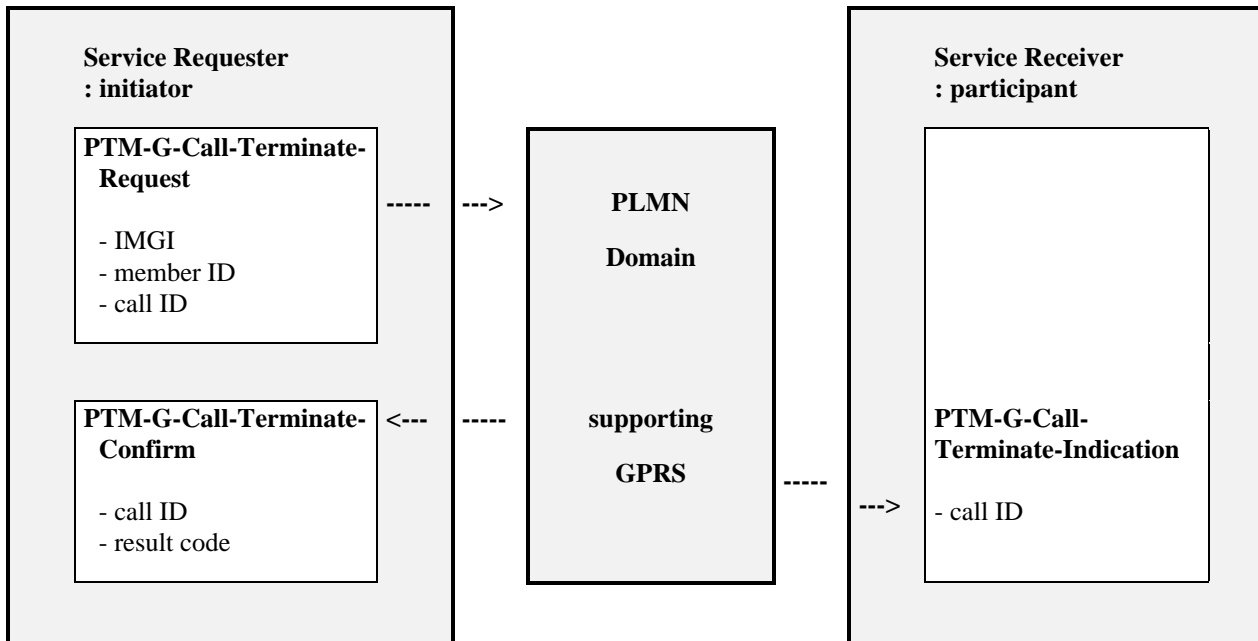

Figure 8: PTM-G call terminate operation

The network may invoke the call terminate operation due to administration reasons (e.g. if the initiator is no longer reachable).

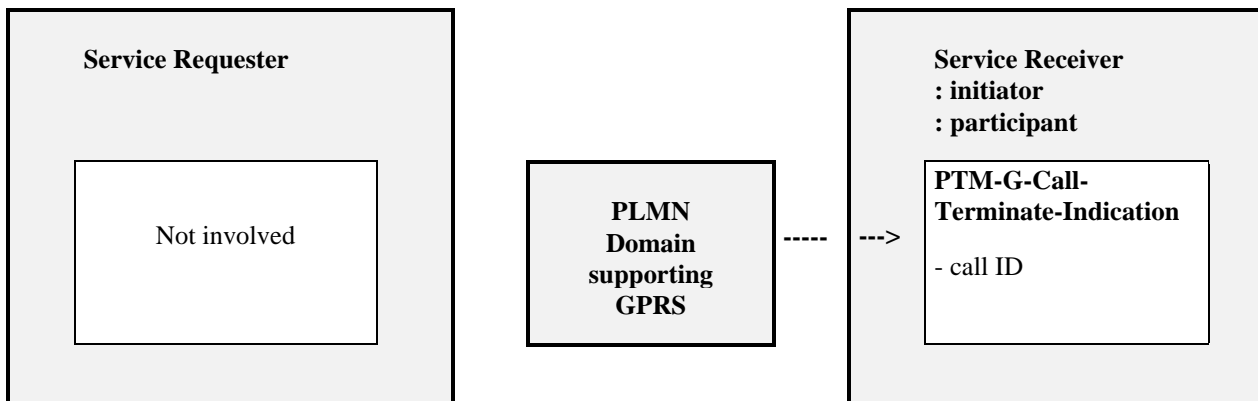

Figure 9: PTM-G network invoked call terminate operation

5.2.5.5 PTM-G call status operation

This operation is used by the group members to obtain status information on all current group calls of which they are members and which have a geographical area that includes the current location of the interrogating group member. The initiator or controller of the call may perform the call status operation when outside the designated geographical area. The interrogating group member may restrict the status request to one or more specific group calls by including the call IDs in the status request operation. The interrogating group member may be currently active in a group call. The network shall respond to the individual interrogating group member indicating the call status information.

The call status information shall include:

- call active or not-active;
- join/leave call indication active or not-active.

The service requestor may request and the network may optionally return the following additional information in the call status information:

- the geographical area;
- a list of the current participants;
- the number of current participants;
- the notification repetition rate;
- QoS information.

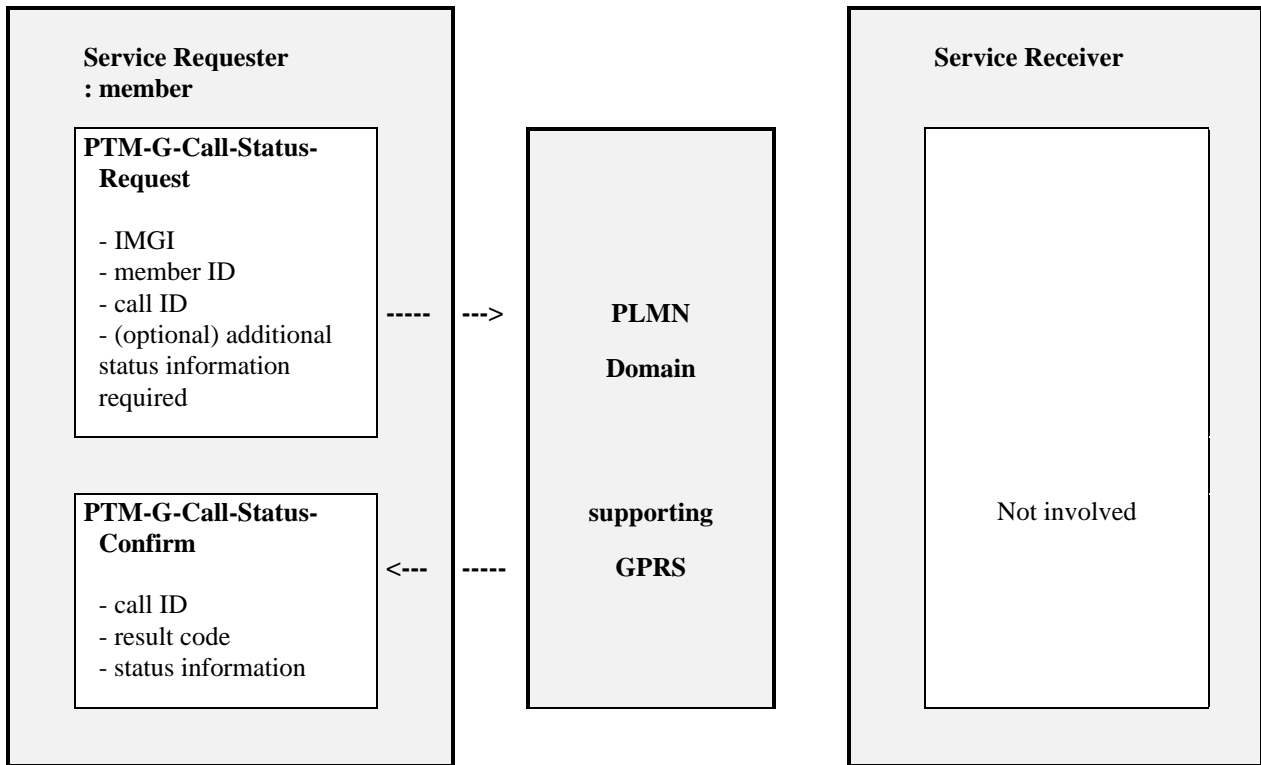

Figure 10: PTM-G call status operation

The network may invoke the PTM-G-Call-Status-Indication operation to inform the controller, initiator, or participants of a call status (e.g. call termination due to network administration reasons).

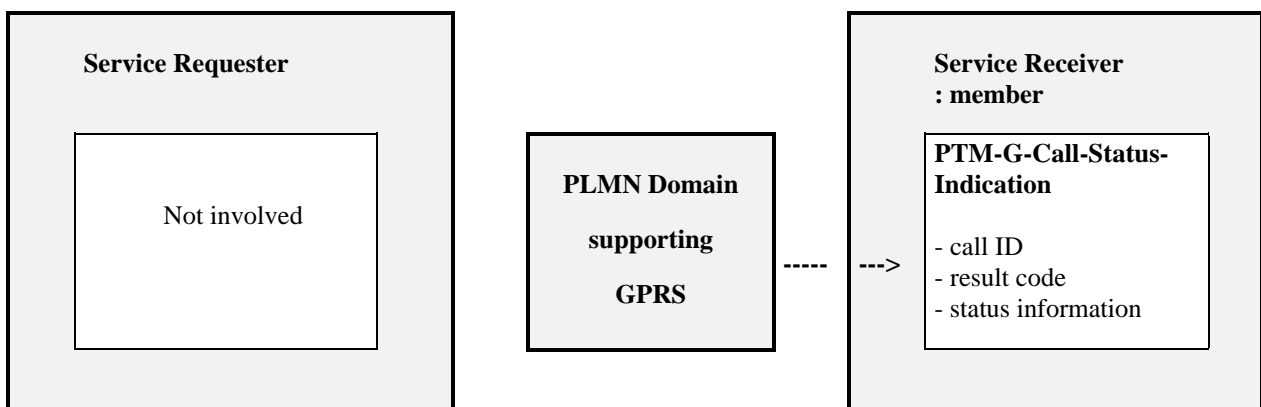

Figure 11: PTM-G network invoked call status operation

5.2.5.6 PTM-G join call operation

This operation is used by a group member to indicate the intention to join a PTM-G call. The user provides the call ID of the group call which the user wishes to participate in. The member ID, the IMGI and the call ID are transferred to the network. If there is a group call established with the specified call ID and IMGI for a geographical area which includes the current location of the user, and the subscriber is authorized to join the group call, then the network responds with the call ID and the optional group cipher key to be used for this group call. If the call ID in the request message indicates "any call ID" for this IMGI, then the network shall select a call ID or reject the request. The network shall indicate the member ID of each group member who joins the call to the call initiator if the "join/leave call indication" option is active. The geographical area restriction shall not apply to fixed network group members.

A group member which has successfully completed this operation is said to be a participant in the PTM-G call. It shall be possible for a group member to be a participant in more than one group call simultaneously. This operation allows the network to track the location of participants so that data transfer operations can be transmitted in cells (or routing areas) containing one or more participants.

The join call operation is not applicable to the initiator of the group call.

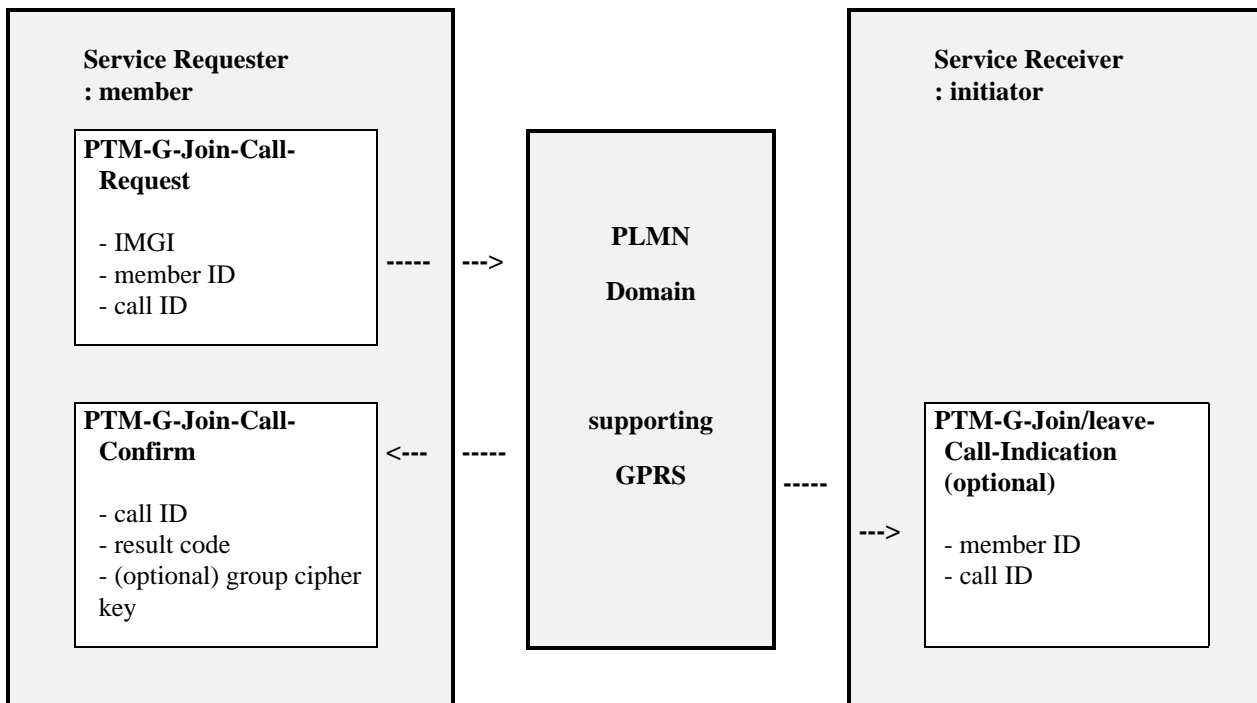

Figure 12: PTM-G join call operation

5.2.5.7 PTM-G leave call operation

This operation is used by a group call participant to indicate their intention to leave a PTM-G call. The participant provides the call ID of the group call which the user wishes to leave.

A group member which has successfully completed this operation is no longer a participant in the PTM-G call. This operation allows the network to remove the member from the list of participants. The network shall indicate the member ID of each participant who leaves the call to the call initiator if the "join/leave call indication" option is active.

The leave call operation is not applicable to the initiator of the group call.

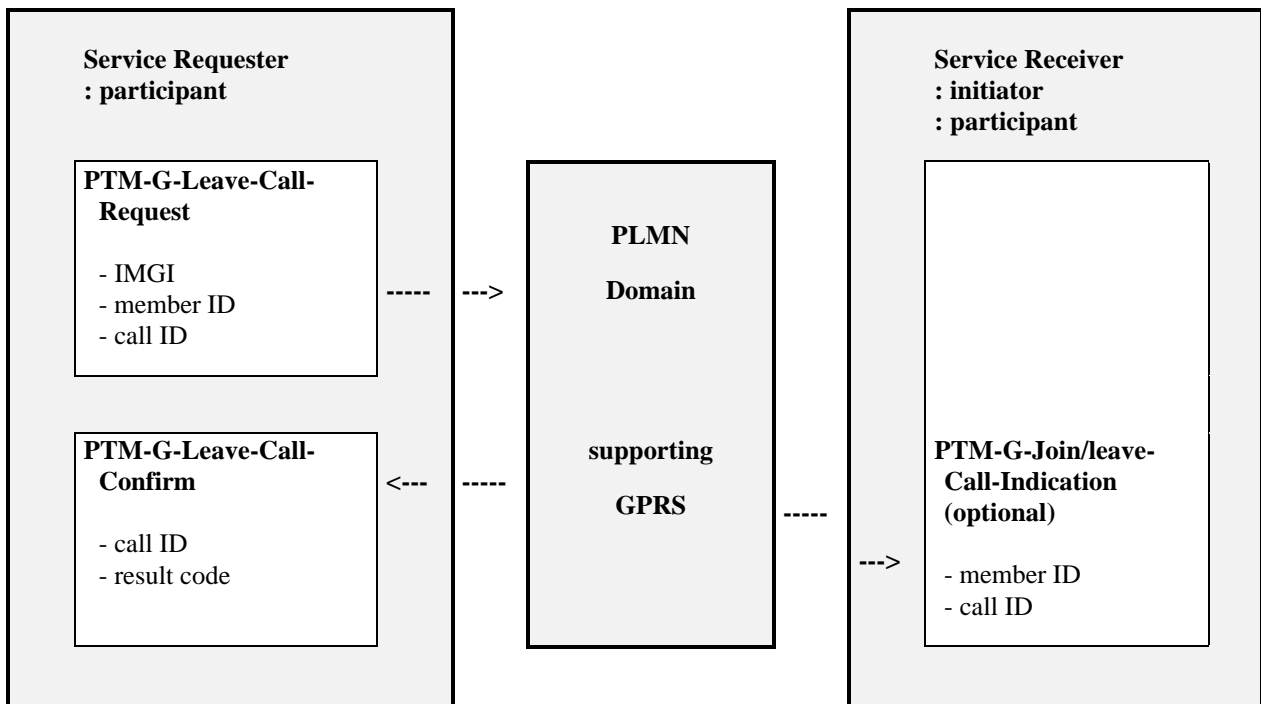

Figure 13: PTM-G leave call operation

A mobile participant automatically leaves the group call (with an optional delay) when that participant leaves the geographical area designated for this group call. This is indicated to the participant and optionally to the initiator by the network.

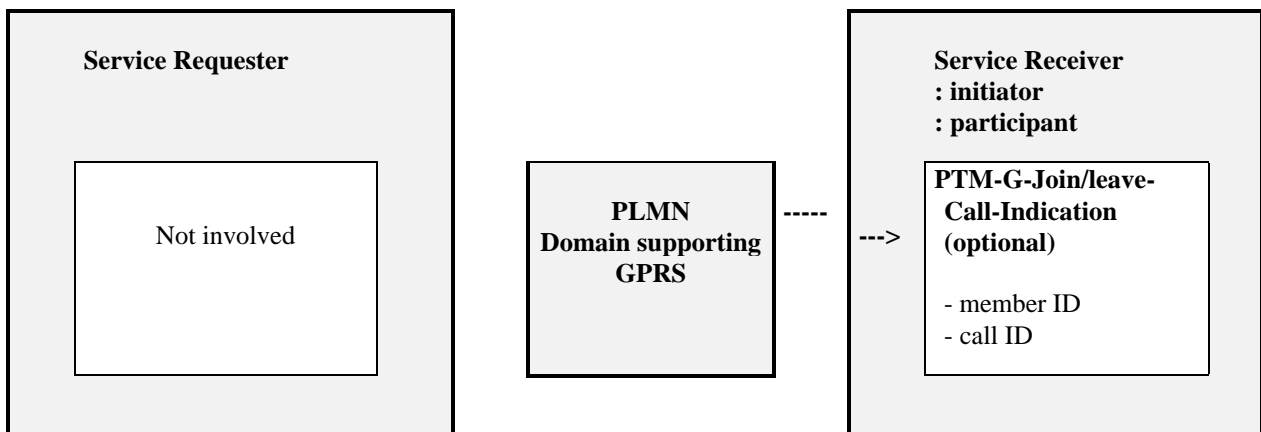

Figure 14: PTM-G location invoked leave call operation

5.2.5.8 PTM-G data transfer operation

The service user performs this operation to transfer the the user data to the participant(s) by informing the network of:

- the service requestor's member identity;
- the call ID to which the data is addressed;
- the user data to be transmitted;
- the (optional) geographical area sub-set (definition or logical name) over which the data is to be transferred.

The network shall either confirm the acceptance of the request or shall reject the request. If the request is accepted the network transfers the user data according to the request parameters.

In response to a user data transfer the service receiver may optionally send an acknowledgement.

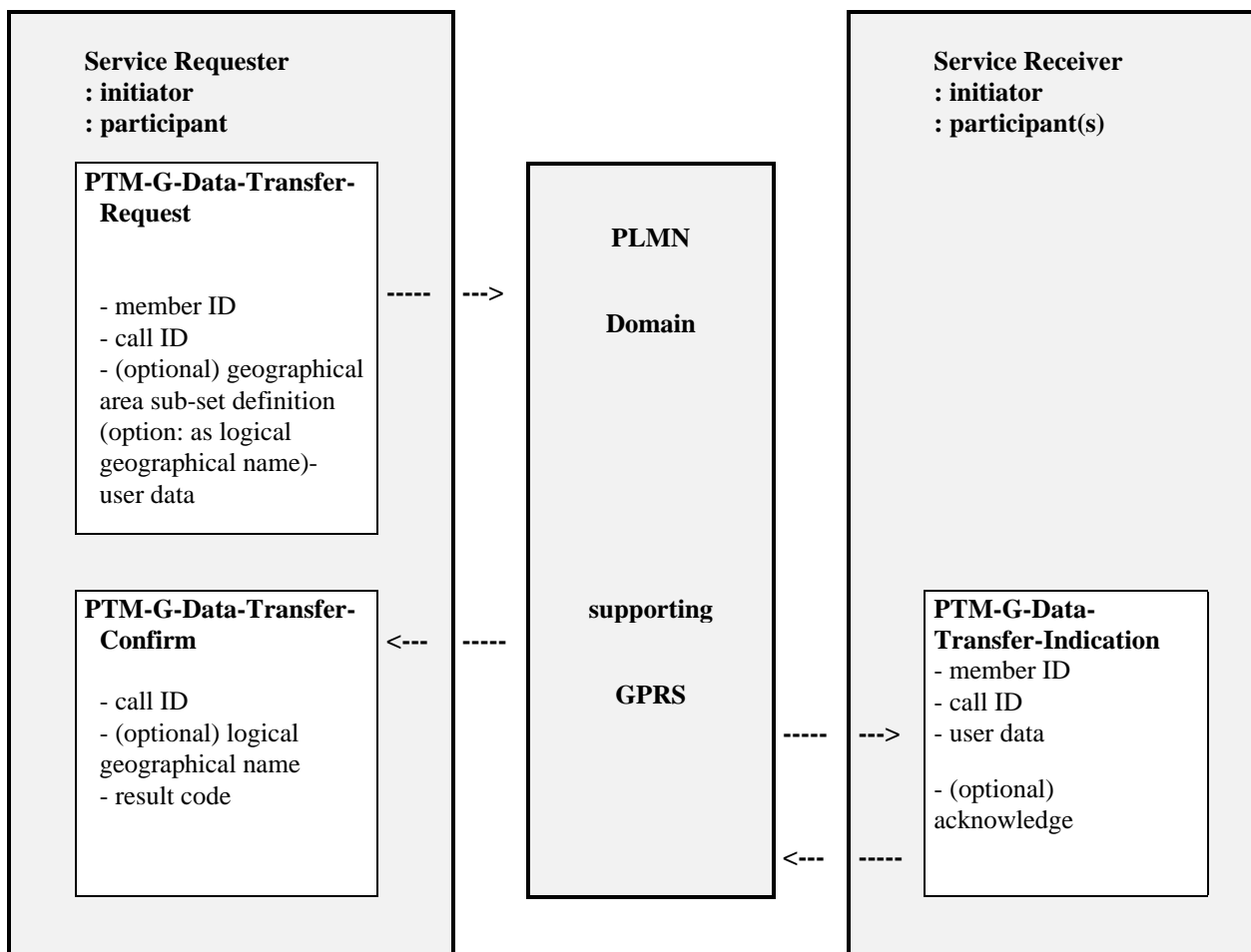

Figure 15: PTM-G data transfer operation

5.3 Transfer Characteristics

The packet multiplexing mechanisms developed for GPRS shall be independent of a given channel type. It shall be possible to operate GPRS over low and high capacity channels. These may be existing and/or future channels whose capacities are as yet unspecified (e.g., a signalling channel, or two time-slots or an entire 200 kHz carrier). Table 3 is only applicable to the GPRS part of the connection.

Table 3: Transfer Characteristics

Attributes		Supported capabilities
Information Transfer Capability		Unrestricted digital information
Information Transfer Mode	Connection mode	Connection orientated, connectionless
	Traffic type ^(a)	Variable bit rate and variable delay
	Timing end-to-end ^(b)	Asynchronous
Information Transfer Rate ^(c)		Maximum bit rate. Values from one TCH (e.g. 9.6 kbit/s) up to eight TCH (e.g. 8x9.6 kbit/s) inclusive.
Information Structure		- Service data unit integrity - Data sequence integrity
Communication Configuration		- Point to point - Point to multipoint multicast - Point to multipoint group call
Establishment of Communication ^(d)		Demand mobile originated or mobile terminated
Negotiation		- Out of band - In band
Symmetry		- Bi-directional - Unidirectional
Radio Channel assignment		Shared, multi-user

- a) Traffic type: describing data streams with constant bit rate or variable bit rate characteristics.
- b) Timing end-to-end: describing the timing relation between the source and destination of signals.
- c) Flexible channels with a maximum bit rate that depends on the type of channel and the number of time slots that are used. This capability defines the maximum capability associated with the channel(s). The actual bit rate for a particular user may be any value up to this maximum value.
- d) Establishment of communication: may be on demand, reserved or permanent.

5.4 Service characteristics

5.4.1 Subscriber profile

The subscriber profile holds subscription information about services and other parameters that have been assigned for an agreed contractual period. It includes the following information:

- subscribed services (PTP-CLNS, PTP-CONS, PTM-M, PTM-G);
- subscribed QoS profile (service precedence(priority), reliability, delay, throughput).

An invocation of a service by any user with the appropriate subscription profile shall be possible.

A subscription is required to allow a subscriber to initiate a PTM-M data transfer operation. No subscription is required to receive PTM-M messages.

It shall be possible to validate a service request against a service subscriber's subscription profile.

5.4.2 Quality of Service (QoS)

The mapping of user application QoS parameters to GPRS QoS parameters is an implementation issue and is not part of GPRS specifications.

It shall be possible to respond to local data traffic conditions adaptively. GPRS shall include the functionality to increase or decrease the amount of radio resources allocated to GPRS on a dynamic basis. The criteria used to decide on dynamic changes of the GPRS part of the radio resource should not be specified. Thus, only the necessary procedure, including radio protocol and timers, needed to perform the change of radio resources shall be specified within the ETSI specifications.

Within GPRS the dynamic allocation of the radio resource for bursty or lengthy file transfer applications shall be such that it can be controlled by the network operator.

5.4.2.1 QoS parameter definitions

The defined QoS parameter values, assume the user is at a location with acceptable GSM-/GPRS-coverage and refer to and are valid for normal network operating conditions or, as in the case of the service precedence parameter, regulate how the network shall handle abnormal conditions.

5.4.2.1.1 Service precedence (priority)

The service precedence indicates the relative priority of maintaining the service. For example under abnormal conditions (e.g. network congestion) packets which may be discarded can be identified. The following precedence levels are defined:

- High precedence: Service commitments will be maintained ahead of all other precedence levels.
- Normal precedence: Service commitments will be maintained ahead of low priority users.
- Low precedence: Service commitments will be maintained after the high and normal priority commitments have been fulfilled.

5.4.2.1.2 Reliability

The reliability parameter indicates the transmission characteristics that are required by an application. The reliability class defines the probability of loss of, duplication of, mis-sequencing of or corruption of SDUs.

NOTE. If a user's application is based on X.25, which requires reliable delivery of X.25 SDUs, it would be incorrect for an application to use an reliability class with a high loss probability.

Table 4 lists the three classes of the data reliability.

Table 4: Reliability classes

Reliability class	Lost SDU probability (a)	Duplicate SDU probability	Out of Sequence SDU probability	Corrupt SDU probability (b)	Example of application characteristics.
1	10^{-9}	10^{-9}	10^{-9}	10^{-9}	Error sensitive, no error correction capability, limited error tolerance capability.
2	10^{-4}	10^{-5}	10^{-5}	10^{-6}	Error sensitive, limited error correction capability, good error tolerance capability.
3	10^{-2}	10^{-5}	10^{-5}	10^{-2}	Not error sensitive, error correction capability and/or very good error tolerance capability.

- a) To protect against buffer overflow or a protocol malfunction, there is a maximum holding time for each SDU in the GPRS network after which the SDU is discarded. The maximum holding time depends on the protocols used (e.g., TCP/IP).
- b) Corrupt SDU probability: the probability that a SDU will be delivered to the user with an undetected error.

5.4.2.1.3 Delay

GPRS is not a „store and forward“ service - although data is temporarily stored at network nodes during transmission - thus, any delay incurred is due to technical transmission characteristics (or limitations) of the system and is to be minimised for a particular delay class. The delay parameter thus defines the maximum values for the mean delay and 95-

percentile delay to be incurred by the transfer of data through the GPRS network(s). The delay parameter defines the end-to-end transfer delay incurred in the transmission of SDUs through the GPRS network(s).

This includes the radio channel access delay (on uplink) or radio channel scheduling delay (on downlink), the radio channel transit delay (uplink and/or downlink paths) and the GPRS-network transit delay (multiple hops). It does not include transfer delays in external networks.

Delay is measured between the R or S (for MS) and Gi (for FS) reference points when applied to "MS to fixed station (FS)" or "FS to MS" transmissions.

Table 5: Delay classes

Delay Class	Delay (maximum values)			
	SDU size: 128 octets		SDU size: 1024 octets	
	Mean Transfer Delay (sec)	95 percentile Delay (sec)	Mean Transfer Delay (sec)	95 percentile Delay (sec)
1. (Predictive)	< 0.5	< 1.5	< 2	< 7
2. (Predictive)	< 5	< 25	< 15	< 75
3. (Predictive)	< 50	< 250	< 75	< 375
4. (Best Effort)	Unspecified			

5.4.2.1.4 Throughput

The throughput parameter indicates the user data throughput requested by the user.

Throughput is defined by two negotiable parameters:

- Maximum bit rate
- Mean bit rate (includes, for example for "bursty" transmissions, the periods in which no data is transmitted.)

The maximum and mean bit rates can be negotiated to a value up to the Information Transfer Rate value (see table 3).

5.4.2.1.5 Scheduled repeated transmission

The scheduled repeated transmission parameter indicates the time of the first transmission, the number of transmissions and the interval between transmissions requested by the user.

5.4.2.2 QoS profile - PTP and PTM-G

The subscriber's QoS profile for the PTP and PTM-G services consists of the following parameters which are negotiated or set to default values:

- service precedence (priority),
- reliability,
- delay,
- user data throughput.

5.4.2.3 QoS profile - PTM-M

The subscriber's QoS profile for the PTM-M service consists of the following parameters which are negotiated or set to default values:

- service precedence (priority),
- reliability,
- user data throughput.
- scheduled repeated transmission.

NOTE: The subscriber, who receives the PTM-M data, is passive and cannot affect the PTM-M QoS parameters.

5.4.2.4 Monitor

As an option, the MS may monitor the current QoS level. If this option is implemented, the following information shall be monitored:

- user data throughput;
- radio channel access delay;
- round-trip-MS/PLMN delay; and
- reliability,

The MS shall provide means of communicating this information to the application(s) via the R and S reference points as shown in Figure 2.

5.4.3 Security services

The use of radio communications for transmission to/from subscribers in mobile networks makes them particularly sensitive to:

- 1) misuse of their resources by unauthorized persons using manipulated MSs;
- 2) eavesdropping on the information being exchanged on the radio path.

Therefore, to protect the system in the two cases mentioned above, the following security features are provided for GPRS:

- MS authentication; i.e., the confirmation by the land-based part of the system that the subscriber identity, transferred by the MS within the identification procedure on the radio path, is the one claimed. The purpose of this authentication is to protect the network against unauthorized use. It also enables the protection of GPRS subscribers by denying intruders the ability to impersonate authorized users;
- access control; i.e., the network can support restrictions on access by or to different GPRS subscribers, such as restrictions by location, screening lists, and so on;
- user identity confidentiality; i.e., the property that the user identity on the radio link is not made available or disclosed to unauthorized individuals, entities or processes. The purpose is to provide privacy of identities of the subscribers who are using GPRS radio resources. It allows for the improvement of other security features, e.g., user information confidentiality, and also provides for the protection against tracing the location of a mobile subscriber by listening to the signalling exchanges on the radio path;
- user information confidentiality; i.e., the property that the user information is not made available or disclosed to unauthorized individuals, entities or processes. The purpose is to provide for confidentiality of user data, i.e., protection of the message part pertaining to layers 3 and above, that passes over the radio path.

Both user identity and user data shall be protected as shown in table 6:

Table 6: Protection of user identity and user data

Service	User Identity Protection	User Data Protection
PTP	Yes	Yes
PTM-Multicast (receiver)	Yes ^{a)}	No ^{b)}
PTM-Group Call	Yes	Yes

- a) The individual identities of the group members that actually receive the PTM-M traffic, are not transferred on the radio path and furthermore are also not known to the network. This is an important aspect for those applications where it is imperative that the location of the user cannot under any circumstances be traced. However, the group identity and the identity of the service requester are sent unciphered on the radio path.

- b) This does not preclude end-to-end ciphering of user data by the PTM-M application, this however, is outside the scope of this specification.

Security mechanisms available for existing teleservices and bearer services should be used if possible.

An optional requirement is that an MS can anonymously initiate a mobile originated, PTP communication to a specific subscriber or server that is registered within the PLMN. This necessitates that all charges shall be made to the called party. For the access to the network the MS shall not send its IMSI or IMEI thus guaranteeing a high level of anonymity. However, in the case of fraud or misuse of the service, the MS shall transfer its IMEI and/or IMSI upon request by the operator. Authentication and ciphering procedures are not required. Such procedures may reside inside or outside the GSM network.

NOTE: An example for such an anonymous service is a toll road system whereby a user can pay the road-toll anonymously using a pre-paid card instead of a normal SIM card. The road-toll application server receives and is charged for all messages of the anonymous service. However, the server has its own means to charge the user (e.g. using electronic money on the anonymous pre-paid card).

5.4.4 Packet size

Both PTP and PTM services shall allow the transfer of variable length Network Service Data Units (NSDU).

5.4.5 Capabilities of GPRS MS Classes

The purpose of the definition of the GPRS MS Classes is to enable the different needs of the various market segments to be satisfied by a number of MS types with distinct capabilities (e.g., simultaneous use and number of time-slots) and to provide a means of indicating the capability upon GPRS-Attach to the network.

Upon GPRS-Attach the MS shall indicate to the network its GPRS MS Class and its multi-slot capabilities. The class of an MS may be reconfigured when detached. E.g., a class A MS configured as 1 slot for circuit switched plus 1 slot for GPRS may be reconfigured when detached as a class C configured as 0 slots for circuit switched plus 2 slots for GPRS.

Three GPRS MS classes are identified:

The term simultaneous (attach, traffic, etc.) is the requirement to simultaneously support GSM GPRS services and GSM circuit switched services including SMS.

Class A: Supports simultaneous attach, simultaneous activation, simultaneous monitor, simultaneous invocation and simultaneous traffic. The mobile user can make and/or receive calls on the two services simultaneously subject to the QoS requirements.

A minimum of one time slot shall be available for each type of service (circuit switched and GPRS) when required.

Class B: Supports simultaneous attach, simultaneous activation and simultaneous monitor. Supports only limited simultaneous invocation: GPRS virtual circuits (GPRS-activation) shall not be cleared down due to invocation or traffic of circuit switched services, the status of the GPRS virtual connection is then "busy or held". Simultaneous traffic shall not be supported. The mobile user can make and/or receive calls on either of the two services sequentially but not simultaneously. The selection of the appropriate service is performed automatically.

Class C: Supports only non-simultaneous attach. Alternate use only. If both services (GPRS and Circuit Switched) are supported then a Class C MS can make and/or receive calls only from the manually or default selected service, i.e., either GPRS or Circuit Switched service. The status of the service which has not been selected is detached i.e., not reachable. The capability for GPRS-attached class-C MSs to receive and transmit SMS messages is optional.

The network shall support SMS message reception and transmission for GPRS-attached class-C MSs.

Non-voice only MSs do not have to (but may) support emergency calls.

5.4.6 Subscriber roaming

GPRS shall provide the ability for subscribers to access the service while roaming between networks. This implies the pre-existence of an international signalling mechanism and a service agreement between the different network operators involved.

GPRS is not required to provide the ability for subscribers to remain GPRS attached when moving from one PLMN to another. However, this may be possible by mutual agreement between operators.

5.4.7 Construction of GPRS subscriber numbers

The number of a GPRS subscriber shall be composed such that the PLMN operator can maintain control of the numbering scheme, thereby ensuring subscriber numbering integrity. The ability to allocate a subset of the numbers privately shall be possible.

5.4.8 Battery life extension

The GPRS service shall provide for a means to extend the battery life of an MS, by allowing the MS to reduce current drain; e.g., by using a discontinuous reception (DRX) strategy. The power conservation strategy should allow the MS to remain in a very low current state for a considerable proportion of the time. Moreover, the power conservation strategy should ensure that no messages are lost and that bandwidth is not wasted.

When conserving power through the use of DRX, or other techniques, the MS shall still meet all QoS requirements of selected classes. Some classes of service may necessitate continuous reception (i.e., no DRX capability).

5.4.9 Format Of Message User Data

The user data is to be presented as an octet string between GPRS's access points, and is not interpreted by the GSM PLMN.

5.4.10 Charging aspects

The charging information that the GPRS network collects for each MS shall be standardized. The information that the operator uses to generate a bill to a subscriber is operator specific. Billing aspects, e.g. a regular fee for a fixed period, are outside the scope of this specification.

The GSM HPLMN Operator/Service Provider may be able to charge the GPRS subscriber for all costs incurred including those costs incurred in an external network be it a GSM VPLMN or a non-GSM data network.

5.4.10.1 PTP and IP-M charging information

The charging information of PTP and IP-M services is collected for the GPRS subscriber. As a minimum the following charging information shall be collected:

- destination and source: The charging information shall describe the destination and source addresses;
- usage of radio interface: The charging information shall describe the amount of data transmitted in MO and MT directions categorized with QoS and user protocols;
- usage of the external data networks: The charging information shall describe the amount of data sent/received to/from the external data network;
- usage of the packet data protocol addresses: The charging information shall describe how long the MS has used the packet data protocol addresses;
- usage of the general GPRS resources: The charging information shall describe the usage of other GPRS related resources and MS's activity in the GPRS network (e.g. Attach/Detach, mobility management);
- location of MS: HPLMN, VPLMN, plus optional higher accuracy location information.

5.4.10.2 PTM-M charging information

The charging information of PTM-M services is collected for the service requester of the data transfer operation. As a minimum the following charging information shall be collected:

- PTM-M group: The charging information shall describe the IMGI of the PTM-M group;
- usage of the radio interface: The charging information, categorized by QoS and geographical area information shall describe the amount of data transmitted.;
- usage of the general GPRS network resources: The charging information shall describe the usage of other GPRS related resources.

5.4.10.3 PTM-G charging information

The charging information of PTM-G services is collected for the group controller, initiator, service requester and optionally members.

As a minimum the following charging information shall be collected for the group controller:

- PTM-G group: the charging information shall describe the IMGI of the PTM-G group;
- creation, modification and deletion of the PTM-G groups.

As a minimum the following charging information shall be collected for the group call initiator:

- PTM-G group: the charging information shall describe the IMGI of the PTM-G group;
- initiation and termination of the calls in the PTM-G groups and geographical area definition.

As a minimum the following charging information shall be collected for each service requester/group member:

- PTM-G group: the charging information shall describe the IMGI of the PTM-G group and service requester/group member identifier;
- usage of the radio interface: the charging information, categorized by QoS, shall describe the amount of data transmitted;
- usage of the general GPRS network resources: the charging information shall describe the usage of other GPRS related resources.

5.4.10.4 Reverse Charging

It shall be possible to provide reverse charging as a subscription option. However, reverse charging may not be applicable to certain external data network protocols.

5.4.11 Message Screening

The message screening function is concerned with filtering out unauthorized or unwanted messages. Message screening may be used to restrict the types of message or the volume of data which may be transferred across the GPRS network to/from an individual subscriber.

5.4.11.1 Network controlled screening

The PLMN administration and/or the GPRS service provider shall be able to provide basic screening functionality (e.g. firewall) to reduce the risk of fraud and misuse, to ensure the integrity of the network and to protect subscribers.

5.4.11.2 Subscription controlled screening

The subscriber is able to negotiate through the subscription, specific message screening requirements within the limitations of the network (HPLMN or VPLMN) controlled screening. The subscriber shall be able to limit the amount

of chargeable data, the source, the destination and the types of messages sent or received. The subscription controlled screening is applicable also when roaming.

It shall be possible for the subscriber to define screening criteria for each interworking profile and for the non-interworking case.

5.4.11.3 User controlled screening

The user is able to individually control message screening within the limitations of the network (HPLMN or VPLMN) and the subscription controlled screening. The user shall be able to limit the amount of chargeable data, the source, the destination and the types of messages sent or received. The user controlled screening is applicable also when roaming.

It shall be possible for the user to define screening criteria for each interworking profile and for the non-interworking case.

6 Normal procedures with successful outcome

6.1 Provision

The GPRS services shall be provided to the subscriber after prior arrangement with the service provider. The provision of each of the following GPRS services independently or any combination thereof shall be possible:

- 1) Point To Point - Connectionless Network Service (PTP-CLNS);
- 2) Point To Point - Connection Orientated Network Service (PTP-CONS);
- 3) Point To Multipoint Multicast (PTM-M);
- 4) Point To Multipoint Group Call (PTM-G).

It shall be possible to subscribe to GPRS services with or without subscription to other GSM services. When a subscriber has subscribed to the Multiple Subscriber Profile (MSP) GSM supplementary service, it shall be possible to assign GPRS services to each of the individual MSPs.

It shall be possible for the network operator to offer GPRS to the Service Provider(s) who may then offer GPRS-based services to the end-user.

GPRS services can be offered to a subscriber with the subscription option of using a password to control the services. A single GPRS-password per subscriber is supported by the network for all GPRS services.

As a subscription option modification of the subscriber's service profile (e.g., registration, erasure) shall be possible only in conjunction with the GPRS-password.

The following Quality of Service (QoS) parameters shall be assigned to the subscriber profile upon provision of the GPRS service(s). These parameters may be negotiated or set to default values:

- service precedence (priority),
- reliability,
- delay,
- user data throughput.
- scheduled repeated transmission.

6.2 Withdrawal

The service(s) shall be withdrawn at the subscriber's request or for administrative reasons. Withdrawal shall de-activate the service.

6.3 GPRS-Attach, GPRS-Detach

GPRS-Attach is performed when the MS indicates its presence to the PLMN for the purpose of using the GPRS PTP or PTM-G services. This can be immediately after the MS has been switched on or later as the user decides to use the GPRS services. The MS identifies itself with its GSM identity (IMSI, TLLI).

GPRS-Detach is performed when the MS indicates to the PLMN that the MS will no longer be using the GPRS services. The MS identifies itself with its GSM identity (IMSI, TLLI).

6.4 Registration

Registration of the service parameters shall enable the subscriber to optimize the actual (dynamic) service profile to the subscriber's present, actual requirements within the limitations of the (static) subscription profile (see subclause 6.1). The result of the registration shall be indicated (i.e. accepted/registered or rejected/not registered). The registered service profile is valid for all GPRS transactions until modified by re-registration or erasure or changes to the subscription profile.

As a subscription option registration of the service parameters shall be possible only in conjunction with a GPRS-password.

Table 7 defines which service parameters shall be able to be registered for the different GPRS services. The range of values for the service parameters is specified in subclause 5.4 and subclause 5.4.2.1.

Table 7: Registration of service parameters

Service Parameter	PTP-CLNS PTP-CONS	IP-M	PTM-G	PTM-M
Service precedence (priority)	2,3,4	2,3,4	2,3,4	2,3,4
Reliability	2,4	2,4	2,4	2,4
Throughput	2, 3, 4	2, 3, 4	4	4
Simultaneous use class	2	2	2	2
Delay	2, 4	2, 4	2, 4	N/A
Security management / encryption	1	1	1	N/A
Interworking profile (a)	2	2	2	2
Password Active / De-active	2	2	2	2
Geographical area Address (b)	N/A	N/A	2, 3	2, 3

Legend: 1 Network determined.

2 User determined per subscription and registration.

3 User determined per request.

4 Negotiable.

N/A Not applicable.

- a) This is the set of subscription attributes (including a user-ID and/or address valid in the external data network if necessary) adopted by the subscriber when utilizing a particular destination network. A set of subscription attributes is required for each destination network. Multiple user-IDs and/or addresses for each destination network are allowed. See subclause 11.1 for address management.

Registration of a non-GSM identity (i.e. a user-ID/address in an external data network, e.g. Internet, X.25 etc.) is performed to couple the non-GSM identity to the GSM identity (IMSI) for the purpose of accessing (MO and/or MT) the non-GSM network. Registration of a non-GSM identity is subject to valid subscription agreements with the network operator. This also provides an effective operator determined barring of access to external data networks.

Each of the registered interworking profiles can be individually activated and de-activated.

Screening parameters can be assigned to a particular interworking profile as a user protection against unwanted costs and/or data.

- b) Optionally a logical geographical name describing the registered, defined geographical area can be registered (see subclause 5.2.3.4).

6.5 Erasure

The subscriber shall be able to erase previously registered service parameter values from the service profile.

Erasure of a non-GSM identity (e.g., Internet, X.25) which is currently registered for an interworking profile shall be possible without erasure of the other parameters of the interworking profile.

As a subscription option erasure shall only be possible in conjunction with the GPRS-password.

6.6 Interrogation

The subscriber shall be able to interrogate the status/value of registered service parameters as defined in the current service profile.

6.7 Activation

The subscriber shall be able to activate each of the registered interworking profiles independently within the limitations of the subscription profile. As an option the GPRS network may request the activation of a specific interworking profile for a GPRS attached mobile, when a mobile terminated packet is received. This option may be available for one or more PDP. The activation of the inter-working profile(s) may be performed automatically by the MS immediately after GPRS Attach. When an interworking profile is activated a dynamic binding between the GSM/GPRS identity of the MS and the external data network user-ID and/or address is made by the system, and the appropriate service parameters are applied thus establishing a virtual connection between the MS and the GPRS network. Activation of an interworking profile results in a dynamic binding until de-activation is performed.

6.8 De-activation

The subscriber shall be able to de-activate the previously activated interworking profiles independently within the limitations of the subscription profile thus releasing the previously established virtual connection. An interworking profile(s) shall be automatically de-activated if the provision for the supporting GPRS service is withdrawn. Interworking profiles are deactivated automatically upon GPRS detach..

De-activation of a particular interworking profile shall abort all presently on-going communication between the MS and the external data network. Any previously negotiated schedule for the PTM-M service shall remain unaffected.

6.9 Invocation and operation

The GPRS service is invoked upon transmission or reception of GPRS data.

It shall be possible for a MS to be a GPRS service requester and a service receiver. This allows generation and origination of GPRS messages from the mobile termination itself as a standalone GPRS data source. It also allows the mobile termination to provide DCE capabilities for user applications based in terminal equipment outside the mobile termination.

It shall be possible for a subscriber to set-up multiple GPRS PTP-CONS communication sessions and maintain these over prolonged periods (e.g. several hours). It shall be possible to establish these connections via more than one external data network. This enables more than one logical data channel to exist to a single mobile termination.

PTP-CONS, PTP-CLNS, IP-M, PTM-M and/or PTM-G communications in any combination shall be possible in parallel. In the case of X.25 the concept of switched virtual circuits shall be maintained between the GPRS environment and the X.25 fixed network.

6.10 PIN and Password Management

GPRS-Attach shall only be possible after correct subscriber identification has been confirmed by entry of the current GSM PIN if this option is active. Thus only one PIN is required to gain access to either the GSM-Circuit Switched Services/SMS or the GSM-GPRS Services or both.

GPRS services can be offered to a subscriber with the subscription option of using a password to control the services. One password per subscriber is supported by the network for all GPRS services. The GPRS password shall be the GSM specified password for supplementary services according to the GSM specifications 02.04 [18] and 02.30 [19].

When this option is selected the following actions shall only be performed with the concurrent entry of the password:

- registration, de-registration/erasure;
- barring of use of an interworking profile(s).

7 Exceptional procedures

7.1 Provision

None.

7.2 Withdrawal

None.

7.3 Registration

An attempt to register a service or service parameter not available to that subscriber shall result in an indication to the user. The reason shall be indicated:

- the service or service parameter is not supported by the PLMN;
- the subscriber's present (static) subscription profile prohibits the use of this service or service parameter;
- parameter is network determined;
- the entered parameter value is outside the range of that supported by the PLMN.

If, in the case of interworking with an external data network, an attempt is made to set a parameter to a value outside the range of that supported by the interworking to the external data network, it shall be indicated to the user and confirmation required before the parameter value is changed to a value selected by the network.

7.4 Erasure

An attempt to erase a service parameter which is not registered shall result in an indication to the user, the service parameter shall remain in the not registered state.

Erasure of a non-GSM identity (e.g., Internet, X.25) which is presently registered as "active" shall result in an indication to the user with a request for confirmation before the de-activation and erasure is performed.

7.5 Interrogation

None.

7.6 Activation

An attempt to activate an interworking profile which is already in the active state shall result in an indication to the user, the interworking profile shall remain in the active state.

7.7 De-activation

An attempt to de-activate an interworking profile which is already in the de-active state shall result in an indication to the user, the interworking profile shall remain in the de-active state.

7.8 Invocation and operation

An attempt to send an MO message with an MS identity which is not valid in the network shall be rejected with an appropriate error status.

An MT message that cannot be delivered due to an invalid MS identity shall be discarded by the network. A message that is received by an incorrect MS shall be discarded by the MS.

7.9 PIN and Password management

PIN and password exceptional procedures are as defined in GSM specifications 02.17 [20] and 02.04 [18].

8 Addressing

8.1 Point to Point services

A GPRS-PTP subscription is identified by an IMSI.

8.2 Point to Multipoint services

For mobile terminated PTM Multicast and for mobile terminated PTM Group Call services an International Mobile Group Identity IMGI is used by the service requester, to address the receiver group. The network may identify the receiver by the IMSI thus allowing PTM-G messages to be delivered to the receiver as point to point messages. Two categories of IMGIs shall be supported:

- IMGI can be used in the HPLMN only;
- IMGI can be used in PLMNs including the HPLMN.

NOTE: The latter category enables a common IMGI to be used for international applications e.g. road congestion information or weather information.

The structure of the IMGI should correspond to the group ID specified for the Voice Group Call Services (VGCS) (reference GSM specifications 02.68 [16], 03.68 [21] and 04.68 [22]), if possible.

For mobile originated PTM communications the IMSI shall be the basis for the access to the network. Additionally, a group identity IMGI shall be sent to be able to address the receivers.

8.3 Overview

How the identities are used within the different services is described in table 8.

Table 8: Services and Identities

Services	mobile originated		mobile terminated
	calling party	called party	
GPRS PTP	IMSI	Address (note 1)	IMSI
GPRS PTP-anonymous originator. (note 2)	-	IMGI-Server ID	not applicable
GPRS PTM-M	IMSI	IMGI	IMGI
GPRS PTM-G	IMSI	IMGI	IMSI or IMGI
IP-M	IMSI	Address (note 1)	IMSI

NOTE 1: The IMSI or in the case of network interworking refer to subclause 11.3.1.
NOTE 2: The subscriber and user identities of a PTP-anonymous-originator message are hidden from the operator.

9 Supplementary Services

9.1 GSM Phase 2 Supplementary Services

It shall be possible to offer to a GPRS subscriber the following GSM Phase 2 Supplementary Services which are subscribable for each of the GPRS basic services PTP-CONS, PTP-CLNS, IP-M and PTM-G). GSM Phase 2 Supplementary Services are not applicable to PTM-M.

Table 9: GSM Phase 2 Supplementary Services

Supplementary Services		Applicability
CLIP	Calling Line Identification Presentation	NA (note 1)
CLIR	Calling Line Identification Restriction	NA (note 1)
CoLP	Connected Line Identification Presentation	NA (note 1)
CoLR	Connected Line Identification Restriction	NA (note 1)
CFU	Call Forwarding Unconditional	A (note 5)
CFB	Call Forwarding on Mobile Subscriber Busy	NA (note 2)
CFNRy	Call Forwarding on No Reply	NA (note 2)
CFNRc	Call Forwarding on Mobile Subscriber Not Reachable	A (note 5)
CW	Call Wait	NA (note 3)
HOLD	Call Hold	NA (note 3)
MPTY	Multi-Party Service	NA (note 4)
CUG	Closed User Group	A
AoCI	Advice of Charge - Information	A
AoCC	Advice of Charge - Charging	A
BAOC	Barring of All Outgoing Calls	NA (note 6)
BOIC	Barring of Outgoing International Calls	NA (note 6)
BOIC-exHC	Barring of Outgoing International Calls except those directed to the HOME PLMN Country	NA (note 6)
BAIC	Barring of All Incoming Calls	NA (note 6)
BIC-Roam	Barring of Incoming Calls when Roaming Outside the HOME PLMN Country	NA (note 6)

NOTE 1: These are not applicable because it is an integral feature of packet data protocols that a PDU arrives at the terminating DTE with a Source and Destination address included. This is similar to SMS.
NOTE 2: These supplementary services may have no meaning in a packet orientated network. For example, the "busy" condition (CFB), as defined in a circuit-switched network, is not possible in a packet data network. Instead, packets experience increased throughput delay.
NOTE 3: The interworking protocols of an external data network make these supplementary services unusable. For example, X.25 networks will time-out, assume a PDU is lost, and either retry or abandon transmission altogether if a significant delay is experienced.
NOTE 4: The PTM-G services cover the requirements of Multiparty applications.
NOTE 5: Call Forwarding may not be applicable when interworking with certain external data networks.
NOTE 6: These are part of the message screening function (see subclause 5.4.11). The concept of call barring (in the sense of circuit switched services) may not be applicable to GPRS with all external data network protocols.

Key: NA: Not Applicable A: Applicable

9.2 GPRS specific supplementary services

It shall be possible to offer the following GPRS specific supplementary services to a GPRS subscriber. The GPRS specific supplementary services are subscribable for each of the GPRS basic services.

9.2.1 Barring of GPRS interworking profile(s) (BGIWP)

BGIWP enables the subscriber to restrict the users access to external data networks by barring the activation of one (or more) interworking profiles.

The use of the BGIWP supplementary service is protected by the optional password.

An interworking profile which is currently activated cannot be barred.

An interworking profile can only be activated if not barred.

The status of each interworking profile is either **barred** or **not barred**.

It shall be possible for the subscriber to interrogate the BGIWP status of each or all of the interworking profiles.

10 Service interworking

It shall be possible for the GPRS PTP services to be utilized as a bearer service for the SMS-MO and SMS-MT services.

11 Network interworking

Network interworking is required whenever a PLMN and a non-PLMN are involved in the execution of a GPRS Service request.

In general the mobile user of a GPRS network will receive and experience all the services provided by an external data network. In this case the external data network refers to the network that the GPRS PLMN interworks with as determined by the network operator. With this in mind it can be said that a user :-

- 1) will require a universal identity(ies) of the form compatible with the interworked with network(s);
- 2) and experience access to and provision of all services as offered by the interworked with networks (some reduction of capability may result from unavoidable restrictions due to the complexity of implementation).

11.1 Interworking with other data networks and other PLMNs

GPRS shall provide means to interwork with external data networks. The GPRS operator provides an appropriate address to the external data network for the subscriber as part of the GPRS subscription. That address can be either dynamic (e.g. the user's IP address is allocated from a pool of unused IP addresses every time the subscriber activates the access to an IP network) or static (e.g. a certain IP address is permanently allocated to a particular subscriber). When connected with some external data networks, the routing protocols of these networks may limit the data network addresses that can be allocated. For example, when interworking with IP networks, the IP address for the GPRS subscriber shall belong to that GPRS operator's IP subnetwork that allocates the address.

The type of interworking between a PLMN and data networks is determined by the network operator.

Interworking with the following types of data networks shall be defined:

- X.25 networks;
- IP networks;
- other GPRS PLMNs, directly or via a transit network;

The MS should interwork with the X.25 network using standardized X.3, X.28 and X.29 mechanisms for asynchronous access and X.25 mechanisms for synchronous access.

11.1.1 QoS when Interworking

GPRS shall satisfy, within the constraints introduced by the mobile radio environment, the QoS requirements of the interworked-with network.

11.1.2 Supplementary Services when interworking

GSM supplementary services may not apply when interworking with an external data network. However, supplementary services supported in the external data network may apply but this is outside the scope of this standard.

11.2 GPRS Numbering Plan

It is required that GPRS MS addresses conform to the numbering plan already defined for GSM.

11.3 Addressing and routing requirements

11.3.1 PTP network layer services

A GPRS subscriber identified by an IMSI, shall have a network layer address(es) temporarily and/or permanently associated with it that conforms to the standard addressing scheme of the respective network layer service used, e.g.:

- E.164 number;
- X.121 address for X.25 CONS;
- IP Version 4 and 6 addresses for Internet CLNS.

11.3.2 PTM services

Routing Information for Multipoint services is a combination of geographical area information and either IMSI or IMGI.

11.4 Interworking for subscriber roaming

Interworking between different GPRS PLMNs is required in order to support subscriber roaming.

It shall be possible for the VPLMN to provide access to the external data network when the external non-GSM data network address is dynamically assigned by the VPLMN.

Annex A (Informative): Change history

Change history					
SMG No.	TDoc. No.	CR. No.	Section affected	New version	Subject/Comments
		A001			
SMG#24	976/97	A002	The complete revised Stage 1 is attached for clarity.	5.2.0	Clarification of GPRS release 1997 content and minor editorial improvements
SMG#24	976/97	A003	Sections 5.4.1, 5.4.2, 6.1 and 6.4.	5.2.0	Clarification/Improvement of definition of Quality of Services aspects

History

Document history		
V5.1.0	October 1997	Publication
V5.2.0	January 1998	Publication