

# TS 101 191 V1.1.1 (1997-04)

---

*Technical Specification*

## **Digital Video Broadcasting (DVB); DVB mega-frame for Single Frequency Network (SFN) synchronization**

---

European Broadcasting Union



Union Européenne de Radio-Télévision

**DVB**  
Digital Video  
Broadcasting



*European Telecommunications Standards Institute*

---

---

**Reference**

DTS/JTC-00DVB-32 (b1000icr.PDF)

---

**Keywords**

Broadcasting, Digital, Video, DVB, TV

***ETSI Secretariat***

---

**Postal address**

F-06921 Sophia Antipolis Cedex - FRANCE

---

**Office address**

650 Route des Lucioles - Sophia Antipolis  
Valbonne - FRANCE  
Tel.: +33 4 92 94 42 00 Fax: +33 4 93 65 47 16  
Siret N° 348 623 562 00017 - NAF 742 C  
Association à but non lucratif enregistrée à la  
Sous-Préfecture de Grasse (06) N° 7803/88

---

**X.400**

c= fr; a=atlas; p=etsi; s=secretariat

---

**Internet**

secretariat@etsi.fr  
<http://www.etsi.fr>

---

***Copyright Notification***

No part may be reproduced except as authorized by written permission.  
The copyright and the foregoing restriction extend to reproduction in all media.

© European Telecommunications Standards Institute 1997.  
© European Broadcasting Union 1997.  
All rights reserved.

---

# Contents

Intellectual Property Rights.....	4
Foreword .....	4
1 Scope.....	5
2 Normative references .....	5
3 Definition and abbreviations.....	5
3.1 Definitions .....	5
3.2 Abbreviations.....	5
4 General description .....	6
5 Mega-frame definition .....	7
6 Mega-frame Initialization Packet (MIP) .....	9
6.1 Functions.....	12
6.1.1 Transmitter time offset function.....	12
6.1.2 Transmitter frequency offset function .....	13
6.1.3 Transmitter power function .....	13
6.1.4 Private data function.....	13
<b>Annex A (normative): CRC decoder model.....</b>	<b>14</b>
<b>Annex B (normative): Functional description of SFN synchronization .....</b>	<b>15</b>
<b>Annex C (normative): Reconfiguration of DVB-T modulator parameters by using the MIP .....</b>	<b>16</b>
History .....	17

---

## Intellectual Property Rights

ETSI has not been informed of the existence of any Intellectual Property Right (IPR) which could be, or could become essential to the present document. However, pursuant to the ETSI Interim IPR Policy, no investigation, including IPR searches, has been carried out. No guarantee can be given as to the existence of any IPRs which are, or may be, or may become, essential to the present document.

### Notified IPRs

Company	Country	Application number(s)	Patent number(s)
NOTE:			

Pursuant to the ETSI Interim IPR Policy, no investigation, including IPR searches, has been carried out by ETSI. No guarantee can be given as to the existence of other IPRs, which are, or may be, or may become, essential to the present document.

---

## Foreword

This Technical Specification (TS) has been produced by the Joint Technical Committee (JTC) of the European Broadcasting Union (EBU), Comité Européen de Normalisation ELECTrotechnique (CENELEC) and the European Telecommunications Standards Institute (ETSI).

NOTE: The EBU/ETSI JTC was established in 1990 to co-ordinate the drafting of ETSs in the specific field of broadcasting and related fields. Since 1995 the JTC became a tripartite body by including in the Memorandum of Understanding also CENELEC, which is responsible for the standardization of radio and television receivers. The EBU is a professional association of broadcasting organizations whose work includes the co-ordination of its Members' activities in the technical, legal, programme-making and programme-exchange domains. The EBU has Active Members in about 60 countries in the European Broadcasting Area; its headquarters is in Geneva\*.

\* European Broadcasting Union

Case Postale 67

CH-1218 GRAND SACONNEX (Geneva)

Switzerland

Tel: +41 22 717 21 11

Fax: +41 22 717 24 81

### Digital Video Broadcasting (DVB) Project

Founded in September 1993, the DVB Project is a market-led consortium of public and private sector organizations in the television industry. Its aim is to establish the framework for the introduction of MPEG-2 based digital television services. Now comprising over 200 organizations from more than 25 countries around the world, DVB fosters market-led systems, which meet the real needs, and economic circumstances, of the consumer electronics and the broadcast industry.

---

# 1 Scope

The present document specifies a mega-frame, including a mega-frame initialization packet (MIP), which may be used for synchronization of the Single Frequency Networks (SFN) as well as for the optional control of other important parameters in an SFN.

---

## 2 Normative references

References may be made to:

- a) specific versions of publications (identified by date of publication, edition number, version number, etc.), in which case, subsequent revisions to the referenced document do not apply; or
- b) all versions up to and including the identified version (identified by "up to and including" before the version identity); or
- c) all versions subsequent to and including the identified version (identified by "onwards" following the version identity); or
- d) publications without mention of a specific version, in which case the latest version applies.

A non-specific reference to an ETS shall also be taken to refer to later versions published as an EN with the same number.

- |     |   |
|-----|---|
| [1] | ISO/IEC 13818-1 (1994): "Information Technology - Generic Coding of Moving Pictures and Associated Audio: Systems".                       |
| [2] | ETS 300 744: "Digital Video Broadcasting (DVB); DVB framing structure, channel coding and modulation for digital terrestrial television". |

---

## 3 Definition and abbreviations

### 3.1 Definitions

For the purposes of the present document, the following definitions apply:

**frame:** For the definition of a DVB-T frame, see ETS 300 744 [2], subclause 4.4.

**super-frame:** For the definition of a DVB-T super-frame, see ETS 300 744 [2], subclause 4.4.

### 3.2 Abbreviations

For the purposes of the present document, the following abbreviations apply:

CRC	Cyclic Redundancy Check
DVB	Digital Video Broadcasting
DVB-T	DVB-Terrestrial
ERP	Effective Radiated Power
GPS	Global Positioning System
HP	High Pass (filter)
LP	Low Pass (filter)
MFN	Multi Frequency Network
MFP	Mega-Frame Packet
MIP	Mega-frame Initialization Packet
MPEG	Moving Pictures Expert Group
PID	Packet IDentifier

pps	pulse per second
RF	Radio Frequency
RS	Reed-Solomon
SFN	Single Frequency Network
SI	Service Information
STS	Synchronization Time Stamp
SYNC	SYNChronization
TPH	Transport Packet Header
TPS	Transport Parameter Signalling
TS	Transport Stream
TX/RX	Transmitter/Receiver

## 4 General description

Figure 1 shows a block diagram of a complete SFN system.

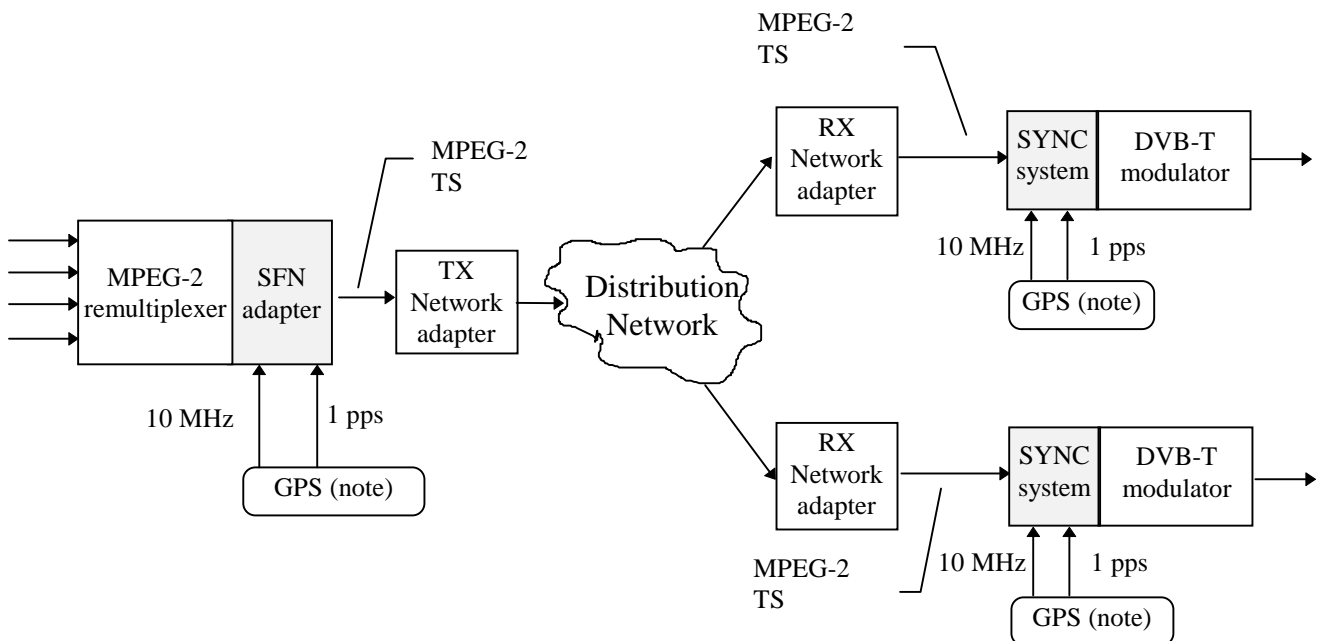

NOTE: Could be any common available frequency reference.

**Figure 1: DVB-T primary distribution with SFN adaptation**

The SFN functionality is an extension to the DVB system. The blocks associated with SFN functionality are the grey boxes in figure 1. These blocks could be implemented either as separate equipment or integrated in the multiplexer and/or the DVB-T modulator.

### SFN system blocks

#### MPEG-2 re-multiplexer

The MPEG-2 re-multiplexer re-multiplexes the programmes from various input channels, updates the SI and provides an MPEG-2 TS which, after SFN adaptation, is transmitted via the DVB-T modulators in the SFN.

#### SFN adapter

The SFN adapter forms a mega-frame, consisting of  $n$  TS-packets corresponding to 8 DVB-T frames in the 8k mode or 32 frames in the 2k mode, and inserts a Mega-frame Initialization Packet (MIP) with a dedicated PID value. Inserted anywhere within a mega-frame of index  $M$ , the MIP of that mega-frame,  $MIP_M$ , allows to uniquely identify the starting

point (i.e. the first packet) of the mega-frame  $M+1$ . This is accomplished by using a pointer carried by the  $MIP_M$  itself to indicate its position with regards to the start of the mega-frame  $M+1$ .

The time difference between the latest pulse of the "one-pulse-per-second" reference, derived e.g. from GPS, that precedes the start of the mega-frame  $M+1$  and the actual start (i.e. first bit of first packet) of this mega-frame  $M+1$  is copied into the  $MIP_M$ . This parameter is called Synchronization Time Stamp (STS).

The time duration of a mega-frame is independent of the duration  $T_u$ , constellation and code rate of the DVB-T signal. Four different time durations exist depending on the chosen guard interval proportion:

$$0,502656 \text{ s } (\Delta/T_u = 1/32);$$

$$0,517888 \text{ s } (\Delta/T_u = 1/16);$$

$$0,548352 \text{ s } (\Delta/T_u = 1/8);$$

$$0,609280 \text{ s } (\Delta/T_u = 1/4).$$

The output of the SFN adapter shall be fully DVB/MPEG-2 TS compliant.

### **Transmitter/Receiver network adapter**

The network adapters shall provide a transparent link for the MPEG-2 TS from the central to the local units. The maximum network delay - caused by the different paths of the transmission network - the SYNC system can handle is 1 second.

### **SYNC system**

The SYNC system will provide a propagation time compensation by comparing the inserted STS with the local time reference and calculate the extra delay needed for SFN synchronization. See annex B for an example of the synchronization process.

### **DVB-T modulator**

The modulator should provide a fixed delay from the input to the air interface. The information inserted in the MIP could be used for the direct control of the modulator modes or control of other transmitter parameters. The modulator clocks at the different sites have to be synchronized. Since it is a requirement of an SFN that all transmitted signals be identical, the MPEG-2 TS inputs to the various DVB-T modulators have to be bit identical.

### **Global Positioning System (GPS)**

GPS is one among many possible time references but it is the only one available globally. GPS receivers are available which provide both a 10 MHz frequency reference and a 1 pulse per second (1 pps) time reference. The 1 pps time reference, used in SFN synchronization, is divided into 100 ns steps of the 10 MHz clock. The 10 MHz system clock is assumed to be available at all nodes in the network.

The functional blocks "SFN adapter" and "SYNC system" are additional elements for SFN use, and not necessary in MFN applications.

## **5 Mega-frame definition**

The output of the SFN adapter shall be a valid MPEG-2 (TS), where the individual packets are organized in groups, which constitute a mega-frame. Each mega-frame consists of  $n$  packets, where  $n$  is an integer number which depends on the number of RS-packets per super-frame in the DVB-T mode that will be used for DVB-T emission of the MPEG-2 TS (see ETS 300 744 [2], subclause 4.7. In the 8k mode  $n$  is (the number of RS-packets per super-frame)  $\times 2$ . In the 2k mode  $n$  is (the number of RS-packets per super-frame)  $\times 8$ .

Each mega-frame contains exactly one Mega-frame Initialization Packet (MIP). The actual position may vary in an arbitrary way from mega-frame to mega-frame. The pointer value in the MIP is used to indicate the start of the following mega-frame. In figure 2 the overall structure of the mega-frame, including the positioning of the MIP, is given. The exact definition of the MIP format is given in clause 6.





## 6 Mega-frame Initialization Packet (MIP)

The MIP is an MPEG-2 compliant Transport Stream (TS) packet, made up of a 4-byte header and a 184-byte data field. The organization of the MIP is shown in table 1.

**Table 1: Mega-frame Initialization Packet (MIP)**

Syntax	Number of bits	Identifier
<code>mega_frame_initialization_packet(){</code>		
<code>transport_packet_header</code>	32	bslbf
<code>synchronization_id</code>	8	uimsbf
<code>section_length</code>	8	uimsbf
<code>pointer</code>	16	uimsbf
<code>periodic_flag</code>	1	bslbf
<code>future_use</code>	15	bslbf
<code>synchronization_time_stamp</code>	24	uimsbf
<code>maximum_delay</code>	24	uimsbf
<code>tps_mip</code>	32	bslbf
<code>individual_addressing_length</code>	8	uimsbf
for (i=0;i<N;i++){		
<code>tx_identifier</code>	16	uimsbf
<code>function_loop_length</code>	8	uimsbf
for(i=0;i<N;i++){	8	uimsbf
<code>function()</code>		
}		
}		
<code>crc_32</code>	32	rpchof
for (i=0, i<N,i++){		
<code>stuffing_byte</code>	8	uimsbf
}		
}		
NOTE 1: Optional parameters are shown in <i>italic</i> .		
NOTE 2: All parameter values in the MIP <sub>M</sub> apply to mega-frame M+1, i.e. to the mega-frame pointed out by the pointer, except for the tps_mip which describes the parameters of mega-frame M+2. See annex C for details.		
NOTE 3: For the definition of the CRC decoder model, see annex A.		
NOTE 4: The length of a MIP shall always be 188 bytes.		

**transport\_packet\_header:** The transport\_packet\_header shall comply with ISO/IEC 13818-1 [1] subclause 2.4.3.2, table 2 and 3.

The PID value for the Mega-frame initialization Packet (MIP) shall be  $0 \times 15$ .

The payload\_unit\_start\_indicator is not used by the SFN synchronization function and shall be set to 1.

The transport\_priority value is not used by the SFN synchronization function and shall be set to 1.

The transport\_scrambling\_control value shall be set to 00 (not scrambled).

The adaptation\_field\_control value shall be set to 01 (payload only).

All other parameters are according to ISO/IEC 13818-1 [1] subclause 2.4.3.2.

The Transport Packet Header (TPH) is mandatory.

### Mandatory SFN parameters

**synchronization\_id:** The synchronization\_id is used to identify the synchronization scheme used (See table 2).

**Table 2: Signalling format for the synchronization\_id**

synchronization_id	Function
0x00	SFN synchronization
0x01-0xFF	Future use

**section\_length:** The section\_length specifies the number of bytes following immediately after the section\_length field until, and including, the last byte of the crc\_32 but not including any stuffing\_byte. The section\_length shall not exceed 182 bytes.

**pointer:** The pointer is a 2-byte binary integer indicating the number of transport packets between the MIP and the first packet of the succeeding mega-frame.

The range of the pointer depends on the DVB-T mode used for emission.

**periodic\_flag:** Indicates if a periodic or an aperiodic insertion of the MIP is performed. Periodic insertion means that the value of the pointer is not time varying. A "0" indicates aperiodic mode and a "1" indicates periodic mode. All SFN "SYNC systems" shall be able to handle both aperiodic and periodic mode.

**future\_use:** Reserved for future use.

**synchronization\_time\_stamp:** The synchronization\_time\_stamp of  $MIP_M$  contains the time difference, expressed as a number of 100 ns steps, between the latest pulse of the "one-pulse-per-second" reference (derived e.g. from GPS) that precedes the start of the mega-frame M+1 and the actual start (i.e. beginning of first bit of first packet) of this mega-frame M+1.

**maximum\_delay:** The maximum\_delay contains the time difference between the time of emission of the start of mega-frame M+1 of the DVB-T signal from the transmitting antenna and the start of mega-frame M+1 at the SFN adapter, as expressed by the value of its synchronization\_time\_stamp in the  $MIP_M$ . The value of maximum\_delay shall be larger than the sum of the longest delay in the primary distribution network and the delays in modulators, power transmitters and antenna feeders. The unit is 100 ns and the range of maximum\_delay is 0x000000-0x98967F, this equals a maximum delay of 1 second.

**tps\_mip:** The tps\_mip consists of 32 bits,  $P_0$ - $P_{31}$ . The relationship between the TPS as defined in ETS 300 744 [2] and tps\_mip as defined in the present document is described in table 3.

**Table 3: Relationship between TPS (as defined in ETS 300 744 [2]) and tps\_mip (as defined in the present document)**

Bit number (TPS)	Format	Purpose/Content	Bit number (tps_mip)
S <sub>0</sub>	see subclause 4.6.2.1, ETS 300 744 [2]	Initialization	Not used
S <sub>1</sub> - S <sub>16</sub>	0011010111101110 or 1100101000010001	Synchronization word	Not used
S <sub>17</sub> - S <sub>22</sub>	010111	Length indicator	Not used
S <sub>23</sub> , S <sub>24</sub>	see table 12, ETS 300 744 [2]	Frame number	Not used
S <sub>25</sub> , S <sub>26</sub>	see table 13, ETS 300 744 [2]	Constellation	P <sub>0</sub> ,P <sub>1</sub>
S <sub>27</sub> , S <sub>28</sub> , S <sub>29</sub>	see table 14, ETS 300 744 [2]	Hierarchy information	P <sub>2</sub> ,P <sub>3</sub> ,P <sub>4</sub>
S <sub>30</sub> , S <sub>31</sub> , S <sub>32</sub>	see table 15, ETS 300 744 [2]	Code rate, HP stream	P <sub>5</sub> ,P <sub>6</sub> ,P <sub>7</sub>
S <sub>33</sub> , S <sub>34</sub> , S <sub>35</sub>	see table 15, ETS 300 744 [2]	Code rate, LP stream	P <sub>5</sub> ,P <sub>6</sub> ,P <sub>7</sub>
S <sub>36</sub> , S <sub>37</sub>	see table 16, ETS 300 744 [2]	Guard interval	P <sub>8</sub> ,P <sub>9</sub>
S <sub>38</sub> , S <sub>39</sub>	see table 17, ETS 300 744 [2]	Transmission mode	P <sub>10</sub> ,P <sub>11</sub>
S <sub>40</sub> - S <sub>53</sub>	all set to "0"	Reserved for future use	P <sub>15</sub> - P <sub>31</sub>
S <sub>54</sub> - S <sub>67</sub>	BCH code	Error protection	Not used
-	see table 4: "Signalling format for the bandwidth"	Bandwidth of the RF channel	P <sub>12</sub> ,P <sub>13</sub>
-	see table 5: "Signalling format for the bit stream priority"	The priority of the transport stream	P <sub>14</sub>
NOTE: There are 17 bits allocated for future use in tps_mip, whereas there are 14 bits allocated in the TPS of ETS 300 744 [2].			

**Table 4: Signalling format for the bandwidth**

Bits P <sub>12</sub> , P <sub>13</sub>	Bandwidth
00	7 MHz
01	8 MHz
10	reserved for future use
11	reserved for future use

**Table 5: Signalling format for the bit stream priority**

Bit P <sub>14</sub>	Transmission mode
0	Low Priority TS
1	High Priority TS

**P<sub>0</sub>-P<sub>13</sub>:** In case of inconsistent values of P<sub>0</sub>-P<sub>13</sub> for the High Priority and Low Priority Transport Streams, the HP value is valid. In case of change of DVB-T mode, see annex C for the time relationship between P<sub>0</sub>-P<sub>13</sub> and the TPS data of the DVB-T signal.

**individual\_addressing\_length:** The individual\_addressing\_length field gives the total length of the individual addressing field in bytes. If individual addressing of transmitters is not performed the field value is 0x00, indicating that the crc\_32 immediately follows the individual\_addressing\_length.

**crc\_32:** This 32 bit crc\_32 field contains the CRC value that gives a zero output of the registers in the decoder defined in annex A of the present document, after processing all 188 bytes of the MIP.

**stuffing\_byte:** Every stuffing\_byte has the value 0xFF.

## Optional MIP section parameters

**tx\_identifier:** The tx\_identifier is a 16 bit word used to address an individual transmitter. The tx\_identifier value 0x0000 is used as a broadcast address to address all transmitters in the network.

**function\_loop\_length:** The function\_loop\_length field gives the total length of the function loop field in bytes.

**function:** The functions are described in subclause 6.1.

## 6.1 Functions

Parameters common to all functions:

**function\_tag:** The function\_tag specifies the function identification.

**function\_length:** The function\_length field gives the total length of the function field in bytes.

Table 6 gives the function\_tag value for the functions defined in this document. All functions are optional and similar commands could be sent via a separate management network.

**Table 6: Tag value of functions**

Function	function_tag value
tx_time_offset_function	0x00
tx_frequency_offset_function	0x01
tx_power_function	0x02
private_data_function	0x03
Future_use	0x04-0xFF

### 6.1.1 Transmitter time offset function

The tx\_time\_offset\_function is used to apply a deliberate offset in time of the transmitted DVB-T signal, relative to the reference transmission time (STS+maximum\_delay) modulo  $10^7$ .

**Table 7: Function transmitter time offset**

Syntax	Number of bits	Identifier
tx_time_offset_function(){		
function_tag	8	uimsbf
function_length	8	uimsbf
time_offset	16	tcimsbf
}		

**time\_offset:** The deliberate time offset of the mega-frames. The unit is 100 ns. The range is  $[-32\ 768, 32\ 767] \times 100$  ns.

NOTE: The use of the complete range is not foreseen.

## 6.1.2 Transmitter frequency offset function

The `tx_frequency_offset_function` is used to apply a deliberate frequency offset of the centre frequency of the emitted DVB-T signal relative to the centre frequency of the RF channel.

**Table 8: Function transmitter frequency offset**

Syntax	Number of bits	Identifier
<code>tx_frequency_offset_function(){</code>		
<code>function_tag</code>	8	uimsbf
<code>function_length</code>	8	uimsbf
<code>frequency_offset</code>	24	tcimsbf
<code>}</code>		

**frequency\_offset:** The deliberate frequency offset relative to the centre frequency of the RF channel in use. The unit is 1 Hz. The range is  $[-8\ 388\ 608, 8\ 388\ 607] \times 1$  Hz.

NOTE: The use of the complete range is not foreseen.

## 6.1.3 Transmitter power function

The `tx_power_function` can be used to configure the transmitter ERP.

**Table 9: Function transmitter power**

Syntax	Number of bits	Identifier
<code>tx_power_function () {</code>		
<code>function_tag</code>	8	uimsbf
<code>function_length</code>	8	uimsbf
<code>power</code>	16	uimsbf
<code>}</code>		

**power:** The power of the transmitter is defined as the ERP. The unit is 0,1 dBm. The range is  $[0,65535] \times 0,1$  dBm.

NOTE: The use of the complete range is not foreseen.

## 6.1.4 Private data function

The `private_data_function` is used to send private data to the transmitters via the MIP.

**Table 10: Function private data**

Syntax	Number of bits	Identifier
<code>private_data_function(){</code>		
<code>function_tag</code>	8	uimsbf
<code>function_length</code>	8	uimsbf
<code>for (i=0;i&lt;N;i++){</code>		
<code>private_data</code>	8	bsb1f
<code>}</code>		
<code>}</code>		

**private\_data:** The private data can be used for proprietary functions.

## Annex A (normative): CRC decoder model

The 32-bit CRC decoder is specified in figure A.1.

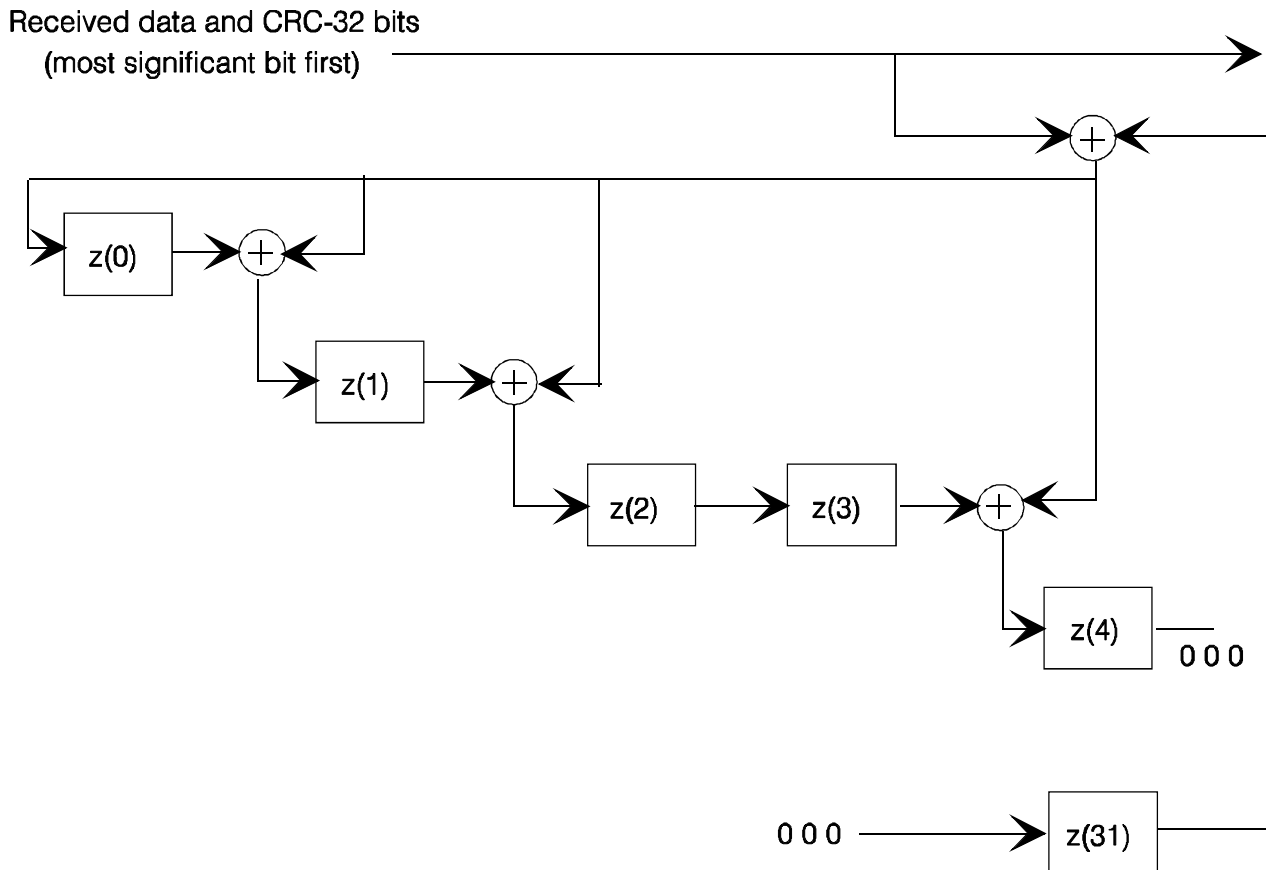

**Figure A.1: 32-bit CRC decoder model**

The 32 bit CRC decoder operates at bit level and consists of 14 adders + and 32 delay elements  $z(i)$ . The input of the CRC decoder is added to the output of  $z(31)$ , and the result is provided to the input  $z(0)$  and to one of the inputs of each remaining adder. The other input of each remaining adder is the output of  $z(i)$ , while the output of each remaining adder is connected to the input of  $z(i+1)$ , with  $i = 0, 1, 3, 4, 6, 7, 9, 10, 11, 15, 21, 22,$  and  $25$  (see figure A.1).

This is the CRC calculated with the polynomial:

$$x^{32} + x^{26} + x^{23} + x^{22} + x^{16} + x^{12} + x^{11} + x^{10} + x^8 + x^7 + x^5 + x^4 + x^2 + x + 1$$

At the input of the CRC decoder bytes are received. Each byte is shifted into the CRC decoder one bit at a time, with the most significant bit (msb) first, i.e. from byte 0x01 (the last byte of the start code prefix), first the seven "0"s enter the CRC decoder, followed by the one "1". Before the CRC processing of the data of a MIP the output of each delay element  $z(i)$  is set to its initial value "1". After this initialization, each byte of the MIP is provided to the input of the CRC decoder, including the four CRC\_32 bytes. After shifting the last bit of the last CRC\_32 byte into the decoder, i.e. into  $z(0)$  after the addition with the output of  $z(31)$ , the output of all delay elements  $z(i)$  is read. In case of no errors, each of the outputs of  $z(i)$  has to be zero. At the CRC encoder the CRC\_32 field is encoded with such value that this is ensured.

## Annex B (normative): Functional description of SFN synchronization

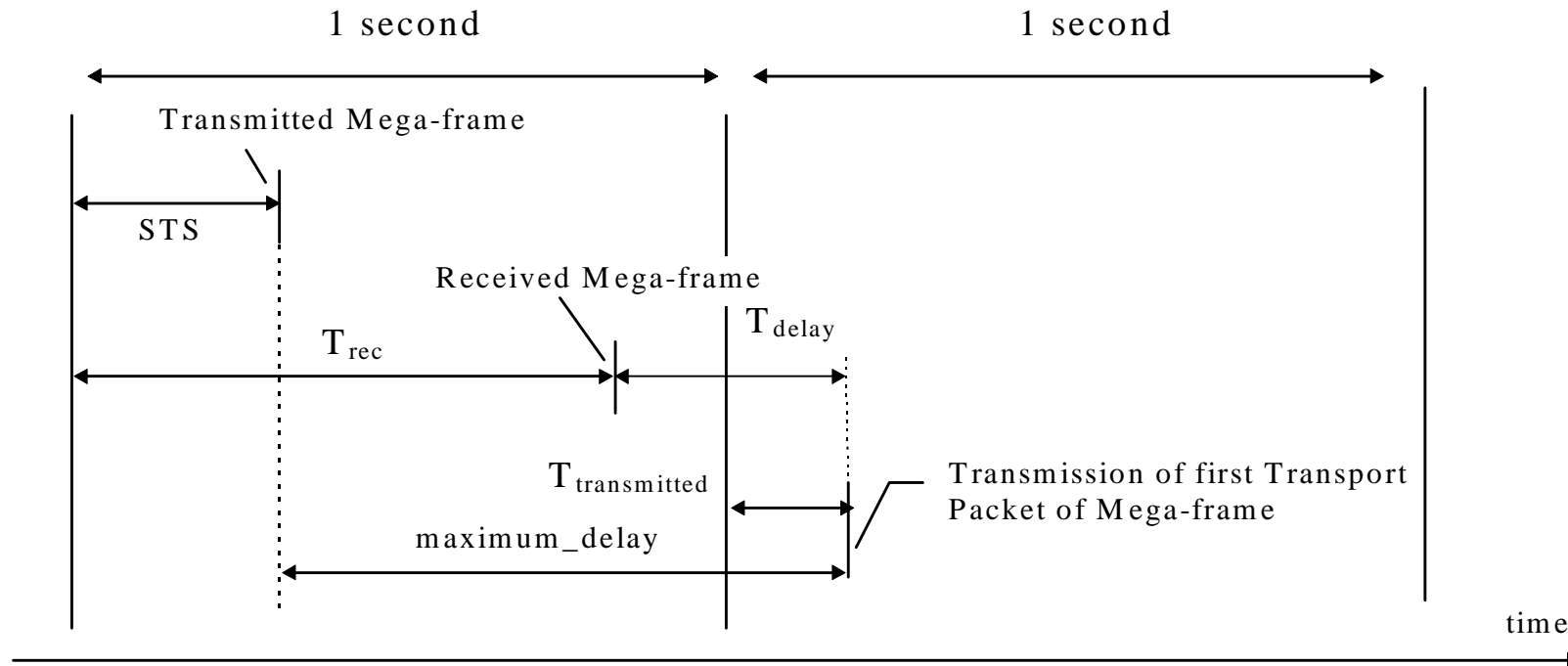

All values are in 100 ns (10 MHz clock)

$$T_{transmitted} = (STS + maximum\_delay) \text{ modulo } 10^7 \text{ (from transmitter)}$$

$$T_{delay} = STS + maximum\_delay - T_{rec}$$

Figure B.1

## Annex C (normative): Reconfiguration of DVB-T modulator parameters by using the MIP

The  $tps\_mip$  bits  $P_0$ - $P_{14}$ , inserted in the MIP at the multiplexer, are used to reconfigure the parameters of the DVB-T modulator. The bits  $P_0$ - $P_{11}$  are also transmitted as the TPS bits  $s_{25}$  -  $s_{39}$  of the DVB-T signal, as information to the receiver. In ETS 300 744 [2], it is stated that the TPS information transmitted in super-frame  $m'$  bits  $s_{25}$  -  $s_{39}$  always apply to super-frame  $m'+1$ , whereas all other bits refer to super-frame  $m'$ . In order to define a non-ambiguous switch time the following shall apply: Inserted in the MIP being sent in mega-frame 1, the  $tps\_mip$  describes the parameters of mega-frame 3. The DVB-T modulator will thus be able:

- first to update the data carried by its TPS carriers at the start of the last (i.e. the second in the 8k mode, and the 8 th in the 2k mode) super frame of mega-frame 2;
- then to update its new configuration at the start of mega-frame 3.

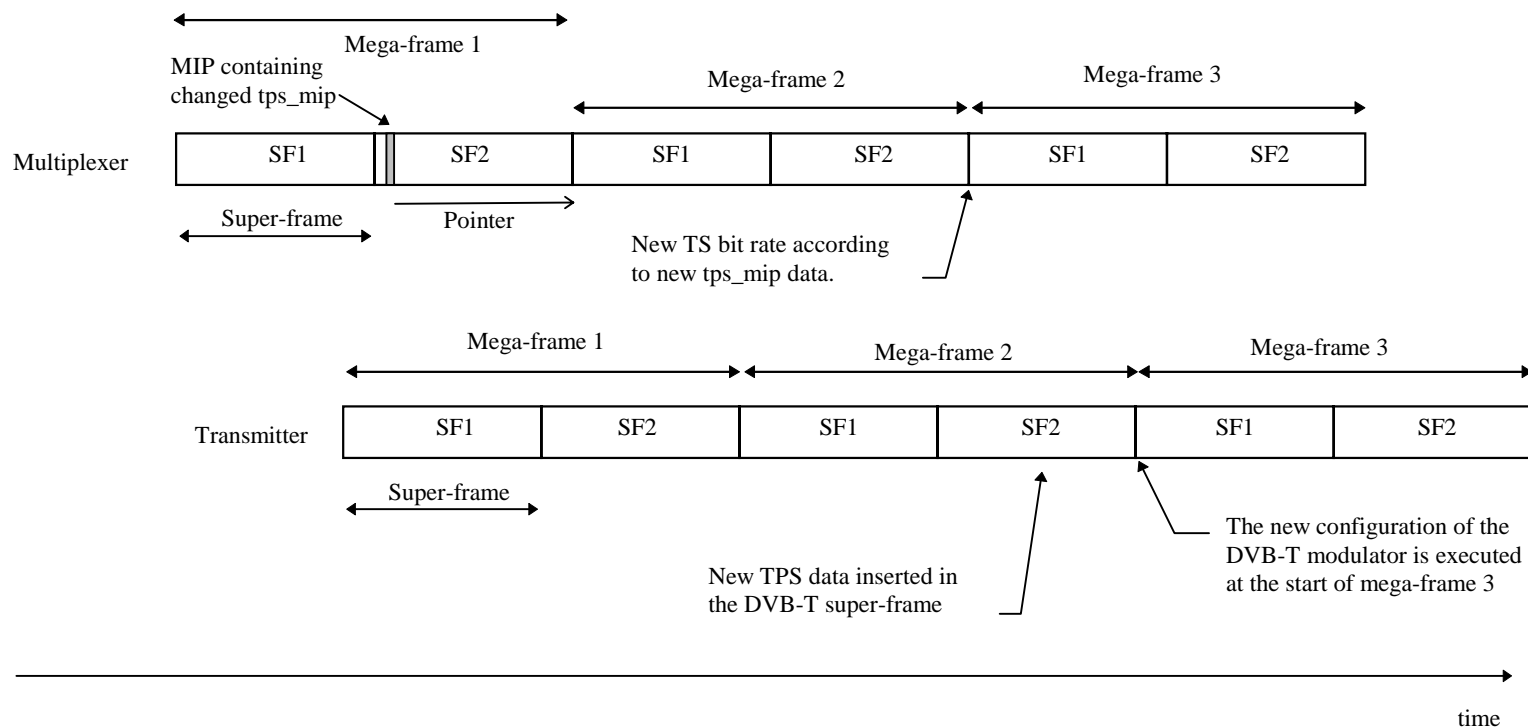

Figure C.1: Reconfiguration of DVB-T modulator parameters by using the MIP



---

## History

<b>Document history</b>		
Version 1.1.1	April 1997	Publication