

TS 101 270-1 V1.1.2 (1998-06)

Technical Specification

**Transmission and Multiplexing (TM);
Access transmission systems on metallic access cables;
Very high speed Digital Subscriber Line (VDSL);
Part 1: Functional requirements**



Reference

RTS/TM-06003-1A (brc90idf.PDF)

Keywords

access, ATM, B-ISDN, transmission, VDSL

ETSI

Postal address

F-06921 Sophia Antipolis Cedex - FRANCE

Office address

650 Route des Lucioles - Sophia Antipolis
Valbonne - FRANCE
Tel.: +33 4 92 94 42 00 Fax: +33 4 93 65 47 16
Siret N° 348 623 562 00017 - NAF 742 C
Association à but non lucratif enregistrée à la
Sous-Préfecture de Grasse (06) N° 7803/88

Internet

secretariat@etsi.fr
<http://www.etsi.fr>
<http://www.etsi.org>

Copyright Notification

No part may be reproduced except as authorized by written permission.
The copyright and the foregoing restriction extend to reproduction in all media.

© European Telecommunications Standards Institute 1998.
All rights reserved.

Contents

| | |
|---|----|
| Intellectual Property Rights..... | 6 |
| Foreword | 6 |
| 1 Scope..... | 7 |
| 2 References..... | 8 |
| 3 Definitions, symbols and abbreviations | 9 |
| 3.1 Definitions | 9 |
| 3.2 Symbols | 9 |
| 3.3 Abbreviations..... | 10 |
| 4 Reference configuration and description | 11 |
| 4.1 General..... | 11 |
| 4.2 Functional decomposition | 14 |
| 4.2.1 The α and β interfaces..... | 14 |
| 4.2.2 Elemental information flows across the α and β interfaces..... | 15 |
| 4.2.2.1 Data flow | 15 |
| 4.2.2.2 Synchronization flow..... | 15 |
| 4.2.2.3 Link Control Flow | 16 |
| 4.2.2.4 Link Performance and Path Characterization flow | 16 |
| 4.2.2.5 VDSL TPS-TC performance information flow..... | 16 |
| 5 Operations and Maintenance..... | 16 |
| 5.1 VDSL Link Control | 16 |
| 5.2 Embedded Operations Channel..... | 16 |
| 6 ElectroMagnetic Compatibility..... | 17 |
| 7 Climatic requirements | 17 |
| 8 Transceiver specific requirements | 17 |
| 8.1 Classes of operation | 17 |
| 8.2 Frequency plan..... | 17 |
| 8.3 Transceiver interface..... | 18 |
| 8.3.1 Impedance | 19 |
| 8.3.2 Return loss..... | 19 |
| 8.3.3 Balance about earth..... | 19 |
| 8.3.4 Wideband launch power..... | 19 |
| 8.3.5 Power spectral density..... | 19 |
| 8.3.5.1 Mask M1 (notched) | 20 |
| 8.3.5.2 Mask M2 (unnotched) | 21 |
| 8.3.6 A-B leg (tip-ring) reversal | 21 |
| 8.4 Transmitter power back-off | 21 |
| 8.4.1 Upstream back-off..... | 21 |
| 8.4.2 Downstream back-off..... | 21 |
| 8.5 Transceiver latency | 22 |
| 8.5.1 Trade-off between channel latency and impulse noise immunity | 22 |
| 8.5.2 Single latency mode | 22 |
| 8.5.3 Dual latency mode..... | 22 |
| 8.5.4 Measuring latency | 22 |
| 8.6 Remote powering | 22 |
| 8.7 Power-down mode | 22 |
| 8.8 Repeated operation | 23 |
| 8.9 Payload bit-rates | 23 |
| 9 Transmission performance..... | 23 |
| 9.1 Test procedure | 23 |
| 9.1.1 Test set-up definition..... | 24 |
| 9.1.2 Signal and noise level definitions..... | 25 |

| | | |
|---------|--|----|
| 9.2 | Test loops..... | 25 |
| 9.3 | Impairment generator..... | 27 |
| 9.3.1 | Functional description..... | 27 |
| 9.3.2 | Cable cross-talk models..... | 29 |
| 9.3.3 | NEXT noise model [G1]..... | 30 |
| 9.3.4 | FEXT noise model [G2]..... | 30 |
| 9.3.5 | Background noise models [G3.xx]..... | 31 |
| 9.3.5.1 | Background noise model [G3.LT.A]..... | 31 |
| 9.3.5.2 | Background noise model [G3.NT.A]..... | 31 |
| 9.3.5.3 | Background noise model [G3.LT.B]..... | 31 |
| 9.3.5.4 | Background noise model [G3.NT.B]..... | 32 |
| 9.3.5.5 | Background noise models [G3.LT.C] and [G3.NT.C]..... | 32 |
| 9.3.5.6 | Background noise models [G3.LT.D] and [G3.NT.D]..... | 33 |
| 9.3.6 | White noise model [G4]..... | 34 |
| 9.3.7 | Broadcast RF noise models [G5.xx]..... | 34 |
| 9.3.7.1 | Broadcast RF noise model [G5.LT.A]..... | 34 |
| 9.3.7.2 | Broadcast RF noise model [G5.NT.A]..... | 34 |
| 9.3.7.3 | Broadcast RF noise model [G5.LT.B]..... | 35 |
| 9.3.7.4 | Broadcast RF noise model [G5.NT.B]..... | 35 |
| 9.3.8 | Amateur RF noise models [G6.xx]..... | 35 |
| 9.3.8.1 | Specification of all Amateur RF noise models..... | 35 |
| 9.3.8.2 | Amateur RF noise model [G6.LT.A]..... | 36 |
| 9.3.8.3 | Amateur RF noise model [G6.NT.A]..... | 36 |
| 9.3.8.4 | Amateur RF noise model [G6.LT.B]..... | 36 |
| 9.3.8.5 | Amateur RF noise model [G6.NT.B]..... | 36 |
| 9.3.9 | Impulse noise model [G7]..... | 36 |
| 9.4 | Transmission Performance tests..... | 37 |
| 9.4.1 | Measuring noise margin..... | 37 |
| 9.4.2 | Bit error ratio requirements..... | 37 |
| 9.4.3 | Upstream tests..... | 37 |
| 9.4.4 | Downstream tests..... | 38 |
| 9.5 | Micro interruptions..... | 39 |
| 10 | Core..... | 39 |
| 10.1 | Activation/deactivation..... | 39 |
| 10.1.1 | Activation/deactivation definitions..... | 39 |
| 10.1.2 | Timing requirements..... | 41 |
| 11 | Spectral compatibility..... | 41 |
| 11.1 | Adjacent wire-pairs..... | 41 |
| 11.2 | Same wire-pair..... | 42 |
| 11.3 | Symmetric versus asymmetric VDSL..... | 42 |
| 12 | Splitter filter..... | 42 |
| 13 | Application specific requirements..... | 44 |
| 13.1 | ATM transport mode..... | 44 |
| 13.1.1 | Latency..... | 44 |
| 13.1.2 | Cell Delay Variation..... | 44 |
| 13.1.3 | TPS-TC requirements..... | 44 |
| 13.1.4 | Payload bit rates..... | 45 |
| 13.1.5 | OAM requirements..... | 45 |
| 13.2 | SDH transport mode at sub STM-1 rates..... | 45 |
| 13.2.1 | Dual Latency..... | 45 |
| 13.2.2 | Jitter and Wander..... | 45 |
| 13.2.3 | TPS-TC Requirements..... | 45 |
| 13.2.4 | Payload bit-rate..... | 45 |
| 13.2.5 | OAM requirements..... | 45 |

| | | |
|-------------------------------|---|-----------|
| Annex A (informative): | Line constants for the test loop-set | 46 |
| Annex B (informative): | Telephony matching impedance..... | 48 |
| B.1 | Germany | 48 |
| B.2 | United Kingdom..... | 48 |
| Annex C (informative): | Proposed changes to CISPR 22 standard..... | 49 |
| Annex D (informative): | Cable information..... | 50 |
| | Bibliography | 51 |
| | History | 52 |

Intellectual Property Rights

IPRs essential or potentially essential to the present document may have been declared to ETSI. The information pertaining to these essential IPRs, if any, is publicly available for **ETSI members and non-members**, and can be found in SR 000 314: *"Intellectual Property Rights (IPRs); Essential, or potentially Essential, IPRs notified to ETSI in respect of ETSI standards"*, which is available **free of charge** from the ETSI Secretariat. Latest updates are available on the ETSI Web server (<http://www.etsi.fr/ipr> or <http://www.etsi.org/ipr>).

Pursuant to the ETSI IPR Policy, no investigation, including IPR searches, has been carried out by ETSI. No guarantee can be given as to the existence of other IPRs not referenced in SR 000 314 (or the updates on the ETSI Web server) which are, or may be, or may become, essential to the present document.

Foreword

This Technical Specification (TS) has been produced by ETSI Technical Committee Transmission and Multiplexing (TM).

The present document is currently intended to be a three part specification as follows:

- Part 1: "Functional requirements";**
- Part 2: "Transceiver specification";
- Part 3: "Interoperability specification".

This version 1.1.2 has been prepared to correct editorial errors in tables A.1 and A.2, present in version 1.1.1.

1 Scope

The present document specifies requirements for transceivers providing very high bit-rate digital transmission on metallic, unshielded, access network wire pairs. The technology is referred to as Very high speed Digital Subscriber Line (VDSL).

The present document is part 1 of the specification for VDSL and is applicable to metallic access transmission systems designed to provide multi-megabit/s digital access over part of the existing, unshielded, metallic access network. It is concerned with the key functional and electrical requirements for VDSL. It is linecode independent and is intended to set the boundary requirements which all compliant VDSL transceivers will be required to meet. Part 2 is concerned with requirements on linecode and duplexing method which will enable the requirements of part 1 to be met. Part 3 is a full interoperability specification for VDSL, designed to ensure that VDSL transceivers from different manufacturers can inter-operate.

The definition of physical interfaces is outside the scope of this specification. However, if an appropriate interface for a specific application is found, it may be included in order to better describe the mapping functionality. The VDSL transmission system, in its most basic form, consists of an application independent core and an application specific block.

The core is purely a transparent STM bit-pump or ATM cell-pump which transports information from one end of the metallic access link to the other. The digital data is mapped into a core frame which is defined logically and not physically. The core frame is therefore considered to be the interface between the application specific and the application independent part of the VDSL system. The application specific part may be subdivided into (at least) two smaller parts: mapping and interface.

The scope of the present document is shown graphically in figure 1 and figure 2, where the Network Termination (NT) and Line Termination (LT) are considered separately.

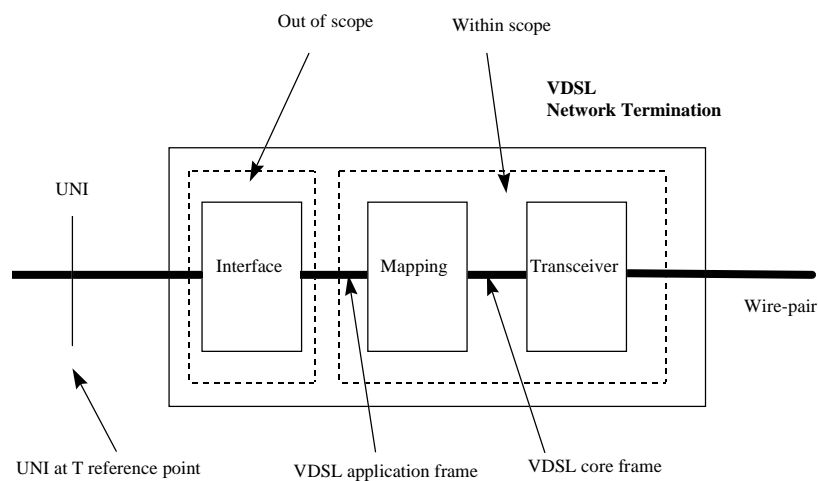

Figure 1: NT reference model scope

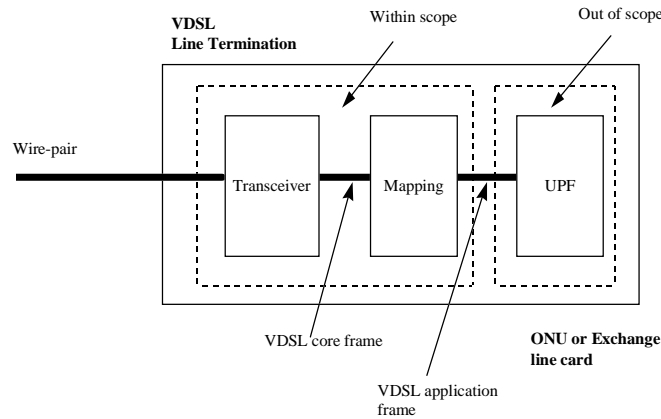

Figure 2: LT reference model scope

2 References

The following documents contain provisions which, through reference in this text, constitute provisions of the present document.

- References are either specific (identified by date of publication, edition number, version number, etc.) or non-specific.
- For a specific reference, subsequent revisions do not apply.
- For a non-specific reference, subsequent revisions do apply.
- A non-specific reference to an ETS shall also be taken to refer to later versions published as an EN with the same number.

[1] ANSI T1.413 Issue 1 (1995): "Asymmetric Digital Subscriber Line (ADSL)".

NOTE: This document is to be updated to Issue 2 during 1998.

- [2] CENELEC EN 55022 (1994): "Limits and methods of measurement of radio disturbance characteristics of information technology equipment".
- [3] CENELEC EN 61000-4-6 (1996): "Electromagnetic compatibility (EMC) Part 4: Testing and measuring techniques Section 6: Immunity to conducted disturbances, included by radio-frequency fields".
- [4] ETR 080 (1993): "Transmission and Multiplexing (TM); Integrated Services Digital Network (ISDN) basic rate access; Digital transmission on metallic local lines".
- [5] ETS 300 001: "Attachments to the Public Switched Telephone Network (PSTN); General technical requirements for equipment connected to an analogue subscriber interface in the PSTN".
- [6] TBR 021: "Terminal Equipment (TE); Attachment requirements for pan-European approval for connection to the analogue Public Switched Telephone Networks (PSTNs) of TE (excluding TE supporting the voice telephony service) in which network addressing, if provided, is by means of Dual Tone Multi Frequency (DTMF) signalling".
- [7] ETS 300 019-1: "Equipment Engineering (EE); Environmental conditions and environmental tests for telecommunications equipment; Part 1: Classification of environmental conditions".

- [8] ETS 300 019-1-3: "Equipment Engineering (EE); Environmental conditions and environmental tests for telecommunications equipment; Part 1-3: Classification of environmental conditions; Stationary use at weatherprotected locations".
- [9] ETS 300 019-2: "Equipment Engineering (EE); Environmental conditions and environmental tests for telecommunications equipment; Part 2: Specification of environmental conditions".
- [10] ITU-T Recommendation G.703 (1991): "Physical/electrical characteristics of hierarchical digital interfaces".
- [11] ITU-T Recommendation G.704 (1995): "Synchronous frame structures used at 1544, 6312, 2048, 8488 and 44 736 kbit/s hierarchical levels".
- [12] ITU-T Recommendation G.117 (1996): "Transmission aspects of unbalance about earth".
- [13] ITU-T Recommendation G.227 (1968): "Conventional telephone signal".
- [14] ITU-T Recommendation O.9 (1988): "Measuring arrangements to assess the degree of unbalance about earth".
- [15] ITU-T Recommendation Q.552 (1996): "Transmission characteristics at 2-wire analogue interfaces of digital exchanges".

3 Definitions, symbols and abbreviations

3.1 Definitions

For the purposes of the present document, the following definitions apply:

clear channel: a transparent bit or byte pipe.

crest factor: peak to RMS voltage ratio.

FTTCab: used to define when VDSL LT transceivers located physically at a node (normally the Cabinet or PCP) in the periphery of the access network.

FTTEx: used to define when VDSL LT transceivers located physically at the serving Local Exchange.

Downstream: transmission in the direction of LT towards NT (network to customer premise).

Upstream: transmission in the direction of NT towards LT (customer premise to network).

3.2 Symbols

For the purposes of the present document, the following symbols apply:

| | |
|-----------|---|
| Z_M | Compromise reference impedance for the VDSL splitter (usually complex) |
| Z_0 | Characteristic impedance of the test loop |
| R_V | VDSL source/load design impedance (purely resistive) |
| f_L | Lower frequency limit of the VDSL operating band |
| f_{L-3} | Lower frequency -3 dB point of the VDSL signal |
| f_H | Upper frequency limit of the VDSL operating band |
| f_{H-3} | Upper frequency -3 dB point of the VDSL signal |
| f_I | Upper frequency limit of the passband for existing narrow-band transmission systems |
| f_T | Test loop calibration frequency for setting the insertion loss of the loop |

3.3 Abbreviations

For the purposes of the present document, the following abbreviations apply:

| | |
|----------|---|
| 2B1Q | Baseband linecode for ISDN-BA (4-PAM) |
| 4B3T | Alternative ISDN-BA baseband linecode with higher frequency spectrum than 2B1Q |
| ADC | Analogue to Digital Converter |
| ADSL | Asymmetric DSL (1,5-8 Mbps downstream, and up to 640 kbps upstream simultaneously over a single wire-pair carrying analogue POTS). |
| AM | Amplitude Modulation |
| AMI | Alternate Mark Inversion |
| ANSI | American National Standards Institute |
| ATM | Asynchronous Transfer Mode |
| BER | Bit Error Ratio |
| CER | ATM Cell Error Ratio |
| CF | Crest Factor |
| CISPR | Committee Internationale Special Radio Perturbation |
| CO | Central Office (Local Exchange) |
| CPE | Customer Premise Equipment |
| CRC | Cyclic Redundancy Check |
| D/S | Downstream (Network to Customer direction) |
| DC | Direct Current |
| DPS | Dynamic Power Saving |
| DSL | Digital Subscriber Line (or Loop) |
| EM | Element Manager |
| EMC | ElectroMagnetic Compatibility |
| EMI | ElectroMagnetic Interference |
| EOC | Embedded Operations Channel |
| ETSI | European Telecommunication Standards Institute |
| FDD | Frequency Division Duplex |
| FEC | Forward Error Correction |
| FEXT | Far-end crosstalk |
| FSAN | Full Services Access Network |
| FTTCab | Fibre To The Cabinet (see definitions) |
| FTTEx | Fibre to the Exchange (see definitions) |
| Gx | FSAN Group of partners |
| HAPI | Hypothetical Application Independent Interface |
| HDB3 | Linecode for ISDN-PRA, Digital Private or Trunk circuits (similar to AMI) |
| HDSL | High bit-rate Digital Subscriber Line (1, 2 or 3 wire-pairs presenting G.703/G.704 2 Mbps symmetric data rates or 2 wire-pairs carrying T1 to a DS1 interface). |
| IL | Insertion Loss |
| ISDN | Integrated Services Digital Network |
| ISDN-BA | ISDN Basic-rate Access (2B+D) |
| ISDN-PRA | ISDN Primary Rate Access |
| ISN | Impedance Stabilization Network |
| kbps | kilo bits per second (1 kbps = 1 000 bits per second = 1 kbit/s) |
| LCL | Longitudinal Conversion Loss |
| LCTL | Longitudinal Conversion Transfer Loss |
| LEx | Local Exchange or Central Office |
| LT | Line Termination |
| Mbps | Mega bits per second (1 Mbps = 1 000 kbps = 1000 kbit/s) |
| NEXT | Near-end crosstalk |
| NT | Network Termination (at the customer premise end of the line) |
| NTR | Network Timing Reference |
| OAM | Operations, Administration and Maintenance |
| O&M | Operations and Management |
| ONU | Optical Network Unit |
| PAM | Pulse Amplitude Modulation |
| PCM | Pulse Code Modulation |
| PE | Poly-Ethylene |

| | |
|--------|--|
| PEP | Peak Envelope Power |
| PLOAM | Physical Layer Operations, Administration and Maintenance |
| PMD | Physical Media Dependent |
| PMS | Physical Media Specific |
| PMS-TC | Physical Media Specific-Transmission Convergence |
| POTS | Plain Old Telephony Service |
| PRC | Payload Rate Change |
| PSD | Power Spectral Density (usually quoted in dBm/Hz, and in the present document is restricted to single sided PSDs). |
| PVC | Poly Vinyl Chloride |
| QoS | Quality of Service |
| RF | Radio Frequency |
| RFI | Radio Frequency Interference |
| RMS | Root Mean Square |
| SDH | Synchronous Digital Hierarchy |
| SNR | Signal to Noise Ratio |
| STM | Synchronous Transfer Mode |
| SW | Short Wave |
| TBD | To Be Decided |
| TC | Transmission Convergence |
| TDD | Time Division Duplex |
| TE | Terminal Equipment |
| Telco | Telecommunications Network Operator |
| TELE | Telephone port for the VDSL splitter |
| TMN | Telecommunication Management Network |
| TPS | Transmission Protocol Specific |
| TPS-TC | Transmission Protocol Specific-Transmission Convergence |
| TS | (ETSI) Technical Specification |
| U/S | Upstream (Customer to Network direction) |
| UNI | User Network Interface |
| UPF | User Port Function |
| VDSL | Very high speed Digital Subscriber Line |
| xDSL | Generic term covering the family of all DSL technologies, e.g. DSL, HDSL, ADSL, VDSL |

4 Reference configuration and description

4.1 General

Figures 3 and 4 show the reference model used for VDSL. It is essentially a Fibre to the Node architecture with an Optical Network Unit (ONU) sited in the existing metallic access network (or at the serving Local Exchange or Central Office). Existing unscreened twisted metallic access wire-pairs are used to convey the signals to and from the customers premises. This architectural model covers both short- and long-range options for the VDSL.

The model provides two or four data channels with bit rate under the control of the network operator, consisting of one or two downstream and one or two upstream channels. A single channel in each direction can be of high latency/low BER or lower latency/higher BER. Dual channels in each direction provides one channel of each type. The dual latency configuration is thought to be the minimum that is capable of supporting a sufficient full service set, although there are organizations supporting both the single latency model with programmable latency, and others requesting more than two channels/latencies. The model assumes that Forward Error Correction (FEC) will be needed for part of the payload and that deep interleaving will be required to provide adequate protection against impulse noise for transport of digitally encoded motion picture signals. The VDSL transceiver shall also be required to transport delay sensitive services (e.g. POTS/Video conferencing). The model introduces service-split functional blocks to accommodate shared use of the physical transmission media for both VDSL and either POTS or ISDN-BA. The rationale behind this is that network operators are then free to evolve their networks in one of two ways: complete change out or overlay. An active Network Termination (NT) provides termination of the point-to-point VDSL transmission system and presents a standardized set of User Network Interfaces (UNIs) at the customer's premises. The NT provides the network operator with the ability to test the network up to the UNI at the customer's premises in the event of a fault condition or via night time routing. The home wiring transmission system is currently outside the scope of the present document.

It is envisaged that VDSL will find applications in the transport of various protocols. Different Transport Protocol Specific - Transmission Convergence Layer (TPS-TC) specifications shall be developed for these applications. This specification covers functional requirements for ATM and STM (SDH) transport. However the VDSL core transceiver shall be capable of supporting future additional applications, for example packet modes. VDSL transceivers shall be required to transport ATM cells to and from broadband customer premise equipment. This is a prime Telco requirement for Full Services Access Networks (see Bibliography, [I-1] and [I-2]). The VDSL ATM TC shall adopt the same methods as described in [1] and shall only deviate, where there are good reasons for an alternative solution.

Furthermore, VDSL transceivers shall be required to transport SDH containers and associated network timing reference(s). This would appear to be an essential functional requirement for STM (SDH) transport. It is not a requirement that SDH and ATM are transported simultaneously.

Any existing narrowband services shall not be affected by failure of power to the broadband NT. This may imply that the splitter filter is of a passive nature not requiring external power in order to provide frequency separation of the VDSL and existing narrowband signals. Further requirements concerning the splitter filter may be found in clause 12.

POTS shall continue to be powered from the existing exchange node and a DC path is required from the local exchange to the customer telephone. Similarly a DC path is required for ISDN-BA in order that emergency power can be provided by the local exchange for one ISDN terminal to function for lifeline service.

POTS and ISDN-BA cannot exist simultaneously on the same pair at present. Network Operators may provide one or the other but not both over a single wire-pair. The use of VDSL on access lines without existing narrowband services is not precluded, but is currently outside the scope of the present document.

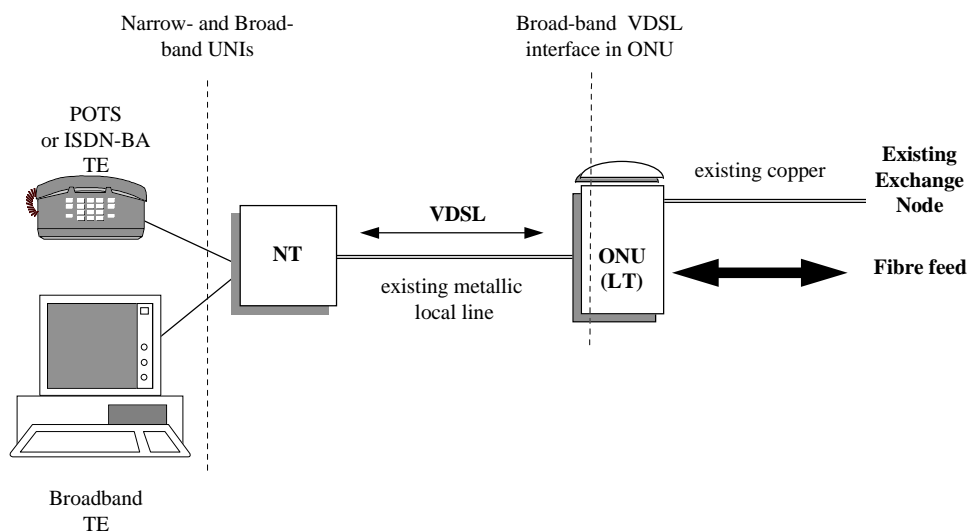
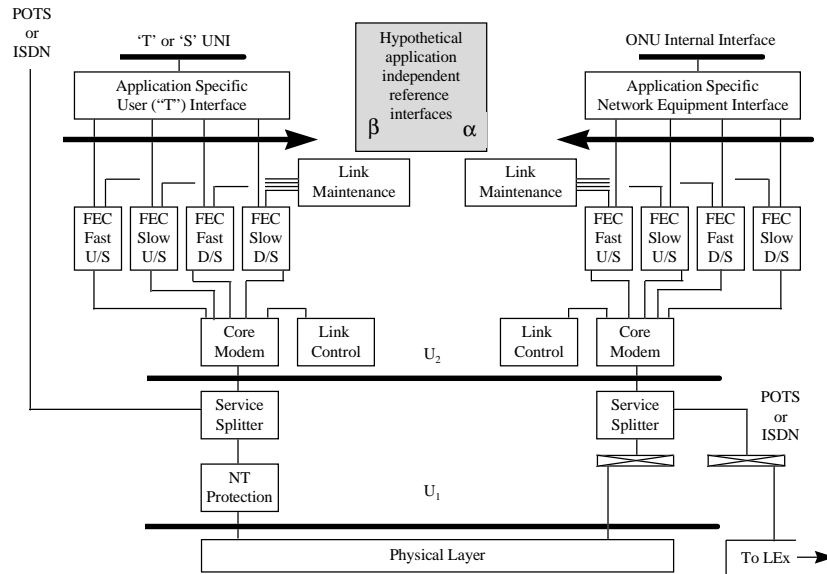

Figure 3: General reference model

Figure 4 shows the VDSL reference model and the various logical and physical interfaces between a VDSL transceiver at the NT and the LT ends of the access link. The α and β interfaces of HAPI interface are shown. The HAPI is only required for performance evaluation purposes and may not be embodied in every VDSL transceiver. For convenience, dual latency paths are shown in both the up- and downstream directions (see note to figure 4).

A VDSL transceiver is not required to implement the ONU internal interface or the broadband UNI. However, this is not precluded by the present document. Link maintenance is required to enable Operations, Administration and Maintenance (OAM) information flows between the LT and NT transceivers. U_2 is the transceiver physical interface and U_1 is the wire-pair interface.



NOTE: It is not compulsory to implement both the fast and slow channels. Single channels with programmable latency are equally acceptable.

Figure 4: VDSL reference model

Figure 5 shows the VDSL application reference model and the functional elements covered by the present document.

NOTE: The full definition of TPS-TC interfaces (γ -R and γ -O) are outside the scope of the present document. However key functional requirements are listed with reference to the particular application under consideration (see clause 13).

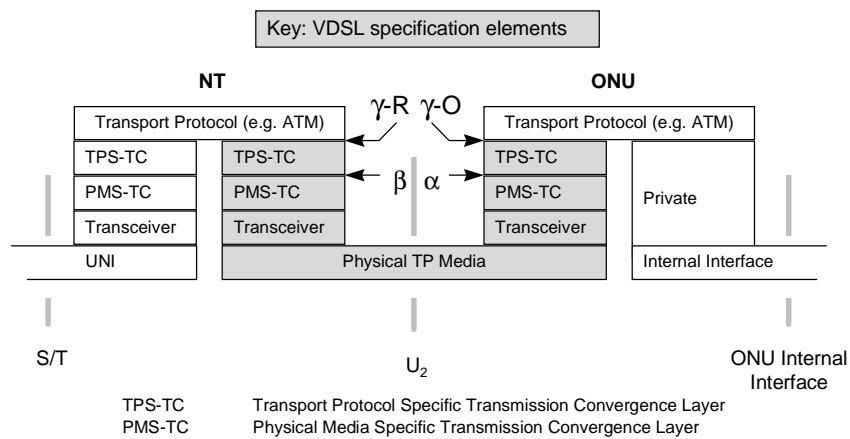
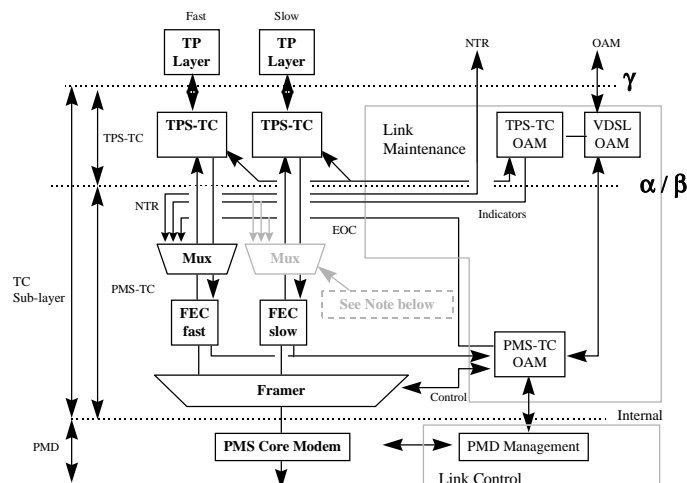

Figure 5: VDSL application reference model

4.2 Functional decomposition

4.2.1 The α and β interfaces

The Hypothetical Application Independent Interface (HAPI) is embodied in the α and β interfaces which apply to the LT and NT ends of the VDSL link respectively. Further requirements relating to the HAPI are given in clause 13.



NOTE 1: It is not compulsory to implement both the fast and slow channels. Single channels with programmable latency are equally acceptable.

NOTE 2: The EOC may be in the fast or slow channel or potentially in a separate TC sub-layer. The actual implementation of the EOC channel is modulation dependent and is the subject of further study.

Figure 6: Generic VDSL functional reference model

Figure 6 above shows the generic functional reference model which indicates the disposition of major functions partitioned by the α and β interfaces. These interfaces define the separation between the application dependent Transport Protocol Specific (TPS) part and the application independent Physical Media Specific (PMS) core transceiver parts of the VDSL transmission system.

The TPS part includes transport protocol layer functions outside the scope of this specification, and transport protocol specific transmission convergence layer functions (TPS-TC).

The application independent part contains Physical Media Specific transmission convergence layer functions (PMS-TC), and transceiver (PMD) functions.

By convention the PMS-TC, TPS-TC, and transceiver layers are assumed to include applicable OAM functions. The overall VDSL link maintenance functions are associated with the application dependent part. Figure 7 shows the VDSL reference points and the scope of the OAM.

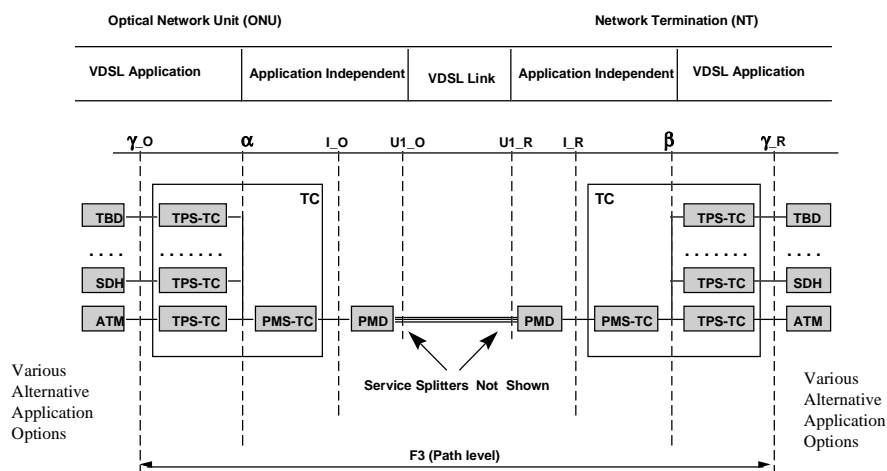

Figure 7: VDSL reference points and OAM scope

4.2.2 Elemental information flows across the α and β interfaces

Five elemental information flows across the α and β interfaces are identified:

- data flow;
- synchronization flow;
- link control flow;
- link performance and path characterization flow;
- VDSL TPS-TC performance information flow.

4.2.2.1 Data flow

The data flow shall be supported by one or two data pipes with different error protection properties and therefore different latency characteristics; it shall be byte oriented and the data shall be treated as unstructured by the application independent part.

4.2.2.2 Synchronization flow

This flow provides the means through which synchronization between the PMD level and the TC level is performed. The different considered items are:

- Data (bit synchronization or byte synchronization or other synchronization flows);
- Performance and Path Characterization Primitives;
- Control and Performance Parameters (asynchronous);
- Network Timing Reference.

With the exception of Control and Performance parameter passing synchronization flows are based on a fixed timing regime. Synchronization of Control and Performance Parameter passing is implied by a message transfer protocol.

4.2.2.3 Link Control Flow

The Link Control flow comprises all the relevant control, configuration and status messages for VDSL link. A non-exhaustive list of Control Primitives is (common to both the α and β interfaces):

- Activation;
- Deactivation;
- Alarms and Anomalies (e.g. Dying Gasp);
- Link status;
- Synchronization status.

Control Parameters may include the Requested Data Rate, Link Status parameters and specific bandwidth allocation parameter (at the α interface).

4.2.2.4 Link Performance and Path Characterization flow

The Link Performance and Path Characterization flow provides all the relevant performance and physical characteristics of the VDSL link.

Performance Primitives typically report defects and errors (e.g. Loss of Signal, Loss of Frame, FEC anomalies etc.) and Performance Parameters include counts of errored blocks, CRC and FEC anomalies.

Typical Path Characterization Parameters are the line attenuation, the Signal to Noise Ratio (SNR) and the Return Loss.

4.2.2.5 VDSL TPS-TC performance information flow

The application independent part shall provide means for transporting indication of remote anomalies detected in the TPS-TC (such as loss of cell delineation in the case of ATM), not relying on the correct operation of the remote TPS TC sub-layer.

5 Operations and Maintenance

5.1 VDSL Link Control

VDSL transceivers shall be capable of sending and receiving pre-defined messages intended for operation and maintenance of the VDSL transmission link. Successful reception of a message shall always be acknowledged by the receiving transceiver. The sending transceiver shall continue to repeat the message until it is successfully acknowledged by the receiving transceiver. The full definition of the protocol is outside the scope of the present document.

5.2 Embedded Operations Channel

The application independent part shall provide a full duplex Embedded Operations Channel (EOC) capable of supporting OAM flows. Operations and Maintenance (OAM) functions relating to the PMD and PMS-TC. Loop-back functionality shall be supported at the TPS-TC layer.

The EOC shall support the transport of indicator states to support the status and performance monitoring of the VDSL PMD layer. It shall provide a control channel to allow management of link characteristics (e.g. transport rates, latency, low-power mode, spectrum utilization etc.).

The payload data rate of the EOC shall not be less than 24 kbps and not more than 64 kbps. It shall be able to operate in a clear channel mode, which is a duplex, transparent bit or byte pipe.

6 ElectroMagnetic Compatibility

The system shall meet the ElectroMagnetic Compatibility (EMC) directive 89/336/EEC. These requirements are further detailed in references EN 55022 [2] and CENELEC EN 61000-4-6 [3]. annex C provides details on the accepted changes CISPR 22 [2] which are applicable to VDSL transceivers. EN 55022 may be updated as a result of changes to CISPR 22.

7 Climatic requirements

As VDSL may be deployed in the FTTCab model, it is necessary to specify the classes of climatic conditions in ETS 300 019 [7] and [9] that are applicable. ETS 300 019 consists of two main parts:

- Equipment Engineering; Environmental conditions and environmental tests for telecommunication equipment; Part 1: Classification of environmental conditions [7].
- Equipment Engineering; Environmental conditions and environmental tests for telecommunication equipment; Part 2: Specification of environmental tests [9].

For classification of environmental conditions, ETS 300 019-1-3 [8] contains five sub-classes, three of which are relevant to VDSL. These are:

- 3.1 Temperature controlled locations;
- 3.2 Partly temperature controlled locations;
- 3.3 Non-temperature controlled locations.

The requirements of the appropriate parts of ETS 300 019 relating to the design environment shall be met by VDSL transceivers.

8 Transceiver specific requirements

The transceiver related functional requirements detailed in this clause are independent of the application or service carried by the VDSL transceiver.

8.1 Classes of operation

Two classes of functional operation are defined for VDSL systems. A compliant VDSL transceiver shall be capable of meeting the requirements of either or both classes.

- Class I** VDSL transceivers which offer asymmetric data rates (i.e. much higher downstream than upstream data rate).
- Class II** VDSL transceivers which offer symmetric data rates (i.e. equal upstream and downstream data rates).

When claiming conformance to the requirements of clause 9 of the present document, the vendor shall quote whether the VDSL transceiver is compliant to class I or class II operation or both.

8.2 Frequency plan

VDSL systems shall operate within the limits of the frequency band f_L to f_H as shown in figure 8. It is important to confine the VDSL signals within these bands to power levels appropriate to ensure spectral compatibility with existing heritage xDSL metallic access systems such as ISDN-BA, HDSL and ADSL, and to prevent unnecessary radiated emissions and increased susceptibility at higher frequencies. Compatibility with existing narrowband services will set limits on the upper passband limit, f_T . This is defined in 11.2.

The limiting values for the VDSL transmission band are defined in table 1. The power spectral density upper limits attributed to the VDSL transceiver are specified further in 8.3.5 where "brick-wall" limits are shown.

Table 1: Upper and lower frequency limits for VDSL

| Class of VDSL operation | f_L lower limit (kHz) | f_H upper limit (MHz) |
|-------------------------|-------------------------|-------------------------|
| I (asymmetric) | 300 | 30 |
| II (symmetric) | 300 | 30 |

NOTE 1: Optimization of the lower frequency limit for VDSL (f_L) is very complex because of the need to ensure spectral compatibility with other xDSL transmission systems operating in the same cable plant (i.e. within the same multi-pair wire grouping) and is therefore the subject of more detailed further study.

NOTE 2: The operation of VDSL below the lower frequency limit (f_L) is not precluded, e.g. on new lines where existing narrowband services may not be present. However, this is beyond the scope of the present document and is subject of further study because it is closely linked to the issue of spectral compatibility. The issue of VDSL transmit energy polluting parts of the spectrum occupied by other xDSL systems (e.g. ADSL) may preclude the use of certain parts of the spectrum, especially in the VDSL upstream direction of transmission. For example, there may be situations where it is possible to use the lower frequencies especially if ADSL systems are not present in the same binder. However, in some circumstances where ADSL is present it may be prudent to place the start of the VDSL band above 1,1 MHz. This issue is complex and necessitates further study.

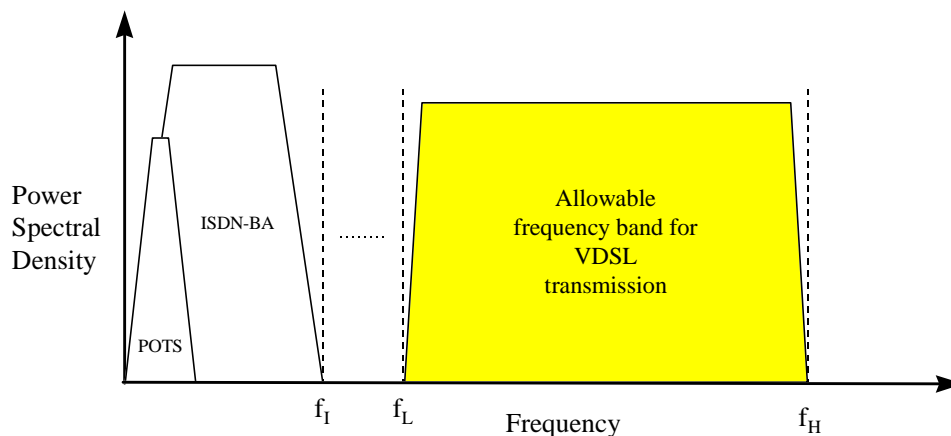

Figure 8: Frequency plan for VDSL

8.3 Transceiver interface

For compliance with the requirements of this clause the following interfaces are defined. These ports are shown in figure 21.

- TELE port:** The physical interface to POTS or ISDN-BA at the service splitter.
- VDSL port:** This port may be internal to the VDSL equipment where part(s) of the splitter are incorporated into ONU linecards or NTs. Physical access may or may not be available for test purposes.
- LINE port:** The physical interface to the wire-line.

8.3.1 Impedance

A reference source/load impedance of $R_V = 135 \Omega$ (i.e. purely resistive, $135 + j0 \Omega$) over the complete VDSL frequency band (f_L to f_H) shall be used for the design of both the LT and NT transceivers when matching to the metallic access wire-pair. This enables a compromise high-frequency impedance match to the various unshielded cable types encountered in European metallic access networks.

NOTE: The optional use of a more optimum impedance for specific countries or regions is not precluded.

8.3.2 Return loss

The minimum return loss requirement is defined to limit signal power uncertainties due to the tolerance of the line interface impedance.

NOTE: The return loss $1/\Gamma = (Z+R_V)/(Z-R_V)$ is an alternative way to specify an impedance (Z) normalized to the chosen design impedance. This makes impedance tolerance and minimum return loss similar quantities. Its definition is independent of the characteristic impedance Z_0 of the cable because VDSL can handle a wide range of cable types having significantly different Z_0 values.

The return loss of the VDSL transceiver, including the high pass part of the splitter (i.e. measured at the LINE port) shall be >20 dB (value subject to further study) from f_L to f_H when measured against a reference impedance of R_V .

8.3.3 Balance about earth

The equipment balance should be better than the anticipated cable balance in order to minimize the unwanted emissions and susceptibility to external RFI. The typical worst case balance for an aerial dropwire has been observed to be in the range 30 dB - 35 dB, therefore the VDSL equipment should be significantly better than this.

The transmitter source balance about earth shall be evaluated according to the LCTL method [14], [12].

The wire-line interface shall exhibit a balance of greater than 55 dB below f_L , and then falling at 6 dB/octave until intercepting 43 dB which is sustained until f_B (value under further study). The response above f_B up to f_H is also for further study. This shall be measured at any exposed port carrying a VDSL signal.

NOTE: A VDSL transceiver, when connected to poorly balanced aerial telephony wire-pairs, could emit levels of unwanted RF emissions which may, in some circumstances, cause interference to existing licensed users of the HF radio spectrum (e.g. SW listeners). The present document currently covers the requirements for VDSL transceivers operating over wire-pairs in normal operation (i.e. non-fault) where the balance of the wire-pair exceeds 30 dB.

8.3.4 Wideband launch power

For compliance with the requirements detailed in this subclause the VDSL transceiver shall be terminated in the design impedance (R_V) and be configured to transmit pseudo-random data with any repetitive framing patterns enabled. Power shall be measured across the termination resistance of R_V .

The average wideband power of the transmitted VDSL signal, measured over the frequency range 10 kHz to 30 MHz, shall be no greater than +11,5 dBm when measured into a termination impedance of R_V . This shall be measured at the LINE port. There should be no energy inserted into the TELE port during this test.

8.3.5 Power spectral density

A VDSL transceiver shall have the capability of operating according to the requirements of both transmitter PSD masks described in this subclause. The transmit PSD mask shown in figure 9 (Mask M1) is to be used by the Network Operator when ElectroMagnetic Interference (EMI) effects are strong and the transmit PSD mask shown in figure 10 (Mask M2) is to be used when EMI effects are weak. These masks are applicable at the LINE port when it is terminated in the standard source/load impedance R_V .

Class I and class II compliant transceivers shall be able to operate within the bounds set by the constraints of Mask M1 and Mask M2. For the purposes of compliance with this requirement, a measurement resolution bandwidth of 10 kHz (in line with standard EMC practice) shall be used.

NOTE: Masks M1 and M2 specify the maximum PSD limit to be -60 dBm/Hz. Further study may result in alternative mask(s) which will:

- allow consideration of a redefinition of the maximum PSD to enable low-frequency spectrum boosting but constrained within the same wideband launch power (+11,5 dBm);
- retain protection for the generation of unwanted RF emissions (e.g. Amateur Radio bands);
- retain spectral compatibility with other xDSL line systems used in metallic access networks.

8.3.5.1 Mask M1 (notched)

The maximum, single-sided, PSD shall be limited to -120 dBm/Hz in the band from DC to f_L and limited to -60 dBm/Hz within the VDSL band from f_L to 10 MHz (see 8.2). Notching is implemented in the internationally standardized amateur radio bands (see table 7) and the maximum allowable PSD shall be no greater than -80 dBm/Hz within these designated bands. Above 10 MHz the maximum allowable PSD shall decrease linearly with the logarithm of frequency to -120 dBm/Hz at f_H and beyond. The notching is provided to reduce the effect of unwanted radiated emissions from VDSL causing undue interference to existing licensed users of that part of the spectrum.

Figure 9 shows the limit of the maximum, single-sided PSD permitted by Mask M1.

Class I and II operation shall be possible within the power density constraints imposed by Mask M1.

NOTE: The negative gradient slope above 10 MHz is required to minimize unwanted RF emissions from aerial cables. It is recognized this may preclude use of the higher symmetrical rates (e.g. class II, S3 and S4 operation). This is the subject of further study.

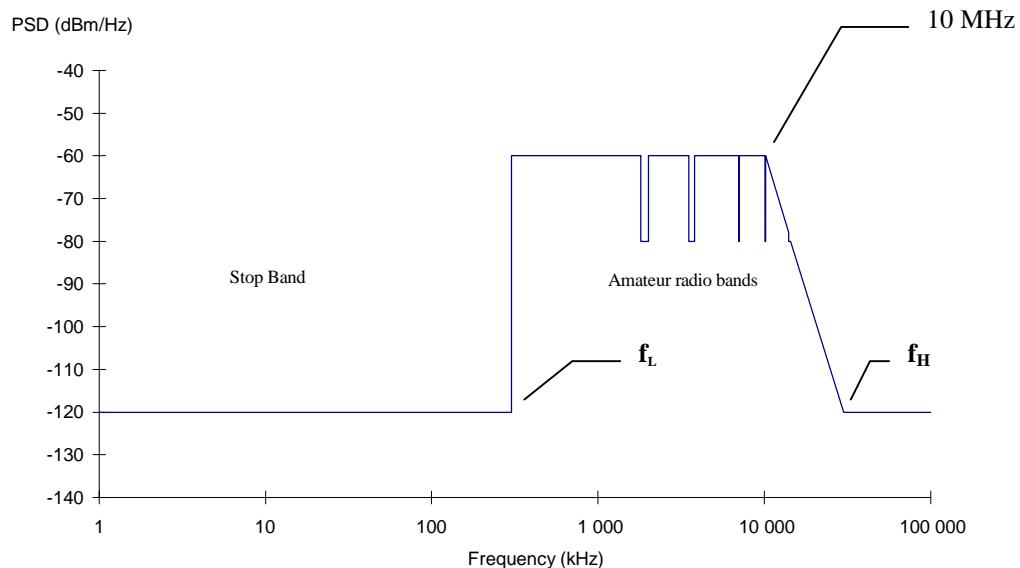

Figure 9: Maximum allowable PSD (Mask M1)

A VDSL transceiver conforming to the requirements of Mask M1 shall be able to reduce the PSD simultaneously to below -80 dBm/Hz in one or more of the internationally standardized Amateur Radio bands listed in table 7.

It is desirable to implement programmability of the notch frequencies to cater for national and regional variations.

8.3.5.2 Mask M2 (unnotched)

The maximum, single-sided, PSD is limited to -120 dBm/Hz from DC to f_L , and limited to -60 dBm/Hz within the VDSL band from f_L to f_H (see 8.2). At and above f_H the maximum PSD shall be limited to -120 dBm/Hz.

Class I and II operation shall be possible within the power density constraints imposed by Mask M2.

Figure 10 shows the limit of the maximum, single-sided PSD permitted by Mask M2.

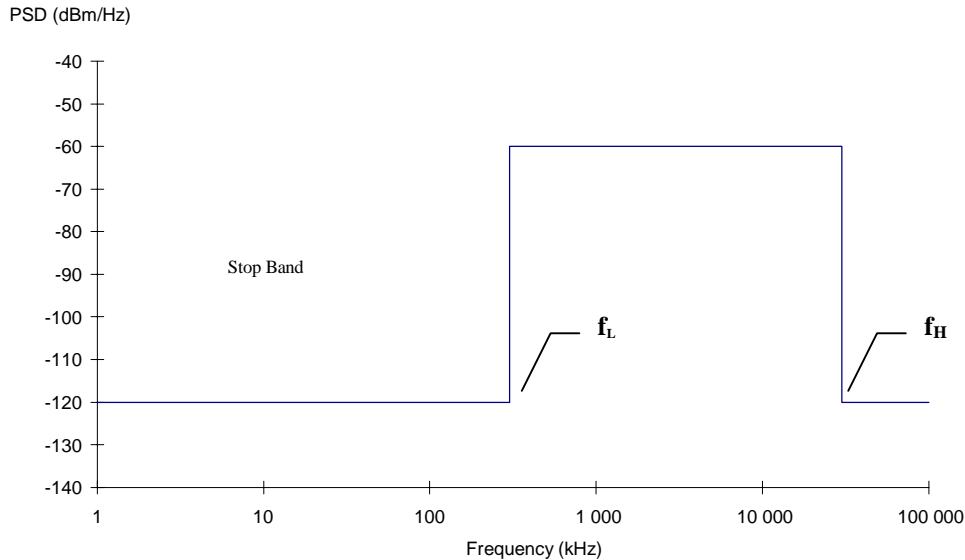

Figure 10: Maximum allowable PSD (Mask M2)

8.3.6 A-B leg (tip-ring) reversal

All requirements in the present document shall be unaffected by reversal of the A and B leg (or tip and ring) connections.

8.4 Transmitter power back-off

In order to prevent unwanted detrimental interactions between VDSL transceivers operating on the same multi-pair cable the ability to lower the transmitter power spectral density shall be provided.

The VDSL transmitter shall have an ability to reduce its transmit PSD whenever the required SNR margin at the corresponding receiver is exceeded significantly when the transmitter operates at its maximum PSD. The adjustment is attenuation to reduce the transmit spectrum below the maximum allowed. The minimum attenuation allowed is zero, i.e. if the system cannot obtain the specified SNR margin at a receiver then the corresponding transmitter will transmit at its maximum allowed power spectral density.

8.4.1 Upstream back-off

Back-off is required in the upstream direction, NT \rightarrow LT, so that crosstalk from systems on short lines does not unduly compromise service on long lines.

8.4.2 Downstream back-off

Back-off is required in the downstream direction, LT \rightarrow NT, to reduce the risk of interference with other xDSL systems running through the cabinet or node containing the VDSL system.

8.5 Transceiver latency

There are currently two options defined These are known as single latency mode and dual latency mode (see 8.5.2 and 8.5.3). It is not intended that both options are implemented within the same transceiver.

8.5.1 Trade-off between channel latency and impulse noise immunity

VDSL systems shall provide protection against disturbance from impulse noise. Furthermore they shall provide at least two levels of protection. The level of protection shall be set and controlled via the Network Management Element Manager. The lowest level of protection is required to support latency sensitive services such as voice, while the highest level is required to support burst error sensitive services such as entertainment video.

NOTE: Some network operators require more than two levels of protection.

A "low-latency" VDSL channel shall exhibit no greater than 1 ms delay (average of upstream and downstream) between the α and β interfaces. A "high-latency" VDSL channel shall have a programmable delay between the α to β interfaces. The maximum delay of 20 ms being capable of sustaining error free performance when the path is subject to a noise burst of up to 500 μ s (see 9.3.9). Optionally, it is permitted to operate with a maximum delay of up to 10 ms when subject to a noise burst of duration up to 250 μ s.

NOTE: The trade-off between latency and impulse noise tolerance is the subject of further study.

8.5.2 Single latency mode

In a "single-latency" configuration, all the VDSL system data payload capacity is dedicated to one channel.

A "single-latency" VDSL system shall provide programmable burst error protection which can provide protection from 1 ms to 10 ms in approximately 1 ms increments. Additional, higher levels of burst-error protection, or different intermediate levels of protection may be provided. Configuration of the burst error correction behaviour shall be provisioned via the Network Management Element Manager.

8.5.3 Dual latency mode

In a dual-latency configuration the VDSL system data payload capacity is divided between two channels - the "fast-channel" and "slow-channel".

A "dual-latency" VDSL system shall provide "low-latency" on the "fast-channel" and "high-latency" on the "slow-channel" concurrently. The configuration of the burst-error correction behaviour of both channels may be programmable via the Network Management Element Manager (in particular to provide various trade-offs between latency and burst error performance for the slow-channel).

The allocation of capacity between the "fast-channel" and "slow-channel" shall be configured at start-up via the Network Management Element Manager.

8.5.4 Measuring latency

Implementations shall provide the means to verify delay between the α to β interfaces for the purposes of laboratory design qualification testing, although this may require additional external hardware and software not required for normal use.

8.6 Remote powering

Remote powering (via. the wire-line) of the broadband VDSL transceiver located in the NT is not required. Existing narrowband services carried in the baseband shall not be affected by removal of local power to the broadband NT.

8.7 Power-down mode

A low-power and/or power down mode shall be provided when the transceiver is not in use (see 10.1).

8.8 Repeatered operation

Repeatered operation for VDSL transceivers is not required.

8.9 Payload bit-rates

The payload rates shown in table 2 shall be provided to ensure that the transmission performance requirements of the present document can be met. The line rate is left to the vendor, but it shall be sufficient to carry the additional overhead necessary to ensure that the transmission performance requirements can be met. The overhead will include components necessary for Forward Error Correction, maintenance channel, synchronization, etc.

Selection of the payload bit rate shall be performed according to one of the following two methods:

- 1) Selection is performed on installation by the Network Operator. The bit rate shall be fixed for the duration of service provision to the customer and would normally be governed by the Element Manager or TMN.
- 2) Selection is performed on installation as in method 1. However, the selected payload can be changed via a Payload Rate Change (PRC) procedure under the responsibility of an Operations and Management (O&M) entity under the control of the Network Operator. The purpose of this O&M is to guarantee that the PRC procedure will never induce network instability or increase spectral incompatibility between VDSL and other services.

NOTE 1: Customer control, or autonomous/dynamic rate adaptation, of the VDSL line rate is specifically excluded for reasons of increased likelihood of spectral incompatibility between different VDSL and other heritage xDSL systems operating in the same multi-pair cable.

Table 2: Payload bit-rates

| Class (code) of operation | Downstream (kbps) | Upstream (kbps) |
|---------------------------|--------------------|--------------------|
| Class I (A3) | $24 \times 1\,024$ | $4 \times 1\,024$ |
| Class I (A2) | $12 \times 1\,024$ | $2 \times 1\,024$ |
| Class I (A1) | $6 \times 1\,024$ | $2 \times 1\,024$ |
| Class II (S4) | $36 \times 1\,024$ | $36 \times 1\,024$ |
| Class II (S3) | $24 \times 1\,024$ | $24 \times 1\,024$ |
| Class II (S2) | $12 \times 1\,024$ | $12 \times 1\,024$ |
| Class II (S1) | $6 \times 1\,024$ | $6 \times 1\,024$ |

NOTE 2: Optionally, other payload data rates may be provided to enhance the granularity of operation. However, transmission performance at these payload rates remains undefined by the present document. The symmetric rates shown may not be efficient for SDH transport bit-rates such as MS1T, MS2T and MS4T and more rates may be added at a later date. This is the subject of further study.

9 Transmission performance

The performance requirements given in this clause shall be met by a VDSL transceiver operating in the specific payload mode outlined by the operation codes given in table 2.

9.1 Test procedure

The purpose of this subclause is to provide an unambiguous specification of the test set-up, the insertion path and the way signal and noise levels are defined. The tests are focused on the noise margin, with respect to the crosstalk noise or impulse noise levels when VDSL signals are attenuated by standard test-loops and interfered with standard crosstalk noise or impulse noise. This noise margin indicates what increase of crosstalk noise or impulse noise level is allowed under (country-specific) operational conditions to ensure sufficient transmission quality.

NOTE: The interpretation of noise margin, and the development of deployment rules based on minimum margin requirements under operational conditions, are not the responsibility of transceiver manufacturers. Nevertheless, it is recommended that manufacturers provide Network Operators with models that enable them to perform reliable predictions on transceiver behaviour under deviant insertion loss or crosstalk conditions. Different linecodes or duplexing techniques may behave differently.

9.1.1 Test set-up definition

Figure 11 illustrates the functional description of the test set-up. It includes:

- The test loops, as specified in 9.2;
- An adding element to add the impairment noise (a mix of random, impulsive and harmonic noise), as specified in 9.3;
- A high impedance, and well balanced (e.g. better than 60 dB across the whole VDSL band) differential voltage probe connected with level detectors such as a spectrum analyser or a true rms volt meter.

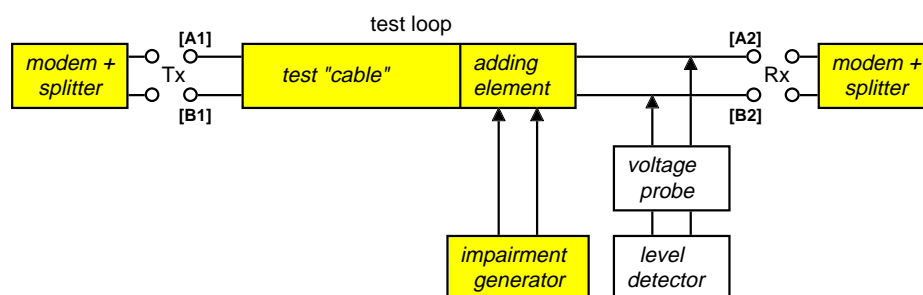

Figure 11: Functional description of the set-up of the performance tests

Test Loop #0 shall always be used for calibrating and verifying the correct settings of generators G1-G7 when performing performance tests.

The two-port characteristics (transfer function, impedance) of the test-loop, as specified in 9.2, is defined between port Tx (node pairs A1, B1) and port Rx (node pair A2, B2). The consequence is that the two-port characteristics of the test "cable" in figure 11 should be properly adjusted to take full account of non-zero insertion loss and non-infinite shunt impedance of the adding element and impairment generator. This is to ensure that the insertion of the generated impairment signals does not appreciably loads the line.

The balance about earth, observed at port Tx at port Rx and at the tips of the voltage probe shall exhibit a value that is 10 dB greater than the transceiver under test. This is to ensure that the impairment generator and monitor function does not appreciably deteriorate the balance about earth of the transceiver under test.

The signal flow through the test set-up is from port Tx to port Rx, which means that measuring upstream and downstream performance requires an interchange of transceiver position and test "cable" ends.

The received signal level at port Rx is the level, measured between node A2 and B2, when port Tx as well as port Rx are terminated with the VDSL transceivers under test. The impairment generator is switched off during this measurement.

The transmitted signal level at port Tx is the level, measured between node A1 and B1, under the same conditions.

The impairment noise shall be a mix of random, impulsive and harmonic noise, as defined in 9.3. The level that is specified in 9.3 is the level at port Rx, measured between node A2 and B2, while port Tx as well as port Rx are terminated with the design impedance R_V . These impedances shall be passive when the transceiver impedance in the switched-off mode is different from this value.

9.1.2 Signal and noise level definitions

The signal and noise levels are probed with a well balanced differential voltage probe, and the differential impedance between the tips of that probe shall be higher than the shunt impedance of 100 k Ω in parallel with 10 pF. Figure 11 shows the probe position when measuring the Rx signal level at the LT or NT receiver. Measuring the Tx signal level requires the connection of the tips to node pair (A1, B1).

NOTE: The various levels (or spectral masks) of signal and noise that are specified in the present document are defined at the Tx or Rx side of this set-up. The various levels are defined while the set-up is terminated, as described above, with design impedance R_V or with VDSL transceivers under test.

Probing an rms-voltage U_{rms} (V) in this set-up, over the full signal band, means a power level of P (dBm) that equals:

$$P = 10 \times \log_{10} (U_{\text{rms}}^2 / R_V \times 1\,000) \text{ dBm}$$

Probing an rms-voltage U_{rms} (V) in this set-up, within a small frequency band of Δf (in Hertz), means an average spectral density level of P (dBm/Hz) within that filtered band that equals:

$$P = 10 \times \log_{10} (U_{\text{rms}}^2 / R_V \times 1\,000 / \Delta f) \text{ (dBm/Hz)}$$

The bandwidth Δf identifies the noise bandwidth of the filter, and not the -3dB bandwidth.

9.2 Test loops

The purpose of the test loops shown in figure 12 is to stress VDSL transceivers in various ways; in particular to test the VDSL performance under quasi realistic circumstances. Loop #0 is a symbolic name for a loop with zero (or near zero) length, to prove that the VDSL transceiver can handle the potentially high signal levels when two transceivers are directly interconnected.

All other test loops in figure 12 have equal insertion loss at a specified test frequency, but differ in input impedance (see figure 13). It is these values for insertion loss and impedance that define an actual test loop set. The loops are not defined in terms of a specific physical length.

The impedances of Loop #1 and #2 are nearly constant over a wide frequency interval. These two loops represent uniform distribution cables, one having a relatively low characteristic impedance and another having a relative high impedance (low capacitance per unit length). These impedance values are chosen to be the lowest and highest values of 0,5 mm gauge distribution cables that are commonly used in Europe.

The impedances of Loop #3 and #4 follow frequency curves that are oscillating in nature. This represents the mismatch effects in distribution cables caused by a short extent with a cable that differs significantly in characteristic impedance. Loop #3 represents this at the LT side to stress downstream signals. Loop #4 does the same at the NT side to stress upstream signals.

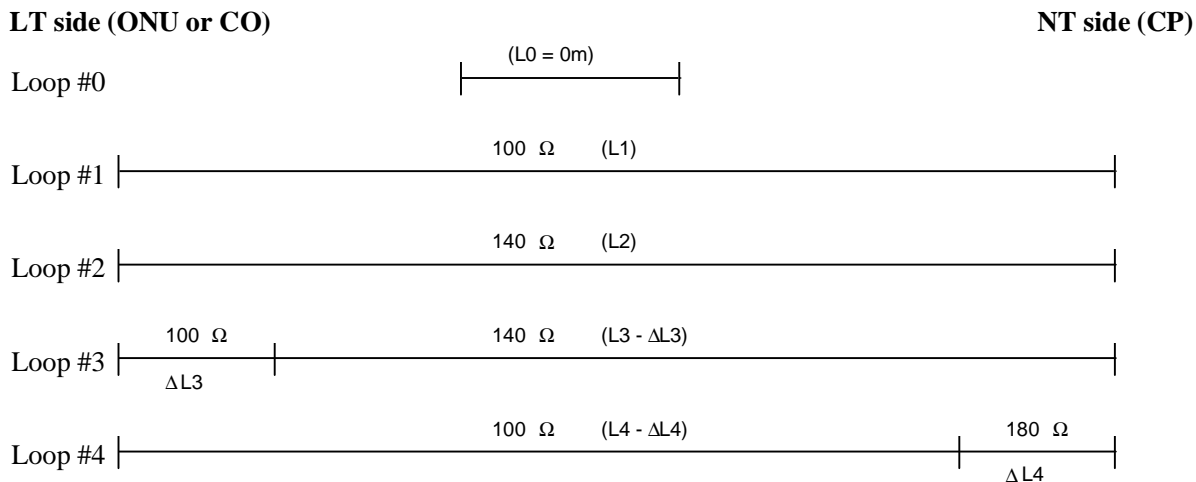

Figure 12: Test loop topology

The variation of input impedance for the various test loops is shown in figure 13. The transfer function of all the loops for each payload bit-rate is shown in figure 14.

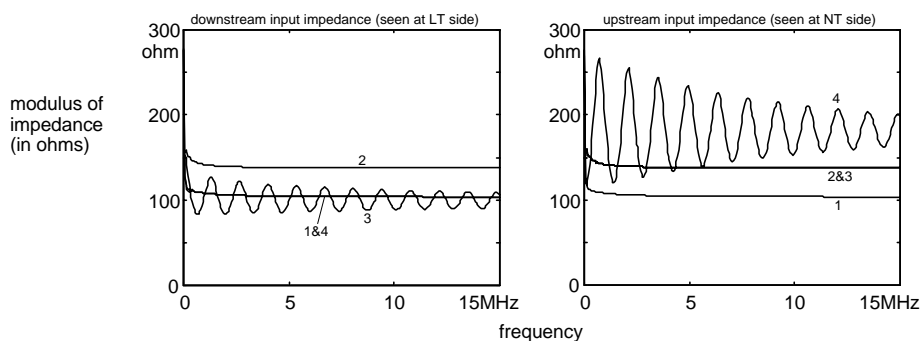

Figure 13: Calculated variation of input impedance, at a normalized loop length of 1 500 m

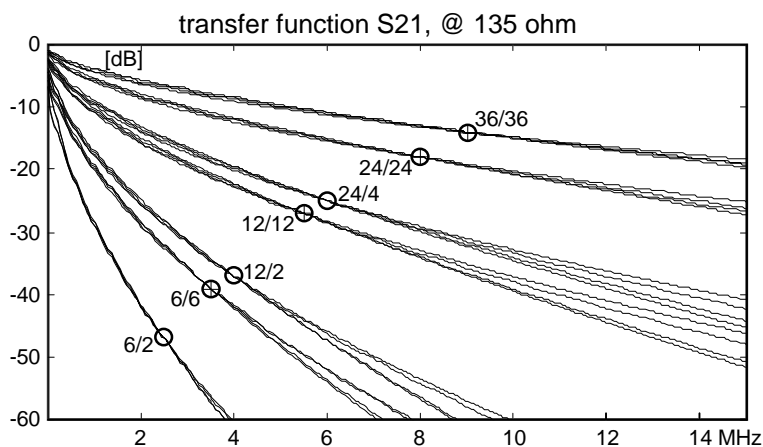

Figure 14: Transmission gain (in $135\ \Omega$) of the test-loops for various payload bit-rates

For each VDSL payload bit-rate, the virtual "length" of the individual test loop is defined in terms of a common insertion loss at resistance R_V , at a common test frequency (f_T). This frequency is chosen to be a typical high-band frequency that is used for transporting that payload bit-rate. The insertion loss is chosen as a typical maximum value that can be handled correctly by the VDSL transceiver. The higher the payload bit-rate, the lower the insertion loss is that can be handled in practice. This is because the crosstalk in real cables increases with the frequency. Table 3 specifies these insertion loss values for the different VDSL payload bit-rates at a fixed test frequency.

Table 3: Insertion loss and test frequencies (f_T) for loops #1 to #4, for various payload bit-rates

| VDSL payload code | Downstream payload bit-rate | Upstream payload bit-rate | Test frequency f_T | Insertion loss @135 Ω , @ f_T |
|---------------------|-----------------------------|---------------------------|----------------------|--|
| A1 (6N/2N) | 6 x 1 024 kbps | 2 x 1 024 kbps | 2,5 MHz | 47 dB |
| A2 (12N/2N) | 12 x 1 024 kbps | 2 x 1 024 kbps | 4,0 MHz | 37 dB |
| A3 (24N/4N) | 24 x 1 024 kbps | 4 x 1 024 kbps | 6,0 MHz | 25 dB |
| S1 (6N/6N) | 6 x 1 024 kbps | 6 x 1 024 kbps | 3,5 MHz | 39 dB |
| S2 (12N/12N) | 12 x 1 024 kbps | 12 x 1 024 kbps | 5,5 MHz | 27 dB |
| S3 (24N/24N) | 24 x 1 024 kbps | 24 x 1 024 kbps | 8,0 MHz | 18 dB |
| S4 (36N/36N) | 36 x 1 024 kbps | 36 x 1 024 kbps | 9,0 MHz | 14 dB |

NOTE: N=1 024 kbps.

The different cable sections are specified by reference models that serve as a template for real twisted-pair cables. The composition of the test-loops is specified in table 4. The associated models and line constants are specified in annex A. Cable simulators as well as real cables can be used for these test loops. In the case that real cables are used, their estimated physical lengths are summarized in annex A.

The magnitude of the test-loop insertion loss shall approximate the insertion loss of the specified models within 3% on a decibel scale, between $0,1 \times f_T$ and $3 \times f_T$.

The magnitude of the test-loop characteristic impedance shall approximate the characteristic impedance of the specified models within 7% on a linear scale, between $0,1 \times f_T$ and $f_T \times 3$.

Table 4: Test-loop composition

| Test loop | Distribution cable (L) | Extension cable (ΔL) LT or NT side | Extension length ΔL |
|-----------|------------------------|--|-----------------------------|
| #0 | - | - | - |
| #1 | "A" | - | - |
| #2 | "B" | - | - |
| #3 | "B" | "C" | 70 m |
| #4 | "A" | "D" | 70 m |

NOTE: The labels "A" to "D" refer to the cable models, specified in annex A: "A"=BT_dwug, "B"=KPN_L1, "C"=KPN_R2, "D"=BT_dw8.

9.3 Impairment generator

The impairment noise for VDSL performance tests is very complex and for the purposes of the present document it has been broken down into smaller, more easily specified components. These separate, and uncorrelated, impairment "generators" may therefore be isolated and summed to form the impairment generator for VDSL. The detailed specifications for the components of the noise model(s) are given in this subclause, together with a brief explanation.

9.3.1 Functional description

Figure 15 defines a functional diagram of the composite impairment noise. It defines a functional description of the combined impairment noise, as it should be probed at the receiver input of a VDSL transceiver under test. This probing is defined in 9.1.2.

The functional diagram has the following elements:

- The seven impairment "generators" G1 to G7 generate noise as defined in 9.3.3 to 9.3.9. Their noise characteristics are independent from the test-loops and bit-rates.
- The transfer function $H_1(f,L)$ models the length and frequency dependency of the NEXT impairment, as specified in 9.3.2. The transfer function is independent of the loop-set number, but changes with the normalized loop length. Its transfer function changes with the frequency f , roughly according to $f^{0,75}$.

- The transfer function $H_2(f,L)$ models the length and frequency dependency of the FEXT impairment, as specified in 9.3.2. Its transfer function is independent of the loop-set number, but changes with the normalized loop length. Its transfer function changes with the frequency f , roughly according to f times the cable transfer function.
- Switches S1-S7 determine whether or not a specific impairment generator contributes to the total impairment during a test.
- Amplifier A1 models the property to increase the level of some generators simultaneously to perform the noise margin tests as defined in 9.4.2. A value of x dB means a frequency independent increase of the level by x dB over the full VDSL band, from f_L to f_H . Unless otherwise specified, its gain is fixed at 0 dB.

In a practical implementation of the test set-up, there is no need to give access to any of the internal signals of the diagram in figure 15. These function blocks may be incorporated with the test-loop and the adding element as one integrated construction.

The average transfer function $s_{T0}(\omega,L)$ of the four test-loops is the s_{21} transfer function parameter in source/load resistance R_V of test-loop #1 at specified payload bit-rate. It is considered as an average of all the four loops, because all these loops are normalized in insertion loss at a specified test frequency.

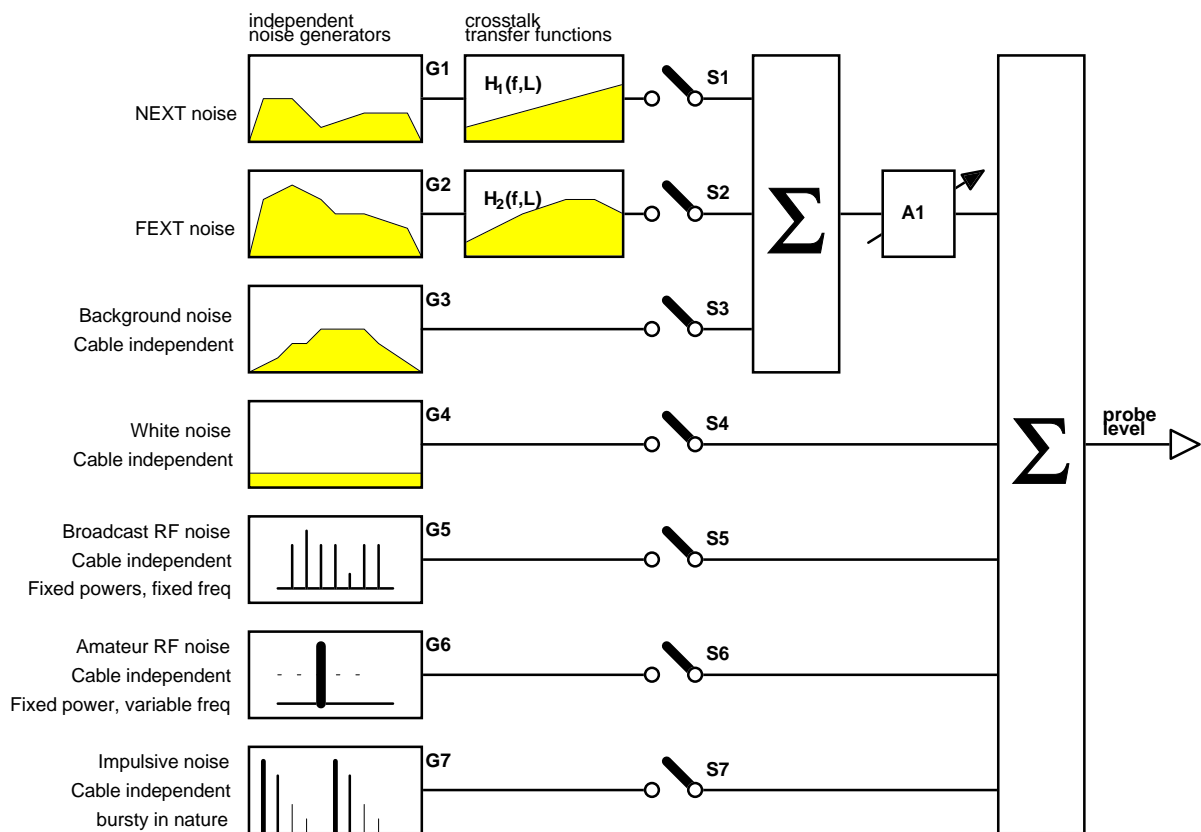

NOTE 1: Generator G7 is the only one which is symbolically shown in the time domain.

NOTE 2: The precise definition of impulse noise margin is for further study.

Figure 15: Functional diagram of the composition of the impairment noise

This functional diagram will be used for impairment tests in downstream and upstream direction. Some of the seven impairment "generators" G1 to G7 are therefore defined by more than one noise model. Each model is dedicated to a performance test, as specified in 9.4. These models are intended to be representative of the impairments found in metallic access networks.

NOTE: **Type "A" models** are intended to represent the situation where VDSL is placed at the Cabinet (i.e. outstationed electronics at the Cabinet - FTTCab). In this scenario VDSL is not co-located with other xDSL disturbers at the Cabinet (although pairs carrying these disturbers emanating from the Local Exchange may be running through the Cabinet). The type "LT.A" models are intended to be applied at the LT end of the test loops to stress the upstream transmission. The type "NT.A" models are intended to be applied at the NT end of the test loops to stress the downstream transmission.

Type "B" models are intended to represent the more harsh situation where VDSL is co-located with other xDSL disturbers (primarily at the Local Exchange but can also be used if xDSL systems are to be co-located at the Cabinet). The type "LT.B" models are intended to be applied at the LT end of the test loops to stress the upstream transmission. The type "NT.B" models are intended to be applied at the NT end of the test loops to stress the downstream transmission.

Type "C" models are intended to represent the situation where ISDN-PRA systems are present in the same multi-pair cable in addition to the environment described for type "A" models. The type "LT.C" models are to be applied at the LT end of the test loops to stress the upstream transmission. The type "NT.C" models are to be applied at the NT end of the test loops to stress the downstream transmission.

Type "D" models are intended to represent the situation where ISDN-PRA systems are present in the same multi-pair cable in addition to the environment described for type "B" models. The type "LT.D" models are to be applied at the LT end of the test loops to stress the upstream transmission. The type "NT.D" models are to be applied at the NT end of the test loops to stress the downstream transmission.

Each test has its own impairment specification. The overall impairment noise shall be characterized by the sum of the individual components as specified in the relevant subclauses. This combined impairment noise is applied to the receiver under test, at either the LT (for upstream) or NT (for downstream) ends of the test-loop.

9.3.2 Cable cross-talk models

The purpose of the cable cross-talk models is to model both the length and frequency dependence of crosstalk measured in real cables. These cross-talk transfer functions adjust the level of the noise generators in figure 15 when the test-loops are changed. The frequency and length dependency of these functions is in accordance with observations from real cables. The specification is based on the following constants, parameters and functions:

- Variable f identifies the frequency in Hertz.
- Constant f_0 identifies a chosen reference frequency, which was set to 1 Hz.

Variable L identifies an average length in meters, averaged over the four test loops at specified payload bit-rate.

Table A.4 in annex A relates the payload bit-rate with the calculated length of each individual test-loop, in the case that real cables are used. The average length is defined as $L=(L_1+L_2+L_3+L_4)/4$, where L_1 to L_4 represent the calculated test-loop lengths according to table A.4.

- Constant L_0 identifies a chosen reference length, which was set to 1 m.
- Transfer function $s_{T0}(f, L)$ represents an average transfer function of the four test-loops at specified payload bit-rate. Its transfer function is independent of the loop-set number, but changes with the specified payload bit-rate. Since all loops are normalized in insertion loss, the transfer function of test loop #1 is chosen to be this average.
- Constant K_{xn} identifies an empirically obtained number that scales the NEXT transfer function $H_1(f, L)$. The resulting transfer function represents a power summed cross-talk model (see Bibliography, [I-3]) of the NEXT as it was observed in a test cable. Although several disturbers and wire pairs were used, this function $H_1(f, L)$ is scaled down as if it originates from a single disturber in a single wire pair.
- Constant K_{xf} identifies an empirically obtained number that scales the FEXT transfer function $H_2(f, L)$. The resulting transfer function represents a power summed cross-talk model (see Bibliography, [I-3]) of the FEXT as it was observed in a test cable. Although several disturbers and wire pairs were used, this function $H_2(f, L)$ is scaled down as if it originates from a single disturber in a single wire pair.

The transfer functions in table 5 shall be used as cross-talk transfer functions in the impairment generator.

Table 5: Definition of the crosstalk transfer functions

| | |
|---|----------------------|
| $H_1(f, L) = K_{xn} \times (f/f_0)^{0,75} \times \sqrt{1 - s_{T0}(f, L) ^4}$ | |
| $H_2(f, L) = K_{xf} \times (f/f_0) \times \sqrt{(L/L_0)} \times s_{T0}(f, L) $ | |
| $K_{xn} = 0,98 \times 10^{-7}$ | $f_0 = 1 \text{ Hz}$ |
| $K_{xf} = 1,7 \times 10^{-10}$ | $L_0 = 1 \text{ m}$ |
| $s_{T0}(f, L) = \text{averaged test loop transfer function}$ | |

NOTE: These values are chosen to be equal to the ANSI T1E1.4 VDSL draft System Requirements (which are consistent with [1]). At this moment, it is by no means sure that these are reasonable values to represent the "average" European cables. The few measurements that are available for European cables demonstrate sometimes significant differences from the above values. This is an area of further study.

9.3.3 NEXT noise model [G1]

The NEXT noise generator represents all impairments that are identified as crosstalk noise from a predominantly Near End origin. This mix is a function of the service mix and PSD profiles only due to a given assumption of service/transmission system mix in a multi-pair cable. It is not related to the cable because the cable portion is modelled separately as transfer function $H_1(f,L)$. The noise profile described below shall be applied to the receiver under test.

The noise shall be random in nature and Gaussian distributed. The crest factor of the noise source shall be between 5 and 8 and the measurement bandwidth shall be equal to or greater than the VDSL bandwidth.

For measuring PSD the measurement bandwidth shall be less than 10 kHz.

NOTE 1: VDSL transceivers are expected to be predominantly FEXT limited. NEXT couplings due to other xDSL systems operating within the same multi-pair cable have been taken into account in the definition of the Background Noise Model generator [G.3].

NOTE 2: In the present document the NEXT noise model is set to zero. All NEXT noise in the present document is modelled as part of the background noise model of 9.3.5. A separation of this background noise model into a NEXT and other components is for further study.

9.3.4 FEXT noise model [G2]

The FEXT noise generator represents all impairments that are identified as crosstalk noise from a predominantly Far End origin. This mix is primarily a function of the VDSL transceiver design (e.g. due to frequency or time duplexing). It is not related to the cable, since the cable portion is modelled separately as transfer function $H_2(f,L)$. The noise profile described below shall be applied to the receiver under test.

For compliance with the requirements of the present document the transceiver manufacturer shall determine the signal spectrum of the VDSL system under test. The spectral profile of generator G2 shall be consistent with these VDSL spectra, but increased in level. This impairment signal, filtered by the FEXT transfer function $H_2(f, L)$ of 9.3.2, simulates the self-FEXT generated by 20 similar VDSL systems operating in a multi-pair cable. Transceiver manufacturers are left to determine these levels because the noise profile will be implementation specific, and may be test loop specific.

The noise spectrum of generator G2 shall be 8 dB above the signal spectrum of the VDSL transceiver under test, over the full VDSL band from f_L to f_H , as it can be observed at the Tx port of the test set-up described in 9.1.1. The measurement bandwidth for PSD shall be less than 10 kHz. This noise shall be random in nature, Gaussian distributed and uncorrelated with the transceiver under test. The Crest Factor of the noise source shall be between 5 and 8.

9.3.5 Background noise models [G3.xx]

The background noise generator represents all impairments that are identified as (remaining) cross-talk noise, but from unidentified origin. This mix is not a function of the VDSL transceiver design and may be attributed to the effects of other xDSL systems operating in the same multi-pair cable. It is not related to the cable, because the origin of this noise has not been explicitly identified.

The noise shall be random in nature and Gaussian distributed. The crest factor of the noise source shall be between 5 and 8 and the measurement bandwidth shall be equal to or greater than the VDSL bandwidth.

For measuring PSD the measurement bandwidth shall be less than 10 kHz.

NOTE 1: Careful attention should be paid to the frequency axis in figures 16 to 22. Some are given with a linear frequency axis whereas others have logarithmic.

NOTE 2: The noise profiles given in 9.3.5.1 to 9.3.5.6 have been approved by network operators. Certain assumptions were made regarding the composite crosstalk from viable mixes of xDSL systems in multi-pair cables.

9.3.5.1 Background noise model [G3.LT.A]

Figure 16 shows the single-sided background noise profile to be applied at the LT end in noise scenario A.

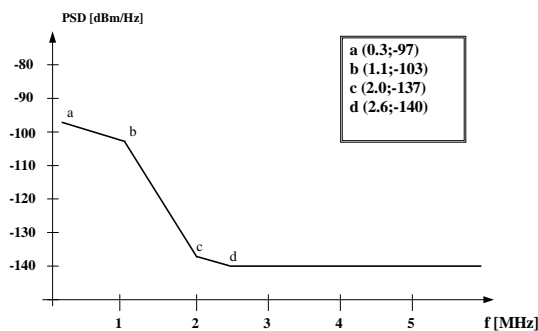

Figure 16: Single-sided background noise model A (LT end)

9.3.5.2 Background noise model [G3.NT.A]

Figure 17 shows the single-sided background noise profile to be applied at the NT end in noise scenario A.

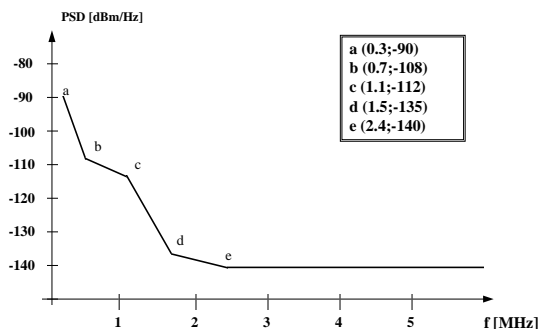

Figure 17: Single-sided background noise model A (NT end)

9.3.5.3 Background noise model [G3.LT.B]

Figure 18 shows the single-sided background noise profile to be applied at the LT end in noise scenario B.

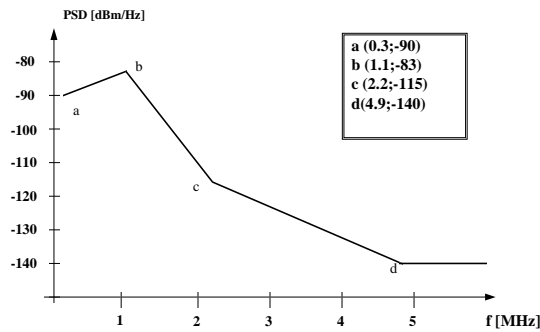

Figure 18: Single-sided background noise model B (LT end)

9.3.5.4 Background noise model [G3.NT.B]

Figure 19 shows the single-sided background noise profile to be applied at the NT end in noise scenario B.

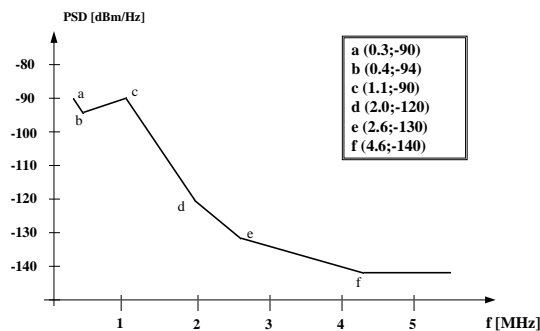

Figure 19: Single-sided background noise model B (NT end)

9.3.5.5 Background noise models [G3.LT.C] and [G3.NT.C]

Figure 20 shows the additional single-sided background noise profile to be added into model "A" when ISDN-PRA systems are present within the same multi-pair cable. This uncorrelated addition forms the model "C" noise.

The background noise [G3.LT.C] shall be created by the addition of the noise from a source with the noise profile shown in figure 20 and the noise from a source with the profile shown in figure 16 ([G3.LT.A]).

The background noise [G3.NT.C] shall be created by the addition of the noise from a source with the noise profile shown in figure 20 and the noise from a source with the profile shown in figure 17 ([G3.NT.A]).

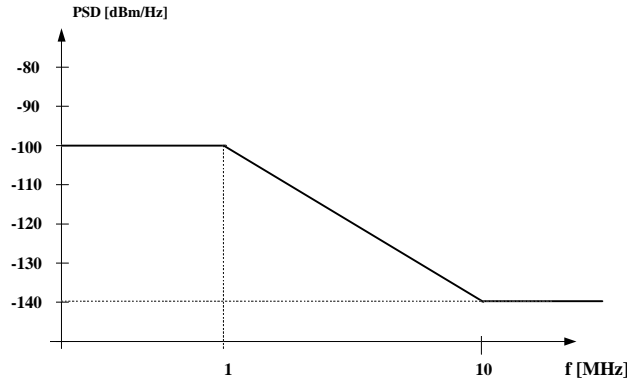

NOTE 1: Some ISDN-PRA systems in use in Europe may have greater high-frequency disturbance effects because of the use of square pulses rather than rounded. The figure above is based on the assumption of a rounded pulse top.

NOTE 2: Logarithmic frequency axis.

Figure 20: Single-sided additional background noise profile for determining model C (LT and NT end)

9.3.5.6 Background noise models [G3.LT.D] and [G3.NT.D]

Figure 21 shows the additional single-sided background noise profile to be added into model "B" when ISDN-PRA systems are present within the same multi-pair cable. This uncorrelated addition forms the model "D" noise.

The background noise [G3.LT.D] shall be created by the addition of the noise from a source with the noise profile shown in figure 21 and the noise from a source with the profile shown in figure 18 ([G3.LT.B]).

The background noise [G3.NT.D] shall be created by the addition of the noise from a source with the noise profile shown in figure 21 and the noise from a source with the profile shown in figure 19 ([G3.NT.B]).

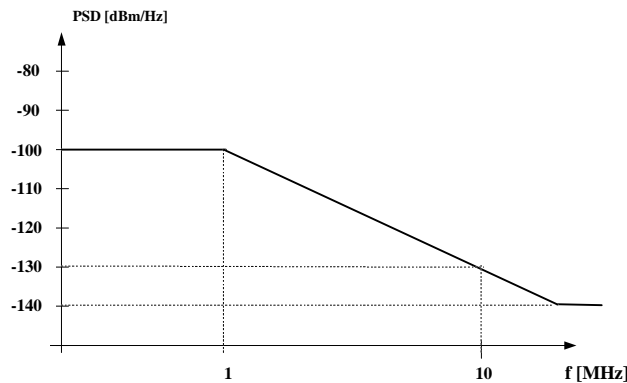

NOTE 1: Some ISDN-PRA systems in use in Europe may have greater high-frequency disturbance effects because of the use of square pulses rather than rounded. The figure above is based on the assumption of a rounded pulse top.

NOTE 2: Logarithmic frequency axis.

Figure 21: Single-sided additional background noise profile for determining model D (LT and NT end)

9.3.6 White noise model [G4]

The white noise generator represents the ever present noise which is intended to be representative of the thermal noise in the DSL line termination.

Additive white Gaussian noise of no lower PSD than -140 dBm/Hz and extending from f_L to f_H shall be applied to the receiver under test. The noise shall be random in nature and Gaussian distributed. The crest factor of the noise source shall be between 5 and 8 and the measurement bandwidth shall be equal to or greater than the VDSL bandwidth.

For measuring PSD the measurement bandwidth shall be less than 10 kHz.

9.3.7 Broadcast RF noise models [G5.xx]

The broadcast RF noise generator represents the discrete tone-line interference caused by amplitude modulated broadcast transmissions in the SW, MW and LW bands which ingress into the differential or transmission mode of the wire-pair. These interference sources have more temporal stability than the amateur/ham interference because their carrier is not suppressed. The modulation index (MI) is usually up to 80%. These signals are detectable using a spectrum analyser and result in line spectra of varying amplitude in the VDSL band. Maximum observable power levels of up to -40 dBm can occur on telephone lines in the distant vicinity of broadcast AM transmitters. The noise is typically dominated by the closest 10 or so transmitters to the victim wire-pair.

Several noise models are specified in this subclause. The average minimum power of each carrier frequency is specified in table 6 for each model.

Table 6: Carrier frequencies and average minimum powers for various [G5.xx] noise models

| Frequency (kHz) | Power (dBm) | Power (dBm) | Power (dBm) | Power (dBm) |
|--------------------|----------------|----------------|----------------|----------------|
| | [G5.LT.A] | [G5.NT.A] | [G5.LT.B] | [G5.NT.B] |
| 99 | -70 | -60 | -80 | -70 |
| 207 | -70 | -60 | -80 | -70 |
| 711 | -70 | -60 | -80 | -70 |
| 801 | -70 | -60 | -80 | -70 |
| 909 | -70 | -60 | -80 | -70 |
| 981 | -50 | -40 | -60 | -50 |
| 1 458 | -50 | -40 | -60 | -50 |
| 6 050 | -50 | -40 | -60 | -50 |
| 7 350 | -50 | -40 | -60 | -50 |
| 9 650 | -50 | -40 | -60 | -50 |

9.3.7.1 Broadcast RF noise model [G5.LT.A]

This broadcast RF noise model is comprised of ten broadcast interferers which are applied simultaneously to the receiver under test. This noise shall be applied to the receiver under test at the LT side of the test-loops, when performing the upstream tests.

Each interfering source shall be modelled by a fixed frequency carrier, 80% AM modulated with a flat (± 3 dB) Gaussian white noise source which is band limited to 0 kHz - 5 kHz. The average minimum power of the modulated signal shall be no lower than that specified in table 6, column [G5.LT.A]. The measurement bandwidth shall be less than 10 kHz.

9.3.7.2 Broadcast RF noise model [G5.NT.A]

This broadcast RF noise model is comprised of ten broadcast interferers which are applied simultaneously to the receiver under test. This noise shall be applied to the receiver under test at the NT side of the test-loops, when performing the downstream tests.

Each interfering source shall be modelled by a fixed frequency carrier, 80% AM modulated with a flat (± 3 dB) Gaussian white noise source which is band limited to 0 kHz - 5 kHz. The average minimum power of the modulated signal shall be no lower than that specified in table 6 column [G5.NT.A]. The measurement bandwidth shall be less than 10 kHz.

9.3.7.3 Broadcast RF noise model [G5.LT.B]

This broadcast RF noise model is comprised of ten broadcast interferers which are applied simultaneously to the receiver under test. This noise shall be applied to the receiver under test at the LT side of the test-loops, when performing the upstream tests.

Each interfering source shall be modelled by a fixed frequency carrier, 80% AM modulated with a flat (± 3 dB) Gaussian white noise source which is band limited to 0 kHz - 5 kHz. The average minimum power of the modulated signal shall be no lower than that specified in table 6, column [G5.LT.B]. The measurement bandwidth shall be less than 10 kHz.

9.3.7.4 Broadcast RF noise model [G5.NT.B]

The broadcast RF noise model is comprised of ten broadcast interferers which are applied simultaneously to the receiver under test. This noise shall be applied to the receiver under test at the NT side of the test-loops, when performing the downstream tests.

Each interfering source shall be modelled by a fixed frequency carrier, 80% AM modulated with a flat (± 3 dB) Gaussian white noise source which is band limited to 0 kHz - 5 kHz. The average minimum power of the modulated signal shall be no lower than that specified in table 6, column [G5.NT.B]. The measurement bandwidth shall be less than 10 kHz.

9.3.8 Amateur RF noise models [G6.xx]

The Amateur RF noise generator represents a large (almost impulse like) RF interference which has radically changing temporal characteristics due to the single-sideband suppressed nature of the amateur radio transmission. The interference exhibits severe temporal variations, can be high in amplitude (up to 0 dBm PEP), can occur anywhere within the internationally standardized HF amateur bands and at any time of day or night. Overhead wiring is especially susceptible to RF ingress of this nature. Coupling into twisted telephone wires is usually via the common mode and then into the differential mode.

This high-level interferer is designed to simulate the worst-case interference from Short Wave amateur radio transmissions coupling from nearby amateur radio transmissions into the differential or transmission mode of the unscreened twisted wire pair of the metallic access network which is being used for VDSL transmission.

This source of interference appears as a component of the noise entering the front-end of a VDSL receiver in the differential or transmission mode. It is very damaging to VDSL transmission because of:

- a) The adverse nature of the temporal characteristics of the single sideband suppressed carrier transmission.
- b) The close proximity of amateur radio transmitters to telephone network aerial cabling and home wiring.
- c) The high transmit powers, typically up to 400 W PEP (+26 dBW).

9.3.8.1 Specification of all Amateur RF noise models

In order to simulate this amateur radio interference, a carrier is amplitude modulated with speech or Morse like properties. The interfering noise shall be injected in the differential mode and set to 0 dBm Peak Envelope Power (PEP) at the VDSL receiver input in any internationally recognized amateur band (see table 7). The baseband modulating signal is speech weighted noise [13] and is interrupted on a 15 s period with 5 s on and 10 s off to simulate speech activity. The resultant base-band signal is further interrupted on a period of 200 ms with 50 ms on and 150 ms off which corresponds to the syllabic rate. The signal is then band-limited to 4 kHz with 6 dB/octave pre-emphasis in-band. The carrier frequency should change by at least 50 kHz every 120 s. This interferer can appear anywhere in the chosen amateur frequency bands listed in table 7 below.

Table 7: International HF amateur radio bands

| Band start (kHz) | Band stop (kHz) |
|-----------------------------|----------------------------|
| 1 810 | 2 000 |
| 3 500 | 3 800 |
| 7 000 | 7 100 |
| 10 100 | 10 150 |
| 14 000 | 14 350 |
| 18 068 | 18 168 |
| 21 000 | 21 450 |
| 24 890 | 24 990 |
| 28 000 | 29 100 |

9.3.8.2 Amateur RF noise model [G6.LT.A]

The amateur RF noise source is specified in 9.3.8.1. This noise shall be applied to the receiver under test at the LT side of the test-loops, when performing the upstream tests.

The level of this noise model shall be no lower than -10 dBm (PEP) anywhere in the internationally standardized amateur radio bands given in table 7.

9.3.8.3 Amateur RF noise model [G6.NT.A]

The amateur RF noise source is specified in 9.3.8.1. This noise shall be applied to the receiver under test at the NT side of the test-loops, when performing the downstream tests.

The level of this noise model shall be no lower than 0 dBm (PEP) anywhere in the internationally standardized amateur radio bands given in table 7.

9.3.8.4 Amateur RF noise model [G6.LT.B]

The amateur RF noise source is specified in 9.3.8.1. This noise shall be applied to the receiver under test at the LT side of the test-loops, when performing the upstream tests.

The level of this noise model shall be no lower than -30 dBm (PEP) anywhere in the internationally standardized amateur radio bands given in table 7.

9.3.8.5 Amateur RF noise model [G6.NT.B]

The amateur RF noise source is specified in 9.3.8.1. This noise shall be applied to the receiver under test at the NT side of the test-loops, when performing the downstream tests.

The level of this noise model shall be no lower than -20 dBm (PEP) anywhere in the internationally standardized amateur radio bands given in table 7.

9.3.9 Impulse noise model [G7]

A test with this noise model is required to prove the burst noise immunity of the VDSL transceiver. This immunity shall be demonstrated on short and long loops and noise to model cross-talk and RFI. Further test details are given in 9.4.

The noise shall consist of burst of Additive White Gaussian Noise injected onto the line with sufficient power to ensure effective erasure of the data for the period of the burst, i.e. the bit error ratio during the burst should be approximately 0,5. The noise burst shall be applied regularly at a repetition rate of at least 1 Hz.

9.4 Transmission Performance tests

9.4.1 Measuring noise margin

At start-up, the level and shape of crosstalk noise or impulse noise are adjusted, while their level is probed at port Rx to meet the impairment level specification in 9.3. This relative level is referred to as 0 dB. The transceiver link is subsequently activated, and the bit error ratio of the link is monitored.

Next the crosstalk noise level of the impairment generator as defined in tables 8 or 9, shall be increased by adjusting the gain of amplifier A1 in figure 15, equally over the full VDSL frequency band, until the bit error ratio is approximately 10^{-7} . This BER will be achieved at an increase of noise of x dB, with a small uncertainty of Δx dB.

NOTE: The value x is defined as the noise margin with respect to a standard noise model and may (optionally) be used to indicate the sensitivity of the system under test to changes in BER. It is expected that the noise level that brings the BER to 10^{-7} is very close to the level associated with a BER of 10^{-5} (usually within a fraction of a dB for a coded system). In order to speed up the iterative search for noise margins, it is a practical approach to start the margin search for a BER of 10^{-5} , and then search for the noise level associated with a BER of 10^{-7} . The BER requirements of 10^{-7} in 9.4.2 remain valid in order to pass the transmission performance test.

The noise margins shall be measured for upstream as well as downstream transmission under test loops #1, #2, #3, and #4.

9.4.2 Bit error ratio requirements

The VDSL system shall operate with a noise margin of at least +6 dB and a long-term bit error ratio of <1 in 10^7 when operated over any of the test loops with the noise models and test conditions as specified in this subclause.

The measurement period shall be at least 30 minutes and the amateur radio interferer (see 9.3.8) shall visit each amateur band at least twice (at different frequencies within the band) during the test period.

A long term performance test shall be performed for a period of not less than 24 hours to ensure long-term temporal stability (see 9.4.3 and 9.4.4).

9.4.3 Upstream tests

Several VDSL performance tests shall be carried out to prove adequate upstream performance. These tests are specified in table 8. Each symbolic name in this table refers to a specified noise model as defined in 9.3. The injection of the impairment noise shall be at the LT side of the test-loop.

Class I compliant VDSL transceivers are required to pass test sets U1, U3, U5, U6 and U7. Class II compliant VDSL transceivers are required to pass test sets U2, U4, U5, U6 and U8. Transceivers which are class I and class II compliant are required to pass all test sets (U1-U8 inc.).

Table 8: Composition of noise models in the upstream tests

| Test set | Class (code) | Loops | G1 | G2 | G3 | G4 | G5 | G6 | G7 |
|----------|-------------------|-------|----|----|---------|----|---------|---------|----|
| U1 | I (A1-A3) | 0-4 | - | G2 | G3.LT.A | G4 | G5.LT.A | G6.LT.A | - |
| U2 (*) | II (S1-S4) | 0-4 | - | G2 | G3.LT.A | G4 | G5.LT.A | G6.LT.A | - |
| U3 (*) | I (A1-A3) | 0-4 | - | G2 | G3.LT.B | G4 | G5.LT.B | G6.LT.B | - |
| U4 | II (S1-S4) | 0-4 | - | G2 | G3.LT.B | G4 | G5.LT.B | G6.LT.B | - |
| U5 | I (Ax) or II (Sx) | 4 | - | - | - | - | - | - | G7 |
| U6 | I (Ax) or II (Sx) | 0-4 | - | - | - | - | - | - | - |
| U7 (*) | I (A1-A3) | 0-4 | - | G2 | G3.LT.D | G4 | G5.LT.B | G6.LT.B | - |
| U8 (*) | II (S1-S4) | 0-4 | - | G2 | G3.LT.D | G4 | G5.LT.B | G6.LT.B | - |

When testing operation at specific payload bit-rates the Manufacturer shall quote the Class and Code of operation as defined in table 2 for all modes of VDSL transceiver operation. If the operational mode is not covered by the code given in table 2 then the manufacturer shall quote an appropriate description of the payload carried under test conditions described in clause 9.

NOTE 1: Test sets U1 and U2 are to be used for VDSL transceivers operating in the noise A scenario.

NOTE 2: Test sets U3 and U4 are to be used for VDSL transceivers operating in the noise B scenario.

NOTE 3: Test set U5 is the broadband impulse noise test.

NOTE 4: Test set U6 is the long term stability test with no injected noise.

NOTE 5: Test sets U7 and U8 are to be used for VDSL transceivers operating in the noise D scenario.

NOTE 6: Ax and Sx refer to class I and class II codes of operation (see table 2 and table 3).

NOTE 7: Generators G1 to G3 are shown shaded to indicate that the amplitude of these generators is varied when determining the noise margin.

NOTE 8: The test sets marked with an asterisk (*) in table 8 have been incorporated without exhaustive verification by computer simulation. These new requirements are thus marked for further study and may result in changes to the requirements.

9.4.4 Downstream tests

Several VDSL performance tests shall be carried out to prove adequate downstream performance. These tests are specified in table 9. Each symbolic name in this table refers to a specified noise model as defined in 9.3. The injection of the impairment noise shall be at the NT side of the test-loop.

Class I compliant VDSL transceivers are required to pass test sets D1, D3, D5, D6 and D7. Class II compliant VDSL transceivers are required to pass test sets D2, D4, D5, D6 and D8. Transceivers which are class I and class II compliant are required to pass all test sets (D1 to D8 inclusive).

Table 9: Composition of noise models in the downstream tests

| Test set | Class (code) | Loops | G1 | G2 | G3 | G4 | G5 | G6 | G7 |
|----------|-------------------|-------|----|----|---------|----|---------|---------|----|
| D1 | I (A1-A3) | 0-4 | - | G2 | G3.NT.A | G4 | G5.NT.A | G6.NT.A | - |
| D2 (*) | II (S1-S4) | 0-4 | - | G2 | G3.NT.A | G4 | G5.NT.A | G6.NT.A | - |
| D3 (*) | I (A1-A3) | 0-4 | - | G2 | G3.NT.B | G4 | G5.NT.B | G6.NT.B | - |
| D4 | II (S1-S4) | 0-4 | - | G2 | G3.NT.B | G4 | G5.NT.B | G6.NT.B | - |
| D5 | I (Ax) or II (Sx) | 4 | - | - | - | - | - | - | G7 |
| D6 | I (Ax) or II (Sx) | 0-4 | - | - | - | - | - | - | - |
| D7 (*) | I (A1-A3) | 0-4 | - | G2 | G3.NT.D | G4 | G5.NT.B | G6.NT.B | - |
| D8 (*) | II (S1-S4) | 0-4 | - | G2 | G3.NT.D | G4 | G5.NT.B | G6.NT.B | - |

When testing operation at specific payload bit-rates the Manufacturer shall quote the Class and Code of operation as defined in table 2 for all modes of VDSL transceiver operation. If the operational mode is not covered by the code given in table 2 then the manufacturer shall quote an appropriate description of the payload carried under test conditions described in clause 9.

NOTE 1: Test sets D1 and D2 are to be used for VDSL transceivers operating in the noise A scenario.

NOTE 2: Test sets D3 and D4 are to be used for VDSL transceivers operating in the noise B scenario.

NOTE 3: Test set D5 is the broadband impulse noise test.

NOTE 4: Test set D6 is the long term stability test with no injected noise.

NOTE 5: Test sets D7 and D8 are to be used for VDSL transceivers operating in the noise D scenario.

NOTE 6: Ax and Sx refer to class I and class II codes of operation (see table 2 and table 3).

NOTE 7: Generators G1 to G3 are shown shaded to indicate that the amplitude of these generators is varied when determining the noise margin.

NOTE 8: The test sets marked with an asterisk (*) in table 9 have been incorporated without exhaustive verification by computer simulation. These new requirements are thus marked for further study and may result in changes to the requirements.

9.5 Micro interruptions

A micro interruption is a temporary line interruption due to external mechanical action on the copper wires constituting the transmission path, for example, at a cable splice. Splices can be hand-made wire-to-wire junctions, and during cable life oxidation phenomena and mechanical vibrations can induce micro interruptions at these critical points.

The effect of a micro interruption on the transmission system can be a failure of the digital transmission link, together with a failure of the power feeding (if provided) for the duration of the micro interruption.

The objective is that in the presence of a micro interruption of specified maximum length the VDSL transceiver should not reset, and the system should automatically reactivate (see 10.1).

The transceiver shall not be reset by a micro interruption event of duration $t = 10$ ms which shall occur at an event frequency of 0,2 Hz.

NOTE: The duration of the micro interruption is for further study.

10 Core

This clause details the functional requirements of the VDSL transceiver core.

10.1 Activation/deactivation

Activation and deactivation may be commanded by network management, or result from autonomous actions caused by transmission anomalies. Additionally, where call-state information is available, activation may be linked to broadband call-state transitions. Such linkage is not applicable to SDH applications, and is not currently supported by ATM level standards. Methods may however be developed to enable the transmission performance advantages for VDSL to be exploited by ATM applications.

10.1.1 Activation/deactivation definitions

On first installation or on demand of the network operator, the start-up of a VDSL transceiver might be subject to an installation procedure under control of the network operator in order to check the spectral compatibility of the transceiver.

NOTE: Such test procedure is for further study.

Following a successful first installation, the activation procedures shall start. Four activation procedures shall exist. These are defined below and shown in figure 22:

Cold-Start: Cold-Start applies when power is first applied to the transceiver after intrusive maintenance or if there have been significant changes in line characteristics (e.g. due to thermal effects). Intrusive maintenance will also apply to the service level, when transmission rates, and other transmission parameters (e.g. margin, spectral masks, class of service, etc.) are altered.

Normal-Start: This start applies when both transceivers start from the Power-Down state. Power-Down is reached when a transceiver had its AC removed on purpose via the Power-Down procedure, forced typically by the customer. Normal-start applies only if there have been little or no changes in line characteristics. This procedure applies also, when there is an accidental AC removal or failure at the customer, provided the transceiver could store all necessary data and parameters to avoid the Cold-Start.

Resume-on-Error: The start-up process that applies to transceivers which lose synchronization during transmission, e.g. due to a large impulse hit or an interruption longer than the specified micro-interruption (see 9.5). This applies only if there have been no changes in line characteristics, and when the clock-frequencies recovery circuits can still predict the sample timing. The event which leads to loss of synchronization, shall be longer than a micro-interruption but limited to a TBD maximum value, related to the loss of frequency locking.

Warm-Resume: The start-up process that applies to transceivers after reaching synchronization and have subsequently responded to a deactivation request. Warm-resume is the usual method of activating the VDSL transmission system on receipt of a first incoming or outgoing broadband call request.

Warm-Resume can only be initiated after a deactivation procedure, towards the Power-Saving state, which keeps both LT and NT VDSL transceivers in a power-saving sleeping mode.

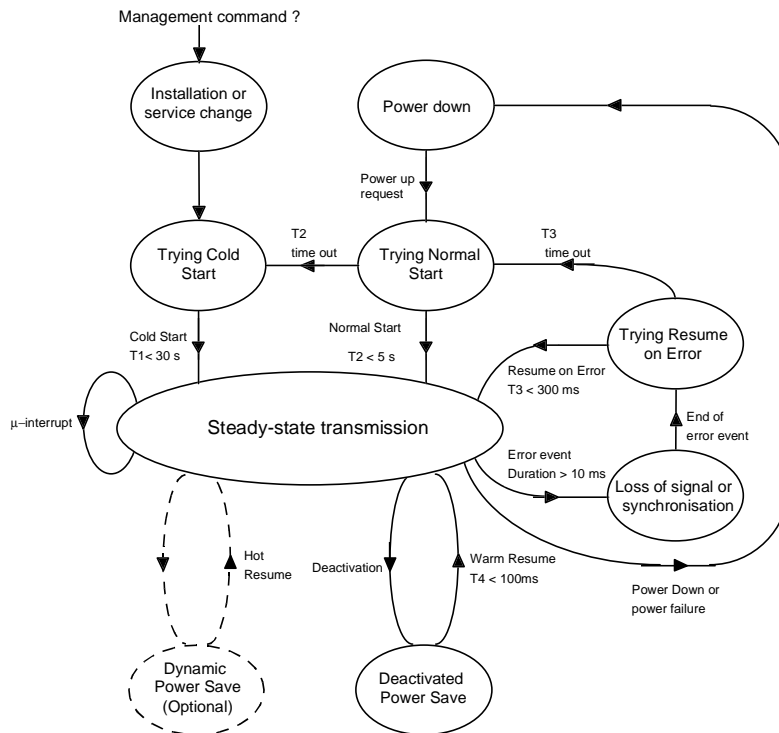

Figure 22: State and timing diagram

Steady State transmission: To achieve Steady State transmission all start-up processes should have been completed. This means full clock and frame synchronization have been achieved and DSP filter adaptations have been performed.

Dynamic Power Save state: The optional Dynamic Power Save State is intended to reduce the overall power consumption of the VDSL LT transceiver, and to reduce the crosstalk level and RFI radiation of the VDSL system. It could be used when ATM or some other application links are active, but are not consuming the full bandwidth of the VDSL transmission. It alternates with the Steady State transmission. No loss of application data shall be tolerated when the VDSL transceiver moves back and forth between Steady State and Dynamic Power Save state. This state implies the Hot-Resume.

Hot-Resume: The implied immediate power-ON, to resume transmission, whenever the VDSL transceiver alternates Steady State with the optional Dynamic Power Save state.

Power-Down procedure: The process by which a pair of fully operational transceivers go to the Power-Down state. It is a guided procedure used e.g. when the customer wants to turn off the transceiver AC power, or when the LT can not go to the Power-Saving deactivation. The VDSL transceivers may store transmission related data, such as equalizer states, line characteristics, and service related parameters to be able to use the Normal-Start procedure later.

Deactivation: This is a process that places the VDSL transceiver into a power-saving state to save ONU power and reduce unwanted RF emissions. Included in this process is the confirmation towards UNI and the network side that the VDSL transmission is terminated. The Deactivation assumes the termination of all broadband traffic.

Power-Down state: The full removal of power at the NT or LT, or the state at the LT when the Power-Saving deactivated state can not used and VDSL transmission shall be halted, e.g. for maintenance (hardware and/or software).

Deactivated Power-Saving state: This state is required to permit the digital transmission system to be placed in a low power consumption mode when no calls are in progress. The NT and LT consume less power but are capable of detecting a wake up signal from the network side and/or from the UNI, and execute a Warm-Resume. When enabled by the Network Management System, this state may be entered automatically after a programmable time after the last broadband call. During the deactivated Power-Saving state the transceivers could continue some (modulation dependent) form of synchronization on some of the following levels: clock-sync, frame-sync, equalizer checking and trimming, etc.

Delay to service start-up: The time from when Activation is requested or power is applied until the broadband dial tone is issued towards the UNI. The VDSL system shall have achieved Steady State transmission before the broadband dial tone (or equivalent) is issued.

10.1.2 Timing requirements

| | |
|---|----------------------------------|
| Delay to service start-up during Cold-Start conditions: | T1 maximum 30 s, typically 15 s. |
| Delay to service start-up during Normal-Start conditions: | T2 maximum 5 s, typically 2 s. |
| Delay to service start-up during Warm-Resume conditions: | T3 < 100 ms. |
| Delay to recovery of service by a successful Resume-on-Error: | T4 < 300 ms. |

11 Spectral compatibility

Ensuring spectral compatibility with existing and future DSL transmission systems is of paramount importance to Network Operators. The following requirements are separated into those which apply to adjacent wire-pairs, and the same wire-pair, which may be used as transmission bearers for other forms of service (e.g. POTS, ISDN-BA, etc.).

NOTE 1: Time division duplex and frequency division duplex VDSL systems within the same frequency bands should not be mixed in the same cable bundle due to fundamental spectral incompatibility.

NOTE 2: The operation of VDSL below the lower frequency limit (f_L) is not excluded, e.g. on new lines where existing narrowband services may not be present. However, this is beyond the scope of the present document and is subject of further study. The issue of VDSL transmit energy polluting parts of the spectrum occupied by other xDSL systems (e.g. ADSL) may preclude the use of lower frequencies, especially in the upstream direction of transmission.

11.1 Adjacent wire-pairs

VDSL systems shall be required to operate with a number of different DSL systems operating on adjacent wire-pairs in a multi-pair cable. Each of the other systems will generate crosstalk which will appear, to a lesser or greater extent, as unwanted noise at the front-end of a VDSL receiver.

Class I and class II VDSL systems shall be able to operate on different wire-pairs within a multi-pair cable. No special arrangements shall be required for pair selection.

All forms of VDSL are required to co-exist with an installed base of heritage xDSL systems (e.g. other VDSL, HDSL, ADSL, ISDN-BA, ISDN-PRA, etc.) operating in the same multi-pair cable.

11.2 Same wire-pair

VDSL is required to co-exist with some existing narrowband services which may be carried on the same wire-pair. This is to ensure that the VDSL system can provide a broadband overlay capability. In particular, VDSL shall be required to operate at frequencies above POTS as described in ETS 300 001 [5], TBR 021 [6], and both 2B1Q and 4B3T forms of ISDN-BA in Europe according to ETR 080 [4].

The splitter filter characteristics are defined in clause 12.

Frequency separation shall be used to separate the VDSL signals from the existing narrowband signals.

11.3 Symmetric versus asymmetric VDSL

Co-existence of asymmetric and symmetric VDSL systems in the same multi-pair cable shall be possible. However, there is an unavoidable performance penalty which shall be managed by the Network Operator via appropriate planning rules for deployment. No special arrangements shall be required for pair selection.

12 Splitter filter

A splitter filter is required at both ends of the line which carries VDSL signals if existing narrowband services are to remain unaffected by the presence of higher frequency VDSL signals on the same wire-pair. The structure of the splitter filter port is given in figure 23. The VDSL port connects to the VDSL transceiver. The TELE port connects to the existing POTS NT or ISDN-BA NT. The TELE-LINE function is that of a low-pass filter, whereas the VDSL-LINE port function is high-pass. Exceptional isolation is required between TELE and VDSL ports to prevent undesirable interaction between VDSL and any existing narrowband services.

Designs shall take into careful account the relevant national specifications. In the absence of national specifications the narrowband requirements of ETS 300 001 [5] and TBR 021 [6] shall be met for POTS and ETR 080 [4] for ISDN-BA.

The splitter filter requirements given at present in this clause are based on key requirements of the low pass filter indicated by several network operators. Those requirements shall guarantee the proper operation of POTS and ISDN on lines which carry VDSL signals, however, there may be some space for an optimization.

The requirements of the high pass filter are more dependent on the VDSL splitter structure than those of the low pass filter. The high pass filter will probably be included in the NT or LT respectively, where the low pass filter may be combined with an all pass function for the VDSL branch.

After more simulations and measurements have been done on topics like mismatching (for example due to the additional line between splitter and exchange in FTTCab scenarios), co-existence and transmission performance (for POTS, ISDN and VDSL) further refinements of the splitter filter requirements are expected to be made.

The splitter shall meet the requirements of this clause 12 with all VDSL transceiver impedances that are tolerated by the return loss specification in 8.3.2.

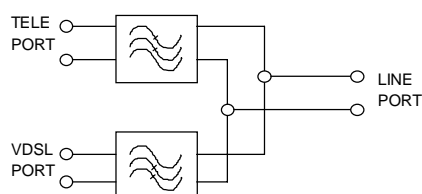

Figure 23: Structure of the VDSL splitter filter

The reference impedances associated with the TELE and VDSL ports are as follows:

TELE port: Z_M for POTS and 135Ω for 2B1Q-based ISDN-BA according to ETR 080 [4], annex A and 150Ω for 4B3T-based ISDN-BA according to ETR 080 [4], annex B.

NOTE: Z_M is country specific - see annex B for more detailed specification.

VDSL port: R_V

The key requirements for the VDSL splitter filter are shown in table 10.

Table 10: Key VDSL splitter filter electrical requirements

| Ref. | Requirement |
|------|---|
| S1 | f_L shall be set to 120 kHz. |
| S2 | TELE port to LINE port insertion loss into Z_M should be $< 0,5$ dB from 200 Hz to 4 kHz, the insertion loss variation (ripple) over this frequency band should be $< 0,2$ dB. |
| S3 | For countries requiring the use of SPM or tax tones, the TELE port to LINE port insertion loss into 200Ω should be < 1 dB at $16\text{kHz} \pm 1\text{kHz}$, and into 200Ω should be < 1 dB at $12\text{kHz} \pm 1\text{kHz}$. The insertion loss variation (ripple) over these frequency bands should be $< 0,2$ dB. |
| S4 | TELE port and LINE port return loss against Z_M when the other port is terminated in Z_M should be better than 18 dB, from 200 Hz to 4 kHz. |
| S5 | TELE port to LINE port insertion loss into 135Ω and into 150Ω should be $< 0,5$ dB from 100 Hz to f_L . |
| S6 | TELE port and LINE port return loss against 135Ω and 150Ω when the other port is terminated in 135Ω and 150Ω respectively, should be better than 18 dB, over the band 0 to f_L . |
| S7 | LINE port to VDSL port insertion loss in R_V of less than 0,5 dB from f_L to f_H . |
| S8 | LINE port and VDSL port return loss to R_V shall both meet the requirements in 8.3.2. NOTE: Both ports shall be better than 14 dB from f_L to f_H . |
| S9 | TELE port to VDSL port isolation should be > 70 dB over the bands 200 Hz to f_L and from f_L to f_H , with some relaxation permissible in the transition band. |
| S10 | The common-mode isolation between TELE and LINE when terminated in a 50Ω common mode circuit from f_L to f_H shall be > 35 dB. |
| S11 | The LCL at the LINE port from 300 Hz to f_H when measured with 50Ω common mode source and R_V differential mode load shall be > 40 dB. Additional requirements at some frequencies are listed in 8.3.3. |
| S12 | TELE port to LINE port DC resistance shall be $< 40 \Omega$. |

The requirements of table 10 shall be met when the port which is not in use for the test of a specific requirement is terminated:

- with the appropriate matching impedance outlined in this clause;
- with a mismatched impedance due to reasonable fault conditions at this port (e.g. line break, typical resistive load, ringer load, etc.).

13 Application specific requirements

This clause specifies additional application specific functional requirements where they differ from the application independent functional requirements detailed elsewhere in the present document.

13.1 ATM transport mode

Figure 24 shows the VDSL functional reference model as applied to the ATM application.

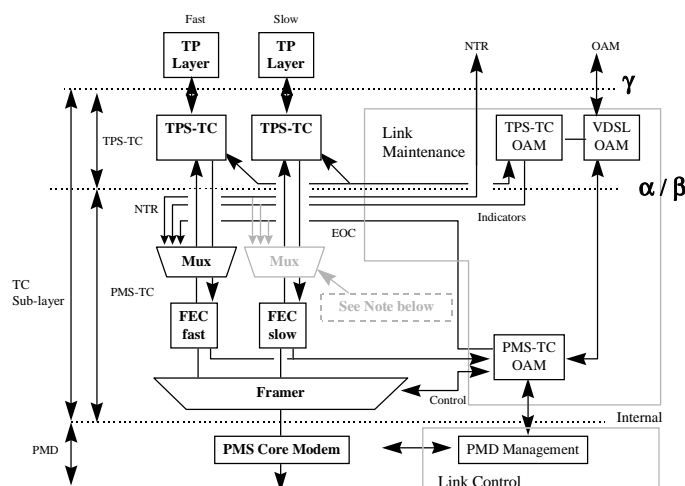

NOTE 1: It is not compulsory to implement both the fast and slow channels. Single channels with programmable latency are equally acceptable.

NOTE 2: The EOC may be in the fast or slow channel or potentially in a separate TC sub-layer. The actual implementation of the EOC channel is modulation dependent and is the subject of further study.

Figure 24: VDSL functional reference model applied to ATM

13.1.1 Latency

Two different latency paths for the transport of ATM cells may be optionally simultaneously provided in VDSL transceiver implementations (also known as dual latency). The "slow" path is associated with Forward Error Correction and Data Interleaving which provides for lower BER at the expense of higher throughput delay or latency. ATM applications requiring this facility would normally be delay insensitive ones requiring very low BER. The transport of an ATM cell through the "fast" path would naturally incur the minimum of delay but at the expense of a worse (higher) BER.

VDSL transceivers shall implement appropriate FEC and data interleaving to meet the performance requirements as detailed in clause 9. Details of the latency requirements may be found in clause 8.

The facility for dual latency for ATM applications is optional.

13.1.2 Cell Delay Variation

For further study.

13.1.3 TPS-TC requirements

For further study.

13.1.4 Payload bit rates

For further study.

13.1.5 OAM requirements

The ATM TPS-TC shall implement loop-back test facilities by PLOAM cells, and the EOC shall provide a control channel to allow loop backs to be applied by the TPS-TC. Responses to other OAM cells may be specified later.

13.2 SDH transport mode at sub STM-1 rates

Figure 25 shows the VDSL functional reference model as applied to the SDH application.

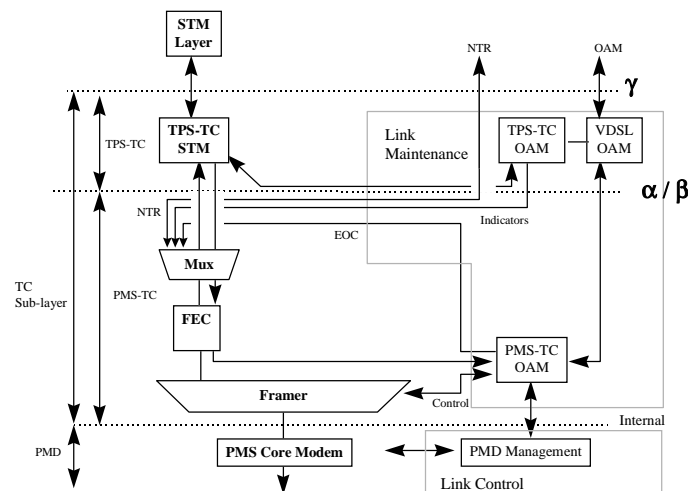

Figure 25: VDSL functional reference model applied to SDH

13.2.1 Dual Latency

Dual latency is not applicable to the SDH application. The latency may need to be programmable to suit the line characteristics. The limits need to be defined.

13.2.2 Jitter and Wander

For further study.

13.2.3 TPS-TC Requirements

For further study.

13.2.4 Payload bit-rate

For further study.

13.2.5 OAM requirements

The SDH TPS-TC shall implement loop-back functionality, and the EOC shall provide a control channel to allow loop backs to be applied by the TPS-TC.

Annex A (informative): Line constants for the test loop-set

This annex details the typical line constants for a number of cable types which are representative of existing European metallic access networks. See Bibliography, [I-3] for an overview of country specific line constants.

The primary cable parameters vary with the frequency. Their typical values may be calculated at any frequency (up to 30 MHz) by using the empirical models contained in table A.1. The line constants are given in table A.2 and table A.3 and may be used (together with the equations) to calculate the values given in figure 14 and determine the transmission mode characteristics of the test loops contained in the main body of the present document.

In the case that real cables are used for these test loops, the estimated lengths of these cables are summarized in table A.4. Their actual lengths may deviate from this because real test-loops have to meet the insertion loss requirements instead of length requirements.

NOTE: Conductance becomes significant at high frequencies and should not be ignored.

Table A.1: Formal models for the BT and the KPN cable parameters in the test loops

| | | |
|--------------|---|--------|
| BT#0 | $Z_s(f) = \sqrt[4]{R_{0C}^4 + a_c \times f^2} + j \times 2\pi \times f \times \left(\frac{L_0 + L_\infty \times \left(\frac{f}{f_m}\right)^{Nb}}{1 + \left(\frac{f}{f_m}\right)^{Nb}} \right)$ | [Ω/km] |
| | $Y_p(f) = (g_0 \times f^{N_{se}}) + j \times 2\pi \times f \times \left(C_\infty + \frac{C_0}{f^{N_{ce}}} \right)$ | [S/km] |
| KPN#1 | $Z_{S0}(\omega) = \frac{j\omega \times Z_{0\infty}}{c} + R_{SS00} \times \left(1 + K_l \times K_f \times \left(\chi \times \coth\left(\frac{4}{3} \times \chi\right) - \frac{3}{4} \right) \right)$ | [Ω/m] |
| | $Y_{p0}(\omega) = \frac{j\omega}{Z_{0\infty} \times c} \times \left(1 + \frac{(K_c - 1)}{1 + \left(\frac{\omega}{\omega_{C0}}\right)^N} \right) + \frac{\tan(\phi)}{Z_{0\infty} \times c} \times \omega^M$ | [S/m] |
| | $\chi = \chi(\omega) = (1 + j) \times \sqrt{\frac{\omega}{2\pi} \times \frac{\mu_0}{R_{SS00}} \times \frac{1}{K_n \times K_f}}$ | |
| | $\omega_{C0} = 2\pi \times f_{C0}$ $\mu_0 = 4\pi \times 10^{-7}$ | |

NOTE: Both models are equally valid from DC to 30 MHz when using the appropriate parameter sets and values given in table A.2 and table A.3.

Table A.2: Line constants for the BT cables in the test loops

| Wire type | R_{oc} N_b | a_c g_0 | R_{os} N_{ge} | a_s C_o | L_o C_∞ | L_∞ N_{ce} | f_m |
|-----------|--------------------|---|----------------------|-----------------------------------|--|---|-----------------|
| "A" | 179 1,2 | $35,89 \times 10^{-3}$ $0,5 \times 10^{-9}$ | --- 1,033 | --- 1×10^{-9} | $0,695 \times 10^{-3}$ 55×10^{-9} | 585×10^{-6} 0,1 | 1×10^6 |
| "D" | 41,16 1,1952665 | $1,2179771 \times 10^{-3}$ 53×10^{-9} | --- 0,88 | --- $31,778569 \times 10^{-9}$ | 1×10^{-3} $22,681213 \times 10^{-9}$ | $910,505 \times 10^{-6}$ 0,110866740 | 174 877 |

Table A.3: Line constants for the KPN cables in the test loops

| | $Z_{0\infty}$ | c/c_0 | R_{ss00} | $2\pi \cdot \tan(\phi)$ | K_f | K_l | K_n | K_c | N | f_{c0} | M |
|-----|---------------|----------|------------|-------------------------|-------|-------|-------|---------|-----|-----------|---|
| "B" | 136,651 | 0,79766 | 0,168145 | 0,13115 | 0,72 | 1,2 | 1 | 1,08258 | 0,7 | 4 521 710 | 1 |
| "C" | 97,4969 | 0,639405 | 0,177728 | 0,0189898 | 0,5 | 1,14 | 1 | 1 | 1 | 100 000 | 1 |

Table A.4: Approximate physical lengths of the cable sections in the test-loops

| Test loop | length L (6N/2N) | length L (12N/2N) | length L (24N/4N) | length L (6N/6N) | length L (12N/12N) | length L (24N/24N) | length L (36N/36N) |
|-----------|---------------------|----------------------|----------------------|---------------------|-----------------------|-----------------------|-----------------------|
| #0 | 0 | 0 | 0 | 0 | 0 | 0 | 0 |
| #1 | 1 598 m | 978 m | 531 m | 1 107 m | 601 m | 327 m | 238 m |
| #2 | 1 514 m | 904 m | 477 m | 1 032 m | 544 m | 286 m | 207 m |
| #3 | 1 510 m | 905 m | 478 m | 1 027 m | 547 m | 293 m | 213 m |
| #4 | 1 600 m | 976 m | 520 m | 1 099 m | 595 m | 310 m | 219 m |
| average | 1 556 m | 941 m | 501 m | 1 066 m | 572 m | 304 m | 219 m |

NOTE: Each bit-rate is stressed by a dedicated insertion loss value, specified at a dedicated test frequency f_T . The choice of these insertion loss values for a downstream bit-rate of xN and an upstream bit-rate of yN ($N=1\ 024$ kbps) is directly related to the value $(x + y)$. The specified values are selected according to the following patterns:

The test frequency is assumed to be a highband representative for the frequency spectra that will be generated for these bit-rates. The chosen value of f_T is the rounded value of a target value that equals:

$$\left(\frac{f_T}{10^6} \right) = 7 \times \log_{10}(x + y) - 4$$

The insertion loss at test frequency f_T is a rounded value, that causes a length for test-loop #1 that approximates a special target length. That length equals:

$$\left(\frac{L_T}{1000} \right) = 9,7 \times 10^{(-0,87 \log_{10}(x+y))}$$

This approach keeps the test-loops consistent for the different payload bit-rates.

Annex B (informative): Telephony matching impedance

The European harmonized matching impedance, Z_M , for non-voice terminals (e.g. voice-band transceivers), is given in figure B.1 below. This compromise impedance is detailed more fully in ITU-T Recommendation Q.552 [15].

Different three-element compromise impedances are used for voice terminal operation in different countries. The subclauses below detail the reference impedances and any other country specific parameters. Component values are $\pm 0,1\%$ unless otherwise stated.

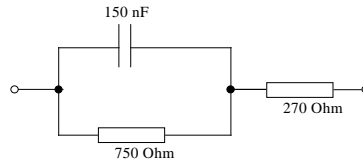

Figure B.1: Z_M compromise reference impedance (European harmonized - non voice terminals)

Unless otherwise required this voice-band matching impedance should be used for the design of the VDSL service splitter filter at voice-band frequencies. Where country specific requirements for the telephony matching impedance differ, they are described within the remainder of annex B.

NOTE: The harmonized matching impedance described above has been advocated in France (by France Telecom) and Spain (by Telefonica) for POTS matching.

B.1 Germany

For POTS operation in Germany, the following compromise matching impedance should be used when meeting the splitter requirements.

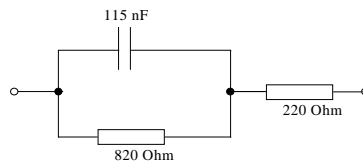

Figure B.2: Z_M compromise reference impedance used by Deutsche Telekom AG (voice terminals)

B.2 United Kingdom

For POTS operation in the UK, the following compromise matching impedance should be used when meeting the splitter requirements.

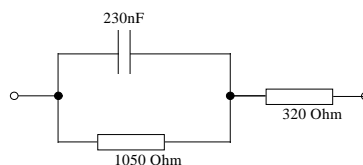

Figure B.3: Z_M compromise reference impedance used by British Telecommunications plc (voice terminals)

Annex C (informative): Proposed changes to CISPR 22 standard

The following tables are extracted from the CISPR 22 amendment of 18th April 1997, which provides limits on conducted disturbance at mains terminals and telecommunications ports. These limits have now been accepted into a revision of CISPR 22. The two tables below, extracted from 5.2 of the amendment, are applicable to VDSL. VDSL is to be normally classed as "B" and so the table C.2 together with the associated notes will form the main EMC limits on conducted common mode disturbance (within the VDSL band) from telecommunication ports. CISPR 22 is reflected subsequently in EN 55022 [2].

Table C.1: Limits of conducted common mode (asymmetric mode) disturbance at telecommunication ports in the frequency range 0,15 MHz to 30 MHz for class A equipment

| Frequency Range (MHz) | Voltage limit dB (μ V) Quasi-peak | Voltage limit dB (μ V) Average | Current limit dB (μ A) Quasi-peak | Current limit dB (μ A) Average |
|-----------------------|---|--|---|--|
| 0,15 to 0,5 | 97 to 87 | 84 to 74 | 53 to 43 | 40 to 30 |
| 0,5 to 30 | 87 | 74 | 43 | 30 |

NOTE 1: The limits decrease linearly with the logarithm of the frequency in the range 0,15 MHz to 0,5 MHz.

NOTE 2: The current and voltage disturbance limits are derived for use with an Impedance Stabilization Network (ISN) which presents a common mode (asymmetric mode) impedance of 150 Ω to the telecommunications port under test. The conversion factor is $20 \log_{10}(150/I) = 44$ dB.

Table C.2: Limits of conducted common mode (asymmetric mode) disturbance at telecommunication ports in the frequency range 0,15 MHz to 30 MHz for class B equipment

| Frequency Range (MHz) | Voltage limit dB (μ V) Quasi-peak | Voltage limit dB (μ V) Average | Current limit dB (μ A) Quasi-peak | Current limit dB (μ A) Average |
|-----------------------|---|--|---|--|
| 0,15 to 0,5 | 84 to 74 | 74 to 64 | 40 to 30 | 30 to 20 |
| 0,5 to 30 | 74 | 64 | 30 | 20 |

NOTE 1: The limits decrease linearly with the logarithm of the frequency in the range 0,15 MHz to 0,5 MHz.

NOTE 2: The current and voltage disturbance limits are derived for use with an impedance stabilization network (ISN) which presents a common mode (asymmetric mode) impedance of 150 Ω to the telecommunications port under test. The conversion factor is $20 \log_{10}(150/I) = 44$ dB.

NOTE 3: Provisionally, a relaxation of 10 dB over the frequency range of 6 MHz to 30 MHz is allowed for high-speed services having significant spectral density in this band. However this relaxation is restricted to the common mode disturbance converted by the cable from the wanted signal.

Annex D (informative): Cable information

The following material, though not specifically referenced in the body of the present document, gives supporting information regarding cable construction.

Cable type BT_dw8

Single pair dropwire. Flat twin (i.e. untwisted). 1,14 mm cadmium copper conductors. PVC insulated. No steel strength member.

Cable type BT_dwug

Multiple pair. 0,5 mm solid copper conductors. Polyethylene insulated. Predominantly used for underground distribution.

Cable type KPN_L1

Multiple quads (4 wires or two pairs), 0,5mm solid copper conductors. Paper insulation. The cables are constructed in concentric layers, and each layer consists of a number of twisted quads. The bundle of quads is mechanically protected by a shield of lead that is grounded to earth. Predominantly used for underground distribution. This cable has 50 quads in a bundle, but similar cables may combine up to 450 quads in the same bundle.

Cable type KPN_R2

Four twisted pairs, 0,5mm solid copper conductors, shielded by a foil. Category 5 LAN cable. Used in Dutch local exchanges as indoor cable, to connect xDSL equipment with distribution cable (Polyethylene insulated).

Bibliography

The following documents have been used in the preparation of the present document:

- [I-1] "VDSL Copper Transport System, Gx telco group concerned with requirements for VDSL technology for Full Services Access Networks", IEEE VIII International Workshop on Optical/Hybrid Access Networks, Atlanta USA, 4 March 1997.
- [I-2] "Specification for Full Services Access Networks (1997), Gx/FSAN group of Network Operators and Manufacturers".
- [I-3] "Cable reference models for simulating metallic access networks", R.F.M. van den Brink, ETSI TM6 Permanent document TM6(97)02 revision 2, Verona, Italy, Nov 1997.

History

| Document history | | |
|-------------------------|------------|-------------|
| V1.1.1 | April 1998 | Publication |
| V1.1.2 | June 1998 | Publication |
| | | |
| | | |
| | | |