

# ETSI TS 101 351 V8.6.0 (2000-12)

---

*Technical Specification*

**Digital cellular telecommunications system (Phase 2+);  
General Packet Radio Service (GPRS);  
Mobile Station - Serving GPRS Support Node (MS-SGSN)  
Logical Link Control (LLC) layer specification  
(3GPP TS 04.64 version 8.6.0 Release 1999)**

---



---

**Reference**

RTS/TSGN-010464Q8R3

---

**Keywords**

GSM

***ETSI***

---

650 Route des Lucioles  
F-06921 Sophia Antipolis Cedex - FRANCE

Tel.: +33 4 92 94 42 00 Fax: +33 4 93 65 47 16

Siret N° 348 623 562 00017 - NAF 742 C  
Association à but non lucratif enregistrée à la  
Sous-Préfecture de Grasse (06) N° 7803/88

---

***Important notice***

---

Individual copies of the present document can be downloaded from:

<http://www.etsi.org>

The present document may be made available in more than one electronic version or in print. In any case of existing or perceived difference in contents between such versions, the reference version is the Portable Document Format (PDF). In case of dispute, the reference shall be the printing on ETSI printers of the PDF version kept on a specific network drive within ETSI Secretariat.

Users of the present document should be aware that the document may be subject to revision or change of status. Information on the current status of this and other ETSI documents is available at <http://www.etsi.org/tb/status/>

If you find errors in the present document, send your comment to:  
editor@etsi.fr

---

***Copyright Notification***

---

No part may be reproduced except as authorized by written permission.  
The copyright and the foregoing restriction extend to reproduction in all media.

© European Telecommunications Standards Institute 2000.

All rights reserved.

---

## Intellectual Property Rights

IPRs essential or potentially essential to the present document may have been declared to ETSI. The information pertaining to these essential IPRs, if any, is publicly available for **ETSI members and non-members**, and can be found in ETSI SR 000 314: "*Intellectual Property Rights (IPRs); Essential, or potentially Essential, IPRs notified to ETSI in respect of ETSI standards*", which is available from the ETSI Secretariat. Latest updates are available on the ETSI Web server (<http://www.etsi.org/ipr>).

Pursuant to the ETSI IPR Policy, no investigation, including IPR searches, has been carried out by ETSI. No guarantee can be given as to the existence of other IPRs not referenced in ETSI SR 000 314 (or the updates on the ETSI Web server) which are, or may be, or may become, essential to the present document.

---

## Foreword

This Technical Specification (TS) has been produced by the ETSI 3<sup>rd</sup> Generation Partnership Project (3GPP).

The present document may refer to technical specifications or reports using their 3GPP identities, UMTS identities or GSM identities. These should be interpreted as being references to the corresponding ETSI deliverables.

The cross reference between GSM, UMTS, 3GPP and ETSI identities can be found under [www.etsi.org/key](http://www.etsi.org/key) .

# Contents

Foreword .....	7
1 Scope .....	8
2 References .....	9
3 Definitions and abbreviations.....	10
3.1 Definitions .....	10
3.2 Abbreviations .....	10
4 Overview description of LLC functions and procedures .....	11
4.1 Reference model.....	12
4.2 General description of the LLC protocol.....	12
4.2.1 Services required by the lower layers .....	13
4.3 Unacknowledged operation.....	13
4.4 Acknowledged operation.....	13
4.5 Establishment of information transfer modes.....	13
4.5.1 Data link connection identification.....	13
4.5.2 Logical link states .....	14
4.5.3 TLLI assignment.....	14
4.5.4 Establishment of ABM operation .....	14
4.6 Data confidentiality .....	14
4.7 LLC layer structure .....	15
4.7.1 Logical Link Entity.....	15
4.7.2 Multiplex procedure.....	16
4.7.3 Logical Link Management.....	16
4.8 GPRS Mobility Management .....	16
4.9 Short Message Service .....	16
4.10 Tunnelling Of Messages.....	16
5 Frame structure.....	16
5.1 General .....	16
5.2 Address field .....	17
5.3 Control field .....	17
5.4 Information field .....	17
5.5 Frame Check Sequence (FCS) field .....	17
5.6 Transparency .....	18
5.6.1 Bit transparency .....	18
5.6.2 Information protection .....	18
5.6.3 Octet alignment.....	18
5.7 Format convention.....	18
5.7.1 Numbering convention .....	18
5.7.2 Order of transmission .....	18
5.7.3 Field mapping convention .....	19
5.8 Invalid frames.....	19
6 Elements of procedures and formats of fields.....	19
6.1 General .....	19
6.2 Address field format and variables.....	20
6.2.1 Protocol Discriminator bit (PD).....	20
6.2.2 Command/Response bit (C/R).....	20
6.2.3 Service Access Point Identifier (SAPI).....	20
6.3 Control field formats, parameters, and variables.....	21
6.3.1 Information transfer format - I.....	23
6.3.2 Supervisory format - S.....	23
6.3.3 Unconfirmed Information format - UI.....	23
6.3.4 Unnumbered format - U.....	23
6.3.5 Control field parameters and associated state variables.....	23
6.3.5.1 Poll/Final bit (P/F) .....	23

6.3.5.2	Acknowledgement request bit (A) .....	23
6.3.5.3	Modulus .....	24
6.3.5.4	ABM variables and sequence numbers .....	24
6.3.5.4.1	Send state variable V(S) .....	24
6.3.5.4.2	Acknowledge state variable V(A) .....	24
6.3.5.4.3	Send sequence number N(S) .....	24
6.3.5.4.4	Receive state variable V(R) .....	24
6.3.5.4.5	Receive sequence number N(R) .....	24
6.3.5.4.6	SACK bitmap R(n) .....	25
6.3.5.4.7	I frame buffer variable B .....	25
6.3.5.4.8	Other parameters and variables .....	25
6.3.5.5	Unacknowledged operation variables and parameters .....	25
6.3.5.5.1	Encryption mode bit (E) .....	25
6.3.5.5.2	Protected Mode bit (PM) .....	25
6.3.5.5.3	Unconfirmed send state variable V(U) .....	25
6.3.5.5.4	Unconfirmed sequence number N(U) .....	26
6.3.5.5.5	Unconfirmed receive state variable V(UR) .....	26
6.3.5.5.6	Other parameters and variables .....	26
6.4	Commands and responses .....	26
6.4.1	Unnumbered (U) frames .....	26
6.4.1.1	Set Asynchronous Balanced Mode (SABM) command .....	26
6.4.1.2	Disconnect (DISC) command .....	27
6.4.1.3	Unnumbered Acknowledgement (UA) response .....	27
6.4.1.4	Disconnected Mode (DM) response .....	27
6.4.1.5	Frame Reject (FRMR) response .....	27
6.4.1.6	Exchange Identification (XID) command/response .....	28
6.4.1.7	NULL command .....	30
6.4.2	Unconfirmed Information (UI) frame .....	31
6.4.2.1	Unconfirmed Information (UI) command .....	31
6.4.3	Combined Information (I) and Supervisory (S) frames .....	31
6.4.3.1	Receive Ready (RR) command / response .....	31
6.4.3.2	Acknowledgement (ACK) command / response .....	31
6.4.3.3	Selective Acknowledgement (SACK) command / response .....	31
6.4.3.4	Receive Not Ready (RNR) command / response .....	32
7	Elements for layer-to-layer communication .....	32
7.1	Definition of service primitives and parameters .....	32
7.1.1	Primitives types .....	32
7.1.1.1	Request .....	33
7.1.1.2	Indication .....	33
7.1.1.3	Response .....	33
7.1.1.4	Confirm .....	33
7.1.2	LLC layer service primitives .....	33
7.2	Primitive procedures .....	34
7.2.1	GMM - LLME primitives .....	34
7.2.1.1	LLGMM-ASSIGN .....	34
7.2.1.2	LLGMM-RESET .....	34
7.2.1.3	LLGMM-TRIGGER .....	35
7.2.1.4	LLGMM-SUSPEND .....	35
7.2.1.5	LLGMM-RESUME .....	35
7.2.1.6	LLGMM-PAGE .....	35
7.2.1.7	LLGMM-IOV .....	35
7.2.1.8	LLGMM-STATUS .....	36
7.2.2	Layer 3 - LLE primitives .....	36
7.2.2.1	LL-RESET .....	36
7.2.2.2	LL-ESTABLISH .....	36
7.2.2.3	LL-RELEASE .....	36
7.2.2.4	LL-XID .....	36
7.2.2.5	LL-DATA .....	36
7.2.2.6	LL-UNITDATA .....	36
7.2.2.7	LL-STATUS .....	36
7.2.3	LLE - RLC/MAC primitives .....	37

7.2.3.1	GRR-DATA .....	37
7.2.3.2	GRR-UNITDATA .....	37
7.2.4	LLE - BSSGP primitives .....	37
7.2.4.1	BSSGP-DL-UNITDATA .....	37
7.2.4.2	BSSGP-UL-UNITDATA .....	37
7.2.5	LLME - LLE primitives .....	37
8	Definition of the LLC peer-to-peer protocol .....	38
8.1	General .....	38
8.2	Procedure for the use of the P/F bit .....	38
8.3	TLLI assignment procedures .....	39
8.3.1	TLLI assignment .....	39
8.3.2	TLLI change .....	39
8.3.3	TLLI unassignment .....	39
8.4	Procedures for unacknowledged information transfer .....	39
8.4.1	Transmission of unacknowledged information .....	39
8.4.2	Receipt of unacknowledged information .....	40
8.5	Procedures for establishment and release of ABM operation .....	40
8.5.1	Establishment of ABM operation .....	40
8.5.1.1	General .....	40
8.5.1.2	Establishment procedures .....	40
8.5.1.3	Procedure on expiry of timer T200 .....	41
8.5.2	Termination of ABM operation .....	41
8.5.2.1	General .....	41
8.5.2.2	Release procedure .....	42
8.5.2.3	Procedure on expiry of timer T200 .....	42
8.5.3	Automatic negotiation of LLC layer and layer-3 parameters .....	42
8.5.3.1	Negotiation of parameter Reset .....	43
8.5.3.2	Negotiation of parameter m .....	44
8.5.3.3	Unsuccessful XID negotiation .....	44
8.5.3.4	Procedure on expiry of timer T200 .....	45
8.5.4	TLLI Assigned / ADM state .....	45
8.5.5	Collision of unnumbered commands .....	45
8.5.5.1	Identical transmitted and received commands .....	45
8.5.5.2	Different transmitted and received commands .....	46
8.5.6	Unsolicited DM response and SABM or DISC command .....	46
8.6	Procedures for information transfer in ABM operation .....	47
8.6.1	Transmitting I frames .....	47
8.6.2	Receiving I frames .....	48
8.6.3	Sending and receiving acknowledgements .....	48
8.6.3.1	Sending acknowledgements .....	48
8.6.3.2	Receiving acknowledgements .....	49
8.6.3.3	Requesting acknowledgements .....	49
8.6.4	Peer receiver busy condition .....	49
8.6.4.1	Supervisory frame selection .....	50
8.6.5	Own receiver busy condition .....	50
8.6.6	Waiting for acknowledgement .....	50
8.7	Re-establishment of ABM operation .....	51
8.7.1	Criteria for re-establishment .....	51
8.7.2	Procedures .....	51
8.8	Exception condition reporting and recovery .....	51
8.8.1	Invalid frame condition .....	51
8.8.2	Frame rejection condition .....	52
8.8.3	Receipt of a FRMR response frame .....	52
8.8.4	Unsolicited response frames .....	52
8.9	List of LLC layer parameters .....	52
8.9.1	LLC version number (Version) .....	53
8.9.2	Input Offset Value (IOV) .....	53
8.9.3	Retransmission timers (T200 and T201) .....	53
8.9.4	Maximum number of retransmissions (N200) .....	53
8.9.5	Maximum number of octets in an information field (N201) .....	53
8.9.6	Maximum number of octets in the layer-3 header (N202) .....	53

8.9.7	Maximum I frame buffer size (m) .....	53
8.9.8	Maximum number of outstanding I frames (k).....	54
8.9.9	LLC layer parameter default values.....	54
<b>Annex A (normative): Ciphering.....</b>		<b>55</b>
A.1	General .....	55
A.2	Ciphering algorithm interface .....	55
A.2.1	Generation of Input .....	56
<b>Annex B (normative): Tunnelling of Messages (TOM) .....</b>		<b>57</b>
B.1	TOM Protocol Envelope structure .....	57
B.1.1	TOM Protocol Discriminator .....	57
B.1.2	Remaining Length of TOM Protocol Header.....	58
B.1.3	Remaining Octets of TOM Protocol Header .....	58
B.1.4	Message Capsule .....	58
<b>Annex C (informative): LLC layer states for peer-to-peer operation .....</b>		<b>59</b>
C.1	General .....	59
C.2	An overview of the peer-to-peer LLC layer states .....	59
<b>Annex D (informative): Document Change Request History .....</b>		<b>61</b>

---

# Foreword

This Technical Specification has been produced by the 3<sup>rd</sup> Generation Partnership Project (3GPP).

The contents of the present document are subject to continuing work within the TSG and may change following formal TSG approval. Should the TSG modify the contents of the present document, it will be re-released by the TSG with an identifying change of release date and an increase in version number as follows:

Version x.y.z

where:

- x the first digit:
  - 1 presented to TSG for information;
  - 2 presented to TSG for approval;
  - 3 or greater indicates TSG approved document under change control.
- y the second digit is incremented for all changes of substance, i.e. technical enhancements, corrections, updates, etc.
- z the third digit is incremented when editorial only changes have been incorporated in the document.



---

# 1 Scope

The present document defines the Logical Link Control (LLC) layer protocol to be used for packet data transfer between the Mobile Station (MS) and Serving GPRS Support Node (SGSN).

It defines the frame structure, elements of procedure, format of fields, and procedures for the proper operation of the logical link control layer. It is based on ideas contained in IS-130 [21], ISO 3309 [16], ISO 4335 [17], and ISO 7809 [18, 19, 20] (HDLC of ISO), as well ITU-T Q.920 [13] and Q.921 [14] (LAPD). The concepts, the overview description of LLC layer functions and procedures, and the relationship with other Technical Specifications are described in general terms in 3GPP TS 03.60 [5].

LLC spans from the Mobile Station (MS) to the Serving GPRS Support Node (SGSN). LLC is intended for use with both acknowledged and unacknowledged data transfer.

The frame formats defined for LLC are based on those defined for LAPD and RLP. However, there are important differences between LLC and other protocols, in particular with regard to frame delimitation methods and transparency mechanisms. These differences are necessary for independence from the radio path.

The LLC procedures are modelled upon the concepts of HDLC as outlined in ISO 4335. Data sequence integrity between the data source and data sink is effected by means of a cyclic numbering scheme. An independent numbering scheme is used for each logical data link, as identified by the a data link connection identifier. LLC supports two modes of operation:

- Unacknowledged peer-to-peer operation:

A logical link entity may initiate transmissions to a peer entity without prior establishment of a logical connection with the peer entity. LLC does not guarantee in-order delivery. LLC can detect errors in a received frame, and, depending on whether the frame is sent in protected mode or not, either discard or deliver the erroneous frame. No error recovery procedures are defined at the LLC layer. Higher-layer protocols can be used to provide reliability, if needed. This mode of operation is known as Asynchronous Disconnected Mode (ADM).

- Acknowledged peer-to-peer operation:

A balanced data link involves two participating entities, and each entity assumes responsibility for the organisation of its data flow and for error recovery procedures associated with the transmissions that it originates. Each entity operates as both a data source and data sink in a balanced link, allowing information to flow in both directions. This mode of operation is known as Asynchronous Balanced Mode (ABM), and provides a reliable service with in-order delivery.

The present document is organised as follows:

- An overview of the LLC layer functions is given in clause 4.
- The frame structure for peer-to-peer communication is given in clause 5.
- The elements of procedure and formats of fields are given in clause 6.
- The elements of layer-to-layer communication are contained in clause 7.
- The details of the peer-to-peer ABM procedures are given in clause 8.
- The details of LLC frame ciphering are given in annex A.
- The details of the TOM protocol layer are contained in annex B.
- An overview of the LLC layer states is provided in annex C.

---

## 2 References

The following documents contain provisions which, through reference in this text, constitute provisions of the present document.

- References are either specific (identified by date of publication, edition number, version number, etc.) or non-specific.
- For a specific reference, subsequent revisions do not apply.
- For a non-specific reference, the latest version applies. In the case of a reference to a 3GPP document (including a GSM document), a non-specific reference implicitly refers to the latest version of that document *in the same Release as the present document*.
- A non-specific reference to an ETS shall also be taken to refer to later versions published as an EN with the same number.
- For this Release 1999 document, references to GSM documents are for Release 1999 versions (version 8.x.y).

- [1] 3GPP TS 01.04: "Digital cellular telecommunications system (Phase 2+); Abbreviations and acronyms".
- [2] 3GPP TS 01.61: "Digital cellular telecommunications system (Phase 2+); GPRS ciphering algorithm requirements".
- [3] 3GPP TS 02.60: "Digital cellular telecommunications system (Phase 2+); General Packet Radio Service (GPRS); Service description; Stage 1".
- [4] 3GPP TS 03.40: "Digital cellular telecommunications system (Phase 2+); Technical realization of the Short Message Service (SMS); Point-to-Point (PP)".
- [5] 3GPP TS 03.60: "Digital cellular telecommunications system (Phase 2+); General Packet Radio Service (GPRS); Service description; Stage 2".
- [6] 3GPP TS 03.64: "Digital cellular telecommunications system (Phase 2+); Overall description of the General Packet Radio Service (GPRS) Radio interface; Stage 2".
- [7] 3GPP TS 04.01: "Digital cellular telecommunications system (Phase 2+); Mobile Station - Base Station System (MS - BSS) interface; General aspects and principles".
- [8] 3GPP TS 04.08: "Digital cellular telecommunications system (Phase 2+); Mobile radio interface layer 3 specification".
- [9] 3GPP TS 04.11: "Digital cellular telecommunication system (Phase 2+); Point-to-Point (PP) Short Message Service (SMS) support on mobile radio interface".
- [10] 3GPP TS 04.22: "Digital cellular telecommunications system (Phase 2+); Radio Link Protocol (RLP) for data and telematic services on the Mobile Station - Base Station System (MS - BSS) interface and the Base Station System - Mobile-services Switching Centre (BSS - MSC) interface".
- [11] 3GPP TS 04.65: "Digital cellular telecommunications system (Phase 2+); General Packet Radio Service (GPRS); Mobile Station (MS) – Serving GPRS Support Node (SGSN); Subnetwork Dependent Convergence Protocol (SNDCP)".
- [12] 3GPP TS 08.18: "Digital cellular telecommunications system (Phase 2+); General Packet Radio Service (GPRS); Base Station System (BSS) - Serving GPRS Support Node (SGSN); BSS GPRS Protocol (BSSGP)".
- [13] ITU-T Q.920 (1988): "ISDN user-network interface data link layer – general aspects".
- [14] ITU-T Q.921 (1988): "ISDN user-network interface – data link layer specification".
- [15] ITU-T Z.100 (1988): "CCITT specification and description language (SDL)".

- [16] ISO 3309 (1984): "Information processing systems – Data communications – High-level logical link control procedures – Frame structure".
- [17] ISO 4335 (1987): "Information processing systems – Data communication – High-level logical link control procedures – Consolidation of elements of procedures".
- [18] ISO 7809 (1984): "Information processing systems – Data communication – High-level logical link control procedures – Consolidation of classes of procedures".
- [19] ISO 7809 (1984): "Information processing systems – Data communication Add. 1: 1987 – High-level logical link control procedures – Consolidation of classes of procedures – Addendum 1".
- [20] ISO 7809 (1984): "Information processing systems – Data communication Add. 2: 1987 – High-level logical link control procedures – Consolidation of classes of procedures – Addendum 2: Description of optional functions".
- [21] TIA IS-130 (1995): "800 MHz Cellular System – TDMA Radio Interface – Radio Link Protocol 1" Arlington: Telecommunications Industry Association.
- [22] TIA/EIA-136 (1999): "TDMA Cellular / PCS"; Arlington: Telecommunications Industry Association.

## 3 Definitions and abbreviations

### 3.1 Definitions

For the purposes of the present document, the following terms and definitions apply. Additional applicable definitions can be found in 3GPP TS 02.60 [3].

**frame rejection condition:** a condition that results from the receipt of an undefined or incorrect frame.

**inquiry process:** a process performed in the peer receiver busy condition in which the LLE checks that the peer LLE is still in the own receiver busy condition.

**invalid frame condition:** a condition that results from the receipt of an invalid frame.

**logical link connection:** the logical connection between two LLE peers. A logical link connection is identified with a Data Link Connection Identifier (DLCI). A logical link connection is always in one of three states: TLLI Unassigned, TLLI Assigned / ADM, or ABM.

**logical link control layer:** the protocol layer between an MS and an SGSN consisting of one or more logical link management entities, one or more logical link entities, and a multiplex procedure.

**logical link entity:** the LLC layer protocol state machine controlling one logical link connection.

**own receiver busy condition:** a condition that results from the inability to accept additional I frames from the peer logical link entity.

**peer receiver busy condition:** a condition that results from the reception in of a RNR frame from the peer logical link entity.

### 3.2 Abbreviations

For the purposes of the present document, the following abbreviations apply. Additional applicable abbreviations and symbols can be found in 3GPP TS 01.04 [1] and 3GPP TS 03.60.

ABM	Asynchronous Balanced Mode
ACK	ACKnowledgement
ADM	Asynchronous Disconnected Mode
CNF	Confirm
DISC	DISConnect

DM	Disconnected Mode
FRMR	FRaMe Reject
GMM	GPRS Mobility Management
GRR	GPRS Radio Resources service access point
I	Information
IOV	Input Offset Value
IND	Indication
LAPD	Link Access Procedure on the D-channel
LL	Logical Link
LLC	Logical Link Control
LLE	Logical Link Entity
LLGMM	LLC to GPRS Mobility Management service access point
LLM	Logical Link Management
LLME	Logical Link Management Entity
REQ	Request
RES	Response
RNR	Receive Not Ready
RR	Receive Ready
S	Supervisory
SABM	Set Asynchronous Balanced Mode
SACK	Selective ACKnowledgement
TIA	Telecommunications Industry Association
TOM	Tunnelling Of Messages
UA	Unnumbered Acknowledgement
UI	Unconfirmed Information
XID	eXchange IDentification

---

## 4 Overview description of LLC functions and procedures

The requirements of the LLC layer can be summarised as follows:

- LLC shall provide a highly reliable logical link between the MS and the SGSN.
- LLC shall be independent of the underlying radio interface protocols in order to allow introduction of alternative GPRS radio solutions with minimal change to the NSS.
- LLC shall support variable-length information frames.
- LLC shall support peer-to-peer data transfers.
- LLC shall support both acknowledged and unacknowledged data transfers.
- LLC shall permit information transfer between the SGSN and one or more MSs using the same physical (e.g., radio) resources. Thus each LLC frame shall uniquely identify the MS sending (uplink) or receiving (downlink) the information.
- LLC shall allow information transfer with different service criteria, such that high-priority data transfers may take precedence over lower-priority transfers to the same MS.
- LLC shall provide user data confidentiality by means of a ciphering function.
- LLC shall support user identity confidentiality.

## 4.1 Reference model

A model of layering the protocols in GPRS is illustrated in Figure 1.

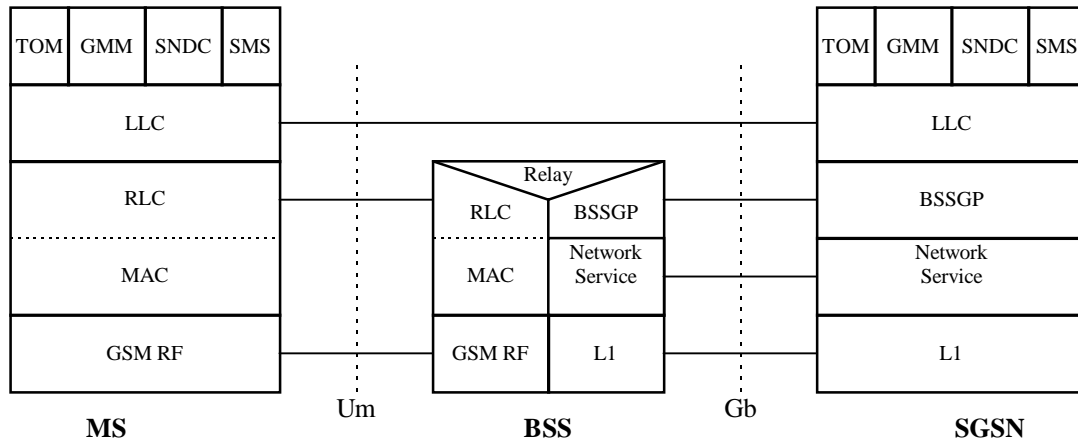

**Figure 1: Protocol layering in GPRS**

The LLC layer operates above the RLC and BSSGP layers in the reference architecture to provide logical links between an MS and its SGSN.

Above the LLC layer is located the SubNetwork Dependent Convergence (SNDC) layer, that controls the transfer of user data network layer PDUs (N-PDUs) between the MS and SGSN. The SNDC functionality is described in 3GPP TS 03.60 and specified in 3GPP TS 04.65 [11].

The logical link control layer Service Access Points (SAPs) are the points at which the LLC layer provides services to the layer-3 protocols in Figure 1. In addition to the SNDC protocol, LLC provides service to the GPRS Mobility Management (GMM) protocol, to the SMS protocol, and to the Tunnelling of Messages (TOM) protocol.

An LLC layer connection is identified by the DLCI consisting of the SAP Identifier (SAPI) and the MS's Temporary Logical Link Identifier (TLLI).

Each LLC frame consists of the header, trailer, and information field. The header and trailer fields contain information such as SAPI, frame number and checksum, that are used to identify the frame and to provide reliable transmission. The information field is variable length. Both transmission and retransmission of each frame are controlled by the LLC layer.

Many of the formats and procedures are similar to the reference protocols, and differences are introduced only where needed to reflect the unique aspects of the GPRS architecture and requirements.

## 4.2 General description of the LLC protocol

LLC is considered to be a sublayer of layer 2 in the ISO 7-layer model. The purpose of LLC is to convey information between layer-3 entities in the MS and SGSN. Specifically, LLC shall support:

- multiple MSs at the Um interface;
- multiple layer-3 entities within an MS.

LLC includes functions for:

- the provision of one or more logical link connections discriminated between by means of a DLCI;
- sequence control, to maintain the sequential order of frames across a logical link connection;
- detection of transmission, format and operational errors on a logical link connection;
- recovery from detected transmission, format, and operational errors;
- notification of unrecoverable errors;

- flow control; and
- ciphering.

LLC layer functions provide the means for information transfer via peer-to-peer logical link connections between an MS and SGSN pair.

## 4.2.1 Services required by the lower layers

LLC requires the following services from the layers below:

- LLC PDU delimitation to allow the LLC layer to determine the first octet and the last octet in each LLC PDU; and
- transport of the MS address (a TLLI) of each LLC PDU between the MS and the SGSN.

To "transmit a frame" and "send a frame" refers to the delivery of a frame by the LLC layer to the layer below.

## 4.3 Unacknowledged operation

With this type of operation, layer-3 information is transmitted in numbered Unconfirmed Information (UI) frames. The UI frames are not acknowledged at the LLC layer. Neither error recovery nor reordering mechanisms are defined, but transmission and format errors are detected. Duplicate UI frames are discarded.

Flow control procedures are not defined.

Two modes of unacknowledged operation are defined:

- protected mode in which the FCS field protects the frame header and information field; and
- unprotected mode in which the FCS field protects the frame header and only the first octets of the information field.

Unacknowledged operation is allowed for all SAPIs that are not reserved (see Table 2).

## 4.4 Acknowledged operation

With this type of operation, layer-3 information is transmitted in order in numbered Information (I) frames. The I frames are acknowledged at the LLC layer. Error recovery and reordering procedures based on retransmission of unacknowledged I frames are specified. Several I frames may be unacknowledged at the same time. In the case of errors that cannot be corrected by the logical link control layer, a report to GPRS mobility management shall be made.

Flow control procedures are defined.

Acknowledged operation requires that ABM operation has been initiated by an establishment procedure using the Set Asynchronous Balanced Mode (SABM) command.

Acknowledged operation is allowed for all SAPIs that are not reserved (see Table 2) except SAPIs 1, 2, 7, and 8.

## 4.5 Establishment of information transfer modes

### 4.5.1 Data link connection identification

A logical link connection is identified by a DLCI consisting of two identifiers: a SAPI and a TLLI.

The SAPI is used to identify the service access point on the SGSN side and the MS side of the LLC interface. SAPI is carried in the address field of each LLC frame.

The TLLI is used to identify a specific MS. TLLI assignment is controlled by GMM. TLLI is not carried in LLC frames, but in BSSGP messages as defined in 3GPP TS 08.18 [12], and in RLC/MAC blocks as defined in 3GPP TS 04.08 [8].

## 4.5.2 Logical link states

A logical link entity may be in one of three basic states:

- TLLI Unassigned state: information transfer shall not be possible with the following exception: the SGSN shall be able to receive UI and XID frames for SAPI = 1;
- TLLI Assigned / ADM state: in this state a TLLI has been assigned. Unacknowledged information transfer and XID negotiation shall be possible on SAPIs that are assigned to a layer-3 entity; or
- ABM state: this state shall be established by means of an ABM establishment procedure. Both acknowledged and unacknowledged information transfer shall be possible.

The basic states and additional states are shown in annex C.

## 4.5.3 TLLI assignment

TLLI assignment is controlled by GMM. TLLIs are assigned, changed, and unassigned with the LLGMM-ASSIGN-REQ primitive, as described in subclause 7.2.1.1.

## 4.5.4 Establishment of ABM operation

Before peer-to-peer acknowledged information transfer can start, an exchange of a SABM frame and an Unnumbered Acknowledgement (UA) frame shall take place. The ABM establishment procedure is specified in clause 8.

## 4.6 Data confidentiality

The LLC layer shall provide data confidentiality by ciphering the information and FCS fields of data frames:

- The information and FCS fields of I frames shall be ciphered whenever ciphering information has been assigned to the TLLI.
- The information and FCS fields of UI frames shall be ciphered whenever layer 3 indicates that the UI frame shall be ciphered and ciphering information has been assigned to the TLLI.

## 4.7 LLC layer structure

The LLC layer structure is shown in Figure 2. This figure is a model shown for illustrative purposes only, and does not constrain implementations.

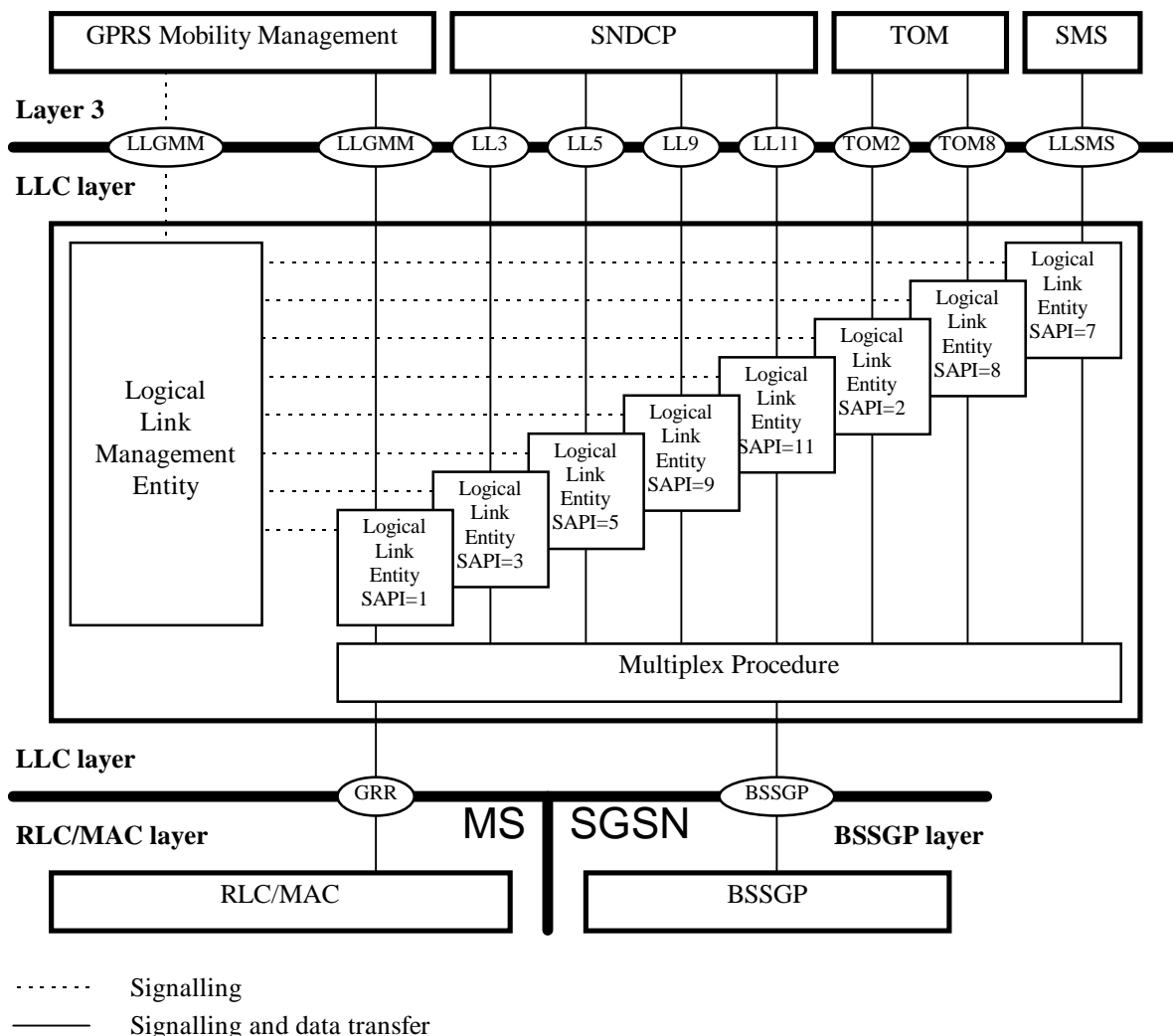

Figure 2: Functional model of the LLC layer

### 4.7.1 Logical Link Entity

The logical link procedures consist of multiple Logical Link Entities (LLEs) that control the information flow of individual connections. There may be multiple LLEs per TLLI. Functions provided by each LLE are:

- unacknowledged information transfer;
- acknowledged information transfer;
- flow control in ABM operation; and
- frame error detection.

The LLE analyses the control field of the received frame (see subclause 6.3) and provides appropriate responses and layer-to-layer indications. In addition, LLE analyses the LLC layer service primitives and transmits the appropriate command and response frames. There is one logical link entity for each DLCI.



## 4.7.2 Multiplex procedure

On frame transmission, the multiplex procedure generates and inserts the FCS, performs the frame ciphering function, and provides SAPI-based logical link control layer contention resolution between the various LLEs.

On frame reception, the multiplex procedure performs the frame decipher function and checks the FCS. If the frame passes the FCS check, the multiplex procedure distributes the frame to the appropriate logical link entity based on the DLCI.

3GPP TS 01.61 [2] contains the requirements for the GPRS ciphering algorithm.

## 4.7.3 Logical Link Management

The Logical Link Management Entity (LLME) manages the resources that have an impact on individual connections. There is one LLME per TLLI. Functions provided by the LLME are:

- parameter initialisation;
- error processing; and
- connection flow control invocation.

The RLC/MAC layer functions are described in 3GPP TS 03.64 [6]. BSSGP is specified in 3GPP TS 08.18. SNDCP is specified in 3GPP TS 04.65.

## 4.8 GPRS Mobility Management

GPRS Mobility Management (GMM) uses the services of the LLC layer to transfer messages between the MS and the SGSN. GMM includes functions such as attach and authentication, and transport of session management messages for functions such as PDP context activation and deactivation. GMM procedures are defined in 3GPP TS 04.08 and are beyond the scope of the LLC layer. Interaction between GMM and LLC is defined in terms of service primitives, see clause 7.

## 4.9 Short Message Service

The Short Message Service (SMS) uses the services of the LLC layer to transfer short messages between the MS and the SGSN. SMS procedures are defined in 3GPP TS 03.40 [4] and 3GPP TS 04.11 [9] and are beyond the scope of the LLC layer. Interaction between SMS and LLC is defined in terms of service primitives, see clause 7.

## 4.10 Tunnelling Of Messages

TOM is a generic protocol layer used for the exchange of TOM Protocol Envelopes between the MS and the SGSN. TOM procedures are defined in annex B.

---

# 5 Frame structure

## 5.1 General

All logical link control layer peer-to-peer exchanges shall be in frames conforming to the format shown in Figure 3. The frame header shall consist of the address and control fields, and is a minimum of 2 octets and a maximum of 37 octets long.

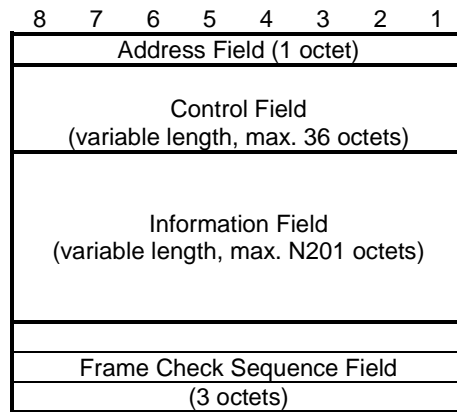

**Figure 3: LLC frame format**

## 5.2 Address field

The address field consists of a single octet. The address field contains the SAPI and identifies the DLCI for which a downlink frame is intended and the DLCI transmitting an uplink frame. The format of the address field is defined in subclause 6.2.

## 5.3 Control field

The control field typically consists of between one and three octets. The SACK supervisory frame also includes a variable-length bitmap field of up to 32 octets. The format of the control field is defined in subclause 6.3.

## 5.4 Information field

The information field of a frame, when present, follows the control field (see subclause 5.4 above). The maximum number of octets in the information field (N201) is defined in subclause 8.9.5.

## 5.5 Frame Check Sequence (FCS) field

The FCS field shall consist of a 24 bit cyclic redundancy check (CRC) code. The CRC-24 is used to detect bit errors in the frame header and information fields.

The FCS field contains the value of a CRC calculation that is performed over the entire contents of the header and information field, except for UI frames transmitted in unprotected mode, in which case the FCS field contains the value of a CRC calculation that is performed over the frame header and the first N202 octets (see subclause 8.9.6) of the information field only (see subclause 6.3.5.5.2). The information over which the CRC is calculated is referred to as the dividend in this subclause. Bit (1, 1) of the dividend is the highest-order term in the calculation (see subclause 5.7.3). CRC calculation shall be done before ciphering at the transmitting side, and after deciphering at the receiving side.

**NOTE:** The definition below is different from that in 3GPP TS 04.22 [10] only with respect to the variable dividend length  $k$  of the LLC frames. In 3GPP TS 04.22, the RLP frame has a fixed dividend length, but the LLC frame has a variable dividend length.

The CRC shall be the ones complement of the sum (modulo 2) of:

- the remainder of  $x^k (x^{23} + x^{22} + x^{21} + \dots + x^2 + x + 1)$  divided (modulo 2) by the generator polynomial, where  $k$  is the number of bits of the dividend; and
- the remainder of the division (modulo 2) by the generator polynomial of the product of  $x^{24}$  by the dividend.

The CRC-24 generator polynomial is:

$$G(x) = x^{24} + x^{23} + x^{21} + x^{20} + x^{19} + x^{17} + x^{16} + x^{15} + x^{13} + x^8 + x^7 + x^5 + x^4 + x^2 + 1$$

The result of the CRC calculation is placed within the FCS field as described in subclause 5.7.3.

NOTE: As a typical implementation at the transmitter, the initial content of the register of the device computing the remainder of the division is pre-set to all "1's" and is then modified by division by the generator polynomial (as described above) of the dividend; the ones complement of the resulting remainder is put into the FCS field.

As a typical implementation at the receiver, the initial content of the register of the device computing the remainder of the division is pre-set to all "1's". The final remainder, after multiplication by  $x^{24}$  and then division (modulo 2) by the generator polynomial of the received frame, will be (in the absence of errors):

$$C(x) = x^{22} + x^{21} + x^{19} + x^{18} + x^{16} + x^{15} + x^{11} + x^8 + x^5 + x^4$$

## 5.6 Transparency

### 5.6.1 Bit transparency

Because of the frame delimitation technique used in LLC, the frame can include any possible sequence of bits without the need for e.g., bit stuffing as defined in Q.921.

### 5.6.2 Information protection

The information carried within a UI frame may be considered as either "protected" or "unprotected" (see subclause 6.3.5.5.2). CRC error detection procedures are only used on the first octets of the information content within unprotected UI frames, supporting applications that can tolerate bit errors.

### 5.6.3 Octet alignment

LLC provides only an octet-aligned service to layer 3. LLC requires that information exchanged with layer 3 contains an integral number of octets.

## 5.7 Format convention

### 5.7.1 Numbering convention

The basic convention used in the present document is illustrated in Figure 4. The bits are grouped into octets. The bits of an octet are shown horizontally and are numbered from 1 to 8. Multiple octets are shown vertically and are numbered from 1 to n.

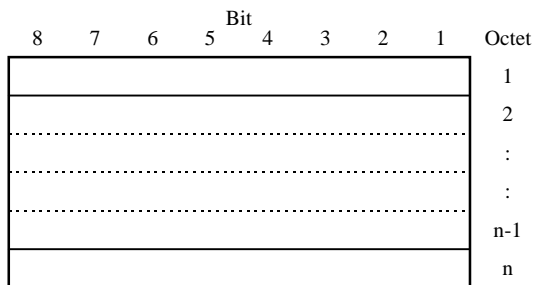

Figure 4: Format convention

### 5.7.2 Order of transmission

Frames are transferred between the LLC layer and underlying protocol layers in units of octets, in ascending numerical octet order (i.e., octet 1, 2, ..., n-1, n). The order of bit transmission is specific to the underlying protocols used across the Um interface (e.g., RLC) and the Gb interface (BSSGP).

### 5.7.3 Field mapping convention

When a field is contained within a single octet, the lowest bit number of the field represents the lowest-order value. When a field spans more than one octet, the order of bit values within each octet progressively decreases as the octet number increases. In that part of the field contained in a given octet the lowest bit number represents the lowest-order value.

For example, a bit number can be identified as a couple (o, b) where o is the octet number and b is the relative bit number within the octet. Figure 5 illustrates a field that spans from bit (1, 3) to bit (2, 7). The high-order bit of the field is mapped on bit (1, 3) and the low-order bit is mapped on bit (2, 7).

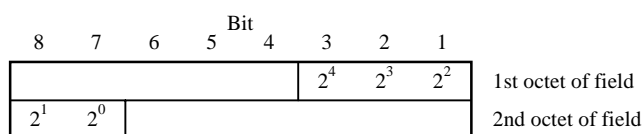

**Figure 5: Field mapping convention**

An exception to the preceding field mapping convention is the FCS field. In this case bit 1 of the first octet is the high-order bit and bit 8 of the last octet is the low-order bit. The field mapping for a 24 bit FCS is shown in Figure 5.

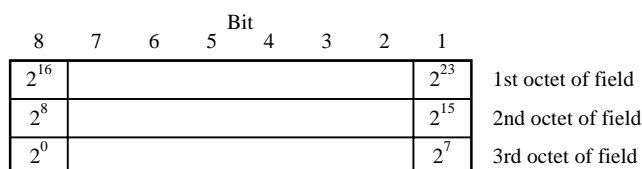

**Figure 6: FCS mapping convention**

## 5.8 Invalid frames

An invalid frame is a frame that:

- contains fewer octets than necessary to include the address field, control field, information field, and FCS field necessary to constitute a complete frame according to the contents of the control field;
- has the PD bit set to 1;
- contains a reserved SAPI or a SAPI that is not supported or not assigned to a layer-3 entity; or
- contains an FCS error.

An invalid frame shall be discarded without notification to the sender. No action shall be taken as the result of that frame.

# 6 Elements of procedures and formats of fields

## 6.1 General

The elements of procedures define the commands and responses that are used on the logical link connections between the MS and SGSN.

Procedures are derived from these elements of procedures and are described in clause 8.

If a bit position is marked as "spare", it shall be coded as 0. A spare bit is indicated with an 'X' in the format figures in this clause. For future compatibility reasons, an entity receiving frames, where spare bit positions are coded otherwise, shall ignore those values without notification of any error.

## 6.2 Address field format and variables

The address field consists of

- the Protocol Discriminator bit PD;
- the Command/Response bit C/R; and
- the SAPI.

The format of the address field is shown in Figure 7.

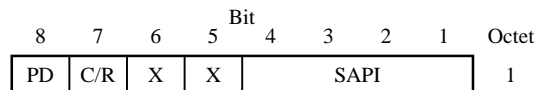

**Figure 7: Address field format**

### 6.2.1 Protocol Discriminator bit (PD)

The PD bit indicates whether a frame is an LLC frame or belongs to a different protocol. LLC frames shall have the PD bit set to 0. If a frame with the PD bit set to 1 is received, then it shall be treated as an invalid frame, see subclause 5.8.

### 6.2.2 Command/Response bit (C/R)

The C/R bit identifies a frame as either a command or a response. The MS side shall send commands with the C/R bit set to 0, and responses with the C/R bit set to 1. The SGSN side shall do the opposite; i.e., commands are sent with C/R set to 1, and responses are sent with C/R set to 0. The combinations for the SGSN side and MS side are shown in Table 1.

**Table 1: C/R field bit usage**

Type	Direction	C/R value
Command	SGSN side to MS side	1
Command	MS side to SGSN side	0
Response	SGSN side to MS side	0
Response	MS side to SGSN side	1

### 6.2.3 Service Access Point Identifier (SAPI)

SAPI identifies a point at which LLC services are provided by an LLE to a layer-3 entity. Consequently, SAPI identifies an LLE that should process an LLC frame and also a layer-3 entity that is to receive information carried by the LLC frame.

SAPI allows 16 service access points to be specified. The SAPI values are allocated as shown in Table 2.

**Table 2: Allocation of SAPI values**

SAPI	Related Service	SAP Name
0000	Reserved	-
0001	GPRS Mobility Management	LLGMM
0010	Tunnelling of messages 2	TOM2
0011	User data 3	LL3
0100	Reserved	-
0101	User data 5	LL5
0110	Reserved	-
0111	SMS	LLSMS
1000	Tunnelling of messages 8	TOM8
1001	User data 9	LL9
1010	Reserved	-
1011	User data 11	LL11
1100	Reserved	-
1101	Reserved	-
1110	Reserved	-
1111	Reserved	-

## 6.3 Control field formats, parameters, and variables

The control field identifies the type of frame. Four types of control field formats are specified:

- confirmed information transfer (I format);
- supervisory functions (S format);
- unconfirmed information transfer (UI format); and
- control functions (U format).

The control field formats for LLC are shown in Figure 8 and Figure 9. For definition of values for supervisory function bits and unnumbered function bits, see Table 4.

Control Field Bits										
Format	8	7	6	5	4	3	2	1	Octet	
I format (I+S)	0	A	X	N(S)						1
	N(S)			X	N(R)					2
	N(R)						S <sub>1</sub>	S <sub>2</sub>	3	
S format	1	0	A	X	X	N(R)			1	
	N(R)						S <sub>1</sub>	S <sub>2</sub>	2	
UI format	1	1	0	X	X	N(U)			1	
	N(U)						E	PM	2	
U format	1	1	1	P/F	M <sub>4</sub>	M <sub>3</sub>	M <sub>2</sub>	M <sub>1</sub>	1	

- A Acknowledgement request bit
- E Encryption function bit
- M<sub>n</sub> Unnumbered function bit
- N(R) Transmitter receive sequence number
- N(S) Transmitter send sequence number
- N(U) Transmitter unconfirmed sequence number
- P/F Poll bit, when issued as a command,  
Final bit, when issued as a response
- PM Protected mode bit
- S<sub>n</sub> Supervisory function bit
- X Spare bit

Figure 8: Control field format

Control Field Bits										
Format	8	7	6	5	4	3	2	1	Octet	
I frame SACK format	0	A	X	N(S)						1
	N(S)			X	N(R)					2
	N(R)						1	1	3	
	X	X	X	K						4
	R(1)	R(2)	R(3)	R(4)	R(5)	R(6)	R(7)	R(8)	5	
	R(9)	R(10)	R(11)	R(12)	R(13)	R(14)	R(15)	R(16)	6	
	...									:
	R(249)	R(250)	R(251)	R(252)	R(253)	R(254)	R(255)	X	36 (max)	
S frame SACK format	1	0	A	X	X	N(R)			1	
	N(R)						1	1	2	
	R(1)	R(2)	R(3)	R(4)	R(5)	R(6)	R(7)	R(8)	3	
	R(9)	R(10)	R(11)	R(12)	R(13)	R(14)	R(15)	R(16)	4	
	...									:
	R(249)	R(250)	R(251)	R(252)	R(253)	R(254)	R(255)	X	34 (max)	

- K Bitmap length indicator
- R(n) Bitmap bit

Figure 9: SACK I and S frame control field format

### 6.3.1 Information transfer format - I

The I format shall be used to perform an information transfer between layer-3 entities. The functions of N(S), N(R), and A are independent; that is, each I frame has an N(S) sequence number, an N(R) sequence number that may or may not acknowledge additional I frames received by the LLE, and an A bit that may be set to 0 or 1. The use of N(S), N(R), and A is defined in clause 8.

Each I frame also contains supervisory information, in effect "piggy-backing" an S frame with each I frame, so that it may be considered to be an I+S frame.

### 6.3.2 Supervisory format - S

The S format shall be used to perform logical link supervisory control functions such as acknowledge I frames and request a temporary suspension of I-frame transmission. The functions of N(R) and the A bit are independent; that is, each supervisory frame has an N(R) sequence number that may or may not acknowledge additional I frames received by the LLE, and an A bit that may be set to 0 or 1. The use of N(R) and the A bit is described in clause 8.

### 6.3.3 Unconfirmed Information format - UI

The UI format shall be used to perform an information transfer between layer-3 entities without acknowledgement. No verification of sequence numbers is performed for UI frames. Therefore, a UI frame may be lost without notification to the layer-3 entity if a logical link exception occurs during transmission of the frame. The information field may be encrypted or not as indicated by the E bit (see subclause 6.3.5.5.1). The frame also includes an PM bit that allows the transfer of unprotected information (see subclause 6.3.5.5.2).

### 6.3.4 Unnumbered format - U

The U format shall be used to provide additional logical link control functions. This format contains no sequence number. The format includes a P/F bit that may be set to 0 or 1.

### 6.3.5 Control field parameters and associated state variables

The various parameters associated with the control field formats are described in this subclause.

#### 6.3.5.1 Poll/Final bit (P/F)

All U frames contain the Poll/Final (P/F) bit. The P/F bit serves a function in both command frames and response frames. In command frames the P/F bit is referred to as the P bit. In response frames it is referred to as the F bit.

The P bit set to 1 is used by an LLE to solicit (poll) a response frame from the peer LLE. The F bit set to 1 is used by an LLE to indicate the response frame transmitted as a result of a soliciting (poll) command.

The use of the P/F bit is described in clause 8.

#### 6.3.5.2 Acknowledgement request bit (A)

All I and S frames contain the Acknowledgement Request (A) bit.

The A bit set to 1 is used by an LLE to solicit an acknowledgement (i.e., an I+S or S frame) from the peer LLE. The A bit set to 0 is used by an LLE to indicate that the peer LLE is not requested to send an acknowledgement.

The use of the A bit is described in clause 8.



### 6.3.5.3 Modulus

Each I and UI frame is sequentially numbered by a sequence number that may have the value 0 through 511.

Arithmetic acting on parameters and variables that are related to such sequence numbers operates modulo 512 (i.e.,  $N(S)$ ,  $N(R)$ ,  $N(U)$ ,  $V(S)$ ,  $V(R)$ ,  $V(A)$ ,  $V(U)$ ,  $V(UR)$ ; see the following subclauses).

NOTE: Modulo 512 operation on negative numbers is performed by adding multiples of 512 to the negative number until the result becomes non-negative. Then common modulo 512 operation is applied.

### 6.3.5.4 ABM variables and sequence numbers

#### 6.3.5.4.1 Send state variable $V(S)$

In Asynchronous Balanced Mode, each LLE peer shall have an associated send state variable  $V(S)$  when using I frames.  $V(S)$  denotes the sequence number of the next in-sequence I frame to be transmitted.  $V(S)$  can take on the value 0 through 511. The value of  $V(S)$  shall be incremented by 1 with each successive I frame transmission, and shall not exceed  $V(A)$  by more than the maximum number of outstanding I frames  $k$ . The value of  $k$  may be in the range  $1 \leq k \leq 255$ , as defined in subclause 8.9.8.  $V(S)$  shall not be incremented when an I frame is retransmitted.

#### 6.3.5.4.2 Acknowledge state variable $V(A)$

In Asynchronous Balanced Mode, each LLE peer shall have an associated acknowledge state variable  $V(A)$  when using I frame and supervisory frame commands and responses.  $V(A)$  identifies the first I frame in the transmit window, so that  $V(A) - 1$  equals  $N(S)$  of the last in-sequence acknowledged I frame.  $V(A)$  can take on the value 0 through 511. The value of  $V(A)$  shall be updated by the valid  $N(R)$  values received from its peer (see subclause 6.3.5.4.5). A valid  $N(R)$  value is one that is in the range  $V(A) \leq N(R) \leq V(S)$ .

These inequalities shall be interpreted in the following way:

$N(R)$  is valid if, and only if,  $(N(R) - V(A)) \bmod 512 \leq (V(S) - V(A)) \bmod 512$ .

Furthermore, from subclause 6.3.5.4.1,  $(V(S) - V(A)) \bmod 512 \leq k$ .

#### 6.3.5.4.3 Send sequence number $N(S)$

In Asynchronous Balanced Mode, only I frames contain  $N(S)$ , the send sequence number of transmitted I frames. At the time that an in-sequence I frame is designated for transmission, the value of  $N(S)$  is set equal to the value of the send state variable  $V(S)$ .

#### 6.3.5.4.4 Receive state variable $V(R)$

In Asynchronous Balanced Mode, each LLE peer shall have an associated receive state variable  $V(R)$  when using I frame and supervisory frame commands and responses.  $V(R)$  denotes the sequence number of the next in-sequence I frame expected to be received.  $V(R)$  can take on the value 0 through 511. The value of  $V(R)$  shall be incremented by one with the receipt of an error-free, in-sequence I frame whose send sequence number  $N(S)$  equals  $V(R)$ .

#### 6.3.5.4.5 Receive sequence number $N(R)$

In Asynchronous Balanced Mode, all I frames and supervisory frames contain  $N(R)$ , the expected send sequence number of the next in-sequence received I frame. At the time that a frame of the above types is designated for transmission, the value of  $N(R)$  is set equal to the value of the receive state variable  $V(R)$ .  $N(R)$  indicates that the LLE transmitting the  $N(R)$  has correctly received all I frames numbered up to and including  $N(R) - 1$ .

#### 6.3.5.4.6 SACK bitmap R(n)

In Asynchronous Balanced Mode, all I+S and S SACK frames contain R(n), the SACK bitmap. At the time that a SACK frame is designated for transmission, the value of each bit R(n) in the bitmap shall be set to 0 or 1 depending on whether I frame number N(R) + n has been received or not. R(n) = 1 indicates that the LLE transmitting the SACK frame has correctly received I frame number N(R) + n. R(n) = 0 indicates that the LLE transmitting the SACK frame has not correctly received I frame number N(R) + n.

The SACK bitmap contains a maximum of 255 bits, or 32 octets, as shown in Figure 9. The bitmap shall be truncated so that only bitmap octets up to and including the last bitmap octet containing at least one bit set to 1 are transmitted. The trailing bitmap octets shall not be transmitted.

The I+S SACK frame contains a bitmap length indicator K. K + 1 indicates the number of octets in the bitmap. K can take any value 0 through 31.

#### 6.3.5.4.7 I frame buffer variable B

In Asynchronous Balanced Mode, each LLE peer shall have an associated I frame buffer variable B when using I frame and supervisory frame commands and responses. The value of B has a range of  $0 \leq B \leq M$ , where M is defined in subclause 8.9.7.

Function L(x) gives the total information field length in octets of the I frame with sequence number x. B shall be incremented with L(x) of each transmitted I frame as defined in subclause 8.6.1. B shall be decremented by L(x) of each acknowledged I frame as defined in subclause 8.6.3.2.

#### 6.3.5.4.8 Other parameters and variables

For definition and values of additional parameters and variables, see subclause 8.9.

### 6.3.5.5 Unacknowledged operation variables and parameters

#### 6.3.5.5.1 Encryption mode bit (E)

The E bit is used to indicate whether the information and FCS fields of the UI frame are encrypted (ciphered) to provide user data confidentiality. The E bit is set to 1 to indicate an encrypted frame. The E bit is set to 0 to indicate a frame sent without encryption.

#### 6.3.5.5.2 Protected Mode bit (PM)

The PM bit is used to indicate whether the FCS field shall be calculated using both the frame header and information fields.

The PM bit is set to 1 to indicate that the FCS covers the frame header and information fields.

The PM bit is set to 0 to indicate that the FCS covers only the frame header field and the first N202 octets of the information field. If the length of the information field is less than N202 octets then the FCS shall cover the complete information field. This permits UI frames to transport "unprotected" information, such that errors beyond the first N202 octets of the information field do not result in the frame being discarded.

**Table 3: UI frame content**

PM	E	UI frame information field
0	0	unprotected, non-ciphered information
0	1	unprotected, ciphered information
1	0	protected, non-ciphered information
1	1	protected, ciphered information

#### 6.3.5.5.3 Unconfirmed send state variable V(U)

Each LLE peer shall have an associated unconfirmed send state variable V(U) when using UI frame commands. V(U)

denotes the sequence number of the next UI frame to be transmitted.  $V(U)$  can take on the value 0 through 511. The value of  $V(U)$  shall be incremented by 1 with each successive UI frame transmission.

#### 6.3.5.5.4 Unconfirmed sequence number $N(U)$

Only UI frames contain  $N(U)$ , the unconfirmed sequence number of transmitted UI frames. At the time that a UI frame is designated for transmission, the value of  $N(U)$  is set equal to the value of the unconfirmed send state variable  $V(U)$ .

#### 6.3.5.5.5 Unconfirmed receive state variable $V(UR)$

Each LLE peer shall have an associated unconfirmed receive state variable  $V(UR)$  when using UI frame commands.  $V(UR)$  denotes the sequence number of the next in-sequence UI frame expected to be received.  $V(UR)$  can take on the value 0 through 511.

#### 6.3.5.5.6 Other parameters and variables

The only other parameter defined for unacknowledged operation is the number of octets ( $N201-U$ ) in the information field of the UI frame. See subclause 8.9.4.

## 6.4 Commands and responses

The following commands and responses are used by the MS and the SGSN LLEs and are represented in Table 4. Each logical link connection shall support the appropriate set of commands and responses for the type of operation desired (see clause 8).

Those frame types not identified in Figure 8, Figure 9, or Table 4, shall be identified as having undefined command and/or response control fields, and shall be treated as defined in subclause 8.8.2.

**Table 4: Commands and responses**

Format	Commands	Responses	Encoding					
			S1	S2	M4	M3	M2	M1
Information + Supervisory	RR	RR	0	0	-	-	-	-
	ACK	ACK	0	1	-	-	-	-
	RNR	RNR	1	0	-	-	-	-
	SACK	SACK	1	1	-	-	-	-
Unnumbered	-	DM	-	-	0	0	0	1
	DISC	-	-	-	0	1	0	0
	-	UA	-	-	0	1	1	0
	SABM	-	-	-	0	1	1	1
	-	FRMR	-	-	1	0	0	0
	XID NULL	XID -	- -	- -	- -	1 0	0 0	1 0

The commands and responses in Table 4 are defined in the following subclauses.

### 6.4.1 Unnumbered (U) frames

#### 6.4.1.1 Set Asynchronous Balanced Mode (SABM) command

The SABM unnumbered command shall be used to place the addressed MS or SGSN side into ABM acknowledged operation.

An LLE shall confirm acceptance of a SABM command by the transmission at the first opportunity of a UA response. Upon acceptance of this command, the LLE's send state variable  $V(S)$ , acknowledge state variable  $V(A)$ , and receive state variable  $V(R)$ , shall be set to 0. The transmission of a SABM command indicates the clearance of any exception condition, and a busy condition that was reported by the earlier transmission of an RNR frame by that same LLE.

Previously transmitted I frames that are unacknowledged when this command is actioned shall be discarded. It is the

responsibility of a higher layer to recover from the possible loss of the contents of such I frames.

An information field is permitted with the SABM command. If included, the information field shall contain XID parameters. This allows the LLC peers to negotiate LLC layer parameters and layer-3 parameters with the SABM command and UA response, using the procedure (but not the XID frames) defined in subclauses 6.4.1.6 and 8.5.3.

#### 6.4.1.2 Disconnect (DISC) command

The DISC unnumbered command shall be transmitted in order to terminate the ABM operation.

No information field is permitted with the DISC command. Prior to executing the command, the LLE receiving the DISC command shall confirm the acceptance of a DISC command by the transmission of a UA response. The LLE sending the DISC command shall terminate the ABM operation when it receives the acknowledging UA or DM response.

Previously transmitted I frames that are unacknowledged when this command is executed shall remain unacknowledged and shall be discarded. It is the responsibility of a higher layer to recover from the possible loss of the contents of such I frames.

#### 6.4.1.3 Unnumbered Acknowledgement (UA) response

The UA unnumbered response shall be used by an LLE to acknowledge the receipt and acceptance of the mode-setting commands (SABM or DISC). Received mode-setting commands are not actioned until the UA response is transmitted.

An information field is only permitted when UA is the response to a SABM command. The UA response shall in this case contain XID parameters with negotiated XID values, using the procedure (but not the XID frames) defined in subclauses 6.4.1.6 and 8.5.3.

The transmission of the UA response indicates the clearance of any busy condition that was reported by the earlier transmission of an RNR frame by that same LLE.

#### 6.4.1.4 Disconnected Mode (DM) response

The DM unnumbered response shall be used by an LLE to report to its peer that the LLE is in a state such that ABM operation cannot be performed. An LLE shall transmit a DM response to any valid command received that it cannot action.

No information field is permitted with the DM response.

#### 6.4.1.5 Frame Reject (FRMR) response

The FRMR unnumbered response may be received by an LLE as a report of a frame rejection condition not recoverable by retransmission of the identical frame:

- 1) receipt of a command or response control field that is undefined or not implemented (see subclause 6.4, second paragraph);
- 2) receipt of a supervisory or unnumbered frame with incorrect length; or
- 3) receipt of an I frame with an information field that exceeds the maximum established length.

An undefined control field is any of the control field encodings that are not identified in Figure 8, Figure 9, or Table 4.

An information field that immediately follows the control field and that consists of 10 octets shall be returned with this response to provide the reason for the FRMR response. This information field format is given in Figure 10. Only the first 6 octets of the control field of the rejected frame shall be sent. If the control field of the rejected frame is fewer than 6 octets, then the unused octets shall be set to 0.

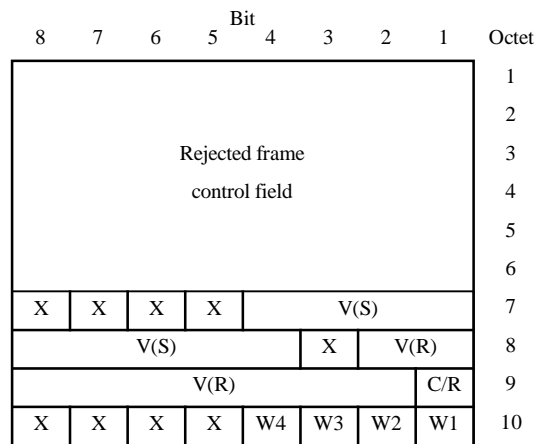

**Figure 10: FRMR frame information field format**

The information fields defined for the FRMR response are listed in Table 5.

**Table 5: FRMR frame fields**

Field	Description
Rejected frame control field	The control field of the received frame that caused the frame reject.
V(S)	The current send state variable value of the LLE reporting the rejection condition.
V(R)	The current receive state variable value of the LLE reporting the rejection condition. V(R) shall not be treated as an acknowledgement of I frames.
C/R	Set to 1 if the frame rejected was a response and set to 0 if the frame rejected was a command.
W1	Set to 1 to indicate that the control field received and returned in octets 1 and 2 was considered invalid because the frame contained an information field that is not permitted within this frame or is a supervisory or unnumbered frame with incorrect length. Bit W3 shall be set to 1 in conjunction with this bit.
W2	Set to 1 to indicate that the information field received exceeded the maximum established information field length (N201) of the LLE reporting the rejection condition.
W3	Set to 1 to indicate that the control field received and returned in octets 1 and 2 was undefined or not implemented.
W4	Set to 1 to indicate that the LLE was in ABM when reporting the rejection condition.

#### 6.4.1.6 Exchange Identification (XID) command/response

This frame shall be used to negotiate and re-negotiate LLC layer parameters and layer-3 parameters. XID frames can be transmitted in ADM and ABM.

The negotiation procedure is one-step, i.e., one side shall start the process by sending an XID command, offering a certain set of parameters from the applicable parameter repertoire (see Table 6) the sending entity wants to negotiate, proposing values within the allowed range. In return, the other side shall send an XID response, either confirming these parameter values by returning the requested values, or offering higher or lower ones in their place. As an optimisation, parameters confirming the requested values may be omitted from the XID response. See Table 6 for sense of negotiation. This shall end the negotiation process.

Parameters that are not included in neither the XID command nor in the XID response, shall retain their current values.

The responding side may respond with parameters that were not included in the XID command. A parameter that was not included in the XID command shall in this case be treated as if the current value of the parameter was included in the XID command. The responding side shall include such a parameter in every XID response until the parameter has been explicitly negotiated, either by responding to an XID command that included the parameter, or by explicitly including the parameter the next time an XID command is transmitted.

Both entities shall support the negotiated values, however under certain conditions one or more parameters may need to be re-negotiated (e.g., in the case of a change in SGSN).

XID frames shall always be used with the P/F bit set to 1.

Without any prior XID exchange, default values shall apply.

Negotiated XID parameters shall apply to the LLE identified by the DLCI of the XID frames used, except Version, Reset, and IOV-UI that applies to an LLME (i.e., a TLLI), and except Layer-3 Parameters that apply to the layer 3 above the LLE.

Table 6 lists the negotiable LLC layer parameters. Figure 11 shows the format of the XID parameter field.

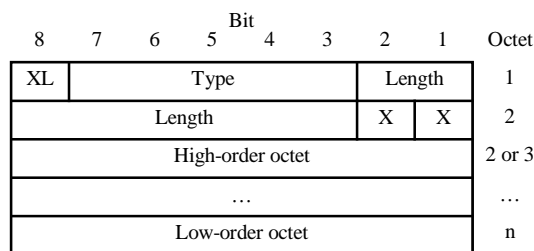

**Figure 11: XID parameter field format**

A parameter item consists of one or two type/length octets followed by the value of that parameter. The XID Length (XL) bit indicates whether the Length field is 2 bits or 8 bits long. If XL is set to 0, then Length consists of 2 bits and type/length occupies one octet. If XL is set to 1 then Length consists of 8 bits and type/length occupies two octets. The length indicator gives the number of octets that the value actually occupies. Length shall be set to the value in Table 6 for XID parameters that do not have a variable length. The parameter items can be arranged in arbitrary order. The parameter items shall begin in the first octet of the XID information field and follow on contiguously.

Table 6: LLC layer parameter negotiation

Parameter Name	Type	Length	Format (87654321)	Range	Units	Sense of Negotiation
Version (LLC version number)	0	1	0000bbbb	0 through 15	-	down
IOV-UI (ciphering Input offset value for UI frames), common for all SAPIs of a TLLI	1	4	bbbbbbbb bbbbbbbb bbbbbbbb bbbbbbbb	0 through $2^{32} - 1$	-	-
IOV-I (ciphering Input offset value for I frames), for the SAPI under negotiation	2	4	bbbbbbbb bbbbbbbb bbbbbbbb bbbbbbbb	0 through $2^{32} - 1$	-	-
T200 (retransmission time-out)	3	2	0000bbbb bbbbbbbb	1 through 4 095	0.1 seconds	up
N200 (maximum number of retransmissions)	4	1	0000bbbb	1 through 15	-	up
N201-U (maximum information field length for U and UI frames)	5	2	00000bbb bbbbbbbb	140 through 1 520	octets	down
N201-I (maximum information field length for I frames)	6	2	00000bbb bbbbbbbb	140 through 1 520	octets	down
mD (I frame buffer size in the downlink direction)	7	2	0bbbbbbb bbbbbbbb	0, 9 through 24 320	16 octets	down
mU (I frame buffer size in the uplink direction)	8	2	0bbbbbbb bbbbbbbb	0, 9 through 24 320	16 octets	down
kD (window size in the downlink direction)	9	1	bbbbbbbb	1 through 255	frames	down
kU (window size in the uplink direction)	10	1	bbbbbbbb	1 through 255	frames	down
Layer-3 Parameters	11	Variable	See 3GPP TS 04.65			
Reset	12	0	-	-	-	-
<ul style="list-style-type: none"> <li>- The Range for N201-U for SAPI 1 is 400 through 1 520 octets, and for SAPIs 2, 7, and 8 270 through 1 520 octets.</li> <li>- All other Types and Ranges are reserved for future versions of the present document.</li> <li>- The length for Layer-3 Parameters shall be set equal to the number of octets received from layer 3. If an empty XID block is received from layer 3, the LLE shall include a zero-length Layer-3 Parameters XID parameter in the XID parameter field to allow the receiving LLE to distinguish between LLC and layer-3 initiated procedures.</li> </ul>						

Version shall not be negotiated while in ABM.

Reset shall only be negotiated with an XID frame, and only be transmitted in the downlink direction. If Reset is present in an XID frame, then it shall be the first XID parameter in the XID information field.

IOV-UI shall only be negotiated in ADM. IOV-I shall only be negotiated with SABM and UA frames. IOV-UI and IOV-I shall only be transmitted in the downlink direction.

T200, N200, and N201-U can be negotiated in ADM and ABM. The new values of T200 shall only apply to timers set after the negotiation has been completed. If N201-U is negotiated to a lower value than previously used, then any queued or new U and UI frames that violates the new value of N201-U should be discarded and not transmitted.

N201-I, mD, mU, kD, and kU can be negotiated to any value in Range in ADM. In ABM, N201-I, mD, mU, kD, and kU can only be negotiated to the same or higher value as previously used.

#### 6.4.1.7 NULL command

The NULL unnumbered command shall be used by an MS LLE to indicate a cell update. The NULL unnumbered command is only allowed if the Cell Notification is indicated by the SGSN (see 3G TS 23.060 and 3G TS 24.008).

No information field is permitted with the NULL command.

## 6.4.2 Unconfirmed Information (UI) frame

### 6.4.2.1 Unconfirmed Information (UI) command

When a layer-3 entity requests unacknowledged information transfer, the UI command shall be used to send information to its peer. No verification of sequence numbers is performed for UI frames. Therefore, the UI frame may be lost without notification to the layer-3 entity if a logical link exception occurs during transmission of the command.

## 6.4.3 Combined Information (I) and Supervisory (S) frames

The function of the information (I) frame is to transfer, across a logical link connection, sequentially-numbered frames containing information fields provided by layer 3. This frame shall only be used in the ABM operation.

Numbered I frames shall also carry supervisory information, and are for this reason also called I+S frames. A separate S frame is sent when there is no information field to be transferred. Whether an I+S or S frame is transmitted as a command or as a response is insignificant in the ABM procedures.

### 6.4.3.1 Receive Ready (RR) command / response

The receive ready (RR) supervisory frame is used by an LLE to:

- indicate that it is ready to receive an I frame; and
- acknowledge previously received I frames numbered up to and including  $N(R) - 1$  (as defined in clause 8).

In addition to indicate the status of an LLE, the RR frame with the A bit set to 1 may be used by the LLE to request an acknowledgement from its peer LLE.

The transmission of an RR frame shall also indicate the clearance of any busy condition within the sending LLE that was reported by the earlier transmission of an RNR frame by the same LLE.

### 6.4.3.2 Acknowledgement (ACK) command / response

The ACK supervisory frame shall be used by an LLE to acknowledge a single or multiple I frames. Frames up to and including  $N(R) - 1$ , and frame  $N(R) + 1$ , have been received correctly. The procedures associated with the ACK control field are defined in subclause 8.6.3.

In addition to indicate the status of an LLE, the ACK frame with the A bit set to 1 may be used by the LLE to request an acknowledgement from its peer LLE.

The transmission of an ACK frame shall also indicate the clearance of any busy condition within the sending LLE that was reported by the earlier transmission of an RNR frame by the same LLE.

### 6.4.3.3 Selective Acknowledgement (SACK) command / response

The SACK supervisory frame shall be used by an LLE to acknowledge a single or multiple I frames. Frames up to and including  $N(R) - 1$ , and frames indicated by the SACK bitmap, have been received correctly. The format of the SACK control field is shown in Figure 9. The procedures associated with the SACK control field are defined in subclause 8.6.3.

In addition to indicate the status of an LLE, the SACK frame with the A bit set to 1 may be used by the LLE to request an acknowledgement from its peer LLE.

The transmission of a SACK frame shall also indicate the clearance of any busy condition within the sending LLE that was reported by the earlier transmission of an RNR frame by the same LLE.



#### 6.4.3.4 Receive Not Ready (RNR) command / response

The receive not ready (RNR) supervisory frame shall be used by an LLE to indicate a busy condition; that is, a temporary inability to accept additional incoming I frames. The value of N(R) in the RNR frame acknowledges I frames numbered up to and including N(R) - 1. Subsequent frames, if any, shall not be considered confirmed. The acceptance status of those is a matter of further status exchange.

In addition to indicate the status of an LLE, the RNR frame with the A bit set to 1 may be used by the LLE to request an acknowledgement from its peer LLE.

---

## 7 Elements for layer-to-layer communication

### 7.1 Definition of service primitives and parameters

Communications between layers and between entities within the logical link control layer are accomplished by means of service primitives. Service primitives represent, in an abstract way, the logical exchange of information and control between the logical link control layer and adjacent layers. They do not specify or constrain implementations.

Service primitives consist of commands and their respective responses associated with the services requested of another layer. The general syntax of a primitive is:

XXX - Generic name - Type (Parameters)

where XXX designates the service access point between the LLC layer and the layer providing or using the service. For the present document XXX is:

- "LLGMM" for the SAP between the LLC layer and the GPRS mobility management function;
- "LL" for the SAPs between the LLEs and layer 3;
- "GRR" for the SAP between the LLC layer and the RLC/MAC layer; and
- "BSSGP" for the SAP between the LLC layer and the BSSGP layer.

#### 7.1.1 Primitives types

The primitives types defined in the present document are:

NOTE: For the action sequence of these primitive types, see 3GPP TS 04.01 [7].

### 7.1.1.1 Request

The Request primitive type is used when a higher layer is requesting a service from the next lower layer.

### 7.1.1.2 Indication

The Indication primitive type is used by a layer providing a service to notify the next higher layer of activities related to the Request primitive type of the peer.

### 7.1.1.3 Response

The Response primitive type is used by a layer to acknowledge receipt, from the next lower layer, of the Indication primitive type.

### 7.1.1.4 Confirm

The Confirm primitive type is used by the layer providing the requested service to confirm that the activity has been completed (successfully or unsuccessfully).

## 7.1.2 LLC layer service primitives

A service primitive specifies the activity that the identified layer should perform. Table 7 lists the primitives defined in the present document.

**Table 7: LLC layer service primitives**

Generic Name	Location		Type				Parameters
	MS	SGSN	REQ	IND	RES	CNF	
<b>GMM ↔ LLME</b>							
LLGMM-ASSIGN	X	X	X				TLLI Old, TLLI New, Kc, Ciphering Algorithm
LLGMM-RESET		X	X			X	TLLI
LLGMM-TRIGGER	X		X				TLLI, Cause
LLGMM-SUSPEND	X		X				TLLI
LLGMM-SUSPEND		X	X				TLLI, Page
LLGMM-RESUME	X	X	X				TLLI
LLGMM-PAGE		X		X			TLLI
LLGMM-IOV		X	X			X	TLLI
LLGMM-STATUS	X	X		X			TLLI, Cause
<b>GMM ↔ LLE, SNDCP ↔ LLE, SMS ↔ LLE, and TOM ↔ LLE</b>							
LL-RESET	X	X		X			TLLI
LL-ESTABLISH	X	X	X				TLLI, XID Req
LL-ESTABLISH	X	X		X			TLLI, XID Req, N201-U, N201-I
LL-ESTABLISH	X	X			X		TLLI, XID Neg
LL-ESTABLISH	X	X				X	TLLI, XID Neg, N201-U, N201-I
LL-RELEASE	X	X	X				TLLI, Local
LL-RELEASE	X	X		X			TLLI, Cause
LL-RELEASE	X	X				X	TLLI
LL-XID	X	X	X				TLLI, XID Req
LL-XID	X	X		X			TLLI, XID Req, N201-U, N201-I
LL-XID	X	X			X		TLLI, XID Neg
LL-XID	X	X				X	TLLI, XID Neg, N201-U, N201-I
LL-DATA	X		X				TLLI, L3-PDU, Reference, QoS Parameters, Radio Priority
LL-DATA		X	X				TLLI, L3-PDU, Reference, QoS Parameters
LL-DATA	X	X		X			TLLI, L3-PDU
LL-DATA	X	X				X	TLLI, Reference
LL-UNITDATA	X		X				TLLI, L3-PDU, QoS Parameters, Radio Priority, Cipher
LL-UNITDATA		X	X				TLLI, L3-PDU, QoS Parameters, Cipher

Generic Name	Location		Type				Parameters
	MS	SGSN	REQ	IND	RES	CNF	
LL-UNITDATA	X	X		X			TLLI, L3-PDU, Cipher
LL-STATUS	X	X		X			TLLI, Cause
<b>LLE ↔ RLC/MAC</b>							
GRR-DATA	X		X				TLLI, LL-PDU, SAPI, Cause, QoS Parameters, Radio Priority
GRR-DATA	X			X			TLLI, LL-PDU
GRR-UNITDATA	X		X				TLLI, LL-PDU, SAPI, QoS Parameters, Radio Priority
GRR-UNITDATA	X			X			TLLI, LL-PDU
<b>LLE ↔ BSSGP</b>							
BSSGP-DL-UNITDATA		X	X				TLLI, LL-PDU, QoS Parameters, RLC Confirm, SAPI
BSSGP-UL-UNITDATA		X		X			TLLI, LL-PDU, Cell Id

## 7.2 Primitive procedures

### 7.2.1 GMM - LLME primitives

#### 7.2.1.1 LLGMM-ASSIGN

The LLGMM-ASSIGN primitive shall be used by the GPRS mobility management entity to assign, change, or unassign the TLLI, the ciphering key (Kc) and the ciphering algorithm.

The TLLI Old and TLLI New parameters shall be interpreted as follows:

- If TLLI Old = all 1's and TLLI New ≠ all 1's then TLLI New shall be assigned and used when (re-)transmitting LLC frames. If a TLLI Old ≠ all 1's was assigned to the LLME, then TLLI Old is unassigned. Only TLLI New shall be accepted when received from the peer. It shall be treated as a TLLI change according to subclause 8.3.2. If TLLI Old = all 1's was assigned to the LLME, then this shall be treated as a TLLI assignment according to subclause 8.3.1, and the LLGMM-ASSIGN-REQ shall be the first primitive sent by GMM in order to enable LLC to process requests from layer 3.
- If TLLI Old ≠ all 1's and TLLI New ≠ all 1's then TLLI Old and TLLI New are assigned, and TLLI New shall be used when (re-)transmitting LLC frames. Both TLLI Old and TLLI New shall be accepted when received from the peer. It shall be treated as a TLLI change according to subclause 8.3.2.
- If TLLI Old ≠ all 1's and TLLI New = all 1's then TLLI Old shall be unassigned. It shall be treated as a TLLI unassignment according to subclause 8.3.3, and the LLGMM-ASSIGN-REQ shall be the last primitive sent by GMM in order to disable LLC to not any longer process requests from layer 3.

An LLC frame received with a DLCI belonging to an unassigned TLLI shall be discarded without any further actions, with the following exception: UI and XID frames with TLLI = unassigned and SAPI = 1 received in the SGSN shall be handled according to the LLC protocol.

Kc and Ciphering Algorithm are associated with TLLI New (and with TLLI Old if assigned):

- If Ciphering Algorithm indicates no ciphering, then the ciphering function shall be disabled.
- Otherwise, the ciphering function shall be enabled. If a Ciphering Algorithm was already associated with TLLI New or TLLI Old, then the new Kc shall replace the previous Kc, and Ciphering Algorithm shall replace the previous algorithm selection. All I frames, and UI frames with the E bit set to 1, shall use the new Kc and algorithm for ciphering. All unacknowledged I frames shall be ciphered using the new Kc and algorithm before retransmission. As an implementation option, the previous Kc and algorithm may be used to decipher received frames.

#### 7.2.1.2 LLGMM-RESET

LLGMM-RESET-REQ shall be used to order LLC in the SGSN to perform an XID negotiation of Reset and IOV-UI.

The LLC layer shall randomly select the value of IOV-UI.

LLGMM-RESET-CNF shall be used to inform GMM in the SGSN that a successful XID negotiation of Reset and IOV-UI has been made.

### 7.2.1.3 LLGMM-TRIGGER

LLGMM-TRIGGER-REQ shall be used in the MS to order LLC to transmit any single frame. If there is a frame waiting to be transmitted in the MS, then this frame shall be transmitted. Otherwise if Cause indicates Cell Update and if Cell Notification is indicated by the SGSN (see 3G TS 24.008), then a NULL frame with P=0 shall be transmitted. Otherwise, and if the LLE is in ABM state, a supervisory frame shall be transmitted according to subclause 8.6.4.1, Or if the LLE is in ADM state a UI frame with no information field shall be transmitted. There is only need to transmit a frame on one SAPI. Which SAPI to choose is implementation dependent.

LLGMM-TRIGGER-REQ is normally used for cell updates or for page responses, and the reason shall be indicated in the Cause parameter. If Cause indicates page response, then the GRR-DATA-REQ Cause parameter shall also indicate page response.

### 7.2.1.4 LLGMM-SUSPEND

LLGMM-SUSPEND-REQ shall be used to order LLC to suspend operation for an MS until LLGMM-RESUME-REQ is received. While suspended, LLC shall:

- reset timer T201 if running and (in the SGSN) if the Page parameter is not set; and
- stop frame transmission.

Frame reception shall still be possible. The Page parameter in the SGSN controls whether LLGMM-PAGE-IND shall be sent to GMM or not (see subclause 7.2.1.6). In the MS, and in the SGSN if the Page parameter is not set, ADM procedures for SAPI = 1 including UI frame transmission shall still be possible, and ABM (re-)establishment, ABM release, and XID negotiation procedures on all SAPIs including U frame transmission shall still be possible.

L3-PDUs and unacknowledged I frames that are buffered shall be preserved while LLC operation is suspended, and may be deleted by procedures allowed while LLC operation is suspended.

The state (e.g., ABM, ADM) and the state variables (e.g., the transmit and receive counters) shall be preserved while LLC operation is suspended, and may be changed by procedures allowed while LLC operation is suspended.

### 7.2.1.5 LLGMM-RESUME

LLGMM-RESUME-REQ shall be used to order LLC to resume a suspended operation for an MS. LLC operation shall continue with the current set of buffered L3-PDUs, buffered unacknowledged I frames, the state, and the state variables. If timer T201 was reset upon reception of LLGMM-SUSPEND-REQ then timer T201 shall be set.

### 7.2.1.6 LLGMM-PAGE

If the Page parameter received in the LLGMM-SUSPEND-REQ primitive is set to true, LLGMM-PAGE-IND shall be sent to GMM in the SGSN whenever LLC has an LL-PDU ready for transmission and LLC operation is suspended. The LL-PDU shall not be transmitted until LLGMM-RESUME-REQ has been received from GMM.

If the Page parameter is set to false, LLGMM-PAGE-IND shall not be sent, and the LL-PDU shall not be transmitted until LLGMM-RESUME-REQ has been received from GMM.

NOTE: LLGMM-PAGE-IND causes GMM to initiate paging of the MS.

### 7.2.1.7 LLGMM-IOV

LLGMM-IOV-REQ shall be used to order LLC in the SGSN to perform an XID negotiation of IOV-UI. The LLC layer shall randomly select the value of IOV-UI.

LLGMM-IOV-CNF shall be used to inform GMM in the SGSN that a successful XID negotiation of IOV-UI has been made.

### 7.2.1.8 LLGMM-STATUS

LLGMM-STATUS-IND shall be used to inform GMM when an LLC error that cannot be corrected by the LLC layer has occurred.

## 7.2.2 Layer 3 - LLE primitives

### 7.2.2.1 LL-RESET

LL-RESET-IND shall be used in the SGSN to indicate that the Reset XID parameter is transmitted to the MS. LL-RESET-IND shall be used in the MS to indicate that the Reset XID parameter has been received from the SGSN.

### 7.2.2.2 LL-ESTABLISH

The LL-ESTABLISH primitives shall be used to request, indicate, respond to, and confirm establishment of ABM operation. XID Req and XID Neg are used to negotiate layer-3 XID parameters between the layer-3 peers, see 3GPP TS 04.65.

### 7.2.2.3 LL-RELEASE

The LL-RELEASE primitives shall be used to request, indicate, and confirm termination of a previously established ABM operation. The Local parameter indicates whether the termination shall be local, i.e., a DISC frame shall not be transmitted, or not local, i.e., a DISC frame shall be transmitted. The Cause parameter indicates the cause for termination of ABM operation.

### 7.2.2.4 LL-XID

The LL-XID primitives shall be used to request, indicate, respond to, and confirm negotiation of layer-3 XID parameters.

### 7.2.2.5 LL-DATA

The LL-DATA primitives shall only be used for LLEs in ABM. The following operations are defined:

- LL-DATA-REQ shall be used to request the confirmed transmission of an L3-PDU to the peer. QoS Parameters in the SGSN includes precedence class, delay class, and peak throughput. QoS Parameters in the MS includes peak throughput. QoS Parameters is defined as part of the Quality of Service information element in 3GPP TS 04.08. Radio Priority indicates the radio priority level to be used by RLC/MAC.
- LL-DATA-IND shall be used to deliver a correctly received L3-PDU to layer 3.
- LL-DATA-CNF shall be used to confirm the delivery of an L3-PDU to layer 3 in the peer. The Reference parameter shall be set to the same value as the Reference parameter received in the corresponding LL-DATA-REQ.

### 7.2.2.6 LL-UNITDATA

LL-UNITDATA-REQ shall be used to request the unconfirmed transmission of an L3-PDU to the peer. QoS Parameters in the SGSN includes precedence class, delay class, reliability class, and peak throughput. QoS Parameters in the MS includes peak throughput and reliability class. Reliability class indicates whether the UI frame carrying the L3-PDU shall be transmitted in protected or unprotected mode, and whether RLC/MAC acknowledged or unacknowledged mode shall be used. Radio Priority indicates the radio priority level to be used by RLC/MAC. Cipher indicates whether the UI frame shall be ciphered or not.

LL-UNITDATA-IND shall be used to deliver an L3-PDU received in a UI frame to layer 3. Cipher indicates whether the received UI frame was ciphered or not.

### 7.2.2.7 LL-STATUS

LL-STATUS-IND shall be used to inform layer 3 when an LLC error that cannot be corrected by the LLC layer has

occurred.

## 7.2.3 LLE - RLC/MAC primitives

Although the GRR-DATA or GRR-UNITDATA primitives are used in all LLC frame transfer operations, for simplicity reasons they are not included in the procedure descriptions in clause 8.

### 7.2.3.1 GRR-DATA

GRR-DATA-REQ shall be used by an LLE in an MS to request the reliable transmission of an LL-PDU. SAPI indicates the SAPI of the LLE. Cause indicates whether GRR-DATA-REQ is sent due to a page response. QoS Parameters includes peak throughput. For UI frames, peak throughput shall be set according to the QoS parameters of the layer-3 entity requesting the transmission of the UI frame. For all other LLC frames, peak throughput may be set according to the QoS parameters for any layer-3 entity that is using the SAPI. Radio Priority indicates the radio priority level to be used by RLC/MAC.

GRR-DATA-IND shall be used by the RLC/MAC layer in an MS to indicate the successful reception of an LL-PDU. The LL-PDU was completely received without errors detected by the RLC layer.

All LLC frames except UI frames for SAPIs 3, 5, 9, and 11 shall be transferred with GRR-DATA primitives. All UI frames for SAPIs 3, 5, 9, and 11 shall be transferred with GRR-DATA or GRR-UNITDATA primitives.

### 7.2.3.2 GRR-UNITDATA

GRR-UNITDATA-REQ shall be used by an LLE in an MS to request the unreliable transmission of a UI frame. SAPI indicates the SAPI of the LLE. QoS Parameters includes peak throughput. Peak throughput shall be set according to the QoS parameters of the layer-3 entity requesting the transmission of the UI frame. Radio Priority indicates the radio priority level to be used by RLC/MAC.

GRR-UNITDATA-IND shall be used by the RLC/MAC layer in an MS to indicate the reception of a UI frame.

Only UI frames for SAPIs 3, 5, 9, and 11 shall be transferred with GRR-UNITDATA primitives.

## 7.2.4 LLE - BSSGP primitives

Although the BSSGP-UNITDATA primitives are used in all LLC frame transfer operations, for simplicity reasons they are not included in the procedure descriptions in clause 8.

### 7.2.4.1 BSSGP-DL-UNITDATA

BSSGP-DL-UNITDATA-REQ shall be used by an LLE in an SGSN to request the transmission of an LL-PDU. QoS Parameters includes precedence class, delay class, and peak throughput. RLC Confirm indicates whether the request shall be mapped into a GRR-DATA-REQ or GRR-UNITDATA-REQ primitive in the BSS. SAPI indicates the SAPI of the LLE.

All LLC frames except UI frames for SAPI 3, 5, 9 and 11 shall be transferred with RLC Confirm indicating mapping into GRR-DATA-REQ primitive. All UI frames for SAPIs 3, 5, 9, and 11 shall be transferred with RLC Confirm indicating mapping into a GRR-DATA-REQ or GRR-UNITDATA-REQ primitives.

### 7.2.4.2 BSSGP-UL-UNITDATA

BSSGP-UL-UNITDATA-IND shall be used by the BSSGP layer in an SGSN to indicate the reception of an LL-PDU. Cell Id indicates the location of the MS when the LL-PDU was transmitted.

## 7.2.5 LLME - LLE primitives

The primitives that co-ordinate activities between the LLM and LL entities are not described. Implementations shall perform the necessary co-ordination between GMM ↔ LLME primitives and LLE operation.

---

## 8 Definition of the LLC peer-to-peer protocol

### 8.1 General

In the following subclauses, a protocol for use by the GPRS logical link control layer between the SGSN and MS is specified, referred to as "LLC".

The LLC elements of procedure (frame types) that apply are:

- for unacknowledged information transfer:
  - UI command; and
- for ABM acknowledged information transfer:
  - SABM command;
  - UA response;
  - DM response;
  - DISC command;
  - RR command / response;
  - RNR command / response;
  - ACK command / response;
  - SACK command / response;
  - I command / response; and
- for both unacknowledged and acknowledged information transfer:
  - FRMR response; and
  - XID command / response.

For handling of timers, the procedures and terminology of Z.100 [15] are used:

Set <timer name> means that:

- a) if the timer is inactive, the timer becomes active, i.e., a timer value is associated with the timer and it starts running; and
- b) if the timer is active, the timer is first reset as in c) below, and then set as in a) above.

Reset <timer name> means that:

- c) if the timer is active, the timer becomes inactive, i.e., the association with the timer value is lost and it stops running; and
- d) if the timer is inactive, it remains inactive.

### 8.2 Procedure for the use of the P/F bit

Timer T200 shall be set when a command frame with the P bit set to 1 is transmitted. An LLE receiving a command frame with the P bit set to 1 shall set the F bit to 1 in the next response frame it transmits. An LLE receiving a command frame with the P bit set to 0 shall discard the command frame with no further action.

Only one frame with a P bit set to 1 shall be outstanding in a given direction at a given time. Before another frame with the P bit set to 1 can be transmitted, a response frame with the F bit set to 1 shall be received, N200 retransmissions of the outstanding frame shall occur, or the frame shall be discarded because of an unnumbered frame collision.

## 8.3 TLLI assignment procedures

TLLI assignment and unassignment is further described in clause 7 and annex C. The following two subclauses illustrate the TLLI assignment and unassignment procedures.

### 8.3.1 TLLI assignment

GMM shall assign a TLLI by sending an LLGMM-ASSIGN-REQ (TLLI New  $\neq$  all 1's) primitive to LLC. Upon receiving LLGMM-ASSIGN-REQ, LLC shall enter the TLLI Assigned state, and set LLC layer parameters, states, and variables as defined in subclause 8.5.3.1. TLLI assignment is illustrated in Figure 12.

### 8.3.2 TLLI change

This procedure is used to change from a previously assigned TLLI value to a new TLLI value. GMM shall change TLLI by sending an LLGMM-ASSIGN-REQ (TLLI Old  $\neq$  all 1's, TLLI New  $\neq$  all 1's) primitive to LLC. Upon receiving LLGMM-ASSIGN-REQ, LLC and all its LLEs shall not change their states. This is illustrated in Figure 12.

### 8.3.3 TLLI unassignment

This procedure is used to unassign a previously assigned TLLI value. GMM shall unassign a TLLI by sending an LLGMM-ASSIGN-REQ (TLLI New = all 1's) primitive to LLC. Upon receiving LLGMM-ASSIGN-REQ, LLC and all its LLEs shall enter the TLLI Unassigned state. This is illustrated in Figure 12.

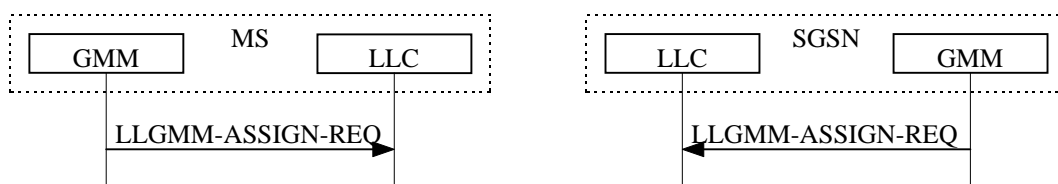

Figure 12: TLLI assignment, change, and unassignment procedure

## 8.4 Procedures for unacknowledged information transfer

The procedures that apply to the unacknowledged transmission of information are defined below. No LLC layer error recovery procedures are defined for unacknowledged operation.

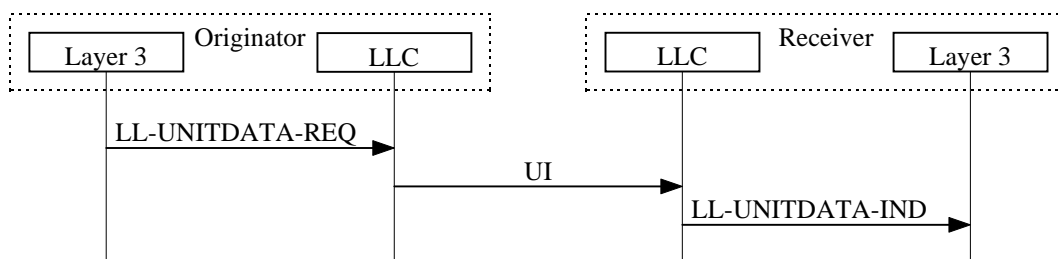

Figure 13: Unacknowledged information transmission

### 8.4.1 Transmission of unacknowledged information

Unacknowledged information shall be passed from layer 3 to the LLC layer with the LL-UNITDATA-REQ (L3-PDU, Protect, Cipher) primitive. The L3-PDU shall be transmitted in a UI command frame to the peer LLE. The PM and E bits in the UI frame shall be set according to the Protect and Cipher parameters received from layer 3.



## 8.4.2 Receipt of unacknowledged information

On receipt of a UI command frame the contents of the information field shall be passed to the appropriate layer-3 entity with an LL-UNITDATA-IND (L3-PDU) primitive, except:

- if the DLCI of the received UI frame is not supported by the receiver; or
- if  $N(U)$  of the received UI frame is in the range  $(V(UR) - 32) \leq N(U) < V(UR)$  and if a UI frame with the same  $N(U)$  has already been received,

then the UI frame shall be discarded without any further actions.

$V(UR)$  shall be set to  $N(U) + 1$  unless  $N(U)$  is in the range  $(V(UR) - 32) \leq N(U) < V(UR)$ .

## 8.5 Procedures for establishment and release of ABM operation

### 8.5.1 Establishment of ABM operation

#### 8.5.1.1 General

These procedures shall be used to establish ABM operation between the SGSN and an MS for a single SAPI.

Layer 3 shall request establishment of ABM operation by use of the LL-ESTABLISH-REQ service primitive. Re-establishment may be initiated as a result of the LLC layer procedures defined in subclause 8.7. All frames other than U and UI frames received during the establishment procedures shall be ignored.

#### 8.5.1.2 Establishment procedures

An LLE shall initiate a request for the ABM operation to be set by transmitting the SABM command. All existing exception conditions shall be cleared, the retransmission counter shall be reset, and timer T200 shall be set. All mode-setting commands shall be transmitted with the P bit set to 1.

Layer 3-initiated establishment procedures imply the discard of all outstanding LL-DATA-REQ primitives and all queued I frames.

An LLE receiving a SABM command, if it is able to enter the ABM state, shall:

- inform layer 3 using the LL-ESTABLISH-IND primitive;
- if the received SABM command contains a Layer-3 Parameters XID parameter, wait for the receipt of an LL-ESTABLISH-RES primitive from layer 3;
- respond with a UA response with the F bit set to the same binary value as the P bit in the received SABM command (i.e.,  $F=1$ );
- reset timer T200 if active;
- set  $V(S)$ ,  $V(R)$ ,  $V(A)$ , and B to 0;
- enter the ABM state;
- clear all existing exception conditions; and
- clear any existing peer receiver busy condition.

Upon reception of the UA response with the F bit set to 1, the originator of the SABM command shall:

- reset timer T200;
- set  $V(S)$ ,  $V(R)$ ,  $V(A)$ , and B to 0; and
- enter the ABM state and inform layer 3 using the LL-ESTABLISH-CNF or LL-ESTABLISH-IND (see subclause 8.7.2) primitive.

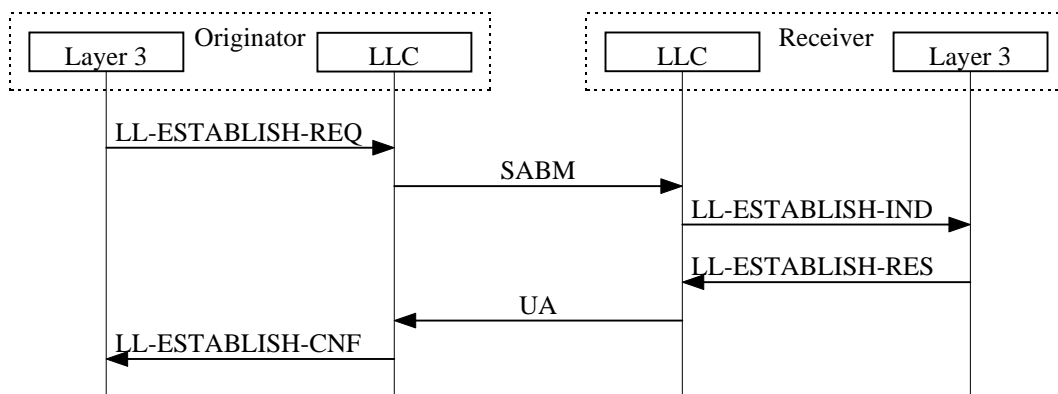

**Figure 14: Layer 3-initiated ABM establishment procedure**

If the receiving LLE is unable to enter the ABM state, it shall respond to the SABM command with a DM response with the F bit set to the same binary value as the P bit in the received SABM command. ABM operation for SAPIs 1, 2, 7, and 8 is not permitted, and reception of a SABM command for these SAPIs shall be responded to with a DM response.

Upon reception of a DM response with the F bit set to 1, the originator of the SABM command shall indicate this to layer 3 by means of the LL-RELEASE-IND (Cause = 'DM Received') primitive, and reset timer T200. It shall then enter the ADM state. DM responses with the F bit set to 0 shall be ignored in this case.

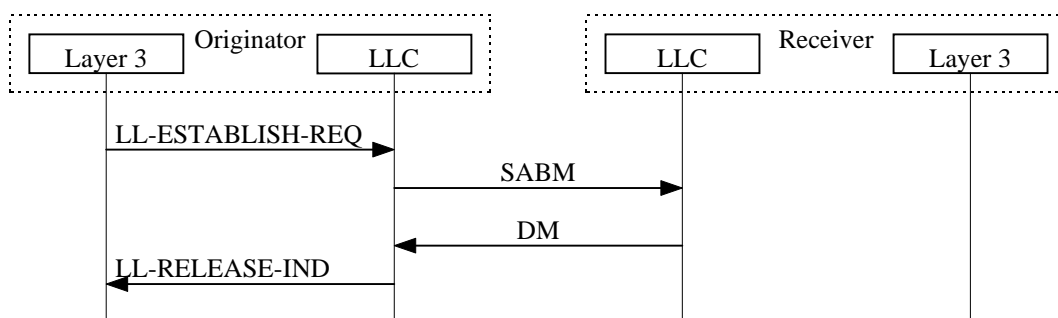

**Figure 15: Layer 3-initiated ABM establishment procedure, unsuccessful**

An LL-RELEASE-REQ primitive received during LLC layer initiated re-establishment shall be serviced on completion of the establishment operation.

### 8.5.1.3 Procedure on expiry of timer T200

If timer T200 expires before the UA or DM response with the F bit set to 1 is received, the LLE shall:

- retransmit the SABM command as defined above;
- set timer T200; and
- increment the retransmission counter.

After retransmission of the SABM command N200 times, LLME shall indicate this to GMM by means of the LLGMM-STATUS-IND primitive, and the LLE shall send an LL-RELEASE-IND (Cause = 'No Peer Response') to layer 3 and enter ADM state. If XID parameters were included with the SABM command, then the status of these parameters in the peer is unknown and should be re-negotiated.

## 8.5.2 Termination of ABM operation

### 8.5.2.1 General

These procedures shall be used to terminate ABM operation between the SGSN and an MS.

Layer 3 shall request termination of ABM operation by use of the LL-RELEASE-REQ service primitive. All frames

other than U and UI frames received during the release procedures shall be ignored.

All outstanding LL-DATA-REQ primitives and all queued I frames shall be discarded.

If the Local parameter received in the LL-RELEASE-REQ primitive indicates local release, the LLE shall enter ADM state, reset timer T200, and notify layer 3 by means of the LL-RELEASE-CNF primitive. Otherwise, the procedures in subclauses 8.5.2.2 and 8.5.2.3 shall be followed.

### 8.5.2.2 Release procedure

An LLE shall initiate a request for release of the ABM operation by transmitting the DISC command with the P bit set to 1. Timer T200 shall then be set and the retransmission counter reset.

An LLE receiving a DISC command while in ABM state shall transmit a UA response with the F bit set to the same binary value as the P bit in the received DISC command. An LL-RELEASE-IND (Cause = 'Normal Release') primitive shall be passed to layer 3, and the ADM state shall be entered.

If the originator of the DISC command receives either:

- a UA response with the F bit set to 1; or
- a DM response with the F bit set to 1, indicating that the peer LLE is already in ADM state;

it shall enter the ADM state and reset timer T200.

The LLE that issued the DISC command is now in the ADM state and shall notify layer 3 by means of the LL-RELEASE-CNF primitive. The conditions relating to this state are defined in subclause 8.5.4.

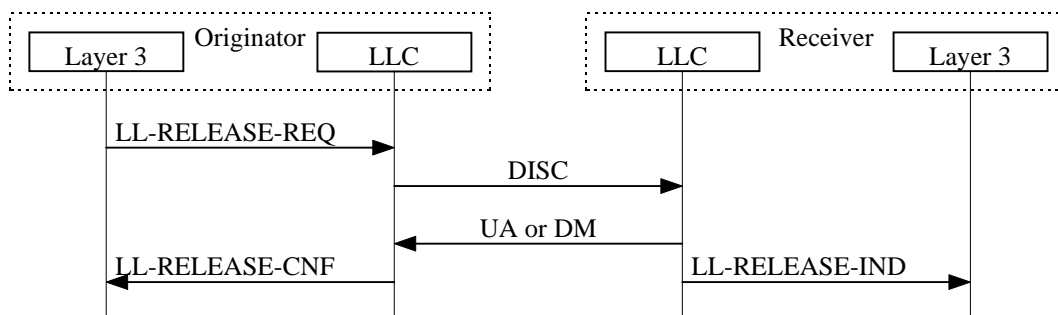

Figure 16: ABM release procedure

### 8.5.2.3 Procedure on expiry of timer T200

If timer T200 expires before a UA or DM response with the F bit set to 1 is received, the originator of the DISC command shall:

- retransmit the DISC command as defined in subclause 8.5.2.2;
- set timer T200; and
- increment the retransmission counter.

If the LLE has not received the correct response as defined in subclause 8.5.2.2 after N200 attempts to recover, then LLME shall indicate this to GMM by means of the LLGMM-STATUS-IND primitive, and the LLE shall enter the ADM state and notify layer 3 by means of the LL-RELEASE-CNF primitive.

## 8.5.3 Automatic negotiation of LLC layer and layer-3 parameters

Each LLE has an associated LLME that has the responsibility for initialising the LLC layer parameters necessary for correct peer-to-peer information transport. Initialisation of the parameters shall be done either according to the default values, or according to the values supplied by the peer entity. The latter method utilises the parameter negotiation procedure. The negotiable parameters are listed in Table 6.

LLC layer and layer-3 parameters may be negotiated in ADM or ABM modes of operation. LLC layer and layer-3 parameters may be negotiated with the exchange of XID frames, or with the exchange of SABM and UA frames. After successful negotiation with SABM and UA frames, the LLE shall be in ABM mode of operation, according to subclauses 8.5.1 and 8.7.

The LLE shall issue an XID command containing the parameters that the LLE wants to negotiate, and set timer T200. The peer LLE shall, upon receipt of the XID command, return an XID response containing the list of parameter values that the peer can support. Timer T200 shall be reset when the XID response is received. XID frames shall be transmitted with the P/F bit set to 1. This is illustrated in Figure 17.

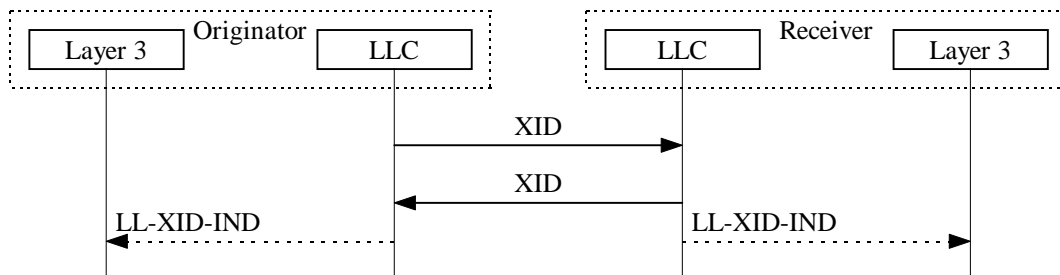

Figure 17: XID negotiation procedure

LL-XID-IND shall be indicated to layer 3 if N201-U or N201-I have been changed.

XID frames can be used to negotiate layer-3 parameters. In this case, layer 3 sends the parameters to an LLE with the LL-XID-REQ primitive. The LLE shall issue an XID command containing the layer-3 parameters, and LLC layer parameters if any LLC layer parameters shall be negotiated. The peer LLE shall, upon receipt of the XID command, indicate the layer-3 parameters to layer 3 and upon receipt of an LL-XID-RES primitive return an XID response containing the list of parameter values that the peer can support. The layer-3 parameters received from the peer is sent to layer 3 with the LL-XID-CNF primitive. The LLE issuing the XID command shall set timer T200 when the XID command is transmitted, and reset timer T200 when the XID response is received. This is illustrated in Figure 18.

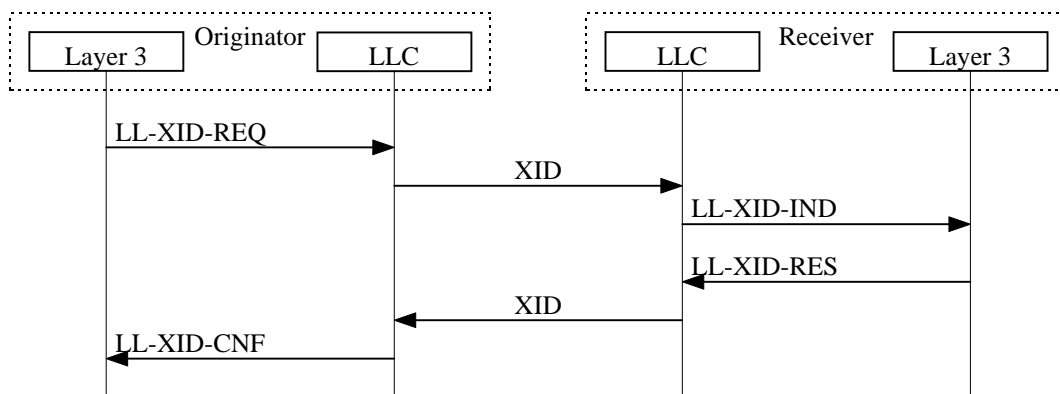

Figure 18: Layer 3 XID negotiation procedure

### 8.5.3.1 Negotiation of parameter Reset

The Reset parameter shall be used, in the SGSN originating Reset and in the MS receiving Reset, to:

- discard all requests pending from layer 3 to the LLEs with no further action;
- abort any ongoing ABM establishment, ABM release, and XID negotiation procedures, except the XID negotiation procedure used to negotiate the Reset parameter;
- set all LLC layer parameters to the default values given in Table 9;
- change any LLEs in ABM state to ADM state;
- set the unconfirmed state variable V(U) to 0;
- set the unconfirmed receive state variable V(UR) to 0; and

- set the OCs for unacknowledged information transfer to 0.

The Reset parameter shall be treated before any additional XID parameters present in the same XID frame.

### 8.5.3.2 Negotiation of parameter m

The following rules shall apply when mD and mU are negotiated:

- If mD is negotiated to 0, then the LLEs shall not keep count of outstanding I frame octets in the downlink direction. If mU is negotiated to 0, then the LLEs shall not keep count of outstanding I frame octets in the uplink direction.
- If a SABM or XID command with  $mD \neq 0$  is received in an LLE, and if the LLE does not want to apply the count of outstanding I frame octets in the downlink direction, then the LLE shall respond with  $mD = 0$  and with N201-I and kD so that N201-I multiplied with kD is less than or equal to the received MD.
- If a SABM or XID command with  $mU \neq 0$  is received in an LLE, and if the LLE does not want to apply the count of outstanding I frame octets in the uplink direction, then the LLE shall respond with  $mU = 0$  and with N201-I and kU so that N201-I multiplied with kU is less than or equal to the received MU.
- mD and mU shall be negotiated to values that allow at least one I frame with information field length equal to the negotiated value of N201-I to be transmitted in each direction.

### 8.5.3.3 Unsuccessful XID negotiation

If a SABM or XID command with an invalid XID information field is received, then the SABM or XID command, respectively, shall be ignored.

If a UA or XID response with an invalid XID information field is received, then the UA or XID response shall be ignored, the SABM or XID command shall be retransmitted, and the retransmission counter shall be incremented. After retransmission of the SABM or XID command N200 times, LLME shall indicate this to GMM by means of the LLGMM-STATUS-IND primitive, and the LLE shall send an LL-RELEASE-IND (Cause = 'Invalid XID Response') to layer 3 if a UA response was received or if the LLE was in ABM state, and enter ADM state if not already in ADM state. If the LLE was in ADM state and the XID command frame contained a Layer-3 Parameters XID parameter, then the LLE shall send an LL-STATUS-IND (Cause = 'Invalid XID Response') to layer 3.

An XID information field shall be treated as invalid if it:

- contains an XID parameter field that violates the LLC frame format (see Figure 3);
- contains the Reset, IOV-UI, or IOV-I parameter in the uplink direction;
- contains the IOV-I parameter in an XID frame;
- contains the Layer-3 Parameters parameter on a SAPI different from 3, 5, 9, and 11;
- in the SABM command case, contains the Reset parameter;
- contains the Reset parameter and this parameter is not the first parameter in the XID information field; or
- in the UA or XID response case:
  - contains the Reset parameter;
  - contains more than one instance of the same XID parameter type;
  - contains an XID parameter with unrecognised Type field;
  - contains an XID parameter with unsupported length;
  - contains an XID parameter with a value that violates the sense of negotiation; or
  - contains an XID parameter with a value that is out of range (see Table 6).

If a SABM or XID command with an XID parameter with an unrecognised Type field is received, then this parameter

shall be ignored. If a SABM or XID command contains more than one instance of the same XID parameter type, then all instances except the first instance shall be ignored. If the received XID information field is valid, and if one or more XID parameters with recognised type but with unsupported lengths or out-of-range values are detected, then these parameters shall be responded to with lengths and values set according to the responder's preferences.

#### 8.5.3.4 Procedure on expiry of timer T200

If timer T200 expires before the XID response with the F bit set to 1 is received, the LLE shall:

- retransmit the XID command;
- set timer T200; and
- increment the retransmission counter.

After retransmission of the XID command N200 times, LLME shall indicate this to GMM by means of the LLGMM-STATUS-IND primitive, and, if the LLE is in ABM state, then the LLE shall send an LL-RELEASE-IND (Cause = 'No Peer Response') to layer 3 and enter ADM state. If the LLE was in ADM state and the XID command frame contained a Layer-3 Parameters XID parameter, then the LLE shall send an LL-STATUS-IND (Cause = 'No Peer Response') to layer 3. The status of the XID parameters that were included in the XID command is unknown in the peer, and should be re-negotiated. If the XID command frame did not contain a Layer-3 Parameters XID parameter, then, as an implementation option, the LLE may wait for an implementation-specific amount of time and re-invoke the XID negotiation procedure.

#### 8.5.4 TLLI Assigned / ADM state

While in the TLLI Assigned / ADM state:

- the receipt of a DISC command shall result in the transmission of a DM response with the F bit set to the value of the received P bit;
- on receipt of a SABM command, the procedures defined in subclause 8.5.1 shall be followed;
- on receipt of UI commands, the procedures defined in subclause 8.4 shall be followed;
- on receipt of XID commands, the procedures defined in subclause 8.5.3 shall be followed;
- on receipt of any unsolicited UA response an LLGMM-STATUS-IND primitive indicating a possible multiple-assignment of a TLLI value shall be issued;
- the receipt of an S or I+S command frame shall result in the transmission of a DM response with the F bit set to 0; and
- all other frame types shall be discarded.

#### 8.5.5 Collision of unnumbered commands

In the collision cases in this subclause, if the XID or SABM command that shall be ignored and treated as not transmitted contains one or more XID parameters that are not negotiated as part of the collision resolution, then negotiation of these XID parameters shall be performed at the earliest opportunity after conclusion of the collision resolution.

An XID command with a valid XID information field that contains the Reset parameter shall not be ignored, and this requirement takes precedence over the collision cases in this subclause.

##### 8.5.5.1 Identical transmitted and received commands

If the transmitted and received unnumbered commands are SABM commands and a Layer-3 Parameters XID parameter is present in both or in neither, then the SABM command transmitted by the SGSN shall be ignored and treated as not transmitted. The LLE in the SGSN shall send the UA response at the earliest possible opportunity if it is able to enter ABM.

If the transmitted and received unnumbered commands are a SABM command with a Layer-3 Parameters XID

parameter and a SABM command without a Layer-3 Parameters XID parameter, then the SABM command without Layer-3 Parameters shall be ignored and treated as not transmitted. This is illustrated in Figure 19.

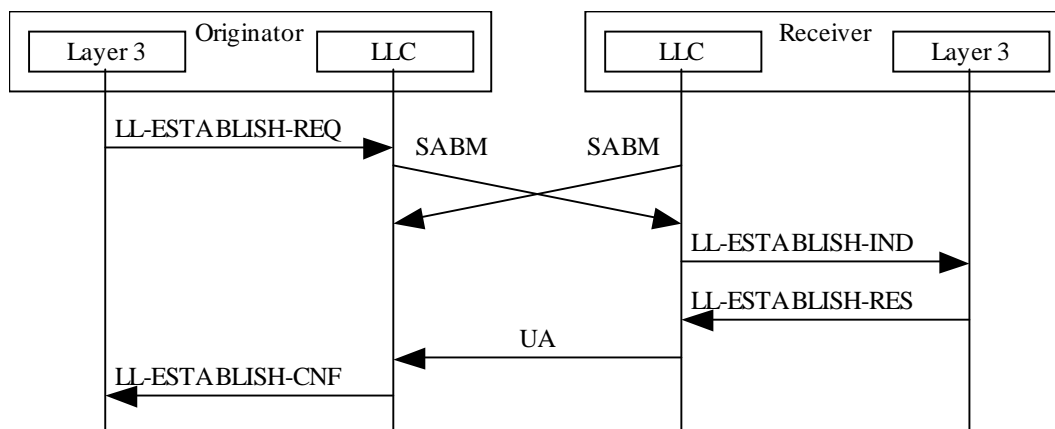

**Figure 19: Collision between LLE-initiated and layer 3-initiated ABM establishment procedure**

If the transmitted and received unnumbered commands are DISC commands, then the LLEs shall send the UA response at the earliest possible opportunity, and enter ADM state after receiving the UA response. The LLEs shall notify layer 3 by means of the LL-RELEASE-CNF primitive.

If the transmitted and received unnumbered commands are XID commands and a Layer-3 Parameters XID parameter is present in both or in neither, then the XID command transmitted by the SGSN shall be ignored and treated as not transmitted.

If the transmitted and received unnumbered commands are an XID command with a Layer-3 Parameters XID parameter and an XID command without a Layer-3 Parameters XID parameter, then the XID command without Layer-3 Parameters shall be ignored and treated as not transmitted.

### 8.5.5.2 Different transmitted and received commands

If the transmitted and received unnumbered commands are a SABM and a DISC command, the LLEs shall issue a DM response at the earliest possible opportunity. Upon receipt of a DM response with the F bit set to 1, the LLE shall enter the ADM state and notify layer 3 by means of the appropriate primitive. The LLE receiving the DISC command shall issue an LL-RELEASE-IND (Cause = 'Normal Release') primitive, while the other LLE shall issue an LL-RELEASE-CNF primitive.

If the transmitted unnumbered command is a SABM command, and the received unnumbered command is an XID command, then the LLE shall ignore the received XID command.

If the transmitted unnumbered command is an XID command, and the received unnumbered command is a SABM command, then the LLE shall send the UA response at the earliest possible opportunity if it is able to enter ABM. The transmitted XID command shall be treated as not transmitted.

If the transmitted and received unnumbered commands are a DISC and an XID command, then this shall not be considered a collision.

### 8.5.6 Unsolicited DM response and SABM or DISC command

When a DM response with the F bit set to 0 is received by an LLE, a collision between a transmitted SABM or DISC command and the unsolicited DM response may have occurred.

In order to avoid misinterpretation of the DM response received, an LLE shall always send its SABM or DISC command with the P bit set to 1.

A DM response with the F bit set to 0 colliding with a SABM or DISC command shall be ignored.

## 8.6 Procedures for information transfer in ABM operation

Having either transmitted the UA response to a received SABM command or received the UA response to a transmitted SABM, I frames and supervisory frames may be transmitted and received. The procedures that apply to the transmission of I frames are defined below.

NOTE: The term "transmission of an I frame" refers to the delivery of an I frame by the LLC layer to the RLC/MAC or BSSGP layer.

Each LLE shall store the history of the transmitted I frames, i.e., the LLE shall remember the I-frame transmission sequence. The history is used to decide which I frames to retransmit. Due to retransmission, the history is not necessarily an in-order sequence.

A frame within the receive window is either:

- received: the frame has been correctly received; or
- not received: the frame has not been correctly received.

A frame within the transmit window is either:

- not yet transmitted: the frame has not yet been transmitted;
- transmitted: the frame has been (re-)transmitted, but the LLE does not know if the frame has been received in the peer LLE;
- acknowledged: the frame has been acknowledged by the peer LLE; or
- marked for retransmission: the LLE has decided to retransmit this I frame.

I frames shall be transmitted in ascending N(S) order. When I frames are retransmitted, the frame with the lowest N(S) shall be retransmitted first. This is used by the receiving LLE to detect lost frames as described in subclause 8.6.3.1.

### 8.6.1 Transmitting I frames

Information received by the LLE from layer 3 by means of an LL-DATA-REQ primitive shall be transmitted in an I frame, provided that the LLE is not in the peer receiver busy condition. The control field parameters N(S) and N(R) shall be assigned the values V(S) and V(R), respectively. V(S) shall be incremented by 1 at the end of the transmission of the I frame.

The I frame buffer variable B shall be incremented with the length of the information field of I frame number N(S), so that  $B = B + L(N(S))$ . The value of B shall never exceed M. If  $L(N(S)) > M - B$  (where M is the maximum buffer size – see subclause 8.9.7), then the LLE shall not transmit any new I frames, but may retransmit I frames as a result of the error recovery procedures as described in subclauses 8.6.3 and 8.6.6.

When there is an opportunity to transmit a frame, then the LLE shall do one of the following in order of priority:

- If there are any I frames marked for retransmission and if the LLE is not in the peer receive busy condition, then the LLE shall increment by 1 the retransmission count variable for the I frame with the lowest send sequence number N(S). If the retransmission count variable exceeds the value of N200, then the LLE shall initiate the re-establishment procedure as described in subclause 8.7.2. If the retransmission count variable does not exceed the value of N200, then the LLE shall retransmit the I frame.
- If the LLE has a new I frame to transmit, if  $V(S) < V(A) + k$  (where k is the maximum number of outstanding I frames – see subclause 8.9.8), and if the LLE is not in the peer receiver busy condition, then the new I frame shall be transmitted.
- If the LLE has an acknowledgement to transmit (see subclause 8.6.3.1), then the LLE shall transmit an S frame.

If the LLE wants to request an acknowledgement (see subclause 8.6.3.3), then the A bit of the transmitted frame shall be set to 1.



When the SGSN or MS is in the own receiver busy condition, it may still transmit I frames, provided that a peer receiver busy condition does not exist.

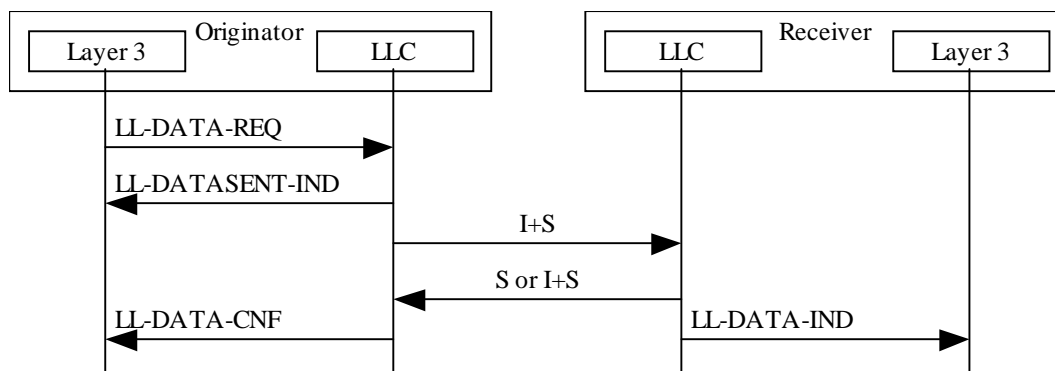

Figure 20: Transmitting and receiving I frames

## 8.6.2 Receiving I frames

When an LLE is not in the own receiver busy condition and receives a valid I frame whose  $N(S)$  is equal to the current  $V(R)$ , the LLE shall:

- pass the information field of this frame to layer 3 using the LL-DATA-IND primitive;
- increment by 1 its  $V(R)$ ; and
- if the A bit of the received I frame was set to 1, then the LLE shall respond to its peer with an RR, RNR, SACK, or ACK frame (see subclause 8.6.4.1).

When an LLE receives a valid I frame whose  $N(S)$  is not in the range  $V(R) \leq N(S) < V(R) + k$ , the LLE shall discard the frame as a duplicate.

When an LLE is not in the own receiver busy condition and receives a valid I frame where  $V(R) < N(S) < V(R) + k$ , then the LLE shall store the I frame until all frames from  $V(R)$  to  $N(S) - 1$  inclusive are correctly received. The LLE shall use the control field information of the received I frame before storing the frame. The LLE shall then:

- pass the information field of this I frame to layer 3 using the LL-DATA-IND primitive; and
- set its  $V(R) = N(S) + 1$ .

When an LLE receives a valid I frame and the LLE is in the own receiver busy condition, then the acceptance of the I frame is implementation dependent.

## 8.6.3 Sending and receiving acknowledgements

NOTE: Sending and receiving acknowledgements refer to the transmission and reception of frames carrying ABM acknowledgement information, i.e., I+S and S frames.

### 8.6.3.1 Sending acknowledgements

Whenever an LLE receives a frame with the A bit set to 1, it shall transmit an I+S or S frame. Whenever an LLE detects an error in the sequence of received I frames, it shall transmit an I+S or S frame. The supervisory function bits of the transmitted frame shall be set according to subclause 8.6.4.1.

The receiving LLE shall use the knowledge of the (re-)transmission strategy of its peer LLE (see subclause 8.6.1) to detect sequence errors. If the LLE receives an I frame with a higher  $N(S)$  than the  $N(S)$  of the previously received I frame, and if there are I frames missing between these two  $N(S)$  values, then the LLE shall assume that the missing I frames have been lost. If the LLE receives an I frame with a lower  $N(S)$  than the  $N(S)$  of the previously received I frame, it can assume that its peer LLE has (re-)started retransmission due to the reception of an acknowledgement.

### 8.6.3.2 Receiving acknowledgements

On receipt of a valid I+S or S frame, the LLE shall, if N(R) is valid, treat the N(R) contained in this frame as an acknowledgement for all the I frames it has transmitted with an N(S) up to and including the received N(R) - 1. A valid N(R) value is one that is in the range  $V(A) \leq N(R) \leq V(S)$ . If N(R) is not valid, then the received A bit shall be treated as defined in subclause 8.6.3.1, and N(R), and the SACK bitmap if received, shall be disregarded.

For each I frame transmitted with N(S) in the range  $V(A) \leq N(S) < N(R)$ :

- the LLE shall issue an LL-DATA-CNF primitive to layer 3 to confirm the delivery of an L3-PDU to layer 3 in the peer; and
- the frame length L(N(S)) shall be subtracted from the I frame buffer variable B, so that  $B = B - L(N(S))$ . The value of B shall never be less than 0.

V(A) shall then be set to N(R).

On receipt of a valid ACK frame, the LLE shall consider the I frame transmitted with sequence number N(R) + 1 as acknowledged.

On receipt of a valid SACK frame, the LLE shall consider all I frames with the corresponding bit set to 1 in the SACK bitmap as acknowledged.

If timer T201 is active and associated with an acknowledged I frame, then timer T201 shall be reset.

The LLE shall determine which I frames to retransmit by analysing its I frame transmission sequence history and the acknowledgements received. An unacknowledged I frame that was transmitted prior to an acknowledged I frame shall be considered lost and shall be marked for retransmission. Acknowledged I frames shall be removed from the I frame transmission sequence history.

### 8.6.3.3 Requesting acknowledgements

The LLE shall request an acknowledgement from the peer LLE by transmitting an I+S or S frame with the A bit set to 1. The LLE may request an acknowledgement at any time. An acknowledgement shall be requested when:

- the last I frame in a sequence of one or more I frames is transmitted; or
- $B > M - N201$  as a result of the transmission of the I frame, unless the next I frame to be transmitted is available and has an information field length that is less than or equal to  $M - B$ ; or
- $V(S) = V(A) + k$  as a result of the transmission of the I frame.

When requesting an acknowledgement, the LLE shall set timer T201 and associate the timer with the I frame currently being transmitted, or, if the A bit is transmitted in an S frame, with the I frame last transmitted.

## 8.6.4 Peer receiver busy condition

After receiving a valid RNR frame, the LLE shall:

- set a peer receiver busy condition;
- not transmit nor retransmit any I frames to the peer LLE;
- treat the N(R) contained in the received RNR frame as an acknowledgement for all the I frames that have been (re-)transmitted with an N(S) up to and including N(R) - 1, and set its V(A) to the value of the N(R) contained in the RNR frame;
- set timer T201 to initiate the inquiry process; and
- reset the retransmission count variable.

If timer T201 expires, the LLE shall:

- if the value of the retransmission count variable is less than N200:

- transmit an appropriate supervisory frame (see subclause 8.6.4.1) with an A bit set to 1;
- set timer T201; and
- add one to its retransmission count variable;
- if the value of the retransmission count variable is equal to N200, initiate a re-establishment procedure as defined in subclause 8.7. LLME shall indicate this by means of the LLGMM-STATUS-IND primitive to GMM.

The LLE receiving the supervisory frame with the A bit set to 1 shall respond, at the earliest opportunity, with an appropriate supervisory frame (see subclause 8.6.4.1) to indicate whether or not its own receiver busy condition still exists.

Upon receipt of the supervisory frame, the LLE shall reset timer T201, and:

- if the frame is an RR, ACK or SACK frame:
  - the peer receiver busy condition shall be cleared;
  - if timer T201 was active before the peer receiver busy condition was set, and if the associated I frame is still not acknowledged, then timer T201 shall be set and associated with the same I frame; and
  - the LLE may transmit new I frames or retransmit I frames as defined in subclauses 8.6.1 or 8.6.3, respectively; or
- if the frame is an RNR frame, then the LLE shall proceed according to subclause 8.6.4, first paragraph.

Upon receipt of a SABM command, the LLE shall clear the peer receiver busy condition.

#### 8.6.4.1 Supervisory frame selection

If the LLE is in the own receiver busy condition, the appropriate supervisory frame is the RNR frame.

Otherwise, if the highest-numbered I frame was received with  $N(S) = V(R)$ , the appropriate supervisory frame is the RR frame.

Otherwise, if the highest-numbered I frame was received with  $N(S) = V(R) + 1$ , the appropriate supervisory frame is the ACK frame.

Otherwise, the appropriate supervisory frame is the SACK frame.

#### 8.6.5 Own receiver busy condition

When the LLE enters the own receiver busy condition, it shall transmit an RNR frame at the earliest opportunity.

All received I frames may be discarded, after updating  $V(A)$ . If the A bit of a received I frame was set to 1, then the LLE shall transmit an RNR frame.

All received supervisory frames shall be processed, including updating  $V(A)$ . If the A bit of a received S frame was set to 1, then the LLE shall transmit an RNR frame.

To indicate to the peer LLE the clearance of the own receiver busy condition, the LLE shall transmit an appropriate supervisory frame (see subclause 8.6.4.1).

The transmission of a SABM command or a UA response (in reply to a SABM command) also indicates to the peer LLE the clearance of the own receiver busy condition.

#### 8.6.6 Waiting for acknowledgement

Frames may be lost any time during transmission due to e.g., transmission errors. An LLE that has not received acknowledgement for a transmitted I frame shall therefore on the expiry of timer T201 take appropriate recovery action.

The LLE shall maintain an internal retransmission count variable for each transmitted I frame.

If timer T201 expires, the LLE shall increment by 1 the retransmission count variable for the I frame associated with

timer T201, and:

- if the value of the retransmission count variable does not exceed N200, set timer T201, and retransmit the I frame with the A bit set to 1; or
- if the value of the retransmission count variable exceeds N200, initiate a re-establishment procedure as defined in subclause 8.7.2. LLME shall indicate this by means of the LLGMM-STATUS-IND primitive to GMM.

## 8.7 Re-establishment of ABM operation

### 8.7.1 Criteria for re-establishment

The criteria for re-establishing the ABM mode of operation are defined in this clause by the following conditions:

- the receipt, while in the ABM state, of a SABM;
- the receipt of an LL-ESTABLISH-REQ primitive from layer 3 (see subclause 8.5.1.1);
- the occurrence of N200 retransmission failures (see subclauses 8.6.4 and 8.6.6);
- the occurrence of a frame rejection condition as identified in subclause 8.8.2; and
- the receipt of an unsolicited DM response with the F bit set to 0 (see subclause 8.8.4) while in ABM state.

### 8.7.2 Procedures

In all re-establishment situations, the LLE shall follow the procedures defined in subclause 8.5.1. All locally-generated conditions for re-establishment shall cause the transmission of the SABM.

In the case of LLC layer and peer-initiated re-establishment, the LLE shall issue an LL-ESTABLISH-IND primitive to layer 3 and discard all outstanding LL-DATA-REQ primitives and all queued I frames, and LLME shall issue an LLGMM-STATUS-IND primitive to GMM.

In case of layer 3-initiated re-establishment, or if an LL-ESTABLISH-REQ primitive occurs pending re-establishment, the LL-ESTABLISH-CNF primitive shall be used.

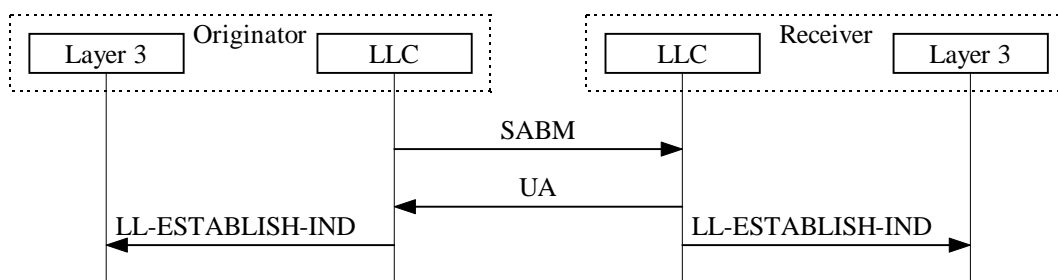

Figure 21: LLC-initiated ABM re-establishment procedure

## 8.8 Exception condition reporting and recovery

Exception conditions may occur as the result of lower layer errors or LLC layer procedural errors.

The error recovery procedures available to effect recovery following the detection of an exception condition at the LLC layer are defined in this subclause.

### 8.8.1 Invalid frame condition

Any received invalid frame shall be discarded, and no action shall be taken as a result of that frame.

## 8.8.2 Frame rejection condition

A frame rejection condition results from one of the conditions described in subclause 6.4.1.5 items 1) to 3).

Upon occurrence of a frame rejection condition, the LLME shall issue an LLGMM-STATUS-IND primitive; and the LLE shall:

- discard the frame causing the frame rejection condition;
- transmit a FRMR response frame; and
- if the LLE is in ABM operation, initiate re-establishment (see subclause 8.7.2).

## 8.8.3 Receipt of a FRMR response frame

Upon receipt of a FRMR response frame, the LLME shall issue an LLGMM-STATUS-IND primitive.

## 8.8.4 Unsolicited response frames

The action to be taken on the receipt of an unsolicited response frame is defined in Table 8. Upon the receipt of an unsolicited UA response, the LLE shall assume a possible multiple-TLLI assignment, and LLME shall inform GMM by means of the LLGMM-STATUS-IND primitive.

**Table 8: Actions taken on receipt of unsolicited response frames**

Unsolicited Response Frame	State				
	TLLI Assigned / ADM	Local Establishment	Local Release	ABM	Timer Recovery
UA response F = 1	LLGMM-STATUS-IND	Solicited	Solicited	LLGMM-STATUS-IND	LLGMM-STATUS-IND
UA response F = 0	LLGMM-STATUS-IND	LLGMM-STATUS-IND	LLGMM-STATUS-IND	LLGMM-STATUS-IND	LLGMM-STATUS-IND
DM response F = 1	Ignore	Solicited	Solicited	LLGMM-STATUS-IND	LLGMM-STATUS-IND Re-establish ABM
DM response F = 0	Ignore	Ignore	Ignore	LLGMM-STATUS-IND Re-establish ABM	LLGMM-STATUS-IND Re-establish ABM
Supervisory response	Ignore	Ignore	Ignore	Solicited	Solicited

A UA or XID response frame with the F bit set to 1, and that does not contain a Layer-3 Parameters XID parameter, received while a SABM or XID command respectively that does contain a Layer-3 Parameters XID parameter is outstanding, shall be ignored.

A UA or XID response frame with the F bit set to 1, and that contains a Layer-3 Parameters XID parameter, received while a SABM or XID command respectively that does not contain a Layer-3 Parameters XID parameter is outstanding, shall be ignored.

## 8.9 List of LLC layer parameters

The LLC layer parameters listed in this subclause are associated with each DLCI, except the LLC version number and IOV-UI that are associated with a TLLI.

A method of assigning these parameters is defined in subclauses 6.4.1.6 and 8.5.3.

Table 9 provides an overview of the LLC layer parameters and summarises the recommended default values to be used in GSM networks. The term default implies that the value defined should be used in the absence of any negotiation of alternative values.

Some of the parameters, e.g., T200, T201, and N200, may have the same name as parameters used in other GSM specifications. All the parameters listed here are local to the LLC layer protocol, and shall not impact or be impacted by parameters with the same name in other specifications.

### 8.9.1 LLC version number (Version)

The LLC version number (Version) is an LLC layer parameter. The default version number is given in Table 9.

### 8.9.2 Input Offset Value (IOV)

The Input Offset Value (IOV) is an LLC layer parameter used for ciphering. IOV is a random 32 bit value, generated by the SGSN. See also annex A.

The value for IOV can be different for I frames and UI frames. IOV-UI is IOV for UI frames. IOV-I is IOV for I frames.

The default values of IOV are given in Table 9. The following rules apply to default IOV values:

- After a change of Kc, negotiation of IOV-I may be omitted and the default value applied. If ABM is re-established for an LLE, and Kc is not changed since ABM was last (re-)established for this LLE, then a random IOV-I value shall be negotiated.
- After a change of Kc, negotiation of IOV-UI may be omitted and the default value applied. If the unconfirmed send state variable V(U) is reset for an LLE, and Kc is not changed since V(U) was last reset for this LLE, then a random IOV-UI value shall be negotiated.

### 8.9.3 Retransmission timers (T200 and T201)

The retransmission timers (T200 and T201) are LLC layer parameters. Upon expiry of timer T200 or T201, retransmission of a frame may be initiated according to the procedures described in clause 8. The default value of timers T200 and T201 for each SAPI is given in Table 9. The value of timer T200 shall be used when setting timer T201.

### 8.9.4 Maximum number of retransmissions (N200)

The maximum number of retransmissions of a frame (N200) is an LLC layer parameter. The default value of N200 for each SAPI is given in Table 9.

### 8.9.5 Maximum number of octets in an information field (N201)

The maximum number of octets in an information field (N201) is an LLC layer parameter. See also subclause 5.4. The default value of N201 for each SAPI is given in Table 9. The minimum value of N201 shall be 140 octets, and the maximum value shall be 1 520 octets.

The value of N201 may be different for I frames and U and UI frames. N201-U is used for U and UI frames, and N201-I is used for I frames.

### 8.9.6 Maximum number of octets in the layer-3 header (N202)

The maximum number of octets in the layer-3 unitdata PDU header (N202) is an LLC layer parameter. The N202 value shall be 4 for LLC version number 0.

NOTE: The N202 value of 4 octets coincides with the maximum-length SNDCP SN-UNITDATA PDU header.

### 8.9.7 Maximum I frame buffer size (m)

The maximum I frame buffer size (m) that may be used to buffer outstanding I frame information fields at any given time is an LLC layer parameter that shall be either 0 or from 9 through 24 320 in units of 16 octets. The default values of m are given in Table 9. If the value of m equals 0, then the LLE shall not keep count of the number of outstanding I frame octets, i.e., the I frame buffer variable B shall not be used. M is the maximum buffer size expressed in octets, so that  $M = m \cdot 16$ .

The value of m can be different in each direction of transmission. mD is m in the downlink direction. mU is m in the uplink direction.

### 8.9.8 Maximum number of outstanding I frames (k)

The maximum number (k) of sequentially-numbered I frames that may be outstanding (i.e., unacknowledged) at any given time is an LLC layer parameter that shall not exceed 255. k is also denoted window size. The default values of k are given in Table 9.

The value of k can be different in each direction of transmission. kD is k in the downlink direction, and kU is k in the uplink direction.

### 8.9.9 LLC layer parameter default values

**Table 9: LLC layer parameter default values**

LLC Parameter	SAPI 1 GMM	SAPI 2 TOM 2	SAPI 3 User Data 3	SAPI 5 User Data 5	SAPI 7 SMS	SAPI 8 TOM 8	SAPI 9 User Data 9	SAPI 11 User Data 11
Version	0							
IOV-UI	0							
IOV-I	Note 2	Note 2	$2^{27} \cdot \text{SAPI}$	$2^{27} \cdot \text{SAPI}$	Note 2	Note 2	$2^{27} \cdot \text{SAPI}$	$2^{27} \cdot \text{SAPI}$
T200 and T201	5 s	5 s	5 s	10 s	20 s	20 s	20 s	40 s
N200	3	3	3	3	3	3	3	3
N201-U	400	270	500	500	270	270	500	500
N201-I	Note 2	Note 2	1 503	1 503	Note 2	Note 2	1 503	1 503
mD	Note 2	Note 2	1 520	760	Note 2	Note 2	380	190
mU	Note 2	Note 2	1 520	760	Note 2	Note 2	380	190
kD	Note 2	Note 2	16	8	Note 2	Note 2	4	2
kU	Note 2	Note 2	16	8	Note 2	Note 2	4	2
<p>NOTE 1: Proper LLC operation requires that timer T200 be greater than the maximum time between transmission of command frames and the reception of their corresponding response or acknowledgement frames.</p> <p>NOTE 2: This parameter applies to ABM procedures. ABM operation is not allowed for GMM, SMS, and TOM that use only UI frames for information transfer.</p> <p>NOTE 3: The default values for SAPIs 3, 5, 9, and 11 have been chosen to correspond with the four GPRS quality of service delay classes, see 3GPP TS 02.60. However, there is no fixed relationship between SAPI and delay class. The LLC layer parameters for any SAPI can be negotiated to support any QoS profile, see 3GPP TS 03.60.</p> <p>NOTE 4: Proper LLC operation requires that the values for N201-U and N201-I are not greater than the maximum number of octets in an information field that can be transmitted or retransmitted over the Gb interface, see 3GPP TS 08.18. It is the responsibility of the SGSN to negotiate N201-U and N201-I to values compatible with the usage of the Gb interface.</p>								

# Annex A (normative): Ciphering

## A.1 General

This annex specifies how LLC shall interface with the GPRS ciphering algorithm. The requirements for the GPRS ciphering algorithm are contained in 3GPP TS 01.61.

## A.2 Ciphering algorithm interface

The ciphering algorithm has three input parameters:

- the ciphering key ( $K_c$ );
- the frame-dependent input (Input); and
- the transfer direction (Direction).

The ciphering algorithm has one output parameter:

- Output.

The relationship between the input and output parameters and the ciphering algorithm is illustrated in Figure A.1.

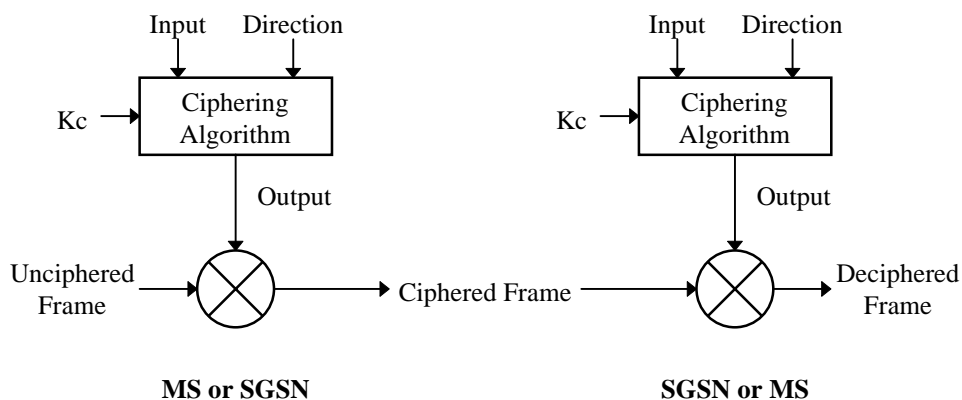

**Figure A.1: GPRS ciphering environment**

The input and output parameters and the other elements from Figure A.1 are defined in Table A.1.



Table A.1: Ciphering parameters and frames

Parameter	Length	Description
Kc	64 bits	The LLGMM-ASSIGN-REQ Kc parameter received from GMM.
Input	32 bits	A modulo counter as defined in subclause A.2.1.
Direction	1 bit	Set to 0 if the direction of LLC frame transmission is from the MS to the SGSN. Set to 1 if the direction of LLC frame transmission is from the SGSN to the MS.
Ciphering Algorithm	-	A GPRS ciphering algorithm as determined by the LLGMM-ASSIGN-REQ Ciphering Algorithm parameter received from GMM.
Output	maximum 1 523 octets	The output of Ciphering Algorithm.
Unciphered Frame	maximum 1 523 octets	An LLC layer I or UI frame to be ciphered.
Ciphered Frame	maximum 1 523 octets	A ciphered LLC layer I or UI frame. Only the information field and the FCS field shall be ciphered. Ciphered Frame shall be generated by bitwise XOR of Output and the Information Field and FCS Field of Unciphered Frame starting from bit (1, 1).
Deciphered Frame	maximum 1 523 octets	A deciphered LLC layer I or UI frame. Deciphered Frame shall be generated by bitwise XOR of Output and the ciphered part of Ciphered Frame starting from bit (1, 1). When transmitting an LLC frame, Deciphered Frame shall be identical to Unciphered Frame if no transmission errors have occurred.

It is an implementation option to optimise the ciphering algorithm by for example producing only as many Output octets as is needed to cipher Unciphered Frame.

## A.2.1 Generation of Input

The Input parameter shall be generated according to the following algorithm if the frame is a UI frame:

$$\text{Input} = ((\text{IOV-UI} \otimes \text{SX}) + \text{LFN} + \text{OC}) \text{ modulo } 2^{32}$$

The Input parameter shall be generated according to the following algorithm if the frame is an I frame:

$$\text{Input} = (\text{IOV-I} + \text{LFN} + \text{OC}) \text{ modulo } 2^{32}$$

where:

- IOV-UI is a 32 bit random value generated by the SGSN.
- IOV-I is a 32 bit random value generated by the SGSN.
- LFN is the LLC frame number in the LLC frame header. LFN is a binary value with a length of nine bits. For I frames, N(S) shall be used as the LFN. For UI frames, N(U) shall be used as the LFN.
- OC is a binary overflow counter that is calculated and maintained independently at the sending and receiving sides. The length of OC is 32 bits. There are four OC counters associated with each DLCI; two for unacknowledged information transfer (one for each direction of transmission), and two for acknowledged information transfer (one for each direction of transmission). An OC for acknowledged operation shall be set to 0 whenever ABM operation is (re-)established for the corresponding DLCI. OC shall be incremented by 512 every time when the corresponding LFN rolls over, i.e., when LFN exhausts its modulo and restarts counting from 0, so that OC and LFN when added together in effect is a 32 bit modulo  $2^{32}$  counter.
- SX is a 32 bit SAPI XOR mask calculated as follows:  $\text{SX} = 2^{27} \cdot \text{SAPI} + 2^{31}$ .
- + is the binary addition operation.
- $\otimes$  is the bitwise XOR operation.

## Annex B (normative): Tunnelling of Messages (TOM)

Tunnelling of Messages (TOM) is a generic protocol layer used for the exchange of TOM Protocol Envelopes (see Figure B.1) between the MS and the SGSN. TOM uses two LLC SAPs, one for high-priority messages and another for low-priority messages. The TOM Protocol Envelope is composed of a TOM Protocol Header (containing one or more octets) and a Message Capsule. The TOM Protocol Header contains information about the specific application using the TOM protocol layer and any other TOM Protocol Discriminator-specific information. The Message Capsule is the actual payload of information in the TOM Protocol Envelope. One of the uses of the TOM protocol layer is to tunnel signalling messages between an MS and a non-GSM MSC/VLR when GPRS network elements are used in non-GSM networks. See 3GPP TS 03.60 and 3GPP TS 09.18.

### B.1 TOM Protocol Envelope structure

All TOM protocol peer-to-peer exchanges shall be in TOM Protocol Envelopes conforming to the format shown in Figure B.1. The TOM Protocol Header shall consist of the TOM Protocol Discriminator, Remaining Length of TOM Protocol Header, and Remaining Octets of TOM Protocol Header fields, and is a minimum of 1 octet and a maximum of 15 octets long.

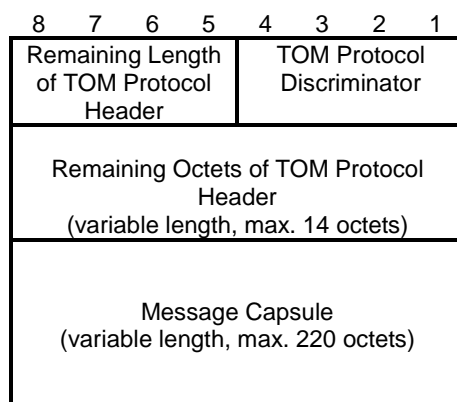

Figure B.1: TOM Protocol Envelope format

#### B.1.1 TOM Protocol Discriminator

TOM Protocol Discriminator indicates the specific technology using TOM, and is coded as follows:

bits	4	3	2	1	
	0	0	0	0	Not specified
	0	0	0	1	TIA/EIA-136 [22]
	1	1	1	1	Reserved for extension

All other values are reserved

If any other value than 0 0 0 1 is received, then the TOM Protocol Envelope shall be discarded with no further action.

## B.1.2 Remaining Length of TOM Protocol Header

Remaining Length of TOM Protocol Header indicates the number of octets remaining in the TOM-protocol-header part of the TOM Protocol Envelope, and is coded as follows:

bits	8 7 6 5
0 0 0 0	0 octets remaining in TOM protocol header
0 0 0 1	1 octet remaining in TOM protocol header
1 1 1 0	14 octets remaining in TOM protocol header
1 1 1 1	Reserved for extension

If the value 1 1 1 1 is received, then the TOM Protocol Envelope shall be discarded with no further action.

## B.1.3 Remaining Octets of TOM Protocol Header

This field contains the octets following the first octet in the TOM-protocol-header. If present, the interpretation of the information contained in this field is TO M Protocol Discriminator-specific.

## B.1.4 Message Capsule

This field contains TOM Protocol Discriminator-specific payload in the TOM Protocol Envelope.

## Annex C (informative): LLC layer states for peer-to-peer operation

### C.1 General

The purpose of this annex is to provide a representative example of the peer-to-peer procedures of the LLC layer, to assist in the understanding of the present document. This representation does not describe all of the possible actions of the LLC layer. The representation does therefore not constrain implementations from exploiting the full scope of the procedures as presented within the text of the present document. The text description of the procedures is normative.

The representation is a model of the peer-to-peer procedures of the LLC layer and is applicable to the LLC layers at both the MS and SGSN sides for all ranges of TLLI values.

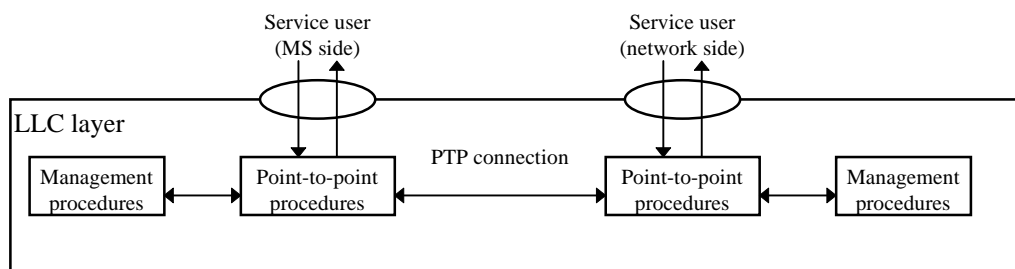

Figure C.1: Model of the LLC layer peer-to-peer procedures

### C.2 An overview of the peer-to-peer LLC layer states

The state diagram representation of the peer-to-peer procedures is based on an expansion of the three basic states identified in subclause 4.5.2 to 7 states. An overview of the inter-relationship of these states is provided in Figure C.2.

An LLME and its LLEs are conceptually initiated in the TLLI Unassigned state (state 1). LLME interacts with GMM in order to be assigned a TLLI value. TLLI assignment causes LLME to transition to the TLLI Assigned state (state 2) and each of its LLEs to transition to the ADM state (state 2).

The receipt of an LL-ESTABLISH-REQ primitive by an LLE in the ADM state (state 2) causes the initiation of the local establishment procedure and the transition to the Local Establishment state (state 3). Completion of the establishment procedure takes the LLE to the ABM state (state 5).

Peer-initiated establishment causes a transition from the ADM state (state 2) to the Remote Establishment state (state 4). The receipt of an LL-ESTABLISH-RES primitive completes the establishment procedure and moves the LLE to the ABM state (state 5). In ABM state (state 5), LL-DATA-REQ primitives can be serviced directly subject to the restrictions of the procedures.

Expiry of timer T200, that is used in both the flow control and data transfer aspects of each LLE's procedures initiates the transition to the Timer Recovery state (state 7). Completion of the timer recovery procedures returns the LLE to the ABM state (state 5). In states 5 and 7, the following conditions that are identified within the LLC specification are observed:

- peer receiver busy; and
- own receiver busy.

A peer-initiated release takes the LLE directly to the ADM state (state 2), whilst an LL-RELEASE-REQ returns the LLE state to the ADM state via the Local Release state (state 6).

TLLI Unassignment causes a transition to the TLLI Unassigned state (state 1) from any other state (states 2-7). Reset causes a transition to the TLLI Assigned / ADM state (state 2) from any other state except state 1.

In addition, all states should observe the suspended operation (reception of LLGMM-SUSPEND-REQ) restrictions, during which LLC frames may not be transmitted.

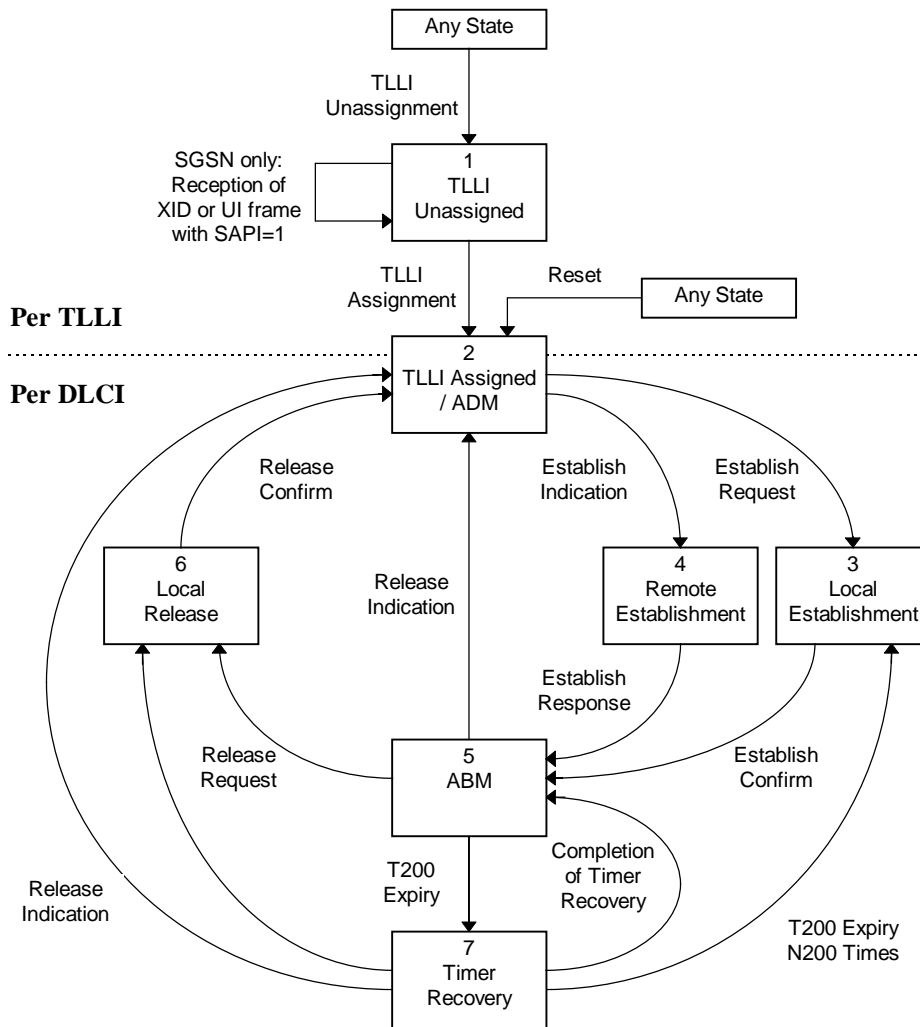

Figure C.2: Overview of the states of the peer-to-peer procedures

## Annex D (informative): Document Change Request History

5.0.0	October 1997	SMG#23 approved.
5.1.0	December 1997	Included SMG#24 approved change requests A001 through A014.
5.2.0	March 1998	Included SMG#25 approved change requests A015 and A017 through A021.
6.0.0	March 1998	New version number as decided by SMG#25.
6.1.0	June 1998	Included SMG#26 approved change requests A016 and A023 through A030.
6.2.0	October 1998	Included SMG#27 approved change requests A031 through A036.
6.3.0	March 1999	Included SMG#28 approved change requests A037, A038, A040 through A046, A048, and A050.
6.4.0	August 1999	Included SMG#29 approved Release 97 change requests A051r1, A054r2, A055r1, A057, A058r2, A059r2, A061, A064r2, A067, and A068r1.
7.0.0	August 1999	Version change to 7.0.0 as part of Release 98 package only.
8.0.0	August 1999	Included SMG#29 approved Release 99 change request A070r2.
8.1.0	November 1999	Included SMG#30 approved Release 99 change requests A083, A085, A086, A088, A090, A093, A095, A097, A100, A103r1, A106r1, A111, and A112r1.
8.2.0	January 2000	Included TSG CN#6 approved Release 99 change requests A115, A118, and A124r2.
8.3.0	February 2000	Included SMG#31 approved Release 99 change requests A127, A130, A133, A136, and A139.
8.4.0	June 2000	Include SMG#32 approved release 99 CR A142r2

TSG Meeting	TSG Doc number	TSG WG doc number	Spec	CR	R v	Ph	Ca t	Vers Old	Vers New	Subject	Workitem	Remarks
NP-09	NP-000441	N1-000987	04.64	A143	1	R99	F	8.4.0	8.5.0	Corrections regarding NULL frame	GPRS	
NP-10	NP-000670	N1-001195	04.64	A145		R99	F	8.5.0	8.6.0	Correction in TOM protocol header	GPRS	
NP-10	NP-000670	N1-001199	04.64	A148		R99	A	8.5.0	8.6.0	Correction of IOV-UI negotiation	GPRS	

---

# History

<b>Document history</b>		
V8.3.0	March 2000	Publication
V8.4.0	August 2000	Publication
V8.5.0	September 2000	Publication
V8.6.0	December 2000	Publication