

# ETSI TS 101 356 V6.4.0 (1999-11)

---

*Technical Specification*

**Digital cellular telecommunications system (Phase 2+);  
General Packet Radio Service (GPRS);  
Mobile Station (MS) supporting GPRS  
(GSM 07.60 version 6.4.0 Release 1997)**

---



**GSM**®  
GLOBAL SYSTEM FOR  
MOBILE COMMUNICATIONS

**ETSI** 

---

Reference

---

RTS/SMG-030760Q6R3 (ck0031c3.PDF)

Keywords

---

Digital cellular telecommunications system,  
Global System for Mobile communications  
(GSM), GPRS

**ETSI**

Postal address

---

F-06921 Sophia Antipolis Cedex - FRANCE

Office address

---

650 Route des Lucioles - Sophia Antipolis  
Valbonne - FRANCE  
Tel.: +33 4 92 94 42 00 Fax: +33 4 93 65 47 16  
Siret N° 348 623 562 00017 - NAF 742 C  
Association à but non lucratif enregistrée à la  
Sous-Préfecture de Grasse (06) N° 7803/88

Internet

---

secretariat@etsi.fr  
Individual copies of this ETSI deliverable  
can be downloaded from  
<http://www.etsi.org>  
If you find errors in the present document, send your  
comment to: editor@etsi.fr

**Important notice**

---

This ETSI deliverable may be made available in more than one electronic version or in print. In any case of existing or perceived difference in contents between such versions, the reference version is the Portable Document Format (PDF). In case of dispute, the reference should be the printing on ETSI printers of the PDF version kept on a specific network drive within ETSI Secretariat.

**Copyright Notification**

---

No part may be reproduced except as authorized by written permission.  
The copyright and the foregoing restriction extend to reproduction in all media.

© European Telecommunications Standards Institute 1999.  
All rights reserved.

# Contents

Intellectual Property Rights .....	5
Foreword.....	5
Introduction .....	5
1 Scope .....	6
2 References .....	6
3 Definitions abbreviations and symbols .....	8
3.1 Definitions .....	8
3.2 Abbreviations .....	8
3.3 Symbols .....	9
4 Access reference configuration .....	9
5 Functions to support data services .....	9
6 Interface to GPRS Bearer Services .....	10
7 Functions common to all configurations of the GPRS MS .....	10
7.1 Mobile Classes .....	10
7.2 Physical Interface .....	10
7.3 Terminal context procedures .....	10
7.3.1 GPRS Attach.....	10
7.3.2 GPRS Detach.....	10
7.3.3 Mobile Originated PDP Context Activation .....	11
7.3.4 Network Requested PDP Context Activation .....	11
7.3.5 PDP Context Deactivation .....	11
7.3.6 PDP context related parameters .....	11
8 X.25 Based Services.....	11
8.1 X.25 Character mode (triple X PAD) service.....	12
8.1.1 PAD Parameters.....	13
8.1.2 Example mapping of functions between the R reference point and the GPRS bearer.....	14
8.2 X.25 Packet mode service .....	14
8.2.1 Layer 1 and Layer 2 options .....	15
8.2.1.1 Synchronous serial interface.....	15
8.2.1.2 Asynchronous serial interface .....	15
8.2.1.3 Synchronous and asynchronous (dual mode) interface.....	15
8.2.2 Example mappings of functions between the R reference point and the GPRS bearer .....	16
8.2.2.1 Standardized X.25 TE .....	16
8.2.2.1.1 Layer 1 control .....	16
8.2.2.1.2 Layer 2 control .....	16
8.2.2.1.3 Layer 3 control .....	17
8.2.2.2 X.25 TE with support for AT commands .....	17
9 IP Based Services .....	18
9.1 Example mapping of functions between the R reference point and the GPRS bearer for IP over PPP .....	18
10 AT commands .....	20
10.1 General on AT commands .....	20
10.1.1 Interaction of AT commands, GPRS management and PDPs .....	20
10.1.1.1 AT commands and responses .....	21
10.1.1.2 PDP and layer 2 protocol operation .....	21
10.1.1.3 GPRS management.....	21
10.1.1.3.1 GPRS attachment.....	21
10.1.1.3.2 PDP context activation .....	21
10.1.2 Use of default context parameter values .....	21
10.1.2.1 PDP type .....	22

10.1.2.2 PDP address (of the MS).....22

10.1.2.3 Access Point Name.....22

10.1.2.4 QoS Requested .....22

10.1.2.5 PDP Configuration Options.....22

10.2 Example command sequences for dial-compatibility mode.....22

10.2.1 PPP in dial compatibility mode.....22

10.2.1.1 Mobile initiated IP context activation .....22

10.2.1.2 Network requested IP context activation.....23

10.2.2 MO X.25 virtual call using a triple-X PAD in modem compatibility mode.....24

10.2.3 Selection and activation of an IP PDP context in modem compatibility mode .....25

**Annex A (informative): Summary of AT commands for GPRS .....26**

**Annex B (informative): Document change history.....27**

History .....28

---

## Intellectual Property Rights

IPRs essential or potentially essential to the present document may have been declared to ETSI. The information pertaining to these essential IPRs, if any, is publicly available for **ETSI members and non-members**, and can be found in SR 000 314: "*Intellectual Property Rights (IPRs); Essential, or potentially Essential, IPRs notified to ETSI in respect of ETSI standards*", which is available from the ETSI Secretariat. Latest updates are available on the ETSI Web server (<http://www.etsi.org/ipr>).

Pursuant to the ETSI IPR Policy, no investigation, including IPR searches, has been carried out by ETSI. No guarantee can be given as to the existence of other IPRs not referenced in SR 000 314 (or the updates on the ETSI Web server) which are, or may be, or may become, essential to the present document.

---

## Foreword

This Technical Specification (TS) has been produced by the Special Mobile Group (SMG).

The present document provides the necessary information to develop a MS for support of GPRS within the digital cellular telecommunications system.

The contents of the present document are subject to continuing work within SMG and may change following formal SMG approval. Should SMG modify the contents of the present document it will then be republished by ETSI with an identifying change of release date and an increase in version number as follows:

Version 6.x.y

where:

- 6 indicates GSM Release 1997 of Phase 2+.
- x the second digit is incremented for changes of substance, i.e. technical enhancements, corrections, updates, etc.
- y the third digit is incremented when editorial only changes have been incorporated in the specification.

---

## Introduction

The present document contains the necessary information to develop a MS for support of GPRS. It is up to the manufacturer how to implement the various functions but the present document and existing GSM 07.01, 07.02, and 07.03 shall be followed where applicable.

It is the intention that the present document shall remain as the specification to develop a MS for support of GPRS and its text includes references to GSM standards.

---

# 1 Scope

The GSM PLMN supports a wide range of voice and non-voice services in the same network. In order to enable non-voice traffic in the GSM PLMN there is a need to connect various kinds of terminal equipments to the Mobile Station (MS). The present document describes the functionality of a MS supporting GPRS, including the protocols and signalling needed to support the first phase of GPRS, as defined in GSM 02.60 and 03.60 (packet based services).

---

# 2 References

The following documents contain provisions which, through reference in this text, constitute provisions of the present document.

- References are either specific (identified by date of publication, edition number, version number, etc.) or non-specific.
- For a specific reference, subsequent revisions do not apply.
- For a non-specific reference, the latest version applies.
- A non-specific reference to an ETS shall also be taken to refer to later versions published as an EN with the same number.
- For this Release 1997 document, references to GSM documents are for Release 1997 versions (version 6.x.y).

- [1] GSM 01.04: "Digital cellular telecommunication system (Phase 2+); Abbreviations and acronyms".
- [2] GSM 02.02: "Digital cellular telecommunication system (Phase 2+); Bearer Services (BS) supported by a GSM Public Land Mobile Network (PLMN)".
- [3] GSM 02.60: "Digital cellular telecommunication system (Phase 2+); General Packet Radio Service (GPRS); Service Description Stage 1".
- [4] GSM 03.02: "Digital cellular telecommunication system (Phase 2+); Network architecture".
- [5] GSM 03.03: "Digital cellular telecommunications system (Phase 2+); Numbering, addressing and identification".
- [6] GSM 03.10: "Digital cellular telecommunication system (Phase 2+); GSM Public Land Mobile Network (PLMN) connection types".
- [7] GSM 03.22: "Digital cellular telecommunications system (Phase 2+); Functions related to Mobile Station (MS) in idle mode and group receive mode".
- [8] GSM 03.40: "Digital cellular telecommunications system (Phase 2+); Technical realization of the Short Message Service (SMS); Point-to-Point (PP)".
- [9] GSM 03.60: "Digital cellular telecommunication system (Phase 2+); General Packet Radio Service (GPRS) Service Description Stage 2".
- [10] GSM 04.02: "Digital cellular telecommunication system (Phase 2+); GSM Public Land Mobile Network (PLMN) access reference configuration".
- [11] GSM 04.07: "Digital cellular telecommunications system (Phase 2+); Mobile radio interface signalling layer 3; General aspects".
- [12] GSM 04.08: "Digital cellular telecommunications system (Phase 2+); Mobile radio interface layer 3 specification".
- [13] GSM 04.60: "Digital cellular telecommunications system (Phase 2+); General Packet Radio Service (GPRS); Mobile Station (MS) - Base Station System (BSS) interface; Radio Link Control / Medium Access Control (RLC/MAC) protocol".

- [14] GSM 04.64: "Digital cellular telecommunications system (Phase 2+); General Packet Radio Service (GPRS); Logical Link Control (LLC)".
- [15] GSM 04.65: "Digital cellular telecommunications system (Phase 2+); General Packet Radio Service (GPRS); Subnetwork Dependent Convergence Protocol (SNDCP)".
- [16] GSM 07.07: "Digital cellular telecommunication system (Phase 2+); AT command set for GSM Mobile Equipment (ME)".
- [17] GSM 09.61: "Digital cellular telecommunication system (Phase 2+); General Packet Radio Service (GPRS); Interworking between the Public Land Mobile Network (PLMN) supporting GPRS and Packet Data Networks (PDN)".
- [18] CCITT Recommendation E.164: "Numbering plan for the ISDN era".
- [19] CCITT Recommendation V.42 bis: "Data communication over the telephone network – Data compression procedures for data circuit-terminating equipment (DCE) using error correction procedures".
- [20] CCITT Recommendation X.3: "Packet assembly disassembly facility (PAD) in a public data network".
- [21] CCITT Recommendation X.25: "Interface between data terminal equipment (DTE) and data circuit-terminating equipment (DCE) for terminals operating in the packet mode and connected to public data networks by dedicated circuit".
- [22] CCITT Recommendation X.28: "DTE / DCE interface for a start-stop mode data terminal equipment accessing the packet assembly / disassembly facility (PAD) in a public data network situated in the same country".
- [23] CCITT Recommendation X.29: "Procedures for the exchange of control information and user data between a packet assembly / disassembly (PAD) facility and a packet mode DTE or another PAD".
- [24] CCITT Recommendation X.75: "Packet-switched signalling system between public networks providing data transmission services".
- [25] CCITT Recommendation X.121: "International Numbering Plan for Public Data Networks".
- [26] IETF RFC 768 (1980): "User Datagram Protocol" (STD 6).
- [27] IETF RFC 791 (1981): "Internet Protocol" (STD 5).
- [28] IETF RFC 792 (1981): "Internet Control Message Protocol" (STD 5).
- [29] IETF RFC 793 (1981): "Transmission Control Protocol" (STD 7).
- [30] ITU-T Recommendation V.250 (ex V.25ter): "Serial asynchronous automatic dialling and control".
- [31] ITU-T Recommendation V.24: "List of definitions for interchange circuits between data terminal equipment (DTE) and data circuit-terminating equipment (DCE)".
- [32] ITU-T Recommendation V.28: "Electrical Characteristics for unbalanced double-current interchange circuits"
- [33] ITU-T Recommendation V.80: "In-band DCE control and synchronous data modes for asynchronous DTE"

## 3 Definitions abbreviations and symbols

### 3.1 Definitions

Refer to: GSM 02.60 [2].

In GSM 02.02 the bearer services are described. The general network configuration is described in GSM 03.02 and the GSM PLMN access reference configuration is defined in GSM 04.02. The various connection types used in the GSM PLMN are presented in GSM 03.10. Terminology used in this Specification is presented in GSM 01.04. For support of data services between GSM PLMN and other networks see GSM 09-series of Specifications.

### 3.2 Abbreviations

For the purposes of the present document, the following abbreviations apply:

APN	Access Point Name
GGSN	Gateway GPRS Support Node
GPRS	General Packet Radio Service
GSN	GPRS Support Node
GTP	GPRS Tunnelling Protocol
HDLC	High Level Data Link Control
ICMP	Internet Control Message Protocol
IETF	Internet Engineering Task Force
IP	Internet Protocol
IPv4	Internet Protocol version 4
IPv6	Internet Protocol version 6
LA	Location Area
LAPB	Link Access Protocol Balanced
LCP	Link Control Protocol
LLC	Logical Link Control
MAC	Medium Access Control
ME	Mobile Equipment
MS	Mobile Station
MT	Mobile Termination
NCP	Network Control Protocol
PAD	Packet Assembler/Disassembler
PDN	Packet Data Network
PDP	Packet Data Protocol , e.g., IP or X.25
PDU	Protocol Data Unit
PSPDN	Packet Switched Public Data Network
PTM	Point To Multipoint
PTP	Point To Point
PVC	Permanent Virtual Circuit
RA	Routing Area
SGSN	Serving GPRS Support Node
SNDCP	SubNetwork Dependent Convergence Protocol
TE	Terminal Equipment
TCP	Transmission Control Protocol
UDP	User Datagram Protocol



### 3.3 Symbols

For the purposes of the present document, the following Symbols apply:

Gb	Interface between an SGSN and a BSC.
Gi	Reference point between GPRS and an external packet data network.
Gn	Interface between two GSNs within the same PLMN.
Gp	Interface between two GSNs in different PLMNs. The Gp interface allows support of GPRS network services across areas served by the co-operating GPRS PLMNs.
Gs	Interface between an SGSN and MSC.
R	The reference point between a non-ISDN compatible TE and MT. Typically this reference point supports a standard serial interface.
Um	The interface between the MS and the GPRS fixed network part. The Um interface is the GPRS network interface for providing packet data services over the radio to the MS. The MT part of the MS is used to access the GPRS services through this interface.

## 4 Access reference configuration

Figure 1 shows the relationship between the MS, its terminal equipment and the GSM network in the overall GPRS environment.

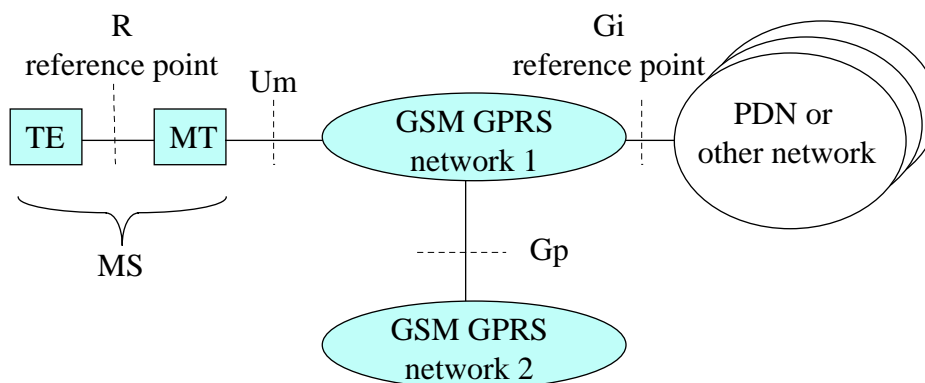

Figure 1: GPRS Access Interfaces and Reference Points

## 5 Functions to support data services

The main functions of the MT to support data services are:

- physical connection at the reference point R;
- flow control between TE and MT;
- mapping of user signalling to/from the GPRS bearer;
- support of data integrity between the terminal equipment and the GPRS bearer;
- functions to support character based data;
- functions to support packet based data;

## 6 Interface to GPRS Bearer Services

The following figure 2: Transmission Plane shows the relationship of the GPRS Bearer terminating at the SNDCP layer to the rest of the GPRS environment. It is shown for reference purposes only and detailed information can be found in GSM 03.60.

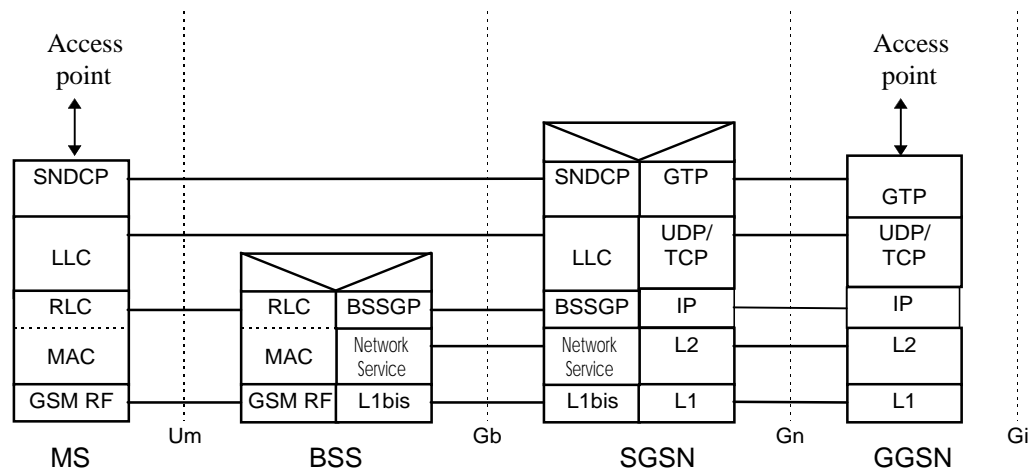

NOTE: In the SGSN and GGSN UDP is mandatory. TCP is optional but recommended for X.25 services.

**Figure 2: GPRS Transmission Plane**

## 7 Functions common to all configurations of the GPRS MS

### 7.1 Mobile Classes

Three GPRS MS classes are identified: Class A, B, and C. These classes are described in GSM 02.60.

### 7.2 Physical Interface

The physical interface between the TE and the MT may conform to CCITT/ITU-T V.24/V.28, or to IrDA IrPHY physical standard specification, or to PCMCIA PC-Card electrical specification. All signal levels and their operation shall be as specified in GSM 07.01, 07.02, and 07.03. This shall not preclude any new developments such as USB (Universal Serial Bus).

### 7.3 Terminal context procedures

This subclause describes the relationships for GPRS Attach and Detach, and PDP Context Activation and Deactivation. The procedures for these functions are described in GSM 03.60.

#### 7.3.1 GPRS Attach

The GPRS Attach shall be performed prior to activating a PDP context. The GPRS Attach may be performed automatically or manually depending on the manufacturer's implementation and configuration.

#### 7.3.2 GPRS Detach

The GPRS Detach may be performed automatically or manually depending on the manufacturer's implementation and configuration. The following cases are valid:

- if the connection between the TE and MT is broken then the MT may perform the GPRS Detach procedure;
- if the network originates a GPRS Detach the MT may inform the TE;
- if the radio connection is broken then the MT may inform the TE;
- if the TE deactivates the last PDP context then the MT may perform the GPRS Detach procedure.

### 7.3.3 Mobile Originated PDP Context Activation

The PDP Context Activation may be performed automatically or manually depending on the manufacturer's implementation and configuration. Depending on the manufacturer's implementation and configuration, 0, 1, or more PDP contexts can be active simultaneously.

### 7.3.4 Network Requested PDP Context Activation

The network can request a GPRS attached MS to activate a specific PDP context.

### 7.3.5 PDP Context Deactivation

The PDP Deactivation may be performed automatically or manually depending on the manufacturer's implementation and configuration. The following cases are valid:

- if the connection between the MT and the TE is broken then the MT may perform the PDP Context Deactivation procedure.
- if the radio connection is broken then the MT may inform the TE.
- if the TE deactivates the last PDP context then the MT may perform the GPRS Detach procedure.

### 7.3.6 PDP context related parameters

It shall be possible to enquire and/or set the following parameters:

- Requested Quality of Service.  
(this includes the peak bit rate, the mean bit rate, the delay requirements, the service precedence, and the reliability level)
- Data Compression on or off.
- TCP/IP Header Compression on or off.
- PDP address
- PDP type
- Access Point Name (APN)

---

## 8 X.25 Based Services

This clause describes the use of X.25 based services over the GPRS bearer. Two services are specified at the R reference point -

- 1) Character mode (specified in ITU-T X.3, X.28, X.29) with the triple X PAD in the MT.
- 2) Packet mode (specified in ITU-T X.25).

NOTE: In order to maintain consistency within GSM specifications, the term TE is used when referring to what CCITT/ITU-T X.25 calls a DTE. Exceptionally, in text quoted from an ITU-T Recommendation, the term DTE is retained.

## 8.1 X.25 Character mode (triple X PAD) service

This mode is an asynchronous character based service allowing the application to set up a single connection using the CCITT/ITU-T X.28 / X.29 procedures. This supports both mobile originate and mobile terminate calls. The MT terminates the X.25 packet layer and provides a triple X PAD function.

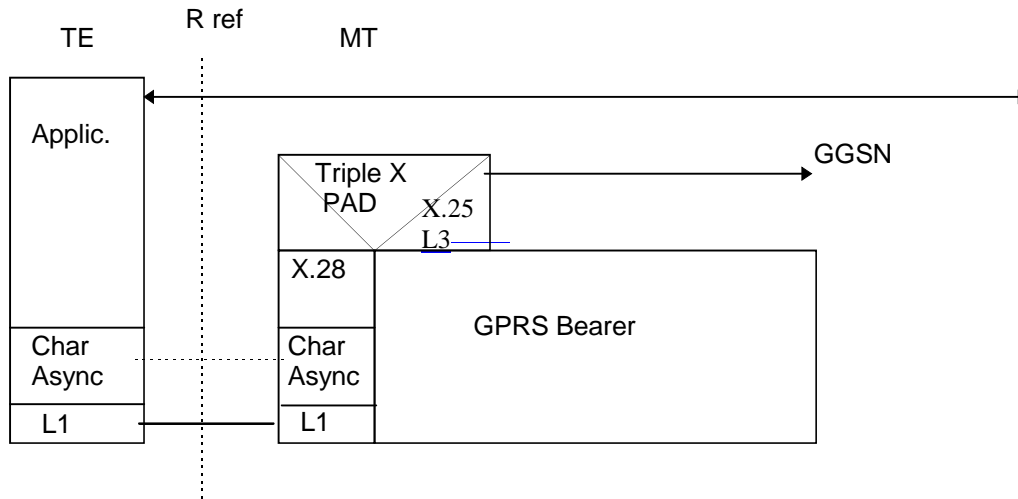

Figure 3: Character (Triple X PAD) mode

### 8.1.1 PAD Parameters

The following table lists the minimum set of X.3 parameters that shall be implemented. A full range is specified in the CCITT/ITU-T X series documents and those parameters not implemented shall be fixed to their defined defaults.

**Table 1: Table of Minimum X.3 Parameters**

Parameter Number	Description	Default Value	Valid Values	Value/Function
1	PAD Recall Character	1	0 1 32-36	(None) DLE Binary representation of decimal value
2	Echo	0	0 1	Off On
3	Data Forwarding Character	2	0 1 2 4 8 16 32 64	(on 128th data byte) A-Z, a-z, 0-9 CR ESC, BEL, ENQ, ACK DEL, CAN, DC2 ETX, EOT HT, LF, VT, FF All characters between NUL & US not listed above
4	Delay Timer	0	0 1-255	Disabled Period of TXD cct inactivity before data forwarded (1/20 of a second). The minimum time-out is 0.5s. Any value of parameter 4 between 1 & 10 will default to 0.5s.
5	Flow Control from Pad (to DTE)	0	0 1	None XON/XOFF
6	Service Signals	5	0 1 5	Disabled Enabled, excluding prompt Enabled, including prompt
7	Action on Break	8	8	PAD escapes from data transfer state
11	Data Rate	13	2 3 4 6 12 13 14	300 bps 1200 bps 600 bps 150 bps 2400 bps 4800 bps 9600 bps Other values may be implemented as long as they conform to the CCITT/ITU-T specifications.
12	Flow Control to Pad (from DTE)	0	0 1	None XON/OFF
13	Line Feed insertion	0	0 1	None LF inserted after CR to DTE
15	Character Deletion	0	0 1	Disabled Enabled

Although not CCITT/ITU-T defined, to be able to specify either X.28 or X.29 modes a Parameter 0 can be used as follows.

For X.28 mode parameter 0 shall be set to 0.

For the four X.29 variants available, each with a corresponding protocol identifier, the parameter value is set as listed below. The identifier octet is supplied with the call request packet when setting up a call.

<u>Value</u>	<u>Description</u>	<u>Protocol Identifier Octet</u>
2	CCITT use	00000001
3	National use	01xxxxxx
4	International User Bodies	10xxxxxx
5	DTE - DTE use	11xxxxxx

x - this digit may be represented by either a 1 or 0 (to be specified in ITU-T Recommendation X.244).

### 8.1.2 Example mapping of functions between the R reference point and the GPRS bearer

The following example illustrates the case when the PAD functionality is used in the MT. In PAD mode only one PDP context can be activated per R reference point.

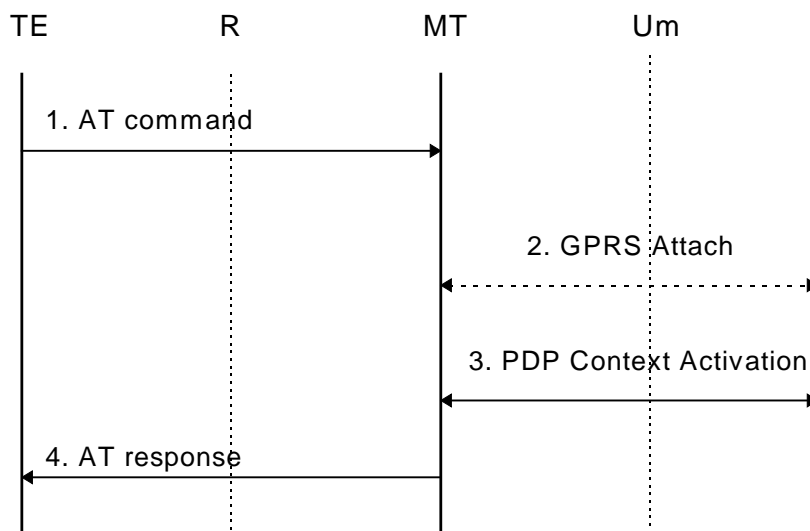

NOTE: The 2 ended arrows indicate an exchange of 0 or more messages.

Figure 4: PAD Service

- 1) The TE issues an AT command to activate PAD mode.
- 2) If the MS is not yet GPRS attached, the MT performs the GPRS Attach procedure as described in GSM 03.60.
- 3) The MT performs the PDP Context Activation as described in GSM 03.60.
- 4) The MT sends an AT response to the TE. Following a positive AT response the PAD prompt is issued.

## 8.2 X.25 Packet mode service

This mode offers a packet based service allowing the application to set up one or more virtual calls using the CCITT/ITU-T X.25 procedures. The maximum permitted number of concurrent virtual calls is implementation dependent. Both mobile originate and mobile terminate calls are supported. The MT performs a relay function for X.25 layer 3 which is terminated in the TE. The layer 2 protocol at the R reference point is terminated in the TE and the MT.

Depending on the application, the TE may or may not incorporate a triple X PAD function.

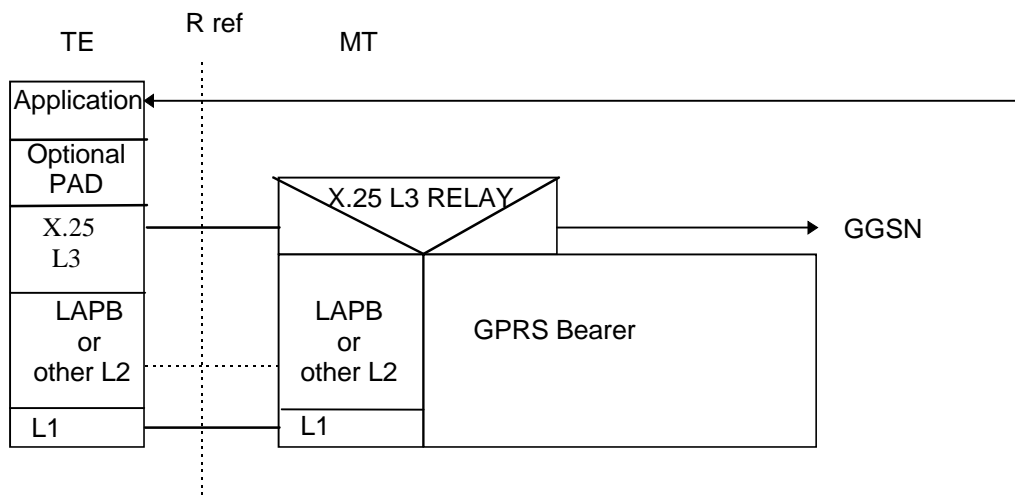

NOTE: The "other L2" could be GSM 07.10 or a manufacturer's defined layer 2

**Figure 5: Packet mode**

## 8.2.1 Layer 1 and Layer 2 options

This subclause describes standardized layers 1 and 2 which may be used for the TE-MT interface. As an alternative, the multiplexing protocol specified in GSM 07.10 or a manufacturer's defined layers 1 and 2 may be used providing they meet the requirements for carrying X.25 layer 3 frames over the R reference point.

### 8.2.1.1 Synchronous serial interface

For TEs with a synchronous serial port -

Layer 1 is synchronous X.21 or X.21bis (V.24/V.28).

Layer 2 is LAP B (X.25 L2) based on bit-oriented HDLC.

NOTE: Configuration of the MT in this case is outside the scope of this specification.

### 8.2.1.2 Asynchronous serial interface

For TEs with an asynchronous serial port -

Layer 1 is asynchronous V.24/V.28.

Layer 2 is LAP B (X.25 L2) based on character-oriented HDLC.

NOTE: The methods described in ITU-T Rec. V.80 may be applicable here.

### 8.2.1.3 Synchronous and asynchronous (dual mode) interface

For TEs with a serial port that can operate in both synchronous and asynchronous modes the following mechanism may be used where the interface supports AT commands. The interface starts in asynchronous mode and AT commands may be used to configure the MT. When configuration is complete, the interface switches to synchronous mode and X.25 starts up in the usual way. Setting Data Terminal Ready (circuit 108/2) to off is a protocol independent way of returning to asynchronous mode. Alternatively, the closing down of LAP B could be used as the signal.

## 8.2.2 Example mappings of functions between the R reference point and the GPRS bearer

The minimum requirement is that the MT shall be GPRS-attached and the X.25 context activated whilst an X.25 virtual call is in progress. Any extension to this requirement depends on whether the MT implements any other GPRS-supported services (e.g. SMS) which might require that the MT remains GPRS-attached even when there is no X.25 virtual call in progress.

The following subclauses describe only the X.25 requirements. These actions may be filtered by the requirements of any other GPRS-supported service. For example, if a GPRS-only MT also supports SMS, a request for 'disconnection' of the X.25 service would result in a deactivation of the X.25 context but not a GPRS-detach.

### 8.2.2.1 Standardized X.25 TE

This case applies to TEs which implement only the X.25 procedures, i.e. they have no support for AT commands. The layer 1 and 2 options described in subclause 8.2.1.1 and 8.2.1.2 apply.

Because of the different implementations of X.25 procedures in existing DTEs, attach/detach and activate/deactivate may need to be controlled at layer 1, 2 or 3 of the X.25 interface. Whilst it is always possible to use layer 3 control, this requires the most complete implementation of the X.25 protocol stack in the MT. Control at a lower layer may result in a simpler implementation. The procedures for connection and disconnection at all three layers are described in CCITT/ITU-T X.25.

In all cases it may be desirable to incorporate a timer to delay the deactivate/detach procedures in order to avoid excessive changes of the activation and attachment states in the course of a number of consecutive calls.

**NOTE:** The activation and deactivation of an X.25 context to carry packets over GPRS is analogous to setting up and clearing a switched ISDN B channel connection to carry them over an ISDN. The call control mapping procedures used in the ISDN case are described in detail in ITU-T X.31 clause 7.3 (layer 1) and appendix I (layers 2 and 3).

#### 8.2.2.1.1 Layer 1 control

This applies to X.25 DTEs which disconnect at the physical layer when no virtual calls are in progress. The TE and MT signal to one another by using V.24 or X.21 control signals.

From TE -

Physical layer connect received by MT -> attach, activate

Physical layer disconnect received by MT -> deactivate, detach

From network -

If the X.25 context is not currently active, an attempt by the network to offer a mobile terminated X.25 virtual call will be signalled by the receipt at the MT of a Request PDP Context Activation message. The MT signals this to the TE by using V.24 or X.21 control signalling and, if successful, -> attach, activate.

A network request that the X.25 context should be deactivated or a failure of the radio link will result in the MT performing a physical layer disconnect.

#### 8.2.2.1.2 Layer 2 control

This applies to X.25 DTEs which keep layer 1 active but disconnect at the data link layer when no virtual calls are in progress. The TE and MT signal to one another by starting and stopping the data link layer protocol.

From TE -

Data link layer set-up received by MT -> attach, activate

Data link layer disconnect received by MT -> deactivate, detach

From network -



If the X.25 context is not currently active, an attempt by the network to offer a mobile terminated X.25 virtual call will be signalled by the receipt at the MT of a Request PDP Context Activation message. The MT signals this to the TE by attempting to start the data link layer and, if successful, -> attach, activate.

A network request that the X.25 context should be deactivated or a failure of the radio link will result in the MT performing a data link layer disconnect.

### 8.2.2.1.3 Layer 3 control

This applies to X.25 DTEs which keep layers 1 and 2 active when no virtual calls are in progress.

From TE -

Call Request packet received by the MT -> attach, activate  
(Action is taken only if there are no X.25 virtual calls already in progress)

Clear Confirmation packet received by the MT from the TE -> deactivate, detach  
(Action is taken only if there are no more X.25 virtual calls in progress.)

From network -

If the X.25 context is not currently active, an attempt by the network to offer a mobile terminated X.25 virtual call will be signalled by the receipt at the MT of a Request PDP Context Activation message. Following activation by the MT, an X.25 Call Request packet will be received from the network.

Clear Confirmation packet received by the MT from the network -> deactivate, detach  
(Action is taken only if there are no more X.25 virtual calls in progress.)

A network request that the X.25 context should be deactivated or a failure of the radio link will result in the MT clearing any outstanding X.25 virtual calls.

The above refer only to normal clearing situations. An actual implementation shall take into account exceptional conditions such as the receipt of a Clear Request packet from the TE but no acknowledging Clear Confirmation from the network.

### 8.2.2.2 X.25 TE with support for AT commands

This case applies to TEs which implement AT commands in addition to supporting X.25 procedures. The layer 1 and 2 options described in subclauses 8.2.1.2 and 8.2.1.3 apply.

The TE sends GPRS AT commands to configure the MT, followed by a command to switch the interface into packet mode and start X.25. A mode of operation may be supported which provides compatibility with existing modem dial procedures.

## 9 IP Based Services

All protocols that are supported by the underlying IP protocol are applicable in the GPRS environment. However there may be some limitations due to the RF environment.

The IP protocol can be run over various underlying protocols as shown in the following figure.

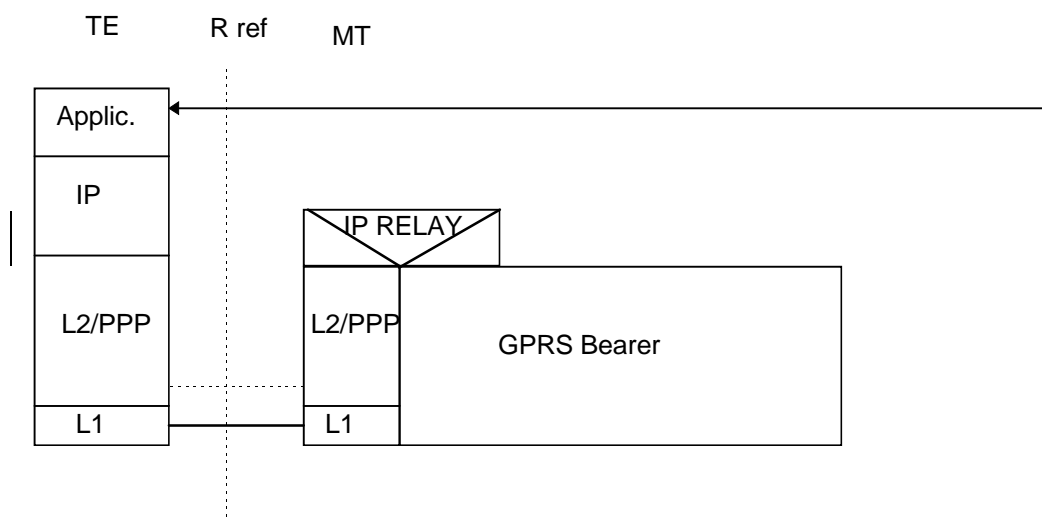

**Figure 6: IP Based Services**

PPP is a widely supported protocol in numerous operating systems and this alleviates the need for any GPRS specific protocol at the TE. PPP at the MT shall comply with the following specifications IETF STD 51 (RFC 1661, RFC 1662), RFC 1570, RFC 1989, and RFC 1332. The Domain Name Server information shall be delivered as defined in RFC 1877. The delivery of vendor-specific packets and options shall conform to RFC 2153.

As an alternative to PPP, an L2 protocol can be used which is defined as a manufacturer's operating system dependent protocol capable of carrying IP frames over the R reference point.

### 9.1 Example mapping of functions between the R reference point and the GPRS bearer for IP over PPP

The following example illustrates the case when the IP over PPP functionality is used in the MT. The example does not include all the details of PPP, but only describes the logical operation of PPP connection establishment, host authentication and IP configuration.

Each interface at the R reference point can support only one PPP connection and each PPP connection can support only one IP session. Therefore, in PPP mode only one IP PDP context can be activated per interface at the R reference point. However, it is possible for a PCMCIA card (or other multiplexed interface) to support multiple virtual interfaces (communications ports) at the R reference point. Multiple PPP connections and IP contexts are possible in this case.

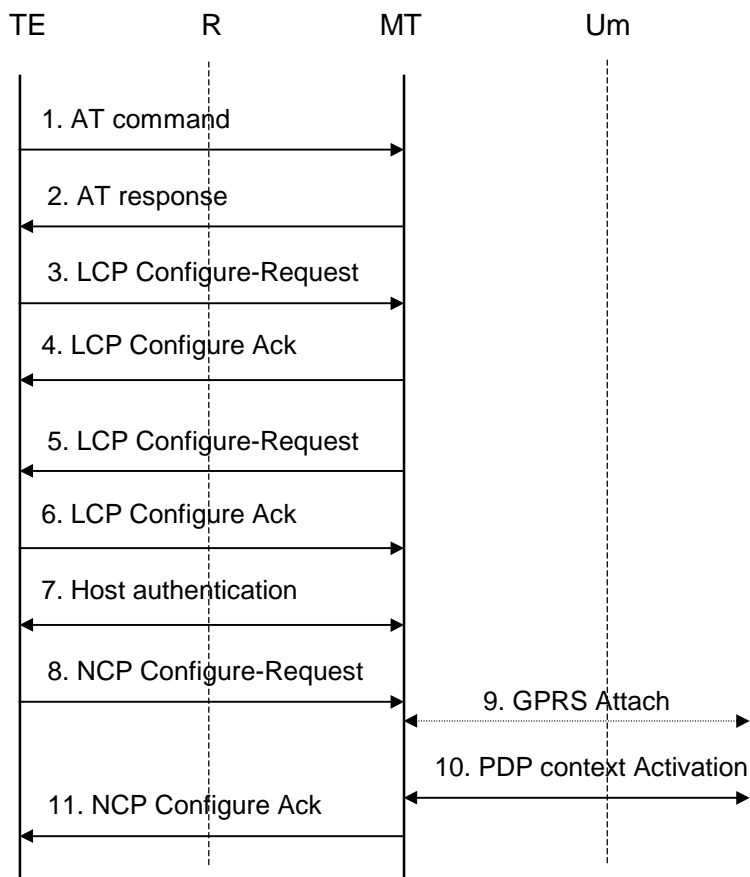

Figure 7: IP Over PPP Based Service

- 1) The TE issues AT commands to set up parameters and enter PPP mode (refer to subclause on AT commands for further details).
- 2) The MT sends AT responses to the TE.
- 3) The PPP protocol in the TE sends a LCP Configure-Request. This command is to establish a PPP link between the TE and the MT.
- 4) The MT returns LCP Configure-Ack to the TE to confirm that the PPP link has been established. The MT might previously have sent a LCP Configure-Nak in order to reject some options proposed by the TE. This in turn might have triggered a retransmission of the LCP Configure-Request with different options.
- 5) The PPP protocol in the MT sends a LCP Configure-Request in order to negotiate for the authentication protocol used for authentication of the host TE towards the MT. The MT shall initially negotiate for CHAP, and if this is unsuccessful, for PAP.
- 6) The TE returns a LCP Configure-Ack to the MT to confirm the use of the specified authentication protocol. The MT might previously have sent a LCP Configure-Nak in order to reject the protocol proposed by the TE. This in turn might have triggered a retransmission of the LCP Configure-Request with different options.
- 7) If the negotiated authentication protocol is either of CHAP or PAP, the TE authenticates itself towards the MT by means of that protocol. The MT stores the necessary authentication data and sends a locally generated positive acknowledgement of the authentication to the TE. If none of the protocols is supported by the host TE no authentication shall be performed. Refer to GSM 09.61 for further details on the authentication.
- 8) The PPP protocol in the TE sends to the MT a NCP Configure-Request. This command activates the IP protocol.
- 9) If the MS is not yet GPRS attached, the MT performs the GPRS Attach procedure as described in GSM 03.60.
- 10) The MT performs a PDP Context Activation as described in GSM 03.60. IP configuration parameters may be carried between the MT and the network in PDP Context Activation messages.

11) The MT acknowledges to the PPP protocol in the TE that the IP protocol is now activated by sending a NCP Configure-Ack command. Before sending a NCP Configure-Ack, the MT might previously have sent a NCP Configure-Nak in order to reject some IP parameters proposed by the TE. This in turn might have triggered a retransmission of the NCP Configure-Request with different parameter values. NCP Configure-Ack may also carry IP protocol related parameters such as dynamic IP address to the TE. The MT shall also pass name server information to the TE if the TE has requested for it and if this information is provided by the GGSN. Other packet types and options may optionally be delivered.

---

## 10 AT commands

GSM 07.07 defines commands that a TE may use to control a GPRS MT via a non-multiplexed character-stream interface. This places certain limitations on the functionality of the interface. For example, it is not possible for the MT to send control information to the TE or for the TE to send commands to the MT whilst the interface is in the V.250 online data state unless the layer 2 protocol itself supports this feature. However, a manufacturer-specific escape mechanism may be provided to enable the TE to switch the MT into the V.250 online command state. The use of a multiplexed interface, for example that specified in GSM 07.10, is not considered here.

It is anticipated that GPRS MTs will vary widely in functionality. At one extreme, a class A MT might support multiple PDP types as well as circuit switched data, and use multiple external networks and QoS profiles. At the other extreme a class C MT might support only a single PDP type using a single external network, and rely on the HLR to contain the context definition.

A comprehensive set of GPRS-specific AT commands is defined in GSM 07.07 to provide the flexibility needed by the more complex MT. The commands are designed to be expandable to accommodate new PDP types and interface protocols, merely by defining new values for many of the parameters. Multiple contexts may be activated if the interface link-layer protocol is able to support them. The commands use the extended information and error message capabilities described in GSM 07.07.

For MTs of intermediate complexity, most commands have simplified forms where certain parameters may be omitted.

For the simplest MTs, and for backwards compatibility with existing communications software, it is possible to control access to the GPRS using existing modem-compatible commands. A special dial-string syntax is defined for use with the D command. This "modem compatible" mode of operation is described in GSM 07.07.

Subclause 10.2 contains examples of command sequences for a number of applications.

Annex A of this document lists the AT commands for GPRS. They are fully defined in GSM 07.07,

### 10.1 General on AT commands

The following sections describe how the AT commands are used for GPRS. The AT commands themselves are fully described in GSM 07.07. Reference to the particular AT command names are shown only for clarity. In all case refer to GSM 07.07 for the latest descriptions.

#### 10.1.1 Interaction of AT commands, GPRS management and PDPs

State machines may be used to describe the behaviour of -

- AT commands (ITU-T V.250).

- GPRS PDP context management (GSM 03.60).

- PDP startup, data transfer and termination (Packet Data Protocol specifications).

- The layer 2 protocol (if any) used across the TE-MT interface (layer 2 protocol specifications).

This subclause does not attempt to describe in detail how these state machines interact but rather to give some general guidance on their relationships.

### 10.1.1.1 AT commands and responses

AT commands may be issued and responses received by the TE only when the TE and MT are in V.250 command state.

The possibility of suspending the PDP and/or layer 2 protocol and entering V.250 online command state is not considered here; neither is the use of a multiplexed interface where the PDP and the AT commands use separate logical channels.

### 10.1.1.2 PDP and layer 2 protocol operation

The PDP (across the TE-MT interface) may startup, transfer data and terminate only when the TE and MT are in V.250 online data state. It may be necessary to startup a layer 2 protocol across the interface before starting the PDP. The PDP startup procedure may provide information needed for the PDP context activation procedure (see 10.1.1.3.2).

### 10.1.1.3 GPRS management

A particular PDP may be used to transfer data only when a context is active for that PDP. Before a context can be activated, the MT must be attached to the GPRS network.

In order to provide flexibility and support a variety of types of GPRS MT and PDP, AT commands are provided which give the TE explicit control over attachment and detachment (+CGATT), and context activation and deactivation (+CGACT) procedures. These commands allow the TE to retain control of the MT, and receive status information from the MT, after these actions have been performed.

#### 10.1.1.3.1 GPRS attachment

The MT may be attached and detached using the +CGATT command. However, it may not be necessary to use the command since attachment may occur -

- on power up or reset;

- when an attempt is made to activate a context either explicitly (+CGACT) or as a result of a PDP startup procedure;

- when the mobile class is changed (+CGCLASS).

Similarly, detachment may occur -

- as a result of a PDP termination procedure (if no other GPRS services are active);

- when the mobile class is changed (+CGCLASS).

#### 10.1.1.3.2 PDP context activation

Certain information must be provided to the network in order for a context activation attempt to be successful. The TE may provide some of this information to the MT during the PDP startup procedure rather than through AT command procedures. In this case the context activation cannot be initiated by the +CGACT command but rather on receipt of the appropriate information during the PDP startup.

## 10.1.2 Use of default context parameter values

The activate context request message sent by the MT to the network contains a number of parameters whose values can usefully be set by the TE. Under certain circumstances the values for some or all of the parameters need not be provided by the TE, either via AT commands or the PDP startup procedure. The storage of context information in the SIM is not considered in this specification. Rules concerning what values shall be sent by the MT to the network under various circumstances are given in 03.60.

One particular rule that is designed to simplify operation in modem compatibility mode is that if there is only one PDP context subscription in the HLR then all of PDP type, PDP address and APN may be omitted.

### 10.1.2.1 PDP type

This may be omitted:

- when the MT supports only one PDP type (it will be provided by the MT);
- or according to the rules given in 03.60.

### 10.1.2.2 PDP address (of the MS)

This shall be omitted when:

- a dynamic address is required;
- or according to the rules given in 03.60.

### 10.1.2.3 Access Point Name

This may be omitted:

- according to the rules given in 03.60.

### 10.1.2.4 QoS Requested

This may be omitted when:

- the default subscribed QoS is acceptable.

### 10.1.2.5 PDP Configuration Options

These shall be omitted:

- when none are required for the PDP concerned;
- or according to the rules given for the PDP.

## 10.2 Example command sequences for dial-compatibility mode

### 10.2.1 PPP in dial compatibility mode

#### 10.2.1.1 Mobile initiated IP context activation

In this mode of operation, the MT behaves like an originating modem and accepts the normal V.250 commands associated with placing and clearing a call to a dial-up PPP server. Although the procedures for setting up the IP context are initiated from the mobile end, IP-based sessions, for example the File Transfer Protocol (FTP), may be initiated from either end once the context is active.

For this example it is assumed that

- the user has subscribed to only one PDP context (of type IP) and therefore no context parameter values are needed,
- the MT supports only PPP at the MT-TE interface and therefore no layer 2 protocol need be specified.

A possible sequence of events is -

*The MT begins in V.250 command state.*

TE -> MT: AT<GPRS-specific configuration commands, if required>

MT -> TE: OK

The TE sends a dial command requesting the GPRS.

TE -> MT: ATD\*99#

MT -> TE CONNECT

The MT enters V.250 online data state.

TE starts up PPP (LCP exchange) -

TE -> MT: LCP Configure-request

MT -> TE: LCP Configure-ack

PPP Authentication may take place (optional)

TE starts up IP (NCP for IP exchange) -

TE -> MT: NCP(IP) Configure-request

MT <-> network: MT performs the GPRS-attach procedure if the MT is not currently attached.

MT <-> network: MT performs the IP context activation procedure.

MT -> TE: NCP(IP) Configure-ack

TE <-> MT <-> network: IP packets may now be transferred

TE stops IP (optional) -

TE-> MT: NCP(IP) Terminate-Request ) this

MT<-> network: MT performs the IP context deactivation procedure ) is

MT -> TE: NCP(IP) Terminate-Ack ) optional

TE stops PPP -

TE-> MT: LCP Terminate-Request

MT <-> network: MT performs the IP context deactivation procedure if it has not already done so.

MT <-> network: MT may perform the GPRS-detach procedure if no other GPRS services are active.

MT -> TE: LCP Terminate-Ack

The MT returns to V.250 command state and issues the final result code -

MT -> TE NO CARRIER

The TE may recognise this as a return to V.250 command state. However, if it is using procedures intended for controlling modems, it may attempt to force a disconnect since in the modem case it cannot rely on the remote modem dropping the carrier. It will use some combination of -

TE -> MT: TE drops circuit 108/2 (Data Terminal Ready)

TE -> MT: escape sequence (e.g. +++)

TE -> MT: ATH

The MT should respond according to V.250 even if it is already in command state.

If the connection is lost at any time, the MT shuts down PPP, returns to V.250 command state and issues the final result code -

MT -> TE NO CARRIER

### 10.2.1.2 Network requested IP context activation

In this mode of operation, the MT behaves like an answering modem and accepts the normal V.250 commands associated with answering a call to a PPP server. Although the procedures for setting up the IP context are initiated from the network end, IP-based sessions, for example the File Transfer Protocol (FTP), may be initiated from either end once the context is active.

Two example sequences of events are given, for the cases of automatic and manual answering -

#### Case 1: automatic answering

The MT begins in V.250 command state.

TE -> MT: AT<GPRS-specific configuration commands, if required >

The TE sets automatic answering mode -

TE -> MT: ATSO=1

MT <-> network: MT performs the GPRS-attach procedure if the MT is not currently attached.

*Subsequently -*

network -> MT: Request PDP Context Activation message

MT -> TE: RING

*The MT returns the intermediate result code -*

MT -> TE CONNECT

*- and enters V.250 online data state.*

*The TE and MT perform the PPP and IP startup procedures which include the MT requesting the network to activate the IP context.*

### **Case 2: manual answering**

*The MT begins in V.250 command state.*

TE -> MT: AT<GPRS-specific configuration commands, if required >

*The TE sets manual answering mode and requests a GPRS-attach (if necessary) -*

TE -> MT: ATSO=0

TE -> MT: AT+CGATT=1

MT <-> network: MT performs the GPRS-attach procedure if the MT is not currently attached.

network -> MT: Request PDP Context Activation message

MT -> TE: RING

*The TE answers manually, -*

TE -> MT: ATA

MT -> TE CONNECT

*- and enters V.250 online data state.*

*The TE and MT perform the PPP and IP startup procedures which include the MT requesting the network to activate the IP context.*

*or the TE rejects the connection -*

TE -> MT: ATH

*- and remains in V.250 command state*

## **10.2.2 MO X.25 virtual call using a triple-X PAD in modem compatibility mode**

This example shows how the <called\_address> string may be used in the D command to make an X.25 call to a specified X.121 address.

*The MT begins in V.250 command state.*

TE -> MT: AT<GPRS-specific configuration commands, if required>

MT -> TE: OK

*The TE sends a dial command requesting the GPRS to X.121 address 1234567890.*



TE -> MT: ATD\*99\*1234567890#

MT -> TE CONNECT

*The MT enters V.250 online data state, performs a GPRS attach if necessary and activates the X.25 context. It then automatically makes an X.25 call to the specified address, bypassing the PAD prompt. If the call is successful the MT responds with the PAD connect message -*

1234567890 COM

### 10.2.3 Selection and activation of an IP PDP context in modem compatibility mode

This example shows how IP PDP contexts may be selected and activated in modem compatibility mode.

The PDP contexts are defined in the modem initialisation AT command string. (In this example, APN = "internet" gives access to the Internet and APN = "abc.com" gives access to a private IP network.)

TE -> MT: AT +CGDCONT=1, "IP", "internet"; +GCDCONT=2, "IP", "abc.com"

MT -> TE: OK

The TE sends a dial (D) command requesting access to the Internet.

TE -> MT: ATD\*99\*\*\*1#

MT -> TECONNECT

The MT enters V.250 online data state, performs a GPRS attach if necessary and activates an IP context to the Internet.

After the context has been deactivated the MT returns

MT -> TENO CARRIER

The TE sends a dial (D) command requesting access to the private IP network.

TE -> MT: ATD\*99\*\*\*2#

MT -> TECONNECT

The MT enters V.250 online data state and activates an IP context to the private IP network.

After the context has been deactivated the MT returns

MT -> TENO CARRIER

## Annex A (informative): Summary of AT commands for GPRS

This informative annex lists the AT commands for GPRS that are fully described in GSM 07.07.

**Table A.1: Summary of AT commands for GPRS**

Command	Description
+CGACT	PDP context activate or deactivate
+CGANS	Manual response to a network request for PDP context activation
+CGATT	GPRS attach or detach
+CGAUTO	Automatic response to a network request for PDP context activation
+CGCLASS	GPRS mobile station class
+CGCLPAD	Configure local triple-X PAD parameters
+CGDATA	Enter data state
+CGDCONT	Define PDP context
+CGEREP	Control unsolicited GPRS event reporting
+CGPADDR	Show PDP address
+CGREG	GPRS network registration status
+CGQMIN	Quality of service profile (minimum acceptable)
+CGQREQ	Quality of service profile (requested)
+CGSMS	Select service for MO SMS messages

**Table A.2: Summary of GPRS Extensions to existing GSM AT commands**

Command	Description
+CEER	Extended error report (refer to 07.07)
+CMEE	Report mobile equipment error (refer to 07.07)
+CR	Service reporting control (refer to 07.07)
+CRC	Cellular result codes (refer to 07.07)

**Table A.3: Summary of AT commands for GPRS modem compatibility mode**

Command	Description
A	Answer - manual acceptance of a network request for PDP context activation
D	Dial - request GPRS service
H	On-hook - manual rejection of a network request for PDP context activation
S0	Automatic answering control - automatic acceptance of a network request for PDP context activation

## Annex B (informative): Document change history

SPEC	SMG#	CR	PH	OLD_VERS	NEW_VERS	SUBJECT
07.60	s23	NEW	R97	2.0.0	5.0.0	Draft GSM 07.60 v. 2.0.0
07.60	s24	A002	R97	5.0.0	5.1.0	IP configuration parameters and PPP clarifications
07.60	s25	A004	R97	5.1.0	6.0.0	X.25 Based Services
07.60	s26	A005	R97	6.0.0	6.1.0	AT commands for GPRS
07.60	s26	A006	R97	6.0.0	6.1.0	Editorial review of 07.60
07.60	s26	A007	R97	6.0.0	6.1.0	Authentication for IP over PPP
				6.1.0	6.1.1	Correction to CR implementation
07.60	s27	A008	R97	6.1.1	6.2.0	Addition of a new AT command, +CGREG, to display current GPRS registration status
07.60	s27	A009	R97	6.1.1	6.2.0	Addition of a new AT command, +CGSMS, to select the service for the transport of MO SMS messages
07.60	s27	A011	R97	6.1.1	6.2.0	Corrections and clarifications, mainly to the AT commands specifications
07.60	s27	A012	R97	6.1.1	6.2.0	Addition of a GPRS extension to the existing 07.07 AT command, Service Reporting Control +CR
07.60	s27		R97	6.2.0	6.2.1	Editorial update to section 8.1
07.60	s29	A016	R97	6.2.1	6.3.0	Correction to +CGAUTO command
07.60	s29	A015	R97	6.2.1	6.3.0	Move AT commands to 07.07
07.60	S30	A017	R97	6.3.0	6.4.0	AT Commands

---

# History

<b>Document history</b>		
V6.1.1	July 1998	Publication
V6.2.1	November 1998	Publication
V6.3.0	July 1999	Publication
V6.4.0	November 1999	Publication