

# ETSI TS 101 376-4-5 V1.1.1 (2001-03)

---

*Technical Specification*

**GEO-Mobile Radio Interface Specifications;  
Part 4: Radio interface protocol specifications;  
Sub-part 5: Data Link Layer General Aspects;  
GMR-1 04.005**

---



---

**Reference**

DTS/SES-001-04005

---

**Keywords**

GMR-1, MSS, MES, satellite, GSO, S-PCN,  
GSM, procedure, radio, access, data, interface,  
mobile

**ETSI**

650 Route des Lucioles  
F-06921 Sophia Antipolis Cedex - FRANCE

Tel.: +33 4 92 94 42 00 Fax: +33 4 93 65 47 16

Siret N° 348 623 562 00017 - NAF 742 C  
Association à but non lucratif enregistrée à la  
Sous-Préfecture de Grasse (06) N° 7803/88

---

**Important notice**

Individual copies of the present document can be downloaded from:

<http://www.etsi.org>

The present document may be made available in more than one electronic version or in print. In any case of existing or perceived difference in contents between such versions, the reference version is the Portable Document Format (PDF). In case of dispute, the reference shall be the printing on ETSI printers of the PDF version kept on a specific network drive within ETSI Secretariat.

Users of the present document should be aware that the document may be subject to revision or change of status. Information on the current status of this and other ETSI documents is available at <http://www.etsi.org/tb/status/>

If you find errors in the present document, send your comment to:  
editor@etsi.fr

---

**Copyright Notification**

No part may be reproduced except as authorized by written permission.  
The copyright and the foregoing restriction extend to reproduction in all media.

© European Telecommunications Standards Institute 2001.  
All rights reserved.

---

# Contents

Intellectual Property Rights .....	4
Foreword .....	6
Introduction .....	7
1 Scope .....	8
2 References .....	8
3 Definitions and abbreviations .....	9
3.1 Definitions .....	9
3.2 Abbreviations .....	9
4 Concepts and terminology .....	9
5 Overview description of LAPSat functions and procedures .....	9
6 Service characteristics .....	10
6.1 General .....	10
6.2 Services provided to layer 3 .....	10
6.2.1 General .....	10
6.2.2 Priority .....	10
6.2.3 Segmentation .....	10
6.2.4 Unacknowledged information transfer service .....	11
6.2.5 Acknowledged information transfer services .....	11
6.2.6 Random access procedure .....	11
6.3 Services required from the physical layer .....	12
6.4 Administrative services .....	12
7 Overview of data link layer structure .....	13
8 Specific requirements .....	14
8.1 Mode of operation and allowed SAPs .....	14
8.2 Acknowledged mode of operation .....	14
8.2.1 Window size .....	14
8.2.2 Processing capacity .....	14
<b>Annex A (informative): Bibliography .....</b>	<b>15</b>
History .....	16

## Intellectual Property Rights

The information pertaining to essential IPRs is publicly available for **ETSI members and non-members**, and can be found in ETSI SR 000 314: "*Intellectual Property Rights (IPRs); Essential, or potentially Essential, IPRs notified to ETSI in respect of ETSI standards*", which is available from the ETSI Secretariat. Latest updates are available on the ETSI Web server (<http://www.etsi.org/ipr>).

The attention of ETSI has been drawn to the Intellectual Property Rights (IPRs) listed below which are, or may be, or may become, Essential to the present document. The IPR owner has undertaken to grant irrevocable licences, on fair, reasonable and non-discriminatory terms and conditions under these IPRs pursuant to the ETSI IPR Policy. Further details pertaining to these IPRs can be obtained directly from the IPR owner.

The present IPR information has been submitted to ETSI and pursuant to the ETSI IPR Policy, no investigation, including IPR searches, has been carried out by ETSI. No guarantee can be given as to the existence of other IPRs not referenced in ETSI SR 000 314 (or the updates on the ETSI Web server) which are, or may be, or may become, essential to the present document.

### IPRs:

Project	Company	Title	Country of Origin	Patent n°	Countries Applicable
TS 101 376 V1.1.1	Digital Voice Systems Inc		US	US 5,226,084	US
TS 101 376 V1.1.1	Digital Voice Systems Inc		US	US 5,715,365	US
TS 101 376 V1.1.1	Digital Voice Systems Inc		US	US 5,826,222	US
TS 101 376 V1.1.1	Digital Voice Systems Inc		US	US 5,754,974	US
TS 101 376 V1.1.1	Digital Voice Systems Inc		US	US 5,701,390	US

IPR Owner: Digital Voice Systems Inc  
One Van de Graaff Drive Burlington,  
MA 01803  
USA

Contact: John C. Hardwick  
Tel.: +1 781-270-1030  
Fax: +1 781-270-0166

Project	Company	Title	Country of Origin	Patent n°	Countries Applicable
TS 101 376 V1.1.1	Ericsson Mobile Communication	Improvements in, or in relation to, equalisers	GB	GB 2 215 567	GB
TS 101 376 V1.1.1	Ericsson Mobile Communication	Power Booster	GB	GB 2 251 768	GB
TS 101 376 V1.1.1	Ericsson Mobile Communication	Receiver Gain	GB	GB 2 233 846	GB
TS 101 376 V1.1.1	Ericsson Mobile Communication	Transmitter Power Control for Radio Telephone System	GB	GB 2 233 517	GB

IPR Owner: Ericsson Mobile Communications (UK) Limited  
The Keytech Centre, Ashwood Way  
Basingstoke  
Hampshire RG23 8BG  
United Kingdom

Contact: John Watson  
Tel.: +44 1256 864821

Project	Company	Title	Country of Origin	Patent n°	Countries Applicable
TS 101 376 V1.1.1	Hughes Network Systems		US	Pending	US

IPR Owner: Hughes Network Systems  
11717 Exploration Lane  
Germantown, Maryland 20876  
USA

Contact: John T. Whelan  
Tel: +1 301-428-7172  
Fax: +1 301-428-2802

Project	Company	Title	Country of Origin	Patent n°	Countries Applicable
TS 101 376 V1.1.1	Lockheed Martin Global Telecommunic. Inc	2.4-to-3 KBPS Rate Adaptation Apparatus for Use in Narrowband Data and Facsimile Communication Systems	US	US 6,108,348	US
TS 101 376 V1.1.1	Lockheed Martin Global Telecommunic. Inc	Cellular Spacecraft TDMA Communications System with Call Interrupt Coding System for Maximizing Traffic Throughput	US	US 5,717,686	US
TS 101 376 V1.1.1	Lockheed Martin Global Telecommunic. Inc	Enhanced Access Burst for Random Access Channels in TDMA Mobile Satellite System	US	US 5,875,182	
TS 101 376 V1.1.1	Lockheed Martin Global Telecommunic. Inc	Spacecraft Cellular Communication System	US	US 5,974,314	US
TS 101 376 V1.1.1	Lockheed Martin Global Telecommunic. Inc	Spacecraft Cellular Communication System	US	US 5,974,315	US
TS 101 376 V1.1.1	Lockheed Martin Global Telecommunic. Inc	Spacecraft Cellular Communication System with Mutual Offset High-margin Forward Control Signals	US	US 6,072,985	US
TS 101 376 V1.1.1	Lockheed Martin Global Telecommunic. Inc	Spacecraft Cellular Communication System with Spot Beam Pairing for Reduced Updates	US	US 6,118,998	US

IPR Owner: Lockheed Martin Global Telecommunications, Inc.  
900 Forge Road  
Norristown, PA. 19403  
USA

Contact: R.F. Franciose  
Tel.: +1 610.354.2535  
Fax: +1 610.354.7244

---

# Foreword

This Technical Specification (TS) has been produced by ETSI Technical Committee Satellite Earth Stations and Systems (SES).

The contents of the present document are subject to continuing work within TC-SES and may change following formal TC-SES approval. Should TC-SES modify the contents of the present document, it shall then be republished by ETSI with an identifying change of release date and an increase in version number as follows:

Version 1.m.n

where:

- the third digit (n) is incremented when editorial only changes have been incorporated in the specification;
- the second digit (m) is incremented for all other types of changes, i.e. technical enhancements, corrections, updates, etc.

The present document is part 4, sub-part 5 of a multi-part deliverable covering the GEO-Mobile Radio Interface Specifications, as identified below:

Part 1: "General specifications";

Part 2: "Service specifications";

Part 3: "Network specifications";

**Part 4: "Radio interface protocol specifications";**

Sub-part 1: "Mobile Earth Station-Gateway Station System (MES-GSS) Interface; GMR-1 04.001";

Sub-part 2: "GMR-1 Satellite Network Access Reference Configuration; GMR-1 04.002";

Sub-part 3: "Channel Structures and Access Capabilities; GMR-1 04.003";

Sub-part 4: "Layer 1 General Requirements; GMR-1 04.004";

**Sub-part 5: "Data Link Layer General Aspects; GMR-1 04.005";**

Sub-part 6: "Mobile earth Station-Gateway Station Interface Data Link Layer Specifications; GMR-1 04.006";

Sub-part 7: "Mobile Radio Interface Signalling Layer 3 General Aspects; GMR-1 04.007";

Sub-part 8: "Mobile Radio Interface Layer 3 Specifications; GMR-1 04.008";

Sub-part 9: "Performance Requirements on the Mobile Radio Interface; GMR-1 04.013";

Sub-part 10: "Rate Adaptation on the Access Terminal-Gateway Station Subsystem (MES-GSS) Interface; GMR-1 04.021";

Sub-part 11: "Radio Link Protocol (RLP) for Data Services; GMR-1 04.022";

Part 5: "Radio interface physical layer specifications";

Part 6: "Speech coding specifications";

Part 7: "Terminal adaptor specifications".

---

## Introduction

GMR stands for GEO (Geostationary Earth Orbit) Mobile Radio interface, which is used for mobile satellite services (MSS) utilizing geostationary satellite(s). GMR is derived from the terrestrial digital cellular standard GSM and supports access to GSM core networks.

Due to the differences between terrestrial and satellite channels, some modifications to the GSM standard are necessary. Some GSM specifications are directly applicable, whereas others are applicable with modifications. Similarly, some GSM specifications do not apply, while some GMR specifications have no corresponding GSM specification.

Since GMR is derived from GSM, the organization of the GMR specifications closely follows that of GSM. The GMR numbers have been designed to correspond to the GSM numbering system. All GMR specifications are allocated a unique GMR number as follows:

GMR-n xx.zyy

where:

- xx.0yy ( $z = 0$ ) is used for GMR specifications that have a corresponding GSM specification. In this case, the numbers xx and yy correspond to the GSM numbering scheme.
- xx.2yy ( $z = 2$ ) is used for GMR specifications that do not correspond to a GSM specification. In this case, only the number xx corresponds to the GSM numbering scheme and the number yy is allocated by GMR.
- n denotes the first ( $n = 1$ ) or second ( $n = 2$ ) family of GMR specifications.

A GMR system is defined by the combination of a family of GMR specifications and GSM specifications as follows:

- If a GMR specification exists it takes precedence over the corresponding GSM specification (if any). This precedence rule applies to any references in the corresponding GSM specifications.

NOTE: Any references to GSM specifications within the GMR specifications are not subject to this precedence rule. For example, a GMR specification may contain specific references to the corresponding GSM specification.

- If a GMR specification does not exist, the corresponding GSM specification may or may not apply. The applicability of the GSM specifications is defined in GMR-1 01.201 [2].

---

# 1 Scope

The present document introduces the link access procedures (LAP) for the satellite channel called LAPSat. The purpose of LAPSat is to carry information between the Layer 3 entities across the GeoMobile (GMR-1) network radio interface using the satellite (Sat) channel. LAPSat is the protocol used for signalling a transfer between a Mobile Earth Station (MES) and a gateway station (GS) in a GMR-1 network.

Most of the procedures defined for LAPSat closely follow those defined for the LAPDm used by Global System for Mobile (GSM). References to the corresponding GSM technical specifications (GSM 04.05 [6]) are made within the present document. Only the significant differences between the LAPs for the mobile D (Dm) and Satellite (Sat) channels are described here.

The present document is based on GSM 04.05 [6].

---

# 2 References

The following documents contain provisions which, through reference in this text, constitute provisions of the present document.

- References are either specific (identified by date of publication and/or edition number or version number) or non-specific.
- For a specific reference, subsequent revisions do not apply.
- For a non-specific reference, the latest version applies.

- [1] GMR-1 01.004 (ETSI TS 101 376-1-1): "GEO-Mobile Radio Interface Specifications; Part 1: General specifications; Sub-part 1: Abbreviations and acronyms; GMR-1 01.004".
- [2] GMR-1 01.201 (ETSI TS 101 376-1-2): "GEO-Mobile Radio Interface Specifications; Part 1: General specifications; Sub-part 2: Introduction to the GMR-1 Family; GMR-1 01.201".
- [3] GMR-1 03.296 (ETSI TS 101 376-3-18): "GEO-Mobile Radio Interface Specifications; Part 3: Network specifications; Sub-part 18: Terminal-to-Terminal Call (TtT); GMR-1 03.296".
- [4] GMR-1 04.006 (ETSI TS 101 376-4-6): "GEO-Mobile Radio Interface Specifications; Part 4: Radio interface protocol specifications; Sub-part 6: Mobile earth Station-Gateway Station Interface Data Link Layer Specifications; GMR-1 04.006".
- [5] GMR-1 04.008 (ETSI TS 101 376-4-8): "GEO-Mobile Radio Interface Specifications; Part 4: Radio interface protocol specifications; Sub-part 8: Mobile Radio Interface Layer 3 Specifications; GMR-1 04.008".
- [6] GSM 04.05 (ETSI ETS 300 554): "European digital cellular telecommunications system (Phase 2); Data Link (DL) layer; General aspects (GSM 04.05 (V4.0.3))".
- [7] GSM 04.10 (ETSI ETS 300 558): "Digital cellular telecommunications system (Phase 2); Mobile radio interface layer 3; Supplementary services specification; General aspects (GSM 04.10 (V4.10.1))".
- [8] GSM 04.11 (ETSI ETS 300 559): "Digital cellular telecommunications system (Phase 2); Point-to-Point (PP) Short Message Service (SMS) support on mobile radio interface (GSM 04.11 (V4.10.0))".



---

## 3 Definitions and abbreviations

### 3.1 Definitions

For the purposes of the present document, the terms and definitions given in GMR-1 01.004 [1] apply. A number of concepts and terms have been borrowed from the GSM 04.05 [6]. Table 3.1 shows how certain terms are mapped from the GSM system documentation to the present document.

**Table 3.1: Mapping of GSM Terms to GMR-1**

Usage in GSM	Usage in GMR-1
MS (Mobile Station)	MES (Mobile Earth Station)
BS (Base Station)	GS (Gateway Station)
Dm (D channel for GSM)	Sat (Satellite channel for GMR-1)

### 3.2 Abbreviations

For the purposes of the present document, the abbreviations given in GMR-1 01.004 [1] apply.

---

## 4 Concepts and terminology

The concepts and terminology used in the present document are identical to those discussed in clause 2 of GSM 04.05 [6].

---

## 5 Overview description of LAPSat functions and procedures

The description of LAPSat functions and procedures is identical to that discussed in clause 3 of GSM 04.05 [6].

The channels used for signalling include the:

- Broadcast Control CHannel (BCCH);
- GPS Broadcast CHannel (GBCH);
- Paging CHannel (PCH);
- Broadcast Alerting CHannel (BACH);
- Random Access CHannel (RACH);
- Access Grant CHannel (AGCH);
- Dedicated Control CHannel (DCCH) (this channel includes the Standalone Dedicated Control CHannel (SDCCH), the Slow Associated Control CHannel (SACCH) and the Fast Associated Control CHannel (FACCH)).
- Terminal-to-terminal Associated Control CHannel (TACCH).

The LAPSat supports the acknowledged (multiple frame) and unacknowledged modes of data transfer.

The following transfer modes apply in addition to those described in clause 3.4 of GSM 04.05 [6].

- The BACH channel exists in the GS-to-MES direction to alert the MES when it does not respond to normal paging. Only unacknowledged operation is possible for this channel.
- The TACCH channel exists in the GS-to-MES direction to send the signalling information to the MES engaged in a terminal-to-terminal (TiT) call. Both acknowledged and unacknowledged operations are possible for this channel.

NOTE: For acknowledged or multiple frame operation on the TACCH, the forward path (from network to MES) is via the TACCH, while the reverse path (from MES to network) is via the associated FACCH.

- The GBCH channel exists in the network-to-MES direction to convey the Global Positioning System (GPS) information to the MESs. Only unacknowledged operation is possible for this channel.

---

## 6 Service characteristics

### 6.1 General

Same as clause 4.1 of GSM 04.05 [6].

### 6.2 Services provided to layer 3

#### 6.2.1 General

Same as clause 4.2 of GSM 04.05 [6].

#### 6.2.2 Priority

The priority between data links differs slightly from that defined in clause 4.2.2 of GSM 04.05 [6]. The priority between data links shall be as follows:

1) Priority on SDCCH

- Highest priority: SAPI = 0; lowest priority: SAPI = 3.

2) Priority on FACCH

- If a SAPI = 2 frame is awaiting transmission, then two SAPI = 0 frames are not sent in consecutive FACCH frames. Additionally, if a SAPI = 0 frame is awaiting transmission, then two SAPI = 2 frames are not sent in consecutive FACCH frames.

3) Priority on SACCH (with TCH3, TCH6, TCH9)

- If a SAPI = 3 frame is awaiting transmission, then two SAPI = 0 frames are not sent in consecutive SACCH frames. Additionally, if a SAPI = 0 frame is awaiting transmission, then two SAPI = 3 frames are not sent in consecutive SACCH frames.

#### 6.2.3 Segmentation

Same as clause 4.2.3 of GSM 04.05 [6].

## 6.2.4 Unacknowledged information transfer service

In this case the information transfer is not acknowledged at the data link layer. Acknowledged procedures may be provided at higher layers.

The characteristics of the unacknowledged information transfer service are summarized in the following:

- a) provision of a data link connection between layer 3 entities for unacknowledged information transfer of layer 3 message units;
- b) identification of data link connection endpoints to permit a layer 3 entity to identify another layer 3 entity;
- c) no verification of message arrival with the data link layer.

The primitives associated with the unacknowledged information transfer service are:

### DL-UNIT-DATA-REQUEST/INDICATION

The DL-UNIT-DATA-REQUEST primitive is used to request that a message unit be sent using the procedures for unacknowledged information transfer service; DL-UNIT-DATA-INDICATION indicates the arrival of a message unit received by means of unacknowledged information transfer. Parameters associated with these primitives are the message unit, service grade, and the type of channel to be used.

The following three service grades are defined for the unacknowledged information transfer over the SACCH on TCH3. For the unacknowledged information transfer over other logical channels, the frame is transmitted at the earliest opportunity and the service grade specified in the DL\_UNIT\_DATA\_REQUEST is not used.

- 1) Immediate: the message unit is transmitted at the earliest opportunity by interrupting the traffic on the channel.
- 2) Wait-then-Go: the message unit waits for speech inactivity on the channel until a maximum waiting time (see GMR-1 04.006 [4]). If the speech inactivity is detected within this time, the message unit is transmitted. If the speech inactivity is not detected within this time, the message unit is transmitted at the next opportunity by interrupting the traffic on the channel.
- 3) Wait-then-Discard: the message unit waits for speech inactivity on the channel until a maximum waiting time (see GMR-1 04.006 [4]). If the speech inactivity is detected within this time, the message unit is transmitted. If the speech inactivity is not detected within this time, the message unit is discarded without further action.

The characteristics of services defined for LAPSat are identical to those defined in GSM 04.05 [6]. Additionally, the following service grade is defined for the acknowledged information transfer using the SACCH on TCH3. For the acknowledged information transfer over other logical channels, the frame is transmitted at the earliest opportunity.

- 1) Wait-then-Discard: the message unit waits for speech inactivity on the channel until a maximum waiting time (see GMR-1 04.006 [4]). If the speech inactivity is detected within this time, the message unit is transmitted. If the speech inactivity is not detected within this time, the message unit is discarded and lost.

The primitives associated with the multiple frame acknowledged mode information transfer services are borrowed from the GSM 04.05 [6]. Additionally, the DL-BEGIN-CIPHERING primitive is required by the data link layer to inform the RR sublayer to set the receiver in the physical layer to cipher-receive mode.

NOTE: The DL-BEGIN-CIPHERING primitive is needed by the data link layer entity only at the network end.

## 6.2.5 Acknowledged information transfer services

Void.

## 6.2.6 Random access procedure

Same as clause 4.2.6 of GSM 04.05 [6].

## 6.3 Services required from the physical layer

The services provided by the physical layer are described in detail in GSM 04.04. They are summarized in the following:

- a) physical layer connection for transparent transmission of frames. The bits of a frame are to be delivered to the peer data link entity in the same order in which they were submitted to the physical layer by the sender;
- b) indication of the physical status of the Sat channel;
- c) transmission of data link layer message units in the same order as they were issued by the data link layer;
- d) provision of frame synchronization;
- e) provision of error protection to ensure a low residual bit error rate at the data link layer;
- f) transmission (in the MS) and reception (in the network) of random access bursts.

The primitives between the data link layer and the physical layer are:

- a) Data transfer:

### PH-DATA-REQUEST/INDICATION

These primitives are used to request that a message unit be sent and to indicate the arrival of message unit. Parameters associated with these primitives are the data link layer message unit, the service grade, and the type of channel being used.

- b) Random access:

### PH-RANDOM ACCESS-REQUEST/INDICATION/CONFIRM

The REQUEST primitive is used to request (in the MS) that a random access frame be sent and the INDICATION primitive is used to indicate (in the network) the arrival of a random access frame. A parameter associated with these primitives is the random access message unit. The CONFIRM primitive is used (in the MS) to confirm in which time slot the random access burst was sent.

- c) Connection establishment:

### PH-CONNECT-INDICATION

This primitive is used to indicate that a specific physical resource has been established on the physical layer. The parameter associated with this primitive is the type of channel.

NOTE: Activation of a physical resource is usually initiated by the layer 3 entity without involving data link layer entities.

- d) Transmission synchronization:

### PH-READY-TO-SEND-INDICATION

This primitive is used to enable the data link layer to synchronize to the next instant of physical transmission. The parameter associated with this primitive is the type of channel.

### PH-EMPTY-FRAME-REQUEST

This primitive is used by the data link layer instead of the PH-DATA-REQUEST primitive when no frame shall be sent after receiving the PH-READY-TO-SEND indication. The parameter associated with this primitive is the type of channel.

## 6.4 Administrative services

Same as clause 4.4 of GSM 04.05 [6].

# 7 Overview of data link layer structure

The data link layer structure is identical to that described in clause 5 of GSM 04.05 [6], with the following changes.

The interface of DL with other layers is shown in figure 7.1

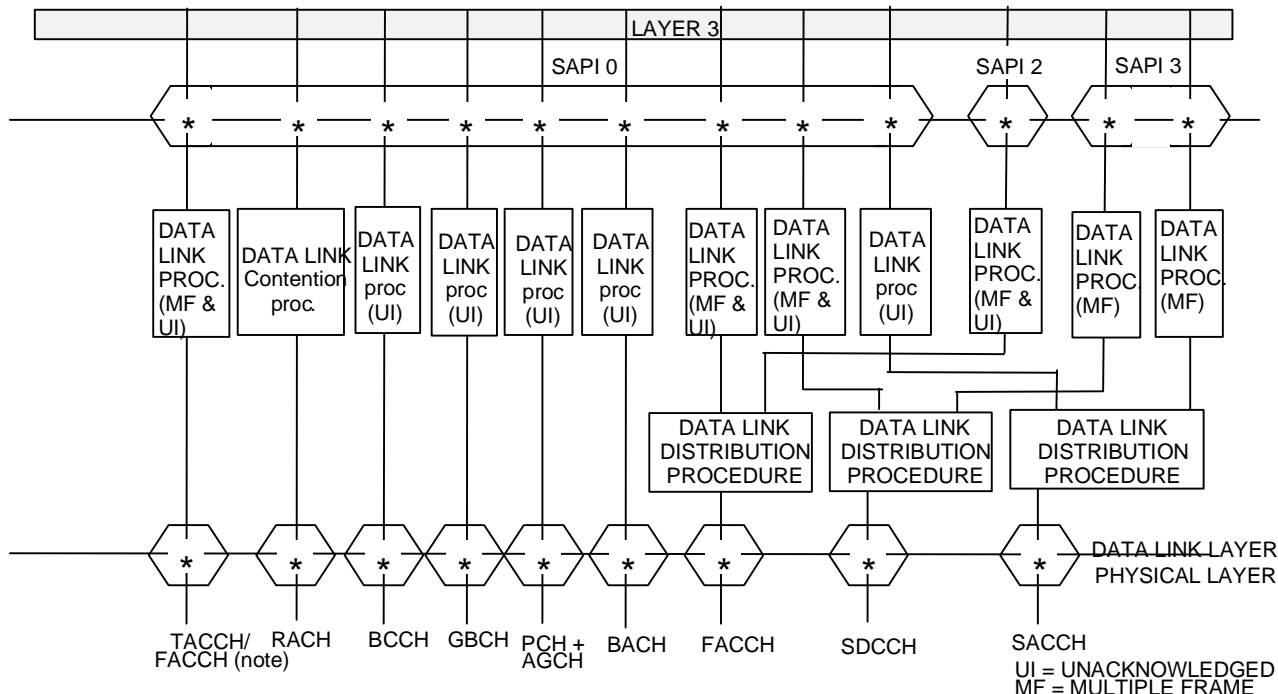

**Figure 7.1: Data Link Layer interfaces**

NOTE: For MF operation on TACCH, the forward path (network to MES) is via the TACCH, while the reverse path (MES to network) is via the FACCH.

The Service Access Point (SAP) takes a specific value for each of the following functions carried on the Sat channel.

- The value for call control signalling, mobility management signalling, supplementary services signalling and radio resource management signalling information (defined in GMR-1 04.008 [5] and GSM 04.10 [7]) is SAPI = 0.
- The value for MES-to-MES signalling for a single-hop call (defined in GMR-1 03.296 [3]) is SAPI = 2.
- The value for short message services (defined in GSM 04.11 [8]) is SAPI = 3.

## 8 Specific requirements

### 8.1 Mode of operation and allowed SAPIs

There are two types of logical link procedures supported by the DL. They are the acknowledged and unacknowledged modes. Some of the Service Access Point Identifiers (SAPIs) support both procedures and some support only one procedure (as listed in table 8.1).

**Table 8.1: Supported modes of operation**

Logical Channel	SAPI = 0	SAPI = 2	SAPI = 3
RACH	Unacknowledged	Not supported	Not supported
PCH	Unacknowledged	Not supported	Not supported
BACH	Unacknowledged	Not supported	Not supported
AGCH	Unacknowledged	Not supported	Not supported
BCCH	Unacknowledged	Not supported	Not supported
GBCH	Unacknowledged	Not supported	Not supported
SDCCH/4	Both Unacknowledged and acknowledged	Not supported	Acknowledged
SACCH	Unacknowledged	Not supported	Acknowledged
FACCH	Both Unacknowledged and acknowledged	Both Unacknowledged and acknowledged	Not supported
TACCH/FACCH	Both Unacknowledged and acknowledged (see note)	Not supported	Not supported
NOTE: The forward path (from network to MES) is via the TACCH for an acknowledged operation on the TACCH. The reverse path (from MES to network) is via the FACCH.			

### 8.2 Acknowledged mode of operation

#### 8.2.1 Window size

The window size  $k$  (see GMR-1 04.006 [4]) shall be:

- $k = 16$  for SAPI = 0;
- $k = 16$  for SAPI = 2;
- $k = 16$  for SAPI = 3.

#### 8.2.2 Processing capacity

The processing capacity should be sufficient that, under normal load, the DL does not go into Receiver Not Ready condition for transactions on SAPI = 0.

---

## Annex A (informative): Bibliography

GMR-1 04.003 (ETSI TS 101 376-4-3): "GEO-Mobile Radio Interface Specifications; Part 4: Radio interface protocol specifications; Sub-part 3: Channel Structures and Access Capabilities; GMR-1 04.003".

GMR-1 05.002 (ETSI TS 101 376-5-2): "GEO-Mobile Radio Interface Specifications; Part 5: Radio interface physical layer specifications; Sub-part 2: Multiplexing and Multiple Access; Stage 2 Service Description; GMR-1 05.002".

---

## History

<b>Document history</b>		
V1.1.1	March 2001	Publication