

TS 101 393 V6.1.0 (1998-10)

Technical Specification

**Digital cellular telecommunications system (Phase 2+);
General Packet Radio Service (GPRS);
GPRS charging
(GSM 12.15 version 6.1.0 Release 1997)**

GSM®

GLOBAL SYSTEM FOR
MOBILE COMMUNICATIONS



Reference

DTS/SMG-061215Q6 (cwc030c3.PDF)

Keywords

Digital cellular telecommunications system,
Global System for Mobile communications (GSM)

ETSI

Postal address

F-06921 Sophia Antipolis Cedex - FRANCE

Office address

650 Route des Lucioles - Sophia Antipolis
Valbonne - FRANCE
Tel.: +33 4 92 94 42 00 Fax: +33 4 93 65 47 16
Siret N° 348 623 562 00017 - NAF 742 C
Association à but non lucratif enregistrée à la
Sous-Préfecture de Grasse (06) N° 7803/88

Internet

secretariat@etsi.fr
<http://www.etsi.org>

Copyright Notification

No part may be reproduced except as authorized by written permission.
The copyright and the foregoing restriction extend to reproduction in all media.

© European Telecommunications Standards Institute 1998.
All rights reserved.

Contents

Intellectual Property Rights.....	5
Foreword	5
1 Scope.....	6
2 Normative references	6
3 Definitions abbreviations and symbols	8
3.1 Definitions	8
3.2 Abbreviations.....	8
3.3 Symbols	9
4 Architecture.....	10
4.1 Charging gateway functionality	11
5. Charging Principles.....	13
5.1 Requirements	13
5.2 Charging Information.....	13
5.3 Charging Data Collection Principles.....	14
5.4 Generation of Charging – ID	15
5.5 Charging for SMS in GPRS.....	15
5.6 Charging for Anonymous Access.....	15
5.7 Charging Triggers – CDR Generation	16
5.7.1 Triggers for S-CDR Charging Information Collection	16
5.7.1.1 Triggers for S-CDR Charging Information Addition.....	16
5.7.1.2 Triggers for S-CDR Closure	16
5.7.2 Triggers for M-CDR Charging Information Collection.....	17
5.7.2.1 Triggers for M-CDR Charging Information Addition	17
5.7.2.2 Triggers for M-CDR Closure.....	17
5.7.3. Triggers for G-CDR Charging Information Collection	17
5.8 Example charging scenarios.....	18
5.8.1 GPRS Mobile to PDN Context.....	18
5.8.2 GPRS Mobile to Mobile Context.....	19
5.8.3 PDN to GPRS Mobile Context.....	20
5.8.4 GPRS Mobile to PDN Context while roaming, GGSN in HPLMN	21
6. Charging Data Collection.....	21
6.1 Record contents	21
6.1.1 GPRS charging data in SGSN (S-CDR).....	23
6.1.2 GPRS charging data in GGSN (G-CDR)	24
6.1.3 GPRS mobile station mobility management data in SGSN (M-CDR)	25
6.1.4 GPRS MO SMS data in SGSN (S-SMO-CDR)	25
6.1.5 GPRS MT SMS data in SGSN (S-SMT-CDR)	26
6.1.6 Description of Record Fields.....	26
6.1.6.1 Access Point Name	26
6.1.6.2 Cause for record closing	26
6.1.6.3 Charging ID	26
6.1.6.4 Diagnostics	27
6.1.6.5 Duration.....	27
6.1.6.6 Dynamic Address Flag.....	27
6.1.6.7 Event time stamps.....	27
6.1.6.8 GGSN address/GGSN address used	27
6.1.6.9 List of traffic data volumes	27
6.1.6.10 Message reference	28
6.1.6.11 Mobile station classmark	29
6.1.6.12 Network initiated PDP context	29
6.1.6.13 Node ID	29

6.1.6.14	PDP Type	29
6.1.6.15	QoS Requested/QoS Negotiated.....	29
6.1.6.16	Record extensions.....	29
6.1.6.17	Record opening time.....	29
6.1.6.18	Record Sequence number	29
6.1.6.19	Record type.....	29
6.1.6.20	Recording entity number	29
6.1.6.21	Remote PDP address	29
6.1.6.22	Routing Area Code/Cell Identity/Change of location	30
6.1.6.23	Served IMEI	30
6.1.6.24	Served IMSI	30
6.1.6.25	Served MSISDN.....	30
6.1.6.26	Served PDP address.....	30
6.1.6.27	Service centre address	30
6.1.6.28	SGSN address.....	30
6.1.6.29	SGSN change.....	30
6.1.6.30	Short message service result	31
7	Charging Protocols.....	31
8	Charging Data Record Structure	31
8.1	ASN.1 definitions for CDR information	31
Annex A(informative):	Change history	37
History		38

Intellectual Property Rights

IPRs essential or potentially essential to the present document may have been declared to ETSI. The information pertaining to these essential IPRs, if any, is publicly available for **ETSI members and non-members**, and can be found in SR 000 314: "*Intellectual Property Rights (IPRs); Essential, or potentially Essential, IPRs notified to ETSI in respect of ETSI standards*", which is available **free of charge** from the ETSI Secretariat. Latest updates are available on the ETSI Web server (<http://www.etsi.org/ipr>).

Pursuant to the ETSI IPR Policy, no investigation, including IPR searches, has been carried out by ETSI. No guarantee can be given as to the existence of other IPRs not referenced in SR 000 314 (or the updates on the ETSI Web server) which are, or may be, or may become, essential to the present document.

Foreword

This Technical Specification (TS) has been produced by the Special Mobile Group (SMG) of the European Telecommunications Standards Institute (ETSI)

This Specification describes the functionality of charging in GPRS needed to support the first phase of GPRS within the digital cellular telecommunications system.

The contents of this TS is subject to continuing work within SMG and may change following formal SMG approval. Should SMG modify the contents of this TS, it will be re-released by SMG with an identifying change of release date and an increase in version number as follows:

Version 6.x.y

where:

- 6 indicates GSM Phase 2+ Release 1997;
- x the second digit is incremented for all other types of changes, i.e. technical enhancements, corrections, updates, etc.;
- y the third digit is incremented when editorial only changes have been incorporated in the specification.

1 Scope

The GSM PLMN supports a wide range of voice and non-voice services in the same network. In order to enable operators the ability to provide a commercially viable service there is a need to provide charging functions. The present document describes the functionality of charging in GPRS needed to support the first phase of GPRS, as defined in GSM 02.60[3] and GSM 03.60[8] (packet based services).

2 Normative references

The following documents contain provisions which, through reference in this text, constitute provisions of the present document.

- References are either specific (identified by date of publication, edition number, version number, etc.) or non-specific.
- For a specific reference, subsequent revisions do not apply.
- For a non-specific reference, the latest version applies.
- A non-specific reference to an ETS shall also be taken to refer to later versions published as an EN with the same number.

- [1] GSM 01.04: "Digital cellular telecommunications system (Phase 2+); Abbreviations and acronyms".
- [2] GSM 01.61: "Digital cellular telecommunications system (Phase 2+); GPRS ciphering algorithm requirements".
- [3] GSM 02.60: "Digital cellular telecommunications system (Phase 2+); General Packet Radio Service (GPRS); Service description; Stage 1".
- [4] GSM 03.03: "Digital cellular telecommunications system (Phase 2+); Numbering, addressing and identification".
- [5] GSM 03.07: "Digital cellular telecommunications system (Phase 2+); Restoration procedures".
- [6] GSM 03.22: "Digital cellular telecommunications system (Phase 2+); Functions related to Mobile Station (MS) in idle mode and group receive mode".
- [7] GSM 03.40: "Digital cellular telecommunications system (Phase 2+); Technical realization of the Short Message Service (SMS); Point-to-Point (PP)".
- [8] GSM 03.60: "Digital cellular telecommunications system (Phase 2+); General Packet Radio Service (GPRS); Service description; Stage 2".
- [9] GSM 03.61: "Digital cellular telecommunications system (Phase 2+); General Packet Radio Service (GPRS); Point to Multipoint Multicast Service Description; Stage 2".
- [10] GSM 03.62: "Digital cellular telecommunications system (Phase 2+); General Packet Radio Service (GPRS); Point to Multipoint Group Call Service Description; Stage 2".
- [11] GSM 03.64: "Digital cellular telecommunications system (Phase 2+); Overall description of the General Packet Radio Service (GPRS) Radio interface; Stage 2".
- [12] GSM 04.07: "Digital cellular telecommunications system (Phase 2+); Mobile radio interface signalling layer 3; General aspects".
- [13] GSM 04.08: "Digital cellular telecommunications system (Phase 2+); Mobile radio interface layer 3 specification".

- [14] GSM 04.64: "Digital cellular telecommunications system (Phase 2+); General Packet Radio Service (GPRS); Logical Link Control (LLC)".
- [15] GSM 04.65: "Digital cellular telecommunications system (Phase 2+); General Packet Radio Service (GPRS); Subnetwork Dependent Convergence Protocol (SNDCP)".
- [16] GSM 08.08: "Digital cellular telecommunications system (Phase 2+); Mobile Switching Centre – Base Station System (MSC - BSS) interface: Layer 3 specification".
- [17] GSM 08.14: "Digital cellular telecommunications system (Phase 2+); General Packet Radio Service (GPRS); Base Station System (BSS) – Serving GPRS Support Node (SGSN) interface; Gb interface layer 1".
- [18] GSM 08.16: "Digital cellular telecommunications system (Phase 2+); General Packet Radio Service (GPRS); Base Station System (BSS) – Serving GPRS Support Node (SGSN) interface; Network Service".
- [19] GSM 08.18: "Digital cellular telecommunications system (Phase 2+); General Packet Radio Service (GPRS); Base Station System (BSS) – Serving GPRS Support Node (SGSN); BSS GPRS Protocol (BSSGP)".
- [20] GSM 08.60: "Digital cellular telecommunications system (Phase 2+); Inband control of remote transcoders and rate adaptors for Enhanced Full Rate (EFR) and full rate traffic channels."
- [21] GSM 09.02: "Digital cellular telecommunications system (Phase 2+); Mobile Application Part (MAP) specification".
- [22] GSM 09.60: "Digital cellular telecommunications system (Phase 2+); General Packet Radio Service (GPRS); GPRS Tunnelling Protocol (GTP) across the Gn and Gp Interface".
- [23] GSM 09.61: "Digital cellular telecommunications system (Phase 2+); General requirements on interworking between the Public Land Mobile Network (PLMN) supporting General Packet Radio Service (GPRS) and Packet Data Networks (PDN)".
- [24] CCITT Recommendations I.130: "General modelling methods – Method for the characterisation of telecommunication services supported by an ISDN and network capabilities of an ISDN".
- [25] CCITT Recommendation E.164: "Numbering plan for the ISDN era".
- [26] CCITT Recommendation Q.65: "Methodology – Stage 2 of the method for the characterization of services supported by an ISDN".
- [27] CCITT Recommendation Q.922: "Digital subscriber signalling system no. 1 (DSS 1) – Data link layer – ISDN data link layer specification for frame mode bearer services".
- [28] CCITT Recommendation Q.933: "Digital subscriber signalling system no. 1 (DSS 1) – Network layer – Signalling specification for frame mode basic call control".
- [29] CCITT Recommendation V.42 bis: "Data communication over the telephone network – Data compression procedures for data circuit-terminating equipment (DCE) using error correction procedures".
- [30] CCITT Recommendation X.3: "Packet assembly disassembly facility (PAD) in a public data network".
- [31] CCITT Recommendation X.25: "Interface between data terminal equipment (DTE) and data circuit-terminating equipment (DCE) for terminals operating in the packet mode and connected to public data networks by dedicated circuit".
- [32] CCITT Recommendation X.28: "DTE / DCE interface for a start-stop mode data terminal equipment accessing the packet assembly / disassembly facility (PAD) in a public data network situated in the same country".
- [33] CCITT Recommendation X.29: "Procedures for the exchange of control information and user data between a packet assembly / disassembly (PAD) facility and a packet mode DTE or another PAD".

- [34] CCITT Recommendation X.75: "Packet-switched signalling system between public networks providing data transmission services".
- [35] CCITT Recommendation X.121: "International Numbering Plan for Public Data Networks".
- [36] IETF RFC 768 (1980): "User Datagram Protocol" (STD 6).
- [37] IETF RFC 791 (1981): "Internet Protocol" (STD 5).
- [38] IETF RFC 792 (1981): "Internet Control Message Protocol" (STD 5).
- [39] IETF RFC 793 (1981): "Transmission Control Protocol" (STD 7).
- [40] ISO8824 (90) / X.208 (88): "Information technology - open System Interconnection - Specification of Abstract Syntax Notation One (ASN.1)".
- [41] ISO8824-1 (94) / X.680 (94): "Information technology - Abstract Syntax Notation One (ASN.1) - Specification of Basic Notation".

3 Definitions abbreviations and symbols

3.1 Definitions

Refer to: GSM 02.60 [3].

In GSM 02.02 the bearer services are described. The general network configuration is described in GSM 03.02 and the GSM PLMN access reference configuration is defined in GSM 04.02. The various connection types used in the GSM PLMN are presented in GSM 03.10. Terminology used in this Specification is presented in GSM 01.04 [1]. For support of data services between GSM PLMN and other networks see GSM 09-series of Specifications.

3.2 Abbreviations

For the purposes of this document the following abbreviations apply. Additional applicable abbreviations can be found in GSM 01.04 [1].

APN	Access Point Name
BG	Border Gateway
BS	Billing System
BSS	Base Station Subsystem
CDR	Call Detail Record
CG	Charging Gateway
CGF	Charging Gateway Functionality
GTP	GPRS Tunnel Protocol
CMIP	Common Management Information Protocol
F/W	Firewall
GGSN	Gateway GPRS Support Node
GPRS	General Packet Radio Service
G-CDR	Gateway GPRS Support Node – Call Detail Record
IP	Internet Protocol
MS	Mobile Station
M-CDR	Mobility Management - Call Detail Record
NE	Network Element
NSS	Network and Switching Subsystem
NMG	Network Management Gateway
NMN	Network Management Node
OMC	Operations and Maintenance Centre
OSF	Operations System Function
PDN	Packet Data Network
PDP	Packet Data Protocol, e.g., IP or X.25

PLMN	Public Land Mobile Network
PSPDN	Packet Switched Public Data Network
PTM-M	Point to Multipoint - Multicast
PTM-G	Point to Multipoint - Group Call
PTM SC	Point to Multipoint Service Centre
RAC	Routing Area Code
SGSN	Serving GPRS Support Node
SNDCP	Sub-Network Dependent Convergence Protocol
SNMP	Simple Network Management Protocol
SS7	Signalling System No. 7
S-CDR	Serving GPRS Support Node – Call Detail Record
S-SMO-CDR	SGSN delivered Short message Mobile Originated – Call Detail Record
S-SMT-CDR	SGSN delivered Short message Mobile Terminated – Call Detail Record
TID	Tunnel Identifier

3.3 Symbols

For the purposes of this document the following Symbols apply:

A	Interface between an MSC and a BSC.
Gb	Interface between an SGSN and a BSC.
Gc	Interface between an GGSN and an HLR.
Gd	Interface between an SMS-GMSC and an SGSN, and between a SMS-IWMSC and an SGSN.
Gf	Interface between an SGSN and an EIR.
Gi	Reference point between GPRS and an external packet data network.
Gn	Interface between two GSNs within the same PLMN.
Gp	Interface between two GSNs in different PLMNs. The Gp interface allows support of GPRS network services across areas served by the co-operating GPRS PLMNs.
Gr	Interface between an SGSN and an HLR.
Gs	Interface between an SGSN and an MSC/VLR.
kbit/s	Kilobits per second.
R	Reference point between a non-ISDN compatible TE and MT. Typically this reference point supports a standard serial interface.
Um	Interface between the mobile station (MS) and the GPRS fixed network part. The Um interface is the GPRS network interface for providing packet data services over the radio to the MS. The MT part of the MS is used to access the GPRS services through this interface.

4 Architecture

The following figures 1 and 2 show the GPRS logical architecture and GPRS charging logical architecture.

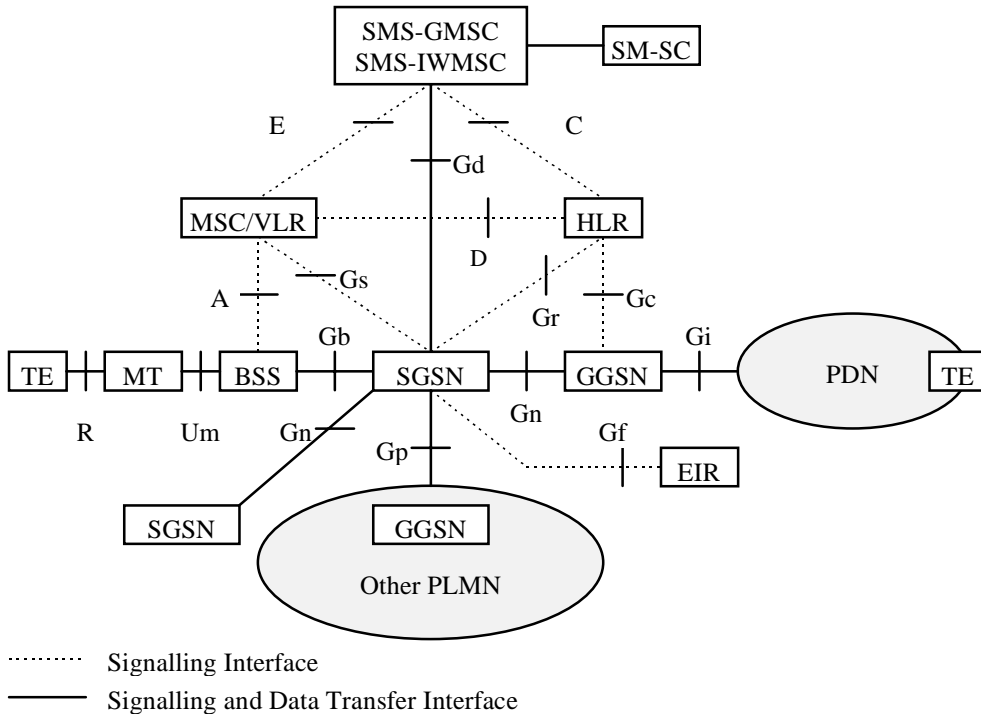

Figure 1: Overview of the GPRS Logical Architecture

GPRS is logically implemented on the GSM structure through the addition of two network nodes, the Serving GPRS Support Node and the Gateway GPRS Support Node. No inference should be drawn about the physical configuration on an interface from Figure 1.

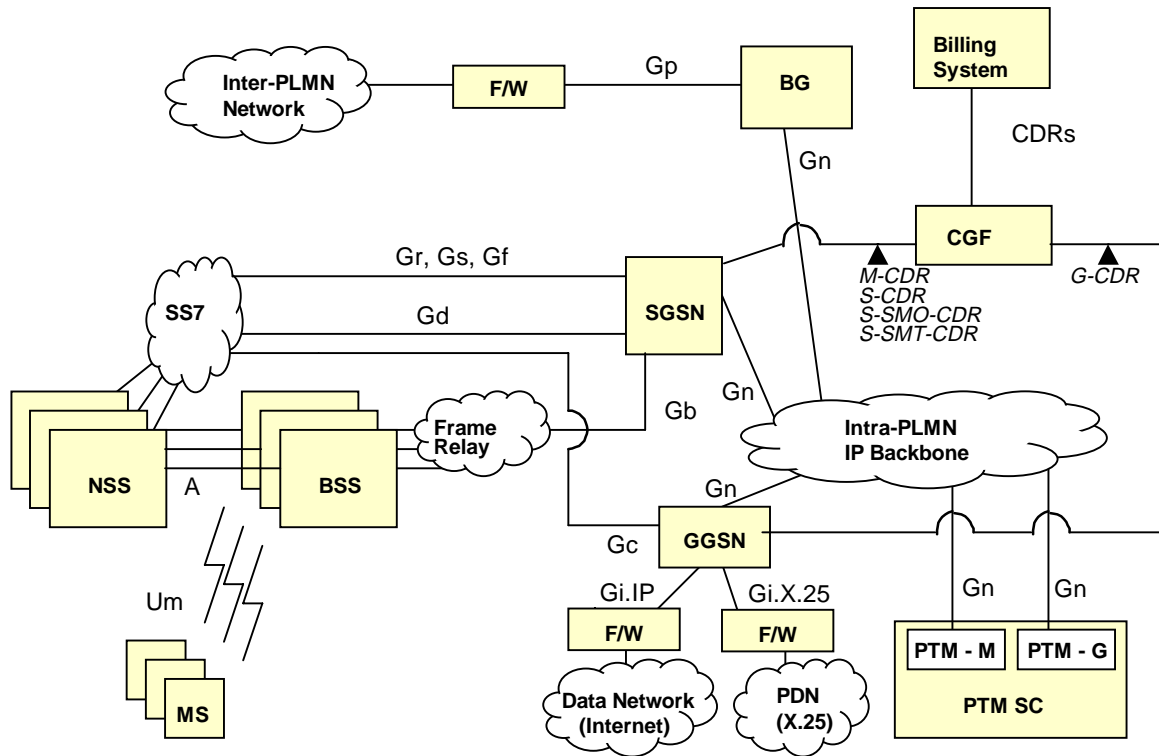

Figure 2: GPRS charging logical architecture

4.1 Charging gateway functionality

The Charging Gateway Functionality (CGF) provides a mechanism to transfer charging information from the SGSN and GGSN nodes to the network operator's chosen Billing Systems (BS). The Charging Gateway concept enables an operator to have just one logical interface between the CGF and the BS. The CGF may be supported in one of the following ways:-

- as a centralised separate network element (Charging Gateway);
- as a distributed functionality resident in the SGSNs and GGSNs.

Support of the centralised or distributed CGF in a network is implementation dependent, and subject to vendor/matrix agreement. Regardless of the way in which the CGF is supported in the network, the functionality of the CGF is similar. Figure 3 gives an overview of the two basic configurations: In scenario 1, the GSNs support an external interface to the charging gateways they are connected to. In scenario 2, the GSNs support the charging gateway functionality internally.

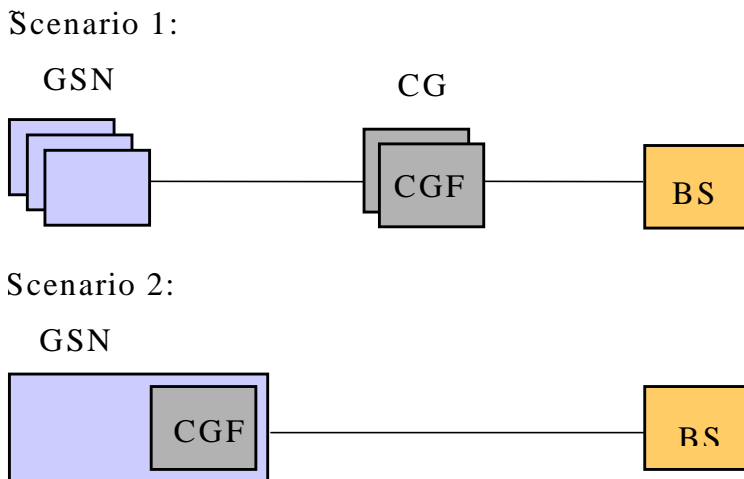

Figure 3: Basic architectural scenarios for the CGF location

If the GSNs with internal charging gateway functionality also support the external interface, additional configurations as shown in figure 4 are possible. In scenario 3, the GSN with integrated charging gateway function also acts as CGF for other GSNs. In scenario 4, the GSN with integrated charging gateway function also supports the transmission of CDRs to external CGFs.

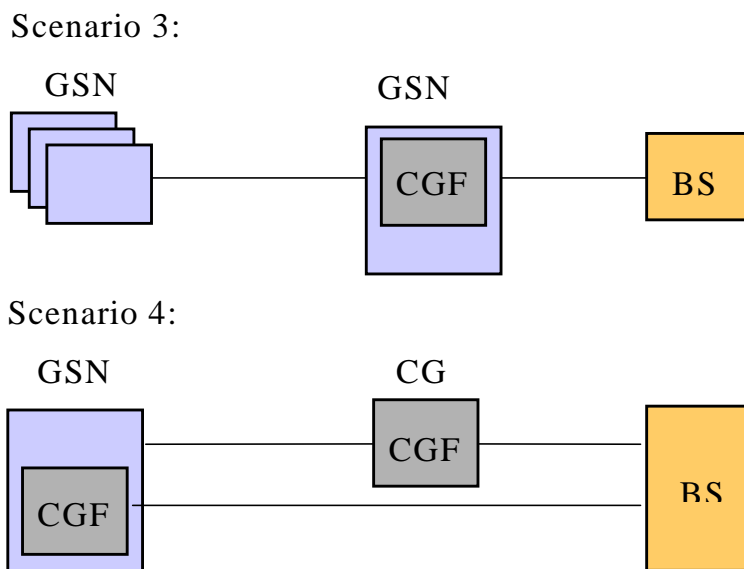

Figure 4: Optional scenarios for the CGF configuration

The above four scenarios are not exhaustive.

The CGF provides the mechanism to transfer charging information from the SGSN and GGSN nodes to the network operator’s chosen Billing Systems(s) (BSs). The main functions of the CGF are:-

- the collection of GPRS CDRs from the GPRS nodes generating CDRs
- intermediate CDR storage buffering
- the transfer of the CDR data to the billing systems

The CGF acts as a storage buffer for real time CDR collection. It provides the CDR data to the billing system. This specification identifies the external interfaces of the CGF, but does not specify the internal functionality of the CGF. However, in order to assist in the understanding of the CGF, it may perform specific activities, such as consolidation of CDRs, pre-processing of CDR fields, filtering of unrequired CDR fields, and adding of Operator defined fields for specific billing systems. These specific activities may be performed to optimise the charging information that is to be forwarded to the Billing System, which should reduce the load in the Billing System.

In addition to the centralised CGF it is possible to have the CGF distributed to the SGSNs and/or GGSNs.

The CGF can reside in a separate network element (Charging Gateway) or be integrated in the GSNs. It can receive CDR fields from the GSNs in real time mode. It should have enough storage to enable it to transmit the collected charging data to the Billing System in file mode.

The CGF may have to support several transmission protocols towards the Billing System, depending on the Billing System(s) used. One of the main purposes of the CG (or even just a CGF) is to reduce the number of different interfaces between the billing system (BS) and the GGSNs and SGSNs sending charging data. If a new BS is introduced it must be interfaced to the CGF, i.e. the protocol stacks and configurations of the GSNs do not need to be updated. The usage and load of mass memory media can be more evenly distributed. The portion of the CGF embedded into a single physical device is called the Charging Gateway entity. The CGF may be distributed to several physical Charging Gateways or GSNs, to facilitate redundancy. If that Charging Gateway entity that is the Primary Charging Gateway entity, does not respond to communication originating from the GSNs, the GSNs will try to send the CDR data to a Secondary Charging Gateway entity. Here each GSN will have several IP addresses (of different priority) for the Charging Gateway entities, thus avoiding downtime of the CGF.

5. Charging Principles

5.1 Requirements

- 1) Every GPRS operator collects and processes their own charging information.
- 2) GPRS charging shall support anonymous access to the GPRS bearer service.
- 3) As much as is possible the GPRS charging functions should support open interfaces for possible use in future cellular digital packet based networks.
- 4) It shall be possible to provide reverse charging as a subscription option. However, reverse charging may not be applicable to certain external data network protocols.
- 5) Every PDP context shall be assigned a unique identity number for billing purposes. (i.e. the charging id).
- 6) Data volumes on both the uplink and downlink direction shall be counted separately. The data volumes shall reflect the application data as precisely as possible as delivered by the user.
- 7) The charging mechanisms shall provide the duration of the PDP context with date and time information.
- 8) The GPRS operator may define a subset of the charging information specified by GPRS charging standards. This means that it shall be possible to configure the SGSN and GGSN for the CDR information generated.
- 9) The SGSN and GGSN are not obliged to have non-volatile memory.

This means that a GSN may lose its data when reset. The only permanent information that must be stored in a GSN is the configuration data (e.g. cell/RA definition in SGSN).

5.2 Charging Information

Charging information in the GPRS network is collected for each MS by the SGSNs and GGSNs which are serving that MS. The information that the operator uses to generate an invoice to the subscriber is operator-specific. Billing aspects, e.g., a regular fee for a fixed period, are outside the scope of this specification.

The SGSN collects charging information for each MS related with the radio network usage, while the GGSN collects charging information for each MS related with the external data network usage. Both GSNs also collect charging information on usage of the GPRS network resources.

PTP charging information is collected for the GPRS subscriber.

As a minimum, the SGSN shall collect the following charging information:

- 1) usage of the radio interface: the charging information shall describe the amount of data transmitted in MO and MT directions categorised with QoS and user protocols;

Charging based on user protocols (PDP context type) for sent/received data volume forms the basis for volume charging. All changes in QoS are recorded separately. This provides post-processing systems, if required, to sort out their charging relevance.

- 2) usage of the packet data protocol addresses: the charging information shall describe how long the MS has used the packet data protocol addresses;

Duration of PDP context is counted as the time interval from PDP Context activation to PDP Context Deactivation.

- 3) usage of the general GPRS resources: the charging information shall describe the usage of other GPRS-related resources and the MSs GPRS network activity (e.g., mobility management).
- 4) location of MS: HPLMN, VPLMN, plus optional higher-accuracy location information;

As a minimum, the GGSN shall collect the following charging information: destination and source: the charging information shall describe the destination and source addresses with a level of accuracy as defined by the GPRS operator;

- 5) Destination and source: the charging information shall describe the destination and source addresses with a level of accuracy as defined by the GPRS Operator.

Distinction of the data traffic to different source and destination or subnetworks may be performed by using the APN (Access Point Name).

- 6) usage of the external data networks: the charging information shall describe the amount of data sent and received to and from the external data network.

External networks can be identified by the APN (access point name). The volume counts can be charged by post-processing as configured.

- 7) usage of the packet data protocol addresses: the charging information shall describe how long the MS has used the PDP addresses.
- 8) location of MS: HPLMN, VPLMN, plus optional higher-accuracy location information.

The highest accuracy location information available in GGSN is SGSN address.

5.3 Charging Data Collection Principles

Call data record generation and contents should be flexible and unnecessary redundancy in data should be avoided.

1. There are two main records types (one for the SGSN and one for the GGSN related to PDP contexts). Each PDP context generates its own record. A third record is provided for mobility management in the SGSN. The SGSN may also provide two SMS related records in case of short message delivery.
2. Optional basic location information may be included in the PDP context records.
3. Records shall only include relevant information, i.e. traffic activity since last record.

The criteria for record generation is based on real time needs, information safety (backup) and some specific events, such as expiry of the partial record timer(s), transferred data volume limit(s), inter SGSN routing area update.

4. Change of tariff period (if used) should not cause new CDRs to be sent to avoid peaks in data transfer. Instead such events should close the existing volume counters and open new ones when appropriate traffic is detected. This can be done by having a new record in the same message. It is up to the operator how often the CDRs are transferred from a GSN.
5. Both SSGN and GGSN nodes shall collect information from same chargeable sessions (PDP contexts). A unique reference (Charging ID and GGSN address) is needed to enable connection between information from several records produced from same PDP context.

5.4 Generation of Charging – ID

The concept of serving connections is different in the GSM switching network to that for the GPRS network. Therefore different mechanisms are needed to supply the billing system centres with charging information.

Circuit switched calls can be charged in one MSC (the anchor MSC) where all relevant data is available. That is guaranteed by routing all signalling information through the anchor MSC even if the traffic channel of a call is routed through another MSC due to handover.

In a GPRS network the complete PDP context handling can be switched over from an old SGSN to a new SGSN due to routing area updates with the consequence that charging records will be generated in more than one SGSN. Furthermore different data has to be collected in the SGSNs and GGSNs. So for one PDP context, charging records are needed from both the SGSN and GGSN.

The billing system shall be provided with all relevant information from the network to charge for that one activated PDP context.

During the active PDP context all records which belong to this context could normally be identified by the TID. However

- an MS can activate and deactivate PDP contexts in a very short time interval, and these PDP contexts can have the same TID (only parallel established PDP contexts have different TIDs);
- different SGSNs can be involved in the same PDP context as described above;
- the timing clocks of the GSN elements may not be fully synchronised.

Therefore it is nearly impossible for a billing post-processing system to gather the records of one PDP context only by using the IMSI, NSAPI (TID) and time.

This is solved by assigning a unique Charging-ID number (C-ID) to all records generated for that one PDP context.

The unique C-ID is generated in the GGSN when the PDP context is activated. A C-ID is generated for each activated context, so that each has a unique C-ID. The C-ID shall be transferred from the SGSN to another SGSN (following a routing area update). All PDP CDRs for each activated PDP context generated by each SGSNs and GGSNs shall therefore contain the same unique combination of the C-ID and GGSN address to permit subsequent Charging Gateway / Billing System correlation of the generated CDRs.

The GGSN address together with the C-ID are a unique identification over a long period of time in all GPRS networks.

5.5 Charging for SMS in GPRS

In GPRS the SMS transmission (MO or MT) can be done via SGSN. The SGSN shall provide an S-SMO-CDR when short message is mobile originated and an S-SMT-CDR when it is mobile terminated. In addition, also SMS-IWMSC (MO-SMS) and SMS-GMSC (MT-SMS) may provide SMS related CDRs as described in GSM 12.05.

No active PDP context is required when sending or receiving short messages. If the subscriber has an active PDP context, volume counters of S-CDR are not updated due to short message delivery.

The contents of S-SMO and S-SMT CDRs are presented in tables 8 and 9.

5.6 Charging for Anonymous Access

S-CDRs and G-CDRs are generated by the SGSNs and GGSNs in the case of Anonymous Access, and separately identified in the CDRs.

The external Anonymous Access server is charged by the Operator based on the APN.

5.7 Charging Triggers – CDR Generation

The S-CDR, M-CDR G-CDR, S-SMO-CDR, and S-SMT-CDR are generated by the SGSN and GGSN to collect charging information such that they may be subsequently transferred to the Charging Gateway Function.

5.7.1 Triggers for S-CDR Charging Information Collection

An S-CDR is used to collect charging information related to the packet data information for a GPRS mobile in the SGSN.

An S-CDR shall be opened for each activated PDP context, and record details such as Record Type, Served IMSI, Sequence Number etc. Not all of the charging information to be collected is static, and other charging information is directly dependent on dynamic GPRS usage.

The subsequent sections identify the conditions for adding information to, and closing, the CDR.

5.7.1.1 Triggers for S-CDR Charging Information Addition

The "List of traffic volumes" attribute of the S-CDR consists of a set of containers which are added when specific trigger conditions are met, and identify the volume count separated for uplink and downlink traffic on encountering that trigger condition.

Table 1 Triggers for S-CDR charging information addition

Trigger Conditions	Description/Behaviour
QoS change	A change in the QoS shall result in a "List of traffic data volumes" container being added to the CDR.
Tariff time change	On reaching the tariff time change a "List of traffic data volumes" container shall be added to the CDR.
CDR Closure	A list of "List of traffic data volumes" container shall be added to the S-CDR.

5.7.1.2 Triggers for S-CDR Closure

The S-CDR shall be closed on encountering some trigger conditions. The following table identifies which conditions are supported to permit closures of the S-CDR.

Table 2 Triggers for S-CDR closure

Closure Conditions	Description/Behaviour
End of PDP context within the SGSN	Deactivation of the PDP context in the SGSN shall result in the CDR being closed. The trigger condition covers:- <ul style="list-style-type: none"> - termination of PDP context, - SGSN change (inter-SGSN routing area update), - any abnormal release.
Partial Record Reason	O&M reasons permit the closure of the CDR for internal reasons. The trigger condition covers:- <ul style="list-style-type: none"> - data volume limit, - time (duration) limit, - maximum number of charging condition changes, - management intervention.

In the event that the S-CDR is closed and the PDP context remains active, a further S-CDR shall be opened with an incremented Sequence Number.

5.7.2 Triggers for M-CDR Charging Information Collection

An M-CDR is used to collect charging information related to the mobility management of a GPRS mobile in the SGSN.

An M-CDR shall be opened for each GPRS mobile upon GPRS Attach, and record details such as Record Type, Served IMSI, Sequence Number etc. Not all of the charging information to be collected is static, and other charging information is directly dependent on GPRS mobility.

The subsequent sections identify the conditions for adding information to, and closing, the CDR.

5.7.2.1 Triggers for M-CDR Charging Information Addition

The "Change of Location" attribute of the M-CDR consists of a set of containers which are added when specific trigger conditions are met, and identify the timestamped routing area on encountering that trigger condition.

Table 3 Triggers for M-CDR Charging Information Addition

Trigger Conditions	Description/Behaviour
Mobility change	A change in the Routing area shall result in a "Change of Location" container being added to the M-CDR.

5.7.2.2 Triggers for M-CDR Closure

The M-CDR shall be closed on encountering some trigger conditions. The following table identifies which conditions are supported to permit closures of the M-CDR.

Table 4 Triggers for M-CDR closure

Closure Conditions	Description/Behaviour
End of MM context within SGSN	Deactivation of the MM context in the SGSN shall result in the CDR being closed. The trigger condition covers:- <ul style="list-style-type: none"> - SGSN change (inter-SGSN routing area update), - GPRS detach, - any abnormal release.
Partial Record Reason	O&M reasons permit the closure of the CDR for internal reasons. The trigger condition covers:- <ul style="list-style-type: none"> - time (duration) limit, - maximum number of mobility changes, and - Management intervention.

In the event that the M-CDR is closed and the GPRS mobile is still known to the SGSN, a further M-CDR shall be opened with an incremented Sequence Number.

5.7.3 Triggers for G-CDR Charging Information Collection

A G-CDR is used to collect charging information related to the packet data information for a GPRS mobile in the GGSN.

A G-CDR shall be opened for each activated PDP context, and record details such as Record Type, Served IMSI, Sequence Number etc. Not all of the charging information to be collected is static, and other charging information is directly dependent on dynamic GPRS usage.

The "List of traffic volumes" attribute of the G-CDR consists of a set of containers which are added following specific trigger conditions, and identify the volume count on encountering that trigger condition. The trigger conditions are as for

the S-CDR (see previous section on "Triggers for S-CDR Charging Information Collection") with exception that the SGSN change does not need to close the CDR.

In the event that the G-CDR is closed and the PDP context remains active, a further G-CDR is opened with an incremented Sequence Number.

5.8 Example charging scenarios

This clause contains a number of example scenarios illustrating the purpose and practical usage of the various types of records defined in the previous subclauses. These examples are by no means exhaustive.

For the purpose of these examples the following assumptions have been made:

- the CDR records are sent to a CGF;
- the generation of all of the CDR record types has been enabled.

The following conventions have been used for the figures contained within this subclause:

- 1) Network connections and signalling transactions are illustrated by means of solid lines and referenced by number e.g. (1).
- 2) Operation & Maintenance actions, such as the transfer of call records, are represented by means of dotted lines and referenced by letter e.g. (A).

5.8.1 GPRS Mobile to PDN Context

Figure 5 illustrates a simple outgoing GPRS context from a PLMN GPRS subscriber "A" to a mainframe "B" via a PDN (1).

The respective PDP context is activated in the SGSN and GGSN and PDP PDUs are routed in MO and MT direction. The SGSN shall create a S-CDR and the GGSN shall create a G-CDR for subscriber "A".

The records generated are subsequently transferred to the CGF (A). The CGF transfers the CDRs to the BS.

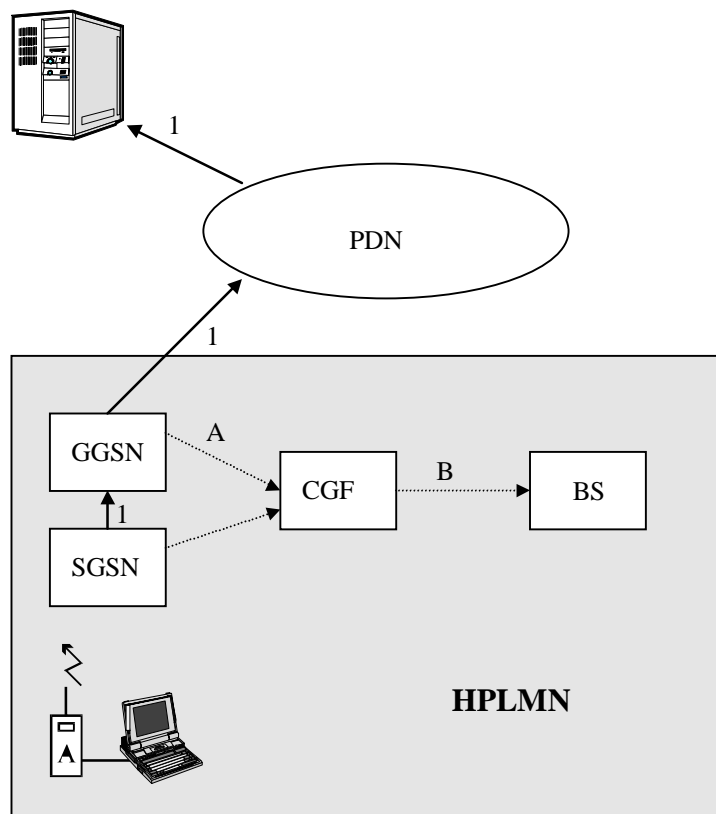

Figure 5: GPRS Mobile to PDN Context

5.8.2 GPRS Mobile to Mobile Context

Figure 6 illustrates a simple GPRS mobile to mobile context within the same HPLMN.

The respective A-party related PDP context is activated in the SGSN-A and the GGSN (1).

After the location of subscriber "B" is determined, the B party related PDP context is activated (2) in the SGSN-B and the GGSN and PDP PDUs are routed in MO and MT direction. The SGSN-A shall create an S-CDR and the GGSN shall create a G-CDR for subscriber A, the SGSN-B shall create a S-CDR and the GGSN shall create a G-CDR for subscriber "B".

If subscriber "A" and subscriber "B" use the same GGSN, both G-CDRs are produced at that GGSN.

If session leg (2) requires a PDP context activation the respective PDP records will contain a network initiated PDP context activation-flag.

The records generated are subsequently transferred to the CGF (A). The CGF transfers the CDRs to the BS.

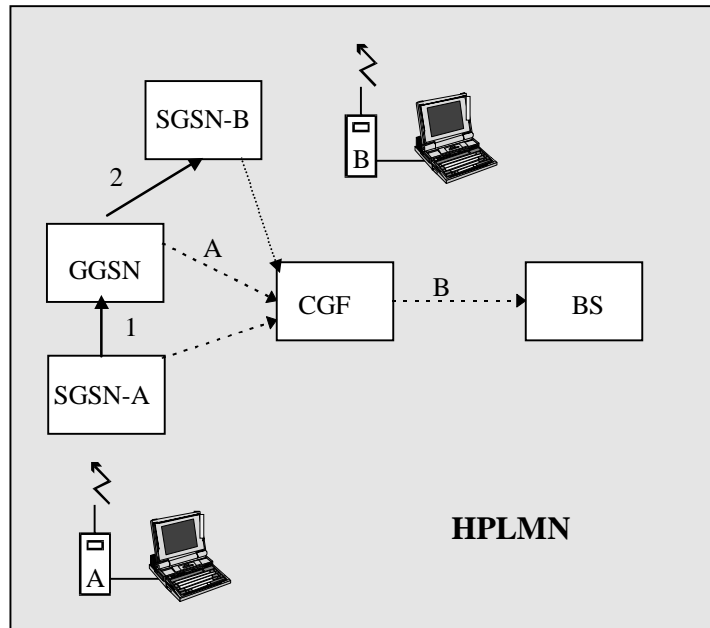

Figure 6: GPRS Mobile to Mobile Context

5.8.3 PDN to GPRS Mobile Context

Figure 7 illustrates a simple incoming GPRS context from a mainframe "A" to GPRS mobile subscriber "B" via a PDN (1). After the location of subscriber "B" is determined, the PDP context is activated (2).

The GGSN receiving the PDUs shall generate a G-CDR whereas the SGSN currently serving subscriber "B" creates an S-CDR. These records contain a flag that the PDP context is activated due to network request.

The records generated are subsequently transferred to the CGF (A). The CGF transfers the CDRs to the BS.

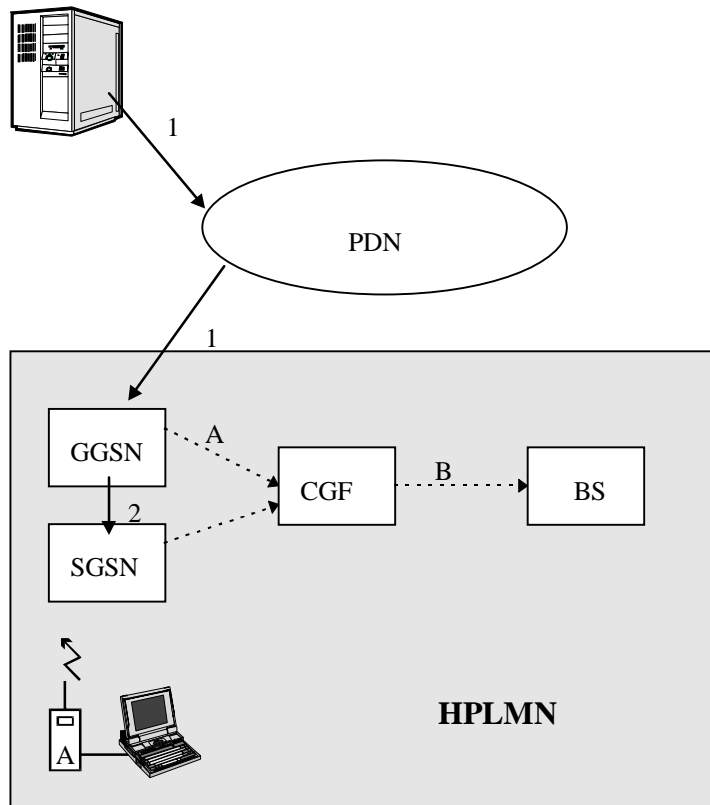

Figure 7: PDN to GPRS Mobile Context

5.8.4 GPRS Mobile to PDN Context while roaming, GGSN in HPLMN

Figure 8 illustrates an outgoing GPRS context from a roaming GPRS mobile subscriber "A" to mainframe "B" via Boarder Gateway, inter PLMN backbone and GGSN of the HPLMN (1).

The respective a-party related PDP context is activated in the SGSN and GGSN and PDUs are routed in MO and MT direction. The SGSN shall create an S-CDR (VPLMN) and a G-CDR is generated at the used GGSN (HPLMN) for subscriber "A". From the GGSN the packets are sent via the PDN to the mainframe "B".

The records generated in the HPLMN and the VPLMN are subsequently transferred to the CGFs (A). The CGFs transfer the CDRs to the BS. (B)

Later on the records created in the VPLMN are transferred from the ADC/BC to the ADC/BC of the HPLMN via TAP procedure (C).

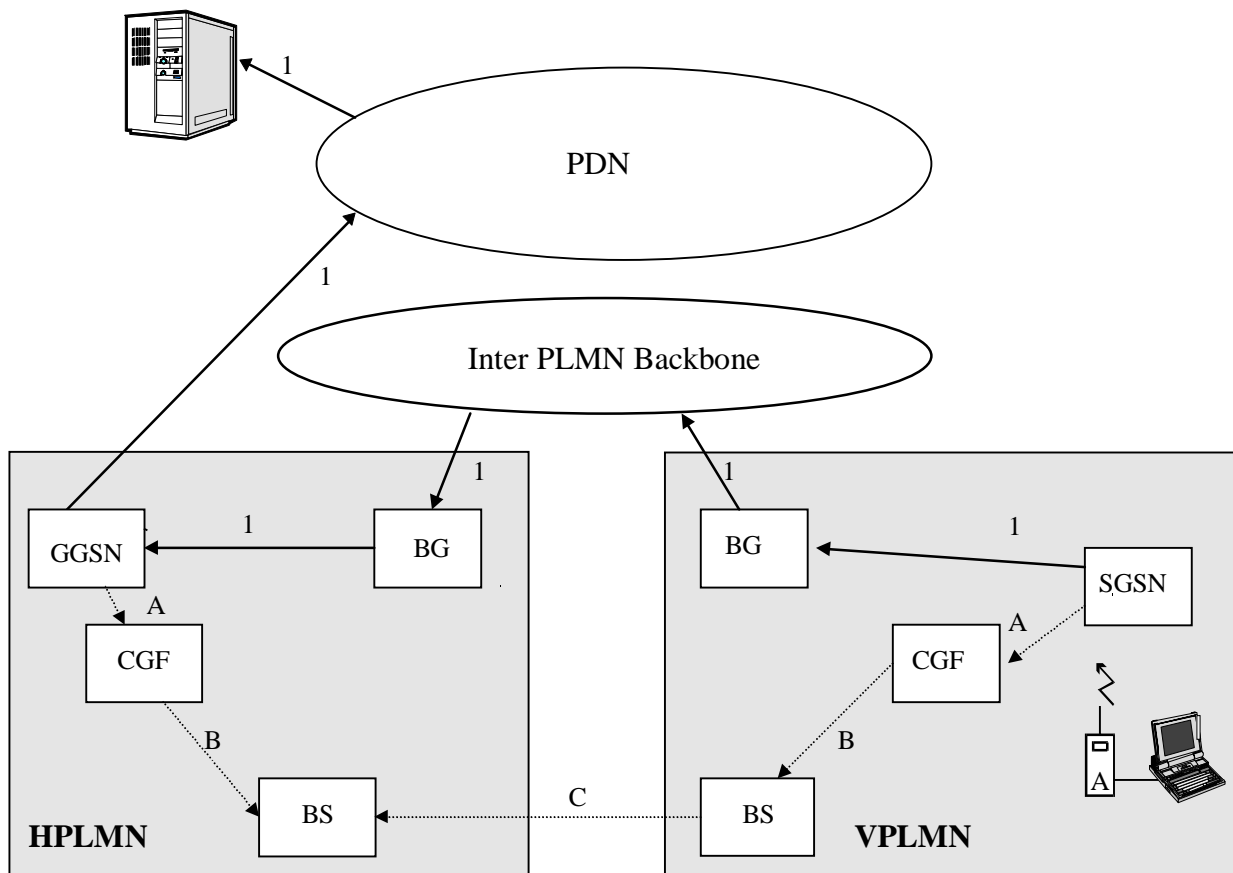

Figure 8: GPRS Mobile to PDN Context whilst roaming via BG

6. Charging Data Collection

6.1 Record contents

The following tables describe the contents of each of the call and event records generated by the GSNs. Each table contains the name of the field, a key indicating whether or not the field is mandatory, and a description of the contents.

The key field has the following meaning:

M This field is mandatory and always present. Any exceptions to this rule are explicitly described.

C This field is only available under certain conditions. If available the field is present.

The conditions under which the field is available are individually described.

O This field is optional and configurable either via additional TMN management functions or manufacturer specific means. For the avoidance of doubt, optional does not mean that the parameter is not supported by the network element. Equipment manufacturers shall be capable of providing all of these fields in order to claim conformance with this document.

The mandatory, conditional, and optional designations are described at the GSN / CGF interface (see exceptions below) and may be available at the CGF / BS interface to meet the Billing System requirement.

All the mandatory or conditional fields are not required in all CDRs at the GSN / CGF interface in the following cases:

- Each information element is included at least in one record. This applies for situations where partial records are produced between the GSN and CGF, and the information has not changed, e.g. "GGSN Address Used". The following primary identifier fields are however needed in all records: Record Type, Served IMSI, and if the CDR is related to a PDP context (G-CDR and S-CDR), then also the Charging ID.
- GSNs are configured to produce only part of the described information. This applies for situations where record types are not produced or some functional component is excluded from the records such as whole M-CDR or time based charging in G-CDR.

In the case of a distributed CGF the following charging data records are not applicable at the GSN / CGF interface and proprietary solutions or variations to this standard are allowed. However, the described information content needs to be supported to be able to conform to the requirements towards the BS.

6.1.1 GPRS charging data in SGSN (S-CDR)

If the collection of SGSN data is enabled then the following GPRS SGSN data shall be available for each PDP context.

Table 5: GPRS SGSN PDP context data

Field		Description
Record Type	M	GPRS SGSN PDP context record.
Network initiated PDP context	C	Present if this is a network initiated PDP context.
Anonymous Access Indicator	C	Set to true to indicate anonymous access (and that the Served IMSI is not supplied)
Served IMSI	M	IMSI of the served party (if Anonymous Access Indicator is FALSE or not supplied).
Served IMEI	C	The IMEI of the ME, if available.
SGSN Address	M	The IP address of the current SGSN.
MS Classmark	O	The mobile station classmark employed.
Routing area	O	Routing area at the time of the record creation.
Local Area Code	O	Location area code at the time of the record creation.
Cell Identity	O	Cell id at the time of the record creation.
Charging ID	M	PDP context identifier used to identify this PDP context in different records created by GSNs
GGSN Address Used	M	The IP address of the GGSN currently used. The GGSN address is always the same for an activated PDP.
Access Point Name	M	The logical name of the connected access point to the external packet data network.
PDP Type	M	PDP type, e.g. X.25 or IP
Served PDP address	M	PDP address of the served IMSI, e.g. an IPv4, IPv6 or X.121.
List of traffic data volumes	M	A list of changes in charging conditions for this PDP context, each time stamped. Charging conditions are used to categorise traffic volumes, such as per QoS/tariff period. Initial and subsequently changed QoS and corresponding data values are listed. Data volumes are in Octets above the SNDCP layer and are separated for uplink and downlink traffic.
Record opening time	M	Time stamp when PDP context activation is created in this SGSN or record opening time on following partial records
Duration	M	Duration of this record in the SGSN.
SGSN change	C	Present if this is first record after SGSN change.
Cause for record closing	M	The reason for the release of record from this SGSN.
Diagnostics	O	A more detailed reason for the release of the connection.
Record Sequence number	C	Partial record sequence number in this SGSN. Only present in case of partial records.
Node ID	O	Name of the recording entity
Record extensions	O	A set of network/ manufacturer specific extensions to the record.

6.1.2 GPRS charging data in GGSN (G-CDR)

If the collection of GGSN data is enabled then the following GPRS GGSN data shall be available for each PDP context.

Table 6: GPRS GGSN PDP context data

Field		Description
Record Type	M	GPRS GGSN PDP context record.
Network initiated PDP context	C	Present if this is a network initiated PDP context.
Anonymous Access Indicator	C	Set to true to indicate anonymous access (and that the Served IMSI is not supplied).
Served IMSI	M	IMSI of the served party (if Anonymous Access Indicator is FALSE or not supplied).
GGSN Address	M	The IP address of the GGSN used.
Charging ID	M	PDP context identifier used to identify this PDP context in different records created by GSNs
SGSN Address	M	List of SGSN addresses used during this record.
Access Point Name	M	The logical name of the connected access point to the external packet data network.
PDP Type	M	PDP type, e.g. X.25 or IP
Served PDP Address	M	PDP address, e.g. an IPv4, IPv6 or X.121.
Remote PDP Address	O	List of PDP addresses of the remote host or DTE e.g. an IPv4, IPv6, or X.121 (Included if the PDP type is X.25)
Dynamic Address Flag	C	Indicates whether served PDP address is dynamic, that is allocated during PDP context activation.
List of traffic data volumes	M	A list of changes in charging conditions for this PDP context, each time stamped. Charging conditions are used to categorise traffic volumes, such as per tariff period. Initial and subsequently changed QoS and corresponding data values are listed. Data volumes are in octets above the GTP layer and are separated for uplink and downlink traffic.
Record opening time	M	Time stamp when this record was opened.
Duration	M	Duration of this record in the GGSN .
Cause for record closing	M	The reason for the release of record from this GGSN .
Diagnostics	O	A more detailed reason for the release of the connection.
Record Sequence number	C	Partial record sequence number, only present in case of partial records.
Node ID	O	Name of the recording entity.
Record extensions	O	A set of network/ manufacturer specific extensions to the record.

6.1.3 GPRS mobile station mobility management data in SGSN (M-CDR)

If the collection of MS mobility management data is enabled then GPRS SGSN shall start collecting information each time the mobile is attached to the SGSN.

Table 7: GPRS SGSN mobile station mobility management data

Field		Description
Record Type	M	GPRS SGSN mobility management record.
Served IMSI	M	IMSI of the MS.
Served IMEI	C	The IMEI of the ME, if available.
SGSN Address	M	The IP address of the current SGSN.
MS Classmark	O	The mobile station classmark employed.
Routing area	O	Routing area at the time of the record creation..
Local Area Code	O	Location area code at the time of record creation.
Cell Identity	O	Cell id at the time of the record creation.
Change of Location	O	A list of changes in Routing Area Identity, each time stamped.
Record opening time	M	Timestamp when this record was opened.
Duration	O	Duration of this record.
SGSN change	C	Present if this is first record after SGSN change.
Cause for record closing	M	The reason for the release of the record in this SGSN.
Diagnostics	O	A more detailed reason for the release of the connection.
Record Sequence number	C	Partial record sequence number in this SGSN, only present in case of partial records.
Node ID	O	Name of the recording entity.
Record extensions	O	A set of network/ manufacturer specific extensions to the record.

6.1.4 GPRS MO SMS data in SGSN (S-SMO-CDR)

If enabled, an S-SMO-CDR SGSN Mobile originated SMS record shall be produced for each short message sent by a mobile subscriber via SGSN.

Table 8: SGSN Mobile originated SMS record

Field		Description
Record Type	M	SGSN Mobile originated SMS.
Served IMSI	M	The IMSI of the subscriber.
Served IMEI	O	The IMEI of the ME, if available.
Served MSISDN	O	The primary MSISDN of the subscriber.
MS Classmark	M	The mobile station classmark.
Service Centre	M	The address (E.164) of the SMS-service centre.
Recording Entity	M	The E.164 number of the SGSN.
Location Area Code	O	The Location Area Code from which the message originated.
Routing Area Code	O	The Routing Area Code from which the message originated.
Cell Identity	O	The Cell Identity from which the message originated.
Event Time stamp	M	The time at which the message was received by the SGSN from the subscriber.
Message Reference	M	A reference, provided by the MS uniquely identifying this message.
SMS Result	C	The result of the attempted delivery if unsuccessful.
Record extensions	O	A set of network/ manufacturer specific extensions to the record.

6.1.5 GPRS MT SMS data in SGSN (S-SMT-CDR)

If enabled, an SGSN Mobile terminated SMS record shall be produced for each short message received by a mobile subscriber via SGSN.

Table 9: SGSN Mobile terminated SMS record

Field		Description
Record Type	M	SGSN Mobile terminated SMS.
Served IMSI	M	The IMSI of the subscriber.
Served IMEI	O	The IMEI of the ME, if available.
Served MSISDN	O	The primary MSISDN of the subscriber.
MS Classmark	M	The mobile station classmark.
Service Centre	M	The address (E.164) of the SMS-service centre.
Recording Entity	M	The E.164 number of the SGSN.
Location Area Code	O	The Location Area Code to which the message was delivered.
Routing Area Code	O	The Routing Area Code to which the message was delivered.
Cell Identity	O	The Cell Identity to which the message was delivered.
Event Time stamp	M	Delivery time stamp, time at which message was sent to the MS by the SGSN.
SMS Result	C	The result of the attempted delivery if unsuccessful.
Record extensions	O	A set of network/ manufacturer specific extensions to the record.

6.1.6 Description of Record Fields

This subclause contains a brief description of each field of the CDRs described in the previous subclause.

6.1.6.1 Access Point Name

This field contains the logical Access Point Name used to determine the actual connected access point. APN comprises of mandatory network identifier and optional operator identifier. APN can also be a wildcard, in which case SGSN selects the access point address. See GSM 09.60 [22] and GSM 03.60 [8] for more information about APN format and access point decision rules.

6.1.6.2 Cause for record closing

This field contains a reason for the release of the CDR including the following:

- normal release: PDP context release or GPRS detach;
- partial record generation: data volume limit, time (duration) limit, SGSN change of maximum number of changes in charging conditions;
- abnormal termination (PDP or MM context);
management intervention (request due to O&M reasons).

A more detailed reason may be found in the diagnostics field.

6.1.6.3 Charging ID

This field is a charging identifier which can be used together with GGSN address to identify all records produced in SGSN(s) and GGSN involved in a single PDP context. Charging ID is generated by GGSN at PDP context activation and transferred to context requesting SGSN. At inter-SGSN routing area update charging ID is transferred to the new SGSN as part of each active PDP context.

Different GGSNs allocate the charging ID independently of each other and may allocate the same numbers. The CGF and/or BS may check the uniqueness of each charging ID together with the GGSN address and optionally (if still unambiguous) with the record opening time stamp.

6.1.6.4 Diagnostics

This field includes a more detailed technical reason for the release of the connection and may contain one of the following:

- a MAP error from GSM 09.02 [17];
- a Cause from GSM 04.08 [16];

The diagnostics may also be extended to include manufacturer and network specific information.

6.1.6.5 Duration

This field contains the relevant duration in seconds for PDP contexts (S-CDR, G-CDR, and attachment (M-CDR)). For partial records this is the duration of the individual partial record and not the cumulative duration.

It should be noted that the internal time measurements may be expressed in terms of tenths of seconds or even milliseconds and, as a result, the calculation of the duration may result in the rounding or truncation of the measured duration to a whole number of seconds.

Whether or not rounding or truncation is to be used is considered to be outside the scope of this Specification subject to the following restrictions:

- 1) A duration of zero seconds shall be accepted providing that the transferred data volume is greater than zero.
- 2) The same method of truncation/rounding shall be applied to both single and partial records.

6.1.6.6 Dynamic Address Flag

This field indicates that PDP address has been dynamically allocated for that particular PDP context. Field is missing if address is static i.e. part of PDP context subscription. Dynamic address allocation might be relevant for charging e.g. the duration of PDP context as one resource offered and possible owned by network operator.

6.1.6.7 Event time stamps

These fields contain the event time stamps relevant for each of the individual record types.

All time-stamps include a minimum of date, hour, minute, and second.

6.1.6.8 GGSN address/GGSN address used

These fields contain one IP address of GGSN.

The S-CDR fields contain a single address of current GGSN used.

The G-CDR fields contain an address of current GGSN.

6.1.6.9 List of traffic data volumes

This list includes one or more containers, which each include the following fields:

Data volume uplink, data volume downlink, change condition and change time.

Data volume includes the number of octets transmitted during the use of packet data services.

Change condition defines the reason for closing the container (see 5.7.1 and 5.7.3), such as tariff time change, QoS change or closing the CDR. Change time is a time stamp which defines the moment when the new volume counts are started or CDR is closed. All the active PDP contexts do not need to have exactly the same time stamp e.g. due to same

tariff time change (variance of the time stamps is implementation and traffic load dependent and is out of the scope of standardisation).

First container includes following optional fields: QoS Requested (not in G-CDR) and QoS Negotiated. In following containers QoS Negotiated is present if previous change condition is QoS change.

Following is an example of a list, which has three containers (sets of volume counts) caused by one QoS change and one tariff time change.

Table 10: Example list of traffic data volumes

QoS Requested = QoS1 QoS Negotiated = QoS1	QoS Negotiated = QoS2	
Data Volume Uplink = 1 Data Volume Downlink = 2	Data Volume Uplink = 5 Data Volume Downlink = 6	Data Volume Uplink = 3 Data Volume Downlink = 4
Change Condition = QoS change Time Stamp = TIME1	Change Condition = Tariff change Time Stamp = TIME2	Change Condition = Record closed Time Stamp = TIME3

First container includes initial QoS values and corresponding volume counts. Second container includes new QoS values and corresponding volume counts before tariff time change. Last container includes volume counts after the tariff time change. Following total volume counts can be itemised (tariff1 is used before and tariff2 after the tariff time change):

		Container
QoS1+Tariff1	uplink = 1, downlink = 2	1
QoS2+Tariff1	uplink = 5, downlink = 6	2
QoS2+Tariff2	uplink = 3, downlink = 4	3
QoS1	uplink = 1, downlink = 2	1
QoS2	uplink = 8, downlink = 10	2+3
Tariff1	uplink = 6, downlink = 8	1+2
Tariff2	uplink = 3, downlink = 4	1

The amount of data counted in the GGSN shall be the data volume sent over the GTP layer. Therefore the data counted already includes the IP/X.25 PDP bearer protocols.

The data volume counted in the SGSN covers the amount of data transferred in the SMDCP PDUs. Therefore the data counted already includes the IP/X.25 PDP bearer protocols.

In order to avoid that downstream packets transmitted from the old SGSN to the new SGSN at inter SGSN RA update induce the increase of the PDP CDR downstream volume counters in both SGSN the following rule is followed :

- for PDP contexts using LLC in unacknowledged mode : an SGSN shall update the PDP CDR when the packet has been sent by the SGSN towards the MS
- for PDP contexts using LLC in acknowledged mode : an SGSN shall only update the PDP CDR at the reception of the acknowledgement of the correct reception of a downstream packet by the MS. This implies that for downstream packets under transmission at inter SGSN RA update a packet sent by the old SGSN actually received by the MS and acknowledged by the MS towards the new SGSN through the RA update complete message induces the update of the PDP CDR record by the new SGSN.

Data volumes retransmitted (by RLC or LLC) due to poor radio link conditions shall not be counted.

6.1.6.10 Message reference

This field contains a unique message reference number allocated by the mobile station when transmitting a short message to the service centre. This field corresponds to the TP-Message-Reference element of the SMS_SUBMIT PDU defined in GSM 03.40.

6.1.6.11 Mobile station classmark

This MS classmark field contains the mobile station classmark 4 employed by the served MS on PDP context activation or on GPRS attachment as defined in GSM 04.08 [16].

6.1.6.12 Network initiated PDP context

This field indicates that PDP context is network initiated. The field is missing in case of mobile activated PDP context.

6.1.6.13 Node ID

This field contains an optional operator configurable identifier string for the node which generated the CDR.

6.1.6.14 PDP Type

This field defines the PDP type, e.g. X.25 or IP (see GSM 09.60 for exact format).

6.1.6.15 QoS Requested/QoS Negotiated

Quality of Service Requested contains the QoS wanted by MS at PDP context activation. QoS Negotiated indicates the applied QoS accepted by the network.

The QoS profile consists of 5 attributes: reliability, delay, precedence, peak throughput and mean throughput. See GSM 03.60 [8] for more details.

6.1.6.16 Record extensions

The field enables network operators and/or manufacturers to add their own extensions to the standard record definitions. This field contains a set of "management extensions" as defined in CCITT X.721 [5].

6.1.6.17 Record opening time

This field contains the time stamp when the record is opened (see GSM 12.05 for exact format).

Record opening reason does not have a separate field. For G-CDR and M-CDR it can be derived from the field "Sequence number" i.e. missing field or value one means activation of PDP context and GPRS attachment. For S-CDR also field "SGSN change" need to be taken into account.

6.1.6.18 Record Sequence number

This field contains a running sequence number employed to link the partial records generated in the SGSN/GGSN for a particular PDP context (characterised with same the Charging ID and GGSN address pair). In the S-CDR the sequence number is always started from one after inter-SGSN routing area update, see field "SGSN change". Sequence number is missing if record is the only one produced in the SGSN/GGSN for the PDP context (e.g. inter-SGSN routing area update can result to two S-CDRs without sequence number and field "SGSN update" present in the second record).

6.1.6.19 Record type

The field identifies the type of the record e.g. S-CDR, G-CDR, M-CDR, S-SMO-CDR and S-SMT-CDR.

6.1.6.20 Recording entity number

This field contains the ITU-T E.164 number assigned to the entity that produced the record. For further details see GSM 03.03.

6.1.6.21 Remote PDP address

Remote PDP address may be used if PDP type is X.25. This parameter is not used if the PDP type is IP. Itemised volume billing is available per Access Point Name. This field contains a list of connected remote PDP addresses.

6.1.6.22 Routing Area Code/Cell Identity/Change of location

The location information contains a combination of the Routing Area Code (RAC) and optionally Cell Identity (CI) of the routing area and cell in which the served party is currently located. Any change of location (i.e. Routing area change) may be recorded in the change of location field including the time at which the change took place.

The change of location field is optional and not required if partial records are generated when the location changes.

The RAC and (optionally) CI are coded according to GSM 04.08 [16].

6.1.6.23 Served IMEI

This field contains the international mobile equipment identity (IMEI) of the equipment served. The term "served" equipment is used to describe the ME involved in the transaction recorded e.g. the called ME in the case of a network initiated PDP context.

The structure of the IMEI is defined in GSM 03.03 [14].

6.1.6.24 Served IMSI

This field contains the international mobile subscriber identity (IMSI) of the served party. The term "served" party is used to describe the mobile subscriber involved in the transaction recorded e.g. the calling subscriber in case of a mobile initiated PDP context.

The structure of the IMSI is defined in GSM 03.03 [14].

6.1.6.25 Served MSISDN

This field contains the mobile station ISDN number (MSISDN) of the served party. The term "served" party is used to describe the mobile subscriber involved in the transaction recorded e.g. the called subscriber in case of an MTC record. In case of multi-numbering the MSISDN stored in a MOC record will be the primary MSISDN of the calling party.

The structure of the MSISDN is defined in GSM 03.03.

6.1.6.26 Served PDP address

This field contains the PDP address of the served IMSI. This is a network layer address e.g. of type IP version 4, IP version 6 or X.121. The address for each PDP type is allocated either temporarily or permanently, see field "Dynamic Address Flag".

6.1.6.27 Service centre address

This field contains a CCITT E.164 number identifying a particular service centre e.g. short message service centre (see GSM 03.40).

6.1.6.28 SGSN address

These fields contain one or several IP addresses of SGSN.

The S-CDR fields contain single address of current SGSN and GGSN used.

The G-CDR fields contain the address of the current GGSN and a list of SGSNs, which have been connected during the record (SGSN change due to inter SGSN routing area update).

The M-CDR only contains the address of the current SGSN. The M-CDR does not identify any information related to active PDP context(s) and thus does not know connected (used) GGSN(s).

6.1.6.29 SGSN change

This field is present only in the S-CDR to indicate that this is the first record after an inter-SGSN routing area update.

6.1.6.30 Short message service result

This field contains the result of an attempt to deliver a short message either to a service centre or to a mobile subscriber (see GSM 09.02). Note that this field is only provided if the attempted delivery was unsuccessful

7 Charging Protocols

For Future Study.

8 Charging Data Record Structure

8.1 ASN.1 definitions for CDR information

Within the current GSM 12-series of specifications the ASN.1 definitions are based on X.208 [40] which has been superseded by X.680. This newer version not only includes new features but also removes some that were present in X.208. It was agreed that where possible, the GPRS work would be based on those ASN.1 features that were common to both. However, where necessary, the new features in X.680 [41] be used in some places. X.208 feature that are no longer in X.680 will not be used.

Changes (enhancements) in GSM1205-DataTypes:

```

CallEventRecordType ::= INTEGER
{
    moCallRecord          (0),
    mtCallRecord          (1),
    roamingRecord         (2),
    incGatewayRecord      (3),
    outGatewayRecord      (4),
    transitCallRecord     (5),
    moSMSRecord           (6),
    mtSMSRecord           (7),
    moSMSIWRecord         (8),
    mtSMSGWRecord         (9),
    ssActionRecord        (10),
    hlrIntRecord          (11),
    termCAMELIntRecord    (12),
    locUpdateHLRRecord    (13),
    locUpdateVLRRecord    (14),
    commonEquipRecord     (15),
    moTraceRecord         (16),
    mtTraceRecord         (17),
    sgsnPDPRecord         (18),
    ggsnPDPRecord         (19),
    sgsnMMRecord          (20),
    sgsnSMORRecord        (21),
    sgsnSMTRRecord        (22)
}
GPRS_Charging-DataTypes { ... }

DEFINITIONS IMPLICIT TAGS ::=
BEGIN

-- EXPORTS everything

IMPORTS

CellId, Classmark, Diagnostics, CallDuration, ManagementExtensions, TimeStamp, MSISDN,
LocationAreaCode, MessageReference, RecordingEntity, SMSResult
FROM GSM1205-DataTypes { ccitt (0) identified-organization (4) etsi(0) mobileDomain (0) gsmOperation-
Maintenance (3) moduleId (3) gsm-12-05 (5) InformationModel (0) asn1Module (2) 1 }

AddressString, ISDN-AddressString, IMSI, IMEI
FROM MAP-CommonDataTypes { ccitt identified-organization (4) etsi(0) mobileDomain (0) gsmNetworkId
(1) moduleId (3) map-CommonDataTypes (18) version2 (2) }

ObjectInstance

```

FROM CMIP-1 {joint-iso-ccitt ms(9) cmip(1) version1 (1) protocol (3)}

ManagementExtension

FROM Attribute-ASN1Module {joint-iso-ccitt ms(9) smi(3) part2 (2) asn1Module(2) 1}

AE-title

FROM ACSE-1 {joint-iso-ccitt association-control(2) abstract-syntax(1) apdus(0) version(1) };

--

-- Note that the syntax of AE-title to be used is from
 -- CCITT Rec. X.227 / ISO 8650 corrigendum and not "ANY"

--

 -- CALL AND EVENT RECORDS
 --

CallEventRecord ::= CHOICE

```
{
  sgsnPDPRecord      [0] SGSNPDPRecord,
  ggsnPDPRecord      [1] GGSNPDPRecord,
  sgsnMMRecord       [2] SGSNMMRecord,
  sgsnSMORRecord     [3] SGSNSMORRecord,
  sgsnSMTRRecord     [4] SGSNSMTRRecord
}
```

GGSNPDPRecord ::= SET

```
{
  recordType          [0] CallEventRecordType,
  networkInitiation  [1] NetworkInitiatedPDPContext OPTIONAL,
  anonymousAccessIndicator [2] BOOLEAN OPTIONAL,
  servedIMSI         [3] IMSI,
  ggsnAddress        [4] GSNAddress,
  chargingID         [5] ChargingID,
  sgsnAddress        [6] SEQUENCE OF GSNAddress,
  accessPointName    [7] AccessPointName,
  pdpType            [8] PDPType,
  servedPDPAddress   [9] PDPAddress,
  remotePDPAddress   [10] SEQUENCE OF PDPAddress OPTIONAL,
  dynamicAddressFlag [11] DynamicAddressFlag OPTIONAL,
  listOfTrafficVolumes [12] SEQUENCE OF ChangeOfCharCondition,
  recordOpeningTime  [13] TimeStamp,
  duration           [14] CallDuration,
  causeForRecClosing [15] CauseForRecClosing,
  diagnostics        [16] Diagnostics OPTIONAL,
  recordSequenceNumber [17] INTEGER OPTIONAL,
  nodeID             [18] IA5 string OPTIONAL
  recordExtensions   [19] ManagementExtensions OPTIONAL
}
```

SGSNMMRecord ::= SET

```
{
  recordType          [0] CallEventRecordType,
  servedIMSI         [1] IMSI,
  servedIMEI         [2] IMEI OPTIONAL,
  sgsnAddress        [3] GSNAddress,
  msClassmark       [4] Classmark OPTIONAL,
  routingArea        [5] RoutingAreaCode OPTIONAL,
  locationAreaCode  [6] LocationAreaCode OPTIONAL,
  cellIdentity       [7] CellId OPTIONAL,
  changeLocation     [8] SEQUENCE OF ChangeLocation OPTIONAL,
  recordOpeningTime  [9] TimeStamp,
  duration           [10] CallDuration OPTIONAL,
  sgsnChange         [11] SGSNChange OPTIONAL,
  causeForRecClosing [12] CauseForRecClosing,
  diagnostics        [13] Diagnostics OPTIONAL,
  recordSequenceNumber [14] INTEGER OPTIONAL,
  nodeID             [15] IA5 string OPTIONAL
  recordExtensions   [16] ManagementExtensions OPTIONAL
}
```

SGSNPDPRecord ::= SET

```
{
  recordType          [0] CallEventRecordType,
  networkInitiation  [1] NetworkInitiatedPDPContext OPTIONAL,
  anonymousAccessIndicator [2] BOOLEAN OPTIONAL,
  servedIMSI         [3] IMSI,
  servedIMEI         [4] IMEI OPTIONAL,
  sgsnAddress        [5] GSNAddress,
  msClassmark       [6] Classmark OPTIONAL,
  routingArea        [7] RoutingAreaCode OPTIONAL,
  locationAreaCode  [8] LocationAreaCode OPTIONAL,
}
```



```

cellIdentity          [9] CellId OPTIONAL,
chargingID            [10] ChargingID,
ggsnAddressUsed      [11] GSNAddress,
accessPointName      [12] AccessPointName,
pdpType              [13] PDPType,
servedPDPAddress     [14] PDPAddress,
listOfTrafficVolumes [15] SEQUENCE OF ChangeOfCharCondition,
recordOpeningTime    [16] TimeStamp,
duration              [17] CallDuration,
sgsnChange           [18] SGSNChange OPTIONAL,
causeForRecClosing   [19] CauseForRecClosing,
diagnostics          [20] Diagnostics OPTIONAL,
recordSequenceNumber [21] INTEGER OPTIONAL,
nodeID               [22] IA5 string OPTIONAL
recordExtensions     [23] ManagementExtensions OPTIONAL
}

```

```
SGSNSMORecord ::= SET
```

```

{
  recordType          [0] CallEventRecordType,
  servedIMSI          [1] IMSI,
  servedIMEI          [2] IMEI OPTIONAL,
  servedMSISDN        [3] MSISDN OPTIONAL,
  msClassmark         [4] Classmark,
  serviceCentre       [5] AddressString,
  recordingEntity     [6] RecordingEntity,
  locationArea        [7] LocationAreaCode OPTIONAL,
  routingArea         [8] RoutingAreaCode OPTIONAL,
  cellIdentity        [9] CellId OPTIONAL,
  messageReference    [10] MessageReference,
  originationTime     [11] TimeStamp,
  smsResult           [12] SMSResult OPTIONAL,
  recordExtensions    [13] ManagementExtensions OPTIONAL
}

```

```
SGSNSMTRecord ::= SET
```

```

{
  recordType          [0] CallEventRecordType,
  servedIMSI          [1] IMSI,
  servedIMEI          [2] IMEI OPTIONAL,
  servedMSISDN        [3] MSISDN OPTIONAL,
  msClassmark         [4] Classmark,
  serviceCentre       [5] AddressString,
  recordingEntity     [6] RecordingEntity,
  locationArea        [7] LocationAreaCode OPTIONAL,
  routingArea         [8] RoutingAreaCode OPTIONAL,
  cellIdentity        [9] CellId OPTIONAL,
  originationTime     [10] TimeStamp,
  smsResult           [11] SMSResult OPTIONAL,
  recordExtensions    [12] ManagementExtensions OPTIONAL
}

```

```

-----
--
-- OBJECT IDENTIFIERS
--
-----

```

```

gsm1205InformationModel OBJECT IDENTIFIER ::=
{ ccitt (0) identified-organization (4) etsi (0) mobileDomain (0)
  gsm-Operation-Maintenance (3) gsm-12-05 (5) informationModel (0) }

```

```

gsm1205ASN1Module OBJECT IDENTIFIER ::=
{ gsm1205InformationModel asn1Module(2) }

```

```

gsm1205ManagedObjectClass OBJECT IDENTIFIER ::=
{ gsm1205InformationModel managedObjectClass(3) }

```

```

gsm1205Package OBJECT IDENTIFIER ::=
{ gsm1205InformationModel package(4) }

```

```

gsm1205NameBinding OBJECT IDENTIFIER ::=
{ gsm1205InformationModel nameBinding(6) }

```

```

gsm1205Attribute OBJECT IDENTIFIER ::=
{ gsm1205InformationModel attribute(7) }

```

```

gsm1205Action OBJECT IDENTIFIER ::=
{ gsm1205InformationModel action(9) }

```

```

gsm1205Notification OBJECT IDENTIFIER ::=
{ gsm1205InformationModel notification(10) }

```

```

-----
--
-- COMMON DATA TYPES
--
-----

AccessPointName ::= IA5String (SIZE(1..63))
--
-- logical (domain) name in "dot" representation
-- see TS GSM 09.60
--

CauseForRecClosing ::= INTEGER
{
--
-- in GGSN the value sGSNChange should be used for partial record
-- generation due to SGSN Address List Overflow
--
pDPContextRelease      (0),
volumeLimit             (1),
timeLimit               (2),
sGSNChange              (3),
maxChangeCond           (4),
gPRSDetach              (5),
managementIntervention (6),
abnormalRelease         (7)
}

ChangeCondition ::= ENUMERATED
{
qoSChange                (0),
tariffTime                (1),
recordClosure             (2)
}

ChangeOfCharCondition ::= SEQUENCE
--
-- used in PDP context record only
--
{
qoSRequested              [1] QoSInformation OPTIONAL,
qoSNegotiated             [2] QoSInformation OPTIONAL,
dataVolumeGPRSUpLink     [3] DataVolumeGPRS,
dataVolumeGPRSDownLink   [4] DataVolumeGPRS,
changeCondition           [5] ChangeCondition,
changeTime                [6] TimeStamp
}

ChangeLocation ::= SEQUENCE
--
-- used in SGSNMMRecord only
--
{
locationAreaCode         [0] LocationAreaCode,
routingAreaCode          [1] RoutingAreaCode,
cellId                   [2] CellID OPTIONAL,
changeTime               [3] TimeStamp
}

ChargingID ::= INTEGER (0..4294967295)
--
-- generated in GGSN, part of PDP context, see TS GSM 03.60
-- 0..4294967295 is equivalent to 0..2**32-1

DataVolumeGPRS ::= INTEGER
--
-- The volume of uncompressed data transferred in octets.
--

DynamicAddressFlag ::= BOOLEAN

ETSIAddress ::= AddressString
--
-- first octet for nature of address, and numbering plan indicator (3 for X.121)
-- other octets TBCD
-- See TS GSM 09.02
--

GSNAddress ::= IPAddress

IPAddress ::= CHOICE
{

```

```

    iPBinaryAddress  IPBinaryAddress,
    iPTextRepresentedAddress  IPTextRepresentedAddress
}
IPBinaryAddress ::= CHOICE
{
    iPBinV4Address      [0] OCTET STRING (SIZE(4)),
    iPBinV6Address      [1] OCTET STRING (SIZE(16))
}
IPTextRepresentedAddress ::= CHOICE
{
    --
    -- IP address in the familiar "dot" notation
    --
    iPTextV4Address     [2] IA5String (SIZE(7..15)),
    iPTextV6Address     [3] IA5String (SIZE(15..45))
}

NetworkInitiatedPDPContext ::= BOOLEAN
--
-- Set to true if PDP context was initiated from network side
--

NodeID ::= IA5 string (SIZE(1..20))

PDPAddress ::= CHOICE
{
    iPAddress           [0] IPAddress,
    eTSIAddress         [1] ETSIAddress
}

PDPTType ::= OCTET STRING (SIZE(2))
--
--OCTET 1: PDP Type Organization
--OCTET 2: PDP Type Number
-- See TS GSM 09.60
--

QoSDelay ::= ENUMERATED
{
    --
    -- See Quality of service TS GSM 04.08
    --
    delayClass1        (0),
    delayClass2        (1),
    delayClass3        (2),
    delayClass4        (3)
}

QoSInformation ::=SEQUENCE
{
    reliability         [0] QoSReliability,
    delay               [1] QoSDelay,
    precedence          [2] QoSPrecedence,
    peakThroughput     [3] QoSPeakThroughput,
    meanThroughput     [4] QoSMeanThroughput
}

QoSMeanThroughput ::= ENUMERATED
{
    --
    -- See Quality of service TS GSM 04.08
    --
    bestEffort         (0),
    mean100octetPh     (1),
    mean200octetPh     (2),
    mean500octetPh     (3),
    mean1000octetPh    (4),
    mean2000octetPh    (5),
    mean5000octetPh    (6),
    mean10000octetPh   (7),
    mean20000octetPh   (8),
    mean50000octetPh   (9),
    mean100000octetPh  (10),
    mean200000octetPh  (11),
    mean500000octetPh  (12),
    mean1000000octetPh (13),
    mean2000000octetPh (14),
    mean5000000octetPh (15),
    mean10000000octetPh (16),
    mean20000000octetPh (17),
    mean50000000octetPh (18)
}

QoSPeakThroughput ::= ENUMERATED

```

```
{
  --
  -- See Quality of service TS GSM 04.08
  --
  unspecified          (0),
  upTo1000OctetPs     (1),
  upTo2000OctetPs     (2),
  upTo4000OctetPs     (3),
  upTo8000OctetPs     (4),
  upTo16000OctetPs    (5),
  upTo32000OctetPs    (6),
  upTo64000OctetPs    (7),
  upTo128000OctetPs   (8),
  upTo256000OctetPs   (9)
}

QoSPrecedence ::= ENUMERATED
{
  --
  -- See Quality of service TS GSM 04.08
  --
  unspecified          (0),
  highPriority         (1),
  normalPriority       (2),
  lowPriority          (3)
}

QoSReliability ::= ENUMERATED
{
  --
  -- See Quality of service TS GSM 04.08
  --
  unspecifiedReliability (0),
  acknowledgedGTP       (1),
  unackGTPAcknowLLC     (2),
  unackGTPLLCAcknowRLC (3),
  unackGTPLLCRLC       (4),
  unacknowUnprotectedData (5)
}

RoutingAreaCode ::= OCTET STRING (SIZE(1))
  --
  -- See TS GSM 04.08 --
  --

SGSNChange ::= BOOLEAN
  --
  -- present if first record after inter SGSN routing area update
  -- in new SGSN
  --
```

Annex A(informative): Change history

This annex lists all phase2+ change requests approved for the present document by ETSI SMG.

SMG#	SMG tdoc	SMG6 tdoc	VERS	CR	RV	PH	CAT	SUBJECT	Resulting Version
s26	98-0335	98p044	2.0.0					GSM 12.15 approved at SMG #26	6.0.0
s27	98-0666	98p057& 98p058	6.0.0	A002		R97	F	Clarification to "GPRS charging logical architecture figure" and other corrections	6.1.0

History

Document history		
V6.1.0	October 1998	Publication