

ETSI TS 101 475 V1.2.2 (2001-02)

Technical Specification

**Broadband Radio Access Networks (BRAN);
HIPERLAN Type 2;
Physical (PHY) layer**



Reference

RTS/BRAN-0023003-R2

Keywordsaccess, broadband, HIPERLAN, LAN, layer 1,
radio**ETSI**

650 Route des Lucioles
F-06921 Sophia Antipolis Cedex - FRANCE

Tel.: +33 4 92 94 42 00 Fax: +33 4 93 65 47 16

Siret N° 348 623 562 00017 - NAF 742 C
Association à but non lucratif enregistrée à la
Sous-Préfecture de Grasse (06) N° 7803/88

Important notice

Individual copies of the present document can be downloaded from:

<http://www.etsi.org>

The present document may be made available in more than one electronic version or in print. In any case of existing or perceived difference in contents between such versions, the reference version is the Portable Document Format (PDF). In case of dispute, the reference shall be the printing on ETSI printers of the PDF version kept on a specific network drive within ETSI Secretariat.

Users of the present document should be aware that the document may be subject to revision or change of status. Information on the current status of this and other ETSI documents is available at <http://www.etsi.org/tb/status/>

If you find errors in the present document, send your comment to:
editor@etsi.fr

Copyright Notification

No part may be reproduced except as authorized by written permission.
The copyright and the foregoing restriction extend to reproduction in all media.

© European Telecommunications Standards Institute 2001.
All rights reserved.

Contents

Intellectual Property Rights	5
Foreword.....	5
1 Scope.....	6
2 References.....	6
3 Definitions, symbols and abbreviations	6
3.1 Definitions	6
3.2 Symbols.....	7
3.3 Abbreviations.....	8
4 Overview.....	9
4.1 Transport channels and PDU trains.....	9
4.2 Reference configuration.....	9
4.3 PHY layer functional entities.....	10
5 Physical layer	10
5.1 Introduction.....	10
5.2 Data scrambling	11
5.3 FEC coding.....	12
5.3.1 Code termination, encoding, P1 puncturing	12
5.3.1.1 Downlink PDU train, Uplink PDU train with short preamble, Uplink PDU train with long preamble, and Direct link PDU train	12
5.3.1.2 Broadcast PDU train, FCH-and-ACH PDU train	15
5.3.2 Code rate dependent puncturing P2	15
5.4 Data interleaving.....	16
5.5 Signal constellations and mapping.....	16
5.6 Modulation technique (OFDM).....	19
5.7 PHY bursts.....	21
5.7.1 Broadcast burst	23
5.7.2 Downlink burst	24
5.7.3 Uplink burst with short preamble.....	24
5.7.4 Uplink burst with long preamble	25
5.7.5 Direct link burst.....	26
5.8 Radio transmission	28
5.8.1 RF carriers.....	28
5.8.1.1 Nominal carriers frequencies.....	28
5.8.1.2 Accuracy and stability of RF carriers	28
5.8.1.3 RF generation and clocking timebase	28
5.8.2 Transmitted power	28
5.8.2.1 Mean Effective Isotropic Radiated Power (EIRP).....	28
5.8.2.2 Transmit spectrum mask	29
5.8.2.3 Transmitter centre frequency leakage and spectral flatness requirements.....	29
5.8.2.4 Transmit power time mask.....	29
5.8.2.5 Transmit power control.....	30
5.8.2.5.1 AP transmission power levels.....	30
5.8.2.5.2 Uplink power control.....	31
5.8.3 Unwanted RF radiation	32
5.9 Modulation accuracy	32
5.10 Switching times.....	32
5.10.1 Radio turn around time.....	32
5.10.2 Time to change RF carrier	32
5.10.3 Guard time between UL bursts	32
5.10.4 Guard time between DiL bursts	33
5.10.5 Guard time between random access bursts	33
5.10.6 Guard time for sector antenna implementations	33
5.11 Receiver parameters	33

5.11.1	Spurious emissions.....	33
5.11.2	Physical layer measurements.....	34
5.11.2.1	RSS0 measurement.....	34
5.11.2.2	RSS1 measurement.....	36
5.11.2.3	RSS2 measurement.....	37
5.11.3	Radio receiver performance.....	38
5.11.3.1	Receiver sensitivity.....	38
5.11.3.2	Maximum input level for operation	38
5.11.3.3	Radio receiver adjacent and non-adjacent channel performance	39
5.11.3.4	Maximum input level without blocking.....	39
Annex A (informative):	Bibliography.....	40
History		41

Intellectual Property Rights

IPRs essential or potentially essential to the present document may have been declared to ETSI. The information pertaining to these essential IPRs, if any, is publicly available for **ETSI members and non-members**, and can be found in ETSI SR 000 314: "*Intellectual Property Rights (IPRs); Essential, or potentially Essential, IPRs notified to ETSI in respect of ETSI standards*", which is available from the ETSI Secretariat. Latest updates are available on the ETSI Web server (<http://www.etsi.org/ipr>).

Pursuant to the ETSI IPR Policy, no investigation, including IPR searches, has been carried out by ETSI. No guarantee can be given as to the existence of other IPRs not referenced in ETSI SR 000 314 (or the updates on the ETSI Web server) which are, or may be, or may become, essential to the present document.

Foreword

This Technical Specification (TS) has been produced by ETSI Project Broadband Radio Access Networks (BRAN).

The present document describes the physical layer specifications for HIgh PErformance Radio Local Area Network type 2 (HIPERLAN/2). Separate ETSI documents provide details on the system overview, data link control layer, radio link control sublayer, convergence sublayers and conformance testing requirements for HIPERLAN/2.

1 Scope

The present document applies to the HIPERLAN/2 air interface with the specifications of layer 1 (physical layer), following the ISO-OSI model. HIPERLAN/2 is confined to only the radio access system consisting of the physical (PHY) layer and DLC layer, which are core network independent, and the core network specific Convergence sublayers. For managing radio resources, association and connection control, the radio link control protocol (see annex A) is applied which uses the transmission services of the DLC layer. The interworking with layers at the top of the radio subsystem is handled by Convergence layers above the DLC layer.

The present document defines the radio aspects like channel coding, interleaving, scrambling, modulation, radio transmission and reception.

The scope of the present document is as follows:

- it gives a description of the physical layer for HIPERLAN/2;
- it identifies those performance requirements needed to meet regulatory rules and service quality targets;
- it specifies the transmission scheme in order to allow interoperability between equipment developed by different manufacturers. This is achieved by describing the signal processing at the transmitter side, while the processing at the receiver side is left open to different implementation solutions.

The present document does not address the requirements and technical characteristics for conformance testing. These are covered by separate documents.

2 References

The following documents contain provisions which, through reference in this text, constitute provisions of the present document.

- References are either specific (identified by date of publication and/or edition number or version number) or non-specific.
- For a specific reference, subsequent revisions do not apply.
- For a non-specific reference, the latest version applies.

[1] ETSI TS 101 761-1: "Broadband Radio Access Networks (BRAN); HIPERLAN Type 2; Data Link Control (DLC) Layer; Part 1: Basic Data Transport Functions".

[2] CEPT/ERC/DEC(99)23: "ERC Decision of 29 November 1999 on the harmonized frequency bands to be designated for the introduction of High Performance Radio Local Area Networks (HIPERLANs)".

3 Definitions, symbols and abbreviations

3.1 Definitions

For the purposes of the present document, the following terms and definitions apply:

Access Feedback Channel (AFC): transport channel where the results of access attempts made in the previous MAC frame is conveyed

Antenna Reference Point (ARP): ARP is defined as the point where the power is equal to the power EIRP which could be measured at the antenna if an ideal isotropic antenna is used

Broadcast Channel (BCH): transport channel that broadcasts control information

Frame CHannel (FCH): transport channel that is broadcast and which carries the frame control channel

DLC connection: HIPERLAN/2 DLC operates connection oriented. A DLC connection carries either user or control data and is identified by a DLC connection identifier

downlink phase: part of the downlink transmission of a MAC Frame during which user and control data is transmitted from the access point or central controller to mobile terminals. The data transmitted can be user as well as control data in unicast, broadcast and multicast modus

Direct Mode (DM): data exchanged between two MTs associated with the same AP or CC takes place without passing but under control of the access point or the central controller

direct link phase: part of a MAC frame that only contains the data exchanged directly between two MTs in a direct link

Error Control (EC): error control is responsible for detection of transmission errors and, where appropriate, for the retransmissions. One error control instance is provided per DLC connection

MAC Frame: periodical structure in time direction that appears on the air interface and that determines the communication of HIPERLAN/2 devices. It consists of a sequence of traffic channels and its composition has to follow a number of rules

PDU train: sequence of transport channels delivered to PHY layer

PHY burst: sequence of OFDM symbols created by PHY layer to deliver a PDU train

PHY mode: PHY mode corresponds to a signal constellation (Modulation alphabet) and a code rate combination

Random CHannel (RCH): transport channel in the uplink of the MAC which carries the logical channels random access channel and association channel

Transport Channel (TC): basic element to construct PDU trains. Transport channels describe the message format

uplink phase: part of the MAC frame in which data is transmitted from mobile terminals to an access point or a central controller

3.2 Symbols

For the purposes of the present document, the following symbols apply:

$b_{e,do}$	Output bit indexed do of de-multiplexed bit stream indexed e of the P2 puncturing demultiplexer
$C_{l,n}$	Complex symbol for carrier l of the OFDM symbol no. n of the PDU train
Δ_f	Sub-carrier spacing
d_n	Output symbol number n from the symbol mapper
f_c	Carrier frequency
f_s	Sampling rate
G_1, G_2	Convolutional code generator polynomials
i	Bit index after the first and before the second permutation of the interleaver
j	Bit index after the second permutation of the interleaver
K_{MOD}	Modulation dependent normalization factor
l	Sub-carrier number
N_{BPSC}	Number of coded bits per subcarrier
N_{CBPS}	Number of coded bits per OFDM symbol
N_{DBPS}	Number of data bits per OFDM symbol
N_{BPDU}	Number of data bits per PDU train
N_{SD}	Number of data sub-carriers
N_{SP}	Number of pilot sub-carriers
N_{ST}	Total number of sub-carriers
N_{SYM}	Number of data OFDM symbols in a PDU train
n	OFDM symbol index inside a PDU train

n_{carrier}	Carrier index
P1	Code rate independent puncturing scheme for tail bit puncturing
P2	Code rate dependent puncturing
$P_{\text{avg},n}$	Mean power of a transmitted preamble during section n ($n = 1, \dots, 8$)
$P_{\text{avg},\text{data}}$	Mean power during a data portion of a PHY burst
$P_{\text{avg},\text{preamble}}$	Mean power of a whole ideal preamble which peak power equals to the maximum power (P_{max}) measured during the transmitted preamble
P_{max}	Maximum power measured during the transmitted preamble
P_n	Sequence to randomize the reference signal
R	Coding rate
$r_n(t)$	Time-domain representation of the baseband format of an OFDM symbol
$r_{\text{BURST}}(t)$	Time-domain representation of the PHY burst baseband format
$r_{\text{PAYLOAD}}(t)$	Time-domain representation of the payload section baseband format
$r_{\text{PREAMBLE}}(t)$	Time-domain representation of the preamble section baseband format
$r_{\text{RF}}(t)$	Time-domain representation of the transmitted signal
$S(x)$	Scrambling sequence generator polynomial
SA	Sequence defining symbols A and RA in the preamble
SB	Sequence defining symbols B and RB in the preamble
SC	Sequence defining the symbol C in the preamble
s	Branch index of the interleaver
T	Elementary time period
T_b	Time duration of a sample
T_{CP}	Cyclic prefix duration
T_S	Symbol interval
T_U	Useful symbol part duration
t_{PREAMBLE}	Preamble duration
X	Output vector from convolutional encoder (G_1)
x_{di}	Input bit number d_i to the puncturing P2
Y	Output vector from convolutional encoder (G_2)

3.3 Abbreviations

For the purposes of the present document, the following abbreviations apply:

ACH	Access feedback CHannel
AP	Access Point
ARP	Antenna Reference Point
BCH	Broadcast CHannel
CC	Central Controller
BPSK	Binary Phase Shift Keying
DFT	Discrete Fourier Transform
DiL	Direct Link
DLC	Data Link Control
DLCC	DLC Connection
DLCC-ID	DLC Connection Identifier
DM	Direct Mode
EC	Error Control
EIRP	Effective Isotropic Radiated Power
FEC	Forward Error Correction
FFT	Fast Fourier Transform
FCH	Frame CHannel
LCH	Long transport CHannel
MAC	Medium Access Control
MT	Mobile Terminal
OFDM	Orthogonal Frequency Division Multiplexing
PDU	Protocol Data Unit
PER	PDU Error Ratio

PHY	PHYSical
QAM	Quadrature Amplitude Modulation
QPSK	Quaternary Phase Shift Keying
RCH	Random CHannel
RSS	Received Signal Strength
SCH	Short transport CHannel

4 Overview

This clause is an overview of the PHY layer of HIPERLAN/2. It consists of a general description of the radio-related functions with the clauses where each part is specified in details. It also introduces the reference configuration that will be used throughout the present document.

4.1 Transport channels and PDU trains

The radio subsystem provides a set of transport channels describing the message format over the air interface. Transport channels are used as basic elements in constructing PDU trains. The PDU trains that consist of a sequence of transport channels represent the interface between the DLC protocol and the PHY layer. DLC specifies six different PDU train types (as specified in TS 101 761-1 [1]):

- 1) Broadcast PDU train;
- 2) FCH and ACH PDU train;
- 3) Downlink PDU train;
- 4) Uplink PDU train with short preamble;
- 5) Uplink PDU train with long preamble;
- 6) Direct link PDU train.

The mapping of PDU trains on PHY layer bursts is described in clause 5.7.

4.2 Reference configuration

For the purpose of elaborating the specification of physical layer functions, a reference configuration of the transmission chain is used as shown in figure 1. It should be noted that only the transmission part is specified, whereas the receiver being specified only via the overall performance requirements.

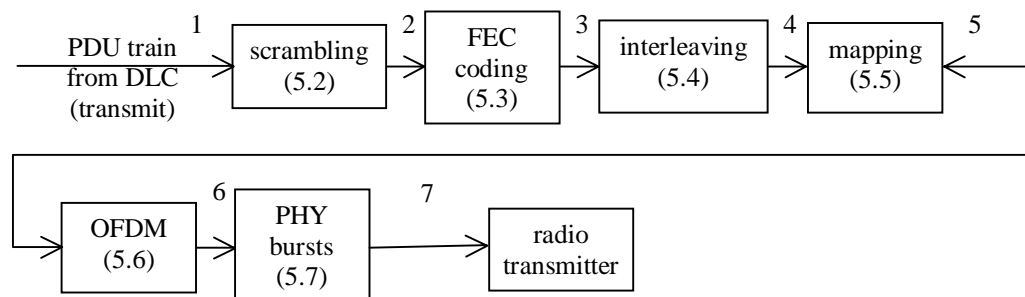

Figure 1: Reference configuration

The numbers 1 to 7 given in the reference configuration define the vocabulary in relation to the names of bits at different levels in the configuration as follows:

- 1) information bits (transmit);
- 2) scrambled bits;
- 3) encoded bits;

- 4) interleaved bits;
- 5) sub-carrier symbols;
- 6) complex baseband OFDM symbols;
- 7) PHY bursts.

The numbers in the functional blocks (clauses 5.2 to 5.7) refer to the clause that defines the respective block. These functional entities are shortly described below.

4.3 PHY layer functional entities

The PHY layer of HIPERLAN/2 offers information transfer services to the DLC of HIPERLAN/2. For this purpose, it provides for functions to map different DLC PDU trains into framing formats called PHY bursts appropriate for transmitting and receiving management and user information between an AP and an MT in the centralized mode or between two MTs in the direct mode. This includes the following functional entities in the transmitter:

- configuring the transmission bit rate by choosing appropriate PHY mode based on the link adaptation mechanism, described in clause 5.1;
- scrambling the PDU train content, described in clause 5.2;
- encoding the scrambled bits according to the forward error correction set during PHY layer configuration, described in clause 5.3;
- interleaving the encoded bits at the transmitter by using the appropriate interleaving scheme for the selected PHY mode, described in clause 5.4;
- sub-carrier modulation by mapping the interleaved bits into modulation constellation points, described in clause 5.5;
- producing the complex base-band signal by OFDM modulation described in clause 5.6;
- inserting pilot sub-carriers, appending appropriate preamble to the corresponding PDU train at the transmitter and building the PHY burst, described in clause 5.7;
- performing radio transmission by modulating the radio frequency carrier with the complex base-band signal at transmitter, described in clause 5.8.

NOTE 1: In the ISO-OSI terminology the DLC PDU trains are called PHY layer Service Data Units (SDUs).

NOTE 2: In the ISO-OSI terminology the PHY bursts are called PHY layer Protocol Data Units (PDUs).

5 Physical layer

5.1 Introduction

The PHY layer of HIPERLAN/2 is based on the modulation scheme Orthogonal Frequency Division Multiplexing (OFDM). In order to improve the radio link capability due to different interference situations and distance of MTs to the access point, a multi-rate PHY layer is applied, where the "appropriate" mode will be selected by a link adaptation scheme. The data rate ranging from 6 Mbit/s to 54 Mbit/s can be varied by using various signal alphabets for modulating the OFDM sub-carriers and by applying different puncturing patterns to a mother convolutional code. BPSK, QPSK, 16QAM are used as mandatory modulation formats, whereas 64QAM is applied as an optional one for both AP and MT. The mode dependent parameters are listed in the table 1.

Table 1: Mode dependent parameters

Modulation	Coding rate R	Nominal bit rate [Mbit/s]	Coded bits per sub-carrier N_{BPSC}	Coded bits per OFDM symbol N_{CBPS}	Data bits per OFDM symbol N_{DBPS}
BPSK	1/2	6	1	48	24
BPSK	3/4	9	1	48	36
QPSK	1/2	12	2	96	48
QPSK	3/4	18	2	96	72
16QAM	9/16	27	4	192	108
16QAM	3/4	36	4	192	144
64QAM	3/4	54	6	288	216

5.2 Data scrambling

The content of each PDU train (N_{BPDU} bits) from the DLC shall be scrambled with a length-127 scrambler. The scrambler uses the generator polynomial $S(x)$ as given by:

$$S(x) = X^7 + X^4 + 1$$

and is illustrated in figure 2. The same scrambler shall be used to scramble transmit data and to descramble receive data. All PDU trains belonging to a MAC frame are transmitted by using the same initial state for scrambling. The initialization shall be performed as follows:

- Broadcast PDU train in case AP uses one sector: scrambler initialized at the 5th bit of BCH, at the 1st bit of FCH and at the 1st bit of ACH;
- Broadcast PDU train in case AP uses multiple sectors: scrambler initialized at the 5th bit of BCH;
- FCH-and-ACH PDU train transmitted only in the case of a multiple sector AP: scrambler initialized at the 1st bit of FCH and at the 1st bit of ACH;
- Downlink PDU train, Uplink PDU train with short preamble, Uplink PDU train with long preamble, and Direct link PDU train: Scrambler initialized at the 1st bit of the PDU train.

The initial state shall be set to a pseudo random non-zero state, which is determined by the Frame counter field in the BCH at the beginning of the corresponding MAC frame. The Frame counter field consists of the first four bits of BCH, represented by $(n_4 n_3 n_2 n_1)_2$, and shall be transmitted unscrambled. n_4 shall be transmitted first. The initial state shall be derived by appending $(n_4 n_3 n_2 n_1)_2$ to the fixed binary number $(111)_2$ in the form $(111 n_4 n_3 n_2 n_1)_2$.

As an example if the Frame counter is given as $(0100)_2$, the initial state of the scrambler shall be $(111 0100)_2$. The transport channel content starting with $(10011101 000\dots)_2$ shall be scrambled to $(00111110 011\dots)_2$.

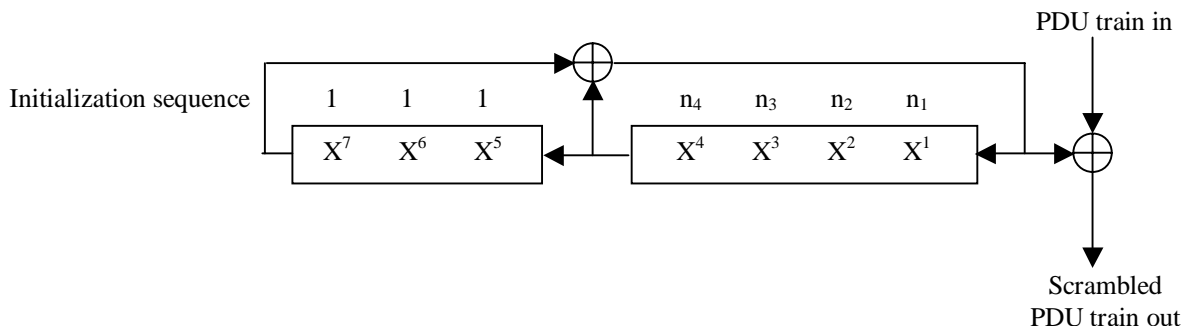

Figure 2: Scrambler schematic diagram

5.3 FEC coding

The scrambled PDU train of N_{BPDU} bits shall be encoded by a channel encoder unit. The mandatory encoder is described in this clause and depicted in figure 3. It consists of four consecutive operational blocks: code termination, encoding, code rate independent puncturing (P1) and code rate dependent puncturing (P2). It should be noted that this sequence of operation indicates a logical operation of the encoding process, but not a specific implementation.

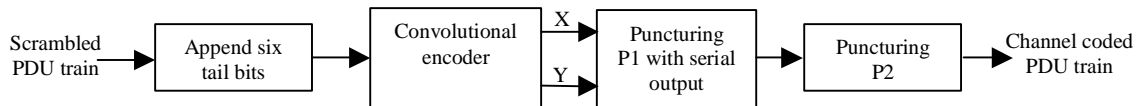

Figure 3: Functional blocks of the FEC coder

The code termination, encoding, and puncturing P1 shall be performed depending on the PDU train type as follows:

- Broadcast PDU train in omni-antenna case: tail bits shall be appended and puncturing P1 shall be performed individually to BCH, FCH and ACH. The encoder shall be initialized at the 1st bit of BCH, at the 1st bit of FCH and at the 1st bit of ACH;
- Broadcast PDU train in sector-antenna case: tail bits shall be appended and puncturing P1 shall be performed to BCH. The encoder shall be initialized at the 1st bit of BCH;
- FCH and ACH PDU train: tail bits shall be appended and puncturing P1 shall be performed separately to FCH and ACH. The encoder shall be initialized at the 1st bit of FCH, at the 1st bit of ACH without priority, and at the 1st bit of ACH with priority;
- Downlink PDU train, Uplink PDU train with short preamble, Uplink PDU train with long preamble, and Direct link PDU train: Tail bits shall be appended and puncturing P1 shall be performed once for the PDU train. The encoder shall be initialized at the 1st bit of the PDU train.

Puncturing P2 shall be performed equally to all the PDU train types as described in clause 5.3.2.

5.3.1 Code termination, encoding, P1 puncturing

5.3.1.1 Downlink PDU train, Uplink PDU train with short preamble, Uplink PDU train with long preamble, and Direct link PDU train

Four of the PDU train types (Downlink PDU train, Uplink PDU train with short preamble, Uplink PDU train with long preamble, and Direct link PDU train) are processed by the encoder as a whole. Tail bits are added once and the respective tail bit puncturing, P1, shall be performed once for the PDU train. The encoder shall also be initialized once at the beginning of the PDU train.

In the first phase six non-scrambled zero ('0') bits are appended to the input data for codetermination purposes. These bits, denoted as tail bits, return the convolutional encoder to "zero state". The resulted ($N_{\text{BPDU}} + 6$) bits shall be coded with a convolutional encoder of code rate 1/2 with 64 states. The generator polynomials of the mother code are $G_1 = 133_{\text{OCT}}$ for X output and $G_2 = 171_{\text{OCT}}$ [ITU reference for G_1 and G_2] for Y output (see figure 4). The encoder shall be set to "zero state" before the encoding process.

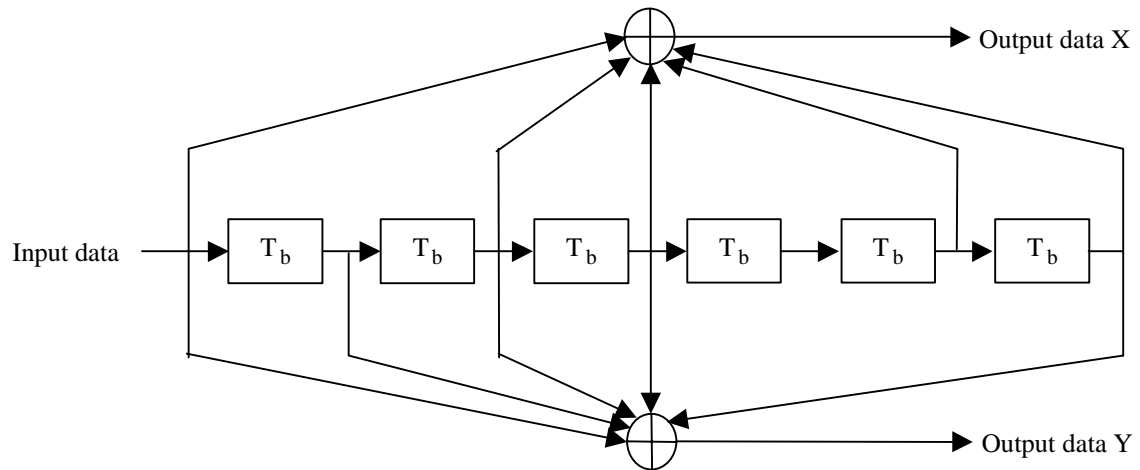

Figure 4: The mother convolutional code of rate 1/2

The first puncturing scheme P1 will be applied independently from the code rate. The puncturing shall be applied always to the first SCH-PDU of the last DLC Connection of the PDU train to be transmitted over the air interface. If there is no such an SCH-PDU in the last DLC Connection, P1 shall be applied to the first LCH-PDU of the last DLC Connection of the PDU train. Four examples of the position of the P1 puncturing inside a PDU train are illustrated in figure 5 as informative information.

The first 156 bits of the PDU, which the P1 puncturing is applied to, are punctured differently from the rest of the encoded bit stream. The puncturing patterns are given in table 2. In this table X and Y refer to the two outputs of the convolutional encoder (see figure 4) where X_1 is sent first.

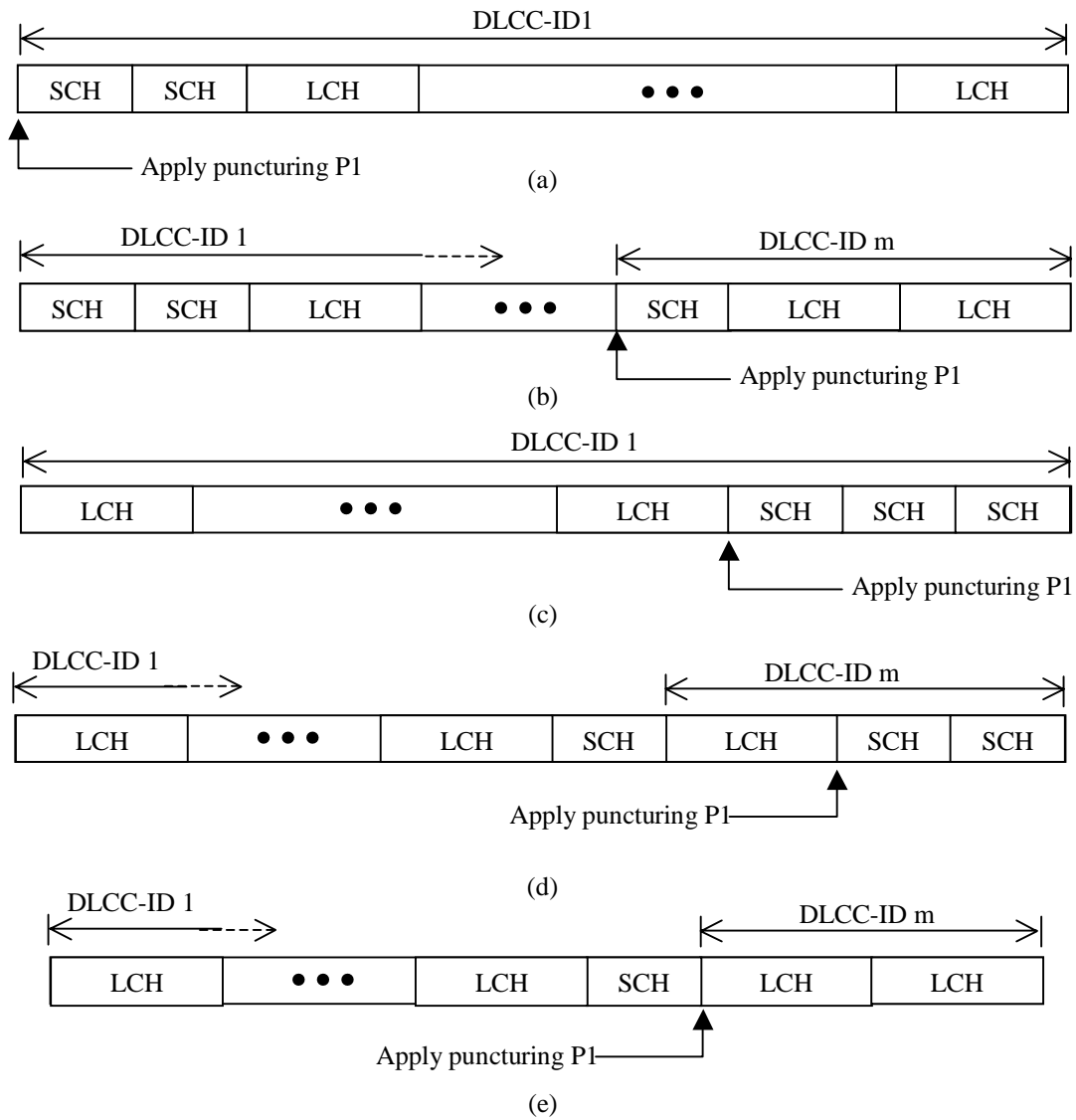

Figure 5: Position of puncturing P1 in cases of,
(a) one DLC Connection (DLCC-ID 1) in a downlink PDU train,
(b) two (or more) DLC Connections (DLCC-ID 1 ... DLCC-ID m) in a downlink PDU train,
(c) one DLC Connection (DLCC-ID 1) in an uplink PDU train,
(d) two (or more) DLC Connections (DLCC-ID 1 ... DLCC-ID m) in an uplink PDU train,
(e) two (or more) DLC Connections (DLCC-ID 1...DLCC-ID m) in an uplink PDU train when no SCH in the last DLC connection

Table 2: Puncturing pattern P1 and transmitted sequence after parallel-to-serial conversion

PDU-wise bit numbering	Puncturing pattern	Transmitted sequence (after parallel-to-serial conversion)
0-155	X: 1 1 1 1 1 1 0 1 1 1 1 1 1 1 Y: 1 1 1 1 1 1 1 1 1 1 1 1 1 0	X ₁ Y ₁ X ₂ Y ₂ X ₃ Y ₃ X ₄ Y ₄ X ₅ Y ₅ X ₆ Y ₆ X ₈ Y ₇ X ₉ Y ₈ X ₁₀ Y ₉ X ₁₁ Y ₁₀ X ₁₂ Y ₁₁ X ₁₃ Y ₁₂
>156	X: 1 Y: 1	X ₁ Y ₁

5.3.1.2 Broadcast PDU train, FCH-and-ACH PDU train

Two of the PDU train types, i.e. Broadcast PDU train and FCH-and-ACH PDU train in the case of a multiple sector AP, are processed transport channel by transport channel. Tail bits shall be appended and additional puncturing shall be performed individually to each transport channel. The encoder shall be also initialized once at the beginning of each transport channel, i.e. at the 1st bit of BCH, FCH and ACH.

In the first phase six non-scrambled zero ('0') bits are appended to each transport channel for codetermination purposes. These bits, denoted as tail bits, return the convolutional encoder to "zero state". The resulted ($N_{\text{BPDU}} + 6$) bits shall be coded with a convolutional encoder of coding rate 1/2 with 64 states. The generator polynomials of the mother code ($G_1 = 133_{\text{OCT}}$ for X output and $G_2 = 171_{\text{OCT}}$ for Y output) are the same as used with other PDU train types shown in figure 4. The encoder shall be set in "zero state" before the encoding process at the beginning of each transport channel.

The first puncturing scheme P1 will be applied independently from the code rate. The puncturing shall be applied always to all the transport channels in the PDU train equally. The first 156 bits of the transport channel, which the P1 puncturing is applied to, are punctured differently from the rest of the encoded bit stream. The puncturing patterns are given in table 2. In this table X and Y refer to the two outputs of the convolutional encoder (see figure 4) where X_1 is sent first.

5.3.2 Code rate dependent puncturing P2

Puncturing P2 is to provide code rates of 9/16 and 3/4 and it is applied to bits from puncturing P1. It shall be performed equally to all the PDU train types. The input is de-multiplexed into 2 sub-streams. The de-multiplexing is defined as a mapping of the input bits x_{di} onto the output bits $b_{e,do}$ (see figure 6):

$$b_{di}(\text{mod})2, di(\text{div})2 = x_{di}$$

where di is the input bit number, do is the output bit number in each sub-stream, mod is the integer modulo operator, and div is the integer division operator.

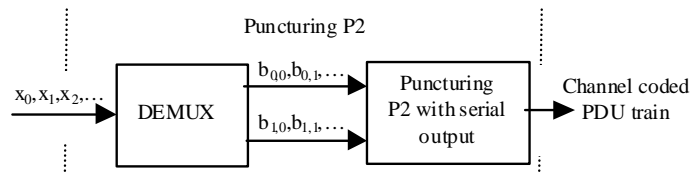

Figure 6: Code rate dependent puncturing P2

Puncturing P2 is applied to the two bit sub-streams $b_{0,do}$ and $b_{1,do}$ as given in table 3. The result is parallel-to-serial converted into a coded and punctured bit stream from which $b_{0,0}$ is sent first.

Table 3: Puncturing pattern P2 and transmitted sequence after parallel-to-serial conversion for the possible code rates

Code Rates r	Puncturing pattern	Transmitted sequence (after parallel-to-serial conversion)
1/2	$b_{0,do}: 1$ $b_{1,do}: 1$	$b_{0,0} b_{1,0}$
9/16	$b_{0,do}: 1 1 1 1 1 1 1 1 0$ $b_{1,do}: 1 1 1 1 0 1 1 1 1$	$b_{0,0} b_{1,0} b_{0,1} b_{1,1} b_{0,2} b_{1,2} b_{0,3} b_{1,3} b_{0,4} b_{1,4} b_{0,5} b_{1,5} b_{0,6} b_{1,6}$ $b_{0,7} b_{1,7} b_{1,8}$
3/4	$b_{0,do}: 1 1 0$ $b_{1,do}: 1 0 1$	$b_{0,0} b_{1,0} b_{0,1} b_{1,2}$

5.4 Data interleaving

All encoded data bits shall be interleaved by a block interleaver with a block size corresponding to the number of bits in a single OFDM symbol, N_{CBPS} . The interleaver is defined by a two step permutation. It should be noted that this sequence of permutations is for the ease of the mathematical representation of the interleaving process, but not a specific implementation. The first ensures that adjacent coded bits are mapped onto nonadjacent sub-carriers. The second permutation ensures that adjacent coded bits are mapped alternately onto less and more significant bits of the constellation, and by this long runs of low reliability bits are avoided.

We shall denote by k the index of the coded bit before the first permutation; i shall be the index after the first and before the second permutation and j shall be the index after the second permutation, just prior to modulation mapping.

The first permutation, is defined by the rule:

$$i = (N_{\text{CBPS}}/16) (k \bmod 16) + \text{floor}(k/16), k = 0, 1, \dots, N_{\text{CBPS}} - 1$$

The function $\text{floor}(\cdot)$ denotes the largest integer not exceeding the parameter, and \bmod is the integer modulo operator.

The second permutation is defined by the rule:

$$j = s \times \text{floor}(i/s) + (i + N_{\text{CBPS}} - \text{floor}(16 \times i/N_{\text{CBPS}})) \bmod s, i = 0, 1, \dots, N_{\text{CBPS}} - 1$$

The value of s is determined by the number of coded bits per sub-carrier, N_{BPSC} , according to:

$$s = \max(N_{\text{BPSC}}/2, 1)$$

5.5 Signal constellations and mapping

HIPERLAN/2 PHY layer uses Orthogonal Frequency Division Multiplex (OFDM) transmission. The OFDM sub-carriers shall be modulated by using BPSK, QPSK, 16QAM or 64QAM modulation depending on the PHY mode selected for data transmission. The interleaved binary serial input data is divided into groups of N_{BPSC} (1, 2, 4 or 6) bits and converted into complex numbers representing BPSK, QPSK, 16QAM or 64QAM constellation points. The conversion shall be performed according to Gray coded constellation mappings, illustrated in figure 7, with the input bit b_1 being the earliest in the stream. Additionally, table 5 illustrates encoding from input bits to the I and Q values for all the modulations. The output values d are formed by multiplying the resulting $(I + jQ)$ value by a normalization factor K_{MOD} :

$$d = (I + jQ) \times K_{\text{MOD}}$$

The normalization factor K_{MOD} depends on the modulation as prescribed in table 4. Note that the modulation type can vary inside a PDU train from one PDU to another while inside one PDU only one modulation type is used. The purpose of the normalization factor is to achieve the same average power for all mappings. The normalization factor K_{MOD} should indicate this fact and no implementation rule. In practical implementations an approximate value of the normalization factor may be used, as long as the device conforms to the general transmitter and receiver performance requirements specified in the present document.

Table 4: Modulation dependent normalization factor K_{MOD}

Modulation	K_{MOD}
BPSK	1
QPSK	$1/\sqrt{2}$
16QAM	$1/\sqrt{10}$
64QAM	$1/\sqrt{42}$

Table 5: Encoding tables for BPSK, QPSK, 16QAM and 64QAM

BPSK		
Input bit b_1	I-out	Q-out
0	-1	0
1	1	0

QPSK			
Input bit b_1	I-out	Input bit b_2	Q-out
0	-1	0	-1
1	1	1	1

16QAM			
Input bit b_1b_2	I-out	Input bit b_3b_4	Q-out
00	-3	00	-3
01	-1	01	-1
11	1	11	1
10	3	10	3

64QAM			
Input bit $b_1b_2b_3$	I-out	Input bit $b_4b_5b_6$	Q-out
000	-7	000	-7
001	-5	001	-5
011	-3	011	-3
010	-1	010	-1
110	1	110	1
111	3	111	3
101	5	101	5
100	7	100	7

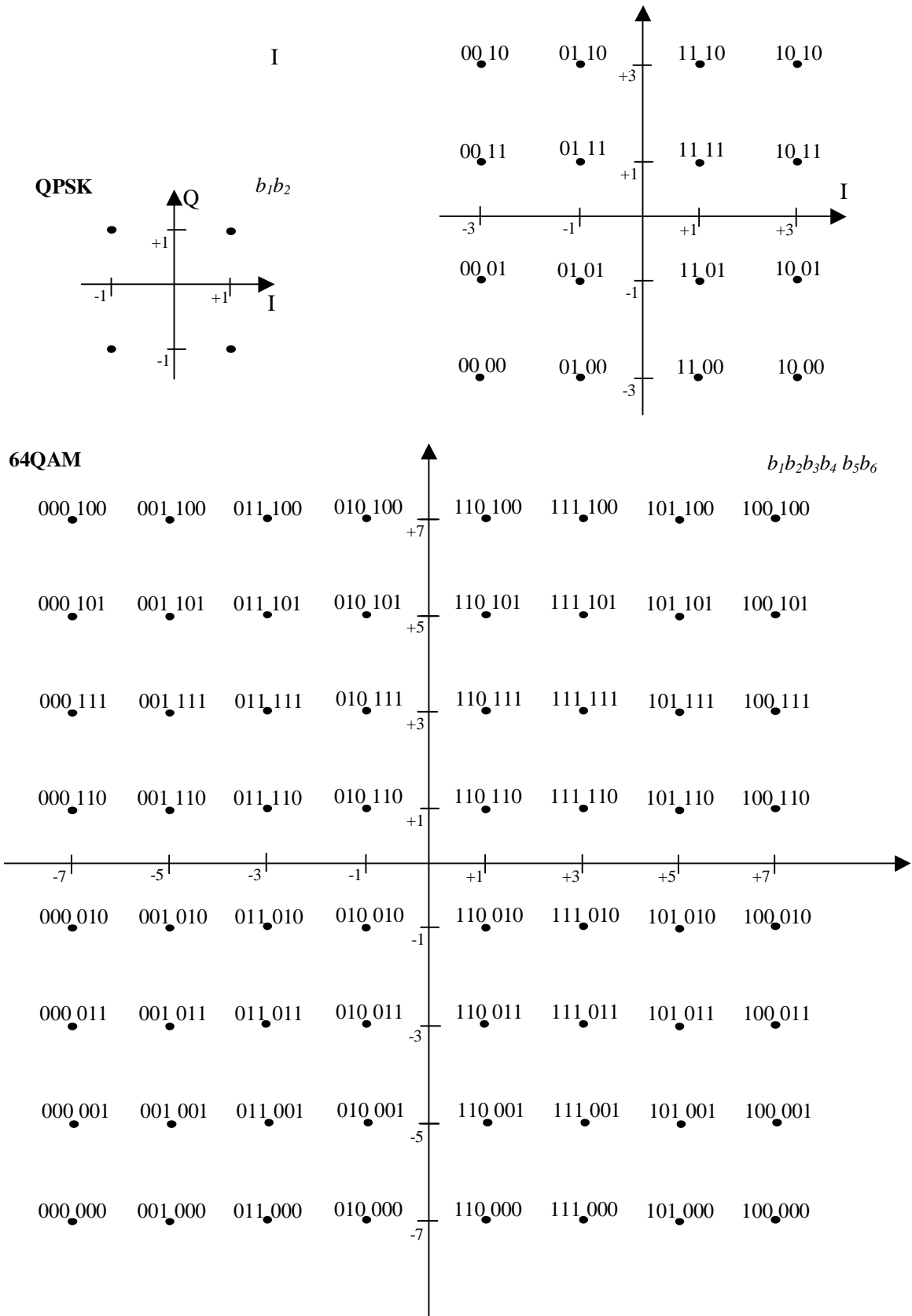

Figure 7: BPSK, QPSK, 16QAM and 64QAM constellation bit encoding

5.6 Modulation technique (OFDM)

The stream of complex valued sub-carrier modulation symbols at the output of mapper, denoted by d_n , shall be divided into groups of $N_{SD} = 48$ complex numbers:

$$D_{m,n}(\text{mod})48, n(\text{div})48 = dn$$

where mod is the integer modulo operator and div is the integer division operator.

Each group $D_{m,n}$ shall be transmitted in an OFDM symbol. All data OFDM symbols contain data in data carriers and reference information in pilot carriers. For data there are $N_{SD} = 48$ carriers and for pilots $N_{SP} = 4$ carriers in each symbol. Thus, each symbol is constituted by a set of $N_{ST} = 52$ carriers and transmitted with a duration T_S . Two parts compose this symbol interval: a useful symbol part with duration T_U and a cyclic prefix with duration T_{CP} . The cyclic prefix consists of a cyclic continuation of the useful part, T_U , and it is inserted before it. Thus the cyclic prefix is a copy of the last T_{CP}/T samples of the symbol part sent in front of the symbol part.

The length of the useful symbol part is equal to 64 samples and its duration is $T_U = 3,2 \mu\text{s}$. For the cyclic prefix length T_{CP} there are two possible values in the HIPERLAN/2 system: mandatory 800 ns and optional 400 ns.

Numerical values for the OFDM parameters are given in table 6. The symbol format is shown in figure 8 in which CP stands for cyclic prefix followed by a useful part, Data n , of the symbol.

Table 6: Numerical values for the OFDM parameters

Parameter	Value	
Sampling rate $f_s = 1/T$	20 MHz	
Useful symbol part duration T_U	$64 \times T$ 3,2 μs	
Cyclic prefix duration T_{CP}	$16 \times T$ 0,8 μs (mandatory)	$8 \times T$ 0,4 μs (optional)
Symbol interval T_S	$80 \times T$ 4,0 μs ($T_U + T_{CP}$)	$72 \times T$ 3,6 μs ($T_U + T_{CP}$)
Number of data sub-carriers N_{SD}	48	
Number of pilot sub-carriers N_{SP}	4	
Total number of sub-carriers N_{ST}	$52 (N_{SD} + N_{SP})$	
Sub-carrier spacing Δ_f	0,3125 MHz ($1/T_U$)	
Spacing between the two outmost sub-carriers	16,25 MHz ($N_{ST} \times \Delta_f$)	

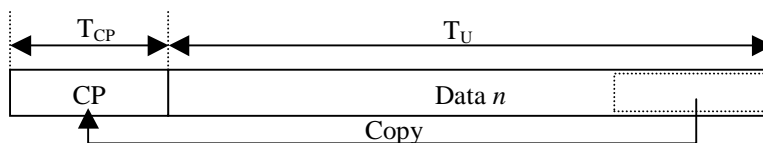

Figure 8: Illustration of an OFDM symbol with cyclic prefix

The mapping from data and pilot complex symbols into the sub-carrier frequencies is shown in figure 9.

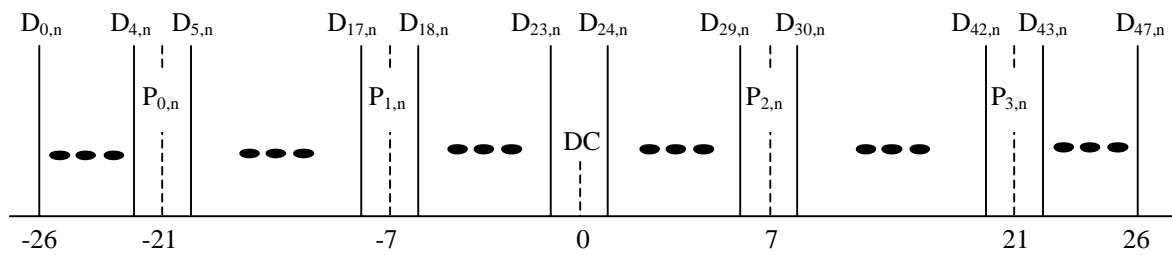

Figure 9: Sub-carrier frequency allocation

The resulted N_{SYM} OFDM symbols are concatenated as:

$$r_{PAYLOAD}(t) = \sum_{n=1}^{N_{SYM}} r_n(t - nT_S)$$

to result the baseband format of the PDU train, called payload. The structure of the payload section is illustrated in figure 10. It consists of variable number (N_{SYM}) of OFDM symbols required to transmit the PDU train payload.

The following relation relates the actual transmitted signal to the complex baseband signal:

$$r_{RF}(t) = \sqrt{2} \operatorname{Re} \left\{ r_{BURST}(t) e^{j2\pi f_c t} \right\}$$

where $\operatorname{Re}(\cdot)$ stands for the real part of complex variable, f_c denotes the carrier centre frequency, and $r_{BURST}(t)$ is baseband format of a PHY burst composed of payload and preamble and is defined in the following clause.

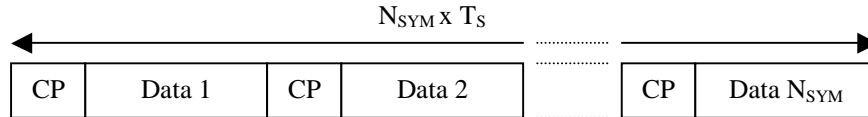

Figure 10: PDU train payload ($r_{PAYLOAD}$) format

5.7 PHY bursts

System has five (5) different kinds of PHY bursts:

- 1) Broadcast burst;
- 2) Downlink burst;
- 3) Uplink burst with short preamble;
- 4) Uplink burst with long preamble;
- 5) Direct link burst (optional).

The PDU trains delivered by DLC are mapped onto the PHY bursts as depicted below depending on the number of sectors used by AP.

- i) Number of sectors per AP = 1.

In this case, the Broadcast PDU train shall be concatenated to FCH-and-ACH PDU train and the resulting Broadcast PDU train is mapped onto the Broadcast burst.

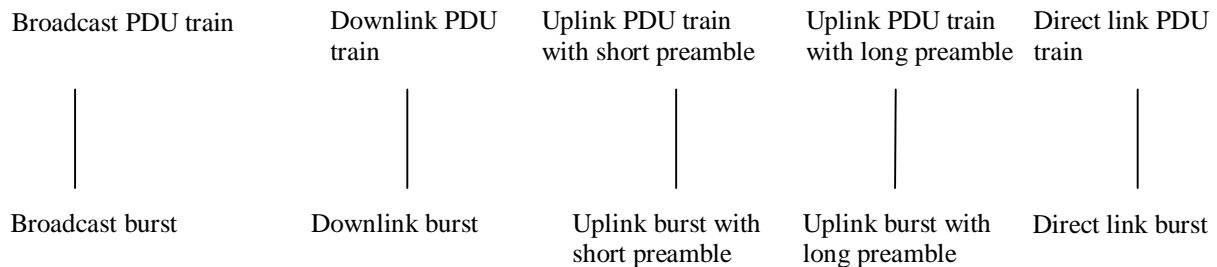

- ii) Number of sectors per AP > 1

In this case only the Broadcast PDU train shall be mapped onto the Broadcast burst. The FCH-and-ACH PDU train shall be mapped onto a downlink burst.

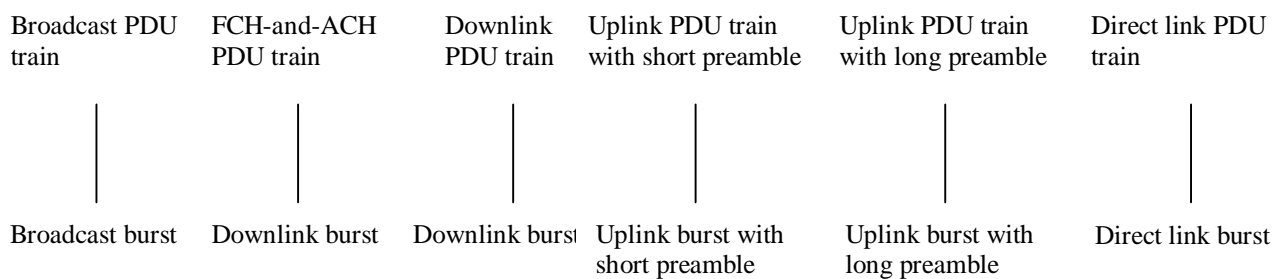

Independently of the burst type each burst consists of two sections: preamble and payload. Each burst is started with a preamble section, r_{PREAMBLE} , which is followed by a payload section, r_{PAYLOAD} , and its baseband format is:

$$r_{\text{BURST}}(t) = r_{\text{PREAMBLE}}(t) + r_{\text{PAYLOAD}}(t - t_{\text{PREAMBLE}})$$

The time offset t_{PREAMBLE} determines the starting point of the payload section of the burst and depends on the burst type. The basic structure of a PHY burst is illustrated in figure 11.

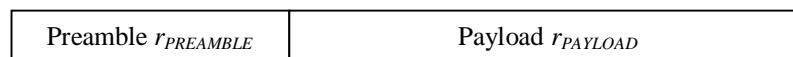

Figure 11: PHY burst format

5.7.1 Broadcast burst

Broadcast burst consists of a preamble of length $t_{\text{PREAMBLE}} = 16,0 \mu\text{s}$ and a payload section of length $N_{\text{SYM}} \times T_{\text{S}}$. Structure of the broadcast burst preamble is illustrated in figure 12.

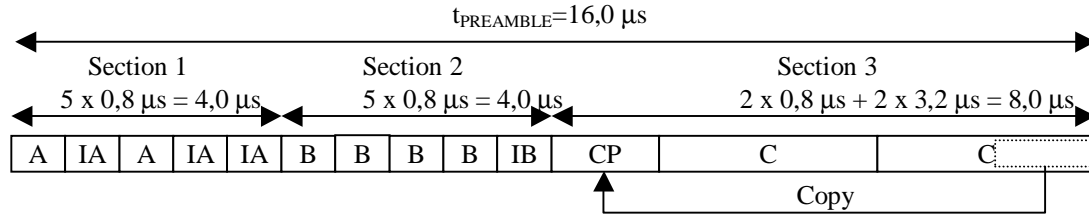

Figure 12: Broadcast burst preamble

In below the term "short OFDM symbol" refers only to its length that is 16 samples instead of a regular OFDM symbol of 64 samples used in HIPERLAN/2 system.

The broadcast burst preamble is composed of three sections: section 1, section 2 and section 3.

Section 1 consists of 5 specific short OFDM symbols that are denoted in figure 12 by A and IA. The first 4 short OFDM symbols in section 1 (A, IA, A, IA) constitute a regular OFDM symbol consisting of 12 loaded sub-carriers ($\pm 2, \pm 6, \pm 10, \pm 14, \pm 18, \text{ and } \pm 22$) given by the frequency-domain sequence SA:

$$SA_{-26...26} = \sqrt{(13/6)} \times \{0, 0, 0, 0, -1+j, 0, 0, 0, 1+j, 0, 0, 0, 1-j, 0, 0, 0, -1-j, 0, 0, 0, -1+j, 0, 0, 0, -1-j, 0, 0, 0, -1+j, 0, 0, 0, -1-j, 0, 0, 0, -1+j, 0, 0, 0, -1-j, 0, 0, 0, 1-j, 0, 0, 0, 1+j, 0, 0, 0, 0\}$$

The last short symbol in section 1 (IA) is a repetition of preceding 16 time-domain samples.

Section 2 consists of 5 specific short OFDM symbols that are denoted in figure 12 by B and IB. The first 4 short OFDM symbols in section 2 (B, B, B, B) constitute a regular OFDM symbol consisting of 12 loaded sub-carriers ($\pm 4, \pm 8, \pm 12, \pm 16, \pm 20, \text{ and } \pm 24$) given by the frequency-domain sequence SB:

$$SB_{-26...26} = \sqrt{(13/6)} \times \{0, 0, 1+j, 0, 0, 0, -1-j, 0, 0, 0, 1+j, 0, 0, 0, -1-j, 0, 0, 0, -1-j, 0, 0, 0, 1+j, 0, 0, 0, 0, 0, 0, 0, -1-j, 0, 0, 0, -1-j, 0, 0, 0, 1+j, 0, 0, 0, 1+j, 0, 0, 0, 1+j, 0, 0, 0, 1+j, 0, 0, 0, 1+j, 0, 0, 0\}$$

The last short symbol in section 2 (IB) is a sign-inverted copy of the preceding short symbol B, i.e. $IB = -B$.

Section 3 consists of two OFDM symbols (C) of normal length preceded by a cyclic prefix (CP) of the symbols. All the 52 sub-carriers are in use and they are modulated by the elements of the frequency-domain sequence SC given by:

$$SC_{-26...26} = \{1, 1, -1, -1, 1, 1, -1, 1, -1, 1, 1, 1, 1, 1, -1, -1, 1, 1, -1, 1, -1, 1, 1, 1, 0, 1, -1, -1, 1, 1, -1, 1, -1, 1, -1, -1, -1, -1, -1, -1, -1, 1, 1, -1, -1, 1, -1, 1, -1, 1, 1, 1\}$$

The cyclic prefix CP is a copy of the 32 last samples of the C symbols and is thus double in length compared to the cyclic prefix of the normal data symbols.

The broadcast burst is formed by concatenating the above described preamble with the data payload. The resulted broadcast burst is as illustrated in figure 17a.

In practical implementations an approximate value of the normalization factor may be used, as long as the device conforms to the general transmitter and receiver performance requirements specified in the present document.

5.7.2 Downlink burst

Downlink burst consists of a preamble of length $t_{\text{PREAMBLE}} = 8,0 \mu\text{s}$ and a payload section of length $N_{\text{SYM}} \times T_{\text{S}}$. Structure of the downlink burst preamble is illustrated in figure 13.

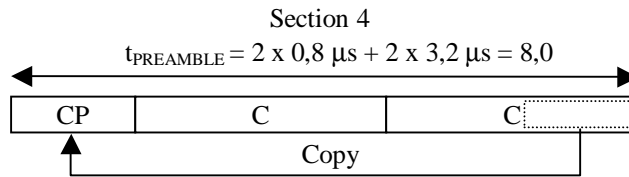

Figure 13: Downlink burst preamble

The downlink burst preamble is equal to the section 3 of the broadcast burst preamble. It is composed of two OFDM symbols (C) of normal length preceded by a cyclic repetition (CP) of the symbols. All the 52 sub-carriers are in use and they are modulated by the elements of the frequency-domain sequence SC given by:

$$SC_{-26\dots26} = \{1, 1, -1, -1, 1, 1, -1, 1, -1, 1, 1, 1, 1, 1, -1, -1, 1, 1, -1, 1, -1, 1, 1, 1, 0, \\ 1, -1, -1, 1, 1, -1, 1, -1, -1, -1, -1, -1, -1, 1, 1, -1, -1, 1, -1, 1, -1, 1, 1, 1\}$$

The cyclic repetition CP is a copy of the 32 last samples of the C symbols and is thus double in length compared to the cyclic prefix of the normal data symbols.

The downlink burst is formed by concatenating the above described preamble with the data payload. The resulted downlink burst is as illustrated in figure 17b.

5.7.3 Uplink burst with short preamble

It consists of a preamble of length $t_{\text{PREAMBLE}} = 12,0 \mu\text{s}$ and a payload section of length $N_{\text{SYM}} \times T_{\text{S}}$. Structure of the short preamble for uplink bursts is illustrated in figure 14.

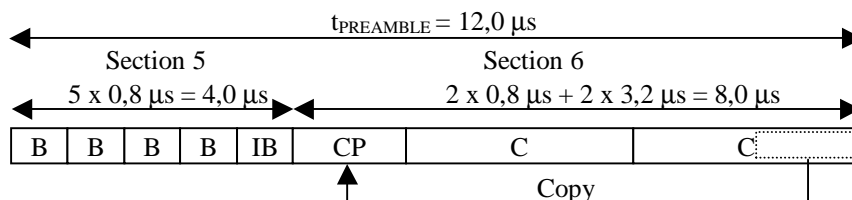

Figure 14: Short preamble for uplink bursts

In below the term "short OFDM symbol" refers only to its length that is 16 samples instead of a regular OFDM symbol of 64 samples used in HIPERLAN/2 system.

The short preamble for uplink bursts is composed of two sections: section 5 and section 6. The sections are equal to the latter two sections of the broadcast burst preamble: section 5 = section 2, section 6 = section 3.

Section 5 consists of 5 specific short OFDM symbols denoted in figure 14 by B and IB. The first 4 short OFDM symbols in this section (B, B, B, B) constitute a regular OFDM symbol consisting of 12 loaded sub-carriers ($\pm 4, \pm 8, \pm 12, \pm 16, \pm 20, \text{ and } \pm 24$) given by the frequency-domain sequence SB:

$$SB_{-26\dots26} = \sqrt{(13/6)} \times \{0, 0, 1+j, 0, 0, 0, -1-j, 0, 0, 0, 1+j, 0, 0, 0, -1-j, 0, 0, 0, -1-j, 0, 0, 0, 1+j, 0, 0, 0, 0, \\ 0, 0, 0, -1-j, 0, 0, 0, -1-j, 0, 0, 0, 1+j, 0, 0, 0, 1+j, 0, 0, 0, 1+j, 0, 0, 0, 1+j, 0, 0\}$$

The last short symbol in section 5 (IB) is a sign-inverted copy of the preceding short symbol B, i.e. $IB = -B$.

Section 6 consists of two OFDM symbols (C) of normal length preceded by a cyclic repetition (CP) of the symbols. All the 52 sub-carriers are in use and they are modulated by the elements of the frequency-domain sequence SC given by:

$$SC_{-26\dots26} = \{1, 1, -1, -1, 1, 1, -1, 1, -1, 1, 1, 1, 1, 1, 1, -1, -1, 1, 1, -1, 1, -1, 1, 1, 1, 0, \\ 1, -1, -1, 1, 1, -1, 1, -1, -1, -1, -1, -1, -1, -1, 1, 1, -1, -1, 1, -1, 1, -1, 1, 1, 1, 1\}$$

The cyclic repetition CP is a copy of the 32 last samples of the C symbols and is thus double in length compared to the cyclic prefix of the normal data symbols.

The uplink burst with short preamble is formed by concatenating the above described preamble with the data payload. The resulted uplink burst is as illustrated in figure 17c.

In practical implementations an approximate value of the normalization factor may be used, as long as the device conforms to the general transmitter and receiver performance requirements specified in the present document.

5.7.4 Uplink burst with long preamble

It consists of a preamble of length $t_{\text{PREAMBLE}} = 16,0 \mu\text{s}$ and a payload section of length $N_{\text{SYM}} \times T_s$. Structure of the long preamble for uplink bursts is illustrated in figure 15.

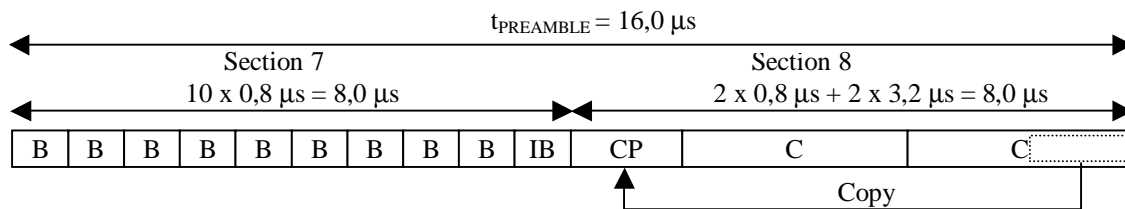

Figure 15: Long preamble for uplink bursts

In below the term "short OFDM symbol" refers only to its length that is 16 samples instead of a regular OFDM symbol of 64 samples used in HIPERLAN/2 system.

The long preamble for uplink bursts is composed of two sections: section 7 and section 8.

Section 7 consists of 10 specific short OFDM symbols denoted in figure 15 by B and IB. The first 4 short OFDM symbols in this section (B, B, B, B) constitute a regular OFDM symbol consisting of 12 loaded sub-carriers ($\pm 4, \pm 8, \pm 12, \pm 16, \pm 20, \text{ and } \pm 24$) given by the frequency-domain sequence SB:

$$SB_{-26\dots 26} = \sqrt{(13/6)} \times \{0, 0, 1+j, 0, 0, 0, -1-j, 0, 0, 0, 0, 1+j, 0, 0, 0, -1-j, 0, 0, 0, -1-j, 0, 0, 0, 0, 1+j, 0, 0, 0, 0, 0, 0, 0, 0, -1-j, 0, 0, 0, -1-j, 0, 0, 0, 1+j, 0, 0, 0, 1+j, 0, 0, 0, 1+j, 0, 0, 0, 1+j, 0, 0\}$$

The last short symbol in section 7 (IB) is a sign-inverted copy of the preceding short symbol B, i.e. $IB = -B$.

Section 8 consists of two OFDM symbols (C) of normal length preceded by a cyclic repetition (CP) of the symbols. All the 52 sub-carriers are in use and they are modulated by the elements of the frequency-domain sequence SC given by:

$$SC_{-26\dots 26} = \{1, 1, -1, -1, 1, 1, -1, 1, -1, 1, 1, 1, 1, 1, 1, -1, -1, 1, 1, -1, 1, -1, 1, 1, 1, 1, 0, 1, -1, -1, 1, 1, -1, 1, -1, 1, -1, -1, -1, -1, -1, -1, -1, 1, 1, -1, -1, 1, -1, 1, -1, 1, 1, 1, 1\}$$

The cyclic repetition CP is a copy of the 32 last samples of the C symbols and is thus double in length compared to the cyclic prefix of the normal data symbols. Thus the section 8 is equal to the section 3, section 4, and section 6.

The uplink burst with long preamble is formed by concatenating the above described preamble with the data payload. The resulted uplink burst is as illustrated in figure 17d.

In practical implementations an approximate value of the normalization factor may be used, as long as the device conforms to the general transmitter and receiver performance requirements specified in the present document.

5.7.5 Direct link burst

Direct link burst is optional. It consists of a preamble of length $t_{\text{PREAMBLE}} = 16,0 \mu\text{s}$ and a payload section of length $N_{\text{SYM}} \times T_{\text{S}}$. Structure of the preamble for direct link bursts is illustrated in figure 16.

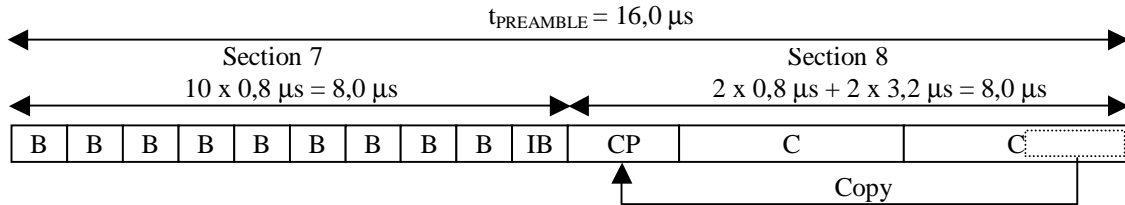

Figure 16: Preamble for direct link bursts

In below the term "short OFDM symbol" refers only to its length that is 16 samples instead of a regular OFDM symbol of 64 samples used in HIPERLAN/2 system.

The preamble for direct link bursts is composed of two sections: section 7 and section 8.

Section 7 consists of 10 specific short OFDM symbols denoted in figure 15 by B and IB. The first 4 short OFDM symbols in this section (B, B, B, B) constitute a regular OFDM symbol consisting of 12 loaded sub-carriers ($\pm 4, \pm 8, \pm 12, \pm 16, \pm 20, \text{ and } \pm 24$) given by the frequency sequence SB:

$$SB_{-26...26} = \sqrt{(13/6)} \times \{0, 0, 1+j, 0, 0, 0, -1-j, 0, 0, 0, 1+j, 0, 0, 0, -1-j, 0, 0, 0, -1-j, 0, 0, 0, 1+j, 0, 0, 0, 0, 0, 1+j, 0, 0, 0, 0, 0, 1+j, 0, 0, 0, 1+j, 0, 0, 0, 1+j, 0, 0\}$$

The last short symbol in section 7 (IB) is a sign-inverted copy of the preceding short symbol B, i.e. $IB = -B$.

Section 8 consists of two OFDM symbols (C) of normal length preceded by a cyclic repetition (CP) of the symbols. All the 52 sub-carriers are in use and they are modulated by the elements of the frequency-domain sequence SC given by:

$$SC_{-26...26} = \{1, 1, -1, -1, 1, 1, -1, 1, -1, 1, 1, 1, 1, 1, 1, -1, -1, 1, 1, -1, 1, -1, 1, 1, 1, 1, 0, 1, -1, -1, 1, 1, -1, 1, -1, 1, -1, -1, -1, -1, -1, -1, -1, 1, 1, -1, -1, 1, -1, 1, -1, 1, 1, 1, 1\}$$

The cyclic repetition CP is a copy of the 32 last samples of the C symbols and is thus double in length compared to the cyclic prefix of the normal data symbols. Thus the section 7 is equal to the section 3, section 4, and section 6.

The direct link burst is formed by concatenating the above described preamble with the data payload. The resulted direct link burst is as illustrated in figure 17e.

In practical implementations an approximate value of the normalization factor may be used, as long as the device conforms to the general transmitter and receiver performance requirements specified in the present document.

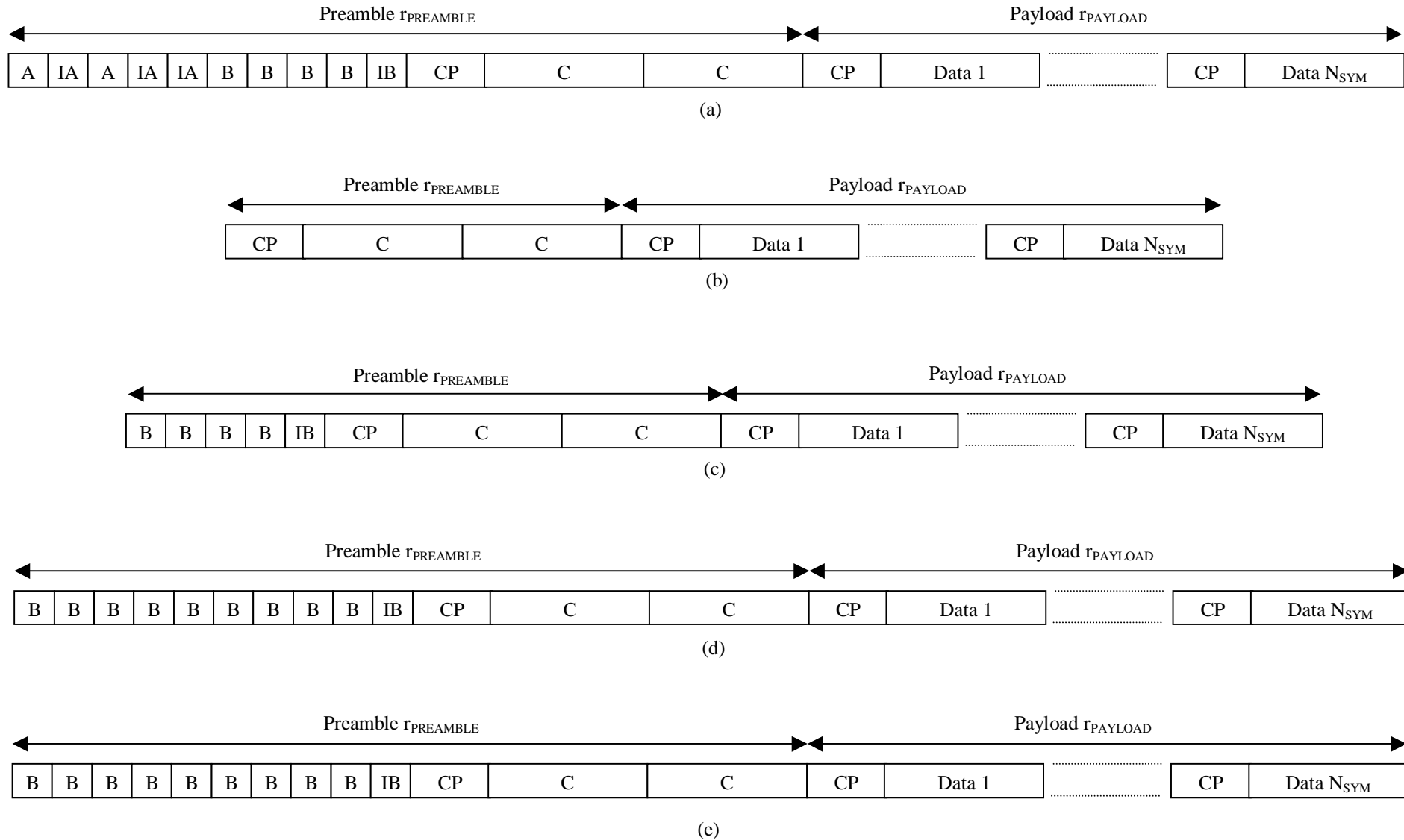

Figure 17: PHY burst structures: (a) Broadcast burst, (b) Downlink burst, (c) Uplink burst with short preamble, (d) Uplink burst with long preamble, (e) Direct link burst

5.8 Radio transmission

5.8.1 RF carriers

5.8.1.1 Nominal carriers frequencies

The nominal carrier frequencies for HIPERLAN/2 are allocated in two frequency bands. In the present document, they are called the lower frequency band 5 150 MHz to 5 350 MHz and the upper frequency band between 5 470 MHz and 5 725 MHz (see CEPT/ERC/DEC(99)23 [2]). The nominal carrier frequency f_c corresponds to its carrier number, n_{carrier} , which is defined as:

$$n_{\text{carrier}} = (f_c - 5\,000 \text{ MHz}) / 5 \text{ MHz}$$

The nominal carrier frequencies are spaced 20 MHz apart. All transmissions shall be centred on one of the nominal carrier frequencies. The centre frequencies in Europe are shown in table 7.

Table 7: Nominal carrier frequency allocation table for HIPERLAN/2 devices in Europe

n_{carrier}	Band	f_c [MHz]	mean EIRP [dBm]
36	lower	5 180	23
40	lower	5 200	23
44	lower	5 220	23
48	lower	5 240	23
52	lower	5 260	23
56	lower	5 280	23
60	lower	5 300	23
64	lower	5 320	23
100	upper	5 500	30
104	upper	5 520	30
108	upper	5 540	30
112	upper	5 560	30
116	upper	5 580	30
120	upper	5 600	30
124	upper	5 620	30
128	upper	5 640	30
132	upper	5 660	30
136	upper	5 680	30
140	upper	5 700	23

Table 8: Void

5.8.1.2 Accuracy and stability of RF carriers

The transmitted RF centre frequency at both AP and MT shall be within ± 20 ppm of the nominal carrier frequencies used.

5.8.1.3 RF generation and clocking timebase

A single frequency source of the accuracy given in clause 5.8.1.2 shall be used for both RF generation and clocking the timebase. Both AP and MT shall fulfil this requirement.

5.8.2 Transmitted power

5.8.2.1 Mean Effective Isotropic Radiated Power (EIRP)

The mean Effective Isotropic Radiated Power (EIRP) shall not exceed the regulatory requirements.

5.8.2.2 Transmit spectrum mask

The transmitted spectrum shall not exceed 0 dBc relative to the maximum spectral power density of the signal between ± 9 MHz frequency offset relative to the nominal carrier frequency, -20 dBc at 11 MHz frequency offset, -28 dBc at 20 MHz frequency offset, and -40 dBc at and above 30 MHz frequency offset. The transmitted spectral density of the transmitted signal shall fall within the spectral mask as shown in figure 18. The measurements shall be done with 1 MHz resolution bandwidth and a 30 kHz video bandwidth.

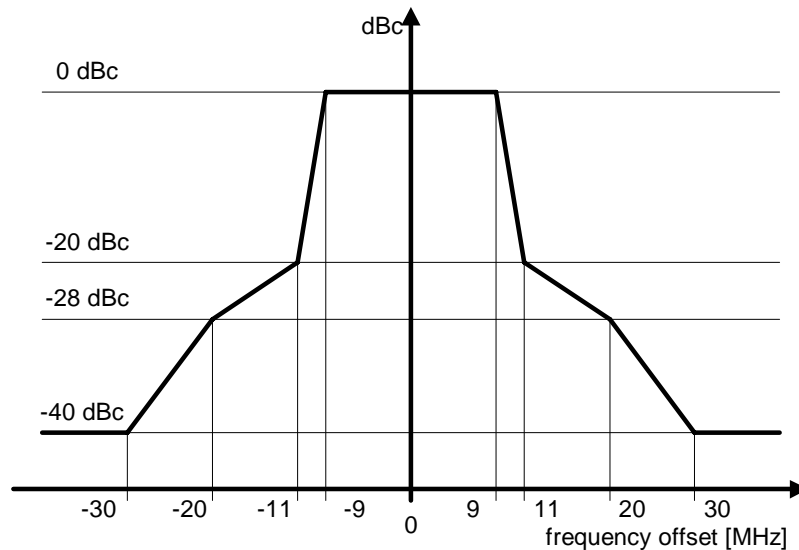

Figure 18: Transmit spectral power mask. dBc is the spectral density relative to the maximum spectral power density of the transmitted signal

5.8.2.3 Transmitter centre frequency leakage and spectral flatness requirements

The power transmitted at the centre of the transmitted spectrum shall not exceed -15 dB relative to overall transmitted power or +2 dB relative to average power of the rest of the sub-carriers whichever is lower.

The average power of the constellations in each of the spectral lines -26 ... -17 and +17 ... +26 (see figure 9) shall deviate no more than +2/-4 dB from the power of spectral lines -16 .. -1 and +1 .. +16 (see figure 9).

5.8.2.4 Transmit power time mask

The output power relative to time when sending a burst is shown in figure 19. In the case where two or more consecutive PHY bursts are transmitted, no requirements are specified to the power ramping between the bursts, and the template shown in figure 18 shall be respected at the beginning and the end of the series of consecutive bursts.

The permitted transmitter power levels for the start, duration and end of transmitted burst are shown in figure 19. The "start of the burst" is the centre of the first sample of the preamble heading the burst. The "end of the burst" is the centre of the last sample in the burst.

The transmitter rise time is the time from when the output power is less than -50 dBm to the start of the burst. The rise time shall be less than 4,0 μ s. The level shall not be more than -50 dBc or -40 dBm, whichever is the greater, until 2,0 μ s from the start of the burst. No minimum rise time is specified explicitly since it will be determined implicitly by spectral requirements.

The transmitter fall time is the time from the end of the burst to when the radiated power is less than -50 dBm. The fall time shall be less than 4,0 μ s. The level shall not be more than -50 dBc or -40 dBm, whichever is the greater, after 2,0 μ s from the end of the burst. No minimum fall time is specified explicitly since it will be determined implicitly by spectral requirements.

During the data portion the average symbol power shall be within ± 1 dB of the $P_{\text{avg,data}}$. The $P_{\text{avg,data}}$ is defined as the mean power during a data portion. During the preamble portion the average power of each section ($P_{\text{avg},1-8}$) shall be within ± 1 dB of the $P_{\text{avg,preamble}}$. The $P_{\text{avg,preamble}}$ is average power of a whole ideal preamble which peak power equals to the maximum power (P_{max}) measured during the transmitted preamble.

The power time mask definition specifies the transmitted power only on the frequency channel in use. All emissions related to other frequency channels shall be in accordance with the spurious emissions requirements.

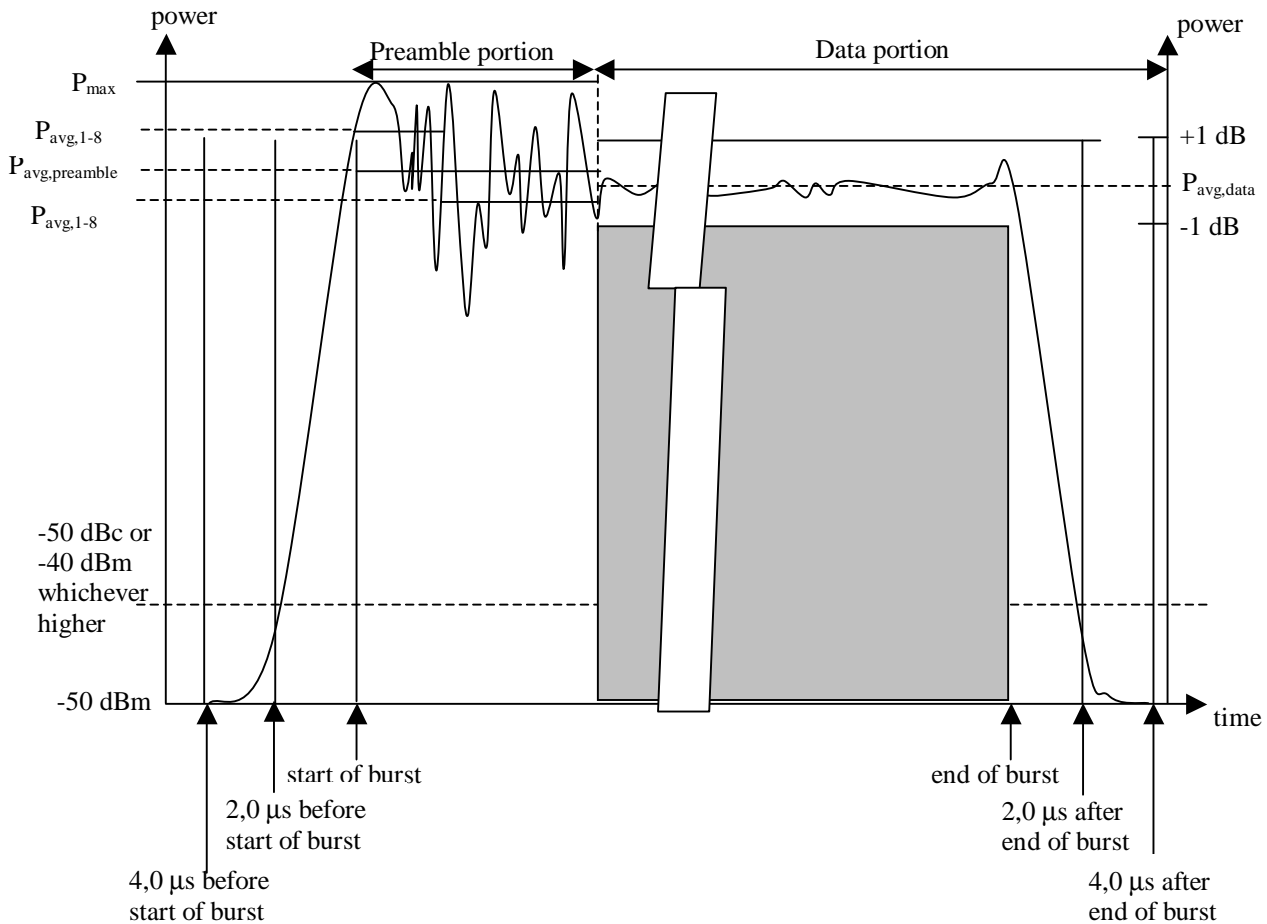

Figure 19: Power time mask

5.8.2.5 Transmit power control

5.8.2.5.1 AP transmission power levels

The AP shall be able to operate with a transmission power ≥ -15 dBm. The maximum output power is an arbitrary power level within the regulatory requirements. The power levels and related accuracies are given in table 9. The transmitted power level at the antenna reference point (ARP) of the AP shall be indicated in the BCH by AP_Tx_level field as indicated in table 9.

5.8.2.5.2 Uplink power control

The MT shall be able to operate with a transmission power ≥ -15 dBm. The maximum output power is an arbitrary power level within the regulatory requirements. The accuracies are given in table 10. The transmission power range shall be composed of power steps equal to or smaller than 3 dB, and the transmitting MT shall ensure that the power levels shall provide monotonic transmission power.

The MT shall define its transmission power level at the ARP as:

- $\min(\text{AP_Tx_Level} - \text{MT_received_power_level} + \text{AP_Rx_UL_Level} + \Sigma(\text{PC_Offset}), \text{AP_Tx_Level}, \text{maximum output power of MT})$

where AP_Tx_Level denotes access point transmit power level and AP_Rx_UL_Level stands for the power level the access point is expecting to receive for all uplink signals. These values are transmitted as part of the BCH information [1]. MT_received_power_level is the estimated power level of the signal received by the MT.

$\Sigma(\text{PC_Offset})$ is the sum of the received PC_Offset values from the AP. When no PC_Offset value has been received from the AP, the value $\Sigma(\text{PC_Offset}) = 0$ shall be used. The PC_Offset parameter is coded with 3 bits according to the table 12.

The power levels for the AP_Tx_Level are defined and coded as given in table 9. The power levels for the AP_Rx_UL_Level values are defined and coded as shown in table 11.

The AP shall fulfil all the receiver performance requirements specified in clauses 5.11.3.3 and 5.11.3.4 for the AP_Rx_UL_Level values up to -63 dBm. The higher levels from -59 dBm to -43 dBm are optional ones but if the AP signals them it shall fulfil all the receiver performance requirements specified in clauses 5.11.3.3. and 5.11.3.4.

Table 9: Power levels and coding table for the AP transmission power

AP_Tx_Level number	Code	Mean power at ARP [dBm]	Accuracy [dB]
1	1111	30	± 4
2	1110	27	± 4
3	1101	24	± 4
4	1100	21	± 4
5	1011	18	± 4
6	1010	15	± 5
7	1001	12	± 5
8	1000	9	± 5
9	0111	6	± 6
10	0110	3	± 6
11	0101	0	± 6
12	0100	-3	± 6
13	0011	-6	± 6
14	0010	-9	± 6
15	0001	-12	± 8
16	0000	-15	± 8

Table 10: MT's transmission power with required accuracies

MT TX power [dBm]	Accuracy [dB]
18 ... 30	± 6
9 ... < 18	± 7
-9 ... < 9	± 8
-15 ... < -9	± 10

Table 11: Power levels and coding table for the AP_Rx_UL_Level

AP_Rx_UL_Level in BCH	Received power expected by AP at ARP [dBm]
111	-43
110	-47
101	-51
100	-55
011	-59
010	-63
001	-67
000	-71

Table 12: PC_Offset signalling

Signalled bits	PC_Offset [dB]
000	For future use
001	6
010	3
011	-3
100	-6
101	For future use
110	For future use
111	Reset

5.8.3 Unwanted RF radiation

During the active transmit time all emission shall fall within the spectral mask described in clause 5.8.2.2. During all the other modes the emission shall be within the values given in table 15. During the transition times the radiated power shall follow the criteria described in clause 5.8.2.4. Outside the HIPERLAN bands the emission shall be below the level described in clause 5.8.2.2, if regulatory requirements do not enforce more stringent limits.

5.9 Modulation accuracy

The modulation accuracy shall not exceed a PHY mode dependent value shown in table 13.

Table 13: Modulation accuracy requirement for different PHY modes

Nominal bit rate [Mbit/s]	Modulation accuracy [dB]
6, 9, 12, 18, 27, 36	19
54	24

5.10 Switching times

5.10.1 Radio turn around time

The maximum time between the end of the transmitted burst and being able to receive a burst and vice versa shall be 6 μ s.

5.10.2 Time to change RF carrier

The time during which a HIPERLAN/2 equipment may be inoperable while changing RF carrier shall be less than 1 ms.

5.10.3 Guard time between UL bursts

The minimum guard time $T_{g,UL}$ between two adjacent UL bursts is 2,0 μ s.

5.10.4 Guard time between DiL bursts

The minimum guard time $T_{g,DiL}$ between two adjacent Direct link bursts is 2,0 μ s. The minimum guard time between the last DiL burst of the DiL phase and the first UL burst of the UL phase is 2,0 μ s.

5.10.5 Guard time between random access bursts

The BCH includes 2 bits which announce the guard time between random access bursts. The guard time is defined and coded as given in the table 14.

Table 14: Guard time between two adjacent random access bursts

Field with 2 bits in BCH	Guard time between random access bursts	
00	$T_{g,UL} = 2,0 \mu$ s	
01	$T_{g,UL} + 800$ ns	
10	$T_{g,UL} + 2\ 000$ ns	
11	$T_{g,UL} + 10\ 000$ ns	

5.10.6 Guard time for sector antenna implementations

In the case of a sector antenna implementation the fixed guard time for sector switching between consecutive PHY bursts of different sectors within one MAC frame is 800 ns.

5.11 Receiver parameters

5.11.1 Spurious emissions

Emissions of the HIPERLAN/2 equipment made outside the time of transmitted bursts shall not exceed the values in the table 15 in the indicated bands. The bandwidths are nominal -3 dB bandwidths.

Table 15: Spurious radiated emission limits

Frequency range	Maximum power	Measurement bandwidth
30 MHz to 1GHz	-57 dBm	100 kHz
1 GHz to 26,5 GHz	-50 dBm	1 MHz

5.11.2 Physical layer measurements

All MTs shall be able to perform a measurement of the actual received and sensed signal strength. The MTs shall be able to produce two different types of received signal strength (RSS) values: RSS0 and RSS1. The MTs that support direct mode operations shall be also able to produce a third type of received signal strength value: RSS2.

5.11.2.1 RSS0 measurement

All MTs shall be able to perform a measurement of the actual received and sensed signal strength during BCH with the accuracy as given in table 16: receiver class 1 MTs up to -20 dBm and class 2 MTs up to -30 dBm. The result, RSS0, shall be transmitted to the AP in terms of Signal Level Number 0 (SLN0) as shown in table 16. SLN0 = 62 is allowed only when RSS > -28 dBm. Additionally, the SLN0 steps shall be monotonic.

Table 16: Parameters for measurement of signal level during BCH

Signal Level Number (SLN0)	RSS0 [dBm]	Tolerance [dB]	Note
0	-91	±8	
1	-90	±7	
2	-89	±6	
3	-88	±5	
4	-87	±5	
5	-86	±5	
6	-85	±5	
7	-84	±5	
8	-83	±5	
9	-82	±5	
10	-81	±5	
11	-80	±5	
12	-79	±5	
13	-78	±5	
14	-77	±5	
15	-76	±5	
16	-75	±5	
17	-74	±5	
18	-73	±5	
19	-72	±5	
20	-71	±5	
21	-70	±5	
22	-69	±5	
23	-68	±5	
24	-67	±5	
25	-66	±5	
26	-65	±5	
27	-64	±5	
28	-63	±5	
29	-62	±5	
30	-61	±5	
31	-60	±5	
32	-59	±5	
33	-58	±5	
34	-57	±5	
35	-56	±5	
36	-55	±5	
37	-54	±5	
38	-53	±5	
39	-52	±5	
40	-51	±5	
41	-50	±5	
42	-49	±5	
43	-48	±5	

Signal Level Number (SLN0)	RSS0 [dBm]	Tolerance [dB]	Note
44	-47	±5	
45	-46	±5	
46	-45	±5	
47	-44	±5	
48	-43	±5	
49	-42	±5	
50	-41	±5	
51	-40	±6	
52	-38	±6	
53	-36	±6	
54	-34	±6	
55	-32	±7	
56	-30	±8	
57	-28	±7	Mandatory only for class 1 receivers
58	-26	±7	Mandatory only for class 1 receivers
59	-24	±8	Mandatory only for class 1 receivers
60	-22	±8	Mandatory only for class 1 receivers
61	-20	±8	Mandatory only for class 1 receivers
62	> -20	-8	Optional
63	--	--	For future use

5.11.2.2 RSS1 measurement

The signal strength outside of BCH shall be given relative to RSS_REF. RSS_REF is defined by:

$$\text{RSS_REF} = \max(\text{RSS0}, -93 \text{ dBm} + 31 \text{ dB}) = \max(\text{RSS0}, -62 \text{ dBm})$$

where RSS0 is the one measured on the frequency the MT is associated with.

The results shall be transmitted to the AP in terms of Signal Level Number 1 (SLN1) as shown in table 17a.

Table 17a: Parameters for measurement of signal level outside of BCH

Signal Level Number (SLN1)	RSS1 [dB]	Relative accuracy [dB]
0	0	±4
1	-1	±4
2	-2	±4
3	-3	±4
4	-4	±4
5	-5	±4
6	-6	±4
7	-7	±4
8	-8	±4
9	-9	±4
10	-10	±4
11	-11	±4
12	-12	±4
13	-13	±4
14	-14	±4
15	-15	±4
16	-16	±4
17	-17	±4
18	-18	±4
19	-19	±4
20	-20	±4
21	-21	±4
22	-22	±4
23	-23	±4
24	-24	±4
25	-25	±4
26	-26	±4
27	-27	±4
28	-28	±4
29	-29	±4
30	-30	±4
31	-31	±4

5.11.2.3 RSS2 measurement

All MTs that support direct mode operation, shall be able to perform a measurement of the actual received and sensed signal strength during direct mode traffic with a peer MT, with the accuracy as given in table 17b: receiver class 1 MTs up to -20 dBm and class 2 MTs up to -30 dBm. The result, RSS2, shall be transmitted to the AP or peer MT, in terms of Signal Level Number 2 (SLN2) as shown in table 17b. SLN2 = 62 is allowed only when RSS > -28 dBm. Additionally, the SLN2 steps shall be monotonic. The mapping of SLN2 is the same as for SLN0.

Table 17b: Parameters for measurement of signal level during DM traffic

Signal Level Number (SLN2)	RSS2 [dBm]	Tolerance [dB]	Note
0	-91	±8	
1	-90	±7	
2	-89	±6	
3	-88	±5	
4	-87	±5	
5	-86	±5	
6	-85	±5	
7	-84	±5	
8	-83	±5	
9	-82	±5	
10	-81	±5	
11	-80	±5	
12	-79	±5	
13	-78	±5	
14	-77	±5	
15	-76	±5	
16	-75	±5	
17	-74	±5	
18	-73	±5	
19	-72	±5	
20	-71	±5	
21	-70	±5	
22	-69	±5	
23	-68	±5	
24	-67	±5	
25	-66	±5	
26	-65	±5	
27	-64	±5	
28	-63	±5	
29	-62	±5	
30	-61	±5	
31	-60	±5	
32	-59	±5	
33	-58	±5	
34	-57	±5	
35	-56	±5	
36	-55	±5	
37	-54	±5	
38	-53	±5	
39	-52	±5	
40	-51	±5	
41	-50	±5	
42	-49	±5	
43	-48	±5	
44	-47	±5	
45	-46	±5	
46	-45	±5	
47	-44	±5	
48	-43	±5	
49	-42	±5	

Signal Level Number (SLN2)	RSS2 [dBm]	Tolerance [dB]	Note
50	-41	±5	
51	-40	±6	
52	-38	±6	
53	-36	±6	
54	-34	±6	
55	-32	±7	
56	-30	±8	
57	-28	±7	Mandatory only for class 1 receivers
58	-26	±7	Mandatory only for class 1 receivers
59	-24	±8	Mandatory only for class 1 receivers
60	-22	±8	Mandatory only for class 1 receivers
61	-20	±8	Mandatory only for class 1 receivers
62	> -20	-8	Optional
63	--	--	For future use

5.11.3 Radio receiver performance

5.11.3.1 Receiver sensitivity

The radio receiver sensitivity is the power level at the ARP of the receiver at which the proportion of erroneously received PDUs shall be less than 10 %. The sensitivity levels for the seven modes are listed in table 18. These requirements shall apply when multipath or additive noise or interference does not distort the signal input to the receiver and for PDUs of 54 bytes.

Table 18: Receiver sensitivity requirements

Nominal bit rate [Mbit/s]	Minimum sensitivity
6	-85 dBm
9	-83 dBm
12	-81 dBm
18	-79 dBm
27	-75 dBm
36	-73 dBm
54	-68 dBm

5.11.3.2 Maximum input level for operation

The maximum input level on the frequency channel in use is the power level at the ARP of the receiver at which the proportion of erroneously received PDUs shall be less than 10 %. This maximum input level for operation shall depend on the receiver class as listed in table 19. This requirement shall apply when multipath or additive noise or interference does not distort the signal input to the receiver and for PDUs of 54 bytes.

Table 19: Maximum input level for operation

Receiver class	Maximum input level
1	-20 dBm
2	-30 dBm

5.11.3.3 Radio receiver adjacent and non-adjacent channel performance

The adjacent/non-adjacent channel rejection is measured by setting the desired signal's strength 3 dB above the mode-dependent sensitivity proposed in clause 5.8.3.1 and raising the power of the interfering HIPERLAN/2 signal until the proportion of erroneously received PDUs exceeds 10 %. The power difference between the interfering and the desired channel is the corresponding adjacent/non-adjacent channel rejection. In the adjacent channel case the interferer is a HIPERLAN/2 signal transmitted on a centre frequency separated by 20 MHz from the centre frequency of the desired signal. The non-adjacent channel interferer is transmitted on a centre frequency separated by a multiple of 20 MHz ($n \times 20$ MHz, $n = 2, 3, \dots$) from the centre frequency of the desired signal.

Mode-dependent adjacent/non-adjacent channel rejection levels are defined in table 20. These shall apply for PDUs of 54 bytes and when multipath or additive noise or interference or power amplifier does not distort the interfering signal input to the receiver.

Table 20: Adjacent channel and non-adjacent channel rejection requirements

Nominal bit rate [Mbit/s]	Adjacent channel rejection	Non-adjacent channel rejection
6	21 dB	40 dB
9	19 dB	38 dB
12	17 dB	36 dB
18	15 dB	34 dB
27	11 dB	30 dB
36	9 dB	28 dB
54	4 dB	23 dB

5.11.3.4 Maximum input level without blocking

Receiver blocking means that the sensitivity of the receiver is degraded in the presence of strong interfering signals due to overloading of receiver stages. The blocking level does define the maximum input power level for an interferer the receiver shall be able to operate with.

The blocking characteristics of the receiver are specified for different frequency ranges as identified in the table 21. The receiver input power level for interferer at a given frequency range, at which the proportion of erroneously received PDUs shall be less than 10 %, is defined as blocking level in the table 21.

Ten interferers with relaxed performance requirements are allowed. The receiver input power level for interferer at a given frequency range, at which the proportion of erroneously received PDUs shall be less than 10 %, is defined as spurious response level in the table 21. The rest of the spurious responses must fulfil the blocking requirement.

Table 21: Input blocking and spurious response levels

Frequency of the interference	Blocking level	Spurious response level
100 kHz ... 2,5 GHz	0 dBm	-20 dBm
2,5 GHz... 4,5 GHz	-10 dBm	-40 dBm
4,5 GHz... 5,15 GHz	-30 dBm	-40 dBm
5,15 GHz ... $f_c - 50$ MHz	-30 dBm	-40 dBm
$f_c + 50$ MHz ... 5,35 GHz	-30 dBm	-40 dBm
5,35GHz ... 5,47 GHz	-30 dBm	-40 dBm
5,47 GHz ... $f_c - 50$ MHz	-30 dBm	-40 dBm
$f_c + 50$ MHz ... 5,725 GHz	-30 dBm	-40 dBm
5,725 GHz ... 7 GHz	-30 dBm	-40 dBm
7 GHz ... 13 GHz	-20 dBm	-40 dBm

Annex A (informative): Bibliography

- ETSI TS 101 761-2: "Broadband Radio Access Networks (BRAN); HIPERLAN Type 2; Data Link Control (DLC) Layer; Part 2: Radio Link Control (RLC) sublayer".
- ETSI TR 101 683: "Broadband Radio Access Networks (BRAN); HIPERLAN Type 2; System Overview".
- ETSI TR 101 031: "Broadband Radio Access Networks (BRAN); High Performance Radio Local Area Network (HIPERLAN) Type 2; Requirements and architectures for wireless broadband access".

History

Document history		
V1.1.1	April 2000	Publication
V1.2.1	November 2000	Publication
V1.2.2	February 2001	Publication