

# ETSI TS 101 524 V1.1.1 (2001-06)

---

*Technical Specification*

**Transmission and Multiplexing (TM);  
Access transmission system on metallic access cables;  
Symmetrical single pair high bitrate  
Digital Subscriber Line (SDSL)**

---



---

**Reference**

DTS/TM-06018

---

**Keywords**

access, adaptation, basic, coding, digital, HDSL,  
IP, ISDN, local loop, PSTN, rate, SDSL,  
subscriber, transmission

**ETSI**

650 Route des Lucioles  
F-06921 Sophia Antipolis Cedex - FRANCE

---

Tel.: +33 4 92 94 42 00 Fax: +33 4 93 65 47 16

Siret N° 348 623 562 00017 - NAF 742 C  
Association à but non lucratif enregistrée à la  
Sous-Préfecture de Grasse (06) N° 7803/88

---

**Important notice**

---

Individual copies of the present document can be downloaded from:

<http://www.etsi.org>

The present document may be made available in more than one electronic version or in print. In any case of existing or perceived difference in contents between such versions, the reference version is the Portable Document Format (PDF). In case of dispute, the reference shall be the printing on ETSI printers of the PDF version kept on a specific network drive within ETSI Secretariat.

Users of the present document should be aware that the document may be subject to revision or change of status. Information on the current status of this and other ETSI documents is available at <http://www.etsi.org/tb/status/>

If you find errors in the present document, send your comment to:  
editor@etsi.fr

---

**Copyright Notification**

---

No part may be reproduced except as authorized by written permission.  
The copyright and the foregoing restriction extend to reproduction in all media.

© European Telecommunications Standards Institute 2001.  
All rights reserved.

# Contents

Intellectual Property Rights .....	9
Foreword .....	9
1 Scope.....	10
2 References .....	10
3 Definitons and abbreviations.....	11
3.1 Definitions .....	11
3.2 Abbreviations.....	11
4 Reference configuration .....	13
4.1 Physical Reference configuration.....	13
4.2 PMS-TC and TPS-TC Layers .....	15
5 Functions.....	15
5.1 Transparent transport of SDSL frames .....	15
5.2 Stuffing and destuffing .....	15
5.3 Transmission error detection.....	15
5.4 Error reporting .....	15
5.5 Failure detection.....	15
5.6 Failure reporting.....	15
5.7 Bit timing.....	16
5.8 Frame alignment.....	16
5.9 Power back-off.....	16
5.10 Transceiver start-up control .....	16
5.11 Loopback control and co-ordination.....	16
5.12 Synchronization of SDSL transceivers .....	16
5.13 Remote power feeding.....	16
5.14 Wetting current .....	16
6 Transmission medium.....	16
6.1 Description.....	16
6.2 Physical characteristics of a digital local line (DLL).....	17
6.3 Electrical characteristics of a digital local line (DLL) .....	17
6.3.1 Principal transmission characteristics.....	17
6.3.2 Crosstalk characteristics.....	18
6.3.3 Unbalance about earth.....	18
6.3.4 Impulse noise.....	18
6.3.5 Micro interruptions .....	18
6.4 Minimum digital local line (DLL) requirements for SDSL applications .....	18
7 Frame structure and bit rates .....	18
7.1 Data Mode Frame Structure.....	18
7.1.1 Introduction .....	18
7.1.2 General structure of SDSL frames .....	19
7.1.3 Frame structures for synchronous and plesiochronous transmission.....	19
7.1.4 Determination of bit rates.....	20
7.1.5 Frame bit assignments.....	21
7.1.6 Scrambling method .....	23
7.2 Activation Mode Frame Structure.....	25
7.2.1 Activation framer.....	25
7.2.1.1 Frame sync .....	25
7.2.1.2 Precoder coefficients .....	25
7.2.1.3 Encoder coefficients .....	25
7.2.1.4 Vendor Data .....	25
7.2.1.5 Reserved .....	25
7.2.1.6 CRC .....	26

8	Clock Architecture.....	26
8.1	Tolerance of the line symbol rate.....	26
8.2	Reference clock architecture.....	26
8.3	Definitions of Clock Sources.....	27
8.3.1	Transmit symbol clock.....	27
8.3.2	Local oscillator.....	27
8.3.3	Network reference clock.....	27
8.3.4	Transmit data clock.....	27
8.3.5	Receive symbol clock.....	28
8.3.6	Receive data clock.....	28
8.4	Synchronization to Clock Sources.....	28
9	PMD Layer Functional Characteristics.....	28
9.1	Activation.....	28
9.1.1	Activation PMD reference model.....	28
9.1.2	Activation sequence.....	29
9.1.2.1	Signal $C_r$ .....	31
9.1.2.2	Signal $S_c$ .....	31
9.1.2.3	Signal $S_r$ .....	32
9.1.2.4	Signal $T_c$ .....	32
9.1.2.5	Signal $T_r$ .....	32
9.1.2.6	Signal $F_c$ .....	32
9.1.2.7	Data <sub>c</sub> and Data <sub>r</sub> .....	32
9.1.2.8	Exception state.....	32
9.1.2.9	Exception condition.....	32
9.1.3	Activation framer.....	33
9.1.4	Scrambler.....	33
9.1.5	Mapper.....	33
9.1.6	Spectral shaper.....	33
9.1.7	Timeouts.....	33
9.2	PMD preactivation sequence.....	33
9.2.1	PMD preactivation reference model.....	34
9.2.2	PMD preactivation sequence description.....	34
9.2.2.1	Signal $P_{ri}$ .....	35
9.2.2.2	Signal $P_{ci}$ .....	35
9.2.3	Scrambler.....	35
9.2.4	Mapper.....	35
9.2.5	Spectral shaper.....	36
9.2.6	Power back-off.....	36
9.2.7	PMMS Target Margin.....	36
9.3	Data mode.....	37
9.3.1	Data mode PMD reference model.....	37
9.3.1.1	PMD rates.....	37
9.3.2	Scrambler.....	37
9.3.3	UC-PAM encoder.....	37
9.3.3.1	Serial-to-parallel converter.....	38
9.3.3.2	Convolutional encoder.....	38
9.3.3.3	Mapper.....	39
9.3.4	Channel precoder.....	39
9.3.5	Spectral shaper.....	40
9.4	PSD masks.....	40
9.4.1	Symmetric PSD masks.....	40
9.4.2	Asymmetric 2 048 kbit/s and 2 304 kbit/s PSD masks.....	42
10	Operation and maintenance.....	45
10.1	Management Reference Model.....	45
10.2	SDSL Primitives and Failures.....	46
10.2.1	Cyclical Redundancy Check Anomaly (CRC).....	46
10.2.2	Segment Anomaly (SEGA).....	46
10.2.3	Loss of Sync Defect (LOSW defect).....	46
10.2.4	Segment Defect (SEGD).....	46
10.2.5	Loop Attenuation Defect.....	46

10.2.6	SNR Margin Defect .....	46
10.2.7	Loss of Sync Word Failure (LOSW failure).....	47
10.2.8	Loss of local power.....	47
10.3	SDSL Line Related Performance Parameters.....	47
10.3.1	Code Violation (CV).....	47
10.3.2	Errored Second (ES) .....	47
10.3.3	Severely Errored Second (SES).....	47
10.3.4	LOSW Second (LOSWS).....	47
10.3.5	Unavailable Second (UAS) .....	47
10.3.6	Inhibiting Rules .....	47
10.4	Performance data storage.....	48
10.5	SDSL embedded operations channel (eoc) .....	48
10.5.1	eoc management reference model .....	48
10.5.2	eoc overview and reference model.....	48
10.5.3	eoc start-up .....	50
10.5.4	Remote management access .....	51
10.5.5	eoc transport .....	52
10.5.5.1	eoc data format .....	52
10.5.5.2	eoc frame format .....	52
10.5.5.3	Data transparency .....	52
10.5.5.4	Frame check sequence .....	53
10.5.5.5	Unit addresses .....	53
10.5.5.6	Message IDs.....	53
10.5.5.7	Message contents.....	54
10.5.5.7.1	Discovery Probe - Message ID 1.....	54
10.5.5.7.2	Discovery Response - Message ID 129 .....	55
10.5.5.7.3	Inventory Request - Message ID 2.....	55
10.5.5.7.4	Inventory Response - Message ID 130.....	55
10.5.5.7.5	Configuration Request - SDSL - Message ID 3 .....	56
10.5.5.7.6	Configuration Request - Loopback Time-Out - Message ID 5 .....	56
10.5.5.7.7	Configuration Response - SDSL - Message ID 131 .....	56
10.5.5.7.8	Configuration Response - Loopback Time-Out - Message ID 133 .....	57
10.5.5.7.9	NTU Config Request - Management: Message ID 18.....	57
10.5.5.7.10	Config Response - Management message: Message ID 146.....	57
10.5.5.7.11	Config Response - Management message: Message ID 146.....	58
10.5.5.7.12	Status Request - Message ID 11.....	58
10.5.5.7.13	Full Status Request - Message ID 12.....	58
10.5.5.7.14	Status Response/SNR - Message ID 139.....	59
10.5.5.7.15	SDSL Network Side Performance Status - Message ID 140.....	59
10.5.5.7.16	SDSL Customer Side Performance Status - Message ID 141 .....	60
10.5.5.7.17	Virtual Terminal Connect/Disconnect Request/Response - Message IDs 6,7,134.....	61
10.5.5.7.18	Screen Message/Keyboard Message - Message IDs 8,136.....	61
10.5.5.7.19	Maintenance Request - System Loopback - Message ID 9.....	62
10.5.5.7.20	Maintenance Request - Element Loopback - Message ID 10.....	62
10.5.5.7.21	Maintenance Status Response - Message ID 137.....	63
10.5.5.7.22	Soft Restart/Power Back-off Disable Message - Message ID 15 .....	63
10.5.5.7.23	Segment Management Message - Message IDs 64 - 88, 192 - 216.....	63
10.5.5.7.24	Proprietary Messages - Message IDs 112 - 119, 240 - 247.....	63
10.5.5.7.25	Proprietary External Message - Message ID 120 .....	64
10.5.5.7.26	G.997.1 External Message - Message ID 121 .....	64
10.5.5.7.27	Generic Unable to Comply (UTC) Message (ID 144).....	64
10.5.6	Examples of Virtual Terminal Control Functions.....	64
11	Electrical characteristics of a SDSL transceiver.....	65
11.1	General .....	65
11.2	Transmitter/Receiver impedance and return loss.....	65
11.3	Unbalance about earth .....	65
11.3.1	Longitudinal conversion loss .....	65
11.3.2	Longitudinal output voltage.....	66
11.4	Signal transfer delay.....	67
12	Laboratory performance measurements .....	67

12.1	General .....	67
12.2	Test procedure.....	67
12.2.1	Test set-up definition.....	68
12.2.2	Signal and noise level definitions .....	69
12.3	Performance test procedure.....	69
12.4	Testloops.....	70
12.4.1	Functional description .....	70
12.4.2	Testloop topology .....	71
12.4.3	Testloop length .....	71
12.5	Impairment generator .....	73
12.5.1	Functional description.....	74
12.5.2	Cable crosstalk models.....	75
12.5.3	Individual impairment generators .....	76
12.5.3.1	Equivalent NEXT disturbance generator [G1.xx].....	76
12.5.3.2	Equivalent FEXT disturbance generator [G2.xx] .....	76
12.5.3.3	Background noise generator [G3].....	77
12.5.3.4	White noise generator [G4].....	77
12.5.3.5	Broadcast RF noise generator [G5].....	77
12.5.3.6	Amateur RF noise generator [G6] .....	77
12.5.3.7	Impulse noise generator [G7].....	77
12.5.4	Profiles of the individual impairment generators.....	77
12.5.4.1	Frequency domain profiles for SDSL .....	78
12.5.4.1.1	Self crosstalk profiles .....	78
12.5.4.1.2	Alien crosstalk profiles.....	79
12.5.4.2	Time domain profiles of generator G1-G4.....	80
12.6	Measurement of noise margin.....	81
12.6.1	Measurement of crosstalk noise margin .....	81
12.6.2	Measurement of impulse noise margin.....	81
12.7	Micro interruptions.....	81
13	Power feeding.....	81
13.1	General .....	81
13.2	Power feeding of the NTU.....	81
13.3	Power feeding of the interface for narrowband services .....	82
13.4	Feeding power from the LTU .....	82
13.5	Power available at the NTU.....	82
13.5.1	Static requirements.....	82
13.5.2	Dynamic requirements .....	82
13.5.3	Reset of NTU.....	83
13.6	DC and low frequency AC termination of NTU .....	83
14	Environmental requirements .....	83
14.1	Climatic conditions.....	83
14.2	Safety.....	83
14.3	Over-voltage protection .....	83
14.4	Electromagnetic compatibility .....	83
<b>Annex A (normative):      Application specific TPS-TC .....</b>		<b>84</b>
A.1	TPS-TC for Clear Channel Data.....	84
A.2	TPS-TC for Clear Channel Byte-Oriented Data.....	84
A.3	TPS-TC for European 2 048 kbit/s Digital Unstructured Leased Line (D2048U) .....	84
A.4	TPS-TC for Unaligned European 2 048 kbit/s Digital Structured Leased Line (D2048S) .....	85
A.5	TPS-TC for Aligned European 2 048 kbit/s Digital Structured Leased Line (D2048S) and Fractional .....	85
A.6	TPS-TC for synchronous ISDN BRA.....	86
A.6.1	ISDN BRA over SDSL frames.....	86
A.6.2	Mapping of ISDN B- and D-channels on SDSL payload channels .....	86
A.6.3	Multi-ISDN BRAs.....	87
A.6.4	ISDN BRA for lifeline service .....	88

A.6.5	Time slot positions of ISDN B- and D <sub>16</sub> -channels (eoc Signalling) .....	88
A.6.6	Time slot positions of ISDN B- and D <sub>16</sub> -channels and the optional fast Signalling channel .....	88
A.6.7	Signalling over the SDSL eoc or the fast Signalling channel.....	90
A.6.7.1	SDSL eoc messages .....	90
A.6.7.2	ISDN Message Codes .....	91
A.6.8	S-Bus control .....	92
A.6.9	BRA termination reset.....	92
A.6.10	Transport of ISDN eoc messages over SDSL eoc .....	93
A.7	TPS-TC for POTS .....	94
A.7.1	Mapping of 64 kbit/s POTS channels onto the SDSL frame.....	94
A.7.2	POTS access for lifeline service.....	94
A.7.3	Signalling.....	95
A.7.3.1	Signalling channel over Z-bit .....	95
A.7.3.2	Signalling channel over a B-channel.....	95
A.8	ATM Transport over SDSL.....	95
A.8.1	Reference Model for ATM Transport.....	95
A.8.2	Flow Control.....	96
A.8.3	ATM-TC sub-layer functionality .....	96
A.8.3.1	Idle Cell Insertion .....	96
A.8.3.2	Header Error Control (HEC) Generation.....	97
A.8.3.3	HEC Verification .....	97
A.8.3.4	Cell payload scrambling/de-scrambling .....	97
A.8.3.5	Cell Delineation .....	97
A.8.3.6	Bit timing, ordering and data rates .....	98
A.8.4	Operations and Maintenance.....	99
A.8.4.1	ATM data path related near-end anomalies .....	99
A.8.4.2	ATM data path related near-end defects.....	99
A.8.4.3	ATM data path related far-end anomalies .....	99
A.8.4.4	ATM data path related far-end defects .....	99
A.8.4.5	ATM cell level protocol performance information collection .....	100
A.8.4.6	Failures and Performance Parameters .....	100
A.8.4.7	EOC ATM Cell Status Request Message Format - Message ID 17 .....	100
A.8.4.8	EOC ATM Cell Status Information Message Format - Message ID 145 .....	100
A.9	Dual Bearer TPS-TC Mode for SDSL.....	101
A.9.1	Dual Bearer Mode Framing .....	101
A.9.2	Bearer Channel Allocation.....	101
A.9.3	Dual Bearer Clock Synchronization .....	102
A.9.4	Dual Bearer Mode Types .....	102
A.10	TPS-TC for LAPV5 enveloped POTS or ISDN.....	103
A.10.1	Mapping of 64 kbit/s payload channels .....	103
A.10.2	Signalling channel .....	103
A.10.3	Signalling and port control.....	103
A.10.4	Protocol architecture for LAPV5 enveloped POTS and ISDN.....	103
<b>Annex B (normative):    Use of G.994.1 in the Pre-Activation Communications Channel.....</b>		<b>105</b>
B.1	G.994.1 Code Point Definitions .....	105
B.2	G.994.1 Tone Support.....	106
B.3	G.994.1 Transactions .....	106
B.4	Operation with Signal Regenerators .....	107
<b>Annex C (normative):    Signal Regenerator Operation.....</b>		<b>108</b>
C.1	Reference Diagram .....	108
C.2	Startup Procedures .....	108
C.2.1	REG-C.....	108
C.2.2	REG-R.....	109
C.2.3	LTU.....	110

C.2.4	NTU .....	111
C.2.5	Segment Failures and Retrains.....	111
C.3	Symbol Rates.....	111
C.4	PSD Masks .....	111
<b>Annex D (informative): Signal Regenerator Startup Description .....</b>		<b>112</b>
D.1	NTU Initiated Startup .....	112
D.2	LTU Initiated Startup.....	113
D.3	REG Initiated Startup.....	114
D.4	Collisions and Retrains .....	114
D.5	Diagnostic Mode Activation .....	115
<b>Annex E (informative): Typical characteristics of cables .....</b>		<b>116</b>
<b>Annex F (informative): Transmission and Reflection of Cable Sections .....</b>		<b>117</b>
F.1	Definition of transfer function and insertion loss .....	117
F.2	Derivation of s-parameters from primary cable parameters .....	118
<b>Annex G (informative): Guideline for the narrowband interfaces implementation in the SDSL NTU .....</b>		<b>119</b>
<b>Annex H (informative): Differences with G.991.2 (G.shdsl annex B) .....</b>		<b>123</b>
<b>Annex I (informative): Bibliography.....</b>		<b>124</b>
History .....		125



---

## Intellectual Property Rights

IPRs essential or potentially essential to the present document may have been declared to ETSI. The information pertaining to these essential IPRs, if any, is publicly available for **ETSI members and non-members**, and can be found in ETSI SR 000 314: *"Intellectual Property Rights (IPRs); Essential, or potentially Essential, IPRs notified to ETSI in respect of ETSI standards"*, which is available from the ETSI Secretariat. Latest updates are available on the ETSI Web server (<http://www.etsi.org/ipr>).

Pursuant to the ETSI IPR Policy, no investigation, including IPR searches, has been carried out by ETSI. No guarantee can be given as to the existence of other IPRs not referenced in ETSI SR 000 314 (or the updates on the ETSI Web server) which are, or may be, or may become, essential to the present document.

---

## Foreword

This Technical Specification (TS) has been produced by ETSI Technical Committee Transmission and Multiplexing (TM).

The present document was created as the merger of the two parts of Version 1.1.1:

- Part 1: "Functional requirements" (TS 101 524-1 (V.1.1.1)); and
- Part 2: "Transceiver requirements" (TS 101 524-2 (V.1.1.1)),

with appropriate enhancements. In addition to the first Edition, an annex specifying the TPS-TC for several applications was created.

---

# 1 Scope

The present document specifies requirements for transceivers providing bi-directional symmetrical high bit rate transmission on a single metallic wire pair using the echo cancellation method. The technology is referred to as Symmetrical single-pair high bit rate Digital Subscriber Line (SDSL), and is applicable to metallic access transmission systems designed to provide digital access over existing, unshielded wire pairs.

The present document and the requirements for their implementation define the functional requirements for SDSL.

The requirements imply interoperability of SDSL systems. Such interoperability will be achieved when SDSL transceivers provided by different manufacturers are used in one SDSL link.

The definition of physical interfaces is outside the scope of the present document. The SDSL transmission system consists of an application independent core and an application specific block. The core is considered a transport bit-pump, which transports information from one end of the metallic link to the other. The data is mapped into a frame, which is considered to be the interface between the application specific and independent parts of the SDSL system. This frame is only used internally and is not accessible.

---

# 2 References

The following documents contain provisions, which, through reference in this text, constitute provisions of the present document.

- References are either specific (identified by date of publication, edition number, version number, etc.) or non-specific.
- For a specific reference, subsequent revisions do not apply.
- For a non-specific reference, the latest version applies.

- [1] ETSI TS 101 135: "Transmission and Multiplexing (TM); High bit-rate Digital Subscriber Line (HDSL) transmission systems on metallic local lines; HDSL core specification and applications for combined ISDN-BA and 2 048 kbit/s transmission".
- [2] ETSI TS 102 080: "Transmission and Multiplexing (TM); Integrated Services Digital Network (ISDN) basic rate access; Digital transmission system on metallic local lines".
- [3] ETSI EN 300 012-1: "Integrated Services Digital Network (ISDN); Basic User-Network Interface (UNI); Part 1: Layer 1 specification".
- [4] ETSI EN 300 001 (1997): "Attachments to the Public Switched Telephone Network (PSTN); General technical requirements for equipment connected to an analogue subscriber interface in the PSTN".
- [5] ETSI EN 60950 (1992): "Safety of information technology equipment".
- [6] ETSI ETS 300 019 (1992): "Equipment Engineering (EE); Environmental conditions and environmental tests for telecommunications equipment".
- [7] ETSI EN 300 386: "Electromagnetic compatibility and Radio spectrum Matters (ERM); Telecommunication network equipment; ElectroMagnetic Compatibility (EMC) requirements".
- [8] ITU-T Recommendation G.997.1 (1999): "Physical layer management for digital subscriber line (DSL) transceivers".
- [9] ITU-T Recommendation K.17 (1988): "Tests on power-fed repeaters using solid-state devices in order to check the arrangements for protection from external interference".
- [10] ITU-T Recommendation K.20 (1991): "Resistibility of telecommunication equipment installed in a telecommunications centre to overvoltages and overcurrents".

- [11] ITU-T Recommendation K.21 (1989): "Resistibility of telecommunication equipment installed in costumer's premises to overvoltages and overcurrents".
- [12] ITU-T Recommendation O.9 (1993): "Measuring arrangements to assess the degree of unbalance about earth".
- [13] ETSI EG 201 185 (V1.1.1): "Terminal support interface for harmonized analogue PSTN terminals".
- [14] IETF RFC 1662: "PPP in HDLC-like Framing".
- [15] ANSI X3.4-1986 (R1997): "Information Systems - Coded Character Sets - 7-Bit American National Standard Code for Information Interchange (7-Bit ASCII)".
- [16] ITU-T Recommendation G.994.1: "Handshake procedures for digital subscriber line (DSL) transceivers".
- [17] ETSI TS 101 012: "Transmission and Multiplexing (TM); Broadband Access Digital Section and NT functional requirements".
- [18] ISO 8601 (2000): "Data elements and interchange formats - Information interchange - Representation of dates and times".
- [19] ITU-T Recommendation G.704: "Synchronous frame structures used at 1544, 6312, 2048, 8448 and 44 736 kbit/s hierarchical levels".
- [20] ITU-T Recommendation I.432.1: "B-ISDN User-Network Interface - Physical layer specification: General characteristics".
- [21] IETF RFC 2495: "Definitions of Managed Objects for the DS1, E1, DS2 and E2 Interface Types".
- [22] ETSI TBR 021: "Terminal Equipment (TE); Attachment requirements for pan-European approval for connection to the analogue Public Switched Telephone Networks (PSTNs) of TE (excluding TE supporting the voice telephony service) in which network addressing, if provided, is by means of Dual Tone Multi Frequency (DTMF) signalling".
- [23] ETSI EN 300 324-1 (V2.1.1): "V interfaces at the digital Local Exchange (LE); V5.1 interface for the support of Access Network (AN); Part 1: V5.1 interface specification".
- [24] ETSI EG 201 900-1 (1.1.1): "Services and Protocols for Advanced Networks (SPAN); Narrowband Services over ATM; Loop Emulation Service (LES) using AAL2; Part 1: LES interface specification [ATM Forum Specification AF-VMOA-0145.000 (2000), modified]".

---

## 3 Definitons and abbreviations

### 3.1 Definitions

For the purposes of the present document, the following terms and definitions apply:

**Bridges Tap:** unterminated twisted pair section bridged across the line

### 3.2 Abbreviations

For the purposes of the present document, the following abbreviations apply:

2B1Q	two binary one quaternary line code
BB	BroadBand
BER	Bit Error Ratio
BERTS	Bit Error Ratio Test Set
BT	Bridged Tap, an unterminated twisted pair section bridged across the line
CRC	Cyclic Redundancy Check

DLL	Digital Local Line
DSL	Digital Subscriber Line
ES	Errored Second
eoc	embedded operations channel
EMC	ElectroMagnetic Compatibility
ETR	ETSI Technical Report
ETS	European Telecommunication Standard
FCS	Frame Check Sequence
FEXT	Far End crosstalk
HDLC	High level Data Link Control
HDSL	High bit rate Digital Subscriber Line
ISDN BA	Integrated Services Digital Network Basic rate Access
ITU-T	International Telecommunication Union - Telecommunication Standardization Sector (former CCITT)
IUT	Item Under Test
LCL	Longitudinal Conversion Loss
LOSW	Loss Of Synch Word failure
lsb	least significant bit
LTU	Line Termination Unit
msb	most significant bit
NB	NarrowBand
NEXT	Near End Crosstalk
NTU	Network Termination Unit
OH	OverHead
OAM	Operation And Maintenance
PACC	Pre-Activation Communication Channel
PAM	Pulse Amplitude Modulation
2-PAM	two-level PAM
PBO	Power Back-Off
PLL	Phase Lock Loop
PMD	Physical Medium Dependent
PMD-TC	Physical Medium Dependent Transmission Convergence
PMMS	Power Measurement Modulation Session (Line Probe)
PMS	Physical Medium Specific
PMS-TC	Physical Medium Specific Transmission Convergence
ppm	parts per million
PPP	Point-to-Point Protocol
PRBS	Pseudo-Random Bit Sequence
PSD	Power Spectral Density
PSL	Power Sum Loss
REG	REGenerator
REG-C	NTU side of the regenerator
REG-R	LTU side of the regenerator
RF	Radio Frequency
rms	root mean square
RSP	Regenerator Silent Period bit
SDH	Synchronous Digital Hierarchy
SDSL	Symmetric single pair high bit rate Digital Subscriber Line
SES	Severely Errored Second
SNR	Signal to Noise Ratio
SRU	Signal Regenerator Unit
TBD	To Be Determined
TC	Transmission Convergence
TC-PAM	Trellis Coded Pulse Amplitude Modulation
TPS	Transmission Protocol Specific
TPS-TC	Transmission Protocol Specific Transmission Convergence
TMN	Telecommunication Management Network
TS	Technical Specification
TU	Termination Unit
TU-12	Tributary Unit-12
UAS	UnAvailable Second
UC-PAM	Ungerboeck Coded Pulse Amplitude Modulation (same as TC-PAM)

UTC Unable To Comply  
 VC-12 Virtual Container-12  
 xDSL a collective term referring to any of the various types of DSL technologies

## 4 Reference configuration

### 4.1 Physical Reference configuration

Figure 4-1 shows the reference configuration of an SDSL transmission system.

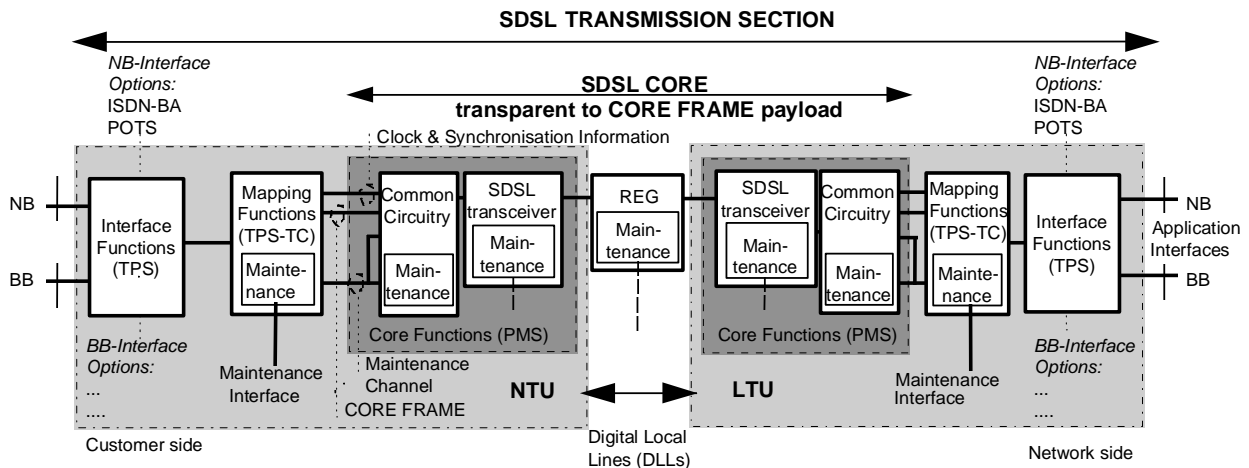

Figure 4-1: Reference configuration

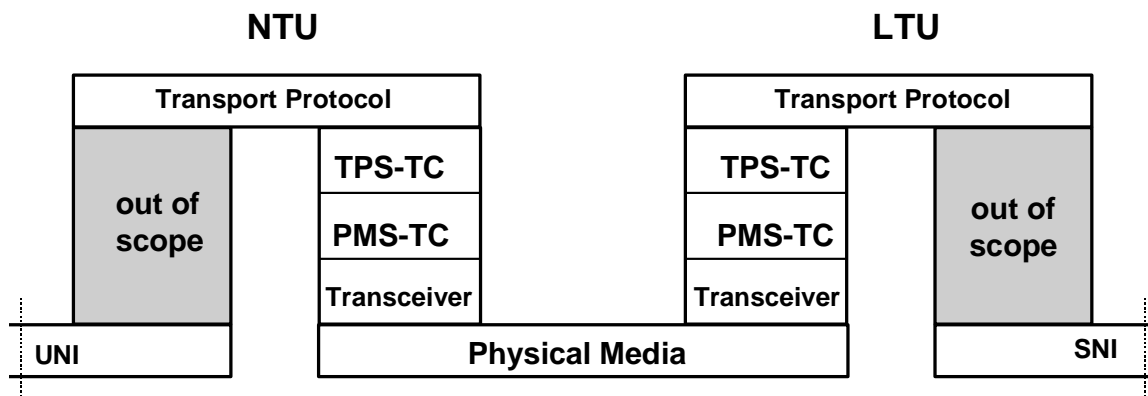

Figure 4-2: Protocol reference model

The reference configuration provides for a bi-directional symmetrical channel with a variable bit rate that is under the control of the network management system of the operator. The maximum aggregate line bit rate is 2 320 kbit/s (allowing the support of TU-12 transport). An option is provided for transporting an independent narrowband channel. The narrowband channel shall be able to carry an ISDN-BA whose clock domain is not necessarily the same as that of the rest of the channel. The narrowband channel shall alternatively be capable of supporting analogue telephone channels. Remote power feeding shall be provided by the central office. In this case, a reduced power mode (for lifeline service in case of local power failure) may be provided for the ISDN-BA or one analogue telephone connection.

The multiplexing of additional narrowband channels into the data channel is not precluded but is outside the scope of the present document. Lifeline service is not required for these channels.

The SDSL transmission system consists of the following functional blocks:

- interface;
- mapping;
- common circuitry;
- SDSL transceiver;
- optional regenerators.

The functions at the central office side constitute the Line Termination Unit (LTU) and act as master to the customer side functions, which constitute the Network Termination Unit (NTU), and to a regenerator where applicable.

The common circuitry providing for Physical Media Specific Transmission Convergence (PMS-TC) Layer and the SDSL transceivers comprise the core functions of the NTU and the LTU which, along with the Digital Local Line (DLL), make up the SDSL core. The DLL is commonly a copper twisted pair and may contain regenerators if an enhanced transmission range is required. A regenerator may be inserted at any convenient intermediate point in the SDSL core with appropriate insertion loss consideration. Power feeding and lifeline service may restrict the maximum achievable loop reach.

The SDSL core is application independent. It transparently transports the SDSL frames that it receives at its internal interfaces. The core functions are physical medium specific (PMS) and include:

- SDSL timing generation and recovery;
- start-up;
- scrambling and descrambling;
- coding and decoding;
- modulation and demodulation;
- echo cancellation;
- line equalization.

The mapping functions and the interface functions are application dependent and transmission protocol specific (TPS). The mapping function handles the Transmission Convergence (TC) Layer of the specific application including the maintenance and the mapping of the application frames into the SDSL frame. The TC-functions contain:

- channel multiplexing and demultiplexing;
- framing;
- frame synchronization;
- error detection;
- justification;
- maintenance.

The interface functional block provides interfaces to the data channel and the optional narrowband subchannel. The physical characteristics of the interfaces are application dependent. Implementation details are defined in the application descriptions.

The interfaces between the functional blocks are only logical separations and are not required to be physically accessible.

A clear embedded operations channel (eoc) is provided for within the system frame structure. The SDSL core is specified so as to promote interoperability of equipment from different vendors.

## 4.2 PMS-TC and TPS-TC Layers

The transport of STM over SDSL, ATM over SDSL and Dual Bearer Mode is defined in this specification. Additional services are defined in details in TS 101 012 [17]. Some applications may require a simultaneous transport of STM- and ATM-traffic. In this case the total SDSL payload is split into  $n_{STM}$  B-channels for STM- and  $n_{ATM}$  B-channels for ATM-transport.

---

## 5 Functions

The functions listed below are necessary for the correct operation of the SDSL core.

Functions related to the SDSL core	LTU	NTU/ REG
Transparent transport of SDSL frames	<---->	
Stuffing and destuffing	<---->	
Transmission error detection	<---->	
Error reporting	<---->	
Failure detection	<---->	
Failure reporting	<---->	
Bit timing	<---->	
Frame alignment	<---->	
Power back-off	<---->	
Transceiver start-up control	----->	
Loopback control and co-ordination	<---->	
Synchronization of SDSL transceivers	----->	
Remote power feeding	----->	
Wetting current (optional)	----->	

### 5.1 Transparent transport of SDSL frames

This function provides for the bi-directional transmission of the SDSL frames.

### 5.2 Stuffing and destuffing

This function, when used, provides for the synchronization of the application data clock to the SDSL transceiver system clock, by means of adding zero or four stuffing bits per SDSL frame.

### 5.3 Transmission error detection

This function provides for error performance monitoring of the SDSL transceiver systems in each SDSL frame.

### 5.4 Error reporting

This function provides for the reporting of errors detected.

### 5.5 Failure detection

This function provides for the detection of failures in the SDSL transceiver system.

### 5.6 Failure reporting

This function provides for the reporting of failures detected in the SDSL transceiver systems.

## 5.7 Bit timing

This function provides bit timing to enable the SDSL transceiver systems to recover information from the aggregate bit stream.

## 5.8 Frame alignment

This function provides information to enable the SDSL transceiver systems to recover the SDSL frame.

## 5.9 Power back-off

The transmitter shall have the ability to reduce its transmitted power in order to reduce crosstalk with transmission systems operating in the same multi pair cable. The power back-off function shall be provided in both directions of transmission. The reduction of power shall be controlled by the network management.

## 5.10 Transceiver start-up control

This function provides for the activation to reach the operational state. It may contain a preactivation procedure.

## 5.11 Loopback control and co-ordination

This function provides for the activation and deactivation of loopbacks in the LTU, the REG and the NTU.

## 5.12 Synchronization of SDSL transceivers

This function provides for the synchronization of the SDSL transceiver systems.

## 5.13 Remote power feeding

This function provides for remote power feeding of the NTU and/or the regenerators from the LTU.

## 5.14 Wetting current

This optional function provides for feeding of a low current on the pair to mitigate the effect of corrosion of contacts.

---

# 6 Transmission medium

## 6.1 Description

The transmission medium over which the digital transmission system is expected to operate is the local line distribution network, known as the digital local line (DLL). A digital local line distribution network employs cables of pairs to provide services to customers. In a local line distribution network, customers are connected to the local exchange via local lines. To simplify the provision of SDSL, a digital transmission system must be capable of satisfactory operation over the majority of metallic local lines without requirement of any special conditioning. In order to permit the use of SDSL transmission systems on the maximum possible number of digital local lines, the restrictions imposed by SDSL requirements are kept to the minimum necessary to guarantee acceptable operation.



## 6.2 Physical characteristics of a digital local line (DLL)

A digital local line (DLL) is constructed of one or more cable sections that are spliced or interconnected together.

The distribution or main cable is structured as follows:

- cascade of cable sections of different diameters and lengths;
- up to two bridged taps (BTs) may exist at various points in installation and distribution cables.

A general description of the DLL physical model is shown in figure 6-1 and typical examples of cable characteristics are given in table 6-1.

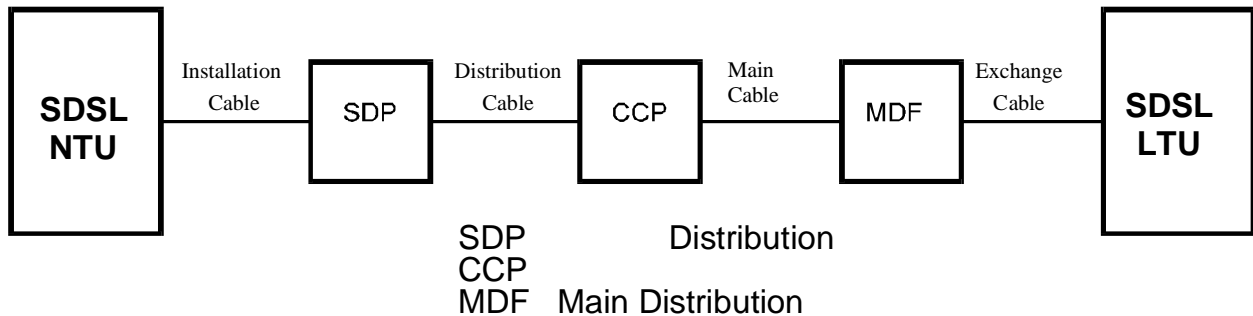

Figure 6-1: DLL physical model

Table 6-1: Typical cable characteristics

	Exchange Cable	Main Cable	Distribution Cable	Installation Cable
<b>Wire diameter (mm)</b>	0,5; 0,6; 0,32; 0,4	0,3 - 1,4	0,3 - 1,4	0,4; 0,5; 0,6; 0,8; 0,9; 0,63
<b>Structure</b>	SQ (B) or TP (L)	SQ (B) or TP (L)	SQ (B) or TP (L)	SQ or TP or UP
<b>Maximum number of pairs</b>	1 200	4 800	600	2 (aerial) 600 (in house)
<b>Installation</b>		underground in ducts	underground or aerial	aerial (drop) or in ducts (in house)
<b>Capacitance (nF/km at 800 Hz)</b>	55 ... 120	25 ... 60	25 ... 60	35 ... 120
<b>Wire insulation</b>	PVC, FRPE	PE, paper pulp	paper, PE, Cell PE	PE, PVC
<b>TP:</b>	Twisted Pairs	<b>PE:</b>	Polyethylene	
<b>SQ:</b>	Star Quads	<b>PVC:</b>	Polyvinylchloride	
<b>UP:</b>	Untwisted Pairs	<b>Pulp:</b>	Pulp of paper	
<b>L:</b>	Layer	<b>Cell PE:</b>	Cellular Foam	
<b>B:</b>	Bundles (units)	<b>FRPE:</b>	Polyethylene Fire Resistant PE	
<b>NOTE:</b>	This table is intended to describe the cables presently installed in the local loop. Not all of the above cable types are suitable for SDSL systems.			

## 6.3 Electrical characteristics of a digital local line (DLL)

The transmitted signal will suffer from impairments due to crosstalk, impulsive noise and the non-linear variation with frequency of DLL characteristics. These impairments are described in more detail in the following clauses.

### 6.3.1 Principal transmission characteristics

The principal electrical characteristics varying nonlinearly with frequency are:

- insertion loss;
- group delay;

- characteristic impedance, comprising real and imaginary parts.

### 6.3.2 Crosstalk characteristics

Crosstalk noise in general is the result of finite coupling loss between pairs sharing the same cable, especially those pairs that are physically adjacent. Finite coupling loss between pairs causes a vestige of the signal flowing on one DLL (disturber DLL) to be coupled into an adjacent DLL (disturbed DLL). This vestige is known as crosstalk noise. Near-end crosstalk (NEXT) is assumed to be the dominant type of crosstalk.

Intersystem NEXT results when pairs carrying different digital transmission systems interfere with each other.

Intrasystem NEXT or self-NEXT results when all pairs interfering with each other in a cable are carrying the same digital transmission system. Intrasystem NEXT noise coupled into a disturbed DLL from a number of DLL disturbers can be represented as being due to an equivalent single disturber DLL with a coupling loss versus frequency characteristics known as Power Sum Loss (PSL). Values for 1 % worst case NEXT loss vary from 40 dB to 70 dB at 150 kHz depending upon the cable type, number of disturbers and environment.

### 6.3.3 Unbalance about earth

The DLL will have finite balance about earth. Unbalance about earth is described in terms of longitudinal conversion loss (LCL). The expected worst case value is 42,5 dB at 150 kHz decreasing with frequency by 5 dB/decade.

### 6.3.4 Impulse noise

The DLL will have impulse noise resulting from other systems sharing the same cables as well as from other sources.

### 6.3.5 Micro interruptions

A micro interruption is a temporary line interruption due to external mechanical action on the copper wires constituting the transmission path, for example, at a cable splice.

## 6.4 Minimum digital local line (DLL) requirements for SDSL applications

- No loading coils;
- Only twisted pair or quad cable;
- No additional shielding necessary;
- When bridged taps are present, the maximum number shall be limited to 2 and the length of each to 500 m.

---

## 7 Frame structure and bit rates

### 7.1 Data Mode Frame Structure

#### 7.1.1 Introduction

This clause describes the proposed SDSL frame structure before scrambling and encoding. This structure is valid during normal operation after symbol timing synchronization, frame alignment and after all internal transceiver coefficients have been stabilized sufficiently to permit a reliable transport of the signals.

The frame structure provides the flexibility to transport variable payload bit rates from 192 kbit/s up to 2 312 kbit/s and the option of plesiochronous or synchronous mode.

In plesiochronous mode, the SDSL transceiver clock is independent of the incoming data clock. It may be derived from the free running local oscillator or from an external clock source. The data is mapped to the SDSL frame employing the HDSL stuffing procedure. Each individual frame contains either 0 or 4 stuffing bits resulting in a variable frame length. The mean length of the SDSL frames is 6 ms.

In synchronous mode, the SDSL transceiver clock is locked to the clock of the transmit data. The SDSL frames have a fixed length of 6 ms. Instead of the stuffing bits, two spare bits are defined at the end of each frame.

### 7.1.2 General structure of SDSL frames

Figure 7-1 illustrates bit sequences of the SDSL frame structure prior to scrambling at the transmit and after descrambling at the receive side.

The nominal SDSL frame length is 6 ms. The frame is subdivided into four groups. The first group of the frame starts with the 14 bit long synchronization word followed by two SDSL overhead bits and 12 blocks of SDSL payload. Each payload block consists of  $i + n \times 8$  bits ( $i = 0..7, n = 3..36$ ) according to the number of B-channels ( $n$ ) and Z-bits ( $i$ ) (service, signalling, maintenance) which are transmitted. Depending on the payload bit rate, each block contains between 24 bits and 289 bits. For  $i = 1$  and  $n = 36$  compatibility with the HDSL frame of TS 101 135 [1] is achieved.

The three groups following the first group all have the same structure. Each consists of ten SDSL overhead bits and 12 SDSL payload blocks as described above. Therefore, one frame contains a 14 bit synchronization word, 32 overhead bits, and between 1 152 and 13 872 payload bits. (The total number of bits in one 6 ms frame is  $48 \times (1 + i + n \times 8)$  [bits]). The corresponding line rates are between 192 kbit/s + 8 kbit/s and 2 312 kbit/s + 8 kbit/s). There are two possibilities for the bits that occur at the end of the frame (after the P48 block). If bit stuffing is used, either zero or four stuffing bits are inserted. If bit stuffing is not used, two spare bits are available.

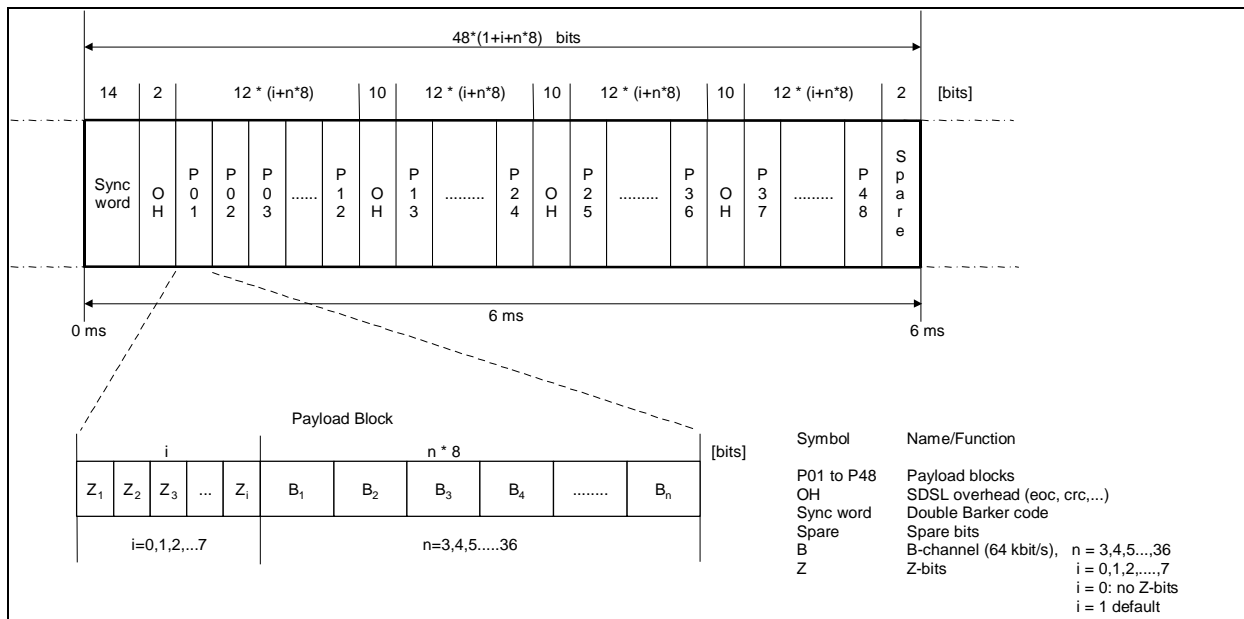
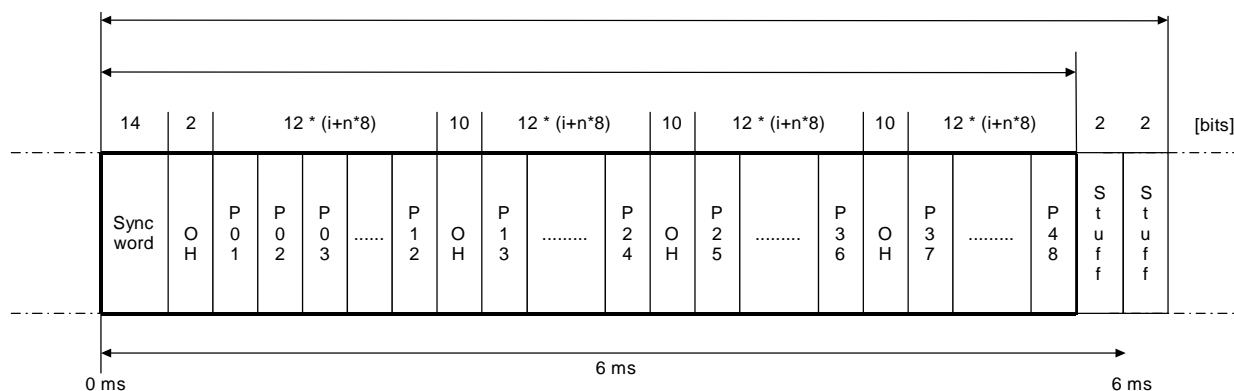

Figure 7-1: SDSL frame structure

### 7.1.3 Frame structures for synchronous and plesiochronous transmission

Figures 7-2 and 7-3 show the general structure of the SDSL frames for plesiochronous and for synchronous transmission.



Symbol	Name/Function
P01 to P48	Payload blocks
OH	SDSL overhead (eoc, crc,...)
Sync word	Double Barker code
Stuff	Stuffing bits

**Figure 7-2: SDSL frame structure for plesiochronous transmission**

In plesiochronous mode either zero or four stuffing bits are inserted at the end of each frame. The average frame length is 6 ms. Due to the insertion of the stuffing bits, the real length of the frame varies and is  $6 \text{ ms} \pm ((2 \times 6) / (\text{Number of bits in frame})) \text{ [ms]}$ . Thus the real frame length is also dependent on the data rate.

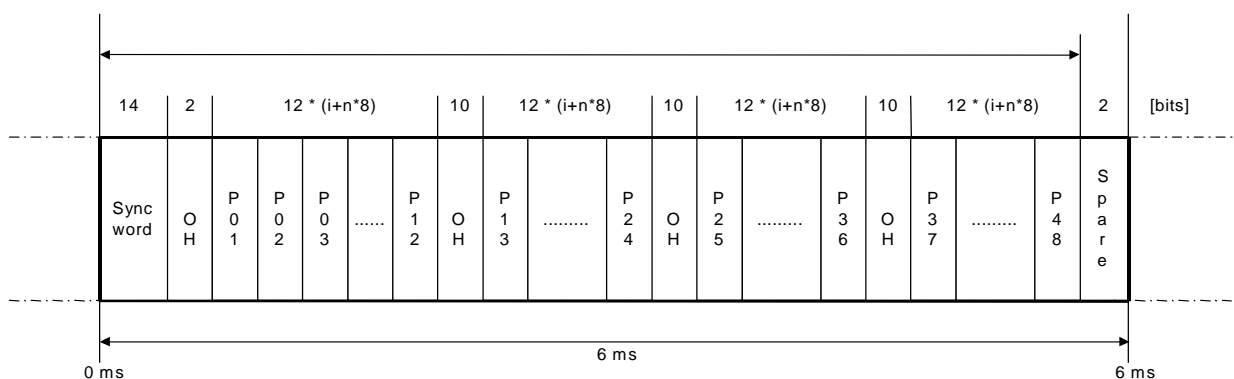

Symbol	Name/Function
P01 to P48	Payload blocks
OH	SDSL overhead (eoc, crc,...)
Sync word	Double Barker code
Spare	Spare bits

**Figure 7-3: SDSL frame structure for synchronous transmission**

The SDSL frame for synchronous transmission (see figure 7-3) is almost the same as described above. The only difference is the spare bits at the end of the frame which replace the stuffing bits. These SDSL frames are always 6 ms long. Instead of the zero or four stuffing bits, two spare bits are always available at the end of each frame in order to equal the average length of (plesiochronous) SDSL frames.

#### 7.1.4 Determination of bit rates

Table 7-1 shows the relationship between the payload bit rate and the line bit rate.

Table 7-1: Bit rates

Bit Type	Channel Type	Number of bits in one frame of 6 ms	Bit rate
Frame bits	Overhead	48 / $48 \pm 2$	8 kbit/s
Payload bits	B-channel ( $n \times 64$ kbit/s) ( $n = 3...36$ )	$n \times 48 \times 8$	$n \times 64$ kbit/s
	Z-bits ( $i \times 8$ kbit/s) ( $i = 0...7$ )	$i \times 48$	$i \times 8$ kbit/s
Total number of bits in frame		$48 \times (1 + i + n \times 8)$	$(n \times 64 + i \times 8 + 8)$ kbit/s

The minimum and maximum values possible for the line bit rate are:

Minimum ( $i = 0; n = 3$ )  $192 \text{ kbit/s} + 8 \text{ kbit/s} = 200 \text{ kbit/s}$

Maximum ( $i = 1; n = 36$ )  $2\,304 \text{ kbit/s} + 8 \text{ kbit/s} + 8 \text{ kbit/s} = 2\,320 \text{ kbit/s}$

### 7.1.5 Frame bit assignments

In table 7-2 the bit sequence of SDSL frame prior to scrambling at the transmit side and after descrambling at the receive side is presented. While the frame structures are identical in both directions of transmission, the functional assignments of individual bits in the direction LTU to NTU or NTU to LTU are different. Unused bits in either direction shall be set to ONE. For example the proposed NTU local power status bit is defined only in the frame transmitted towards the LTU and the corresponding bit position in the reverse direction has no assignment.

The value  $k$  is defined as  $k = i + n \times 8$ .

Table 7-2: SDSL Frame Structure

Time	Frame Bit #	OH Bit #	Abr. Name	Full Name	Notes
0 ms	1-14	1-14	SW 1-14	sync word	
	15	15	fbit1	loisd - loss of input signal at the far end application interface	
	16	16	fbit2	sega - segment anomaly	
	17- $12k + 16$	-----	B01-B12	payload blocks 1-12	SDSL payload including Z-bits
	$12k + 17$	17	eoc01	eoc message bit 1	
	$12k + 18$	18	eoc02	eoc message bit 2	
	$12k + 19$	19	eoc03	eoc message bit 3	
	$12k + 20$	20	eoc04	eoc message bit 4	
	$12k + 21$	21	crc1	cyclic redundancy check	CRC-6
	$12k + 22$	22	crc2	cyclic redundancy check	CRC-6
	$12k + 23$	23	fbit3	ps - NTU local power status bit	NTU -----> LTU only
	$12k + 24$	24	sbid1	stuffing indicator bit 1	spare in synchronous mode
	$12k + 25$	25	eoc05	eoc message bit 5	
	$12k + 26 -$	26	eoc06	eoc message bit 6	
	$12k + 27 -$ $24k + 26$	-----	B13-B24	Payload blocks 13-24	SDSL payload including Z bits
	$24k + 27$	27	eoc07	eoc message bit 7	
	$24k + 28$	28	eoc08	eoc message bit 8	
	$24k + 29$	29	eoc09	eoc message bit 9	
	$24k + 30$	30	eoc10	eoc message bit 10	
	$24k + 31$	31	crc3	cyclic redundancy check	CRC-6
	$24k + 32$	32	crc4	cyclic redundancy check	CRC-6
	$24k + 33$	33	fbit4	segd - segment defect	
	$24k + 34$	34	eoc11	eoc message bit 11	
	$24k + 35$	35	eoc12	eoc message bit 12	
	$24k + 36$	36	sbid2	stuffing indicator bit 2	spare in synchronous mode
	$24k + 37 -$ $36k + 36$	-----	B25-B36	payload blocks 25-36	SDSL payload including Z bits

Time	Frame Bit #	OH Bit #	Abr. Name	Full Name	Notes
	36 k + 37	37	eoc13	eoc message bit 13	
	36 k + 38	38	eoc14	eoc message bit 14	
	36 k + 39	39	eoc15	eoc message bit 15	
	36 k + 40	40	eoc16	eoc message bit 16	
	36 k + 41	41	crc5	cyclic redundancy check	CRC-6
	36 k + 42	42	crc6	cyclic redundancy check	CRC-6
	36 k + 43	43	eoc17	eoc message bit 17	
	36 k + 44	44	eoc18	eoc message bit 18	
	36 k + 45	45	eoc19	eoc message bit 19	
	36 k + 46	46	eoc20	eoc message bit 20	
6 + 12 / (number of bits in frame) ms	36 k + 47 - 48 k + 46	-----	B37-B48	payload blocks 37-48	SDSL payload including Z bits
	48k + 47	47	stb1/spa1	stuff/spare bit 1	frame stuffing/spare in synch mode
6 ms nominal	48 k + 48	48	stb2/spa2	stuff/spare bit 2	frame stuffing/spare in synch mode
	48 k + 49	49	stb3	stuff bit 3	frame stuffing/not present in synch mode
6 + 12 / (number of bits in frame) ms	48 k + 50	50	stb4	stuff bit 4	frame stuffing/not present in synch mode

The following gives a short description of the currently defined overhead bits.

- sync word:
  - the synchronization word (SW) enables the SDSL receivers to acquire frame alignment. The synchronization word consists of the following 14-bit sequence: 11111100001100. This sequence shall be passed as parameter for both upstream and downstream directions during the pre-activation;
  - the SW is present in every frame and is the same in both the upstream and downstream directions.
- losd-bit (loss of signal):
  - if there is no signal from the application interface, the losd-bit shall be set to ZERO in the next frame towards the far end. Under normal conditions, this bit shall be set to ONE.
- sega (segment anomaly):
  - the sega-bit shall be used to indicate CRC-errors on the incoming SDSL frames. It is set to ZERO if CRC-errors are detected and to ONE in normal operation.
- segd (segment defect):
  - the segd-bit shall be used to indicate loss of synchronization on the incoming SDSL frames. It is set to ZERO if loss of synchronization is detected and to ONE in normal operation.
- eoc-bits (embedded operations channel):
  - 20 bits (eoc01...eoc20) are provided as a separate maintenance channel. For a description of codes and the messaging procedure in this channel, see clause 10.5.
- crc-bits:
  - the SDSL frame shall have six bits assigned to a cyclic redundancy check (CRC) code. The CRC is generated for each transmitted frame, and then transmitted in the following frame.

The six crc-bits transmitted in the  $(N + 1)^{\text{th}}$  frame shall be determined as follows:

- 1) all bits of the  $N^{\text{th}}$  frame except the fourteen sync word bits, the six crc-bits and any stuffing bits, for a total of  $m$  bits, are used, in order of occurrence, to construct a polynomial in "X" such that bit "0" of the  $N^{\text{th}}$  frame is the coefficient of the term  $X^{m-1}$  and bit  $m-1$  of the  $N^{\text{th}}$  frame is the coefficient of the term  $X^0$ ;

- 2) the polynomial is multiplied by the factor  $X^6$ , and the result is divided, modulo 2, by the generator polynomial  $X^6 \oplus X \oplus 1$ . The coefficients of the remainder polynomial are used, in order of occurrence, as the ordered set of check bits, crc1 through crc6, for the  $(N + 1)^{\text{th}}$  frame. The ordering is such that the coefficient of the term  $X^5$  in the remainder polynomial is check bit crc1 and the coefficient of the term  $X^0$  in the remainder polynomial is check bit crc6;
- 3) the check bits, crc1 through crc6, contained in a frame are those associated with the content of the preceding frame. When there is no immediately preceding frame, the check bits may be assigned any value.
- ps-bit (power supply bit):
    - the power supply bit ps is used to indicate the status of the local power supply in the NTU. The power status bit is set to ONE if power is normal and to ZERO if the power has failed;
    - on loss of power at the NTU, there shall be enough power left to communicate three "Power Loss" messages towards the LTU. Regenerators shall pass this bit transparently.
  - sbid (stuff indicator bits):
    - (sbid1, sbid2);
    - these bits are only needed in plesiochronous mode and are spare in synchronous mode. These stuff indicator bits indicate whether or not a stuffing event has occurred in the frame. Both bits shall be set to 1 if the 4 stuff bits are present at the end of that frame. Both bits shall be set to 0 if there are no stuff bits at the end of the current frame.
  - stb (stuffing bits):
    - (stb1, stb2, stb3, stb4);
    - these bits are only needed in plesiochronous mode and are spare in synchronous mode. They are always used together. Either zero or four stuffing bits are inserted, depending on the relation of the timing. If not used the stuffing bits shall be set to ONE;
    - spa (spare bits);
    - (spa1, spa2).

These bits are only available in synchronous mode and always used together.

### 7.1.6 Scrambling method

SDSL transceiver systems use the same self synchronizing scrambling as the 2B1Q transmission system for ISDN-BA as defined in TS 102 080 [2], annex A and HDSL as defined in TS 101 135 [1]. The data stream with the exception of the 14 bits of the sync word and the stuffing bits is scrambled by means of a 23rd-order polynomial prior to encoding.

**Table 7-3: Scrambler polynomials**

Transmit direction	Polynomial	Scrambler/Descrambler
NTU → LTU	$x^{-23} \oplus x^{-18} \oplus 1$	Transmit NTU Receive LTU
LTU → NTU	$x^{-23} \oplus x^{-5} \oplus 1$	Transmit LTU Receive NTU
NOTE: The sign $\oplus$ stands for modulo 2 summation.		

Figure 7-4 shows block diagrams for the scramblers and the descramblers. It also shows that the binary data stream is recovered in the receiver by applying the same polynomial used for scrambling to the scrambled data.

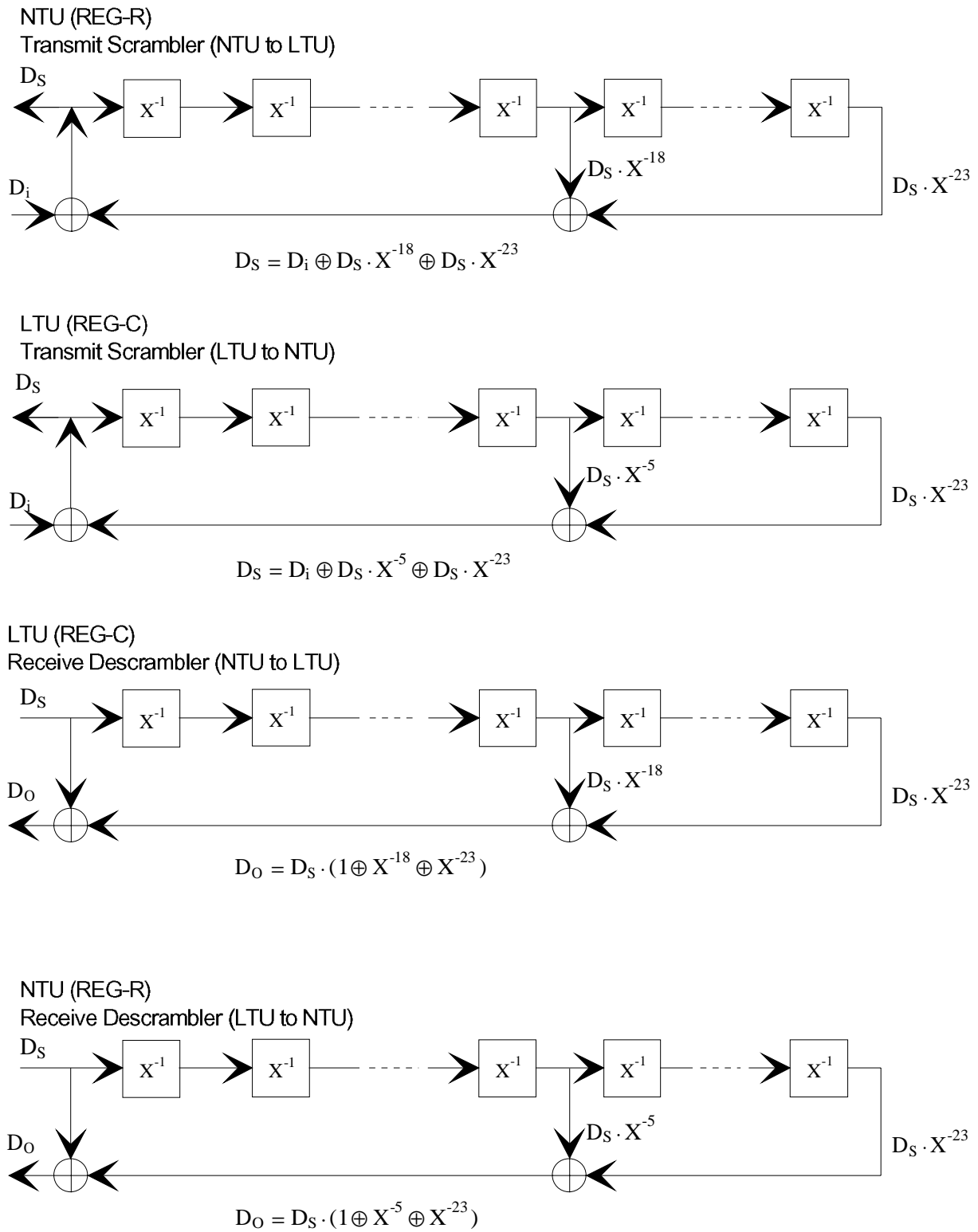

$D_S$  = scrambled (s) data

$D_i$  = unscrambled input (i) data

$D_0$  = unscrambled output (o) data

$X^{-n}$  = delay of n bit periods

$\oplus$  = logical exclusive or

$\cdot$  = multiplication

**Figure 7-4: Scramblers and descramblers**



## 7.2 Activation Mode Frame Structure

### 7.2.1 Activation framer

The format of the activation frame is shown in table 7-4. A  $T_c$  or  $T_r$  signal shall be generated by repetitively applying the activation frame information shown in table 7-4 to the scrambler shown in figure 9-1. The activation frame contents shall be constant during the transmission of  $T_c$  and  $T_r$ . The activation frame sync bits are not scrambled, so they shall be applied directly to the uncoded 2-PAM constellation. The total number of bits in the activation frame is 4227. The activation frame shall be sent starting with bit 1 and ending with bit 4227.

**Table 7-4: Activation frame format**

Activation frame bit lsb:msb	Definition
1:14	Frame sync for $T_c$ and $T_r$ : 11111001101011, where the left-most bit is sent first in time Frame Sync for $F_c$ : 11010110011111, where the left-most bit is sent first in time
15:36	Precoder Coefficient 1: 22 bit signed two's complement format with 17 bits after the binary point, where the LSB is sent first in time
37:58	Precoder Coefficient 2
59:3952	Precoder Coefficients 3 - 179
3953:3974	Precoder Coefficient 180
3975:3995	Encoder Coefficient A: 21 bits where the LSB is sent first in time
3996:4016	Encoder Coefficient B: 21 bits where the LSB is sent first in time
4017:4144	Vendor Data: 128 bits of proprietary information
4145:4211	Reserved: 67 bits set to logical zeros
4212:4227	CRC: $C_1$ sent first in time, $C_{16}$ sent last in time

#### 7.2.1.1 Frame sync

The frame sync for  $T_c$  and  $T_r$  is a 14 bit Barker code. In binary, the code shall be 11111001101011, and shall be sent from left to right. For  $F_c$  and  $F_r$ , the frame sync shall be 11010110011111, or the reverse of the frame sync for  $T_c$  and  $T_r$ .

#### 7.2.1.2 Precoder coefficients

The precoder coefficients are represented as 22-bit two's complement numbers, with the 5 most significant bits representing integer numbers from -16 (10000) to +15 (01111), and the remaining 17 bits are the fractional bits. The coefficients are sent sequentially, starting with coefficient  $C_1$  and ending with coefficient  $C_N$  (from figure 9-10), and the least significant bit of each coefficient is sent first in time. The minimum number of precoder coefficients shall be 128 and the maximum number shall be 180. If fewer than 180 precoder coefficients are used, the remaining bits in the field shall be set to zero.

#### 7.2.1.3 Encoder coefficients

Referring to figure 9-9, the coefficients for the programmable encoder are sent in the following order:  $a_0$  is sent first in time, followed by  $a_1$ ,  $a_2$ , ..., and  $b_{20}$  is sent last in time.

#### 7.2.1.4 Vendor Data

These 128 bits are reserved for vendor-specific data.

#### 7.2.1.5 Reserved

These 67 bits are reserved for future use and shall be set to logical zeros.

### 7.2.1.6 CRC

The sixteen CRC bits ( $c_1$  to  $c_{16}$ ) shall be the coefficients of the remainder polynomial after the message polynomial, multiplied by  $D^{16}$ , is divided by the generating polynomial. The message polynomial shall be composed of the bits of the activation frame, where  $m_0$  is bit 15 and  $m_{4196}$  is bit 4 211 of the activation frame, such that:

$$\text{CRC}(D) = m_1(D) D^{16} \bmod g(D)$$

where:

$$m(D) = m_0 D^{4196} \oplus m_1 D^{4195} \oplus \dots \oplus m_{4195} D \oplus m_{4196}$$

is the message polynomial,

$$g(D) = D^{16} \oplus D^{12} \oplus D^5 \oplus 1$$

is the generating polynomial,

$$\text{CRC}(D) = c_1 D^{15} \oplus c_2 D^{14} \oplus \dots \oplus c_{15} D \oplus c_{16}$$

is the CRC check polynomial,  $\oplus$  indicates modulo-2 addition (exclusive OR), and  $D$  is the delay operator.

## 8 Clock Architecture

### 8.1 Tolerance of the line symbol rate

At all rates, the transmit symbol clock during data mode from any SDSL device shall be accurate to within  $\pm 32$  ppm of the nominal frequency. During activation, the LTU shall maintain  $\pm 32$  ppm accuracy of its transmit symbol clock, but the NTU transmit symbol clock may vary up to  $\pm 100$  ppm.

### 8.2 Reference clock architecture

Due to the multiple applications and variable bit rates called for in SDSL, a flexible clocking architecture is required. The LTU and NTU symbol clocks are described in terms of their allowed synchronization references. Other clock domains may be accommodated via the supported bit-stuffing mechanism or by using other methods of clock information transport (as in the ISDN-BA narrowband transport option).

The SDSL reference configuration permits the flexibility to provide a symbol clock reference based on the sources shown in figure 8-1. These sources may be chosen independently in the up and downstream directions (with bit stuffing employed as required by the application). The clock accuracy and jitter requirements are specified in a separate clauses or application dependent annexes. It illustrates the clock reference options in the context of a simplified SDSL reference model. Table 8-1 lists the normative synchronization configurations as well as example applications.

The clock domain of embedded ISDN-BA channels may be different from that of the data channel. In this case separate stuffing and framing procedures have to be provided for these channels, which shall be described in the relevant application dependent annex.

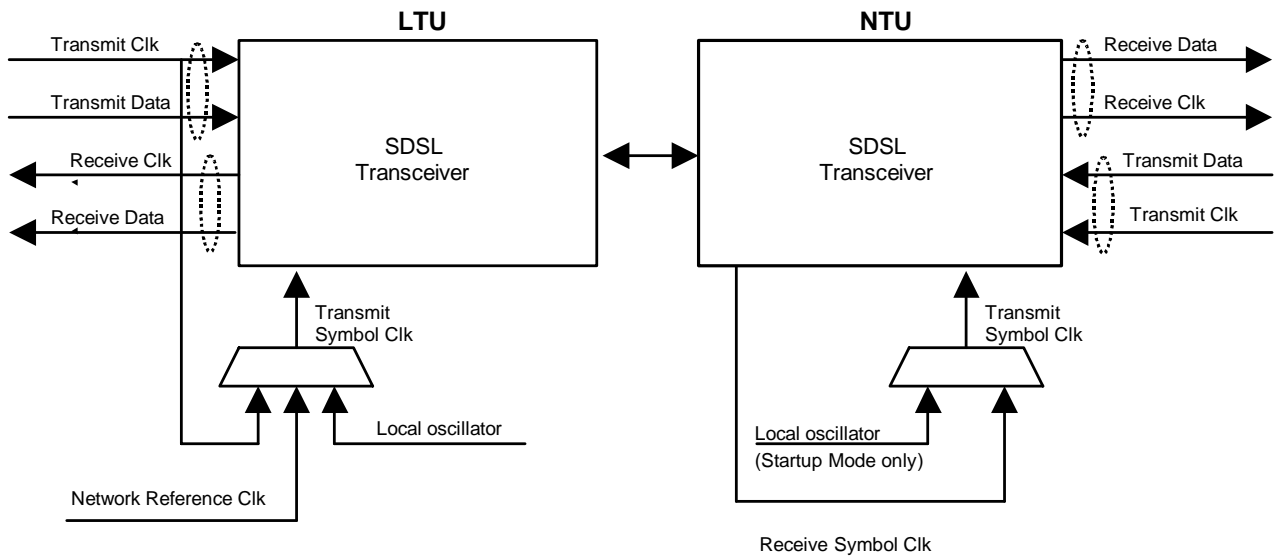

**Figure 8-1: SDSL Symbol Clock Synchronization References**

**Table 8-1: SDSL symbol clock synchronization configurations**

Mode No.	LT symbol clock source	NT symbol clock source	Example application	Mode
1	Local oscillator	Received symbol clock	"Classic" HDSL	Plesiochronous
2	Network reference	Received symbol clock	"Classic" HDSL with embedded timing reference	Plesiochronous with timing reference
3a (see note)	Transmit data clock	Received symbol clock	Main application is synchronous transport in both directions	Synchronous
3b (see note)	Transmit data clock	Received symbol clock	Synchronous downstream transport and bit-stuffed upstream is also possible	Downstream: synchronous Upstream: plesiochronous
NOTE: Both modes 3a and 3b are possible with the same clock sources depending on clock tolerances.				

## 8.3 Definitions of Clock Sources

The following definitions shall apply to the clock sources shown in figure 8-1.

### 8.3.1 Transmit symbol clock

A reference clock from which the actual transmit symbol clock is derived (i.e. the TU's transmit symbol clock is synchronized to this reference).

### 8.3.2 Local oscillator

A clock derived from an independent local crystal oscillator.

### 8.3.3 Network reference clock

A primary reference clock derived from the network.

### 8.3.4 Transmit data clock

A clock that is synchronous with the transmitted data at the application interface.

### 8.3.5 Receive symbol clock

A clock that is synchronous with the downstream received symbols at the SDSL line interface. This clock is used as the transmit symbol clock reference in the NTU.

### 8.3.6 Receive data clock

A clock that is synchronous with the received data at the application interface.

## 8.4 Synchronization to Clock Sources

In synchronous mode, the LTU can be synchronized to the transmit data clock or to a network reference clock. If a network reference clock is used, the transmit data clock must be synchronized to the network reference clock. (The various transmit data rates are independent of the reference clock frequency).

When available, the network reference clock shall be either a fundamental 8 kHz network clock or a related reference clock at some multiple of 8 kHz. Such reference clocks are typically 1,544 MHz or 2,048 MHz, although in some applications other frequencies, such as 64 kHz, may be available. These related clocks include implicit 8 kHz timing signals. Selection of a specific network clock reference frequency shall be application dependent.

## 9 PMD Layer Functional Characteristics

### 9.1 Activation

This clause describes waveforms at the loop interface and associated procedures during activation mode. The direct specification of the performance of individual receiver elements is avoided when possible. Instead, the transmitter characteristics are specified on an individual basis and the receiver performance is specified on a general basis as the aggregate performance of all receiver elements. Exceptions are made for cases where the performance of an individual receiver element is crucial to interoperability.

In clause 9.1.2 "convergence" refers to the state where all adaptive elements have reached steady state. The declaration of convergence by a transceiver is therefore vendor dependent. Nevertheless, actions based on the state of convergence are specified to improve interoperability.

#### 9.1.1 Activation PMD reference model

The block diagram of the activation mode PMD layer of an LTU or NTU transmitter is shown in figure 9-1.

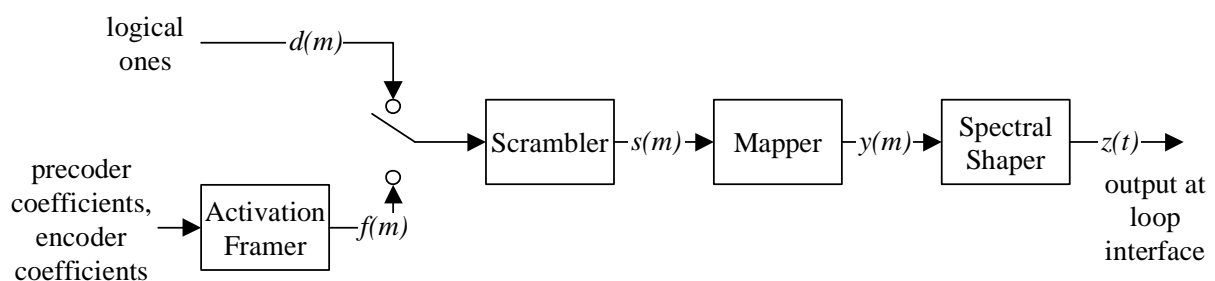

**Figure 9-1: Activation reference model**

The time index  $m$  represents the symbol time, and  $t$  represents analogue time. Since activation uses 2-PAM modulation, the bit time is equivalent to the symbol time. The output of the framer is the framed information bits  $f(m)$ . The output of the scrambler is  $s(m)$ . Both the framer and the scrambler are contained in the PMS-TC layer and are shown here only for clarity. The output of the mapper is  $y(m)$ , and the output of the spectral shaper at the loop interface is  $z(t)$ .  $d(m)$  is an initialization signal that shall be logical ones for all  $m$ . The modulation format shall be uncoded 2-PAM, with the full symbol rate selected for data mode operation. During activation, the timing reference for the activation signals have a tolerance of  $\pm 32$  ppm at the LTU and  $\pm 100$  ppm at the NTU.

### 9.1.2 Activation sequence

The timing diagram for the activation sequence is given in figure 9-2. The state transition diagram for the activation sequence is given in figure 9-4. Each activation signal in the activation sequence shall satisfy the tolerance values listed in table 9-1.

NOTE: A warm-start procedure is under study for use in systems that can go into a deactivated state, when no communication is going on.

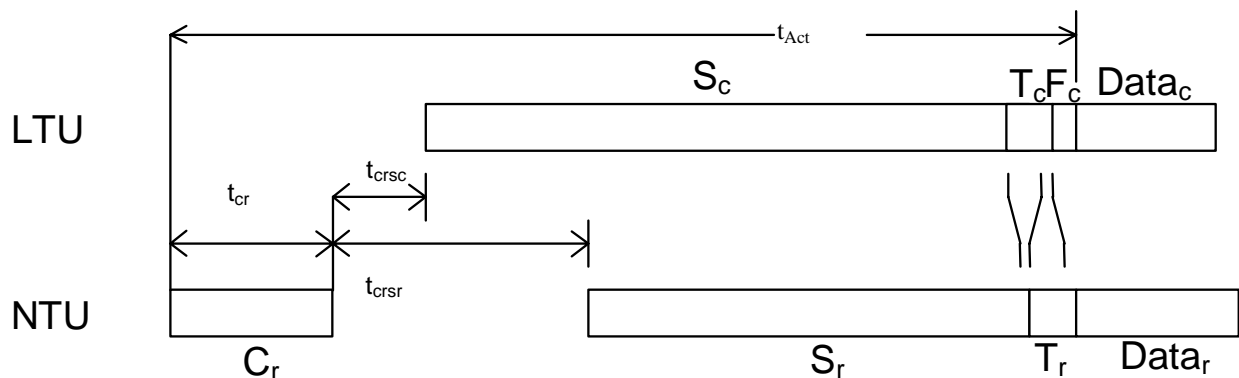

Figure 9-2: Timing Diagram for activation sequence

Figure 9-3 shows the total activation sequence at a high level for SDSL, which includes preactivation and core activation. Included, as an example in the pre-activation phase, are two sessions of handshake per PACC and line probe.

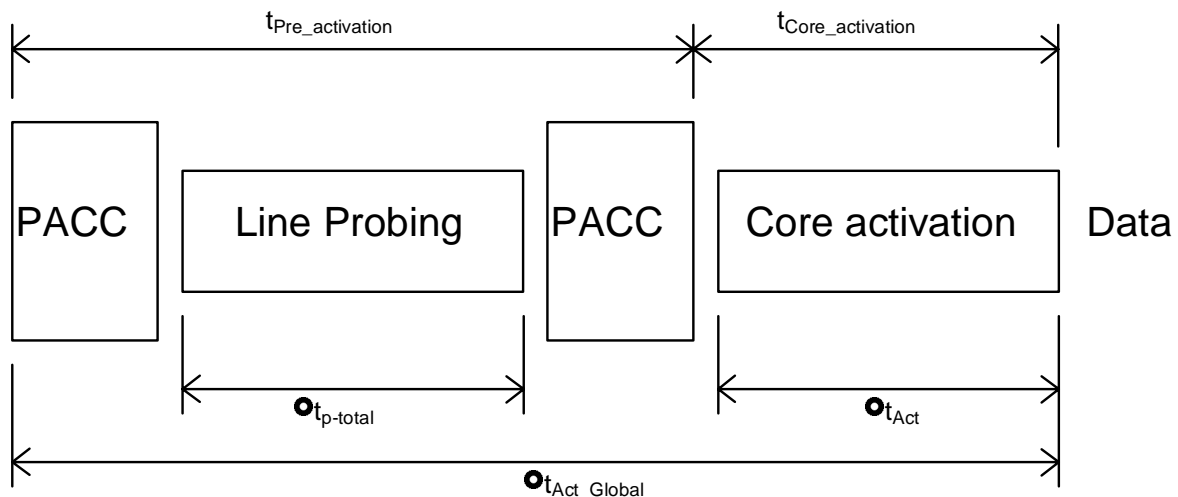

Figure 9-3: SDSL Total Activation Sequence

The global activation time is the sum of the preactivation and core activation times. Therefore, from figure 9-3,

$$t_{Pre\_activation} + t_{Core\_activation} \leq t_{Act\_Global}$$

where  $t_{\text{Pre activation}}$  is the combined duration of the PACC sessions (see clause 9.2) and line probing (see clause 9.2.2),  $t_{\text{Core activation}}$  is the core activation duration (see clause 9.1). The values for  $t_{\text{Act}}$  and  $t_{\text{Act\_Global}}$  are defined in table 9-1. The value for  $t_{\text{p-total}}$  is given in table 9-4.

**Table 9-1: Tolerance values for activation signals**

Signal	Parameter	Reference	Nominal Value	Tolerance
$t_{\text{cr}}$	Duration of $C_r$	clause 9.1.2.1	$1 \times \beta$ s (see note)	$\pm 20$ ms
$t_{\text{crsc}}$	time from end of $C_r$ to beginning of $S_c$	clause 9.1.2.2	0,5 s	$\pm 20$ ms
$t_{\text{crsr}}$	time from end of $C_r$ to beginning of $S_r$	clause 9.1.2.3	$1,5 \times \beta$ s (see note)	$\pm 20$ ms
$t_{\text{Act}}$	Maximum time from start of $C_r$ to $\text{Data}_r$		$15 \times \beta$ s (see note)	
$t_{\text{Act\_Global}}$	Maximum time from start of Initial handshake to $\text{Data}_r$		30 s	
NOTE: $\beta$ is dependent on bit-rate. $\beta = 1$ for $n > 12$ , $\beta = 2$ for $n \leq 12$ .				

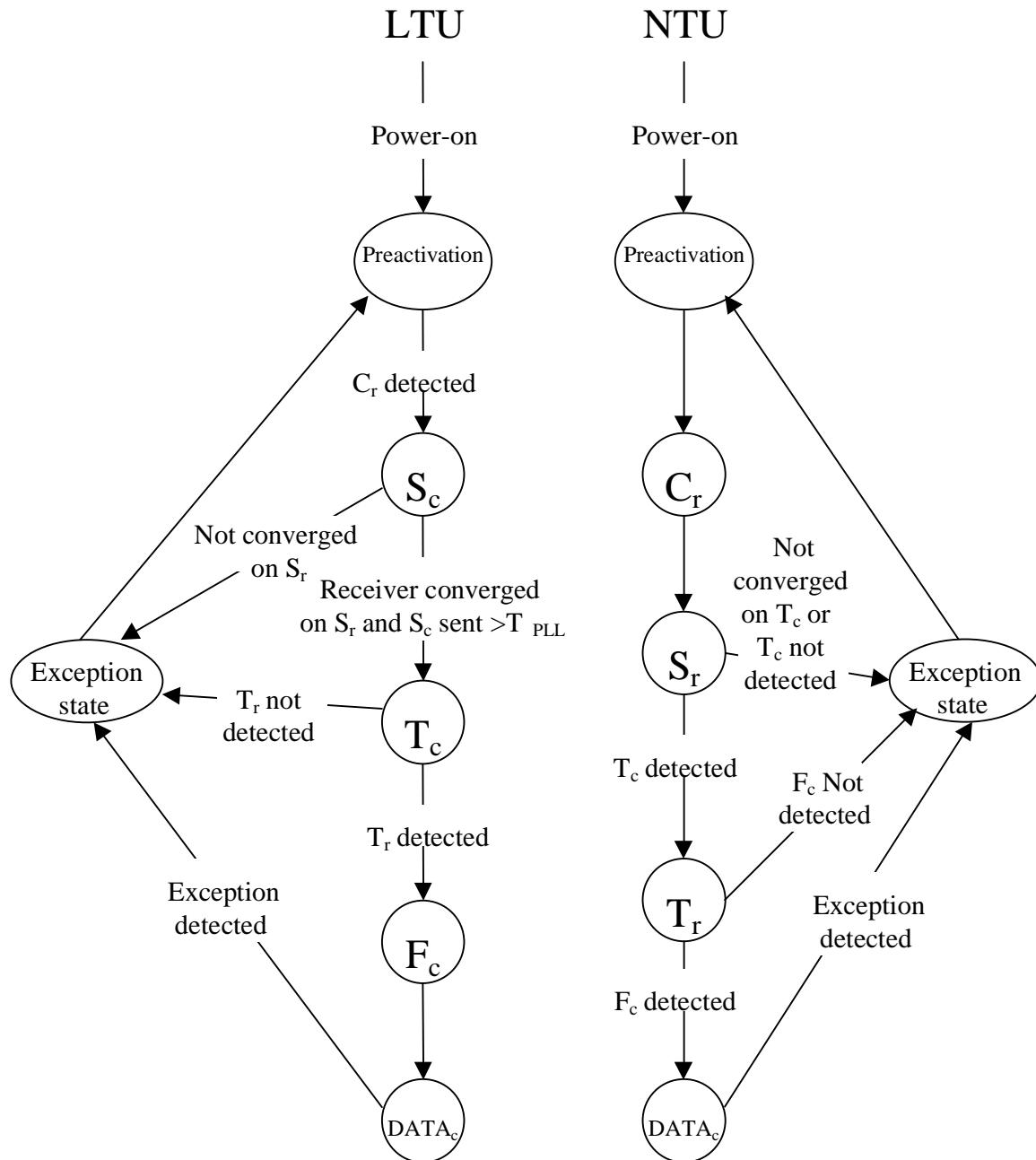

Figure 9-4: LTU and NTU Transmitter State Transition Diagram

#### 9.1.2.1 Signal $C_r$

After exiting the preactivation sequence (see clause 9.2), the NTU shall send  $C_r$ . Waveform  $C_r$  shall be generated by connecting the signal  $d(m)$  to the input of the NTU scrambler as shown in figure 9-1. The PSD mask for  $C_r$  shall be the upstream PSD mask, as negotiated during preactivation sequence.  $C_r$  shall have a duration of  $t_{cr}$  s and shall be sent 0,3 s after the end of preactivation.

#### 9.1.2.2 Signal $S_c$

After detecting  $C_r$ , the LTU shall send  $S_c$ . Waveform  $S_c$  shall be generated by connecting the signal  $d(m)$  to the input of the LTU scrambler as shown in figure 9-1. The PSD mask for  $S_c$  shall be the downstream PSD mask, as negotiated during preactivation sequence.  $S_c$  shall be sent  $t_{crsc}$  s after the end of  $C_r$ . If the LTU does not converge while  $S_c$  is transmitted, it shall enter the exception state (clause 9.1.2.8).

### 9.1.2.3 Signal $S_r$

The NTU shall send  $S_r$ , beginning  $t_{\text{crsf}}$  s after the end of  $C_r$ . Waveform  $S_r$  shall be generated by connecting the signal  $d(m)$  to the input of the NTU scrambler as shown in figure 9-1. The PSD mask for  $S_r$  shall be the same as for  $C_r$ . If the NTU does not converge and detect  $T_c$  while  $S_r$  is transmitted, it shall enter the exception state (clause 9.1.2.8). The method used to detect  $T_c$  is vendor dependent. In timing modes supporting loop timing, waveform  $S_r$  and all subsequent signals transmitted from the NTU shall be loop timed, i.e. the NTU symbol clock shall be locked to the LTU symbol clock.

### 9.1.2.4 Signal $T_c$

Once the LTU has converged and has been sending  $S_c$  for at least  $T_{\text{PLL}}$  seconds (see table 9-3), it shall send  $T_c$ . Waveform  $T_c$  contains the precoder coefficients and other system information.  $T_c$  shall be generated by connecting the signal  $f(m)$  to the input of the LTU scrambler as shown in figure 9-1. The PSD mask for  $T_c$  shall be the same as for  $S_c$ . The signal  $f(m)$  is the activation frame information as described in clause 9.1.3. If the LTU does not detect  $T_r$  while sending  $T_c$ , it shall enter the exception state (clause 9.1.2.8). The method used to detect  $T_r$  is vendor dependent.

### 9.1.2.5 Signal $T_r$

Once the NTU has converged and has detected the  $T_c$  signal, it shall send  $T_r$ . Waveform  $T_r$  contains the precoder coefficients and other system information.  $T_r$  shall be generated by connecting the signal  $f(m)$  to the input of the NTU scrambler as shown in figure 9-1. The PSD mask for  $T_r$  shall be the same as for  $C_r$ . The signal  $f(m)$  is the activation frame information as described in clause 9.1.3. If the NTU does not detect  $F_c$  while sending  $T_r$ , it shall enter the exception state (clause 9.1.2.8). The method used to detect  $F_c$  is vendor dependent.

### 9.1.2.6 Signal $F_c$

Once the LTU has detected  $T_r$ , it shall send  $F_c$ . The first bit of the first  $F_c$  frame shall follow contiguously the last bit of the last  $T_c$  frame. Signal  $F_c$  shall be generated by connecting the signal  $f(m)$  to the input of the LTU scrambler as shown in figure 9-1. The PSD mask for  $F_c$  shall be the same as for  $S_c$ . The signal  $f(m)$  is the activation frame information as described in clause 9.1.3 with the following exceptions: the frame sync word shall be reversed in time and the payload information bits shall be set to arbitrary values. The payload information bits correspond to the following fields in table 7-4: Precoder Coefficients, Encoder Coefficients and Reserved. The CRC shall be calculated on this arbitrary-valued payload. The signal  $F_c$  shall be transmitted for exactly two activation frames. As soon as the first bit of  $F_c$  is transmitted, the payload data in the  $T_r$  signal shall be ignored.

### 9.1.2.7 $\text{Data}_c$ and $\text{Data}_r$

Within 200 symbols after the end of the second frame of  $F_c$ , the LTU shall send  $\text{Data}_c$ , and the NTU shall send  $\text{Data}_r$ . These signals are described in clause 9.2. The PSD mask for  $\text{Data}_r$  shall be the same as for  $C_r$ , and the PSD mask for  $\text{Data}_c$  shall be the same as for  $S_c$ . There is no required relationship between the end of the activation frame and any bit within the SDSL data-mode frame.  $T_{\text{PayloadValid}}$  seconds (see table 9-3) after the end of  $F_c$ , the SDSL payload data shall be valid.

### 9.1.2.8 Exception state

If activation is not achieved within  $t_{\text{act}}$  (table 9-1) or if preactivation and activation are not completed within  $t_{\text{Act\_Global}}$  (table 9-1) or if any exception condition occurs, then the exception state shall be invoked. During the exception state the TU shall be silent for at least  $t_{\text{silence}}$  (table 9-3), then wait for transmission from the far end to cease, then return to the corresponding initial startup state; the NTU and LTU shall begin preactivation, as per clause 9.2.

### 9.1.2.9 Exception condition

An exception condition shall be declared during activation if any of the timeouts given in table 9-3 expire or if any vendor-defined abnormal event occurs. An exception condition shall be declared during data mode if the vendor-defined abnormal event occurs. A vendor-defined abnormal event shall be defined as any event that requires loop restart for recovery.



### 9.1.3 Activation framer

See clause 7.2.1.

### 9.1.4 Scrambler

The scrambler in the LTU and the NTU transmitters shall operate as shown in figure 7-4. The frame sync bits in the activation frame shall not be scrambled. While the frame sync bits are present at  $f(n)$ , the scrambler shall not be clocked, and  $f(n)$  shall be directly connected to  $s(n)$ .

### 9.1.5 Mapper

The output bits from the scrambler  $s(m)$  shall be mapped to the an output level  $y(m)$  as follows.

**Table 9-2: Bit-to-level mapping**

Scrambler output $s(m)$	Mapper output level $y(m)$	Data mode index
0	-9/16	0011
1	+9/16	1000

These levels corresponding in the scrambler outputs 0 and 1 shall be identical to the levels in the 16-TC-PAM constellation (table 9-8) corresponding to indexes 0011 and 1000 respectively.

### 9.1.6 Spectral shaper

The same spectral shaper shall be used for data mode and activation mode as described in clause 9.3.5.

### 9.1.7 Timeouts

Figures 9-4 and 9-1 show the system timeouts and their values.  $t_{act\_Global}$  shall be the maximum time from the start of initial handshake to the start of  $Data_r$ . It controls the overall time of the train, including handshake, line probe and activation.  $T_{act}$  shall be the maximum time from the start of  $C_r$  to the start of  $Data_r$ .  $T_{PayloadValid}$  shall be the time between the start of data mode and when the SDSL payload data is valid (this accounts for settling time, data flushing, frame synchronization, etc).  $T_{Silence}$  shall be the minimum time in the exception state where the LTU or NTU are silent before returning to pre-activation.  $T_{PLL}$  shall be the time allocated for the NTU to pull in the LTU timing. The LTU shall transmit  $S_c$  for at least  $T_{PLL}$  seconds.

**Table 9-3: Timeout values**

Parameter	Name	Value
Time from start of $Data_c$ or $Data_r$ to valid SDSL payload data	$T_{PayloadValid}$	1 s
Minimum silence time from exception condition to start of train	$T_{Silence}$	2 s
Time from start of $S_c$ to NTU PLL lock	$T_{PLL}$	5 s

## 9.2 PMD preactivation sequence

This clause describes waveforms at the loop interface and associated procedures during preactivation mode. The direct specification of the performance of individual receiver elements is avoided when possible. Instead, the transmitter characteristics are specified on an individual basis and the receiver performance is specified on a general basis as the aggregate performance of all receiver elements. Exceptions are made for cases where the performance of an individual receiver element is crucial to interoperability.

The preactivation communication channel (PACC) shall use the modulation and message structure as described in ITU-T Recommendation G.994.1 [16]. The preactivation communication channel shall allow the selection of the synchronization word described in clause 7.1.5. Annex B specifies the use of ITU-T Recommendation G.994.1 [16] in the context of SDSL.

## 9.2.1 PMD preactivation reference model

The reference model of the preactivation mode of an LTU or NTU transmitter is shown in figure 9-5.

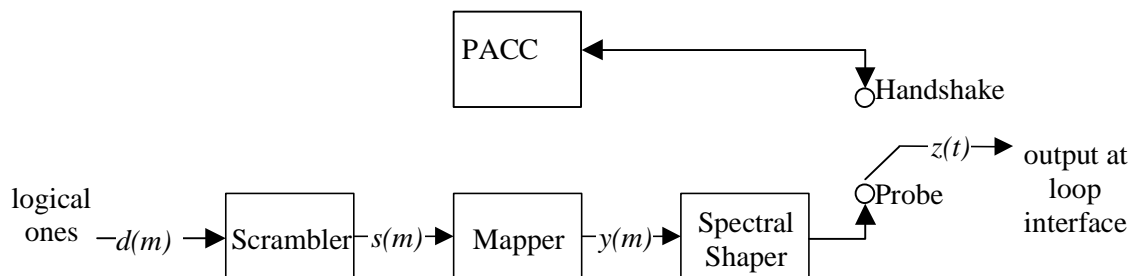

Figure 9-5: Preactivation reference model

The time index  $m$  represents the symbol time, and  $t$  represents analogue time. Since the probe signal uses 2-PAM modulation, the bit time is equivalent to the symbol time. The output of the scrambler is  $s(m)$ . Both the framer and the scrambler are contained in the PMS-TC layer and are shown here only for clarity. The scrambler used in the PMD preactivation may differ from the PMS-TC scrambler used in the activation and data mode (see clause 9.2.3). The output of the mapper is  $y(m)$  and the output of the spectral shaper at the loop interface is  $z(t)$ .  $d(m)$  is an initialization signal that shall be logical ones for all  $m$ . The probe modulation format shall be uncoded 2-PAM, with the symbol rate, spectral shape, duration, and power back-off selected by PACC. Probe results shall be exchanged by PACC.

## 9.2.2 PMD preactivation sequence description

A typical timing diagram for the preactivation sequence is given in figure 9-6. Each signal in the preactivation sequence shall satisfy the tolerance values listed in table 9-4.

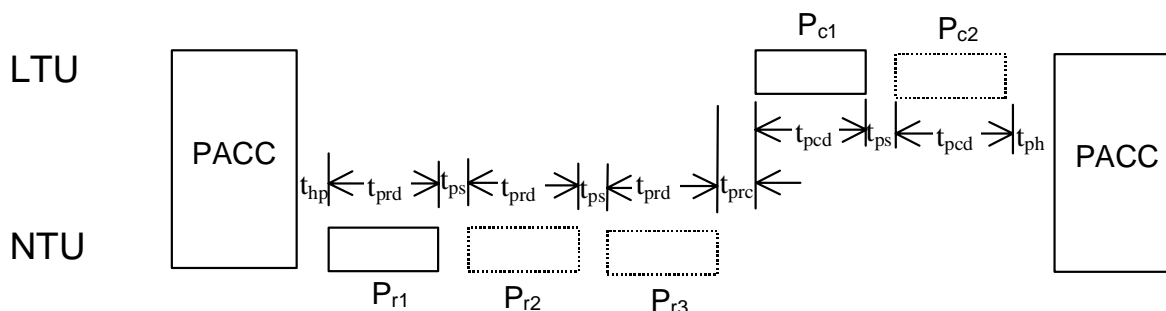

Figure 9-6: Typical timing diagram for preactivation sequence

Table 9-4: Timing for preactivation signals

Time	Parameter	Nominal value	Tolerance
$t_{hp}$	Time from end of handshake to start of remote probe	0,2 s	$\pm 10$ ms
$t_{prd}$	Duration of remote probe	Selectable from 50 ms to 3,1 s	$\pm 10$ ms
$t_{ps}$	Time separating two probe sequences	0,2 s	$\pm 10$ ms
$t_{prc}$	Time separating last remote and first central probe sequences	0,2 s	$\pm 10$ ms
$t_{pcd}$	Duration of central probe	Selectable from 50 ms to 3,1 s	$\pm 10$ ms
$t_{ph}$	Time from end of central probe to start of handshake	0,2 s	$\pm 10$ ms
$t_{p-total}$	Total probe duration, from end of the first G.994.1 session to the start of the second G.994.1 session	10 s maximum	
NOTE: Tolerances are relative to the nominal or ideal value. They are not cumulative across the preactivation sequence.			

### 9.2.2.1 Signal $P_{ri}$

If the optional line probe is selected during the PACC session (see clause 9.2), the NTU shall send the remote probe signal. The symbol rate for the remote probe signal shall be negotiated during the PACC session, and shall correspond to the symbol rate used during activation for the specified data rate. If multiple remote probe symbol rates are negotiated during the PACC session, then multiple probe signals will be generated, starting with the lowest symbol rate negotiated and ending with the highest symbol rate negotiated.  $P_{ri}$  is the  $i^{\text{th}}$  probe signal (corresponding to the  $i^{\text{th}}$  symbol rate negotiated). Waveform  $P_{ri}$  shall be generated by connecting the signal  $d(m)$  to the input of the NTU scrambler as shown in figure 9-5. The PSD mask for  $P_{ri}$  shall be the upstream PSD mask used for signal  $C_r$  at the same symbol rate, and shall be selectable between the PSDs for activating at data rates of 192 kbit/s to 2 304 kbit/s in steps of 64 kbit/s. The duration ( $t_{prd}$ ) and power back-off shall be the same for all  $P_{ri}$ , and shall be negotiated during the PACC session. The duration shall be selectable between 50 ms and 3,1 s in steps of 50 ms, and the power back-off shall be selectable between 0 dB and 15 dB in steps of 1 dB. The probe signal power back-off can be selected using either the received PACC signal power or *a priori* knowledge. If no information is available, implementers are encouraged to select a probe power back-off of at least 6 dB. The first remote probe signal shall begin  $t_{hp}$  seconds after the end of the PACC session. There shall be a  $t_{ps}$  second silent interval between successive remote probe signals.

### 9.2.2.2 Signal $P_{ci}$

The LTU shall send the central probe signal  $t_{prc}$  seconds after the end of the last remote probe signal. The symbol rate for the central probe signal shall be negotiated during the PACC session, and shall correspond to the symbol rate used during activation for the specified data rate. If multiple central probe symbol rates are negotiated during the PACC session, then multiple probe signals will be generated, starting with lowest symbol rate negotiated and ending with the highest symbol rate negotiated. Waveform  $P_{ci}$  is the  $i^{\text{th}}$  probe signal (corresponding to the  $i^{\text{th}}$  symbol rate negotiated). Waveform  $P_{ci}$  shall be generated by connecting the signal  $d(m)$  to the input of the LTU scrambler as shown in figure 9-5. The PSD mask for  $P_{ci}$  shall be the downstream PSD mask used for signal  $S_c$  at the same symbol rate, and shall be selectable between the PSDs for activating at data rates of 192 kbit/s to 2 304 kbit/s in steps of 64 kbit/s. The duration ( $t_{pcd}$ ) and power back-off shall be the same for all  $P_{ci}$ , and shall be negotiated during the PACC session. The duration shall be selectable between 50 ms and 3,1 s in steps of 50 ms, and the power back-off shall be selectable between 0 dB and 15 dB in steps of 1 dB. The probe signal power back-off can be selected using either the received PACC signal power or *a priori* knowledge. If no information is available, implementers are encouraged to select a probe power back-off of at least 6 dB. There shall be a  $t_{ps}$  silent interval between successive central probe signals, and there shall be a  $t_{ph}$  second silent interval between the last central probe signal and the start of the following PACC session.

## 9.2.3 Scrambler

The scrambler used in the PMD preactivation has the same basic structure as the data mode scrambler, but can have different scrambler polynomial. During the PACC session, the scrambler polynomial for each probe sequence is selected by the receiver from the set of allowed scrambler polynomials listed in table 9-5. The transmitter shall support all the polynomials in table 9-5. During PMD preactivation, the transmit scrambler shall use the scrambler polynomial selected by the receiver during the PACC session. The scrambler shall be initialized to all zero.

**Table 9-5: Preactivation scrambler polynomials**

Index	LTU polynomial	NTU polynomial
0	$s(n) = s(n-5) \oplus s(n-23) \oplus d(n)$	$s(n) = s(n-18) \oplus s(n-23) \oplus d(n)$
1	$s(n) = s(n-1) \oplus d(n)$	$s(n) = s(n-1) \oplus d(n)$
2	$s(n) = s(n-2) \oplus s(n-5) \oplus d(n)$	$s(n) = s(n-3) \oplus s(n-5) \oplus d(n)$
3	$s(n) = s(n-1) \oplus s(n-6) \oplus d(n)$	$s(n) = s(n-5) \oplus s(n-6) \oplus d(n)$
4	$s(n) = s(n-3) \oplus s(n-7) \oplus d(n)$	$s(n) = s(n-4) \oplus s(n-7) \oplus d(n)$
5	$s(n) = s(n-2) \oplus s(n-3) \oplus s(n-4) \oplus s(n-8) \oplus d(n)$	$s(n) = s(n-4) \oplus s(n-5) \oplus s(n-6) \oplus s(n-8) \oplus d(n)$

## 9.2.4 Mapper

The output bits from the scrambler  $s(m)$ , shall be mapped to the output level  $y(m)$ , as described in clause 9.1.5.

## 9.2.5 Spectral shaper

The same spectral shaper shall be used for data mode and activation mode as described in clause 9.3.5.

## 9.2.6 Power back-off

In order to save power and reduce ingress to other xDSL transmission systems, power back-off shall be implemented. The selected power back-off value shall be communicated through the use of parameter selections during the preactivation procedure. The power back-off value shall be selected to meet the requirements shown in table 9-6, which shall be understood as a minimum requirement.

The power back-off calculations are based on "Estimated Power Loss" (EPL), which is defined as:

$$\text{Estimated Power Loss} = \text{Transmit Power} - \text{Estimated Receive Power evaluated for the data mode PSD}$$

No explicit specification is given herein for the method of calculating "Estimated Receive Power". Depending upon the application, this value may be determined based on line probe results, a priori knowledge or levels of tones used during the preactivation procedure.

The power back-off that is applied shall be no less than the default power back-off, and it shall not exceed the maximum power back-off value.

**Table 9-6: Required power back-off values.**

Estimated power loss/dB	Maximum power back-off/dB	Default power back-off/dB
$EPL \geq 6$	31	0
$5 \leq EPL < 6$	31	1
$4 \leq EPL < 5$	31	2
$3 \leq EPL < 4$	31	3
$2 \leq EPL < 3$	31	4
$1 \leq EPL < 2$	31	5
$0 \leq EPL < 1$	31	6

## 9.2.7 PMMS Target Margin

PMMS target margin is used by the receiver to determine if a data rate can be supported with this margin under current noise and/or reference worst-case noise. A data rate may be included in the capabilities list resulting from line probe only if the estimated SNR associated with that data rate minus the SNR required for  $BER=10^{-7}$  is greater than or equal to target margin in dB. If both worst-case target margin and current-condition target margin are specified, then the capabilities exchanged shall be the intersection of data rates calculated using each noise condition separately.

The use of negative target margins with respect to reference worst-case noise corresponds to reference noise with fewer disturbers. This may be applicable when the number of disturbers is known to be substantially fewer than specified by the reference worst-case noise. Use of negative target margins with respect to current-conditions is not advised. Use of the current-condition target margin mode may result in retrains if the noise environment changes significantly.

If the optional line probe is selected during the G.994.1 session, the receiver shall use the negotiated target margin. If worst-case PMMS target margin is selected, then the receiver shall assume the disturbers of table 9-7 to determine if a particular rate can be supported. Reference crosstalk shall be computed using the cable crosstalk models of clause 12.5.2, assuming infinite loop length so that FEXT components are ignored and NEXT is independent of loop length. The reference crosstalk specified in this clause may not be representative of worst-case conditions in all networks. Differences between crosstalk environments may be compensated by adjusting the target margin.

**Table 9-7: Reference Disturbers Used During PMMS for Worst-Case Target Margin**

Rate (kbit/s)	PSD (direction)	Reference disturber
all	Symmetric (US/DS)	49 SDSL
2 048	Asymmetric (US)	49 SDSL-SYM with $f_{sym} = 685\,333$ Hz
2 048	Asymmetric (DS)	49 SDSL-SYM with $f_{sym} = 685\,333$ Hz
2 304	Asymmetric (US)	49 SDSL-SYM with $f_{sym} = 770\,667$ Hz
2 304	Asymmetric (DS)	49 SDSL-SYM with $f_{sym} = 770\,667$ Hz

## 9.3 Data mode

This clause describes the waveform at the line interface during data mode given the input bit stream from the TC layer.

### 9.3.1 Data mode PMD reference model

The block diagram of the data mode PMD layer of an LTU or NTU transmitter is shown in figure 9-7.

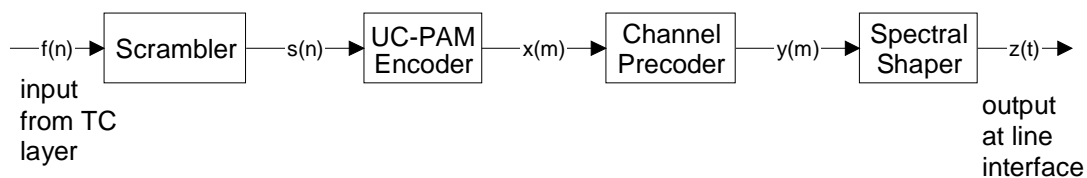
**Figure 9-7: Data mode PMD reference model**

The time index  $n$  represents the bit time, the time index  $m$  represents the symbol time, and  $t$  represents analogue time. The input from the TC layer is  $f(n)$ ,  $s(n)$  is the output of the scrambler. Both the framer and the scrambler are contained in the PMS-TC layer and are shown here only for clarity.  $x(m)$  is the output of the UC-PAM (Ungerboeck Coded Pulse Amplitude Modulation) encoder,  $y(m)$  is the output of the channel precoder, and  $z(t)$  is the analogue output of the spectral shaper at the line interface. When transferring  $K$  information bits per one-dimensional PAM symbol, the symbol duration is  $K$  times the bit duration, so the  $K$  values of  $n$  for a given value of  $m$  are  $\{mK, mK + 1, \dots, mK + K - 1\}$ .

#### 9.3.1.1 PMD rates

The transmission is 16 UC-PAM. There are 3 data bits and 1 redundant bit transmitted each symbol. The TU shall support a line rate of  $(n \times 64 + i \times 8 + 8)$  kbit/s, where  $n$  is an integer value from 3 to 36 and  $i$  is an integer value from 0 to 7. The tolerance on the symbol rate shall be  $\pm 32$  ppm.

### 9.3.2 Scrambler

The scrambler in the LTU and the NTU transmitters are described in clause 7.1.6. While the frame sync bits and stuff bits are present at  $f(n)$ , the scrambler shall not be clocked and  $f(n)$  shall be directly connected to  $s(n)$ .

### 9.3.3 UC-PAM encoder

The block diagram of the UC-PAM encoder is shown in figure 9-8. The serial bit stream from the scrambler  $s(n)$  shall be converted to a  $K$ -bit parallel word at the  $m^{\text{th}}$  symbol time, then processed by the convolutional encoder. The resulting  $K+1$ -bit word shall be mapped to one of  $2^{K+1}$  pre-determined levels forming  $x(m)$ .

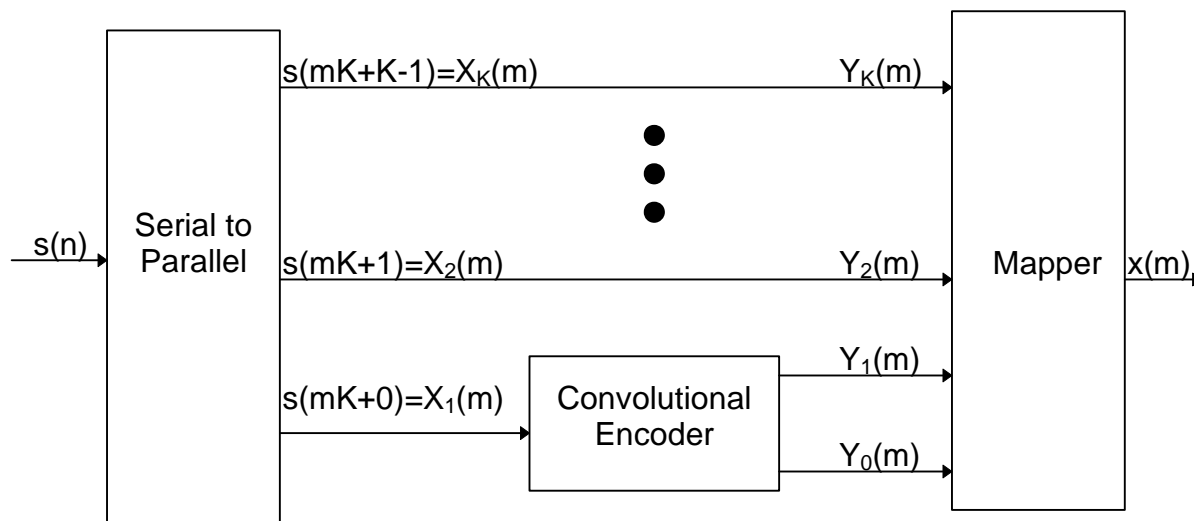

Figure 9-8: Block diagram of the UC-PAM encoder

### 9.3.3.1 Serial-to-parallel converter

The serial bit stream from the scrambler,  $s(n)$ , shall be converted to a  $K$ -bit parallel word  $\{X_1(m) = s(mK), X_2(m) = s(mK + 1), \dots, X_K(m) = s(mK + K-1)\}$  at the  $m^{\text{th}}$  symbol time, where  $X_1(m)$  is the first in time.

### 9.3.3.2 Convolutional encoder

Figure 9-9 shows the feed forward non-systematic convolutional encoder, where  $T_s$  is a delay of one symbol time, " $\oplus$ " is binary exclusive-OR, and " $\otimes$ " is binary AND.  $X_1(m)$  shall be applied to the convolutional encoder,  $Y_1(m)$  and  $Y_0(m)$  shall be computed, then  $X_1(m)$  shall be shifted into the shift register.

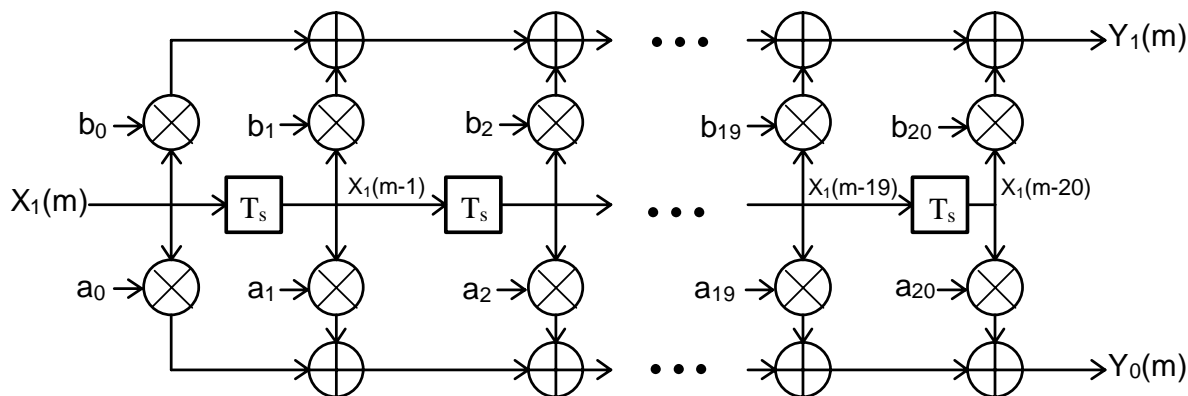

Figure 9-9: Block diagram of the convolutional encoder

The binary coefficients  $a_i$  and  $b_i$  shall be passed to the encoder from the receiver during the activation phase specified in clause 9.1. A numerical representation of these coefficients is  $A$  and  $B$ , where:

$$A = a_{20} \cdot 2^{20} + a_{19} \cdot 2^{19} + a_{18} \cdot 2^{18} + \dots + a_0 \cdot 2^0$$

and

$$B = b_{20} \cdot 2^{20} + b_{19} \cdot 2^{19} + b_{18} \cdot 2^{18} + \dots + b_0 \cdot 2^0$$

The specific choice of Ungerboeck code is vendor specific. The Ungerboeck code shall be chosen such that the system performance requirements are satisfied.

### 9.3.3.3 Mapper

For  $K=3$ , the bits  $Y_3(m)$ ,  $Y_2(m)$ ,  $Y_1(m)$ , and  $Y_0(m)$  shall be mapped to a level  $x(m)$  as specified in table 9-8.

**Table 9-8: Data mode bit-to-level mapping**

Trellis encoder output, $Y_3(m) Y_2(m) Y_1(m) Y_0(m)$	Level $x(m)$ (see note)
0000	-15/16
0001	-13/16
0010	-11/16
0011	-9/16
0100	-7/16
0101	-5/16
0110	-3/16
0111	-1/16
1100	1/16
1101	3/16
1110	5/16
1111	7/16
1000	9/16
1001	11/16
1010	13/16
1011	15/16

NOTE: The values are fractions of the value 1 as defined in clause 9.3.4.

### 9.3.4 Channel precoder

The block diagram of channel precoder is shown in figure 9-10, where  $T_s$  is a delay of one symbol time.

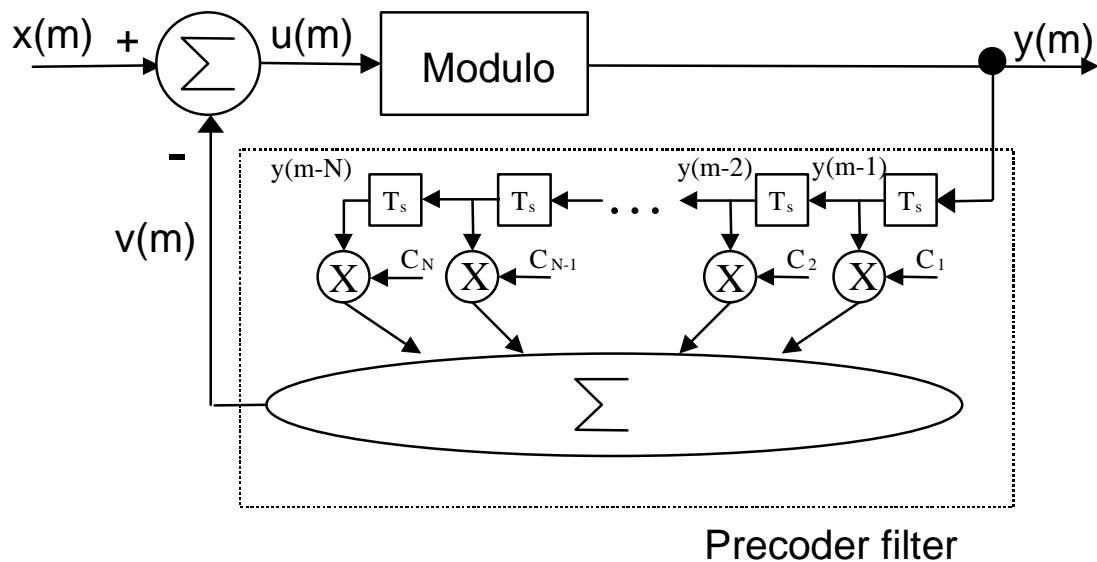

**Figure 9-10: Block diagram of the channel precoder**

The coefficients  $C_k$  of the precoder filter shall be transferred to the channel precoder as described in clause 7.2.1.2. The output of the precoder filter  $v(m)$  shall be computed as follows:

$$v(m) = \sum_{k=1}^N C_k y(m-k)$$

The function of the modulo block shall be to determine  $y(m)$  as follows: for each value of  $u(m)$ , find an integer  $d(m)$  such that:

$$-1 \leq u(m) + 2d(m) < 1$$

and then:

$$y(m) = u(m) + 2d(m)$$

### 9.3.5 Spectral shaper

The spectral shaper for the LTU and the NTU transmitters shall operate on the output of the respective precoders (data mode) or mappers (activation and preactivation mode). The analogue output  $z(t)$  of the spectral shaper is coupled to the loop, and shall have a power spectral density, which is limited by masks, and have a limited total power. Power and power spectral density is measured into a load impedance of  $135 \Omega$ . The power spectral density for all modes, including preactivation probing signals, shall be measured using a 3 kHz wide sliding window. The test procedure for transmit power compliance is specified in TBD.

## 9.4 PSD masks

For all data rates, the measured transmit PSD of each LTU OR NTU shall not exceed the PSD masks specified in this clause ( $\text{PSDMASK}_{\text{SDSL}}(f)$ ), and the measured total power measured into a load impedance of  $135 \Omega$  shall fall within the range specified in this clause ( $P_{\text{SDSL}} \pm 0,5 \text{ dB}$ ). The symmetric PSD masks shall be mandatory, and the asymmetric PSD masks shall be optional. Table 9-9 lists the supported PSDs and the associated constellation sizes.

**Table 9-9: PSD and constellation size**

Symmetric PSDs		Asymmetric PSDs			
DS	US	DS	US	DS	US
Coded 16-PAM	Coded 16-PAM	Coded 16-PAM	Coded 16-PAM	Coded 8-PAM	Coded 16-PAM
Mandatory		Optional		For further study	

### 9.4.1 Symmetric PSD masks

For all values of framed data rate available in the LTU or NTU, the following set of PSD masks ( $\text{PSDMASK}_{\text{SDSL}}(f)$ ) shall be selectable:

$$\text{PSDMASK}_{\text{SDSL}}(f) = \begin{cases} 10^{\frac{-\text{PBO}}{10}} \times \frac{\text{K}_{\text{SDSL}}}{135} \times \frac{1}{f_{\text{sym}}} \times \frac{\left[ \sin\left(\frac{\pi f}{f_{\text{sym}}}\right) \right]^2}{\left(\frac{\pi f}{f_{\text{sym}}}\right)^2} \times \frac{1}{1 + \left(\frac{f}{f_{3\text{dB}}}\right)^{2 \times \text{Order}}} \times 10^{\frac{\text{MaskOffset dB}(f)}{10}}, & f < f_{\text{int}} \\ 0,5683 \times 10^{-4} \times f^{-1,5}, & f_{\text{int}} \leq f \leq 1,5 \text{ MHz} \\ \text{See Table 9-11} & 1,5 \text{ MHz} < f \leq 11,040 \text{ MHz} \end{cases}$$

where  $\text{MaskOffsetdB}(f)$  is defined as:

$$\text{MaskOffset dB}(f) = \begin{cases} 1 + 0,4 \times \frac{f_{3\text{dB}} - f}{f_{3\text{dB}}}, & f < f_{3\text{dB}} \\ 1, & f \geq f_{3\text{dB}} \end{cases}$$



$f_{int}$  is the frequency where the two equations governing  $PSDMASK_{SDSL}(f)$  intersect. PBO is the power back-off value in dB.  $K_{SDSL}$ , Order,  $f_{sym}$ ,  $f_{3dB}$ , and  $P_{SDSL}$  are defined in table 9-10.  $P_{SDSL}$  is the range of power in the transmit PSD with 0 dB power back-off. R is the payload data rate.

**Table 9-10: Symmetric PSD parameters**

Payload Data Rate, R	$K_{SDSL}$	Order	$f_{sym}$	$f_{3dB}$	$P_{SDSL}$
$R < 2\,048$ kbit/s	7,86	6	$(R+8$ kbit/s) / 3	$1,0 \times f_{sym} / 2$	$P1(R) \leq P_{SDSL} \leq 13,5$ dBm
$R \geq 2\,048$ kbit/s	9,90	6	$(R+8$ kbit/s) / 3	$1,0 \times f_{sym} / 2$	14,5 dBm

$P1(R)$  -with R given in bit/s- is defined as follows:

$$P1(R) = 0,3486 \log_2 (R + 8\,000) + 6,06$$

For 0 dB power back-off, the measured transmit power measured into a load impedance of 135  $\Omega$  shall fall within the range  $PSDSL \pm 0,5$  dB. For power back-off values other than 0 dB, the measured transmit power measured into a load impedance of 135  $\Omega$  shall fall within the range  $PSDSL \pm 0,5$  dB minus the power back-off value in dB. The measured transmit PSD measured into a load impedance of 135  $\Omega$  shall remain below  $PSDMASK_{SDSL}(f)$ . The inband PSD for  $0 < f < 1,5$  MHz shall be measured with a 10 kHz resolution bandwidth.

**Table 9-11: Out of band limitation**

Frequency band	PSD constraint (see note)
$1,5$ MHz $\leq f \leq 11,04$ MHz	-90 dBm/Hz peak with maximum power in a $[f, f+1$ MHz] window of -50 dBm
NOTE: This value is under study and may change to reflect a common value for all DSL systems	

Figure 9-11 shows the PSD masks with 0 dB power back-off for data rates of 256 kbit/s, 512 kbit/s, 768 kbit/s, 1 536 kbit/s, 2 048 kbit/s and 2 304 kbit/s plus 8 kbit/s of overhead.

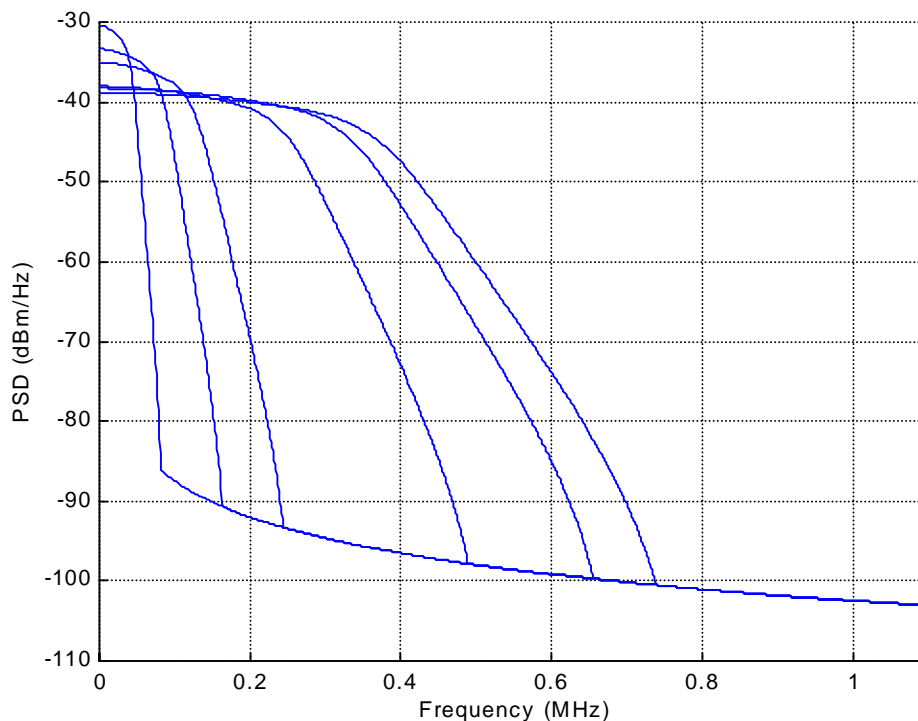

**Figure 9-11: Symmetric PSD masks for 0 dB power back-off**

The equation for the nominal PSD measured at the terminals is:

$$\text{NominalPSD}(f) = \begin{cases} 10^{\frac{-PBO}{10}} \times \frac{K_{SDSL}}{135} \times \frac{1}{f_{\text{sym}}} \times \frac{\left[ \sin\left(\frac{\pi f}{f_{\text{sym}}}\right) \right]^2}{\left(\frac{\pi f}{f_{\text{sym}}}\right)^2} \times \frac{1}{1 + \left(\frac{f}{f_{3\text{dB}}}\right)^{2 \times \text{Order}}} \times \frac{f^2}{f^2 + f_c^2}, & f < f_{\text{int}} \\ 0,5683 \times 10^{-4} \times f^{-1,5}, & f_{\text{int}} \leq f \leq 1,5 \text{ MHz} \\ \text{See Table 9-11}, & 1,5 \text{ MHz} < f \leq 11,040 \text{ MHz} \end{cases}$$

where  $f_c$  is the transformer cut-off frequency, assumed to be 5 kHz. The inband PSD for  $0 < f < 1,5$  MHz shall be measured with a 10 kHz resolution bandwidth. Figure 9-12 shows the nominal transmit PSDs with 13,5 dBm power for data rates of 256 kbit/s, 512 kbit/s, 768 kbit/s, 1 536 kbit/s, 2 048 kbit/s and 2 304 kbit/s plus 8 kbit/s of overhead.

NOTE 1: The nominal PSD is given for information only.

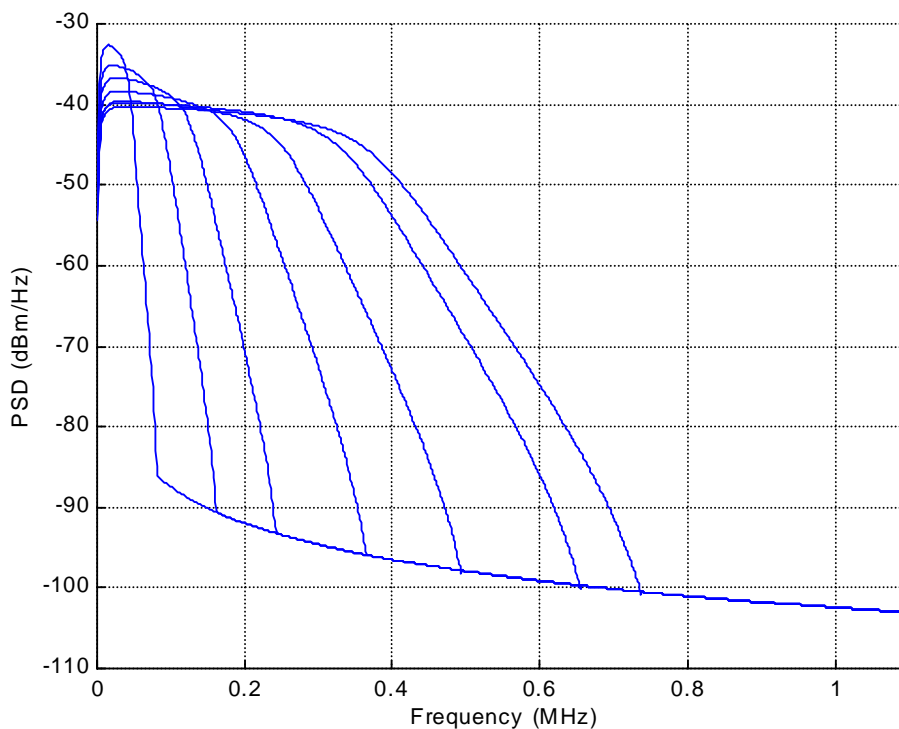

**Figure 9-12: Nominal symmetric PSDs for 0 dB power back-off**

NOTE 2: In this clause,  $PSDMASK(f)$  and  $NominalPSD(f)$  are in units of W/Hz unless otherwise specified and  $f$  is in units of Hz.

#### 9.4.2 Asymmetric 2 048 kbit/s and 2 304 kbit/s PSD masks

The asymmetric PSD mask set specified in this clause shall optionally be supported for the 2 048 kbit/s and the 2 304 kbit/s payload data rate.

NOTE 1: Power and power spectral density are measured into a load impedance of 135  $\Omega$ .

NOTE 2: Other optional asymmetric PSD masks are for further study.

For the 2 048 kbit/s and the 2 304 kbit/s payload data rates available in the LTU or NTU, the following set of PSD masks (PSDMASK<sub>SDSL</sub>(f)) shall be selectable:

$$\text{PSDMASK}_{\text{SDSL}}(f) = \begin{cases} 10^{\frac{-\text{PBO}}{10}} \times \frac{K_{\text{SDSL}}}{135} \times \frac{1}{f_x} \times \frac{\left[ \sin\left(\frac{\pi f}{f_x}\right) \right]^2}{\left(\frac{\pi f}{f_x}\right)^2} \times \frac{1}{1 + \left(\frac{f}{f_{3\text{dB}}}\right)^{2 \times \text{Order}}} \times 10^{\frac{\text{MaskOffsetdB}(f)}{10}}, & f < f_{\text{int}} \\ 0,5683 \times 10^{-4} \times f^{-1,5}, & f_{\text{int}} \leq f \leq 1,5 \text{ MHz} \\ \text{See Table 9-11} & 1,5 \text{ MHz} < f \leq 11,040 \text{ MHz} \end{cases}$$

where MaskOffsetdB(f) is defined as:

$$\text{MaskOffsetdB}(f) = \begin{cases} 1 + 0,4 \times \frac{f_{3\text{dB}} - f}{f_{3\text{dB}}}, & f < f_{3\text{dB}} \\ 1, & f \geq f_{3\text{dB}} \end{cases}$$

$f_{\text{int}}$  is the frequency where the two equations governing PSDMASK<sub>SDSL</sub>(f) intersect. PBO is the power back-off value in dB.  $K_{\text{SDSL}}$ , Order,  $f_x$ ,  $f_{3\text{dB}}$  and  $P_{\text{SDSL}}$  are defined in table 9-12.  $P_{\text{SDSL}}$  is the range of power in the transmit PSD with 0 dB power back-off. R is the payload data rate.

**Table 9-12: Asymmetric PSD parameters**

Payload data rate	Transmitter	$K_{\text{SDSL}}$	Order	$f_x$	$f_{3\text{dB}}$	$P_{\text{SDSL}}$
2 048 kbit/s	LTU	16,86	7	1 370 667 Hz	548 267 Hz	16,25 dBm
2 048 kbit/s	NTU	15,66	7	685 333 Hz	342 667 Hz	16,50 dBm
2 304 kbit/s	LTU	12,48	7	1 541 333 Hz	578 000 Hz	14,75 dBm
2 304 kbit/s	NTU	11,74	7	770 667 Hz	385 333 Hz	15,25 dBm

For 0 dB power back-off, the measured transmit power measured into a load impedance of 135 Ω shall fall within the range PSDSL ± 0,5 dB. For power back-off values other than 0 dB, the measured transmit power measured into a load impedance of 135 Ω shall fall within the range PSDSL ± 0,5 dB minus the power back-off value in dB. The measured transmit PSD measured into a load impedance of 135 Ω shall remain below PSDMASK<sub>SDSL</sub>(f). The inband PSD for 0 < f < 1,5 MHz shall be measured with a 10 kHz resolution bandwidth.

Figure 9-13 shows the asymmetric PSD masks with 0 dB power back-off for payload data rates of 2 048 kbit/s and 2 304 kbit/s.

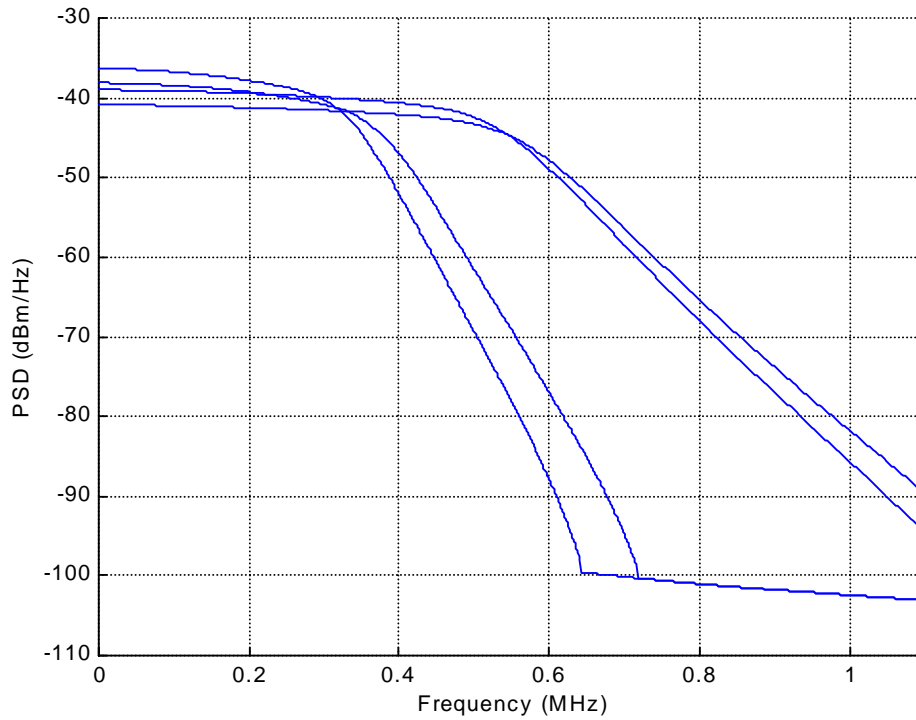

**Figure 9-13: Asymmetric PSD masks for 0 dB power back-off**

The equation for the nominal PSD measured at the terminals is:

$$\text{NominalPSD}(f) = \begin{cases} 10^{\frac{-\text{PBO}}{10}} \times \frac{K_{\text{SDSL}}}{135} \times \frac{1}{f_x} \times \frac{\left[ \sin\left(\frac{\pi f}{f_x}\right) \right]^2}{\left(\frac{\pi f}{f_x}\right)^2} \times \frac{1}{1 + \left(\frac{f}{f_{3\text{dB}}}\right)^{2 \times \text{Order}}} \times \frac{f^2}{f^2 + f_c^2}, & f < f_{\text{int}} \\ 0,5683 \times 10^{-4} \times f^{-1,5}, & f_{\text{int}} \leq f \leq 1,5\text{MHz} \\ \text{See Table 9-11} & 1,5\text{MHz} < f \leq 11,040\text{MHz} \end{cases}$$

where  $f_c$  is the transformer cut-off frequency, assumed to be 5 kHz. The inband PSD for  $0 < f < 1,5$  MHz shall be measured with a 10 kHz resolution bandwidth. Figure 9-14 shows the nominal transmit PSDs with 0 dB power back-off for payload data rates of 2 048 kbit/s and 2 304 kbit/s.

NOTE 3: The nominal PSD is given for information only.

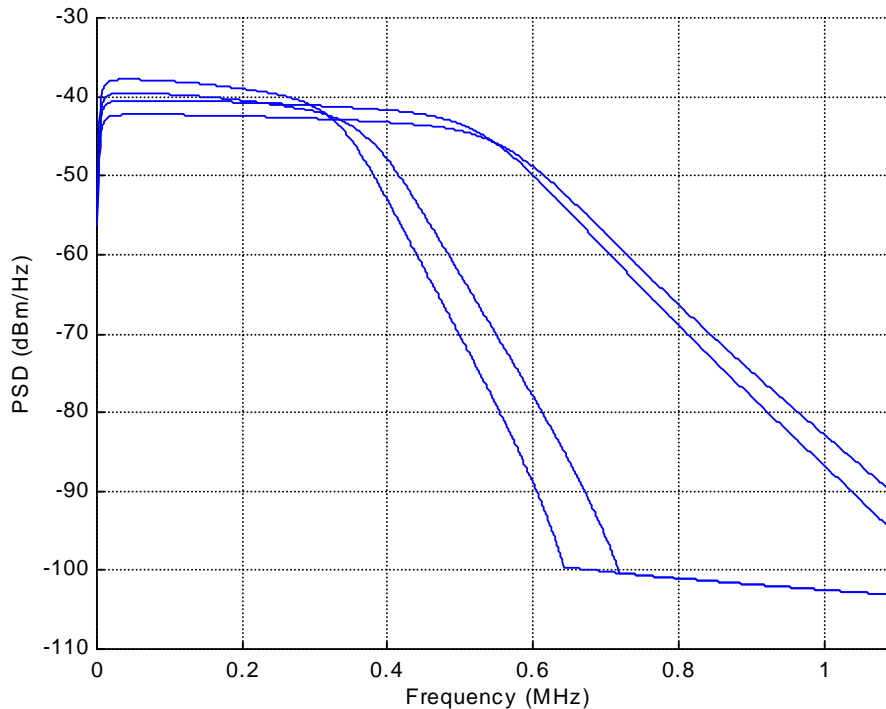
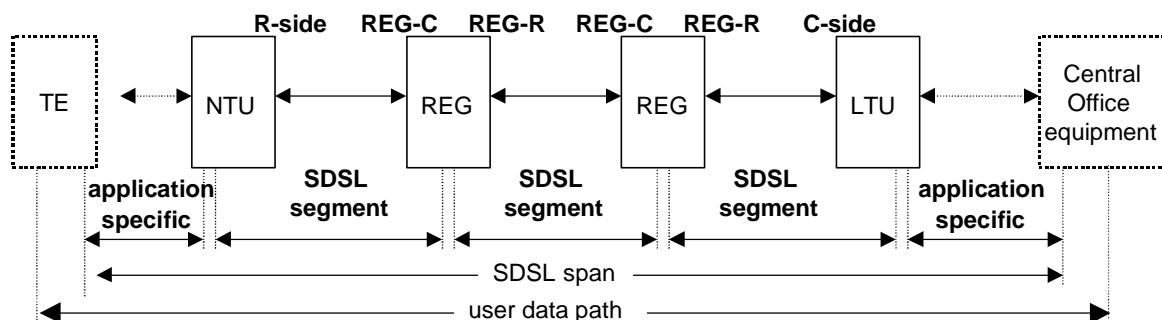

**Figure 9-14: Nominal asymmetric PSDs for 0 dB power back-off**

NOTE 4: In this clause,  $PSDMASK(f)$  and  $NominalPSD(f)$  are in units of W/Hz unless otherwise specified and  $f$  is in units of Hz.

## 10 Operation and maintenance

### 10.1 Management Reference Model



**Figure 10-1: Management Reference Model**

Figure 10-1 shows the management reference model for user data transport over SDSL. This example includes two regenerator units for informative purposes. The presence of two regenerators is not intended to be a requirement or limit. An SDSL segment is characterized by a metallic transmission medium utilizing an analogue coding algorithm, which provides both analogue and digital performance monitoring at the segment entity. An SDSL segment is delimited by its two end points, known as segment terminations. An SDSL segment termination is the point at which the analogue coding algorithms end and the subsequent digital signal is monitored for integrity.

All SDSL performance monitoring data is transported over the eoc. The fixed indicator bits in the SDSL frame *losd*, *sega*, *segd* and *ps* are used for rapid communication of interface or SDSL segment defects, which may lead to protection switching. In addition, the fixed indicator bits may be used for rapid alarm filtering SDSL segment failures.

## 10.2 SDSL Primitives and Failures

### 10.2.1 Cyclical Redundancy Check Anomaly (CRC)

A CRC anomaly shall be declared when the crc-bits generated locally on the data in the received SDSL frame do not match the crc-bits (*crc1 - crc6*) received from the transmitter. A CRC anomaly only pertains to the frame over which it was declared.

### 10.2.2 Segment Anomaly (SEGA)

An upstream segment anomaly shall be declared when any signal regenerator declares a CRC anomaly for an SDSL frame moving in the direction from NTU to LTU. A downstream segment anomaly shall be declared when any signal regenerator declares a CRC anomaly for an SDSL frame moving in the direction from LTU to NTU. A segment anomaly indicates that a regenerator operating on a segment has received corrupted data and therefore the regenerated data is unreliable. The purpose of segment anomaly is to ensure internal SDSL PMD integrity; it is not intended to be reported to an external management entity. A segment anomaly is indicated via the *sega*-bit in the SDSL frame.

### 10.2.3 Loss of Sync Defect (LOSW defect)

This defect is indicated in the eoc through message ID 140 and from regenerators additionally through *segd*-bit.

In plesiochronous mode, an LOSW defect shall be declared when at least 3 consecutive received frames contain one or more errors in the framing bits. The term framing bits shall refer to that portion of *Sync word*, *stuffing bits* and *stuff indicator bits*, which are used for frame synchronization. An LOSW defect shall be cleared when at least 2 consecutive received frames contain no errors in the framing bits.

In synchronous mode, an LOSW defect shall be declared when at least 3 consecutive received frames contain one or more bit errors in the Frame Sync Word. An LOSW defect shall be cleared when at least 2 consecutive received frames contain no errors in the Frame Sync Word.

### 10.2.4 Segment Defect (SEGD)

An upstream segment defect shall be declared when any signal regenerator declares a LOSW defect for data moving in the direction from NTU to LTU. A downstream segment defect shall be declared when any signal regenerator declares a LOSW defect for data moving in the direction from LTU to NTU. A segment defect indicates that a regenerator has lost SDSL synchronization and therefore the regenerated data is unavailable. A segment defect shall be cleared when all regenerators have no LOSW defects. This primitive is typically reported to an external management entity and is used to ensure timely protection switching, alarm filtering, etc. A segment defect is indicated via the *segd*-bit in the SDSL frame.

### 10.2.5 Loop Attenuation Defect

A Loop Attenuation Defect shall be declared when the observed Loop Attenuation is at a level higher than the configured threshold (clause 10.55.7.5).

### 10.2.6 SNR Margin Defect

An SNR Margin Defect shall be declared when the observed SNR Margin is at a level lower than the configured threshold (clause 10.5.5.7.5). SNR Margin is defined as the maximum dB increase in equalized noise or the maximum dB decrease in equalized signal that a system can tolerate and maintain a BER of  $10^{-7}$ .

NOTE: The SNR Margin assumes additive Gaussian noise.

## 10.2.7 Loss of Sync Word Failure (LOSW failure)

This defect is indicated in the eoc through message ID 141 and from regenerators additionally through *segd*-bit.

An LOSW failure shall be declared after  $2,5 \text{ s} \pm 0,5 \text{ s}$  of contiguous LOSW defect. The LOSW failure shall be cleared when the LOSW defect is absent for 20 s or less (i.e. clear within 20 s). The minimum hold time for indication of LOSW failure shall be 2 s.

## 10.2.8 Loss of local power

The NTU shall indicate loss of local power to the LTU through *ps*-bit. The NTU shall be able to send the *ps*-bit in at least 3 consecutive frames after loosing local power.

NOTE: Keeping transmitting capability for at least three frames, which means 24 ms, may lead to high expenditures, i.e. very large capacitors keeping enough energy. The definition of a special, easy detectable bit pattern occupying the entire frame may be more adequate.

## 10.3 SDSL Line Related Performance Parameters

### 10.3.1 Code Violation (CV)

The SDSL parameter Code Violation is defined as a count of the SDSL CRC anomalies occurring during the accumulation period. This parameter is subject to inhibiting - see clause 10.3.6.

### 10.3.2 Errored Second (ES)

The SDSL parameter Errored Second is defined as a count of 1-second intervals during which one or more CRC anomalies are declared and/or one or more LOSW defects are declared. This parameter is subject to inhibiting - see clause 10.3.6.

### 10.3.3 Severely Errored Second (SES)

The SDSL parameter Severely Errored Second is defined as a count of 1-second intervals during which at least 50 CRC anomalies are declared or one or more LOSW defects are declared. (50 CRC anomalies during a 1 second interval is equivalent to a 30 % errored frame rate for a nominal frame length.) This parameter is subject to inhibiting - see clause 10.3.6.

### 10.3.4 LOSW Second (LOSWS)

The SDSL parameter LOSW Second is defined as a count of 1 second intervals during which one or more SDSL LOSW defects are declared.

### 10.3.5 Unavailable Second (UAS)

The SDSL parameter Unavailable Second is a count of 1-second intervals for which the SDSL line is unavailable. The SDSL line becomes unavailable at the onset of 10 contiguous SESs. The 10 SESs are included in the unavailable time. Once unavailable, the SDSL line becomes available at the onset of 10 contiguous seconds with no SESs. The 10 s with no SESs are excluded from unavailable time.

### 10.3.6 Inhibiting Rules

- UAS parameter counts shall not be inhibited;
- ES and SES shall be inhibited during UAS. Inhibiting shall be retroactive to the onset of unavailable time and shall end retroactively to the end of unavailable time;
- the CV parameter shall be inhibited during SES.

Further information on inhibiting rules and how ES and SES are decremented can be found in IETF RFC 2495 [21]: Definitions of Managed Objects for the DS1, E1, DS2 and E2 Interface Types.

## 10.4 Performance data storage

Performance history for all SDSL segment endpoints shall be maintained at the LTU. In order to support SDSL performance history storage at the LTU, each SDSL network element shall monitor performance and maintain a modulo counter for each performance parameter that is specified in clauses 10.5.5.7.15 and 10.5.5.7.16, as appropriate. No initialization of these modulo counters is specified or necessary. By comparing the current reading of the modulo counter with the previous reading stored in memory, the data base manager in the LTU can determine the number of counts to add to the appropriate performance history bin. (Note that the number of counts may decrease under some fault conditions - see clause 10.3 for additional information.) The modulo counters are reported in the SDSL Performance Status Messages (clauses 10.5.5.7.15 and 10.5.5.7.16.)

In order to monitor ES and SES, each SDSL element shall maintain a 1 second timer and an 8 bit modulo counter for each receiver. (An NTU or LTU shall have 1 counter. A signal regenerator shall have 2 counters.) The corresponding counter shall be incremented for every ES or SES that is declared. The LTU shall collect performance history by polling each SDSL network element with a time interval that precludes overflow of the modulo counter. The LTU should maintain performance history registers for each SDSL segment endpoint. The performance history registers shall include the total collected counts for the current 15 minute period, 32 previous 15 minute periods, current 24 hour period, and 7 previous 24 hour periods.

## 10.5 SDSL embedded operations channel (eoc)

### 10.5.1 eoc management reference model

The LTU shall maintain a management information database for external access by network management or via craft terminal interface.

Optionally, the NTU may maintain a management information database, which can be locally accessed (through a craft terminal interface). This is particularly useful when the LTU, due to fault conditions, is unreachable via the eoc.

Access to the management information database from craft terminal interfaces on attached units shall be provided through a virtual terminal interface.

### 10.5.2 eoc overview and reference model

The eoc allows terminal units to maintain information about the span. There are two basic flows of data, differentiated by which terminal unit initiates the data flow (and subsequently stores the information for external access.) The data flow initiating from the LTU is mandatory. The data flow initiating from the NTU is optional, but all units must respond to requests in either direction of data flow. In all cases the "master database" shall be stored at the LTU and all conflicts shall be resolved in favour of the LTU (i.e. the information at the LTU takes precedence). The data flows are illustrated in table 10-1 for a 2 regenerator link (Q denotes a query or command message, R denotes a response message). Up to 8 regenerators are supported by the protocol definition. Asterisks denote optional message transmissions.



Table 10-1: Illustration of eoc flow with 2 regenerators

Messages from LTU Msg(src,dest)	Messages from REG1 Msg(src,dest)	Messages from REG2 Msg(src,dest)	Messages from NTU Msg(src,dest)
Q(1,3) →	→ Process		
Process ←	← R(3,1)		
Q(1,4) →	→ Forward →	→ Process	
Process ←	← Forward ←	← R(4,1)	
Q(1,2) →	→ Forward →	→ Forward →	→ Process
Process ←	← Forward ←	← Forward ←	←R(2,1)
		Process ←	←Q(2,3)*
		R(3,2) →	→ Process
	Process ←	← Forward ←	←Q(2,4)*
	R(4,2) →	→ Forward →	→ Process
Process ←	← Forward ←	← Forward ←	←Q(2,1)*
R(1,2) →	→ Forward →	→ Forward →	→ Process

NOTE: \* indicates optional messages.

The data link layer of SDSL eoc checks the FCS and if valid passes the packet to the network layer. If the CRC is invalid the entire packet is ignored. The network layer consists of three possible actions: Process, Forward, and Ignore/Terminate. Process means that the source address and HDLC information field are passed on to the application layer. Forward means that the packet is sent onward to the next SDSL element. (Note that only REGs will forward packets.) Ignore/Terminate means that the HDLC packet is ignored and is not forwarded. An REG may both process and forward a packet in the case of a broadcast message. If the segment is not active in the forwarding direction, the REG shall discard the packet instead. When the segment is active in the forwarding direction, the maximum forwarding delay in an REG shall be 300 ms. All retransmission and flow control is administered by the LTU or NTU.

To accommodate the dual data flows, SDSL regenerators have dual addresses as shown in table 10-1. One address is for communication with the LTU and the other address is for communication with the NTU. During Discovery, the LTU and optionally the NTU send discovery probe messages, which propagate across the span and allow the REGs to be numbered via a hop count field in the message. This process is explained in detail below.

The SDSL terminal units communicate unidirectionally and thus have only one address. The LTU is assigned a fixed address of 1 and the NTU is assigned a fixed address of 2. At power-up, each REG is assigned the address of 0 for each direction. Under a LOSW failure condition, the REG shall reset its source address to 0 for the direction in which the LOSW failure exists. The REG source address shall be changed from 0 if and only if a discovery probe message is received and processed. In this way, a regenerator will only communicate in the direction of a database. For instance, if a regenerator receives a probe message from the LTU and not from the NTU then its address will remain 0 in the direction towards the remote.

### 10.5.3 eoc start-up

After loop activation, the SDSL eoc goes through three initialization stages: Discovery, Inventory and Configuration. During Discovery, the LTU and optionally the NTU will learn if any mid-span regenerators exist and their addresses will be determined. During Inventory, the LTU will poll each REG and the NTU to establish inventory information on each element for the terminal unit's database. (Similarly, the NTU may poll each REG and the LTU to establish its own database, although this is optional.) During Configuration, the LTU configures the NTU and any REGs for alarm thresholds, signal characteristics, etc. There is no enforcement of the order or time of the Inventory and Configuration phases; the initiating LTU or NTU is in control.

The following table is an example of Discovery starting from the LTU and then followed by an optional Discovery initiated by the NTU. Although these are shown sequentially in this example, they are actually independent; it is not necessary for the NTU to wait until it received the probe from the LTU before initiating its own Discovery phase. The NTU may send its probe as soon as its eoc is active. The Discovery Response contains the current hop count, the vendor ID, eoc version and an indication of LOSW in the forward direction (i.e. in the direction of eoc flow that is opposite to the direction that the Discovery Response is sent).

**Table 10-2: Illustration of eoc discovery phase**

Messages from LTU Msg(src,dest,h)	Messages from REG1 Msg(src,dest,h)	Messages from REG2 Msg(src,dest,h)	Messages from NTU Msg(src,dest,h)
DP(1,0,0)→			
	← DR(3,1,1)		
	DP(0,0,1)→		
	←Forward ←	← DR(4,1,2)	
		DP(0,0,2)→	
	←Forward ←	←Forward ←	← DR(2,1,3)
			← DP(2,0,0)
		DR(3,2,1)→	
		← DP(4,0,1)	
	DR(4,2,2)→	→Forward →	
	← DP(3,0,2)		
DR(1,2,3) →	→Forward →	→Forward →	

NOTE: h = hop count, DP = Discovery Probe, DR = Discovery Response).

After the initiator (LTU and optionally NTU) has received a Discovery Response message from an element, it shall then begin the Inventory phase for that particular element. This is accomplished by polling that particular element for its inventory information. After the initiator has received the inventory information for a unit, it shall then begin the Configuration phase by sending the appropriate configuration information to the corresponding element. The Inventory and Configuration phases operate independently for each responding terminal/regenerator unit.

To ensure interoperability, the behaviour of slave or responding units is carefully specified by the present document. The particular method for handling dropped packets or no response is left to the discretion of the initiating LTU or NTU.

Table 10-3 shows the eoc state table for the network side of an REG. Note that an identical, but independent, state machine exists for the customer side of an REG to support messages originating from the NTU.

The state machine consists of 3 states: Offline, Discovery, and eoc Online. The Offline state is characterized by LOSW failure (a loss of SDSL sync). The Discovery state is characterized by an unknown address. Once the address is learned through the Discovery message, the REG enters the eoc online or active state. At this point, the REG will respond to inventory, configuration, maintenance, or other messages from the LTU.

Table 10-3: REG network eoc state table

<b>Offline state</b>	
<b>Event</b>	<b>Action</b>
Network LOSW = 0	eoc state = Discovery Ready;
<b>Discovery Ready state</b>	
Event	Action
Network LOSW = 1	Network eoc address = 0; Network eoc state = offline;
Discovery probe message received from the network side	Increment hop count Set network eoc address to hop count + 2; Compose and present Discovery message to customer side application layer; Send Discovery response to LTU; Network eoc state = eoc online;
Message with address not equal to unit's address received from the Network side.	Request forwarding of the message from the Customer side network layer;
Message forwarding requested from customer side	Send requested message toward network if eoc idle;
<b>eoc Online state</b>	
Event	Action
Network LOSW = 1	Network eoc Address = 0; Network eoc State = Offline;
Discovery message received from the network side	Increment hop count Set network eoc address to hop count + 2; Compose and present Discovery message to customer side application layer; Send Discovery Response to LTU;
Message with broadcast destination address received from the Network side	Process the message; Request the customer side eoc network layer to forward the message;
Message with unit's destination address or address 0 received from the network side	Process the message;
Message with address not equal to unit's address received from the network side	Request forwarding of message from the customer side network layer;
Message forwarding requested from customer side network layer	Send requested message toward network as soon as eoc available;

## 10.5.4 Remote management access

The LTU shall maintain the master management database for each SDSL segment. (An optional second database is maintained at the NTU.) Other units are only required to store enough information to accurately send information via the eoc. The information contained in the master database shall be accessible from any SDSL unit that has a craft terminal port and from network management if it is available. The craft terminal access is in the form of a virtual terminal interface (or virtual craft terminal interface). This interface is defined so that it can be used by any attached unit to access the terminal screen of another unit. Support for this feature is optional, with the exception of the LTU, which shall support the host side of at least one remote terminal connection. (Whether this interface can be active simultaneously with local craft terminal access to the LTU is a vendor decision and beyond the scope of the present document.) The virtual terminal interface consists of connect, disconnect, keyboard, and screen messages. After a connection has been established, input characters from the craft terminal port are sent in keyboard data messages to the host unit. The host unit, in turn, shall send information in the form of ASCII text and ASCII control codes, and screen control functions in screen messages, whose contents are transmitted back to the craft terminal port. The host unit shall echo characters.

The method for determining that remote access through the local craft terminal port is desired or should be terminated is vendor specific, and beyond the scope of the present document. Whatever method is used, capability for transmitting all valid key sequences (ASCII characters and control codes) shall be provided.

## 10.5.5 eoc transport

The eoc shall be transported in the SDSL frame in bits *eoc1* through *eoc20*. Five octets are contained in each two SDSL frames, with specified alignment. The least significant bit (LSB) of the octets are located in bits 1, 9, and 17 of the eoc bits in the first frame and bits 5 and 13 of the second frame; each octet is transmitted LSB first. Octet alignment across frames is achieved through detection of the alignment of the HDLC sync pattern ( $7E_{16}$ ).

### 10.5.5.1 eoc data format

Numerical data and strings are placed in the eoc with octet alignment. Data items that are not an integral number of octets may be packed together to minimize message sizes.

Numerical fields shall be transmitted most significant octet first, least significant bit first within an octet.

Strings shall be represented in the data stream with their first character (octet) transmitted first. Strings shall be padded with spaces or terminated with a NULL ( $00_{16}$ ) to fill the allocated field size. String fields are fixed length so characters after a NULL in a string data field are "don't care".

### 10.5.5.2 eoc frame format

The eoc channel shall carry messages in an HDLC-like format as defined in ITU-T Recommendation G.997.1 [8], clause 6.2. The channel shall be treated as a stream of octets; all messages shall be an integral number of octets.

The frame format uses a compressed form of the HDLC header, as illustrated in table 10-4. The destination address field shall be the least significant 4 bits of octet 1; the source address field shall occupy the most significant 4 bits of the same octet (the address field.) There is no control field. One or more sync octets ( $7E_{16}$ ) shall be present between each frame. Inter-frame fill shall be accomplished by inserting sync octets as needed. Discovery probe messages shall be preceded by at least 5 sync octets to assure proper detection of octet alignment. The Information Field contains exactly one message as defined below. The maximum length of a frame shall be 75 octets, not including the sync pattern or any octets inserted for data transparency.

**Table 10-4: Frame format for SDSL eoc**

Octet #	MSB	LSB	
	Contents		
	Sync pattern ( $7E_{16}$ )		
1	Source address bits 7..4	Destination address bits 3..0	
2	Message ID per table 10-6		information field
	Message content - octet 1		
	...		
	Message content - octet L		
L + 3	FCS octet 1		
L + 4	FCS octet 2		
	Sync pattern ( $7E_{16}$ )		

### 10.5.5.3 Data transparency

Transparency for the information payload to the sync pattern ( $7E_{16}$ ) and the control escape pattern ( $7D_{16}$ ) shall be achieved by octet stuffing.

Before transmission:

- octet pattern ( $7E_{16}$ ) is encoded as two octets ( $7D_{16}$ ), ( $5E_{16}$ );
- octet pattern ( $7D_{16}$ ) is encoded as two octets ( $7D_{16}$ ), ( $5D_{16}$ );

At reception:

- octet sequence ( $7D_{16}$ ), ( $5E_{16}$ ) is replaced by octet ( $7E_{16}$ );
- octet sequence ( $7D_{16}$ ), ( $5D_{16}$ ) is replaced by octet ( $7D_{16}$ );

- any other two-octet sequence beginning with 7D<sub>16</sub> aborts the frame.

#### 10.5.5.4 Frame check sequence

The frame check sequence (FCS) shall be calculated as specified in IETF RFC 1662 [14]. (Note that the FCS is calculated before data transparency). The FCS shall be transmitted as specified in IETF RFC 1662 [14]: Bit 1 of the first octet is the MSB and bit 8 of the second octet is the LSB, i.e. the FCS bits are transmitted reversed from the normal order.

#### 10.5.5.5 Unit addresses

Each unit uses one source and destination address when communicating with upstream units and a separate independent source and destination address when communicating with downstream units. Each address shall have a value between (0<sub>16</sub>) and (F<sub>16</sub>). Units shall be addressed in accordance with table 10-5. Address (F<sub>16</sub>) may only be used as a destination address and shall specify that the message is addressed to all units. Address (0<sub>16</sub>) is used to address the next attached or adjacent unit.

**Table 10-5: Device addresses**

Address (Base <sub>16</sub> )	Device
0	Adjacent device
1	LTU
2	NTU
3 - A	Regenerators 1 - 8
B - E	Reserved (D and E not allowed)
F	Broadcast message to all stations
NOTE: The present document is not intended to indicate how many regenerators can or should be supported by a product; only how to identify them if they exist.	

#### 10.5.5.6 Message IDs

Table 10-6 summarizes message ID and expected message lengths. Message IDs are listed as decimal numbers. Messages 0-64 represent request messages. Messages 128-192 represent messages that are sent in response to request messages. Each request message is acknowledged with the corresponding response. Request/Response Message IDs usually differ by an offset of 128.

**Table 10-6: Summary of Message IDs**

Message ID(decimal)	Message type	Initiating Unit	Reference (clause)
0	Reserved		
1	Discovery Probe	LTU, NTU*, REG	10.5.5.7.1
2	Inventory Request	LTU, NTU*	10.5.5.7.3
3	Configuration Request - SDSL	LTU	10.5.5.7.5
4	Reserved for Application Interface Configuration		
5	Configuration Request - Loopback Time-Out	LTU, NTU*	10.5.5.7.6
6	Virtual Terminal Connect Request	NTU*, REG*	10.5.5.7.17
7	Virtual Terminal Disconnect Request	NTU*, REG*	10.5.5.7.17
8	Keyboard Data Message	NTU*, REG*	10.5.5.7.18
9	Maintenance Request - System Loopback	LTU, NTU*	10.5.5.7.19
10	Maintenance Request - Element Loopback	LTU, NTU*	10.5.5.7.20
11	Status Request	LTU, NTU*	10.5.5.7.12
12	Full Status Request	LTU, NTU*	10.5.5.7.13
13 - 14	Reserved		
15	Soft Restart/Power back-off Disable Request	LTU	10.5.5.7.22
16	Reserved (Future)		
17	ATM Cell Status Request	LTU, NTU	A.8.4.7
18	NTU Configuration Request - Management	LTU	10.5.5.7.9
19	Reserved for Voice Transport Request (Future)	Undefined	
20	ISDN Request	LTU, NTU	A.6.7.1

Message ID(decimal)	Message type	Initiating Unit	Reference (clause)
21 - 63	Reserved (Future)		
64 - 88	Reserved for Line Management Request	Undefined	10.5.5.7.23
89 - 111	Reserved		
112 - 119	Proprietary Message	Undefined	10.5.5.7.24
120	External Message	Undefined	10.5.5.7.25
121	G.997.1 Message	LTU*, NTU*	10.5.5.7.26
122 - 124	Reserved		
125 - 127	Excluded (7D <sub>16</sub> , 7E <sub>16</sub> , 7F <sub>16</sub> )		
128	Reserved		
129	Discovery Response	all	10.5.5.7.2
130	Inventory Response	all	10.5.5.7.4
131	Configuration Response - SDSL	NTU, REG	10.5.5.7.7
132	Reserved for Application Interface Configuration		
133	Configuration Response - Loopback Time-Out	all	10.5.5.7.8
134	Virtual Terminal Connect Response	LTU, REG*, NTU*	10.5.5.7.17
135	Reserved		
136	Screen Data Message	LTU, REG*, NTU*	10.5.5.7.18
137	Maintenance Status	all	10.5.5.7.21
138	Reserved		
139	Status/SNR	all	10.5.5.7.14
140	Performance Status SDSL Network Side	REG, NTU	10.5.5.7.15
141	Performance Status SDSL Customer Side	LTU, REG	10.5.5.7.16
142	Reserved for Application Interface Performance		
143	Reserved (Future)		
144	Generic Unable to Comply (UTC)		10.5.5.7.27
145	ATM Cell Status Information	all	A.8.4.8
146	Configuration Response - Management	NTU, REG*	10.5.5.7.10
147	Reserved for Voice Transport Response (Future)	Undefined	
148	ISDN Response	LTU, NTU	A.6.7.1
149 - 191	Reserved (Future)		
192 - 216	Segment Management Response (reserved)	Undefined	10.5.5.7.23
217 - 239	Reserved (Future)		
240 - 247	Proprietary Message Response	Undefined	10.5.5.7.2
248 - 252	Reserved		
253 - 255	Excluded (FD <sub>16</sub> , FE <sub>16</sub> , FF <sub>16</sub> )		

NOTE: \* denotes optional support. A unit may initiate this message.

### 10.5.5.7 Message contents

Each message shall have the contents in the format specified in table 10-4 through table 10-6. If any message has a message length longer than expected and is received in a frame with a valid FCS, then the known portion of the message shall be used and the extra octets discarded. This will permit addition of new fields to existing messages and maintain backward compatibility. New data fields shall only be placed in reserved bits after the last previously defined data octet. Reserved bits and octets shall be filled with the value (00<sub>16</sub>) for forward compatibility.

Response messages may indicate UTC (Unable to Comply.) Note that this is not in indication of non-compliance. UTC indicates that the responding unit was unable to implement the request.

#### 10.5.5.7.1 Discovery Probe - Message ID 1

The Discovery Probe message shall be assigned Message ID 1, and is used to allow a LTU or NTU to determine how many devices are present and assign addresses to those units.

**Table 10-7: Discovery Probe Information Field**

Octet #	Contents	Data type	Reference
1	1	Message ID	
2	Hop count	unsigned character	clause 0

### 10.5.5.7.2 Discovery Response - Message ID 129

The Discovery Response message shall be assigned Message ID 129. This message shall be sent in response to a Discovery Probe Message. The Hop Count field shall be set to 1 larger than the value received in the Discovery Probe Message causing the response. (The Full Receive State Machine is described in table 10-3.) Forward LOSW indication means that the segment is down in the forward direction from the REG. In this case, the REG is unable to forward the Discovery Probe message to the adjacent unit and it reports this fact to the initiating LTU or NTU. The Forward LOSW octet field shall be set to (00<sub>16</sub>) for responses from a LTU or NTU.

**Table 10-8: Discovery Response Information Field**

Octet #	Contents	Data Type	Reference
1	129	Message ID	
2	Hop count	Unsigned character	0
3	Reserved		
-4-11	Vendor ID (ordered identically to bits in G.994.1 Vendor ID)		
12	Vendor eoc Software Version	Unsigned character	
13	SDSL version #	Unsigned character	
14 bits 7..1	Reserved		
14 bit 0	Forward LOSW indication, eoc unavailable	Bit	1 = Unavailable 0 = Available

### 10.5.5.7.3 Inventory Request - Message ID 2

The Inventory Request message shall be assigned Message ID 2. This message is used to request an Inventory Response from a particular unit. It shall only be transmitted by LTU or NTU devices. There shall be no octets of content for this message.

**Table 10-9: Inventory Request Information Field**

Octet #	Contents	Data type	Reference
1	2	Message ID	

### 10.5.5.7.4 Inventory Response - Message ID 130

The Inventory Response message shall be assigned Message ID 130. This message shall be sent in response to an Inventory Request message.

**Table 10-10: Inventory Response Information Field**

Octet #	Contents	Data type	Reference
1	130	Message ID	
2	SDSL version #	Unsigned character	
3 - 5	Vendor list #	3 octet string	
6 - 7	Vendor issue #	2 octet string	
8 - 13	Vendor software version	6 octet string	
14 - 23	Unit identification code	10 octet string	
24	Reserved		
25 - 32	Vendor ID (ordered identically to bits in G.994.1 Vendor ID)		
33 - 44	Vendor model #	12 octet string	
45 - 56	Vendor serial #	12 octet string	
57 - 68	Other vendor information	12 octet string	

### 10.5.5.7.5 Configuration Request - SDSL - Message ID 3

The Configuration Request - SDSL message is transmitted by the LTU to configure the SDSL interface(s) of attached units. This message may be broadcast or addressed to specific units. It is acknowledged with a Configuration Response - SDSL message. For SDSL, SNR is measured internal to the transceiver decision device as opposed to the external segment termination. The "Off" setting indicates that threshold crossings are not reported. Loop Attenuation and SNR Margin are local alarms that are reported in Messages 140 and 141. In addition, these alarms may be physically indicated on the equipment. SDSL Loop Attenuation shall be defined as follows:

$$LoopAtten_{SDSL}(H) = \frac{2}{f_{sym}} \left( \int_0^{f_{sym}} \frac{1}{2} 10 \cdot \log_{10} \left[ \sum_{n=0}^1 S(f - nf_{sym}) \right] df - \int_0^{f_{sym}} \frac{1}{2} 10 \cdot \log_{10} \left[ \sum_{n=0}^1 S(f - nf_{sym}) |H(f - nf_{sym})|^2 \right] df \right)$$

where  $f_{sym}$  is the symbol rate,  $\frac{1}{H(f)}$  is the insertion loss of the loop, and  $S(f)$  is the nominal transmit PSD.

**Table 10-11: Configuration Request - SDSL Information Field**

Octet #	Contents	Data Type	Reference
1	3	Message ID	
2 bit 7	Config Type	Bit	0 = normal, 1 = Read only
2 bits 6..0	SDSL Loop Attenuation threshold (dB)	Enumerated	0 = off, 1 to 127
3 bits 7..4	SDSL SNR Margin threshold (dB)	Enumerated	0 = off, 1 to 15
3 bits 3..0	Reserved		set to 0

### 10.5.5.7.6 Configuration Request - Loopback Time-Out - Message ID 5

The Configuration Request - Loopback Time-Out message is transmitted by the LTU (and optionally the NTU) to set loopback time-outs for individual elements. If a loopback is not cleared before the expiration of the time-out, then the element shall revert to normal operation. This message may be broadcast or addressed to specific units. It is acknowledged with a Configure Response - Loopback Time-Out message. If date and time information is sent in octets 4 - 21, then these strings conform to ISO 8601 [18]. If date and time information is not sent, then these fields shall be filled with zeros.

**Table 10-12: Configuration Request - Loopback Time-Out Information Field**

Octet #	Contents	Data Type	Reference
1	5	Message ID	
2 bit 7	Config Type	Bit	0 = normal, 1 = Read-only
2 bits 6..4	Reserved		
2 bits 3..0 - 3	Loopback time-out	12-bit unsigned integer	In minutes, 0 = no timeout
4 - 13	YYYY-MM-DD	10 octet date string	ISO 8601 [18]
14 - 21	HH:MM:SS	8 octet time string	ISO 8601 [18]

### 10.5.5.7.7 Configuration Response - SDSL - Message ID 131

The Configuration Response - SDSL message is transmitted to the LTU in response to a Configuration Request - SDSL message. This response is sent after the applicable configuration changes have been made. The values of the response shall be set to the new values, after they have been applied. If a transceiver unit is unable to comply with the request, the bit in the Compliance Octet is set and the current settings are reported. If the Config Request message was received with a Config Type of "Read-Only," then no changes are made to the current configuration and the current values are reported.



**Table 10-13: Configuration Response - SDSL Information Field**

Octet #	Contents	Data Type	Reference
1	131	Message ID	
2 bits 7..1	Reserved		
2 bit 0	UTC (Unable to Comply)	Bit	0 = OK, 1 = UTC
3	SDSL Loop Attenuation threshold (dB)	Char	0 = off, 1 to 127
4 bits 7..4	SDSL SNR Margin threshold (dB)	Enumerated	0 = off, 1 to 15
4 bits 3..0	Reserved		set to 0

#### 10.5.5.7.8 Configuration Response - Loopback Time-Out - Message ID 133

The Configuration Response - Loopback Time-Out message is transmitted to acknowledge the Configuration Request - Loopback Time-Out message. This response is sent after the applicable configuration changes have been made. The values of the response shall be set to the new values, after they have been applied. If a transceiver unit is unable to comply with the request, the bit in the Compliance Octet is set and the current settings are reported. If the Config Request message was received with a Config Type of "Read-Only", then no changes are made to the current configuration and the current values are reported.

**Table 10-14: System Loopback Time-Out Response Information Field**

Octet #	Information Field	Data Type	Reference
1	133	Message ID	
2 bits 7..1	Reserved		
2 bit 0	UTC (Unable to Comply)	bit	0 = OK, 1 = UTC
3 bits 7..4	Reserved		
3 bits 3..0 - 4	Loopback time-out	12-bit unsigned integer	In minutes, 0 = no timeout
5 - 14	YYYY-MM-DD	10 octet date string	ISO 8601 [18]
15 - 22	HH:MM:SS	8 octet time string	ISO 8601 [18]

#### 10.5.5.7.9 NTU Config Request - Management: Message ID 18

The Config Request - Management message is transmitted by the LTU to enable or disable NTU initiated management flow. The destination address shall be F<sub>16</sub> to indicate this is a broadcast message. NTU Initiated Management Flow is enabled by default. When disabled, an NTU shall not respond to any NTU-initiated Request messages, and the NTU shall not issue any such messages (messages 2-12). Config Type of Read-Only indicates that the addressed unit ignore the subsequent values in the message and report back its current configuration.

Octet #	Contents	Data Type	Reference
1	Message ID - 18	Message ID	
2 Bit 7	Config Type	Bit	0-normal, 1-Read-Only
2 Bits 6..1	Reserved		
2 Bit 0	NTU Initiated Management Flow	Bit	0-Enable, 1-Disabled

#### 10.5.5.7.10 Config Response - Management message: Message ID 146

Config Response - Management message is sent by all units to acknowledge to the Config Request - Management message.

Octet #	Contents	Data Type	Reference
1	Message ID - 146	Message ID	
2 Bits 7..1	Reserved		
2 Bit 0	UTC (Unable to Comply)	Bit	0-OK, 1-UTC
3 Bits 7..1	Reserved		
3 Bit 0	NTU Initiated Management Flow Status	Bit	0-Enabled, 1-Disabled

### 10.5.5.7.11 Config Response - Management message: Message ID 146

Config Response - Management message is sent by all units to acknowledge to the Config Request - Management message.

Octet #	Contents	Data Type	Reference
1	Message ID - 146	Message ID	
2 Bits 7..1	Reserved		
2 Bit 0	UTC (Unable to Comply)	Bit	0-OK, 1-UTC
3 Bits 7..1	Reserved		
3 Bit 0	NTU Initiated Management Flow Status	Bit	0-Enabled, 1-Disabled

### 10.5.5.7.12 Status Request - Message ID 11

The Status Request message is used to poll an element for alarm and general performance status.

The relevant status response messages are:

- status/SNR Response - 139 (clause 10.5.5.7.14);
- SDSL Network Side Performance Status - 140 (clause 10.5.5.7.15);
- SDSL Customer Side Performance Status - 141 (clause 10.5.5.7.16);
- maintenance Status - 137 (clause 10.5.5.7.21).

If no active alarm, fault or maintenance conditions exist and there is no change in any of the values of the performance monitoring fields then the polled unit shall respond with the Status/SNR Response - 139 (clause 10.5.5.7.14). If no active alarm, fault or maintenance conditions exist and the only change in any of the values of the performance monitoring fields is in the SNR margin then the polled unit shall respond with the Status/SNR Response - 139 (clause 10.5.5.7.14).

If active alarm, fault or maintenance conditions exist then the polled unit shall respond with the messages that correspond to the active conditions.

If there has been any change in performance status other than SNR margin since the last time a unit was polled then the unit shall respond with the messages which contain the change in performance status.

**Table 10-15: Status Request Information Field**

Octet #	Information field	Data type
1	Message ID - 11	Message ID

### 10.5.5.7.13 Full Status Request - Message ID 12

The Full Status Request message is used to poll an element for its complete current status. The following messages shall be sent in response to the Full Status Request:

- SDSL Network Side Performance Status (clause 10.5.5.7.15);
- SDSL Customer Side Performance Status (clause 10.5.5.7.16);
- maintenance Status (clause 10.5.5.7).

**Table 10-16: Full Status Request Information Field**

Octet #	Information Field	Data Type
1	Message ID - 12	Message ID

## 10.5.5.7.14 Status Response/SNR - Message ID 139

The Performance Status OK/SNR message shall be sent in response to the Status Request message under the conditions specified in clause 10.5.5.7.12. The reported integer represents dB SNR noise margin values rounded up. Because each LTU or NTU only connects to one SDSL segment, the application interface side SNR margin data shall be 0. (The network side SNR margin shall be 0 at the LTU and the customer side SNR margin shall be 0 at the NTU).

**Table 10-17: Status Response OK/SNR Information Field**

Octet #	Information Field	Data Type
1	Message ID - 139	Message ID
2	Network Side SNR Margin (dB)	Signed char (127 = Not Available)
3	Customer Side SNR Margin (dB)	Signed char (127 = Not Available)
4	Loop ID	Unsigned char (1 = Loop 1, 2 = Loop 2)

## 10.5.5.7.15 SDSL Network Side Performance Status - Message ID 140

This message provides the SDSL network side performance status. Device Fault shall be used to indicate HW or SW problems on the addressed unit. The definition of Device Fault is vendor dependent but is intended to indicate diagnostic or self-test results. DC Continuity Fault shall be used to indicate conditions that interfere with span powering such as short and open circuits. The definition of DC Continuity Fault is vendor dependent.

In octet 11, bits 7..4 are used to indicate that an overflow or reset has occurred in one or more of the modulo counters. Bits 7 and 5 shall indicate that an overflow has occurred since the last SDSL Network Side status response. For example, if more than 256 Errored Seconds occur between SDSL Network Side status responses, then the ES modulo counter will overflow. Bits 6 and 4 shall be used to indicate that one or more of the modulo counters have been reset for any reason (e.g. system power-up or a non service-affecting reset.) Bits 7 and 6 shall be cleared to 0 after a SDSL Network Side status response is sent to the LTU. Bits 5 and 4 shall be cleared to 0 after a SDSL Network Side status response is sent to the NTU.

**Table 10-18: SDSL-Network Side Performance Status Information Field**

Octet #	Contents	Data Type	Reference
1	Message ID - 140	Message ID	
2 bit 7	Reserved		
bit 6	N - Power Back-off Status	Bit	0 = default 1 = selected
bit 5	Device Fault	Bit	0 = OK, 1 = Fault
bit 4	N - DC Continuity Fault	Bit	0 = OK, 1 = Fault
bit 3	N - SNR Margin alarm	Bit	0 = OK, 1 = alarm
bit 2	N - Loop Attenuation Alarm	Bit	0 = OK, 1 = alarm
bit 1	N - SDSL LOSW Failure Alarm	Bit	0 = OK, 1 = alarm
bit 0	Reserved		set to 0
3	N - SDSL SNR Margin (dB)	Signed char (127 = NA)	
4	N - SDSL Loop Attenuation (dB)	Signed char (-128 = NA)	
5	N - SDSL ES Count modulo 256	Unsigned char	
6	N - SDSL SES Count modulo 256	Unsigned char	
7-8	N - SDSL CRC Anomaly Count modulo 65,536	Unsigned int	
9	N - SDSL LOSW Defect Second Count modulo 256	Unsigned char	
10	N - SDSL UAS Count modulo 256	Unsigned char	
11 bit 7	N - Counter Overflow Indication to LTU		0 = OK 1 = Overflow
11 bit 6	N - Counter Reset Indication to LTU		0 = OK 1 = Reset
11 bit 5	N - Counter Overflow Indication to NTU		0 = OK 1 = Overflow
11 bit 4	N - Counter Reset Indication to NTU		0 = OK 1 = Reset
11 bits 3 ..0	N-Power Back-Off Base Value (dB)	Unsigned char	0 .. 15

Octet #	Contents	Data Type	Reference
12 bit 7	N-Power Back-off Extension (dB)	Bit	0 -> PBO = Base Value + 0 dB 1-> PBO = Base Value + 16 dB
12 bits 6..2	Reserved		
12 bits 1..0	Loop ID	Unsigned char	1 = Loop 1 2 = Loop 2

#### 10.5.5.7.16 SDSL Customer Side Performance Status - Message ID 141

This message provides the SDSL customer side performance status. Device Fault shall be used to indicate HW or SW problems on the addressed unit. The definition of Device Fault is vendor dependent but is intended to indicate diagnostic or self-test results. DC Continuity Fault shall be used to indicate conditions that interfere with span powering such as short and open circuits. The definition of DC Continuity Fault is vendor dependent.

In octet 11, bits 7..4 are used to indicate that an overflow or reset has occurred in one or more of the modulo counters. Bits 7 and 5 shall indicate that an overflow has occurred since the last SDSL Customer Side status response. For example, if more than 256 Errored Seconds occur between SDSL Customer Side status responses, then the ES modulo counter will overflow. Bits 6 and 4 shall be used to indicate that one or more of the modulo counters have been reset for any reason (e.g. system power-up or a non-service-affecting reset.) Bits 7 and 6 shall be cleared to 0 after a SDSL Customer Side status response is sent to the LTU. Bits 5 and 4 shall be cleared to 0 after a SDSL Customer Side status response is sent to the NTU.

**Table 10-19: SDSL-Customer Side Performance Status Information Field**

Octet #	Contents	Data Type	Reference
1	Message ID - 141	Message ID	
2 bit 7	Reserved		
bit 6	C - Power Back-off Status	Bit	0 = default 1 = selected
bit 5	Device Fault	Bit	0 = OK, 1 = Fault
bit 4	C- DC Continuity Fault	Bit	0 = OK, 1 = Fault
bit 3	C - SNR Margin alarm	Bit	0 = OK, 1 = alarm
bit 2	C- Loop Attenuation Alarm	Bit	0 = OK, 1 = alarm
bit 1	C - SDSL LOSW Failure Alarm	Bit	0 = OK, 1 = alarm
bit 0	Reserved		set to 0
3	C - SDSL SNR Margin (dB)	Signed char (127 = NA)	
4	C - SDSL Loop Attenuation (dB)	Signed char (-128 = NA)	
5	C - SDSL ES Count modulo 256	Unsigned char	
6	C - SDSL SES Count modulo 256	Unsigned char	
7-8	C - SDSL CRC Anomaly Count modulo 65536	Unsigned int	
9	C - SDSL LOSW Defect Second Count modulo 256	Unsigned char	
10	C - SDSL UAS Count modulo 256	Unsigned char	
11 bit 7	C - Counter Overflow Indication to LTU		0 = OK 1 = Overflow
11 bit 6	C - Counter Reset Indication to LTU		0 = OK 1 = Reset
11 bit 5	C - Counter Overflow Indication to NTU		0 = OK 1 = Overflow
11 bit 4	C - Counter Reset Indication to NTU		0 = OK 1 = Reset
11 bits 3 ..0	C - Power Back-Off Base Value (dB)	Unsigned char	0 .. 15
12 bit 7	C-Power Back-off Extension (dB)	Bit	0 -> PBO = Base Value + 0 dB 1-> PBO = Base Value + 16 dB
12 bits 6..2	Reserved		
12 bits 1..0	Loop ID	Unsigned char	1 = Loop 1 2 = Loop 2

### 10.5.5.7.17 Virtual Terminal Connect/Disconnect Request/Response - Message IDs 6,7,134

Three messages are used to maintain (establish, tear down) virtual terminal sessions between units. A unit may request a connection but must wait for "connect" status response before using the connection. The connection shall remain until a disconnect request is processed or, if implemented, a timeout occurs. At least one session shall be supported by the LTU. NTU and REG may silently ignore the connect request or may respond with a "no connect" status if terminal screens are not supported.

The connect/disconnect process is necessary for handling the case where keyboard messages are received from more than one device. If a unit cannot accommodate another connect request it shall send the "no connect" response.

The connect request message can be sent to cause a refresh of the current screen. When a connect request is accepted the "connect" response shall be transmitted, followed by screen messages with the current screen. If this is a new connection then the first screen shall be sent.

**Table 10-20: Virtual Terminal Connect**

Octet #	Contents	Data type	Reference
1	Message ID - 6 - Virtual Terminal Connect	Message ID	

**Table 10-21: Virtual Terminal Disconnect**

Octet #	Contents	Data type	Reference
1	Message ID - 7 - Virtual Terminal Disconnect	Message ID	

**Table 10-22: Virtual Terminal Connect Response**

Octet #	Contents	Data type	Definition
1	Message ID - 134 - Virtual Terminal Connect response	Message ID	
2	Connection status		1 - connected 0 - no connect

### 10.5.5.7.18 Screen Message/Keyboard Message - Message IDs 8,136

Keyboard and screen messages are only sent over an active connection between units. Keyboard messages shall be 1 to 8 data octets per message. Queuing of keystrokes from the customer may affect user response times and should be done with care. Screen messages shall be 1 to 24 data octets per message. See clause 10.5.6 for more information on Screen/Keyboard messages.

**Table 10-23: Keyboard Information Field**

Octet #	Contents	Data type	Reference
1	Message ID - 8 - Keyboard	Message ID	
Octet. 2 - L + 1	ASCII character(s) and escape sequences	character array	

**Table 10-24: Screen Information Field**

Octet #	Contents	Data type	Reference
1	Message ID - 136 - Screen	Message ID	
Octet. 2 - L + 1	ASCII characters and escape sequences	character array	

### 10.5.5.7.19 Maintenance Request - System Loopback - Message ID 9

The Maintenance Request-System Loopback message contains loopback commands for all of the elements on the span. The contents of the Maintenance Request-System Loopback message are shown in table 10-25. The System Loopback message shall have a broadcast destination address when sent from the LTU. When optionally sent from the NTU, the System Loopback message shall have the LTU as its destination address. Upon reception of this message, each REG and LTU or NTU shall comply with its corresponding command field and respond to the sender with the Maintenance Status message. Note that the REGs are numbered consecutively beginning with closest REG to the LTU. Each REG shall determine its number by subtracting 2 from its network side eoc address. Since the network side eoc addresses must be known, the NTU shall not use the System Loopback Message if the LTU is offline. To invoke REG loopbacks while the LTU is offline, the NTU shall use the Maintenance Request-Element Loopback message. (Maintenance request messages may also be used by the LTU or NTU devices to poll for current loopback status, using the unchanged bit flags.)

**Table 10-25: Maintenance Request - System Loopback Information Field**

Octet #	Contents	Data type	Reference
Octet 1	Message ID - 9 - Maintenance Request-System Loopback		
Octet 2	LTU Loopback commands	Bit flags	Table 10-26
Octet 3	NTU Loopback commands	Bit flags	Table 10-26
Octet 4	REG #1 Loopback commands	Bit flags	Table 10-26
Octet 5	REG #2 Loopback commands	Bit flags	Table 10-26
Octet 6	REG #3 Loopback commands	Bit flags	Table 10-26
Octet 7	REG #4 Loopback commands	Bit flags	Table 10-26
Octet 8	REG #5 Loopback commands	Bit flags	Table 10-26
Octet 9	REG #6 Loopback commands	Bit flags	Table 10-26
Octet 10	REG #7 Loopback commands	Bit flags	Table 10-26
Octet 11	REG #8 Loopback commands	Bit flags	Table 10-26

**Table 10-26: Loopback Command Bit Flag Definitions**

Bit positions	Definition
Bit 7	Reserved
Bit 6	Clear all maintenance states (including any proprietary states)
Bit 5	Initiate special loopback
Bit 4	Terminate special loopback
Bit 3	Initiate loopback toward the network
Bit 2	Initiate loopback toward the customer
Bit 1	Terminate loopback toward the network
Bit 0	Terminate loopback toward the customer

NOTE: Bit set to 1 - perform action; bit Set to 0 - no action taken, report current status.

### 10.5.5.7.20 Maintenance Request - Element Loopback - Message ID 10

The Maintenance Request-Element Loopback message contains loopback commands for an individual element. The contents of the Maintenance Request-Element Loopback message are shown in table 10-27. The Element Loopback message shall have an individual unit's destination address according to the data flow addresses described in clause 10.5.2. Upon reception of the Element Loopback message, the addressed unit shall comply with the loopback commands and reply with the Maintenance Status Response message.

**Table 10-27: Maintenance Request - Element Loopback Information Field**

Octet #	Contents	Data type	Reference
1	Message ID - 10 - Maintenance Request	Message ID	
2	Loopback commands	Bit flags	Table 10-26

### 10.5.5.7.21 Maintenance Status Response - Message ID 137

Maintenance status is sent in response to the Maintenance Request-System Loopback and the Maintenance Request-Element Loopback Query messages. The "Special Loopback" is defined for the NTU as a Maintenance Termination Unit (MTU) Loopback; it is not defined at other units.

**Table 10-28: Maintenance Status Information Field**

Octet #	Contents	Data type	Definition
1	Message ID - 137 - Maintenance Status-Loopback	Message ID	
2 bit 7	Reserved		
2 bit 6	Proprietary Maintenance State active	Bit	0-off, 1-on
2 bit 5	Special loopback active	Bit	0-off, 1-on
2 bit 4	Loopback active toward NTU	Bit	0-off, 1-on
2 bit 3	Loopback active toward LTU	Bit	0-off, 1-on
2 bit 2	Local or span-powered unit	Bit	0 = span powered 1 = local powered
2 bit 1	Customer Tip/Ring reversal	Bit	0 = normal 1 = reversed
2 bit 0	Network Tip/Ring reversal	Bit	0 = normal 1 = reversed

### 10.5.5.7.22 Soft Restart/Power Back-off Disable Message - Message ID 15

The purpose of this message is to switch a receiver between the default and selected modes of power back-off. If default mode is set, PBO shall be set to the default value. Otherwise, in selected mode, PBO may be negotiated through the PACC to another value. In order for a change in power back-off mode to take effect, the receiver must reactivate. The Soft Restart request shall cause the receiving unit to terminate the corresponding SDSL connection and enter the Exception State (figure 9-4). The connection shall not be terminated unless the corresponding Soft Restart bit is set in this message. The receiving unit shall wait  $5\text{ s} \pm 1\text{ s}$  before terminating the SDSL connection.

This message carries the command to set the power back-off mode. The power back-off mode received in this message shall be maintained as long as power is applied to the unit. Maintaining the power back-off mode in non-volatile storage is optional. Note that the configuration of power back-off mode applies to the receiver; i.e. the receiver requests a PSD mask based on both the received power and the configuration of its power back-off mode.

**Table 10-29: Soft Restart Information Field**

Octet #	Contents	Data Type	Reference
1	Message ID - 15 - Soft Restart/Back-off	Message ID	
2 Bits 7..2	Reserved		
2 Bit 1	Network Side Power Back-off Setting	Bit	0 = default 1 = selected
2 Bit 0	Network Side Soft Restart (after 5 s)	Bit	0 = no Restart 1 = Restart
3 Bits 7..2	Reserved		
3 Bit 1	Customer Side Power Back-off Setting	Bit	0 = default 1 = selected
3 Bit 0	Customer Side Soft Restart (after 5 s)	Bit	0 = no Restart 1 = Restart

### 10.5.5.7.23 Segment Management Message - Message IDs 64 - 88, 192 - 216

A range of Message IDs is reserved for segment management (e.g. continuous precoder update).

### 10.5.5.7.24 Proprietary Messages - Message IDs 112 - 119, 240 - 247

A range of Message IDs is reserved for proprietary messages. It is the responsibility of the LTU or NTU to address Proprietary Messages to the appropriate destination. An REG shall either process or forward a proprietary message. A proprietary message shall not be broadcast.

### 10.5.5.7.25 Proprietary External Message - Message ID 120

Support for external data ports is optional. No interface for an external data port is specified in the present document. If an LTU or NTU does not have an external data port, then it shall ignore any received Proprietary External Messages.

**Table 10-30: External Information Field**

Octet #	Contents	Data type	Reference
1	Message ID - 120 - external	Message ID	
2	Logical Port Number	Unsigned character	
Octets 3 .. L + 2	External message data		

### 10.5.5.7.26 G.997.1 External Message - Message ID 121

Support for G.997.1 external messaging is optional. The interface for G.997.1 messages is beyond the scope of the present document. If an LTU or NTU does not have an interface for G.997.1 messaging, it shall ignore any received G.997.1 External Messages. Logical port number FF<sub>16</sub> is reserved for indicating the transport of SNMP packets, as described in clause 6.3 of G.997.1 [8]. SNMP packets may be transmitted using one or more such messages.

**Table 10-31: G.997.1 External Information Field**

Octet #	Contents	Data type	Reference
1	Message ID - 121	Message ID	
2	Logical Port Number	Unsigned character	
octets 3 .. L + 2	G.997.1 External message data		

### 10.5.5.7.27 Generic Unable to Comply (UTC) Message (ID 144)

The Generic UTC message should be sent back to the source unit in the event that the destination unit is unable to comply with the request. In this case, the definition of UTC is vendor dependent. Note that this message is not meant to replace the UTC bit in those response messages that contain a UTC bit.

**Table 10-32: Generic Unable to Comply (UTC) Information Field**

Octet #	Contents	Data Type	Reference
1	Message ID - 144 - Generic UTC	Message ID	
2	Message ID of request message	Unsigned char	

## 10.5.6 Examples of Virtual Terminal Control Functions

This informative note gives examples of some common ANSI X3.4-1986 (R1997) [15] escape sequences.

**Table 10-33: Examples of ANSI X3.4-1986 (R1997) Control Functions**

Description	Format	Comments
Erase entire screen (ED)	ESC [ 2 J ]	
Position cursor (CUP)	ESC [ RR;CCH ]	(see note)
Position cursor (in column 1)	ESC [ RRH ]	Subset of position cursor
Home cursor	ESC [ H ]	Subset of position cursor
NOTE: ESC has the value of 1B <sub>16</sub> . RR is the row number; CC is the column number expressed as ASCII digits. As an example, row 4 column 12 would encode as ESC [ 4;12H. The hexadecimal equivalent of this sequence is 1B <sub>16</sub> 5B <sub>16</sub> 34 <sub>16</sub> 3B <sub>16</sub> 31 <sub>16</sub> 32 <sub>16</sub> 48 <sub>16</sub> . The screen starts with row 1, column 1.		



## 11 Electrical characteristics of a SDSL transceiver

### 11.1 General

This clause describes the electrical characteristics of an SDSL transceiver.

The electrical characteristics of an SDSL transceiver shall be such as to enable the performance requirements of appropriate applications, which are described in application dependent annexes, to be met. In addition, the following specific electrical line characteristics are required.

### 11.2 Transmitter/Receiver impedance and return loss

The nominal driving point impedance at the line side of an SDSL transceiver shall be  $135 \Omega$ . The minimum return loss with respect to  $135 \Omega$  over a frequency band of 1 kHz to 1 MHz shall be:

- 14 dB from 20 kHz to  $f_{\text{Baud}} / 2$  kHz as shown in figure 11-1 with a slope of 20 dB/decade below/above, respectively, these frequencies.

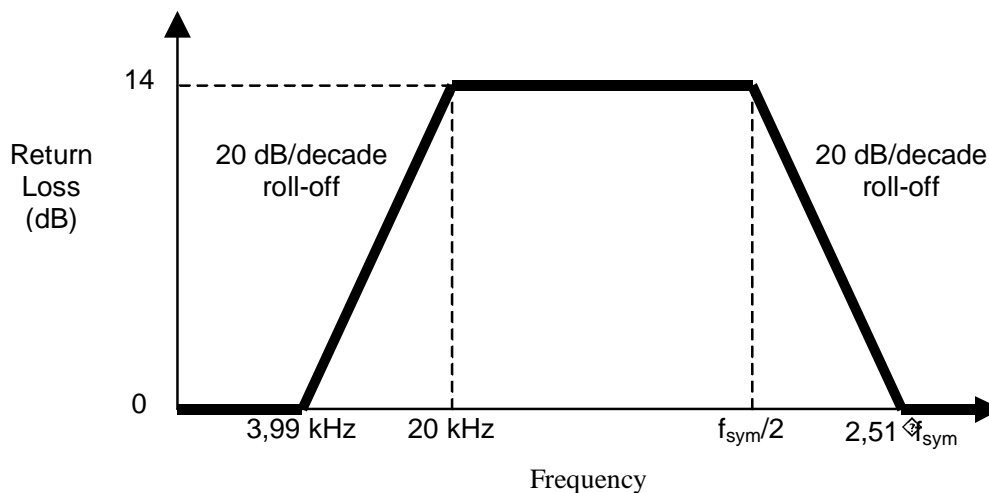

NOTE: It is expected that the above specification of return loss will be replaced by a specification of another electrical characteristic that is more appropriate and will probably be a frequency dependent output impedance. This enables a prediction of signal levels on real cables from signal level measurements under different impedance conditions.

Figure 11-1: Minimum return loss of a SDSL system

### 11.3 Unbalance about earth

#### 11.3.1 Longitudinal conversion loss

The longitudinal conversion loss is given by:  $LCL = 20 \log (e_l/e_m)$  [dB]:

- where  $e_l$  is the applied longitudinal voltage referenced to the building ground and  $e_m$  is the resultant metallic voltage appearing across a  $135 \Omega$  termination.

The longitudinal conversion loss of the system shall meet the requirement of: 40 dB between 5 kHz and  $f_{\text{Baud}} / 2$  kHz as shown in figure 11-2, with a slope of 20 dB/decade below respectively above these frequencies. This requirement ensures that the overall LCL is not significantly worse than that of the DLLs alone.

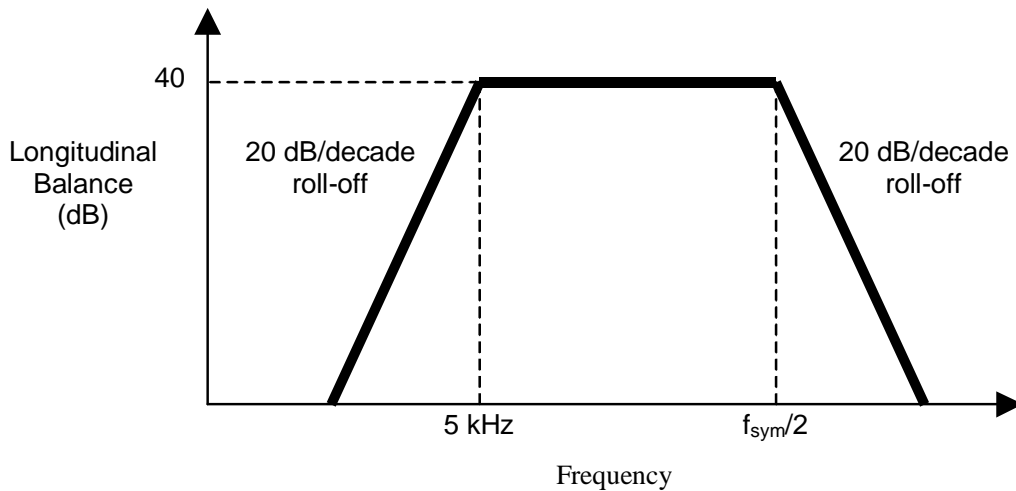

**Figure 11-2: Minimum longitudinal conversion loss for a SDSL system**

Figure 11-3 defines a measurement method for longitudinal conversion loss. For direct use of this configuration, measurement should be performed with the IUT powered up but inactive (no transmitted signal; driving 0 V).

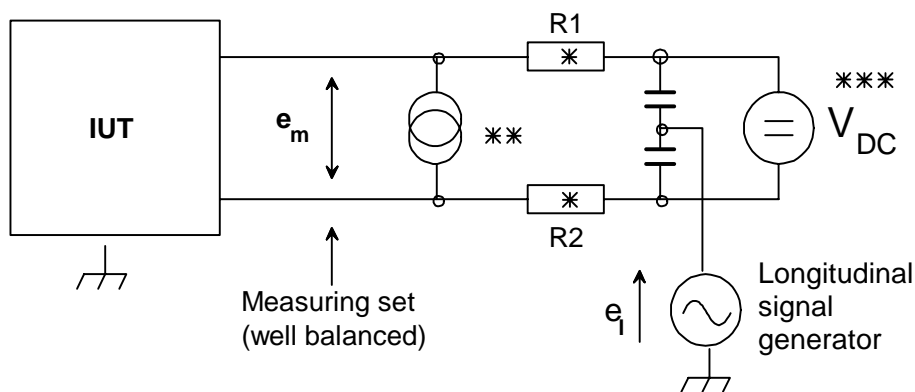

NOTE 1: \*These resistors have to be matched:  $R1 = R2 = 135/2 \Omega$  and  $R1/R2 = 1 \pm 0,1 \%$ .

NOTE 2: \*\*For LTU test only if remote power feeding is supplied.

NOTE 3: \*\*\*For NTU test only if remote power feeding is required.

NOTE 4: During regenerator test (where required) each wire on the side which is not under test has to be connected to ground by a terminating impedance having the value of  $135/2 \Omega$  in series with a capacitance of  $0,33 \mu F$ .

**Figure 11-3: Measurement method for longitudinal conversion loss**

### 11.3.2 Longitudinal output voltage

The longitudinal component of the output signal shall have an rms voltage, in any 4 kHz equivalent bandwidth averaged in any second period,  $< -50$  dBV over the frequency range 100 Hz to 400 kHz. Compliance with this limitation is required with a longitudinal termination having an impedance of  $100 \Omega$  in series with  $0,15 \mu F$  nominal. Note that the EMC requirements of clause 14.4 must also be met.

Figure 11-4 defines a measurement method for longitudinal output voltage. For direct use of this test configuration, the IUT should be able to generate a signal in the absence of a signal from the far end. The ground reference for these measurements shall be the building ground.

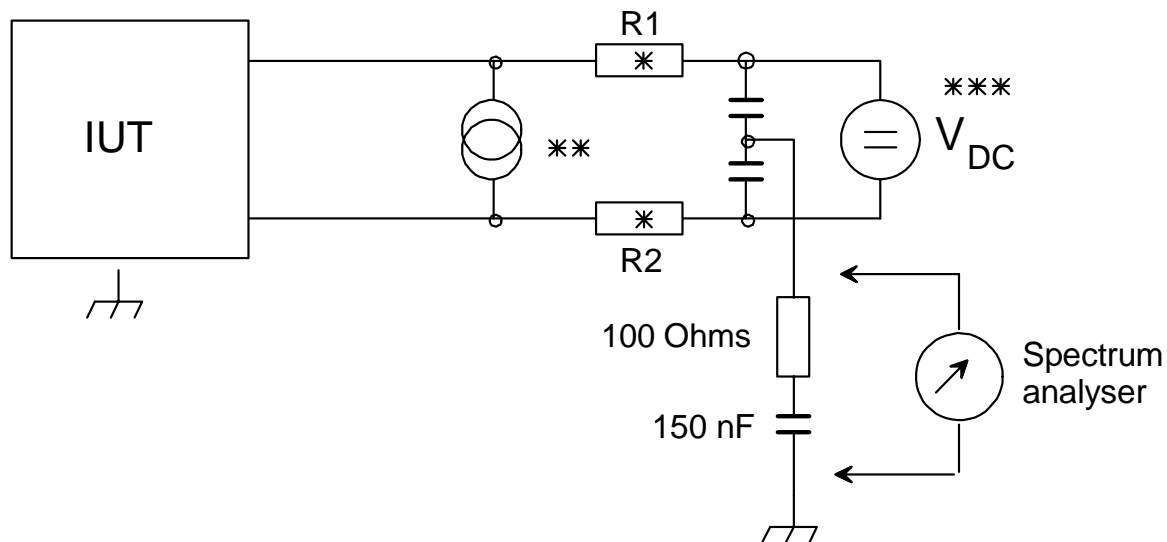

NOTE 1: \*These resistors have to be matched:  $R1 = R2 = 135/2 \Omega$  and  $R1/R2 = 1 \pm 0,1 \%$ .

NOTE 2: \*\*For LTU test only if remote power feeding is supplied.

NOTE 3: \*\*\*For NTU test only if remote power feeding is required.

NOTE 4: During regenerator test (where required) each wire on the side which is not under test has to be connected to ground by a terminating impedance having the value of  $135/2 \Omega$  in series with a capacitance of  $0,33 \mu\text{F}$ .

Figure 11-4: Measurement method for longitudinal output voltage

## 11.4 Signal transfer delay

The SDSL-core as specified in clause 4 Reference Configuration shall be capable of providing one-way, single-span latency of  $\leq 500 \mu\text{s}$  for user data rates  $\geq 1,5 \text{ Mbit/s}$  and  $\leq 1,25 \text{ ms}$  for user data rates  $< 1,5 \text{ Mbit/s}$ .

However, for STM based services the one-way signal transfer delay between the application interfaces at the customer and the network side calculated as the mean value of both directions shall be  $\leq 1,25 \text{ ms}$ .

# 12 Laboratory performance measurements

## 12.1 General

The purpose of transmission performance tests is to stress SDSL transceivers in a way that is representative to a high penetration of systems scenario in operational access networks. This high penetration approach enables operators to define deployment rules that apply to most operational situations. It also means that, in individual operational cases, characterized by lower noise levels and/or insertion loss values, the SDSL system under test may perform better than tested.

The performance requirements given in this clause are dedicated to SDSL transceivers, but the concept is upgradable to other systems such as "ADSL over ISDN". The design impedance  $R_V$  is  $135 \Omega$ . All spectra are representing single sided power spectral densities (PSD).

## 12.2 Test procedure

The purpose of this clause is to provide an unambiguous specification of the test set-up, the insertion path and the way signal and noise levels are defined. The tests are focused on the noise margin, with respect to the crosstalk noise or impulse noise levels when SDSL signals under test are attenuated by standard test-loops and interfered with standard crosstalk noise or impulse noise. This noise margin indicates what increase of crosstalk noise or impulse noise level is allowed under (country-specific) operational conditions to ensure sufficient transmission quality.

## 12.2.1 Test set-up definition

Figure 12-1 illustrates the functional description of the test set-up. It includes:

- a bit error ratio test set (BERTS) that applies a  $2^{15}-1$  pseudo random bit sequence (PRBS) test signal to the transmitter in the direction under test at the bit rate required. The transmitter in the opposite direction shall be fed with a similar PRBS signal, although the reconstructed signal in this path need not be monitored;
- the testloops, as specified in clause 12.4;
- an adding element to add the (common mode and differential mode) impairment noise (a mix of random, impulsive and harmonic noise), as specified in clause 12.5;
- an impairment generator, as specified in clause 12.5, to generate both the differential mode and common mode impairment noise, that are fed to the adding element;
- a high impedance, and well-balanced differential voltage probe (e.g. better than 60 dB across the whole band of the SDSL system under test) connected with level detectors such as a spectrum analyser or a true rms voltmeter;
- a high impedance, and well-balanced common mode voltage probe (e.g. better than 60 dB across the whole band of the SDSL system under test) connected with level detectors such as a spectrum analyser or a true rms voltmeter.

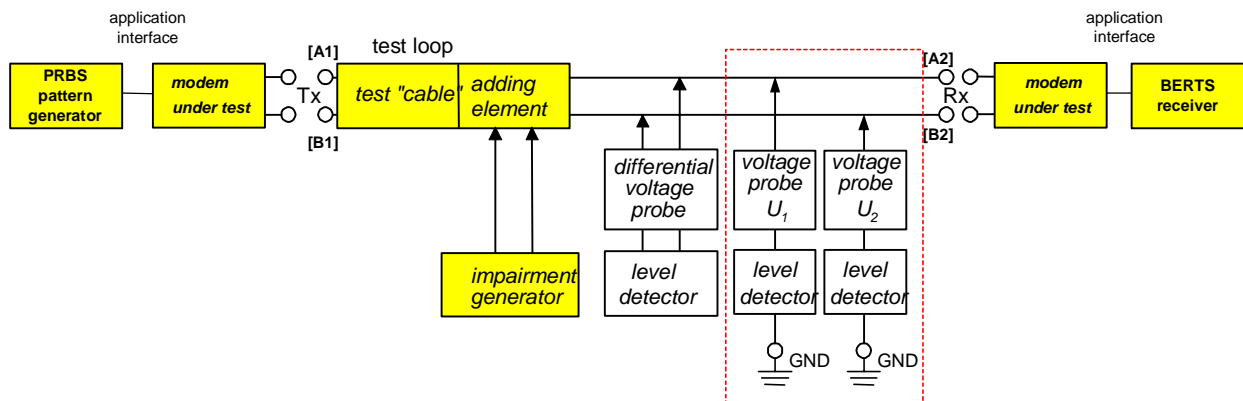

NOTE: To allow test reproducibility, the testing equipment and the Termination Units (LTU and NTU) should refer to an artificial earth. If the Termination Units have no earth terminal, the test should be performed while the Termination Units are placed on a metal plate (of sufficient large size) connected to earth.

**Figure 12-1: Functional description of the set-up of the performance tests**

NOTE: The functional description of injecting ingress noise is not complete and requires further study.

The two-port characteristics (transfer function, impedance) of the test-loop, as specified in clause 12.4, are defined between port Tx (node pairs A1, B1) and port Rx (node pair A2, B2). The consequence is that the two-port characteristics of the test "cable" in figure 12-1 must be properly adjusted to take full account of non-zero insertion loss and non-infinite shunt impedance of the adding element and impairment generator. This is to ensure that the insertion of the generated impairment signals does not appreciably loads the line.

The balance about earth, observed at port Tx, at port Rx and at the tips of the voltage probe shall exhibit a value that is 10 dB greater than the transceiver under test. This is to ensure that the impairment generator and monitor function do not appreciably deteriorate the balance about earth of the transceiver under test.

The signal flow through the test set-up is from port Tx to port Rx, which means that measuring upstream and downstream performance requires an interchange of transceiver position and test "cable" ends.

The received signal level at port Rx is the level, measured between node A2 and B2, when port Tx as well as port Rx are terminated with the SDSL transceivers under test. The impairment generator is switched off during this measurement.

Testloop #1, as specified in clause 12.4.2, shall always be used for calibrating and verifying the correct settings of generators G1-G7, as specified in clause 12.5, when performing performance tests.

The transmitted signal level at port Tx is the level, measured between node A1 and B1, under the same conditions.

The impairment noise shall be a mix of random, impulsive and harmonic noise, as defined in clause 12.5. The level that is specified in clause 12.5 is the level at port Rx, measured between node A2 and B2, (and includes both differential mode and common mode impairments) while port Tx as well as port Rx are terminated with the design impedance  $R_V$ . These impedances shall be passive when the transceiver impedance, in the switched-off mode, is different from this value.

## 12.2.2 Signal and noise level definitions

The differential mode signal and noise levels are probed with a well-balanced differential voltage probe ( $U_1 - U_2$ ). The differential impedance between the tips of that probe shall be higher than the shunt impedance of 100 k $\Omega$  in parallel with 10 pF. Figure 12-1 shows the probe position when measuring the Rx signal level at the LTU or NTU. Measuring the Tx signal level requires the connection of the tips to node pair [A1, B1].

The common mode signal and noise levels are measured with a well-balanced common mode voltage probe as the voltage between nodes [A2, B2] and ground. Figure 10.1 shows the position of the two voltage probes when measuring the common mode signal. The common mode voltage is defined as  $(U_1 + U_2) / 2$ .

NOTE: The various levels (or spectral masks) of signal and noise that are specified in the present document are defined at the Tx or Rx side of this set-up. The various levels are defined while the set-up is terminated, as described above, with design impedance  $R_V$  or with SDSL transceivers under test.

Probing an rms-voltage  $U_{\text{rms}}$  [V] in this set-up, over the full signal band, means a power level of P [dBm] that equals:

$$- P = 10 \times \log_{10} ( U_{\text{rms}}^2 / R_V \times 1\,000 ) \text{ [dBm]}.$$

Probing an rms-voltage  $U_{\text{rms}}$  [V] in this set-up, within a small frequency band of  $\Delta f$  [Hz], means an average spectral density level of P [dBm/Hz] within that filtered band that equals:

$$- P = 10 \times \log_{10} ( U_{\text{rms}}^2 / R_V \times 1\,000 / \Delta f ) \text{ [dBm/Hz]};$$

- the bandwidth  $\Delta f$  identifies the noise bandwidth of the filter, and not the -3 dB bandwidth.

## 12.3 Performance test procedure

The test performance of the SDSL transceiver shall be such that the bit error ratio (BER) on the disturbed system is less than  $10^{-7}$ , while transmitting a pseudo random bit sequence. The BER should be measured after at least  $10^9$  bits have been transmitted.

The tests are carried out with a margin which indicates what increase of noise is allowed to ensure sufficient transmission quality. Network operators may calculate their own margins for planning purposes based on a knowledge of the relationship between this standard test set and their network characteristics.

A test sequence as specified in table 12-1 shall be conducted. The testloops are specified in figure 12-2. They are characterized by the insertion loss Y, which depends on the data rate to be transported and has to be scaled adequately.

A test is defined as the measurement of a given BER associated with a single test path, direction, test noise, rate and margin. The ensemble of tests associated with a particular value of N in table 12-1 is defined as a test set.

Table 12-1: Test sequence for performance testing

N	Test Path	Direction (note 6)	Comments
1	#1 (note 1)	Upstream	Y = 0 dB; Test noise A (notes 5 and 7)
2	#2	Upstream	Y = Y1 (note 2); Test noise A, C, and D (note 7)
3	#3	Upstream	Y = Y1; Test noise D (notes 5 and 7)
4	#4	Downstream	Y = Y1; Test noise A and C (notes 5 and 7)
5	#5	Upstream	Y = Y1; Test noise B (notes 5 and 7)
6	#6	Upstream	Y = Y1; Test noise A and C (notes 5 and 7)
7	#7	Upstream	Y = Y1; Test noise A, B, C, and D (notes 5 and 7)
8			Common mode rejection test (note 4)
9	(note 3)	(note 3)	Y = Y2; Test noise is the noise corresponding to the test with the highest BER in test sets 1 through 7 (note 7)
10	(note 3)	(note 3)	Y = Y3 ; No added impairment; BER < 10 <sup>-8</sup>
11	#2	Upstream	Y = Y1 ; Impulse test as described in <TBD>
12	As <TBD>	<TBD>	Micro interruption test as described in <TBD>
<p>NOTE 1: Test Path = #1 means that the path under test shall be connected with testloop #1 as defined in figure 12-2.</p> <p>NOTE 2: Y1 = Y dB (as specified in Table 10.3 for noise models B, C and D and in table 10.2 for noise model A), Y2 = Y1 - 10 dB, Y3 = Y1 + 3 dB.</p> <p>NOTE 3: The tests [for any data rate] are carried out on the loop that gives the highest BER [for that data rate] in test sets 1 through 7, when the test noise is increased by 6 dB. If no errors in 10<sup>9</sup> bits are recorded for all the tests in test sets 1 through 7, then loop #3 upstream is used for this test set by default.</p> <p>NOTE 4: The measuring arrangement for this test is specified in ITU-T Recommendation O.9 [12].</p> <p>NOTE 5: Only tested for lowest and highest data rate in tables 12-2 and 12-3 that the equipment supports and for asymmetric PSDs when supported.</p> <p>NOTE 6: Upstream means that the unit under test is connected to the LT end of the testloop and downstream means that the unit under test is connected to the NT end of the testloop. For example, test set 5 for an LTU would connect the LTU under test to the LT end of the loop as shown in figure 12-2 and apply noise model B.LT to the LT end. The same test for an NTU would connect the NTU under test to the LT end of the loop as shown in figure 12-2 and apply noise model B.NT to the LT end.</p> <p>NOTE 7: The BER shall be less than 10<sup>-7</sup> when the test noise is increased by 6 dB (this is equivalent to 6 dB of margin).</p>			

NOTE: Table 12-1 constitutes a rationalized subset of tests that are considered to be representative of the full set of tests. For conformance, these tests (subset) are required. Other tests (possibly based on other testloops) are currently under study with ETSI TM6.

## 12.4 Testloops

### 12.4.1 Functional description

The testloops in figure 12-2 are based on the existing HDSL testloops as defined in TS 101 135 [1]. A Technical Specification for unified testloops across all DSL-technologies is currently under development. When the present document becomes available and is judged appropriate for SDSL testing, it will replace the current testloops.

The length of the individual loops are chosen such that the transmission characteristics of all loops are comparable (see figure 12-2). The purpose of this is to stress the equalizer of the SDSL modem under test similarly over all loops, when testing SDSL at a specific bit rate. The total length of each loop is described in terms of *physical* length, and the length of the individual sections as a fixed fraction of this total. If implementation tolerances of one testloop result in its *electrical* length being out of specification, then its total physical length shall be scaled accordingly to correct this error.

One testloop includes bridged taps to achieve rapid variations in amplitude and phase characteristics of the cable transfer function. In some European access networks, these bridge taps have been implemented in the past, which stresses the SDSL modem under test differently.

Loop #1 is a symbolic name for a loop with zero (or near zero) length, to prove that the SDSL transceiver under test can handle the potentially high signal levels when two transceivers are directly connected.

## 12.4.2 Testloop topology

The topology of the testloops is specified in figure 12-2. The basic test cable characteristics are shown in annex E.

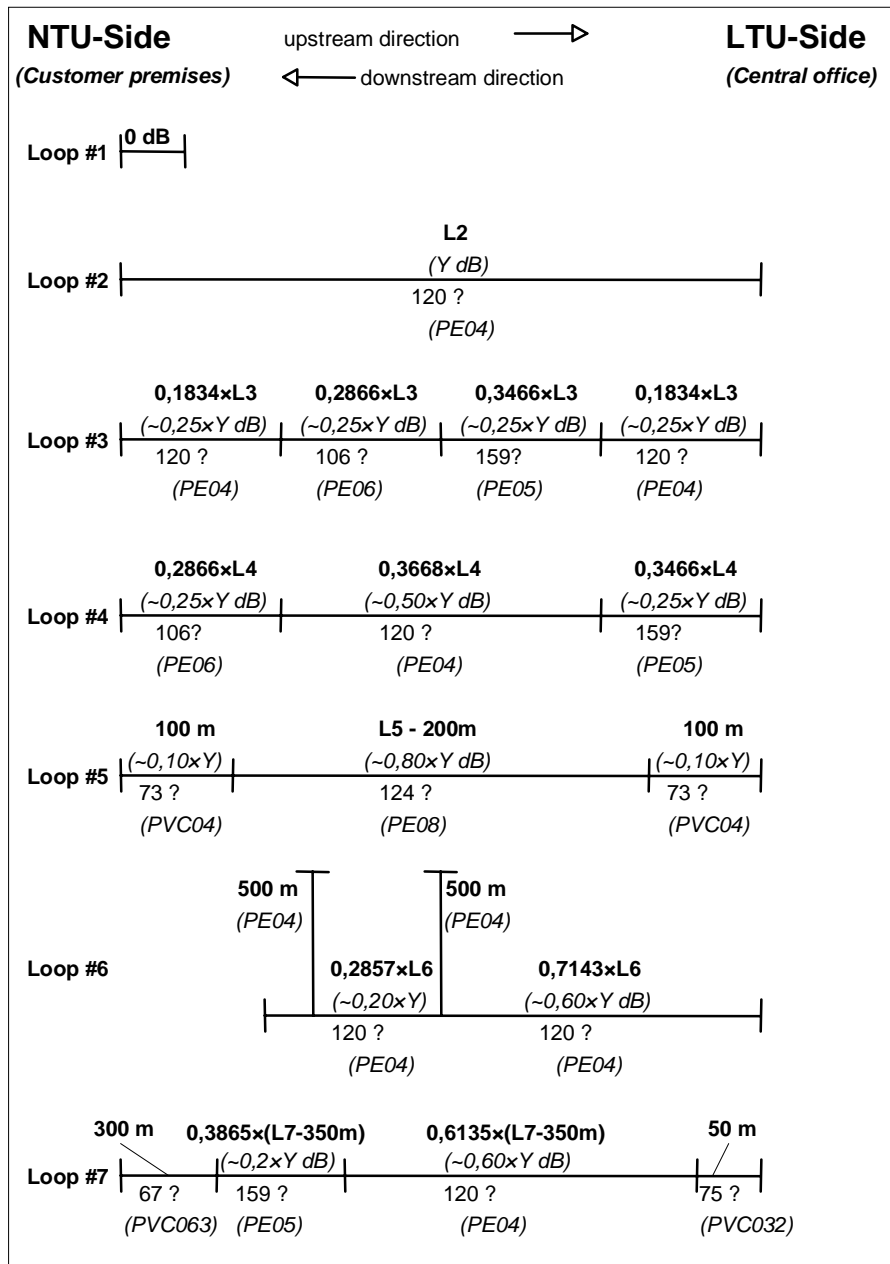

NOTE 1: The values for Y and L are to be found in tables 12-2 and 12-3.

NOTE 2: Due to mismatches and Bridged Taps, the total attenuation of the testloops differs from the sum of the attenuation of the parts.

NOTE 3: The impedances are for information only. They refer to the characteristic impedances of the test cables measured at 300 kHz.

Figure 12-2: Testloop topology

## 12.4.3 Testloop length

The length of each testloop for SDSL transmission systems is specified in tables 12-2 and 12-3. The specified insertion loss Y at the specified test frequency measured with a 135 Ω termination (*electrical* length) is mandatory. If implementation tolerances of one testloop result in its *electrical* length being out of specification, then its total *physical* length shall be scaled accordingly to adjust this error.

The test frequency  $f_T$  is chosen to be a typical mid-band frequency in the spectrum of long range SDSL systems. The length is chosen to be a typical maximum value that can be handled correctly by the SDSL transceiver under test. This value is bit rate dependent; the higher the payload bit rate, the lower is the insertion loss that can be handled in practice.

**Table 12-2: Values of the electrical length Y of the SDSL noise testloops, when testing SDSL at noise model A**

Payload Bit rate [kb/s]	$f_T$ [kHz]	Y [dB] @ $f_T$ , @135 $\Omega$	L1 [m]	L2 [m]	L3 [m]	L4 [m]	L5 [m]	L7 [m]	$f_T$ [kHz]	Y [dB] @ $f_T$ , @135 $\Omega$	L6 [m]
384	150	43,0	< 3	4 106	5 563	5 568	11 064	4 698	115	40,5	3 165
512	150	37,0	< 3	3 535	4 787	4 789	9 387	3 996	115	35,0	2 646
768	150	29,0	< 3	2 773	3 747	3 753	7 153	3 062	275	34,5	1 904
1 024	150	25,5	< 3	2 439	3 285	3 291	6 174	2 668	275	30,0	1 547
1 280	150	22,0	< 3	2 105	2 829	2 837	5 193	2 266	275	26,0	1 284
1 536	150	19,0	< 3	1 820	2 453	2 455	4 357	1 900	250	21,5	1 052
2 048 (s)	200	17,5	< 3	1 558	2 046	2 052	3 285	1 550	250	18,5	748
2 304 (s)	200	15,5	< 3	1 381	1 815	1 820	2 789	1 331	250	16,5	583
2 048 (a)	250	21,0	< 3	1 743	2 264	2 272	3 618	1 726	250	21,0	1 001
2 304 (a)	250	18,0	< 3	1 494	1 927	1 937	2 915	1 402	250	18,0	702

NOTE: The electrical length Y (insertion loss at specified frequency  $f_T$ ) is mandatory, the (estimated) physical lengths L1-L7 are informative.  
(s) those electrical lengths apply to the symmetric PSD.  
(a) those electrical lengths apply to the asymmetric PSD.

**Table 12-3: Values of the electrical length Y of the SDSL noise testloops, when testing SDSL at noise model B, C or D**

Payload Bit rate [kb/s]	$f_T$ [kHz]	Y [dB] @ $f_T$ , @135 $\Omega$	L1 [m]	L2 [m]	L3 [m]	L4 [m]	L5 [m]	L7 [m]	$f_T$ [kHz]	Y [dB] @ $f_T$ , @135 $\Omega$	L6 [m]
384	150	50,0	< 3	4 773	6 471	6 477	13 021	5 508	115	47,5	3 859
512	150	44,0	< 3	4 202	5 692	5 698	11 344	4 814	115	41,5	3 261
768	150	35,5	< 3	3 392	4 592	4 596	8 970	3 815	275	42,0	2 536
1 024	150	32,0	< 3	3 058	4 135	4 141	7 990	3 403	275	38,0	2 223
1 280	150	28,5	< 3	2 725	3 678	3 684	7 011	3 006	275	33,5	1 816
1 536	150	25,5	< 3	2 439	3 285	3 291	6 174	2 673	250	29,0	1 680
2 048 (s)	200	24,0	< 3	2 135	2 812	2 820	4 886	2 271	250	25,5	1 426
2 304 (s)	200	21,5	< 3	1 913	2 509	2 518	4 257	2 010	250	23,0	1 208
2 048 (a)	250	28,0	< 3	2 323	3 030	3 034	5 189	2 389	250	28,0	1 607
2 304 (a)	250	25,0	< 3	2 075	2 699	2 705	4 514	2 102	250	25,0	1 387

NOTE: The electrical length Y (insertion loss at specified frequency  $f_T$ ) is mandatory, the (estimated) physical lengths L1-L7 are informative.  
(s) those electrical lengths apply to the symmetric PSD.  
(a) those electrical lengths apply to the asymmetric PSD.



## 12.5 Impairment generator

The noise injected by the impairment generator into the test set-up is frequency and testloop length dependent. The noise is also different for downstream performance tests and upstream performance tests. Figure 12-3 illustrates this for the *alien* noise (other than the SDSL modem under test) when the length of testloop #2 is fixed at 3 km. Figure 12-4 illustrates this for various loop lengths in the case that the *alien* noise of model 'B' is applied. These figures show the alien noise only. The self noise (of SDSL) shall be combined with this alien noise.

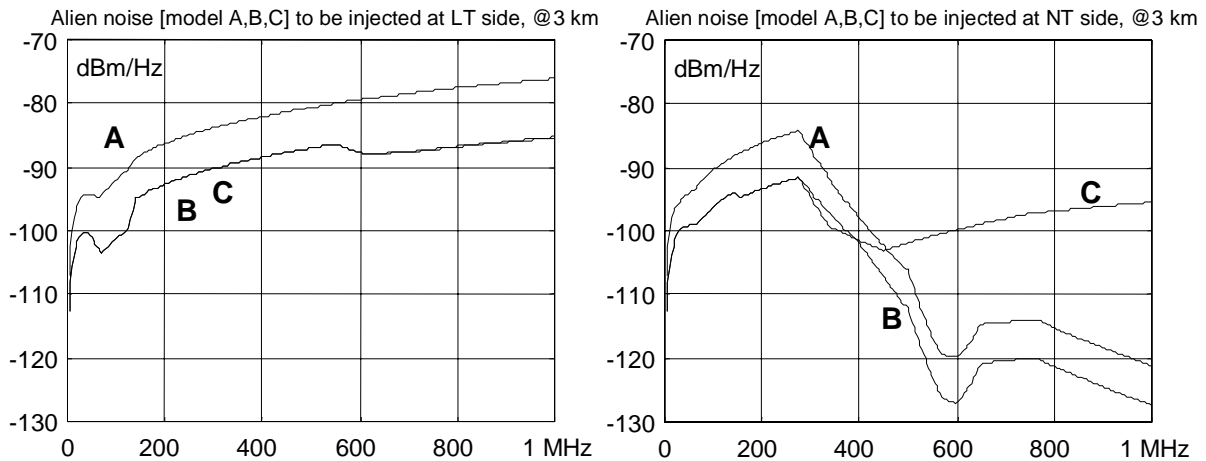

NOTE: This is the noise, resulting from three of the four noise models for SDSL, in the case that the length of testloop #2 is fixed at 3 km.

**Figure 12-3: Examples of alien noise spectra that are to be injected into the test set-up, while testing SDSL systems**

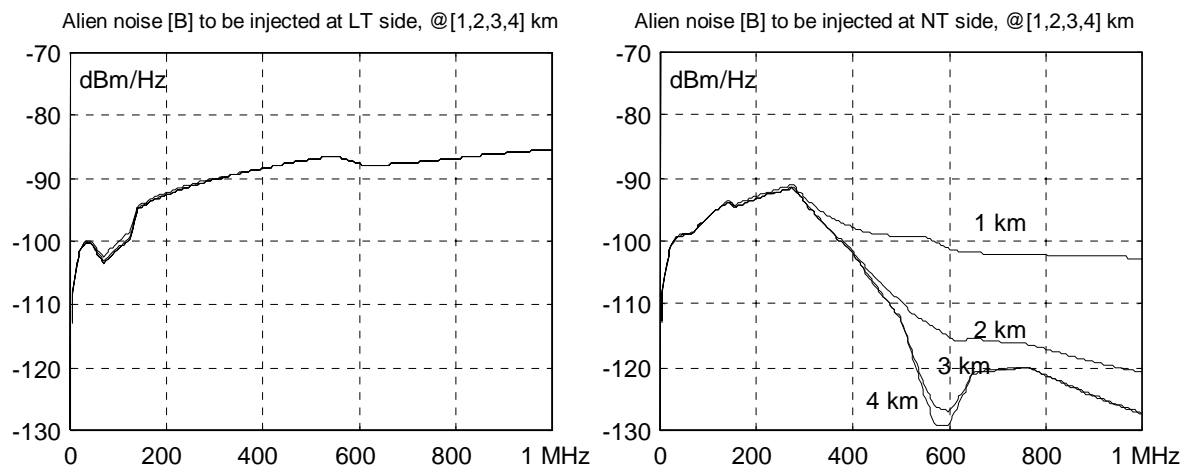

NOTE: This is the alien noise, resulting from noise model B for SDSL, in the case that the length of testloop #2 varies from 1 km to 4 km. This demonstrates that the test noise is length dependent, to represent the FEXT in real access network cables.

**Figure 12-4: Examples of alien noise spectra that are to be injected into the test set-up, while testing SDSL systems**

The definition of the impairment noise for SDSL performance tests is very complex and for the purposes of the present document has been broken down into smaller, more easily specified components. These separate, and uncorrelated, impairment "generators" may therefore be isolated and summed to form the impairment generator for the SDSL system under test. The detailed specifications for the components of the noise model(s) are given in this clause, together with a brief explanation.

## 12.5.1 Functional description

Figure 12-5 defines a functional diagram of the composite impairment noise. It defines a functional description of the combined impairment noise, as it must be probed at the receiver input of the SDSL transceiver under test. The probing is described in clause 12.2.2.

The functional diagram has the following elements:

- the seven impairment "generators" G1 to G7 generate noise as defined in clauses 12.5.3.1 to 12.5.3.7. Their noise characteristics are independent from the testloops and bit rates;
- the transfer function  $H_1(f,L)$  models the length and frequency dependency of the NEXT impairment, as specified in clause 12.5.3.1. The transfer function changes with the electrical length of the testloop and with the frequency  $f$ , roughly according to  $f^{0,75}$ ;
- the transfer function  $H_2(f,L)$  models the length and frequency dependency of the FEXT impairment, as specified in clause 12.5.3.2. The transfer function changes with the electrical length of the testloop and with the frequency  $f$ , roughly according to  $f$  times the cable transfer function;
- switches S1-S7 determine whether or not a specific impairment generator contributes to the total impairment during a test;
- amplifier A1 models the property to increase the level of some generators simultaneously to perform the noise margin tests. A value of  $x$  dB means a frequency independent increase of the level by  $x$  dB over the full band of the SDSL system under test, from  $f_L$  to  $f_H$ . Unless otherwise specified, its gain is fixed at 0 dB.

In a practical implementation of the test set-up, there is no need to give access to any of the internal signals of the diagram in figure 12-5. These functional blocks may be incorporated with the testloop and the adding element as one integrated construction.

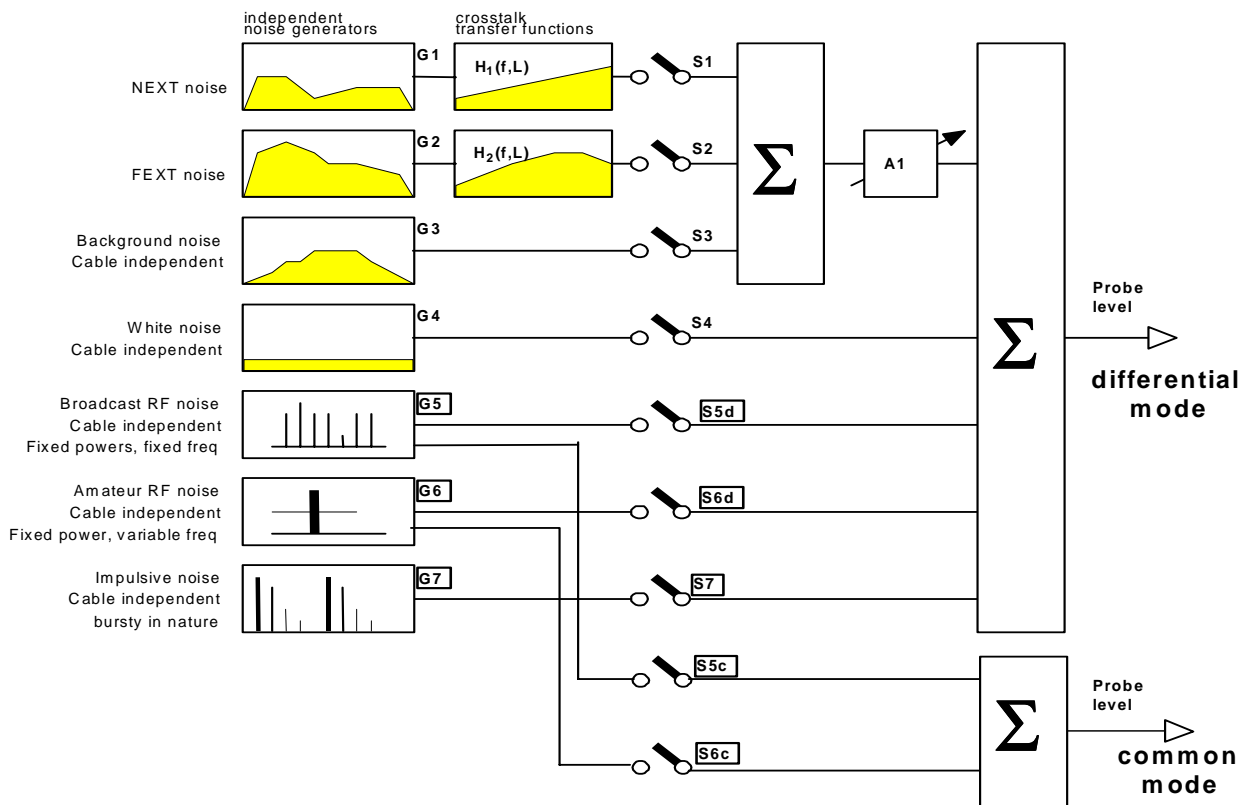

**Figure 12-5: Functional diagram of the composition of the impairment noise**

NOTE 1: Generator G7 is the only one, which is symbolically shown in the time domain.

NOTE 2: The precise definition of impulse noise margin is for further study.

This functional diagram will be used for impairment tests in downstream and upstream direction. Several scenarios have been identified to be applied to SDSL testing. These scenarios are intended to be representative of the impairments found in metallic access networks.

Each scenario (or noise model) results in a length dependent PSD description of noise. Each noise model is subdivided into two parts: one representing the noise at the LT-side, and another representing the noise present at the NT-side of the SDSL modem link under test. Some of the seven individual impairment "generators" G1 to G7 are therefore defined by more than one noise model.

Each test has its own impairment specification. The overall impairment noise shall be characterized by the sum of the individual components as specified in the relevant clauses. This combined impairment noise is applied to the receiver under test, at either the LT (for upstream) or NT (for downstream) end of the testloop.

## 12.5.2 Cable crosstalk models

The purpose of the cable cross-talk models is to model both the length and frequency dependency of crosstalk measured in real cables. These crosstalk transfer functions adjust the level of the noise generators in figure 12-5 when the electrical length of the testloops is changed. The frequency and length dependency of these functions is in accordance with observations from real cables. The specification is based on the following constants, parameters and functions:

- variable  $f$  identifies the frequency in Hz;
- constant  $f_0$  identifies a chosen reference frequency, which was set to 1 MHz;
- variable  $L$  identifies an average physical length in meters. This physical length is derived from the specified electrical length using the cable models in annex F and the cable characteristics of annex E. Values are summarized in tables 12-2 and 12-3 for each combination of payload bit rate, noise model and testloop;
- constant  $L_0$  identifies a chosen reference length, which was set to 1 km;
- transfer function  $s_{T0}(f, L)$  represents the frequency and length dependent amplitude of the transfer function of the actual testloop. This value equals  $s_{T0} = |s_{21}|$ , where  $s_{21}$  is the transmission s-parameter of the loop normalized to 135  $\Omega$ . Annex F provides formulas to calculate this s-parameter;
- constant  $K_{xn}$  identifies an empirically obtained number that scales the NEXT transfer function  $H_1(f, L)$ . The resulting transfer function represents a power summed crosstalk model of the NEXT as it was observed in a test cable. Although several disturbers and wire pairs were used, this function  $H_1(f, L)$  is scaled down as if it originates from a single disturber in a single wire pair;
- constant  $K_{xf}$  identifies an empirically obtained number that scales the FEXT transfer function  $H_2(f, L)$ . The resulting transfer function represents a power summed crosstalk model of the FEXT as it was observed in a test cable. Although several disturbers and wire pairs were used, this function  $H_2(f, L)$  is scaled down as if it originates from a single disturber in a single wire pair.

The transfer functions in table 12-4 shall be used as crosstalk transfer functions in the impairment generator.

**Table 12-4: Definition of the crosstalk transfer functions**

$H_1(f, L) = K_{xn} \times (f/f_0)^{0,75} \times \sqrt{1 -  s_{T0}(f, L) ^4}$ $H_2(f, L) = K_{xf} \times (f/f_0) \times \sqrt{(L/L_0)} \times  s_{T0}(f, L) $
$K_{xn} = 10^{(-50/20)} \approx 0,0032, \quad f_0 = 1 \text{ MHz}$ $K_{xf} = 10^{(-45/20)} \approx 0,0056, \quad L_0 = 1 \text{ km}$ $s_{T0}(f, L) = \text{testloop transfer function}$
<p>NOTE: These values are rounded values, and chosen to be close to the ANSI T1E1.4 VDSL draft System Requirements. This choice is equivalent to 50 dB NEXT loss and 45 dB EL-FEXT loss at a cable section of 1 km. At this moment, it is by no means sure that these are reasonable values to represent the "average" European cables. The few measurements that are available for European cables demonstrate sometimes significant differences from the above values. This is an area of further study.</p>

## 12.5.3 Individual impairment generators

### 12.5.3.1 Equivalent NEXT disturbance generator [G1.xx]

The NEXT noise generator represents the equivalent disturbance of all impairment that is identified as crosstalk noise from a predominantly near end origin. This noise, filtered by the NEXT crosstalk coupling function of clause 12.5.2, will represent the contribution of all NEXT to the composite impairment noise of the test.

The PSD of this noise generator is one of the PSD profiles, as specified in clause 12.5.4. For testing upstream and downstream performance different PSD profiles shall be used, as specified below.

$$\mathbf{G1.UP.\#} = \mathbf{X.LT.\#} = (\mathbf{XS.LT.\#} \blacklozenge \mathbf{XA.LT.\#})$$

$$\mathbf{G1.DN.\#} = \mathbf{X.NT.\#} = (\mathbf{XS.NT.\#} \blacklozenge \mathbf{XA.NT.\#})$$

The symbols in this expression, refer to the following:

- Symbol "#" is a placeholder for noise model "A", "B", "C" or "D".
- Symbol "X.LT.#" and "X.NT.#" refers to the **overall** crosstalk profile, as defined in 12.5.4.1.
- Symbol "XS.LT.#" and "XS.NT.#" refers to the **self** crosstalk profile, as defined in 12.5.4.1.1.
- Symbol "XA.LT.#" and "XA.NT.#" refers to the **alien** crosstalk profile, as defined in 12.5.4.1.2.
- Symbol "◆" refers to the FSAN crosstalk sum of two PSDs. This FSAN crosstalk sum is defined as  $P_X = (P_{XS}^{K_n} + P_{XA}^{K_n})^{1/K_n}$ , where P denotes the PSDs in W/Hz, and  $K_n = 1 / 0,6$ .

In the case that the overall crosstalk noise is defined as the combination of self-crosstalk and alien crosstalk, a weighed sum "◆" of two individually defined profiles has to be evaluated.

The NEXT transfer function  $H_1(f,L)$  is modelled separately in clause 12.5.2.

The noise of this noise generator shall be uncorrelated with all the other noise sources in the impairment generator, and uncorrelated with the SDSL system under test. The noise shall be random in nature and near Gaussian distributed, as specified in clause 12.5.4.2.

### 12.5.3.2 Equivalent FEXT disturbance generator [G2.xx]

The FEXT noise generator represents the equivalent disturbance of all impairment that is identified as crosstalk noise from a predominantly Far End origin. This noise, filtered by the FEXT crosstalk coupling function of clause 12.5.2, will represent the contribution of all FEXT to the composite impairment noise of the test.

The PSD of this noise generator is one of the PSD profiles, as specified in clause 12.5.4. For testing upstream and downstream performance different PSD profiles shall be used, as specified below.

$$\mathbf{G2.UP.\#} = \mathbf{X.NT.\#} = (\mathbf{XS.NT.\#} \blacklozenge \mathbf{XA.NT.\#})$$

$$\mathbf{G2.DN.\#} = \mathbf{X.LT.\#} = (\mathbf{XS.LT.\#} \blacklozenge \mathbf{XA.LT.\#})$$

The symbols in this expression, refer to the following:

- Symbol "#" is a placeholder for noise model "A", "B", "C" or "D".
- Symbol "X.LT.#" and "X.NT.#" refers to the **overall** crosstalk profiles, as defined in clause 12.5.4.1.
- Symbol "XS.LT.#" and "XS.NT.#" refers to the **self** crosstalk profiles, as defined in clause 12.5.4.1.1.
- Symbol "XA.LT.#" and "XA.NT.#" refers to the **alien** crosstalk profiles, as defined in clause 12.5.4.1.2.
- Symbol "◆" refers to the FSAN crosstalk sum of two PSDs. This FSAN crosstalk sum is defined as  $P_X = (P_{XS}^{K_n} + P_{XA}^{K_n})^{1/K_n}$ , where P denotes the PSDs in W/Hz, and  $K_n = 1 / 0,6$ .

In the case that the overall crosstalk noise is defined as the combination of self crosstalk and alien crosstalk, a weighed sum "♦" of two individually defined profiles has to be evaluated.

The FEXT transfer function  $H_2(f,L)$  is modelled separately in clause 12.5.2.

The noise of this noise generator shall be uncorrelated with all the other noise sources in the impairment generator, and uncorrelated with the SDSL system under test. The noise shall be random in nature and near Gaussian distributed, as specified in clause 12.5.4.2.

### 12.5.3.3 Background noise generator [G3]

The background noise generator is inactive and set to zero.

### 12.5.3.4 White noise generator [G4]

The white noise generator has a fixed, frequency independent value, and is set to -140 dBm/Hz, into 135  $\Omega$ . The noise of this noise generator shall be uncorrelated with all the other noise sources in the impairment generator, and uncorrelated with the SDSL system under test. The noise shall be random in nature and near Gaussian distributed, as specified in clause 12.5.4.2.

### 12.5.3.5 Broadcast RF noise generator [G5]

The broadcast RF noise generator represents the discrete tone-line interference caused by amplitude modulated broadcast transmissions in the SW, MW and LW bands which ingress into the differential or transmission mode of the wire-pair. These interference sources have more temporal stability than the amateur/ham interference because their carrier is not suppressed. The modulation index (MI) is usually up to 80 %. These signals are detectable using a spectrum analyser and result in line spectra of varying amplitude in the frequency band of the SDSL system under test. Maximum observable power levels of up to -40 dBm can occur on telephone lines in the distant vicinity of broadcast AM transmitters. The noise is typically dominated by the closest 10 or so transmitters to the victim wire-pair.

Several noise models are specified in this clause. The average minimum power of each carrier frequency is specified in table 12-5 for each model, but these values are for further study.

**Table 12-5: Average minimum RFI noise power versus frequency**

<b>frequency</b>	99	207	333	387	531	603	711	801	909	981	kHz
<b>power</b>	-70	-40	-60	-60	-40	-50	-40	-50	-60	-60	dBm

### 12.5.3.6 Amateur RF noise generator [G6]

The amateur radio noise generator is identical to the broadcast RF noise generator with different frequency and power values. These values are for further study.

### 12.5.3.7 Impulse noise generator [G7]

A test with this noise generator is required to prove the burst noise immunity of the SDSL transceiver. This immunity shall be demonstrated on short and long loops and noise to model cross-talk and RFI. The impulsive noise is for further study.

## 12.5.4 Profiles of the individual impairment generators

Crosstalk noise represents all impairment that originates from systems connected to adjacent wire pairs that are bundled in the same cable. Their wires are coupled to the wires of the xDSL system under test, causing this spectrum of crosstalk noise to vary with the electrical length of the testloop.

To simplify matters, the definition of crosstalk noise has been broken down into smaller, more easily specified components. The two generators G1 and G2 represent the "equivalent disturbance". Their noise level originates from a mixture of many disturbers in a real scenario, as if all disturbers are collocated at the ends of the testloops.

This equivalent disturbance, filtered by the NEXT and FEXT coupling functions, will represent the crosstalk noise that is to be injected in the test set-up. This approach has isolated their definition from the NEXT and FEXT coupling functions of the cable.

For SDSL testing, several models for crosstalk noise have been defined. The noise generated by these two equivalent disturbers is specified in this clause in the frequency domain as well as in the time domain.

The frequency domain characteristics of each generator G1 and G2 is defined by a spectral profile, so each noise model has its own pair of spectral profiles:

- the profiles X.LT.# in this clause describe the total equivalent disturbance of a technology mix that is virtually co-located at the LT end of the testloop. This noise is represented by equivalent disturbance generator G1, when stressing upstream signals, and by equivalent disturbance generator G2 when stressing downstream signals;
- the profiles X.NT.# in this clause describe the total equivalent disturbance of a technology mix that is virtually co-located at the NT end of the testloop. This noise is represented by equivalent disturbance generator G2, when stressing upstream signals, and by equivalent disturbance generator G1 when stressing downstream signals.

The PSD levels of equivalent disturbance generator G1 and G2 are interchanged for upstream and downstream testing.

#### 12.5.4.1 Frequency domain profiles for SDSL

This clause specifies the PSD profiles X.LT.# and X.NT.# that apply for the equivalent disturbers G1 and G2 when testing SDSL systems. In this nomenclature "#" is used as a placeholder for noise model "A", "B", "C", and "D".

Four noise models have been defined for SDSL:

- **type "A" models** are intended to represent a high penetration scenario where the SDSL system under test is placed in a distribution cable (up to hundreds of wire pairs) that is filled with many other (potentially incompatible) transmission systems;
- **type "B" models** are intended to represent a medium penetration scenario where the SDSL system under test is placed in a distribution cable (up to tens of wire pairs) that is filled with many other (potentially incompatible) transmission systems;
- **type "C" models** are intended to represent a legacy scenario that accounts for systems such as ISDN-PRI (HDB3), in addition to the medium penetration scenario of model "B";
- **type "D" models** are intended to represent a reference scenario consisting of a cable filled with SDSL systems all operating at the same rate, or filled with SDSL systems operating at different rates.

Noise generator G1 specifies the NEXT component of the noise and is specified in clause 12.5.3.1 for upstream and downstream testing. Noise generator G2 specifies the FEXT component of the noise and is specified in clause 12.5.3.2 for upstream and downstream testing.

These profiles shall be met for all frequencies between 1 kHz to 1 MHz.

##### 12.5.4.1.1 Self crosstalk profiles

The noise profiles XS.LT.# and XS.NT.#, representing the equivalent disturbance of self crosstalk, are implementation specific of the SDSL system under test. Transceiver manufacturers are left to determine these levels. For compliance with the requirements of the present document, the transceiver manufacturer shall determine the signal spectrum of the SDSL system under test, as it can be observed at the Tx port of the test set-up as described in clause 12.2.1. The measurement bandwidth for PSD shall be 1 kHz or less.

For testing SDSL, four noise models for self crosstalk have been defined. The LT- and NT-profiles are specified in table 12-6.

In this nomenclature "#" is a placeholder for model "A", "B", "C" or "D". "SDSL.dn" is the signal spectrum that SDSL transmits in the downstream direction, and "SDSL.up" in the upstream direction.

Table 12-6: Definition of the self crosstalk for SDSL testing

	Model A (XS.#.A)	Model B (XS.#.B)	Model C (XS.#.C)	Model D (XS.#.D)
XS.LT.#:	"SDSL.dn" + 11,7 dB	"SDSL.dn" + 7,1 dB	"SDSL.dn" + 7,1 dB	"SDSL.dn" + 10,1 dB
XS.NT.#:	"SDSL.up" + 11,7 dB	"SDSL.up" + 7,1 dB	"SDSL.up" + 7,1 dB	"SDSL.up" + 10,1 dB
NOTE:	The different noise models use different Gain factors.			

## 12.5.4.1.2 Alien crosstalk profiles

The noise profiles XA.LT.# and XA.NT.#, representing the equivalent disturbance of alien crosstalk. For testing SDSL, four noise models for alien crosstalk have been defined. The LT-profiles are specified in table 12-7 and the NT-profiles in table 12-8. Each PSD profile originates from a mix of disturbers. The alien noise in model D is made inactive, to achieve one pure self crosstalk scenario.

Table 12-7: Break frequencies of the "XA.LT.#" PSD profiles that specify the equivalent disturbance spectra of alien disturbers

XA.LT.A	135 $\Omega$	XA.LT.B	135 $\Omega$	XA.LT.C	135 $\Omega$	XA.LT.D	135 $\Omega$
[Hz]	[dBm/Hz]	[Hz]	[dBm/Hz]	[Hz]	[dBm/Hz]	[Hz]	[dBm/Hz]
1	-20,0	1	-25,7	1	-25,7	ALL	- $\infty$
15 k	-20,0	15 k	-25,7	15 k	-25,7		
30 k	-21,5	30 k	-27,4	30 k	-27,4		
67 k	-27,0	45 k	-30,3	45 k	-30,3		
125 k	-27,0	70 k	-36,3	70 k	-36,3		
138 k	-25,7	127 k	-36,3	127 k	-36,3		
400 k	-26,1	138 k	-32,1	138 k	-32,1		
1 104 k	-26,1	400 k	-32,5	400 k	-32,5		
2,5 M	-66,2	550 k	-32,5	550 k	-32,5		
4,55 M	-96,5	610 k	-34,8	610 k	-34,8		
30 M	-96,5	700 k	-35,4	700 k	-35,3		
		1 104 k	-35,4	1 104 k	-35,3		
		4,55 M	-103,0	1,85 M	-58,5		
		30 M	-103,0	22,4 M	-103,0		
				30 M	-103,0		
NOTE:	The PSD profiles are constructed with straight lines between these break frequencies, when plotted against a <b>logarithmic</b> frequency scale and a <b>linear</b> dBm scale. The levels are defined with into a 135 $\Omega$ resistive load.						

Table 12-8: Break frequencies of the "XA.NT.#" PSD profiles that specify the equivalent disturbance spectra of alien disturbers

XA.NT.A	135 $\Omega$	XA.NT.B	135 $\Omega$	XA.NT.C	135 $\Omega$	XA.NT.D	135 $\Omega$
[Hz]	[dBm/Hz]	[Hz]	[dBm/Hz]	[Hz]	[dBm/Hz]	[Hz]	[dBm/Hz]
1	-20,0	1	-25,7	1	-25,7	ALL	- $\infty$
15 k	-20,0	15 k	-25,7	15 k	-25,7		
60 k	-25,2	30 k	-26,8	30 k	-26,8		
276 k	-25,8	67 k	-31,2	67 k	-31,2		
500 k	-51,9	142 k	-31,2	142 k	-31,2		
570 k	-69,5	156 k	-32,7	156 k	-32,7		
600 k	-69,9	276 k	-33,2	276 k	-33,2		
650 k	-62,4	400 k	-46,0	335 k	-42,0		
763 k	-62,4	500 k	-57,9	450 k	-47,9		
1,0 M	-71,5	570 k	-75,7	750 k	-45,4		
2,75 M	-96,5	600 k	-76,0	1 040 k	-45,5		
30 M	-96,5	650 k	-68,3	2,46 M	-63,6		
		763 k	-68,3	23,44 M	-103,0		
		1,0 M	-77,5	30 M	-103,0		
		2,8 M	-103,0				
		30 M	-103,0				
NOTE:	The PSD profiles are constructed with straight lines between these break frequencies when plotted against a <b>logarithmic</b> frequency scale and a <b>linear</b> dBm scale. The levels are defined with into a 135 $\Omega$ .						

### 12.5.4.2 Time domain profiles of generator G1-G4

The noise, as specified in the frequency domain in clauses 12.5.3.1 to 12.5.3.7, shall be random in nature and near Gaussian distributed. This means that the amplitude distribution function of the combined impairment noise injected at the adding element shall lie between the two boundaries as illustrated in figure 12-6, where the non-shaded area is the allowed region. The boundaries of the mask are specified in table 12-9.

The amplitude distribution function  $F(a)$  of noise  $u(t)$  is the fraction of the time that the absolute value of  $u(t)$  exceeds the value "a". From this definition, it can be concluded that  $F(0) = 1$  and that  $F(a)$  monotonically decreases up to the point where "a" equals the peak value of the signal. From there on,  $F(a)$  vanishes:

$$F(a) = 0, \text{ for } a \geq |u_{peak}|$$

The boundaries on the amplitude distribution ensure that the noise is characterized by peak values that are occasionally significantly higher than the rms-value of that noise (up to 5 times the rms-value).

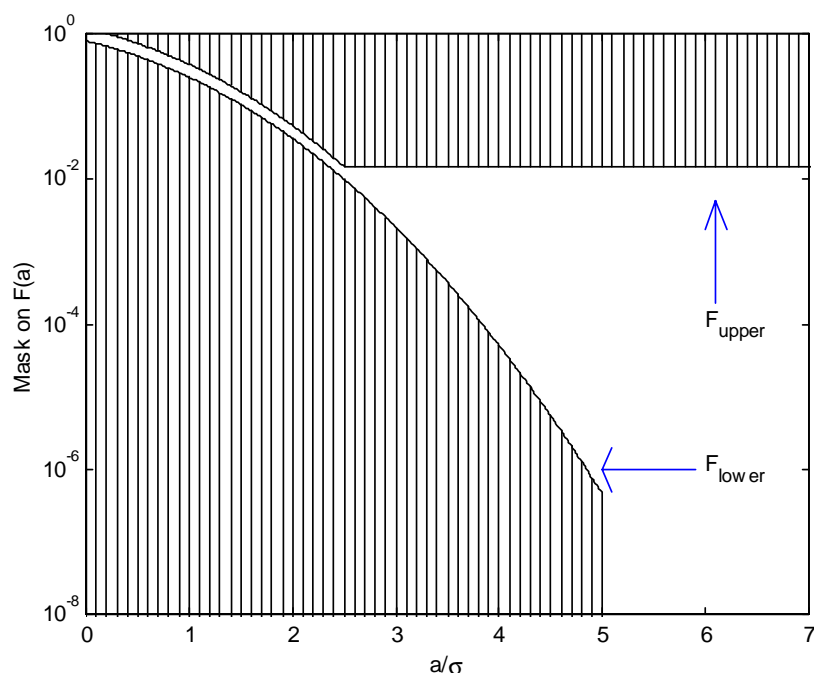

Figure 12-6: Mask for the amplitude distribution function

Table 12-9: Upper and lower boundaries of the amplitude distribution function of the noise

Boundary ( $\sigma = \text{rms value of noise}$ )	interval	parameter	value
$F_{lower}(a) = (1 - \varepsilon) \cdot \{1 - \text{erf}((a/\sigma)/\sqrt{2})\}$	$0 \leq a/\sigma < CF$	crest factor	$CF = 5$
$F_{lower}(a) = 0$	$CF \leq a/\sigma < \infty$	Gaussian gap	$\varepsilon = 0,1$
$F_{upper}(a) = (1 + \varepsilon) \cdot \{1 - \text{erf}((a/\sigma)/\sqrt{2})\}$	$0 \leq a/\sigma < A$		$A = CF/2 = 2,5$
$F_{upper}(a) = (1 + \varepsilon) \cdot \{1 - \text{erf}(A/\sqrt{2})\}$	$A \leq a/\sigma < \infty$		

The meaning of the parameters in table 12-9 is as follows:

- CF denotes the minimum crest factor of the noise, that characterizes the ratio between the absolute peak value and rms value ( $CF = |u_{peak}| / u_{rms}$ );
- $\varepsilon$  denotes the Gaussian gap that indicates how "close" near Gaussian noise approximates true Gaussian noise;
- A denotes the point beyond which the upper limit is relaxed to allow the use of noise signals of practical repetition length.



## 12.6 Measurement of noise margin

At start-up, the level and shape of crosstalk noise or impulse noise are adjusted, while their level is probed at port Rx to meet the impairment level specification in clause 12.2.2. This relative level is referred to as 0 dB. The transceiver link is subsequently activated, and the bit error ratio of the link is monitored.

### 12.6.1 Measurement of crosstalk noise margin

For measuring the crosstalk margin, the crosstalk noise level of the impairment generator as defined in clause 12.5.4.1, shall be increased by adjusting the gain of amplifier A1 in figure 12-5, equally over the full frequency band of the SDSL system under test, until the bit error ratio is higher than  $10^{-7}$ . This BER will be achieved at an increase of noise of  $x$  dB, with a small uncertainty of  $\Delta x$  dB. This value  $x$  is defined as the crosstalk noise margin with respect to a standard noise model.

The noise margins shall be measured using the testloops specified in figure 12-2 and scaled according to tables 12-2 and 12-3.

### 12.6.2 Measurement of impulse noise margin

For further study.

## 12.7 Micro interruptions

A micro interruption is a temporary line interruption due to external mechanical action on the copper wires constituting the transmission path, for example, at a cable splice. Splices can be hand-made wire-to-wire junctions, and during cable life oxidation phenomena and mechanical vibrations can induce micro interruptions at these critical points.

The effect of a micro interruption on the transmission system can be a failure of the digital transmission link, together with a failure of the power feeding (if provided) for the duration of the micro interruption.

The objective is that in the presence of a micro interruption of specified maximum length the SDSL transceiver should not reset, and the system should automatically reactivate.

The transceiver shall not be reset by a micro interruption event with a duration  $t = 10$  ms which shall occur at an event frequency of 0,2 Hz.

For further study.

---

## 13 Power feeding

### 13.1 General

This clause deals with power feeding of the NTU, regenerators (if required) and the provision of power to the application interface for narrowband services under restricted conditions (lifeline circuit).

The requirements given in this clause imply compliance to EN 60950 [5].

### 13.2 Power feeding of the NTU

The NTU shall be able to consume power from the remote power feeding circuit when the local power supply fails.

NOTE 1: The remote feeding strategy may not be applicable for extremely long lines or lines including regenerators. In those cases specific feeding methods may be applied, which are for further study.

The NTU shall be able to draw up to a maximum of 10 mA as wetting current from the remote feeding circuit when the NTU is being powered locally.

NOTE 2: The 10mA current limit is not derived from any electrical safety specification. Its aim is to limit the power budget delivered by the network when wetting current is applied.

NOTE 3: The details of wetting current need further study.

### 13.3 Power feeding of the interface for narrowband services

When simultaneous telephone service is provided by the NTU, feeding of restricted mode power for lifeline service has to be provided for at least one telephone set in case of local power fail. The requirements for ISDN-BA are described in EN 300 012-1 [3] and information on power feeding for analogue access is described in EN 300 001 [4], TR 101 185 [13] and TBR 021 [22].

NOTE: The remote feeding strategy may not be applicable for extremely long lines or lines including regenerators. In those cases, specific feeding methods may be applied which are for further study.

### 13.4 Feeding power from the LTU

The feeding power shall be limited to the values specified in EN 60950 [5] to meet the requirements for TNV-3.

### 13.5 Power available at the NTU

#### 13.5.1 Static requirements

The NTU shall be able to deal with any polarity.

The maximum power drawn by the SDSL NTU when the local power fails and lifeline service has to be provided is 2,1 W.

NOTE: In order to enhance the performances in the critical conditions (longest loops and lower input voltages) and to avoid giving unnecessary burden to the design of the NTU, compliance to the 2,1 W limit is requested only when the NTU input voltage is < 70 V. With NTU input voltages higher than 70 V (short loops and higher LTU feeding voltages), a power consumption up to 2,5 W is permitted.

#### 13.5.2 Dynamic requirements

The values given in this clause represent currently used practice of testing dynamic power feeding behaviour.

The test shall be carried out with the test circuit given in figure 13-1.

The current drawn, by the test circuit, from the voltage source shall be below X mA, where X is given in table 13-1, 1,5 s after switch-on of the feeding voltage.

When the voltage at the NTU exceeds for a first time 28 V, this voltage limit shall be maintained further on and shall not go below 28 V again.

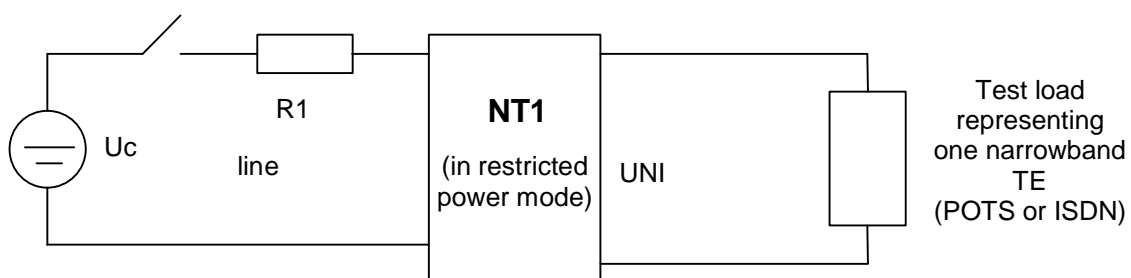

Figure 13-1: Test circuit for NTU

**Table 13-1: Values of components for NTU power source test load according to figure 13-1**

Voltage range (V)	R1 (Ohm)	X (mA)
51 - 69	283	TBD (see note)
66 - 70	473	TBD (see note)
90 - 110	880	60
95 - 99	981	60
107 - 112	1 244	60
NOTE: These values are left for further study.		

### 13.5.3 Reset of NTU

The NTU, independently from the operating condition such as feeding voltage, line resistance, active/deactivated state and power drawn by the user/network interface, shall enter a reset state (i.e. physical reset of the line transceiver) no later than 2 s after interruption of the remote current fed towards the NTU.

## 13.6 DC and low frequency AC termination of NTU

When remote power feeding is provided by the network, the NTU and the side of the REG directed towards the LTU shall enter a high impedance state within 2 s after interruption of the remote current fed towards the NTU or the REG respectively. This state shall be maintained as long as the voltage on the line stays below 18 V (DC + AC peak). In this state, the leakage current shall be less than 10  $\mu$ A and the capacitance shall be greater than 2  $\mu$ F.

---

## 14 Environmental requirements

### 14.1 Climatic conditions

Climatograms applicable to the operation of SDSL equipment can be found in ETS 300 019 [6]. The choice of classes is under national responsibility.

### 14.2 Safety

Safety requirements are mentioned in clause 13 "Power feeding".

### 14.3 Over-voltage protection

No over-voltage protection requirements are specified under the present document.

NOTE: Depending on the equipment NTU, LTU or REG, the ITU-T Recommendations K.21 [11], K.20 [10] or K.17 [9] should be applied.

### 14.4 Electromagnetic compatibility

The EMC requirements are defined according to the equipment type and as described in EN 300 386 [7].

NOTE: Additional EMC requirements may be imposed under EMC Directive (89/336/EEC) (see bibliography).

## Annex A (normative): Application specific TPS-TC

### A.1 TPS-TC for Clear Channel Data

In Clear Channel mode, there shall be no specified relationship between the structure of the user data and its positioning within the Payload Sub-Blocks.  $k_s$  bits of contiguous user data shall be contained within each Sub-Block, as specified in clause 7.1.2. The temporal relationship between the user data stream and the data within the Sub-Blocks shall be maintained such that the order of bits in time from the user data stream shall match the order of transmission within the SDSL Payload Sub-Blocks. Any additional structure within the user data shall be maintained by an unspecified higher layer protocol and is outside the scope of this recommendation.

### A.2 TPS-TC for Clear Channel Byte-Oriented Data

In the byte-oriented clear channel mode, the input byte stream shall be aligned within the SDSL Payload Sub-Block such that the byte boundaries are preserved. Each Payload Sub-Block is treated as containing  $n$  8-bit time slots. Each byte from the input data stream is mapped LSB-first into the next available time slot. The first time slot begins at the first bit position within the Payload Sub-Block, followed by time slot 2, time slot 3, ..., time slot  $n$ .  $k_s$  bits (or  $n$  bytes) of contiguous data shall be contained within each Sub-Block, as specified in clause 7.1.2.  $k_s = i + n \times 8$ , and, in this mode,  $i = 0$  and  $3 \leq n < 36$ . See clause A.1 for additional details.

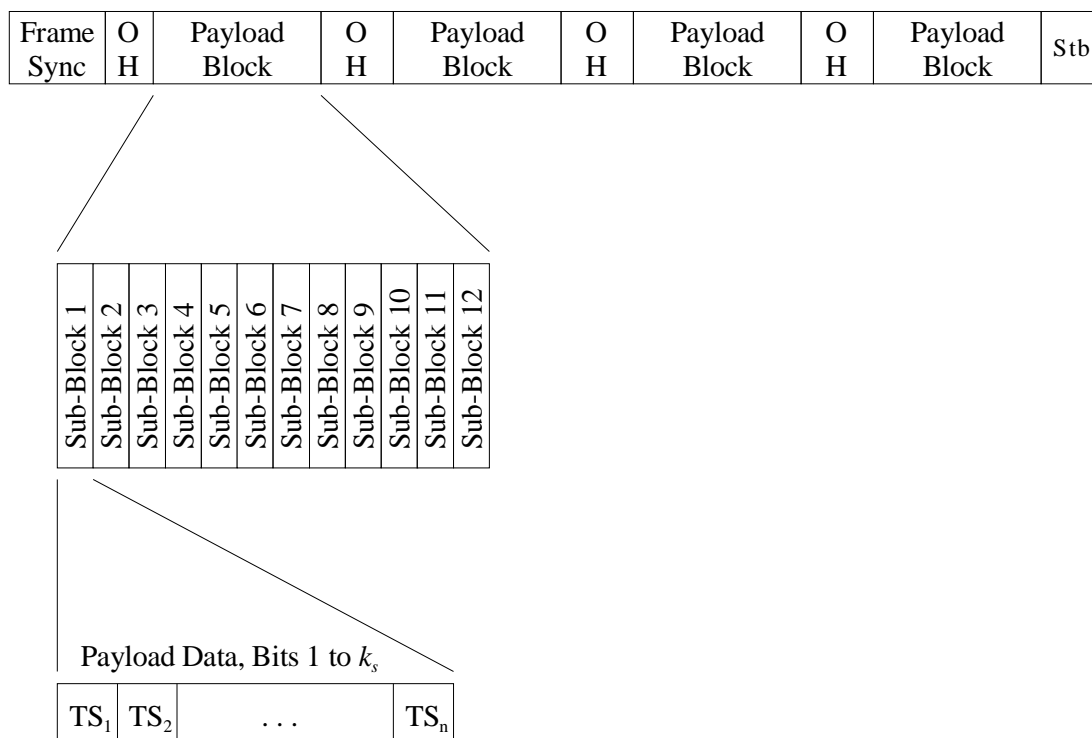

Figure A-1: Clear Channel Byte-Oriented Framing

### A.3 TPS-TC for European 2 048 kbit/s Digital Unstructured Leased Line (D2048U)

D2048U data streams contain unstructured 2,048 Mbit/s data with no specified framing. These data streams shall be carried using the Clear Channel TPS-TC described in clause A.1.

## A.4 TPS-TC for Unaligned European 2 048 kbit/s Digital Structured Leased Line (D2048S)

Much of the data within the European network is structured as D2048S data streams, which, for purposes of this recommendation, can be described as 2,048 Mbit/s data streams containing 8 kHz framing, with each frame containing 32 8-bit time slots. Details of D2048S framing and associated data structure can be found in G.704 [19] clause 2.3.

In Unaligned D2048S mode, there shall be no specified relationship between the D2048S frames and their positioning within the Payload Sub-Blocks.  $k_s$  bits of contiguous data shall be contained within each Sub-Block, as specified in clause 7.1.2.  $k_s = i + n \times 8$ , and, in this mode,  $n = 32$  and  $i = 0$ . The D2048S framing clocks shall be synchronized to the SDSL clocks such that the D2048S frame always appears in the same position within each SDSL Payload Sub-Block; however, no particular alignment is specified. The temporal relationship between the D2048S data stream and the data within the Sub-Blocks shall be maintained, such that that the order of bits in time from the D2048S data stream shall match the order of transmission within the SDSL Payload Sub-Blocks.

## A.5 TPS-TC for Aligned European 2 048 kbit/s Digital Structured Leased Line (D2048S) and Fractional

As noted in clause A.4, D2048S data streams consist of 2,048 Mbit/s data streams containing 8 kHz framing, with each frame containing 32 8-bit time slots. In some cases, Fractional D2048S data streams are used, where frames contain less than the normal 32 8-bit time slots.

In the aligned D2048S mode, each D2048S frame shall be aligned within the SDSL Payload Sub-Block such that the first time slot begins at the first bit position within the Payload Sub-Block, followed by time slot 2, time slot 3, ..., time slot  $n$ .  $k_s$  bits of contiguous data shall be contained within each Sub-Block, as specified in clause 7.1.2.  $k_s = i + n \times 8$ , and, in this mode,  $i = 0$ . In D2048S applications,  $n = 32$ , and, in Fractional D2048S applications,  $3 \leq n < 32$ . The D2048S framing clocks shall be synchronized to the SDSL clocks such that the D2048S frame always appears in the defined position within each SDSL Payload Sub-Block. See figure A-2 for additional details.

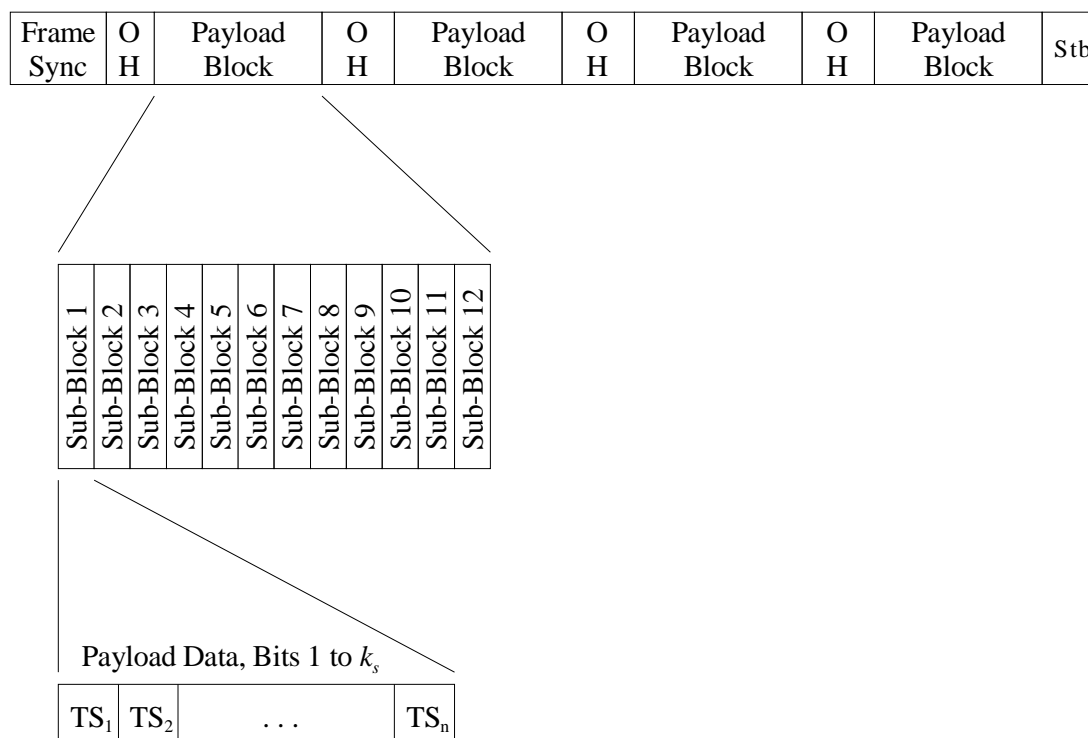

Figure A-2: Aligned D2048S/Fractional D2048S Framing

## A.6 TPS-TC for synchronous ISDN BRA

In this TPS-TC mode, the mapping of the ISDN customer data channels to SDSL payload channels is specified for synchronous transport of multiple ISDN BRAs using clock mode 3a, as specified in clause 8.2.

The ISDN customer data channels are embedded into the payload data within the SDSL frames. ISDN channels and SDSL frames (and any other TPS-TC if Dual Bearer mode is utilized) are synchronized to the same clock domain.

### A.6.1 ISDN BRA over SDSL frames

Figure A-3 illustrates typical transport of ISDN BRAs within the SDSL frames. The basic characteristics of this transport are as follows:

- B channels and D channels are mapped on SDSL payload channels;
- The ISDN BRA does not need a separate synchronization since the SDSL frames are synchronized to the same clock domain. Therefore, the ISDN frame word (12 kbit/s) is not needed;
- The ISDN M-channel transports ISDN line status bits, transmission control information as well as signalling to control the ISDN connection. Only the ISDN M-channel functions, which are needed to control the interface to the ISDN terminal equipment, are transported over a messaging channel (SDSL eoc or fast signalling channel).

### A.6.2 Mapping of ISDN B- and D-channels on SDSL payload channels

The ISDN B- and D- channels are transported within the SDSL payload sub-blocks. The SDSL payload data is structured within the SDSL frames as follows:

- Each payload block contains  $k_s = i + n \times 8$  bits ( $i = 0..7$  and  $n = 3..36$ );
- Each block is ordered in the following way:  $i$  1-bit timeslots followed by  $n$  8-bit timeslots;
- 1-bit timeslots are referred to as Z-bits, and 8-bit timeslots are referred to as  $B_1 \dots B_n$ .

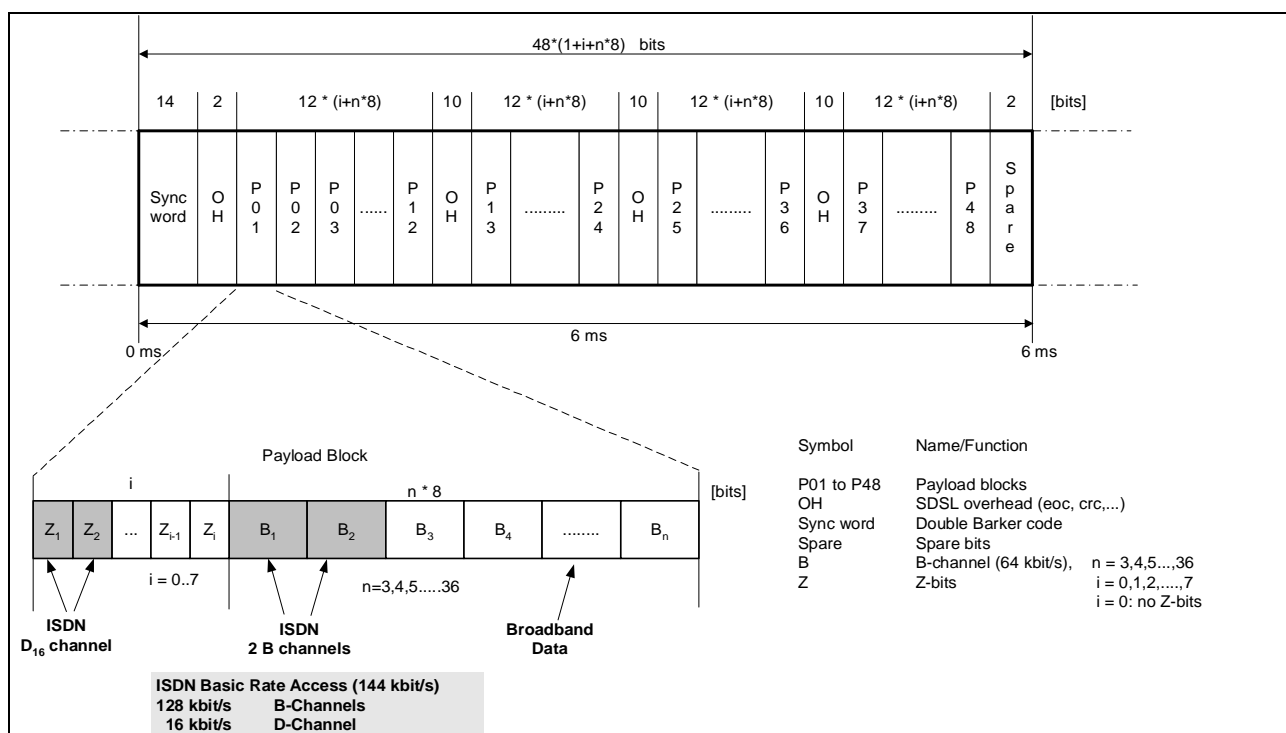

Figure A-3: Mapping of ISDN B- and D-channels

The payload blocks are composed of combinations of  $n \times 8$  bit B timeslots and  $i \times 1$  bit Z-timeslots:

- $n$  corresponds to the number of 64 kbit/s payload channels;
- $i$  corresponds to the number of 8 kbit/s channels.

This payload structure allows efficient mapping of ISDN BRA channels on SDSL frames.

- Data channels (64 kbit/s each, designated  $B_1 - B_y$ ) are mapped onto 64 kbit/s B-channels;
- Signalling channels (16 kbit/s each, designated  $D_1 - D_x$ ) are mapped onto two 8 kbit/s Z-channels each.

NOTE: If four or more ISDN BRAs are transported, four  $D_{16}$  channels are mapped on one 64 kbit/s B-channel.

A general example of this mapping technique is shown in figure A-3.

### A.6.3 Multi-ISDN BRAs

The transport of up to 6 ISDN BRAs is described in detail in the next clauses. Figure A-4 shows a mapping example for two ISDN BRAs.

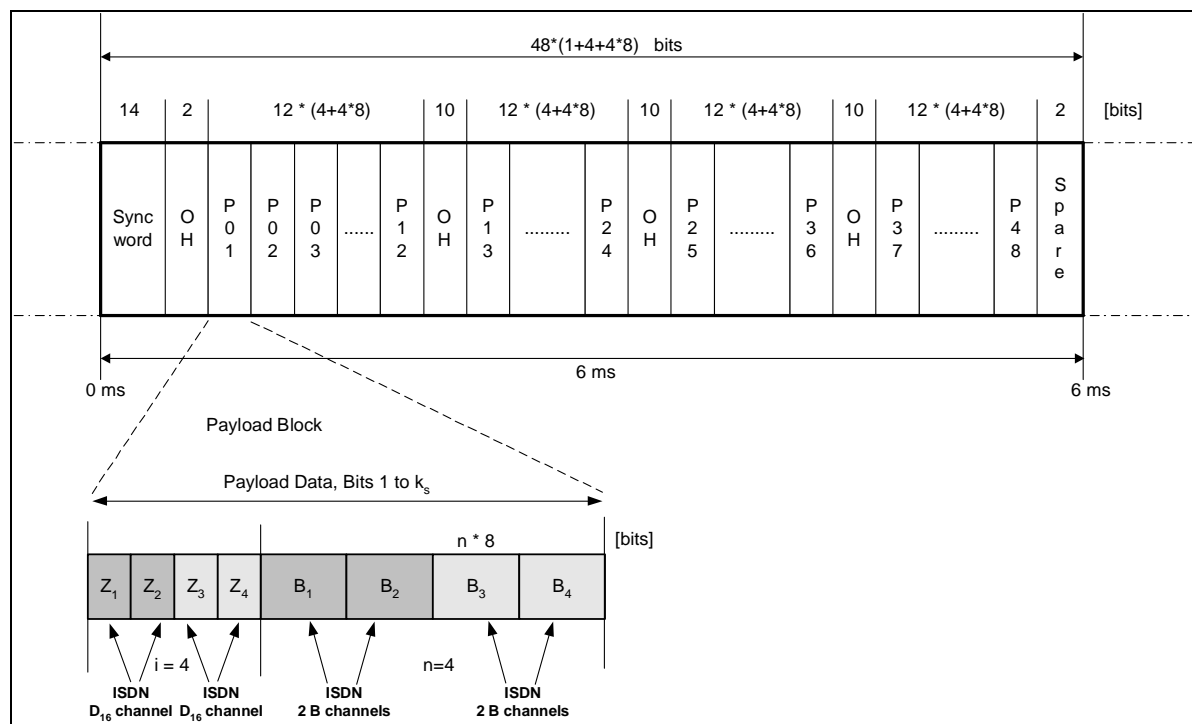

Figure A-4: Framing example: 2 x ISDN BRA

The transport of the customer data channels of each ISDN BRA requires 144 kbit/s bandwidth. Table A-1 shows the number of required B- and Z-channels.

Table A-1:  $K \times$  ISDN BRA

Number of ISDN BRA $K$	Payload bit rate $K \times (128 \text{ kbit/s} + 16 \text{ kbit/s})$	Application	B-channels (64 kbit/s) $n$	Z-channels (8 kbit/s) $i$
1	144	1 ISDN BRA	2	2
2	288	2 ISDN BRA	4	4
3	432	3 ISDN BRA	6	6
4	576	4 ISDN BRA	9	0
5	720	5 ISDN BRA	11	2
6	864	6 ISDN BRA	13	4

## A.6.4 ISDN BRA for lifeline service

Lifeline service in case of local power failure can be provided by one ISDN BRA. The lifeline BRA is always the one that is transported over the first time slots of each payload sub block (e.g.  $Z_1$ ,  $Z_2$ ,  $B_1$ ,  $B_2$ ). Remote power feeding is provided by the central office such that the transceiver can operate in a reduced power mode.

## A.6.5 Time slot positions of ISDN B- and $D_{16}$ -channels (eoc Signalling)

If multiple ISDN BRAs are transported over SDSL, certain data channels in the SDSL payload blocks must be assigned to each ISDN BRA. Tables A-2 to A-5 show the allocation of the ISDN data channels of up to 4 BRAs. The Signalling is transmitted over the SDSL eoc. In order to avoid unnecessary shifting of ISDN D- and B- bits, the respective D-bits are transmitted after their B- bits in the subsequent SDSL payload block (B-bits in  $N$ th payload block and D-bits in  $N+1$ th payload block; if the B-bits are transmitted in the last payload block of an SDSL frame, the D-bits are transmitted in the first payload block of the next SDSL frame).

**Table A-2: Time slot allocation for 1 ISDN BRA**

ISDN BRA number	ISDN $B_1$ time slot	ISDN $B_2$ time slot	ISDN $D_{16}$ time slots
1	$B_1$	$B_2$	$Z_1+Z_2$

**Table A-3: Time slot allocation for 2 ISDN BRAs**

ISDN BRA number	ISDN $B_1$ time slot	ISDN $B_2$ time slot	ISDN $D_{16}$ time slots
1	$B_1$	$B_2$	$Z_1+Z_2$
2	$B_3$	$B_4$	$Z_3+Z_4$

**Table A-4: Time slot allocation for 3 ISDN BRAs**

ISDN BRA number	ISDN $B_1$ time slot	ISDN $B_2$ time slot	ISDN $D_{16}$ time slots
1	$B_1$	$B_2$	$Z_1+Z_2$
2	$B_3$	$B_4$	$Z_3+Z_4$
3	$B_5$	$B_6$	$Z_5+Z_6$

**Table A-5: Time slot allocation for 4 ISDN BRAs**

ISDN BRA number	ISDN $B_1$ time slot	ISDN $B_2$ time slot	ISDN $D_{16}$ time slots
1	$B_2$	$B_3$	$B_1$ (Bit 1 and 2)
2	$B_4$	$B_5$	$B_1$ (Bit 3 and 4)
3	$B_6$	$B_7$	$B_1$ (Bit 5 and 6)
4	$B_8$	$B_9$	$B_1$ (Bit 7 and 8)

## A.6.6 Time slot positions of ISDN B- and $D_{16}$ -channels and the optional fast Signalling channel

The optional 8 kbit/s fast signalling channel is always conveyed in  $Z_1$ , as shown in figure A-5. If this fast signalling channel is used, up to 6 ISDN BRA can be transported over SDSL.

In order to avoid unnecessary shifting of ISDN D- and B- bits, the respective D-bits are transmitted after their B-bits in the subsequent SDSL payload block (B-bits in  $N$ th payload block and D-bits in  $N+1$ th payload block; if the B-bits are transmitted in the last payload block of an SDSL frame, the D-bits are transmitted in the first payload block of the next SDSL frame). Tables A-6 to A-11 show the time slot allocation using the fast signalling channel for up to 6 ISDN BRA.



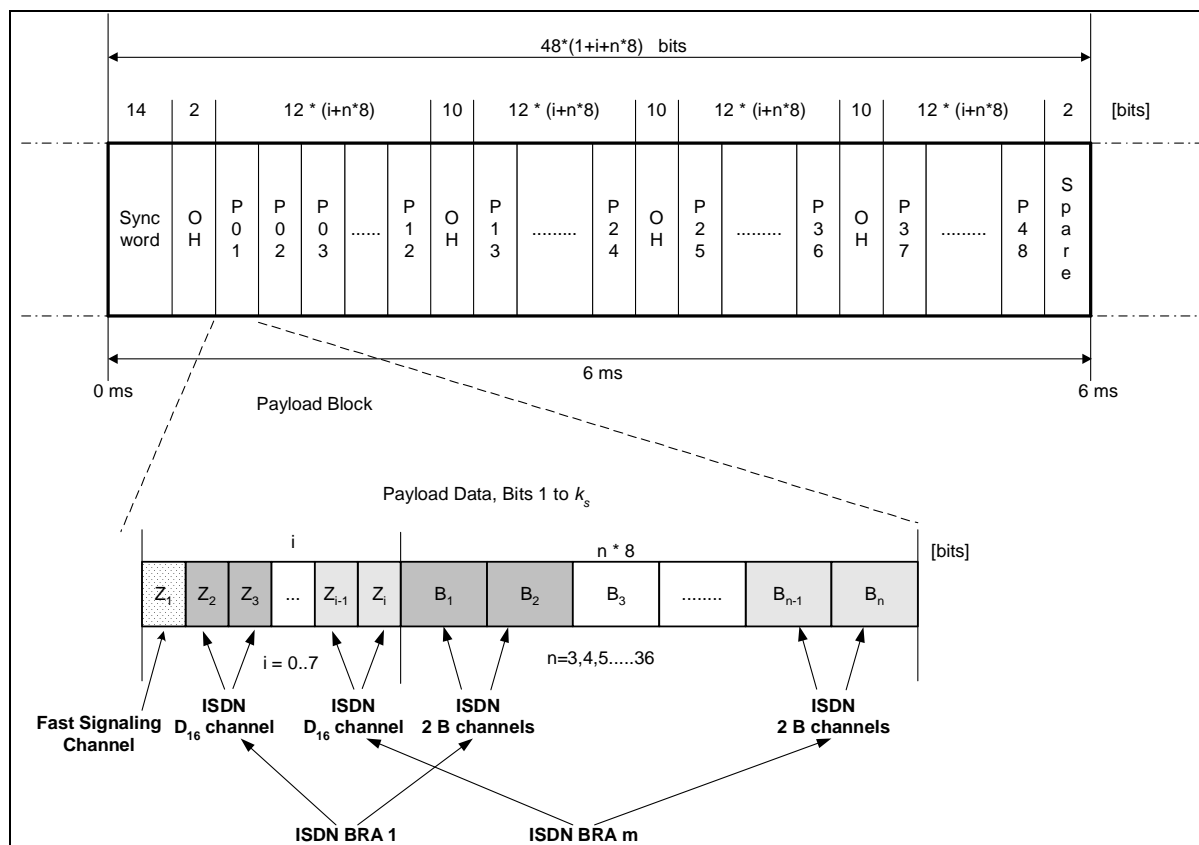

Figure A-5: Mapping of ISDN B- and D- channels with a fast Signalling channel

Table A-6: Time slot allocation for 1 ISDN BRA using the fast Signalling channel

ISDN BRA number	ISDN B <sub>1</sub> time slot	ISDN B <sub>2</sub> time slot	ISDN D <sub>16</sub> time slots
1	B <sub>1</sub>	B <sub>2</sub>	Z <sub>2</sub> +Z <sub>3</sub>

Table A-7: Time slot allocation for 2 ISDN BRA using the fast Signalling channel

ISDN BRA number	ISDN B <sub>1</sub> time slot	ISDN B <sub>2</sub> time slot	ISDN D <sub>16</sub> time slots
1	B <sub>1</sub>	B <sub>2</sub>	Z <sub>2</sub> +Z <sub>3</sub>
2	B <sub>3</sub>	B <sub>4</sub>	Z <sub>4</sub> +Z <sub>5</sub>

Table A-8: Time slot allocation for 3 ISDN BRA using the fast Signalling channel

ISDN BRA number	ISDN B <sub>1</sub> time slot	ISDN B <sub>2</sub> time slot	ISDN D <sub>16</sub> time slots
1	B <sub>1</sub>	B <sub>2</sub>	Z <sub>2</sub> +Z <sub>3</sub>
2	B <sub>3</sub>	B <sub>4</sub>	Z <sub>4</sub> +Z <sub>5</sub>
3	B <sub>5</sub>	B <sub>6</sub>	Z <sub>6</sub> +Z <sub>7</sub>

Table A-9: Time slot allocation for 4 ISDN BRA using the fast Signalling channel

ISDN BRA number	ISDN B <sub>1</sub> time slot	ISDN B <sub>2</sub> time slot	ISDN D <sub>16</sub> time slots
1	B <sub>2</sub>	B <sub>3</sub>	B <sub>1</sub> (Bit 1 and 2)
2	B <sub>4</sub>	B <sub>5</sub>	B <sub>1</sub> (Bit 3 and 4)
3	B <sub>6</sub>	B <sub>7</sub>	B <sub>1</sub> (Bit 5 and 6)
4	B <sub>8</sub>	B <sub>9</sub>	B <sub>1</sub> (Bit 7 and 8)

**Table A-10: Time slot allocation for 5 ISDN BRA using the fast Signalling channel**

ISDN BRA number	ISDN B <sub>1</sub> time slot	ISDN B <sub>2</sub> time slot	ISDN D <sub>16</sub> time slots
1	B <sub>2</sub>	B <sub>3</sub>	Z <sub>2</sub> +Z <sub>3</sub>
2	B <sub>4</sub>	B <sub>5</sub>	B <sub>1</sub> (Bit 1 and 2)
3	B <sub>6</sub>	B <sub>7</sub>	B <sub>1</sub> (Bit 3 and 4)
4	B <sub>8</sub>	B <sub>9</sub>	B <sub>1</sub> (Bit 5 and 6)
5	B <sub>10</sub>	B <sub>11</sub>	B <sub>1</sub> (Bit 7 and 8)

**Table A-11: Time slot allocation for 6 ISDN BRA using the fast Signalling channel**

ISDN BRA number	ISDN B <sub>1</sub> time slot	ISDN B <sub>2</sub> time slot	ISDN D <sub>16</sub> time slots
1	B <sub>2</sub>	B <sub>3</sub>	Z <sub>2</sub> +Z <sub>3</sub>
2	B <sub>4</sub>	B <sub>5</sub>	Z <sub>4</sub> +Z <sub>5</sub>
3	B <sub>6</sub>	B <sub>7</sub>	B <sub>1</sub> (Bit 1 and 2)
4	B <sub>8</sub>	B <sub>9</sub>	B <sub>1</sub> (Bit 3 and 4)
5	B <sub>10</sub>	B <sub>11</sub>	B <sub>1</sub> (Bit 5 and 6)
6	B <sub>12</sub>	B <sub>13</sub>	B <sub>1</sub> (Bit 7 and 8)

## A.6.7 Signalling over the SDSL eoc or the fast Signalling channel

The ISDN status signalling information can be optionally transmitted over two different channels:

- SDSL eoc;
- Fast signalling channel.

In both cases SDSL eoc messages with their HDLC-like format are used to transport the ISDN message code. The LT as well as NT unit can initiate eoc messages. Generally, the ISDN related eoc messages are transported over the SDSL eoc. In some applications, it is necessary to set up an additional fast signalling channel with 8 kbit/s bandwidth for these ISDN related eoc messages. This is the case when more than four ISDN BRAs are used. It may also be used when low latency signalling is required or when another TPS-TC signalling (e.g. ATM) has substantially restricted the use of the SDSL eoc channel.

### A.6.7.1 SDSL eoc messages

The eoc messages number 20 and 148 are used to transmit the ISDN maintenance and control functions as well as the other ISDN eoc messages.

**Table A-12: ISDN Request- Message ID 20**

Octet #	Contents	Data type	Reference
1	Message ID 20	Message ID	
2 bits 4 - 7	ISDN BRA Number	Unsigned char	
2 bits 0 - 3			Set to 0000 <sub>2</sub>
3	ISDN message code		

**Table A-13: ISDN Response - Message ID 148**

Octet #	Contents	Data type	Reference
1	Message ID 148	Message ID	
2 bits 4 - 7	ISDN BRA Number	Unsigned char	
2 bits 0 - 3	Unused		Set to 0000 <sub>2</sub>
3	ISDN message code		

**ISDN BRA Number:** Each ISDN BRA can be addressed independently. To each ISDN BRA, a four digit number is assigned (BRA 1 = 0000, ... BRA 6 = 0101).

## A.6.7.2 ISDN Message Codes

The message codes, which are contained as an octet in the SDSL eoc message "ISDN Requests", are listed in table A-14. The message codes, which are contained as an octet in the SDSL eoc message "ISDN Response", are listed in table A-15.

**Table A-14: ISDN Message Codes Requests**

Function	Message	eoc message code	Comment
S-Bus Control	SIA	0001 0000	S-interface activate (LT → NT)
	SID	0001 0001	S-interface deactivate (LT → NT)
	SAI	0001 0010	S-interface activated (NT → LT)
	SDI	0001 0011	S-interface deactivated
ISDN Transceiver Status	ACT	0000 0001	Readiness for layer 2 communication (LT → NT) (NT → LT)
	DEA	0000 0010	Intention to deactivate (LT → NT)
	CSO	0000 0011	Cold start only (NT → LT)
BRA Termination Reset	S reset	0000 0000	Reset of ISDN control unit at NT (LT → NT)
	Operate 2B+D loopback	0011 0001	(LT → NT)
	Operate B1-channel loopback (see note)	0011 0010	(LT → NT)
ISDN eoc Messages	Operate B2-channel loopback	0011 0011	(LT → NT)
	Return to normal	0011 1111	(LT → NT)
	Hold state	0011 0000	(LT → NT)

**Table A-15: ISDN Message Codes Responses**

Function	Message	eoc message code	Comment
S-Bus Control	SIA	1001 0000	S-interface activate
	SIAF	1101 0000	S-interface activation failed
	SID	1001 0001	S-interface deactivation failed
	SIDF	1101 0001	S-interface deactivate
	SAI	1001 1010	S-interface activated
ISDN Transceiver Status	SDI	1001 0011	S-interface deactivated
	ACT	1000 0001	Readiness for layer 2 communication
	DEA	1000 0010	Intention to deactivate
BRA Termination Reset	CSO	1000 0011	Cold start only
	S reset ack	1000 0000	Reset of ISDN control unit at NT
	Operate 2B+D loopback (success)	1011 0001	
	Operate 2B+D loopback (failure)	1111 0001	
	Operate B1-channel loopback (success)	1011 0010	
	Operate B1-channel loopback (failure)	1111 0010	
	ISDN eoc Messages	Operate B2-channel loopback (success)	1011 0011
Operate B2-channel loopback (failure)		1111 0011	
Return to normal (success)		1011 1111	
	Return to normal (failure)	1111 1111	

Function	Message	eoc message code	Comment
	Hold state	1011 0000	
	Unable to comply acknowledgement	1111 0100	

## A.6.8 S-Bus control

The ISDN S-buses, which connect the ISDN terminals with the NT, can be controlled independently with the respective message codes (SIA, SID, SAI, and SDI) for each S-bus. The LT side can activate and deactivate the S-bus and get status information. These messages are transmitted as SDSL eoc messages.

The S-interfaces of each ISDN BRA can be addressed independently. To each ISDN BRA, a four digit number is (BRA 1 = 0000, ... BRA 6 = 0101) contained in the ISDN related SDSL eoc messages.

**SIA:** In LT to NT direction, this function is used to request the NT to activate the interface at the S reference point. If the interface at the S reference point is to be activated, this message may be sent.

In NT or LT direction, the respective responses are SIA (S-interface activated) or SIAF (S-interface activation failed).

**SID:** In LT to NT direction, this function is used to request the NT to deactivate the interface at the S reference point. If the interface at the S reference point is to be deactivated, this message may be sent.

In NT or LT direction, the respective responses are SID (S-interface deactivated) or SIDF (S-interface deactivation failed).

**SAI:** In NT to LT direction, this message is used to inform the LT, that the S-interface and S-bus have been activated.

**SDI:** In NT to LT direction, this message is used to inform the LT, that the S-interface and S-bus have been deactivated.

**Table A-16: Flowchart: S-interface**

LT: activate S-interface command	eoc S act (SIA) →	NT: activate and send result
	← eoc S act ackn (SIA/SIAF)	
LT: deactivate S-interface command	eoc S deact (SID) →	NT: deactivate and send result
	← eoc S deact ackn (SID/SIDF)	
LT: acknowledge	← eoc S ActInd (SAI)	NT: indicate activation
	eoc S ActInd ackn (SAI) →	
LT: acknowledge	← eoc S DeactInd (SDI)	NT: indicate deactivation
	(SDI)	

## A.6.9 BRA termination reset

The status and condition of each ISDN BRA and its S-interface at the NT side can be individually monitored from the LT side. If a failure or blocking at one ISDN BRA is detected this situation can be resolved by a reset. "BRA termination reset" puts the control unit of the S-interface into its default state (the deactivated state). Other BRAs or other services are not affected.

**Table A-17: Reset request**

Message	eoc message code	Comment
S reset	0000 0000	

**Table A-18: Reset response**

Message	eoc message code	Comment
S reset acknowledge	1000 0000	

## A.6.10 Transport of ISDN eoc messages over SDSL eoc

Table A-19 shows the six necessary eoc code functions for ISDN operation over SDSL out of the eight eoc possible code functions defined in the ISDN standard. (The two messages concerning the corrupted CRC are not required.)

**Table A-19: ISDN eoc Message Codes**

Origin (o) and destination (d) and transfer (t)				
Message	Message code	Network	NT1	REG
Operate 2B+D loopback	0011 0001	o	d	t/d
Operate B1-channel loopback (see note)	0011 0010	o	d	t/d
Operate B2-channel loopback	0011 0011	o	d	t/d
Return to normal	0011 1111	o	d	t/d
Hold state	0011 0000	d/o	o/d	o/d/t
NOTE: The use of B1 and B2 channel loopbacks is optional. However, the loopback codes are reserved for these functions.				

## A.7 TPS-TC for POTS

In this TPS-TC mode, the mapping of digitized 64 kbit/s POTS channels onto SDSL frame payload channels is specified for one or multiple POTS access.

### A.7.1 Mapping of 64 kbit/s POTS channels onto the SDSL frame

Figure A-6 illustrates POTS transport within the SDSL frames.

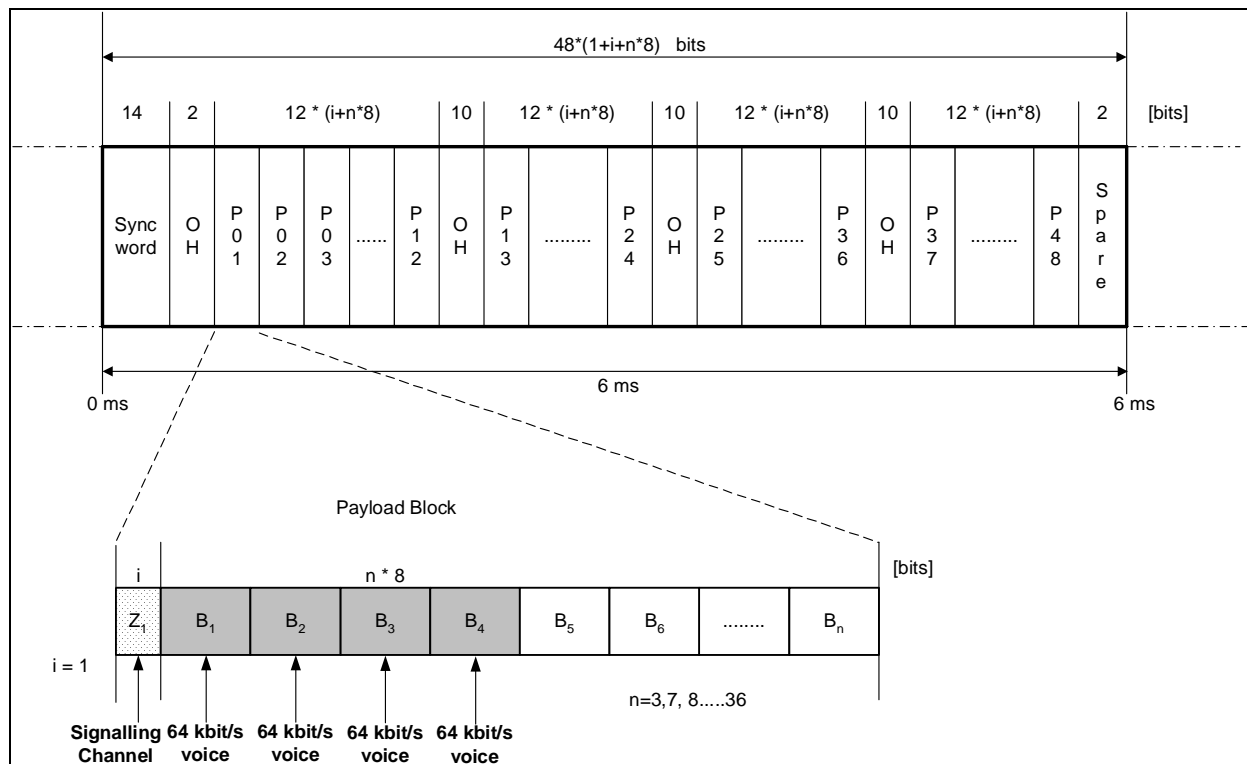

**Figure A-6: Mapping example of 64 kbit/s voice channels**

The 64 kbit/s PCM voice channels, one for each POTS access, are transported within the SDSL payload sub-blocks. The SDSL payload data is structured within the SDSL frames as follows:

- Each payload block contains  $k_s = i + n \times 8$  bits ( $i = 0..7$  and  $n = 3..36$ );
- Each block is ordered in the following way:  $i$  1-bit timeslots followed by  $n$  8-bit timeslots;
- 1-bit timeslots are referred to as Z-bits (note that figure A-1 as an example shows only one 1-bit timeslot, denoted as  $Z_1$ ), and 8-bit timeslots are referred to as  $B_1 \dots B_n$ .

The payload blocks are composed of combinations of  $n \times 8$  bit B timeslots and  $i \times 1$  bit Z-timeslots:

- $n$  corresponds to the number of 64 kbit/s payload channels;
- $i$  corresponds to the number of 8 kbit/s channels.

As a mapping example, figure A-6 shows the transport of four POTS channels.

### A.7.2 POTS access for lifeline service

Lifeline service, in case of local power failure, can be provided by one POTS access. The lifeline POTS access is always the one that is transported over the first available 64 kbit/s time slot of each payload sub block (e.g.  $B_1$ ). Remote power feeding is provided by the central office such that the transceiver can operate in a reduced power mode.

## A.7.3 Signalling

Signalling as well as the other POTS related messages are conveyed over a dedicated Signalling channel for which two options exist.

NOTE 1: Signalling format and protocol is outside the scope of the present document and shall be specified by ETSI TC SPAN 13.

NOTE 2: An initial proposal for signalling format and protocol is given in clause 0. The proposal is for further study.

### A.7.3.1 Signalling channel over Z-bit

The signalling channel is established over one or multiple Z-bits of the payload block , as shown in figure A-6. One channel provides 8 kbit/s, may be used for multiple POTS-accesses and caters for an effective use of transport capacity. On the other hand, multiple Z-bits (1 to 7) may be necessary for the signalling channel, depending on the number of POTS-accesses and the amount of signalling information expected.

### A.7.3.2 Signalling channel over a B-channel

A common signalling channel is established over a 64 kbit/s communication channel, mapped to the first time slot of each sub block.

---

## A.8 ATM Transport over SDSL

### A.8.1 Reference Model for ATM Transport

The proposed ATM TC layer for SDSL is based on ITU-T Recommendation I.432. It provides the following functions:

- Rate de-coupling between ATM layer and SDSL PMS-TC layer;
- Insertion/extraction of Idle cells;
- Insertion/extraction of the Header Error Control (HEC) byte;
- Cell payload scrambling/de-scrambling;
- Cell delineation in the receive channel;
- Bit timing and ordering.

NOTE 1: RxRef is present at the LTU-side.

NOTE 2: RxRef is present at the NTU-side.

Figure A-7 shows the logical interfaces between the ATM Layer, the ATM-TC function and the SDSL PMS-TC function. In this example, an ATM UTOPIA Level 2 interface connects the ATM-TC to the ATM Layer. This interface may also be realized logically, and its specification is beyond the scope of the present document.

The SDSL PMS-TC provides a clear channel to the ATM-TC and cells are mapped into the SDSL payload on a byte by byte basis. Bytes are transmitted msb first, in accordance with ITU-T Recommendation I.432.1 [20]. Cell alignment to the SDSL frame is not required.

Logical data and clock lines are also present between the PMS-TC and ATM-TC blocks, as well as OAM information flow.

Some ATM applications require an 8 kHz Network Timing Reference (NTR). In these applications, the SDSL PMS-TC shall deactivate the stuffing function and the SDSL frame shall be synchronized to the clock reference at the LTU (Broadband line termination) (clock synchronization mode 3a in the SDSL reference clock architecture). At the NTU (Broadband network termination), the NTR may then be extracted from the SDSL Frame Synchronization Word (FSW). The TxRef (LTU-side) and RxRef (NTU-side) lines provide NTR directly between SDSL PMS-TC and the ATM Layer.

When available, the network reference clock shall be either a fundamental 8 kHz network clock or a related reference clock at some multiple of 8 kHz. Such reference clocks are typically 1,544 MHz or 2,048 MHz, although in some applications other frequencies, such as 64 kHz, may be available. These related clocks include implicit 8 kHz timing signals. Selection of specific network clock reference shall be application dependent.

The SDSL frame is always 6 ms long, independent of the line rate. This frame-length could easily be used to generate an 8 kHz NTR signal, because the 6 ms SDSL frame for synchronous data transport and the 8 kHz network clock have a fixed relationship. Each SDSL frame contains  $48 \times (1 + i + n \times 8)$  bits ( $i = 0 \dots 7$  and  $n = 3 \dots 36$ ). The relationship can therefore be calculated with:  $T = 6 \text{ ms} / 48 = 125 \mu\text{s}$  and  $f = 1 / T = 8 \text{ kHz}$ .

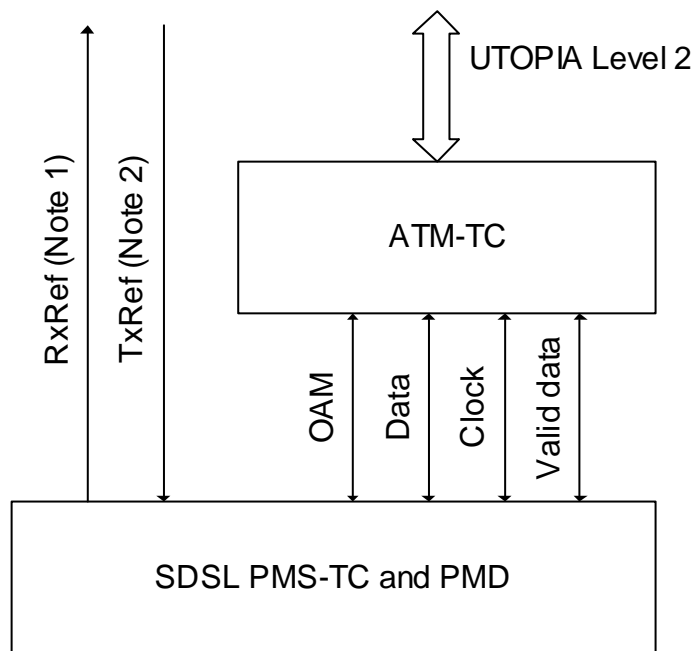

NOTE 1: RxRef is present at the LTU-side.

NOTE 2: TxRef is present at the NTU-side.

**Figure A-7: Reference Model for ATM mode**

## A.8.2 Flow Control

The ATM-TC shall provide flow control, allowing the LTU and NTU to control the cell flow from the ATM layer. This functionality is important to avoid cell overflow and underflow at the ATM-TC layer.

This functionality is implemented on the UTOPIA interface through the Tx\_Cell\_available (Tx\_Clav) handshake and Rx\_Cell\_available (Rx\_Clav) handshake. A cell may be transferred from the ATM layer to the ATM-TC layer only after the completion of a Tx\_Clav handshake. Similarly, a cell may be transferred from the ATM-TC to the ATM Layer only after completion of an Rx\_Clav\_handshake.

## A.8.3 ATM-TC sub-layer functionality

### A.8.3.1 Idle Cell Insertion

Idle cells shall be inserted in the transmit direction for cell rate de-coupling and extracted in the receive direction. Idle cells are identified by the standardized pattern for the cell header given in ITU-T Recommendation I.432.1 [20].



NOTE: This recommendation is written on the assumption that idle cells will be discarded by the far end receiver.

### A.8.3.2 Header Error Control (HEC) Generation

The HEC byte shall be generated in the transmit direction as described in ITU-T Recommendation I.432.1 [20], including the recommended modulo 2 addition (XOR) of the pattern 01010101<sub>2</sub> to the HEC bits.

The generator polynomial coefficient set used and the HEC sequence generation procedure shall be in accordance with ITU-T Recommendation I.432.1 [20].

### A.8.3.3 HEC Verification

The HEC covers the entire cell header. The code used for this function is capable of either:

- single bit error correction; or
- multiple bit error detection.

Error detection shall be implemented as defined in ITU-T Recommendation I.432.1 [20] with the exception that any HEC error shall be considered as a multiple bit error, and therefore, HEC error correction shall not be performed.

### A.8.3.4 Cell payload scrambling/de-scrambling

Scrambling of the cell payload field shall be used in the transmit direction to improve the security and robustness of the HEC cell delineation mechanism. In addition, it randomizes the data in the information field for possible improvement of the transmission performance. The self-synchronizing scrambler polynomial  $x^{43}+1$  and procedures defined in ITU-T Recommendation I.432.1 [20] shall be implemented.

NOTE: This recommendation is written on the assumption that the cell payload will be de-scrambled by the far end receiver

### A.8.3.5 Cell Delineation

The cell delineation function permits the identification of cell boundaries in the payload. It uses the HEC field in the cell header.

Cell delineation shall be performed using a coding law checking the HEC field in the cell header according to the algorithm described in ITU-T Recommendation I.432.1 [20]. The ATM cell delineation state machine is shown in figure A-8. The details of the state diagram are described below:

- 1) In the HUNT state, the delineation process is performed by checking byte by byte for the correct HEC. Once such an agreement is found, it is assumed that one header has been found, and the method enters the PRESYNC state.
- 2) In the PRESYNC state, the delineation process is performed by checking cell by cell for the correct HEC. The process repeats until the correct HEC has been confirmed *DELTA* (see note) times consecutively. If an incorrect HEC is found, the process returns to the HUNT state.
- 3) In the SYNC state the cell delineation will be assumed to be lost if an incorrect HEC is obtained *ALPHA* times consecutively.
- 4) Cells with correct HEC, that are processed while in the SYNC state, shall be passed to the ATM layer. Cells with correct HEC that are checked while in the PRESYNC state may optionally be passed to the ATM layer, but only when they are part of the *DELTA* consecutive correct HECs necessary for transition to the SYNC state. The cell associated with the first correct HEC (in the HUNT state) may also optionally be passed to the ATM layer in conjunction with the *DELTA* cells just mentioned. In any case, idle cells are not passed to the ATM layer.

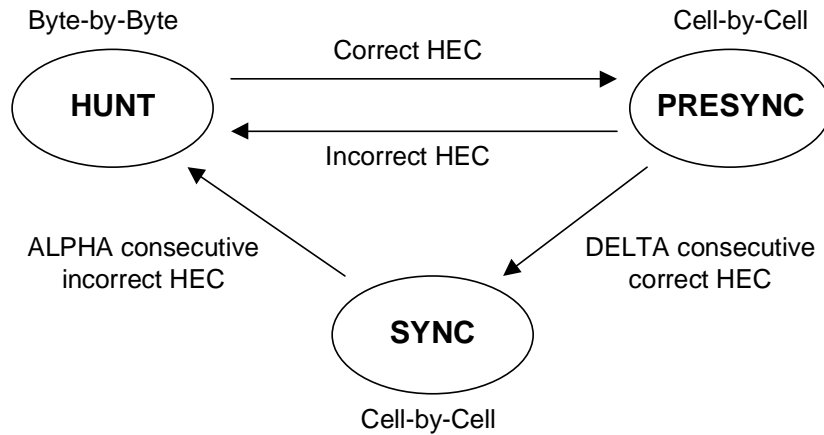

Figure A-8: ATM cell delineation state machine

NOTE: With reference to ITU-T Recommendation I.432, no recommendation is made for the values of *ALPHA* and *DELTA* as the choice of these values is not considered to effect interoperability. However, it should be noted that the use of the values suggested in ITU-T Recommendation I.432.1 [20] (*ALPHA* = 7, *DELTA* = 6) may be inappropriate due to the particular transmission characteristics of SDSL.

### A.8.3.6 Bit timing, ordering and data rates

When interfacing ATM data bytes to the SDSL payload, the most significant bit (msb) shall be sent first. The SDSL payload data rate, when transporting ATM cells shall be  $n \times 64 + i \times 8$  kbit/s, where *n* is an integer value between 3 and 36 ( $3 \leq n \leq 36$ ) according to the SDSL frame structure (see clause 7.1) and *i* = 0. This is shown in figure A.9.

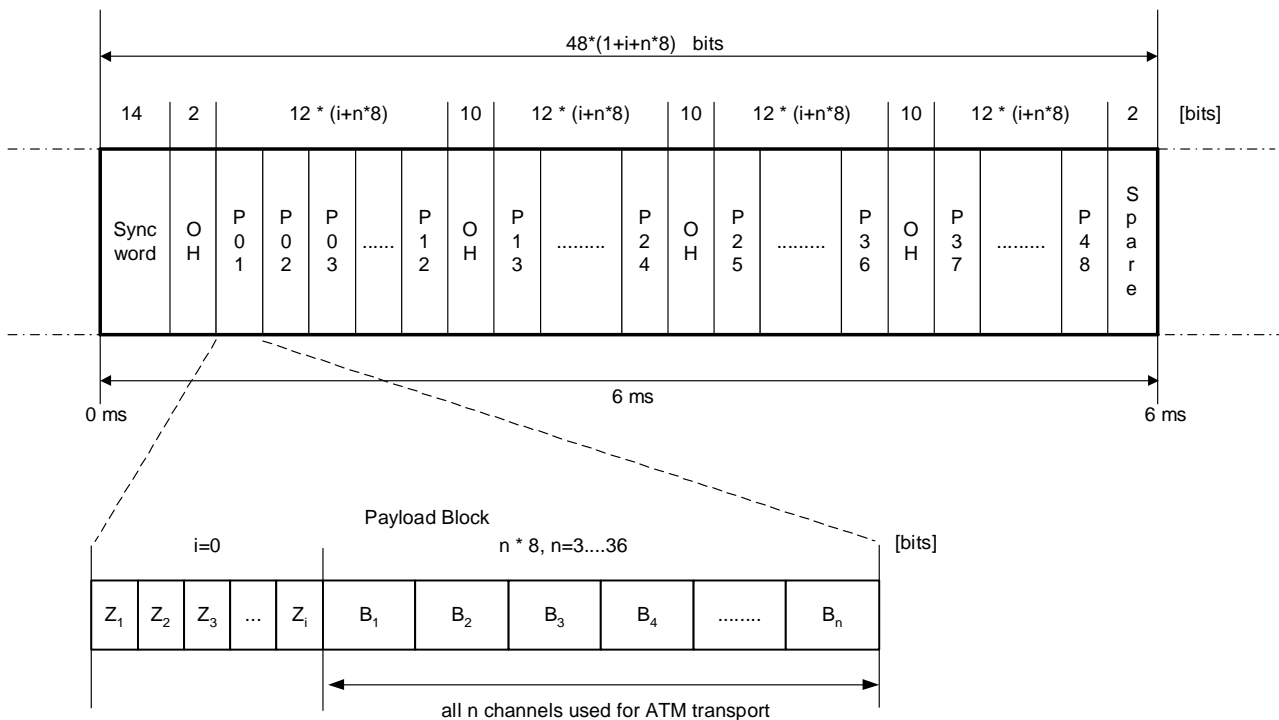

Figure A-9: ATM transport over SDSL

## A.8.4 Operations and Maintenance

The ATM-TC requires Operation and Maintenance (OAM) functionality. The messaging protocol and format should be handled in accordance with clause 10. The OAM functions notify the OAM entity at the opposite end of the line upon the status of the cell delineation process (e.g. Header Error Check (HEC) anomalies and Loss of Cell Delineation defects (LCD)). Performance parameters are derived from anomalies and defects.

### A.8.4.1 ATM data path related near-end anomalies

- *Near-end No Cell Delineation (nncd) anomaly*: An nncd anomaly occurs immediately after ATM-TC start-up, when ATM data is received and the cell delineation process is in HUNT or PRESYNC state. Once cell delineation is acquired, subsequent losses of cell delineation shall be considered nocd anomalies.
- *Near-end Out of Cell Delineation (nocd) anomaly*: A nocd anomaly occurs when the cell delineation process in operation transitions from the SYNC state to HUNT state. A nocd anomaly terminates when the cell delineation process transition from PRESYNC to SYNC state or when nlcd defect maintenance status is entered.
- *Near-end Header Error Control (nhec) anomaly*: An nhec anomaly occurs when an ATM cell header error control fails.

### A.8.4.2 ATM data path related near-end defects

- *Near-end Loss of Cell Delineation (nlcd) defect*: An nlcd defect occurs when at least one nocd is present in 9 consecutive SDSL frames and no losw defect (loss of synchronization word) is detected.

### A.8.4.3 ATM data path related far-end anomalies

- *Far-end No Cell Delineation (fncd) anomaly*: An fncd anomaly is an nncd anomaly that is reported from the far end by the NCD indicator in the EOC ATM Cell Status Information message. An fncd anomaly occurs immediately after start-up and terminates if the received NCD indicator is coded 0.

NOTE: Since the far-end reports the NCD indicator only on request, the fncd anomaly may be inaccurate for derivation of the far-end NCD failure. Therefore, the NCD failure is autonomously reported from the far-end.

- *Far-end Out of Cell Delineation (focd) anomaly*: A focd anomaly is a nocd anomaly that is reported from the far end by the OCD indicator in the EOC ATM Cell Status Information message. The OCD indicator shall be coded 0 to indicate no nocd anomaly has occurred since last reporting and shall be coded 1 to indicate that at least one nocd anomaly has occurred since last reporting. A focd anomaly occurs if no fncd anomaly is present and a received OCD indicator is coded 1. A focd anomaly terminates if a received OCD indicator is coded 0.
- *Far-end Header Error Control (fhec) anomaly*: An fhec anomaly is an nhec anomaly that is reported from the far end by the HEC indicator in the EOC ATM Cell Status Information message. The HEC indicator shall be coded 0 to indicate no nhec anomaly has occurred since last reporting and shall be coded 1 to indicate that at least one nhec anomaly has occurred since last reporting. An fhec anomaly occurs if a received HEC indicator is coded 1. An fhec anomaly terminates if a received HEC indicator is coded 0.

### A.8.4.4 ATM data path related far-end defects

- *Far-end Loss of Cell Delineation (flcd) defect*: An flcd defect is an nlcd that is reported from the far end of the line by the LCD indicator in the EOC ATM Cell Status Information message. The LCD indicator shall be coded 0 to indicate no nlcd defect has occurred since last reporting and shall be coded 1 to indicate that at least one nlcd defect has occurred since last reporting. An flcd defect occurs when the LCD indicator is coded 1. An flcd defect terminates when the LCD indicator is coded 0.

NOTE: Since the far-end reports the LCD indicator only on request, the flcd defect may be inaccurate for derivation of the far-end LCD failure. Therefore, the LCD failure is autonomously reported from the far-end.

### A.8.4.5 ATM cell level protocol performance information collection

- *HEC violation count (hvc)*: An hvc performance parameter is the count of the number of nhec anomalies since the last reporting.
- *HEC total count (htc)*: A htc performance parameter is the count of the total number of cells passed through the cell delineation process, while operating in the SYNC state, since the last reporting.

These values shall be counted, such that the Management system is able to retrieve current counts on a 15-minutes and 24-hour basis.

### A.8.4.6 Failures and Performance Parameters

A near-end NCD failure and near-end LCD failure relates to a persistent nncd anomaly and persistent nlcd defect respectively. They are defined in ITU-T Recommendation G.997.1 [8], clause 7.1.2 and reported in the ATM Cell Status Information message.

### A.8.4.7 EOC ATM Cell Status Request Message Format - Message ID 17

The ATM Cell Status Request/Confirmation message is used for two purposes. This message is used as ATM Cell Status Request message to get the NTU ATM Status. For this purpose, the whole information of EOC ATM Cell Status Information message - Message ID 145 shall be sent in response to this message. If an unexpected receipt of ATM Cell Status message, Message ID 145 is received including NCD or LCD failure indication, this message may be used to confirm the reception and stop future autonomous transmission of the ATM Cell Status message, Message ID 145 due to the current failure condition.

**Table A-20: ATM Cell Status Request Information Field**

Octet #	Information Field	Data Type
1	Message ID - 17	Message ID

### A.8.4.8 EOC ATM Cell Status Information Message Format - Message ID 145

The ATM Cell Status Information message shall be sent in response to the ATM Cell Status Request message and shall be sent autonomously upon the occurrence of an *nlcd* Failure or an *nncd* Failure. Table A.21 shows the OAM message bit encoding for an ATM Cell Status Information message. The HEC Indicator is implicitly defined as set to 1 if the HEC violation count has changed since last reporting and set to 0 otherwise. If sent autonomously, message ID 145 shall be sent once every second until a message ID 17 is received from the LTU or the failure is cleared.

The NCD, OCD, and LCD Indicator bits shall indicate the state of *nncd* anomaly, *nocd* anomaly, and *nlcd* defect, respectively. NCD Failure and LCD Failure bits shall serve as indications of *nncd* failure and *nlcd* failure, respectively.

**Table A-21: ATM Cell Status Information message**

Octet #	Contents	Data Type	Reference
1	Message ID # 145	Message ID	
2, bit 7	NCD Indicator (see note)	Bit	0 = OK, 1 = alarm
2, bit 6	OCD Indicator (see note)	Bit	0 = OK, 1 = alarm
2, bit 5	LCD Indicator (see note)	Bit	0 = OK, 1 = alarm
2, bit 4-2	Reserved		
2, bit 1	NCD Failure	Bit	0 = OK, 1 = alarm
2, bit 0	LCD Failure	Bit	0 = OK, 1 = alarm
3	HEC violation count (hvc)	MS Byte	16-bit counter
4	HEC violation count (hvc)	LS Byte	16-bit counter

NOTE: Only one of the NCD, OCD and LCD Indicators can be set to 1 at any time.

## A.9 Dual Bearer TPS-TC Mode for SDSL

The TPS-TC modes in clauses A.1 to A.8 are described as operating in Single-Bearer Mode; i.e. the payload is treated as a single data stream, and the TPS-TC uses all of the bits in each payload block. In some applications, however, it is desirable to split the payload into separate data streams supporting multiple user interfaces or different data types. Dual-Bearer Mode provides support for these cases.

Support for Dual-Bearer Mode is optional, as is support for each of the Dual-Bearer TPS-TC combinations specified in table A-22.

### A.9.1 Dual Bearer Mode Framing

In Dual-Bearer Mode, each Payload Sub-Block is split between two separate TPS-TC instances. The TPS-TC modes are negotiated independently in the PACC (see clause 9.2, and there is no direct interaction between them. TPS-TC<sub>a</sub> is assigned the first  $k_{sa}$  bits of each payload block, and TPS-TC<sub>b</sub> is assigned the last  $k_{sb}$  bits of each payload block (see figure A-10). For each of the two TPS-TCs, the  $k_s$  bits assigned to it are treated as if they constituted a complete Payload Sub-Block, and appropriate framing is applied, as described in the paragraph associated with the selected TPS-TC.

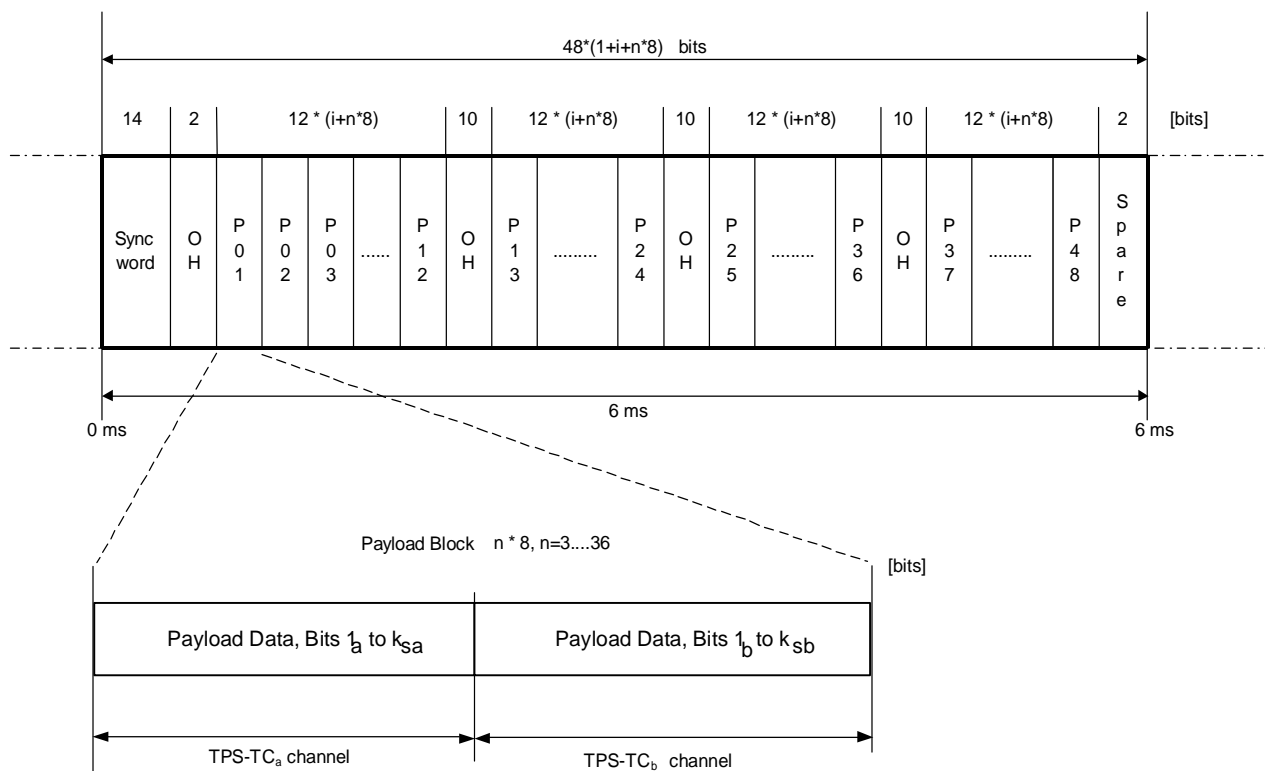

Figure A-10: Dual-Bearer Mode TPS-TS Framing

### A.9.2 Bearer Channel Allocation

In the Dual Bearer mode, the available payload bandwidth of  $n$  B-channels and  $i$  Z-channels is configurable as follows:

- TPS-TC<sub>a</sub> bandwidth:  $n_a$  B-channels +  $i$  Z-channels;
- TPS-TC<sub>b</sub> bandwidth:  $n_b$  B-channels;
- $n_a + n_b = n$ ;
- $0 \leq n_a \leq n$  and  $0 \leq n_b \leq n$ .

Figure A-11 shows an example of a Dual-Bearer mode in which Synchronous ISDN BRA is TPS-TC<sub>a</sub> and ATM is TPS-TC<sub>b</sub>. The block of B-channels used for ATM transport shall be contiguous.

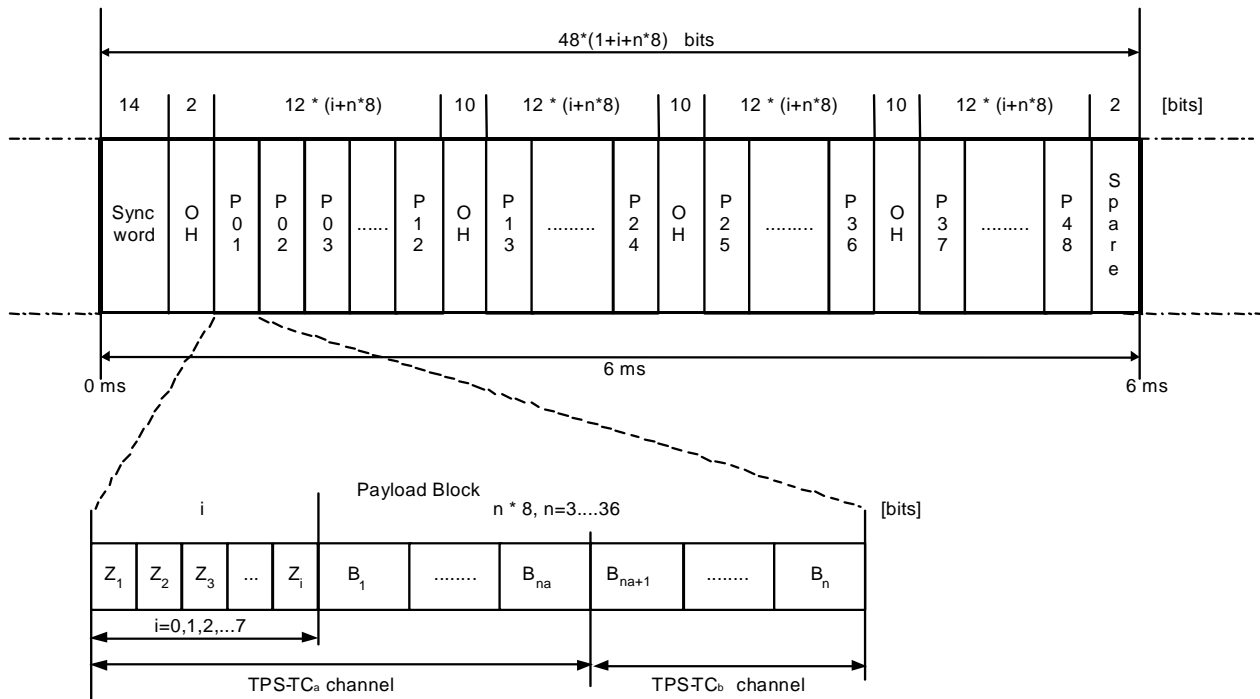

Figure A-11: Example of Dual-Bearer Mode TPS-TS Framing

### A.9.3 Dual Bearer Clock Synchronization

In Dual-Bearer Mode, it is assumed that timing for the two Bearer Channels is derived from a common source and that the two data streams thus have a definite clocking relationship. As such, no mechanism is provided within the payload blocks to maintain synchronization between the Bearer Channels, regardless of the clock mode that is selected.

Note that some TPS-TCs have limitations on the clock modes that are supported. Specifically, ATM using NTR and Synchronous ISDN BRA are only defined for Clock Mode 3a. When either of these TPS-TCs is used as part of a Dual-Bearer Mode, the system shall operate in Clock Mode 3a.

### A.9.4 Dual Bearer Mode Types

The following two types of dual bearer modes are supported within SDSL:

- Type 1 - STM + ATM;
- Type 2 - STM + STM.

For each type of dual bearer mode, separate specification bits are provided within ITU-T Recommendation G.hs for the selection of the two TPS-TCs to be used. Table A-22 lists the combinations that are supported.

Table A-22: Supported TPS-TCs in Dual Bearer Mode

Type	Description	TPS-TC <sub>a</sub>	TPS-TC <sub>b</sub>
1	STM + ATM	Synchronous ISDN BRA Other supported types are for further study	ATM
2	STM + STM	Synchronous ISDN BRA Other supported types are for further study	Synchronous N × 64 kbit/s Other supported types are for further study

NOTE: TPS-TC<sub>a</sub> has to be used for services, which require 8 kbit/s granularity.

## A.10 TPS-TC for LAPV5 enveloped POTS or ISDN

NOTE: The content of this clause is for further study.

The mapping and time slot allocation of STM based, LAPV5 enveloped POTS or ISDN transport is specified, which is for ISDN an alternative procedure to the simple use of D-channel messages as described in clause A.6. Either STM based POTS or ISDN transport is possible at a time, simultaneous transport of POTS and ISDN needs further study.

### A.10.1 Mapping of 64 kbit/s payload channels

One or multiple 64 kbit/s POTS voice channels or one or multiple ISDN B-channel pairs are mapped alternatively onto the SDSL frame as specified in clauses A.7, for POTS, and A.6 for ISDN, respectively. Simultaneous mapping of POTS and ISDN payload channels is for further study.

### A.10.2 Signalling channel

Signalling as well as the other POTS or ISDN related messages are transported over a common signalling channel. Depending on the required amount of signalling and port control information, 8 bits or multiples of 8 bits and/or 1 bit to 7 bits per payload sub-block may be used for POTS or ISDN signalling and POTS/ISDN port control. Within the SDSL frame, 1 to 7 signalling bits are mapped onto the Z-channel(s), and 8 or multiples of 8 bits are transported in 1 or more B-channel time slots. The B-channels for signalling are mapped onto the first 8-bit time slots of each sub-block.

### A.10.3 Signalling and port control

The common TPS-TC is addressed by a common eoc Message-ID, designated as "LAPV5 enveloped POTS and ISDN". The Message-ID identifies the POTS and ISDN related messages in this TPS-TC and can be allocated in the eoc structure within the reserved sets 21 - 63 for Request and 149 - 191 for Response. The subsequent message Bytes contains the subsequent sub-layers. The message content is enveloped by LAPV5-EF. Envelope functions and message contents are specified in EN 300 324-1 [23] and EG 201 900-1 [24].

NOTE: A detailed definition of the structure of the eoc messages, the allocated message-Ids and a procedure for the transfer of information on the channels used for signalling and the number of POTS and ISDN connections is necessary. This task is for further study.

### A.10.4 Protocol architecture for LAPV5 enveloped POTS and ISDN

Table A-23 shows the layered structure for LAPV5 enveloped POTS and ISDN services.

**Table A-23: Protocol architecture**

POTS signalling EN 300 324-1 [23], clause 13	POTS/ISDN port control EN 300 324-1 [23], clause 14	ISDN signalling
LAPV5-DL EN 300 324-1 [23], clause 10		LAPD
LAPV5-EF address EN 300 324-1 [23], clause 9		
TPS-TC Message-ID: <i>LAPV5 enveloped POTS and ISDN</i>		
PMD-TC, PMS-TC		

The LAPV5-EF envelope address (EN 300 324-1 [23], clause 9) envelopes the frames for signalling of an individual ISDN access, or for POTS signalling or for POTS/ISDN port control.

For the reliable transport of POTS signalling and POTS/ISDN port control messages the data link protocol LAPV5-DL is used which is a simplified version of LAPD. The LAPV5-DL protocol is specified as in EN 300 324-1 [23], clause 10, with the exceptions of EG 201 900-1 [24], clause 5.4.1.2, which means that only one common instance of LAPV5-DL is used for both the POTS signalling and the POTS/ISDN port control, and that the LAPV5-DL address (EN 300 324-1 [23], clause 10.3.2.3) takes the value of all zeros. Additionally the exceptions of EG 201 900-1 [24], clauses 5.4.1.2 d.2 and 5.4.4.2 apply, which means that the NTU shall not initiate unblocking during system start-up and that at system restart a downtime of 20 s shall be enforced. POTS signalling messages and POTS/ISDN port control messages are distinguished by means of the Message type information element (EN 300 324-1 [23], clause 13.4.4).

Operation of ISDN layer 2 links is defined as usual by LAPD.

NOTE: The existing TPS-TC for ISDN as described in clause A.6 remains unchanged. It provides a lean alternative for networks where no POTS, but only ISDN is provided.



---

## Annex B (normative): Use of G.994.1 in the Pre-Activation Communications Channel

As noted in clause 9.2, G.994.1 [16] shall be used to begin the preactivation sequence. A second G.994.1 sequence shall follow the preactivation line probe, as described in that clause. The G.994.1 protocol shall be the mechanism for exchanging capabilities and negotiating the operational parameters for each SDSL connection. The use of a line probe sequence, as described in clause 9.2 is optional. If each TU has sufficient *a priori* knowledge of the line characteristics and the capabilities of the other TU, either from a previous connection or from user programming, the line probe sequence may be bypassed. In this case, the G.994.1 sequence will be followed by SDSL activation, as described in clause 9.1.

---

### B.1 G.994.1 Code Point Definitions

The following definitions shall be applied to the SDSL parameters specified in G.994.1 [16]:

Training mode	An indication that an LTU (or REG) is prepared to begin SDSL Activation using the associated parameters.
PMMS mode	An indication that an LTU (or REG) is prepared to begin a PMMS ("Power Measurement Modulation Session", or Line Probe) using the associated parameters.
4-Wire	Set to indicate 4-wire operation (Note: this parameter is not used for SDSL).
SRUS	Set to indicate that the unit is a Signal Regenerator and not an LTU.
Diagnostic Mode	Set to indicate a diagnostic mode train (for use with REGs).
Base Data Rate/PSD	These octets are used as follows: <ul style="list-style-type: none"> <li>- for PMMS, they indicate rates for line probing segments;</li> <li>- for training, they indicate payload data rates.</li> </ul> Separate bits are provided for symmetric and asymmetric PSDs.
Sub Data Rate	For symmetric PSDs, the Data Rate octets indicate the base data rate in 64 kbit/s increments ( $n \times 64$ kbit/s). The Sub Data Rate bits indicate additional 8 kbit/s increments ( $i \times 8$ kbit/s) of Data. The total payload data rate is set by: Base Data Rate + Sub Data Rate. The Sub Data Rate bits do not apply to the asymmetric 2,048 Mbit/s, and 2,304 Mbit/s PSDs.
PBO	Power Back-off (in 1,0 dB increments).
PMMS Duration	The length of each line probe (PMMS) segment (in 50 ms increments).
PMMS Scrambler	The scrambler polynomial used during line probe (PMMS). See clause 9.2.3.
PMMS Target Margin	If worst-case target margin is selected, target margin is relative to reference worst-case crosstalk specified in table 9-7. If current-condition target margin is selected, specified target margin is relative to noise measured during line probe. The 5 bit target margin is specified by (bits 5-1 x 1,0 dB) - 10 dB. For example, 101111 <sub>2</sub> in the worst-case PMMS target margin octet corresponds to 15 dB - 10 dB = 5 dB target margin relative to reference worst-case noise.

	If the capability for PMMS mode is indicated in a G.994.1 CLR/CL capabilities exchange, both target margin octets shall be sent. The specific values for target margin shall be ignored during the capabilities exchange, as all LTUs (and REGs) shall be capable of evaluating the results of PMMS using both types of target margin.
Clock Modes	Set to indicate clock mode, as defined in table 8-1.
Low Latency	Set to indicate that low latency operation, as defined in clause 11.4 is required. If not set, an LTU may choose a higher latency encoding scheme.
TPS-TC	The TPS-TC mode is selected from the set of modes specified in annex A.
Sync Word	Indicates the value that the upstream and downstream <i>sw1</i> - <i>sw14</i> bits shall take on. See clause 7.1.5 for details.
Stuff Bits	Indicates the value that the upstream and downstream <i>stb1</i> - <i>stb4</i> bits shall take on. See clause 7.1.5 for details.
Regenerator Silent Period (RSP)	A bit used to force an LTU or REG into a 1-minute silent interval to facilitate startup of spans including regenerators.

---

## B.2 G.994.1 Tone Support

SDSL devices shall support half-duplex mode G.994.1 operation using the A4 carrier set from the 4 kHz signalling family. Manufacturers are encouraged to support additional carrier sets, the 4,3125 kHz signalling family, and full-duplex operation of G.994.1 to provide interoperable handshake sequences with other types of DSL equipment.

---

## B.3 G.994.1 Transactions

If no *a priori* capabilities information is available to the NTU, it should begin the G.994.1 session by initiating Transaction C (CLR/CL). Otherwise, it may begin immediately with one of the mode selection transactions (e.g. A or B). In this capabilities exchange (CLR/CL sequence), each unit shall indicate the functions that it is currently capable of performing. This means that user options that have been disabled shall not be indicated as capabilities of the unit. If a unit's capabilities change due to user option settings or other causes, that unit shall cause a capabilities exchange to occur during the next G.994.1 session.

If both the NTU and LTU indicate the capability for line probing and no *a priori* information exists concerning the characteristics of the loop, the NTU should initiate Transaction D (MP/MS/Ack(1)) by sending an MP with the SDSL line probe mode selected. This MP message shall include parameters for the downstream line probe sequence. The LTU shall then issue a corresponding MS message containing the upstream line probe parameters and an echo of the downstream line probe parameters. Following an Ack(1) from the NTU, the units shall exit G.994.1 and enter the SDSL line probe mode, as described in clause 9.2. Following the completion of line probing, the LTU shall initiate a new G.994.1 session. The NTU shall then initiate a Transaction C (CLR/CL) capabilities exchange to indicate the results of the line probe. Each unit shall, in this exchange, indicate the intersection of its capabilities and the capabilities of the loop, as determined during the line probe sequence. The PBO octet shall be used to indicate the desired received Power Back-off. Following this second capabilities exchange, the units may use any valid transaction to select operational SDSL parameters.

Following the selection of the SDSL parameter set, G.994.1 shall terminate and the SDSL Activation sequence (clause 9.1) shall begin.

---

## B.4 Operation with Signal Regenerators

In general, REGs will act as LTUs during G.994.1, as described in clause B.3. In some situations, however, they are required to issue "Regenerator Silent Period" (via the G.994.1 RSP bit) mode selections rather than selecting a SDSL operational mode, as described in annexes C and D. The parameters that REGs report during capabilities exchanges are also slightly different. The advertised capabilities of an NTU shall be the intersection of its own capabilities and those reported across the regenerator's internal interface as indicative of the capabilities of the downstream units and line segments. The lone exception to this rule shall be the PBO octet, which shall be considered as a local parameter for each segment.

## Annex C (normative): Signal Regenerator Operation

In order to achieve data transmission over greater distances than are achievable over a single SDSL segment, one or more signal regenerators (REGs) may be employed. This annex specifies operational characteristics of signal regenerators and the startup sequence for SDSL spans containing signal regenerators. Additional explanatory text is included in annex D.

### C.1 Reference Diagram

Figure C-1 is a reference diagram of a SDSL span containing two regenerators. Up to eight (8) regenerators per span are supported within the EOC addressing scheme (clause 10.5.5.5), and no further limitation is intended herein. Each REG shall consist of two parts: an REG-R for interfacing with the LTU (or a separate REG-C), and an REG-C for interfacing with the NTU (or a separate REG-R). An internal connection between the REG-R and REG-C shall provide the communication between the two parts during start-up and normal operation. An SDSL span containing  $X$  regenerators shall contain  $X+1$  separated SDSL segments, designated TR1 (LTU to REG<sub>1</sub>), TR2 (REG<sub>X</sub>-C to NTU), and RR <sub>$n$</sub>  (REG <sub>$n$</sub> -C to REG <sub>$n+1$</sub> -R, where  $1 \leq n \leq X-1$ ). Each segment shall follow the general principles described in clauses 9.1, 9.2, and 7.2 for the preactivation and activation procedures. Additional requirements specific to spans containing regenerators are described in this annex.

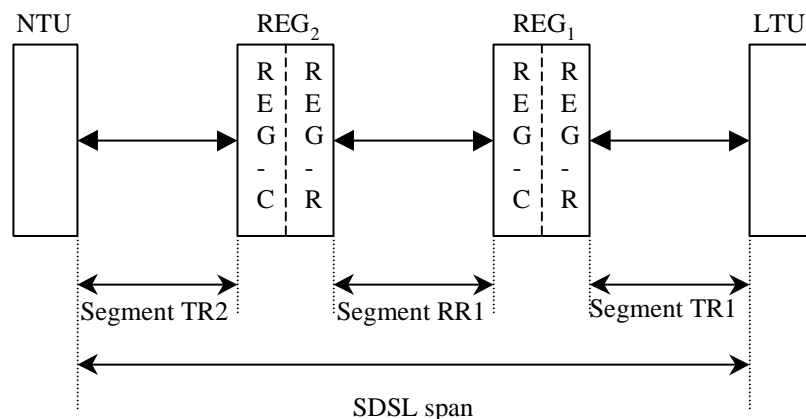

Figure C-1: Block Diagram of a SDSL Span with Two Signal Regenerators

### C.2 Startup Procedures

#### C.2.1 REG-C

Figure C-2 shows the State Transition Diagram for REG-C startup and operation. The REG-C begins in the "Idle" state and, in the case of an NTU initiated startup, transitions first to the "Wait for LTU" state. For an LTU initiated startup, the REG-C moves from "Idle" to the "G.994.1 Session 1" state. An REG initiated startup shall function identically to an LTU initiated startup from the perspective of the REG-C.

The REG-C shall communicate "Capabilities Available" status and transfer a list of its capabilities to the REG-R across the regenerator's internal interface upon entering the "Wait for LTU" state. The REG-C's capabilities list, as transferred to the REG-R, shall be the intersection of its own capabilities, the capabilities list it received from the NTU (or REG-R) in its G.994.1 session, and the segment capabilities determined by the line probe, if used.

The REG-C shall receive mode selection information from the REG-R in association with the "REG-R Active" indication. In the subsequent G.994.1 session, the REG-C shall select the same mode and parameter settings for the SDSL session.

The timer  $T_{REGC}$  shall be set to 4 minutes. If  $T_{REGC}$  expires before the REG-C reaches the "Active" state, the REG-C shall return to the "Idle" state and shall indicate link failure to the REG-R across the internal interface. The REG-C shall also indicate failure and return to the "Idle" state if a G.994.1 initiation is unsuccessful after 30 s.

The "Diagnostic Mode" bit, if set in the G.994.1 Capabilities Exchange, shall cause an REG-C to function as an LTU if the subsequent segment fails. This implies that an internal failure indication received while in the "Wait for LTU" state shall cause the REG-C to select an operational mode, initiate a G.994.1 session, and transition to state "G.994.1 Session 2".

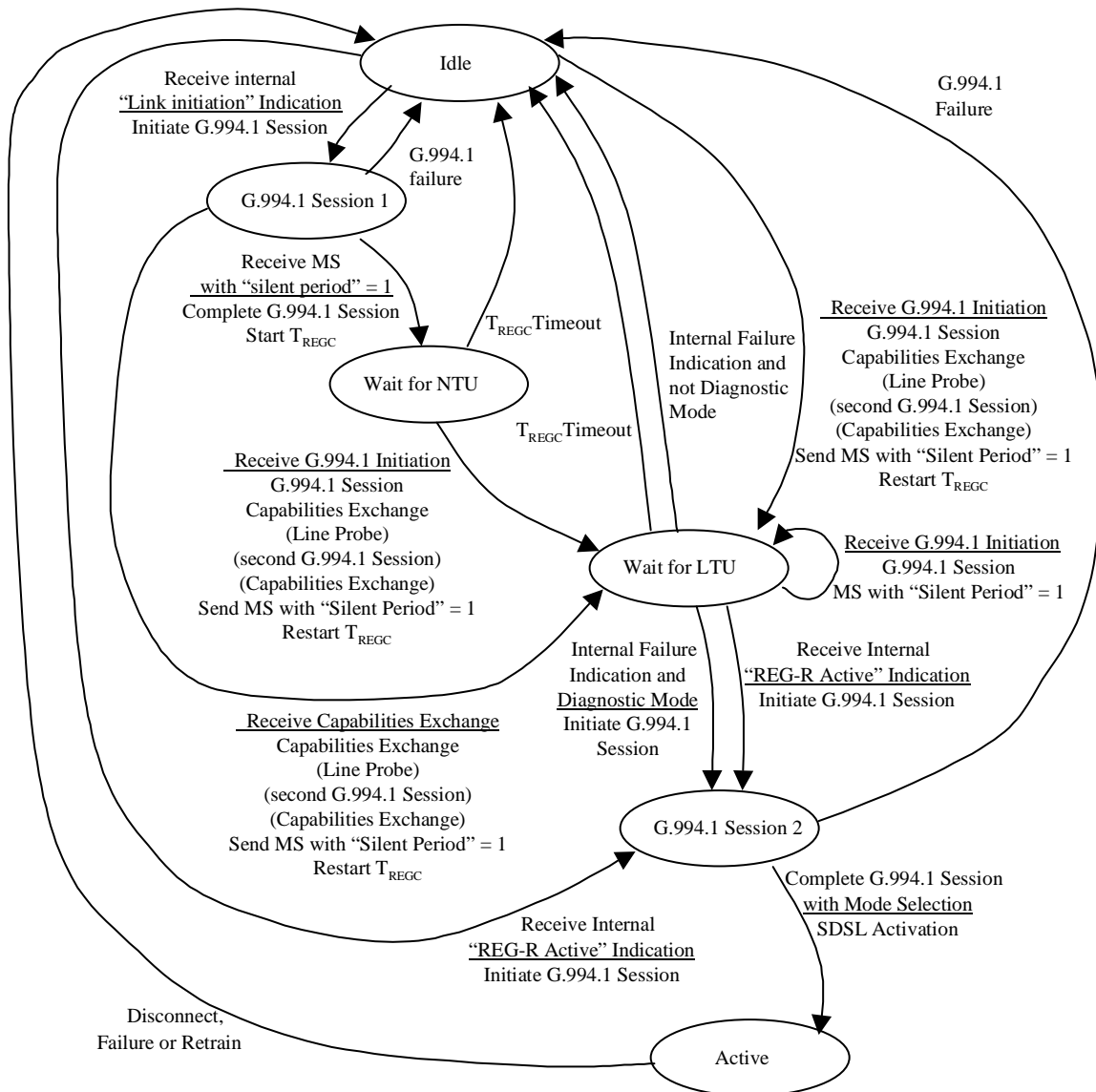

Figure C-2: REG-C State Transition Diagram

## C.2.2 REG-R

Figure C-3 shows the State Transition Diagram for REG-R startup and operation. The REG-R begins in the "Idle" state and, in the case of an NTU initiated train, transitions first to the "G.994.1 Session 1" state. For an LTU initiated train, the REG-C moves from "Idle" to the "G.994.1 Session 2" state.

The REG-R shall communicate "Link Initiation" status to the REG-C across the regenerator's internal interface upon entering the "Wait for NTU" state. Upon entering the "Active" state, it shall communicate "REG-R Active" status to the REG-C. If plesiochronous operation (Clock Mode 1; see clause 10) is selected, the REG-R may optionally indicate its entry into the "Active" state to the REG-C prior to the completion of the SDSL activation sequence. If synchronous or network referenced plesiochronous clocking is selected (Clock Modes 2, 3a, or 3b; see clause 10), the REG-R shall not indicate entry into the "Active" state until the SDSL activation sequence has been completed.

The REG-R shall receive a list of capabilities from the REG-C across the regenerator's internal interface in association with the "Capabilities Available" indication. The REG-R's capabilities list, as indicated in the subsequent G.994.1 session, shall be the intersection of its own capabilities with the capabilities list it received from the REG-C.

The REG-R shall provide mode selection information to the REG-C in association with the "REG-R Active" indication, based on the selections it has received in the G.994.1 session.

The timer  $T_{REGR}$  shall be set to 4 minutes. If  $T_{REGR}$  expires before the REG-R reaches the "Active" state, the REG-R shall return to the "Idle" state and shall indicate link failure to the REG-C across the internal interface. The REG-R shall also indicate failure and return to the "Idle" state if a G.994.1 initiation is unsuccessful after 30 s.

The "Diagnostic Mode" bit, if set in the G.994.1 Capabilities Exchange, shall cause an REG-R to function as an NTU if the subsequent segment fails. This implies that an internal failure indication received while in the "Wait for NTU" state shall cause the REG-R to initiate a G.994.1 session and transition to state "G.994.1 Session 2".

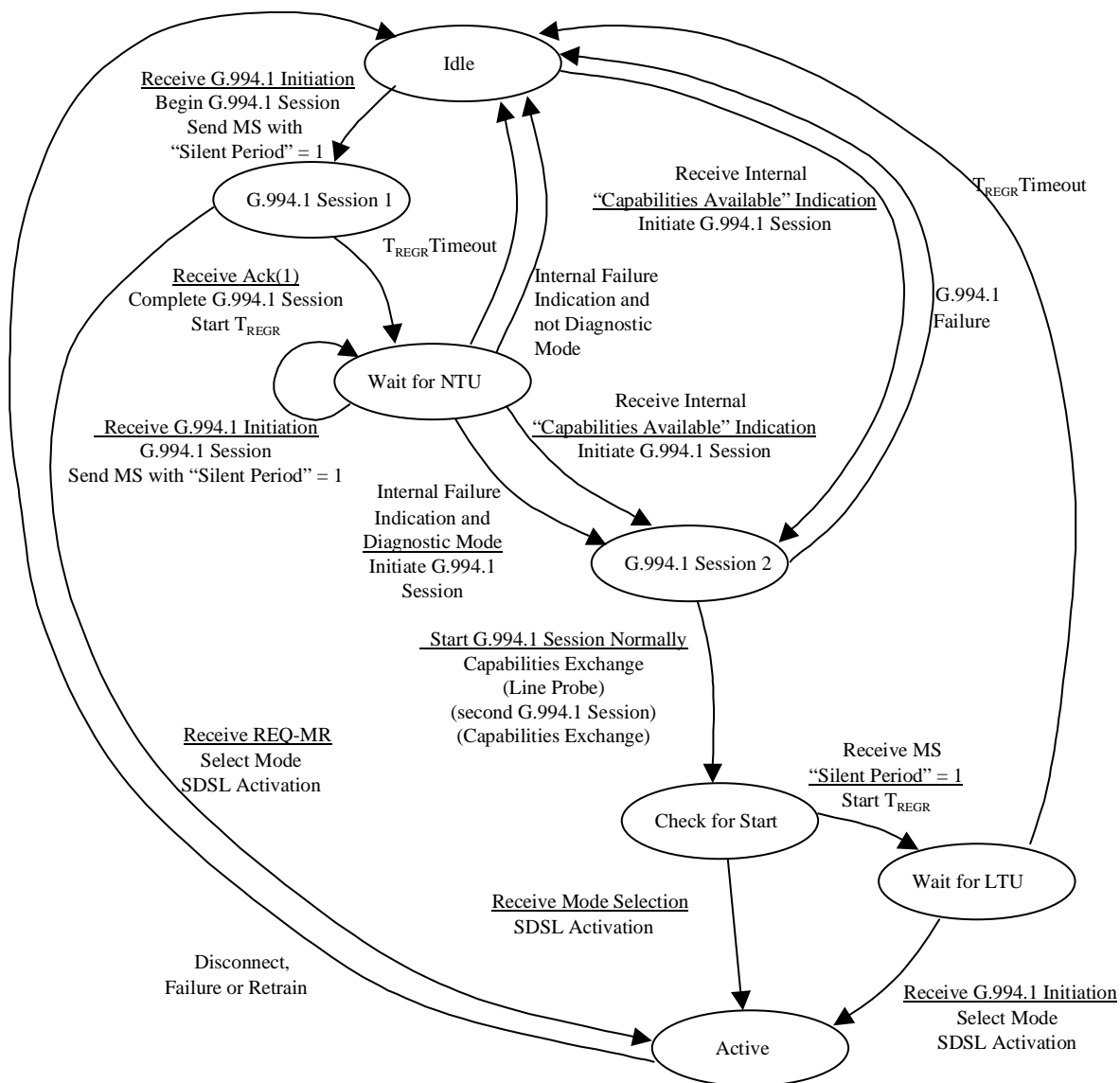

Figure C-3. REG-R State Transition Diagram

### C.2.3 LTU

In order to support operation with regenerators, each LTU shall support the Regenerator Silent Period (RSP) bit, as specified in ITU-T Recommendation G.994.1 [16]. Second, the LTU shall not indicate a training failure or error until it has been forced into "silent" mode for at least 5 consecutive minutes.

## C.2.4 NTU

In order to support operation with regenerators, each NTU shall support the Regenerator Silent Period (RSP) bit, as specified in ITU-T Recommendation G.994.1 [16]. The NTU shall not indicate a training failure or error until it has been forced into "silent" mode for at least 5 consecutive minutes.

## C.2.5 Segment Failures and Retrains

In the case of a segment failure or a retrain, each segment of the span shall be deactivated, with each REG-C and each REG-R returning to its "Idle" state. The restart may then be initiated by the REG, the NTU, or the LTU.

---

## C.3 Symbol Rates

Signal regenerators may transmit at symbol rates up to and including 685,33 ksymbol/s in either two-wire or the optional four-wire mode. This corresponds, for 16-TCPAM, to maximum user data rates (not including framing overhead) of 2,048 Mbit/s. Operation at higher symbol rates is for further study.

Each TU and REG on a span shall select the same operational data rate.

---

## C.4 PSD Masks

Any of the PSDs may be used for the TR1 segment (LTU to REG<sub>1</sub>-R), as appropriate to the given region. All other segments shall employ one of the appropriate symmetric PSDs, as described in clause 9.4.1. The selection of PSD shall be limited by the symbol rate considerations of clause C.3.

## Annex D (informative): Signal Regenerator Startup Description

This annex describes the startup sequence used on spans employing regenerators. The sequence applies to spans with an arbitrary number of regenerators (up to 8), but for simplicity, the description here assumes a two-regenerator link. The use of line probing is optional, but its use is assumed for the purpose of this description.

The basic premise is that capability lists and line probe results propagate from the NTU toward the LTU and that the SDSL training begins at the LTU and propagates in the direction toward the NTU. The Regenerator Silent Period (RSP) bit in ITU-T Recommendation G.994.1 [16] is used to hold off segments while the startup process propagates across the span.

The block diagram in figure D-1 shows a typical SDSL span with two regenerators as a reference for the startup sequences described below.

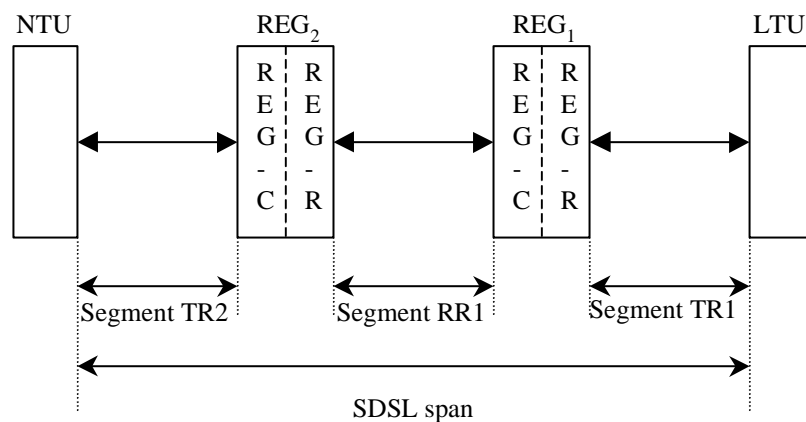

Figure D-1: Block Diagram of a SDSL Span with Two Signal Regenerators

### D.1 NTU Initiated Startup

In most typical SDSL installations, the NTU can be expected to initiate the startup process. The proposed SDSL startup process for NTU initiation is described in the text below and shown graphically in table D-1.

In this mode, the NTU triggers the startup process by initiating a G.994.1 session with the regenerator closest to it (over segment TR2). The NTU and the REG<sub>2</sub>-C then exchange capabilities and optionally perform a line probe and a second capabilities exchange. The units do not have enough information to begin SDSL activation at this point, so the REG<sub>2</sub>-C issues an MS with the RSP bit set to hold off the NTU while the startup process propagates across the span. The G.994.1 session terminates normally, and the NTU begins its waiting period.

Next, the REG<sub>2</sub>-C conveys the capabilities from Segment TR2 to the REG<sub>2</sub>-R across the regenerator's internal interface. The REG<sub>2</sub>-R then initiates a G.994.1 session with the REG<sub>1</sub>-C and performs the same capabilities exchange and line probing sequence described above for the first segment. The capabilities expressed by the REG<sub>2</sub>-R are the intersection of its own capabilities with the capabilities it has received for Segment TR2. The units still do not have sufficient information to begin SDSL activation, so, again, the REG<sub>1</sub>-R issues an MS with the RSP bit set. The G.994.1 session terminates normally, and the REG<sub>2</sub>-R begins its waiting period.

As before, the REG<sub>1</sub>-C then conveys the capabilities from Segment RR1 (including the information from Segment TR2) to the REG<sub>1</sub>-R across the regenerator's internal interface. The REG<sub>1</sub>-R initiates a G.994.1 session with the LTU and performs a capabilities exchange. Optionally, a line probe and a second capabilities exchange may be used. As before, the capabilities expressed by the REG<sub>1</sub>-R are the intersection of its own capabilities with the capabilities it has received for Segments RR1 and TR2. At this point, the LTU possesses all of the required information to select the span's operational parameters. The data rate and other parameters are selected, just as in a normal (non-regenerator) preactivation sequence and then the SDSL activation begins for Segment TR1.



When the LTU/REG<sub>1</sub>-R link (over Segment TR1) has completed the SDSL activation sequence (or the G.994.1 session, if clock mode 1 is selected), the REG<sub>1</sub>-R communicates the selected operational parameters to the REG<sub>1</sub>-C across the regenerator's internal interface. At this point, the REG<sub>1</sub>-C initiates a G.994.1 session with the REG<sub>2</sub>-R over Segment RR1. Parameters are selected - there should be no need for another CLR-CL exchange at this point - and the units perform the normal SDSL activation. If clock mode 1 is selected (classic plesiochronous) there is no need to lock symbol timing to a network clock reference. In this case, the REG<sub>1</sub>-C/REG<sub>2</sub>-R G.994.1 session and activation should begin as soon as the LTU/REG<sub>1</sub>-R G.994.1 sessions completes. In clock modes 2, 3a, and 3b, such a network or data clock reference is necessary for establishing symbol timing. In these modes, the REG<sub>1</sub>-C will delay the initiation of its G.994.1 session until the LTU/REG<sub>1</sub>-R activation is complete. In this way, the required reference clock will be available for symbol timing on the REG<sub>1</sub>-C/REG<sub>2</sub>-R segment.

When the REG<sub>1</sub>-C/REG<sub>2</sub>-R link (over Segment RR1) has completed the SDSL activation sequence (or the G.994.1 session, if clock mode 1 is selected), the REG<sub>2</sub>-R communicates the selected operational parameters to the REG<sub>2</sub>-C across the regenerator's internal interface. The REG<sub>2</sub>-C initiates a G.994.1 session with the NTU over Segment TR2. Parameters are selected and the units perform the normal SDSL activation. When this activation sequence is complete, the span can become fully operational.

**Table D-1: NTU Initiated Startup Sequence**

Segment TR2 (NTU/REG <sub>2</sub> -C)	Segment RR1 (REG <sub>2</sub> -R/REG <sub>1</sub> -C)	Segment TR1 (REG <sub>1</sub> -R/LTU)
G.994.1 Start → Capabilities exchange <i>Line probe</i> Capabilities exchange ← MS (RSP)	G.994.1 Start → Capabilities exchange <i>Line probe</i> Capabilities exchange ← MS (RSP)	G.994.1 Start → Capabilities exchange <i>Line probe</i> Capabilities exchange Mode Selection SDSL activation
← G.994.1 Start Mode Selection SDSL activation	← G.994.1 Start Mode Selection SDSL activation	

## D.2 LTU Initiated Startup

In some cases, it may be desirable for the LTU to initiate the startup process. The proposed SDSL startup process for LTU initiation is described in the text below and shown graphically in table D-2.

In this mode, the LTU triggers the startup process by initiating a G.994.1 session with the regenerator closest to it (over segment TR1). The REG<sub>2</sub>-C issues an MS with the RSP bit set to hold off the LTU while the startup process propagates across the span. The G.994.1 session terminates normally, and the LTU begins its wait period. Next, the REG<sub>1</sub>-C initiates a G.994.1 session with the REG<sub>2</sub>-R, which, again is terminated following an MS from the REG<sub>2</sub>-R with the RSP bit set.

The REG<sub>2</sub>-C next initiates a G.994.1 session with the NTU. From this point on, the start sequence is as described in clause D.1 for the NTU initiated startup.

Table D-2: LTU Initiated Startup Sequence

Segment TR2 (NTU/REG <sub>2</sub> -C)	Segment RR1 (REG <sub>2</sub> -R/REG <sub>1</sub> -C)	Segment TR1 (REG <sub>1</sub> -R/LTU)
		← G.994.1 Start MS (RSP) →
	← G.994.1 Start MS (RSP) →	
← G.994.1 Start Capabilities exchange <i>Line probe</i> Capabilities exchange ← MS (RSP)	G.994.1 Start → Capabilities exchange <i>Line probe</i> Capabilities exchange ← MS (RSP)	
		G.994.1 Start → Capabilities exchange <i>Line probe</i> Capabilities exchange Mode Selection SDSL activation
	← G.994.1 Start Mode Selection SDSL activation	
← G.994.1 Start Mode Selection SDSL activation		

### D.3 REG Initiated Startup

In some limited applications (including some maintenance and retrain scenarios), it may be desirable for a regenerator to initiate the start sequence. In this mode, the REG will initiate the train in the downstream direction - i.e. toward the NTU in the same manner that it would have for the corresponding segment of the LTU Startup Procedure (as described in clause D.2). The NTU will then initiate the capabilities exchange and line probing procedure toward the LTU, as in a normal LTU initiated startup. The startup sequence begins with the initiating REG-C and propagating toward the NTU.

### D.4 Collisions and Retrains

Collisions (equivalent to "glare" conditions in voice applications) can occur in cases where both the LTU and the NTU attempt to initiate connections simultaneously. Using the process described above, these collisions are resolved by specifying that R-to-C capabilities exchanges and probes will always take precedence over C-to-R train requests. G.994.1 sessions inherently resolve collisions on individual segments.

In G.994.1, the RSP timeout is specified as approximately 1 minute. For spans with no more than one regenerator, this is ideal. For multi-regenerator spans, however, a TU may time out and initiate a new G.994.1 session before the REG is prepared to begin the next phase of the train. In such cases, the REG should respond to the G.994.1 initiation and issue an MS message with the RSP bit set to hold off the TU once again. For its part, the REG should implement an internal timer and should not consider a startup to have failed until that timer has expired. The timer should be started when the REG receives a RSP bit in an MS message and should not expire for at least 4 minutes.

If any segment must retrain due to line conditions or other causes, each segment of the span shall be deactivated and the full startup procedure shall be reinitiated.

---

## D.5 Diagnostic Mode Activation

If a segment fails, the startup procedure will also fail for the entire span. This would normally be characterized at the TU by being told to enter a silent interval via the RSP bit and never receiving another G.994.1 request. Without some diagnostic information, the service provider would have no easy way to test the integrity of the various segments.

This concern is resolved by the use of the "Diagnostic Mode" in G.994.1 to trigger a diagnostic training mode. This bit, when set, causes an REG connected to a failed segment to act as a TU and allow the startup procedure to finish. In this way, all of the segments before the failed segment may be tested using loopbacks and EOC-initiated tests. This would allow network operators to quickly isolate the segment where the failure has occurred.

## Annex E (informative): Typical characteristics of cables

The primary cable parameters  $Z_s = R_s + j\omega \cdot L_s$  and  $Y_p = 0 + j\omega \cdot C_p$  per unit length are specified for various frequencies in tables E-1 and E-2. They are based on existing RLCG tables specified in the HDSL specification [1], and extended up to 2 MHz. The values of the RLC parameters for other frequencies can be found by using a "cubic spline interpolation".

**Table E-1: Line constants for the cable sections in the SDSL testloops**

freq [Hz] $\times 10^{-3}$	SDSL.PE04			SDSL.PE05			SDSL.PE06			SDSL.PE08		
	$R_s$ [ $\Omega/m$ ] $\times 10^{-3}$	$L_s$ [H/m] $\times 10^{-9}$	$C_p$ [F/m] $\times 10^{-12}$	$R_s$ [ $\Omega/m$ ] $\times 10^{-3}$	$L_s$ [H/m] $\times 10^{-9}$	$C_p$ [F/m] $\times 10^{-12}$	$R_s$ [ $\Omega/m$ ] $\times 10^{-3}$	$L_s$ [H/m] $\times 10^{-9}$	$C_p$ [F/m] $\times 10^{-12}$	$R_s$ [ $\Omega/k$ ] $\times 10^{-3}$	$L_s$ [H/k] $\times 10^{-9}$	$C_p$ [F/k] $\times 10^{-12}$
0	268	680	45,5	172	680	25	119	700	56	67	700	37,8
10	268	678	45,5	172	678	25	120	695	56	70,0	700	37,8
20	269	675	45,5	173	675	25	121	693	56	72,5	687	37,8
40	271	669	45,5	175	667	25	125	680	56	75,0	665	37,8
100	282	650	45,5	190	646	25	146	655	56	91,7	628	37,8
150	295	642	45,5	207	637	25	167	641	56	105	609	37,8
200	312	635	45,5	227	629	25	189	633	56	117	595	37,8
400	390	619	45,5	302	603	25	260	601	56	159	568	37,8
500	425	608	45,5	334	592	25	288	590	56	177,5	<b>543 + 17</b>	37,8
700	493	593	45,5	392	577	25	340	576	56	209	553	37,8
1 000	582	582	45,5	466	572	25	405	570	56	250	547	37,8
2 000	816	571	45,5	655	565	25	571	560	56	353	540	37,8

**Table E-2: Line constants for the cable sections in the SDSL testloops**

freq [Hz] $\times 10^{-3}$	SDSL.PVC032			SDSL.PVC04			SDSL.PVC063		
	$R_s$ [ $\Omega/m$ ] $\times 10^{-3}$	$L_s$ [H/m] $\times 10^{-9}$	$C_p$ [F/m] $\times 10^{-12}$	$R_s$ [ $\Omega/m$ ] $\times 10^{-3}$	$L_s$ [H/m] $\times 10^{-9}$	$C_p$ [F/m] $\times 10^{-12}$	$R_s$ [ $\Omega/m$ ] $\times 10^{-3}$	$L_s$ [H/m] $\times 10^{-9}$	$C_p$ [F/m] $\times 10^{-12}$
0	419	650	120	268	650	120	108	635	120
10	419	650	120	268	650	120	108	635	120
20	419	650	120	268	650	120	108	635	120
40	419	650	120	268	650	120	111	630	120
100	427	647	120	281	635	120	141	604	120
150	453	635	120	295	627	120	173	584	120
200	493	621	120	311	619	120	207	560	120
400	679	577	120	391	592	120	319	492	120
500	750	560	120	426	579	120	361	469	120
700	877	546	120	494	566	120	427	450	120
1 000	1 041	545	120	584	559	120	510	442	120
2 000	1 463	540	120	817	550	120	720	434	120

## Annex F (informative): Transmission and Reflection of Cable Sections

### F.1 Definition of transfer function and insertion loss

Transfer function and insertion loss are quantities that are related to the values of the (complex) source and load impedance. Within the context of the present document, a simplified definition is used in which source and load are the same and equal to a real value  $R_V$ . The transfer function and insertion loss associated with a two-port network, normalized to a chosen reference resistance  $R_V$ , are defined as the following voltage ratios (see figures F-1 and F-2):

$$\text{Transfer Function} = \frac{U_2}{U_1}$$

$$\text{Insertion Loss} = \frac{U_1}{U_2}$$

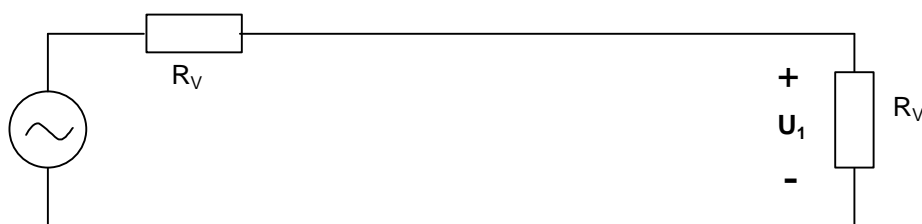

Figure F-1: Voltage across the load

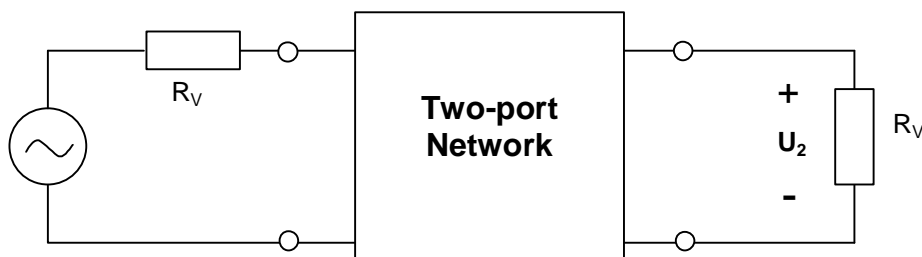

Figure F-2: Voltage across the load with a two-port network inserted

These quantities are directly related to the scattering parameters associated with the two-port network as defined in clause F.2:

$$\text{Transfer Function} = S_{21} \quad \text{Magnitude of TF (in dB)} = 20 \log_{10}(|S_{21}|)$$

$$\text{Insertion Loss} = 1/S_{21} \quad \text{Magnitude of IL (in dB)} = -20 \log_{10}(|S_{21}|)$$

## F.2 Derivation of s-parameters from primary cable parameters

The testloops are defined by one or a cascade of cable sections. The characteristics of each section are specified by means of primary cable parameters  $\{Z_s, Y_p\}$  per unit length ( $L_0$ ). This clause gives the equations to evaluate the relevant characteristics of cable sections (s-parameters) from the primary parameters and to handle cascade of cable sections.

Insertion loss and return loss of a cable section, for SDSL, can be calculated from the primary parameters  $\{Z_s, Y_p\}$  per unit length ( $L_0$ ) by evaluating the two-port s-parameters, normalized to  $R_v = 135 \Omega$ .

$Z_{sx} = (L/L_0) \cdot Z_s$	$\gamma_x = \sqrt{Z_{sx} \cdot Y_{px}}$	$\alpha_x = \text{real}(\gamma_x)$	$R_{sx} = \text{real}(Z_{sx})$	$G_{px} = \text{real}(Y_{px})$
$Y_{px} = (L/L_0) \cdot Y_s$	$Z_0 = \sqrt{Z_{sx} / Y_{px}}$	$\beta_x = \text{imag}(\gamma_x)$	$L_{sx} = \text{imag}(Z_{sx} / \omega)$	$C_{px} = \text{imag}(Y_{px} / \omega)$

$$S = \begin{bmatrix} s_{11} & s_{12} \\ s_{21} & s_{22} \end{bmatrix} = \frac{1}{(Z_0 / R_v + R_v / Z_0) \cdot \tanh(\gamma_x) + 2} \times \begin{bmatrix} (Z_0 / R_v - R_v / Z_0) \cdot \tanh(\gamma_x) & 2 / \cosh(\gamma_x) \\ 2 / \cosh(\gamma_x) & (Z_0 / R_v - R_v / Z_0) \cdot \tanh(\gamma_x) \end{bmatrix}$$

Insertion Loss:  $1/s_{21}$

Return Loss:  $1/s_{11}$

The s-parameters of two cable sections (a and b) in cascade,  $S_{ab}$ , can be calculated from the s-parameters  $S_a$  and  $S_b$  as described below:

$$S_{ab} = \begin{bmatrix} s_{11} & s_{12} \\ s_{21} & s_{22} \end{bmatrix} = \frac{1}{1 - s_{22a} \cdot s_{11b}} \cdot \begin{bmatrix} s_{11a} - \Delta_{sa} \cdot s_{11b} & s_{12b} \cdot s_{12a} \\ s_{21a} \cdot s_{21b} & s_{22b} - \Delta_{sb} \cdot s_{22a} \end{bmatrix} \quad \Delta_{si} = s_{11i} \cdot s_{22i} - s_{12i} \cdot s_{21i}$$

---

## Annex G (informative): Guideline for the narrowband interfaces implementation in the SDSL NTU

This annex provides information needed for the implementation of power efficient narrowband interfaces (at the SDSL NTU) when lifeline service has to be guaranteed.

Narrowband interfaces and conditions that were taken into account are:

- ISDN user-network interface (S-interface);
- Analogue interface (PSTN) in the following conditions:
  - "On Hook" with ringing applied;
  - "On Hook" with no transmission and normal battery applied;
  - "Off Hook", normal talk state;
  - "On Hook", with FSK/DTMF data transfer;
  - "Power denial".

The PSTN interface has been identified as the highest power consuming interface and, in particular, the operational state *"Off Hook", normal talk state*.

The following tables provide a guideline to the implementation of voice-band analogue interfaces (a/b interfaces) offered to the final user by means of adapter devices terminating various types of digital networks such as xDSL or ISDN. Particular attention is given to the power budget implied by the individual requirements.

The information was derived from EG 201 185 (see bibliography), EG 201 188 (see bibliography) and experience gained in the use of intelligent ISDN Network Terminations widely used for the ISDN network (NTs providing analogue terminal adapter interfaces to the user). The tables allow a comparison between those two ETSI Guides (EG) in order to facilitate the harmonization of the network side of the analogue voice band switched interface (PSTN). The suggested values are very close to EG 201 185 (see bibliography), however they add important information on parameters affecting the power consumption (vital for the lifeline service) that are lacking in the EG.

<b>General</b>				
	<b>EG 201 185 V1.1.1</b>	<b>EG 201 188 V1.2.1</b>	<b>Suggested values</b>	<b>notes</b>
applicability (loop length)	≤ 100 Ω	≤ 750 Ω	≤ 100 Ω	
mechanical aspects	RJ-11 (3 and 4)	RJ-11	RJ-11	
<b>Signalling</b>				
on-hook voltage (min, max)	38 V to 78 V @ 100 kΩ	38 V to 78 V @ 100 MΩ/LF	38 V to 78 V @ 1 mA	1
on-hook voltage @ 2,5 mA	≥ 32 V	≥ 32 V	≥ 32 V	2
off-hook resistance (d.c.)	n.a.	n.a.	≤ 800 Ω	3
non-seizure	$I_{loop} < 3 \text{ mA}$	$I_{loop} < 3 \text{ mA}$	$I_{loop} < 4 \text{ mA}$	
seize current	$I_{loop} \geq 6 \text{ mA}$	$I_{loop} \geq 10 \text{ mA}$	$I_{loop} > 6 \text{ mA}$	4
seize surely recognized	150 ms	150 ms	≥ 250 ms	
seize surely not recognized	≤ 25 ms	≤ 25 ms	≤ 50 ms	
loop current (min-max)	≥ 18 mA @	18 mA to 55 mA	≥ 18 mA @ 800 Ω ≥ 25 mA @ 400 Ω	
loop current (recommended)	32 mA ± 7 mA	25 mA to 40 mA	See line above	
clear signal threshold	≤ 1 mA	≤ (seize curr. - 2 mA)	≤ 6 mA	
clear signal not recognized	≤ 350 ms	≤ 250 ms	≤ 150 ms	
clear signal recognized	≥ 500 ms	≥ 500 ms	≥ 200 ms	
clear signal from the network	release tone	release tone	release tone	5
DTMF recognition level	-5 dBV ÷ -15 dBV	-5 dBV ÷ -15 dBV	-5 ÷ -15 dBV	
DTMF max twist	4 dB	n.a.	4 dB	
DTMF frequency error	± (1,5 % + 2 Hz)	n.a.	± (1,5 % + 2 Hz)	
DTMF min duration	40 ms	40 ms	40 ms	
DTMF min pause	40 ms	40 ms	40 ms	
Ring voltage (required)	≥ 35 V <sub>rms</sub> @ 4 kΩ (a.c.)	≥ 35 V <sub>rms</sub> @ 400 kΩ/LF	≥ 40 V <sub>rms</sub> (2 KΩ, φ ≥ 60°)	6
Ring frequency	25 Hz (or 50 Hz) ± 2 Hz	25 Hz (or 50 Hz) ± 2 Hz	25 Hz (or 50 Hz) ± 2 Hz	
Distortion	≤ 5 %, symmetric	≤ 5 %, symmetric	10 %, symmetric	
Max ringing current	n.a.	n.a.	80 mA	
Superimposed d.c.	38 V to 78 V (optional)	38 V to 78 V (optional)	38 V to 78 V	7
Ring Trip threshold	≤ 700 Ω (@ 25 Hz or 50 Hz)	dc seize / 750 Ω @ 25 Hz	dc seize	
Ring Trip Delay	≤ 100 ms	≤ 200 ms	200 ms	
Tone level	-18 dBV ± 6 dB	-18 dBV ± 6 dB	-18 dBV ± 6 dB	
<b>Signal Quality</b>				
Impedance	270 Ω+(750 Ω//150 nF)	270 Ω+(750Ω//150 nF)	270 Ω+(750 Ω//150 nF)	
return loss	200-500 Hz: 14-18 dB 500-2 500 Hz: > 18 dB 2 000-3 800 Hz: 18-14 dB	200-300 Hz: > 8 dB 300-500 Hz: 8-10 dB 500-1 250 Hz: 10-14 dB 1250-3 400 Hz: > 14 3400-3 800: 14-12	200-500 Hz:14-18 dB 500-2 500 Hz: > 18 dB 2 000-3 800 Hz: 18-14 dB	8
balance	200-3 800 Hz: > 46 dB	50: > 40 dB 200-600 Hz: > 40 dB 600-3 800 Hz: > 46 dB	50: > 20 dB 200-600 Hz: > 40 dB 600-3 800 Hz: > 46 dB	
transmit relative level	+ 4 dBr ± 1 dB	+ 4 dBr ± 2 dB	+ 4 dBr ± 1 dB	9
receive relative level	-11 dBr ± 1 dB	-11 dBr ± 2 dB	-11 dBr ± 1 dB	
Frequency Response	300 Hz: -0,3 ÷ +1,0 dB 400 Hz: -0,3 ÷ +0,75 dB 0,6 ÷ 2 kHz: -0,3 ÷ + 0,75 dB 2,4 kHz: -0,3 ÷ + 0,45 dB 3 kHz: -0,3 ÷ + 0,7 dB 3,4 kHz: -0,3 ÷ + 1,7 dB	as per Q.552	as per Q.552	
loss vs. signal level	see figure	as per Q.552	as per Q.552	
input levels	3,14 dB over nominal level	1,8 V <sub>rms</sub> (+5,7 dBm)	3,14 dB over nominal level	
receive noise	≤ -67 dBVp	as per Q.552	-64 dBm0p	
transmit noise	≤ -64 dBm0p	as per Q.552	-64 dBm0p	
absolute delay	≤ 2 ms	n.a.	1,5 ms	



<b>General</b>				
	<b>EG 201 185 V1.1.1</b>	<b>EG 201 188 V1.2.1</b>	<b>Suggested values</b>	<b>notes</b>
relative delay (relative to the minimum)	500 to 600: 1,8 ms 600 to 1 000: 0,9 ms 1 000 to 2 600: 0,3 ms 2 600 to 2 800: 1,5 ms	n.a.	500 to 600: 0,9 ms 600 to 1 000: 0,45 ms 1 000 to 2 600: 0,15 ms 2 600 to 2 800: 0,75 ms	
	<b>EG 201 185 V1.1.1</b>	<b>EG 201 188 V1.2.1</b>	<b>Suggested values</b>	<b>notes</b>
<b>Optional Features</b>				
Pulse dialling rate	8 ÷ 12 pulse/s	8 ÷ 12 pulse/s	8 ÷ 12 pulse/s	
break/pulse ratio	50 % to 75 %	50 % to 75 %	50 % to 75 %	
Interdigit Pulse	≥ 240 ms	≥ 240 ms	≥ 240 ms	
Register Recall	50 ms ÷ 135 ms	50 ms ÷ 135 ms	25 ms ÷ 150 ms	
Hook Flash	75 ms ÷ 850 ms	n.a.	n.a.	10
Metering Pulses frequency	12 kHz or 16 kHz	12 kHz or 16 kHz	12 kHz or 16 kHz	
Metering Pulses level	approx. 500 mV <sub>rms</sub>	approx. 100 mV <sub>rms</sub>	≥ 200 mV <sub>rms</sub>	

NOTE 1: A concept present in EG 201 188 is the Loading Factor (LF). The operator must state a single LF number for the Network Termination Point (NTP). Based on this LF information, the user can determine the number or the type of terminals that can be connected at the NTP. The operator must guarantee a minimum LF of 100.

The single LF number stated by the operator is the minimum value among the LF calculated for four key parameters: the resistance to ground, the DC resistance in quiescent conditions, the ringing voltage, and the DC current during ringing. A skilled user may take advantage of the operator providing individual LF's for these parameters. As an example, the ringing voltage is specified to be greater than 35 V<sub>rms</sub> at a load of 400 k $\Omega$ /LF. If the operator specifies a LF of 100, this means that the 35 V<sub>rms</sub> are guaranteed across a load of 4 k $\Omega$ .

NOTE 2: Meeting this value is an optional feature required to support ALASS services.

NOTE 3: 800  $\Omega$  represents the sum of the loop and the terminal resistance (d.c.).

NOTE 4: There is an additional recommendation (mentioned in EG 201 185 and in EG 201 188): during any transient state in the transition from quiescent to loop state, the NTP should be able to supply at least 4 mA over a 5 k $\Omega$  load for at least 20 ms. The reason for this requirements is that some TE may expect the full current immediately after going off-hook while some NTP may use high resistance supply to provide quiescent state "high" battery voltage (e.g. 50 V through a 10 k $\Omega$  resistance) and will not able to deliver the full current before switching in a lower value DC "battery" voltage. The combination of the two cases may cause problems, and the recommendation for the NTP is paired with a recommendation for the TE to be developed so that they can correctly seize the loop under this limited current transient.

NOTE 5: Polarity reversal or K-break may be required by some operators, additionally to release tones.

NOTE 6: EG 201 185 recommends supplying 35 V<sub>rms</sub> over 2 k $\Omega$ , ac coupled.

NOTE 7: A note specifies that TBR21 compliant devices are not guaranteed to operate with ringing sources without a superimposed DC voltage.

NOTE 8: For EG 201 188, return loss measurements include the loop between the NTP and the "line card". It is also stated than the specified value for the return loss at low-mid frequency may not be achieved for loop resistance ≥ 750  $\Omega$ .

NOTE 9: Including loop loss for EG 201 188 (see bibliography).

NOTE 10: As a network option, the hook flash is an alternative to Register Recall. When hook-flash is used, the minimum recognition time for clear originated from the TE raises to 950 ms ÷ 1 050 ms.

### ALASS services

Common ALASS services include provision of Calling Line Identity (CLI) and Message Waiting Indication (MWI).

These services are delivered to the terminal equipment using voice-band data, either during incoming call set-up, while the terminal is in the quiescent state or in the off-hook state (e.g. CLI during a CW offering). See EN 300 659-1 (see bibliography), EN 300 659-2 (see bibliography) and ETS 300 778 (see bibliography).

In order to support ALASS services to the TE, the equipment should be able to support one or more additional features, such as:

- a) control of polarity reversal;
- b) a single burst of ringing current, with or without polarity reversal;
- c) provision of 2,5 mA @ 32 V in the quiescent state;
- d) ignore on-line d.c. current pulses not exceeding 25 ms duration;
- e) generation of DTMF digits to the TE.

## Annex H (informative): Differences with G.991.2 (G.shdsl annex B)

Number	Description
1	Fixed Frame Sync Word versus selectable in G.shdsl Resolution: specify the transmission of the SDSL sync word during PACC see clause 7.1.5
2	No 4-wire mode (optional in G.shdsl) Resolution: the possible inclusion of 4-wire mode will be discussed for inclusion in the next revision of SDSL
3	In chapter 11 of G.shdsl, there is a clause 11.4 for "transmit power testing". In ETSI SDSL, the power measurement is only implicitly mentioned in the definition of PSD-masks Resolution: such a proposal will be discussed for inclusion in the next revision of SDSL
4	- Sync word: The synchronization word (SW) enables the SDSL receivers to acquire frame alignment. He synchronization word consists of the following 14-bit sequence: 11111100001100 The SW is present in every frame and is the same in both the upstream and downstream directions. ITU: 7.1.2.1. sw1 - sw14 (Frame Sync Word) The frame synchronization word (FSW) enables SHDSL receivers to acquire frame alignment. The FSW (bits sw1 - sw14) is present in every frame and is specified independently for the upstream and downstream directions Resolution: see difference #1
5	Section 13. Power Feeding
6	Annex E. Cable characteristics
7	

---

## Annex I (informative): Bibliography

- ETSI TS 101 272: "Transmission and Multiplexing (TM); Optical Access Networks (OANs) for evolving services; ATM Passive Optical Networks (PONs) and the transport of ATM over digital subscriber lines".
- ETSI EG 201 188: "Public Switched Telephone Network (PSTN); Network Termination Point (NTP) analogue interface; Specification of physical and electrical characteristics at a 2-wire analogue presented NTP for short to medium length loop applications".
- ETSI EN 300 659-1: "Access and Terminals (AT); Analogue access to the Public Switched Telephone Network (PSTN); Subscriber line protocol over the local loop for display (and related) services; Part 1: On-hook data transmission".
- ETSI EN 300 659-2: "Access and Terminals (AT); Analogue access to the Public Switched Telephone Network (PSTN); Subscriber line protocol over the local loop for display (and related) services; Part 2: Off-hook data transmission".
- ETSI ETS 300 788: "Digital Enhanced Cordless Telecommunications (DECT); Global System for Mobile communications (GSM); Integrated Services Digital Network (ISDN); DECT access to GSM via ISDN; Functional capabilities and information flows".
- Council Directive 89/336/EEC of 3 May 1989 on the approximation of the laws of the Member States relating to electromagnetic compatibility.

---

## History

<b>Document history</b>		
V1.1.1	April 2000	Publication as TS 101 524-1
V1.1.1	June 2000	Publication as TS 101 524-2
V1.1.1	June 2001	Publication