



TECHNICAL SPECIFICATION

Lawful Interception (LI); Handover interface for the lawful interception of telecommunications traffic

Reference

RTS/LI-00153

Keywordsdata, handover, interface, Lawful Interception,
security, speech**ETSI**

650 Route des Lucioles
F-06921 Sophia Antipolis Cedex - FRANCE

Tel.: +33 4 92 94 42 00 Fax: +33 4 93 65 47 16

Siret N° 348 623 562 00017 - NAF 742 C
Association à but non lucratif enregistrée à la
Sous-Préfecture de Grasse (06) N° 7803/88

Important notice

The present document can be downloaded from:

<http://www.etsi.org/standards-search>

The present document may be made available in electronic versions and/or in print. The content of any electronic and/or print versions of the present document shall not be modified without the prior written authorization of ETSI. In case of any existing or perceived difference in contents between such versions and/or in print, the only prevailing document is the print of the Portable Document Format (PDF) version kept on a specific network drive within ETSI Secretariat.

Users of the present document should be aware that the document may be subject to revision or change of status.

Information on the current status of this and other ETSI documents is available at

<https://portal.etsi.org/TB/ETSIDeliverableStatus.aspx>

If you find errors in the present document, please send your comment to one of the following services:

<https://portal.etsi.org/People/CommiteeSupportStaff.aspx>

Copyright Notification

No part may be reproduced or utilized in any form or by any means, electronic or mechanical, including photocopying and microfilm except as authorized by written permission of ETSI.

The content of the PDF version shall not be modified without the written authorization of ETSI.

The copyright and the foregoing restriction extend to reproduction in all media.

© ETSI 2018.

All rights reserved.

DECT™, **PLUGTESTS™**, **UMTS™** and the ETSI logo are trademarks of ETSI registered for the benefit of its Members.

3GPP™ and **LTE™** are trademarks of ETSI registered for the benefit of its Members and of the 3GPP Organizational Partners.

oneM2M logo is protected for the benefit of its Members.

GSM® and the GSM logo are trademarks registered and owned by the GSM Association.

Contents

Intellectual Property Rights	9
Foreword.....	9
Modal verbs terminology.....	9
Introduction	9
1 Scope	10
2 References	11
2.1 Normative references	11
2.2 Informative references.....	15
3 Definitions and abbreviations.....	15
3.1 Definitions.....	15
3.2 Abbreviations	18
4 General requirements	21
4.0 General	21
4.1 Basic principles for the Handover Interface	21
4.2 Legal requirements	22
4.3 Functional requirements	22
5 Overview of Handover Interface.....	22
5.0 General	22
5.1 Handover Interface port 1 (HI1).....	23
5.1.0 General.....	23
5.1.1 Manual interface	24
5.1.2 Electronic interface	24
5.2 Handover Interface port 2 (HI2).....	24
5.3 Handover Interface port 3 (HI3).....	24
6 Specific identifiers for LI	24
6.0 General	24
6.1 Lawful Interception IDentifier (LIID).....	25
6.2 Communication IDentifier (CID).....	25
6.2.0 General.....	25
6.2.1 Network IDentifier (NID).....	25
6.2.2 Communication Identity Number (CIN) - optional	26
7 HI1: Interface port for administrative information.....	26
7.0 General	26
7.1 Information for the activation of lawful interception	26
7.2 LI notifications towards the LEMF	27
8 HI2: Interface port for Intercept Related Information	27
8.0 General	27
8.1 Data transmission protocols	27
8.1.0 General.....	27
8.1.1 Application for IRI (HI2 information).....	28
8.2 Types of IRI records.....	28
9 HI3: Interface port for Content of Communication.....	28
10 Performance and quality.....	29
10.1 Timing	29
10.2 Quality.....	29
11 Security aspects	29
11.0 General	29
11.1 Security properties.....	29
11.2 Security mechanisms.....	30

12	Quantitative aspects.....	30
Annex A (normative): Circuit switched network handover		31
A.0	General	31
A.1	Specific identifiers for LI	31
A.1.0	General	31
A.1.1	CC Link Identifier (CCLID).....	31
A.1.2	Circuit switched LI correlation between CC and IRI	31
A.1.3	Usage of identifiers	31
A.2	HI1: interface port for administrative state	32
A.3	HI2: interface port for IRI	32
A.3.1	Definition of Intercept Related Information (IRI)	32
A.3.2	Structure of IRI records	33
A.3.2.0	General.....	33
A.3.2.1	Control information for HI2.....	33
A.3.2.2	Basic call information	34
A.3.2.3	Information on Supplementary Services, related to a call in progress	34
A.3.2.4	Information on non-call related Supplementary Services	35
A.3.3	Selection of parameters for IRI records.....	35
A.3.4	Coding of parameters in IRI records	38
A.3.5	Information content of the IRI record types	38
A.4	HI3: interface port for Content of Communication	38
A.4.0	General	38
A.4.1	Delivery of Content of Communication (CC)	38
A.4.1.0	General.....	38
A.4.1.1	Delivery of TETRA CC over circuit switched handover networks	39
A.4.2	Delivery of packetized Content of Communication (CC) (general).....	39
A.4.2.0	General.....	39
A.4.2.1	Delivery of TETRA CC over packet switched handover networks	40
A.4.3	Control information for circuit switched Content of Communication (CC).....	40
A.4.4	Exception handling	41
A.4.4.1	Failure of CC links.....	41
A.4.4.2	Fault reporting	41
A.4.5	Security requirements at the interface port HI3.....	42
A.4.5.0	General.....	42
A.4.5.1	LI access verification	42
A.4.5.2	Access protection.....	42
A.4.5.3	Authentication.....	42
A.5	LI procedures for circuit switched supplementary services	43
A.5.1	General	43
A.5.2	CC link Impact	45
A.5.3	IRI impact, general principle for sending IRI records	45
A.5.4	Multi party calls - general principles, options A, B.....	46
A.5.4.0	General.....	46
A.5.4.1	CC links for active and non-active calls (option A).....	46
A.5.4.2	Reuse of CC links for active calls (option B)	46
A.5.5	Subscriber Controlled Input (SCI): Activation/Deactivation/Interrogation of services	47
A.6	Detailed procedures for circuit switched supplementary services.....	47
A.6.1	Advice of Charge services (AOC).....	47
A.6.2	Call Waiting (CW)	47
A.6.2.1	Call Waiting (CW) at target: CC links.....	47
A.6.2.2	Call Waiting: IRI records.....	48
A.6.2.2.1	Target is served user.....	48
A.6.2.2.2	Other party is served user.....	48
A.6.3	Call Hold/Retrieve.....	48
A.6.3.1	CC links for active and non-active calls (option A).....	48
A.6.3.2	Reuse of CC links for active calls (option B)	48

A.6.3.3	IRI records	48
A.6.3.3.1	Invocation of Call Hold or Retrieve by target	48
A.6.3.3.2	Invocation of Hold or Retrieve by other parties	48
A.6.4	Explicit Call Transfer (ECT)	48
A.6.4.1	Explicit Call Transfer (ECT), CC link	48
A.6.4.2	Explicit Call Transfer (ECT), IRI records	49
A.6.5	Calling Line Identification Presentation (CLIP) (IRI Records)	49
A.6.5.1	Call originated by target (other party is served user)	49
A.6.5.2	Call terminated at target (target is served user)	49
A.6.6	Calling Line Identification Restriction (CLIR)	49
A.6.7	COnnected Line identification Presentation (COLP)	49
A.6.7.1	Call terminated at target (other party is served user)	49
A.6.7.2	Call originated by target (target is served user)	49
A.6.8	COnnected Line identification Restriction (COLR)	49
A.6.9	Closed User Group (CUG)	50
A.6.10	Completion of Call to Busy Subscriber (CCBS)	50
A.6.11	CONFERence call, add-on (CONF)	50
A.6.11.1	CONFERENCE calls, add on: CC links	50
A.6.11.2	Conference calls: IRI records	50
A.6.12	Three party service (3PTY) (conference)	50
A.6.12.1	CC links	50
A.6.12.2	Three party service, IRI records	50
A.6.13	Meet-Me Conference (MMC)	50
A.6.14	Direct Dialling In (DDI)	51
A.6.15	Multiple Subscriber Number (MSN)	51
A.6.16	DIVersion services (DIV)	51
A.6.16.0	General	51
A.6.16.1	Call Diversion by target	51
A.6.16.1.1	Call Diversion by target, CC links	51
A.6.16.1.2	Call Diversion by target, IRI records	52
A.6.16.2	Forwarded call terminated at target	52
A.6.16.3	Call from target forwarded	52
A.6.17	Variants of call diversion services	52
A.6.18	Void	52
A.6.19	Malicious Call IDentification (MCID)	52
A.6.20	SUBaddressing (SUB)	52
A.6.21	Terminal Portability (TP)	52
A.6.21.1	CC links	52
A.6.21.2	IRI records	52
A.6.21.2.1	Invocation of Terminal Portability by target	52
A.6.21.2.2	Invocation of Terminal Portability by other parties	53
A.6.22	User-to-User Signalling (UUS)	53
A.6.23	Abbreviated Address (AA)	53
A.6.24	Fixed Destination Call (FDC)	53
A.6.25	Alarm Call (AC)/Wake-Up Service (WUS)	53
A.6.26	Incoming Call Barring (ICB)	53
A.6.27	Outgoing Call Barring (OCB)	53
A.6.28	Completion of Calls on No Reply (CCNR)	53
A.6.29	Reverse charging	53
A.6.30	Line hunting	54
A.6.31	Message Wait Indication (MWI)	54
A.6.32	Name display	54
A.6.33	Tones, announcements	54
A.7	Void	54
A.8	GSM circuit switched technology annex	54
A.8.1	Functional architecture	54
A.8.2	Correlation of CC and IRI (see clause 6)	55
A.8.3	HI3 (delivery of CC)	55
A.8.4	HI2 (delivery of IRI)	56
A.9	TETRA technology annex	58

A.9.0	General	58
A.9.1	According ETSI EN 301 040	58
A.9.2	Based on ETSI EN 301 040 adapted to common handover interface	58
A.9.2.0	HI 2 event definitions	58
A.9.2.1	IRI event definitions	58
A.9.2.1.0	General	58
A.9.2.1.1	BEGIN event information	59
A.9.2.1.1.0	General	59
A.9.2.1.1.1	Call Setup Mobile Originating	59
A.9.2.1.1.2	Call Setup Mobile Terminating	59
A.9.2.1.2	CONTINUE event information	60
A.9.2.1.2.0	General	60
A.9.2.1.2.1	Ringing	60
A.9.2.1.2.2	Queueing	60
A.9.2.1.2.3	Connected	61
A.9.2.1.2.4	Handover	61
A.9.2.1.2.5	Call Forwarding	61
A.9.2.1.2.6	Call Hold	62
A.9.2.1.2.7	TxGranted	62
A.9.2.1.3	END event information	62
A.9.2.1.3.0	General	62
A.9.2.1.3.1	Call Release	63
A.9.2.1.4	REPORT event information	63
A.9.2.1.4.0	General	63
A.9.2.1.4.1	Location Update	63
A.9.2.1.4.2	SDS Mobile Originating	64
A.9.2.1.4.3	SDS Mobile Terminating	64
A.9.2.1.4.4	Group Indication	64
A.9.2.1.4.5	Mobile On	65
A.9.2.1.4.6	Mobile Off	65
A.9.2.1.4.7	DMO	65
A.10	NGN PSTN/ISDN emulation and simulation services technology annex	66
A.10.0	General	66
A.10.1	Functional architecture	66
A.10.2	Correlation	66
A.10.3	HI2	66
A.10.4	HI3	66
Annex B (normative): Packet switched network handover		67
B.1	Specific identifiers for LI	67
B.2	HI1: interface port for administrative state	67
B.3	HI2: interface port for IRI	67
B.3.1	Definition of Interception Related Information for packet switched	67
B.3.2	Exception handling	67
B.3.3	Security aspects	67
B.4	HI3: interface port for Content of Communication (CC)	68
B.5	GPRS technology annex	68
B.5.1	Functional architecture	68
B.5.2	Correlation	69
B.5.2.1	Correlation of the present document IDs to GSM IDs	69
B.5.2.2	GPRS LI correlation between CC and IRI	69
B.5.3	HI2 (delivery of IRI)	69
B.5.4	HI3 (Delivery of CC)	70
Annex C (normative): HI2 Delivery mechanisms and procedures		71
C.0	General	71
C.1	ROSE	71

C.1.1	Architecture	71
C.1.2	ASE_HI procedures.....	71
C.1.2.1	Sending part.....	71
C.1.2.2	Receiving part.....	73
C.1.2.3	Data link management	73
C.1.2.3.0	General	73
C.1.2.3.1	Data link establishment	73
C.1.2.3.2	Data link release.....	74
C.1.2.4	Handling of unrecognized fields and parameters.....	74
C.1.3	Void.....	74
C.2	FTP.....	74
C.2.1	Introduction	74
C.2.2	Usage of the FTP.....	75
C.2.3	Profiles	77
C.2.4	File content.....	78
C.2.5	Exceptional procedures	78
C.2.6	Other considerations.....	79
Annex D (normative): Structure of data at the Handover Interface.....		80
D.0	General	80
D.1	Syntax definitions.....	80
D.2	Object tree	81
D.3	HI management operation	82
D.4	LI management notification	83
D.5	Intercept related information (HI2 PS and CS).....	85
D.6	User data packet transfer (HI3 CS)	101
D.7	TETRA data transfer (HI3 interface)	102
D.8	Definition of the UUS1 content associated to the CC link.....	102
D.9	Content of Communication (HI3 GPRS)	103
D.10	TETRA ASN.1 details.....	104
D.10.0	General	104
D.10.1	HI management operation	104
D.10.2	LI management notification	106
D.10.3	HI2 definitions.....	108
Annex E (informative): Use of subaddress and calling party number to carry correlation information.....		124
E.1	Introduction	124
E.2	Subaddress options.....	124
E.3	Subaddress coding.....	124
E.3.0	General	124
E.3.1	BCD values	124
E.3.2	Field order and layout.....	125
E.4	Field coding.....	130
E.4.0	General	130
E.4.1	Direction.....	131
E.4.2	Coding of the Calling Party Number.....	131
E.5	Length of fields	132
Annex F (informative): GPRS HI3 interface.....		133
F.1	Functional architecture.....	133

F.2	Correlation.....	133
F.3	HI3 Delivery Content of Communication (CC).....	133
F.3.0	General	133
F.3.1	GPRS LI correlation header	134
F.3.1.1	Introduction.....	134
F.3.1.2	Definition of GLIC header.....	134
F.3.1.3	Exceptional procedure	135
F.3.1.4	Other considerations	136
F.3.2	FTP.....	136
F.3.2.1	Introduction.....	136
F.3.2.2	Usage of the FTP	136
F.3.2.3	Profiles.....	138
F.3.2.4	Exceptional procedures.....	140
F.3.2.5	CC contents for FTP	140
F.3.2.5.1	Fields.....	140
F.3.2.5.2	Information Element syntax	142
F.3.2.6	Other considerations	144
Annex G (informative):	LEMF requirements - handling of unrecognized fields and parameters.....	145
Annex H (informative):	IP Multimedia Subsystem (IMS) handover.....	146
H.0	General	146
H.1	Specific identifiers for LI	146
H.1.0	General	146
H.1.1	Lawful interception identifier.....	147
H.1.2	Network identifier	147
H.1.3	Correlation number.....	147
H.1.4	IRI for IMS.....	148
H.1.4.0	General.....	148
H.1.4.1	Events and information	149
H.1.5	Correlation indications of IMS IRI with GSN CC at the LEMF	150
Annex I (normative):	Evolved Packet System handover.....	152
Annex J (informative):	Latest ASN.1 module versions	153
Annex K (informative):	Bibliography.....	154
Annex L (informative):	Change Request history.....	155
History		161

Intellectual Property Rights

Essential patents

IPRs essential or potentially essential to normative deliverables may have been declared to ETSI. The information pertaining to these essential IPRs, if any, is publicly available for **ETSI members and non-members**, and can be found in ETSI SR 000 314: "*Intellectual Property Rights (IPRs); Essential, or potentially Essential, IPRs notified to ETSI in respect of ETSI standards*", which is available from the ETSI Secretariat. Latest updates are available on the ETSI Web server (<https://ipr.etsi.org/>).

Pursuant to the ETSI IPR Policy, no investigation, including IPR searches, has been carried out by ETSI. No guarantee can be given as to the existence of other IPRs not referenced in ETSI SR 000 314 (or the updates on the ETSI Web server) which are, or may be, or may become, essential to the present document.

Trademarks

The present document may include trademarks and/or tradenames which are asserted and/or registered by their owners. ETSI claims no ownership of these except for any which are indicated as being the property of ETSI, and conveys no right to use or reproduce any trademark and/or tradename. Mention of those trademarks in the present document does not constitute an endorsement by ETSI of products, services or organizations associated with those trademarks.

Foreword

This Technical Specification (TS) has been produced by ETSI Technical Committee Lawful Interception (LI).

The ASN.1 module is also available as an electronic attachment to the original document from the ETSI site (see clause D.2 for more details).

Modal verbs terminology

In the present document "**shall**", "**shall not**", "**should**", "**should not**", "**may**", "**need not**", "**will**", "**will not**", "**can**" and "**cannot**" are to be interpreted as described in clause 3.2 of the [ETSI Drafting Rules](#) (Verbal forms for the expression of provisions).

"**must**" and "**must not**" are **NOT** allowed in ETSI deliverables except when used in direct citation.

Introduction

References within the main body of the present document are made if applicable to the 3GPP specification number with in square brackets the reference number as listed in clause 2. In clause 2 "References" the corresponding ETSI specification number is indicated with a reference to the 3GPP specification number. 3GPP specifications are available faster than the equivalent ETSI specifications.

The present document is made historical and is therefore no longer maintained or revised. It has been superseded by ETSI TS 102 232 (all parts) [i.6] and ETSI TS 103 280 [i.7].

1 Scope

The present document is step 3 of a three-step approach to describe a generic Handover Interface (HI) for the provision of lawful interception from a Network Operator, an Access Provider or a Service Provider (NWO/AP/SvP) to the Law Enforcement Agencies (LEAs). The provision of lawful interception is a requirement of national law, which is usually mandatory for the operation of any telecommunication service.

Step 1 contains the requirements for lawful interception from a users (LEAs) point of view and is published in ETSI TS 101 331 [1].

Step 2 describes the derived network functions and the general architecture (or functional model) and is published in ETSI ES 201 158 [2].

The present document specifies:

- the **generic flow of information** as well as the procedures and information elements, which are applicable to any future telecommunication network or service;
- the **network/service specific protocols** relating to the provision of lawful interception at the Handover Interface (HI), for the following networks/services:
 - switched circuit; and
 - packet data.

The technologies covered in the present document are: GSM, TETRA, GPRS, ISDN, PSTN, fixed NGN (including PSTN/ISDN emulation) and fixed IMS PSTN simulation.

NOTE 1: Void.

New telecommunication networks and services are IP based Packet Switched networks and Packet Switched services . Some legacy networks and services are still Circuit Switched networks and/or services even if the transport might be IP based. For new LI implementations it is therefore recommended to use the ETSI TS 102 232 series (part 1 to 7) [i.6] instead of the present document. Current implementations of the present document are advised to migrate to the ETSI TS 102 232 series [i.6].

NOTE 2: The HI3 transport technology change may have an impact on the delivery network between the CSP and the LEA.

NOTE 3: The ETSI TS 102 232 series [i.6], 3GPP TS 33.107 [64] and 3GPP TS 33.108 [61] make use of imports from the present document. Taking the current IP based networks and services into account, these imports from circuit switched specifications seem not to be appropriate anymore. These imports will therefore be removed. After these imports are made obsolete in these specifications, the present document will be made "historical" according to the ETSI Directive. This does not exclude local regulations continuing to require the use of ETSI TS 101 671. The imports from the present document can be made obsolete by updating ETSI TS 103 280 [i.7] and redirecting the imports to ETSI TS 103 280 [i.7]. In the ETSI TC LI plenary meeting #29 in Dun Laoghaire, January 2012 it was decided not to upgrade the the present document anymore to ETSI ES 201 671 [i.5].

2 References

2.1 Normative references

References are either specific (identified by date of publication and/or edition number or version number) or non-specific. For specific references, only the cited version applies. For non-specific references, the latest version of the reference document (including any amendments) applies.

Referenced documents which are not found to be publicly available in the expected location might be found at <http://docbox.etsi.org/Reference>.

NOTE: While any hyperlinks included in this clause were valid at the time of publication, ETSI cannot guarantee their long term validity.

The following referenced documents are necessary for the application of the present document.

- [1] ETSI TS 101 331: "Lawful Interception (LI); Requirements of Law Enforcement Agencies".
- [2] ETSI ES 201 158: "Telecommunications security; Lawful Interception (LI); Requirements for network functions".
- [3] ETSI ETR 330: "Security Techniques Advisory Group (STAG); A guide to legislative and regulatory environment".
- [4] Void.
- [5] ETSI EN 300 356 (all parts): "Integrated Services Digital Network (ISDN); Signalling System No. 7 (SS7); ISDN User Part (ISUP) version 4 for the international interface".
- [6] ETSI EN 300 403-1 (V1.3.2): "Integrated Services Digital Network (ISDN); Digital Subscriber Signalling System No. one (DSS1) protocol; Signalling network layer for circuit-mode basic call control; Part 1: Protocol specification [ITU-T Recommendation Q.931 (1993), modified]".

NOTE: Reference [6] is specific, because the format of the sub parameters "dSS1-Format, DSS1-parameters-codeset-0", "DSS1-SS-parameters-codeset-0" and "UUS1-Content" are defined by V1.3.2.

- [7] Void.
- [8] Void.
- [9] Void.
- [10] ETSI EN 300 061-1: "Integrated Services Digital Network (ISDN); Subaddressing (SUB) supplementary service; Digital Subscriber Signalling System No. one (DSS1) protocol; Part 1: Protocol specification".
- [11] Void.
- [12] Void.
- [13] Void.
- [14] ETSI EN 300 097-1 (V1.2.4): "Integrated Services Digital Network (ISDN); Connected Line Identification Presentation (COLP) supplementary service; Digital Subscriber Signalling System No. one (DSS1) protocol; Part 1: Protocol specification".

NOTE: Reference [14] is specific, because several parameter format definitions point to V1.2.4.

- [15] Void.
- [16] ETSI EN 300 130-1: "Integrated Services Digital Network (ISDN); Malicious Call Identification (MCID) supplementary service; Digital Subscriber Signalling System No. one (DSS1) protocol; Part 1: Protocol specification".

- [17] Void.
- [18] Void.
- [19] ETSI EN 300 185-1: "Integrated Services Digital Network (ISDN); Conference call, add-on (CONF) supplementary service; Digital Subscriber Signalling System No. one (DSS1) protocol; Part 1: Protocol specification".
- [20] ETSI EN 300 188-1: "Integrated Services Digital Network (ISDN); Three-Party (3PTY) supplementary service; Digital Subscriber Signalling System No. one (DSS1) protocol; Part 1: Protocol specification".
- [21] ETSI EN 300 207-1 (V1.2.5): "Integrated Services Digital Network (ISDN); Diversion supplementary services; Digital Subscriber Signalling System No. one (DSS1) protocol; Part 1: Protocol specification".
- NOTE: Reference [21] is specific, because the format of the sub parameters for "DSS1-SS-Invoke-Components" is defined by V1.2.5. In addition several parameter format definitions point to V1.2.5.
- [22] Void.
- [23] ETSI EN 300 286-1: "Integrated Services Digital Network (ISDN); User-to-User Signalling (UUS) supplementary service; Digital Subscriber Signalling System No. one (DSS1) protocol; Part 1: Protocol specification".
- [24] Void.
- [25] ETSI EN 300 369-1 (V1.2.4): "Integrated Services Digital Network (ISDN); Explicit Call Transfer (ECT) supplementary service; Digital Subscriber Signalling System No. one (DSS1) protocol; Part 1: Protocol specification".
- NOTE: Reference [25] is specific, because the format of the sub parameters for "DSS1-SS-Invoke-Components" is defined by V1.2.4.
- [26] Void.
- [27] Void.
- [28] Void.
- [29] ETSI EN 300 196-1 (V1.3.2): "Integrated Services Digital Network (ISDN); Generic functional protocol for the support of supplementary services; Digital Subscriber Signalling System No. one (DSS1) protocol; Part 1: Protocol specification".
- NOTE: Reference [29] is specific, because several parameter format definitions point to V1.3.2.
- [30] Void.
- [31] Recommendation ITU-T Q.850 (1998): "Usage of cause and location in the Digital Subscriber Signalling System No. 1 and the Signalling System No. 7 ISDN user part".
- NOTE: Reference [31] is specific, because several parameter format definitions point to version 1988.
- [32] ETSI TS 100 974: "Digital cellular telecommunications system (Phase 2+); Mobile Application Part (MAP) specification (3GPP TS 09.02)".
- [33] Recommendation ITU-T X.680: "Information technology - Abstract Syntax Notation One (ASN.1): Specification of basic notation".
- [34] Recommendation ITU-T X.690: "Information technology - ASN.1 encoding rules: Specification of Basic Encoding Rules (BER), Canonical Encoding Rules (CER) and Distinguished Encoding Rules (DER)".
- [35] Recommendation ITU-T X.880: "Information technology - Remote Operations: Concepts, model and notation".
- [36] Void.

- [37] Recommendation ITU-T X.882: "Information technology - Remote Operations: OSI realizations - Remote Operations Service Element (ROSE) protocol specification".
- [38] Void.
- [39] ETSI EN 300 122-1: "Integrated Services Digital Network (ISDN); Generic keypad protocol for the support of supplementary services; Digital Subscriber Signalling System No. one (DSS1) protocol; Part 1: Protocol specification".
- [40] ETSI EN 300 392-1: "Terrestrial Trunked Radio (TETRA); Voice plus Data (V+D); Part 1: General network design".
- [41] ETSI TS 124 008: "Digital cellular telecommunications system (Phase 2+) (GSM); Universal Mobile Telecommunications System (UMTS); LTE; Mobile radio interface Layer 3 specification; Core network protocols; Stage 3 (3GPP TS 24.008)".
- [42] ETSI TS 101 509: "Digital cellular telecommunications system (Phase 2+) (GSM); Lawful interception; Stage 2 (3GPP TS 03.33)".
- [43] ETSI TS 100 927: "Digital cellular telecommunications system (Phase 2+); Numbering, addressing and identification (3GPP TS 03.03)".
- [44] Void.
- [45] ETSI TS 101 347: "Digital cellular telecommunications system (Phase 2+); General Packet Radio Service (GPRS); GPRS Tunnelling Protocol (GTP) across the Gn and Gp Interface (3GPP TS 09.60)".
- [46] IETF RFC 959: "File Transfer Protocol".
- [47] Void.
- [48] Recommendation ITU-T Q.763: "Signalling System No.7 - ISDN User Part formats and codes".
- [49] ETSI TS 101 393: "Digital cellular telecommunications system (Phase 2+); General Packet Radio Service (GPRS); GPRS Charging (3GPP TS 12.15)".
- [50] Void.
- [51] IETF RFC 791: "Internet Protocol".
- [52] IETF RFC 793: "Transmission Control Protocol".
- [53] Void.
- [54] ETSI EN 300 089: "Integrated Services Digital Network (ISDN); Calling Line Identification Presentation (CLIP) supplementary service; Service description".
- [55] ETSI TS 100 940: "Digital cellular telecommunications system (Phase 2+); Mobile radio interface layer 3 specification (3GPP TS 04.08)".
- [56] Recommendation ITU-T Q.931: "ISDN user-network interface layer 3 specification for basic call control".
- [57] ETSI TS 101 109: "Digital cellular telecommunications system (Phase 2+); Universal Geographical Area Description (GAD) (3GPP TS 03.32)".
- [58] Recommendation ITU-T E.164: "The international public telecommunication numbering plan".
- [59] IETF RFC 3261: "SIP: Session Initiation Protocol".
- [60] ETSI TS 129 060: "Digital cellular telecommunications system (Phase 2+) (GSM); Universal Mobile Telecommunications System (UMTS); General Packet Radio Service (GPRS); GPRS Tunnelling Protocol (GTP) across the Gn and Gp interface (3GPP TS 29.060)".
- [61] ETSI TS 133 108: "Universal Mobile Telecommunications System (UMTS); LTE; 3G security; Handover interface for Lawful Interception (LI) (3GPP TS 33.108)".

- [62] Void.
- [63] Recommendation ITU-T Q.731.3: "Stage 3 description for number identification supplementary services using Signalling System No. 7: Calling line identification presentation (CLIP)".
- [64] Recommendation ITU-T Q.951.1: "Stage 3 description for number identification supplementary services using DSS 1: Direct-dialling-in (DDI)".
- [65] Recommendation ITU-T Q.951.3: "Stage 3 description for number identification supplementary services using DSS 1: Calling line identification presentation".
- [66] ETSI EN 300 092 (all parts): "Integrated Services Digital Network (ISDN); Digital Subscriber Signalling System No. one (DSS1) protocol; Calling Line Identification Presentation (CLIP) supplementary service".
- [67] ISO 3166-1: "Codes for the representation of names of countries and their subdivisions - Part 1: Country codes".
- [68] IETF RFC 3966: "The tel URI for Telephone Numbers".
- [69] ETSI TS 101 909-20-1: "Digital Broadband Cable Access to the Public Telecommunications Network; IP Multimedia Time Critical Services; Part 20: Lawful Interception; Sub-part 1: CMS based Voice Telephony Services".
- [70] ETSI TS 123 228: "Digital cellular telecommunications system (Phase 2+) (GSM); Universal Mobile Telecommunications System (UMTS); LTE; IP Multimedia Subsystem (IMS); Stage 2 (3GPP TS 23.228)".
- [71] ETSI TS 133 107: "Universal Mobile Telecommunications System (UMTS); LTE; Digital cellular telecommunications system (Phase 2+) (GSM); 3G security; Lawful interception architecture and functions (3GPP TS 33.107)".
- [72] ETSI EN 301 040: "Terrestrial Trunked Radio (TETRA); Security; Lawful Interception (LI) interface".
- [73] ETSI TS 100 392-3-6: "Terrestrial Trunked Radio (TETRA); Voice plus Data (V+D); Part 3: Interworking at the Inter-System Interface (ISI); Sub-part 6: Speech format implementation for circuit mode transmission".
- [74] ETSI TS 100 392-3-7: "Terrestrial Trunked Radio (TETRA); Voice plus Data (V+D); Part 3: Interworking at the Inter-System Interface (ISI); Sub-part 7: Speech Format Implementation for Packet Mode Transmission".
- [75] Void.
- [76] ETSI TS 123 003: "Digital cellular telecommunications system (Phase 2+) (GSM); Universal Mobile Telecommunications System (UMTS); Numbering, addressing and identification (3GPP TS 23.003)".
- [77] ETSI TS 123 060: "Digital cellular telecommunications system (Phase 2+) (GSM); Universal Mobile Telecommunications System (UMTS); General Packet Radio Service (GPRS); Service description; Stage 2 (3GPP TS 23.060)".
- [78] ETSI TS 123 401: "LTE; General Packet Radio Service (GPRS) enhancements for Evolved Universal Terrestrial Radio Access Network (E-UTRAN) access (3GPP TS 23.401)".
- [79] ETSI TS 123 402: "Universal Mobile Telecommunications System (UMTS); LTE; Architecture enhancements for non-3GPP accesses (3GPP TS 23.402)".
- [80] ETSI TS 129 002: "Digital cellular telecommunications system (Phase 2+) (GSM); Universal Mobile Telecommunications System (UMTS); Mobile Application Part (MAP) specification (3GPP TS 29.002)".
- [81] ETSI TS 101 671 (V3.5.1): "Lawful Interception (LI); Handover interface for the lawful interception of telecommunications traffic".

- [82] ETSI TS 125 413: "Universal Mobile Telecommunications System (UMTS); UTRAN Iu interface Radio Access Network Application Part (RANAP) signalling (3GPP TS 25.413)".
- [83] ETSI TS 129 118: "Universal Mobile Telecommunications System (UMTS); LTE; Mobility Management Entity (MME) - Visitor Location Register (VLR) SGs interface specification (3GPP TS 29.118)".
- [84] SMS forum: "Short Message Peer-to-Peer Protocol Specification (SMPP) v5.0".
- [85] EMI-UCP interface (UCP) v5.2.
- [86] ETSI TS 101 671 (V2.5.1): "Telecommunications security; Lawful Interception (LI); Handover interface for the lawful interception of telecommunications traffic".

2.2 Informative references

References are either specific (identified by date of publication and/or edition number or version number) or non-specific. For specific references, only the cited version applies. For non-specific references, the latest version of the reference document (including any amendments) applies.

NOTE: While any hyperlinks included in this clause were valid at the time of publication, ETSI cannot guarantee their long term validity.

The following referenced documents are not necessary for the application of the present document but they assist the user with regard to a particular subject area.

- [i.1] ISO 9798 (all parts): "Information technology - Security techniques - Entity authentication".
- [i.2] Void.
- [i.3] ETSI TS 187 005: "Telecommunications and Internet converged Services and Protocols for Advanced Networking (TISPAN); NGN Lawful Interception; Stage 1 and Stage 2 definition".
- [i.4] ETSI TR 102 503: "Lawful Interception (LI); ASN.1 Object Identifiers in Lawful Interception and Retained data handling Specifications".
- [i.5] ETSI ES 201 671: "Lawful Interception (LI); Handover interface for the lawful interception of telecommunications traffic".

NOTE: Periodically ETSI TS 101 671 is published as ETSI ES 201 671. A reference to the latest version of the TS reflects the latest stable content from ETSI/TC LI.

- [i.6] ETSI TS 102 232 series: "Lawful Interception (LI); Handover Interface and Service-Specific Details (SSD) for IP delivery".
- [i.7] ETSI TS 103 280: "Lawful Interception (LI); Dictionary for common parameters".

3 Definitions and abbreviations

3.1 Definitions

For the purposes of the present document, the following terms and definitions apply:

Access Provider (AP): provides a user of some network with access from the user's terminal to that network

NOTE: This definition applies specifically for the present document. In a particular case, the access provider and network operator may be a common commercial entity.

activation/deactivation of supplementary services: procedures for activation, which is the operation of bringing the service into the "ready for invocation" state, and deactivation, which is the complementary action

(to) buffer: temporary storing of information in case the necessary telecommunication connection to transport information to the LEMF is temporarily unavailable

call: any temporary switched connection capable of transferring information between two or more users of a telecommunications system

NOTE: In this context a user may be a person or a machine.

CC link: communication channel for HI3 information between a mediation function and a LEMF

NOTE: It is used for transmission of the Content of Communication (CC). This term refers to circuit switched only.

CC Link Identifier (CCLID): See definition in clause A.1.

communication: information transfer according to agreed conventions

Communication Identifier (CID): See definition in clause 6.

Communication Identity Number (CIN): See definition in clause 6.

communications session: session that consists of either a single self-contained transaction or a series of protocol data units that together form a single self-contained communication

Content of Communication (CC): information exchanged between two or more users of a telecommunication service, excluding Intercept Related Information

NOTE: This includes information which may, as part of some telecommunication service, be stored by one user for subsequent retrieval by another.

Handover Interface (HI): physical and logical interface across which the interception measures are requested from network operator/access provider/service provider, and the results of interception are delivered from a network operator/access provider/service provider to a law enforcement monitoring facility

identity: technical label which may represent the origin or destination of any telecommunications traffic, as a rule clearly identified by a physical telecommunication identity number (such as a telephone number) or the logical or virtual telecommunication identity number (such as a personal number) which the subscriber can assign to a physical access on a case-by-case basis

information: intelligence or knowledge capable of being represented in forms suitable for communication, storage or processing

NOTE: Information may be represented for example by signs, symbols, pictures or sounds.

interception: action (based on the law), performed by a network operator/access provider/service provider, of making available certain information and providing that information to a law enforcement monitoring facility

NOTE: In the present document the term interception is not used to describe the action of observing communications by a law enforcement agency.

interception configuration information: information related to the configuration of interception

interception interface: physical and logical locations within the network operator's/access provider's/service provider's telecommunication facilities where access to the Content of Communication and Intercept Related Information is provided

NOTE: The interception interface is not necessarily a single, fixed point.

interception measure: technical measure which facilitates the interception of telecommunications traffic pursuant to the relevant national laws and regulations

interception subject: person or persons, specified in a lawful authorization, whose telecommunications are to be intercepted

Intercept Related Information (IRI): collection of information or data associated with telecommunication services involving the target identity, specifically communication associated information or data (including unsuccessful communication attempts), service associated information or data (e.g. service profile management by subscriber) and location information

Internal Interception Function (IIF): point within a network or network element at which the Content of Communication and the Intercept Related Information are made available

Internal Network Interface (INI): network's internal interface between the Internal Interception Function and a mediation function

invocation and operation: describes the action and conditions under which the service is brought into operation

NOTE 1: In the case of a lawful interception this may only be on a particular communication. It should be noted that when lawful interception is activated, invocation is applicable on all communications (invocation takes place either subsequent to or simultaneously with activation). Operation is the procedure which occurs once a service has been invoked.

NOTE 2: The definition is based on Recommendation ITU-T X.882 [37], but has been adapted for the special application of lawful interception, instead of supplementary services.

Law Enforcement Agency (LEA): organization authorized by a lawful authorization based on a national law to request interception measures and to receive the results of telecommunications interceptions

Law Enforcement Monitoring Facility (LEMF): designated as the transmission destination for the results of interception relating to a particular interception subject

lawful authorization: permission granted to a LEA under certain conditions to intercept specified telecommunications and requiring co-operation from a network operator/access provider/service provider

NOTE: Typically this refers to a warrant or order issued by a lawfully authorized body.

Lawful Interception (LI): See interception.

Lawful Interception Identifier (LIID): See definition in clause 6.

location information: information relating to the geographic, physical or logical location of an identity relating to an interception subject

Mediation Function (MF): mechanism which passes information between a network operator, an access provider or service provider and a Handover Interface, and information between the Internal Network Interface and the Handover Interface

network element: component of the network structure, such as a local exchange, higher order switch or service control processor

Network Element Identifier (NEID): See definition in clause 6.

Network Identifier (NID): See definition in clause 6.

NetWork Operator (NWO): operator of a public telecommunications infrastructure which permits the conveyance of signals between defined network termination points by wire, by microwave, by optical means or by other electromagnetic means

PSTN/ISDN Emulation Service: mimics a PSTN/ISDN network from the point of view of legacy terminals (or interfaces) by an IP network, through a gateway

NOTE: All PSTN/ISDN services remain available and identical (i.e. with the same ergonomics); such that end users are unaware that they are not connected to a TDM-based PSTN/ISDN.

PSTN/ISDN Simulation Service: defines the provision of PSTN/ISDN-like services to advanced terminals (IP-phones) or IP-interfaces

NOTE: There is no strict requirement to make all PSTN/ ISDN services available or identical, although end users expect to have access to the most popular ones, possibly with different ergonomics.

Quality of Service (QoS): quality specification of a telecommunications channel, system, virtual channel, computer-telecommunications session, etc.

NOTE: Quality of service may be measured, for example, in terms of signal-to-noise ratio, bit error rate, message throughput rate or call blocking probability.

reliability: probability that a system or service will perform in a satisfactory manner for a given period of time when used under specific operating conditions

result of interception: information relating to a target service, including the Content of Communication and Intercept Related Information, which is passed by a network operator, an access provider or a service provider to a law enforcement agency

NOTE: Intercept related information is provided whether or not call activity is taking place.

sequence number: number that counts individual intercepted protocol data units within a communications session

service information: information used by the telecommunications infrastructure in the establishment and operation of a network related service or services

NOTE: The information may be established by a network operator, an access provider, a service provider or a network user.

Service Provider (SvP): natural or legal person providing one or more public telecommunications services whose provision consists wholly or partly in the transmission and routing of signals on a telecommunications network

NOTE: A service provider needs not necessarily run his own network.

Short Message Service (SMS): service that gives the ability to send character messages to phones

NOTE: SMS messages can be MO (Mobile Originated) or MT (Mobile Terminated).

target identity: technical identity (e.g. the interception's subject directory number), which uniquely identifies a target of interception

NOTE: One target may have one or several target identities.

target service: telecommunications service associated with an interception subject and usually specified in a lawful authorization for interception

NOTE: There may be more than one target service associated with a single interception subject.

telecommunications: any transfer of signs, signals, writing images, sounds, data or intelligence of any nature transmitted in whole or in part by a wire, radio, electromagnetic, photoelectronic or photo-optical system

3.2 Abbreviations

For the purposes of the present document, the following abbreviations apply:

3PTY	Three-ParTY service
AA	Abbreviated Address
AC	Alarm Call
ADMF	ADMinistration Function
AOC	Advice Of Charge service
AP	Access Provider
API	Access Point Identifier
ASCII	American Standard Code for Information Interchange
ASE	Application Service Element
ASN.1	Abstract Syntax Notation One
BA	DSS1 Basic Access
BC	Bearer Capability
BCD	Binary Coded Decimal
BER	Basic Encoding Rules
BRA	Basic Rate Access

BRI	Basic Rate Interface
BS	Basic Service
CC	Content of Communication
CC/IRI	Content of Communication / Intercept Related Information
CCBS	Completion of Calls to Busy Subscriber
CCLID	CC Link IDentifier
CCNR	Completion of Calls on No Reply
CD	Call Deflection
CdP	Called Party
CF	Call Forwarding
CFB	Call Forwarding on Busy
CFNR	Call Forwarding on No Reply
CFU	Call Forwarding Unconditional
CGI	Cell Global Id
CgP	Calling Party
CID	Communication IDentifier
CIN	Communication Identity Number
CLI	Calling Line Identity (Calling Party Number)
CLIP	Calling Line Identification Presentation
CLIR	Calling Line Identification Restriction
COL	COnnected Line identity (Connected Number)
COLP	COnnected Line identification Presentation
COLR	COnnected Line identification Restriction
CONF	CONFerence call, add-on
CS	Circuit Switched
CSCF	Call Session Control Function
CUG	Closed User Group
CW	Call Waiting
DDI	Direct Dialling In
DF	Delivery Function
DIR	Direction
DIV	call DIVersion services
DMO	Direct Mode Operation
DN	Directory Number
DNS	Domain Name Service
DSS1	Digital Subscriber Signalling system No.1
E-CGI	E-UTRAN Cell Global Identity
ECT	Explicit Call Transfer
EPS	Evolved Packet System
FB	FallBack procedure
FDC	Fixed Destination Call
FPH	Free PHone
FTP	File Transfer Protocol
GCID	GPRS Charging ID (GGSN address)
GGSN	Gateway GPRS Support Node
GLIC	GPRS LI Correlation
GMSC	Gateway Mobile Switching Centre
GPRS	General Packet Radio Service
GSM	Global System for Mobile communications
GSN	GPRS Support Node (SGSN or GGSN)
GTP	GPRS Tunnelling Protocol
GTSI	Group TETRA Subscriber Identity
HI	Handover Interface
HI1	Handover Interface port 1 (for administrative information)
HI2	Handover Interface port 2 (for Intercept Related Information)
HI3	Handover Interface port 3 (for Content of Communication)
HLC	High Layer Compatibility
HLR	Home Location Register
HOLD	call HOLD service
IA5	International Alphabet No. 5
IAP	Interception Access Point
ICB	Incoming Call Barring

ICID	IMS Charging ID
IE	Information Element
IIF	Internal Interception Function
IMEI	International Mobile station Equipment Identity
IMS	IP Multimedia Subsystem
IMSI	International Mobile Subscriber Identity
IN	Intelligent Network
INI	Internal Network Interface
IP	Internet Protocol
IP-CAN	IP-Connectivity Access Network
IRI	Intercept Related Information
ISDN	Integrated Services Digital Network
ISUP	ISDN User Part
ITSI	Individual TETRA Subscriber Identity
LAC	Location Area Code
LAES	Lawfully Authorized Electronic Surveillance
LEA	Law Enforcement Agency
LEMF	Law Enforcement Monitoring Facility
LI	Lawful Interception
LIID	Lawful Interception IDentifier
LLC	Lower Layer Compatibility
MAP	Mobile Application Part
MCID	Malicious Call IDentification
ME	Mobile Equipment
MF	Mediation Function
MMC	Meet-Me Conference
MME	Mobility Management Entity
MO	Mobile Originated
MO&MT	Mobile Originated and Mobile Terminated
MOC	Mandatory / Optional / Conditional
MOC	Mobile Originated Call
MS	Mobile Station
MSISDN	Mobile Subscriber ISDN Number
MSN	Multiple Subscriber Number
MT	Mobile Terminated
MTC	Mobile Terminated Call
MWI	Message Wait Indication
NDUB	Network Determined User Busy
NEID	Network Element IDentifier
NGN	Next Generation Network
NID	Network IDentifier
NSAPI	Network layer Service Access Point Identifier
NWO	NetWork Operator
OCB	Outgoing Call Barring
OID	Object IDentifiers
OTOA	Originator Type Of Address
PABX	Private Automatic Branch Exchange
PDP	Packet Data Protocol
PDU	Protocol Data Unit
PLMN	Public Land Mobile Network
PR	Partial Rerouting
PRA	Primary Rate Access
PRI	Primary Rate Interface
PS	Packet Switched
PSTN	Public Switched Telephone Network
QoS	Quality of Service
RA	Routing Area
RAI	Routeing Area Identifier
RAM	Random Access Memory
ROSE	Remote Operation Service Element
RTP	Real Time Protocol

R _x	Receive direction
SAC	System Area Code
SCF	Service Control Function
SCI	Subscriber Controlled Input
SDP	Session Description Protocol
SDS	Short Data Service
SGSN	Serving GPRS Support Node
SIP	Session Initiation Protocol
SMPP	Short Message Peer to Peer Protocol
SMS	Short Message Service
SS	Supplementary Service
SS No.7	common channel Signalling System ITU (T) No. 7
SSF	Service Switching Function
SUB	SUBaddressing (supplementary service)
SvP	Service Provider
TAI	Tracking Area Identity
TCP	Transmission Control Protocol
TDM	Time Division Multiplexing
TEI	Terminal Equipment Identity
TEL URI	Uniform Resource Identifier for Telephone Numbers
TETRA	TErrestrial Trunked RAdio
TLV	TypeLengthValue
TMR	Transmission Medium Requirement
TP	Terminal Portability
T-PDU	Tunnelled PDU
T _x	Transmit direction
UCP	Universal Computer Protocol
UDP	User Datagram Protocol
UDUB	User Determined User Busy
UE	User Equipment
UMTS	Universal Mobile Telecommunication System
URI	Uniform Resource Identifier
URL	Universal Resource Locator
UTC	Universal Time Coordinated
UTM	Universal Transverse Mercator
UUS	User-to-User Signalling
WGS	World Geodetic System
WUS	Wake-Up Service
xGSN	SGSN or GGSN

4 General requirements

4.0 General

The present document focuses on the Handover Interface related to the provision of information related to LI between a network operator, access provider and/or service provider and a Law Enforcement Agency (LEA).

4.1 Basic principles for the Handover Interface

The network requirements mentioned in the present document are derived, in part, from the requirements defined in ETSI ES 201 158 [2].

Lawful interception requires functions to be provided in some, or all of, the switching or routing nodes of a telecommunications network.

The specification of the Handover Interface is subdivided into three parts each optimized to the different purposes and types of information being exchanged.

The interface is extensible.

4.2 Legal requirements

It shall be possible to select elements from the Handover Interface specification to conform with:

- national requirements;
- national law;
- any law applicable to a specific LEA.

As a consequence, the present document shall define, in addition to mandatory requirements, which are always applicable, supplementary options, in order to take into account the various influences listed above. See also ETSI TS 101 331 [1] and ETSI ETR 330 [3].

4.3 Functional requirements

A lawful authorization shall describe the kind of information (Intercept Related Information (IRI) or both IRI and Content of Communication (CC)) that is required by this LEA, the interception subject, the start and stop time of LI, and the addresses of the LEAs for CC and/or IRI and further information.

A single interception subject may be the subject to interception by different LEAs. It shall be possible strictly to separate these interception measures.

If two targets are communicating with each other, each target is dealt with separately.

5 Overview of Handover Interface

5.0 General

The generic Handover Interface adopts a three-port structure such that administrative information (HI1), Intercept Related Information (HI2) and the Content of Communication (HI3) are logically separated.

Figure 1 shows a block diagram with the relevant entities for Lawful Interception (LI).

The outer circle represents the NWO/AP/SvP's domain with respect to lawful interception. It contains the network internal functions, the Internal Network Interface (INI), the administration function and the mediation functions for IRI and CC. The inner circle contains the internal functions of the network (e.g. switching, routing, and handling of the communication process). Within the network internal function the results of interception (IRI, CC) are generated in the IIF.

The Internal Interception Functions (IIF) provide the Content of Communication (CC) and the Intercept Related Information (IRI), respectively, at the Internal Network Interface INI. For both kinds of information, mediation functions may be used, which provide the final representation of the standardized Handover Interfaces at the NWO/AP/SvP's domain boundary.

Within the NWO/AP/SvP's administration centre, the LI related tasks, as received via interface HI1, are translated into man machine commands for the NWO/AP/SvP's equipment.

Depending on the type of network, there might be a need to standardize also some or all of the Internal Network Interfaces (INI). Such standards are not in the scope of the present document.

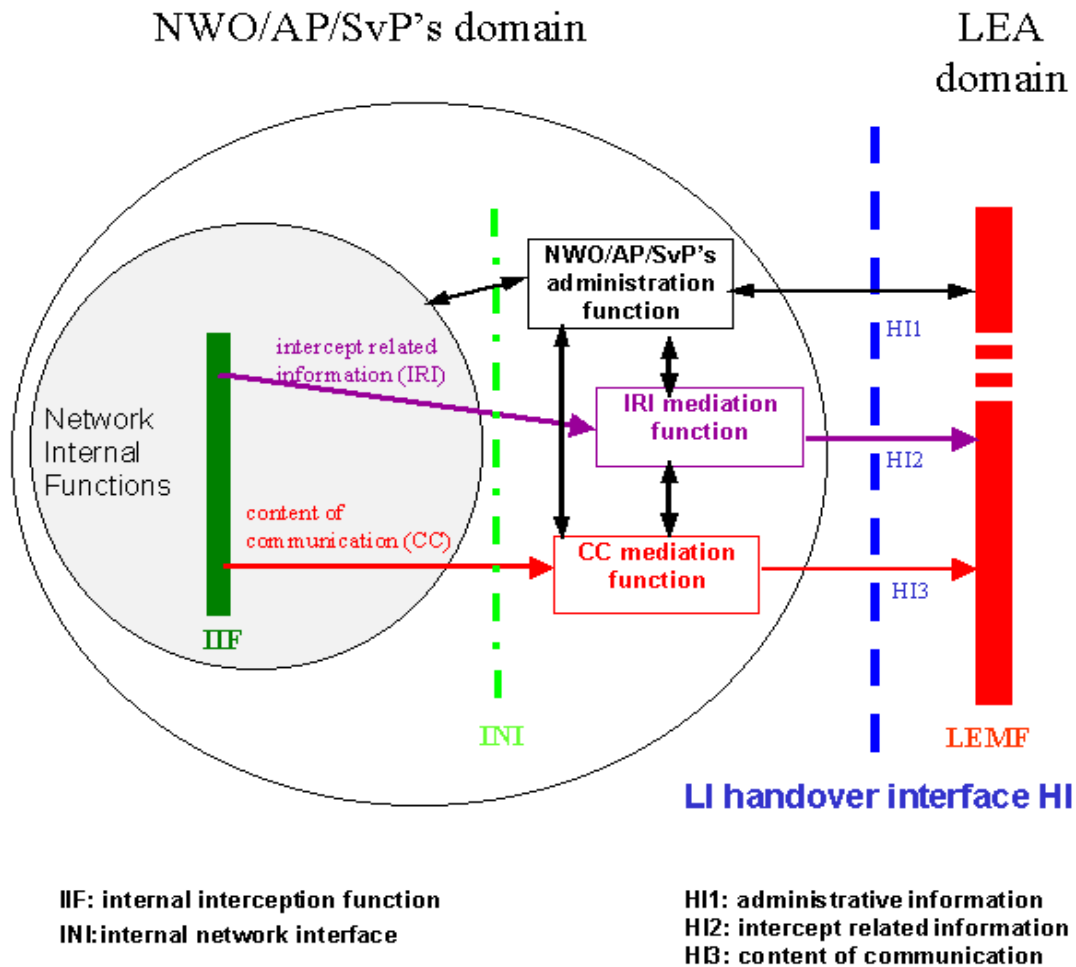

NOTE 1: Figure 1 shows only a reference configuration, with a logical representation of the entities involved in lawful interception and does not mandate separate physical entities.

NOTE 2: The mediation functions may be transparent.

Figure 1: Functional block diagram showing Handover Interface HI

5.1 Handover Interface port 1 (HI1)

5.1.0 General

The Handover Interface port 1 shall transport various kinds of administrative information from/to the LEA and the organization at the NWO/AP/SvP, which is responsible for LI matters. This interface may be manual or electronic.

The HI1 interface may be crossing borders between countries. This possibility is subject to corresponding international laws or agreements.

A complete separation is required between the administrative part (HI1) and the technical part (INI) of the interface. No direct access to the switching function shall be given to the LEMF. Activation, deactivation or modification of an interception in the switching function shall only be possible by the NWO/AP/SvP.

As an option, in direction to the LEA, some HI1 related information (e.g. fault reporting) may be delivered directly using the HI2 mechanism. As an additional option, in direction to the LEA, some HI1 related information may be delivered directly, for example, as part of a lawful authorization procedure.

Further description of HI1 is given in clause 7.

5.1.1 Manual interface

If the HI1 is designed as a manual interface, it will normally consist of paper documents. The request for lawful interception may be sent via letter or via fax to the administration centre of the NWO/AP/SvP. The personnel of the administration centre will take the request and activate it in the network element (activation of interception). After the interception specified in the lawful authorization is activated, the LEA will be informed, see clause 7. From this point in time on, the LEA shall be prepared to receive Intercept Related Information (IRI) via HI2 and Content of Communication (CC) via HI3.

5.1.2 Electronic interface

An alternative solution may be the electronic transmission of the request for lawful interception.

The information content shall be such that the authorized personnel of the NWO/AP/SvP is able to map it to the information which is required to activate the interception with a minimum of manual translation. This principle reduces the probability of errors.

5.2 Handover Interface port 2 (HI2)

The Handover Interface port 2 shall transport the IRI from the NWO/AP/SvP's IIF to the LEMF.

The delivery shall be performed via data communication methods which are suitable for the network infrastructure and for the kind and volume of data to be transmitted.

The delivery can in principle be made via different types of lower communication layers, which should be standard or widely used data communication protocols.

The individual IRI parameters shall be coded using ASN.1 and the Basic Encoding Rules (BER). The format of the parameter's information content shall be based on existing telecommunication standards, where possible.

The individual IRI parameters have to be sent to the LEMF at least once (if available).

The IRI records are transmitted individually, or as an option, IRI records can be aggregated for delivery to the same LEA (i.e. in a single delivery interaction). As there are time constraints associated with the delivery of IRI, the use of this optional feature is subject to national or regional requirements. As a general principle, IRI records shall be sent immediately and shall not be held in the MF/DF in order to use the IRI record aggregation option.

The IRI records shall contain information available from normal network or service operating procedures. In addition the IRI records shall include information for identification and control purposes as specifically required by the HI2 port.

The IIF is not required to make any attempt to request explicitly extra information which has not already been supplied by a signalling system.

5.3 Handover Interface port 3 (HI3)

The appropriate form of HI3 depends upon the technology being intercepted, see clause 9.

6 Specific identifiers for LI

6.0 General

Specific identifiers are necessary to identify a target for interception uniquely and to correlate between the data, which is conveyed over the different Handover Interfaces (HI1, HI2 and HI3). The identifiers, which apply to all communication technologies, are defined in the clauses below. Additional technology specific identifiers are defined in related annexes.

6.1 Lawful Interception Identifier (LIID)

For each target identity related to an interception measure, the authorized NWO/AP/SvP operator shall assign a special Lawful Interception Identifier (LIID), which has been agreed between the LEA and the NWO/AP/SvP. It is used within parameters of all HI interface ports.

Using an indirect identification, pointing to a target identity makes it easier to keep the knowledge about a specific interception target limited within the authorized NWO/AP/SvP operators and the handling agents at the LEA.

The Lawful Interception Identifier LIID is a component of the CC delivery procedure and of the IRI records. It shall be used within any information exchanged at the Handover Interfaces HI2 and HI3 for identification and correlation purposes.

The LIID format shall consist of alphanumeric characters (or digit string for subaddress option, see annex E). It might for example, among other information, contain a lawful authorization reference number, and the date, when the lawful authorization was issued.

The authorized NWO/AP/SvP shall either enter a unique LIID for each target identity of the interception subject or as a national option a single LIID for multiple target identities all pertaining to the same interception subject.

EXAMPLE: The interception subject has an ISDN access with three MSNs. The NWO/AP/SvP enters for each MSN an own LIID, or optionally enters one LIID for all three MSNs.

If more than one LEA intercepts the same target identity, there shall be unique LIIDs assigned, relating to each LEA.

6.2 Communication Identifier (CID)

6.2.0 General

NOTE 1: Was called "Call Identifier" in V1.1.1 of ETSI ES 201 671 [i.5]. It is renamed because of new technologies.

For each activity relating to a target identity a CID is generated by the relevant network element. The CID consists of the following two identifiers:

- Network Identifier (NID).
- Communication Identity Number (CIN) - optional.

NOTE 2: For all non CC related records like SMS, SCI, etc. no correlation to a CC could be made.

The CID distinguishes between the different activities of the target identity. It is also used for correlation between IRI records and CC connections. It is used at the interface ports HI2 and HI3.

The Communication Identifier is specified in the clauses below. For ASN.1 coding details, see annex D.

6.2.1 Network Identifier (NID)

The Network Identifier (NID) is a mandatory parameter; it should be internationally unique. It consists of one or both of the following two identifiers:

- 1) NWO/AP/SvP- identifier (mandatory):
Unique identification of network operator, access provider or service provider.
- 2) Network Element Identifier (NEID) (optional):
The purpose of the network element identifier is to uniquely identify the relevant network element carrying out the LI operations, such as LI activation, IRI record sending, etc.

A network element identifier may be:

- an E.164 international node number in the case of circuit switched networks, such as ISDN, PSTN, GSM;

- an X.25 address;
- an IP address.

6.2.2 Communication Identity Number (CIN) - optional

NOTE 1: Was called "Call Identity Number" in V1.1.1 of ETSI ES 201 671 [i.5]. It is renamed because of new technologies.

This parameter is mandatory for IRI in case of reporting events for connection-oriented types of communication (e.g. circuit switched calls).

The Communication Identity Number (CIN) identifies uniquely an intercepted communication session within the relevant network element. All the results of interception within a single communications session shall have the same CIN. If a single interception subject has two or more communications sessions through the same operator, and through the same network element then the CIN for each session shall be different.

NOTE 2: If two or more target identities, related either to a unique interception subject or to different interception subjects, are involved in the same communication the same CIN value may be assigned by the relevant network element to the communication sessions of the different target identities.

7 HI1: Interface port for administrative information

7.0 General

The interface HI1 is typically bi-directional. It is used to hand over the requests for lawful interception to the NWO/AP/SvP, such as orders for activation, deactivation and modification, and the corresponding notifications, and send other information to the LEA.

There shall be no direct control over the NWO/AP/SvP's equipment by the LEA/LEMF.

7.1 Information for the activation of lawful interception

The HI1 interface may be realized as manual or electronic processing, see clause 5.1.

If the LEA requests lawful interception, the NWO/AP/SvP needs a minimum set of information to activate lawful interception in the network.

The LEA shall provide the following information, for activation of LI:

- 1) Identification of the interception subject: target identity.
- 2) The agreed Lawful Interception Identifier (LIID).
- 3) Start and end (or duration) of the interception.
- 4) Further specification of type of interception, i.e. kind of information to be provided (IRI or both IRI and CC).
- 5) HI2 destination address of the LEMF, to which the IRI-Records shall be sent (if applicable).
- 6) HI3 destination address of the LEMF, to which the Content of Communication (CC) shall be sent (if applicable).
- 7) Other network dependent parameters (e.g. location information, delivery mechanisms used for HI2 and HI3).
- 8) A reference for authorization of the interception.
- 9) Technical contact for issues relating to set-up and execution of the interception (e.g. solution of problems with communication links to the LEMF).
- 10) Other information as required.

7.2 LI notifications towards the LEMF

LI management notifications to the LEMF shall be sent in the following cases:

- 1) After the activation of lawful interception.
- 2) After the deactivation of lawful interception.
- 3) After modification of an active lawful interception.
- 4) In case of certain exceptional situations.

For the definition of the information content of these LI management notifications, see clause D.4.

8 HI2: Interface port for Intercept Related Information

8.0 General

The HI2 interface port shall be used to transport all Intercept Related Information (IRI), i.e. the information or data associated with the communication services of the target identity apparent to the network. It includes signalling information used to establish the telecommunication service and to control its progress, timestamps, and, if available, further information such as supplementary service information or location information. Only information which is part of standard network signalling procedures shall be used within communication related IRI, see also clause 5.2; e.g. if information of the other party is not available, it need not be requested from the origin, by extra procedures, especially when such procedures are not provided by the used network protocols.

Sending of the Intercept Related Information (IRI) to the LEMF shall in general take place as soon as possible, after the relevant information is available.

In exceptional cases (e.g. data link failure), the Intercept Related Information (IRI) may be buffered for later transmission for a specified period of time.

Within this clause only definitions are made which apply in general for all network technologies. Additional technology specific HI2 definitions are specified in related annexes (e.g. for circuit switched communication technologies, see clause A.3).

8.1 Data transmission protocols

8.1.0 General

The protocol used by the "LI application" for the encoding and the sending of data between the MF and the LEMF is based on already standardized data transmission protocols like ROSE or FTP, see annex C.

The specified data communication methods provide a general means of data communication between the LEA and the NWO/AP/SvP's mediation function. They are used for the delivery of:

- HI1 type of information (notifications and alarms);
- HI2 type of information (IRI records);
- HI3 data type of information in certain circumstances (UUS, SMS, etc.).

The present document specifies the use of the two possible methods for delivery: ROSE or FTP on the application layer and the BER on the presentation layer. The lower layers for data communication may be chosen in agreement with the NWO/AP/SvP and the LEA.

The delivery to the LEMF should use the Internet protocol stack.

8.1.1 Application for IRI (HI2 information)

As defined in clause 5.2, the Handover Interface port 2 shall transport the Intercept Related Information (IRI) from the NWO/AP/SvP's MF to the LEMF.

The individual IRI parameters shall be coded using ASN.1 and the Basic Encoding Rules (BER). Where possible, the format of the information content shall be taken over from existing telecommunication standards, which are used for these parameters with the network already (e.g. the ISDN user part, DSS1, MAP and IP). Within the ASN.1 coding for IRI, such standard parameters are typically defined as octet strings.

8.2 Types of IRI records

Intercept related information shall be conveyed to the LEMF in messages, or IRI data records, respectively. Four types of IRI records are defined:

- 1) IRI-BEGIN record at the first event of a communication attempt, opening the IRI transaction;
- 2) IRI-END record at the end of a communication or communication attempt, closing the IRI transaction;
- 3) IRI-CONTINUE record at any time during a communication or communication attempt within the IRI transaction;
- 4) IRI-REPORT record used in general for non-communication related events.

For information related to an existing communication case, the record types 1 to 3 shall be used. They form an IRI transaction for each communication case or communication attempt, which corresponds directly to the communication phase (set-up, active or release).

Record type 4 is used for non-communication related subscriber action, like Subscriber Controlled Input (SCI) for service activation. For simple cases, it can also be applicable for reporting unsuccessful communication attempts.

The record type is an explicit part of the record. The 4 record types are defined independently of target communication events. The actual indication of one or several communication events, which caused the generation of an IRI record, is part of further parameters within the record's information content. Consequently, the record types of the IRI transactions are not related to specific messages of the signalling protocols of a communication case, and are therefore independent of future enhancements of the intercepted services, of network specific features, etc. Any transport level information (i.e. higher-level services) on the target communication-state or other target communication related information is contained within the information content of the IRI records.

9 HI3: Interface port for Content of Communication

The port HI3 shall transport the Content of the Communication (CC) of the intercepted telecommunication service to the LEMF. The Content of Communication (CC) shall be presented as a transparent en-clair copy of the information flow during an established, frequently bi-directional, communication of the interception subject. When encryption is provided and managed by the network, it shall be a national option as to whether the network provides the CC to the LEA decrypted, or encrypted with keys and additional information to make decryption possible. Encryption not provided or managed by the network, e.g. user provided end-to-end encryption, cannot be removed by the network.

As the appropriate form of HI3 depends upon the service being intercepted, HI3 is described in relevant annexes.

The HI2 and HI3 are logically different interfaces, even though in some installations the HI2 and HI3 packet streams might also be delivered via a common transmission path from a MF to a LEMF. It is possible to correlate HI2 and HI3 packet streams by having common (referencing) data fields embedded in the IRI and the CC packet streams. This may be possible, e.g. for packet switched, but not for analogue circuit switched networks.

10 Performance and quality

10.1 Timing

As a general principle, within a telecommunication system, Intercept Related Information (IRI), if buffered, should be buffered for as short a time as possible.

NOTE: If the transmission of Intercept Related Information fails, it may be buffered or lost.

10.2 Quality

The Quality of Service (QoS) associated with the result of interception should be (at least) equal to the Quality of Service (QoS) of the original Content of Communication (CC).

11 Security aspects

11.0 General

This clause will give an informative overview of the security properties and mechanisms that can be used to meet possible security requirements for the transportation of Lawful Intercepted data.

11.1 Security properties

A secure communication channel has the following properties:

- confidentiality;
- integrity;
- authentication;
- availability.

Confidentiality means that it is impossible to interpret the data by eavesdropping on the communication link.

Integrity means that any alteration or mutilation of the transported data is immediately detected.

Authentication means that the communicating parties have verified and confirmed each others' identities.

Availability means that the communicating parties have made agreements about up- and downtimes of the systems. In case of irregularities, alarm messages should be sent through another communication channel. Because of the nature of the transported data, confidentiality can be an issue. Lawful Intercepted data can also be confidential or secret by law and appropriate measures need to be taken to prevent eavesdropping by unauthorized third parties.

Integrity can be an issue when Lawful Intercepted data is used as evidence in a criminal investigation. It shall be provable that the data is unaltered and an exact representation of the intercepted communication.

In the process of Lawful Interception (LI) it is very important to know that the LEMF is receiving the data from a real MF and the MF needs to be sure that it is sending its data to a real LEMF. If this verification of identity does not take place, Lawful Intercepted data might end up in the wrong place or the LEMF is processing data that is originating from an unauthorized source.

The process of Lawful Interception (LI) takes place during well-defined periods of time. In case of any irregularities, appropriate actions need to be taken. Irregularities can be a sign of a breach of security, loss of data or detection of interception.

11.2 Security mechanisms

This clause will give an overview of possible mechanisms to achieve the properties as described above. Technical details are to be decided during the process of implementation.

Confidentiality can be achieved by using encryption. A common technique is to use a symmetric encryption algorithm. A symmetric algorithm is an algorithm where both communicating parties use the same key for encryption and decryption. This key shall be exchanged in a secure way.

Integrity can be achieved using hashing algorithms. These algorithms generate a unique fingerprint of the transported data. When the transported data is altered, the fingerprint does not match anymore and appropriate actions can be undertaken (like retransmission of data).

Authentication can be achieved using cryptographic techniques. A common technique is to use asymmetric encryption. In this technique, both parties have two keys: A public key and a private key. Data encrypted with one key can only be deciphered with the other. If party X encrypts something using the public key of party Y then party Y is the only one able to decrypt this data using his private key. If party X encrypts something using his private key then this data can only be deciphered using his public key. By combining these properties, both parties can make sure that they are communicating with the right party.

12 Quantitative aspects

See ETSI ES 201 158 [2]. The number of targets based on a percentage of subscribers should be provided at a national level together with an indication as to the expected usage.

Annex A (normative): Circuit switched network handover

A.0 General

This annex is applicable to 64 kbit/s based circuit switched networks.

A.1 Specific identifiers for LI

A.1.0 General

In this clause, additional identifiers, which are needed in circuit switched networks are described here. See clause 6.

A communication is a call in a circuit switched network.

A.1.1 CC Link Identifier (CCLID)

This identifier is only used at the interface ports HI2 and HI3 in case of the reuse of CC links (option B, see clause A.5.4.2).

For each CC link, which is set up by the mediation function towards the LEMF, a CC Link Identifier (CCLID) is transmitted in the HI2 records and HI3 set-up message in addition to CIN and NID. For the correct correlation of multiparty calls this identity number indicates in the IRI records of each multiparty call, which CC link is used for the transmission of the CC.

The CCLID may use the same format as the CIN; in this case, it need not be transmitted explicitly during set up of the CC links, as part of HI3. The CIN may also implicitly represent the CCLID.

A.1.2 Circuit switched LI correlation between CC and IRI

To assure correlation between the independently transmitted Content of Communication (CC) and Intercept Related Information (IRI) of an intercepted call the following parameters are used:

- Lawful Interception Identifier (LIID), see clause 6.1;
- Communication Identifier (CID), see clause 6.2;
- CC Link Identifier (CCLID), see clause A.1.1.

These parameters are transferred from the MF to the LEMF in:

- HI2, see clause A.3.2.1;
- HI3, see clause A.4.2.

A.1.3 Usage of identifiers

The identifiers are exchanged between the mediation function and the LEMF via the interfaces HI1, HI2 and HI3. There exist several interface options for the exchange of information. Tables A.1.1 and A.1.2 define the usage of numbers and identifiers depending on these options.

NOTE: X in tables A.1.1 and A.1.2: Identifier used within parameters of the interface.

Table A.1.1: Usage of identifiers, IRI and CC transmitted; options A, B (see clause A.5.4)

Identifier	IRI and CC transmitted (option A)			IRI and CC transmitted (option B)		
	HI1	HI2	HI3	HI1	HI2	HI3
LIID	X	X	X	X	X	X
NID		X	X		X	X
CIN		X	X		X	X (see note 1)
CCLID					X	X (see note 2)

NOTE 1: The CIN of the first call for which this CC link has been set-up.
NOTE 2: The CCLID may be omitted, see clause A.1.1.

Table A.1.2: Usage of identifiers, only IRI transmitted

Identifier	Only IRI transmitted	
	HI1	HI2
LIID	X	X
NID		X
CIN		X
CCLID		

A.2 HI1: interface port for administrative state

There are no additions beyond clause 7.

A.3 HI2: interface port for IRI

A.3.1 Definition of Intercept Related Information (IRI)

Intercept Related Information (IRI) will in principle be available in the following phases of a call (successful or not):

- 1) At call initiation when the target identity becomes active, at which time call destination information may or may not be available (set up phase of a call, target may be the originating or terminating party, or be involved indirectly by a supplementary service).
- 2) At the end of a call, when the target identity becomes inactive (release phase of call).
- 3) At certain times between the above phases, when relevant information becomes available (active phase of call).

In addition, information on non-call related actions of a target constitutes IRI and is sent via HI2, e.g. information on Subscriber Controlled Input (SCI).

The Intercept Related Information (IRI) may be subdivided into the following categories:

- 1) Control information for HI2 (e.g. correlation information).
- 2) Basic call information, for standard calls between two parties.
- 3) Information related to supplementary services, which have been invoked during a call.
- 4) Information on non-call related target actions.

A.3.2 Structure of IRI records

A.3.2.0 General

Each IRI-record contains several parameters. In the clauses below, the usage of these parameters is explained in more detail.

Mandatory parameters are indicated as HI2 control information. Optional parameters are provided depending on the availability at the MF. For the internal structure of the IRI records, the ASN.1 description, with the application of the Basic Encoding Rules (BER) is used. This ASN.1 specification is enclosed in annex D.

A.3.2.1 Control information for HI2

The main purpose of this information is the unique identification of records related to a target identity, including their unique mapping to the links carrying the Content of Communication (CC). In general, parameters of this category are mandatory, i.e. they have to be provided in any record.

The following items are identified (in brackets: ASN.1 name and reference to the ASN.1 definition or clause D.5):

- 1) Record type (*IRIContent*, see clause D.5)
IRI-BEGIN, IRI-CONTINUE, IRI-END, IRI-REPORT-record types.
- 2) Version indication (*iRIversion*, see clause D.5)
Identification of the particular version of the HI2 interface specification.
- 3) Communication IDentifier (*CommunicationIdentifier*, see clauses 6.2 and D.5).
- 4) Lawful Interception IDentifier (*LawfulInterceptionIdentifier*, see clauses 6.1 and D.5).
- 5) Date and time (*TimeStamp*, see clause D.5)
Date and time of record trigger condition.
The parameter shall have the capability to indicate whether the time information is given as Local time without time zone, or as UTC. Normally, the NWO/AP/SvP shall define these options.
- 6) CC Link IDentifier (*CC-Link-Identifier*, see clause A.1.2 for definition and clause D.5 for ASN.1 definition).

Table A.3.1 summarizes the items of HI2 control information. It is mandatory information, except the CID - it may be omitted for non-call related IRI records - and the CCLID. Their format and coding definition is LI specific, i.e. not based on other signalling standards.

Table A.3.1: Parameters for LI control information in IRI records (HI2 interface port)

IRI parameters: LI control information	
IRI parameter name	ASN.1 name (used in annex D)
Type of record	IRIContent
Version indication	iRIversion
Lawful Interception IDentifier (LIID)	LawfulInterceptionIdentifier
Communication IDentifier (CID): - Communication Identity Number (CIN); - Network IDentifier (NID).	CommunicationIdentifier
Date and time	TimeStamp
CC Link IDentifier (CCLID) (only used in case of option B)	CC-Link-Identifier

A.3.2.2 Basic call information

This clause defines parameters within IRI records for basic calls, i.e. calls, for which during their progress no supplementary services have been invoked. In general, the parameters are related to either the originating or terminating party of a call; consequently, ASN.1 containers are defined for the originating/terminating types of parties, which allow including the relevant, party-related information. The structure of these containers and the representation of individual items are defined in clause D.5.

NOTE: A third type of party information is defined for the forwarded-to-party (see clause A.3.2.3 on calls with supplementary services being invoked).

The items below are to be included, when they become available for the first time during a call in progress. If the same item appears identically several times during a call, it needs only to be transmitted once, e.g. in an IRI-BEGIN record. The ASN.1 name of the respective parameters, as defined in clause D.5, is indicated in brackets:

- 1) Direction of call (*intercepted-Call-Direct*)
Indication, whether the target identity is originating or terminating Party.
- 2) Address of originating and terminating parties (*CallingPartyNumber* or *CalledPartyNumber*)
If e.g. in case of call originated by the target at transmission of the IRI-BEGIN record only a partial terminating address is available, it shall be transmitted, the complete address shall follow, when available.
- 3) Basic Service, LLC (*Services-Information*)
Parameters as received from signalling protocol (e.g. BC, HLC, TMR, LLC).
- 4) Cause (*ISUP-parameters* or *DSS1-parameters-codeset-0*)
Reason for release of intercepted call. Cause value as received from signalling protocol. It is transmitted with the ASN.1 container of the party, which initiated the release; in case of a network-initiated release, it may be either one.
- 5) Additional network parameters
E.g. location information (*Location*).

Parameters defined within tables A.3.2 and A.3.3 shall be used for existing services, in the given ETSI format. National extensions may be possible using the ASN.1 parameter *National-Parameters*.

A.3.2.3 Information on Supplementary Services, related to a call in progress

The general principle is to transmit service related information within IRI records, when the corresponding event/information, which needs to be conveyed to the LEMF, is received from the signalling protocol. Where possible, the coding of the related information shall use the same formats as defined by standard signalling protocols.

The selection, which types of events or information elements are relevant for transmission to the LEAs is conforming to the requirements defined in ETSI TS 101 331 [1] and ETSI ES 201 158 [2].

A dedicated ASN.1 parameter is defined for supplementary services related to forwarding or re-routing calls (*forwarded-to-Party* information), due to the major relevance of these kinds of services with respect to LI. For the various cases of forwarded calls, the information related to forwarding is included in the *originatingParty/terminatingParty/forwarded-to-Party* information:

- 1) If a call to the target has been previously forwarded, available parameters relating to the redirecting party(ies) are encapsulated within the *originatingPartyInformation* parameter.
- 2) If the call is forwarded at the target's access (conditional or unconditional forwarding towards the forwarded-to-party), the parameters which are related to the redirecting party (target) are encapsulated within the *terminatingPartyInformation* parameter.
- 3) All parameters related to the forwarded-to-party or beyond the forwarded-to-party are encapsulated within the *forwarded-to-Party* ASN.1 coded parameter. In addition, this parameter includes the *supplementary-Services-Information*, containing the forwarded-to address, and the redirection information parameter, with the reason of the call forwarding, the number of redirection, etc.).

For the detailed specification of supplementary services related procedures see clause A.5.

Parameters defined within tables A.3.2 and A.3.3 shall be used for existing services, in the given ETSI format. National extensions may be possible using the ASN.1 parameter National-Parameters.

A.3.2.4 Information on non-call related Supplementary Services

The general principle is to transmit non-call related service information as received from the signalling protocol.

A typical user action to be reported is Subscriber Controlled Input (SCI).

For the detailed specification of the related procedures see clause A.5.

A.3.3 Selection of parameters for IRI records

Relevant information on a call is taken from the call handling process, using wherever possible the coding specifications of the standardized ISDN protocols, or other standard network protocols. The protocol-defined information content is copied transparently into the information elements of the IRI records. This principle enables to reuse of internationally agreed standardization results; it allows reuse of existing functions within the NWO/AP/SvP equipment and in the terminal area (LEMF).

Consequently, the present document needs for a large number of IRI-relevant items only to refer to other, existing standards, instead of including separate definitions in its scope. By this principle, also consistency issues and dependencies on the ongoing enhancements of the various protocols are minimized.

The relevant parameters are listed in tables A.3.2 and A.3.3.

For other signalling systems, which are not included in table A.3.2, the parameters shall be interpreted on a functional level, for defining their applicability in an IRI record; e.g. in case of a local call between analogue users, the *called party number* may only exist in an internal format of the switching system. Within the IRI records, such parameters shall also use the standardized coding. Existing interworking specifications, like ETSI EN 300 097-1 [14] shall be used for the conversion to the standard format. If the signalling system provides less information than defined by the standards in table A.3.2, spare or default values may be used instead.

This method avoids the need to analyse for all situations, especially in the area of supplementary services, each detail of the service procedures, with specification of which parameter shall be sent in which state or situation. Instead, only a reference to the applicable standards is made. As soon as a parameter defined in one of the parameter tables appears within the target call protocol, it shall be transmitted within an IRI record.

In addition to parameters taken from the call handling process, further, lawful interception specific parameters are needed, like the control information for LI.

Three types of origins for the specification of HI2 parameters in IRI records can be differentiated:

- 1) Parameters for LI control information; they are specific for the LI HI2 interface, and are specified in the present document (see table A.3.1).
- 2) Parameters used to convey information to the LEMF, which is retrieved from the target's call or service signalling protocol information (see table A.3.2). Within the IRI a standardized protocol coding is used.

The relevant protocol specifications are the ISDN user part, as a generic protocol, used by several types of networks, and dedicated network protocols, e.g. DSS1 or GSM standards. For a common implementation in different countries and to guarantee the possibility of an interception measure across borders only parameters defined in ETSI standards shall be used.

- 3) Parameters used to convey information from events relating to the target call, but with no equivalent parameters being available in protocol standards. Such parameters shall be specified in the present document (see table A.3.3).

The LI control information is a mandatory part of each IRI record (exception: CID), the information defined in table A.3.3 is included in IRI records, if the according parameter or event is detected during processing a call or a target identity related action.

Table A.3.2: List of parameters from standard protocols, which may be contained in IRI records

IRI parameters: target call information, based on standard protocols			
IRI parameter name	Name of ASN.1 parameter (of annex D)	Related standard	Reference
Three party conference invoke/result components (see note 2)	PartyInformation supplementary-Services-Information	DSS1	ETSI EN 300 188-1 [20]
Add on conference invoke/result components (see note 2)	PartyInformation supplementary-Services-Information	DSS1	ETSI EN 300 185-1 [19]
Bearer capability	PartyInformation services-Information	DSS1	ETSI EN 300 403-1 [6]
Call diversion information	PartyInformation supplementary-Services-Information	ISUP/DSS1	ETSI EN 300 356 [5], ETSI EN 300 207-1 [21]
Call transfer number	PartyInformation supplementary-Services-Information	ISUP	ETSI EN 300 356 [5]
Called party number	PartyInformation CalledPartyNumber	ISUP/DSS1/M AP	ETSI EN 300 356 [5], ETSI EN 300 403-1 [6], 3GPP TS 09.02 [32]
Called Party Subaddress	PartyInformation supplementary-Services-Information	DSS1	ETSI EN 300 061-1 [10]
Calling party number	PartyInformation CallingPartyNumber	ISUP/DSS1	ETSI EN 300 356 [5], ETSI EN 300 403-1 [6]
Calling Party Subaddress	PartyInformation supplementary-Services-Information	DSS1	ETSI EN 300 061-1 [10]
Cause indicator	Release-Reason-Of-Intercepted-Call CallContentLinkCharacteristics	ISUP/DSS1	ETSI EN 300 356 [5], ETSI EN 300 403-1 [6]
Cell id	Location	MAP/ISUP	3GPP TS 09.02 [32], ETSI EN 300 356 [5]
Closed User Group interlock code	PartyInformation supplementary-Services-Information	ISUP	
Connected number	PartyInformation supplementary-Services-Information	ISUP/DSS1	ETSI EN 300 356 [5], ETSI EN 300 097-1 [14]
Connected subaddress	PartyInformation supplementary-Services-Information	DSS1	ETSI EN 300 097-1 [14]
Explicit Call Transfer invoke/result components (see note 2)	PartyInformation supplementary-Services-Information	DSS1	ETSI EN 300 369-1 [25]
Facility (see note 3)	PartyInformation supplementary-Services-Information	DSS1	ETSI EN 300 196-1 [29]
Generic notification indicator	PartyInformation supplementary-Services-Information	ISUP	ETSI EN 300 356 [5]
Generic number	PartyInformation supplementary-Services-Information	ISUP	ETSI EN 300 356 [5]
High layer compatibility	PartyInformation services-Information	DSS1	ETSI EN 300 403-1 [6]
IMEI	PartyInformation imei	MAP	3GPP TS 09.02 [32]
IMSI	PartyInformation imsi	MAP	3GPP TS 09.02 [32]
Keypad facility	PartyInformation supplementary-Services-Information	DSS1	ETSI EN 300 196-1 [29]
Location number	Location	ISUP/MAP	ETSI EN 300 356 [5], 3GPP TS 09.02 [32]
Low layer compatibility	PartyInformation services-Information	DSS1	ETSI EN 300 403-1 [6]
MCID response indicator	PartyInformation services-Information	ISUP	ETSI EN 300 356 [5]
MSISDN	PartyIdentity/msISDN	MAP	3GPP TS 09.02 [32]
Original called number	PartyInformation supplementary-Services-Information	ISUP	ETSI EN 300 356 [5]
Redirecting number	PartyInformation supplementary-Services-Information	ISUP/DSS1	ETSI EN 300 356 [5], ETSI EN 300 207-1 [21]
Redirection information	PartyInformation supplementary-Services-Information	ISUP	ETSI EN 300 356 [5]
Redirection number	PartyInformation supplementary-Services-Information	ISUP/DSS1	ETSI EN 300 356 [5], ETSI EN 300 207-1 [21]

IRI parameters: target call information, based on standard protocols			
IRI parameter name	Name of ASN.1 parameter (of annex D)	Related standard	Reference
Subaddress transfer	PartyInformation supplementary-Services-Information	DSS1	ETSI EN 300 369-1 [25]
Transmission Medium Requirement (TMR)	PartyInformation services-Information	ISUP	ETSI EN 300 356 [5]
Alphanumeric partyIdentity	PartyInformation alphanumeric	SMPP/UCP	SMPP [84] UCP [85]
NOTE 1: Column "Related standard" indicates the ETSI standard, which specifies the format and coding of the parameter.			
NOTE 2: Refers to several ASN.1 encoded elements, which are in the DSS1 protocol embedded in a facility information element.			
NOTE 3: The facility IE is only included, if it contains one or more of the parameters, which are parts of this table.			

Table A.3.3: List of LI specific parameters, which may be contained in IRI

IRI parameters: target call information, LI specific definition	
IRI parameter name	ASN.1 name (used in annex D)
Direction of call	intercepted-Call-Direct
Call event, e.g.: - answer indication - call waiting indication - hold indication - retrieve indication - suspend indication - resume indication	simpleIndication
Ringing duration	ringingDuration
Conversation duration	conversationDuration
CC link information	callContentLinkInformation
Subscriber controlled input data	dSS1-parameters-codeset-0, or sciData
NOTE: Format and coding details (see annex D).	

The general principle is that, if parameters included in table A.3.2 are available, they shall be included in an IRI record, and be sent to the LEMF. Parameters of table A.3.3, which are not part of standard protocols, shall be included, when the according event or parameter, which needs to be reported to the LEMF, is detected.

Parameters of table A.3.1 are present in all IRI records, except the Communication Identifier: it may be missing in IRI-REPORT records; if no target call is related to it.

The list can be adapted to the requirements and feature specifications of an NWO/AP/SvP, and the laws and regulations of a country. That is, tables A.3.2 and A.3.3 may be extended nationally, or by a NWO/AP/SvP. Further in the present document, such extensions are referred to as national extensions or national parameters.

The IIF for IRI parameter generation may be seen as a kind of screening function, which watches the signalling information flow related to a target, and copies those information elements, which match with an element type in the screening lists, defined by tables A.3.2 and A.3.3.

The NWO/AP/SvP is not required to filter information out of the IRI.

An instance of the IIF for IRI generation needs in general not to store the information it has sent, or other information on a call, for the purpose to be aware of the status or context of a call. Each IRI parameter is independent from previous or future parameters. Exceptions from this general principle can exist, e.g. in order to avoid multiple transmission of the same information. In such a case identical parameters do not have to be repeated in succeeding records, unless their content or value has changed.

As it is indicated in table A.3.2, for a given logical parameter different format types may be used, depending on the type of network, and the call configuration. If a parameter is specified in the ISDN user part, and also identically in other standards, only the ISDN user part is referenced.

In certain SMS protocols, an alphanumeric party identifier can be used. The alphanumeric partyIdentity may only be used if the underlying network protocol identifies the party identifier as alphanumeric. In SMPP [84] the alphanumeric identifier is signalled by the "Type of Number" parameter. In UCP [85] the alphanumeric identifier is signalled by the "OTOA" parameter.

A.3.4 Coding of parameters in IRI records

The parameters shall be included in the IRI records in a structured way. The structure is defined using ASN.1, the individual parameters are in terms of the ASN.1 notation octet strings, which are taken over from the applicable standards. The ASN.1 detailed coding specification is described in annex D.

In case of the delivery of the IRI records to a LEA, when network specific extensions are used, the network specific parameters are transmitted as defined by the sending network.

A.3.5 Information content of the IRI record types

In principle, no restriction is made on which parameters shall or may be present in which IRI record type, except for the mandatory parameters, which are needed in all records. However, the logical information flow of calls implies that certain parameters will normally not appear in specific records; e.g. a called party number parameter is not included in an IRI-END record, because it has already been transmitted earlier.

A.4 HI3: interface port for Content of Communication

A.4.0 General

The port HI3 shall transport the Content of the Communication (CC) of the intercepted telecommunication service to the LEMF. The Content of Communication (CC) shall be presented as a transparent en-clair copy of the information flow during an established, frequently bi-directional, communication of the interception subject. When encryption is provided and managed by the network, it shall be a national option as to whether the network provides the CC to the LEA decrypted, or encrypted with keys and additional information to make decryption possible. Encryption not provided or managed by the network, e.g. user provided end-to-end encryption, cannot be removed by the network.

It may contain voice or data. A target call has two directions of transmission associated with it, to the target, and from the target. Two communication channels to the LEMF are needed for transmission of the Content of Communication (stereo transmission).

The network does not record or store the Content of Communication (CC).

A.4.1 Delivery of Content of Communication (CC)

A.4.1.0 General

The transmission media used to support the HI3 port shall be standard ISDN calls, based on 64 kbit/s circuit switched bearer connections. The CC links are set up on demand to the LEMF. The LEMF constitutes an ISDN DSS1 user function, with an ISDN DSS1 basic or primary rate access. It may be locally connected to the target switching node, or it may be located somewhere in the target network or in another network, with or without a transit network in between. For network signalling, the standard ISDN user part shall be used. No modifications of the existing ISDN protocols shall be required. Any information needed for LI, like to enable correlation with the IRI records of a call, can be inserted in the existing messages and parameters, without the need to extend the ETSI standard protocols for the LI application.

For each LI activation, a fixed LEMF address is assigned; this address is, within the present document, not used for any identification purposes. Identification and correlation of the CC links is performed by separate, LI specific information, see clauses 6 and A.1.

The functions defined in the ISDN user part standard, Version 1 (ETSI ISUP V1) are required as a minimum within the target network and, if applicable, the destination and transit networks, especially for the support of:

- Correlation of HI3 information to the other HI port's information, using the supplementary service User-to-User Signalling 1 implicit (UUS1).
- Access verification of the delivery call (see clause A.4.5).

The bearer capability used for the CC links is 64 kbit/s unrestricted digital information; this type guarantees that the information is passed transparently to the LEMF. No specific HLC parameter value is required.

The CC communication channel is a one-way connection, from the NWO/AP/SvP's IIF to the LEMF, the opposite direction is not switched through in the switching node of the target.

The scenario for delivery of the Content of Communication (CC) is as follows:

- 1) At call attempt initiation, for one 64 kbit/s bi-directional target call, two ISDN delivery calls are established from the MF to the LEMF. One call offers the Content of Communication (CC) towards the target identity (CC R_x call/channel), the other call offers the Content of Communication (CC) from the target identity (CC T_x call/channel). See figure A.4.1.
- 2) During the establishment of each of these calls, appropriate checks are made (see clause A.4.5).
- 3) The MF passes during call set up, within the signalling protocol elements of the CC link the LIID and the CID to the LEMF. The LEMF uses this information to identify the target identity and to correlate between the IRI and CC (see clause A.4.2).
- 4) At the end of a call attempt, each delivery call associated with that call attempt shall be released by the MF.

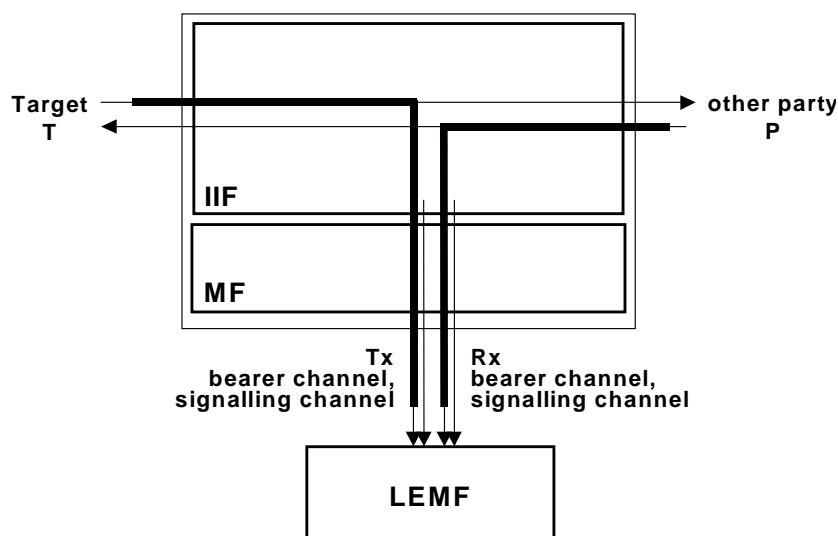

Figure A.4.1: Content of Communication transmission from MF to LEMF

A.4.1.1 Delivery of TETRA CC over circuit switched handover networks

The mechanisms described above apply with the additional constraint that TETRA encoded speech shall be further encoded in accordance with the mechanisms defined in ETSI TS 100 392-3-6 [73] to fit to a standard 64 kbit/s bearer.

NOTE: TETRA Switching and Management Infrastructures will in most cases carry TETRA encoded speech to allow for transcoder free operation (tandem-free operation) and where transcoding is not provided the referenced specification describes a means to transport the TETRA encoded speech over 64 kbit/s TDM bearers.

A.4.2 Delivery of packetized Content of Communication (CC) (general)

A.4.2.0 General

The operation for transmission of UUS and SMS may use the same mechanisms as used for HI2, or a dedicated link may be used. The ROSE operations for the transmission of the Content of Communication (HI3 data interface) shall follow the same rules as the one defined for the HI2 interface in clause 8.1.

A differentiation is made between:

- 1) bearer related or bearer unrelated end user information; and
- 2) packet data services.

NOTE: Exceptionally, for the GSM SMS service, this information may be passed via HI2. HI2 may be used optionally to pass the UUS information to the LEMF.

The physical or logical links supporting the Handover Interface traffic should be dimensioned to handle the bandwidth of the expected CC.

A.4.2.1 Delivery of TETRA CC over packet switched handover networks

The mechanisms described above apply with the additional constraint that TETRA encoded speech shall be encoded in accordance with the mechanisms defined in ETSI TS 100 392-3-7 [74].

A.4.3 Control information for circuit switched Content of Communication (CC)

The delivery calls shall use unmodified standard ISDN protocols (DSS1, ISDN user part). Table A.4.1 summarizes specific settings of parameters for the CC links. The User-to-User service 1 parameter is used during call set up (within the ISUP Initial Address Message (ETSI EN 300 356 [5]) or DSS1 Set Up Message (ETSI EN 300 403-1 [6]), respectively) to transmit LI-specific control information. This information is carried transparently and delivered to the specific LEMF remote user.

To identify the delivered information, including correlating the delivery calls with the IRI records, parameters 1 to 3 and 5 shall be included in the call set up. Parameters 6 to 9 specify settings of further relevant information. Other parameters of the ISDN protocols shall correspond to normal basic calls.

**Table A.4.1: Definition of HI3 specific signalling information;
UUS1 coding details (see clause D.8)**

No.	Used information element of CC link signalling protocol	Information	Purpose
1	CLI-Parameter with attribute "network provided"	See clause A.4.5	LEMf can check identity of origin of call
2	UUS1-parameter	Lawful Interception IDentifier (LIID); see clause 6	Identifier, identifying target identity
3	UUS1-parameter	Communication IDentifier (CID), see clause 6	Identifier, identifying specific call of target identity
4	UUS1-parameter	CC Link IDentifier (CCLID), if required; see clause A.1	Identifier, used for correlation CC link-IRI records
5	UUS1-parameter	Direction indication (communication from/towards target/combined (mono))	Signal from (T _x)/towards (R _x) target identity or combined
6	UUS1-parameter	Bearer capability of target call	Indication to the LEMf of the basic service in use by the target
7	Closed User Group interlock code	Closed User Group interlock code	Supplementary Service CUG Security measure at set up of the CC link
8	Basic Service (BS)	Basic Service (BS) of CC link: 64 kbit/s unrestricted	Guarantee transparent transmission of CC copy from MF to LEMf
9	ISDN user part forward call indicators parameter	ISDN user part preference indicator: "ISDN user part required all the way"	Guarantee transparent transmission of UUS1 and other supplementary services information
10	ISDN user part optional forward call indicators parameter	Connected line identity request parameter: requested	Sending of the connected number by the destination network

Parameters 2, 3 and 4 are also present in the IRI records, for correlation with the CC links. Parameter 5 indicates in case of separate transmission of each communication direction, which part is carried by a CC link. Parameter 6, the basic service of the target call, can be used by the LEMF for processing of the CC signal, e.g. to apply compression methods for speech signals, in order to save storage space. Parameter 7 contains the CUG of the LEA. It is optionally used at set up the CC link to the LEA. Parameter 8, the basic service of the CC link, is set to "64 kbit/s unrestricted": All information of the R_x , T_x channels can be transmitted fully transparently to the LEA. The setting of the ISDN user part indicator guarantees, that the services supporting the LI CC link delivery are available for the complete CC link connection.

The MF uses en-bloc dialling, i.e. there exists only one message in forward direction to the LEA.

NOTE: The LEMF should at reception of the set up message not use the alerting state, it should connect immediately, to minimize time delay until switching through the CC links. Not all networks will support such a transition. Exceptionally, it may be necessary to send an alerting message before the connected message.

The maximum length of the user information parameter can be more than the minimum length of 35 octets (national option, see ETSI EN 300 356 [5]), i.e. the network transmitting the CC links shall support the standard maximum size of 131 octets for the UUS1 parameter.

The User-to-User service 1 parameter cannot be discarded by the ETSI ISUP procedures: the only reason, which would allow the ISUP procedures to discard it would be, if the maximum length of the message carrying UUS1 would be exceeded. With the specified amount of services used for the CC links, this cannot happen.

The signalling messages of the two CC channels (stereo mode) carry the same parameter values, except for the direction indication.

See clause D.8 for the ASN.1 definition of the UUS1 LI specific content of the UUS1 parameter.

A.4.4 Exception handling

A.4.4.1 Failure of CC links

If a CC link cannot be set up, a certain number of repeat attempts during a certain period of time shall be made.

NOTE: Typical values are three tries during 10 s.

In case of a delay or total failure to transmit the Content of Communication, the target call is handled fully independent of the CC link, the CC information gets lost.

A.4.4.2 Fault reporting

For several events the target switching function sends messages to the NWO/AP/SvP administration centre. Some example events are given in table A.4.2.

Alternatively, all or some of these events may be transmitted directly to the LEMF. In this case, they are part of the LI management notification type of information.

Delivery to the NWO/AP/SvP administration centre is not part of the HI.

Table A.4.2: Typical events causing messages

Event type	Event causing message with LI alarm information
CC link failure	No answer from LEA
	LEA is busy
	CC link failed due to a COLP error
	CC link failed due to a CUG error
	CC link set up failure within the network
	CC link failed due to a lack of system resources
	General CC link set up failure

A.4.5 Security requirements at the interface port HI3

A.4.5.0 General

The process of access verification and additional (optional) authentication between the MF and the LEMF shall not delay the set up of the CC.

For the protection and access verification of the Content of Communication (CC) delivery call the ISDN supplementary services CLIP, COLP and CUG shall be used when available in the network involved.

Generally any authentication shall be processed before the set-up of the CC links between the MF and the LEMF is completed. If this is technically not feasible the authentication may be processed after completion of the CC connection in parallel to the existing connection.

A.4.5.1 LI access verification

The supplementary service CLIP shall be used to check for the correct origin of the delivery call.

NOTE: When using CLIP, the supplementary service CLIR is not applicable.

The supplementary service COLP shall be used to ensure that only the intended terminal on the LEA's side accepts incoming calls from the Handover Interface (HI).

To ensure access verification the following two checks shall be performed:

- check of Calling Line Identification Presentation (CLIP) at the LEMF; and
- check of COnnected Line identification Presentation (COLP) at the Handover Interface (HI) (due to the fact that the connected number will not always be transported by the networks involved, there shall be the possibility for deactivating the COLP check for a given interception measure. In addition, the COLP check shall accept two different numbers as correct numbers, i.e. the user provided number and the network provided number. Usually, the user provided number contains a DDI extension).

A.4.5.2 Access protection

In order to prevent faulty connections to the LEA, the CC links may be set up as CUG calls.

In this case, the following settings of the CUG parameters should be used:

- Incoming access: not allowed.
- Outgoing access: not allowed.
- Incoming calls barred within a CUG: no.
- Outgoing calls barred within a CUG: yes.

A.4.5.3 Authentication

In addition to the minimum access verification mechanisms described above, optional authentication mechanisms according to the standard series ISO 9798 [i.1]: "Information technology - Entity authentication" parts 1 to 5 may be used.

These mechanisms shall only be used in addition to the access verification and protection mechanisms.

A.5 LI procedures for circuit switched supplementary services

A.5.1 General

In general, LI shall be possible for all connections and activities in which the target is involved. The target shall not be able to distinguish alterations in the offered service. It shall also not be possible to prevent interception by invoking supplementary services. Consequently, from a supplementary services viewpoint, the status of interactions with LI is "no impact", i.e. the behaviour of supplementary services shall not be influenced by interception.

Depending on the type of supplementary service, additional CC links to the LEA may be required, in addition to already existing CC links.

Within the IRI records, the transmission of additional, supplementary service specific data may be required.

Supplementary services, which have an impact on LI, with respect to CC links or IRI record content, are shown in table A.5.1. The table is based on ISDN services (DSS1 protocol specifications), it considers the services which have been standardized at the time of finalizing the present document. Future services should be treated following the same principles.

NOTE 1: Co-ordination of handling of new services should be performed via ETSI/TC LI. If required, additions will be included in a subsequent version of the present document.

Services defined for other signalling protocols, which can be related to the services in the table shall be treated in the same manner (see also below). Other protocols are e.g.:

- Analogue user signalling; in general, no ETSI standards are available for supplementary services.
- Mobile user protocols of the GSM, defined within the MAP (3GPP TS 09.02 [32]).

The question of Lawful Interception (LI) with Intelligent Networks is not covered in the present document (see note 2).

NOTE 2: The general principle is, that LI takes place on the basis of a technical identity, i.e. a directory number. Only numbers which are known to the NWO/AP/SvP, and for which LI has been activated in the standard way, can be intercepted. No standardized functions are available yet which would enable an SCF to request from the SSF the invocation of LI for a call.

Additional CC links are only required, if the target is the served user. IRI Records may also carry data from other parties being served users.

Clause A.6 specifies details for relevant services:

- The procedures for CC links, depending on the call scenario of the target.
- Related to the IRI records, the point in time of sending and supplementary service specific information.
- Additional remarks for services with "no impact" on LI.

The specifications for supplementary services interactions are kept as far as possible independent of the details of the used signalling protocols; service related events are therefore described in more general terms, rather than using protocol dependent messages or parameters.

Interactions with services of the same family, like call diversion services, are commonly specified, if the individual services behaviour is identical, with respect to LI.

With respect to the IRI records, clause A.6 specifies typical cases; the general rules for data which shall be included in IRI records are defined in clause 8, specifically in clauses A.3.3 and A.5.3.

Services, which are not part of table A.5.1, do not require the generation of LI information: no CC links are generated or modified, and no specific information on the service is present in the IRI records. That is, these services have "no impact" on LI; no special functions for LI are required. However, within the IIF, functions may be required to realize the principle, that the service behaviour shall not be influenced by LI.

"No impact" is not automatically applicable for new services. Each new service has to be checked for its impact on LI. Additionally, also services using other than the DSS1 protocols, which cannot be related to one of the DSS1 based services, may have impact on LI.

The present document does not intend to give a complete description of all possible cases and access types of interactions with supplementary services.

Table A.5.1: Supplementary Services with impact on LI CC links or IRI records content; see also clause A.6

Supplementary Service	Abbr.	CC links: additional calls, impact	IRI items related to service
Call Waiting	CW	CC links for active or all calls (option A/B)	Target: call waiting indication, calling party address other party: generic notification indicator
call HOLD	HOLD	CC links for active or all calls (option A/B)	Target: call hold indication other party: generic notification indicator
call RETRIEVE	RETRIEVE	CC links for active or all calls (option A/B)	Target: call retrieve indication other party: generic notification indicator
Explicit Call Transfer	ECT	Before transfer: see HOLD After transfer: LI may or may not be stopped	Target: components of Facility IE other party: generic notification indicator
Terminal Portability	TP	No impact on CC links	Target: call suspend/resume indications other party: generic notification indicator
SUBaddressing	SUB	No impact on CC links	Subaddress IE, as available (calling, called, etc.)
Calling Line Identification Presentation	CLIP	No impact on CC links	CLI parameter: part of originating-Party information
Calling Line Identification Restriction	CLIR	No impact on CC links	Restriction indicator is part of CLI parameter
COnnected Line identification Presentation	COLP	No impact on CC links	COL parameter: part of terminating-Party information
COnnected Line identification Restriction	COLR	No impact on CC links	Restriction indicator is part of COL parameter
Closed User Group	CUG	No impact on CC links	CUG interlock code
add on CONFerence	CONF	T _x : signal from target; R _x call sum signal CC links depending on option A/B	Target: components of Facility IE other party: generic notification indicator
Three PartY conference	3PTY	Initially: held and active calls see HOLD Conf.: see CONF	Target: components of Facility IE other party: generic notification indicator
Call Forwarding Unconditional; (see note)	CFU	One CC link for each call, which is forwarded by the target Forwarding by other parties: no impact	Target: see clause A.3.2.3, point 2, 3; if redirecting no. = target DN: not included Other party (call to target is a forwarded call): See clause A.3.2.3, point 1 Other party (call from target gets forwarded): See clause A.3.2.3, point 3
Call Forwarding No Reply; (see note)	CFNR	1) basic call with standards CC links, released after time-out (incl. CC links) 2) forwarding: same as CFU	1) basic call, released after time-out, standard IRI 2) forwarding: same parameters as for CFU
Call Forwarding Busy; (see note)	CFB	Network determined user busy: see CFU User determined user busy: see CFNR	Network determined user busy: see CFU user determined user busy: see CFNR
Call Deflection	CD	See CFNR	See CFNR
Partial Rerouting	PR	See CFNR	See CFNR
Malicious Call IDentification	MCID	No impact on CC links	MCID response indicator sent at invocation

Supplementary Service	Abbr.	CC links: additional calls, impact	IRI items related to service
User-to-User Signalling 1, 2, 3	UUS	No impact on CC links	User-to-user information, more data IE (part of HI2 information, see clause D.5, part of HI3 information, see clause D.6)
FallBack procedure (not a Supplementary Service)	FB	No impact on CC links	Target or other party: new basic service IE
NOTE: Other variants of Call Forwarding (CF), like forwarding to fixed numbers, to information services, etc. are assumed to be covered by the listed services.			

A.5.2 CC link Impact

The column "CC links: additional calls, impact" (see table A.5.1) defines, whether:

- for the related service CC links shall be set up, in addition to the CC links for a basic call;
- already existing calls are impacted, for example by disconnecting their information flow.

The CC link impact relates always to actions of a target being the served user. Services invoked by other parties have no CC link impact.

A.5.3 IRI impact, general principle for sending IRI records

The column "IRI items related to service" (see table A.5.1) specifies, which parameters may be transmitted to the LEA within the IRI records. For several services, it is differentiated, whether the target or the other party is the served user.

The table specifies which parameters are applicable in principle. That is, these parameters are normally sent to the LEA, immediately when they are available from the protocol procedures of the service. In many cases, additional IRI-CONTINUE records, compared to a basic call, will be generated. However, not each service related signalling event needs to be sent immediately within an individual record. Exceptions may exist, where several events are included in one record, even if this would result in some delay of reporting an event (this may be implementation dependent). Each record shall contain all information, which is required by the LEA to enable the interpretation of an action.

EXAMPLE: The indication of call forwarding by the target shall include the forwarded-to number and the indication of the type of forwarding within the same record.

The complete set of parameters, which are applicable for IRI, is specified in clause A.3.3 (see tables A.3.2 and A.3.3).

If during procedures involving supplementary services protocol parameters, which are listed in tables A.3.2 and A.3.3 become available, they shall be included in IRI Records. This rule is directly applicable for parameters received via ISUP and DSS1 signalling protocols. Regarding all other protocols, e.g. of analogue users, the mapping to the ISDN protocols, as defined in clause A.3.3 is assumed, before discriminating, which (mapped) parameters are copied to the IRI records.

IRI data are not stored by the IIF or MF for the purpose of keeping information on call context or call configuration, including complex multiparty calls. The LEMF (electronically) or the LEA's agent (manually) shall always be able, to find out the relevant history on the call configuration, to the extent, which is given by the available signalling protocol based information, within the telecommunication network.

Service invocations, which result in invoke and return result components (as defined in table A.3.2) need only be reported in case of successful invocations. One IRI record, containing the invoke component, possibly including additional parameters from the return result component, is sufficient. Instead of the DSS1 functional protocol components, for specific networks other ETSI-standardized components may be used, e.g. of the MAP (3GPP TS 09.02 [32]).

With respect to the inclusion of LI specific parameters, see also the parameter specifications and example scenarios in clause E.3 for more details.

Details of e.g. the definition of the used record type, their content, the exact points in time of sending, etc. follow from the according service specifications; in some cases, they are specified explicitly in clauses A.6 and E.3.

A.5.4 Multi party calls - general principles, options A, B

A.5.4.0 General

Each network shall adopt option A or B according to local circumstances.

With respect to IRI, each call or call leg owns a separate IRI transaction sequence, independent of whether it is actually active or not.

With respect to the CC links, two options (A, B) exist, which depend on laws and regulations, see below. Active call or call leg means in this context, that the target is actually in communication with the other party of that call or call leg; this definition differs from the definition in ETSI EN 300 403-1 [6].

A.5.4.1 CC links for active and non-active calls (option A)

For each call, active or not, separate CC links shall be provided. This guarantees, that:

- changes in the call configuration of the target are reflected immediately, with no delay, at the LEMF;
- the signal from held parties can still be intercepted.

It is a network option, whether the communication direction of a non-active call, which still carries a signal from the other party, is switched through to the LEMF, or switched off.

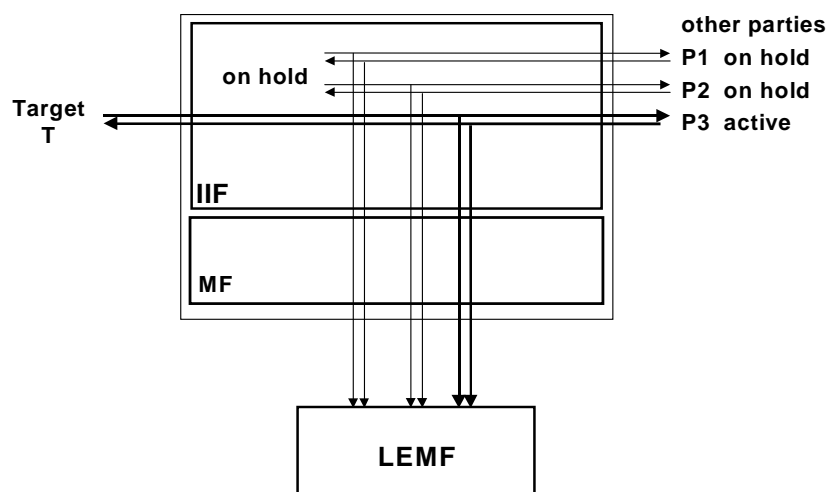

Figure A.5.1: CC link option A (example for call hold supplementary service)

A.5.4.2 Reuse of CC links for active calls (option B)

CC links are only used for calls active in their communication phase. Changes in the call configuration may not be reflected at the LEMF immediately, because switching in the IIF/MF is required, and the signal from the held party is not available.

Each time, another target call leg uses an existing CC link, an IRI-CONTINUE record with the correct CID and CCLID shall be sent.

NOTE: Even when option B is used, more than one CC link may be required simultaneously.

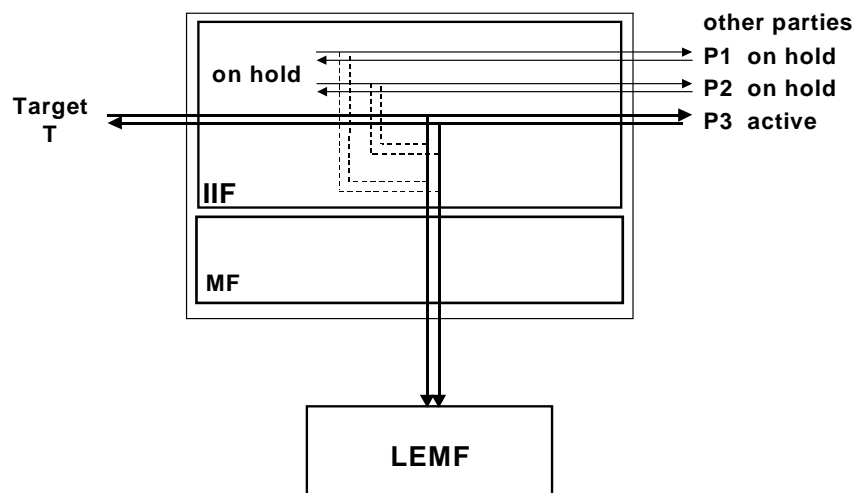

Figure A.5.2: CC link option B (example for call hold supplementary service)

A.5.5 Subscriber Controlled Input (SCI): Activation/Deactivation/Interrogation of services

For user procedures for control of Supplementary Services (Activation/Deactivation/Interrogation), a special IRI record type (IRI-REPORT record) is defined to transmit the required information.

If the DSS1 Functional Protocol (ETSI EN 300 196-1 [29]) is used by the target, the functional information elements, usually ASN.1 encoded, are copied to the IRI-REPORT record as received by the target exchange. In case of analogue targets or use of the ISDN keypad protocol (ETSI EN 300 122-1 [39]) (digits or IA5-characters), other appropriate parameters identifying the services are used. They may consist of the string sent by the user, or system-specific parameters, which identify the service sufficiently.

The IRI-REPORT record shall contain an indicator, whether the request of the target has been processed successfully or not.

At the exchange, where the subscriber data of a target shall be modified via a remote control procedure, an IRI-REPORT record shall be generated as if the control procedure had taken place locally.

A.6 Detailed procedures for circuit switched supplementary services

A.6.1 Advice of Charge services (AOC)

No impact.

Advice of Charge information is not included in IRI records.

A.6.2 Call Waiting (CW)

A.6.2.1 Call Waiting (CW) at target: CC links

In case of option A "CC links for all calls", a CC link is set up for the waiting call, using the standard procedures for terminating calls. In case of option B "CC links for active calls", no CC link is set up for the waiting call, it is treated like a held call.

With respect to CC links, the same configurations as for Call Hold apply.

Procedure, when the target accepts the waiting call: see retrieve of a held call (see clause A.6.3).

A.6.2.2 Call Waiting: IRI records

A.6.2.2.1 Target is served user

If Call Waiting is invoked at the target access by another (calling) party: the IRI-BEGIN record or a following IRI-CONTINUE record for the waiting call shall contain the LI specific parameter *call waiting indication*.

A.6.2.2.2 Other party is served user

If Call Waiting is invoked at the other (called) party's access: if a *CW notification* is received by the target's switching node, it shall be included in an IRI-CONTINUE record; it may be a separate record, or the next record of the basic call sequence.

A.6.3 Call Hold/Retrieve

A.6.3.1 CC links for active and non-active calls (option A)

If an active call is put on hold, its CC links shall stay intact; as an option, the signal from the held party is not switched through to the LEMF.

If the target sets up a new call, while one call is on hold, this call is treated like a normal originating call, i.e. a new LI configuration (CC links, IRI records) is established.

A.6.3.2 Reuse of CC links for active calls (option B)

If an active call is put on hold, its CC links shall not immediately be disconnected; as an option, the signal from the held party is not switched through to the LEMF.

If the target sets up a new call, or retrieves a previously held call, while one target call, which still owns CC links, is on hold, these CC links shall be used for the signals of the new active call.

A.6.3.3 IRI records

A.6.3.3.1 Invocation of Call Hold or Retrieve by target

An IRI-CONTINUE record with the LI specific parameter hold indication or retrieve indication, respectively, shall be sent.

A.6.3.3.2 Invocation of Hold or Retrieve by other parties

An IRI-CONTINUE record with a call hold or retrieve notification shall be sent if it has been received by the signalling protocol entity of the target call.

A.6.4 Explicit Call Transfer (ECT)

A.6.4.1 Explicit Call Transfer (ECT), CC link

During the preparation phase of a transfer, the procedures for Call Hold/Retrieve are applicable.

If the served (transferring) user is the target, its original call is released. This terminates also the CC link, and causes an IRI-END record to be sent.

After transfer, two options exist:

- 1) For the transferred call, CC links (and IRI records) shall be generated, in principle like for a forwarded call (similar to procedures in clause A.6.16.1, case b).
- 2) The transferred call shall not be intercepted.

A.6.4.2 Explicit Call Transfer (ECT), IRI records

In addition to the basic or hold/retrieve/waiting call related records and parameters, during the reconfiguration of the call, ECT-specific information at the target's access is sent to the LEMF within IRI-CONTINUE records.

When the target leaves the call after transfer, an IRI-END record is sent, and the LI transaction is terminated. Options for the new call, after transfer: see clause A.6.4.1.

A.6.5 Calling Line Identification Presentation (CLIP) (IRI Records)

A.6.5.1 Call originated by target (other party is served user)

The standard CLI parameter of an originating target is included as a supplementary service parameter in the IRI records.

If for the access (BRI or PRI) of the target a special arrangement according to ETSI EN 300 089 [54] exists, whereby the user provides a user provided, not screened number, this number is included in the IRI-BEGIN record (originating-Party information), as a generic number parameter. The network provided default number of the access is, as without this arrangement, also included in the IRI record.

A.6.5.2 Call terminated at target (target is served user)

The CLI sent from the other party is included in the IRI-BEGIN record (*originating-Party* information), irrespective of a restriction indication. An eventually received second number (case two number delivery option) is included in the IRI record as supplementary services information (Generic Number parameter).

A.6.6 Calling Line Identification Restriction (CLIR)

For use by LI, the restriction is ignored, but copied within the CLI parameter to the IRI record.

A.6.7 COnnected Line identification Presentation (COLP)

A.6.7.1 Call terminated at target (other party is served user)

A connected number parameter received from the target shall be included in an IRI record (terminating-Party information). In cases where a special arrangement applies, the user provided and the network provided default number of the access is included in the IRI record.

A.6.7.2 Call originated by target (target is served user)

If available, a connected number parameter as received from the other (terminating) party shall be included in an IRI record (terminating-Party information). Any additional number, e.g. a Generic Number, shall also be included in the IRI record.

A.6.8 COnnected Line identification Restriction (COLR)

For use by LI, the restriction is ignored, but copied within the COL parameter to the IRI record.

A.6.9 Closed User Group (CUG)

In case of a CUG call, the Closed User Group interlock code shall be included in an IRI.

A.6.10 Completion of Call to Busy Subscriber (CCBS)

No impact.

The first call, which meets a (terminating) busy subscriber, and is released subsequently, is treated like a standard busy call, with no CCBS related IRI information.

The procedures for CCBS, until starting a new call attempt from the served user to the terminating user, including the CCBS recall, are not subject of LI.

A.6.11 CONFERENCE call, add-on (CONF)

A.6.11.1 CONFERENCE calls, add on: CC links

The CC links carry the same bit stream as sent to/received from the target, that is, the R_x call contains the sum signal of the conference, and the T_x call contains the signal from the target.

The general rules for multi party calls (see clause A.5.4) apply also for the various possible states during a conference (isolate, split, etc.). The call to the conference device as such is treated like a standard call. In case of a n-party conference, there exist $n + 1$ CC links in case of option "CC link for all calls", or just one CC link, in case of option "CC link for active calls".

A.6.11.2 Conference calls: IRI records

In addition to the basic or hold/retrieve/waiting call related records and parameters, during the set up and eventual reconfigurations of a conference, CONF-specific information is sent to the LEMF within IRI records.

A.6.12 Three party service (3PTY) (conference)

A.6.12.1 CC links

- a) Target is conference controller:

The 3PTY conference originates from a configuration with two single calls (one active, one held). When joining the calls to a conference, the CC links, which have carried the signals of the active target call are used to transmit the conference signals; that is, the R_x call contains the sum signal of the conference, the T_x call contains the signal from the target.

The second CC link set, for the previously held call stays intact. If the conference is released, and the initial state (1 held, 1 active call) is re-established, the required CC links are still available.

- b) Target is passive party of conference:
No impact on CC links.

A.6.12.2 Three party service, IRI records

For the events indicating the start and the end of the 3PTY conference, IRI records are generated.

A.6.13 Meet-Me Conference (MMC)

No impact; calls to a MMC are treated as standard calls; the MMC device is not required to be subject of LI.

A.6.14 Direct Dialling In (DDI)

LI may be applied to a PABX access DN or to a DDI extension number according to national laws and requirements.

A.6.15 Multiple Subscriber Number (MSN)

LI shall be activated individually per MSN.

If LI has to be activated for a whole ISDN BA, activation commands shall be input by the LI administrator for each number; administrative procedure shall ensure that all numbers are covered. If during a surveillance a MSN is added or removed, a LI administrative message shall be generated, see clause 7.2.

A.6.16 DIVersion services (DIV)

A.6.16.0 General

Calls to a target, with a called party number equal to the intercepted target DN(s), but forwarded, are intercepted, i.e. CC links are set up, and IRI records are sent to the LEA. This applies for all kinds of call forwarding.

For calls forwarded by the other party (calling or called), the available diversion-related information is sent to the LEA.

A.6.16.1 Call Diversion by target

A.6.16.1.1 Call Diversion by target, CC links

In order to handle call diversion services by applying, as far as possible, common procedures, the following two cases are differentiated:

- a) Call Forwarding Unconditional (CFU), Call Forwarding Busy (NDUB):
In these cases, forwarding is determined, before seizing the target access. CC links are set up, immediately, for the forwarded call.

Other variants of Call Forwarding (CF) with immediate forwarding, i.e. without first seizing the target access, are handled in the same way (e.g. unconditional Selective Call Forwarding).

- b) Call Forwarding No Reply, Call Forwarding Busy (UDUB), Call Deflection, Partial Rerouting:
Initially, the target call is set up, and the call is intercepted like a basic call.

When forwarding takes place (e.g. after expiry of the CFNR timer), the original call is released; this may cause also a release of the CC links. In such case two optional IRI record handling may apply:

- 1) For the original call an IRI-END record is sent. For the forwarded call a new set up procedure, including new LI transaction may take place with new set of IRI records (starting with IRI-BEGIN record sent to the LEA).
- 2) For the forwarded call the IRI-CONTINUE record is generated and sent to a LEA, indicating the CFNR invocation.

Other variants of Call Forwarding (CF) with forwarding after first seizing the target access, are handled in the same way.

In case of multiple forwarding, one call may be intercepted several times, if several parties are targets. Considering the maximum number of diversions for one call of 5 (ITU recommended limit), one call can be intercepted 7 times, from the same or different LEAs. In principle, these procedures are independent of each other.

A.6.16.1.2 Call Diversion by target, IRI records

See clause A.3.2.3, case 2, related to the target's information, and case 3, related to the forwarded-to-party information.

As above for the CC links, the diversion types a) and b1, 2) are differentiated:

- for case a) and b2) diversions, the IRI is part of one transaction, IRI-BEGIN, -CONTINUE, -END;
- for case b1) diversions, a first transaction informs about the call section, until diversion is invoked (corresponding to a basic, prematurely released call), a second transaction informs about the call section, when diversion is invoked (corresponding to case a)).

A.6.16.2 Forwarded call terminated at target

The CC link is handled in the standard way. The IRI-BEGIN record contains the available call diversion information, see clause A.3.2.3, case 1.

A.6.16.3 Call from target forwarded

The CC link is handled in the standard way. The IRI-BEGIN and possibly IRI-CONTINUE records contain the available call diversion related information, see clause A.3.2.3, case 3.

A.6.17 Variants of call diversion services

Variants of the above "standard" diversion services are treated in the same way as the corresponding "standard" diversion service.

A.6.18 Void

A.6.19 Malicious Call IDentification (MCID)

CC links: no impact.

IRI records: If a terminating target or other party invokes MCID, the MCID response indicator parameter shall be included in a dedicated or the next regular IRI record.

A.6.20 SUBaddressing (SUB)

The different types of subaddress information elements are part of the IRI records, in all basic and supplementary services cases, where they are present.

A.6.21 Terminal Portability (TP)

A.6.21.1 CC links

No impact.

A.6.21.2 IRI records

A.6.21.2.1 Invocation of Terminal Portability by target

Sending of the LI parameters suspend indication or resume indication in an IRI-CONTINUE record.

A.6.21.2.2 Invocation of Terminal Portability by other parties

Sending of the generic notification indicator, values user suspended or user resumed in an IRI-CONTINUE record.

A.6.22 User-to-User Signalling (UUS)

User-to-User parameters of services UUS1, UUS2 and UUS3 shall be reported as HI3, see clause A.4, or via HI2, see clause A.5.

If User-User information is not delivered from a target to the other party (e.g. due to overload in the SS No.7 network), no notification is sent to the LEA.

A.6.23 Abbreviated Address (AA)

No impact. The service access code and abbreviated number (user input) is not included in IRI records.

A.6.24 Fixed Destination Call (FDC)

No impact. The service access code (if applicable) is not included in IRI records.

A.6.25 Alarm Call (AC)/Wake-Up Service (WUS)

No impact. A Wake-up call is intercepted in the standard way; the identity of the originating party may be missing.

A.6.26 Incoming Call Barring (ICB)

No impact.

a) **Case terminating call to a target with ICB active:**

In general, the barring condition of a target is detected before the target access is determined, consequently, an IRI-REPORT records is generated.

If the access would be determined, a standard IRI-END record is generated, with the applicable cause value.

b) **Case target calls a party with ICB active:**

In general, an IRI-BEGIN record has been sent already, and CC links have been set up. Consequently, a standard IRI-END record is generated, with the applicable cause value.

A.6.27 Outgoing Call Barring (OCB)

No impact.

For a barred call, a standard record may be generated; its type and content are depending on the point in the call, where the call was released due to OCB restrictions.

A.6.28 Completion of Calls on No Reply (CCNR)

No impact. See remarks to service CCBS.

A.6.29 Reverse charging

No impact.

A.6.30 Line hunting

All accesses of the group shall get the interception profile, independently of each other, if the whole group has to be intercepted (responsibility of the LI operator).

A.6.31 Message Wait Indication (MWI)

No impact. The information, that a message is waiting, is not sent to the LEA.

A.6.32 Name display

No impact. Name strings are not included in IRI records.

A.6.33 Tones, announcements

No impact.

If the normal procedures, depending on the call state, result in sending the tone or announcement signal on the R_x CC link channel, this shall be transmitted as CC.

A.7 Void

A.8 GSM circuit switched technology annex

A.8.1 Functional architecture

The following Figures A.8.1 and A.8.2 contain the reference configuration for the lawful interception (see 3GPP TS 03.33 [42]).

There is one ADMINISTRATION FUNCTION (ADMF) in the network. Together with the delivery functions it is used to hide from the MSC/VLR and GMSC that there might be multiple activations by different Law Enforcement Agencies (LEAs) on the same target.

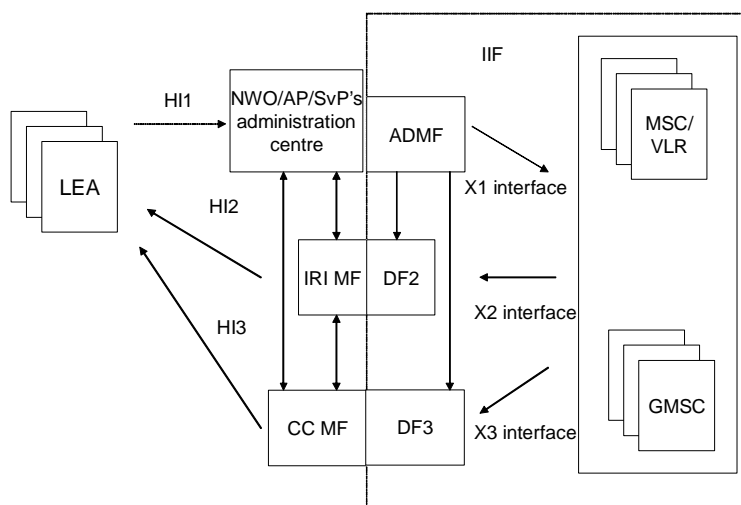

Figure A.8.1: Reference configuration of MSC/VLR for GSM circuit switched

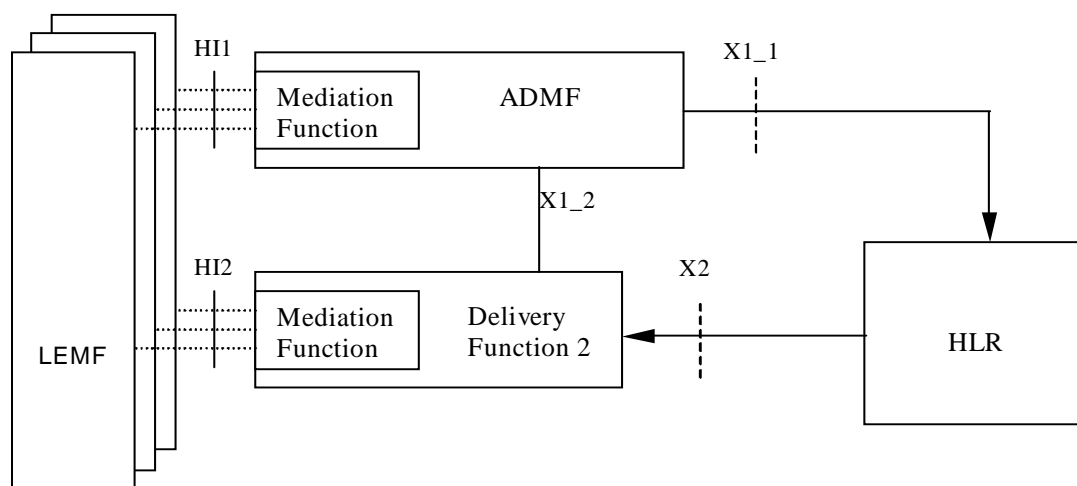

Figure A.8.2: Reference configuration of HLR for GSM circuit switched

The reference configuration is only a logical representation of the entities involved in lawful interception and does not mandate separate physical entities. This allows for higher levels of integration.

A call could be intercepted based on several identities (MSISDN, IMSI, IMEI) of the same target.

Interception based on IMEI could lead to a delay in start of interception at the beginning of a call and interception of non-call related events is not possible.

For the delivery of the CC and IRI the MSC/VLR or GMSC provides correlation number and target identity to the DF2 and DF3 which is used there in order to select the different LEAs where the product shall be delivered to.

A.8.2 Correlation of CC and IRI (see clause 6)

Correlation of the present document IDs to 3GPP TS 03.33 [42] IDs.

The ID Lawful Interception Identifier (LIID) out of the present document is supported at the IIF (GSM) with warrant reference number.

Parameters out of the present document, see clause 6.2:

- Communication Identifier (CID).

For each call or other activity relating to a target identity a CID is generated by the relevant network element. The CID consists of the following two identifiers:

- Network Identifier (NID);
- Communication Identity Number (CIN).

Intercepting Node ID is used for the NID in the GSM system.

The correlation number is used for the CIN.

For the Communication Identifier (CID) in the GSM system the combination of Intercepting Node ID and the correlation number is used.

A.8.3 HI3 (delivery of CC)

CC will be delivered as described in clause A.4.

Exceptionally, SMS will be delivered via HI2.

Correlation information in HI3 will be delivered as described in clause D.8 and as an option annex E.

A.8.4 HI2 (delivery of IRI)

The events defined in 3GPP TS 03.33 [42] are used to generate records for the delivery via HI2.

There are nine different events type received at DF2 level. According to each event, a record is sent to the LEMF if this is required. Table A.8.1 gives the mapping between event type received at DF2 level and record type sent to the LEMF.

It is an implementation option if the redundant information will be sent for each further event.

Table A.8.1: Structure of the records for GSM (CS)

Event	IRI record type
Call establishment	BEGIN
Answer	CONTINUE
Supplementary service	CONTINUE
Handover	CONTINUE
Release	END
Location update	REPORT
Subscriber controlled input	REPORT
SMS	REPORT
Serving System	REPORT

A set of information is used to generate the records. The records used transmit the information from mediation function to LEMF. This set of information can be extended in MSC/VLR or GMSC or HLR or DF2/MF, if this is necessary in a specific country. Table A.8.2 gives the mapping between information received per event and information sent in records.

The Serving System report event is generated at the HLR, when the HLR has detected that the intercept subject has roamed.

IRI-related information, such as receiving MSISDN, which is included as header information in the SMS message body that is sent to the SMS service centre, is to be included in IRI records.

NOTE: In some jurisdictions an authorization for interception of IRI only means that SMS message body is not included in what the LEA is allowed to receive. In such cases it is essential that the relevant party information is included in IRI records, even if such information for technical reasons is included in what the intercepting network element sees as "contents".

Table A.8.2: Description of parameters

Parameter	Definition	ASN.1 parameter
observed MSISDN	Target Identifier with the MSISDN of the target subscriber (monitored subscriber)	PartyInformation/msISDN
observed IMSI	Target Identifier with the IMSI of the target subscriber (monitored subscriber)	PartyInformation/imsi
observed IMEI	Target Identifier with the IMEI of the target subscriber (monitored subscriber), it shall be checked for each call over the radio interface	PartyInformation/imei
event type	Description which type of event is delivered: Establishment, Answer, Supplementary service, Handover, Release, SMS, Location update, Subscriber controlled input	There is no one-to-one mapping for this information. Parameters presence on HI2 indicates the event type (e.g. sms or sciData parameter presence)
event date	Date of the event generation in the MSC/VLR or GMSC	TimeStamp
event time	Time of the event generation in the MSC/VLR or GMSC	
dialled number	Dialled number before digit modification, IN-modification, etc.	PartyInformation (= originating)/DSS1-parameters/calledpartynumber
connected number	Number of the answering party	PartyInformation/supplementary-Services-Info
other party address	Directory number of the other party for originating calls Calling party for terminating calls	PartyInformation (= terminating)/calledpartynumber PartyInformation/callingpartynumber
call direction	Information if the monitored subscriber is calling or called e.g. MOC/MTC or originating/terminating in or/out	intercepted-Call-Direct
CID	Unique number for each call sent to the DF, to help the LEA, to have a correlation between each call and the IRI (combination of Interception Node ID and the correlation number)	communicationIdentifier
lawful interception identifier	Unique number for each surveillance lawful authorization	LawfulInterceptionIdentifier
cell id	Cell number of the target; for the location information	locationOfTheTarget
location area code	Location-area-code of the target defines the Location Area in a PLMN	
basic service	Information about Tele service or bearer service	PartyInformation/DSS1-parameters-codeset-0
supplementary service	Supplementary services used by the target e.g. CF, CW, ECT	PartyInformation/Supplementary-Services
forwarded to number	Forwarded to number at CF	PartyInformation/calledPartyNumber (party-Qualifier indicating forwarded-to-party)
call release reason	Call release reason of the target call	Release-Reason-Of-intercepted-Call
SMS	The SMS content with header which is sent with the SMS-service	SMS
SCI	Non-call related Subscriber Controlled Input (SCI) which the MSC/VLR receives from the ME	PartyInformation/sciData
Serving System	Identity of the serving network element (MSC/VLR)	ServingSystem

NOTE: LIID parameter shall be present in each record sent to the LEMF.

A.9 TETRA technology annex

A.9.0 General

TETRA details are fixed via two options:

- Clause A.9.1 according ETSI EN 301 040 [72].
- Clause A.9.2 based on ETSI EN 301 040 [72] adapted to common handover interface.

A.9.1 According ETSI EN 301 040

Clause A.4 applies to TETRA.

TETRA intercepted data is defined in ETSI EN 301 040 [72] and in the ASN.1 module identified below:

```
EN301040 {itu-t(0) identified-organization(4) etsi(0) en301040(1040) interceptVersion(0)}
```

A.9.2 Based on ETSI EN 301 040 adapted to common handover interface

A.9.2.0 HI 2 event definitions

Based on the requirements of clause 8.2, "Types of IRI records", following events for TETRA exist.

Table A.9.1: List of IRI records generated

Event	IRI record name	IRI record type
Start of call, A party is target	<i>CallSetupMobileOriginating</i>	BEGIN
Start of call, B party is target	<i>CallSetupMobileTerminating</i>	BEGIN
Call reaches other party	<i>Ringing</i>	CONTINUE
Call waiting at other party	<i>Queueing</i>	CONTINUE
Call established	<i>Connected</i>	CONTINUE
Location change during call	<i>Handover</i>	CONTINUE
Call is released	<i>CallRelease</i>	END
TETRA switch change while not in call	<i>LocationUpdate</i>	REPORT
Target sends SDS	<i>SDSMobileOriginating</i>	REPORT
Target receives SDS	<i>SDSMobileTerminating</i>	REPORT
Call forwarded to C party	<i>CallForward</i>	CONTINUE
Call on hold	<i>CallHold</i>	CONTINUE
Group indication action	<i>GroupIndication</i>	REPORT
Group talker tx granted	<i>TxGranted</i>	CONTINUE
Handset switched on	<i>MobileOn</i>	REPORT
Handset switched off	<i>MobileOff</i>	REPORT
Direct Mode Operation	<i>DMO</i>	REPORT

A.9.2.1 IRI event definitions

A.9.2.1.0 General

This clause shows the detailed definitions of event / record and parameters provided with them.

nature-Of-The-intercepted-call shall be tETRA-circuit-call.

Notes related to specific information fields will be given on their first appearance but continue to be valid for the value in all records.

A.9.2.1.1 BEGIN event information

A.9.2.1.1.0 General

The BEGIN record is used to convey the first event of TETRA interworking communication interception.

The BEGIN record shall be triggered when:

- Call Setup Mobile Originating → Start of call, A party is target.
- Call Setup Mobile Terminating → Start of call, B party is target.

A.9.2.1.1.1 Call Setup Mobile Originating

Table A.9.2: Data fields for CallSetupMobileOriginating record

Information	ASN.1 field used	MOC
IRI record type	iRI-Begin-record	M
IRI record name	tETRA-LI-Event	M
LIID	lawfulInterceptionIdentifier	M
Call ID (see note 1)	communicationIdentifier	M
TETRA location (see note 2)	locationOfTheTarget	C
HI3 Line ID (see note 3)	tARGETCOMMSMONITORind: targetcommsid:CircuitIdType	M
Target ID	tETRA-PartyInformation	M
Other Party ID	tETRA-Other-PartyInformation	M
Event time	timeStamp	M
Network Identification	networkIdentifier	M
Call information	nature-Of-The-intercepted-call	M
Call type	callDirection	M
Transaction type	callTransactionType	M
Service type	basicService:teleServiceCode	M
Call State	intercepted-Call-State	M
NOTE 1: This value is used to correlate all IRI belonging to one call. The value shall be the same for all records related to a call from BEGIN to END and shall be unique for a LIID over a longer period (at least several days).		
NOTE 2: Alternatively the ETSI TS 101 671 defined value tetraLocation can be used.		
NOTE 3: This value is used for correlation of IRI and CC.		

A.9.2.1.1.2 Call Setup Mobile Terminating

Table A.9.3: Data fields for CallSetupMobileTerminating record

Information	ASN.1 field used	MOC
IRI record type	iRI-Begin-record	M
IRI record name	tETRA-LI-Event	M
LIID	lawfulInterceptionIdentifier	M
Call ID	communicationIdentifier	M
TETRA location	locationOfTheTarget	C
HI3 Line ID	tARGETCOMMSMONITORind: targetcommsid:CircuitIdType	M
Target ID	tETRA-PartyInformation	M
Other Party ID	tETRA-Other-PartyInformation	M
Event time	timeStamp	M
Network Identification	networkIdentifier	M
Call information	nature-Of-The-intercepted-call	M
Call type	callDirection	M
Transaction type	callTransactionType	M
Service type	basicService:teleServiceCode	M
Call State	intercepted-Call-State	M

A.9.2.1.2 CONTINUE event information

A.9.2.1.2.0 General

The CONTINUE record is used to convey the additional information's within an ongoing communication of TETRA interworking communication interception.

The CONTINUE record shall be triggered when:

- Ringing → Call reaches other party.
- Queueing → Call waiting at other party.
- Connected → Call established.
- Handover → Location change during call.
- Call Forward → Call forwarded to C party.
- Call Hold → Call on hold.
- TxGranted → Group talker tx granted.

A.9.2.1.2.1 Ringing

Table A.9.4: Data fields for Ringing record

Information	ASN.1 field used	MOC
IRI record type	iRI-Continue-record	M
IRI record name	tETRA-LI-Event	M
LIID	lawfulInterceptionIdentifier	M
Call ID	communicationIdentifier	M
TETRA location	locationOfTheTarget	C
Target ID	tETRA-PartyInformation	M
Other Party ID	tETRA-Other-PartyInformation	M
Event time	timeStamp	M
Network Identification	networkIdentifier	M
Call information	nature-Of-The-intercepted-call	M
Call State	intercepted-Call-State	M

A.9.2.1.2.2 Queueing

Table A.9.5: Data fields for Queueing record

Information	ASN.1 field used	MOC
IRI record type	iRI-Continue-record	M
IRI record name	tETRA-LI-Event	M
LIID	lawfulInterceptionIdentifier	M
Call ID	communicationIdentifier	M
TETRA location	locationOfTheTarget	C
Target ID	tETRA-PartyInformation	M
Other Party ID	tETRA-Other-PartyInformation	M
Event time	timeStamp	M
Network Identification	networkIdentifier	M
Call information	nature-Of-The-intercepted-call	M
Call State	intercepted-Call-State	M

A.9.2.1.2.3 Connected

Table A.9.6: Data fields for Connected record

Information	ASN.1 field used	MOC
IRI record type	iRI-Continue-record	M
IRI record name	tETRA-LI-Event	M
LIID	lawfulInterceptionIdentifier	M
Call ID	communicationIdentifier	M
TETRA location	locationOfTheTarget	C
Target ID	tETRA-PartyInformation	M
Other Party ID	tETRA-Other-PartyInformation	M
Event time	timeStamp	M
Network Identification	networkIdentifier	M
Call information	nature-Of-The-intercepted-call	M
Call State	intercepted-Call-State	M

A.9.2.1.2.4 Handover

Table A.9.7: Data fields for Handover record

Information	ASN.1 field used	MOC
IRI record type	iRI-Continue-record	M
IRI record name	tETRA-LI-Event	M
LIID	lawfulInterceptionIdentifier	M
Call ID	communicationIdentifier	M
TETRA location (new)	locationOfTheTarget	C
HI3 Line ID	tTARGETCOMMSMONITORind: targetcommsid:CircuitIdType	M
Target ID	tETRA-PartyInformation	M
Event time	timeStamp	M
Network Identification	networkIdentifier	M
Call information	nature-Of-The-intercepted-call	M

A.9.2.1.2.5 Call Forwarding

Table A.9.8: Data fields for CallForwardRecord

Information	ASN.1 field used	MOC
IRI record type	iRI-Continue-record	M
IRI record name	tETRA-LI-Event	M
LIID	lawfulInterceptionIdentifier	M
Call ID	communicationIdentifier	M
TETRA location	locationOfTheTarget	C
HI3 Line ID	tTARGETCOMMSMONITORind: targetcommsid:CircuitIdType	M
Target ID	tETRA-PartyInformation	M
Other Party ID	tETRA-Other-PartyInformation	M
Event time	timeStamp	M
Network Identification	networkIdentifier	M
Call information	nature-Of-The-intercepted-call	M
Call type	callDirection	M
Transaction type	callTransactionType	M
Service type	basicService:teleServiceCode	M
Supplementary Service type (see note)	supplementaryService	M
Forwarded-to ID	forwardedToNumber	M
NOTE: Possible values: cfb, cw, etc.		

A.9.2.1.2.6 Call Hold

Table A.9.9: Data fields for CallHold record

Information	ASN.1 field used	MOC
IRI record type	iRI-Continue-record	M
IRI record name	tETRA-LI-Event	M
LIID	lawfulInterceptionIdentifier	M
Call ID	communicationIdentifier	M
TETRA location	locationOfTheTarget	C
Target ID	tETRA-PartyInformation	M
Other Party ID	tETRA-Other-PartyInformation	M
Event time	timeStamp	M
Network Identification	networkIdentifier	M
Call information	nature-Of-The-intercepted-call	M
Call type	callDirection	M
Transaction type	callTransactionType	M
Service type	basicService:teleServiceCode	M
Supplementary Service type	supplementaryService	M
Status of the call (see note)	callRetrieve	M
NOTE: FALSE when call is put on hold, TRUE when call is retrieved from hold.		

A.9.2.1.2.7 TxGranted

This IRI record provides information about the talker status in groups.

Table A.9.10: Data Fields for TxGranted record

Information	ASN.1 field used	MOC
IRI record type	iRI-Continue-record	M
IRI record name	tETRA-LI-Event	M
LIID	lawfulInterceptionIdentifier	M
Call ID	communicationIdentifier	M
TETRA location	TETRACGIType	C
Target ID	tETRA-PartyInformation	M
Group ID	tETRA-Other-PartyInformation	M
Event time	timeStamp	M
Network Identification	networkIdentifier	M
Call information	nature-Of-The-intercepted-call	M
Call type	callDirection	M
Transaction type	callTransactionType	M
Service type	basicService:teleServiceCode	M
Status (see note)	txGrantedStatus	M
NOTE: FALSE TxCeased, TRUE TxGranted.		

A.9.2.1.3 END event information

A.9.2.1.3.0 General

The END record is used to convey the additional information's within an ending communication of TETRA interworking communication interception.

The END record shall be triggered when:

- Call Release → Call is released.

A.9.2.1.3.1 Call Release

Table A.9.11: Data fields for CallRelease record

Information	ASN.1 field used	MOC
IRI record type	iRI-End-record	M
IRI record name	tETRA-LI-Event	M
LIID	lawfulInterceptionIdentifier	M
Call ID (see note 1)	communicationIdentifier	M
TETRA location	locationOfTheTarget	C
HI3 Line ID (see note 2)	tARGETCOMMSMONITORind: targetcommsid:CircuitIdType	M
Target ID	tETRA-PartyInformation	M
Other Party ID	tETRA-Other-PartyInformation	M
Event time	timeStamp	M
Network Identification	networkIdentifier	M
Call information	nature-Of-The-intercepted-call	M
Call type	callDirection	M
Transaction type	callTransactionType	M
Service type	basicService:teleServiceCode	M
Reason for release	callReleaseReason	M
Call State	intercepted-Call-State	M
NOTE 1: incoming / outgoing depending on call type.		
NOTE 2: moc / mtc depending on call type.		

A.9.2.1.4 REPORT event information

A.9.2.1.4.0 General

The REPORT record is used to convey the additional information's outside a communication of TETRA interworking communication interception.

The REPORT record shall be triggered when:

- LocationUpdate → TETRA switch change while not in call.
- SDS Mobile Originating → Target sends SDS.
- SDS Mobile Terminating → Target receives SDS.
- Group Indication → Group indication action.
- Mobile On → Handset switched on.
- Mobile Off → Handset switched off.
- DMO → Direct Mode Operation.

A.9.2.1.4.1 Location Update

Table A.9.12: Data fields for LocationUpdate record

Information	ASN.1 field used	MOC
IRI record type	iRI-Report-record	M
IRI record name	tETRA-LI-Event	M
LIID	lawfulInterceptionIdentifier	M
TETRA location (new)	locationOfTheTarget	C
Target ID	tETRA-PartyInformation	M
Event time	timeStamp	M
Network Identification	networkIdentifier	M

A.9.2.1.4.2 SDS Mobile Originating

Table A.9.13: Data fields for SDSMobileOriginating record

Information	ASN.1 field used	MOC
IRI record type	iRI-Report-record	M
IRI record name	tETRA-LI-Event	M
LIID	lawfulInterceptionIdentifier	M
TETRA location	locationOfTheTarget	C
Target ID	tETRA-PartyInformation	M
Event time	timeStamp	M
Network Identification	networkIdentifier	M
Call type	callDirection	M
Transaction type	callTransactionType	M
Content of SDS	forwardSM-Arg (see note)	M
NOTE: Contains address of called ID (sM-RP-DA), again address of originator (sM-RP-OA) and SDS value (signalInfo).		

A.9.2.1.4.3 SDS Mobile Terminating

Table A.9.14: Data fields for SDSMobileTerminating record

Information	ASN.1 field used	MOC
IRI record type	iRI-Report-record	M
IRI record name	tETRA-LI-Event	M
LIID	lawfulInterceptionIdentifier	M
TETRA location	locationOfTheTarget	C
Target ID	tETRA-PartyInformation	M
Event time	timeStamp	M
Network Identification	networkIdentifier	M
Call type	callDirection	M
Transaction type	callTransactionType	M
Content of SDS	forwardSM-Arg (see note)	M
NOTE: Contains again address of called ID (sM-RP-DA), address of originator (sM-RP-OA) and SDS value (signalInfo).		

A.9.2.1.4.4 Group Indication

Information about the groups the observed subscriber has joined. One record will be sent for every such group.

Table A.9.15: Data fields for GroupIndication record

Information	ASN.1 field used	MOC
IRI record type	iRI-Report-record	M
IRI record name	tETRA-LI-Event	M
LIID	lawfulInterceptionIdentifier	M
Call ID	communicationIdentifier	M
TETRA location	locationOfTheTarget	C
Target ID (see note 1)	tETRA-PartyInformation	M
Other Party ID (see note 1)	tETRA-Other-PartyInformation	M
Event time	timeStamp	M
Network Identification	networkIdentifier	M
Group status (see note 2)	groupStatus	M
NOTE 1: If observation of individual subscriber, Target ID is ITSI, Other Party ID is GTSI. If group observation, Target ID is GTSI, Other Party ID is ITSI.		
NOTE 2: FALSE when leaving group, TRUE when joining group.		

A.9.2.1.4.5 Mobile On

The observed subscriber's handset has been turned on.

Table A.9.16: Data fields for MobileOn record

Information	ASN.1 field used	MOC
IRI record type	iRI-Report-record	M
IRI record name	tETRA-LI-Event	M
LIID	lawfulInterceptionIdentifier	M
TETRA location	locationOfTheTarget	C
Target ID	tETRA-PartyInformation	M
Event time	timeStamp	M
Network Identification	networkIdentifier	M

A.9.2.1.4.6 Mobile Off

The observed subscriber's handset has been turned off.

Table A.9.17: Data fields for MobileOff record

Information	ASN.1 field used	MOC
IRI record type	iRI-Report-record	M
IRI record name	tETRA-LI-Event	M
LIID	lawfulInterceptionIdentifier	M
TETRA location	locationOfTheTarget	C
Target ID	tETRA-PartyInformation	M
Event time	timeStamp	M
Network Identification	networkIdentifier	M

A.9.2.1.4.7 DMO

The indication of Direct Mode Operations informs LEA that the observed party has entered into radio communications which cannot be observed by the TETRA switch.

Table A.9.18: Data fields for Direct Mode Operations

Information	ASN.1 field used	MOC
IRI record type	iRI-Report-record	M
IRI record name	tETRA-LI-Event	M
LIID	lawfulInterceptionIdentifier	M
TETRA location	locationOfTheTarget	C
Target ID	tETRA-PartyInformation	M
Event time	timeStamp	M
Network Identification	networkIdentifier	M
DirectModeOperations	dMO-Indicator	M

A.10 NGN PSTN/ISDN emulation and simulation services technology annex

A.10.0 General

This clause applies for PSTN/ISDN emulation services and for PSTN/ISDN simulation services which interwork with the Circuit Switched telephony network.

Target identity consists in the target's E.164 Directory Number, TEL_URL and/or SIP_URI.

A.10.1 Functional architecture

Figure A.10.1 contains a high level functional architecture. ETSI TS 187 005 [i.3] provides an example of a model for NGN PSTN/ISDN emulation and NGN PSTN/ISDN simulation services which could provide a suitable example of "source of emulated/simulated PSTN/ISDN".

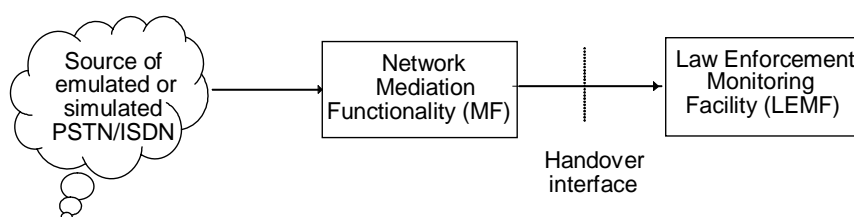

Figure A.10.1: High level functional architecture for PSTN/ISDN emulation and simulation services

A.10.2 Correlation

Clause A.1 applies.

Correlation for IRI and CC delivery is the same as for PSTN/ISDN, meaning via LIID, CID and CCLID used in the same way.

A.10.3 HI2

IRIs are elaborated and delivered as described in clause A.3.

A.10.4 HI3

CC will be delivered as described in clause A.4.

Correlation information in HI3 will be delivered as described in clause D.8 and as an option in annex E.

Annex B (normative): Packet switched network handover

B.1 Specific identifiers for LI

Beyond clause 6, at present the Correlation Number as specific LI identifier for packet switched networks is defined.

The Correlation Number is unique per PDP context and is used for the following purposes:

- correlate CC with IRI;
- correlate different IRI records within one PDP context.

As an example, in the GSM GPRS system, the Correlation Number may be the combination of GGSN address and charging ID.

B.2 HI1: interface port for administrative state

There are no additions beyond clause 7.

B.3 HI2: interface port for IRI

B.3.1 Definition of Interception Related Information for packet switched

Intercept related information will in principle be available in the following phases of a data transmission:

- 1) At connection attempt when the target identity becomes active, at which time packet transmission may or may not occur (set up of a data context, target may be the originating or terminating party).
- 2) At the end of a connection, when the target identity becomes inactive (removal of a data context).
- 3) At certain times when relevant information are available.

In addition, information on non-transmission related actions of a target constitute IRI and is sent via HI2, e.g. information on Subscriber Controlled Input (SCI).

The Intercept Related Information (IRI) may be subdivided into the following categories:

- 4) Control information for HI2 (e.g. correlation information).
- 5) Basic data context information, for standard data transmission between two parties.

B.3.2 Exception handling

Exception handling is a national matter.

B.3.3 Security aspects

For security aspects see clause 11.

B.4 HI3: interface port for Content of Communication (CC)

Details on the HI3 interface port are described in clause 9.

B.5 GPRS technology annex

B.5.1 Functional architecture

Figure B.5.1 contains the reference configuration for the lawful interception (see 3GPP TS 03.33 [42]).

There is one Administration Function (ADMf) in the network. Together with the delivery functions it is used to hide from the xGSN that there might be multiple activations by different Law Enforcement Agencies (LEAs) on the same target identity.

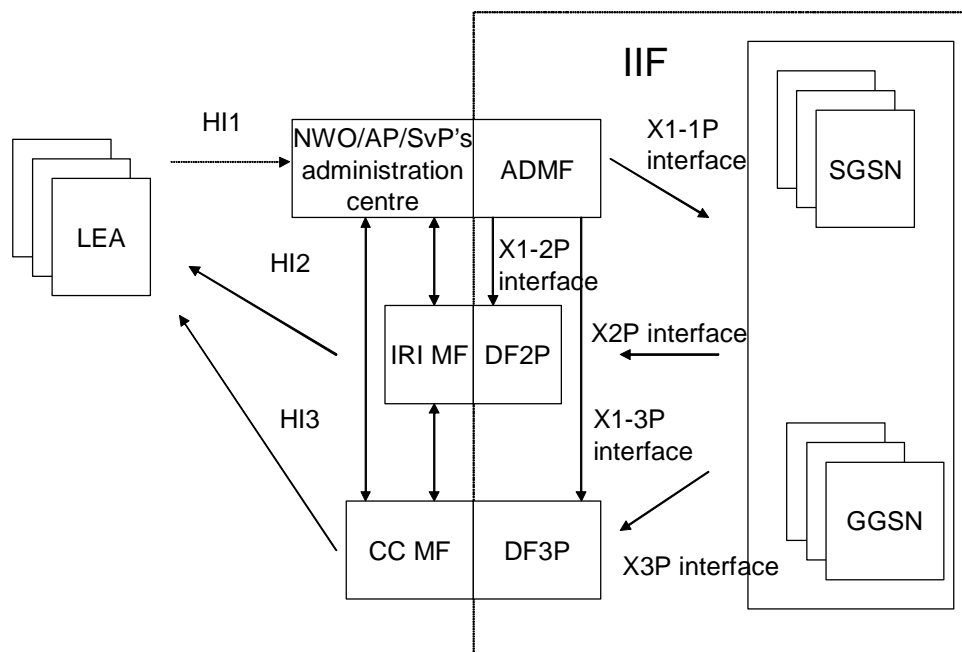

NOTE: GGSN interception is a national option.

Figure B.5.1: Reference configuration

The reference configuration is only a logical representation of the entities involved in lawful interception and does not mandate separate physical entities. This allows for higher levels of integration.

A communication could be intercepted based on several identities (MSISDN, IMSI, IMEI) of the same target.

For the delivery of the CC and IRI the xGSN provides a correlation number and target identity to the DF2P and DF3P which is used there to select the different LEAs where the CC/IRI shall be delivered to.

B.5.2 Correlation

B.5.2.1 Correlation of the present document IDs to GSM IDs

The ID Lawful Interception IDentifier (LIID) out of the present document is supported at the IIF (GSM) with warrant reference number.

Parameters from the present document, see clause 6.2.

- Communication IDentifier (CID).

For each communication or other activity relating to a target identity a CID is generated by the relevant network element. The CID consists of the following two identifiers:

- Network IDentifier (NID);
- Communication Identity Number (CIN).

NOTE: If interception has been activated for both parties of the packet data communication both CC and IRI will be delivered for each party as separate intercept activity.

B.5.2.2 GPRS LI correlation between CC and IRI

For the delivery of CC and IRI, the SGSN or GGSN provides correlation numbers and target identities to the HI2 and HI3. The correlation number is unique per PDP context and is used to correlate CC with IRI and the different IRIs of one PDP context.

B.5.3 HI2 (delivery of IRI)

The events defined in 3GPP TS 03.03 [43] are used to generate records for the delivery via HI2.

There are ten different event types received at DF2 level. According to each event, a record is sent to the LEMF if this is required. Table B.5.1 gives the mapping between event type received at DF2 level and record type sent to the LEMF.

Table B.5.1: Mapping between GPRS Events and HI2 records type

Event	IRI record type
GPRS attach	REPORT
GPRS detach	REPORT
PDP context activation (successful)	BEGIN
PDP context activation (unsuccessful)	REPORT
Start of intercept with PDP context active	BEGIN or optionally CONTINUE
PDP context modification	CONTINUE
PDP context deactivation	END
Cell and/or RA update	REPORT
SMS	REPORT
End of intercept with PDP context active	REPORT

For some packet oriented data services such as GPRS, the first event of a communication attempt shall be the PDP context activation or a similar event and an IRI-BEGIN record shall be issued. The end of the communication attempt shall be the PDP context deactivation or a similar event and an IRI-END record shall be issued. While a PDP context is active, IRI-CONTINUE records shall be used for CC relevant IRI data records, IRI-REPORT records otherwise.

For some packet-oriented data services such as GPRS, when LI is activated during an already active PDP context or similar, which the IAP is aware of, it is recommended that an IRI-BEGIN message is generated to mark the start of interception and the specific event type of *startOfInterceptionWithPDPContextActive* shall be used.

When LI is deactivated during an already active PDP context or similar, which the IAP is aware of, as a national option the MF may choose to either generate an IRI-REPORT message to mark the end of interception and shall use the specific event type of *endOfInterceptionWithPDPContextActive*, or not to generate an IRI-REPORT message and only communicate the end of interception by other means (e.g. HI1 *liDeactivated* message).

A set of information is used to generate the records. The records used transmit the information from mediation function to LEMF. This set of information can be extended in xGSN or DF2P/MF, if this is necessary in a specific country. Table B.5.2 gives the mapping between information received per event and information sent in records.

Table B.5.2: Mapping between events information and IRI information

Parameter	Description	HI2 ASN.1 parameter
observed MSISDN	Target Identifier with the MSISDN of the target subscriber (monitored subscriber)	PartyInformation/msISDN
observed IMSI	Target Identifier with the IMSI of the target subscriber (monitored subscriber)	PartyInformation/imsi
observed IMEI	Target Identifier with the IMEI of the target subscriber (monitored subscriber)	PartyInformation/imei
observed PDP address	PDP address(es) used by the target. In case of IPv4v6 two addresses may be carried	PartyInformation/pDP-address-allocated-to-the-target
event type	Description which type of event is delivered: PDP Context Activation, PDP Context Deactivation, GPRS Attach, etc.	gPRSevent
event date	Date of the event generation in the xGSN	TimeStamp
event time	Time of the event generation in the xGSN	
Access point name	The access point name contains a logical name (see 3GPP TS 23.060 [77])	PartyInformation/aPN
PDP type	This field describes the PDP type as defined in 3GPP TS 09.60 [45], 3GPP TS 29.060 [60], 3GPP TS 04.08 [55], 3GPP TS 24.008 [41], 3GPP TS 09.02 [32], 3GPP TS 29.002 [80]	PartyInformation/pDP-type
Correlation number	Unique number for each PDP context delivered to the LEMF, to help the LEA, to have a correlation between each PDP Context and the IRI	gPRSCorrelationNumber
lawful interception identifier	Unique number for each lawful authorization	LawfulInterceptionIdentifier
CGI (Cell Global ID)	Cell number of the target; for the location information	locationOfTheTarget/globalCellId
routing area identifier	Routing-area-identifier of the target defines the Routing Area in a GPRS-PLMN	locationOfTheTarget/rAI
SMS	The SMS content with header which is sent with the SMS-service	SMS
failed context activation reason	This field gives information about the reason(s) for failed context(s) activation of the target subscriber	gPRSOperationErrorCode
failed attach reason	This field gives information about the reason(s) for failed attach attempts of the target subscriber	gPRSOperationErrorCode
NSAPI	Network layer Service Access Point Identifier information element contains an NSAPI identifying a PDP Context in a mobility management context specified by the Tunnel Endpoint Identifier Control Plane	nSAPI
NOTE: LIID parameter shall be present in each record sent to the LEMF.		

B.5.4 HI3 (Delivery of CC)

For a GPRS HI3 interface port for Content of Communication (CC) see annex F.

Annex C (normative): HI2 Delivery mechanisms and procedures

C.0 General

There are two possible methods for delivery of IRI to the LEMF:

- a) ROSE (see clause C.1);
- b) FTP (see clause C.2).

According to national requirements at least one of these methods shall be provided.

C.1 ROSE

C.1.1 Architecture

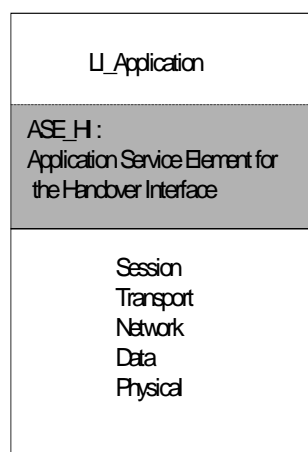

Figure C.1.1: Architecture

The ASE_HI manages the data link, the coding/decoding of the ROSE operations and the sending/receiving of the ROSE operations.

C.1.2 ASE_HI procedures

C.1.2.1 Sending part

To request the sending of data to a peer entity, the LI_Application provides the ASE_HI, the address of the peer entity, the nature of the data and the data.

On receiving a request of the LI_Application:

- If the data link toward the peer entity address is active, the ASE_HI, from the nature of the data provided, encapsulates this data in the relevant RO-Invoke operation.
- If the data link toward the peer entity address is not active, the ASE_HI reports the data link unavailability to LI_Application.

NOTE: Until the data link is established by the LI_Application according to clause C.1.2.3.1, the request of the LI_Application cannot be successfully processed by ASE_HI.

Depending on the natures of the data provided by the LI_Application, the ASE_HI encapsulates this data within the relevant ROSE operation:

- LI management notification: in this case the data provided by the application are encoded within the class 2 RO-Invoke operation "sending-of-HI1-Notification". The ASN.1 format is described in clauses D.2 and D.4 (HI1 interface).
- IRI: in this case the data provided by the application are encoded within the class 2 RO-Invoke operation "sending-of-IRI". The ASN.1 format is described in clauses D.2 and D.5 (HI2 interface).
- SMS: in this case the data provided by the application are encoded within the class 2 RO-Invoke operation "sending-of-IRI". The ASN.1 format is described in clauses D.2 and D.5 (HI2 interface).
- User packet data transfer (used for data which can be exchanged via ISUP/DSS1/MAP signalling: e.g. UUS): in this case the data provided by the application are encoded:
 - either within the class 2 RO-Invoke operation "circuit-Call-related-Services" in case of data associated to a circuit call (for e.g. UUS1, UUS2, UUS3). The ASN.1 format is described in clauses D.2 and D.6 (HI3 interface);
 - or within the class 2 RO-Invoke operation "no-Circuit-Call-related-Services" in case of data not associated with a circuit call (for e.g. SMS). The ASN.1 format is described in clauses D.2 and D.6 (HI3 interface).
- TETRA data transfer: in this case all the information provided by the application is encoded within the class 2 RO-Invoke operation "Sending-of-TETRA-Data". The ASN.1 format is described in clauses D.2 and D.7.

Depending on the class of the operation, the ASE_HI may have to wait for an answer. In this case a timer, depending on the operation, is started on the sending of the operation and stopped on the receipt of an answer (RO_Result, RO_Error, RO_Reject).

On timeout of the timer, the ASE_HI indicates to the LI_Application that no answer has been received. It is under the LI_Application responsibility to send again the data or to inform the administrator of the problem.

On receipt of an answer component (after verification that the component is not erroneous), the ASE_HI stop the relevant timer and acts depending on the type of component:

- On receipt of a RO_Result, the ASE_HI provide the relevant LI_Application an indication that the data has been received by the peer LI_Application and the possible parameters contained in the RO_Result.
- On receipt of a RO_Error, the ASE_HI provide the relevant LI_Application an indication that the data has not been received by the peer LI_Application and the possible "Error cause". The error causes are defined for each operation in the relevant ASN.1 script. It is under the LI_Application responsibility to generate or not an alarm message toward an operator or administrator.
- On receipt of a RO_Reject_U/P, the ASE_HI provide the relevant LI_Application an indication that the data has not been received by the peer LI_Application and the "Problem cause". The problem causes are defined in Recommendations ITU-T X.880 [35] and X.882 [37]. It is under the LI_Application responsibility to send again the data or to inform the operator/administrator of the error.

On receipt of an erroneous component, the ASE_HI acts as described in Recommendations ITU-T X.880 [35] and X.882 [37].

C.1.2.2 Receiving part

On receipt of a ROSE operation from the lower layers:

- When receiving operations from the peer entity, the ASE_HI verifies the syntax of the component and transmits the parameters to the LI_Application. If no error/problem is detected, in accordance with the Recommendations ITU-T X.880 [35] and X.882 [37] standard result (only Class2 operation are defined), the ASE_HI sends back a RO_Result which coding is determined by the relevant operation ASN.1 script. The different operations which can be received are:
 - RO-Invoke operation "sending-of-HI1-Notification" (HI1 interface);
 - RO-Invoke operation "sending-of-IRI" (HI2 interface);
 - RO-Invoke operation "circuit-Call-related-Services" (HI3 interface);
 - RO-Invoke operation "no-Circuit-Call-related-Services" (HI3 interface);
 - RO-Invoke operation "Sending-of-TETRA-Data" (HI3 interface).

In case of error, the ASE_HI acts depending on the reason of the error or problem:

- In accordance with the rules defined by Recommendations ITU-T X.880 [35] and X.882 [37], a RO_Error is sent in case of unsuccessfully operation at the application level. The Error cause provided is one among those defined by the ASN.1 script of the relevant operation.
- In accordance with the rules defined in Recommendations ITU-T X.880 [35] and X.882 [37], a RO_Reject_U/P is sent in case of erroneous component. On receipt of an erroneous component, the ASE_HI acts as described in Recommendations ITU-T X.880 [35] and X.882 [37].

C.1.2.3 Data link management

C.1.2.3.0 General

This function is used to establish or release a data link between two peer LI_Applications entities (MF and LEMF).

C.1.2.3.1 Data link establishment

Depending on a per destination address configuration data, the data link establishment may be required either by the LEMF LI_Application or by the MF LI_Application.

To request the establishment of a data link toward a peer entity, the LI_Application provides, among others, the destination address of the peer entity (implicitly, this address defined the protocol layers immediately under the ASE_HI: TCP/IP, X25, etc.). On receipt of this request, the ASE_HI request the establishment of the data link with respect of the rules of the under layers protocol.

As soon as the data link is established, the requesting LI_Application initiates an authentication procedure:

- The origin LI_Application requests the ASE_HI to send the class 2 RO-Invoke operation "sending-of-Password" which includes the "origin password" provided by the LI_Application.
- The peer LI_Application, on receipt of the "origin password" and after acceptance, requests to its ASE_HI to send back a RO_Result. In addition, this destination application requests the ASE_HI to send the class 2 RO-Invoke operation "sending-of-Password" which includes the "destination password" provided by the LI_Application.
- The origin LI_Application, on receipt of the "destination password" and after acceptance, requests to its ASE_HI to send back a RO_Result. This application is allowed to send data.
- After receipt of the RO_Result, this application is allowed to send data.

In case of erroneous password, the data link is immediately released and a "password error indication" is sent toward the operator.

Optionally a *Data link test* procedure may be used to verify periodically the data link:

- When no data have been exchanged during a network dependent period of time toward an address, (may vary from 1 minute to 30 minutes) the LI_Application requests the ASE_HI to send the class 2 RO-Invoke operation "data-Link-Test".
- The peer LI_Application, on receipt of this operation, requests to its ASE_HI to send back a RO_Result.
- On receipt of the Result the test is considered valid by the LI_Application.
- If no Result is received or if a Reject/Error message is received, the LI_Application requests the ASE_LI to release the data link and send an error message toward the operator.

C.1.2.3.2 Data link release

- The End of the connection toward the peer LI_Application is under responsibility of the LI_Application. E.g. the End of the connection may be requested in the following cases:
 - when all the data (IRI, etc.) has been sent. To prevent unnecessary release, the datalink may be released only when no LI_Application data have been exchanged during a network dependent period of time;
 - the data link is established when a call is intercepted and released when the intercepted call is released (and all the relevant data have been sent);
 - for security purposes;
 - for changing of password or address of the LEMF/IIF;
 - etc.
- To end the connection a LI_Application requests the ASE_HI to send the class 2 RO-Invoke operation "end-of-Connection".
- The peer LI_Application, on receipt of this operation, requests to its ASE_HI to send back a RO_Result.
- On receipt of the Result the LI_Application requests the ASE_LI to release the data link.
- If no Result is received after a network dependent period of time, or if a Reject/Error message is received, the LI_Application requests the ASE_LI to release the data link and to send an error message toward the operator/administrator.

C.1.2.4 Handling of unrecognized fields and parameters

See annex G.

C.1.3 Void

C.2 FTP

C.2.1 Introduction

At HI2 interface FTP is used over Internet protocol stack for the delivery of the IRI. The FTP is defined in IETF RFC 959 [46]. The IP is defined in IETF RFC 791 [51]. The TCP is defined in IETF RFC 793 [52].

FTP supports reliable delivery of data. The data may be temporarily buffered in the Mediation Function (MF) in case of link failure. FTP is independent of the payload data it carries.

C.2.2 Usage of the FTP

The MF acts as the FTP client and the LEMF acts as the FTP server. The client pushes the data to the server.

The receiving node LEMF stores the received data as files. The MF may buffer files.

Several records may be gathered to bigger packages prior to sending, to increase bandwidth efficiency.

The following configurable intercept data collection (= transfer package closing/file change) threshold parameters should be supported:

- frequency of transfer, based on send timeout, e.g. X ms;
- frequency of transfer, based on volume trigger, e.g. X octets.

Every file shall contain only complete IRI records. The single IRI record shall not be divided into several files.

There are two possible ways how the interception data may be sent from the MF to the LEMF. One way is to produce files that contain interception data only for one observed target (ref: "File naming method A"). The other way is to multiplex all the intercepted data that MF receives to the same sequence of general purpose interception files sent by the MF (ref: "File naming method B").

File naming:

The names for the files transferred to a LEA are formed according to one of the two available formats, depending on the delivery file strategy chosen (e.g. due to national convention or operator preference).

Either each file contains data of only one observed target (as in method A) or several targets' data is put to files common to all observed target traffic through MF (as in method B).

The maximum set of allowed characters in interception file names are "a"..."z", "A"..."Z", "-", "_", ".", and decimals "0"..."9".

File naming method A):

<LIID>_<seq>.<ext>

where:

- LIID** = As defined in the present document clause "Lawful Interception Identifier (LIID)". This field has a character string (or digit string for subaddress option) value, e.g. "ABCD123456". This is a unique interception request identifier allocated by the ADMF. It will be given by the ADMF to the LEA via the HI1 interface after the ADMF has been authorized to command the start of the interception of a specific target. The possible network operator identifier part used should be agreed with (and allocated by) the regulatory organization administrating the local telecommunication practises.
- seq** = Integer ranging between $[0 \dots 2^{64}-1]$, in ASCII form (not exceeding 20 ASCII digits), identifying the sequence number for file transfer from this node per a specific target.
- ext** = ASCII integer ranging between ["1"..."8"] (in hex: 31H...38H), identifying the file type. The possible file types are shown in table C.2.1. Type "1" is reserved for IRI data files and type "8" is reserved for data files according to a national requirement by using the same file naming concept.

Table C.2.1: Possible file types

File types that the LEA may get	Intercepted data types
"1" (in binary: 0011 0001)	IRI/ as option HI1 notifications
"2" (in binary: 0011 0010)	CC (MO) (see clause F.3.2.2)
"4" (in binary: 0011 0100)	CC (MT) (see clause F.3.2.2)
"6" (in binary: 0011 0110)	CC (MO&MT) (see clause F.3.2.2)
"7" (in binary: 0011 0111)	IRI + CC (MO&MT) (see clause F.3.2.2)
"8" (in binary: 0011 1000)	for national use

This alternative A is used when each target's IRI is gathered per observed target to dedicated delivery files. This method provides the result of interception in a very refined form to the LEAs, but requires somewhat more resources in the MF than alternative B. With this method, the data sorting and interpretation tasks of the LEMF are considerably easier to facilitate in near real time than in alternative B.

File naming method B):

The other choice is to use monolithic fixed format file names (with no trailing file type part in the file name):

<filenamestring> of the format ABXYyymmddhhmssseeeet

where:

AB = Two letter ASCII Operator ID (as agreed with the national telecom regulators).
XY = Two letter ASCII identification of the MF node (as assigned by the operator).
yy = Two digits ASCII integer ranging between ["00"..."99"], identifying the last two digits of the year.
mm = Two digits ASCII integer ranging between ["01"..."12"], identifying the month.
dd = Two digits ASCII integer ranging between ["01"..."31"], identifying the day.
hh = Two digits ASCII integer ranging between ["00"..."23"], identifying the hour.
mm = Two digits ASCII integer ranging between ["00"..."59"], identifying the minute.
ss = Two digits ASCII integer ranging between ["00"..."59"], identifying the second.
eeee = Alphanumeric extension made up of four characters chosen at the discretion of the Operator and/or the MF to avoid file name clashes within the MF. Each of the position shall be out of "A"..."Z", "0"..."9".
t = ASCII integer ranging between ["1"..."8"] (in hex: 31H...38H), identifying the file type. The possible file types are shown in table C.2.1. Type "1" is reserved for IRI data files and type "8" is reserved for data files according to a national requirement by using the same file naming concept.

EXAMPLE: <filenamestring> (e.g. ABXY00041014084400001).

where:

ABXY = source node identifier part, used for all files by the mobile network operator "AB" from this MF node named "XY".
00 = year 2000.
04 = month April.
10 = day 10.
14 = hour.
08 = minutes.
44 = seconds.
0000 = extension.
1 = file type. The type "1" is reserved for IRI data files and type "8" is reserved for national use. (Codings "2" = CC(MO), "4" = CC(MT), "6" = CC(MO&MT) are reserved for HI3).

This alternative B is used when several targets' intercepted data is gathered to common delivery files. This method does not provide the result of interception in as refined form to the LEAs as the alternative A, but it is faster in performance for the MF point of view. With this method, the MF does not need to keep many files open like in alternative A.

C.2.3 Profiles

NOTE: This clause is informative only.

As there are several ways (usage profiles) how data transfer can be arranged by using the FTP, this clause contains practical considerations how the communications can be set up. Guidance is given for client-server arrangements, session establishments, time outs, the handling of the files (in RAM or disk). Example batch file is described for the case that the sending FTP client uses files. If instead (logical) files are sent directly from the client's RAM memory, then the procedure can be in principle similar though no script file would then be needed.

At the LEMF side, FTP server process is run, and at MF, FTP client. No FTP server (which could be accessed from outside the operator network) shall run in the MF. The FTP client can be implemented in many ways, and here the FTP usage is presented with an example only. The FTP client can be implemented by a batch file or a file sender program that uses FTP via an API. The login needs to occur only once per e.g. <destaddr> and <leouser> - pair. Once the login is done, the files can then be transferred just by repeating "mput" command and checking the transfer status (e.g. from the API routine return value). To prevent inactivity timer triggering, a dummy command (e.g. "pwd") can be sent every T seconds (T should be less than L, the actual idle time limit). If the number of FTP connections is wanted to be as minimized as possible, the FTP file transfer method "B" is to be preferred to the method A (though the method A helps more the LEMF by pre-sorting the data sent).

Simple example of a batch file extract:

FTP commands usage scenario for transferring a list of files:

To prevent FTP cmd line buffer overflow the best way is to use wildcarded file names, and let the FTP implementation do the file name expansion (instead of shell). The number of files for one mput is not limited this way:

```
ftp <flags> <destaddr>
user <leouser> <leapasswd>
cd <destpath>
lcd <srcpath>
bin
mput <files>
nlist <lastfile> <checkfile>
close
EOF
```

This set of commands opens an FTP connection to a LEA site, logs in with a given account (auto-login is disabled), transfers a list of files in binary mode, and checks the transfer status in a simplified way.

Brief descriptions for the FTP commands used in the example:

user <user-name> <password>	Identify the client to the remote FTP server.
cd <remote-directory>	Change the working directory on the remote machine to remote-directory.
lcd <directory>	Change the working directory on the local machine.
bin	Set the file transfer type to support binary image transfer
mput <local-files>	Expand wild cards in the list of local files given as arguments and do a put for each file in the resulting list. Store each local file on the remote machine.
nlist <remote-directory> <local-file>	Print a list of the files in a directory on the remote machine. Send the output to local-file.
close	Terminate the FTP session with the remote server, and return to the command interpreter. Any defined macros are erased.

The parameters are as follows:

<flags> contains the FTP command options, e.g. "-i -n -V -p" which equals to "interactive prompting off", "auto-login disabled", "verbose mode disabled", and "passive mode enabled". (These are dependent on the used ftp-version.)

<destaddr> contains the IP address or DNS address of the destination (LEA)

<leouser> contains the receiving (LEA) username

<leapasswd> contains the receiving (LEA) user's password

<destpath> contains the destination path

<srcpath> contains the source path

<files> wild carded file specification (matching the files to be transferred)

<lastfile> the name of the last file to be transferred

<checkfile> is a (local) file to be checked upon transfer completion; if it exists then the transfer is considered successful

The FTP application should do the following things if the check file is not found:

- keep the failed files;
- raise "file transfer failure" error condition (i.e. send alarm to the corresponding LEA);
- the data can be buffered for a time that the buffer size allows. If that would finally be exhausted, DF would start dropping the corresponding target's data until the transfer failure is fixed;
- the transmission of the failed files is retried until the transfer eventually succeeds. Then the DF would again start collecting the data;
- upon successful file transfer the sent files are deleted from the DF.

The FTP server at LEMF shall not allow anonymous login of an FTP client.

It is required that FTP implementation guarantees that LEMF will start processing data only after data transfer is complete.

The following implementation example addresses a particular issue of FTP implementation. It is important however to highlight that there are multiple ways of addressing the problem in question, and therefore the given example does not in any way suggest being the default one.

- MF sends data with a filename, which indicates that the file is temporary. Once data transfer is complete, MF renames temporary file into ordinary one (as defined in clause C.2.2).

The procedure for renaming filename should be as follow:

- 1) open FTP channel (if not already open) from MF to LEMF;
- 2) sends data to LEMF using command "put" with temporary filename;
- 3) after MF finished sending the file, renaming it as ordinary one with command "ren".

Brief descriptions for the FTP commands used in the example:

ren <from-name> <to-name> renaming filename from-name to to-name.

If the ftp-client want to send file to LEMF using the command "mput" (e.g. MF stored many IRI files and want to send all together with one command), every filename transferred successfully shall be renamed each after command "mput" ended.

C.2.4 File content

The file content is in method A relating to only one intercepted target.

In the file transfer method B, the file content may relate to any intercepted targets whose intercept records are sent to the particular LEMF address.

Individual IRI records shall not be fragmented into separate files at the FTP layer.

C.2.5 Exceptional procedures

Overflow at the receiving end (LEMF) is avoided due to the nature of the protocol.

In case the transit network or receiving end system (LEMF) is down for a reasonably short time period, the local buffering at the MF will be sufficient as a delivery reliability backup procedure.

In case the transit network or receiving end system (LEMF) is down for a very long period, the local buffering at the MF may have to be terminated. Then the following intercepted data coming from the intercepting nodes to the MF would be discarded, until the transit network or LEMF is up and running again.

C.2.6 Other considerations

The FTP protocol mode parameters used:

- Transmission Mode: stream.
- Format: non-print.
- Structure: file-structure.
- Type: binary.

The FTP client (= user-FTP process at the MF) uses e.g. the default standard FTP ports 20 (for data connection) and 21 (for control connection), "passive" mode is supported. The data transfer process listens the data port for a connection from a server-FTP process.

For the file transfer from the MF to the LEMF(s) e.g. the following data transfer parameters are provided for the FTP client (at the MF):

- transfer destination (IP) address, e.g. "194.89.205.4";
- transfer destination username, e.g. "LEA1";
- transfer destination directory path, e.g. "/usr/local/LEA1/1234-8291";
- transfer destination password;
- interception file type, "1" (this is needed only if the file naming method A is used).

LEMF may use various kind directory structures for the reception of interception files. It is strongly recommended that at the LEMF machine the structure and access and modification rights of the storage directories are adjusted to prevent unwanted directory operations by a FTP client.

Timing considerations for the HI2 FTP transmission:

The MF and LEMF sides control the timers to ensure reliable, near-real time data transfer. The transmission related timers are defined within the lower layers of the used protocol and are out of scope of the present document.

The following timers may be used within the LI application.

Table C.2.2: Timing considerations

Name	Controlled by	Units	Description
T1 inactivity timer	LEMF	Seconds	Triggered by no activity within the FTP session (no new files). The FTP session is torn down when the T1 expires. To send another file the new connection will be established. The timer avoids the FTP session overflow at the LEMF side.
T2 send file trigger	MF	Milliseconds	Forces the file to be transmitted to the LEMF (even if the size limit has not been reached yet in case of volume trigger active). If the timer is set to 0 the only trigger to send the file is the file size parameter (see clause C.2.2).

Annex D (normative): Structure of data at the Handover Interface

D.0 General

This annex specifies the coding details at the Handover Interface HI for all data, which may be sent from the NWO/AP/SvP's equipment to the LEMF, across HI.

At the three Handover Interface (HI) ports, the following data may be present:

- interface port HI1: Interception administration information;
- interface port HI2: Intercept Related Information (IRI);
- interface port HI3: records containing Content of Communication (CC).

The detailed coding specification for these types of information is contained in this annex, including sufficient details for a consistent implementation in the NWO/AP/SvP's equipment and the LEMF.

It shall be noticed some data are ROSE specific and have no meaning when FTP is used. Those specificities are described at the beginning of each clause (clauses D.3 to D.6).

D.1 Syntax definitions

The transferred information and messages are encoded to be binary compatible with Recommendations ITU-T X.680 [33] (Abstract Syntax Notation One (ASN.1)) and X.690 [34] (Basic Encoding Rules (BER)).

These recommendations use precise definitions of the words *type*, *class*, *value*, and *parameter*. Those definitions are paraphrased below for clarity.

A *type*, in the context of the abstract syntax or transfer syntax, is a set of all possible values. For example, an INTEGER is a type for all negative and positive integers.

A *class*, in the context of the abstract syntax or transfer syntax, is a one of four possible domains for uniquely defining a type. The classes defined by ASN.1 and BER are: UNIVERSAL, APPLICATION, CONTEXT, and PRIVATE.

The UNIVERSAL class is reserved for international standards such as Recommendations ITU-T X.680 [33] and X.690 [34]. Most parameter type identifiers in the HI ROSE operations are encoded as CONTEXT specific class. Users of the protocol may extend the syntax with PRIVATE class parameters without conflict with the present document, but risk conflict with other users' extensions. APPLICATION class parameters are reserved for future extensions.

A *value* is a particular instance of a type. For example, five (5) is a possible value of the type INTEGER.

A *parameter* in the present document is a particular instance of the transfer syntax to transport a value consisting of a tag to identify the parameter type, a length to specify the number of octets in the value, and the value.

In the BER a *tag* (a particular type and class identifier) may either be a primitive or a constructor. A *primitive* is a pre-defined type (of class UNIVERSAL) and a *constructor* consists of other types (primitives or other constructors). A constructor type may either be IMPLICIT or EXPLICIT. An IMPLICIT type is encoded with the constructor identifier alone. Both ends of a communication shall understand the underlying structure of the IMPLICIT types. EXPLICIT types are encoded with the identifiers of all the contained types. For example, an IMPLICIT Number of type INTEGER would be tagged only with the *Number* tag, where an EXPLICIT number of type INTEGER would have the *INTEGER* tag within the *Number* tag. The present document uses IMPLICIT tagging for more compact message encoding.

For the coding of the value part of each parameter the general rule is to use a widely use a standardized format when it exists (ISUP, DSS1, MAP, etc.).

As a large part of the information exchanged between the users may be transmitted within ISUP/DSS1 signalling, the using of the coding defined for this signalling guarantee the integrity of the information provided to the LEMF and the evolution of the interface. For example if new values are used within existing ISUP parameters, this new values shall be transmitted transparently toward the LEMF.

For the ASN.1 parameters of the type "OCTET STRING", the ordering of the individual halfoctets of each octet shall be such that the most significant halfoctet is put into bit position 5 to 8 and the least significant halfoctet into bit position 1 to 4. This general rule shall not apply when parameter formats are imported from other standards, e.g. an E.164 number coded according to ISUP (Recommendation ITU-T Q.763 [48]). In this case the ordering of the halfoctet shall be according to that standard and not be changed.

D.2 Object tree

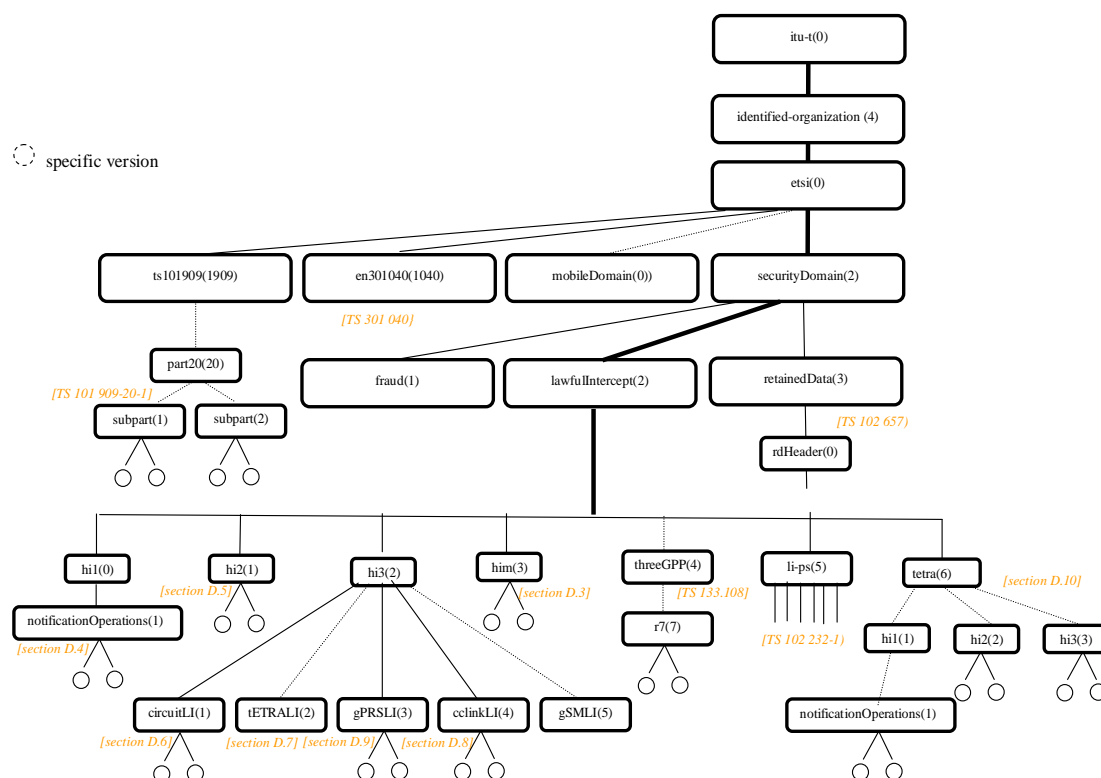

Figure D.2.1: Object Tree: Lawful Interception in ETSI domain

ETSI TR 102 503 [i.4] describes the structure for the ETSI domain with the included Lawful Intercept (LI) domain and ASN.1 modules from other Lawful Intercept specifications in detail. It gives an overview over all the relevant Object Identifiers (OID) used in ASN.1 modules of the Lawful Intercept specifications and point to the specification where the modules can be found.

The ASN.1 definitions are contained in nine .txt files:

- "HIManagementOperations,ver3.txt";
- "HI1NotificationOperations,ver7.txt";
- "HI2Operations,ver18.txt";
- "HI3CircuitDataOperations,ver4.txt";
- "HI3CCLinkData,ver4.txt";
- "Gprs-HI3-PS,ver3.txt";
- "TETRA-HIManagementOperations,ver0.txt";

- "TETRA-HI1NotificationOperations,ver0.txt"; and
- "TETRA-HI2Operations,ver3.txt";

contained in archive "ts_101671v031501p0.zip" which accompanies the present document.

D.3 HI management operation

This data description applies only for ROSE delivery mechanism.

ASN.1 description of HI management operation (any HI interface)

HIManagementOperations

```
{itu-t(0) identified-organization(4) etsi(0) securityDomain(2) lawfulIntercept(2) him(3)
version3(3)}
```

```
DEFINITIONS IMPLICIT TAGS ::=
BEGIN
```

```
EXPORTS
    sending-of-Password,
    data-Link-Test,
    end-Of-Connection;
```

```
IMPORTS
    OPERATION,
    ERROR
    FROM Remote-Operations-Information-Objects
    {joint-iso-itu-t(2) remote-operations(4) informationObjects(5) version1(0)};
```

```
-- =====
-- Object Identifier definitions
-- =====

-- LawfulIntercept DomainId
lawfulInterceptDomainId OBJECT IDENTIFIER ::= {itu-t(0) identified-organization(4) etsi(0)
securityDomain(2) lawfulIntercept(2)}

-- him Domain
himDomainId OBJECT IDENTIFIER ::= {lawfulInterceptDomainId him(3)}
himOperationId OBJECT IDENTIFIER ::= {himDomainId version3(3)}
```

```
sending-of-Password OPERATION ::=
{
    ARGUMENT      Password-Name
    ERRORS        {ErrorsHim}
    CODE          global:{himDomainId sending-of-Password(1) version1(1)}
}
-- Class 2 operation. The timer shall be set to a value between 3s and 240s
-- The timer default value is 60s
```

```
data-Link-Test OPERATION ::=
{
    ERRORS        {other-failure-causes}
    CODE          global:{himDomainId data-link-test(2) version1(1)}
}
-- Class 2 operation. The timer shall be set to a value between 3s and 240s
-- The timer default value is 60s
```

```
end-Of-Connection OPERATION ::=
{
    ERRORS        {other-failure-causes}
    CODE          global:{himDomainId end-of-connection(3) version1(1)}
}
-- Class 2 operation. The timer shall be set to a value between 3s and 240s
-- The timer default value is 60s
```

```
other-failure-causes      ERROR ::= {CODE local:0}
missing-parameter       ERROR ::= {CODE local:1}
unknown-parameter       ERROR ::= {CODE local:2}
erroneous-parameter     ERROR ::= {CODE local:3}
```

```

ErrorsHim ERROR ::=
{
  other-failure-causes |
  missing-parameter |
  unknown-parameter |
  erroneous-parameter
}

```

```

Password-Name ::= SEQUENCE
{
  domainID [0] OBJECT IDENTIFIER (himOperationId) OPTIONAL,
  -- Once using FTP delivery mechanism
  password [1] OCTET STRING (SIZE (1..25)),
  name [2] OCTET STRING (SIZE (1..25)),
  ...
}
-- IA5 string recommended

```

END -- end of **HIManagementOperations**

D.4 LI management notification

Declaration of ROSE operation "sending-of-HI1-Notification" is ROSE delivery mechanism specific. When using FTP delivery mechanism, data HI1-Operation shall be considered.

NOTE: This annex does not describe an electronic Handover Interface, but HI1 information, which is sent to the LEMF across the HI2 port.

ASN.1 description of LI management notification operation (HI1 interface)

```

HI1NotificationOperations
{itu-t(0) identified-organization(4) etsi(0) securityDomain(2) lawfulIntercept(2) hi1(0)
notificationOperations(1) version7(7)}

```

```

DEFINITIONS IMPLICIT TAGS ::=
BEGIN

```

```

IMPORTS
  OPERATION,
  ERROR
  FROM Remote-Operations-Information-Objects
  {joint-iso-itu-t(2) remote-operations(4) informationObjects(5) version1(0)}

  -- from clause D.5
  CommunicationIdentifier,
  TimeStamp,
  LawfulInterceptionIdentifier
  FROM HI2Operations
  {itu-t(0) identified-organization(4) etsi(0) securityDomain(2) lawfulIntercept(2) hi2(1)
version10(10)};

```

```

-- =====
-- Object Identifier Definitions
-- =====

-- LawfulIntercept DomainId
lawfulInterceptDomainId OBJECT IDENTIFIER ::= {itu-t(0) identified-organization(4) etsi(0)
securityDomain(2) lawfulIntercept(2)}

-- hil Domain
hilNotificationOperationsId OBJECT IDENTIFIER ::= {lawfulInterceptDomainId hil(0)
notificationOperations(1)}
hilOperationId OBJECT IDENTIFIER ::= {hilNotificationOperationsId version6(6)}

```

```

sending-of-HI1-Notification OPERATION ::=
{
  ARGUMENT      HI1-Operation
  ERRORS        {ErrorHI1Notifications}
  CODE          global:{hi1NotificationOperationsId version1(1)}
}
-- Class 2 operation. The timer shall be set to a value between 3s and 240s.
-- The timer default value is 60s.
-- NOTE: The value for this timer is to be set on the equipment waiting for the returned message;
-- its value shall be agreed between the NWO/AP/SvP and the LEA, depending on their equipment
-- properties.

```

```

other-failure-causes   ERROR ::= {CODE local:0}
missing-parameter     ERROR ::= {CODE local:1}
unknown-parameter     ERROR ::= {CODE local:2}
erroneous-parameter   ERROR ::= {CODE local:3}

```

```

ErrorHI1Notifications ERROR ::=
{
  other-failure-causes |
  missing-parameter |
  unknown-parameter |
  erroneous-parameter
}

```

```

HI1-Operation ::= CHOICE
{
  liActivated           [1] Notification,
  liDeactivated        [2] Notification,
  liModified           [3] Notification,
  alarms-indicator     [4] Alarm-Indicator,
  ...,
  national-HI1-ASN1parameters [5] National-HI1-ASN1parameters
}

```

```

-- =====
-- PARAMETERS FORMATS
-- =====

```

```

Notification ::= SEQUENCE
{
  domainID              [0] OBJECT IDENTIFIER (hi1OperationId) OPTIONAL,
  -- Once using FTP delivery mechanism
  lawfulInterceptionIdentifier [1] LawfulInterceptionIdentifier,
  -- This identifier is the LIID identity provided with the lawful authorization
  -- for each target.
  communicationIdentifier [2] CommunicationIdentifier OPTIONAL,
  -- Only the NWO/PA/SvPIDentifier is provided (the one provided with the Lawful
  -- authorization).
  -- Called "callIdentifier" in V1.1.1 of ES 201 671 [i.5]
  timeStamp            [3] TimeStamp,
  -- date and time of the report.
  ...,
  national-HI1-ASN1parameters [5] National-HI1-ASN1parameters OPTIONAL,
  target-Information      [6] OCTET STRING (SIZE (1..256)) OPTIONAL
  -- provides information about the number or the characteristic of the target
  -- (e.g. E-mail address, E.164 number), ASCII format
}

```

```

Alarm-Indicator ::= SEQUENCE
{
  domainID              [0] OBJECT IDENTIFIER (hi1OperationId) OPTIONAL,
  -- Once using FTP delivery mechanism
  communicationIdentifier [1] CommunicationIdentifier OPTIONAL,
  -- Only the NWO/PA/SvPIDentifier is provided (the one provided with the
  -- Lawful authorization)
  timeStamp            [2] TimeStamp,
  -- date and time of the report.
  alarm-information     [3] OCTET STRING (SIZE (1..256)),
  -- Provides information about alarms (free format).
  -- Until ASN.1 version 6 (document version v3.12.1) the octet string
  -- was limited to a size of 25
  ...,
  lawfulInterceptionIdentifier [4] LawfulInterceptionIdentifier OPTIONAL,
  -- This identifier is the LIID identity provided with the lawful authorization
  -- for each target in according to national law
  national-HI1-ASN1parameters [5] National-HI1-ASN1parameters OPTIONAL
}

```

```

}
}
National-HI1-ASN1parameters ::= SEQUENCE
{
  domainID          [0] OBJECT IDENTIFIER (hi1OperationId) OPTIONAL,
    -- Once using FTP delivery mechanism.
  countryCode      [1] PrintableString (SIZE (2)),
    -- Country Code according to ISO 3166-1 [67],
    -- the country to which the parameters inserted after the extension marker apply.
  ...
    -- In case a given country wants to use additional national parameters according to its law,
    -- these national parameters should be defined using the ASN.1 syntax and added after the
    -- extension marker (...).
    -- It is recommended that "version parameter" and "vendor identification parameter" are
    -- included in the national parameters definition. Vendor identifications can be
    -- retrieved from IANA web site (see annex K). Besides, it is recommended to avoid
    -- using tags from 240 to 255 in a formal type definition.
}

```

END -- end of **HI1NotificationOperations**

D.5 Intercept related information (HI2 PS and CS)

Declaration of ROSE operation "sending-of-IRI" is ROSE delivery mechanism specific. When using FTP delivery mechanism, data IRIsContent shall be considered.

ASN.1 description of IRI (HI2 interface)

HI2Operations

```
{itu-t(0) identified-organization(4) etsi(0) securityDomain(2) lawfulIntercept(2) hi2(1)
version18(18)}
```

-- It is advised not to use version11(11) of this ASN.1 module since it contains a syntax error.
-- Version11(11) of **HI2Operations** is only defined in ETSI TS 101 671 v3.5.1 [81].

DEFINITIONS IMPLICIT TAGS ::=

BEGIN

```

IMPORTS OPERATION,
  ERROR
    FROM Remote-Operations-Information-Objects
      {joint-iso-itu-t(2) remote-operations(4) informationObjects(5) version1(0)}

  -- from 3GPP TS 33.108 [61]
  UmtsQos,
  IMSevent,
  LDIEvent,
  CorrelationValues
    FROM UmtsHI2Operations
      {itu-t(0) identified-organization(4) etsi(0) securityDomain(2) lawfulintercept(2)
threeGPP(4) hi2(1) r11(11) version-0(0)}

  -- from TS 101 909-20-01 [69]
  TARGETACTIVITYMONITOR-1
    FROM TS101909201
      {itu-t(0) identified-organization(4) etsi(0) ts101909(1909) part20(20) subpart1(1)
interceptVersion(0)}

  -- from EN 301 040 [72]
  TARGETACTIVITYMONITORind,
  TARGETCOMMSMONITORind,
  TTRAFFICind,
  CTTRAFFICind
    FROM EN301040
      {itu-t(0) identified-organization(4) etsi(0) en301040 (1040) interceptVersion (0)};

```

```

-- =====
-- Object Identifier Definitions
-- =====

-- LawfulIntercept DomainId
lawfulInterceptDomainId OBJECT IDENTIFIER ::= {itu-t(0) identified-organization(4) etsi(0)
securityDomain(2) lawfulIntercept(2)}

-- Security Subdomains
hi2DomainId OBJECT IDENTIFIER ::= {lawfulInterceptDomainId hi2(1)}
hi2OperationId OBJECT IDENTIFIER ::= {hi2DomainId version18(18)}

```

```

sending-of-IRI OPERATION ::=
{
  ARGUMENT      IRIsContent
  ERRORS        {OperationErrors}
  CODE          global:{hi2DomainId sending-of-IRI(1) version1(1)}
}
-- Class 2 operation. The timer shall be set to a value between 3s and 240s.
-- The timer default value is 60s.
-- NOTE: The same note as for HI management operation applies.

```

```

IRIsContent ::= CHOICE
{
  iRIContent      IRISContent,
  iRISequence    IRISSequence
}

```

```

IRISequence ::= SEQUENCE OF IRISContent
-- Aggregation of IRISContent is an optional feature.
-- It may be applied in cases when at a given point in time several IRI records are
-- available for delivery to the same LEA destination.
-- As a general rule, records created at any event shall be sent immediately and shall
-- not held in the DF or MF in order to apply aggregation.
-- When aggregation is not to be applied, IRISContent needs to be chosen.

```

```

IRISContent ::= CHOICE
{
  iRI-Begin-record      [1] IRI-Parameters,
  -- At least one optional parameter shall be included within the iRI-Begin-Record.
  iRI-End-record        [2] IRI-Parameters,
  iRI-Continue-record [3] IRI-Parameters,
  -- At least one optional parameter shall be included within the iRI-Continue-Record.
  iRI-Report-record     [4] IRI-Parameters,
  -- At least one optional parameter shall be included within the iRI-Report-Record.
  ...
}

```

```

unknown-version          ERROR ::= {CODE local:0}
missing-parameter        ERROR ::= {CODE local:1}
unknown-parameter-value ERROR ::= {CODE local:2}
unknown-parameter        ERROR ::= {CODE local:3}

```

```

OperationErrors ERROR ::=
{
  unknown-version |
  missing-parameter |
  unknown-parameter-value |
  unknown-parameter
}
-- These values may be sent by the LEMF, when an operation or a parameter is misunderstood.

```

```

IRI-Parameters ::= SEQUENCE
{
  domainID [0] OBJECT IDENTIFIER (hi2OperationId) OPTIONAL,
  -- for the sending entity the inclusion of the Object Identifier is mandatory
  iRIVersion [23] ENUMERATED
  {
    version2(2),
    ...,
    version3(3),
    version4(4),
    version5(5),
    version6(6),
    version7(7),
    lastVersion(8)
  } OPTIONAL,
  -- Optional parameter "iRIVersion" (tag 23) is redundant starting
  -- from ETSI TS 101 671 v2.5.1 [86]
  -- where to the object identifier "domainID" was introduced into IRI-Parameters.
  -- In order to keep backward compatibility, even when the version of the "domainID"
  -- parameter will be incremented it is recommended to always send to LEMF the same:
  -- enumeration value "lastVersion(8)".
  -- if not present, it means version 1 is handled
  lawfulInterceptionIdentifier [1] LawfulInterceptionIdentifier,
  -- This identifier is associated to the target.
  communicationIdentifier [2] CommunicationIdentifier,
  -- used to uniquely identify an intercepted call.
  -- Called "callIdentifier" in v1.1.1 of ES 201 671 [i.5].
  timeStamp [3] TimeStamp,
  -- date and time of the event triggering the report.
  intercepted-Call-Direct [4] ENUMERATED
  {
    not-Available(0),
    originating-Target(1),
    -- In case of GPRS, this indicates that the PDP context activation, modification
    -- or deactivation is MS requested.
    terminating-Target(2),
    -- In case of GPRS, this indicates that the PDP context activation, modification
    -- or deactivation is network initiated.
    ...
  } OPTIONAL,
  intercepted-Call-State [5] Intercepted-Call-State OPTIONAL,
  ringingDuration [6] OCTET STRING (SIZE (3)) OPTIONAL,
  -- Duration in seconds. BCD coded: HHMMSS
  conversationDuration [7] OCTET STRING (SIZE (3)) OPTIONAL,
  -- Duration in seconds. BCD coded: HHMMSS
  locationOfTheTarget [8] Location OPTIONAL,
  -- location of the target subscriber
  partyInformation [9] SET SIZE (1..10) OF PartyInformation OPTIONAL,
  -- This parameter provides the concerned party (Originating, Terminating or forwarded
  -- party), the identity(ies) of the party and all the information provided by the party.
  callContentLinkInformation [10] SEQUENCE
  {
    cCLink1Characteristics [1] CallContentLinkCharacteristics OPTIONAL,
    -- Information concerning the Content of Communication Link Tx channel established
    -- toward the LEMF (or the sum signal channel, in case of mono mode).
    cCLink2Characteristics [2] CallContentLinkCharacteristics OPTIONAL,
    -- Information concerning the Content of Communication Link Rx channel established
    -- toward the LEMF.
    ...
  } OPTIONAL,
  release-Reason-Of-Intercepted-Call [11] OCTET STRING (SIZE (2)) OPTIONAL,
  -- Release cause coded in ITU-T Q.850 [31] format.
  -- This parameter indicates the reason why the intercepted call cannot be established or
  -- why the intercepted call has been released after the active phase.
  nature-Of-The-intercepted-call [12] ENUMERATED
  {
    -- Nature of the intercepted "call":
    gSM-ISDN-PSTN-circuit-call(0),
    -- the possible UUS content is sent through the HI2 or HI3 "data" interface
    -- the possible call content call is established through the HI3 "circuit" interface
    gSM-SMS-Message(1),
    -- the SMS content is sent through the HI2 or HI3 "data" interface
    uUS4-Messages(2),
    -- the UUS content is sent through the HI2 or HI3 "data" interface
    tETRA-circuit-call(3),
    -- the possible call content call is established through the HI3 "circuit" interface
    -- the possible data are sent through the HI3 "data" interface
    teTRA-Packet-Data(4),

```

```

-- the data are sent through the HI3 "data" interface
gPRS-Packet-Data(5),
-- the data are sent through the HI3 "data" interface
...,
uMTS-circuit-call(6),
-- the possible call content call is established through the HI3 "circuit" interface
-- the possible data are sent through the HI3 "data" interface
lte-SMS-Message(7),
-- indicator for SMS from LTE handset
-- the SMS content is sent through the HI2 or HI3 "data" interface
lte-circuit-call(8)
-- indicator for CS call from LTE handset
} OPTIONAL,
serverCenterAddress [13] PartyInformation OPTIONAL,
-- e.g. in case of SMS message this parameter provides the address of the relevant
-- server within the calling (if server is originating) or called
-- (if server is terminating) party address parameters
sms [14] SMS-report OPTIONAL,
-- this parameter provides the SMS content and associated information
cC-Link-Identifier [15] CC-Link-Identifier OPTIONAL,
-- Depending on a network option, this parameter may be used to identify a CC link
-- in case of multiparty calls.
national-Parameters [16] National-Parameters OPTIONAL,
gPRSCorrelationNumber [18] GPRSCorrelationNumber OPTIONAL,
gPRSevent [20] GPRSevent OPTIONAL,
-- This information is used to provide particular action of the target
-- such as attach/detach
sgsnAddress [21] DataNodeAddress OPTIONAL,
gPRSOperationErrorCode [22] GPRSOperationErrorCode OPTIONAL,
...,
ggsnAddress [24] DataNodeAddress OPTIONAL,
qoS [25] UmtsQos OPTIONAL,
-- This parameter is duplicated from 3GPP TS 33.108 [61].
networkIdentifier [26] Network-Identifier OPTIONAL,
-- This parameter is duplicated from 3GPP TS 33.108 [61].
sMSOriginatingAddress [27] DataNodeAddress OPTIONAL,
-- This parameter is duplicated from 3GPP TS 33.108 [61].
sMSTerminatingAddress [28] DataNodeAddress OPTIONAL,
-- This parameter is duplicated from 3GPP TS 33.108 [61].
imSevent [29] IMSevent OPTIONAL,
sIPMessage [30] OCTET STRING OPTIONAL,
-- This parameter is duplicated from 3GPP TS 33.108 [61].
servingSGSN-number [31] OCTET STRING (SIZE (1..20)) OPTIONAL,
-- This parameter is duplicated from 3GPP TS 33.108 [61].
servingSGSN-address [32] OCTET STRING (SIZE (5..17)) OPTIONAL,
-- Octets are coded according to 3GPP TS 23.003 [76]
-- This parameter is duplicated from 3GPP TS 33.108 [61].
tARGETACTIVITYMONITOR [33] TARGETACTIVITYMONITOR-1 OPTIONAL,
-- Parameter is used in TS 101 909-20-1 [69]
ldiEvent [34] LDiEvent OPTIONAL,
-- The "Location Dependent Interception" parameter is duplicated from 3GPP TS 33.108 [61]
correlation [35] CorrelationValues OPTIONAL,
-- This parameter is duplicated from 3GPP TS 33.108 [61]
tARGETACTIVITYMONITORind [36] TARGETACTIVITYMONITORind OPTIONAL,
-- Parameter is used in EN 301 040 [72]
tARGETCOMMSMONITORind [37] TARGETCOMMSMONITORind OPTIONAL,
-- Parameter is used in EN 301 040 [72]
tTRAFFICind [38] TTRAFFICind OPTIONAL,
-- Parameter is used in EN 301 040 [72]
cTRAFFICind [39] CTRAFFICind OPTIONAL,
-- Parameter is used in EN 301 040 [72]
servingSystem [40] Network-Element-Identifier OPTIONAL,
-- Parameter identifies the visited network element
national-HI2-ASN1parameters [255] National-HI2-ASN1parameters OPTIONAL
}

```



```
-- =====
-- PARAMETERS FORMATS
-- =====
```

```
CommunicationIdentifier ::= SEQUENCE
{
  communication-Identity-Number [0] OCTET STRING (SIZE (1..8)) OPTIONAL,
  -- Temporary Identifier of an intercepted call to uniquely identify an intercepted call
  -- within the node. This parameter is mandatory if there is associated
  -- information sent over HI3interface (CCLink, data,..) or when
  -- CommunicationIdentifier is used for IRI other than IRI-Report-record
  -- This parameter was called "call-Identity-Number" in V1.1.1 of ES 201 671 [i.5]
  -- The individual digits of the communication-Identity-Number shall be represented in
  -- ASCII format, e.g. "12345678" = 8 octets 0x31 0x32 0x33 0x34 0x35 0x36 0x37 0x38.
  -- For subaddress option only "0"..."9" shall be used.
  network-Identifier [1] Network-Identifier,
  ...
}
-- NOTE: The same "CommunicationIdentifier" value is sent:
-- with the HI3 information for correlation purpose between the IRI and the information sent
-- on the HI3 interfaces (CCLink, data, ..) with each IRI associated to a same intercepted
-- call for correlation purpose between the different IRI.
```

```
Network-Identifier ::= SEQUENCE
{
  operator-Identifier [0] OCTET STRING (SIZE (1..5)),
  -- It is a notification of the NWO/AP/SvP in ASCII- characters.
  -- For subaddress option only "0"..."9" shall be used.
  -- The parameter is mandatory.
  network-Element-Identifier [1] Network-Element-Identifier OPTIONAL,
  ...
}
```

```
Network-Element-Identifier ::= CHOICE
{
  e164-Format [1] OCTET STRING (SIZE (1..25)),
  -- E164 address of the node in international format. Coded in the same format as the
  -- calling party number parameter of the ISUP (parameter part: EN 300 356 [5]).
  x25-Format [2] OCTET STRING (SIZE (1..25)),
  -- X25 address
  iP-Format [3] OCTET STRING (SIZE (1..25)),
  -- IP address
  dns-Format [4] OCTET STRING (SIZE (1..25)),
  -- DNS address
  ...,
  iP-Address [5] IPAddress
}
```

```
CC-Link-Identifier ::= OCTET STRING (SIZE (1..8))
-- Depending on a network option, this parameter may be used to identify a CCLink
-- in case of multiparty calls.
-- The individual digits of the CC-Link-Identifier shall be represented in
-- ASCII format, e.g. "12345678" = 8 octets 0x31 0x32 0x33 0x34 0x35 0x36 0x37 0x38.
-- For subaddress option only "0"..."9" shall be used.
```

```
TimeStamp ::= CHOICE
{
  -- The minimum resolution required is one second.
  -- "Resolution" is the smallest incremental change that can be measured for time and
  -- is expressed with a definite number of decimal digits or bits.
  localTime [0] LocalTimeStamp,
  utcTime [1] UTCTime
}
```

```
LocalTimeStamp ::= SEQUENCE
{
  generalizedTime [0] GeneralizedTime,
  -- The minimum resolution required is one second.
  -- "Resolution" is the smallest incremental change that can be measured for time and
  -- is expressed with a definite number of decimal digits or bits.
  winterSummerIndication [1] ENUMERATED
  {
    notProvided(0),
    winterTime(1),
    summerTime(2),
    ...
  }
}
```

```

}
}
PartyInformation ::= SEQUENCE
{
  party-Qualifier [0] ENUMERATED
  {
    originating-Party(0),
      -- In this case, the partyInformation parameter provides the identities related to
      -- the originating party and all information provided by this party.
      -- This parameter provides also all the information concerning the redirecting
      -- party when a forwarded call reaches a target.
    terminating-Party(1),
      -- In this case, the partyInformation parameter provides the identities related to
      -- the terminating party and all information provided by this party.
    forwarded-to-Party(2),
      -- In this case, the partyInformation parameter provides the identities related to
      -- the forwarded to party and parties beyond this one and all information
      -- provided by this parties, including the call forwarding reason.
    gPRS-Target(3),
    ...
  },
  partyIdentity [1] SEQUENCE
  {
    imei [1] OCTET STRING (SIZE (8)) OPTIONAL,
      -- See MAP format 3GPP TS 09.02 [32]
    tei [2] OCTET STRING (SIZE (1..15)) OPTIONAL,
      -- ISDN-based Terminal Equipment Identity
    imsi [3] OCTET STRING (SIZE (3..8)) OPTIONAL,
      -- See MAP format 3GPP TS 09.02 [32] International Mobile
      -- Station Identity E.212 number beginning with Mobile Country Code
    callingPartyNumber [4] CallingPartyNumber OPTIONAL,
      -- The calling party format is used to transmit the identity of a calling party
    calledPartyNumber [5] CalledPartyNumber OPTIONAL,
      -- The called party format is used to transmit the identity of a called party or
      -- a forwarded to party.
    msISDN [6] OCTET STRING (SIZE (1..9)) OPTIONAL,
      -- MSISDN of the target, encoded in the same format as the AddressString
      -- parameters defined in MAP format 3GPP TS 09.02 [32]
    ...
    e164-Format [7] OCTET STRING (SIZE (1..25)) OPTIONAL,
      -- E164 address of the node in international format. Coded in the same format as
      -- the calling party number parameter of the ISUP (parameter part: EN 300 356 [5])
    sip-uri [8] OCTET STRING OPTIONAL,
      -- Session Initiation Protocol - Uniform Resource Identifier. See RFC 3261 [59].
      -- This parameter is duplicated from 3GPP TS 33.108 [61].
    tel-url [9] OCTET STRING OPTIONAL,
      -- See "URLs for Telephone Calls", RFC 3966 [68].
      -- This parameter is duplicated from 3GPP TS 33.108 [61].
    party-Validity [10] ENUMERATED
    {
      trusted(0),
        -- The operator has assured the party identity
      untrusted(1),
        -- The operator does not assure the party identity
      operator-added(2),
        -- The party identity is added by the operator, e.g. the roaming number
      ...
    } OPTIONAL,
    alphanumeric [11] UTF8String OPTIONAL
      -- See clause A.3.3 on usage of this parameter
  },
  services-Information [2] Services-Information OPTIONAL,
  -- This parameter is used to transmit all the information concerning the
  -- complementary information associated to the basic call
  supplementary-Services-Information [3] Supplementary-Services OPTIONAL,
  -- This parameter is used to transmit all the information concerning the
  -- activation/invoke of supplementary services during a call or out-of call not
  -- provided by the previous parameters.
  services-Data-Information [4] Services-Data-Information OPTIONAL,
  -- This parameter is used to transmit all the information concerning the complementary
  -- information associated to the basic data call.
  ...
}

```

```

CallingPartyNumber ::= CHOICE
{
  iSUP-Format      [1] OCTET STRING (SIZE (1..25)),
  -- Encoded in the same format as the calling party number (parameter field)
  -- of the ISUP (see EN 300 356 [5]).
  dSS1-Format      [2] OCTET STRING (SIZE (1..25)),
  -- Encoded in the format defined for the value part of the Calling party number
  -- information element of DSS1 protocol EN 300 403-1 [6].
  -- The DSS1 Information element identifier and the DSS1 length are not included.
  ...,
  mAP-Format       [3] OCTET STRING (SIZE (1..25))
  -- Encoded as AddressString of the MAP protocol 3GPP TS 09.02 [32].
}

```

```

CalledPartyNumber ::= CHOICE
{
  iSUP-Format      [1] OCTET STRING (SIZE (1..25)),
  -- Encoded in the same format as the called party number (parameter field)
  -- of the ISUP (see EN 300 356 [5]).
  mAP-Format       [2] OCTET STRING (SIZE (1..25)),
  -- Encoded as AddressString of the MAP protocol 3GPP TS 09.02 [32].
  dSS1-Format      [3] OCTET STRING (SIZE (1..25)),
  -- Encoded in the format defined for the value part of the Called party number information
  -- element of DSS1 protocol ETSI EN 300 403-1 [6].
  -- The DSS1 Information element identifier and the DSS1 length are not included.
  ...
}

```

```

Location ::= SEQUENCE
{
  e164-Number      [1] OCTET STRING (SIZE (1..25)) OPTIONAL,
  -- Coded in the same format as the ISUP location number (parameter field)
  -- of the ISUP (see EN 300 356 [5]).
  globalCellID     [2] OCTET STRING (SIZE (5..7)) OPTIONAL,
  -- See MAP format (see 3GPP TS 09.02 [32]).
  tetraLocation    [3] TetraLocation OPTIONAL,
  -- This optional parameter is not in use anymore, but is kept for backwards compatibility.
  rAI               [4] OCTET STRING (SIZE (6)) OPTIONAL,
  -- The Routeing Area Identifier (RAI) in the current SGSN is coded in accordance with
  -- 3GPP TS 24.008 [41] without the Routing Area Identification IEI (only the
  -- last 6 octets are used).
  gsmLocation      [5] GSMLocation OPTIONAL,
  umtsLocation     [6] UMTSLocation OPTIONAL,
  sAI               [7] OCTET STRING (SIZE (7)) OPTIONAL,
  -- format:  PLMN-ID 3 octets (no. 1-3),
  --          LAC    2 octets (no. 4-5),
  --          SAC    2 octets (no. 6-7)
  --          (according to 3GPP 25.413 [82]).
  ...,
  oldRAI           [8] OCTET STRING (SIZE (6)) OPTIONAL,
  -- the "Routeing Area Identifier" in the old SGSN is coded in accordance with
  -- 3GPP TS 24.008 [41] without the Routing Area Identification IEI
  -- (only the last 6 octets are used).
  -- This parameter is duplicated from 3GPP TS 33.108 [61].
  tAI              [9] OCTET STRING (SIZE (6)) OPTIONAL,
  -- The "Tracking Area Identity" (TAI) is coded in accordance with 3GPP TS 29.118 [83]
  -- without the TAI IEI.
  -- The tAI parameter is applicable only to the CS traffic cases where the available
  -- location information is the one received from the Mobility Management Entity (MME).
  -- This parameter is duplicated from 3GPP TS 33.108 [61].
  eCGI             [10] OCTET STRING (SIZE (8)) OPTIONAL
  -- the "E-UTRAN Cell Global Identity" (E-CGI) is coded in accordance with
  -- 3GPP TS 29.118 [83] without the E-CGI IEI.
  -- The eCGI parameter is applicable only to the CS traffic cases where
  -- the available location information is the one received from the MME.
  -- This parameter is duplicated from 3GPP TS 33.108 [61].
}

```

```

TetraLocation ::= CHOICE
  -- This optional parameter is not in use anymore, but is kept for backwards compatibility.
  {
    ms-Loc      [1] SEQUENCE
    {
      mcc        [1] INTEGER (0..1023),
      -- 10 bits EN 300 392-1 [40]
      mnc        [2] INTEGER (0..16383),
      -- 14 bits EN 300 392-1 [40]
      lai        [3] INTEGER (0..65535),
      -- 14 bits EN 300 392-1 [40]
      ci         [4] INTEGER OPTIONAL
    },
    ls-Loc      [2] INTEGER
  }

```

```

GSMLocation ::= CHOICE
  {
    geoCoordinates [1] SEQUENCE
    {
      latitude [1] PrintableString (SIZE(7..10)),
      -- format: XDDMMSS.SS
      longitude [2] PrintableString (SIZE(8..11)),
      -- format: XDDMMSS.SS
      mapDatum [3] MapDatum DEFAULT WGS84,
      ...,
      azimuth [4] INTEGER (0..359) OPTIONAL
      -- The azimuth is the bearing, relative to true north
    },
    -- format: XDDMMSS.SS
    -- X : N(orth), S(outh), E(ast), W(est)
    -- DD or DDD : degrees (numeric characters)
    -- MM : minutes (numeric characters)
    -- SS.SS : seconds, the second part (.SS) is optional
    -- Example:
    -- latitude short form N502312
    -- longitude long form E1122312.18

    utmCoordinates [2] SEQUENCE
    {
      utm-East [1] PrintableString (SIZE(10)),
      utm-North [2] PrintableString (SIZE(7)),
      -- Universal Transverse Mercator
      -- example utm-East 32U0439955
      -- utm-North 5540736
      mapDatum [3] MapDatum DEFAULT WGS84,
      ...,
      azimuth [4] INTEGER (0..359) OPTIONAL
      -- The azimuth is the bearing, relative to true north
    },

    utmRefCoordinates [3] SEQUENCE
    {
      utmref-string PrintableString (SIZE(13)),
      mapDatum MapDatum DEFAULT WGS84,
      ...
    },
    -- example 32UPU91294045

    wGS84Coordinates [4] OCTET STRING
    -- format is as defined in 3GPP TS 03.32 [57]
  }

```

```

MapDatum ::= ENUMERATED
  {
    wGS84,
    -- World Geodetic System 1984
    wGS72,
    eD50,
    -- European Datum 50
    ...
  }

```

```

UMTSLocation ::= CHOICE
{
  point                [1] GA-Point,
  pointWithUncertainty [2] GA-PointWithUncertainty,
  polygon              [3] GA-Polygon,
  ...
}

```

```

GeographicalCoordinates ::= SEQUENCE
{
  latitudeSign    ENUMERATED
  {
    north,
    south
  },
  latitude        INTEGER (0..8388607),
  longitude       INTEGER (-8388608..8388607),
  ...
}

```

```

GA-Point ::= SEQUENCE
{
  geographicalCoordinates GeographicalCoordinates,
  ...
}

```

```

GA-PointWithUncertainty ::= SEQUENCE
{
  geographicalCoordinates GeographicalCoordinates,
  uncertaintyCode        INTEGER (0..127)
}

```

```

maxNrOfPoints INTEGER ::= 15

```

```

GA-Polygon ::= SEQUENCE (SIZE (1..maxNrOfPoints)) OF
SEQUENCE
{
  geographicalCoordinates GeographicalCoordinates,
  ...
}

```

```

CallContentLinkCharacteristics ::= SEQUENCE
{
  cCLink-State [1] CCLink-State OPTIONAL,
  -- current state of the CCLink
  release-Time [2] TimeStamp OPTIONAL,
  -- date and time of the release of the Call Content Link.
  release-Reason [3] OCTET STRING (SIZE(2)) OPTIONAL,
  -- Release cause coded in Q.850 [31] format
  lEMF-Address [4] CalledPartyNumber OPTIONAL,
  -- Directory number used to route the call toward the LEMF
  ...
}

```

```

CCLink-State ::= ENUMERATED
{
  setUpInProgress(1),
  -- The set-up of the call is in process
  callActive(2),
  callReleased(3),
  lack-of-resource(4),
  -- The lack-of-resource state is sent when a CC Link cannot
  -- be established because of lack of resource at the MF level.
  ...
}

```

```

Intercepted-Call-State ::= ENUMERATED
{
  idle(1),
    -- When the intercept call is released, the state is IDLE and the reason is provided
    -- by the release-Reason-Of-Intercepted-Call parameter.
  setUpInProgress(2),
    -- The set-up of the call is in process
  connected(3),
    -- The answer has been received
  ...
}

```

```

Services-Information ::= SEQUENCE
{
  iSUP-parameters [1] ISUP-parameters OPTIONAL,
  dSS1-parameters-codeset-0 [2] DSS1-parameters-codeset-0 OPTIONAL,
  ...,
  mAP-parameters [3] MAP-parameters OPTIONAL
}

```

```

ISUP-parameters ::= SET SIZE (1..256) OF OCTET STRING (SIZE (1..256))
-- Each "OCTET STRING" contains one additional ISUP parameter TLV coded not already defined in
-- the previous parameters. The Tag value is the one given in EN 300 356 [5].

-- In version 1 of the present document "iSUP-parameters" is defined as mandatory.
-- It might occur that no ISUP parameter is available. In that case in a version 1
-- implementation the value "zero" may be included in the first octet string of the SET.

-- The Length and the Value are coded in accordance with the parameter definition in
-- EN 300 356 [5]. Hereafter are listed the main parameters.
-- However other parameters may be added:

-- Transmission medium requirement: format defined in EN 300 356 [5].
-- This parameter can be provided with the "Party Information" of the "calling party".

-- Transmission medium requirement prime: format defined in EN 300 356 [5].
-- This parameter can be provided with the "Party Information" of the "calling party".

```

```

DSS1-parameters-codeset-0 ::= SET SIZE (1..256) OF OCTET STRING (SIZE (1..256))
-- Each "OCTET STRING" contains one DSS1 parameter of the codeset-0. The parameter is coded as
-- described in EN 300 403-1 [6] (The DSS1 Information element identifier and the DSS1 length
-- are included). Hereafter are listed the main parameters.
-- However other parameters may be added:

-- Bearer capability: this parameter may be repeated. Format defined in EN 300 403-1 [6].
-- This parameter can be provided with the "Party Information" of the "calling party",
-- "called party" or "forwarded to party".

-- High Layer Compatibility: this parameter may be repeated. Format defined in EN 300 403-1 [6]
-- This parameter can be provided with the "Party Information" of the "calling party",
-- "called party" or "forwarded to party".

-- Low Layer capability: this parameter may be repeated. Format defined in EN 300 403-1 [6].
-- This parameter can be provided with the "Party Information" of the "calling party",
-- "called party" or "forwarded to party".

```

```

MAP-parameters ::= SET SIZE (1..256) OF OCTET STRING (SIZE(1..256))
-- Each "OCTET STRING" contains one MAP parameter. The parameter is coded as described in
-- 3GPP TS 09.02 [32] (The map-TS-Code is included).

```

```

Supplementary-Services ::= SEQUENCE
{
  standard-Supplementary-Services [1] Standard-Supplementary-Services OPTIONAL,
  non-Standard-Supplementary-Services [2] Non-Standard-Supplementary-Services OPTIONAL,
  other-Services [3] Other-Services OPTIONAL,
  ...
}

```

```

Standard-Supplementary-Services ::= SEQUENCE
{
  iSUP-SS-parameters           [1] ISUP-SS-parameters OPTIONAL,
  dSS1-SS-parameters-codeset-0 [2] DSS1-SS-parameters-codeset-0 OPTIONAL,
  dSS1-SS-parameters-codeset-4 [3] DSS1-SS-parameters-codeset-4 OPTIONAL,
  dSS1-SS-parameters-codeset-5 [4] DSS1-SS-parameters-codeset-5 OPTIONAL,
  dSS1-SS-parameters-codeset-6 [5] DSS1-SS-parameters-codeset-6 OPTIONAL,
  dSS1-SS-parameters-codeset-7 [6] DSS1-SS-parameters-codeset-7 OPTIONAL,
  dSS1-SS-Invoke-components    [7] DSS1-SS-Invoke-Components OPTIONAL,
  mAP-SS-Parameters           [8] MAP-SS-Parameters OPTIONAL,
  mAP-SS-Invoke-Components    [9] MAP-SS-Invoke-Components OPTIONAL,
  ...
}

```

```

Non-Standard-Supplementary-Services ::= SET SIZE (1..20) OF CHOICE
{
  simpleIndication           [1] SimpleIndication,
  sciData                   [2] SciDataMode,
  ...
}

```

```

Other-Services ::= SET SIZE (1..50) OF OCTET STRING (SIZE (1..256))
-- Reference manufacturer manuals.

```

```

ISUP-SS-parameters ::= SET SIZE (1..256) OF OCTET STRING (SIZE (1..256))
-- It shall be noticed this parameter is retained for compatibility reasons.
-- It is recommended not to use it in new work but to use ISUP-parameters parameter.

-- Each "OCTET STRING" contains one additional ISUP parameter TLV coded not already defined in
-- the previous parameters. The Tag value is the one given in EN 300 356 [5].
-- The Length and the Value are coded in accordance with the parameter definition in
-- EN 300 356 [5]. Hereafter are listed the main parameters.
-- However other parameters may be added:

-- Connected Number: format defined in EN 300 356 [5].
-- This parameter can be provided with the "Party Information" of the
-- "called party" or "forwarded to party".

-- RedirectingNumber: format defined in EN 300 356 [5].
-- This parameter can be provided with the "Party Information" of the "originating party"
-- or/and of the "terminating party".

-- Original Called Party Number: format defined in EN 300 356 [5].
-- This parameter can be provided with the "Party Information" of the "originating party".

-- Redirection information: format defined in EN 300 356 [5].
-- This parameter can be provided with the "Party Information" of the
-- "originating party", "forwarded to party" or/and "Terminating party".

-- Redirection Number: format defined in EN 300 356 [5].
-- This parameter can be provided with the "Party Information" of the
-- "forwarded to party" or "Terminating party".

-- Call diversion information: format defined in EN 300 356 [5].
-- This parameter can be provided with the "Party Information" of the
-- "forwarded to party" or "Terminating party".

-- Generic Number: format defined in EN 300 356 [5].
-- This parameter can be provided with the "Party Information" of the
-- "calling party", "called party" or "forwarded to party".
-- This parameters are used to transmit additional identities (additional, calling party
-- number, additional called number, etc.).

-- Generic Notification: format defined in EN 300 356 [5].
-- This parameter may be provided with the "Party Information" of the
-- "calling party", "called party" or "forwarded to party".
-- This parameters transmit the notification to the other part of the call of the supplementary
-- services activated or invoked by a subscriber during the call.

-- CUG Interlock Code: format defined in EN 300 356 [5].
-- This parameter can be provided with the "Party Information" of the "calling party".

```

```

DSS1-SS-parameters-codeset-0 ::= SET SIZE (1..256) OF OCTET STRING (SIZE (1..256))
-- Each "OCTET STRING" contains one DSS1 parameter of the codeset-0. The parameter is coded as
-- described in EN 300 403-1 [6] (The DSS1 Information element identifier and the DSS1 length
-- are included). Hereafter are listed the main parameters.
-- However other parameters may be added:

-- Calling Party Subaddress: format defined in EN 300 403-1 [6].
-- This parameter can be provided with the "Party Information" of the "calling party".

-- Called Party Subaddress: format defined in EN 300 403-1 [6].
-- This parameter can be provided with the "Party Information" of the "calling party".

-- Connected Subaddress: format defined in recommendation (see ETSI EN 300 097-1 [14]).
-- This parameter can be provided with the "Party Information" of the
-- "called party" or "forwarded to party".

-- Connected Number: format defined in recommendation (see ETSI EN 300 097-1 [14]).
-- This parameter can be provided with the "Party Information" of the
-- "called party" or "forwarded to party".

-- Keypad facility: format defined in EN 300 403-1 [6].
-- This parameter can be provided with the "Party Information" of the
-- "calling party", "called party" or "forwarded to party".

-- Called Party Number: format defined in EN 300 403-1 [6].
-- This parameter could be provided with the "Party Information" of the "calling party"
-- when target is the originating party; it contains the dialled digits before modification
-- at network level (e.g. IN interaction, translation, etc ...).

-- User-user: format defined in EN 300 286-1 [23]).
-- This parameter can be provided with the "Party Information" of the
-- "calling party", "called party" or "forwarded to party".

```

```

DSS1-SS-parameters-codeset-4 ::= SET SIZE (1..256) OF OCTET STRING (SIZE (1..256))
-- Each "OCTET STRING" contains one DSS1 parameter of the codeset-4. The parameter is coded as
-- described in the relevant recommendation.

```

```

DSS1-SS-parameters-codeset-5 ::= SET SIZE (1..256) OF OCTET STRING (SIZE (1..256))
-- Each "OCTET STRING" contains one DSS1 parameter of the codeset-5. The parameter is coded as
-- described in the relevant national recommendation.

```

```

DSS1-SS-parameters-codeset-6 ::= SET SIZE (1..256) OF OCTET STRING (SIZE (1..256))
-- Each "OCTET STRING" contains one DSS1 parameter of the codeset-6. The parameter is coded as
-- described in the relevant local network recommendation.

```

```

DSS1-SS-parameters-codeset-7 ::= SET SIZE (1..256) OF OCTET STRING (SIZE (1..256))
-- Each "octet string" contains one DSS1 parameter of the codeset-7. The parameter is coded as
-- described in the relevant user specific recommendation.

```



```

DSS1-SS-Invoke-Components ::= SET SIZE (1..256) OF OCTET STRING (SIZE (1..256))
-- Each "octet string" contains one DSS1 Invoke or Return Result component.
-- The invoke or return result component is coded as
-- described in the relevant DSS1 supplementary service recommendation.

-- Invoke or Return Result component (BeginCONF): EN 300 185-1 [19]
-- Invoke or Return Result component (AddCONF): EN 300 185-1 [19]
-- Invoke or Return Result component (SplitCONF): EN 300 185-1 [19]
-- Invoke or Return Result component (DropCONF): EN 300 185-1 [19]
-- Invoke or Return Result component (IsolateCONF): EN 300 185-1 [19]
-- Invoke or Return Result component (ReattachCONF): EN 300 185-1 [19]
-- Invoke or Return Result component (PartyDISC): EN 300 185-1 [19]
-- Invoke or Return Result component (MCIDRequest): EN 300 130-1 [16]
-- Invoke or Return Result component (Begin3PTY): EN 300 188-1 [20]
-- Invoke or Return Result component (End3PTY): EN 300 188-1 [20]
-- Invoke or Return Result component (ECTExecute): EN 300 369-1 [25]
-- Invoke or Return Result component (ECTInform): EN 300 369-1 [25]
-- Invoke or Return Result component (ECTLinkIdRequest): EN 300 369-1 [25]
-- Invoke or Return Result component (ECTLoopTest): EN 300 369-1 [25]
-- Invoke or Return Result component (ExplicitECTExecute): EN 300 369-1 [25]
-- Invoke or Return Result component (ECT: RequestSubaddress): EN 300 369-1 [25]
-- Invoke or Return Result component (ECT: SubaddressTransfer): EN 300 369-1 [25]
-- Invoke or Return Result component (CF: ActivationDiversion): EN 300 207-1 [21]
-- Invoke or Return Result component (CF: DeactivationDiversion): EN 300 207-1 [21]
-- Invoke or Return Result component (CF: ActivationStatusNotification): EN 300 207-1 [21]
-- Invoke or Return Result component (CF: DeactivationStatusNotification): EN 300 207-1 [21]
-- Invoke or Return Result component (CF: InterrogationDiversion): EN 300 207-1 [21]
-- Invoke or Return Result component (CF: InterrogationServedUserNumber): EN 300 207-1 [21]
-- Invoke or Return Result component (CF: DiversionInformation): EN 300 207-1 [21]
-- Invoke or Return Result component (CF: CallDeflection): EN 300 207-1 [21]
-- Invoke or Return Result component (CF: CallRerouting): EN 300 207-1 [21]
-- Invoke or Return Result component (CF: DivertingLegInformation1): EN 300 207-1 [21]
-- Invoke or Return Result component (CF: DivertingLegInformation2): EN 300 207-1 [21]
-- Invoke or Return Result component (CF: DivertingLegInformation3): EN 300 207-1 [21]
-- other invoke or return result components ...

```

```

MAP-SS-Invoke-Components ::= SET SIZE (1..256) OF OCTET STRING (SIZE (1..256))
-- Each "octet string" contains one MAP Invoke or Return Result component.
-- The invoke or return result component is coded as
-- described in the relevant MAP supplementary service recommendation.

```

```

MAP-SS-Parameters ::= SET SIZE (1..256) OF OCTET STRING (SIZE (1..256))
-- Each "octet string" contains one MAP Parameter. The parameter is coded as
-- described in the relevant MAP supplementary service recommendation.

```

```

SimpleIndication ::= ENUMERATED
{
  call-Waiting-Indication(0),
  -- The target has received a call waiting indication for this call
  add-conf-Indication(1),
  -- this call has been added to a conference
  call-on-hold-Indication(2),
  -- indication that this call is on hold
  retrieve-Indication(3),
  -- indication that this call has been retrieved
  suspend-Indication(4),
  -- indication that this call has been suspended
  resume-Indication(5),
  -- indication that this call has been resumed
  answer-Indication(6),
  -- indication that this call has been answered
  ...
}

```

```

SciDataMode ::= OCTET STRING (SIZE (1..256))

```

```

SMS-report ::= SEQUENCE
{
  communicationIdentifier [1] CommunicationIdentifier,
  -- used to uniquely identify an intercepted call: the same used for the
  -- relevant IRI
  -- Called "callIdentifier" in V1.1.1 of ES 201 671 [i.5]
  timeStamp [2] TimeStamp,
  -- date and time of the report. The format is
  -- the one defined in case a) of the ASN.1 Recommendation ITU-T X.680 [33].
  -- (year month day hour minutes seconds)
  SMS-Contents [3] SEQUENCE
  {
    initiator [1] ENUMERATED
    {
      -- party which sent the SMS
      target(0),
      server(1),
      undefined-party(2),
      ...
    },
    transfer-status [2] ENUMERATED
    {
      succeed-transfer(0),
      --the transfer of the SMS message succeeds
      not-succeed-transfer(1),
      undefined(2),
      ...
    } OPTIONAL,
    other-message [3] ENUMERATED
    {
      -- In case of terminating call, indicates if the server will send other SMS.
      yes(0),
      no(1),
      undefined(2),
      ...
    } OPTIONAL,
    content [4] OCTET STRING (SIZE (1..270)) OPTIONAL,
    -- Encoded in the format defined for the SMS mobile.
    -- The content and enhancedContent fields are mutually exclusive.
    -- The content field is dedicated for 3GPP purposes.
    ...,
    enhancedContent [5] SEQUENCE
    {
      content [1] OCTET STRING,
      -- The character encoding used in the content field is specified in the
      -- character-encoding field.
      character-encoding [2] ENUMERATED
      {
        gsm-7-bit-ascii(0),
        eight-bit-ascii(1),
        eight-bit-binary(2),
        ucs-2(3),
        utf-8(4),
        utf-16(5),
        other(6),
        ...
      }
    } OPTIONAL
  }
}

```

```

LawfulInterceptionIdentifier ::= OCTET STRING (SIZE (1..25))
  -- It is recommended to use ASCII characters in "a".."z", "A".."Z", "-", "_", ".", and "0".."9".
  -- For subaddress option only "0".."9" shall be used.

```

```

National-Parameters ::= SET SIZE (1..40) OF OCTET STRING (SIZE (1..256))
  -- Content defined by national law.

```

```

GPRSCorrelationNumber ::= OCTET STRING (SIZE(8..20))

```

```

GPRSEvent ::= ENUMERATED
  -- see 3GPP TS 03.33 [42]
  {
    pDPContextActivation(1),
    startOfInterceptionWithPDPContextActive(2),
    pDPContextDeactivation(4),
    gPRSAttach(5),
    gPRSDetach(6),
    cellOrRAUpdate(10),
    SMS(11),
    ...,
    pDPContextModification(13),
    endOfInterceptionWithPDPContextActive(14)
  }

```

```

Services-Data-Information ::= SEQUENCE
  {
    gPRS-parameters      [1] GPRS-parameters OPTIONAL,
    ...
  }

```

```

GPRS-parameters ::= SEQUENCE
  {
    pDP-address-allocated-to-the-target [1] DataNodeAddress OPTIONAL,
    apn [2] OCTET STRING (SIZE(1..100)) OPTIONAL,
    -- The Access Point Name (APN) is coded in accordance with
    -- 3GPP TS 24.008 [41] without the APN IEI (only the last 100 octets are used).
    -- Octets are coded according to 3GPP TS 23.003 [76].
    -- This parameter is duplicated from 3GPP TS 33.108 [61].
    pDP-type [3] OCTET STRING (SIZE(2)) OPTIONAL,
    -- when PDP-type is IPv4 or IPv6, the IP address is carried by parameter
    -- pDP-address-allocated-to-the-target when PDP-type is IPv4v6,
    -- the additional IP address is carried by parameter additionalIPAddress
    ...,
    nSAPI [4] OCTET STRING (SIZE (1)) OPTIONAL,
    additionalIPAddress [5] DataNodeAddress OPTIONAL
  }

```

```

GPRSOperationErrorCode ::= OCTET STRING (SIZE(2))
  -- Refer to 3GPP TS 24.008 [41] for values (GMM cause or SM cause parameter).

```

```

DataNodeAddress ::= CHOICE
  {
    ipAddress [1] IPAddress,
    x25Address [2] X25Address,
    ...
  }

```

```

IPAddress ::= SEQUENCE
{
  iP-type [1] ENUMERATED
  {
    iPV4(0),
    iPV6(1),
    ...
  },
  iP-value [2] IP-value,
  iP-assignment [3] ENUMERATED
  {
    static(1),
    -- The static coding shall be used to report a static address.
    dynamic(2),
    -- The dynamic coding shall be used to report a dynamically allocated address.
    notKnown(3),
    -- The notKnown coding shall be used to report other than static or dynamically
    -- allocated IP addresses.
    ...
  } OPTIONAL,
  ...,
  iPv6PrefixLength [4] INTEGER (1..128) OPTIONAL,
  -- Indicates the length of the prefix delegated by the CSP to the subscriber
  -- example: 60 if IP address is "2001:db8:0:85a3::ac1f:8001/60"
  -- Mandatory in case where the iP-value contains an IPv6 binary value
  iPv4SubnetMask [5] OCTET STRING (SIZE(4)) OPTIONAL
  -- For IPv4 addresses, this indicates the subnetmask to be applied to the iP-value field.
  -- The subnet mask is intended to be presented as a binary value, e.g. "ff ff ff f8" to
  -- represent the dotted-decimal subnet mask of "255.255.255.248" corresponding to
  -- a /29 CIDR-format subnet mask
}

```

```

IP-value ::= CHOICE
{
  iPBinaryAddress [1] OCTET STRING (SIZE(4..16)),
  -- In case of IPv6, the Prefix Length is provided by the "iPv6PrefixLength"
  -- In case of IPv4, the netmask is provided by the "iPv4SubnetMask"
  iPTextAddress [2] IA5String (SIZE(7..45)),
  -- In case of IPv6, the delivered iPTextAddress field could include a complete
  -- single IPv6-Address or an IPv6-Prefix for a subnetwork on the target side.
  -- In case of IPv4, the delivered iPTextAddress field could include a single
  -- IPv4 address or an IPv4address/netmask, for example "192.168.1.1" or "192.168.1.1/24"
  ...
}

```

```

X25Address ::= OCTET STRING (SIZE(1..25))

```

```

National-HI2-ASN1parameters ::= SEQUENCE
{
  countryCode [1] PrintableString (SIZE (2)),
  -- Country Code according to ISO 3166-1 [67],
  -- the country to which the parameters inserted after the extension marker apply.
  ...
  -- In case a given country wants to use additional national parameters according to its law,
  -- these national parameters should be defined using the ASN.1 syntax and added after the
  -- extension marker (...).
  -- It is recommended that "version parameter" and "vendor identification parameter" are
  -- included in the national parameters definition. Vendor identifications can be
  -- retrieved from the IANA web site (see annex K). Besides, it is recommended to avoid
  -- using tags from 240 to 255 in a formal type definition.
}

```

```

END -- end of HI2Operations

```

D.6 User data packet transfer (HI3 CS)

Declaration of ROSE operations "circuit-Call-related-Services" and "no-Circuit-Call-related-Services" are ROSE delivery mechanism specific. When using FTP delivery mechanism, data Content-Report shall be considered.

ASN.1 description of circuit data transfer operation (HI3 interface)

HI3CircuitDataOperations

```
{itu-t(0) identified-organization(4) etsi(0) securityDomain(2) lawfulIntercept(2) hi3(2)
circuitLI(1) version4(4)}
```

DEFINITIONS IMPLICIT TAGS ::=

-- The following operations are used to transmit user data which can be exchanged via the DSS1, ISUP
-- or MAP signalling (e.g. UUS, SMS).

BEGIN

```
IMPORTS OPERATION,
  ERROR
  FROM Remote-Operations-Information-Objects
  {joint-iso-itu-t(2) remote-operations(4) informationObjects(5) version1(0)}

  -- from clause D.5
  LawfulInterceptionIdentifier,
  CommunicationIdentifier,
  TimeStamp,
  OperationErrors,
  Supplementary-Services,
  SMS-report
  FROM HI2Operations
  {itu-t(0) identified-organization(4) etsi(0) securityDomain(2) lawfulIntercept(2) hi2(1)
version13(13)};
```

```
-- =====
-- Object Identifier definitions
-- =====

-- LawfulIntercept DomainId
lawfulInterceptDomainId OBJECT IDENTIFIER ::= {itu-t(0) identified-organization(4) etsi(0)
securityDomain(2) lawfulIntercept(2)}

-- hi3 Domain
hi3CircuitLIId OBJECT IDENTIFIER ::= {lawfulInterceptDomainId hi3(2) circuitLI(1)}
hi3CircuitLIOperationId OBJECT IDENTIFIER ::= {hi3CircuitLIId version3(3)}
```

```
circuit-Call-related-Services OPERATION ::=
{
  ARGUMENT      Content-Report
  ERRORS        {OperationErrors}
  CODE          global:{hi3CircuitLIId circuit-Call-Serv(1) version1(1)}
}
-- Class 2 operation. The timer shall be set to a value between 3s and 240s.
-- The timer default value is 60s.
-- NOTE: The same note as for HI management operation applies.
```

```
no-Circuit-Call-related-Services OPERATION ::=
{
  ARGUMENT      Content-Report
  ERRORS        {OperationErrors}
  CODE          global:{hi3CircuitLIId no-Circuit-Call-Serv(2) version1(1)}
}
-- Class 2 operation. The timer shall be set to a value between 10s and 120s.
-- The timer default value is 60s.
```

```

Content-Report ::= SEQUENCE
{
  domainID [0] OBJECT IDENTIFIER (hi3CircuitLIOperationId) OPTIONAL,
  -- Once using FTP delivery mechanism
  lawfulInterceptionIdentifier [6] LawfulInterceptionIdentifier OPTIONAL,
  communicationIdentifier [1] CommunicationIdentifier,
  -- Used to uniquely identify an intercepted call: the same as used for the relevant IRI.
  -- Called "callIdentifier" in V1.1.1 of ES 201 671 [i.5]
  timeStamp [2] TimeStamp,
  initiator [3] ENUMERATED
  {
    originating-party(0),
    terminating-party(1),
    forwarded-to-party(2),
    undefined-party(3),
    ...
  } OPTIONAL,
  content [4] Supplementary-Services OPTIONAL,
  -- UUI are encoded in the format defined for the User-to-user information parameter
  -- of the ISUP protocol (see EN 300 356 [5]). Only one UUI parameter is sent per message.
  sms-report [5] SMS-report OPTIONAL,
  ...
}

```

END -- end of HI3CircuitDataOperations

D.7 TETRA data transfer (HI3 interface)

Clauses A.4.1.1, A.4.2.1 and A.9 apply.

D.8 Definition of the UUS1 content associated to the CC link

ASN.1 description of the UUS1 content associated to the CC link

```

HI3CCLinkData
{itu-t(0) identified-organization(4) etsi(0) securityDomain(2) lawfulIntercept(2) hi3(2) cclinkLI(4)
version4(4)}

```

DEFINITIONS IMPLICIT TAGS ::=

BEGIN

```

IMPORTS
  -- from clause D.5
  LawfulInterceptionIdentifier,
  CommunicationIdentifier,
  CC-Link-Identifier
  FROM HI2Operations
  {itu-t(0) identified-organization(4) etsi(0) securityDomain(2) lawfulIntercept(2) hi2(1)
version10(10)};

```

```

-- =====
-- Object Identifier Definitions
-- =====

-- LawfulIntercept DomainId
lawfulInterceptDomainId OBJECT IDENTIFIER ::= {itu-t(0) identified-organization(4) etsi(0)
securityDomain(2) lawfulIntercept(2)}

-- hi3 Domain
hi3CCLinkId OBJECT IDENTIFIER ::= {lawfulInterceptDomainId hi3(2) ccLinkLI(4)}
hi3CCLinkIdOperationId OBJECT IDENTIFIER ::= {hi3CCLinkId version4(4)}

```

```

UUS1-Content ::= SEQUENCE
{
  domainID [0] OBJECT IDENTIFIER (hi3CCLinkIdOperationId) OPTIONAL,
  -- Once using FTP delivery mechanism
  lawfullInterceptionIdentifier [1] LawfulInterceptionIdentifier,
  communicationIdentifier [2] CommunicationIdentifier,
  cC-Link-Identifier [3] CC-Link-Identifier OPTIONAL,
  direction-Indication [4] Direction-Indication,
  bearer-capability [5] OCTET STRING (SIZE(1..12)) OPTIONAL,
  -- transport the Bearer capability information element (value part)
  -- Protocol: EN 300 403-1 [6]
  service-Information [7] Service-Information OPTIONAL,
  ...
}

```

```

-- =====
-- PARAMETERS FORMATS
-- =====

```

```

Direction-Indication ::= ENUMERATED
{
  mono-mode(0),
  cc-from-target(1),
  cc-from-other-party(2),
  ...,
  direction-unknown(3)
}

```

```

Service-Information ::= SET
{
  high-layer-capability [0] OCTET STRING (SIZE(1)) OPTIONAL,
  -- HLC (octet 4 only)
  -- Protocol: EN 300 403-1 [6]
  tMR [1] OCTET STRING (SIZE(1)) OPTIONAL,
  -- Transmission Medium Requirement
  -- Protocol: ISUP EN 300 356 [5]
  bearerServiceCode [2] OCTET STRING (SIZE(1)) OPTIONAL,
  teleServiceCode [3] OCTET STRING (SIZE(1)) OPTIONAL
  -- from MAP, 3GPP TS 09.02 [32]
}

```

```

END -- end of HI3CCLinkData

```

D.9 Content of Communication (HI3 GPRS)

ASN.1 description of the GPRS content

Gprs-HI3-PS

```

{itu-t(0) identified-organization(4) etsi(0) securityDomain(2) lawfulIntercept(2) hi3(2) gPRSLI(3)
version3(3)}

```

```

DEFINITIONS IMPLICIT TAGS ::=

```

```

BEGIN

```

```

IMPORTS
  -- from 3GPP TS 33.108 [61]
  CC-PDU
  FROM Umts-HI3-PS
  {itu-t(0) identified-organization(4) etsi(0) securityDomain(2) lawfulintercept(2)
threeGPP(4) hi3(2) r7(7) version-0(0)};

```

```

-- =====
-- Object Identifier definitions
-- =====

-- LawfulIntercept DomainId
lawfulInterceptDomainId OBJECT IDENTIFIER ::= {itu-t(0) identified-organization(4) etsi(0)
securityDomain(2) lawfulIntercept(2)}

-- hi3 Domain
hi3GPRSLIId OBJECT IDENTIFIER ::= {lawfulInterceptDomainId hi3(2) gPRSLI(3)}
hi3GPRSLIIdOperationId OBJECT IDENTIFIER ::= {hi3GPRSLIId version3(3)}

```

```

ETSI-CC-PDU ::= SEQUENCE
{
  domainID [0] OBJECT IDENTIFIER (hi3GPRSLIIdOperationId) OPTIONAL,
  -- Once using FTP delivery mechanism
  eTSI-CC-PDU [1] CC-PDU,
  ...
}

```

END -- end of **Gprs-HI3-PS**

D.10 TETRA ASN.1 details

D.10.0 General

Details for:

- HI management.
- HI1.
- HI2.

D.10.1 HI management operation

This data description applies only for ROSE delivery mechanism.

ASN.1 description of HI management operation (any HI interface)

```

TETRA-HIManagementOperations
{itu-t(0) identified-organization(4) etsi(0) securityDomain(2) lawfulIntercept(2) tetra(6) him(3)
version0(0)}

```

```

DEFINITIONS IMPLICIT TAGS ::=
BEGIN

```

```

IMPORTS
  OPERATION,
  ERROR
  FROM Remote-Operations-Information-Objects
  {joint-iso-itu-t(2) remote-operations(4) informationObjects(5) version1(0)};

```

```

tETRA-sending-of-Password OPERATION ::=
{
  ARGUMENT    TETRA-Password-Name
  ERRORS      {ErrorsHim}
  CODE        global:{himDomainId sending-of-Password(1) version1(1)}
}
-- Class 2 operation. The timer shall be set to a value between 3 s and 240s
-- The timer default value is 60s

```



```

tETRA-data-Link-Test OPERATION ::=
{
  ERRORS      {other-failure-causes}
  CODE        global:{himDomainId data-link-test(2) version1(1)}
}
-- Class 2 operation. The timer shall be set to a value between 3s and 240s
-- The timer default value is 60s

```

```

tETRA-end-Of-Connection OPERATION ::=
{
  ERRORS      {other-failure-causes}
  CODE        global:{himDomainId end-of-connection(3) version1(1)}
}
-- Class 2 operation. The timer shall be set to a value between 3s and 240s
-- The timer default value is 60s

```

```

other-failure-causes  ERROR ::= {CODE local:0}
missing-parameter   ERROR ::= {CODE local:1}
unknown-parameter   ERROR ::= {CODE local:2}
erroneous-parameter ERROR ::= {CODE local:3}

```

```

ErrorsHim ERROR ::=
{
  other-failure-causes |
  missing-parameter   |
  unknown-parameter   |
  erroneous-parameter
}

```

```

-- =====
-- Object Identifier Definitions
-- =====

-- himDomainId
lawfulInterceptDomainId OBJECT IDENTIFIER ::= {itu-t(0) identified-organization(4) etsi(0)
securityDomain(2) lawfulIntercept(2)}

-- Security Subdomains
tETRADomainId OBJECT IDENTIFIER ::= {lawfulInterceptDomainId tETRA(6)}
himDomainId OBJECT IDENTIFIER ::= {tETRADomainId him(3) version0(0)}

```

```

TETRA-Password-Name ::= SEQUENCE
{
  password  [1] OCTET STRING (SIZE (1..25)),
  name      [2] OCTET STRING (SIZE (1..25)),
  ...
}
-- IA5 string recommended

```

END -- end of **TETRA-HIManagementOperations**

D.10.2 LI management notification

Declaration of ROSE operation "sending-of-HI1-Notification" is ROSE delivery mechanism specific. When using FTP delivery mechanism, data HI1-Operation shall be considered.

NOTE: This annex does not describe an electronic Handover Interface, but HI1 information, which is sent to the LEMF across the HI2 port.

ASN.1 description of LI management notification operation (HI1 interface)

TETRA-HI1NotificationOperations

```
{itu-t(0) identified-organization(4) etsi(0) securityDomain(2) lawfulIntercept(2) tetra(6) hi1(1)
notificationOperations(1) version0(0)}
```

```
DEFINITIONS IMPLICIT TAGS ::=
BEGIN
```

```
IMPORTS
  OPERATION,
  ERROR
  FROM Remote-Operations-Information-Objects
    {joint-iso-itu-t(2) remote-operations(4) informationObjects(5) version1(0)}

  -- from clause D.5
  CommunicationIdentifier,
  TimeStamp,
  LawfulInterceptionIdentifier
  FROM HI2Operations
    {itu-t(0) identified-organization(4) etsi(0) securityDomain(2) lawfulIntercept(2) hi2(1)
version10(10)}

  -- from ETSI EN 301 040 [72]
  TETRACGType
  FROM EN301040
    {itu-t(0) identified-organization(4) etsi(0) en301040(1040) interceptVersion(0)};
```

```
-- =====
-- Object Identifier Definitions
-- =====

-- LawfulIntercept DomainId
lawfulInterceptDomainId OBJECT IDENTIFIER ::= {itu-t(0) identified-organization(4) etsi(0)
securityDomain(2) lawfulIntercept(2)}

-- hi1 Domain
tETRADomainId OBJECT IDENTIFIER ::= {lawfulInterceptDomainId tETRA(6)}
hi1OperationId OBJECT IDENTIFIER ::= {tETRADomainId hi1(1) notificationOperations(1) version0(0)}
```

```
sending-of-HI1-Notification OPERATION ::=
{
  ARGUMENT      HI1-Operation
  ERRORS        {ErrorHI1Notifications}
  CODE          global:{tETRADomainId version1(1)}
}

-- Class 2 operation. The timer shall be set to a value between 3s and 240s.
-- The timer default value is 60s.
-- NOTE: The value for this timer is to be set on the equipment waiting for the returned message;
-- its value shall be agreed between the NWO/AP/SvP and the LEA, depending on their equipment
-- properties.
```

```
other-failure-causes ERROR ::= {CODE local:0}
missing-parameter ERROR ::= {CODE local:1}
unknown-parameter ERROR ::= {CODE local:2}
erroneous-parameter ERROR ::= {CODE local:3}
```

```
ErrorHI1Notifications ERROR ::=
{
  other-failure-causes |
  missing-parameter |
  unknown-parameter |
  erroneous-parameter
}
```

```

Hil-Operation ::= CHOICE
{
  liActivated           [1] Notification,
  liDeactivated        [2] Notification,
  liModified           [3] Notification,
  alarms-indicator    [4] Alarm-Indicator,
  ...,
  national-Hil-ASN1parameters [5] National-Hil-ASN1parameters
}

```

```

-- =====
-- PARAMETERS FORMATS
-- =====

```

```

Notification ::= SEQUENCE
{
  domainID              [0] OBJECT IDENTIFIER (hilOperationId) OPTIONAL,
  -- Once using FTP delivery mechanism
  lawfulInterceptionIdentifier [1] LawfulInterceptionIdentifier,
  -- This identifier is the LIID identity provided with the lawful authorization
  -- for each target.
  communicationIdentifier [2] CommunicationIdentifier OPTIONAL,
  -- Only the NWO/PA/SvPIDentifier is provided (the one provided with the Lawful
  -- authorization)
  -- Called "callIdentifier" in V1.1.1 of ES 201 671 [i.5]
  timeStamp             [3] TimeStamp,
  -- date and time of the report
  location              [4] TETRACGIType OPTIONAL,
  -- only a valid location can be provided at the time of the notification
  ...,
  national-Hil-ASN1parameters [5] National-Hil-ASN1parameters OPTIONAL
}

```

```

Alarm-Indicator ::= SEQUENCE
{
  domainID              [0] OBJECT IDENTIFIER (hilOperationId) OPTIONAL,
  -- Once using FTP delivery mechanism
  communicationIdentifier [1] CommunicationIdentifier OPTIONAL,
  -- Only the NWO/PA/SvPIDentifier is provided (the one provided with the
  -- Lawful authorization)
  timeStamp             [2] TimeStamp,
  -- date and time of the report
  alarm-information    [3] OCTET STRING (SIZE (1..25)),
  -- Provides information about alarms (free format)
  ...,
  lawfulInterceptionIdentifier [4] LawfulInterceptionIdentifier OPTIONAL,
  -- This identifier is the LIID identity provided with the lawful authorization
  -- for each target in according to national law
  national-Hil-ASN1parameters [5] National-Hil-ASN1parameters OPTIONAL
}

```

```

National-Hil-ASN1parameters ::= SEQUENCE
{
  domainID              [0] OBJECT IDENTIFIER (hilOperationId) OPTIONAL,
  -- Once using FTP delivery mechanism
  countryCode          [1] PrintableString (SIZE (2)),
  -- Country Code according to ISO 3166-1 [67],
  -- the country to which the parameters inserted after the extension marker apply.
  ...,
  -- In case a given country wants to use additional national parameters according to its law,
  -- these national parameters should be defined using the ASN.1 syntax and added after the
  -- extension marker (...).
  -- It is recommended that "version parameter" and "vendor identification parameter" are
  -- included in the national parameters definition. Vendor identifications can be
  -- retrieved from IANA web site (see annex K). Besides, it is recommended to avoid
  -- using tags from 240 to 255 in a formal type definition.
}

```

```

END -- end of TETRA-HilNotificationOperations

```

D.10.3 HI2 definitions

The ASN.1 (Recommendation ITU-T X.680 [33]) module that represents the information in the present document and meets all stated requirements is shown below:

TETRA-HI2Operations

```
{itu-t(0) identified-organization(4) etsi(0) securityDomain(2) lawfulIntercept(2) tetra(6) hi2(2)
version3(3)}
```

```
DEFINITIONS IMPLICIT TAGS ::=
```

```
BEGIN
```

```
IMPORTS
    OPERATION,
    ERROR
    FROM Remote-Operations-Information-Objects
        {joint-iso-itu-t(2) remote-operations(4) informationObjects(5) version1(0)}

    -- from 3GPP TS 33.108 [61]
    UmtsQos,
    IMSevent,
    LDIEvent,
    CorrelationValues
    FROM UmtsHI2Operations
        {itu-t(0) identified-organization(4) etsi(0) securityDomain(2) lawfulintercept(2)
threeGPP(4) hi2(1) r10(10) version-1(1)}

    -- from TS 101 909-20-01 [69]
    TARGETACTIVITYMONITOR-1
    FROM TS101909201
        {itu-t(0) identified-organization(4) etsi(0) ts101909(1909) part20(20) subpart1(1)
interceptVersion(0)}

    -- from EN 301 040 [72]
    TARGETACTIVITYMONITORind,
    TARGETCOMMSMONITORind,
    TTRAFFICind,
    TETRAAddressType,
    CTTRAFFICind
    FROM EN301040
        {itu-t(0) identified-organization(4) etsi(0) en301040(1040) interceptVersion(0)};
```

```
tetra-sending-of-IRI OPERATION ::=
{
    ARGUMENT    TETRAIRIsContent
    ERRORS      {OperationErrors}
    CODE        global:{tETRADomainId hi2(1) opcode(1)}
}
-- Class 2 operation . The timer shall be set to a value between 3s and 240s
-- The timer.default value is 60s
-- NOTE: The same note as for HI management operation applies
```

```
TETRAIRIsContent ::= CHOICE
{
    tetraiRIContent      TetraIRIContent,
    tetraIRISequence     TetraIRISequence
}
```

```
TetraIRISequence ::= SEQUENCE OF TetraIRIContent
```

```
-- Aggregation of UmtsIRIContent is an optional feature.
-- It may be applied in cases when at a given point in time
-- several IRI records are available for delivery to the same LEA destination.
-- As a general rule, records created at any event shall be sent
-- immediately and not withheld in the DF or MF in order to apply aggregation.
-- When aggregation is not to be applied, UmtsIRIContent needs to be chosen.
```

```

-- =====
-- Object Identifier Definitions
-- =====

-- LawfulIntercept DomainId
lawfulInterceptDomainId OBJECT IDENTIFIER ::= {itu-t(0) identified-organization(4) etsi(0)
securityDomain(2) lawfulIntercept(2)}

-- hil Domain
tETRADomainId OBJECT IDENTIFIER ::= {lawfulInterceptDomainId tETRA(6)}
hi2OperationId OBJECT IDENTIFIER ::= {tETRADomainId hi2(2) version3(3)}

```

```

TetraIRIContent ::= CHOICE
{
  iRI-Begin-record [1] Tetra-IRI-Parameters,
  -- include at least one optional parameter
  iRI-End-record [2] Tetra-IRI-Parameters,
  iRI-Continue-record [3] Tetra-IRI-Parameters,
  -- include at least one optional parameter
  iRI-Report-record [4] Tetra-IRI-Parameters
  -- include at least one optional parameter
}

```

```

unknown-version ERROR ::= {CODE local:0}
missing-parameter ERROR ::= {CODE local:1}
unknown-parameter-value ERROR ::= {CODE local:2}
unknown-parameter ERROR ::= {CODE local:3}

```

```

OperationErrors ERROR ::=
{
  unknown-version |
  missing-parameter |
  unknown-parameter-value |
  unknown-parameter
}
-- This values may be sent by the LEMF, when an operation or a parameter is misunderstood

```

```

Tetra-IRI-Parameters ::= SEQUENCE
{
  domainID [0] OBJECT IDENTIFIER (hi2OperationId) OPTIONAL,
  -- for the sending entity the inclusion of the Object Identifier is mandatory
  iRIversion [23] ENUMERATED
  {
    version0(0),
    ...
  } OPTIONAL,
  -- if not present, it means version 1 is handled
  lawfulInterceptionIdentifier [1] LawfulInterceptionIdentifier,
  -- This identifier is associated to the target
  communicationIdentifier [2] CommunicationIdentifier,
  -- used to uniquely identify an intercepted call
  -- Called "callIdentifier" in V1.1.1 of ES 201 671 [i.5]
  timeStamp [3] TimeStamp,
  -- date and time of the event triggering the report
  intercepted-Call-Direct [4] ENUMERATED
  {
    not-Available(0),
    originating-Target(1),
    -- In case of GPRS, this indicates that the PDP context activation, modification
    -- or deactivation is MS requested
    terminating-Target(2),
    -- In case of GPRS, this indicates that the PDP context activation, modification
    -- or deactivation is network initiated
    ...
  } OPTIONAL,
  intercepted-Call-State [5] Intercepted-Call-State OPTIONAL,
  ringingDuration [6] OCTET STRING (SIZE (3)) OPTIONAL,
  -- Duration in seconds. BCD coded : HHMMSS
  conversationDuration [7] OCTET STRING (SIZE (3)) OPTIONAL,
  -- Duration in seconds. BCD coded : HHMMSS
  locationOfTheTarget [8] Location OPTIONAL,
  -- location of the target subscriber
  partyInformation [9] SET SIZE (1..10) OF PartyInformation OPTIONAL,
  -- This parameter provides the concerned party (Originating, Terminating or forwarded
  -- party), the identity(ies) of the party and all the information provided by the party
  callContentLinkInformation [10] SEQUENCE
  {

```

```

cCLink1Characteristics [1] CallContentLinkCharacteristics OPTIONAL,
  -- Information concerning the Content of Communication Link Tx channel established
  -- toward the LEMF (or the sum signal channel, in case of mono mode)
cCLink2Characteristics [2] CallContentLinkCharacteristics OPTIONAL,
  -- Information concerning the Content of Communication Link Rx channel established
  -- toward the LEMF
  ...
} OPTIONAL,
release-Reason-Of-Intercepted-Call [11] OCTET STRING (SIZE (2)) OPTIONAL,
  -- Release cause coded in ITU-T Q.850 [31] format.
  -- This parameter indicates the reason why the intercepted call cannot be established or
  -- why the intercepted call has been released after the active phase.
nature-Of-The-intercepted-call [12] ENUMERATED
{
  -- Nature of the intercepted "call":
gsm-ISDN-PSTN-circuit-call(0),
  -- the possible UUS content is sent through the HI2 or HI3 "data" interface
  -- the possible call content call is established through the HI3 "circuit" interface
gsm-SMS-Message(1),
  -- the SMS content is sent through the HI2 or HI3 "data" interface
uUS4-Messages(2),
  -- the UUS content is sent through the HI2 or HI3 "data" interface
tETRA-circuit-call(3),
  -- the possible call content call is established through the HI3 "circuit" interface
  -- the possible data are sent through the HI3 "data" interface
teTRA-Packet-Data(4),
  -- the data are sent through the HI3 "data" interface
gPRS-Packet-Data(5),
  -- the data are sent through the HI3 "data" interface
  ...,
uMTS-circuit-call(6),
  -- the possible call content call is established through the HI3 "circuit" interface
  -- the possible data are sent through the HI3 "data" interface
lte-SMS-Message(7),
  -- indicator for SMS from LTE handset
  -- the SMS content is sent through the HI2 or HI3 "data" interface
lte-circuit-call(8)
  -- indicator for CS call from LTE handset
} OPTIONAL,
serverCenterAddress [13] PartyInformation OPTIONAL,
  -- e.g. in case of SMS message this parameter provides the address of the relevant
  -- server within the calling (if server is originating) or called
  -- (if server is terminating) party address parameters
sms [14] SMS-report OPTIONAL,
  -- this parameter provides the SMS content and associated information
cc-Link-Identifier [15] CC-Link-Identifier OPTIONAL,
  -- Depending on a network option, this parameter may be used to identify a CC link
  -- in case of multiparty calls.
national-Parameters [16] National-Parameters OPTIONAL,
gPRSCorrelationNumber [18] GPRSCorrelationNumber OPTIONAL,
gPRSevent [20] GPRSevent OPTIONAL,
  -- This information is used to provide particular action of the target
  -- such as attach/detach
sgsnAddress [21] DataNodeAddress OPTIONAL,
gPRSOperationErrorCode [22] GPRSOperationErrorCode OPTIONAL,
  ...,
ggsnAddress [24] DataNodeAddress OPTIONAL,
qoS [25] UmtsQos OPTIONAL,
  -- This parameter is duplicated from 3GPP TS 33.108 [61].
networkIdentifier [26] Network-Identifier OPTIONAL,
  -- This parameter is duplicated from 3GPP TS 33.108 [61].
smsOriginatingAddress [27] DataNodeAddress OPTIONAL,
  -- This parameter is duplicated from 3GPP TS 33.108 [61].
smsTerminatingAddress [28] DataNodeAddress OPTIONAL,
  -- This parameter is duplicated from 3GPP TS 33.108 [61].
imSevent [29] IMSevent OPTIONAL,
sIPMessage [30] OCTET STRING OPTIONAL,
  -- This parameter is duplicated from 3GPP TS 33.108 [61].
servingSGSN-number [31] OCTET STRING (SIZE (1..20)) OPTIONAL,
  -- This parameter is duplicated from 3GPP TS 33.108 [61].
servingSGSN-address [32] OCTET STRING (SIZE (5..17)) OPTIONAL,
  -- Octets are coded according to 3GPP TS 23.003 [76]
  -- This parameter is duplicated from 3GPP TS 33.108 [61].
TARGETACTIVITYMONITOR [33] TARGETACTIVITYMONITOR-1 OPTIONAL,
  -- Parameter is used in TS 101 909-20-1 [69]
ldiEvent [34] LDIEvent OPTIONAL,
  -- The "Location Dependent Interception" parameter is duplicated from 3GPP TS 33.108 [61].
correlation [35] CorrelationValues OPTIONAL,

```

```

-- This parameter is duplicated from 3GPP TS 33.108 [61]
tTARGETACTIVITYMONITORind [36] TARGETACTIVITYMONITORind OPTIONAL,
-- Parameter is used in EN 301 040 [72]
tTARGETCOMMSMONITORind [37] TARGETCOMMSMONITORind OPTIONAL,
-- Parameter is used in EN 301 040 [72]
tTRAFFICind [38] TTRAFFICind OPTIONAL,
-- Parameter is used in EN 301 040 [72]
ctTRAFFICind [39] CTTRAFFICind OPTIONAL,
-- Parameter is used in EN 301 040 [72]
tTETRA-LI-Event [40] TETRA-LI-Event OPTIONAL,
dMO-Indicator [41] DMO-Indicator OPTIONAL,
tTETRA-PartyInformation [42] TETRAAddressType OPTIONAL,
tTETRA-Other-PartyInformation [43] TETRAAddressType OPTIONAL,
txGrantedStatus [44] TxGrantedStatus OPTIONAL,
groupStatus [45] GroupStatus OPTIONAL,
national-HI2-ASNlparameters [255] National-HI2-ASNlparameters OPTIONAL
}

```

```

-- =====
-- PARAMETER FORMATS
-- =====

```

```

TETRA-LI-Event ::= ENUMERATED
{
  callSetupMobileOriginating(1),
    -- Start of call, A party is target
  callSetupMobileTerminating(2),
    -- Start of call, B party is target
  ringing(3),
    -- Call reaches other party
  queueing(4),
    -- Call waiting at other party
  connected(5),
    -- Call established
  handover(6),
    -- Location change during call
  callRelease(7),
    -- Call is released
  locationUpdate(8),
    -- TETRA switch change while not in call
  sDSMobileOriginating(9),
    -- Target sends SDS
  sDSMobileTerminating(10),
    -- Target receives SDS
  callForward(11),
    -- Call forwarded to C party
  callHold(12),
    -- Call on hold
  groupIndication(13),
    -- Group indication action
  txGranted(14),
    -- Group talker tx granted
  mobileOn(15),
    -- Handset switched on
  mobileOff(16),
    -- Handset switched off
  dMO(17),
    -- Direct Mode Operation
  ...
}

```

```

DMO-Indicator ::= ENUMERATED
{
  dMOSTATETUNKNOWNC(0),
  dMOSTATETTMOC(1),
  dMOSTATETDMOC(2),
  dMOSTATETIDLEDUALWATCHC(3),
  dMOSTATETFULLDUALWATCHC(4),
  dMOSTATETTXINHIBITC(5),
  ...
}

```

```

TxGrantedStatus ::= BOOLEAN
-- FALSE TxCeased, TRUE TxGranted

```

```

GroupStatus ::= BOOLEAN
-- FALSE when leaving group, TRUE when joining group

```

```

CommunicationIdentifier ::= SEQUENCE
{
  communication-Identity-Number      [0] OCTET STRING (SIZE (1..8)) OPTIONAL,
  -- Temporary Identifier of an intercepted call to uniquely identify an intercepted call
  -- within the node. This parameter is mandatory if there is associated
  -- information sent over HI3interface (CCLink, data,..) or when
  -- CommunicationIdentifier is used for IRI other than IRI-Report-record
  -- This parameter was called "call-Identity-Number" in V1.1.1 of ES 201 671 [i.5].
  -- The individual digits of the communication-Identity-Number shall be represented in
  -- ASCII format, e.g. "12345678" = 8 octets 0x31 0x32 0x33 0x34 0x35 0x36 0x37 0x38.
  network-Identifier                [1] Network-Identifier,
  ...
}
-- NOTE: The same "CommunicationIdentifier" value is sent:
-- with the HI3 information for correlation purpose between the IRI and the information sent on
-- the HI3 interfaces (CCLink, data, ..) with each IRI associated to a same intercepted call
-- for correlation purpose between the different IRI.

```

```

Network-Identifier ::= SEQUENCE
{
  operator-Identifier                [0] OCTET STRING (SIZE (1..5)),
  -- It is a notification of the NWO/AP/SvP in ASCII- characters
  -- The parameter is mandatory
  network-Element-Identifier        [1] Network-Element-Identifier OPTIONAL,
  ...
}

```

```

Network-Element-Identifier ::= CHOICE
{
  e164-Format                        [1] OCTET STRING (SIZE (1..25)),
  -- E164 address of the node in international format. Coded in the same format as the
  -- calling party number parameter of the ISUP (parameter part: EN 300 356 [5])
  x25-Format                         [2] OCTET STRING (SIZE (1..25)),
  -- X25 address
  iP-Format                          [3] OCTET STRING (SIZE (1..25)),
  -- IP address
  dns-Format                         [4] OCTET STRING (SIZE (1..25)),
  -- DNS address
  ...
  iP-Address                        [5] IPAddress
}

```

```

CC-Link-Identifier ::= OCTET STRING (SIZE (1..8))
-- Depending on a network option, this parameter may be used to identify a CCLink
-- in case of multiparty calls.
-- The individual digits of the communication-Identity-Number shall be represented in
-- ASCII format, e.g. "12345678" = 8 octets 0x31 0x32 0x33 0x34 0x35 0x36 0x37 0x38.

```

```

TimeStamp ::= CHOICE
{
  -- The minimum resolution required is one second.
  -- "Resolution" is the smallest incremental change that can be measured for time and
  -- is expressed with a definite number of decimal digits or bits.
  localTime                          [0] LocalTimeStamp,
  utcTime                             [1] UTCTime
}

```

```

LocalTimeStamp ::= SEQUENCE
{
  generalizedTime                    [0] GeneralizedTime,
  -- The minimum resolution required is one second.
  -- "Resolution" is the smallest incremental change that can be measured for time and
  -- is expressed with a definite number of decimal digits or bits.
  winterSummerIndication             [1] ENUMERATED
  {
    notProvided(0),
    winterTime(1),
    summerTime(2),
    ...
  }
}

```



```

PartyInformation ::= SEQUENCE
{
  party-Qualifier          [0] ENUMERATED
  {
    originating-Party(0),
    -- In this case, the partyInformation parameter provides the identities related to
    -- the originating party and all information provided by this party.
    -- This parameter provides also all the information concerning the redirecting
    -- party when a forwarded call reaches a target.
    terminating-Party(1),
    -- In this case, the partyInformation parameter provides the identities related to
    -- the terminating party and all information provided by this party.
    forwarded-to-Party(2),
    -- In this case, the partyInformation parameter provides the identities related to
    -- the forwarded to party and parties beyond this one and all information
    -- provided by this parties, including the call forwarding reason.
    gPRS-Target(3),
    ...
  },
  partyIdentity           [1] SEQUENCE
  {
    imei                  [1] OCTET STRING (SIZE (8)) OPTIONAL,
    -- See MAP format 3GPP TS 09.02 [32]
    tei                    [2] OCTET STRING (SIZE (1..15)) OPTIONAL,
    -- ISDN-based Terminal Equipment Identity
    imsi                   [3] OCTET STRING (SIZE (3..8)) OPTIONAL,
    -- See MAP format 3GPP TS 09.02 [32] International Mobile
    -- Station Identity E.212 number beginning with Mobile Country Code
    callingPartyNumber     [4] CallingPartyNumber OPTIONAL,
    -- The calling party format is used to transmit the identity of a calling party
    calledPartyNumber      [5] CalledPartyNumber OPTIONAL,
    -- The called party format is used to transmit the identity of a called party or
    -- a forwarded to party.
    msISDN                 [6] OCTET STRING (SIZE (1..9)) OPTIONAL,
    -- MSISDN of the target, encoded in the same format as the AddressString
    -- parameters defined in MAP format 3GPP TS 09.02 [32], clause 14.7.8.
    ...,
    e164-Format            [7] OCTET STRING (SIZE (1..25)) OPTIONAL,
    -- E164 address of the node in international format. Coded in the same format as
    -- the calling party number parameter of the ISUP (parameter part: EN 300 356 [5])
    sip-uri                [8] OCTET STRING OPTIONAL,
    -- Session Initiation Protocol - Uniform Resource Identifier. See RFC 3261 [59].
    -- This parameter is duplicated from 3GPP TS 33.108 [61].
    tel-url                [9] OCTET STRING OPTIONAL,
    -- See "URLs for Telephone Calls", RFC 3966 [68].
    -- This parameter is duplicated from 3GPP TS 33.108 [61].
  },
  services-Information    [2] Services-Information OPTIONAL,
  -- This parameter is used to transmit all the information concerning the
  -- complementary information associated to the basic call
  supplementary-Services-Information [3] Supplementary-Services OPTIONAL,
  -- This parameter is used to transmit all the information concerning the
  -- activation/invocation of supplementary services during a call or out-of call not
  -- provided by the previous parameters.
  services-Data-Information [4] Services-Data-Information OPTIONAL,
  -- This parameter is used to transmit all the information concerning the complementary
  -- information associated to the basic data call.
  ...
}

```

```

CallingPartyNumber ::= CHOICE
{
  iSUP-Format            [1] OCTET STRING (SIZE (1..25)),
  -- Encoded in the same format as the calling party number (parameter field)
  -- of the ISUP (see EN 300 356 [5]).
  dSS1-Format           [2] OCTET STRING (SIZE (1..25)),
  -- Encoded in the format defined for the value part of the Calling party number
  -- information element of DSS1 protocol EN 300 403-1 [6].
  -- The DSS1 Information element identifier and the DSS1 length are not included.
  ...,
  mAP-Format            [3] OCTET STRING (SIZE (1..25))
  -- Encoded as AddressString of the MAP protocol 3GPP TS 09.02 [32].
}

```

```

CalledPartyNumber ::= CHOICE
{
  iSUP-Format      [1] OCTET STRING (SIZE (1..25)),
    -- Encoded in the same format as the called party number (parameter field)
    -- of the ISUP (see EN 300 356 [5]).
  mAP-Format      [2] OCTET STRING (SIZE (1..25)),
    -- Encoded as AddressString of the MAP protocol 3GPP TS 09.02 [32].
  dSS1-Format     [3] OCTET STRING (SIZE (1..25)),
    -- Encoded in the format defined for the value part of the Called party number information
    -- element of DSS1 protocol EN 300 403-1 [6].
    -- The DSS1 Information element identifier and the DSS1 length are not included.
  ...
}

```

```

Location ::= SEQUENCE
{
  e164-Number      [1] OCTET STRING (SIZE (1..25)) OPTIONAL,
    -- Coded in the same format as the ISUP location number (parameter field)
    -- of the ISUP (see EN 300 356 [5]).
  globalCellID    [2] OCTET STRING (SIZE (5..7)) OPTIONAL,
    -- See MAP format (see 3GPP TS 09.02 [32]).
  tetraLocation   [3] TetraLocation OPTIONAL,
    -- This optional parameter is not in use anymore, but is kept for backwards compatibility.
  rAI              [4] OCTET STRING (SIZE (6)) OPTIONAL,
    -- The Routeing Area Identifier (RAI) in the current SGSN is coded in accordance with
    -- 3GPP TS 24.008 [41] without the Routing Area Identification IEI (only the
    -- last 6 octets are used).
  gsmLocation     [5] GSMLocation OPTIONAL,
  umtsLocation    [6] UMTSLocation OPTIONAL,
  sAI              [7] OCTET STRING (SIZE (7)) OPTIONAL,
    -- format: PLMN-ID 3 octets (no. 1-3),
    -- LAC 2 octets (no. 4-5),
    -- SAC 2 octets (no. 6-7)
    -- (according to 3GPP TS 25.413 [82])
  ...
  oldRAI          [8] OCTET STRING (SIZE (6)) OPTIONAL
    -- the "Routeing Area Identifier" in the old SGSN is coded in accordance with
    -- 3GPP TS 24.008 [41] without the Routing Area Identification IEI
    -- (only the last 6 octets are used).
    -- This parameter is duplicated from 3GPP TS 33.108 [61]
}

```

```

TetraLocation ::= CHOICE
{
  ms-Loc          [1] SEQUENCE
  {
    mcc           [1] INTEGER (0..1023),
      -- 10 bits EN 300 392-1 [40]
    mnc           [2] INTEGER (0..16383),
      -- 14 bits EN 300 392-1 [40]
    lai           [3] INTEGER (0..65535),
      -- 14 bits EN 300 392-1 [40]
    ci            [4] INTEGER OPTIONAL,
    ...
  },
  ls-Loc          [2] INTEGER
}

```

```

GSMLocation ::= CHOICE
{
  geoCoordinates          [1] SEQUENCE
  {
    latitude      [1] PrintableString (SIZE(7..10)),
    -- format: XDDMMSS.SS
    longitude     [2] PrintableString (SIZE(8..11)),
    -- format: XDDMMSS.SS
    mapDatum      [3] IMPLICIT MapDatum OPTIONAL,
    -- DEFAULT WGS84
    ...,
    azimuth       [4] INTEGER (0..359) OPTIONAL
    -- The azimuth is the bearing, relative to true north.
  },
  -- format: XDDMMSS.SS
  -- X : N(orth), S(outh), E(ast), W(est)
  -- DD or DDD : degrees (numeric characters)
  -- MM : minutes (numeric characters)
  -- SS.SS : seconds, the second part (.SS) is optional
  -- Example:
  -- latitude short form N502312
  -- longitude long form E1122312.18

  utmCoordinates        [2] SEQUENCE
  {
    utm-East         [1] PrintableString (SIZE(10)),
    utm-North        [2] PrintableString (SIZE(7)),
    -- Universal Transverse Mercator
    -- example utm-East 32U0439955
    -- utm-North 5540736
    mapDatum        [3] IMPLICIT MapDatum OPTIONAL,
    -- DEFAULT WGS84
    ...,
    azimuth         [4] INTEGER (0..359) OPTIONAL
    -- The azimuth is the bearing, relative to true north.
  },

  utmRefCoordinates     [3] SEQUENCE
  {
    utmref-string    [2] PrintableString (SIZE(13)),
    mapDatum         [3] IMPLICIT MapDatum OPTIONAL,
    -- DEFAULT WGS84
    ...
  },
  -- example 32UPU91294045

  WGS84Coordinates     [4] OCTET STRING
  -- format is as defined in 3GPP TS 03.32 [57].
}

```

```

MapDatum ::= ENUMERATED
{
  wGS84(0),
  -- World Geodetic System 1984
  wGS72(1),
  eD50(2),
  -- European Datum 50
  ...
}

```

```

UMTSLocation ::= CHOICE
{
  point              [1] GA-Point,
  pointWithUncertainty [2] GA-PointWithUncertainty,
  polygon            [3] GA-Polygon,
  ...
}

```

```

GeographicalCoordinates ::= SEQUENCE
{
  latitudeSign    [0] ENUMERATED
  {
    north(1),
    south(2)
  },
  latitude        [1] INTEGER (0..8388607),
  longitude       [2] INTEGER (-8388608..8388607),
  ...
}

```

```

GA-Point ::= SEQUENCE
{
  geographicalCoordinates    [0] GeographicalCoordinates,
  ...
}

```

```

GA-PointWithUncertainty ::=SEQUENCE
{
  geographicalCoordinates    [0] GeographicalCoordinates,
  uncertaintyCode            [1] INTEGER (0..127)
}

```

```

maxNrOfPoints INTEGER ::= 15

```

```

GA-Polygon ::= SEQUENCE (SIZE (1..maxNrOfPoints)) OF
SEQUENCE
{
  geographicalCoordinates [0] GeographicalCoordinates,
  ...
}

```

```

CallContentLinkCharacteristics ::= SEQUENCE
{
  cCLink-State      [1] CCLink-State OPTIONAL,
  -- current state of the CCLink
  release-Time      [2] TimeStamp OPTIONAL,
  -- date and time of the release of the Call Content Link
  release-Reason    [3] OCTET STRING (SIZE(2)) OPTIONAL,
  -- Release cause coded in Q.850 [31] format
  lEMF-Address      [4] CalledPartyNumber OPTIONAL,
  -- Directory number used to route the call toward the LEMF
  ...
}

```

```

CCLink-State ::= ENUMERATED
{
  setUpInProgress(1),
  -- The set-up of the call is in process.
  callActive(2),
  callReleased(3),
  lack-of-resource(4),
  -- The lack-of-resource state is sent when a CC Link cannot
  -- be established because of lack of resource at the MF level
  ...
}

```

```

Intercepted-Call-State ::= ENUMERATED
{
  idle(1),
  -- When the intercept call is released, the state is IDLE and the reason is provided
  -- by the release-Reason-Of-Intercepted-Call parameter
  setUpInProgress(2),
  -- The set-up of the call is in process
  connected(3),
  -- The answer has been received
  ...
}

```

```

Services-Information ::= SEQUENCE
{
  iSUP-parameters           [1] ISUP-parameters OPTIONAL,
  dSS1-parameters-codeset-0 [2] DSS1-parameters-codeset-0 OPTIONAL,
  ...,
  mAP-parameters           [3] MAP-parameters OPTIONAL
}

```

```

ISUP-parameters ::= SET SIZE (1..256) OF OCTET STRING (SIZE (1..256))
-- Each "OCTET STRING" contains one additional ISUP parameter TLV coded not already defined in
-- the previous parameters. The Tag value is the one given in EN 300 356 [5].

-- In version 1 of the present document "iSUP-parameters" is defined as mandatory.
-- It might occur that no ISUP parameter is available. In that case in a version 1
-- implementation the value "zero" may be included in the first octet string of the SET.

-- The Length and the Value are coded in accordance with the parameter definition in
-- EN 300 356 [5]. Hereafter are listed the main parameters.
-- However other parameters may be added:

-- Transmission medium requirement: format defined in EN 300 356 [5].
-- This parameter can be provided with the "Party Information" of the "calling party".

-- Transmission medium requirement prime: format defined in EN 300 356 [5].
-- This parameter can be provided with the "Party Information" of the "calling party".

```

```

DSS1-parameters-codeset-0 ::= SET SIZE (1..256) OF OCTET STRING (SIZE (1..256))
-- Each "OCTET STRING" contains one DSS1 parameter of the codeset-0. The parameter is coded as
-- described in EN 300 403-1 [6] (The DSS1 Information element identifier and the DSS1 length
-- are included). Hereafter are listed the main parameters
-- However other parameters may be added:

-- Bearer capability: this parameter may be repeated. Format defined in EN 300 403-1 [6].
-- This parameter can be provided with the "Party Information" of the "calling party",
-- "called party" or "forwarded to party".

-- High Layer Compatibility: this parameter may be repeated. Format defined in EN 300 403-1 [6]
-- This parameter can be provided with the "Party Information" of the "calling party",
-- "called party" or "forwarded to party".

-- Low Layer capability: this parameter may be repeated. Format defined in EN 300 403-1 [6].
-- This parameter can be provided with the "Party Information" of the "calling party",
-- "called party" or "forwarded to party".

```

```

MAP-parameters ::= SET SIZE (1..256) OF OCTET STRING (SIZE(1..256))
-- Each "OCTET STRING" contains one MAP parameter. The parameter is coded as described in
-- 3GPP TS 09.02 [32] (The map-TS-Code is included).

```

```

Supplementary-Services ::= SEQUENCE
{
  standard-Supplementary-Services [1] Standard-Supplementary-Services OPTIONAL,
  non-Standard-Supplementary-Services [2] Non-Standard-Supplementary-Services OPTIONAL,
  other-Services [3] Other-Services OPTIONAL,
  ...
}

```

```

Standard-Supplementary-Services ::= SEQUENCE
{
  iSUP-SS-parameters [1] ISUP-SS-parameters OPTIONAL,
  dSS1-SS-parameters-codeset-0 [2] DSS1-SS-parameters-codeset-0 OPTIONAL,
  dSS1-SS-parameters-codeset-4 [3] DSS1-SS-parameters-codeset-4 OPTIONAL,
  dSS1-SS-parameters-codeset-5 [4] DSS1-SS-parameters-codeset-5 OPTIONAL,
  dSS1-SS-parameters-codeset-6 [5] DSS1-SS-parameters-codeset-6 OPTIONAL,
  dSS1-SS-parameters-codeset-7 [6] DSS1-SS-parameters-codeset-7 OPTIONAL,
  dSS1-SS-Invoke-components [7] DSS1-SS-Invoke-Components OPTIONAL,
  mAP-SS-Parameters [8] MAP-SS-Parameters OPTIONAL,
  mAP-SS-Invoke-Components [9] MAP-SS-Invoke-Components OPTIONAL,
  ...
}

```

```

Non-Standard-Supplementary-Services ::= SET SIZE (1..20) OF CHOICE
{
  simpleIndication [1] SimpleIndication,
  sciData [2] SciDataMode,
  ...
}

```

```
Other-Services ::= SET SIZE (1..50) OF OCTET STRING (SIZE (1..256))
-- Reference manufacturer manuals.
```

```
ISUP-SS-parameters ::= SET SIZE (1..256) OF OCTET STRING (SIZE (1..256))
-- It shall be noticed this parameter is retained for compatibility reasons.
-- It is recommended not to use it in new work but to use ISUP-parameters parameter.

-- Each "OCTET STRING" contains one additional ISUP parameter TLV coded not already defined in
-- the previous parameters. The Tag value is the one given in EN 300 356 [5].
-- The Length and the Value are coded in accordance with the parameter definition in
-- EN 300 356 [5].
-- Hereafter are listed the main parameters. However other parameters may be added:

-- Connected Number: format defined in EN 300 356 [5].
-- This parameter can be provided with the "Party Information" of the
-- "called party" or "forwarded to party".

-- RedirectingNumber: format defined in EN 300 356 [5].
-- This parameter can be provided with the "Party Information" of the "originating party"
-- or/and of the "terminating party".

-- Original Called Party Number: format defined in EN 300 356 [5].
-- This parameter can be provided with the "Party Information" of the "originating party".

-- Redirection information: format defined in EN 300 356 [5].
-- This parameter can be provided with the "Party Information" of the
-- "originating party", "forwarded to party" or/and "Terminating party".

-- Redirection Number: format defined in EN 300 356 [5].
-- This parameter can be provided with the "Party Information" of the
-- "forwarded to party" or "Terminating party".

-- Call diversion information: format defined in EN 300 356 [5].
-- This parameter can be provided with the "Party Information" of the
-- "forwarded to party" or "Terminating party".

-- Generic Number: format defined in EN 300 356 [5].
-- This parameter can be provided with the "Party Information" of the
-- "calling party", "called party" or "forwarded to party".
-- This parameters are used to transmit additional identities (additional, calling party
-- number, additional called number, etc).

-- Generic Notification: format defined in EN 300 356 [5].
-- This parameter may be provided with the "Party Information" of the
-- "calling party", "called party" or "forwarded to party".
-- This parameters transmit the notification to the other part of the call of the supplementary
-- services activated or invoked by a subscriber during the call.

-- CUG Interlock Code: format defined in EN 300 356 [5].
-- This parameter can be provided with the "Party Information" of the "calling party".
```

```

DSS1-SS-parameters-codeset-0 ::= SET SIZE (1..256) OF OCTET STRING (SIZE (1..256))
-- Each "OCTET STRING" contains one DSS1 parameter of the codeset-0. The parameter is coded as
-- described in EN 300 403-1 [6] (The DSS1 Information element identifier and the DSS1 length
-- are included). Hereafter are listed the main parameters
-- (However other parameters may be added):

-- Calling Party Subaddress: format defined in EN 300 403-1 [6].
-- This parameter can be provided with the "Party Information" of the "calling party".

-- Called Party Subaddress: format defined in EN 300 403-1 [6].
-- This parameter can be provided with the "Party Information" of the "calling party".

-- Connected Subaddress: format defined in recommendation (see EN 300 097-1 [14]).
-- This parameter can be provided with the "Party Information" of the
-- "called party" or "forwarded to party".

-- Connected Number: format defined in recommendation (see EN 300 097-1 [14]).
-- This parameter can be provided with the "Party Information" of the
-- "called party" or "forwarded to party".

-- Keypad facility: format defined in EN 300 403-1 [6].
-- This parameter can be provided with the "Party Information" of the
-- "calling party", "called party" or "forwarded to party".

-- Called Party Number: format defined in EN 300 403-1 [6].
-- This parameter could be provided with the "Party Information" of the "calling party"
-- when target is the originating party; it contains the dialled digits before modification
-- at network level (e.g. IN interaction, translation, etc ...).

-- User-user: format defined in EN 300 286-1 [23]).
-- This parameter can be provided with the "Party Information" of the
-- "calling party", "called party" or "forwarded to party".

```

```

DSS1-SS-parameters-codeset-4 ::= SET SIZE (1..256) OF OCTET STRING (SIZE (1..256))
-- Each "OCTET STRING" contains one DSS1 parameter of the codeset-4. The parameter is coded as
-- described in the relevant recommendation.

```

```

DSS1-SS-parameters-codeset-5 ::= SET SIZE (1..256) OF OCTET STRING (SIZE (1..256))
-- Each "OCTET STRING" contains one DSS1 parameter of the codeset-5. The parameter is coded as
-- described in the relevant national recommendation.

```

```

DSS1-SS-parameters-codeset-6 ::= SET SIZE (1..256) OF OCTET STRING (SIZE (1..256))
-- Each "OCTET STRING" contains one DSS1 parameter of the codeset-6. The parameter is coded as
-- described in the relevant local network recommendation.

```

```

DSS1-SS-parameters-codeset-7 ::= SET SIZE (1..256) OF OCTET STRING (SIZE (1..256))
-- Each "octet string" contains one DSS1 parameter of the codeset-7. The parameter is coded as
-- described in the relevant user specific recommendation.

```

```

DSS1-SS-Invoke-Components ::= SET SIZE (1..256) OF OCTET STRING (SIZE (1..256))
-- Each "octet string" contains one DSS1 Invoke or Return Result component.
-- The invoke or return result component is coded as
-- described in the relevant DSS1 supplementary service recommendation.

-- Invoke or Return Result component (BeginCONF): EN 300 185-1 [19]
-- Invoke or Return Result component (AddCONF): EN 300 185-1 [19]
-- Invoke or Return Result component (SplitCONF): EN 300 185-1 [19]
-- Invoke or Return Result component (DropCONF): EN 300 185-1 [19]
-- Invoke or Return Result component (IsolateCONF): EN 300 185-1 [19]
-- Invoke or Return Result component (ReattachCONF): EN 300 185-1 [19]
-- Invoke or Return Result component (PartyDISC): EN 300 185-1 [19]
-- Invoke or Return Result component (MCIDRequest): EN 300 130-1 [16]
-- Invoke or Return Result component (Begin3PTY): EN 300 188-1 [20]
-- Invoke or Return Result component (End3PTY): EN 300 188-1 [20]
-- Invoke or Return Result component (ECTExecute): EN 300 369-1 [25]
-- Invoke or Return Result component (ECTInform): EN 300 369-1 [25]
-- Invoke or Return Result component (ECTLinkIdRequest): EN 300 369-1 [25]
-- Invoke or Return Result component (ECTLoopTest): EN 300 369-1 [25]
-- Invoke or Return Result component (ExplicitECTExecute): EN 300 369-1 [25]
-- Invoke or Return Result component (ECT: RequestSubaddress): EN 300 369-1 [25]
-- Invoke or Return Result component (ECT: SubaddressTransfer): EN 300 369-1 [25]
-- Invoke or Return Result component (CF: ActivationDiversion): EN 300 207-1 [21]
-- Invoke or Return Result component (CF: DeactivationDiversion): EN 300 207-1 [21]
-- Invoke or Return Result component (CF: ActivationStatusNotification): EN 300 207-1 [21]
-- Invoke or Return Result component (CF: DeactivationStatusNotification): EN 300 207-1 [21]
-- Invoke or Return Result component (CF: InterrogationDiversion): EN 300 207-1 [21]
-- Invoke or Return Result component (CF: InterrogationServedUserNumber): EN 300 207-1 [21]
-- Invoke or Return Result component (CF: DiversionInformation): EN 300 207-1 [21]
-- Invoke or Return Result component (CF: CallDeflection): EN 300 207-1 [21]
-- Invoke or Return Result component (CF: CallRerouting): EN 300 207-1 [21]
-- Invoke or Return Result component (CF: DivertingLegInformation1): EN 300 207-1 [21]
-- Invoke or Return Result component (CF: DivertingLegInformation2): EN 300 207-1 [21]
-- Invoke or Return Result component (CF: DivertingLegInformation3): EN 300 207-1 [21]
-- other invoke or return result components ...

```

```

MAP-SS-Invoke-Components ::= SET SIZE (1..256) OF OCTET STRING (SIZE (1..256))
-- Each "octet string" contains one MAP Invoke or Return Result component.
-- The invoke or return result component is coded as
-- described in the relevant MAP supplementary service recommendation.

```

```

MAP-SS-Parameters ::= SET SIZE (1..256) OF OCTET STRING (SIZE (1..256))
-- Each "octet string" contains one MAP Parameter. The parameter is coded as
-- described in the relevant MAP supplementary service recommendation.

```

```

SimpleIndication ::= ENUMERATED
{
  call-Waiting-Indication(0),
  -- The target has received a call waiting indication for this call
  add-conf-Indication(1),
  -- this call has been added to a conference
  call-on-hold-Indication(2),
  -- indication that this call is on hold
  retrieve-Indication(3),
  -- indication that this call has been retrieved
  suspend-Indication(4),
  -- indication that this call has been suspended
  resume-Indication(5),
  -- indication that this call has been resumed
  answer-Indication(6),
  -- indication that this call has been answered
  ...
}

```

```

SciDataMode ::= OCTET STRING (SIZE (1..256))

```



```

SMS-report ::= SEQUENCE
{
  communicationIdentifier      [1] CommunicationIdentifier,
  -- used to uniquely identify an intercepted call: the same used for the
  -- relevant IRI
  -- Called "callIdentifier" in V1.1.1 of ES 201 671 [i.5].
  timeStamp                    [2] TimeStamp,
  -- date and time of the report. The format is
  -- the one defined in case a) of the ASN.1 ITU-T Recommendation X.680 [33].
  -- (year month day hour minutes seconds)
  SMS-Contents                 [3] SEQUENCE
  {
    initiator                  [1] ENUMERATED
    {
      -- party which sent the SMS
      target(0),
      server(1),
      undefined-party(2),
      ...
    },
    transfer-status           [2] ENUMERATED
    {
      succeed-transfer(0),
      -- the transfer of the SMS message succeeds
      not-succeed-transfer(1),
      undefined(2),
      ...
    } OPTIONAL,
    other-message             [3] ENUMERATED
    {
      -- In case of terminating call, indicates if the server will send other SMS.
      yes(0),
      no(1),
      undefined(2),
      ...
    } OPTIONAL,
    content                   [4] OCTET STRING (SIZE (1..270)) OPTIONAL,
    -- Encoded in the format defined for the SMS mobile.
    ...
  }
}

```

```

LawfulInterceptionIdentifier ::= OCTET STRING (SIZE (1..25))
-- It is recommended to use ASCII characters in "a"..."z", "A"..."Z", "-", "_", ".", and "0"..."9".
-- For subaddress option only "0"..."9" shall be used.

```

```

National-Parameters ::= SET SIZE (1..40) OF OCTET STRING (SIZE (1..256))
-- Content defined by national law

```

```

GPRSCorrelationNumber ::= OCTET STRING (SIZE(8..20))

```

```

GPRSEvent ::= ENUMERATED
{
  pDPContextActivation(1),
  startOfInterceptionWithPDPContextActive(2),
  pDPContextDeactivation(4),
  gPRSAttach(5),
  gPRSDetach(6),
  cellOrRAUpdate(10),
  SMS(11),
  ...,
  pDPContextModification(13)
}
-- see 3GPP TS 03.33 [42]

```

```

Services-Data-Information ::= SEQUENCE
{
  gPRS-parameters           [1] GPRS-parameters OPTIONAL,
  ...
}

```

```

GPRS-parameters ::= SEQUENCE
{
  pDP-address-allocated-to-the-target [1] DataNodeAddress OPTIONAL,
  aPN [2] OCTET STRING (SIZE(1..100)) OPTIONAL,
  pDP-type [3] OCTET STRING (SIZE(2)) OPTIONAL,
  -- when PDP-type is IPv4 or IPv6, the IP address is carried by parameter
  -- pDP-address-allocated-to-the-target when PDP-type is IPv4v6,
  -- the additional IP address is carried by parameter additionalIPAddress
  ...,
  nSAPI [4] OCTET STRING (SIZE (1)) OPTIONAL,
  additionalIPAddress [5] DataNodeAddress OPTIONAL
}

```

```

GPRSOperationErrorCode ::= OCTET STRING (SIZE(2))
-- Refer to 3GPP TS 24.008 [41] for values (GMM cause or SM cause parameter).

```

```

DataNodeAddress ::= CHOICE
{
  ipAddress [1] IPAddress,
  x25Address [2] X25Address,
  ...
}

```

```

IPAddress ::= SEQUENCE
{
  iP-type [1] ENUMERATED
  {
    iPV4(0),
    iPV6(1),
    ...
  },
  iP-value [2] IP-value,
  iP-assignment [3] ENUMERATED
  {
    static(1),
    -- The static coding shall be used to report a static address.
    dynamic(2),
    -- The dynamic coding shall be used to report a dynamically allocated address.
    notKnown(3),
    -- The notKnown coding shall be used to report other than static or dynamically
    -- allocated IP addresses.
    ...
  } OPTIONAL,
  ...,
  iPv6PrefixLength [4] INTEGER (1..128) OPTIONAL
  -- Indicates the length of the prefix delegated by the CSP to the subscriber
  -- example: 60 if IP address is 2001:db8:0:85a3::ac1f:8001/60
  -- Mandatory in case where the iP-value contains an IPv6 binary value
}

```

```

IP-value ::= CHOICE
{
  iPBinaryAddress [1] OCTET STRING (SIZE(4..16)),
  -- In case of IPv6, the Prefix Length is provided by the "iPv6PrefixLength"
  iPTextAddress [2] IA5String (SIZE(7..45)),
  -- In case of IPv6, the delivered iPTextAddress field could include a complete
  -- single IPv6-Address or an IPv6-Prefix for a subnetwork on the target side.
  ...
}

```

```

X25Address ::= OCTET STRING (SIZE(1..25))

```

```
National-HI2-ASN1parameters ::= SEQUENCE
{
  countryCode      [1] PrintableString (SIZE (2)),
    -- Country Code according to ISO 3166-1 [67],
    -- the country to which the parameters inserted after the extension marker apply.
  ...
  -- In case a given country wants to use additional national parameters according to its law,
  -- these national parameters should be defined using the ASN.1 syntax and added after the
  -- extension marker (...).
  -- It is recommended that "version parameter" and "vendor identification parameter" are
  -- included in the national parameters definition. Vendor identifications can be
  -- retrieved from the IANA web site (see annex K). Besides, it is recommended to avoid
  -- using tags from 240 to 255 in a formal type definition.
}
```

```
END -- end of TETRA-HI2Operations
```

Annex E (informative): Use of subaddress and calling party number to carry correlation information

E.1 Introduction

Not all ISDN networks fully support the use of the UUS1 service ETSI EN 300 286-1 [23]. Some networks may be limited to the transfer of only 32 octets of UUS1 user information rather than the 128 required for full support of the UUS1 service. Some networks may not support UUS1 at all.

This annex describes a procedure to provide correlation information which is appropriate:

- 1) if a network does not support the delivery of UUS1; or
- 2) if a network does not support the delivery of 128 octets for UUS1.

If all network involved support the delivery of 128 octets for UUS1 then the procedure (described in this annex) is not appropriate.

The calling party number, the Calling Party Subaddress (CgP Sub) and the Called Party Subaddress (CdP Sub) are used to carry correlation information.

E.2 Subaddress options

The coding of a subaddress information element is given in ETSI EN 300 403-1 [6]. The following options are chosen:

Table E.2.1: Subaddress options

Option	Value
Type of subaddress	user specified
Odd/even indicator	employed for Called Party Subaddress when no national parameters are used

E.3 Subaddress coding

E.3.0 General

The coding of subaddress information is in accordance with ETSI EN 300 403-1 [6].

E.3.1 BCD values

The values 0 to 9 are BCD coded according to their natural binary values. The hexadecimal value F is used as a field separator. This coding is indicated in table E.3.1.

Table E.3.1: Coding BCD values

Item	BCD representation			
	Bit 4	Bit 3	Bit 2	Bit 1
0	0	0	0	0
1	0	0	0	1
2	0	0	1	0
3	0	0	1	1
4	0	1	0	0
5	0	1	0	1
6	0	1	1	0
7	0	1	1	1
8	1	0	0	0
9	1	0	0	1
Field separator	1	1	1	1

When items are packed two to an octet, the least significant item is coded by mapping bit 4 to bit 8, bit 3 to bit 7, etc.

E.3.2 Field order and layout

The fields are presented into the subaddress in the following order.

Table E.3.2: Fields in the Called Party Subaddress

Order	Field
1	Operator-ID
2	CIN
3	CCLID
4	National Parameters

Table E.3.3: Fields in the Calling Party Subaddress

Order	Field
1	Lawful Interception Identifier (LIID)
2	Direction
3	Service Octets

Apart from "National Parameters", inclusion and format of which is determined by national regulations, each field noted above is included, whether empty or not. Each of the Operator-ID, CIN, CCLID, LIID and Direction fields is ended by a field separator.

When the sending entity does not have a valid value for either of Operator-ID, CIN, CCLID, LIID or Direction fields, then the field is considered empty and it is represented only by its field separator (see table E.3.6 as example of the Called party subaddress without the CIN parameter).

The parameters within the Information Elements "Called Party Subaddress" and "Calling Party Subaddress" are variable. Because of this variable length the parameters may start in different octets in the related Information Element. I.e. in the Calling Party Subaddress the Direction can be found in octet 17 when the LIID is 25 digits long (table E.3.5).

When the LIID is composed of less than 25 digits, the field separator and direction indicator "moves up" and the rest of the octets is spare till octet 19 as shown in table E.3.7. Between the last digit of the LIID and the Direction is always a Field separator (value F). Also after the "Direction" one Field Separator is given. The last Field separator separates the relevant data from the spare part. So the location of the TMR and the other service Octets below are fixed within the Subaddress. The total length of the Calling Party Subaddress is fixed to 23 octets (including the two Mobile service octets) or 21 octets (without the two Mobile service octets).

The Service Octets as available are always be mapped into octets 19 to 23 of the Calling Party Subaddress, as appropriate. If one of the parameters TMR, BC or HLC is not available, the octet is filled with "FF" hex.

In relation to Mobile Bearer Service Code and Mobile Teleservice Code, the mapping of the values into octets 22 and 23, respectively, is done as follows:

- if both, Mobile Bearer Service Code and Mobile Teleservice Code are provided by signalling, octets 22 and 23, are present, each containing the mapped value;
- if Mobile Bearer Service Code is provided by signalling, and Mobile Teleservice Code is NOT provided by signalling, octet 22 is present containing the mapped value, and octet 23 is omitted;
- if Mobile Teleservice Code is provided by signalling, and Mobile Bearer Service Code is NOT provided by signalling, there are two implementation options:
 - neither octet 22 nor octet 23 are present;
 - octet 22 is filled with "FF" hex and octet 23 is present containing the mapped value;
- if neither Mobile Teleservice Code nor Mobile Bearer Service Code is provided by signalling, neither octet 22 nor octet 23 are present.

As an option the Calling Party Subaddress and Called Party Subaddress may have a variable length. The length is given in octet 2.

When the LIID is composed of less than 25 digits in the Calling Party Subaddress, the Field separator, Direction indicator, Field separator and all the Service Octets "moves up" as shown in table E.3.8.

National Parameters in a variable length Called Party Subaddress may have variable length.

Table E.3.4 represent Called Party Subaddress and table E.3.5 Calling Party Subaddress with the maximum length of the identifiers.

Table E.3.4: Called Party Subaddress

Bits							Octets
8	7	6	5	4	3	2	
Called Party Subaddress identifier							1
Length of Called Party Subaddress contents							2
Type of subaddress = user specified, odd/even indicator							3
Operator-ID ②			Operator-ID ①				4
Operator-ID ④			Operator-ID ③				5
Field separator			Operator-ID ⑤				6
CIN ②			CIN ①				7
CIN ④			CIN ③				8
CIN ⑥			CIN ⑤				9
CIN ⑧			CIN ⑦				10
CCLID ①			Field separator				11
CCLID ③			CCLID ②				12
CCLID ⑤			CCLID ④				13
CCLID ⑦			CCLID ⑥				14
Field separator			CCLID ⑧				15
(see note)							16
							17
							18
							19
							20
							21
							22
NOTE: The Octets after the final field (CCLID) of the Called Party Subaddress are reserved for national use, e.g. for authentication purposes.							23

Table E.3.5: Calling Party Subaddress

Bits							Octets
8	7	6	5	4	3	2	
Calling Party Subaddress identifier							1
Length of Calling Party Subaddress contents							2
Type of subaddress = user specified, odd/even indicator according to the amount of BCD-digits							3
LIID ②			LIID ①				4
LIID ④			LIID ③				5
LIID ⑥			LIID ⑤				6
LIID ⑧			LIID ⑦				7
LIID ①⑩			LIID ⑨				8
LIID ①②			LIID ①①				9
LIID ①④			LIID ①③				10
LIID ①⑥			LIID ①⑤				11
LIID ①⑧			LIID ①⑦				12
LIID ②⑩			LIID ①⑨				13
LIID ②②			LIID ②①				14
LIID ②④			LIID ②③				15
Field separator			LIID ②⑤				16
Field separator			Direction				17
spare			spare				18
Recommendation ITU-T Q.763 [48] TMR (see note 1)							19
Recommendation ITU-T Q.931 BC [56] octet 3 (see note 2)							20
Recommendation ITU-T Q.931 HLC [56] octet 4 (see note 3)							21
Mobile Bearer Service Code (see note 4)							22
Mobile Teleservice Code (see note 5)							23
<p>NOTE 1: If available, the Transmission Medium Requirement according to ETSI EN 300 356 [5]. If not available, the value is "FF" hex.</p> <p>NOTE 2: If available, only octet 3 of the Bearer Capability i.e. according to ETSI EN 300 403-1 [6]. If not available, the value is "FF" hex.</p> <p>NOTE 3: If available, only octet 4 of the High Layer Compatibility i.e. according to ETSI EN 300 403-1 [6]. If not available, the value is "FF" hex.</p> <p>NOTE 4: If available, the Mobile Bearer Service Code according to 3GPP TS 09.02 [32]. If not available, the octets 22 and 23 (even if the mobile teleservice code is available) are not transmitted. If the mobile teleservice code is available optionally octet 22 could be filled with "FF" hex and be transmitted.</p> <p>NOTE 5: If available, the mobile teleservice code according to 3GPP TS 09.02 [32]. If not available, the octet 23 is not transmitted.</p>							

**Table E.3.6: Example how field separator should be used when field is empty
Called Party Subaddress without CIN parameter**

Bits							Octets
8	7	6	5	4	3	2	
Called Party Subaddress identifier							1
Length of Called Party Subaddress contents							2
Type of subaddress = user specified, odd/even indicator							3
Operator-ID ②			Operator-ID ①				4
Operator-ID ④			Operator-ID ③				5
Field separator			Operator-ID ⑤				6
CCLID ①			Field separator				7
CCLID ③			CCLID ②				8
CCLID ⑤			CCLID ④				9
CCLID ⑦			CCLID ⑥				10
Field separator			CCLID ⑧				11
spare			spare				12
spare			spare				13
spare			spare				14
spare			spare				15
(see note)							16
							17
							18
							19
							20
							21
							22
							23
NOTE: The Octets after the final field (CCLID) of the Called Party Subaddress are reserved for national use, e.g. for authentication purposes.							

Tables E.3.7 and E.3.8 represent the Calling Party Subaddress containing an LIID with a length of only 5 octets.

Table E.3.7: Calling Party Subaddress
(fixed length of 23 octets; example with LIID of only 5 digits)

Bits							Octets
8	7	6	5	4	3	2	
Calling Party Subaddress identifier							1
Length of Calling Party Subaddress contents							2
Type of subaddress = user specified, odd/even indicator according to the amount of BCD-digits							3
LIID ②				LIID ①			4
LIID ④				LIID ③			5
Field separator				LIID ⑤			6
Field separator				Direction			7
spare				spare			8
spare				spare			9
spare				spare			10
spare				spare			11
spare				spare			12
spare				spare			13
spare				spare			14
spare				spare			15
spare				spare			16
spare				spare			17
spare				spare			18
Recommendation ITU-T Q.763 [48] TMR (see note 1)							19
Recommendation ITU-T Q.931 BC [56] octet 3 (see note 2)							20
Recommendation ITU-T Q.931 HLC [56] octet 4 (see note 3)							21
Mobile Bearer Service Code (see note 4)							22
Mobile Teleservice Code (see note 5)							23
<p>NOTE 1: If available, the Transmission Medium Requirement according to ETSI EN 300 356 [5]. If not available, the value is "FF" hex.</p> <p>NOTE 2: If available, only octet 3 of the Bearer Capability i.e. according to ETSI EN 300 403-1 [6]. If not available, the value is "FF" hex.</p> <p>NOTE 3: If available, only octet 4 of the High Layer Compatibility i.e. according to ETSI EN 300 403-1 [6]. If not available, the value is "FF" hex.</p> <p>NOTE 4: If available, the Mobile Bearer Service Code according to 3GPP TS 09.02 [32]. If not available, the octets 22 and 23 (even if the mobile teleservice code is available) are not transmitted. Optional octet 22 could be filled with "FF" hex and the Mobile Teleservice Code be transmitted.</p> <p>NOTE 5: If available, the Mobile Teleservice Code according to 3GPP TS 09.02 [32]. If not available, the octet 23 is not transmitted.</p>							

**Table E.3.8: Calling Party Subaddress
(variable length; example with LIID of only 5 digits)**

Bits							Octets
8	7	6	5	4	3	2	
Calling Party Subaddress identifier							1
Length of Calling Party Subaddress contents							2
Type of subaddress = user specified, odd/even indicator according to the amount of BCD-digits							3
LIID ②			LIID ①				4
LIID ④			LIID ③				5
Field separator			LIID ⑤				6
Field separator			Direction				7
spare (see note 6)			spare (see note 6)				8
Recommendation ITU-T Q.763 [48] TMR (see note 1)							9
Recommendation ITU-T Q.931 BC [56] octet 3 (see note 2)							10
Recommendation ITU-T Q.931 HLC [56] octet 4 (see note 3)							11
Mobile Bearer Service Code (see note 4)							12
Mobile Teleservice Code (see note 5)							13
NOTE 1: If available, the Transmission Medium Requirement according to ETSI EN 300 356 [5]. If not available, the value is "FF" hex.							
NOTE 2: If available, only octet 3 of the Bearer Capability i.e. according to ETSI EN 300 403-1 [6]. If not available, the value is "FF" hex.							
NOTE 3: If available, only octet 4 of the High Layer Compatibility i.e. according to ETSI EN 300 403-1 [6]. If not available, the value is "FF" hex.							
NOTE 4: If available, the Mobile Bearer Service Code according to 3GPP TS 09.02 [32]. If not available, the octet (even if the mobile teleservice code is available) is not transmitted. Optional this octet could be filled with "FF" hex and the Mobile Teleservice Code be transmitted.							
NOTE 5: If available, the Mobile Teleservice Code according to 3GPP TS 09.02 [32]. If not available, the octet is not transmitted.							
NOTE 6: If the number of half octets for the LIID field and the direction field including the field separators is odd, then three half octets with the spare pattern "F" are included. If the number of half octets for the LIID field and the direction field including the field separators is even, then two half octets with the spare pattern "F" are included.							

E.4 Field coding

E.4.0 General

Each field employs decimal coding, except for the Service Octets (octets 19 to 23 of the CgP Sub) and the octets reserved for national use (octets 16 to 23 of the CdP Sub). Other values are not permitted.

E.4.1 Direction

The direction field is coded as follows.

Table E.4.1: Direction coding

Indication	Value
Mono mode (combined signal) (historic)	0
CC from target	1
CC to target	2
Direction unknown	3
NOTE: CC stereo mode (values 1 and 2) is the default mode. CC mono mode (value 0) is reserved to be compatible with previous versions of the present document and it could be adopted according to national requirements.	

E.4.2 Coding of the Calling Party Number

The Network Element Identifier (NEID) is carried by the calling party number information element. The coding is as follows, depending on the type of network access (see note).

NOTE: The relevant national specification of the Signalling System Number 7 may also specify requirements on the Nature of address for national specific use in national variants of ISUP.

Table E.4.2: Calling Party Number coding

Field	Value
Numbering plan identification	ISDN/telephony numbering plan (Recommendation ITU-T E.164 [58])
Nature of address	As specified in Recommendation ITU-T Q.731.3 [63] (see note 1) (e.g. national (significant) number or international number) (in case of ISUP signalling)
Type of number	As specified in Recommendation ITU-T Q.951.1 [64] and Recommendation ITU-T Q.951.3 [65], ETSI EN 300 092 [66] (e.g. unknown, subscriber number, national number or international number), and Network Operator specific type of access (BRA or PRA) (in case of DSS1 signalling, see notes 2 and 3)
Screening indicator	Network provided (in case ISUP signalling)
Screening indicator	User-provided, not screened (in case of DSS1 signalling, see note 3)
Presentation indicator	Presentation allowed
NOTE 1: The relevant national specification of the Signalling System Number 7 may also specify requirements on the Nature of address for national specific use in national variants of ISUP.	
NOTE 2: Usually, the IIF respectively the Mediation Function is connected to the network by links using Signalling System Number 7 and ISDN User Part (ISUP), whereby the parameters are coded according to ETSI EN 300 356 [5]. But in some cases, the IIF respectively the Mediation Function may be connected via a Basic Rate Access or a Primary Rate Access using D-Channel signalling, whereby the parameters are coded according to ETSI EN 300 403-1 [6].	
NOTE 3: The network will perform screening, i.e. the number will arrive at the LEMF as "user-provided, verified and passed" with the appropriate "type of number" indicator. A network provided number is also accepted at the LEMF.	

E.5 Length of fields

The length of the identifiers is variable. The maximum and recommended minimum length of each field is given in table E.5.1.

Table E.5.1: Field length

Field	Minimum length (decimal digits)	Maximum length (decimal digits)	Maximum length (Half-Octets)	I.E.
Operator ID	2	5	5 + 1	CdP Sub
CIN	6	8	8 + 1	CdP Sub
CCLID	1	8	8 + 1	CdP Sub
LIID	2	25	25 + 1	CgP Sub
Direction	1	1	1 + 1	CgP Sub
Service Octets			10	CgP Sub

Annex F (informative): GPRS HI3 interface

F.1 Functional architecture

Figure F.1.1 contains the reference configuration for lawful interception (see 3GPP TS 03.33 [42]).

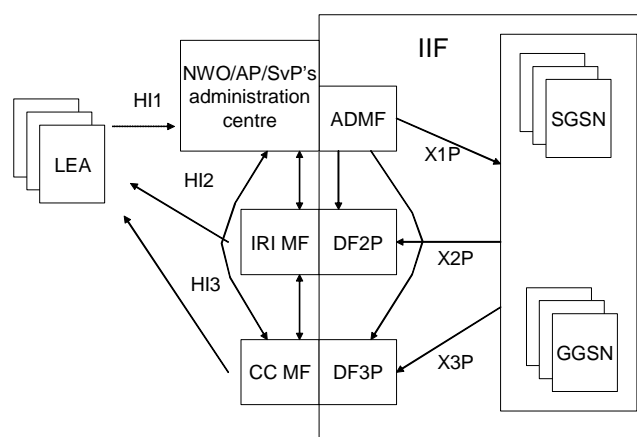

Figure F.1.1: Reference configuration

There is one ADMINISTRATION Function (ADMF) in the network. Together with the delivery functions it is used to hide from the xGSN that there might be multiple activations by different Law Enforcement Agencies (LEAs) on the same target.

NOTE: GGSN interception is a national option.

The reference configuration is only a logical representation of the entities involved in lawful interception and does not mandate separate physical entities. This allows for higher levels of integration.

A call could be intercepted based on several identities (MSISDN, IMSI, IMEI) of the same target.

For the delivery of the CC and IRI the xGSN provides a correlation number and target identity to the DF2P and DF3P which is used there to select the different LEAs where CC/IRI is delivered to.

F.2 Correlation

Correlation of GSM IDs of 3GPP TS 03.33 [42] to the present document IDs.

Warrant reference number	→	Lawful Interception Identifier (LIID).
xGSN address	→	Network Identifier (NID).

F.3 HI3 Delivery Content of Communication (CC)

F.3.0 General

There are two possible methods for delivery of Content of Communication to the LEMF:

- GPRS LI Correlation (GLIC) Header and UDP/TCP (see clause F.3.1);

- FTP/TCP (see clause F.3.2).

According to national requirements at least one of these methods have to be provided.

However, when TCP is used as across the HI3, real time delivery of the result of the interception cannot be guaranteed.

NOTE: Apart from transport layer protocol selection, real time delivery depends on network performance.

F.3.1 GPRS LI correlation header

F.3.1.1 Introduction

The header and the payload of the communication between the intercepted subscriber and the other party (later called: Information Element) are duplicated. A new header (later called: GLIC-Header, see table F.3.1) is added (see table F.3.3) before it is sent to LEMF.

Data packets with the GLIC header are sent to the LEA via UDP or TCP/IP.

F.3.1.2 Definition of GLIC header

GLIC header contains the following attributes:

- correlation number;
- message type (a value of 255 is used for HI3-PDUs);
- direction;
- sequence number;
- length;
- GPRS Support Node (GSN) type.

T-PDU contains the intercepted information.

Table F.3.1: Outline of GLIC header

Octets	Bits							
	8	7	6	5	4	3	2	1
1	Version ("0 0 0")			"1"	Spare "1"	GSN type	DIR	"0"
2	Message Type (value 255)							
3-4	Length							
5-6	Sequence Number							
7-8	not used (value 0)							
9	not used (value 255)							
10	not used (value 255)							
11	not used (value 255)							
12	not used (value 255)							
13-20	correlation number							

For interception tunnelling the GLIC header is used as follows:

- version is set to 0 to indicate the first version of GLIC header;
- DIR indicates the direction of the T-PDU:
 - "1" indicating uplink (from observed mobile user); and
 - "0" indicating downlink (to observed mobile user);

- message type is set to 255 (the unique value that is used for T-PDU within GTP (3GPP TS 09.60 [45]));
- length is the length, in octets, of the signalling message excluding the GLIC header. Bit 8 of octet 3 is the most significant bit and bit 1 of octet 4 is the least significant bit of the length field;
- sequence number is an increasing sequence number for tunnelled T-PDUs. Bit 8 of octet 5 is the most significant bit and bit 1 of octet 6 is the least significant bit of the sequence number field;

NOTE: When a handoff occurs between SGSNs, the DF3 serving the LEA may change. If the DF3 serving an LEA changes as a result of an handoff between SGSNs, contiguous sequencing may not occur as new sequencing may be initiated at the new DF3. Accordingly, the LEA should not assume that sequencing is contiguous when handoff occurs between SGSNs and the DF3 serving the LEA changes.

- correlation number consists of two parts: GGSN-ID identifies the GGSN which creates the Charging-ID:
 - Charging-ID is defined in 3GPP TS 09.60 [45] and assigned uniquely to each PDP context activation on that GGSN (4 octets).
 - The correlation number consists of 8 octets and guarantees a unique identification of the tunnel to the LEA over a long time. The requirements for this identification are similar to that defined for charging in 3GPP TS 09.60 [45], clause 5.4. Therefore it is proposed to use the Charging-ID, defined in 3GPP TS 09.60 [45], clause 5.4 as part of correlation number. The Charging-ID is signalled to the new SGSN in case of SGSN-change so the tunnel identifier could be used "seamlessly" for the HI3 interface.

Table F.3.2: Outline of correlation number

0	1	2	3	4	5	6	7	8	9	0	1	2	3	4	5	6	7	8	9	0	1	2	3	4	5	6	7	8	9	0	1	3			
Charging-ID Octet 1								Charging-ID Octet 2								Charging-ID Octet 3								Charging-ID Octet 4								Octets			
																GGSN-ID																13-16		17-20	

The GLIC header is followed by a subsequent payload information element. Only one information element is allowed in a single signalling message.

Table F.3.3: GLIC header followed by the subsequent payload Information Element (IE)

Octets	Bits							
	8	7	6	5	4	3	2	1
1-20	GLIC- Header							
21-n	Information Element							

- GPRS Support Node (GSN) type. Indicates whether the T-PDU was intercepted in the GGSN or in the SGSN: "0" indicating GGSN; and "1" indicating SGSN.

This parameter is needed only in case the GGSN and the SGSN use the same Delivery Function/Mediation Function for the delivery of Content of Communication (CC).

The Information Element (IE) contains the header and the payload of the communication between the intercepted subscriber and the other party.

F.3.1.3 Exceptional procedure

With UDP and GLIC: the delivering node does not take care about any problems at LEMF.

With TCP and GLIC: TCP tries to establish a connection to LEMF and resending (buffering in the sending node) of packets is also supported by TCP.

In both cases it might happen that call content gets lost (in case the LEMF or the transit network between MF and LEMF is down for a long time).

F.3.1.4 Other considerations

The use of IPsec for this interface is recommended.

The required functions in LEMF are:

- Collecting and storing of the incoming packets in line with the sequence numbers.
- Correlating of CC to IRI with the use of the correlation number in the GLIC header.

F.3.2 FTP

F.3.2.1 Introduction

At HI3 interface FTP is used over the Internet protocol stack for the delivery of the result of interception. FTP is defined in IETF RFC 959 [46]. The IP is defined in IETF RFC 791 [51]. The TCP is defined in IETF RFC 793 [52].

FTP supports reliable delivery of data. The data may be temporarily buffered in the sending node (MF) in case of link failure. FTP is independent of the payload data it carries.

F.3.2.2 Usage of the FTP

In the packet data LI the MF acts as the FTP client and the receiving node (LEMF) acts as the FTP server. The client pushes the data to the server.

The receiving node LEMF stores the received data as files. The sending entity (MF) may buffer files.

Several smaller intercepted data units may be gathered to bigger packages prior to sending, to increase bandwidth efficiency.

The following configurable intercept data collection (= transfer package closing/file change) threshold parameters should be supported:

- frequency of transfer, based on send timeout, e.g. X ms;
- frequency of transfer, based on volume trigger, e.g. X octets.

There are two possible ways how the interception data may be sent from the MF to the LEMF. One way is to produce files that contain interception data only for one observed target (ref: "File naming method A"). The other way is to multiplex all the intercepted data that MF receives to the same sequence of general purpose interception files sent by the MF (ref: "File naming method B").

The HI2 and HI3 are logically different interfaces, even though in some installations the HI2 and HI3 packet streams might also be delivered via a common transmission path from a MF to a LEMF. It is possible to correlate HI2 and HI3 packet streams by having common (referencing) data fields embedded in the IRI and the CC packet streams.

File naming:

The names for the files transferred to a LEA are formed according to one of the 2 available formats, depending on the delivery file strategy chosen (e.g. due to national convention or operator preference).

Either each file contains data of only one observed target (as in method A) or several targets' data is put to files common to all observed target traffic through a particular MF node (as in method B).

The maximum set of allowed characters in interception file names are "a"..."z", "A"..."Z", "-", "_", ".", and decimals "0"..."9".

File naming method A):

<LIID>_<seq>.<ext>

- LIID** = as defined in the present document. This field has a character string value, e.g. "ABCD123456". This is a unique interception request identifier allocated by the ADMF. It will be given by the ADMF to the LEA via the HI1 interface after the ADMF has been authorized to command the start of the interception of a specific target. The possible network operator identifier part used should be agreed with (and allocated by) the regulatory organization administrating the local telecommunication practises.
- seq** = integer ranging between $[0..2^{64}-1]$, in ASCII form (not exceeding 20 ASCII digits), identifying the sequence number for file transfer from this node per a specific target.
- ext** = ASCII integer ranging between ["1"..."8"] (in hex: 31H...38H), identifying the file type. The possible file type codings for intercepted data are shown in table F.3.4. The types "2", "4", and "6" are reserved for the HI3 interface and type "8" is reserved for data files according to a national requirement by using the same file naming concept.

Table F.3.4: Possible file types

File types that the LEA may get	Intercepted data types
"1" (in binary: 0011 0001)	IRI/ as option HI1 notifications (see clause C.2.2)
"2" (in binary: 0011 0010)	CC (MO)
"4" (in binary: 0011 0100)	CC (MT)
"6" (in binary: 0011 0110)	CC (MO&MT)
"7" (in binary: 0011 0111)	IRI + CC (MO&MT)
"8" (in binary: 0011 1000)	for national use

The least significant bit that is "1" in file type 1, is reserved for indicating IRI data and may be used for indicating that the HI2 and HI3 packet streams are delivered via a common transmission path from a MF to a LEMF.

The bit 2 of the **ext** tells whether the Mobile Originated (MO) Content of Communication (CC) is included to the intercepted data.

The bit 3 of the **ext** tells whether the Mobile Terminated (MT) Content of Communication (CC) is included to the intercepted data.

The bit 4 of the **ext** tells whether the intercepted data is according to a national requirement.

Thus, for Mobile Originated Content of Communication data, the file type is "2", for MT CC data "4", for MO&MT CC data "6" and for "national use" data the file type is "8".

Thus, for Mobile Originated Content of Communication data, the file type is "2", for MT CC data "4" and for MO&MT CC data "6".

When HI2 and HI3 packet streams are delivered via a common transmission path from a MF to a LEMF, then the file type is "7", that indicates the presence of both the IRI and the CC(MO&MT) data.

This alternative A is used when each target's intercepted data is gathered per observed target to dedicated delivery files. This method provides the result of interception in a very refined form to the LEAs, but requires somewhat more resources in the sending node than alternative B. With this method, the data sorting and interpretation tasks of the LEMF are considerably easier to facilitate in near real time than in alternative B.

File naming method B):

The other choice is to use monolithic fixed format file names (with no trailing file type part in the file name):

<filenamestring> of the format ABXYyymmddhhmssseeeet

where:

AB = Two letter ASCII Operator ID (as agreed with the national telecom regulators).
XY = Two letter ASCII identification of the MF node (as assigned by the operator).
yy = Two digits ASCII integer ranging between ["00"..."99"], identifying the last two digits of the year.
mm = Two digits ASCII integer ranging between ["01"..."12"], identifying the month.
dd = Two digits ASCII integer ranging between ["01"..."31"], identifying the day.
hh = Two digits ASCII integer ranging between ["00"..."23"], identifying the hour.
mm = Two digits ASCII integer ranging between ["00"..."59"], identifying the minute.
ss = Two digits ASCII integer ranging between ["00"..."59"], identifying the second.
eeee = Alphanumeric extension made up of four characters chosen at the discretion of the Operator and/or the MF to avoid file name clashes within the MF. Each of the position is out of "A"..."Z", "0"..."9".
t = ASCII integer ranging between ["1"..."8"] (in hex: 31H...38H), identifying the file type. The possible file type codings for intercepted data are shown in table F.3.4.

EXAMPLE: <filenamestring> (e.g. ABXY00041014084400006).

where:

ABXY = Source node identifier part, used for all files by the mobile network operator "AB" from this MF node named "XY".
00 = year 2000.
04 = month April.
10 = day 10.
14 = hour.
08 = minutes.
44 = seconds.
0000 = extension.
6 = file type. Coding: "2" = CC (MO), "4" = CC (MT), "6" = CC (MO&MT), "8" = national use. The type "1" is reserved for IRI data files and may be used for indicating that the HI2 and HI3 packet streams are delivered via a common transmission path from a MF to a LEMF. In such case, the file type is "7", that indicates the presence of both the IRI and the CC(MO&MT) data.

This alternative B is used when several targets' intercepted data is gathered to common delivery files. This method does not provide the result of interception in as refined form to the LEAs as the alternative A, but it is faster in performance for the MF point of view. With this method, the MF does not need to keep many files open like in alternative A.

F.3.2.3 Profiles

NOTE: This clause is informative only.

As there are several ways (usage profiles) how data transfer can be arranged by using the FTP, this clause contains practical considerations how the communications can be set up. Guidance is given for client-server arrangements, session establishments, time outs, the handling of the files (in RAM or disk). Example batch file is described for the case that the sending FTP client uses files. If instead (logical) files are sent directly from the client's RAM memory, then the procedure can be in principle similar though no script file would then be needed.

At the LEMF side, FTP server process is run, and at MF, FTP client. No FTP server (which could be accessed from outside the operator network) is run in the MF. The FTP client can be implemented in many ways, and here the FTP usage is presented with an example only. The FTP client can be implemented by a batch file or a file sender program that uses FTP via an API. The login needs to occur only once per e.g. <destaddr> and <leouser> - pair. Once the login is done, the files can then be transferred just by repeating "mput" command and checking the transfer status (e.g. from the API routine return value). To prevent inactivity timer triggering, a dummy command (e.g. "pwd") can be sent every T seconds (T should be less than L, the actual idle time limit). If the number of FTP connections is wanted to be as minimized as possible, the FTP file transfer method "B" is to be preferred to the method A (though the method A helps more the LEMF by pre-sorting the data sent).

Simple example of a batch file extract:

FTP commands usage scenario for transferring a list of files:

To prevent FTP cmd line buffer overflow the best way is to use wildcarded file names, and let the FTP implementation do the file name expansion (instead of shell). The number of files for one mput is not limited this way:

```
ftp <flags> <destaddr>
user <leouser> <leapasswd>
cd <destpath>
lcd <srcpath>
bin
mput <files>
nlist <lastfile> <checkfile>
close
EOF
```

This set of commands opens an FTP connection to a LEA site, logs in with a given account (auto-login is disabled), transfers a list of files in binary mode, and checks the transfer status in a simplified way.

Brief descriptions for the FTP commands used in the example:

user <user-name> <password>	Identify the client to the remote FTP server.
cd <remote-directory>	Change the working directory on the remote machine to remote-directory.
lcd <directory>	Change the working directory on the local machine.
bin	Set the file transfer type to support binary image transfer
mput <local-files>	Expand wild cards in the list of local files given as arguments and do a put for each file in the resulting list. Store each local file on the remote machine.
nlist <remote-directory> <local-file>	Print a list of the files in a directory on the remote machine. Send the output to local-file.
close	Terminate the FTP session with the remote server, and return to the command interpreter. Any defined macros are erased.

The parameters are as follows:

<flags> contains the FTP command options, e.g. "-i -n -V -p" which equals to "interactive prompting off", "auto-login disabled", "verbose mode disabled", and "passive mode enabled". (These are dependent on the used ftp-version.)

<destaddr> contains the IP address or DNS address of the destination (LEA).

<leouser> contains the receiving (LEA) username.

<leapasswd> contains the receiving (LEA) user's password.

<destpath> contains the destination path.

<srcpath> contains the source path.

<files> wild carded file specification (matching the files to be transferred).

<lastfile> the name of the last file to be transferred.

<checkfile> is a (local) file to be checked upon transfer completion; if it exists then the transfer is considered successful.

The FTP application should do the following things if the check file is not found:

- keep the failed files;
- raise "file transfer failure" error condition (i.e. send alarm to the corresponding LEA);
- the data can be buffered for a time that the buffer size allows. If that would finally be exhausted, DF would start dropping the corresponding target's data until the transfer failure is fixed;
- the transmission of the failed files is retried until the transfer eventually succeeds. Then the DF would again start collecting the data;
- upon successful file transfer the sent files are deleted from the DF.

The FTP server at LEMF is not allowed anonymous login of an FTP client.

It is required that FTP implementation guarantees that LEMF will start processing data only after data transfer is complete.

The following implementation example addresses a particular issue of FTP implementation. It is important however to highlight that there are multiple ways of addressing the problem in question, and therefore the given example does not in any way suggest being the default one.

- MF sends data with a filename, which indicates that the file is temporary. Once data transfer is complete, MF renames temporary file into ordinary one (as defined in clause F.3.2.2).

The procedure for renaming filename should be as follow:

- 1) open FTP channel (if not already open) from MF to LEMF;
- 2) sends data to LEMF using command "put" with temporary filename;
- 3) after MF finished to send the file, renaming it as ordinary one with command "ren".

Brief descriptions for the FTP commands used in the example:

ren <from-name> <to-name> renaming filename from-name to to-name.

If the ftp-client want to send file to LEMF using the command "mput" (e.g. MF stored many IRI files and want to send all together with one command), every filename transferred successfully is renamed each after command "mput" ended.

F.3.2.4 Exceptional procedures

Overflow at the receiving end (LEMF) is avoided due to the nature of the protocol.

In case the transit network or receiving end system (LEMF) is down for a reasonably short time period, the local buffering at the MF will be sufficient as a delivery reliability backup procedure.

In case the transit network or receiving end system (LEMF) is down for a very long period, the local buffering at the MF may have to be terminated. Then the following intercepted data coming from the intercepting nodes towards the MF would be discarded, until the transit network or LEMF is up and running again.

F.3.2.5 CC contents for FTP

F.3.2.5.1 Fields

The logical contents of the CC-header are described here.

CC-header = (Version, HeaderLength, PayloadLength, PayloadType, PayloadTimeStamp, PayloadDirection, CCSeqNumber, CorrelationNumber, LIID, PrivateExtension).

The Information Element CorrelationNumber forms the means to correlate the IRI and CC of the communication session intercepted.

The first column indicates whether the Information Element (IE) referred is Mandatory, Conditional or Optional.

The second column is the Type in decimal.

The third column is the length of the Value in octets.

(Notation used in table F.3.5: M = Mandatory, O = Optional, C = Conditional.)

Table F.3.5: Information Elements in the first version of the CC header

Mode	Type	Length	Value
M	130	2	Version = The version number of the format version to be used. This field has a decimal value, this enables version changes to the format version. The values are allocated according to national conventions.
O	131	2	HeaderLength = Length of the CC-header up to the start of the payload in octets. (This field is optional since it is useful only in such cases that these information elements would be transferred without a dynamic length encapsulation that contains all the length information anyway. This field could be needed in case of e.g. adapting to a local encapsulation convention.)
O	132	2	PayloadLength = Length of the payload following the CC-header. (This field is optional since it is useful only in such cases that these information elements would be transferred without a dynamic length encapsulation that contains all the length information anyway. This field could be needed in case of e.g. adapting to a local encapsulation convention.)
M	133	1	PayloadType = Type of the payload, indicating the type of the CC. Type of the payload. This field has a decimal value. The possible PDP Type values can be found in the standards, e.g. 3GPP TS 09.60 [45]. The value 255 is reserved for future PDP Types and means: "Other".
O	134	4	PayloadTimeStamp = Payload timestamp according to intercepting node. (Precision: 1 s, timezone: UTC). Format: Seconds since 1970-01-01 as in e.g. Unix (length: 4 octets).
C	137	1	PayloadDirection = Direction of the payload data. This field has a decimal value 0 if the payload data is going towards the target (i.e. downstream), or 1 if the payload data is being sent from the target (i.e. upstream). If this information is transferred otherwise, e.g. in the protocol header, this field is not required as mandatory. If the direction information is not available otherwise, it is mandatory to include it here in the CC header.
O	141	4	CCSeqNumber = Identifies the sequence number of each CC packet during interception of the target. This field has a 32-bit value.
M	144	8 or 20	CorrelationNumber = Identifies an intercepted session of the observed target. This can be implemented by using e.g. the Charging Id (4 octets, see 3GPP TS 12.15 [49]) with the (4-octet/16-octet) Ipv4/Ipv6 address of the PDP context maintaining GGSN node attached after the first 4 octets.
			<Possible future parameters are to be allocated between 145 and 253>.
O	254	1-25	LIID = Field indicating the LIID as defined in the present document. This field has a character string value, e.g. "ABCD123456".
O	255	1-N	PrivateExtension = An optional field. The optional Private Extension contains vendor or LEA or operator specific information. It is described in 3GPP TS 09.60 [45].

Table F.3.6: Information Elements in the second version of the CC header

Mode	Type	Length	Value
M	130	2	Version = The version number of the format version to be used. This field has a decimal value, this enables version changes to the format version. The values are allocated according to national conventions.
O	131	2	HeaderLength = Length of the CC-header up to the start of the payload in octets. (This field is optional since it is useful only in such cases that these information elements would be transferred without a dynamic length encapsulation that contains all the length information anyway. This field could be needed in case of e.g. adapting to a local encapsulation convention.)
O	132	2	PayloadLength = Length of the payload following the CC-header in octets. (This field is optional since it is useful only in such cases that these information elements would be transferred without a dynamic length encapsulation that contains all the length information anyway. This field could be needed in case of e.g. adapting to a local encapsulation convention.)
M	133	1	PayloadType = Type of the payload, indicating the type of the CC. Type of the payload. This field has a decimal value. The possible PDP Type values can be found in the standards (e.g. 3GPP TS 29.060 [60]). The value 255 is reserved for future PDP Types and means: "Other".
O	134	4	PayloadTimeStamp = Payload timestamp according to intercepting node. (Precision: 1 second, timezone: UTC). Format: Seconds since 1970-01-01 as in e.g. Unix (length: 4 octets).
C	137	1	PayloadDirection = Direction of the payload data. This field has a decimal value 0 if the payload data is going towards the target (i.e. downstream), or 1 if the payload data is being sent from the target (i.e. upstream). If this information is transferred otherwise, e.g. in the protocol header, this field is not required as mandatory. If the direction information is not available otherwise, it is mandatory to include it here in the CC header.
O	141	4	CCSeqNumber = Identifies the sequence number of each CC packet during interception of the target. This field has a 32-bit value.
M	144	8 or 20	CorrelationNumber = Identifies an intercepted session of the observed target. This can be implemented by using e.g. the Charging Id (4 octets, see ETSI EN 300 097-1 [14]) with the (4-octet/16-octet) Ipv4/Ipv6 address of the PDP context maintaining GGSN node attached after the first 4 octets.
			<Possible future parameters are to be allocated between 145 and 250>
M	251	2	MainElementID = Identifier for the TLV element that encompasses one or more HeaderElement-PayloadElement pairs for intercepted packets.
M	252	2	HeaderElementID = Identifier for the TLV element that encompasses the CC-header of a PayloadElement.
M	253	2	PayloadElementID = Identifier for the TLV element that encompasses one intercepted Payload packet.
O	254	1-25	LIID = Field indicating the LIID as defined in the present document. This field has a character string value, e.g. "ABCD123456".
O	255	1-N	PrivateExtension = An optional field. The optional Private Extension contains vendor or LEA or operator specific information. It is described in 3GPP TS 29.060 [60].

F.3.2.5.2 Information Element syntax

The dynamic TypeLengthValue (TLV) format is used for its ease of implementation and good encoding and decoding performance. Subfield sizes: Type = 2 octets, Length = 2 octets and Value = 0...N octets. From Length the T and L subfields are excluded. The Type is different for every different field standardized.

The octets in the Type and Length subfields are ordered in the little-endian order, (i.e. least significant octet first). Any multi-octet Value subfield is also to be interpreted as being little-endian ordered (word/double word/long word) when it has a (hexadecimal 2/4/8-octet) numeric value, instead of being specified to have an ASCII character string value. This means that the least significant octet/word/double word is then sent before the more significant octet/word/double word.

TLV encoding:

<u>T</u> ype (2 octets)	<u>L</u> ength (2 octets)	<u>V</u> alue (0-N octets)
-------------------------	---------------------------	----------------------------

TLV encoding can always be applied in a nested fashion for structured values.

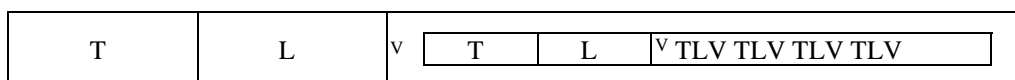

NOTE: The small "V" refers to the start of a Value field that has inside it a nested structure.

In figure F.3.1, the TLV structure for GPRS HI3 transfer is presented for the case that there is just one intercepted packet inside the CC message. (There can be more CC Header IEs and CC Payload IEs in the CC, if there are more intercepted packets in the same CC message.)

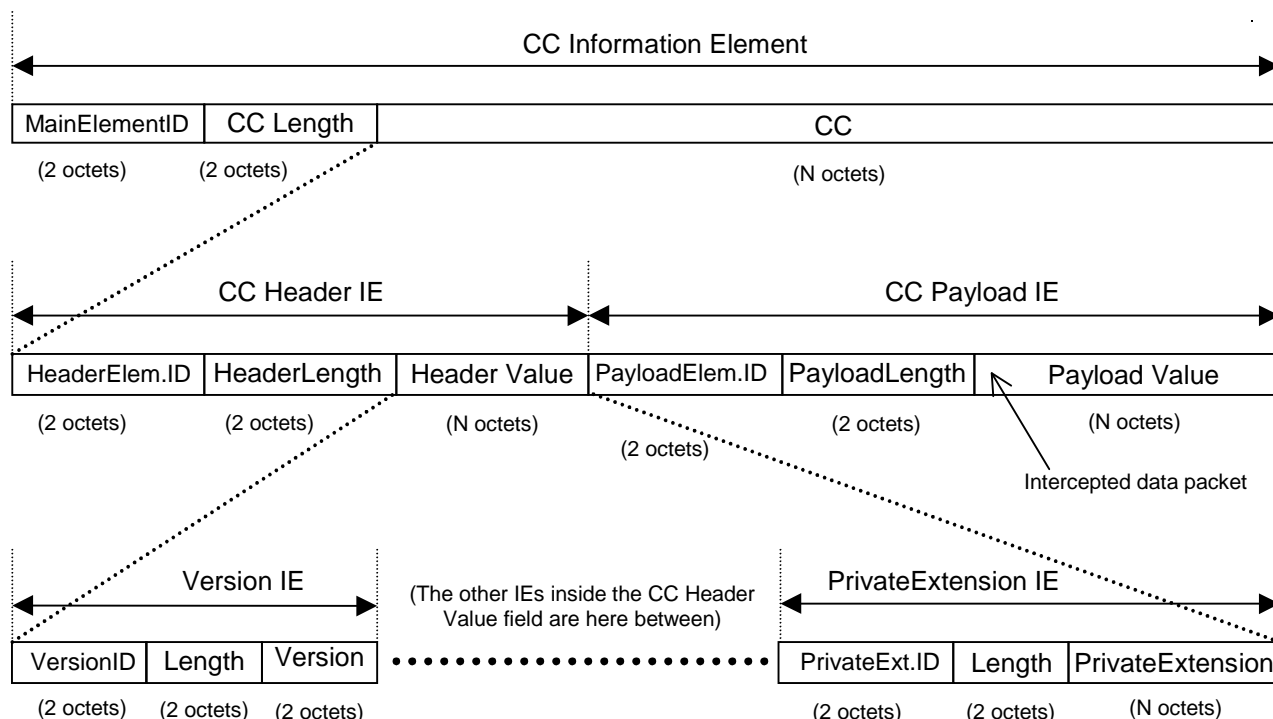

Figure F.3.1: IE structure of a CC message that contains one intercepted packet

The first octet of the first TLV element will start right after the last octet of the header of the protocol that is being used to carry the CC information.

The first TLV element (i.e. the main TLV IE) comprises the whole dynamic length CC information, i.e. the dynamic length CC header and the dynamic length CC payload.

Inside the main TLV IE there are at least 2 TLV elements: the Header of the payload and the Payload itself. The Header contains all the ancillary IEs related to the intercepted CC packet. The Payload contains the actual intercepted packet.

There may be more than one intercepted packet in one GPRS HI3 delivery protocol message. If the Value of the main TLV IE is longer than the 2 (first) TLV Information Elements inside it, then it is an indication that there are more than one intercepted packets inside the main TLV IE (i.e. 4 or more TLV IEs in total). The number of TLV IEs in the main TLV IE is always even, since for every intercepted packet there is one TLV IE for header and one TLV IE for payload.

F.3.2.6 Other considerations

The FTP protocol mode parameters used:

- transmission mode: stream;
- format: non-print;
- structure: file-structure;
- type: binary.

The FTP service command to define the file system function at the server side: STORE mode for data transmission.

The FTP client- (= user - FTP process at the MF) uses e.g. the default standard FTP ports 20 (for data connection) and 21 (for control connection), "passive" mode is supported. The data transfer process listens the data port for a connection from a server-FTP process.

For the file transfer from the MF to the LEMF(s) e.g. the following data transfer parameters are provided for the FTP client (at the MF):

- transfer destination (IP) address, e.g. "194.89.205.4";
- transfer destination username, e.g. "LEA1";
- transfer destination directory path, e.g. "/usr/local/LEA1/1234-8291";
- transfer destination password;
- interception file type, e.g. "2" (this is needed only if the file naming method A is used).

LEMF may use various kind directory structures for the reception of interception files. It is strongly recommended that at the LEMF machine the structure and access and modification rights of the storage directories are adjusted to prevent unwanted directory operations by a FTP client.

The use of IPSec services for this interface is recommended.

Timing considerations for the FTP transmission:

The MF and LEMF sides control the timers to ensure reliable, near-real time data transfer. The transmission related timers are defined within the lower layers of the used protocol and are out of scope of the present document.

The following timers may be used within the LI application.

Name	Controlled by	Units	Description
T1 inactivity timer	LEMF	Seconds	Triggered by no activity within the FTP session (no new files). The FTP session is torn down when the T1 expires. To send another file the new connection will be established. The timer avoids the FTP session overflow at the LEMF side.
T2 send file trigger	MF	Milliseconds	Forces the file to be transmitted to the LEMF (even if the size limit has not been reached yet in case of volume trigger active). If the timer is set to 0 the only trigger to send the file is the file size parameter (see clause C.2.2).

Annex G (informative): LEMF requirements - handling of unrecognized fields and parameters

During decoding of a record at the LEA, the following exceptional situations may occur:

- 1) Unrecognized parameter: The parameter layout can be recognized, but its name is not recognized:
The parameter is ignored, the processing of the record proceeds.
- 2) The parameter content or value is not recognized or not allowed:
The parameter is ignored, the processing of the record proceeds.
- 3) The record cannot be decoded (e.g. it seems to be corrupted):
The whole record is rejected when using ROSE delivery mechanism or ignored.

NOTE: In cases 2 and 3, the LEMF may wish to raise an alarm to the NWO/AP/SvP administration centre. For case 1, no special error or alarm procedures need be started at the LEA because the reason may be the introduction of a new version of the specification in the network, not be an error as such security aspects.

Annex H (informative): IP Multimedia Subsystem (IMS) handover

H.0 General

This annex deals with IRI reporting in the IMS. IRI reporting in multi-media domain specified in this clause does not depend on the IP-Connectivity Access Network IP-CAN 3GPP TS 23.228 [70] used to transport the CC. When the IP-CAN is the UMTS PS domain, annex B applies for CC interception at the SGSN/GGSN.

According to 3GPP TS 33.107 [71], interception has to be supported in P-CSCF and S-CSCF. For the identification of the intercepted traffic only the SIP-URL and TEL-URL are available. In the intercepting nodes (CSCFs) the relevant SIP-Messages are duplicated and forwarded to the MF HI2.

For clarification see figure H.0.1. If P-CSCF and S-CSCF are in the same network the events are sent twice to the LEMF.

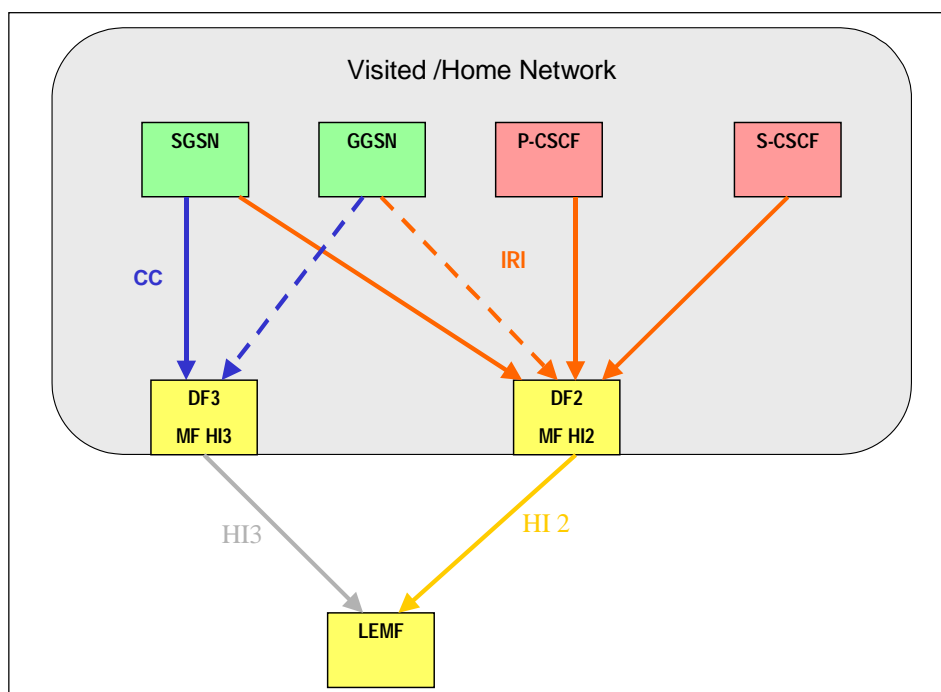

NOTE: GGSN interception is a national option.

Figure H.0.1: IRI Interception at a CSCF

H.1 Specific identifiers for LI

H.1.0 General

Specific identifiers are necessary to identify a target for interception uniquely and to correlate between the data, which is conveyed over the different handover interfaces (HI2 and HI3). The identifiers are defined in the clauses below.

For the delivery of CC and IRI the SGSN, GGSN and CSCFs (Call Session Control Function) provide correlation numbers and target identities to the HI2 and HI3. The correlation number provided in the PS domain (SGSN, GGSN) is unique per PDP context and is used to correlate CC with IRI and the different IRIs of one PDP context.

Interception is performed on an IMS identifier(s) associated with the intercept subject including identifiers such as SIP-URL and Tel-URL, IETF RFC 3966 [68].

H.1.1 Lawful interception identifier

For each target identity related to an interception measure, the authorized operator (NWO/AP/SvP) assigns a special LIID, which has been agreed between the LEA and the operator (NWO/AP/SvP).

Using an indirect identification, pointing to a target identity makes it easier to keep the knowledge about a specific interception target limited within the authorized operator (NWO/AP/SvP) and the handling agents at the LEA.

The LIID is a component of the CC delivery procedure and of the IRI records. It is used within any information exchanged at the handover interfaces HI2 and HI3 for identification and correlation purposes.

The LIID format consists of alphanumeric characters. It might for example, among other information, contain a lawful authorization reference number, and the date, when the lawful authorization was issued.

The authorized operator (NWO/AP/SvP) is either enter, based on an agreement with each LEA, a unique LIID for each target identity of the interception subject or a single LIID for multiple target identities all pertaining to the same interception subject.

Note that, in order to simplify the use of the LIID at LEMF for the purpose of correlating IMS signalling with GSN CC, the use of a single LIID in association with potentially numerous IMS identities (SIP and TEL URIs) is recommended.

If more than one LEA intercepts the same target identity, there are unique LIIDs assigned relating to each LEA.

In case the LIID of a given target has different values in the GSN and in the CSCF, it is up to the LEMF to recover the association between the two LIIDs.

H.1.2 Network identifier

The network identifier (NID) is a mandatory parameter; it should be internationally unique. It consists of the following two identifiers.

- 1) Operator- (NWO/AP/SvP) identifier (mandatory):
Unique identification of network operator, access network provider or service provider.
- 2) Network element identifier NEID (optional):
The purpose of the network element identifier is to uniquely identify the relevant network element carrying out the LI operations, such as LI activation, IRI record sending, etc.

A network element identifier may be an IP address or other identifier.

H.1.3 Correlation number

The GPRS Correlation Number is unique per PDP context and used for the following purposes:

- correlate CC with GPRS Support Node (GSN) IRI;
- correlate different GSN IRI records within one PDP context.

As an example, in the UMTS system, the GPRS Correlation Number may be the combination of GGSN address and charging ID.

NOTE 1: It is an implementation matter how CSCF generates Correlation number value. However, in this release CSCF should use `gPRSCorrelationNumber` ASN.1 parameter as a container.

If two PDP contexts are used for the communication (one for signalling and one for bearer) also two correlation numbers may be delivered via the CSCFs.

Different identifiers may be used for correlating target's various SIP messages such as:

- LIID;
- implementation dependent number.

NOTE 2: The implementation dependent number may be e.g. a "Call-id". However, when CSCF acts as a back-to-back user agent CSCF can have different "Call-id" values for different legs of signalling. Therefore some other number would be needed in such a case.

NOTE 3: The LIID may be used to associate SIP messages with respective GSN IRI records. In case the target has a single SIP session active, the LIID is sufficient to correlate IMS IRI records with GSN IRI records. In case the target has multiple SIP sessions active, a combination of the LIID and an implementation dependent number may be used to correlate the IMS IRI records with the GSN IRI records.

In case the LIID of a given target has different values in the GSN and in the CSCF, it is up to the LEMF to recover the association between the two LIIDs.

SIP correlation number is used to correlate events of one specific SIP session.

H.1.4 IRI for IMS

H.1.4.0 General

In addition, information on non-transmission related actions of a target constitute IRI and is sent via HI2, e.g. information on subscriber controlled input.

The IRI may be subdivided into the following categories:

- 1) Control information for HI2 (e.g. correlation information).
- 2) Basic data context information, for standard data transmission between two parties (e.g. SIP-message).

For each event, a Record is sent to the LEMF, if this is required. The following table gives the mapping between event type received at DF2 level and record type sent to the LEMF.

Table H.1.1: Mapping between IMS Events and HI2 Records Type

Event	IRI Record Type
SIP-Message	REPORT

A set of information is used to generate the record. The records used transmit the information from mediation function to LEMF. This set of information can be extended in the CSCF or DF2 MF, if new IEs are available and if this is necessary in a specific country. The following table gives the mapping between information received per event and information sent in records.

Once IRI only interception is underway, LEMF receives IMS specific IRI only (SIP IRI) from CSCF. LEMF does not receive CC, and therefore it is not possible to correlate IMS specific IRI with CC.

Once IRI and CC interception is underway, LEMF receives IMS specific IRI both from a GSN and from a CSCF. LEMF receives SIP messages also from a GSN within CC. In certain cases, however, SIP messages within CC may be encrypted between UE and CSCF. In these cases LEMF needs to receive unencrypted SIP IRI straight from CSCF.

Table H.1.2: Mapping between IMS Events Information and IRI Information

Parameter	Description	HI2 ASN.1 parameter
Observed SIP URI	Observed SIP URI	partyInformation (sip-uri)
Observed TEL URL	Observed TEL URL	partyInformation (tel-uri)
Event type	IMS Event	iMSevent
Event date	Date of the event generation in the CSCF	timeStamp
Event time	Time of the event generation in the CSCF	
Network identifier	Unique number of the intercepting CSCF	networkIdentifier
Correlation number	Unique number for each PDP context delivered to the LEMF, to help the LEA, to have a correlation between each PDP Context and the IRI. Parameter of Rel. 5 and on	gPRSCorrelationNumber
Correlation	<p>Correlation number; unique number for each PDP context delivered to the LEMF, to help the LEA, to have a correlation between each PDP Context and the IRI. ASN.1 as: iri-to-CC</p> <p>Signalling PDP context correlation number; unique number for signalling PDP context delivered to the LEMF, to help the LEA, to have a correlation between each PDP Context and the IRI. Used in the case two PDP contexts are used. ASN.1 as: iri-to-CC</p> <p>SIP correlation number; either Call-id or some implementation dependent number that uniquely identify SIP messages of the same SIP session. ASN.1 as: iri-to-iri</p>	correlation
Lawful interception identifier	Unique number for each lawful authorization.	lawfulInterceptionIdentifier
SIP message	Either whole SIP message, or SIP message header (plus SDP body, if any). SIP message header (plus SDP) is used if warrant requires only IRI. In such case, specific content in the SIPMessage (e.g. "Message", etc.) is deleted; unknown headers are not deleted	SIPMessage

NOTE 1: LIID parameter is present in each record sent to the LEMF.

NOTE 2: Details for the parameter SIP message. If the warrant requires only signalling information, specific content in the parameter "SIP message" like IMS (Immediate Messaging) has to be deleted/filtered.

NOTE 3: In case of IMS event reporting, the gPRSCorrelationNumber HI2 ASN.1 parameter, which is also used in the IRIs coming from PS nodes, is used as container.

H.1.4.1 Events and information

This clause describes the information sent from the Delivery Function (DF) to the Law Enforcement Monitoring Facility (LEMF) to support Lawfully Authorized Electronic Surveillance (LAES). The information is described as records and information carried by a record. This focus is on describing the information being transferred to the LEMF.

The IRI events and data are encoded into records as defined in the table H.1.1 Mapping between IMS Events and HI2 Records Type and clause B.3 Intercept related information (HI2). IRI is described in terms of a "causing event" and information associated with that event. Within each IRI Record there is a set of events and associated information elements to support the particular service.

The communication events described in table H.1.1: Mapping between the IMS Event and HI2 Record Type and table H.1.2: Mapping between IMS Events Information and IRI Information convey the basic information for reporting the disposition of a communication. This clause describes those events and supporting information.

Each record described in this clause consists of a set of parameters. Each parameter is either:

Mandatory (M): required for the record;

Conditional (C): required in situations where a condition is met (the condition is given in the Description); or

Optional (O): provided at the discretion of the implementation.

The information to be carried by each parameter is identified. Both optional and conditional parameters are considered to be OPTIONAL syntactically in ASN.1 Stage 3 descriptions. The Stage 2 inclusion takes precedence over Stage 3 syntax.

Table H.1.3: SIP-Message REPORT Record

Parameter	MOC	Description/Conditions
observed SIP-URI	C	SIP URI of the interception target (if available)
observed TEL-URL	C	TEL URL of the interception target (if available)
event type	M	Provide IMS event type
event date	M	Provide the date and time the event is detected
event time		
network identifier	M	To be provided
lawful intercept identifier	M	To be provided
correlation number	O	If available and not included in the SIP-message
correlation	O	If applicable for this communication
SIP message	M	The relevant SIP message or SIP message header

H.1.5 Correlation indications of IMS IRI with GSN CC at the LEMF

This clause is informative and provides some guidelines pertaining to correlating IMS IRI with GSN CC at the LEMF.

For IMS-enabled multimedia communication scenarios involving a lawful intercept target, it will be necessary for the LEMF to be able to correlate the media streams (as provided in the CC intercepted by the GSN) with the specific SIP signalling (as provided in the IRI intercepted by the CSCFs) used to establish those media streams. The principal reason for this is that the Session Description Protocol (SDP) content within the SIP signalling may provide the information required to even be able to decode the media streams. In certain cases, for example, the information in the RTP header within the media stream packets may not be sufficient to be able to determine the specific encoding used. The SDP portion of the SIP signalling would need to provide this information. Another important reason is that the SIP signalling provides information about the participants in a SIP session (other than the target) sending and receiving the associated media streams. The LIID parameter in the IMS IRI and GSN CC can be used to correlating all of the IMS IRI and all of the GSN CC associated with a particular target. If a single LIID is used in association all of the target's IMS identities (as per a NWO/AP/SvP agreement with the LEA), the process of associating the IMS IRI and GSN CC information is fairly straightforward. If, however, multiple LIIDs are used (e.g. one per IMS identity) then the LEMF needs to be able to associate each of the LIIDs that may be used for the IMS IRI with the LIID used for the CC.

The SIP messages provided to the LEMF would contain a number of additional items of information that could be relevant with respect to supporting correlations of various types. Their potential role in correlating IMS IRI and GSN CC (or, more specifically, correlating SIP dialogs with media streams) is discussed below:

- **Call-ID, From tag, To tag:** These SIP headers would identify different SIP messages belonging to the same SIP dialog (a call leg between the target user and a peer SIP user). It should be noted that the Call-ID alone is not sufficient to identify a dialog. Correlating specific SIP dialogs with specific media streams is the principal objective of this discussion.
- **P-Charging-Vector (IMS Charging ID):** The principal purpose of the IMS Charging ID (ICID) in IMS is to correlate charging information provided by different network entities for the same call. The ICID could be useful in correlating SIP messages belonging to the same call, even if their SIP dialog identifiers are modified (e.g. by a B2BUA application server). It should be noted, however, that the use of the ICID is not necessary for the purpose of correlating SIP dialogs and the corresponding media streams.

- **P-Charging-Vector (GPRS Charging ID, GGSN address):** GCIDs, along with the GGSN address, may be used as identifiers of the PDP contexts. These identifiers (one for each PDP context used by the SIP session) are made available to the P-CSCF and subsequently to the S-CSCF. They could be used to correlate SIP messages with the PDP context(s) used. For the purpose of correlating SIP dialogs with media streams, this type of correlation would be useful, although not essential.
- **SDP Connection addresses and ports:** The address and port information within the SDP of the SIP messages need to be matched with the addresses and ports corresponding to the media streams as provided in the CC reports. This implies a need to look both at the SDP content of the SIP messages as well as in the packets provided by the GSN. The set of PDP context identifiers included in the P-Charging-Vector could be used to simplify the search for a match. It should also be noted that the SDP contained in the SIP message may also include essential information about the encoding of each of the media streams, without which it may not be possible to decode.

Annex I (normative): Evolved Packet System handover

The Evolved Packet System (EPS) is specified in 3GPP TS 23.401 [78] and 3GPP TS 23.402 [79]. The LI functional requirements (applicable intercepting nodes, events and parameters to be reported by the nodes to DF/MF) are specified in 3GPP TS 33.107 [71].

In order to provide all the needed information to the LEMF the LI handover interface specified in 3GPP TS 33.108 [61], clauses B.9 and B.10 shall be used. In particular, an implementation compliant to the present document shall adopt for the HI2 and the HI3 the following ASN.1 modules:

HI2:

```
EpsHI2Operations {itu-t(0) identified-organization(4) etsi(0) securityDomain(2) lawfulIntercept(2)
threeGPP(4) hi2eps(8) r[m]([m]) version-[n]([n])}
```

HI3:

```
Eps-HI3-PS {itu-t(0) identified-organization(4) etsi(0) securityDomain(2) lawfulIntercept(2)
threeGPP(4) hi3eps(9) r[k]([k]) version-[l]([l])}
```

where "[m]", "[k]" are related to the 3GPP release number and "[n]", "[l]" identify the module version number for the given 3GPP release; these values define the version(s) of 3GPP TS 33.108 [61] which the implementation is compliant to.

Annex J (informative): Latest ASN.1 module versions

This annex is listing the ASN.1 modules with the actual version numbers as defined in annex D. In case of any discrepancy the definitions given in annex D are the valid ones. This annex is just a summary of the ASN.1 modules. ETSI TR 102 503 [i.4] gives a complete overview over the relevant Object Identifiers (OID) used in ASN.1 modules of the Lawful Intercept specifications and point to the specification where the modules can be found.

Defined in clause D.3:

```
HIManagementOperations
{itu-t(0) identified-organization(4) etsi(0) securityDomain(2) lawfulIntercept(2) him(3)
version3(3)}
```

Current version is 3.

Defined in clause D.4:

```
HI1NotificationOperations
{itu-t(0) identified-organization(4) etsi(0) securityDomain(2) lawfulIntercept(2) hi1(0)
notificationOperations(1) version6(6)}
```

Current version is 6.

Defined in clause D.5:

```
HI2Operations
{itu-t(0) identified-organization(4) etsi(0) securityDomain(2) lawfulIntercept(2) hi2(1)
version17(17)}
```

Current version is 17.

Defined in clause D.6:

```
HI3CircuitDataOperations
{itu-t(0) identified-organization(4) etsi(0) securityDomain(2) lawfulIntercept(2) hi3(2)
circuitLI(1) version4(4)}
```

Current version is 4.

Defined in clause D.7 and clause A.9.1:

```
EN301040
{{itu-t(0) identified-organization(4) etsi(0) en301040(1040) interceptVersion(0)}}
```

Current version is 0.

Defined in clause D.8:

```
HI3CCLinkData
{itu-t(0) identified-organization(4) etsi(0) securityDomain(2) lawfulIntercept(2) hi3(2) cclinkLI(4)
version4(4)}
```

Current version is 4.

Defined in clause D.9:

```
Gprs-HI3-PS
{itu-t(0) identified-organization(4) etsi(0) securityDomain(2) lawfulIntercept(2) hi3(2) gPRSLI(3)
version3(3)}
```

Current version is 3.

Defined in clause D.10.1:

```
TETRA-HIManagementOperations
{itu-t(0) identified-organization(4) etsi(0) securityDomain(2) lawfulIntercept(2) tetra(6) him(3)
version0(0)}
```

Current version is 0.

Defined in clause D.10.2:

```
TETRA-HI1NotificationOperations
{itu-t(0) identified-organization(4) etsi(0) securityDomain(2) lawfulIntercept(2) tetra(6) hi1(1)
notificationOperations(1) version0(0)}
```

Current version is 0.

Defined in clause D.10.3:

```
TETRA-HI2Operations
{itu-t(0) identified-organization(4) etsi(0) securityDomain(2) lawfulIntercept(2) tetra(6) hi2(2)
version2(2)}
```

Current version is 2.

Annex K (informative): Bibliography

- ETSI EN 300 052-1: "Integrated Services Digital Network (ISDN); Multiple Subscriber Number (MSN) supplementary service; Digital Subscriber Signalling System No. one (DSS1) protocol; Part 1: Protocol specification".
- ETSI EN 300 055-1: "Integrated Services Digital Network (ISDN); Terminal Portability (TP) supplementary service; Digital Subscriber Signalling System No. one (DSS1) protocol; Part 1: Protocol specification".
- ETSI EN 300 058-1: "Integrated Services Digital Network (ISDN); Call Waiting (CW) supplementary service; Digital Subscriber Signalling System No. one (DSS1) protocol; Part 1: Protocol specification".
- ETSI EN 300 064-1: "Integrated Services Digital Network (ISDN); Direct Dialling In (DDI) supplementary service; Digital Subscriber Signalling System No. one (DSS1) protocol; Part 1: Protocol specification".
- ETSI EN 300 093-1: "Integrated Services Digital Network (ISDN); Calling Line Identification Restriction (CLIR) supplementary service; Digital Subscriber Signalling System No. one (DSS1) protocol; Part 1: Protocol specification".
- ETSI EN 300 141-1: "Integrated Services Digital Network (ISDN); Call Hold (HOLD) supplementary service; Digital Subscriber Signalling System No. one (DSS1) protocol; Part 1: Protocol specification".
- ETSI EN 300 210-1: "Integrated Services Digital Network (ISDN); Freephone (FPH) supplementary service; Digital Subscriber Signalling System No. one (DSS1) protocol; Part 1: Protocol specification".
- ETSI EN 300 359-1: "Integrated Services Digital Network (ISDN); Completion of Calls to Busy Subscriber (CCBS) supplementary service; Digital Subscriber Signalling System No. one (DSS1) protocol; Part 1: Protocol specification".
- ETSI EN 300 745-1: "Integrated Services Digital Network (ISDN); Message Waiting Indication (MWI) supplementary service; Digital Subscriber Signalling System No. one (DSS1) protocol; Part 1: Protocol specification".
- ETSI EN 301 001-1 (V1.2.2): "Integrated Services Digital Network (ISDN); Outgoing Call Barring (OCB) supplementary services; Digital Subscriber Signalling System No. one (DSS1) protocol; Part 1: Protocol specification".
- ETSI EN 301 065-1 (V1.2.2): "Integrated Services Digital Network (ISDN); Completion of Calls on No Reply (CCNR) supplementary service; Digital Subscriber Signalling System No. one (DSS1) protocol; Part 1: Protocol specification".
- Recommendation ITU-T Q.699: "Interworking between ISDN access and non-ISDN access over ISDN User Part of Signalling System No. 7".
- Recommendation ITU-T I.210: "Principles of telecommunication services supported by an ISDN and the means to describe them".
- ETSI EN 300 138-1: "Integrated Services Digital Network (ISDN); Closed User Group (CUG) supplementary service; Digital Subscriber Signalling System No. one (DSS1) protocol; Part 1: Protocol specification".
- ETSI EN 301 344: "Digital cellular telecommunications system (Phase 2+) (GSM); General Packet Radio Service (GPRS); Service description; Stage 2 (GSM 03.60)".
- IETF RFC 2228: "FTP Security Extensions".
- IANA Private Enterprise numbers.

NOTE: Available at <http://www.iana.org/assignments/enterprise-numbers>.

- Recommendation ITU-T X.881: "Information technology - Remote Operations: OSI realizations - Remote Operations Service Element (ROSE) service definition".

Annex L (informative): Change Request history

Status of the present document: ETSI TS 101 671 Handover interface for the lawful interception of telecommunications traffic		
TC LI approval date	Version	Remarks
July 1999	Ed 1	Publication as ETSI ES 201 671 first Edition (v1.1.1)
September 2001	Ed 2	Publication as ETSI ES 201 671 second Edition (v2.1.1)
July 2001	1.1.1	TS version of ETSI ES 201 671 v2.1.1 (see note 1)
December 2001 (internal SEC-LI)	2.2.1	<p>Included Change Requests: TS101671CR001 (category D) on Removal of reference to ETSI TR 101 876 TS101671CR002 rev1 (category D) on Example on missing information TS101671CR003 (category D) on Sending of IRI-END and IRI-CONTINUE records TS101671CR004 (category D) on Moving GPRS related text from main body to annex B TS101671CR005 rev1 (category F) on No additional work on HI1 interface port for administrative state TS101671CR006 rev1 (category F) on Version indication TS101671CR007 rev1 (category F) on No additional identifiers for Packet switched network handover TS101671CR008 rev2 (category D) on Several editorials TS101671CR009 (category F) on UUS1-parameter no. 6: "bearer capability of target call" TS101671CR010 rev1 (category D) on Modification of the definition "CC link" TS101671CR011 (category D) on Modification of the definition "Internal Network Interface": change "mediation device" into "mediation function" TS101671CR013 (category D) on Deletion of the definition "mediation device"</p> <p>all CRs approved by SEC-LI#31 (27-29 November 2001; Wien) version 2.2.1 prepared by Peter van der Arend (KPN) (rapporteur)</p>
April 2002 (internal SEC-LI)	2.3.1	<p>Included Change Requests: TS101671CR014 rev 2 (cat F) on annex E, Coding of the Calling Party Number TS101671CR015 rev 2 (cat F) on clause D.5 Coordinates TS101671CR016 (cat C) on clause D.5 - Exports Capabilities TS101671CR017 rev 1 (cat D) on clause C.2.2 - File naming method B; clause F.3.2.2 - File naming method B TS101671CR018 rev 1 (cat C) on clause D.5 - TimeStamp TS101671CR019 (cat F) on Correction of superfluous spaces in ASN.1 coding TS101671CR021 (cat D) on Reintroduction of deleted references TS101671CR022 rev 2 (cat F) on Aligning ETSI TS 101 671 with 3GPP TS 33.108 [61] TS101671CR025 (cat F) on Correction of Misalignment between the text and the ASN.1</p> <p>all CRs approved by SEC-LI#32 (19-21 March 2002, Sophia Antipolis) version 2.3.1 prepared by Peter van der Arend (KPN) (rapporteur)</p>
June 2002 (internal SEC-LI)	2.4.1	<p>Included Change Requests: TS101671CR026 (cat F) on Correcting "ccitt" into "itu-t" in ASN.1 Object Tree TS101671CR027 rev 1 (cat C) on Missing ISUP parameter in version 1 TS101671CR028 rev 1 (cat B) on Use of the object identifier within the IRI TS101671CR030 rev 1 (cat B) on Extension/alignment of ASN.1 module with 33.108 TS101671CR031 (cat F) on Missing/old reference TS101671CR032 rev 2 (cat B) on ASN.1 alignment with the UMTS module TS101671CR033 (cat B) on Adding a graphical ASN.1- Object tree</p> <p>all CRs approved by SEC-LI#33 (18-20 June 2002, Sophia Antipolis); version 2.4.1 prepared by Peter van der Arend (KPN) (rapporteur)</p>

Status of the present document: ETSI TS 101 671		
Handover interface for the lawful interception of telecommunications traffic		
TC LI approval date	Version	Remarks
October 2002	2.5.1	<p>Included Change Requests: TS101671CR034 rev 1 (cat B) on Aggregation of IRI Records TS101671CR036 (cat F) on ASN.1 version number TS101671CR037 rev 1 (cat F) on Missing pDPContextModification parameter TS101671CR038 rev 1 (cat F) on Missing ggsnAddress parameter</p> <p>all CRs approved by TC LI#01 (15-17 October 2002, Dublin); version 2.5.1 prepared by Peter van der Arend (KPN) (rapporteur)</p> <p>Including editorial modifications by ETSI</p>
March 2003 (internal TC LI)	2.6.1	<p>Included Change Requests: TS101671CR035 (cat F) on Coding of ASN.1 parameters of the type OCTET STRING TS101671CR039r1 (cat C) on Composition of Calling Party Subaddress TS101671CR041 (cat C) on Additional value direction indication (PARTLY) TS101671CR042r2 (cat F) on Data Link Establishment and Sending part for ROSE operation TS101671 CR043r1 (cat C) on Clarification of definitions of sequence number and communication identity number TS101671CR045 (cat C) on HI3 delivery of CC TS101671CR046r1 (cat D) on Field separator in subaddress TS101671CR047r1 (cat F) on Essential correction to the LI events generated during RAU when PDP context is active TS101671CR048r2 (cat F) on Adjustments to the requirements on the delivery of the intercepted RT data over TCP</p> <p>all CRs approved by TC LI#02 (4-6 March 2003, Benalmádena);</p> <p>See note 2.</p> <p>TS101671CR044r1 (cat C) on Additional value antenna direction GSM location information TS101671CR049 (cat C) on CallingPartyNumber and mAP-Format</p> <p>version 2.6.1 prepared by Peter van der Arend (KPN) (rapporteur)</p>
June 2003	2.7.1	<p>agreed CRs in TC LI#02: 049, 041(partly) were put on hold because of changes to ASN.1 and these ASN.1 parts are included now (CRs 044r1 was modified): TS101671CR041 (cat C) on Additional value direction indication (PARTLY) TS101671CR049 (cat C) on CallingPartyNumber and mAP-Format</p> <p>Included Change Requests: TS101671CR044r3 (cat C) on Additional value antenna direction GSM location information TS101671CR050 (cat C) on Precision about Services-Information field TS101671CR051 (cat F) on Use of identifiers, elimination of "CC only" delivery option these CRs were approved by TC LI#03 (3-5 June 2003, Copenhagen);</p> <p>Involved ASN.1 modules: HI2Operations ->v4 HI3CCLinkData ->v3</p> <p>version 2.7.1 prepared by Peter van der Arend (KPN) (rapporteur)</p>
October 2003	2.8.1	<p>Included Change Request: ETSI TS 101 671CR052r1 (cat F) on Inconsistency regarding definition of CIN length this CR was approved by TC LI#04 (14-16 October 2003, Moscow);</p> <p>version 2.8.1 prepared by Peter van der Arend (KPN) (rapporteur)</p>

Status of the present document: ETSI TS 101 671		
Handover interface for the lawful interception of telecommunications traffic		
TC LI approval date	Version	Remarks
March 2004	2.9.1	<p>Included Change Requests:</p> <p>TS101671CR054 (cat D) Editorials to clause C.1.2.1</p> <p>TS101671CR055 (cat D) Removal of superfluous spaces from ASN.1 description</p> <p>TS101671CR056r2 (cat B) Introduction of national parameters in the him module</p> <p>TS101671CR058r1 (cat B) Introduction of national ASN.1 coded parameters in HI2</p> <p>TS101671CR059 (cat D) Correction of the Routing Area Identifier</p> <p>TS101671CR060 (cat D) Correction of wrong use of abbreviations</p> <p>TS101671CR061 (cat D) Alignment names of RO-operations</p> <p>TS101671CR062r1 (cat B) Decoding HI1 Notification and HI2 IRI-Parameters FTP file</p> <p>TS101671CR063r1 (cat F) WGS 84 Coordinates updates</p> <p>TS101671CR064r2 (cat D) Editorial corrections to CS domain</p> <p>TS101671CR065 (cat F) Correction to the reference for Called Party Number</p> <p>TS101671CR066r2 (cat C) Field separator in subaddress</p> <p>TS101671CR068 (cat F) No SMS content in case of IRI only</p> <p>TS101671CR069r3 (cat F) Correction of the Subaddressing definitions</p> <p>These CRs were approved by TC LI#05 (23-25 March 2004, Oxford);</p> <p>version 2.9.1 prepared by Peter van der Arend (KPN) (rapporteur)</p>
July 2004	2.10.1	<p>Included Change Request:</p> <p>ETSI TS 101 671CR072r4 (cat B) Extensions to the "National-HI2-ASN1parameters" data type</p> <p>ETSI TS 101 671CR073r1 (cat D) Clarifying clause titles</p> <p>ETSI TS 101 671CR076r2 (cat F) References in ETSI TS 101 671</p> <p>ETSI TS 101 671CR077 (cat B) Nature of the intercepted call</p> <p>ETSI TS 101 671CR078 (cat F) Served User for CLIP and COLP and other minor correction</p> <p>ETSI TS 101 671CR079r4 (cat B) Importing CC definition for PS domain from 3GPP module</p> <p>ETSI TS 101 671CR080r1 (cat D) Spare Octets in the Subaddress in annex E</p> <p>ETSI TS 101 671CR081 (cat D) ed correction of parameter name "setUpInProcess"</p> <p>These CRs were approved by TC LI#06 (22-23 July, Póvoa de Varzim);</p> <p>version 2.10.1 prepared by Peter van der Arend (KPN) (rapporteur)</p>
September 2004	2.11.1	<p>Included Change Request:</p> <p>TS101671CR082r1 (cat B) Addition of HI2 via to transfer UUS information</p> <p>TS101671CR083 (cat D) Explanation concerning the Sequence Number</p> <p>TS101671CR084r1 (cat D) Format of the CIN and CC-Link-Identifier</p> <p>TS101671CR085 (cat C) Addition of the domainID in the parameter "National-HI1-ASN1" parameters</p> <p>TS101671CR086 (cat C) Addition of the Lawful Interception Identifier in the parameter "Alarm-Indicator"</p> <p>TS101671CR087 (cat D) New annex listing latest ASN.1 module versions in ETSI TS 101 671</p> <p>ETSI TS 101671 CR088 (cat D) PDP Context modification request</p> <p>TS101 671 CR089r2 (cat B) Aligning "IRI-Parameters" with those defined in 3GPP TS 33.108 [61]</p> <p>TS101671CR090 (cat B) Interception of fixed NGN (including PSTN/ISDN emulation) and fixed IMS PSTN simulation</p> <p>Alignment of latest ASN.1 version of the imported ASN.1 modules</p> <p>These CRs were approved by TC LI#07 (28-30 September 2004, Bremen);</p> <p>version 2.11.1 prepared by Peter van der Arend (KPN) (rapporteur)</p>

Status of the present document: ETSI TS 101 671		
Handover interface for the lawful interception of telecommunications traffic		
TC LI approval date	Version	Remarks
February 2005 June 2005	2.12.1	<p>Included Change Request: ETSI TS 101 671CR091r2 (cat B) Support of ETSI TS 101 909-20 [69] Sub-Part 1 LI parameters ETSI TS 101 671CR092 (cat F) Correction to GLIC header - Alignment with 3GPP TS 33.108 [61] TS101671CR093 (cat F) References in ETSI TS 101 671 These CRs were approved by TC LI#08 (22-24 February 2005, Kijkduin);</p> <p>ETSI TS 101 671CR095 (cat C) Removing the SecurityDomainDefinitions in clause D.2. ETSI TS 101 671CR096r3 (cat D) Clarification of requirement to assign CIN values by relevant network element ETSI TS 101 671CR097r2 (cat D) Clarification of requirement to provide full IRI for intercepted SMS messages, even if some of the information is embedded in the SMS message body (IRI for SMS) TS101671CR098 (cat F) Updating imports statement for ASN.1 definition of the ULICv1 header ETSI TS 101 671CR099r1 (cat F) Alignment CR for IMS LI ETSI TS 101 671CR100r2 (cat C) Freezing "iRlVersion" parameter in ASN.1 module ETSI TS 101 671CR102r1 (cat D) Resolution ETSI TS 101 671CR103 (cat B) New parameters defined in 3GPP TS 33.108 [61] These CRs were approved by TC LI#09 (28-30 June 2005, Rovaniemi) See note 3. version 2.12.1 prepared by Peter van der Arend (KPN) (rapporteur)</p>
October 2005	2.13.1	<p>Included Change Request: TS101671CR101r1 (cat C) Aligning LIID definitions TS101671CR105 (cat D) Informative example of FTP implementation across HI2/HI3 These CRs were approved by TC LI#10 (4-6 October 2005, Sorrento)</p> <p>See note 4.</p> <p>version 2.13.1 prepared by Peter van der Arend (KPN) (rapporteur)</p>
February 2006	2.14.1	<p>Included Change Request: TS101671CR104r3 (cat C) Extending table C.2.1 and table F.3.4 for national use TS101671CR106r1 (cat D) Explanation on Open Issues TS101671CR107 (cat F) Correction on polygon type of shape TS101671CR109 (cat F) Handling of unknown SIP headers TS101671CR110r1 (cat F) TETRA finalization TS101671CR111 (cat F) Re-correcting changes made during publication process These CRs were approved by TC LI#11 (30 January - 1 February 2006, Saint Martin).</p> <p>See note 5.</p> <p>version 2.14.1 prepared by Peter van der Arend (KPN) (rapporteur)</p>
September 2006	2.15.1	<p>Included Change Request: TS101671CR108r1 (cat B) TISPAN NGN PSTN Emulation Service and PSTN Simulation Service Stage 3 description TS101671CR112r1 (cat D) Modifications as requested by ETSI EditHelp These CRs were approved by TC LI#13 (6-8 September 2006 in Stockholm).</p> <p>See note 6.</p> <p>version 2.15.1 prepared by Peter van der Arend (KPN) (rapporteur)</p>
May 2007	Ed 3	Publication as ETSI ES 201 671 third Edition (v3.1.1)
June 2007	3.1.1	<p>TS version of ETSI ES 201 671 v3.1.1 as basis for further work</p> <p>version 3.1.1 prepared by Peter van der Arend (KPN) (rapporteur)</p>

Status of the present document: ETSI TS 101 671		
Handover interface for the lawful interception of telecommunications traffic		
TC LI approval date	Version	Remarks
October 2007	3.2.1	<p>Included Change Requests: TS101671CR114r1 (cat D) Correction of abbreviation and figure in IMS part TS101671CR115 (cat D) Add the explanation of characters limitation for specific identifiers in subaddress option TS101671CR116r3 (cat B) Add mono mode definition These CRs were approved by TC LI#15 (23-25 April 2007 in Riga).</p> <p>TS101671CR113r4 (cat D) CC Encryption TC101671CR117 (cat D) Tag Values in IRIsContent These CRs were approved by TC LI#16 (2-4 October 2007 in Berlin).</p> <p>version 3.2.1 prepared by Peter van der Arend (KPN) (rapporteur)</p>
January 2008	3.3.1	<p>Included Change Requests: TS101671CR118r1 (cat F) on Clarifications to FTP filenaming conventions TS101671CR119 (cat C) on Correction reference to GSM 09.02 TS101671CR120 (cat B) on Addition of the possibility to provide a target information via the HI1 These CRs were approved by TC LI#17 (22-24 January 2008 in Como).</p> <p>version 3.3.1 prepared by Peter van der Arend (KPN) (rapporteur)</p>
October 2008	3.4.1	<p>Included Change Request: TS101671CR121r1 (cat F) on Clarification of encoding of Access Point Name (APN) This CR was approved by TC LI#19 (30 September - 2 October 2008 in Prague).</p> <p>version 3.4.1 prepared by Peter van der Arend (KPN) (rapporteur)</p>
September 2009	3.5.1	<p>Included Change Requests: TS101671CR123 (cat D) on Call forwarded description enhancement TS101671CR124 (cat C) on Update of FTP table details These CRs were approved by TC LI#21 (29 June - 1 July 2009 in Sophia Antipolis).</p> <p>TS101671CR122r2 (cat C) on TETRA details for IRI This CR was approved by TC LI#22 (22-24 September 2009 in Trouville). (note 7)</p> <p>version 3.5.1 prepared by Peter van der Arend (Vodafone) (rapporteur)</p>
June 2010	3.6.1	<p>Included Change Requests: TS101671CR125 (cat B) on Inclusion of EPS TS101671CR126 (cat B) on Reporting of Dual Stack PDP address TS101671CR128r1 (cat F) on ASN.1 Correction These CRs were approved by TC LI#24 (15-17 June 2010 in Aachen)</p> <p>version 3.6.1 prepared by Peter van der Arend (Vodafone) (rapporteur)</p>
February 2011	3.7.1	<p>Included Change Requests: TS101671CR130r2 (cat B) on Extensions of the sms-report structure TS101671CR131r1 (cat B) on Addition of Party-validity to IRI These CRs were approved by TC LI#26 (15-17 February 2011 in Sophia Antipolis)</p> <p>version 3.7.1 prepared by Peter van der Arend (Vodafone) (rapporteur)</p>
June 2011	3.8.1	<p>Included Change Request: TS101671CR132r1 (cat B) on Addition Ipv6PrefixLength parameter This CR was approved by TC LI#27 (28-30 June 2011 in Mariehamn)</p> <p>version 3.8.1 prepared by Peter van der Arend (Vodafone) (rapporteur)</p>
September 2011	3.9.1	<p>Included Change Requests: TS101671CR133 (cat D) on Correction of wrong reference to 3GPP TS 25.431 TS101671CR134r1 (cat B) on Modification of IPAddress type to accommodate IPv4 netmask These CRs were approved by TC LI#28 (13-15 September 2011 in Otranto)</p> <p>version 3.9.1 prepared by Peter van der Arend (Vodafone) (rapporteur)</p>

Status of the present document: ETSI TS 101 671		
Handover interface for the lawful interception of telecommunications traffic		
TC LI approval date	Version	Remarks
May 2012	3.10.1	Included Change Request: TS101671CR136 (cat D) on Referencing SAI This CR was approved by TC LI#29 (24-26 January 2012, Dun Laoghaire) TS101671CR137r1 (cat C) on CSFB Location transfer over the HI2 interface This CR was approved by TC LI#30 (14-16 May 2012, Amsterdam) version 3.10.1 prepared by Peter van der Arend (Vodafone) (rapporteur)
September 2012	3.11.1	Included Change Request: TS101671CR138r1 (cat C) on Addition of alphanumeric partyIdentity This CR was approved by TC LI#31 (25-27 September 2012, Split) The ASN.1 definitions are contained in a .zip which accompanies the present document version 3.11.1 prepared by Peter van der Arend (Vodafone) (rapporteur)
September 2013	3.12.1	Included CRs from LI#34 CR53: HLR Lawful Interception CR54: Change to IRI-REPORT to signal end of intercept whilst session remains active CR55: Change to <i>nature-Of-The-intercepted-call</i> value for SMS and voice call from LTE UE after CSFB Version 3.12.1 prepared by rapporteur
September 2015	3.13.1	Included CR from LI#40 CR56: Extension of Alarm Information
February 2016	3.14.1	Included CR from TC-LI#41 CR57r2: Explaining the route to historical for the present document (ETSI TS 101 671) in the scope Obsolete note removed from the scope
February 2018	3.15.1	Included CR from TC LI#47 CR59: Marking ETSI TS 101 671 as historical Version 3.15.1 prepared by rapporteur
NOTE 1: The V1.1.1 of the TS should also have been V2.1.1 (PvdA).		
NOTE 2: Agreed CRs 044r1, 049, 041(partly) are put on hold because of changes to ASN.1 and will be included in a next version if the specification.		
NOTE 3: Rapporteur: The new imported ASN.1 elements related to the nonpublished versions of ETSI TS 101 909-20-1 and 3GPP TS 33.108 R7 are put on hold and will be included later in V2.13.1.		
NOTE 4: The new imported ASN.1 elements related to the non published versions of ETSI TS 101 909-20-1 are still not included and put on hold and will be included later in V2.14.1. The imported parameters from 3GPP TS 33.108 R7 are included now in V2.13.1.		
NOTE 5: In V2.14.1 the ASN.1 parameter imported from ETSI TS 101 909-20-1 is included now.		
NOTE 6: V2.15.1 is the basis for Edition 3 (V3.1.1) of ETSI ES 201 671.		
NOTE 7: In the informative annexes all "shall" and "shall" statements have been "corrected" (as required by editHelp).		

History

Document history		
V1.1.1	July 1999	Publication as ETSI ES 201 671 (Historical)
V1.1.1	July 2001	Publication (Historical)
V2.1.1	September 2001	Publication as ETSI ES 201 671 (Historical)
V2.5.0	November 2002	Publication (Withdrawn)
V2.5.1	January 2003	Publication (Historical)
V2.7.1	September 2003	Publication (Historical)
V2.8.1	November 2003	Publication (Historical)
V2.9.1	May 2004	Publication (Historical)
V2.10.1	September 2004	Publication (Historical)
V2.11.1	November 2004	Publication (Historical)
V2.12.1	August 2005	Publication (Historical)
V2.13.1	January 2006	Publication (Historical)
V2.14.1	May 2006	Publication (Historical)
V2.15.1	November 2006	Publication (Historical)
V3.1.1	May 2007	Publication as ETSI ES 201 671 (Historical)
V3.1.1	June 2007	Publication (Historical)
V3.2.1	December 2007	Publication (Historical)
V3.3.1	February 2008	Publication (Historical)
V3.4.1	January 2009	Publication (Historical)
V3.5.1	November 2009	Publication (Historical)
V3.6.1	August 2010	Publication (Historical)
V3.7.1	May 2011	Publication (Historical)
V3.8.1	August 2011	Publication (Historical)
V3.9.1	November 2011	Publication (Historical)
V3.10.1	June 2012	Publication (Historical)
V3.11.1	November 2012	Publication (Historical)
V3.12.1	October 2013	Publication (Historical)
V3.13.1	November 2015	Publication (Historical)
V3.14.1	March 2016	Publication (Historical)
V3.2.1	May 2018	Publication as ETSI ES 201 671 (Historical)
V3.15.1	June 2018	Publication (Historical)