

ETSI TS 101 761-1 V1.2.1 (2000-11)

Technical Specification

Broadband Radio Access Networks (BRAN); HIPERLAN Type 2; Data Link Control (DLC) Layer; Part 1: Basic Data Transport Functions



Reference

RTS/BRAN-0020004-1R1

Keywordsaccess, broadband, radio, LAN, HIPERLAN,
layer 2**ETSI**

650 Route des Lucioles
F-06921 Sophia Antipolis Cedex - FRANCE

Tel.: +33 4 92 94 42 00 Fax: +33 4 93 65 47 16

Siret N° 348 623 562 00017 - NAF 742 C
Association à but non lucratif enregistrée à la
Sous-Préfecture de Grasse (06) N° 7803/88

Important notice

Individual copies of the present document can be downloaded from:

<http://www.etsi.org>

The present document may be made available in more than one electronic version or in print. In any case of existing or perceived difference in contents between such versions, the reference version is the Portable Document Format (PDF). In case of dispute, the reference shall be the printing on ETSI printers of the PDF version kept on a specific network drive within ETSI Secretariat.

Users of the present document should be aware that the document may be subject to revision or change of status. Information on the current status of this and other ETSI documents is available at <http://www.etsi.org/tb/status/>

If you find errors in the present document, send your comment to:
editor@etsi.fr

Copyright Notification

No part may be reproduced except as authorized by written permission.
The copyright and the foregoing restriction extend to reproduction in all media.

© European Telecommunications Standards Institute 2000.
All rights reserved.

Contents

Intellectual Property Rights	7
Foreword.....	7
Introduction.....	7
1 Scope.....	8
2 References.....	8
3 Definitions, symbols and abbreviations	8
3.1 Definitions	8
3.2 Symbols	10
3.3 Abbreviations.....	10
4 Overview.....	11
4.1 Functional entities	12
4.1.1 Error Control (EC).....	13
4.1.2 Medium Access Control (MAC).....	13
4.1.3 Radio link Control (RLC) sublayer	14
4.1.4 Physical layer (PHY).....	14
4.1.5 Other functions (informative)	14
4.2 Service Access Points to the CL (Informative)	14
4.2.1 Primitive types	15
4.2.2 Parameter definitions	15
4.2.3 DLC-U-SAP	15
5 Logical and Transport channels.....	16
5.1 Logical Channels and their characteristics.....	16
5.1.1 Logical Channels	16
5.1.2 Broadcast Control CHannel (BCCH)	16
5.1.3 Frame Control CHannel (FCCH)	16
5.1.4 Random access Feedback CHannel (RFCH)	16
5.1.5 RLC Broadcast CHannel (RBCH)	17
5.1.6 Dedicated Control CHannel (DCCH).....	17
5.1.7 User Broadcast CHannel (UBCH)	17
5.1.8 User Multicast CHannel (UMCH)	18
5.1.9 User Data CHannel (UDCH).....	18
5.1.10 Link Control CHannel (LCCH)	18
5.1.11 ASSociation Control CHannel (ASCH).....	18
5.2 Transport channels and their characteristics	18
5.2.1 Transport Channels	18
5.2.2 Broadcast CHannel (BCH)	19
5.2.3 Frame CHannel (FCH).....	19
5.2.4 Access Feedback CHannel (ACH).....	19
5.2.5 Long transport CHannel (LCH)	20
5.2.6 Short transport CHannel (SCH).....	20
5.2.7 Random CHannel (RCH)	20
5.3 Mapping between Logical and Transport Channels	20
5.4 Overview of the MAC Frame	21
5.5 DLC addressing.....	22
5.5.1 MAC ID	22
5.5.2 DLC Connection ID.....	22
5.5.3 NET ID.....	22
5.5.4 Access point ID.....	23
5.5.5 Sector ID	23
5.5.6 Logical channels addressing.....	23
5.5.6.1 BCCH	23
5.5.6.2 FCCH.....	23
5.5.6.3 RFCH.....	23

5.5.6.4	RBCH	23
5.5.6.5	DCCH	23
5.5.6.6	UBCH	23
5.5.6.7	UMCH	23
5.5.6.8	UDCH	24
5.5.6.9	LCCH	24
5.5.6.10	ASCH	24
5.5.7	Identification of transport channels.....	24
5.5.7.1	BCH.....	24
5.5.7.2	FCH.....	24
5.5.7.3	ACH.....	24
5.5.7.4	LCH.....	24
5.5.7.5	SCH.....	25
5.5.7.6	RCH.....	25
6	Radio transmission and reception functions.....	25
6.1	Format of the transport channels.....	25
6.1.1	Broadcast CHannel (BCH) format.....	25
6.1.2	Frame CHannel (FCH) Format.....	25
6.1.3	Access feedback CHannel (ACH) format.....	26
6.1.4	Long transport CHannel (LCH) format.....	26
6.1.5	Short transport CHannel (SCH) format.....	27
6.1.6	Random CHannel (RCH) format.....	28
6.2	Logical channel formats.....	28
6.2.1	BCCH message format.....	28
6.2.2	FCCH information element contents and message formats.....	31
6.2.2.1	IE for allocating resources for: RBCH, DCCH, UBCH, UMCH, and UDCH and LCCH for downlink and uplink.....	31
6.2.2.2	IE for allocating resources for RBCH, DCCH, UBCH, UMCH, UDCH and LCCH in the direct link.....	33
6.2.2.3	IE for empty parts in the MAC frame.....	34
6.2.2.4	IE for padding.....	34
6.2.3	RFCH message format.....	35
6.2.4	RBCH message formats.....	36
6.2.4.1	RBCH message in an LCH.....	36
6.2.4.2	Downlink RBCH message in an SCH.....	36
6.2.4.2.1	Messages from the RLC.....	36
6.2.4.2.2	Encryption seed.....	37
6.2.4.3	Direct link RBCH message in an SCH.....	37
6.2.5	DCCH message formats.....	37
6.2.5.1	DCCH message in an LCH.....	37
6.2.5.2	DCCH message in a downlink SCH.....	38
6.2.5.3	DCCH message in an uplink SCH or RCH.....	38
6.2.5.4	DCCH message in a direct link SCH.....	39
6.2.6	UBCH message formats.....	39
6.2.7	UMCH message formats.....	40
6.2.8	UDCH message formats.....	40
6.2.9	LCCH message formats.....	41
6.2.9.1	Resource Request message formats.....	41
6.2.9.1.1	Resource Request message for the uplink.....	41
6.2.9.1.2	Resource Request message for the direct link.....	42
6.2.9.2	ARQ message formats.....	43
6.2.9.2.1	ARQ feedback message format in the uplink phase.....	43
6.2.9.2.2	ARQ feedback message format in the downlink and direct link phase.....	44
6.2.9.2.3	Discard message format in the uplink phase.....	45
6.2.9.2.4	Discard message format in the downlink and direct link phase.....	46
6.2.10	ASCH message format.....	47
6.3	MAC protocol.....	47
6.3.1	MAC operation.....	47
6.3.1.1	Access Point MAC Operation.....	48
6.3.1.2	MT MAC Operation.....	48
6.3.2	Rules for the composition of MAC frames.....	48

6.3.2.1	BCH.....	48
6.3.2.2	FCH.....	49
6.3.2.3	ACH.....	49
6.3.2.4	SCH.....	50
6.3.2.5	RCH.....	51
6.3.2.6	Order of the transport channels	51
6.3.2.7	Logical Channels.....	53
6.3.2.8	Handling of resource request messages	53
6.3.3	Accessing the RCH.....	54
6.3.4	Fixed capacity agreement (optional).....	55
6.3.4.1	General.....	55
6.3.4.2	AP/CC Operation.....	55
6.3.4.3	MT Operation.....	56
6.3.5	Timing requirements	57
6.3.5.1	Reference point and start pointers	57
6.3.5.2	Minimum time between ACH and UL phase	58
6.3.5.3	Minimum time between ACH and DiL phase	59
6.3.5.4	Request - Grant delay	59
6.3.5.5	ARQ delays	59
6.3.6	Handling extra capacity allocated to MTs in uplink or direct link direction.....	60
6.3.7	Error indication bits	60
6.3.7.1	General.....	60
6.3.7.2	Generation of the Error Indication Bits.....	61
6.3.7.3	Direct Mode	62
6.3.7.3.1	Generation of the Error Indication Bits in DM	62
6.4	Error Control.....	63
6.4.1	General.....	63
6.4.2	Acknowledged mode.....	64
6.4.2.1	General.....	64
6.4.2.2	Notations.....	65
6.4.2.3	LCH Sequence Number SN	65
6.4.2.4	Window Sizes k_s	65
6.4.2.5	Receiver window	65
6.4.2.6	Transmitter window.....	66
6.4.2.7	Bitmap Blocks (BMB) and Bitmaps Block Numbers (BMN)	66
6.4.2.8	Cumulative Acknowledgement (CumAck)	68
6.4.2.9	EC Reset of the connection	68
6.4.2.10	Error Control Procedures for the Receiver	68
6.4.2.11	Error Control Procedures for the Transmitter.....	69
6.4.2.12	Discarding of LCHs.....	69
6.4.2.12.1	Actions of the transmitter	70
6.4.2.12.2	Actions of the receiver.....	70
6.4.2.13	Handling of Dynamic ARQ bandwidth allocation.....	70
6.4.2.14	Flow Control	71
6.4.2.14.1	Receiver actions	71
6.4.2.14.2	Transmitter actions.....	71
6.4.3	Repetition mode.....	71
6.4.3.1	General.....	71
6.4.3.2	Notations.....	72
6.4.3.3	LCH Sequence Number SN	72
6.4.3.4	Window Sizes k_s	72
6.4.3.5	Acceptance range.....	72
6.4.3.6	Receiver window	72
6.4.3.7	Transmitter behaviour.....	72
6.4.3.8	Error Control Procedures for the Receiver	72
6.4.3.9	Discarding of LCHs.....	74
6.4.3.9.1	General	74
6.4.3.9.2	Actions of the transmitter	74
6.4.3.9.3	Actions of the receiver.....	74
6.4.4	Unacknowledged mode	74
6.4.4.1	General.....	74
6.4.4.2	LCH Sequence Number SN	75

6.4.4.3	Transmitter actions	75
6.4.4.4	Receiver actions	75
6.5	Multicast transmission	75
6.6	CRC calculation	75
6.7	Encryption	76
6.7.1	Introduction	76
6.7.2	Encryption of LCHs	76
6.7.3	Algorithms.....	76
6.7.3.1	DES	77
6.7.3.2	TripleDES	77
6.7.4	Encryption and decryption procedure	77
6.7.5	Encryption keys	78
6.7.6	Encryption Seed.....	78
6.7.6.1	General.....	78
6.7.6.2	Seed generation in the AP.....	78
6.7.6.3	Seed transfer.....	79
6.7.6.4	Seed generation in the MT	79
6.7.7	Initialization Vector (IV).....	80
6.8	Transmission power	81
6.9	Mapping between MAC frame and PHY frame.....	81
6.9.1	Number of OFDM symbols per transport channel excluding physical layer preambles.....	81
6.9.2	PDU trains	82
6.9.2.1	General.....	82
6.9.2.2	Broadcast PDU train	82
6.9.2.3	FCH-and-ACH PDU train.....	83
6.9.2.4	Downlink PDU train.....	83
6.9.2.5	Uplink PDU train with short preamble	83
6.9.2.6	Uplink PDU train with long preamble	84
6.9.2.7	Direct link PDU train.....	84
6.9.3	PHY modes for transport channels and special cases for logical channels.....	84
6.9.4	Guard times	85
6.9.4.1	Radio turn-around times.....	85
6.9.4.2	Propagation delay guard times	85
6.9.4.3	Sector switch guard time.....	85
Annex A (informative): Bibliography.....		86
History		87

Intellectual Property Rights

IPRs essential or potentially essential to the present document may have been declared to ETSI. The information pertaining to these essential IPRs, if any, is publicly available for **ETSI members and non-members**, and can be found in ETSI SR 000 314: *"Intellectual Property Rights (IPRs); Essential, or potentially Essential, IPRs notified to ETSI in respect of ETSI standards"*, which is available from the ETSI Secretariat. Latest updates are available on the ETSI Web server (<http://www.etsi.org/ipr>).

Pursuant to the ETSI IPR Policy, no investigation, including IPR searches, has been carried out by ETSI. No guarantee can be given as to the existence of other IPRs not referenced in ETSI SR 000 314 (or the updates on the ETSI Web server) which are, or may be, or may become, essential to the present document.

Foreword

This Technical Specification (TS) has been produced by ETSI Project Broadband Radio Access Networks (BRAN).

The present document describes the basic data transport functions of the Data Link Control (DLC) of High Performance Radio Local Area Network Type 2 (HIPERLAN/2) systems. Separate ETSI documents provide details on the system overview, physical layer, radio link control sublayer, convergence sublayers and conformance testing requirements for HIPERLAN/2.

The present document is part 1 of a multi-part deliverable covering the HIPERLAN Type 2; Data Link Control (DLC) Layer, as identified below:

- Part 1: "Basic Data Transport Functions";**
- Part 2: "Radio Link Control Sublayer";
- Part 3: "Extension for Business Environment";
- Part 4: "Extension for Home Environment";
- Part 5: "Profile for Home Environment".

Introduction

HIPERLAN/2 is confined to the functions, which are located in the two lowest layers of the open systems interconnection (OSI) model, the physical and the data link control layers. The HIPERLAN/2 specifications also define some functionalities related to the network layer in the OSI model. The HIPERLAN/2 system overview document, TR 101 683 [6], contains an overall description of the HIPERLAN/2 system.

Extensions for different applications of the DLC are specified in other HIPERLAN/2 DLC extension technical specifications (see Bibliography). The radio link control (RLC) sublayer [5] contains functions for radio resource control, association control and connection control. The interworking with higher layers is handled by convergence layers on top of the data link control layer. Packet and cell based convergence layers are defined in other HIPERLAN/2 specifications (see TS 101 493 and TS 101 763 in Bibliography). The specification of a management information base is described in TS 101 763 (see Bibliography).

1 Scope

The present document specifies the first phase of the basic data transport mechanism of the Data Link Control layer (DLC) of the HIPERLAN/2 system. It describes the technical characteristics of the following parts of the DLC layer: Error Control, Medium Access Control (MAC) and the mapping between the PHY and the MAC layers of HIPERLAN/2. The present document does not address the requirements and technical characteristics for type approval and conformance testing. These are covered in separate Technical Specifications.

2 References

The following documents contain provisions which, through reference in this text, constitute provisions of the present document.

- References are either specific (identified by date of publication and/or edition number or version number) or non-specific.
- For a specific reference, subsequent revisions do not apply.
- For a non-specific reference, the latest version applies.

- [1] US National Bureau of Standards "Data Encryption Standard", Federal Information Processing Standard (FIPS) Publication 46-2, December 1993.
- [2] US National Bureau of Standards "Guidelines for Implementing and Using the NBS Data Encryption Standard", Federal Information Processing Standard (FIPS) Publication 74.
- [3] US National Bureau of Standards "DES Modes of Operation", Federal Information Processing Standard (FIPS) Publication 81, December 1980.
- [4] ETSI TS 101 475: "Broadband Radio Access Networks (BRAN); HIPERLAN Type 2; Physical (PHY) Layer".
- [5] ETSI TS 101 761-2: "Broadband Radio Access Networks (BRAN); HIPERLAN Type 2; Data Link Control (DLC) Layer; Part 2: Radio Link Control (RLC) sublayer".
- [6] ETSI TR 101 683 (V1.1.2): "Broadband Radio Access Networks (BRAN); HIPERLAN Type 2; System overview".

3 Definitions, symbols and abbreviations

3.1 Definitions

For the purposes of the present document, the following terms and definitions apply:

Access Feedback CHannel (ACH): transport channel where the results of access attempts made in the random access phase of the previous MAC frame is conveyed

Access Point (AP): device that is responsible for the centralized control of the resources in a radio cell. It is usually connected to a fixed network

Association Control Function (ACF): group of control functions that uses the services of the RLC. These functions are responsible for the handling of the association between MT and AP

ASsociation control CHannel (ASCH): logical channel in the uplink that conveys new association and re-association request messages

Broadcast CHannel (BCH): transport channel that broadcasts control information

Broadcast Control CHannel (BCCH): logical channel that broadcasts control information which is relevant for the current MAC frame

Central Controller (CC): provides control functionality equivalent to that of an access point but is not necessarily attached to a fixed network. This term is normally used if central controller and MT functionality are located in a single device. It mostly involves direct mode communication

Centralized Mode (CM): in centralized mode, all data transmitted or received by a mobile terminal pass the access point or the centralized controller, even if the data exchange is between mobile terminals associated to the same access point or centralized controller

DLC connection: HIPERLAN/2 DLC operates connection oriented. A DLC connection carries user or control data and is identified by a DLC connection identifier. A connection has a set of properties for the transfer of data agreed upon between the MT and the AP or between MT's and a CC

DLC User Connection: DLC user connection is uniquely identified by the DLC connection ID and a MAC ID

DLC User Connection Control (DUCC): group of control functions that uses the services of the RLC. It is responsible for the handling of DLC user connections

Direct Mode (DM): data exchange between MTs associated with the same AP or CC takes place without passing but under control of the access point or the central controller

direct link phase: part of a MAC frame that only contains the data exchanged directly between MTs using direct mode communication methods

downlink phase: part of the Downlink transmission of a MAC Frame during which user and control data is transmitted from the access point or central controller to mobile terminals. The data transmitted can be user as well as control data in unicast, broadcast and multicast modes

encryption function: function that is responsible for keeping user data and part of RLC signalling secret between HIPERLAN/2 devices

Error Control (EC): error control is responsible for detection of transmission errors and, where appropriate, for the retransmissions. It is assumed that one error control instance is provided per DLC connection

Frame CHannel (FCH): transport channel that is broadcast and which carries the frame control channel

Frame Control CHannel (FCCH): logical channel that contains the information defining how the resources are allocated in the current MAC frame. Its content changes in general dynamically from frame to frame

logical channel: generic term for any distinct data path. A set of logical channel types is defined for different kinds of data transfer services. Each logical channel type is defined by the type of information it carries. Logical channels can be considered to operate between logical connection end points

MAC frame: periodical structure in time that appears on the air interface and that determines the communication of HIPERLAN/2 devices

Mobile Terminal (MT): device that communicates with an access point or with each other via a radio link. It is typically a user terminal

PDU train: sequence of transport channels delivered to and received from the physical layer

PHY mode: PHY mode corresponds to a signal constellation (Modulation alphabet) and a code rate combination

radio cell: radio cell is the area covered by an access point or central controller. It is sometimes used as a term to describe an AP or CC and its associated terminals

Radio Link Control (RLC) sublayer: control plane of the DLC which offers transport services for the radio resource control, association control function and the DLC user connection control

Radio Resource Control (RRC): group of control functions that use the services of the RLC. It controls the handling of radio resources

Random Access CHannel (RACH): logical channel in the uplink of the MAC frame in which the MTs can send signalling data for the DLC or the RLC. It is transported in the random channel

Random access Feedback CHannel (RFCH): logical channel where the result of the access attempts to the random channel made in the previous MAC frame is conveyed

Random CHannel (RCH): transport channel in the uplink of the MAC that carries the logical channels random access channel and association control channel. A contention scheme is applied to access it

Random Access Phase: period of the MAC Frame where any MT can try to access the system. The access to this phase is based on a contention scheme

Resource Grant (RG): allocation of transmission resources by an access point or a central controller

Resource Request (RR): message from a terminal to an access point or central controller in which the current buffer status is conveyed to request for transmission opportunities in the uplink or direct link phase

sector antenna: term is used to describe if an access point or central controller uses one or more antenna element

transport channel: basic element to construct PDU trains. Transport channels describe the message format

uplink phase: part of the MAC frame in which data is transmitted from mobile terminals to an access point or a central controller

3.2 Symbols

For the purposes of the present document, the following symbols apply:

a	Number of retransmission access attempts made by an MT
BoW	Bottom of Window. Used when window handling is needed
CW_a	Contention window
k	Window size
L	RSS level
n	Number of RCH slots in a frame where r_a is calculated
R	Coding rate
r_a	A uniformly distributed random integer between 1 and CW_a
RxBoW	Receivers BoW
TxBoW	Transmitters BoW
X_b	The bitmap block number that contains the PDU of sequence number X_s
X_{bs}	The first sequence number in block X_b
X_s	A PDU sequence number

3.3 Abbreviations

For the purposes of the present document, the following abbreviations apply:

ABIR	ARQ Bandwidth Increase Request
ACF	Association Control Function
ACH	Access feedback CHannel
AP	Access Point
ARB	ARQ feedback message request bit
ARQ	Automatic Repeat reQuest
ASCH	ASsociation control CHannel
BCCH	Broadcast Control CHannel
BCH	Broadcast Channel
BMB	Bit Map Block
BMN	Bit Map block Number
BPSK	Binary Phase Shift Keying
CAI	Cumulative Acknowledgement Indicator
CC	Central Controller
CL	Convergence Layer
CM	Centralized Mode
CRC	Cyclic Redundancy Check
C-SAP	Control Service Access Point
DCCH	Dedicated Control CHannel

DES	Data Encryption Standard
DFS	Dynamic Frequency Selection
DiL	Direct Link
DL	DownLink
DLC	Data Link Control
DLCC	DLC Connection
DUC	DLC User Connection
DUCC	DLC User Connection Control
DM	Direct Mode
EC	Error Control
FC	Flow Control
FCCH	Frame Control CHannel
FCH	Frame CHannel
H/2	HIPERLAN type 2
IE	Information Element
IV	Initialization Vector
LCCH	Link Control CHannel
LCH	Long transport CHannel
LFSR	Linear Feedback Shift Register
LSB	Least Significant Bit
MAC	Medium Access Control
MAC ID	MAC IDentifier
MSB	Most Significant Bit
MT	Mobile Terminal
NET ID	NETwork IDentifier
OFB	Output FeedBack mode
OFDM	Orthogonal Frequency Division Multiplexing
PDU	Protocol Data Unit
RACH	Random Access CHannel
RBCH	RLC Broadcast CHannel
RCH	Random CHannel
RFCH	Random access Feedback CHannel
RLC	Radio Link Control Protocol
RG	Resource Grant
RR	Resource Request
RRC	Radio Resource Control
RSS	Received Signal Strength
SAP	Service Access Point
SCH	Short transport CHannel
SDU	Service Data Unit
TDD	Time Division Duplex
TDMA	Time Division Multiple Access
UL	UpLink
U-SAP	User Service Access Point
UBCH	User Broadcast CHannel
UDCH	User Data CHannel
UMCH	User Multicast CHannel

4 Overview

The present document describes the basic DLC functions for the purpose of transporting data and control information between HIPERLAN/2 devices. It consists of the functions and message formats for the AP and MT side. An overview of HIPERLAN/2 is given in TR 101 683 [6]. It is recommended that TR 101 683 [6] has been read before reading the present document.

4.1 Functional entities

The HIPERLAN/2 basic protocol stack on the AP side and its functions are shown in figure 1. It consists of the PHY layer on the bottom, the DLC layer in the middle and one or more convergence layers on top. The scope of the H/2 standard ends at the upper end of the CL on top of which higher layers are located.

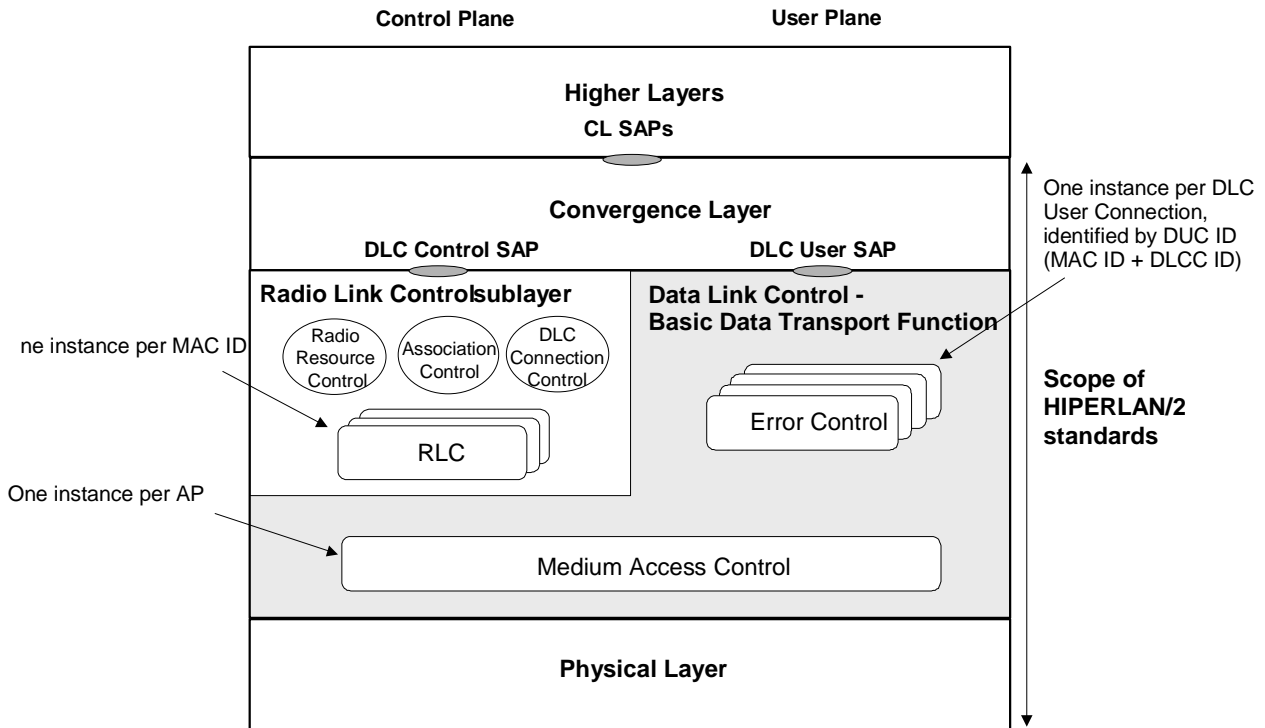

Figure 1: BRAN H/2 protocol stack in the AP/CC

The HIPERLAN/2 basic protocol stack on the MT side and its functions are depicted in figure 2. The difference to the model of the AP is that it contains only one RLC and MAC entity. The functionality of the MAC and RLC entity differs from that of the AP/CC whereas the error control functions are symmetrical, although this is not visible in the drawing.

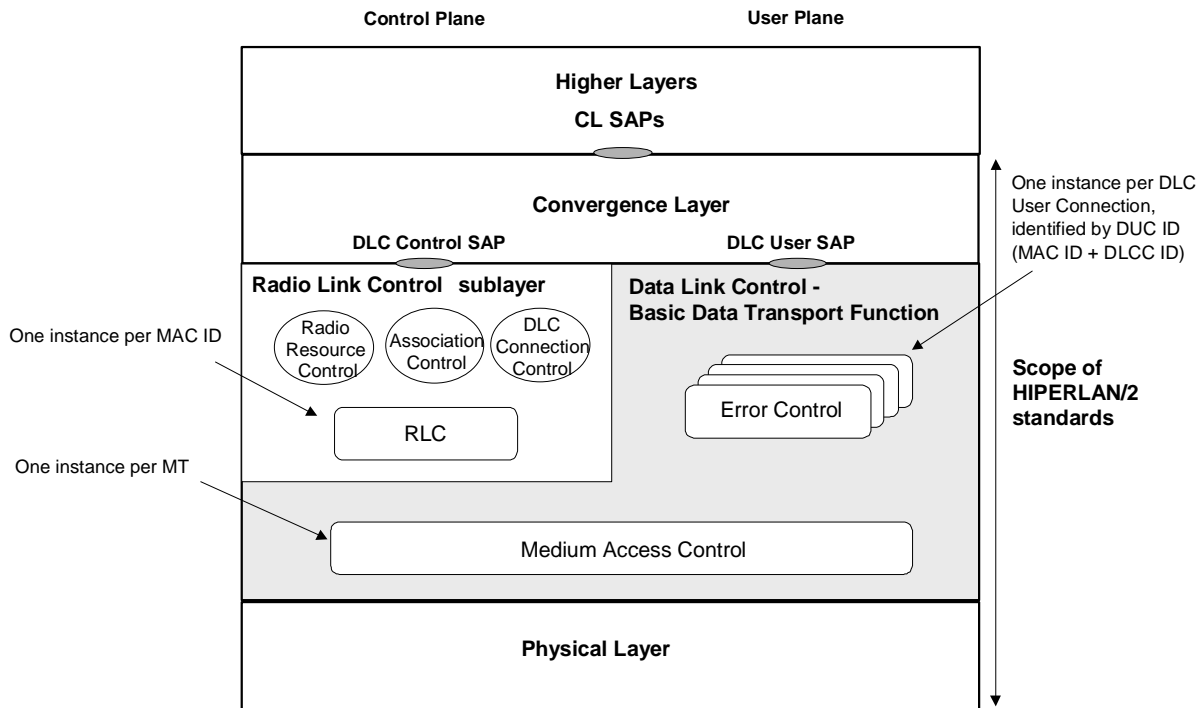

Figure 2: BRAN H/2 protocol stack in the MT

The present document is confined to the definition of the highlighted part shaded in grey, the DLC basic data transport functions. It describes mainly the messages and their format and, where appropriate, the functions of the MAC and EC.

NOTE: Architectures where the AP is split into an AP controller and one or more AP transceivers are not precluded by this specification. If the split between AP controller and AP transceiver is below the DLC layer, more than one MAC entity may exist in the AP controller.

4.1.1 Error Control (EC)

The EC is responsible for detection and recovery from transmission errors on the radio link. Moreover, it ensures in-sequence delivery of data packets. It is assumed that a dedicated EC instance is assigned to each DLC user connection.

NOTE: No ARQ is applied to the RLC data and the error handling is performed by the RLC itself.

4.1.2 Medium Access Control (MAC)

The Medium Access Control protocol is based on a dynamic TDMA/TDD scheme with centralized control. The MAC frame appears with a period of 2 ms. The allocation of resources is controlled by an AP or CC. It is assumed that one MAC entity with one instance is provided per AP or per MT. The MAC IDs are also used to administer broadcast and multicast services. The relation between MAC entities are created by a MAC ID which is unique in a radio cell, see clause 5.5.1.

NOTE: The terms access point and central controller are partly used synonymously in the present document.

In order to control the allocation of resources, the AP or CC needs to know the state of its own buffers and of the buffers in the MT. Therefore, the MTs report their buffer states in Resource Request (RR) messages to the AP or CC. Using this mechanism, the MTs request for resources in terms of transmission capacity. Moreover, an optional feature is to negotiate a fixed capacity allocation over multiple frames. The AP allocates the resources according to the buffer states on a fair basis and, if required, taking quality of service parameters into account. The allocation of resources is conveyed by Resource Grant (RG) messages. RRs and RGs are defined on a per-connection basis.

Data and control information are mapped onto transport channels. The transport channels are the basic elements to construct PDU trains that are delivered to and received from the physical layer. Six types of PDU trains are allowed: Broadcast, FCH-and-ACH, Downlink, Uplink with short preamble, Uplink with long preamble, and Direct link PDU train, see clause 6.9.2.

4.1.3 Radio link Control (RLC) sublayer

The Radio Link Control Sublayer (RLC) provides a transport service to the DLC User Connection Control, the Radio Resource Control and the Association Control Function. The Radio link Control sublayer is described in TS 101 761-2 [5].

4.1.4 Physical layer (PHY)

The physical (PHY) layer of HIPERLAN/2 is specified in TS 101 475 [4]. It is based on the modulation scheme Orthogonal Frequency Division Multiplexing (OFDM). In order to improve the radio link capability due to different interference situations and distances of MTs to the AP or CC, a multi-rate PHY layer is applied, where the appropriate mode can be selected by a link adaptation scheme. The data rate, which ranges from 6 Mbit/s to 54 Mbit/s, can be varied by using different signal alphabets for modulating the OFDM sub-carriers and by applying different puncturing patterns to a mother convolutional code. BPSK, QPSK, 16QAM are used as mandatory modulation formats, whereas 64QAM is applied as an optional one. The mode dependent parameters are listed in table 1.

Table 1: Mode dependent parameters

Modulation	Coding rate R	Nominal bit rate [Mbit/s]	Data bits per OFDM symbol
BPSK	1/2	6	24
BPSK	3/4	9	36
QPSK	1/2	12	48
QPSK	3/4	18	72
16QAM	9/16	27	108
16QAM	3/4	36	144
64QAM	3/4	54	216

4.1.5 Other functions (informative)

The present document is mostly restricted to the definition of messages that are exchanged between HIPERLAN/2 devices. It does not, however, describe where the data in devices are stored and which entity is responsible for their generation. Therefore, the functional model may seem to be not complete and the allocation of a logical channel to a logical entity is not always possible with the simple model given above.

For information, this clause lists some functions that are or may be assumed to be present in a device but which will not be described in this specification. The list is and cannot be complete.

Among these entities are the following functions:

- MAC scheduler. This function is responsible for the allocation of resources for the transmission of user and control data in the uplink, downlink and direct link phases as well as the allocation of the appropriate number of RCH per MAC frame;
- a function that performs radio resource management, e.g. link adaptation, power control, admission control, congestion control, dynamic frequency selection, handover initiation, etc.

NOTE: This specification describes the behaviour of some of the mentioned functions that may be normative.

4.2 Service Access Points to the CL (Informative)

The DLC exchanges service primitives with the Convergence Layer at the DLC-U-SAP and DLC-C-SAP. The primitives exchanged at the DLC-C-SAP between the convergence layer and the RLC are specified in TS 101 761-2 [5].

NOTE: The primitives are defined only for the purpose of describing layer-to-layer interactions. These primitives are defined as an abstract list of parameters, and their concrete realization may vary between implementations. The following primitive definitions are informative.

4.2.1 Primitive types

Interface between layers

Four primitive types may be used:

- req (request)
for a higher layer to request service from a lower layer;
- cnf (confirm)
for the layer providing the service to confirm the activity has been completed;
- ind (indication)
for a layer providing service to notify the next higher layer of any specific service related activity;
- rsp (response)
for a layer to acknowledge receipt of an indication primitive from the next lower layer.

4.2.2 Parameter definitions

Endpoint identifiers: some primitives contain an endpoint identifier. This identifier shall be used to distinguish primitives related to different protocol instances. As identifier the DLC User Connection ID shall be used. The use of this identifier is a local matter not defined in the present document. The identifier is defined as:

- DLC User Connection ID (DUC_ID)

Message unit: each piece of higher layer information that is included in the primitive is called a message unit. A series of one or more message units may be associated with each primitive where each separate unit is related to one information element in the corresponding CL layer message. The list of message units is derived from the message definitions by reference to the information elements that may contain information from or to the DLC.

4.2.3 DLC-U-SAP

The DLC-U-SAP describes the interface to the CL that offers a data transfer service for in-sequence delivery of DLC-SDUs.

The following primitives are used:

- DLC_UNITDATA {req, ind}

Table 2: Primitives at the DLC user SAP

PARAMETER	REQ	IND
DLC User Connection ID	Present	Present
Message units (possible elements) Interface Data	Present	Present

Interface Data (ID)

This parameter specifies the Interface Data unit exchanged between the CL and the DLC entity. The Interface Data represents a complete DLC-SDU. The DLC SDU has a size of 396 bits and is carried in the payload field of the UBCH, UMCH and UDCH, see clause 6.2.

5 Logical and Transport channels

Logical and transport channels are introduced in order to improve readability and to define exact terms for the structures that are used to construct MAC frames. In that sense, they are informative. However, the definitions of message contents and their meaning, numbers of bits and rules to construct them are normative.

The names of the logical channels will mostly be used when message contents and their meaning are addressed and the names of the transport channels should reflect message lengths, rules to assemble a MAC frame and access methods, e.g. to the RCH.

This clause describes basic properties of the logical and transport channels and their addressing. Their contents and formats are given in clause 6. Logical channels are referred to with four letters abbreviation, e.g. DCCH. Transport channels are referred to with three letters abbreviation, e.g. BCH.

5.1 Logical Channels and their characteristics

5.1.1 Logical Channels

A logical channel is a generic term for any distinct data path. A set of logical channel types is defined for different kinds of data transfer services as offered by the MAC entity. Each logical channel type is defined by the type of information it carries and the interpretation of the values in the corresponding messages. Logical channels can be considered to operate between logical connection end points and, hence, between logical entities.

5.1.2 Broadcast Control CHannel (BCCH)

The Broadcast Control Channel is used in downlink direction and conveys broadcast control channel information concerning the whole radio cell. It contains a fixed amount of data.

The support of the BCCH is mandatory for APs and CCs. MTs shall be able to interpret the BCCH.

5.1.3 Frame Control CHannel (FCCH)

The FCCH is sent in downlink direction and conveys information that describes the structure of the MAC frame visible at the air interface. This structure is announced by resource grants (RGs).

In the case of the RBCH, the DCCH and other DUCs, an RG corresponds to a number of LCHs and SCHs, the PHY modes to be used, and the location in the frame where the reception/transmission will take place.

The following information can be transmitted in the FCCH:

- an RG for SCHs and LCHs that can be used to transport information for: RBCH, DCCH, LCCH, UDCH, UBCH and UMCH;
- announcements of empty parts of the MAC frame.

The length of the FCCH is variable and depends on the amount of IEs sent per MAC frame per sector. The support of the FCCH is mandatory for APs and CCs. MTs shall be able to interpret the FCCH.

5.1.4 Random access Feedback CHannel (RFCH)

The purpose of the random access feedback channel is to inform the terminals that have used the RCH in the previous MAC frame about the result of their access attempts. It is transmitted once per MAC frame per sector.

The support of the RFCH is mandatory for APs and CCs. MTs shall be able to interpret the RFCH.

5.1.5 RLC Broadcast CHannel (RBCH)

The RBCH is used in downlink phase in CM and may be used by an MT in direct link phase in DM. It conveys broadcast control information concerning the whole radio cell. The information is only transmitted when necessary, which is determined by the AP/CC in CM, and determined by the originating MT in DM. Following information may be sent in the downlink RBCH:

- Broadcast RLC messages (see TS 101 761-2 [5]);
- transmission of the assigned MAC ID to a non-associated mobile terminal (see TS 101 761-2 [5]);
- convergence Layer ID information;
- encryption seed.

NOTE: The encryption seed is defined in clause 6.7.

The support of the downlink RBCH in APs/CCs and MTs is mandatory. The downlink RBCH shall be transmitted only when required but not more than once per MAC frame per sector antenna.

The DiL RBCH shall be supported if the DM is supported. The DiL RBCH is used to convey broadcast control information in DM from any one MT to all other MTs in DM.

5.1.6 Dedicated Control CHannel (DCCH)

The DCCH is used to carry RLC messages over the air interface, see TS 101 761-2 [5]. It can be used in the uplink, downlink and direct link phase. RLC messages between two terminals in DM are transmitted over the DCCH in the DiL phase, which is uniquely identified by the transmit and receive MAC IDs. The DCCH may also be used for the transmission of RRs in uplink direction according to the rules in clause 6.3.

NOTE: All RLC messages have a unique length that is selected such that the messages can be sent either in an SCH/RCH or in an LCH, see TS 101 761-2 [5]. It is assumed that the MAC decides whether an RLC message is mapped to an SCH or RCH. The method of this mapping process is out of the scope of the present document.

The DCCH is established implicitly during association of a terminal without any explicit signalling. A DLCC ID and corresponding connection parameters are predefined, i.e. no connection setup is needed. Each associated terminal can use the DCCH for downlink and uplink and, if implemented, for the direct link phase. The unacknowledged error control mode is used for the DCCH, see clause 6.4.

DCCHs are transmitted in PDU trains (see clause 6.9.2) together with UDCH and LCCH if those exist in the current frame.

The support of the DCCH in both MT and AP/CC is mandatory for the uplink and downlink. It shall be supported for the direct link if the DM features are supported.

5.1.7 User Broadcast CHannel (UBCH)

The UBCH is used to transmit user broadcast data from the convergence layer. If the AP supports multiple convergence layers, multiple UBCHs may exist. The UBCH can be sent either in the downlink (by an AP or CC) or direct link (by an MT).

UBCHs are transmitted in PDU trains (see clause 6.9.2) together with or without LCCHs.

The support of the UBCH in APs/CCs and MTs is mandatory. It shall be supported for the direct link if the DM features are supported.

The UBCH shall either be transmitted in repetition or unacknowledged mode, see clause 6.4.

5.1.8 User Multicast CHannel (UMCH)

The UMCH is used to transmit user multicast data. The UMCH can be sent either in the downlink (by an AP or CC) or direct link (by an MT).

UMCHs are transmitted in PDU trains (see clause 6.9.2).

The UMCH shall be transmitted in unacknowledged mode, see clause 6.4. The support of the UMCH in the AP and CC, respectively, is mandatory. MTs shall be able to interpret the UMCH if they join a multicast group. It shall be supported for the direct link if the DM features are supported.

5.1.9 User Data CHannel (UDCH)

The UDCH is used to transmit user data between the AP and an MT in CM, or between two terminals in DM. A UDCH is always granted together with zero or more SCHs for a DUC that is announced in an RG in the FCCH.

UDCHs are transmitted in PDU trains (see clause 6.9.2) together with or without LCCHs.

The support of UDCH for uplink and downlink is mandatory for both MTs and APs/CCs. The support of the UDCH for the direct link is mandatory if the DM features are supported.

5.1.10 Link Control CHannel (LCCH)

The LCCH is in general bi-directional and is used to transmit ARQ feedback and discard messages between the EC functions in the AP and an MT for a certain UDCH in centralized mode. In direct mode, it is bi-directional and conveys ARQ feedback and discard messages between the EC functions in two MTs for a certain DLCC in the DiL phase. The LCCH is also used in uplink direction for the transmission of RRs for the uplink. RRs for the direct link shall not be transmitted in DiL LCCHs. The method to transmit RRs for the direct link is described in clause 6.2.9.1.2.

The LCCH is also used to transmit discard messages between the EC functions in the AP/CC and the MTs for a UBCH using repetition mode for both centralized mode and direct mode.

LCCHs are transmitted in PDU trains (see clause 6.9.2) together with or without UDCHs/UBCHs.

The support of the LCCH for uplink and downlink is mandatory for both MTs and APs/CCs. The support of the LCCH for the direct link is mandatory if the DM features are supported.

5.1.11 ASsociation Control CHannel (ASCH)

The ASCH is only used in the uplink and conveys new association request and handover request messages on behalf of the RLC, see TS 101 761-2 [5]. These messages shall only be sent by terminals that are not associated to an AP or CC.

The support of the ASCH is mandatory for APs/CCs and MTs.

5.2 Transport channels and their characteristics

5.2.1 Transport Channels

The logical channels are mapped onto different transport channels that are referred to with three letter abbreviations, e.g. LCH. The transport channels are the basic elements to construct PDU trains. Transport channels describe the basic message format. In the case of the RCH, the random access method and the collision resolution scheme is also a property of the transport channel. The message contents and their interpretation, however, are subject to the logical channels. Transport channels can carry a fixed amount of data, except the FCH that can carry a variable amount.

The transport channel's names will be used in the present document for the purpose of an abstract definition of a message as well as the actual occurrence of the respective message. The rules for the handling of transport channels are given in clause 6.

All transmissions of messages shall start with the most significant bit of the first octet, followed by the remaining bits of this octet, then the most significant bit of the second octet, etc. An example for this rule is given in figure 3. If not defined otherwise, the bits in a field are a binary representation of a number.

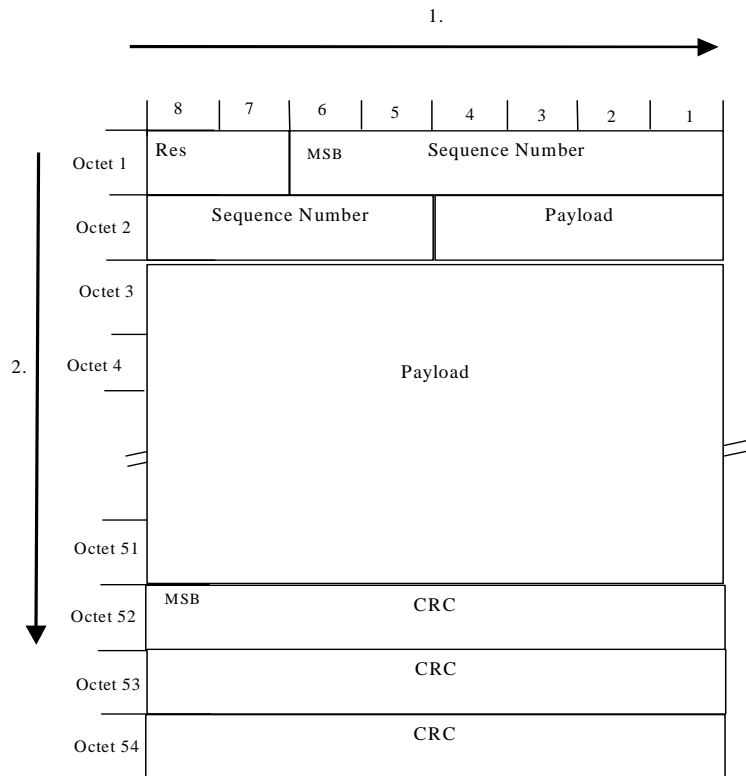

Figure 3: Example for the transmission order of DLC messages

An overview of the characteristics of the transport channels is given in table 3.

Table 3: Characteristics of Transport channels

Transport channel	Direction	PHY mode	Length [octets]	Comments
BCH	Downlink	Binary PSK and code rate $\frac{1}{2}$.	15	Sent in every MAC frame for each sector.
FCH	Downlink	Binary PSK and code rate $\frac{1}{2}$.	Multiple of 27	Sent in every MAC frame for each sector that contains scheduled data.
SCH	DL/UL/DiL	Set in FCCH.	9	PHY mode is set and adapted per connection.
LCH	DL/UL/DiL	Set in FCCH.	54	PHY mode is set and adapted per connection.
ACH	Downlink	Binary PSK and code rate $\frac{1}{2}$.	9	Sent in every MAC frame for each sector.
RCH	Uplink	Binary PSK and code rate $\frac{1}{2}$.	9	Contention based access.

5.2.2 Broadcast Channel (BCH)

The BCH carries the BCCH. It shall be broadcast in downlink direction. One BCH shall be sent per MAC frame per sector antenna. The support of the BCH is mandatory for APs/CCs and MTs.

5.2.3 Frame Channel (FCH)

The FCH carries the FCCH. It shall be broadcast in downlink direction. The support of the FCH is mandatory for APs/CCs and MTs.

5.2.4 Access Feedback Channel (ACH)

The ACH shall be used for sending RFCH in the downlink. The support of the ACH is mandatory for APs/CCs and MTs.

5.2.5 Long transport CHannel (LCH)

The LCH transports user data for the connections related to the granted UDCHs, UBCHs and UMCHs, as well as control information for the connections related to the DCCH and RBCH. Rules for the use of LCHs are given in clause 6.

The support of the LCH is mandatory for APs/CCs and MTs.

5.2.6 Short transport CHannel (SCH)

The SCH transports short control information for the DCCH, LCCH and RBCH. Rules for the use of SCHs are given in clause 6.

The support of the SCH is mandatory for APs/CCs and MTs.

5.2.7 Random CHannel (RCH)

The RCH is defined for the purpose of giving an MT the opportunity to send control information to the AP or CC when it has no granted SCH available. It can carry RRs, ASCH and DCCH data. The support of the RCH is mandatory for APs/CCs and MTs.

The access scheme is a distributed random access method described in clause 6.

5.3 Mapping between Logical and Transport Channels

The mapping between logical channels and transport channels is depicted below for the uplink, downlink, and direct link.

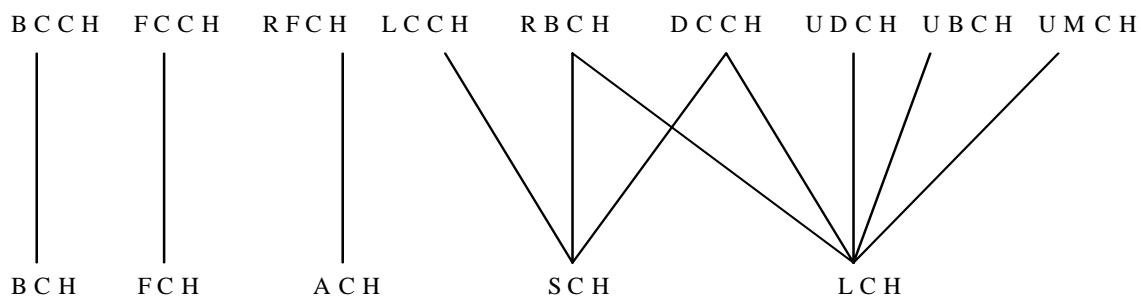

Figure 4: Mapping between logical channels and transport channels for the downlink

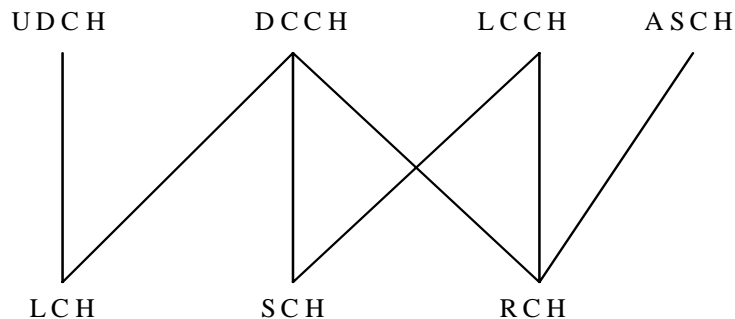

Figure 5: Mapping between logical channels and transport channels for the uplink

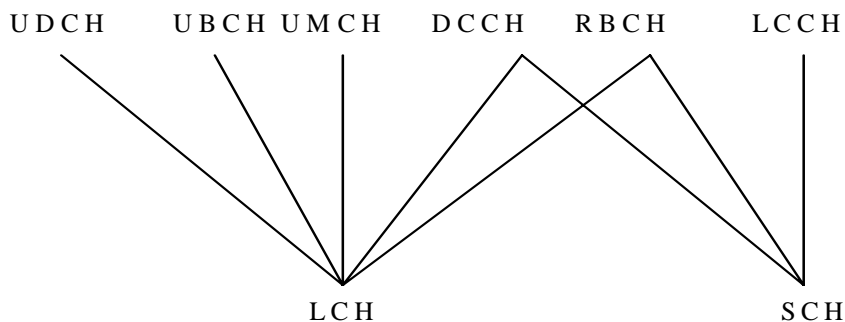

Figure 6: Mapping between logical channels and transport channels for the direct link

The BCCH, FCCH and RFCH are directly mapped to the corresponding transport channels BCH, FCH and ACH. The LCCH carries control information (i.e. RRs, discard and ARQ feedback messages). These are mapped to the SCH. For the uplink it is also possible to use the RCH for RR messages. In the case of the DiL, the LCCH carries only ARQ feedback and discard messages between two terminals. These are mapped to the SCH only.

The DCCH conveys information between two RLC entities and can be mapped to the LCH or SCH in the downlink and the LCH, SCH or RCH in the uplink. The DCCH in the DiL phase conveys information between two RLC entities and can be mapped to the LCH or SCH. The RBCH is mapped to the SCH or LCH. The UDCH transfers user data and is mapped to the LCH. The UBCH and UMCH for broadcast and multicast are mapped to the LCH. The ASCH is mapped to the RCH.

5.4 Overview of the MAC Frame

The basic MAC frame structure for a single sector system is shown in figure 7. Each MAC frame shall consist of the transport channels BCH, FCH, ACH and at least one RCH. If user data is to be transmitted, a DL phase and/or an UL phase shall be provided. If direct mode is used and data has to be transmitted, it shall also contain a DiL phase between the DL and UL phase. The duration of the BCH is fixed. The duration of the FCH, DL phase, DiL phase, UL phase and the number of RCHs are dynamically adapted by the AP/CC depending on the current traffic situation. The order of the subcomponents shall be: BCH - FCH - ACH - DL phase - UL phase - RCHs for centralized mode, or BCH - FCH - ACH - DL phase - DiL phase - UL phase - RCHs for direct mode from the point of view of an MT.

NOTE: The specified order is from an MT's point of view. This means that an AP may e.g. have several DL & UL phases and mix the phases randomly, as long as the order is kept for each individual MT.

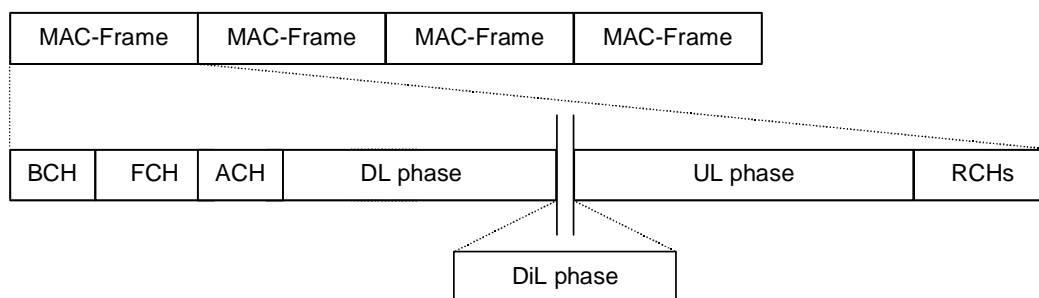
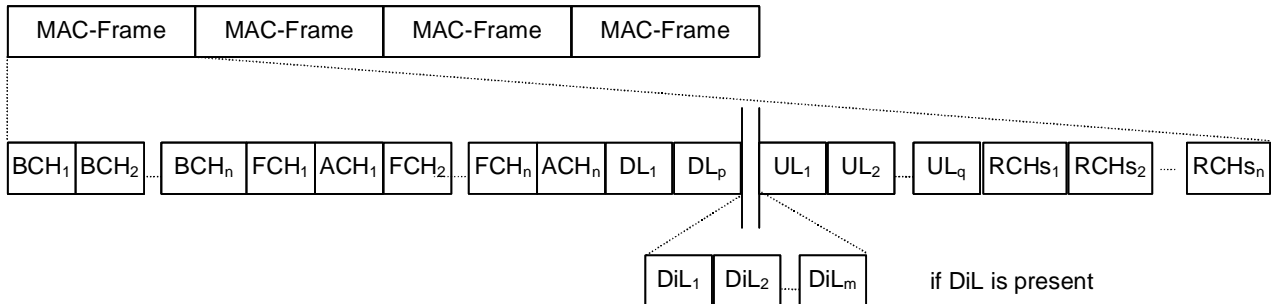

Figure 7: Basic MAC frame structure (Direct link phase optional) for a single sector system

An example of the basic MAC frame structure from the AP's point of view in the case where multiple sectors are used is shown in figure 8. Each MAC frame shall consist of a sequence of BCHs. The number of BCHs is equal to the number of sectors the AP is using. After the sequence of BCHs that have a fixed duration, a sequence of FCH-and-ACH PDU trains (see clause 6.9.2) follows for each sector. The FCH shall not be transmitted if no traffic is scheduled for that sector in the current frame. A sequence of RCHs is located after the uplink phase. At least one RCH per sector shall be present. The frame also contains at least one DL phase and/or UL phase for a particular sector if the corresponding FCH is present.

If direct mode is used and data is to be transmitted, the frame also contains a DiL phase. The DiL phase is located between the DL and UL phase. The duration of the FCH, DL phase, DiL phase, UL phase and the number of RCHs are dynamically adapted by the AP depending on the current traffic situation.

Detailed rules for the composition of MAC frames are given in clause 6.3.2.



**Figure 8: Basic MAC frame structure for multiple sectors
(N = number of sector used by the AP)**

5.5 DLC addressing

5.5.1 MAC ID

Each MT is assigned a MAC ID that is unique for the AP by the AP RLC entity during association. The MAC ID is coded with 8 bits. The association procedure is described in TS 101 761-2 [5].

If the AP or CC acts also as a terminal, it shall be assigned a unique MAC ID.

NOTE: This MAC ID assignment is done internally by the AP or CC.

MAC IDs 0 and 224 - 255 are reserved for special purposes, see clause 5.5.6.

5.5.2 DLC Connection ID

A DLC Connection ID (DLCC ID) is assigned to a connection by the AP RLC entity during connection setup. The DLCC ID is coded with 6 bits. The connection setup procedure is described in TS 101 761-2 [5].

In CM, the MT and the access point or central controller shall use the MAC ID and the DLCC ID to identify for which connection an MT is requesting and the AP/CC is granting resources. The combined MAC ID and DLCC ID are referred to as DLC User Connection ID (DUC ID) and shall be unique in a radio cell. The DLCC ID is used as a reference to a connection during its lifetime.

In DM, the DLCC ID is used in combination with two MAC IDs, the source and destination MAC IDs. The combination of source MAC ID, destination MAC ID, and the DLCC ID uniquely defines a DUC ID for DM.

5.5.3 NET ID

The NET ID in the BCCH shall be the same for all access points that belong to the same network of a certain operator/owner for a given geographic area. APs or CCs with the same NET ID shall support the same set of convergence layers.

The NET ID is split into two ranges:

- 0-959: for common use. Before selecting a NET ID in this range, it should be assured that the chosen NET ID is unique in the coverage area of a network;
- 960-1023: reserved for public systems. The assignment of a NET ID within this range is beyond the scope of the present document.

5.5.4 Access point ID

Each AP/CC shall be assigned an access point ID (AP ID) with a length of 10 bits. This ID should be unique for a network in a certain geographic area.

If an AP is decomposed into several transceivers, then each transceiver shall be allocated an AP ID.

5.5.5 Sector ID

Each sector in the AP/CC is assigned a sector ID with a length of three bits. If the sector ID is equal to zero, a single sector is used and the respective rules apply. If more than one sector is used, these shall be allocated a sector ID from 0 to 7 in the order in which the BCH is transmitted.

5.5.6 Logical channels addressing

5.5.6.1 BCCH

The BCCH is transmitted in the BCH and is identified by the occurrence of the BCH.

5.5.6.2 FCCH

The FCCH is transmitted in the FCH and is identified by the occurrence of the FCH.

5.5.6.3 RFCH

The RFCH is transmitted in the ACH and is identified by the occurrence of the ACH.

5.5.6.4 RBCH

The RBCH is announced in the FCCH and is identified by MAC ID = 0 and DLCC ID = 0 in the case of the downlink. In the direct link, it is identified by the source MAC ID of the transmitting MT, MAC ID = 0 and DLCC ID = 0.

5.5.6.5 DCCH

The DCCH is identified by DLCC ID = 0 for each MAC ID in the centralized mode. For the direct mode, the DCCH is identified by the source and destination MAC IDs of the concerned MTs and DLCC ID = 0. The DCCH is announced in the FCCH.

5.5.6.6 UBCH

The UBCH for a particular convergence layer is identified by the unique MAC ID that shall be assigned dynamically by the RLC (see TS 101 761-2 [5]) in the AP/CC from the address range MAC ID = [1 – 223] and DLCC ID = 63.

In direct mode, this unique MAC ID is used as the destination MAC ID of a direct link UBCH. The source MAC ID shall identify the originator of the direct link UBCH.

5.5.6.7 UMCH

MAC IDs = [224 – 255] shall be reserved for multicast connections. The assignment is performed by the AP/CC and details can be found in TS 101 761-2 [5]. For multicast traffic using multicast MAC IDs = [224 – 254], DLCC ID = 63 shall be used. The use of other DLCC IDs for multicast connections with MAC IDs = [224 – 254] is not considered in the present document. The MAC ID identifies the UMCH for the MT.

NOTE: The use of other DLCC IDs may be specified in a future extension of the present document.

In order to handle situations where more multicast connections are required, it shall be allowed to multiplex traffic from several multicast groups over MAC ID = 255. The support of multicast addresses is mandatory for MTs and APs/CCs.

In direct mode, the MAC ID from [224 - 255] shall be used as the destination MAC ID of a direct link UMCH. The source MAC ID shall identify the originator of the direct link UMCH.

5.5.6.8 UDCH

A MAC ID, a DLCC ID, a start pointer, number of LCH and a type field in an RG in the FCCH identify the UDCH for centralized mode. The DLCC ID is selected during connection setup or by a default value provided by the convergence layer. The connection setup procedure is described in TS 101 761-2 [5]. Both directions of a bi-directional UDCH shall use the same DLCC ID.

In direct mode, an additional destination MAC ID is used to identify an outgoing connection for the transmitting terminal and a source MAC ID identifies an incoming connection for the receiving terminal. It is permitted to have outgoing simplex connections with the same DLCC ID to different destination MAC IDs and to have incoming simplex connections with the same DLCC ID from different source MAC IDs. But between a source and destination MAC ID pair, both directions of a bi-directional UDCH shall use the same DLCC ID.

NOTE: The UDCH is identified by the MAC ID(s), DLCC ID and the assigned capacity for LCHs in the RG in the FCCH. No MAC ID(s) or DLCC ID is included in the actually transmitted UDCH.

5.5.6.9 LCCH

A MAC ID, a DLCC ID, a start pointer, number of SCH and a type field in a RG in the FCCH identify the LCCH for centralized mode. Additional identification information is given in an SCH type field. In the case of RRs that are sent in the RCH, the LCCH is identified by an RCH type field, the source MAC ID, and the DLCC ID.

Both directions of a bi-directional LCCH shall use the same DLCC ID.

In direct mode, an additional destination MAC ID is used to identify an outgoing connection for the transmitting terminal, and a source MAC ID identifies an incoming connection for the receiving terminal.

5.5.6.10 ASCH

A set of ASCH specific RLC type field values in the RCH identifies ASCH RLC messages. Further information can be found in TS 101 761-2 [5].

5.5.7 Identification of transport channels

5.5.7.1 BCH

The BCH is identified by its location in the MAC frame. Further details can be found in clause 6.

5.5.7.2 FCH

In the case of a single sector, the FCH is identified by its location in a MAC frame. In the case of multiple sectors, the location of the FCH of each sector is indicated by a 12-bit pointer in the BCCH corresponding to this sector.

5.5.7.3 ACH

In the case of a single sector, the ACH is located in the MAC frame immediately following the FCH. In the case of multiple sectors, its location is indicated in the BCCH by a 12-bit pointer and the length of the FCH, see clause 6.

5.5.7.4 LCH

LCHs are identified by Resource Grant Information Elements (IE) in the FCCH and a set of rules, see clause 6.

5.5.7.5 SCH

SCHs are identified by Resource Grant Information Elements (IE) in the FCCH and a set of rules, see clause 6.

5.5.7.6 RCH

The BCCH announces the location of the RCH.

6 Radio transmission and reception functions

6.1 Format of the transport channels

This clause describes the exact contents and formats of the transport channels. All bit representations of information fields are displayed such that the MSB appears on the left end. Fields that are for future use can have arbitrary values if no specific values are defined.

6.1.1 Broadcast CHannel (BCH) format

The BCH contains 120 bits. The content is the BCCH.

6.1.2 Frame CHannel (FCH) Format

The FCH carries the FCCH. The basic structure of the FCH is shown in figure 9. The FCH shall be built of fixed size IE blocks. The AP or CC determines the number of blocks. Every IE block shall contain three IEs, each with a length of 8 octets, and a CRC of length 24 bits which shall be calculated over the three preceding IEs. The rules for the calculation of the CRC and for the use of the FCH when building a MAC frame are described in the subsequent clauses.

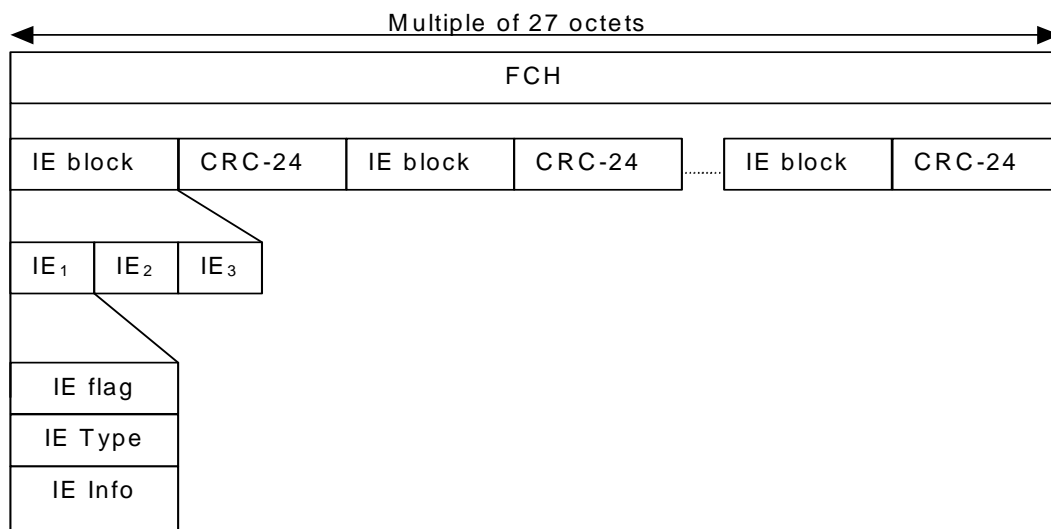

Figure 9: FCH structure

The content of the IE is shown in table 4. Figure 10 shows the resulting transfer syntax.

Table 4: Contents of the FCH IEs

Name	Length (bits)	Purpose	
IE-flag	1	Always set to one (Used for future purposes to make this structure expandable)	
IE-type	4	Identifies the IE type The mapping of the field is as follows	
		IE-Type	Purpose
		0000	Downlink RG
		0001	Uplink RG
		0010	Direct link RG
		0011	Future use
		0100	Empty parts in the frame
		0101	Padding IE
0110-1111	Future use		
IE Info	59	FCCH IE content	

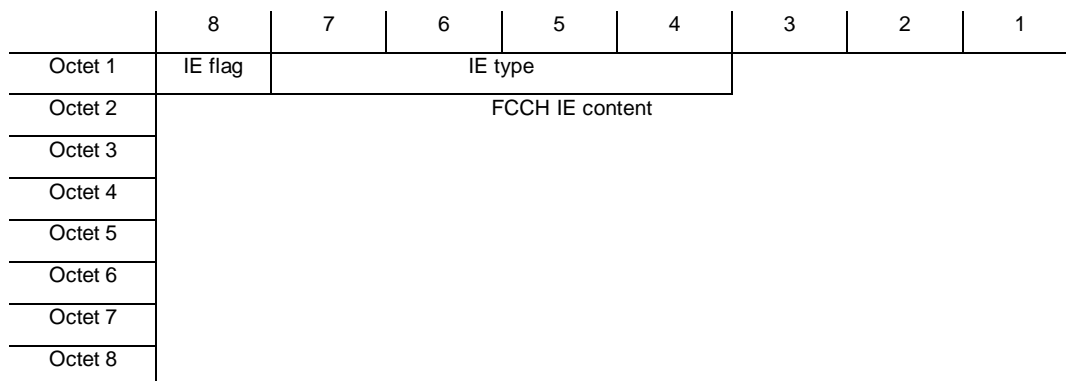

Figure 10: FCH transfer syntax

The content of the FCH padding IE is not specified.

6.1.3 Access feedback CHannel (ACH) format

The ACH carries the RFCH (see clause 6.2). The ACH have a total size of nine octets. The format is identical to the SCH format and has a type field with the binary coding 0110 at its beginning. The value of this type field shall not be used for SCH message types.

6.1.4 Long transport CHannel (LCH) format

The LCH consists of 54 octets. The contents are DCCH, RBCH, UDCH, UBCH or UMCH messages. It contains a LCH PDU type field that is coded according to table 5.

Table 5: LCH type field

LCH PDU type	Purpose
00	Carries a UDCH, UBCH, UMCH, DCCH or RBCH message
01	Dummy LCH
10	Future use
11	Future use

The transfer syntax for an LCH is given in figure 11.

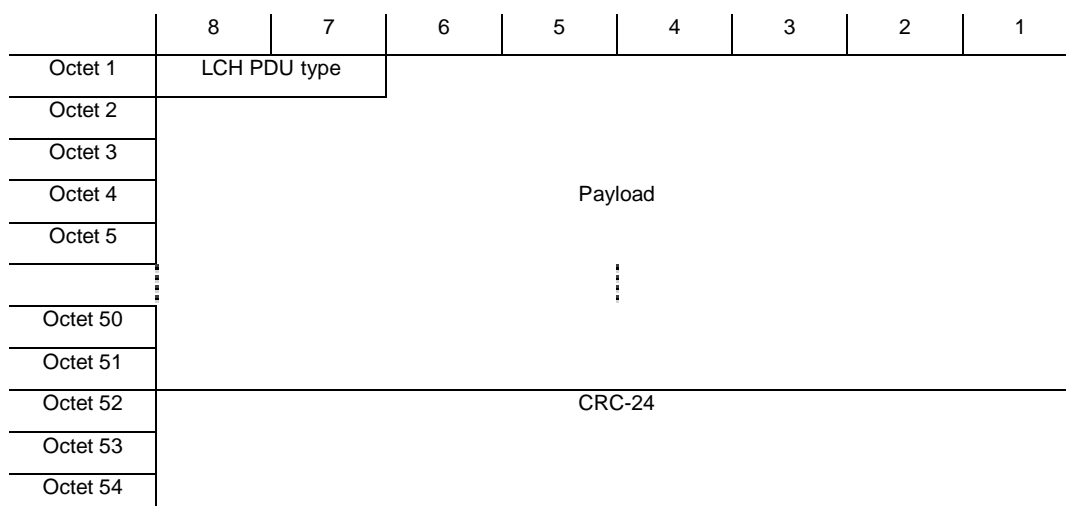

Figure 11: LCH transfer syntax

NOTE: The RG in the FCCH defines which logical channel is to be transferred.

6.1.5 Short transport CHannel (SCH) format

The SCH consists of 9 octets. The SCH carries messages for various logical channels which themselves contain messages for different purposes. A type field distinguishes these message types. The allocation of identifiers in this type field is shown in table 6.

Table 6: SCH type field

SCH PDU Type MSB-LSB	Purpose
0000	Reserved
0001	ARQ feedback
0010	Discarding
0011	RR for uplink
0100	RLC to/from the AP/CC
0101	RR for direct link
0110	Not allowed (used for ACH)
0111	RLC in DM (RBCH, DCCH)
1000	Encryption Seed (only in downlink RBCH)
1001	Dummy SCH
1010-1111	Reserved

The content of the dummy SCH payload field is not specified.

Table 7 shows the general SCH format. The general SCH transfer syntax is depicted in figure 12.

Table 7: General contents of the SCH

Name	Bits	Purpose
MAC PDU Type	4	Determines the type of information in the SCH
Info	52	Information transported in the SCH
CRC	16	CRC-16
Total	72	

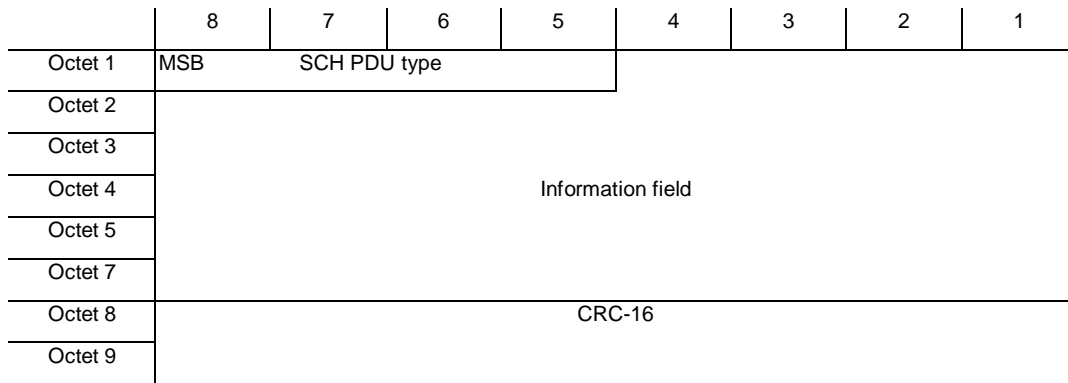

Figure 12: General SCH transfer syntax

6.1.6 Random CHannel (RCH) format

The RCH consists of 9 octets. Its format is identical to the format of the SCH. The RCH does not carry all message types that are allowed for SCH. Table 8 shows the allowed SCH PDU type values for the RCH.

Table 8: RCH type identifier

SCH PDU Type MSB-LSB	Purpose
0000	Reserved
0001	Not allowed (ARQ feedback)
0010	Not allowed (Discarding)
0011	RR for uplink
0100	RLC to the AP/CC
0101	RR for direct link
0110	Not allowed (ACH)
0111	Not allowed (RLC for direct mode)
1000	Not allowed (Encryption Seed)
1001	Not allowed (Dummy)
1010-1111	Reserved

NOTE: In the above table the RCH PDU type uses the same mapping of the RCH PDUs as for SCH PDUs. Therefore the term SCH PDU type is used instead of RCH PDU type.

6.2 Logical channel formats

The following clause shows the message formats of the logical channels. The contents are listed in a table together with a description of the meaning of the field contents. Where appropriate, the contents of the logical channels are described including the surrounding traffic channel contents in order to increase readability.

6.2.1 BCCH message format

The content of the BCCH and a description of the contents is given in table 9. The CRC in the end shall be calculated over the preceding 12 octets according to the algorithm given in clause 6.6.

Table 9: Contents of the BCCH

Name	Bits	Purpose
Frame counter (scrambler seed)	4	Identifies which scrambling pattern shall be applied to the DLC PDU trains in the MAC frame. The counter shall be incremented by one modulo 16 every MAC frame. The scrambling is described in TS 101 475 [4].
NET ID	10	Network identifier (see clause 5.5).
AP ID	10	AP identifier (see clause 5.5). The MT shall check the AP ID in each frame. If the AP ID is different from what the MT expects to receive, the MT shall not transmit anything in the frame.
Sector ID	3	Identifies the used sector. Each sector is numbered from 0 up to 7 and is increased by one for each sector. The BCHs are transmitted in the order according to their Sector ID. 000 = First sector antenna (this number is also used for a single sector AP). 001 = Second sector. ... 111 = Eighth sector.
AP TX level	4	Identifies AP transmission power (see TS 101 475 [4]).
AP RX UL level	3	Identifies the expected AP reception power level. It covers both normal uplink data and RCH data (see TS 101 475 [4]).
Pointer to FCH	12	A pointer to the FCH is needed in the case multiple sectors are used by the AP. The pointer is pointing to the ACH instead if the length of the FCH is set to zero for a sector (this means that the sector will not transmit any FCH). The reference point for the pointer is defined in clause 6.3.5.
Length of FCH	4	Identifies the number of IE blocks in the FCH. If length is set to zero for an sector, this means that the sector will not transmit any FCH
PHY Mode of FCH	2	00 = BPSK, code rate 1/2. 01-11 = Future use.
Pointer to RCH	13	Identifies the starting point of the RCHs. The reference point for the pointer is defined in clause 6.3.5.
Length of RCH	5	Identifies the number of RCHs. 00000 = Future use. 00001 = 1 RCH in the frame. 00010 = 2 RCH in the frame. 11111 = 31 RCH in the frame.
RCH Guard space	2	Identifies the guard time used between the RCHs, see TS 101 475 [4].
DL RBCH indicator	1	Indicates that the downlink RBCH will be sent in this frame.
DST (Data to sleeping terminals)	1	Indicates whether the current MAC frame contains data for at least one sleeping terminal. 0 = The frame does not contain data for sleeping terminals. 1 = The frame contains data for sleeping terminals. For details, see TS 101 761-2 [5].
Uplink preamble	1	Indicate which preamble is used in the uplink. 0 = Short. 1 = Long (see TS 101 475 [4]).
Phase indicator	4	Indicates the phase according to which the AP/CC has been built. 0001 = Phase 1.

Name	Bits	Purpose
AP traffic load indicator	3	000 = Default. 001 = Message transmission to this AP not permitted. 010 – 111 = Future use.
Maximum power indicator	1	0 = The AP transmits with either its maximum power or its maximum power-3dB. 1 = The AP does not transmit within the power range given above.
Number of sectors	3	Identifies the number of sectors the AP uses. 000 = Single sector. 001 = Two sectors. 010 = Three sectors. 011 = Four sectors. ... 111 = Eight sectors.
Future use	10	For future use.
CRC	24	CRC-24
Total length	120	

The transfer syntax of the BCCH is given in figure 13.

	8	7	6	5	4	3	2	1
Octet 1	MSB Frame counter [n ₄ , n ₃ , n ₂ , n ₁]				MSB			
Octet 2	FCH pointer							
Octet 3	MSB Length of FCH				MSB FCH PHY mode		DST	DL RBCH ind
Octet 4	MSB AP ID							
Octet 5	MSB AP TX Level						MSB	
Octet 6	NET ID							
Octet 7	MSB Sector ID				MSB			
Octet 8	RCH pointer							
Octet 9	MSB Length of RCH				MSB AP RX level			
Octet 10	MSB RCH Guard space		MSB Number of sectors			MSB AP traffic load ind		
Octet 11	Prea ind	Max Pow ind	MSB Phase indicator				Future use	
Octet 12	Future use							
Octet 13	CRC-24							
Octet 14								
Octet 15								

Figure 13: Transfer syntax of the BCCH

The use of the pointers to the FCHs in the case of multiple sectors is illustrated in figure 14.

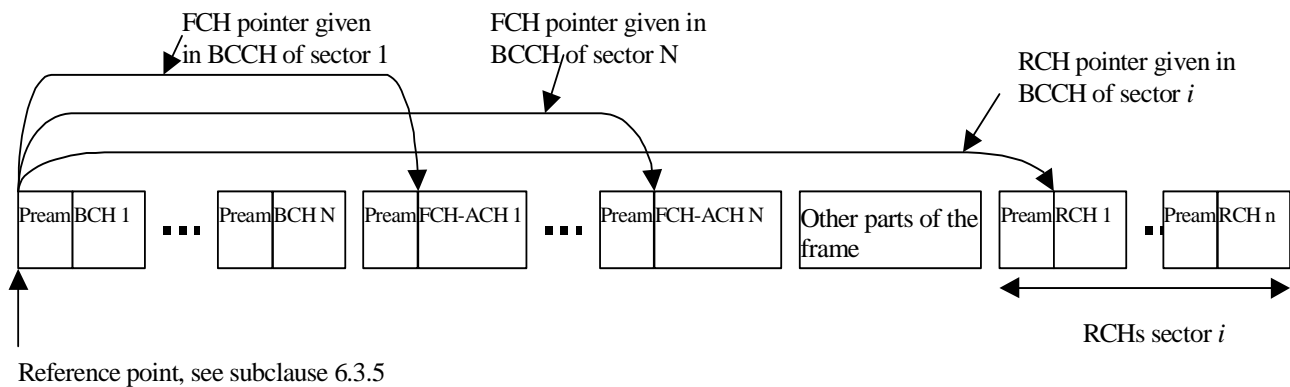

Figure 14: Illustration of the use of the pointers in the BCCH

6.2.2 FCCH information element contents and message formats

6.2.2.1 IE for allocating resources for: RBCH, DCCH, UBCH, UMCH, and UDCH and LCCH for downlink and uplink

Table 10 illustrates the structure of the IE that shall be used to allocate resources for the downlink transmission of RBCH, DCCH, UBCH, UMCH, UDCH and LCCH.

Table 10: Format of RG IE for downlink allocation in centralized mode

Fields	Bits	Purpose
IE flag	1	Shall be set to 1.
IE Type	4	0000 (downlink).
MAC ID	8	Identifies which MAC ID the resource grant belongs to.
DLCC ID	6	Identifies which DLCC ID the resource grant belongs to.
Start Pointer	13	Identifies the starting point of transmission, see clause 6.3.5.
# SCH	6	Specifies the number of SCHs allocated for this particular DUC.
RR poll	1	Future use.
PHY mode SCH	3	Sets the PHY mode for the granted SCHs.
# LCH	8	Specifies the number of LCH allocated for this particular DUC.
PHY mode LCH	4	Sets the PHY mode for the granted LCHs.
Future use	10	
Total	64	

The message content of RGs for the allocation of capacity in the uplink is shown in table 11. This message can only be used for the allocation of DCCHs, UDCHs and LCCHs in uplink direction.

Table 11: Format of RG IE for the uplink allocation in centralized mode

Fields	Bits	Purpose
IE flag	1	Shall be set to 1.
IE Type	4	0001 (uplink).
MAC ID	8	Identifies which MAC ID the resource grant belongs to.
DLCC ID	6	Identifies which DLCC ID the resource grant belongs to.
Start Pointer	13	Identifies the starting point of the transmission, see clause 6.3.5.
# SCH	6	Specifies the number of SCHs. Rules for the use are given in clause 6.3.2.4.
RR poll	1	Only valid for uplink RGs. Rules for the use are given in clause 6.3.2.4.
PHY mode SCH	3	Sets the PHY mode for the granted SCHs.
# LCH	8	Specifies the number of LCHs allocated for this particular DUC.
PHY mode LCH	4	Sets the PHY mode for the granted LCHs.
Future use	10	
Total	64	

The transfer syntax of the RG IE for uplink and downlink is shown in figure 15.

	8	7	6	5	4	3	2	1	
Octet 1	IE flag	MSB IE type				MSB	MAC ID		
Octet 2	MSB MAC ID					Future use			
Octet 3	Future use					MSB	DLCC ID		
Octet 4	DLCC ID			MSB	Start pointer				
Octet 5	Start pointer								
Octet 6	Future use	MSB	SCH PHY mode		MSB	LCH PHY mode			
Octet 7	MSB # LCH								
Octet 8	MSB # SCH						RR poll	Future use	

Figure 15: Transfer syntax of the RGs for up- and downlink in centralized mode

The support of the RG IEs for uplink and downlink is mandatory for both APs/CCs and MTs.

The possible PHY mode for the RBCH is fixed to BPSK with code rate $\frac{1}{2}$. All other logical channels announced with the above described RG may use all mandatory and, if agreed, optional PHY modes (see clause 6.9).

The AP/CC shall be responsible to select any of the mandatory and, if agreed, optional PHY modes for the downlink and uplink transmission. The PHY modes continuously proposed by the MT should be considered as recommendations to the AP/CC when setting the PHY modes for the downlink transmission. The AP/CC shall itself determine which PHY modes are used in the uplink transmission.

NOTE 1: It is up to the scheduler in the AP/CC to determine the needed capacity for LCHs and SCHs. It is allowed that the scheduler allocates more LCHs and SCHs than have been requested or negotiated by the MTs.

NOTE 2: The AP/CC is responsible to schedule the number of ARQ feedback messages that are to be transmitted in SCHs.

6.2.2.2 IE for allocating resources for RBCH, DCCH, UBCH, UMCH, UDCH and LCCH in the direct link

Table 12 illustrates the structure of the IE that shall be used to allocate resources for RBCHs, DCCHs, UBCHs, UMCHs, UDCHs and LCCHs in the direct link.

Table 12: Format of RG IE for direct link (optional feature)

Fields	Bits	Purpose
IE flag	1	Shall be set to 1.
IE Type	4	0010 (direct link).
Source MAC ID	8	Identifies the source MAC ID the resource grant belongs to.
Destination MAC ID	8	Identifies the destination MAC ID the resource grant belongs to.
DLCC ID	6	Identifies which DLCC ID the resource grant belongs to.
Start Pointer	13	Identifies the starting point of the transmission/reception, see clause 6.3.5.
# SCH	6	Specifies the number of SCHs per DUC. Rules for the use are given in clause 6.3.2.4.
PHY mode SCH	3	Sets the PHY mode for the granted SCHs.
# LCH	8	Specifies the number of LCHs per DUC.
PHY mode LCH	4	Sets the PHY mode for the granted LCHs.
Future use	3	
Total	64	

The transfer syntax of the RG IE for direct link is shown in figure 16.

	8	7	6	5	4	3	2	1
Octet 1	IE flag	MSB IE type			MSB Source MAC ID			
Octet 2	MSB Source MAC ID					MSB Destination MAC ID		
Octet 3	MSB Destination MAC ID					MSB DLCC ID		
Octet 4	DLCC ID			MSB Start pointer				
Octet 5	Start pointer							
Octet 6	Future use	MSB SCH PHY mode			MSB LCH PHY mode			
Octet 7	MSB # LCH							
Octet 8	MSB # SCH						Future use	

Figure 16: Transfer syntax of RG for direct link

The RG IE for DiL includes an additional field, the Destination MAC ID, which indicates the destination of the simplex transmission. The support of this IE is optional for both AP/CC and MT. If the use of direct mode has been agreed between MT and AP/CC in the negotiation during association, this message and according rules shall be supported.

The possible PHY mode for the RBCH is fixed to BPSK with code rate $\frac{1}{2}$. All other logical channels announced with the above described RG may use all mandatory and, if agreed, optional PHY modes (see clause 6.9).

If the AP/CC is involved in DM communication itself, the first LCHs and SCHs in the DiL phase shall be granted to the AP/CC to minimize RF transceiver turn-arounds.

All LCHs and SCHs used by the same transmitting MT to different receiving MTs shall be granted consecutively without interruption in order to avoid unnecessary RF transceiver turn-arounds. This means that, in DM the transmission of LCHs and SCHs from one MT to different destinations shall not be interrupted by the transmission of another MT.

NOTE 1: It is up to the scheduler in the AP/CC to determine the needed capacity for LCHs and SCHs. It is allowed that the scheduler allocates more LCHs and SCHs than have been requested or negotiated by transmitting MT.

NOTE 2: The AP/CC is responsible to schedule the number of DiL ARQ feedback messages that are to be transmitted in SCHs.

The AP/CC is responsible to select any of the mandatory and, if agreed, optional PHY modes for the direct link transmission. The receiving entity of a DiL connection proposes a PHY mode for SCH and LCH in the RR for DiL. The RR for DiL shall be sent in the uplink in the DCCH via an SCH or RCH.

6.2.2.3 IE for empty parts in the MAC frame

This IE is used by the AP/CC to announce a fraction of the MAC frame that is not used for any traffic. The AP/CC shall send this message only when it has ordered at least one MT to make DFS measurements in the current frame. The DFS measurement procedures are described in TS 101 761-2 [5]. The MT performs measurements of the interference from other APs/CCs in the announced empty parts. The content of this IE is described in table 13.

Table 13: IE for empty parts in the MAC frame

Name	Bits	Purpose
IE flag	1	Set to 1.
IE type	4	0100.
Start pointer	13	Identify the start of an empty part.
Stop pointer	11	Identify the stop of the empty part. The pointer is relative the start pointer for the empty part.
Start pointer	13	Identify the start of an empty part.
Stop pointer	11	Identify the stop of the empty part. The pointer is relative the start pointer for the empty part.
Future use	11	
Total	64	

The transfer syntax of the RG IE for empty parts is shown in figure 17.

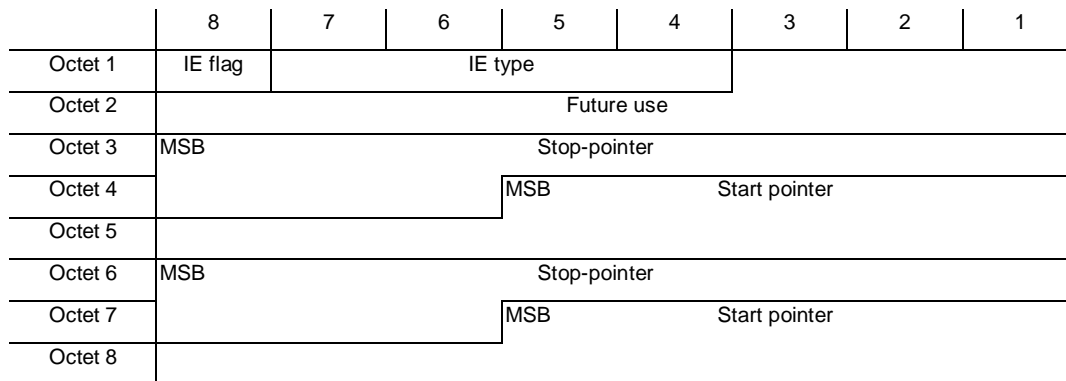

Figure 17: Transfer Syntax of the RG for empty parts in a MAC frame

The support of this IE is mandatory for both APs/CCs and MTs.

6.2.2.4 IE for padding

The IE for padding shall be used to fill an FCH IE block if the total number of RGs does not end up in a multiple of three (i.e. the RGs cannot itself fill up the IE blocks). The IE format is shown in table 14.

Table 14: IE for padding

Name	Bits	Purpose
IE flag	1	Set to 1.
IE type	4	0101.
Future Use	59	Unused.
Total	64	

The transfer syntax of the RG IE fields is shown in figure 18.

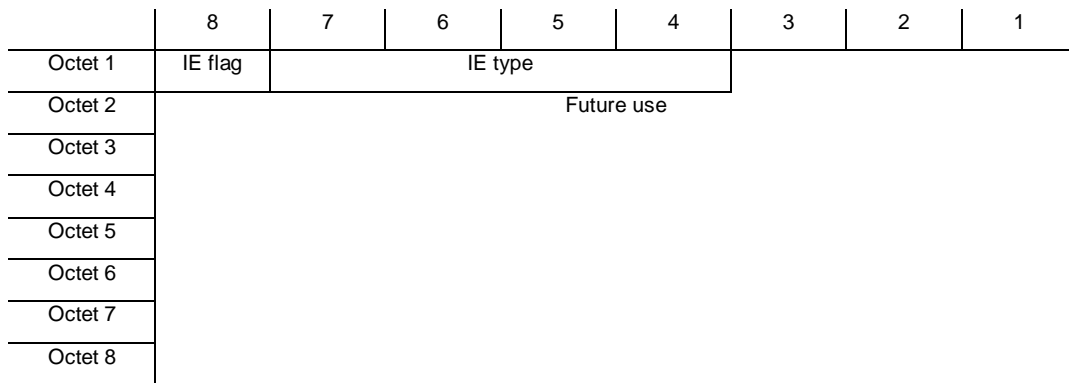

Figure 18: Transfer Syntax of the RG for empty parts in a MAC frame

The support of this IE is mandatory for both MTs and APs/CCs.

6.2.3 RFCH message format

The contents of the RFCH are shown in table 15.

Table 15: contents of the RFCH

Name	Bits	Purpose
SCH PDU Type	4	0110.
RFCH type	4	Defines the type of the RFCH message. 0000 = RFCH for the RCH. 0001 – 1111 = For future use.
RCH1	1	Feedback for the RCH1 of the previous frame. 0 = No success (collision or idle). 1= success.
...
RCH31	1	Feedback for the RCH31 of the previous frame. 0 = No success (collision or idle). 1= success.
Future Use	17	For future use.
CRC	16	CRC-16.
Total	72	

Figure 19 shows the transfer syntax of the RFCH.

	8	7	6	5	4	3	2	1
Octet 1	MSB SCH PDU type				RFCH type			
Octet 2	RCH 8	RCH 7	RCH 6	RCH 5	RCH 4	RCH 3	RCH 2	RCH 1
Octet 3	RCH 16	RCH 15	RCH 14	RCH 13	RCH 12	RCH 11	RCH 10	RCH 9
Octet 4	RCH 24	RCH 23	RCH 22	RCH 21	RCH 20	RCH 19	RCH 18	RCH 17
Octet 5	Fut. use	RCH 31	RCH 30	RCH 29	RCH 28	RCH 27	RCH 26	RCH 25
Octet 6	Future use							
Octet 7								
Octet 8	CRC-16							
Octet 9								

Figure 19: Transfer syntax of the RFCH

The support and the use of this message are mandatory for the AP/CC. MTs shall be able to interpret this message. The feedback to the use of the RCHs in MAC frame i is transmitted in the ACH in MAC frame $i+1$, as illustrated in figure 20.

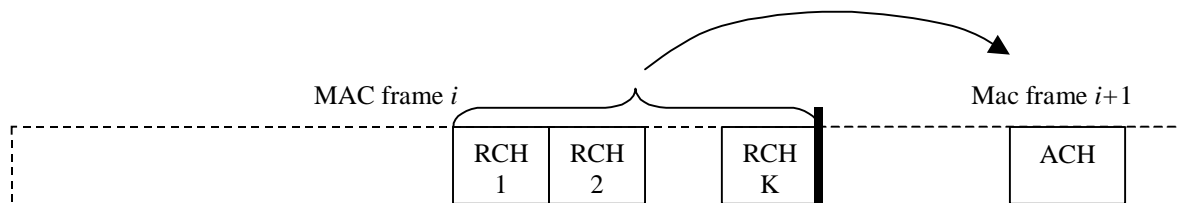

Figure 20: Illustration of the operation of the ACH

6.2.4 RBCH message formats

6.2.4.1 RBCH message in an LCH

Downlink and direct link RBCH messages in LCHs have the same format as the DCCH messages in downlink, and direct link phase, respectively, see clause 6.2.5. The support of the downlink RBCH in an LCH is mandatory for APs/CCs and MTs. The support of the direct link RBCH in an LCH is optional for MTs and APs/CCs. If the use of direct mode has been agreed between MT and AP/CC in the negotiation during association, the direct link RBCH in an LCH shall be supported.

6.2.4.2 Downlink RBCH message in an SCH

6.2.4.2.1 Messages from the RLC

RBCH messages in SCHs have generally the same format as DCCH messages in a downlink SCH, see clause 6.2.5.2. The transmission of the encryption seed is an exception and is described in the subsequent clause. The support of the RBCH in a downlink SCH is mandatory for APs/CCs and MTs.

6.2.4.2.2 Encryption seed

The contents of the RBCH message with the encryption seed in an SCH are shown in table 16.

Table 16: Contents of the downlink RBCH message with the encryption seed in an SCH

Name	Bits	Purpose
SCH PDU Type	4	1000.
Info	52	Encryption seed (see clause 6.7).
CRC	16	CRC-16.
Total	72	

Figure 21 shows the transfer syntax of the downlink RBCH message with the encryption seed in an SCH.

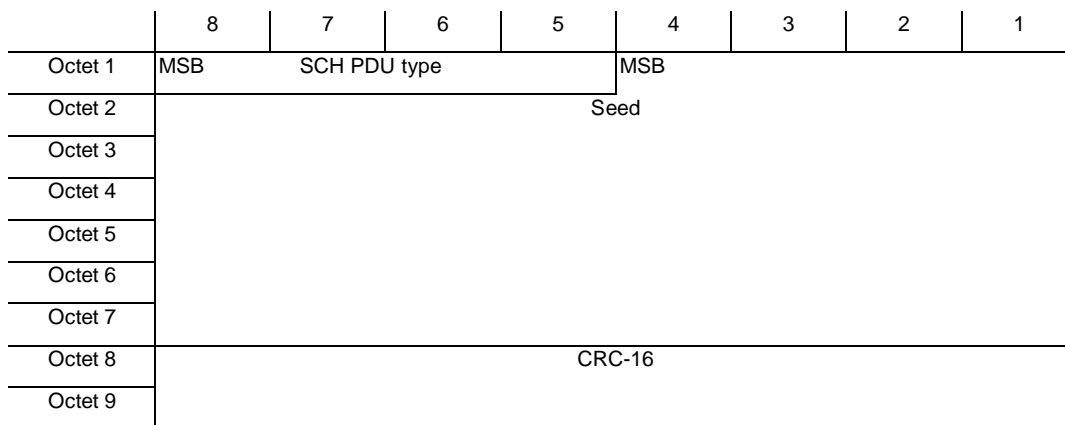

Figure 21: Transfer syntax of the downlink RBCH message with the encryption seed in an SCH

The support of this message is mandatory for both MTs and APs.

6.2.4.3 Direct link RBCH message in an SCH

Direct link RBCH messages in SCHs have the same format as the DCCH messages in direct link SCHs, see clause 6.2.5.4. The support of the direct link RBCH in an SCH is optional for MTs and APs/CCs. If the use of direct mode has been agreed between MT and AP/CC in the negotiation during association, the direct link RBCH in an SCH shall be supported.

6.2.5 DCCH message formats

DCCH message can be mapped on LCHs, SCHs or RCHs, depending on their length. The mapping procedure is out of the scope of the present document.

Different message formats are used for uplink, downlink and direct link RLC messages in an SCH. The type field for uplink and downlink RLC messages is identical. The message formats for uplink DCCHs transmitted in SCHs and in RCHs are identical.

6.2.5.1 DCCH message in an LCH

The message format for a DCCH message in an LCH is identical to the message format of the UDCH, see clause 6.2.8. The support of this message is mandatory for APs/CCs and MTs. The sequence number shall be increased by one for every RLC message sent in an LCH.

6.2.5.2 DCCH message in a downlink SCH

The contents of the downlink RLC message in an SCH are shown in table 17.

Table 17: Contents of the downlink RLC message in an SCH

Name	Bits	Purpose
SCH PDU Type	4	0100.
Future use	7	Future use.
RLC message	45	RLC message contents (see TS 101 761-2 [5]).
CRC	16	CRC-16.
Total	72	

Figure 22 shows the transfer syntax of the downlink RLC message in an SCH.

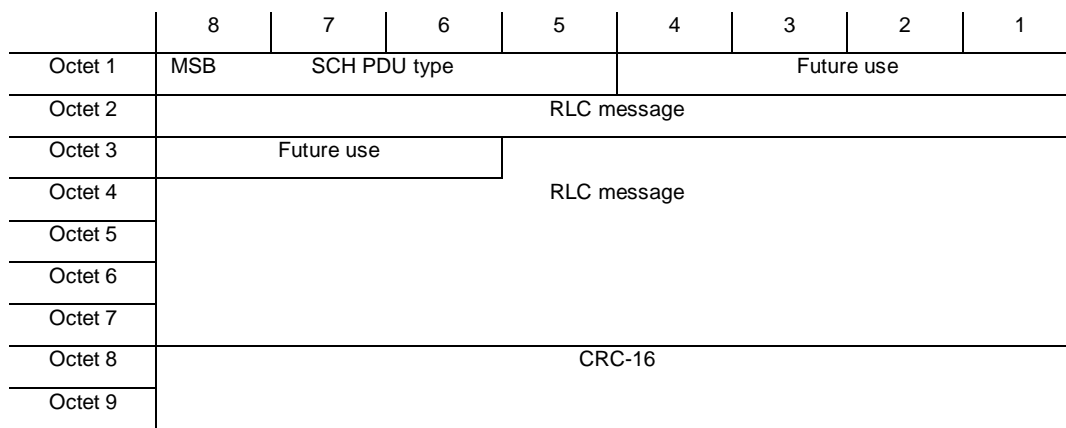

Figure 22: Transfer syntax of the downlink RLC message in an SCH

This support of this message is mandatory for APs/CCs and MTs.

6.2.5.3 DCCH message in an uplink SCH or RCH

The DCCH messages in an uplink SCH or RCH are either resource request messages or uplink RLC messages.

The message format for a resource request message in an SCH or RCH is identical to the message format of the resource request message for LCCH, see clause 6.2.9.1.

The contents of the uplink RLC message in an SCH or RCH are shown in table 18.

Table 18: Contents of the uplink RLC message in an SCH or RCH

Name	Bits	Purpose
SCH PDU Type	4	0100.
LCH PHY mode	4	Proposed PHY mode for downlink LCHs related to this DLCC ID, i.e. DLCC ID=0.
SCH PHY mode	3	Proposed PHY mode for downlink SCHs related to this DLCC ID, i.e. DLCC ID=0.
RLC message	45	RLC message contents (see TS 101 761-2 [5]).
CRC	16	CRC-16.
Total	72	

Figure 23 shows the transfer syntax of the uplink RLC message in an SCH or RCH.

	8	7	6	5	4	3	2	1
Octet 1	MSB SCH PDU type				LCH PHY mode			
Octet 2	RLC message							
Octet 3	SCH PHY mode				MSB			
Octet 4	RLC message							
Octet 5	RLC message							
Octet 6	RLC message							
Octet 7	RLC message							
Octet 8	CRC-16							
Octet 9	CRC-16							

Figure 23: Transfer syntax of the uplink RLC message in an SCH

The support of these messages is mandatory for APs/CCs and MTs.

6.2.5.4 DCCH message in a direct link SCH

The contents of the direct link RLC message in an SCH are shown in table 19.

Table 19: Contents of the direct link RLC message in an SCH

Name	Bits	Purpose
SCH PDU Type	4	0111
RLC message	52	RLC message contents (see TS 101 761-2 [5]).
CRC	16	CRC-16
Total	72	

Figure 24 shows the transfer syntax of the direct link RLC message in an SCH.

	8	7	6	5	4	3	2	1
Octet 1	MSB SCH PDU type							
Octet 2	RLC message							
Octet 3	RLC message							
Octet 4	RLC message							
Octet 5	RLC message							
Octet 6	RLC message							
Octet 7	RLC message							
Octet 8	CRC-16							
Octet 9	CRC-16							

Figure 24: Transfer syntax of the direct link RLC message in an SCH

The support of this message is optional for MTs and APs/CCs. If the use of direct mode has been agreed between MT and AP/CC during the negotiation during association, this message shall be supported.

6.2.6 UBCH message formats

This message shall be sent either in the downlink (by an AP or CC) or direct link (by an MT). It has the same format as UDCH messages. The error control mechanisms for broadcast traffic is described in clause 6.4.

6.2.7 UMCH message formats

This message shall be sent either in the downlink (by an AP or CC) or direct link (by an MT). It has the same format as UDCH messages. The treatment of multicast traffic is described in clause 6.5.

6.2.8 UDCH message formats

The contents of the UDCH message are shown in table 20. UDCHs are subject to error control mechanisms. These mechanisms are defined in clause 6.4.

Table 20: Contents of the UDCH

Name	Bits	Purpose
LCH PDU type	2	See table 1.
SN	10	Sequence number (provided by EC function).
Payload	396	Payload field.
CRC	24	CRC-24
Total:	432	

The transfer syntax for a UDCH in an LCH is given in figure 25.

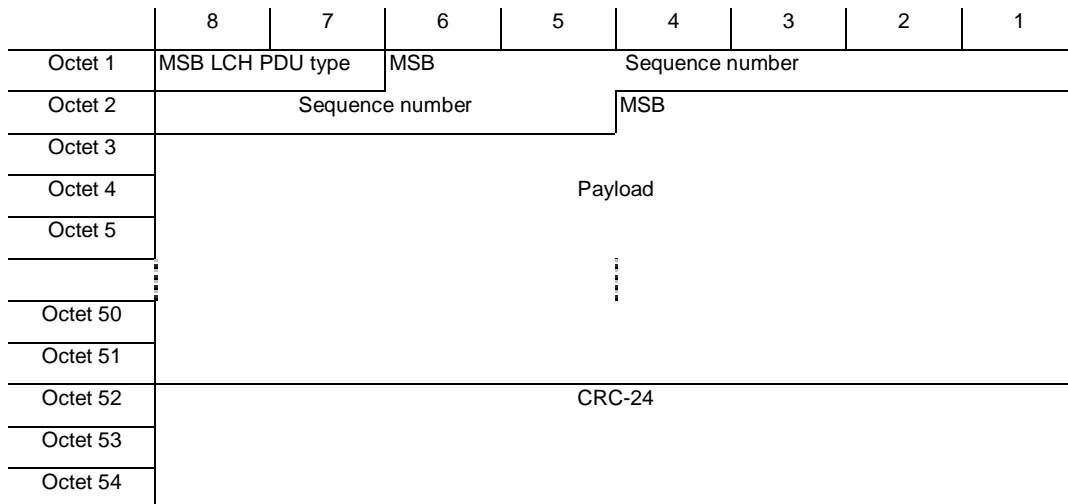

Figure 25: UDCH transfer syntax

The support of this message is mandatory for APs/CCs and MTs.

6.2.9 LCCH message formats

6.2.9.1 Resource Request message formats

6.2.9.1.1 Resource Request message for the uplink

Resource request messages for the uplink phase can be transmitted in an SCH or RCH. The contents of the RR message are shown in table 21.

Table 21: Contents of the RR message for uplink

Name	Bits	Purpose
SCH PDU Type	4	0011
PHY mode SCH	3	Proposed PHY mode for downlink SCHs related to this DLCC ID. The coding is given in clause 6.9.
PHY mode LCH	4	Proposed PHY mode for downlink LCHs related to this DLCC ID. The coding is given in clause 6.9.
MAC ID	8	MAC ID.
DLCC ID	6	DLC connection ID.
# SCH	5	Number of SCHs requested for the particular DUC. Rules for the use are described in clause 6.3.2.8.
# LCH	10	Number of LCHs requested for the particular DUC, but not more than the FC limit. Rules for the use are described in clause 6.3.2.8.
Error indication	3	See clause 6.3.7.
RSS0 sample	6	The sample shall be taken in the current frame. See TS 101 475 [4].
Retry Bit	1	Represents whether this specific RCH/SCH content was transmitted once or more than once. 0 = first attempt. 1 = more than one attempt. See clause 6.3.2.8.
ARQ feedback message request bit (ARB)	1	See clause 6.3.2.8.
Future use	5	Future use.
CRC	16	CRC-16
Total	72	

Figure 26 shows the transfer syntax of the uplink RR message.

	8	7	6	5	4	3	2	1
Octet 1	MSB SCH PDU type				LCH PHY mode			
Octet 2	MSB MAC ID							
Octet 3	Future use		MSB RSS0 sample value					
Octet 4	MSB DLCC ID					ARB	Future use	
Octet 5	Future use		Error indication			SCH PHY mode		
Octet 6	MSB # LCH							
Octet 7	MSB # SCH					Retry bit		
Octet 8	CRC-16							
Octet 9								

Figure 26: Transfer syntax of the uplink RR message

Rules for the use of this message are given in clause 6.3.2.8.

The support of this message is mandatory for APs/CCs and MTs.

6.2.9.1.2 Resource Request message for the direct link

This message is transmitted from the MT to the AP/CC in the uplink and can be mapped to an SCH or RCH. The contents of the RR message for direct link is shown in table 22.

Table 22: Contents of the RR message for direct link

Name	Bits	Purpose
SCH PDU Type	4	0101
PHY mode SCH	3	Proposed PHY mode for direct link SCHs for the given DLCC ID (simplex). The coding is given in clause 6.9.
PHY mode LCH	4	Proposed PHY mode for incoming direct link LCHs related to this DLCC ID (simplex). The coding is given in clause 6.9.
Source MAC ID	8	Transmitting MT MAC ID.
Destination MAC ID	8	Receiving MT MAC ID.
DLCC ID	6	DLC connection ID. DLCC ID = 0 is used to indicate the request for DiL DCCHs.
# SCH	5	Number of SCHs requested for the particular DUC. Rules for the use are described in 6.3.2.8.
# LCH	10	Number of LCHs requested for the particular DUC, but not more than the FC limit. Rules for the use are described in 6.3.2.8.
Error indication	2	See clause 6.3.7.
Retry Bit	1	Represents whether this specific RCH/SCH content was transmitted once or more than once. 0 = first attempt 1 = more than one attempt See clause 6.3.2.8.
ARQ-feedback message request bit (ARB)	1	See clause 6.3.2.8.
Future use	4	Future use.
CRC	16	CRC-16.
Total	72	

Figure 27 shows the transfer syntax of the RR message for direct link.

	8	7	6	5	4	3	2	1
Octet 1	MSB SCH PDU type				LCH PHY mode			
Octet 2	MSB Source MAC ID							
Octet 3	MSB Destination MAC ID							
Octet 4	MSB DLCC ID						ARB	Future use
Octet 5	Future use			Error indication		SCH PHY mode		
Octet 6	MSB # LCH							
Octet 7	MSB # SCH						Retry bit	
Octet 8	CRC-16							
Octet 9								

Figure 27: Transfer syntax of the RR message for direct link

Rules for the use of this message are given in clause 6.3.2.8.

The PHY mode proposed in RRs for DiL is related to DiL connections. For proposing a PHY mode for a downlink DCCH, an RR for the uplink DCCH is used as described in clause 6.2.9.1.1.

The support of this message is optional for MTs and APs/CCs. If the use of direct link has been agreed between MT and AP/CC in the negotiation during association, this message shall be supported.

6.2.9.2 ARQ message formats

6.2.9.2.1 ARQ feedback message format in the uplink phase

ARQ feedback messages in the uplink phase shall only be transmitted in SCHs that have been granted for a specific DUC. Since no further addressing information is given in the ARQ feedback message, this is necessary in order to create an unambiguous relation between the DUC and the ARQ feedback messages. In particular, ARQ messages shall not be transmitted in RCHs. The content of the uplink ARQ feedback message is shown in table 23. More detailed explanations on the fields, meaning, and related rules are given in clause 6.4.

Table 23: Contents of the uplink ARQ feedback message

Name	Bits	Purpose
SCH PDU Type	4	0001
LCH PHY mode	4	Proposed PHY mode for downlink LCHs related to this DLCC ID. The coding is given in clause 6.9.
SCH PHY mode	3	Proposed PHY mode for downlink SCHs related to this DLCC ID. The coding is given in clause 6.9.
FC	1	When set to 1, indicates that flow control is active.
ABIR	1	When set to 1, indicates that more SCH bandwidth is needed by the receiver for the signalling of ARQ feedback.
CAI	1	When set to 1, indicates that BMB1 contains a CumAck.
Future use	1	Future use.
BMN1	7	Block Number of the Bit Map Block 1. Absolute block number.
BMB1	8	Bit Map Block 1.
BMN2	5	Block Number of the Bit Map Block 2. Relative to BMN1.
BMB2	8	Bit Map Block 2.
BMN3	5	Block Number of the Bit Map Block 3. Relative to BMN2.
BMB3	8	Bit Map Block 3.
CRC	16	CRC-16
Total	72	

Figure 28 shows the transfer syntax of the uplink ARQ feedback message.

	8	7	6	5	4	3	2	1
Octet 1	MSB SCH PDU type				LCH PHY mode			
Octet 2	CAI	MSB			BMN1			
Octet 3	MSB			BMB1				
Octet 4	SCH PHY mode			MSB	BMN2			
Octet 5	MSB			BMB2				
Octet 6	FC	ABIR	Future use	MSB BMN3				
Octet 7	MSB			BMB3				
Octet 8	CRC-16							
Octet 9								

Figure 28: Transfer syntax of the uplink ARQ feedback message

The treatment of this PDU is described in clause 6.4. The support of this message is mandatory for AP/CC and MT.

EXAMPLE: PDUs with sequence number 0-6 have been correctly received at the receiver. PDU with sequence number 7 is erroneous. The receiver then sets BMN1 equal to 0 and BMB1 equal to [1111 1110].

NOTE: The bit representation given above is such that the MSB represents the lowest sequence number of a bit map block.

6.2.9.2.2 ARQ feedback message format in the downlink and direct link phase

ARQ feedback messages in the downlink and direct link phase shall only be transmitted in SCHs that have been granted for a specific DUC of the respective link. Since no further addressing information is given in the ARQ message, this is necessary in order to create an unambiguous relation between the DUC and the ARQ messages. The content of the downlink and direct link ARQ feedback message is shown in table 24. More detailed explanations on the fields, meaning, and related rules are given in clause 6.4.

Table 24: Contents of the downlink and direct link ARQ feedback message

Name	Bits	Purpose
SCH PDU Type	4	0001
Future use	9	Future use.
FC	1	When set to 1, indicates that flow control is active.
CAI	1	When set to 1, indicates that BMB1 contains a CumAck.
BMN1	7	Block Number of the Bit Map Block 1. Absolute block number.
BMB1	8	Bit Map Block 1.
BMN2	5	Block Number of the Bit Map Block 2. Relative to BMN1.
BMB2	8	Bit Map Block 2.
BMN3	5	Block Number of the Bit Map Block 3. Relative to BMN2.
BMB3	8	Bit Map Block 3.
CRC	16	CRC-16
Total	72	

Figure 29 shows the transfer syntax of the downlink and direct link ARQ feedback message.

	8	7	6	5	4	3	2	1
Octet 1	MSB SCH PDU type				Future use			
Octet 2	CAI	MSB			BMN1			
Octet 3	MSB			BMB1				
Octet 4	Future use			MSB	BMN2			
Octet 5	MSB			BMB2				
Octet 6	FC	Future use		MSB	BMN3			
Octet 7	MSB			BMB3				
Octet 8	CRC-16							
Octet 9								

Figure 29: Transfer syntax of the downlink and direct link ARQ feedback message

The treatment of this PDU is described in clause 6.4. The bit representation of the bit map blocks is the same as in the uplink ARQ feedback message.

The support of the downlink ARQ feedback message is mandatory for MT and AP/CC.

The support of the direct link ARQ feedback message is optional for MT and AP/CC. If the use of the DM features has been agreed between MT and AP/CC in the negotiation during association, this message shall be supported.

6.2.9.2.3 Discard message format in the uplink phase

Discard messages in the uplink phase shall only be transmitted in SCHs that have been granted for a specific DUC. Discard messages can only be sent for connections using the acknowledged mode in uplink. The content of the uplink discard message is shown in table 25. More detailed explanations on the fields, meaning, and related rules are given in clause 6.4.

Table 25: Contents of the uplink discard message

Name	Bits	Purpose
SCH PDU Type	4	0010
PHY mode SCH	3	Proposed PHY mode for downlink SCHs related to this DLCC ID. The coding is given in clause 6.9.
PHY mode LCH	4	Proposed PHY mode for downlink LCHs related to this DLCC ID. The coding is given in clause 6.9.
Discard Sequence Number	10	Indicates which PDUs the receiver shall discard.
Repeated Discard sequence Number	10	Duplicated Discard sequence number.
# SCH	5	Number of SCHs required for this particular DUC.
# LCH	10	Number of LCHs required for this particular DUC, but not more than the FC limit. Rules for the use are described in 6.3.2.8.
Error indication	3	See clause 6.3.7.
RSS0 sample	6	The sample shall be the one taken in the current frame. See TS 101 475 [4].
Retry Bit	1	See clause 6.3.2.8.
CRC	16	CRC-16
Total	72	

Figure 30 shows the transfer syntax of the uplink discard message.

	8	7	6	5	4	3	2	1
Octet 1	MSB SCH PDU type				LCH PHY mode			
Octet 2	MSB Discard sequence number							
Octet 3					MSB RSS0 sample value			
Octet 4	MSB Repeated Discard sequence number							
Octet 5					Error indication		SCH PHY mode	
Octet 6	MSB # LCH							
Octet 7					MSB # SCH			Retry bit
Octet 8	CRC-16							
Octet 9								

Figure 30: Transfer syntax of the uplink discard message

The uplink discard message contains fields that are defined in the RR message, e.g. # SCH, # LCH. The rules and restrictions for these fields are given in clause 6.3.2.8.

The support of this message is mandatory for AP/CC and MT.

6.2.9.2.4 Discard message format in the downlink and direct link phase

Discard messages in the downlink and direct link phase shall only be transmitted in SCHs that have been granted for a specific DUC of the respective link. Discard messages can only be sent for connections using the acknowledged or repetition error control mode. The content of the downlink and direct link discard message is shown in table 26. More detailed explanations on the fields, meaning, and related rules are given in clause 6.4.

Table 26: Contents of the downlink and direct link discard message

Name	Bits	Purpose
SCH PDU Type	4	0010
Discard sequence Number	10	Indicates which PDUs the receiver shall discard.
Repeated Discard sequence Number	10	Duplicated Discard sequence number.
Future use	32	Future use.
CRC	16	CRC-16
Total	72	

Figure 31 shows the transfer syntax of the downlink and direct link discard message.

	8	7	6	5	4	3	2	1
Octet 1	MSB SCH PDU type				Future use			
Octet 2	MSB Discard sequence number							
Octet 3					Future use			
Octet 4	MSB Repeated Discard sequence number							
Octet 5					Future use			
Octet 6					Future use			
Octet 7					Future use			
Octet 8	CRC-16							
Octet 9								

Figure 31: Transfer syntax of the downlink and direct link discard message

The support of the downlink discard message is mandatory for AP/CC and MT. The support of the direct link discard message is optional for MTs and APs/CCs. If the use of the DM features has been agreed between MT and AP/CC in the negotiation during association, this message shall be supported for direct link. The handling of the fields is explained in clauses 6.3.2.8 and 6.4.

6.2.10 ASCH message format

The content of an ASCH message is shown in table 27. The ASCH message is mapped to an RCH. The contents of the payload are generated by the RLC and are described in TS 101 761-2 [5].

Table 27: Contents of ASCH message in the RCH

Name	Bits	Purpose
SCH PDU Type	4	0100
LCH PHY mode	4	Proposed PHY mode for downlink LCHs transporting DCCH. The coding is given in clause 6.9.
SCH PHY mode	3	Proposed PHY mode for downlink SCHs transporting DCCH. The coding is given in clause 6.9.
RLC message	45	RLC message, see TS 101 761-2 [5].
CRC	16	CRC-16
Total	72	

Figure 32 shows the transfer syntax of the uplink RLC message in an SCH or RCH.

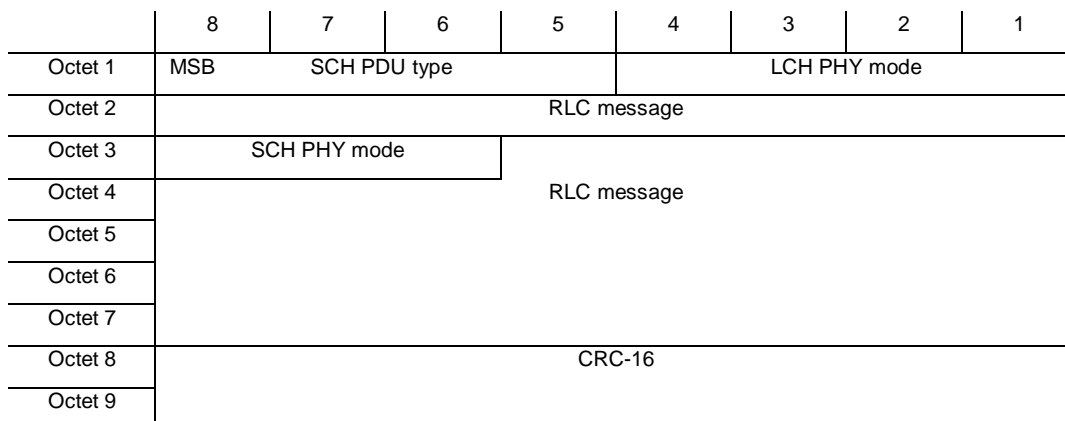

Figure 32: Transfer syntax of uplink RLC messages in SCHs

The support of this message is mandatory for both MTs and APs/CCs.

6.3 MAC protocol

The MAC protocol is based on the information elements and their formats given in the previous clause.

6.3.1 MAC operation

The role of the MAC layer is to build valid TDMA/TDD MAC frames. This involves the following functions and operations:

- a scheduler, centralized in the AP, or CC, which determines the frame composition according to the rules defined in clause 6.3.2. It is assumed that the scheduler uses the information obtained from MTs through RRs and the status of its own downlink transmission buffers to compose the frame;

- a transmission and reception process in the AP/CC and the MTs that transmits and receives PDUs in accordance with the MAC frame defined by the AP/CC, and maps logical channels onto transport channels;
- MAC entities shall exchange control (signalling) information such as the frame composition in the FCCH (AP/CC to MTs), feedback for the contention channel (AP/CC to MTs) and resource requests (MTs to AP/CC), through specific transport channels.

6.3.1.1 Access Point MAC Operation

The AP/CC operation is the following:

- The AP/CC shall calculate the frame composition, prepare and transmit the BCH, FCH and ACH according to the rules specified in clause 6.3.2. A BCH contains the position and length of its associated FCH as well as the position and the number of the RCHs. The FCH IEs contain resource grants for the transmission of PDUs in the RBCH, the UDCHs, the UBCHs, the UMCHs, the DCCH and the LCCHs. The FCH IEs can also contain an indication of empty parts of a frame, see clause 6.2.2.3. The identification of the logical channels associated to a resource grant is specified in clause 5.5. The type of the IE identifies whether the grant is in an uplink phase, downlink phase, direct link phase or an empty part of the frame.
- The AP/CC prepares an ACH (RCH feedback) for every sector. The ACH is either part of the broadcast PDU train (single sector AP) or part of the FCH-ACH-PDU train (multiple sector AP), see clause 6.9.
- The AP/CC transmits PDUs from logical channels in the downlink phase according to the current frame composition and the rules defined in clause 6.3.2. If the CC itself is involved in DM operation, it also transmits PDUs from logical channels in the direct link phase.
- The AP/CC receives and processes the PDUs transmitted by the MTs in the uplink phase. If a CC itself is involved in DM operation, it also receives and processes the PDUs meant for the CC which are transmitted by another MT in the direct link phase.
- The AP/CC receives and processes PDUs transmitted by the MTs in the RCH.

6.3.1.2 MT MAC Operation

MT operation is the following:

- the MT receives and processes the BCH and the FCH and evaluates the FCCH with respect to the logical and transport channels relevant for it;
- the MT shall evaluate the ACH if it has used the RCH in the previous frame;
- the MT receives and processes the PDUs transmitted by the AP/CC in the downlink phase in CM, and/or by other MTs in the direct link phase in DM, in accordance with the frame structure contained in the FCH;
- the MT transmits PDUs from logical channels in the uplink phase in CM, and/or in direct link phase in DM, in accordance with the frame structure and the rules defined in clause 6.3.2;
- the MT may access the RCH.

6.3.2 Rules for the composition of MAC frames

The following rules exist for the composition of MAC frames:

6.3.2.1 BCH

- A sequence of BCHs is sent at the beginning of the MAC frame. The number of BCHs is equal to the number of sectors used by the AP. PHY layer preambles are added according to the rules specified in clause 6.9. BCHs are transmitted according to the ascending sector ID number, i.e. BCH having a sector ID equal to 0 shall be transmitted first, the BCH with sector ID equal to 1 next and so forth.
- A single BCH is used per sector.

- BCHs are transmitted periodically every 2 ms, except in cases where the AP is performing its own measurements related to the DFS procedure; see TS 101 761-2 [5].
- BCHs shall be transmitted using BPSK and coding rate $\frac{1}{2}$.

6.3.2.2 FCH

- The FCH shall follow directly after the BCH in the case of one sector. In the case of more than one sector, a pointer shall be used in the BCCH to identify the starting point of the FCH. If the FCH does not exist, the starting point in the BCCH shall identify the location of the ACH.
- In the case the numbers of sectors field in the BCCH is set to 0, a single sectored antenna is applied and the FCH shall follow directly after the BCH without any physical layer preamble. The pointer in the BCCH shall still point to the location of the FCH.

If a single sector is used, the FCH shall be present and have a minimum length of 36 μ s. If there are not enough information elements to fill the FCH, one or more padding IEs shall be inserted. The minimum length of the FCH is 0 in the case where multiple sectors are used. FCH with length 0 shall be used for each sector where no downlink, uplink or direct link PDU trains are allocated in FCCH.

- Whenever padding IEs are to be inserted, they shall be allocated at the end of the IE blocks.
- Not more than one FCH per sector per MAC frame shall be transmitted.
- Information elements shall be ordered in the FCH according to the order of their occurrence in the MAC frame, i.e. with increasing start pointer values (see figure 33). An exception is the information element for empty parts which contains two start pointers. For this IE the first start pointer shall be used for the purpose of ordering the IEs in the FCH. Not more than one RG shall be used per DUC per direction per FCH. The ordering shall be valid individually for each sector.

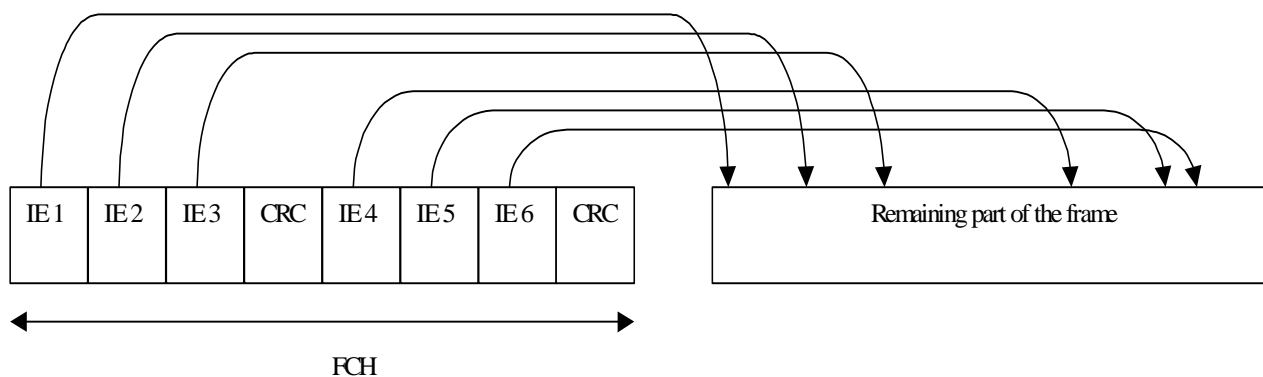

Figure 33: An illustration of the order of the IEs in the FCH and their occurrence in the MAC frame

- The use of the RR polling bit in RG messages is mandatory for APs/CCs in CM, i.e. the bit shall be set when the AP/CC polls for RRs for the uplink. MTs shall be able to interpret it correctly. The rules for the use of SCHs given in clause 6.3.2.4 shall apply.
- Whenever the AP/CC wants to poll for RRs for the direct link, it shall schedule uplink SCHs with DLCC ID = 0 (i.e. uplink DCCHs) for the related MT, see clause 6.3.2.4.

6.3.2.3 ACH

- The AP/CC prepares an ACH (RCH feedback) for every sector. The ACH is either part of the broadcast PDU train (single sector AP) or part of the FCH-ACH-PDU train (multiple sector AP), see clause 6.9.
- The ACH shall use BPSK and coding rate $\frac{1}{2}$.
- The ACH shall contain feedback to the RCHs of the previous frame.

- No explicit resource grant is needed for the ACH.
- An ACH that has not been received correctly, for whatever reason, shall lead to a behaviour of an MT equal to that for an unsuccessful access attempt to an RCH and shall result in a new contention cycle, see clause 6.3.3.

6.3.2.4 SCH

The way SCHs are granted for uplink and downlink is described in clause 6.2.2.1. The way SCHs are granted for direct link is described in clause 6.2.2.2. The following rules shall apply to the use of SCHs granted for LCCH or DCCH:

The uplink SCHs granted for a particular DLCC ID > 0 (i.e. not the DCCH) shall not be used for messages other than RR messages for this particular DUC, ARQ feedback messages for this particular DUC or discard messages for this particular DUC.

- If the RR poll bit is set to 1, the following priority rules shall apply for the first SCH granted:
 - 1) if a discard message is available, this message shall be sent with highest priority;
 - 2) if no discard message is to be sent, an RR message for this particular DUC shall be sent.

For acknowledged mode, the remaining granted SCHs shall be used for ARQ feedback messages for this particular DUC.

For unacknowledged mode, the remaining granted SCHs shall be filled with dummy SCHs.

- If the RR poll bit is set to 0, the following rules shall apply:
 - 1) For acknowledged mode, all granted SCH shall be used for ARQ feedback messages for this particular DUC.
 - 2) For unacknowledged mode, all granted SCH shall be filled with dummy SCH.

Following rules shall apply to MTs to access SCHs that are granted for the DCCH (DLCC ID = 0) in uplink direction:

- 1) RLC messages shall be sent with highest priority if available.
- 2) If SCHs are left and resources for the DCCH are to be requested, a RR for the DCCH shall be sent with second priority.

If SCHs are left, RRs for other DUCs shall be sent, including RRs for direct link.

NOTE 1: The RR poll bit is not used for the DCCH (DLCC ID = 0).

NOTE 2: A result of rule 3 may be that the same RR is sent twice in a frame. This occurs if the AP/CC happens to poll for a RR for the same DLCC that the MT decided to send in the SCH granted for DCCH.

The rules above make sure that it is mostly the AP/CC that determines whether a RR for a DUC shall be created by an MT. If the AP/CC does not poll for an RR, the RCH shall be used if necessary. The use of SCHs for the DCCH to transmit RRs for other DUCs may help to decrease the load on the RCH.

Polling of RRs for the DiL is not possible. RCH and SCHs for the uplink DCCH shall be used to transmit RRs for direct link DUCs. To reduce the load on the RCH in DM, the AP/CC should schedule uplink SCHs with DLCC ID = 0 (i.e. uplink DCCHs).

The downlink SCHs granted for a particular DLCC ID > 0 (i.e. not the DCCH) shall not be used for messages other than ARQ feedback messages for this particular DUC or discard messages for this particular DUC.

Downlink SCHs with DLCC ID = 0 shall only be used for downlink RLC messages.

The priority for the use of downlink SCHs granted for a particular DLCC ID is an internal AP/CC decision and is out of the scope of the present document.

The direct link SCHs granted for a particular DLCC ID > 0 (i.e. not the DCCH and RBCH) shall not be used for messages other than ARQ feedback messages for this particular DUC or discard messages for this particular DUC (same as for downlink SCHs). No RR poll bit is available in the RG for the direct link.

The following priority rules apply for the first SCH that is granted for a DUC with a DLCC ID > 0 in the direct link:

- 1) If a discard message is available, this message shall be sent with highest priority.
- 2) If no discard message is available, an ARQ feedback message for this particular DUC shall be sent in case of acknowledged mode. For unacknowledged mode, a dummy SCH shall be sent.
- 3) All other SCHs shall be used for ARQ feedback messages for this particular DUC in the case of acknowledged mode. For unacknowledged mode, dummy SCHs shall be sent.

Direct link SCHs with DLCC ID = 0 shall only be used for RLC messages.

6.3.2.5 RCH

- At least one RCH shall be allocated per sector in each MAC frame.
- The RCHs for all sectors shall be clustered together, i.e. the RCH phases for different sectors shall follow directly each other.
- The RCH shall use BPSK with coding rate $\frac{1}{2}$.
- Between RCHs shall be space for preamble and guard time, see clause 6.9.
- A terminal shall use not more than one RCH per MAC frame.
- Recommendation: A RR for a particular DLCC should be transmitted in an RCH only if the buffer status has changed significantly or after a minimum number of MAC frames.
- Recommendation: The transmission of RR messages in RCHs should be kept to a minimum. In particular, for active DUCs it is recommended to wait for the grant of an SCH for at least one MAC frame before accessing the RCH.

6.3.2.6 Order of the transport channels

- For a single sector in the AP/CC, the order of the transport channels from an MT's point of view shall be BCH - FCH – ACH – DL phase – (DiL phase) – UL phase – RCH. The DiL phase can only exist if both AP/CC and MT support it. All possible combinations of the MAC frame for an AP or CC using a single sector is depicted in figure 34.

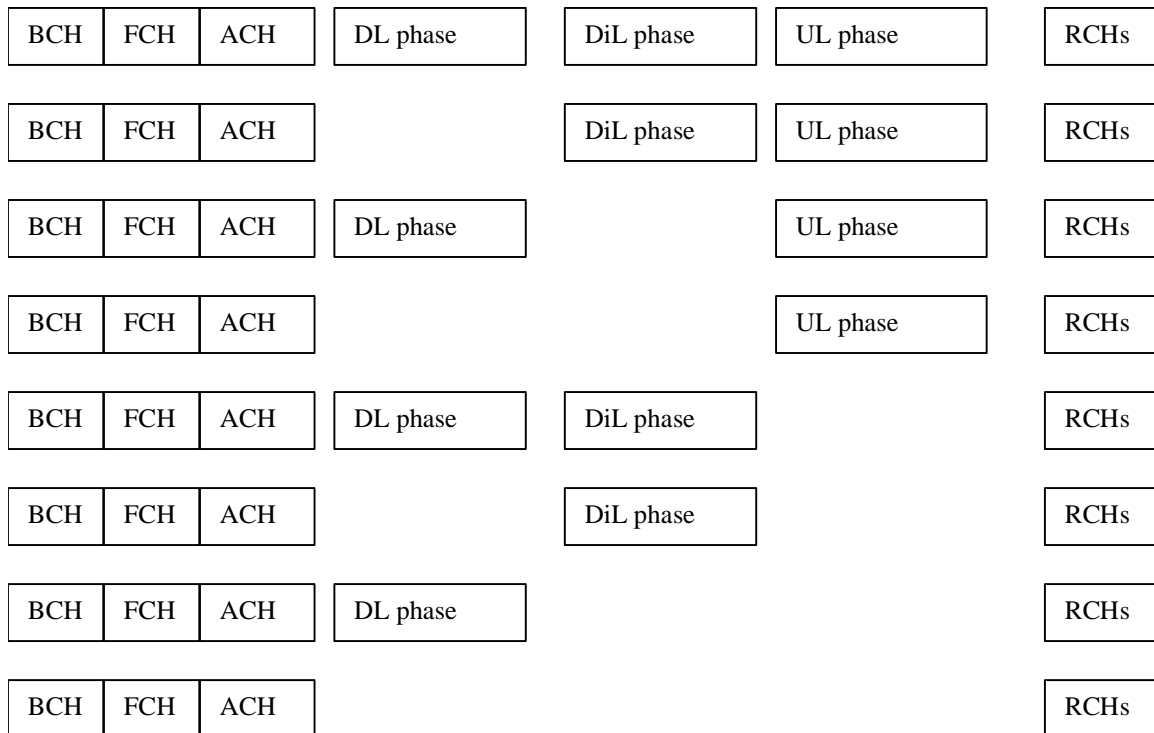

Figure 34: All possible combinations of MAC frames for an AP using a single sector

- For an AP with n sectors, the sequence of channels shall be: BCH1, BCH2, ..., BCHn, FCH1, ACH1, ..., FCH #k, ACH #n, DL #i, ..., DL #k, UL #i, ..., UL #k, RCHs #1, RCHs #2, RCHs #n. Several RCHs can be allocated for a particular sector.
- It is mandatory for MTs to support multiple sectors. It is optional for the AP.
- For the downlink, the SCH PDUs belonging to a particular DUC shall be transmitted in before the LCHs belonging to this connection.
- For the uplink, the LCH PDUs belonging to a particular DUC shall be transmitted before the SCHs belonging to this connection.
- For direct link, the LCH PDUs belonging to a particular DUC shall be transmitted before the SCHs belonging to this connection.
- All granted downlink LCHs and SCHs for a single MT shall be grouped together.
- All granted uplink LCHs and SCHs for a single MT shall be grouped together.
- All granted direct link LCHs and SCHs between a pair of MTs shall be grouped together.
- If an MT has been granted resources in the uplink or direct link for a specific DUC, it is not allowed to transmit data for a different DUC.
- If an AP/CC has been granted resources in the downlink or direct link for a specific DUC, it is not allowed to transmit data for a different DUC.
- All RGs in the FCCH belonging to one MAC ID in CM or belonging to the same pair of source and destination MAC IDs in DM, shall be grouped such that they result in a single PDU train.

NOTE: The MAC ID may refer to MTs but also to the RBCH, UBCHs or UMCHs. Examples for the consequences of this rule are:

- all UBCHs originated from the same transmitter for a single CL are sent in one PDU train;
- RBCHs originated from the same transmitter are sent in one PDU train;
- each UMCH is sent in a separate PDU train.

6.3.2.7 Logical Channels

The following rules apply for the use of logical channels:

- Not more than one RG for the downlink RBCH shall be present per MAC frame per sector. Its existence in the MAC frame is indicated in the BCCH.
- Not more than one RG for each downlink UBCH shall be present per MAC frame per sector per implemented convergence layer.
- Not more than one RG shall be present for each downlink UMCH per MAC frame per sector.
- Not more than one RG shall be present for each direct link UMCH per MAC frame per sector.
- Not more than one RG shall be present for each direct link UBCH per MAC frame per sector per implemented convergence layer.
- Not more than one RG shall be present for each direct link RBCH per MAC frame per sector.
- Not more than one RG shall be present for the DCCH per MT per direction per MAC frame in CM.
- Not more than one RG shall be present for the DCCH per MT pair per direction per MAC frame.
- If resources for the DCCH are granted, they shall always be located at the end of a PDU train.

6.3.2.8 Handling of resource request messages

If a RR or discard message for a particular CM DUC has been sent in an SCH in the current MAC frame, additional RRs for this particular DUC shall not be sent in an RCH in this MAC frame. If a RR for a particular DM DUC has been sent in an SCH with DLCC ID = 0 in the current MAC frame, additional RRs for this particular DUC shall not be sent in an RCH in the MAC frame.

A new RR or discard message shall update the #LCH and #SCH fields of a previously sent RR or discard message.

In centralized mode, the #SCH field in RRs for DLCC ID = 0 is used to indicate the number of requested SCHs for the DCCH in the uplink. These RRs can be sent in an SCH of the uplink DCCH or in an RCH. In direct mode, the #SCH field in RRs for DLCC ID = 0 is used to indicate the number of requested SCHs for the DCCH or RBCH in the direct link. These RRs can be sent in an SCH of the uplink DCCH or in an RCH.

In centralized mode, the #SCH field in a RR or discard message for DLCC ID > 0 shall always be set to zero if it is sent in an SCH. If the MT requests to send a discard message, an RR with the #SCH field set to one shall be sent in an RCH.

For DiL DUCs, the #SCH field in an RR for DLCC ID > 0 shall be set to one if the MT requests to send a discard message. Otherwise it shall be set to zero. The RR for a DiL DUC with the #SCH field set to one can be sent in an RCH or an uplink SCH for DLCC ID = 0 (uplink DCCH).

The #LCH field in the RR or discard message that is to be sent in a certain MAC frame shall be equal to or less than the number of LCHs that are waiting for transmission in the respective transmission buffer. The MT is not allowed to request resources for LCHs that were first sent in the last rtt frames (including the current frame), see clause 6.3.5. This means, the RR or discard message shall not contain LCHs that have been sent the first time less than one rtt ago.

NOTE: This rule does not apply to LCHs that have already been retransmitted. In the case of flow control, the MT is only allowed to request a number of LCHs up to the flow control limit, see clause 6.4.2.14.

The value of the #LCH field in an RR or discard message shall have been calculated not more than one MAC frame ago. Newly arriving PDUs should be taken into account at the latest in the MAC frame after their arrival. The granted volume in a frame shall be taken into account in RRs or discard messages.

EXAMPLE: If the MT has 100 new LCHs for a DUC waiting for transmission and the granted volume is 10 LCHs, then the #LCH field shall not exceed 90.

The LCHs that are discarded in a MAC frame by sending a discard message shall not be included in the #LCH field of the corresponding discard message or of an RR that is sent in the same MAC frame.

The retry bit shall be set per MT and its status shall be sent in all RRs. Upon a not successful RCH access attempt indicated by the RFCH, the retry bit status for the MT shall be set to 1. The status of the retry bit is kept until any RR has been delivered successfully, irrespective over which transport channel the RR is sent. The retry bit status shall be set to 0 after successful delivery of any RR message. If the RR has been sent in an SCH, it shall be assumed as successfully received. If the RR has been sent in an RCH, it shall be assumed as successfully received if the RFCH indicates a successful transmission.

The ARB bit shall be used as follows:

- 1) If the transmitter has unacknowledged (transmitted and waiting for feedback) LCHs or new (not yet transmitted) LCHs to be transmitted or negatively acknowledged LCHs, the transmitter shall set the ARB = 1.
- 2) If the transmitter has neither unacknowledged nor new nor negatively acknowledged LCHs, the transmitter shall set ARB = 0. An exception to the rule is given below.

Applying the above rules, the following three combinations of the number of the LCHs (#LCH) and ARB are considered.

- #LCH = 0 and ARB = 0: The transmitter has neither unacknowledged LCH nor new nor negatively acknowledged LCHs to be transmitted (i.e. the buffer is empty).
- #LCH > 0 and ARB = 1: The transmitter has unacknowledged LCH(s) or new LCH(s) or negatively acknowledged LCHs or any combination of the three to be transmitted.
- #LCH = 0 and ARB = 1: Within the transmitters window or flow control (FC) limitation, neither unacknowledged nor negatively acknowledged LCHs nor new LCHs are to be transmitted but the transmitter buffer is not empty (e.g. stalled or flow control activated).

NOTE: The combination #LCH > 0 and ARB = 0 is not allowed because ARB = 0 indicates that the transmitter buffer is completely empty.

6.3.3 Accessing the RCH

The access to RCHs shall be controlled by a contention window CW_a maintained by each MT. The contention window shall be derived from the number a , where a is the number of retransmission attempts made by the MT. For the first access attempt, a shall be set to 0. The size of the contention window, CW_a , is defined as follows, where n is the number of RCHs in the MAC frame where r_a is calculated:

1) Initial Attempt: $a = 0$, $CW_0 = n$

$$2) \text{ Retransmission: } a \geq 1, CW_a = \begin{cases} 256 & 2^a \geq 256 \\ 2^a & n < 2^a \leq 256 \\ n & n \geq 2^a \end{cases}$$

The RCH used for the a^{th} retransmission attempt including an initial transmission ($a = 0$) shall be chosen by a uniformly distributed random integer value r_a within the interval $[1, CW_a]$. The random number generator is not specified. MT shall start counting r_a from the first RCH in the MAC frame, in which the ACH indicates the failure of the previous access attempt. In case of a equal to 0, the MT starts counting with the first RCH in the current frame. This first RCH is specified by number $r_a = 1$. The RCH with number equal to r_a is the RCH that the MT shall access. The MT shall not access the RCH before its counter has reached the RCH with the number equal to r_a . After receiving the ACH with a positive feedback, a shall be reset to 0.

NOTE: The number n of RCH slots may vary from frame to frame.

EXAMPLE 1: Figure 35 shows an example for the third retransmission access attempt. After ACH announces failure of the previous retransmission access attempt $a = 2$, MT determines CW_3 from $\max(2^3, n)$. Then the MT determines a random number r_3 within the interval $[1, CW_3]$, where r_3 is assumed to be 4 in the example. Figure 35 indicates that RCH4 is located in the same MAC frame.

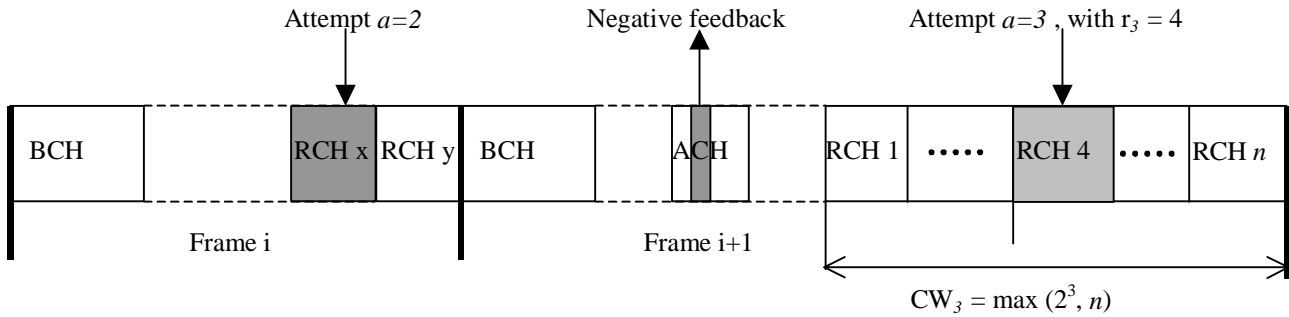

Figure 35: An example of the next access RCH $r_{\#a+1}$ within the current MAC frame

EXAMPLE 2: Figure 36 shows the situation where the third retransmission access RCH r_3 is located in the subsequent MAC frame. In this example, the frame $i+1$ has two RCHs = n that are announced by the BCH and the negative feedback for the previous retransmission $a = 2$ is received in the ACH. The current CW_3 is chosen from $\max(2^3, n = 2)$. r_3 is assumed to be 4 and the MT starts counting r_3 starting with the first RCH of the current MAC frame, i.e. the frame where the negative feedback has been received. Consequently, the MT is supposed to access the fourth of the following RCHs, irrespective of whether it is in the current or a subsequent MAC frame. In case of sector antenna, the MT shall count the RCHs within its own sector.

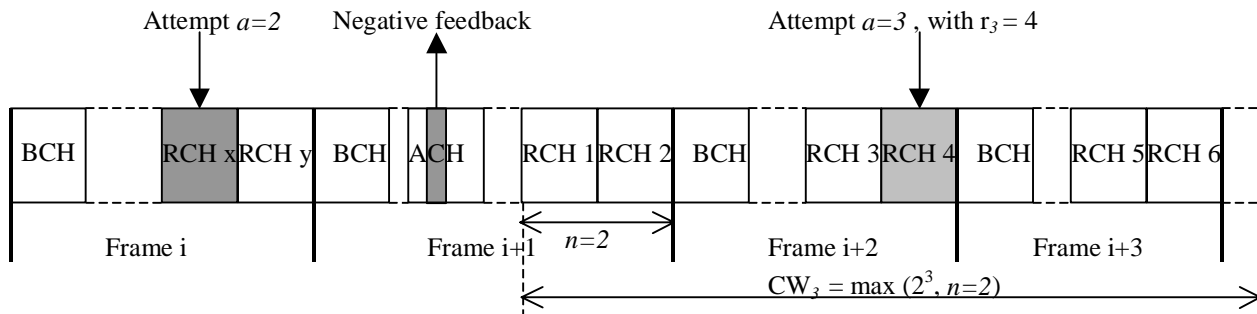

Figure 36: An example of the next access RCH $r_{\#a+1}$ located in the subsequent MAC frame

6.3.4 Fixed capacity agreement (optional)

6.3.4.1 General

The AP/CC and MTs may negotiate that the AP shall schedule a certain number of LCH and SCH in a certain number of frames. This negotiation is done during the DUC setup or a DUC modify, see TS 101 761-2 [5]. The negotiated fixed capacity shall be valid either until the DUC parameters are modified or until it is released. Additional resources may be requested using RRs as specified in clause 6.2.

If fixed capacity allocation has been negotiated for a DUC, see TS 101 761-2 [5], AP/CC and MT shall perform additionally the operations in the following clauses 6.3.4.2 and 6.3.4.3.

6.3.4.2 AP/CC Operation

The AP/CC operation shall be the following:

- After DUC setup or DUC modify the AP/CC shall wait for one Resource Request before granting resources in the case of an UL or DiL connection. With this Resource Request the MT signals to the AP/CC that it is ready to start the fixed capacity allocation. The requested resources in this RR may be zero. For a DL connection, the AP/CC may start the fixed capacity allocation whenever it decides. If an MT using a fixed capacity agreement is absent for any RLC reason, see TS 101 761-2 [5], e.g. MT Absence or MT DFS Measurement, the AP/CC shall stop granting the fixed capacity for the time the MT is absent. After the MT has returned from absence, e.g. MT Absence or MT DFS Measurement, the AP/CC can only start granting the fixed capacity agreement according to the above rules for UL, DiL and DL connections.

- The AP/CC shall stop granting the fixed capacity for the time it is absent for any RLC reason, see TS 101 761-2 [5], e.g. AP Absence. After the AP/CC has returned from absence, e.g. AP Absence, the AP/CC shall start granting the fixed capacity agreement again.
- The AP/CC shall grant the number of SCHs and LCHs per a certain number of MAC Frames as negotiated in the fixed capacity agreement. The periodicity of SCH and LCH is aligned to each other, i.e. both shall be granted in the same MAC Frame.

EXAMPLE: If #LCH = 4 for every second MAC Frame and #SCH = 1 for every fourth MAC Frame, the granted resources according to polling are the as shown in table 28.

Table 28: Example for Fixed Capacity Agreement

MAC Frame Number	Granted Resources
1	-
2	4 LCH
3	-
4	4 LCH, 1 SCH

The maximum number of SCHs, which can be negotiated in the fixed capacity agreement, is one, see TS 101 761-2 [5].

- The number of SCHs, as negotiated in the fixed capacity agreement, shall be used for RRs only.
- If an SCH is granted for an uplink DUC according to the fixed capacity agreement, the AP shall set the RR poll bit in the RG IE. If additional SCHs are granted according to the basic procedure, the RR poll bit shall be set according to the AP's choice.
- If an SCH is granted according to the fixed capacity agreement for a DiL connection, this SCH shall be granted for the uplink DCCH (DLCC ID = 0) instead of the DiL LCCH.
- If the MT requests resources by using RRs for a connection using the fixed capacity agreement, the AP/CC shall consider the requested resources in addition to the resources negotiated in the fixed capacity agreement.

NOTE 1: The AP/CC does not need to take into account that LCHs may have been queued during MT absence. The transmitter of LCHs is responsible for doing so (MT for UL and DiL, AP for DL).

NOTE 2: Power saving is not allowed for MTs using a fixed capacity agreement, see TS 101 761-2 [5].

NOTE 3: The AP/CC is allowed to allocate more SCHs than what has been agreed during the negotiation.

If the AP/CC cannot grant the number of SCHs and LCHs as negotiated in the fixed capacity agreement, the AP/CC shall use the appropriate RLC procedures to modify the negotiated resource allocation or to release the connection, see TS 101 761-2 [5].

NOTE 4: The above situation could for example occur when the MT requests for a more robust PHY mode in a Resource Request.

6.3.4.3 MT Operation

The MT operation is the following:

- After DUC setup, the MT shall transmit one Resource Request in order to start using the fixed capacity agreement in the case of an UL or DiL connection. The content of the RR is according to the rules for composing a RR.
- If the MT is not granted the number of SCH and LCH as negotiated in the fixed capacity agreement, the MT may use Resource Requests to request for the resources not granted by the fixed capacity agreement in the case of an UL or DiL connection.
- The MT may use Resource Requests for requesting resources required additionally to the fixed capacity agreement.

- A Resource Request with the #SCH and #LCH fields set to 0 shall be used to change the PHY mode of a connection with fixed capacity assignment without requesting additional resources.
- If the MT is polled for a Resource Request with the RR poll bit set to 1 in CM, the MT shall transmit a Resource Request or Discard Message.

6.3.5 Timing requirements

6.3.5.1 Reference point and start pointers

The basic time unit of the MAC frame shall be called slot and shall have a duration of 400 ns. The position of the transmission of transport channels and PDU trains in the MAC frame shall be identified by either a 12 or 13 bit pointers given in the FCCH and BCCH. The smallest addressable granularity of these pointers is a slot of 400 ns. The duration of each MAC frame shall be 2 ms.

The following rules apply to the timing between APs/CCs and MTs:

- The reference point of an MT for all start pointers shall be the first sample of the first BCH preamble of a MAC frame. This means that the first sample of the first BCH preamble shall be addressed with a value of 0 in the start pointer. In the case where multiple sectors are used, the MTs shall also use the first sample of the preamble of the first BCH as the reference point. This is illustrated in figure 37.

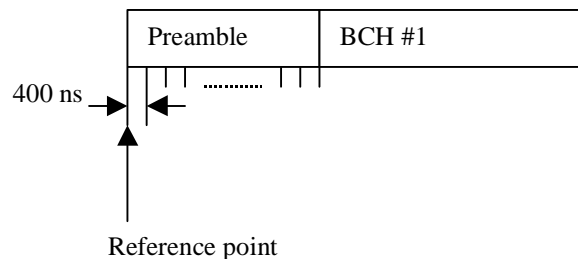

Figure 37: Definition of the reference point

- When calculating the pointers in the BCCH and the FCCH, the AP's scheduler shall take the PHY layer preambles and the needed guard spaces into account, see clause 6.9.2. The MT has to take the preambles implicitly into account when evaluating the pointers. This is explained for the up- and downlink by the arrows in the examples in figure 38 and for the direct link in figure 39. For the random access phase the MTs have to take into account the RCH guard space which is broadcast in the BCCH, see TS 101 475 [4], and implicitly the preamble as depicted in figure 40.

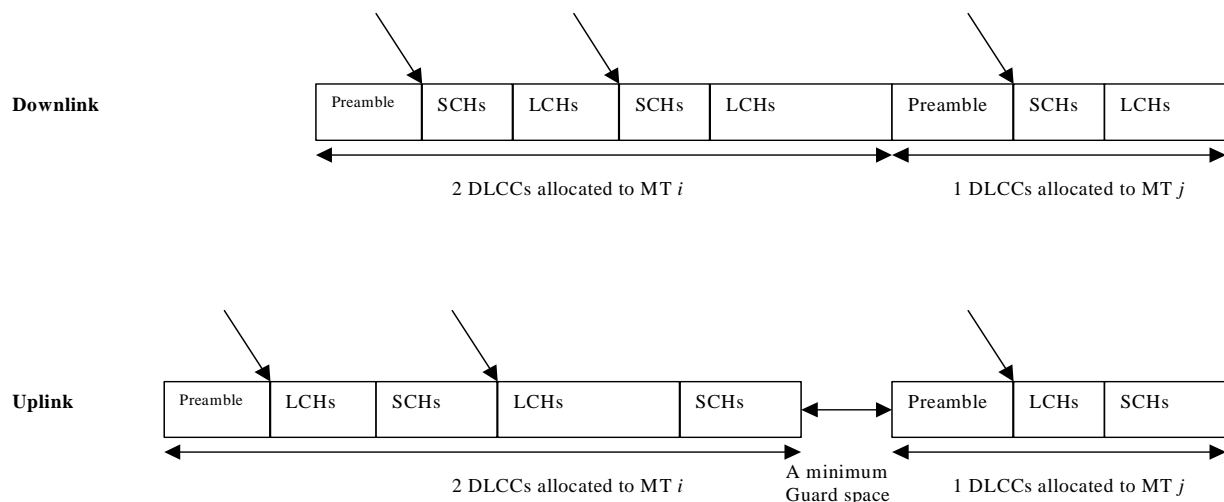

Figure 38: Example for pointers for the up- and downlink

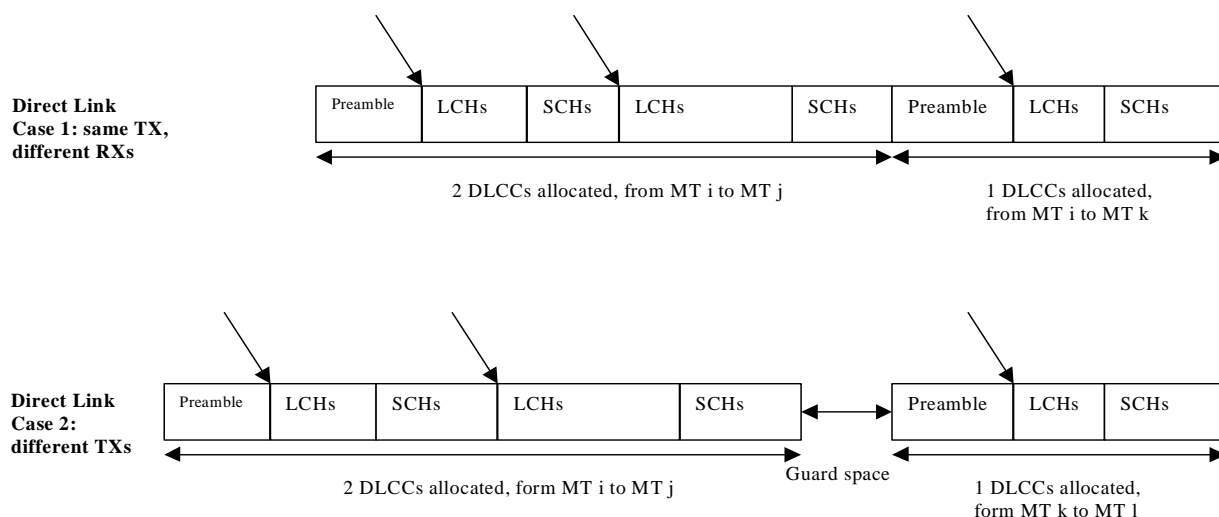

Figure 39: Example for pointers for the direct link

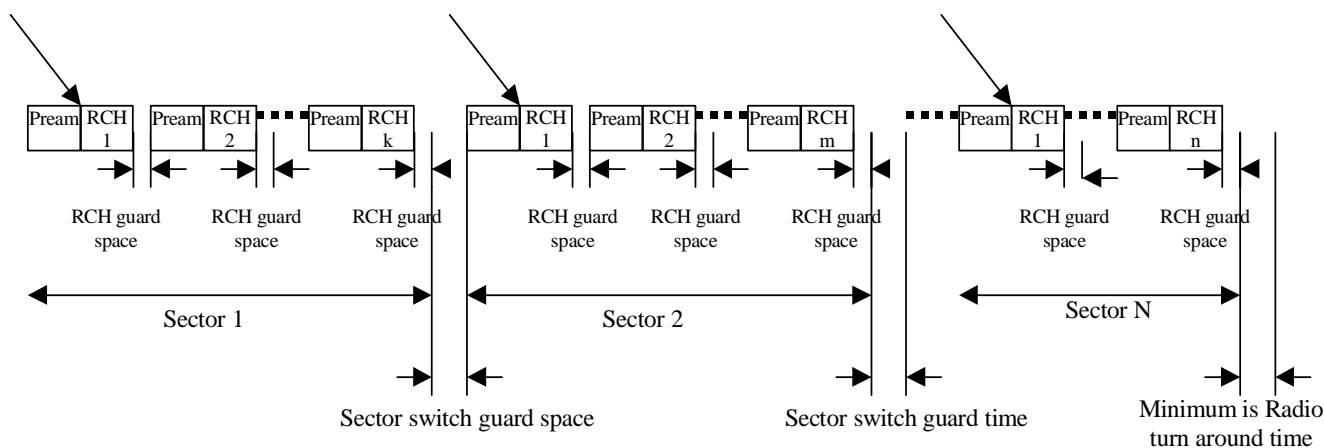

Figure 40: Examples for pointers for RCHs for different sectors

- The selection of the duration of the guard time between uplink transmissions and direct link transmissions of different MTs shall be performed by the AP/CC.
- In direct link, guard spaces are only required if the transmitter of the next PDU train is different from the transmitter of the previous PDU train.
- Each PDU train transmitted by MTs shall be preceded by only one PHY preamble in CM and DM.

NOTE: The PHY layer is responsible to insert and remove the preambles. It is assumed that some control information about the insertion is passed down from the MAC to the physical layer.

6.3.5.2 Minimum time between ACH and UL phase

The default value for the gap between the end of the ACH announced for a particular sector and the first uplink transmission of each individual MT which receives a RG for this particular sector shall be 1 024 μ s. MTs can optionally request a different value during association, see TS 101 761-2 [5]. The handling of the gap is illustrated in figure 41.

If an MT requests a longer gap than the default value, the AP/CC shall support this. If the MT requests a shorter gap than the default gap, the AP/CC may support this. The gap is due to a processing delay and is based on the processing categories given in table 29.

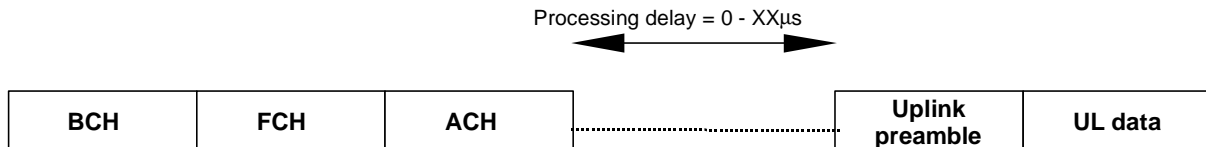

Figure 41: Example for the gap between the ACH and the uplink

Table 29: Processing category

Processing category MSB - LSB	Gap between the end of ACH and the beginning of the UL transmission [μ s]	Gap in OFDM symbols (assuming 4 μ s duration per OFDM symbol)
000	0	0
001	16	4
010	32	8
011	64	16
100	128	32
101	256	64
110	512	128
111	1 024	256

Before the processing delay is negotiated, the AP/CC shall schedule the MT according to the default class 111, i.e. a processing delay of 1 024 μ s shall be assumed.

6.3.5.3 Minimum time between ACH and DiL phase

If a DiL phase exists before the uplink phase, the minimum time values listed in clause 6.3.5.2 shall apply to the gap between the end of the ACH and the beginning of the DiL transmission of the first DiL terminal which is not the AP or CC.

6.3.5.4 Request - Grant delay

There is no explicit minimum or maximum delay of resource granting. If an MT does not get any grant it may send the resource request again. More detailed rules about the use of RR messages are given in clause 6.3.2.8.

6.3.5.5 ARQ delays

Both the AP/CC and the MT announce their ARQ processing delay in number of MAC frames for both the transmit and receive direction during association time (see TS 101 761-2 [5]). The extra ARQ processing delay in transmit direction (denoted by $d_{tx,AP}$ and $d_{tx,MT}$) means the minimum number of frames before the transmitter can transmit LCHs based on the processing of an ARQ feedback message after its reception. The extra ARQ processing delay in receive direction (denoted by $d_{rx,AP}$ and $d_{rx,MT}$) means the minimum number of frames the receiver has to wait before it can produce an ARQ feedback message for received LCHs. The round-trip times (rtt) in the uplink and downlink directions are then given in numbers of MAC frames by

$$rtt_{uplink} = d_{tx,MT} + d_{rx,AP} + 1$$

$$rtt_{downlink} = d_{rx,MT} + d_{tx,AP} + 1$$

The scheduler in the AP/CC shall take the values $d_{tx,AP}$ and $d_{rx,MT}$ defined in table 30 into account and should grant SCHs for ARQ feedback messages only when the receiver is ready to send them. For ARQ delay class 0, it should not be allowed to grant reception and transmission within a shorter interval of 40 μ s.

For direct link communication, the AP/CC knows the ARQ processing delay for both terminals of a DiL connection after their association. The round-trip times for the send and receive directions of a DiL connections are given in numbers of frames by

$$rtt_{forward} = d_{tx,MT1} + d_{rx,MT2} + 1$$

$$rtt_{backward} = d_{rx,MT1} + d_{tx,MT2} + 1$$

The scheduler in the AP/CC shall take $d_{rx,MT2}$ and $d_{rx,MT1}$ defined in table 30 into account and should grant SCHs for ARQ feedback messages only when the receiver is ready to send them. For ARQ delay class 0, it should not be allowed to grant reception and transmission within a shorter interval of 40 μ s.

Table 30: ARQ delay class

Delay class	MSB - LSB	d_{TX} , d_{RX} value for rtt calculation (i.e. # frames)	Required <u>maximum</u> processing delay
0	00	0	40 μ s
1	01	1	2 ms
2	10	2	4 ms
3	11	3	6 ms

6.3.6 Handling extra capacity allocated to MTs in uplink or direct link direction

An MT need not use all granted resources for uplink and/or direct link traffic. The MT shall not leave any gaps in a PDU train.

If a transmitter is in unacknowledged mode and has no data for an LCH available, it shall send the dummy LCH (see clause 6.4). In acknowledged and repetition mode, the transmitter may repeat the respective LCH. The content of the dummy LCH payload field is not specified.

6.3.7 Error indication bits

6.3.7.1 General

The error indication bits shall be included into uplink Resource Requests and Discarding PDUs. The first two of the error indication bits, starting with the MSB, shall be called the error reason Bits. They shall contain a summary of the error reasons of either the BCHs and FCHs or LCHs, calculated over a number of MAC frames. The LSB shall contain an indication of the overall channel quality and is called the channel quality bit. The mapping of the error indication bits is presented in figure 42. Table 31 introduces the semantics of the error reason bits, table 32 of the channel quality bit.

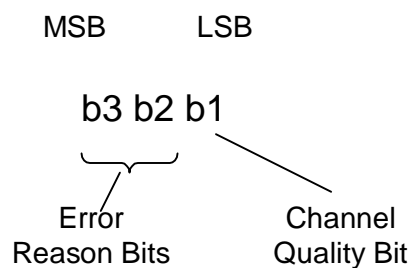

Figure 42: Bit representation of the Error indication bits

Table 31: Error reason bits

Bits	Meaning
00	OK/Not enough measurements
01	Fading
10	Interference
11	Receiver Compression

Table 32: Control Channel Quality bit

Bits	Meaning
0	OK
1	Not OK

The error reason bits shall be calculated by each MT separately for each connection that uses resource requests. Thus for e.g. broadcast and multicast connections the bits are not calculated.

6.3.7.2 Generation of the Error Indication Bits

For the purpose of describing the actions of the MT, some informative variables are introduced. They are used as an intermediate storage and are evaluated in one step to derive the error indication bits:

- **Frame-error-reason:** it describes the error reason in a MAC frame for a connection. The frame error reasons are finally evaluated to derive the error reason bits.
- **Frame-channel-quality bits:** it indicates the occurrence of an error in a MAC frame for a BCH or FCH. The frame channel quality bits are finally evaluated to derive the control channel quality bit.
- **Latest-frame-channel-error:** an element that describes the latest error reason for the control channels (BCH and FCH).

A reference RSS level shall be obtained from the preamble of the BCH of the current frame. If the CRC of a BCH, FCH or LCH fails, the reference RSS level shall be compared to an RSS threshold value (see TS 101 475 [4] on receiver sensitivity) that corresponds to the used PHY mode. The reason for failure shall then be one of the following:

- 1.1 **Fading (F)**, if the reference RSS level was lower than the threshold,
- 1.2 **Interference (I)**, if the reference RSS level is higher than the threshold but lower than L dBm,
- 1.3 **Receiver Compression (RC)**, if the reference RSS level is higher than L dBm (caused by the receiver being too close to the transmitter).

L is –25 for device class 1 terminals and –35 for device class 2 terminals (see TS 101 475 [4]).

If the CRC evaluations are successful, the BCH, FCH or LCH shall be considered successful (OK).

If the RSS measurement of the BCH has not been successful, the frame-error-reason and the latest-frame-channel-error shall be set to F for all connections. If the RSS measurement of the BCH has been successful and any CRC check in the BCH or FCH has failed, then the following rules shall be applied:

- 2.1 The frame-error-reason for this frame shall be set either to F, RC or I for all connections according to the rules to calculate the reason for failure given above. In the calculation, the sensitivity threshold for BPSK with code rate $\frac{1}{2}$ shall be used.
- 2.2 The frame-channel-quality bit for this frame shall be set to NOT OK.
- 2.3 The frame-error-reason according to 2.1 is stored in the latest-frame-channel-error.

If the RSS measurement of the BCH has been successful and no CRC in BCH or FCH has failed, then:

- 3.1 If no DL traffic has been allocated for the MT in the current frame, the frame-error-reason bit shall be set to OK for all connections.
- 3.2 If DL traffic has been allocated for the MT, it shall update the frame-error-reason and frame-channel-quality according to 3.3, 3.4 and 3.5 for the particular connections that have been granted resources. For all other connections shall the frame-error-reason bit be set to OK.
- 3.3 If no CRC of any LCH has failed, the frame-error-reason shall be set to OK.
- 3.4 If one or more CRC of LCHs has failed, the MT shall set the frame-error-reason (F, I or RC) for this connection, depending on the reference RSS value.
- 3.5 The frame-channel-quality for this frame shall be set to OK.

NOTE: In the first version of the DLC TS basic transport function both the BCH and FCH will use the same PHY mode. In future phases, the PHY modes may be different.

The frame-error-reasons of the last 50 frames shall be stored. The frame-error-reason shall be cleared after handover, frequency change or if the mobile is absent intentionally for more than 10 frames (e.g. making measurements or due to sleep mode). In case of lost MAC frames, the frame error reason shall be set to (F), i.e. the rule given above for the loss of the RSS measurements applies.

When a PDU containing error indication bits is to be transmitted, the MT shall perform the following actions:

- 4.1 The Control Channel Quality bit shall be set to 1 if any frame-channel-quality has been set to NOT OK in the last 20 frames. Otherwise Control Channel Quality shall be set to 0.
- 4.2 If the Control Channel Quality bit is set to 1, the error reason bits shall be set according to the latest-frame-channel-error field (F, I or RC).
- 4.3 If the Control channel quality bit is set to zero the error reason Bits shall be set according to 4.4.
- 4.4 The Frame-error-reasons belonging to the connection shall be evaluated. If there has been no errors in the last 50 frames or there are less than 50 frame-error-reasons available, OK/not enough measurements (00) shall be set for the PDU. Otherwise, the error reason that occurred most often shall be transmitted in the PDU, i.e. 01 for fading, 10 for interference or 11 for receiver compression. If there is an equal number of faded and interfered frames, anyone of these two can be selected. As an MT transmits the Error Indication Bits, it shall make sure that they have been produced not later than at the end of the previous MAC frame.

6.3.7.3 Direct Mode

The two Error Reason bits of the Error Indication bits shall be included into Resource Request messages for the direct link. The Error Reason Bits shall always describe the error reason for the control channel, namely BCH and FCH. Each MT that uses direct link resource requests shall calculate the error reason bits, and include them in all its RR PDUs for direct link unicast, multicast or broadcast, independent of the connection.

6.3.7.3.1 Generation of the Error Indication Bits in DM

A reference RSS level shall be obtained as in CM. If the CRC of a BCH or FCH fails, the reference RSS level shall be compared to an RSS threshold value (see TS 101 475 [4] on receiver sensitivity) that corresponds to the used PHY mode. The reason for failure shall then be as in CM.

If the RSS measurement of the BCH has not been successful, the latest-frame-channel-error shall be set to F. If the RSS measurement of the BCH has been successful and any CRC check in the BCH or FCH has failed, then the following rules shall be applied:

- 1.1 The latest-frame-error-reason shall be set either to F, RC or I according to the rules given in 6.3.7.2.
- 1.2 The frame-channel-quality bit for this frame shall be set to NOT OK.

If the RSS measurement of the BCH has been successful and no CRC in BCH or FCH has failed:

- 2.1 The frame-channel-quality for this frame shall be set to OK.

NOTE 1: In the first version of the DLC TS basic transport function both the BCH and FCH will use the same PHY mode. In future phases, the PHY modes may be different.

All the frame-channel-qualities shall be set to OK after handover, frequency change or if the mobile is absent intentionally for more than 10 frames (e.g. making measurements or due to sleep mode). In case of lost MAC frames, the latest-frame-error-reason shall be set to (F), i.e. the rule given above for the loss of the RSS measurements applies.

When a PDU containing error indication bits is to be transmitted, the MT in direct mode shall perform the following actions:

- 3.1 If any frame-channel-qualities have been set to NOT OK in the last 20 frames, the error reason bits shall be set according to the latest-frame-channel-error field (F, I or RC).
- 3.2 Otherwise the error reason bits shall be set to indicate OK (00).

NOTE 2: The Control Channel Quality bit is not available in Resource Request for DiL.

6.4 Error Control

6.4.1 General

The AP/CC and MT shall support three error control modes:

- 1) Acknowledged mode: Provides with reliable transmissions using retransmissions to improve the link quality. The retransmissions are based on acknowledgements from the receiver. Low latency can be provided by a discard mechanism.
- 2) Repetition mode: Provides a reliable transmission by repeating the LCHs.
- 3) Unacknowledged mode: Provides an unreliable, low latency transmission.

UDCHs for a certain connection shall either be sent in acknowledged or unacknowledged mode. The negotiation during connection set up is defined in TS 101 761-2 [5]. In the case of the acknowledged mode, an implicit bi-directional LCCH is set up (without RLC signalling).

UMCH, DCCH on LCH and RBCH on LCH shall use the unacknowledged mode.

UBCHs shall either be sent in repetition or unacknowledged mode. In the case where multiple convergence layers are supported, the UBCHs may use different error control modes. In the case of the repetition mode, an implicit unidirectional LCCH is set up corresponding to a UBCH.

The figures below illustrate the possible setups. In these examples, the terms "transmitter" and "receiver" mean that the data transmission under consideration is from the transmitter to the receiver, although e.g. a connection using the UDCH is in general bi-directional. The RR message control flow is not considered.

Figure 43 illustrates the situation in the case of the acknowledged mode. A corresponding LCCH is available which is used for ARQ feedback messages from the receiver to the transmitter and for discard messages from the transmitter to the receiver.

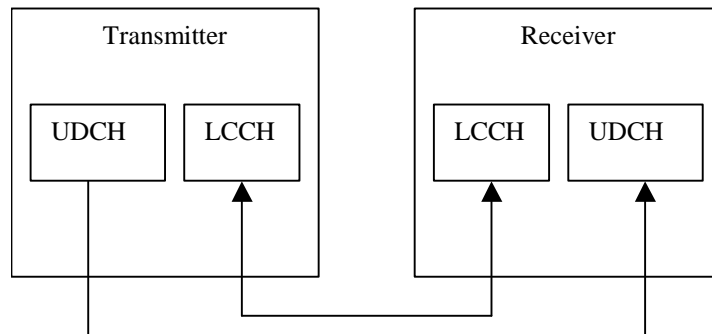

Figure 43: Illustration of the data and control flow in acknowledged mode

Figure 44 illustrates the situation in the case of the unacknowledged mode. The data flows only from the transmitter to the receiver, no control data flow for ARQ feedback or discard messages is allowed.

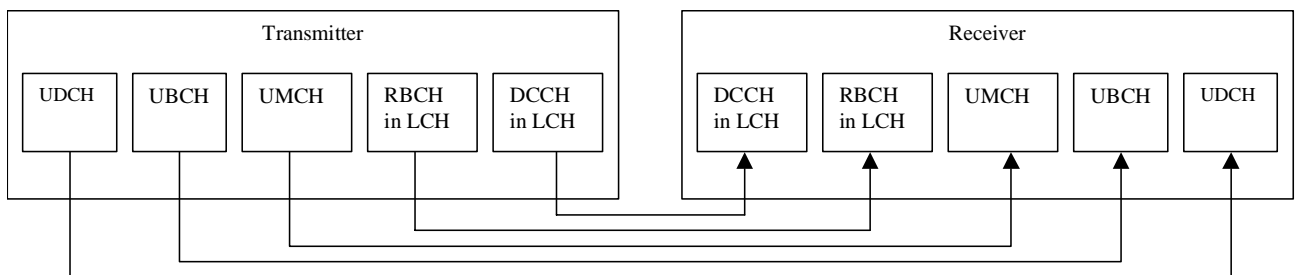

Figure 44: Illustration of the data and control flow in unacknowledged mode

Figure 45 illustrates the situation in the case of the repetition mode. In this case, an implicit unidirectional LCCH for discard messages from the transmitter to the receiver is available.

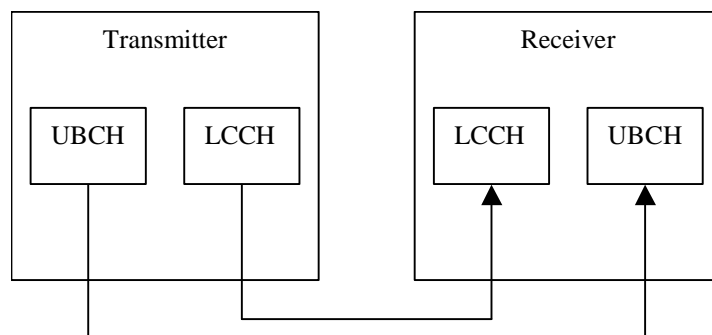

Figure 45: Illustration of the data and control flow in repetition mode

6.4.2 Acknowledged mode

6.4.2.1 General

The EC functions using acknowledge mode can be applied to DLC user connections.

The error control function is responsible for:

- Evaluation and generation of the CRC for LCHs.

- Detection of missing LCHs, i.e. LCHs that have not been received yet or detected by the CRC function as erroneous.
- Handling of LCHs: Where applicable, performing retransmission of missing LCHs (ARQ function), in order delivery of LCHs to the CL.
- Generation and analysis of ARQ feedback messages.
- Generation of discard messages and act accordingly.

NOTE 1: The scheduler is responsible for the allocation of resources for ARQ feedback messages.

NOTE 2: The term "positively acknowledged" means that an LCH has been correctly received and this is reported to the transmitter. The term "negatively acknowledged" means that an LCH has not been correctly received and this is reported to the transmitter.

The support of the acknowledged mode for UDCHs is mandatory for MT and optional for AP/CC.

6.4.2.2 Notations

LCHs are identified by a sequence number of length 10 bits, which is interpreted modulo 2^{10} . The relation $[A < B] \bmod 2^{10}$ holds, if B is in the set $[A + 1, A + 2, \dots, A + 2^9 - 1] \bmod 2^{10}$.

A set of sequence numbers $[A, B] \bmod 2^{10}$ is the set of sequence numbers $[A, A + 1, \dots, B] \bmod 2^{10}$.

A set of sequence numbers $[A, B) \bmod 2^{10}$ is the set of sequence numbers $[A, A + 1, \dots, B - 1] \bmod 2^{10}$.

Furthermore, X_s denotes an LCH sequence number, X_b denotes the bitmap block number that contains the LCH of sequence number X_s , and X_{bs} denotes the first sequence number in block X_b .

NOTE 1: X_b may be obtained by truncating the 3 LSBs of X_s .

NOTE 2: X_{bs} may be obtained by concatenating [000] after the LSB of X_b .

The terms higher and lower sequence numbers are interpreted within a window (i.e. interval of at most 512 LCHs) of sequence numbers.

6.4.2.3 LCH Sequence Number SN

Each LCH shall be assigned a 10-bit sequence number. Sequence numbers shall be incremented by 1 for subsequent LCHs and calculated modulo 2^{10} .

NOTE: The sequence number is generated and evaluated by the EC function.

6.4.2.4 Window Sizes k_s

The window size k_s is negotiated at connection set up, see TS 101 761-2 [5]. Possible window sizes are: 32, 64, 128, 256, 512.

NOTE: The maximum window size is half the size of the sequence number space to prevent ambiguities in the interpretation of sequence numbers.

6.4.2.5 Receiver window

The receiver window is the interval of sequence numbers that are eligible for reception. The bottom of the receiver window $RxBoW_s$ is the lowest sequence number not yet received correctly by the receiver.

The receiver shall maintain $RxBoW_s$ as a full 10 bit sequence number since $RxBoW_s$ may not be aligned on bitmap blocks boundaries.

The receiver window is the set of sequence numbers $[RxBoW_s, RxBoW_{bs} + k_s)$.

6.4.2.6 Transmitter window

The transmitter window is the interval of sequence numbers that are eligible for transmission. The bottom of the transmitter window TxBoW_s is the lowest sequence number that has not yet been positively acknowledged by the receiver.

The transmitter window is the set of sequence numbers $[\text{TxBoW}_s, \text{TxBoW}_{bs} + k_s)$.

TxBoW_s shall be updated to the lowest negatively acknowledged LCH within BMB1 when the transmitter receives an ARQ feedback message with the CAI bit set.

6.4.2.7 Bitmap Blocks (BMB) and Bitmaps Block Numbers (BMN)

The ARQ feedback messages sent by the receiver shall contain Bitmap Blocks. The sequence number space, starting from sequence number 0, is partitioned into consecutive intervals of sequence numbers. A bitmap block is mapped to an interval of sequence numbers in the following way. A bit having a given position in the bitmap block is associated to the sequence number having the same position in the sequence number interval, e.g. the most significant bit of a bitmap block is the lowest sequence number of the interval. A bit set to 1 in the bitmap block positively acknowledges the LCH with the sequence number associated to the bit. A bit set to 0 in the bitmap block signals the negative acknowledgement of the corresponding LCH.

The sequence number intervals are of size 8, and therefore Bitmap Blocks shall be of length 8 bits. The address, or Bitmap Block Number BMN_b , of a bitmap block is the position of the sequence number interval it covers. A bitmap block in the ARQ control message can be addressed either by an absolute or a relative address. An absolute address is 7 bits long. A relative address is 5 bits long. The address of BMB2 that is relative to BMB1 is the absolute address of BMB2 minus the absolute address of BMB1. In addition, the address of BMB3 relatively to BMB2 is the absolute address of BMN_3 minus the absolute address of BMN_2 .

NOTE 1: The absolute address is the common first 7 bits of the sequence numbers covered by the bitmap block.

Bitmap blocks shall appear in increasing order in the ARQ control message.

NOTE 2: Details about the handling of processing delays can be found in clause 6.3.5.

NOTE 3: An ARQ feedback message contains information concerning only a fraction of the receivers' window. Those LCHs whose sequence numbers are not covered, e.g. LCHs between BMN_1 and BMN_2 , cannot be considered as positive acknowledged based on only this ARQ feedback message.

NOTE 4: A 7 bit long absolute address can address any bitmap blocks. A 5 bit long relative address might in some cases limit the set of bitmap blocks that can be addressed.

An example for the ARQ feedback handling is depicted in figure 46.

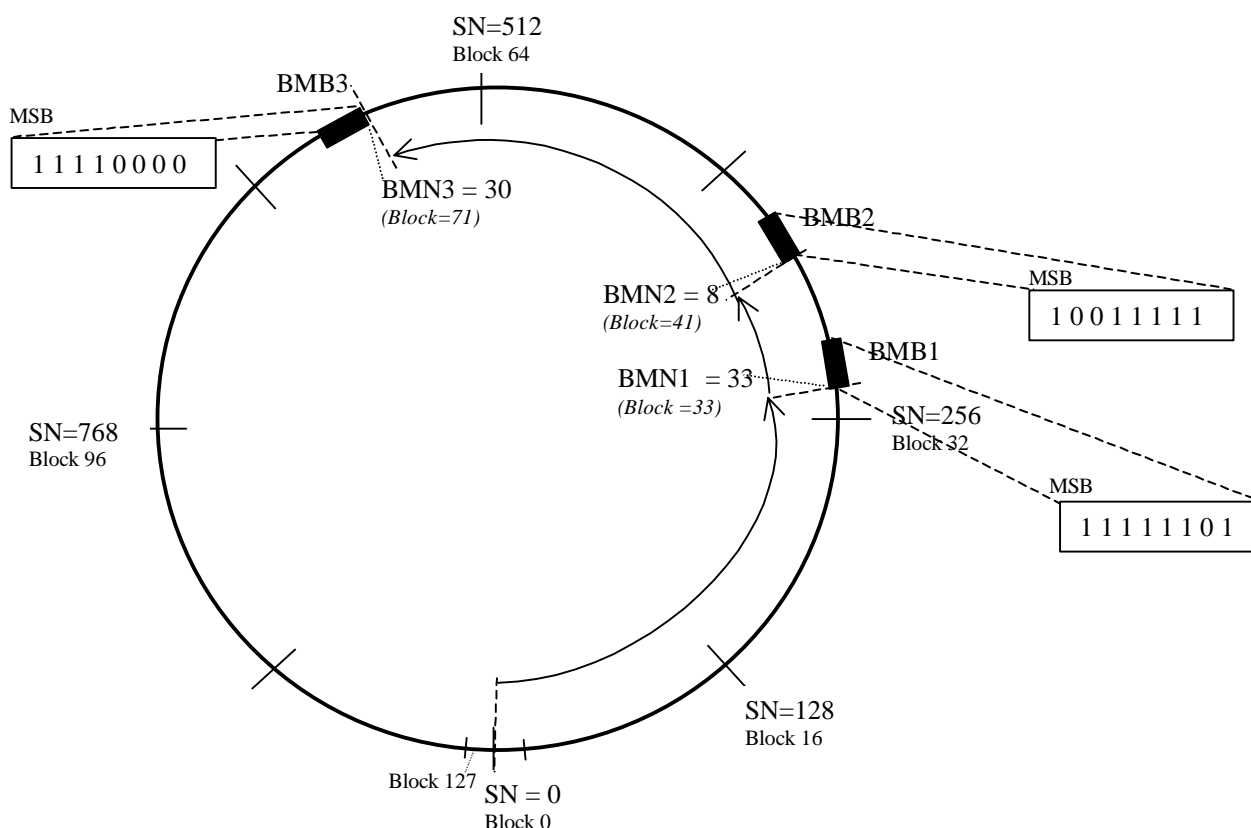

Figure 46: Example for the ARQ feedback handling

The example describes the bitmap coding in the case of reception errors of the LCHs with sequence numbers <270>, <329>, <330>. It is assumed that the receiver has received the LCHs with sequence numbers of up to <571> before transmitting the ARQ feedback message. The numbers given in the example have the following meaning:

- BMN1 = 33 represents the absolute coding of the block number 33 that comprises sequence numbers <264> to <271>.
- BMB1 = [11111101] indicates the LCH with sequence number <270> as erroneous.
- BMN2 = 8 refers to block number 41, which covers sequence numbers <328> to <335>. It is relative to the block number indicated in BMN1, which is 33 in this example.
- BMB2 = [10011111] indicates reception errors of LCH with sequence numbers <329> and <330>.
- BMN3 = 30 refers to block number 71 (sequence numbers <568> to <575>). It is relative to BMN2. It indicates the highest correctly received LCH with the sequence number <571>.
- BMB3 = [11110000] indicates the correct reception of the LCHs with sequence numbers <568> to <571>.

Upon reception of the ARQ feedback message, the transmitter can release previously transmitted packets with sequence numbers up to and including sequence number <269> if the CAI bit is set, and the logical check of the ARQ feedback message was successful (see clause 6.4.2.10).

In this case, the transmit window (TxBoW_s) is advanced to <270>.

The receiver window (RxBoW_s) is set to <270>.

6.4.2.8 Cumulative Acknowledgement (CumAck)

The receiver may positively acknowledge all LCHs with sequence numbers up to a certain value, CumAck_s, by setting the CAI bit in the ARQ feedback message. The BMB1 shall contain at least one negatively acknowledged LCH. The transmitter sets its bottom of window, TxBoW_s, to the lowest negatively acknowledged LCH within BMB1. The LCHs below but excluding TxBoW_s are regarded as cumulatively positively acknowledged by the receiver.

If the receiver has not generated an ARQ feedback message with the CAI bit set in the last rtt including the current frame, then it shall generate a cumulative acknowledgement (set the CAI bit) in at least one ARQ feedback message the next time ARQ feedback messages are transmitted. An exception of this rule is defined when the receiver is in flow control, see clause 6.4.2.14.

At the receiver side, the CumAck_s sequence number shall be the bottom of the receive window, RxBoW_s.

6.4.2.9 EC Reset of the connection

The EC reset procedures set both transmitter and receiver in a well-defined state from which communication can start or restart. The support of the Reset procedure is mandatory. Each side of a connection shall be able to initiate a Reset. The peer entity shall accept the Reset request and shall acknowledge it. The message exchange for the EC connection reset is defined in TS 101 761-2 [5].

The EC connection reset message exchange in the RLC shall be triggered to exit abnormal states of the EC protocol. The reset procedure that shall be performed in the EC entity shall include the following actions:

- The receiver shall discard all data in its reception buffer;
- The transmitter may discard data in its transmission buffer;
- The bottom of windows are set to 0;
- If the connection is flow controlled, exit the flow control state;
- Clear all other ARQ state information (such as acknowledgement bitmaps, rtt considerations etc.).

Regardless of the EC connection reset procedure, the reset actions given above shall be performed for single or all connections with acknowledged mode in certain situations that are originated in the RLC, see TS 101 761-2 [5].

Examples are:

- association;
- re-association;
- connection setup;
- connection modify;
- handover to a new AP;
- connection reset requested by the peer entity.

6.4.2.10 Error Control Procedures for the Receiver

Upon receiving an LCH, the receiver shall check the LCH's CRC. If the CRC is not correct, the receiver shall discard the LCH. Otherwise, the receiver shall perform the following actions:

- if the LCH's sequence number is outside the receiver's window, then discard the LCH;
- if the LCH's sequence number is inside the receiver's window, store the LCH in the receiver's buffer and update the variable RxBoW_s if appropriate.

Upon receiving the discard message, the receiver shall perform the actions described in clause 6.4.2.12.

If the receiver is in flow control state, it may discard all LCHs that are above the flow control limit that it has signalled to the transmitter, see clause 6.4.2.14. In this case the receiver sets the flow control indication bit to 1 in the ARQ feedback messages.

6.4.2.11 Error Control Procedures for the Transmitter

In this clause, D_s denotes the sequence number set in the latest discard message sent in the current transmit window. If no discard message has been sent in the window, D_s is regarded to be equal to $TxBow_s$.

As a general rule, the transmitter shall keep all LCHs that have not yet been cumulatively acknowledged in its buffer. Even if an LCH is positively acknowledged in a bitmap block, the transmitter shall keep it in its memory until it is cumulatively acknowledged, and shall be prepared to retransmit it when necessary.

The transmitter shall not transmit LCHs with sequence numbers outside its window. The transmitter shall transmit new LCHs in consecutive ascending order of their sequence numbers.

Upon receiving an ARQ feedback message with a correct CRC, the transmitter shall perform a logical integrity check on it. The check consists of mandatory and optional checks.

The following check is mandatory:

- if the CAI bit is set to 1, the lowest negatively acknowledged LCH within BMB1 in the block with number BMN1 shall be in the interval $[TxBoW_s, TxBoW_{bs} + k_s]$.

The following checks are optional:

- if the relative block numbers $BMN2_b$ or $BMN3_b$ are zero, BMB2 and BMB3 shall be identical to BMB1;
- a positively acknowledged LCH shall be placed within the negotiated window.

An exception exists for BMB1 that may contain LCHs outside the window because SNs are signalled in blocks of 8 bits and not individually.

A counter F is set to zero if the logical integrity check of the ARQ feedback message containing the CumAck is correct.

If the logical integrity check fails, the following actions shall be performed:

- the ARQ feedback message shall be ignored;
- the counter F shall be incremented by 1;

If $F = F_{max} = 2$, the connection shall be reset following the procedure described in clause 6.4.2.9. The counter F is reset to 0.

NOTE: If the transmitter's and the receiver's windows get unsynchronized, the following may happen:

- either the receiver's $RxBoW_s$ is within the transmitter's window, and the transmitter updates $TxBow_s$ based on the cumulative acknowledgements received in the ARQ feedback message; or
- the receiver's $RxBoW_s$ is outside the transmitter's window, then the cumulative acknowledgements cause the logical integrity checks to fail, and the connection is reset.

The transmitter shall maintain a timer that shall be reset each time the $TxBow_s$ is advanced. If this timer reaches a threshold value of 5 seconds, the connection shall be reset following the procedure described in clause 6.4.2.9. The timer's status shall be enabled if the transmitter has LCHs waiting for acknowledgements and disabled otherwise. Whenever the timer is disabled, it shall be reset.

When the receiver signals a flow control indication, the transmitter should transmit or retransmit only LCHs that are at or below the flow control limit.

6.4.2.12 Discarding of LCHs

This clause describes a mechanism that a transmitter can use if it does not intend to transmit LCHs it has in its transmission buffer. The reasons to discard LCHs are out of the scope of the present document. The discard message format is given in clause 6.2.

6.4.2.12.1 Actions of the transmitter

The discard procedure is initiated by the transmission of a discard message by the transmitter. The Discard sequence number shall be inside the transmitter window $[TxBoW_s, TxBoW_{bs} + k_s)$. The transmitter's intention of sending the discard message is to inform the receiver that it wants to discard the LCHs with SNs up to but not including the discard sequence number D_s .

The update of the transmit window and the deletion of the LCHs from the buffer shall be performed only after the transmitter has received the cumulative acknowledgement, as described in the subsequent clause.

The discard sequence number shall be higher or equal than the discard sequence numbers previously sent in the current transmit window.

Whenever the transmitter receives negative acknowledgements from the receiver for LCHs that the transmitter has announced in a discard message, the transmitter shall retransmit the discard message in order to make sure that the transmission does not stall when the discard message is lost.

6.4.2.12.2 Actions of the receiver

Upon reception of the discard message, the receiver shall perform the following actions:

- it shall process the discard message after it has processed the LCHs in the same frame. A receiver may process the discard message in a later frame than the one in which it has been received, but it shall make sure that the same LCHs are discarded as if the message was logically processed in the frame when it was received;
- it checks the CRC of the discard message and ignores the discard message if the CRC is not correct;
- it checks whether the discard sequence number and the repeated discard sequence number fields in the discard message are equal. If both sequence numbers are identical, the discard message is processed. If the sequence numbers are not identical, the message is ignored;
- it checks whether the discard sequence number is inside its receive window, i.e., it is inside $[RxBoW_s, RxBoW_{bs} + k_s)$. If not, the discard message is ignored;
- if the discard sequence number is inside the receive window, the receiver may deliver the payloads of received LCHs starting with $SN = RxBoW_s$ up to the discard sequence number (not included) to the CL. Which LCHs that are delivered to the CL is vendor specific;
- it shall set $RxBoW_s$ to the discard sequence number.

6.4.2.13 Handling of Dynamic ARQ bandwidth allocation

The number of SCHs available for ARQ feedback messages may change from MAC frame to MAC frame. Therefore the number of bitmap blocks that can be signalled in a frame changes dynamically, as determined by the AP scheduler.

The receiver in the MT may request for more uplink ARQ signalling capacity by setting the ABIR (ARQ Bandwidth Increase Request) bit to 1 in the ARQ feedback message. The reason for setting it may be that the MT has an increased amount of ARQ messages to transmit, e.g. because of a high number of transmission errors. The decision is up to the MT and is out of the scope of the present document.

NOTE 1: The ABIR bit is not available for the direct link.

NOTE 2: The calculation of the amount of extra SCH capacity granted by the scheduler in the AP is out of the scope of the present document.

6.4.2.14 Flow Control

The receiver may use the FC (Flow Control indication) bit in the ARQ feedback message to control the amount of traffic the transmitter transmits. Upon receiving the ARQ feedback message with the FC bit set, at least after an rtt the transmitter shall send only LCHs with sequence numbers up to the highest sequence number signalled in the Bitmap Blocks included in any previously received ARQ feedback messages. The receiver shall continuously set the FC bit to 1 as long as it needs the flow control. When the transmitter is completely stopped (i.e. can not send more LCHs due to the flow control limitation), the ARQ feedback message request bit (ARB) in the RR is used to request the receiver to send ARQ feedback messages in CM. In DM the ARB bit in the RR is used to request the AP/CC scheduler to grant SChs for ARQ feedback messages to the receiver.

The transmitter shall update the highest bitmap block number upon receipt of any ARQ feedback message independent of if the receiver is in flow control mode or not.

6.4.2.14.1 Receiver actions

When the receiver is in flow control state, it shall generate ARQ feedback messages containing only such bitmap blocks for which it can accept all the corresponding LCHs. The flow control limit is then defined as the highest SN in the ARQ feedback messages. If the receiver receives an LCH above its flow control limit, it may discard this LCH.

A receiver that is in flow control mode need not send a cumulative acknowledgement. This is an exception to the rule given in clause 6.4.2.8. In the case a discard message is received, the receiver may accept and process the discard message and send a cumulative acknowledgement, see clause 6.4.2.12.

NOTE: When the receiver enters the flow control mode, is out of the scope of the present document.

6.4.2.14.2 Transmitter actions

Whenever the flow control bit is set to 1 in an ARQ feedback message, the transmitter shall enter flow control mode. When the flow control bit is not set to 1, the transmitter shall exit the flow control mode.

In the case the transmitter is an MT, it shall set the number of LCHs requested in RRs at maximum up to the amount given by the flow control limit.

In the case of an MT as a transmitter which is completely stopped (it has LCHs not yet transmitted but transmission is not allowed due to flow control), the MT shall send an RR with #LCH = 0 and ARB = 1. Upon reception of such an RR, the AP/CC scheduler should allocate appropriate resources. This allows the transmitter to probe the receiver whether it can accept new LCHs.

NOTE 1: The timing of when the transmitter sends such a RR with #LCH = 0 and ARB = 1 is not specified.

NOTE 2: The ARB bit can be used in other occasions, e.g. stalled transmitter window, missing ARQ feedback or immediately on entering flow control mode.

6.4.3 Repetition mode

6.4.3.1 General

The EC functions using repetition mode may be applied to UBCHs.

The error control function is responsible for:

- evaluation and generation of the CRC for LCHs;
- detection of missing LCHs, i.e. LCHs that have not been received yet or detected by the CRC function as erroneous;
- handling of LCHs: Where applicable, performing repetition of LCHs. In order delivery of LCHs to the CL;
- generation of discard messages and act accordingly.

NOTE 1: The scheduler is responsible for the allocation of resources for discard messages.

NOTE 2: The transmitter can use arbitrary repetitions of LCH's for UBCHs to improve the reception quality. The choice of the use of the repetition scheme is left to each vendor.

The support of the repetition mode for the UBCH is mandatory for the receiving side at the MT, optional for the transmitting side at the MT and optional for receiving and transmitting side at the AP/CC.

6.4.3.2 Notations

The same notation as given in clause 6.4.2.2 shall be used.

6.4.3.3 LCH Sequence Number SN

Each LCH shall be assigned a 10-bit sequence number. Sequence numbers shall be incremented by 1 for subsequent LCHs and calculated modulo 2^{10} .

Each copy of a specific LCH shall have the same sequence number.

6.4.3.4 Window Sizes k_s

The window size k_s is conveyed from the AP/CC to the MT when the MT joins a certain convergence layer broadcast, see TS 101 761-2 [5]. Possible window sizes are 32, 64, 128, 256. The MT shall accept all combinations.

6.4.3.5 Acceptance range

For the exception case where a receiver fails to receive all LCH's despite the transmitter's repetition, the receiver window shall be shifted upon reception of LCH's with sequence number outside the receiver window. In order to prevent any sequence number to change the receiver window, the receiver shall only accept LCH's that are within the receiver acceptance range.

The acceptance range shall be 512, measured from $RxBoW_s$, according to: $[RxBoW_s; RxBoW_{bs} + 512)$.

6.4.3.6 Receiver window

The receiver window is the interval of sequence numbers that are eligible for reception. The bottom of the receiver window $RxBoW_s$ shall be the lowest sequence number not yet received correctly by the receiver.

The receiver window shall be the set of sequence numbers $[RxBoW_s, RxBoW_s + k_s)$.

6.4.3.7 Transmitter behaviour

The transmitter shall transmit new LCHs in consecutive ascending order of their sequence numbers. The transmitter is allowed to make arbitrary repetitions of each LCH.

Due to the behaviour of the receiver, the transmitter should keep repetitions of each LCH within the range of the receiver window.

NOTE: Due to for example residual bit errors, the transmitter may not always be able to exactly predict the receiver window.

The exact behaviour of the transmitter is out of the scope of the present document.

6.4.3.8 Error Control Procedures for the Receiver

Upon receiving an LCH, the receiver shall check the LCH's CRC. If the CRC is not correct, the receiver shall discard the LCH. Otherwise, the receiver shall perform the following actions:

- if the LCH's sequence number is inside the receiver's window, store the PDU in the receiver's buffer and update the variable $RxBoW_s$;

- if the LCH's sequence number (X_s) is outside the receiver's window, but inside the acceptance range:
 - the receiver may deliver the payloads of the correctly received LCHs starting with SN = RxBoW_s up to $X_s - k_s + 1$ (not included) to the CL in the order of their sequence numbers;
 - change the RxBoW_s to $X_s - k_s + 1$;
 - store the PDU in the receiver's buffer;
- if the LCH's sequence number is outside the receiver's acceptance range, then discard the LCH.

Upon receiving the discard message, the receiver shall perform the actions described in clause 6.4.2.12.

EXAMPLE: A Window size of 32 is assumed, see figure 47.

- a) A receiver which has not correctly received the LCHs with SN = 0 and SN = 3. The highest SN received is SN = 31.
- b) The MT has received LCH with sequence number 32. It shifts its ToWs and subsequently its BoWs, thus LCH with SN 0 is ignored and the LCHs with SNs 1 and 2 may be delivered to the convergence layer.
- c) Since 1 and 2 are correctly received, RxBoW_s is moved to SN = 3.

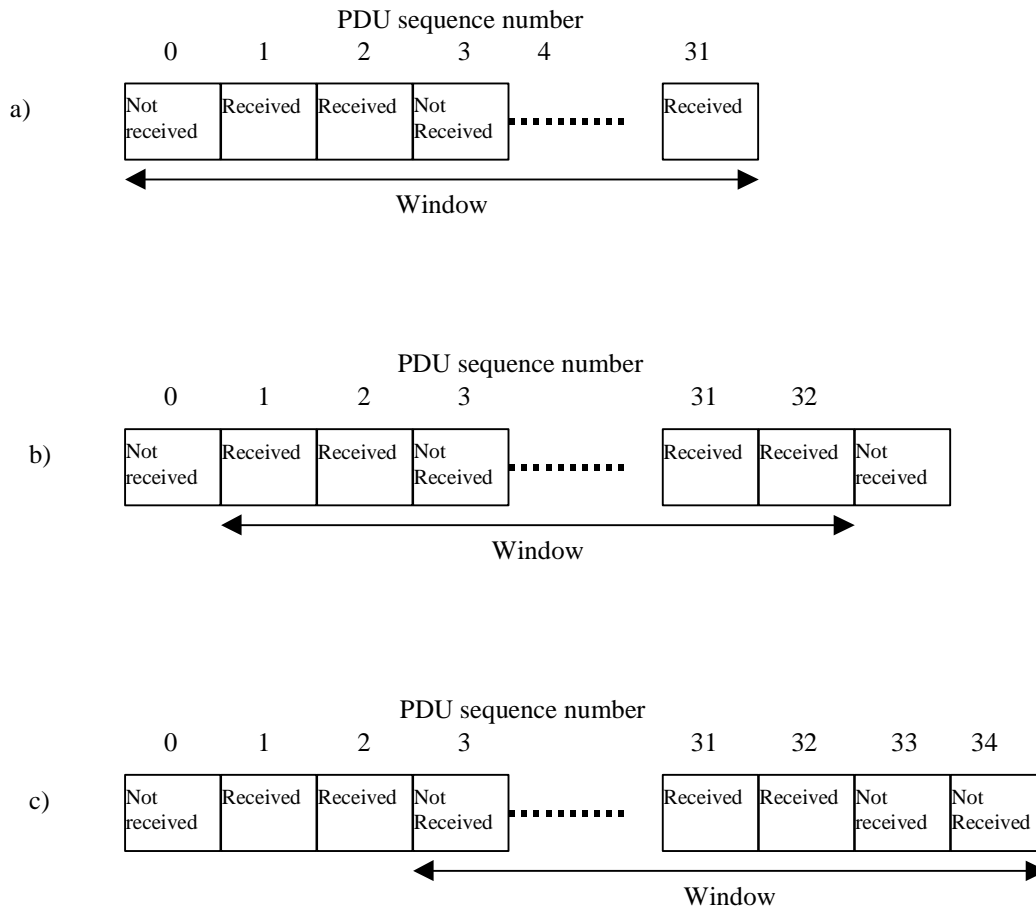

Figure 47: Example for shift of the receive window

6.4.3.9 Discarding of LCHs

6.4.3.9.1 General

This clause describes a mechanism that a transmitter may use in conjunction with the repetition scheme for UBCHs. The discard message format is given in clause 6.2.

The support and use of this feature is optional for APs/CCs and mandatory for MTs. In order to avoid major delays of UBCH messages, it is recommended to use this discard mechanism to overcome situations when incorrect reception at the receiver's BoW stalls the UBCH deliverance to the higher layer.

6.4.3.9.2 Actions of the transmitter

The discard procedure shall be initiated by the transmission of a discard message by the transmitter. The transmitter's intention of sending the discard message is to inform the receiver that no more repetition will occur up to but not including the discard sequence number D_s .

6.4.3.9.3 Actions of the receiver

The following actions shall be performed upon reception of the discard message:

- it shall process the discard message after it has processed the LCHs in the same frame. The receiver may process the discard message in a later frame than the one in which it has been received, but it shall make sure that the same LCHs are discarded as if the message was logically processed in the frame during which it has been received;
- it checks the CRC of the discard message and ignores the discard message if the CRC is not correct;
- it checks whether the discard sequence number and the repeated discard sequence number fields in the discard message are equal. If both sequence numbers are identical, the discard message is processed. If the sequence numbers are not identical, the message is ignored;
- it checks whether the discard sequence number is inside its receive acceptance range, i.e., it is inside $[RxBoW_s, RxBoW_s + 512)$. If not, the discard message is ignored;
- if the discard sequence number is inside the receivers acceptance range, the receiver may deliver the payloads of the correctly received LCHs starting with $SN = RxBoW_s$ up to the discard sequence number (not included) to the CL in the order of their sequence numbers;
- it shall set $RxBoW_s$ to the discard sequence number.

6.4.4 Unacknowledged mode

6.4.4.1 General

The EC functions using unacknowledged mode can be applied to UBCHs and UDCHs. It shall be applied to UMCHs, the RBCH using LCHs as well as the DCCH using LCHs. The error control function is responsible for:

- evaluation and generation of the CRC for LCHs;
- in order delivery of LCHs to a CL or the RLC, depending on which logical channel the LCH carries;
- utilize the resource request procedure for UDCH and DCCH, see clause 6.3.2.

NOTE: Unacknowledged transmission provides an unreliable transmission with low latency through the DLC layer.

The support of the unacknowledged mode for UDCHs and UBCHs is mandatory for MTs and optional for APs/CCs.

6.4.4.2 LCH Sequence Number SN

Each LCH is assigned a 10-bit sequence number. Sequence numbers are incremented by 1 for subsequent LCHs and calculated modulo 2^{10} .

6.4.4.3 Transmitter actions

The transmitter shall send the PDUs in ascending sequence number ordering.

If ARQ feedback messages are received, they shall be ignored by the transmitter. This is also valid for flow control indications.

6.4.4.4 Receiver actions

- Deliver the correctly received LCHs in the order of their sequence numbers to the convergence layer.
- Utilize the same rule for the SCH as given in clause 6.3.2.4, except that ARQ feedback messages shall not be transmitted.

6.5 Multicast transmission

When a multicast transmission is negotiated in CM, the AP/CC can select to transmit the multicast traffic on a UMCH or on a UDCH. If a UDCH is used, the error control mode specified for the particular UDCH shall be used, see clause 6.4. The AP/CC can distribute multicast data to several MTs by using individual UDCH for each MT. If a UMCH is used, then the unacknowledged error control mode shall be used, see clause 6.4.4.

In DM, the transmitter of a multicast connection internally decides whether the multicast traffic shall be transmitted on a DiL UMCH or on an individual DiL UDCH for each receiver. If a UDCH is used, the error control mode specified for the particular UDCH shall be used, see clause 6.4. If UMCH is used, then the unacknowledged error control mode shall be used, see clause 6.4.4.

NOTE: Extensions of the DLC may allow for additional error control modes.

6.6 CRC calculation

All messages shall be protected by a CRC. The following procedure is performed:

- 1) Preset the shift register to all ones
- 2) Shift the data part of the PDU through the shift register with the MSB first, i.e. in the sending order, see clause 5.2.1.
- 3) Add the CRC to the message as described for each message type.

The CRC shall be the remainder generated by the module 2 divisions by the specified polynomial (see table 33):

Table 33: CRC polynomial

	G(x)
CRC-16	$X^{16} + X^{12} + X^8 + X^7 + X^6 + X^3 + X + 1$
CRC-24	$X^{24} + X^{10} + X^9 + X^6 + X^4 + X^3 + X + 1$

The protected bits shall be processed in the transmit order.

Figure 48 shows how to generate the CRC-16.

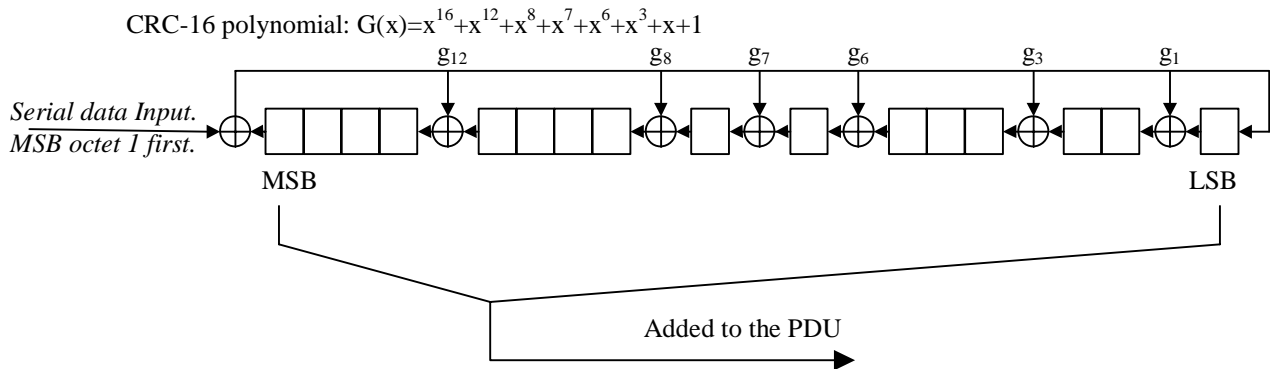

Figure 48: Definition of CRC-16 polynomial

6.7 Encryption

6.7.1 Introduction

The security solution for HIPERLAN/2 has two main functions, encryption and authentication. Key management is a supporting function for both encryption and authentication. The key management and authentication functions are described in TS 101 761-2 [5].

Encryption provides confidentiality to transferred data. It is possible to encrypt UDCH, UMCH, UBCH and DCCH messages carried by LCHs. The downlink RLC broadcast channel, RBCH that can be carried by LCHs is not encrypted, as it has to reach all MT's.

If encryption is agreed during association or handover, the unicast encryption shall start as soon as the necessary key exchange has taken place during the association or handover procedure as described in TS 101 761-2 [5]. The use of encryption as well as the choice of the encryption algorithm to be used is negotiated between the AP/CC and the MT. Encrypted communication for multicast and broadcast may be established after unicast encryption has been set up.

NOTE: The exact procedures for encryption startup and key management are defined in TS 101 761-2 [5]. The encryption keys for uplink and downlink are always between the AP and one or more MTs, whereas in DiL it is between a pair of MTs (the CC may also act as an MT in this case). The key management for DM communication is defined in TS 101 761-4 (see Bibliography).

Two encryption algorithms, DES and TripleDES, are used in order to support different security levels. These algorithms need an Initialization Vector (IV). Periodical transfer of a seed from the AP/CC to the MT supports the generation of the IV in the MT.

A mapping between the encryption key for DES as well as the ones for TripleDES and a MAC ID is defined in TS 101 761-2 [5]. Multicast and broadcast encryption use group specific key(s) or key(s) common to several groups. Access restrictions for individual multicast groups are handled on higher layers and are outside the scope of HIPERLAN/2.

6.7.2 Encryption of LCHs

If encryption and the algorithm have been agreed and the encryption key(s) have been exchanged during the link capability negotiation, each concerned LCH shall be encrypted completely.

6.7.3 Algorithms

Two encryption algorithms are supported: DES (Data Encryption Standard) and TripleDES. The former is mandatory to implement for MTs and APs/CCs, whereas the implementation of the latter is optional for APs and MTs. The use is negotiated at association and connection setup time, respectively.

6.7.3.1 DES

DES is a block cipher that works on 64-bit blocks using a 56-bit key. DES is defined in Data Encryption Standard [1] and its different modes in DES Modes of Operation [3]. The DES algorithm has been evaluated for a long time and has no known weaknesses, except some weak and semi-weak keys that shall not be used which is described in Guidelines for Implementing and Using the Data Encryption Standard [2]. Key handling, including how weak and semi-weak keys shall be handled, is described in TS 101 761-2 [5].

6.7.3.2 TripleDES

Triple DES is using the DES algorithm described above three times to offer a higher security level. It shall be run in the EDE mode, that is, to use DES to encrypt, decrypt and encrypt in sequence with three different keys. The total key length therefore is $3 \times 56 = 168$ bits. The EDE mode is illustrated in figure 49.

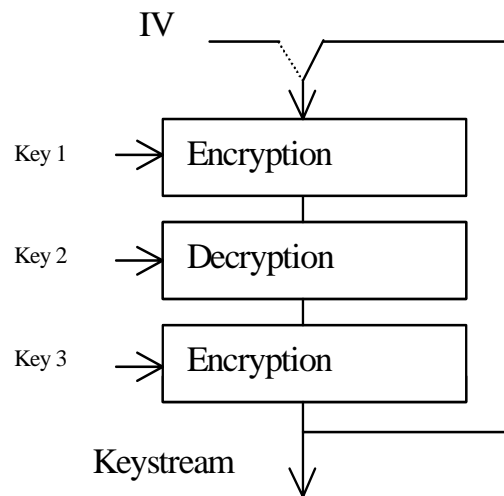

Figure 49: TripleDES encryption in OFB mode

The key handling for TripleDES is described in TS 101 761-2 [5].

6.7.4 Encryption and decryption procedure

Each LCH PDU shall be encrypted and decrypted individually as follows:

- the encryption module is first loaded with a 64-bit/8-octet Initialization Vector (IV). How the IV is generated is described in clause 6.7.7;
- the output from the encryption module (DES or TripleDES), called keystream, is XORed with the first 64-bit plaintext block to give the resulting ciphertext. The keystream shall also be fed back to the encryption module in order to generate a new keystream for encrypting the next plaintext block, that is the Output FeedBack (OFB) mode as described in DES Modes of Operation [3] shall be used;
- the procedure continues until the last plain text block (= 6 octets) has been encrypted. The plain text shall be encrypted in transmission order, starting with MSB and ending with LSB of the output from the encryption module, see clause 5.2.1.

The encryption module at the receiver side shall use the same input to generate the keystream as the transmitter side. Note that the encryption function, not decryption, is used at the receiving side. The keystream shall be XORed with the ciphertext to give the plaintext. The ciphertext shall be decrypted in the receiving order, starting with the MSB and ending with the LSB of the output of the encryption module. The procedure is illustrated in figure 50.

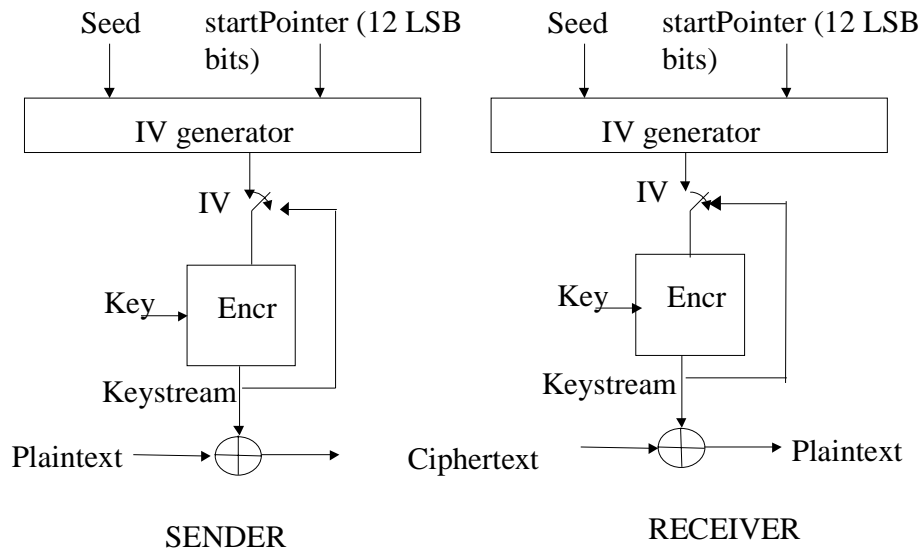

Figure 50: LCH PDU encryption and decryption

6.7.5 Encryption keys

A mapping between MAC IDs and encryption keys is established by RLC signalling. For more information about key management (generation, distribution, refresh, etc.) see TS 101 761-2 [5].

6.7.6 Encryption Seed

6.7.6.1 General

A seed is used to support the IV generation. While one IV value is valid for only one LCH PDU, one seed value is valid for one MAC frame. A seed generator cycles stepwise to produce non-repeating seeds (before it wraps) for each MAC frame.

Start pointers in FCCH Information Elements, in combination with the seed, are responsible for the generation of variable IVs for different PDU trains. An IV generator cycles stepwise to produce non-repeating IVs (before it wraps) for each LCH in a PDU train.

6.7.6.2 Seed generation in the AP

Both AP and MT shall have a seed generator consisting of a 52-bit linear feedback shift register (LFSR) based on the polynomial $x^{52} + x^3 + 1$ as illustrated in figure 51. The AP shall generate a 52-bit initial value and load its seed generator. This initial value may be any random bit sequence, except all "0"s. If a bit sequence with all "0"s is obtained, the AP shall make sure that another non all "0" sequence is generated and used as the initial value instead.

With the initial value loaded, the AP seed generator LFSR produces seeds for MAC frames by cycling stepwise. To cycle one step, the LFSR generates the new MSB bit by XORing the b_3 and b_0 bits together and then shifts the original content one bit to the right. The new bit sequence formed in the LFSR is then taken as the seed for the next MAC frame as illustrated in figure 52.

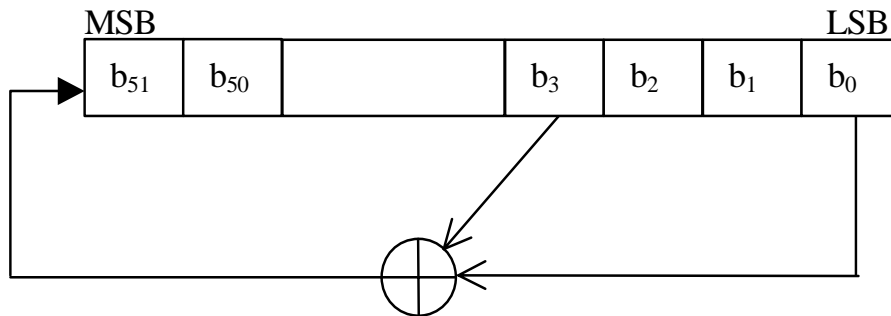

Figure 51: Seed generator cycle one step

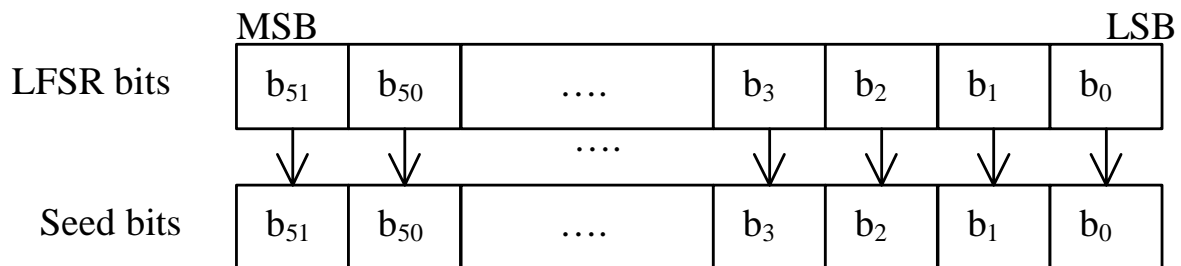

Figure 52: Seed generator output

6.7.6.3 Seed transfer

The AP shall send the seed for the current MAC frame in the RBCH, see figure 53. The AP controls the seed transmission and shall ensure that the seed is sent in a proper way to sleeping terminal(s), during handover and association, see TS 101 761-2 [5]. The seed shall be transferred in each Nth frame. Further details are defined in TS 101 761-2 [5].

6.7.6.4 Seed generation in the MT

The seed generation shall consist of two steps in the following order, see figure 53:

- 1) The MT seed generator cycles and produces a seed to be used during the current frame based on the latest correctly received seed.
- 2) The MT checks whether a seed has been received in the RBCH. If a non-all "0" seed with correct CRC has been received, the MT loads/updates its seed generator with the received value. The MT shall not load/update the seed generator if a non-correct CRC has been detected. The next output (when the generator has cycled one step) is used as the seed for the next MAC frame

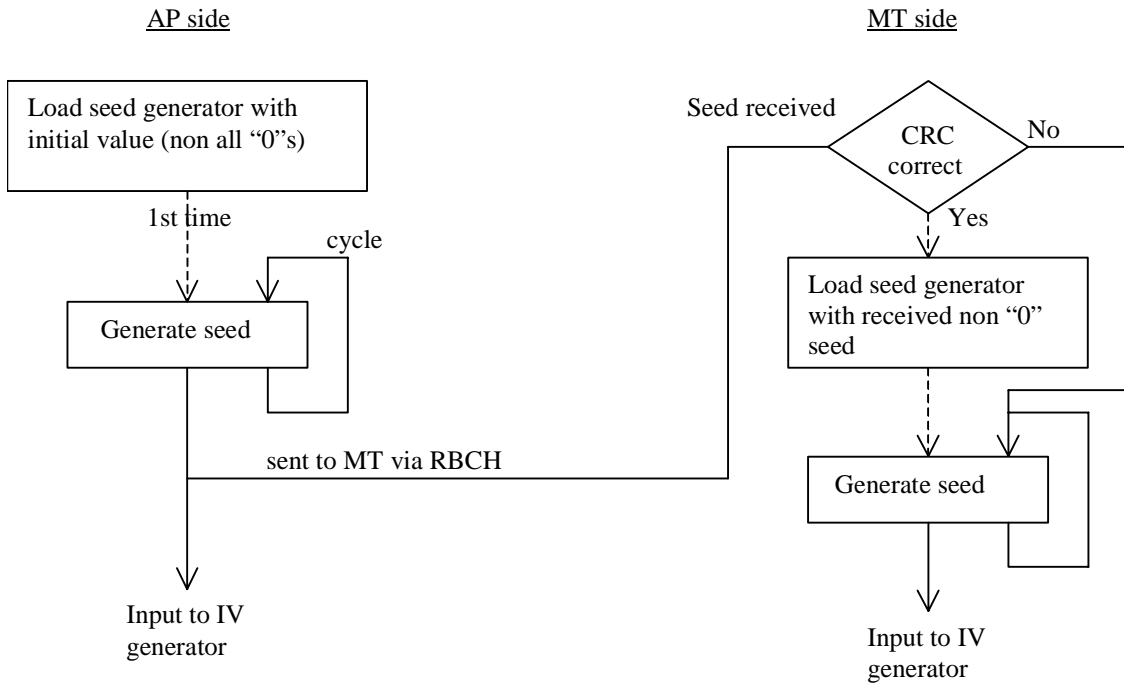

Figure 53: Seed generation and transmission procedures

6.7.7 Initialization Vector (IV)

The initialization vector is used for encrypting/decrypting the first 8 octets of each LCH. Both APs and MTs shall have an IV generator which is a 64-bit LFSR using the polynomial $x^{64} + x^4 + x^3 + x + 1$ as illustrated in figure 54 to generate a new IV for each LCH.

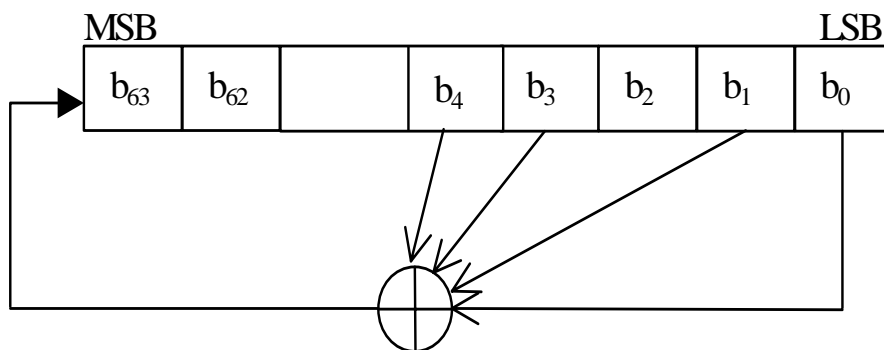

Figure 54: IV generator cycle one step

Before encrypting/decrypting the first LCH PDU for a particular connection, the IV generator LFSR shall be loaded with the concatenation of the seed (for the current MAC frame) and the 12 least significant bits of the start pointer value (see clause 6.2.2) in the FCCH IE for that particular connection, see figure 55.

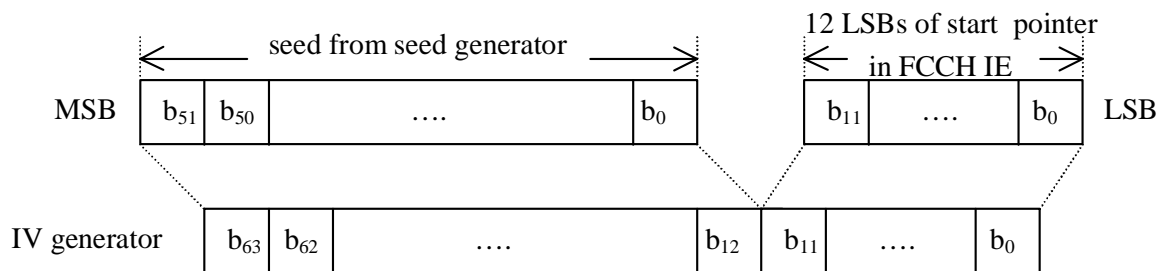

Figure 55: IV generator load with seed and 12-bit start pointer

The current content of the IV generator shall be used as IV bits, see figure 56, for encrypting/decrypting the first 8 octets of the first LCH PDU for that particular connection.

The IV generator LFSR shall cycle one step for each new LCH PDU for that particular connection. That is, the LFSR generates the new MSB bit by XORing the b_4 , b_3 , b_1 and b_0 bits together and then shifts the original content one bit to the right, see figure 54. The new bit sequence formed in the LFSR shall be used as IV for the next LCH PDU. The LFSR cycles step by step until the IV for the last LCH PDU of a particular DUC has been generated and used.

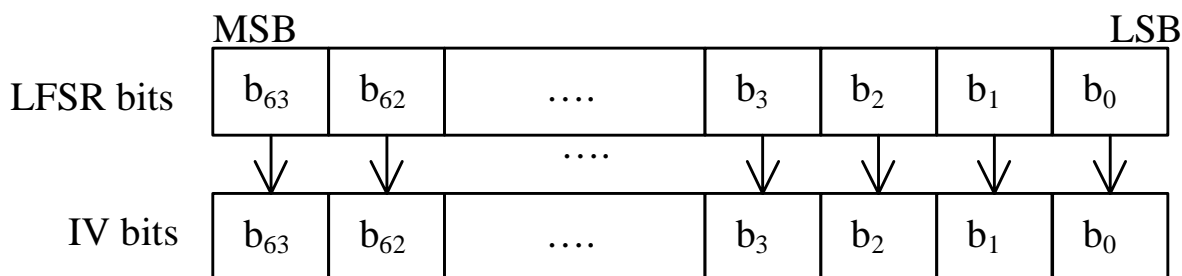

Figure 56: IV generator output

6.8 Transmission power

The rules for the selection of the appropriate transmission power for the different parts in MAC frames are defined in TS 101 761-2 [5]. This involves the rules for transmitter power control.

6.9 Mapping between MAC frame and PHY frame

6.9.1 Number of OFDM symbols per transport channel excluding physical layer preambles

The number of OFDM symbols per transport channels is shown in table 34.

Table 34: Number of OFDM symbols per transport channel excluding physical layer preambles

PHY mode	BCH, 15oct.	FCH, 27oct.	ACH, 9 oct.	SCH, 9 oct.	LCH, 54 oct.	RCH, 9 oct.
BPSK, code rate=1/2	5	9	3	3	18	3
BPSK, code rate=3/4	-	-	-	2	12	-
QPSK, code rate=1/2	-	-	-	-	9	-
QPSK, code rate=3/4	-	-	-	1	6	-
16QAM, code rate=9/16	-	-	-	-	4	-
16QAM, code rate=3/4	-	-	-	-	3	-
64QAM, code rate=3/4	-	-	-	-	2	-

The FCH in the table refers to one IE block of 27 octets.

The Duration of one OFDM symbol is equal to 4 μ s if the long guard interval is used or 3,6 μ s if the short guard interval is used. The long guard interval is mandatory to support and is the default value, i.e. it is used if not negotiated otherwise. The short guard interval is optional and can be used for SCHs and LCHs that carry a UDCH and its corresponding LCCH. The support of the short guard interval by both MT and AP/CC is negotiated during association or handover. The use of the short interval is negotiated for each individual DUC, i.e. for a UDCH, during DLC connection set up. Further details can be found in TS 101 475 [4] and TS 101 761-2 [5].

6.9.2 PDU trains

6.9.2.1 General

The radio subsystem provides a set of transport channels describing the message format over the air interface. Transport channels are used as basic elements in constructing PDU trains. The PDU trains that consist of a sequence of transport channels represent the interface between the DLC and the PHY layer:

- 1) Broadcast PDU train.
- 2) FCH-and-ACH PDU train.
- 3) Downlink PDU train.
- 4) Uplink PDU train with short preamble.
- 5) Uplink PDU train with long preamble.
- 6) Direct link PDU train.

NOTE: The preambles in the following figures are not a part of the DLC PDU train. They are added by the PHY layer, see TS 101 475 [4].

6.9.2.2 Broadcast PDU train

The Broadcast PDU train can have the formats according to figure 57 depending on the number of sectors the AP uses. The upper drawing applies to the case of a single sector, the lower drawing to multiple sectors. In the case of multiple sectors, each BCH is transmitted using an individual broadcast PDU train.

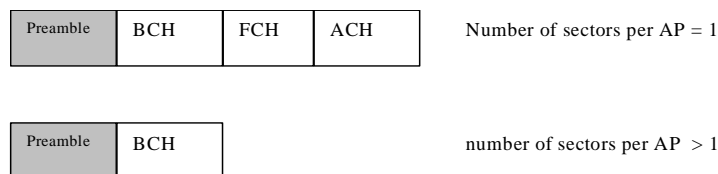

Figure 57: Possible Broadcast PDU trains

The preamble of the BCH shall consist of 4 OFDM symbols (16 μ s), see TS 101 475 [4].

6.9.2.3 FCH-and-ACH PDU train

One preamble shall be added in the beginning of each FCH-and-ACH PDU train if multiple sectors are used per AP. The preamble of the FCH-and-ACH PDU train shall be 2 OFDM symbols, see TS 101 475 [4]. Possible FCH-and-ACH PDU trains are shown in figure 58. The upper drawing shows the case where an FCH is present, whereas the length of the FCH is zero in the lower drawing.

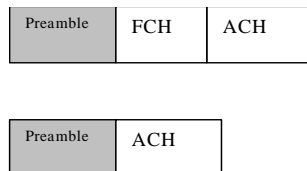

Figure 58: Possible FCH-and-ACH PDU trains

6.9.2.4 Downlink PDU train

One preamble shall be added at the beginning of each downlink PDU train, see figure 59. The preamble of the Downlink PDU train shall have a length of 2 OFDM symbols, see TS 101 475 [4].

A set of SCHs and LCHs is granted for each DLCC by one RG. An MT shall receive not more than one downlink PDU train containing UDCHs, the DCCH and LCCHs per MAC frame, i.e. all corresponding DLCCs shall be grouped in a single PDU train. It shall receive the RBCH, UMCHs and UBCHs in separate PDU trains.

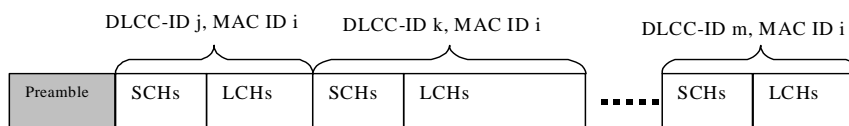

Figure 59: Possible downlink PDU train

6.9.2.5 Uplink PDU train with short preamble

One preamble shall be added at the beginning of each uplink PDU train, see figure 60. The preamble used for uplink PDU trains is announced in the BCCH in the "uplink preamble" field, which is set to zero for the short preamble. The preamble of the uplink PDU train with short preamble shall have a length of 3 OFDM symbols, see TS 101 475 [4].

A number of SCHs and LCHs is granted for each DLCC by one RG. An MT shall be granted not more than one uplink PDU train for the transmission of data, i.e. all corresponding DLCCs shall be grouped in a single PDU train. Additionally it may make an access attempt to the RCH.

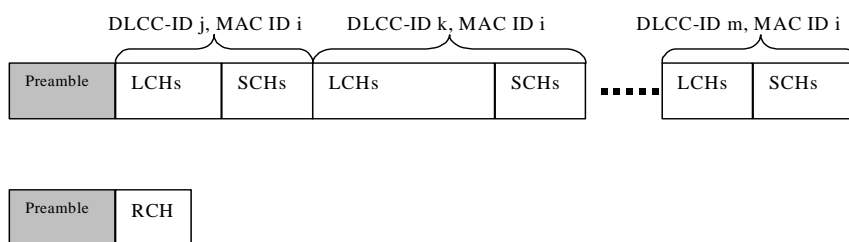

Figure 60: Possible uplink PDU train with short preamble

6.9.2.6 Uplink PDU train with long preamble

One preamble shall be added at the beginning of each uplink PDU train, see figure 61. The preamble used for uplink PDU trains is announced in the BCCH in the "uplink preamble" field, which is set to 1 for the long preamble. The preamble of the uplink PDU train with long preamble shall have a length of 4 OFDM symbols, see TS 101 475 [4].

A set of SCHs and LCHs is granted for each DLCC by one RG. An MT shall be granted not more than one uplink PDU train for the transmission of data, i.e. all corresponding DLCCs shall be grouped in a single PDU train. Additionally it may make an access attempt to the RCH.

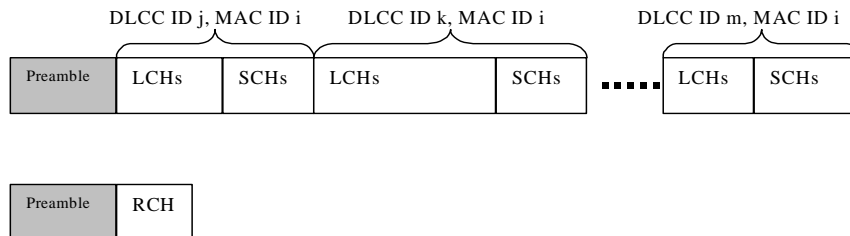

Figure 61: Possible uplink PDU train with long preamble

6.9.2.7 Direct link PDU train

One preamble shall be added at the beginning of each direct link PDU train, see figure 62. The preamble of the direct link PDU train shall have a length of 4 OFDM symbols, see TS 101 475 [4].

A direct link PDU train shall consist of all LCHs and SCHs belonging to the same pair of source and destination MAC IDs. A set of SCHs and LCHs is granted for each DLCC by one RG. An MT shall receive not more than one direct link PDU train containing UDCHs, DCCHs, and LCCHs per MAC frame per source MAC ID, i.e. all corresponding DLCCs shall be grouped in a single PDU train. A receiver may receive the RBCH, UMCHs, and UBCHs from the same transmitter in separate PDU trains.

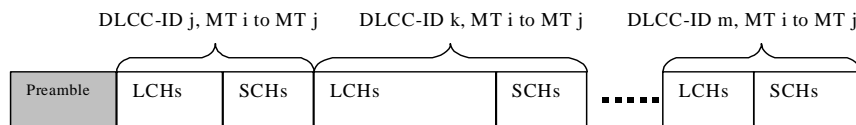

Figure 62: Direct link PDU train

6.9.3 PHY modes for transport channels and special cases for logical channels

The possible PHY modes that can be used for the different transport channels are listed in table 35.

Table 35: Possible PHY modes for transport channels

PHY mode	PHY mode identifier: FCH	PHY mode identifier: SCH	PHY mode identifier: LCH
BPSK, code rate=1/2	00	000	0000
BPSK, code rate=3/4	-	001	0001
QPSK, code rate=1/2	-	-	0100
QPSK, code rate=3/4	-	011	0011
16QAM, code rate=9/16	-	-	0010
16QAM, code rate=3/4	-	-	0101
64QAM, code rate=3/4	-	-	0111

The remaining unspecified PHY mode identifiers for the FCH are for future use.

The remaining unspecified PHY mode identifiers for the SCH are for future use.

The remaining unspecified PHY mode identifiers for the LCH are for future use.

The BCH, ACH, and RCH shall use BPSK with code rate $\frac{1}{2}$. The logical channel RBCH using SCHs and LCHs shall use BPSK with code rate $\frac{1}{2}$. The PHY mode of all other logical channels shall be set in the corresponding RG.

6.9.4 Guard times

6.9.4.1 Radio turn-around times

The maximum radio turn-around time (switch from transmit to receive and vice versa) is 6 μ s, see TS 101 475 [4]. The AP/CC shall separate an MT's receive and transmit opportunities by at least the radio turn-around time.

6.9.4.2 Propagation delay guard times

A guard time between uplink PDU trains, and/or between DiL PDU trains shall be inserted by the AP/CC scheduler in order to cope with propagation delays. The method to select an appropriate guard time is out of the scope of the present document. The guard time between RCHs is announced in the BCCH.

A minimum guard time is specified in TS 101 475 [4]. To compensate for large propagation delays, an increased guard time can be used by the access point.

6.9.4.3 Sector switch guard time

The time to switch sectors is below 800 ns, see TS 101 475 [4]. The AP/CC scheduler shall take this time to sector switching into account by introducing an appropriate time interval whenever the sector is changed.

The duration of the time interval shall be 800 ns between different broadcast PDU trains, between different FCH-and-ACH PDU trains as well as between the last broadcast PDU train and the first FCH-and-ACH PDU train. This is further explained by the drawing in figure 63.

NOTE 1: The interval defined in the clause above is fixed in order to enable MTs to correctly calculate the reference point, see clause 6.3.5.1.

For all other guard times, its duration depends on the implementation and is out of the scope of this specification.

NOTE 2: This interval needs not be inserted in the case of radio turn-around time and RF carrier change, see TS 101 475 [4].

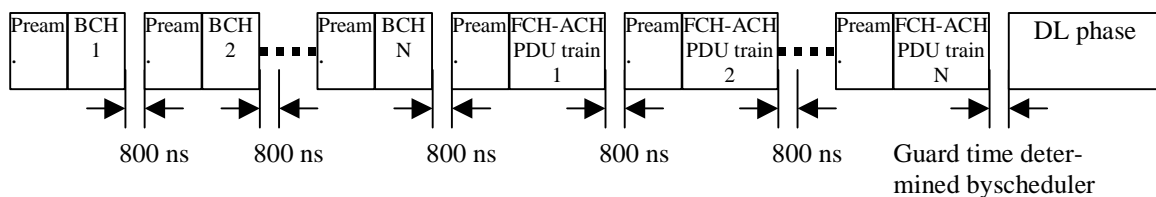

Figure 63: Guard times due to sector switching in the transmission of BCHs, FCHs and ACHs

Annex A (informative): Bibliography

- ETSI TS 101 761-3: "Broadband Radio Access Networks (BRAN); HIPERLAN Type 2; Data Link Control (DLC) Layer; Part 3: Profile for Business Environment".
- ETSI TS 101 761-4: "Broadband Radio Access Networks (BRAN); HIPERLAN Type 2; Data Link Control (DLC) Layer; Part 4: Extension for Home Environment".
- ETSI TS 101 762: "Broadband Radio Access Networks (BRAN); HIPERLAN Type 2; Network Management".
- ETSI TS 101 763-1: "Broadband Radio Access Networks (BRAN); HIPERLAN Type 2; Cell based Convergence Layer; Part 1: Common Part".
- ETSI TS 101 763-2: "Broadband Radio Access Networks (BRAN); HIPERLAN Type 2; Cell based Convergence Layer; Part 2: UNI Service Specific Convergence Sublayer (SSCS)".
- ETSI TS 101 493-1: "Broadband Radio Access Networks (BRAN); HIPERLAN Type 2; Packet based Convergence Layer; Part 1: Common Part".
- ETSI TS 101 493-2: "Broadband Radio Access Networks (BRAN); HIPERLAN Type 2; Packet based Convergence Layer; Part 2: Ethernet Service Specific Convergence Sublayer (SSCS)".
- ETSI TR 101 031: "Broadband Radio Access Networks (BRAN); High Performance Radio Local Area Network (HIPERLAN) Type 2; Requirements and architectures for wireless broadband access."

History

Document history		
V1.1.1	April 2000	Publication
V1.2.1	November 2000	Publication