

# ETSI TS 101 885 V1.1.1 (2002-03)

---

*Technical Specification*

## **Telecommunications and Internet Protocol Harmonization Over Networks (TIPHON) Release 3; Technology Mapping; Technology Mapping of TIPHON reference point N to H.248/MEGACO protocol**

---



---

**Reference**

DTS/TIPHON-03019

---

**Keywords**architecture, configuration, internet, network,  
protocol, telephony**ETSI**

---

650 Route des Lucioles  
F-06921 Sophia Antipolis Cedex - FRANCE

Tel.: +33 4 92 94 42 00 Fax: +33 4 93 65 47 16

Siret N° 348 623 562 00017 - NAF 742 C  
Association à but non lucratif enregistrée à la  
Sous-Préfecture de Grasse (06) N° 7803/88

---

**Important notice**

Individual copies of the present document can be downloaded from:

<http://www.etsi.org>

The present document may be made available in more than one electronic version or in print. In any case of existing or perceived difference in contents between such versions, the reference version is the Portable Document Format (PDF). In case of dispute, the reference shall be the printing on ETSI printers of the PDF version kept on a specific network drive within ETSI Secretariat.

Users of the present document should be aware that the document may be subject to revision or change of status. Information on the current status of this and other ETSI documents is available at

<http://portal.etsi.org/tb/status/status.asp>

If you find errors in the present document, send your comment to:

[editor@etsi.fr](mailto:editor@etsi.fr)

---

**Copyright Notification**

No part may be reproduced except as authorized by written permission.  
The copyright and the foregoing restriction extend to reproduction in all media.

© European Telecommunications Standards Institute 2002.  
All rights reserved.

# Contents

Intellectual Property Rights .....	5
Foreword.....	5
Introduction .....	5
1 Scope .....	7
2 References .....	7
3 Definitions and abbreviations.....	8
3.1 Definitions .....	8
3.2 Abbreviations .....	9
4 Introduction .....	10
4.1 Supported service capabilities .....	11
4.2 General note on compliance .....	11
4.3 Error handling .....	11
4.4 Security .....	12
5 Setting up of MGC-MG control interface .....	12
6 General notes about the TIPHON H.248 usage.....	12
6.1 Packages supported .....	13
7 TIPHON template usage scenarios.....	13
7.1 Process used .....	13
7.1.1 General note on source filtering used in the scenarios.....	13
7.2 Default TIPHON media setup procedure .....	13
7.3 IP to IP media gateway without source filtering .....	14
7.4 IP to IP media gateway with source filtering.....	17
7.5 IP-SCN Flow without source filtering.....	21
7.6 SCN to IP media gateway without source filtering .....	23
8 Options on the basic scenarios .....	26
8.1 Media activation option.....	26
8.2 QoS on media flows .....	27
8.3 Media events .....	27
9 Management operations .....	27
<b>Annex A (normative): Mapping from TS 101 882.....</b>	<b>28</b>
A.1 Code point mapping .....	28
A.1.1 Primitive mappings.....	28
A.1.2 Binary Encoding.....	29
A.1.2.1 For an IP-based media flow .....	29
A.1.2.2 For an SCN media flow .....	29
A.1.3 Text Encoding .....	30
A.1.3.1 For an IP-based media flow .....	30
A.1.3.2 For an SCN media flow .....	30
A.2 Error reasons .....	30
<b>Annex B (normative): Meta-protocol to SDP mapping.....</b>	<b>31</b>
B.1 Mappable fields .....	31
B.2 Specifying the OriginatorMpoA.....	32
B.3 Unmappable fields.....	32
<b>Annex C (informative): Bibliography .....</b>	<b>33</b>

List of figures.....34  
History .....35

---

## Intellectual Property Rights

IPRs essential or potentially essential to the present document may have been declared to ETSI. The information pertaining to these essential IPRs, if any, is publicly available for **ETSI members and non-members**, and can be found in ETSI SR 000 314: *"Intellectual Property Rights (IPRs); Essential, or potentially Essential, IPRs notified to ETSI in respect of ETSI standards"*, which is available from the ETSI Secretariat. Latest updates are available on the ETSI Web server (<http://webapp.etsi.org/IPR/home.asp>).

Pursuant to the ETSI IPR Policy, no investigation, including IPR searches, has been carried out by ETSI. No guarantee can be given as to the existence of other IPRs not referenced in SR 000 314 (or the updates on the ETSI Web server) which are, or may be, or may become, essential to the present document.

---

## Foreword

This Technical Specification (TS) has been produced by ETSI Project Telecommunications and Internet Protocol Harmonization Over Networks (TIPHON).

---

## Introduction

The approach being taken to standardization in TIPHON represents a departure from that used in the past for PSTN, ISDN and GSM. Its aim is to allow much greater scope for competition through innovation in the design of equipment and services. Its aim is also to provide adequate standardization to facilitate the operation of services across interconnected networks, even networks that use different technologies. The present document presents the initial core set of service capabilities envisaged to be required to enable service providers to offer services on TIPHON networks that may safely interwork with existing PSTN services while enabling more advanced services to be subsequently developed.

Figure 1 shows the relationship of the present document with other TIPHON Release 3 deliverables.

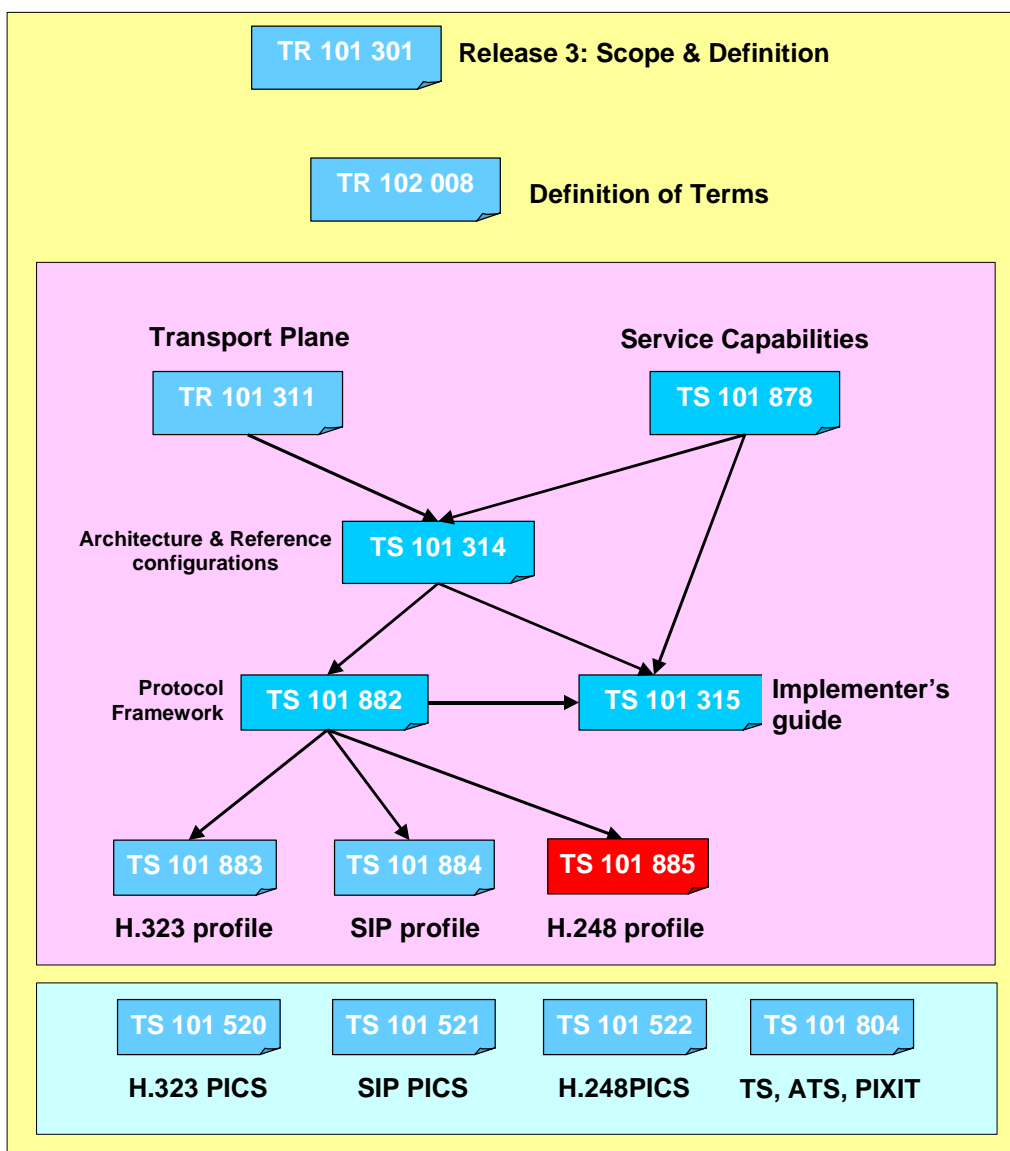

**Figure 1: Relationship with other TIPHON Release 3 documents**

- TR 101 311 [4] provides the requirements on the transport plane,
- TS 101 878 [5] defines service capabilities that are used in the TIPHON Release 3 for a simple call,
- TS 101 882 [2] provides the Protocol Framework based on the TIPHON Release 3 architecture to implement the simple call service capabilities as defined in the present document,
- TS 101 315 [6] is an implementer's guide that shows how to use of the meta-protocol to realize the capabilities as defined in TS 101 878 [5],
- TS 101 883 [7] provides the protocol mappings for the ITU-T H-323 profile,
- TS 101 884 (see bibliography) provides the protocol mappings for the SIP profile,
- TS 101 885 (the present document) provides the protocol mappings for the ITU-T H-248 profile,
- TS 101 314 [3] provides the architecture and reference configurations for TIPHON Release 3.

---

# 1 Scope

The present document describes how the H.248/MEGACO [1] protocol can be used to implement the architecture, defined in TS 101 314 [3] and the primitives, information elements and behaviours, defined in TS 101 882 [2].

The present document defines the mapping of the Media Control meta-protocol.

The document is applicable to equipment performing the roles of Terminal, Gateway, Gatekeeper and also to entities within the IP network that are necessary to support TIPHON Release 3.

NOTE: Where the text indicates the status of a requirement (i.e. as strict command or prohibition, as authorizations leaving freedom or as a capability or possibility), this may modify the nature of a requirement within a referenced standard used to provide the capability.

---

# 2 References

The following documents contain provisions which, through reference in this text, constitute provisions of the present document.

- References are either specific (identified by date of publication and/or edition number or version number) or non-specific.
- For a specific reference, subsequent revisions do not apply.
- For a non-specific reference, the latest version applies.

- [1] ITU-T Recommendation H.248 (2000): "Gateway control protocol".
- [2] ETSI TS 101 882: "Telecommunications and Internet protocol Harmonization Over Networks (TIPHON) Release 3; Protocol Framework Definition and Interface Requirement Definition; General (meta-protocol)".
- [3] ETSI TS 101 314 (V2.1.1): "Telecommunications and Internet Protocol Harmonization Over Networks (TIPHON) Release 3; Abstract Architecture and Reference Points Definition; Network Architecture and Reference Points".
- [4] ETSI TR 101 311: "Telecommunications and Internet Protocol Harmonization Over Networks (TIPHON) Release 3; Service Independent requirements definition; Transport Plane".
- [5] ETSI TS 101 878: "Telecommunications and Internet Protocol Harmonization Over Networks (TIPHON) Release 3; Service Capability Definition; Service Capabilities for a simple call".
- [6] ETSI TS 101 315: "Telecommunications and Internet Protocol Harmonization Over Networks (TIPHON) Release 3; Functional Entities, Information Flow and Reference Point Definitions; Guidelines for application of TIPHON functional architecture to inter-domain services".
- [7] ETSI TS 101 883: "Telecommunications and Internet Protocol Harmonization Over Networks (TIPHON) Release 3; Technology Mapping; Implementation of TIPHON architecture using H.323".
- [8] ETSI TR 101 301: "Telecommunications and Internet Protocol Harmonization Over Networks (TIPHON) Release 3; Release Definition; TIPHON Release 3 Definition".
- [9] ETSI TR 102 008: "Telecommunications and Internet Protocol Harmonization Over Networks (TIPHON) Release 3; Terms and Definitions".
- [10] ETSI TS 101 520: "Telecommunications and Internet Protocol Harmonization Over Networks (TIPHON); Implementation Conformance Statement (ICS) proforma for the support of packet based multimedia communications systems; Support of ITU-T Recommendation H.323".

- [11] ETSI TS 101 521: "Telecommunications and Internet Protocol Harmonization Over Networks (TIPHON); Protocol Implementation Conformance Statement (PICS) proforma for the support of call signalling protocols and media stream packetization for packet-based multimedia communication systems; Support of ITU-T Recommendation H.225.0".
- [12] ETSI TS 101 522: "Telecommunications and Internet Protocol Harmonization Over Networks (TIPHON); Protocol Implementation Conformance Statement (PICS) proforma for the support of control protocol for multimedia communication; Support of ITU-T Recommendation H.245".
- [13] ETSI TS 101 804 (all parts): "Telecommunications and Internet Protocol Harmonization Over Networks (TIPHON) Release 3; Technology compliance specifications".
- [14] IETF RFC 1890: "RTP Profile for Audio and Video Conferences with Minimal Control".

---

## 3 Definitions and abbreviations

### 3.1 Definitions

For the purposes of the present document, the following terms and definitions apply:

**call:** any connection (fixed or temporary) capable of transferring information between two or more users of a telecommunications system

NOTE: In this context a user may be a person or a machine.

**charging:** process of determining the amount of money a user shall pay for usage of a certain service

**codec:** combined speech encoder and decoder

**flow:** single data stream, identified by a tuple of characteristic values (source address, source port, destination address, destination port, protocol number)

**functional entity:** entity in a system that performs a specific set of functions

**functional group:** collection of functional entities within a domain

NOTE: In TIPHON systems Functional Groups are used to structure the necessary functionality to offer IP telephony services across domains.

**IP address:** each network unit connected to an IP network must have a unique Internet or IP address

NOTE: Today's IP addresses is based on IPv4 and are 32-bit numbers with its predefined structure. The IP address (IPv4) is written as four decimal numbers separated by a point.

**IP endpoint:** device that originates or terminates the IP based part of a call

NOTE: Endpoints include H.323 clients, and IP telephony gateways.

**IP network:** packet transport network comprising one or more transport domains each employing the IP protocol

**network:** telecommunications network that provides telecommunications services

**protocol:** set of semantics, syntax and procedures which govern the exchange of information across an interface

**Quality of Service (QoS):** quality specification of a telecommunications channel, system, virtual channel, computer-telecommunications session, etc.

NOTE: Quality of Service may be measured, for example, in terms of signal-to-noise ratio, bit error rate, message throughput rate or call blocking probability.



**Switched Circuit Network (SCN):** telecommunications network, e.g. Public Switched Telephone Network (PSTN), Integrated Services Digital Network (ISDN), and General System for Mobile communications (GSM), that uses circuit-switched technologies for the support of voice calls

NOTE: The SCN may be a public network or a private network.

**telephone call:** two-way speech communication between two users by means of terminals connected via network infrastructure

**terminal:** endpoint within the user equipment on which signalling and media flows originate and/or terminate

**TIPHON compliant:** entity that complies with the mandatory requirements identified in the TIPHON requirements documents together with compliance to the parts of the TIPHON specifications in which these requirements are embodied

## 3.2 Abbreviations

For the purposes of the present document, the following abbreviations apply:

BC	Bearer Control
CC	Call Control
IP	Internet Protocol
MC	Media Control
QoS	Quality of Service
SCN	Switched Circuit Networks
SDL	Specification and Description Language
SIP	Session Initiation Protocol
ISDN	Integrated Services Digital Network
GSM	General System for Mobile communications
PSTN	Public Switched Telephone Network

## 4 Introduction

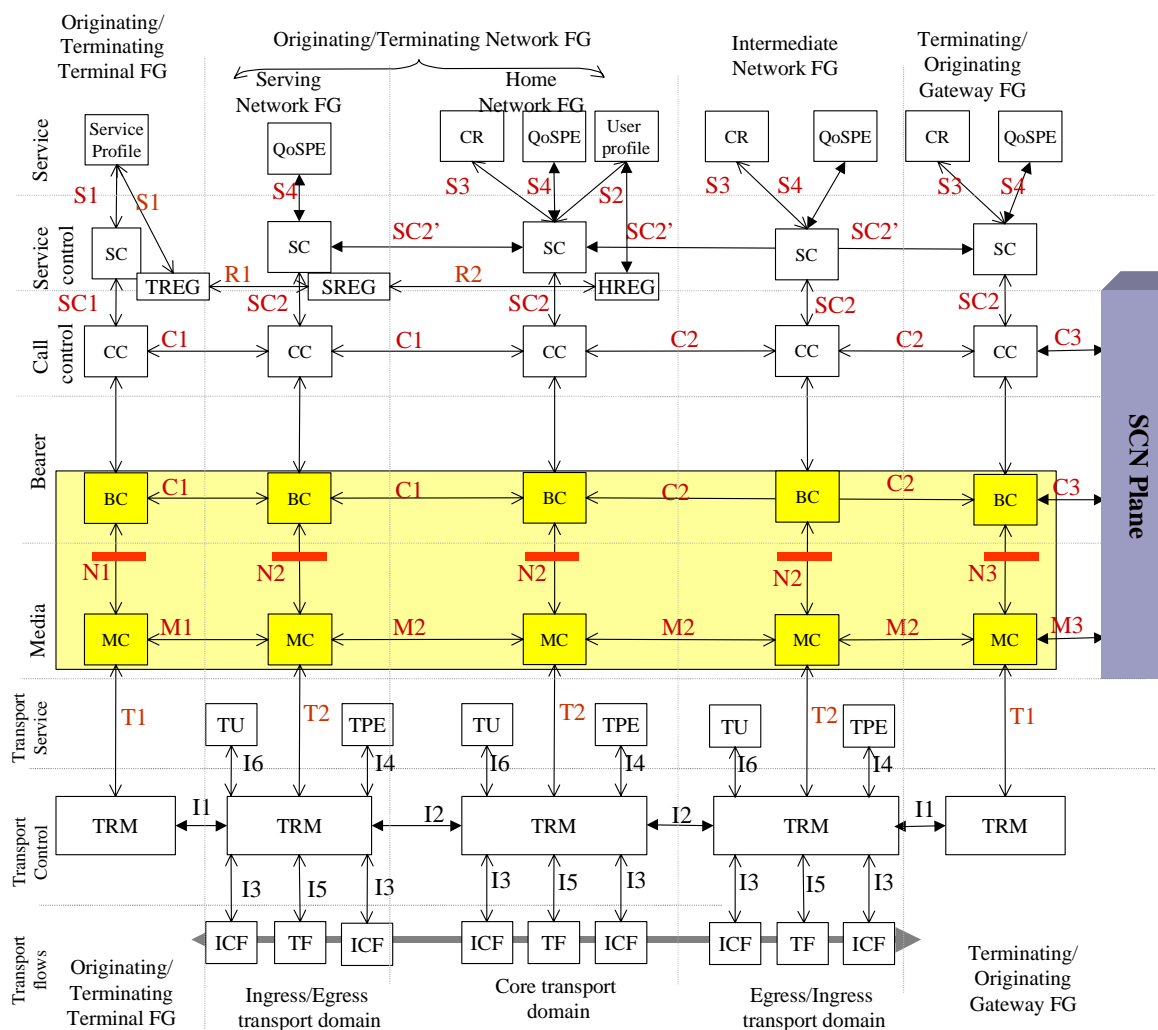
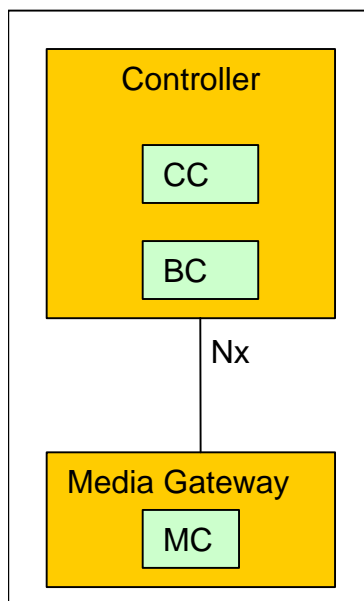

**Figure 2: TIPHON architecture with reference points N highlighted**

The present document describes an implementation of reference point N of the meta-protocol described in annex C of TS 101 882 [2], producing an interoperable profile of H.248/MEGACO. Figure 2 shows the TIPHON architecture copied from [3] with the reference points N highlighted.

H.248/MEGACO has been created to control a range of media devices. For the purpose of the present document we address several categories:

- Residential gateways implementing reference point N1 and a user interface. The user interface component is not addressed in this version of the present document.
- IP-IP Media devices for the control, transcoding and monitoring of media streams in TIPHON networks. These devices implement reference point N2.
- Trunk gateways, between TIPHON networks and the SCN implementing reference point N3.



**Figure 3: Entities involved**

The mapping described in the present document describes the messages between a media gateway and its controller. The media gateway implements the MC functional entity as described in TS 101 314 [3] the controller implements at least a BC and CC entity as described in TS 101 314 [3].

## 4.1 Supported service capabilities

This release defines media setup for basic bearers.

QoS bearers supported in the binary encoding ONLY due to lack of support of QoS parameters in SDP.

## 4.2 General note on compliance

Any options in the H.248 protocol not mentioned in the present document MAY be supported by MG or MGC, however are outside the scope of TIPHON compliance and testing.

## 4.3 Error handling

The present document describes a profile that mandates certain optional parts of the H.248 protocol and does not mandate certain other options. General use of the error codes can be found in clause A.2.

If an H.248 information element is received (descriptor or parameter), which is not within the context of this profile, the receiver shall ignore the information element and act as if the information element were not received.

If an unknown H.248 command or an information element not within the context of this profile, the receiver shall ignore the command and send an appropriate error (443 - unsupported or unknown command or 444 - unsupported or unknown descriptor, 445 - unsupported or unknown property, 446 - unsupported or unknown parameter).

If an H.248 command with a mandatory information element missing is received, the receiver shall act as if the information element was received carrying the default values, or reject with the appropriate error message if there is no default value specified in the ITU-T Recommendation H.248 [1].

If an H.248 information element is received with syntactically invalid contents the receiver shall:

- If the information element is optional, ignore the information element;

or

- If the information element is mandatory, act as if the information element was received correctly coded carrying the default values and reject/Fail if there is no default value specified in the present document.

If an H.248 information element is received with a value not allowed within the context of the present document, the receiver shall:

- If the information element is optional, pass on, but otherwise ignore the information element;

or

- If the information element is mandatory reject/fail.

NOTE: The security policy of an operator's network or the security policy implemented in a network element may override the error handling as described above.

## 4.4 Security

TIPHON does not prescribe security measures in Release 3.

---

## 5 Setting up of MGC-MG control interface

For TIPHON Release 3 clause 11 of ITU-T Recommendation H.248 [1] shall apply without restrictions. This may change in future releases of the present document.

---

## 6 General notes about the TIPHON H.248 usage

TIPHON prescribes the basic messages of H.248 and prescribes the support of certain packages depending on the reference point that is implemented. This clause describes the messages used, the exact encoding is given in annex B.

The TIPHON semantics require that when multiple alternatives are returned by the MG to the MGC for a termination the MG shall support whichever one the MGC chooses. Failure to support parameters for a termination offered earlier is considered a fault.

H.248 does not have semantics as strict as those prescribed by TIPHON. To align the semantics, **ReserveGroup** needs to be set for all alternative media flow descriptions that are requested from the MC entity and that **ReserveValue** needs to be set for all requests where the MC entity is given the choice to provide flow descriptions.

The optional ModemDescriptor, MuxDescriptor, EventsDescriptor, DigitMapDescriptor, AuditDescriptor are not prescribed in this profile.

A transaction level timer shall be provided.

The flows in TS 101 882 [2] use an **InvokingControllerReference**, is mapped to StreamID in ITU-T Recommendation H.248 [1]

The contextID is a value that is local to the MG-MGC relationship and is not mapped to the meta-protocol.

The TIPHON type **mcReservedMediaReference** and **mcEstablishedMediaReference** shall be mapped to the H.248 TerminationID.

Code point mapping for the **Local** and **Remote Descriptors** is provided in the annexes.

The error codes are taken from ITU-T Recommendation H.248 [1], annex L, error codes applicable to the present document are described in clause A.2.

## 6.1 Packages supported

The following packages shall be supported for all TIPHON Reference point N implementations:

- Generic package (ITU-T Recommendation H.248 [1], clause E.1)
- Base Root package (ITU-T Recommendation H.248 [1], clause E.2)
- Network package (ITU-T Recommendation H.248 [1], clause E.11)
- RTP package (ITU-T Recommendation H.248 [1], clause E.12)

The following packages are to be supported for each of the reference points mentioned:

- N2 -<none>
- N3 TDM circuit package (ITU-T Recommendation H.248 [1], clause E.13)

---

## 7 TIPHON template usage scenarios

This clause provides template TIPHON messages for the use of H.248 on reference points N.

The process used is given in clause 7.1.

The generic TIPHON media flows are summarized from [2] in clause 7.2.

In the remainder of the clause three scenarios are shown:

- 7.3 Reference point N2 (IP to IP) Media Gateway without source address filtering.
- 7.4 Reference point N2 (IP to IP) Media Gateway with source address filtering.
- 7.5 Reference point N3 (IP to SCN) Media Gateway without source address filtering.
- 7.6 Reference point N3 (SCN to IP) Media Gateway without source address filtering.

### 7.1 Process used

This clause provides the mapping of the flows in TS 101 882 [2], annex C, to H.248 message flows. Please note that the source is ITU-T Recommendation H.248 [1] and hence parts of H.248 may not be covered in the present document where they do not contribute to the requirements of TIPHON deployments. The present document also aligns the parameter and error reason definitions in TS 101 882 [2], annex C to ensure interoperability of these values across the mappings of these reference points. In general each of the primitives defined on the N reference points in TS 101 882 [2] each map to one or more commands in ITU-T Recommendation H.248 [1]. Please note that additional messaging may be necessary where applicable for the correct execution of the protocol.

#### 7.1.1 General note on source filtering used in the scenarios

SDP specifies in clause B.2.1 a means for specifying unicast sessions. This provides the means to encode the Originator MpoA. In clause B.2 it is shown how the recvnly and sendonly attribute are used for specifying the sender side behaviour of media flows.

### 7.2 Default TIPHON media setup procedure

Media control allows reservation and allocation of resources for formatting of the media stream (e.g. to reserve processing capability for soft codecs, or to switch into the path hard codecs). See TS 101 882 [2] for a full definition of the primitives involved.

**NOTE:** The following text is derived from the SDL in TS 101 882 [2]. Should there be discrepancies between TS 101 882 [2] and the present document, the text in TS 101 882 [2] is authoritative.

The Media Gateway shall establish the media elements required to support the media flows required for the call. If so required, the media gateway shall establish a QoS controlled transport capability in accordance with the QoS class identified by the call control protocol.

Step	TS 101 882 [2] Primitive	Meaning
		BC layer decides it needs a bearer.
1	<b>MediaRsvReq</b>	Asks the MC to support it with a QoS-enabled media stream (aka a <i>bearer</i> ) and wants to know what parameters it can support there.
2	<b>MediaRsvConf</b>	The MC acknowledges to the BC, providing the possible bearer characteristics for the BC to decide upon. The MC-entity hereby <b>commits</b> to provide the flows as identified in the <b>MediaRsvConf</b> .
		The BC negotiates with peer on the bearer properties.
3	<b>MediaEstReq</b>	The MC informs the MC of the choice.
4	<b>MediaEstConf</b>	The MC acknowledges the <b>establishment</b> of the media flow.
5	<b>MediaReleaseRequest</b>	The MC is requested to release the media flows.
6	<b>MediaReleaseConf</b>	The MC confirms the release of the media flows.

### 7.3 IP to IP media gateway without source filtering

This flow assumes a reference point N2 flow with RTP terminations on two sides.

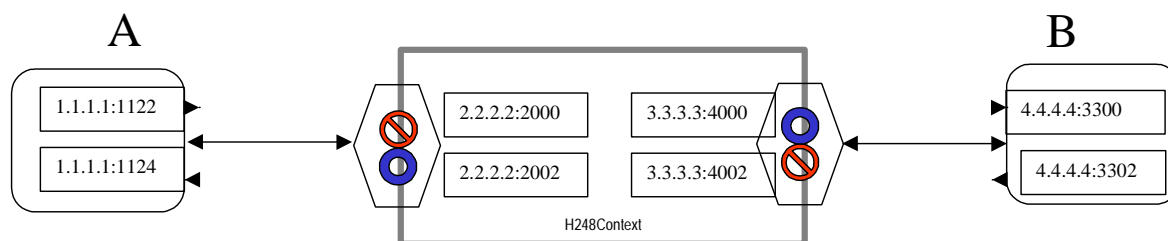

Figure 4: Example H.248 context

Each termination sinks/sources one bi-directional stream with each a LocalDescriptor, RemoteDescriptor and a LocalControlDescriptor. The StreamIds are used to link the streams that are connected.

For figure 4, the following table:

Stream	StreamId	Address in LocalDescr entering the media gateway	Addresses in RemoteDescr leaving the media gateway
A to B	1	Source =*:* Sink =2.2.2.2:2000	Source =*:* Sink =4.4.4.4:3300
B to A	1	Source =*:* Sink =3.3.3.3:4002	Source =*:* Sink =1.1.1.1:1124

The meta-protocol exchange above maps to the following H.248 message flow for this scenario.

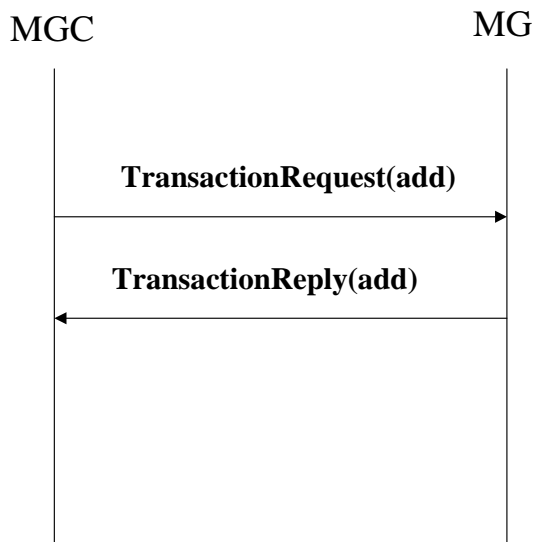

## 1) MGC→MG:

The MGC must provide the MG with enough information to create sending and a receiving media flow. This information may contain codec information. The below example shows only one codec being requested, however the MGC may request multiple codecs.

```

MEGACO/1 [MGC IP Address]:55555
Transaction = 1{
  Context = ${
    Add = ${
      Media{Stream = 1{
        Local{
v=0
m=audio $ RTP/AVP [AtoMG CODEC TYPE]
c=IN IP4 $ -- for the <A-Side dest IP address of MG>
        }
        Remote{
v=0
m= audio 1124 RTP/AVP [MGtoA CODEC TYPE]
c=IN IP4 1.1.1.1
        }
      } /*of Stream*/
    } /*of Media*/
  } /*of ADD*/
    Add = ${
      Media{Stream = 1{
        Local{
v=0
m=audio $ RTP/AVP [BtoMG CODEC TYPE]
c=IN IP4 $ -- <B-side dest IP address of MG>
        }
        Remote{
v=0
m= audio $ RTP/AVP [BtoMG CODEC TYPE]
c=IN IP4 $ -- <B-side source IP address of MG>
        }
      } /*of Stream*/
    } /*of Media*/
  } /*of ADD*/
} /* of context*/
} /*of transaction*/
  
```

## 2) MG→MGC:

The MG provides the information on the possible media flows it can support. If the MG can support multiple media streams that satisfy the request, multiple local and remote Descriptors are to be returned.

```
MEGACO/1 [MG IP Address]:55555
Reply = 1{
  Context = 3001{
    Add = 1234{
      Media{Stream = 1{
        Local{
          v=0
          m=audio 2000 RTP/AVP [AtoMG CODEC TYPE]
          c=IN IP4 2.2.2.2
        }
      } /*of Stream*/
    } /*of Media*/
  } /*of ADD*/
  Add = 1235{
    Media{Stream = 1{
      Local{
        v=0
        m=audio 4002 RTP/AVP [BtoMG CODEC TYPE]
        c=IN IP4 3.3.3.3
      }
    } /*of Stream*/
  } /*of Media*/
} /*of ADD*/
} /* of context*/
} /*of transaction*/
```

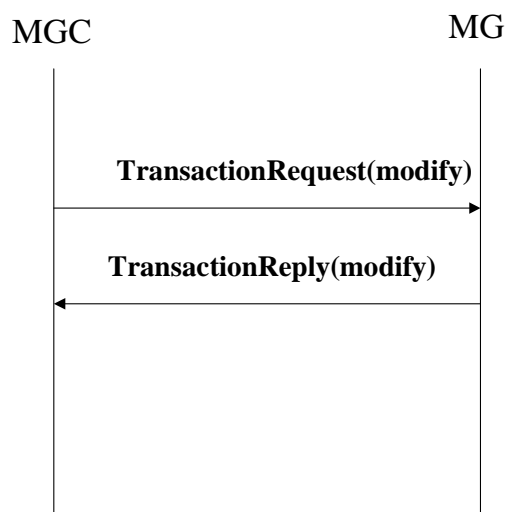

## 3) MGC→MG:

If there was a choice to be made, the MGC has decided which Local/Remote Descriptor shall be used and collapses the choices in the terminations created. The terminations are modified by the MGC to contain only the Local/Remote Descriptors required. If not provided earlier, additional information such as remote transport addresses are filled in.

```
MEGACO/1 [MGC IP Address]:55555
Transaction = 2{
  Context = 3001{
    Modify = 1235{
      Media{Stream=1{
        Local{
          v=0
          m=audio 4002 RTP/AVP [BtoMG CODEC TYPE]
          c=IN IP4 3.3.3.3
        }
        Remote{
```



```

v=0
m=audio 3300 RTP/AVP [MGtoB CODEC TYPE]
c=IN IP4 4.4.4.4
    }
    } /*of Stream*/
  } /*of Media*/
} /*of Modify*/
} /* of context*/
} /*of transaction*/

```

#### 4) MG→MGC:

The MG collapses the terminations to a usable state and media starts to flow.

```

MEGACO/1 [MG IP Address]:55555
Reply = 2{
  Context = 3001{
    Modify = 1235{
    } /* of context*/
  } /*of transaction*/
}

```

#### 5) MGC→MG:

When the MGC decides that the media flows are to be terminated. Terminations are subtracted in the normal fashion.

```

TransactionRequest.
  Subtract { originating and terminating sides }

```

#### 6) MC→BC:

```

TransactionReply.Subtract

```

## 7.4 IP to IP media gateway with source filtering

This flow assumes a reference point N2 flow with RTP terminations on two sides.

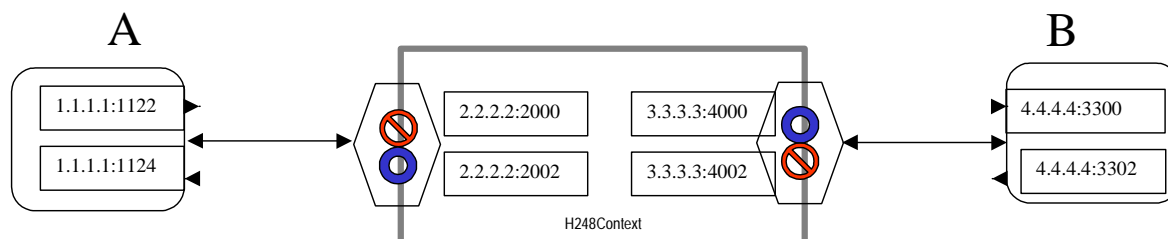

**Figure 5: Example H.248 context**

Each termination sinks/sources one bi-directional stream with each a LocalDescriptor, RemoteDescriptor and a LocalControlDescriptor. The StreamIds are used to link the streams that are connected.

For figure 5, the following table:

Stream	StreamId	Address in LocalDescr Entering the media gateway	Addresses in RemoteDescr Leaving the media gateway
A to B	1	Source =1.1.1.1:1122 Sink =2.2.2.2:2000	Source =3.3.3.3:4000 Sink =4.4.4.4:3300
B to A	1	Source =4.4.4.4:3302 Sink =3.3.3.3:4002	Source =2.2.2.2:2002 Sink =1.1.1.1:1124

The meta-protocol exchange above maps to the following H.248 message flow for this scenario.

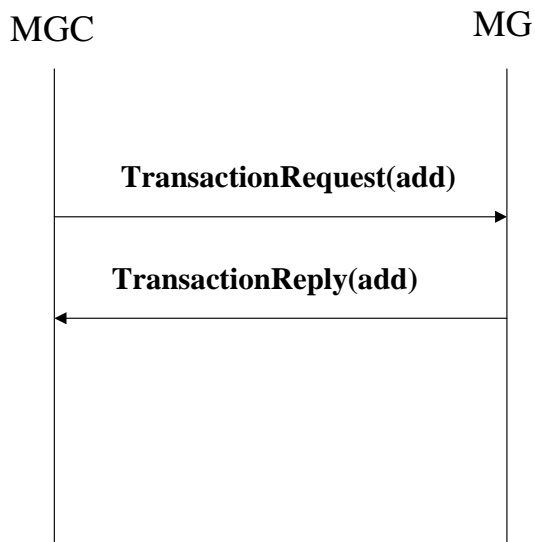

## 1) MGC→MG:

The MGC must provide the MG with enough information to create sending and a receiving media flow. This information may contain codec information. The below example shows only one codec being requested, however the MGC may request multiple codecs.

```

MEGACO/1 [MGC IP Address]:55555
Transaction = 1{
  Context = ${
  Add = ${
    Media{Stream = 1{
      Local{
v=0
m=audio $ RTP/AVP [AtoMG CODEC TYPE]
c=IN IP4 $ -- for the <A-Side dest IP address of MG>
a=recvonly
m=audio 1122 RTP/AVP [AtoMG CODEC TYPE]
c=IN IP4 1.1.1.1
a=sendonly
      }
      Remote{
v=0
m= audio 1124 RTP/AVP [MGtoA CODEC TYPE]
c=IN IP4 1.1.1.1
a=recvonly
m=audio $ RTP/AVP [MGtoA CODEC TYPE]
c=IN IP4 $
a=sendonly
      }
    } /*of Stream*/
  } /*of Media*/
} /*of ADD*/
  Add = ${
    Media{Stream = 1{
      Local{
v=0
m=audio $ RTP/AVP [BtoMG CODEC TYPE]
c=IN IP4 $ -- <B-side dest IP address of MG>
a=recvonly
      }
      Remote{
v=0
m= audio $ RTP/AVP [BtoMG CODEC TYPE]
c=IN IP4 $ -- <B-side source IP address of MG>
a=sendonly
      }
    } /*of Stream*/
  } /*of Media*/
} /*of ADD*/
} /* of context*/
} /*of transaction*/
  
```

## 2) MG→MGC:

The MG provides the information on the possible media flows it can support. If the MG can support multiple media streams that satisfy the request, multiple local and remote Descriptors are to be returned.

```

MEGACO/1 [MG IP Address]:55555
Reply = 1{
  Context = 3001{
    Add = 1234{
      Media{Stream = 1{
        Local{
          v=0
          m=audio 2000 RTP/AVP [AtoMG CODEC TYPE]
          c=IN IP4 2.2.2.2
          a=recvonly
          m=audio 1122 RTP/AVP [AtoMG CODEC TYPE]
          c=IN IP4 1.1.1.1
          a=sendonly
        }
        Remote{
          v=0
          m= audio 1123 RTP/AVP [MGtoA CODEC TYPE]
          c=IN IP4 1.1.1.1
          a=recvonly
          m=audio 2002 RTP/AVP [MGtoA CODEC TYPE]
          c=IN IP4 2.2.2.2
          a=sendonly
        }
      } /*of Stream*/
    } /*of Media*/
  } /*of ADD*/
  Add = 1235{
    Media{Stream = 1{
      Local{
        v=0
        m=audio 4002 RTP/AVP [BtoMG CODEC TYPE]
        c=IN IP4 3.3.3.3
        a=recvonly
      }
      Remote{
        v=0
        m= audio 4000 RTP/AVP [MGtoB CODEC TYPE]
        c=IN IP4 3.3.3.3
        a=sendonly
      }
    } /*of Stream*/
  } /*of Media*/
} /* of context*/
} /*of transaction*/

```

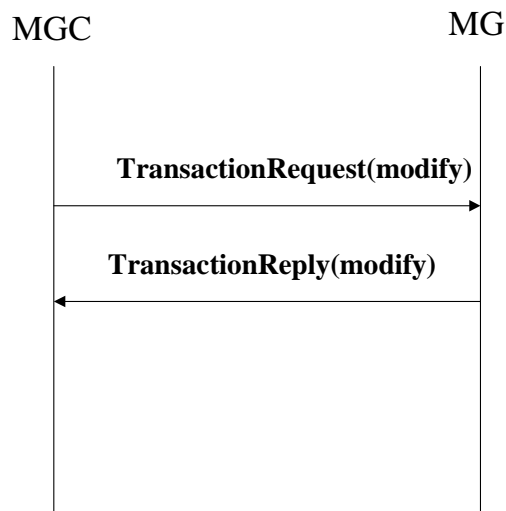

## 3) MGC→MG:

If there was a choice to be made, the MGC has decided which Local/Remote Descriptor shall be used (probably after signalling with its peers) and collapses the choices in the terminations created. The terminations are modified by the MGC to contain only the Local/Remote Descriptors required. If not provided earlier, additional information such as remote transport addresses are filled in.

```
MEGACO/1 [MGC IP Address]:55555
Transaction = 2{
  Context = 3001{
    Modify = 1235{
      Media{Stream=1{
        Local{

v=0
m=audio 4002 RTP/AVP [BtoMG CODEC TYPE]
c=IN IP4 3.3.3.3
a=recvonly
m=audio 3302 RTP/AVP [BtoMG CODEC TYPE]
c=IN IP4 4.4.4.4
a=sendonly
        }
        Remote{

v=0
  m=audio 3300 RTP/AVP [MGtoB CODEC TYPE]
  c=IN IP4 4.4.4.4
  a=recvonly
  m= audio 4000 RTP/AVP [MGtoB CODEC TYPE]
  c=IN IP4 3.3.3.3
  a=sendonly
        }
      } /*of Stream*/
    } /*of Media*/
  } /*of Modify*/
} /* of context*/
} /*of transaction*/
```

## MG→MGC:

The MG collapses the terminations to a usable state and media starts to flow.

```
MEGACO/1 [MG IP Address]:55555
Reply = 2{
  Context = 3001{
    Modify = 1235{
      } /* of context*/
    } /*of transaction*/
```

## 4) MGC→MG:

When the MGC decides that the media flows are to be terminated. Terminations are subtracted in the normal fashion.

```
TransactionRequest.
  Subtract { originating and terminating sides }
```

## 5) MC→BC:

```
TransactionReply.Subtract
```

## 7.5 IP-SCN Flow without source filtering

This flow assumes a reference point N3 flow originating on an RTP termination and terminating towards SCN on the other.

NOTE: H.248 allows the **Circuit identification** from SCN protocols to be mapped to a MG-specific TerminationID.

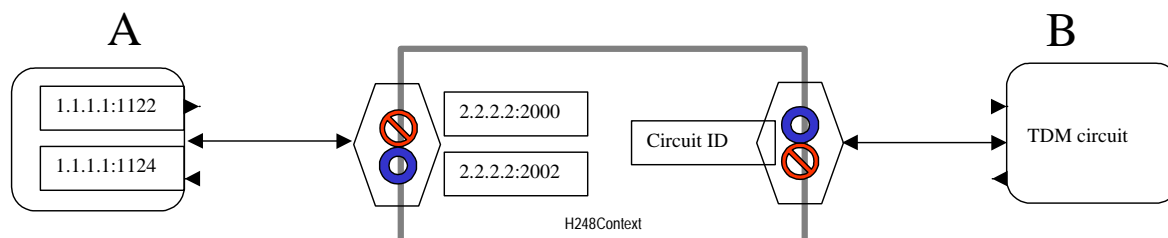

**Figure 6: Example H.248 context**

Each termination sinks/sources one bi-directional stream with each a LocalDescriptor, RemoteDescriptor and a LocalControlDescriptor. The StreamIds are used to link the streams that are connected.

For figure 6, the following table:

Stream	StreamId	Address in LocalDescr Entering the media gateway	Addresses in RemoteDescr Leaving the media gateway
A to B	1	Source =*:* Sink =2.2.2.2:2000	
B to A	1		Source =*:* Sink =1.1.1.1:1124

The meta-protocol exchange above maps to the following H.248 message flow for this scenario.

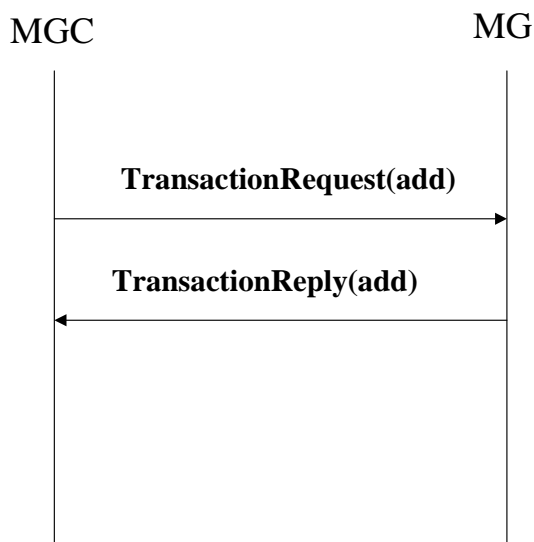

### 1) MGC→MG:

The MGC must provide the MG with enough information to create sending and a receiving media flow. This information may contain codec information. The below example shows only one codec being requested, however the MGC may request multiple codecs.

```

MEGACO/1 [MGC IP Address]:55555
Transaction = 1{
  Context = ${
Add = ${
      Media{Stream = 1{
        Local{
v=0
m=audio $ RTP/AVP [AtoMG CODEC TYPE]
c=IN IP4 $ -- for the <A-Side dest IP address of MG>
        }
        Remote{
v=0
m= audio 1124 RTP/AVP [MGtoA CODEC TYPE]
c=IN IP4 1.1.1.1
        }
      } /*of Stream*/
    } /*of Media*/
  } /*of ADD*/
Add = [TDM/${
  } /*of ADD*/
} /* of context*/
} /*of transaction*/
  
```

### 2) MG→MGC:

The MG provides the information on the possible media flows it can support. If the MG can support multiple media streams that satisfy the request, multiple local and remote Descriptors are to be returned.

```

MEGACO/1 [MG IP Address]:55555
Reply = 1{
  Context = 3001{
Add = 1234{
      } /*of ADD*/
Add = TDM/CircuitID /*of ADD*/
} /* of context*/
} /*of transaction*/
  
```

### 3) MGC→MG:

These steps are not used, as the B-side is a TDM trunk for which all parameters are provisioned.

### 4) MG→MGC

## 5) MGC→MG:

When the MGC decides that the media flows are to be terminated. Terminations are subtracted in the normal fashion.

```
TransactionRequest.
  Subtract { originating and terminating sides }
```

## 6) MC→BC:

```
TransactionReply.Subtract
```

## 7.6 SCN to IP media gateway without source filtering

This flow assumes a reference point N3 flow originating on an SCN termination and terminating on RTP.

NOTE: H.248 allows the **Circuit identification** from SCN protocols to be mapped to a MG-specific TerminationID.

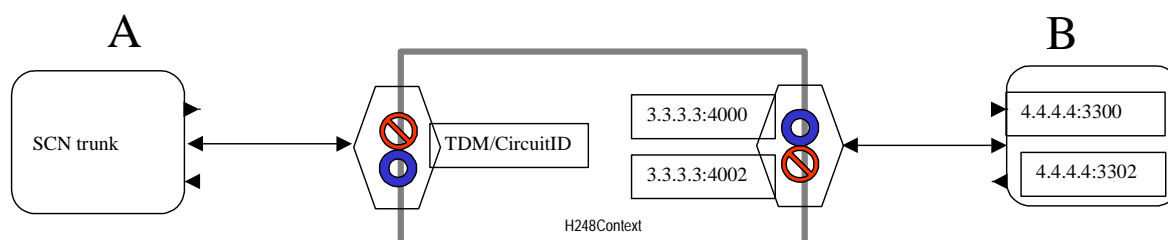

Figure 7: Example H.248 context

Each termination sinks/sources one bi-directional stream with each a LocalDescriptor, RemoteDescriptor and a LocalControlDescriptor. The StreamIds are used to link the streams that are connected.

For figure 7, the following table:

Stream	StreamId	Address in LocalDescr Entering the media gateway	Addresses in RemoteDescr Leaving the media gateway
A to B	1		Source =*:* Sink =4.4.4.4:3300
B to A	1	Source =*:* Sink =3.3.3.3:4002	

The meta-protocol exchange above maps to the following H.248 message flow for this scenario.

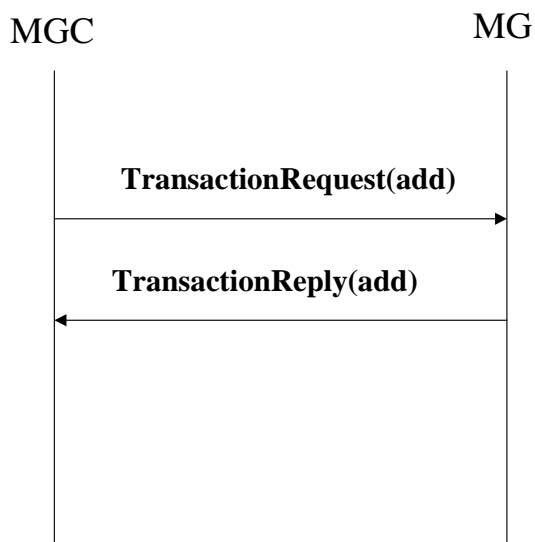

## 1) MGC→MG:

The MGC must provide the MG with enough information to create sending and a receiving media flow. This information may contain codec information. The below example shows only one codec being requested, however the MGC may request multiple codecs.

```

MEGACO/1 [MGC IP Address]:55555
Transaction = 1{
  Context = ${
    Add = TDM/CircuitID,
    Add = ${
      Media{Stream = 1{
        Local{
v=0
m=audio $ RTP/AVP [BtoMG CODEC TYPE]
c=IN IP4 $ -- <B-side dest IP address of MG>
        }
      } /*of Stream*/
    } /*of Media*/
  } /*of ADD*/
} /* of context*/
} /*of transaction*/
  
```

## 2) MG→MGC:

The MG provides the information on the possible media flows it can support. If the MG can support multiple media streams that satisfy the request, multiple local and remote Descriptors are to be returned.

```

MEGACO/1 [MG IP Address]:55555
Reply = 1{
  Context = 3001{
    Add = TDM/CircuitID,
    Add = 1235{
      Media{Stream = 1{
        Local{
v=0
m=audio 4002 RTP/AVP [BtoMG CODEC TYPE]
c=IN IP4 3.3.3.3
        }
      } /*of Stream*/
    } /*of Media*/
  } /*of ADD*/
} /* of context*/
} /*of transaction*/
  
```



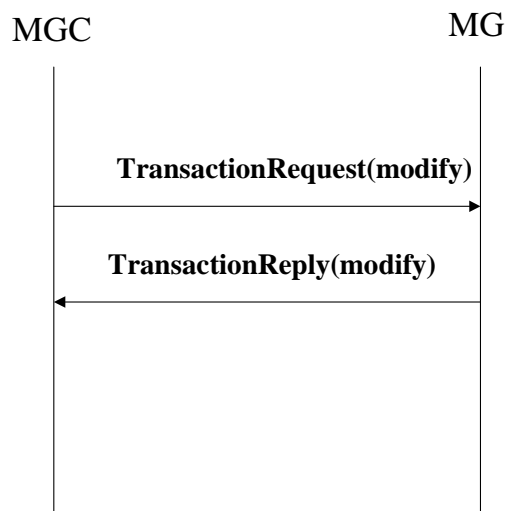

### 3) MGC→MG:

If there was a choice to be made, the MGC has decided which Local/Remote Descriptor shall be used (probably after signalling with its peers) and collapses the choices in the terminations created. The terminations are modified by the MGC to contain only the Local/Remote Descriptors required. If not provided earlier, additional information such as remote transport addresses are filled in.

```

MEGACO/1 [MGC IP Address]:55555

Transaction = 2{
  Context = 3001{
    Modify = 1235{
      Media{Stream=1{
        Local{
          v=0
          m=audio 4002 RTP/AVP [BtoMG CODEC TYPE]
          c=IN IP4 3.3.3.3
        }
        Remote{
          v=0
          m=audio 3300 RTP/AVP [MgtoB CODEC TYPE]
          c=IN IP4 4.4.4.4
        }
      } /*of Stream*/
    } /*of Media*/
  } /*of Modify*/
} /* of context*/
} /*of transaction*/
  
```

### 4) MG→MGC:

The MG collapses the terminations to a usable state and media starts to flow.

```

MEGACO/1 [MG IP Address]:55555
Reply = 2{
  Context = 3001{
    Modify = 1235{
    } /* of context*/
  } /*of transaction*/
}
  
```

### 5) MGC→MG:

When the MGC decides that the media flows are to be terminated. Terminations are subtracted in the normal fashion.

```

TransactionRequest.
  Subtract { originating and terminating sides }
  
```

### 6) MC→BC:

```

TransactionReply.Subtract
  
```

## 8 Options on the basic scenarios

### 8.1 Media activation option

TIPHON provides the option to mute the forward media path until the call has been established.

This has the following change to the procedure as provided above. In step 1. Set **LocalControl descriptor { Mode=SendOnly }** to the protocol message.

Which then looks like:

```
MEGACO/1 [MGC IP Address]:55555
Transaction = 1{
  Context = ${
    Add = ${
      Media{Stream = 1{
        LocalControl{
          Mode=ReceiveOnly,
        }
        Local{
          v=0
          m=audio $ RTP/AVP [AtoMG CODEC TYPE]
          c=IN IP4 $ -- for the <A-Side dest IP address of MG>
          a=recvonly
          m=audio 1122 RTP/AVP [AtoMG CODEC TYPE]
          c=IN IP4 1.1.1.1
          a=sendonly
        }
        Remote{
          v=0
          m= audio 1124 RTP/AVP [MgtoA CODEC TYPE]
          c=IN IP4 1.1.1.1
          a=recvonly
          m=audio $ RTP/AVP [MgtoA CODEC TYPE]
          c=IN IP4 $
          a=sendonly
        }
      } /*of Stream*/
    } /*of Media*/
  } /*of ADD*/
  Add = ${
    Media{Stream = 1{
      Local{
        v=0
        m=audio $ RTP/AVP [BtoMG CODEC TYPE]
        c=IN IP4 $ -- <B-side dest IP address of MG>
        a=recvonly
      }
      Remote{
        v=0
        m= audio $ RTP/AVP [BtoMG CODEC TYPE]
        c=IN IP4 $ -- <B-side source IP address of MG>
        a=sendonly
      }
    } /*of Stream*/
  } /*of Media*/
} /*of ADD*/
} /* of context*/
} /*of transaction*/
```

Between step 4 and step 5 insert:

The flow is set to duplex.

```
MEGACO/1 [MGC IP Address]:55555
Transaction = 3{
  Context = 3001{
Modify= 1234{
  Media{Stream = 1{
    LocalControl{
      Mode=SendReceive,
    }
  } /*of Stream*/
} /*of Media*/
} /*of Modify*/
} /* of context*/
} /*of transaction*/
```

Generating the response:

```
MEGACO/1 [MG IP Address]:55555
Reply = 3{
  Context = 3001{
Modify = 1234{
  } /* of context*/
} /*of transaction*/
```

As is shown in TS 101 882 [2], this shall happen after the call has been accepted by the remote party.

## 8.2 QoS on media flows

The TIPHON semantics demand that an MG provides QoS when the QoS parameters are set in the Local and Control Descriptors. The same flows are used as in the template scenarios above. Only the H.248 binary encoding supports the QoS parameters to be conveyed. TIPHON intends to amend this in a separate deliverable.

## 8.3 Media events

This subject is FFS.

---

# 9 Management operations

TIPHON release 3 does not prescribe any management operations on MG. Behaviour regarding ServiceChange and Restart shall therefore be as specified by ITU-T Recommendation H.248 [1].

## Annex A (normative): Mapping from TS 101 882

### A.1 Code point mapping

This clause describes a generic mapping that is generally used for all primitives and parameters.

#### A.1.1 Primitive mappings

<b>TIPHON primitives</b>	<b>H.248 message types</b>
<i>MediaReservationRequest</i>	<i>TransactionRequest.Add</i>
<i>MediaReservationConfirm</i>	<i>TransactionReply.Add</i>
<i>MediaEstablishmentRequest</i>	<i>TransactionRequest.Modify</i>
<i>MediaEstablishmentConfirm</i>	<i>TransactionReply.Modify</i>
<i>MediaReleaseRequest</i>	<i>TransactionRequest.Subtract</i>
<i>MediaReleaseConfirm</i>	<i>TransactionReply.Subtract</i>
<b>TIPHON primitives with data elements</b>	<b>H.248 data elements</b>
<i>MediaReservationRequest</i>	<i>TransactionRequest.Add</i>
<i>MediaHandleType</i> (requested handle)	ContextId (see clause 6)
SET OF <i>FlowDescriptorType</i> (rx)	LocalDescriptor
SET OF <i>FlowDescriptorType</i> (tx)	RemoteDescriptor
<i>MediaReservationConfirm</i>	<i>TransactionReply.Add</i>
<i>MediaHandleType</i> (requested handle)	ContextId (see clause 6)
<i>MediaStatusType</i>	<b>See table of error messages</b>
SET OF <i>MediaDescriptorWithHandle</i>	LocalDescriptor, RemoteDescriptor
<i>MediaEstablishmentRequest</i>	<i>TransactionRequest.Modify</i>
<i>MediaHandleType</i> (reserved handle)	ContextId (see clause 6)
<i>MediaEstablishmentConfirm</i>	<i>TransactionReply.Modify</i>
<i>MediaHandleType</i> (reserved handle)	ContextId (see clause 6)
<i>MediaStatusType</i>	<b>See table of error messages</b>
<i>MediaHandleType</i> (established handle)	TerminationID
<i>MediaReleaseRequest</i>	<i>TransactionRequest.Subtract</i>
<i>MediaHandleType</i> (established handle)	TerminationID
<i>MediaReleaseConfirm</i>	<i>TransactionReply.Subtract</i>
<i>MediaHandleType</i> (established handle)	TerminationID
<i>MediaStatusType</i>	<b>See table of error messages</b>

## A.1.2 Binary Encoding

### A.1.2.1 For an IP-based media flow

TIPHON data elements	H.248 data elements
<i>MediaDescriptorWithHandle</i>	
<b>ReservedMediaHandleType</b>	<b>ContextId (see clause 6)</b>
<i>FlowDescriptorType (rx)</i>	LocalDescriptor
<i>FlowDescriptorType (tx)</i>	RemoteDescriptor
<i>MediaStatusType</i>	<b>See table of error messages</b>
RequestedMediaHandleType	StreamID
<i>FlowDescriptorType</i>	
<i>CodecDescriptorType</i>	
Frames per packet	SamplePP
Frame Rate	Sampling rate
SET OF <i>TransportDescriptorType</i>	
<i>TransportDescriptorType</i>	
<i>GenericQoSDescriptorType</i>	
<i>SpecificQoSDescriptorType</i>	<not supported>
<i>MpoAType (originator)</i>	<not supported>
<i>MpoAType (destination)</i>	
<i>GenericQoSDescriptorType</i>	
delay budget	PropDelay
Packet rate	Bitrate (shall be computed as follows: packetRate*MaximumPacketSize/100)
MaximumPacketSize	<b>Not used in reference point N</b>
Packet delay variation (jitter in milliseconds)	Jitterbuffer
packet loss	<not supported> the MG shall support an adequately low number
<i>CodecDescriptorType</i>	
CodecID (enumerated list of codecs)	RTPpayload (IETF RFC 1890 [14])
SilenceSuppressionEnabled	Silencesupp
<b>CodecSpecificParameters</b>	
<i>IPv4Type</i>	
Address	IPv6
Protocol	PortType (value =1 (UDP), RTP is implied)
Port	Port
<i>IPv6Type</i>	
Address	IPv4
Protocol	PortType (value =1 (UDP), RTP is implied)
Port	Port
<i>MpoAType</i>	
iPv4	ITU-T Recommendation H.248 [1], clause C.6, tag value 6001
IPv6	ITU-T Recommendation H.248 [1], clause C.6, tag value 6002
<i>MpoAProtocolType</i>	
ENUMERATED (list from STD02)	See above

### A.1.2.2 For an SCN media flow

TIPHON data elements	H.248 data elements
<i>MediaDescriptorWithHandle</i>	
<i>ReservedMediaHandleType</i>	ContextId
<i>FlowDescriptorType (rx)</i>	TerminationID (SCN terminations are indicated with special TerminationIDs)
<i>FlowDescriptorType (tx)</i>	TerminationID (SCN terminations are indicated with special TerminationIDs)
<i>MediaStatusType</i>	<b>See table of error messages</b>

## A.1.3 Text Encoding

### A.1.3.1 For an IP-based media flow

TIPHON data elements	H.248 data elements
<i>MediaDescriptorWithHandle</i>	
<i>ReservedMediaHandleType</i>	ContextId (see clause 6)
<i>FlowDescriptorType (rx)</i>	LocalDescriptor (for the contents see annex D)
<i>FlowDescriptorType (tx)</i>	RemoteDescriptor (for the contents see annex D)
<i>MediaStatusType</i>	<b>See table of error messages</b>
<i>InvokingControllerMediaHandleType</i>	StreamID

### A.1.3.2 For an SCN media flow

TIPHON data elements	H.248 data elements
<i>MediaDescriptorWithHandle</i>	
<i>MediaHandleType</i>	ContextId (see clause 6)
<i>FlowDescriptorType (rx)</i>	TerminationID (SCN terminations are indicated with special TerminationIDs)
<i>FlowDescriptorType (tx)</i>	TerminationID (SCN terminations are indicated with special TerminationIDs)
<i>MediaStatusType</i>	<b>See table of error messages</b>

## A.2 Error reasons

The following table provides a list of H.248 error reasons that an MG shall use and their corresponding TIPHON meanings.

TIPHON Reason	TIPHON diagnostic	H.248 error reason
<b>flowDescriptor</b> invalid		444 - unsupported or unknown descriptor
<b>flowDescriptor</b> not supported	CODEC unsupported Framing unsupported	515 - Unsupported stream 445 - Unsupported or Unknown Property
<b>flowDescriptor</b> unavailable	CODEC unavailable QoS not available	510 - Insufficient resources 526 - Insufficient bandwidth
<b>invokingControllerReference</b> does not exist		411 - The transaction refers to an unknown ContextId
<b>CircuitID</b> invalid		430 - Unknown TerminationID
<b>CircuitID</b> unavailable		510 - Insufficient resources
Insufficient resources	no more bearers no more media flows	412 - No ContextIDs available 432 - Out of TerminationIDs or No TerminationID available
<b>mcReservedMediaReference</b> does not exist		430 - Unknown TerminationID
<b>mcReservedMediaReference</b> invalid		433 - termination ID is already in a context
<b>mcReservedMediaReference</b> unavailable		432 - put of terminationIDs or no terminationID available

Please note that TIPHON reference point N reject primitives usually pertain to a mediaID within a bearerID. H.248 error codes are used as normal commands and hence apply to a particular context or termination and hence carry the context ID and termination ID to which the error message pertains.

---

## Annex B (normative): Meta-protocol to SDP mapping

SDP [1] is a description language for media sessions. This mapping therefore has no states just the codepoints.

---

### B.1 Mappable fields

The Protocol Version field (`v=line`) shall contain 0 as per page 8 of ITU-T Recommendation H.248 [1].

The Origin field (`o=line`) shall be filled according to page 8 of ITU-T Recommendation H.248 [1].

The Session Field (`s=line`) shall be filled according to page 9 of ITU-T Recommendation H.248 [1].

The connection Field (`c=line`) shall contain the `address` value of the `destinationMpoA` in TS 101 882 [2].

- In the case of IPv4 and IPv6 addresses this shall take the form as prescribed on page 33 of ITU-T Recommendation H.248 [1].
- Other cases are undefined in ITU-T Recommendation H.248 [1] and may be extended in future versions of either ITU-T Recommendation H.248 [1] or the present document.

The Bandwidth field (`b=line`) shall contain the value of `maxPacketSize` times `packetRate` divided by 8 AS shall be used as the bandwidth modifier.

The time filed (`t=line`) shall be filled according to page 14 of ITU-T Recommendation H.248 [1].

The Media field (`m=line`) shall be filled as follows:

- `<media>` shall contain the type of media flow. For Release 3 this shall be `audio`.
- `<port>` shall contain `port` value of the `destinationMpoA` in TS 101 882 [2].
- `<transport>` shall contain the text `RTP/AVP`.
- `<fmt list>` shall be filled according to IETF RFC 1890 [14]. SDP encoding of TIPHON flow specs shall contain only one CODEC per `m=line`.

Following attributes shall be used:

- `a=rtpmap:`
  - `<payload type>` is identical to the value in `<fmt list>`.
  - `<encoding name>` is taken from IETF RFC 1890 [14].
  - `<clock rate>` equals the meta-protocol values `packetRate * framesPerPacket` for this media flow.
  - `<encoding parameters>` is filled per page 21 of ITU-T Recommendation H.248 [1].
- `a=ptime:` shall contain the meta-protocol value of `framesPerPacket`.
- `a=fmtp:`
  - `<format>` is identical to the value in `<fmt list>`.
  - `<format specific parameters>` shall contain the value of the meta-protocol field `codecSpecificParameters`.

---

## B.2 Specifying the OriginatorMpoA

SDP specifies in clause B.2.1 a means for specifying unicast sessions. This provides the means to encode the Originator MpoA. The `recvonly` and `sendonly` attribute are specifying the sender side behaviour of this message.

- The receive-only stream specifies the IP address and port where RTP should be sent to. Implicitly (port + 1) is the port where the RTCP should be sent to.
- The send-only stream specifies the IP address and port where RTP will be sent from. Implicitly (port + 1) is the port where the RTCP will be sent from.

EXAMPLE: 

```
m=audio 1110 RTP/AVP 0
c=IN IP4 1.1.1.1
a=recvonly
m=audio 2220 RTP/AVP 0
c=IN IP4 2.2.2.2
a=sendonly
```

The sender of this SDP specifies that it wants to receive RTP packets on 1.1.1.1:1110 and send RTCP packets from 1.1.1.1:1111. It will send RTP packets from 2.2.2.2:2220 and receive RTCP packets on 2.2.2.2:2221.

NOTE: These semantics are compatible with current use of SDP. In the example above this leads to a scenario where a multihomed host receives RTP on 1.1.1.1 and sends the RTCP feedback on the stream from 2.2.2.2. The feedback on RTP that is sent from 2.2.2.2 will be received on 1.1.1.1. A more logical semantics would be that the RTCP is sent from (port in `recvonly` + 1) and received on (port in `sendonly` + 1). This way the RTP and related RTCP stream are neatly tied together.

---

## B.3 Unmappable fields

At this time SDP has no provisions for the following meta-protocol values:

- DelayBudget;
- packetDelayVariation;
- packetLoss;
- specificQoSDescriptor;
- originatorMpoA;
- SCN MpoAs.

TIPHON will register codepoints in SDP with IANA for these values.



---

## Annex C (informative): Bibliography

ETSI TS 101 884: "Telecommunications and Internet Protocol Harmonization Over Networks (TIPHON) Release 3; Technology Mapping; Implementation of TIPHON architecture using SIP".

IETF RFC 2327: "SDP: Session Description Protocol".

---

## List of figures

Figure 1: Relationship with other TIPHON Release 3 documents .....	6
Figure 2: TIPHON architecture with reference points N highlighted.....	10
Figure 3: Entities involved .....	11
Figure 4: Example H.248 context.....	14
Figure 5: Example H.248 context.....	17
Figure 6: Example H.248 context.....	21
Figure 7: Example H.248 context.....	23

---

## History

<b>Document history</b>		
V1.1.1	March 2002	Publication