

**Digital Broadband Cable Access to the
Public Telecommunications Network;
IP Multimedia Time Critical Services;
Part 2: Architectural framework for the delivery
of time critical services over cable Television networks
using cable modems**



Reference

RTS/AT-020028-02-02

Keywords

Access, broadband, cable, IP, multimedia, PSTN

ETSI

650 Route des Lucioles
F-06921 Sophia Antipolis Cedex - FRANCE

Tel.: +33 4 92 94 42 00 Fax: +33 4 93 65 47 16

Siret N° 348 623 562 00017 - NAF 742 C
Association à but non lucratif enregistrée à la
Sous-Préfecture de Grasse (06) N° 7803/88

Important notice

Individual copies of the present document can be downloaded from:

<http://www.etsi.org>

The present document may be made available in more than one electronic version or in print. In any case of existing or perceived difference in contents between such versions, the reference version is the Portable Document Format (PDF). In case of dispute, the reference shall be the printing on ETSI printers of the PDF version kept on a specific network drive within ETSI Secretariat.

Users of the present document should be aware that the document may be subject to revision or change of status. Information on the current status of this and other ETSI documents is available at

<http://portal.etsi.org/tb/status/status.asp>

If you find errors in the present document, send your comment to:

editor@etsi.fr

Copyright Notification

No part may be reproduced except as authorized by written permission.
The copyright and the foregoing restriction extend to reproduction in all media.

© European Telecommunications Standards Institute 2002.
All rights reserved.

DECTTM, **PLUGTESTS**TM and **UMTS**TM are Trade Marks of ETSI registered for the benefit of its Members.
TIPHONTM and the **TIPHON logo** are Trade Marks currently being registered by ETSI for the benefit of its Members.
3GPPTM is a Trade Mark of ETSI registered for the benefit of its Members and of the 3GPP Organizational Partners.

Contents

Intellectual Property Rights	5
Foreword.....	5
Introduction	5
1 Scope	6
2 References	6
3 Definitions and abbreviations.....	7
3.1 Definitions	7
3.2 Abbreviations	8
4 IPcablecom	9
4.1 IPcablecom architecture framework	9
4.2 IPcablecom zones and domains	10
4.3 IPcablecom specifications	10
4.4 IPcablecom design considerations.....	10
4.4.1 General architectural goals	11
4.4.2 Quality of Service	12
4.4.3 CODEC and media stream.....	12
4.4.4 Device provisioning and OSS	13
4.4.5 Security	13
4.4.6 Managed IP network.....	13
5 IPcablecom functional components.....	13
5.1 Multimedia Terminal Adapter (MTA)	14
5.1.1 MTA functional requirements.....	14
5.1.2 MTA identifiers	15
5.2 Cable Modem (CM)	15
5.3 HFC Access Network.....	16
5.4 Access Node (AN).....	16
5.4.1 AN gate.....	16
5.5 Call Management Server (CMS)	16
5.6 PSTN Gateway	17
5.6.1 Media Gateway Controller (MGC).....	17
5.6.2 Media Gateway (MG).....	18
5.6.2.1 Media Gateway Functions.....	18
5.6.3 Signalling Gateway (SG)	19
5.6.3.1 Signalling System Number 7 Signalling Gateway Functions	19
5.7 OSS back office components.....	19
5.7.1 TGS.....	19
5.7.2 Dynamic Host Configuration Protocol Server (DHCP).....	20
5.7.3 Domain Name System Server (DNS)	20
5.7.4 Trivial File Transfer Protocol Server or HyperText Transfer Protocol Server (TFTP or HTTP)	20
5.7.5 SYSLOG Server (SYSLOG)	20
5.7.6 Record Keeping Server (RKS).....	20
5.8 Announcement Server (ANS).....	20
5.8.1 Announcement Controller (ANC).....	20
5.8.2 Announcement Player (ANP)	21
6 Protocol interfaces	21
6.1 Call signalling interfaces	21
6.1.1 Network-based Call Signalling (NCS) framework	22
6.1.2 PSTN signalling framework	23
6.2 Media Streams	23
6.3 MTA Device Provisioning	25
6.4 SNMP element management layer interfaces.....	26
6.5 Event messages interfaces	27

6.5.1	Event message framework	27
6.6	Quality of Service (QoS)	28
6.6.1	QoS framework.....	28
6.6.2	Layer two vs. layer three MTA QoS signalling	31
6.6.3	Dynamic Quality of Service.....	31
6.7	Announcement services.....	32
6.7.1	ANS physical vs. logical configuration	33
6.8	Security	33
6.8.1	Overview	33
6.8.2	Device provisioning security	36
6.8.2.1	Subscriber enrolment	36
6.8.2.2	Device provisioning	36
6.8.2.3	Dynamic provisioning.....	36
6.8.2.4	Device authorization	36
6.8.2.5	Signalling security.....	36
6.8.2.6	Media stream security	36
6.8.2.7	OSS and billing system security.....	37
7	Network design considerations	37
7.1	Time keeping and reporting issues	37
7.2	Timing for playout buffer alignment with coding rate	37
7.3	IP addressing	37
7.4	Dynamic IP addressing assignment.....	38
7.5	FQDN assignment	38
7.6	Priority marking of signalling and media stream packets.....	39
7.7	Fax support.....	39
7.8	Analogue modem support	40
Annex A (informative):	Bibliography.....	41
History		43

Intellectual Property Rights

IPRs essential or potentially essential to the present document may have been declared to ETSI. The information pertaining to these essential IPRs, if any, is publicly available for **ETSI members and non-members**, and can be found in ETSI SR 000 314: "*Intellectual Property Rights (IPRs); Essential, or potentially Essential, IPRs notified to ETSI in respect of ETSI standards*", which is available from the ETSI Secretariat. Latest updates are available on the ETSI Web server (<http://webapp.etsi.org/IPR/home.asp>).

Pursuant to the ETSI IPR Policy, no investigation, including IPR searches, has been carried out by ETSI. No guarantee can be given as to the existence of other IPRs not referenced in ETSI SR 000 314 (or the updates on the ETSI Web server) which are, or may be, or may become, essential to the present document.

Foreword

This Technical Specification (TS) has been produced by ETSI Technical Committee Access and Terminals (AT).

The present document is part 2 of a multi-part deliverable a multi-part deliverable covering Digital Broadband Cable Access to the Public Telecommunications Network; IP Multimedia Time Critical Services. Full details of the entire series can be found in TS 101 909-1 [10].

NOTE 1: The choice of a multi-part format for the present document is to facilitate maintenance and future enhancements.

NOTE 2: The term **MUST** or **MUST NOT** is used as a convention in the present document to denote an absolutely mandatory aspect of the specification.

Introduction

The cable industry in Europe and across other Global regions have already deployed broadband cable television hybrid fibre coax (HFC) data networks running the Cable Modem Protocol. The Cable Industry is in the rapid stages of deploying IP Voice and other time critical multimedia services over these broadband cable television networks.

The cable industry has recognized the urgent need to develop ETSI Technical Specifications aimed at developing interoperable interface specifications and mechanisms for the delivery of end-to-end advanced real time IP multimedia time critical services over bi-directional broadband cable networks.

IPCablecom is a set of protocols and associated element functional requirements developed to deliver Quality of Service (QoS) enhanced secure IP multimedia time critical communications services using packetized data transmission technology to a consumer's home over the broadband cable television Hybrid Fibre/Coaxial (HFC) data network running the Cable Modem Protocol. IPCablecom utilizes a network superstructure that overlays the two-way data-ready cable television network. While the initial service offerings in the IPCablecom product line are anticipated to be Packet Voice, the long-term project vision encompasses packet video and a large family of other packet-based services.

The cable industry is a global market and therefore the ETSI standards are developed to align with standards either already developed or under development in other regions. The ETSI Specifications are consistent with the CableLabs/PacketCable set of specifications as published by the SCTE. An agreement has been established between ETSI and SCTE in the US to ensure, where appropriate, that the release of PacketCable and IPCablecom set of specifications are aligned and to avoid unnecessary duplication. The set of IPCablecom ETSI specifications also refers to ITU-SG9 draft and published specifications relating to IP Cable Communication.

The whole set of multi-part ETSI deliverables to which the present document belongs specify a Cable Communication Service for the delivery of IP Multimedia Time Critical Services over a HFC Broadband Cable Network to the consumers home cable telecom terminal. "IPCablecom" also refers to the ETSI working group program that shall define and develop these ETSI deliverables.

1 Scope

The present set of documents specify IPCablecom, a set of protocols and associated element functional requirements. These have been developed to deliver Quality of Service (QoS), enhanced secure IP multimedia time critical communication services, using packetized data transmission technology to a consumer's home over a cable television Hybrid Fibre/Coaxial (HFC) data network.

NOTE 1: IPCablecom set of documents utilize a network superstructure that overlays the two-way data-ready cable television network, e.g. as specified within ES 201 488 [8] and ES 200 800 [9].

While the initial service offerings in the IPCablecom product line are anticipated to be Packet Voice and Packet Video, the long-term project vision encompasses a large family of packet-based services. This may require in the future, not only careful maintenance control, but also an extension of the present set of documents.

NOTE 2: The present set of documents aims for global acceptance and applicability. It is therefore developed in alignment with standards either already existing or under development in other regions and in International Telecommunications Union (ITU).

2 References

The following documents contain provisions which, through reference in this text, constitute provisions of the present document.

- References are either specific (identified by date of publication and/or edition number or version number) or non-specific.
- For a specific reference, subsequent revisions do not apply.
- For a non-specific reference, the latest version applies.

- [1] ETSI EN 300 356 (all parts): "Integrated Services Digital Network (ISDN); Signalling System No.7 (SS7); ISDN User Part (ISUP) version 4 for the international interface" (ETSI ISUP Common Channel Signalling)".
- [2] ETSI EN 300 008-1: "Integrated Services Digital Network (ISDN); Signalling System No.7; Message Transfer Part (MTP) to support international interconnection; Part 1: Protocol specification [ITU-T Recommendations Q.701, Q.702, Q.703, Q.704, Q.705, Q.706, Q.707 and Q.708 modified]".
- [3] ETSI EN 300 009 (parts 1 and 2): "Integrated Services Digital Network (ISDN); Signalling System No.7; Signalling Connection Control Part (SCCP) (connectionless and connection-oriented) to support international interconnection".
- [4] ETSI ETS 300 287: "Integrated Services Digital Network (ISDN); Signalling System No.7; Transaction Capabilities Application Part (TCAP) version 2".
- [5] ITU-T Recommendation G.711 (1988): "Pulse code modulation (PCM) of voice frequencies".
- [6] ITU-T Recommendation J.112: "Transmission systems for interactive cable television services".
- [7] ITU-T Recommendation E.164: "The international public telecommunication numbering plan".
- [8] ETSI ES 201 488: "Data-Over-Cable Service Interface Specifications; Radio Frequency Interface Specification".
- [9] ETSI ES 200 800: "Digital Video Broadcasting (DVB); DVB interaction channel for Cable TV distribution systems (CATV)".
- [10] ETSI TS 101 909-1: "Digital Broadband Cable Access to the Public Telecommunications Network; IP Multimedia Time Critical Services; Part 1: General".

- [11] IETF RFC 1890: "RTP Profile for Audio and Video Conferences with Minimal Control".
- [12] IETF RFC 1899: "Request for Comments Summary RFC Numbers 1800-1899".
- [13] IETF RFC 2131: "Dynamic Host Configuration Protocol".
- [14] IETF RFC 2132: "DHCP Options and BOOTP Vendor Extensions".
- [15] IETF RFC 2705: "Media Gateway Control Protocol (MGCP)", Version 1.0, October, 1999, <http://www.ietf.org>
- [16] ITU-T Recommendation H.248: "Gateway Control Protocol".
- [17] IETF RFC 3015: "Megaco Protocol Version 1.0".
- [18] ETSI TR 101 618: "Network Aspects (NA); Number Portability Task Force (NPTF); Working package 8; Location portability".
- [19] ETSI TR 101 621 (V1.1.1): "Network Aspects (NA); Number Portability Task Force (NPTF); Consequences of mobile number portability on the PSTN/ISDN and synergy between geographic and mobile number portability".
- [20] ETSI TR 101 697 (V1.1.1): "Number Portability Task Force (NPTF); Guidance on choice of network solutions for service provider portability for geographic and non-geographic numbers".

3 Definitions and abbreviations

3.1 Definitions

For the purposes of the present document, the following terms and definitions apply:

Access Node (AN): layer two termination device that terminates the network end of the J.112 connection

NOTE: It is technology specific. In ITU-T Recommendation J.112 [6], annex A it is called the INA while in annex B it is the CMTS.

architecture framework: architecture framework for IPCablecom networks including all major system components and network interfaces necessary for delivery of IPCablecom services

audio/video codecs: audio and video codecs necessary to provide the highest quality and the most resource-efficient service delivery to the customer

NOTE: It also specifies the performance required in client devices to support future IPCablecom codecs and describes suggested methodology for optimal network support for codecs.

Cable Modem (CM): layer two termination device that terminates the customer end of the J.112 connection

dynamic Quality of Service: QoS Architecture for the "Access" portion of the PacketCable network, provided to requesting applications on a per-flow basis

NOTE: The access portion of the network is defined to be between the Multimedia Terminal Adapter (MTA) and the Cable Modem Termination System (CMTS). The method of QoS allocation over the backbone is unspecified in the present document.

event messages: concept used to collect usage for the purposes of billing within the IPCablecom architecture

Internet Signalling Transport Protocol (ISTP): protocol that provides a signalling interconnection service between the IPCablecom network control elements (Call Management Server and Media Gateway Controller) and the PSTN Switched Circuit Network (SCN) through the Signalling System Number 7 Signalling Gateway

IPCablecom: ETSI working group project that includes an architecture and a series of specifications that enable the delivery of real time services (such as telephony) over the cable television networks using cable modems

MIBs framework: framework in which IPCablecom MIBs (Management Information Base) are defined, providing information on the management requirements of IPCablecom specified devices and functions, how these requirements are supported in the MIB

NOTE: It is intended to support and complement the actual MIB documents, which are issued separately.

MTA device provisioning: protocol mechanisms for provisioning of an IPCablecom embedded-MTA device by a single provisioning and network management provider

MTA MIB: MIB module which supplies the basic management objects for the MTA Device

NCS MIB: MIB module which supplies the basic management object for the NCS protocol

Network-based Call Signalling (NCS): profile of the Media Gateway Control Protocol (MGCP) for IPCablecom embedded clients, referred to as the Network-based Call Signalling (NCS) protocol

NOTE: MGCP is a call signalling protocol for use in a centralized call control architecture, and assumes relatively simple client devices.

PSTN gateway call signalling: Trunking Gateway Control Protocol (TGCP) for use in a centralized call control architecture that assumes relatively simple endpoint devices and is designed to meet the protocol requirements for the Media Gateway Controller to Media Gateway interface defined in the IPCablecom architecture

security: security architecture, protocols, algorithms, associated functional requirements and any technological requirements that can provide for the security of the system for the IPCablecom network

3.2 Abbreviations

For the purposes of the present document, the following abbreviations apply:

AN	Access Node
ANC	ANnouncement Controller
ANP	ANnouncement Player
ANS	ANnouncement Server
CM	Cable Modem
CMS	Call Management Server
CMTS	Cable Modem Termination System
CPE	Customer Premise Equipment
DHCP	Dynamic Host Configuration Protocol
DNS	Domain Name System
DTMF	Dual Tone Multi-Frequency
FQDN	Fully Qualified Domain Name
GC	Gate Controller
HFC	Hybrid Fibre/Coax
HTTP	HyperText Transfer Protocol
IEEE	Institute of Electrical and Electronic Engineers
IETF	Internet Engineering Task Force
IP	Internet Protocol
ISTP	Internet Signalling Transport Protocol
ISUP	Integrated Services digital network User Part
MAC	Media Access Control
MF	Multi-Frequency
MG	Media Gateway
MGC	Media Gateway Controller
MIB	Management Information Base
MMH	Multilinear Modular Hash
MTA	Multimedia Terminal Adapter
MTP	Message Transfer Part
NCS	Network based Call Signalling
OSS	Operational Support System
PSTN	Public Switched Telephone Network
QoS	Quality of Service
RKS	Record Keeping Server

RTP	Real-Time Transfer Protocol
SCCP	Signalling Connection Control Part
SCN	Signalling Circuit Network
SG	Signalling Gateway
SID	System IDentification number
SNMP	Simple Network Management Protocol
TCAP	Transaction Capabilities Application Part
TFTP	Trivial File Transfer Protocol
TGCP	Trunking Gateway Control Protocol
TGS	Ticket Granting Server
TOS	Type Of Service
UDP	User Datagram Protocol

4 IPCablecom

4.1 IPCablecom architecture framework

At a very high level, the IPCablecom architecture contains three networks: the "J.112 HFC Access Network", the "Managed IP Network" and the PSTN. The Access Node (AN) provides connectivity between the "J.112 HFC Access Network" and the "Managed IP Network". Both the Signalling Gateway (SG) and the Media Gateway (MG) provide connectivity between the "Managed IP Network" and the PSTN. The reference architecture for IPCablecom is shown in figure 1.

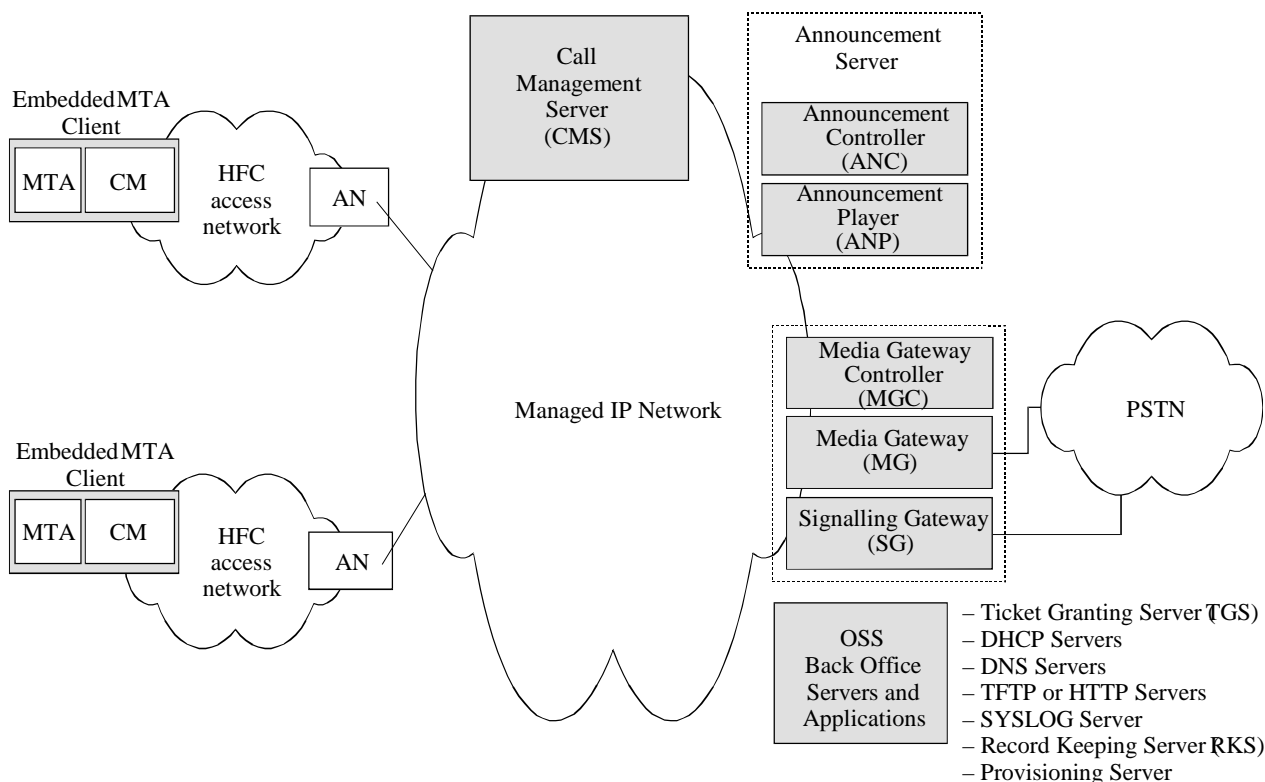

Figure 1: IPCablecom reference architecture

The J.112 HFC access network provides high-speed, reliable, and secure transport between the customer premise and the cable headend. This access network may provide all J.112 capabilities including Quality of Service. The J.112 HFC access network includes the following functional components: the Cable Modem (CM), Multimedia Terminal Adapter (MTA), and the Access Node (AN).

The Managed IP network serves several functions. First, it provides interconnection between the basic IPCablecom functional components responsible for signalling, media, provisioning, and quality of service establishment. In addition, the managed IP network provides long-haul IP connectivity between other Managed IP and J.112 HFC networks. The Managed IP network includes the following functional components: Call Management Server (CMS), Announcement Server (ANS), several Operational Support System (OSS) back-office servers, Signalling Gateway (SG), Media Gateway (MG), and Media Gateway Controller (MGC).

The individual network components that are shown in figure 1 are described in detail in clause 6.

4.2 IPCablecom zones and domains

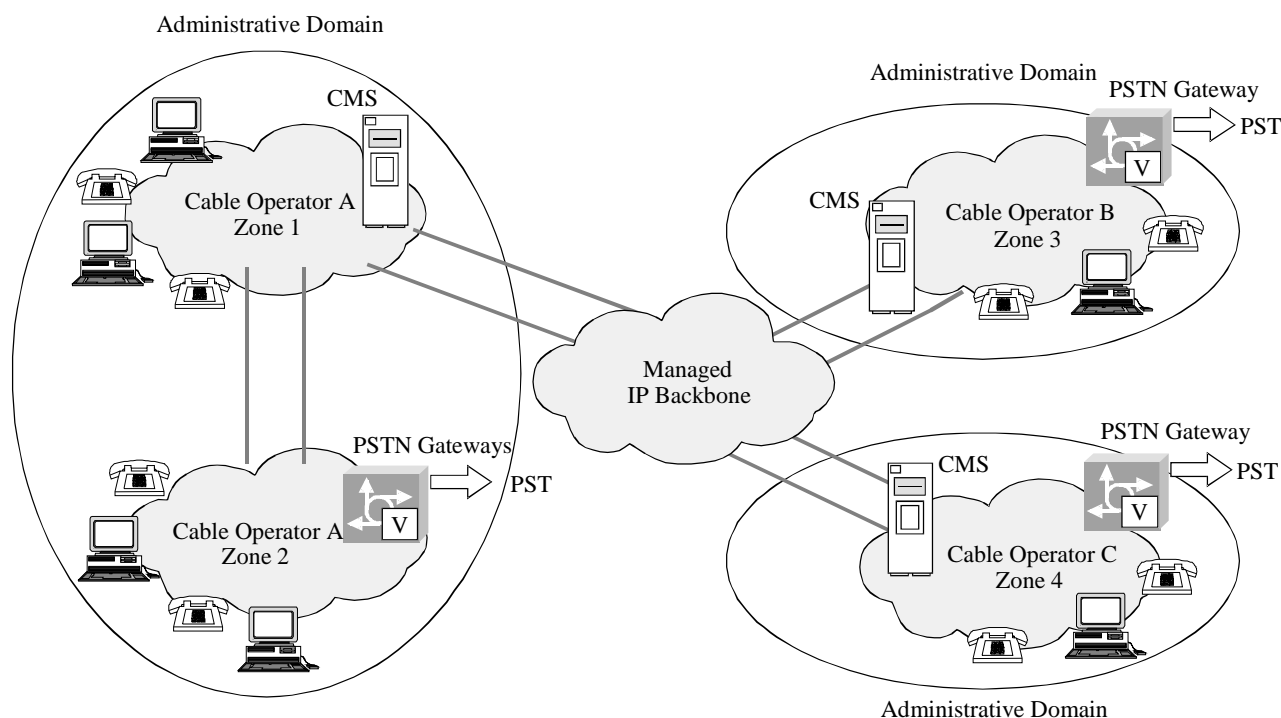

Figure 2: Zones and administrative domains

An IPCablecom zone consists of the set of MTAs in one or more J.112 HFC access networks that are managed by a single functional CMS as shown in figure 2. Interfaces between functional components within a single zone are defined in the IPCablecom specifications. Interfaces between zones (e.g. CMS-CMS) have not been defined and will be addressed in future phases of the IPCablecom architecture.

An IPCablecom domain is made up of one or more IPCablecom zones that are operated and managed by a single administrative entity. An IPCablecom domain may also be referred to as an administrative domain. Interfaces between domains have not been defined in IPCablecom and are for further study.

4.3 IPCablecom specifications

Refer to clause 2 for a list of IPCablecom Specifications. Should a technical detail in one of these Specifications conflict with TS 101 909-1 [10], the IPCablecom Specifications in clause 2 take precedence.

4.4 IPCablecom design considerations

This clause provides an overview of the high-level design goals and concepts used in developing the specifications that define the IPCablecom reference architecture.

4.4.1 General architectural goals

- Enable voice quality capabilities comparable to or better than the PSTN as perceived by the end-user.
- Provide a network architecture that is scalable and capable of supporting millions of subscribers.
- Ensure the one-way delay for local IP access and IP egress (i.e. excluding the IP backbone network) can meet the delay requirements for all IPCablecom real-time services, including voice.
- Ensure the packet loss rate, jitter, and latency (delay) for the Managed IP Network can meet the requirements for all IPCablecom real-time services, including voice.
- Support primary and/or secondary line residential voice communications capabilities.
- Leverage existing standards. IPCablecom strives to specify open, approved industry standards that have been widely adopted in commercial communication networks. This includes standards approved by the ITU, IETF, IEEE, and other communications standards organizations.
- Leverage and build upon the data transport and Quality of Service capabilities enabled by the J.112 infrastructure.
- Define an architecture that allows multiple vendors to rapidly develop low-cost interoperable solutions to meet time-to-market requirements.
- Ensure that the probability of blocking a call can be engineered to meet service provider's requirements.
- Ensure that call cut offs and call defects can be engineered to be less than 1 per 10 000 completed calls.
- Support modems (up to V.90 56 kbit/s) and fax (up to 14,4 kbit/s).
- Ensure that frame slips due to unsynchronized sampling clocks or due to lost packets occur less than 0,25 per minute Call Signalling.
- Define a network-based signalling paradigm.
- Provide end-to-end call signalling for the following call models:
 - calls that originate from the PSTN and terminate on the cable network;
 - calls that originate on the cable network and terminate on the cable network within a single IPCablecom zone;
 - calls that originate from the cable network and terminate on the PSTN;
 - calls that originate within one IPCablecom zone and terminate in another IPCablecom zone are for further study;
 - calls that originate on the PSTN, transit the IPCablecom network, and terminate on the PSTN are not specifically considered in this architecture.
- Provide signalling to support calling features such as:
 - Call Waiting;
 - Cancel Call Waiting;
 - Call Forwarding (no-answer, busy, variable);
 - Three-way Calling;
 - Voice mail Message Waiting Indicator;
 - Calling Number Delivery;
 - Calling Name Delivery;

- Calling Identity Delivery On Call Waiting;
 - Calling Identity Delivery Blocking;
 - Anonymous Call Rejection;
 - Automatic Callback;
 - Automatic Recall;
 - Distinctive Ringing/Call Waiting;
 - Customer Originated Trace.
- Support a signalling paradigm consistent with existing IP telephony standards for use within a cable operator's IP-Cablecom network and when connecting to the PSTN.
 - Ability to direct dial any domestic or international telephone number (ITU-T Recommendation E.164 address).
 - Ability to receive a call from any domestic or international telephone number supported by the PSTN.
 - Ensure that a new subscriber is able to retain current phone number via Local Number Portability (LNP).
 - Ability to use the carrier of choice for long distance calls. This includes pre-subscription and per call selection.
 - Support Call Blocking/Call Blocking Toll restrictions (e.g. blocking calls to specific prefixes).

4.4.2 Quality of Service

- Provide a rich set of policy mechanisms to provide and manage QoS for IP-Cablecom services over the access network.
- Provide admission control mechanisms for both upstream and downstream directions.
- Allow dynamic changes in QoS in the middle of IP-Cablecom calls.
- Enable transparent access to all of the QoS mechanisms defined in ITU-T Recommendation J.112 [6]. IP-Cablecom clients need not be aware of specific J.112 QoS primitives and parameters.
- Minimize and prevent abusive QoS usage including theft-of and denial-of service attacks. Ensure QoS policy is set and enforced by trusted IP-Cablecom network elements.
- Provide a priority mechanism for emergency and other priority based signalling services.

4.4.3 CODEC and media stream

- Minimize the effects that delay, packet-loss, and jitter have on voice-quality in the IP telephony environment.
- Define a minimum set of audio codecs that must be supported on all IP-Cablecom endpoint devices (MTAs). Evaluation criteria for mandatory codecs are selected as those most efficient with respect to voice quality, bandwidth utilization, and implementation complexity.
- Accommodate evolving narrow-band and wide-band codec technologies.
- Specify echo cancellation and voice activity detection mechanisms.
- Support for transparent, error-free DTMF transmission and detection.
- Support terminal devices for the deaf and hearing impaired.
- Provide mechanisms for codec switching when fax and modem services are required.

4.4.4 Device provisioning and OSS

- Support dynamic and static provisioning of customer premise equipment (MTA and CM).
- Provisioning changes should not require reboot of MTA.
- Allow dynamic assignment and management of IP addresses for subscriber devices.
- Ensure that real-time provisioning and configuration of MTA software does not adversely affect subscriber service.
- Define SNMP MIBs for managing customer premise equipment (MTA).

4.4.5 Security

- Enable residential voice capabilities with the same or higher level of perceived privacy as in the PSTN.
- Provide protection against attacks on the MTA.
- Protect the cable operator from various denial of service, network disruption and theft of service attacks.
- Design considerations include confidentiality, authentication, integrity, non-repudiation and access control.

4.4.6 Managed IP network

The network needs to have bounds on the QoS performance parameters, e.g. packet loss, for packets traversing the network.

5 IPCablecom functional components

This clause describes the functional components present in an IPCablecom network. Component descriptions are not intended to define or imply product implementation requirements but instead to describe the functional role of each of these components in the reference architecture. Note that specific product implementations may combine functional components as needed. Not all components are required to be present in an IPCablecom Network.

The IPCablecom architecture contains trusted and untrusted network elements. Trusted network elements are typically located within a Cable Operator's managed backbone network. Untrusted network elements, such as the CM and MTA, are typically located within the subscriber's home and outside of the Cable Operator's facility.

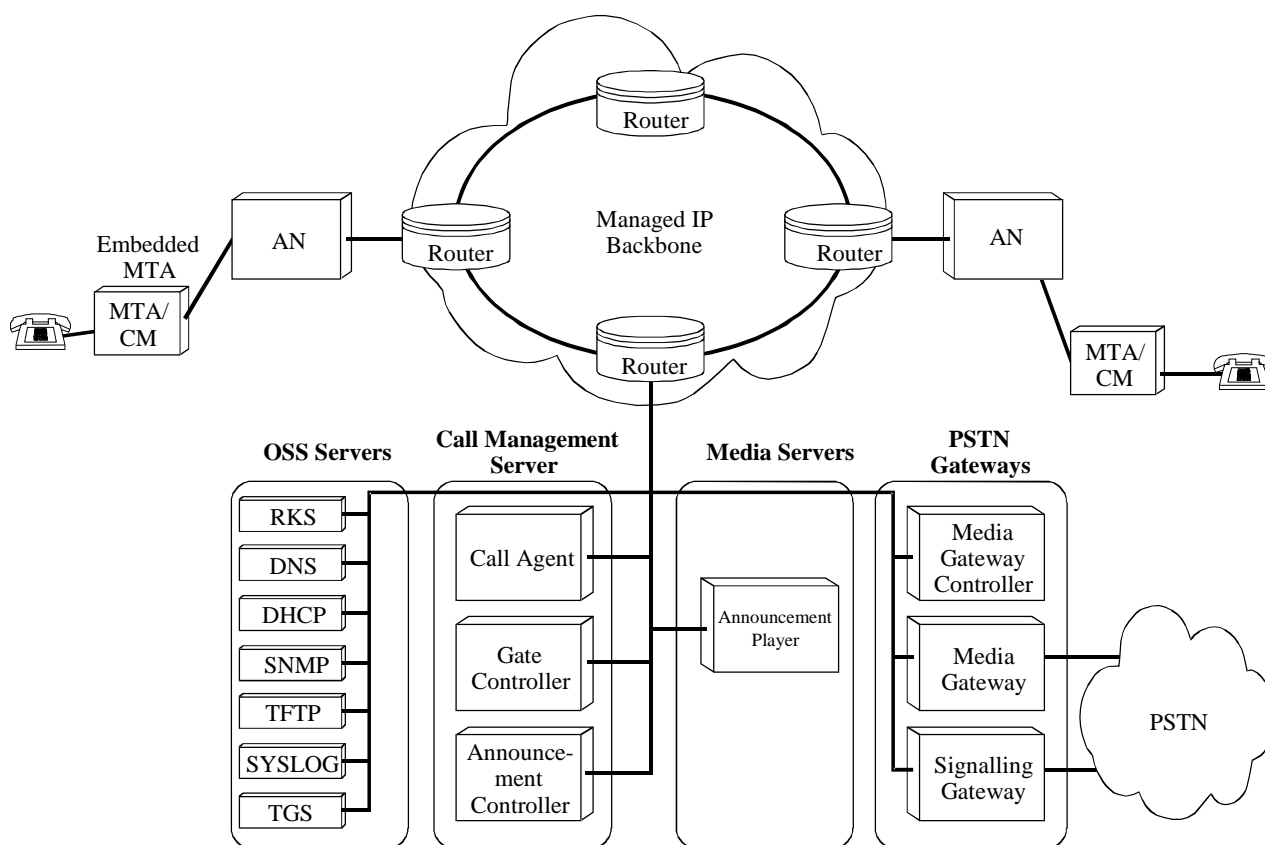

Figure 3: IPCablecom component reference model

5.1 Multimedia Terminal Adapter (MTA)

An MTA is an IPCablecom client device that contains a subscriber-side interface to the subscriber's CPE (e.g. telephone) and a network-side signalling interface to call control elements in the network. An MTA provides codecs and all signalling and encapsulation functions required for media transport and call signalling.

MTAs reside at the customer site and are connected to other IPCablecom network elements via the HFC access network (ITU-T Recommendation J.112 [6]). IPCablecom MTAs are required to support the Network Call Signalling (NCS) protocol.

An embedded MTA (E-MTA) is a single hardware device that incorporates a cable modem as well as an IPCablecom MTA component. Figure 4 shows a representative functional diagram of an E-MTA.

IPCablecom specifications only require support for embedded MTAs. Throughout the present document, unless otherwise noted, the term MTA refers to an embedded MTA.

5.1.1 MTA functional requirements

An MTA is responsible for the following functionality:

- NCS call signalling with the CMS.
- QoS signalling with the CMS and the AN.
- Authentication, confidentiality and integrity of some messages between the MTA and other IPCablecom network elements.
- Mapping media streams to the MAC services of the J.112 access network.
- Encoding/decoding of media streams.

- Providing multiple audio indicators to phones, such as ringing tones, call-waiting tones, stutter dial tone, dial tone, etc.
- Standard PSTN analogue line signalling for audio tones, voice transport, caller-id signalling, DTMF, and message waiting indicators.
- The G.711 audio codec.
- One or more analogue and/or ISDN BRI interface(s).
- Additional MTA functionality is defined in other IPCablecom specifications.

5.1.2 MTA identifiers

The following identifiers characterize the E-MTA:

- An embedded MTA has two MAC addresses, one for the CM and one for the MTA.
- An embedded MTA has two IP addresses, one for the CM and one for the MTA.
- An embedded MTA has two Fully Qualified Domain Names (FQDN), one for the CM and one for the MTA.
- At least one telephone number per configured physical port.
- Device capabilities.
- The MTA's associated CMS.

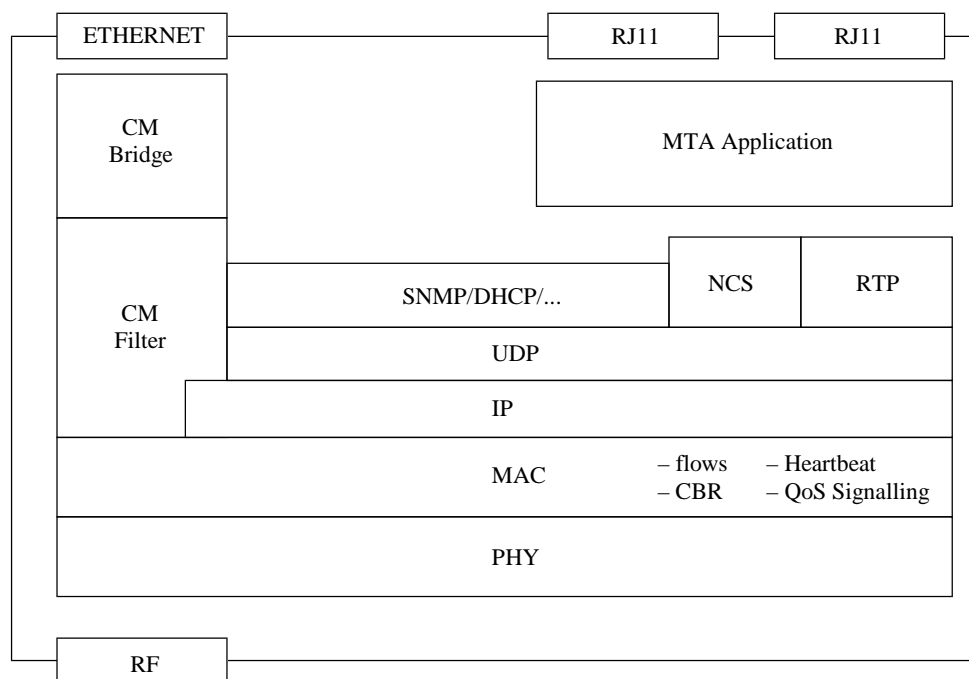

Figure 4: E-MTA conceptual functional architecture

5.2 Cable Modem (CM)

The CM is a modulator/demodulator residing on the customer premise that provides data transmission over the cable network using the J.112 protocol. In IPCablecom, the CM plays a key role in handling the media stream and provides services such as classification of traffic into service flows, rate shaping, and prioritized queuing.

5.3 HFC Access Network

IPCablecom-based services are carried over the Hybrid Fibre/Coax (HFC) access network. The access network is a bi-directional, shared-media system that consists of the CM, the AN, and the J.112 MAC and PHY access layers.

5.4 Access Node (AN)

The AN provides data connectivity and complimentary functionality to CMs over the HFC access network. It also provides connectivity to wide area networks. The AN is located at the cable television system head-end or distribution hub.

The AN is responsible for the following functions:

- Providing the required QoS to the CM based upon policy configuration.
- Allocating upstream bandwidth in accordance to CM requests and network QoS policies.
- Classifying each arriving packet from the network side interface and assigning it to a QoS level based on defined filter specifications.
- Policing the TOS field in received packets from the cable network to enforce TOS field settings per network operator policy.
- Altering the TOS field in the downstream IP headers based on the network operator's policy.
- Performing traffic shaping and policing as required by the flow specification.
- Forwarding downstream packets to the J.112 network using the assigned QoS.
- Forwarding upstream packets to the backbone network devices using the assigned QoS.
- Converting and classifying QoS Gate parameters into J.112 QoS parameters.
- Signalling and reserving any backbone QoS necessary to complete the service reservation.
- Recording usage of resources per call using IPCablecom Event Messages.

5.4.1 AN gate

The AN Gate is a functional component of the AN that performs traffic classification and enforces QoS policy on media streams as directed by the Gate Controller (GC).

5.5 Call Management Server (CMS)

The Call Management Server provides call control and signalling related services for the MTA, AN, and PSTN gateways in the IPCablecom network. The CMS is a trusted network element that resides on the managed IP portion of the IPCablecom network.

An IPCablecom CMS consists of the following logical IPCablecom components:

- **Call Agent (CMS/CA):** In an IPCablecom, the Call Agent (CA) refers to the control component of the CMS that is responsible for providing signalling services using the NCS protocol to the MTA. In this context, Call Agent responsibilities include but are not limited to:
 - implementing call features;
 - maintaining call progress state;
 - the use of codecs within the subscriber MTA device;
 - collecting and pre-processing dialled digits;

- collecting and classifying user actions.

NOTE: Call Agent is a term that is often used interchangeably with CMS.

- **Gate Controller (CMS/GC):** The Gate Controller (GC) is a logical QoS management component within the CMS that coordinates all quality of service authorization and control. Gate Controller functionality is defined in the Dynamic Quality of Service specification.

The CMS may also contain the following logical components:

- **Media Gateway Controller:** The MGC is logical signalling management component used to control PSTN Media Gateways. The MGC function is defined in detail later in this clause.
- **Announcement Controller:** The ANC is a logical signalling management component used to control network announcement servers. The ANC function is defined in detail in clause 6.8.

The CMS may also provide the following functions:

- call management and enhanced features;
- directory services and address translation;
- call routing;
- record usage of local number portability services;
- zone-to-zone call signalling (for further study) and QoS admission control.

For the purposes of the present document, protocols that implement the functionality of the CMS are specified as terminating at the CMS - actual implementations may distribute the functionality in one or more servers that sit "behind" the Call Management Server.

5.6 PSTN Gateway

IPCablecom allows MTAs to inter-operate with the current PSTN through the use of PSTN Gateways.

In order to enable operators to minimize cost and optimize their PSTN interconnection arrangements, the PSTN Gateway is decomposed into three functional components:

- **Media Gateway Controller (MGC):** The MGC maintains the Call State and controls the overall behaviour of the PSTN gateway.
- **Signalling Gateway (SG):** The SG provides a signalling interconnection function between the PSTN Switched Circuit Network (SCN) and the IP network.
- **Media Gateway (MG):** The MG terminates the bearer paths and transcodes media between the PSTN and IP network.

5.6.1 Media Gateway Controller (MGC)

The Media Gateway Controller (MGC) receives and mediates call-signalling information between the IPCablecom network and the PSTN. It maintains and controls the overall Call State for calls requiring PSTN interconnection.

The MGC controls the MG by instructing it to create, modify, and delete connections that support the media stream over the IP network. The MGC also instructs the MG to detect and generate events and signals such as continuity test tones for ISUP [1] trunks, or MF signalling for MF trunks. Each trunk is represented as an endpoint.

The following is a list of functions performed by the Media Gateway Controller:

- **Call Control Function:** Maintains and controls the overall PSTN Gateway Call State for the portion of a call that traverses the PSTN Gateway. The function interfaces with external PSTN elements as needed for PSTN Gateway call control, e.g. by generating TCAP [3] queries.

- **IPCablecom Signalling:** Terminates and generates the call signalling from and to the IPCablecom side of the network.
- **MG Control:** The MG Control function exercises overall control of endpoints in the Media Gateway:
 - Event Detection instructs the MG to detect events, e.g. in-band tones and seizure state, on the endpoint and possibly connections;
 - Signal Generation instructs the MG to generate in-band tones and signals on the endpoint and possibly connections;
 - Connection Control instructs the MG on the basic handling of connections from and to endpoints in the MG;
 - Attribute Control instructs the MG regarding the attributes to apply to an endpoint and/or connection, e.g. encoding method, use of echo cancellation, security parameters, etc.
- **External Resource Monitoring:** Maintains the MGC's view of externally visible MG resources and packet network resources, e.g. endpoint availability.
- **Call Routing:** Makes call routing decisions.
- **Security:** Ensures that any entity communicating with the MGC adheres to the security requirements.
- **Usage Recording via Event Messages:** Records usage of resources per call.

5.6.2 Media Gateway (MG)

The Media Gateway provides bearer connectivity between the PSTN and the IPCablecom IP network. Each bearer is represented as an endpoint and the MGC instructs the MG to set-up and control media connections to other endpoints on the IPCablecom network. The MGC also instructs the MG to detect and generate events and signals relevant to the Call State known to the MGC.

5.6.2.1 Media Gateway Functions

The following is a list of functions performed by the Media Gateway:

- Terminates and controls physical circuits in the form of bearer channels from the PSTN.
- Discriminates between media and Channel Associated In-band signalling information from the PSTN circuit.
- Detects events on endpoints and connections as requested by the MGC. This includes events needed to support in-band signalling, e.g. MF.
- Generates signals on endpoints and connections, e.g. continuity tests, alerting, etc. as instructed by the MGC. This includes signals needed to support in-band signalling.
- Creates, modifies, and deletes connections to and from other endpoints as instructed by the MGC.
- Controls and assigns internal media processing resources to specific connections upon receipt of a general request from the Media Gateway Controller.
- Performs media transcoding between the PSTN and the IPCablecom network. This includes all aspect of the transcoding such as codecs, echo cancellation, etc.
- Ensures that any entity communicating with the MG adheres to the security requirements.
- Determines usage of relevant resources and attributes associated with those resources, e.g. number of media bytes sent and received.
- Reports usage of resources to the MGC.

5.6.3 Signalling Gateway (SG)

The Signalling Gateway function sends and receives circuit-switched network signalling at the edge of the IPCablecom network. For IPCablecom, the signalling gateway function only supports non-facility associated signalling in the form of Signalling System Number 7. Facility associated signalling in the form of MF is supported by the MG function directly.

5.6.3.1 Signalling System Number 7 Signalling Gateway Functions

The following is a list of functions performed by the Signalling Gateway function:

- Terminates physical Signalling System Number 7 signalling links from the PSTN.
- Implements security features, to ensure that the Gateway security is consistent with IPCablecom and Switched Circuit Network (SCN) security requirements.
- Terminates Message Transfer Part (MTP [2]) levels 1, 2 and 3.
- Implements MTP [2] network management functions as required for any Signalling System Number 7 signalling point.
- Performs ISUP [1] Address Mapping to support flexible mapping of Point Codes (both Destination Point Code and Origination Point Code) and/or Point Code/CIC code combination contained within Signalling System Number 7 ISUP [1] messages to the appropriate Media Gateway Controller (MGC) (either a domain name or an IP address). The addressed MGC will be responsible for controlling the Media Gateway, which terminates the corresponding trunks.
- Performs TCAP [3] Address Mapping to map Point Code/Global Title/SCCP [3] Subsystem Number combinations within Signalling System Number 7 TCAP [3] messages to the appropriate Media Gateway Controller or Call Management Server.
- Provides mechanism for certain trusted entities ("TCAP [3] Users") within the IPCablecom network, such as Call Agents, to query external PSTN databases via TCAP [3] messages sent over the Switched Circuit Network (SCN).
- Implements the transport protocol required to transport the signalling information between the Signalling Gateway and the Media Gateway Controller.

5.7 OSS back office components

The OSS back office contains business, service, and network management components supporting the core business processes. As defined by the ITU TMN framework, the main functional areas for OSS are fault management, performance management, security management, accounting management, and configuration management. These topics will be covered in detail in a future IPCablecom OSS Framework Specification.

IPCablecom defines a limited set of OSS functional components and interfaces to support MTA device provisioning and Event Messaging to carry billing information.

5.7.1 TGS

For IPCablecom, the term TGS (Ticket Granting Server) is utilized for a Kerberos server. The Kerberos protocol with the public key PKINIT extension is used for key management on the MTA-CMS interface.

The TGS grants Kerberos tickets to the MTA. A ticket contains information used to set up authentication, privacy, integrity and access control for the call signalling between the MTA and the CMS. This ticket is issued in three different scenarios.

- During device provisioning, the MTA requests a ticket from the TGS. It is strongly recommended that the MTA save Kerberos tickets in persistent storage. In the case when the MTA reboots, if the saved ticket is still valid, then the MTA will not need to execute the PKINIT to request a new ticket from the TGS.

- In normal operation, each time a ticket expires, the MTA will request a new ticket during the grace period from the TGS.

NOTE: In the case of power failure in the CMS, the MTA will no longer be associated with this CMS. When this CMS restarts it will request "wake up" information from the MTA. If the ticket the MTA currently holds is beyond the expiration time, often referred to as a stale ticket, the MTA will request a new ticket from the TGS. If the MTA is still holding a valid ticket then it should send this ticket to the CMS without requesting a new one from the TGS.

- When the TGS is not available on the network and the MTA can not get a new ticket during the grace period, the MTA must hold on to the current, but stale ticket until a TGS is available to grant a new ticket. The request from the MTA during this condition will be specified in a future IPCablecom Security Specification.

5.7.2 Dynamic Host Configuration Protocol Server (DHCP)

The DHCP server is a back office network element used during the MTA device provisioning process to dynamically allocate IP addresses and other client configuration information.

5.7.3 Domain Name System Server (DNS)

The DNS server is a back office network element used to map between ASCII domain names and IP addresses.

5.7.4 Trivial File Transfer Protocol Server or HyperText Transfer Protocol Server (TFTP or HTTP)

The TFTP Server is a back office network element used during the MTA device provisioning process to download configuration files to the MTA. An HTTP Server may be used instead of a TFTP server to download configuration files to the MTA.

5.7.5 SYSLOG Server (SYSLOG)

The SYSLOG server is a back office network element used to collect events such as traps and errors from an MTA.

5.7.6 Record Keeping Server (RKS)

The RKS is a trusted network element component that receives IPCablecom Event Messages from other trusted IPCablecom network elements such as the CMS, AN, and MGC. The RKS also, at a minimum, is a short-term repository for IPCablecom Event Messages. The RKS may assemble the Event Messages into coherent sets or Call Detail Records (CDRs), which are then made available to other back office systems such as billing, fraud detection, and other systems.

5.8 Announcement Server (ANS)

An Announcement Server is a network component that manages and plays informational tones and messages in response to events that occur in the network. An Announcement Server (ANS) is a logical entity composed of an Announcement Controller (ANC) and an Announcement Player (ANP).

5.8.1 Announcement Controller (ANC)

The ANC initiates and manages all announcement services provided by the Announcement Player. The ANC requests the ANP to play announcements based on Call State as determined by the CMS. When information is collected from the end-user by the ANP, the ANC is responsible for interpreting this information and manage the session accordingly. Hence, the ANC may also manage Call State.

5.8.2 Announcement Player (ANP)

The Announcement Player is a media resource server. It is responsible for receiving and interpreting commands from the ANC and for delivering the appropriate announcement(s) to the MTA. The ANP also is responsible for accepting and reporting user inputs (e.g. DTMF tones). The ANP functions under the control of the ANC.

6 Protocol interfaces

Protocol specifications have been defined for most of the component interfaces in the IPCablecom architecture. An overview of each protocol interface is provided within this clause. The individual IPCablecom specifications should be consulted for the complete protocol requirements.

It is possible that some of these interfaces may not exist in a given vendor's product implementation. For example, if several functional IPCablecom components are combined then it is possible that some of these interfaces are internal to that component.

6.1 Call signalling interfaces

Call signalling requires multiple interfaces within the IPCablecom architecture. These interfaces are identified in figure 5. Each interface in the diagram is labelled, and further described in the subsequent table 1.

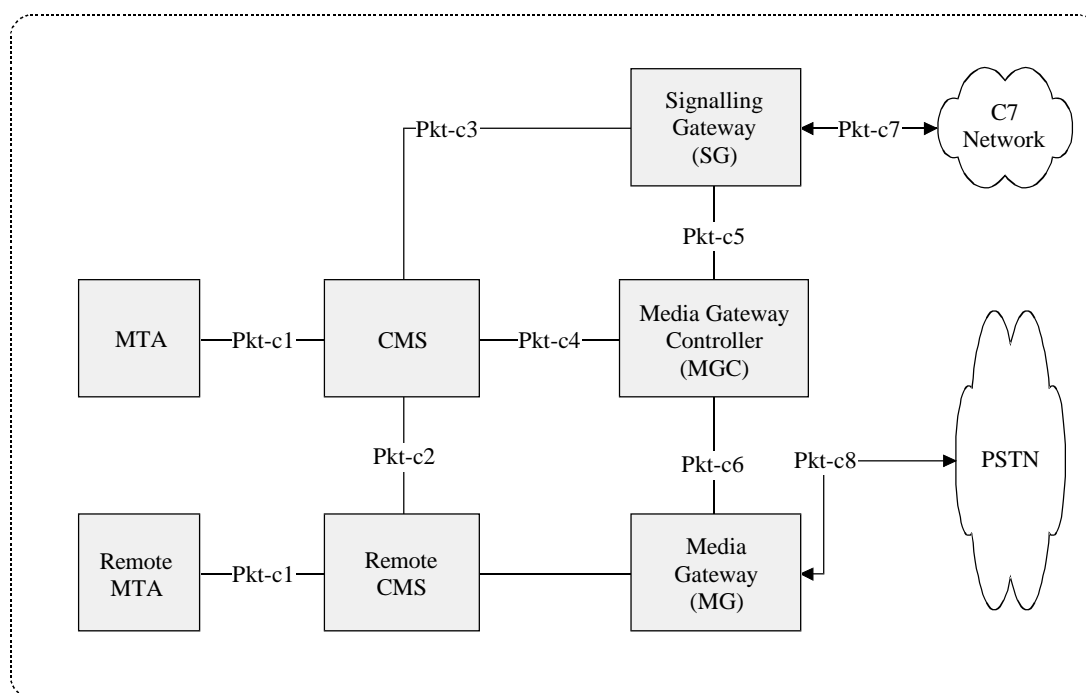

Figure 5: Call signalling interfaces

Table 1: Call signalling interfaces

Interface	IP-Cablecom Functional Components	Description
Pkt-c1	MTA-CMS	Call signalling messages exchanged between the MTA and CMS using the NCS protocol, which is a profile of MGCP.
Pkt-c2	CMS-CMS	Call signalling messages exchanged between CMS's. The protocol for this interface is undefined.
Pkt-c3	CMS-SG	Call signalling messages exchanged between CMS and SG using the I-ISTP/TCAP [3] protocol.
Pkt-c4	CMS-MGC	Call signalling messages exchanged between the CMS and MGC. The protocol for this interface is undefined.
Pkt-c5	SG-MGC	Call signalling messages exchanged between the MGC and SG using the I-ISTP/ISUP [1] and I-ISTP/TCAP [3] protocol.
Pkt-c6	MGC-MG	Interface for media control of the media gateway and possibly in-band signalling using the TGCP protocol.
Pkt-c7	SG-Signalling System Number 7	The SG terminates physical Signalling System Number 7 signalling links from the PSTN. The following protocols are supported: <ul style="list-style-type: none"> ISUP [1] User Interface. Provides a Signalling System Number 7 ISUP [1] signalling interface to external PSTN carriers. TCAP [3] User Interface. Provides mechanism for certain trusted entities ("TCAP [3] Users") within the IP-Cablecom network, such as Call Agents, to query external PSTN databases via TCAP [3] messages sent over the Switched Circuit Network (SCN).
Pkt-c8	MG-PSTN	This interface defines bearer channel connectivity from the Media Gateway to the PSTN and supports the following call signalling protocols: <ul style="list-style-type: none"> In-Band MF Signalling. A future version of IP-Cablecom may support ISDN PRI (see note).
NOTE: This function may be viewed as belonging in the Signalling Gateway function.		

6.1.1 Network-based Call Signalling (NCS) framework

The IP-Cablecom Network-Based Call Signalling (NCS) protocol (Pkt-c1) is an extended variant of the IETF's MGCP call signalling protocol. The NCS architecture places Call State and feature implementation in a centralized component, the Call Management Server (CMS), and places device control intelligence in the MTA. The MTA passes device events to the CMS, and responds to commands issued from the CMS. The CMS, which may consist of multiple geographically or administratively distributed systems, is responsible for setting up and tearing down calls, providing advanced services [enhanced calling features], performing call authorization, and generating billing event records, etc.

Examples of the partition of function would be for the CMS to instruct the MTA to inform the CMS when the phone goes off hook, and the appropriate number of DTMF digits has been entered.

When this sequence of events occurs, the MTA notifies the CMS. The CMS may then instruct the MTA to create a connection, reserve QoS resources through the access network for the pending voice connection, and also to play a locally generated ringback tone. The CMS in turn communicates with a remote CMS (or MGC) to setup the call. When the CMS detects answer from the far end, it instructs the MTA to stop the ringback tone, activate the media connection between the MTA and the far-end MTA, and begin sending and receiving media stream packets.

By centralizing Call State and service processing in the CMS, the service provider is in a position to centrally manage the reliability of the service provided. In addition the service provider gains full access to all software and hardware in the event that a defect that impacts subscriber services occurs. Software can be centrally controlled, and updated in quick debugging and resolution cycles that do not require deployment of field personnel to the customer premise. Additionally, the service provider has direct control over the services introduced and the associated revenue streams associated with such services.

6.1.2 PSTN signalling framework

PSTN signalling interfaces are summarized in table 1 (Pkt-c3 through Pkt-c8). These interfaces provide access to PSTN-based services and to PSTN subscribers from the IP-Cablecom network.

The IP-Cablecom PSTN signalling framework consists of a PSTN gateway that is subdivided into three functional components:

- Media Gateway Controller (MGC);
- Media Gateway (MG);
- Signalling Gateway (SG).

The Media Gateway Controller and Media Gateway are analogous to, respectively, the CMS and MTA in the NCS framework. The Media Gateway provides bearer and in-band signalling connectivity to the PSTN. The Media Gateway Controller implements all the Call State and intelligence and controls the operation of the Media Gateway through the TGCP protocol (pkt-c6). This includes creation, modification and deletion of connections as well as in-band signalling information to and from the MG. TGCP contains two variants, one closely aligned with NCS [TS101 909-4] which is an extended variant of the IETF MGCP call signalling protocol in RFC 2705 [15]; the other is a profile of the IETF MEGACO call signalling protocol in RFC 3015 [17] and H.248.

The CMS and the MGC may each send routing queries (e.g. freephone number lookup, LNP lookup) to a Signalling System Number 7 Service Control Point (SCP) via the SG (pkt-c3 and pkt-c5). The MGC, via the SG, also exchanges ISUP [1] signalling with the PSTN's Signalling System Number 7 entities for trunk management and control. The ISTP protocol provides the signalling interconnection service between the IP-Cablecom network call control elements (Call Management Server and Media Gateway Controller) and the PSTN Switched Circuit Network (SCN) through the Signalling System Number 7 Signalling Gateway. ISTP contains features for initialization; address mapping from the Signalling System Number 7 domain to the IP domain; message delivery for Signalling System Number 7 ISUP [1] and TCAP [3]; congestion management, fault management, maintenance operations; and redundant configuration support. ISTP bridges the gap between basic IP transport mechanisms and application level signalling. Although not a translation of the Signalling System Number 7 MTP3 [2] and SCCP [3] protocols, ISTP implements analogues to some of the MTP3 [2] and SCCP [3] functions in a fashion appropriate to distributed systems communicating over an IP network. These capabilities allow the IP network to interact with and receive all the services of the PSTN. As service capabilities evolve over time, these same signalling capabilities may be used to support PSTN access to the IP-Cablecom network's own routing and service databases.

6.2 Media Streams

The IETF standard RTP (RFC 1899 [12]) is used to transport all media streams in the IP-Cablecom network. IP-Cablecom utilizes the RTP profile for audio and video streams as defined in RFC 1890 [11].

The primary media flow paths in the IP-Cablecom network architecture are shown in figure 6 and are further described below the figure.

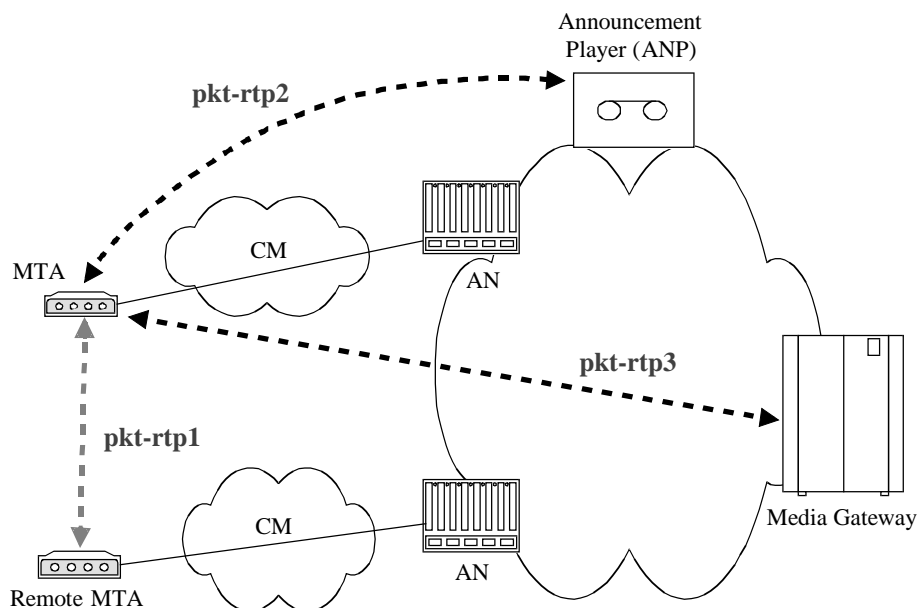

Figure 6: RTP media stream flows in an IP network

pkt-rtp1: Media flow between MTAs. Includes, for example, encoded voice, video, and fax.

pkt-rtp2: Media flow between the ANP and the MTA. Includes, for example, tones and announcements sent to the MTA by the Announcement Player.

pkt-rtp3: Media flow between the MG and the MTA. Includes, for example, tones, announcements, and PSTN media flow sent to the MTA from the Media Gateway.

RTP encodes a single channel of multimedia information in a single direction. The standard calls for an 8-byte header with each packet. An 8-bit RTP "Payload Type" is defined to indicate which encoding algorithm is used. Most of the standard audio and video algorithms are assigned to particular payload type values in the range 0 through 95. The range 96 through 127 is reserved for "dynamic" RTP payload types. The range 128 through 255 is reserved for private administration.

The packet format for RTP data transmitted over IP over Ethernet is depicted in figure 7.

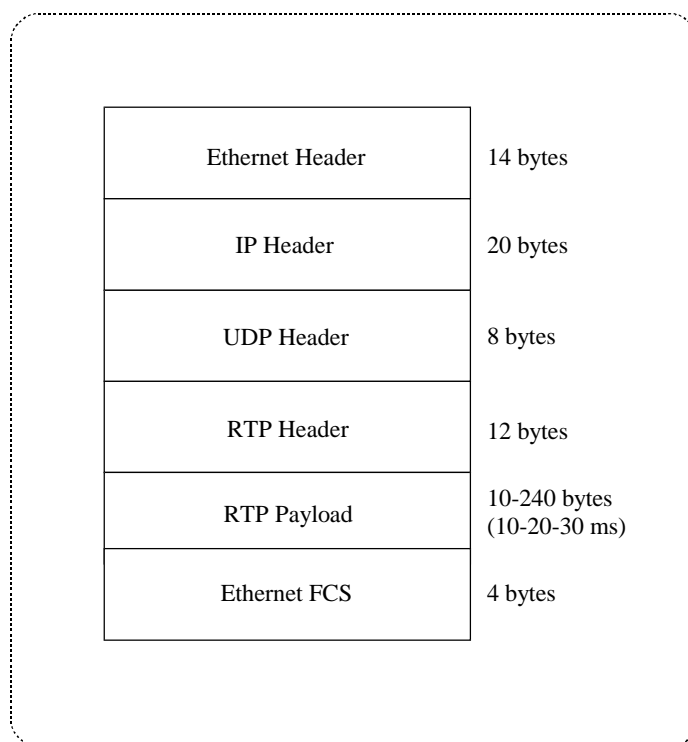

Figure 7: RTP packet format

The length of the RTP Payload as well as the frequency with which packets are transmitted depends on the algorithm as defined by the Payload Type field.

RTP sessions are established dynamically by the endpoints involved, so there is no "well-known" UDP port number. The Session Description Protocol (SDP) was developed by the IETF to communicate the particular IP address and UDP port an RTP session is using.

The packet header overhead of Ethernet, IP, UDP, and RTP is significant when compared to a typical RTP Payload size, which can be as small as 10 bytes for packetized voice. J.112 addresses this issue with a Payload Header Suppression feature for abbreviating common headers.

6.3 MTA Device Provisioning

The scope of MTA Device Provisioning is to enable a MTA to register and provide subscriber services over the HFC network. Provisioning covers initialization, authentication, and registration functions required for MTA device provisioning. The Provisioning Specification also includes attribute definitions required in the MTA configuration file.

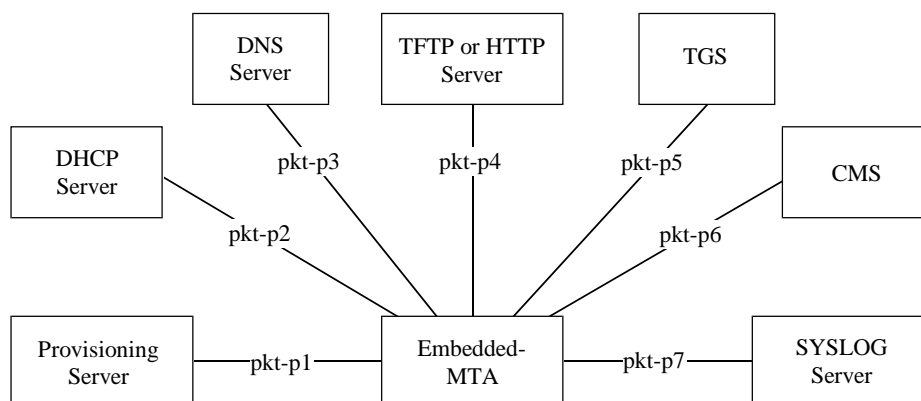

Figure 8: IPCablecom provisioning interfaces

Table 2 describes the provisioning interfaces shown in figure 8.

Table 2: Device provisioning interfaces

Interface	IPCablecom Functional Components	Description
Pkt-p1	MTA-PROV Server	Interface to exchange device capability as well as MTA device and endpoint information between the MTA and Provisioning Server using the SNMP protocol. The MTA also sends notification that provisioning has completed along with a pass/fail status using the SNMP protocol.
Pkt-p2	MTA-DHCP Server	DHCP interface between the MTA and DHCP Server used to assign an IP address to the MTA. If a DNS server is required during provisioning, then the address of this server is also included.
Pkt-p3	MTA-DNS Server	DNS interface between the MTA and DNS Server used to obtain the IP address of an IPCablecom server given its fully qualified domain name.
Pkt-p4	MTA-HTTP or TFTP Server	MTA configuration file is downloaded to the MTA from the TFTP Server or HTTP Server.
Pkt-p5	MTA-TGS	MTA obtains a Kerberos ticket from the Ticket Granting Server using the Kerberos protocol.
Pkt-p6	MTA-CMS	MTA establishes an IPsec Security Association with the CMS using the Kerberos protocol.
Pkt-p7	MTA-SYSLOG	MTA sends notification that provisioning has completed along with a pass/fail status to the SYSLOG server via UDP.

6.4 SNMP element management layer interfaces

IPCablecom requires SNMPv3 to interface the MTA to element management systems for MTA device provisioning. SNMPv3 "traps" and "informs" are supported for event handling, as well as "sets" and "gets" for provisioning. IPCablecom MIBs will be defined in a future MTA MIB Specifications.

The IPCablecom NCS MIB contains Network Call Signalling information for provisioning on both a device and a per endpoint basis. The MTA MIB contains data for device provisioning and for supporting provisioned functions such as event logging. More detailed information on the MIB's framework can be found in the IPCablecom MIB's framework specification.

6.5 Event messages interfaces

6.5.1 Event message framework

An Event Message is a data record containing information about network usage and activities. A single Event Message may contain a complete set of data regarding usage or it may only contain part of the total usage information. When correlated by the Record Keeping System (RKS), information contained in multiple Event Messages provides a complete record of the service. This complete record of the service is often referred to as a Call Detail Record (CDR). Event Messages or CDRs may be sent to one or more back office applications such as a billing system, fraud detection system, or pre-paid services processor.

This IP-Cablecom Event Messages specification defines the structure of the Event Message data record and defines RADIUS as the transport protocol. Event Message data record is designed to be flexible and extensible in order to carry information about network usage for a wide variety of services. Additional transport protocols may be recommended in future releases of the present document. Although the scope of the specification is limited to defining Event Messages for basic residential voice capabilities, it is expected that the present document will be expanded to support additional IP-Cablecom-based services. Figure 9 shows a representative Event Message architecture.

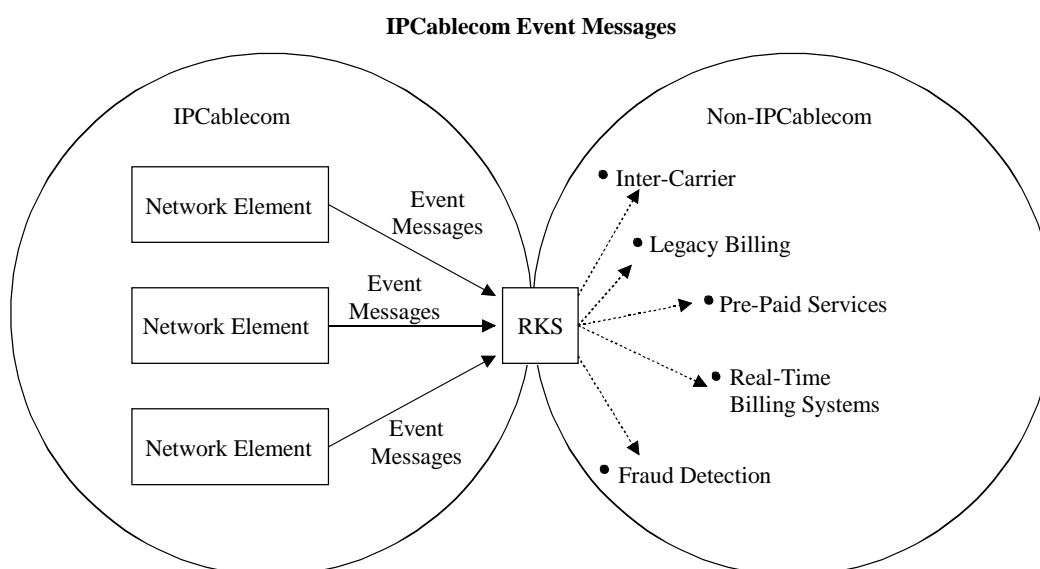
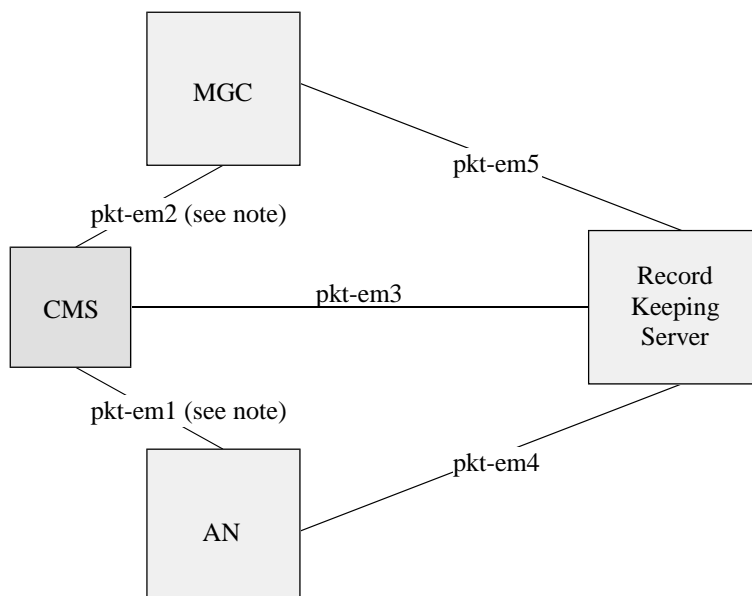

Figure 9: Representative event messages architecture



NOTE: Indicates that the Billing Correlation ID and other billing data is carried on an existing signalling interface.

Figure 10: Event message interfaces

Table 3 describes the Event Message interfaces shown in figure 10.

Table 3: Event message interfaces

Interface	IPcablecom Functional Component	Description
pkt-em1	CMS-AN	DQoS Gate-Set message carrying Billing Correlation ID and other data required for AN to send Event Messages to an RKS.
Pkt-em2	CMS-MGC	Vendor-proprietary interface carrying Billing Correlation ID and other data required billing data. Either the CMS or MGC may originate a call and therefore need to create the Billing Correlation ID and send this data to the other.
Pkt-em3	CMS-RKS	RADIUS protocol carrying IPcablecom Event Messages.
Pkt-em4	AN-RKS	RADIUS protocol carrying IPcablecom Event Messages.
Pkt-em5	MGC-RKS	RADIUS protocol carrying IPcablecom Event Messages.

6.6 Quality of Service (QoS)

6.6.1 QoS framework

Quality of Service signalling interfaces are defined between many of the components of the IPcablecom network. Signalling may be handled at the application layer (e.g. SDP parameters), network layer (e.g. RSVP), or the data-link layer (e.g. J.112 QoS).

From the perspective of the MTA and its access network the IPcablecom QoS Framework is represented in figure 11.

IPCablecom Network - QoS Signalling Interfaces

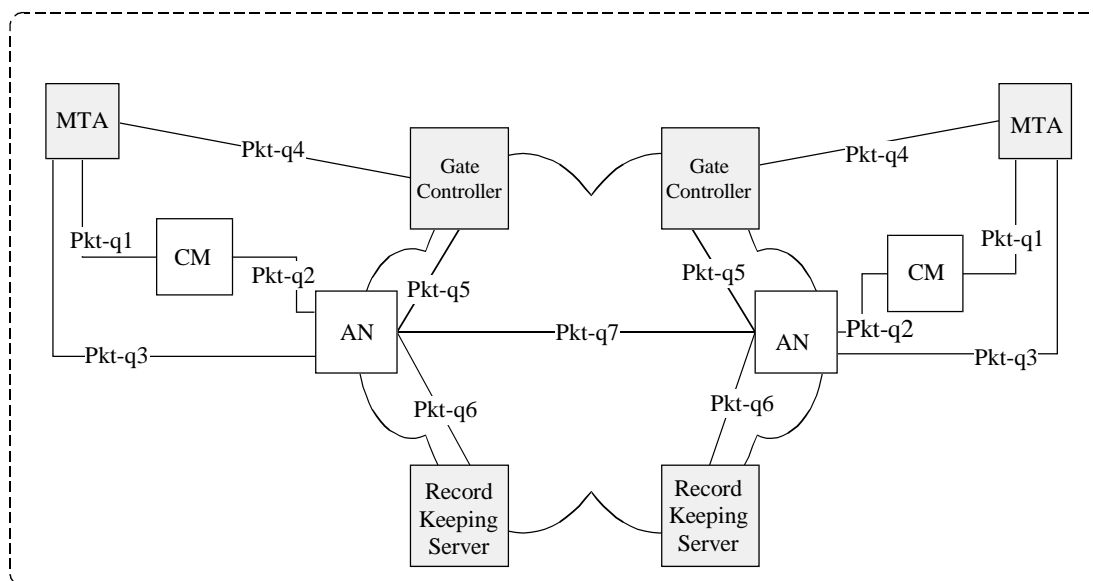

NOTE: Gate Controller is a function contained within a CMS node.

Figure 11: IPCablecom QoS signalling interfaces

Table 4 briefly identifies each interface and how each interface is used in the Dynamic QoS Specification (DQoS). Two alternatives are shown for the present document: first a general interface that is applicable to either embedded or standalone MTAs; and second, an optional interface that is available only to embedded MTAs.

Table 4: QoS interfaces for standalone and embedded MTAs

Interface	IPCablecom Functional Components	DQoS Embedded/ Standalone MTA	D-QoS Embedded MTA
Pkt-q1	MTA-CM	N/A	E-MTA, MAC Control Service Interface
Pkt-q2	CM-AN	J.112 [6], AN-initiated	J.112 [6], CM-initiated
Pkt-q3	MTA-AN	RSVP+ (see note)	N/A
Pkt-q4	MTA-GC/CMS	NCS/DCS	NCS
Pkt-q5	GC-AN	Gate Management	Gate Management
Pkt-q6	AN-RKS	Billing	Billing
Pkt-q7	AN-AN	Gate Management	Gate Management
NOTE:	For IPCablecom, only the embedded MTA interfaces as defined in clause 7 of the Dynamic Quality of Service specification are required. The CMTS is not required to support RSVP across the MTA-CMTS interface as defined in DQoS clause 6.		

The function of each QoS interface is further described is defined in table 5.

Table 5: QoS interfaces

Interface	IPCablecom Functional Components	Description
Pkt-q1	MTA-CM	This interface is only defined for the embedded MTA. The interface decomposes into three sub-interfaces: <ul style="list-style-type: none"> - <i>Control</i>: used to manage J.112 service-flows and their associated QoS traffic parameters and classification rules. - <i>Synchronization</i>: used to synchronize packet and scheduling for minimization of delay and jitter. - <i>Transport</i>: used to process packets in the media stream and perform appropriate per-packet QoS processing. The MTA/CM interface is conceptually defined in J.112 [6].
Pkt-q2	CM-AN	This is the J.112 QoS interface (control, scheduling, and transport). It should be noted that, architecturally, control functions can be initiated from either the CM or the AN. However the AN is the final policy arbiter and granter of admission into the J.112 access network. The following capabilities of the J.112 MAC are used within IPCablecom: <ul style="list-style-type: none"> • Multiple service flows, each with its own class of upstream traffic, both single and multiple voice connections per J.112 service flow. • Prioritized classification of traffic streams to service flows. • Guaranteed minimum/constant bit rate scheduling service. • Constant bit rate scheduling with traffic activity detection service (slow down, speed up, stop, and restart scheduling). • J.112 packet header suppression for increased call density. • J.112 classification of voice flows to service flow. • J.112 synchronization of CODEC to AN clock and Grant Interval. • Two-phase activation of QoS resources. • TOS packet marking at network layer. • Guarantees on delay and jitter. • Internal sublayer signalling between IPCablecom MTA and the CM (embedded MTA). • This interface is further defined in J.112 [6].
Pkt-q3	MTA-AN	The interface is used for request of bandwidth and QoS resources related to the bandwidth. The interface runs on top of layer 4 protocols that bypass the CM. As a result of message exchanges between the MTA and AN, service flows are activated using AN-originated signalling on interface PKT-Q2. An enhanced version of RSVP is utilized for this signalling.
Pkt-q4	MTA -CMS/GC	Signalling interface between the MTA and CMS/GC. Many parameters are signalled across this interface such as media stream, IP addresses, and Codec selection, but it is possible for certain protocols to either derive QoS semantics from the signalling, or to extend the application layer signalling protocol to contain explicit QoS signalling parameters.
Pkt-q5	CMS/GC-AN	This interface is used to manage the dynamic Gates for media stream bearer channels. This interface enables the IPCablecom network to request and authorize QoS changes without requiring any layer two J.112 access network QoS control functions in MTA. When supporting standalone MTAs no new client-side QoS signalling protocol needs to be designed. The GC/CMS takes responsibility for requesting policy, and the AN takes responsibility for access control and quickly setting up QoS on the J.112 access link.
Pkt-q6	AN-RKS	This interface is used by the AN to signal to the RKS all changes in call authorization and usage. This interface is defined in the Event Messages specification.
Pkt-q7	AN-AN	This interface is used for coordination of resources between the AN of the local MTA and the AN of the remote MTA. The AN is responsible for the allocation and policing of local QoS resources.

6.6.2 Layer two vs. layer three MTA QoS signalling

QoS signalling from the MTA can be performed either at layer two (J.112 [6]) or layer three (RSVP). Layer two signalling is accessible to CM and AN devices that exist at the RF boundary of the J.112 access network. Layer three signalling is required for devices that are one or more hops removed from the RF boundary of the J.112 access network.

If layer two QoS signalling is initiated by the MTA, the MTA must be an embedded MTA. The MTA utilizes the implicit interface for controlling the J.112 MAC service flows as suggested by ITU-T Recommendation J.112 [6].

Layer three QoS signalling is initiated by the MTA; the MTA may be either an embedded MTA or standalone MTA. Enhanced RSVP is used for this signalling and is intercepted by the AN. The AN utilizes layer two QoS signalling to communicate QoS signalling changes to the CM.

6.6.3 Dynamic Quality of Service

IPCablecom Dynamic QoS (D-QoS) utilizes the call signalling information at the time that the call is made to dynamically authorize resources for the call. Dynamic QoS prevents various thefts of service attack types by integrating the QoS messaging with other protocols and network elements. The network elements that are necessary for a Dynamic QoS control are shown in figure 11.

The function within the AN that performs traffic classification and enforces QoS policy on media streams is called a Gate. The Gate Controller element manages Gates for IPCablecom media streams. The following key information is included in signalling between the GC and the AN:

- **Maximum Allowed QoS Envelope:** The maximum allowed QoS envelope enumerates the maximum QoS resource (e.g. "2 grants of 160 bytes per 10 ms") the MTA is allowed to admit for a given media stream bearer flow. If the MTA requests a value greater than the parameters contained within the envelope the request will be denied.
- **Identity of the media stream endpoints:** The GC/CMS authorizes the parties that are involved in a media stream bearer flow. Using this information the AN can police the data stream to ensure that the data stream is destined and originated from the parties that are authorized.
- **Billing Information:** The GC/CMS creates opaque billing information that the AN does not have to decode. The information might be as simple as billing identity or the nature of the call. The AN forwards this billing information to the RKS as the call is activated or terminated.

The role of each of the IPCablecom components in implementing D-QoS is as follows:

- **Call Management Server/Gate Controller:** The CMS/GC is responsible for QoS authorization. The QoS authorization might depend on the type of call, type of user or other parameters defined by policy.
- **AN:** Using information supplied by the GC/CMS the AN performs admission control on the QoS requests and at the same time polices the data stream to make sure that the data stream is originated and sent to authorized-media stream parties. The AN interacts with CM, RKS, MTA, and Terminating AN. The responsibilities of AN with respect to each of these elements is:
 - **AN to CM:** The AN is responsible of setting up and tearing down service flows in such a way that the service level agreement it made with the MTA is met. Inasmuch as the AN does not trust the CM it polices the traffic from the CM such that the CM works in the way AN requested.
 - **AN to Record Keeping Server:** The AN updates the Record Keeping Server (RKS) each time there is a change in the QoS Service Level Agreement between AN and MTA. It uses the Billing Information that is given by GC/CMS to identify each authorized QoS link. The AN puts timing information in the message it sends and also buffers the messages if the connection to RKS is severed.
 - **AN to MTA:** The MTA makes dynamic requests for modification of QoS traffic parameters. When the AN receives the request it makes an authorization check to find out whether the requested characteristics are within the authorized QoS envelope and also whether the media stream endpoints are authorized. Then it provisions the QoS attributes for the RFI link on the AN and activates the appropriate QoS traffic parameters via signalling with the CM. When all the provisioning and authorization checks succeed the AN sends a success message to the GC/CMS indicating that MTA and AN are engaged in a Service Level Agreement.

- **AN to Terminating AN:** The AN sends messages to the terminating end AN (or other terminating access networking device) to ensure that the committed bandwidth on both sides is the same. If the committed bandwidth is not the same then both sides close the connection.
- **Cable Modem (CM):** Even though the CM is an untrusted entity the CM is responsible for the correct operation of the QoS link between itself and the AN. The AN makes sure that the CM cannot abuse the RFI link, but it is the responsibility of the CM to utilize the RFI link to provide services that are defined by J.112 [6].
- **Record Keeping Server (RKS):** The RKS acts as a database and stores each event as sent by the AN. The RKS stores the messages by attaching received time and network element information. The RKS has to have sufficient interface and/or processing power to allow additional processing to be done.
- **MTA:** The MTA is the entity to which the Service Level Agreement is provided by the access network. The MTA is responsible for the proper use of the QoS link. If it exceeds the traffic authorized by the SLA than it the MTA will not receive the QoS characteristics that it requested. The MTA uses two stage QoS bandwidth allocation - while the call origination is proceeding the QoS resources are admitted, then when the call is answered the resources are activated.

6.7 Announcement services

Announcements are typically needed for calls that do not complete. Additionally, they may be used to provide enhanced information services to the caller. The signalling interfaces to support IPCablecom Announcement Services are shown in figure 12 and are summarized in table 6.

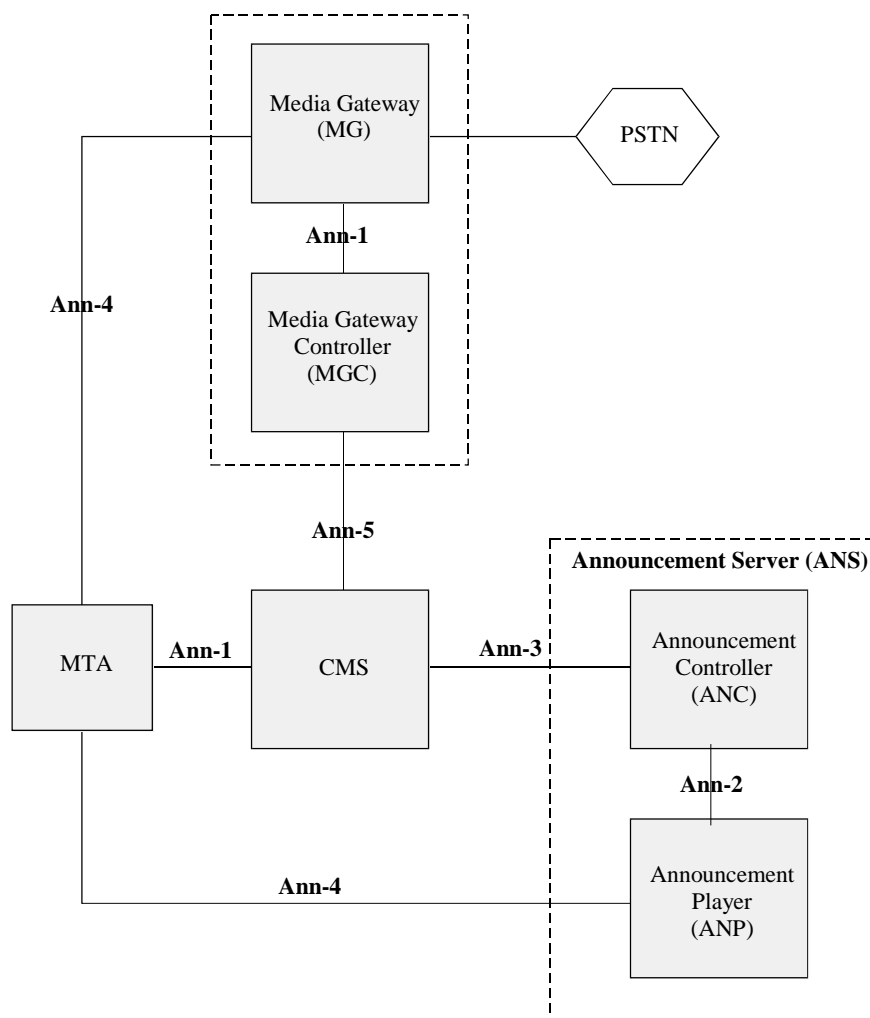

Figure 12: Announcement services components and interfaces

Table 6: Announcement interfaces

Interface	IPCablecom Functional Components	Protocol
Pkt-ann1	MTA-CMS MGC-MG	The CMS to MTA interface provides a mechanism for the CMS to signal the MTA to play locally stored announcements. Storing announcements in the MTA allows for providing informative progress tones to the end user independently of the network state (e.g. congestion). An NCS-based announcement package has been defined that can be used for both the CMS-MTA and MGC-MG interfaces. Simple, fixed-content announcements (e.g. all-lines-busy) may also be stored at the Media Gateway to provide announcements to PSTN users. The MGC to MG interface provides a mechanism for the MG to play fixed-content announcements to PSTN end-users involved in off-net to on-net calls.
Pkt-ann2	MPC-MP	When the CMS identifies a need for an ANS-based announcement, it sends a request to the MPC over interface Ann-3. Upon receiving a request from the CMS, the MPC opens a session with the Announcement Player using the NCS package.
Pkt-ann3	CMS-MPC	The protocol for the Ann-3 interface is undefined for IPCablecom.
Pkt-ann4	MP-MTA	Defines the media stream format (RTP) for delivery of the announcement from the Announcement Player to the MTA using the RTP protocol.
Pkt-ann5	CMS-MGC	The Ann-5 protocol interface is undefined for IPCablecom.

6.7.1 ANS physical vs. logical configuration

The MP and MPC are logical components that may reside in the same physical entities. When logical components reside in the same physical entity, interfaces between these components become optional. In addition, standalone components using the Ann-2 and Ann-3 interfaces may be shared by many network entities.

6.8 Security

6.8.1 Overview

Each of IPCablecom's protocol interfaces is subject to threats that could pose security risks to both the subscriber and service provider. The IPCablecom architecture addresses these threats by specifying, for each defined protocol interface, the underlying security mechanisms (such as IPSec) that provide the protocol interface with the security services it requires, e.g. authentication, integrity, confidentiality.

For example, the media stream path may traverse a large number of potentially unknown Internet service and backbone service providers' wires. As a result, the media stream may be vulnerable to malicious eavesdropping, resulting in a loss of communications privacy. IPCablecom core security services include a mechanism for providing end-to-end encryption of RTP media streams, thus substantially reducing the threat to privacy.

The security services available through IPCablecom's core service layer are authentication, access control, integrity, confidentiality and non-repudiation. An IPCablecom protocol interface may employ zero, one or more of these services to address its particular security requirements.

IPCablecom security addresses the security requirements of each constituent protocol interface by:

- identifying the threat model specific to each constituent protocol interface;
- identifying the security services (authentication, authorization, confidentiality, integrity, and non-repudiation) required to address the identified threats;
- specifying the particular security mechanism providing the required security services.

The security mechanisms include both the security protocol (e.g. IPSec, RTP-layer security, and SNMPv3 security) and the supporting key management protocol (e.g. IKE, PKINIT/Kerberos).

Figure 13 provides a summary of all the IPCablecom security interfaces.

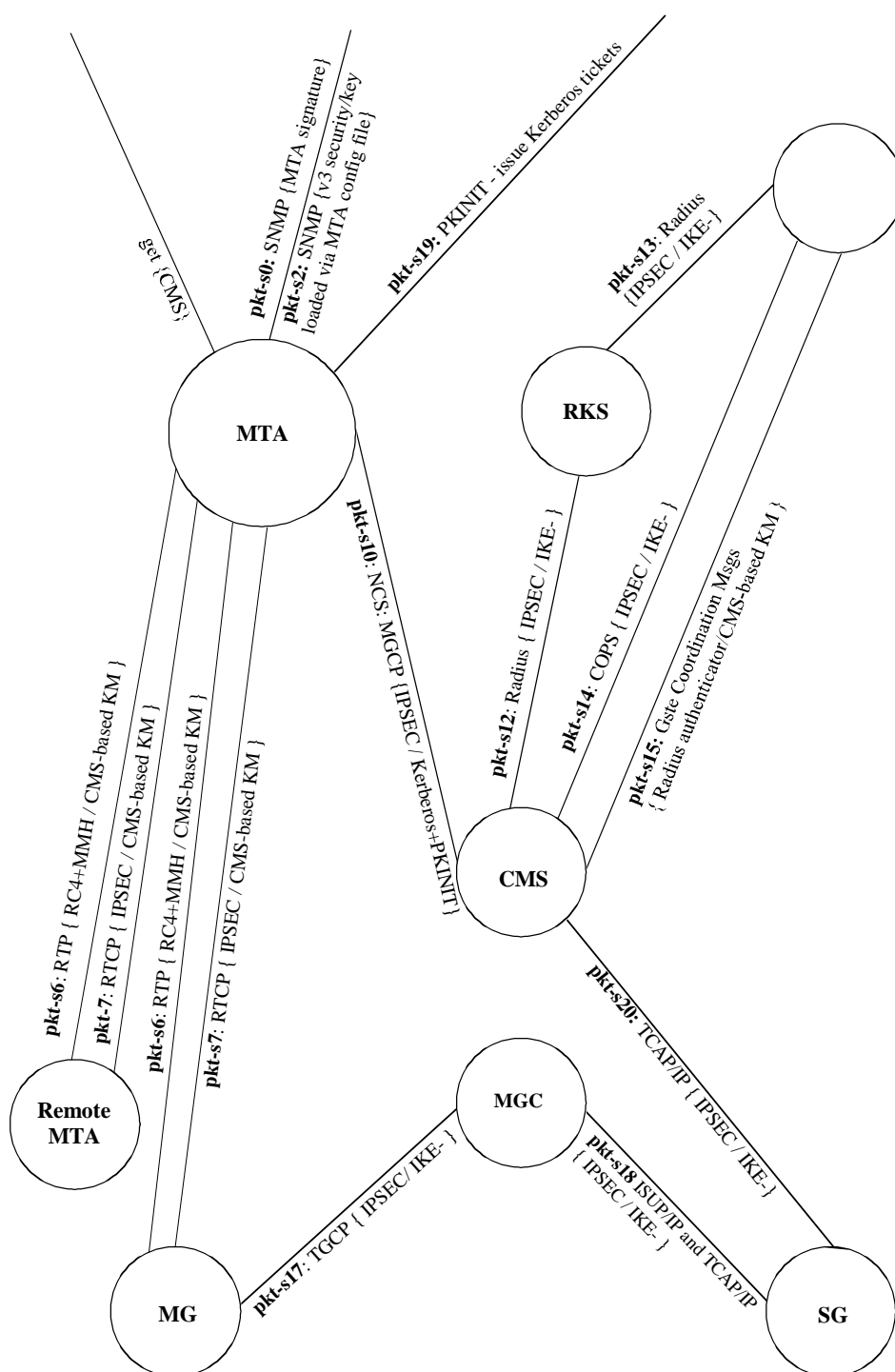

Figure 13: IPCablecom security interfaces

In figure 13, each interface is labelled as:

- <label>: <protocol> { <security protocol>/<key management protocol> }.

If the key management protocol is missing, it means that it is not needed for that interface. IPCablecom interfaces that do not require security are not shown in figure 13.

The following abbreviations are used in figure 13:

- **IKE-:** IKE with pre-shared keys;
- **IKE+:** IKE requires public key certificates;
- **CMS-based KM:** Keys randomly generated and distributed by CMS.

Table 7 describes each of the interfaces shown in figure 13.

Table 7: Security interfaces

Interface	IPCablecom Functional Components	Description
pkt-s0	MTA-Provisioning App	SNMPv3 INFORM from the MTA to the SNMP Manager, followed by optional SNMP GET(s) by the SNMP Manager are used to query MTA device capabilities. This occurs at the time where SNMPv3 keys may not be available, and security is provided with an RSA signature, formatted according to CMS (Cryptographic Message Syntax).
Pkt-s1	MTA-TFTP or HTTP Server	MTA Configuration file download. The MTA downloads a configuration file (with TFTP-get) that is signed by the TFTP server and sealed with the MTA public key, with a CMS (Cryptographic Message Syntax) wrapper. This flow occurs right after an SNMPv3 INFORM followed by an optional SNMP GET(s) - see flow pkt-s0.
pkt-s2	MTA-Provisioning App	Standard SNMPv3 security. The SNMPv3 keys are downloaded with the MTA configuration file, using interface pkt-s1.
Pkt-s3	CM-AN	BPI+ privacy layer on the HFC link. Both security and key management are defined by ITU-T Recommendation J.112 [6].
pkt-s6	MTA-MTA	End-to-end media packets between two MTAs, or between MTA and MG. RTP packets are encrypted directly with RC4, without any additional security layers. An MMH-based MAC (Message Authentication Code) optionally provides message integrity. Keys are distributed by the CMS to the two endpoints.
Pkt-s7	MTA-MTA	RTCP control protocol for RTP, defined above. Message integrity and encryption provided with IPSEC. Key management is same as for RTP - keys are distributed by CMS.
Pkt-s10	MTA-CMS	MTA-CMS signalling for NCS. Message integrity and privacy via IPSEC. Key management is with Kerberos with PKINIT (public key initial authentication) extension.
Pkt-s12	CMS-RKS	Radius billing events sent by the CMS to the RKS. Radius authentication keys are hardcoded to 0. Instead, IPSEC is used for message integrity as well as privacy. Key management is IKE-.
Pkt-s13	AN-RKS	Radius events sent by the AN to the RKS. Radius authentication keys are hardcoded to 0. Instead, IPSEC is used for message integrity, as well as privacy. Key management is IKE-.
Pkt-s14	CMS-AN	COPS protocol between the GC and the AN, used to download QoS authorization to the AN. Message integrity and privacy provided with IPSEC. Key management is IKE-.
Pkt-s15	CMS-AN	Gate Coordination messages for DQoS. Message integrity is provided with an application-layer (Radius) authenticator. Keys are distributed by local CMS over COPS.
Pkt-s16	N/A	N/A
pkt-s17	MGC-MG	IPCablecom interface to the PSTN Media Gateway. IPSEC is used for both message integrity and privacy. Key management is IKE-.
Pkt-s18	MGC-SG	IPCablecom interface to the PSTN Signalling Gateway. IPSEC is used for both message integrity and privacy. Key management is IKE-.
Pkt-s19	MTA-TGS	Kerberos/PKINIT key management protocol, where the TGS issues CMS tickets to the MTAs.
Pkt-s20	CMS-SG	CMS queries the PSTN Gateway for NP (Number Portability) [117, 18, 19] and other telephony services. IPSEC is used for both message integrity and privacy. Key management is IKE-.

6.8.2 Device provisioning security

The IPCablecom security architecture divides device provisioning into three distinct activities: subscriber enrolment, device provisioning and device authorization.

6.8.2.1 Subscriber enrolment

The subscriber enrolment process establishes a permanent subscriber billing account that uniquely identifies the MTA to the CMS via the MTA's serial number or MAC address. The billing account is also used to identify the services subscribed to by the subscriber for the MTA.

Subscriber enrolment may occur in-band or out-of-band. The actual specification of the subscriber enrolment process is out of scope for IPCablecom and may be different for each Service Provider.

6.8.2.2 Device provisioning

The MTA device verifies the authenticity of the configuration file it downloads from the boot server. Privacy of the configuration data is also provided. The configuration data will be "signed and sealed" by packaging it into a PKCS #7 sealed object.

6.8.2.3 Dynamic provisioning

SNMPv3 security will be used for dynamically provisioning voice communications capabilities on an embedded-MTA.

6.8.2.4 Device authorization

Device authorization is when a provisioned MTA Device authenticates itself to the Call Management Server, and establishes a security association with that server prior to becoming fully operational. Device authorization allows subsequent call signalling to be protected under the established security association.

6.8.2.5 Signalling security

All signalling traffic, which includes QoS signalling, call signalling, and signalling with the PSTN Gateway Interface, will be secured via IPSec. IPSec security association management will be done through the use of two key management protocols: Kerberos/PKINIT and IKE. Kerberos/PKINIT will be used to exchange keys between MTA clients and their CMS server; IKE will be used to manage all other signalling IPSec SAs.

6.8.2.6 Media stream security

Each media RTP packet is encrypted for privacy. The MTAs have an ability to negotiate a particular encryption algorithm, although the only one that is currently specified is RC4. Encryption is applied to the packet's payload but not to its header.

Each RTP packet may include an optional message authentication code (MAC). The MAC algorithm can also be negotiated, although the only one that is currently specified is MMH. The MAC computation spans the packet's unencrypted header and encrypted payload.

Keys for the encryption and MAC calculation are derived from the End-End secret, which is exchanged between sending and receiving MTA as part of the call signalling. Thus, the key exchanges for media stream security are secured themselves by the call signalling security.

6.8.2.7 OSS and billing system security

The SNMP agents in IPCablecom devices implement SNMPv3. The SNMPv3 User Security Model (RFC 2274, see Bibliography) provides authentication and privacy services for SNMP traffic. SNMPv3 view-based access control (RFC 2275, see Bibliography) may be used for access control to MIB objects.

The IKE key management protocol is used to establish encryption and authentication keys between the Record Keeping Server (RKS) and each IPCablecom network element that generates Event Messages. When the network IPSec Security Associations are established, these keys must be created between each RKS (primary, secondary, etc) and every CMS and AN. The key exchange between the MGC and RKS may exist and is left to vendor implementation in IPCablecom Phase 1. The Event Messages are sent from the CMS and AN to the RKS using the RADIUS transport protocol, which is in turn secured by IPSec.

7 Network design considerations

7.1 Time keeping and reporting issues

In order to maintain service quality, it is highly recommended that all network equipment clocks be maintained to within 200 ms of Universal Time Coordinated (UTC).

It is recommended that IPCablecom networks maintain a timeserver that is accurate to within a specified interval of Universal Time Coordinated (UTC). It is recommended that the server be able to exchange time information with other network equipment such that the receiving equipment is able to be synchronized to the timeserver clock at the completion of the synchronization protocol exchange.

Network Time Protocol (NTP) is the recommended protocol for IPCablecom time synchronization.

All systems that generate billing event messages must synchronize their clocks to a network clock source. Synchronization should be done to ensure that the reporting device's own clock remains within ± 100 ms of the last synchronization value.

7.2 Timing for playout buffer alignment with coding rate

Packet generating and packet handing equipment generally operate with free-running clocks. Problems may arise in the offering of isochronous services due to the plesiochronous nature of these clocks. The difference in clock speed between these plesiochronous entities are generally exhibited as overrun or underrun of the playout buffers.

In order to minimize the occurrence of these conditions, all ANs should lock their downstream transmission rate to a clock derived from a source that reflects a Stratum-3 clock. Embedded MTAs should use the downstream transmission rate to derive the clock used to determine packetization period. MTAs should also use this clock to determine the rate of playout from the receive buffer. Non-embedded MTAs should use the average packet arrival interval (see note) as the basis for determining their packetization and playout clock.

NOTE: I.e. the interval from arrival of the first bit of packet N to the arrival of the first bit of packet N+1, ignoring intervals where a packet does not arrive within 5 ms of the expected periodicity.

7.3 IP addressing

An embedded MTA is a multi-function entity with one function required for CM administration and the second function being the MTA function itself. All IP addresses in an IPCablecom network are IPV4.

All IPCablecom embedded MTAs are required to have two IP addresses - one for the CM and one for the MTA. All IPCablecom embedded MTAs are required to have 2 MAC addresses - one for the CM and one for the MTA.

The following requirements can be met using the dual IP address configuration:

- An embedded MTA containing a dual IP address can assign a private IP address for the CM host function, in the case where NAT translation is not provided elsewhere in the IPCablecom network.

- With two IP addresses per MTA, the IPCablecom operator can route the voice service packets over a voice backbone and all other packets (data) over a data backbone. Essentially the routing backbone must be configured such that different routing paths are followed for each of the two destination IP addresses.
- The IPCablecom operator can simplify network side administration and management functions using separate IP addresses. For example, policy filters can be instantiated that block or permit traffic from the MTA component of the node. In addition, network service providers can provide source address screening services, and network traffic statistics and diagnostics can be collected based upon the IP address of the MTA.

Dual IP addresses result in special considerations that affect the following:

- IP protocol stack implementation of the MTA;
- Implementation of IPCablecom OSS and device provisioning protocols;
- Network routing implementations.

7.4 Dynamic IP addressing assignment

An operational issue exists regarding the dynamic IP addresses assignment for MTAs. The NCS model specified in IPCablecom is based on a Call Management Server mapping a subscriber's service to an endpoint identifier and an IP address. Therefore, call-processing operations would be affected if the MTA's IP address changed during an active call. However, there are some specifications that network operators and MTA vendors can employ to eliminate this situation.

- 1) When configuring DHCP options for an MTA, the network operator should configure the IP Address Lease Time (Option Code 51) to specify a very long lease time. This option is detailed in "Dynamic Host Configuration Protocol" (RFC 2131 [13]) and "DHCP Options and BOOTP Vendor Extensions" (RFC 2132 [14]). Per clause 3.3 of RFC 2131 [13], a lease time setting of "0xffffffff" represents an infinite lease. Use of long lease times will minimize the possibility that an active MTA would be unable to renew its assigned IP address lease.
- 2) Network operators should also configure an MTA's DHCP Timer T1 and T2 values (Option Codes 58 and 59, respectively) to be no more than the default values specified in clause 4.4.5 of RFC 2131 [13]. Configuring an MTA to begin its IP address lease time renewal process at no more than 50 % of the assigned lease time, combined with the use of very long lease time values, will further ensure that an MTA will be able to renew its IP address lease.
- 3) MTA vendors should implement mechanisms to prevent an MTA from entering the RENEWING state (as specified in RFC 2131 [13]) while call processing is active. It is left to vendor implementation to determine exactly how this capability might best be implemented in their product.

7.5 FQDN assignment

The following are potential operational issues that are expected to be resolved through vendor-specific implementations.

It is assumed that the OSS back office will generate the appropriate FQDNs for all IPCablecom devices, and pass this data to the appropriate IPCablecom devices and other network elements. These interfaces are not defined in IPCablecom (phase 1).

An operational issue exists regarding synchronization of databases within the provisioning domain. Specifically the DHCP database, and the DNS table's require concurrent updates when a subscriber record changes (this includes creation). RFC 2131 [13] provides a mechanism by which a host (a DHCP client) could acquire certain configuration information, specifically its IP address(es). However, DHCP does not provide any mechanisms to update the DNS Resource Records that contain the information about mapping between the host's FQDN and its IP address(es) (i.e. the Address and Pointer Resource Records). Thus the information maintained by DNS for a DHCP client may be incorrect - a host (the client) could acquire its address by using DHCP, but the Address Resource Record for the host's FQDN would not reflect the address that the host acquired, and the Pointer Resource Record for the acquired address would not reflect the host's FQDN.

The problem has two main issues. One, how do you update the DNS system when a new IP address is dispensed, and two, how long do you make time out values for RR's. Both of these issues are vendor implementation issues and therefore lie outside of the scope of IPCablecom specifications. However, some specifications on "best practices" are outlined in RFC 2131 [13].

7.6 Priority marking of signalling and media stream packets

Both the media stream and the signalling stream for IPCablecom-based services require methods for properly marking and transporting packets at a sufficiently high level of quality of service, both in the J.112 access network and in the managed IP backbone.

The primary mechanism for providing low-delay quality of service for media streams in the access network is the J.112 flow classification service. This service classifies packets into specific flows based upon packet fields such as IP source and destination addresses and UDP port number parameters. In the upstream such classified packets are transported via an appropriate constant bit rate service (for current codecs) as dynamically scheduled by the AN. In the downstream the packets are transported via an appropriate high priority queuing and scheduling mechanism. DQoS (between CMS and AN) and J.112 (between AN and CM) signalling mechanisms are used to dynamically setup the media stream flow classification rules and service flow QoS traffic parameters.

In addition to flow classification, it is useful to mark media stream packets with appropriate priority markings. Such priority markings can be utilized within AN/CM queuing systems and also within Diff-serv managed QoS backbones (which may not contain flow classification mechanisms) in order to provide high priority QoS treatment of such packets. It should be noted that while no definition is provided as to how QoS is managed in the Managed IP backbone in the current architecture, it is expected that the mechanisms defined for IPCablecom QoS will be usable within such a managed backbone.

Signalling packets may also benefit from prioritized QoS services. In particular as an access network becomes loaded to capacity, it may be important to forward signalling packets at a higher priority than data packets in order to avoid excessive signalling delay. It should be noted that, from a network traffic-engineering point of view, it has not yet been determined whether high priority treatment of signalling packets is required. If signalling prioritization is desired, then the method for providing prioritized QoS is based upon two mechanisms. First mark all signalling packets with a high priority marking, and second provide a J.112 Classifier that classifies such packets to be transported on a higher priority service flow. The Classifier can be as simple as mapping all upstream packets with this priority to the high priority SID, or can be more complex and also identify the IP address of the MTA(s) which originate the signalling. The higher priority service flow may be either statically provisioned or dynamically created by the administrator of the AN. It should be noted that if the administrator is concerned about theft of service of the high-priority service flow, then he may configure the service flow for high priority (low delay) but low bandwidth.

Marking of packets for both the media stream and the signalling stream (NCS) is performed by the MTA and the CMS. The marking is performed at the IP layer using a field that has alternately been called the TOS byte or the Diff-serv Code Point (DSCP). The TOS byte was the original definition of the byte while DSCP is the new definition of the byte as used by the IETF Diff-serv architecture. Because two formats for this byte exist, the configuration of the values should be done in a format and type independent way (in the MIBs for the MTA and Call Agent).

Management Information Bases (MIBS) are defined in IPCablecom for assigning the provisioned and default values for media stream priority marking and signalling stream priority marking (e.g. a value of "3" for signalling and a value of "5" for media). It should be noted that in NCS the signalled SDP parameters may contain overrides for the configured media stream priority marking value on a connection by connection basis. No mechanism currently exists for dynamically overriding the provisioned priority marking value of the signalling stream on a call-by-call basis.

7.7 Fax support

IPCablecom supports real-time fax transmission. Fax is "best" accomplished using the G.711 standard for audio encoding/decoding. If a call is established using a compressed codec, the embedded MTA will have to be instructed to look for fax tones. If fax tones are detected, the CMS will have to be notified and the MTA will be instructed to switch to using G.711 [5]. Note that this places a requirement on the embedded device to monitor the media stream and detect fax tones.

Support for switching over to fax from a voice call is required; however, switching back to voice from fax is not required (i.e. monitoring the fax media stream for an ending signal and then switching back to a low bandwidth codec).

Local termination of fax and translating the fax stream to an IP fax relay data stream is not required in this version of the architecture.

7.8 Analogue modem support

Analogue modems are supported in a similar fashion to fax - a MTA will be asked to detect modem tones and, when such tones are detected, the CMS will instruct the MTA to switch over to the G.711 codec if it is not already in use. Note that this places a requirement on the embedded device to monitor the voice stream and to detect analogue modem tones.

Switching over to G.711 to support analogue modem signalling from a voice call will be supported; however, switching back to voice from modem signalling will not be required to be supported (i.e. monitoring the modem media stream for an ending signal and then switching back to a low-bandwidth codec).

Local termination of modems and translating the modem stream to an IP modem relay data stream is not required in this version of the architecture.

Annex A (informative): Bibliography

IETF RFC 2274: "User-based Security Model (USM) for version 3 of the Simple Network Management Protocol (SNMPv3)".

IETF RFC 2275: "View-based Access Control Model (VACM) for the Simple Network Management Protocol (SNMP) (Obsoleted by RFC2575)".

IETF RFC 2575: "View-based Access Control Model (VACM) for the Simple Network Management Protocol (SNMP) (Obsoletes RFC2275)".

ITU-T Recommendation Q.704 (1996): "Signalling network functions and messages".

ITU-T Recommendation J.83 (1997): "Digital multi-programme systems for television, sound and data services for cable distribution".

ETSI TS 101 909-3: "Access and Terminals (AT); Digital Broadband Cable Access to the Public Telecommunications Network; IP Multimedia Time Critical Services; Part 3: Audio Codec Requirements for the Provision of Bi-Directional Audio Service over Cable Television Networks using Cable Modems".

ETSI TS 101 909-4: "Access and Terminals (AT); Digital Broadband Cable Access to the Public Telecommunications Network; IP Multimedia Time Critical Services; Part 4: Network Call signalling Protocol".

ETSI TS 101 909-5: "Access and Terminals (AT); Digital Broadband Cable Access to the Public Telecommunications Network; IP Multimedia Time Critical Services; Part 5: Dynamic Quality of Service for the Provision of Real Time Services over Cable Television Networks using Cable Modems".

ETSI TS 101 909-6: "Access and Terminals (AT); Digital Broadband Cable Access to the Public Telecommunications Network; IP Multimedia Time Critical Services; Part 6: Media Terminal Adapter (MTA) device provisioning".

ETSI TS 101 909-7: "Access and Terminals (AT); Digital Broadband Cable Access to the Public Telecommunications Network; IP Multimedia Time Critical Services; Part 7: Management Information Base (MIB) Framework".

ETSI TS 101 909-8: "Access and Terminals (AT); Digital Broadband Cable Access to the Public Telecommunications Network; IP Multimedia Time Critical Services; Part 8: Media Terminal Adaptor (MTA) Management Information Base (MIB)".

ETSI TS 101 909-9: "Access and Terminals (AT); Digital Broadband Cable Access to the Public Telecommunications Network; IP Multimedia Time Critical Services; Part 9: Network Call Signalling (NCS) MIB Requirements".

ETSI TS 101 909-10: "Access and Terminals (AT); Digital Broadband Cable Access to the Public Telecommunications Network; IP Multimedia Time Critical Services; Part 10: Event Message Requirements for the Provision of Real Time Services over Cable Television Networks using Cable Modems".

ETSI TS 101 909-11: "Access and Terminals (AT); Digital Broadband Cable Access to the Public Telecommunications Network; IP Multimedia Time Critical Services; Part 11: Security".

ETSI TS 101 909-12: "Access and Terminals (AT); Digital Broadband Cable Access to the Public Telecommunications Network; IP Multimedia Time Critical Services; Part 12: Internet Signalling Transport Protocol".

ETSI TS 101 909-13: "Access and Terminals (AT); Digital Broadband Cable Access to the Public Telecommunications Network; IP Multimedia Time Critical Services; Part 13: Trunking Gateway Control Protocol".

ITU-T Recommendation X.500: "Information technology - Open Systems Interconnection - The Directory: Overview of concepts, models and services".

List of ITU-T Recommendations referring to IPCablecom

ITU-T Recommendation J.160: "Architectural framework for the delivery of time critical services over cable television networks using cable modems".

ITU-T Recommendation J.161: "Audio codec requirements for the provision of bi-directional audio service over cable television networks using cable modems".

ITU-T Recommendation J.162: "Network call signalling protocol for the delivery of time critical services over cable television networks using cable modems".

ITU-T Recommendation J.163: "Dynamic quality of service for the provision of real time services over cable television networks using cable modems".

ITU-T Recommendation J.164: "Event message requirements for the support of real-time services over cable television networks using cable modems".

ITU-T Recommendation J.165: "IPcablecom Internet Signalling Transport Protocol".

ITU-T Recommendation J.166: "IPcablecom management information base (MIB) framework".

ITU-T Recommendation J.167: "Media terminal adapter (MTA) device provisioning requirements for the delivery of real time services over cable television networks using cable modems".

ITU-T Recommendation J.168: "IPcablecom Media Terminal Adapter (MTA) MIB requirements".

ITU-T Recommendation J.169: "IPcablecom Network Call Signaling (NCS) MIB Requirements".

ITU-T Recommendation J.170: "IPcablecom Security specification".

ITU-T Recommendation J.171: "IPcablecom Trunking Gateway Control Protocol (TGCP)".

ETSI TR 101 073 (V1.1.1): "Number portability for pan-European services".

ETSI TR 101 118 (V1.1.1): "Network Aspects (NA);High level network architecture and solutions to support number portability".

ETSI TR 101 119 (V1.1.1): "Network Aspects (NA);High level description of number portability".

ETSI TR 101 122 (V1.1.1): "Network Aspects (NA);Numbering and addressing for Number Portability".

History

Document history		
V1.1.1	July 2001	Publication
V1.1.2	October 2001	Publication
V1.2.1	August 2002	Publication