

**Access network xDSL transmission filters;
Part 1: ADSL splitters for European deployment;
Sub-part 3: Specification of ADSL/ISDN splitters**

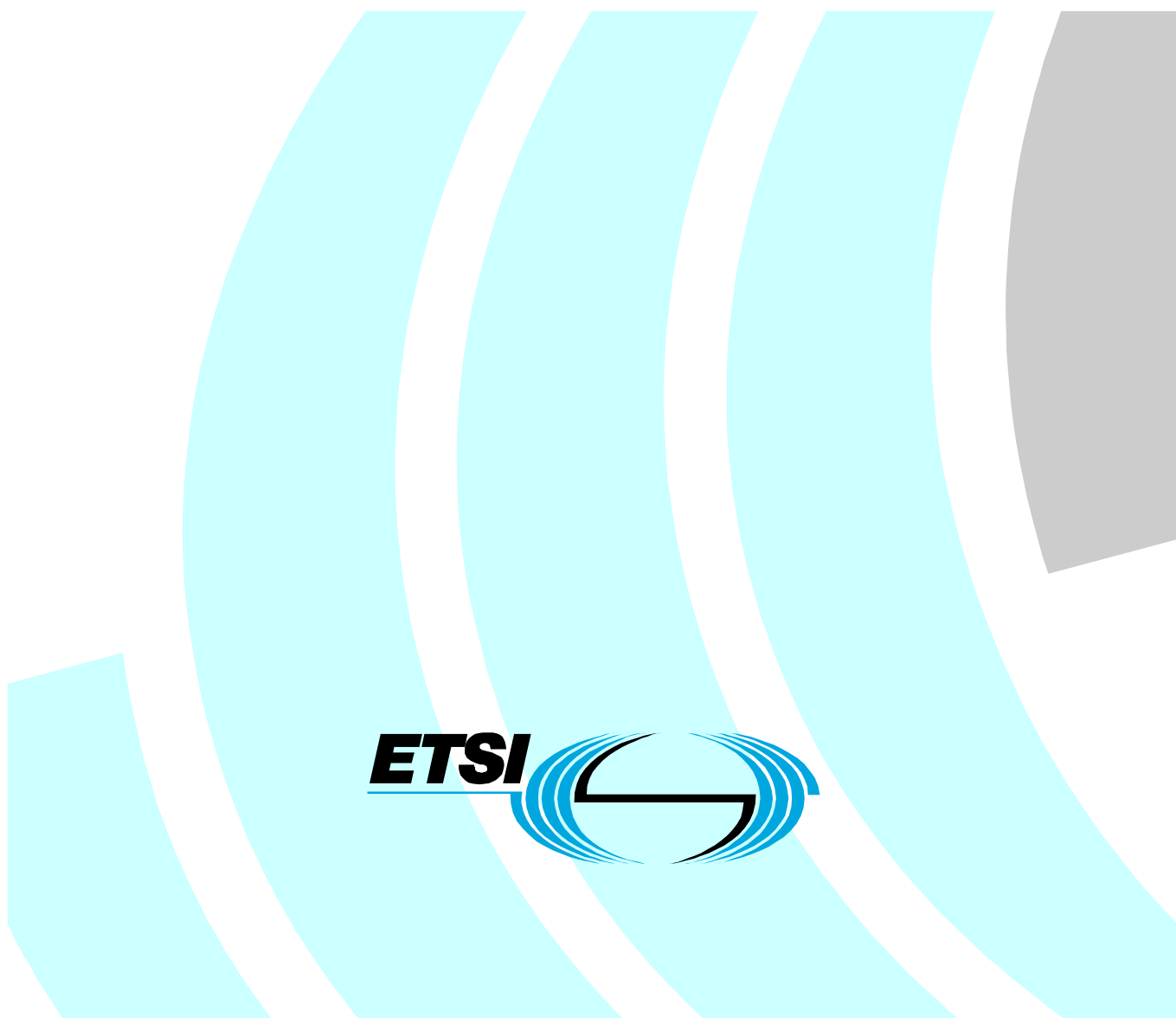

Reference

DTS/TM-06028-1-3

Keywords

ADSL, ISDN, splitter

ETSI

650 Route des Lucioles
F-06921 Sophia Antipolis Cedex - FRANCE

Tel.: +33 4 92 94 42 00 Fax: +33 4 93 65 47 16

Siret N° 348 623 562 00017 - NAF 742 C
Association à but non lucratif enregistrée à la
Sous-Préfecture de Grasse (06) N° 7803/88

Important notice

Individual copies of the present document can be downloaded from:

<http://www.etsi.org>

The present document may be made available in more than one electronic version or in print. In any case of existing or perceived difference in contents between such versions, the reference version is the Portable Document Format (PDF). In case of dispute, the reference shall be the printing on ETSI printers of the PDF version kept on a specific network drive within ETSI Secretariat.

Users of the present document should be aware that the document may be subject to revision or change of status. Information on the current status of this and other ETSI documents is available at

<http://portal.etsi.org/tb/status/status.asp>

If you find errors in the present document, send your comment to:

editor@etsi.fr

Copyright Notification

No part may be reproduced except as authorized by written permission.
The copyright and the foregoing restriction extend to reproduction in all media.

© European Telecommunications Standards Institute 2002.
All rights reserved.

DECTTM, **PLUGTESTS**TM and **UMTS**TM are Trade Marks of ETSI registered for the benefit of its Members.
TIPHONTM and the **TIPHON logo** are Trade Marks currently being registered by ETSI for the benefit of its Members.
3GPPTM is a Trade Mark of ETSI registered for the benefit of its Members and of the 3GPP Organizational Partners.

Contents

Intellectual Property Rights	4
Foreword.....	4
1 Scope	5
2 References	5
3 Definitions and abbreviations.....	5
3.1 Definitions	5
3.2 Abbreviations	5
4 General functional description of ADSL/ISDN splitters.....	6
4.1 Functional diagram.....	6
5 Splitter testing conditions.....	7
5.1 DC testing conditions	7
5.1.1 Polarity independence.....	7
5.1.2 DC feeding current.....	7
5.2 Terminating impedances	7
5.2.1 $Z_{\text{ADSL-I}}$	7
5.2.2 Z_{T} and Z_{L}	8
5.3 General transmission test setup	8
6 Splitter requirements	9
6.1 DC requirements	9
6.1.1 DC resistance to earth	9
6.1.2 Isolation resistance between A-wire and B-wire	9
6.1.3 DC series resistance	9
6.2 High pass path of the splitter	9
6.3 Passband insertion loss requirements for the LPF	10
6.4 Passband return loss requirements for the LPF	10
6.5 Unbalance about earth	11
6.6 Isolation requirements (insertion loss in ADSL band)	12
6.7 Noise	13
6.8 Delay distortion	14
6.9 ADSL related requirements	14
6.9.1 ADSL insertion loss.....	14
6.9.2 ADSL band distortion.....	15
Annex A (informative): Bibliography.....	16
History	17

Intellectual Property Rights

IPRs essential or potentially essential to the present document may have been declared to ETSI. The information pertaining to these essential IPRs, if any, is publicly available for **ETSI members and non-members**, and can be found in ETSI SR 000 314: "*Intellectual Property Rights (IPRs); Essential, or potentially Essential, IPRs notified to ETSI in respect of ETSI standards*", which is available from the ETSI Secretariat. Latest updates are available on the ETSI Web server (<http://webapp.etsi.org/IPR/home.asp>).

Pursuant to the ETSI IPR Policy, no investigation, including IPR searches, has been carried out by ETSI. No guarantee can be given as to the existence of other IPRs not referenced in ETSI SR 000 314 (or the updates on the ETSI Web server) which are, or may be, or may become, essential to the present document.

Foreword

This Technical Specification (TS) has been produced by ETSI Technical Committee Transmission and Multiplexing (TM) and in co-operation with ETSI Technical Committee Access and Terminals (AT).

The present document is part 1, sub-part 3 of a multi-part deliverable covering Access network xDSL transmission filters, as identified below:

Part 1: "ADSL splitters for European deployment";

Sub-part 1: "Specification of the low pass part of ADSL/POTS splitters";

Sub-part 2: "Specification of the high pass part of ADSL/POTS splitters";

Sub-part 3: "Specification of ADSL/ISDN splitters";

Sub-part 4: "Specification for ADSL/"ISDN or POTS" universal splitters";

Sub-part 5: "Specification for ADSL/POTS distributed splitters";

Part 2: "VDSL splitters for European deployment".

NOTE: The choice of a multi-part format for the present document is to facilitate maintenance and future enhancements.

The present document is fully in line with initiative "eEurope 2002 - An Information Society For All", under "The contribution of European standardization to the eEurope Initiative, A rolling Action Plan" especially under the key objective of a cheaper, faster and secure Internet.

1 Scope

The present document specifies requirements and test methods for DSL splitters. These splitters are intended to be installed at the Local Exchange side of the local loop and at the user side near the NTP.

The present document specifies requirements and test methods for ADSL/ISDN splitters.

2 References

The following documents contain provisions which, through reference in this text, constitute provisions of the present document.

- References are either specific (identified by date of publication and/or edition number or version number) or non-specific.
- For a specific reference, subsequent revisions do not apply.
- For a non-specific reference, the latest version applies.

[1] ETSI TS 102 080: "Transmission and Multiplexing (TM); Integrated Services Digital Network (ISDN) basic rate access; Digital transmission system on metallic local lines".

[2] ITU-T Recommendation O.9: "Measuring arrangements to assess the degree of unbalance about earth".

3 Definitions and abbreviations

3.1 Definitions

For the purposes of the present document, the following terms and definitions apply:

A-wire and B-wire: wires in the 2-wire local loop connection provided from the exchange to the NTP

signature network: circuitry included in the splitter, the values and configuration of which may be operator dependent, which has the purpose of enabling network operator's remote line testing equipment to determine the presence of a splitter on a line

3.2 Abbreviations

For the purposes of the present document, the following abbreviations apply:

2B1Q	Baseband linecode for ISDN-BA (4-PAM)
4B3T	(or MMS43) Alternative ISDN-BA baseband linecode with higher frequency spectrum than 2B1Q
ADSL	Asymmetric Digital Subscriber Line
CPE	Customer Premise Equipment
HPF	High Pass Filter
ISDN-BA	Integrated Services Digital Network-Basic Access
ITU	International Telecommunication Union
LPF	Low Pass Filter
LT	Line Termination
NT	Network Termination
NTP	Network Termination Point
ONU	Optical Network Unit
PAM	Pulse Amplitude Modulation

4 General functional description of ADSL/ISDN splitters

The main purpose of the ADSL/ISDN splitter filter is to separate the transmission of ISDN-BA signals, and ADSL band signals, enabling the simultaneous transmission of both services on the same twisted pair. The splitter also serves to protect ISDN from interference due to egress (and ingress) from ADSL signals. Equally it protects the ADSL transmission from interference due to the underlying ISDN service.

Insertion of a splitter filter in existing ISDN-BA lines shall have only a low impact on the performance of the ISDN-BA service.

The splitter filter may be implemented as an independent unit, separately from the ADSL transceiver, or may be integrated with the ADSL termination unit.

4.1 Functional diagram

The functional diagram for the splitter combination is given in figure 1.

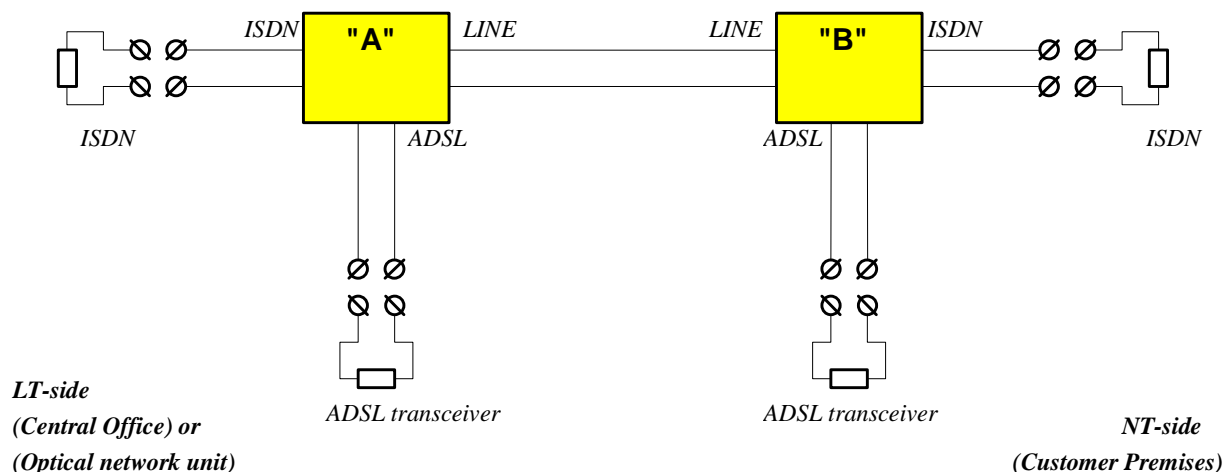

Figure 1: Functional diagram of the ADSL splitter configuration

The transfer functions between the different ports of the splitter can be understood as follows:

- The transfer function from the ISDN port to the line port and vice-versa is that of a low-pass filter.
- A high level of isolation is required from the ADSL port to the ISDN port to prevent undesirable interaction between ADSL and existing narrowband services.
- The transfer function from the ADSL port to the line port and vice-versa will be that of a first order high-pass filter (i.e. blocking capacitors).

NOTE: The splitters designed according to the present document are expected to be adequate under a wide range of operational conditions. The issue of general interoperability between ISDN equipment and splitters is for further study.

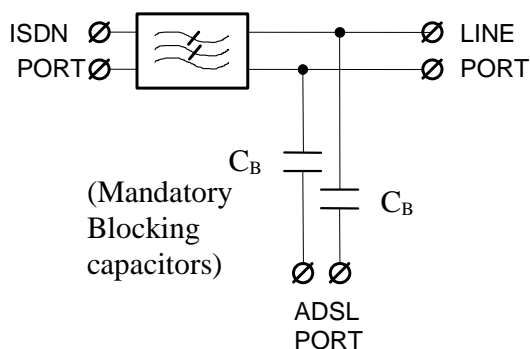

Figure 2: Structure of the ADSL/ISDN splitter filter

5 Splitter testing conditions

5.1 DC testing conditions

5.1.1 Polarity independence

The splitter shall conform to all the applicable requirements of the present document for both polarities of the DC line feeding voltage (and the DC line current) provided by the local exchange.

This may not apply in the case where a "signature network" is used as this may be polarity dependant.

5.1.2 DC feeding current

The requirements in the present document are valid for a DC current of 0 mA to 60 mA.

NOTE: Dynamic behaviour at switch on of ISDN systems can result in DC currents beyond 60 mA being present in the loop during short periods of time (< 50 ms). The effect of these dynamic current peaks on ADSL transmission is for further study.

5.2 Terminating impedances

The terminating impedances given in clauses 5.2.1 and 5.2.2 are to be used.

5.2.1 $Z_{\text{ADSL-I}}$

In many of the tests with ISDN-BA frequencies, the ADSL port of the splitter is terminated with an impedance called $Z_{\text{ADSL-I}}$. This impedance model as shown in figure 3, represents the input impedance of the ADSL transceiver as seen from the ADSL port of the splitter, and does not include the blocking capacitors. The model is intended for splitter specification in the context of the present document. The purpose of this model impedance is for splitter specification, it is not a requirement on the input impedance of the ADSL transceiver.

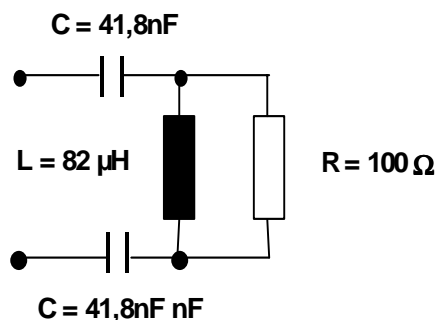

NOTE: Z_{ADSL-I} does not include the blocking capacitors C_B .

Figure 3: Schematic diagram of the impedance Z_{ADSL-I} for verifying requirements of the low pass filter

5.2.2 Z_T and Z_L

For requirements relating to ISDN band frequencies described in the present document, the terminating impedance Z_T is used to terminate the ISDN port, while Z_L is used to terminate the Line port. Z_T is defined as being equal to Z_L , and both shall follow the definitions of TS 102 080 [1], annex A for 2B1Q (135 Ω), annex B for 4B3T (150 Ω) ISDN-BA.

5.3 General transmission test setup

For many of the transmission related tests that are specified in the current document, a common general test setup is valid. This test setup is given in figures 4 and 5, for measurements at the Line port and ISDN port respectively.

It is necessary that a splitter also fulfils all requirements (with the exception of those specified in clauses 6.5, 6.6, 6.7 and 6.9) if there is no ADSL load (the ADSL transceiver) connected to the splitter.

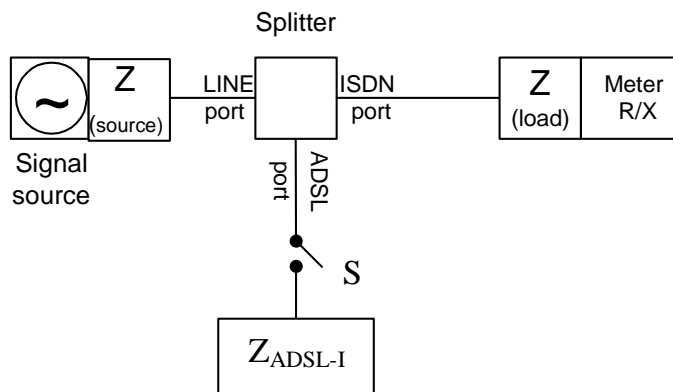

Figure 4: Test set-up for transmission testing from LINE to ISDN

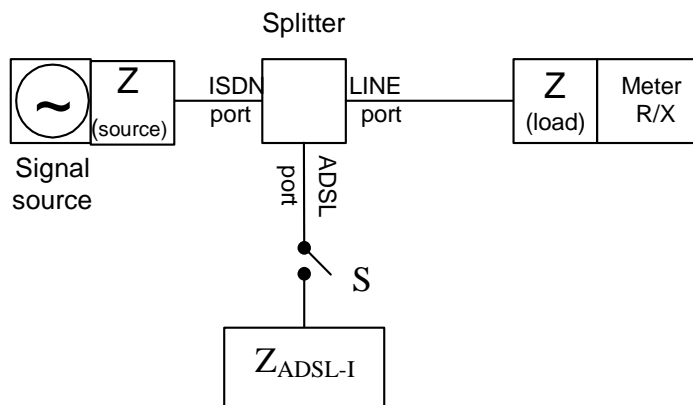

Figure 5: Test set-up for transmission testing from ISDN to LINE

6 Splitter requirements

6.1 DC requirements

6.1.1 DC resistance to earth

The DC resistance between each terminal (i.e. A-wire and B-wire) of the splitter and earth, when tested with 120 V DC, shall not be less than 20 M Ω .

This requirement only applies to splitters with a terminal directly connected to earth.

6.1.2 Isolation resistance between A-wire and B-wire

The DC resistance between the A-wire and B-wire terminal of the splitter, when tested with 120 V DC, shall not be less than 5 M Ω .

In the case where the splitter is fitted with a signature network, measurement of the DC isolation resistance becomes more difficult. Possible solutions include a switching system in order to open circuit the signature network for the measurement, or indeed performing the measurement before the signature network is added to the splitter card. It is left to the individual operator to determine how this measurement should be carried out. Depending on the particular test methodology used, the requirement shall be set accordingly.

6.1.3 DC series resistance

The DC resistance from the A-wire to the B-wire at the Line interface with the ISDN terminal shorted, or at the ISDN interface with the Line terminal shorted shall be less than or equal to 12,5 Ω .

This requirement shall be met for the feeding conditions described in clause 5.1.2.

6.2 High pass path of the splitter

The high pass part of the splitter, i.e. the filter between the LINE and ADSL ports, shall be a first order high pass filter made up of two blocking capacitors (one on each wire). The value of each of these capacitors shall be 27 nF. A tolerance of 5 % shall be allowed for the practical implementation of these capacitors. Each of these capacitors shall retain their nominal value for DC voltages up to 120 V.

6.3 Passband insertion loss requirements for the LPF

The passband insertion loss shall be measured from both the LINE to ISDN port, and the ISDN to LINE port. The test setups are given in figures 4 and 5. The DC feeding current is specified in clause 5.1.2.

- In the case where the source is at the line port of the splitter (i.e. the setup of figure 4), then the source impedance shall be Z_L , and the load impedance shall be Z_T .
- In the case where the source is at the ISDN port of the splitter (i.e. the setup of figure 5), then the source impedance shall be Z_T , and the load impedance shall be Z_L .

For an ADSL/ISDN 2B1Q splitter, the low pass filter of the splitter shall meet the requirements stated in table 1.

Table 1: Insertion loss requirements for ADSL/ISDN 2B1Q splitter

Frequency band	Insertion loss	$Z_T = Z_L$
1 kHz to 40 kHz	< 0,8 dB	135 Ω
40 kHz to 80 kHz	< 2 dB	135 Ω

For an ADSL/ISDN 4B3T splitter, the low pass filter of the splitter shall meet the requirements stated in table 2.

Table 2: Insertion loss requirements for ADSL/ISDN 4B3T splitter

Frequency band	Insertion loss	$Z_T = Z_L$
1 kHz to 60 kHz	< 1,2 dB	150 Ω
60 kHz to 80 kHz	< 2 dB	150 Ω

6.4 Passband return loss requirements for the LPF

The return loss of the splitter shall be measured at the ISDN port only. The test setup is given in figure 5. For an ADSL/ISDN 2B1Q splitter, the low pass filter of the splitter shall meet the requirements stated in table 3. The DC feeding current is specified in clause 5.1.2.

Table 3: Return loss requirements for ADSL/ISDN 2B1Q splitter

Frequency band	Return loss	$Z_T = Z_L$
1 kHz to 40 kHz	> 16 dB	135 Ω
40 kHz to 80 kHz	> 14 dB	135 Ω

For an ADSL/ISDN 4B3T splitter, the low pass filter of the splitter shall meet the requirements stated in table 4. The test setup is given in figure 5.

Table 4: Return loss requirements for ADSL/ISDN 4B3T splitter

Frequency band	Return loss	$Z_T = Z_L$
1 kHz to 60 kHz	> 16 dB	150 Ω
60 kHz to 80 kHz	> 14 dB	150 Ω

The calculation of return loss shall be carried out according to the definition in figure 6.

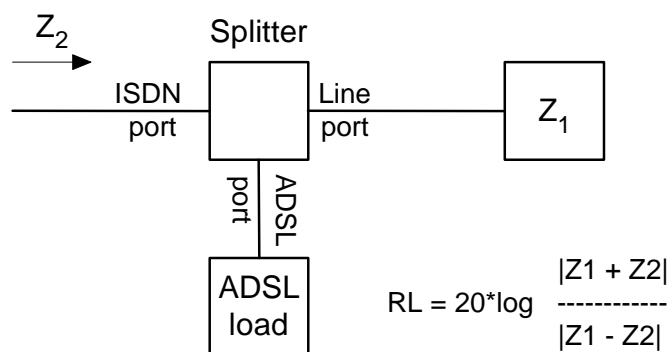

Figure 6: Definition of return loss at the ISDN port of the splitter

6.5 Unbalance about earth

The basic test setup for measuring unbalance at the ISDN port is shown in figure 7. In the case of measuring at the LINE port, the test setup of figure 7 is used, however with the ISDN and LINE terminations reversed. The test shall be carried out for the combinations described in table 5. Note that the source and measurement are always at the same port.

The DC feeding current is specified in clause 5.1.2.

In the case of performing measurements at frequencies above 30kHz, for reasons of practical testing a 150 Ω impedance should be used in series with the longitudinal source (i.e. S1 in figure 7 should be open).

Table 5: Unbalance about earth, test setups

#Test setup	Source and Measurement	State of S2
1	ISDN port	Open
2	ISDN port	Closed
3	LINE port	Closed

The ADSL port shall be terminated by a 100 Ω resistor for all unbalance tests described in the present document. Z_L is as defined in clause 5.2.2.

For each of the three test setups described above, the splitter shall meet the unbalance about earth requirements as specified in table 6.

Table 6: Unbalance about earth, minimum values

Frequency range	State of S1	Value of R	Minimum unbalance value
300 Hz to 30 kHz	Closed	$Z_L/2$	40 dB
30 kHz to 1 104 kHz	Open	50 Ω	46 dB
1 104 kHz to 5 MHz	Open	50 Ω	40 dB

The unbalance about earth is calculated by using the following equation:

$$\text{Unbalance} = 20 \log_{10} \left| \frac{U_0}{U_T} \right| \quad (\text{dB})$$

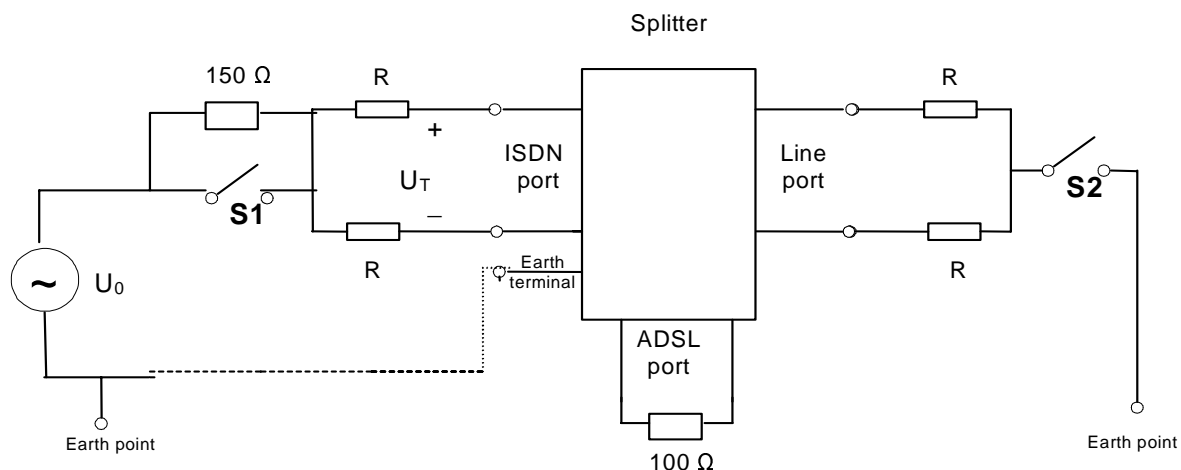

NOTE 1: The dotted circuit is only used if the splitter has an earth terminal.

NOTE 2: The DC current feeding circuitry is not shown. Care should be taken that this circuitry is implemented in such a way as not to have significant influence on the accuracy of the measurement.

NOTE 3: For resistances R an equivalent circuit according to ITU-T Recommendation O.9 [2] can be used.

Figure 7: Unbalance about earth test set-up

If the splitter has no earth terminal, the test should be performed while the splitter is placed on an earthed metal plate of a sufficiently large size.

6.6 Isolation requirements (insertion loss in ADSL band)

- When the splitter is to support ADSL over ISDN 2B1Q the low pass filter of the splitter shall meet the requirements specified in table 7.
- In the case where the source is at the ISDN port of the splitter (i.e. the setup of figure 8), then the source impedance shall be Z_T , and the load impedance should be Z_{ADSL-I} .
- In the case where the source is at the ADSL port of the splitter (i.e. the setup of figure 9), then the source impedance shall be Z_{ADSL-I} , and the load impedance should be Z_T .

The test setups are given in figures 8 and 9.

Table 7: Isolation requirements for ADSL/ISDN 2B1Q splitter

Frequency band	Minimum isolation	$Z_T = Z_L$
150 kHz to 1 104 kHz	65 dB	135 Ω

When the splitter is to support ADSL over ISDN 4B3T the low pass filter of the splitter shall meet the requirements specified in table 8. The basic test setups are given in figures 8 and 9. An example of a test setup implementation is given in figure 10.

Table 8: Isolation requirements for ADSL/ISDN 4B3T splitter

Frequency band	Minimum isolation	$Z_T = Z_L$
150 kHz to 1 104 kHz	65 dB	150 Ω

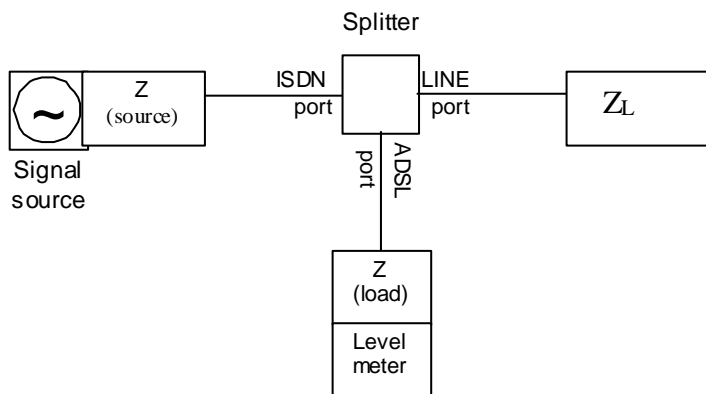

Figure 8: Test set-up for transmission testing from ISDN to ADSL

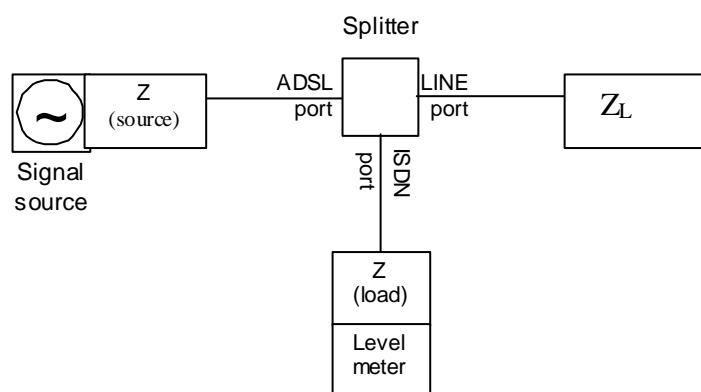

Figure 9: Test set-up for transmission testing from ADSL to ISDN

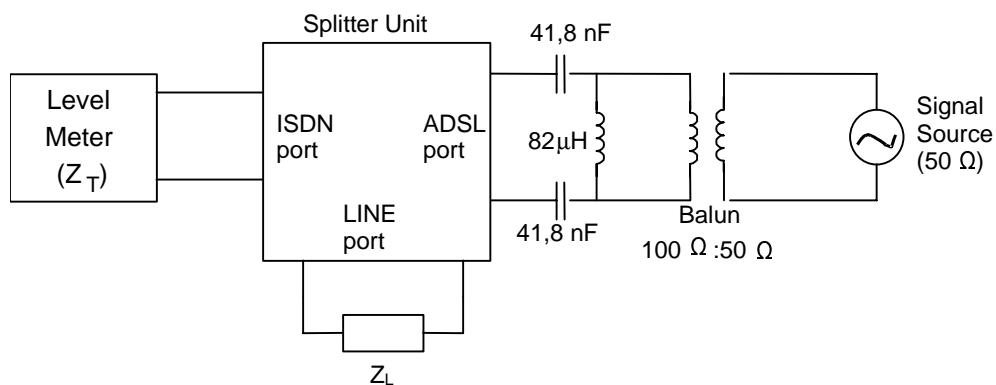

Figure 10: Example test set-up for isolation testing from ADSL to ISDN

6.7 Noise

In the case of a LT (CO or ONU) side splitter, the noise in the frequency range 138 kHz to 1 104 kHz due to the splitter, measured at the both the ADSL port and at the Line port, should be less than -125 dBm/Hz measured in a bandwidth of 10 kHz.

In the case of a NT (CPE) side splitter, the noise in the frequency range 138 kHz to 1 104 kHz due to the splitter, measured at the both the ADSL port and at the Line port, should be less than -140 dBm/Hz measured in a bandwidth of 10 kHz.

The test set-ups of figures 11 and 12 shall be used.

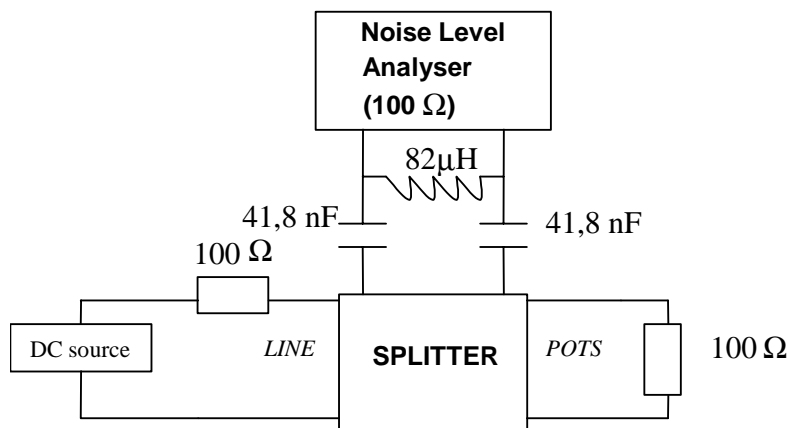

Figure 11: Test set-up for measuring ADSL band noise at the ADSL port

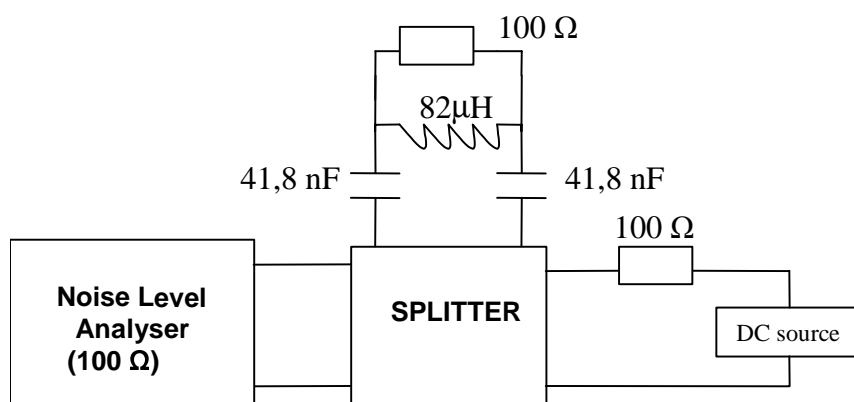

Figure 12: Test set-up for measuring ADSL band noise at the LINE port

6.8 Delay distortion

The signal delay distortion of the low pass filter of the splitter shall be $< 20 \mu\text{s}$ up to 80 kHz. The signal delay distortion is defined as the absolute difference between the minimum signal delay (as measured at a discrete frequency in the range up to 80 kHz) and the maximum signal delay as measured at a discrete frequency over the same frequency range.

The set-up for measuring group delay distortion is given in figure 4. The DC feeding current is specified in clause 5.1.2.

6.9 ADSL related requirements

6.9.1 ADSL insertion loss

The insertion loss between Line port and ADSL port shall be as specified in table 9.

The test setup of figure 13 is to be used. The source impedance shall be 100Ω , and the load impedance shall be $Z_{\text{ADSL-I}}$.

The requirements of table 9 shall be met with the ISDN port both open circuited, and terminated with Z_T (135Ω for ISDN-BA 2B1Q, 150Ω for ISDN-BA 4B3T).

Table 9: Insertion loss between LINE and ADSL port for ADSL/ISDN splitters

Frequency range	Insertion loss between Line and ADSL port
120 kHz to 170 kHz	< 3 dB
170 kHz to 1 104 kHz	< 1 dB

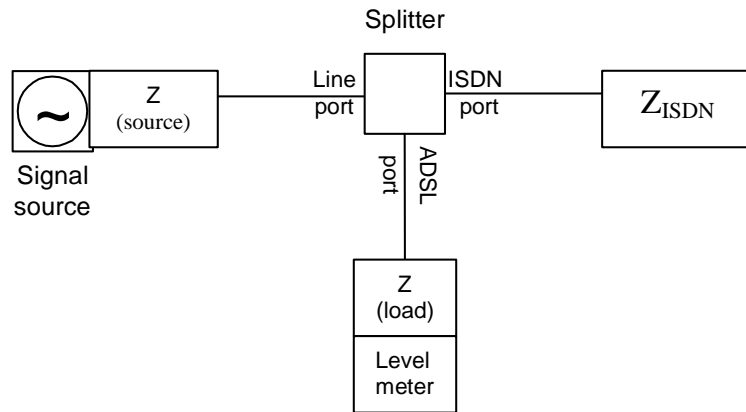
**Figure 13: Test set-up for transmission testing from LINE to ADSL**

6.9.2 ADSL band distortion

For further study.

Annex A (informative): Bibliography

ITU-T Recommendation G.992.1: "Asymmetrical digital subscriber line (ADSL) transceivers".

History

Document history		
V1.1.1	May 2002	Publication