

**Broadband Radio Access Networks (BRAN);
HIPERACCESS;
DLC protocol specification**



Reference

RTS/BRAN-0030002-R2

Keywords

access, broadband, HIPERACCESS, radio

ETSI

650 Route des Lucioles
F-06921 Sophia Antipolis Cedex - FRANCE

Tel.: +33 4 92 94 42 00 Fax: +33 4 93 65 47 16

Siret N° 348 623 562 00017 - NAF 742 C
Association à but non lucratif enregistrée à la
Sous-Préfecture de Grasse (06) N° 7803/88

Important notice

Individual copies of the present document can be downloaded from:

<http://www.etsi.org>

The present document may be made available in more than one electronic version or in print. In any case of existing or perceived difference in contents between such versions, the reference version is the Portable Document Format (PDF). In case of dispute, the reference shall be the printing on ETSI printers of the PDF version kept on a specific network drive within ETSI Secretariat.

Users of the present document should be aware that the document may be subject to revision or change of status. Information on the current status of this and other ETSI documents is available at

<http://portal.etsi.org/tb/status/status.asp>

If you find errors in the present document, send your comment to:

editor@etsi.org

Copyright Notification

No part may be reproduced except as authorized by written permission.
The copyright and the foregoing restriction extend to reproduction in all media.

© European Telecommunications Standards Institute 2002.
All rights reserved.

DECTTM, **PLUGTESTS**TM and **UMTS**TM are Trade Marks of ETSI registered for the benefit of its Members.
TIPHONTM and the **TIPHON logo** are Trade Marks currently being registered by ETSI for the benefit of its Members.
3GPPTM is a Trade Mark of ETSI registered for the benefit of its Members and of the 3GPP Organizational Partners.

Contents

Intellectual Property Rights	8
Foreword.....	8
Introduction	8
1 Scope	10
2 References	10
3 Definitions, symbols and abbreviations	11
3.1 Definitions	11
3.2 Symbols.....	16
3.3 Abbreviations	16
4 Overview	20
4.1 Applications and services	20
4.2 Point-to-Multipoint (PMP) architecture	20
4.2.1 General.....	20
4.2.2 Interoperability aspects	21
4.2.3 Duplex Schemes (FDD, TDD) and H-FDD operation.....	21
4.2.4 Multiplexing techniques and frame structure.....	22
4.3 Basic Arrangement of HA networks	22
4.3.1 System and reference configuration.....	22
4.3.2 External and internal interfaces, interworking functions	24
4.3.3 Layer architecture and functional entities	25
4.4 Convergence Layers	26
4.4.1 Cell-based Convergence Layer	27
4.4.2 Packet-based Convergence Layer	27
4.4.3 Handling of DLC QoS classes	27
4.5 Data Link Control (DLC) Layer.....	29
4.5.1 Overview and basic features	29
4.5.2 Radio Link Control (RLC) sublayer	29
4.5.3 Medium Access Control (MAC) sublayer	30
4.5.4 Error control (ARQ) within the MAC sublayer	30
4.5.5 Security control within the RLC sublayer.....	30
4.5.6 Multicast connections	31
4.6 Physical (PHY) layer.....	31
4.6.1 Adaptive coding and modulation	31
4.6.2 Automatic Transmit Power Control (ATPC).....	32
5 Interface to PHY layer.....	32
5.1 Definition of MAC PDU	33
5.1.1 Layer overview and general definitions (CL PDU and MAC PDU)	33
5.1.2 Long MAC PDUs	34
5.1.3 Short MAC PDU.....	35
5.2 Interface DLC-PHY	35
5.2.1 Informal description in terms of detailed parameter lists.....	35
5.2.2 Data units in transmitter and receiver chain.....	38
5.2.3 Downlink with FDD mode	39
5.2.4 Uplink with FDD mode	41
5.2.5 TDD mode	42
5.2.6 Structure of RS codewords and preambles in UL bursts	43
6 DLC addressing and identities	44
6.1 General	44
6.2 APC Identity (APC-ID).....	44
6.3 Access Terminal (AT) Identities	44
6.3.1 AT MAC address (equipment ID based on MAC-48).....	44
6.3.2 Terminal Identity (TID).....	45

6.4	Connection IDentity (CID).....	45
6.5	Connection aggregate identity (CAID).....	46
7	MAC management messages: mapping to MAC management connections, transport and list of all messages.....	46
7.1	Overview of connection types.....	46
7.2	Transport of MAC management messages with MAC Signalling PDUs.....	47
7.2.1	Some general rules.....	48
7.2.2	The use of long MAC signalling PDUs.....	48
7.2.3	The use of short MAC signalling PDUs.....	49
7.3	Transport of MAC management messages (packing, encoding, segmentation).....	50
7.3.1	Overview of message formats.....	50
7.3.2	Overview of packing, encoding and segmentation.....	51
7.3.3	Encoding rule.....	52
7.3.4	Packing of MAC management messages.....	52
7.3.5	Segmentation and Reassembly (SAR).....	52
7.4	List of protocol primitives and mapping of messages to connections (normative).....	52
7.4.1	List of all MAC management messages.....	52
7.4.2	Messages for packing.....	55
7.4.3	Messages for multiple-TID.....	55
7.4.4	Overview of Connections.....	56
7.5	List of service primitives (informative).....	56
8	Multiplexing and MAC frame structure.....	57
8.1	MAC PDU format.....	58
8.1.1	Overview.....	58
8.1.2	MAC PDU header.....	58
8.1.3	MAC data PDU.....	60
8.1.4	Long MAC signalling PDU.....	60
8.1.5	Short MAC signalling PDU.....	60
8.1.6	Long and short MAC dummy PDU.....	61
8.2	Frame structure.....	61
8.2.1	Frame structure for downlink.....	62
8.2.2	Frame structure for uplink.....	63
8.3	Support of FDD, H-FDD and TDD in DLC layer.....	65
8.3.1	FDD mode.....	65
8.3.2	H-FDD operation.....	65
8.3.3	TDD Mode.....	66
8.4	Entries for downlink and uplink maps.....	67
8.4.1	Downlink map entries.....	67
8.4.2	Uplink map entries.....	69
8.5	Automatic Repeat Request (ARQ).....	70
8.5.1	Operational conditions for ARQ.....	70
8.5.2	Frame structure for ARQ.....	70
8.5.3	ARQ map entries.....	71
8.5.4	Rules for re-transmissions.....	72
8.5.5	Impact of ARQ on delay and overhead (informal).....	73
8.6	Structure of the control zone.....	73
8.6.1	Overview of main fields.....	73
8.6.2	Further details of all fields.....	75
8.6.3	FEC scheme for fast decoding.....	76
8.7	Time Relevance of Starting Symbols (SS) and maps.....	77
8.7.1	Starting Symbols for UL bursts.....	77
8.7.2	Time relevance of maps for FDD mode.....	79
8.7.3	Time relevance of maps for TDD mode.....	80
8.7.4	Timing rule for some specific short grants.....	81
8.8	General Broadcast Information (GBI) message.....	82
8.9	AT reaction to undefined parameters.....	85
9	Resource-Grant Control (RGC) and contention resolution.....	85
9.1	General.....	85
9.2	Grants.....	86
9.3	Requests.....	87

9.3.1	General request strategy.....	87
9.3.2	Requests per MAC PDU header	87
9.3.3	Requests per bandwidth request message	88
9.3.4	AP-requested queue status report.....	89
9.4	Allocation mechanisms	90
9.4.1	Continuous grant.....	90
9.4.2	Polling.....	90
9.4.3	Piggyback	91
9.4.4	Poll-me bit	91
9.4.5	Contention reservation.....	92
9.5	Contention resolution	92
9.5.1	Contention resolution algorithm	93
9.5.2	Bandwidth request contention window.....	93
10	Initialization control (IC).....	94
10.1	Overview	94
10.2	Process of initialization	95
10.3	Steps from frequency scanning to downlink synchronization	97
10.3.1	Frequency scanning	97
10.3.2	Synchronization acquisition.....	97
10.3.3	APC identification	98
10.3.4	UL and DL parameters acquisition	99
10.3.5	Summary.....	100
10.4	Ranging	101
10.4.1	Overview	101
10.4.2	Messages for Ranging.....	102
10.4.3	Ranging described with MSC diagrams.....	105
10.4.4	Ranging described with state diagrams.....	107
10.5	Capabilities negotiation and authentication.....	109
10.5.1	Physical capabilities negotiation.....	109
10.5.2	Authentication.....	111
10.5.3	Other capabilities negotiation	112
11	Radio Resource Control (RRC).....	113
11.1	Overview	113
11.2	Link supervision	114
11.2.1	Detection of link loss	114
11.2.2	Reaction on link loss.....	114
11.2.3	Reaction on AT malfunction.....	117
11.2.4	Performance monitoring	118
11.3	Change of PHY mode, ATPC and ATTC	118
11.3.1	Overview	118
11.3.2	Measurement of uplink RF carrier at AP	120
11.3.3	Measurement of downlink RF carrier at AT and measurement reports to AP	121
11.3.4	Change of downlink PHY mode	124
11.3.5	Automatic Uplink Transmit Power Control (UL ATPC) and Automatic Uplink Transmit Time Control (UL ATTC).....	130
11.3.6	Automatic Downlink Transmit Power Control (DL ATPC).....	131
11.4	Change of PHY Mode Set.....	132
11.5	Change of UL structure	133
11.6	Load levelling (inter-carrier handover)	134
12	Security control	136
12.1	Operational overview	136
12.1.1	Privacy initialization.....	136
12.1.2	AT Key update mechanism.....	137
12.1.3	PKM key management messages.....	138
12.2	Privacy key management protocol	138
12.2.1	AT authorization.....	138
12.2.1.1	Initial authorization	139
12.2.1.2	Reauthorization	141
12.2.1.3	First key requests	142
12.2.2	Authorization finite state machine	148

12.2.2.1	States	150
12.2.2.2	Messages	151
12.2.2.3	Configuration parameters	151
12.2.2.4	Events	152
12.2.2.5	Actions	152
12.2.3	TEK Finite State Machine	155
12.2.3.1	States	156
12.2.3.2	Messages	157
12.2.3.3	Configuration parameters	157
12.2.3.4	Events	157
12.2.3.5	Actions	158
12.3	TEK usage	160
12.3.1	TEK usage for APs	160
12.3.2	TEK usage for ATs	161
12.3.3	Encryption and decryption with TEK	161
13	Connection Control (CC)	162
13.1	Common part layer primitives (informative only)	162
13.1.1	Use of primitives	163
13.1.2	DlcConnectionAdditionInitReq	164
13.1.3	DlcConnectionAdditionReq	164
13.1.4	DlcConnectionAdditionInitInd	165
13.1.5	DlcConnectionAdditionInd	165
13.1.6	DlcConnectionAdditionRsp	165
13.1.7	DlcConnectionAdditionCnf	165
13.1.8	Changing an existing connection	166
13.1.9	DlcConnectionDeletionReq	166
13.1.10	DlcConnectionDeletionInd	166
13.1.11	DlcConnectionDeletionRsp	166
13.1.12	DlcConnectionDeletionCnf	167
13.1.13	DlcDataReq	167
13.1.14	DlcDataInd	167
13.2	MSC diagrams (informative only)	168
13.3	DLC service categories	170
13.4	Connection control procedures	171
13.4.1	Overview of protocol primitives	172
13.4.1.1	HMSC of procedures	172
13.4.1.2	Parameters	173
13.4.2	Connection establishment procedure	174
13.4.2.1	AT initiated connection establishment procedure	175
13.4.2.2	AP initiated connection establishment procedure	176
13.4.3	Change of established connection procedure	177
13.4.4	Connection deletion procedure	179
13.5	Multicast connections	180
13.6	Connection management message description	181
Annex A (normative):	Parameters and constants	184
A.1	List of optional/mandatory features	184
A.2	Detailed specification of PHY parameters in protocol primitives	185
A.3	Timers	186
Annex B (normative):	Formats of protocol primitives	187
Annex C (informative):	Formats of service primitives	200
Annex D (informative):	MSC interpretation guidelines	201
Annex E (normative):	SDL specification of DLC protocol	204
E.1	The HIPERACCESS SDL model	204

E.2	Radio Resource Control SDL model.....	204
E.2.1	RRC AP.....	205
E.2.2	RRC AT	210
E.3	Initialization control SDL model.....	214
E.3.1	IC AP.....	214
E.3.2	IC AT	225
E.4	Connection control SDL model.....	234
E.4.1	CC AP	234
E.4.2	CC AT	239
E.5	Security control SDL model.....	244
E.5.1	AP_SC.....	244
E.5.2	AT_SC.....	251
E.5.3	AP_TEK.....	257
E.5.4	AT_TEK.....	266
Annex F (informative):	ASN.1 interpretation guidelines	275
Annex G (informative):	List of all PHY parameters	276
Annex H (informative):	Bibliography.....	278
	List of Figures.....	279
	List of Tables.....	281
	List of Diagrams	283
	History	285

Intellectual Property Rights

IPRs essential or potentially essential to the present document may have been declared to ETSI. The information pertaining to these essential IPRs, if any, is publicly available for **ETSI members and non-members**, and can be found in ETSI SR 000 314: *"Intellectual Property Rights (IPRs); Essential, or potentially Essential, IPRs notified to ETSI in respect of ETSI standards"*, which is available from the ETSI Secretariat. Latest updates are available on the ETSI Web server (<http://webapp.etsi.org/IPR/home.asp>).

All published ETSI deliverables shall include information which directs the reader to the above source of information.

Foreword

This Technical Specification (TS) has been produced by ETSI Project Broadband Radio Access Networks (BRAN).

The present document describes the basic data transport functions of the Data Link Control (DLC) layer for fixed wireless access systems above 11 GHz according to the High Performance Radio Access (HIPERACCESS) project. Separate ETSI documents provide details of the system overview, the PHYSical (PHY) layer, the Convergence Layer (CL) and the conformance test requirements defined for HIPERACCESS.

For the purpose of the present document, a "system" constitutes the PHY and DLC layers, which are independent of the core network, and the core network specific convergence layers. It should be noted that to specify a complete system, other specifications, e.g. for the network layer and higher layers are required. These specifications are assumed to be available or to be developed by other bodies.

Introduction

The main field of application of HIPERACCESS systems is to provide access to a broad range of core networks including ATM, IP, PSTN, PDN, etc. By means of a Point-to-Multipoint (PMP) architecture the network service area may cover scattered subscriber locations. The systems may be applied to build new access networks by means of a multi-cellular architecture, covering both suburban, urban and regional areas.

Subscribers are offered the full range of services by the particular public or private network. Subscribers will have access to these services by means of the various standardized user network interfaces. HIPERACCESS systems provide standard network interfaces and transparently connect subscribers to the appropriate network node. These systems allow a service to be connected to a number of subscribers ranging from a few to several thousand, and over a wide range of distances, e.g. up to 2 km to 5 km.

The essential features of a HIPERACCESS system are:

- efficient use of the radio spectrum;
- high multiplex gain;
- maintaining QoS.

Radio is often the ideal way of obtaining communications at low cost and difficult topography. Moreover, a small number of sites are required for these installations, thus facilitating rapid implementation and minimizing maintenance requirements of the systems.

Multiplexing means that m subscribers can share n radio channels (m being larger than n), allowing a better use to be made of the available frequency spectrum and at a lower equipment cost. The term "multi-access" derives from the fact that every subscriber has access to every channel (instead of a fixed assignment as in most multiplex systems). When a call or service is initiated the required resource is allocated to it. When the call or service is terminated, the resource is released. Concentration requires the use of distributed intelligent control which in turn allows many other operations and maintenance functions to be added.

Maintenance of QoS means that the exchange (service node) and the subscriber equipment can communicate with each other without being restricted by the actual quality of the radio link.

The implementation of an HIPERACCESS system includes at least one subscriber unit (referred to as terminal or Access Termination, AT) that communicates with a base station (referred to as Access Point, AP) via an interoperable air-interface, the interfaces to external networks, and services transported by the DLC and PHY protocol layers.

1 Scope

The present document applies to the HIPERACCESS air-interface with the specifications of layer 2 (Data Link Control (DLC) layer) following the ISO-OSI model. HIPERACCESS is confined to only the radio subsystem consisting of the physical (PHY) layer and the DLC layer, which are both core network independent, and the core network specific convergence sublayer.

The DLC layer contains functions and protocols for:

- Radio link control (RLC) for managing the resources of both directions of the radio link between AP and AT, including:
 - Initialization Control (IC), for managing the access of a terminal to the HIPERACCESS system;
 - Radio Resource Control (RRC), for managing adaptive PHY mode operation, adaptive power control, load levelling, etc.;
 - Connection Control (CC), for managing the setup and the quality of connections;
 - Security Control (SC), for managing privacy of traffic data and terminal authentication.
- Medium Access Control (MAC) for managing the access to the shared radio resource, including Resource Grant Control (RGC) and the control of the frame structure.
- The interworking with layers at the top of the radio subsystem is handled by convergence layers above the DLC layer. The scope of the present document is as follows:
 - it gives a description of the basic data transport functions of the DLC layer of HIPERACCESS systems;
 - it specifies the protocols (including all messages and their formats) in full detail in order to allow interoperability between equipment developed by different manufacturers.

For the purpose of interoperability and completeness the present document includes the detailed specification of the normal and exceptional behaviour. ASN.1 is used for the description of the content of all protocol primitives (normative) and service primitives (informative), a graphical view of the message flow over interfaces is provided by the use of MSCs (informative) and HMSCs (informative) and the protocol and system behaviour is extensively specified in SDL (normative).

The present document does not address the requirements and technical characteristics for conformance testing. These are covered in separate deliverables.

2 References

The following documents contain provisions which, through reference in this text, constitute provisions of the present document.

- References are either specific (identified by date of publication and/or edition number or version number) or non-specific.
- For a specific reference, subsequent revisions do not apply.
- For a non-specific reference, the latest version applies.

Referenced documents which are not found to be publicly available in the expected location might be found at <http://docbox.etsi.org/Reference>.

- [1] ETSI TS 101 999: "Broadband Radio Access Networks (BRAN); HIPERACCESS; PHY protocol specification".
- [2] ETSI TR 102 003: "Broadband Radio Access Networks (BRAN); HIPERACCESS; System Overview".

- [3] ITU-T Recommendation G.821: "Error performance of an international digital connection operating at a bit rate below the primary rate and forming part of an integrated services digital network".
- [4] ITU-T Recommendation G.826: "Error performance parameters and objectives for international, constant bit rate digital paths at or above the primary rate".
- [5] ITU-T Recommendation G.827: "Availability parameters and objectives for path elements of international constant bit-rate digital paths at or above the primary rate".
- [6] ITU-T Recommendation M.2100: "Performance limits for bringing-into-service and maintenance of international PDH paths, sections and transmission systems".
- [7] ITU-T Recommendation X.691: "Information technology - ASN.1 encoding rules - Specification of Packed Encoding Rules (PER)".
- [8] ITU-T Recommendation Z.120: "Message sequence chart (MSC)".
- [9] ITU-T Recommendation X.509: "Information technology - Open Systems Interconnection - The Directory: Public-key and attribute certificate frameworks".

3 Definitions, symbols and abbreviations

3.1 Definitions

For the purposes of the present document, the following terms and definitions apply:

Access Point (AP): generalized equipment consisting of an Access Point Controller (APC) and several Access Point Transceivers (APT)

NOTE 1: Also addressed as base station.

NOTE 2: A typical configuration is one APC per cell and one APT per RF channel.

Access Terminal (AT): generalized equipment consisting of an Radio Termination (RT, transceiver) and Interworking Function (IWF)

NOTE 1: The number of ATs per RF channel and per sector is limited to 254.

NOTE 2: An AT can only transmit and receive on a single RF channel, but can be switched from one RF channel to another one by the load-levelling procedure (non-seamless handover).

authentication: method to prove the claimed identity of the communication partner

NOTE: The AT shall be authenticated against the AP.

burst: generic term for DL burst or UL burst, describing a sequence of channel symbols consisting of guard periods at beginning and end (only for UL), a preamble and the data symbols

NOTE: A burst transports one or several MAC PDUs with a given PHY mode, i.e. different PHY modes within a burst are excluded. The data part contains one or several FEC blocks (where each FEC block shall have its own trellis termination if applicable and padding bits to complete a modulation symbol).

- **DL burst:** Is present only in the optional TDMA zone of the DL frame. It contains FEC blocks of a specific PHY mode, i.e. the DL burst corresponds to a PHY mode region plus the preamble of that PHY mode region. A DL burst can serve several ATs. Several DL bursts with the same PHY mode can appear in the TDMA zone of one DL frame.
- **UL burst:** Applies for all transmissions in the UL. The UL burst shall be preceded by a guard time required for power ramp-up at the AT. An UL burst can contain up to several FEC blocks or in the shortest case only one short MAC signalling PDU. An UL burst can contain either one preamble at the beginning after the guard time or several preambles (i.e. one midamble per FEC block).

cell: term with two different meanings:

- **(ATM) cell:** a data unit referenced by the cell-based CL for ATM networks
- **(Geographical) cell:** a geographical area controlled by an

NOTE: A geographical cell can be split into several sectors, where this split could be different for different RF channels at the same cell site.

certificate: secure binding between the identity and the public key of an AT

cluster: set of cells where all frequencies available to the operator are used

control zone: part of the DL frame, that consists of the DL map, the UL map, the ARQ map and some further signalling fields.

DownLink (DL): the direction from AP to AT

FEC block: result from the inner convolutional encoding (if applicable) of one RS codeword, including the trellis termination bits and further padding bits to complete a modulation symbol

NOTE: If no inner convolutional code is present, the FEC block shall be simply identical to the RS codeword plus the padding bits. Hence, a FEC block carries one or up to four MAC PDUs. This applies both for DL and UL transmissions (except for the protection of the control zone in the DL and the short MAC signalling PDU in the UL).

frame: sequence of data stream with a fixed duration of 1 ms

NOTE 1: The frame structure appears both in PHY and DLC layer.

NOTE 2: The frame structure is different for FDD and TDD mode:

- **FDD Frame:** the frames appear both in DL and UL with the same fixed length and DL frames and UL frames are synchronized with a fixed offset between them:
 - **DL frame:** it consists in this order of a preamble, a control zone, a TDM zone, and optionally a TDMA zone and some padding symbols if necessary;
 - **UL frame:** it consists of a number of short signalling bursts, long signalling bursts and data bursts in any order.
- **TDD frame:** it consists of two subframes for DL and UL transmissions.

General Broadcast Information (GBI or R1cGeneralBroadcastInformation) message: broadcast message that is transmitted occasionally, i.e. not in every DL frame, containing several broadcast information fields (which are not that time-critical as the broadcast information fields in the control zone) and the PHY mode set descriptor (PSD)

NOTE: During the transition phase from one PHY mode set to another PHY mode set, the GBI carries two PSDs.

guard time: generic term for:

- **"Normal" guard time:** time at the beginning and end of each UL burst to allow power ramping up and down at the AT;
- **Extended guard time (EGT):** time required (e.g. for the ranging UL burst to compensate for the maximum round-trip delay (RTD), where the $RTD = 2 * TD$ depends on the location of the AT within the sector (the Transmission Delay TD is half of the RTD). The EGT shall be defined by an AT at the sector border. The EGT is known at the AP according to the radius of the sector. Each AT only knows its own RTD but not the EGT.

NOTE: The EGT shall be defined by an AT at the sector border. The EGT is known at the AP according to the radius of the sector. Each AT only knows its own RTD but not the EGT.

H-FDD AT: FDD AT transmitting and receiving data not simultaneously

NOTE: DL and UL carriers are separated in frequency (paired bands). This is referred to as H-FDD operation.

initialization: generic term for first and re-initialization

NOTE 1: In both cases, the AT shall synchronize to the DL and then wait for a ranging invitation.

- **First Initialization:** process which is required to bring the AT into the operational mode (i.e. the ability to establish connections)

NOTE 2: The initialization shall be performed whenever a new AT enters the network.

- **Re-initialization:** process that occurs when the AT is recovering from an out-of-service state or after a link loss or after a power supply interruption (PSI)

NOTE 3: Re-initialization does not include the frequency scanning step and the AP can command if the capabilities negotiation steps and the authentication step shall be skipped or not.

MAC PDU: data unit exchanged between the MAC sublayers of AP and AT, consisting of the MAC PDU header and the MAC PDU payload

NOTE 1: The MAC PDU header is different for DL and UL.

NOTE 2: Several types of MAC PDUs have to be distinguished:

- **MAC data PDU:** created in the CL.
- **Long MAC signalling PDU:** created in the DLC layer with exactly the same format as a MAC data PDU and carries one or several MAC management messages.

NOTE 3: By using SAR within the DLC layer, a MAC management message can be spread to several MAC PDUs, applicable both for DL and UL directions.

- **Short MAC signalling PDU:** created in the DLC layer to carry one short MAC management messages.

NOTE 4: This is restricted to the UL direction.

- **MAC dummy PDU:** is created in the DLC layer for a purpose as follows:
 - DL direction: to support continuous transmission in the DL. MAC dummy PDU can be inserted at any position in the DL frame, i.e. in any PHY mode region of the TDM or TDMA zones (to allow more flexibility of the AP scheduler, however, a location of the MAC dummy PDUs at the beginning of the TDM zone with the most robust PHY mode would improve synchronization).
 - UL direction: to fill up the UL burst if grants are given but nothing is to be transmitted (e.g. if grants are given for ARQ-retransmissions but cannot be used completely in case of non-ARQ connections).

map: generic term for the DL map, the UL map or the ARQ map:

- **DL map:** part of the control zone that defines the Starting Symbols (SS) for the PHY mode regions inside the TDM or TDMA zones for the downlink.
- **UL map:** part of the control zone that defines the SSs of the UL bursts.
- **ARQ map:** part of the control zone that lists the SS of the erroneously received RS codewords (from the respective UL frame).

mode: generic term for the duplex scheme:

- **FDD mode:** Both AP and AT are transmitting and receiving data at the same time, the DL and UL RF carriers are separated by the duplex frequency, the two paired RF carriers form an RF channel.
- **TDD mode:** DL and UL transmissions use the same RF carrier, both AP and AT are transmitting and receiving data not simultaneously, the RF channel is simply identical to one (unpaired) RF carrier.

NOTE 1: In case of two paired RF carriers, it is not excluded to operate two independent HA systems each in TDD mode in the two RF carriers.

NOTE 2: The word "mode" is also used in the terms "PHY mode" and "initialization mode".

Offset (or Frame Offset, FO): The fixed time difference between DL frame and UL frame, selected by the AP. This applies only for the FDD mode

NOTE 1: FO should be at least $2/5$ of the frame duration (i.e. the UL frame starts at least 0,40 ms after the DL frame) as an upper bound of the maximum length of the control zone, including also the maximum Round Trip Delay (RTD) and the processing time (TP) to allow for the decoding of the UL map in the AT before the first granted UL transmissions.

NOTE 2: FO should be limited to the frame duration, i.e. in this case the DL and UL frames are exactly aligned.

packet: data unit of variable length referenced by the packet-based CL

PHY mode: combination of a signal constellation (modulation alphabet) and FEC parameters (coding scheme, i.e. inner and outer code, code rates, block lengths, etc)

PHY mode Set Description (PSD): The PSD shall be carried in the GBI message. It contains a description of the $C/(N + I)$ thresholds for one set of PHY modes.

NOTE: Two specific PHY modes are selected for DL and UL (could be identical or different) on a frame-by-frame basis under control of the AP and communicated to the AT by messages (for DL) and UIUC (for UL).

PHY mode region: part of the TDM (or TDMA) zone with fixed PHY mode, containing one or several FEC blocks

NOTE: This applies only for the DL.

preamble: specific sequence of channel symbols with a given auto-correlation property assisting modem synchronization and channel estimation

Specific preambles are:

- **DL frame preamble:** at the beginning of each DL frame, prior to the control zone, consisting of 32 symbols.
- **DL burst preamble:** at the beginning of each DL PHY mode region in the optional TDMA zone, consisting of 16 symbols.
- **UL burst preamble:** at the beginning of each UL burst, after the guard time, consisting of 16 or 32 symbols. The preamble length shall be commanded to the AT at initialization. Both lengths shall be supported by all ATs.

ranging: process through which the AP compensates the individual delay of each AT up to the farthest distance allowed in the sector (i.e. the process that enables the AT to adjust its correct transmission time) and to define the correct AT transmit power setting

NOTE: The ranging process can only be started with a ranging invitation and is identical for first and re-initialization: the AT transmits several times with increasing power in granted ranging bursts, terminated by a ranging response from the AP.

RF block: group of one or several contiguous RF carriers

NOTE 1: The FDD mode requires two separated RF blocks, one for the DL transmission (DL RF block) and one for the UL transmission (UL RF block).

NOTE 2: The TDD mode can be accommodated in a single RF block or in several separated RF blocks.

RF channel: pair of downlink and uplink carriers (in case of FDD mode)

NOTE: For TDD mode, an RF channel is simply a carrier. For all modes, each carrier shall have a width of 28 MHz.

RS codeword: result from the outer encoding of a number of information bytes

NOTE: A RS codeword shall be subjected to a further inner encoding if applicable. A FEC block corresponds exactly to the combination of an RS codeword together with the trellis termination bits and the padding bits to complete a modulation symbol. The following cases can be distinguished:

- Long RS codewords (for MAC data PDU or long MAC signalling PDU in the DL): an RS codeword contains four MAC PDUs (or down to one MAC PDU by RS shortening if less MAC PDUs per PHY mode region are to be transmitted), i.e. (1 or 2 or 3 or 4) x (51 + 3 or 4) bytes are protected.
- Short RS codewords (for short MAC signalling PDU in the UL): An RS codeword protects one short MAC signalling PDU with a fixed length of 12 = 8 + 4 bytes.
- Short RS codewords (for the control zone in the DL): An RS codeword protects 30 bytes of the control zone. No RS shortening occurs since the length of the control zone shall be a multiple of 30 bytes due to padding.

sector: geographical area resulting from the splitting of a cell achieved by the use of the sector antenna

NOTE: A sector can be covered by one or several antennas but all with the same azimuth and beamwidth. Depending on the implementation, one or several RF channels can be combined for a single antenna.

Segmentation and Reassembly (SAR): segmentation of very long MAC management messages (created in the DLC layer) in the MAC sublayer

NOTE: The length of a segment shall be 50 bytes, together with 1 additional byte for segmentation control (SCF). Segmented and non-segmented long MAC signalling PDUs are distinguished by the PT field in the MAC PDU header. SAR can be applied for DL and UL, but not for short MAC signalling PDUs and not in combination with packing.

set of PHY modes: group of several PHY modes

NOTE: Adaptive changes of PHY modes are only possible within the fixed set. Occasionally, a switch from one set of PHY mode to another set of PHY mode is possible.

Starting Symbol (SS): numbering of modulation symbols in the DL frame used in the entries for all maps of the control zone:

- **DL map:** the SS indicates the beginning of a PHY mode region, both for TDM and TDMA zones. The length of a PHY mode region shall be calculated from the difference of subsequent SSs.
- **ARQ map:** the SS indicates the RS codeword (from the respective UL frame) where all MAC PDUs from this RS codeword for connections with ARQ shall be re-transmitted.
- **UL map:** the SS indicates the beginning of a window or the beginning of a scheduled UL burst (with reference to the reception at the AP). Note that the SS does not include the AT-specific RTD and that each AT shall compute the real starting transmit time from the SS of the UL map and the RTD and the FO.

subframe (or TDD subframe): part of the TDD frame, used either for DL or UL transmissions

NOTE: The partitioning into DL and UL subframes can be adaptive (i.e. variable over time) or non-adaptive as well as synchronous (i.e. between APs of a network) or asynchronous.

time: generic term for:

- **Starting time of UL bursts:** Shall be computed from the Starting Symbol (SS) in the UL map and the Round Trip Delay (RTD) and the Frame Offset (FO).
- **Transmission Delay (TD):** AT-specific delay for the transmission in DL or UL direction.
- **Round Trip Delay (RTD):** equal to two times TD, depending on the specific AT.

NOTE 1: The RTD and the TD are known and fixed at AP and AT after completion of the initialization process.

- **Extended Guard Time (EGT):** the maximum of the Round Trip Delay (RTD), depending on the sector radius.

NOTE 2: The EGT shall be fixed and is not known outside of the AP.

- **Time for Processing (TP):** time to decode the UL map from the control zone in the AT.

NOTE 3: The TP shall not be broadcasted and only used in AP to select the appropriate Frame Offset (FO). Note that the fast decoding of the DL map shall be supported by the short RS codewords used for the protection of the control zone.

- **Frame Offset (FO):** selected by the AP, could depend on the maximum length on the control zone under worst-case conditions and the Extended Guard Time (EGT).

NOTE 4: The FO shall be fixed and broadcasted in the GBI message.

Tx/Rx-Switching time: amount of time required to switch from reception to transmission or vice versa; in FDD mode used for H-FDD ATs; in TDD mode used for both AT and AP

UpLink (UL): direction from AT to AP

window (or **bandwidth contention window**): specific part of the UL frame which can be used in contention mode by all ATs for the bandwidth request message

NOTE: The type and position of the window shall be broadcasted by one entry in the UL map. Note that the window is not always present in all frames. All UL transmissions in the window shall use the most robust PHY mode and always short MAC signalling PDUs.

zone: generic term for a part of the DL frame (with continuous transmission, of variable length):

- **TDM zone:** part of the DL frame consisting of different PHY mode regions, starting with the most robust PHY mode (decreasing order of PHY mode robustness).
- **TDMA zone:** optional part of the DL frame consisting of different PHY mode regions, where each PHY mode region starts with a preamble used for synchronization of H-FDD ATs. A TDMA region may serve more than one AT by time division multiplexing DL data to several ATs.

3.2 Symbols

For the purposes of the present document, the following symbols apply:

dBm	decibel relative to 1 mW
ppm	parts per million

3.3 Abbreviations

For the purposes of the present document, the following abbreviations apply:

ABR	Available Bit Rate
ACK	ACKnowledge
AES	Advanced Encryption Standard
AK	Authentication Key
AP	Access Point (= base station)
APC	AP Controller
APC-ID	APC Identity
APT	AP Transceiver
AR	Aggregate Request
ARQ	Automatic Repeat reQuest
ASN.1	Abstract Syntax Notation One
AT	Access Termination (= terminal subscriber station)
ATM	Asynchronous Transfer Mode
ATPC	Automatic Transmit Power Control
ATTC	Automatic Transmit Time Control

BCH	Broadcast CHannel
BER	Bit Error Rate
BFWA	Broadband Fixed Wireless Access
BR	Bandwidth Request
C/I	Carrier-to-Interference power ratio
CA	Connection Aggregate
CAC	Call Admission Control
CAID	Connection Aggregate IDentity
CBR	Constant Bit Rate
CC	Connection Control
CDV	Cell Delay Variation
CI	CRC Indicator
CID	Connection ID
CL	Convergence Layer
CLID	Convergence Layer IDentity
CLP	Cell Loss Priority
CNF	CoNFirm
CNR	Carrier-to-Noise power Ratio (also denoted by C/N)
CPE	Customer Premises Equipment
CTD	Cell Transfer Delay
CW	CodeWord
DES	Data Encryption Standard
DHCP	Dynamic Host Configuration Protocol
DIUC	Downlink Interval Usage Code
DL	DownLink
DLC	Data Link Control (layer)
DOCSIS	Data Over Cable Service Interface Specifications
DVB	Digital Video Broadcasting
EC	Error Control (refers to ARQ)
ECN	Encoding Control Notation
EDE	Encrypt-Decrypt-Encrypt
EGT	Extended Guard Time
EKS	Encryption Key Sequence
EMS	Element Management System
FDD	Frequency Division Duplex
FDMA	Frequency Division Multiple Access
FEC	Forward Error Correction
FO	Frame Offset
FSM	Finite State Machines
FSN	Fragmentation Sequence Number
FWA	Fixed Wireless Access
GBI	General Broadcast Information
GFC	Generic Flow Control
GFR	Guaranteed Frame Rate
GM	Grant Management field
GPT	Grant Per Terminal
H/2	HIPERLAN Type 2
HA	HIPERACCESS
HCS	Header Check Sequence
HEC	Header Error Check
H-FDD	Half-duplex Frequency Division Duplex
HIPERACCESS	High Performance Radio Access Network
HIPERLAN	High Performance Radio Local Area Network
HIPERMAN	High Performance Radio Metropolitan Access Network
HL	HIPERLAN
HM	HIPERMAN
HMSC	High-level MSC
HT	Header Type
IC	Initialization Control
ID	IDentity
IDU	InDoor Unit
IETF	Internet Engineering Task Force

IF	Intermediate Frequency
IMA	Inverse Multiple Access
IND	INDication
IP	Internet Protocol
ISDN	Integrated Services Digital Network
ISO	International Standards Organization
ITU	International Telecommunications Union
IUC	Interval Usage Code (both for DL or UL)
IV	Initialization Vector (for encryption)
IVP	Indicator of Variable MAC PDU
IWF	InterWorking Function
LAN	Local Area Network
LL	Leased Line
LLC	Logical Link Control
LoS	Line of Sight (connection)
MAC	Medium Access Control
MC	MultiCast
MIB	Management Information Base
MPLS	Multi Protocol Label Switching
MSC	Message Sequence Charts
MT	Message Type
MTL	Minimum Traffic Load
NMS	Network Management System
NNI	Network Node Interface
nrt	non-realtime
NT	Network Termination
ODU	OutDoor Unit
OSI	Open System Interconnect
PABX	Private Automatic Branch eXchange
PB	Piggyback Byte
PDN	Public Digital Network
PDU	Protocol Data Unit
PER	Packet Encoding Rule
PHS	Payload Header Suppression
PHY	PHYSical (layer)
PKM	Privacy Key Management
PM	Poll-Me bit
PMP	Point-to-MultiPoint
POTS	Plain Old Telephone Service
PSD	PHY mode Set Descriptor
PSDI	PHY mode Set Descriptor Indicator
PSI	Power Supply Interruption
PSTN	Public Switched Telephone Network
PT	PDU Type
PTC	Product Turbo Code
PTD	PDU Transfer Delay
PTI	Payload Type Indicator
PVC	Permanent Virtual Connection
QAM	Quadrature Amplitude Modulation
QoS	Quality of Service
QPSK	Quadrature Phase Shift Keying
REQ	REQuest
RF	Radio Frequency
RGC	Resource Grant Control
RLC	Radio Link Control
RNC	Radio Network Controller
RRC	Radio Resource Control
RS	Reed-Solomon (code)
RSA	Rivest Shamir Adleman (standard for asymmetric cryptography)
RSB	Request bit for Short UL Burst
RSP	ReSPonse
RT	Radio Termination

rt	real-time
RTD	Round Trip Delay (equal to 2 times TD, AT-dependent)
SA	Security Association
SAID	Security Association IDentity
SAP	Service Access Point
SAR	Segmentation And Reassembly
SC	Security Control
SCF	Segmentation Control Field
SCID	Service Class IDentity
SDL	Specification and Description Language
SDU	Service Data Unit
SI	Slip Indicator
SLA	Service Level Agreement
SME	Small to Medium sized Enterprise
SNI	Service Node Interface
SNMP	Simple Network Management Protocol
SNR	Signal-to-Noise power Ratio (also denoted by S/N)
SO	System Overview
SOHO	Small Office/Home Office
SS	Starting Symbol
STM	Synchronous Transfer Mode
SVC	Switched Virtual Connection
TC	Transmission Convergence layer
TD	Transmission Delay (one direction, AT-dependent)
TDD	Time Division Duplex
TDM	Time Division Multiplex
TDMA	Time Division Multiple Access
TEK	Traffic Encryption Key
TFTP	Trivial File Transfer Protocol
TID	Terminal ID
TP	Time for Processing
UBR	Unspecified Bit Rate
UIUC	Uplink Interval Usage Code
UL	UpLink
UMTS	Universal Mobile Telecommunication System
UNI	User-Network Interface
VBR	Variable Bit Rate
VBRnrt	Variable Bit Rate non real time
VBRrt	Variable Bit Rate real time
VC	Virtual Connection
VCI	Virtual Connection Identity
VoD	Video on Demand
VP	Virtual Path
VPI	Virtual Path Identity
VPN	Virtual Private Network
WWW	World Wide Web
xDSL	x (= generic) Digital Subscriber Line

4 Overview

This clause contains a short overview of the general HIPERACCESS (HA) features, the network architecture and the interfaces as well as a summary of the main properties of the DLC layer and its relationship with other layers.

4.1 Applications and services

Potential applications of HA systems include, for example, residential customers, SMEs and UMTS backhaul service. HA will provide the support for a wide range of voice and broadband data services and facilities, including "bandwidth on demand" to deliver the appropriate data rate needed by the customer. For more details, see TR 102 003 [2].

The QoS of HA systems will behave, from the user perspective, like the QoS of wired broadband systems, such as xDSL and cable modems. The end users need not be aware that the services are delivered via radio. The performance in terms of BER, access delays, connection setup times and availability is to be comparable with the equivalent competing systems. QoS objectives are to be maintained even under adverse conditions of propagation, interference, equipment failure and increasing network load.

HA systems are bearers for a wide diversity of applications. Not all applications need to be supported in all implementations of such systems. They may support a subset of the total set of possibilities, provided the services are supported in the specified manner. The data rate supported shall be variable on demand up to peak of tens of Mbit/s in UL plus DL directions delivered at the user network interface. It may be useful in some systems to allow only lower data rates to be supported, thereby decreasing the overall traffic requirement, which could reduce costs and lead to longer ranges. The average user rate varies for different applications. Generally, the peak data rate for a single user is required only for limited periods of time. The UL and DL user rates are usually not identical.

4.2 Point-to-Multipoint (PMP) architecture

4.2.1 General

HA network deployments will potentially cover large areas like cities etc. Due to the large capacity requirements of the network, millimetre wave spectrum will be used, causing a limitation of the transmission ranges to a few kilometres. A typical network will therefore consist of some number of cells each covering a part of the designated deployment area.

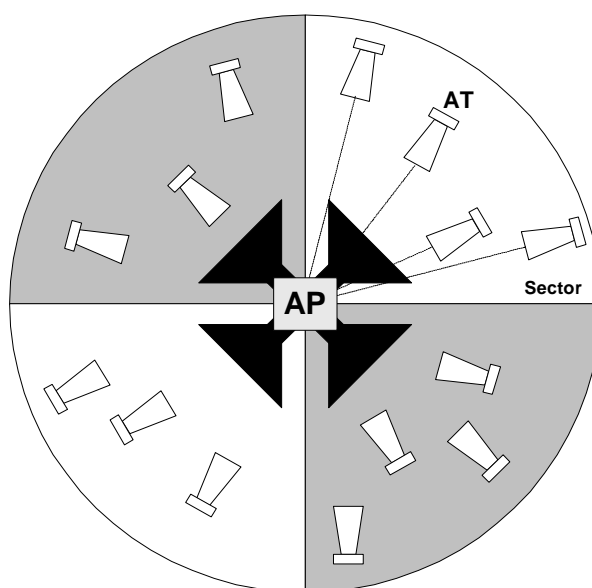

Figure 1: Example of cellular configuration (4 x 90 sectors)

As shown in figure 1, a cell is partitioned into a small number of sectors by using sector azimuth patterned antennas at the AP, increasing spectrum efficiency by the possibility of re-using available RF channels in a systematic manner within the deployment area. Each sector is operated in a Point-to-Multipoint (PMP) manner, where an Access Point (AP) equipment device (also known as base station) located approximately at the cell centre, communicates with a number of Access Termination (AT) devices (also known as terminals or subscriber equipment) which are spread across the cell.

It is emphasized that more than one subscriber within the sector may share an RF channel assigned to a specific sector, meaning that the ratio between AT equipment count and AP equipment count is typically a large number. As Line of Sight (LoS) conditions are essential for millimetre wave communications, cells may overlap in their coverage patterns. The overlap increases the likelihood of LoS conditions hence allowing for better market penetration.

4.2.2 Interoperability aspects

The HIPERACCESS standard will support interoperability at the air-interface, where interoperability means the ability of an AT designed and built according to the standards to interoperate with an AP designed and built independently to the same standards and to provide defined services according to an "inter-operation profile" specification. For interoperable systems, the following will be specified:

- PHY layer,
- DLC layer,
- Interworking functions (to support UNIs and SNIs).

Additional aspects to be specified for interoperable systems include:

- Service management issues (for the control of allowed services, to generate traffic statistics, charging for use of network, etc.).
- Network management issues (for the control of network resources, for the control of routing, to provide fault reporting, etc.).

4.2.3 Duplex Schemes (FDD, TDD) and H-FDD operation

As the communication channel between the AP and the ATs is bi-directional, the DL (downlink, direction from AP to AT) and UL (uplink, direction from AT to AP) paths shall be established utilizing the spectrum resource available to the operator. Two duplex schemes are specified, one is frequency-domain based (FDD) and one is time-domain based (TDD), used by two different operation modes of HA systems. Therefore FDD and TDD modes are optional for the AP; so one of the two modes shall be implemented. Each AT shall support the FDD mode (full or H-FDD) or the TDD mode.

- For a Frequency Division Duplex (FDD) duplex scheme, the available spectrum is partitioned into a DL RF block and an UL RF block. An RF channel is actually a pair of carriers, one from the DL RF block and one for the UL RF block, hence DL and UL transmissions are established on separate and independent radio channels. In HIPERACCESS both DL and UL carriers are equal in size and fixed to a width of 28 MHz.
- In the half-duplex FDD (H-FDD) operational mode, the AT radio equipment is limited to a half-duplex operation (i.e. transmission and reception cannot occur simultaneously), thus a relaxation of some RF design parameters is possible (e.g. isolation) and an AT cost reduction is facilitated. The DLC layer acknowledging AT limitations shall schedule the DL reception events and the UL transmission events accordingly. Furthermore the AP recognizes in this case the fact that switching from transmission operation to reception operation (and vice versa) at the AT is not immediately possible (i.e. a guard time for ramp up and down of the transmit power is required).
- It is emphasized that the H-FDD operation is an AT feature only. The AP has a different impact on the deployment cost and on system capacity (if H-FDD operation is employed at the AP). Note that in addition to the AT burst transmission capability, the H-FDD operation requires burst reception capability as well. The H-FDD operation in the AT equipment is an optional feature. However the AP equipment shall support AT equipment which has implemented this feature.

- In contrast to FDD, the Time Division Duplex (TDD) duplex scheme shall use a single carrier of 28 MHz bandwidth for DL and UL communications. The AP establishes a frame based transmission as for FDD, but additionally the frame is divided into two parts: a subframe of the frame is allocated for DL purposes and the remainder of the frame for UL purposes. This time sharing ensures that DL and UL transmission events never overlap. The ratio between the allocated time for DL transmissions and the time allocated for UL transmissions is configurable. This ratio will be identical for a given deployment region in order to maximize capacity requirements by frame synchronization of all cells.

Note that in general the TDD standard is based completely on the FDD standard. This means that the TDD operation shall use identical parameters to those of FDD, which is straightforward as the FDD operation consists of fixed length framed transmissions. In other words, FDD is the main application of HIPERACCESS systems and no specific opposed or additional optimizations for TDD are envisaged.

4.2.4 Multiplexing techniques and frame structure

As more than one AT is sharing the same UL carrier, the AP shall employ techniques controlling the access of ATs. Only TDMA (Time Division Multiple Access) shall be used. After an AT has been initialized with the system, its UL transmission events are scheduled by the AP. Scheduled events are basically time coordinates which uniquely define when the AT shall begin and end its transmission. The schedule data for UL transmission is organized in an UL map which is broadcasted in the DL. An AT can transmit in a contention based manner only for bandwidth requests.

The DL data stream to different ATs is multiplexed in the time domain (TDM). As HA systems employ adaptive PHY modes, a frame consists of a few TDM regions. Each TDM region is assigned with a specific PHY mode. Only ATs capable of receiving (i.e. successfully demodulating and decoding) the assigned PHY mode may find their DL data multiplexed in the associated TDM region. For simplifying the demodulation process, TDM regions are allocated in a robustness descending order. For example, an AT with excellent link conditions, which is assigned to a spectrum efficient PHY mode, starts its reception process at the beginning of the frame and continues through all TDM regions (using a more robust PHY mode) ending its reception process with its associated TDM region. An AT with worse link conditions will be assigned to a more robust PHY mode and its reception process will end before the AT of the previous example. Note that in any case all synchronization related operation is performed once per frame for all ATs.

The TDM region location within a frame is broadcasted at the beginning of a DL frame in the DL map, together with the UL map, used instead to give grants to different ATs. Both DL and UL maps together with the ARQ map and some other information fields are referred to as the control zone at the beginning of the frame.

TDMA transmissions could be optionally present in a TDMA zone on the DL in addition to the DL TDM zone. In this scheme, an H-FDD AT may be assigned to receive DL transmissions either in a TDM region as previously discussed or in a TDMA region. The TDMA region allocations are broadcasted as part of the DL map. With no DL TDMA zone, a half-duplex AT has limited opportunities to transmit as it is forced to demodulate the DL continuously from the beginning of the DL frame and once it transmits it shall wait for the next DL frame to re-synchronize. With the DL TDMA option the AT may seek DL reception opportunities immediately after it ceased its UL transmission within the current DL frame. The AP scheduling procedures should use the DL TDMA feature as it increases channel utilization and minimizes latencies. Note that a TDMA region may serve more than one AT by time division multiplexing DL data of several ATs.

4.3 Basic Arrangement of HA networks

4.3.1 System and reference configuration

The HA radio access system can be deployed to connect user-network interfaces (UNI, also referred to as W.3) located in and physically fixed to the customer premises equipment (CPE) to a service node interface (SNI, also referred to as W.2) of a broadband core network (e.g. IP, ATM, LL).

As it is illustrated in figure 2, the AP typically manages the communication of more than one sector. If there is more than one sector per geographical cell or more than one RF channel per sector, the AP can be split into an APC and several APTs as shown in figure 2. Each APT serves only one RF channel, but a single APC can serve all RF channels and all sectors of a geographical cell. An AT can be switched from one to another RF channel under control of the APC (addressed as load-levelling or inter-carrier handover). An AT can not be switched from one to another sector.

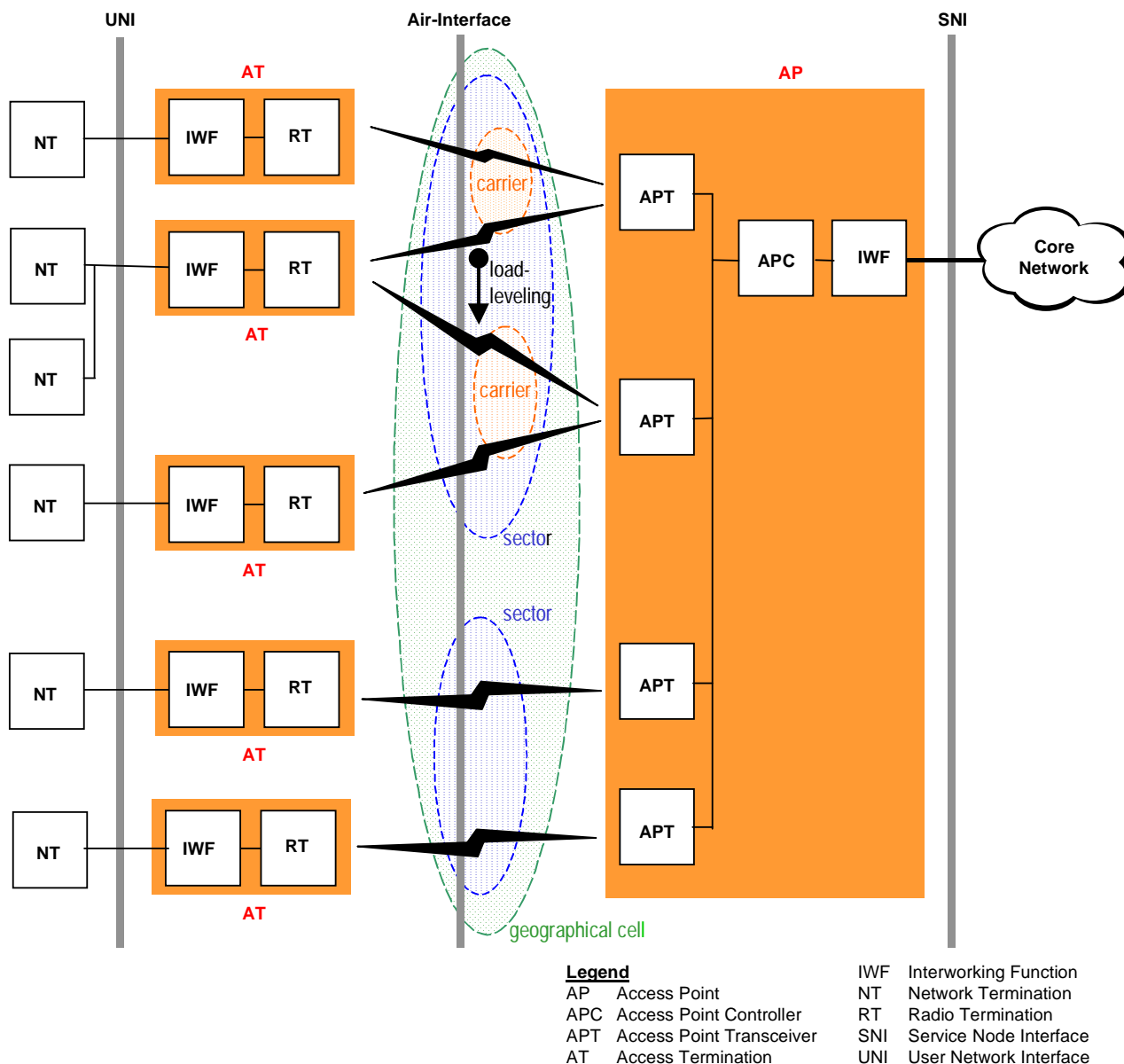

Figure 2: Configuration model for HA systems

For each sector one antenna (or maybe more) is positioned to cover the deployment region. A feeding structure connects all APTs serving one sector with the antenna(s). In other words, several carriers are using the same antenna, but different sectors require different antennas.

The AT antenna is highly directional, pointed to the serving AP. A feeding structure connects the radio transceiver with the antenna. At the AT side, the Network Termination (NT) interface connects the AT with the local user network interface (UNI).

The AT and the AP are connected via the air-interface (also referred to as W.1), where its DLC layer specification will be described in the present document. The communication channel between the AP and the ATs is bi-directional, the DL (from AP to AT) and the UL (from AT to AP) paths shall be established utilizing the spectrum resource available to the operator.

The internal interface between APT and APC is not considered in the present document.

4.3.2 External and internal interfaces, interworking functions

The detailed HA reference model illustrated in figure 3 provides an overview of the interworking functions as well as the internal and external interfaces.

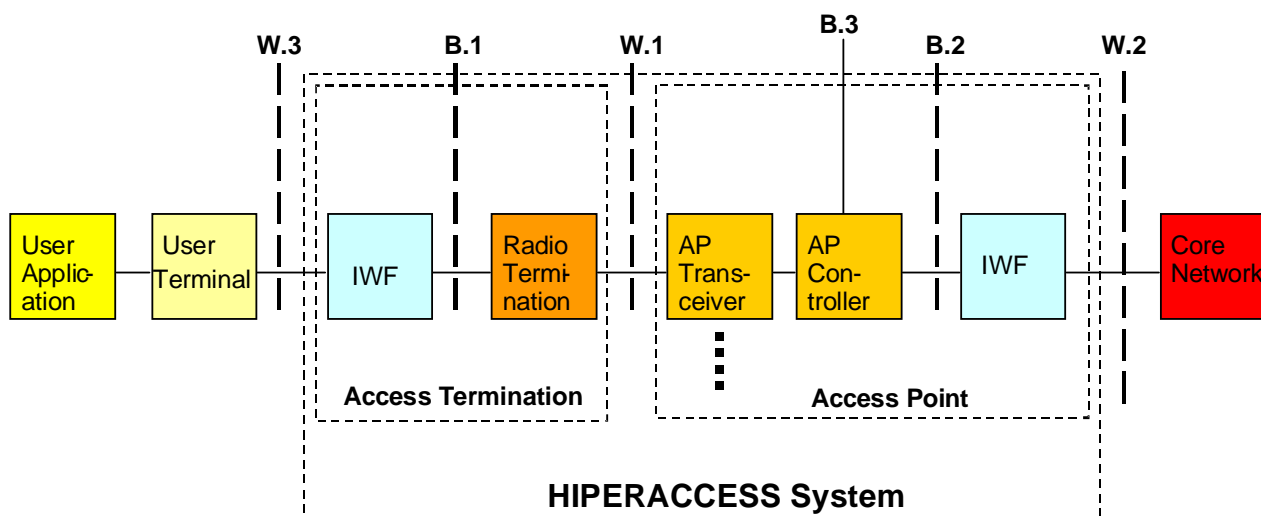

Figure 3: Reference model and interfaces for HA systems

InterWorking Functions (IWF) occur at two points to translate the internal HA interfaces to external interfaces:

- One type of IWF is required to translate the internal interface B.2 into network-specific interfaces of the particular core network (such as ATM or IP).
- The other type of IWF is required to translate the internal interface B.1 into external interfaces with the terminal equipment.

IWFs are logical entities and no particular physical location is implied by their position in the HA configuration diagram. The interfaces B.1 and B.2 are internal service interfaces, which are specified at logical level only, the implementations may vary.

The external interfaces between network elements (i.e. access termination and access point) are the following:

- **Interface between AT and AP** (air-interface, W.1): fully specified by the HA PHY and DLC TS documents.
- **Interface between AP and core networks** (W.2, identical to SNI): specified by other bodies, the list of supported interfaces and related IWF definition shall be specified within the CL.
- **Interface between AT and terminal equipment or user application** (W.3, identical to UNI): specified by other bodies, the list of supported interfaces and related IWF definition shall be specified within the CL.
- **Interface between AP and element management system** (B.3): use of an available open standard protocol.

4.3.3 Layer architecture and functional entities

The HA protocol stack consists of the unique PHY layer on the bottom, the unique DLC layer in the middle and one or more convergence layers (CL, also addressed as IWF) on top as shown in figure 4. The interfaces between layers are as follows:

- **Interface between DLC and PHY layer:** a normative and testable interface between these two layers is not specified, but an informative description is provided both in the DLC and PHY TSs.
- The DLC layer is responsible for the construction of entire PDUs, so the PHY layer shall handle only entire MAC PDUs and different fields within a MAC PDU are not visible for, and are not interpreted by the PHY layer.
- **Interfaces within DLC:** sublayers within the DLC layer are not formally specified, so there are no normative and testable interfaces within the DLC layer.
- **Interface between DLC and CL (SAP):** is described informally in detail in the present document.

The scope of the HA standard ends at the upper end of the CL. On top of the CL further higher layers are located.

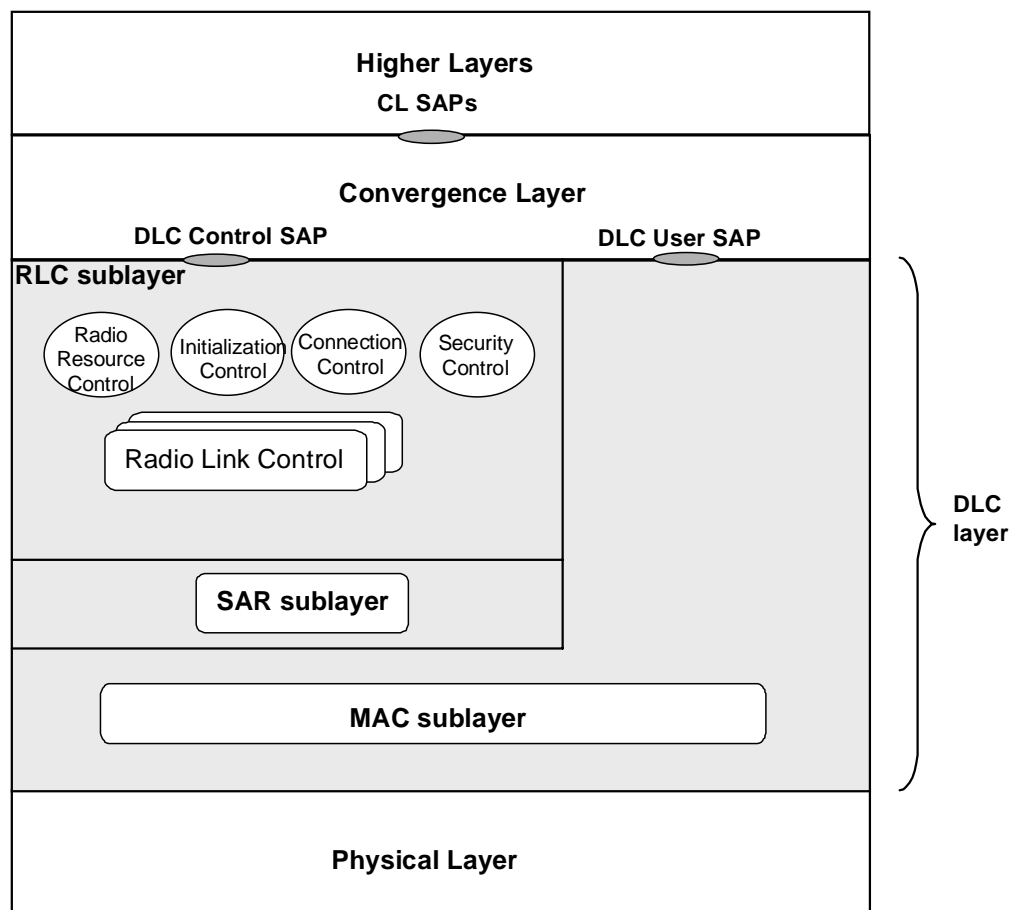

Figure 4: Protocol layer structure (for AP)

The difference of the protocol stack between AP and AT is that the AT contains only one RLC and MAC entity, whereas the AP contains one RLC entity per AT. The RLC sublayer shall contain:

- radio resource control (including load levelling, power levelling and change of PHY modes),
- initialization control (first initialization and re-initialization of ATs),
- connection control (on DLC level), and
- security control (encryption for privacy, authentication of ATs).

Service primitives to the CL only exist for connection control, since radio resource control and initialization control are related to the AT in total and not to particular connections and security control shall be completely invisible for the CL.

The present document is confined to the definition of the highlighted part shaded in grey. Hence, it describes mainly the DLC basic data transport functions, the messages to be transmitted over the air-interface including their formats for RLC and MAC (including ARQ functions) as well as the SAP to the CL.

The MAC protocol is based on TDM/TDMA access scheme(s) with centralized control and either FDD or TDD mode support. The allocation of resources is fully controlled by the AP. It is assumed that one MAC entity with one instance is provided per AP as well as per AT. The algorithms for MAC and schedulers are out of the scope of the present document.

In order to control the allocation of resources, the AP needs to know the state of its own buffers and of the buffers in all ATs. Therefore, the ATs report their buffer states in resource request messages to the AP. Using this mechanism, the ATs request for resources in terms of transmission capacity. Moreover, an optional feature is to negotiate a fixed capacity allocation over multiple frames. The AP allocates the resources according to the buffer states on a fair basis and, if required, taking QoS parameters into account. The allocation of resources is conveyed by resource grant messages. Requests are defined on a per connection or per connection aggregate basis, whereas grants are given on a per AT basis.

The MAC sublayer includes also an instance for EC (Error Control) which is responsible for detection and recovery from transmission errors on the radio link. An ARQ (Automatic Repeat Request) protocol can be applied on a per connection basis. Most ARQ functions (like the mechanisms for requests and grants of re-transmissions) are indeed DLC related, however, the error detection itself is performed in the PHY layer. ARQ also ensures the in-sequence delivery of MAC PDUs. A dedicated ARQ instance can be assigned to each DLC connection for non-real time data services and maybe even for real time CBR services if the delay requirements are less strict. ARQ is negotiated at connection establishment. In particular ARQ shall not be applied to any RLC signalling. ARQ is only applied to the UL direction. The support and implementation of ARQ is optional for the AP but mandatory for all ATs.

NOTE: Architectures where the AP is split into an AP controller and one or more AP transceivers are not precluded by the present document. If the split between AP controller and AP transceiver is below the DLC layer, more than one MAC entity may exist in the AP controller.

4.4 Convergence Layers

The function of the Convergence Layer (CL) is the Interworking Function (IWF) for mapping services over the DLC frame, specified for different services at the AT side and different core networks at the AP side. There are at least two convergence layers, a cell-based CL for ATM and a packet-based CL for IP.

The RLC sublayer receives from the CL a QoS description for each connection. The grouping of connections into connection aggregates is performed in the DLC layer.

The identifier of the Convergence Layer is called Clid and it is transported in a lot of messages. The format of the Clid is described in table 1.

Table 1: Clid format

<pre> Clid ::= INTEGER {cellBased (1), packetBased (2)}(0..7) </pre>
--

4.4.1 Cell-based Convergence Layer

The cell-based CL (Convergence Layer) is dedicated to interface the ATM layer to the HA DLC layer. At ATM level several classes of service are defined together with the requirements on QoS they are able to respect. The DLC level shall be able to be compliant with the QoS requirements coming from at least the following ATM class of service:

- Constant Bit Rate (CBR)
- Variable Bit Rate real time (VBRrt)
- Variable Bit Rate non real time (VBRnrt)
- Unspecified Bit Rate (UBR)

To ensure the support of these service classes four different service categories have been defined within the DLC layer (see clause 4.4.3).

For the handling of data cells coming from the ATM layer (see clause 5.2.1).

4.4.2 Packet-based Convergence Layer

The packet-based CL (Convergence Layer) is dedicated to interface any packet oriented upper layer to the HA DLC layer. At CL a Segmentation and Reassembly (SAR) functionality shall be provided in order to exchange with the DLC level fixed packet data units.

NOTE: Another different SAR entity within the MAC sublayer is defined to segment long MAC management messages.

Quality and priority classes (as needed for different QoS levels) shall be supported. This is accomplished by mapping the quality and priority classes of the specific packet-based CL to the service categories defined within the DLC layer (see clause 4.4.3).

Requirements to specify the support of e.g. differentiated services are mainly an issue of the CL and not of the DLC layer.

The way the segmentation (and reassembly) shall be performed (i.e. the payload length and header attachment) is specified in clause 5.2.2.

4.4.3 Handling of DLC QoS classes

The HA system is supposed to support applications like business access, residential access, 2G and 3G backhaul traffic transport etc. These services have different characteristics and as a consequence different timing limitations. At the DLC level four service categories have been defined:

- Periodic Real Time
 - Periodic bandwidth guaranteed; tight constraints on both delay and delay variation. This class is intended for support of e.g. ATM CBR services.
- Real Time
 - Minimum bandwidth guaranteed; tight constraints on both delay and delay variation.
- Non Real Time
 - Minimum bandwidth guaranteed; no constraints on delay and delay variation.
- Best Effort
 - No bandwidth guaranteed; no constraints on delay and delay variation.

Once the service classes for the DLC level have been stated, they define the service offered to the upper layers.

Upper level service categories can require strict time constraints defining a bound for delay parameters (i.e. in the ATM case the CTD or CDV parameters). To allow the CL to fulfil the delay requirements according to the needs of the supported service classes, an upper limit on the MAC PDU transfer delay shall be introduced. This value shall refer to the path from the transmitting to the receiving end specifying the total guaranteed traffic load during the measure.

This limit means the maximum delay that a MAC data PDU belonging to a connection of the highest service category may experience since entering the DLC at the transmitting side until it is passed to the upper layer at the receiving side.

The whole MAC PDU delay constraint, represented by maximum MAC PDU transfer delay, introduced by the path from the transmitting to the receiving side allows to state a limit on the delay that the DLC introduces for the highest priority DLC service category. Every MAC PDU belonging to the Real Time service will experience a delay smaller than the maximum transfer delay. Instead, for the excess traffic it is not possible to define a time constraint, since the delay is a function of the system congestion.

Since the PTD is a function of the guaranteed traffic load, a practical way to define a measure is to state the guaranteed traffic load condition when the maximum PTD is reached or maximum PTD at 100 % of guaranteed traffic load, if the PTD is lower than the limit.

Table 2 is normative. It shows the performance the HIPERACCESS system shall be able to meet. More relaxed values can be set for individual connections.

Table 2: DLC Service Category Limitation (transmitter side)

Service category	Priority	Max PDU Delay variation	Max PDU transfer delay	Bit rate
Periodic Real Time	0	5 ms	5 ms	Periodic guaranteed
Real Time	1	5 ms	5 ms	Min guaranteed
Non Real Time	2	NA	NA	Min guaranteed
Best Effort	3	NA	NA	No guarantees

The delay variation reported in the table refers to the maximum peak-to-peak delay variation (PDV_{peak-to-peak}) that is given by the difference PTD_{max} - PTD_{min}, where PTD_{min} is the minimum delay experienced by a PDU in the transit through the DLC layer. If PTD_{min} is negligible respect to the PTD_{max}, the PDV_{peak-to-peak} and the PTD_{max} have the same value. In the table above the reported delay variation is the maximum reachable value, supposing the PTD_{min} = 0. In case the ARQ is used the PTD_{min} is 3 ms at least. If PTD_{min} is not zero, the sum of the delay variation and the PTD_{min} shall be within the PTD_{max}. The maximum transfer delay for any single PDU shall not be larger than PTD_{max}.

It should be noticed that the DLC functionality, is distributed between two separated entities: for the DL the AP is the only entity involved in traffic handling, while for UL traffic decisions are taken both in AP and AT.

The AP in DL and both the AP and the AT in UL are congestion points and, due to the statistical multiplexing of traffic, they introduce a delay variation.

In the downlink direction the values of the system parameters on delay are referred to the AP only, whereas in the uplink direction, being the AT a congestion point for the incoming traffic from the line and the AP a congestion point related to the handling of the bandwidth requested by the ATs, two contributions can be defined:

- Uplink AT PTD: maximum delay introduced by the statistical multiplexing at AT level when a continuous flow of transmission grants is received from the AP.
- Uplink AP PTD: maximum delay introduced by the statistical multiplexing at AP level supposing the ATs has continuously PDUs to be transmitted.

The downlink PTD and the sum of the uplink PTDs have to be within the maximum PTD defined as system parameter, supposing the ARQ is not used. When the ARQ is adopted, the PTD that it introduces has to be added to the uplink AT and AP PTDs and the total value shall be within the maxPTD defined as system parameter.

Since the PTD is a function of the guaranteed traffic load, a practical way to define a measure is to state the guaranteed traffic load condition when the maximum PTD is reached or the maximum PTD at 100 % of guaranteed traffic load, if the PTD is lower than the limit.

4.5 Data Link Control (DLC) Layer

4.5.1 Overview and basic features

The DLC layer is connection oriented (this means that MAC PDUs are received in the same order as sent and that a connection is set up before MAC PDUs are sent) to guarantee QoS. Connections are set up over the air during the initialization of an AT, and additionally new connections may be established when new services are required.

Both ATM and IP are supported efficiently by means of a fixed MAC PDU size of 51 bytes:

- The efficient support of ATM is achieved by a one-to-one correspondence between the ATM cells of 51 bytes (full ATM cell except HEC and VPI fields) and the MAC PDU. All mechanisms for:
 - request-grant,
 - ARQ (optional for AP),
 - error-detection and performance monitoring,
 are oriented towards MAC PDUs and thus towards ATM cells in case of cell-based CL. The solution with the shortened ATM header (of 3 bytes) offers also the unconditional support of VP switching.
- For the efficient support of IP, the variable length IP packets are mapped by SAR to the fixed size MAC PDUs.

It should be noted for cell-based CL that other solutions like selectable MAC PDU size, segmentation of ATM cells in the CL to 48 bytes or hand-shaking procedures for a (VPI,VCI) mapping to CID during connection establishments do not offer any advantages.

ARQ is not specified for the DL direction but it shall be supported by the DLC and PHY layer for the UL direction where the AP shall switch on/off ARQ on a per connection basis.

A short description of the main functional entities of the DLC and PHY layers follows.

4.5.2 Radio Link Control (RLC) sublayer

The RLC sublayer contains radio resource control in particular, initialization control, connection control (on a DLC level) and security control.

- **Radio resource control:** This includes all mechanisms for load levelling, power levelling (UL ATPC and DL ATPC) and change of PHY modes. These functions are radio link-specific and thus AT-specific except for the carrier-specific DL ATPC.
- **Initialization control:** This includes all mechanisms for the initial access (first initialization) and release of a terminal to/from the network as well as the re-initialization process required in case of link interruptions or PSI. These functions are AT-specific.
- **DLC connection control:** This includes all mechanisms for connection establishment, connection change and connection release; the association of a specific connection to a specific Connection Aggregate IDentity (CAID), Security Aggregate IDentity (SAID) and a specific Service Category IDentity (SCID). The configuration of QoS parameters for a certain connection is also part of connection control. All these functions are of course connection-specific. The following table gives the correspondence between SCID values and the QoS classes:

SCID value	QoS Class
0	PRT
1	RT
2	nRT
3	BE

- **Security control:** This includes all mechanisms for authentication of ATs and the connection-specific encryption control. These functions are both terminal - and connection - specific.

4.5.3 Medium Access Control (MAC) sublayer

Some important key features are:

- Requests are per connection or per connection aggregate.
- Grants are given per terminal.
- Connections are grouped into connection aggregates.
- Several request-grant mechanisms are supported.
- ARQ is optionally supported in the AP.

4.5.4 Error control (ARQ) within the MAC sublayer

The adaptive operation of modulation and coding is able to counteract the slow propagation behaviour in case of rain fading but is powerless against the fast behaviour of the uplink interference.

Indeed while the C/I (carrier-to-interference power ratio) in the DL can be deterministically evaluated and effectively counteracted by FEC mechanism at the PHY layer, the interference in the UL direction is time-variant, as it depends on the location and the number of the simultaneous interfering ATs from other cells or sectors. The time-variant C/I behaviour in the UL can cause unacceptable service unavailability when exceeding the FEC capability. The higher the "PHY mode" throughput, the higher is the related unavailable time. Therefore the UL PHY modes with higher code rates or higher-level modulation schemes are more effectively usable if particular mechanism like ARQ are applicable.

The ARQ protocol shall be implemented at the DLC level, where the error detection is performed in the PHY layer. It is based on a selective-repeat approach as described in clause 8.5, where only the PDUs carried by erroneously received RS codewords are to be re-transmitted. In the AP, the received RS codewords are checked and in case of detected errors the RS codeword itself and all PDUs carried by this codeword are discarded. If one erroneous RS codeword in an UL frame is detected, then the AP will set an indication in the control zone of the next DL frame, enforcing a re-transmission procedure for all PDUs belonging to all erroneous RS codewords of those ATs which have at least one connection with ARQ. The impact of ARQ in terms of delay and spectrum efficiency is described in clause 8.5.5.

4.5.5 Security control within the RLC sublayer

The most important security requirements are as follows:

- Protection of traffic privacy.
- Fraud prevention.
- Checks for legitimate use.
- A "medium" security level seems enough since high-security applications will use their own end-to-end security mechanisms. As a consequence, a protection against active attacks (e.g. message integrity protection) is not provided. Furthermore, a legal interception from the air-interface is not supported, since this should be supported by the network or in higher layers.

The key mechanisms and protocols for security control are as follows:

- Authentication of ATs based on X.509 [9] certificates.
- Three-level cryptographic scheme:
 - asymmetric RSA, used for authentication and AK transmission;
 - symmetric AK (Authentication Key), encrypted with RSA for transmission, used for TEK transmission;
 - symmetric TEK (Traffic Encryption Key), encrypted with AK for transmission, used for the encryption of the payload part of all unicast traffic connections (all management connections and all broadcast and multicast connections shall not be encrypted).
- Frequent changes of keys are possible during traffic transmission. Lifetime for AK and TEK.

- Security functions (authentication and encryption) can be switched off (to allow the operation of HA systems in countries where encryption is legally not allowed).

4.5.6 Multicast connections

A multicast connection is defined as follows:

The same stream of information is addressed to a group of connections (belonging to the same or different terminals), which is referred to as a multicast group. To save bandwidth, the information is transmitted only once over the air, whereas the transmission at the SNI could be once per connection or once per multicast group. Multicast transmissions exist only in the DL. Several multicast groups comprising different sets of connections can exist in parallel. All multicast groups are dynamic, i.e. connections can be allocated to a group or withdrawn from a group at any time.

Multicast connections shall be supported. Encryption for multicast on the PHY and DLC layer is not supported in the standard but not excluded for future versions of HA.

4.6 Physical (PHY) layer

A short description of the PHY layer is included here for a comprehensive understanding, since the following key features of the PHY layer have to be supported by the DLC layer:

- Adaptive PHY mode (coding and modulation) for DL and UL.
- Transmit power control (ATPC) for DL (optional) and UL.

Some more details are given in clauses 4.6.1 and 4.6.2.

4.6.1 Adaptive coding and modulation

Typically when a carrier is shared by more than one AT, modulation and coding parameters are set according to the AT which has the greatest path loss or is exposed to the greatest amount of interference. Coupled with the fact that the operator wishes to maximize the coverage, the modulation and coding scheme in these cases shall be robust yet spectrum inefficient (i.e. QPSK with a low code rate).

Even if the cell size is greatly reduced, potentially allowing for higher order modulation schemes (i.e. 64QAM) to be used, the self-interference conditions (due to the multi-cell deployment) will dominate and prevent service to some large number of ATs (i.e. coverage dead spots).

HA uses adaptive PHY modes for solving this problem. A PHY mode is a predefined combination of modulation and coding parameters. In contrast with other transmission systems where one PHY mode dominated the entire DL transmission, for HA more than one PHY mode is used occupying different parts of the DL frame. In the UL different ATs use different PHY modes according to their individual link conditions.

The AP controls the use of a specific PHY mode. If for example link conditions deteriorate (i.e. rain) then it is expected that more ATs will be assigned to more robust PHY modes. If the link recovers then it is expected that more ATs will be assigned to more spectrum efficient PHY modes within their link limitations. Although in some deployment scenarios UL transmissions can employ similar techniques to those of the DL, there will be some cases where it will be useful to limit the choices of PHY modes for the UL due to a different, random-like, interference behaviour especially apparent when the available spectrum is re-used aggressively.

All modulation formats are M-QAM based. The forward error correction scheme will be based on an RS code concatenated with a convolutional code with no interleaving.

In order to guarantee the interoperability, the following rules shall be applied:

- The indication of the PHY mode shall be done on a burst-by-burst basis.
- Each AT shall measure the $C/(N + I)$ ratio and the received power and communicate these values to the AP. Then, following these parameters, AP centrally decides to change the DL PHY mode or not.
- For the UL a minimum amount of traffic shall be ensured in order for the AP to be able to continuously measure the $C/(N + I)$ ratio with a given accuracy.
- HA shall use one mandatory and one optional predefined set of PHY modes. The first set of PHY modes shall be supported by the AT and AP; where the second set shall be mandatory for AT and optional for AP.
- Out of these sets of PHY modes, only one set of PHY modes shall be used per sector. The choice of the set of PHY modes could be determined by the network management system. A change of the PHY mode set should be synchronized between all RF channels of a sector.

4.6.2 Automatic Transmit Power Control (ATPC)

The transmit power control is needed in order to cope with attenuation effects due to rain fading. Both UL ATPC and DL ATPC are under full control of the AP.

For the UL ATPC, each AT receives individual power adjustment commands from the AP. Usually, the UL transmit power is only changed in case of a rain fading. The AP gains the information about each AT's reasonable transmit power from the measurement of the received UL signal as well as from the parameters in the measurement reports from the ATs (where the present document contains the current transmit power and the current power margin among other parameters). As for the adaptive UL PHY mode, the AP gives enough grants to all ATs (even if the AT has no traffic to transmit) to measure the received UL power with the required precision.

In order to guarantee the interoperability, the following rules shall be applied for UL ATPC:

- The change of the transmit power shall be done on a frame-by-frame basis (both for DL and UL).
- Each AT shall report the current transmit power to the AP. Then, following these parameters and own measurements of the received UL signal, the AP decides to command an UL power adjustment.
- For the UL a minimum amount of traffic shall be ensured in order for the AP to be able to continuously measure the received UL power with a given accuracy.

In case of initial ranging, the AT shall start the transmission of the UL ranging bursts with an estimation of the proper power level. Then the power shall be increased with a pre-defined step size until the UL ranging burst is received by the AP for the first time and the AP replies with a power adjustment message. Only in case of short link interruptions, the AP can allow the AT to resume its UL transmission with the old UL transmit power setting.

The DL ATPC is an optional feature to fulfil regulatory requirements (where applicable). The DL transmit power can be changed for all carriers of a sector without notifying the ATs in advance. The DL transmit power shall be increased only if the current DL transmit power is not high enough for at least one AT in the most robust mode. In other words, the DL transmit power shall be minimized to allow the reception of the most robust PHY mode even for the AT with the worst DL radio channel conditions, but shall not be maximized to allow the use of the most efficient PHY mode for a large number of ATs.

5 Interface to PHY layer

The interface between the DLC layer and the PHY layer is only informative.

Further interfaces within the DLC layer are not specified, i.e. the MAC and RLC sublayers of the DLC layer are introduced to improve the readability of the present document and are of informative character only.

5.1 Definition of MAC PDU

5.1.1 Layer overview and general definitions (CL PDU and MAC PDU)

Protocol Data Units (PDU) and Service Data Units (SDU) are only defined with respect to a specific layer. In the downward direction, the SDU is the input from an upper layer to a lower layer and the PDU is exchanged between the respective layers of transmitting and receiving entity.

To reduce the number of names and definitions, the term SDU is not widely used in the present document. For the purpose of the DLC specification, only the CL SDU and the MAC PDU are of major importance. Two overviews are provided: in figure 5 with regards to the protocol stack and in figure 6 with regards to the structure of the data fields.

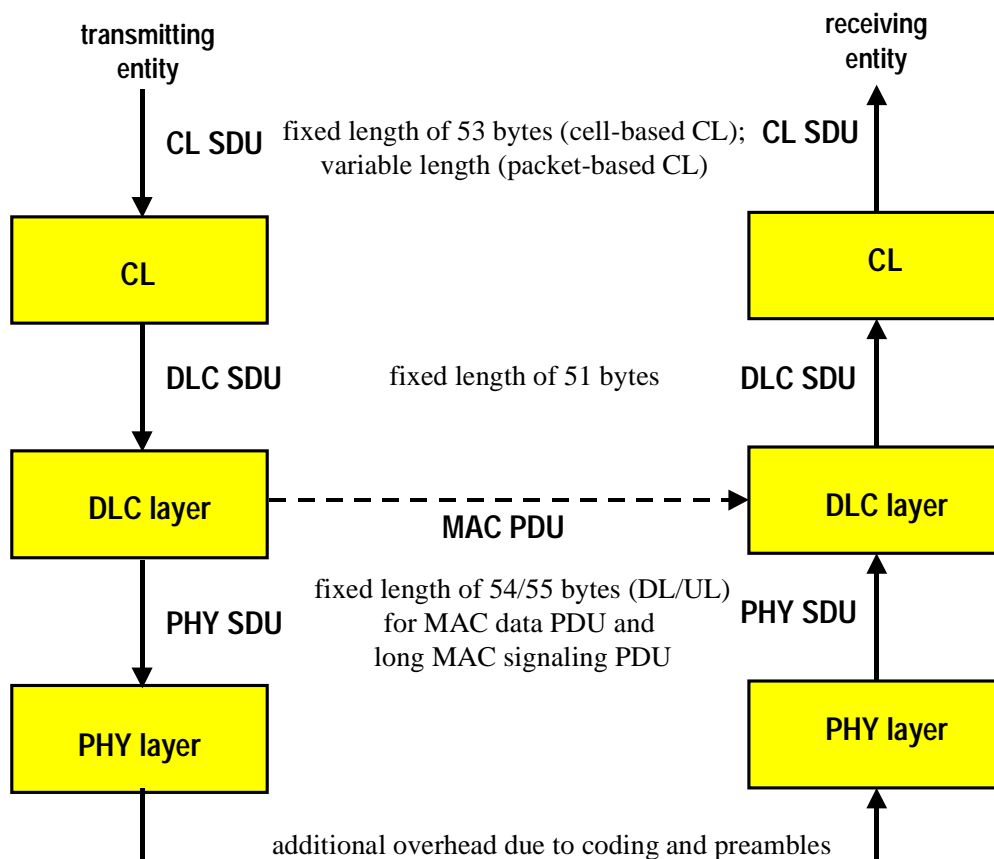

Figure 5: SDU and PDU in the protocol stack

As shown in figure 5, the DLC SDUs received from the CL have a fixed length of 51 bytes, regardless of a cell-based CL (the HEC and VPI fields of an ATM cell are suppressed in the CL) or a packet-based CL (long IP packets are segmented within the CL).

In the DLC layer, a DLC SDU is addressed as MAC data PDU payload and extended by the MAC PDU header to form the MAC PDU. The format of a MAC data PDU and a long MAC signalling PDU are identical. Additionally, there are also short MAC signalling PDUs for the UL direction. Both long and short MAC signalling PDUs carry messages that are created in the DLC layer. If these messages are too long then they are segmented to 51 bytes (including FC information) within the DLC layer.

5.1.2 Long MAC PDUs

Figure 6 provides a more detailed overview of the structure of a MAC data PDU and a long MAC signalling PDU, where the numbers specify the length in bytes. The length of a MAC PDU payload is always fixed to 51 bytes except for short MAC signalling PDUs.

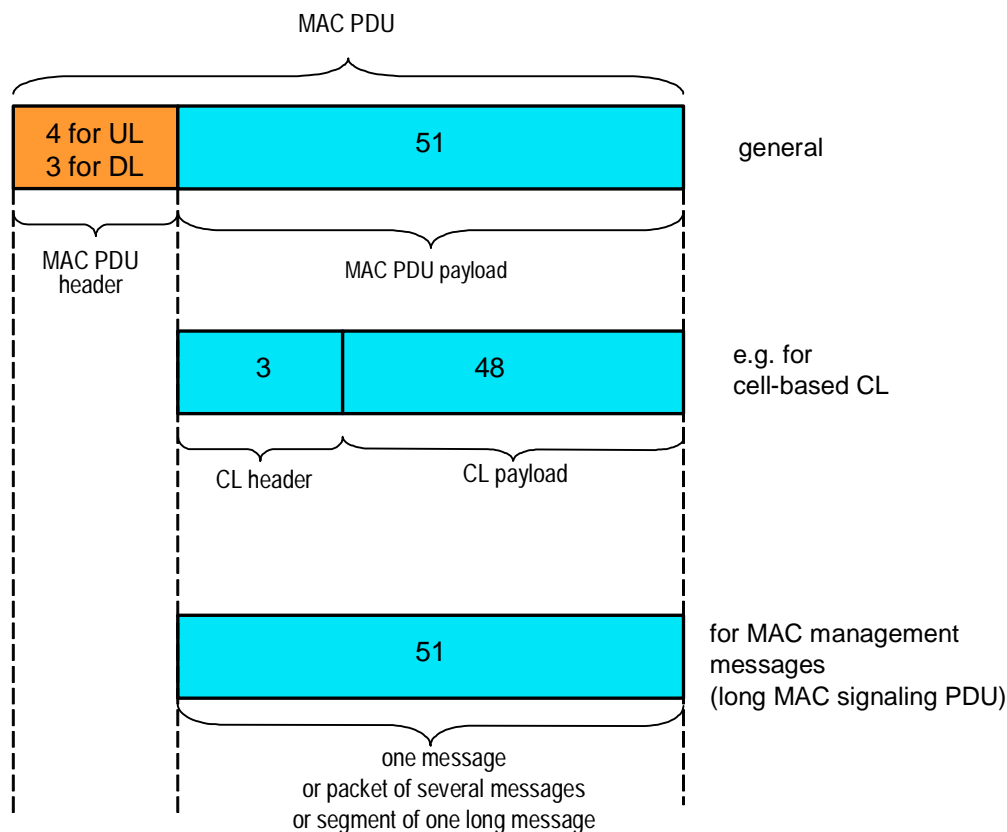

Figure 6: Structure of MAC data PDU and long MAC signalling PDU

The MAC PDUs are created in the DLC layer. The MAC PDU payload is either received from the CL (consisting of CL header and CL payload) or generated as MAC management message in the DLC layer. Only the MAC PDU header has a format depending on the direction of the transmission.

PDUs received from the CL are distinguished from PDUs created in the DLC layer (like MAC management messages or broadcast messages) by the CID field in the MAC PDU header, and additionally MAC data PDUs are distinguished from MAC signalling PDUs by the PT field in the header.

A long MAC signalling PDU can carry one or several MAC management message(s) or a segment as shown in figure 6 (see clause 7.4 for the lists of message format).

MAC data PDUs shall be used to carry data only. Only the payload part of a unicast MAC data PDU is encrypted in the DLC layer to guarantee for privacy, whereas MAC signalling PDUs or multicast MAC data PDUs are not encrypted. The MAC PDU header is not encrypted.

5.1.3 Short MAC PDU

Figure 7 shows the definition of the short MAC signalling PDU used only for UL which is created in the DLC layer. The payload length is 8 bytes (including the MT field) to accommodate the ranging request message.

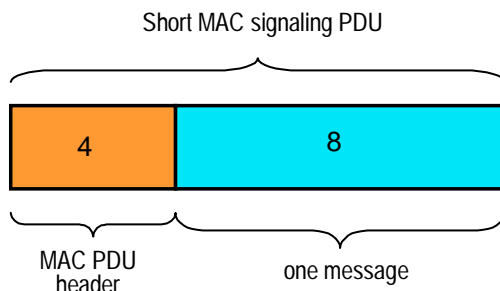

Figure 7: Structure of short MAC signalling PDU (UL only)

5.2 Interface DLC-PHY

The interface between DLC and PHY layer is not formally specified, so this clause is only informative. As long as the interoperability is guaranteed, the exact implementation of this interface is a manufacturer design.

Clause 5.2.1 provides a description of the informative interface by block diagrams and parameter lists. Clause 5.2.2 shows an overview of the data units in the transmitter and receiver chains and the following clauses give a description of how MAC PDUs are converted to PHY SDUs and are transmitted over the PHY layer and the air-interface, especially their allocation to FEC blocks. Their interrelation with maps and zones is covered in detail in clause 8.

5.2.1 Informal description in terms of detailed parameter lists

A normative and testable interface between these two layers is not specified, but an informative description is provided. The DLC layer is responsible for the construction of entire PDUs, so the PHY layer shall handle only entire PHY SDUs and the different fields within a PHY SDU are not visible for, and are not interpreted by, the PHY layer.

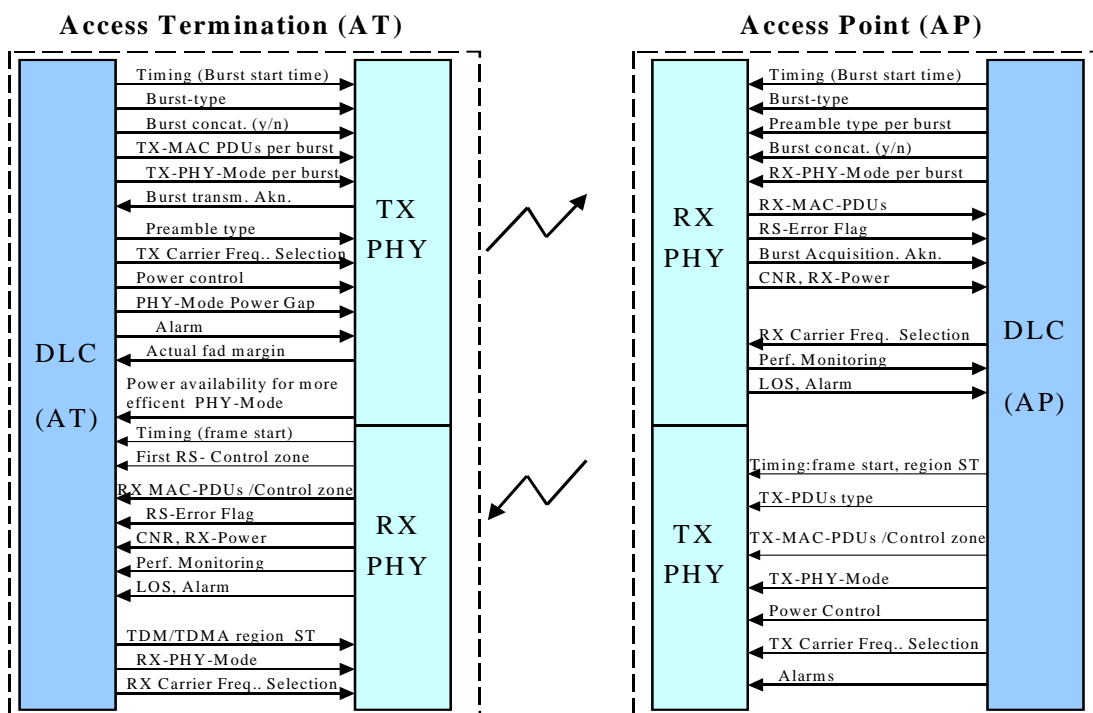

Figure 8: Block-diagram of the DLC-PHY interface

Figure 8 shows the block-diagram of this interface in AP and in AT.

All messaging between the PHY and DLC layers in AP and AT and for transmitter and receiver sides are listed in table 3 to table 6.

Table 3: Interface between DLC and PHY in AP (transmitter side)

Signals/Messages Transmission Side	Detailed parameters
Timing	Start of a frame and Start time of TDM or TDMA PHY mode regions
PDU-Type	Transmit Long MAC PDUs of 54 bytes or control zone bytes
TX MAC PDUs/Control zone bytes	MAC PDUs bytes or control zone bytes to be transmitted per TDM/TDMA Phy mode region
TX-PHY-Mode	PHY mode for each TDM or TDMA region
Power control	Relative power control signal
TX-Carrier Freq. Select	Selection of the TX carrier frequency, load levelling
Alarm	Alarm from DLC for stopping the transmission in the PHY

Table 4: Interface between DLC and PHY in AP (receiver side)

Signals/Messages Reception Side	Detailed parameters
Timing	Time to start to detect a burst
Burst-Type	Long burst of n x 55 MAC-PDUs-bytes or short signalling burst carrying 12 bytes
Preamble type	16 or 32 symbols
Burst concatenation	Burst concatenation: Yes or not
RX-PHY-Mode	PHY mode for each UL-burst
RX-Carrier Freq.Select	Selection of the Rx carrier frequency, load levelling
RX-MAC-PDUs	Received n x 55 long MAC-PDUs bytes or short signalling MAC-PDU bytes
RS-error flag	Error flag per each RS decoded block
Burst acquisition Akn.	Acknowledgment for a successful acquisition of a burst
CNR, RX-Power	Measured CNR and RX-power
Perf. Monitoring	Information collected by the PHY-layer about link quality following ITU-T Recommendations G.821 [3]/G.826 [4]/M.2100 [6].
Alarm, LOS	Alarm for anomaly from RX-PHY to DLC or Los of synchronization signalling

Table 5: Interface between DLC and PHY in AT (transmitter side)

Signals/Messages Transmission Side	Detailed parameters
Timing	Start time for the transmission of a burst
Burst-Type	Long burst carrying n x 55 long MAC-PDUs bytes or short burst carrying 12 short signalling MAC-PDU bytes
Burst concatenation	Burst concatenation: Yes or not
TX MAC PDUs	Short or long MAC-PDUs to be transmitted per burst
TX-PHY-Mode	PHY mode for each transmitted burst
Power control	Relative power control signal
TX-Carrier Freq. Select	Selection of the TX carrier frequency, load levelling
Preamble type	16 or 32 symbols
PHY power Gap	Automatic power correction/adaptation in case of change of PHY mode
Burst transm. Akn.	Acknowledgment for the successful transmission of a burst
Tx power margin reserve	The actual power reserve available
Power availability for changing to a more efficient PHY mode	The indication from the PHY layer to the DLC layer to notify that the amount of available power is sufficient in order to switch to a more spectral efficient PHY mode.
Alarm	Alarm from DLC for stopping the PHY transmission

Table 6: Interface between DLC and PHY in AT (receiver side)

Signals/Messages Reception Side	Detailed parameters
Timing	Detection of the beginning of a frame: Frame start time
First RS-Control zone	First 30 bytes of control zone
RX MAC-PDUs/Control zone bytes	Received n x long MAC-PDUs of 55 bytes or control zone bytes
RS-error flag	Error flag per each RS decoded block
CNR, RX-Power	Measured CNR and RX-power
Perf. Monitoring	Information collected by the PHY-layer about link quality following ITU-T Recommendations G.821 [3]/G.826 [4]/M.2100 [6].
Alarm, LOS	Alarm for anomaly from RX-PHY to DLC or Los of synchronization signalling
TDM/TDMA region ST	Start time for detecting each TDM or TDMA PHY mode region
RX-PHY-Mode	PHY mode for each DL TDM or TDMA PHY mode region
RX-Carrier Freq.Select	Selection of the Rx carrier frequency, load levelling

Some additional remarks:

NOTE 1: PHY functions include (for transmitter): insertion of zero bits for trellis termination; insertion of padding bits to complete a modulation symbol; insertion of padding channel symbols to complete the fixed frame duration; creation and insertion of preambles; scrambling; timing for frame and burst duration; maintaining of time synchronization.

NOTE 2: DLC functions include (for transmitter): creation of MAC PDUs or PHY SDUs; creation of control zone (including frame number); organization of re-transmissions for ARQ and creation of ARQ entries; creation of MAC dummy PDUs; creation of ranging request messages (for AT only); maintaining of minimum data rate in UL; segmentation of MAC management messages; encryption and decryption of MAC PDU payload.

The frame structure with a fixed duration of 1 ms is both relevant for DLC and PHY layers.

5.2.2 Data units in transmitter and receiver chain

Figure 9 shows a block diagram of the operations in the transmitter and receiver chain to indicate the relations between MAC PDU, RS codewords, FEC blocks and bursts.

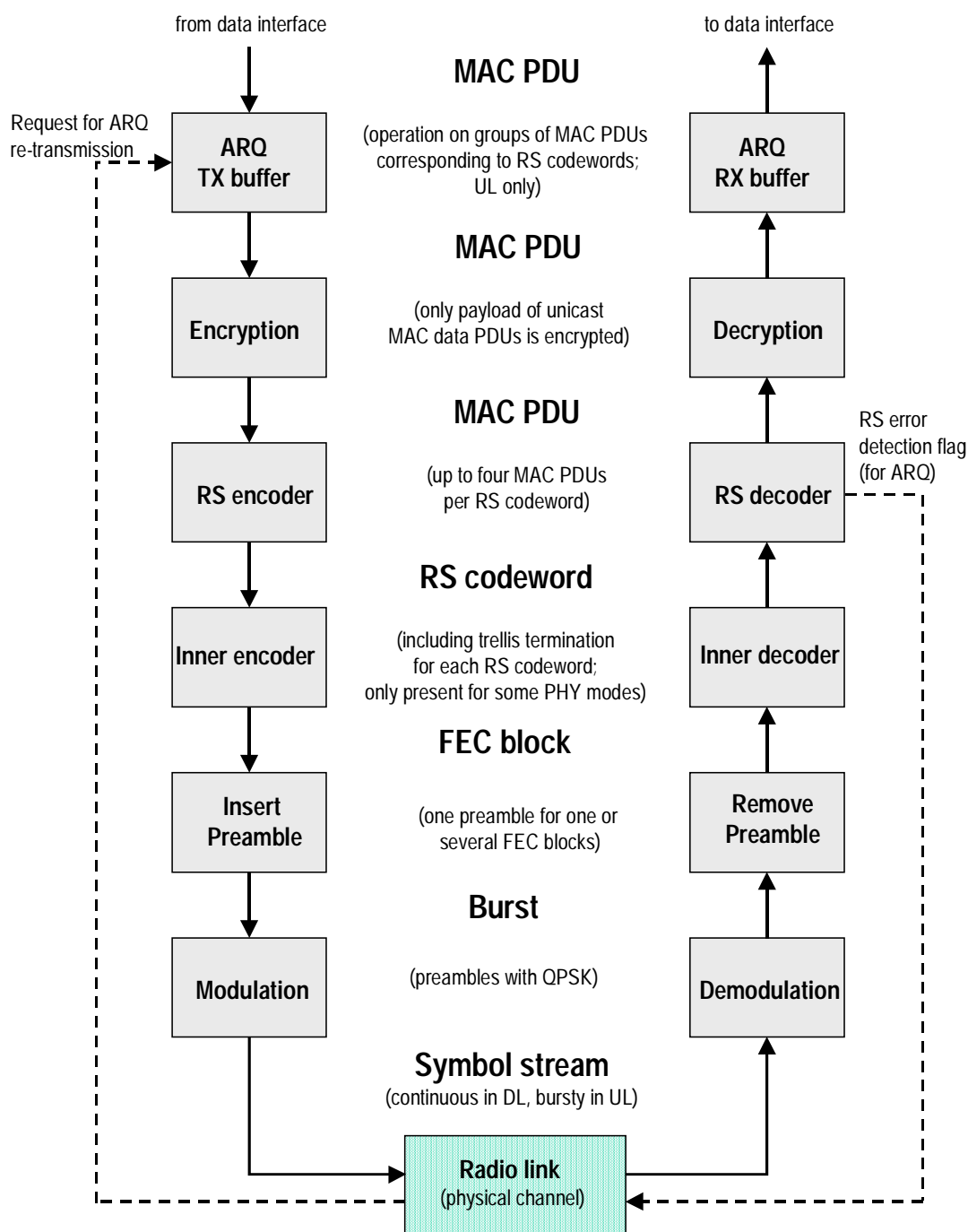

Figure 9: Block diagram of transmitter and receiver chain

The ARQ operation is only applicable for the UL direction (where the requests for re-transmissions are sent in DL direction as part of the ARQ map in the control zone), but all other operations apply for both transmission directions. If an RS codeword carries only one MAC PDU, then MAC PDUs can be re-transmitted individually. Otherwise, if an RS codeword carries only several MAC PDUs, then all MAC PDUs of this RS codeword can be re-transmitted.

The encryption is done individually per MAC PDU, depending on the Initialization Vector (IV) which is generated from the frame counter. A MAC PDU to be re-transmitted per ARQ is newly encrypted, i.e. repetitions of the same plaintext imply different ciphertext on the air.

The RS encoding operation is always present, whereas the inner convolutional encoding operation is only applicable for some PHY modes.

The scrambling operation between encryption and RS encoder (and the inverse de-scrambling) operation is not shown in figure 9.

The mapping of MAC PDUs to the PHY structure (RS codewords, FEC blocks, PHY mode regions and zones) is shown in the following figures, firstly for DL and UL directions in case of FDD mode and secondly for the TDD mode.

5.2.3 Downlink with FDD mode

The mapping of MAC PDUs to the PHY structure for the DL direction is shown in figure 10 without the TDMA option and in figure 11 especially for the optional TDMA zone.

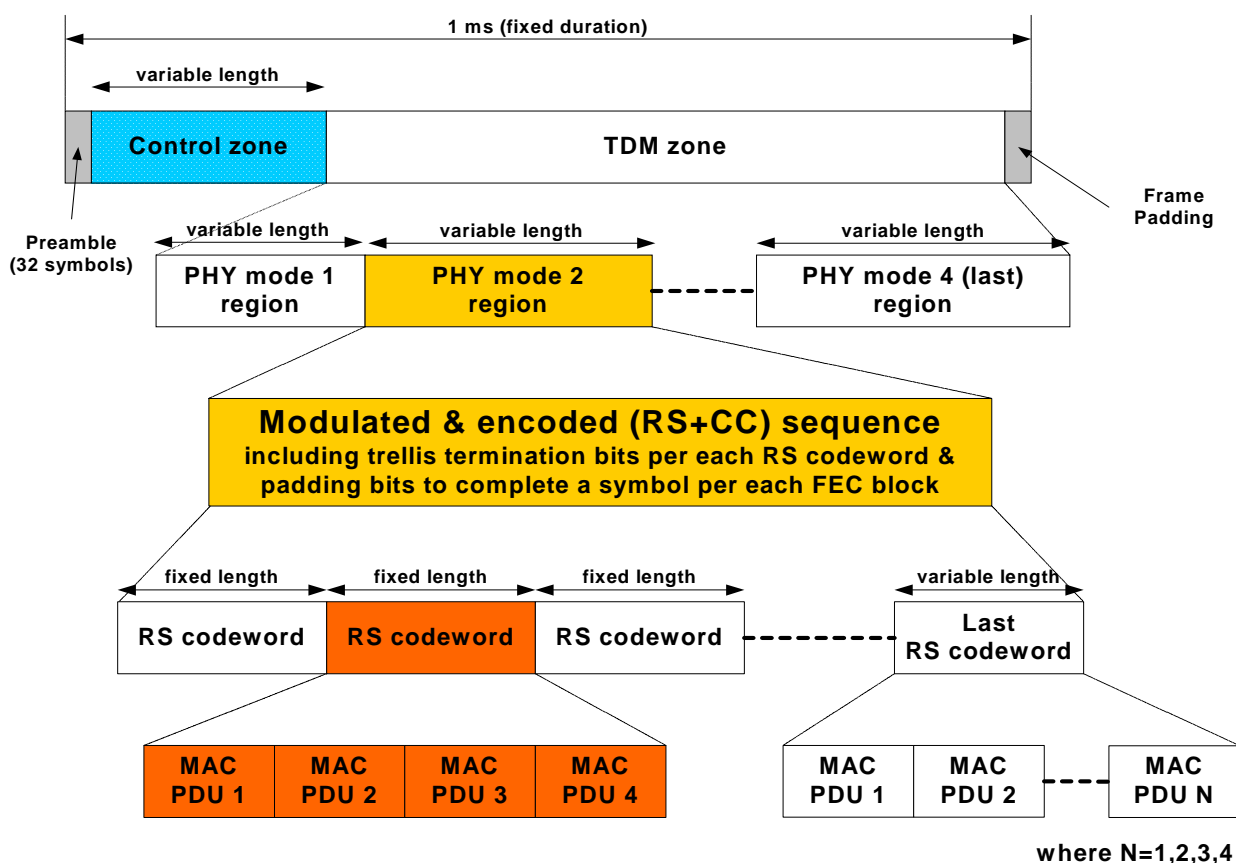

Figure 10: Transmission of MAC PDUs in DL without TDMA option

Figure 10 shows the mapping of MAC PDUs to the frame structure in the DL without the TDMA option. The frame starts with a preamble of 32 symbols. A control zone follows the preamble containing the DL, ARQ and UL maps. The maps indicate events (i.e. PHY modes as well as location and duration within a frame). The DL map defines the TDM zone and optionally a TDMA zone. The UL map defines signalling events and different kinds of windows and specific user transmission events. The term "length" refers to the duration in the upper parts and to the size in bytes in the lower parts of figure 10.

A TDM zone consists of different PHY mode regions by descending robustness order (i.e. QPSK precedes 16QAM). Each PHY mode region time multiplexes data associated with different ATs capable of demodulating and decoding the associated PHY mode. As the number of addressed ATs within a PHY mode varies and such does their instantaneous DL data rate, all PHY mode region durations can vary from frame to frame.

Each PHY mode consists of data which was concatenated (by an outer RS block code and, for some PHY modes, an inner convolutional code) encoded using an RS codeword encapsulating four MAC PDUs, except the last RS codeword where shortening is applied if the remaining number of PDUs per RS codeword is less than four. In case of an inner convolutional code, trellis terminating bits are added to each RS codeword, so an FEC block corresponds to an RS codeword. The number of symbols required for the transmission of a PHY mode region depends on the modulation scheme. At the end of a PHY mode region, padding bits are added to complete a modulation symbol. To fill up the TDM zone, MAC dummy PDUs are inserted (in arbitrary PHY mode regions of the TDM or TDMA zone) and additional padding symbols are added at the end of the TDM or TDMA zone to complete exactly the frame.

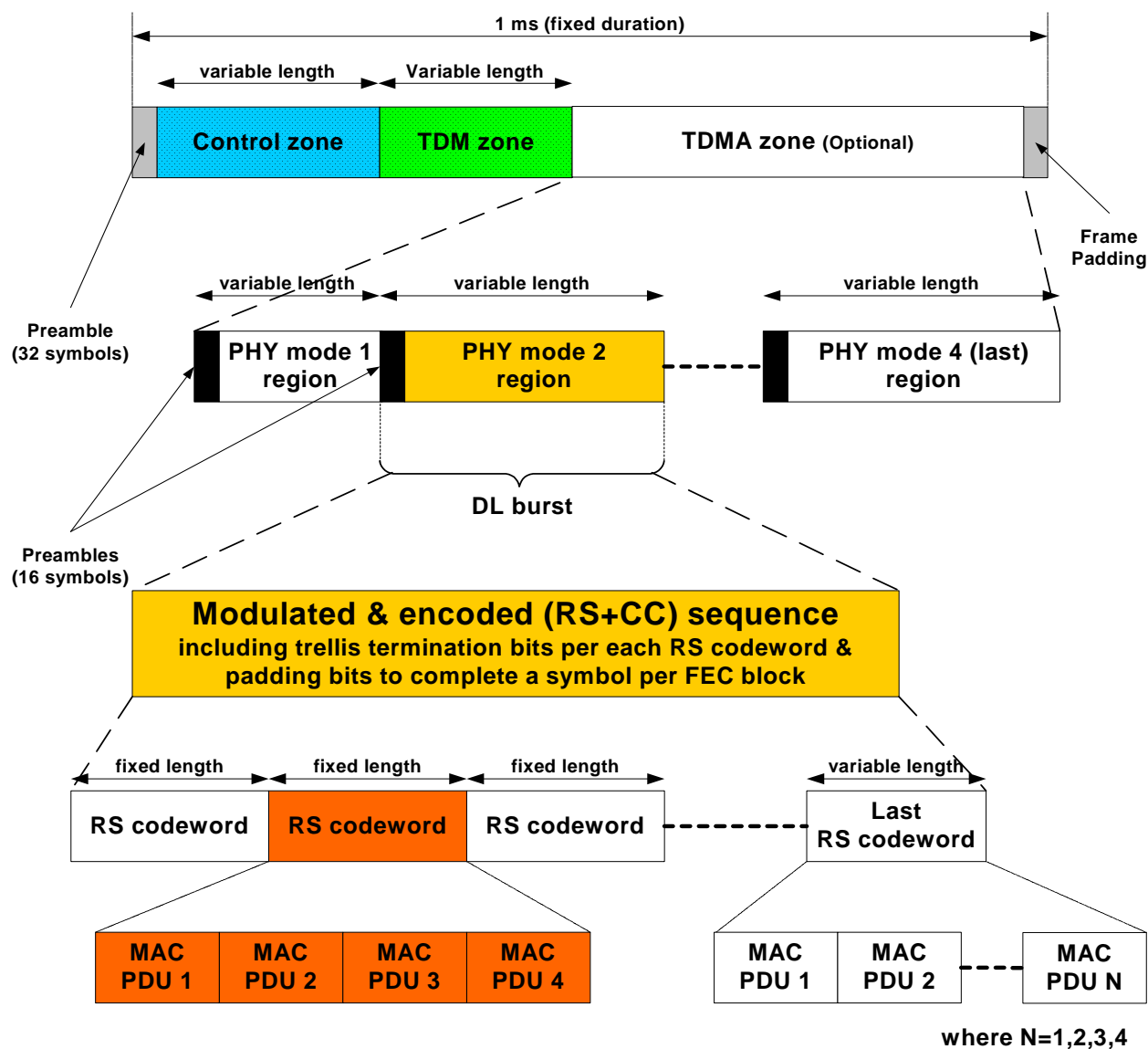

Figure 11: Transmission of MAC PDUs in DL with TDMA option

Figure 11 shows the mapping of MAC PDUs to the frame structure in the DL in case of the additional TDMA zone. The term "length" refers to the duration in the upper parts and to the size in bytes in the lower parts of the figure. Optionally, a TDMA zone follows the TDM zone. Similar to the TDM zone, the TDMA zone consists of different PHY mode regions (bursts) with the following differences:

- No specific robustness order will be applied.
- Each PHY mode region starts with a short preamble of 16 symbols.

Note that the TDMA zone is intended to be used by H-FDD ATs. The H-FDD AT is expected to demodulate and decode the beginning of the frame containing the control zone. Depending on its recent UL transmission event, it is expected that the H-FDD AT will switch back to DL reception and recover its data in a TDMA PHY mode region suitable for its link conditions.

The PHY mode region shall be composed of one or more FEC blocks. Every FEC block shall contain 4 MAC PDUs, only the last FEC block in a PHY burst shall contain a number of MAC PDUs equal to 1, 2, 3 or 4 in order to complete the transmission of the number of MAC PDUs foreseen for the burst. The number of symbols within each FEC block depends on the relevant PHY mode. The total length of a burst shall be an integer number of symbols, the last symbol shall be padded with bit values equal to 0 as necessary.

5.2.4 Uplink with FDD mode

The UL frame is subdivided in:

- A window for contention-based access (i.e. non-scheduled transmissions) where only bandwidth requests are allowed. Only short MAC signalling PDUs with the most robust PHY mode shall be transmitted in the contention window.
- Scheduled bursts (i.e. granted bursts for invited traffic from AT), applies for:
 - MAC data PDUs,
 - long MAC signalling PDUs,
 - short MAC signalling PDUs,
 - ranging bursts (always with the most robust PHY mode),

where each PHY mode can be scheduled for the first three cases).

The locations of these different parts within an UL frame are indicated by the UIUC entries in the UL map which is broadcasted in the control zone in the DL at the beginning of each frame. See clause 8.2.2 for more details on the UL frame structure.

An UL burst for an AT transmission may include more than one MAC PDU or more than one FEC block similar to the DL direction. MAC PDUs shall be encapsulated into RS codewords of fixed length. The last RS codeword will be shortened in the case where the number of remaining MAC PDUs is less than four. As the AT finishes to transmit its UL burst, it may ramp-down its transmitter. This period of time is expected to overlap a ramp-up period of the next AT UL burst scheduled for transmission.

An UL burst can either contain a mixture of MAC data PDUs and long MAC signalling PDUs (and maybe dummy PDUs if nothing else is to be transmitted) or one short MAC signalling PDU. In other words, an UL burst with one short MAC signalling PDU can not contain a further short MAC signalling PDU or a long MAC PDU.

Figure 12 shows the mapping of MAC PDUs to the PHY structure for the UL direction. The term "length" refers to the duration and in the lower parts in the figure also to the size in bytes. The options of only one MAC PDU per FEC block or one FEC block per preamble are not explicitly shown.

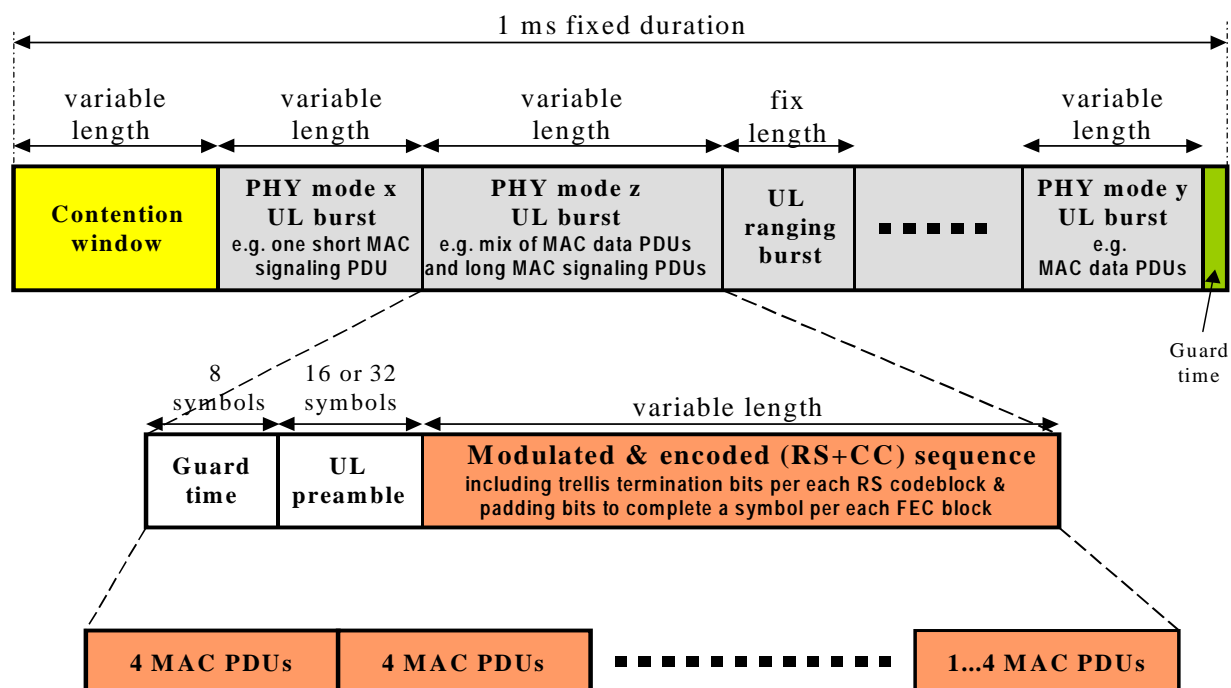

Figure 12: Transmission of MAC PDUs in UL

Note that all UL bursts will be preceded by a guard time and a preamble. The order of the basic UL frame structure shown in figure 12 is just an example and it is up to the scheduler in the AP to decide on the order.

An AT, which the UL map has indicated the existence of an UL transmission event for it, is expected to transmit its data at the indicated time. The PHY mode used by the AT for the transmission is specified as well by the UL map. The AT begins its transmission with a preamble with length of 16 or 32 symbols (commanded from AP at initialization).

5.2.5 TDD mode

There are still some differences for the TDD mode compared to the FDD mode. The frame with a fixed duration of 1 ms (as for the FDD mode) is split in a DL subframe and a UL subframe. The subframes are shorter than 1 ms as only a portion of the full frame is allocated for each direction. The partitioning into DL and UL subframes can be adaptive (i.e. variable over time, to be supported by AP and AT) or non-adaptive as well as synchronous (i.e. between APs of a network) or asynchronous.

At the end of each subframe, a Tx/Rx-switching time is required for switching of the AT from reception to transmission or vice versa.

For the TDD mode, no explicit TDMA zone is necessary, as inherently all ATs are H-FDD operated and no special handling is required.

The SSs for UL transmissions are determined by the UL map as for the FDD mode.

More information on the TDD mode can be found in clause 8.3.3.

5.2.6 Structure of RS codewords and preambles in UL bursts

Two specific features and their combinations can be enabled for the UL transmission (note that in this context a strict distinction between RS codewords and FEC blocks is not necessary):

- **None to several midambles per burst:**
 - **No midamble:** Only one preamble is used for grouping all FEC blocks in an UL burst.
 - **Several midambles:** Each RS codeword is preceded by its own preamble (in this case, the preamble is called midamble), i.e. if there are several FEC blocks for one AT to be transmitted, a new preamble is used for each FEC block. This feature could allow for simpler synchronization at the AP, maybe if the first preamble is destroyed by UL interference.
- **One or several MAC PDUs per FEC block:**
 - **One:** Only one MAC PDU (applies for data PDU or long signalling PDU) instead of four MAC PDUs is transmitted by one FEC block. This feature could allow for simpler demodulation at AP and a smaller number of re-transmissions for ARQ, since the error detection of RS codewords is effectively related to PDUs.
 - **Several:** Each FEC block (except for the last FEC block in an UL burst) carries four MAC PDUs.

Both features are handled on a per carrier basis and can be time-variant, i.e. they are broadcasted in the GBI message. The support of these features is mandatory for the AT and optional for the AP. For all combinations, only one single UL map entry is required per UL burst.

The two features are demonstrated in figure 13 for an example of 5 PDU to be transmitted for the AT under consideration.

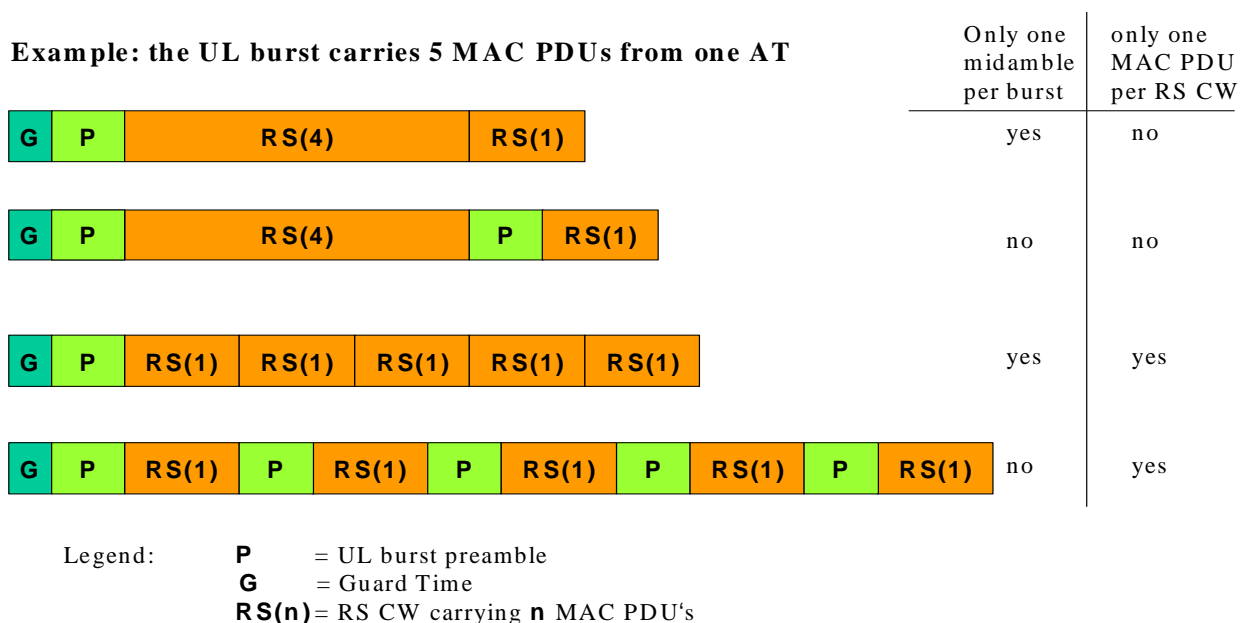

Figure 13: Structure of RS codewords and preambles in an UL burst

NOTE: Padding to complete a modulation symbol is required at the end of a FEC block if the UL burst is finished or continued with another preamble.

6 DLC addressing and identities

6.1 General

In case of FDD mode, an RF channel is always a pair of DL and UL RF carriers. Only for TDD, an RF channel simply reduces to an unpaired single RF channel and both transmission directions are separated by the two subframes of the frame. Concerning addressing and logical channel structure, there is no difference between FDD and TDD modes.

The main identities to be handled in a HA system are as follows:

- The APC-ID (24 bits) is used to identify the sector during initialization.
- The AT MAC address (based on MAC-48, 48 bits) is used to identify the AT during initialization and authentication.
- The terminal identity (TID, 10 bits) is used in the control zone for the UL map for the allocation of grants to the ATs, in the multiple-TID message.
- The connection identity (CID, 16 bits) is used in the MAC PDU header for DL and UL to identify the connection. Some specific CIDs are used to identify MAC management connections and are thus AT-specific.
- The connection aggregate identity (CAID, 16 bits) is used in the bandwidth request message and the queue status request message.
- The security associate identity (SAID, 16 bits) is used in security and connection control messages and is specified in clause 12.

6.2 APC Identity (APC-ID)

The APC-ID (APC Identity) is used to identify the access point controller and so the cell site. The scope is to facilitate and speed up the initialization process by identifying the cell site.

The APC-ID consists of 24 bits. The first 4 bits are used to distinguish between different operators (operator colour code) and the remaining 20 bits are used to identify the APC.

The APC-ID is transmitted in each control zone, i.e. with a period of 1 ms.

6.3 Access Terminal (AT) Identities

A long world-wide unique terminal identity of 48 bits related to the terminal equipment (AT MAC address) and a short sector-wide unique terminal identity (TID) of 10 bits have to be distinguished.

6.3.1 AT MAC address (equipment ID based on MAC-48)

A permanent world-wide unique AT MAC address of 48 bits length is used for terminal identification during the first initialization or re-initialization, especially for the initial ranging message and for authentication.

The AT MAC address is based on MAC-48 (see IEEE 802 in bibliography) and related to the terminal equipment. Hence, this is not a logical identity, in case of equipment replacement (e.g. due to an equipment failure) the AT MAC address will change.

6.3.2 Terminal Identity (TID)

The terminal identity (TID) of 10 bit is used in the control zone for the UL map entries for the allocation of grants to the ATs and also in multiple-TID messages. The TID is unique per carrier. Up to 1024 ATs per carrier are supported with regards to addressing. However, due to the noise floor limitation, the number of ATs per sector is limited to 256 and the number of ATs per carrier is also limited to 256.

According to table 7, some specific TIDs shall be used for:

- UL map entries that indicate the bandwidth request contention window.
- End of map entries.

Table 7: Specific TID values (10 bits)

•	TID ::= INTEGER(0..1023)
•	
•	-- Normative specifications for specific Tid values:
•	-- ContentionWindowTid ::= 0
•	-- EndOfMapTid ::= 1
•	-- normal Tid shall be in the range [2,1023]

6.4 Connection IDentity (CID)

The CID (Connection IDentity) is an unstructured field of 16 bits and present in each MAC PDU header for DL and UL.

All CIDs are under full control of the AP both for DL and UL, so the mapping of the VPI field to CID in case of cell-based CL is under control of the AP and need not to be specified.

The CID is unique per RF channel. The CIDs are generated in the AP, both for DL and UL.

The CIDs are uni-directional and not bi-directional. For all bi-directional unicast data traffic connections, the AP shall assign two identical uni-directional CIDs to the two directions.

According to table 8, specific CIDs shall be used to identify:

- Broadcast messages (DL only, important examples are RlcGeneralBroadcastInformation and RlcFrequencyList, etc.).
- Multiple-TID messages RlcMultipleTidBroadcastBasic (DL only, only for basic MAC management connections).
- Broadcasted MAC dummy PDUs (applies for long and short PDUs in DL as well as for short PDUs in UL).
- Ranging invitation message in DL (where the AT is addressed by its AT MAC address).

Table 8: Specific CID values (16 bits)

Cid	::= INTEGER(0.. 65535)
BasicCid	::= Cid(10..1033)
PrimaryCid	::= Cid(1034..2057)
SecondaryCid	::= Cid(2058..3081)
DataCid	::= Cid(3082..65535)
--	Normative specifications for specific Cid values:
--	BroadcastCid ::= 0
--	MultipleTidBroadcastBasicCid ::= 1
--	DummyCid ::= 3
--	RangingCid ::= 4

For each AT three individual uni-directional CIDs for each direction are used for the MAC management connections. Note that the ranges for these CIDs are specified by the present document, although the allocation of CIDs to ATs is under full control of the AP in general.

Additionally, several CIDs are used for multicast connections. Since these are uni-directional connections, the CIDs only exist for the DL direction. A specific range for multicast CIDs is not required.

6.5 Connection aggregate identity (CAID)

The grouping of connections to connection aggregates shall be under full control of the AP and the result of the grouping is communicated to the AT during connection establishment. Later re-groupings are possible.

Connections belonging to different QoS classes should not be grouped into the same connection aggregate (to allow vendor-specific QoS implementations).

A specific identity for a connection aggregate does exist with 16 bits. For requests, connection aggregates in total are addressed by an arbitrary CID inside the connection aggregate, i.e. the CAID is not used for requests per grant management field in the MAC PDU header. However, the CAID is used in the payload of the queue status request message and the bandwidth request message.

In order to request bandwidth especially for MAC management messages by using the bandwidth request message `RlcBandwidthRequest` or the queue status request message `RlcQueueStatusReq` (where both messages contain only references to connection aggregates), specific CAID values (which can be selected arbitrarily at AP) are provided to the AT during the ranging procedure with the `RlcRangingInvitation` message. See table 9 for the CAID specification.

Table 9: Specific connection aggregate ID values (16 bits)

<code>Caid</code>	<code>::= INTEGER(0..65535)</code>	<code>-- 16 bit</code>
-------------------	------------------------------------	------------------------

7 MAC management messages: mapping to MAC management connections, transport and list of all messages

Transport and logical channels are not formally introduced in the present document.

7.1 Overview of connection types

Three management connections are established for both directions at AT initialization with AT-specific CIDs:

- **Basic MAC management connection** is used to transport shorter, more delay-intolerant (urgent) MAC management messages such as ranging requests, signalling for adaptive operation and power control and for connection management, etc.
- **Primary MAC management connection** is used to exchange longer, more delay-tolerant MAC management messages such as key management, etc.
- **Secondary management connection** is set up to transfer delay-tolerant standards based information such as DHCP, SNMP, TFTP, etc.

The basic and primary MAC management connections are dedicated for the communication between the DLC protocol entities. The secondary management connection is dedicated for the communication between upper layers.

In addition to these AT-specific management connections, certain MAC management messages can also be transmitted per broadcast:

- **Broadcast connection** exists only for DL and is characterized by the broadcast CID. It shall be used with the most robust PHY mode (even if all current initialized ATs are able to decode high-level modulation, to guarantee the reception of the broadcast channel for new ATs during initialization).
- An important particular message for the broadcast connection is the GBI message:
 - RlcGeneralBroadcastInformation carrying general information relevant to all ATs and especially the description of the current PHY mode set (and new PHY mode set, if applicable).

Another type of broadcast connection is:

- Multiple-TID message:
 - RlcMultipleTidBroadcastBasic (with the CID MultipleTidBroadcastBasicCid), addressing several ATs. The payload of these messages is a packet of pairs (TID, one message for the respective AT), where only basic MAC management messages are carried. The specification of the multiple-TID messages is shown in table 10 and also illustrated in figure 14.

Table 10: Multiple-TID message

RlcMultipleTidBroadcastBasic	::= SEQUENCE (SIZE(1..50)) OF PairTidMessageBasic
PairTidMessageBasic	::= SEQUENCE {
tid	Tid,
messagesForTidPackingBasic	MessagesForTidPackingBasic
}	
MessagesForTidPackingBasic	::= CHOICE {
-- see Table in clause 7.4.3	
}	

Furthermore, several:

- **Multicast connections** can be set up for specific groups of ATs to transport multicast MAC data PDUs. The multicast CIDs have the same generic format as all other CIDs.

Broadcast information can be transmitted in the broadcast connection (e.g. GBI message or other MAC management messages) or in the control zone. The control zone appears at the beginning of each frame ("fast channel"), whereas the GBI message is usually transmitted in long intervals only ("slow connection").

All MAC management messages transmitted in the three MAC management connections or in the broadcast connection are carried with the same generic MAC PDU format (MAC signalling PDU) as used for the regular traffic (MAC data PDU).

The basic, primary and secondary MAC management connections are of unicast type and can be transmitted with any PHY mode in DL or UL. The broadcast connection (but not the multicast connections) shall be transmitted always with the most robust PHY mode in the DL to guarantee their reception by all ATs.

7.2 Transport of MAC management messages with MAC Signalling PDUs

Long (both DL and UL) as well as short (UL only) MAC signalling PDUs are specified, see clause 8.1 for the exact formats. These MAC signalling PDUs and the MAC data PDUs (and additionally MAC dummy PDUs) are identified by the PT field in the generic MAC PDU header.

7.2.1 Some general rules

Some general rules for the use of MAC signalling PDUs are summarized below.

- Opportunities for transmitting with both long and short MAC signalling PDUs in the UL can be granted to the AT. It should be noted that grants for MAC data PDUs and long MAC signalling PDUs can not be distinguished in the UL map.
- The AT can issue requests for bandwidth (both MAC data PDUs and long MAC signalling PDUs). Specific requests for short MAC signalling PDUs are also possible via the RSB bit in the MAC PDU header.
- The AT can use granted bandwidth for sending a MAC management message, but this shall be in the form of a long MAC signalling PDU (instead of a MAC data PDU) or short MAC signalling PDU. Specific rules for using granted short MAC signalling PDUs are summarized in clause 7.2.3.
- In the bandwidth contention window only short MAC signalling PDUs are allowed with PHY mode #1 carrying the message for bandwidth requests. However, the bandwidth request message can also be sent in granted short UL bursts.
- Short MAC signalling PDUs shall be used for granted short bursts and for the bandwidth contention window as well as for granted ranging bursts (during first initialization or re-initialization).
- It is possible to combine several messages into one long MAC signalling PDU for the same AT (applies for DL) or from the same AT (applies for UL) by packing. The short MAC signalling PDU (UL only) contains always only one or no message (to avoid problems with packing).
- It is possible to combine messages for several ATs (applies only for DL) into one MAC signalling PDU as `RlcMultipleTidBroadcastBasic` message.
- Segmentation of MAC management messages is possible for DL and UL directions, but not in combination with packing or multiple-TID message.
- An UL burst contains either one or several long MAC PDUs (can be a mixture of long MAC signalling PDUs and MAC data PDUs and MAC dummy PDUs, can consist of several FEC blocks) or exactly one short MAC signalling PDU (a specific UL ranging burst with extra guard time is specified for short MAC signalling PDUs carrying ranging requests). A mixture of short and long MAC PDUs or several short MAC signalling PDUs in one UL burst shall not be supported.
- If the AT receives grants for transmission without having any data (traffic or signalling) to transmit, then it shall send long or short MAC dummy PDUs (as specified by the grant).
- It is up to the schedulers in the AP (giving grants for UL) and the AT (using grants for UL) to determine how MAC management messages shall be transmitted, e.g. with long or short MAC signalling PDUs (if applicable). Hence there is no pre-defined binding between MAC management messages and MAC signalling PDUs in the UL (with some exceptions, see clause 7.2.3).
- Padding shall be used to fill up any unfilled payload part of any MAC signalling PDU.

7.2.2 The use of long MAC signalling PDUs

The long MAC signalling PDUs are created in the DLC layer.

Short (i.e. compared to 51 bytes) MAC management messages shall have the option to be packed and transmitted in one long MAC signalling PDU as specified in clause 7.3. This applies both for DL (for the same AT) and UL (from the same AT). Additionally, several short messages for different ATs can be packed together in one multiple-TID message. All messages that are allowed to be packed are listed in clause 7.4.

Long (i.e. longer than 51 bytes) MAC management messages shall be segmented (SAR, segmentation and reassembly, part of the MAC sublayer) as specified in clause 7.3. Examples for very long MAC management messages are asymmetric keys and the AT certificate.

Two types of long MAC signalling PDUs are distinguished by the PT field in the header:

- **Non-segmented long MAC signalling PDU** carries one MAC management message or a packet of several MAC management messages, if the total length is smaller than or equal to 51 bytes (after encoding).
- **Segmented long MAC signalling PDU** carries segments of long MAC management messages. The payload of 51 bytes consists of 1 byte for segmentation control (SCF) and up to 50 bytes for the segment.

Packing and segmentation shall not be combined.

7.2.3 The use of short MAC signalling PDUs

As for long MAC signalling PDUs, the short MAC signalling PDUs are also created in the DLC layer.

Short signalling PDUs shall be used only in the UL and shall be precluded for the DL. A burst containing a short MAC signalling PDU contains only this one short MAC signalling PDU, i.e. several short MAC signalling PDU within one burst or a mixture with long MAC signalling PDUs or MAC data PDUs shall be precluded. The following rules shall be applied when using short MAC signalling PDUs:

- Short MAC signalling PDUs shall be used to carry the following types of MAC management messages, where only granted bursts are allowed for transmission (see exception for bandwidth request below) and all PHY mode are allowed (see exception for ranging request below):
 - Bandwidth request message `RlcBandwidthRequest`, possible not only in granted short UL bursts but also in the bandwidth request contention window.
 - Queues status reply message `RlcQueueStatusRsp`, but only after reception of the queue status request message `RlcQueueStatusReq`.
 - Measurement report message `RlcMeasurementReportData`, used for the signalling for ATPC and DL PHY mode change, where the message can be initiated by:
 - i) changed link conditions measured by the AT,
 - ii) AP request, or
 - iii) expiration of period. The measurement report can also be transmitted in a long MAC signalling PDU.
 - Ranging request message `RlcRangingReq`, but only with PHY mode #1 and only for granted UL ranging bursts (i.e. not for granted normal short bursts).
 - Short MAC dummy PDU.
 - All other messages that are short enough to fit into a short MAC signalling PDU.
- Any UL burst, if used to transmit short MAC signalling PDUs, shall contain only one short MAC signalling PDU.
- If short MAC signalling PDUs are to be transmitted in scheduled bursts, the UIUC entry of the UL map shall be one that indicates short MAC signalling PDUs (and not long PDUs) or ranging bursts.
- Packed messages shall not be transmitted with short MAC signalling PDUs.

Three additional rules are mandatory:

- After reception of the message `RlcQueueStatusReq`, the next granted short burst shall be used for the message `RlcQueueStatusRsp`.
- If periodic measurement reports are commanded, then the report `RlcMeasurementReportData` shall be sent in the next granted short PDU after expiration of the report period.

- In case that the messages `RlcQueueStatusRsp` and `RlcMeasurementReportData` shall be transmitted at the "same" time, the message `RlcQueueStatusRsp` shall have a higher priority than the message `RlcMeasurementReportData`. However, the AP shall be smart enough to grant enough short UL bursts for such conditions.
- The AT can also request a grant for a short UL burst with the RSB bit in the MAC PDU header. This shall not affect the three rules stated above.

7.3 Transport of MAC management messages (packing, encoding, segmentation)

7.3.1 Overview of message formats

The principal formats for MAC management messages are outlined in figure 14. The message length can range from very few bytes to 256 bytes (corresponding to a 2 048-bit asymmetric key) or more. Moreover, the length can be variable for the same message types due to optional fields. Several messages can be packed. The message length is increased by PER encoding.

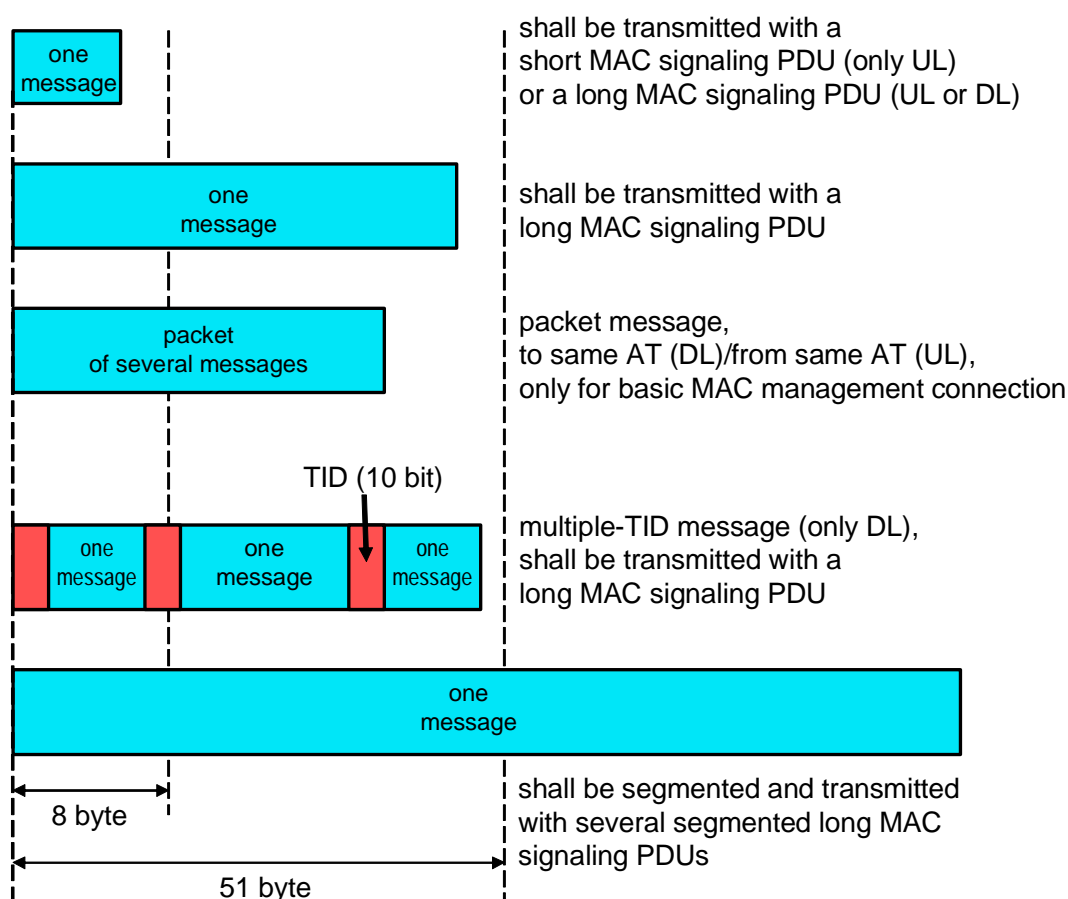

Figure 14: MAC management message formats

There shall be no pre-defined binding between MAC management messages or MAC signalling PDUs and PHY modes (except for the cases mentioned in clause 7.2.3). All PHY modes can be used for long MAC signalling PDUs in DL and UL as well as for the scheduled short MAC signalling PDUs in the UL.

Very long MAC management messages shall be segmented and carried by several long MAC signalling PDUs. There is a general instance for SAR (Segmentation and Reassembly) in the MAC sublayer, applicable for all types of messages as shown in figure 4.

7.3.2 Overview of packing, encoding and segmentation

An overview of packing, ASN.1 encoding with PER (Packet Encoding Rule) [7] and SAR within the transmitter path and the mapping to long or short MAC signalling PDUs is shown in figure 15.

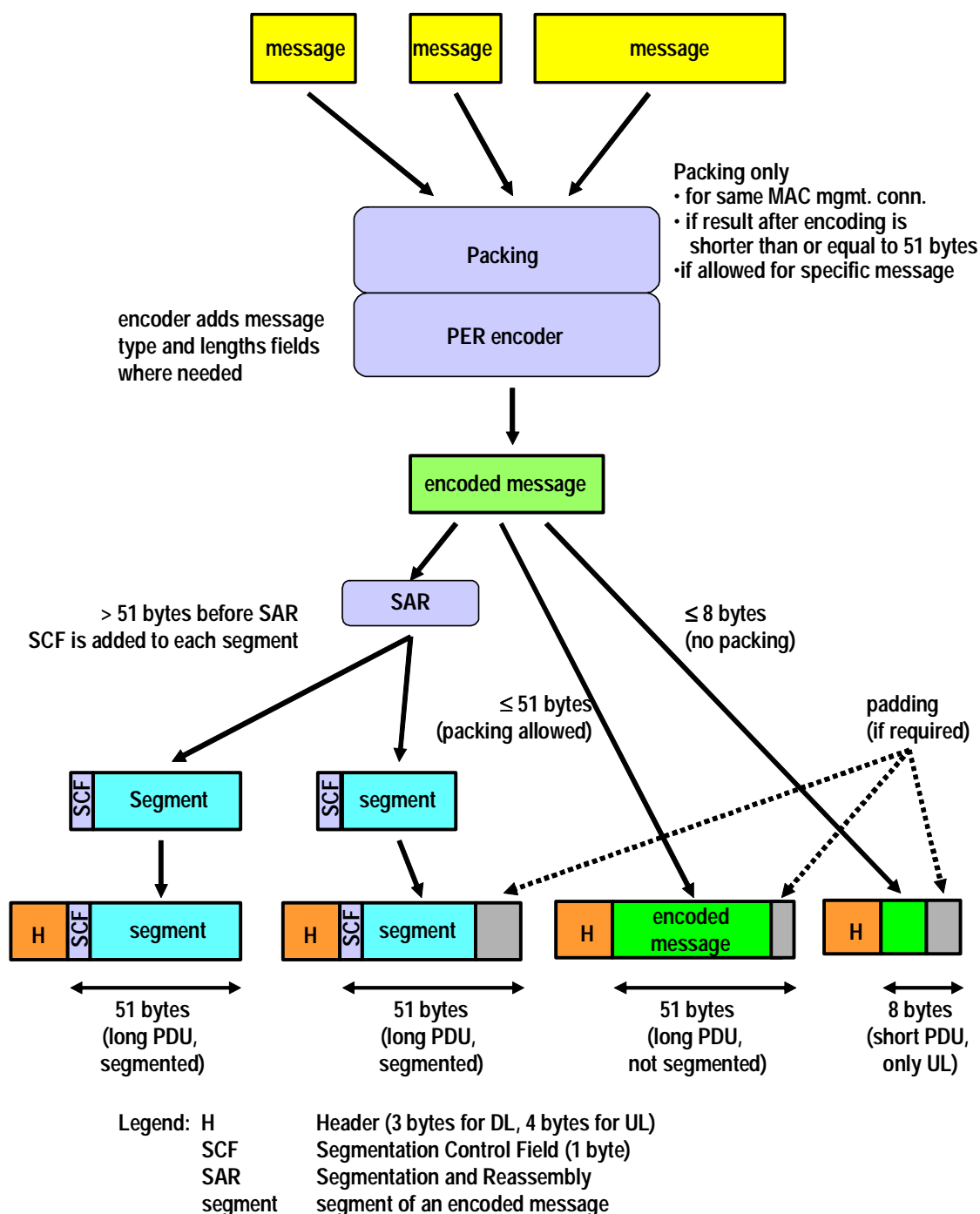

NOTE: Packing and SAR shall not be combined.

Figure 15: Overview of packing, encoding, SAR and mapping on MAC signalling PDUs

7.3.3 Encoding rule

PER encoding with byte alignment shall be applied to each message according to [7]. There is no kind of pre-defined classification of messages according to their lengths.

NOTE: For all messages that are specified to be transmitted with a short MAC signalling PDU it is guaranteed that the message length after PER encoding (including message type indication) is shorter than or equal to 8 bytes.

7.3.4 Packing of MAC management messages

Packing of messages is possible for DL and UL if applicable according to the message type. Packing is only allowed for basic MAC management connections.

Packing is not allowed in combination with segmentation (applies for DL and UL) and for the multiple-TID message (applies only for DL).

7.3.5 Segmentation and Reassembly (SAR)

No overhead is introduced by SAR since the SCF (Segmentation Control Field) is only present for segmented long MAC signalling PDUs. The MAC PDU header contains no kind of SCF itself but an indication of SCF by the PT field, i.e. segmented or non-segmented long MAC signalling PDU.

The segments shall have a length of 50 bytes (the last segment can be shorter). SAR shall not be applied for packet messages (i.e. the result of packing shall be shorter than or equal to 51 bytes).

The 1-byte SCF (Segmentation Control Field) consists of a 2-bit field SI (Segmentation Indication) as defined in table 11 and a 6-bit field SSN (Segmentation Sequence Number).

Table 11: Definition of Segmentation Indication (SI, 1 byte)

Segment	SI
First fragment	00
Continuing fragment	01
Last fragment	10
undefined	11

The segmentation control field (SCF) is shown in figure 16.

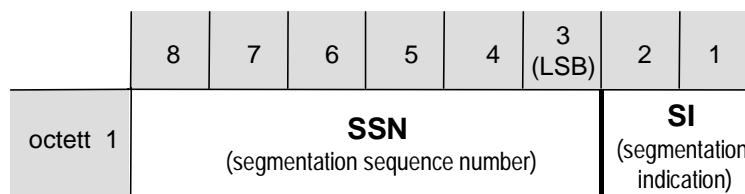

Figure 16: Definition of Segmentation Control Field (SCF, 1 byte, left bit transmitted first)

7.4 List of protocol primitives and mapping of messages to connections (normative)

7.4.1 List of all MAC management messages

Table 12 provides an overview and a short description of all MAC management messages. The detailed message contents are given in annex B.

Legend for "connection" column in table 12 :

- 0 = broadcast (only for DL)
- 1 = basic MAC management connection (AT-specific)
- 2 = primary MAC management connection (AT-specific)
- 3 = secondary management connection (AT-specific)
- p = allowed for packing
- m = allowed for multiple-TID message
- R-NR = direction from requesting to non-requesting entity
- NR-R = direction from non-requesting to requesting entity

Table 12: List of MAC management messages (protocol primitives)

Name	Direction	Connection	Description and remarks
Broadcast messages			
RlcGeneralBroadcastInformation (GBI message)	DL	0	Broadcast information (Frequencies, operation modes, frame offset, contention resolution parameters, timers, PHY mode set descriptor(s))
RlcFrequencyList	DL	0	Frequency list
RlcMultipleTidBroadcastBasic	DL	0	Addresses several ATs, contains a packet of (TID, basic MAC management message) pairs
Request-grant messages			
RlcBandwidthReq	UL	1	Bandwidth request, shall be used in granted short PDUs or in bandwidth request contention window
RlcQueueStatusReq	DL	1, p, m	Request to report the queue status of listed CAs
RlcQueueStatusRsp	UL	1	Response, containing the queue lengths, to be transmitted in next granted short PDU
Initialization control messages			
RlcRangingInvitation	DL	1	Invitation to initial ranging (binding between MAC address and TID, allocation of CIDs, start of ranging). Multiple-TID message not possible
RlcRangingReq	UL	1	Ranging request in granted UL ranging burst, contains formally EGT, transmitted with increasing or adapted power
RlcRangingContinue	DL	1, m	Response from AP, contains power and timing offset information and indicates continuation of ranging
RlcRangingSuccess	DL	1, m	Response from AP, contains power and timing offset information and indicates termination of ranging, informs about termination of initialization
RlcRangingAck	UL	1	Acknowledgement of reception of RlcRangingSuccess, in granted UL ranging burst
RlcPhyCapabilitiesReq	DL	1, p, m	AP request to send RlcPhyCapabilitiesInfo
RlcPhyCapabilitiesInfo	UL	1 non-PTC	AT informs about its optional PHY capabilities, PTC not allowed
RlcPhyCapabilitiesCnf	DL	1, p, m	AP commands PHY features to be used, informs about termination of initialization
RlcOtherCapabilitiesReq	DL	1, p, m	AP request to send RlcOtherCapabilitiesInfo
RlcOtherCapabilitiesInfo	UL	1	AT informs about its optional other capabilities, PTC not allowed
RlcOtherCapabilitiesCnf	DL	1, p, m	AP commands other features to be used, informs about termination of initialization
Radio resource control messages			
RlcInitializationCmd	DL	1, p, m	AP to command a new first/re-initialization or to reject AT from network or to stop/re-start UL transmission
RlcMeasurementReportData	UL	1, p	Measurement report or request for DL PHY mode change, shall be transmitted in granted short (packing not allowed) or long (packing allowed) PDUs

Name	Direction	Connection	Description and remarks
Broadcast messages			
RlcDownlinkPhyModeChange	DL	1, p, m	Announcement of DL PHY mode change
RlcDownlinkPhyModeChangeAck	UL	1, p	Acknowledgement of reception of RlcDownlinkPhyModeChange
RlcUplinkCorrection	DL	1, p, m	Correction step for UL power and timing (incremental) and possible request for measurement report
RlcMeasurementReportCriterium	DL	1, p, m	AT-specific update of period for measurement reports
RlcHandoverCmd	DL	1, m	Command for handover, contains the new RF channel. No other messages for AT at this time
RlcHandoverCnf	UL	1	Acknowledgement of reception of RlcHandoverCmd
Security control messages			
RlcAuthCmd	DL	2	Initiates authentication
RlcAuthManufacturerInfo	UL	2	Contains the AT manufacturer's X.509 Certificate, issued by an external authority
RlcAuthReq	UL	2	To request an AK and list of authorized SAIDs
RlcAuthReply	DL	2	To reply an AK and a list of authorized SAIDs
RlcAuthReject	DL	2	Rejection of an RlcAuthReq
RlcAuthInvalid	DL	2	Unsolicited indication or a response to an UL message
RlcTekReq	UL	2	Requesting a TEK for the privacy of one of its authorized SAIDs
RlcTekAllocation	DL	2	Carrying the two active sets of traffic keying material for the SAID
RlcTekReject	DL	2	Indication that the SAID is no longer valid and no key will be sent
RlcTekInvalid	DL	2	If AP determines that the AT uses an invalid TEK for encryption
Connection control messages			
RlcConnectionAdditionInit	UL	1, p	Request issued by the AT for establishing a new connection
RlcConnectionAdditionSetup	DL	1, p, m	Message issued by the AP for establish a new connection or answering a request coming from an AT
RlcConnectionAdditionAck	UL	1, p	Acknowledgement of RlcConnectionAdditionSetup message
RlcConnectionChangeInit	UL	1, p	Request issued by the AT for change some parameters of an already established connection
RlcConnectionChangeSetup	DL	1, p, m	Message issued by the AP for change some parameters of an already established connection or answering a request for change some parameters of an already established connection coming from an AT
RlcConnectionChangeAck	UL	1, p	Acknowledgement of RlcConnectionChangeSetup message
RlcConnectionDeletionInit	R-NR	1, p, m (DL)	Message initializing a Connection Deletion procedure
RlcConnectionDeletionAck	NR-R	1, p, m (DL)	Acknowledgement of RlcConnectionDeletionInit message
Packed messages			
PackedMessageDownlinkBasic	DL	1	Packet of basic MAC management messages for DL
PackedMessageUplinkBasic	UL	1	Packet of basic MAC management messages for UL

7.4.2 Messages for packing

Table 13: List of DL basic MAC management messages for packing

Name
RlcQueueStatusReq
RlcPhyCapabilitiesReq
RlcPhyCapabilitiesCnf
RlcOtherCapabilitiesReq
RlcOtherCapabilitiesCnf
RlcInitializationCmd
RlcDownlinkPhyModeChange
RlcUplinkCorrection
RlcMeasurementReportCriterium
RlcConnectionAdditionSetup
RlcConnectionChangeSetup
RlcConnectionDeletionInit (if DL)
RlcConnectionDeletionAck (if DL)

Table 14: List of UL basic MAC management messages for packing

Name
RlcMeasurementReportData
RlcDownlinkPhyModeChangeAck
RlcConnectionAdditionInit
RlcConnectionAdditionAck
RlcConnectionChangeInit
RlcConnectionChangeAck
RlcConnectionDeletionInit (if UL)
RlcConnectionDeletionAck (if UL)

7.4.3 Messages for multiple-TID

Table 15: List of DL basic MAC management messages for multiple-TID message

Name
RlcQueueStatusReq
RlcRangingContinue
RlcRangingSuccess
RlcPhyCapabilitiesReq
RlcPhyCapabilitiesCnf
RlcOtherCapabilitiesReq
RlcOtherCapabilitiesCnf
RlcInitializationCmd
RlcDownlinkPhyModeChange
RlcUplinkCorrection
RlcMeasurementReportCriterium
RlcHandoverCmd
RlcConnectionAdditionSetup
RlcConnectionChangeSetup
RlcConnectionDeletionInit (if DL)
RlcConnectionDeletionAck (if DL)

7.4.4 Overview of Connections

Table 16: Overview of connections and related parameters

Connection type	Direction	Identification	PHY mode	UL PDU length	PT
data	both	DataCid (per AT, allocated to CA)	all	L	0
basic MAC mgmt	both	BasicCid, BasicCaid (per AT)	all	L or S	1, 2, 4
primary MAC mgmt	both	PrimaryCid, PrimaryCaid (per AT)	all	L or S	1, 2, 4
secondary mgmt	both	SecondaryCid (per AT)	all	L	1
broadcast (e.g., GBI message)	DL	BroadcastCid=0	1	-	1
control zone (not a connection)	DL	frame preamble, DIUC, UIUC, EndOfMapTid=1	0	-	n/a
multiple-TID	DL	MultipleTidBroadcastBasicCid=1	all	-	1
multicast	DL	DataCid (per AT group)	all	-	0
ranging burst (not a connection)	UL	RangingCid=4 (per AT), UIUC	1	Ranging burst	4
Contention window (RlcBandwidthRequest)	UL	ContentionWindowTid=0, UIUC	1	S	4
MAC dummy PDU (not a connection)	both	DummyCid=3 (per AT)	all	L or S	3, 5

Legend: UL PDU length: L=long, S=short

PT: 0=data, 1=long non-seg, 2=long seg, 3=long dummy, 4=short, 5=short dummy

7.5 List of service primitives (informative)

The HA DLC layer supports 18 different service primitives dedicated to connection control functionality. These primitives are exchanged at the DLC Service Access Point and can be divided up into four different groups according to the related procedure.

The complete list is reported in table 17. The detailed message contents are given in annex B. Legend for "direction" and "type" columns:

- Up: from DLC layer to CL,
- Down: from CL to DLC layer,
- Ctrl: primitive that generates or is generated by a basic MAC management message at DLC level,
- Data: primitive that transports data to be mapped into the relevant connection ID at DLC level.

Table 17: List of connection control service primitives

Primitive Name	Direction	Type	Description and remarks
Connection Establishment			
DlcConnectionAdditionInitReq	Down	Ctrl	Generates an RlcConnectionAdditionInit message at DLC layer
DlcConnectionAdditionInitInd	Up	Ctrl	Generated by the RlcConnectionAdditionInit message
DlcConnectionAdditionReq	Down	Ctrl	Generates an RlcConnectionAdditionSetup message at DLC layer
DlcConnectionAdditionInd	Up	Ctrl	Generated by the RlcConnectionAdditionSetup message
DlcConnectionAdditionRsp	Down	Ctrl	Generates an RlcConnectionAdditionAck message at DLC layer
DlcConnectionAdditionCnf	Up	Ctrl	Generated by the RlcConnectionAdditionAck message
Connection Change			
DlcConnectionChangeInitReq	Down	Ctrl	Generates an RlcConnectionChangeInit message at DLC layer
DlcConnectionChangeInitInd	Up	Ctrl	Generated by the RlcConnectionChangeInit message
DlcConnectionChangeReq	Down	Ctrl	Generates an RlcConnectionChangeSetup message at DLC layer
DlcConnectionChangeInd	Up	Ctrl	Generated by the RlcConnectionChangeSetup message
DlcConnectionChangeRsp	Down	Ctrl	Generates an RlcConnectionChangeAck message at DLC layer
DlcConnectionChangeCnf	Up	Ctrl	Generated by the RlcConnectionChangeAck message
Connection Release			
DlcConnectionDeletionReq	Down	Ctrl	Generates an RlcConnectionDeletionInit message at DLC layer
DlcConnectionDeletionInd	Up	Ctrl	Generated by the RlcConnectionDeletionInit message
DlcConnectionDeletionRsp	Down	Ctrl	Generates an RlcConnectionDeletionAck message at DLC layer
DlcConnectionDeletionCnf	Up	Ctrl	Generated by the RlcConnectionDeletionAck message
Data primitives			
DlcDataReq	Down	Data	This primitive is responsible of passing data from CL to the DLC
DlcDataInd	Up	Data	This primitive is responsible of receiving data from CL to the DLC

8 Multiplexing and MAC frame structure

This clause is structured as follows:

- MAC PDU formats; especially the MAC PDU headers for DL and UL directions, for MAC data PDU, MAC dummy PDU, long and short MAC signalling PDU.
- Frame Structure for DL and UL directions.
- Support of FDD and TDD modes and H-FDD operation.
- Structure of maps for DL and UL.
- Support of ARQ (operation of ARQ, frame structure and map for ARQ).
- Detailed structure of the control zone.
- MAC Support of PHY layer (time relevance of the maps, map protection, PHY mode set description).

The mapping of the MAC PDUs to the PHY structure (i.e. to codewords, PHY mode regions and zones) is described in clause 5.2 about the interface between DLC and PHY layers.

8.1 MAC PDU format

8.1.1 Overview

The MAC PDU is the data unit exchanged between the MAC sublayers of AP and AT. The MAC PDU shall have a fixed length in bytes, but a variable duration and a variable length in symbols due to the use of adaptive PHY mode (i.e. adaptive modulation and coding schemes).

Four MAC PDU types are defined, each consisting of the MAC PDU payload part and the MAC PDU header as shown in figure 6 and figure 7:

- **MAC data PDU:** shall be used to carry data only. The total length is 54 bytes for DL and 55 bytes for UL where for both directions the traffic payload is fixed to 51 bytes. In case of a cell-based CL, this is suitable for carrying ATM cells, corresponding to 48 bytes ATM payload plus 3 bytes header (i.e. full ATM header except HEC and VPI field).
- **MAC dummy PDU:** the long MAC dummy PDU is a specific MAC PDU with the same total length as the MAC data PDU to fill up the DL TDM zone if not enough MAC PDUs are to be transmitted or to fill up an UL burst if more MAC PDU have been granted than are available for transmission. The short MAC dummy PDU exists only in the UL with a total length of 12 bytes and is used if more grants for short PDUs are given than short MAC signalling PDUs are available for transmission.
- **Long MAC signalling PDU:** shall have the same length as the MAC data PDU with 51 bytes for the payload part. Two subtypes have to be distinguished (both for DL and UL):
 - The **segmented long MAC signalling PDU** shall be used to carry the segments of long (unpacked) messages after SAR, i.e. the PT field in the PDU header indicates that the first byte of the payload contains segmentation information. The length of the segments itself are limited to 50 bytes.
 - The **non-segmented long MAC signalling PDU** shall be used to carry one message or a packet of several messages. The length of the payload is limited to 51 bytes.
- **Short MAC signalling PDU:** carries only one message, exists only in the UL. The payload length is 8 bytes and the total length is 12 bytes.

Encryption for privacy is only applied for MAC data PDUs (i.e. for PT = 000) and only for the 51 bytes of the payload part and only for unicast connections.

8.1.2 MAC PDU header

The MAC PDU headers for DL and UL transmissions are different and shown in table 18 for the DL with a length of 3 bytes (applies for MAC data PDU, MAC dummy PDU, long MAC signalling PDU) and table 19 for the UL with a length of 4 bytes (applies for MAC data PDU, MAC dummy PDU, long MAC signalling PDU, short MAC signalling PDU). The difference in the length is caused by the additional GM field required in the UL header.

Table 18: MAC PDU header for DL (3 bytes, left bit transmitted first)

Number of bits	Field description
3	PT = PduType
2	EKS = EncrKeySeq
16	CID = ConnId
1	IVP = IndVarPdu
2	Rsvd = reserved

	8	7	6	5	4	3	2	1	
octet 1	CID								LSB
octet 2	CID								
octet 3	PT			EKS		IVP	Rsvd		

Table 19: MAC PDU header for UL (4 bytes, left bit transmitted first)

Number of bits	Field description
3	PT = PduType
2	EKS = EncrKeySeq
16	CID = ConnId
8	PB = Piggyback
1	PM = poll-me
1	RSB = request for short UL burst (for MAC signalling PDU)
1	IVP = IndVarPdu

	8	7	6	5	4	3	2	1	
octet 1	CID								LSB
octet 2	CID								
octet 3	PT			EKS		IVP	PM	RSB	
octet 4	PB								

The EKS field is required for the key exchange procedure, hence it shall be ignored for all PDU types except MAC data PDUs. If a connection is not encrypted, the EKS field shall be set to "00" and shall be ignored by the receiving side.

The CID field is required to identify the connection. An exception appears for MAC dummy PDUs (see below).

The combination of PB, PM and RSB is also called GM (Grant management field 10 bits) and carries information required for the request-grant mechanism. The piggyback field (PB, 8 bit) describes the number of PDUs in the queue for the connection aggregate the CID belongs to. The poll-me bit (PM, 1 bit) refers to the AT that transmits the MAC PDU. The request bit for a short UL burst (RSB) can be used to request a transmit opportunity for a short MAC signalling PDU. The PM and RSB bits are described in clause 9.4.

The MAC PDU types are distinguished by the PT (PDU Type) field of 3 bits as shown in table 20. Not all types are present in both directions.

Table 20: PT field for MAC PDU headers

PT pattern	Description	Direction
000	MAC data PDU	DL and UL
001	long MAC signalling PDU (not segmented)	DL and UL
010	long MAC signalling PDU (segmented)	DL and UL
011	long MAC dummy PDU	DL and UL
100	short MAC signalling PDU	UL
101	short MAC dummy PDU	UL
110	reserved	
111	reserved	

The IVP (Indication of variable MAC PDU) bit shall be set to zero.

- If a MAC PDU is received by the AT where the IVP bit is unequal to zero, then this MAC PDU and all the following MAC PDUs until the end of the PHY mode region shall be discarded.
- If a MAC PDU is received by the AP where the IVP bit is unequal to zero, then this indicates a malfunction of the AT and the AT shall be re-initialized (and should be removed from the network in case of repeated failure).

Note that MAC PDUs for multicast connections are not distinguished from MAC PDUs for unicast connections by the PT field, this applies for all types of MAC PDUs.

Two bits in the MAC PDU header for the DL are reserved for future upgrades and shall be set to zero.

Note that ARQ does not need additional fields in the MAC PDU header.

NOTE: For the PHY layer, the MAC PDUs appear as coherent units, i.e. the PHY layer can not distinguish between the header and the payload of a PHY SDU.

8.1.3 MAC data PDU

This is the main type of all MAC PDUs, so the header is optimized for this MAC PDU type.

Encryption for privacy is applied only for all unicast MAC data PDUs, and only for the 51 bytes of the payload part. Multicast MAC data PDUs shall not be encrypted.

8.1.4 Long MAC signalling PDU

The long signalling PDU shall be used to carry a MAC management message only, both for DL and UL directions. In the payload part, it may carry one message (can also be a packet of several messages or a multiple-TID message) or a segment of a long message.

The length of long MAC signalling PDUs is the same as for MAC data PDUs, i.e. 51 bytes for the payload and 3 bytes or 4 bytes for the header in DL or UL, respectively, where the same header formats are used as for MAC data PDUs.

The indication of the message type is contained in the encoded message.

Segmentation of long messages by SAR (Segmentation and Reassembly) applies only for long MAC signalling PDUs, both for DL and UL. Only very few messages require for segmentation, e.g. the transmission of public asymmetric keys with 2 048 bit. The indication of segmentation is done per PT field in the header. In case of non-segmented long MAC signalling PDUs, all 51 bytes of the payload can be used to carry the message. In case of segmented long MAC signalling PDUs, the first byte of the payload contains the segmentation control (SCF) information, so the message segment is limited to 50 bytes.

The payload of long MAC signalling PDUs shall not be encrypted.

8.1.5 Short MAC signalling PDU

The short MAC signalling PDU shall be used to carry signalling messages only. They are only used in the UL direction.

The length of short MAC signalling PDUs is 8 bytes for the payload plus 4 bytes for the header, where the same header format is used as for MAC data PDUs or long MAC signalling PDUs in the UL.

NOTE: In some cases the type of the message is known in advance from the appearance in a specific window (e.g. bandwidth request message in bandwidth request contention window).

The payload of short MAC signalling PDUs shall not be encrypted.

8.1.6 Long and short MAC dummy PDU

MAC dummy PDUs are generated in the DLC layer.

The payload and header format of long MAC dummy PDUs is identical to the MAC data PDU format. The long MAC dummy PDU shall be used in DL or UL to fill up:

- The DL TDM zone if not enough MAC data PDUs are to be transmitted. They can be transmitted with any PHY mode, i.e. within any PHY mode region of the TDM or TDMA zone.
- An UL burst if more MAC PDU have been granted than are available for transmission (usually, the AP scheduler knows the number of MAC PDU in the AT, however, it is possible that grants are given for ARQ re-transmissions which cannot be used for non-ARQ connections).

The payload and header format of short MAC dummy PDUs is identical to the short MAC signalling data PDU format. The short MAC dummy PDU shall be used in the UL to fill up:

- An UL burst if more grants for short PDUs have been received than are required for transmission of short MAC signalling PDUs.

Grants for long or short PDUs can also be given by the AP to enforce the AT to transmit in any case. The AT shall transmit if grants are received, maybe with long or short (according to the grant) MAC dummy PDUs (if no other data is available). This allows the AP to measure the properties of the UL radio link.

The content of the header of all MAC dummy PDUs is ignored in the receiver after reading the PT field. A MAC dummy PDU shall be both marked by the PT field and a specific "MAC dummy CID".

The 51 byte payload of a long MAC dummy PDU shall be identical to an ATM idle cell, i.e. the first three bytes corresponding to the compressed ATM header shall be zero with the exception of 1 for the CLP bit, and the content of the information field is 0110 1010 repeated 48 times.

The 8-byte payload of a short MAC dummy PDU shall be set to zero.

MAC dummy PDUs shall not be encrypted.

8.2 Frame structure

The frame structure shall be flexible enough to support either the FDD or the TDD operational mode. With reference to the FDD mode, the frame structure gives the possibility to support in the same frame both the FDD ATs as well as the H-FDD ATs.

The transmissions of AP and AT shall be structured in frames of fixed length. The frame structure is relevant for the DLC layer (especially with regards to scheduling and multiplexing) as well as for the PHY layer (especially with regards to synchronization and preambles). The frame duration shall be fixed to 1 ms, both for DL and UL directions, and shall be independent of the FDD and TDD mode and the H-FDD operation.

For FDD, the frames for DL and UL shall be synchronized in time with a fixed frame offset (FO), where FO is configurable by the AP. An offset of zero would mean an exact alignment (i.e. on the AP antenna, the UL frame starts at the same time as the DL frame starts), however, the minimum FO shall be at least 0,4 ms, since this corresponds to about the maximum length of the control zone in DL under worst-case conditions, i.e. the UL frame does not start earlier than the end of the UL map where also some extra time for the decoding of the UL map should be spent. Formally, FO is not defined for TDD systems.

The basic multiple access scheme shall be TDM for the DL and TDMA for the UL. Optionally, a TDMA zone for the DL is possible in addition to the regular TDM zone.

8.2.1 Frame structure for downlink

The DL frame consists of the DL frame preamble, the control zone with a variable length, the TDM zone and the optional TDMA zone as described in figure 17 (see also the figures in clauses 5.2.2 and 5.2.3 describing the DLC-PHY interface). The length of the TDM zone (in case of TDM only) or the lengths of TDM and TDMA zones (in case of additional TDMA) are variable.

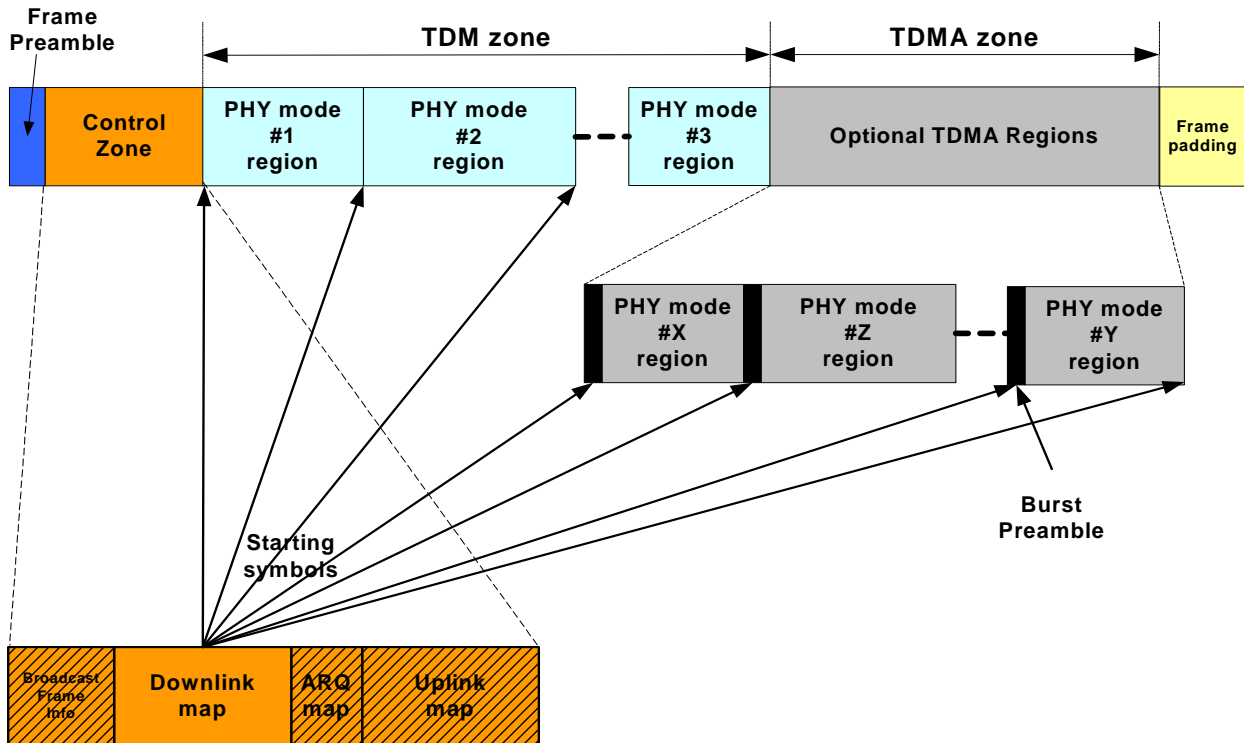

Figure 17: Maps and basic DL frame structure with TDMA option

The DL data to different ATs shall be multiplexed in the time domain (TDM). The TDM zone of the DL frame consists of a few TDM regions (with the same PHY mode in one region) in a robustness descending order (PHY mode #1, #2, etc.), where the number of regions is given by the cardinality of the PHY mode set. The control zone at the beginning of the DL frame shall be transmitted with the most robust PHY mode #0 to allow the reception of the control zone by all ATs.

TDMA regions are optionally present on the DL. In this case, an AT (supporting TDMA) may be assigned to receive DL transmissions either in a TDM region as previously described or in a TDMA region. The TDMA region allocations shall be broadcasted as part of the DL map. The AP scheduler could use the DL TDMA feature as it increases channel utilization and minimizes latencies. Note that a TDMA region may serve more than one AT by time division multiplexing DL data to several ATs.

A DL burst in the TDMA zone constitutes FEC blocks of a specific PHY mode, i.e. the DL burst corresponds to a PHY mode region plus the preamble of the PHY mode region. A DL burst can serve several ATs. Several DL bursts with the same PHY mode can appear.

The DL regions shall be identified by the DIUC that indicates the PHY parameters as well as whether the region is preceded by a preamble (in case of TDMA) or not (in case of TDM). The UL data stream for different ATs shall be broken into UL bursts, where the grants to the ATs are given by the Starting Symbols (SS) together with the PHY modes.

The control zone consists of three maps:

- The SSs of the TDM and TDMA regions within the DL frame together with the DIUCs to identify the PHY modes shall be broadcasted in the DL map. The ATs are implicitly identified by the CIDs in the MAC PDU headers.
- The SSs of the UL bursts in the UL frame together with the UIUCs to identify the PHY modes and the TIDs to address the ATs shall be broadcasted in the UL map.
- Required re-transmissions in case of ARQ shall be broadcasted in the ARQ map and identified by the SSs of the "original" UL frame.

All SSs in all maps refer to symbol granularity.

The implementation of TDMA for the DL is optional for AP and AT. Hence, for the FDD case, there are two types of terminals, where the interoperability shall be guaranteed:

- FDD terminals. These ATs shall be able to transmit and receive simultaneously. They shall support TDM in the DL.
- H-FDD terminals. These ATs are not able to transmit and receive simultaneously. They shall support both TDM and TDMA in the DL.

The AP shall not schedule any data to FDD ATs in the TDMA zone of the DL frame.

NOTE: The DL frame is structured to give maximum bandwidth usage by allowing TDM for efficiency while allowing TDMA for maximum statistical multiplexing of half-duplex terminals. Obviously, in an FDD system with only FDD ATs, there is no need for a TDMA portion. The same is true for an individual frame in which only FDD ATs are scheduled to transmit in the UL. In reality, the TDMA portion need only be used in the presence of H-FDD ATs and then only when they cannot be scheduled to receive earlier in the frame than they transmit.

8.2.2 Frame structure for uplink

As more than one AT is sharing the same RF channel, the AP shall employ techniques controlling the access of ATs. For the UL of HA systems, TDMA shall be used. After an AT has been initialized with the system, its UL bursts are scheduled by the AP. An AT can transmit in a contention based manner only for bandwidth requests.

The UL frame is subdivided in:

- One contention-based window for bandwidth requests (maybe not present in every UL frame).
- One or several scheduled UL ranging bursts for invited ranging request messages (maybe not present in every UL frame).
- One or several scheduled UL bursts for regular traffic from the AT, where:
 - long bursts carrying a mixture of several MAC data PDUs and long MAC signalling PDUs (transmitted with one or several FEC blocks), and
 - short bursts carrying one short MAC signalling PDU (transmitted with one FEC block), have to be distinguished (see also clause 5.2.4 for more details for the mapping on FEC blocks).

The location of the window and the bursts within a frame shall be indicated by the grants in the UL map which shall be broadcasted in the DL control zone.

The time allocated by AP for an UL ranging burst contains the EGT (where the ATs do not need to know the value of the EGT). The EGT shall be in the range between 10 μ s and 80 μ s and shall depend on the radius of the sector.

The time scheduled for each type of UL burst shall be large enough to provision for AT transmitter ramp-up, see TS 101 999 [1]. The grants in the UL maps notify the location of the burst within a frame, by pointing to the symbol where the AT shall start transmitting the burst preamble.

The PHY mode used by the AT for the scheduled UL bursts shall be specified by the UL map, whereas all transmissions in the bandwidth contention window and for the UL ranging burst shall use PHY mode #1. The AT begins its transmission with a preamble with a length of 16 or 32 symbols, depending on the AP capability that shall be negotiated during the initialization phase. The preamble for ranging bursts is fixed to 32 symbols.

An UL burst for an AT transmission may include more than one MAC PDU or more than one FEC block similar to the DL direction. MAC PDUs shall be encapsulated into RS codewords of fixed length. The last RS codeword shall be shortened in the case where the number of remaining MAC PDUs is less than four. As the AT finishes to transmit its UL burst, it ramps down its transmitter. This period of time is expected to overlap a ramp-up period of the next AT UL burst scheduled for transmission.

An UL burst shall carry one of the following:

- MAC data PDUs or long MAC signalling PDUs or dummy PDUs or a mixture of these.
- One short MAC signalling PDU.

NOTE: An UL burst with one short MAC signalling PDU can not contain a further short MAC signalling PDU or a long MAC PDU.

Figure 18 shows a general case of UL frame composed by the window and a series of scheduled bursts transmitted by different ATs. The order of the basic UL frame structure shown in figure 18 is just an example and it is up to the scheduler in the AP to decide on the order. The window and the ranging bursts are typically not to present in every frame. The structure of the UL frame can change from frame to frame.

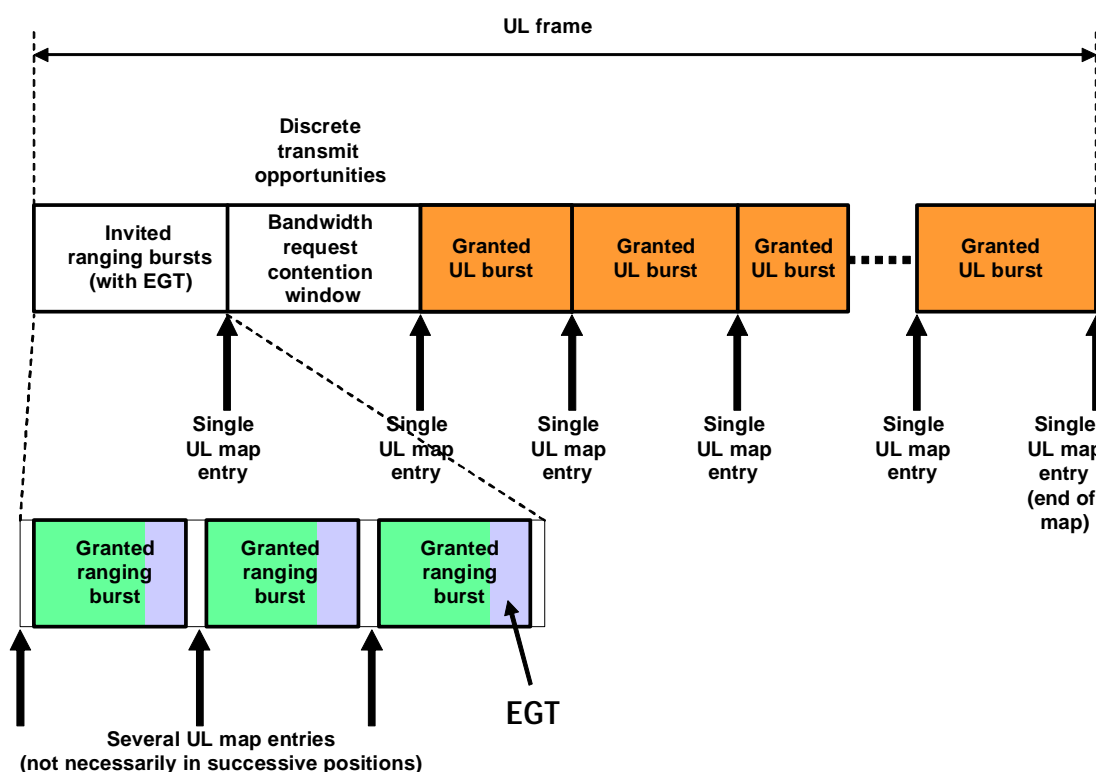

NOTE 1: The window and the ranging bursts are not present in all frames.

NOTE 2: The order of window and granted bursts is just an example.

NOTE 3: Arbitrary positions in case of several granted ranging bursts are possible.

Figure 18: Basic UL frame structure

A contention resolution algorithm is only required for the bandwidth request contention window, see clause 9.5. The contention window shall be identified by the respective UIUC entry in the UL map, the start of the window shall be described by the corresponding SS (Starting Symbol), and the end of the window by the next SS of the UL map.

Note that the SSS (of the window and of all scheduled UL bursts) in the UL map do not include the AT-dependent RTD (otherwise the end of the window or the end of the UL burst can not be calculated since a AT does not know the RTDs of all other ATs). The AT shall calculate its transmit times from the SSS in the UL map entries and its specific RTD, see clauses 8.7.1 and 8.7.2 for more details.

8.3 Support of FDD, H-FDD and TDD in DLC layer

As the communication channel between the AP and ATs is bi-directional, the DL and UL paths shall be established utilizing the spectrum resource available to the operator. Two duplex schemes are available, one is frequency-domain based and one is time-domain based.

The differences between FDD and TDD as well as the H-FDD operation have impact on the DLC layer, in particular on the frame structure, the allocation and scheduling mechanisms.

All modes of operations shall use the same fixed frame duration of 1 ms.

8.3.1 FDD mode

Frequency Division Duplex (FDD) partitions the available spectrum into a DL RF block and an UL RF block as shown in figure 19. An RF channel is actually a pair of RF carriers, one from the DL RF block and one from the UL RF block, hence DL and UL transmissions are established on separate and independent radio channels. For HA systems both DL and UL RF carriers are equal in size with a width of 28 MHz.

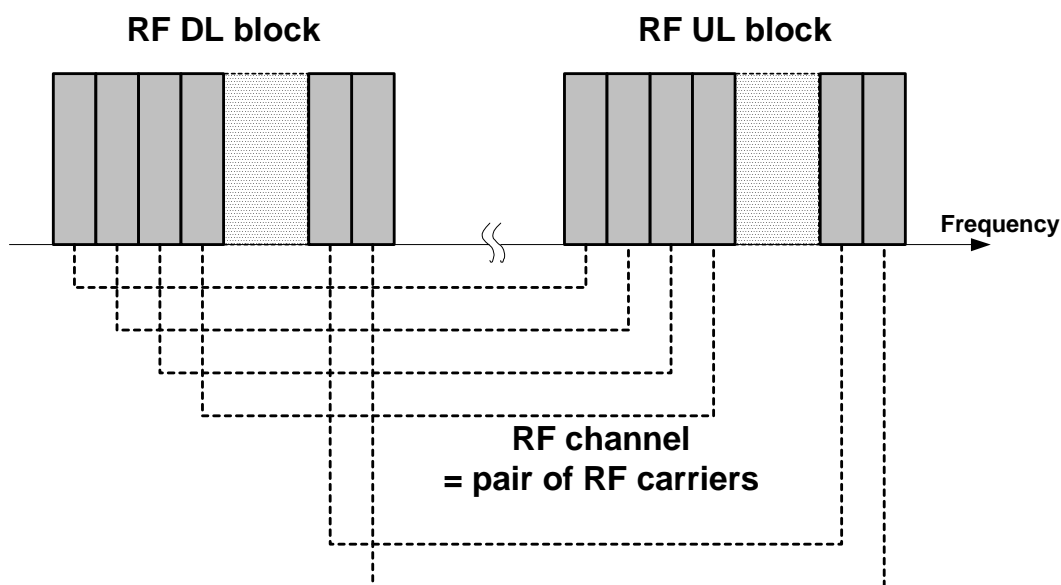

Figure 19: FDD frequency assignment

Within the allocated spectrum, DL and UL RF carriers are separated equally simplifying the required radio architecture.

8.3.2 H-FDD operation

For the FDD mode (where the RF channel consists of a pair of a DL RF carrier and an UL RF carrier), an AT can be limited to half-duplex operation (H-FDD), where the transmission and reception of an AT can not occur simultaneously). However, the AP shall be able to transmit and receive simultaneously. Figure 20 shows an example with one or several FDD ATs and two H-FDD ATs.

For H-FDD ATs, the DLC layer shall schedule DL reception events and UL reception events accordingly. Furthermore, the AP shall reserve a guard time for the fact that the H-FDD AT can not switch immediately from transmission to reception and vice versa (due to power ramping). H-FDD and FDD ATs can be served on the same RF channel. As figure 20 shows for an example of one (or several FDD ATs) and two H-FDD ATs, an arbitrary mix and order of appearance is possible.

Apart from the specific scheduling requirements for H-FDD ATs, the H-FDD operation is an AT feature only, that could simplify the implementation of an H-FDD AT at the expense of reduce peak data rates.

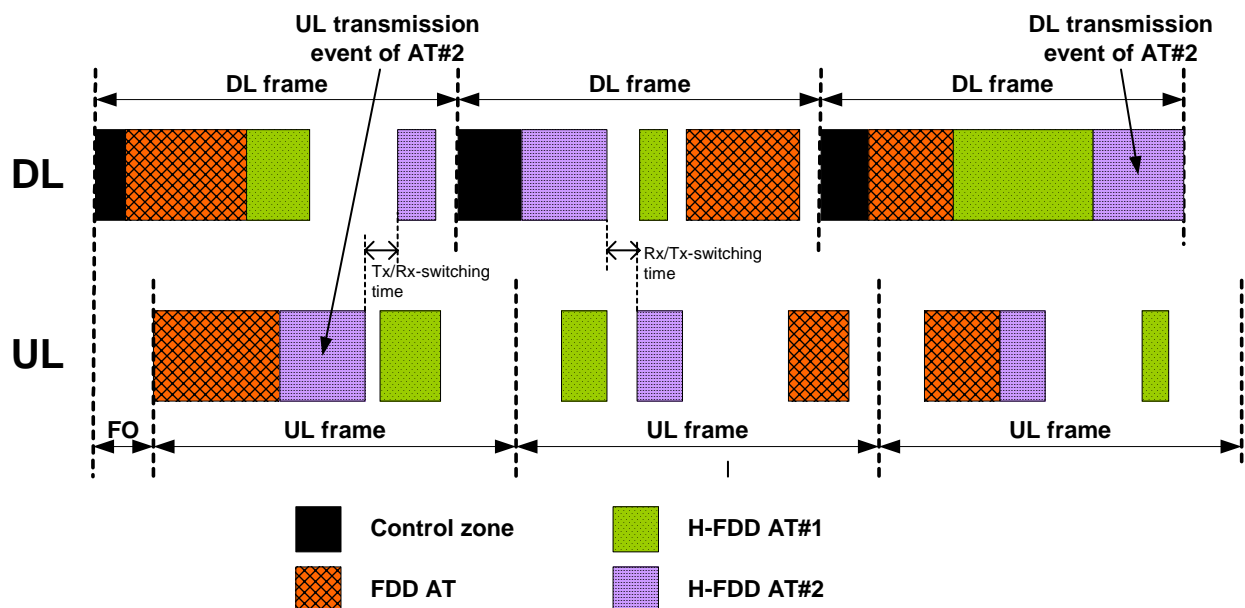

Figure 20: H-FDD operation

NOTE: In addition to the burst transmission capability of each type of AT, the H-FDD operation requires also the burst reception capability of H-FDD ATs as well. For H-FDD ATs, the AP should not give grants while the DL control zone is broadcasted.

The H-FDD operation in the AT equipment is an optional feature. However the AP shall support the operation of H-FDD ATs.

8.3.3 TDD Mode

In the Time Division Duplex (TDD) case, a single RF channel (i.e. an RF carrier, unpaired bands) is used for DL and UL transmission. Both the AP and AT equipment are half-duplex.

In contrast to FDD, the TDD mode uses the same RF carrier for DL and UL communications. The DL and UL transmissions are established by time-sharing the radio channel where DL and UL transmission events never overlap as shown in figure 22. For TDD systems the channel size is 28 MHz wide as in the FDD case.

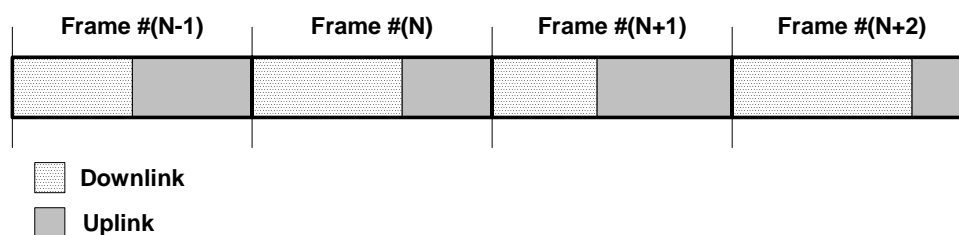

Figure 21: TDD frame sequence

Figure 22 shows the general case of variable borders frame-by-frame between DL and UL subframes (adaptive TDD). However, if the border is not variable frame-by-frame, then there could be advantages for the frequency planning (i.e. a higher frequency re-use factor could be achieved).

Obviously, as shown in figure 22 for the TDD operational mode the TDMA portion (from the DL) shall not be included, since ATs shall receive in the DL subframe and transmit in the UL subframe.

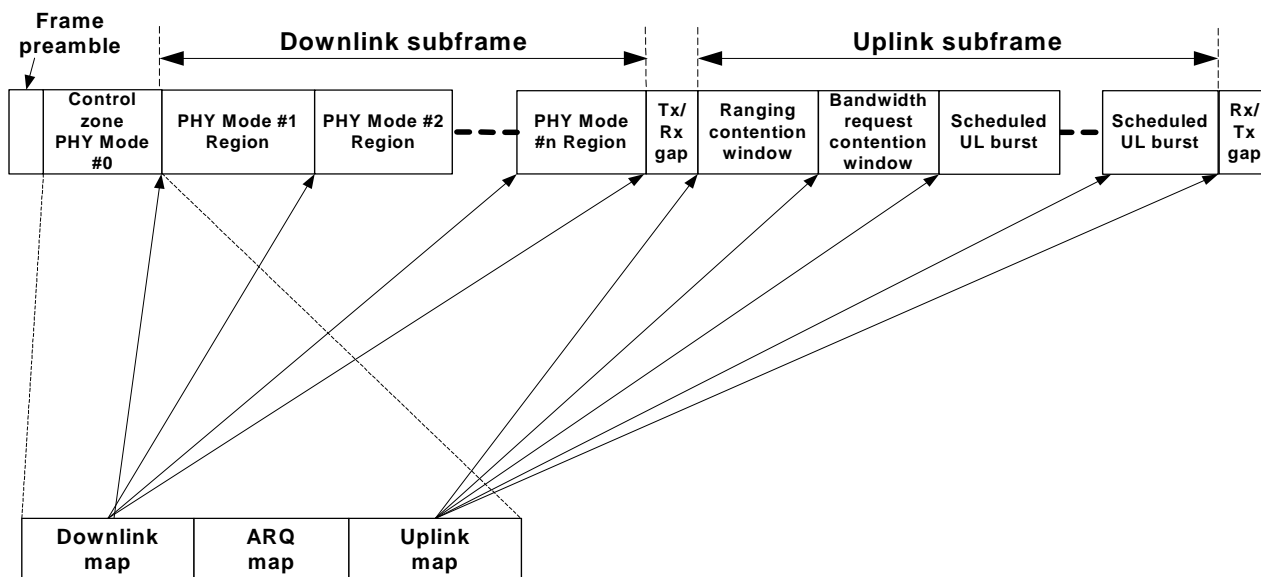

Figure 22: TDD frame structure

The following timing issues shall be considered for the TDD operational mode.

Gaps for switching from DL to UL (Tx/Rx) and from UL to DL (Rx/Tx) shall be used. These gaps shall be provisioned within a frame as the transceiver in the AT and AP requires time to switch from transmission to reception and vice versa. This situation is identical to the one encountered by the H-FDD AT, as in DL TDMA the scheduler recognizes the AT transceiver switching limitations. The only difference is that in the TDD case the gaps are "visible" in the frame structure.

The duration of the gap will be identical to the gap required by the H-FDD AT. It should be noted that the gaps are not required to be larger than the EGT.

Although the TDD UL may start immediately after the DL events terminate (plus the Tx/Rx gap), the scheduler may be instructed to start UL bursts only after an additional guard time. This is useful in the case where the operator employs cell cluster (set of cells where all frequencies available to the operator are used) TDD frame synchronization to mitigate relevant TDD interference scenarios (i.e. hub to hub). In this case some allowance for propagation delays between the interferer and the victim translates into a guard time within the frame - hence reducing the probability of hub to hub and AT to AT interference scenarios. Note that inherently all ATs implement this feature as they are instructed by the AP where UL events occur.

8.4 Entries for downlink and uplink maps

The control zone containing the DL map, the UL map and the ARQ map and some other information fields shall be broadcasted at the beginning of each DL frame, immediately after the frame preamble.

8.4.1 Downlink map entries

The DL map shall be used by the ATs to recognize PHY mode transitions. The ATs shall receive and decode all data they are capable of receiving (see clause 11.3 for further details) and keep or discard MAC PDUs based on the CID in the PDU headers. This means that the DL map contains the ordered PHY modes descriptions for group of ATs. Since the ATs know the least robust PHY scheme the AP will use to transmit to them, the ATs shall only listen to PHY mode regions that are of this or a more robust type (see clause 11.3.4 for more details).

In case of presence of the TDMA optional zone, the DL part of the map shall contain also the transitions between the PHY modes in the TDMA zone (i.e. the map is unique for DL both for TDM only or TDM combined with TDMA); the TDM and TDMA zones shall be distinguished by means of the DIUC.

The DL map entries shall indicate the transition between the different PHY mode regions for the TDM zone and the SS for DL bursts in the optional TDMA zone. For each type of zone, two fields shall compose the DL map entry:

- DIUC (4 bits): DL interval usage code that indicates the usage of a region of the DL frame; it specifies the PHY mode that shall be used in the relevant region.
- Starting Symbol (SS, 15 bits): indicates where the channel symbol at which the relevant region or DL burst starts.

Figure 23 summarizes the entries for the DL map.

as in table 19	LSB
DIUC (4 bits)	SS (15 bits)

Figure 23: DL map entry format (left bit transmitted first)

The duration of a PHY mode region is obtained as the difference between the SSs of the consecutive DL map entries.

The last DL map entry shall be constituted by a well-known DIUC together with the SS in order to calculate the length of the last PHY mode region.

The coding of the DIUCs is reported in table 21.

Table 21: DIUC coding

DIUC	Description
0000	Region with PHY mode #1 of PHY mode set for TDM
0001	Region with PHY mode #2 of PHY mode set for TDM
0010	Region with PHY mode #3 of PHY mode set for TDM
0011	Region with PHY mode #4 of PHY mode set for TDM
0100	Reserved
0101	Reserved
0110	Burst with mode #1 of PHY mode set for TDMA
0111	Burst with mode #2 of PHY mode set for TDMA
1000	Burst with mode #3 of PHY mode set for TDMA
1001	Burst with mode #4 of PHY mode set for TDMA
1010	Reserved
1011	Reserved
1100	Reserved
1101	Reserved
1110	Reserved
1111	End of map

All relevant parameters for the PHY mode sets (i.e. $C/(N + I)$ thresholds for DL and AT transmit power gaps for UL) shall be described in the PSD (PHY mode Set Descriptor), together with a PSDI (PSD indicator). The control zone contains the PSDI and the GBI message contains the PSD. Hence, new PHY mode sets could be specified for future extensions of HA.

A change from one PHY mode set to another PHY mode set shall be communicated by the corresponding PSDI in the control zone. This requires only that the new PHY mode set is specified in advance by the PSD (see clause 11.4 for the detailed description).

For the TDM zone, there are at most 4 DL map entries required (excluding the end-of-map entry), i.e. a DL map entry corresponds to a PHY mode region.

The duration of a PHY mode region is obtained as difference between the SS of the relevant region and the SS of the following region. From the duration and the PHY mode of the region, the ATs can calculate the number of FEC blocks and PDU if necessary. The same applies for the DL bursts in the DL TDMA zone.

8.4.2 Uplink map entries

The UL map shall be used by the ATs to recognize when they shall start and stop the transmission of their bursts. The UL map contains the PHY mode descriptions together with the TIDs and the SSs. For each granted UL burst three fields shall compose the UL map entry:

- UIUC (4 bits): UL interval usage code that indicates the usage of an UL burst; it specifies the PHY mode that shall be used in the relevant burst;
- TID (10 bits): terminal identity of the terminal that shall transmit in the relevant UL burst;
- Starting Symbol (SS, 15 bits): indicates where the channel symbol at which the relevant burst starts (first symbol of the burst preamble).

This is shown in figure 24.

as in table 20	LSB	LSB
UIUC (4 bits)	TID (10 bits)	SS (15 bits)

Figure 24: UL map entry format (left bit transmitted first)

The last UL map entry shall be constituted by a well-known UIUC together with the SS field (and a specific "end" TID, see clause 6.4.2); it states the end of the UL part of the map. The duration of a burst is obtained as difference between the SS of the relevant burst and the SS of the following burst.

The coding of the UIUC is reported in table 22.

Table 22: UIUC coding

UIUC	Description
0000	Burst with mode #1 of PHY mode set for data/long MAC PDU
0001	Burst with mode #2 of PHY mode set for data/long MAC PDU
0010	Burst with mode #3 of PHY mode set for data/long MAC PDU
0011	Burst with mode #1 of PHY mode set for short MAC signalling PDU
0100	Burst with mode #2 of PHY mode set for short MAC signalling PDU
0101	Burst with mode #3 of PHY mode set for short MAC signalling PDU
0110	Bandwidth request contention window with mode #1
0111	Invited ranging burst with mode #1
1000	Reserved
1001	Reserved
1010	Reserved
1011	Reserved
1100	Reserved
1101	Reserved
1110	Reserved
1111	End of map

The first three UIUC codes in table 22 refer to the long MAC PDUs.

The following rules shall be applied concerning the use of the Turbo code option:

- Depending on the result of the PHY capabilities negotiation during initialization, the AT shall use PTC (Product Turbo Code) in the first three UIUC entries (i.e. for long PDUs) if applicable, but not for the short PDUs.
- Unless the PHY capabilities process is not completely finished, PTC shall not be used.

For the contention window, only one entry per window is required in the UL map (if the window is present). Since the contention window is not AT-specific, a specific TID field ("broadcast TID") shall be used for the contention window (see clause 6.3.2), so the distinction between PDUs transmitted in the contention window and invited MAC PDUs is made by the TID as well as by the position within the frame. The PHY mode for the contention windows shall always be mode #1, since this enhances the robustness of the contention detection algorithm (even if longer UL bursts increase the probability of contentions).

Similarly, for the granted UL ranging burst, the PHY mode shall be again always mode #1, since this enhances the robustness of the measurements at the AP to gain the power and timing corrections for the ranging response message. Note that each UL ranging burst requires its own entry in the UL map (since TID is required for the entry).

For the granted short MAC signalling PDUs, all PHY modes are possible. However, an UL burst for a granted short MAC signalling PDU shall only contain this short PDU and nothing more, i.e. each short MAC signalling PDU requires an extra entry for the UL map. Note that it is not excluded (but it makes no sense) to grant more than one short MAC signalling PDU to an AT (since otherwise one long MAC signalling PDU is more efficient but not longer than two short MAC signalling PDUs).

8.5 Automatic Repeat Request (ARQ)

8.5.1 Operational conditions for ARQ

The support of ARQ with up to two re-transmissions is mandatory for all ATs. An AT can have simultaneously connections with ARQ on and connections with ARQ off, i.e. ARQ can be switched on/off on a per connection basis and is negotiated during the connection set-up or connection change procedure.

The application of ARQ is optional for the AP. The maximum number of re-transmissions can be limited to 0 (i.e. no ARQ) or 1 or 2 by the AP. ARQ shall not be applied to any RLC signalling, i.e. ARQ is not applied to the MAC management connections.

8.5.2 Frame structure for ARQ

The ARQ protocol organizing re-transmissions for corrupted received MAC PDUs is performed in the DLC layer and the error detection for ARQ is provided by the PHY layer. The ARQ mechanism shall be based on a selective-repeat approach, where only the MAC PDUs carried by erroneously received RS codewords shall be re-transmitted.

In the AP, the received RS codewords are checked and in case of detected errors the RS codeword itself and all MAC PDUs carried by this codeword shall be discarded. If at least one erroneous RS codeword in the UL frame #N is detected (and if the grant for this burst was scheduled to an AT that has at least one ARQ-enabled connection), then the AP shall set an indication in the ARQ map of the control zone of the DL frame #(N + 2). This indication shall enforce the AT to re-transmit in the UL frame #(N + 2) all MAC PDUs for ARQ-enabled connections contained in the erroneous RS codeword. MAC PDUs for non-ARQ-enabled connections shall not be re-transmitted.

The indication in the ARQ map shall be signalled by an ARQ_ACK field of 1 bit, where ARQ_ACK = 0 for the first field in the ARQ map means no re-transmissions. The number of ARQ entries depends on the number of erroneously detected RS codewords.

An example is shown in figure 25 (note that this figure shows the transmission of the UL frame at the AT, whereas the figures in clause 8.7 show the reception of the UL frame at the AP).

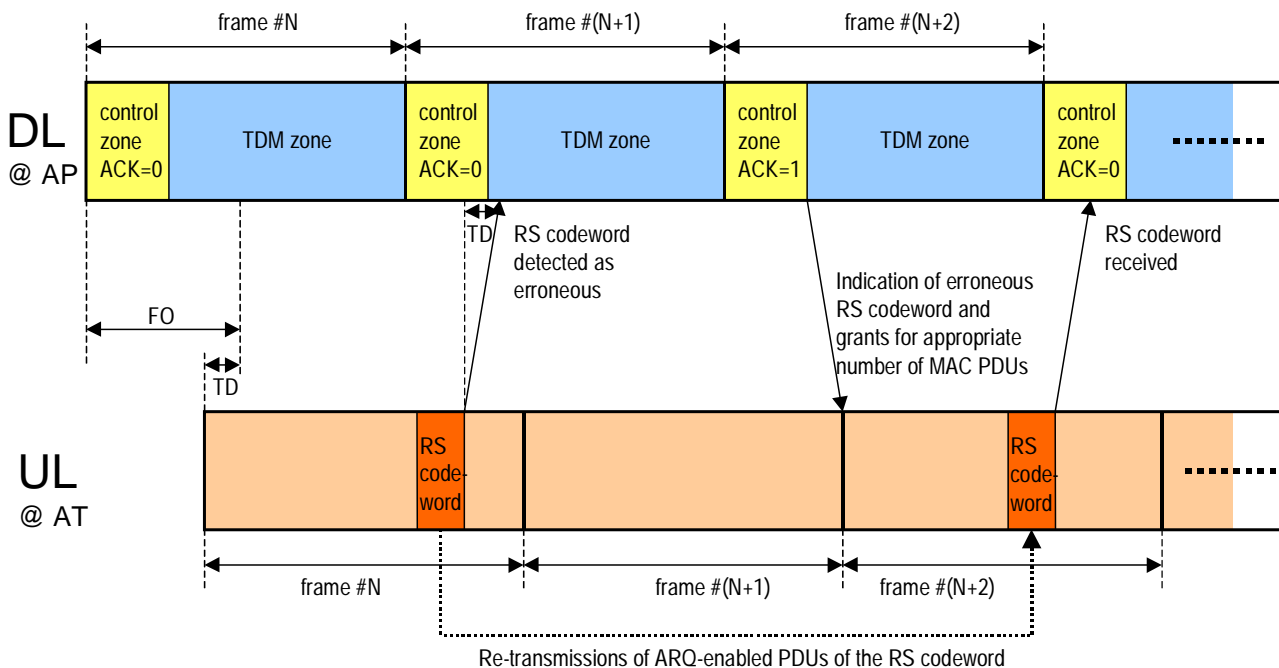

Figure 25: Relation between DL and UL frames for ARQ

NOTE: The re-transmission scheme shall have an RS codeword-based granularity, i.e. not a PDU-based granularity. However, this difference disappears with the option of only one MAC PDU per RS codeword.

8.5.3 ARQ map entries

The entries in the ARQ map shall be composed of the following three fields:

- Starting Symbol (SS, 15 bits);
- ARQ_CW_NUM is the number of consecutive RS codewords to be re-transmitted for the same AT (2 bits, hence indicating up to another four RS codewords, where ARQ_CW_NUM = 0 means one RS codeword);
- ARQ_ACK (1 bit) shall indicate whether the ARQ map is terminated (ARQ_ACK = 0) or further ARQ entries are following (ARQ_ACK = 1).

The entries for the ARQ map are shown in figure 26. One ARQ map entry addresses only one AT but not several ATs.

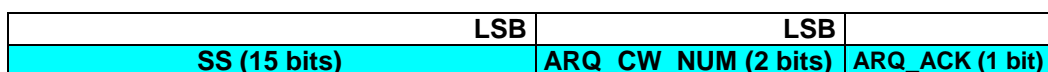

Figure 26: ARQ map entry format (left bit transmitted first)

If there are more than four consecutive corrupted RS codewords from the same AT or if there are corrupted RS codewords with at least one non-interrupted RS codeword in between, then this will cause several entries in the ARQ map for this single AT.

The ARQ re-transmission mechanism is based on the SSs of the RS codewords (or FEC blocks) in the concerned UL frame.

The ATs shall keep in memory all the ARQ-enabled MAC PDUs sent and their exact positioning in frame #N, till the ARQ map for frame #(N + 2) is received. This shall be extended till frame #(N + 4) if a second re-transmission is possible. In case of a second re-transmission, the ARQ map in frame #(N + 4) contains the appropriate SS of UL frame #(N + 2), i.e. not of UL frame #N.

On the AP side, all received MAC PDUs for which ARQ is enabled shall be kept in the AP memory until all previously received MAC PDUs are positively acknowledged in frame #(N + 2) or #(N + 4), in order to preserve the order of the MAC PDU sequence.

8.5.4 Rules for re-transmissions

The following rules shall be applied:

- Re-transmitted MAC PDUs and "new" MAC PDUs can be transmitted within the same RS codeword.
- The grants for an AT are for the combination of "old" RS codewords to be re-transmitted and the "new" MAC PDUs (if applicable) where re-transmitted RS codewords shall be transmitted first.
- If an AT is given a re-transmission grant for an RS codeword that partly or completely contains MAC PDUs belonging to non-ARQ connections, then the AT shall either replace non-ARQ MAC PDUs by MAC dummy PDUs or by "new" MAC PDUs for non-ARQ enabled connections.
- The grant given to an AT (by the UL map) shall be large enough to accommodate all re-transmissions as requested (by the ARQ map).

NOTE: Re-transmission of RS codewords means exactly, that the MAC PDUs of the old RS codeword are again grouped together to form the new RS codeword, where the individual new encryption of each MAC PDU is different to the old encryption due to the dependence on the frame counter. Hence the ciphertext subjected to the RS encoder is not the same for a re-transmission. Moreover, non-ARQ enabled MAC PDUs can be replaced by MAC dummy PDUs or new MAC PDUs for the respective RS codeword, see above.

Figure 27 shows an example for the re-transmission of MAC PDUs.

The AT has a grant for 6 PDUs and transmits two FEC blocks as follows in frame #N:

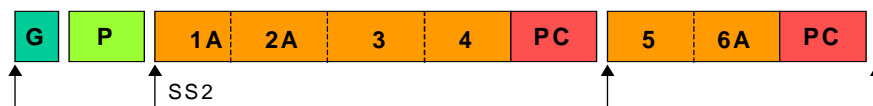

Both FEC blocks are received in AP with errors...

- the ARQ map contains the entries (SS=SS2, CW_NUM=2, ARQ_END),...
 - the UL map contains the entries (UIUC,TID=1,SS=SS5), (UIUC,TID=x,SS=SS9),...
- (Note: SS9-SS5 must be calculated in AP so that no spectrum is wasted)

The AT has many other PDUs (7, 8, 9,...) to transmit, but receives a grant for only 8 PDUs in frame #(N+2)

First possibility for the AT (dummy PDUs to replace old non-ARQ enabled PDUs)

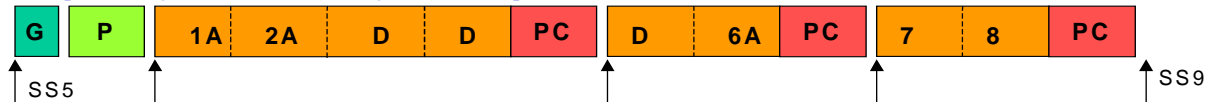

Second possibility for the AT (new PDUs to replace old non-ARQ enabled PDUs)

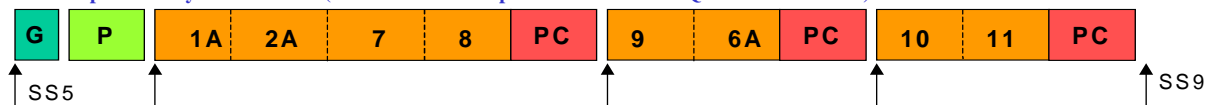

Legend: 1,2,3,... enumerates all PDUs of an AT (TID=1),
A = ARQ-enabled connection, D = dummy PDU, G = guard time, P = preamble, PC = parity checks,
solid line = border between RS CWs, dashed line = border between PDUs in an RS CW

Figure 27: ARQ re-transmission example

8.5.5 Impact of ARQ on delay and overhead (informal)

The impact of ARQ in terms of delay and spectrum efficiency is as follows:

- In terms of delay, the support of an ARQ feature in the UL direction implies:
 - The introduction of a fixed delay for all data to be retransmitted from the AT to the AP, depending on the maximum number of re-transmissions (selected by AP). So ARQ is only applicable for those connections for which this additional delay is tolerable.
 - Additional CDV can be avoided by appropriate implementations.
 - For connections without ARQ it is not necessary to send the MAC PDUs (identified by CID) through the ARQ buffers to avoid any additional delay.
- In terms of spectrum efficiency, the support for ARQ feature implies:
 - One additional bit of fixed overhead in the control zone of the DL (if there is no ARQ this is the only overhead due to ARQ).
 - An additional ARQ map in the control zone where the length depends on the number of PDUs to be re-transmitted.
 - Additional re-transmissions in the UL.
 - Wasted grants for non-ARQ enabled connections.

8.6 Structure of the control zone

8.6.1 Overview of main fields

The control zone shall be broadcasted at the beginning of each DL frame immediately after the frame preamble and its general structure is reported in figure 28.

Description	Length [bit]
Broadcast Frame Information (Length, frame counter, APC-ID, PSDI, map version number)	60
DL map entries for TDM (DIUC, SS)	typically 4 × 19 (without EndOfMap)
DL map entries for TDMA (optional) (DIUC, SS)	variable × 19
ARQ map entries (optional) (SS, ARQ_CW_NUM, ARQ_ACK)	variable, ≥ 1
UL map entries for windows (UIUC, TID, SS)	variable × 29
UL map entries (UIUC, TID, SS)	variable × 29
Padding till end of short RS block	variable, ≤ 239

**Figure 28: General structure of the control zone
(not all details shown)**

The following fields shall compose the control zone:

- Broadcast Frame Information (60 bits), consisting of:
 - Length of the control zone in FEC blocks (4 bits);
 - Frame counter used for the IV generation for encryption (24 bits);
 - APC-ID (24 bits);
 - PSDI (4 bits);
 - Map version number (4 bits, shall be set to all-zero in AP and shall be ignored by all ATs).
- Entries for DL map for TDM and TDMA zones, indicating the transitions between PHY modes, consisting of:
 - DIUC (4 bits) to indicate the type of PHY mode region or DL burst;
 - SS (15 bits) to indicate the channel symbol the relevant region (or DL burst, for TDMA) shall start from.
- Entries for ARQ map, consisting of:
 - ARQ_ACK (1 bit) to indicate whether the ARQ map consists of this bit only (ARQ_ACK = 0, i.e. no re-transmissions) or further entries will follow (ARQ_ACK = 1, i.e. re-transmissions are specified by subsequent ARQ map entries);
 - SS (15 bits) to reference to the RS codewords from the previous frame;
 - ARQ_CW_NUM is the number of consecutive RS codewords to be re-transmitted for the same AT (2 bits, hence indicating up to another three RS codewords);
 - ARQ_ACK (1 bit) shall indicate whether the ARQ map is terminated (ARQ_ACK = 0) or further ARQ entries are following (ARQ_ACK = 1).
- Entries for UL map, indicating when the ATs shall transmit their bursts, consisting of:
 - UIUC (4 bits) to indicate the PHY mode that shall be used in the relevant burst or to indicate a contention window or to indicate a request and grant for the MTL PDU;
 - TID (10 bits) to identify the terminal that shall transmit in the relevant burst;
 - SS (15 bits) to indicate the channel symbol the relevant burst shall start from.
- Padding bits to avoid any shortening of the short RS codewords used for the protection of the control zone (less than 30 padding bytes).

The length of the control zone is variable, but shall be at least three short map FEC blocks (and so three short RS codewords, see clause 8.6.3) and shall always be an integer multiple of the FEC length. The short RS codewords are not shortened.

NOTE: If less than four PHY mode regions are present, then it is allowed to repeat the EndOfMap entry in the DL map so to have always 5 entries for the DL map (if no TDMA zone is present).

8.6.2 Further details of all fields

A more detailed representation of the control zone is reported in figure 29.

Description	Length [bits]
Length of control zone (number of FEC blocks)	4
Frame counter	24
APC-ID	24
PSDI	4
Map version number	4
DL map entry (DIUC, SS)	4 + 15
DL map entry (DIUC, SS)	4 + 15
.....variable number of repetitions.....
DL map entry (DIUC, SS)	4 + 15
end of DL map (DIUC = 1111, SS)	4 + 15
ARQ_ACK	1
ARQ map entry (SS, CW_NUM, ARQ_ACK = 1)	15 + 2 + 1
ARQ map entry (SS, CW_NUM, ARQ_ACK = 1)	15 + 2 + 1
.....variable number of repetitions.....
ARQ map entry (SS, CW_NUM, ARQ_ACK = 1)	15 + 2 + 1
ARQ map entry (SS, CW_NUM, ARQ_ACK = 0)	15 + 2 + 1
UL map entry for window (UIUC, TID, SS)	4 + 10 + 15
.....variable number of repetitions.....
UL map entry for window (UIUC, TID, SS)	4 + 10 + 15
UL map entry for grant (UIUC, TID, SS)	4 + 10 + 15
UL map entry for grant (UIUC, TID, SS)	4 + 10 + 15
.....variable number of repetitions.....
UL map entry for grant (UIUC, TID, SS)	4 + 10 + 15
end of UL map for grant (UIUC = 1111, TID, SS)	4 + 10 + 15
Padding till end of short RS block	variable

Figure 29: Control zone details

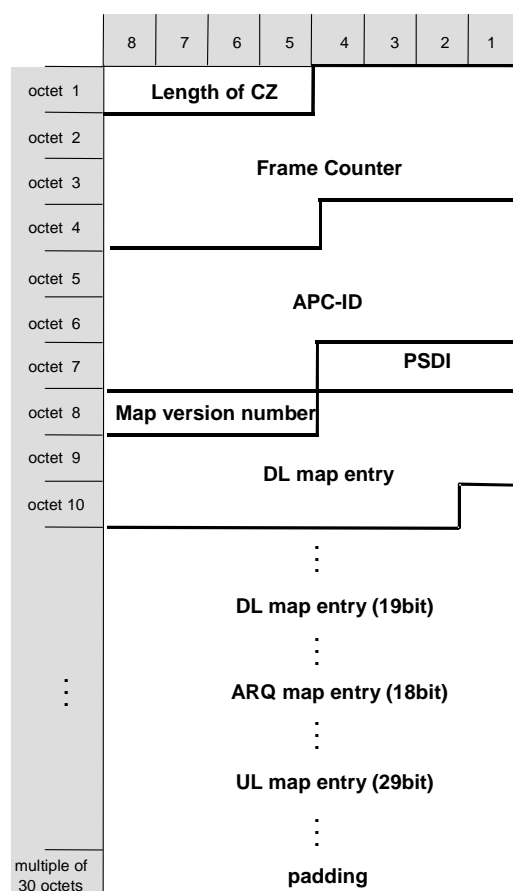

Figure 30: Bit structure of control zone (left bit transmitted first)

Some additional background information:

- The DIUC positions are fixed, so DIUC = 1111 and ARQ_ACK are clearly detected in the AT receiver. The SS (means first symbol after last DL entry) together with DIUC = 1111 is included to allow the calculation of the length of the last PHY mode region (or DL burst in case of TDMA).
- The further ARQ_ACK positions are fixed, so the end of the ARQ map is clearly detected in the AT receiver.
- The first UIUC position is clearly detected and the further UIUC positions are fixed. The SS (means first symbol after last UL entry) together with UIUC = 1111 is included to allow the calculation of the length of the last UL burst.
- In case of TDD mode, the end of the DL subframe and the start of the UL subframe are also clear from the control zone.

8.6.3 FEC scheme for fast decoding

The control zone shall be broadcasted at the beginning of each DL frame with PHY mode #0. Since this information is the most important one, it is strongly protected with a very robust PHY mode:

- outer shortened RS(46,30,t = 8) code (i.e. same type as for traffic data, only different shortening);
- inner convolutional code of rate 1/2 (i.e. this is not a PHY mode out of the regular PHY mode set) without puncturing;
- QPSK modulation.

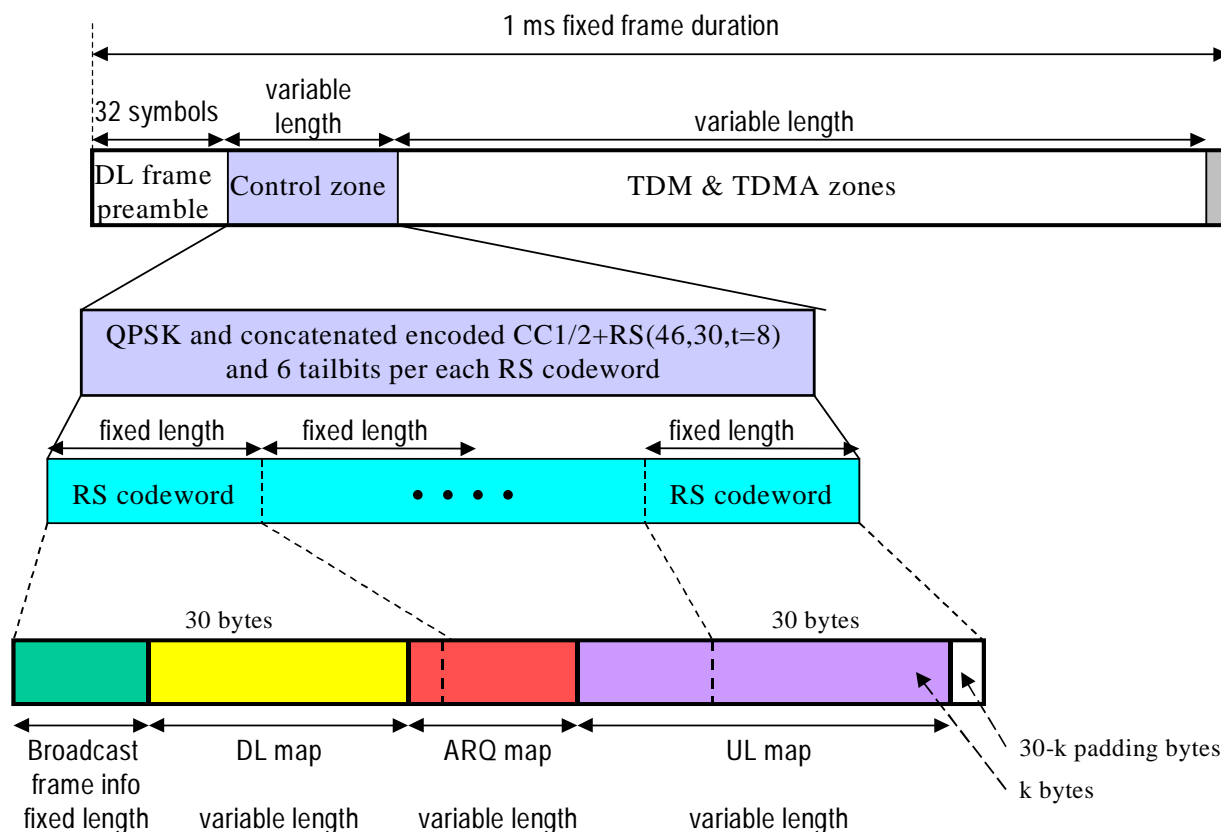

Figure 31: FEC protection of the control zone

The coding procedure for protecting the control zone is illustrated in figure 31. The map byte sequence shall be segmented into segments of 30 bytes. Each of these 30 bytes shall be encoded with the outer RS code. The remaining k bytes if less than 30 bytes shall be padded with dummy bytes in order to have a constant length codeword, i.e. 30 bytes before RS coding.

8.7 Time Relevance of Starting Symbols (SS) and maps

This clause and the next clause describe issues related to the interface between DLC and PHY layers.

In this clause, firstly, the time relevance of the Starting Symbols (SS) and the computation of the actual transmit times for scheduled UL bursts is covered. Secondly, the time relevance of maps, or in other words the influence of the Frame Offset (FO) is presented, especially for the UL map since the timing for the DL map is trivial.

8.7.1 Starting Symbols for UL bursts

The AT knows:

- The sector-specific Frame Offset (FO) from reading the GBI message; and
- its individual Transmission Delay (TD) or the Round Trip Delay (RTD) from the initialization phase (and updated by further AT-specific messages in the DL if required).
- The RTD is simply the double of TD and EGT shall be equal or larger than the maximum of RTD (determined by the farthest AT in the sector).
- The FO is chosen by the AP, however, usually the FO should be larger than the sum of the maximum length of the control zone plus the EGT plus the TP (Time for Processing), where TP denotes the time required in the AT to decode the UL map after complete reception of the control zone.

The calculation of the physical starting time (derived from the numbering of the received DL frame) for an UL burst from the Starting Symbol (SS) contained in the UL map entries is shown in figure 32.

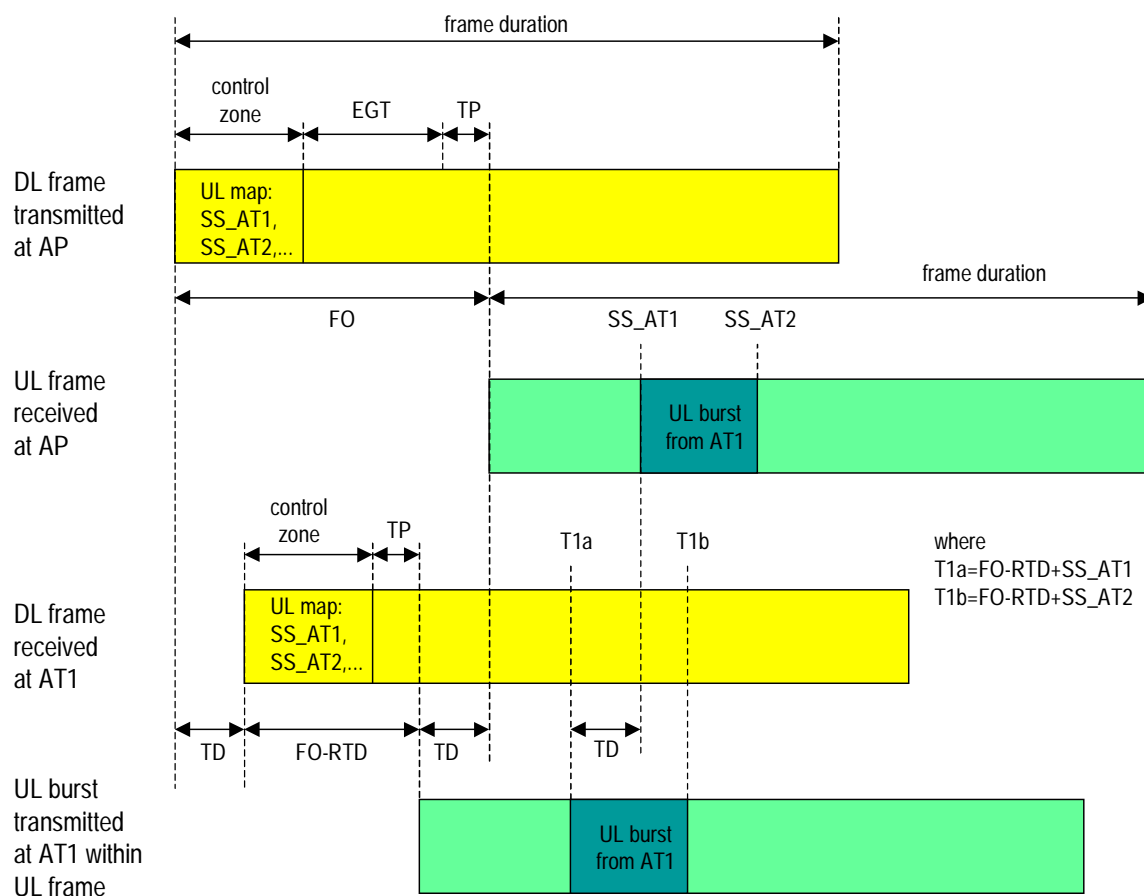

Figure 32: Starting times for UL bursts

In figure 32, the terminal AT1 is assumed at the maximum distance from the AP for simplicity, so $EGT = RTD$. The UL map contains an entry for AT1 with the starting symbol SS_AT1 . The next entry in the UL map contains a starting symbol SS_AT2 for another terminal AT2. The SS values refer to the numbering of the UL frame at the AP, where the range is determined by $0 \leq SS \leq 22\,399$ (note that the symbol rate is 22,4 MBaud and the frame duration is 1 ms).

The AT1 counts the symbols in the received DL frame, from 1 to 22 400. With regard to this counter, AT1 is allowed to transmit from $T1a = FO - RTD + SS_AT1$ till $T1b = FO - RTD + SS_AT2$.

NOTE 1: This follows from the specific case of $SS_AT1 = 0$ (which is immediately intelligible).

NOTE 2: It is not possible to incorporate the specific RTD in the UL grant SS_AT1 , since the AT1 need to know RTD for AT2 to calculate $T1b$, and so AT1 could not calculate the number of granted PDUs. In other words, the granted SSs of the UL map are under the assumption of $RTD = 0$ and each AT has to compute $T1a$ and $T1b$ from SS and its own RTD.

8.7.2 Time relevance of maps for FDD mode

In the FDD operational mode, the DL map shall pertain to the current frame (protected by at least two short RS codewords to allow for a processing time for the decoding of the first DL map entries whilst the rest of the control zone is still on air). The time relevance of UL maps may be as follows (with respect to the reception at the AP):

- **Minimum time relevance:** The UL frame starts as soon as possible, i.e. the Frame Offset (FO) attains the minimum value of $2/5$ of a frame (0,4 ms) to provide for the maximum Round Trip Delay (RTD) plus the required Time for Processing (TP) in the AT to decode the UL map (see figure 33) and to encode the UL burst. This choice is determined by the maximum length of the control zone under worst-case conditions plus RTD plus TP. This was also the assumption in figure 32.
- **Maximum time relevance:** The UL frame starts late at the following frame (see figure 34). The FO is identical to the frame duration.
- **Other time relevance:** The UL frame starts something in between minimum and maximum time relevance.

The computation of the transmit time T_a in clause 8.7.1 for scheduled UL bursts and in clause 8.7.2 is valid for all of the scenarios listed above.

The minimum time relevance of the UL map is shown in figure 33.

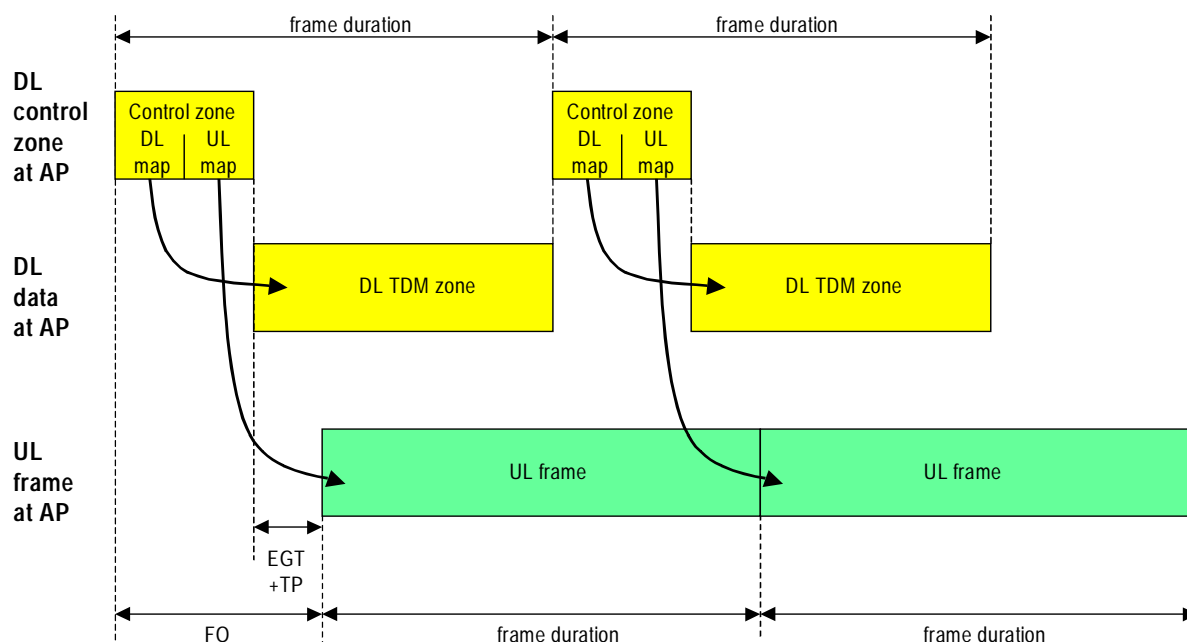

Figure 33: Minimum time relevance for UL map (FDD mode)

The maximum time relevance of the UL map is shown in figure 34.

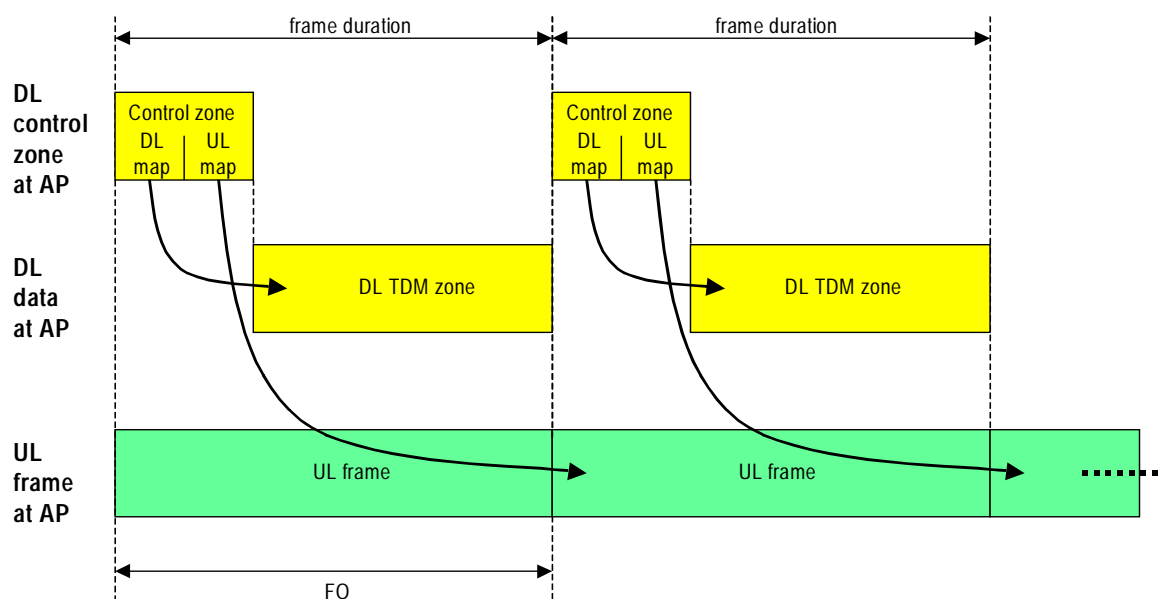

Figure 34: Maximum time relevance for UL map (FDD mode)

8.7.3 Time relevance of maps for TDD mode

In the TDD operational mode, the UL map may pertain to the UL frame of either the current frame (minimum time relevance, see figure 35) or the next frame (see figure 36).

For a fixed partition of the frame into DL and UL subframes, the handling of the Frame Offset (FO) can be exactly identical to that for the FDD mode. However, even for an adaptive TDD split (ATDD), the computation of the transmit times can be done as presented in clauses 8.7.1 and 8.7.2, where the FO is set to zero and the UL map entries refer directly to the SS of the UL subframe. The UL map entries depend also on the minimum or maximum time relevance.

The minimum time relevance of the UL map is shown in figure 35. In case of adaptive TDD, the lengths of the DL and UL subframes can be variable over time, however, the length of the DL subframe shall be at least the Extended Guard Time (EGT) plus the Time for Processing (TP).

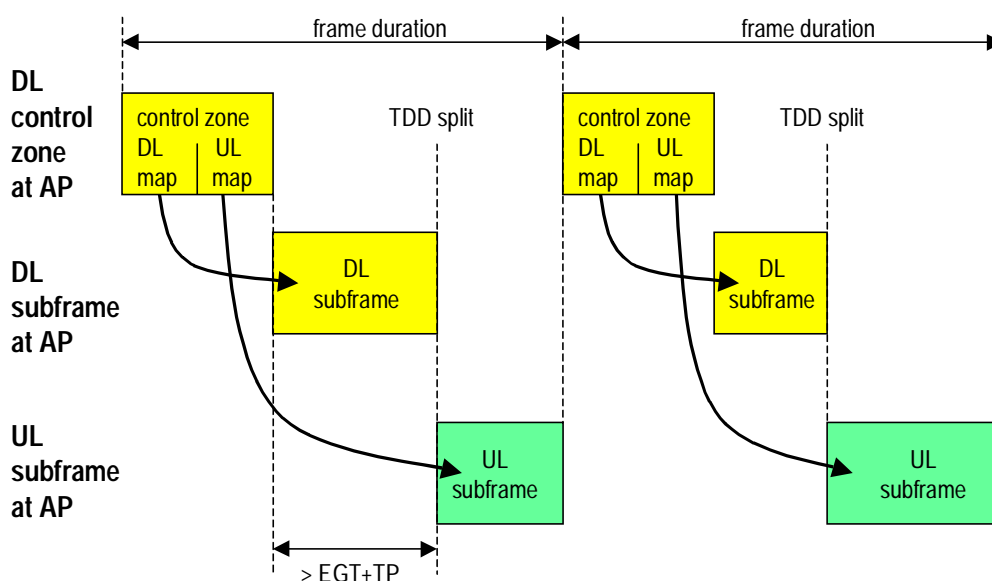

Figure 35: Minimum time relevance for UL map (TDD mode)

The maximum time relevance of the UL map is shown in figure 36:

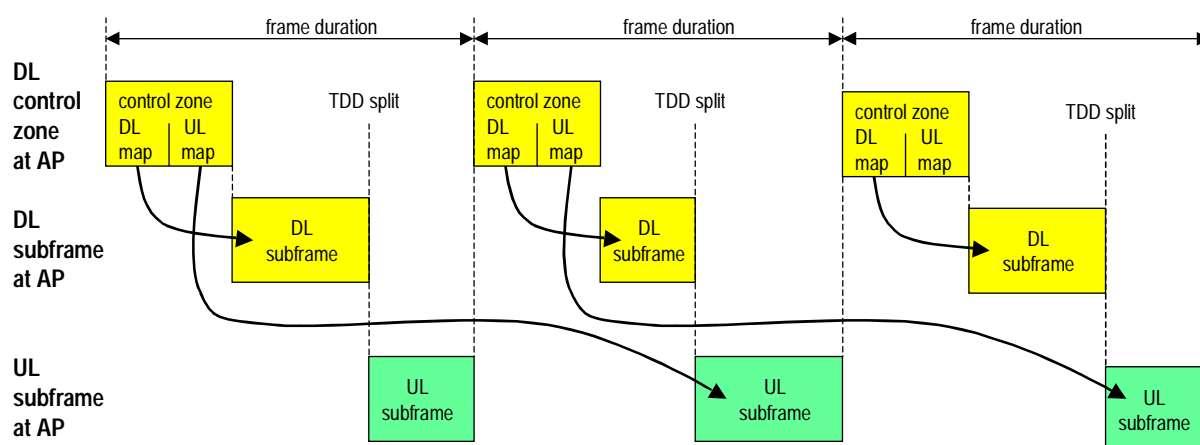

Figure 36: Maximum time relevance for UL map (TDD mode)

8.7.4 Timing rule for some specific short grants

There are a few situations where the AP sends a message in the DL and gives a grant for a short MAC PDU that shall be used with a specific UL message:

- The message `RlcRangingContinue` is sent in DL, the next grant for an UL ranging burst shall be used to transmit the message `RlcRangingReq`.
- The message `RlcRangingSuccess` is sent in DL, the next grant for an UL ranging burst shall be used to transmit the message `RlcRangingAck`.
- The message `RlcQueueStatusReq` is sent in DL, the next grant for a short MAC PDU shall be used to transmit the message `RlcQueueStatusRsp`.
- The message `RlcUplinkCorrection` is sent in DL with the parameter `MeasurementReportReq=1`, the next grant for a short MAC PDU shall be used to transmit the message `RlcMeasurementReportData`.

For all these cases, the following timing rule shall be applied: If the DL message is transmitted in frame #N, then the grant for the short burst (i.e. short MAC PDU or UL ranging burst) shall be given as follows:

- For `RlcRangingContinue` messages: At frame N+10 or later.
- For `RlcRangingSuccess` messages: At frame N+10 or later.
- For `RlcQueueStatusReq` messages: At frame N+1 or later.
- For `RlcUplinkCorrection` messages: At frame N+4 or later.

8.8 General Broadcast Information (GBI) message

The GBI (General Broadcast Information) message `RlcGeneralBroadcastInformation` is a broadcast message containing general carrier-specific information that does not need to be transmitted in each frame (in contrast to the broadcast information contained in the control zone of each DL frame). The content of the GBI message can be grouped into several parts:

- General information about the carrier (and the network) related to operation modes, frame offset, message periods, structure of UL bursts, parameters for contention resolution and some other information fields.
- The PSD (PHY mode Set Descriptor) containing the $C/(N + I)$ thresholds for all relevant sets of PHY modes (currently up to two) together with a PSD-specific PSDI (PSD Indicator). The PSDI is just a reference to the PSD. The description of the PHY mode includes the thresholds for up (channel improves) and down (channel is worse off) direction together with the respective changes of the transmit power that shall be applied during PHY mode switching.

Normally, only one set shall be described by the PSD. However, if a change from one PHY mode set to another PHY mode set shall be performed, then the new set shall be described by the PSD some time in advance, where a strict period is not required. The GBI message with the new PSD shall be broadcasted several times to guarantee that almost all ATs have received the information correctly.

The parameters carried in the PSD part are described in figure 37:

- $2n$ C/N thresholds (each threshold requires 8 bit prior to encoding); and
- $4(m-1)$ transmit power gaps (each gap requires 6 bit prior to encoding);
- shall be transmitted for one PHY mode set, where n and m are the numbers of PHY modes for DL and UL direction, respectively.

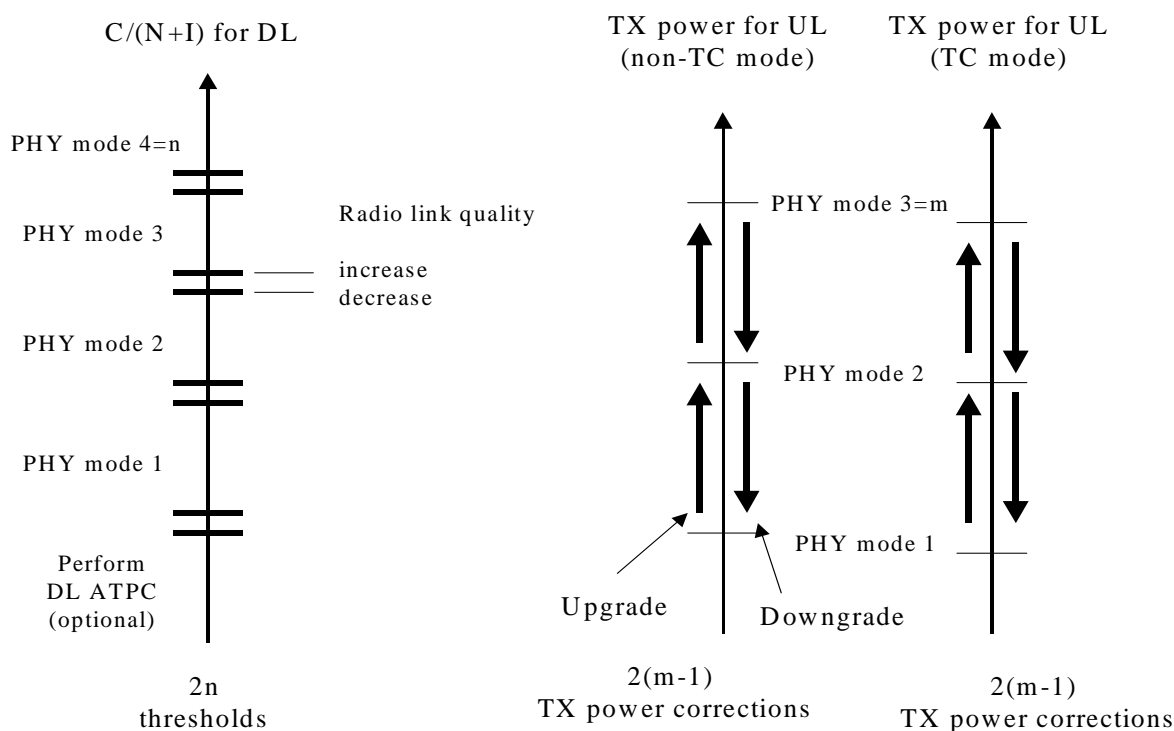

Figure 37: Parameters for PHY mode set description

The dynamic use of the $C/(N + I)$ threshold pairs is specified in clause 11.3.4. The first (lower values) $C/(N + I)$ threshold pair is only relevant if the optional DL ATPC is activated (see clause 11.3.6) but shall be always contained in the GBI message. The transmit power gaps for PTC are only relevant if at least one AT in the carrier uses the PTC option, but again these values shall be always contained in the GBI message.

The complete GBI message is described in table 23. Note that normally only one PHY mode set is present, and two PHY mode sets are only present during the PHY mode set exchange phase (even in this case, the GBI message fits into one long MAC signalling PDU).

Table 23: GBI message (update, fixVar)

RlcGeneralBroadcastInformation ::= SEQUENCE {	-- broadcast
duplexMode	DuplexMode, -- 1 bit
frameOffset	FrameOffset, -- 5 bit
tdmaZoneDownlink	TdmaZoneDownlink, -- 1 bit
encryptionMode	EncryptionMode, -- 1 bit
uplinkPowerIncRangingStart	UplinkPowerIncRangingStart, -- 3 bit
uplinkPowerMaxRangingStart	UplinkPowerMax, -- 4 bit
downlinkPowerControl	DownlinkPowerControl, -- 1 bit
periodMeasurementReportGBI	PeriodMeasurementReportGBI, -- 3 bit
periodRangingInvitation	PeriodRangingInvitation, -- 8 bit
timerGranuConnection	TimerGranuConnection, -- 8 bit
timerGranuSecurity	TimerGranuSecurity, -- 6 bit
uplinkNumberPduPerFecBlock	UplinkNumberPduPerFecBlock, -- 1 bit
uplinkNumberMidamblePerBurst	UplinkNumberMidamblePerBurst, -- 1 bit
crMaxNumberRetries	CrMaxNumberRetries, -- 4 bit
crStartingWindowSize	CrStartingWindowSize, -- 3 bit
crMaxBackoffWindow	CrMaxBackoffWindow, -- 6 bit
fixedVariableChannelInd	FixedVariableChannelInd, -- 1 bit
phyModeSetDescriptorCurrent	PhyModeSetDescriptor, -- variable
phyModeSetDescriptorFuture	PhyModeSetDescriptor OPTIONAL -- variable
}	
DuplexMode ::= ENUMERATED {	
fdd (0),	
tdd (1)	
}	
TdmaZoneDownlink ::= ENUMERATED {	
present (0),	
notPresent (1)	
}	
DownlinkPowerControl ::= ENUMERATED {	
downlinkPowerControlNo (0),	-- ignore PhyThresholdsList(0)
downlinkPowerControlYes (1)	
}	
EncryptionMode ::= ENUMERATED {	
encryptionOn (0),	
encryptionOff (1)	
}	
FrameOffset ::= INTEGER(8..16)	-- 5 bit, granu=0.05ms, range=[0.4,1]ms
PeriodRangingInvitation ::= INTEGER(0..255)	-- 8 bit, granu=1000frame -- 0 means no invitations
PeriodMeasurementReportGBI ::= PeriodMeasurementReport	(period050..noPeriodicReports)
PeriodMeasurementReport ::= INTEGER {	
usePeriodicMeasurementReportGBI (0),	-- only for periodMeasurementReportAtSpecific in RlcMeasurementReportCriterium, -- but not for
-- periodMeasurementReportGBI in RlcGeneralBroadcastInformation	
period050 (1),	-- 50 ms
period100 (2),	-- 100 ms
period150 (3),	-- 150 ms
period200 (4),	-- 200 ms
noPeriodicReports (5)	
}	
TimerGranuConnection ::= INTEGER(8..255)	-- 8 bit, granu=1frame

```

TimerGranuSecurity ::= INTEGER(1..63) -- 6 bit, granu=128frame

UplinkNumberPduPerFecBlock ::= ENUMERATED {
    onePduPerFecBlock (0),
    severalPerFecBlock (1)
}

UplinkNumberMidamblePerBurst ::= ENUMERATED {
    oneMidamblePerBurst (0),
    severalMidamblePerBurst (1)
}

CrMaxNumberRetries ::= INTEGER(0..15) -- 4 bit
CrStartingWindowSize ::= INTEGER(0..7) -- 3 bit
CrMaxBackoffWindow ::= INTEGER(0..63) -- 6 bit

FixedVariableChannelInd ::= ENUMERATED {
    fixedChannel (0), -- shall be used
    variableChannel (1) -- not allowed
}

PhyModeSetDescriptor ::= SEQUENCE {
    psdi Psdi, -- 4 bit
    downlinkPhyThresholdsList PhyThresholdsList, -- variable
    uplinkPowerModChangeListNonTc UplinkPowerModChangeList, -- variable
    uplinkPowerModChangeListTc UplinkPowerModChangeList -- variable
}

Psdi ::= INTEGER {phyModeSet1 (1), phyModeSet2 (2)} (0..15) -- 4 bit

PhyThresholdsList ::= SEQUENCE (SIZE(2..7)) OF PhyThresholdPair
-- allows 2..7 PHY modes per set, 2*8 bit per pair, see RRC
-- 1st pair for DL ATPC, to be ignored if no DL ATPC
-- 2nd pair for mode1/mode2, 3rd pair for mode2/mode3, etc.

UplinkPowerModChangeList ::= SEQUENCE (SIZE(1..6)) OF UplinkPowerModChangePair
-- allows 2..7 PHY modes per set, 6 bit per entry, see common
-- TX power steps for UL PHY change
-- 1st gap pair for mode1/mode2,
-- 2nd gap pair for mode2/mode3, etc.

UplinkPowerModChangePair ::= SEQUENCE {
    upPowerModChange UplinkPowerModChange, -- channel quality increase
    downPowerModChange UplinkPowerModChange -- channel quality decrease
}

PhyThresholdPair ::= SEQUENCE {
    upThreshold CnrThreshold, -- channel quality increase
    downThreshold CnrThreshold -- channel quality decrease
}

PhyThresholdPair ::= SEQUENCE {
    upThreshold CnrThreshold, -- channel quality increase
    downThreshold CnrThreshold -- channel quality decrease
}

CnrThreshold ::= INTEGER(0..255) -- 8 bit, granu=0.25dB, range=[4,40]dB, absolute

UplinkPowerIncRangingStart ::= INTEGER(0..7) -- 3 bit, granu=1.0dB, range=[ +1, +8]dB
UplinkPowerModChange ::= INTEGER(0..32) -- 6 bit, granu=0.5dB, range=[ -8, +8]dB
UplinkPowerMax ::= INTEGER(10..20) -- 4 bit, granu=1.0dB, range=[+10,+20]dBm

```

The parameter `FixedVariableChannelInd` shall be set to the value `fixedChannel` and the ATs shall ignore this parameter.

A change of PHY modes is performed as follows:

- A change from one to another PHY mode for a specific AT is part of the regular adaptive operation in DL and UL and is communicated by the DIUC and UIUC, respectively.
- A change from one to another PHY mode set for a sector is communicated by the corresponding PSDI in the control zone.

More details are specified in clause 11.4. Some rules for the PHY mode sets:

- PHY mode #1 is identical for all PHY mode sets. The PHY mode sets are listed in table 24.

Table 24: PHY mode sets

Mode #	Set 1 (mandatory for AP and AT) PSDI = 1	Set 2 (optional for AP) PSDI = 2
0	QPSK + RS(t = 8) + CC1/2 (only for control zone, independent of PHY mode set)	
1	QPSK + RS(t = 8) + CC2/3	QPSK + RS(t = 8) + CC2/3
2	QPSK + RS(t = 8)	QPSK + RS(t = 8)
3	16 - QAM + RS(t = 8) + CC7/8	16 - QAM + RS(t = 8)
4	64 - QAM + RS(t = 8) + CC5/6	64 - QAM + RS(t = 8)

- The DL PHY mode set consists of 4 modes (where the highest mode is optional).
- The UL PHY mode set consists of 3 modes (where the highest mode is optional per AT).
- The PHY mode set in use should be always the same for all carriers of a sector.

NOTE: The fact that the UL PHY mode is a subset of the DL PHY modes (without the PTC option) has no impact on the DLC layer.

8.9 AT reaction to undefined parameters

For the reception in the DL of undefined values of parameters the AT shall ignore this message. For undefined parameters in the control zone, the complete control zone shall be ignored, i.e. the AT does not transmit in the UL frame.

9 Resource-Grant Control (RGC) and contention resolution

9.1 General

While the downlink data stream will be a continuous sequence of frames broadcasted to all ATs, the uplink will be a discontinuous burst point-to-point transmission from each AT to the AP.

The Medium Access Control (MAC) protocol is a central feature of a PMP system. The function of the MAC sublayer in a shared-medium network is to deal with the fact that the physical medium is shared. All ATs cannot transmit at the same time successfully, as they could in a dedicated-medium situation such as pertains with a switch and point-to-point wiring. The MAC layer determines who transmits when, and if contention is allowed, the MAC controls the contention process and resolves any collisions that occur.

Each burst in the uplink is reserved to transmissions from an AT that is activated in that particular burst by a message, called Grant, sent by the AP on the downlink channel.

The MAC Processor of the AP selects the AT that will have access to the radio channel; the operation is performed burst by burst by the AP processor and a signalling message is inserted into downlink containing the TID of the relevant AT.

All ATs will receive all the downlink signalling messages (broadcast mode); the AT decodes all the received messages and enables the uplink transmission burst by burst only in case the TID in the grant is assigned to it.

MAC functionality, located in AP, is in charge of generating these "grant" messages in order to satisfy bandwidth requests from ATs. The AP receives requests for transmission rights and grants these requests within the time available. The resource allocation protocol consists of these two types of messages: Grant and Request.

9.2 Grants

The AP shall use the UL map to allocate bandwidth, i.e. to give grants (see clause 8.4.2).

The grant shall contain the TID. Following a successful detection of a grant the AT gains access to the related uplink burst.

Figure 38 shows the procedure of the AT when it receives a grant. When an AT receives a grant it shall transmit MAC PDUs in order to honour the grant. If the AT has no traffic (data or messages) to transmit it shall send MAC dummy PDUs.

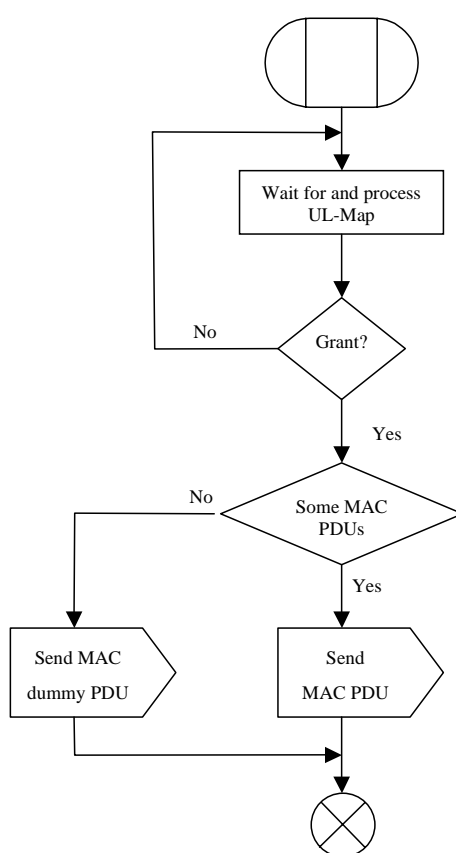

Figure 38: Grant per terminal

9.3 Requests

9.3.1 General request strategy

In the uplink each AT sends to the AP indications about (instantaneous) queue status and instantaneous bandwidth needed for bandwidth allocation, i.e. bandwidth requests. Such information will allow the AP to assign the proper capacity to each AT.

Rules for requests:

- The resource requests shall be on a per connection aggregate basis.
- The resource requests shall be encoded in aggregate form (i.e. the complete queue status of all connections in the relevant group shall be sent).

The AP decides on the grouping of connections into connection aggregates. The number of connections, connection aggregates and maximum number of connections per connection aggregate that the AT can handle simultaneously is negotiated between AP and AT during initialization with the `RlcOtherCapabilitiesInfo` and `RlcOtherCapabilitiesCnf` messages.

The AP shall not send acknowledgements of resource requests to the AT.

The three possible signalling mechanisms in the UL for bandwidth requests are specified in the following clauses:

- per MAC PDU header;
- per `RlcBandwidthRequest` MAC management message;
- per queue status report procedure.

9.3.2 Requests per MAC PDU header

Every MAC data PDU in the UL transports, within its header, a request for bandwidth allocations.

The request format is clear from the MAC PDU header for the UL as defined by table 19. A total of 26 bits (3 bytes and 2 bit) are needed for the bandwidth request:

- CID (16 bits): the connection ID is exactly that assigned to the particular connection whose PDU is transmitted in the burst. The CID associated to the bandwidth request identifies the connection aggregate that MAC Data PDU belongs to.
- PB (8 bits): the request byte (piggyback field) describes the number of PDUs in the queue for the connection aggregate associated with the connection aggregate of the MAC data PDU.
- PM (1 bit): the poll-me bit is used to indicate whether the AT has traffic to send or not for the connection aggregates associated to the poll-me bit with the exclusion of the connection aggregate specified by the CID field.

PM = 1 means poll-me and PM = 0 means do not poll-me.

- RSB (1 bit): a request for an UL grant to send a short MAC signalling PDU. If the AP replies with a grant, then this can be used for all MAC management messages that fit into a short MAC signalling PDU, e.g. measurement reports, bandwidth request, connection control messages, etc.

RSB = 1 means request and RSB = 0 means no request.

The three fields PB, PM and RSB are also addressed as the GM (Grant Management) field with 10 bit.

The use of RSB is shown in diagram 1.

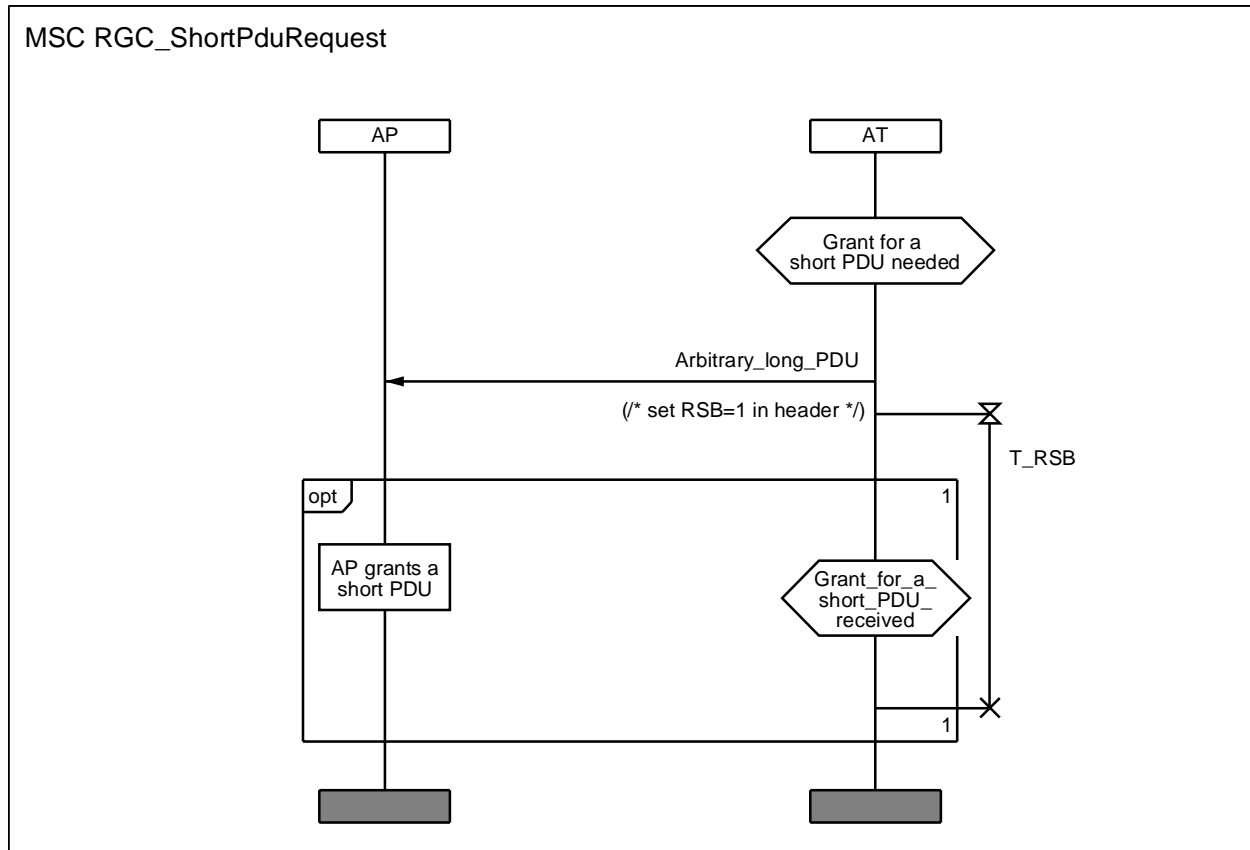

Diagram 1: MSC for the use of RSB

9.3.3 Requests per bandwidth request message

A MAC management messages `RlcBandwidthRequest` is defined for the UL to transmit information about the queue status of several connection aggregates. This message can be transported in a short MAC signalling PDU and can be sent according to the UL frame structure expressed in the UL map (see table 22) as follows:

- by using the bandwidth request contention window; or
- by using a granted short MAC signalling PDU.

The `RlcBandwidthRequest` message is specified in table 25 and the usage is illustrated in diagram 2.

Table 25: Message for bandwidth request

<code>RlcBandwidthReq</code>	<code>::= SEQUENCE {</code>		
<code>caid2</code>	<code>Caid,</code>	-- 2 byte, common	
<code>piggyback2</code>	<code>Piggyback,</code>	-- 1 byte, common	
<code>caid3</code>	<code>Caid,</code>	-- 2 byte, common	
<code>piggyback3</code>	<code>Piggyback</code>	-- 1 byte, common	
	<code>}</code>		
<code>Caid</code>	<code>::= INTEGER(0..65535)</code>	-- 16 bit, connection aggregate ID	
<code>Piggyback</code>	<code>::= INTEGER(0..255)</code>	-- 8 bit, piggyback field	

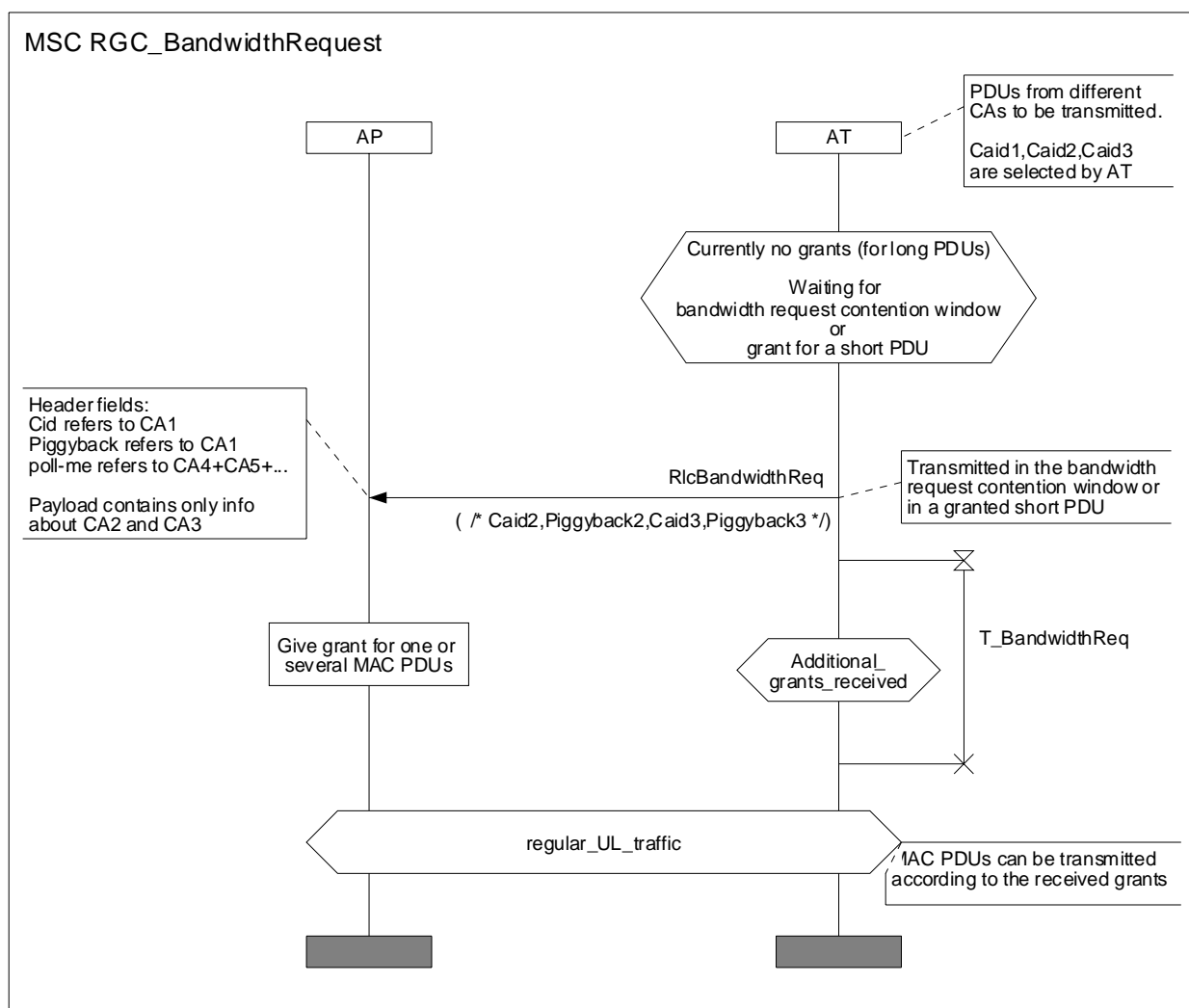

Diagram 2: MSC for bandwidth request message

The three connection aggregates that are referred to in the message RlcBandwidthReq can be selected by the AT without any restrictions.

9.3.4 AP-requested queue status report

The AP can request an AT to report the queue status of up to six connection aggregates. The DL message RlcQueueStatusReq contains the identities of up to six connection aggregates. The UL message RlcQueueStatusRsp contains only the corresponding piggyback bytes (as for the MAC PDU headers and for RlcBandwidthReq) describing the queue status of the connection aggregates.

The restriction to six connection aggregates ensures that the message RlcQueueStatusRsp can be transmitted in a short MAC signalling PDU. After reception of RlcQueueStatusReq, the AT shall use the next granted short PDU to transmit RlcQueueStatusRsp. The messages are specified in table 26 and shown in diagram 3.

Table 26: Messages for queue status report

RlcQueueStatusReq	::= SEQUENCE (SIZE(1..6)) OF Caid	-- DL
RlcQueueStatusRsp	::= SEQUENCE (SIZE(1..6)) OF Piggyback	-- UL
Caid	::= INTEGER(0..65535)	-- 16 bit, connection aggregate ID
Piggyback	::= INTEGER(0..255)	-- 8 bit, piggyback field

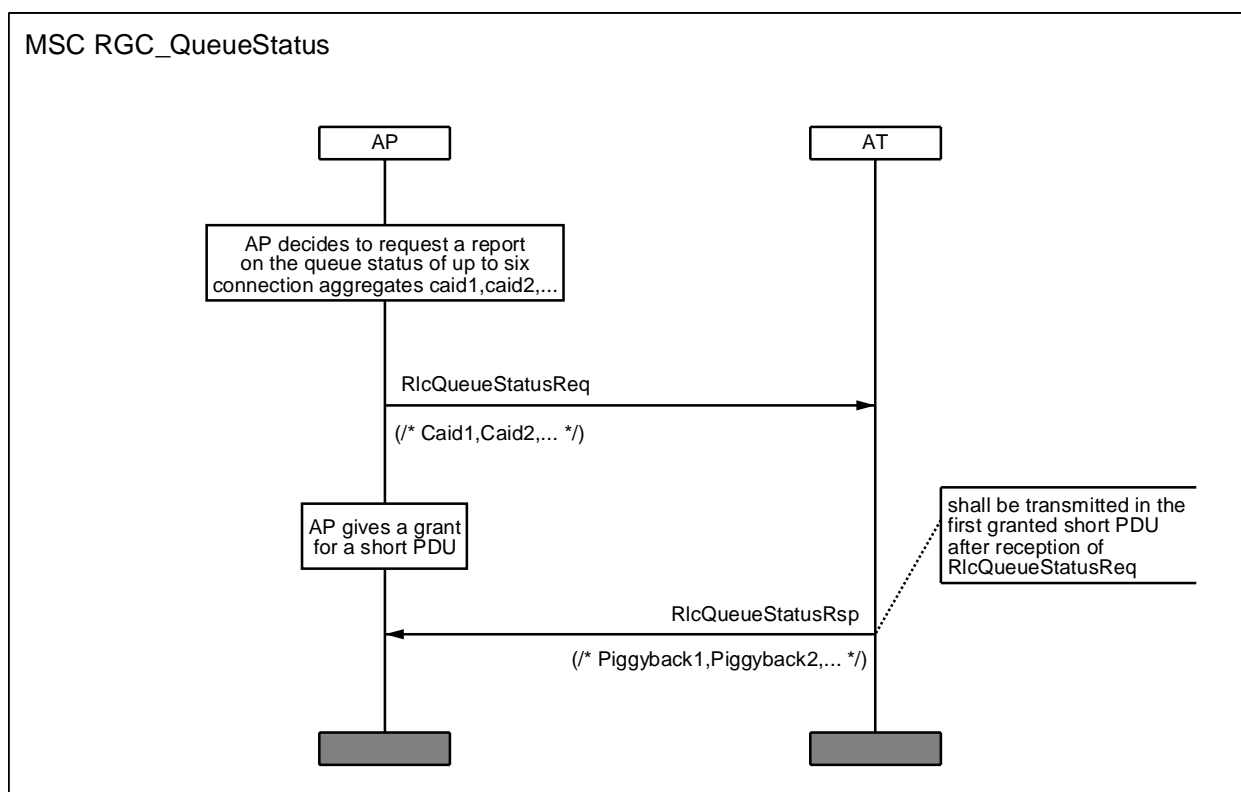

Diagram 3: MSC for queue status report

9.4 Allocation mechanisms

Different allocations mechanisms are defined to be suitable for different types of traffic.

9.4.1 Continuous grant

Continuous Grant is the periodic assignment of transmission burst to ATs with a fixed rate. It corresponds to the assignment of a fixed capacity, equal to a constant grant rate, to a certain AT, that is a certain group of connections with constant traffic profile. This predetermined capacity to each requesting AT shall be guaranteed.

The AP is not influenced by the status of the queue related to the static allocation connections. For these connections there is no need for AT to transmit Request information. The periodicity of bandwidth assignment is defined at the connection establishment by the QoS parameters.

Continuous grant is usually applied to CBR traffic.

9.4.2 Polling

Polling is the process by which the AP allocates to the ATs bandwidth specifically for the purpose of making bandwidth requests. These allocations shall be to individual ATs. The AP polls the ATs that will send a short MAC signalling PDU the bandwidth request. If the polled AT has no traffic to transmit the request sent shall be empty.

Note that polling is done on a per AT basis, bandwidth is requested on per connection aggregate basis, and bandwidth is allocated on per AT basis.

The AP shall have the full control of the mechanism.

9.4.3 Piggyback

All the MAC data PDUs have within the header a bandwidth request field. The piggyback byte describes the number of PDUs in the queue for the connection aggregate including the connection of the MAC data PDU.

The first 255 combinations refer to 0 to 254 data PDUs, the last all-one combination means 255 or more PDUs in the queue.

The use of piggyback is sketched in figure 39.

9.4.4 Poll-me bit

Poll-me bit is a form of piggyback mechanism. It's a request of polling and the format is represented by one bit added in every PDU header.

During the connection set-up procedure, the configuration of the poll-me bit, active or non-active, is set in conformance to the connection aggregate the connection belongs to. The configuration of the poll-me bit is under the full control of the AP.

The poll-me bit shall be used to indicate whether the AT has traffic to send or not for the connection aggregates associated with the poll-me bit with the exclusion of the one that the CID of the MAC PDU belongs to.

The use of poll-me bit and piggyback is sketched in figure 39.

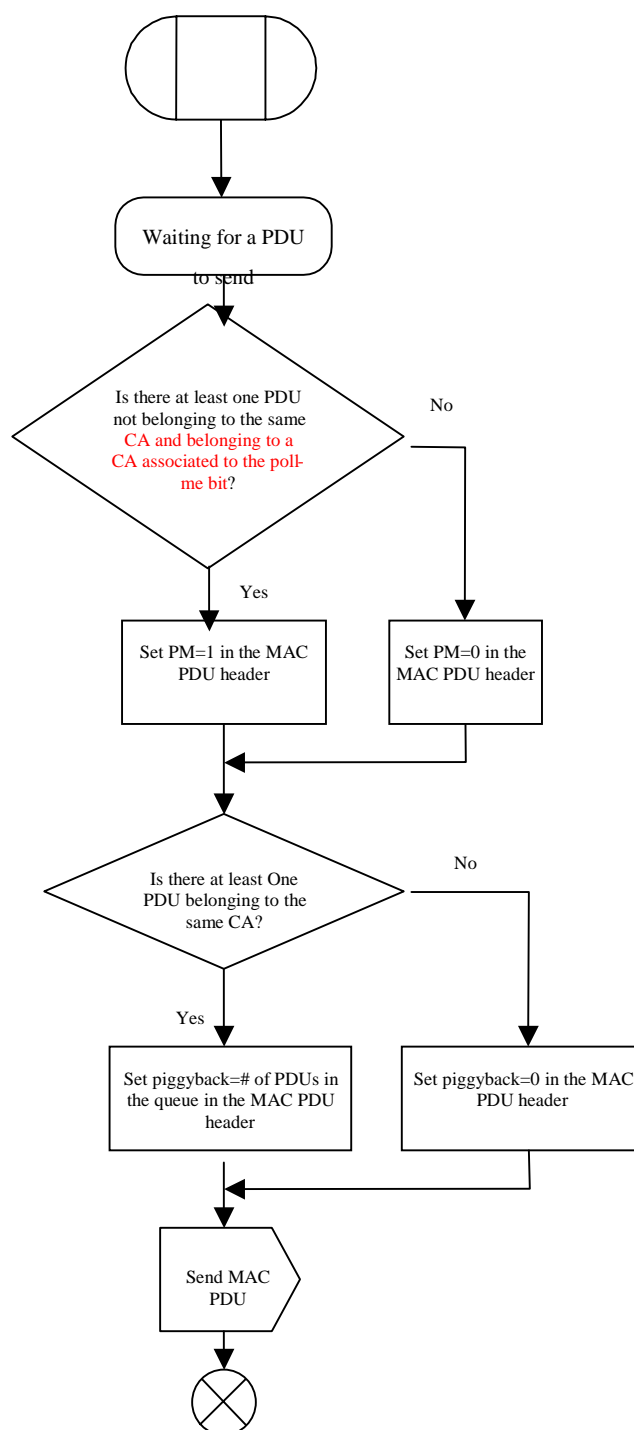

Figure 39: Usage of piggyback and poll-me bit by an AT

9.4.5 Contention reservation

With a specific grant, an UL burst is dedicated to contention requests. This kind of grant is broadcasted to all the ATs (or a subset of), and ATs could submit a contention request in this burst via a short MAC signalling PDU.

The implementation of the bandwidth request contention procedure is optional for both sides.

9.5 Contention resolution

The bandwidth request contention window may consist of a number of transmission opportunities, which depend on the size of the contention window.

9.5.1 Contention resolution algorithm

The contention resolution algorithm shall be based on a truncated binary exponential back-off algorithm, where the initial back-off window and the maximum back-off window shall be controlled by the AP. The size of the back-off window shall be broadcasted periodically to all ATs via the GBI message. These values shall represent a power-of-two value. For example, a value of 4 indicates a window between 0 and 15 while a value of 10 indicates a window between 0 and 1 023.

When an AT has information to send and wants to enter the contention resolution process:

- 1) the AT shall set its internal back-off window equal to the initial back-off window defined in the GBI message currently in effect;
- 2) the AT shall randomly select a number within its internal back-off window indicating the number of contention transmission opportunities that the AT shall defer before transmitting;
- 3) the AT shall consider the contention transmission lost if no response has been given within the time in which they were to be received;
- 4) the AT shall increase its back-off window by a factor of two (as long as it is less than the maximum back-off window defined in the GBI message currently in effect) if the contention transmission is lost;
- 5) the AT shall randomly select a another number within its new back-off window and repeat the deferring process described above if the contention transmission is lost;
- 6) the retry process shall continue until a maximum number of retries (broadcasted in the GBI message) (say 16 retries, for example) has been reached.

9.5.2 Bandwidth request contention window

The bandwidth request contention window shall be scheduled in the uplink with a particular UIUC entry in the UL map. This contention window can be used by all ATs that are requesting for a bandwidth grant. In this contention window only short MAC signalling PDU shall be transmitted.

If the AT receives a granted uplink burst at any time while deferring, it shall stop the contention resolution process and use the explicit transmission opportunity for bandwidth request.

If bandwidth request contention process continues to fail, after the maximum number of retries is reached the AT shall wait for a regular grant in order to request bandwidth using poll-me bit or piggyback mechanism.

In figure 40 is sketched the bandwidth request contention process performed by an AT.

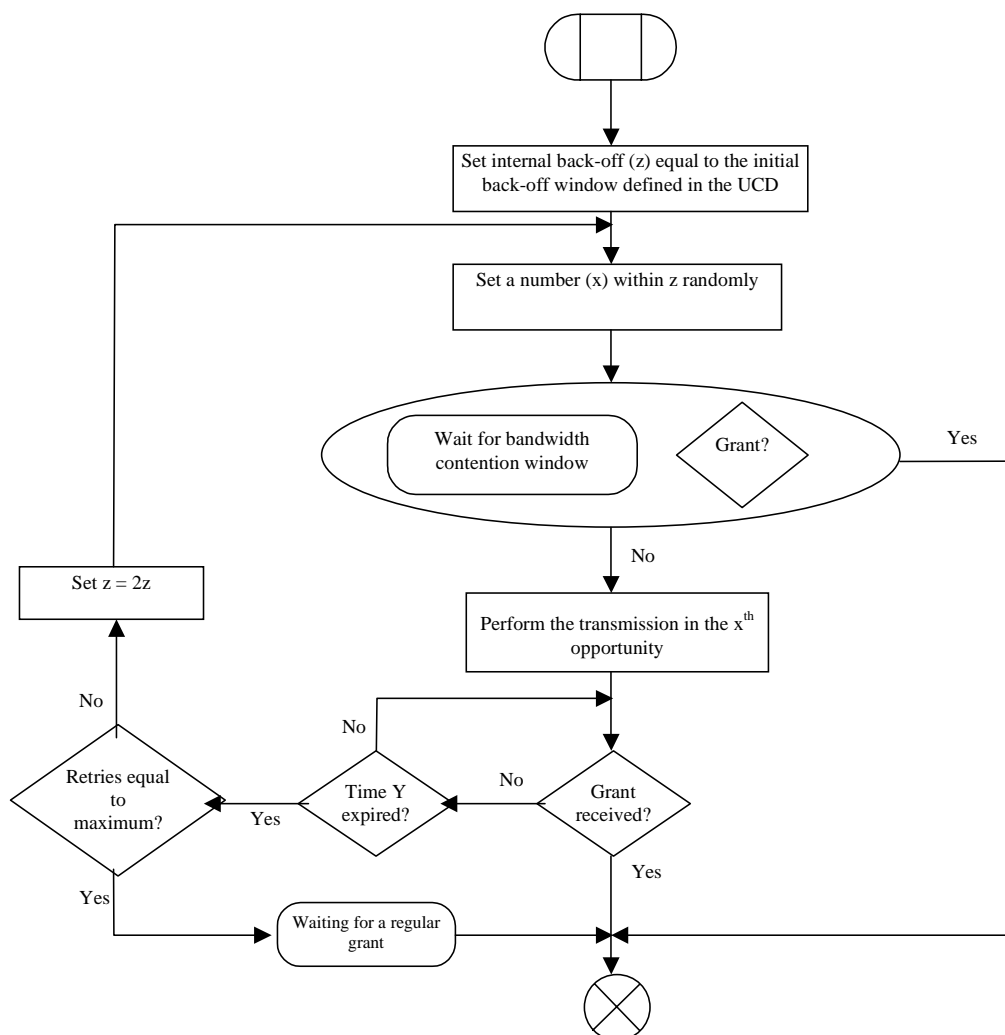

Figure 40: Contention algorithm for bandwidth request

10 Initialization control (IC)

10.1 Overview

Initialization is the procedure that occurs when an AT enters into the network. At the end of the initialization process the AT becomes operational. Initialization is a general term that includes the following cases:

- A new AT enters into the network.
- After PSI (Power Supply Interruption), breakdown or replacement of AT equipment.
- An already initialized AT loses the radio link; this may happen due to deep rain fading or co-channel interference (may affect both or only one direction).
- Malfunction of the AP, e.g. loss of the status of the AT and its parameters or breakdown of the AP.

In the first two cases the process is named first initialization, while in the other two cases the process is named re-initialization. Differences between first initialization and re-initialization are mainly related to the fact that during re-initialization a new frequency scanning procedure is not required and consequently the process of re-initialization is easier and faster.

Initialization is always invited, i.e. the AP knows the AT MAC address in advance and the AP knows when to perform a first initialization (e.g. AP knows that AT need initial access) or re-initialization (e.g. AP is aware of link interruptions).

10.2 Process of initialization

The initialization process shall be divided into the following steps:

- DL frequency scanning (search all DL channels of full RF block).
- Synchronization acquisition (carrier, phase, clock, by processing the DL frame preamble).
- UL and DL transmission parameters acquisition (by decoding the control zone in PHY mode #0 and the PHY mode region #1 used for broadcast messages including the reception of the broadcasted GBI message `RlcGeneralBroadcastInformation`).
- Initial ranging: during this phase of UL and DL transmissions the AT gets:
 - TID (to be used instead of AT MAC address for all other addressing or identification of AT).
 - CIDs for management connections (basic, primary and secondary).
 - Transmit timing offset (and thus TD and RTD), including fine-tuning.
 - UL transmit power level, including fine-tuning.

NOTE: Timing and transmit power settings are also updated during regular operation by the message `RlcUplinkCorrection`.

The whole UL communication during ranging is restricted to the use of granted UL ranging bursts.

From the AP point of view, after reception of the `RlcRangingAck` message the ranging process is finished and the AP shall start to give regular grants.

From the AT point of view, after reception of the `RlcRangingSuccess` message and reception of another message not related to ranging, the ranging process is finished.

- Physical capabilities negotiation (informs AP about ATs DL and UL PHY capabilities and AP commands on what to use).
- AT authentication (including AK transmission).
- Other AT capabilities negotiation (maximum numbers of CIDs and CAs, etc.).

After these steps the AT is called operational and connections can be established (and allocated to connection aggregates and security associations).

The overview of the entire initialization process is reported in diagram 4, where the upper left entry refers to first initialization when an AT enters the network for the first time and the upper right entry represents the situation after a link loss.

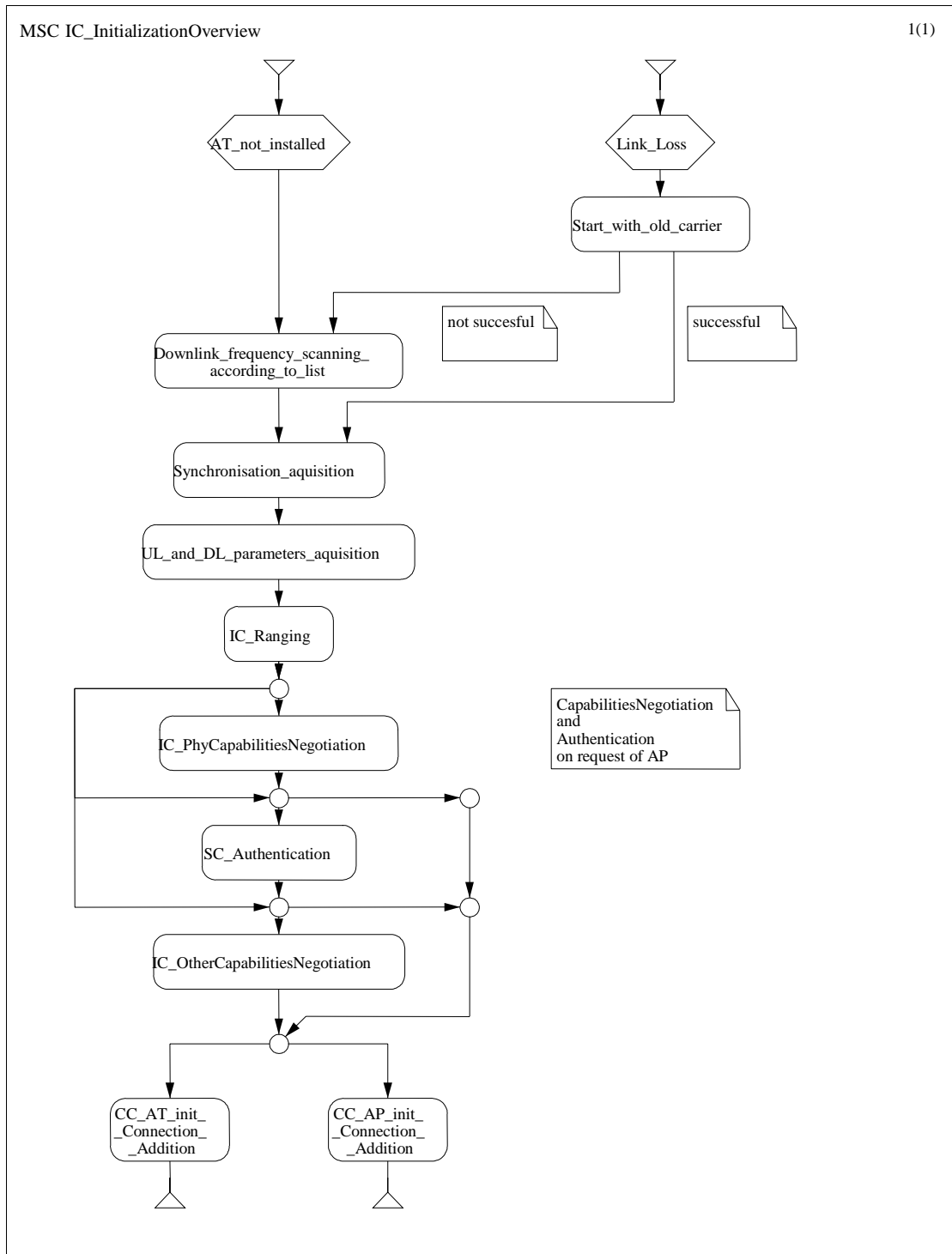

Diagram 4: HMSC for AT activities and states for initialization (update)

10.3 Steps from frequency scanning to downlink synchronization

10.3.1 Frequency scanning

The first operation that the AT shall perform is the frequency scanning. Before installation the list of possible downlink RF channels (all downlink frequency available in the RF block assigned to an operator), that AT shall scan during this phase, shall be stored in the AT non-volatile storage. Any change on this list shall be communicated by the `RlcFrequencyList` message.

The AT shall order all scanned frequencies in a descending order based on the signal strength and select the frequency with the strongest received DL signal power.

The frequency scanning step during re-initialization is very similar to that during initialization with the simplification that AT shall try to find before the DL frequency used during previous operations. If AT does not find this frequency, then it shall go to next frequency in the ordered list of frequencies.

10.3.2 Synchronization acquisition

The AT modem shall synchronize, in time and frequency, to the preamble of the DL frame. Once the PHY layer has achieved synchronization, the MAC sublayer shall decode the control zone. As it has received and decoded at least one control zone, the AT achieves the frame synchronization and remains synchronized until it fails to receive or decode control zones. If the timer `T_synchronization` elapsed before a map has been received and decoded, the AT shall come back to the DL frequency scanning step. The synchronization acquisition step shall be as in figure 41.

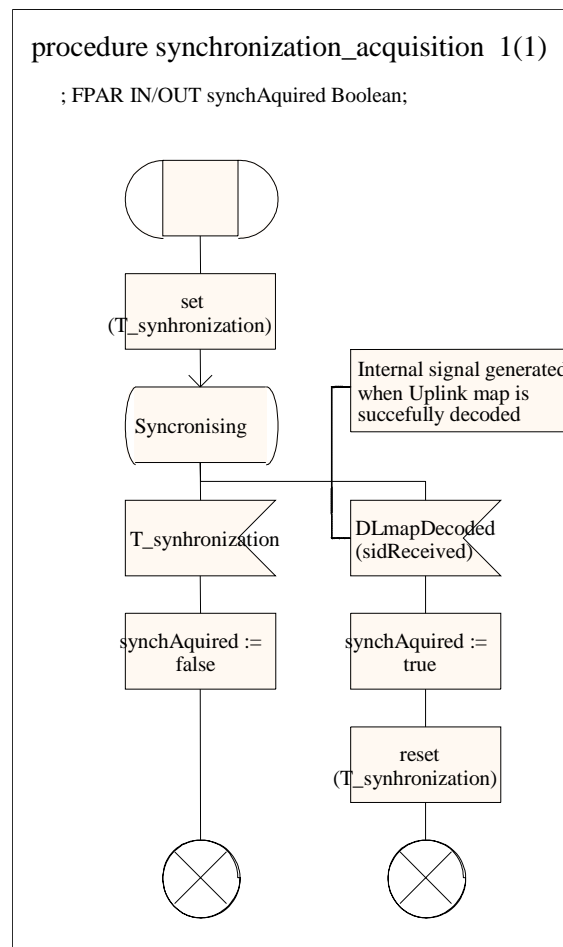

Figure 41: Synchronization acquisition

10.3.3 APC identification

After the AT synchronizes, it shall be sure to be on the right APC. It may compare the APC-ID introduced in its non-volatile memory before installation to the APC-ID received in the frame control zone. If those are equal, the AT shall proceed with the initialization process, otherwise the DL frequency channel previously selected during the frequency scanning step does not belong to the right sector and the AT should use the next frequency in the ordered list of frequencies.

The probability that the AT selects a frequency, that does not belong to the APC that the AT should be paired to, is very low, but not negligible in a deployment with a very high frequency re-use. The use of APC-ID, transmitted in each frame, facilitates and speeds up the initialization process and avoids that any message is sent from the AT to the AP if this one is not the right one.

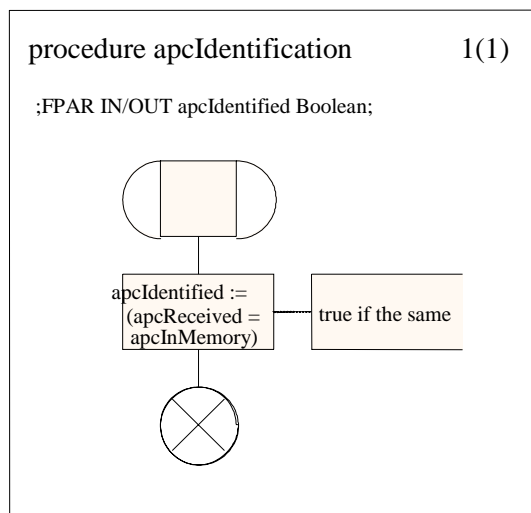

Figure 42: APC identification

10.3.4 UL and DL parameters acquisition

In order to retrieve the right set of transmission parameters, the AT shall wait for a GBI message. The GBI message contains general broadcast information as specified in clause 8.8, important parameters especially for the initialization are the power increment step for ranging and the period of the ranging invitation. The GBI message shall be broadcasted with a certain periodicity defined by the operator (where the specification of a formal period is not required).

The procedure for parameters acquisition is summarized in figure 43.

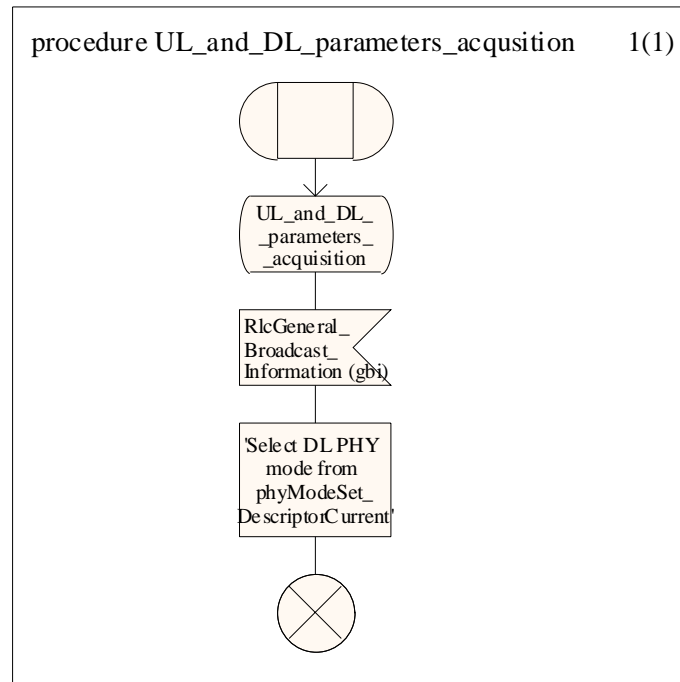

Figure 43: UL and DL parameters acquisition

10.3.5 Summary

All initialization steps from the start up to the AT operational status are summarized in figure 44 with special emphasis on frequency scanning.

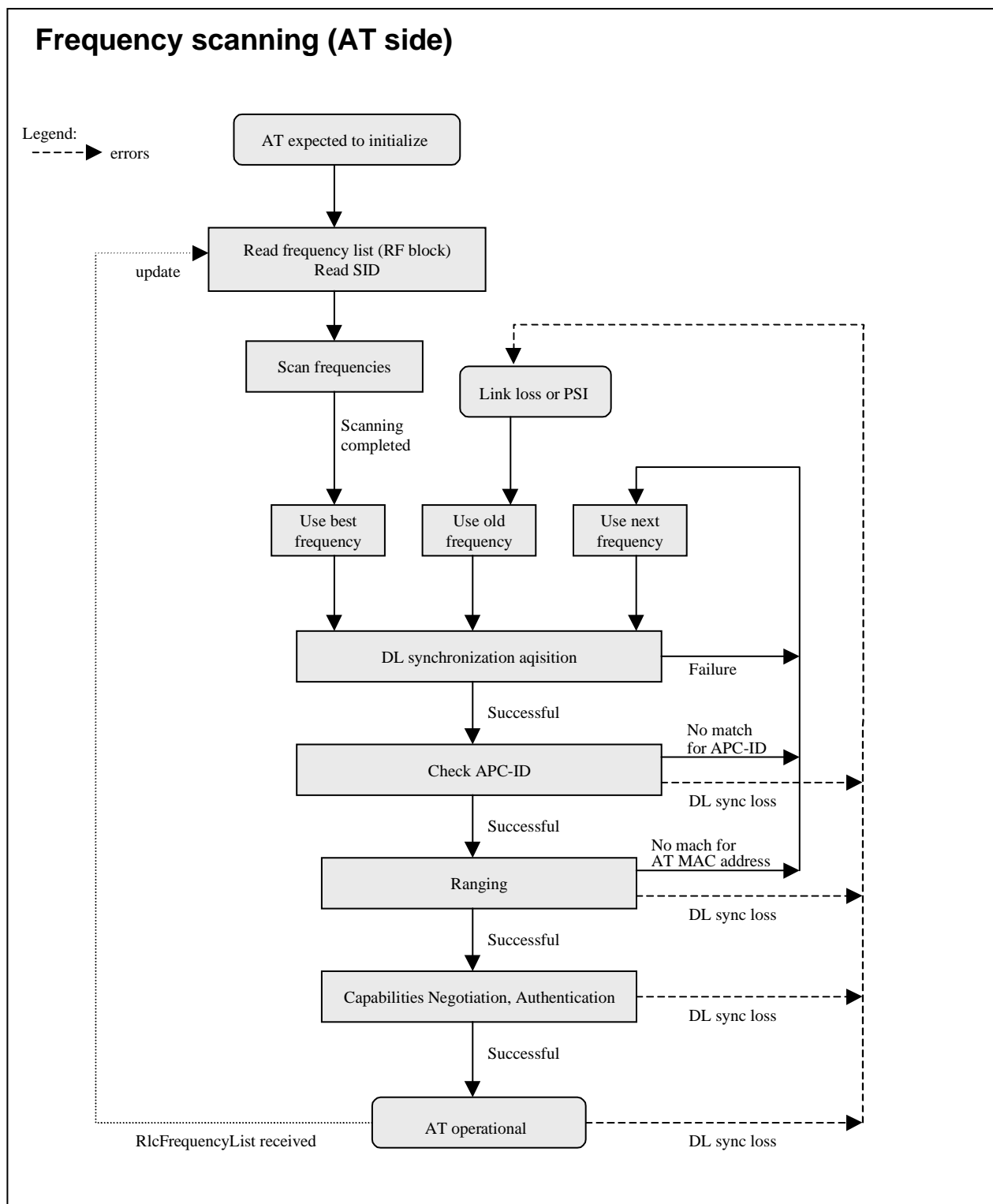

Figure 44: Frequency scanning in the context of initialization steps

10.4 Ranging

10.4.1 Overview

The ranging process is required in order that the AT shall be able to get:

- the right timing offset so that its transmission is aligned to a symbol that marks the beginning of MAC frame (the PHY layer timing delays shall be relatively constant); and
- the right Tx power parameters that it will use during normal operations.

The ranging process shall be started as soon as the AT has acquired the right frequency, synchronization and uplink transmission parameters and after the reception of the `RlcRangingInvitation` message. The `RlcRangingInvitation` message contains the AT MAC address to identify the AT and provides the binding between the AT MAC address and the TID. Moreover, the `RlcRangingInvitation` message contains the CIDs and CAIDs for the three management connections and the current power level of the transmitted signal of the AP (`apTxPowerIndication` parameter).

After reception of the `RlcRangingInvitation` message and before transmission of the `RlcRangingComplete` messages (including the message itself), the AT is only allowed to transmit with granted ranging bursts.

The ranging process is started with the reception of the `RlcRangingInvitation` message. At this point the AT can calculate an estimation of the proper transmission power level to be used in the first ranging burst by analysing the link attenuation derived as difference between transmitted and received power in the downlink and applying a proper backoff. Exact figures do not need to be standardized provided that the terminal transmits the first ranging burst with a somewhat lower power than the operative transmission power.

The AT uses each ranging grant to send an `RlcRangingReq` message with increasing transmit power, starting from `ATxPower`, where the transmit power increments are specified in the GBI message.

- If the AT receives an `RlcRangingContinues` message then it adapts its transmit power and timing according to this message and waits for next ranging grant to send an `RlcRangingReq` message.
- If the AT receives an `RlcRangingSuccess` message then it adapts its transmit power and timing according to this message and waits for the next ranging grant to send an `RlcRangingAck` message.
- After transmission of the `RlcRangingAck` message, the AT has to respond:
 - to a ranging grant with the `RlcRangingReq` message and increased transmit power (error case);
 - to a normal grant with a regular transmission (normal case).
- Whenever the AT receives two subsequent ranging grants without an `RlcRangingContinue` or `RlcRangingSuccess` message in between (indicates loss of message in DL), then it shall return to the transmit power increase mechanism. The same applies whenever the AT receives two messages without a ranging grant in between (AP error).

The AP shall not give ranging grants in the same frame as it transmits the `RlcRangingContinue` or `RlcRangingSuccess` message.

However, it should be noted that there is no rule how to combine `RlcRangingInvitation` messages and ranging grants, since the first requires DL capacity and the latter UL capacity. So several `RlcRangingInvitation` messages between two ranging grants are allowed (but not recommended), but also several ranging grants between two `RlcRangingInvitation` messages (recommended). In other words, `RlcRangingInvitation` message and ranging grants can be given whenever there is free capacity in the DL or UL frame, so the ranging process does not cause any considerable overhead at all.

If no `RlcRangingInvitation` message was transmitted for any AT, then the AP should not give any ranging grants. However, if the AT receives a ranging grant without having received an `RlcRangingInvitation` message, then it shall ignore the ranging grant.

A maximum gap between two subsequent RlcRangingInvitation messages to the same AT shall be transmitted in the GBI message in order to limit waiting times during the frequency scanning process.

If an RlcRangingInvitation message is received during normal operation, then the AT shall stop all transmissions, wait for ranging grants and start from the updated ATtxPower. After reaction to an RlcRangingInvitation message, the AT shall ignore all further RlcRangingInvitation messages. The AP stops issuing RlcRangingInvitation messages after reception of the first RlcRangingReq message. The AT can react again to an RlcRangingInvitation messages after InitializationStatus = InitializationFinished in one of the initialization DL messages.

10.4.2 Messages for Ranging

The messages for ranging are shown in table 27.

Table 27: Messages for ranging

RlcRangingInvitation	::= SEQUENCE {	-- DL
atMacAddress	AtMacAddress,	-- 48 bit, common
tid	Tid,	-- 10 bit, common
basicCid	BasicCid,	-- 16 bit, common
primaryCid	PrimaryCid,	-- 16 bit, common
secondaryCid	SecondaryCid,	-- 16 bit, common
basicCaid	Caid,	-- 16 bit, common
primaryCaid	Caid,	-- 16 bit, common
secondaryCaid	Caid,	-- 16 bit, common
apTxPowerIndication	ApTxPowerIndication	-- 5 bit, common
}		
RlcRangingReq	::= SEQUENCE {	-- UL, increasing or adapted
power		
rangingStatus	RangingStatus	-- 2 bit
}		
RlcRangingContinue	::= SEQUENCE {	-- DL, adapt power, send Req
timingAdjustRanging	TimingAdjustRanging,	-- 13 bit, common
uplinkPowerInc	UplinkPowerInc	-- 6 bit, common
}		
RlcRangingSuccess	::= SEQUENCE {	-- DL, adapt power, send Ack
timingAdjustRanging	TimingAdjustRanging,	-- 13 bit, common
uplinkPowerInc	UplinkPowerInc,	-- 6 bit, common
initializationStatus	InitializationStatus	-- 1 bit
}		
RlcRangingAck	::= SEQUENCE {	
rangingStatus	RangingStatus	-- 2 bit
}		
RlcPhyCapabilitiesReq	::= SEQUENCE {	
}		
RlcPhyCapabilitiesInfo	::= SEQUENCE {	-- AT offers its optional cap.
downlink64QamSupport	Downlink64QamSupport,	-- 1 bit
uplink16QamSupport	Uplink16QamSupport,	-- 1 bit
uplinkTurboEncSupport	UplinkTurboEncSupport,	-- 1 bit
uplinkPowerMaxQpsk	UplinkPowerMax,	-- 4 bit, common
uplinkPowerMax16Qam	UplinkPowerMax,	-- 4 bit, common
numberSaidSupport	NumberSaidSupport,	-- 10 bit
terminalType	TerminalType,	-- 1 bit
pairOfCarrierFrequenciesLow	PairOfCarrierFrequencies,	-- 34 bit
pairOfCarrierFrequenciesHigh	PairOfCarrierFrequencies	-- 34 bit
}		
RlcPhyCapabilitiesCnf	::= SEQUENCE {	-- AP commands what to use
downlink64QamUse	Downlink64QamUse,	-- 1 bit
uplink16QamUse	Uplink16QamUse,	-- 1 bit

```

    uplinkTurboEncUse      UplinkTurboEncUse,    -- 1 bit
    uplinkPreambleLength  UplinkPreambleLength, -- 1 bit
    uplinkPowerMaxQpsk    UplinkPowerMax,      -- 4 bit, common
    uplinkPowerMax16Qam   UplinkPowerMax,      -- 4 bit, common
    initializationStatus   InitializationStatus -- 1 bit
}

RlcOtherCapabilitiesReq ::= SEQUENCE {
}

RlcOtherCapabilitiesInfo ::= SEQUENCE { -- UL
    numberUplinkConnsSupport      NumberUplinkConnsSupport, -- 2 byte
    numberDownlinkConnsSupport    NumberDownlinkConnsSupport, -- 2 byte
    numberConnAggsSupport         NumberConnAggsSupport, -- 2 byte
    numberConnsPerConnAggSupport  NumberConnsPerConnAggSupport, -- 2 byte
    crSupport                     CrSupport, -- 1 bit
    tripleDesSupport              TripleDesSupport, -- 1 bit
    terminalClCapabilities        TerminalClCapabilities -- variable
}

RlcOtherCapabilitiesCnf ::= SEQUENCE {
    numberUplinkConnsUse      NumberUplinkConnsUse,
    numberDownlinkConnsUse    NumberDownlinkConnsUse,
    numberConnAggsUse         NumberConnAggsUse,
    numberConnsPerConnAggUse  NumberConnsPerConnAggUse,
    tripleDesUse              TripleDesUse
}

RangingStatus ::= ENUMERATED { -- 2 bit
    txPowerMax      (0),
    txPowerBetween  (1),
    txPowerMin      (2)
}

InitializationStatus ::= ENUMERATED { -- 1 bit
    initializationContinue (0), -- AT to expect further messaging for init
    initializationFinished (1) -- init finished
}

RlcInitializationCmd ::= SEQUENCE { -- DL
    initializationCmd      InitializationCmd -- 3 bit
}

InitializationCmd ::= ENUMERATED {
    rejectedFromNetwork      (0),
    rejectedFromChannel      (1),
    firstInitialization      (2),
    transmissionStop         (3),
    transmissionReStart     (4)
}

UplinkPreambleLength ::= ENUMERATED {
    length16bit (0),
    length32bit (1)
}

Downlink64QamSupport ::= ENUMERATED {
    downlink64QamNotSupported (0),
    downlink64QamSupported    (1)
}

Uplink16QamSupport ::= ENUMERATED {
    uplink16QamNotSupported (0),
    uplink16QamSupported    (1)
}

Downlink64QamUse ::= ENUMERATED {
    downlink64QamNotUsed (0),
    downlink64QamUsed    (1)
}

```

```

}

Uplink16QamUse      ::= ENUMERATED {
    uplink16QamNotUsed    (0),
    uplink16QamUsed      (1)
}

UplinkTurboEncSupport ::= ENUMERATED {
    uplinkTurboEncNotSupported (0),
    uplinkTurboEncSupported   (1)
}

UplinkTurboEncUse   ::= ENUMERATED {
    uplinkTurboEncNotUsed    (0),
    uplinkTurboEncUsed      (1)
}

TerminalType        ::= ENUMERATED {
    terminalFdd              (0),
    terminalHfddWithTdmAndTdma (1)
}

TripleDesSupport     ::= ENUMERATED {
    tripleDesNotSupported    (0),
    tripleDesSupported       (1)
}

TripleDesUse         ::= ENUMERATED {
    tripleDesNotUsed        (0),
    tripleDesUsed           (1)
}

TerminalClCapabilities ::= OCTET STRING (SIZE(0..32)) -- variable

NumberUplinkConnsSupport ::= INTEGER(4..65535) -- 2 byte, incl MAC mgmt conns
NumberDownlinkConnsSupport ::= INTEGER(5..65535) -- 2 byte, incl MAC mgmt conns
NumberConnAggsSupport ::= INTEGER(1..65535) -- 2 byte
NumberConnsPerConnAggSupport ::= INTEGER(1..65535) -- 2 byte

NumberSaidSupport ::= INTEGER(1..maxNumberSaidSupport) -- 10 bit
maxNumberSaidSupport NumberSaidSupport ::= 1023

NumberUplinkConnsUse ::= INTEGER(4..65535) -- 2 byte, incl MAC mgmt conns
NumberDownlinkConnsUse ::= INTEGER(5..65535) -- 2 byte, incl MAC mgmt conns
NumberConnAggsUse ::= INTEGER(1..65535) -- 2 byte
NumberConnsPerConnAggUse ::= INTEGER(1..65535) -- 2 byte

CrSupport ::= ENUMERATED {
    crSupportNo    (0),
    crSupportYes   (1)
}

```

10.4.3 Ranging described with MSC diagrams

Diagram 5 shows the basic principle of the ranging procedure.

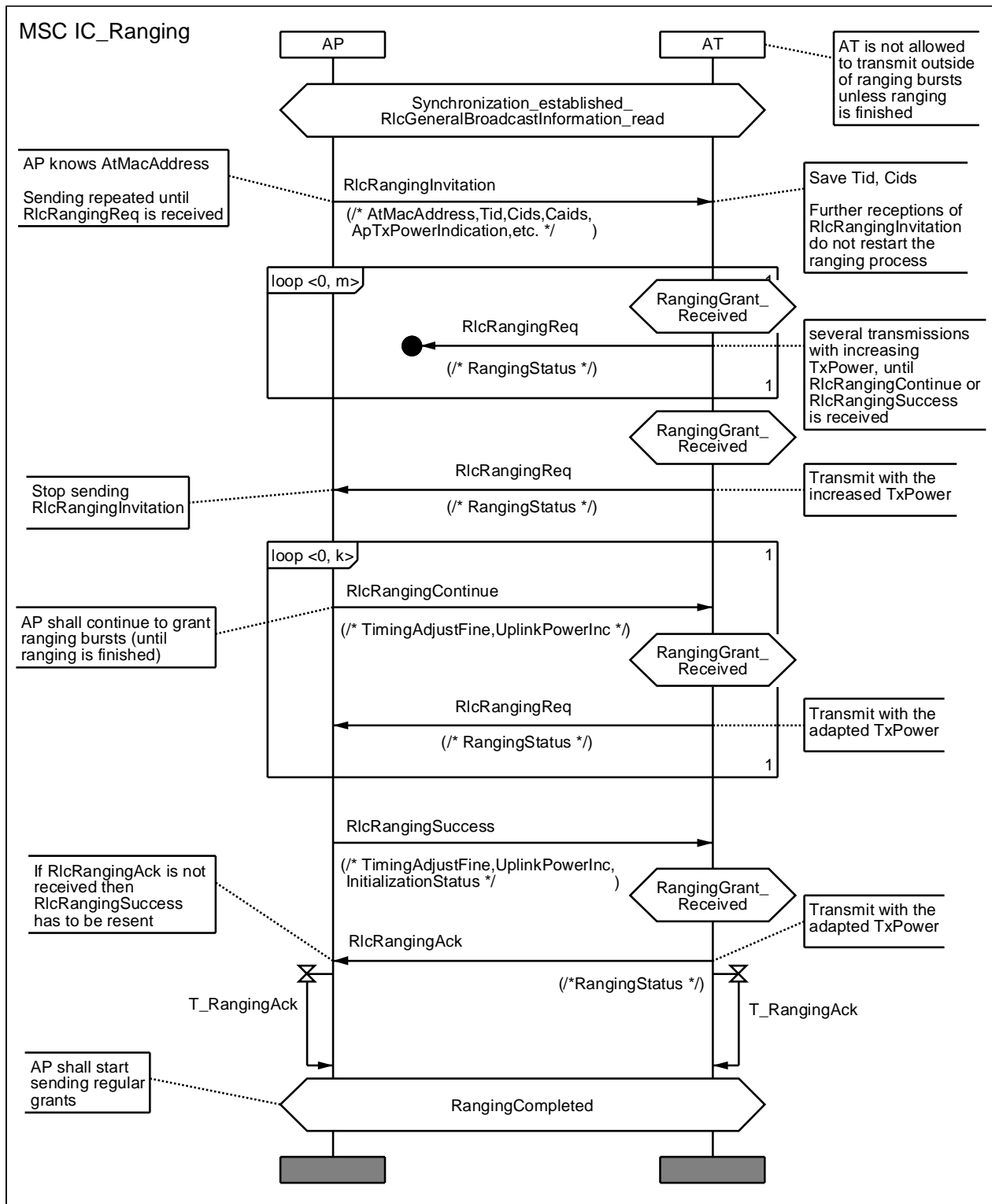

Diagram 5: MSC for the ranging principle

Diagram 6 contains an example of the message exchange for ranging, where several messages are lost.

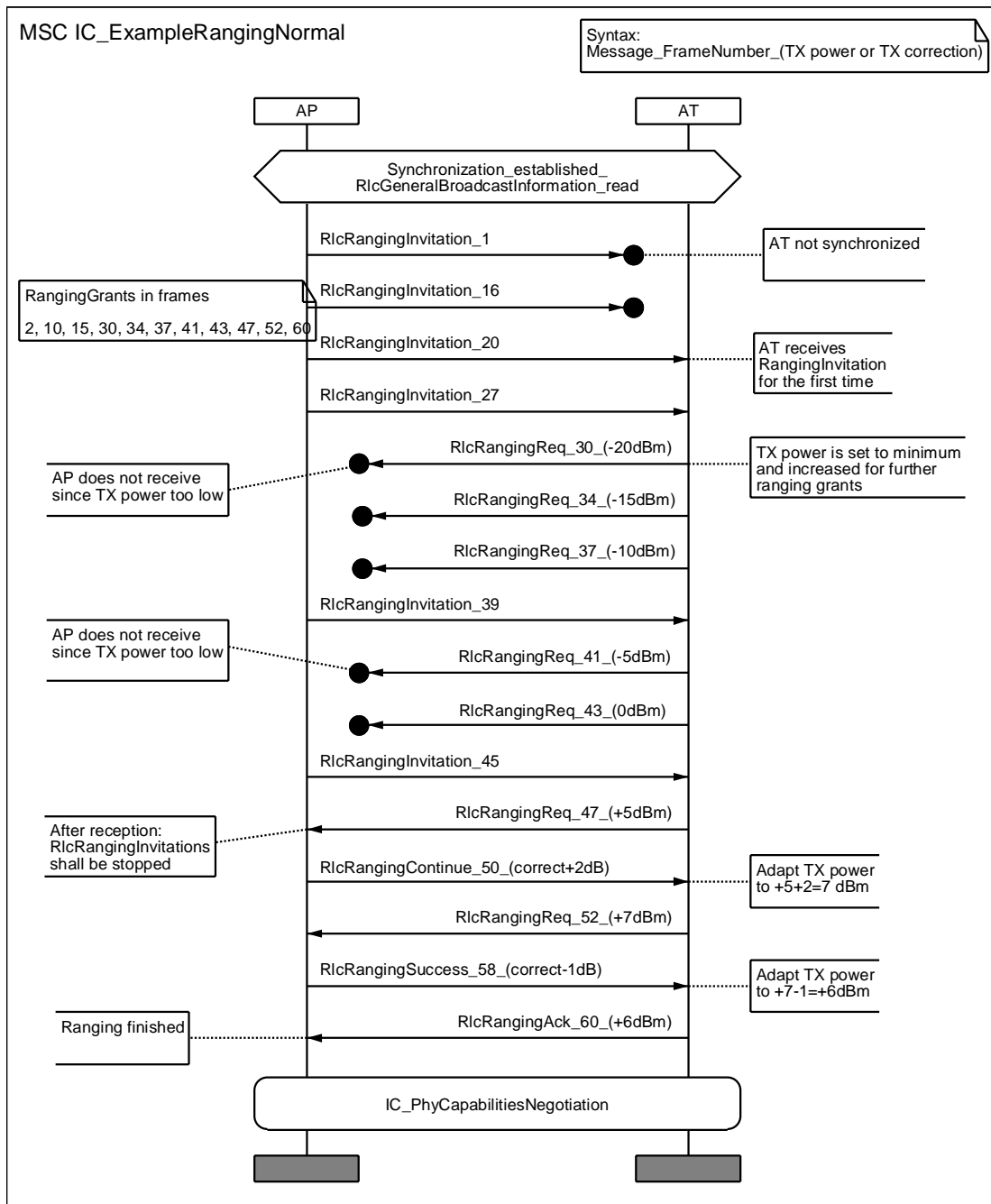

Diagram 6: MSC of a ranging example with many errors

10.4.4 Ranging described with state diagrams

Diagrams 7 and 8 describe the ranging process on the AP side and the AT side.

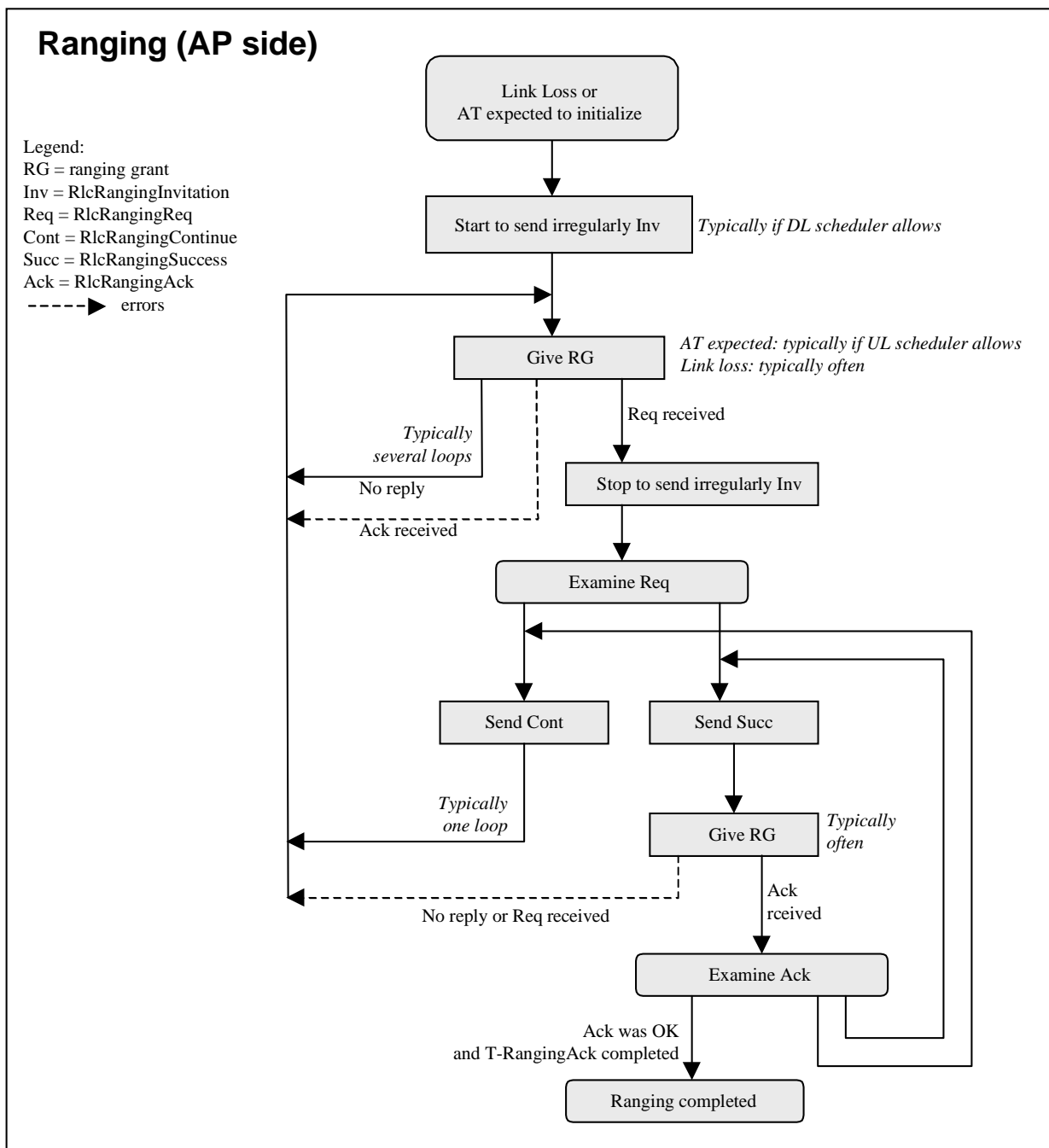

Diagram 7: State diagram for ranging (AP side)

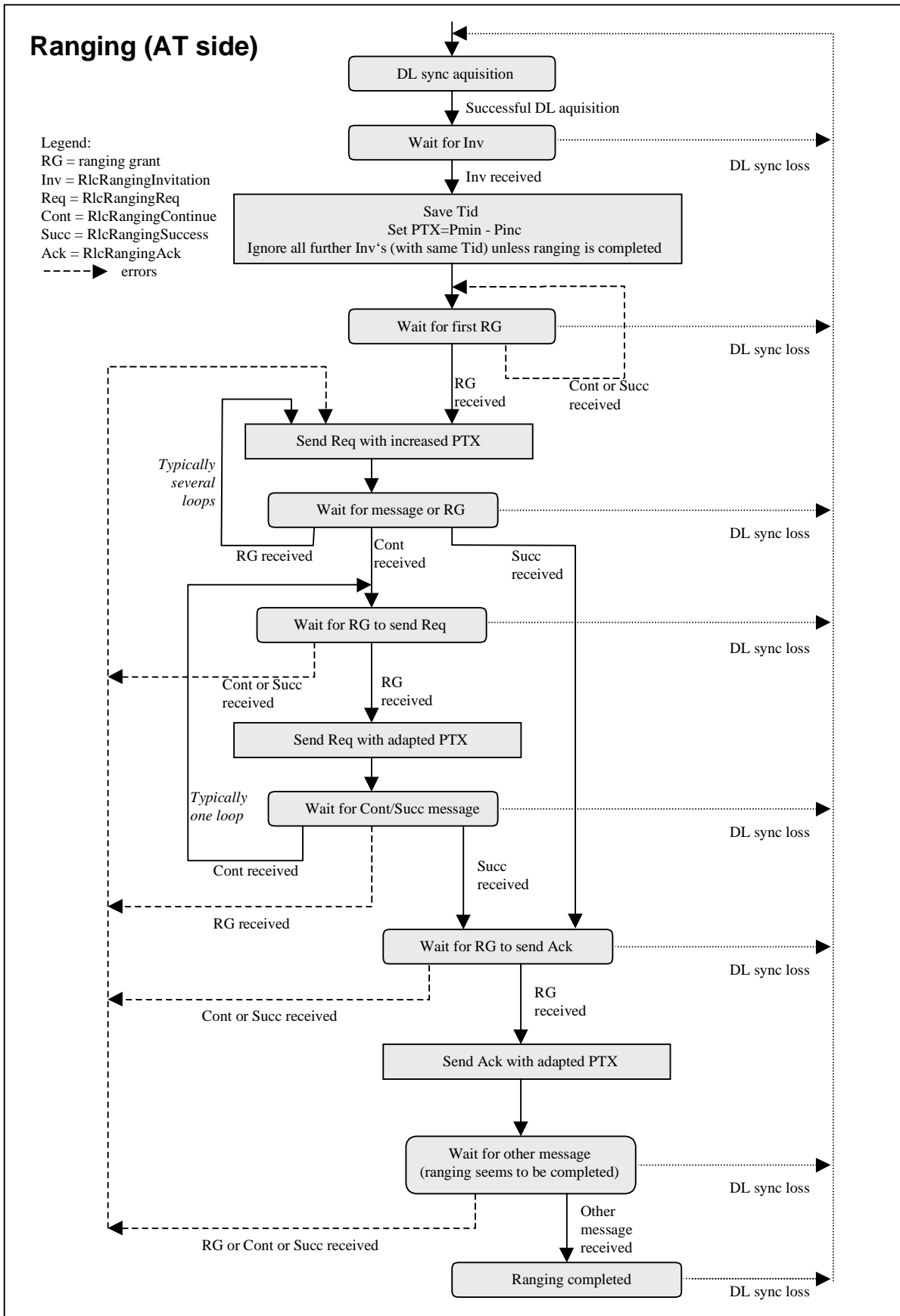

Diagram 8: State diagram for ranging (AT side)

10.5 Capabilities negotiation and authentication

This procedure includes three steps: PHY capabilities negotiation, authentication of AT against AP and other capabilities negotiation.

10.5.1 Physical capabilities negotiation

After completion of the ranging process, the AT shall inform AP of its physical capabilities. In order to let the AP decide on whether this step can be skipped for re-initialization, a 3-way protocol is used.

The AP starts the procedure by sending `RlcPhyCapabilitiesReq`, the AT informs with `RlcPhyCapabilitiesInfo` and the AP terminates with `RlcPhyCapabilitiesCnf`. The following features are negotiated:

- 64 QAM in DL.
- 16 QAM in UL.
- Support of Turbo encoding.
- Maximum UL transmit power for QPSK.
- Maximum UL transmit power for 16 QAM.
- Terminal type (FDD with TDM only or H-FDD with both TDM and TDMA).
- Uplink preamble length (16 or 32 symbols, the support of both lengths is mandatory for the AT).
- Number of SAIDs.
- Supported RF frequency range (AT informs only).

The messages for PHY capabilities negotiation are shown in table 28.

Table 28: Messages for physical capabilities negotiation

<code>RlcPhyCapabilitiesReq</code>	<code>::= SEQUENCE {</code>	<code>-- DL</code>
	<code>}</code>	
<code>RlcPhyCapabilitiesInfo</code>	<code>::= SEQUENCE {</code>	<code>-- UL</code>
<code>downlink64QamSupport</code>	<code>Downlink64QamSupport,</code>	<code>-- 1 bit</code>
<code>uplink16QamSupport</code>	<code>Uplink16QamSupport,</code>	<code>-- 1 bit</code>
<code>uplinkTurboEncSupport</code>	<code>UplinkTurboEncSupport,</code>	<code>-- 1 bit</code>
<code>uplinkPowerMaxQpsk</code>	<code>UplinkPowerMax,</code>	<code>-- 4 bit, common</code>
<code>uplinkPowerMax16Qam</code>	<code>UplinkPowerMax,</code>	<code>-- 4 bit, common</code>
<code>numberSaidSupport</code>	<code>NumberSaidSupport,</code>	<code>-- 10 bit</code>
<code>terminalType</code>	<code>TerminalType,</code>	<code>-- 1 bit</code>
<code>pairOfCarrierFrequenciesLow</code>	<code>PairOfCarrierFrequencies,</code>	<code>-- 34 bit</code>
<code>pairOfCarrierFrequenciesHigh</code>	<code>PairOfCarrierFrequencies</code>	<code>-- 34 bit</code>
	<code>}</code>	
<code>RlcPhyCapabilitiesCnf</code>	<code>::= SEQUENCE {</code>	<code>-- DL</code>
<code>downlink64QamUse</code>	<code>Downlink64QamUse,</code>	<code>-- 1 bit</code>
<code>uplink16QamUse</code>	<code>Uplink16QamUse,</code>	<code>-- 1 bit</code>
<code>uplinkTurboEncUse</code>	<code>UplinkTurboEncUse,</code>	<code>-- 1 bit</code>
<code>uplinkPreambleLength</code>	<code>UplinkPreambleLength,</code>	<code>-- 1 bit</code>
<code>uplinkPowerMaxQpsk</code>	<code>UplinkPowerMax,</code>	<code>-- 4 bit, common</code>
<code>uplinkPowerMax16Qam</code>	<code>UplinkPowerMax,</code>	<code>-- 4 bit, common</code>
<code>initializationStatus</code>	<code>InitializationStatus</code>	<code>-- 1 bit</code>
	<code>}</code>	
<code>UplinkPreambleLength</code>	<code>::= ENUMERATED {</code>	
<code>length16bit</code>	<code>(0),</code>	
<code>length32bit</code>	<code>(1)</code>	
	<code>}</code>	
<code>Downlink64QamSupport</code>	<code>::= ENUMERATED {</code>	

```

    downlink64QamNotSupported (0),
    downlink64QamSupported    (1)
}

Uplink16QamSupport ::= ENUMERATED {
    uplink16QamNotSupported (0),
    uplink16QamSupported    (1)
}

Downlink64QamUse ::= ENUMERATED {
    downlink64QamNotUsed (0),
    downlink64QamUsed    (1)
}

Uplink16QamUse ::= ENUMERATED {
    uplink16QamNotUsed (0),
    uplink16QamUsed    (1)
}

UplinkTurboEncSupport ::= ENUMERATED {
    uplinkTurboEncNotSupported (0),
    uplinkTurboEncSupported    (1)
}

UplinkTurboEncUse ::= ENUMERATED {
    uplinkTurboEncNotUsed (0),
    uplinkTurboEncUsed    (1)
}

TerminalType ::= ENUMERATED {
    terminalFdd (0),
    terminalHfddWithTdmAndTdma (1)
}

NumberSaidSupport ::= INTEGER(1..maxNumberSaidSupport) -- 10 bit
maxNumberSaidSupport ::= 1023

InitializationStatus ::= ENUMERATED { -- 1 bit
    initializationContinue (0), -- AT to expect further messaging
                                -- for initialization
    initializationFinished (1) -- initialization finished
}

PairOfCarrierFrequencies ::= SEQUENCE {
    uplinkCarrierFrequency CarrierFrequency,
    downlinkCarrierFrequency CarrierFrequency -- equal to uplinkFrequency for TDD
}

CarrierFrequency ::= INTEGER(0..65000) -- 17 bit, granu=0,5 5MHz, range=[0,65] GHz

```

The InitializationStatus parameter informs the AT:

- if InitializationStatus = initializationContinue, then further initialization steps have to be performed;
- if InitializationStatus = initializationFinished, then the initialization is now finished and the AT can start connection setups and can start requesting for DL PHY mode changes.

The PHY capabilities negotiation procedure is described by the MSC in diagram 9.

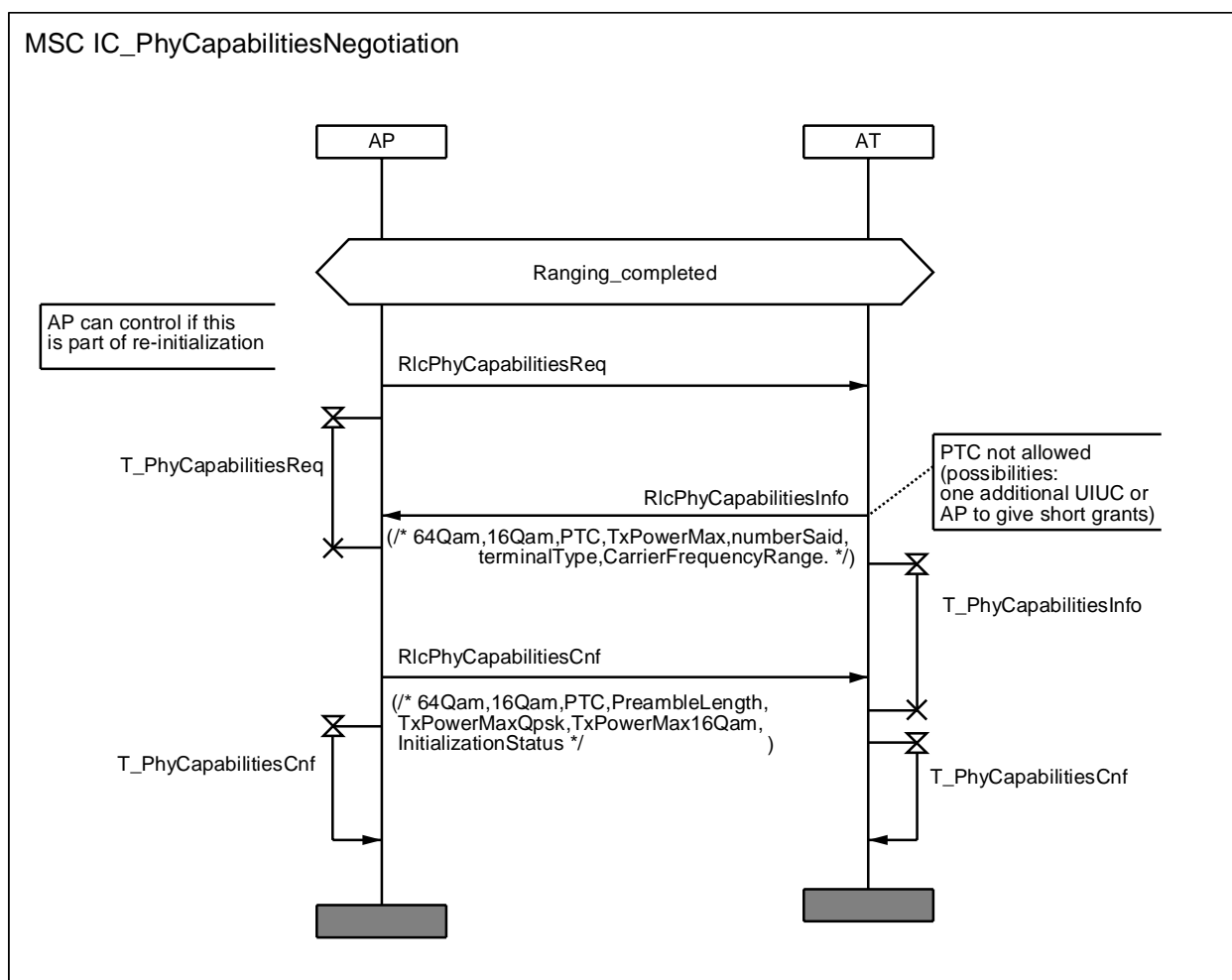

Diagram 9: MSC for PHY capabilities negotiation

It is important that the AT does not use Turbo codes for the transmission of `RlcPhyCapabilitiesInfo` since the use of Turbo codes is just negotiated with these messages. This can be achieved in either one of the following two ways:

- The AP grants only short PDUs at this stage of initialization (Turbo codes are only applicable for long PDUs).
- The AP assumes no Turbo codes for the decoding of this message and the AT does not use Turbo codes without the reception of the commanding message `RlcPhyCapabilitiesCnf`.

10.5.2 Authentication

The authentication step is described in clause 12.

10.5.3 Other capabilities negotiation

After ranging and authentication, AT shall negotiate with the AP the other parameters that shall be used. As for the PHY capabilities negotiation, again a 3-way protocol is used with a similar structure. The AP starts the procedure by sending `RlcOtherCapabilitiesReq`, the AT informs with `RlcOtherCapabilitiesInfo` and the AP terminates with `RlcOtherCapabilitiesCnf`. The following features are negotiated:

- The number of uplink connections (hence CIDs) the AT can support.
- The number of downlink connections (hence CIDs) the AT can support.
- The number of simultaneous connection aggregates the AT can support.
- The maximum number of connections per connection aggregate the AT can properly handle.
- The maximum number of security associates the AT can support.
- The AT informs about its support for contention resolution mechanism (no reply in DL required).
- Support of triple-DES by AT and AP for encryption of the MAC data PDUs.
- AT informs about its CL capabilities. The exchange of this information between DLC and CL is not specified.

The messages for other capabilities negotiation are shown in table 29.

Table 29: Messages for other capabilities negotiation (update)

<code>RlcOtherCapabilitiesReq</code>	<code>::= SEQUENCE {</code>	
	<code>}</code>	
<code>RlcOtherCapabilitiesInfo</code>	<code>::= SEQUENCE {</code>	
<code>numberUplinkConnsSupport</code>		<code>NumberUplinkConnsSupport,</code>
<code>numberDownlinkConnsSupport</code>		<code>NumberDownlinkConnsSupport,</code>
<code>numberConnAggsSupport</code>		<code>NumberConnAggsSupport,</code>
<code>numberConnsPerConnAggSupport</code>		<code>NumberConnsPerConnAggSupport,</code>
<code>crSupport</code>		<code>CrSupport,</code>
<code>tripleDesSupport</code>		<code>TripleDesSupport,</code>
<code>terminalClCapabilities</code>		<code>TerminalClCapabilities</code>
	<code>}</code>	
<code>RlcOtherCapabilitiesCnf</code>	<code>::= SEQUENCE {</code>	
<code>numberUplinkConnsUse</code>		<code>NumberUplinkConnsUse,</code>
<code>numberDownlinkConnsUse</code>		<code>NumberDownlinkConnsUse,</code>
<code>numberConnAggsUse</code>		<code>NumberConnAggsUse,</code>
<code>numberConnsPerConnAggUse</code>		<code>NumberConnsPerConnAggUse,</code>
<code>tripleDesUse</code>		<code>TripleDesUse</code>
	<code>}</code>	
<code>NumberUplinkConnsSupport</code>	<code>::= INTEGER</code>	
<code>NumberDownlinkConnsSupport</code>	<code>::= INTEGER</code>	
<code>NumberConnAggsSupport</code>	<code>::= INTEGER</code>	
<code>NumberConnsPerConnAggSupport</code>	<code>::= INTEGER</code>	
<code>NumberUplinkConnsUse</code>	<code>::= INTEGER</code>	
<code>NumberDownlinkConnsUse</code>	<code>::= INTEGER</code>	
<code>NumberConnAggsUse</code>	<code>::= INTEGER</code>	
<code>NumberConnsPerConnAggUse</code>	<code>::= INTEGER</code>	
<code>CrSupport</code>	<code>::= ENUMERATED {</code>	
<code>crSupportNo</code>		<code>(0),</code>
<code>crSupportYes</code>		<code>(1)</code>
	<code>}</code>	
<code>TerminalClCapabilities</code>	<code>::= OCTET STRING (SIZE(0..32))</code>	
<code>TripleDesSupport</code>	<code>::= ENUMERATED {</code>	
<code>tripleDesNotSupported</code>		<code>(0),</code>
<code>tripleDesSupported</code>		<code>(1)</code>

```

}
TripleDesUse ::= ENUMERATED {
    tripleDesNotUsed (0),
    tripleDesUsed (1)
}

```

The PHY capabilities negotiation procedure is described by the MSC in diagram 10.

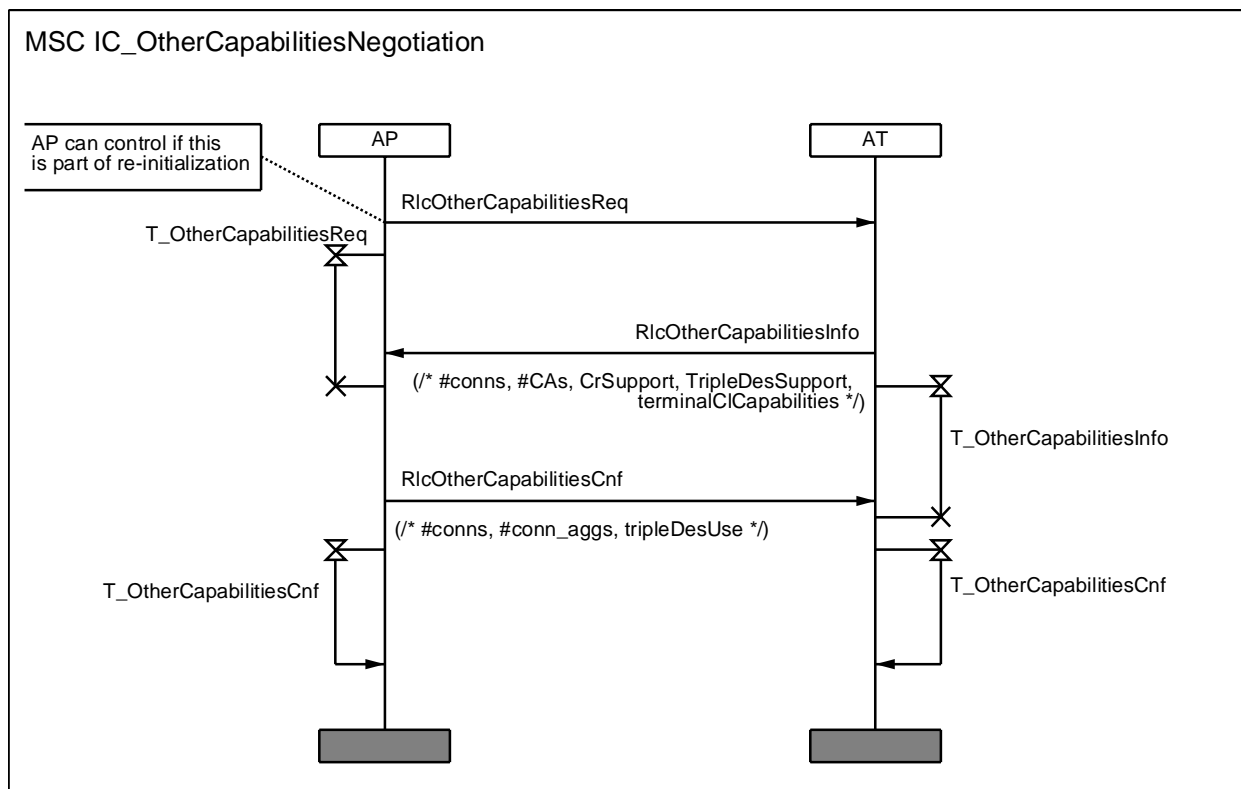

Diagram 10: MSC for other capabilities negotiation

11 Radio Resource Control (RRC)

11.1 Overview

Radio Resource Control (RRC) is an important part of the Radio Link Control (RLC) sublayer as shown in figure 4. The other three RLC functions are initialization control (IC, see clause 10), security control (SC, see clause 12) and connection control (CC, see clause 13). It should be noted that ARQ is not allocated to the same level but is part of the MAC sublayer (see clause 8.5).

The main functions for radio resource control include the supervision of the radio link (and the start of a new initialization procedure if required), the adaptive change of the DL and UL PHY modes (i.e. adaptive coding and modulation) and the automatic power control for DL (optional) and UL. Other parts are the change of the PHY mode set, load-levelling (inter-channel handover) and the control of the UL structure (i.e. number of FEC blocks per preamble, number of MAC PDUs per UL burst). The present document describes:

- all messages required for the report of measurements and the exchange of information between AT and AP (e.g. measurement of C/N, transmit power and received power);
- all messages or mechanisms for the synchronized change of a parameter (e.g. PHY mode or transmit power or carrier frequency);
- the responsibility (i.e. whether AP or AT or both can or shall change a parameter).

The algorithms and the criteria for a change of a parameter are implementation-specific in most cases and therefore not addressed in the present document.

11.2 Link supervision

11.2.1 Detection of link loss

Possible reasons for link interruptions are as follows:

- Deep rain fading event (applies for DL and UL).
- Interference from other AP (applies for DL, typically time-invariant) or from other AT (applies for UL, typically time-variant).
- PSI (Power Supply Interruption) at AP or AT (affects both DL and UL).
- Equipment failure at AP or AT (with impact on transmit or receive direction or both directions).

The detection of a link interruption is based on the fact that AP gives grants to each AT on a regular basis even if the AT has no traffic data to transmit (the replies to these grants are needed to allow for UL channel measurements at the AP, see clause 11.3).

- If the DL is interrupted, then the AT can detect this by failing to decode the control zone. Since the AT cannot reply to the regular grants from the AP, the AP shall be able to detect the link interruption.
- If the UL is interrupted, then the AP will detect this since the replies of the AT to the regular grants are missing. The AT might not be able to detect the UL interruption very soon.

If the AT receives grants for each frame, then the AP can detect the DL or UL interruption very fast. The AP can detect the link interruption after one or several missing replies in at least two subsequent frames.

11.2.2 Reaction on link loss

As a basic principle, the reaction to a link interruption shall be under full control of the AP.

For the definition or detection of a link loss at the AT side and the appropriate reaction of the AT it is not required to define any timers. For the AP side, timers might be required but these are implementation-specific and out of the scope of the present document.

The AT shall always try to maintain or to re-establish as soon as possible the synchronization of the DL (on the same RF channel as before) and to decode the control zone and PHY mode region #1 in order to receive or wait for commands from the AP.

The AP shall react on a link interruption by sending the ranging invitation `RlcRangingInvitation` and by giving ranging grants to the AT. During the re-initialization process, the AP can command whether the PHY and other capabilities steps and the authentication and key distribution steps shall be skipped or re-performed. The AP can also use the initialization command `RlcInitializationCmd` for this situation.

The AT shall delete all connection and security settings after reception of a ranging invitation.

The details for AT reaction in case of link loss and during regular operation are shown in diagram 11 and also specified below:

- If the AT receives a ranging grant during regular operation or after a link interruption without having received a ranging invitation, then this ranging grant shall be ignored. This situation can only occur for specific error scenarios.
- If the AT receives an `RlcRangingInvitation` during regular operation or after a link interruption, then it shall stop all transmissions (if applicable) and shall not reply to any grants other than ranging grants (if applicable) and shall start the ranging procedure and the capabilities negotiation steps (if commanded) by using the granted ranging bursts.

- During the ranging process, repeated RlcRangingInvitation messages shall be ignored after reception of the first RlcRangingInvitation message.
- If the AT lost the DL synchronization (i.e. failed to decode the control zone), then it shall try to re-establish the DL synchronization and wait for further commands.

The details for AP reaction in case of link loss are specified below:

- If the AT does not reply to grants, then the AP shall start to issue irregularly RlcRangingInvitation messages and irregularly ranging grants.

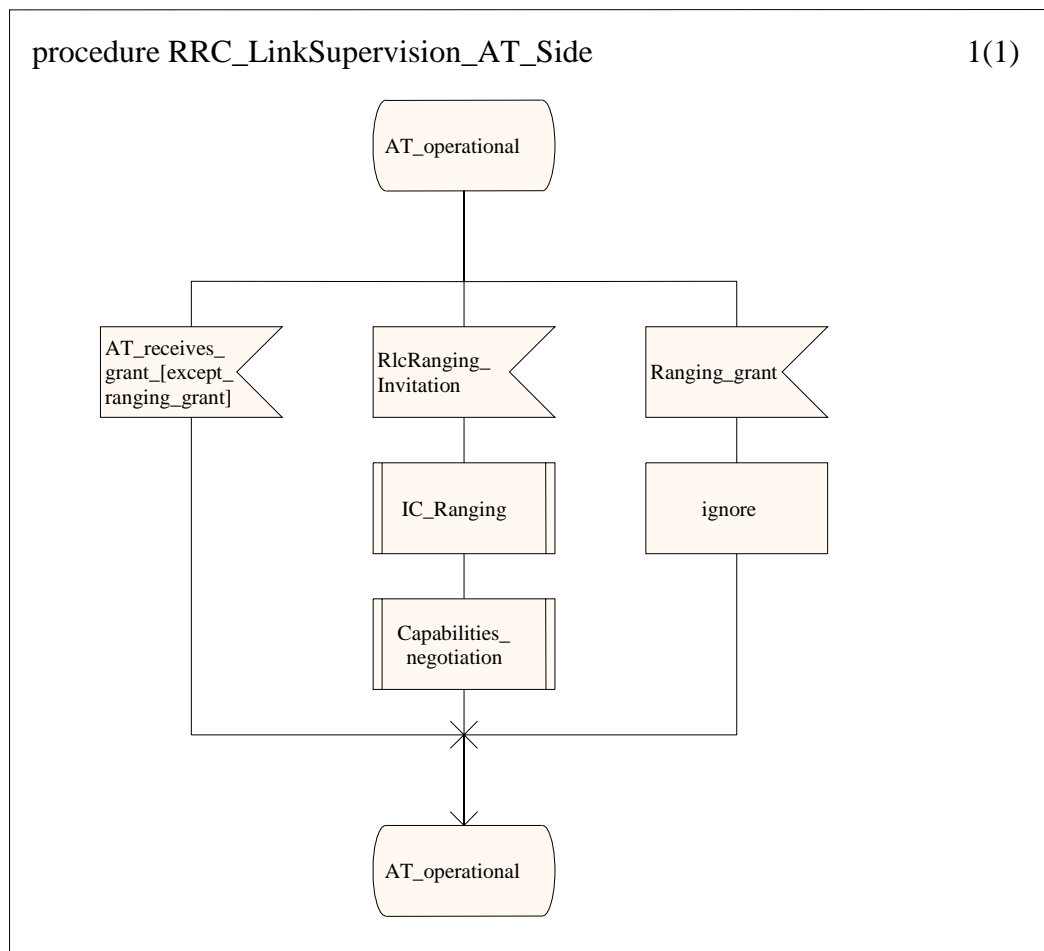

Diagram 11: SDL diagram for link loss reaction (AT side) (update)

An example for the link supervision at the AP side is shown in diagram 12. In this case, the AP commands a re-initialization by sending the ranging invitation message after two missing replies to regular grants. The example of two missing grants could be reasonable to ensure a fast reaction in case that the AT has no traffic data to transmit (i.e. there are only replies to periodic grants that are needed to maintain a minimum traffic load in the UL). In other cases with high data rates in the UL of the respective AT, more missing replies could be tolerated in order to avoid unnecessary re-initializations.

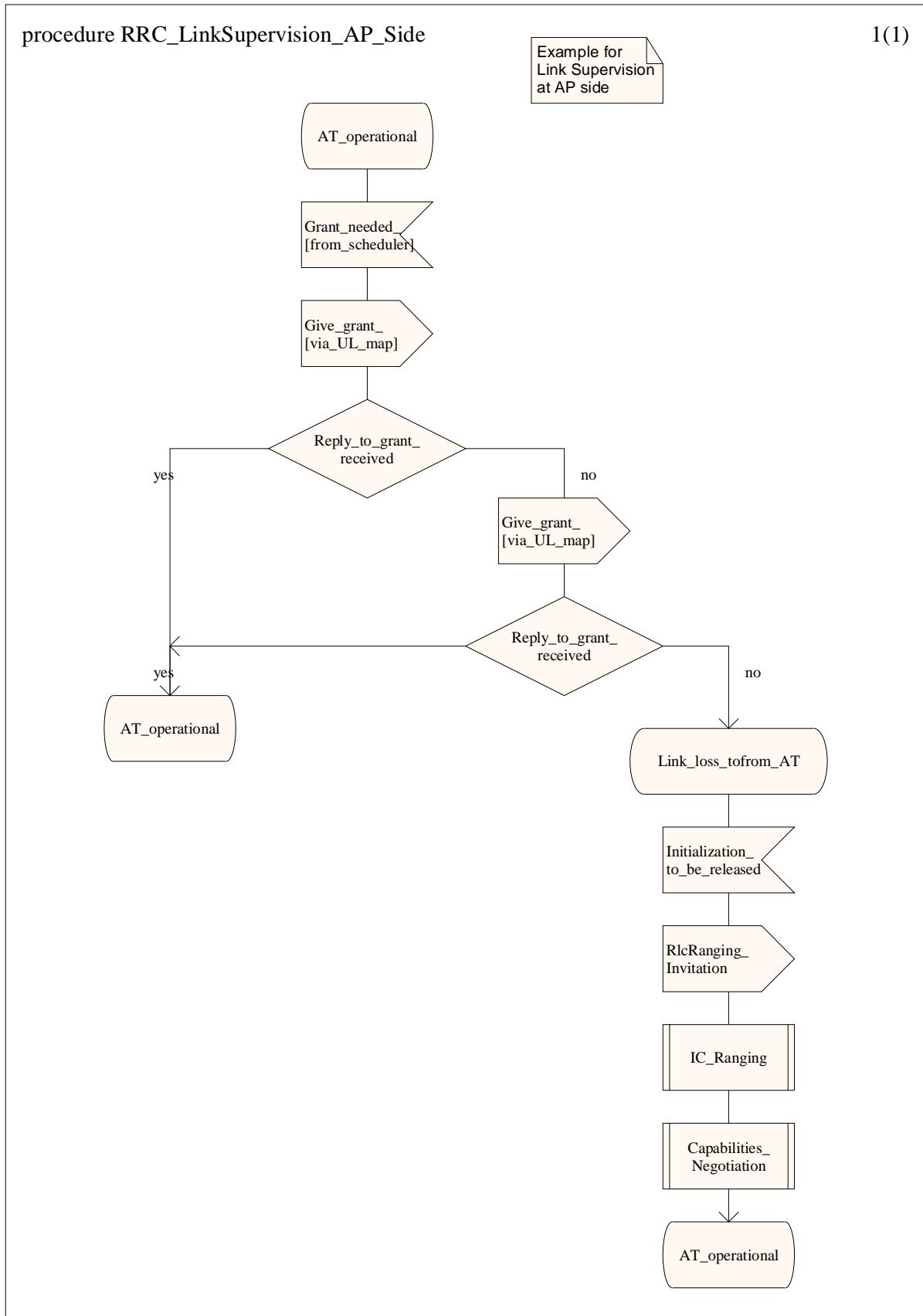

Diagram 12: SDL diagram for link loss supervision and reaction (AP side, example)

11.2.3 Reaction on AT malfunction

In case of a malfunction of the AT the following procedures shall be applied:

- If the DL operation fails then the AT can not establish or re-establish synchronization. The AT can not react on ranging grants or ranging invitations. After some time, the AP is aware of this and can decide to stop any ranging grants or ranging invitations to this AT. The AT does not transmit anything and additional specifications are not given.
- If the UL operations fails or if there is some malfunction (e.g. UL transmit power too high or uncontrollable), then the AP can switch off the AT with the `RlcInitializationCmd` message shown in table 30.

Table 30: Message for initialization commands

<code>RlcInitializationCmd</code>	<code>::= SEQUENCE {</code>	<code>-- DL</code>
<code>initializationCmd</code>	<code>InitializationCmd</code>	<code>-- 3 bit</code>
<code>}</code>		
<code>InitializationCmd</code>	<code>::= ENUMERATED {</code>	
<code>rejectedFromNetwork</code>	<code>(0),</code>	
<code>rejectedFromChannel</code>	<code>(1),</code>	
<code>firstInitialization</code>	<code>(2),</code>	
<code>transmissionStop</code>	<code>(3),</code>	
<code>transmissionReStart</code>	<code>(4)</code>	
<code>}</code>		

For the parameter `InitializationCmd`, the following rules shall be applied:

- `InitializationCmd = rejectedFromNetwork`: the AT shall stop all transmissions and the reception and shall not try to synchronize to the network again. The AP shall not give any grants to the AT after this command.
- `InitializationCmd = rejectedFromChannel`: the AT shall stop all transmissions and the reception and shall not try to synchronize to the same RF channel again. The AT shall be reset completely. The AT is allowed to perform frequency scanning. The AP shall not give any grants to the AT after this command.
- `InitializationCmd = firstInitialization`: the AT shall stop all transmissions. The AT shall be reset completely and then shall perform a first initialization procedure on the same carrier, started with `RlcRangingInvitation`. The AP shall not give any grants to the AT after this command except for ranging grants.
- `InitializationCmd = transmissionStop`: the AT shall stop all transmissions but continue to receive and wait for further commands. The AT shall react on `InitializationStatus = transmissionReStart` (or on other values of `InitializationStatus` if applicable) or on `RlcRangingInvitation`. The AP shall not give grants to the AT after this command except for ranging grants.
- `InitializationCmd = transmissionReStart`: the AT shall reply to all grants and can use the bandwidth request contention window. It is recommended to use this command only after a short period of silence since the link conditions may have changed otherwise.

If the AT does not react on `RlcInitializationCmd` as expected from the AP, then the AP shall re-send the command again as shown in diagram 13.

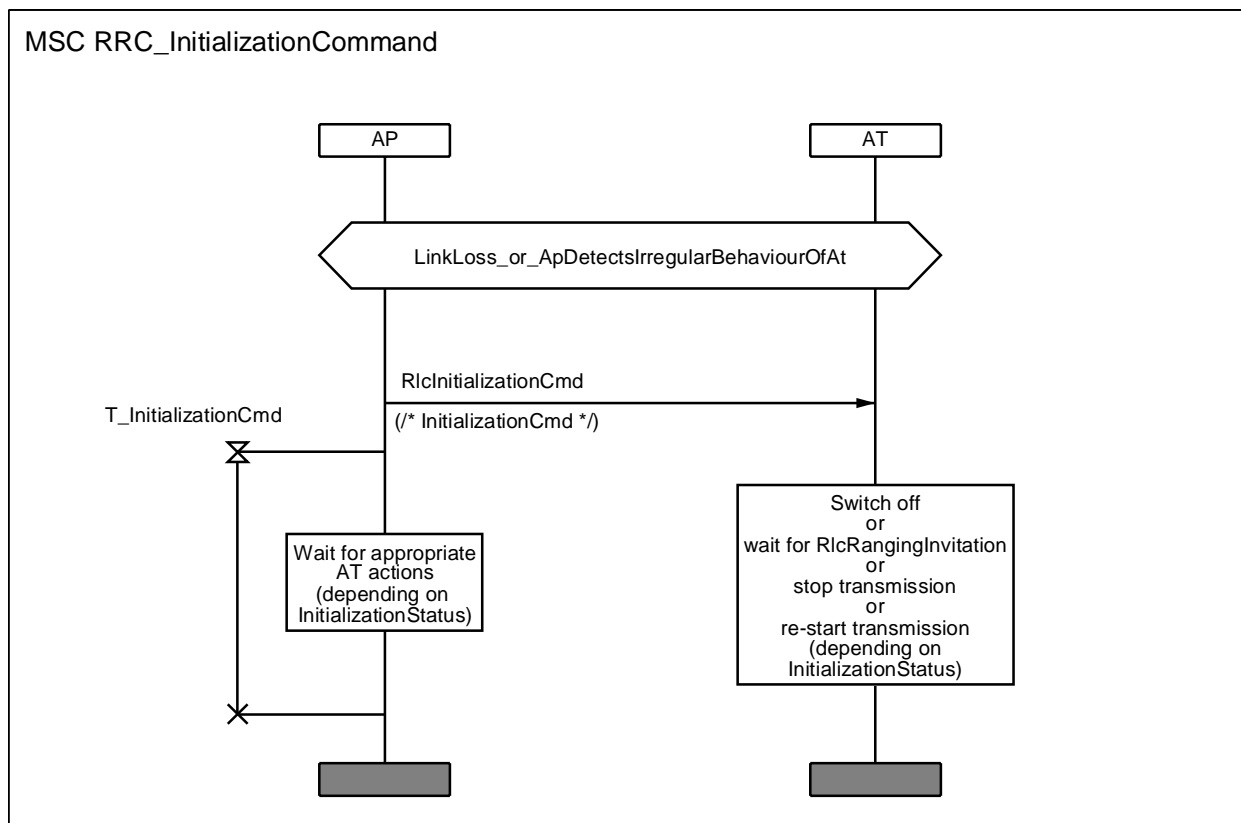

Diagram 13: MSC for initialization command

11.2.4 Performance monitoring

There might be a need for reports from AT to AP on performance monitoring and on information concerning events relevant for NMS. These reports are transmitted via the AT-specific secondary MAC management connection and are out of the scope of the present document.

11.3 Change of PHY mode, ATPC and ATTC

11.3.1 Overview

The PHY mode (modulation and coding scheme) is adaptive both for DL and UL and the adaptive operation shall be supported by AP and AT. The automatic transmit power control is mandatory for the uplink (UL ATPC) and shall be supported by AP and AT, but optional for the downlink (DL ATPC). The support of the automatic UL transmit timing control (UL ATTC) is mandatory.

The commanding of new PHY modes and updating of transmit power is summarized as follows:

- 1) Usually an AT receives all its MAC PDUs for unicast connections in the currently highest PHY mode region, and additionally all PHY mode regions between the current highest PHY mode (inclusive) and the most robust PHY mode (inclusive) shall be monitored by each AT to ensure the reception of broadcast and multicast connections. The DL map only contains the starting symbols (SS) of the PHY mode regions but no information on the allocation of ATs to PHY mode regions.

The allocation of an AT to a PHY mode region shall be announced from AP to AT (where this shall be done in advance in case of changing to a more efficient PHY mode, and shall be done after switching in case of changing to a more robust PHY mode) and shall be acknowledged by the AT.

A new DL PHY mode can be requested by the AT if certain $C/(N + I)$ thresholds (derived from the received and decoded DL signal) are crossed (where the thresholds themselves are commanded by the AP to the ATs in the GBI message) as well as commanded by the AP.

- 2) The DL transmit power for the complete sector can be changed by the AP without notifying the ATs in advance. The DL transmit power shall be increased only if the current DL transmit power is not high enough for at least one AT in the most robust PHY mode. The DL ATPC is an optional feature.
- 3) The UL PHY mode is commanded from AP to AT by addressing each active AT (i.e. ATs that receive grants) in the UL map. Each UL map entry consists of the triplet UIUC, TID, SS (where TID is replaced by a specific contention window TID for the contention windows). The UL PHY mode is selected in the AP. For the contention windows (i.e. for non-granted UL transmissions), the most robust PHY mode shall be used.
- 4) The UL transmit power for each AT is commanded by AT-specific MAC management messages (via basic MAC management connection) when required, i.e. UL transmit power changes are usually only commanded when the rain fading conditions change. During PHY mode switching the AT automatically corrects the transmitted power according to the `UplinkPowerModChangeList` values broadcast in the GBI message.

The information required at the AP for the appropriate allocation of PHY modes and the appropriate choice of the transmit power is gained as follows:

- The selection of the DL PHY mode and the DL transmit power is under full control of the AP and is based on the DL channel measurements at the ATs and the measurement reports from the ATs to the AP. The parameters to be measured and the reporting mechanisms are specified in detail in the present document.
- The selection of the UL PHY mode and the UL transmit power is under full control of the AP and is based on the UL channel measurements at the AP. Therefore each AT is granted bandwidth appropriately to maintain a minimum traffic load in order to allow for reliable measurements at the AP. More details about the channel measurement procedure in the AP and the calculation of the UL parameters are implementation-specific and thus out of the scope of the present document.

An overview of the DL PHY mode change procedure and the measurement report mechanisms are shown in diagram 14.

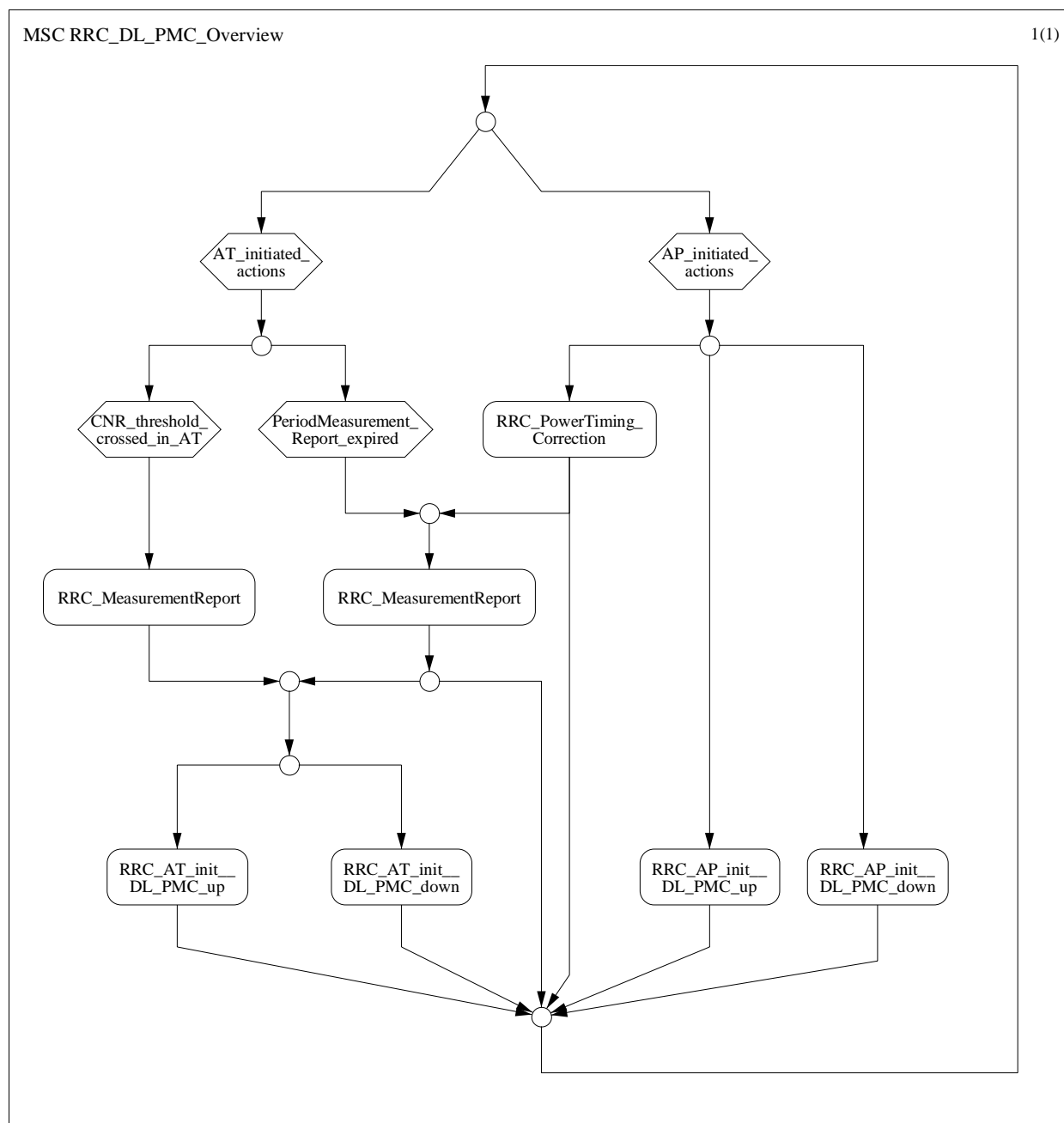

Diagram 14: HMSC for DL PHY mode change and measurement report

11.3.2 Measurement of uplink RF carrier at AP

The AP measures the received UL signal from the ATs in order to update its knowledge about the UL radio channels from each initialized AT.

This requires to maintain a minimum traffic load for each AT, i.e. each AT shall be granted bandwidth at least each 50 ms to 200 ms, depending on the choice of the AP.

Each AT shall transmit as indicated in the UL map whenever it receives a grant. If no traffic or management information is to be transmitted, then a MAC dummy PDU shall be sent. This applies both for grants of long or short MAC PDUs.

11.3.3 Measurement of downlink RF carrier at AT and measurement reports to AP

The AT shall measure the following two parameters from the received DL signal:

- **CnrMeasured** = measured absolute current $C/(N + I)$ from the received and decoded DL signal; resolution = 8 bit; range = [4, 40] dB; granularity = 0,25 dB. The measurement accuracy is specified with 1 dB and all other details (like averaging period) are implementation-specific.
- **RxPowerMeasured** = measured absolute current received power of the DL signal; resolution = 8 bit; range = [-88, -28] dBm; granularity = 0,25 dB.

Both parameters are independent of the current DL PHY mode. The measurement report shall also contain the following four parameters:

- **TxPowerMeasured** = current UL transmit power of the measurement report; resolution = 6 bit, range = [-26, +20] dBm, granularity = 1,0 dB.
- **TxPowerMargin** = gap between current uplink transmit power and the maximum uplink transmit power; resolution = 6 bit; range = [0, 12] dB; granularity = 0,25 dB.
- **DownlinkPhyModeWanted** = wanted PHY mode as a result of CnrMeasured; resolution = 3 bit.
- **MaxUplinkPhyMode** = most efficient PHY mode that is possible for the AT with the current transmitted power; resolution = 3 bit.

Table 31: Message for measurement report

RlcMeasurementReportData	::= SEQUENCE {	-- UL
downlinkPhyModeWanted	DownlinkPhyMode,	-- 3 bit
cnrMeasured	CnrMeasured,	-- 8 bit
rxPowerMeasured	RxPowerMeasured,	-- 8 bit
txPowerMeasured	TxPowerMeasured,	-- 6 bit
txPowerMargin	TxPowerMargin,	-- 6 bit
maxUplinkPhyMode	UplinkPhyMode	-- 3 bit
}		
CnrMeasured	::= INTEGER(0..255)	-- 8 bit, granu=0.25dB, range=[4,40]dB
RxPowerMeasured	::= INTEGER(0..255)	-- 8 bit, granu=0.25dB, range=[-88,-28]dBm
TxPowerMeasured	::= INTEGER(0..63)	-- 6 bit, granu=1.00dB, range=[-26,+20]dBm
TxPowerMargin	::= INTEGER(0..63)	-- 6 bit, granu=0.25dB, range=[0,12]dB
DownlinkPhyMode	::= ENUMERATED {	-- 3 bit
noNewPhyMode	(0),	
downlinkPhyMode1	(1),	
downlinkPhyMode2	(2),	
downlinkPhyMode3	(3),	
downlinkPhyMode4	(4),	
downlinkPhyModeFutureReserved	(7)	
}		
UplinkPhyMode	::= ENUMERATED {	-- 3 bit
undefined	(0),	
uplinkPhyMode1	(1),	
uplinkPhyMode2	(2),	
uplinkPhyMode3	(3),	
uplinkPhyModeFutureReserved	(7)	
}		

The measurement report `RlcMeasurementReportData` is specified in table 31 and is transmitted from AT to AP in the following cases:

- If certain $C/(N + I)$ thresholds are crossed, where these thresholds `CnrThreshold` are broadcasted with the GBI message for all PHY modes of the current PHY mode set. The thresholds are different for increasing or decreasing channel quality to support hysteresis, see clause 11.3.4 for more details.
- If the parameter `MeasurementReportReq` in the message `RlcUplinkCorrection` (used to command power or timing correction to the AT) indicates the AP request, see table 34. The AP can control that a correction message is always or never or sometimes replied by the report, see table 32.
- According to the period `PeriodReportGeneral` in the GBI message. This carrier-specific report period can be overwritten by the `PeriodReportAtSpecific` parameter contained in the AT-specific message `RlcMeasurementReportCriterium`, see table 32. Switching on/off of periodic reports is possible on a per carrier basis as well as on a per AT basis.

The transmission of the measurement report is shown in diagram 15.

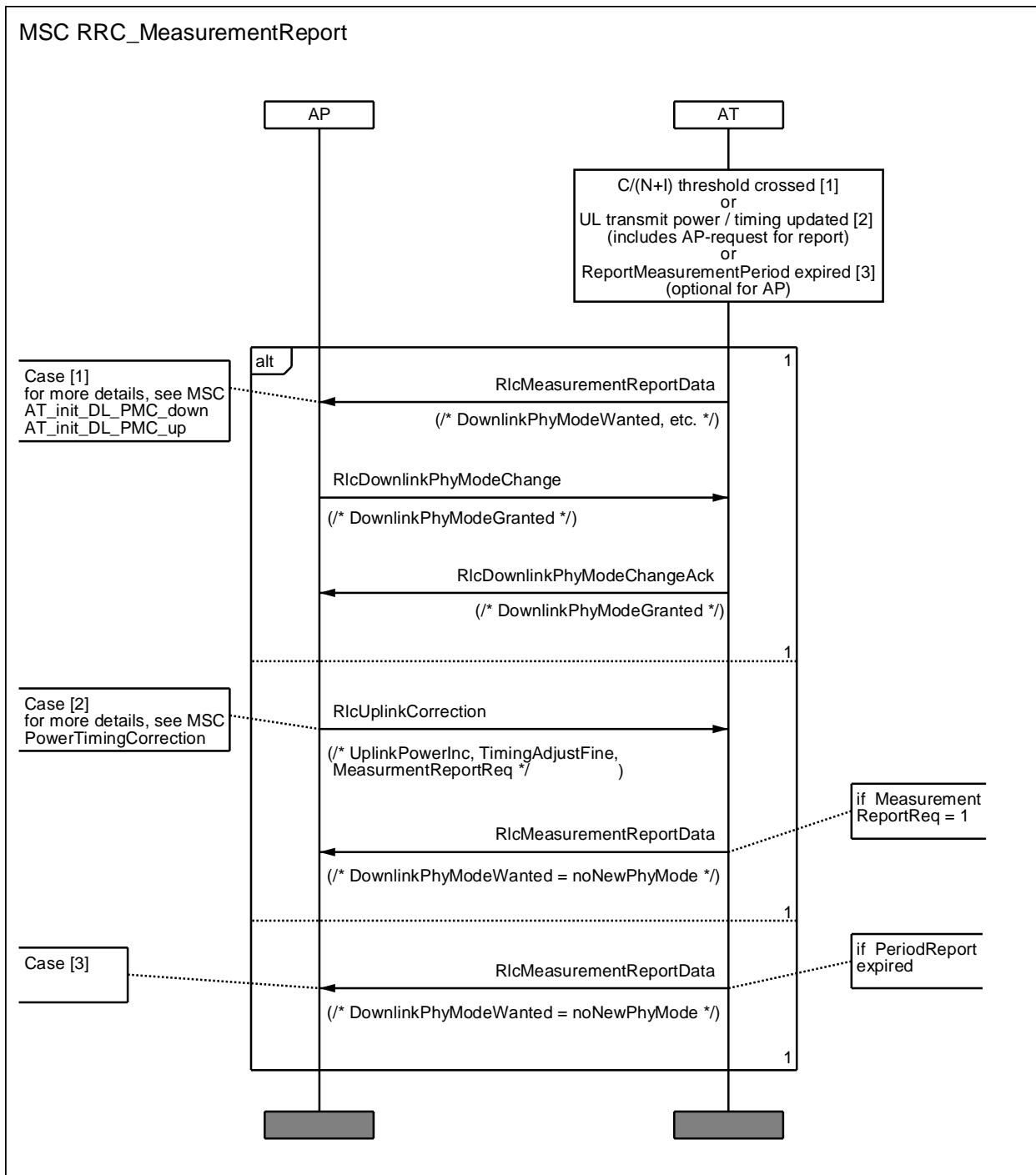

Diagram 15: MSC for transmission of the measurement report

The parameter `periodMeasurementReportAtSpecific` is contained in the message `RlcMeasurementReportCriterium` as shown in table 32.

Table 32: Message for measurement report criteria

<code>RlcMeasurementReportCriterium ::= SEQUENCE {</code>		<code>-- DL,</code>
<code>periodMeasurementReportAtSpecific</code>	<code>PeriodMeasurementReport</code>	<code>-- 3 bit,</code>
		<code>-- overwrites periodMeasurementReportGBI</code>
<code>}</code>		
<code>PeriodMeasurementReport ::= INTEGER {</code>		
<code>usePeriodicMeasurementReportGBI</code>	<code>(0),</code>	
<code>-- only for periodMeasurementReportAtSpecific in</code>		
<code>RlcMeasurementReportCriterium,</code>		
<code>-- but not for</code>		
<code>--</code>	<code>periodMeasurementReportGBI</code>	<code>in</code>
<code>RlcGeneralBroadcastInformation</code>		
<code>period050</code>	<code>(1),</code>	<code>-- 50 ms</code>
<code>period100</code>	<code>(2),</code>	<code>-- 100 ms</code>
<code>period150</code>	<code>(3),</code>	<code>-- 150 ms</code>
<code>period200</code>	<code>(4),</code>	<code>-- 200 ms</code>
<code>noPeriodicReports</code>	<code>(5)</code>	
<code>}</code>		

The measurement report shall be transmitted in a short or long MAC signalling PDU. It shall be transmitted only when the AT receives a grant but not in the bandwidth contention window. Real-time traffic shall have a higher priority than the report.

11.3.4 Change of downlink PHY mode

The change of the DL PHY mode can be initiated by AT or AP. Both possibilities shall be supported. More exactly, the DL PHY mode referred to in the following MAC management messages is the current highest PHY mode that shall be monitored by the AT, i.e. the AT shall decode all PHY mode regions between the most robust PHY mode and the highest current PHY mode.

For the AT initiated DL PHY mode change, the AT measures the $C/(N + I)$ ratio of the received DL signal (which is also forwarded to the AP in the measurement report). The AT knows the $C/(N + I)$ thresholds that have been broadcasted to all ATs in the PHY mode set descriptor section of the GBI message (for all PHY modes of the current PHY mode set and the thresholds are different for increasing or decreasing channel quality).

The AT can issue a request for the DL PHY mode change by transmitting the measurement report `RlcMeasurementReportData` as described in table 31. The request is based on the `CnrMeasured` value and explicitly stated by `downlinkPhyModeWanted`, where the value `noNewPhyMode` shall not be used in this context.

The AP sends a confirmation of the DL PHY mode change request in the DL in form of an announcement `rlcDownlinkPhyModeChange` and an acknowledgement of this announcement is sent in the UL with the message `rlcDownlinkPhyModeChangeAck`. These two messages are shown in table 33. It should be noted that the content of these two messages is identical but the messages appear in different contexts.

Table 33: Messages for DL PHY mode change request

RlcDownlinkPhyModeChange	::= SEQUENCE {	-- DL for AP or AT initiated change
downlinkPhyModeGranted	DownlinkPhyMode	-- 3 bit
}		
RlcDownlinkPhyModeChangeAck	::= SEQUENCE {	-- UL for AP or AT initiated change
downlinkPhyModeGrantedAck	DownlinkPhyMode	-- 3 bit
}		
DownlinkPhyMode	::= ENUMERATED {	-- 3 bit
noNewPhyMode	(0),	
downlinkPhyMode1	(1),	
downlinkPhyMode2	(2),	
downlinkPhyMode3	(3),	
downlinkPhyMode4	(4),	
downlinkPhyModeFutureReserved	(7)	
}		

For the order of the messages two cases have to be distinguished:

- Changing to a more robust PHY mode as shown in diagram 16 (AT initiated) and diagram 18 (AP initiated): The PHY mode switching should be performed as soon as possible after reception of RlcMeasurementReportData and shall be done before the transmission or reception of RlcDownlinkPhyModeChange and RlcDownlinkPhyModeChangeAck.
- Changing to a more efficient PHY mode as shown in diagram 17 (AT initiated) and diagram 19 (AP initiated): The PHY mode switching shall be performed after the reception of RlcMeasurementReportData and RlcDownlinkPhyModeChange and RlcDownlinkPhyModeChangeAck.

Except for the RlcMeasurementReportData message in the UL for AT initiated DL PHY mode change, the two subsequent messages RlcDownlinkPhyModeChange and RlcDownlinkPhyModeChangeAck are identical for AT or AP initiated DL PHY mode change.

For the AT initiated DL PHY mode changes, the whole procedure is only performed if DownlinkPhyMode = New, since the report RlcMeasurementReportData is also sent in other situations with DownlinkPhyMode = noNewPhyMode. (However, even a reception of RlcMeasurementReportData with DownlinkPhyMode = noNewPhyMode can stimulate the AP to command a DL PHY mode change.)

After transmission of rlcDownlinkPhyModeChange in DL, the reception of RlcDownlinkPhyModeChangeAck is controlled with the timer T_DownlinkPhyModeChange. If this timer expires then RlcDownlinkPhyModeChange shall be repeated.

After transmission of RlcMeasurementReportData in UL with DownlinkPhyMode = New, the reception of RlcDownlinkPhyModeChange is controlled with the timer T_MeasurementReportData. If this timer expires then RlcMeasurementReportData shall be repeated.

If the AT receives RlcDownlinkPhyModeChange (maybe without having sent RlcMeasurementReportData), the AT shall reply with RlcDownlinkPhyModeChangeAck.

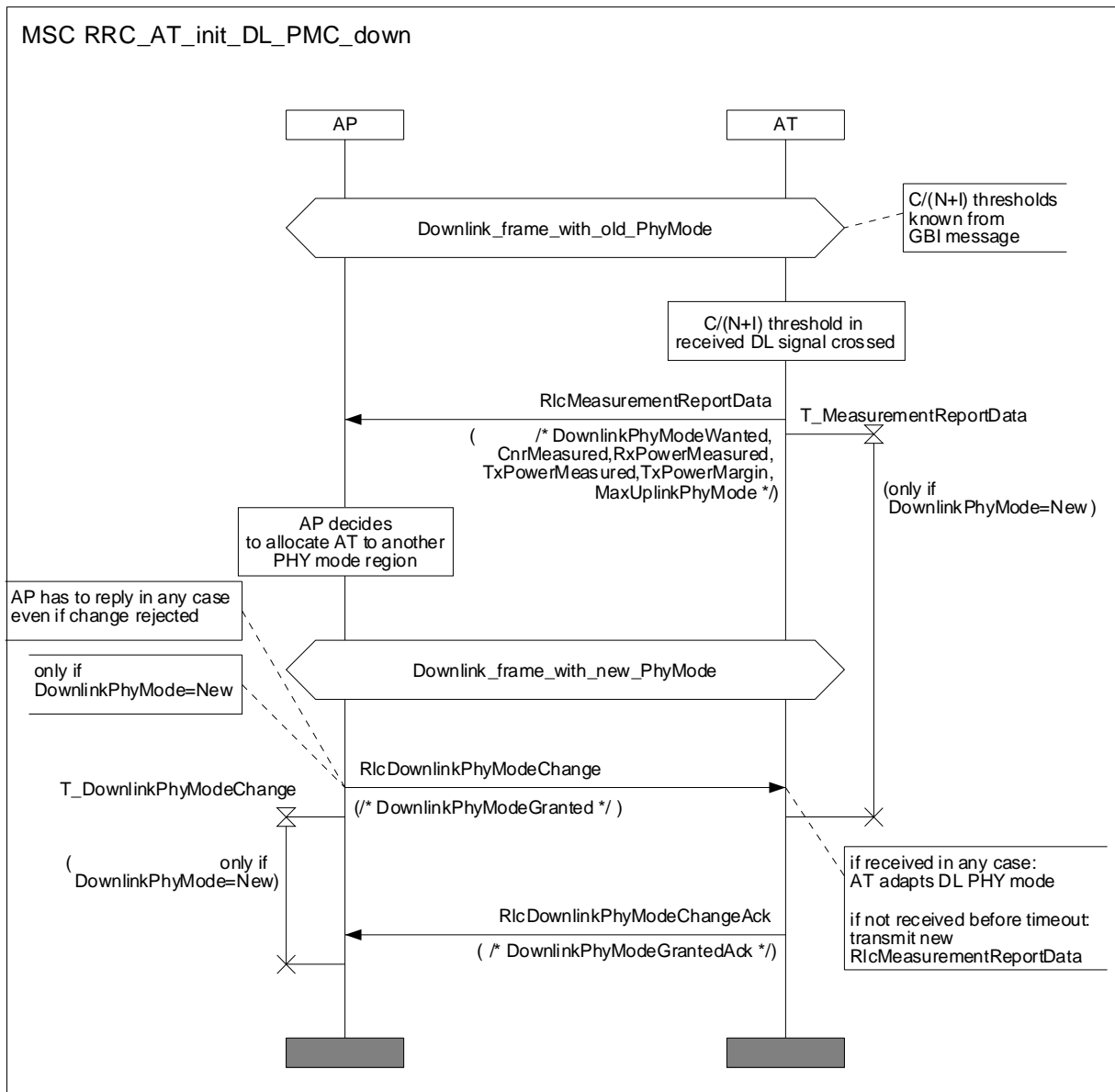

Diagram 16: MSC for AT initiated DL PHY mode change (to a more robust mode)

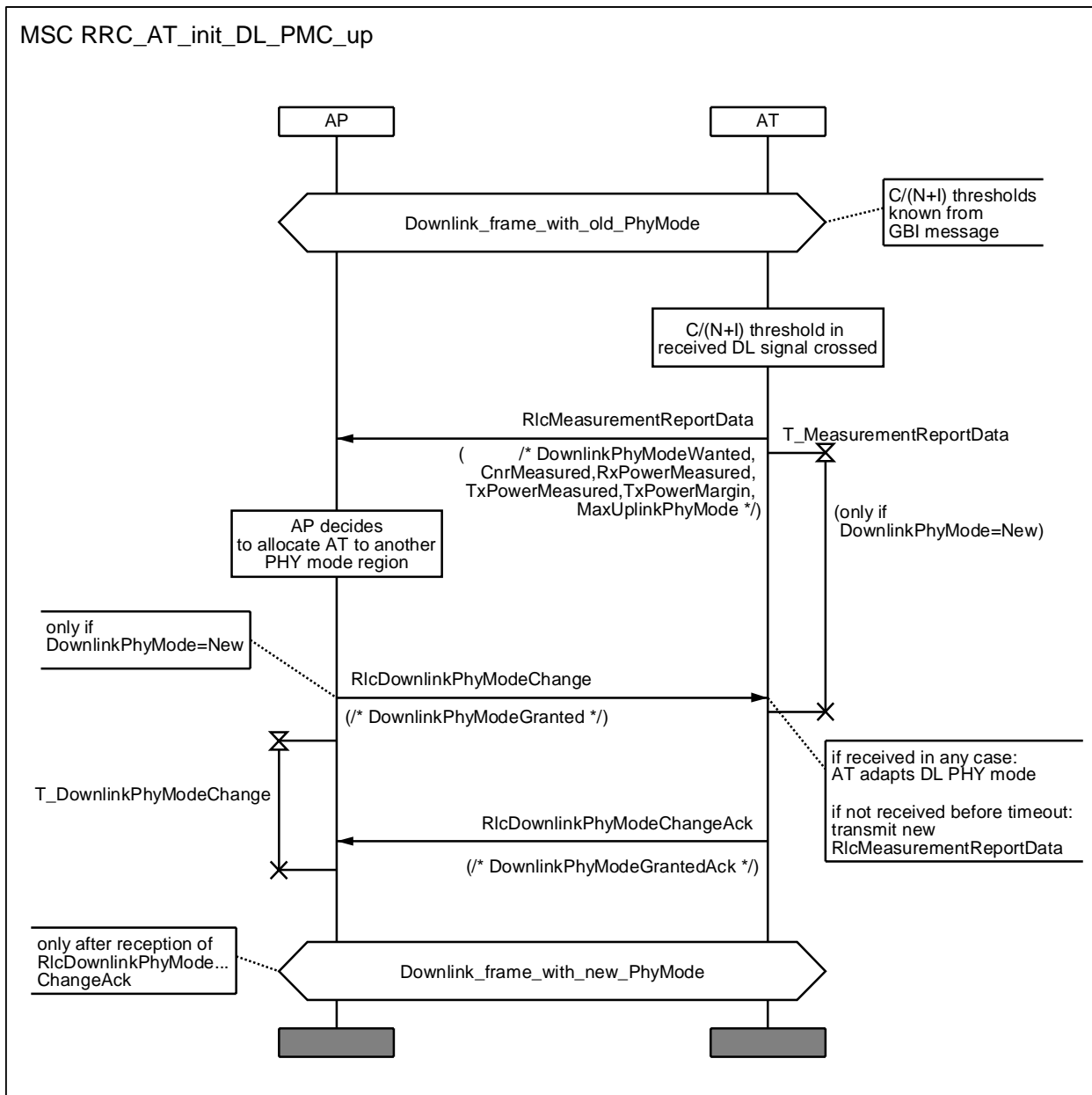

Diagram 17: MSC for AT initiated DL PHY mode change (to a more efficient mode)

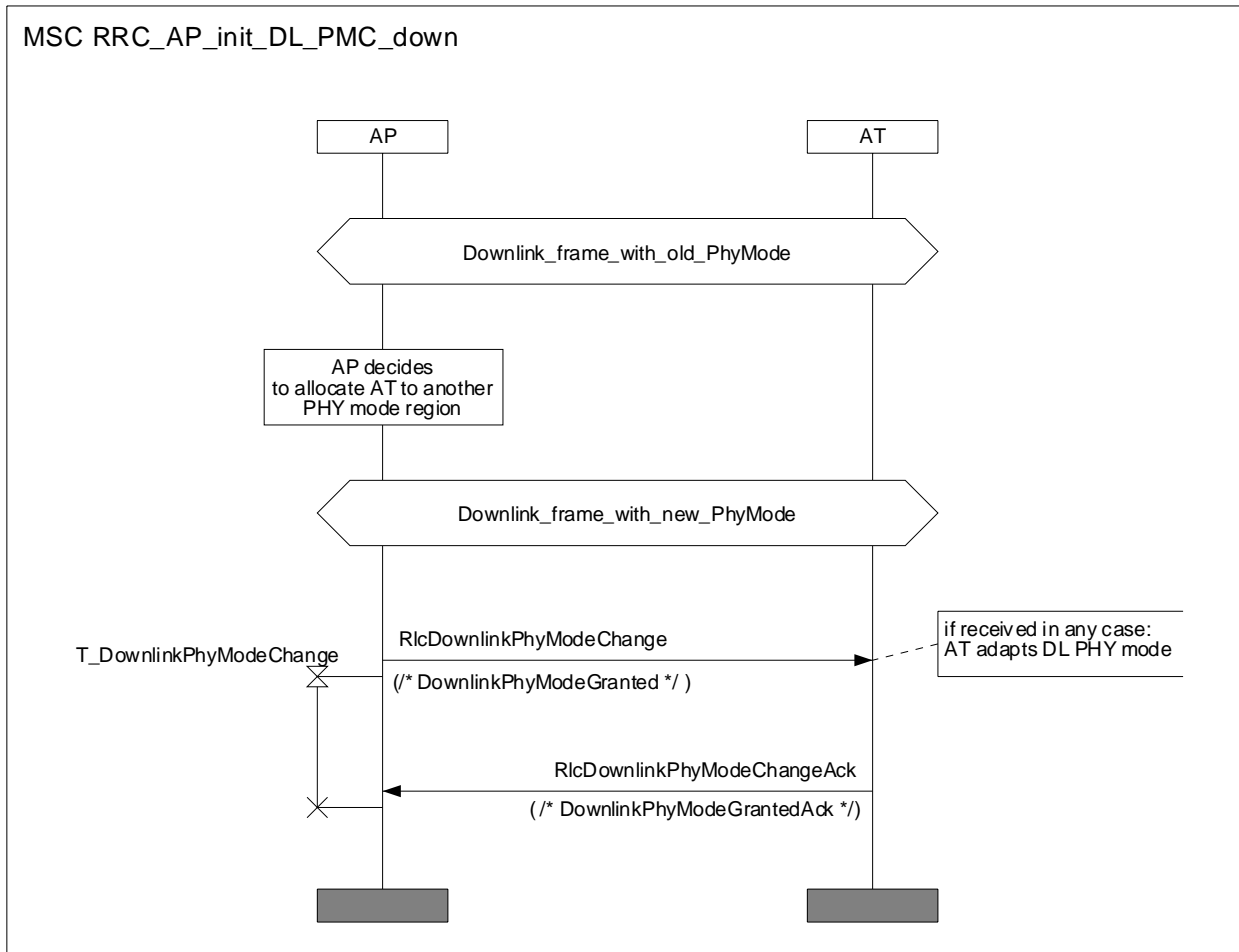

Diagram 18: MSC for AP initiated DL PHY mode change (to a more robust mode)

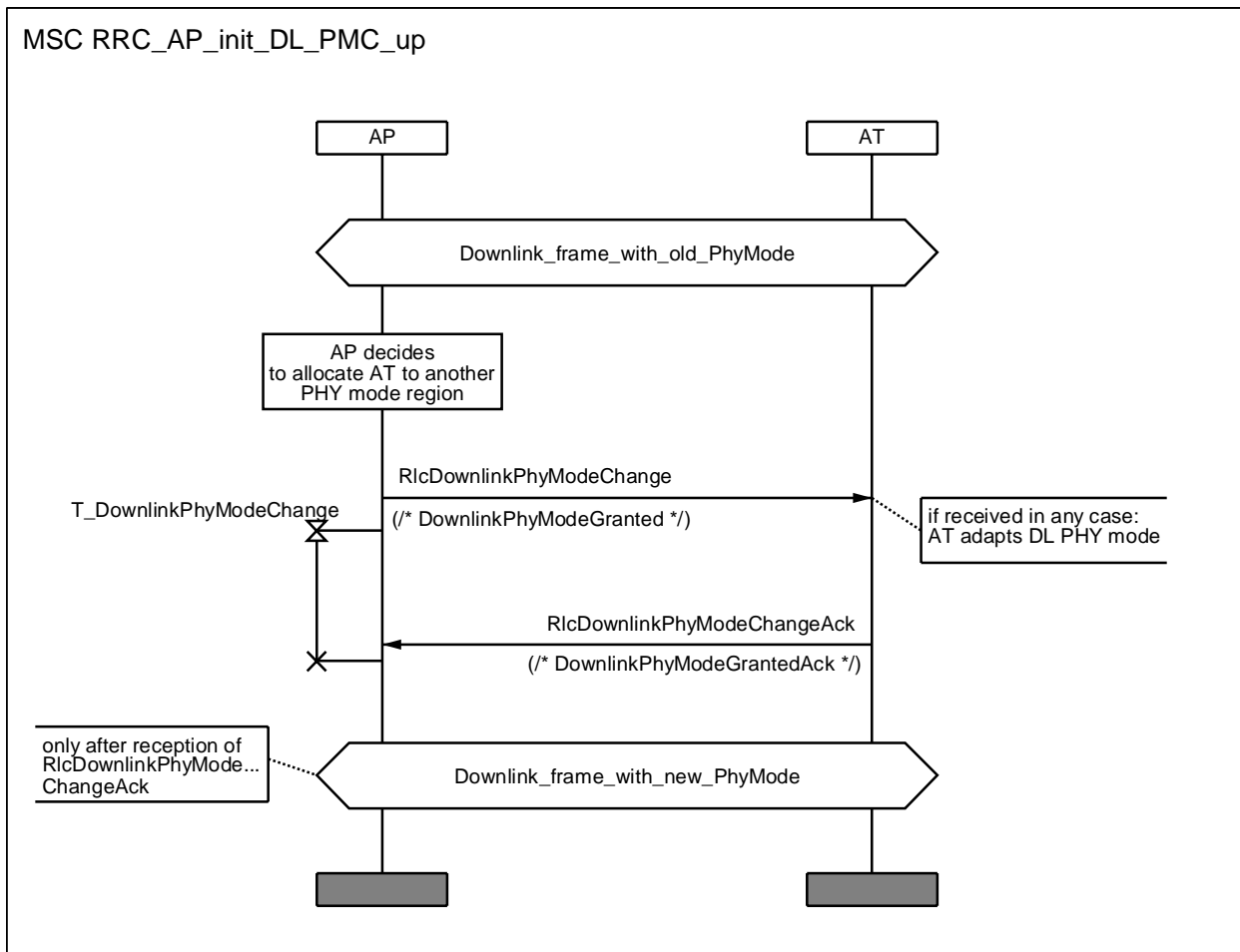

Diagram 19: MSC for AP initiated DL PHY mode change (to a more efficient mode)

The use of PhyThresholdPair (contained in the GBI message) consisting of the two thresholds upThreshold and downThreshold for the measured C/(N + I) ratio of the received DL signal is shown in figure 45.

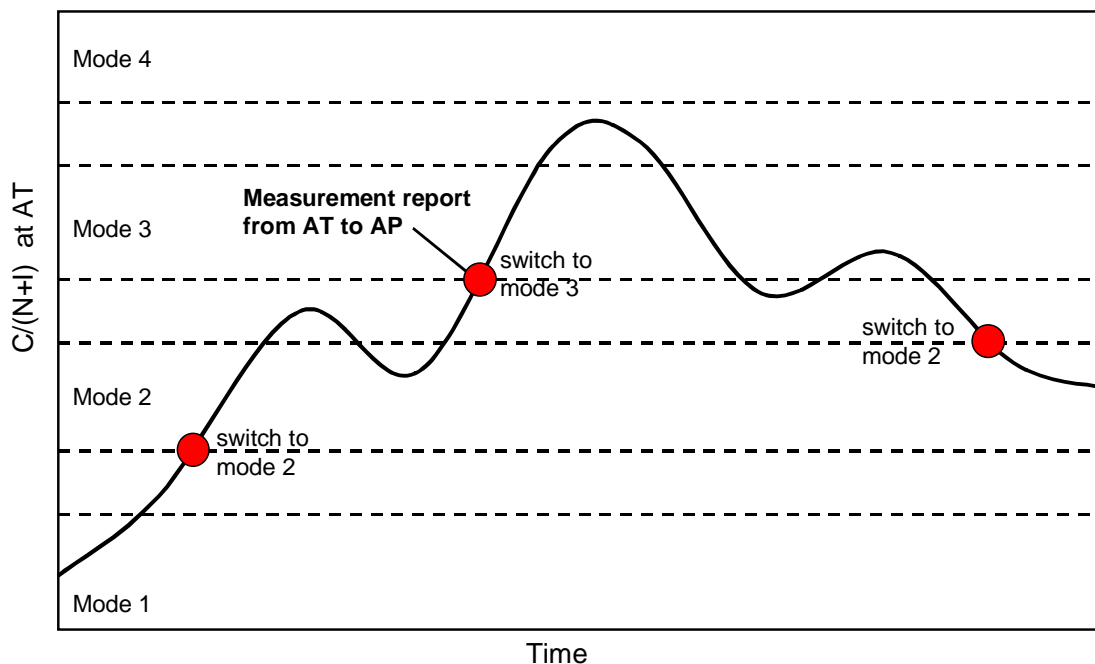

Figure 45: Exemplary illustration of the dynamic behaviour of adaptive DL PHY mode change

11.3.5 Automatic Uplink Transmit Power Control (UL ATPC) and Automatic Uplink Transmit Time Control (UL ATTC)

The maximum UL transmit power of the AT is handled as follows: The maximum UL transmit power for initial ranging is broadcasted with the parameter `uplinkPowerMaxRangingStart` in the GBI message. The AT informs the AP about its maximum UL transmit power for QPSK and 16QAM in the `RlcAtPhyCapabilitiesInfo` message and the AP sets the limit in the `RlcAtPhyCapabilitiesCnf` message and can restrict the maximum UL transmit power furthermore with the `RlcUplinkCorrection` message.

From the received UL signal the AP can derive information about necessary corrections of UL transmit power and transmit timing for each AT. The AT-specific DL message `RlcUplinkCorrection` for ATPC and ATTC is specified in table 34.

The UL transmit power correction step shall be limited to ± 4 dB for the regular operation. For ranging, the correction step shall be in the interval $[-20, +4]$ dB to allow for fast power reductions in case of using ranging grants after link interruptions. The granularity is 0,5 dB in any case.

Table 34: Message for UL transmit power and transmit timing correction

<code>RlcUplinkCorrection</code>	<code>::= SEQUENCE {</code>	<code>-- DL</code>
<code>uplinkPowerInc</code>	<code>UplinkPowerInc,</code>	<code>-- 6 bit</code>
<code>timingAdjustFine</code>	<code>TimingAdjustFine,</code>	<code>-- 5 bit</code>
<code>measurementReportReq</code>	<code>MeasurementReportReq</code>	<code>-- 1 bit</code>
	<code>}</code>	
<code>RlcUplinkPowerCorrection</code>	<code>::= SEQUENCE {</code>	<code>-- DL</code>
<code>uplinkPowerInc</code>	<code>UplinkPowerInc</code>	<code>-- 6 bit</code>
	<code>}</code>	
<code>RlcUplinkTimingCorrection</code>	<code>::= SEQUENCE {</code>	<code>-- DL</code>
<code>timingAdjustFine</code>	<code>TimingAdjustFine</code>	<code>-- 4 bit</code>
	<code>}</code>	
<code>UplinkPowerInc</code>	<code>::= INTEGER(0..64)</code>	<code>-- 6 bit, granu=0,5dB,</code> <code>-- range=[-20,+4]dB</code>
<code>TimingAdjustFine</code>	<code>::= INTEGER(0..16)</code>	<code>-- 5 bit, granu=0,25*symbol,</code> <code>-- range=[-2,+2]symbols</code>
<code>MeasurementReportReq</code>	<code>::= ENUMERATED {</code>	
<code>measurementReportRequestedNo</code>	<code>(0),</code>	
<code>measurementReportRequestedYes</code>	<code>(1)</code>	
	<code>}</code>	

The MSC for UL transmit power and transmit timing is shown in diagram 20. The reception of `RlcUplinkCorrection` with `MeasurementReportReq = measurementReportRequestedYes` shall be acknowledged by the AT with the measurement report `RlcMeasurementReportData` (by using the next granted short MAC signalling PDU after a minimum time of 4 frames as described in clause 8.7.4) where the parameters refer to the new AT settings. The reception of the measurement report at AP is controlled with the timer `T_UplinkCorrection`. If this timer expires then `RlcUplinkCorrection` shall be repeated in DL.

In this case, usually `DownlinkPhyModeWanted = noNewPhyMode` can be expected in `RlcMeasurementReportData`, but in case of `DownlinkPhyModeWanted = new` the AT initiated DL PHY mode change procedure shall be performed.

If periodic measurement reports are requested by the AP, then the report cycle shall not be affected by additional intervening reports (i.e. the report period shall not be reset after transmission of a measurement report as a consequence of the `RlcUplinkCorrection` message).

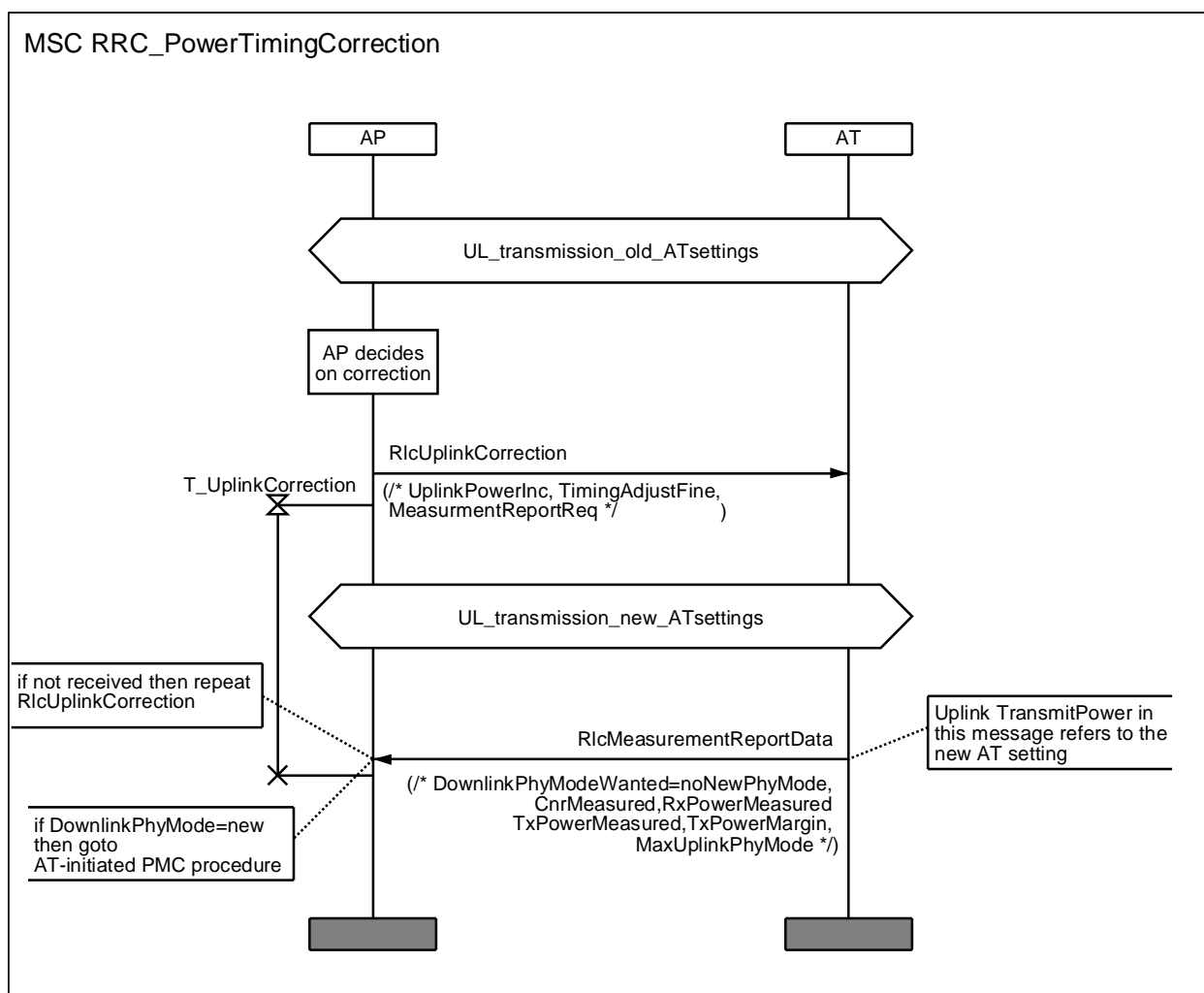

Diagram 20: MSC for Correction of AT's transmit parameters

11.3.6 Automatic Downlink Transmit Power Control (DL ATPC)

DL ATPC is an optional feature (to fulfil regulatory requirements if applicable) of HA systems.

The DL transmit power in AP can be changed for the complete sector without any messaging or notification of the ATs in advance. The following rules are mandatory for the AP:

- The DL transmit power shall be increased only if the current DL transmit power is not high enough for at least one AT in the most robust PHY mode, i.e. only after exploiting the adaptive PHY mode procedure.
- The DL power correction shall be applied immediately before the frame preamble.
- The DL power correction step shall not exceed 1 dB per 50 ms and 1 dB per step.

All other features of DL ATPC are implementation-specific and thus out of the scope of the present document. However, it is recommended to combine DL ATPC with periodic measurement reports, to allow for a DL ATPC algorithm at the AP that is based on the received power measurements at the ATs.

The use of the first `PhyThresholdPair` in `PhyThresholdsList` (contained in the GBI message) consisting of the two thresholds `upThreshold` and `downThreshold` for the measured $C/(N + I)$ ratio of the received DL signal is shown in the lower parts of figure 46.

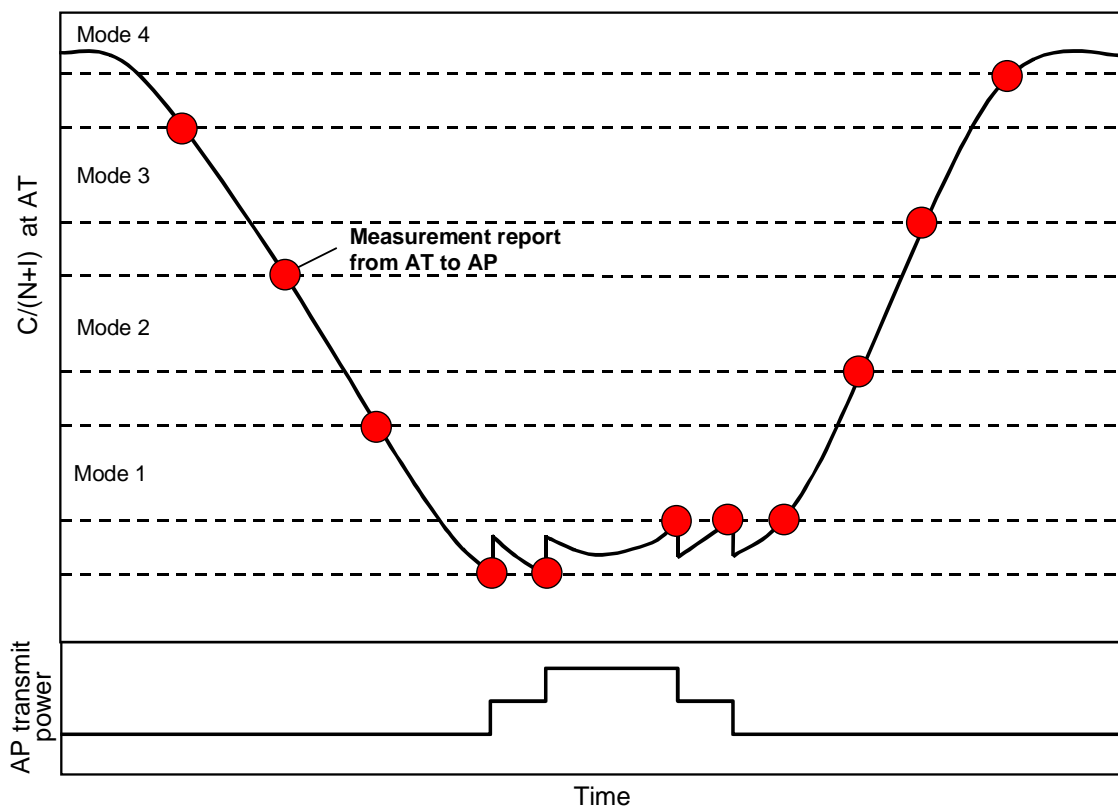

Figure 46: Exemplary illustration of the dynamic behaviour of DL ATPC

NOTE: The dynamic behaviour of DL ATPC shown in figure 46 is just an example. However, the DL transmit power correction steps shall be small enough to guarantee that the resulting steps in $C/(N + I)$ are smaller than the gap between the two lower thresholds. (Otherwise the following situation is possible: after a DL power correction step $C/(N + I)$ will be always above the upper threshold of the lower threshold pair. If the channel improves now immediately, then the DL power will not be reduced before crossing the thresholds between mode #1 and mode #2.)

11.4 Change of PHY Mode Set

The PHY mode set descriptor (PSD) is part of the GBI message which is broadcasted from time to time (e.g. after some seconds, however, a strict period is not required). The GBI message is also used during the initialization process as described in clause 10. The PSD carries:

- the $C/(N + I)$ thresholds for the received and decoded DL signal;
- the required changes of the UL transmit power in case of changing the UL PHY mode;
- for all PHY modes within the current PHY mode set.

A switch from one PHY mode set to another PHY mode set shall be supported (both for DL and UL RF carriers in case of FDD mode), where this appears only occasionally (e.g. after hours or months). The AP (or the NMS) shall initiate the change where the algorithms or criteria in the AP are implementation-specific and thus not specified. However, the procedure for the switch is specified and shown in figure 47.

The change of the PHY mode set requires no kind of UL communication and it is possible to perform this in a synchronized manner for all RF channels of a sector, so that it is possible to guarantee always the same PHY mode set for all RF channels of a sector (however, this is not a requirement for the load-leveiling feature).

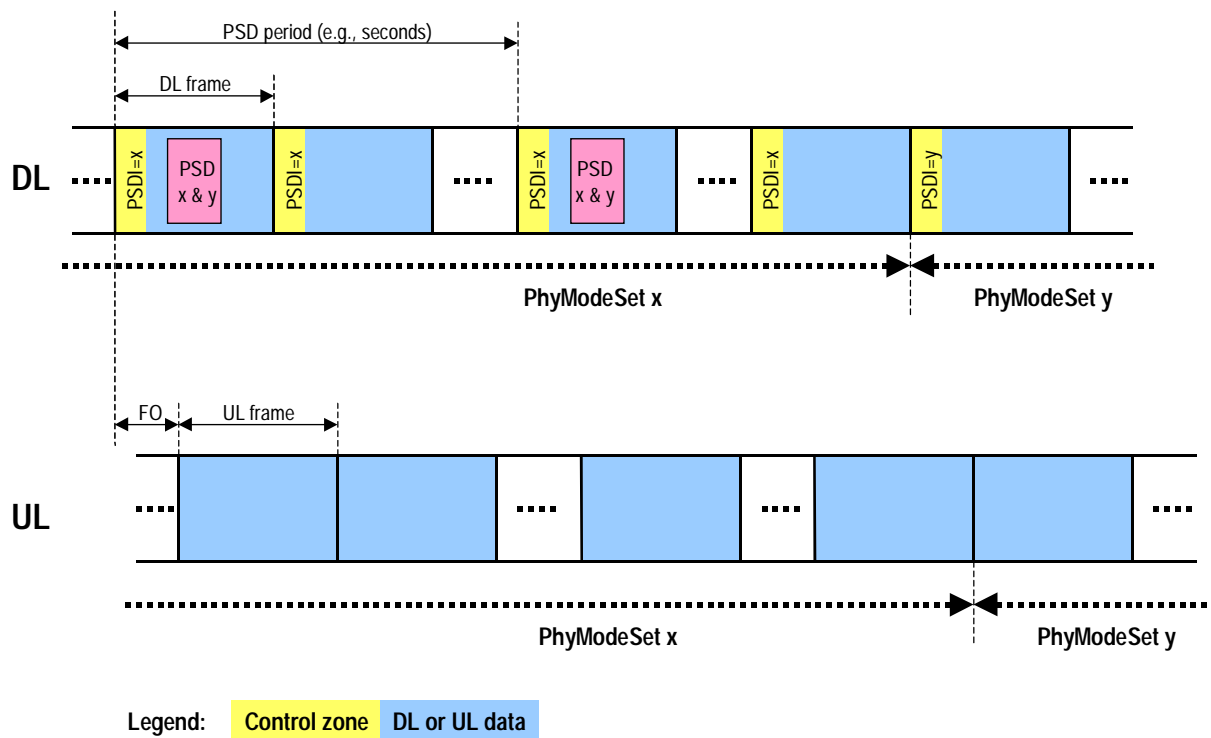

Figure 47: Change of PHY mode set

The procedure for switching from PHY mode set x to PHY mode set y requires that both sets are broadcasted over a certain period before the switching time (except for this "transition period" only one set is always contained in the GBI message). The GBI message with both modes is transmitted several times (e.g. 2...4 times) to guarantee with a very high probability that all ATs receive this information correctly at least once. Each set is uniquely referenced to by a PSDI (PSD indicator), which is contained in the GBI message as shown in table 23. A length of 4 bits for the PSDI field allows in theory to manage up to 16 different PHY mode sets. The PSDI field is contained in each control zone as shown in figure 29, so a switch from set x to set y can be commanded with immediate effect by switching the PSDI field from x to y.

The frequency of the GBI message and the number of PSD repetitions for the transition period can be selected by the AP.

For the transition phase from PHY mode set x to PHY mode set y, the following recommendations should be observed:

- A change of the mode number in the UL is not recommended (e.g. from mode 2 of set x to mode 3 of set y), since the necessary power correction step is unknown to the ATs.
- It is recommended to switch all ATs (in DL and UL) to the most robust mode #1 before the transition phase (since modes #1 of PHY mode sets x and y are identical, the UL transmit power of all ATs does not need any corrections after the change).
- PHY mode change procedures should be avoided during the transition phase.

11.5 Change of UL structure

As defined in clause 5.2.6 and figure 13, the following two features can be switched on/off for the UL direction:

- None to several midambles per FEC block.
- One MAC PDU per FEC block.

Both features are handled on a per carrier basis (i.e. identical for all ATs) and can be time-variant (i.e. can change on a frame-by-frame basis). Each feature is broadcasted to all ATs by one bit in the GBI message as shown in table 23.

11.6 Load levelling (inter-carrier handover)

Load levelling means the switching from one RF channel (i.e. pair of RF carriers for DL and UL communication in case of FDD) to another RF channel, where this shall be initiated by the NMS (Network Management System) or by the AP.

In order to avoid unnecessary complexity, a fast dynamic load levelling procedure is not supported. The PHY layer needs about 100 ms for changing the carrier frequencies, so a seamless load-levelling is not possible (with only one transceiver per AT).

The specified load levelling procedure means basically that an AT shall be switched off from the old RF channel and shall perform a new first initialization procedure on the new RF channel. All parameters settings are commanded and negotiated again, i.e. an information exchange between the two APTs is not required.

The implementation of load levelling is optional for AP and mandatory for AT.

The details of the load levelling procedure are described in table 35 and diagram 21. The load levelling command `RlcHandoverCmd` contains a description of the new RF channel (and the AT MAC Address) and no other information. The AT shall reply with the message `RlcHandoverAck` and then the new APT is informed from the old APT to start the initialization process by issuing the `RlcRangingInvitation` message. All parameter setting at the AT are cancelled and new established as for a first initialization.

Table 35: Messages for load levelling

<code>RlcHandoverCmd</code>	<code>::= SEQUENCE {</code>	<code>-- DL</code>
<code>atMacAddress</code>	<code>AtMacAddress,</code>	<code>-- 48 bit</code>
<code>newPairOfCarrierFrequencies</code>	<code>PairOfCarrierFrequencies</code>	<code>-- 34 bit</code>
<code>apcId</code>	<code>ApcId</code>	<code>-- 24 bit }</code>
<code>RlcHandoverAck</code>	<code>::= SEQUENCE {</code>	<code>-- DL</code>
<code>atMacAddress</code>	<code>AtMacAddress</code>	<code>-- 48 bit</code>
	<code>}</code>	
<code>AtMacAddress</code>	<code>::= OCTET STRING (SIZE(6))</code>	
<code>PairOfCarrierFrequencies</code>	<code>::= SEQUENCE {</code>	
<code>uplinkCarrierFrequency</code>	<code>CarrierFrequency,</code>	
<code>downlinkCarrierFrequency</code>	<code>CarrierFrequency</code>	<code>-- equal to uplinkFrequency for TDD</code>
	<code>}</code>	
<code>CarrierFrequency</code>	<code>::= INTEGER(1..130000)</code>	<code>-- 17 bit, granu=0,5 MHz, range=[0,65] GHz</code>
<code>ApcId</code>	<code>::= INTEGER(1..16777216)</code>	

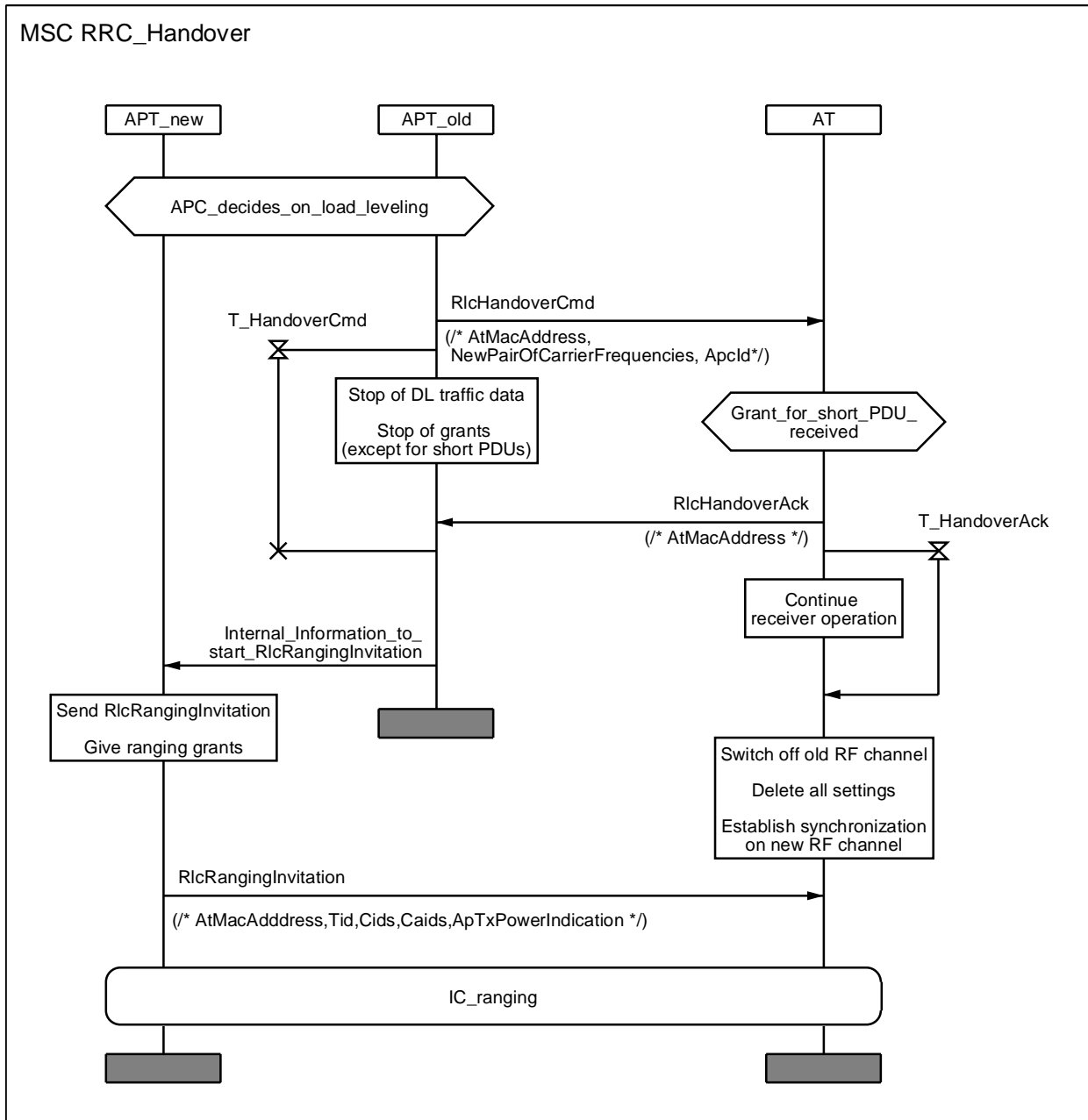

Diagram 21: MSC for load levelling

12 Security control

12.1 Operational overview

12.1.1 Privacy initialization

Authentication and privacy establishment shall be part of the AT initialization process. During the initial ranging process, the AP has been assigned the basic, primary and secondary MAC management connections to the AT. The AT shall use the primary management connection ID to exchange the security control messages with the AP.

Privacy initialization begins with the AP sending the AT an authentication command (RlcAuthCmd) message. The AT shall reply with the authentication information (RlcAuthManufacturerInfo) and an authorization request (RlcAuthReq) message. If the AP determines the requesting AT is authorized, the AP shall respond with an Authorization Reply (RlcAuthReply) message containing the authorization key AK, which shall be used to encrypt the AT's traffic encryption key (TEK). The AP shall encrypt the AK with the receiving AT's public key.

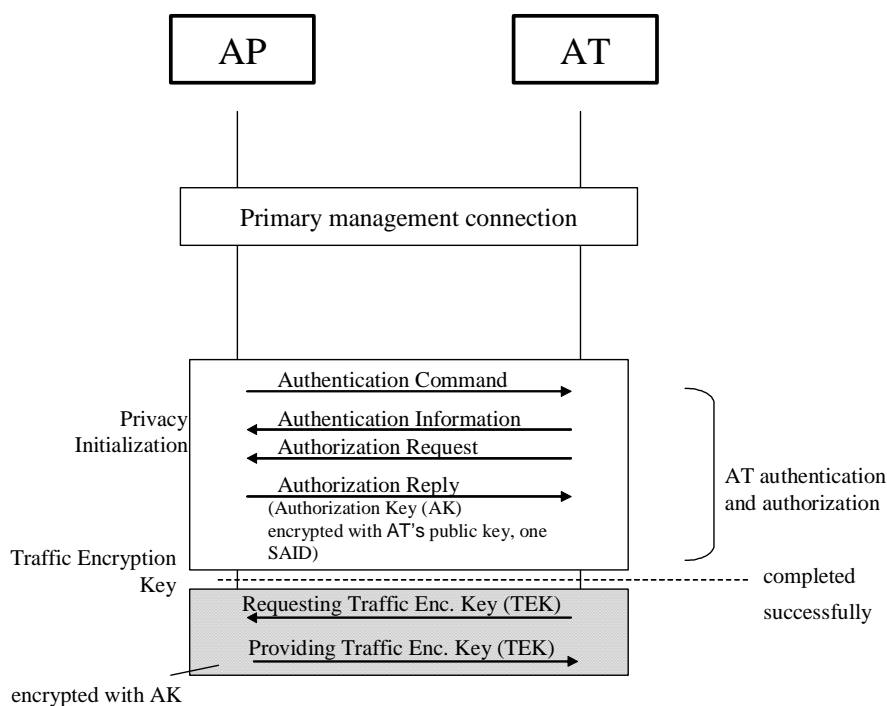

Figure 48: Illustration of the authentication and privacy initialization

After successfully completing authentication and authorization with the AP, the AT shall request a traffic encryption key for the Security Association IDentity (SAID) received together with the AK in the RlcAuthReply message. Therefore, the AT shall send a TEK Request (RlcTekReq) message to the AP. The AP shall respond with two TEK Allocation (RlcTekAllocation) messages, each containing one TEK, which is triple DES encrypted, i.e. Encrypt-Decrypt-Encrypt (EDE) mode, with the AK. Each TEK has a lifetime which is given together with the TEK and the assigned TEK sequence number. The TEK sequence number is used to synchronize the switch over from one TEK to the other.

The security overview figure below illustrates the different sequences. The left path of authentication and First Tek Allocation shall be used after first initialization. In case of re-initialization, supposing that AK and TEKs are not expired, the authentication and First Tek Allocation procedures shall not be applied. As AK has a limited lifetime the new AK shall be provided performing re-authentication. There exists also a lifetime for the TEK, therefore the TEK shall be refreshed using the TEK refresh allocation procedure. In case that the expiration time for AK and TEK match, the re-authentication procedure shall be used before the TEK Refresh Allocation.

MSC SC_SecurityOverview

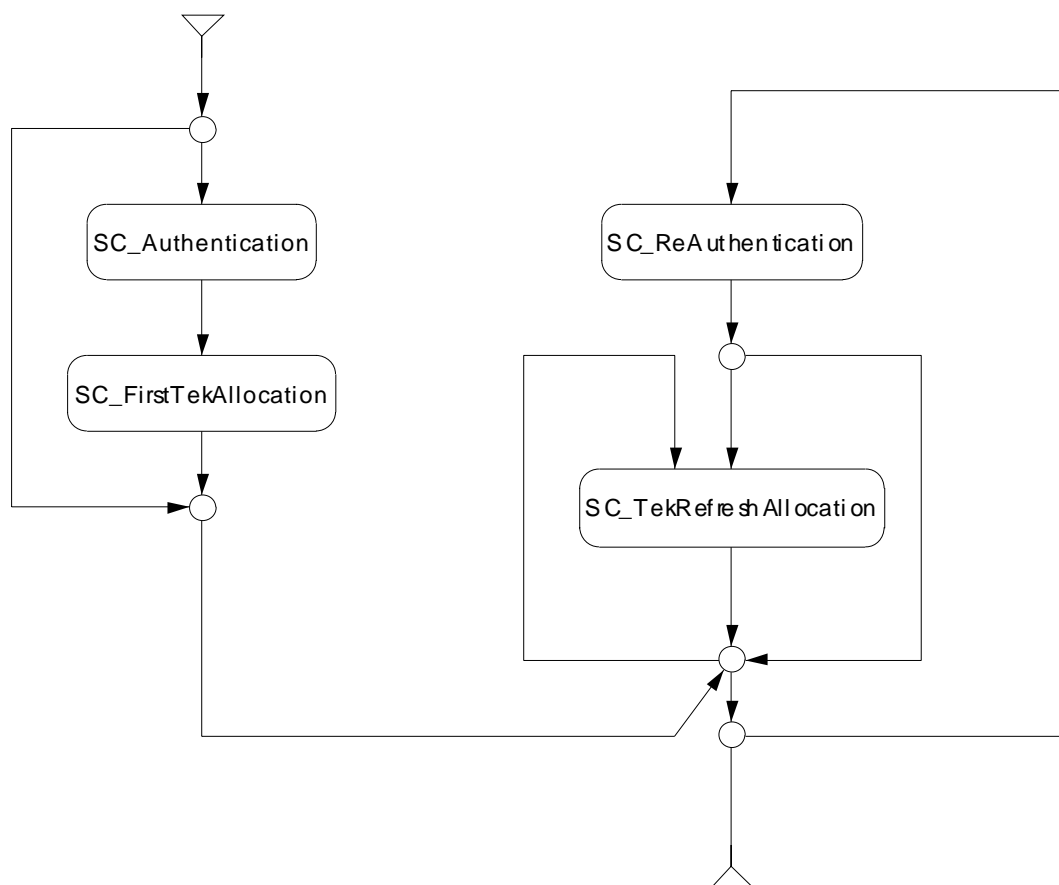

Figure 49: HMSC for security overview

12.1.2 AT Key update mechanism

The TEKs, which the AP provides to its ATs, have a limited lifetime. The AP delivers a key's remaining lifetime, along with the key value, in the TEK Allocation message it sends to its AT. The AP controls which keys are current by flushing expired keys and generating new keys. It is the responsibility of individual ATs to insure the keys they are using match those the AP is using. ATs do this by tracking when a particular TEK is scheduled to expire and issuing a new TEK Request (RlcTekReq) message for the latest key prior to that expiration time.

In addition, ATs are required to periodically re-authorize with the AP. As is the case with TEKs, an AK has a finite lifetime, which the AP provides the AT along with the key value. It is the responsibility of each AT to re-authorize and obtain a fresh AK before the AP expires the AT's current AK.

12.1.3 PKM key management messages

The PKM key management messages are summarized in table 36.

Table 36: PKM key management messages

PKM Message	Description
RlcAuthCmd	The Authentication command message sent from the AP to the AT starts the first authentication process after first initialization.
RlcAuthManufacturerInfo	The RlcAuthManufacturerInfo message is transmitted from the AT to the AP and contains the AT manufacturer's X.509 Certificate, issued by an external authority.
RlcAuthReq	An Authorization Request message is sent from an AT to its AP to request an AK and one SAID. The AT provides the AT X.509 certificate, manufacturer ID and the AT's public key.
RlcAuthReply	An Authorization Reply message is sent from an AP to an AT to reply an AK, AK lifetime and sequence number and an SAID.
RlcAuthReject	An Authorization Reject message is sent from an AP to an AT in rejection of an Authorization Request message sent by the AT.
RlcAuthInvalid	An Authorization Invalid message is sent from an AP to an AT as an unsolicited indication or a response to a message received from that AT.
RlcTekReq	A TEK Request message is sent from an AT to its AP requesting a TEK for the privacy of its authorized SAID.
RlcTekAllocation	A TEK Allocation message is sent from an AP to an AT carrying one traffic encryption keying material for the SAID.
RlcTekRejct	A TEK Reject message is sent from an AP to an AT indicating that the SAID is no longer valid and no key will be sent.
RlcTekInvalid	A TEK Invalid message is sent from an AP to an AT if it determines that the AT encrypted uplink traffic with an invalid TEK.

12.2 Privacy key management protocol

This clause contains the details of the PKM protocol, which is specified by two separate, but interdependent, Finite State Machines (FSMs): the Authorization FSM and the TEK FSM. Communication between the Authorization FSM and TEK FSM occurs through the passing of events and protocol messaging. The Authorization FSM generates events (i.e. Stop, Authorized, Authorization Pending, and Authorization Complete events) that are targeted at its child TEK FSMs. TEK FSMs do not target events at their parent Authorization FSM. The TEK FSM affects the Authorization FSM indirectly through the messaging that an AP sends in response to an AT's requests. For example, an AP may respond to a TEK machine's Key Request messages with an Authorization Invalid message that shall be handled by the Authorization FSM.

The rest of this clause describes the AT authorization and defines the two FSMs. These FSMs shall be used as the definitive specification of protocol actions associated with each state transition.

12.2.1 AT authorization

AT authorization, controlled by the Authorization FSM, contains the process of:

- the AP authenticating a client AT's identity,
- the AP providing the authenticated AT with an AK, and
- the AP providing the authenticated AT with the SAID that the AT is authorized to obtain keying information for.

After achieving initial authorization, an AT periodically seeks re-authorization with its AP, which is also managed by the AT's Authorization FSM. An AT shall maintain its authorization status with the AP in order to be able to refresh aging TEKs, which are managed by TEK FSMs.

12.2.1.1 Initial authorization

An AT shall begin authorization as soon as it is invited with an RlcAuthCmd message from the AP (see diagram 22). The AT shall reply with an RlcAuthManufacturerInfo message to its AP. The RlcAuthManufacturerInfo message contains the AT manufacturer's X.509 certificate, issued by an external authority. The RlcAuthManufacturerInfo message shall be strictly informative, i.e. the AP may choose to ignore it. However it does provide a mechanism for an AP to learn the manufacturer certificates of its ATs.

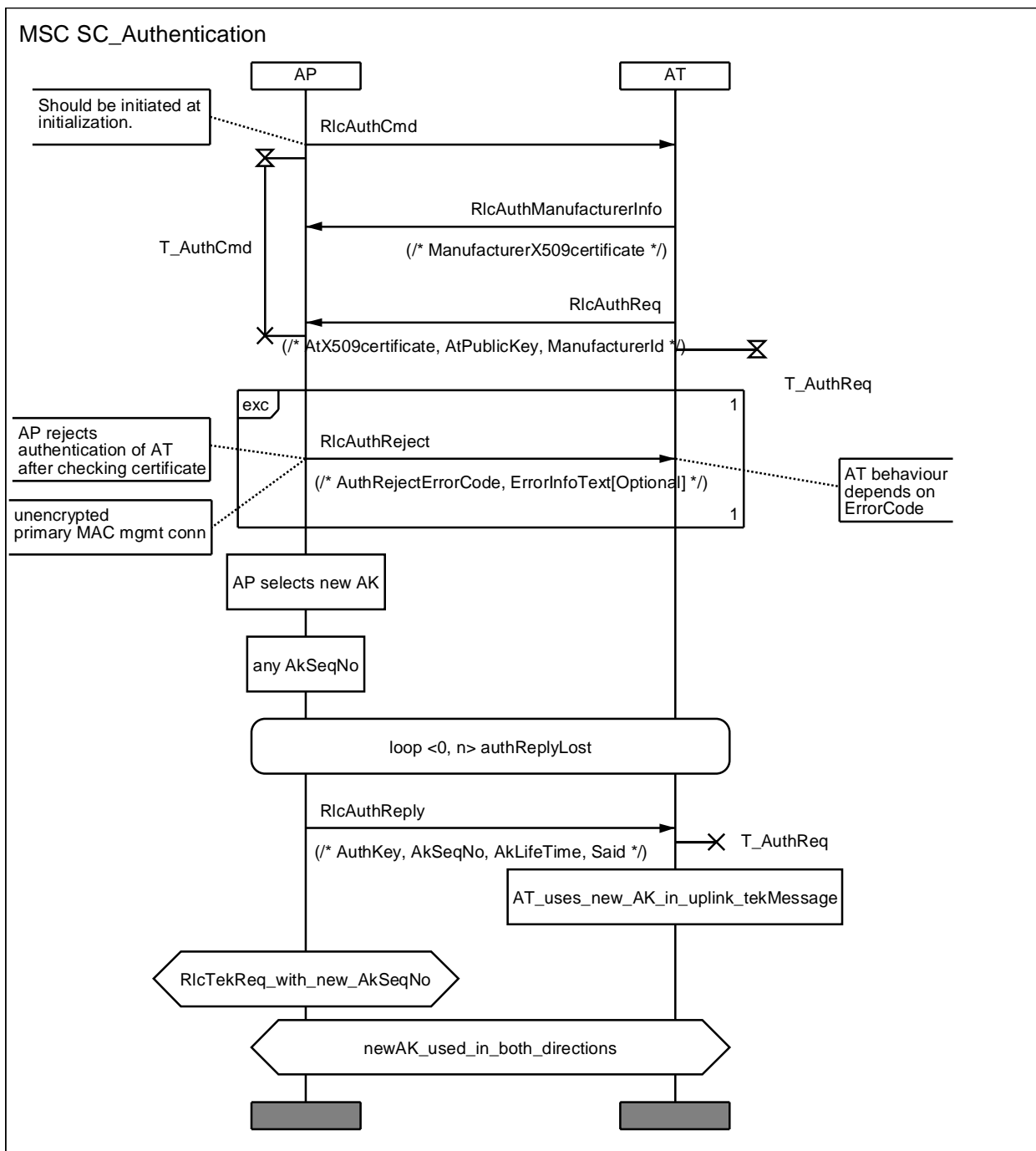

Diagram 22: MSC for successful initial authentication

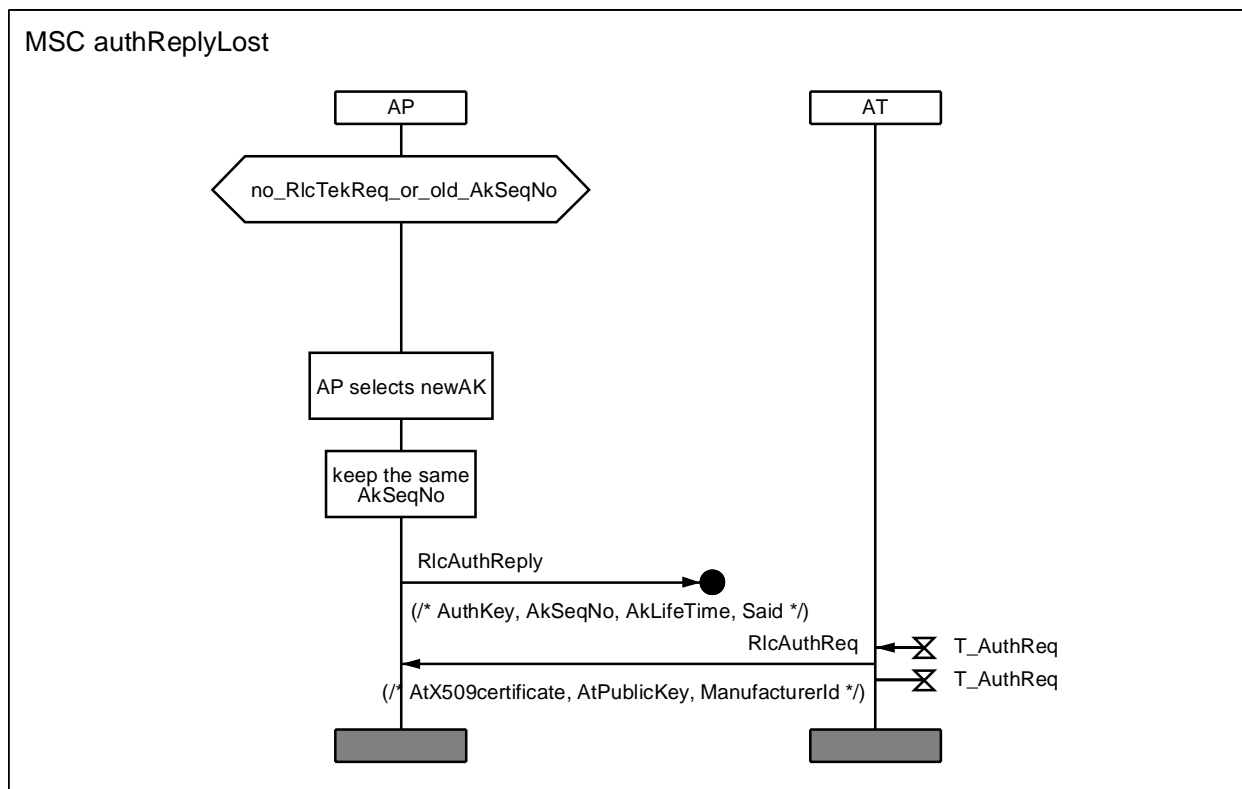

Diagram 23: MSC for retransmission in case of RlcAuthReply loss

After transmitting the RlcAuthManufacturerInfo message the AT shall send an RlcAuthReq message to request an AK from its AP. The RlcAuthReq message shall include:

- the AT's manufacturer ID,
- the AT's public key,
- an AT X.509 certificate,

together with the transmission of the RlcAuthCmd the AP shall set a timer (T_AuthCmd) and shall resend the RlcAuthCmd if it does not receive the RlcAuthManufacturerInfo and RlcAuthReq messages before the timer expires.

In response to an RlcAuthReq message, the AP validates the requesting AT's identity, activates an AK for the AT, encrypts the AK with the AT's public key, and sends the encrypted AK back to the AT in an RlcAuthReply message. The AT expects the RlcAuthReply message before the timer T_AuthReply is expired, otherwise the AT shall resend the RlcAuthReq message. The RlcAuthReply message shall include:

- an AK encrypted with the AT's public key,
- a 2-bit key sequence number used to distinguish between successive generations of AKs,
- the AK's lifetime, and
- one SAID the AT is authorized to obtain keying material for.

After the T_AuthReply timer is expired the AP and AT can use the AK.

If the AP, in responding to an AT's RlcAuthReq message, rejects the AT's request, the AP shall send an RlcAuthReject message to the AT. RlcAuthReject message shall include:

- an error code indicating the reason for the rejection;
- an optional text string providing reason for the rejection.

If the error code does not indicate a permanent rejection the AT shall request for authorization again with the RlcAuthReq message.

12.2.1.2 Reauthorization

An AT shall periodically refresh its AK by re-issuing an RlcAuthReq message to the AP. Reauthorization is identical to authorization with the exception that the AT is not commanded by the AP and does not send any RlcAuthManufacturerInfo message during reauthorization cycles. Clause 12.2.2 provides details on the Authorization FSM, which clearly indicates when RlcAuthManufacturerInfo messages are sent.

If the AT has not received the RlcAuthReply message before the timer T_AuthReq has expired it shall generate the RlcAuthReq again.

- After the AP has received the RlcAuthReq, the AP shall generate a new AK and reply with the RlcAuthReply as described in clause 12.2.1.1.

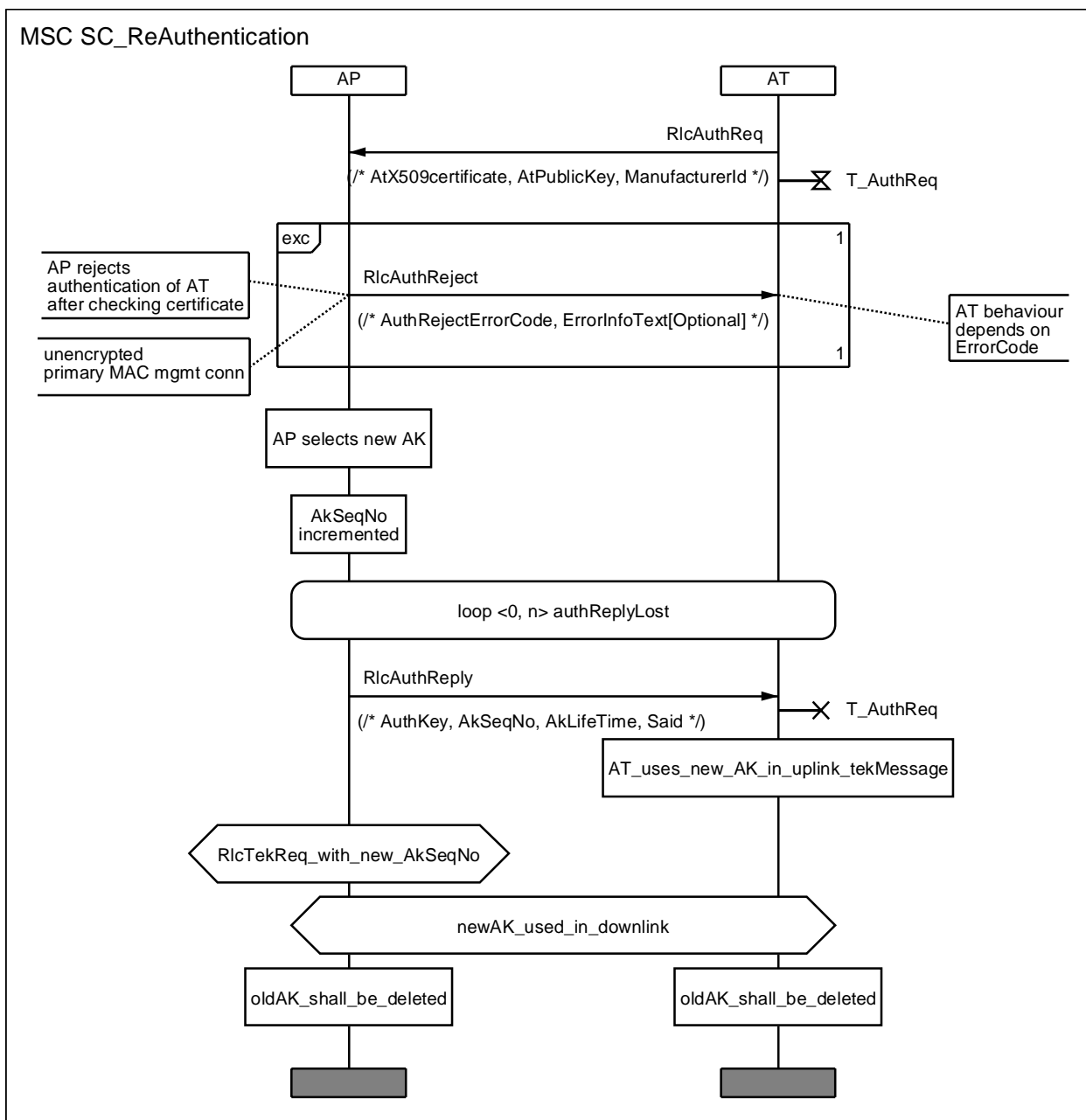

Diagram 24: MSC for re-authorization of AT before AK lifetime expiration

To avoid service interruptions during reauthorization, successive generations of the AT's AKs shall have overlapping lifetimes determined by the AK Lifetime, which is a predefined AP system configuration parameter. Both AT and AP shall be able to support up to two simultaneously active AKs during these transition periods. The operation of the Authorization FSM's Authorization Request message scheduling algorithm (see clause 12.2.2), combined with the AP's regimen for updating and using an AT's AKs, insures that AT be able to refresh TEK keying material without interruption over the course of the AT's reauthorization periods.

12.2.1.3 First key requests

Upon achieving authorization, an AT shall start a TEK FSM for the SAID identified in the RlcAuthReply message. The TEK FSM operating within the AT is responsible for managing the keying material associated with its respective SAID. TEK FSM periodically sends RlcTekReq messages to the AP, requesting a refresh of keying material for their respective SAID. A RlcTekReq message shall include:

- the SAID whose keying material is being requested.

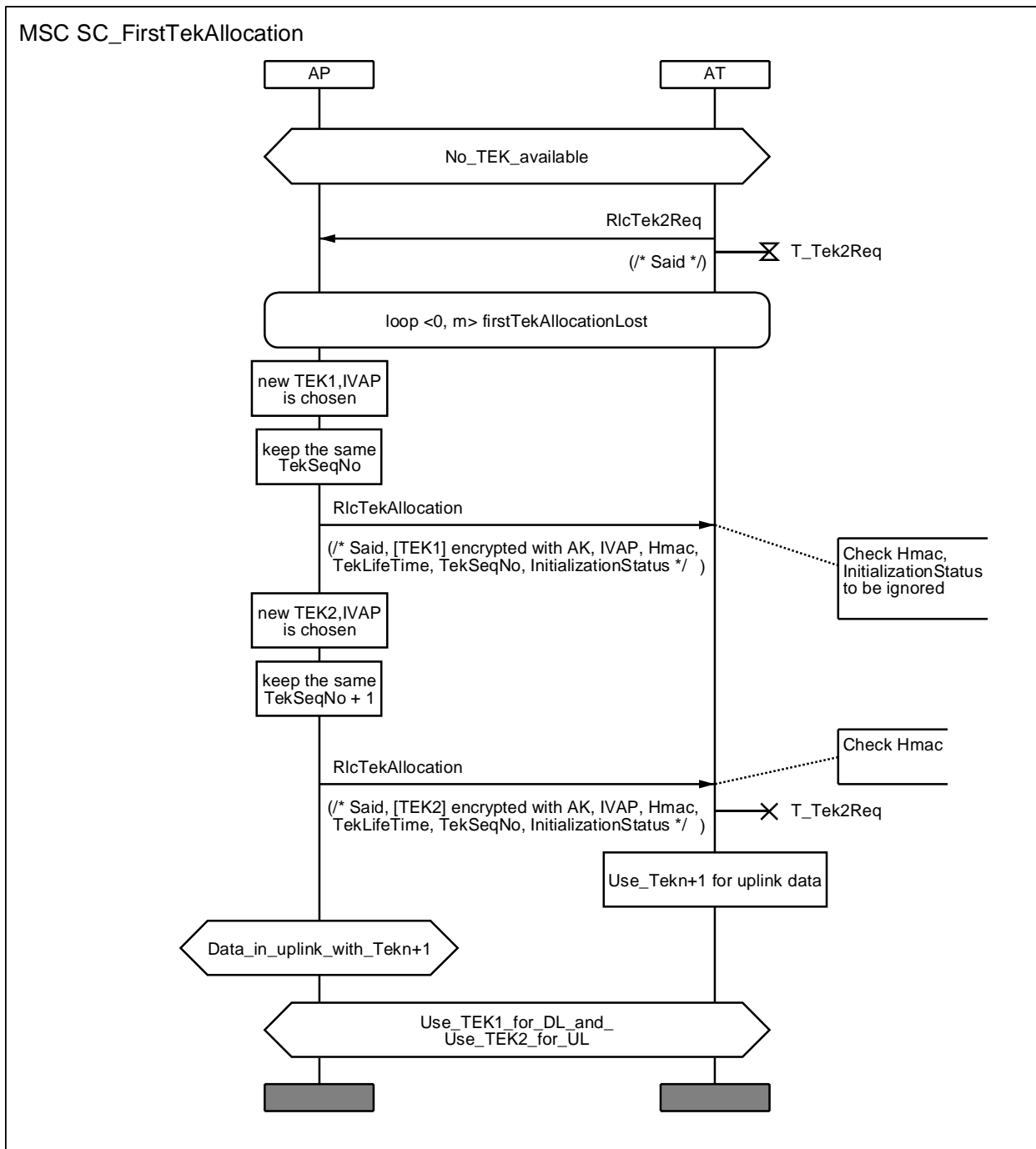

Diagram 25: MSC for first TEK requests

In case of re-initialization, the same diagram applies since the existing TEKs are not valid and are destroyed pending re-initialization.

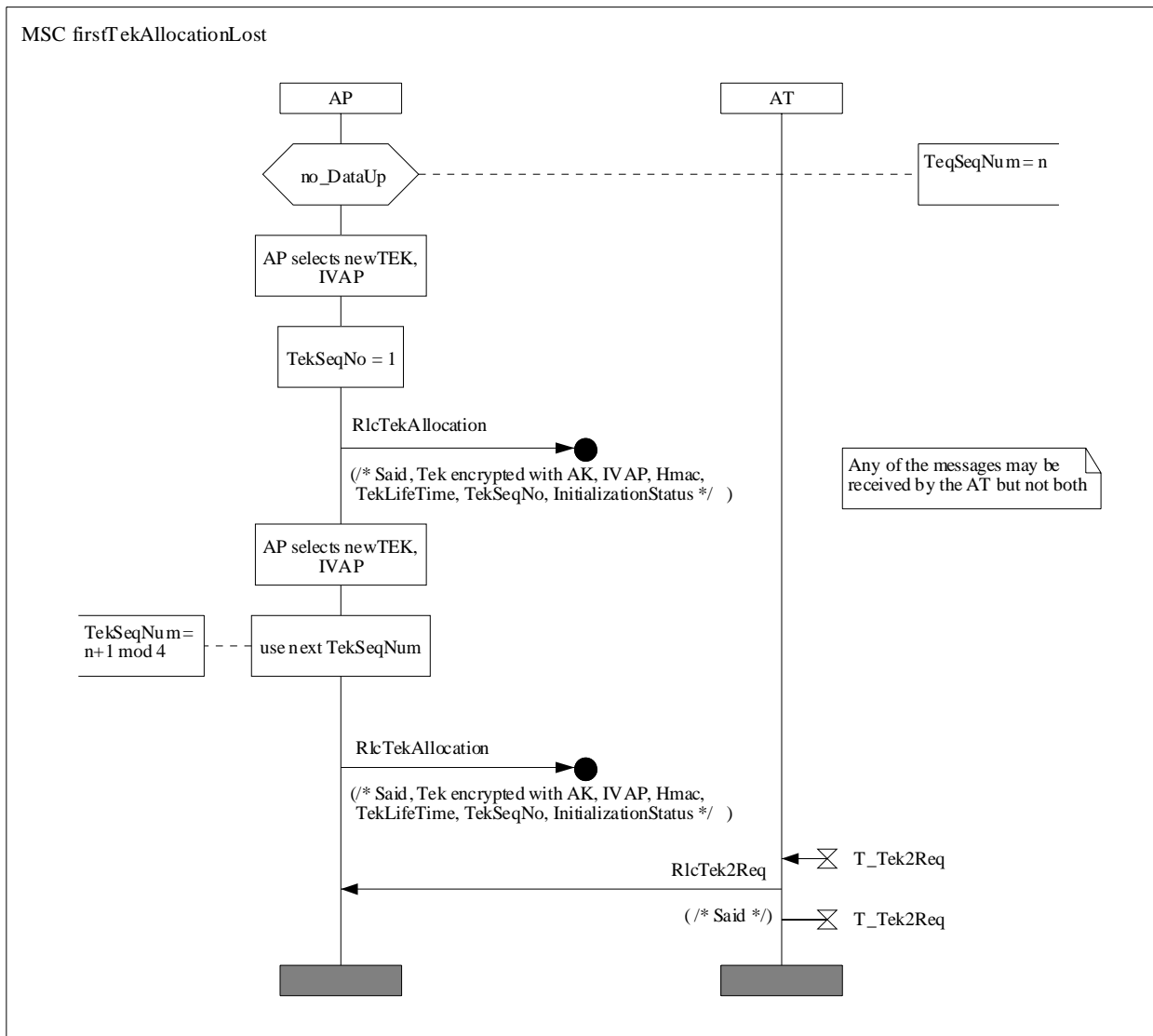

Diagram 26: MSC for retransmission in case of RlcTekAllocation loss during first initialization

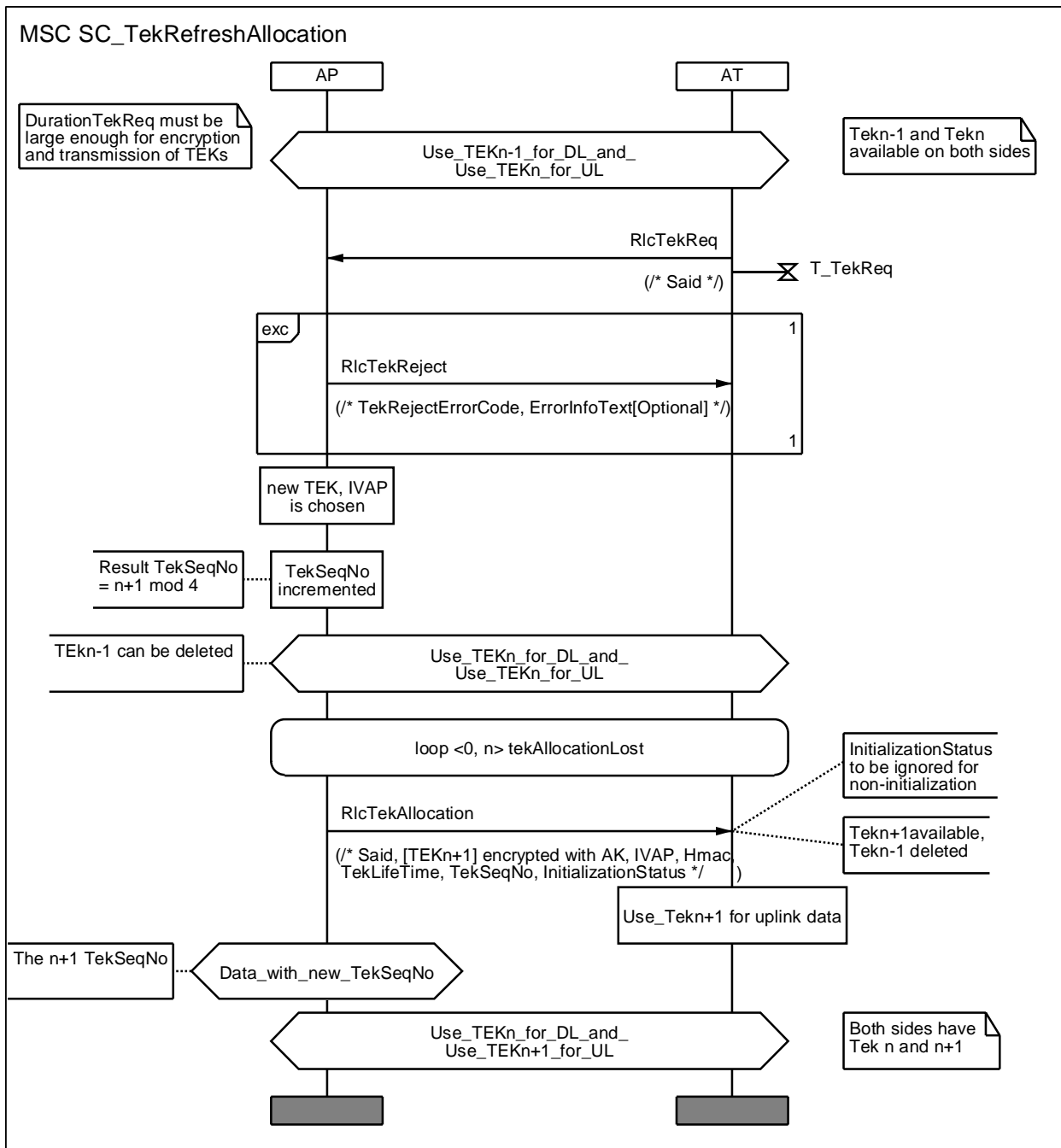

Diagram 27: MSC for key renewal before life time expiration

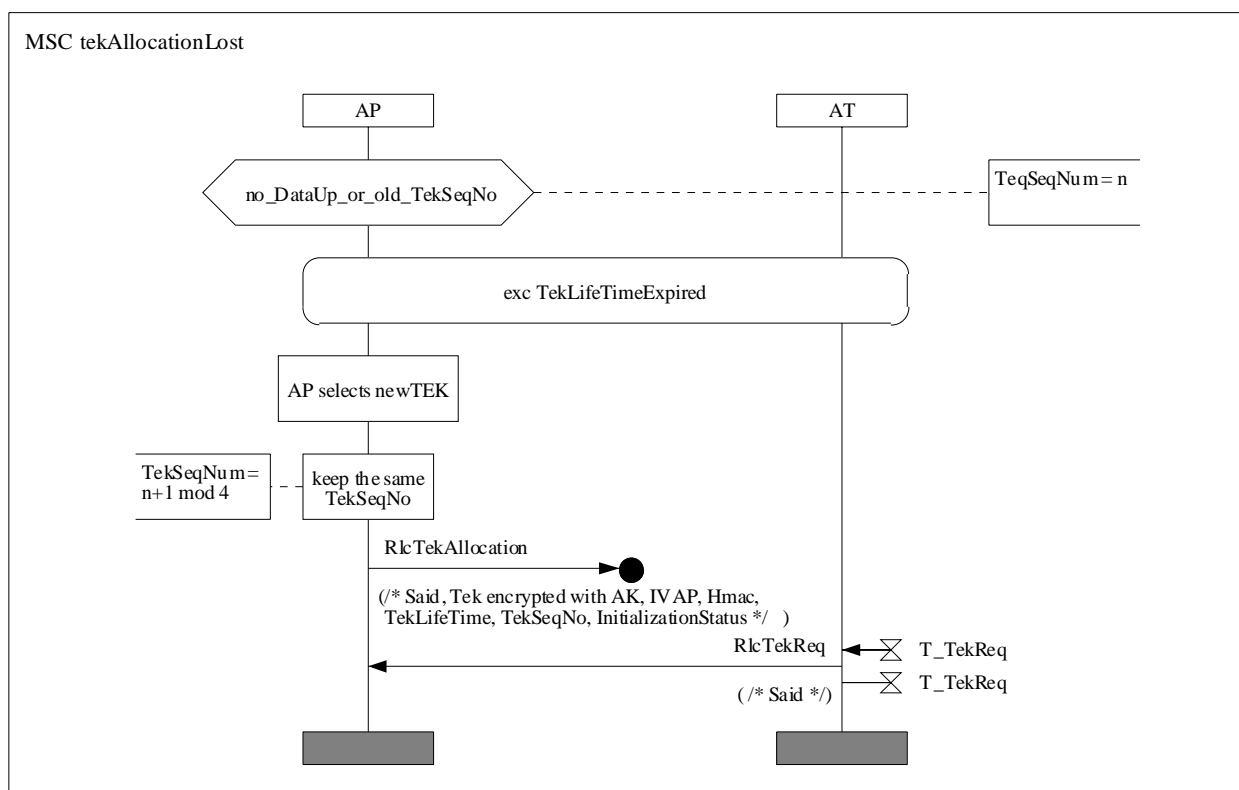

Diagram 28: MSC for retransmission in case of RlcTekAllocation loss during key renewal

The AP shall respond to a first RlcTekReq message with two RlcTekAllocation messages containing each one keying material for the SAID. This keying material includes:

- the triple-DES-encrypted TEK,
- 64-bit IV parameter derived from the random number,
- a 2-bit key sequence number used to distinguish between successive generations of TEKs,
- the TEK's remaining lifetime, and
- an HMAC keyed message ensuring the integrity of the RlcTekAllocation message.

At all times the AP maintains two active sets of keying material per SAID. The two generations of the AT's TEKs shall have overlapping lifetimes (see clause 12.3.1) determined by the TEK Lifetime, which is a predefined AP system configuration parameter. The lifetimes shall overlap so that each generation becomes active halfway through the life of its predecessor and expires halfway through the life of its successor. This is achieved by providing the second delivered TEK with a longer lifetime than the TEK given by the first RlcTekAllocation message, see figure 49.

The AP transitions between the two active TEKs happen differently -depending on whether the TEK is used for downlink or uplink traffic. For each of its SAIDs, the AP shall switch from old TEK to new TEK according to the following rules:

- Downlink: The AP shall use the older of the two active TEKs for encrypting downlink traffic. Before the expiration of the older TEK, the AP shall start to use the newer TEK for encryption (see figure 50).
- Uplink: The transition period begins from the time the AP sends the newer TEK in an RlcTekAllocation message and concludes once the older TEK expires. While in the transition period, the AP shall be able to decrypt uplink frames using either the older or newer TEK.

Note that the AP encrypts with a given TEK for only the second half of that TEK's total lifetime. The AP is able, however, to decrypt with a TEK for the TEK's entire lifetime.

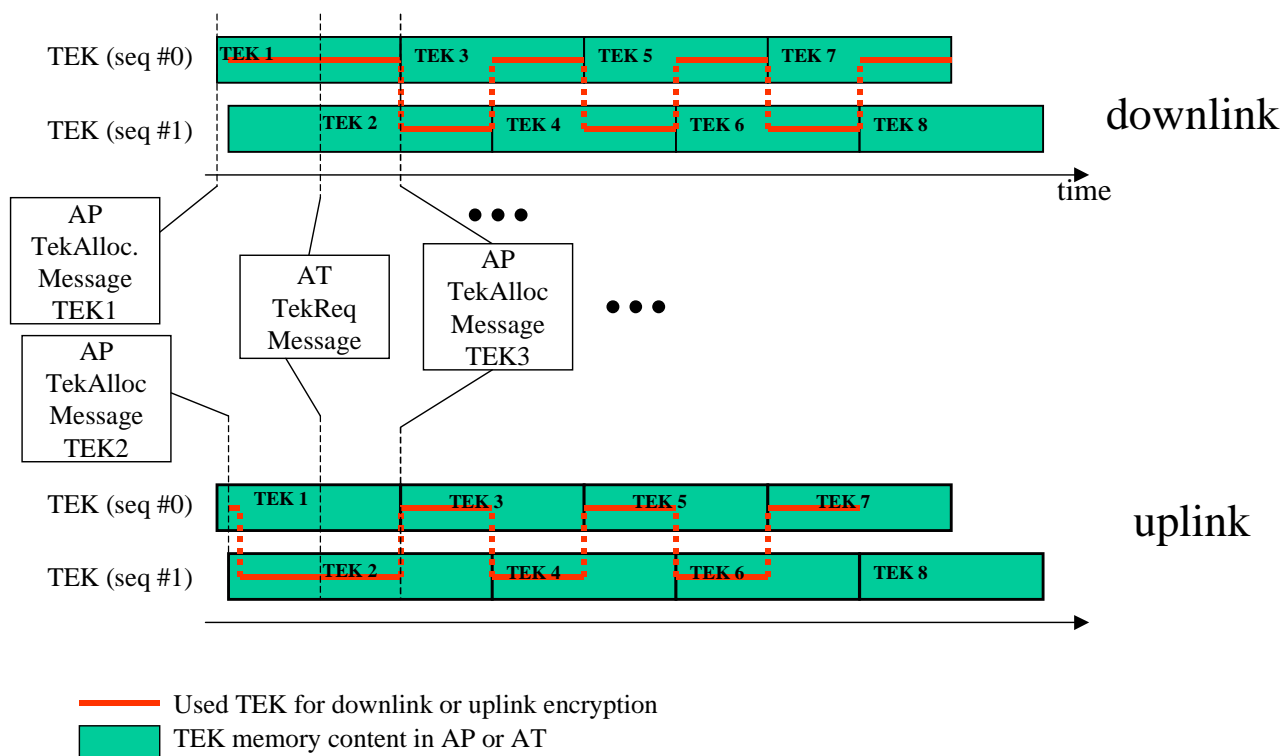

Figure 50: TEK lifetime and switch over (AT viewpoint)

An AT shall be capable of maintaining two successive sets of traffic keying material for the authorized SAID. Through operation of its TEK FSMs, an AT shall attempt to always maintain two sets of traffic keying material.

For its authorized SAID, the AT:

- shall use the newer of its two TEKs to encrypt newly received uplink traffic (traffic already queued up may use either TEK for a brief period of time covering the transition from the old to the new key), and
- shall be able to decrypt downlink traffic encrypted with either of the TEKs.

The receiving AT uses these remaining lifetimes to estimate when the AP will invalidate a particular TEK. It then schedules future RlcTekReq messages so that the new keying material is requested and received before the AP expires the current keying material.

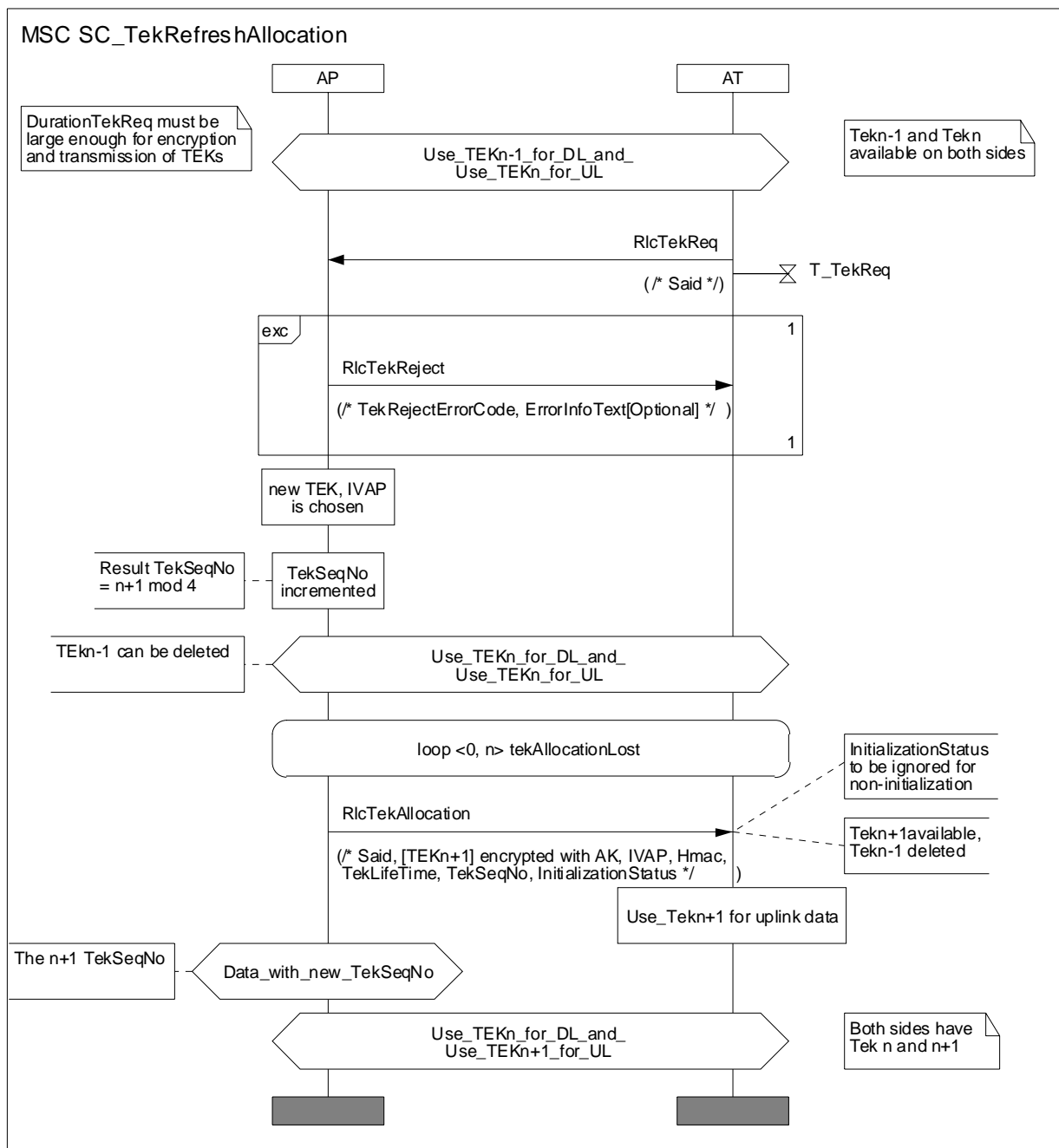

Diagram 29: MSC for TEK re-requesting due to loss of key request or key reply message

The operation of the TEK FSM's Key Request message scheduling algorithm, combined with the AP's regimen for updating and using an SAID's keying material (see clause 12.3.1), insures that the AT will be able to continually exchange encrypted traffic with the AP.

A TEK FSM shall remain active as long as the AT has a valid AK and the AP continues to provide fresh keying material during re-key cycles. The parent Authorization FSM shall stop all of its child TEK FSMs when the AT receives from the AP an RlcAuthReject message during a reauthorization process.

12.2.2 Authorization finite state machine

The Authorization FSM consists of six states and eight distinct events (including receipt of messages) that trigger state transitions. The Authorization FSM is presented below in a graphical format, as a state flow diagram (see figure 51), and in a tabular format, as a state transition matrix (see table 37).

The state flow diagram depicts the protocol messages transmitted and internal events generated for each of the state transitions. However, the diagram does not indicate additional internal actions, such as the clearing or starting of timers, which accompany the specific state transitions. Accompanying the state transition matrix is a detailed description of the specific actions accompanying each state transition. The state transition matrix shall be used as the definitive specification of protocol actions associated with each state transition.

The following legend applies to the FSM flow diagrams depicted in figure 49 and figure 50.

- Ovals are states.
- Events are in italics.
- Messages are in normal font.
- State transitions (i.e. the lines between states) are labelled with <what causes the transition>/<messages and events triggered by the transition>. So "timeout/Auth Request" means that the state received a "timeout" event and sent an Authorization Request message. If there are multiple events or messages before the slash "/" separated by a comma, any of them can cause the transition. If there are multiple events or messages listed after the slash, all of the specified actions must accompany the transition.

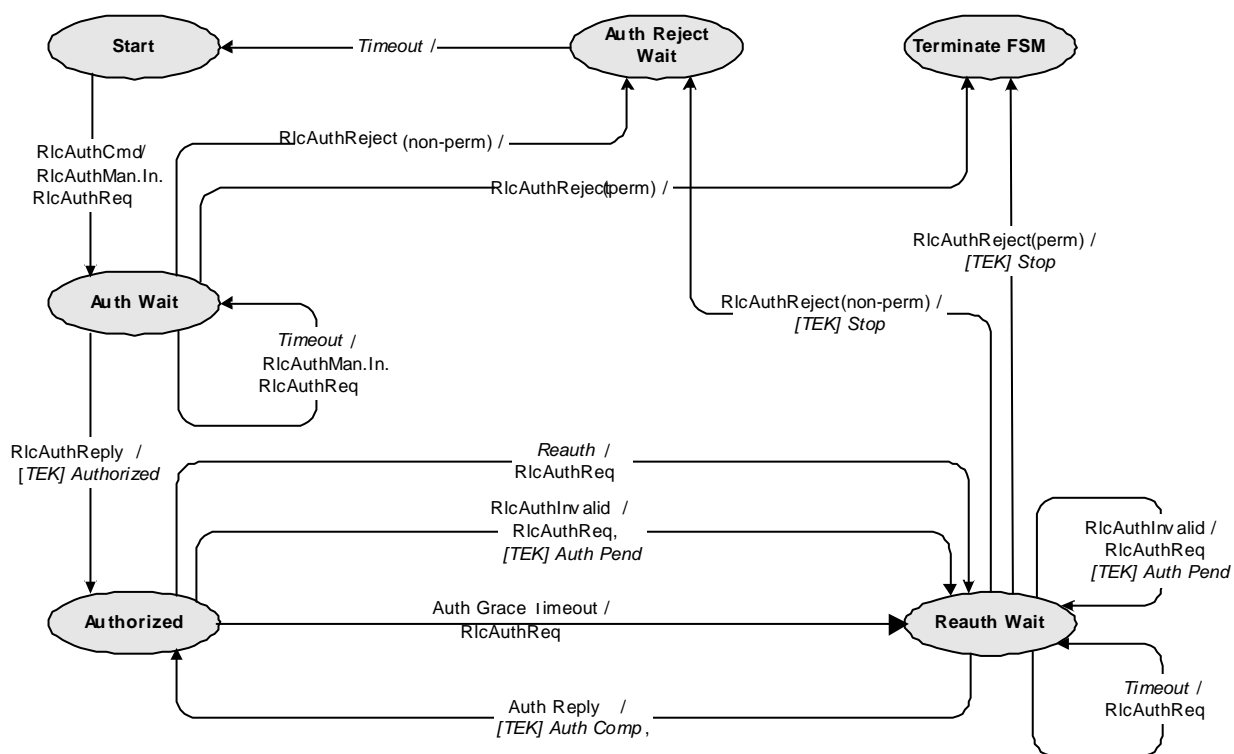

Figure 51: Authorization finite state machine flow diagram (AT side)

The Authorization state transition matrix presented in table 37 lists the six Authorization FSM states as the columns and the eight Authorization FSM events (includes message receipts) as rows. Any cell within the matrix represents a specific combination of a state and an event, with the next state (the state transitioned to) displayed within the cell. For example, cell 4-B represents the receipt of an Authorization Reply message when in the Authorize Wait state. Within cell 4-B is the name of the next state, "Authorized." Thus, when an AT's Authorization FSM is in the Authorize Wait state and an Authorization Reply message is received, the Authorization FSM shall transition to the Authorized state. In conjunction with this state transition, several protocol actions shall be taken; these are described in the listing of protocol actions, under the heading 4-B, in clause 12.2.2.5.

Table 37: Authorization FSM state transition matrix

State Event or Rcvd msg	(A) Starting	(B) Auth Wait	(C) Authorized	(D) Reauth Wait	(E) Auth Reject Wait	(F) Terminate FSM
(1) RlcAuthCmd	Auth Wait					
(2) RlcAuthReject (non-perm)		Auth Reject Wait		Auth Reject Wait		
(3) RlcAuthReject (perm)		Silent		Silent		
(4) RlcAuthReply		Authorized		Authorized		
(5) T_AuthReq		Auth Wait		Reauth Wait	Starting	
(6) T_AuthGrace			Reauth Wait			
(7) RlcAuthInvalid			Reauth Wait	Reauth Wait		
(8) ReAuth			Reauth Wait			
(9) T_AuthReply						

A shaded cell within the state transition matrix implies that either the specific event cannot or should not occur within that state and that if the event does occur the FSM shall ignore it. For example, if an Authorization Reply message arrives when in the Authorized state (see cell 4-C), that message shall be ignored. The AT may, however, in response to an improper event, log its occurrence, generate an SNMP event, or take some other vendor-defined action. These actions, however, are not specified within the context of the Authorization FSM, which shall simply ignore improper events.

12.2.2.1 States

Start: This is the initial state of the FSM. No resources are assigned to or used by the FSM in this state, i.e. all timers are off and no processing is scheduled. The AT waits for an RlcAuthCmd from the AP.

Authorize Wait (Auth Wait): The AT receives the RlcAuthCmd message indicating that it can start with the first authorization. In response to receiving the message, the AT shall send an RlcAuthManufacturerInfo message and an RlcAuthReq message to the AP and shall wait for a response.

Authorized: The AT receives an RlcAuthReply message, which contains a SAID for this AT. At this point, the AT has a valid AK and SAID. Transition into this state shall trigger the creation of a TEK FSM for the AT's privacy-enabled SAIDs.

Reauthorize Wait (Reauth Wait): The AT has an outstanding reauthorization request. The AT either is about to time out its current authorization or has received an indication (i.e. an Authorization Invalid message from the AP) that its authorization is no longer valid. The AT shall send an RlcAuthReq message to the AP and shall wait for a response.

Authorize Reject Wait (Auth Reject Wait): The AT receives an RlcAuthReject message in response to its last RlcAuthReq message. The RlcAuthReject message's error code indicated the error is not of a permanent nature. In response to receiving this reject message, the AT shall set a timer and shall transition to the Authorize Reject Wait state. The AT shall remain in this state until the timer expires.

Terminate FSM: The AT received an RlcAuthReject message in response to its last RlcAuthReq message. The RlcAuthReject message's error code indicated the error is of a permanent nature. This shall trigger a transition to the Terminate FSM state, where the AT is not permitted to pass subscriber traffic.

12.2.2.2 Messages

Authentication Command (RlcAuthCmd): This message commands the AT to start the authentication and authorization process.

Authentication Information (rlcAuthManufacturerInfo): The Authentication Information message contains the AT manufacturer's X.509 Certificate, issued by an external authority. The Authentication Information message is strictly an informative message the AT sends to the AP. With an Authentication Information message, an AP may dynamically learn the manufacturer certificate of an AT. Alternatively, an AP may require out-of-band configuration of its list of manufacturer certificates.

Authorization Request (RlcAuthReq): Sent from an AT to its AP to request an AK and the authorized SAID.

Authorization Reply (RlcAuthReply): Sent from an AP to an AT to reply an AK and an authorized SAID. The AK is encrypted with the AT's public key.

Authorization Reject (RlcAuthReject): Sent from an AP to an AT in rejection of an Authorization Request message sent by the AT. The error code in the Authorization Reject message indicates the error. If the indicated error is of type "permanentRejection" this error should be subject to administrative control within the AP. Authorization Request message processing errors that can be interpreted as permanent error conditions may include:

- unknown manufacturer (do not have Certification Authority certificate of the issuer of the AT Certificate);
- invalid signature on AT certificate.

When an AT receives an Authorization Reject message indicating a permanent failure condition, the Authorization FSM moves into a TerminateFSM state where the AT is not permitted to pass Subscriber traffic. The AT shall, however, respond to MAC management messages from the AP issuing the Authorization Reject message.

If the indicated error in the RlcAuthReject is of type "reAuthorizationRequested" sent from an AP to an AT in rejection of an Authorization Request the error is not of a permanent nature. As a result, the AT's Authorization FSM shall set a wait timer and transition into the Authorization Reject Wait State. The AT shall remain in this state until the timer expires, at which time it may re-attempt authorization.

Authorization Invalid (RlcAuthInvalid): The AP may send an RlcAuthInvalidmessage to an AT as:

- 1) an unsolicited indication, or
- 2) a response to a message received from that AT.

In either case, the RlcAuthInvalidmessage instructs the receiving AT to reauthorize with the AP. The AP shall respond to a Key Request message with an Authorization Invalid message if (1) the AP does not recognize the AT as being authorized (i.e. no valid AK associated with AT) or (2) verification of the RlcTekRequest message's keyed message digest (in HMAC-Digest Attribute) failed. Note that the Authorization Invalid event, referenced in both the state flow diagram and the state transition matrix (FSM), signifies either the receipt of an RlcAuthInvalid message or an internally generated event.

12.2.2.3 Configuration parameters

If Privacy is enabled, all Privacy configuration parameters shall be present and shall be supported by all ATs.

Authorize Wait Timeout: Timeout period between sending of two consecutive Authorization Request messages from Authorize Wait state.

Reauthorize Wait Timeout: Timeout period between sending of two consecutive Authorization Request messages from Reauthorize Wait state.

Authorization Grace Time: Amount of time before authorization is scheduled to expire that the AT starts reauthorization process.

Authorize Reject Wait Timeout: Amount of time an AT's Authorization FSM remains in the Authorize Reject Wait state before transitioning to the Start state.

12.2.2.4 Events

Timeout: A retransmission or wait timer timed out. Generally a request is resent.

Authorization Grace Timeout (Auth Grace Timeout): The Authorization Grace timer times out. This timer fires a configurable amount of time (the Authorization Grace Time) before the current authorization is supposed to expire, signalling the AT to reauthorize before its authorization actually expires.

Authorization Invalid (Auth Invalid): This event can be internally generated by the AT when there is a failure authenticating an RlcTekReplymessage or RlcTekReqmessage. It can also be externally generated by the receipt of an RlcAuthInvalidmessage sent from the AP to the AT. An AP shall respond to an RlcTekReqmessage with an RlcAuthInvalidmessage if verification of the request's message authentication code fails. Both cases indicate AP and AT have lost AK synchronization. An AP may also send an unsolicited RlcAuthInvalidmessage to an AT, forcing an RlcAuthInvalidevent.

NOTE: the following events are sent by an Authorization FSM to its child TEK FSMs.

[TEK] Stop: Sent by the Authorization FSM to an active (non-Start state) TEK FSM to terminate the FSM and remove the corresponding SAID keying material from the AT's key table.

[TEK] Authorized: Sent by the Authorization FSM to a non-active (Start state), but valid TEK FSM.

[TEK] Authorization Pending (Auth Pend): Sent by the Authorization FSM to a specific TEK FSM to place that TEK FSM in a wait state until the Authorization FSM can complete its reauthorization operation.

[TEK] Authorization Complete (Auth Comp): Sent by the Authorization FSM to a TEK FSM in the Operational Reauthorize Wait (Op Reauth Wait) or Rekey Reauthorize Wait (Rekey Reauth Wait) state to clear the wait state triggered by a [TEK] Authorization Pending event.

12.2.2.5 Actions

Actions taken in association with state transitions are listed by <event/rcvd message>-<state> below:

1-A received RlcAuthCmd message, transition from Start to Auth Wait:

- send an RlcAuthManufacturerInfo message to the AP,
- send an RlcAuthReq message to the AP,
- set the RlcAuthReq retry timer to Authorize Wait Timeout.

2-B received RlcAuthReject (non-perm) message, transition from Auth Wait to Auth Reject Wait:

- clear Authorization Request retry timer,
- set a wait timer to Authorize Reject Wait Timeout.

2-D received RlcAuthReject (non-perm) message, transition from Reauth Wait to Auth Reject Wait:

- clear RlcAuthReq retry timer,
- generate TEK Stop events for all active TEK FSMs,
- set a wait timer to Authorize Reject Wait Timeout.

3-B received RlcAuthReject () message, transition from Auth Wait to TerminateFSM state:

- clear RlcAuthReq retry timer,
- disable all forwarding of AT traffic.

3-D received Auth Reject (permanentRejection) message, transition from Reauth Wait to Silent:

- clear RlcAuthReq retry timer,
- generate TEK Stop events for all active TEK FSMs,
- disable all forwarding of AT traffic.

4-B received RlcAuthReply message, transition from Auth Wait to Authorized:

- clear Authorization Request retry timer,
- decrypt and record AK delivered with RlcAuthReply message,
- start TEK FSMs for all SAIDs listed in RlcAuthReply message and issue a TEK Authorized event for each of the new TEK FSMs,
- set the Authorization Grace timer to go off "Authorization Grace Time" seconds prior to the supplied AK's scheduled expiration time.

4-D received Auth Reply message, transition from Reauth Wait to Authorized:

- clear Authorization Request retry timer,
- decrypt and record AK delivered with RlcAuthReply message,
- generate a TEK Authorization Complete event for each currently active TEK FSM whose corresponding SAIDs are listed in Authorization Reply message,
- generate a TEK Stop event for each currently active TEK FSM whose corresponding SAID are not listed in Authorization Reply message,
- set the Authorization Grace timer to go off "Authorization Grace Time" seconds prior to the supplied AK's scheduled expiration time.

5-B received Timeout event, transition from Auth Wait to Auth Wait:

- send RlcAuthManufacturerInfo message to the AP,
- send RlcAuthReq message to the AP,
- set Authorization Request retry timer to Authorize Wait Timeout.

5-D received Timeout event, transition from Reauth Wait to Reauth Wait:

- send RlcAuthReq message to the AP,
- set RlcAuthReq retry timer to Reauthorize Wait Timeout.

5-E received Timeout event, transition from Auth Reject Wait to Start:

- no protocol actions associated with this state transition.

6-C received Auth Grace Timeout event, transition from Authorized to Reauth Wait:

- send RlcAuthReq message to the AP,
- set RlcAuthReq retry timer to Reauthorize Wait Timeout.

7-C received Auth Invalid event, transition from Authorized to Reauth Wait:

- clear Authorization Grace timer,
- send RlcAuthReq message to the AP,
- set RlcAuthReq retry timer to Reauthorize Wait Timeout,
- if the Authorization Invalid event is associated with a particular TEK FSM, generate a TEK FSM Authorization Pending event for the TEK FSM responsible for the Authorization Invalid event (i.e. the TEK FSM that either generated the event, or sent the Key Request message the AP responded to with an Authorization Invalid message).

7-D received Auth Invalid event, transition from Reauth Wait to Reauth Wait:

- if the Authorization Invalid event is associated with a particular TEK FSM, generate a TEK FSM Authorization Pending event for the TEK FSM responsible for the Authorization Invalid event (i.e. the TEK FSM that either generated the event, or sent the Key Request message the AP responded to with an Authorization Invalid message),

8-C received Reauth event, transition from Authorized to Reauth Wait:

- clear Authorization Grace timer,
- send RlcAuthReq message to the AP,
- set RlcAuthReq retry timer to Reauthorize Wait Timeout.

12.2.3 TEK Finite State Machine

The TEK FSM consists of seven states and nine events (including receipt of messages) that may trigger state transitions. Like the Authorization FSM, the TEK FSM is presented in both a state flow diagram (see figure 52) and a state transition matrix (see table 38). And as was the case for the Authorization FSM, the state transition matrix shall be used as the definitive specification of protocol actions associated with each state transition.

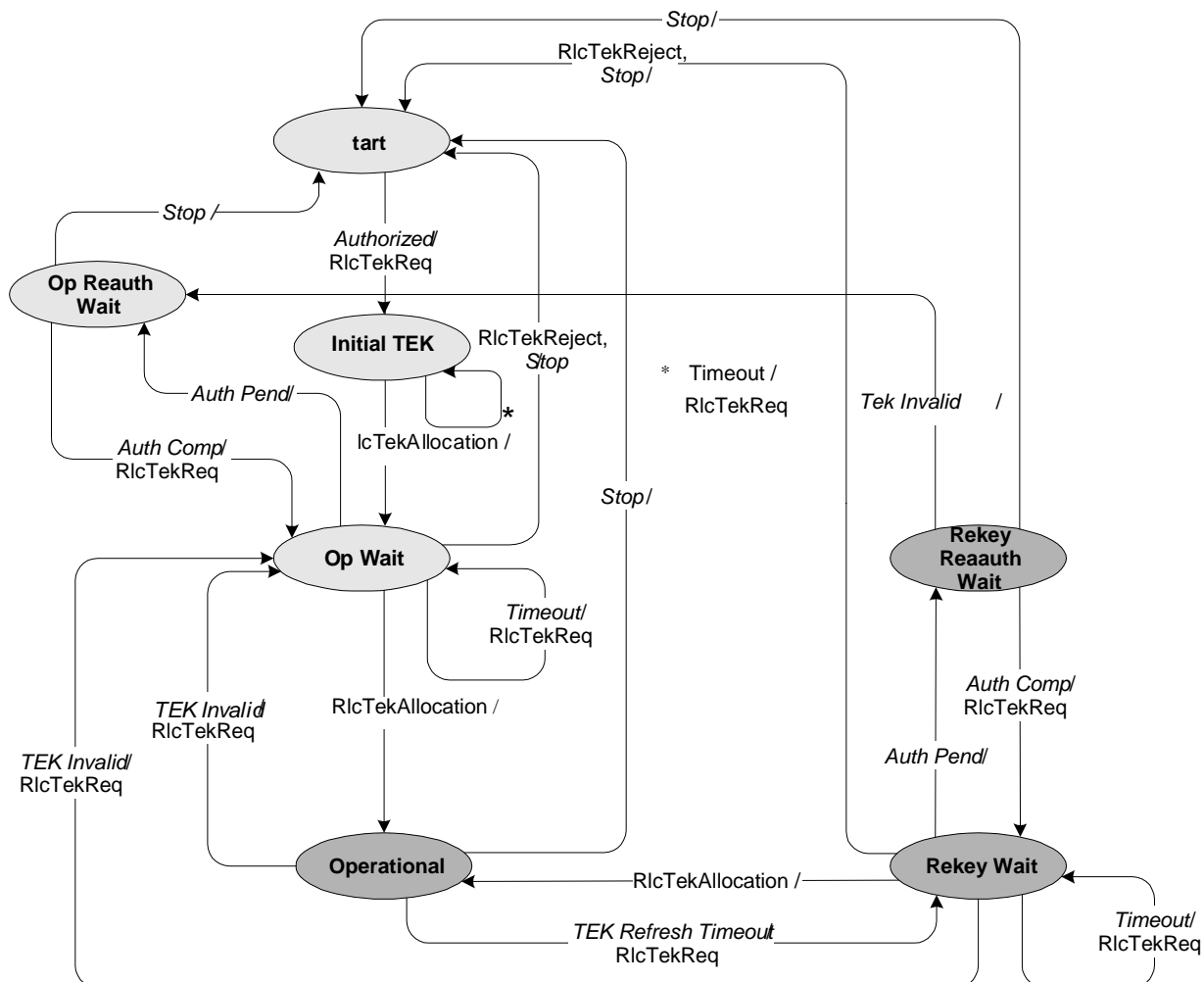

Figure 52: TEK Finite State Machine Flow Diagram

Heavily shaded states in figure 52 (i.e. Operational, Rekey Wait, and Rekey Reauthorize Wait states) have valid keying material and encrypted traffic may be transmitted.

The Authorization FSM starts an independent TEK FSM for the authorized SAID.

As mentioned previously in clause 12.2.1.3 the AP maintains two active TEKs per SAID. The AP includes in its Key Reply messages both of these TEKs along with their remaining lifetimes. The AP encrypts downlink traffic with the older of its two TEKs and decrypts uplink traffic with either the older or newer TEK, depending upon which of the two keys the AT was using at the time. The AT encrypts uplink traffic with the newer of its two TEKs and decrypts downlink traffic with either the older or newer TEK, depending upon which of the two keys the AP was using at the time. See clause 6 for details on AT and AP key usage requirements.

Through operation of a TEK FSM, the AT attempts to keep its copies of an SAID's TEKs synchronized with those of its AP. A TEK FSM issues RlcTekReq messages to refresh copies of its SAID's keying material soon after the scheduled expiration time of the older of its two TEKs and before the expiration of its newer TEK. To accommodate for AT/AP clock skew and other system processing and transmission delays, the AT schedules its RlcTekReq messages a configurable number of seconds before the newer TEK's estimated expiration in the AP. With the receipt of the Key Reply message, the AT shall always update its records with the TEK Parameters from both TEKs contained in the Key Reply Message. Figure 52 illustrates the AT's scheduling of its key refreshes in conjunction with its management of an SAID's active TEKs.

Table 38: TEK FSM State Transition Matrix

State Event or Rcvd msg	(A) Start	(G) Initial TEK	(B) Op Wait	(C) Op Reauth Wait	(D) Opera- tional	(E) Rekey Wait	(F) Rekey Reauth Wait
(1) Stop			Start	Start	Start	Start	Start
(2) Authorized	Initial TEK						
(3) Auth Pend			Op Reauth Wait			Rekey Reauth Wait	
(4) Auth Comp				Op Wait			Rekey Wait
(5) RlcTekInvalid					Op Wait	Op Wait	Op Reauth Wait
(6) Timeout			Op Wait			Rekey Wait	
(7) TEKRefresh Timeout					Rekey Wait		
(8) RlcTekAllocation		Op Wait	Operational			Operational	
(9) RlcTekReject			Start			Start	

12.2.3.1 States

Start: This is the initial state of the FSM. No resources are assigned to or used by the FSM in this state, i.e. all timers are off and no processing is scheduled.

Initial Tek: This is the intermediate state to Op Wait state. The TEK FSM has sent its initial request for its SAID keying material and is waiting for a initial, first TEK allocation message from the AP.
Operational Wait (Op Wait): The TEK FSM has sent its request (RlcTekReq message) for its SAID's keying material (TEK and CBC IV parameter), and is waiting for a reply from the AP.

Operational Reauthorize Wait (Op Reauth Wait): The wait state the TEK FSM is placed in if it does not have valid keying material while the Authorization FSM is in the middle of a reauthorization cycle.

Operational: The AT has valid keying material for the associated SAID.

Rekey Wait: The TEK Refresh Timer has expired and the AT has requested a key update for this SAID. Note that the newer of its two TEKs has not expired and can still be used for both encrypting and decrypting data traffic.

Rekey Reauthorize Wait (Rekey Reauth Wait): The wait state the TEK FSM is placed in if the TEK FSM has valid traffic keying material, has an outstanding request for the latest keying material, and the Authorization FSM initiates a reauthorization cycle.

12.2.3.2 Messages

Key Request: An RlcTekReq message is sent from an AT to its AP requesting a TEK for the privacy of its authorized SAID.

Key Reply: An RlcTekAllocation message is sent from an AP to an AT carrying only the new traffic keying material for the SAID. The message includes the SAID's TEKs, triple DES encrypted with the AK. The RlcTekAllocation message is authenticated with an HMAC. Additionally the "initializationStatus" bit is provided with this message. This status information is only used during the first TEK allocation procedure. It indicates that the other capability negotiations can start hereafter.

Key Reject: An RlcTekReject message is sent from an AP to an AT indicating that the SAID is no longer valid and no key will be sent. The RlcTekReject message is authenticated with a HMAC.

TEK Invalid: An RlcTekInvalid message is sent from an AP to an AT if it determines that the AT encrypted uplink traffic with an invalid TEK, i.e. an SAID's TEK key sequence number, contained within the received MAC PDU Header, is out of the AP's range of known, valid sequence numbers for that SAID.

12.2.3.3 Configuration parameters

If Privacy is enabled, all Privacy configuration parameters shall be present and shall be supported by all ATs.

Operational Wait Timeout: Timeout period between sending of two consecutive RlcTekReq messages from the Op Wait state.

Rekey Wait Timeout: Timeout period between sending of two consecutive RlcTekReq messages from the Rekey Wait state.

TEK Grace Time: Time interval before the estimated expiration of a TEK that the AT starts rekeying for a new TEK. TEK Grace Time shall be the same across all SAIDs.

12.2.3.4 Events

Stop: Sent by the Authorization FSM to an active (non-Start state) TEK FSM to terminate the TEK FSM and remove the corresponding SAID's keying material from the AT's key table.

Authorized: Sent by the Authorization FSM to a non-active (Start state) TEK FSM to notify the TEK FSM of successful authorization.

Authorization Pending (Auth Pend): Sent by the Authorization FSM to a TEK FSM to place the TEK FSM in a wait state while Authorization FSM completes reauthorization.

Authorization Complete (Auth Comp): Sent by the Authorization FSM to a TEK FSM in the Operational Reauthorize Wait or Rekey Reauthorize Wait state to clear the wait state begun by the prior Authorization Pending event.

TEK Invalid: This event may be triggered by either an AT's data packet decryption logic or by the receipt of an RlcTekInvalid message from the AP. An AT's data packet decryption logic shall trigger a TEK Invalid event if it recognizes a loss of TEK key synchronization between itself and the encrypting AP, i.e. an SAID's TEK key sequence number, contained within the received downlink MAC PDU Header, is out of the AT's range of known sequence numbers for that SAID. An AP shall send an AT an RlcTekInvalid message, triggering a TEK Invalid event within the AT, if the AP's decryption logic recognizes a loss of TEK key synchronization between itself and the AT.

Timeout: A retry timer timeout. Generally, the particular request is retransmitted.

TEK Refresh Timeout: The TEK refresh timer timed out. This timer event signals the TEK FSM to issue a new RlcTekReq message in order to refresh its keying material. The refresh timer is set to fire a configurable length of time (TEK Grace Time) before the expiration of the newer TEK the AT currently holds. This is configured via the AP to occur after the scheduled expiration of the older of the two TEKs.

12.2.3.5 Actions

- 1-B received Stop event, transition from Op Wait to Start:
- clear Key Request retry timer,
 - terminate the TEK FSM.
- 1-C received Stop event, transition from Op Reauth Wait to Start:
- terminate the TEK FSM.
- 1-D received Stop event, transition from Operational to Start:
- clear TEK refresh timer, which is a timer set to go off "TEK Grace Time" seconds prior to the TEK's scheduled expiration time,
 - terminate the TEK FSM,
 - remove the SAID keying material from key table.
- 1-E received Stop event, transition from Rekey Wait to Start:
- clear Key Request retry timer,
 - terminate the TEK FSM,
 - remove the SAID keying material from key table.
- 1-F received Stop event, transition from Rekey Reauth Wait to Start:
- terminate the TEK FSM,
 - remove the SAID keying material from key table.
- 2-A received Authorized event, transition from Start: to Op Wait:
- send RlcTekReq message to the AP,
 - set Key Request retry timer to Operational Wait Timeout.
- 3-B received Auth Pend event, transition from Op Wait to Op Reauth Wait:
- clear Key Request retry timer.
- 3-E received Auth Pend event, transition from Rekey Wait to Rekey Reauth Wait:
- clear Key Request retry timer.
- 4-C received Auth Comp event, transition from Op Reauth Wait to Op Wait:
- send RlcTekReq message to the AP,
 - set Key Request retry timer to Operational Wait Timeout.
- 4-F received Auth Comp event, transition from Rekey Reauth Wait to Rekey Wait:
- send RlcTekReq message to the AP,
 - set Key Request retry timer to Rekey Wait Timeout.
- 5-D received TEK Invalid event, transition from Operational to Op Wait:
- clear TEK refresh timer,
 - send RlcTekReq message to AP,
 - set Key Request retry timer to Operational Wait Timeout,

- remove the SAID keying material from key table.
- 5-E received TEK Invalid event, transition from Rekey Wait to Op Wait:
- clear Key Request retry timer,
 - send RlcTekReq message to the AP,
 - set Key Request retry timer to Operational Wait Timeout,
 - remove the SAID keying material from key table.
- 5-F received TEK Invalid event, transition from Rekey Reauth Wait to Op Reauth Wait:
- remove the SAID keying material from key table.
- 6-B received Timeout event, transition from Op Wait to Op Wait:
- send RlcTekReq message to the AP,
 - set Key Request retry timer to Operational Wait Timeout.
- 6-E received Timeout event, transition from Rekey Wait to Rekey Wait:
- send RlcTekReq message to the AP,
 - set Key Request retry timer to Rekey Wait Timeout.
- 7-D received TEK Grace Timeout event, transition from Operational to Rekey Wait:
- send RlcTekReq message to the AP,
 - set Key Request retry timer to Rekey Wait Timeout.
- 8-B received RlcTekAllocation message, transition from Op Wait to Operational
- clear Key Request retry timer,
 - process contents of RlcTekAllocation message and incorporate new keying material into key database,
 - set the TEK refresh timer to go off "TEK Grace Time" seconds prior to the key's scheduled expiration.
- 8-E received RlcTekAllocation message, transition from Rekey Wait to Operational
- clear Key Request retry timer,
 - process contents of RlcTekAllocation message and incorporate new keying material into key database,
 - set the TEK refresh timer to go off "TEK Grace Time" seconds prior to the key's scheduled expiration time.
- 9-B received RlcTekReject message, transition from Op Wait to Start:
- clear Key Request retry timer,
 - terminate the TEK FSM.
- 9-E received RlcTekReject message, transition from Rekey Wait to Start:
- clear Key Request retry timer,
 - terminate the TEK FSM,
 - remove the SAID keying material from key table.
- 8-G received RlcTekAllocation message, transition from Initial TEK to OP Wait.

12.3 TEK usage

12.3.1 TEK usage for APs

The AP's first receipt of an Authorization Request message from an unauthorized AT shall initiate the activation of a new AK, which the AP sends back to the requesting AT in an Authorization Reply message. This AK shall remain active until it expires according to its predefined lifetime, AK Lifetime, which is an AP system configuration parameter.

The AP shall use the AT's AK for:

- encrypting (triple-DES with EDE-mode) the TEKs in the RlcTekAllocation messages it sends to that AT, and
- calculating the HMAC-Digests it writes into RlcTekAllocation messages sent to that AT.

The AP shall reply to the AT's request of an AK. The AP shall be able to support up to two simultaneously active AKs for each AT. The AP shall have two active AKs during any AK transition period. The two active keys shall have overlapping lifetimes.

An AK transition period begins when the AP receives an RlcAuthReq message from an AT and the AP has a single active AK for that AT. In response to this RlcAuthReq message, the AP activates a second AK, which it shall send back to the requesting AT in an RlcAuthReply message. The AP shall set the active lifetime of this second AK to be the remaining lifetime of the first AK, plus the predefined AK Lifetime. Thus, the second, "newer" key will remain active for one AK Lifetime beyond the expiration of the first, "older" key. The key transition period will end with the expiration of the older key.

The Authorization Key lifetime that an AP reports in its RlcAuthReply message shall reflect, as accurately as an implementation permits, the remaining lifetimes of the AK at the time the message is sent.

As long as the AP is in the midst of an AT's AK transition period, and thus is holding two active AKs for that AT, it shall respond to RlcAuthReq messages with the newer of the two active keys. Once the older key expires, an RlcAuthReq message shall trigger the activation of the newer AK and start a new key transition period.

If an AT fails to reauthorize before the expiration of its most current AK, the AP shall hold no active AKs for the AT and shall consider the AT unauthorized. An AP shall remove from its keying tables all TEKs associated with an unauthorized AT.

An AP shall use one of the AT's two active AKs to verify the HMAC-digest in RlcTekReq messages received from the AT. If an AP receives an RlcTekReq message while in an AK transition period, and the accompanying AK Key Sequence Number indicates the RlcTekReq message is authenticated with the newer of the two AKs, the AP identifies this as an implicit acknowledgment that the AT has obtained the newer of the AT's two active AKs.

An AP shall use an active AK when calculating HMAC-Digests in Key Reply and RlcTekReject messages, and when encrypting the TEK in RlcTekAllocation messages. When sending Key Reply and RlcTekReject messages within a key transition period (i.e. when two active AKs are available), if the newer key has been implicitly acknowledged, the AP shall use the newer of the two active AKs. If the newer key has not been implicitly acknowledged, the AP shall use the older of the two active AKs.

The AP shall maintain two valid TEKs per SAID. The two valid TEKs shall have overlapping lifetimes determined by the TEK Lifetime, which is a predefined AP system configuration parameter. The newer TEK shall have a key sequence number one greater than (modulo 4) that of the older TEK. Each TEK shall become active half way through the lifetime of its predecessor, and shall expire half way through the lifetime of its successor. Once a TEK's lifetime expires, the TEK shall become inactive and shall no longer be used.

The Privacy Key Management protocol defined in the present document describes a mechanism for synchronizing this keying information between an AP and its ATs. It shall be the responsibility of the AT to update its keys in a timely fashion. The AP shall transition to a new downlink encryption key regardless of whether an AT has retrieved a copy of that TEK.

12.3.2 TEK usage for ATs

All ATs shall be responsible for sustaining authorization with their AP(s) and maintaining an active AK. An AT shall be prepared to use its two most recently obtained AKs. All AKs shall have a limited lifetime and must be periodically refreshed. An AT refreshes its AK by re-issuing an RlcAuthReq message to its AP. The Authorization FSM (see clause 12.2.2) manages the scheduling of RlcAuthReq messages for refreshing AKs.

An AT's Authorization FSM schedules at the beginning of reauthorization a configurable length of Authorization Grace Time (AGT) before the AT's latest AK is scheduled to expire. The AGT is configured to provide an AT with an authorization retry period that is sufficiently long to allow for system delays and provide adequate time for the AT to successfully complete an Authorization exchange before the expiration of its most current AK.

Note that the AP does not require knowledge of the AGT. The AP, however, shall track the lifetimes of its AKs and shall deactivate a key once it has expired.

An AT shall use the newer of its two most recent AKs when calculating the HMAC-Digests it attaches to RlcTekReq messages. It shall be able to use either of its two most recent AKs to authenticate Key Reply and RlcTekReject messages, and to decrypt an RlcTekAllocation message's encrypted TEK. The AT shall use the accompanying AK Key Sequence Number to determine which of the two AKs to use.

12.3.3 Encryption and decryption with TEK

Only the payload part (with 51 bytes) of every unicast MAC data PDU shall be encrypted.

A block cipher is used, based on the single-DES (64 bit from the first part of the TEK field) with CBC mode. The CBC IV of 64 bit shall be calculated from the 24-bit frame counter for the frame that is used for the transmission and the 64-bit IV parameter. The IV parameter shall be generated by the AP randomly and it shall be sent by the AP to the AT in RlcTekAllocation message. The CBC IV is a XOR of the IV parameter and the frame counter (with padding of 40 zeros).

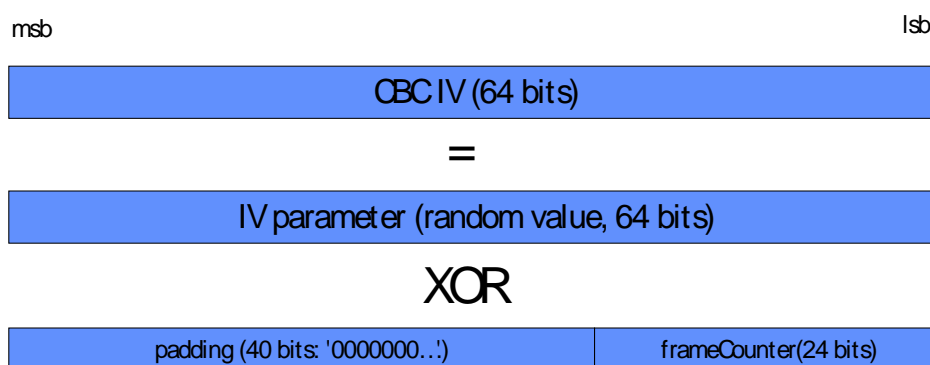

Figure 53: CBC IV generation

If the use of triple-DES (128 bit TEK) was negotiated during initialization, then the encrypt-decrypt-encrypt (EDE) mode shall be applied. The CBC-mode and the IV generation shall be identical to the single-DES usage.

The implementation of triple-DES for the encryption and decryption of MAC data PDUs is optional both for AP and AT.

13 Connection Control (CC)

Connections can be created, changed or deleted, where this can be initiated by AP or AT. This shall be accomplished through a series of MAC management messages that are defined in the next clauses together with the procedures for Connection Set-up, Connection Change and Connection Release.

The following rules shall be applied:

- The AP has all necessary knowledge to determine what has to be done at any time as far as the connection establishment or change or deletion procedures are concerned. The AP shall either approve or disapprove all connection management proposals by the AT.
- Either the AP or the AT can initiate a connection termination procedure only in response to the reception of a deletion primitive from the higher layers (except for re-initialization procedures). The connection deletion procedure priority is higher than all other connection control procedures.

When setting a connection the QoS parameters for the MAC PDUs exchanged on the connection itself are implicitly defined.

13.1 Common part layer primitives (informative only)

The HA DLC layer supports 18 different service primitives at the DLC Service Access Point. These primitives can be divided up into four different groups according to the related procedure. The complete list is reported in hereafter:

- Connection addition:
 - DlcConnectionAdditionInitReq
 - DlcConnectionAdditionInitInd
 - DlcConnectionAdditionReq
 - DlcConnectionAdditionInd
 - DlcConnectionAdditionRsp
 - DlcConnectionAdditionCnf
- Connection change:
 - DlcConnectionChangeInitReq
 - DlcConnectionChangeInitInd
 - DlcConnectionChangeReq
 - DlcConnectionChangeInd
 - DlcConnectionChangeRsp
 - DlcConnectionChangeCnf
- Connection deletion:
 - DlcConnectionDeletionReq
 - DlcConnectionDeletionInd
 - DlcConnectionDeletionRsp
 - DlcConnectionDeletionCnf

- Data:
 - DlcDataReq
 - DlcDataInd

When a request for establish/change/delete for a specific connection is received at one of the end points the "request" or the "init request" primitive is generated within the requesting entity. The term "init" in the primitive name means that the requesting entity is the AT and a different kind of Connection Establishment/Change procedure is initiated. This request is transmitted by means of management messages to the peer RLC Layer, and, as a consequence, an "indication" or "init indication" primitive is generated. The answer of the non-initiating DLC entity is reported within the Response primitive. In this primitive is also contained (if possible) the reasons why the request is accepted or refused. Finally an RLC message is transmitted to the originating side and as a consequence a "confirm" primitive is generated to the original requesting entity.

In some cases, it is not necessary to send any information and the "confirm" primitive is issued directly by the RLC on the originating side. Such cases may occur, for example, when the RLC entity on the requesting side rejects the request. In figure 54 there is a description of the use of primitives.

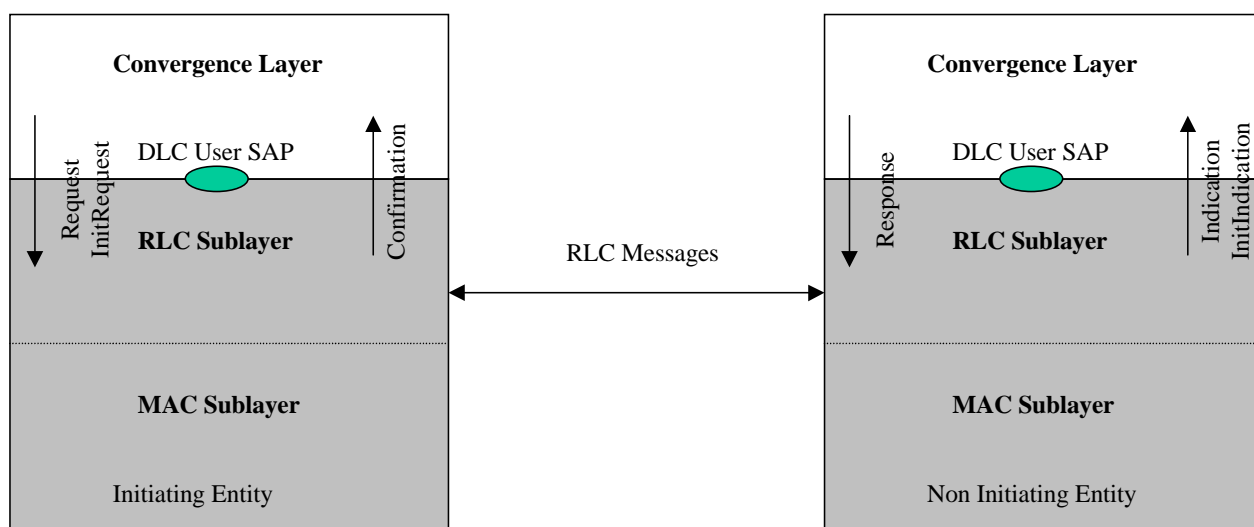

Figure 54: Use of primitives

13.1.1 Use of primitives

In this clause an example of how the primitives and messages are generated and exchanged in case a connection has to be created is given. Two different cases have to be considered:

- The initiating side is the AT: the initiating Convergence Layer entity sends a `DlcConnectionAdditionInitReq` primitive to the relevant RLC Layer. The initiating side RLC Layer sends the appropriate `RlcConnectionAdditionInit` message. The non-initiating RLC side generates an "init indication" primitive towards the relevant Convergence Layer and waits for a `DlcConnectionAdditionReq` primitive. If there is the possibility to establish the requested connection, then an `RlcConnectionAdditionSetup` message is sent. The initiating side responds to the relevant CL with an "indication" primitive. The reply coming from the upper layer is contained in the `DlcConnectionAdditionRsp` and as a consequence the `RlcConnectionAdditionAck` message shall be sent at RLC level. When it is received, a "confirmation" primitive is generated towards the CL of the initiating entity (AT) and this represents the end of the events sequence. At any point along the way, the request may be rejected.
- The initiating side is the AP: the initiating Convergence Layer entity sends a `DlcConnectionAdditionReq` primitive to the relevant RLC Layer. This causes the sending of an `RlcConnectionAdditionSetup` message from the initiating side. The non-initiating side issues to the relevant CL an "indication" primitive. The reply coming from the upper layer is contained in the `DlcConnectionAdditionRsp` and as a consequence the `RlcConnectionAdditionAck` message shall be sent at RLC level. When it is received, a "confirmation" primitive is generated towards the CL of the initiating entity and this represents the end of the events sequence. At any point along the way, the request may be rejected.

This algorithm is valid also in case of a Connection Change procedure by using the correct messages/primitives.

The DLC layer is never responsible of connection deletion; in case of link failure there will be no notification to the higher layers. The DLC is instead responsible of recovering from the failure unless a specific deletion issue is received from the upper layer.

For Connection Deletion the events sequence is described in diagram 34. If this sequence starts when some of the former procedures for the same connection have not yet been completed, it will overrule the others causing an abortion of the former procedures and the deletion of the connection.

DlcDataReq and DlcDataInd are used during the usual transport of data when the connection the data is exchanged on has already been established.

13.1.2 DlcConnectionAdditionInitReq

When a new connection is to be established, and the initiating entity is the AT then the DlcConnectionAdditionInitReq primitive shall be issued from the Convergence Layer of the generating entity to the relevant RLC Layer.

The parameters contained in the primitive are listed hereafter:

```
DlcConnectionAdditionInitReq
(
Scheduling service type,
Convergence Layer ID,
Convergence Layer parameters,
Encryption indicator,
ARQ on/off
ARQ number of retransmissions
Sequence number
)
```

The Convergence Layer (CL) parameter indicates the Convergence Layer that data received on this connection shall refer to. There shall be one specific value for each specific convergence Layer type plus a specific value indicating that no convergence Layer is used.

This CID shall be returned to the requesting convergence Layer via the "confirmation" primitive.

13.1.3 DlcConnectionAdditionReq

When a new connection is to be established, and the initiating entity is the AP then the DlcConnectionAdditionReq primitive shall be issued from the Convergence Layer of the generating entity to the relevant RLC Layer.

The parameters contained in the primitive are listed hereafter:

```
DlcConnectionAdditionReq
(
Scheduling service type,
Convergence Layer ID,
Convergence Layer parameters,
Encryption indicator,
ARQ on/off
ARQ number of retransmissions
Sequence number
)
```

13.1.4 DlcConnectionAdditionInitInd

The use of this primitive applies to the AT initiating Connection Establishment procedure. The RLC Layer of the AP generates this primitive when it receives an RlcConnectionAdditionInit message from the initiating side at RLC level.

The parameters contained in the primitive are listed hereafter:

```
DlcConnectionAdditionInd
(
Service type,
Convergence Layer,
Convergence Layer Parameters,
Sequence number
)
```

13.1.5 DlcConnectionAdditionInd

The use of this primitive applies to the AP initiating Connection Establishment procedure. The RLC Layer of AT generates this primitive when it receives an RlcConnectionAdditionSetup message from the initiating side at RLC level.

The parameters contained in the primitive are listed hereafter:

```
DlcConnectionAdditionInd
(
Service type,
Connection ID,
Convergence Layer,
Convergence Layer Parameters,
Sequence number
)
```

13.1.6 DlcConnectionAdditionRsp

This primitive is generated by the Convergence Layer entity when it has received a DlcConnectionAdditionInd primitive. This event causes the RLC Layer to send the RlcConnectionAdditionAck message.

The parameters contained in the primitive are listed hereafter:

```
DlcConnectionAdditionRsp
(
Response code,
Sequence number,
ARQ on/off
ARQ number of retransmissions
)
```

The response code indicates success or the reason for rejecting the request.

The sequence number is returned to the requesting entity to correlate this response with the original request.

13.1.7 DlcConnectionAdditionCnf

This primitive confirms that a connection has been successfully established. This primitive is generated after the receipt of the RlcConnectionAdditionAck message.

The parameters contained in the primitive are listed hereafter:

```
DlcConnectionAdditionCnf
(
Connection ID,
Response code,
Sequence number
ARQ on/off
ARQ number of retransmissions
)
```

13.1.8 Changing an existing connection

The following primitives are used:

- DlcConnectionChangeInitReq
- DlcConnectionChangeInitInd
- DlcConnectionChangeReq
- DlcConnectionChangeInd
- DlcConnectionChangeRsp
- DlcConnectionChangeCnf

The meaning of these primitives together with all-relevant parameters and consequent actions are exactly the same as creating primitives.

13.1.9 DlcConnectionDeletionReq

When a Connection Deletion is to be performed, the DlcConnectionDeletionReq primitive shall be issued. This primitive can be generated by convergence Layer of either an AP or an AT.

As a consequence of receiving this primitive an RlcConnectionDeletionInit message is sent to the non-initiating side and if it is received correctly the connection shall be terminated. Higher levels can initiate the deletion procedure at any moment. It will immediately cause the effect of tearing down the DLC connection, regardless of other procedures that were being performed upon the same connection.

The parameters contained in the primitive are listed hereafter:

```
DlcConnectionDeletionReq
(
  Connection ID
)
```

The only parameter needed is the Connection ID that specifies which connection is to be terminated.

13.1.10 DlcConnectionDeletionInd

This primitive is issued by the non-initiating side entity at the RLC level towards the CL. It requires the termination of a connection.

This primitive is generated by the RLC Layer when it receives an RlcConnectionDeletionInit message. The parameters contained in the primitive are listed hereafter:

```
DlcConnectionDeletionInd
(
  Connection ID
)
```

13.1.11 DlcConnectionDeletionRsp

When a CL entity receives an indication primitive it generates the DlcConnectionDeletionRsp primitive. The receipt of this primitive causes the RLC Layer to pass the RlcConnectionDeletionAck message.

The parameters contained in the primitive are listed hereafter:

```
DlcConnectionDeletionRsp
(
  Connection ID,
  Response code,
)
```

The response code indicates if the deletion has been successful or the reason for the rejection.

13.1.12 DlcConnectionDeletionCnf

The receipt of this primitive is the confirmation that a connection has been terminated. Connection ID contained in the primitive shall be no longer used for transmission of data.

The parameters contained in the primitive are listed hereafter:

```
DlcConnectionDeletionCnf
(
  Connection ID,
  Response code,
)
```

13.1.13 DlcDataReq

A convergence Layer generates this primitive whenever data is to be transferred to a peer entity or entities. The specified Connection ID shall be used at RLC level together with the relevant QoS parameters. QoS parameters have been already defined for the considered connection during the Connection Establishment procedure.

The parameters contained in the primitive are listed hereafter:

```
DlcDataReq
(
  Connection ID,
  Length,
  Data,
)
```

DLC SDU is reported in the primitive as Data parameter.

13.1.14 DlcDataInd

This primitive is generated whenever an RLC SDU is to be transferred to a peer convergence entity or entities.

The parameters contained in the primitive are listed hereafter:

```
DlcDataInd
(
  Connection ID,
  Length,
  Data,
  CS pass through
)
```

The Connection ID parameter specifies the connection used at RLC level to transport data.

13.2 MSC diagrams (informative only)

Hereafter the events sequences for each procedure are depicted. Both primitives and RLC messages involved in the procedures are specified.

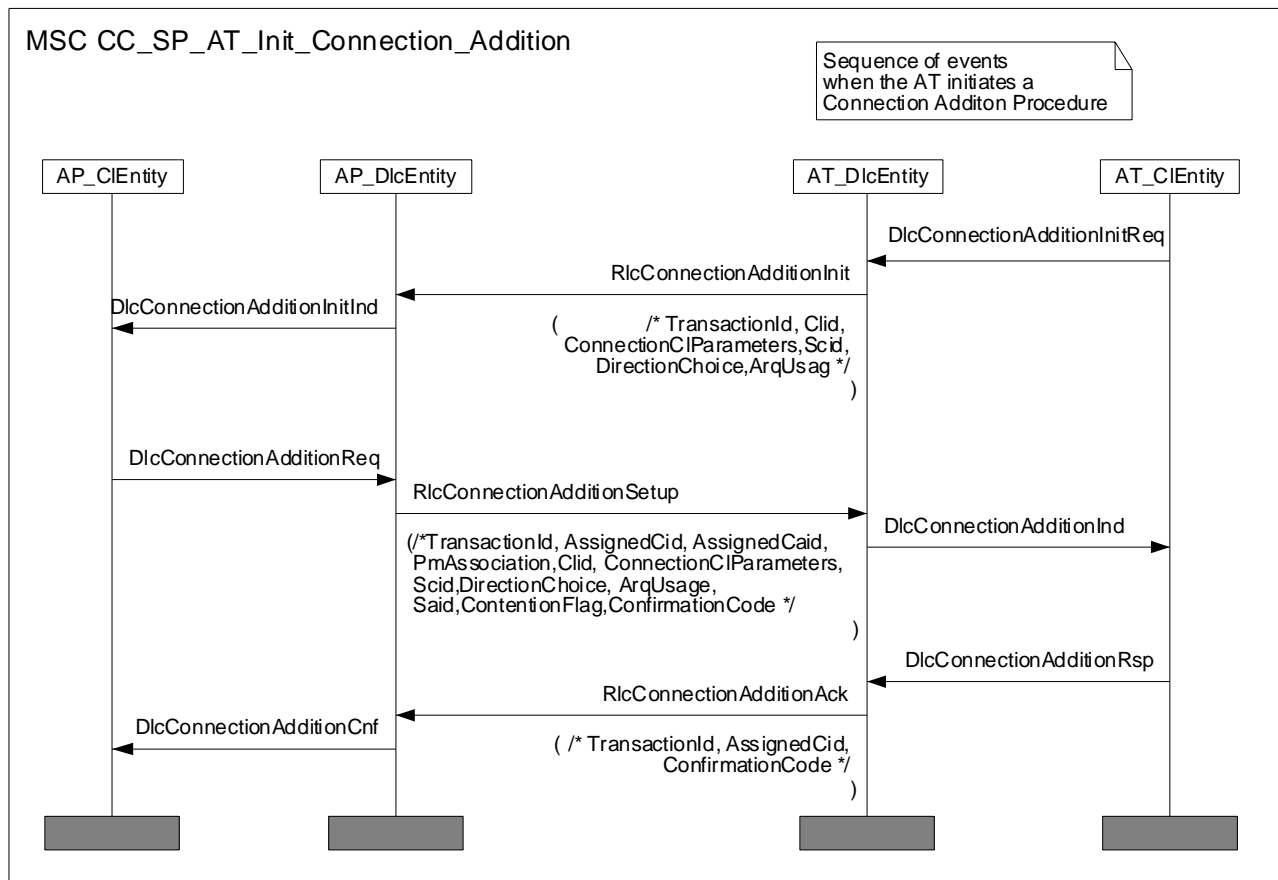

Diagram 30: MSC (4 entities) for AT initiated connection set up

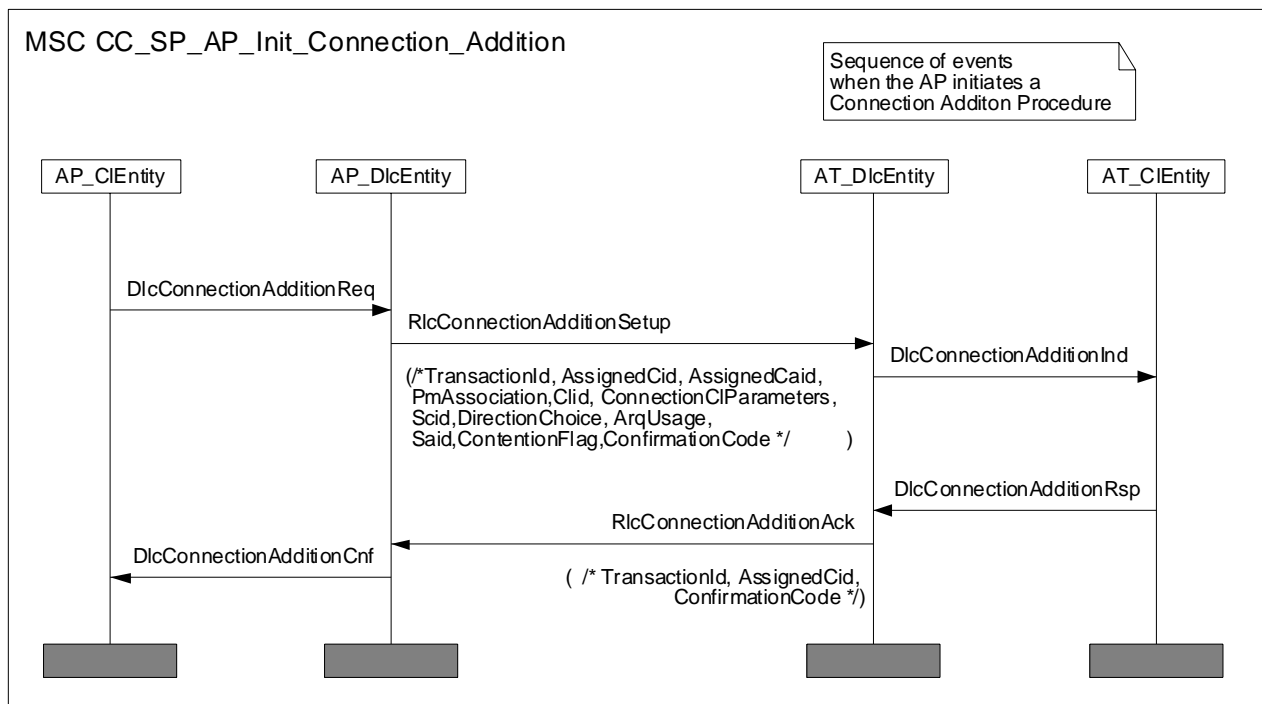

Diagram 31: MSC (4 entities) for AP initiated connection set up

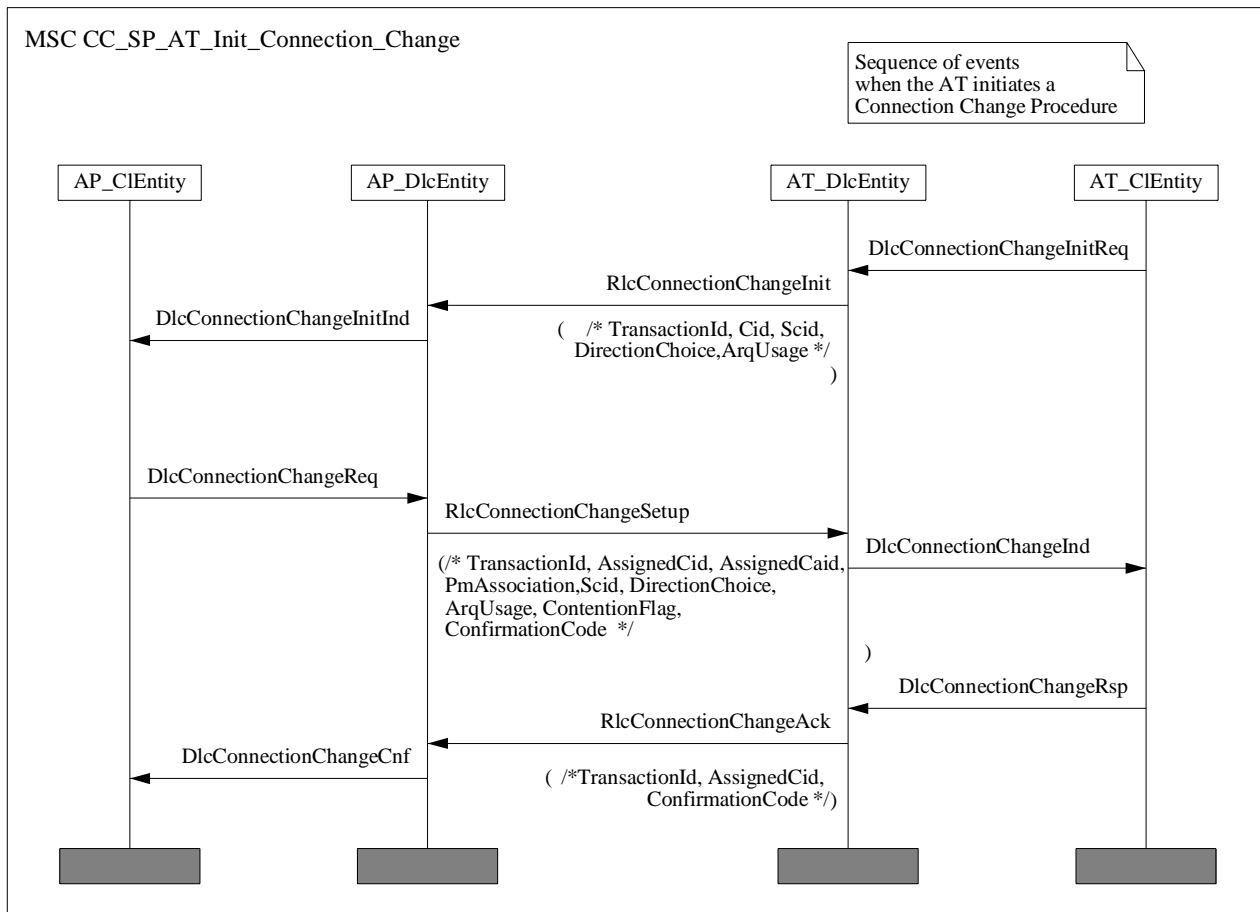

Diagram 32: MSC (4 entities) for AT initiated connection change

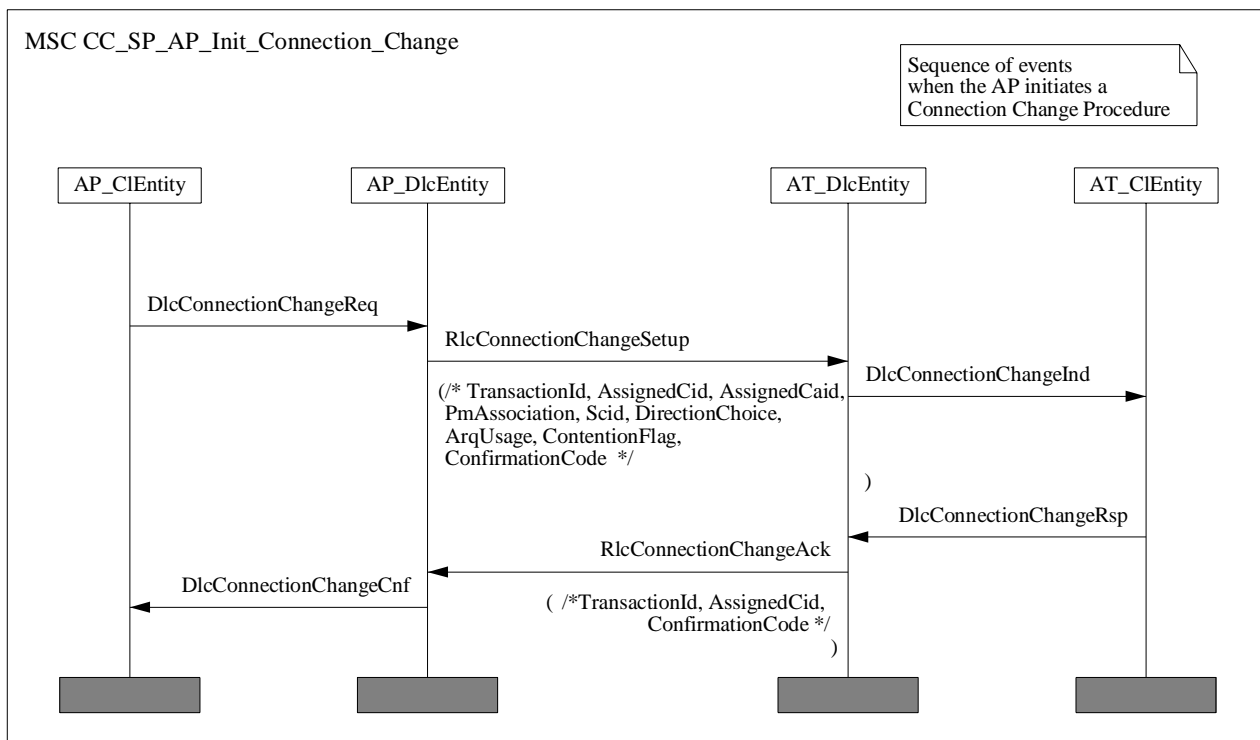

Diagram 33: MSC (4 entities) for AP initiated connection change

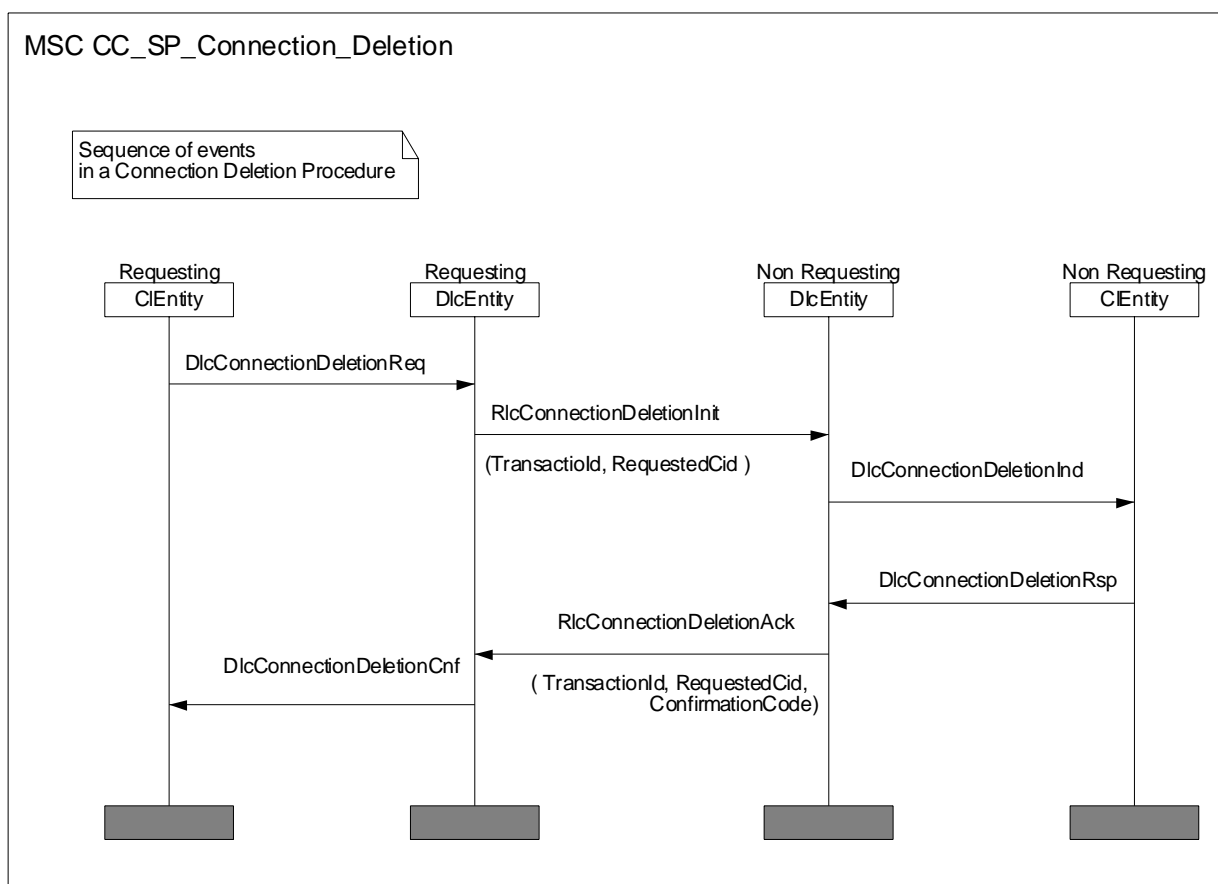

Diagram 34: MSC (4 entities) for AP/AT initiated connection release

13.3 DLC service categories

Four Service Categories are defined at the DLC level. In a descending priority order they are named:

- 0) Periodic Real Time (PRT)
- 1) Real Time (RT)
- 2) Non Real Time (NRT)
- 3) Best effort (BE)

The Periodic Real Time service category has the highest priority; it is recommended to be used for the support of traditional CBR traffic such as E1 voice using AAL-1. It is recommended to use the same value for guaranteed and maximum bit rate.

The Real Time service category has the next highest priority; it is recommended to use it for traffic with strict delay constraints. This is the only service category besides PRT for which it is possible to state the maximum value for Transfer Delay and Delay Variation introduced for a MAC PDU belonging to this class. It is described by the Maximum Bit Rate and the Guaranteed Bit Rate parameters (in addition to the Transfer Delay and Delay Variation parameters).

The Non Real Time (NRT) service category has a lower priority with respect to the RT category. It is recommended to use the NRT for transporting traffic with a variable bit rate. No limitations on delay parameters are specified for this service category. It is described by both Maximum bit rate and Guaranteed bit rate since only a part of the requested bandwidth is always granted by the system.

The Best Effort category is the lowest priority service class. It is recommended to use this category for transporting traffic with neither requirements on delay nor guaranteed bandwidth, allowing the system to perform a deep statistical multiplexing. No parameter is needed at the DLC level for this category. The Maximum Bit Rate parameter can be negotiated.

In order to achieve the service related to each Service Category listed above the following parameters shall be configured during the connection establishing phase.

- Guaranteed bit rate: it is the guaranteed rate for the connection (it can be used or not by the connection, but, if requested, it is always available).
- Maximum bit rate: it is the maximum rate allowed for the connection.
- Maximum Burst Length: it is the maximum number of consecutive MAC PDUs that a connection is allowed to transmit.
- Transfer Delay: it is the maximum delay that a PDU may experience in passing through the system.

13.4 Connection control procedures

In the following clauses the procedures for connection set-up, connection Change and connection deletion are described.

Guard timers are needed on both sides to make the procedures able to recover from the loss of messages. Possible error scenarios are analyzed within the relevant clauses.

Guard timers shall be achieved by *AP* and *AT* with simple calculations starting from the value set for the *TimerGranuConnection* parameter. The *AP* communicates to the *AT*s the value for this parameter within the *GBI* message; see clause 8.8. The *AP* shall set this value within the range of 8-255 frames. The granularity for guard timers shall be selectable because the time needed to set, change, or delete a connection might be heavily dependent by the management system.

Guard timers defined in the CC procedures shall be divided into two different categories:

- Short timers: the duration of the Short timer shall be set to the value of *TimerGranuConnection* parameter.
- Medium timers: the duration of the Medium timer shall be set to $8 \times$ (*TimerGranuConnection* parameter).

The *AT* shall use the latest received value of *TimerGranuConnection* when setting the timers.

Guard timers belonging to the Short category are:

- *T_ConnectionAdditionInit*
- *T_ConnectionAdditionSetup*
- *T_ConnectionChangeInit*
- *T_ConnectionChangeSetup*
- *T_ConnectionDeletionInit*

Guard timers belonging to the Medium category are:

- *T_ConnectionAdditionAck*
- *T_ConnectionChangeAck*
- *T_ConnectionDeletionAck*

The meaning of all these timers is described in the following clauses.

13.4.1 Overview of protocol primitives

13.4.1.1 HMSC of procedures

An overview is provided with diagram 35.

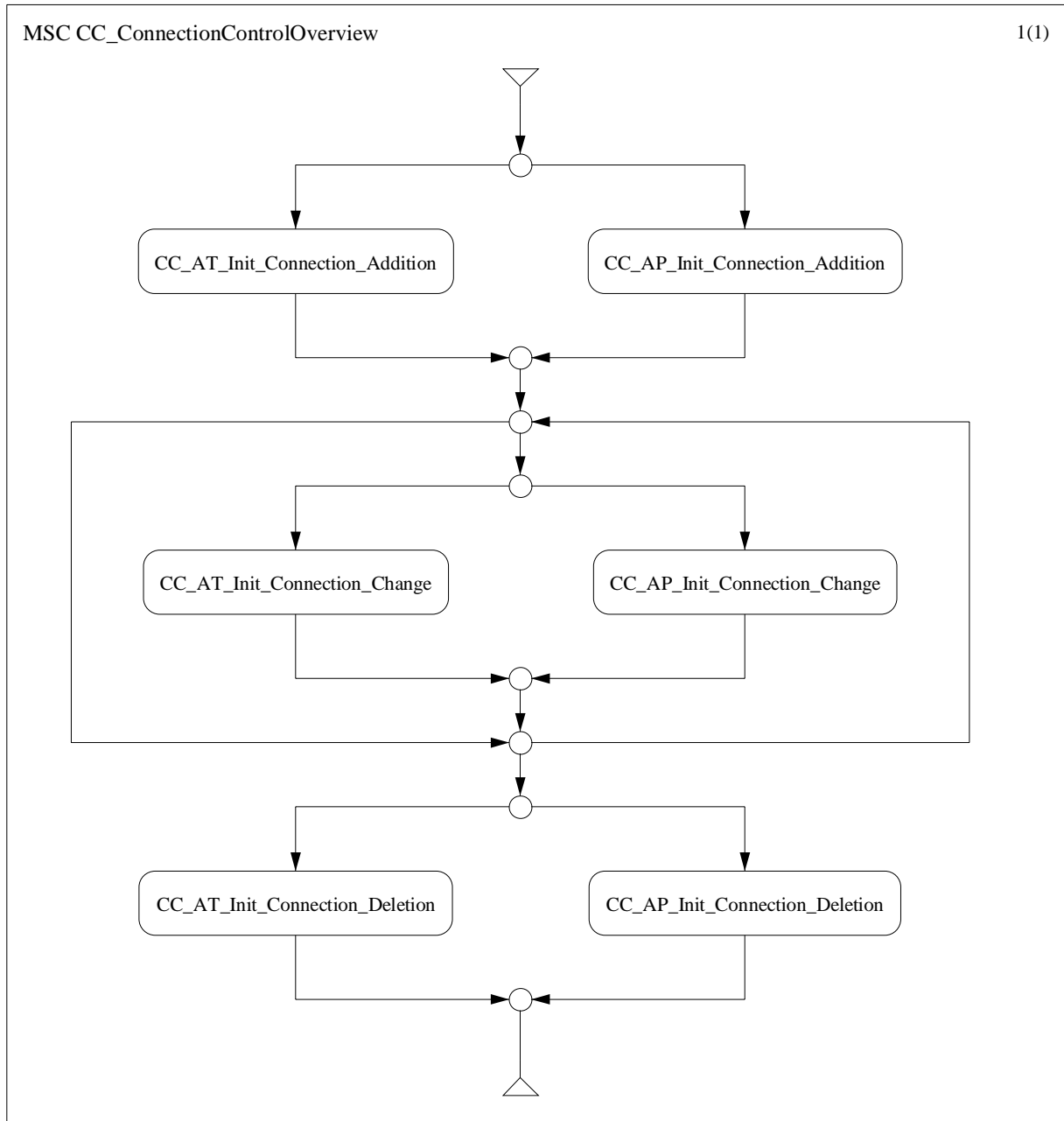

Diagram 35: HMSC for connection control messaging

13.4.1.2 Parameters

All parameters to be communicated during the three procedures are relevant only to the data connections. Management connections are defined at the first initialization phase and have specific characteristics and parameters. The list of parameters is reported hereafter.

- **Connection Aggregate ID:** Connection Aggregate ID (Caid) defines the way connections are considered at the AP side during their activity. The single connection is visible at the AP only at establishment, change and deletion operations. During the connection lifetime, they are handled only as part of the Connection Aggregate they belong to. The maximum number of possible CAs that the AP can establish with the same AT is negotiated in the initialization procedure.
- **Poll-me bit association:** This parameter associates, or not, the connection aggregate ID specified in the previous field with the poll-me bit usage. The poll-me bit association shall have the same value for all the connections within the same connection aggregate.
- **Transaction ID:** A Transaction ID is associated to each procedure by the initiating device (AP or AT). To help pre-vent ambiguity and provide simple checking, the Transaction ID number space is split between the AT and AP. In this case the AT shall select its Transaction IDs from the first half of the number space and the AP shall select its Transaction IDs from the second half of the number space. The transactions may consist of a request/response/confirmation or a setup/confirmation sequence. The response and confirmation messages shall return a confirmation code specifying whether the transaction had a positive ending or some exception condition was detected.
- **Service Category Identifier (ScId):** Identifier of the DLC service category.
- **Contention Flag:** For an uplink connection this parameter indicates if the AT is allowed to issue contention requests for bandwidth.
- **Convergence Layer Identifier (CIId):** This parameter identifies the convergence layer the connection belongs to.
- **Convergence Layer Parameters (ConnectionCIParameters):** This parameter contains information used by the convergence layer. It's transported transparently by the DLC layer that passes this parameter to the higher layer. The format is a string octet of variable length. Each CL specification defines how this parameter is used.
- **Security Association Identifier (SaId):** This parameter shall be carried in Downlink direction only and indicates the association between the connection and the security association.
- **ARQ Usage:** This parameter indicates the ARQ functionality for the connection. The possible options are the following (the value 0 means that the function is disabled):
 - No ARQ (0),
 - Once ARQ (1),
 - Twice ARQ (2).
- **Direction Choice:** This parameter describes the characteristics of the data flow. It can assume 4 different forms depending on the direction of the transported data flow and if the data rate is symmetrical or not. Specifically:
 - Uplink Direction
 - Downlink Direction
 - Bi-directional Symmetrical
 - Bi-directional Asymmetrical

In the first three cases the description contains only one entry, while in the last case two entries are needed. Each entry is composed by a list of parameters that characterize the connection:

- **Guaranteed bit rate:** In the Real Time and Non Real Time service categories, this parameter means the amount of bandwidth that the system reserves to the connection. Its granularity is 1 kbit/s so that the maximum flexibility is achieved.

- **Maximum bit rate:** This parameter means the maximum load that the system can receive from the connection. It is mandatory for Real Time and Non Real Time service categories, while for the Best Effort traffic it can be an informative field. Its granularity is 1 kbit/s.
- **ConnectionMinPhyMode:** For both Uplink and Downlink direction, this parameter indicates the most robust Phy Mode in which the AT has to consider the connection as active. If set to the lowest PHY mode, this parameter has no effect on connection handling. The minimum PHY mode shall be the same for all connections of a connection aggregate.

13.4.2 Connection establishment procedure

The DLC layer is connection-oriented and connection may be provisioned when one of the end points requires a new data flow to be transported or a subscriber needs to change its service parameters.

A connection can be established within the first initialization phase, in a pre-provisioned way or dynamically created.

Pre-provisioned connections are defined via provisioning by the network management system. The AP can be requested to establish a connection by specifying CID and the associated QoS parameters set.

The CID is always assigned by the AP. The APC shall not assign the same CID to more than one connection per RF channel. In case of bi-directional connections, either symmetric or asymmetric, only one CID is assigned and it identifies the connection in both directions.

Dynamic connections are created via signalling exchange at any time by the AP or by an already signed-on AT. In the dynamic connections establishment, both the AP and the AT can request to create an Uplink, Downlink or bi-directional connection.

The procedure can be initiated by either the AP or the AT and can create only one Uplink, Downlink or bi-directional connection. Once it has been established, a connection can be modified with the Change procedure, by changing the parameter sets of the flow. Regardless the initiating entity the connection can be:

- **Downlink connection:** the data flow that is transported by the considered connection flows in Downlink direction only.
- **Uplink connection:** the data flow that is transported by the considered connection flows in Uplink direction only.
- **Bi-directional Symmetric connection:** the connection transports data flows both in Uplink and in Downlink directions and the bit rate is symmetric (the same for the Uplink and the Downlink).
- **Bi-directional Asymmetric connection:** the connection transports data flows both in Uplink and in Downlink directions and the bit rate is Asymmetric (different values for the Uplink or the Downlink).

Once established, a bi-directional connection cannot be deleted in one way only. A bi-directional symmetric connection can be changed in a bi-directional asymmetric connection by means of a connection change procedure and vice-versa. Either the Uplink or Downlink set of parameter belonging to a specific asymmetric bi-directional connection can be changed independently.

The algorithms for connection Establishment are (depending on the generating point):

- **AT initiated (only dynamic connections):** Three-way handshaking.
- **AP initiated:** Two-way handshaking.

The three-way handshaking is needed in the former case because when the AT requires a new connection, it is not aware of the traffic load and can only request the AP to establish a connection with the proposed set of QoS parameters.

If one of the requested QoS parameters exceeds some relevant limitations then the connection cannot be established/changed and a new set of values for the parameters shall be defined.

The AP may decide to group connections into Connection Aggregates according to its allocation mechanisms. The rules on grouping connections into CAs are:

- Connection Aggregates cannot be defined among different ATs in Uplink direction.
- Connections belonging to different QoS classes should not be grouped into the same connection aggregate.
- When a connection is added to an aggregate the set of parameter of the aggregate shall be updated.
- QoS info are required for grouping to CA (or for setup of new CA) and thus for choice of appropriate allocation mechanism.

13.4.2.1 AT initiated connection establishment procedure

The algorithm used for connection Establishment when initiated by the AT is based on the Three-way handshaking. The AT will request the AP for a connection with the RlcConnectionAdditionInit message. If there are available resources and the AT has no basic limitations, the AP will send an RlcConnectionAdditionSetup message with all relevant information to the AT. The AT will confirm with an RlcConnectionAdditionAck message. The AP will not be allowed to schedule any data traffic before confirmation is received.

In the RlcConnectionAdditionInit message, the AT proposes values of the QoS parameters, but these values are decided by the AP and sent in the RlcConnectionAdditionSetup message.

Guard timers are needed on both sides to make the procedure able to recover from the loss of messages. In particular three situations need to be handled by the use of timers, during the Establishment procedure initialized by the AT.

The first case happens at the AT side in order to re-send the RlcConnectionAdditionInit message. This timer is named T_ConnectionAdditionInit and it shall be configurable during first initialization procedure for the considered Terminal. When this timer expires and the RlcConnectionAdditionSetup message is not received the RlcConnectionAdditionInit message is re-sent. The reason why the duration of this timer cannot be optimized in the general case is that the time the AP entity needs to send the Setup message after the RlcConnectionAdditionInit message has been received is not only dependent from the DLC level but also on sector management actions. This timer is reset when the RlcConnectionAdditionSetup is received.

The second timer needed is the T_ConnectionAdditionSetup timer. It is defined at AP side and shall be configurable by the system management. This timer is reset when the RlcConnectionAdditionAck is received. If it expires without any reception of ack message, then the RlcConnectionAdditionSetup is re-sent.

Finally a T_ConnectionAdditionAck timer is needed on both sides. This because the connection that is going to be established can be unidirectional or bi-directional and no data can be exchanged on the new connection ID until the ack message is received at AP side. So if no waiting time is foreseen there is the risk of losing data because the ID is not considered valid already. Each time the one at AT side expires without receiving an RlcConnectionAdditionSetup message an RlcConnectionAdditionAck is sent. At AP side after the AP has received the RlcConnectionAdditionAck message the T_ConnectionAdditionSetup is reset and the T_ConnectionAdditionAck is started.

When T_ConnectionAdditionAck timers at both side expires the new connection ID is considered valid and data can be exchanged on it.

The recovering actions from message loss scenarios are described below:

- Loss of RlcConnectionAdditionInit: If the AT has not received an RlcConnectionAdditionSetup message from the AP when the T_ConnectionAdditionInit timer expires, the AT will issue a second RlcConnectionAdditionInit message. In case the AT receives multiple RlcConnectionAdditionSetup messages then it shall discard the duplicate ones.
- Loss of RlcConnectionAdditionSetup: If a duplicate RlcConnectionAdditionInit message is received by the AP (entities are aware of duplicated messages from the Transaction ID field) before an RlcConnectionAdditionSetup message has been sent then the AP shall discard the message. If the AP receives an RlcConnectionAdditionInit message when an RlcConnectionAdditionSetup message has already been sent then the RlcConnectionAdditionSetup message shall be re-sent.

- Loss of RlcConnectionAdditionAck: If the Ack message is lost then the AP shall re-send a further RlcConnectionAdditionSetup message until it receives the relevant ack. The AT is not aware of the loss of the ack message and the risk is that if the connection that is going to be established also encompasses the Uplink direction, the AT starts to transmit data using the new connection ID. So the AT shall wait for the expiring of T_ConnectionAdditionAck timer before transmitting in order to be sure that no further setup messages are received.

Hereafter the MSC of the AT initiated Connection Addition procedure is reported.

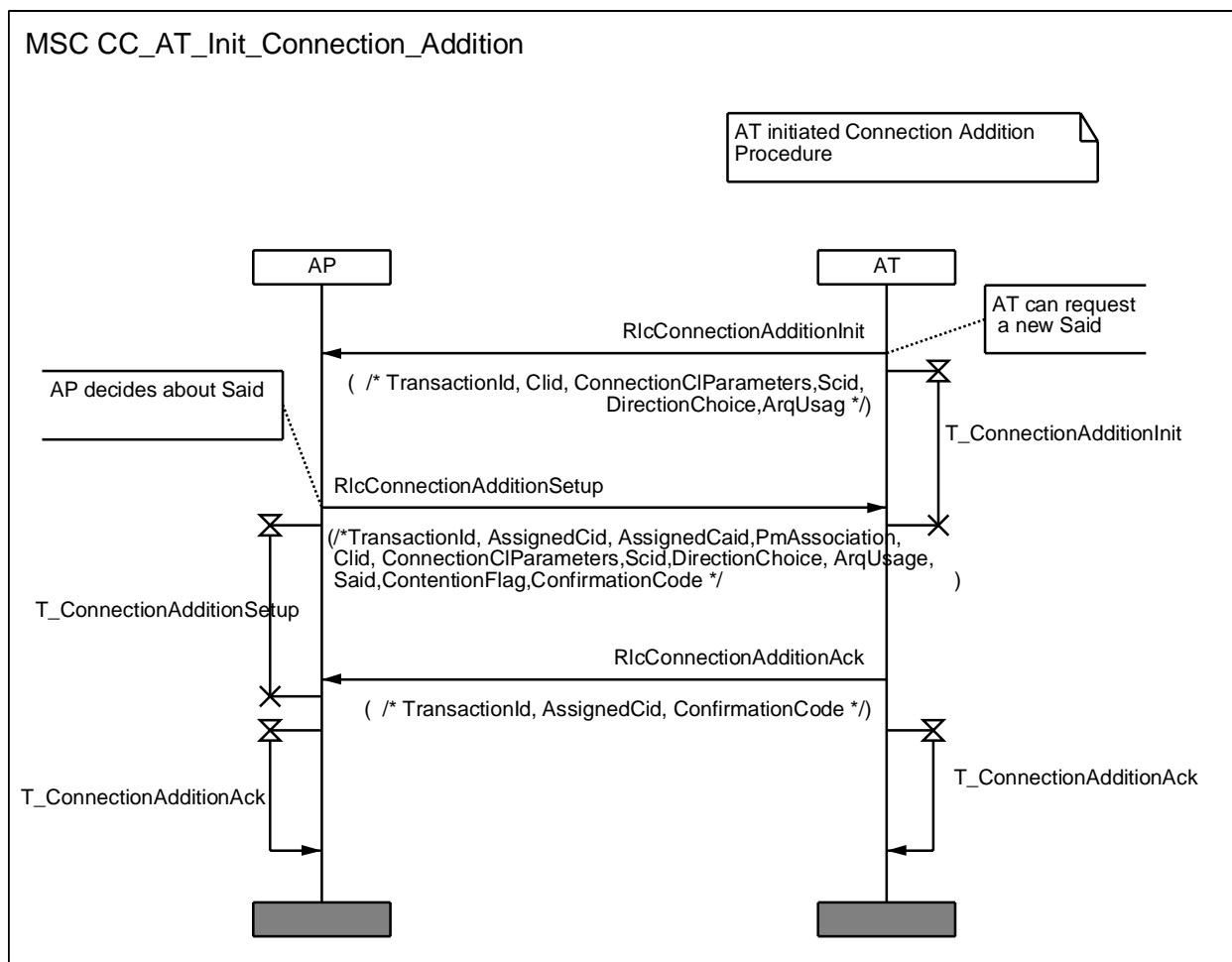

Diagram 36: MSC for AT initiated Connection Establishment

13.4.2.2 AP initiated connection establishment procedure

The algorithm used for connection Establishment when initialized by the AP is based on the Two-way handshaking mechanism. If AP needs to establish a new connection, the `RlcConnectionAdditionSetup` message is sent to the AT.

In the `RlcConnectionAdditionSetup` message, the AP sends the values of the QoS parameters in accordance to the sector available resources.

Since even in this procedure the direction of the connection is independent of the entity that initializes the procedure there is the need of a timer in order to ensure that both entities are not allowed to transmit data that could be lost using the new connection ID.

Hereafter the MSC of the AP connection Establishment procedure is reported.

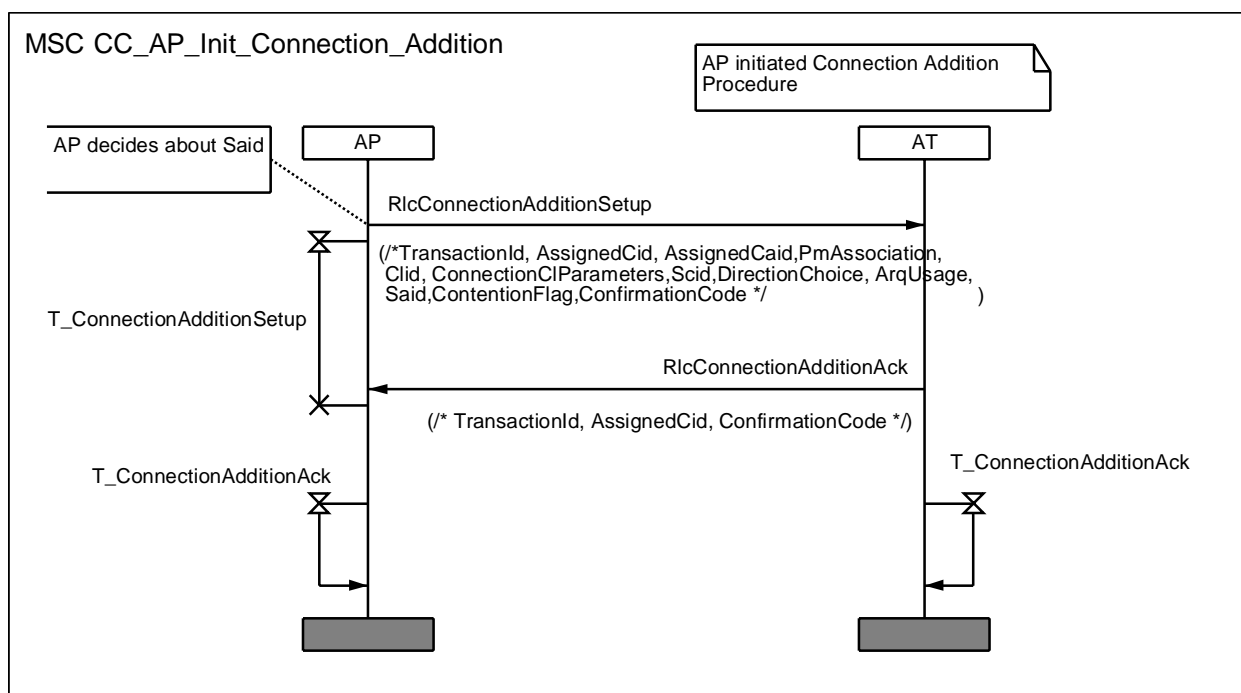

Diagram 37: MSC for AP initiated Connection Establishment

13.4.3 Change of established connection procedure

The change of established connection procedure is needed when any connection parameters shall be modified.

Both the AP and the AT can initiate a change of established connection procedure. There are several reasons why some QoS parameters shall be changed and sometimes they are not strictly relevant to the connection itself (load levelling or the initialization of a new subscriber, etc.).

The Connection Change procedure is not used to change the CID of a connection.

It shall be allowed to change the DirectionChoice parameter so that an asymmetric bi-directional connection is changed into a symmetric one and vice-versa. It shall not be allowed to use the Connection Change procedure to turn a uni-directional connection from uplink to downlink or vice-versa, neither to turn it into a bi-directional connection.

The modification is achieved via signalling procedure described in diagram 38 when initiated by the AT and diagram 39 when initiated by the AP. The procedure is the same as the connection Establishment. When initiated by the AT is based on the Three-way handshaking whereas when initiated by the AP is based on the Two-way handshaking.

The formats of MAC management messages are the same as the messages exchanged in the connection Establishment procedure except for the RlcConnectionChangeInit that contains the Connection ID (CID) of the connection whose parameters are going to be exchanged. Hereafter the procedures are depicted.

With connection change procedure it is not possible to change the convergence layer a connection belongs to.

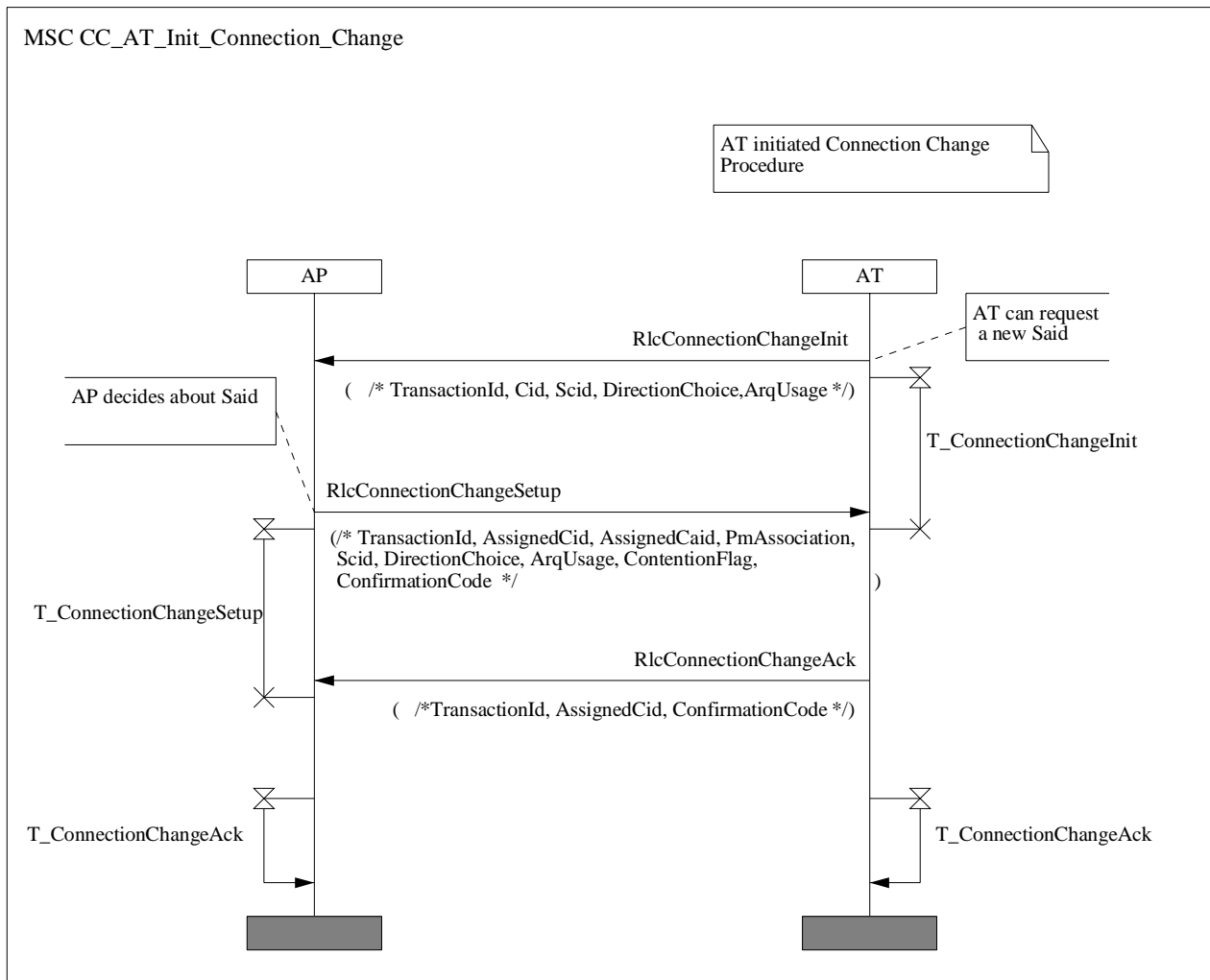

Diagram 38: MSC for AT initiated connection change

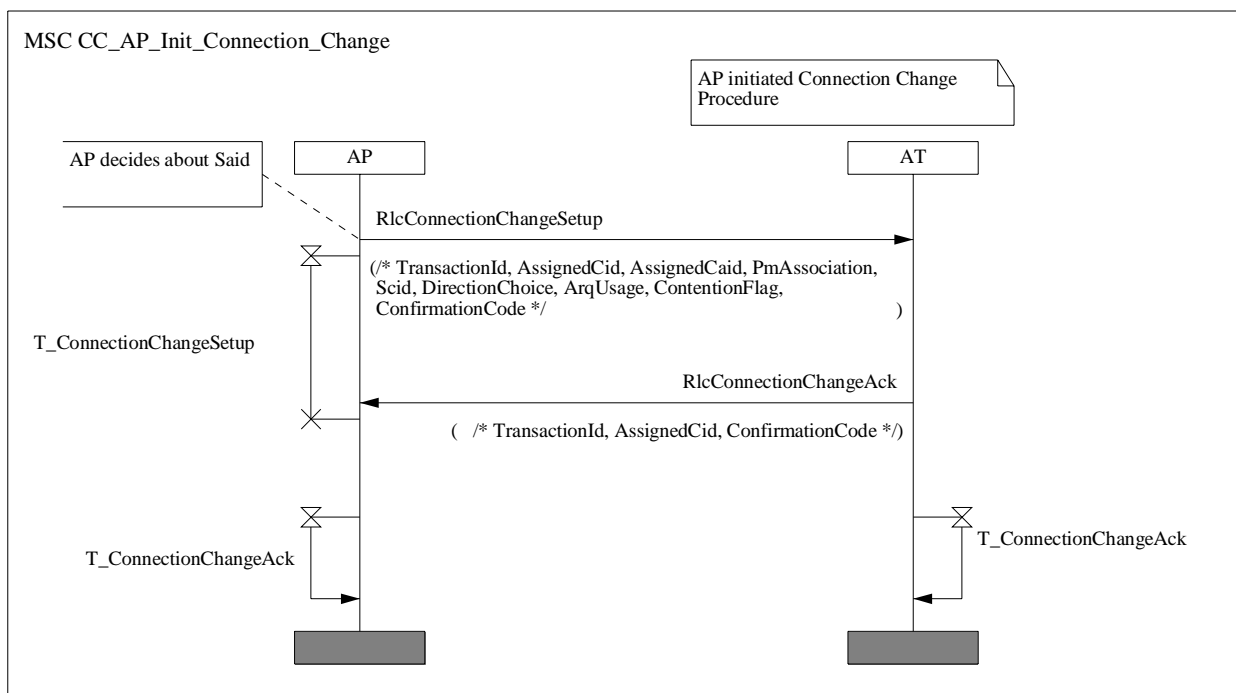

Diagram 39: MSC for AP initiated connection change

13.4.4 Connection deletion procedure

Every data connection can be released. When a connection is deleted, all resources associated to it are deleted. The connection ID value shall be available to be associated again to new connections and all the values regarding RF channel parameters shall be uploaded.

Either the AP or the AT can initiate a connection termination procedure at any time only in response to the reception of a deletion primitive from the higher layers. This is the only occasion in which this procedure is initiated. The DLC layer shall always try to recover from failures without sending any warning to the upper layer until either the DLC connection is re-established or an incoming deletion primitive is received.

The algorithm used for connection deletion is always a Two-way handshaking.

Two different timers are needed in these procedures:

- **T_ConnectionDeletionInit**: this is the timer that controls the re-transmission of the RlcConnectionDeletionInit message. When this timer expires a further RlcConnectionDeletionInit message is sent. This timer shall be implemented both in the AT and AP since both entities can initiate a Connection Deletion procedure.
- **T_ConnectionDeletionAck**: this timer is needed in order to recover the loss of RlcConnectionDeletionAck message. In fact the non-initiating side will be sure that the ack message is received on the initiating side only if no further RlcConnectionDeletionInit message is received. It can be concluded that both sides shall wait a waiting time corresponding to the expiring time of the T_ConnectionDeletionAck timer.

The connection termination procedure is depicted in diagram 40 for AT and in diagram 41 for AP initiated connection termination respectively. The formats of the MAC management messages are specified in clause 13.6.

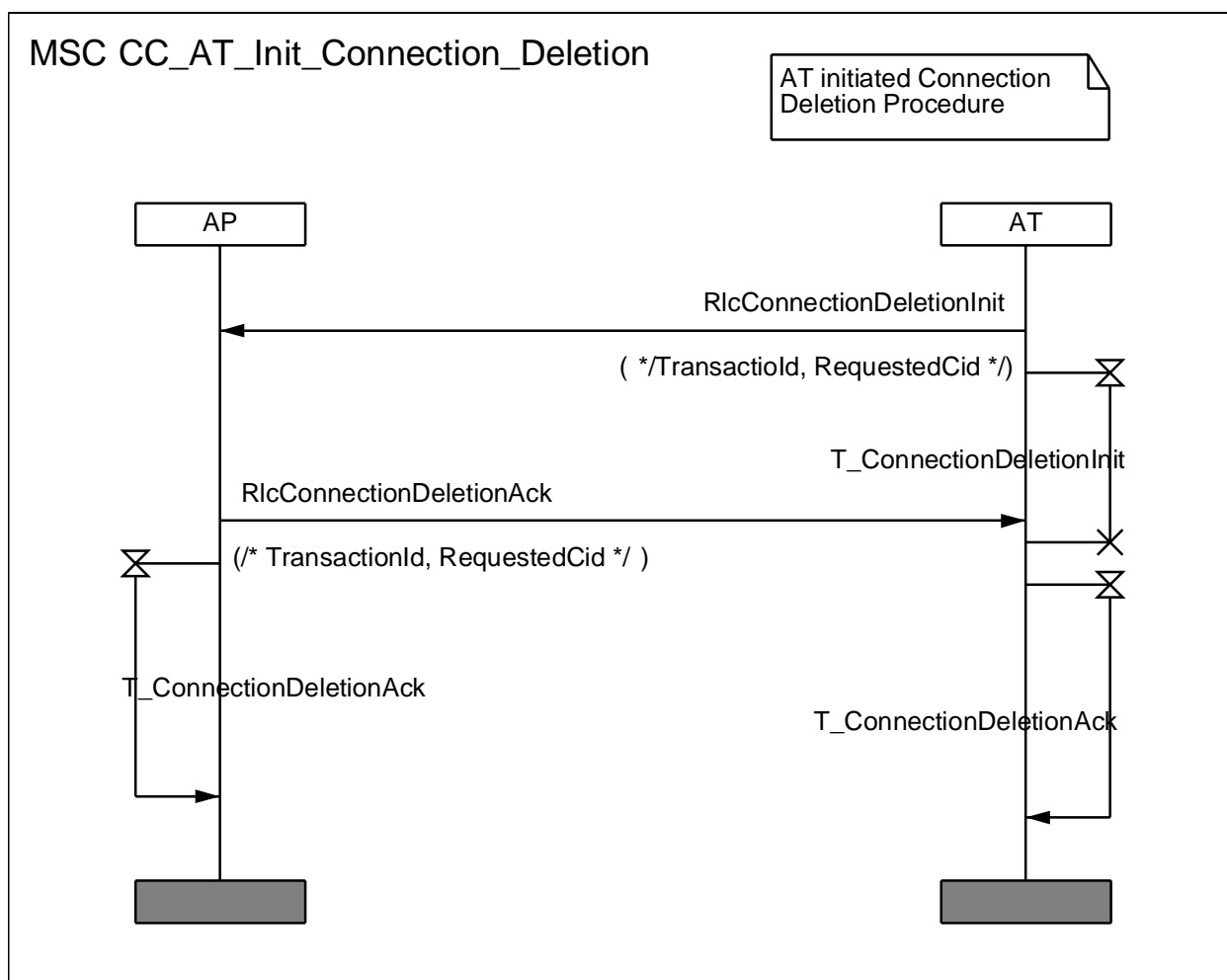

Diagram 40: MSC for AT initiated connection release

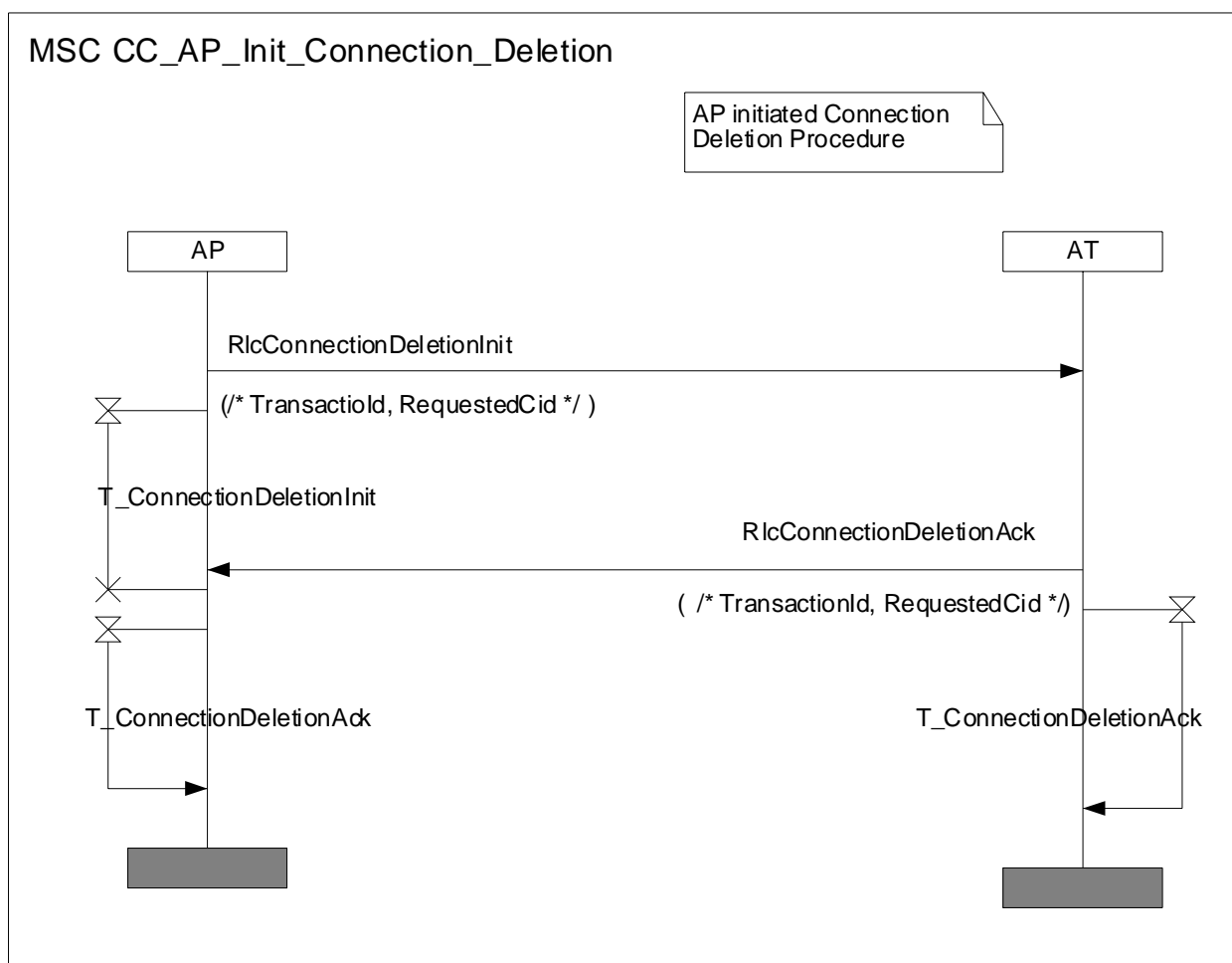

Diagram 41: MSC for AP initiated connection release

13.5 Multicast connections

The same downstream (and only downstream) flow of information may have to be delivered to a group of different users (terminals), in this case a multicast connection can be established. This allows the AP to transmit information only once over the air interface. Several multicast groups with different sets of connections can exist in parallel. There is not a special procedure for setting up of a multicast connection. The AP establishes a Downlink unicast connection with each AT included in the multicast group assigning to the each connection the same CID.

The AT is not aware of the multicast nature of the connection or of the other ATs included in the multicast group.

Since the AP is the only part aware of the multicast groups, the maximum flexibility is achieved.

All multicast groups can be dynamically updated, i.e. connections can be allocated to a group or withdrawn from a group or switched between two groups at any time with a normal unicast connection deletion and connection Establishment procedure.

13.6 Connection management message description

Hereafter the ASN.1 description of all messages exchanged in connection management procedures is reported:

Table 39: ASN.1 Connection management messages description

```

RlcConnectionAdditionInit ::= SEQUENCE {
    transactionId      TransactionId,      -- 17 bit
    clid               Clid,              -- 3 bit
    connectionClParameters ConnectionClParameters, -- variable
    scid               Scid,              -- 2 bit
    directionChoice    DirectionChoice,    -- variable
    arqUsage           ArqUsage           -- 2 bit
}

RlcConnectionAdditionSetup ::= SEQUENCE {
    transactionId      TransactionId,      -- 17 bit
    assignedCid        AssignedCid,        -- 16 bit
    assignedCaid        AssignedCaid,       -- 16 bit
    pmAssociation       PmAssociation,      -- 1 bit
    clid               Clid,              -- 3 bit
    connectionClParameters ConnectionClParameters, -- variable
    scid               Scid,              -- 4 bit
    directionChoice    DirectionChoice,    -- variable
    arqUsage           ArqUsage,          -- 2 bit
    said               Said,              -- 16 bit
    contentionFlag      ContentionFlag,     -- 1 bit
    confirmationCode    ConfirmationCode    -- 1 bit
}

RlcConnectionAdditionAck ::= SEQUENCE {
    transactionId      TransactionId,      -- 17 bit
    assignedCid        AssignedCid,        -- 16 bit
    confirmationCode    ConfirmationCode    -- 1 bit
}

RlcConnectionChangeInit ::= SEQUENCE {
    transactionId      TransactionId,      -- 17 bit
    cid                Cid,                -- 16 bit
    scid               Scid,              -- 2 bit
    directionChoice    DirectionChoice,    -- variable
    arqUsage           ArqUsage           -- 2 bit
}

RlcConnectionChangeSetup ::= SEQUENCE {
    transactionId      TransactionId,      -- 17 bit
    assignedCid        AssignedCid,        -- 16 bit
    assignedCaid        AssignedCaid,       -- 16 bit
    pmAssociation       PmAssociation,      -- 1 bit
    scid               Scid,              -- 2 bit
    directionChoice    DirectionChoice,    -- variable
    arqUsage           ArqUsage,          -- 2 bit
    contentionFlag      ContentionFlag,     -- 1 bit
    confirmationCode    ConfirmationCode    -- 1 bit
}

RlcConnectionChangeAck ::= SEQUENCE {
    transactionId      TransactionId,      -- 17 bit
    assignedCid        AssignedCid,        -- 16 bit
    confirmationCode    ConfirmationCode    -- 1 bit
}

RlcConnectionDeletionInit ::= SEQUENCE {
    transactionId      TransactionId,      -- 17 bit
    requestedCid        RequestedCid       -- 16 bit
}

RlcConnectionDeletionAck ::= SEQUENCE {

```

```

    transactionId      TransactionId,      -- 17 bit
    requestedCid      RequestedCid        -- 16 bit
}

ConfirmationCode ::= ENUMERATED {      -- 1 bit, request status
    connAccepted (0),
    connReject (1)
}

RequestedCid ::= DataCid                -- 16 bit, temp for AT initiated req
AssignedCid  ::= DataCid                -- 16 bit, temp for AT initiated req

AssignedCaid  ::= Caid                  -- 16 bit, temp for AT initiated req

TransactionId ::= INTEGER(0..131071)    -- 17 bit, uniquely assigned by sender

Clid ::= INTEGER {                      -- 3 bit
    cellBased (1),
    packetBased (2)} (0..7)

ConnectionClParameters ::= OCTET STRING (SIZE(0..63)) -- variable, contains VPI for
CBCS

Scid ::= ENUMERATED {                  -- 2 bit
    periodicRealTime (0),
    realTime (1),
    nonRealTime (2),
    bestEffort (3)
}

PmAssociation ::= ENUMERATED {
    pmAssociated (0),
    pmNonAssociated (1)
}

Said ::= INTEGER(0..65535)            -- 16 bit

ArqUsage ::= ENUMERATED {
    noARQ (0),
    onceARQ (1),
    twiceARQ (2)
}

ContentionFlag ::= ENUMERATED { -- 1 bit
    contentionReqsNotAllowed (0),
    contentionReqsAllowed (1)
}

DirectionChoice ::= CHOICE {
    uplinkDirection      DirectionDescr,
    downlinkDirection    DirectionDescr,
    bidirectionalSymmetrical DirectionDescr,
    bidirectionalAsymmetrical BidirectionalAsymmetrical
}

DirectionDescr ::= SEQUENCE {
    guaranteedBitRate      GuaranteedBitRate,
    maximumBitRate         MaximumBitRate,
    maximumBurstSize       MaximumBurstSize,
    connectionMinPhyMode   UplinkPhyMode, -- 0 for all DL DirectionDescr
    transferDelay          TransferDelay
}

BidirectionalAsymmetrical ::= SEQUENCE {
    uplinkDirection      DirectionDescr,
    downlinkDirection    DirectionDescr
}

BitRate ::= INTEGER(1..130000) -- 17 bit, granu=1kbit/s,max=130Mbit/s

```

```
GuaranteedBitRate ::= BitRate
MaximumBitRate    ::= BitRate

TransferDelay     ::= INTEGER(0|5..63)-- 6 bit, granu=1ms,max=63ms,
                                     -- 0 means TransferDelay=infinity
MaximumBurstSize  ::= INTEGER(0..255) -- 8 bit, granu=1PduPayload=51byte
                                     -- 0 means MaxBurstSize=infinity
                                     -- applies only for data conns
```

Annex A (normative): Parameters and constants

A.1 List of optional/mandatory features

Table A.1: List of optional/mandatory features

Feature	AP status	AT status	Signalling
UL preamble length	S	M	initialization
Frame offset	S	M	GBI
TDMA in DL	O	M (only for H-FDD ATs)	GBI
One or several midambles per UL burst	S	M	GBI
One or several MAC PDUs per UL FEC block	S	M	GBI
64-QAM for DL	O	O	initialization
16-QAM for UL	O	O	initialization
Turbo code encoder	O	O	initialization
H-FDD capability	M	O	initialization
Duplex mode	S	O	GBI
Encryption mode	S	M	GBI
Contention resolution parameters	S	M	GBI
Contention resolution feature	O	O	UL map, initialization
PHY mode thresholds	S	M	GBI
PHY mode power steps	S	M	GBI
APC-ID	S	n/a	control zone
APC-ID check during initialization	n/a	O	control zone
Measurement report criteria	S	M	GBI and individual message
Legend: M = mandatory to handle the feature or all possible parameter value, O = optional, S = selected at AP (means that at least one of the possible options shall be implemented)			
NOTE: The signalling column only gives information where a feature or parameter is exchanged.			

A.2 Detailed specification of PHY parameters in protocol primitives

Table A.2: Detailed specification of PHY parameters carried by protocol primitives

Parameter	Description	Messages containing the parameter	Range	Granularity	Bit
TimingAdjustRanging	Adjustment of timing during initial ranging	RlcRangingRsp	[0, 80] μs	0,25 symbol	13
TimingAdjustFine	Incremental timing correction	RlcUplinkTimingCorrection	[-2, +2] symbols	0,25 symbol	5
UplinkPowerInc	Incremental step for UL transmit power (full range only for ranging, otherwise [-4,+4]dB)	RlcRangingRsp, RlcUplinkPowerCorrection	[-20, +4] dB	0,5 dB	6
UplinkPowerIncRangingStart	Incremental increase of UL transmit power for ranging	RlcGeneralBroadcastInformation	[+1, +8] dB	1 dB	3
UplinkPowerModChange	Incremental change step for UL power in case of PHY mode change, per PHY mode, per UL, per upgrade/downgrade. The high range is reserved for future PHY mode sets	RlcGeneralBroadcastInformation	[-8, +8] dB	0,5 dB	6
UplinkPowerMax	Max transmit power of AT	RlcAtPhyCapabilitiesInfo	[10, 20] dBm	1 dB	4
RxPowerMeasured	Absolute measured received power in AT	RlcDownlinkPhyModeChangeReq, RlcMeasurementReportData	[-88, -28] dBm	0,25 dB	8
TxPowerMeasured	Absolute current transmit power in AT	RlcDownlinkPhyModeChangeReq, RlcMeasurementReportData	[-26, 20] dBm	1 dB	6
TxPowerMargin	Current transmit power margin in AT	RlcDownlinkPhyModeChangeReq, RlcMeasurementReportData	[0, 12] dB	0,25 dB	6
CnrMeasured	Absolute C/N measured in DL	RlcDownlinkPhyModeChangeReq, RlcMeasurementReportData	[4, 40] db	0,25 dB	8
CnrThreshold	Absolute C/N threshold at AT to request DL PHY mode change, per PHY mode, per DL, per upgrade/downgrade	RlcGeneralBroadcastInformation	[4, 40] db	0,25 dB	8
PeriodReport	Period for measurement reports	RlcGeneralBroadcastInformation, RlcMeasurementReportCriterium	[50, 200] ms	50 ms	3
PeriodRangingReq	Minimum period between subsequent ranging request messages	RlcGeneralBroadcastInformation	[0, 15] frame	1 frame	4
FrameOffset	Frame offset	RlcGeneralBroadcastInformation	[0,4, 1] ms	0,05 ms	5
CrMaxNumberRetries	CR max no of retries for bandwidth contention	RlcGeneralBroadcastInformation	[1, 16] retries	1 retry	4
CrStartingWindowSize	CR starting window size for bandwidth contention	RlcGeneralBroadcastInformation			3
CrMaxBackoffWindow	CR max backoff window for bandwidth contention	RlcGeneralBroadcastInformation			6

A.3 Timers

Table A.3: Detailed specification of AP timers

Name	Duration	Standard Ref. OR Operator-Defined
AP Initialization Timers		
T_RangingAck		
T_PhyCapabilitiesReq		
T_PhyCapabilitiesCnf		
T_OtherCapabilitiesReq		
T_OtherCapabilitiesCnf		
AP Connection Control Timers		
T_ConnectionAdditionSetup		
T_ConnectionAdditionAck		
T_ConnectionChangeSetup		
T_ConnectionChangeAck		
T_ConnectionDeletionInit		
T_ConnectionDeletionAck		
AP Radio Resource Control Timers		
T_DownlinkPhyModeChange		
T_DownlinkPhyModeChangeAck		
T_UplinkCorrection		
T_Handover_Cmd		

Table A.4: Detailed specification of AT timers

Name	Duration	Standard Ref. OR Operator-Defined
AT Initialization Timers		
T_RangingAck		
T_PhyCapabilitiesInfo		
T_PhyCapabilitiesCnf		
T_OtherCapabilitiesInfo		
T_OtherCapabilitiesCnf		
AT Connection Control Timers		
T_ConnectionAdditionInit		
T_ConnectionAdditionAck		
T_ConnectionChangeInit		
T_ConnectionChangeAck		
T_ConnectionDeletionInit		
T_ConnectionDeletionAck		
AT Radio Resource Control Timers		
T_MeasurementReportData		
T_DownlinkPhyModeChangeAck		
T_HandoverAck		

Annex B (normative): Formats of protocol primitives

The electronic attachment containing the ASN.1 message description is the normative specification, just in case of discrepancies to this printed complete description and all printed extracts in clauses 1 to 13 (for the purpose of better readability).

The statements about granularity and range of variables in the form of ASN.1 comments are to be considered as normative specifications.

PER encoding with byte alignment shall be applied to each message.

Table B.1: Complete ASN.1 description of protocol primitives

```
-- *****
-- Abbreviations:  inc    = increment
--                 granu  = granularity
--                 ann    = announcement
--                 tx/rx  = transmit/receive
--                 cnr    = carrier-to-(noise&interference) ratio
--                 cr     = contention resolution
--                 at     = AT
--                 conn   = connection
--                 agg    = aggregate
--                 OD     = origination -> destination
--                 DO     = destination -> origination
--                 AK     = Authorization Key
--                 KEK    = Key Encryption Key
--                 MAK    = Message Authentication Key
--                 SA     = Security Association
--                 SAID   = Security Association Identifier
--                 TEK    = Traffic Encryption Key
-- *****

HApProtocolPrimitives
DEFINITIONS

    AUTOMATIC TAGS ::=

BEGIN

EXPORTS RlcConnectionAdditionInit, RlcConnectionAdditionSetup,
        RlcConnectionAdditionAck,  RlcConnectionChangeInit,
        RlcConnectionChangeSetup,  RlcConnectionChangeAck,
        RlcConnectionDeletionInit, RlcConnectionDeletionAck;

-- *****
-- Lists of Messages
-- *****

MacManagementMessage ::= CHOICE {
    rlcGeneralBroadcastInformation  RlcGeneralBroadcastInformation, -- DL Br
    rlcFrequencyList                RlcFrequencyList,                -- DL Br
    rlcMultipleTidBroadcastBasic    RlcMultipleTidBroadcastBasic,  -- DL Br

    rlcBandwidthReq                 RlcBandwidthReq,                 -- UL Ba
    rlcQueueStatusReq               RlcQueueStatusReq,               -- DL Ba
    rlcQueueStatusRsp               RlcQueueStatusRsp,               -- UL Ba

    rlcRangingInvitation            RlcRangingInvitation,            -- DL Ba
    rlcRangingReq                   RlcRangingReq,                   -- UL Ba
    rlcRangingContinue              RlcRangingContinue,              -- DL Ba
    rlcRangingSuccess               RlcRangingSuccess,               -- DL Ba
    rlcRangingAck                   RlcRangingAck,                   -- UL Ba
    rlcPhyCapabilitiesReq           RlcPhyCapabilitiesReq,           -- DL Ba
}
```

rlcPhyCapabilitiesInfo	RlcPhyCapabilitiesInfo,	-- UL Ba
rlcPhyCapabilitiesCnf	RlcPhyCapabilitiesCnf,	-- DL Ba
rlcOtherCapabilitiesReq	RlcOtherCapabilitiesReq,	-- DL Ba
rlcOtherCapabilitiesInfo	RlcOtherCapabilitiesInfo,	-- UL Ba
rlcOtherCapabilitiesCnf	RlcOtherCapabilitiesCnf,	-- DL Ba
rlcInitializationCmd	RlcInitializationCmd,	-- DL Ba
rlcMeasurementReportData	RlcMeasurementReportData,	-- UL Ba
rlcDownlinkPhyModeChange	RlcDownlinkPhyModeChange,	-- DL Ba
rlcDownlinkPhyModeChangeAck	RlcDownlinkPhyModeChangeAck,	-- UL Ba
rlcUplinkCorrection	RlcUplinkCorrection,	-- DL Ba
rlcMeasurementReportCriterium	RlcMeasurementReportCriterium,	-- DL Ba
rlcHandoverCmd	RlcHandoverCmd,	-- DL Ba
rlcHandoverAck	RlcHandoverAck,	-- UL Ba
rlcAuthManufacturerInfo	RlcAuthManufacturerInfo,	-- UL Pr
rlcAuthReq	RlcAuthReq,	-- UL Pr
rlcAuthReply	RlcAuthReply,	-- DL Pr
rlcAuthReject	RlcAuthReject,	-- DL Pr
rlcAuthInvalid	RlcAuthInvalid,	-- DL Pr
rlcTekReq	RlcTekReq,	-- UL Pr
rlcTek2Req	RlcTek2Req,	-- UL Pr
rlcTekAllocation	RlcTekAllocation,	-- DL Pr
rlcTekReject	RlcTekReject,	-- DL Pr
rlcTekInvalid	RlcTekInvalid,	-- DL Pr
rlcConnectionAdditionInit	RlcConnectionAdditionInit,	-- UL Ba
rlcConnectionAdditionSetup	RlcConnectionAdditionSetup,	-- DL Ba
rlcConnectionAdditionAck	RlcConnectionAdditionAck,	-- UL Ba
rlcConnectionChangeInit	RlcConnectionChangeInit,	-- UL Ba
rlcConnectionChangeSetup	RlcConnectionChangeSetup,	-- DL Ba
rlcConnectionChangeAck	RlcConnectionChangeAck,	-- UL Ba
rlcConnectionDeletionInit	RlcConnectionDeletionInit,	-- Req->NonReq Ba
rlcConnectionDeletionAck	RlcConnectionDeletionAck,	-- NonReq->Req Ba
packedMessageDownlinkBasic	PackedMessageDownlinkBasic,	-- DL Ba
packedMessageUplinkBasic	PackedMessageUplinkBasic	-- UL Ba
}		
MessagesForPackingDownlinkBasic	::= CHOICE {	
rlcQueueStatusReq	RlcQueueStatusReq,	-- DL Ba
rlcRangingContinue	RlcRangingContinue,	-- DL Ba
rlcRangingSuccess	RlcRangingSuccess,	-- DL Ba
rlcPhyCapabilitiesReq	RlcPhyCapabilitiesReq,	-- DL Ba
rlcPhyCapabilitiesCnf	RlcPhyCapabilitiesCnf,	-- DL Ba
rlcOtherCapabilitiesReq	RlcOtherCapabilitiesReq,	-- DL Ba
rlcOtherCapabilitiesCnf	RlcOtherCapabilitiesCnf,	-- DL Ba
rlcInitializationCmd	RlcInitializationCmd,	-- DL Ba
rlcDownlinkPhyModeChange	RlcDownlinkPhyModeChange,	-- DL Ba
rlcUplinkCorrection	RlcUplinkCorrection,	-- DL Ba
rlcMeasurementReportCriterium	RlcMeasurementReportCriterium,	-- DL Ba
rlcConnectionAdditionSetup	RlcConnectionAdditionSetup,	-- DL Ba
rlcConnectionChangeSetup	RlcConnectionChangeSetup,	-- DL Ba
rlcConnectionDeletionInit	RlcConnectionDeletionInit,	-- Req->NonReq Ba
rlcConnectionDeletionAck	RlcConnectionDeletionAck	-- NonReq->Req Ba
}		
MessagesForPackingUplinkBasic	::= CHOICE {	
rlcMeasurementReportData	RlcMeasurementReportData,	-- UL Ba
rlcDownlinkPhyModeChangeAck	RlcDownlinkPhyModeChangeAck,	-- UL Ba
rlcConnectionAdditionInit	RlcConnectionAdditionInit,	-- UL Ba
rlcConnectionAdditionAck	RlcConnectionAdditionAck,	-- UL Ba
rlcConnectionChangeInit	RlcConnectionChangeInit,	-- UL Ba
rlcConnectionChangeAck	RlcConnectionChangeAck,	-- UL Ba
rlcConnectionDeletionInit	RlcConnectionDeletionInit,	-- Req->NonReq Ba
rlcConnectionDeletionAck	RlcConnectionDeletionAck	-- NonReq->Req Ba
-- excluded for PackingUplink: ranging bursts, short PDUs,		
-- initialization (due to PTC), handoverAck		

```

}

PackedMessageDownlinkBasic ::= SEQUENCE (SIZE(1..50)) OF MessagesForPackingDownlinkBasic
PackedMessageUplinkBasic   ::= SEQUENCE (SIZE(1..50)) OF MessagesForPackingUplinkBasic

-- *****
-- Messages for Broadcast and MAC (Clause 1 to 8)
-- *****

RlcGeneralBroadcastInformation ::= SEQUENCE {
    duplexMode           DuplexMode,           -- 1 bit
    frameOffset          FrameOffset,          -- 5 bit
    tdmaZoneDownlink    TdmaZoneDownlink,     -- 1 bit
    encryptionMode      EncryptionMode,       -- 1 bit
    uplinkPowerIncRangingStart UplinkPowerIncRangingStart, -- 3 bit, common
    uplinkPowerMaxRangingStart UplinkPowerMax, -- 4 bit, common
    downlinkPowerControl DownlinkPowerControl, -- 1 bit
    periodMeasurementReportGBI PeriodMeasurementReportGBI, -- 3 bit, RRC
    periodRangingInvitation PeriodRangingInvitation, -- 8 bit,
    timerGranuConnection TimerGranuConnection, -- 8 bit
    timerGranuSecurity   TimerGranuSecurity,   -- 6 bit
    uplinkNumberPduPerFecBlock UplinkNumberPduPerFecBlock, -- 1 bit
    uplinkNumberMidamblePerBurst UplinkNumberMidamblePerBurst, -- 1 bit
    crMaxNumberRetries   CrMaxNumberRetries,   -- 4 bit
    crStartingWindowSize CrStartingWindowSize, -- 3 bit
    crMaxBackoffWindow   CrMaxBackoffWindow,   -- 6 bit
    fixedVariableChannelInd FixedVariableChannelInd, -- 1 bit
    phyModeSetDescriptorCurrent PhyModeSetDescriptor, -- variable
    phyModeSetDescriptorFuture PhyModeSetDescriptor OPTIONAL -- variable
}

DuplexMode ::= ENUMERATED {
    fdd (0),
    tdd (1)
}

TdmaZoneDownlink ::= ENUMERATED {
    present (0),
    notPresent (1)
}

DownlinkPowerControl ::= ENUMERATED {
    downlinkPowerControlNo (0), -- ignore PhyThresholdsList(0)
    downlinkPowerControlYes (1)
}

EncryptionMode ::= ENUMERATED {
    encryptionOn (0),
    encryptionOff (1)
}

FrameOffset ::= INTEGER(0..20) -- 5 bit, granu=0,05 ms,range=[0,1] ms

PeriodRangingInvitation ::= INTEGER(0..255) -- 8 bit, granu=1000 frame
-- 0 means no invitations

TimerGranuConnection ::= INTEGER(8..255) -- 8 bit, granu=1 frame
TimerGranuSecurity ::= INTEGER(1..63) -- 6 bit, granu=128 frame

UplinkNumberPduPerFecBlock ::= ENUMERATED {
    onePduPerFecBlock (0),
    severalPerFecBlock (1)
}

UplinkNumberMidamblePerBurst ::= ENUMERATED {
    oneMidamblePerBurst (0),
    severalMidamblePerBurst (1)
}

```

```

CrMaxNumberRetries ::= INTEGER(0..15) -- 4 bit
CrStartingWindowSize ::= INTEGER(0..7) -- 3 bit
CrMaxBackoffWindow ::= INTEGER(0..63) -- 6 bit

FixedVariableChannelInd ::= ENUMERATED {
    fixedChannel (0), -- shall be used
    variableChannel (1) -- not allowed
}

PhyModeSetDescriptor ::= SEQUENCE {
    psdi Psdi, -- 4 bit
    downlinkPhyThresholdsList PhyThresholdsList, -- variable
    uplinkPowerModChangeListNonTc UplinkPowerModChangeList, -- variable
    uplinkPowerModChangeListTc UplinkPowerModChangeList -- variable
}

Psdi ::= INTEGER {phyModeSet1 (1), phyModeSet2 (2)} (0..15) -- 4 bit

PhyThresholdsList ::= SEQUENCE (SIZE(2..7)) OF PhyThresholdPair
-- allows 2..7 PHY modes per set, 2*8 bit per pair, see RRC
-- 1st pair for DL ATPC, to be ignored if no DL ATPC
-- 2nd pair for mode1/mode2, 3rd pair for mode2/mode3, etc.

UplinkPowerModChangeList ::= SEQUENCE (SIZE(1..6)) OF UplinkPowerModChangePair
-- allows 2..7 PHY modes per set, 6 bit per entry, see common
-- TX power steps for UL PHY change
-- 1st gap pair for mode1/mode2,
-- 2nd gap pair for mode2/mode3, etc.

PhyThresholdPair ::= SEQUENCE {
    upThreshold CnrThreshold, -- channel quality increase
    downThreshold CnrThreshold -- channel quality decrease
}

UplinkPowerModChangePair ::= SEQUENCE {
    upPowerModChange UplinkPowerModChange, -- channel quality increase
    downPowerModChange UplinkPowerModChange -- channel quality decrease
}

RlcFrequencyList ::= SEQUENCE (SIZE(1..32)) OF PairOfCarrierFrequencies

PairOfCarrierFrequencies ::= SEQUENCE {
    uplinkCarrierFrequency CarrierFrequency,
    downlinkCarrierFrequency CarrierFrequency -- equal to uplinkFrequency for TDD
}

CarrierFrequency ::= INTEGER(0..130000) -- 17 bit, granu=0,5 MHz, range=[0,65] GHz

RlcMultipleTidBroadcastBasic ::= SEQUENCE (SIZE(1..50)) OF PairTidMessageBasic

PairTidMessageBasic ::= SEQUENCE {
    tid Tid,
    messagesForTidPackingBasic MessagesForTidPackingBasic
}

MessagesForTidPackingBasic ::= CHOICE {
    rlcQueueStatusReq RlcQueueStatusReq, -- DL Ba
    rlcRangingContinue RlcRangingContinue, -- DL Ba
    rlcRangingSuccess RlcRangingSuccess, -- DL Ba
    rlcPhyCapabilitiesReq RlcPhyCapabilitiesReq, -- DL Ba
    rlcPhyCapabilitiesCnf RlcPhyCapabilitiesCnf, -- DL Ba
    rlcOtherCapabilitiesReq RlcOtherCapabilitiesReq, -- DL Ba
    rlcOtherCapabilitiesCnf RlcOtherCapabilitiesCnf, -- DL Ba
    rlcInitializationCmd RlcInitializationCmd, -- DL Ba
    rlcDownlinkPhyModeChange RlcDownlinkPhyModeChange, -- DL Ba
    rlcUplinkCorrection RlcUplinkCorrection, -- DL Ba
    rlcMeasurementReportCriterium RlcMeasurementReportCriterium, -- DL Ba
}

```

```

rlcHandoverCmd          RlcHandoverCmd,          -- DL Ba
rlcConnectionAdditionSetup  RlcConnectionAdditionSetup, -- DL Ba
rlcConnectionChangeSetup   RlcConnectionChangeSetup,  -- DL Ba
rlcConnectionDeletionInit  RlcConnectionDeletionInit,  -- Req->NonReq Ba
rlcConnectionDeletionAck   RlcConnectionDeletionAck   -- NonReq->Req Ba
}

-- *****
-- Messages for Request-Grant (Clause 9)
-- *****

RlcBandwidthReq ::= SEQUENCE {
    caid2      Caid,          -- 2 byte, common
    piggyback2 Piggyback,     -- 1 byte, common
    caid3      Caid,          -- 2 byte, common
    piggyback3 Piggyback     -- 1 byte, common
}
-- This message carries the queue status of three connection aggregates that are
-- selectable by the AT without any restrictions. CA2 and CA3 are contained in the
-- payload, CA1 is represented by the CID and piggyback fields in the header.

RlcQueueStatusReq ::= SEQUENCE (SIZE(1..6)) OF Caid -- DL, common

RlcQueueStatusRsp ::= SEQUENCE (SIZE(1..6)) OF Piggyback -- UL, common

-- *****
-- Messages for Initialization (Clause 10)
-- *****

RlcRangingInvitation ::= SEQUENCE { -- DL
    atMacAddress  AtMacAddress, -- 48 bit, common
    tid           Tid,          -- 10 bit, common
    basicCid      BasicCid,     -- 16 bit, common
    primaryCid    PrimaryCid,   -- 16 bit, common
    secondaryCid  SecondaryCid, -- 16 bit, common
    basicCaid     Caid,         -- 16 bit, common
    primaryCaid   Caid,         -- 16 bit, common
    secondaryCaid Caid,         -- 16 bit, common
    apTxPowerIndication ApTxPowerIndication -- 5 bit, common
}

RlcRangingReq ::= SEQUENCE { -- UL, increasing or adapted power
    rangingStatus RangingStatus -- 2 bit
}

RlcRangingContinue ::= SEQUENCE { -- DL, adapt power, send Req
    timingAdjustRanging TimingAdjustRanging, -- 13 bit, common
    uplinkPowerInc      UplinkPowerInc      -- 6 bit, common
}

RlcRangingSuccess ::= SEQUENCE { -- DL, adapt power, send Ack
    timingAdjustRanging TimingAdjustRanging, -- 13 bit, common
    uplinkPowerInc      UplinkPowerInc,     -- 6 bit, common
    initializationStatus InitializationStatus -- 1 bit
}

RlcRangingAck ::= SEQUENCE {
    rangingStatus RangingStatus -- 2 bit
}

RlcPhyCapabilitiesReq ::= SEQUENCE {
}

RlcPhyCapabilitiesInfo ::= SEQUENCE { -- AT offers its optional cap.
    downlink64QamSupport Downlink64QamSupport, -- 1 bit
    uplink16QamSupport   Uplink16QamSupport,   -- 1 bit
    uplinkTurboEncSupport UplinkTurboEncSupport, -- 1 bit
}

```

```

uplinkPowerMaxQpsk      UplinkPowerMax,      -- 4 bit, common
uplinkPowerMax16Qam     UplinkPowerMax,      -- 4 bit, common
numberSaidSupport       NumberSaidSupport,    -- 10 bit
terminalType            TerminalType,        -- 1 bit
pairOfCarrierFrequenciesLow  PairOfCarrierFrequencies, -- 34 bit
pairOfCarrierFrequenciesHigh PairOfCarrierFrequencies -- 34 bit
}

RlcPhyCapabilitiesCnf ::= SEQUENCE { -- AP commands what to use
  downlink64QamUse      Downlink64QamUse,    -- 1 bit
  uplink16QamUse        Uplink16QamUse,      -- 1 bit
  uplinkTurboEncUse     UplinkTurboEncUse,    -- 1 bit
  uplinkPreambleLength UplinkPreambleLength, -- 1 bit
  uplinkPowerMaxQpsk    UplinkPowerMax,      -- 4 bit, common
  uplinkPowerMax16Qam   UplinkPowerMax,      -- 4 bit, common
  initializationStatus   InitializationStatus -- 1 bit
}

RlcOtherCapabilitiesReq ::= SEQUENCE {
}

RlcOtherCapabilitiesInfo ::= SEQUENCE { -- UL
  numberUplinkConnsSupport      NumberUplinkConnsSupport,    -- 2 byte
  numberDownlinkConnsSupport    NumberDownlinkConnsSupport, -- 2 byte
  numberConnAggsSupport         NumberConnAggsSupport,      -- 2 byte
  numberConnsPerConnAggSupport  NumberConnsPerConnAggSupport, -- 2 byte
  crSupport                      CrSupport,                  -- 1 bit
  tripleDesSupport               TripleDesSupport,           -- 1 bit
  terminalClCapabilities         TerminalClCapabilities       -- variable
}

RlcOtherCapabilitiesCnf ::= SEQUENCE {
  numberUplinkConnsUse      NumberUplinkConnsUse,
  numberDownlinkConnsUse    NumberDownlinkConnsUse,
  numberConnAggsUse         NumberConnAggsUse,
  numberConnsPerConnAggUse  NumberConnsPerConnAggUse,
  tripleDesUse              TripleDesUse
}

RangingStatus ::= ENUMERATED { -- 2 bit
  txPowerMax      (0),
  txPowerBetween  (1),
  txPowerMin      (2)
}

InitializationStatus ::= ENUMERATED { -- 1 bit
  initializationContinue (0), -- AT to expect further messaging for init
  initializationFinished (1) -- init finished
}

RlcInitializationCmd ::= SEQUENCE { -- DL
  initializationCmd      InitializationCmd -- 3 bit
}

InitializationCmd ::= ENUMERATED {
  rejectedFromNetwork (0),
  rejectedFromChannel (1),
  firstInitialization (2),
  transmissionStop    (3),
  transmissionReStart (4)
}

UplinkPreambleLength ::= ENUMERATED {
  length16bit (0),
  length32bit (1)
}

Downlink64QamSupport ::= ENUMERATED {
  downlink64QamNotSupported (0),

```



```

    downlink64QamSupported      (1)
}

Uplink16QamSupport ::= ENUMERATED {
    uplink16QamNotSupported    (0),
    uplink16QamSupported      (1)
}

Downlink64QamUse ::= ENUMERATED {
    downlink64QamNotUsed      (0),
    downlink64QamUsed        (1)
}

Uplink16QamUse ::= ENUMERATED {
    uplink16QamNotUsed      (0),
    uplink16QamUsed        (1)
}

UplinkTurboEncSupport ::= ENUMERATED {
    uplinkTurboEncNotSupported (0),
    uplinkTurboEncSupported   (1)
}

UplinkTurboEncUse ::= ENUMERATED {
    uplinkTurboEncNotUsed    (0),
    uplinkTurboEncUsed      (1)
}

TerminalType ::= ENUMERATED {
    terminalFdd              (0),
    terminalHfddWithTdmAndTdma (1)
}

TripleDesSupport ::= ENUMERATED {
    tripleDesNotSupported    (0),
    tripleDesSupported      (1)
}

TripleDesUse ::= ENUMERATED {
    tripleDesNotUsed        (0),
    tripleDesUsed          (1)
}

TerminalClCapabilities ::= OCTET STRING (SIZE(0..32)) -- variable

NumberUplinkConnsSupport ::= INTEGER(4..65535) -- 2 byte, incl MAC mgmt conns
NumberDownlinkConnsSupport ::= INTEGER(5..65535) -- 2 byte, incl MAC mgmt conns
NumberConnAggsSupport ::= INTEGER(1..65535) -- 2 byte
NumberConnsPerConnAggSupport ::= INTEGER(1..65535) -- 2 byte

NumberSaidSupport ::= INTEGER(1..maxNumberSaidSupport) -- 10 bit
maxNumberSaidSupport NumberSaidSupport ::= 1023

NumberUplinkConnsUse ::= INTEGER(4..65535) -- 2 byte, incl MAC mgmt conns
NumberDownlinkConnsUse ::= INTEGER(5..65535) -- 2 byte, incl MAC mgmt conns
NumberConnAggsUse ::= INTEGER(1..65535) -- 2 byte
NumberConnsPerConnAggUse ::= INTEGER(1..65535) -- 2 byte

CrSupport ::= ENUMERATED {
    crSupportNo              (0),
    crSupportYes            (1)
}

-- *****
-- Messages for Radio Resource Control (Clause 11)
-- *****

RlcMeasurementReportData ::= SEQUENCE { -- UL
    downlinkPhyModeWanted DownlinkPhyMode, -- 3 bit, common

```

```

    cnrMeasured          CnrMeasured,          -- 8 bit
    rxPowerMeasured      RxPowerMeasured,      -- 8 bit
    txPowerMeasured      TxPowerMeasured,      -- 6 bit
    txPowerMargin        TxPowerMargin,        -- 6 bit
    maxUplinkPhyMode     UplinkPhyMode         -- 3 bit, common
}

RlcDownlinkPhyModeChange ::= SEQUENCE {          -- DL
    downlinkPhyModeGranted DownlinkPhyMode     -- 3 bit, common
}

RlcDownlinkPhyModeChangeAck ::= SEQUENCE {      -- UL
    downlinkPhyModeGrantedAck DownlinkPhyMode  -- 3 bit, common
}

RlcUplinkCorrection ::= SEQUENCE {             -- DL
    uplinkPowerInc        UplinkPowerInc,      -- 6 bit, common
    timingAdjustFine      TimingAdjustFine,    -- 5 bit, common
    measurementReportReq   MeasurementReportReq -- 1 bit
}

RlcMeasurementReportCriterium ::= SEQUENCE {    -- DL,
    periodMeasurementReportAtSpecific PeriodMeasurementReport -- 3 bit,
    -- overwrites periodMeasurementReportGBI
}

RlcHandoverCmd ::= SEQUENCE {                  -- DL
    atMacAddress          AtMacAddress,         -- 48 bit, common
    newPairOfCarrierFrequencies PairOfCarrierFrequencies, -- 34 bit
    apcId                 ApcId                -- 24 bit
}

ApcId ::= INTEGER(1..16777216)

RlcHandoverAck ::= SEQUENCE {                  -- UL
    atMacAddress          AtMacAddress         -- 48 bit, common
}

MeasurementReportReq ::= ENUMERATED {
    measurementReportRequestedNo (0),
    measurementReportRequestedYes (1)
}

CnrMeasured ::= INTEGER(0..255) -- 8 bit, granu=0.25dB, range=[4,40]dB, absolute
CnrThreshold ::= INTEGER(0..255) -- 8 bit, granu=0.25dB, range=[4,40]dB, absolute

RxPowerMeasured ::= INTEGER(0..255) -- 8 bit, granu=0.25dB, range=[-88,-28]dBm, absolute
TxPowerMeasured ::= INTEGER(0..63) -- 6 bit, granu=1.00dB, range=[-26,+20]dBm, absolute
TxPowerMargin ::= INTEGER(0..63) -- 6 bit, granu=0.25dB, range=[0,12]dB, incremental

PeriodMeasurementReport ::= INTEGER {
    usePeriodicMeasurementReportGBI (0),
    -- only for periodMeasurementReportAtSpecific in RlcMeasurementReportCriterium,
    -- but not for
    -- periodMeasurementReportGBI in RlcGeneralBroadcastInformation
    period050 (1), -- 50 ms
    period100 (2), -- 100 ms
    period150 (3), -- 150 ms
    period200 (4), -- 200 ms
    noPeriodicReports (5)
}

PeriodMeasurementReportGBI ::= PeriodMeasurementReport
    (period050..noPeriodicReports)

-- *****
-- Messages for Security Control (Clause 12)
-- *****

```

```

RlcAuthCmd ::= SEQUENCE {
}
-- DL

RlcAuthManufacturerInfo ::= SEQUENCE {
    manufacturerX509certificate ManufacturerX509certificate
}
-- UL

RlcAuthReq ::= SEQUENCE {
    manufacturerID ManufacturerID,
    atPublicKey AtPublicKey,
    atX509certificate AtX509certificate
}
-- UL

RlcAuthReply ::= SEQUENCE {
    authKey AuthKey,
    akSeqNo AkSeqNo,
    akLifeTime AkLifeTime,
    said Said
}
-- DL

RlcAuthReject ::= SEQUENCE {
    authRejectErrorCode AuthErrorCode,
    errorInfoText ErrorInfoText OPTIONAL
}
-- DL

RlcAuthInvalid ::= SEQUENCE {
    authInvalidErrorCode AuthErrorCode,
    errorInfoText ErrorInfoText OPTIONAL
}
-- DL, unsolicited information

RlcTekAllocation ::= SEQUENCE {
    said Said,
    tek1 Tek, -- authentication with HMAC, encrypted with AK
    tek1LifeTime TekLifeTime, -- remaining TEK lifetime
    tek1SequenceNumber TekSeqNo,
    ivParameter IvParameter,
    hmac HmacKeyedMessageDigest,
    initializationStatus InitializationStatus -- 1 bit
}
-- message send twice with different lifetimes tek1 is shorter than the one for tek2

RlcTekReq ::= SEQUENCE {
    said Said,
    hmacDigest HmacDigest
}
-- UL, requesting TEK, authentication with HMAC

RlcTek2Req ::= RlcTekReq

RlcTekReject ::= SEQUENCE {
    tekSeqNo TekSeqNo,
    said Said,
    tekErrorCode TekErrorCode,
    errorInfoText ErrorInfoText OPTIONAL
}
-- DL

RlcTekInvalid ::= SEQUENCE {
    tekSeqNo TekSeqNo,
    said Said,
    tekErrorCode TekErrorCode,
    errorInfoText ErrorInfoText OPTIONAL
}
-- DL, if AT uses invalid TEK for encryption

AtPublicKey ::= OCTET STRING (SIZE(128)) -- 128 bytes
AuthKey ::= OCTET STRING (SIZE(20)) -- 20 bytes
Tek ::= OCTET STRING (SIZE(16)) -- 16 bytes

TekLifeTime ::= INTEGER ( 1..1048575) -- 20 bit, granu=1min, max=2years
AkLifeTime ::= INTEGER (10..1048575) -- 20 bit, granu=1min, max=2years

```

```

TekErrorCode ::= INTEGER(0..255)
AuthInvalidErrorCode ::= INTEGER(0..255)
TekSeqNo ::= INTEGER(0..3) -- 2 bit (instead of 1 byte)
AkSeqNo ::= INTEGER(0..3) -- 2 bit (instead of 1 byte)

HmacDigest ::= OCTET STRING (SIZE(20)) -- 20 byte, HMAC with SHA-1

AuthErrorCode ::= ENUMERATED {
    reAuthorizationRequested (0),
    permanentRejection (1)
}

HmacKeyedMessageDigest ::= OCTET STRING (SIZE(20))
ManufacturerX509certificate ::= OCTET STRING (SIZE(64))
AtX509certificate ::= OCTET STRING (SIZE(64))
KeyReplyMsgAuthentication ::= OCTET STRING (SIZE(20))
ManufacturerID ::= OCTET STRING (SIZE(10))

IvParameter ::= OCTET STRING (SIZE(8)) -- 64 bit

ErrorInfoText ::= IA5String(SIZE(0..128))

-- *****
-- Messages for Connection Control (Clause 13)
-- *****

RlcConnectionAdditionInit ::= SEQUENCE {
    transactionId TransactionId, -- 17 bit
    clid Clid, -- 3 bit
    connectionClParameters ConnectionClParameters, -- variable
    scid Scid, -- 2 bit
    directionChoice DirectionChoice, -- variable
    arqUsage ArqUsage -- 2 bit
}

RlcConnectionAdditionSetup ::= SEQUENCE {
    transactionId TransactionId, -- 17 bit
    assignedCid AssignedCid, -- 16 bit
    assignedCaid AssignedCaid, -- 16 bit
    pmAssociation PmAssociation, -- 1 bit
    clid Clid, -- 3 bit
    connectionClParameters ConnectionClParameters, -- variable
    scid Scid, -- 4 bit
    directionChoice DirectionChoice, -- variable
    arqUsage ArqUsage, -- 2 bit
    said Said, -- 16 bit
    contentionFlag ContentionFlag, -- 1 bit
    confirmationCode ConfirmationCode -- 1 bit
}

RlcConnectionAdditionAck ::= SEQUENCE {
    transactionId TransactionId, -- 17 bit
    assignedCid AssignedCid, -- 16 bit
    confirmationCode ConfirmationCode -- 1 bit
}

RlcConnectionChangeInit ::= SEQUENCE {
    transactionId TransactionId, -- 17 bit
    cid Cid, -- 16 bit
    scid Scid, -- 2 bit
    directionChoice DirectionChoice, -- variable
    arqUsage ArqUsage -- 2 bit
}

RlcConnectionChangeSetup ::= SEQUENCE {
    transactionId TransactionId, -- 17 bit
    assignedCid AssignedCid, -- 16 bit

```

```

    assignedCaid      AssignedCaid,      -- 16 bit
    pmAssociation     PmAssociation,    -- 1 bit
    scid              Scid,            -- 2 bit
    directionChoice   DirectionChoice, -- variable
    arqUsage          ArqUsage,        -- 2 bit
    contentionFlag    ContentionFlag,  -- 1 bit
    confirmationCode  ConfirmationCode -- 1 bit
}

RlcConnectionChangeAck ::= SEQUENCE {
    transactionId      TransactionId,    -- 17 bit
    assignedCid        AssignedCid,      -- 16 bit
    confirmationCode    ConfirmationCode  -- 1 bit
}

RlcConnectionDeletionInit ::= SEQUENCE {
    transactionId      TransactionId,    -- 17 bit
    requestedCid       RequestedCid     -- 16 bit
}

RlcConnectionDeletionAck ::= SEQUENCE {
    transactionId      TransactionId,    -- 17 bit
    requestedCid       RequestedCid     -- 16 bit
}

ConfirmationCode ::= ENUMERATED {
    connAccepted (0),
    connReject   (1)
} -- 1 bit, request status

RequestedCid ::= DataCid -- 16 bit, temp for AT initiated req
AssignedCid  ::= DataCid -- 16 bit, temp for AT initiated req

AssignedCaid ::= Caid -- 16 bit, temp for AT initiated req

TransactionId ::= INTEGER(0..131071) -- 17 bit, uniquely assigned by sender

Clid ::= INTEGER {
    cellBased (1),
    packetBased (2)} (0..7) -- 3 bit

ConnectionClParameters ::= OCTET STRING (SIZE(0..63)) -- variable, contains VPI for CBCS

Scid ::= ENUMERATED {
    periodicRealTime (0),
    realTime (1),
    nonRealTime (2),
    bestEffort (3)
} -- 2 bit

PmAssociation ::= ENUMERATED {
    pmAssociated (0),
    pmNonAssociated (1)
}

Said ::= INTEGER(0..65535) -- 16 bit

ArqUsage ::= ENUMERATED {
    noARQ (0),
    onceARQ (1),
    twiceARQ (2)
}

ContentionFlag ::= ENUMERATED { -- 1 bit
    contentionReqsNotAllowed (0),
    contentionReqsAllowed (1)
}

DirectionChoice ::= CHOICE {

```

```

    uplinkDirection          DirectionDescr,
    downlinkDirection        DirectionDescr,
    bidirectionalSymmetrical DirectionDescr,
    bidirectionalAsymmetrical BidirectionalAsymmetrical
}

DirectionDescr ::= SEQUENCE {
    guaranteedBitRate      GuaranteedBitRate,
    maximumBitRate         MaximumBitRate,
    maximumBurstSize       MaximumBurstSize,
    connectionMinPhyMode   UplinkPhyMode, -- 0 for all DL DirectionDescr
    transferDelay          TransferDelay
}

BidirectionalAsymmetrical ::= SEQUENCE {
    uplinkDirection        DirectionDescr,
    downlinkDirection      DirectionDescr
}

BitRate ::= INTEGER(1..130000) -- 17 bit, granu=1kbit/s,max=130Mbit/s
GuaranteedBitRate ::= BitRate
MaximumBitRate ::= BitRate

TransferDelay ::= INTEGER(0|5..63) -- 6 bit, granu=1ms,max=63ms,
-- 0 means TransferDelay=infinity
MaximumBurstSize ::= INTEGER(0..255) -- 8 bit, granu=1PduPayload=51byte
-- 0 means MaxBurstSize=infinity
-- applies only for data conns

-- *****
-- Common part
-- *****

Cid ::= INTEGER(0..65535) -- 16 bit, connection ID
Tid ::= INTEGER(0..1023) -- 10 bit, terminal ID
Caid ::= INTEGER(0..65535) -- 16 bit, connection aggregate ID
AtMacAddress ::= OCTET STRING (SIZE(6)) -- 48 bit, MAC-48 address

BasicCid ::= Cid(10..1033)
PrimaryCid ::= Cid(1034..2057)
SecondaryCid ::= Cid(2058..3081)
DataCid ::= Cid(3082..65535)

-- Normative specifications for specific Cid values:
-- BroadcastCid ::= 0
-- MultipleTidBroadcastBasicCid ::= 1
-- DummyCid ::= 3
-- RangingCid ::= 4

-- Normative specifications for specific Tid values:
-- ContentionWindowTid ::= 0
-- EndOfMapTid ::= 1
-- normal Tid shall be in the range [2,1023]

Piggyback ::= INTEGER(0..255)

UplinkPowerInc ::= INTEGER(0..48) -- 6 bit, granu=0.5dB, range=[-20, +4]dB
UplinkPowerIncRangingStart ::= INTEGER(0..7) -- 3 bit, granu=1.0dB, range=[ +1, +8]dB
UplinkPowerModChange ::= INTEGER(0..32) -- 6 bit, granu=0.5dB, range=[ -8, +8]dB
UplinkPowerMax ::= INTEGER(10..20) -- 4 bit, granu=1.0dB, range=[+10,+20]dBm

ApTxPowerIndication ::= INTEGER(0..31) -- 5 bit, granu=1dB, range=[0,+31]dBm

TimingAdjustFine ::= INTEGER(0..16) -- 5 bit, granu=0.25*symbol,
-- range=[-2,+2]symbols, incremental

```

```
TimingAdjustRanging      ::= INTEGER(0..8191)-- 13 bit,granu=0.25*symbol,
                                -- range}[0,80]µs, absolute value

DownlinkPhyMode          ::= ENUMERATED {      -- 3 bit
    noNewPhyMode          (0),
    downlinkPhyMode1      (1),
    downlinkPhyMode2      (2),
    downlinkPhyMode3      (3),
    downlinkPhyMode4      (4),
    downlinkPhyModeFutureReserved (7)
}

UplinkPhyMode            ::= ENUMERATED {      -- 3 bit
    undefined              (0),
    uplinkPhyMode1         (1),
    uplinkPhyMode2         (2),
    uplinkPhyMode3         (3),
    uplinkPhyModeFutureReserved (7)
}

END
```

Annex C (informative): Formats of service primitives

Table C.1: Complete ASN.1 description of service primitives

```

HAservicePrimitives
DEFINITIONS

    AUTOMATIC TAGS ::=

BEGIN

IMPORTS RlcConnectionAdditionInit, RlcConnectionAdditionSetup,
        RlcConnectionAdditionAck, RlcConnectionChangeInit,
        RlcConnectionChangeSetup, RlcConnectionChangeAck,
        RlcConnectionDeletionInit, RlcConnectionDeletionAck

FROM HAservicePrimitives;

-- *****
-- Lists of service primitives (for connection control)
-- *****

DlcConnectionAdditionInitReq ::= RlcConnectionAdditionInit
DlcConnectionAdditionInitInd ::= RlcConnectionAdditionInit
DlcConnectionAdditionReq     ::= RlcConnectionAdditionSetup
DlcConnectionAdditionInd     ::= RlcConnectionAdditionSetup
DlcConnectionAdditionRsp     ::= RlcConnectionAdditionAck
DlcConnectionAdditionCnf     ::= RlcConnectionAdditionAck
DlcConnectionChangeInitReq  ::= RlcConnectionChangeInit
DlcConnectionChangeInitInd  ::= RlcConnectionChangeInit
DlcConnectionChangeReq      ::= RlcConnectionChangeSetup
DlcConnectionChangeInd      ::= RlcConnectionChangeSetup
DlcConnectionChangeRsp      ::= RlcConnectionChangeAck
DlcConnectionChangeCnf      ::= RlcConnectionChangeAck
DlcConnectionDeletionReq    ::= RlcConnectionDeletionInit
DlcConnectionDeletionInd    ::= RlcConnectionDeletionInit
DlcConnectionDeletionRsp    ::= RlcConnectionDeletionAck
DlcConnectionDeletionCnf    ::= RlcConnectionDeletionAck

END

```



Annex D (informative): MSC interpretation guidelines

This Technical specification contains a number of Message Sequence Diagrams and High Level Message Sequence Diagrams. In order to facilitate the reading of the present document this annex gives a light guideline on the way these diagrams should be read and interpreted.

MSC language is a graphical and textual language for the description of the interactions between system components. The language is an international standard defined in ITU-T Recommendation Z.120 [8]. Each MSC diagram represents one scenario of either a typical or an exceptional exchange of messages between system parts.

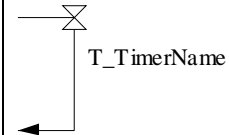
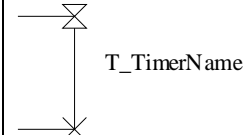
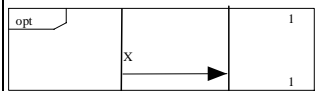
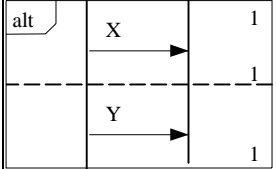
Most common elements are described in the example MSC diagram. In addition the following table list the language elements used in the present document.

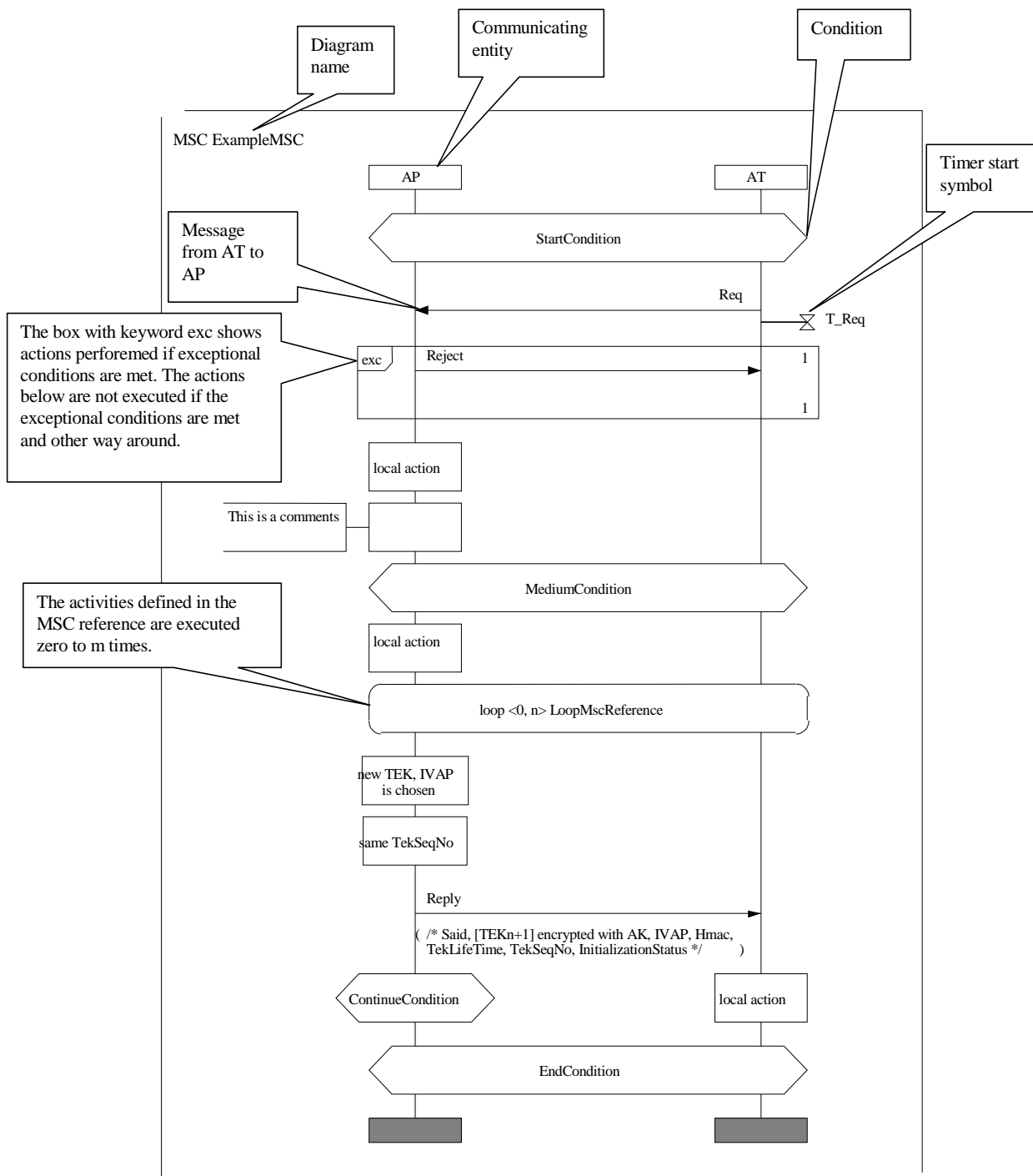
	One of the forms of comment.
	The timer symbol with upper part denoting the start and the bottom arrow the timer expiry.
	The timer symbol with the bottom arrow denoting the timer expiry.
	The opt keyword indicates optional message sending.
	The alt keyword indicates alternative, in this case either message X or message Y is sent.



HMSC diagrams can be productively used to specify more complex patterns of message flows by showing sequences or alternatives of atomic MSC scenarios shown only as MSC references.

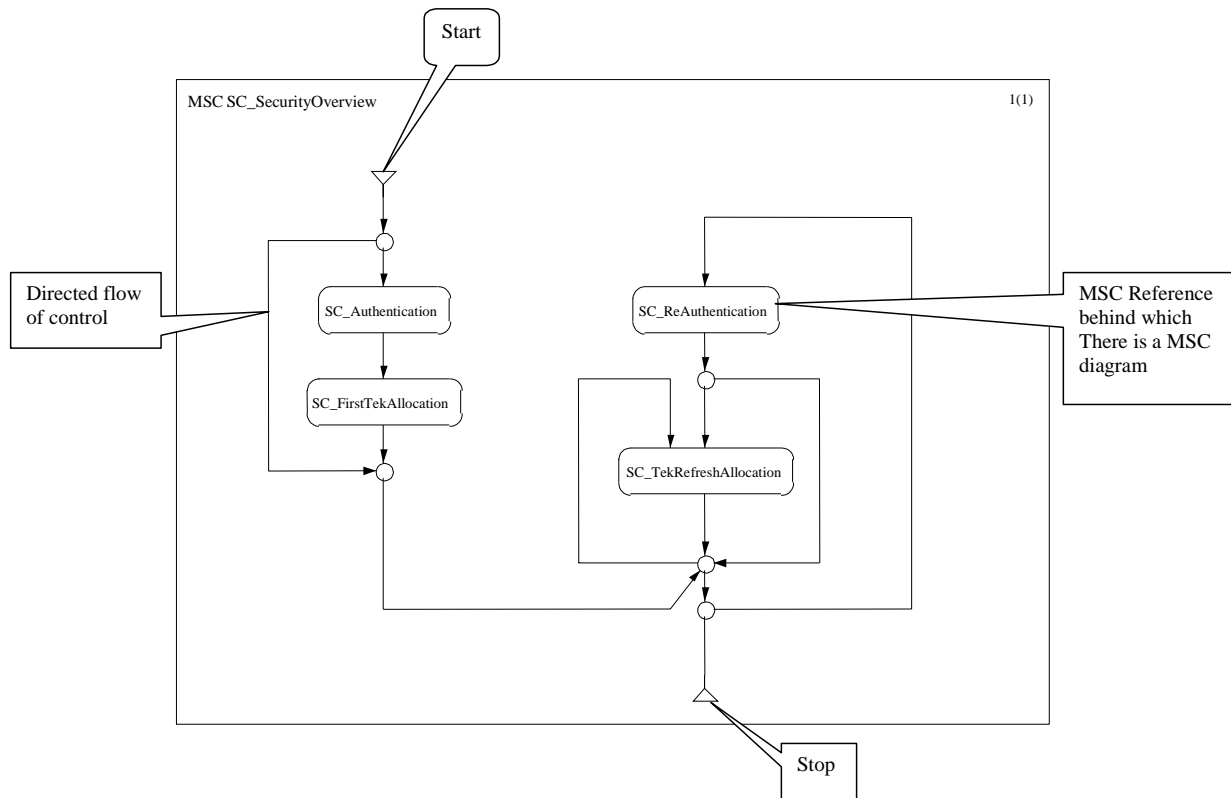

Annex E (normative): SDL specification of DLC protocol

E.1 The HIPERACCESS SDL model

The HIPERACCESS SDL model is at this stage a collection of individual models matching more important clauses of the present document. There are models for:

- Radio Resource control,
- Initialization control,
- Connection management control,
- Security control.

The SDL models are formal in the sense that they are free of any syntactic and semantic errors. As such they are suitable for simulation and validation and can serve as a reference implementation or an initial basis for implementation.

The models are integrated with DLC protocol message specification in ASN.1.

Each SDL model has been validated and has been improved until there was no behaviour that is undesired, such as deadlocks, livelocks or similar. There are no states where a message could come without a specified transition that handles such a case.

The models are always trying to capture what is going on in reality. In every model, there are simplifications and these are no exception. In introduction to each model the most notable simplifications will be highlighted and explained.

E.2 Radio Resource Control SDL model

The Radio Resource Control is developed as a closed system, i.e. there are two communicating processes representing AP and AT side respectively and there are no other external events that affect the behaviour of the model. In order to do that, the use of some SDL constructs needs to be shortly explained.

- The None event: this is an event that can trigger a transition without any obvious or explained reason. Both AP and AT radio resource control entities need to make some decisions based on some measurements and other elements. It would be beyond the scope of the model to describe the precise relations between the external conditions leading to some action and the actions that come. For modelling such behaviour the None event is ideal since it models the decision taken by AP or AT without going into the reasons for such a step. For example, one of the None events simulates that some thresholds have been crossed leading to the appropriate Rlc message being sent to the AP side.
- The decision containing the SDL "ANY" operator. The semantic of this is that any of the branches following the decision is taken without linking the path with any specific condition. This construct is useful to show all possible behaviour alternatives without going into details of why a particular branch was chosen. The advantage of using this is that state exploration tools explore possible traces through such decisions thus exercising the model in all ways possible.
- The expression containing "ANY" operator applied to a specific type. For example the application of ANY operator to a type Boolean will yield either true or false. There are situations in modelling where some message parameters need to be filled but their values do not affect the behaviour in any way (or at least not the behaviour of the part that is modelled). It is exactly for such situations that the operator was used.

E.2.1 RRC AP

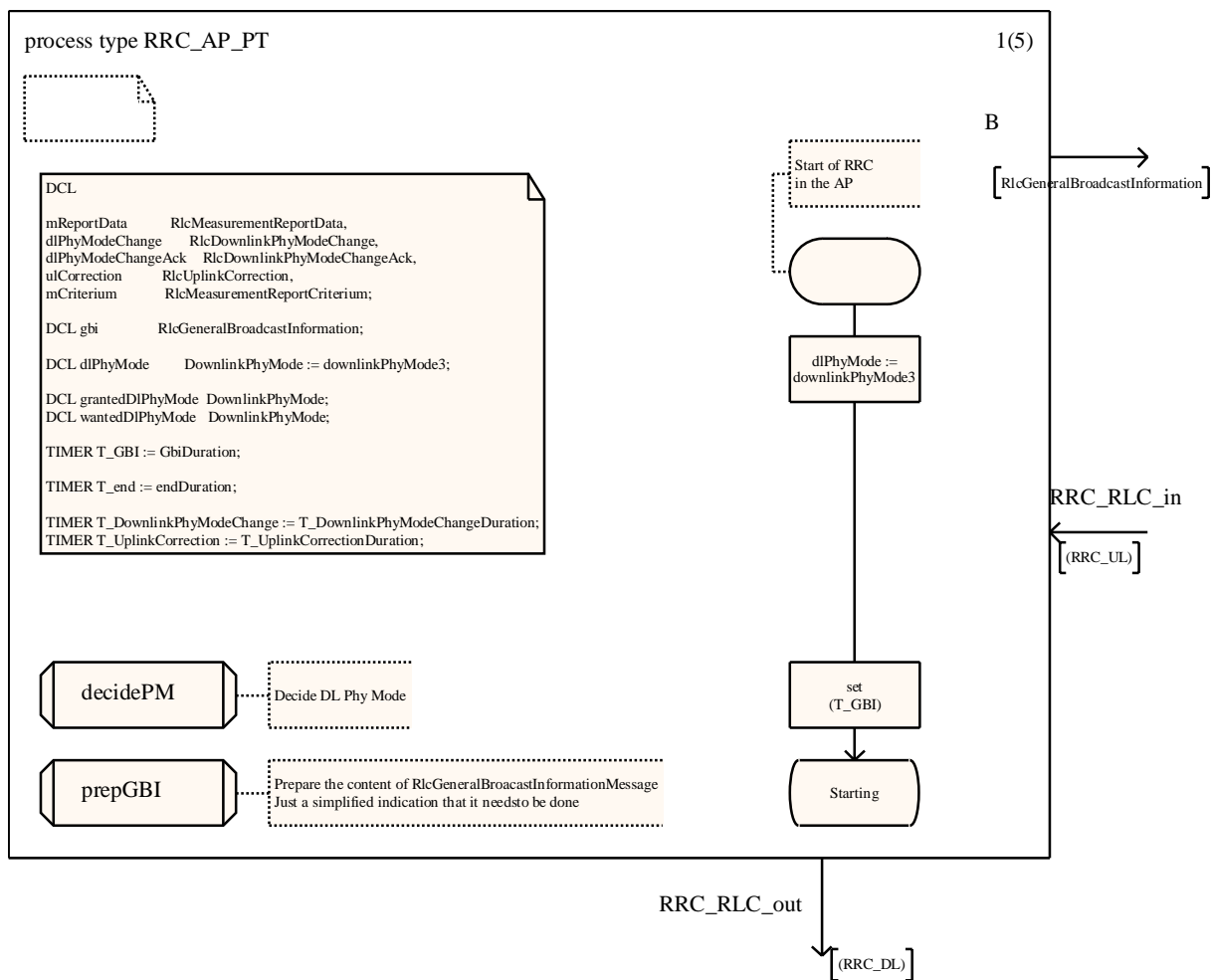

process type RRC_AP_PT

2(5)

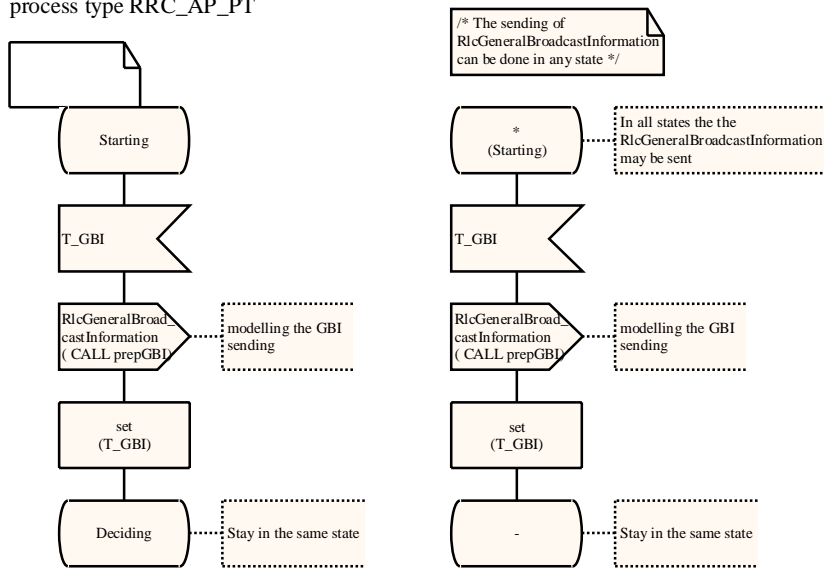

```

newtype RrcDownlinkPhyModeChangeOperators
operators prepPMC: DownlinkPhyMode -> RlcDownlinkPhyModeChange;
operator prepPMC;
fpar dpm DownlinkPhyMode;
returns pmc RlcDownlinkPhyModeChange;
start;
task pmc!downlinkPhyModeGranted := dpm;
return;
endoperator;
endnewtype;
    
```

```

newtype RrcMeasurementReportCriteriumOperators
operators prepCri: Integer /* dummy */ -> RlcMeasurementReportCriterium;
operator prepCri;
fpar dummy Integer;
returns mrCri RlcMeasurementReportCriterium;
start;
decision any;
(* *) task mrCri!periodMeasurementReportAtSpecific := period050;
(* *) task mrCri!periodMeasurementReportAtSpecific := period100;
(* *) task mrCri!periodMeasurementReportAtSpecific := period150;
(* *) task mrCri!periodMeasurementReportAtSpecific := period200;
(* *) task mrCri!periodMeasurementReportAtSpecific := noPeriodicReports;
enddecision; return;
endoperator;
endnewtype;
    
```

```

newtype RlcUplinkCorrectionOperators
operators prepULcorr: Integer /* dummy */ -> RlcUplinkCorrection;
operator prepULcorr;
fpar dummy Integer;
returns ulc RlcUplinkCorrection;
start;
task
    ulc!uplinkPowerInc := any(UplinkPowerInc),
    ulc!timingAdjustFine := any(TimingAdjustFine);
decision any;
(* *) task ulc!measurementReportReq := measurementReportRequestedNo;
(* *) task ulc!measurementReportReq := measurementReportRequestedYes;
enddecision; return;
endoperator;
endnewtype;
    
```

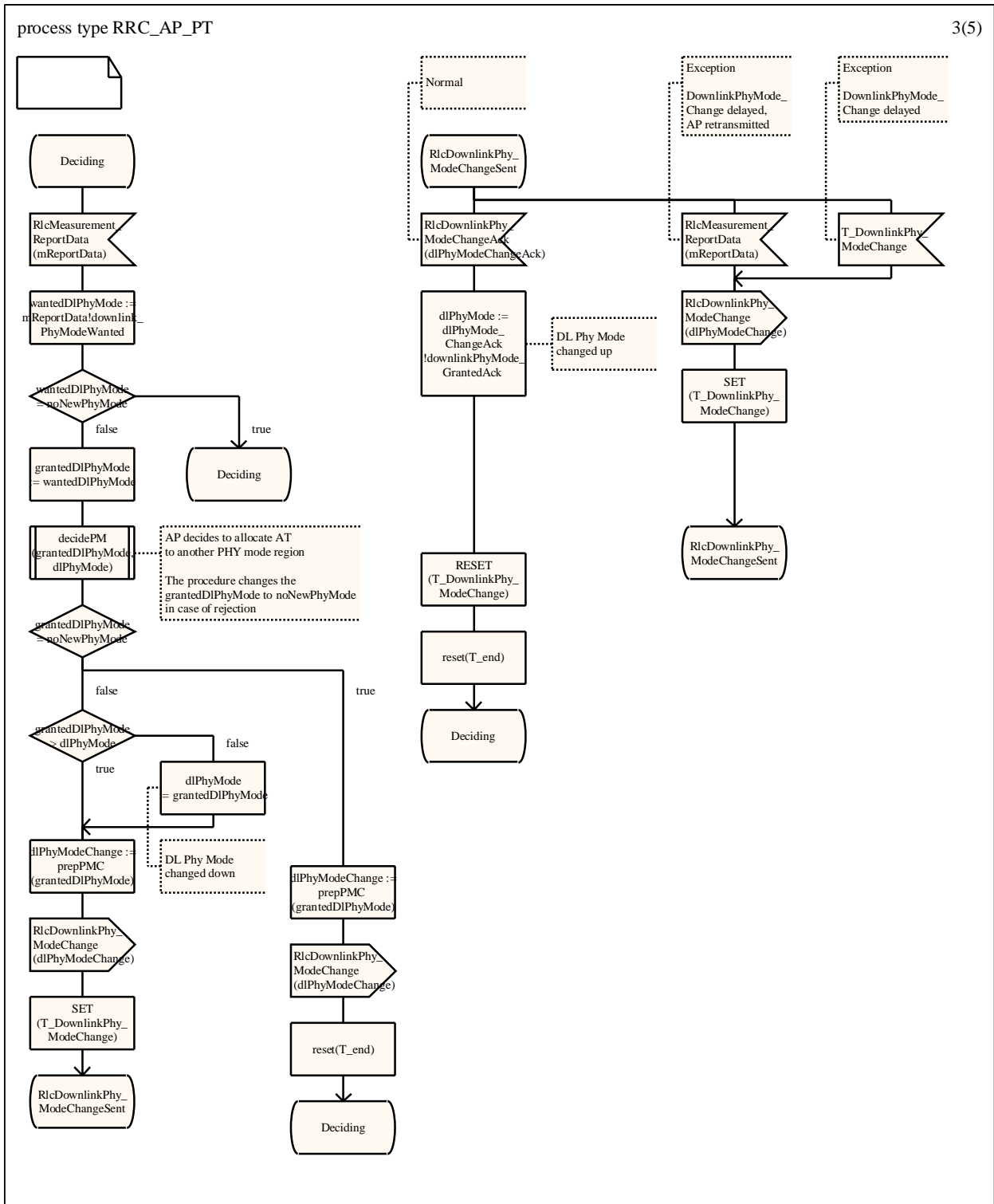

process type RRC_AP_PT

4(5)

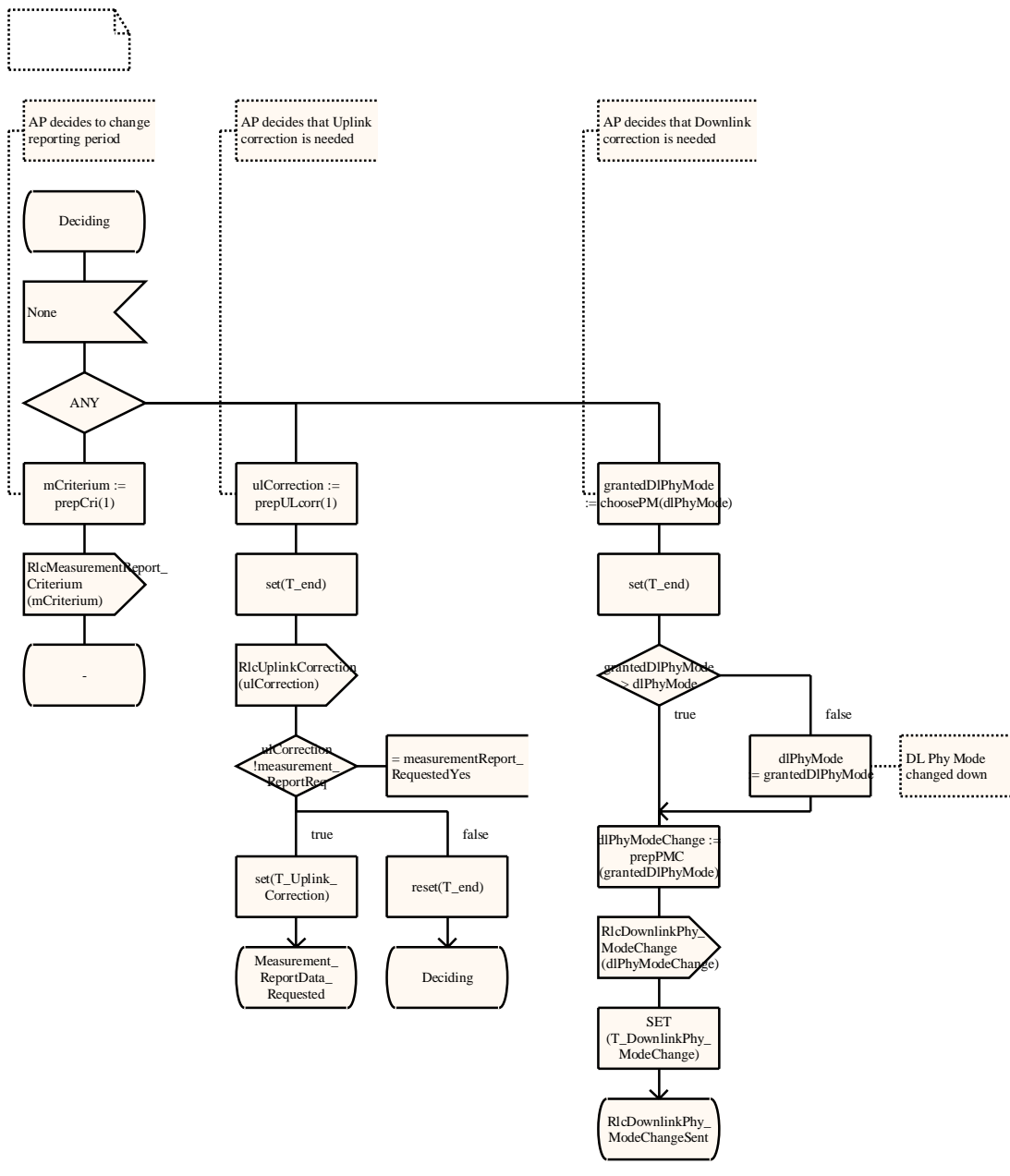

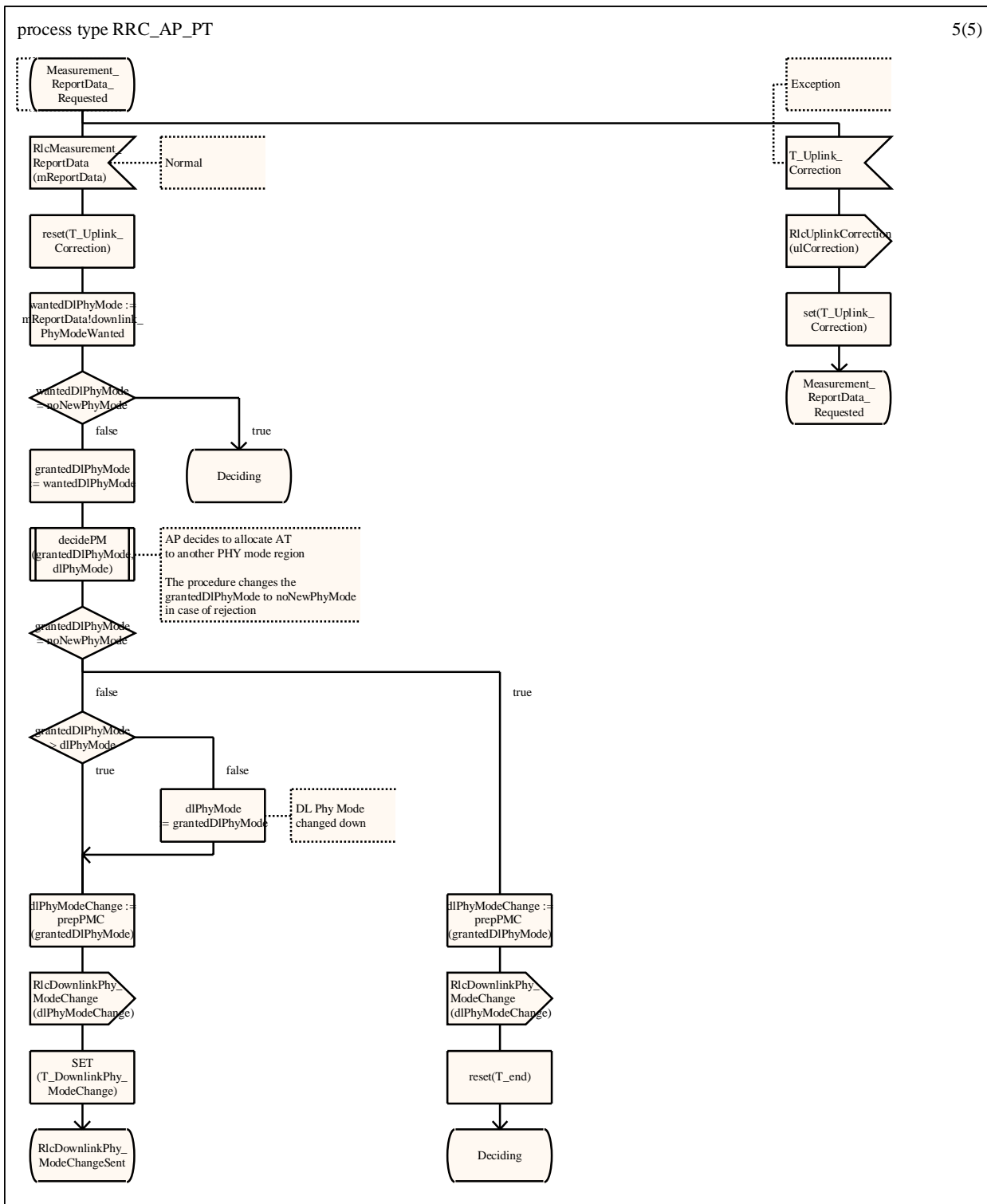

E.2.2 RRC AT

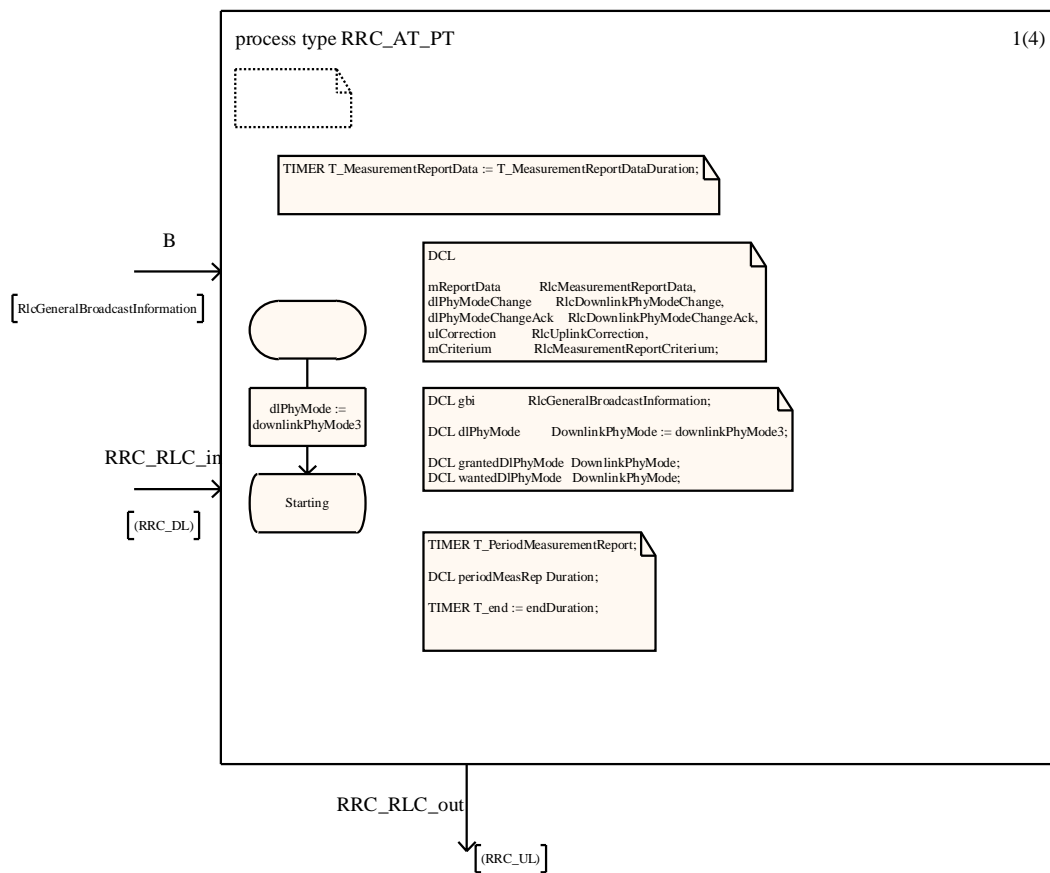

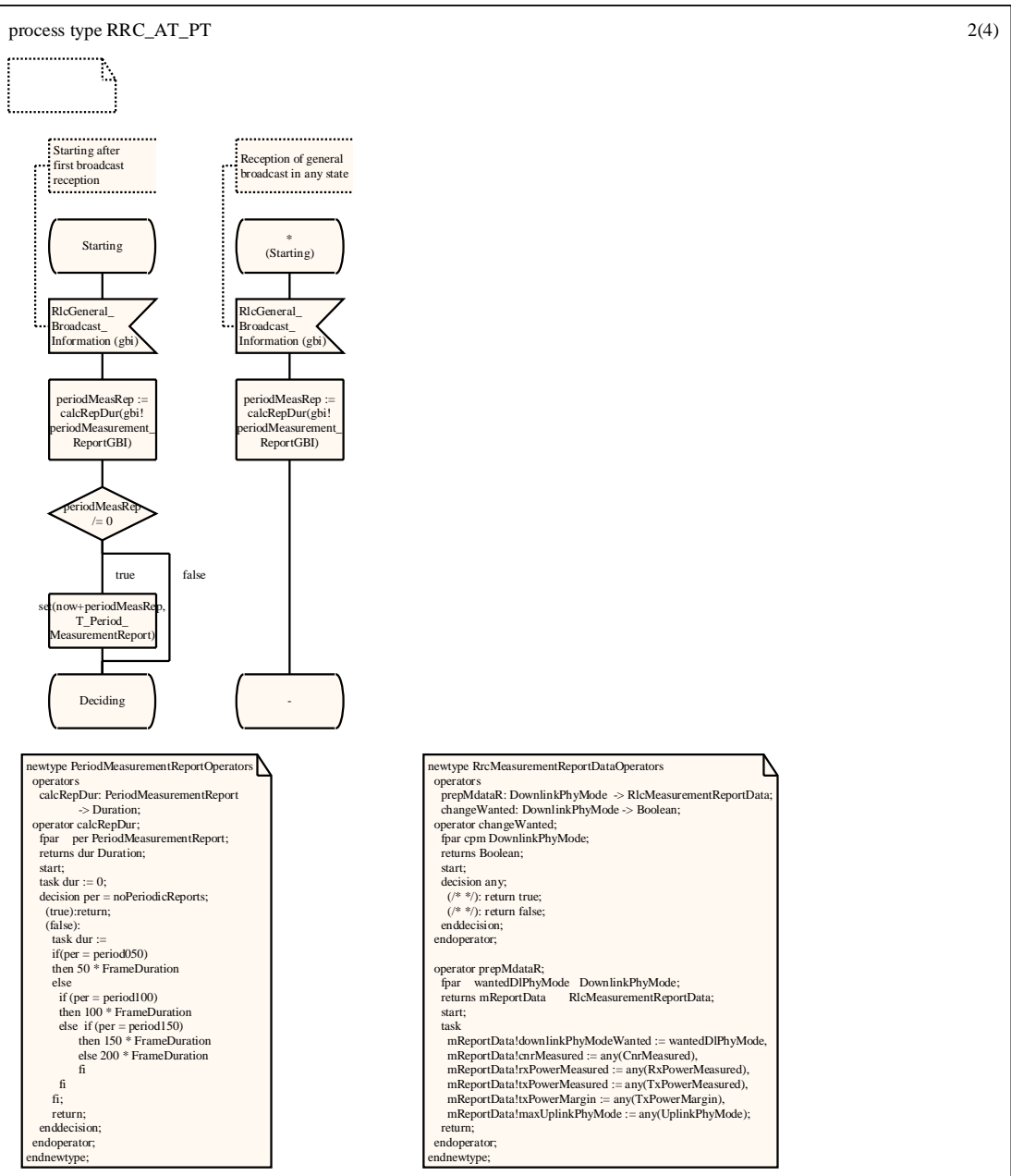

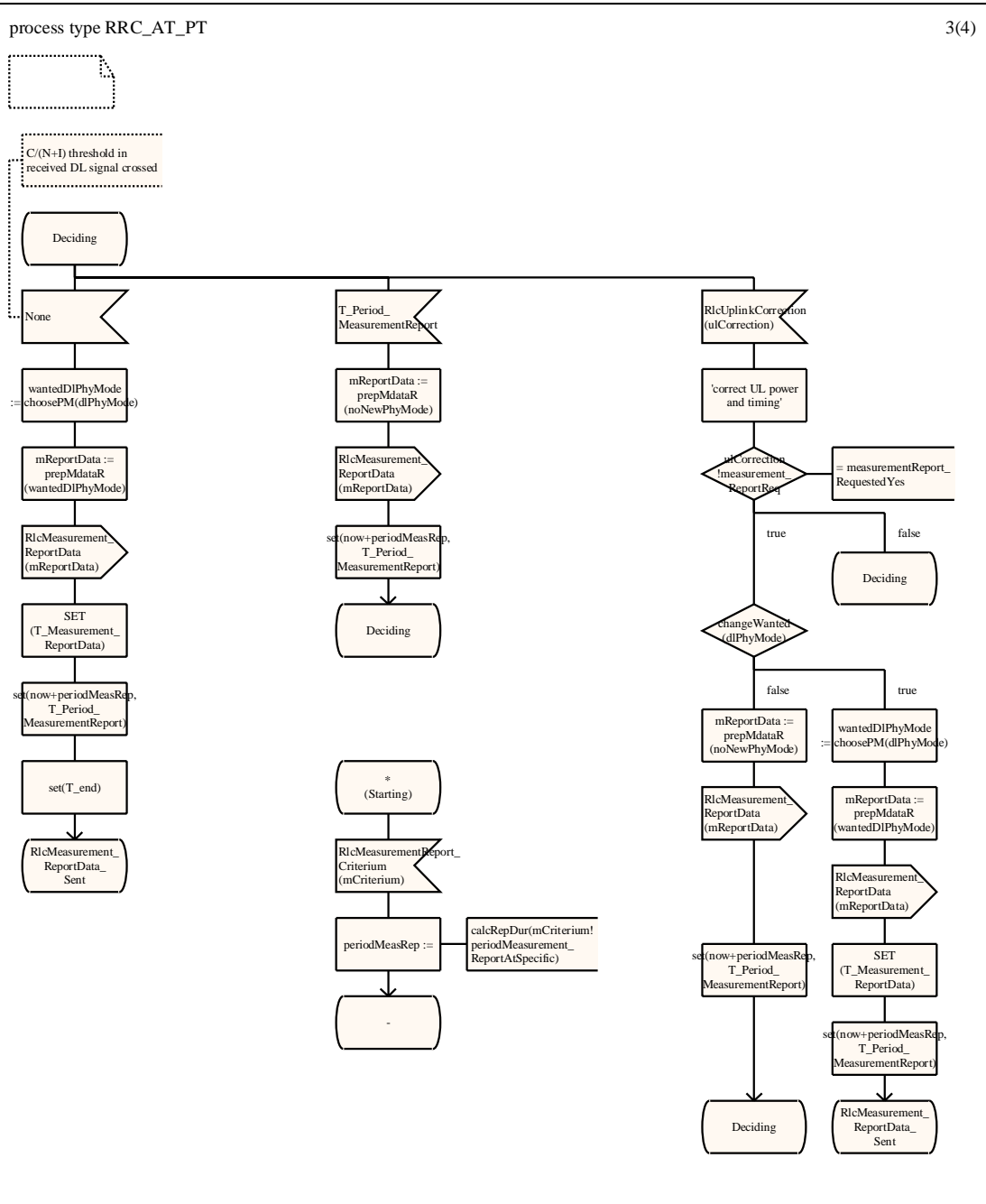

process type RRC_AT_PT

4(4)

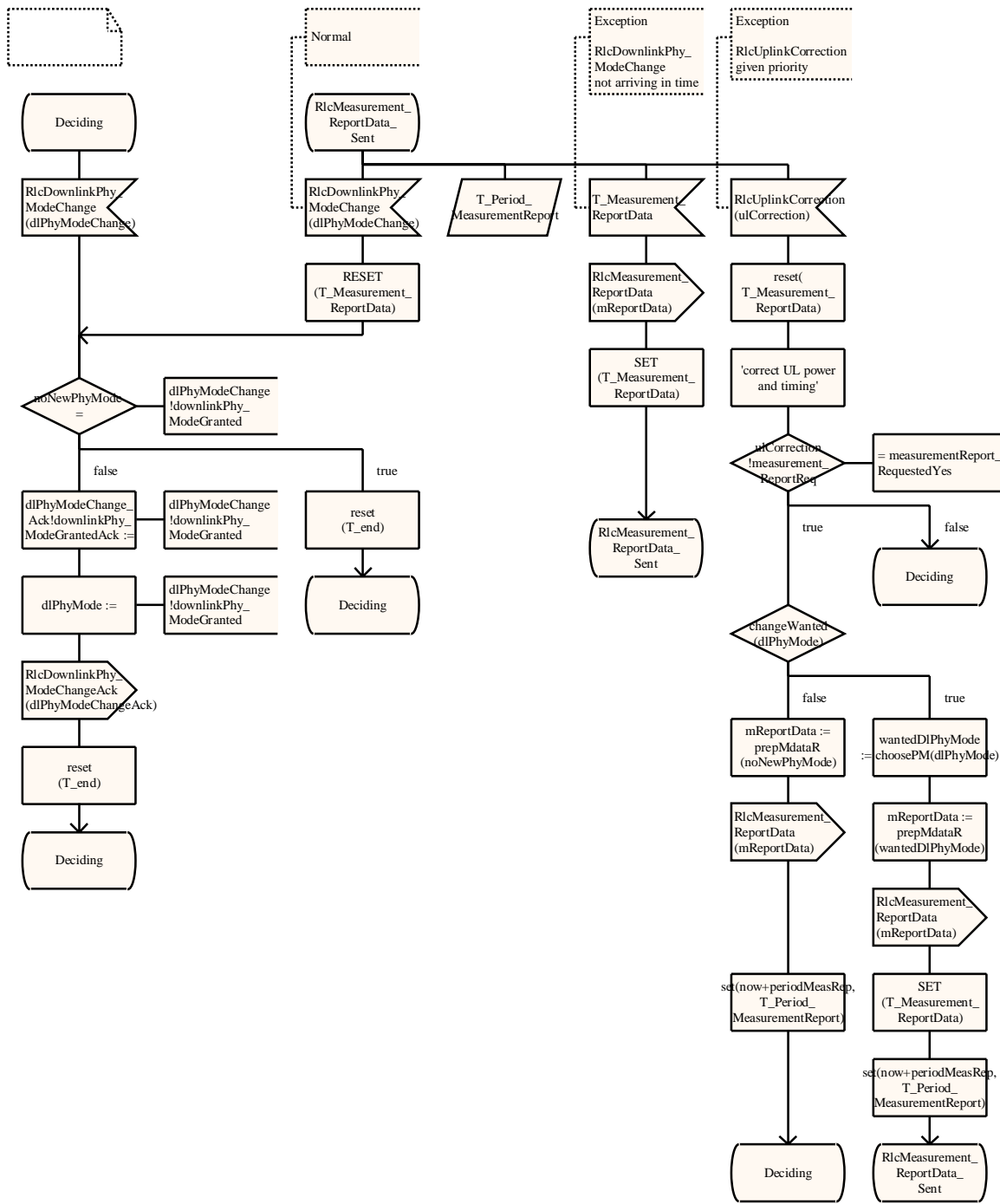

E.3 Initialization control SDL model

The initialization control model uses several SDL signals that in principle match the protocol messages. However, there are two exceptions worth mentioning:

- RangingGrant signal is used to simulate to the AT side that the AP has given an Ranging grant.
- EmptyGrant signal is used to simulate to the AP side that there is no content in the place for which an Ranging grant was given.

E.3.1 IC AP

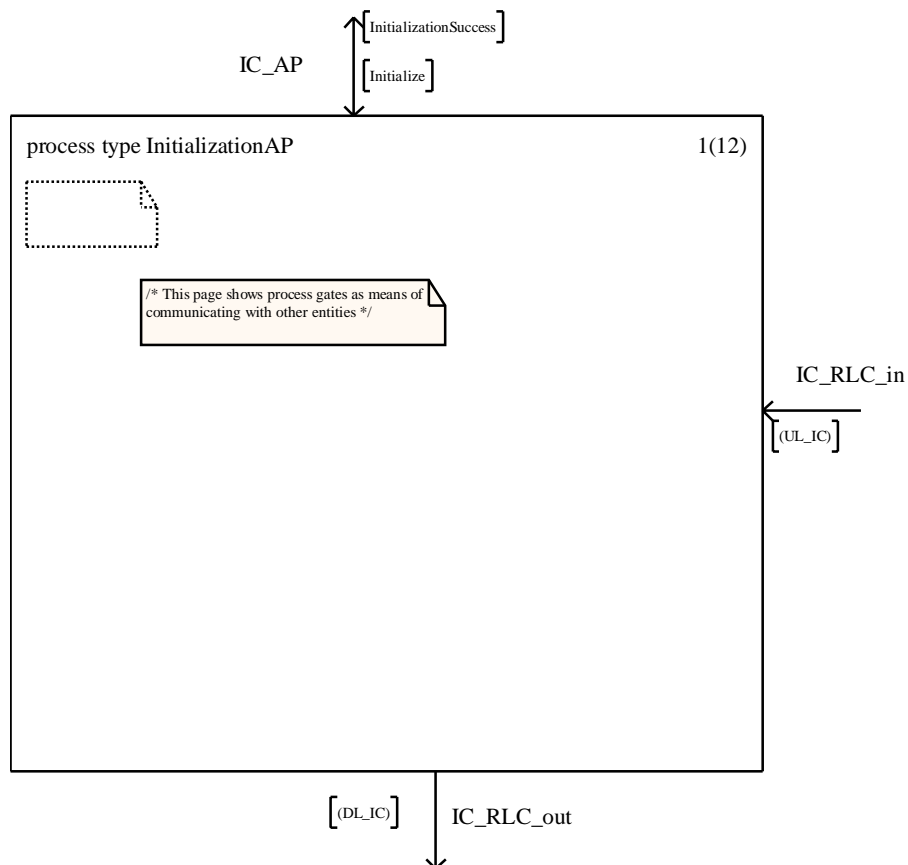

process type InitializationAP

2(12)



/ Specification of local timers */*

```
TIMER T_RangingAck      := RangingAckDuration;
TIMER T_PhyCapabilitiesReq := PhyCapabilitiesReqDuration;
TIMER T_PhyCapabilitiesCnf := PhyCapabilitiesCnfDuration;
TIMER T_OtherCapabilitiesReq := OtherCapabilitiesReqDuration;
TIMER T_OtherCapabilitiesCnf := OtherCapabilitiesCnfDuration;
```

/ Specification of local variables */*

```
DCL
rangingInvitation      RlcRangingInvitation,
rangingReq             RlcRangingReq,
rangingContinue       RlcRangingContinue,
rangingSuccess        RlcRangingSuccess,
rangingAck            RlcRangingAck,
phyCapabilitiesReq    RlcPhyCapabilitiesReq,
phyCapabilitiesInfo   RlcPhyCapabilitiesInfo,
phyCapabilitiesCnf    RlcPhyCapabilitiesCnf,
otherCapabilitiesReq  RlcOtherCapabilitiesReq,
otherCapabilitiesInfo RlcOtherCapabilitiesInfo,
otherCapabilitiesCnf  RlcOtherCapabilitiesCnf,
initializationCmd     RlcInitializationCmd;

DCL rangingResponseKind RangingResponseKind;
DCL rangingAckOK        RangingAckOK;
DCL gbi                 RlcGeneralBroadcastInformation;
DCL timingAdjust        TimingAdjustRanging;
DCL powerInc            UplinkPowerInc;

DCL phyCapNeeded        Boolean;
DCL authNeeded          Boolean;
DCL otherCapNeeded      Boolean;
DCL iStatus             InitializationStatus;
```

/ Some special timers used only for modelling purposes. These place no normative requirements on the implementations */*

```
TIMER T_GBI := GbiDuration;
/* Not mandatory, used in the model to show regular sending of
RlcGeneralBroadcastInformation messages */

TIMER T_AdjustingDelayGrant := T_AdjustingDelayGrantDuration;
TIMER T_SuccessDelayGrant := T_SuccessDelayGrantDuration;
```

process type InitializationAP

3(12)



/* Procedures used in AP by the Initialization process */

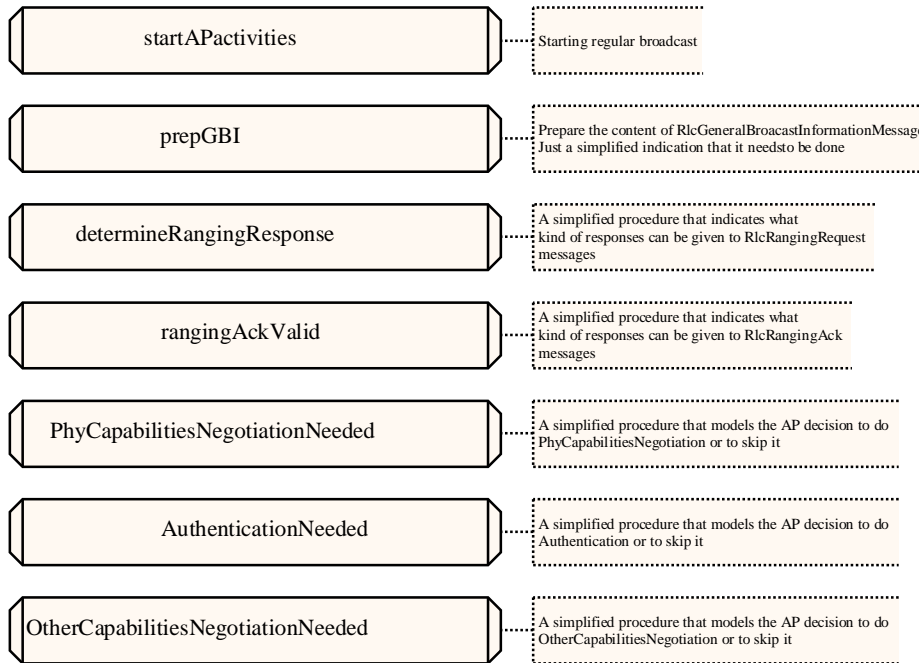

/* Start of the initialization process for the first time */

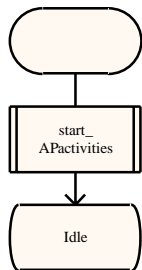

/* The sending of RlcGeneralBroadcastInformation can be done in any state */

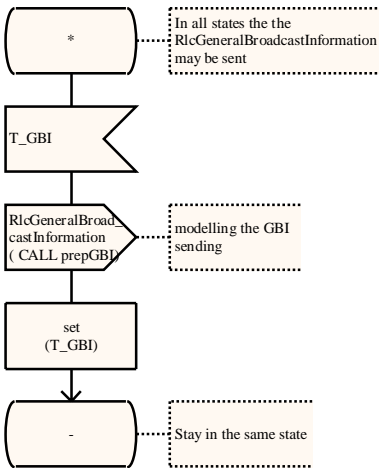

process type InitializationAP

4(12)



```

newtype RlcRangingInvitationOperators
operators
  prepInvitation: Integer /*dummy*/ -> RlcRangingInvitation;
operator prepInvitation;
  fpar i Integer;
  returns RlcRangingInvitation;
start;
  return ( (. atMacAddress, defTid, defBasicCid, defPrimaryCid, defSecondaryCid .) );
endoperator;
endnewtype;

newtype RlcPhyCapabilitiesCnfOperators
operators
  prepPhyCapabilitiesCnf: RlcPhyCapabilitiesInfo, InitializationStatus -> RlcPhyCapabilitiesCnf;
operator prepPhyCapabilitiesCnf;
  fpar in info RlcPhyCapabilitiesInfo,
  is InitializationStatus;
  returns cnf RlcPhyCapabilitiesCnf;
start;
task cnf!downlink64QamUse := if (info!downlink64QamSupport = downlink64QamNotSupported)
  then downlink64QamNotUsed
  else any(Downlink64QamUse)
  fi;
task cnf!uplink16QamUse := if (info!uplink16QamSupport = uplink16QamNotSupported)
  then uplink16QamNotUsed
  else any(Uplink16QamUse)
  fi;
task cnf!uplinkTurboEncUse := if (info!uplinkTurboEncSupport = uplinkTurboEncNotSupported)
  then uplinkTurboEncNotUsed
  else any(UplinkTurboEncUse)
  fi;
task cnf!uplinkPowerMaxQpsk := any(UplinkPowerMax);
task cnf!uplinkPowerMax16Qam := any(UplinkPowerMax);
task cnf!uplinkPreambleLength := any(UplinkPreambleLength);
task cnf!initializationStatus := is;
return;
endoperator;
endnewtype;

newtype RlcOtherCapabilitiesCnfOperators
operators
  prepOtherCapabilitiesCnf: RlcOtherCapabilitiesInfo, InitializationStatus -> RlcOtherCapabilitiesCnf;
operator prepOtherCapabilitiesCnf;
  fpar in info RlcOtherCapabilitiesInfo,
  is InitializationStatus;
  returns cnf RlcOtherCapabilitiesCnf;
start;
task cnf!numberUplinkConnsUse := info!numberUplinkConnsSupport; /* or smaller */
task cnf!numberDownlinkConnsUse := info!numberDownlinkConnsSupport; /* or smaller */
task cnf!numberConnAggsUse := info!numberConnAggsSupport; /* or smaller */
task cnf!numberConnsPerConnAggUse := info!numberConnsPerConnAggSupport; /* or smaller */
task cnf!initializationStatus := is;
return;
endoperator;
endnewtype;

```

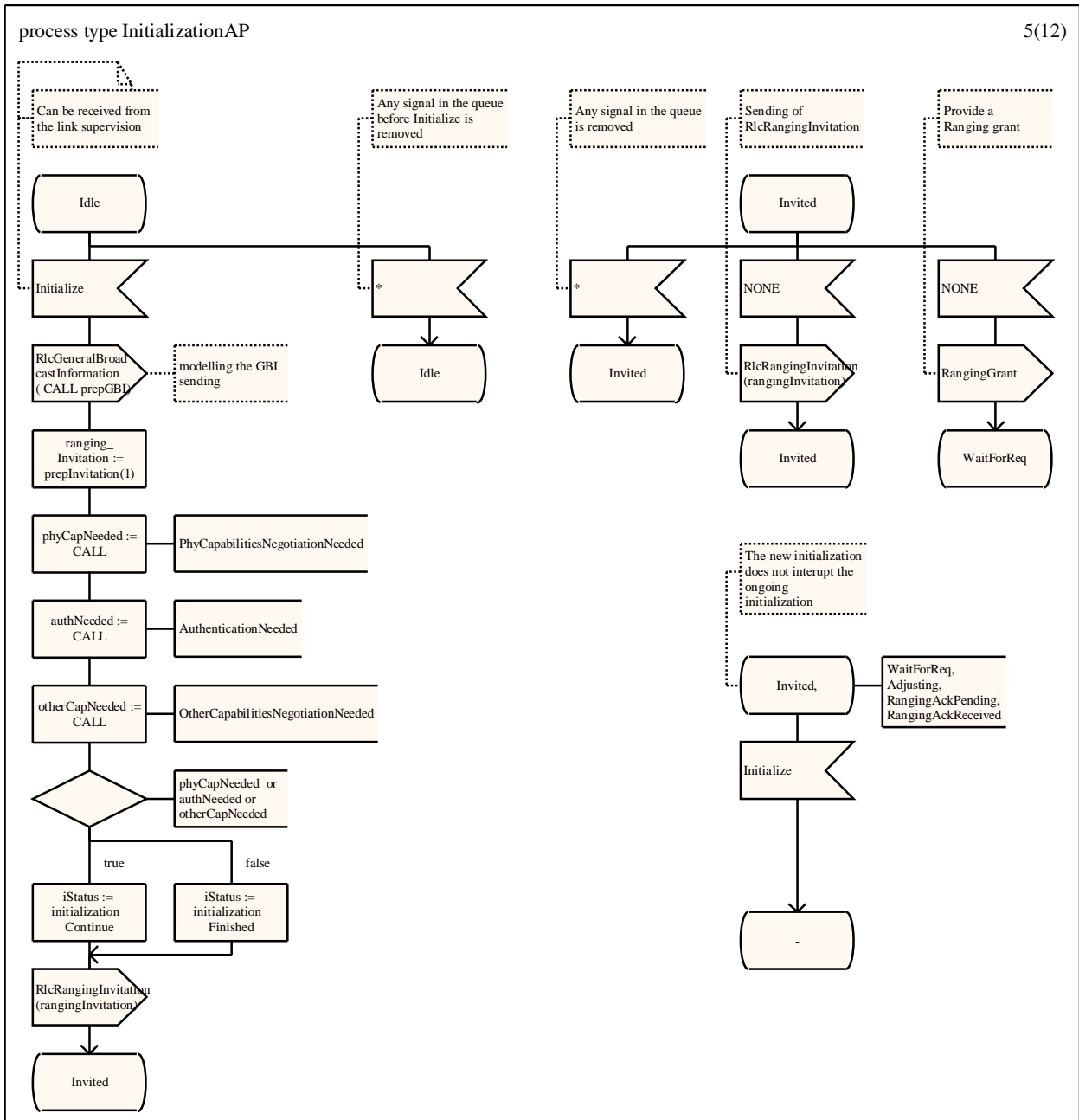

process type InitializationAP

6(12)

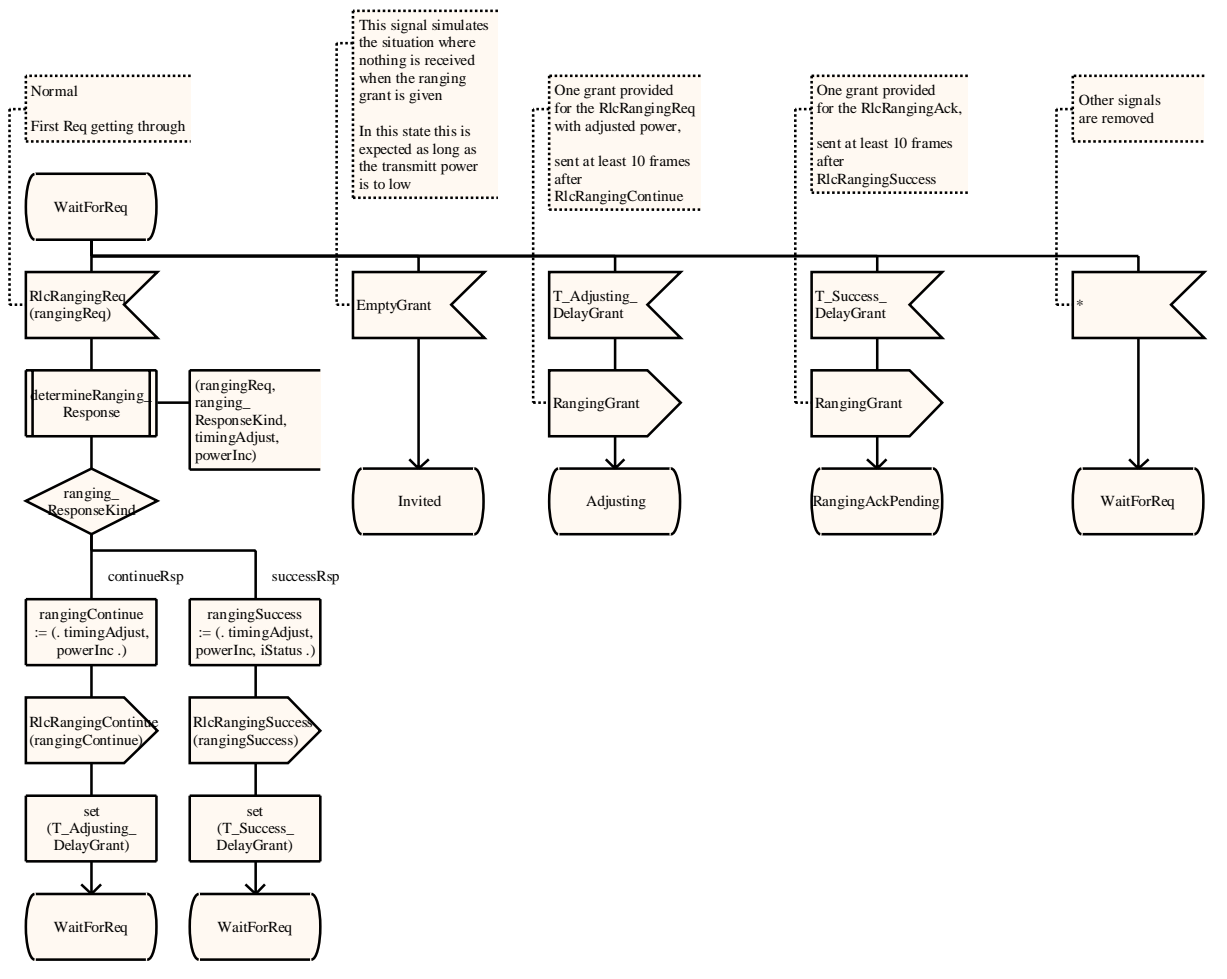

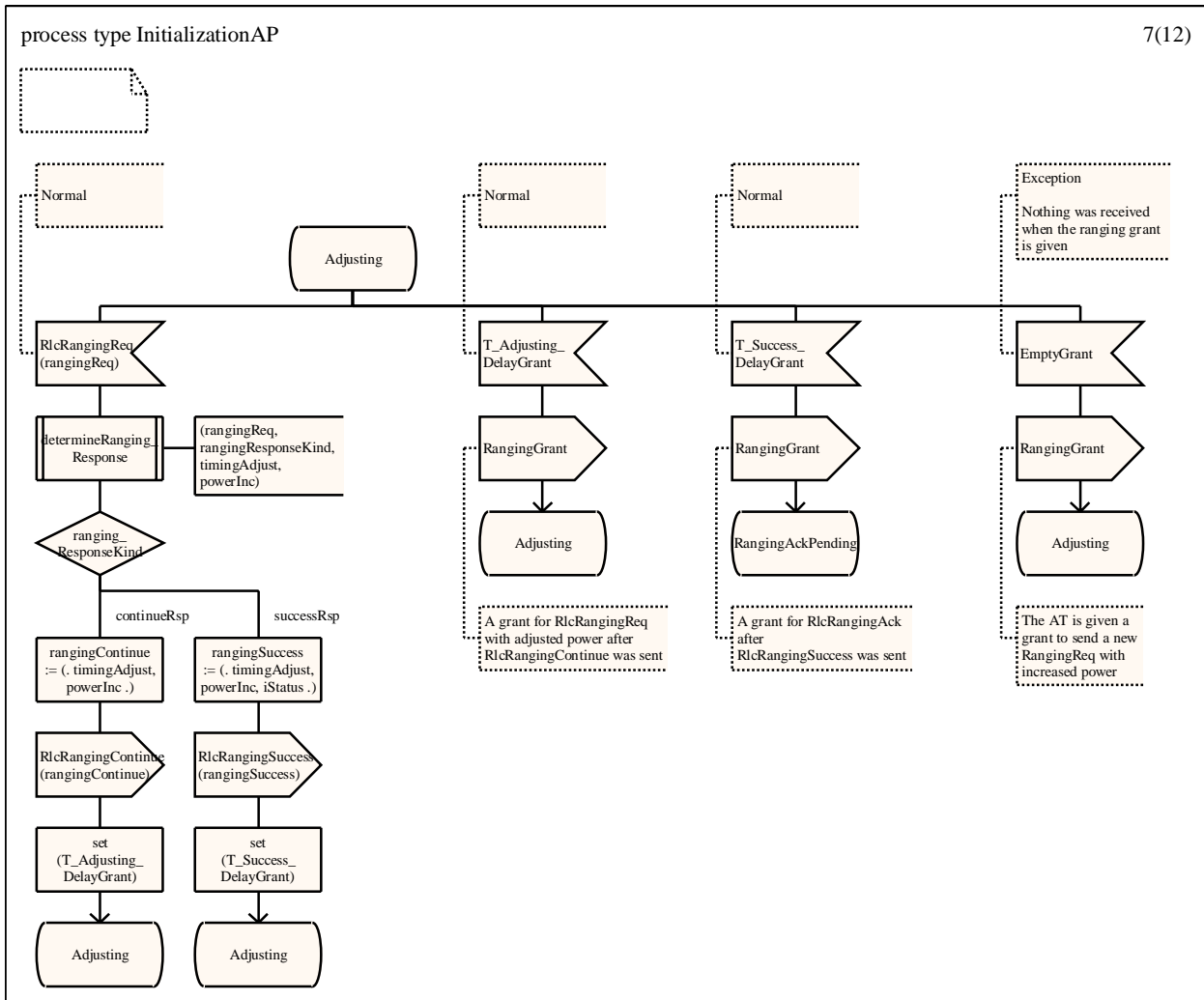

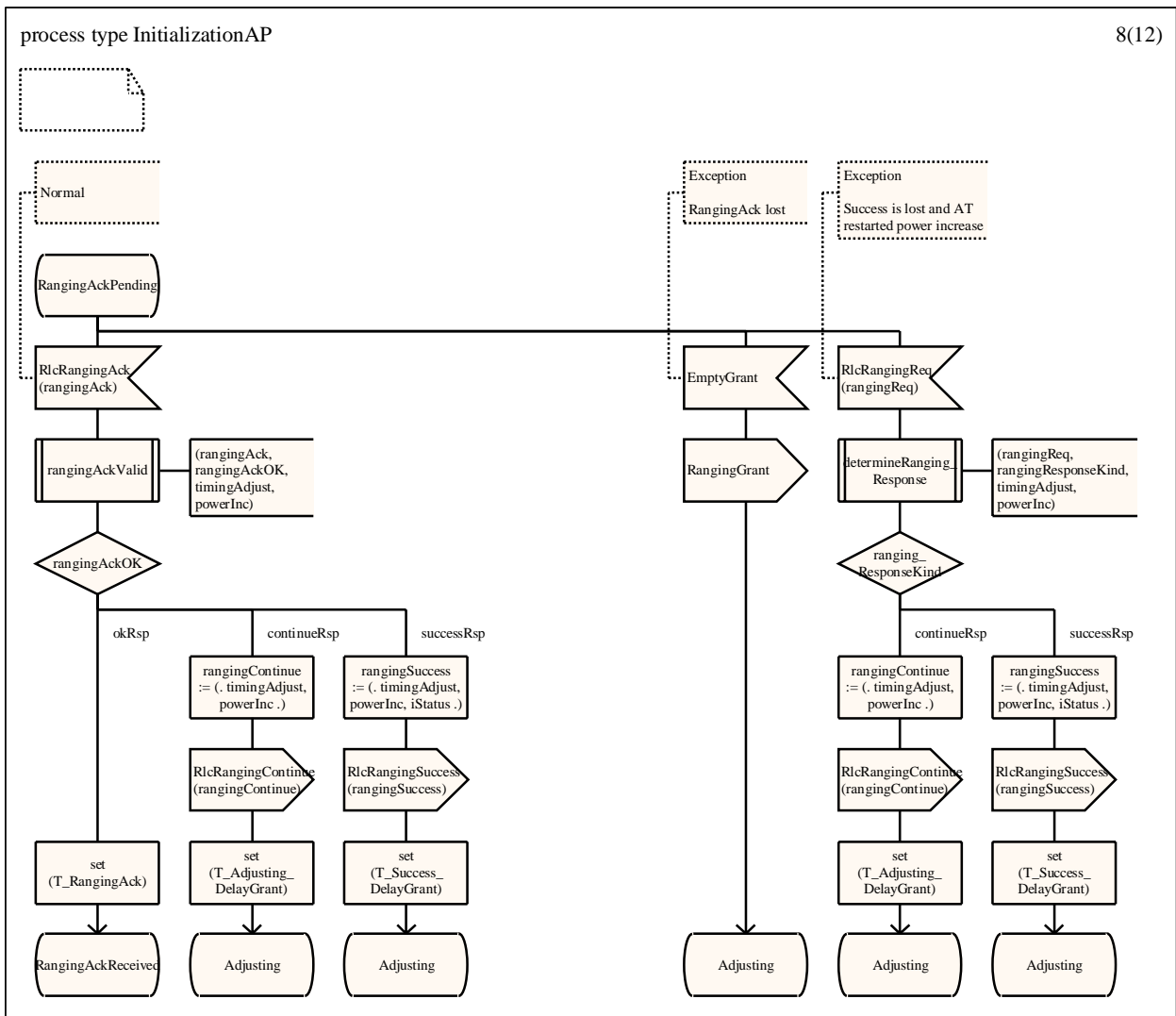

process type InitializationAP

9(12)

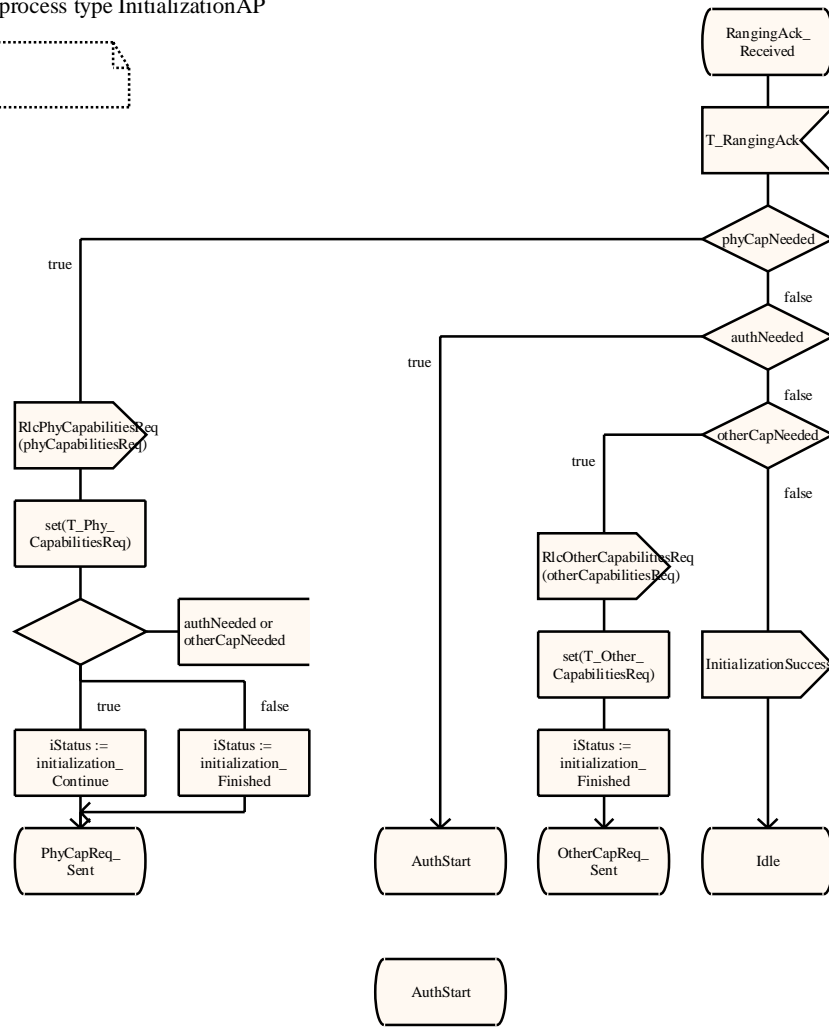

process type InitializationAP

10(12)

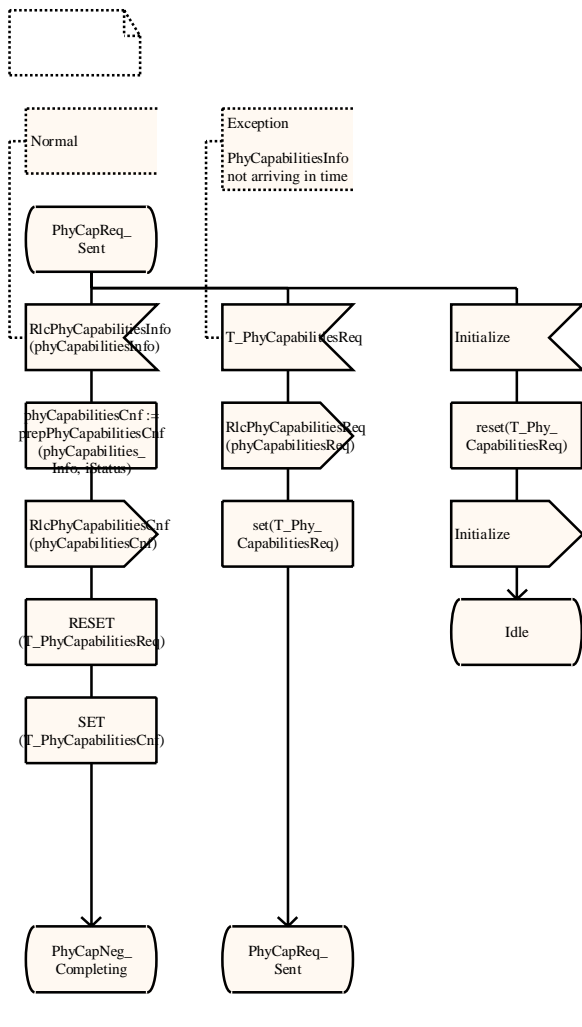

process type InitializationAP

11(12)

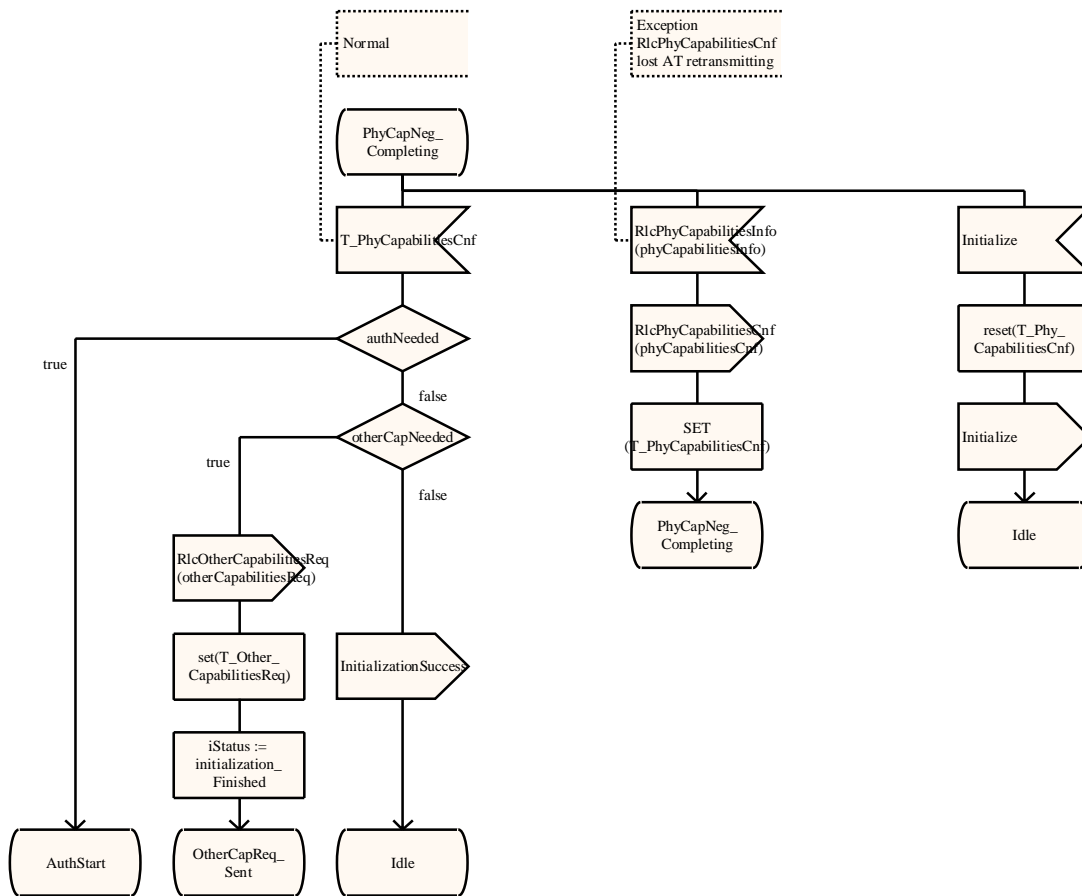

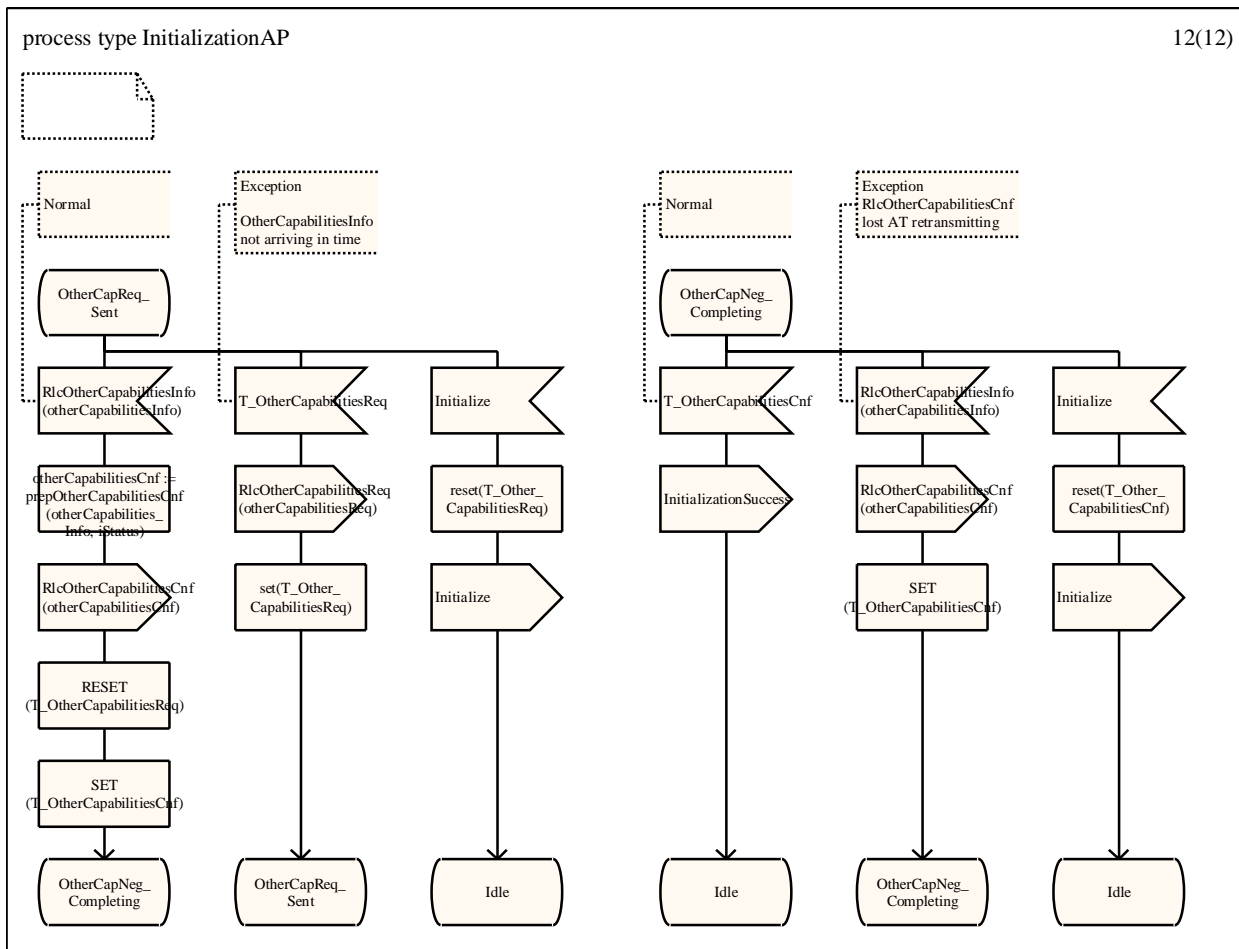

E.3.2 IC AT

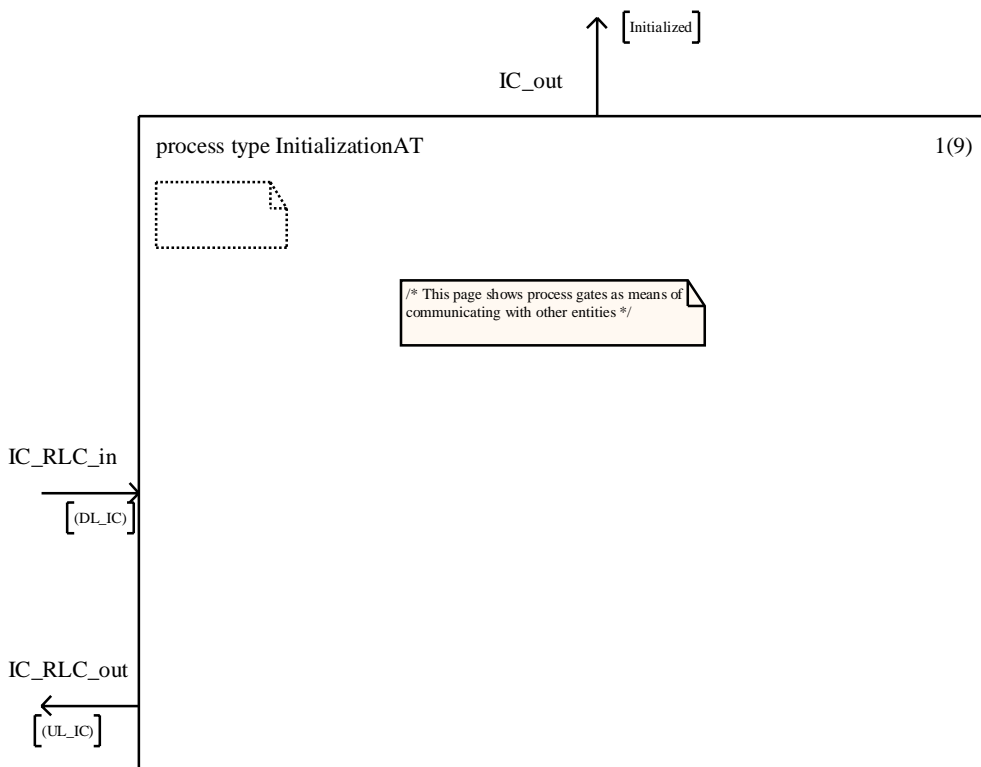

process type InitializationAT

2(9)



/* Specification of local variables */

DCL

```

rangingInvitation  RlcRangingInvitation,
rangingReq         RlcRangingReq,
rangingContinue   RlcRangingContinue,
rangingSuccess    RlcRangingSuccess,
rangingAck        RlcRangingAck,
phyCapabilitiesReq RlcPhyCapabilitiesReq,
phyCapabilitiesInfo RlcPhyCapabilitiesInfo,
phyCapabilitiesCnf RlcPhyCapabilitiesCnf,
otherCapabilitiesReq RlcOtherCapabilitiesReq,
otherCapabilitiesInfo RlcOtherCapabilitiesInfo,
otherCapabilitiesCnf RlcOtherCapabilitiesCnf,
initializationCmd RlcInitializationCmd;

```

DCL powerLevel PowerLevel;

DCL numberOfAttempts Integer;

DCL synchAcquired Boolean;

DCL paramAcquired Boolean;

DCL gbi RlcGeneralBroadcastInformation;

DCL iStatus InitializationStatus;

DCL rangingStatus RangingStatus;

DCL sidReceived Sid;

/* Specification of local timers */

```

TIMER T_RangingAck      := RangingAckDuration;
TIMER T_PhyCapabilitiesInfo := PhyCapabilitiesInfoDuration;
TIMER T_PhyCapabilitiesCnf := PhyCapabilitiesCnfDuration;
TIMER T_OtherCapabilitiesInfo := OtherCapabilitiesInfoDuration;
TIMER T_OtherCapabilitiesCnf := OtherCapabilitiesCnfDuration;
TIMER T_synchronization := SynchronizationDuration;

```

syntype PowerLevel = Real constants 20:40 endsyntype;

synonym minPower PowerLevel = 20;

synonym maxPower PowerLevel = 40;

synonym powerStep PowerLevel = 4;

synonym SynchronizationDuration Duration = 10 * FrameDuration;

synonym sidDefault Sid = 1;

synonym sidInMemory Sid = 1;

process type InitializationAT

3(9)



DL_frequency_scanning

Simple procedure modelling
downlink frequency scanning

UL_and_DL_
parameters_acquisition



synchronization_acquisition

setTransmittPower

adjustPower

Reception of general
broadcast in any state

*

RlcGeneral_
Broadcast_
Information (gbi)

-

process type InitializationAT

4(9)



```

newtype RlcPhyCapabilitiesInfoOperators
operators
  setPhyCapAT: Integer /* dummy */ -> RlcPhyCapabilitiesInfo;
operator setPhyCapAT;
  fpar int Integer;
  returns info RlcPhyCapabilitiesInfo;
  start;
  decision any;
    (* #); task info!downlink64QamSupport := downlink64QamNotSupported;
    (* #); task info!downlink64QamSupport := downlink64QamSupported;
  enddecision;
  decision any;
    (* #); task info!uplink16QamSupport := uplink16QamNotSupported;
    (* #); task info!uplink16QamSupport := uplink16QamSupported;
  enddecision;
  decision any;
    (* #); task info!uplinkTurboEncSupport := uplinkTurboEncNotSupported;
    (* #); task info!uplinkTurboEncSupport := uplinkTurboEncSupported;
  enddecision;
  decision any;
    (* #); task info!terminalType := terminalFdd;
    (* #); task info!terminalType := terminalHfddWithTdmAndTdma;
  enddecision;
  task info!uplinkPowerMaxQpsk := any(UplinkPowerMax);
  task info!uplinkPowerMax16Qam := any(UplinkPowerMax);
  return;
endoperator;
endnewtype;

```

```

newtype RlcOtherCapabilitiesInfoOperators
operators
  setOtherCapAT: Integer /* dummy */ -> RlcOtherCapabilitiesInfo;
operator setOtherCapAT;
  fpar int Integer;
  returns oInfo RlcOtherCapabilitiesInfo;
  start;
  task
    oInfo!numberUplinkConnsSupport := any(NumberUplinkConnsSupport),
    oInfo!numberDownlinkConnsSupport := any(NumberDownlinkConnsSupport),
    oInfo!numberConnAggsSupport := any(NumberConnAggsSupport),
    oInfo!numberConnsPerConnAggSupport := any(NumberConnsPerConnAggSupport);
  return;
endoperator;
endnewtype;

```

```

newtype SectorIdentificationOperators
operators
  sectorIdentified: Integer /*dummy*/ -> Boolean;
operator sectorIdentified;
  fpar dummy Integer;
  returns Boolean;
  start;
  decision any;
    (* #); return true;
    (* #); return false;
  enddecision;
endoperator;
endnewtype;

```

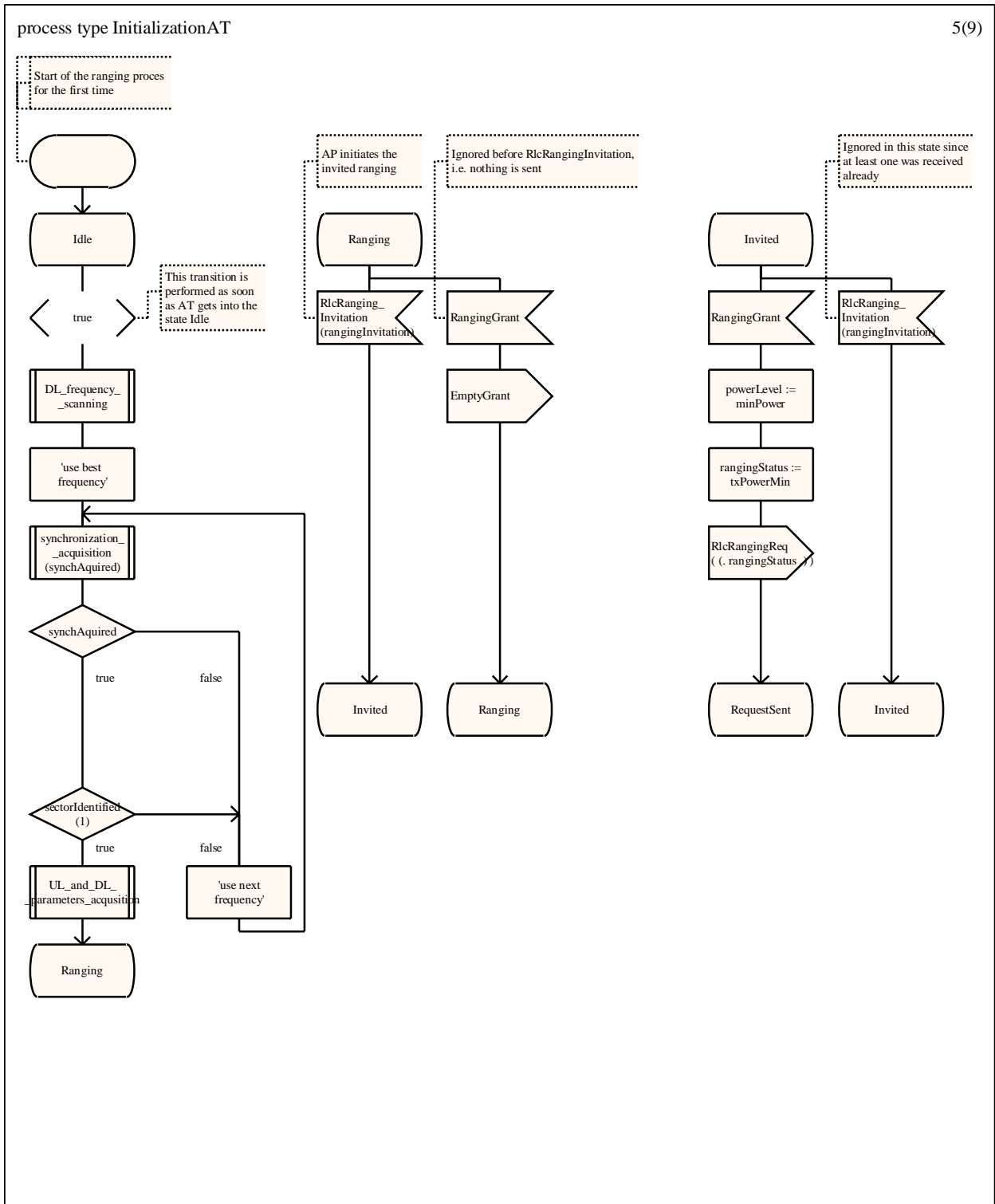

process type InitializationAT

6(9)

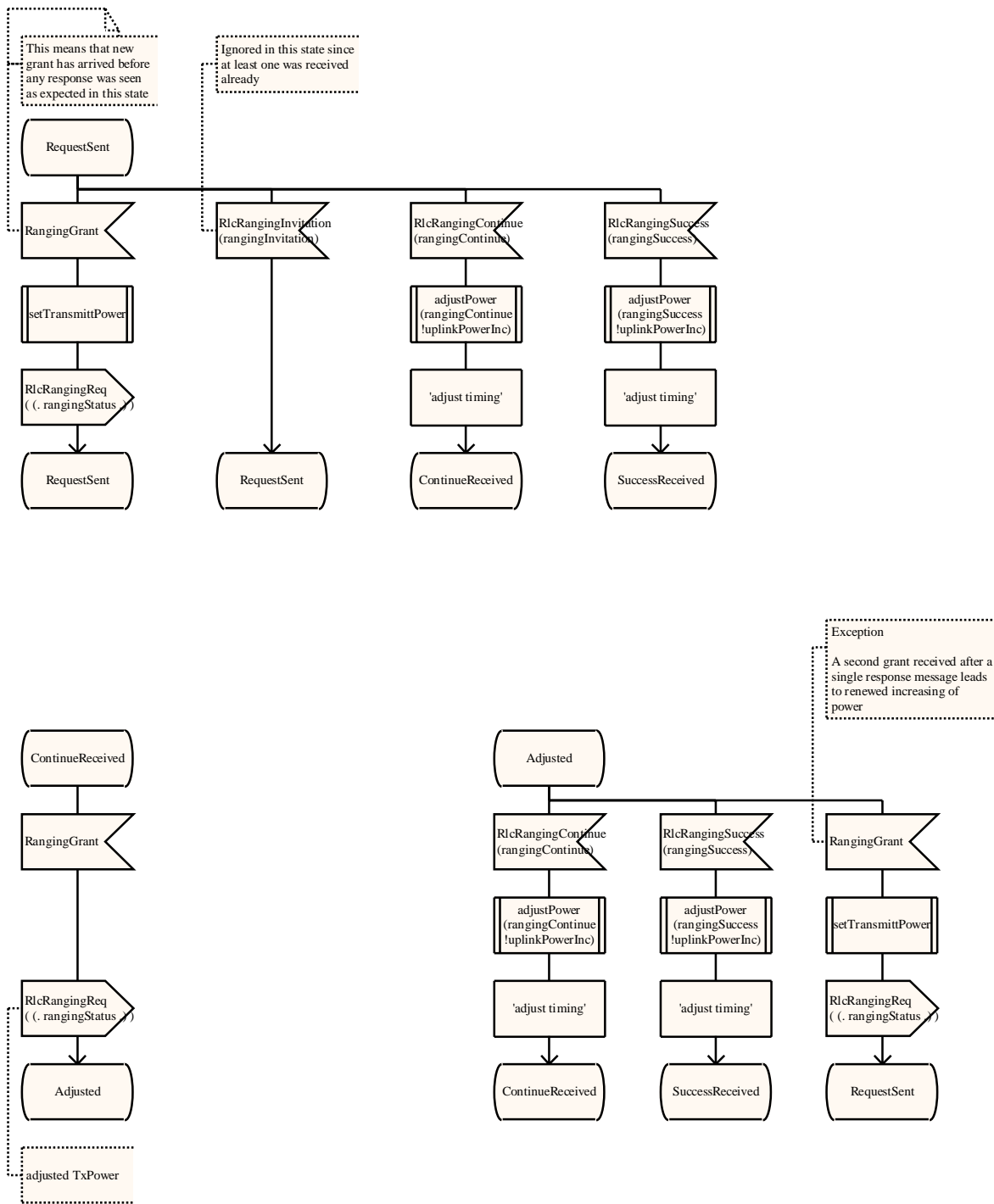

process type InitializationAT

7(9)

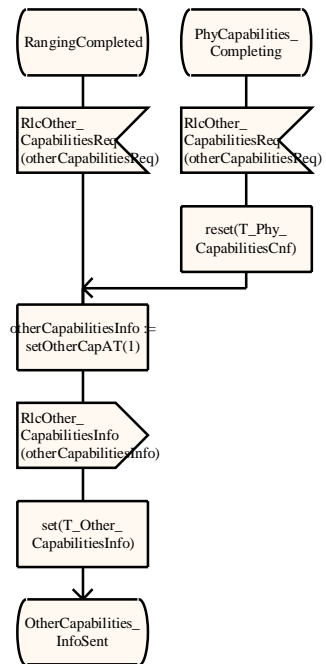
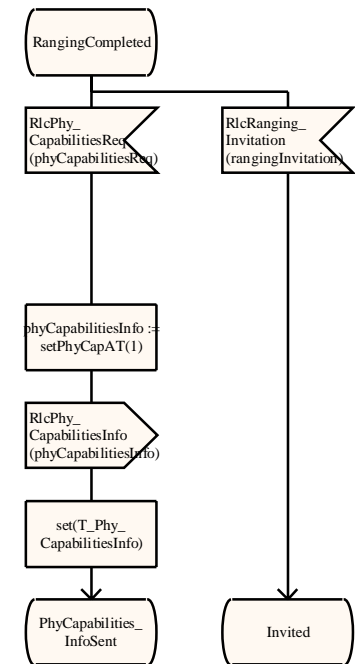
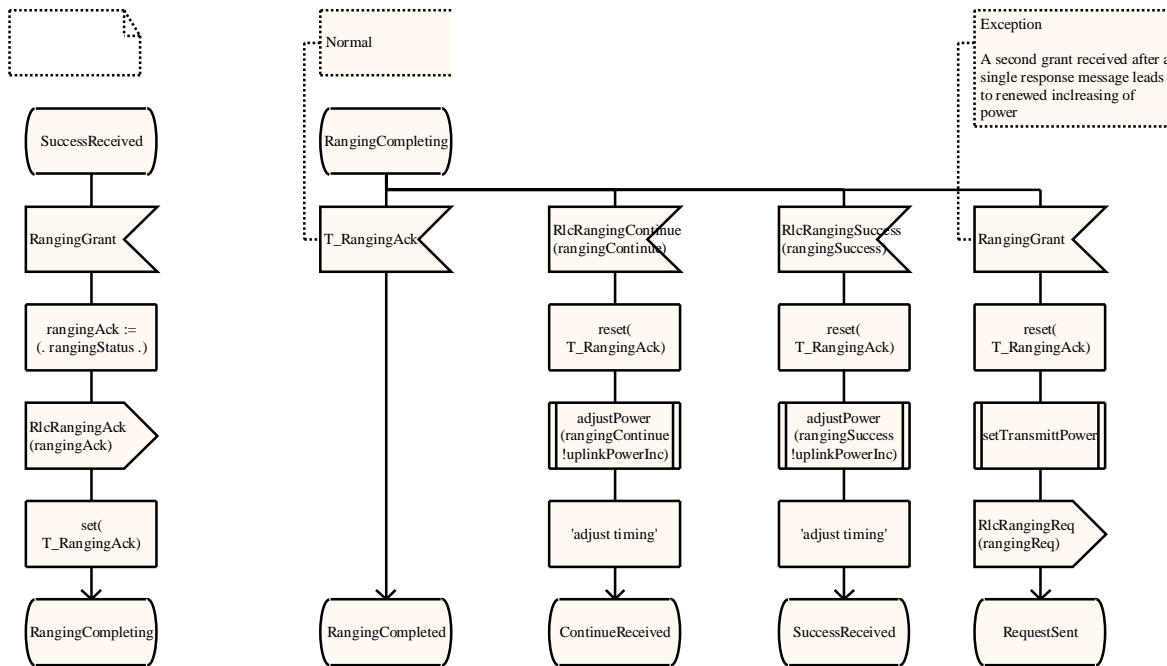

Exception
A second grant received after a single response message leads to renewed increasing of power

process type InitializationAT

8(9)

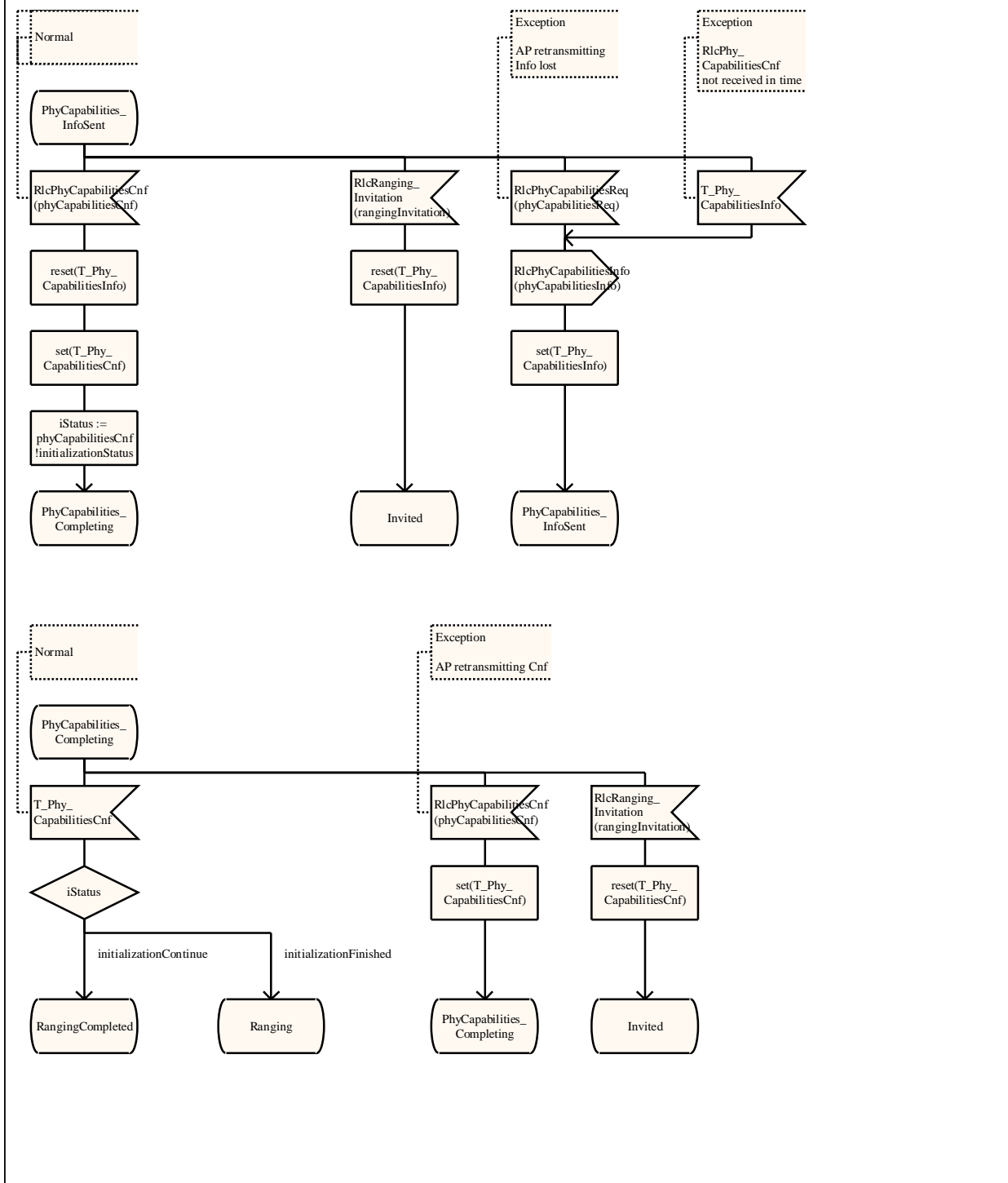

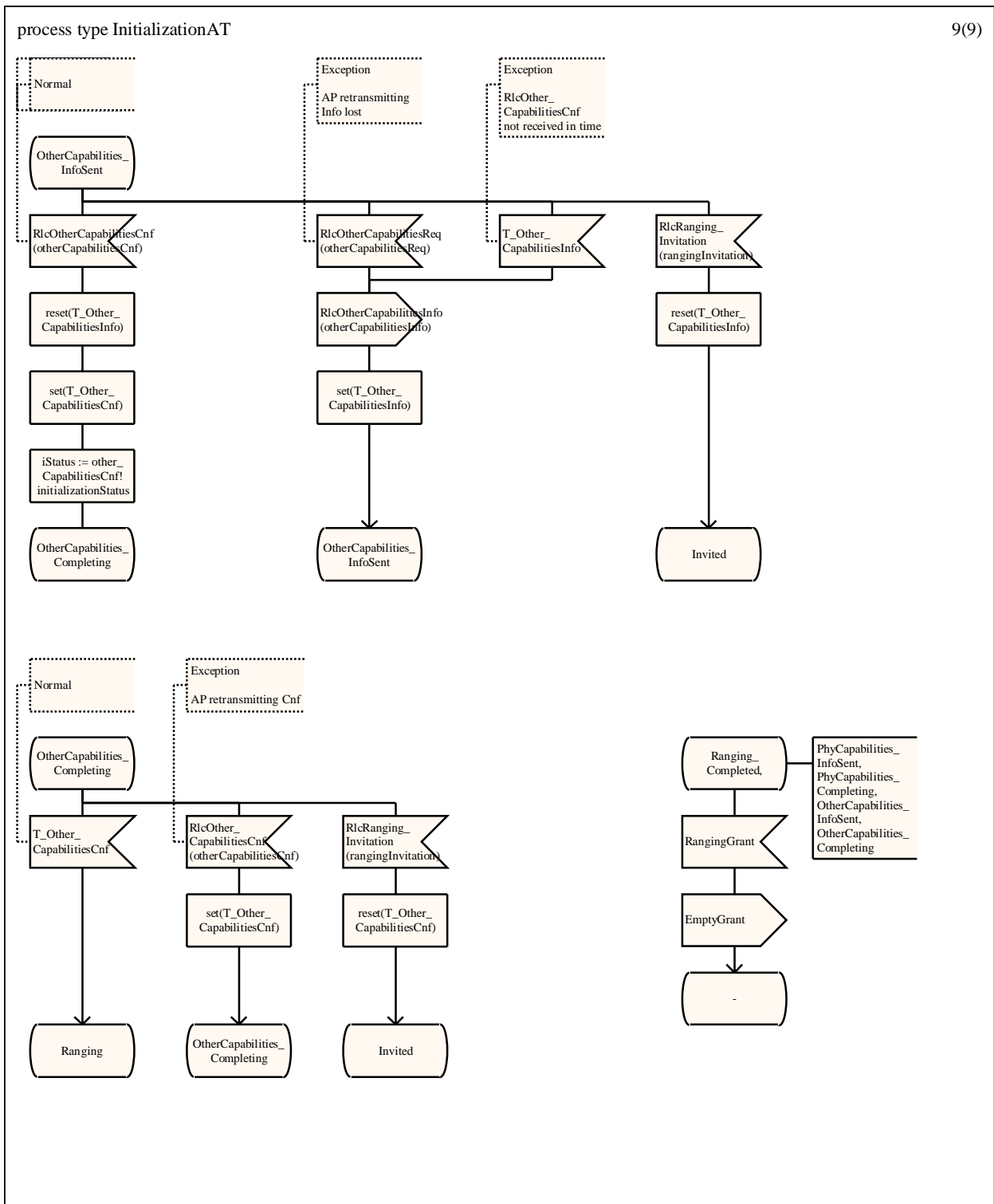

E.4 Connection control SDL model

The Connection Control model is an open system where the two sides AP and AT exchange protocol messages while each side communicates with its upper layer using service primitives. In contrast to the protocol messages, the format of the service primitives messages is considered informative. Therefore a model is based on the simplification that essentially the service primitives related to a particular protocol message are equal in structure to the protocol message.

The model likely to need some minor modifications following the completion of the Security model.

E.4.1 CC AP

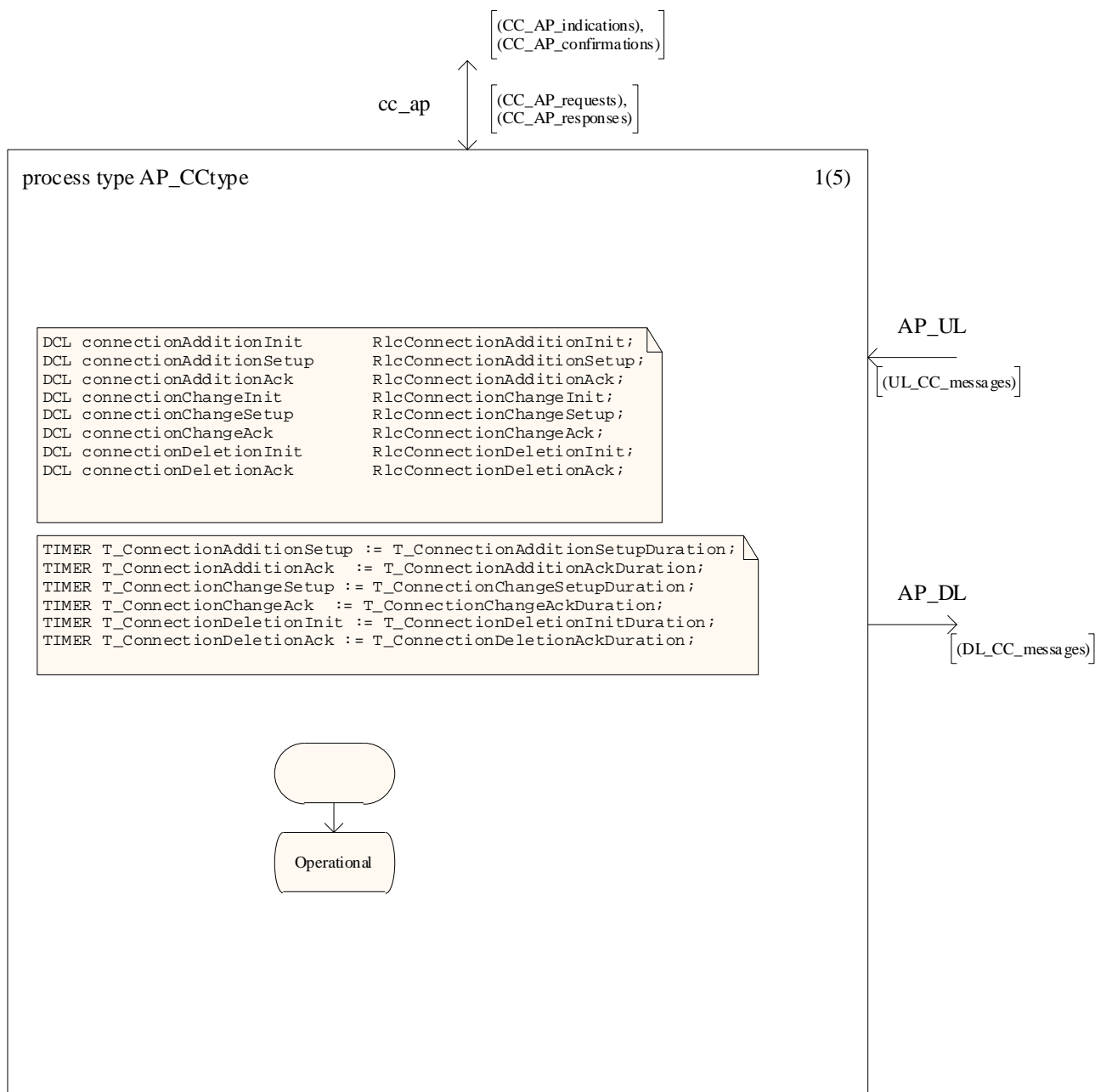

process type AP_CCtype

2(5)

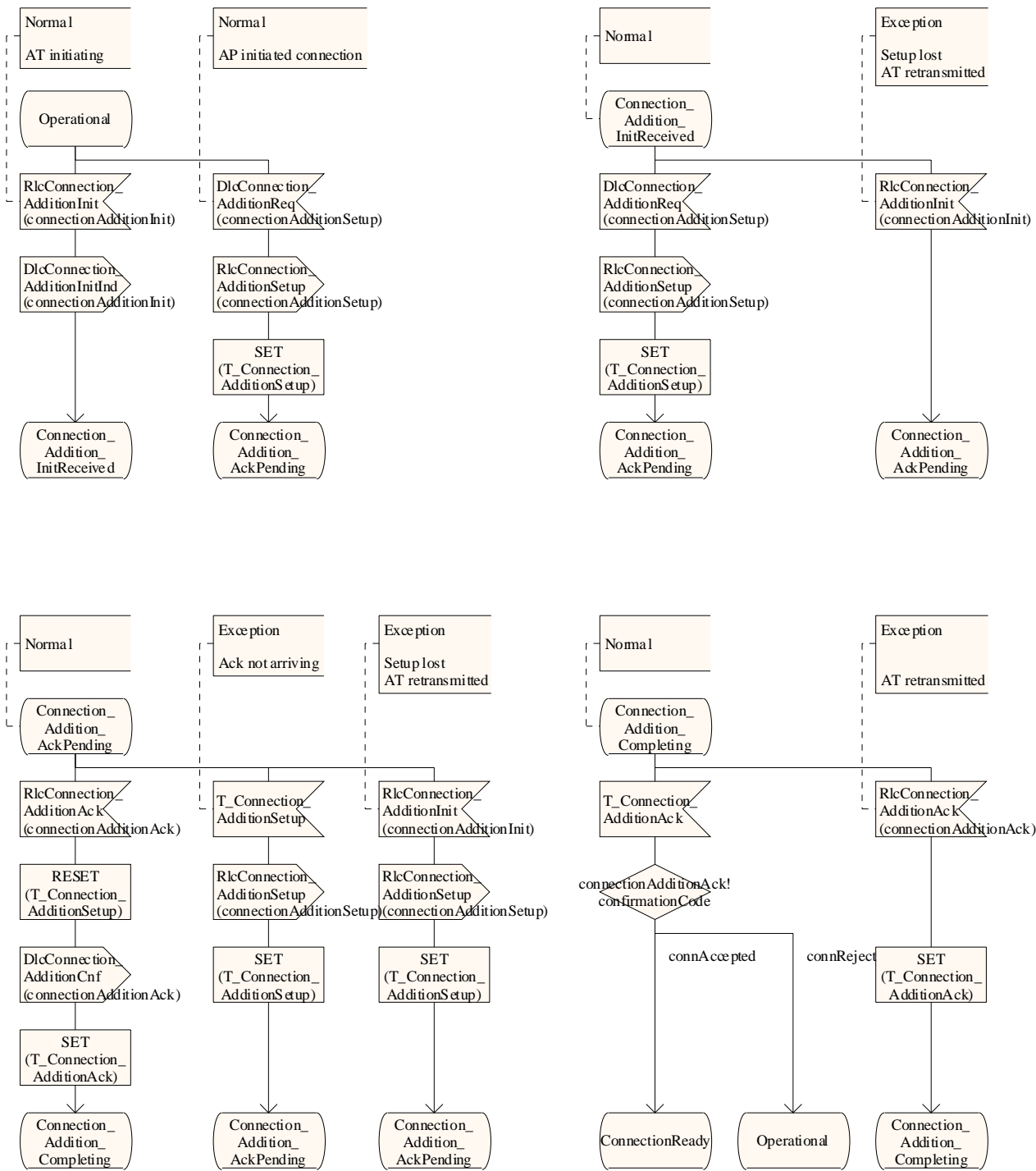

process type AP_CCtype

3(5)

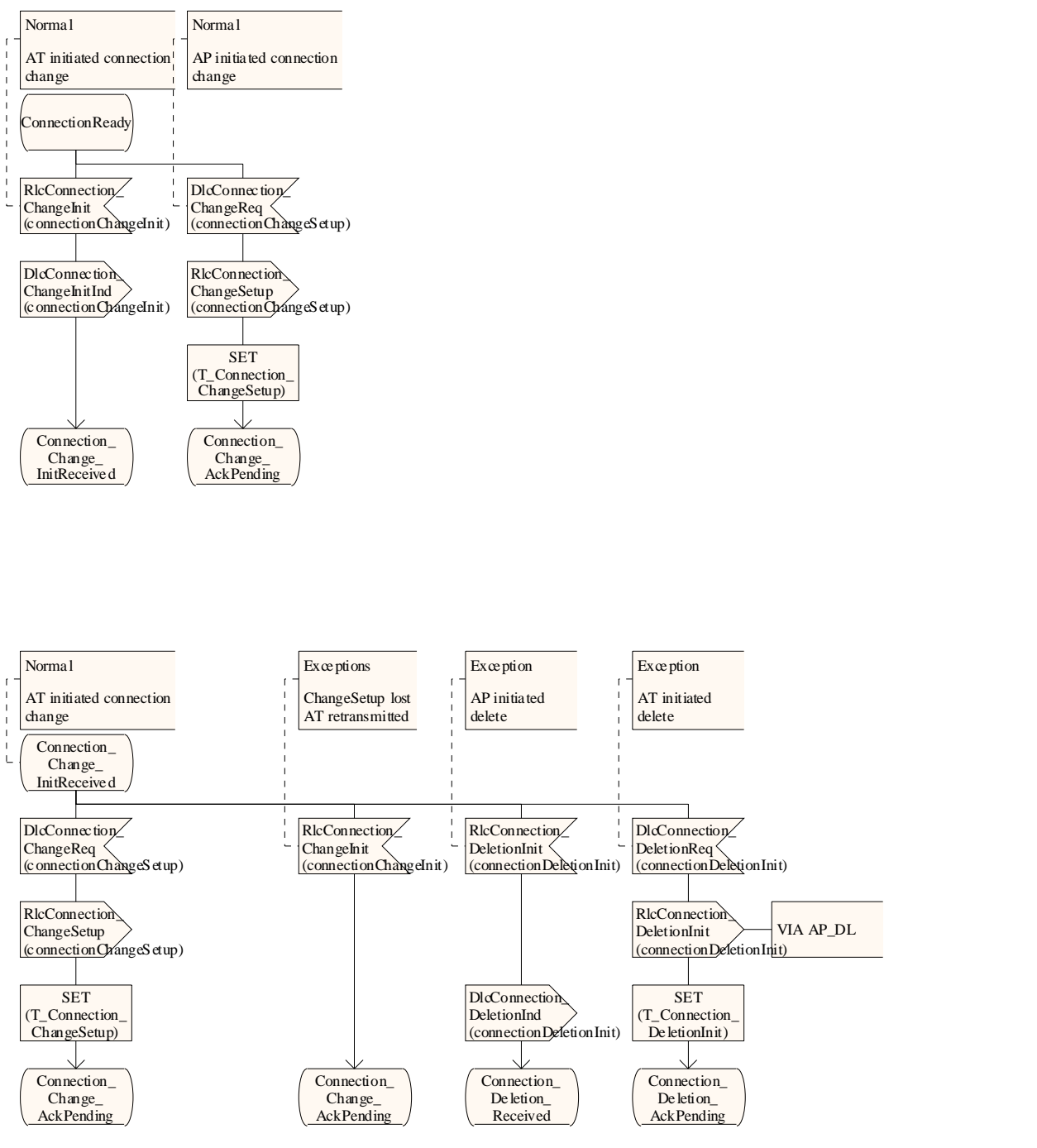

process type AP_CCtype

4(5)

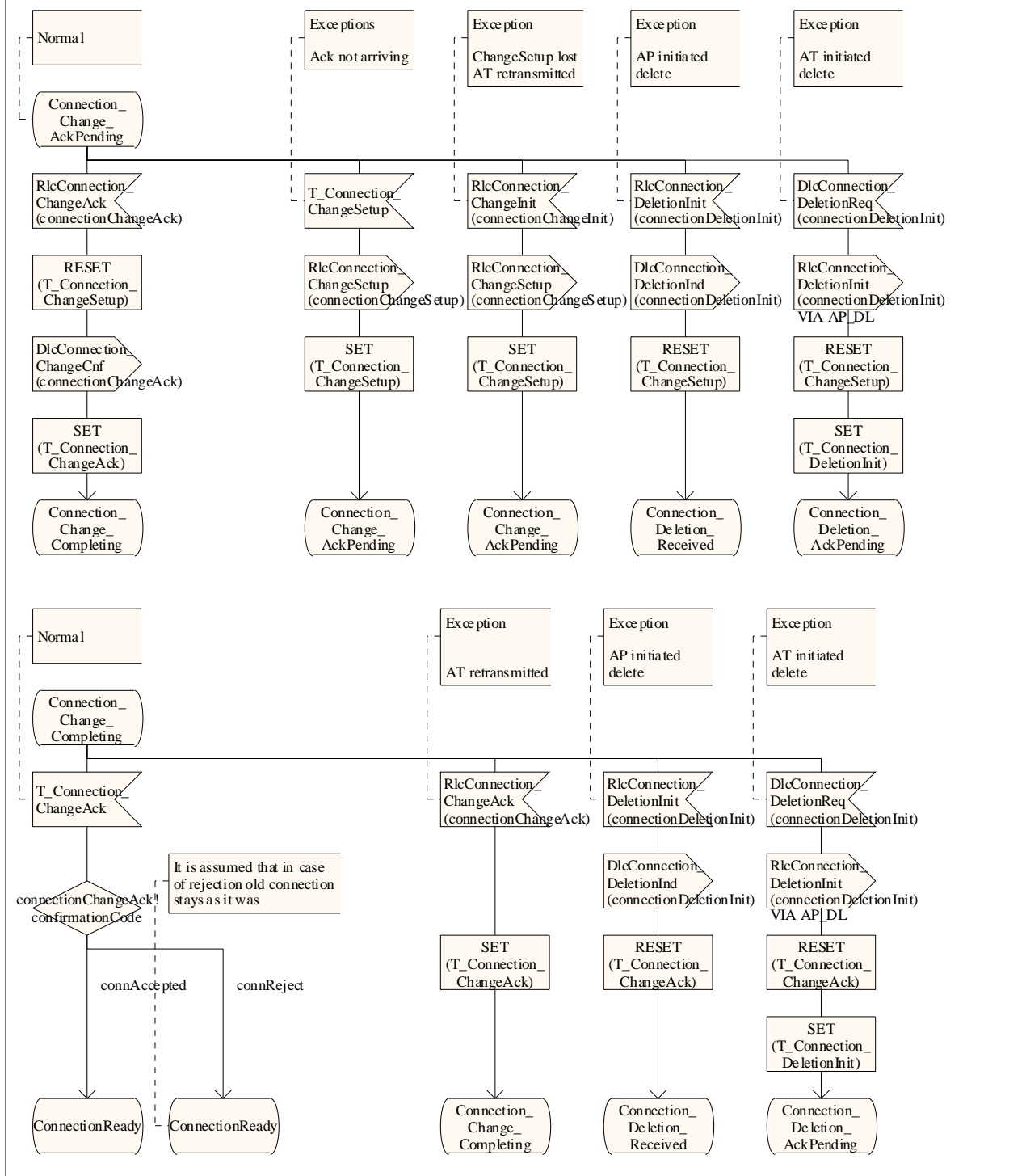

process type AP_CCtype

5(5)

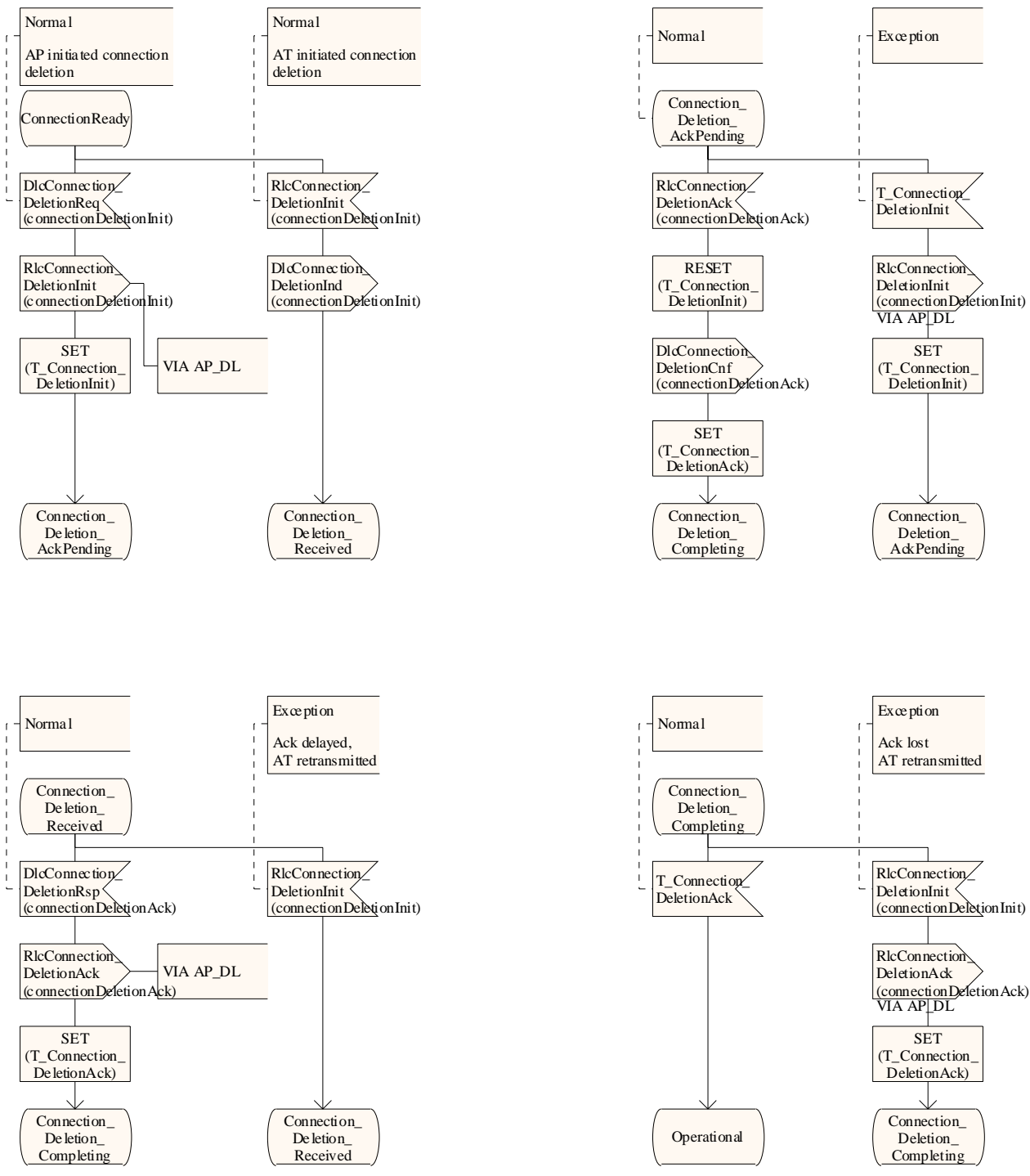

E.4.2 CC AT

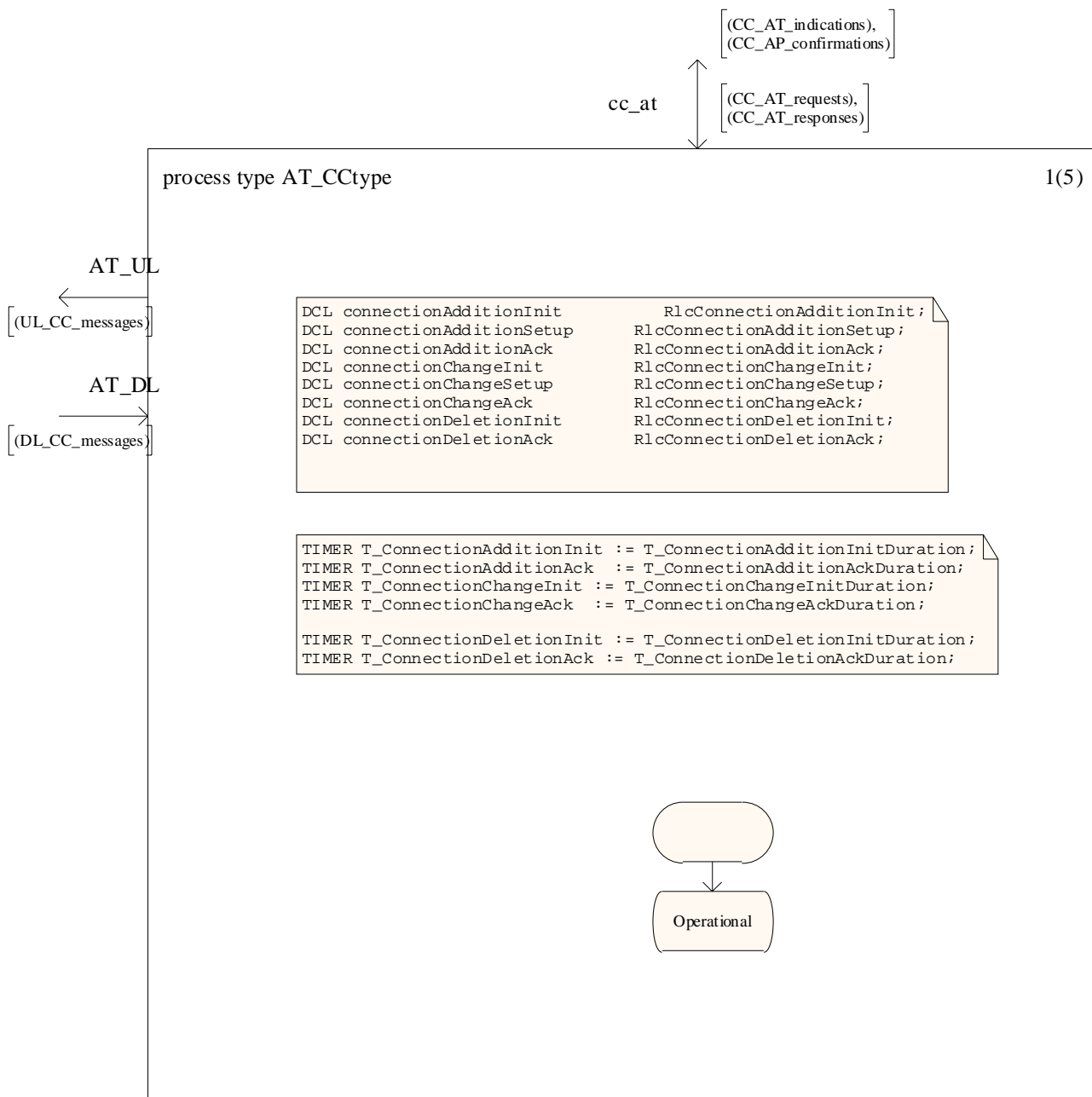

process type AT_CCtype

2(5)

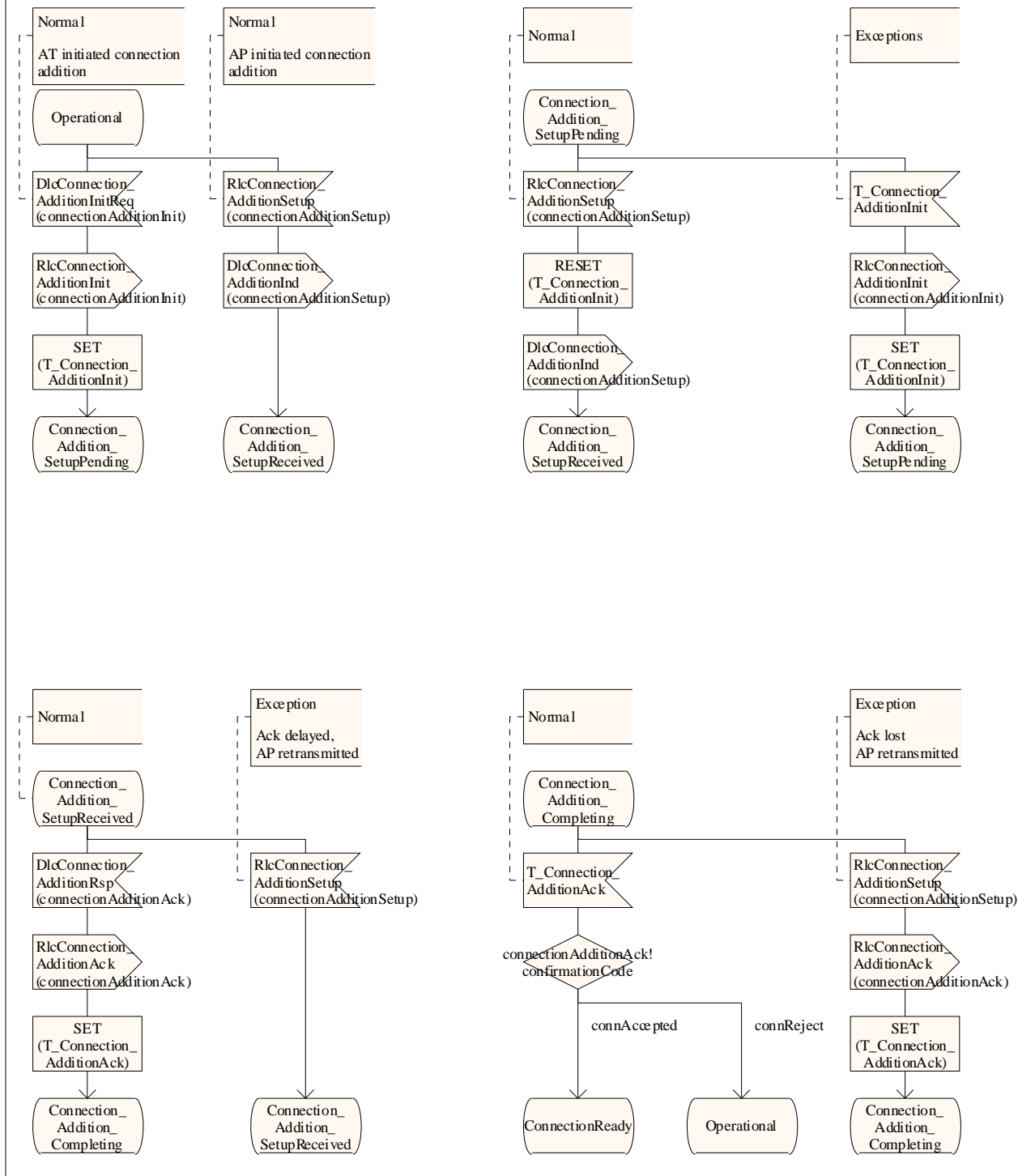

process type AT_CCtype

3(5)

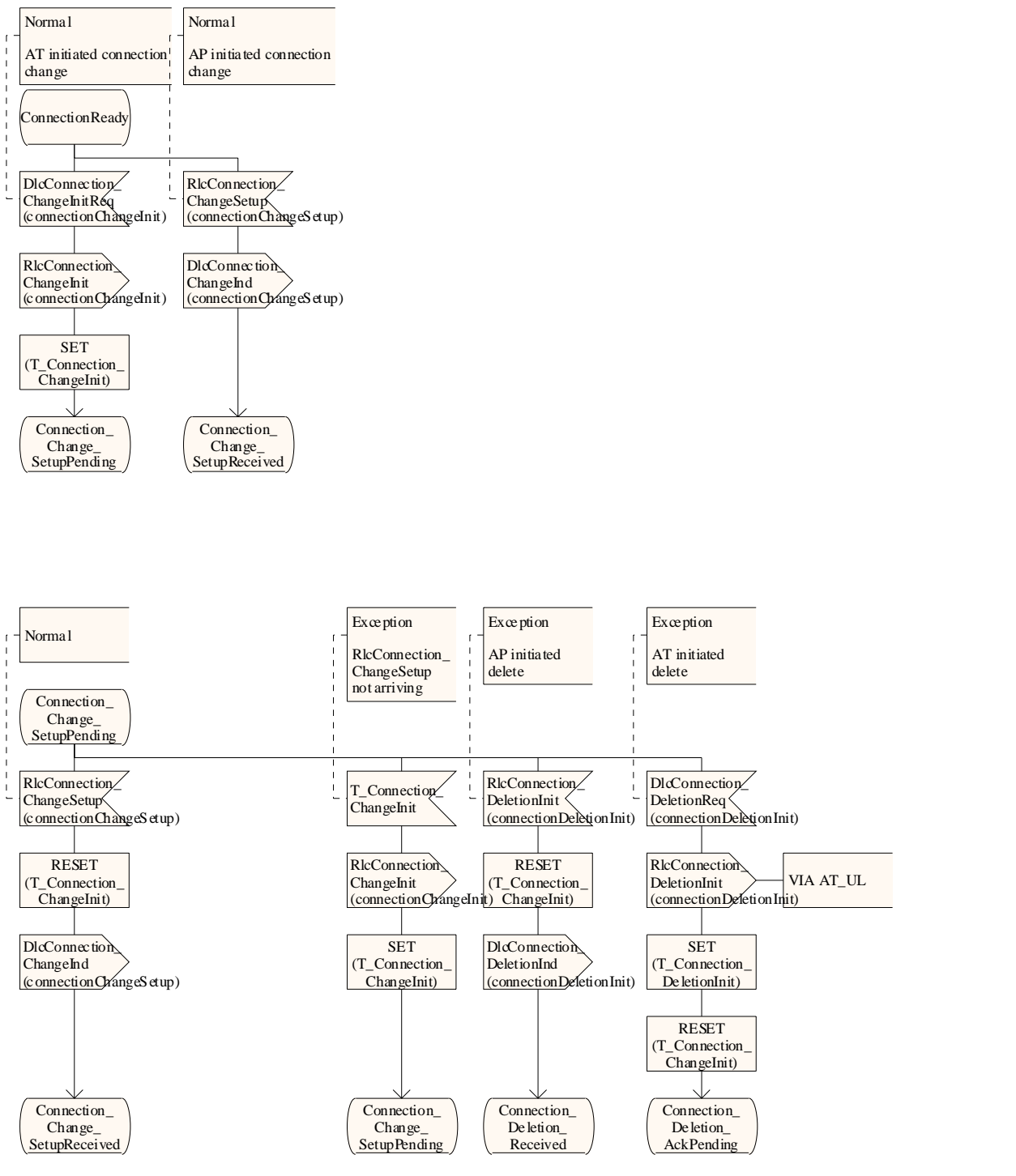

process type AT_CCtype

4(5)

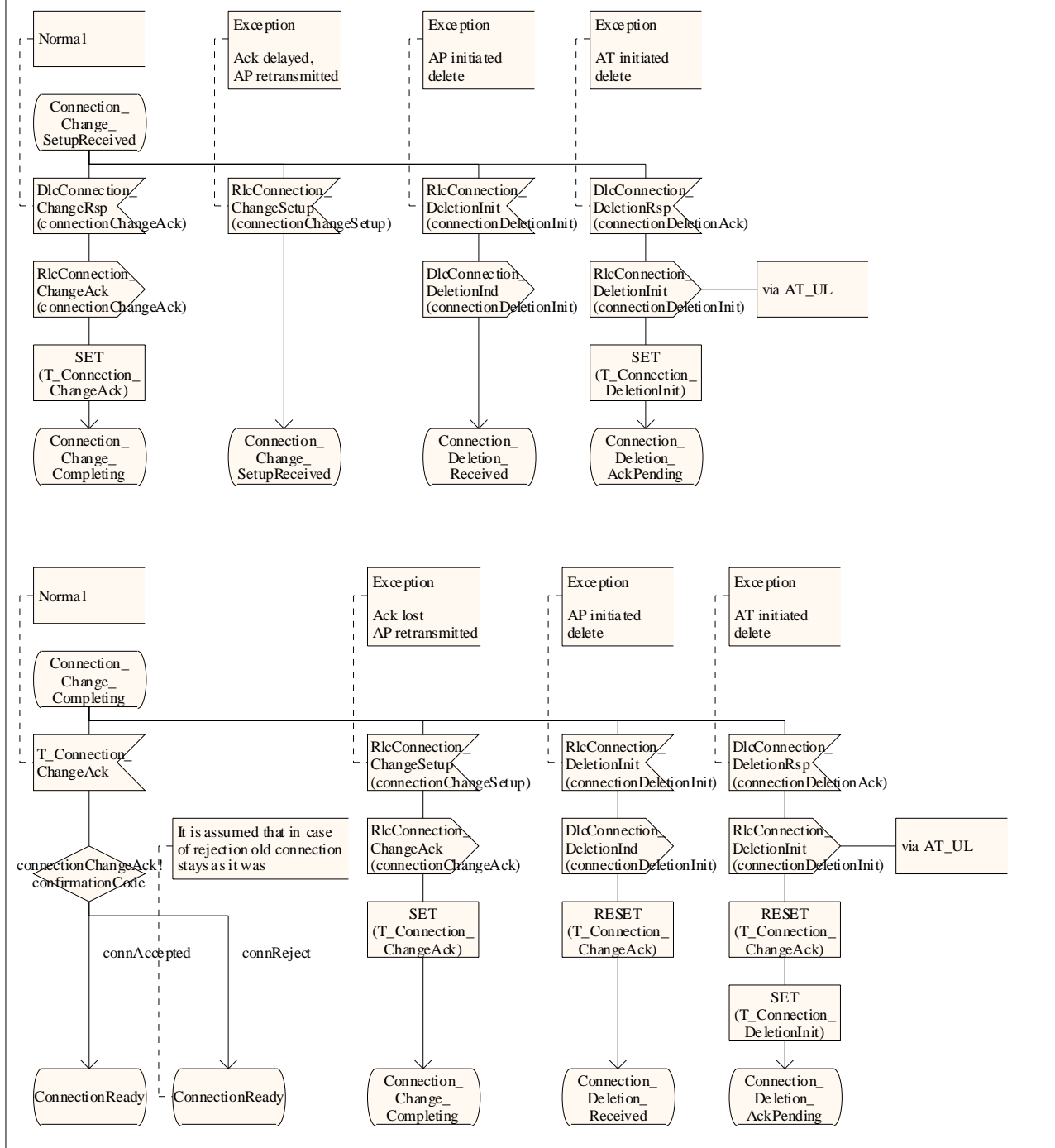

process type AT_CCtype

5(5)

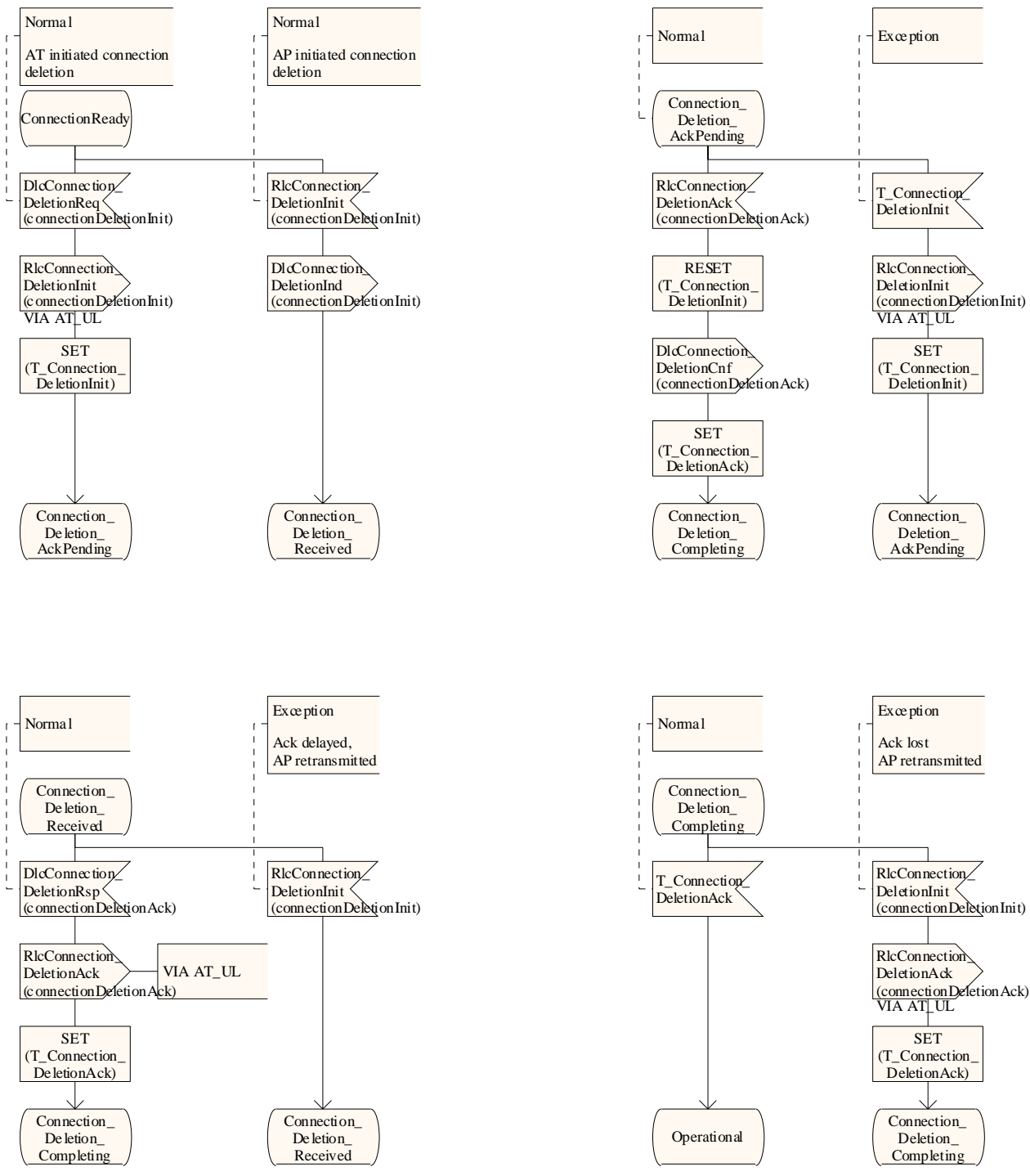

E.5 Security control SDL model

The current version of SDL model for security control is provided for information since the validation of the model is still in progress.

E.5.1 AP_SC

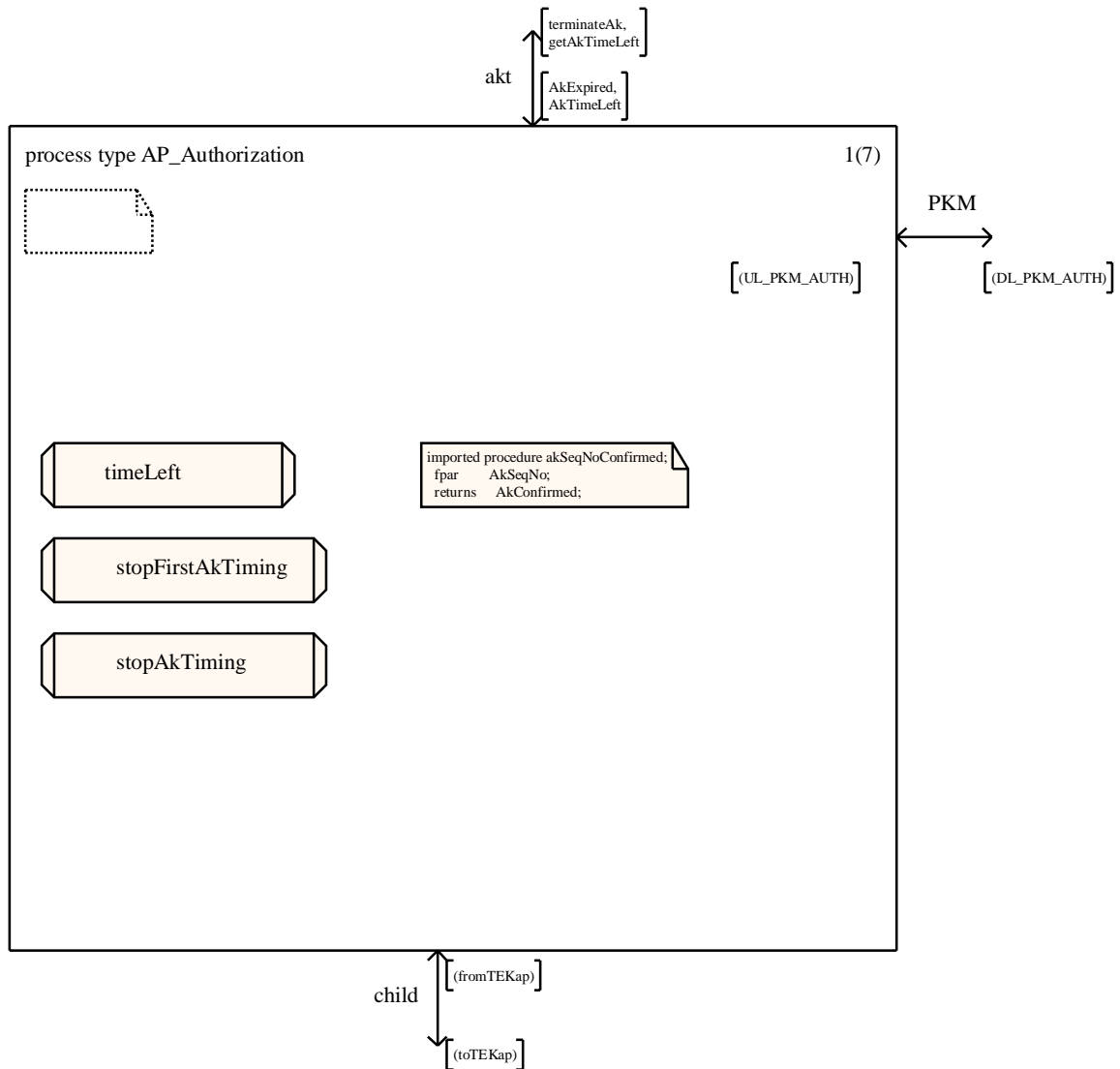

process type AP_Authorization

2(7)



```

DCL authManufacturerInfo  RlcAuthManufacturerInfo;
/* fields:
manufacturerX509certificate */

DCL authReq  RlcAuthReq;
/* fields:
AtX509certificate, AtPublicKey, ManufacturerId */

DCL authReply  RlcAuthReply;
/* fields:
AuthKey, AkSeqNo, AkLifeTime, Said */

DCL authReject  RlcAuthReject;
/* fields:
AuthErrorCode, ErrorInfoText[Optional]*/

DCL authInvalid  RlcAuthInvalid;
/* fields:
authInvalidErrorCode
errorInfoText OPTIONAL */

DCL tekReq  RlcTekReq;
/* fields: Said */

DCL akSeqNo  AkSeqNo;
DCL said  Said;

DCL akRecord  AkRecord;
DCL akList  AkList;
DCL akTimeLeft  Integer;

DCL isAkInvalid  IsAkInvalid := maxAkInvalid;

```

```
TIMER T_AuthCmd := T_AuthCmdDuration;
```

```
TIMER T_AuthRequestRetry;
```

```
exported procedure SaidApInvalid;
```

```
start;
```

```
return;
```

```
endprocedure;
```

process type AP_Authorization

3(7)

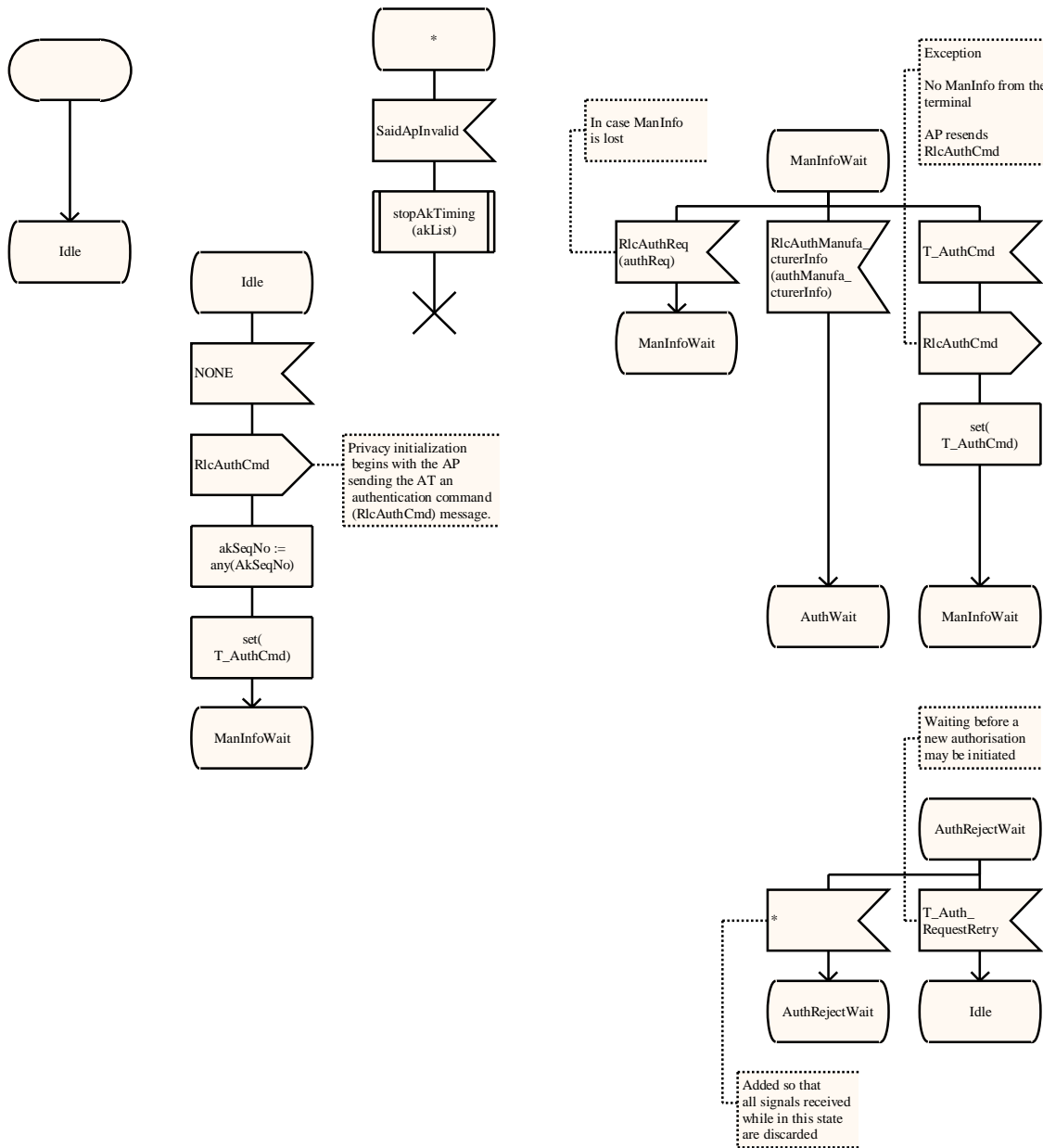

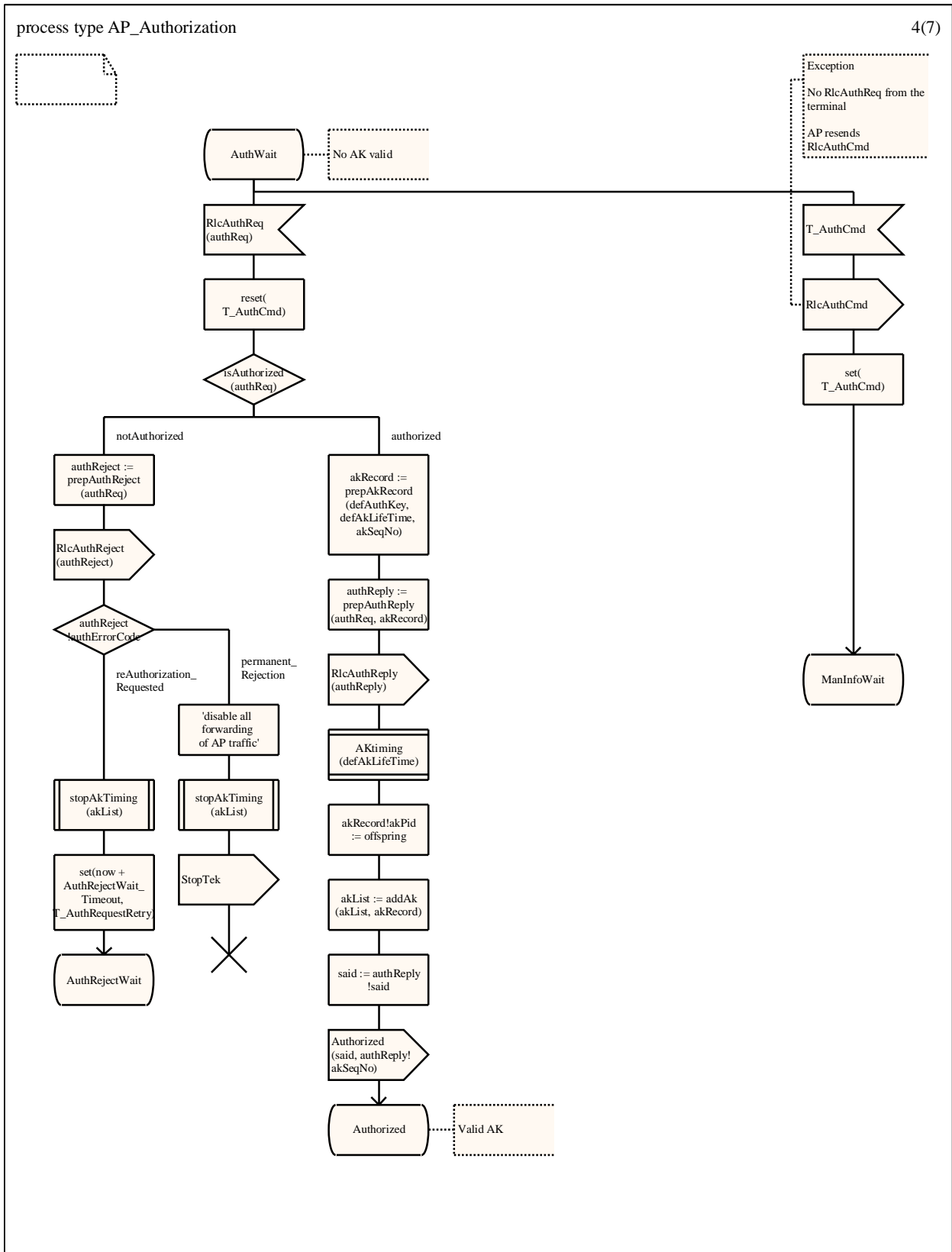

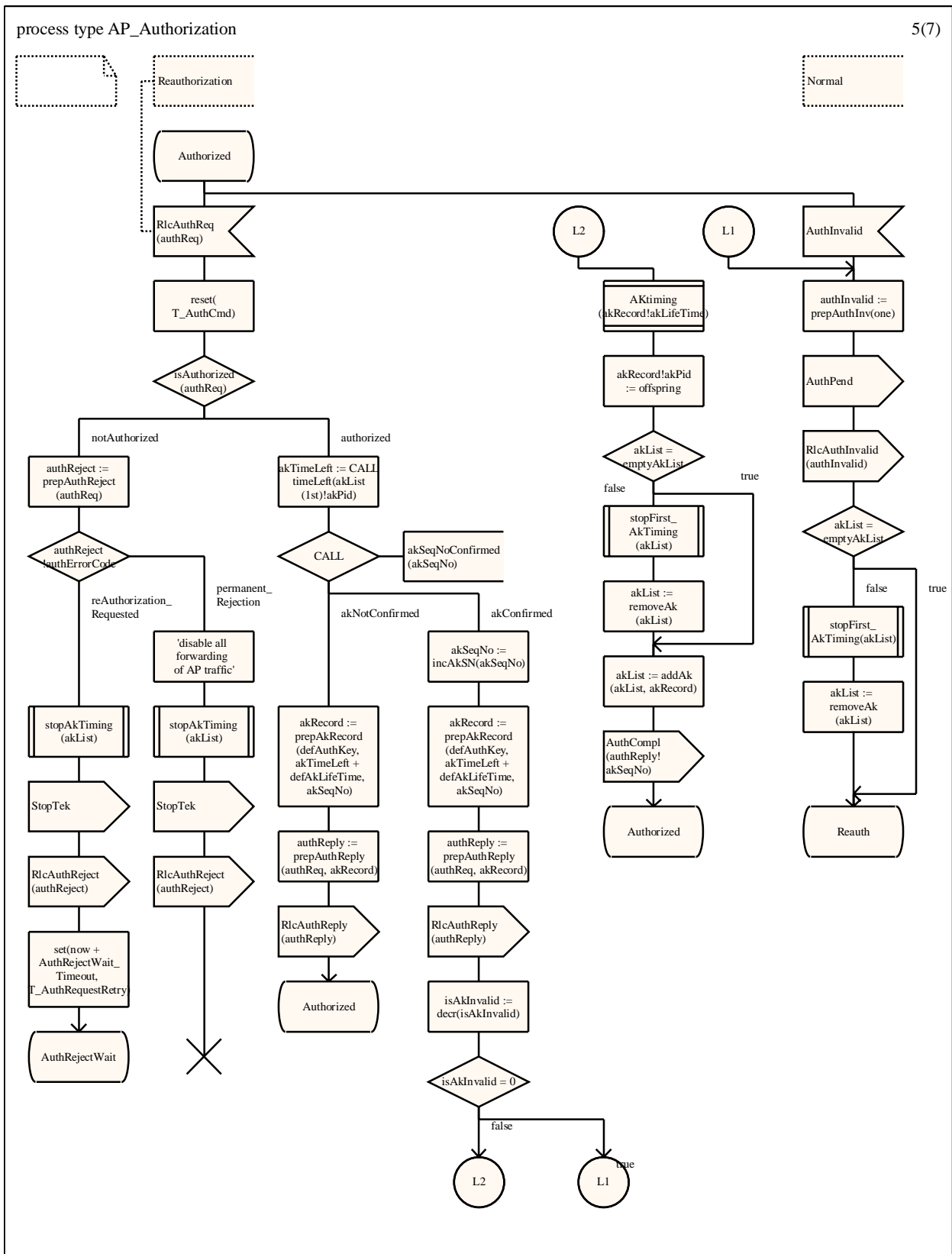

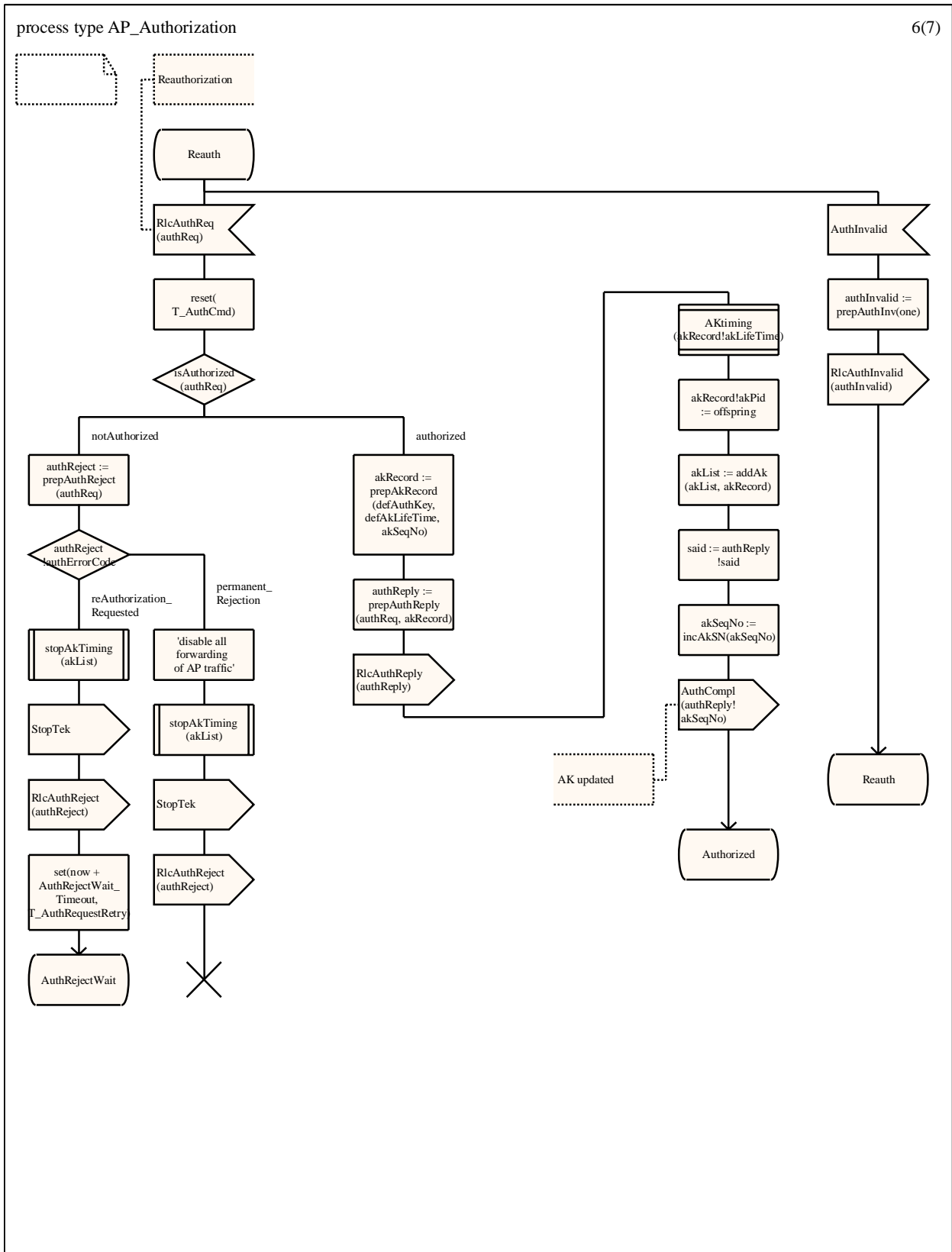

process type AP_Authorization

7(7)

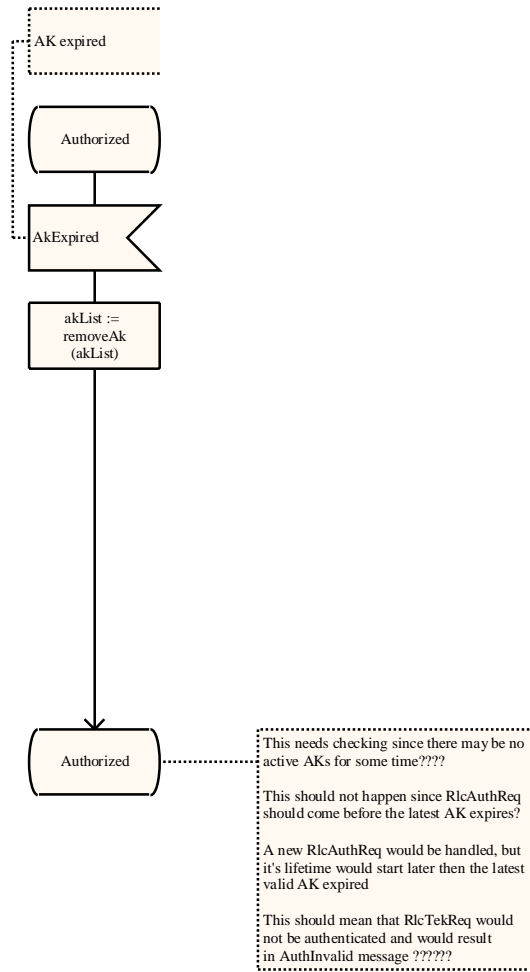

E.5.2 AT_SC

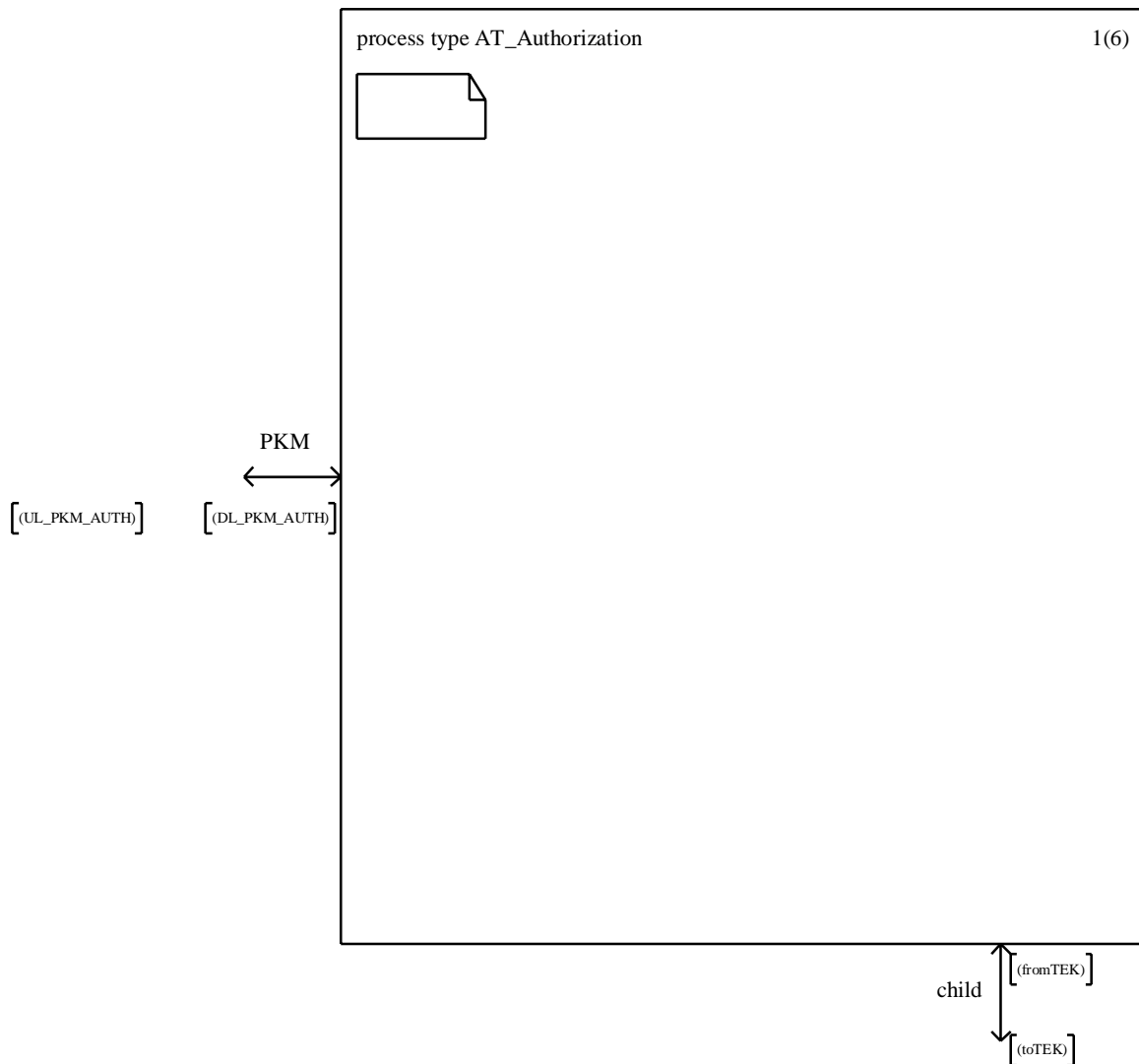

process type AT_Authorization

2(6)



```
TIMER T_AuthReq := T_AuthReqDuration;
TIMER T_AuthRequestRetry;
```

```
DCL authManufacturerInfo RlcAuthManufacturerInfo;
/* fields:
manufacturerX509certificate */

DCL authReq RlcAuthReq;
/* fields:
AtX509certificate, AtPublicKey, ManufacturerId */

DCL authReply RlcAuthReply;
/* fields:
AuthKey, AkSeqNo, AkLifeTime, Said */

DCL authReject RlcAuthReject;
/* fields:
AuthErrorCode, ErrorInfoText[Optional]*/

DCL authInvalid RlcAuthInvalid;
/* fields:
authInvalidErrorCode
errorInfoText OPTIONAL */
```

```
DCL said Said;
DCL currentAkSeqNo AkSeqNo;
DCL akList AkList;
DCL akRecord AkRecord;
```

```
exported procedure SaidInvalid;
start;
return;
endprocedure;
```

process type AT_Authorization

3(6)

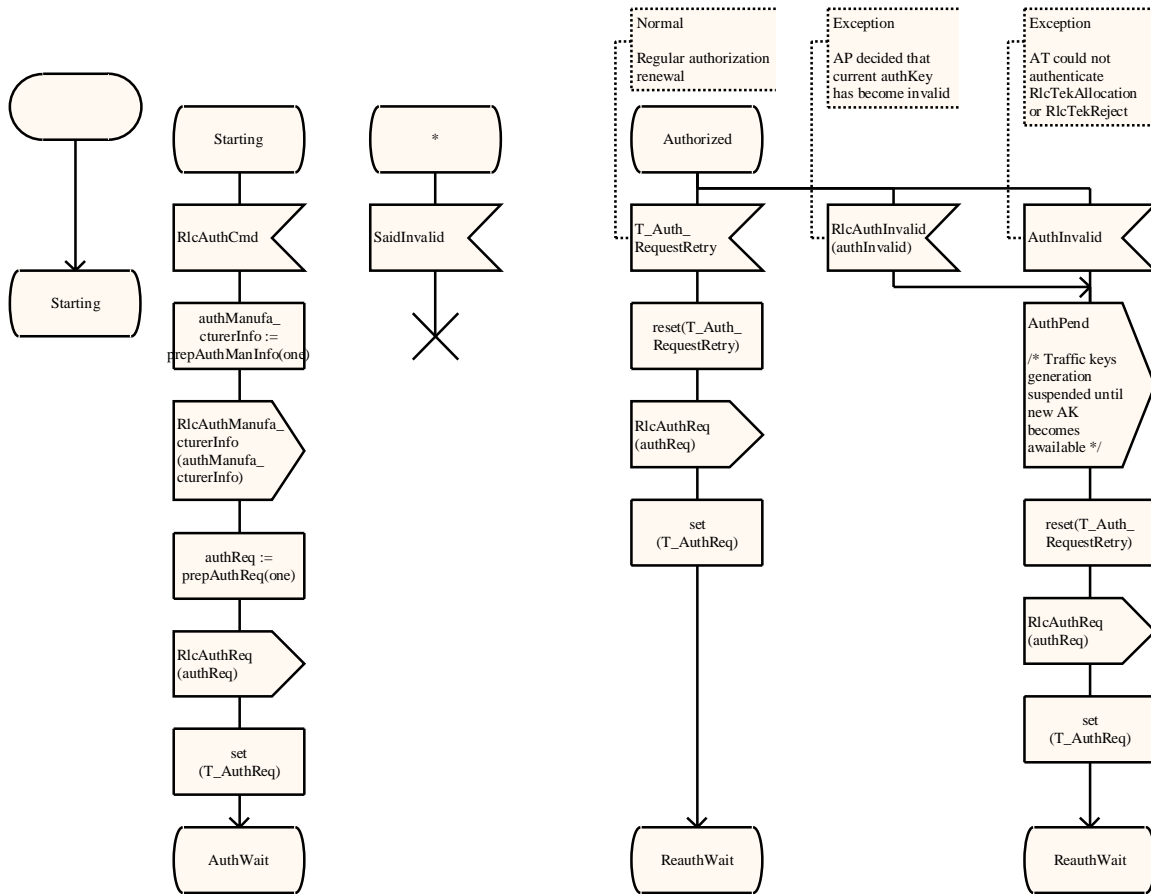

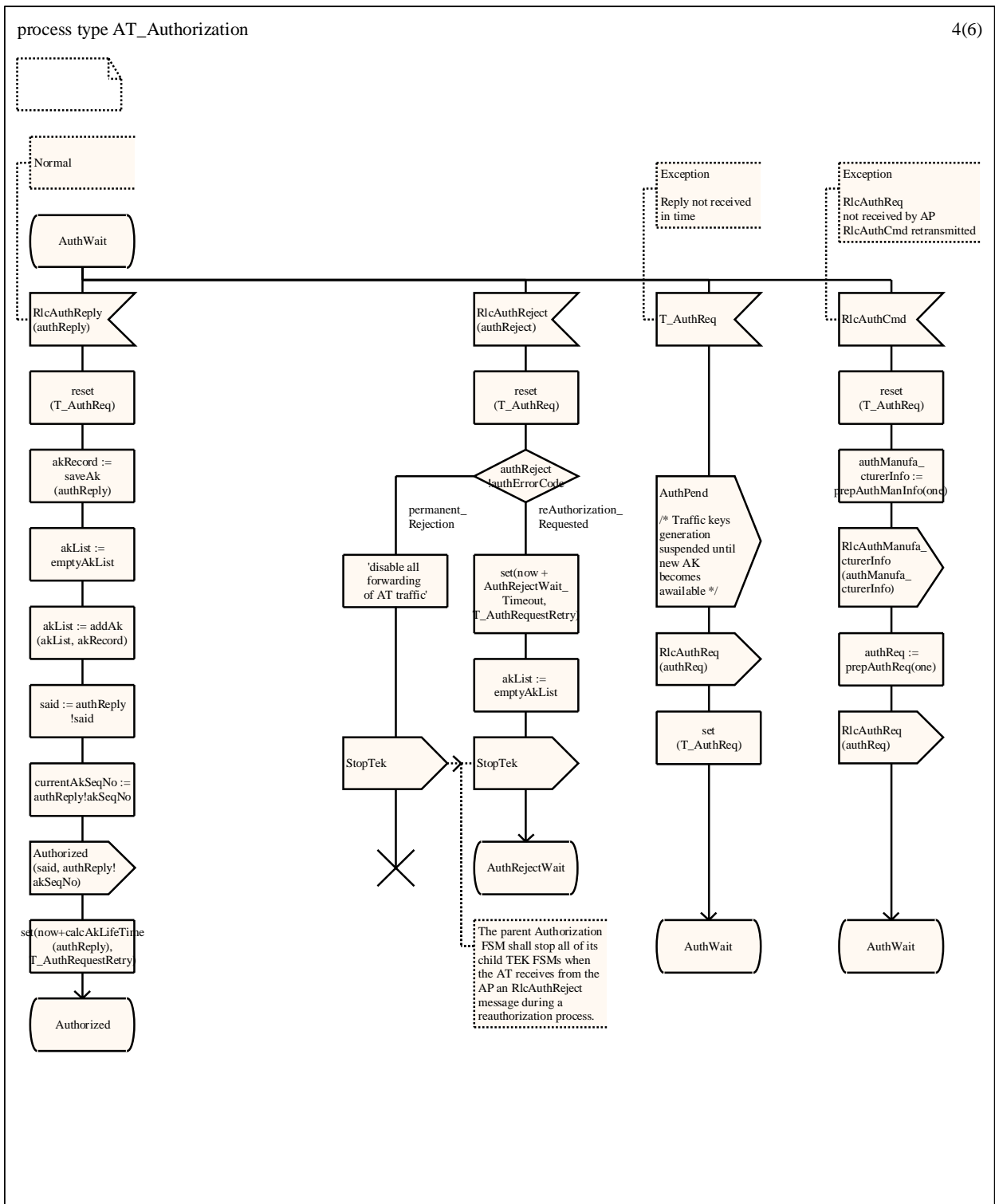

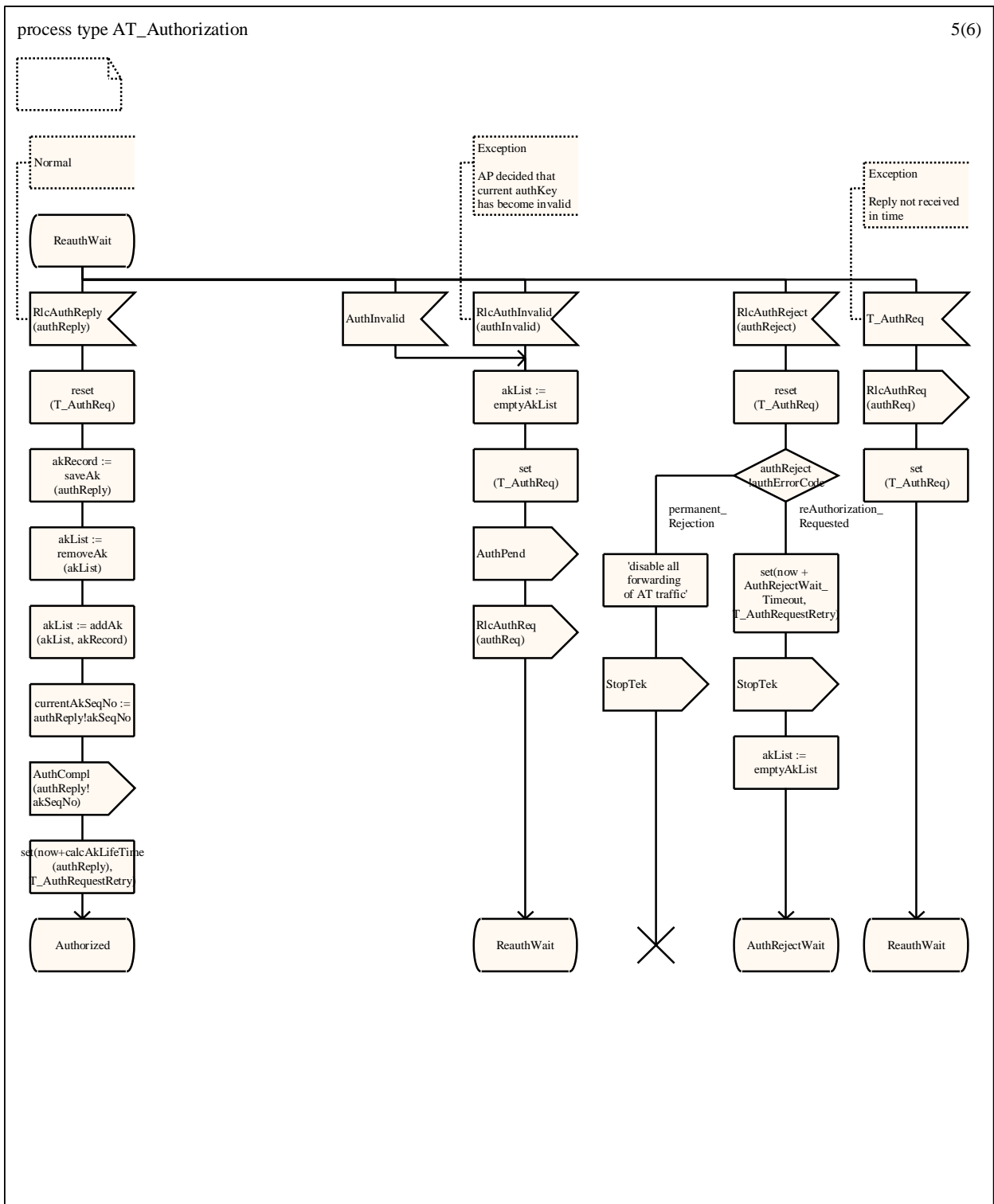

process type AT_Authorization

6(6)

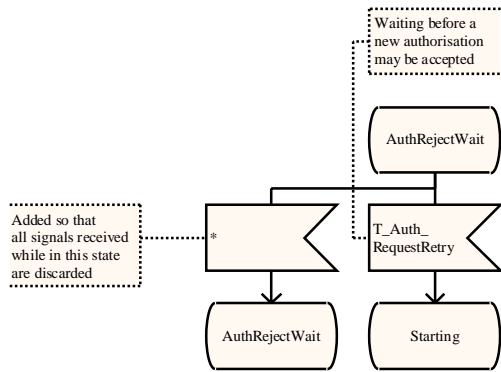

E.5.3 AP_TEK

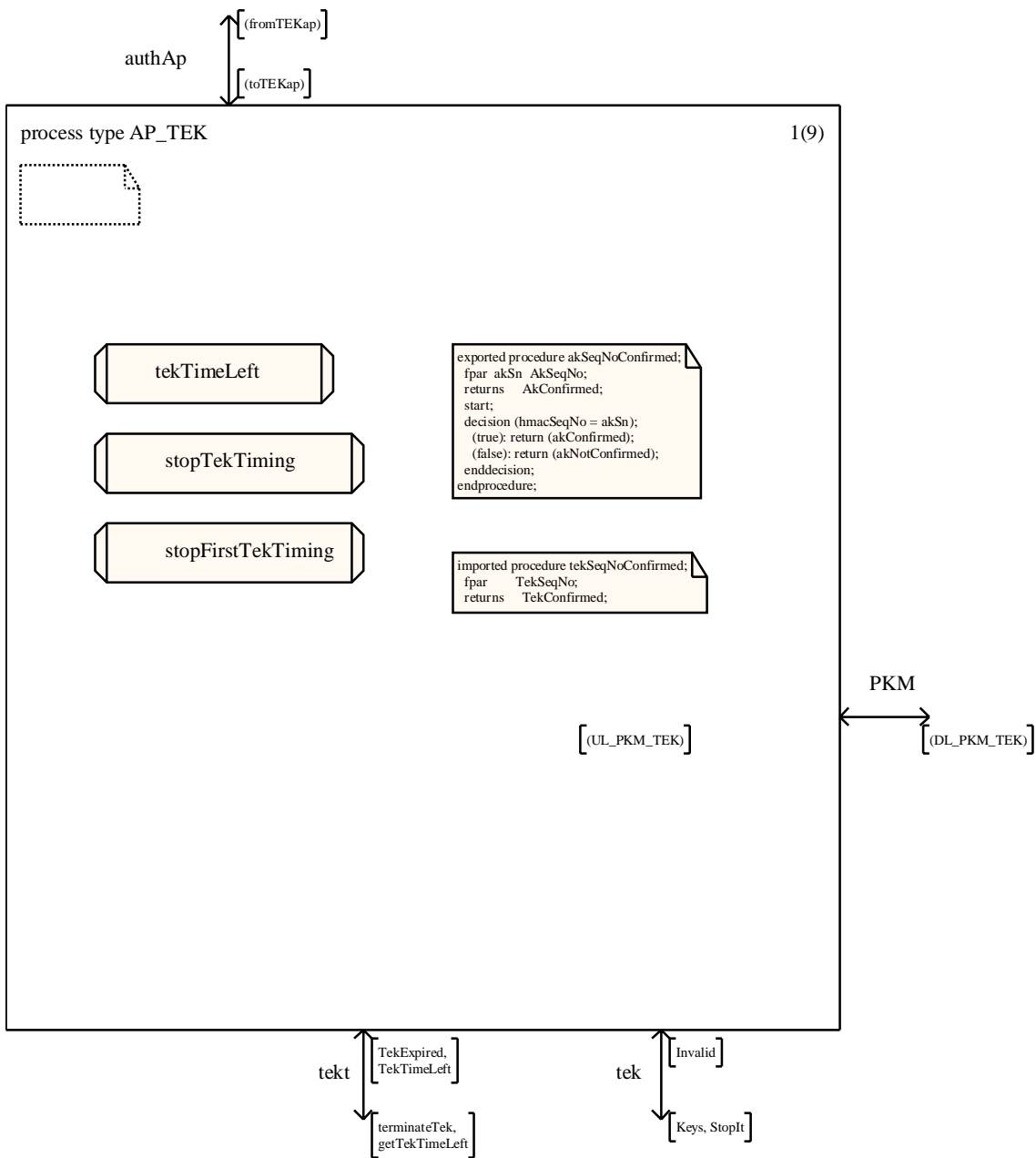

process type AP_TEK

2(9)



DCL tekReq	RlcTekReq;
DCL tekAllocation	RlcTekAllocation;
DCL tekReject	RlcTekReject;
DCL tekSN	TekSeqNo;
DCL tekList	TekList;
DCL activeDLsn	TekSeqNo;
DCL activeULsn	TekSeqNo;
DCL tekLifeTime	TekLifeTime;
DCL tekRecord1, tekRecord2	TekRecord;
DCL said	Said;
DCL authKey	AuthKey;
DCL tekInvalid	RlcTekInvalid;
DCL tekTimeLeft	Integer;
DCL isTekInvalid	IsTekInvalid := maxTekInvalid;
DCL isAkInvalid	IsAkInvalid := maxAkInvalid;
DCL akSeqNo	AkSeqNo; /* seqNumReceived from Auth */
DCL hmacSeqNo	AkSeqNo; /* latest AkSeqNum derived from hmac */

imported procedure SaidApInvalid;

DCL testData Boolean := false;

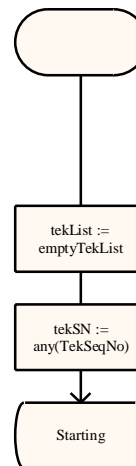

process type AP_TEK

3(9)

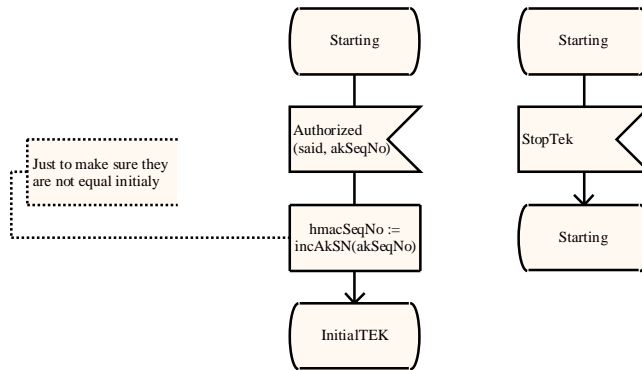

process type AP_TEK

4(9)

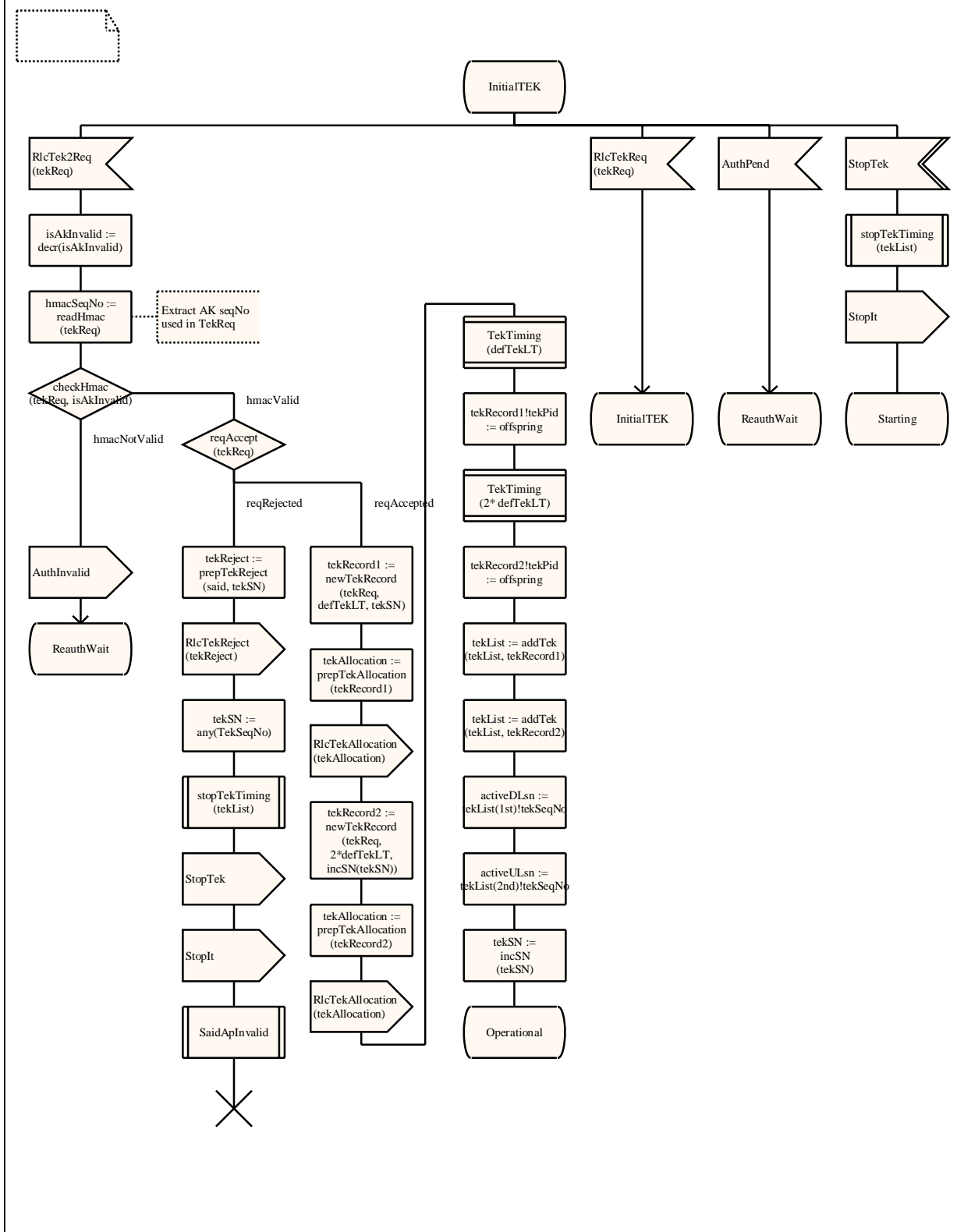

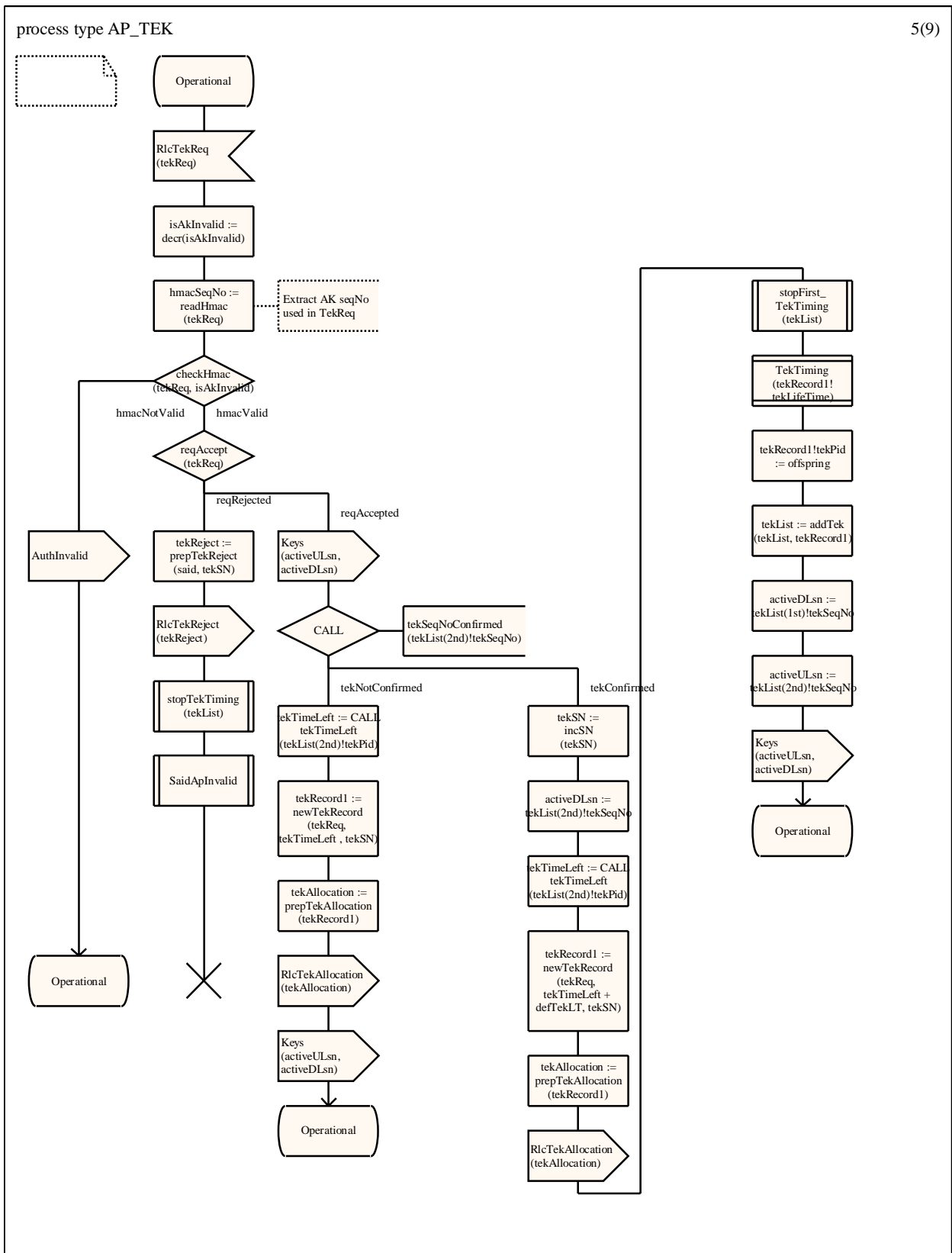

process type AP_TEK

6(9)

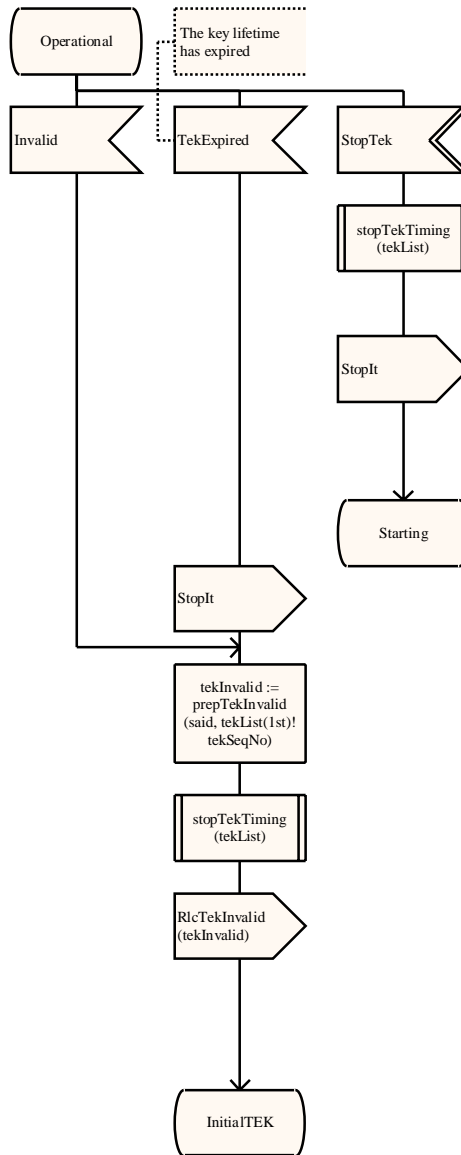

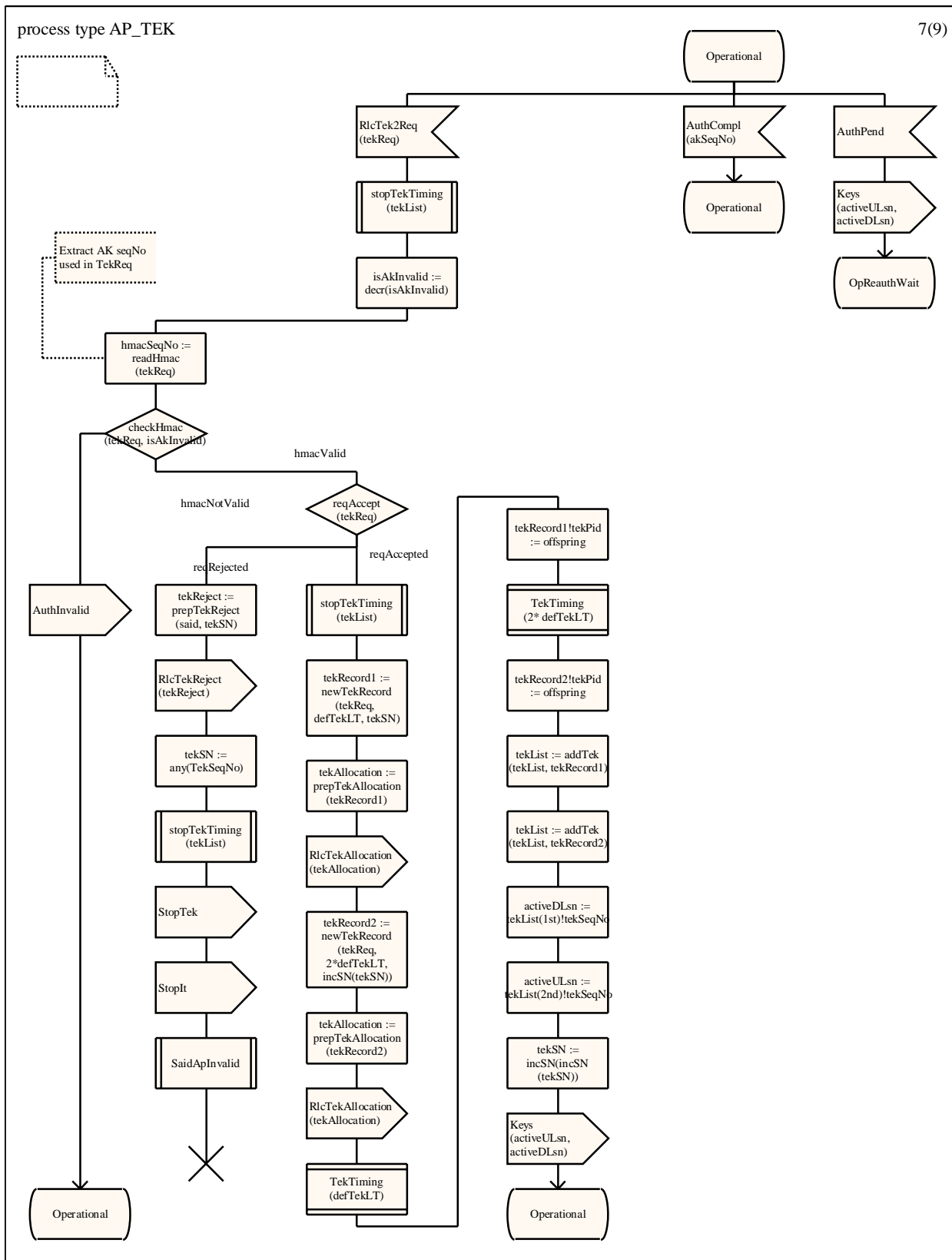

process type AP_TEK

8(9)

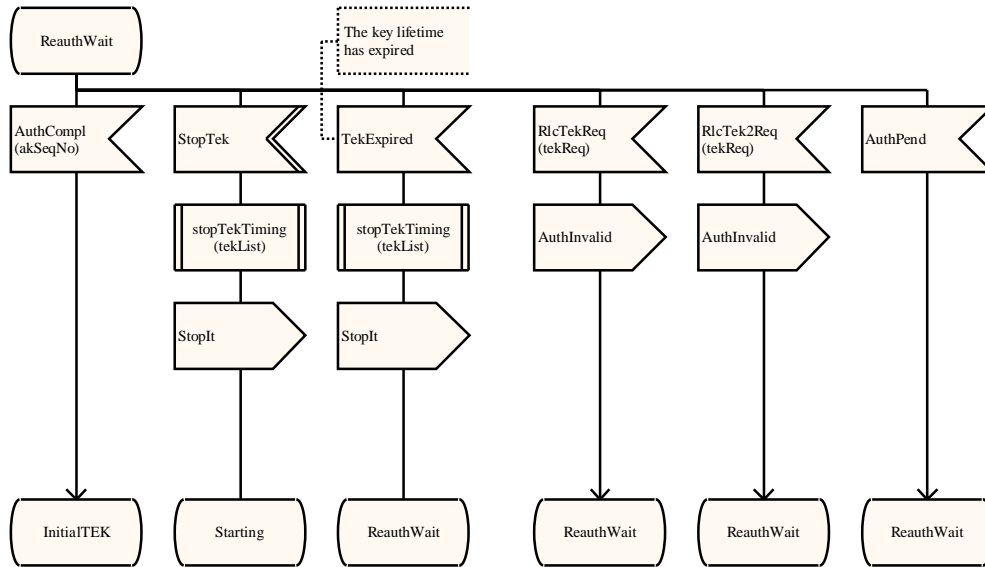

process type AP_TEK

9(9)

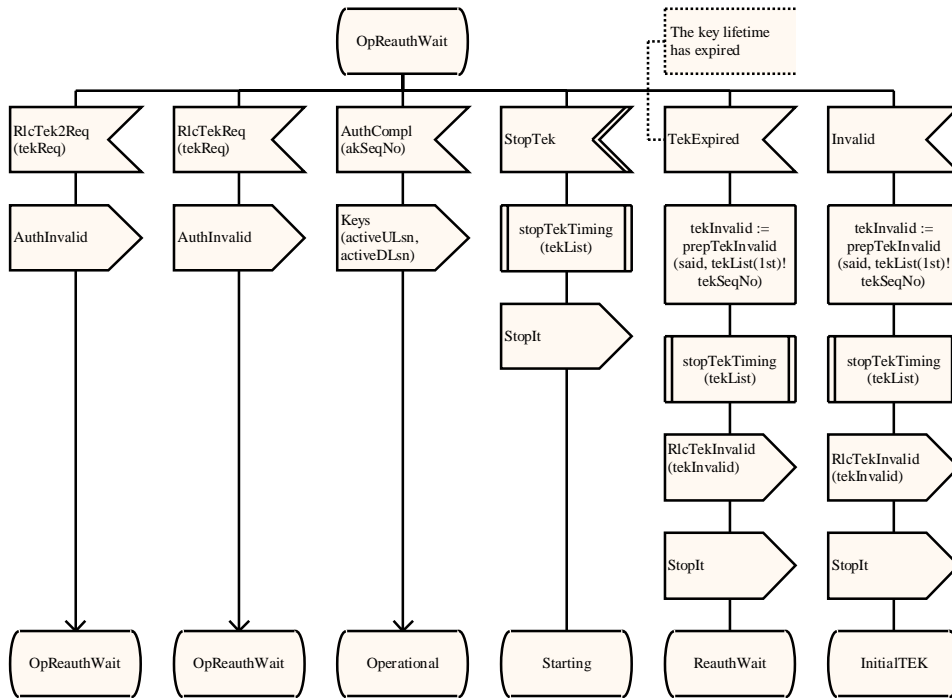

E.5.4 AT_TEK

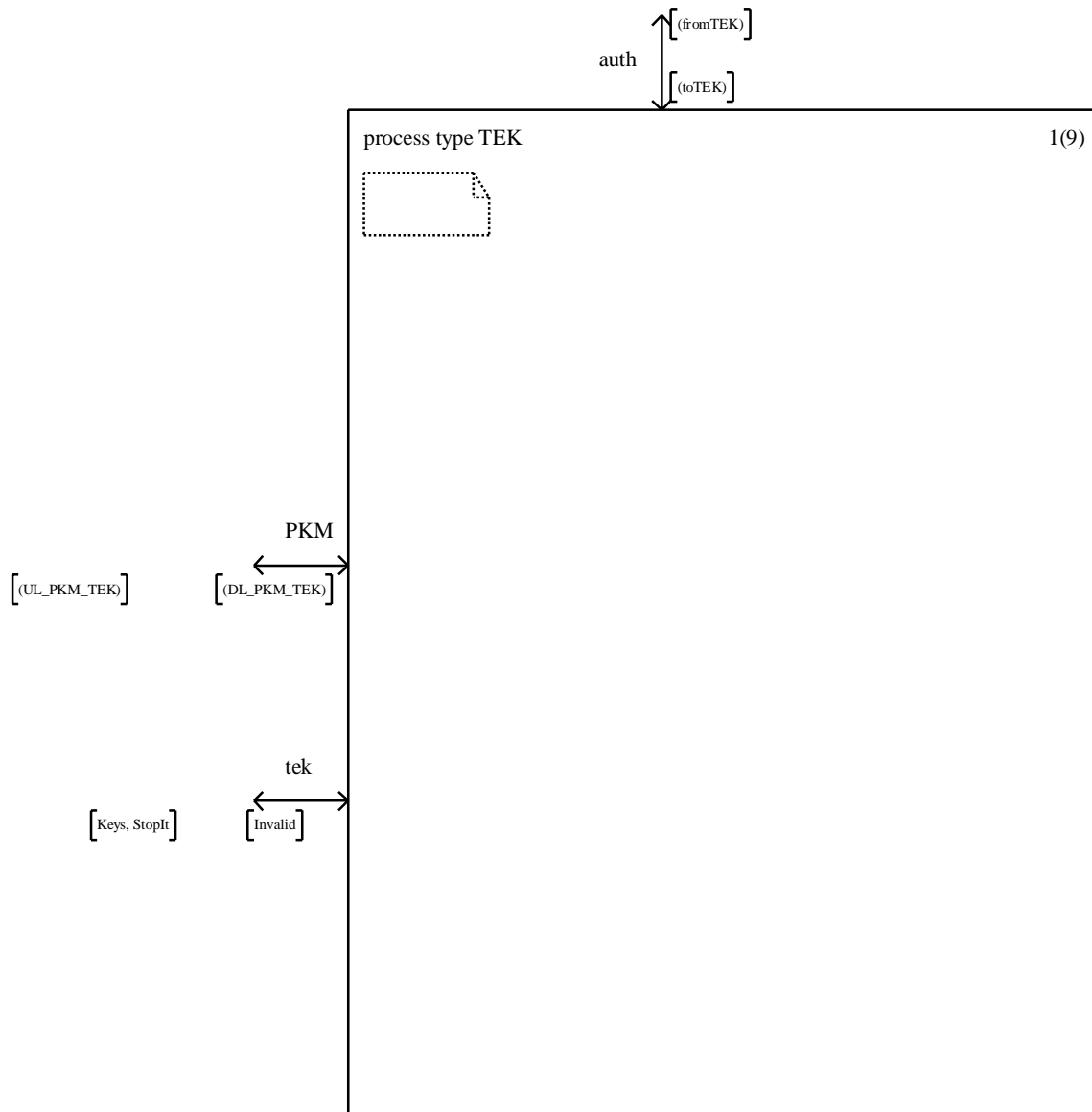

process type TEK

2(9)

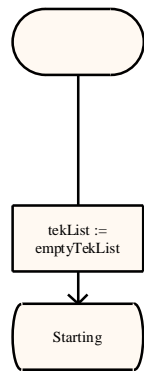

```

DCL tekReq          RlcTekReq;
/* files: Said */

DCL tekAllocation  RlcTekAllocation;
/* files:
said, tek1, tek1LifeTime, tek1SeqNo,
hmac, initializationStatus */

DCL tekReject      RlcTekReject;
/* files:
tekSeqNo, said, tekErrorCode,
errorInfoText OPTIONAL, hmacDigest */

DCL tekInvalid     RlcTekInvalid;
/* files:
tekSeqNo, said, tekErrorCode,
errorInfoText OPTIONAL, hmacDigest */

DCL authKey        AuthKey;
/* the key to be used for decrypting TekKey info */

DCL activeDLsn     TekSeqNo;
DCL activeULsn     TekSeqNo;

DCL said           Said;
DCL tekList        TekList;
DCL tekRecord1     TekRecord;

DCL isAkInvalid    IsAkInvalid := maxAkInvalid;
DCL isTekInvalid   IsTekInvalid := maxTekInvalid;

DCL akSeqNo        AkSeqNo;
    
```

```

TIMER T_TekReq := T_TekReqDuration;
TIMER T_Tek2Req := T_Tek2ReqDuration;
    
```

```

/* Amount of time before key
/* is scheduled to expire that the AT
/* starts asking for new keys.
TIMER TEKrefreshTimer;
    
```

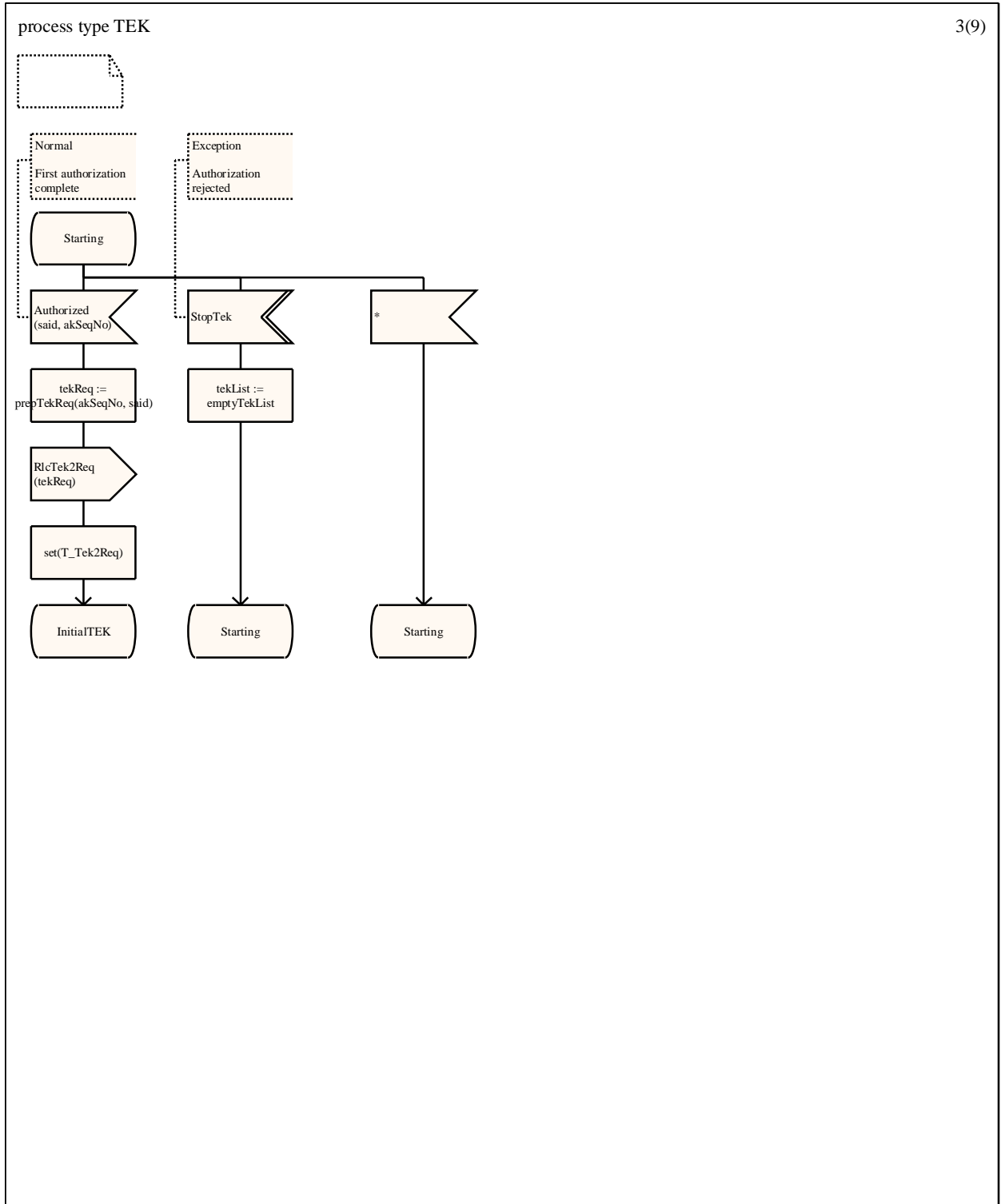

process type TEK

4(9)

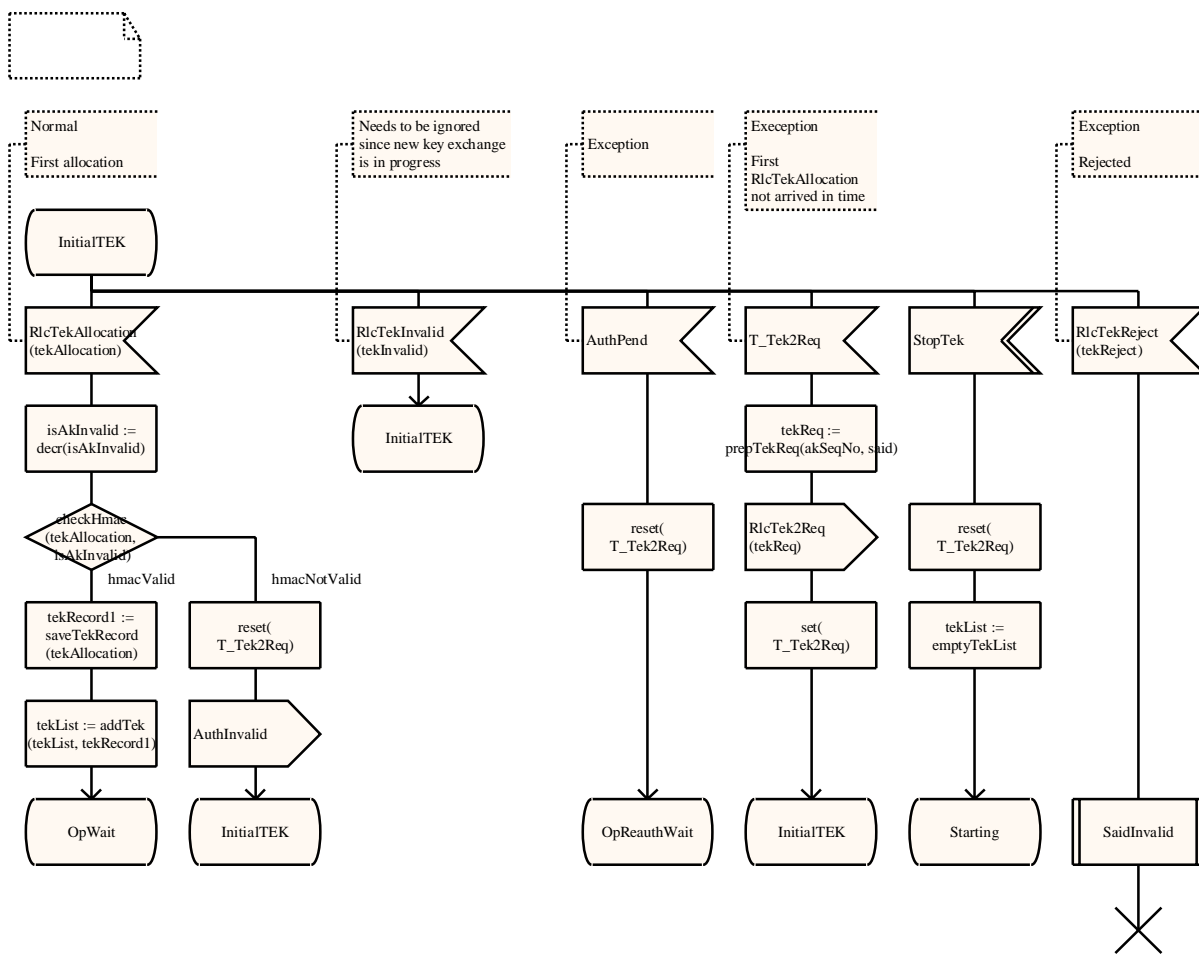

process type TEK

5(9)

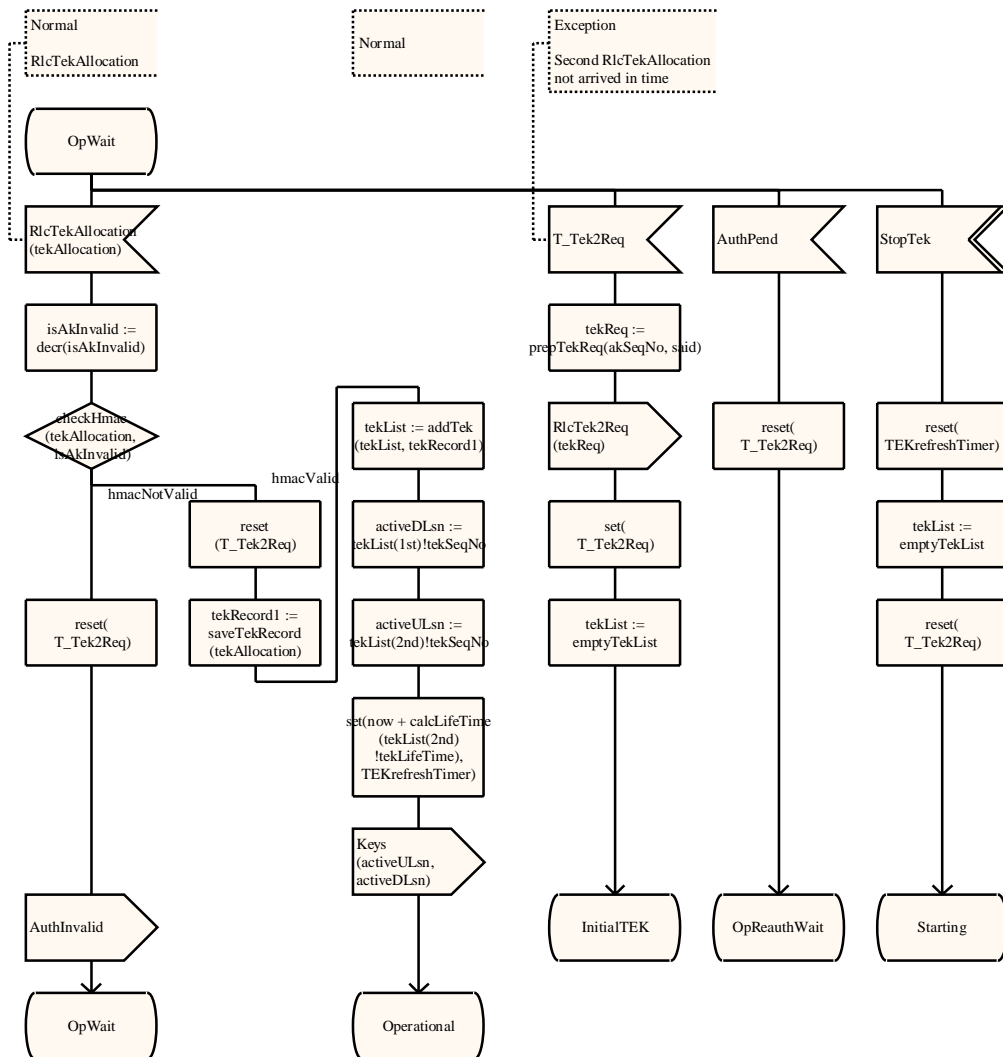
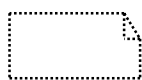

process type TEK

6(9)

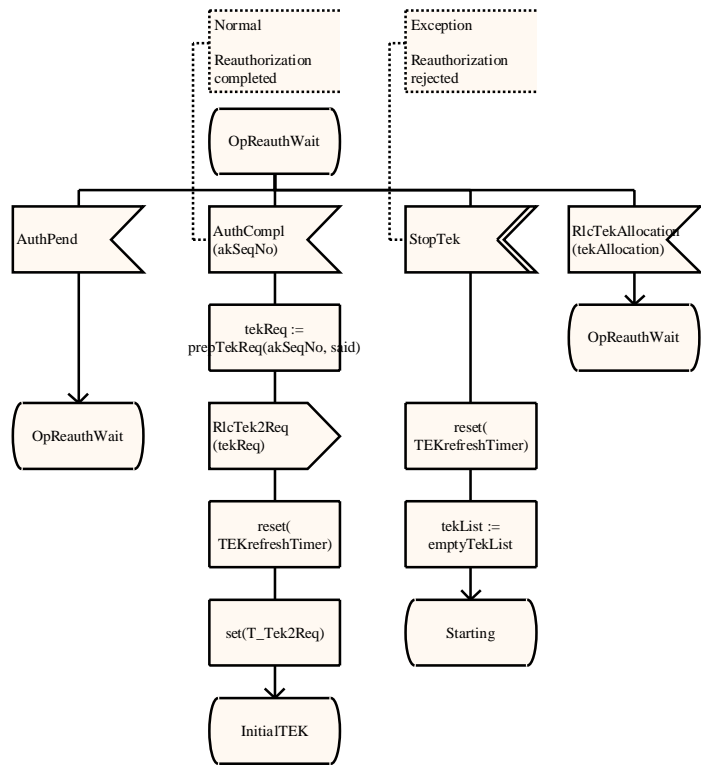

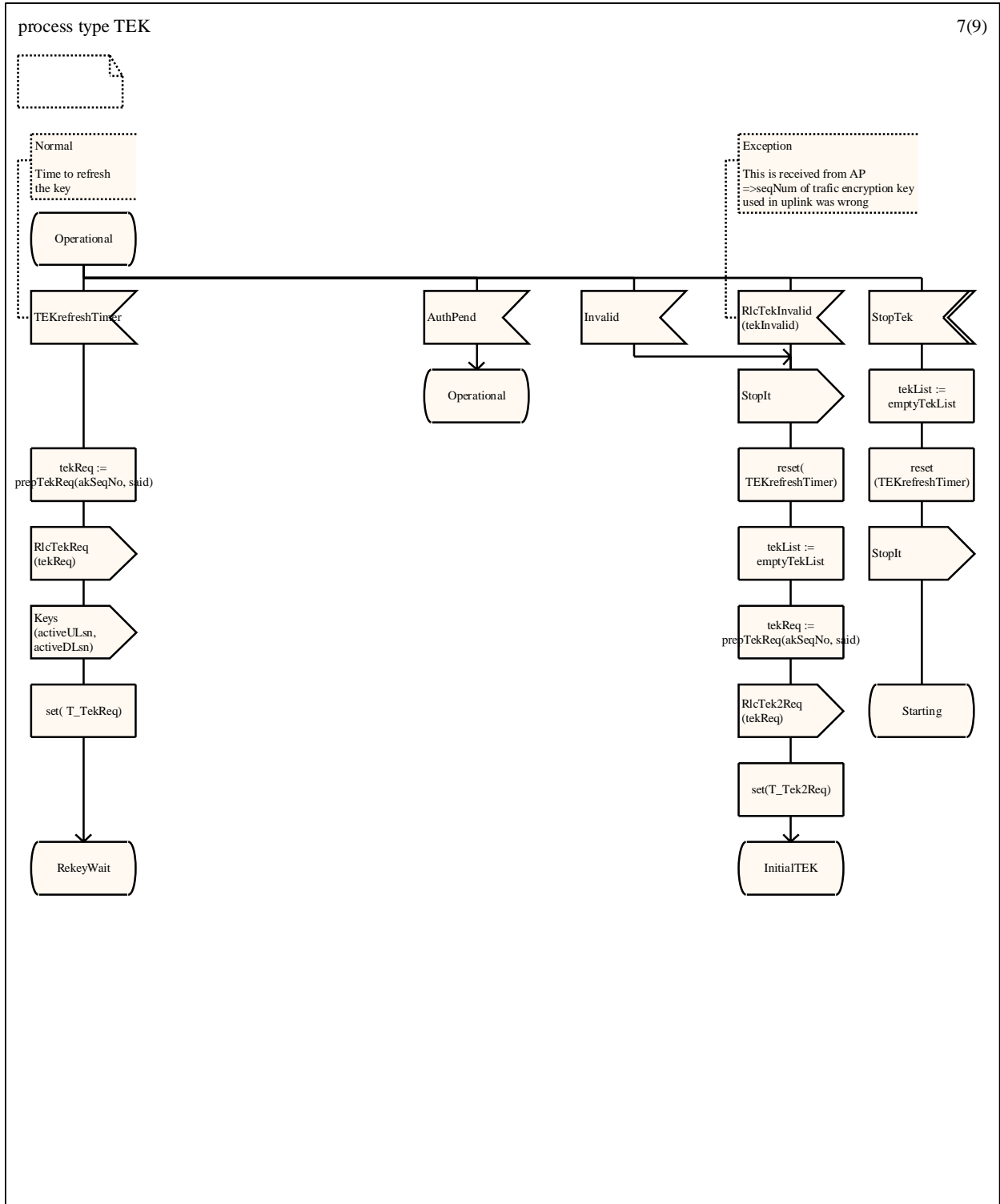

process type TEK

8(9)

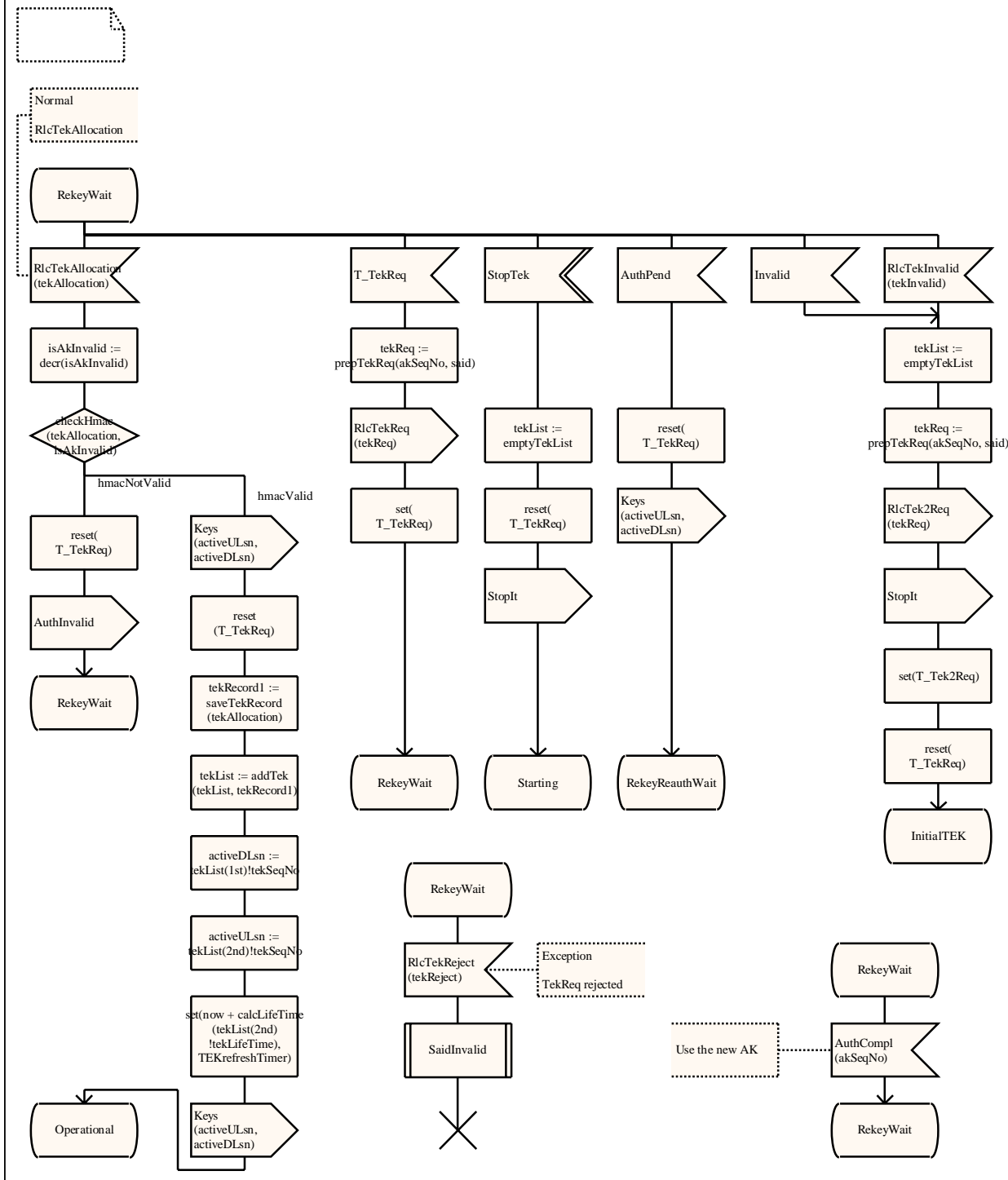

process type TEK

9(9)

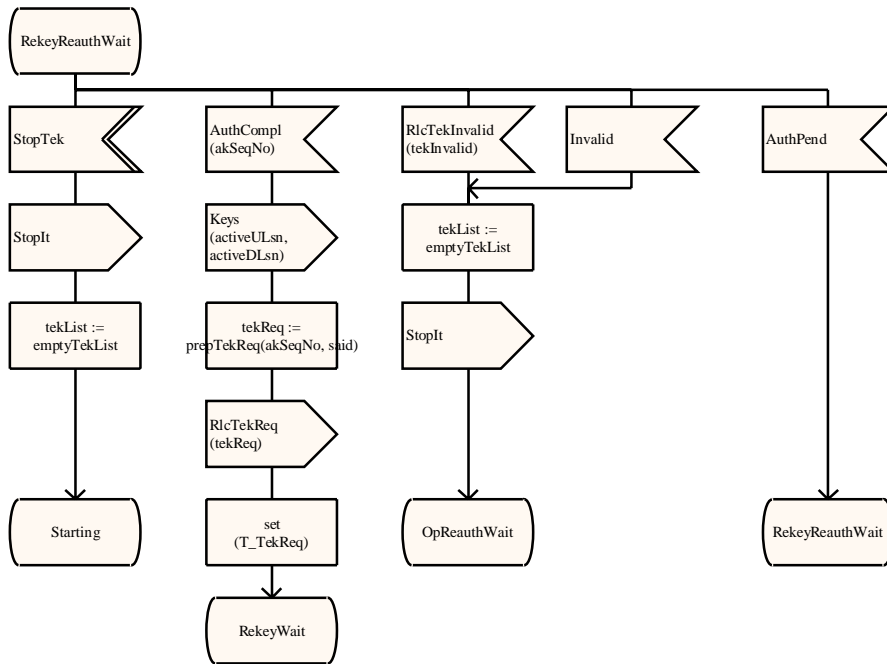

Annex F (informative): ASN.1 interpretation guidelines

ASN.1 module contains a number of user defined types which have the form:

$$X ::= Y$$

where X represents the type that is defined and Y is another user defined type or one of the basic ASN.1 types. Basic ASN.1 types used in this module are INTEGER and OCTET STRING.

ASN.1 has also a way to define values and give those values a name. A statement

$$x \ X ::= 1$$

defines x to be of type X and having a value 1. Note that ASN.1 is case sensitive, where basic types and keyword have to be spelled exactly as defined by ASN.1 rules and all user defined types have to start with a capital letter. Words starting with lower case letters can only be used for naming components of types and values.

HApProtocolPrimitives DEFINITIONS	ASN.1 module name
AUTOMATIC TAGS	When values are transmitted tags (values) need to be inserted by the encoder so that the receiving side know what is being transmitted. This statement says that values needed for this will be generated automatically.
BEGIN	ASN.1 keyword indication the beginning of the module
EXPORTS	The statement listing types defined in this module that are visible outside of this module
INTEGER (64..128)	This specifies the type that is in principle integer but the range of values is restricted to 64 through 128
(0 5..63)	Another way of specifying the range. Zero and values from 5 to 63 are allowed.
ENUMERATED { fdd (0), tdd (1) }	Type definition where one of the two named values can be used. Note that in the HA DLC specification these values are explicitly said to be normative.
INTEGER {phyModeSet1 (1), phyModeSet2 (2)} (0..15)	Here the values can go from 0 to 15 but two of them are named with the intention to have a specific meaning within a system.
OCTET STRING	A string of octets.
(SIZE(128))	SIZE keyword can be used to limit the length of some list. In this example this is a fixed length of 128 elements of the list.
(SIZE(1..128))	This is a variable length list which can have from 1 to 128 number of elements.
SEQUENCE (SIZE(1..50)) OF X	SEQUENCE OF defines a list of elements of type X. The size constraint is explained above.
SEQUENCE { x X, y Y }	The type means that two component exist, where for each of them the name of the component and its type are given.
SEQUENCE { x X, y Y OPTIONAL}	Unlike above where both components are mandatory, here the component y may be omitted.
CHOICE { x X, y Y }	Choice is a type that can hold one of the components listed at the particular point in time.
--	In most cases the beginning of the comment in ASN.1. The comment goes until the end of the line or until another pair of hyphens on the same line.
MacManagementMessage ::= CHOICE { -- all messages }	In this module, this is the root of all type definitions. It represents the type of the message that can be transmitted, this being one of those listed choices.
END	The keyword that ends the module definition.

Annex G (informative): List of all PHY parameters

Table G.1 gives specifications from TS 101 999 [1], reported here for easy reference. In any case of existing or perceived difference in contents between the present document and TS 101 999 [1], the correct specification is that given in TS 101 999 [1].

Table G.1: Complete list of PHY parameters

Parameter	Value or range
Channel spacing (UL and DL)	28 MHz
Max number of ATs per carrier/sector	254/256
BER	10E-11
Rain fading for HA	20 dB/s
MAC PDU length	- Downlink: 54 bytes - Uplink: 55 or 12 bytes
Number of PDU per FEC block	1 or up to 4
Control zone length	Variable (n x 30 bytes)
Scrambler	Length $2^{15}-1$ with "100101010000000" initial. state
Inner mandatory FEC coding	Punctured Convolutional with rate 1/2, 2/3, 5/6, 7/8 and 1
Tail bits for the inner mandatory FEC coding	6 bits (per FEC block)
Outer mandatory FEC scheme	Reed Solomon (k + 16, k, t = 8)
Optional product turbo code (PTC)	Only UL (encoder in AT and decoder in AP) with 24 bit CRC
Means for ARQ	Only for the UL via RS or CRC in case of PTC
Number of PHY mode sets	2 (one optional)
Number of PHY modes per set	4
Modulation	4-16 QAM (optional) for UL and 4-16 and 64QAM (optional) for the DL with constant rms.
Mapping	Gray
Types of UL bursts	Three types of bursts: Long burst (data or long signalling), short burst (short signalling) and ranging burst
Preamble length	- TDM DL preamble: 32 symbols - TDMA DL preamble: 16 symbols - UL TDMA: 16 or 32 symbols - UL ranging burst: 32 symbols
Roll-off factor	0,25
Symbol clock rate	22,4 MHz with ± 8 ppm APT clock accuracy
Frame length	1 ms
Frame offset	0,40 to 1 ms
Load levelling time/carrier recovery time after short link interruption	< 100 ms
UL ramping up /down time	8 symbols
TDD switching time	48 symbols
H-FDD switching time	480 symbols
Extended guard time	up to 80 μ s
Timing advance correction during initialization	0 to 80 μ s with 1/4 symbol granularity
Timing advance correction, fine tuning	[-2, 2] symbol with 1/4 symbol granularity
Report period time	[50, 200] ms with 50 ms granularity
PHY processing delay	200 symbols (without pipelining)
AT transmit power margin	0- 12 dB on the top, with 0,25 dB granularity
AT C/(N+I) measurement	4 - 40 dB with 0,25 dB granularity
AT receiver dynamic range	60 dB minimum
Measured received power in AT	[-88, -28] dBm (for minimal dynamic) with 0,25 dB granularity
APT receiver dynamic range	30 dB minimum
Measured received power in AP	[-86, -56] dBm (for minimal dynamic)
UL power control	40 dB dynamic minimum
AT transmit power measurement	[-26, 14] dBm (for minimal dynamic) with 1 dB granularity

Parameter	Value or range		
Uplink power steps (increments)	[-4, +4] dB with 0,25 dB granularity, during initialization up to [-8,+8] dB		
DL dynamic power control (optional)	<ul style="list-style-type: none"> - 4 dB dynamic for APT-class-1 - 7 dB dynamic for APT-class-2 - 10 dB dynamic for APT-class-3 		
DL power steps (increments)	[-1, 1] dB		
DL static power setting (optional)	10 dB dynamic		
Carrier frequencies	> 11 GHz with ± 8 ppm accuracy for APT and ± 1 ppm relative accuracy for AT		
Frequency resolution	1 MHz, except 0,25 MHz for 28 GHz		
Antenna base station	TM4 specifications (e.g. 45, 60 and 90°)		
Antenna terminal	TM4 specifications		
Output power at maximum setting	15 dBm for APT and 14 dBm for AT		
Max. EIRP AP (Class-1)	33 dBm + 3 dB accuracy		
Max. EIRP AT (42 GHz)	51 dBm + 3 dB accuracy		
Modulation Accuracy: EVM	<ul style="list-style-type: none"> - 12 % and 6 % for 4-QAM, 16-QAM (without equalization) - 10 %, 3 % and 1,5 % for 4-QAM, 16-QAM and 64-QAM (without equalization) 		
NFD-Figures	35,5 dB for the DL 29 dB for the UL		
UL carrier on/off (time mask)	FDD	H-FDD	TDD
PHY mode: PHY1	38 dB	30 dB	30 dB
PHY mode: PHY2	42 dB	34 dB	34 dB
PHY mode: PHY3	48 dB	40 dB	40 dB
Performance monitoring	According to ITU-T Recommendations G.826 [4], G.821 [3], G.827 [5] and M.2100 [6]		

Annex H (informative): Bibliography

Bruce Schneier, "*Applied Cryptography: Protocols, Algorithms, and Source Code in C*", 2nd edition, John Wiley and Sons, 1996.

IEEE 802 (1990): "IEEE Standards for Local and Metropolitan Area Networks: Overview and Architecture".

ETSI TR 101 177: "Broadband Radio Access Networks (BRAN); Requirements and architectures for broadband fixed radio access networks (HIPERACCESS)".

ETSI TR 101 856: "Broadband Radio Access Networks (BRAN); Functional Requirements for Fixed Wireless Access systems below 11 GHz: HIPERMAN".

ETSI TR 101 031: "Broadband Radio Access Networks (BRAN); High Performance Radio Local Area Network (HIPERLAN) Type 2; Requirements and architectures for wireless broadband access".

ETSI TS 101 475: "Broadband Radio Access Networks (BRAN); HIPERLAN Type 2; Physical (PHY) layer".

ETSI TS 101 761-1: "Broadband Radio Access Networks (BRAN); HIPERLAN Type 2; Data Link Control (DLC) Layer; Part 1: Basic Data Transport Functions".

ETSI TS 101 761-2: "Broadband Radio Access Networks (BRAN); HIPERLAN Type 2; Data Link Control (DLC) Layer; Part 2: Radio Link Control (RLC) sublayer".

List of Figures

Figure 1: Example of cellular configuration (4 x 90° sectors)	20
Figure 2: Configuration model for HA systems	23
Figure 3: Reference model and interfaces for HA systems	24
Figure 4: Protocol layer structure (for AP).....	25
Figure 5: SDU and PDU in the protocol stack	33
Figure 6: Structure of MAC data PDU and long MAC signalling PDU	34
Figure 7: Structure of short MAC signalling PDU (UL only).....	35
Figure 8: Block-diagram of the DLC-PHY interface	35
Figure 9: Block diagram of transmitter and receiver chain	38
Figure 10: Transmission of MAC PDUs in DL without TDMA option.....	39
Figure 11: Transmission of MAC PDUs in DL with TDMA option.....	40
Figure 12: Transmission of MAC PDUs in UL.....	42
Figure 13: Structure of RS codewords and preambles in an UL burst	43
Figure 14: MAC management message formats.....	50
Figure 15: Overview of packing, encoding, SAR and mapping on MAC signalling PDUs.....	51
Figure 16: Definition of Segmentation Control Field (SCF, 1 byte, left bit transmitted first)	52
Figure 17: Maps and basic DL frame structure with TDMA option	62
Figure 18: Basic UL frame structure	64
Figure 19: FDD frequency assignment.....	65
Figure 20: H-FDD operation	66
Figure 21: TDD frame sequence.....	66
Figure 22: TDD frame structure	67
Figure 23: DL map entry format (left bit transmitted first)	68
Figure 24: UL map entry format (left bit transmitted first)	69
Figure 25: Relation between DL and UL frames for ARQ.....	71
Figure 26: ARQ map entry format (left bit transmitted first).....	71
Figure 27: ARQ re-transmission example	72
Figure 28: General structure of the control zone (not all details shown).....	73
Figure 29: Control zone details.....	75
Figure 30: Bit structure of control zone (left bit transmitted first)	76
Figure 31: FEC protection of the control zone	77
Figure 32: Starting times for UL bursts.....	78
Figure 33: Minimum time relevance for UL map (FDD mode)	79
Figure 34: Maximum time relevance for UL map (FDD mode)	80
Figure 35: Minimum time relevance for UL map (TDD mode).....	80

Figure 36: Maximum time relevance for UL map (TDD mode)	81
Figure 37: Parameters for PHY mode set description	82
Figure 38: Grant per terminal	86
Figure 39: Usage of piggyback and poll-me bit by an AT	92
Figure 40: Contention algorithm for bandwidth request	94
Figure 41: Synchronization acquisition	97
Figure 42: APC identification.....	98
Figure 43: UL and DL parameters acquisition	99
Figure 44: Frequency scanning in the context of initialization steps	100
Figure 45: Exemplary illustration of the dynamic behaviour of adaptive DL PHY mode change.....	129
Figure 46: Exemplary illustration of the dynamic behaviour of DL ATPC	132
Figure 47: Change of PHY mode set.....	133
Figure 48: Illustration of the authentication and privacy initialization.....	136
Figure 49: HMSC for security overview	137
Figure 50: TEK lifetime and switch over (AT viewpoint)	147
Figure 51: Authorization finite state machine flow diagram (AT side).....	149
Figure 52: TEK Finite State Machine Flow Diagram.....	155
Figure 53: CBC IV generation.....	161
Figure 54: Use of primitives	163

List of Tables

Table 1: Clid format	26
Table 2: DLC Service Category Limitation (transmitter side)	28
Table 3: Interface between DLC and PHY in AP (transmitter side)	36
Table 4: Interface between DLC and PHY in AP (receiver side).....	36
Table 5: Interface between DLC and PHY in AT (transmitter side).....	36
Table 6: Interface between DLC and PHY in AT (receiver side)	37
Table 7: Specific TID values (10 bits).....	45
Table 8: Specific CID values (16 bits)	45
Table 9: Specific connection aggregate ID values (16 bits)	46
Table 10: Multiple-TID message.....	47
Table 11: Definition of Segmentation Indication (SI, 1 byte)	52
Table 12: List of MAC management messages (protocol primitives).....	53
Table 13: List of DL basic MAC management messages for packing	55
Table 14: List of UL basic MAC management messages for packing	55
Table 15: List of DL basic MAC management messages for multiple-TID message	55
Table 16: Overview of connections and related parameters.....	56
Table 17: List of connection control service primitives	57
Table 18: MAC PDU header for DL (3 bytes, left bit transmitted first)	58
Table 19: MAC PDU header for UL (4 bytes, left bit transmitted first)	59
Table 20: PT field for MAC PDU headers	60
Table 21: DIUC coding	68
Table 22: UIUC coding	69
Table 23: GBI message (update, fixVar).....	83
Table 24: PHY mode sets	85
Table 25: Message for bandwidth request	88
Table 26: Messages for queue status report.....	89
Table 27: Messages for ranging.....	102
Table 28: Messages for physical capabilities negotiation	109
Table 29: Messages for other capabilities negotiation (update)	112
Table 30: Message for initialization commands	117
Table 31: Message for measurement report.....	121
Table 32: Message for measurement report criteria	124
Table 33: Messages for DL PHY mode change request.....	125
Table 34: Message for UL transmit power and transmit timing correction.....	130
Table 35: Messages for load levelling.....	134

Table 36: PKM key management messages	138
Table 37: Authorization FSM state transition matrix	150
Table 38: TEK FSM State Transition Matrix	156
Table 39: ASN.1 Connection management messages description	181
Table A.1: List of optional/mandatory features	184
Table A.2: Detailed specification of PHY parameters carried by protocol primitives	185
Table A.3: Detailed specification of AP timers	186
Table A.4: Detailed specification of AT timers	186
Table B.1: Complete ASN.1 description of protocol primitives	187
Table G.1: Complete list of PHY parameters	276

List of Diagrams

Diagram 1: MSC for the use of RSB	88
Diagram 2: MSC for bandwidth request message	89
Diagram 3: MSC for queue status report	90
Diagram 4: HMSC for AT activities and states for initialization (update).....	96
Diagram 5: MSC for the ranging principle	105
Diagram 6: MSC of a ranging example with many errors.....	106
Diagram 7: State diagram for ranging (AP side)	107
Diagram 8: State diagram for ranging (AT side).....	108
Diagram 9: MSC for PHY capabilities negotiation	111
Diagram 10: MSC for other capabilities negotiation.....	113
Diagram 11: SDL diagram for link loss reaction (AT side) (update)	115
Diagram 12: SDL diagram for link loss supervision and reaction (AP side, example).....	116
Diagram 13: MSC for initialization command	118
Diagram 14: HMSC for DL PHY mode change and measurement report	120
Diagram 15: MSC for transmission of the measurement report.....	123
Diagram 16: MSC for AT initiated DL PHY mode change (to a more robust mode).....	126
Diagram 17: MSC for AT initiated DL PHY mode change (to a more efficient mode)	127
Diagram 18: MSC for AP initiated DL PHY mode change (to a more robust mode).....	128
Diagram 19: MSC for AP initiated DL PHY mode change (to a more efficient mode).....	129
Diagram 20: MSC for Correction of AT's transmit parameters.....	131
Diagram 21: MSC for load levelling	135
Diagram 22: MSC for successful initial authentication.....	139
Diagram 23: MSC for retransmission in case of RlcAuthReply loss	140
Diagram 24: MSC for re-authorization of AT before AK lifetime expiration	141
Diagram 25: MSC for first TEK requests.....	143
Diagram 26: MSC for retransmission in case of RlcTekAllocation loss during first initialization.....	144
Diagram 27: MSC for key renewal before life time expiration.....	145
Diagram 28: MSC for retransmission in case of RlcTekAllocation loss during key renewal	146
Diagram 29: MSC for TEK re-requesting due to loss of key request or key reply message.....	148
Diagram 30: MSC (4 entities) for AT initiated connection set up.....	168
Diagram 31: MSC (4 entities) for AP initiated connection set up.....	168

Diagram 32: MSC (4 entities) for AT initiated connection change.....	169
Diagram 33: MSC (4 entities) for AP initiated connection change.....	169
Diagram 34: MSC (4 entities) for AP/AT initiated connection release.....	170
Diagram 35: HMSC for connection control messaging.....	172
Diagram 36: MSC for AT initiated Connection Establishment.....	176
Diagram 37: MSC for AP initiated Connection Establishment.....	177
Diagram 38: MSC for AT initiated connection change.....	178
Diagram 39: MSC for AP initiated connection change.....	178
Diagram 40: MSC for AT initiated connection release.....	179
Diagram 41: MSC for AP initiated connection release.....	180

History

Document history		
V1.1.1	June 2002	Publication
V1.2.1	September 2002	Publication
V1.3.1	December 2002	Publication