

## **Broadband Radio Access Networks (BRAN); HiperMAN Physical (PHY) layer**

---



---

**Reference**

RTS/BRAN-0040001r1

---

**Keywords**access, broadband, FWA, HiperMAN, layer 1,  
MAN, radio**ETSI**

---

650 Route des Lucioles  
F-06921 Sophia Antipolis Cedex - FRANCE

Tel.: +33 4 92 94 42 00 Fax: +33 4 93 65 47 16

Siret N° 348 623 562 00017 - NAF 742 C  
Association à but non lucratif enregistrée à la  
Sous-Préfecture de Grasse (06) N° 7803/88

---

**Important notice**

Individual copies of the present document can be downloaded from:

<http://www.etsi.org>

The present document may be made available in more than one electronic version or in print. In any case of existing or perceived difference in contents between such versions, the reference version is the Portable Document Format (PDF). In case of dispute, the reference shall be the printing on ETSI printers of the PDF version kept on a specific network drive within ETSI Secretariat.

Users of the present document should be aware that the document may be subject to revision or change of status. Information on the current status of this and other ETSI documents is available at

<http://portal.etsi.org/tb/status/status.asp>

If you find errors in the present document, please send your comment to one of the following services:

[http://portal.etsi.org/chaicor/ETSI\\_support.asp](http://portal.etsi.org/chaicor/ETSI_support.asp)

---

**Copyright Notification**

No part may be reproduced except as authorized by written permission.  
The copyright and the foregoing restriction extend to reproduction in all media.

© European Telecommunications Standards Institute 2005.  
All rights reserved.

**DECT**<sup>TM</sup>, **PLUGTESTS**<sup>TM</sup> and **UMTS**<sup>TM</sup> are Trade Marks of ETSI registered for the benefit of its Members.  
**TIPHON**<sup>TM</sup> and the **TIPHON logo** are Trade Marks currently being registered by ETSI for the benefit of its Members.  
**3GPP**<sup>TM</sup> is a Trade Mark of ETSI registered for the benefit of its Members and of the 3GPP Organizational Partners.

# Contents

Intellectual Property Rights .....	5
Foreword.....	5
1 Scope .....	6
2 References .....	6
3 Definitions, symbols and abbreviations .....	6
3.1 Definitions .....	6
3.2 Symbols.....	7
3.3 Abbreviations .....	7
4 OFDM symbol and transmitted signal .....	8
4.1 OFDM symbol description .....	8
4.2 Transmitted signal .....	10
5 Channel coding.....	12
5.1 Randomization .....	12
5.2 Forward Error Correction (FEC) .....	13
5.2.1 Concatenated Reed-Solomon / convolutional code (RS-CC) .....	13
5.2.2 Convolutional Turbo Coding (Optional).....	15
5.2.2.1 CTC Interleaver.....	16
5.2.2.2 Determination of CTC circulation states.....	16
5.2.2.3 CTC puncturing.....	17
5.3 Interleaving.....	17
5.4 Modulation .....	18
5.4.1 Data Modulation .....	18
5.4.2 Pilot modulation.....	19
5.4.3 Rate ID encodings.....	19
5.5 Example UL RS-CC Encoding.....	19
5.5.1 Full Bandwidth (16 subchannels) .....	20
5.5.2 Subchannelization (2 subchannels).....	20
5.5.3 Subchannelization (1 subchannel) .....	21
5.6 Preamble structure and modulation .....	22
5.6.1 Transmission Convergence (TC) sublayer.....	24
6 Frame structures .....	24
6.1 PMP.....	24
6.1.1 Duplexing modes .....	24
6.1.2 DL Frame Prefix .....	28
6.1.3 PMP-AAS zone .....	28
6.2 Mesh.....	29
6.3 Frame duration codes .....	30
7 Control Mechanisms.....	30
7.1 Synchronization.....	30
7.1.1 Network synchronization .....	30
7.2 Ranging .....	31
7.2.1 Initial Ranging in AAS systems.....	31
7.3 Bandwidth requesting.....	32
7.3.1 Parameter selection .....	32
7.3.2 Full Contention Transmission.....	33
7.3.3 Focused Contention Transmission.....	34
7.4 Power control .....	34
8 Space-Time Coding (optional) .....	35
9 Channel quality measurements.....	36
9.1 Introduction .....	36
9.2 RSSI mean and standard deviation.....	36

9.3	CINR mean and standard deviation.....	37
10	Transmitter requirements .....	38
10.1	Transmitter channel bandwidth .....	38
10.2	Transmit power level control.....	38
10.2.1	Transmitter spectral flatness .....	38
10.2.2	Transmitter constellation error and test method.....	39
11	Receiver requirements .....	40
11.1	Receiver sensitivity .....	40
11.2	Receiver adjacent and alternate channel rejection.....	41
11.3	Receiver maximum input signal .....	41
11.4	Receiver linearity .....	41
11.5	Out-of-Band signal rejection .....	41
11.6	Spurious emissions .....	42
12	Frequency and timing requirements .....	42
13	Parameters and constants.....	42
	<b>Annex A (informative): Bibliography.....</b>	<b>43</b>
	History .....	44

---

## Intellectual Property Rights

IPRs essential or potentially essential to the present document may have been declared to ETSI. The information pertaining to these essential IPRs, if any, is publicly available for **ETSI members and non-members**, and can be found in ETSI SR 000 314: "*Intellectual Property Rights (IPRs); Essential, or potentially Essential, IPRs notified to ETSI in respect of ETSI standards*", which is available from the ETSI Secretariat. Latest updates are available on the ETSI Web server (<http://webapp.etsi.org/IPR/home.asp>).

Pursuant to the ETSI IPR Policy, no investigation, including IPR searches, has been carried out by ETSI. No guarantee can be given as to the existence of other IPRs not referenced in ETSI SR 000 314 (or the updates on the ETSI Web server) which are, or may be, or may become, essential to the present document.

---

## Foreword

This Technical Specification (TS) has been produced by ETSI Project Broadband Radio Access Networks (BRAN).

The present document describes the physical layer specifications for High PERFORMANCE Radio Metropolitan Area Network (HiperMAN), which operate on frequencies below 11 GHz. Separate ETSI documents provide details on the system overview, Data Link Control layer (DLC), Convergence Layers (CL) and conformance testing requirements for HiperMAN.

With permission of IEEE® (on file as BRAN32\_5d009), portions of the present document are excerpted from IEEE Standard 802.16-2001 and IEEE Standard 802.16a-2003.

---

# 1 Scope

The present document specifies the HiperMAN air interface with the specification layer 1 (physical layer), following the ISO-OSI model. HiperMAN is confined only to the radio subsystems consisting of the *Physical (PHY) layer* and the *DLC layer* - which are both core network independent - and the core network specific *convergence sub-layer*.

For managing radio resources and connection control, the Data Link Control (DLC) protocol is applied, which uses the transmission services of the DLC layer. Convergence layers above the DLC layer handle the inter-working with layers at the top of the radio sub-system.

The scope of the present document is as follows:

- It gives a description of the physical layer for HiperMAN systems.
- It specifies the transmission scheme in order to allow interoperability between equipment developed by different manufacturers. This is achieved by describing scrambling, channel coding, modulation, framing, control mechanisms, and power control to assist in radio resource management.
- It does cover the receiver and transmitter performance requirements which are specific for HiperMAN systems.
- Some information clauses and annexes describe parameters and system models to assist in preparing conformance, interoperability, and coexistence specifications.

---

# 2 References

The following documents contain provisions which, through reference in this text, constitute provisions of the present document.

- References are either specific (identified by date of publication and/or edition number or version number) or non-specific.
- For a specific reference, subsequent revisions do not apply.
- For a non-specific reference, the latest version applies.

Referenced documents which are not found to be publicly available in the expected location might be found at <http://docbox.etsi.org/Reference>.

- [1] ETSI TS 102 178: "Broadband Radio Access Networks (BRAN); HIPERMAN; Data Link Control (DLC) Layer".
- [2] IEEE 802.16-2004: "IEEE Standard for Local and Metropolitan Area Networks – Part 16: Air Interface for Fixed Broadband Wireless Access Systems".

---

# 3 Definitions, symbols and abbreviations

## 3.1 Definitions

For the purposes of the present document, the following terms and definitions apply:

**Base Station (BS):** generalized equipment consisting of one or more Base Station Controllers and one or more Base Station transceivers

**channel coding:** sequence composed of three steps; randomizer, forward error correction, and interleaving

**DL-MAP:** structured data sequence that defined the mapping of the DL

**DownLink (DL):** direction from BS to SS

**frequency offset index:** index number identifying a particular carrier in an OFDM signal

NOTE: Frequency offset indices may be positive or negative and are counted relative to the DC carrier.

**full duplex:** equipment that is capable of transmitting and receiving at the same time

**guard time:** time at the beginning or end of each burst to allow power ramping up and down

**half duplex:** equipment that cannot transmit and receive at the same time

**preamble:** sequence of symbols with a given auto-correlation property assisting modem synchronization and channel estimation

**Receive-Transmit Transition Gap (RTG):** time to switch from receive to transmit at the BS

**Subscriber Station (SS):** generalized equipment consisting of a Subscriber Station Controller and Subscriber Station Transceiver

**Transmit-Receive Transition Gap (TTG):** time to switch from transmit to receive at the BS

**UL MAP:** MAC message scheduling UL bursts

**UpLink (UL):** direction from SS to BS

## 3.2 Symbols

For the purposes of the present document, the following symbols apply:

$BW$	Nominal channel bandwidth (MHz)
$F_{sa}$	Sampling frequency (MHz)
$N_{cbps}$	Number of coded bits per OFDM symbol (on allocated subchannels)
$N_{FFT}$	Nominal size of the FFT operator
$N_{used}$	Number of carriers used to transport either data or pilots within a single OFDM symbol
$R_{os}$	BW over sampling ratio
$T_b$	Useful OFDM symbol time (s)
$T_F$	Frame duration (ms)
$T_g$	OFDM symbol guard time or CP time (s)
$T_s$	OFDM symbol time (s)
$\alpha_{avg}$	Channel measurement averaging constant
$\Delta f$	Carrier spacing (Hz)

## 3.3 Abbreviations

For the purposes of the present document, the following abbreviations apply:

AAS	Adaptive Antenna System
AWGN	Average White Gaussian Noise
BER	Bit Error Rate
BS	Base Station
BW	BandWidth
CC	Convolutional Coding
CID	Connection IDentifier
CINR	Carrier to Interference Noise Ratio
CL	Convergence Layer
CP	Cyclic Prefix
CTC	Convolutional Turbo Code

DC	Direct Current
DCD	Downlink Channel Descriptor
DIUC	Downlink Interval Usage Code
DL	DownLink
DLC	Data Link Control
FCH	Frame Control Header
FDD	Frequency Division Duplexing
FEC	Forward Error Correction
FFT	Fast Fourier Transform
HCS	Header Check Sequence
H-FDD	Half duplex Frequency Division Duplexing
IE	Information Element
lsb	least significant bit
MAC	Media Access Control
MAN	Metropolitan Area Network
msb	most significant bit
OFDM	Orthogonal Frequency Division Multiplexing
PDU	Protocol Data Unit
PHY	PHYSical
PMP	Point to Multi Point
PRBS	Pseudo Random Binary Sequence
PS	Physical Slot
QAM	Quadrature Amplitude Modulation
QPSK	Quadrature Phase Shift Keying
REQ	REQuest
RF	Radio Frequency
RMS	Root Mean Square
RS	Reed-Solomon
RS-CC	Reed-Solomon / Convolutional Code
RSSI	Received Signal Strength Indicator
RTG	Receive / Transmit Transition Gap
Rx	Receive
SNR	Signal to Noise Ratio
SS	Subscriber Station
SSRTG	Subscriber Station Receive Transmit Gap
STC	Space Time Coding
TC	Transmission Convergence
TDD	Time Division Duplexing
TLV	Type Length Value
TTG	Transmit / Receive Transition Gap
Tx	Transmit
UCD	Uplink Channel Descriptor
UIUC	Uplink Interval Usage Code
UL	UpLink
XOR	eXclusive OR

---

## 4 OFDM symbol and transmitted signal

### 4.1 OFDM symbol description

An OFDM waveform is created by applying an Inverse-Fourier-transform to the source data. The resultant time duration is referred to as the useful symbol time  $T_b$ . A copy of the last  $T_g$   $\mu$ s of the useful symbol period, termed Cyclic Prefix (CP), is prepended to enable the collection of multipath at the receiver, without loss of orthogonality between the tones. The resulting waveform is termed the symbol time  $T_s$ . Figure 1 illustrates this structure.



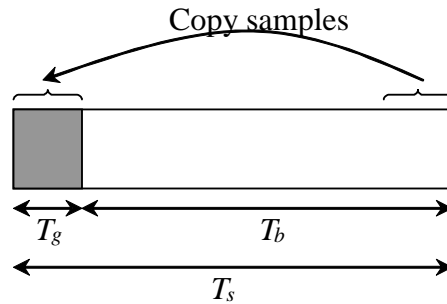

**Figure 1: OFDM symbol time structure**

The transmitter energy increases with the length of the CP while the receiver energy remains the same (the CP is discarded), so there is a  $10\log(1 - T_g / (T_b + T_g)) / \log(10)$  dB loss in SNR. Using the CP, the samples required for performing the FFT at the receiver can be taken anywhere over the length of the extended symbol. This provides multipath immunity as well as a tolerance for symbol time synchronization errors.

On system initialization, the Base Station (BS) CP fraction ( $T_g / T_b$ ) shall be set to a specific value for use on the Downlink (DL). Once the BS is operational the CP value shall not be changed. On initialization, the Subscriber Station (SS) shall search all possible values of CP until it finds the CP being used by the serving BS. The SS shall use the same CP values determined in DL for the UL. Changing the CP value parameter at the BS through (re)initialization forces all SS registered on that BS to re-synchronize.

In the frequency domain, each OFDM symbol is comprised of multiple carriers (see figure 2), which belong to one of three types:

- Data carriers - for data transmission.
- Pilot carriers - for channel estimation and other purposes.
- Null carriers - for guard bands and the DC carrier.

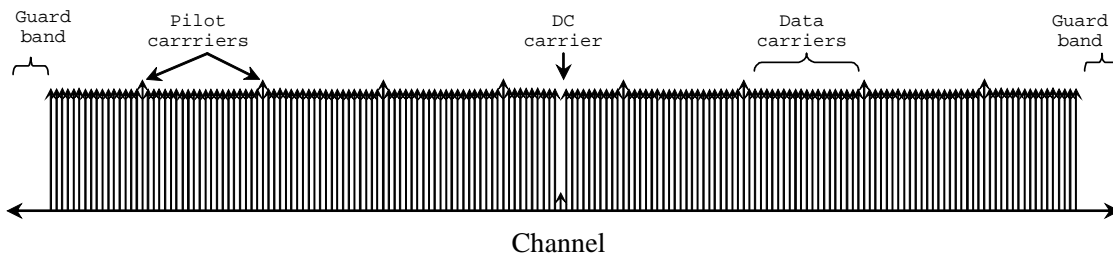

**Figure 2: OFDM symbol frequency structure**

## 4.2 Transmitted signal

Equation 1 specifies the transmitted signal voltage  $s(t)$  to the antenna, as a function of time, during any OFDM symbol.

$$s(t) = \operatorname{Re} \left\{ e^{2j\pi f_c t} \sum_{\substack{k=-N_{\text{used}}/2 \\ k \neq 0}}^{k=N_{\text{used}}/2} c_k \times e^{2j\pi k \Delta f (t-T_g)} \right\} \quad (1)$$

where:  $t$  is the time elapsed since the beginning of the subject OFDM symbol, with  $0 < t < T_s$ .

$C_k$  is a complex number; the data to be transmitted on the carrier whose frequency offset index is  $k$ , during the subject OFDM symbol. It specifies a point in a Quadrature Amplitude Modulation (QAM) constellation. In the case of subchannelization,  $C_k$  is zero for all unallocated subcarriers.

$f_c$  is the RF carrier frequency, being the centre frequency of the intended RF frequency channel.

$k$  is the frequency offset index.

The parameters of the transmitted OFDM signal, which shall be used, are given in table 1.

Table 1: OFDM symbol parameters

Parameter	Value
$N_{\text{FFT}}$	256
$N_{\text{used}}$	200
$T_g / T_b$	1/4, 1/8, 1/16, 1/32
Frequency offset indices of guard carriers	-128, -127..., -101 +101, +102, ..., 127
Frequency offset indices of Pilots	-88, -63, -38, -13, 13, 38, 63, 88
Subchannel Index	Allocated frequency offset indices of carriers
<div style="display: flex; align-items: center;"> <div style="margin-right: 20px;"> <p>b10000</p> <ul style="list-style-type: none"> <li>0b01000               <ul style="list-style-type: none"> <li>0b00100                   <ul style="list-style-type: none"> <li>0b00010                       <ul style="list-style-type: none"> <li>0b00001</li> <li>0b00011</li> </ul> </li> <li>0b00101</li> <li>0b00110                       <ul style="list-style-type: none"> <li>0b00101</li> <li>0b00111</li> </ul> </li> </ul> </li> <li>0b01100                   <ul style="list-style-type: none"> <li>0b01001</li> <li>0b01011</li> <li>0b01101</li> <li>0b01110                       <ul style="list-style-type: none"> <li>0b01101</li> <li>0b01111</li> </ul> </li> </ul> </li> </ul> </li> <li>0b11000               <ul style="list-style-type: none"> <li>0b10100                   <ul style="list-style-type: none"> <li>0b10010                       <ul style="list-style-type: none"> <li>0b10001</li> <li>0b10011</li> </ul> </li> <li>0b10101</li> <li>0b10110                       <ul style="list-style-type: none"> <li>0b10101</li> <li>0b10111</li> </ul> </li> </ul> </li> <li>0b11100                   <ul style="list-style-type: none"> <li>0b11101                       <ul style="list-style-type: none"> <li>0b11101</li> <li>0b11111</li> </ul> </li> </ul> </li> </ul> </li> </ul> </div> <div> <ul style="list-style-type: none"> <li>{-100:-98, -37:-35, 1:3, 64:66}</li> <li>{-38}</li> <li>{-97:-95, -34:-32, 4:6, 67:69}</li> <li>{-94:-92, -31:-29, 7:9, 70:72}</li> <li>{13}</li> <li>{-91:-89, -28:-26, 10:12, 73:75}</li> <li>{-87:-85, -50:-48, 14:16, 51:53}</li> <li>{-88}</li> <li>{-84:-82, -47:-45, 17:19, 54:56}</li> <li>{-81:-79, -44:-42, 20:22, 57:59}</li> <li>{63}</li> <li>{-78:-76, -41:-39, 23:25, 60:62}</li> <li>{-75:-73, -12:-10, 26:28, 89:91}</li> <li>{-13}</li> <li>{-72:-70, -9:-7, 29:31, 92:94}</li> <li>{-69:-67, -6:-4, 32:34, 95:97}</li> <li>{38}</li> <li>{-66:-64, -3:-1, 35:37, 98:100}</li> <li>{-62:-60, -25:-23, 39:41, 76:78}</li> <li>{-63}</li> <li>{-59:-57, -22:-20, 42:44, 79:81}</li> <li>{-56:-54, -19:-17, 45:47, 82:84}</li> <li>{88}</li> <li>{-53:-51, -16:-14, 48:50, 85:87}</li> </ul> </div> </div>	<p>Note that pilot carriers are allocated only if two or more subchannels are allocated.</p>

Using the parameters as specified in table 1, the following relationships shall hold.

$$F_{sa} = \text{floor} (R_{os} \times BW / 8000) \times 8000$$

$$\Delta f = R_{os} \times BW / N_{\text{FFT}}$$

$$T_b = 1 / \Delta f$$

$$T_g = \left( \frac{T_g}{T_b} \right) \times T_b$$

$$T_s = T_b + T_g$$

$$T_{sa} = 1/F_{sa}$$

$$F_{sa} = R_{os} \times BW$$

## 5 Channel coding

Channel coding is composed of three steps: randomization, forward error correction, and interleaving. They shall be applied in this order at transmission. The complementary operations shall be applied in reverse order at reception.

### 5.1 Randomization

Data randomization is performed on each burst of data (i.e. not on pilots and preambles) independently. If the amount of data to transmit does not fit exactly the amount of data allocated, padding of 0xFF ("1"s only) shall be added to the end of the transmission block, up to the amount of data allocated. For RS-CC and CC encoded data, padding will be added to the end of the transmission block, up to the amount of data allocated minus one byte, which shall be reserved for the introduction of a 0x00 tail byte by the FEC. For CTC, if implemented, padding will be added to the end of the transmission block, up to the amount of data allocated.

The Pseudo Random Binary Sequence (PRBS) generator shall be  $1 + x^{14} + x^{15}$  as shown in figure 3. Each data byte to be transmitted shall enter sequentially into the randomizer, most significant bit (msb) first. The seed value shall be used to calculate the randomization bits, which are combined in an XOR operation with the serialized bit stream of each burst. The "data out" bits from the randomizer shall be applied to the FEC.

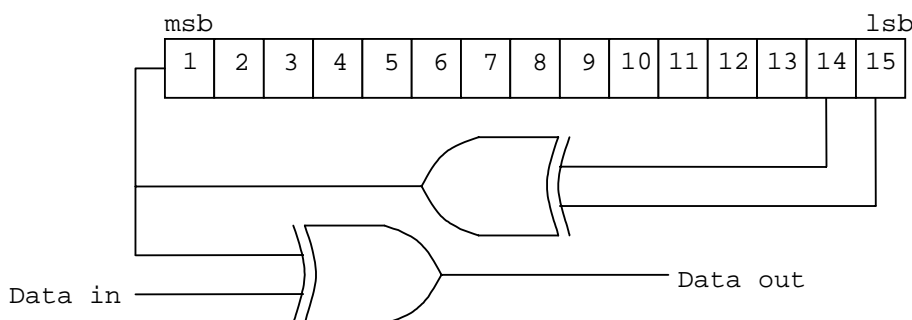

Figure 3: Data randomization PRBS

On the DL, the randomizer shall be initialized at the start of the FCH with the vector: 1 0 0 1 0 1 0 1 0 0 0 0 0 0. The randomizer shall not be reset at the start of burst #1. At the start of subsequent bursts the randomizer shall be initialized with the vector shown in figure 4. The frame number used for initialization refers to the frame in which the downlink burst is transmitted.

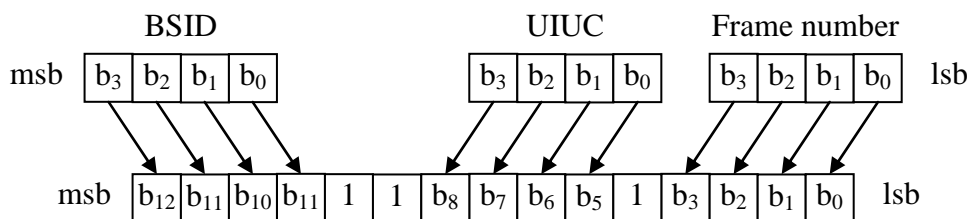

Figure 4: Scrambler DL initialization vector for bursts #2..N

On the UL, the randomizer shall be initialized with the vector shown in figure 5. The frame number used for initialization is that of the frame in which the UL map that specifies the uplink burst was transmitted.

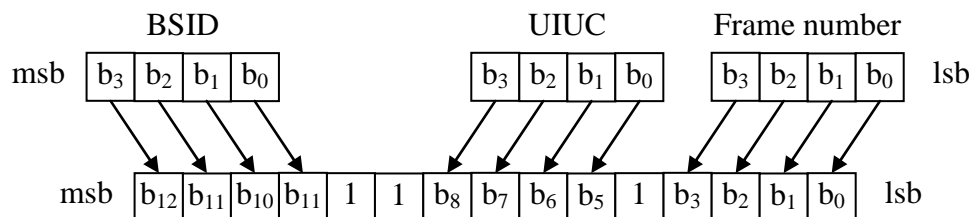

Figure 5: Scrambler UL initialization vector

## 5.2 Forward Error Correction (FEC)

The FEC consisting of the concatenation of a Reed-Solomon outer code and a rate-compatible convolutional inner code shall be supported on both UL and DL. Support of Convolutional Turbo Code (CTC) is optional. The Reed-Solomon-Convolutional coding rate 1/2 shall always be used as the coding mode when requesting access to the network (except in subchannelization modes, which uses only convolutional coding 1/2) and in the Frame Control Header (FCH) burst.

The encoding is performed by first passing the data in block format through the RS encoder and then passing it through a convolutional encoder. Eight tail bits are introduced at the end of each allocation, which are set to zero. This tail Byte shall be appended after randomization. In the RS encoder, the redundant bits are sent before the input bits, keeping the tail bits at the end of the allocation. When the total number of data bits in a burst is not an integer number of Bytes, zero pad bits are added after the zero tail bits. The zero pad bits are not randomized. Note that this situation can occur only in subchannelization. In this case the RS encoding is not employed.

### 5.2.1 Concatenated Reed-Solomon / convolutional code (RS-CC)

The RS encoding shall be derived from a systematic RS ( $N = 255$ ,  $K = 239$ ,  $T = 8$ ) code using  $GF(2^8)$ , where:

$N$  is the number of overall bytes after encoding.

$K$  is the number of data bytes before encoding.

$T$  is the number of data bytes which can be corrected.

For the systematic code, the code generator polynomial  $g(x)$ , shown in equation 2, and field generator polynomial  $p(x)$ , shown in equation 3, shall be used.

$$g(x) = (x + \lambda^0)(x + \lambda^1)(x + \lambda^2) \dots (x + \lambda^{2T-1}), \quad \lambda = 02_{\text{HEX}} \quad (2)$$

$$p(x) = x^8 + x^4 + x^3 + x^2 + 1 \quad (3)$$

This code is shortened and punctured to enable variable block sizes and variable error-correction capability. When a block is shortened to  $K'$  data bytes, add  $239 - K'$  zero bytes as a prefix. After encoding discard these  $239 - K'$  zero bytes. When a codeword is punctured to permit  $T'$  bytes to be corrected, only the first  $2T'$  of the total 16 parity bytes shall be employed. The bit/byte conversion shall be msb first.

Each RS block is encoded by the binary convolutional encoder, which shall have native rate of 1/2, a constraint length equal to 7, and shall use the generator polynomials codes shown in equation 4 to derive its two code bits.

$$\begin{aligned} G_1 &= 171_{\text{OCT}} && \text{for } X \\ G_2 &= 133_{\text{OCT}} && \text{for } Y \end{aligned} \quad (4)$$

The generator is depicted in figure 6.

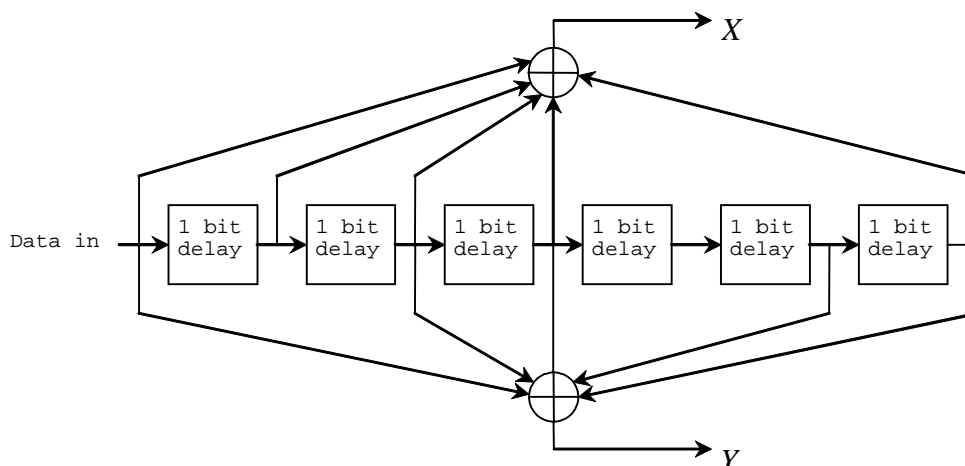

**Figure 6: Convolutional encoder of rate 1/2**

Puncturing patterns and serialization order which shall be used to realize different code rates are defined in table 2. Transmitted bits are denoted by "1" and removed bits are denoted by "0".  $X$  and  $Y$  are in reference to figure 6. Puncturing for code rate 1/2 shall always be used when requesting access to the network.

**Table 2: Convolutional code puncturing configuration**

Code rate	$d_{\text{free}}$	$X$	$Y$	Order
1/2	10	1	1	$X_1 Y_1$
2/3	6	10	11	$X_1 Y_1 Y_2$
3/4	5	101	110	$X_1 Y_1 Y_2 X_3$
5/6	4	10101	11010	$X_1 Y_1 Y_2 X_3 Y_4 X_5$

In order to allow sharing of the error correction decoder, each of the multiple data streams subdivides its data into RS blocks. Each RS block is encoded by zero tail convolutional encoder. Eight tail bits are introduced at the end of each burst. In the RS encoder, the redundant bits are sent before the input bits, keeping the tail bits at the end of the burst.

Table 3 defines the block sizes for the different modulation levels and code rates. As 64 QAM is optional for license exempt bands, the codes for this modulation shall only be implemented if the modulation is implemented.

**Table 3: Channel encodings**

Modulation	Uncoded block size (bytes)	Coded block size (bytes)	Overall coding rate	RS code	CC code rate
BPSK	12	24	1/2	(12,12,0)	1/2
QPSK	24	48	1/2	(32,24,4)	2/3
QPSK	36	48	3/4	(40,36,2)	5/6
16 QAM	48	96	1/2	(64,48,8)	2/3
16 QAM	72	96	3/4	(80,72,4)	5/6
64 QAM	96	144	2/3	(108,96,6)	3/4
64 QAM	108	144	3/4	(120,108,6)	5/6

When subchannelization is applied in the UL, the FEC shall bypass the RS encoder and use the Overall Coding Rate as indicated in table 3 as CC Code Rate. The Uncoded Block Size and Coded Block Size may be computed by multiplying the values listed in table 3 by the number of allocated subchannels divided by 16. In the case of BPSK modulation, RS encoder should be bypassed.

## 5.2.2 Convolutional Turbo Coding (Optional)

The Convolutional Turbo Code encoder, including its constituent encoder, is depicted in figure 7. It uses a double binary Circular Recursive Systematic Convolutional code. The bits of the data to be encoded are alternately fed to A and B, starting with the msb of the first byte being fed to A. The encoder is fed by blocks of  $k$  bits or  $N$  couples ( $k = 2 \times N$  bits). For all the frame sizes  $k$  is a multiple of 8 and  $N$  is a multiple of 4. Further  $N$  shall be limited to:  $8 \leq N/4 \leq 1\,024$ . For subchannelization, the coding block size is limited to blocks at least 48 bits in length, and no more than 1 024 bits in length. In addition,  $k$  cannot be a multiple of 7.

The polynomials defining the connections are described in octal and symbol notations as follows:

- for the feedback branch:  $0 \times B$ , equivalently  $1 + D + D^3$  (in symbolic notation);
- for the Y parity bit:  $0 \times D$ , equivalently  $1 + D^2 + D^3$ .

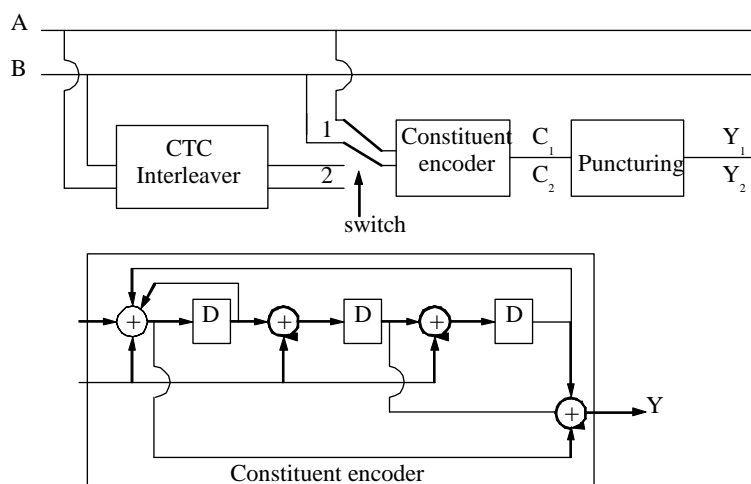

**Figure 7: CTC encoder**

First, the encoder (after initialization by the circulation state  $Sc_1$ , see below) is fed the sequence in the natural order (position 1) with the incremental address  $i = 0 \dots N-1$ . This first encoding is called  $C_1$  encoding. Then the encoder (after initialization by the circulation state  $Sc_2$ , see below) is fed by the interleaved sequence (switch in position 2) with incremental address  $j = 0, \dots N-1$ . This second encoding is called  $C_2$  encoding.

The order in which the encoded bit shall be fed into the interleaver (see clause 5.3) is:

$$A_0, B_0 \dots A_{N-1}, B_{N-1}, Y_{1,0}, Y_{1,1} \dots Y_{1,M}, Y_{2,0}, Y_{2,1} \dots Y_{2,M},$$

where  $M$  is the number of parity bits.

Table 4 gives the block sizes, code rates, channel efficiency, and code parameters for the different modulation and coding schemes. As 64 QAM is optional for license exempt bands, the codes for this modulation shall only be implemented if the modulation is implemented.

**Table 4: Optional CTC Coding per Modulation**

Modulation	Overall Code Rate	N	P <sub>0</sub>
QPSK	1/2	$6 \times N_{sub}$	7
QPSK	2/3	$8 \times N_{sub}$	11
QPSK	3/4	$9 \times N_{sub}$	17
16QAM	1/2	$12 \times N_{sub}$	11
16QAM	3/4	$18 \times N_{sub}$	13
64QAM	2/3	$24 \times N_{sub}$	17
64QAM	3/4	$27 \times N_{sub}$	17

In table 4,  $N_{sub}$  denotes the number of subchannels of the allocation in which the encoded data will be transmitted. The data block size (in Bytes per OFDM symbol) may be calculated as  $N/4$ . Further,  $P_1$  equals  $3N/4$ .

### 5.2.2.1 CTC Interleaver

The interleaver requires the parameters  $P_0$ , shown in table 4, and  $P_1$ .

The two-step interleaver shall be performed by:

#### Step 1: Switch alternate couples

*for*  $j = 1$  to  $N$

*if* ( $j_{\text{mod}2} = 0$ ) *let*  $(B, A) = (A, B)$  (*i.e. switch the couple*)

#### Step 2: $P_i(j)$

The function  $P_i(j)$  provides the interleaved address  $i$  of the consider couple  $j$ .

*for*  $j = 1 \dots N$

switch  $j_{\text{mod}4}$ :

- case 0 or 1:  $i = (P_0 \times j + 1)_{\text{mod}N}$
- case 2:  $i = (P_0 \times j + 1 + P_1)_{\text{mod}N}$
- case 3:  $i = (P_0 \times j + 1 + N/2 + P_1)_{\text{mod}N}$

### 5.2.2.2 Determination of CTC circulation states

The state of the encoder is denoted  $S$  ( $0 \leq S \leq 7$ ) with  $S$  the value read binary (left to right) out of the constituent encoder memory (see figure 7). The circulation states  $Sc_1$  and  $Sc_2$  are determined by the following operations:

- 1) Initialize the encoder with state 0. Encode the sequence in the natural order for the determination of  $Sc_1$  or in the interleaved order for determination of  $Sc_2$ . In both cases the final state of the encoder is  $S0_{N-1}$ ;
- 2) according to the length  $N$  of the sequence, use table 5 to find  $Sc_1$  or  $Sc_2$ .



**Table 5: Circulation state lookup table (Sc)**

$N_{\text{mod}}$	S0N-1							
	0	1	2	3	4	5	6	7
1	0	6	4	2	7	1	3	5
2	0	3	7	4	5	6	2	1
3	0	5	3	6	2	7	1	4
4	0	4	1	5	6	2	7	3
5	0	2	5	7	1	3	4	6
6	0	7	6	1	3	4	5	2

### 5.2.2.3 CTC puncturing

The three code-rates are achieved through selectively deleting the parity bits (puncturing). The puncturing patterns are identical for both codes  $C_1$  and  $C_2$ .

**Table 6: Circulation state lookup table (Sc)**

Rate $R_n/(R_n+1)$	Y					
	0	1	2	3	4	5
1/2	1	1				
2/3	1	0	1	0		
3/4	1	0	0	1	0	0

## 5.3 Interleaving

A block interleaver shall interleave all encoded data bits with a block size corresponding to the number of coded bits per the allocated subchannels per OFDM symbol,  $N_{\text{cbps}}$ . The interleaver is defined by a two step permutation. The first, shown in equation 5, ensures that adjacent coded bits are mapped onto nonadjacent subcarriers. The second permutation, shown in equation 6, ensures that adjacent coded bits are mapped alternately onto less or more significant bits of the constellation, thus avoiding long runs of less reliable bits.

Let  $N_{\text{cpc}}$  be the number of coded bits per subcarrier, i.e. 2, 4 or 6 for QPSK, 16QAM or 64QAM, respectively. Let  $s = \text{ceil}(N_{\text{cpc}}/2)$ . Within a block of  $N_{\text{cbps}}$  bits at transmission, let  $k$  be the index of a coded bit before the first permutation;  $mk$  be the index of that coded bit after the first and before the second permutation; and let  $jk$  be the index of that coded bit after the second permutation, just prior to modulation mapping.

The first permutation is defined by the formula:

$$m_k = (N_{\text{cbps}}/12)k \bmod (12) + \text{floor}(k/12) \quad k = 0,1, \text{ to, } N_{\text{cbps}} - 1 \quad (5)$$

The second permutation is defined by the formula:

$$j_k = s \times \text{floor}(m_k / s) + (m_k + N_{\text{cbps}} - \text{floor}(12 \times m_k / N_{\text{cbps}})) \bmod (s) \quad k = 0,1, \text{ to, } N_{\text{cbps}} - 1 \quad (6)$$

The de-interleaver, which performs the inverse operation, is also defined by two permutations. Within a received block of  $N_{\text{cbps}}$  bits, let  $j$  be the index of a bit before the first permutation; let  $m_j$  be the index of that bit after the first and before the second permutation; and let  $k_j$  be the index of that bit after the second permutation, just prior to delivering the block to the convolutional decoder.

The first permutation is defined by the rule formula:

$$m_j = s \times \text{floor}(j / s) + (j + \text{floor}(12 \times j / N_{\text{cbps}})) \bmod (s) \quad j = 0,1, \text{ to, } N_{\text{cbps}} - 1 \quad (7)$$

The second permutation is defined by the rule formula:

$$k_j = 12m_j - (N_{\text{cbps}} - 1) \text{floor}(12m_j / N_{\text{cbps}}) \quad j = 0,1, \text{ to, } N_{\text{cbps}} - 1 \quad (8)$$

The first permutation in the de-interleaver is the inverse of the second permutation in the interleaver, and conversely. table 7 shows the bit interleaver sizes as a function of modulation and coding.

**Table 7: Block sizes of bit interleaver**

	$N_{cbps}$				
	Default (16 subchannels)	8 subchannels	4 subchannels	2 subchannels	1 subchannels
BPSK	192	96	48	24	12
QPSK	384	192	96	48	24
16 QAM	768	384	192	96	48
64 QAM	1152	576	288	144	72

## 5.4 Modulation

### 5.4.1 Data Modulation

After bit interleaving, the data bits are entered serially to the constellation mapper. BPSK, Gray-mapped QPSK, 16QAM, and 64QAM as shown in figure 8 shall be supported. Support of 64QAM is optional for unlicensed bands. The constellations as shown in figure 8 shall be normalized by multiplying the constellation point with the indicated factor  $c$  to achieve equal average power. For each modulation,  $b_0$  denotes the lsb. The first bit out of the interleaver shall be mapped to the msb and so forth.

Per-allocation adaptive modulation and coding shall be supported in the DL. The UL shall support different modulation schemes for each SS based on the Media Access Control (MAC) burst configuration messages coming from the BS. The constellation-mapped data shall be subsequently modulated onto all allocated data carriers in order of increasing frequency offset index. The first symbol out of the data constellation mapping shall be modulated onto the allocated carrier with the lowest frequency offset index.

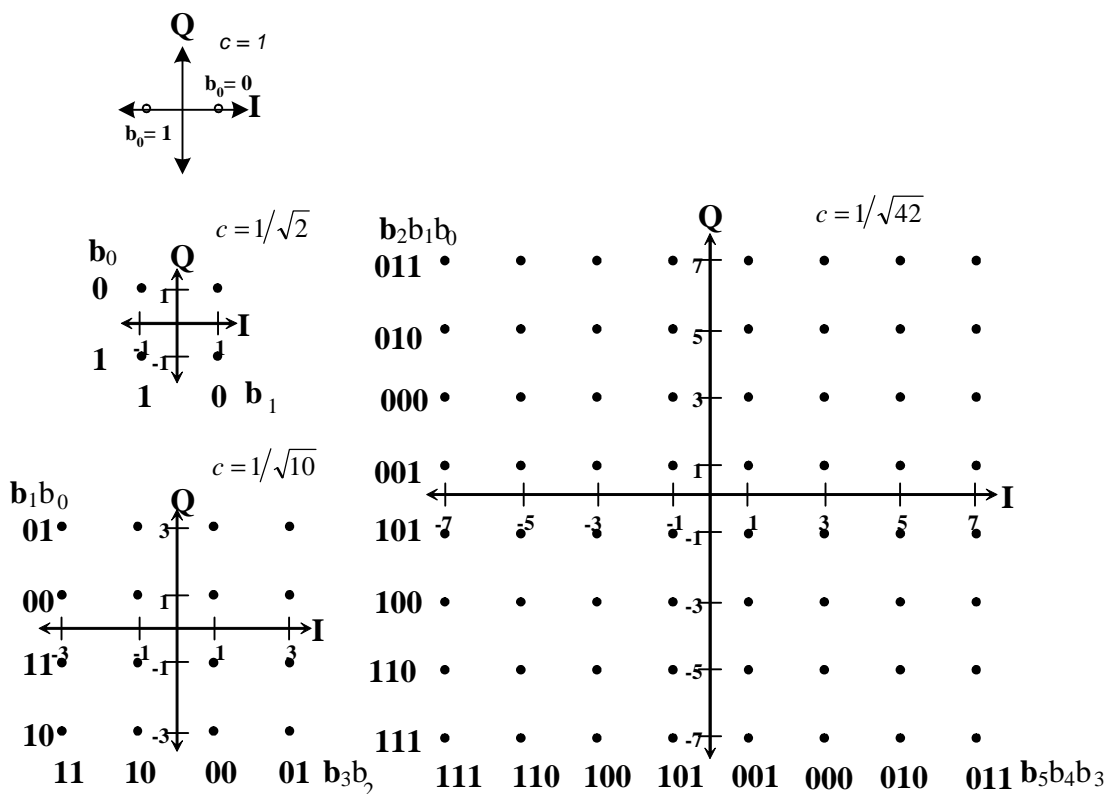
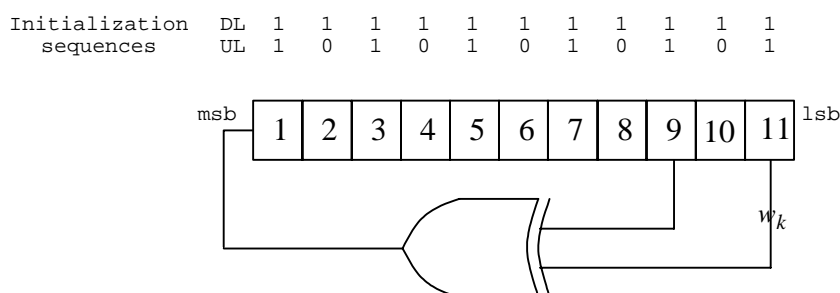

**Figure 8: Modulation constellations**

## 5.4.2 Pilot modulation

Pilot subcarriers shall be inserted into each data burst in order to constitute the Symbol and they shall be modulated according to their carrier location within the OFDM symbol. The PRBS generator in Figure 9 shall be used to produce the sequence.

The value of the pilot modulation for OFDM symbol  $k$  shall be derived from  $w_k$ , generated from PRBS  $x^{11} + x^9 + 1$  as shown in figure 9. On the downlink the index  $k$  represents the symbol index relative to the beginning of the downlink subframe. On the uplink the index  $k$  represents the symbol index relative to the beginning of the burst. The initialization sequences that shall be used on the DL and UL are indicated in figure 9 as well. On the DL, this shall result in the sequence 111111111100000000110... where the 3<sup>rd</sup> 1, i.e.  $w_2 = 1$ , shall be used in the first OFDM DL symbol following the frame preamble.



**Figure 9: Pilot modulation PRBS**

For each pilot (indicated by frequency offset index), the BPSK modulation shall be derived as shown in table 8.

**Table 8: Pilot modulation**

	$c_{88}$	$c_{63}$	$c_{38}$	$c_{13}$	$c_{13}$	$c_{38}$	$c_{63}$	$c_{88}$
DL	$2^{(\frac{1}{2} - w_k)}$	$2^{(\frac{1}{2} - w_k)}$	$2^{(\frac{1}{2} - w_k)}$	$2^{(\frac{1}{2} - w_k)}$	$2^{(\frac{1}{2} - w_k)}$	$2^{(\frac{1}{2} - w_k)}$	$2^{(\frac{1}{2} - w_k)}$	$2^{(\frac{1}{2} - w_k)}$
UL	$2^{(\frac{1}{2} - w_k)}$	$2^{(\frac{1}{2} - w_k)}$	$2^{(\frac{1}{2} - w_k)}$	$2^{(\frac{1}{2} - w_k)}$	$2^{(\frac{1}{2} - w_k)}$	$2^{(\frac{1}{2} - w_k)}$	$2^{(\frac{1}{2} - w_k)}$	$2^{(\frac{1}{2} - w_k)}$

In an allocation of 1 subchannel, pilots shall not be modulated or transmitted.

## 5.4.3 Rate ID encodings

Rate\_ID's, which indicate modulation and coding to be used in the first DL burst immediately following the FCH, are shown in table 9. The Rate\_ID encoding is static and cannot be changed during system operation

**Table 9: Rate\_ID encodings**

Rate_ID	Modulation RS-CC rate
0	BPSK 1/2
1	QPSK 1/2
2	QPSK 3/4
3	16QAM 1/2
4	16QAM 3/4
5	64QAM 2/3
6	64QAM 3/4
7 to 15	Reserved

## 5.5 Example UL RS-CC Encoding

To illustrate the use of the RS-CC encoding, an example of one frame of OFDM UL data is provided, illustrating each process from randomization through carrier modulation.

### 5.5.1 Full Bandwidth (16 subchannels)

Modulation Mode: QPSK, rate 3/4, Symbol Number within burst: 1, UIUC: 7, BSID: 1, Frame Number: 1 (decimal values)

Input Data (Hex)

45 29 C4 79 AD 0F 55 28 AD 87 B5 76 1A 9C 80 50 45 1B 9F D9 2A 88 95 EB AE B5 2E 03 4F 09 14 69 58  
0A 5D

Randomized Data (Hex)

D4 BA A1 12 F2 74 96 30 27 D4 88 9C 96 E3 A9 52 B3 15 AB FD 92 53 07 32 C0 62 48 F0 19 22 E0 91 62  
1A C1

Reed-Solomon encoded Data (Hex)

49 31 40 BF D4 BA A1 12 F2 74 96 30 27 D4 88 9C 96 E3 A9 52 B3 15 AB FD 92 53 07 32 C0 62 48 F0 19  
22 E0 91 62 1A C1 00

Convolutionally Encoded Data (Hex)

3A 5E E7 AE 49 9E 6F 1C 6F C1 28 BC BD AB 57 CD BC CD E3 A7 92 CA 92 C2 4D BC 8D 78 32 FB BF  
DF 23 ED 8A 94 16 27 A5 65 CF 7D 16 7A 45 B8 09 CC

Interleaved Data (Hex)

77 FA 4F 17 4E 3E E6 70 E8 CD 3F 76 90 C4 2C DB F9 B7 FB 43 6C F1 9A BD ED 0A 1C D8 1B EC 9B  
30 15 BA DA 31 F5 50 49 7D 56 ED B4 88 CC 72 FC 5C

Carrier Mapping (frequency offset index: I value Q value)

-100: 1 -1, -99: -1 -1, -98: 1 -1, -97: -1 -1, -96: -1 -1, -95: -1 -1, -94: -1 1, -93: -1 1, -92: 1 -1, -91: 1 1,  
-90: -1 -1, -89: -1 -1, -88:pilot= 1 0, -87: 1 1, -86: 1 -1, -85: 1 -1, -84: -1 -1, -83: 1 -1, -82: 1 1, -81: -1 -1,  
-80: -1 1, -79: 1 1, -78: -1 -1, -77: -1 -1, -76: -1 1, -75: -1 -1, -74: -1 1, -73: 1 -1, -72: -1 1, -71: 1 -1, -70: -1 -1,  
-69: 1 1, -68: 1 1, -67: -1 -1, -66: -1 1, -65: -1 1, -64: 1 1, -63:pilot= -1 0, -62: -1 -1, -61: 1 1, -60: -1 -1,  
-59: 1 -1, -58: 1 1, -57: -1 -1, -56: -1 -1, -55: -1 -1, -54: 1 -1, -53: -1 -1, -52: 1 -1, -51: -1 1, -50: -1 1, -49: 1 -1,  
-48: 1 1, -47: 1 1, -46: -1 -1, -45: 1 1, -44: 1 -1, -43: 1 1, -42: 1 1, -41: -1 1, -40: -1 -1, -39: 1 1, -38:pilot= 1 0,  
-37: -1 -1, -36: 1 -1, -35: -1 1, -34: -1 -1, -33: -1 -1, -32: -1 -1, -31: -1 1, -30: 1 -1, -29: -1 1, -28: -1 -1,  
-27: 1 -1, -26: -1 -1, -25: -1 -1, -24: -1 -1, -23: -1 1, -22: -1 -1, -21: 1 -1, -20: 1 1, -19: 1 1, -18: -1 -1, -17: 1 -1,  
-16: -1 1, -15: -1 -1, -14: 1 1, -13:pilot= -1 0, -12: -1 -1, -11: -1 -1, -10: 1 1, -9: 1 -1, -8: -1 1, -7: 1 -1, -6: -1 1,  
-5: -1 1, -4: -1 1, -3: -1 -1, -2: -1 -1, -1: 1 -1, 0: 0 0, 1: -1 -1, 2: -1 1, 3: -1 -1, 4: 1 -1, 5: 1 1, 6: 1 1, 7: -1 1,  
8: -1 1, 9: 1 1, 10: 1 -1, 11: -1 -1, 12: 1 1, 13:pilot= 1 0, 14: -1 -1, 15: 1 -1, 16: -1 1, 17: 1 1, 18: 1 1, 19: 1 -1,  
20: -1 1, 21: -1 -1, 22: -1 -1, 23: -1 1, 24: -1 -1, 25: 1 1, 26: -1 1, 27: 1 -1, 28: -1 1, 29: -1 -1, 30: 1 1, 31: -1 -1,  
32: 1 1, 33: 1 1, 34: 1 1, 35: 1 -1, 36: 1 -1, 37: 1 -1, 38:pilot= 1 0, 39: -1 1, 40: -1 -1, 41: -1 1, 42: -1 1,  
43: -1 -1, 44: 1 -1, 45: -1 1, 46: -1 1, 47: 1 1, 48: -1 -1, 49: 1 1, 50: 1 -1, 51: -1 -1, 52: -1 -1, 53: 1 -1, 54: 1 -1,  
55: 1 -1, 56: 1 -1, 57: 1 1, 58: 1 1, 59: 1 -1, 60: 1 1, 61: -1 1, 62: 1 -1, 63:pilot= 1 0, 64: 1 -1, 65: -1 -1,  
66: -1 -1, 67: 1 -1, 68: 1 -1, 69: 1 -1, 70: 1 -1, 71: -1 1, 72: -1 -1, 73: -1 1, 74: -1 -1, 75: 1 -1, 76: -1 1, 77: -1 -1,  
78: 1 -1, 79: 1 1, 80: -1 1, 81: 1 1, 82: -1 1, 83: 1 1, 84: -1 -1, 85: 1 1, 86: -1 -1, 87: 1 1, 88:pilot= 1 0, 89: 1 -1,  
90: -1 -1, 91: 1 1, 92: -1 1, 93: -1 -1, 94: -1 -1, 95: -1 -1, 96: 1 1, 97: 1 -1, 98: 1 -1, 99: -1 -1, 100: 1 1

NOTE: The above QPSK values (all values with exception of the BPSK pilots) are to be normalized with a factor  $1/\sqrt{2}$  as indicated in figure 8.

### 5.5.2 Subchannelization (2 subchannels)

Modulation Mode: 16-QAM, rate 3/4, Symbol Numbers within burst: 1-3, UIUC: 7, BSID: 1, Frame Number: 1, subchannel index: 0b00010 (decimal values)

Input Data (Hex)

45 29 C4 79 AD 0F 55 28 AD 87 B5 76 1A 9C 80 50 45 1B 9F D9 2A 88 95 EB AE B5

## Randomized Data (Hex)

D4 BA A1 12 F2 74 96 30 27 D4 88 9C 96 E3 A9 52 B3 15 AB FD 92 53 07 32 C0 62 00

## Convolutionally Encoded Data (Hex)

EE C6 A1 CB 7E 04 73 6C BC 61 95 D3 B7 C4 EF 0E 4C 76 CF DC 70 69 B3 CE DB E0 E5 B7 B5 4E 88  
7D A4 AE 31 30

## Interleaved Data (Hex)

B4 FF DA 06 E5 42 EC 1F 86 7C 29 93 9C AD 83 42 6B FE FC 6D CB F6 53 85 AE 68 22 7A CE B1 E7 52  
B0 EC BA 95

## Subcarrier Mapping (frequency offset index: I value Q value)

1<sup>st</sup> data symbol:

-100: -1 -3, -99: 3 1, -98: -3 -3, -97: -3 -3, -96: -3 3, -95: -1 -1, -38: pilot = 1 0, -37: 1 1, -36: 3 -1, -35: -3 -1,  
-34: 3 3, -33: 3 1, -32: 1 -1, 1: -3 -1, 2: -3 1, 3: 1 3, 4: -3 -3, 5: -1 1, 6: 3 -1, 64: 3 -3, 65: -3 1, 66: 1 -1, 67: -1 3,  
68: -1 3, 69: 1 -3

2<sup>nd</sup> data symbol:

-100: -1 3, -99: -3 1, -98: -1 -1, -97: -3 3, -96: -1 1, -95: 1 -3, -38: pilot = -1 0, -37: 3 1, -36: 1 -1, -35: 3 -1,  
-34: -1 -3, -33: -3 -3, -32: -3 -1, 1: -3 -3, 2: -3 1, 3: 3 -1, 4: -3 3, 5: -3 1, 6: -1 -3, 64: -3 -3, 65: 3 -1, 66: 3 3,  
67: 1 -3, 68: -1 1, 69: 3 3

3<sup>rd</sup> data symbol:

-100: -1 -1, -99: -3 -1, -98: 3 -1, -97: -1 1, -96: 1 -1, -95: 1 -1, -38: pilot = 1 0, -37: 3 -3, -36: -1 -1, -35: -3 1,  
-34: -3 -1, -33: -1 -3, -32: 1 3, 1: -3 -1, 2: 3 -3, 3: 3 3, 4: 1 -1, 5: -1 -3, 6: 1 1, 64: -3 -1, 65: -3 1, 66: -1 -3,  
67: -1 -1, 68: -1 3, 69: 3 3

NOTE: The above 16-QAM values (all values with exception of the BPSK pilots) are to be normalized with a factor as indicated in figure 8.

### 5.5.3 Subchannelization (1 subchannel)

Modulation Mode: QPSK, rate 3/4, Symbol Numbers within burst: 1-5, UIUC: 7, BSID: 1, Frame Number: 1, subchannel index: 0b00001 (decimal values)

## Input Data (Hex)

45 29 C4 79 AD 0F 55 28 AD 87

## Randomized Data (Hex)

D4 BA A1 12 F2 74 96 30 27 D4 00 00

## Convolutionally Encoded Data (Hex)

EE C6 A1 CB 7E 04 73 6C BC 61 95 D3 B7 DF 00

## Interleaved Data (Hex)

BC EC A1 F4 8A 3A 7A 4F 78 39 53 87 DF 2A A2

## Subcarrier Mapping (frequency offset index: I value Q value)

1<sup>st</sup> data symbol:

-100: -1 1, -99: -1 -1, -98: -1 -1, -37: 1 1, -36: -1 -1, -35: -1 1, 1: -1 -1, 2: 1 1, 3: -1 1, 64: -1 1, 65: 1 1, 66: 1 -1

2<sup>nd</sup> data symbol:

-100: -1 -1, -99: -1 -1, -98: 1 -1, -37: 1 1, -36: -1 1, -35: 1 1, 1: -1 1, 2: -1 1, 3: 1 1, 64: -1 -1, 65: -1 1, 66: -1 1

3<sup>rd</sup> data symbol:

-100: 1 -1, -99: -1 -1, -98: -1 1, -37: -1 1, -36: 1 -1, -35: 1 1, 1: -1 -1, 2: -1 -1, 3: 1 -1, 64: -1 -1, 65: -1 1, 66: 1 1

4<sup>th</sup> data symbol:

-100: 1 1, -99: -1 -1, -98: -1 1, -37: 1 -1, -36: 1 -1, -35: 1 -1, 1: 1 1, 2: -1 -1, 3: -1 1, 64: 1 1, 65: 1 -1, 66: -1 -1

5<sup>th</sup> data symbol:

-100: -1 -1, -99: 1 -1, -98: -1 -1, -37: -1 -1, -36: 1 1, -35: -1 1, 1: -1 1, 2: -1 1, 3: -1 1, 64: -1 1, 65: 1 1, 66: -1 1

NOTE: The above QPSK values are to be normalized with a factor  $1/\sqrt{2}$  as indicated in figure 8.

## 5.6 Preamble structure and modulation

All preambles are structured as either one or two OFDM symbols. The OFDM symbols are defined by the values of the composing subcarriers. Each of those OFDM symbols contains a cyclic prefix, of the same length as CP for data OFDM symbols.

The first preamble in the DL PHY PDU, as well as the initial ranging preamble, consists of two consecutive OFDM symbols. The first OFDM symbol uses only subcarriers the indices of which are a multiple of 4. As a result, the time domain waveform of the first symbol consists of 4 repetitions of 64-sample fragment, preceded by a CP. The second OFDM symbol utilizes only even subcarriers, resulting in time domain structure composed of 2 repetitions of a 128-sample fragment, preceded by a CP. The time domain structure is exemplified in figure 10. This combination of the two OFDM symbols is referred to as the long preamble.

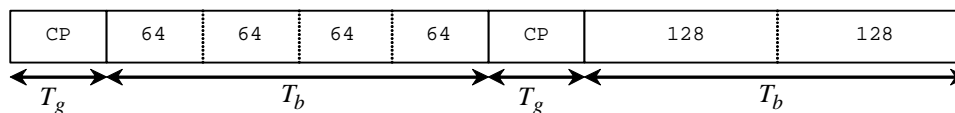

Figure 10: DL and network entry preamble structure

The frequency domain sequences for all full-bandwidth preambles are derived from the sequence:

$$\begin{aligned}
 \text{PALL}(-100:100) = \{ & 1-j, 1-j, -1-j, 1+j, 1-j, 1-j, -1+j, 1-j, 1-j, 1-j, 1+j, -1-j, 1+j, 1+j, -1-j, 1+j, -1-j, -1-j, 1-j, -1+j, 1-j, \\
 & 1-j, -1-j, 1+j, 1-j, 1-j, -1+j, 1-j, 1-j, 1-j, 1+j, -1-j, 1+j, 1+j, -1-j, 1+j, -1-j, -1-j, 1-j, -1+j, 1-j, 1-j, -1+j, \\
 & 1-j, 1-j, 1-j, 1+j, -1-j, 1+j, 1+j, -1-j, 1+j, -1-j, -1-j, 1-j, -1+j, 1+j, 1+j, 1-j, -1+j, 1+j, 1+j, -1-j, 1+j, 1+j, -1+j, 1-j, \\
 & -1+j, -1+j, 1-j, -1+j, 1-j, 1-j, 1+j, -1-j, -1-j, -1-j, -1+j, 1-j, -1-j, -1-j, 1+j, -1-j, -1-j, -1-j, 1-j, -1+j, 1-j, -1+j, 1-j, \\
 & -1+j, -1+j, -1-j, 1+j, 0, -1-j, 1+j, -1+j, -1+j, -1-j, 1+j, 1+j, 1+j, -1-j, 1+j, 1-j, 1-j, -1+j, -1+j, -1+j, 1-j, -1-j, \\
 & -1-j, -1+j, 1-j, 1+j, 1+j, -1+j, 1-j, 1-j, -1+j, 1-j, -1-j, -1-j, 1+j, 1+j, 1+j, 1+j, -1-j, -1+j, -1+j, 1+j, -1-j, 1-j, 1-j, \\
 & 1+j, -1-j, -1-j, -1-j, 1+j, -1-j, -1+j, -1+j, -1+j, 1-j, 1-j, 1-j, 1-j, -1+j, 1+j, 1+j, -1-j, 1+j, -1+j, -1-j, 1+j, 1+j, \\
 & -1-j, 1+j, 1-j, 1-j, 1-j, -1+j, -1+j, -1+j, 1-j, -1-j, -1-j, 1-j, -1+j, -1-j, -1-j, 1-j, -1+j, -1+j, -1+j, 1-j, -1+j, 1+j, 1+j, \\
 & 1+j, -1-j, -1-j, -1-j, -1-j, 1+j, 1-j, 1-j\} \quad (9)
 \end{aligned}$$

The frequency domain sequence for the 4 times 64 sequence  $P_{4 \times 64}$  is defined by:

$$P_{4 \times 64}(k) = \begin{cases} \sqrt{2} \cdot \sqrt{2} \cdot \text{conj}(P_{\text{ALL}}(k)) & k_{\text{mod}4} = 0 \\ 0 & k_{\text{mod}4} \neq 0 \end{cases} \quad (10)$$

In equation 10, the factor of  $\text{sqrt}(2)$  equates the Root-Mean-Square (RMS) power with that of the data section. The additional factor of  $\text{sqrt}(2)$  is related to the 3 dB boost.

The frequency domain sequence for the 2 times 128 sequence  $P_{\text{EVEN}}$  is defined by:

$$P_{\text{EVEN}}(k) = \begin{cases} \sqrt{2} \cdot P_{\text{ALL}}(k) & k_{\text{mod}2} = 0 \\ 0 & k_{\text{mod}2} \neq 0 \end{cases} \quad (11)$$

In  $P_{\text{EVEN}}$ , the factor of  $\sqrt{2}$  is related to the 3 dB boost.

In the UL, when the entire 16 subchannels are used, the data preamble, as shown in figure 11 consists of one OFDM symbol utilizing only even subcarriers. The time domain waveform consists of 2 times 128 samples preceded by a CP. The subcarrier values shall be set according to the sequence  $P_{\text{EVEN}}$ . This preamble is referred to as the short preamble. This preamble shall also precede all allocations during the AAS portion of a frame and shall be used as burst preamble on the DL bursts when indicated in the DL-MAP\_IE.

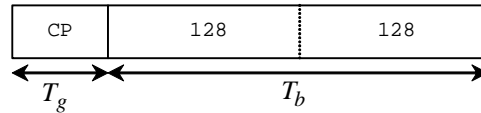

**Figure 11: UL data and DL AAS preamble structure**

In the DL bursts which start with a preamble and which fall within the STC-encoded region, the preamble shall be transmitted from both transmit antennas simultaneously and shall consist of a single OFDM symbol. The preamble transmitted from the first antenna shall use only even subcarriers, the values of which are set according to the sequence  $P_{\text{EVEN}}$ . The preamble transmitted from the second antenna shall use only odd subcarriers, the values of which shall be set according to the sequence  $P_{\text{ODD}}$ .

$$P_{\text{ODD}}(k) = \begin{cases} 0 & k_{\text{mod}2} = 0 \\ \sqrt{2} \times P_{\text{ALL}}(k) & k_{\text{mod}2} \neq 0 \end{cases} \quad (12)$$

The AAS preamble shall be composed of two identical OFDM symbols. Each symbol shall be transmitted from up to 4 beams. The same beams shall be used in the first and second symbols. This preamble shall be used to mark AAS DL zone slots and to perform channel estimation. If the BS supports more than four antennas, the subset that is transmitted on a single AAS preamble may be varied from frame to frame. The preamble from beam  $m$ ,  $m = 0 \dots 3$ , shall be transmitted on subcarriers  $m \bmod 4$  and shall use the sequence  $P_{\text{AAS}}^{(m)}$  given by the following equations.

For  $m = 0$

$$P_{\text{AAS}}^{(m)}(k) = \begin{cases} 0 & k_{\text{mod}4} = 0 \\ \text{conj}(P_{\text{ALL}}(k)) & k_{\text{mod}4} \neq 0 \end{cases} \quad (13)$$

For  $m = 1 \dots 3$

$$P_{\text{AAS}}^{(m)}(k) = \begin{cases} 0 & k_{\text{mod}4} \neq m \\ \text{conj}(P_{\text{ALL}}(k + 2 - m)) & k_{\text{mod}4} = m \end{cases} \quad (14)$$

Using mesh, bursts sent in the control subframe shall start with the long preamble. In the data subframe, the bursts shall by default start with the long preamble, but neighbours may negotiate to use the short preamble by setting the preamble flag in the Neighbour Link Info field.

In mesh mode, bursts sent in the control subframe shall start with the long preamble. In the mesh data sub-frame, the bursts shall by default start with the long preamble, but neighbours may negotiate to use the short preamble by setting the preamble flag in the Neighbour Link Info field.

In the UL, when subchannelization transmissions are employed, the data preamble consists of a 256 sample sequence preceded by a CP whose length is the same as the cyclic prefix for data OFDM symbols. This preamble is referred to as the subchannelization preamble. The frequency domain sequence for the 256 samples is defined by  $P_{\text{SUB}}$ . Preamble carriers that do not fall within the allocated subchannels shall be set to zero.

$$P_{\text{SUB}}(-100:100) = \{1+j, 1+j, -1-j, 1+j, -1+j, 1+j, 1+j, 1+j, -1-j, -1-j, 1-j, -1-j, 1-j, 1+j, 1-j, 1+j, 1+j, -1-j, -1-j, 1+j, 1-j, 1+j, -1-j, 1+j, 1+j, 1+j, -1-j, 1+j, -1+j, 1+j, 1+j, -1-j, -1-j, 1+j, 1-j, 1+j, 1+j, -1-j, 1+j, 1+j, 1+j, -1-j, 1+j, 1+j, 1+j, -1-j, 1+j, 1+j, 1+j, -1-j, -1-j, 1+j, 1-j, 1+j, 1+j, -1-j, -1-j, 1+j, 1+j, -1-j, 1+j, -1+j, -1-j, 1+j, 1+j, -1-j, -1-j, 0, 1+j, 1+j, -1-j, 1+j, -1+j, 1+j, 1+j, 1+j, -1-j, -1-j, 1-j, -1-j, 1-j, 1+j, 1+j, -1+j, 1+j, -1-j, 1+j, 1+j, -1-j, -1-j, 1+j, 1+j, -1-j, -1-j, 1+j, 1+j, -1-j, 1+j, 1+j, -1-j, -1-j, 1+j, 1+j, -1-j, -1-j, 1+j, 1+j, -1-j, 1+j, 1+j, -1-j, -1-j, 1+j, 1+j, -1-j, -1-j, 1+j, 1+j, -1-j, -1-j, 1+j, 1+j, 1+j, 1+j, 1+j, -1-j, 1+j, -1+j, 1+j, 1+j, -1-j, 1+j, -1-j, -1-j, -1-j, -1-j, -1-j, 1+j, 1+j, -1-j, -1-j, 1+j, 1+j, -1-j, -1-j, 1+j, 1+j, -1-j, -1-j, 1+j, 1+j, -1-j, -1-j\} \quad (15)$$

In the case that the UL allocation contains midambles, the midambles will consist of one OFDM symbol and shall be identical to the preamble used with the allocation.

UL preambles and midambles may be cyclically delayed by an integer number of samples. This is indicated by the UL-Physical modifier IE.

## 5.6.1 Transmission Convergence (TC) sublayer

The TC sublayer as described in section 8.3.4 in IEEE 802.16 [2].

---

# 6 Frame structures

## 6.1 PMP

### 6.1.1 Duplexing modes

The PHY shall support Frequency Division Duplexing (FDD) or Time Division Duplexing (TDD). FDD SSs may be Half Duplex FDD (H-FDD). In license exempt bands, the duplexing method shall be TDD.

The OFDM PHY supports a frame-based transmission. The frame interval contains BS and SS transmissions comprised of PHY PDUs, Transmit/receive Transition Gap (TTG) and Receive/transmit Transition Gap (RTG) gaps, and guard intervals. A frame consists of a DL sub-frame and an UL sub-frame. A DL sub-frame consists of only one DL PHY PDU. A UL sub-frame consists of contention intervals scheduled for initial ranging and bandwidth request purposes and one or multiple UL PHY PDUs, each transmitted from a different SS.

A UL PHY PDU consists of only one burst, which is made up of a short preamble and an integer number of OFDM symbols. The burst PHY parameters of an UL PHY PDU are specified by a 4-bit UIUC in the UL-MAP. The UIUC encoding is defined in the Uplink Channel Descriptor (UCD) messages. Note the difference between a PHY PDU and a Burst.

A DL PHY PDU starts with a long preamble, which is used for PHY synchronization. The preamble is followed by a FCH burst. The FCH burst is one OFDM symbol long and is transmitted using QPSK rate 1/2 with the mandatory coding scheme. The FCH contains DL\_Frame\_Prefix (DLFP) to specify the burst profile and length of one or several DL bursts immediately following the FCH.. The Rate\_ID encoding for the burst immediately following the FCH is defined in table 9. The location and profile of the maximum possible number of subsequent bursts shall also be specified in the DLFP. For these bursts, DIUC is used instead of Rate\_ID. The DIUC encoding is defined in the DCD messages. The HCS field occupies the last byte of the DLFP. If there are unused IEs in the DLFP, the first unused IE must have all fields encoded as zeros.

Location and profile of other bursts are specified in DL-MAP. The profile is specified by Rate\_ID (for the first DL burst) or by DIUC. Each of DL bursts following the FCH is transmitted with different burst profile. Each DL burst consists of an integer number of OFDM symbols.



A DL-MAP message, if transmitted in the current frame, shall immediately follow the DLFP. An UL-MAP message shall immediately follow either the DL-MAP message (if one is transmitted) or the DLFP. If UCD and DCD messages are transmitted in the frame, they shall immediately follow the DL-MAP and UL-MAP messages. All forementioned messages must be transmitted in the burst immediately following the FCH (burst #1). Although burst #1 contains broadcast MAC control messages, it is not necessary to use the most robust well-known modulation/coding. A more efficient modulation/coding may be used if it is supported and applicable to all the SSs of a BS.

At least one full DL-MAP must be broadcast in burst #1 within the Lost DL-MAP Interval specified in table 340 in IEEE 802.16 [2].

The DL Subframe may optionally contain an STC zone in which all DL bursts are STC encoded. If an STC zone is present, the last used IE in the DLFP shall have DIUC = 0 (see table 13 in TS 102 178 [1]) and the IE shall contain information on the start time of STC zone (see table 16 in TS 102 178 [1]). The STC zone ends at the end of the frame.

The STC zone starts from a preamble and an STC encoded FCH-STC burst, which is one symbol with the same payload format as specified in table 16 in TS 102 178 [1]. The FCH-STC burst is transmitted at BPSK rate  $\frac{1}{2}$ . It is followed by one or several STC encoded PHY bursts. The first burst in the STC zone may contain a DL-MAP applicable only to the STC zone. If DL-MAP is present, it shall be the first MAC PDU in the payload of the burst.

With the OFDM PHY, a PHY burst, either a downlink PHY burst or an uplink PHY burst, consists of an integer number of OFDM symbols, carrying MAC messages, i.e. MAC PDUs. To form an integer number of OFDM symbols, unused bytes in the burst payload may be padded by the bytes 0xFF, as defined in clause 5.1. Then the payload should be randomized, encoded, and modulated using the burst PHY parameters specified by this standard. If an SS does not have any data to be transmitted in an UL allocation, the SS shall transmit an UL PHY burst containing a bandwidth request header as defined in Figure 20, with BR=0 and its basic CID. If the allocation is large enough, an AAS enabled SS may also provide an AAS Feedback Response (AAS-FBCK-RSP) message (clause 4.3.23 in TS 102 178 [1]). An SS shall transmit during the entirety of all of its UL allocations, using the standard padding mechanism (clause 6.3.3.7 in IEEE 802.16 [2]) to fill allocations if necessary.

In each TDD frame (see figure 12), the Tx/Rx transition gap (TTG) and Rx/Tx transition gap (RTG) shall be inserted between the DL and UL sub-frame and at the end of each frame respectively to allow the BS to turn around.

In TDD and H-FDD systems subscriber station allowances must be made by a transmit-receive turnaround gap SSRTG and by a receive-transmit turnaround gap SSTTG. The BS shall not transmit DL information to a station later than (SSRTG+RTD) before its scheduled UL allocation, and shall not transmit DL information to it earlier than (SSTTG-RTD) after the end of scheduled UL allocation, where RTD denotes Round-Trip Delay. The parameters SSRTG and SSTTG are capabilities provided by the SS to BS upon request during network entry.

For TDD mode SSRTG and SSTTG shall be no more than 50  $\mu$ s. For H-FDD mode SSRTG and SSTTG shall be no more than 100  $\mu$ s.

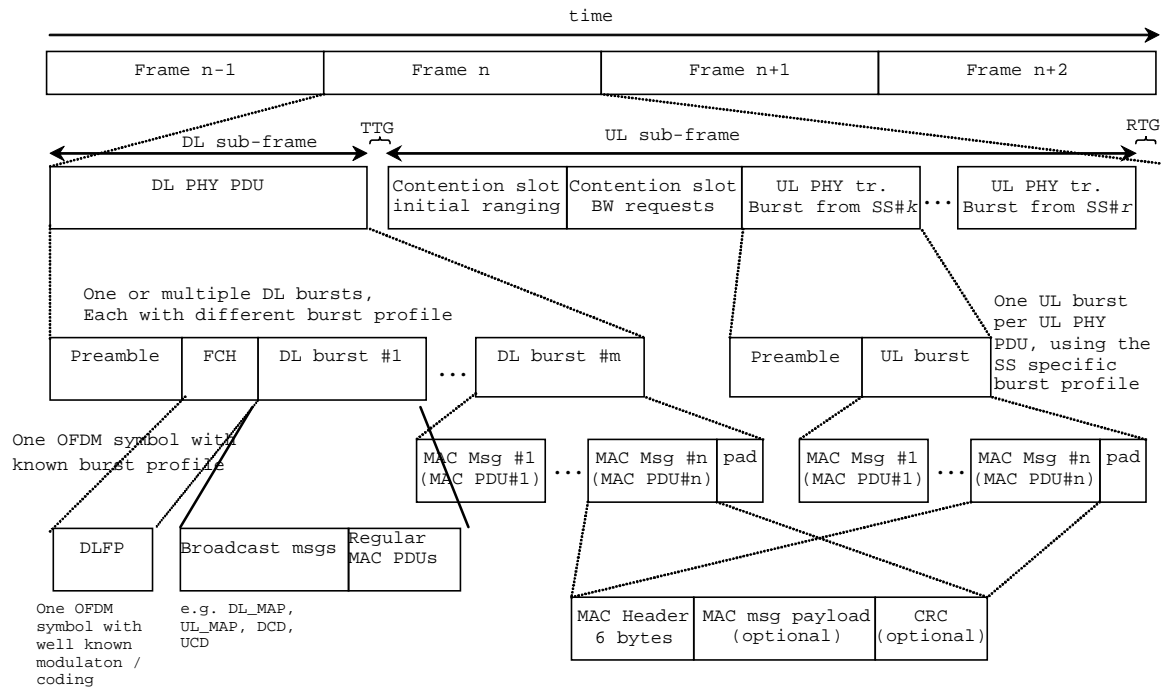

Figure 12: Example of OFDM PMP frame structure with TDD

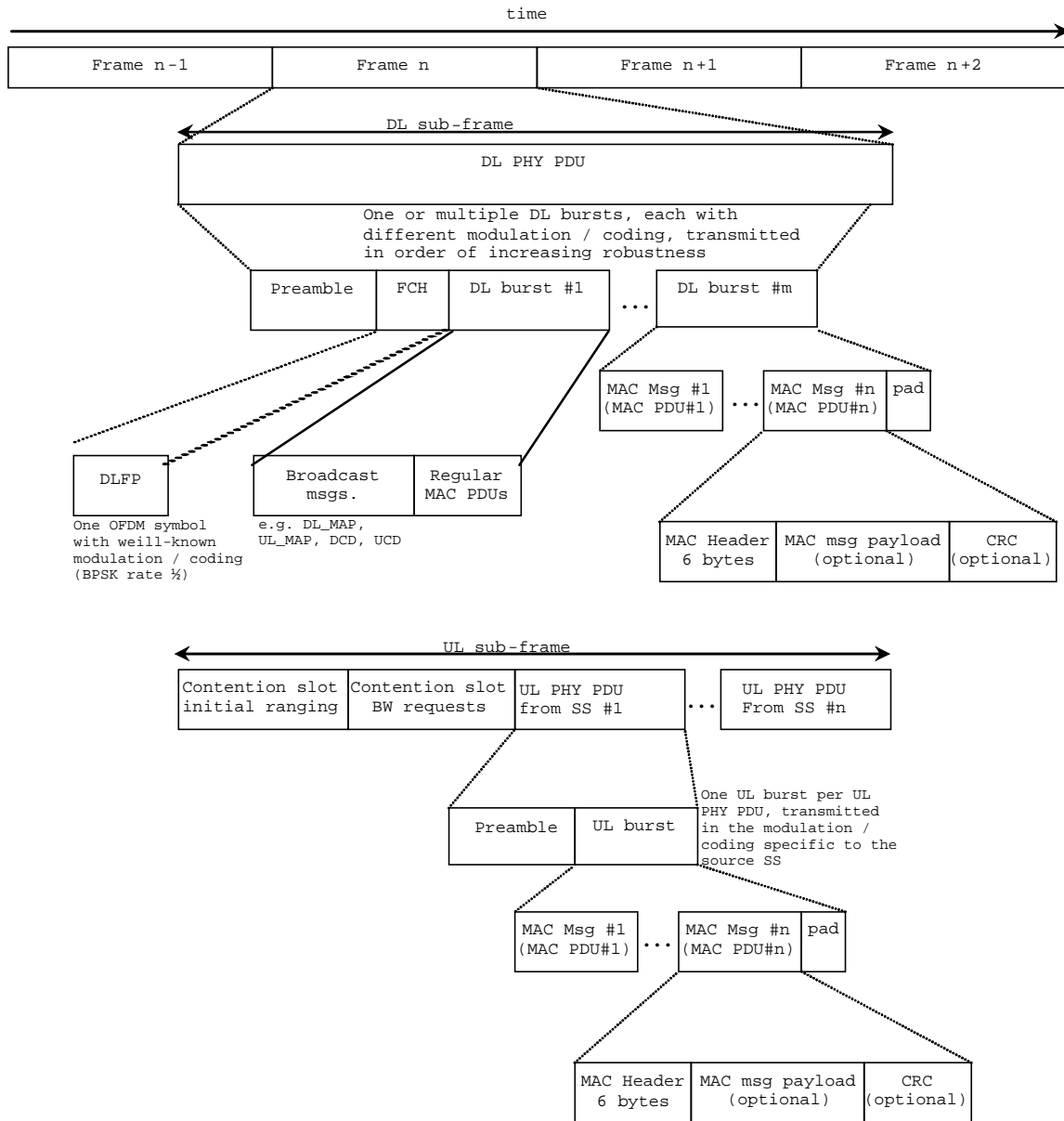

Figure 13: Example of OFDM PMP frame structure with FDD

## 6.1.2 DL Frame Prefix

Table 10: OFDM DL Frame Prefix format

Syntax	Size	Notes
DL_Frame_Prefix_Format() {		
Base_Station_ID	4 bits	4 LSB of BS ID. The burst specified by the DLFP shall not be decoded if these bits do not match those of the BS on which it is registered
Frame_Number	4 bits	4 LSB of the Frame Number DCD Channel Encoding as specified in table 6 in TS 102 178 [1]
Configuration_Change_Count	4 bits	4 LSB of Change Count value as specified in section 6.3.2.3.1 in IEEE 802.16 [2]
Reserved	4 bits	Shall be set to zero
For (n=0;n<4; n++) {		
DL_Frame_Prefix_IE() {		
Rate_ID/DIUC	4 bits	For the first information element it shall be Rate_ID encoded according to the table 222 in IEEE 802.16 [2]. For following IEs this field is DIUC that defines the burst profile of the corresponding burst.
If (DIUC !=0) {		
Preamble_present	1 bit	If '1', preamble is placed before the burst
Length	11 bits	Number of OFDM symbols in the burst
} else {		
Start_Time	12 bits	Start time of STC zone in units of symbol duration counted from the beginning of the frame
}		
}		
}		
HCS	8 bits	An 8 bit Header Check Sequence calculated as specified in clause 4.1.2 in TS 102 178 [1]
}		

## 6.1.3 PMP-AAS zone

DL transmission to an SS or group of SSs consists of two fractions. The first fraction of the transmission consists of one or several repetitions of a pair composed of the short preamble followed by FCH symbol (figure 14). The second fraction is called Body.

FCH payload is called "AAS DL Frame Prefix" (AAS\_DLFP). FCH shall be transmitted at the lowest possible modulation. Each pair preamble-FCH may be transmitted either at narrow beam or at wide beam. Optionally same preamble-FCH pair may be repeated at several beams thus implementing space diversity.

AAS\_DLFP contains information (DL IEs or UL IEs) on location and transmission rate of PHY bursts. There is a possibility of more than one concatenated DL PHY bursts, each one described by a DL IE. UL Ies specify either UL PHY burst (a single burst per SS) or contention region for initial ranging or bandwidth requesting.

Body may be transmitted at a directed beam and may start either immediately after FCH or at some distance. In the latter case, it shall start from a preamble. The payload of the burst may contain private DL-MAP and / or UL-MAP messages.

Alternatively, AAS\_DLFP may contain UL IEs. There are two options:

- 1) A single UL IE.
- 2) "Compressed" UL IE, which contains a network entry allocation and a regular allocation.

An example of AAS zone layout is shown in figure 14.

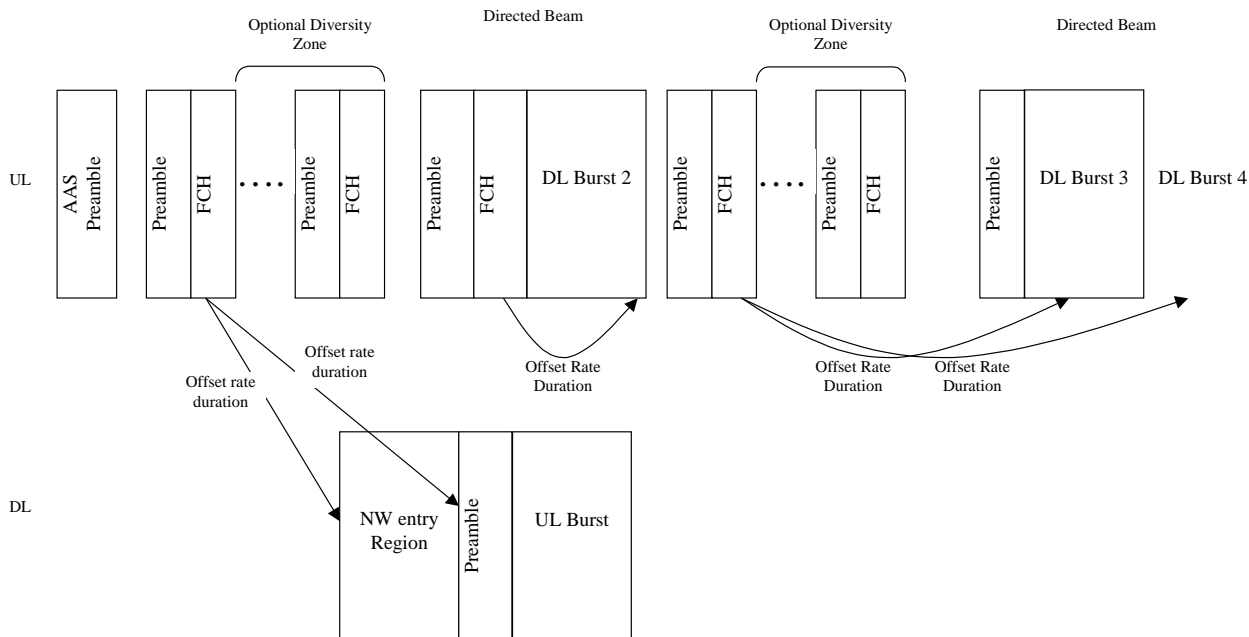

Figure 14: Structure of AAS Zone

## 6.2 Mesh

In addition to the PMP frame structure, an optional frame structure (see figure 15) is defined to facilitate mesh networks.

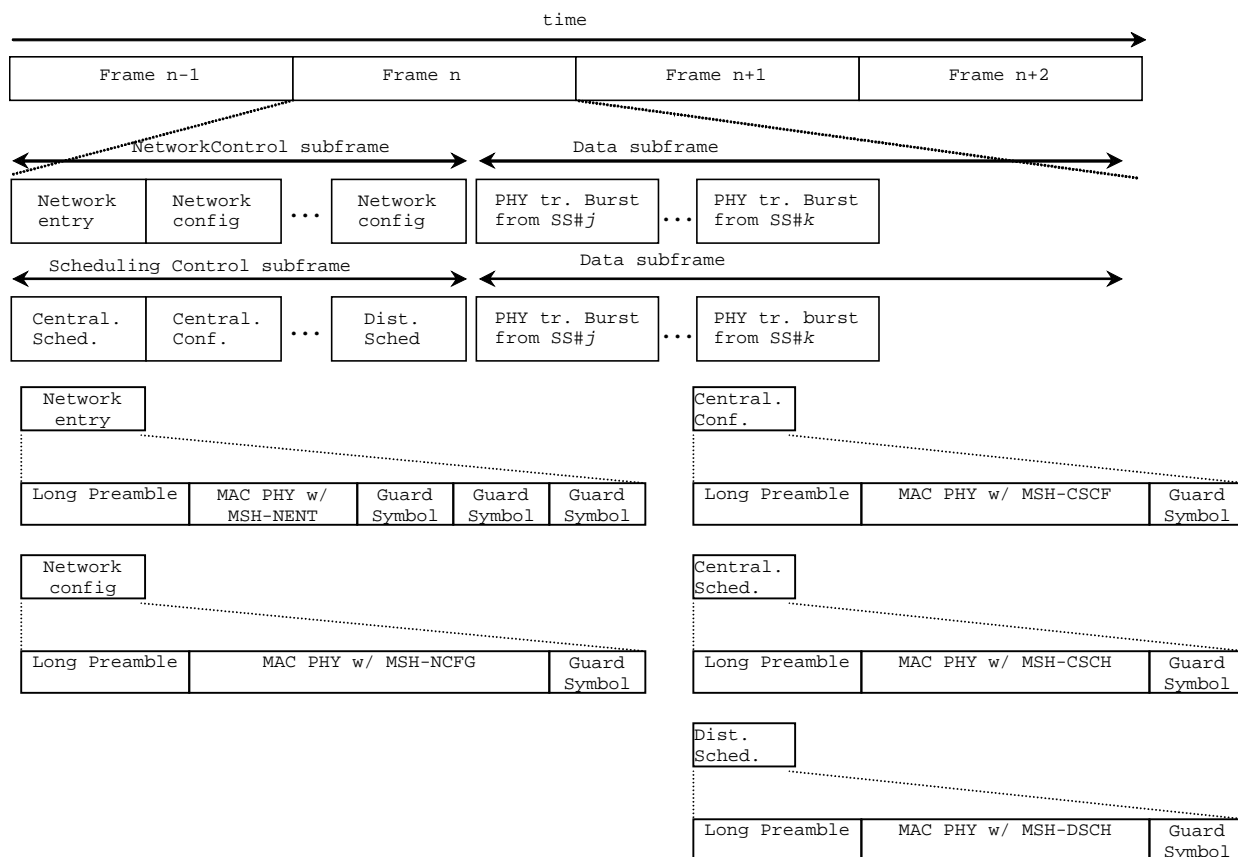

Figure 15: Mesh frame structure

A mesh frame consists of a control and data subframe. The control subframe has two basic functionalities. One is the creation and maintenance of cohesion between the different systems, termed "network control" in figure 15. The other is the co-ordinated scheduling of data-transfers between systems, termed "schedule control" figure 15. Frames with a network control subframe occur periodically, as indicated in the network descriptor. All other frames have a schedule control subframe. The length of the control subframe is fixed and of length  $\text{MSH-CTRL-LEN} \times 7$  OFDM symbols, with  $\text{MSH-CRTL-LEN}$  indicated in the network descriptor.

During a network control subframe, the first 7 symbols are allocated for network entry, followed by  $\text{MSH-CTRL-LEN} - 1$  sets of 7 symbols for network configuration. During a schedule control subframe, the network descriptor indicates how many ( $\text{MSH-DSCH-NUM}$ ) distributed scheduling messages may occur in the control subframe. The first  $(\text{MSH-CRTL-LEN} - \text{MSH-DSCH-NUM}) \times 7$  symbols are allocated to transmission bursts containing  $\text{MSH-CSCH}$  and  $\text{MSH-CSCF}$  PDUs, whereas the remainder is allocated to transmission bursts containing  $\text{MSH-DSCH}$  PDUs.

Distributed scheduling messages (using the long preamble) may further occur in the data subframe if not in conflict with the scheduling dictated in the control subframe.

All transmissions in the control subframe are sent using the most robust mandatory burst profile. The data subframe is divided into minislots, which are, with possible exception of the last minislot in the frame, of size ceiling  $((\text{OFDM symbols per frame} - \text{MSH-CTRL-LEN} \times 7) / 256)$ . A scheduled allocation consists of one or more minislots.

## 6.3 Frame duration codes

Table 11 indicates the specific frame durations that are allowed. The frame duration used can be determined by the periodicity of the frame start preambles. Once a specific frame duration has been selected by the BS, it should not be changed. Changing the frame duration shall force all SSs to resynchronize to the BS.

**Table 11: Frame duration Codes**

Code	Frame Duration (ms)	Frames/s
0	2,5	400
1	4	250
2	5	200
3	8	125
4	10	100
5	12,5	80
6	20	50
7 to 255	<i>reserved</i>	

---

# 7 Control Mechanisms

## 7.1 Synchronization

### 7.1.1 Network synchronization

It is recommended (but not required) that all BSs be time synchronized to a common timing signal. In the event of the loss of the network timing signal, BSs may continue to operate and shall automatically resynchronize to the network timing signal when it is recovered. The synchronizing reference shall be a 1pps timing pulse based on a 10 MHz frequency reference. These signals are typically provided by a GPS receiver.

Frequency references derived from the timing reference may be used to control the frequency accuracy of Base-Stations provided that they meet the frequency accuracy requirements of clause 12. This applies during normal operation and during loss of timing reference.

## 7.2 Ranging

There are two types of ranging processes, initial ranging and periodic ranging. Initial ranging (coarse synchronization) and power control are performed during (re)registration, after synchronization is lost; and the second is done on a periodic basis. Initial ranging uses the initial ranging contention-based interval, which requires a long preamble and the use of the most robust mandatory burst profile. Periodic ranging uses the regular UL burst.

During registration, a new subscriber registers during the random access channel and if successful enters into a ranging process under control of the BS. The ranging process is cyclic in nature where default time and power parameters are used to initiate the process followed by cycles where (re)calculated parameters are used in succession until parameters meet acceptance criteria for a new subscriber. These parameters are monitored, measured and stored at the BS and transmitted to the SS for use during normal exchange of data. The stored parameters are updated in a periodic manner based on configurable update intervals to ensure changes in the channel can be accommodated. The update intervals shall vary in a controlled manner on a SS by SS basis.

Ranging on re-registration follows the same process as new registration.

One of the parameters that limit cell radius is the round trip propagation time. Round trip propagation time shall be taken into account when determining the time open for initial ranging. This time should be at least equal to the maximum tolerable round trip delay plus the number of OFDM symbols necessary to transmit the ranging burst.

SSs that compute their  $P_{TX\_IR\_max}$  to exceed their maximum power level and SSs that have attempted initial ranging with the maximum power level using RNG-REQ may, if the BS supports subchannelization, attempt initial ranging in an initial ranging slot using the following burst format:

- The SS shall transmit the long preamble as defined in clause 5.6. This shall be followed by a single odd numbered randomly selected subchannel with duration of two OFDM symbols, containing the preamble for this subchannel as defined in clause 5.6. Note that the long preamble is transmitted on the entire BW while the subchannelized preamble is transmitted on 1/16 of the BW.
- The long preamble and subchannelized preamble shall be transmitted using the same total power. A result the spectral density of the long preamble shall be lower by a factor of 16 (about 12 dB) with respect to the power spectral density of the subchannelized preamble.
- The BS need only detect that energy is sent on a single subchannel and may respond by allocating a single subchannel identifying the SS by the Transmit Opportunity, Frame Number, and ranging subchannel in which the transmission was received. The allocation is accomplished using the Initial Ranging CID. The allocated bandwidth shall be sufficient to contain at least one RNG-REQ message.
- A SS attempting subchannelized initial ranging shall use its maximum power setting for the initial ranging burst.

### 7.2.1 Initial Ranging in AAS systems

A BS supporting the AAS option may allocate in the uplink subframe an AAS alert slot for AAS SSs that have to initially alert the BS of their presence. This period shall be marked as Initial-Ranging (UIUC=1), but shall be marked by a well known AAS initial ranging CID (0xFEFF) such that no non -AAS subscriber (or AAS subscriber that can decode the UL-MAP message) uses this interval for Initial Ranging. Additionally this period shall be marked using AAS map (see table 249 in IEEE 802.16 [2]). The SS shall transmit the long preamble as defined in clause 8.3.3.6 of IEEE 802.16 [2]. This shall be followed by a burst carrying the AAS\_NW\_ENTRY\_REQ message (see table 257 in IEEE 802.16 [2]). This burst shall use the most robust mandatory rate.

The BS may respond to the network entry request by transmitting a RNG-RSP message indicating the required changes to the ranging parameters. The SS is identified by specifying the transmit opportunity and the entry code of the AAS\_NW\_ENTRY\_REQ message. When transmitting the response, the BS may use the feedback information embedded in the AAS\_NW\_ENTRY\_REQ to direct the beam to the SS.

BS may additionally assign subchannelized AAS alert slot for SSs supporting subchannelization. AAS SSs which have attempted initial ranging with the maximum power level using AAS\_NW\_ENTRY\_REQ may attempt initial ranging in the subchannelized AAS alert slot. The SS shall transmit the long preamble. This shall be followed by subchannelized burst carrying the AAS\_SBCH\_NW\_ENTRY\_REQ message. This message shall be sent on the subchannel indicated by the UL-MAP information element used to allocate the ranging period.

## 7.3 Bandwidth requesting

There may be two types of Request (REQ) Regions in a frame. These two types are REQ Region-Full and REQ Region-Focused.

In a REQ Region-Full, a SS may send a message containing a Bandwidth Request MAC Header. Such transmission may be either subchannelized or non-subchannelized, as defined in clause 7.3.2.

In a REQ Region-Focused, a station shall send a short code over a TO which consists of 4 subcarriers by two OFDM symbols. Each TO within a MAC frame shall be indexed by consecutive TO Indices. The first TO shall be indexed zero.

All SSs shall be capable of the Full Contention Transmission. Capability of the focused contention transmission is optional. The SS shall follow the backoff procedure as described in IEEE 802.16 [2], clause 6.2.8.

### 7.3.1 Parameter selection

The SS shall examine the UL\_MAP message for a future frame and select (in accordance with clause 6.2.8 of IEEE 802.16 [2]) a future REQ Region during which to make its request. If Focused Contention Supported = 1 is returned by the BS in the SBC-RSP message during SS initialization and if the SS is capable of focused contention, it may choose either a REQ Region-Full or REQ Region-Focused. Otherwise, it shall choose a REQ Region-Full.

For REQ Region-Focused, the SS shall also select, at random with equal probability, a contention code from table 12 and similarly a contention channel from table 13. The indices {-100 to +100} in the body of table 13 refer to the subcarrier indices as defined in table 1. The number of contention codes that can be used by a subchannelized capable SS is denoted by  $C_{SE}$ . The contention code shall be selected at random with equal probability from the appropriate subset of codes in table 12 according to the value of  $C_{SE}$ .

If the BS supports subchannelization, the last  $C_{SE}$  contention codes shall only be used by subchannelization enabled SSs that wish to receive a subchannelized allocation. In response, the BS may provide the requested allocation as a subchannelized allocation; may provide the requested allocation as a full (default) allocation, or may provide no allocation at all. The value of  $C_{SE}$  is transmitted in the UCD channel encoding TLV messages. The default value of  $C_{SE}$  is 0.

A BS that supports Focused Contention may allocate the Focused Contention region based upon the BSID, thereby reducing the probability of interference from SSs operating in nearby cells operating on the same frequency.

Any Focused Contention region allocation shall be restricted to an even Subchannel Index (meaning that it be no finer than a 1/8 subchannel, see table 1), providing between 6 and 48 contention channels.

**Table 12: OFDM contention codes**

Contention Code Index	bit 0	bit 1	bit 2	bit 3
0	1	1	1	1
1	1	-1	1	-1
2	1	1	-1	-1
3	1	-1	-1	1
4	-1	-1	-1	-1
5	-1	1	-1	1
6	-1	-1	1	1
7	-1	1	1	-1



Table 13: OFDM contention channels

Contention Channel Index	frequency offset index 0	frequency offset index 1	frequency offset index 2	frequency offset index 3	Contention Channel belongs to subchannel (see table 1)
0	-100	-37	1	64	0b00010
1	-99	-36	2	65	0b00010
2	-98	-35	3	66	0b00010
3	-97	-34	4	67	0b00010
4	-96	-33	5	68	0b00010
5	-95	-32	6	69	0b00010
6	-94	-31	7	70	0b00110
7	-93	-30	8	71	0b00110
8	-92	-29	9	72	0b00110
9	-91	-28	10	73	0b00110
10	-90	-27	11	74	0b00110
11	-89	-26	12	75	0b00110
12	-87	-50	14	51	0b01010
13	-86	-49	15	52	0b01010
14	-85	-48	16	53	0b01010
15	-84	-47	17	54	0b01010
16	-83	-46	18	55	0b01010
17	-82	-45	19	56	0b01010
18	-81	-44	20	57	0b01110
19	-80	-43	21	58	0b01110
20	-79	-42	22	59	0b01110
21	-78	-41	23	60	0b01110
22	-77	-40	24	61	0b01110
23	-76	-39	25	62	0b01110
24	-75	-12	26	89	0b10010
25	-74	-11	27	90	0b10010
26	-73	-10	28	91	0b10010
27	-72	-9	29	92	0b10010
28	-71	-8	30	93	0b10010
29	-70	-7	31	94	0b10010
30	-69	-6	32	95	0b10110
31	-68	-5	33	96	0b10110
32	-67	-4	34	97	0b10110
33	-66	-3	35	98	0b10110
34	-65	-2	36	99	0b10110
35	-64	-1	37	100	0b10110
36	-62	-25	39	76	0b11010
37	-61	-24	40	77	0b11010
38	-60	-23	41	78	0b11010
39	-59	-22	42	79	0b11010
40	-58	-21	43	80	0b11010
41	057	-20	44	81	0b11010
42	-56	-19	45	82	0b11110
43	-55	-18	46	83	0b11110
44	-54	-17	47	84	0b11110
45	-53	-16	48	85	0b11110
46	-52	-15	49	86	0b11110
47	-51	-14	50	87	0b11110

### 7.3.2 Full Contention Transmission

If the chosen REQ Region is a REQ Region-Full, the SS shall transmit the short preamble as defined in clause 5.6, followed by a Bandwidth Request MAC Header.

If the Full Contention allocation appears in a subchannelized region, the allocation is partitioned into Transmission Opportunities (TOs) both in frequency and in time. The width (in subchannels) and length (in OFDM symbols) of each TO is defined in the UCD message defining UIUC=2. The transmission of an SS shall contain a subchannelized preamble corresponding to the TO chosen, followed by data OFDM symbols using the most robust mandatory burst profile.

### 7.3.3 Focused Contention Transmission

The REQ Region-Focused bandwidth requesting mechanism consists of two phases as defined in TS 102 178 [1]. In the first phase, a SS requesting bandwidth shall send a signal to the BS in the UL interval of REQ Region Focused identified by UIUC=3. One REQ Region Focused UL TO with UIUC=3 shall be 4 subcarriers by two OFDM symbols. This bandwidth requesting signal transmission is described below. In the second phase, the BS may include in its UL-MAP an allocation for the SS using UIUC=4 and the Focused\_Contention\_IE. The SS is identified by the Frame Number index, TO index, Contention Channel index, and Contention Code index that the SS used to send the bandwidth request signal during the first phase.

For REQ Region-Focused, after choosing its four parameters, the SS shall transmit four subcarriers that comprise the chosen contention channel. The amplitude of all other carriers shall be zero.

During both OFDM symbols, the amplitude of each of the four carriers shall be boosted somewhat above its normal amplitude, i.e. that used during a non-contention OFDM symbol, including the current power-control correction. The boost in dB shall equal the value of the Focused Contention Power Boost parameter in the current Uplink Channel Descriptor (UCD).

During the first OFDM symbol of the TO, the phase of the four carriers is not specified.

During the second OFDM symbol of the TO, the phases shall depend on the corresponding bit in the chosen contention code, and the phase transmitted during the first OFDM symbol on the same carrier. If the code bit is +1, the phase shall be the same as that transmitted during the first OFDM symbol. If the code bit is -1, the phase shall be inverted, 180 degrees with respect to the phase transmitted during the first OFDM symbol.

## 7.4 Power control

As with frequency control, a power control algorithm shall be supported for the uplink channel with both an initial calibration and periodic adjustment procedure without loss of data. The objective of the power control algorithm is to bring the received power density from a given subscriber to a desired level. The received power density is defined as total power received from a given subscriber divided by the number of active subcarriers. When subchannelization is not employed, the number of active subcarriers is equal for all the subscribers and the power control algorithm shall bring the total received power from a given subscriber to the desired level. The base station shall be capable of providing accurate power measurements of the received burst signal. This value can then be compared against a reference level, and the resulting error can be fed back to the subscriber station in a calibration message coming from the MAC sublayer. The power control algorithm shall be designed to support power attenuation due to distance loss or power fluctuations at rates of at most 30 dB/s with depths of at least 10 dB. The exact algorithm implementation is vendor-specific.

The total power control range consists of both a fixed portion and a portion that is automatically controlled by feedback. The power control algorithm shall take into account the interaction of the Radio Frequency (RF) power amplifier with different burst profiles. For example, when changing from one burst profile to another, margins should be maintained to prevent saturation of the amplifier and to prevent violation of emissions masks.

When subchannelization is employed the SS shall maintain the same transmitted power density unless the maximum power level is reached. That is, when the number of active subchannels allocated to a user is reduced, the total transmitted power shall be reduced proportionally by the SS, without additional power control messages. When the number of subchannels is increased the total transmitted power shall also be increased proportionally. However, the transmitted power level shall not exceed the maximum levels dictated by signal integrity considerations and regulatory requirements.

When subchannelization is employed, SS shall interpret power control messages as the required changes to the transmitted power density.

Subscriber stations shall report the maximum available power, and the current normalized transmitted power. These parameters may be used by the Base station for optimal assignment of coding schemes, modulations, and for optimal allocation of subchannels. The algorithm is vendor specific. These parameters are reported in the SBC-REQ message. The current normalized transmitted power shall also reported in the REP-RSP message if the relevant flag in the REP-REQ message has been set.

The current transmitted power is the power of the burst which carries the message. The maximum available power is reported for QPSK 16QAM and 64QAM constellations. The current transmitted power and the maximum power parameters are reported in dBm. The parameters are quantized in 0,5 dBm steps ranging from -64 dBm (encoded 0x00) to 63,5 dBm (encoded 0xFF). Values outside this range shall be assigned the closest extreme. SSS that do not support 64QAM shall report the value of 0x00 in the maximum 64QAM power field.

## 8 Space-Time Coding (optional)

STC (see for example IEEE journal on select areas in communications (see bibliography)), may be used on the downlink to provide 2<sup>nd</sup> order (Space) transmit diversity.

There are two transmit antennas on the BS side and one reception antenna on the SS side. This scheme requires Multiple Input Single Output channel estimation. Decoding is very similar to maximum ratio combining.

Figure 16 shows STC insertion into the OFDM chain. Each Tx antenna has its own OFDM chain, but they have the same Local Oscillator for synchronization purposes.

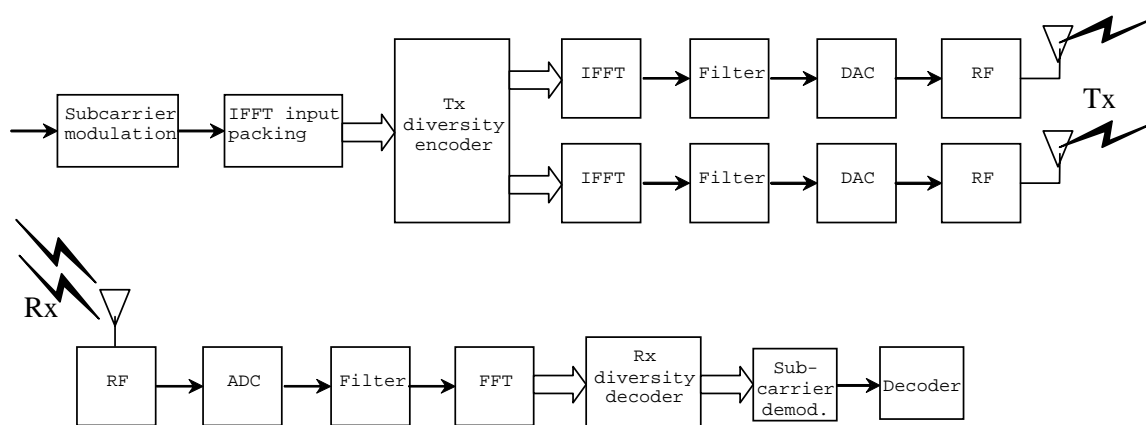

**Figure 16: Illustration of STC**

Both antennas transmit in the same time two different OFDM data symbols. Transmission is performed twice so as to decode and get 2<sup>nd</sup> order diversity. Time domain (Space-Time) repetition is used.

Both antennas transmit at the same time, and they share the same Local Oscillator. Thus, the received signal has exactly the same auto-correlation properties as for a single antenna. So, time and frequency coarse and fine estimation can be performed in the same way as for a single antenna. The scheme requires Multiple Input Single Output channel estimation, which is provisioned by starting the PHY burst following the STC\_IE with a preamble transmitted from both antennas (see clause 5.6) to estimate the channel from both transmit antennas.

The basic scheme transmits two complex symbols  $s_0$  and  $s_1$ , using the channel twice with channel vector values  $h_0$  (for antenna 0) and  $h_1$  (for antenna 1).

First channel use (i.e. first OFDM symbol): Antenna 0 transmits  $s_0$ , antenna 1 transmits  $s_1$ .

Second channel use (i.e. second OFDM symbol): Antenna 0 transmits  $-s_1^*$ , antenna 1 transmits  $s_0^*$ .

Receiver gets  $r_0$  (first channel use) and  $r_1$  (second channel use) and computes  $s_0$  and  $s_1$  estimates:

$$\hat{s}_0 = h_0^* \times r_0 + h_1 \times r_1^* \quad (16)$$

$$\hat{s}_1 = h_1^* \times r_0 - h_0 \times r_1^* \quad (17)$$

These estimates benefit from 2<sup>nd</sup> order diversity as in the 1Tx-2Rx Maximum Ratio Combining scheme. OFDM symbols are processed by pairs. The precoding operation, and consecutively the receive decoding (as described in equations 16 and 17), is applied independently to same-numbered subcarriers in two consecutive OFDM data symbols. Note that the two OFDM symbols may belong to different PHY bursts and even use different constellations. An individual PHY burst may contain any integer number of symbols. The aggregate duration of all PHY bursts following the last STC preamble or between any two STC preambles shall be a multiple of 2.

On a given pilot subcarrier, the same pilot symbol is used for the STC block. If the STC block consists of OFDM symbol  $k$  and  $k+1$  and  $p_s$  is the pilot symbol for pilot subcarrier  $s$  as derived for OFDM symbol  $k$  from clause 5.4.2, then the modulation on pilot subcarrier  $s$  during OFDM symbol  $k$  shall be  $p_s$  on both antenna 0 and 1. During OFDM symbol  $k+1$ , it shall be  $-p_s$  on antenna 0 and  $p_s$  on antenna 1.

For decoding, the receiver waits for 2 symbols and combines them on a subcarrier basis according to equations 16 and 17.

## 9 Channel quality measurements

### 9.1 Introduction

Receive Signal Strength Indicator (RSSI) and Carrier to Interference Noise Ratio (CINR) signal quality measurements and associated statistics can aid in such processes as BS selection/assignment and burst adaptive profile selection. As channel behaviour is time-variant, both mean and standard deviation are defined. Implementation of the RSSI and CINR statistics and their reports is mandatory.

The process by which RSSI measurements are taken does not necessarily require receiver demodulation lock; for this reason, RSSI measurements offer reasonably reliable channel strength assessments even at low signal levels. On the other hand, although CINR measurements require receiver lock, they provide information on the actual operating condition of the receiver, including interference, noise levels, and signal strength.

### 9.2 RSSI mean and standard deviation

When the BS mandates collection of RSSI measurements, a SS shall obtain an RSSI measurement from the OFDM DL preambles. From a succession of RSSI measurements, the SS shall derive and update estimates of the mean and the standard deviation of the RSSI, and report them when solicited via REP-RSP messages.

Mean and standard deviation statistics shall be reported in units of dBm. To prepare such reports, statistics shall be quantized in 1 dB increments, ranging from -40 dBm (encoded 0x53) to -123 dBm (encoded 0x00). Values outside this range shall be assigned the closest extreme value within the scale.

The method used to estimate the RSSI of a single message is left to individual implementation, but the relative accuracy of a single signal strength measurement, taken from a single message, shall be  $\pm 2$  dB, with an absolute accuracy of  $\pm 4$  dB. The specified accuracy shall apply to the range of RSSI values starting from 6 dB below the sensitivity level of the most robust mode or -123 dBm (whichever is higher) up to -40 dBm. In addition, the range over which these single-message measurements are measured should extend 3 dB on each side beyond the -40 dBm to -123 dBm limits for the final averaged statistics that are reported. All measurements are taken at the antenna connector.

One possible method for estimating the RSSI of a received signal of interest is given by:

$$RSSI = 10^{\frac{G_{rf}}{10}} \frac{1,256 \times 10^4 V_c^2}{(2^{2B})R} \left( \frac{1}{N} \sum_{n=0}^{N-1} |Y_{IorQ}[k, n]| \right)^2 \quad mW \quad (18)$$

where:

- $B$  is ADC precision, number of bits of ADC.
- $R$  is ADC input resistance [Ohms].

- $V_c$  is ADC input clip level [Volts].
- $G_{rf}$  is analog gain from antenna connector to ADC input.
- $Y_{IofQ}[k,n]$  is the  $n^{\text{th}}$  sample at the ADC output of I or Q branch within signal  $k$ .
- $N$  is the number of samples.

The (linear) mean RSSI statistics (in mW), derived from a multiplicity of single messages, shall be updated using:

$$\hat{\mu}_{\text{RSSI}}[k] = \begin{cases} R[0] & k = 0 \\ (1 - \alpha_{\text{avg}})\hat{\mu}_{\text{RSSI}}[k-1] + \alpha_{\text{avg}}R[k] & k > 0 \end{cases} \quad \text{mW} \quad (19)$$

where  $k$  is the time index for the message (with the initial message being indexed by  $k = 0$ , the next message by  $k = 1$ , etc.),  $R[k]$  is the RSSI in mW measured during message  $k$ , and  $\alpha_{\text{avg}}$  is an averaging parameter specified by the BS. The mean estimate in dBm shall then be derived from:

$$\hat{\mu}_{\text{RSSI dBm}}[k] = 10 \log(\hat{\mu}_{\text{RSSI}}[k]) \quad \text{dBm} \quad (20)$$

To solve for the standard deviation in dB, the expectation-squared statistic shall be updated using:

$$\hat{x}_{\text{RSSI}}^2[k] = \begin{cases} |R[0]|^2 & k = 0 \\ (1 - \alpha_{\text{avg}})\hat{x}_{\text{RSSI}}^2[k-1] + \alpha_{\text{avg}}|R[k]|^2 & k > 0 \end{cases} \quad (21)$$

and the result applied to:

$$\hat{\sigma}_{\text{RSSI dB}} = 5 \log\left(\hat{x}_{\text{RSSI}}^2[k] - \hat{\mu}_{\text{RSSI}}^2[k]\right) \quad \text{dB} \quad (22)$$

### 9.3 CINR mean and standard deviation

When Carrier to Interference and Noise Ratio (CINR) measurements are mandated by the BS, a SS shall obtain a CINR measurement from the OFDM DL preamble. From a succession of these measurements, the SS shall derive and update estimates of the mean and the standard deviation of the CINR, and report them when solicited via REP-RSP messages

Mean and standard deviation statistics for CINR shall be reported in units of dB. To prepare such reports, statistics shall be quantized in 1 dB increments, ranging from a minimum of -10 dB (encoded 0x00) to a maximum of 53 dB (encoded 0x3F). Values outside this range shall be assigned the closest extreme value within the scale.

The method used to estimate the CINR of a single message is left to individual implementation, but the relative and absolute accuracy of a CINR measurement derived from a single message shall be  $\pm 1$  dB and  $\pm 2$  dB, respectively. The specified accuracy shall apply to the range of CINR values starting from 3 dB below SNR of the most robust rate, to 10 dB above the SNR of the least robust rate. In addition, the range over which these single-packet measurements are measured should extend 3 dB on each side beyond the -10 dB to 53 dB limits for the final reported, averaged statistics.

One possible method to estimate the CINR of a single message is to compute the ratio of signal power to residual error for each data sample, and then average the results from each data sample, using:

$$\text{CINR}[k] = \frac{\sum_{n=0}^{n-1} |s[k,n]|^2}{\sum_{n=0}^{n-1} |r[k,n] - s[k,n]|^2} \quad (23)$$

where  $r[k,n]$  is received sample  $n$  within message  $k$ ;  $s[k,n]$  is the corresponding detected or pilot sample (with channel state weighting) corresponding to received symbol  $n$ .

The mean CINR statistic (in dB) shall be derived from a multiplicity of single messages using:

$$\hat{\mu}_{\text{CINR dB}}[k] = 10 \log(\hat{\mu}_{\text{CINR}}[k]) \quad \text{dB} \quad (24)$$

where:

$$\hat{\mu}_{\text{CINR}}[k] = \begin{cases} \text{CINR}[0] & k = 0 \\ (1 - \alpha_{\text{avg}})\hat{\mu}_{\text{CINR}}[k-1] + \alpha_{\text{avg}}\text{CINR}[k] & k > 0 \end{cases} \quad (25)$$

$k$  is the time index for the message (with the initial message being indexed by  $k = 0$ , the next message by  $k = 1$ , etc.);  $\text{CINR}[k]$  is a linear measurement of CINR (derived by any mechanism which delivers the prescribed accuracy) for message  $k$ ; and  $\alpha_{\text{avg}}$  is an averaging parameter specified by the BS.

To solve for the standard deviation, the expectation-squared statistic shall be updated using:

$$\hat{x}_{\text{CINR}}^2[k] = \begin{cases} |\text{CINR}[0]|^2 & k = 0 \\ (1 - \alpha_{\text{avg}})\hat{x}_{\text{RSSI}}^2[k-1] + \alpha_{\text{avg}}|\text{CINR}[k]|^2 & k > 0 \end{cases} \quad (26)$$

and the result applied to:

$$\hat{\sigma}_{\text{CINR}} \text{ dB} = 5 \log \left( \left| \hat{x}_{\text{RSSI}}^2[k] - \hat{\mu}_{\text{RSSI}}^2 \right| \right) \quad \text{dB} \quad (27)$$

## 10 Transmitter requirements

The parameters mentioned in this clause are intended to be used to guarantee the performance of HiperMAN compliant systems. The parameters relevant to essential requirements under Article 3.2 of the R&TTE Directive and their limits may be found in the appropriate Harmonized EN.

### 10.1 Transmitter channel bandwidth

Transmitter channel bandwidths allowed shall be limited to the regulatory provisioned bandwidth divided by any integer rounded down to the nearest multiple of 250 kHz, resulting in channel bandwidths no less than 1,25 MHz.

If the resulting bandwidth is an odd multiple of 250 kHz, then for any band for which support is claimed, the RF carrier shall only be tunable to every odd multiple of 125 kHz within that band. If the resulting channel bandwidth is an even multiple of 250 kHz, then for any band for which support is claimed, the RF carrier shall only be tunable to every even multiple of 125 kHz within that band. For FDD systems, support shall be claimed separately for UL and DL.

### 10.2 Transmit power level control

For an SS not supporting subchannelization, the transmitter shall support monotonic power level control of 30 dB minimum. For an SS supporting subchannelization, the transmitter shall support a monotonic power level control of 50 dB minimum. The minimum step size shall be no more than 1 dB. The relative accuracy of the power control mechanism shall be  $\pm 1,5$  dB for step sizes not exceeding 30 dB and  $\pm 3$  dB for step sizes greater than 30 dB. For a BS, the transmitter shall support a monotonic power level control of 10 dB minimum.

#### 10.2.1 Transmitter spectral flatness

The average energy of the constellations in each of the spectral lines shall deviate no more than indicated in table 14. The absolute difference between adjacent carriers shall not exceed 0,1 dB. This data shall be taken from the channel estimation step.

**Table 14: OFDM Spectral Flatness**

Spectral Lines	Spectral Flatness
Spectral lines from -50 to -1 and +1 to +50	$\pm 2$ dB from the measured energy averaged over all 200 active tones
Spectral lines from -100 to -50 and +50 to +100	$\pm 2$ dB/-4dB from the measured energy averaged over all 200 active tones

## 10.2.2 Transmitter constellation error and test method

To ensure that the receiver SNR does not degrade more than 0,5 dB due to the transmitter SNR, the relative constellation RMS error, averaged over carriers, OFDM frames, and packets, shall not exceed a burst profile dependent value according to table 15.

**Table 15: Allowed relative constellation error versus data rate**

Burst type	Relative constellation error (dB)
BPSK 1/2	-13
QPSK 1/2	-16
QPSK 3/4	-18,5
16QAM 1/2	-21,5
16QAM 3/4	-25
64QAM 2/3	-28,5
64QAM 3/4	-31

The sampled signal shall be processed in a manner similar to an actual receiver, according to the following steps, or an equivalent procedure:

- a) Start of frame shall be detected.
- b) Transition from short sequences to channel estimation sequences shall be detected, and fine timing (with one sample resolution) shall be established.
- c) Coarse and fine frequency offsets shall be estimated.
- d) The packet shall be de-rotated according to estimated frequency offset.
- e) The complex channel response coefficients shall be estimated for each of the carriers.
- f) For each of the data OFDM symbols: transform the symbol into carrier received values, estimate the phase from the pilot carriers, de-rotate the carrier values according to estimated phase, and divide each carrier value with a complex estimated channel response coefficient. In the case of subchannelization transmission, the estimated channel coefficient of the nearest allocated subcarrier shall be used for those subcarriers not part of the allocated subchannels.
- g) For each data-carrying carrier, find the closest constellation point and compute the Euclidean distance from it. In the case of subchannelization transmission, for data-carrying subcarriers not part of the allocated subchannels, the Euclidean distance shall be computed relative to  $0+0j$ .
- h) Compute the RMS average of all errors in a packet. It is given by:

$$Error_{RMS} = \frac{1}{N} \sum_{i=1}^{N_f} \frac{\sum_{j=1}^{L_p} \left[ \sum_{\substack{k=-N_{used}/2 \\ k \neq 0}}^{N_{used}/2} \left\{ (I(i, j, k) - I_0(i, j, k))^2 + (Q(i, j, k) - Q_0(i, j, k))^2 \right\} \right]}{\sum_{j=1}^{L_p} \left[ \sum_{\substack{k=N_{used}/2 \\ k \neq 0}}^{N_{used}/2} \left\{ I_0(i, j, k)^2 + Q_0(i, j, k)^2 \right\} \right]} \quad (28)$$

where:

$L_p$  is the length of the packet.

$N_f$  is the number of frames for the measurement.

$\{I_0(i, j, k), Q_0(i, j, k)\}$  denotes the ideal symbol point of the  $i^{th}$  frame,  $j^{th}$  OFDM symbol of the frame,  $k^{th}$  carrier of the OFDM symbol in the complex plane.

$\{I(i, j, k), Q(i, j, k)\}$  denotes the point of the  $i^{th}$  frame,  $j^{th}$  OFDM symbol of the frame,  $k^{th}$  carrier of the OFDM symbol in the complex plane.

# 11 Receiver requirements

The parameters mentioned in this clause are intended to be used to guarantee the performance of HiperMAN compliant systems. The parameters relevant to essential requirements under Article 3.2 of the R&TTE Directive and their limits may be found in the appropriate Harmonized EN.

## 11.1 Receiver sensitivity

The Bit Error Rate (BER) after FEC shall be less than  $10^{-6}$  at the power levels indicated by equation 29 for standard message and test conditions. The minimum input levels are measured as follows:

- at the antenna connector or through a calibrated radiated test environment;
- using the defined standardized message packet formats; and
- using an AWGN channel.

The receiver minimum input level sensitivity ( $RSS$ ) shall be better than (assuming 5 dB implementation margin and 7 dB Noise figure):

$$RSS = -102 + SNR_{Rx} + 10 \times \log_{10} \left( F_s \times \frac{N_{used}}{N_{FFT}} \times \frac{N_{subchannels}}{16} \right) \quad (29)$$

where:

$SNR_{Rx}$  the assumed receiver SNR as per table 16 in dB.

$F_s$  the sampling frequency in MHz.

$N_{subchannels}$  the number of allocated subchannels (default 16 if no subchannelization is used).

**Table 16: Receiver SNR assumptions**

Modulation	Coding rate	Receiver SNR (dB)
BPSK	1/2	6,4
QPSK	1/2	9,4
	3/4	11,2
16QAM	1/2	16,4
	3/4	18,2
64QAM	2/3	22,7
	3/4	24,4

Test messages for measuring Receiver Sensitivity shall be based on a continuous stream of MAC PDUs, each with a payload consisting of an  $R$  times repeated sequence  $S_{modulation}$ . For each modulation, a different sequence applies:

$$S_{BPSK} = [0xE4, 0xB1]$$

$$S_{QPSK} = [0xE4, 0xB1, 0xE1, 0xB4]$$

$$S_{16QAM} = [0xA8, 0x20, 0xB9, 0x31, 0xEC, 0x64, 0xFD, 0x75]$$

$$S_{64QAM} = [0xB6, 0x93, 0x49, 0xB2, 0x83, 0x08, 0x96, 0x11, 0x41, 0x92, 0x01, 0x00, 0xBA, 0xA3, 0x8A, 0x9A, 0x21, 0x82, 0xD7, 0x15, 0x51, 0xD3, 0x05, 0x10, 0xDB, 0x25, 0x92, 0xF7, 0x97, 0x59, 0xF3, 0x87, 0x18, 0xBE, 0xB3, 0xCB, 0x9E, 0x31, 0xC3, 0xDF, 0x35, 0xD3, 0xFB, 0xA7, 0x9A, 0xFF, 0xB7, 0xDB]$$



For each mandatory test message, the  $(R, S_{modulation})$  tuples that shall apply are:

- Short length test message payload (288 data bytes):  $(72, S_{QPSK})$ ,  $(36, S_{16QAM})$ ,  $(6, S_{64QAM})$ .
- Mid length test message payload (864 data bytes):  $(216, S_{QPSK})$ ,  $(108, S_{16QAM})$ ,  $(18, S_{64QAM})$ .
- Long length test message payload (1536 data bytes):  $(384, S_{QPSK})$ ,  $(192, S_{16QAM})$ ,  $(32, S_{64QAM})$ .

The test condition requirements are: ambient room temperature, shielded room, conducted measurement at the RF port if available, radiated measurement in a calibrated test environment if the antenna is integrated, and RS FEC is enabled. The test shall be repeated for each test message length and for each  $(R, S_{modulation})$  tuple as identified above, using the mandatory FEC scheme. The results shall meet or exceed the sensitivity requirements indicated by equation 29.

## 11.2 Receiver adjacent and alternate channel rejection

The receiver adjacent and alternate channel rejection shall be met over the required dynamic range of the receiver, from 3 dB above the reference sensitivity level specified in clause 11.1 to the maximum input signal level as specified in clause 11.3.

The adjacent channel rejection and alternate channel rejection shall be measured by setting the desired signal's strength 3 dB above the rate dependent receiver sensitivity (see equation 29) and raising the power level of the interfering signal until the specified error rate of  $1 \times 10^{-6}$  is obtained. The adjacent channel rejection and alternate channel rejection shall also be measured at maximum input level by setting the interfering channel signal strength to the receiver maximum signal level as specified in clause 11.3 and decreasing the power level of the desired signal until the specified error rate is obtained. In both cases, the power difference between the desired signal and the interfering channel is the corresponding C/I ratio.

The interfering signal shall be a conforming OFDM signal, unsynchronized with the signal in the channel under test. The requirement shall be met on both sides of the desired signal channel. For nonadjacent channel testing the test method is identical except the interfering channel shall be any channel other than the adjacent channel or the co-channel. For the PHY to be compliant, the minimum rejection shall exceed the levels shown in table 17.

**Table 17: Adjacent and Non-Adjacent Channel rejection**

Modulation/coding	Adjacent channel Interference C/I (dB)	Non-adjacent channel rejection C/I (dB)
16QAM-3/4	-11	-30
64QAM-3/4	-4	-23

## 11.3 Receiver maximum input signal

The receiver shall be capable of receiving a maximum on-channel signal of -30 dBm, and shall tolerate a maximum signal of 0 dBm without damage. Power levels are measured at the antenna connector.

## 11.4 Receiver linearity

The receiver shall have a minimum Input Intercept Point (IIP3) of -10 dBm.

## 11.5 Out-of-Band signal rejection

The receiver's immunity for out-of-band signals shall be measured by setting the desired signal's strength to a given level, and raising the power level of the out-of-band signal until the specified BER of  $10^{-6}$  is obtained. The out-of-band signal shall be a CW signal.

For the PHY to be compliant, the minimum out-of-band immunity level shall exceed the values of table 18, for the levels of the desired input signal: receiver minimum input sensitivity level +  $n \times 3$ dB (n being a positive, non-zero integer) until the maximum input signal level is reached.

**Table 18: Out-of-Band Signal Immunity Levels**

Out-of-Band frequency	Minimum Out-of-Band immunity level
$ f_{\text{blocker}} - f_{\text{signal}}  < 100 \text{ MHz}$	Idem to the interference levels of clause 12.2
$100 \text{ MHz} <  f_{\text{blocker}} - f_{\text{signal}}  < 1 \text{ GHz}$	-30 dBm or +20 dBr (see notes 1 and 2)
$1 \text{ GHz} <  f_{\text{blocker}} - f_{\text{signal}} $	-10 dBm or +30 dBr (see note 1)

NOTE 1: Whichever of the two is larger. "dBr" indicates a level relative to the desired input signal's level, whereas "dBm" indicates an absolute level.

NOTE 2: Up to two out-of-band frequency bands with a bandwidth of 30 MHz are tolerated, where this specification is relaxed by 10 dB.

All power levels are measured at the antenna connector.

## 11.6 Spurious emissions

Emissions of HiperMAN equipment made outside the time of transmitted bursts shall not exceed the following values.

**Table 19: Spurious emissions**

Frequency Range	Maximum power	Measurement bandwidth
30 MHz to 1 GHz	-57 dBm	100 kHz
1 GHz to 26,5 GHz	-50 dBm	1 MHz

The indicated bandwidths are nominal -3 dB bandwidths. All power levels measured at the antenna connector.

---

## 12 Frequency and timing requirements

The BS transmitted centre frequency, receive centre frequency, and the symbol clock frequency shall be derived from the same reference oscillator. The reference frequency tolerance for the BS shall be better than  $\pm 8 \times 10^{-6}$  in licensed bands up to 10 years from the date of equipment manufacture.

The SS shall synchronize its transmitted centre frequency and symbol clock frequency to the BS with a maximum tolerance of 2 % of the FFT carrier spacing.

For mesh capable devices, all devices shall have a  $\pm 20$  ppm maximum frequency tolerance and achieve synchronization to its neighbouring nodes with a tolerance of maximum 3 % of the carrier spacing.

During the synchronization period, the SS shall acquire frequency synchronization within the specified tolerance before attempting any uplink transmission. During normal operation, the SS shall track the frequency changes and shall defer any transmission if synchronization is lost.

All SSs shall acquire and adjust their timing such that all uplink OFDM symbols arrive time coincident at the Base-Station to an accuracy of  $\pm 50$  % of the minimum guard-interval or better.

---

## 13 Parameters and constants

A number of parameters and constants are defined, which are used by the DLC.

- Physical Slot (PS):

$$PS = \frac{4}{\Delta f} \times N_{\text{FFT}} \quad (30)$$

- Timing Adjust Units:

$$\text{Timing Adjust Unit} = \frac{1}{\Delta f} \times N_{\text{FFT}} \quad (31)$$

---

## Annex A (informative): Bibliography

- Alamouti, S.M., "A Simple Transmit Diversity Technique for Wireless Communications", IEEE journal on select areas in communications, Vol.16, No. 8, pages 1451-1458, October 1998.

---

## History

<b>Document history</b>		
V1.1.1	November 2003	Publication
V1.2.1	January 2005	Publication