

# ETSI TS 102 177 V1.5.1 (2010-05)

---

*Technical Specification*

**Broadband Radio Access Networks (BRAN);  
HiperMAN;  
Physical (PHY) layer**

---



---

**Reference**

RTS/BRAN-0040001r6

---

**Keywords**access, broadband, FWA, HiperMAN, layer 1,  
MAN, nomadic, radio**ETSI**

---

650 Route des Lucioles  
F-06921 Sophia Antipolis Cedex - FRANCE

Tel.: +33 4 92 94 42 00 Fax: +33 4 93 65 47 16

Siret N° 348 623 562 00017 - NAF 742 C  
Association à but non lucratif enregistrée à la  
Sous-Préfecture de Grasse (06) N° 7803/88

---

**Important notice**

Individual copies of the present document can be downloaded from:

<http://www.etsi.org>

The present document may be made available in more than one electronic version or in print. In any case of existing or perceived difference in contents between such versions, the reference version is the Portable Document Format (PDF). In case of dispute, the reference shall be the printing on ETSI printers of the PDF version kept on a specific network drive within ETSI Secretariat.

Users of the present document should be aware that the document may be subject to revision or change of status. Information on the current status of this and other ETSI documents is available at

<http://portal.etsi.org/tb/status/status.asp>

If you find errors in the present document, please send your comment to one of the following services:

[http://portal.etsi.org/chaicor/ETSI\\_support.asp](http://portal.etsi.org/chaicor/ETSI_support.asp)

---

**Copyright Notification**

No part may be reproduced except as authorized by written permission.  
The copyright and the foregoing restriction extend to reproduction in all media.

© European Telecommunications Standards Institute 2010.  
All rights reserved.

**DECT™**, **PLUGTESTS™**, **UMTS™**, **TIPHON™**, the TIPHON logo and the ETSI logo are Trade Marks of ETSI registered for the benefit of its Members.

**3GPP™** is a Trade Mark of ETSI registered for the benefit of its Members and of the 3GPP Organizational Partners.

**LTE™** is a Trade Mark of ETSI currently being registered

for the benefit of its Members and of the 3GPP Organizational Partners.

**GSM®** and the GSM logo are Trade Marks registered and owned by the GSM Association.

# Contents

Intellectual Property Rights .....	5
Foreword.....	5
1 Scope .....	6
2 References .....	6
2.1 Normative references .....	6
2.2 Informative references.....	7
3 Definitions, symbols and abbreviations .....	7
3.1 Definitions.....	7
3.2 Symbols.....	7
3.3 Abbreviations .....	8
4 HiperMAN OFDM PHY .....	9
4.1 OFDM symbol description.....	9
4.2 Transmitted signal .....	10
4.3 Channel coding.....	12
4.3.1 Randomization.....	12
4.3.2 Forward Error Correction (FEC) .....	13
4.3.2.1 Concatenated Reed-Solomon / Convolutional Code (RS-CC).....	13
4.3.2.2 Convolutional Turbo Coding (Optional).....	15
4.3.2.2.1 CTC interleaver .....	16
4.3.2.2.2 Determination of CTC circulation states .....	17
4.3.2.2.3 CTC puncturing.....	17
4.3.3 Interleaving.....	17
4.3.4 Modulation.....	18
4.3.4.1 Data modulation.....	18
4.3.4.2 Pilot modulation.....	19
4.3.4.3 Rate ID encodings.....	20
4.3.5 Example UL RS-CC Encoding .....	20
4.3.5.1 Full bandwidth (16 subchannels) .....	20
4.3.5.2 Subchannelization (2 subchannels) .....	21
4.3.5.3 Subchannelization (1 subchannel).....	22
4.3.6 Preamble structure and modulation .....	22
4.3.6.1 Transmission Convergence (TC) sublayer.....	25
4.4 Frame structures .....	25
4.4.1 PMP .....	25
4.4.1.1 Duplexing modes .....	25
4.4.1.2 DL frame prefix .....	28
4.4.1.3 PMP DL subchannelization zone .....	28
4.4.1.4 PMP-AAS zone.....	31
4.4.2 Mesh .....	34
4.4.3 Frame duration codes.....	35
4.5 Control mechanisms .....	35
4.5.1 Synchronization .....	35
4.5.1.1 Network synchronization .....	35
4.6 Ranging .....	35
4.6.1 Initial Ranging in AAS systems.....	38
4.6.2 Bandwidth requesting .....	38
4.6.2.1 Parameter selection .....	38
4.6.2.2 Full contention transmission .....	40
4.6.2.3 Focused contention transmission .....	40
4.6.3 Power control.....	41
4.6.3.1 Closed loop power control .....	41
4.6.3.2 Open loop power control (optional).....	41
4.7 Transmit diversity space-time coding (optional).....	43
4.7.1 STC 2X2 .....	44

4.7.1.1	STC 2x2 coding .....	44
4.7.1.2	STC 2x2 decoding.....	45
4.8	Channel quality measurements.....	45
4.8.1	Introduction.....	45
4.8.2	RSSI mean and standard deviation .....	46
4.8.3	CINR mean and standard deviation .....	47
4.9	Transmitter requirements .....	47
4.9.1	Transmitter channel bandwidth.....	48
4.9.2	Transmit power level control.....	48
4.9.2.1	Transmitter spectral flatness.....	48
4.9.2.2	Transmitter constellation error and test method.....	48
4.10	Receiver requirements.....	49
4.10.1	Receiver sensitivity.....	49
4.10.2	Receiver adjacent and alternate channel rejection .....	50
4.10.3	Receiver maximum input signal .....	51
4.10.4	Receiver linearity.....	51
4.11	Frequency and timing requirements .....	51
4.12	Parameters and constants.....	51
5	HiperMAN OFDMA PHY .....	52
	History .....	53

---

## Intellectual Property Rights

IPRs essential or potentially essential to the present document may have been declared to ETSI. The information pertaining to these essential IPRs, if any, is publicly available for **ETSI members and non-members**, and can be found in ETSI SR 000 314: "*Intellectual Property Rights (IPRs); Essential, or potentially Essential, IPRs notified to ETSI in respect of ETSI standards*", which is available from the ETSI Secretariat. Latest updates are available on the ETSI Web server (<http://webapp.etsi.org/IPR/home.asp>).

Pursuant to the ETSI IPR Policy, no investigation, including IPR searches, has been carried out by ETSI. No guarantee can be given as to the existence of other IPRs not referenced in ETSI SR 000 314 (or the updates on the ETSI Web server) which are, or may be, or may become, essential to the present document.

---

## Foreword

This Technical Specification (TS) has been produced by ETSI Technical Committee Broadband Radio Access Networks (BRAN).

The present document describes the physical layer specifications for High PERFORMANCE Radio Metropolitan Area Network (HiperMAN). Separate ETSI documents provide details on the system overview, Data Link Control (DLC) layer, Convergence Layers (CL) and conformance testing requirements for HiperMAN.

With permission of IEEE® (on file as BRAN43d016), portions of the present document are excerpted from IEEE Standards [2] and [3].

---

# 1 Scope

The present document specifies the HiperMAN air interface with the specification layer 1 (physical layer), which can be used to provide Fixed applications, in frequencies below 11 GHz, and Nomadic and converged Fixed-Nomadic applications, in frequencies below 6 GHz. The present document follows the ISO-OSI model. HiperMAN is confined only to the radio subsystems consisting of the *Physical (PHY) layer* and the *DLC layer* - which are both core network independent - and the core network specific *convergence sub-layer*.

For managing radio resources and connection control, the Data Link Control (DLC) protocol is applied, which uses the transmission services of the DLC layer. Convergence layers above the DLC layer handle the inter-working with layers at the top of the radio sub-system.

The scope of the present document is as follows:

- It gives a description of the physical layer for HiperMAN systems.
- It specifies the transmission scheme in order to allow interoperability between equipment developed by different manufacturers. This is achieved by describing scrambling, channel coding, modulation, framing, control mechanisms, and power control to assist in radio resource management.
- It does cover the receiver and transmitter performance requirements which are specific for HiperMAN systems.
- Some information clauses and annexes describe parameters and system models to assist in preparing conformance, interoperability and coexistence specifications.

---

# 2 References

References are either specific (identified by date of publication and/or edition number or version number) or non-specific. For specific references, only the cited version applies. For non-specific references, the latest version of the reference document (including any amendments) applies.

Referenced documents which are not found to be publicly available in the expected location might be found at <http://docbox.etsi.org/Reference>.

NOTE: While any hyperlinks included in this clause were valid at the time of publication ETSI cannot guarantee their long term validity.

## 2.1 Normative references

The following referenced documents are necessary for the application of the present document.

- [1] ETSI TS 102 178: "Broadband Radio Access Networks (BRAN); HiperMAN; Data Link Control (DLC) layer".
- [2] IEEE 802.16-2004: "IEEE Standard for Local and Metropolitan Area Networks - Part 16: Air Interface for Fixed Broadband Wireless Access Systems".
- [3] IEEE 802.16e-2005: "IEEE Standard for Local and metropolitan area networks - Part 16: Air Interface for Fixed and Mobile Broadband Wireless Access Systems - Amendment 2: Physical and Medium Access Control Layers for Combined Fixed and Mobile Operation in Licensed Bands and Corrigendum 1".
- [4] Directive 1999/5/EC of the European Parliament and of the Council of 9 March 1999 on radio equipment and telecommunications terminal equipment and the mutual recognition of their conformity (R&TTE Directive).
- [5] IEEE Std 802.16<sup>TM</sup>-2009: "IEEE Standard for Local and metropolitan area networks Part 16: Air Interface for Broadband Wireless Access Systems".

## 2.2 Informative references

The following referenced documents are not necessary for the application of the present document but they assist the user with regard to a particular subject area.

- [i.1] Alamouti, S.M.: "A Simple Transmit Diversity Technique for Wireless Communications", IEEE journal on select areas in communications, Vol.16, No. 8, pages 1451-1458, October 1998.

---

## 3 Definitions, symbols and abbreviations

### 3.1 Definitions

For the purposes of the present document, the following terms and definitions apply:

**Base Station (BS):** generalized equipment consisting of one or more Base Station Controllers and one or more Base Station transceivers

**channel coding:** sequence composed of three steps; randomizer, forward error correction and interleaving

**DL-MAP:** structured data sequence that defined the mapping of the DL

**DownLink (DL):** direction from BS to SS

**frequency offset index:** index number identifying a particular carrier in an OFDM signal

NOTE: Frequency offset indices may be positive or negative and are counted relative to the DC carrier.

**full duplex:** equipment that is capable of transmitting and receiving at the same time

**guard time:** time at the beginning or end of each burst to allow power ramping up and down

**half duplex:** equipment that cannot transmit and receive at the same time

**preamble:** sequence of symbols with a given auto-correlation property assisting modem synchronization and channel estimation

**Receive-Transmit Transition Gap (RTG):** time to switch from receive to transmit at the BS

**Subscriber Station (SS):** generalized equipment consisting of a Subscriber Station Controller and Subscriber Station Transceiver

**Transmit-Receive Transition Gap (TTG):** time to switch from transmit to receive at the BS

**UL MAP:** MAC message scheduling UL bursts

**UpLink (UL):** direction from SS to BS

### 3.2 Symbols

For the purposes of the present document, the following symbols apply:

$BW$	Nominal channel bandwidth (MHz)
$F_{sa}$	Sampling frequency (MHz)
$N_{cbps}$	Number of coded bits per OFDM symbol (on allocated subchannels)
$N_{FFT}$	Nominal size of the FFT operator
$N_{used}$	Number of carriers used to transport either data or pilots within a single OFDM symbol
$R_{os}$	BW over sampling ratio
$T_b$	Useful OFDM symbol time (s)
$T_F$	Frame duration (ms)

$T_g$	OFDM symbol guard time or CP time (s)
$T_s$	OFDM symbol time (s)
$\alpha_{\text{avg}}$	Channel measurement averaging constant
$\Delta f$	Carrier spacing (Hz)

### 3.3 Abbreviations

For the purposes of the present document, the following abbreviations apply:

AAS	Adaptive Antenna System
AWGN	Average White Gaussian Noise
BER	Bit Error Rate
BPSK	Binary Phase Shift Keying
BS	Base Station
BSID	Base Station IDentification
BW	BandWidth
CC	Convolutional Coding
CCH	Control subCHannel
CID	Connection IDentifier
CINR	Carrier to Interference Noise Ratio
CL	Convergence Layer
CNR	Carrier to Noise Ratio
CP	Cyclic Prefix
CTC	Convolutional Turbo Code
DC	Direct Current
DCD	Downlink Channel Descriptor
DIUC	Downlink Interval Usage Code
DL	DownLink
DLC	Data Link Control
DLFP	DownLink Frame Prefix
FCH	Frame Control Header
FDD	Frequency Division Duplexing
FEC	Forward Error Correction
FFT	Fast Fourier Transform
HCS	Header Check Sequence
H-FDD	Half duplex Frequency Division Duplexing
IE	Information Element
IFFT	Inverse Fast Fourier Transform
LSB	least Significant Bit
MAC	Media Access Control
MAN	Metropolitan Area Network
MSB	Most Significant Bit
OFDM	Orthogonal Frequency Division Multiplexing
OFDMA	Orthogonal Frequency Division Multiple Access
PDU	Protocol Data Unit
PHY	PHYsical
PMP	Point-to-MultiPoint
PRBS	Pseudo Random Binary Sequence
PS	Physical Slot
QAM	Quadrature Amplitude Modulation
QPSK	Quadrature Phase Shift Keying
REQ	REQuest
RF	Radio Frequency
RMS	Root Mean Square
RS	Reed-Solomon
RS-CC	Reed-Solomon / Convolutional Code
RSSI	Received Signal Strength Indicator
RTG	Receive-Transmit Transition Gap
Rx	Receive



SNR	Signal to Noise Ratio
SS	Subscriber Station
SSRTG	Subscriber Station Receive Transmit Gap
STC	Space Time Coding
TC	Transmission Convergence
TDD	Time Division Duplexing
TLV	Type Length Value
TOs	Transmission Opportunities
TTG	Transmit-receive Transition Gap
Tx	Transmit
UCD	Uplink Channel Descriptor
UIUC	Uplink Interval Usage Code
UL	UpLink
XOR	eXclusive OR

## 4 HiperMAN OFDM PHY

### 4.1 OFDM symbol description

An OFDM waveform is created by applying an Inverse-Fourier-transform to the source data. The resultant time duration is referred to as the useful symbol time  $T_b$ . A copy of the last  $T_g$   $\mu$ s of the useful symbol period, termed Cyclic Prefix (CP), is prepended to enable the collection of multipath at the receiver, without loss of orthogonality between the tones. The resulting waveform is termed the symbol time  $T_s$ . Figure 1 illustrates this structure.

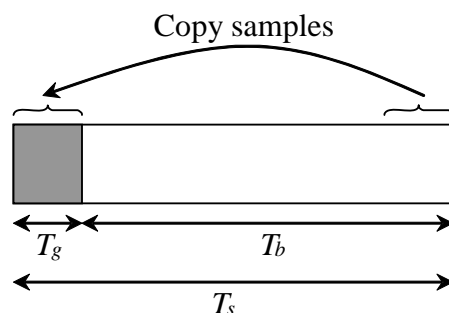

**Figure 1: OFDM symbol time structure**

The transmitter energy increases with the length of the CP while the receiver energy remains the same (the CP is discarded), so there is a  $10 \log (1 - T_g / (T_b + T_g)) / \log(10)$  dB loss in SNR. Using the CP, the samples required for performing the FFT at the receiver can be taken anywhere over the length of the extended symbol. This provides multipath immunity as well as a tolerance for symbol time synchronization errors.

On system initialization, the Base Station (BS) CP fraction ( $T_g / T_b$ ) shall be set to a specific value for use on the Downlink (DL). Once the BS is operational the CP value shall not be changed. On initialization, the Subscriber Station (SS) shall search all possible values of CP until it finds the CP being used by the serving BS. The SS shall use the same CP values determined in DL for the UL. Changing the CP value parameter at the BS through (re)initialization forces all SS registered on that BS to re-synchronize.

In the frequency domain, each OFDM symbol is comprised of multiple carriers (see figure 2), which belong to one of three types:

- Data carriers - for data transmission.
- Pilot carriers - for channel estimation and other purposes.
- Null carriers - for guard bands and the DC carrier.

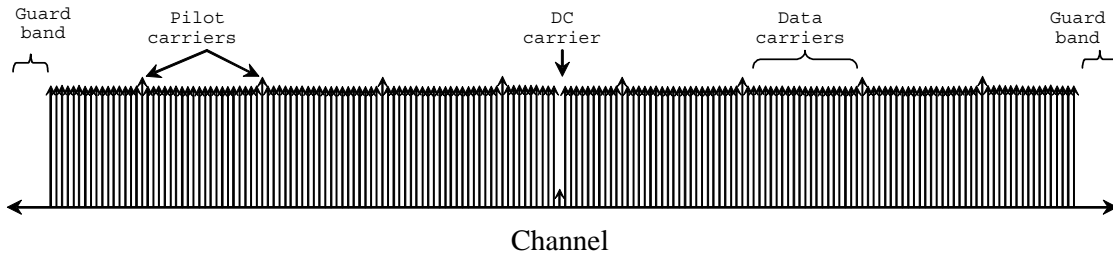

Figure 2: OFDM symbol frequency structure

## 4.2 Transmitted signal

Equation 1 specifies the transmitted signal voltage  $s(t)$  to the antenna, as a function of time, during any OFDM symbol.

$$s(t) = \text{Re} \left\{ e^{2j\pi f_c t} \sum_{\substack{k=-N_{\text{used}}/2 \\ k \neq 0}}^{k=N_{\text{used}}/2} c_k \times e^{2j\pi k \Delta f (t-T_g)} \right\} \quad (1)$$

where:  $t$  is the time elapsed since the beginning of the subject OFDM symbol, with  $0 < t < T_s$ .

$C_k$  is a complex number; the data to be transmitted on the carrier whose frequency offset index is  $k$ , during the subject OFDM symbol. It specifies a point in a Quadrature Amplitude Modulation (QAM) constellation. In the case of subchannelization,  $C_k$  is zero for all unallocated.

$f_c$  is the RF carrier frequency, being the centre frequency of the intended RF frequency channel.

$k$  is the frequency offset index.

The parameters of the transmitted OFDM signal, which shall be used, are given in table 1.

Table 1: OFDM symbol parameters

Parameter	Value
$N_{\text{FFT}}$	256
$N_{\text{used}}$	200
$T_g / T_b$	1/4, 1/8, 1/16, 1/32
Frequency offset indices of guard carriers	-128, -127 to -101 +101, +102 to 127
Frequency offset indices of Pilots	-88, -63, -38, -13, 13, 38, 63, 88
Subchannel Index	Allocated frequency offset indices of carriers
	<ul style="list-style-type: none"> <li>0b00001 {-100:-98, -37:-35, 1:3, 64:66}</li> <li>0b00010 {-38}</li> <li>0b00011 {-97:-95, -34:-32, 4:6, 67:69}</li> <li>0b00101 {-94:-92, -31:-29, 7:9, 70:72}</li> <li>0b00110 {13}</li> <li>0b00111 {-91:-89, -28:-26, 10:12, 73:75}</li> <li>0b01001 {-87:-85, -50:-48, 14: 16, 51:53}</li> <li>0b01010 {-88}</li> <li>0b01011 {-84:-82, -47:-45, 17: 19, 54:56}</li> <li>0b01101 {-81:-79, -44:-42, 20:22, 57:59}</li> <li>0b01110 {63}</li> <li>0b01111 {-78:-76, -41:-39, 23:25, 60:62}</li> <li>0b10001 {-75:-73, -12:-10, 26:28, 89:91}</li> <li>0b10010 {-13}</li> <li>0b10011 {-72:-70, -9: -7, 29:31, 92:94}</li> <li>0b10101 {-69:-67, -6: -4, 32:34, 95:97}</li> <li>0b10110 {38}</li> <li>0b10111 {-66:-64, -3: -1, 35:37, 98:100}</li> <li>0b11001 {-62:-60, -25:-23, 39:41, 76:78}</li> <li>0b11010 {-63}</li> <li>0b11011 {-59:-57, -22:-20, 42:44, 79:81}</li> <li>0b11101 {-56:-54, -19:-17, 45:47, 82:84}</li> <li>0b11110 {88}</li> <li>0b11111 {-53:-51, -16:-14, 48:50, 85:87}</li> </ul>
NOTE: Pilot carriers are allocated only if two or more subchannels are allocated.	

Using the parameters as specified in table 1, the following relationships shall hold.

$$F_{sa} = \text{floor} (R_{os} \times BW / 8\,000) \times 8\,000$$

$$\Delta f = R_{os} \times BW / N_{\text{FFT}}$$

$$T_b = 1 / \Delta f$$

$$T_g = \left( \frac{T_g}{T_b} \right) \times T_b$$

$$T_s = T_b + T_g$$

$$T_{sa} = 1 / F_{sa}$$

$$F_{sa} = R_{os} \times BW$$

## 4.3 Channel coding

Channel coding is composed of three steps: randomization, forward error correction, and interleaving. They shall be applied in this order at transmission. The complementary operations shall be applied in reverse order at reception.

### 4.3.1 Randomization

Data randomization is performed independently on each burst of uplink and downlink data (i.e. not on pilots and preambles) on the subchannels in the frequency domain and OFDM symbols in the time domain. If the amount of data to transmit does not fit exactly the amount of data allocated, padding of 0xFF ("1"s only) shall be added to the end of the transmission block for the unused integer number of bytes, up to the amount of data allocated. For RS-CC and CC encoded data, padding will be added to the end of the transmission block, up to the amount of data allocated minus one byte, which shall be reserved for the introduction of a 0x00 tail byte by the FEC. For CTC, if implemented, padding will be added to the end of the transmission block, up to the amount of data allocated.

The Pseudo Random Binary Sequence (PRBS) generator shall be  $1 + x^{14} + x^{15}$  as shown in figure 3. Each data byte to be transmitted shall enter sequentially into the randomizer, most significant bit (MSB) first. The seed value shall be used to calculate the randomization bits, which are combined in an XOR operation with the serialized bit stream of each burst. The "data out" bits from the randomizer shall be applied to the FEC.

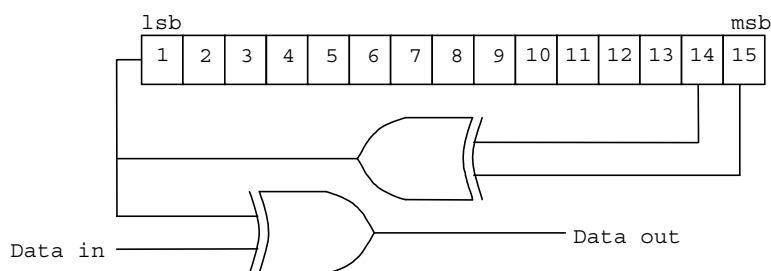

**Figure 3: Data randomization PRBS**

On the DL, the randomizer shall be re-initialized at the start of the FCH and at the start of the STC zone only in the case a FCH-STC is present, with the vector: 1 0 0 1 0 1 0 0 0 0 0 0. The randomizer shall not be reset at the start of the burst immediately following FCH or FCH-STC. At the start of subsequent bursts the randomizer shall be initialized with the vector shown in figure 4. The OFDM symbol number (i.e. the number of the first OFDM symbol of the data burst) shall be counted from the start of the DL-subframe, the first symbol being counted as symbol #0.

For a DL subchannelization zone the randomizer is initialized in an equivalent manner. At the start of the DL subchannelized zone, the randomizer shall be re-initialized to the sequence 1 0 0 1 0 1 0 1 0 0 0 0 0 0 0. The randomizer shall not be reset at the start of the first burst in the CCH. At the start of subsequent bursts, the randomizer shall be initialized with the vector shown in figure 4. The frame number used for initialization refers to the frame in which the subchannelized burst is transmitted and can be obtained from the SBCH\_DLFP (refer to table 12).

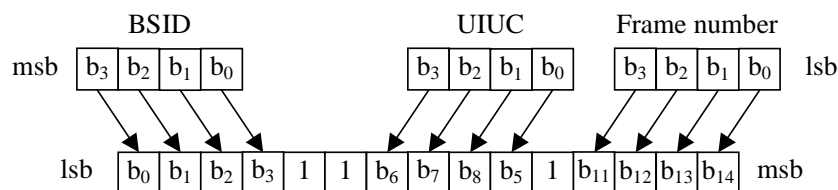

Figure 4: Scrambler DL initialization vector for bursts #2 to  $N$

On the UL, the randomizer shall be initialized with the vector shown in figure 5. The frame number used for initialization is that of the frame in which the UL map that specifies the uplink burst was transmitted.

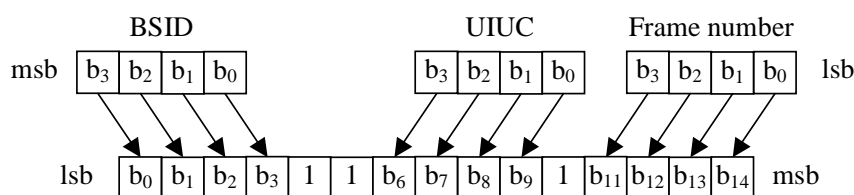

Figure 5: Scrambler UL initialization vector

### 4.3.2 Forward Error Correction (FEC)

The FEC consisting of the concatenation of a Reed-Solomon outer code and a rate-compatible convolutional inner code shall be supported on both UL and DL. Support of Convolutional Turbo Code (CTC) is optional. The most robust burst profile shall always be used as the coding mode when requesting access to the network and in the Frame Control Header (FCH) burst.

The encoding is performed by first passing the data in block format through the RS encoder and then passing it through a convolutional encoder. Eight tail bits are introduced at the end of each allocation, which are set to zero. This tail Byte shall be appended after randomization. In the RS encoder, the redundant bits are sent before the input bits, keeping the tail bits at the end of the allocation. When the total number of data bits in a burst is not an integer number of Bytes, zero pad bits are added after the zero tail bits. The zero pad bits are not randomized. Note that this situation can occur only in subchannelization. In this case the RS encoding is not employed.

#### 4.3.2.1 Concatenated Reed-Solomon / Convolutional Code (RS-CC)

The RS encoding shall be derived from a systematic RS ( $N = 255$ ,  $K = 239$ ,  $T = 8$ ) code using  $GF(2^8)$ , where:

$N$  is the number of overall bytes after encoding.

$K$  is the number of data bytes before encoding.

$T$  is the number of data bytes which can be corrected.

For the systematic code, the code generator polynomial  $g(x)$ , shown in equation 2, and field generator polynomial  $p(x)$ , shown in equation 3, shall be used.

$$g(x) = (x + \lambda^0)(x + \lambda^1)(x + \lambda^2) \dots (x + \lambda^{2T-1}), \quad \lambda = 02_{\text{HEX}} \quad (2)$$

$$p(x) = x^8 + x^4 + x^3 + x^2 + 1 \quad (3)$$

This code is shortened and punctured to enable variable block sizes and variable error-correction capability. When a block is shortened to  $K'$  data bytes, add  $239 - K'$  zero bytes as a prefix. After encoding discard these  $239 - K'$  zero bytes. When a codeword is punctured to permit  $T'$  bytes to be corrected, only the first  $2T'$  of the total 16 parity bytes shall be employed. The bit/byte conversion shall be MSB first.

Each RS block is encoded by the binary convolutional encoder, which shall have native rate of  $1/2$ , a constraint length equal to 7, and shall use the generator polynomials codes shown in equation 4 to derive its two code bits.

$$\begin{aligned} G_1 &= 171_{\text{OCT}} && \text{for } X \\ G_2 &= 133_{\text{OCT}} && \text{for } Y \end{aligned} \quad (4)$$

The generator is depicted in figure 6.

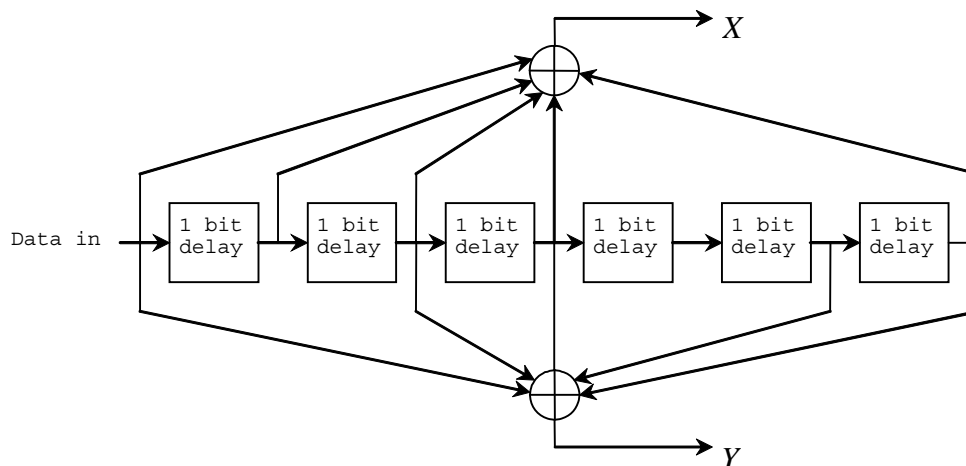

**Figure 6: Convolutional encoder of rate 1/2**

Puncturing patterns and serialization order which shall be used to realize different code rates are defined in table 2. Transmitted bits are denoted by "1" and removed bits are denoted by "0".  $X$  and  $Y$  are in reference to figure 6.

**Table 2: The inner convolutional code puncturing configuration**

Code rate	$d_{\text{free}}$	$X$	$Y$	Order
1/2	10	1	1	$X_1 Y_1$
2/3	6	10	11	$X_1 Y_1 Y_2$
3/4	5	101	110	$X_1 Y_1 Y_2 X_3$
5/6	4	10101	11010	$X_1 Y_1 Y_2 X_3 Y_4 X_5$

The encoding is performed by first passing the data in block format through the RS encoder and then passing it through a convolutional encoder. A single tail 0x00 tail byte is appended to the end of each burst. This tail byte shall be appended after randomization. In the RS encoder, the redundant bits are sent before the input bits, keeping the 0x00 tail byte at the end of the allocation. To ensure that the number of bits after the convolutional encoder is divisible by  $N_{\text{cbps}}$ , as specified in table 7, zero (0b0) pad bits added after the zero tail bits before the encoder. The zero bits are not randomized. Note that this situation can occur only in the subchannelization. In this case, the RS encoding is not employed.

Table 3 defines the block sizes for the different modulation levels and code rates. As 64-QAM is optional for license exempt bands, the codes for this modulation shall only be implemented if the modulation is implemented.

Table 3: Mandatory channel encodings

Modulation	Uncoded block size (bytes)	Coded block size (bytes)	Overall coding rate	RS code	CC code rate
BPSK	12	24	1/2	(12,12,0)	1/2
QPSK	24	48	1/2	(32,24,4)	2/3
QPSK	36	48	3/4	(40,36,2)	5/6
16-QAM	48	96	1/2	(64,48,8)	2/3
16-QAM	72	96	3/4	(80,72,4)	5/6
64-QAM	96	144	2/3	(108,96,6)	3/4
64-QAM	108	144	3/4	(120,108,6)	5/6

Table 3 gives the block sizes and code rates for the different modulation and code rates. Since 64-QAM is optional for license-exempt bands, these codes are only implemented if the option is implemented.

When subchannelization is applied in the UL, the FEC shall bypass the RS encoder and use the Overall Coding Rate as indicated in table 3 as CC Code Rate. The Uncoded Block Size and Coded Block Size may be computed by multiplying the values listed in table 3 by the number of allocated subchannels divided by 16. In the case of BPSK modulation, RS encoder should be bypassed.

In the case of BPSK modulation, the RS coder should be bypassed.

#### 4.3.2.2 Convolutional Turbo Coding (Optional)

The Convolutional Turbo Code encoder, including its constituent encoder, is depicted in figure 7. It uses a double binary Circular Recursive Systematic Convolutional code. The bits of the data to be encoded are alternately fed to A and B, starting with the MSB of the first byte being fed to A. The encoder is fed by blocks of  $k$  bits or  $N$  couples ( $k = 2 \times N$  bits). For all the frame sizes  $k$  is a multiple of 8 and  $N$  is a multiple of 4. Further  $N$  shall be limited to:  $8 \leq N/4 \leq 1024$ . For subchannelization, the coding block size is limited to blocks at least 48 bits in length, and no more than 1024 bits in length. In addition,  $k$  cannot be a multiple of 7.

The polynomials defining the connections are described in octal and symbol notations as follows:

- for the feedback branch:  $0 \times B$ , equivalently  $1 + D + D^3$  (in symbolic notation);
- for the Y parity bit:  $0 \times D$ , equivalently  $1 + D^2 + D^3$ .

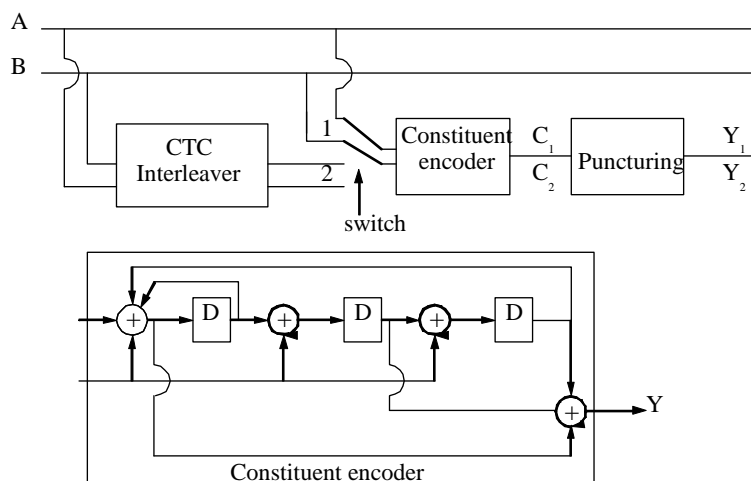

Figure 7: CTC encoder

First, the encoder (after initialization by the circulation state  $Sc_1$ , see below) is fed the sequence in the natural order (position 1) with the incremental address  $i = 0$  to  $N-1$ . This first encoding is called  $C_1$  encoding. Then the encoder (after initialization by the circulation state  $Sc_2$ , see below) is fed by the interleaved sequence (switch in position 2) with incremental address  $j = 0$  to  $N-1$ . This second encoding is called  $C_2$  encoding.

The order in which the encoded bit shall be fed into the interleaver (see clause 4.3.3) is:

$$A_0, B_0 \text{ to } A_{N-1}, B_{N-1}, Y_{1,0}, Y_{1,1} \text{ to } Y_{1,M}, Y_{2,0}, Y_{2,1} \text{ to } Y_{2,M},$$

where  $M$  is the number of parity bits.

Table 4 gives the block sizes, code rates, channel efficiency, and code parameters for the different modulation and coding schemes. As 64-QAM is optional for license exempt bands, the codes for this modulation shall only be implemented if the modulation is implemented.  $N_{sub}$  denotes the number of subchannels of the allocation in which the encoded data will be transmitted. The data block size in bytes per OFDM symbol may be calculated as  $N/4$ . Further,  $P_1$  equals  $3N/4$ .

**Table 4: Optional CTC Coding per Modulation**

Modulation	Overall Code Rate	N	$P_0$
QPSK	1/2	$6 \times N_{sub}$	7
QPSK	2/3	$8 \times N_{sub}$	11
QPSK	3/4	$9 \times N_{sub}$	17
16-QAM	1/2	$12 \times N_{sub}$	11
16-QAM	3/4	$18 \times N_{sub}$	13
64-QAM	2/3	$24 \times N_{sub}$	17
64-QAM	3/4	$27 \times N_{sub}$	17

In table 4,  $N_{sub}$  denotes the number of subchannels of the allocation in which the encoded data will be transmitted. The data block size (in Bytes per OFDM symbol) may be calculated as  $N/4$ . Further,  $P_1$  equals  $3N/4$ .

#### 4.3.2.2.1 CTC interleaver

The interleaver requires the parameters  $P_0$ , shown in table 4, and  $P_1$ .

The two-step interleaver shall be performed by:

##### Step 1: Switch alternate couples

for  $j = 1$  to  $N$

if  $(j \bmod 2 == 0)$  let  $(B, A) = (A, B)$  (i.e. switch the couple)

##### Step 2: $P_i(j)$

The function  $P_i(j)$  provides the interleaved address  $i$  of the consider couple  $j$ .

for  $j = 1$  to  $N$

switch  $j \bmod 4$ :

- case 0:  $i = (P_0 \times j + 1) \bmod N$
- case 1:  $i = (P_0 \times j + 1 + N/4 + P_1) \bmod N$
- case 2:  $i = (P_0 \times j + 1 + P_1) \bmod N$
- case 3:  $i = (P_0 \times j + 1 + N/2 + P_1) \bmod N$



#### 4.3.2.2.2 Determination of CTC circulation states

The state of the encoder is denoted  $S$  ( $0 \leq S \leq 7$ ) with  $S$  the value read binary (left to right) out of the constituent encoder memory (see figure 7). The circulation states  $Sc_1$  and  $Sc_2$  are determined by the following operations:

- 1) initialize the encoder with state 0. Encode the sequence in the natural order for the determination of  $Sc_1$  or in the interleaved order for determination of  $Sc_2$ . In both cases the final state of the encoder is  $S0_{N-1}$ ;
- 2) according to the length  $N$  of the sequence, use table 5 to find  $Sc_1$  or  $Sc_2$ .

**Table 5: Circulation state lookup table ( $Sc$ )**

$N_{\text{mod}}$	S0N-1							
	0	1	2	3	4	5	6	7
1	0	6	4	2	7	1	3	5
2	0	3	7	4	5	6	2	1
3	0	5	3	6	2	7	1	4
4	0	4	1	5	6	2	7	3
5	0	2	5	7	1	3	4	6
6	0	7	6	1	3	4	5	2

#### 4.3.2.2.3 CTC puncturing

The three code-rates are achieved through selectively deleting the parity bits (puncturing). The puncturing patterns are identical for both codes  $C_1$  and  $C_2$ .

**Table 6: Circulation state lookup table ( $Sc$ )**

Rate $R_n/(R_n+1)$	Y					
	0	1	2	3	4	5
1/2	1	1				
2/3	1	0	1	0		
3/4	1	0	0	1	0	0

### 4.3.3 Interleaving

A block interleaver shall interleave all encoded data bits with a block size corresponding to the number of coded bits per the allocated subchannels per OFDM symbol,  $N_{\text{cbps}}$ . The interleaver is defined by a two step permutation. The first, shown in equation 5, ensures that adjacent coded bits are mapped onto nonadjacent subcarriers. The second permutation, shown in equation 6, ensures that adjacent coded bits are mapped alternately onto less or more significant bits of the constellation, thus avoiding long runs of less reliable bits.

Let  $N_{\text{cpc}}$  be the number of coded bits per subcarrier, i.e. 1, 2, 4 or 6 for BPSK, QPSK, 16-QAM or 64-QAM, respectively. Let  $s = \text{ceil}(N_{\text{cpc}}/2)$ . Within a block of  $N_{\text{cbps}}$  bits at transmission, let  $k$  be the index of a coded bit before the first permutation;  $mk$  be the index of that coded bit after the first and before the second permutation; and let  $jk$  be the index of that coded bit after the second permutation, just prior to modulation mapping.

The first permutation is defined by the formula:

$$m_k = (N_{\text{cbps}}/12)k \bmod(12) + \text{floor}(k/12) \quad k = 0,1, \text{ to, } N_{\text{cbps}} - 1 \quad (5)$$

The second permutation is defined by the formula:

$$j_k = s \times \text{floor}(m_k / s) + (m_k + N_{\text{cbps}} - \text{floor}(12 \times m_k / N_{\text{cbps}})) \bmod(s) \quad k = 0,1, \text{ to, } N_{\text{cbps}} - 1 \quad (6)$$

The de-interleaver, which performs the inverse operation, is also defined by two permutations. Within a received block of  $N_{cbps}$  bits, let  $j$  be the index of a bit before the first permutation; let  $m_j$  be the index of that bit after the first and before the second permutation; and let  $k_j$  be the index of that bit after the second permutation, just prior to delivering the block to the convolutional decoder.

The first permutation is defined by the rule formula:

$$m_j = s \times \text{floor}(j/s) + (j + \text{floor}(12 \times j / N_{cbps})) \bmod(s) \quad j = 0, 1, \text{ to, } N_{cbps} - 1 \quad (7)$$

The second permutation is defined by the rule formula:

$$k_j = 12m_j - (N_{cbps} - 1) \text{floor}(12m_j / N_{cbps}) \quad j = 0, 1, \text{ to, } N_{cbps} - 1 \quad (8)$$

The first permutation in the de-interleaver is the inverse of the second permutation in the interleaver, and conversely. table 7 shows the bit interleaver sizes as a function of modulation and coding. The first bit of the interleaver shall map to the MSB in the constellation.

**Table 7: Block sizes of bit interleaver**

	$N_{cbps}$				
	<b>Default (16 subchannels)</b>	<b>8 subchannels</b>	<b>4 subchannels</b>	<b>2 subchannels</b>	<b>1 subchannel</b>
BPSK	192	96	48	24	12
QPSK	384	192	96	48	24
16-QAM	768	384	192	96	48
64-QAM	1 152	576	288	144	72

## 4.3.4 Modulation

### 4.3.4.1 Data modulation

After bit interleaving, the data bits are entered serially to the constellation mapper. BPSK, Gray-mapped QPSK, 16-QAM, and 64-QAM as shown in figure 8 shall be supported. Support of 64-QAM is optional for unlicensed bands. The constellations as shown in figure 8 shall be normalized by multiplying the constellation point with the indicated factor  $c$  to achieve equal average power. For each modulation,  $b_0$  denotes the LSB. The first bit out of the interleaver shall be mapped to the MSB and so forth.

Per-allocation adaptive modulation and coding shall be supported in the DL. The UL shall support different modulation schemes for each SS based on the Media Access Control (MAC) burst configuration messages coming from the BS. The constellation-mapped data shall be subsequently modulated onto all allocated data carriers in order of increasing frequency offset index. The first symbol out of the data constellation mapping shall be modulated onto the allocated carrier with the lowest frequency offset index.

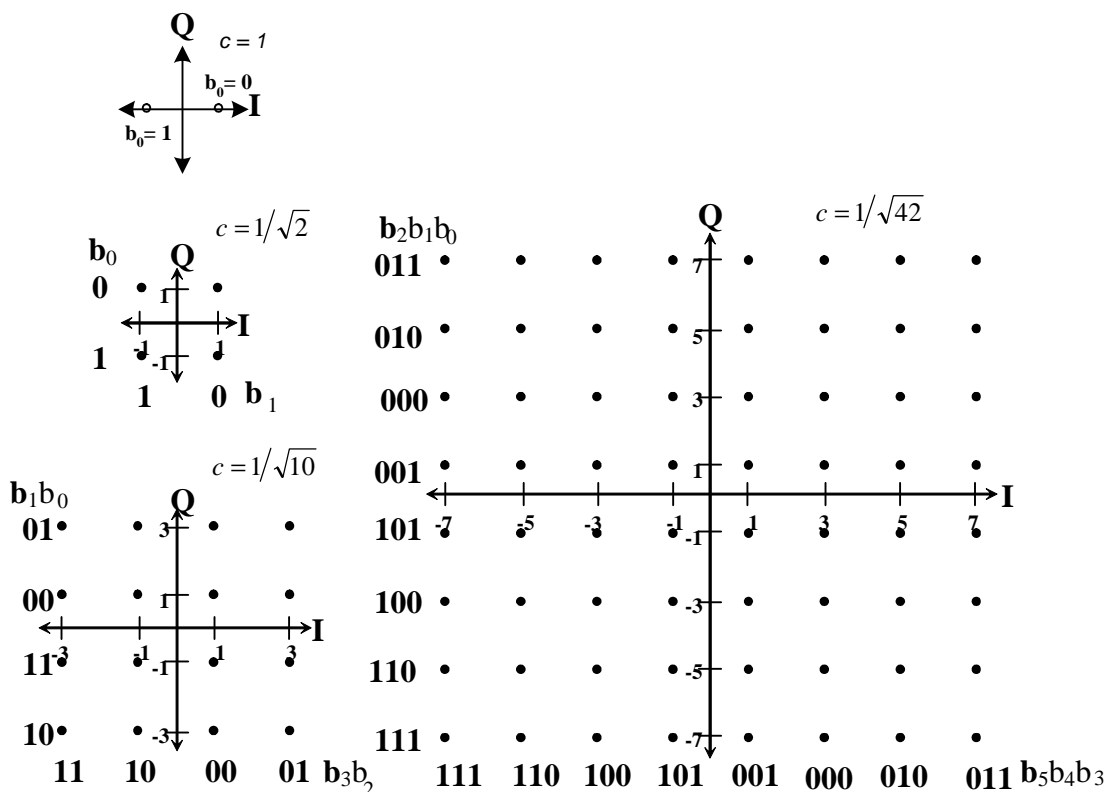

Figure 8: Modulation constellations

4.3.4.2 Pilot modulation

The value of the pilot modulation for OFDM symbol  $k$  shall be derived from  $w_k$ . On the downlink the index  $k$  represents the symbol index relative to the beginning of the downlink subframe. In the DL Subchannelization Zone, the index  $k$  represents the symbol index relative to the beginning of the burst. For bursts contained in the STC zone when the FCH-STC is present, index  $k$  represents the symbol index relative to the beginning of the STC zone. On the uplink the index  $k$  represents the symbol index relative to the beginning of the burst. On both uplink and downlink, the first symbol of the preamble is denoted by  $k=0$ . The initialization sequences that shall be used on the downlink and uplink are shown in figure 9. On the downlink the index  $k$  represents the symbol index relative to the beginning of the downlink subframe. On the uplink the index  $k$  represents the symbol index relative to the beginning of the burst. The initialization sequences that shall be used on the DL and UL are indicated in figure 9 as well. On the DL, this shall result in the sequence 111111111100000000110... where the 3<sup>rd</sup> 1, i.e.  $w_2 = 1$ , shall be used in the first OFDM DL symbol following the frame preamble. For each pilot (indicated by frequency offset index), the BPSK modulation shall be derived as follows:

$$\text{DL: } c_{-88}=c_{-38}=c_{63}=c_{88}=1-2w_k \text{ and } c_{-63}=c_{-13}=c_{13}=c_{38}=1-2w_k \quad (9)$$

$$\text{UL: } c_{-88}=c_{-38}=c_{13}=c_{38}=c_{63}=c_{88}=1-2w_k \text{ and } c_{-63}=c_{-13}=c_{13}=1-2w_k \quad (10)$$

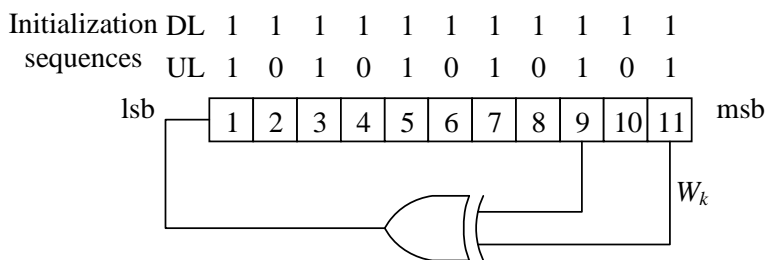

Figure 9: Pilot modulation PRBS

For each pilot (indicated by frequency offset index), the BPSK modulation shall be derived as shown in table 8.

**Table 8: Pilot modulation**

	$c_{-88}$	$c_{-63}$	$c_{-38}$	$c_{-13}$	$c_{13}$	$c_{38}$	$c_{63}$	$c_{88}$
DL	$2^{(1/2 - w_k)}$	$2^{(1/2 - \overline{w_k})}$	$2^{(1/2 - w_k)}$	$2^{(1/2 - \overline{w_k})}$	$2^{(1/2 - \overline{w_k})}$	$2^{(1/2 - \overline{w_k})}$	$2^{(1/2 - w_k)}$	$2^{(1/2 - w_k)}$
UL	$2^{(1/2 - w_k)}$	$2^{(1/2 - \overline{w_k})}$	$2^{(1/2 - w_k)}$	$2^{(1/2 - \overline{w_k})}$	$2^{(1/2 - w_k)}$	$2^{(1/2 - w_k)}$	$2^{(1/2 - w_k)}$	$2^{(1/2 - w_k)}$

In an allocation of 1 subchannel, pilots shall not be modulated or transmitted.

#### 4.3.4.3 Rate ID encodings

Rate\_IDs, which indicate modulation and coding to be used in the first DL burst immediately following the FCH, are shown in table 9. The Rate\_ID encoding is static and cannot be changed during system operation.

**Table 9: Rate\_ID encodings**

Rate_ID	Modulation RS-CC rate
0	BPSK 1/2
1	QPSK 1/2
2	QPSK 3/4
3	16-QAM 1/2
4	16-QAM 3/4
5	64-QAM 2/3
6	64-QAM 3/4
7 to 15	Reserved

#### 4.3.5 Example UL RS-CC Encoding

To illustrate the use of the RS-CC encoding, an example of one frame of OFDM UL data is provided, illustrating each process from randomization through carrier modulation.

##### 4.3.5.1 Full bandwidth (16 subchannels)

Modulation Mode: QPSK, rate 3/4, Symbol Number within burst: 1, UIUC: 7, BSID: 1, Frame Number: 1 (decimal values)

Input Data (Hex)

45 29 C4 79 AD 0F 55 28 AD 87 B5 76 1A 9C 80 50 45 1B 9F D9 2A 88 95 EB AE B5 2E 03 4F 09 14 69 58  
0A 5D

Randomized Data (Hex)

D4 BA A1 12 F2 74 96 30 27 D4 88 9C 96 E3 A9 52 B3 15 AB FD 92 53 07 32 C0 62 48 F0 19 22 E0 91 62  
1A C1

Reed-Solomon encoded Data (Hex)

49 31 40 BF D4 BA A1 12 F2 74 96 30 27 D4 88 9C 96 E3 A9 52 B3 15 AB FD 92 53 07 32 C0 62 48 F0 19  
22 E0 91 62 1A C1 00

Convolutionally Encoded Data (Hex)

3A 5E E7 AE 49 9E 6F 1C 6F C1 28 BC BD AB 57 CD BC CD E3 A7 92 CA 92 C2 4D BC 8D 78 32 FB BF  
DF 23 ED 8A 94 16 27 A5 65 CF 7D 16 7A 45 B8 09 CC

Interleaved Data (Hex)

77 FA 4F 17 4E 3E E6 70 E8 CD 3F 76 90 C4 2C DB F9 B7 FB 43 6C F1 9A BD ED 0A 1C D8 1B EC 9B  
30 15 BA DA 31 F5 50 49 7D 56 ED B4 88 CC 72 FC 5C

## Carrier Mapping (frequency offset index: I value Q value)

-100: 1 -1, -99: -1 -1, -98: 1 -1, -97: -1 -1, -96: -1 -1, -95: -1 -1, -94: -1 1, -93: -1 1, -92: 1 -1, -91: 1 1,  
 -90: -1 -1, -89: -1 -1, -88:pilot= 1 0, -87: 1 1, -86: 1 -1, -85: 1 -1, -84: -1 -1, -83: 1 -1, -82: 1 1, -81: -1 -1,  
 -80: -1 1, -79: 1 1, -78: -1 -1, -77: -1 -1, -76: -1 1, -75: -1 -1, -74: -1 1, -73: 1 -1, -72: -1 1, -71: 1 -1, -70: -1 -1,  
 -69: 1 1, -68: 1 1, -67: -1 -1, -66: -1 1, -65: -1 1, -64: 1 1, -63:pilot= -1 0, -62: -1 -1, -61: 1 1, -60: -1 -1,  
 -59: 1 -1, -58: 1 1, -57: -1 -1, -56: -1 -1, -55: -1 -1, -54: 1 -1, -53: -1 -1, -52: 1 -1, -51: -1 1, -50: -1 1, -49: 1 -1,  
 -48: 1 1, -47: 1 1, -46: -1 -1, -45: 1 1, -44: 1 -1, -43: 1 1, -42: 1 1, -41: -1 1, -40: -1 -1, -39: 1 1, -38:pilot= 1 0,  
 -37: -1 -1, -36: 1 -1, -35: -1 1, -34: -1 -1, -33: -1 -1, -32: -1 -1, -31: -1 1, -30: 1 -1, -29: -1 1, -28: -1 -1,  
 -27: 1 -1, -26: -1 -1, -25: -1 -1, -24: -1 -1, -23: -1 1, -22: -1 -1, -21: 1 -1, -20: 1 1, -19: 1 1, -18: -1 -1, -17: 1 -1,  
 -16: -1 1, -15: -1 -1, -14: 1 1, -13:pilot= -1 0, -12: -1 -1, -11: -1 -1, -10: 1 1, -9: 1 -1, -8: -1 1, -7: 1 -1, -6: -1 1,  
 -5: -1 1, -4: -1 1, -3: -1 -1, -2: -1 -1, -1: 1 -1, 0: 0 0, 1: -1 -1, 2: -1 1, 3: -1 -1, 4: 1 -1, 5: 1 1, 6: 1 1, 7: -1 1,  
 8: -1 1, 9: 1 1, 10: 1 -1, 11: -1 -1, 12: 1 1, 13:pilot= 1 0, 14: -1 -1, 15: 1 -1, 16: -1 1, 17: 1 1, 18: 1 1, 19: 1 -1,  
 20: -1 1, 21: -1 -1, 22: -1 -1, 23: -1 1, 24: -1 -1, 25: 1 1, 26: -1 1, 27: 1 -1, 28: -1 1, 29: -1 -1, 30: 1 1, 31: -1 -1,  
 32: 1 1, 33: 1 1, 34: 1 1, 35: 1 -1, 36: 1 -1, 37: 1 -1, 38:pilot= 1 0, 39: -1 1, 40: -1 -1, 41: -1 1, 42: -1 1,  
 43: -1 -1, 44: 1 -1, 45: -1 1, 46: -1 1, 47: 1 1, 48: -1 -1, 49: 1 1, 50: 1 -1, 51: -1 -1, 52: -1 -1, 53: 1 -1, 54: 1 -1,  
 55: 1 -1, 56: 1 -1, 57: 1 1, 58: 1 1, 59: 1 -1, 60: 1 1, 61: -1 1, 62: 1 -1, 63:pilot= 1 0, 64: 1 -1, 65: -1 -1,  
 66: -1 -1, 67: 1 -1, 68: 1 -1, 69: 1 -1, 70: 1 -1, 71: -1 1, 72: -1 -1, 73: -1 1, 74: -1 -1, 75: 1 -1, 76: -1 1, 77: -1 -1,  
 78: 1 -1, 79: 1 1, 80: -1 1, 81: 1 1, 82: -1 1, 83: 1 1, 84: -1 -1, 85: 1 1, 86: -1 -1, 87: 1 1, 88:pilot= 1 0, 89: 1 -1,  
 90: -1 -1, 91: 1 1, 92: -1 1, 93: -1 -1, 94: -1 -1, 95: -1 -1, 96: 1 1, 97: 1 -1, 98: 1 -1, 99: -1 -1, 100: 1 1

NOTE: The above QPSK values (all values with exception of the BPSK pilots) are to be normalized with a factor  $1/\sqrt{2}$  as indicated in figure 8.

## 4.3.5.2 Subchannelization (2 subchannels)

Modulation Mode: 16-QAM, rate 3/4, Symbol Numbers within burst: 1-3, UIUC: 7, BSID: 1, Frame Number: 1, subchannel index: 0b00010 (decimal values)

## Input Data (Hex)

45 29 C4 79 AD 0F 55 28 AD 87 B5 76 1A 9C 80 50 45 1B 9F D9 2A 88 95 EB AE B5

## Randomized Data (Hex)

D4 BA A1 12 F2 74 96 30 27 D4 88 9C 96 E3 A9 52 B3 15 AB FD 92 53 07 32 C0 62 00

## Convolutionally Encoded Data (Hex)

EE C6 A1 CB 7E 04 73 6C BC 61 95 D3 B7 C4 EF 0E 4C 76 CF DC 70 69 B3 CE DB E0 E5 B7 B5 4E 88  
 7D A4 AE 31 30

## Interleaved Data (Hex)

B4 FF DA 06 E5 42 EC 1F 86 7C 29 93 9C AD 83 42 6B FE FC 6D CB F6 53 85 AE 68 22 7A CE B1 E7 52  
 B0 EC BA 95

## Subcarrier Mapping (frequency offset index: I value Q value)

1<sup>st</sup> data symbol:

-100: -1 -3, -99: 3 1, -98: -3 -3, -97: -3 -3, -96: -3 3, -95: -1 -1, -38: pilot = 1 0, -37: 1 1, -36: 3 -1, -35: -3 -1,  
 -34: 3 3, -33: 3 1, -32: 1 -1, 1: -3 -1, 2: -3 1, 3: 1 3, 4: -3 -3, 5: -1 1, 6: 3 -1, 64: 3 -3, 65: -3 1, 66: 1 -1, 67: -1 3,  
 68: -1 3, 69: 1 -3

2<sup>nd</sup> data symbol:

-100: -1 3, -99: -3 1, -98: -1 -1, -97: -3 3, -96: -1 1, -95: 1 -3, -38: pilot = -1 0, -37: 3 1, -36: 1 -1, -35: 3 -1,  
 -34: -1 -3, -33: -3 -3, -32: -3 -1, 1: -3 -3, 2: -3 1, 3: 3 -1, 4: -3 3, 5: -3 1, 6: -1 -3, 64: -3 -3, 65: 3 -1, 66: 3 3,  
 67: 1 -3, 68: -1 1, 69: 3 3

3<sup>rd</sup> data symbol:

-100: -1 -1, -99: -3 -1, -98: 3 -1, -97: -1 1, -96: 1 -1, -95: 1 -1, -38: pilot = 1 0, -37: 3 -3, -36: -1 -1, -35: -3 1, -34: -3 -1, -33: -1 -3, -32: 1 3, 1: -3 -1, 2: 3 -3, 3: 3 3, 4: 1 -1, 5: -1 -3, 6: 1 1, 64: -3 -1, 65: -3 1, 66: -1 -3, 67: -1 -1, 68: -1 3, 69: 3 3

NOTE: The above 16-QAM values (all values with exception of the BPSK pilots) are to be normalized with a factor as indicated in figure 8.

#### 4.3.5.3 Subchannelization (1 subchannel)

Modulation Mode: QPSK, rate 3/4, Symbol Numbers within burst: 1-5, UIUC: 7, BSID: 1, Frame Number: 1, subchannel index: 0b00001 (decimal values)

Input Data (Hex)

45 29 C4 79 AD 0F 55 28 AD 87

Randomized Data (Hex)

D4 BA A1 12 F2 74 96 30 27 D4 00 00

Convolutionally Encoded Data (Hex)

EE C6 A1 CB 7E 04 73 6C BC 61 95 D3 B7 DF 00

Interleaved Data (Hex)

BC EC A1 F4 8A 3A 7A 4F 78 39 53 87 DF 2A A2

Subcarrier Mapping (frequency offset index: I value Q value)

1<sup>st</sup> data symbol:

-100: -1 1, -99: -1 -1, -98: -1 -1, -37: 1 1, -36: -1 -1, -35: -1 1, 1: -1 -1, 2: 1 1, 3: -1 1, 64: -1 1, 65: 1 1, 66: 1 -1

2<sup>nd</sup> data symbol:

-100: -1 -1, -99: -1 -1, -98: 1 -1, -37: 1 1, -36: -1 1, -35: 1 1, 1: -1 1, 2: -1 1, 3: 1 1, 64: -1 -1, 65: -1 1, 66: -1 1

3<sup>rd</sup> data symbol:

-100: 1 -1, -99: -1 -1, -98: -1 1, -37: -1 1, -36: 1 -1, -35: 1 1, 1: -1 -1, 2: -1 -1, 3: 1 -1, 64: -1 -1, 65: -1 1, 66: 1 1

4<sup>th</sup> data symbol:

-100: 1 1, -99: -1 -1, -98: -1 1, -37: 1 -1, -36: 1 -1, -35: 1 -1, 1: 1 1, 2: -1 -1, 3: -1 1, 64: 1 1, 65: 1 -1, 66: -1 -1

5<sup>th</sup> data symbol:

-100: -1 -1, -99: 1 -1, -98: -1 -1, -37: -1 -1, -36: 1 1, -35: -1 1, 1: -1 1, 2: -1 1, 3: -1 1, 64: -1 1, 65: 1 1, 66: -1 1

NOTE: The above QPSK values are to be normalized with a factor  $1/\sqrt{2}$  as indicated in figure 8.

#### 4.3.6 Preamble structure and modulation

All preambles are structured as either one or two OFDM symbols. The OFDM symbols are defined by the values of the composing subcarriers. Each of those OFDM symbols contains a cyclic prefix, of the same length as CP for data OFDM symbols.







UL preambles and midambles may be cyclically delayed by an integer number of samples. This is indicated by the UL-Physical modifier IE.

#### 4.3.6.1 Transmission Convergence (TC) sublayer

The TC sublayer as described in clause 8.3.4 in IEEE 802.16 [2].

## 4.4 Frame structures

### 4.4.1 PMP

#### 4.4.1.1 Duplexing modes

The PHY shall support Frequency Division Duplexing (FDD) or Time Division Duplexing (TDD). FDD SSs may be Half Duplex FDD (H-FDD). In license exempt bands, the duplexing method shall be TDD.

The OFDM PHY supports a frame-based transmission. The frame interval contains BS and SS transmissions comprised of PHY PDUs, Transmit/receive Transition Gap (TTG) and Receive/transmit Transition Gap (RTG) gaps, and guard intervals. A frame consists of a DL sub-frame and an UL sub-frame. A DL sub-frame consists of only one DL PHY PDU. A UL sub-frame consists of contention intervals scheduled for initial ranging and bandwidth request purposes and one or multiple UL PHY PDUs, each transmitted from a different SS.

A UL PHY PDU consists of only one burst, which is made up of a short preamble and an integer number of OFDM symbols. The burst PHY parameters of an UL PHY PDU are specified by a 4-bit UIUC in the UL-MAP. The UIUC encoding is defined in the Uplink Channel Descriptor (UCD) messages. Note the difference between a PHY PDU and a Burst.

A DL PHY PDU starts with a long preamble, which is used for PHY synchronization. The preamble is followed by a FCH burst. The FCH burst is one OFDM symbol long and is transmitted using QPSK rate 1/2 with the mandatory coding scheme. The FCH contains DL\_Frame\_Prefix (DLFP) to specify the burst profile and length of one or several DL bursts immediately following the FCH. The Rate\_ID encoding for the burst immediately following the FCH is defined in table 9. The location and profile of the maximum possible number of subsequent bursts shall also be specified in the DLFP. For these bursts, DIUC is used instead of Rate\_ID. The DIUC encoding is defined in the DCD messages. The HCS field occupies the last byte of the DLFP. If there are unused IEs in the DLFP, the first unused IE must have all fields encoded as zeros.

Location and profile of other bursts are specified in DL-MAP. The profile is specified by Rate\_ID (for the first DL burst) or by DIUC. Each of DL bursts following the FCH is transmitted with different burst profile. Each DL burst consists of an integer number of OFDM symbols.

A DL-MAP message, if transmitted in the current frame, shall immediately follow the DLFP. An UL-MAP message shall immediately follow either the DL-MAP message (if one is transmitted) or the DLFP. If UCD and DCD messages are transmitted in the frame, they shall immediately follow the DL-MAP and UL-MAP messages. All aforementioned messages must be transmitted in the burst immediately following the FCH (burst #1). Although burst #1 contains broadcast MAC control messages, it is not necessary to use the most robust well-known modulation/coding. A more efficient modulation/coding may be used if it is supported and applicable to all the SSs of a BS.

At least one full DL-MAP must be broadcast in burst #1 within the Lost DL-MAP Interval specified in IEEE 802.16 [2], table 340.

The DL sub-frame may optionally contain an STC zone in which all DL bursts are STC encoded. If an STC zone is present, the last used IE in the DLFP shall have DIUC = 0 (see table 13 in TS 102 178 [1]) and the IE shall contain information on the start time of STC zone (see table 16 in TS 102 178 [1]). The STC zone ends at the end of the frame.

The STC zone starts from a preamble. The BS can choose between two modes of operation:

- 1) No FCH-STC Present: If the regular DL-MAP describes allocations in the STC zone, then the STC zone shall start with an STC preamble that may be immediately followed by encoded PHY bursts, with no FCH-STC present.

- 2) FCH-STC Present: If the DL-MAP does not describe allocations in the STC zone, then the STC zone shall start with an STC preamble that is immediately followed by and an STC encoded FCH-STC burst, which is one symbol with the same payload format as specified in table 20. The FCH-STC burst is transmitted at BPSK rate  $\frac{1}{2}$ . It is followed by one or several STC encoded PHY bursts. The first burst in the STC zone may contain a DL-MAP applicable only to the STC zone, in which the DL Ies start time refer to the beginning of the STC zone, including preamble. If DL-MAP is present, it shall be the first MAC PDU in the payload of the burst. The STC zone may also contain an UL-MAP, as well as DCD and UCD messages. The UL-MAP, if present, shall not duplicate or overlap any unicast allocations made in the regular UL-MAP, and the allocation start time shall refer to the beginning of the STC zone. The UL-MAP if present shall not contain duplicate or overlapping unicast allocations (defined within same or any other UL-MAP). Contention region allocations may be duplicated, in which case, they shall fully overlap. The randomizer and pilot modulation shall be reinitialized at the beginning of the STC zone.

The SS will be able to determine that there is not STC data allocation in frame K-1 STC Zone by determining that there as been no STC zone in the previous frame K-2.

The DL sub-frame may contain a DL subchannelization zone as described in clause 4.4.1.3 PMP DL subchannelization zone.

With the OFDM PHY, a PHY burst, either a downlink PHY burst or an uplink PHY burst, consists of an integer number of OFDM symbols, carrying MAC messages, i.e. MAC PDUs. To form an integer number of OFDM symbols, unused bytes in the burst payload may be padded by the bytes 0xFF, as defined in clause 4.3.1. Then the payload should be randomized, encoded, and modulated using the burst PHY parameters specified by the present document. If an SS does not have any data to be transmitted in an UL allocation, the SS shall transmit an UL PHY burst containing a bandwidth request header as defined in figure 2 of [1], with BR=0 and its basic CID. If the allocation is large enough, an AAS enabled SS may also provide an AAS Feedback Response (AAS-FBCK-RSP) message (clause 4.3.23 in TS 102 178 [1]). An SS shall transmit during the entirety of all of its UL allocations, using the standard padding mechanism (clause 6.3.3.7 in IEEE 802.16 [2]) to fill allocations if necessary.

In each TDD frame (see figure 12), the Tx/Rx transition gap (TTG) and Rx/Tx transition gap (RTG) shall be inserted between the DL and UL sub-frame and at the end of each frame respectively to allow the BS to turn around.

In TDD and H-FDD systems subscriber station allowances must be made by a transmit-receive turnaround gap SSRTG and by a receive-transmit turnaround gap SSTTG. The parameters SSRTG and SSTTG are capabilities provided by the SS to BS upon request during network entry.

For TDD mode SSRTG and SSTTG shall be no more than 50  $\mu$ s. For H-FDD mode SSRTG and SSTTG shall be no more than 100  $\mu$ s.

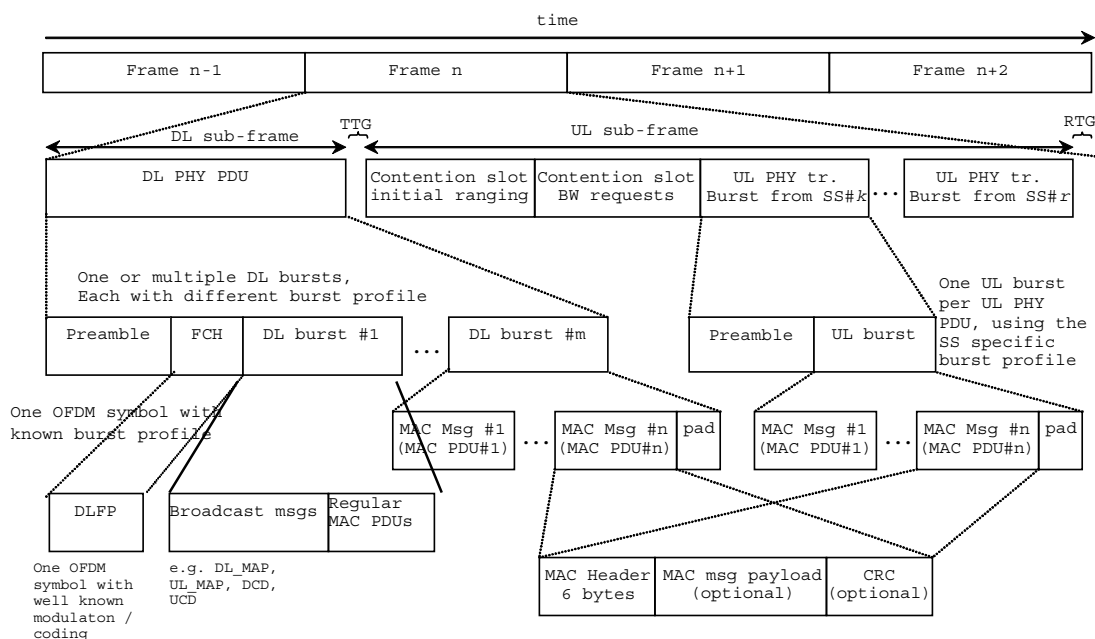
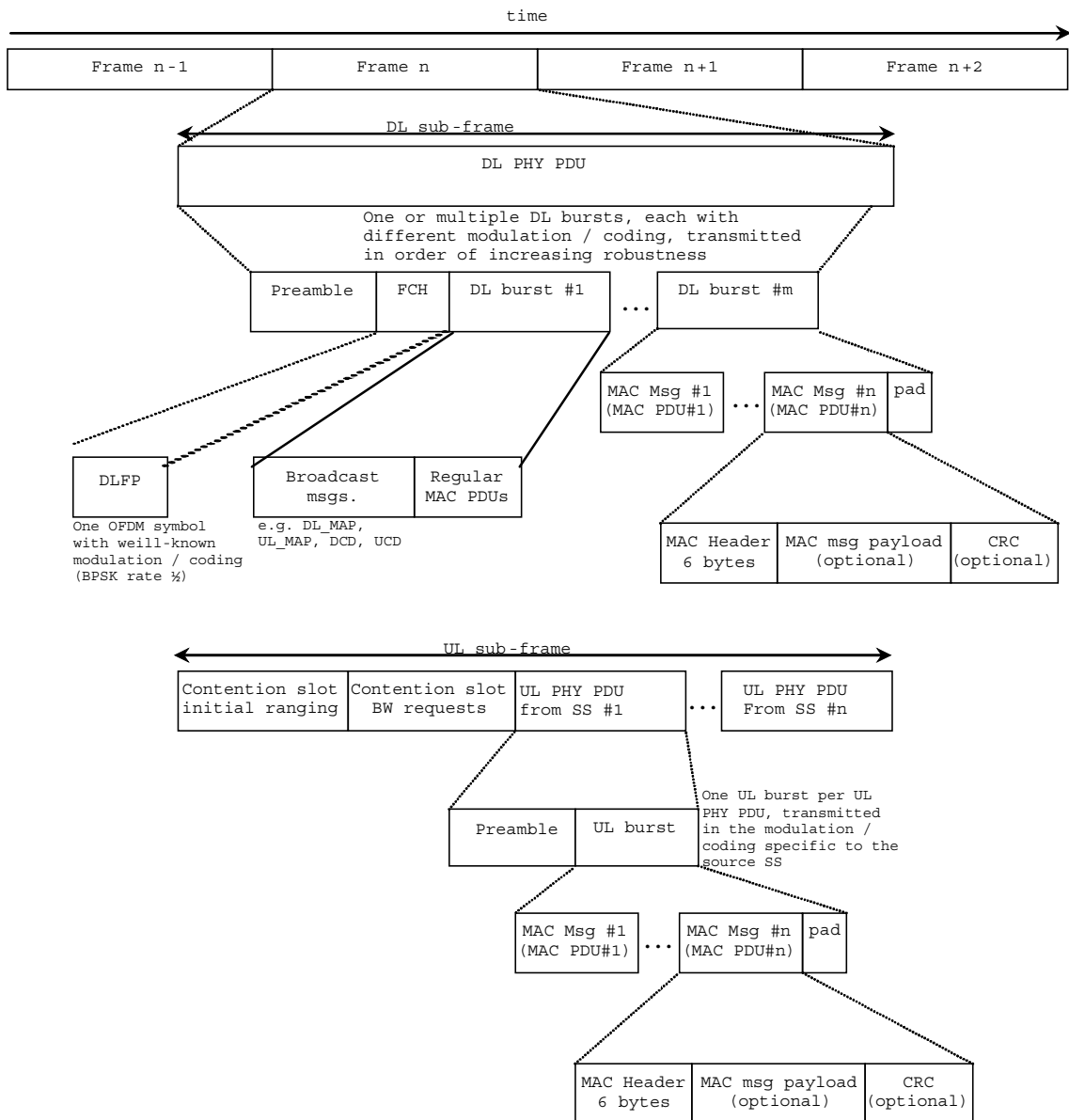

Figure 12: Example of OFDM PMP frame structure with TDD



**Figure 13: Example of OFDM PMP frame structure with FDD**

Because the optional STC and AAS zones may contain UL-MAPs, along with the UL-MAP transmitted in the mandatory part of the frame, and because the allocation start time for frames may vary from one frame to the next, there is a possibility that UL-MAPs from two frames, or from different zones, may describe overlapping time intervals. Where MAP IEs (contained in either a AAS-DLFP or a UL-MAP) describe overlapping time intervals with MAP IEs from another UL-MAP (or AAS-DLFP) then an SS shall interpret and use those from the most recently received map. MAP IEs that do not conflict with MAP IEs received in earlier UL-MAPs (or AAS-DLFP) shall augment the uplink map.

## 4.4.1.2 DL frame prefix

Table 10: OFDM DL Frame Prefix format

Syntax	Size	Notes
DL_Frame_Prefix_Format() {		
<b>Base_Station_ID</b>	4 bits	4 LSB of BS ID. Prior to completion of network entry, the SS shall ignore this field and decode all bursts specified by the DLFP. Upon completion of network entry, the SS shall validate these bits with those of the BS on which it is registered. The burst specified by the DLFP shall not be decoded if these bits do not match those of the BS on which it is registered
<b>Frame_Number</b>	4 bits	4 LSB of the Frame Number DCD Channel Encoding as specified in table 6 in TS 102 178 [1]
<b>Configuration_Change_Count</b>	4 bits	4 LSB of Change Count value as specified in clause 6.3.2.3.1 in IEEE 802.16 [2]
<i>Reserved</i>	4 bits	Shall be set to zero
For (n=0;n<4; n++) {		
DL_Frame_Prefix_IE() {		
<b>Rate_ID/DIUC</b>	4 bits	For the first information element it shall be Rate_ID encoded according to the table 222 in IEEE 802.16 [2]. For following IEs this field is DIUC that defines the burst profile of the corresponding burst
If (DIUC !=0) {		
<b>Preamble present</b>	1 bit	If "1", preamble is placed before the burst
Length	11 bits	Number of OFDM symbols in the burst
} else {		
<b>Start Time</b>	12 bits	Start time of STC zone in units of symbol duration counted from the beginning of the frame
}		
}		
}		
<b>HCS</b>	8 bits	An 8 bit Header Check Sequence calculated as specified in clause 4.1.2 in TS 102 178 [1]
}		

## 4.4.1.3 PMP DL subchannelization zone

The DL sub-frame may optionally contain a DL subchannelization zone. This zone is marked by a DL\_SUBCH\_IE in the DL Map.

The DL subchannelization zone is shown in figure 14.

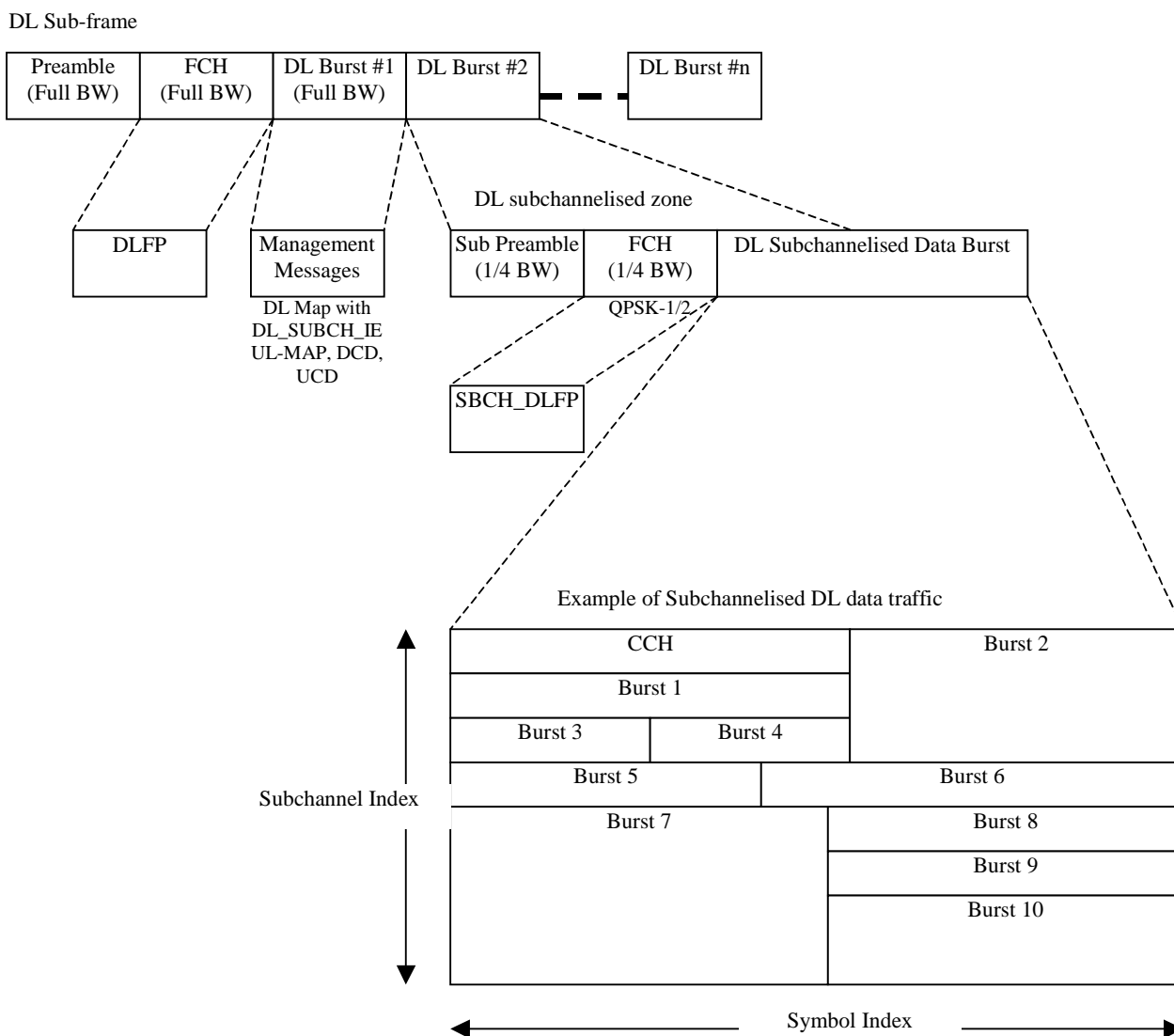

**Figure 14: DL subchannelization zone format**

The DL subchannelization zone begins with a subchannelized preamble followed by a subchannelized FCH burst. The FCH is transmitted using QPSK 1/2. The FCH is transmitted over 1/4 of the bandwidth. The carrier allocation is as given in table 1 (OFDM symbol parameters).

The subchannel index of the FCH shall be one of the codes 0b00100, 0b01100, 0b10100 or 0b11100. The subchannel index should preferably be provisioned by the operator to avoid illumination of an area by base stations using the same frequency channel with the same subchannel index. If not provisioned, the subchannel index shall, by default, be derived from the 2 LSBs of the BSID as in table 11.

**Table 11: DL subchannel index table**

2 LSBs of BSID (binary)	Subchannel index (binary)
00	00100
01	01100
10	10100
11	11100

The FCH contains the SBCH\_DLFP, which points to the control subchannel (CCH), and contains the profile and length of the first burst in it. The SBCH\_DLFP is shown in table 12.

Table 12: SBCH\_DLFP

Field	Size (bits)	Comments
SBCH_DL_Frame_Prefix_Format(){		
Base_Station_ID	4	4 LSBs of BS ID. The burst specified by the DLFP shall not be decoded if these bits do not match those of the BS on which the SS is registered
Frame_Number	4	4 LSBs of Frame Number field
Configuration_Change_Count	4	4 LSBs of Change Count value as specified in IEEE 802.16 [2], clause 6.3.2.3.1
CCH_Rate_ID	4	The Rate ID, according to table 9 of the first burst in the CCH
CCH_duration	8	The duration of the first burst in the CCH
Reserved	1	Shall be set to zero
CCH_subchannel_index	5	The subchannel index in which the CCH is transmitted. See table 1
CCH_midamble_repetition	2	The midamble repetition rate of the first burst of the CCH: 0b00: Preamble only 0b01: Midamble after every 4 data symbols 0b10: Midamble after every 8 data symbols 0b11: Midamble after every 16 data symbols
HCS	8	An 8 bit Header Check sequence; calculated as specified in table 5
}		

The FCH is followed by subchannelized traffic on allocated subchannels. The subcarrier allocation of the subchannels is given in table 1. Bursts in the DL subchannelized zone shall contain midambles when indicated in the midamble repetition field.

The CCH may carry UL and DL maps. UL maps shall use the format of UL\_MAP\_IE as in table 40 (UL map IE). DL maps shall use the format if SBCH\_DL\_MAP\_IE as in table 13.

Table 13: SBCH\_DL\_MAP\_IE

Syntax	Size (bits)	Notes
SBCH_DL_MAP_IE()		
CID	16	
Start Time	11	This field indicates the start time in units of symbol duration, relative to the beginning of the subsequent DL subchannelized zone (including preamble)
Subchannel Index	5	
DIUC	4	
Duration	10	In OFDM symbols
Midamble repetition interval	2	The midamble repetition rate of the first burst of the CCH: 0b00: Preamble only 0b01: Midamble after every 4 data symbols 0b10: Midamble after every 8 data symbols 0b11: Midamble after every 16 data symbols
}		

A BS shall assume that the SS is not capable of receiving more than one burst in a single frame. Therefore downlink allocations contained in SBCH\_DL\_MAP\_IEs in the CCH shall point to future frames. When an allocation is present for a given SS, the BS shall assume that the SS may not be capable of demodulating the CCH in that frame, and therefore not include any SBCH\_DL\_MAP\_IEs or UL\_MAP\_IEs for that SS.

#### 4.4.1.4 PMP-AAS zone

DL transmission to an SS or group of SSs consists of two fractions. The first fraction of the transmission consists of one or several repetitions of a pair composed of the short preamble followed by FCH symbol (figure 14). The second fraction is called Body.

FCH payload is called "AAS DL Frame Prefix" (AAS\_DLFP). FCH shall be transmitted at the lowest possible modulation. Each pair preamble-FCH may be transmitted either at narrow beam or at wide beam. Optionally same preamble-FCH pair may be repeated at several beams thus implementing space diversity.

AAS\_DLFP contains information (DL IEs or UL IEs) on location and transmission rate of PHY bursts. There is a possibility of more than one concatenated DL PHY bursts, each one described by a DL IE. UL IES specify either UL PHY burst (a single burst per SS) or contention region for initial ranging or bandwidth requesting.

Body may be transmitted at a directed beam and may start either immediately after FCH or at some distance. In the latter case, it shall start from a preamble. The payload of the burst may contain private DL-MAP and / or UL-MAP messages.

Alternatively, AAS\_DLFP may contain UL IEs. There are two options:

- 1) A single UL IE.
- 2) "Compressed" UL IE, which contains a network entry allocation and a regular allocation. The minimum time between an UL IE and the corresponding UL burst shall be equal to the relevance time of an UL-MAP as described in IEEE 802.16 [2], clause 6.3.7.5.

An example of AAS zone layout is shown in figure 15.

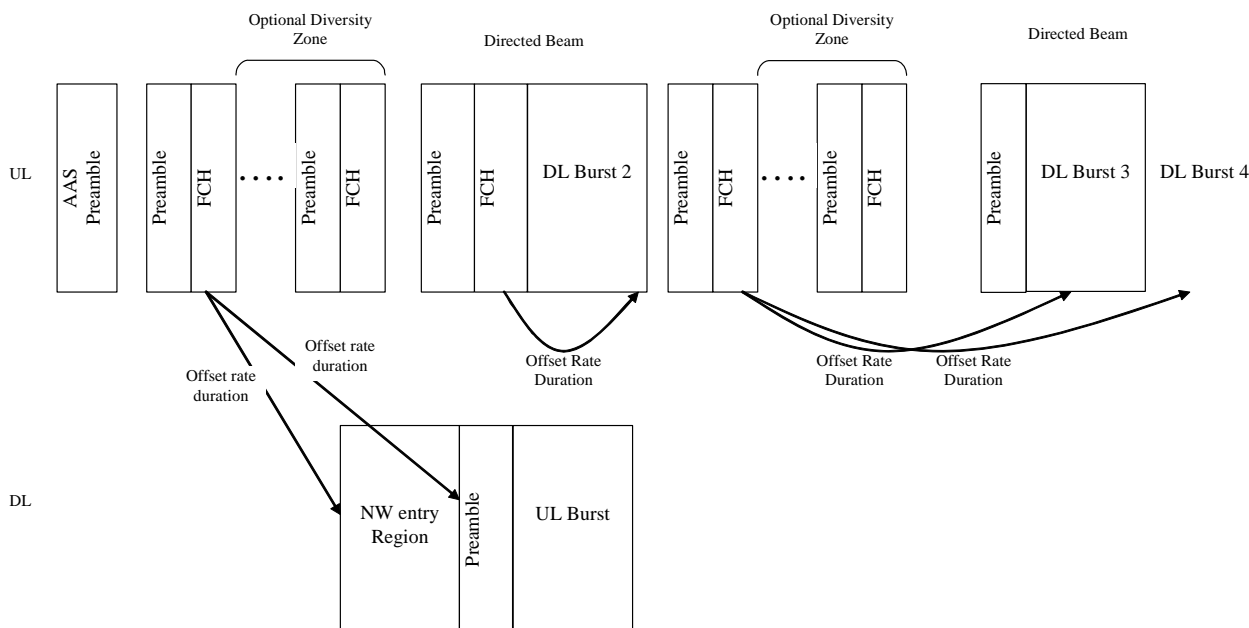

Figure 15: Structure of AAS Zone

The structure of AAS\_DLFP is specified in table 14.

**Table 14: AAS\_DLFP structure**

Syntax	Size	Notes
AAS_DLFP(){		
<b>Base_Station_ID</b>	4 bits	4 LSB of BS ID
<b>Frame_Number</b>	4 bits	4 LSB of the Frame Number DCD Channel Encoding as specified in IEEE 802.16 [2], table 312
Reserved	6 bits	Shall set to zero
<b>Dir</b>	1 bit	Allocation direction: Dir="1" means UL
<b>Allocation Start</b>	13 bits	Points to the start of Body fraction; expressed in the terms of offset from the beginning of the AAS preamble
If (Dir=="1") {		
<b>UCD_Configuration_Change_Count</b>	3 bits	3 LSB of UCD Change Count value as specified in IEEE 802.16 [2], clause 6.3.2.3.3
<b>Comp_UL</b>	1 bit	Compressed UL IE is present if 1 bit is set to 1, else full UL IE
If (Comp_UL=="1"){		
AAS_Comp_UL_IE()	48 bits	
} else {		
AAS_DLFP_UL_IE()	48 bits	
}		
} else {		
Reserved	1 bit	
<b>DCD_Configuration_Change_Count</b>	3 bits	3 LSB of DCD Change Count value as specified in IEEE 802.16 [2], clause 6.3.2.3.1
AAS_DLFP_DL_IE()	16 bits	
AAS_DLFP_DL_IE()	16 bits	
AAS_DLFP_DL_IE()	16 bits	
}		
<b>HCS</b>		
}		

**Table 15: AAS\_DLFP\_DL IE format**

Syntax	Size	Notes
AAS_DLFP_DL_IE() {		
<b>Rate_ID/DIUC</b>	4 bits	For the first information element it shall be Rate_ID encoded to the table 9. For following IEs this field is DIUC that defines the burst profile of the corresponding burst
<b>Preamble present</b>	1 bit	If "1", midamble is placed before the burst
<b>Length</b>	11 bits	Number of OFDM symbols in the burst
}		



Table 16: AAS\_DLFP\_UL IE format

Syntax	Size	Notes
AAS_DLFP_UL_IE(){		
<b>UIUC</b>	4 bits	UIUC value; see table 18
<b>If (UIUC==1) {</b>		
AAS_NW_Entry_Response_IE()	16 bits	
<b>} else If (UIUC==3) {</b>		
<b>Focused_Contention_Response_IE()</b>	16 bits	If UIUC=2, must be multicast or broadcast CID, the allocation will be used for multicast polling
<b>} else {</b>		
<b>Preamble time shift</b>	8 bits	Shift to be performed on preamble and midambles
reserved	1 bit	Shall be set to zero
<b>Subchannel_Index</b>	5 bits	
<b>Midamble repetition interval</b>	2 bits	0b00: Preamble only 0b01: Interval 5; Midamble after every 4 data symbols 0b10: Interval 9; Midamble after 8 data symbols 0b11: Interval 17; Midamble after every 16 data symbols
<b>Duration</b>	12 bits	In OFDM symbols
<b>}</b>		
<b>}</b>		

AAS\_Comp\_ULIE shall be used to specify two UL allocations; one of them must be for network entry; another one is either unicast allocation or multicast/broadcast polling system.

Table 17: AAS\_COMP\_UL IE format

Syntax	Size	Notes
AAS_COMP_UL_IE(){		
<b>UIUC</b>	4 bits	UIUC value; see table 18
<b>If(UIUC==1) {</b>		
AAS_NW_Entry_Response_IE()	16 bits	
<b>} else { If (UIUC==4) {</b>		
<b>Focused_Contention_Response_IE()</b>	16 bits	
<b>} else {</b>		
<b>CID</b>	16 bits	For regular allocations
<b>}</b>		
Subchannel_Index_NW_Entry	5 bits	For NW entry allocation
Duration_NW_Entry	9 bits	Duration of NW entry allocation in OFDM symbols
Subchannel_Index	5 bits	For regular allocation
<b>Duration</b>	9 bits	Duration of regular allocation in OFDM symbols
<b>}</b>		

NOTE: In the case when AAS-FCH is repeated for diversity, all copies have the same content and therefore soft combining might be employed at the SS receiver.

Table 18: UIUC usage in AAS Zone

UIUC	Usage
0	Reserved
1	AAS NW Entry Response
2	REQ Region Full
3	REQRegion Focused
4	Focused Contention response IE
5-13	Burst Profiles (Data Grant Burst Type)

Table 19: AAS Network Entry Response IE format

Syntax	Size	Notes
AAS_NW_Entry_Response_IE()		
<b>Frame Number Index</b>	4 bits	4 LSB of Frame Number field
<b>Network Entry Code</b>	4 bits	Random code sent by the SS in AAS Network Entry Request
Reserved	8 bits	Shall set to zero
}		

Frame Number Index:

- Identifies the frame in which the network entry request, which this message responds to, was transmitted. The 4 least significant bits of the frame number are used as the frame number index.

Network Entry Code:

- Random code sent by the SS in AAS Network Entry Request.

## 4.4.2 Mesh

In addition to the PMP frame structure, an optional frame structure (see figure 16) is defined to facilitate mesh networks.

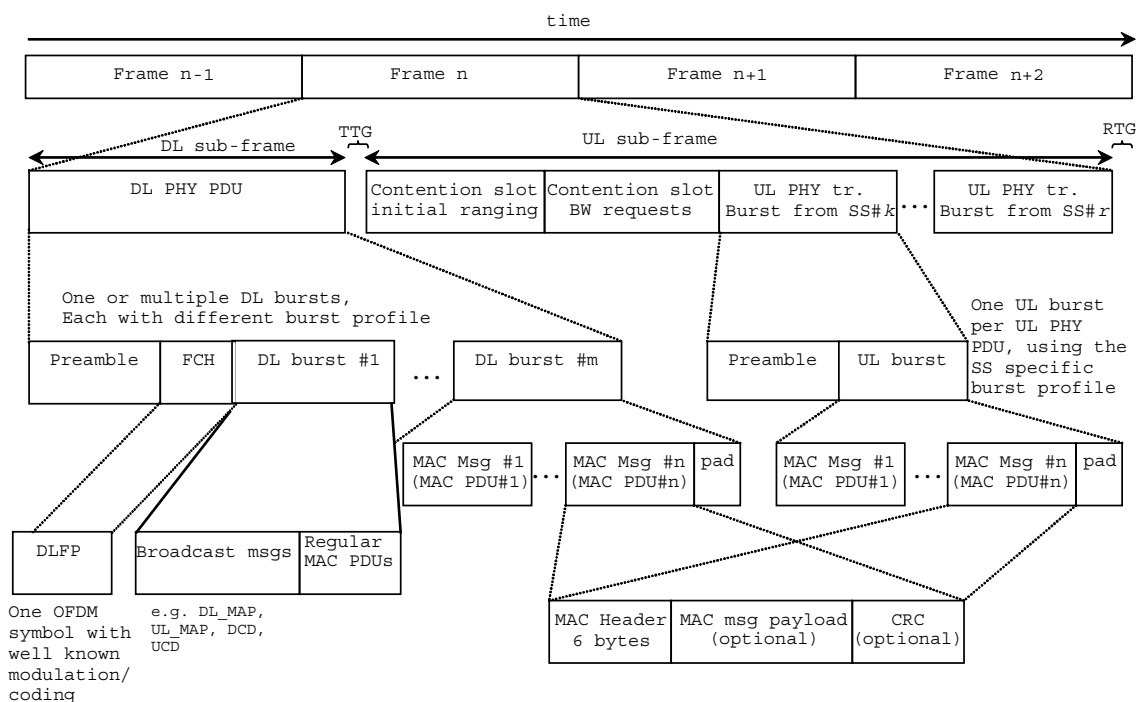

Figure 16: Mesh frame structure

A mesh frame consists of a control and data subframe. The control subframe has two basic functionalities. One is the creation and maintenance of cohesion between the different systems, termed "network control" in figure 16. The other is the co-ordinated scheduling of data-transfers between systems, termed "schedule control" figure 16. Frames with a network control subframe occur periodically, as indicated in the network descriptor. All other frames have a schedule control subframe. The length of the control subframe is fixed and of length  $MSH-CTRL-LEN \times 7$  OFDM symbols, with  $MSH-CTRL-LEN$  indicated in the network descriptor.

During a network control subframe, the first 7 symbols are allocated for network entry, followed by  $MSH-CTRL-LEN - 1$  set of 7 symbols for network configuration. During a schedule control subframe, the network descriptor indicates how many ( $MSH-DSCH-NUM$ ) distributed scheduling messages may occur in the control subframe.

The first  $(\text{MSH-CRTL-LEN} - \text{MSH-DSCH-NUM}) \times 7$  symbols are allocated to transmission bursts containing MSH-CSCH and MSH-CSCF PDUs, whereas the remainder is allocated to transmission bursts containing MSH-DSCH PDUs.

Distributed scheduling messages (using the long preamble) may further occur in the data subframe if not in conflict with the scheduling dictated in the control subframe.

All transmissions in the control subframe are sent using the most robust mandatory burst profile. The data subframe is divided into minislots, which are, with possible exception of the last minislot in the frame, of size ceiling  $((\text{OFDM symbols per frame} - \text{MSH-CTRL-LEN} \times 7) / 256)$ . A scheduled allocation consists of one or more minislots.

### 4.4.3 Frame duration codes

Table 20 indicates the specific frame durations that are allowed. The frame duration used can be determined by the periodicity of the frame start preambles. Once a specific frame duration has been selected by the BS, it should not be changed. Changing the frame duration shall force all SSSs to resynchronize to the BS.

**Table 20: Frame duration codes**

Code	Frame Duration (ms)	Frames/s
0	2,5	400
1	4	250
2	5	200
3	8	125
4	10	100
5	12,5	80
6	20	50
7 to 255	<i>reserved</i>	

## 4.5 Control mechanisms

### 4.5.1 Synchronization

#### 4.5.1.1 Network synchronization

It is recommended (but not required) that all BSs be time synchronized to a common timing signal. In the event of the loss of the network timing signal, BSs may continue to operate and shall automatically resynchronize to the network timing signal when it is recovered. The synchronizing reference shall be a 1 pps timing pulse based on a 10 MHz frequency reference. These signals are typically provided by a GPS receiver.

Frequency references derived from the timing reference may be used to control the frequency accuracy of Base-Stations provided that they meet the frequency accuracy requirements of clause 4.11. This applies during normal operation and during loss of timing reference.

## 4.6 Ranging

There are two types of ranging processes, initial ranging and periodic ranging.

Ranging and power control are performed during (re)registration, after synchronization is lost; and on a periodic basis. Initial ranging uses the initial ranging contention-based interval, which requires a long preamble. Periodic ranging uses the regular UL burst.

During registration, a new subscriber registers during the random access channel and if successful enters into a ranging process under control of the BS. The ranging process is cyclic in nature where default time and power parameters are used to initiate the process followed by cycles where (re)calculated parameters are used in succession until parameters meet acceptance criteria for a new subscriber. These parameters are monitored, measured and stored at the BS and transmitted to the SS for use during normal exchange of data. During normal exchange of data, the stored parameters are updated in a periodic manner based on configurable update intervals to ensure changes in the channel can be accommodated. The update intervals shall vary in a controlled manner on a SS by SS basis. Initial ranging transmissions shall use a long preamble and the most robust mandatory burst profile.

Ranging on re-registration follows the same process as new registration.

Regardless of Duplexing mode, the appropriate duration of the Initial Ranging slot used for initial system access depends on the intended cell radius.

SSs that compute their  $P_{TX\_IR\_max}$  to exceed their maximum power level and SSs that have attempted initial ranging with the maximum power level using RNG-REQ may, if the BS supports subchannelization, attempt initial ranging in an initial ranging slot using the following burst format to be referred to as the Subchannelized Initial Ranging Signal as indicated in figures 17 and 18:

- The SS shall transmit the long preamble as defined in clause 4.3.6. This shall be followed by a single odd numbered randomly selected subchannel with duration of two OFDM symbols, containing the preamble for this subchannel as defined in clause 4.3.6. Note that the long preamble is transmitted on the entire BW while the subchannelized preamble is transmitted on 1/16 of the BW.
- The long preamble and subchannelized preamble shall be transmitted using the same total power. As a result the spectral density of the long preamble shall be lower by a factor of 16 (about 12 dB) with respect to the power spectral density of the subchannelized preamble.
- The BS need only detect that energy is sent on a single subchannel and may respond by allocating a single subchannel identifying the SS by the Transmit Opportunity, Frame Number, and ranging subchannel in which the transmission was received. The allocation is accomplished using the Initial Ranging CID as shown in figure 18. The allocated bandwidth shall be sufficient to contain at least one RNG-REQ message.
- A SS attempting subchannelized initial ranging shall use its maximum power setting for the initial ranging burst.

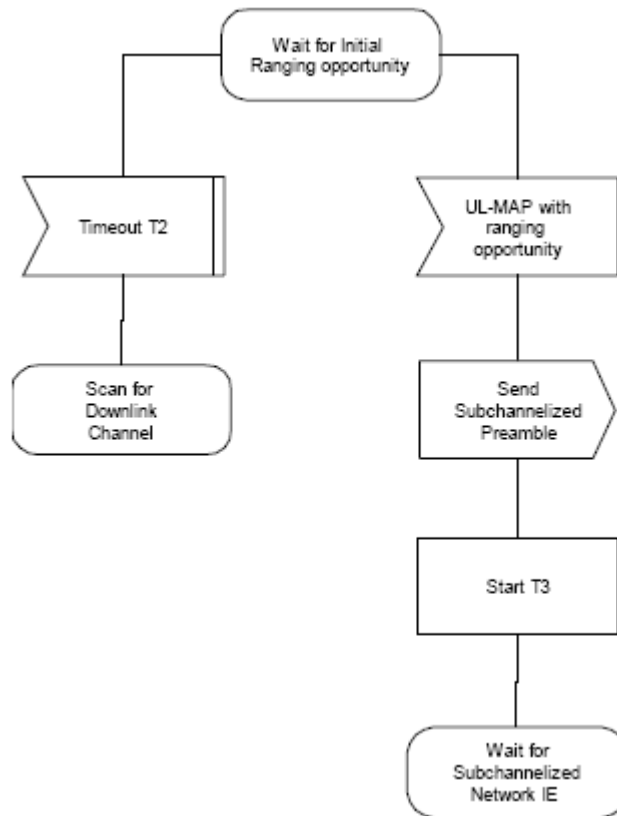

Figure 17: Subchannelized Initial Ranging - SS (part 1a)

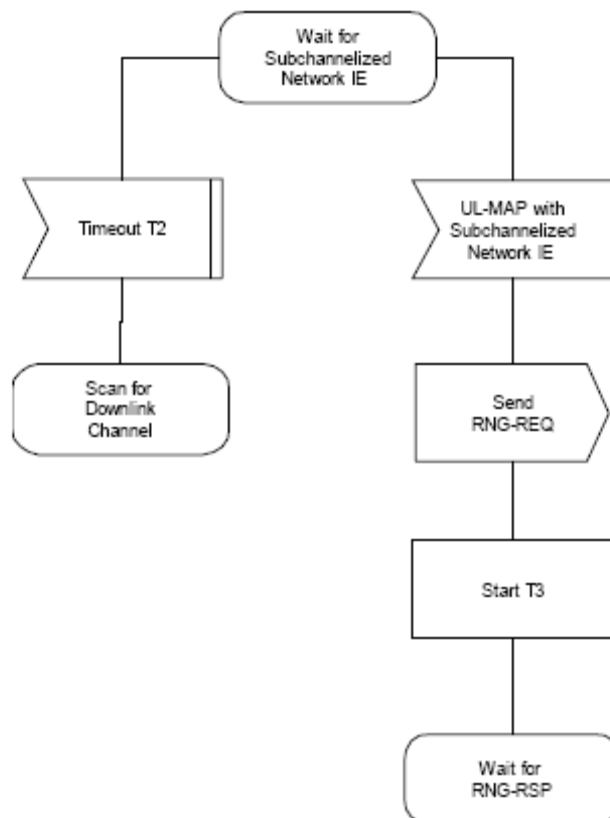

Figure 18: Subchannelized Initial Ranging - SS (part 1b)

### 4.6.1 Initial Ranging in AAS systems

A BS supporting the AAS option may allocate in the uplink subframe an AAS alert slot for AAS SSs that have to initially alert the BS of their presence. This period shall be marked as Initial-Ranging (UIUC=1), but shall be marked by a well known AAS initial ranging CID (0xFEFF) such that no non -AAS subscriber (or AAS subscriber that can decode the UL-MAP message) uses this interval for Initial Ranging. Additionally this period shall be marked using AAS map (see table 249 in IEEE 802.16 [2]). The SS shall transmit the long preamble as defined in clause 8.3.3.6 of IEEE 802.16 [2]. This shall be followed by a burst carrying the AAS\_NW\_ENTRY\_REQ message (see table 257 in IEEE 802.16 [2]). This burst shall use the most robust mandatory rate.

The BS may respond to the network entry request by transmitting a RNG-RSP message indicating the required changes to the ranging parameters. The SS is identified by specifying the transmit opportunity and the entry code of the AAS\_NW\_ENTRY\_REQ message. When transmitting the response, the BS may use the feedback information embedded in the AAS\_NW\_ENTRY\_REQ to direct the beam to the SS.

BS may additionally assign subchannelized AAS alert slot for SSs supporting subchannelization. AAS SSs which have attempted initial ranging with the maximum power level using AAS\_NW\_ENTRY\_REQ may attempt initial ranging in the subchannelized AAS alert slot. The SS shall transmit the long preamble. This shall be followed by subchannelized burst carrying the AAS\_SBCH\_NW\_ENTRY\_REQ message. This message shall be sent on the subchannel indicated by the UL-MAP information element used to allocate the ranging period.

### 4.6.2 Bandwidth requesting

There may be two types of Request (REQ) Regions in a frame. These two types are REQ Region-Full and REQ Region-Focused.

In a REQ Region-Full, when subchannelization is not active, each Transmit Opportunity shall consist of a short preamble and one OFDM symbol using the most robust mandatory coding method (BPSK ½). When subchannelization is active, the allocation is partitioned into Transmission Opportunities (TOs) both in frequency and in time. The width (in subchannels) and length (in OFDM symbols) of each Transmission Opportunity (TO) is defined in the UCD message (see IEEE 802.16 [2], table 350). The transmission of an SS shall contain a subchannelized preamble corresponding to the TO chosen, followed by data OFDM symbols using the most robust mandatory burst profile (BPSK ½).

In a REQ Region-Focused, a station shall send a short code over a TO which consists of 4 subcarriers by two OFDM symbols. Each TO within a MAC frame shall be indexed by consecutive TO Indices. The first TO shall be indexed zero.

All SSs shall be capable of the Full Contention Transmission. Capability of the focused contention transmission is optional. The SS shall follow the back off procedure as described in IEEE 802.16 [2], clause 6.2.8.

#### 4.6.2.1 Parameter selection

The SS shall examine the UL\_MAP message for a future frame and select (in accordance with IEEE 802.16 [2], clause 6.2.8) a future REQ Region during which to make its request. If Focused Contention Supported = 1 is returned by the BS in the SBC-RSP message during SS initialization and if the SS is capable of focused contention, it may choose either a REQ Region-Full or REQ Region-Focused. Otherwise, it shall choose a REQ Region-Full.

For REQ Region-Focused, the SS shall also select, at random with equal probability, a contention code from table 21 and similarly a contention channel from table 22. The indices {-100 to +100} in the body of table 22 refer to the subcarrier indices as defined in table 1. The number of contention codes that can be used by a subchannelized capable SS is denoted by  $C_{SE}$ . The contention code shall be selected at random with equal probability from the appropriate subset of codes in table 21 according to the value of  $C_{SE}$ .

If the BS supports subchannelization, the last  $C_{SE}$  contention codes shall only be used by subchannelization enabled SSs that wish to receive a subchannelized allocation. In response, the BS may provide the requested allocation as a subchannelized allocation; may provide the requested allocation as a full (default) allocation, or may provide no allocation at all. The value of  $C_{SE}$  is transmitted in the UCD channel encoding TLV messages. The default value of  $C_{SE}$  is 0.

A BS that supports Focused Contention may allocate the Focused Contention region based upon the BSID, thereby reducing the probability of interference from SSSs operating in nearby cells operating on the same frequency.

Any Focused Contention region allocation shall be restricted to an even Subchannel Index (meaning that it be no finer than a 1/8 subchannel, see table 1), providing between 6 and 48 contention channels.

**Table 21: OFDM contention codes**

Contention Code Index	bit 0	bit 1	bit 2	bit 3
0	1	1	1	1
1	1	-1	1	-1
2	1	1	-1	-1
3	1	-1	-1	1
4	-1	-1	-1	-1
5	-1	1	-1	1
6	-1	-1	1	1
7	-1	1	1	-1

**Table 22: OFDM contention channels**

Contention Channel Index	frequency offset index 0	frequency offset index 1	frequency offset index 2	frequency offset index 3	Contention Channel belongs to subchannel (see table 1)
0	-100	-37	1	64	0b00010
1	-99	-36	2	65	0b00010
2	-98	-35	3	66	0b00010
3	-97	-34	4	67	0b00010
4	-96	-33	5	68	0b00010
5	-95	-32	6	69	0b00010
6	-94	-31	7	70	0b00110
7	-93	-30	8	71	0b00110
8	-92	-29	9	72	0b00110
9	-91	-28	10	73	0b00110
10	-90	-27	11	74	0b00110
11	-89	-26	12	75	0b00110
12	-87	-50	14	51	0b01010
13	-86	-49	15	52	0b01010
14	-85	-48	16	53	0b01010
15	-84	-47	17	54	0b01010
16	-83	-46	18	55	0b01010
17	-82	-45	19	56	0b01010
18	-81	-44	20	57	0b01110
19	-80	-43	21	58	0b01110
20	-79	-42	22	59	0b01110
21	-78	-41	23	60	0b01110
22	-77	-40	24	61	0b01110
23	-76	-39	25	62	0b01110
24	-75	-12	26	89	0b10010
25	-74	-11	27	90	0b10010
26	-73	-10	28	91	0b10010
27	-72	-9	29	92	0b10010
28	-71	-8	30	93	0b10010
29	-70	-7	31	94	0b10010
30	-69	-6	32	95	0b10110
31	-68	-5	33	96	0b10110
32	-67	-4	34	97	0b10110
33	-66	-3	35	98	0b10110
34	-65	-2	36	99	0b10110
35	-64	-1	37	100	0b10110

Contention Channel Index	frequency offset index 0	frequency offset index 1	frequency offset index 2	frequency offset index 3	Contention Channel belongs to subchannel (see table 1)
36	-62	-25	39	76	0b11010
37	-61	-24	40	77	0b11010
38	-60	-23	41	78	0b11010
39	-59	-22	42	79	0b11010
40	-58	-21	43	80	0b11010
41	-57	-20	44	81	0b11010
42	-56	-19	45	82	0b11110
43	-55	-18	46	83	0b11110
44	-54	-17	47	84	0b11110
45	-53	-16	48	85	0b11110
46	-52	-15	49	86	0b11110
47	-51	-14	50	87	0b11110

#### 4.6.2.2 Full contention transmission

If the chosen REQ Region is a REQ Region-Full, the SS shall transmit the short preamble as defined in clause 4.3.6, followed by a Bandwidth Request MAC Header.

If the Full Contention allocation appears in a subchannelized region, the allocation is partitioned into Transmission Opportunities (TOs) both in frequency and in time. The width (in subchannels) and length (in OFDM symbols) of each TO is defined in the UCD message. The transmission of an SS shall contain a subchannelized preamble corresponding to the TO chosen, followed by data OFDM symbols using the most robust mandatory burst profile (BPSK ½).

#### 4.6.2.3 Focused contention transmission

The REQ Region-Focused bandwidth requesting mechanism consists of two phases as defined in TS 102 178 [1]. In the first phase, a SS requesting bandwidth shall send a signal to the BS in the UL TO interval of REQ Region Focused identified by UIUC=3. One REQ Region Focused UL TO with UIUC=3 shall be 4 subcarriers by two OFDM symbols. This bandwidth requesting signal transmission is described below. In the second phase, the BS may include in its UL-MAP an allocation for the SS using UIUC=4 and the Focused\_Contention\_IE. The SS is identified by the Frame Number index, TO index, Contention Channel index, and Contention Code index that the SS used to send the bandwidth request signal during the first phase. In the second phase, Phase-2, the SS requesting bandwidth responds to this UL-MAP allocation with a bandwidth request MAC header as defined in TS 102 178 [1], clause 7.2.1. The Phase-2 uplink interval with UIUC=4 shall consist of a short preamble and shall have the duration indicated by the relevant field of the UL-MAP\_IE() and shall use the most robust mandatory burst profile.

For REQ Region-Focused, after choosing its four parameters, the SS shall transmit four subcarriers that comprise the chosen contention channel. The amplitude of all other carriers shall be zero.

During both OFDM symbols, the amplitude of each of the four carriers shall be boosted somewhat above its normal amplitude, i.e. that used during a non-contention OFDM symbol, including the current power-control correction. The boost in dB shall equal the value of the Focused Contention Power Boost parameter in the current Uplink Channel Descriptor (UCD).

During the first OFDM symbol of the TO, the phase of the four carriers is not specified.

During the second OFDM symbol of the TO, the phases shall depend on the corresponding bit in the chosen contention code, and the phase transmitted during the first OFDM symbol on the same carrier. If the code bit is +1, the phase shall be the same as that transmitted during the first OFDM symbol. If the code bit is -1, the phase shall be inverted, 180 degrees with respect to the phase transmitted during the first OFDM symbol.



## 4.6.3 Power control

### 4.6.3.1 Closed loop power control

As with frequency control, a power control algorithm shall be supported for the uplink channel with both an initial calibration and periodic adjustment procedure without loss of data. The objective of the power control algorithm is to bring the received power density from a given subscriber to a desired level. The received power density is defined as total power received from a given subscriber divided by the number of active subcarriers. When subchannelization is not employed, the number of active subcarriers is equal for all the subscribers and the power control algorithm shall bring the total received power from a given subscriber to the desired level. The base station shall be capable of providing accurate power measurements of the received burst signal. This value can then be compared against a reference level, and the resulting error can be fed back to the subscriber station in a calibration message coming from the MAC sublayer. The power control algorithm shall be designed to support power attenuation due to distance loss or power fluctuations at rates of at most 30 dB/s with depths of at least 10 dB. The exact algorithm implementation is vendor-specific.

The total power control range consists of both a fixed portion and a portion that is automatically controlled by feedback. The power control algorithm shall take into account the interaction of the Radio Frequency (RF) power amplifier with different burst profiles. For example, when changing from one burst profile to another, margins should be maintained to prevent saturation of the amplifier and to prevent violation of emissions masks.

When subchannelization is employed in the uplink the SS shall maintain the same transmitted power density unless the maximum power level is reached. That is, when the number of active subchannels allocated to a user is reduced, the total transmitted power shall be reduced proportionally by the SS, without additional power control messages. When the number of subchannels is increased the total transmitted power shall also be increased proportionally. However, the transmitted power level shall not exceed the maximum levels dictated by signal integrity considerations and regulatory requirements.

When subchannelization is employed in the downlink, the BS may vary the power of individual subchannelized allocations to improve the link budget to particular SSs. The transmitted power level shall not exceed the maximum levels dictated by signal integrity considerations and regulatory requirements. Within a given DL subchannelized allocation the spectral flatness requirement as specified in IEEE 802.16 [2], clause 8.3.10.1.1 applies to all the energized subcarriers.

When subchannelization is employed, SS shall interpret power control messages as the required changes to the transmitted power density.

Subscriber stations shall report the maximum available power, and the current average transmitted power. These parameters may be used by the Base station for optimal assignment of coding schemes, modulations, and for optimal allocation of subchannels. The algorithm is vendor specific. These parameters are reported in the SBC-REQ message. The current normalized transmitted power shall also report in the REP-RSP message if the relevant flag in the REP-REQ message has been set.

Explicitly, let PSDref be the reference level of power spectrum density of the SS. This can only be changed by power control messages. The transmit power of the SS is defined as current tx power = min((number used subchannels) × PSDref, maximum available power). Thus in the case of saturation, the reference level of power spectrum density shall not be changed.

The current transmitted power is the power of the burst which carries the message. The maximum available power is reported for QPSK 16-QAM and 64-QAM constellations. The current transmitted power and the maximum power parameters are reported in dBm. The parameters are quantized in 0,5 dBm steps ranging from -64 dBm (encoded 0x00) to 63,5 dBm (encoded 0xFF). Values outside this range shall be assigned the closest extreme. SSs that do not support 64-QAM shall report the value of 0x00 in the maximum 64-QAM power field.

### 4.6.3.2 Open loop power control (optional)

When the open loop power control is supported and the uplink power control mode is changed to open loop power control by PMC\_RSP, the power per a subcarrier shall be maintained for the UL transmission as follows.

This open loop power control shall be applied for all the uplink bursts.

$$EIRP^{(dBm)} = PL + CNR + R + (N + 1) + 10 \log_{10}(BW_{sch}) + Offset_{SS_{perSS}} + Offset_{BS_{perSS}} \quad (18)$$

where:

- $P_{EIRP}$  is the Tx effective isotropic radiated power (EIRP) level, expressed in dBm, per subcarrier for the current transmission. It includes the SS Tx antenna gain and its related coupling losses.
- $PL$  is the estimated average current UL path loss.
- $CNR$  is the normalized Carrier to Noise Ratio (per subcarrier) for the given modulation, FEC and the related Convolutional Coding scheme used for the current transmission as presented in table 23. The normalized Carrier to Noise Ratio can be modified by UCD (Normalized C/N override).
- $R$  is the number or repetitive sequences used by the receiving circuitry employed to determine the path losses.
- $BW_{sch}$  is the bandwidth occupied by an OFDM subcarrier, expressed in Hz.
- $N+I$  is the estimated normalized average power level (dBm) of the noise and interference per subcarrier at the Rx antenna port of the receiving side (BS), for BW=1 Hz. It does not include the equivalent gain of the Rx antenna and its related coupling losses.
- $Offset_{MS\_UL}$  represents the correction term for SS-specific power offset. Practically it amounts to the desired Fade Margin for the respective UL link. It is controlled by the SS and initially is set to zero.
- $Offset_{BS\_UL}$  represents the SS-specific power offset, controlled by the BS through the power control messages. When  $Offset_{BS\_UL}$  is set through the PMC\_RSP message, it shall include the equivalent BS Rx antenna gain, including its related coupling losses, measured at the antenna port of the equipment.

**Table 23: Normalized CINR per modulation (BER=1e-6)**

Modulation/FEC-CC Rate	Normalized CNR (dB)
BPSK $\frac{1}{2}$	13,9
QPSK $\frac{1}{2}$	16,9
QPSK $\frac{3}{4}$	18,65
16QAM $\frac{1}{2}$	23,7
16QAM $\frac{3}{4}$	25,45
64QAM $\frac{1}{2}$	29,7
64QAM $\frac{3}{4}$	31,45

The normalized CNR is calculated based on Noise Figure=7 dB and MIL (Modulation Implementation Losses=5 dB).

The estimated average current UL propagation loss,  $PL_{UL}$ , shall be calculated based on the total power received on the active subcarriers of the frame preamble, referenced to the  $BS\_EIRP$  parameter sent by the BS.

Table 23 returns the default normalized CNR values per modulation. The operating parameters  $BS\_EIRP$  and  $NI$  are signalled by a DCD message (see IEEE 802.16 [2], table 358 DCD channel encoding).

Additionally, the BS controls the  $Offset_{BS\_perSS}$  using PMC\_RSP message IEEE 802.16 [2], clause 6.3.2.3.58 to override the  $Offset_{BS\_perSS}$  value or using RNG-RSP IEEE 802.16 [2], clause 6.3.2.3.6, Fast Power Control (FPC) message TS 102 178 [1], clause 7.4.27, Power Control IE IEEE 802.16 [2], clause 8.3.6.3.5 to adjust the  $Offset_{BS\_perSS}$  value. The accumulated power control value shall be used for  $Offset_{BS\_perSS}$ .

The  $Offset_{BS\_perSS}$  can be updated using relative or fixed form (as a function of the relevant adjustment commands used). Fixed form is used when the parameter is obtained from a PMC\_RSP message. In this case, the SS should replace the old  $Offset_{SS\_perSS}$  value by the new  $Offset_{SS\_perSS}$  sent by the BS. With all other messages mentioned in the previous clause, relative form is used. In this case, SS should increase and decrease the  $Offset_{SS\_perSS}$  according to the offset value sent by BS.

The actual power setting shall be quantized to the nearest implementable value, subject to the specification. For each transmission, the SS shall limit the power, as required to satisfy the spectral masks and EVM (Error Vector Magnitude) requirements.

### Passive Uplink open loop power control

- In passive Uplink open loop power control the SS will set  $Offset\_SS_{perSS}$  to zero and modify the TX power value using equation 18.

### Active Uplink open loop power control

- An alternative way is that the SS may adjust  $Offset\_SS_{perSS}$  value within a range.

$$Offset\_Bound_{lower} \leq Offset_{perSS} \leq Offset\_Bound_{upper}$$

where:

$Offset\_Bound_{upper}$  is the upper bound of  $Offset\_SS_{perSS}$

$Offset\_Bound_{lower}$  is the lower bound of  $Offset\_SS_{perSS}$

## 4.7 Transmit diversity space-time coding (optional)

STC (see for example IEEE journal on select areas in communications [i.1]), may be used on the downlink to provide higher order (Space) transmit diversity.

There are two transmit antennas on the BS side and one reception antenna on the SS side. This scheme requires Multiple Input Single Output channel estimation. Decoding is very similar to maximum ratio combining.

Figure 19 shows STC insertion into the OFDM chain. Each Tx antenna has its own OFDM chain, but they have the same Local Oscillator for synchronization purposes.

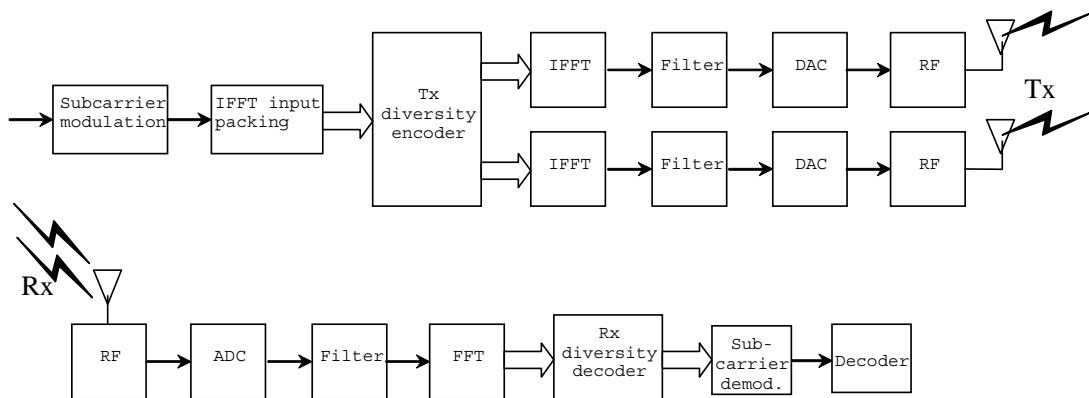

**Figure 19: Illustration of STC**

Both antennas transmit in the same time two different OFDM data symbols. Transmission is performed twice so as to decode and get 2<sup>nd</sup> order diversity. Time domain (Space-Time) repetition is used.

Both antennas transmit at the same time, and they share the same Local Oscillator. Thus, the received signal has exactly the same auto-correlation properties as for a single antenna. So, time and frequency coarse and fine estimation can be performed in the same way as for a single antenna. The scheme requires Multiple Input Single Output channel estimation, which is provisioned by starting the PHY burst following the STC\_IE with a preamble transmitted from both antennas (see clause 4.3.6) to estimate the channel from both transmit antennas.

The basic scheme transmits two complex symbols  $s_0$  and  $s_1$ , using the channel twice with channel vector values  $h_0$  (for antenna 0) and  $h_1$  (for antenna 1).

First channel use (i.e. first OFDM symbol): Antenna 0 transmits  $s_0$ , antenna 1 transmits  $s_1$ .

Second channel use (i.e. second OFDM symbol): Antenna 0 transmits  $-s_1^*$ , antenna 1 transmits  $s_0^*$ .

Receiver gets  $r_0$  (first channel use) and  $r_1$  (second channel use) and computes  $s_0$  and  $s_1$  estimates:

$$\hat{s}_0 = h_0^* \times r_0 + h_1 \times r_1^* \quad (19)$$

$$\hat{s}_1 = h_1^* \times r_0 - h_0 \times r_1^* \quad (20)$$

These estimates benefit from 2<sup>nd</sup> order diversity as in the 1Tx-2Rx Maximum Ratio Combining scheme. OFDM symbols are processed by pairs. The precoding operation, and consecutively the receive decoding (as described in equations 19 and 20), is applied independently to same-numbered subcarriers in two consecutive OFDM data symbols. Note that the two OFDM symbols may belong to different PHY bursts and even use different constellations. An individual PHY burst may contain any integer number of symbols. The aggregate duration of all PHY bursts following the last STC preamble or between any two STC preambles shall be a multiple of 2.

On a given pilot subcarrier, the same pilot symbol is used for the STC block. If the STC block consists of OFDM symbol  $k$  and  $k+1$  and  $p_s$  is the pilot symbol for pilot subcarrier  $s$  as derived for OFDM symbol  $k$  from clause 4.3.4.2, then the modulation on pilot subcarrier  $s$  during OFDM symbol  $k$  shall be  $p_s$  on both antenna 0 and 1. During OFDM symbol  $k+1$ , it shall be  $-p_s$  on antenna 0 and  $p_s$  on antenna 1.

For decoding, the receiver waits for 2 symbols and combines them on a subcarrier basis according to equations 19 and 20.

### 4.7.1 STC 2X2

The block diagram of a STC 2x2 implementation is presented in figure 20.

A STC 2x1 solution shall be based on the STC specifications as detailed in IEEE 802.16 [2], clause 8.3.8.2. This solution could be implemented optionally on DL and UL.

For a STC 2x2 solution the following procedures are implemented.

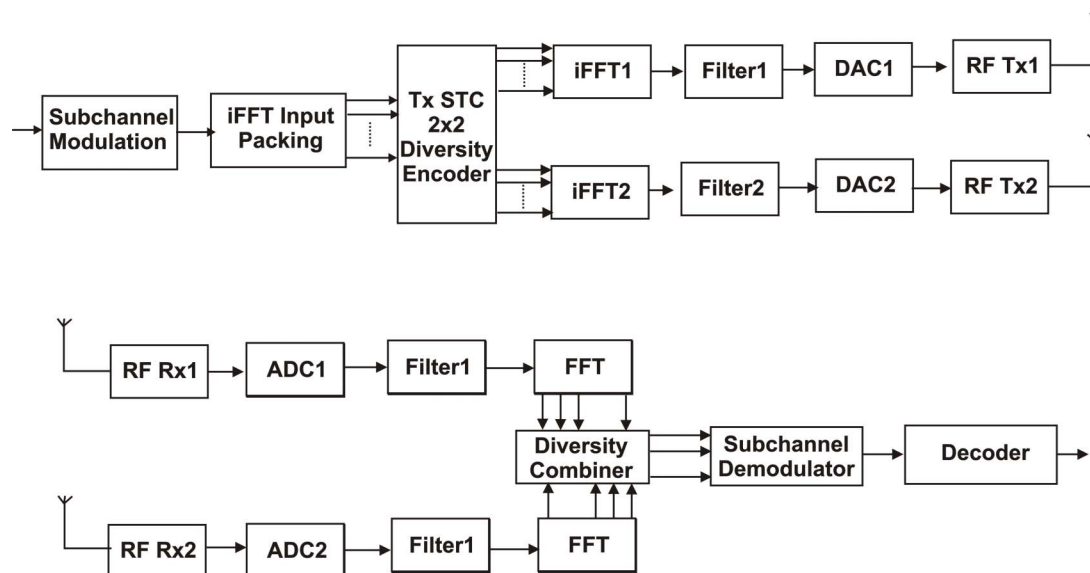

Figure 20: STC 2x2 Block diagram

#### 4.7.1.1 STC 2x2 coding

The basic STC 2x2 implementation transmits two complex symbols  $s_0$  and  $s_1$ , using the multiple input multiple output channel (two Tx, two Rx) twice with channel vector values  $h_1$  (Tx1 to Rx1),  $h_2$  (Tx1 to Rx2),  $h_3$  (Tx2 to Rx1) and  $h_4$  (Tx2 to Rx2), as presented in table 24.

**Table 24: Channel definitions for STC 2X2 implementation**

	Rx 1	Rx 2
Tx 1	h1	h2
Tx 2	h3	h4

The related received signals for a STC 2x2 implementation are presented in table 25.

**Table 25: Received signals for a STC 2x2 implementation**

	Rx 1	Rx 2
time t	r1	r2
time t+T	r3	r4

The channel noise contributions are defined by  $n_1, n_2, n_3, n_4$ . These noise contributions represent complex random variables covering the interference and the thermal noise. The related received signals are presented in the equations 21 through 24.

$$r_1 = h_1 s_1 + h_2 s_2 + n_1 \quad (21)$$

$$r_2 = -h_1 s_2^* + h_2 s_1^* + n_2 \quad (22)$$

$$r_3 = h_3 s_1 + h_4 s_2 + n_3 \quad (23)$$

$$r_4 = -h_3 s_2^* + h_4 s_1^* + n_4 \quad (24)$$

Such an implementation is a 4<sup>th</sup> order diversity system. The STC 2x2 coding could be implemented symmetrically (UL and DL) or asymmetrically (DL or UL). The STC 2x2 implementation shall be downgradable to STC 2x1 or non-STC 1x1.

#### 4.7.1.2 STC 2x2 decoding

The diversity combiner waits for two symbols, and combines them on a subcarrier basis according to equations 21 through 24.

## 4.8 Channel quality measurements

### 4.8.1 Introduction

Receive Signal Strength Indicator (RSSI) and Carrier to Interference Noise Ratio (CINR) signal quality measurements and associated statistics can aid in such processes as BS selection/assignment and burst adaptive profile selection. As channel behaviour is time-variant, both mean and standard deviation are defined. Implementation of the RSSI and CINR statistics and their reports is mandatory.

The process by which RSSI measurements are taken does not necessarily require receiver demodulation lock; for this reason, RSSI measurements offer reasonably reliable channel strength assessments even at low signal levels. On the other hand, although CINR measurements require receiver lock, they provide information on the actual operating condition of the receiver, including interference, noise levels, and signal strength.

## 4.8.2 RSSI mean and standard deviation

When the BS mandates collection of RSSI measurements, a SS shall obtain an RSSI measurement from the OFDM DL long preambles. From a succession of RSSI measurements, the SS shall derive and update estimates of the mean and the standard deviation of the RSSI, and report them when solicited via REP-RSP messages.

Mean and standard deviation statistics shall be reported in units of dBm. To prepare such reports, statistics shall be quantized in 1 dB increments, ranging from -40 dBm (encoded 0x53) to -123 dBm (encoded 0x00). Values outside this range shall be assigned the closest extreme value within the scale.

The method used to estimate the RSSI of a single message is left to individual implementation, but the relative accuracy of a single signal strength measurement, taken from a single message, shall be  $\pm 2$  dB, with an absolute accuracy of  $\pm 4$  dB. The specified accuracy shall apply to the range of RSSI values starting from 6 dB below the sensitivity level of the most robust mode or -123 dBm (whichever is higher) up to -40 dBm. In addition, the range over which these single-message measurements are measured should extend 3 dB on each side beyond the -40 dBm to -123 dBm limits for the final averaged statistics that are reported. All measurements are taken at the antenna connector.

One possible method for estimating the RSSI of a received signal of interest is given by:

$$\text{RSSI} = 10^{\frac{G_{rf}}{10}} \frac{1,256 \times 10^4 V_c^2}{(2^{2B}) R} \left( \frac{1}{N} \sum_{N=0}^{N-1} |Y_{IorQ}[k, n]| \right)^2 \text{ mW} \quad (25)$$

where:

- $B$  is ADC precision, number of bits of ADC.
- $R$  is ADC input resistance [Ohms].
- $V_c$  is ADC input clip level [Volts].
- $G_{rf}$  is analog gain from antenna connector to ADC input.
- $Y_{IorQ}[k, n]$  is the  $n^{\text{th}}$  sample at the ADC output of I or Q branch within signal  $k$ .
- $N$  is the number of samples.

The (linear) mean RSSI statistics (in mW), derived from a multiplicity of single messages, shall be updated using:

$$\hat{\mu}_{\text{RSSI}}[k] = \begin{cases} R[0] & k = 0 \\ (1 - \alpha_{\text{avg}}) \hat{\mu}_{\text{RSSI}}[k-1] + \alpha_{\text{avg}} R[k] & k > 0 \end{cases} \text{ mW} \quad (26)$$

where  $k$  is the time index for the message (with the initial message being indexed by  $k = 0$ , the next message by  $k = 1$ , etc.),  $R[k]$  is the RSSI in mW measured during message  $k$ , and  $\alpha_{\text{avg}}$  is an averaging parameter specified by the BS. The mean estimate in dBm shall then be derived from:

$$\hat{\mu}_{\text{RSSI dBm}}[k] = 10 \log(\hat{\mu}_{\text{RSSI}}[k]) \text{ dBm} \quad (27)$$

To solve for the standard deviation in dB, the expectation-squared statistic shall be updated using:

$$\hat{\chi}_{\text{RSSI}}^2[k] = \begin{cases} |R[0]|^2 & k = 0 \\ (1 - \alpha_{\text{avg}}) \hat{\chi}_{\text{RSSI}}^2[k-1] + \alpha_{\text{avg}} |R[k]|^2 & k > 0 \end{cases} \quad (28)$$

and the result applied to:

$$\hat{\sigma}_{\text{RSSI dB}} = 5 \log\left(\left|\hat{\chi}_{\text{RSSI}}^2[k] - \hat{\mu}_{\text{RSSI}}^2[k]\right|\right) \text{ dB} \quad (29)$$

### 4.8.3 CINR mean and standard deviation

When Carrier to Interference and Noise Ratio (CINR) measurements are mandated by the BS, a SS shall obtain a CINR measurement from the OFDM DL preamble. From a succession of these measurements, the SS shall derive and update estimates of the mean and the standard deviation of the CINR, and report them when solicited via REP-RSP messages

Mean and standard deviation statistics for CINR shall be reported in units of dB. To prepare such reports, statistics shall be quantized in 1 dB increments, ranging from a minimum of -10 dB (encoded 0x00) to a maximum of 53 dB (encoded 0x3F). Values outside this range shall be assigned the closest extreme value within the scale.

The method used to estimate the CINR of a single message is left to individual implementation, but the relative and absolute accuracy of a CINR measurement derived from a single message shall be  $\pm 1$  dB and  $\pm 2$  dB, respectively. The specified accuracy shall apply to the range of CINR values starting from the SNR of the most robust rate, to 3 dB above the SNR of the least robust rate. In addition, the range over which these single-packet measurements are measured should extend 3 dB on each side beyond the -10 dB to 53 dB limits for the final reported, averaged statistics.

One possible method to estimate the CINR of a single message is to compute the ratio of signal power to residual error for each data sample, and then average the results from each data sample, using:

$$CINR[k] = \frac{\sum_{n=0}^{n-1} |s[k, n]|^2}{\sum_{n=0}^{n-1} |r[k, n] - s[k, n]|^2} \quad (30)$$

where  $r[k, n]$  is received sample  $n$  within message  $k$ ;  $s[k, n]$  is the corresponding detected or pilot sample (with channel state weighting) corresponding to received symbol  $n$ .

The-mean CINR statistic (in dB) shall be derived from a multiplicity of single messages using:

$$\hat{\mu}_{CINR \text{ dB}}[k] = 10 \log(\hat{\mu}_{CINR}[k]) \quad \text{dB} \quad (31)$$

where:

$$\hat{\mu}_{CINR}[k] = \begin{cases} CINR[0] & k = 0 \\ (1 - \alpha_{avg}) \hat{\mu}_{CINR}[k-1] + \alpha_{avg} CINR[k] & k > 0 \end{cases} \quad (32)$$

$k$  is the time index for the message (with the initial message being indexed by  $k = 0$ , the next message by  $k = 1$ , etc.);  $CINR[k]$  is a linear measurement of CINR (derived by any mechanism which delivers the prescribed accuracy) for message  $k$ ; and  $\alpha_{avg}$  is an averaging parameter specified by the BS.

To solve for the standard deviation, the expectation-squared statistic shall be updated using:

$$\hat{x}_{CINR}^2[k] = \begin{cases} |CINR[0]|^2 & k = 0 \\ (1 - \alpha_{avg}) \hat{x}_{RSSI}^2[k-1] + \alpha_{avg} |CINR[k]|^2 & k > 0 \end{cases} \quad (33)$$

and the result applied to:

$$\hat{\sigma}_{CINR \text{ dB}} = 5 \log\left(\left|\hat{x}_{RSSI}^2[k] - \hat{\mu}_{RSSI}^2\right|\right) \quad \text{dB} \quad (34)$$

## 4.9 Transmitter requirements

The parameters mentioned in this clause are intended to be used to guarantee the performance of HiperMAN compliant systems. The parameters relevant to essential requirements under article 3.2 of the R&TTE Directive [4] and their limits may be found in the appropriate Harmonized EN.

### 4.9.1 Transmitter channel bandwidth

Transmitter channel bandwidths allowed shall be limited to the regulatory provisioned bandwidth divided by any integer rounded down to the nearest multiple of 250 kHz, resulting in channel bandwidths no less than 1,25 MHz.

If the resulting bandwidth is an odd multiple of 250 kHz, then for any band for which support is claimed, the RF carrier shall only be tunable to every odd multiple of 125 kHz within that band. If the resulting channel bandwidth is an even multiple of 250 kHz, then for any band for which support is claimed, the RF carrier shall only be tunable to every even multiple of 125 kHz within that band. For FDD systems, support shall be claimed separately for UL and DL.

### 4.9.2 Transmit power level control

For an SS not supporting subchannelization, the transmitter shall support monotonic power level control of 30 dB minimum. For an SS supporting subchannelization, the transmitter shall support a monotonic power level control of 50 dB minimum. The minimum step size shall be no more than 1 dB. The relative accuracy of the power control mechanism shall be  $\pm 1,5$  dB for step sizes not exceeding 15 dB,  $\pm 3$  dB for step sizes from 15 dB to 30 dB, and  $\pm 5$  dB for step sizes greater than 30 dB. For a BS, the transmitter shall support a monotonic power level control of 10 dB minimum.

#### 4.9.2.1 Transmitter spectral flatness

The average energy of the constellations in each of the spectral lines shall deviate no more than indicated in table 26. The absolute difference between adjacent carriers shall not exceed 0,1 dB. This data shall be taken from the channel estimation step.

**Table 26: OFDM Spectral Flatness**

Spectral Lines	Spectral Flatness
Spectral lines from -50 to -1 and +1 to +50	$\pm 2$ dB from the measured energy averaged over all 200 active tones
Spectral lines from -100 to -50 and +50 to +100	$\pm 2$ dB/-4 dB from the measured energy averaged over all 200 active tones

The power transmitted at spectral line 0 shall not exceed -15 dB relative to total transmitted power.

#### 4.9.2.2 Transmitter constellation error and test method

To ensure that the receiver SNR does not degrade more than 0,5 dB due to the transmitter SNR, the relative constellation RMS error, averaged over carriers, OFDM frames and packets, shall not exceed a burst profile dependent value according to table 27.

**Table 27: Allowed relative constellation error versus data rate**

Burst type	Relative constellation error for SS (dB)	Relative constellation error BS (dB)
BPSK 1/2	-13,0	-13,0
QPSK 1/2	-16,0	-16,0
QPSK 3/4	-18,5	-18,5
16-QAM 1/2	-21,5	-21,5
16-QAM 3/4	-25	-25,0
64-QAM 2/3	-29,0	-29,0
64-QAM 3/4	-30,0	-31,0

The sampled signal shall be processed in a manner similar to an actual receiver, according to the following steps, or an equivalent procedure:

- Start of frame shall be detected.
- Transition from short sequences to channel estimation sequences shall be detected, and fine timing (with one sample resolution) shall be established.
- Coarse and fine frequency offsets shall be estimated.



- d) The packet shall be de-rotated according to estimated frequency offset.
- e) The complex channel response coefficients shall be estimated for each of the carriers.
- f) For each of the data OFDM symbols: transform the symbol into carrier received values, estimate the phase from the pilot carriers, de-rotate the carrier values according to estimated phase, and divide each carrier value with a complex estimated channel response coefficient. In the case of subchannelization transmission, the estimated channel coefficient of the nearest allocated subcarrier shall be used for those subcarriers not part of the allocated subchannels.
- g) For each data-carrying carrier, find the closest constellation point and compute the Euclidean distance from it. In the case of subchannelization transmission, for data-carrying subcarriers not part of the allocated subchannels, the Euclidean distance shall be computed relative to  $0+0j$ .
- h) Compute the RMS average of all errors in a packet. It is given by:

$$Error_{RMS} = \frac{1}{N} \sum_{i=1}^{N_f} \frac{\sum_{j=1}^{L_p} \left[ \sum_{\substack{k=-N_{used}/2 \\ k \neq 0}}^{N_{used}/2} \left\{ (I(i, j, k) - I_0(i, j, k))^2 + (Q(i, j, k) - Q_0(i, j, k))^2 \right\} \right]}{\sum_{j=1}^{L_p} \left[ \sum_{\substack{k=-N_{used}/2 \\ k \neq 0}}^{N_{used}/2} \left\{ I_0(i, j, k)^2 + Q_0(i, j, k)^2 \right\} \right]} \quad (35)$$

where:

$L_p$  is the length of the packet.

$N_f$  is the number of frames for the measurement.

$\{I_0(i, j, k), Q_0(i, j, k)\}$  denotes the ideal symbol point of the  $i^{th}$  frame,  $j^{th}$  OFDM symbol of the frame,  $k^{th}$  carrier of the OFDM symbol in the complex plane.

$\{I(i, j, k), Q(i, j, k)\}$  denotes the point of the  $i^{th}$  frame,  $j^{th}$  OFDM symbol of the frame,  $k^{th}$  carrier of the OFDM symbol in the complex plane.

## 4.10 Receiver requirements

The parameters mentioned in this clause are intended to be used to guarantee the performance of HiperMAN compliant systems. The parameters relevant to essential requirements under article 3.2 of the R&TTE Directive [4] and their limits may be found in the appropriate Harmonized EN.

### 4.10.1 Receiver sensitivity

The Bit Error Rate (BER) after FEC shall be less than  $10^{-6}$  at the power levels indicated by equation 36 for standard message and test conditions. The minimum input levels are measured as follows:

- using the defined standardized message packet formats; and
- using an AWGN channel.

The receiver minimum input level sensitivity ( $RSS$ ) shall be better than (assuming 5 dB implementation margin and 7 dB Noise Figure):

$$RSS = -101 + SNR_{Rx} + 10 \times \log_{10} \left( F_s \times \frac{N_{used}}{N_{FFT}} \times \frac{N_{subchannels}}{16} \right) \quad (36)$$

where:

$SNR_{Rx}$ : the assumed receiver SNR as per table 28 in dB.

$F_{sa}$ : the sampling frequency in MHz as defined in clause 3.2.

$N_{subchannels}$ : the number of allocated subchannels (default 16 if no subchannelization is used).

**Table 28: Receiver SNR assumptions**

Modulation	Coding rate	Receiver SNR (dB)
BPSK	1/2	3,0
QPSK	1/2	6,0
	3/4	8,5
16-QAM	1/2	11,5
	3/4	15,0
64-QAM	2/3	19,0
	3/4	21,0

Test messages for measuring Receiver Sensitivity shall be based on a continuous stream of MAC PDUs, each with a payload consisting of an  $R$  times repeated sequence  $S_{modulation}$ . For each modulation, a different sequence applies:

$$S_{BPSK} = [0xE4, 0xB1]$$

$$S_{QPSK} = [0xE4, 0xB1, 0xE1, 0xB4]$$

$$S_{16-QAM} = [0xA8, 0x20, 0xB9, 0x31, 0xEC, 0x64, 0xFD, 0x75]$$

$$S_{64-QAM} = [0xB6, 0x93, 0x49, 0xB2, 0x83, 0x08, 0x96, 0x11, 0x41, 0x92, 0x01, 0x00, 0xBA, 0xA3, 0x8A, 0x9A, 0x21, 0x82, 0xD7, 0x15, 0x51, 0xD3, 0x05, 0x10, 0xDB, 0x25, 0x92, 0xF7, 0x97, 0x59, 0xF3, 0x87, 0x18, 0xBE, 0xB3, 0xCB, 0x9E, 0x31, 0xC3, 0xDF, 0x35, 0xD3, 0xFB, 0xA7, 0x9A, 0xFF, 0xB7, 0xDB]$$

For each mandatory test message, the  $(R, S_{modulation})$  tuples that shall apply are:

- Short length test message payload (288 data bytes):  $(144, S_{BPSK}), (72, S_{QPSK}), (36, S_{16-QAM}), (6, S_{64-QAM})$ .
- Mid length test message payload (864 data bytes):  $(431, S_{BPSK}), (216, S_{QPSK}), (108, S_{16-QAM}), (18, S_{64-QAM})$ .
- Long length test message payload (1 488 data bytes):  $(744, S_{BPSK}), (372, S_{QPSK}), (186, S_{16-QAM}), (31, S_{64-QAM})$ .

The test condition requirements are: ambient room temperature, shielded room, conducted measurement at the RF port if available, radiated measurement in a calibrated test environment if the antenna is integrated, and RS FEC is enabled. The test shall be repeated for each test message length and for each  $(R, S_{modulation})$  tuple as identified above, using the mandatory FEC scheme. The results shall meet or exceed the sensitivity requirements indicated by equation 36.

## 4.10.2 Receiver adjacent and alternate channel rejection

The receiver adjacent and alternate channel rejection shall be met over the required dynamic range of the receiver, from 3 dB above the reference sensitivity level specified in clause 4.10.2 to the maximum input signal level as specified in clause 4.10.3.

The adjacent channel rejection and alternate channel rejection shall be measured by setting the desired signal's strength 3 dB above the rate dependent receiver sensitivity (see equation 36) and raising the power level of the interfering signal until the specified error rate of  $1 \times 10^{-6}$  is obtained. The adjacent channel rejection and alternate channel rejection shall also be measured at maximum input level by setting the interfering channel signal strength to the receiver maximum signal level as specified in clause 4.10.3 and decreasing the power level of the desired signal until the specified error rate is obtained. In both cases, the power difference between the desired signal and the interfering channel is the corresponding C/I ratio.

The interfering signal shall be a conforming OFDM signal, unsynchronized with the signal in the channel under test. The requirement shall be met on both sides of the desired signal channel. For non-adjacent channel testing the test method is identical except the interfering channel shall be any channel other than the adjacent channel or the co-channel. For the PHY to be compliant, the minimum rejection shall exceed the levels shown in table 29.

**Table 29: Adjacent and Non-Adjacent channel rejection**

Modulation/coding	Adjacent channel Interference C/I (dB)	Non-adjacent channel rejection C/I (dB)
16-QAM-3/4	-11	-30
64-QAM-3/4	-4	-23

### 4.10.3 Receiver maximum input signal

The receiver shall be capable of receiving a maximum on-channel signal of -30 dBm, and shall tolerate a maximum signal of 0 dBm without damage. Power levels are measured at the antenna connector.

### 4.10.4 Receiver linearity

The receiver shall have a minimum Input Intercept Point (IIP3) of -10 dBm.

## 4.11 Frequency and timing requirements

The BS transmitted centre frequency, receive centre frequency, and the symbol clock frequency shall be derived from the same reference oscillator. The reference frequency tolerance for the BS shall be better than  $\pm 8 \times 10^{-6}$  in licensed bands up to 10 years from the date of equipment manufacture.

The SS shall synchronize its transmitted centre frequency and symbol clock frequency to the BS with a maximum tolerance of 2 % of the FFT subcarrier spacing, and 5 ppm for the sampling clock frequency. In the case of subchannelization, the tolerance for transmitted centre frequency shall be a maximum of 1 % of the subcarrier spacing.

For mesh capable devices, all devices shall have a  $\pm 20$  ppm maximum frequency tolerance and achieve synchronization to its neighbouring nodes with a tolerance of maximum 3 % of the carrier spacing.

During the synchronization period, the SS shall acquire frequency synchronization within the specified tolerance before attempting any uplink transmission. During normal operation, the SS shall track the frequency changes and shall defer any transmission if synchronization is lost.

All SSs shall acquire and adjust their timing such that all uplink OFDM symbols arrive time coincident at the Base-Station to an accuracy of  $\pm 50$  % of the minimum guard-interval or better.

## 4.12 Parameters and constants

A number of parameters and constants are defined, which are used by the DLC.

- Physical Slot (PS):

$$PS = \frac{4}{\Delta f} \times N_{FFT} \quad (37)$$

- Timing Adjust Units:

$$\text{Timing Adjust Unit} = \frac{1}{\Delta f} \times N_{FFT} \quad (38)$$

---

## 5 HiperMAN OFDMA PHY

A compliant device shall implement the OFDMA PHY mode as specified in clause 8.4 of IEEE P802.16<sup>TM</sup>-2009 [5].

---

## History

<b>Document history</b>		
V1.1.1	November 2003	Publication
V1.2.1	January 2005	Publication
V1.2.2	November 2005	Publication
V1.3.1	February 2006	Publication
V1.3.2	March 2006	Publication
V1.4.1	November 2007	Publication
V1.5.1	May 2010	Publication