

# ETSI TS 102 188-7 V1.1.2 (2004-07)

---

*Technical Specification*

## **Satellite Earth Stations and Systems (SES); Regenerative Satellite Mesh - A (RSM-A) air interface; Physical layer specification; Part 7: Synchronization**

---



---

Reference

RTS/SES-00209-7

---

Keywords

air interface, broadband, IP, multimedia, satellite

**ETSI**

650 Route des Lucioles  
F-06921 Sophia Antipolis Cedex - FRANCE

Tel.: +33 4 92 94 42 00 Fax: +33 4 93 65 47 16

Siret N° 348 623 562 00017 - NAF 742 C  
Association à but non lucratif enregistrée à la  
Sous-Préfecture de Grasse (06) N° 7803/88

---

**Important notice**

Individual copies of the present document can be downloaded from:

<http://www.etsi.org>

The present document may be made available in more than one electronic version or in print. In any case of existing or perceived difference in contents between such versions, the reference version is the Portable Document Format (PDF). In case of dispute, the reference shall be the printing on ETSI printers of the PDF version kept on a specific network drive within ETSI Secretariat.

Users of the present document should be aware that the document may be subject to revision or change of status. Information on the current status of this and other ETSI documents is available at

<http://portal.etsi.org/tb/status/status.asp>

If you find errors in the present document, send your comment to:

[editor@etsi.org](mailto:editor@etsi.org)

---

**Copyright Notification**

No part may be reproduced except as authorized by written permission.  
The copyright and the foregoing restriction extend to reproduction in all media.

© European Telecommunications Standards Institute 2004.  
All rights reserved.

**DECT™**, **PLUGTESTS™** and **UMTS™** are Trade Marks of ETSI registered for the benefit of its Members.  
**TIPHON™** and the **TIPHON logo** are Trade Marks currently being registered by ETSI for the benefit of its Members.  
**3GPP™** is a Trade Mark of ETSI registered for the benefit of its Members and of the 3GPP Organizational Partners.

# Contents

Intellectual Property Rights .....	4
Foreword.....	4
1 Scope .....	5
2 References .....	5
3 Definitions and abbreviations.....	5
3.1 Definitions .....	5
3.2 Abbreviations .....	5
4 General description of synchronization system.....	6
4.1 System timing structure.....	8
4.2 General requirement .....	8
4.2.1 Timing and frequency reference point.....	8
4.2.2 ST requirement .....	8
4.2.3 Network requirement .....	8
4.2.4 Measurement conditions .....	8
5 Timing synchronization.....	9
5.1 Introduction .....	9
5.2 Frequency accuracy and stability .....	9
5.2.1 ST Frequency accuracy and stability .....	9
5.3 Timing error .....	9
5.3.1 Initial ST timing error.....	9
5.3.2 ST Timing error .....	9
5.4 Time of Day information.....	9
5.4.1 ToD definition .....	9
5.4.2 ToD format .....	10
5.4.3 UTC time .....	11
5.5 Beacon transmission (Satellite to ST direction) .....	11
5.5.1 Superframe.....	11
5.5.2 Frame alignment .....	11
5.5.3 Beacon burst structure .....	12
5.5.3.1 Beam settling bit pattern .....	13
5.5.3.2 Unique Word bit pattern.....	14
5.5.3.3 PN sequence bit pattern.....	14
5.6 Early/Late timing measurement field .....	15
5.7 Initial timing acquisition .....	15
5.8 Timing synchronization maintenance.....	15
6 Frequency synchronization.....	16
6.1 Calculate the Initial Doppler value.....	16
<b>Annex A (normative):      Timing calculations.....</b>	<b>17</b>
A.1 General description.....	17
A.1.1 Calculation of Path Length.....	17
A.1.2 GPS accuracy .....	17
A.2 Calculate the timing offset .....	17
<b>Annex B (informative):      Bibliography.....</b>	<b>18</b>
History .....	19

---

## Intellectual Property Rights

IPRs essential or potentially essential to the present document may have been declared to ETSI. The information pertaining to these essential IPRs, if any, is publicly available for **ETSI members and non-members**, and can be found in ETSI SR 000 314: *"Intellectual Property Rights (IPRs); Essential, or potentially Essential, IPRs notified to ETSI in respect of ETSI standards"*, which is available from the ETSI Secretariat. Latest updates are available on the ETSI Web server (<http://webapp.etsi.org/IPR/home.asp>).

Pursuant to the ETSI IPR Policy, no investigation, including IPR searches, has been carried out by ETSI. No guarantee can be given as to the existence of other IPRs not referenced in ETSI SR 000 314 (or the updates on the ETSI Web server) which are, or may be, or may become, essential to the present document.

---

## Foreword

This Technical Specification (TS) has been produced by ETSI Technical Committee Satellite Earth Stations and Systems (SES).

The present document is part 7 of a multi-part deliverable covering the BSM Regenerative Satellite Mesh - A (RSM-A) air interface; Physical layer specification, as identified below:

- Part 1: "General description";
- Part 2: "Frame structure";
- Part 3: "Channel coding";
- Part 4: "Modulation";
- Part 5: "Radio transmission and reception";
- Part 6: "Radio link control";
- Part 7: "Synchronization".**

---

# 1 Scope

The present document presents the requirements for synchronizing timing and frequency between the ST and the satellite network within the TC-SES BSM Regenerative Satellite Mesh - A (RSM-A) air interface family.

---

## 2 References

The following documents contain provisions which, through reference in this text, constitute provisions of the present document.

- References are either specific (identified by date of publication and/or edition number or version number) or non-specific.
- For a specific reference, subsequent revisions do not apply.
- For a non-specific reference, the latest version applies.

Referenced documents which are not found to be publicly available in the expected location might be found at <http://docbox.etsi.org/Reference>.

- [1] ETSI TS 102 189-2: "Satellite Earth Stations and Systems (SES); Regenerative Satellite Mesh - A (RSM-A) air interface; MAC/SLC layer specification; Part 2: MAC layer".
- [2] IETF RFC 1305: "Network Time Protocol (Version 3) Specification, Implementation and Analysis".
- 

## 3 Definitions and abbreviations

### 3.1 Definitions

For the purposes of the present document, the following terms and definitions apply:

**Network Operations Control Centre (NOCC):** centre that controls the access of the satellite terminal to an IP network and also provides element management functions and control of the address resolution and resource management functionality

**satellite payload:** part of the satellite that provides air interface functions

NOTE: The satellite payload operates as a packet switch that provides direct unicast and multicast communication between STs at the link layer.

**Satellite Terminal (ST):** terminal installed in the user premises

**terrestrial host:** entity on which application level programs are running

NOTE: It may be connected directly to the Satellite Terminal or through one or more networks.

### 3.2 Abbreviations

For the purposes of the present document, the following abbreviations apply:

AWGN	Additive White Gaussian Noise
BPSK	Binary Phase Shift Keying
ECEF	Earth Centred Earth Fixed
IP	Internet Protocol
kbps	kilo bits per second (thousands of bits per second)
LHCP	Left Hand Circular Polarization

LLA	Latitude, Longitude and Altitude
LSB	Least Significant Bit
MIP	Management Information Packet
MMI	Man Machine Interface
NOCC	Network Operations Control Centre
PHY	PHYSical
PN	Pseudo Noise
PTP	Point-to-Point
QPSK	Quaternary Phase Shift Keying
RHCP	Right Hand Circular Polarization
RSM	Regenerative Satellite Mesh
SLC	Satellite Link Control
ST	Satellite Terminal
TDMA	Time Division Multiple Access
TIP	Transmission Information Packet
ToD	Time of Day
ULPC	UpLink Power Control
UTC	Universal Coordinated Time
UW	Unique Word

---

## 4 General description of synchronization system

BSM RSM-A is a multi-spot beam, multicarrier, synchronous system where the timing and frequency on the satellite serve as the reference to synchronize the TDMA transmissions for the STs, and other network elements. The satellite includes a packet switch designed to provide single-hop, point to point packet routing between downlink cells.

The functions of the physical layer are different for the uplink and downlink. The major functions are illustrated in figure 4. The present document describes the synchronization functions - this group of functions is highlighted in figure 4.

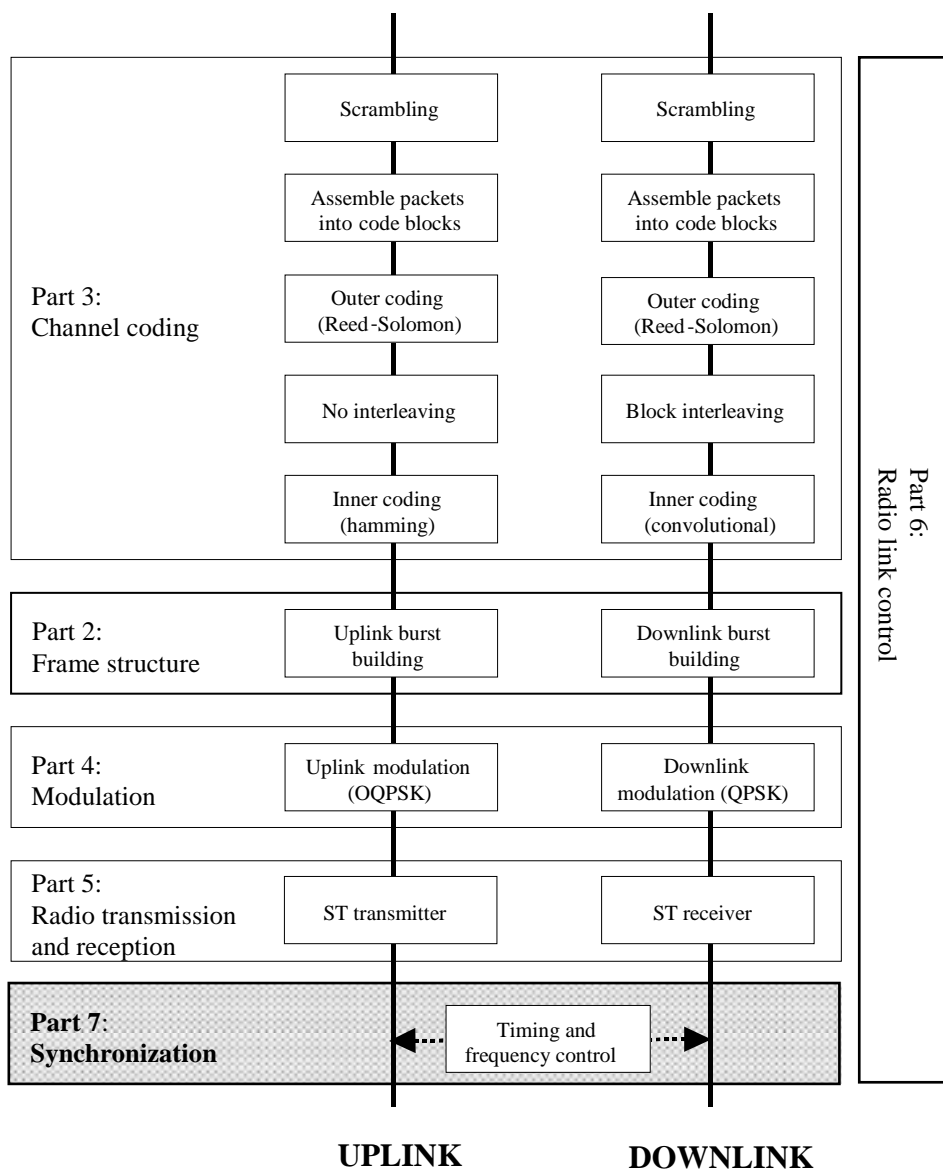

**Figure 4: Physical layer functions**

The timing synchronization requirements are described in clause 5, and the frequency synchronization requirements are described in clause 6.

Synchronization in the RSM-A system is composed of three major tasks:

- timing synchronization;
- frequency synchronization;
- frame synchronization;

A master oscillator onboard the RSM-A spacecraft is the primary reference for all synchronization processes. The fundamental goal of synchronization is to have all STs operate such that all bursts arrive at the satellite synchronized in timing and frequency.

## 4.1 System timing structure

The RSM-A satellite system is a TDMA system. Timing configuration in the system is composed of superframe, frame, timeslot, symbol and bit.

One superframe equals to 768 ms, and is divided into eight uplink frames or 256 downlink frames. The downlink frame counter is called the Time of Day (ToD) counter. Each uplink frame has 32 timeslots. The uplink frame duration is 96 ms, one timeslot duration is 3 ms. Each symbol corresponds to 2 bits. The complete uplink and downlink frame structure is defined in BSM RSM-A Physical Layer Specification, TS 102 188-2.

A superframe always starts from the first time slot in a frame that meets  $\text{ToD} \bmod 256 = 0$ . An Uplink frame always starts with time slot 0 when  $\text{ToD} \bmod 32 = 0$ .

## 4.2 General requirement

### 4.2.1 Timing and frequency reference point

The satellite is selected to be the reference point for both timing and frequency.

### 4.2.2 ST requirement

The ST timing and frequency requirements are:

- Both transmitter and receiver timing shall be derived from the same timebase.
- Both transmitter and receiver frequency shall be derived from the same frequency source.
- The ST shall use the same source for both RF frequency generation and the timebase generator.
- All return link signals (control and user data) transmitted from the STs shall achieve frame/timeslot alignment on the satellite timing reference point, i.e. input of satellite antenna.

In various operation modes, synchronization shall be maintained under the worst case timing and frequency drift rate due to ST-satellite relative motion and ST master oscillator stability. The ST oscillator short-term stability shall maintain all timing offset, frequency offset and symbol rate requirement specified in BSM RSM-A physical layer specification, TS 102 188-5.

### 4.2.3 Network requirement

The Network timing and frequency requirements are:

- The network should make multiple rate and volume timeslot assignments on the same uplink frequency or with the same carrier designator (see BSM RSM-A physical layer specification, TS 102 188-5) as far as possible.
- When assigning timeslots on different carrier designators the network shall provide at least 3 ms guard time for the ST to switch between the two different transmit frequencies. An ST may ignore assignments which it cannot use.
- At ST initialization, the network shall be able to estimate the slotted aloha signal arrival to the accuracy better than 15 Hz 1-sigma in frequency, 2,6  $\mu\text{s}$  1-sigma in timing, under the condition of AWGN channel.

### 4.2.4 Measurement conditions

In the present document, all timing and frequency related parameters are defined under the condition of AWGN channel, when the Beacon is received at a  $C/N_0 = 78$  dB-Hz minimum. Unless specified otherwise, all timing and frequency related parameters are defined as 1-sigma value.



---

## 5 Timing synchronization

### 5.1 Introduction

The BSM RSM-A synchronization function is to align satellite and ST frequencies and timing to allow uplink and downlink communications.

The Satellite is in geosynchronous orbit with a very small inclination; however, there are still range changes that give rise to frequency offsets (Doppler) and a varying time delay that would put signals outside the required limit if they were not corrected. Satellite and ST receivers have a dynamic but limited capability to acquire and demodulate the signal within a single burst in the presence of time and frequency errors.

Two key elements are implemented to provide the necessary accuracy. First, a full coverage synchronization beacon signal is transmitted from the satellite. It contains frequency and time references to allow the STs to synchronize to the satellite. Propagation effects and receiver noise corrupt the transfer. Second, the Satellite ephemeris is disseminated to the STs so that they may each independently compute their range to the satellite and the Doppler frequency offsets. The ST uplink timing is refined and tracked by using early/late replies from the satellite.

### 5.2 Frequency accuracy and stability

The satellite reference consists of a reference oscillator and a reference timing section. All transmitted uplink signal frequencies and clock rates as well as all transmitted downlink signal frequencies and clock rates, including PTP, shaped beams, and beacons are derived from the same source.

#### 5.2.1 ST Frequency accuracy and stability

The ST shall modify its transmitter frequency to compensate for Doppler variations of up to  $\pm 300$  Hz referred to the nominal uplink transmit frequency.

### 5.3 Timing error

#### 5.3.1 Initial ST timing error

At installation, the ST shall have a mechanism whereby the uplink bursts are timed to arrive within  $\pm 4$   $\mu$ s relative to the transmitted downlink LHCP beacon superframe at the satellite. In order to achieve this accuracy, an ST shall have a mechanism to know its position with an accuracy of  $\pm 1$  000 m. See also, BSM RSM-A, Physical Layer Specifications, TS 102 188-6.

#### 5.3.2 ST Timing error

The maximum ST timing error for all uplink transmissions relative to the ideal uplink timing, shall not exceed 2,6  $\mu$ s, except during installation.

### 5.4 Time of Day information

#### 5.4.1 ToD definition

The Time of Day (ToD) counter on board the satellite is a master timing reference for the BSM RSM-A system.

The ToD counter on board the satellite shall be initialized such that all-zeroes correspond to January 1, 2000 at 00:00:00 UTC. The ToD counter then continues to increment.

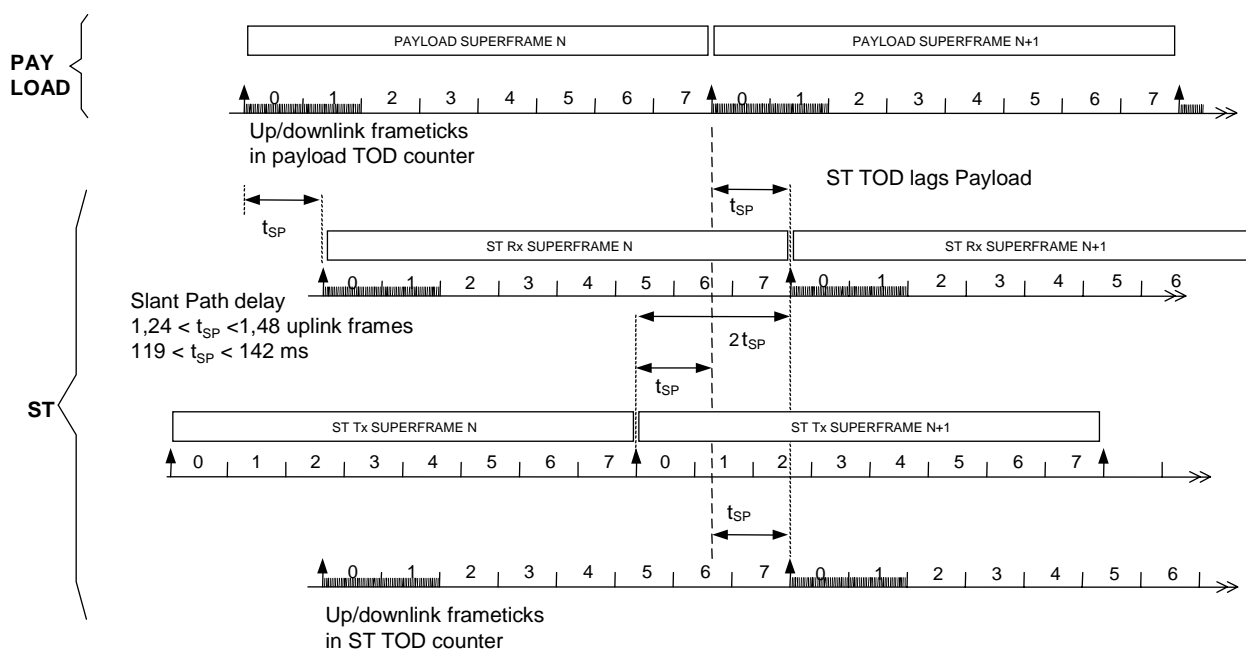

Figure 5.4.1: ToD reference

The ST ToD counter lags the satellite ToD by the slant path delay,  $t_{SP}$  as shown in figure 5.4.1.

### 5.4.2 ToD format

The ToD resolution is 3 ms or one downlink frame time. The satellite maintains a 40-bit coarse downlink frame counter. The ST shall maintain a 40 bit time of day counter, which it shall align to the signal the ST receives from the satellite. The definitions of the different ToD formats used in the BSM RSM-A specifications are listed in table 5.4.2.

Table 5.4.2: ToD format and definition

Symbol	ToD counter	Definition
ToD[39,0]	ToD counter; bits 39-0	Absolute downlink frame count in 3 ms increments
ToD[39,5]	ToD counter; bits 39-5	Absolute uplink frame count in 96 ms increments
ToD[39,8]	ToD counter; bits 39-8	Absolute superframe count in 768 ms increments (downlink and uplink)
ToD[7,0]	ToD counter; bits 7-0	Relative downlink frame count within a superframe
ToD[7,5]	ToD counter; bits 7-5	Relative uplink frame count within a superframe
ToD[36,5]	ToD counter; bits 36-5	32-bit truncated uplink frame count
ToD[12,5]	ToD counter; bits 12-5	8-bit truncated uplink frame count
ToD[15,8]	ToD counter; bits 15-8	8-bit truncated superframe count

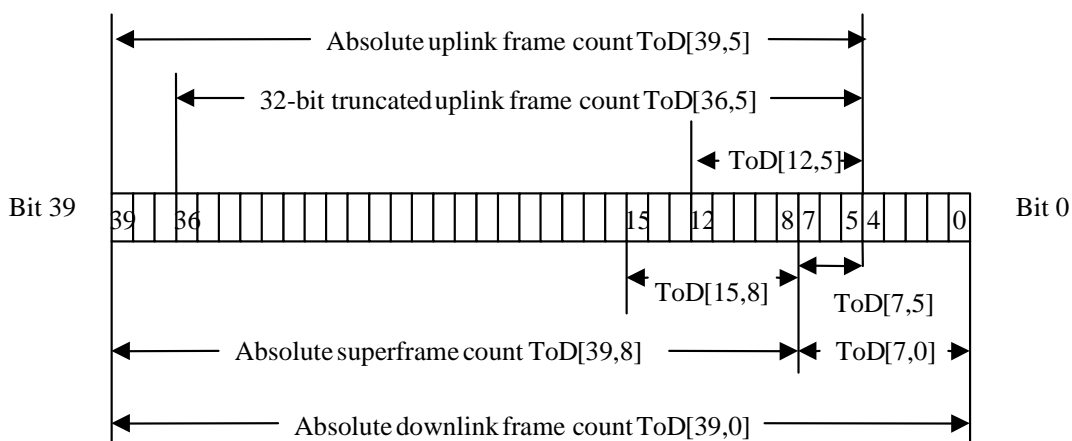

Figure 5.4.2: Time of Day reference

### 5.4.3 UTC time

The NOCC monitors the satellite ToD counter to correlate it with Universal Coordinated Time (UTC) time. Any drift between the satellite's ToD counter and UTC shall be distributed to STs via the transmission information packet message in the ToD-to-UTC offset field described in BSM RSM-A SMAC/SLC layer specification TS 102 189-2 [1]. The ST shall calculate universal coordinated time using the ToD counter and the ToD-to-UTC offset via the following formula.

$$UTC = 3,155,673,600 + (ToD[39,8] \times 0,768) + (ToD\text{-to-UTC offset} \times 0,768) + t_{SP} s,$$

where the first term is Network Time Protocol [2] seconds at 00:00:00 January 1, 2000.

If an ST receives a new ToD-to-UTC offset value in superframe N, it shall apply it in superframe N+1.

## 5.5 Beacon transmission (Satellite to ST direction)

### 5.5.1 Superframe

The beacon PN sequence repeats once per superframe using the beacon slots of each downlink frame. The start of the PN sequence corresponds to the start of the superframe. A superframe period is 768 ms. A superframe comprises of 8 uplink frames or 256 downlink frames.

The satellite maintains a ToD counter that is used to derive the superframe counter. The satellite disseminates the superframe counter values in transmission information packet messages as discussed in TS 102 189-2 [1].

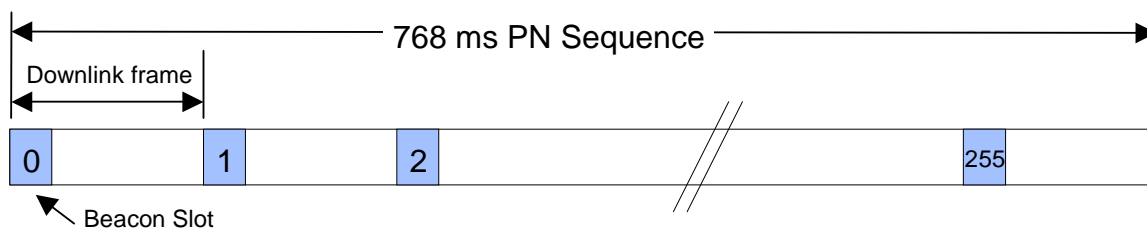

Figure 5.5.1: Superframe

### 5.5.2 Frame alignment

The 96 ms uplink frames and 3 ms downlink frames are aligned with superframes as shown in figure 5.5.2.1.

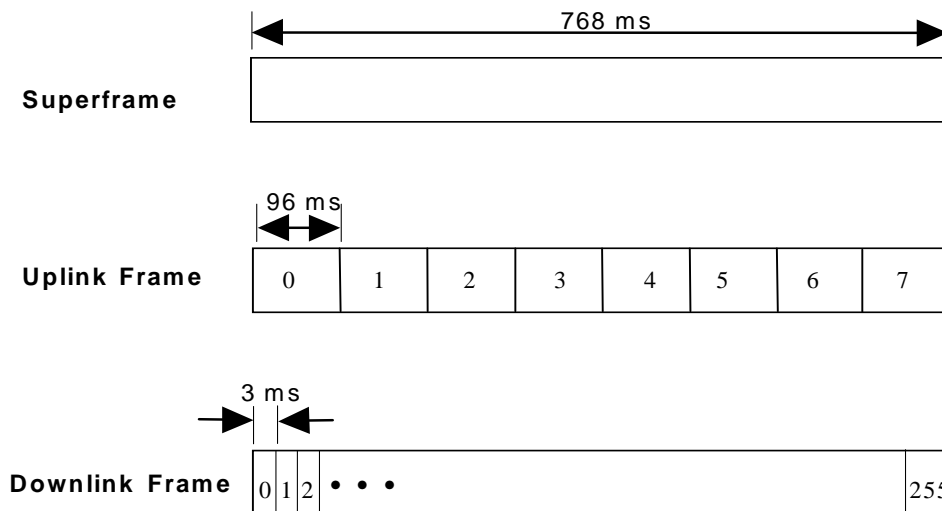
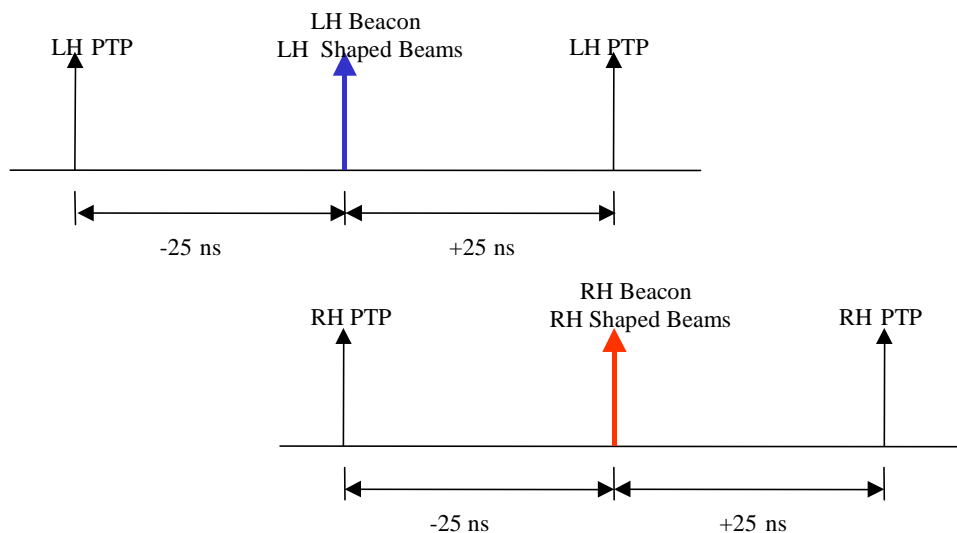

Figure 5.5.2.1: Frame relationships

On each polarization the ST shall use the beacon bursts as the timing reference for downlink frames and time slots. All bursts transmitted by the satellite shall be within  $\pm 25$  ns of the Beacon reference time. An ST shall be able to receive bursts which are within  $\pm 25$  ns of the Beacon reference time.

The superframe of the LHCP beacon shall be offset from the superframe of the RHCP beacon by no more than 25 ns peak-to-peak.



**Figure 5.5.2.2: Downlink beam timing example**

### 5.5.3 Beacon burst structure

The timing beacon is implemented as a burst in the first slot (beacon slot) of each downlink (3 ms) frame. The downlink frame is composed of a beacon slot, an idle slot, and a combination of shaped broadcast and PTP time slots. See BSM RSM-A physical layer specification, TS 102 188-2 for details.

The beacon slot shall contain a unique word and partial PN sequence so that the beginning of the superframe can be identified.

Each polarization has its own UW and PN code. The characteristics of the beacon slot are described in figure 5.5.3.2 and table 5.5.3. It is intended that polarization switching should occur at the end of the Beacon PN sequences shown in figure 5.5.3.1 in the "as received" diagram.

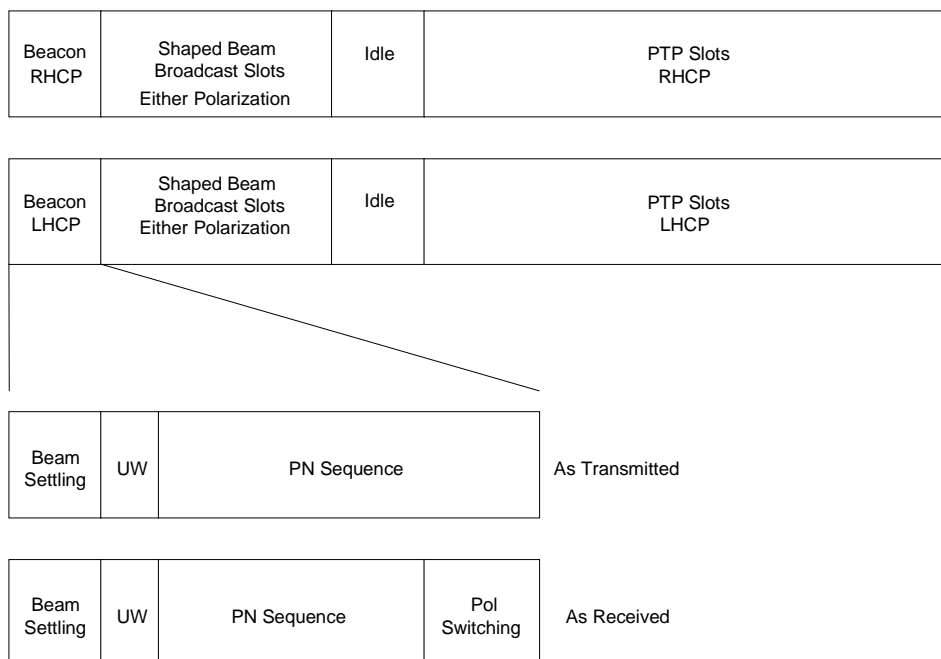

**Figure 5.5.3.1: Beacon burst structure with respect to downlink frame**

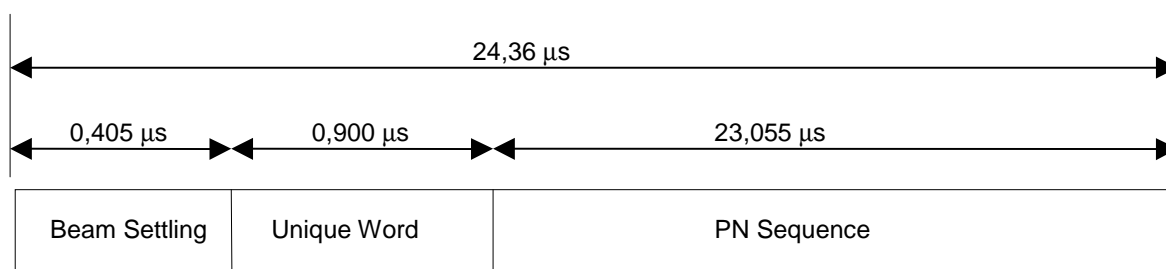

**Figure 5.5.3.2: Beacon burst structure as transmitted**

**Table 5.5.3: Beacon slot characteristics as transmitted**

Interval	Number of symbols	Duration (ns)
Beam settling	54	405
Unique Word	120	900
PN sequence	3,074	23,055

### 5.5.3.1 Beam settling bit pattern

The beam settling bit pattern for indices 18 to 21 is given in table 5.5.3.1. Each polarization has the same beam settling bit pattern. Indices 0 through 17 for non-beacon pattern are listed in BSM RSM-A physical layer specification, TS 102 188-2.

**Table 5.5.3.1: Beam settling bit pattern**

Index No	Polarization	Transmitted Bit pattern (54 bits)
18	LHCP: Satellite 1	011001010111100110101101000001101110001001001100011101
19	RHCP: Satellite 1	011001010111100110101101000001101110001001001100011101
20	LHCP: Satellite 2	011001010111100110101101000001101110001001001100011101
21	RHCP: Satellite 2	011001010111100110101101000001101110001001001100011101

NOTE 1: Patterns are transmitted from left to right (the first bit of the bit pattern is the MSB. The last bit of the bit pattern is the LSB. The MSB is the first bit that is presented, and the LSB is the last bit that is presented).

NOTE 2: Both I and Q send out the same bit pattern.

### 5.5.3.2 Unique Word bit pattern

The satellite shall be capable of implementing up to four distinct UWs.

The UW is given in table 5.5.3.2. Each polarization uses its own UW.

**Table 5.5.3.2: Unique Word bit pattern**

Index No.	Polarization	Unique Word Bit Pattern (120 bits)
18	LHCP: Satellite 1	1101010010111001100011101111101101100110111100000011001010000 01011000101011000001010011111101100001010000011011000110010
19	RHCP: Satellite 1	1001100100001100000100010010101010011100011010000110101001011 11110010111100100100111111111000100010100110100011000110010
20	LHCP: Satellite 2	1011001101011001111100110001010001010110100101011111100011000 00010010111010100110110101000000111100000010000011000110010
21	RHCP: Satellite 2	11110100101001100001010110010101011101001000000011000001011 00111110000101001110110111000110010010001110110011000110010

NOTE 1: Patterns are transmitted from left to right (the first bit of the bit pattern is the MSB. The last bit of the bit pattern is the LSB. The MSB is the first bit that is presented, and the LSB is the last bit that is presented).

NOTE 2: Both I and Q send out the same bit pattern.

### 5.5.3.3 PN sequence bit pattern

The PN sequence stops at the end of each slot and resumes at the next beacon slot. The total duration of the PN sequence is  $3\,074 \text{ bits/slot} \times 256 \text{ slots} = 786,944 \text{ bits}$  (BPSK symbols). The actual PN sequence is given in table 5.5.3.3 and figure 5.5.3.3. The adder in this figure performs module-2 arithmetic. Each polarization uses its own unique PN sequence. The PN sequence generator polynomial for all polarizations is  $1 + X^2 + X^{21}$ .

The ST derives the uplink and downlink frame counts within a superframe from the beacon PN sequence bit pattern.

**Table 5.5.3.3: Beacon slot PN sequence**

Polarization	Initial PN Vector (Seed) $X_0, X_1, \dots, X_{20}$
LHCP: Satellite 1	000110000110011000000
RHCP: Satellite 1	011100111000110000001
LHCP: Satellite 2	000110000110011000000
RHCP: Satellite 2	011100111000110000001

NOTE 1: The same PN sequence is transmitted on both arms of the modulator (I, Q) (Effectively generating BPSK symbols from QPSK modulators).

NOTE 2: The MSB is the first bit that is presented, and the LSB is the last bit that is presented.

NOTE 3: The PN generator registers are re-initialized at the beginning of every superframe.

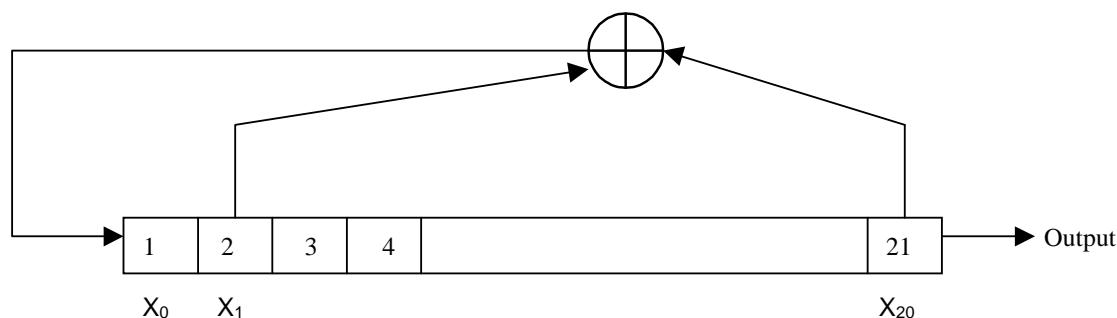

**Figure 5.5.3.3: Beacon slot PN sequence**

## 5.6 Early/Late timing measurement field

Time of arrival is determined and reported on whether a burst arrived early or late (with respect to the satellite time reference), with the following performance:

- 1) The satellite shall estimate the arrival time of each uplink burst relative to the burst start time and report the resulting early/late as described in the ULPC status packet message in BSM RSM-A SMAC/SLC layer specification TS 102 189-2 [1].
- 2) If the arriving signal is within one symbol early or late or on time, the satellite may randomly report early or late.

The measured time of arrival is represented using 1 bit. Binary 0 represents early arrival. Binary 1 represents late arrival. The actual bit and byte field assignments are shown in TS 102 188-1.

## 5.7 Initial timing acquisition

The burst probing and power ramping process requires an initial estimate of the slant path delay of the ST. The ST may calculate this value using the method described in annex A or any suitable method which achieves the required accuracy.

During installation an ST shall first acquire the satellite beacon channel and receive both the Transmission Information Packet (TIP) message for supervisory contention channel assignments and the indirect management information packet message (indirect MIP) for initial polarization and downlink destination ID assignments before it attempts to register. Both messages are described in BSM RSM-A SMAC/SLC layer specification TS 102 189-2 [1]. The ST shall compute the necessary nominal power (or EIRP) for its particular location to close the link with the desired satellite.

From the TIP message, the ST shall read the ephemeris data for the satellite. See BSM RSM-A SMAC/SLC layer specification TS 102 189-2 [1].

From the TIP message, the ST shall also read the carrier designator for the supervisory contention channel, and adjust its uplink synthesizer frequency to send the probing bursts at the 512 kbps carrier mode rate into this assigned channel in accordance to the algorithm described below.

The ST shall transmit each probing burst in a different uplink frame, but on a random time slot within each frame.

The ST shall transmit each probing bursts on the same physical channel, i.e. using the same carrier designator.

All bursts in a round are sent sequentially without waiting for any satellite feedback regarding the status of the bursts already transmitted in the same round.

## 5.8 Timing synchronization maintenance

The ST shall designate a superframe as a measurement superframe, insofar as time synchronization maintenance is concerned.

During a measurement superframe, and ST shall transmit data and collect early/late indications from the satellite based on this data.

The ST shall subtract 0,5 from each early/late measurement report from the satellite for all bursts the ST transmitted during the measurement superframe.

The ST shall add all early/late data collected.

If the result is positive, the ST shall add 0,375 symbols  $\pm$ 0,125 symbols to the transmit timing offset.

The ST shall store accumulated transmit timing offsets in non-volatile memory.

The ST shall immediately apply the correction within one superframe of receiving the last measurement report from the satellite based on all bursts the ST transmitted during the measurement superframe. This is called the correction superframe. The ST shall ignore early/late reports received from the satellite based on all bursts the ST transmitted during non-measurement superframes.

The first superframe after the correction superframe in which an ST transmits is another measurement superframe.

---

## 6 Frequency synchronization

### 6.1 Calculate the Initial Doppler value

The inputs to this calculation are the satellite velocity vector (derived from the satellite ephemeris data) and the positional data for the ST and the satellite (in vector form). The positional data is available from clause A.1.1. The ST first calculates the satellite's velocity vector,  $\mathbf{V}_{\text{satellite}}$ , as projected onto the unit vector,  $\mathbf{u}_{\text{ST-Sat}}$ , that points from the satellite to the ST.

$$\mathbf{V}_{\text{satellite}} \bullet \mathbf{u}_{\text{ST-Sat}} = [V_{X_{\text{SAT}}} (X_{\text{SAT}} - X_{\text{ST}}) + V_{Y_{\text{SAT}}} (Y_{\text{SAT}} - Y_{\text{ST}}) + V_{Z_{\text{SAT}}} (Z_{\text{SAT}} - Z_{\text{ST}})] / \text{PATH\_LEN}$$

The ST then calculates the initial Doppler frequency error (INIT\_DOPPLER\_FREQ\_ERR) for this satellite (relative to the ST).

$$\text{INIT\_DOPPLER\_FREQ\_ERR} = (\mathbf{V}_{\text{satellite}} \bullet \mathbf{u}_{\text{ST-Sat}}) / (2 c \text{ UL\_frequency}) \quad \{\text{Hz}\}$$



## Annex A (normative): Timing calculations

### A.1 General description

These calculations determine the slant path (distance from satellite to ST). These calculations assume the ST Latitude, Longitude and Altitude (LLA) are known at installation. For example, the ST may have an integrated GPS receiver or may have a suitable Man Machine Interface (MMI) such that the information may be entered into the ST by an installer. Alternatively, some GPS receivers can output in Earth Centred Earth Fixed (ECEF) Cartesian coordinates. The satellite ephemeris broadcast in the transmission information packet message uses ECEF coordinates.

Any other algorithm may be used to locate an ST provided that the timing and cell selection requirements can be met.

#### A.1.1 Calculation of Path Length

Given the satellite positional ephemeris data (ECEF Cartesian coordinates), we can calculate the path length between the satellite and the ST.

$$PATH\_LEN = \sqrt{(X_{ST} - X_{SAT})^2 + (Y_{ST} - Y_{SAT})^2 + (Z_{ST} - Z_{SAT})^2} \quad (\text{m})$$

where,  $X_{SAT}$ ,  $Y_{SAT}$  and  $Z_{SAT}$  are the satellite positional ephemeris data in earth-centred Cartesian coordinates (in 0,1 m). The ephemeris of the satellite is broadcast in the transmission information packet message, BSM RSM-A SMAC/SLC layer specification TS 102 189-2 [1].

#### A.1.2 GPS accuracy

If the GPS, or other location method, does not use ECEF, the receiver should use the WGS84 datum and output in DDMM.SS format (D = Degrees, M = minutes, S = Seconds) with entries using N latitude and E longitude as positive and S latitude and W longitude as negative values. If using ECEF, the number of significant digits shall be at least as great as the selective availability (SA) accuracy of GPS. SA for GPS provides 100 m horizontal and 150 m vertical accuracy. The display or other output shall support at least this resolution.

**Table A.1.2: Conversion from DDMM.SS to metres at the equator**

Lat/Lon unit	Conversion	Metres at the equator
1 degree of latitude		110,874
1 minute of latitude	1/60 of a degree	1 848
1 second of latitude	1/60 of a minute	31
1 degree of longitude		111,194
1 minute of longitude	1/60 of a degree	1 853
1second of longitude	1/60 of a minute	31

### A.2 Calculate the timing offset

This calculation is fairly straightforward; it involves taking the path length and calculating the signal delay of that path (ignoring any atmospheric effects). The calculation is given below:

$$t_o = PATH\_LEN / c \quad \text{s}$$

where,  $c = 2,99792458 \times 10^8$  m/s is the speed of light.  $t_o$  is used as the initial value for slant path delay.

---

## Annex B (informative): Bibliography

ETSI TR 101 984: "Satellite Earth Stations and Systems (SES); Broadband Satellite Multimedia; Services and Architectures".

ETSI TS 102 188-1: "Satellite Earth Stations and Systems (SES); Regenerative Satellite Mesh - A (RSM-A) air interface; Physical layer specification; Part 1: General description".

ETSI TS 102 188-2: "Satellite Earth Stations and Systems (SES); Regenerative Satellite Mesh - A (RSM-A) air interface; Physical layer specification; Part 2: Frame structure".

ETSI TS 102 188-3: "Satellite Earth Stations and Systems (SES); Regenerative Satellite Mesh - A (RSM-A) air interface; Physical layer specification; Part 3: Channel coding".

ETSI TS 102 188-4: "Satellite Earth Stations and Systems (SES); Regenerative Satellite Mesh - A (RSM-A) air interface; Physical layer specification; Part 4: Modulation".

ETSI TS 102 188-5: "Satellite Earth Stations and Systems (SES); Regenerative Satellite Mesh - A (RSM-A) air interface; Physical layer specification; Part 5: Radio transmission and reception".

ETSI TS 102 188-6: "Satellite Earth Stations and Systems (SES); Regenerative Satellite Mesh - A (RSM-A) air interface; Physical layer specification; Part 6: Radio link control".

---

## History

<b>Document history</b>		
V1.1.1	March 2004	Publication
V1.1.2	July 2004	Publication