

ETSI TS 102 189-2 V1.1.2 (2004-07)

Technical Specification

**Satellite Earth Stations and Systems (SES);
Regenerative Satellite Mesh - A (RSM-A);
SMAC/SLC layer specification;
Part 2: Satellite Medium Access Control and
Satellite Link Control detailed specification**



Reference

RTS/SES-BSM 211-2

Keywords

air interface, broadband, IP, multimedia, satellite

ETSI

650 Route des Lucioles
F-06921 Sophia Antipolis Cedex - FRANCE

Tel.: +33 4 92 94 42 00 Fax: +33 4 93 65 47 16

Siret N° 348 623 562 00017 - NAF 742 C
Association à but non lucratif enregistrée à la
Sous-Préfecture de Grasse (06) N° 7803/88

Important notice

Individual copies of the present document can be downloaded from:

<http://www.etsi.org>

The present document may be made available in more than one electronic version or in print. In any case of existing or perceived difference in contents between such versions, the reference version is the Portable Document Format (PDF). In case of dispute, the reference shall be the printing on ETSI printers of the PDF version kept on a specific network drive within ETSI Secretariat.

Users of the present document should be aware that the document may be subject to revision or change of status. Information on the current status of this and other ETSI documents is available at

<http://portal.etsi.org/tb/status/status.asp>

If you find errors in the present document, send your comment to:

editor@etsi.org

Copyright Notification

No part may be reproduced except as authorized by written permission.
The copyright and the foregoing restriction extend to reproduction in all media.

© European Telecommunications Standards Institute 2004.
All rights reserved.

DECTTM, **PLUGTESTS**TM and **UMTS**TM are Trade Marks of ETSI registered for the benefit of its Members.
TIPHONTM and the **TIPHON logo** are Trade Marks currently being registered by ETSI for the benefit of its Members.
3GPPTM is a Trade Mark of ETSI registered for the benefit of its Members and of the 3GPP Organizational Partners.

Contents

Intellectual Property Rights	9
Foreword.....	9
1 Scope	10
2 References	10
3 Definitions and abbreviations.....	10
3.1 Definitions	10
3.2 Abbreviations	11
4 SMAC/SLC overview	12
4.1 General aspects.....	12
4.2 Terminal identities and addresses.....	12
4.2.1 ST Site ID	12
4.2.2 Electronic Serial Number (ESN)	12
4.2.3 Source ID.....	12
4.2.4 Bandwidth Control ST ID (BCSTID)	13
4.2.5 Destination MAC Address	13
4.2.6 Destination Sub-Address (DSA).....	13
4.2.7 Multicast Group ID (MGID).....	13
4.2.8 Satellite Next Hop Address (SNHA)	13
5 Satellite Link Control (SLC) sub-layer	14
5.1 Overview	14
5.1.1 Modes of operation	16
5.1.1.1 SLC-unack mode.....	16
5.1.1.2 SLC-ack mode.....	17
5.1.1.3 SLC-transparent mode	17
5.1.2 Procedure description	17
5.1.2.1 Procedures at transmitting side	17
5.1.2.2 Procedures at receiving side.....	17
5.1.3 Backwards compatibility requirements.....	18
5.2 Compression.....	18
5.3 Security procedures	18
5.4 Cyclic Redundancy Check	18
5.5 Special messaging procedures.....	20
5.6 Segmentation and reassembly	20
5.6.1 Session creation	20
5.6.1.1 Session creation on the transmit side	20
5.6.1.2 Session creation on the receive side.....	20
5.6.2 Segmentation	21
5.6.2.1 Extended Data Unit (EDU) construction.....	21
5.6.2.2 Segmentation rules	22
5.6.3 Reassembly	23
5.6.4 Session termination.....	24
5.6.4.1 Session termination on the transmit side.....	24
5.6.4.2 Session termination on the receive side	24
5.7 Ack-mode	24
5.8 Diagnostic test procedure	25
5.8.1 Overview	25
5.8.2 Interfaces, SAPs, service definitions and service primitives	25
5.8.3 SLC peer-to-peer delay tests.....	25
5.8.3.1 Initiating ST procedure description.....	25
5.8.3.2 Receiving ST procedures	25
5.8.4 Satellite delay tests.....	26
5.8.4.1 Initiating ST procedure description.....	26
5.8.4.2 Receiving ST procedures	26

5.9	Interfaces, SAPs, service definitions, and service-primitives.....	27
5.9.1	Interfaces with higher layers: IP-SLC.....	27
5.9.1.1	Service Access Point-SLC-SAP.....	27
5.9.1.2	Service definitions.....	27
5.9.1.3	Service primitives.....	27
5.9.1.3.1	SLC_UNITDATA.....	28
5.9.1.3.2	Primitive parameters.....	28
5.9.2	Interface with specific ST entities.....	28
5.9.3	Logical interface with peer layer.....	28
5.9.4	Satellite Dependent Adaptation Function.....	29
6	Medium Access Control sub-layer.....	30
6.1	Overview.....	30
6.1.1	Modes of operation.....	30
6.1.1.1	BoD mode.....	30
6.1.1.2	HVUL mode.....	30
6.2	Interfaces, SAPs, service definitions, and service primitives.....	31
6.2.1	Interface with physical layer: MAC-PHY.....	31
6.2.1.1	Service Access Point.....	31
6.2.1.2	Service used.....	31
6.2.2	Interfaces with layer management entities.....	31
6.2.3	Logical interfaces with peer layer.....	31
6.3	MAC procedures.....	31
6.3.1	General procedures.....	31
6.3.1.1	Network.....	31
6.3.1.1.1	System information broadcasting.....	31
6.3.2	Medium access procedures.....	32
6.3.2.1	Initial access procedure.....	32
6.3.3	Bandwidth control procedures.....	32
6.3.3.1	Volume request protocol.....	33
6.3.3.1.1	Mapping of downlink destination ID into destination region IDs.....	34
6.3.3.2	Rate request protocol.....	34
6.3.3.3	Rate modification procedure.....	35
6.3.3.4	Rate de-allocation procedure.....	35
6.3.4	Bandwidth management procedures.....	36
6.3.4.1	Description of UDTS.....	36
6.3.4.1.1	Constant Rate (CR).....	36
6.3.4.1.2	Constant Rate With Burst (CRWB).....	36
6.3.4.1.3	High Priority Burst/Normal Priority Burst.....	36
6.3.4.1.4	Low Volume Low Latency (LVLL).....	37
6.3.4.1.5	Ack-Return UDTS.....	37
6.3.4.2	Description of PDS.....	37
6.3.4.2.1	High priority rate/Low priority rate.....	37
6.3.4.2.2	High priority volume/Normal priority volume.....	37
6.3.4.2.3	Slotted Aloha (SA).....	37
6.3.4.2.4	Persistent Aloha (PA).....	37
6.3.4.3	UDTS to PDS mapping.....	38
6.3.4.3.1	Constant Rate UDTS mapping.....	38
6.3.4.3.2	High Priority Burst/Normal Priority Burst UDTS mapping.....	38
6.3.4.3.3	Constant Rate with Burst mapping.....	38
6.3.4.3.4	Low Volume Low Latency mapping.....	38
6.3.4.3.5	Ack Return UDTS mapping.....	39
6.3.4.4	Management Transport Services (MTS).....	39
6.3.4.5	Queue servicing and flow control procedures.....	40
6.3.4.5.1	Servicing of rate queues.....	40
6.3.4.5.2	Servicing of volume queues.....	40
6.3.4.5.3	Queue servicing regulation procedures.....	41
6.3.5	Contention channel access procedures.....	43
6.3.5.1	General.....	43
6.3.5.1.1	Types of access protocols.....	43
6.3.5.1.2	Success or failure indication.....	43
6.3.5.1.3	Retransmission.....	43

6.3.5.1.4	Mapping transmission probability to potential contention transmission opportunity	44
6.3.5.2	Slotted-Aloha channel access	44
6.3.5.2.1	Types of Slotted Aloha channels	45
6.3.5.2.2	State machine definitions	45
6.3.5.2.3	State machine	45
6.3.5.2.4	Mapping transmission probability to potential SA transmission opportunity	47
6.3.5.2.5	Channel selection	47
6.3.5.2.6	Slot selection	47
6.3.5.3	Persistent Aloha channel access procedure	48
6.3.5.3.1	Introduction	48
6.3.5.3.2	State machine	49
6.3.5.3.3	Channel selection	51
6.3.5.3.4	Slot selection algorithm for PACTO	52
6.3.5.4	Persistent Aloha channel access procedure-one slot per frame	53
6.3.5.4.1	Introduction	53
6.3.5.4.2	State machine	53
6.3.5.4.3	Channel selection	54
6.3.5.4.4	Slot selection algorithm for PACTO	55
6.3.5.5	Variables	55
6.3.6	Packet filtering procedures	55
6.3.6.1	Packet discrimination procedure	55
6.3.6.1.1	Data packets	56
6.3.6.1.2	Signalling packets	56
7	Message functional definition and contents	57
7.1	General	57
7.1.1	Packet order of presentation	57
7.1.2	Order of bits within a field	57
7.2	MAC block format	58
7.2.1	MAC downlink block format	58
7.2.2	MAC uplink block format	58
7.3	Packet header format	59
7.3.1	Satellite routing field	59
7.3.1.1	Congestion bit field	59
7.3.1.2	Drop class field	60
7.3.1.3	Destination type field	60
7.3.1.4	Downlink destination ID field	60
7.3.2	ST Identification field	61
7.3.2.1	Destination Sub-Address field	61
7.3.2.2	Aloha field	63
7.3.2.3	SLC mode field	64
7.3.2.4	Source ID field	64
7.4	SLC packet data unit format	64
7.4.1	SLC unack mode header format	64
7.4.1.1	Header for unfragmented (whole) data packet	65
7.4.1.2	Header for first segment data packet	65
7.4.1.3	Header for middle segment data packet	65
7.4.1.4	Header for last segment data packet	65
7.4.2	SLC ack mode header format	65
7.4.3	SLC header field definitions	66
7.4.3.1	Session number field	66
7.4.3.2	First and last bits fields	66
7.4.3.3	Packet sequence number field	66
7.4.3.4	Cmp field	66
7.4.3.5	Frm field	66
7.4.3.6	Sec field	66
7.4.3.7	CRC type field	67
7.4.3.8	Bytes in last segment field	67
7.4.3.9	E bit field	67
7.4.4	SLC extension header format	67
7.4.4.1	Extension header length field ⁹	67
7.4.4.2	Extension header type	67

7.4.4.3	Extension header value	68
7.4.5	Frame header format	68
7.4.6	Security header format	68
7.4.6.1	A/B field.....	68
7.4.6.2	Pad count field	68
7.4.6.3	Initial vector field.....	69
7.4.7	Null packet format	69
7.5	MAC/SLC message types	69
7.5.1	Common field definitions	70
7.5.1.1	Spare fields.....	70
7.5.1.2	Carrier mode field	70
7.5.1.3	Rate	71
7.5.1.4	D/C field.....	71
7.5.1.5	Sub band designator	71
7.5.1.6	Carrier designator.....	71
7.5.1.7	Channel Group ID	71
7.5.1.8	Bandwidth Control ST ID	71
7.5.1.9	A/B key	71
7.5.1.10	Bandwidth control message common fields.....	71
7.5.1.10.1	Message type	72
7.5.1.10.2	IF version.....	72
7.5.1.10.3	Number assignments/acknowledgements/spare (5 bits).....	72
7.5.1.10.4	Uplink frame number	72
7.5.1.10.5	Number of contention channels/spare	72
7.5.1.11	TOD check	72
7.5.1.11.1	Uplink frame number TOD check relationship	72
7.5.1.12	Padding byte.....	73
7.5.2	Transmission Information Packet message.....	73
7.5.2.1	Packet header field values	75
7.5.2.2	Transmission information packet message field definition	75
7.5.2.2.1	Satellite Network ID.....	75
7.5.2.2.2	CM bit	75
7.5.2.2.3	TM bit.....	75
7.5.2.2.4	CP bit.....	75
7.5.2.2.5	TP bit.....	75
7.5.2.2.6	Current PTP slot number	76
7.5.2.2.7	Transition PTP slot number.....	76
7.5.2.2.8	TDM frame transition superframe number	76
7.5.2.2.9	TDM frame transition downlink frame number	76
7.5.2.2.10	Future spare 1 and protocol switch.....	76
7.5.2.2.11	Future spare 2 and protocol switch.....	76
7.5.2.2.12	TOD to UTC offset.....	77
7.5.2.2.13	Absolute superframe count.....	77
7.5.2.2.14	Ephemeris data	77
7.5.2.2.15	Nb cont	77
7.5.2.2.16	Dedicated contention channel information	77
7.5.3	ULPC status message format	77
7.5.3.1	ULPC status message field definition	80
7.5.3.1.1	Carrier groupings.....	80
7.5.3.1.2	Uplink frame number field	80
7.5.3.1.3	Superframe number field	80
7.5.3.1.4	Noise measurement field	80
7.5.3.1.5	Time slot measurement field	80
7.5.4	Bandwidth request message	81
7.5.4.1	Authorization information.....	81
7.5.4.2	Frame Count.....	82
7.5.4.3	Bandwidth Request Header.....	82
7.5.4.3.1	Uplink Cell ID.....	82
7.5.4.3.2	Number of Requests	82
7.5.4.3.3	Void.....	82
7.5.4.3.4	IF V	82
7.5.4.3.5	BC.....	83

7.5.4.3.6	AA bit	83
7.5.4.4	Bandwidth request data	83
7.5.4.4.1	Follow-up bit	83
7.5.4.4.2	Sub band designator/Spare	83
7.5.4.4.3	Destination region ID	83
7.5.4.4.4	Request action	83
7.5.4.4.5	Number of slots	84
7.5.4.4.6	Carrier designator/spare	84
7.5.4.4.7	Request ID	84
7.5.4.5	Integrity check	85
7.5.5	Bandwidth assignment message	85
7.5.5.1	Assignment field	85
7.5.5.1.1	TSMF	86
7.5.5.1.2	Start index	86
7.5.5.1.3	Number of consecutive indices	86
7.5.5.1.4	Last	86
7.5.5.1.5	Number of frames	86
7.5.5.1.6	Request ID	86
7.5.5.1.7	Assignment integrity check	86
7.5.6	Negative acknowledgement message	86
7.5.6.1	Acknowledgement fields 1-16	87
7.5.6.1.1	Cause code	88
7.5.6.1.2	Request ID	89
7.5.7	Dynamic contention channel assignment message	89
7.5.7.1	Dynamic contention assignment field definition	90
7.5.8	Void	91
7.5.9	SLC test messages	91
7.5.9.1	Version Number	91
7.5.9.2	R/C	91
7.5.9.3	Message type	91
7.5.9.4	Sequence number	91
7.5.9.5	Test Id	91
7.5.9.6	Packet type	92
7.5.9.7	Time sent	92
7.5.9.7.1	SLC peer-to-peer delay timestamp	92
7.5.9.7.2	Satellite delay timestamp	92
7.5.9.8	Time received	93
7.5.9.8.1	SLC peer-to-peer delay timestamp	93
7.5.9.8.2	Satellite delay timestamp	93
7.5.9.9	Return MAC address±	93
7.5.9.10	Number of designated addresses	93
7.5.9.11	List of recipients	93
7.5.9.12	Padding bytes	94
8	Configurable parameters	94
8.1	SLC un-ack mode configurable parameters	94
8.1.1	Timers	94
8.2	SLC ack-mode configurable parameters	94
8.3	SLC CRC configurable parameters	94
8.4	MAC configurable parameters	95
8.4.1	Bandwidth control parameters	95
8.4.2	Contention access protocol parameters	96
8.4.3	Miscellaneous MAC parameters	96
Annex A (normative):	Uplink Frame, Beams and Channels.....	97
A.1	Uplink frame structure, beams and channels	97
Annex B (informative):	Message sequence diagrams.....	98
B.1	Message sequence diagrams	98
B.1.1	Rate request - Positive response	98
B.1.2	Rate request - Negative response	98

B.1.2.1	Rate request - Negative response due to insufficient bandwidth	99
B.1.3	Message corruption/Lost	100
B.1.4	Rate request - Changes in the traffic pattern	100
B.1.5	Rate de-allocation.....	101
B.1.6	Volume request	101
B.1.7	Volume request - partial assignment	102
Annex C (informative):	Void	103
Annex D (normative):	Satellite terminal capability	104
D.1	ST basic capability set.....	104
Annex E (informative):	CRC Examples	105
Annex F (informative):	Bibliography.....	106
History		107

Intellectual Property Rights

IPRs essential or potentially essential to the present document may have been declared to ETSI. The information pertaining to these essential IPRs, if any, is publicly available for **ETSI members and non-members**, and can be found in ETSI SR 000 314: "*Intellectual Property Rights (IPRs); Essential, or potentially Essential, IPRs notified to ETSI in respect of ETSI standards*", which is available from the ETSI Secretariat. Latest updates are available on the ETSI Web server (<http://webapp.etsi.org/IPR/home.asp>).

Pursuant to the ETSI IPR Policy, no investigation, including IPR searches, has been carried out by ETSI. No guarantee can be given as to the existence of other IPRs not referenced in ETSI SR 000 314 (or the updates on the ETSI Web server) which are, or may be, or may become, essential to the present document.

Foreword

This Technical Specification (TS) has been produced by ETSI Technical Committee Satellite Earth Stations and Systems (SES).

The present document is part 2 of a multi-part deliverable covering Regenerative Satellite Mesh - A (RSM-A) air interface SMAC/SLC layer specification, as identified below:

Part 1: "General description";

Part 2: "Satellite Medium Access Control and Satellite Link Control detailed specification";

Part 3: "ST-SAM interface specification".

1 Scope

The present document is the detailed specification of the SMAC/SLC layer protocol for the TC-SES BSM Regenerative Satellite Mesh - A (RSM-A) air interface family. In particular, it contains SMAC and SLC procedures, messages and message formats.

2 References

The following documents contain provisions which, through reference in this text, constitute provisions of the present document.

- References are either specific (identified by date of publication and/or edition number or version number) or non-specific.
- For a specific reference, subsequent revisions do not apply.
- For a non-specific reference, the latest version applies.

Referenced documents which are not found to be publicly available in the expected location might be found at <http://docbox.etsi.org/Reference>.

- [1] ETSI TS 102 188-1: "Satellite Earth Stations and Systems (SES); Regenerative Satellite Mesh - A (RSM-A) air interface; Physical layer specification; Part 1: General description".
- [2] ETSI TS 102 188-2: "Satellite Earth Stations and Systems (SES); Regenerative Satellite Mesh - A (RSM-A) air interface; Physical layer specification; Part 2: Frame structure".
- [3] ETSI TS 102 188-5: "Satellite Earth Stations and Systems (SES); Regenerative Satellite Mesh - A (RSM-A) air interface; Physical layer specification; Part 5: Radio transmission and reception".
- [4] ETSI TS 102 188-6: "Satellite Earth Stations and Systems (SES); Regenerative Satellite Mesh - A (RSM-A) air interface; Physical layer specification; Part 6: Radio link control".
- [5] ETSI TS 102 189-1: "Satellite Earth Stations and Systems (SES); Regenerative Satellite Mesh - A (RSM-A); SMAC/SLC layer specification; Part 1: General description".
- [6] ETSI TS 102 189-3: "Satellite Earth Stations and Systems (SES); Regenerative Satellite Mesh - A (RSM-A); SMAC/SLC layer specification; Part 3: ST-SAM Interface specification".
- [7] IETF RFC 2373: "IP Version 6 Addressing Architecture".
- [8] ETSI TS 102 295: "Satellite Earth Stations and Systems (SES); Broadband Satellite Multimedia (BSM) services and architectures; BSM Traffic Classes".
- [9] ETSI TS 102 188-3: "Satellite Earth Stations and Systems (SES); Regenerative Satellite Mesh - A (RSM-A) air interface; Physical layer specification; Part 3: Channel coding".

3 Definitions and abbreviations

3.1 Definitions

For the purposes of the present document, the following terms and definitions apply:

Network Control Centre (NCC): centre that controls the access of the satellite terminal to an IP network and also provides element management functions and control of the address resolution and resource management functionality

satellite payload: part of the satellite that provides air interface functions

NOTE: The satellite payload operates as a packet switch that provides direct unicast and multicast communication between STs at the link layer.

Satellite Terminal (ST): terminal that is installed in the user premises

terrestrial host: entity on which application level programs are running

NOTE: It may be connected directly to the Satellite Terminal or through one or more networks.

3.2 Abbreviations

For the purposes of the present document, the following abbreviations apply:

ACF	Access Control Field
ARM	Asynchronous Response Mode
BCP	Bandwidth Control Protocol
BCS	Bandwidth Control Subsystem
BoD	Bandwidth on Demand
CA	Conditional Access
CoS	Class of Service
CR	Constant Rate
CRC	Cyclic Redundancy Check
CRWB	Constant Rate With Burst
DSA	Destination Sub-Address
EDU	Extended Data Unit
ESN	Electronic Serial Number
HPB	High Priority Burst
HVUL	High Volume UpLink
IP	Internet Protocol
kbps	kilo bits per second (thousands of bits per second)
LLDC	Link Layer Data Confidentiality
LSB	Least Significant Bit
LVLL	Low Volume Low Latency
MAC	Medium Access Control
Mbps	Mega bits per second (millions of bits per second)
MGID	Multicast Group ID
MIP	Management Information Packet
MSB	Most Significant Bit
MTS	Management Transport Services
NCC	Network Control Centre
NIP	Network Information Packet
NPB	Normal Priority Burst
PA	Persistent Aloha
PDS	Packet Delivery Service
PDU	Protocol Data Unit
PEP	Performance Enhancing Proxy
PHY	PHYSical
PTO	Packet Transmission Opportunity
PTP	Point-To-Point
QoS	Quality of Service
RS	Reed-Solomon
RSM	Regenerative Satellite Mesh
SA	Slotted Aloha
SAM	Security Access Module
SAP	Service Access Point
SAR	Segmentation And Reassembly
SDAF	Satellite Dependent Adaptation Function
SDU	Service Data Unit
SI-SAP	Satellite Independent-SAP
SLC	Satellite Link Control

SNHA	Satellite Next Hop Address
SRF	Satellite Routing Field
ST	Satellite Terminal
TCP	Transmission Control Protocol
TDM	Time Division Multiplexing
TIP	Transmission Information Packet
TOD	Time Of Day
UDTS	User Data Transport Services
ULPC	UpLink Power Control
UTC	Universal Coordinated Time

4 SMAC/SLC overview

4.1 General aspects

The general aspects of the SMAC/SLC is described in BSM RSM-A, TS 102 189-1 [5]. The present document contains the detailed specification of the SMAC/SLC and is organised as follows:

- Clause 5 describes the SLC procedures including segmentation and reassembly, cyclic redundancy check, interfaces, SAPs, service definitions, and service primitives, and diagnostic testing.
- Clause 6 described the Bandwidth on demand and contention channel access procedures.
- Clause 7 gives the format and syntax for the SMAC/SLC headers, messages and information elements.
- Clause 8 lists the air interface parameters called out in the document.

4.2 Terminal identities and addresses

4.2.1 ST Site ID

The ST Site ID is the number by which an instance of ST service is known external to the system. This number is used at the system external interfaces, e.g. by an operator at a NOCC user interface or by an ST installer at an installer interface. An ST Site ID remains associated with a logical instance of ST service that is defined at the NOCC even if the equipment for that ST is replaced and/or the ST is relocated. Hence, an ST Site ID is not fixed to a particular geographic location or to a particular unit of equipment. The ST Site ID is unique across all satellite regions, such that no 2 STs will have the same ST Site ID, even when they are in different satellite regions.

4.2.2 Electronic Serial Number (ESN)

Each unit of ST equipment or SAM is identified by a 48 bit Electronic Serial Number (ESN) which is referred to as an ST Equipment ESN or SAM ESN (respectively). The association of an ESN to a unit of ST Equipment or SAM is permanent, globally unique, and can be discovered from the hardware by the ST or SAM software.

4.2.3 Source ID

The Source ID is the primary identification of an ST at the network layer. The 24 bit Source ID appears in the RSM-A packet header to identify the ST that sent a RSM-A packet. When an ST sends a RSM-A packet to another ST, this value is also referred to as the ST Source ID. The Source ID is also used by the payload to identify itself as the source when it sends a RSM-A packet to an ST. An ST distinguishes between and keeps track of packets from multiple sources via the Source ID. Source IDs are not used for addressing nor switching purposes.

4.2.4 Bandwidth Control ST ID (BCSTID)

The 21-bit Bandwidth Control ST ID (BCSTID) is the primary identification of an ST for bandwidth control between the ST and the payload. The BCSTID is unique within the scope of the satellite. The BCSTID is not used as the Source ID within satellite packet headers. There is no numeric or algorithmic relationship between the BCSTID and the Source ID.

4.2.5 Destination MAC Address

According to the system model whereby an ST is considered a router, the ST has two types of router interfaces, terrestrial interfaces (e.g. Ethernet) and satellite interfaces. Most STs have a single terrestrial interface and a single satellite interface, however ST Gateways have multiple of each kind of interface. Corresponding to an Ethernet address which is the Medium Access Control (MAC) layer address of an Ethernet terrestrial interface, the Destination MAC Address is the MAC layer address of the satellite interface.

The Destination MAC Address is a 32-bit value that combination of the 1 bit downlink polarization, 10 bit downlink microcell ID, and 21-bit Destination Sub-Address sub-fields of the satellite packet header are used for addressing a RSM-A packet to an ST virtual port or the management port. Each ST virtual port and management port has a unique (within the satellite network) Destination MAC Address.

4.2.6 Destination Sub-Address (DSA)

The Destination Sub-Address is the 21 least significant bits of the Destination MAC Address. A Destination Sub-Address value is associated with each virtual port and the management port of an ST and is unique within the scope of the downlink microcell and polarization. Satellite packets addressed to an ST virtual or management port has the corresponding Destination Sub-Address in the "Destination Sub-Address" sub-field of the satellite packet header.

When the 3 most significant bits of the Destination Sub-Address are all zero, the remaining 18 bits are interpreted as a Multicast Group ID (MGID) as described in clause 4.2.7.

4.2.7 Multicast Group ID (MGID)

An MGID is used to address a satellite packet to multiple STs. The Multicast Group ID (MGID) is the 18 least significant bits of the 21 bit Destination Sub-Address sub-field of a satellite packet header whenever the most significant 3 bits of that sub-field are all zero. Hence, MGIDs are a reserved subset of Destination Sub-Address values. When an MGID is used, the Satellite Routing Field (SRF) polarization and downlink destination ID sub-fields of the satellite packet header may be for a spot beam or shaped beam. In the uplink direction, these SRF sub-fields may contain a replication group number that directs the satellite to replicate the packet in the downlink direction. Certain MGID values are allocated for special purposes and a range of MGIDs is set aside for management purposes. The remaining pool of MGIDs are used for user traffic. This partitioning of MGIDs is defined in clause 7.

4.2.8 Satellite Next Hop Address (SNHA)

The Satellite Next Hop Address (SNHA) is an internal satellite network layer address that is assigned to the satellite interface of an ST, i.e. to each ST Virtual Port. Each SNHA is a 128-bit IPv6 address value that is unique across the entire satellite system, i.e. globally. As such, each ST Virtual Port is uniquely identified by a SNHA; and the set of SNHAs for a satellite effectively form a subnet.

A SNHA is statically configured for each ST Virtual Port at the NOCC and downloaded to the ST. Inter-ST hops for routing IP packets across the satellite subnet are expressed in terms of SNHAs. For satellite transmission, each SNHA is translated to a Destination MAC Address.

The SNHA shall conform to the format of the Aggregatable Global Unicast Address specified in RFC 2373 [7]. The lower 32 bits of this format comprise a class E IPv4 address in which the Satellite Network ID is included thereby ensuring uniqueness across all satellites of a satellite region. The upper 96 bits of the SNHA have distinct values per satellite region thereby ensuring the uniqueness of SNHAs across all satellite regions of the system.

For typical STs, the Virtual Port to SNHA to Destination MAC address resolution mapping is fixed as there is only one Destination MAC address per Virtual Port.

5 Satellite Link Control (SLC) sub-layer

5.1 Overview

The satellite link control layer is the sub-layer of the Data link layer that is responsible for transmission and reception of Service Data Units (SDUs) between peer ST. It supports two modes of delivery, reliable and unreliable. Support of the reliable delivery mode is optional.

The functional responsibilities of the SLC are described below.

The SLC shall be responsible for maintaining order of transmission of SDUs, such that once SDUs assigned to the same class of service, and destined for the same destination region, have been enqueued together in the SLC/MAC layer in the appropriate queue for that combination of class of service and destination region, they shall be transmitted in the order in which they were enquired.

The SLC is responsible for building Extended Data Units (EDUs) by compressing and/or encrypting SDUs, and adding security headers, frame headers, extension headers and Cyclic Redundancy Checks (CRCs) to SDUs as appropriate. The construction of EDUs is described in clause 5.6. Figure 5.1 illustrates the SLC functions necessary to build an EDU from an SDU.

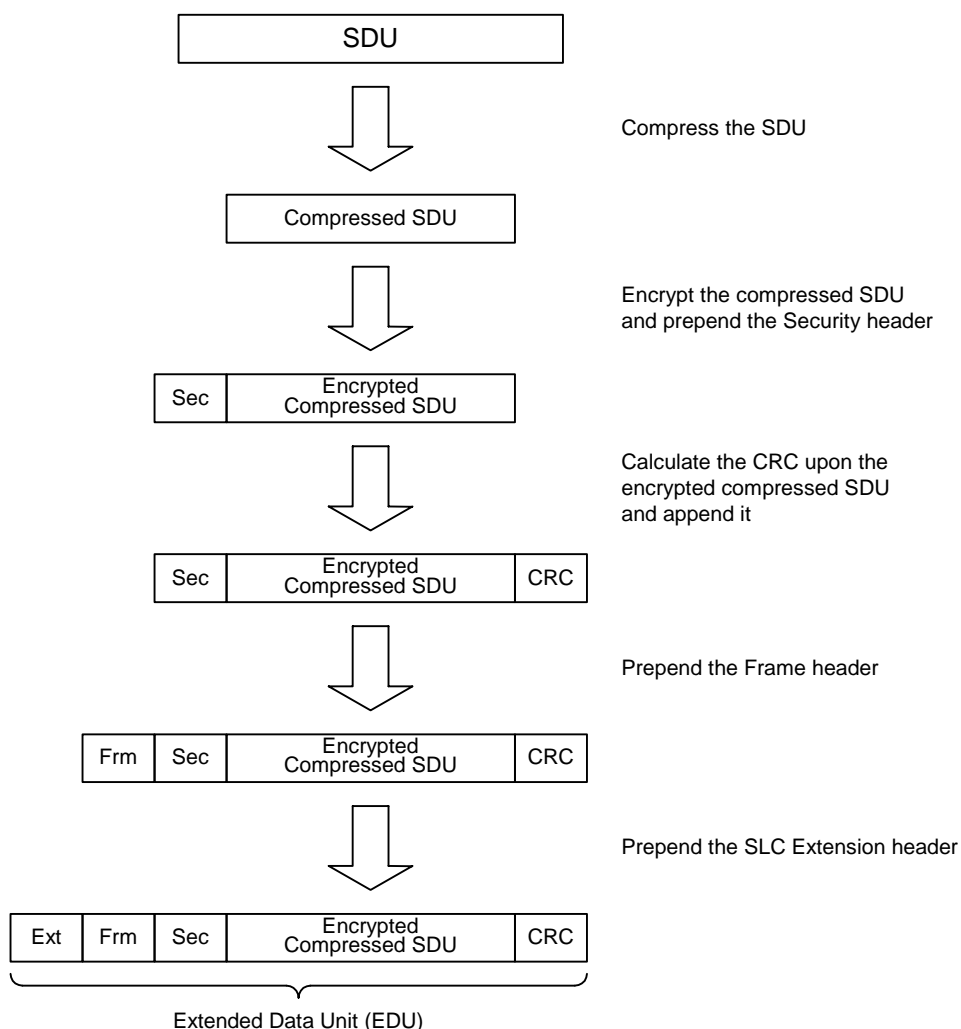

Figure 5.1: Construction of an EDU

Implementation of compression algorithm at the ST is optional. Compression, if supported, can be applied independently to individual SDUs. Compression is described in clause 5.2.

Over-the-air data encryption includes both point-to-point data transfer, called Link Layer Data Confidentiality (LLDC) and data multicasting, called Conditional Access (CA). Such encryption is performed per SDU. Security headers are also generated by the SLC. Data security is described in clause 5.3.

The SLC is responsible for the generation of a CRC per SDU. The CRC is described in clause 5.4. The SLC sub-layer shall calculate the CRC based only on the encrypted and/or compressed SDU if the SDU is encrypted and/or compressed but shall not include the security header, if the SDU is encrypted, in the calculation. The SLC sub-layer shall calculate the CRC based only on the SDU if the SDU is not encrypted or compressed.

The SLC performs peer-to-peer signalling using two methods, namely SLC extension headers, which are effectively peer-to-peer SLC messages and the frame header. The SLC extension header is used for capability recognition and reconciliation procedures at start of a session. When two STs of different capabilities have to communicate with each other, the transmitting ST starts off with a transmission mode set to what it believes the receiver can support and based on feedback from the receiver, it may modify the mode to a more compatible and/or optimal mode. This protocol is described in clause 5.5. The frame header is used for other types of SLC peer-to-peer signalling such as diagnostic testing.

The SLC is responsible for segmentation and reassembly of EDUs. This function is described in clause 5.6.

Delivery of data in-sequence to the peer using the reliable/unreliable mode of delivery is affected by the SLC header construction as described in clause 5.6 for unreliable mode and in clause 5.7 for reliable mode delivery.

The SLC is responsible for support of diagnostic test procedures. This is a peer-to-peer protocol described in clause 5.8.

Interaction with other ST protocol layers and with other ST management entities are described in clause 5.9.

The SLC is responsible for delivering 100-byte SLC-PDUs to the MAC sub-layer for transmission on the uplink and is responsible for receiving 100-byte SLC-PDUs from the MAC sub-layer, which the MAC has received on the downlink.

Figure 5.2 shows the terminology used in the SLC/MAC description in clauses 5 to 7.

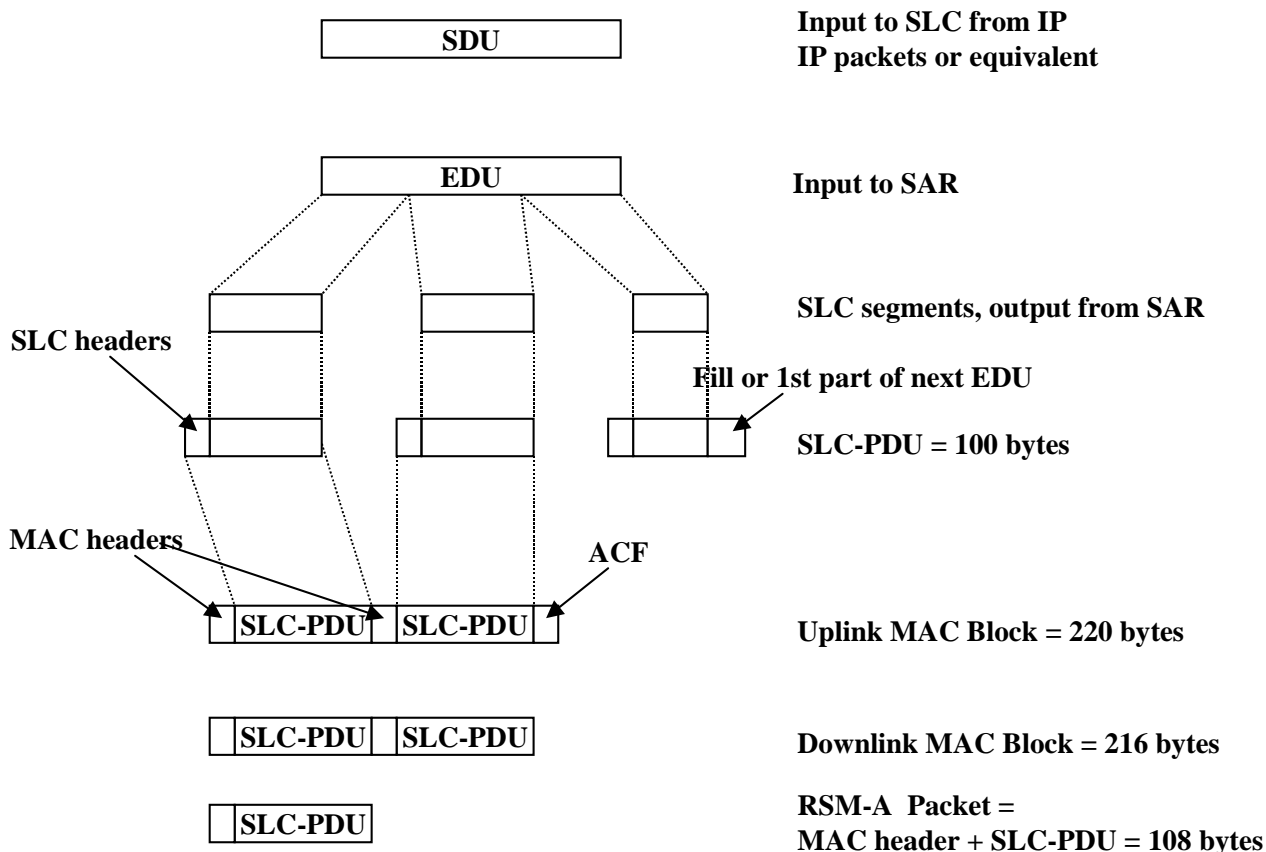

Figure 5.2: Terminology of the SLC/MAC

5.1.1 Modes of operation

5.1.1.1 SLC-unack mode

In SLC-unack mode, data is sent as a sequential data stream without any feedback from the receiver. The function of the SLC in this mode is to construct SLC segments from EDU segments before transmission and to recover EDUs from received SLC segments on the receiving side.

An SLC entity operating in unacknowledged mode essentially comprises of two components:

- 1) The segmentation component segments an EDU before transmission, including the application of appropriate SLC headers. The segmentation procedure is detailed in clause 5.6.2.
- 2) The reassembly component reassembles the received segments to recover, if possible, the original EDU. In addition, fields of the SLC header are used for missing packet detection at the receiver. The Reassembly procedure is described in clause 5.6.3.

5.1.1.2 SLC-ack mode

In SLC-ack mode, reliable delivery of the data is ensured using a modified sliding-window ARQ protocol. The SLC sub-layer may support a mode of operation wherein it offers a packet stream service with reliable delivery. This is the acknowledged mode of operation (SLC-ack mode). The receiving ST uses SLC acknowledgement packets to give feedback to the sender about the SLC segments received. The Sending ST and Receiving ST operate in a point-to-point, and unbalanced configuration. The Sending ST is responsible for initiating transmission, and establishing and maintaining the link. The Receiving ST can initiate acknowledgement packets with or without explicit permission from the Sending ST. Hence, while transferring data, the Sending ST and the Receiving ST communicate in Asynchronous Response Mode (ARM).

A receiving ST which does not support SLC ACK-mode shall drop SLC-PDUs transmitted in ACK-mode. The transmitting ST which supports ACK-mode shall be responsible to determine if the peer ST also supports ACK mode.

5.1.1.3 SLC-transparent mode

In SLC-transparent mode, SDU are segmented to fit within RSM-A packets but no SLC headers are applied.

5.1.2 Procedure description

5.1.2.1 Procedures at transmitting side

The SLC sub-layer conducts the following procedures at the sending side:

- compression (optional);
- data encryption;
- Cyclic Redundancy Check computation;
- SLC peer-to-peer capabilities negotiation (optional for an ST which only supports the ST basic capabilities set in annex D);
- SDU Segmentation;
- recovery from SLC segment lost, via retransmission of data (optional);
- diagnostic test procedures.

5.1.2.2 Procedures at receiving side

The SLC sub-layer conducts the following procedures at the receiving side:

- decompression (optional);
- data decryption;
- error detection via CRC;
- SLC peer-to-peer capabilities negotiation (optional for an ST which only supports the ST basic capabilities set in annex D);
- SLC Reassembly;
- recovery from SLC segment loss, via acknowledge mode ARQ protocol (optional);
- diagnostic test procedures.

5.1.3 Backwards compatibility requirements

An ST shall be able to operate in a mode consistent with the ST basic capability set as defined in annex D. An ST is not required to support capabilities beyond those contained in the ST basic capability set. An ST which supports capabilities beyond those listed in the ST basic capability set shall be able to determine the capabilities of a peer ST and shall be able to, at least, operate with the ST basic capability set with any peer ST.

5.2 Compression

Compression is not presently supported.

5.3 Security procedures

Security procedures include capacity protection, and user data privacy, i.e. link layer confidentiality and conditional access.

Capacity protection is assured by the SAM, which is required for a ST to operate within a RSM-A system. The RSM-A MAC/SLC protocols enable capacity protection negotiation between the satellite and the SAM but are independent of the actual capacity protection algorithms.

User data privacy at the link layer is under the control of the satellite network operator and its customers (wholesalers, retailers and end users). The RSM-A protocol design accommodates link layer data security without mandating it or limiting the algorithms by specification. The optional security header specified in clause 7, allows receiving terminals to recognize encrypted packets and then either drop them or negotiate with the sending terminal.

The security header allows the service provider to configure closed user groups which can engage in secure data exchange using appropriate security algorithms in their terminals to provide encryption at the link layer. In this case, the security header allows receivers of such data to choose keys and other relevant decryption input appropriately. STs not configured to be members of the closed user group will not have received key material from the service provider and would therefore be unable to decrypt the packets should they receive or intercept them.

5.4 Cyclic Redundancy Check

An N-bit Cyclic Redundancy Check (CRC-ST-N) (where N is 16, 32, or 64) is applied to the data block for error detection at the receiver. The CRC shall be computed on the all the data octets. If the data is encrypted, then the CRC shall be computed on the encrypted data and the encrypted padding octets if any. The CRC generator polynomials are shown in table 5.1.

Table 5.1: CRC generator polynomials

CRC Type	CRC-ST-N	Generator polynomial
0	No CRC	None
1	CRC-ST-16	$G_{16}(D) = D^{16} + D^{15} + D^2 + 1$
2	CRC-ST-32	$G_{32}(D) = D^{32} + D^{26} + D^{23} + D^{22} + D^{16} + D^{12} + D^{11} + D^{10} + D^8 + D^7 + D^5 + D^4 + D^2 + D + 1$
3	CRC-ST-64	$G_{64}(D) = D^{64} + D^4 + D^3 + D + 1$

An ST shall apply the correct generator polynomial based on the length of the SDL using the following rules:

If $0 \leq \text{SDL length} < \text{TH1}$, use CRC Type = 0

If $\text{TH1} \leq \text{SDL length} < \text{TH2}$, use CRC Type = 1

If $\text{TH2} \leq \text{SDL length} < \text{TH3}$, use CRC Type = 2

If $\text{TH3} \leq \text{SDL length}$, use CRC Type = 3

TH1, TH2 and TH3 are defined in clause 8.

CRC Type is described in clause 7.4.3.7.

The N-bit CRC sequence $\{c(0), c(1), \dots, c(N-1)\}$ shall be the ones complement of the sum (modulo 2) of:

- the remainder of the division (modulo 2) by the CRC generator polynomial, of the product of D^K by the N-bit CRC initial value;
- the remainder of the division (modulo 2) by the CRC generator polynomial, of the product of D^N by the content of the K-bit data block $\{d(0), d(1), \dots, d(K-1)\}$.

where:

K is the number of bits in the data blocks $\{d(0), d(1), \dots, d(K-1)\}$;

N is the number of bits in the CRC (16, 32 or 64);

the CRC initial value for each CRC shall be all 1s.

As a typical implementation at the sending side, the initial content of the register of the device computing the remainder of the division is preset to all-1s and is then modified by division by the generator polynomial (as described above) on the complete data block.

The resulting N-bit CRC sequence shall be mapped into the CRC field as follows:

Table 5.2: Ordering of CRC bits for CRC-ST-16

(MSB) Bit 7	Bit 6	Bit 5	Bit 4	Bit 3	Bit 2	Bit 1	(LSB) Bit 0	Byte
c(15)	c(14)	c(13)	c(12)	c(11)	c(10)	c(9)	c(8)	0
c(7)	c(6)	c(5)	c(4)	c(3)	c(2)	c(1)	c(0)	1

Table 5.3: Ordering of CRC bits for CRC-ST-32

(MSB) Bit 7	Bit 6	Bit 5	Bit 4	Bit 3	Bit 2	Bit 1	(LSB) Bit 0	Byte
c(31)	c(30)	c(29)	c(28)	c(27)	c(26)	c(25)	c(24)	0
c(23)	c(22)	c(21)	c(20)	c(19)	c(18)	c(17)	c(16)	1
c(15)	c(14)	c(13)	c(12)	c(11)	c(10)	c(9)	c(8)	2
c(7)	c(6)	c(5)	c(4)	c(3)	c(2)	c(1)	c(0)	3

Table 5.4: Ordering of CRC bits for CRC-ST-64

(MSB) Bit 7	Bit 6	Bit 5	Bit 4	Bit 3	Bit 2	Bit 1	(LSB) Bit 0	Byte
c(63)	c(62)	c(61)	c(60)	c(59)	c(58)	c(57)	c(56)	0
c(55)	c(54)	c(53)	c(52)	c(51)	c(50)	c(49)	c(48)	1
c(47)	c(46)	c(45)	c(44)	c(43)	c(42)	c(41)	c(40)	2
c(39)	c(38)	c(37)	c(36)	c(35)	c(34)	c(33)	c(32)	3
c(31)	c(30)	c(29)	c(28)	c(27)	c(26)	c(25)	c(24)	4
c(23)	c(22)	c(21)	c(20)	c(19)	c(18)	c(17)	c(16)	5
c(15)	c(14)	c(13)	c(12)	c(11)	c(10)	c(9)	c(8)	6
c(7)	c(6)	c(5)	c(4)	c(3)	c(2)	c(1)	c(0)	7

NOTE: The CRC bit is transmitted in "natural" bit order (i.e. same order as the data block). This is the reverse of the ITU CRC bit ordering (in the ITU serial interface standards such as LAP.D; LAP.M; the CRC bits are sent in reverse order with respect to the order of the bit transmission of the data block).

These CRC requirements assume the following pseudo code implementation:

```

while (Message is not exhausted) {
    Table_index = (Most significant 4-bit nibble of the CRC register) xor (Most significant 4-bit nibble of
                  the message)

    CRC_register = CRC_register left shift by 4 bits

    Message = Message left shift by 4 bits

    CRC_register = CRC_register xor Table_value (Table_index)
}

```

Examples of CRC-ST-16, CRC-ST-32, and CRC-ST-64 calculated for different inputs are given in annex E.

5.5 Special messaging procedures

The RSM-A frame header and extension header are provided for future extensions to the air interface. Special handling for reception of unrecognised headers is defined in clause 5.6.3.

5.6 Segmentation and reassembly

5.6.1 Session creation

5.6.1.1 Session creation on the transmit side

An internal classification function within the ST determines if an SDU is to be sent using SLC unack-mode or SLC ack-mode. Only SLC unack mode is described in this clause. For a description of SLC ack-mode, see clause 5.7.

Before sending a segmented EDU, the ST shall generate a session identifier according to the rules presented below. A SAR session is uniquely defined by the combination of characteristics including SLC mode (either unack-mode or ack-mode), the Source ID (see clause 4.2.3), the session number (0-63) selected by the source ST, and the Destination MAC address (see clause 4.2.5). The session identifier shall be unique for all sessions between the initiating ST and a Destination MAC address. When the Destination MAC address is a multicast group, SLC ack-mode shall not be used. Within a single SLC session, all segments of an EDU shall be sent before any segment of another EDU may be sent.

5.6.1.2 Session creation on the receive side

SLC Layer Management entity at the Receiving ST creates appropriate per-session data structures, as necessary to reassemble an EDU, upon receiving an SLC segment with First bit set and there is no such pre-existing session, uniquely defined by a combination of characteristics described in clause 5.6.1.1. The session is established in acknowledged or unacknowledged mode based on the value set in the SLC control sub-field in the MAC header. A session creation shall be aborted if the first packet indicates a mode or a feature that the receiving ST does not or cannot support.

5.6.2 Segmentation

The segmentation function segments an Extended Data Unit (EDU), described below, into segments that can be fit into empty or partially empty SLC-PDUs. Segmentation of EDUs must be done strictly in the order of presentation to the MAC layer for transmission.

A segmented EDU has one First segment, zero or more Middle segments, and one Last segment. An SLC header corresponding to each segment type is prepended to each segment, see clause 7.4.1. The First-type SLC header also indicates the possible use of various features and the corresponding presence, within the EDU, of fields necessary for such features.

An SLC header is also defined for a Whole segment, namely for an EDU that does not require breaking into multiple smaller pieces before transmission. Like the First-type SLC header, the Whole-type SLC header also indicates the possible use of various features.

Terms such as "segment", "segmentation", "segmented", etc. shall be interpreted hereafter as also including a case of a Whole-type SLC header prepended to an EDU that is not broken into multiple smaller pieces. Such terms shall also be interpreted as including the case of an EDU being segmented in a fashion which yields zero EDU bytes in a Last segment, i.e. the EDU's Last segment consists entirely of a Last-type SLC header (this case is explained the description of the bytes in last segment field in clause 5.6.2.2).

5.6.2.1 Extended Data Unit (EDU) construction

In order to specify the segmentation procedure, it is useful to define an Extended Data Unit (EDU) as the construct formed from an SDU after applying one or more of the following, which are hereafter collectively designated as EDU Features:

- compression;
- encryption, with security header for link-layer data confidentiality;
- a CRC, for data integrity checking;
- a Frame header;
- an SLC Extension header.

An EDU is defined more rigorously by the output of following procedure applied to an SDU (with no gaps allowed after elements prepended to the SDU or before elements appended to the SDU):

- 1) If compression is required, compress the SDU.
- 2) If encryption is required, encrypt the result of the previous step, and prepend a Security header.
- 3) If a CRC is required, calculate it upon the result of the previous step, ignoring the possible presence of the Security header.
- 4) If a Frame header is required, prepend it to the result of the previous step.
- 5) If an SLC extension header is required, prepend it to the result of the previous step.

NOTE: The output of this procedure is termed an Extended Data Unit even if no EDU Special Features are employed, i.e. even if the procedure's output and the corresponding input SDU are identical.

5.6.2.2 Segmentation rules

The following rules apply for segmenting an EDU, and for "packing" of multiple segments within a RSM-A packet:

- 1) An EDU shall be segmented before transmission.
- 2) The SLC mode, either unack-mode or ack-mode, for transmitting an EDU shall not change once any segment of the EDU has been transmitted.
- 3) An SLC header of type First, Middle, Last, or Whole, as appropriate, and bearing a session number and packet sequence number, shall be prepended upon each segment.
- 4) Special features of the EDU shall be appropriately indicated in First-type and Whole-type SLC headers.
- 5) The session number in an SLC header may be chosen arbitrarily, but must be the same in the SLC headers of all segments of a segmented EDU. That is, segments of an EDU may not be sent using multiple SLC sessions.
- 6) An ST shall not interleave segments of multiple EDUs within a single SLC session. Interleaving segments of multiple EDUs of different SLC sessions is permitted, but the segments of each EDU must be sent in order as prescribed below.
- 7) The packet sequence number may be chosen arbitrarily for a First-type or Whole-type SLC header.
- 8) The packet sequence numbers in SLC headers of consecutive segments of a segmented EDU must increase consecutively. Packet sequence numbers roll over: if the maximum positive packet sequence number value is used in the SLC header for a segment, then the value zero shall be used for the packet sequence number of the next segment, if any, of the same EDU.
- 9) Consecutive segments of a segmented EDU must be sent consecutively within an SLC session. In SLC unack-mode, an EDU shall be discarded if not all of its segments arrive in order.
- 10) A First segment must extend to the end of an SLC-PDU.
- 11) A Middle segment, with its associated Middle-type SLC header, must occupy an entire SLC-PDU.
- 12) A Last segment, with its associated Last-type SLC header, must be positioned within an SLC-PDU and at the start of the SLC-PDU.
- 13) An SLC segment may bear at most one each of Extension header, Frame header and Security header. If the EDU bears an SLC Extension header, a Frame header, and/or a Security header, all bytes of all such headers must be carried within a single segment (either a First or Whole segment).
- 14) The bytes in last segment field, in a Whole-type or Last-type SLC header, indicates the number of EDU bytes in the segment, beginning with the first segment byte following the aforementioned SLC header. This field assumes non-negative integer values. The bytes in last segment field assumes a value of zero in the case of an EDU being segmented so that the EDU's last byte is the last byte of the payload field of a RSM-A packet, and a Last-type SLC header for that EDU follows immediately thereafter in the SLC session.
- 15) One segment may be followed immediately by another segment within a single RSM-A packet. However, all the segments packed into a single RSM-A packet must be associated with different EDUs, and no gaps are permitted between segments.
- 16) A SLC-PDU may be packed with SLC unack-mode segments, or with SLC ack-mode segments, but not both.
- 17) If SLC segments do not fill up the entire SLC-PDU, the SLC sub-layer shall use padding bytes to ensure that the length of the SLC-PDU is 100 bytes.

- 18) An ST shall support processing the following examples of multiple segments packed within a single received SLC-PDU:
- A Last segment, followed by a First segment.
 - A Last segment, followed by a Whole segment, followed by zero or more padding bytes.
 - A Last segment, followed by a Whole segment, followed by a First segment.
 - A Whole segment, followed by a Whole segment, followed by zero or more padding bytes.
 - A Whole segment, followed by a First segment.
- 19) A zero length EDU shall not be transmitted.
- 20) An EDU may carry zero bytes of SDU if an extension header is present in the EDU.
- 21) An extension header's length shall not exceed 40 bytes.

5.6.3 Reassembly

The SLC sub-layer receives SLC-PDUs. For each session, the SLC sub-layer maintains a next expected packet sequence number in SLC-unack mode or a window of expected sequence number in SLC-ack mode. A segment's packet sequence number is contained in that segment's SLC header. The next expected sequence number is initialized, upon receiving a First SLC header, to the packet sequence number carried in that header. The next expected packet sequence number is incremented with each SLC-PDU received. In SLC-unack mode, if a received segment's sequence number does not match the next expected sequence number for that SLC session, indicating a loss or re-ordering of segments, all segments of that SLC session are discarded. However, a Whole segment may bear any packet sequence number and so would not be discarded.

- 1) The following rules apply for processing a received SLC segment within an SLC-PDU. The SLC sub-layer shall deliver packets in order of arrival to the upper layers. If there are missing segments for a certain EDU, the other segments belonging to that EDU are discarded. Each EDU shall be processed for reassembly independently of other EDUs.
- 2) The SLC sub-layer shall start a Reassembly_timer (see clause 8) for an SLC session upon receiving a First segment. An SLC session's Reassembly_timer shall be reset each time another in-order Middle segment for that SLC session is received and shall be cancelled upon receipt of an in-order Last segment for that SLC session.
- 3) If the Reassembly_timer for an SLC session expires, all received segments for that session shall be discarded.
- 4) When the First segment or Whole segment of an EDU in a single SLC-PDU is received, the SLC sub-layer notes the settings of the Cmp, Frame, Sec, CRC and E fields (see clause 7.4.3). These values apply to all other segments of the same EDU as applicable.
- 5) If the SLC header indicates that it is a Whole or the Last segment of a packet, the receiving ST uses the Bytes in Last Segment field to identify the length of that segment. If, within the same SLC-PDU, the byte immediately following the end of that segment is non-zero, the SLC sub-layer shall try to interpret the bytes following the aforementioned segment as the SLC header for a segment for another EDU.
- 6) If the SLC header indicates a CRC, the ST shall compute the CRC for the EDU after reassembling all the segments of that EDU. If the CRC does not match, the EDU shall be discarded.
- 7) If a security header exists in the EDU, the EDU shall be decrypted after reassembly, on the basis of the security header contents.
- 8) If the SLC header indicates compression was employed before transmission, the receiving ST shall decompress the EDU.
- 9) If a frame header is present the SDU shall be delivered to the ST specific entity indicated by the frame header contents.
- 10) If an extension header is present, the extension header shall be delivered to the ST-specific entity indicated by the extension header contents.

- 11) If an ST should receive a segment bearing an extension header with a type not supported by the ST, then the ST shall ignore the entire extension header, but shall otherwise regard the entire segment bearing the extension header.
- 12) An ST shall discard a segment upon receipt if any of the following should be true:
 - The segment does not comply with the segmentation rules specified in clause 5.6.2.2.
 - The segment is a Whole or Last segment, and, based upon the position of the segment with the RSM-A packet, the Bytes in Last Segment field indicates more bytes than are available until the end of the RSM-A packet.
 - The segment bears a frame header value not supported by the ST.
 - The segment bears an extension header indicating a length exceeding 40 bytes.
 - The segment bears an extension header, and, based upon the position of the segment within the RSM-A packet, the extension header length field indicates more bytes than are available until the end of the RSM-A packet.

5.6.4 Session termination

5.6.4.1 Session termination on the transmit side

In unacknowledged mode, there are different cases where an active session is terminated, i.e. any data structures associated with that SLC session may be freed and the SLC session number may be re-used. These cases are defined below:

- For unacknowledged-mode, the SLC sub-layer may close a session immediately upon transmitting the Last segment of an EDU.
- SLC entity may also close a session due to an unrecoverable error. Any packets pending internally for that SLC session are flushed. Assigned slots that have not been used are also lost.

The upper layers may request an abrupt termination of an existing session. In this case, the SLC sub-layer may abort that session and drop all untransmitted segments.

5.6.4.2 Session termination on the receive side

In unacknowledged mode, there are different cases where an active session is terminated. The closing of session is an explicit decision of the implementation. The cases are defined below:

- The SLC sub-layer may close a session normally after receiving all the segments of an EDU.
- The SLC sub-layer may close the session when any missing packet(s) is detected. In this case session is closed abnormally.
- The SLC sub-layer may close the session when the Reassembly_timer expires.
- In normal or abnormal termination all the resources allocated to the session are released. When session is terminated abnormally partially received EDUs are dropped.

5.7 Ack-mode

SLC Ack-mode is not currently supported.

5.8 Diagnostic test procedure

5.8.1 Overview

The diagnostics module injects diagnostic SLC test messages into the system and further, receives the diagnostic SLC test messages from the link layer for analysis. It interacts only with the SLC sub-layer. Two distinct types of tests are possible. One test is used to measure peer-to-peer SLC delay and the other is used to measure satellite delay. These are distinguished by a message type field within the message format (see clause 7.5.9). A receiving ST shall drop any SLC test message type it receives which it does not support. Both test message types require a frame header (see clause 7.4.5).

5.8.2 Interfaces, SAPs, service definitions and service primitives

The diagnostic module does not provide any service directly to any other layer. It uses the SLC-SAP to deliver SLC test-messages to the SLC layer and receive SLC test-messages from that layer.

5.8.3 SLC peer-to-peer delay tests

An ST shall support SLC peer-to-peer delay tests.

5.8.3.1 Initiating ST procedure description

The ST which initiates the test procedure does so by creating a new test with a unique test id. If sequencing is required and if the ST supports sequencing the starting sequence number shall be 0. The ST shall create the appropriate SLC test messages using the format specified in clause 7.5.9. The initiating ST shall encode the time received field as all zeros. The destinations, periods and rate at which these messages are created are configured within the diagnostics module.

If the initiating ST is to collect the statistics, it shall set the R/C bit to "1". If the receiving ST is to collect the statistics, the initiating ST shall set the R/C bit to "0".

Once the SLC test message is created, the diagnostics module uses the SLC_TESTDATA.req primitive to transfer these messages to the SLC layer. The initiating ST shall time stamp the SLC test message using the time sent field prior to calculation of the CRC. The SLC shall calculate a CRC, create a frame header and perform segmentation and may support encryption of SLC test messages as required. The SLC shall not perform compression or other SLC services on the SLC test messages. The test module may use any combination of delivery mode or UDTS, as per the testing requirements.

If the destination address is a point-to-point address, the initiating ST does not need to explicitly mark the list of addresses field with the ST Site ID (see clause 4.2.1) of the recipient. If the address is a multicast destination and the test requires a response from a particular receiving ST, the initiating ST shall explicitly add the receiving ST's ST Site ID to the list of recipients in the transmitted message. On receiving the response from the receiving side, the receiving ST's SLC sub-layer reassembles the returned SLC test message and after checking the CRC shall time stamp the message if required and transfers it to the local diagnostics module for further processing.

5.8.3.2 Receiving ST procedures

If the R/C bit is set to "1"; and

- The packet has been sent point-to-point to the receiving ST or;
- The packet has been being sent to a multicast address, and the receiving ST's ST Site ID is present in the list of recipients field;

the receiving ST shall to respond to the initiating ST.

To respond to the initiating ST, the receiving ST shall time stamp the received time field immediately after checking the CRC of the received SLC test message. If there was more than one receiving ST's ST Site ID in the list of recipients, the receiving ST shall recode the list of recipients field with only its own ST Site ID and code the remainder of the list of recipients field with all zeros.

The receiving ST responding to a multicast SLC test message shall delete all the padding bytes prior to computing the CRC and transmitting the reformatted message back to the initiating ST. The receiving STs, responding to a point-to-point SLC test message with packet type satellite connectivity QoS packet, specified channel test packet or background QoS packet, shall delete all the padding bytes prior to computing the CRC and transmitting the reformatted message back to the initiating ST. The SLC test message is transmitted back to the initiating ST using the Destination MAC address contained in the Return MAC Address field. A drop class of 0 or 1 may be used for the response.

If the R/C bit is set to "0", the receiving ST should collect the message statistics instead of responding, keeping distinction of test IDs and sequence numbers. If a test ID/sequence number combination is received for which there is already a record, the newest information shall replace the older record. A receiving ST is not required to support the collection of statistics when receiving SLC test messages from another ST. Such an ST shall drop the received SLC test messages with R/C bit set to "0".

If the receiving ST receives a SLC test message with packet type indicating Satellite Loopback packet and the receiving ST was not the initiator, the receiving ST shall drop the message.

5.8.4 Satellite delay tests

An ST should support satellite delay tests. This test is not in the ST basic capability set. See annex D.

5.8.4.1 Initiating ST procedure description

The ST which initiates the test procedure does so by creating a new test with a unique test id. If sequencing is required and if the ST supports sequencing the starting sequence number shall be 0. The ST shall create the appropriate SLC test messages using the format specified in clause 7.5.9. The initiating ST shall encode the time received field as all zeros. The destinations, periods and rate at which these messages are created are configured within the diagnostics module.

If the initiating ST is to collect the statistics, it shall set the R/C bit to "1". If the receiving ST is to collect the statistics, the initiating ST shall set the R/C bit to "0".

Once the SLC test message is created, the diagnostics module uses the SLC_TESTDATA.req primitive to transfer these messages to the SLC layer. The initiating ST shall time stamp the SLC test message using the time sent field prior to transmission with the uplink time slot and frame number. The SLC shall create a frame header. The SLC shall not encrypt, perform compression, or compute a CRC or other SLC services on the SLC test messages. The test module may use any combination of delivery mode or UDTS, as per the testing requirements. The SLC test message shall fit within one SLC-PDU.

If the destination address is a point-to-point address, the initiating ST does not need to explicitly mark the list of addresses field with the ST Site ID of the recipient. If the address is a multicast destination and the test requires a response from a particular receiving ST, the initiating ST shall explicitly add the receiving ST's ST Site ID to the list of recipients in the transmitted message. On receiving the response from the receiving side, the initiating ST's SLC sub-layer shall transfer it to the local diagnostics module for further processing.

5.8.4.2 Receiving ST procedures

If the R/C bit is set to "1"; and

- The packet has been sent point-to-point to the receiving ST; or
- The packet has been being sent to a multicast address, and the receiving ST's ST Site ID is present in the list of recipients field;

the receiving ST shall respond to the initiating ST.

To respond to the initiating ST, the receiving ST shall time stamp the received time field with the downlink frame number in which the message was received. If there was more than one receiving ST's ST Site ID in the list of recipients, the receiving ST shall recode the list of recipients field with only its own ST Site ID and code the remainder of the list of recipients field with all zeros.

The SLC test message is transmitted back to the initiating ST using the Destination MAC address contained in the Return MAC Address field. A drop class of 0 or 1 may be used for the response.

If the R/C bit is set to "0", the receiving ST should collect the message statistics instead of responding, keeping distinction of test IDs and sequence numbers. If a test ID/sequence number combination is received for which there is already a record, the newest information shall replace the older record. A receiving ST is not required to support the collection of statistics when receiving SLC test messages from another ST. Such an ST shall drop the received SLC test messages with R/C bit set to "0".

If the receiving ST receives a SLC test message with packet type indicating Satellite Loopback packet and the receiving ST was not the initiator, the receiving ST shall drop the message. A receiving ST is not required to support the collection of statistics when receiving SLC test messages from another ST. Such an ST shall drop the received SLC test messages.

5.9 Interfaces, SAPs, service definitions, and service-primitives

5.9.1 Interfaces with higher layers: IP-SLC

5.9.1.1 Service Access Point-SLC-SAP

The SLC-SAP is used by the upper layers to deliver and receive packets to and from SLC respectively. Packets from the IP layer are delivered to the SLC-SAP, and received from the SLC-SAP via the Satellite Dependent Adaptation Function (SDAF) as illustrated in figure 5.4. The SDAF adapts between the SI-SAP primitives and the SLC-SAP primitives.

5.9.1.2 Service definitions

The services provided by the SLC are as follows:

- Resource reservation for specific Classes of Service (CoS).
- Option for acknowledged mode of SDU delivery (not currently supported).
- Unacknowledged mode of SDU delivery.
- Segmentation And Reassembly (SAR) of the SDU.
- Optional compression of SDUs.
- Option to encrypt/cipher information on flow basis.

5.9.1.3 Service primitives

The primitives provided by the SLC sub-layer are listed in table 5.5.

Table 5.5: SLC sub-layer service primitives

primitive name	Type				Parameters
	Request	Indication	Response	Confirm	
SLC_UNITDATA	X				SDU Destination MAC_Address of the source Destination MAC_Address of the destination CoS_Profile
SLC_UNITDATA		X			SDU Destination MAC address

5.9.1.3.1 SLC_UNITDATA

The upper layer uses SLC_UNITDATA-request to send the SDU. At the far end, the SDU is delivered to the upper layer using the SLC_UNITDATA-indication.

5.9.1.3.2 Primitive parameters

5.9.1.3.2.1 SDU

The Service Data Unit (SDU) corresponds to the "payload" of the primitive. The SDU contains the IP packet to be transported over the RSM-A network.

5.9.1.3.2.2 Destination MAC_Address

The Destination MAC_Address is defined in clause 4.2.5.

5.9.1.3.2.3 CoS_Profile

The CoS_Profile is defined using a set of CoS Tags. These CoS Tags can take the following values.

Table 5.6

CoS Tag	Possible Tag Values
Class of Service Flow ID	UDTS (CR, CRWB, NPB, HPB, LVLL, AckReturn) (note 1)
Encryption	Yes/No (note 2)
Compression	Yes/No (note 3)
SLC Mode	SLC_Unack/SLC_Ack (note 4)
Destination Type	MAC_replication_true, MAC_replication_false
NOTE 1: The Flow_ID defines the Class of Service and also identifies specific flows within certain Classes of Service. For CR and CRWB services the Flow_ID is used to indicate specific resource reservations using a unique identification number; for NPB and HPB services the Flow_ID is used to indicate one of four different priority levels.	
NOTE 2: Encryption is defined in clause 5.3.	
NOTE 3: Compression is defined in clause 5.2.	
NOTE 4: SLC_Unack mode is defined in clause 5.6. SLC Ack mode is defined in clause 5.7.	

5.9.2 Interface with specific ST entities

The ST specific entities (e.g. diagnostic test controller, management) can be conceptually considered to use separate SAPs for accessing the services offered by the SLC sub-layer.

For diagnostic test messages, The SLC shall combine the ST specific frame header with the diagnostic message and extract it on the receiving side as described in clause 5.8.

For management messages, the SLC sub-layer provides a set of Management Transport Services (MTS) as described in clause 6.3.4.4.

5.9.3 Logical interface with peer layer

The SLC sub-layer has a logical interface (P interface) with peer SLC sub-layer. The P interface can be conceptually said to connect two individual SLC entities. The P interface supports multiple sessions between SLC entities, where each session corresponds to a specific instance of SLC-SAP service. If there are multiple SLC sessions between two STs, it is conceptually equivalent to having multiple connections over the U interface.

NOTE: All SLC sessions are unidirectional in nature.

Figure 5.3 also shows the logical SLC-SAP interface between the SLC sub-layer and the upper layers. Note that the figure does not show all the layers of protocol stack architecture.

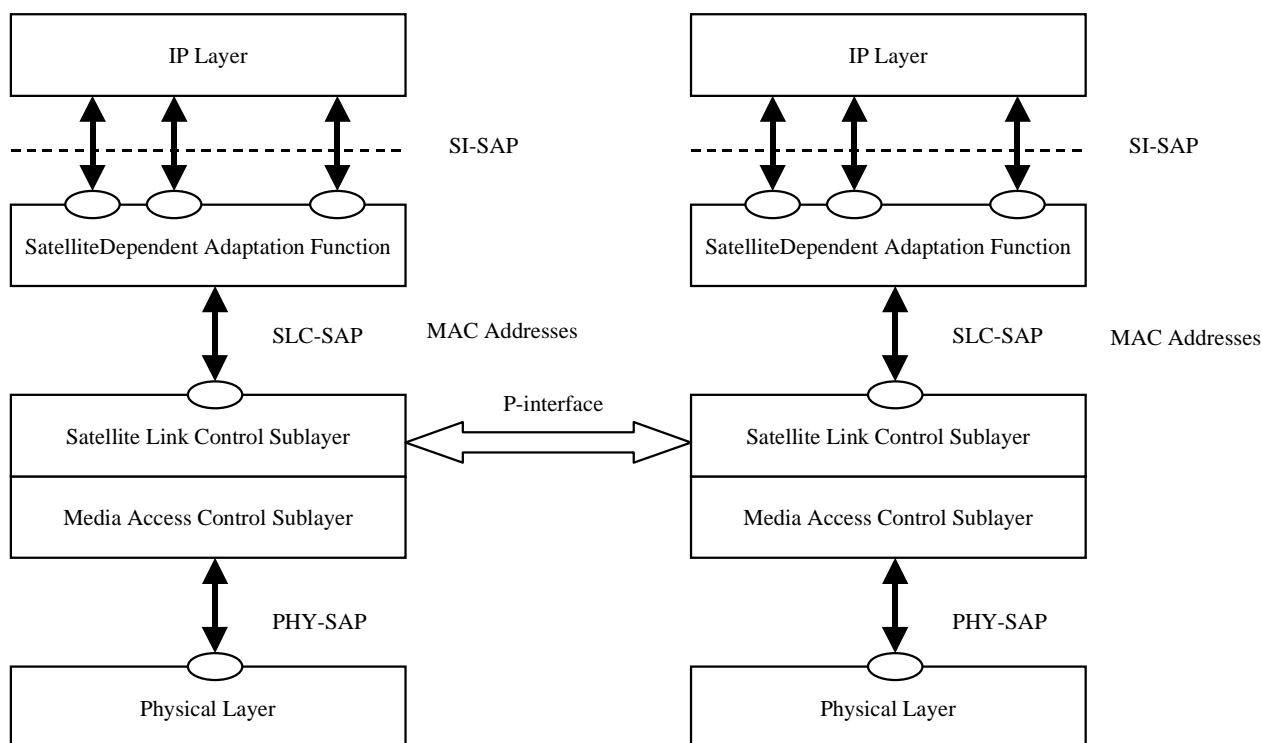

Figure 5.3: Logical Interface between peer SLC sub-layer

5.9.4 Satellite Dependent Adaptation Function

The Satellite Dependent Adaptation Function (SDAF) contains the functions that map between the SLC-SAP services and the SI-SAP services.

The service mapping between the BSM traffic classes TS 102 295 [8] and the RSM-A User Data Transport Services (UDTS) is shown in table 5.7.

Table 5.7: Mapping between BSM traffic classes and RSM-A UDTS

BSM Traffic Classes [8]		RSM-A
Traffic Class	Service Categories	UDTS (note 1)
0	Pre-emption, emergency services, essential network services	Any
1	Real-Time, Jitter sensitive, high interaction - Fixed size cells (VoIP)	CR
2	Real-Time, Jitter sensitive, interactive - Variable size packets (Real Time Video)	CRWB
3	Transaction Data, Highly Interactive, (Signalling, traffic engineering, PEPs)	LVLL (note 2)
4	Transaction Data, PEP, Interactive	HPB (note 2)
5	Low Loss Only (Short Transactions, Bulk Data, Video Streaming)	NPB
6	Medium loss, higher delay (Traditional Applications of IP Networks)	NPB
7	Not specified. Could be used for low priority broadcast/multicast traffic or storage networks (with reliable higher layer)	NPB

NOTE 1: The RSM-A UDTS are defined in clause 6.3.4.1.
 NOTE 2: PEP acknowledgements are treated as a special case and mapped to the UDTS Ack-Return service.

6 Medium Access Control sub-layer

6.1 Overview

Medium Access Control (MAC) is a sub-layer of the Data link layer. This layer shall control the way ST uses its uplink resources, i.e. contention channel and the dedicated channel resources. This layer handles the following functions:

- bandwidth negotiations;
- multiplexing of SLC sessions to uplink data channels;
- interaction with security access module;
- layer QoS requirements management;
- discriminate and filter traffic received by the ST;
- MAC block construction;
- scheduling of the outbound traffic;
- receipt of MAC messages;
- contention channel access protocol;
- congestion detection and reporting.

6.1.1 Modes of operation

The Medium Access Control sub-layer has two modes of operation. These are the Bandwidth on Demand (BoD) mode and the High Volume UpLink (HVUL) mode. If an ST is capable of both HVUL mode and BoD mode, it shall switch between the two modes at the command of the NCC within 768 ms. User data service may be interrupted during this transition. In the rest of this specification, unless otherwise mentioned, it should be assumed that we are referring to the BoD mode of operation.

6.1.1.1 BoD mode

In the BoD mode of operation, the ST shares all uplink resources with other STs in the same geographical area based on configuration. The contention channels are used by STs for initial access to the system. The bandwidth control protocol has to be continuously executed to get resources allocated by the Bandwidth Control Subsystem (BCS) in the network for usage on the uplink dedicated channels. The slotted Aloha and persistent Aloha protocols are used for getting resources on the uplink contention channels. All STs are continuously required to control the amount of resources they use by the use of a token bucket mechanism.

6.1.1.2 HVUL mode

In the HVUL mode of operation there are a set of uplink resources reserved for the exclusive usage of the ST, without the ST having to execute any protocol or make any explicit request to the network. Consequently, the ST does not have to use the contention channels, nor implement the bandwidth control protocol. There is no token-bucket based flow-control, because the resources are not shared. However, the ST is required to ensure that the usage of uplink resources is distributed between the downlink regions based on configuration from the NCC. This ensures equitable handling of data streams to all destinations within the ST.

6.2 Interfaces, SAPs, service definitions, and service primitives

This clause gives details on different interfaces that the MAC sub-layer has with other layers and entities.

6.2.1 Interface with physical layer: MAC-PHY

6.2.1.1 Service Access Point

This SAP shall provide the means for transfer of RSM-A packet to the physical layer for transmission over the air link.

6.2.1.2 Service used

Medium Access Control sub-layer expects the following service from the physical layer:

- Transmission of RSM-A packet on the assigned channel (contention or dedicated) and timeslot.
- Current status of radio link.

6.2.2 Interfaces with layer management entities

6.2.3 Logical interfaces with peer layer

The peer to the ST's MAC sub-layer resides in the network. The ST interacts with the Bandwidth Control component on the satellite over the "U" interface for negotiating the required channel and bandwidth for both the rate and volume traffic.

This logical interface shall be supported with the set of messages listed in clause 7.5.

6.3 MAC procedures

6.3.1 General procedures

6.3.1.1 Network

The following MAC procedures are implemented by the network.

6.3.1.1.1 System information broadcasting

The network transmits system information in broadcast mode. The system information is classified into the following types:

- 1) Transmission Information Packet (TIP). This message contains basic information required by the terminal to initiate access to the RSM-A system. This message is described in clause 7.5.2. The messages are transmitted once per superframe from the network. The ST shall read a complete TIP within the last 5 superframes prior to initiating any network access. Further the ST shall declare "downlink failure" if it fails to read a complete TIP within the last 5 superframes.
- 2) Network Information Packet (NIP) messages. NIP messages include bandwidth assignment, negative acknowledgement, and dynamic contention channel assignment messages. These messages are described in clause 7.5.
- 3) Uplink Power Control Status message. This message is transmitted on a per-uplink frame basis by the system, individually for each physical channel. This message contains power and timing adjustment information required by the ST to adjust its transmission as well as contention information for contention channels. For contention channels, the ST shall read this information in each frame if it needs to access the system. This message is described in clause 7.5.3.

- 4) Management Information Packet (MIP) messages. Management Information Packets are of two types direct and indirect. An ST should be able to operate indefinitely without direct MIP. Both types are generated by the network and broadcast to all STs. They contain information required by the ST to register itself with the network and negotiate for services.

6.3.2 Medium access procedures

6.3.2.1 Initial access procedure

A ST that does not have any radio resources currently allocated to it shall make the initial access on a contention channel, i.e. a Slotted Aloha (SA) or Persistent Aloha (PA) channel. The use of SA or PA channel is dependent on the classification of the traffic by classifier.

- If the traffic is classified as "constant rate", the ST shall issue a BoD request using the available SA channels to get a dedicated rate allocation (refer to clause 6.3.3).
- If the traffic is classified as "constant rate with burst", the ST shall issue a BoD request using the available SA channel to get a dedicated rate allocation and a volume allocation for the excess burst traffic (refer to clause 6.3.3).
- If the traffic is classified as "normal priority burst or high priority burst", it shall issue a BoD request to BCP using the SA channel to get a dedicated volume allocation (refer to clause 6.3.3).
- If the traffic is classified as LVLL, then the ST may use the one of the SA channels to transport them as specified in clause 6.3.5.2 or shall issue a BoD request to BCP using the SA channel to get a dedicated volume allocation.
- If the traffic is classified as AckReturn, it may set up a PA channel as described in clause 6.3.5.3.2 if PA is available. If PA is not available then AckReturn traffic is treated as LVLL traffic (Transmitted on one of SA contention channel).

6.3.3 Bandwidth control procedures

The bandwidth control protocol for rate requests, volume requests, rate modification and rate de-allocation is essentially the same. The ST shall not use bandwidth control procedures for HVUL traffic or for any traffic class which uses contention channel for data transfer (see clause 6.3.4).

An ST is required to request bandwidth assignments from the network in order to transfer rate or volume traffic. An ST shall evaluate its bandwidth requirements at least once per uplink frame.

The ST shall aggregate, or queue, volume traffic requirements according to downlink destination region ID and priority. The volume request protocol is described in clause 6.3.3.1. The number of slots requested should reflect the total number of packets per queue corresponding to each downlink destination region and priority. For volume requests, the ST shall not make a request for more volume than the data it already has queued corresponding to each downlink destination region ID / priority pair.

The ST shall aggregate all rate requirements into two rate requests based on priority (high or low) but independent of destination. Each of these requirements is the number of slots per uplink frame required to service all rate requests. The protocol for rate requests is described in clause 6.3.3.2. If one of these aggregated rate requirements changes from one frame to the next, the ST shall apply the protocol described in clause 6.3.3.3. If one of these requirements changes from one frame to the next to a zero value, the ST shall apply the protocol described in clause 6.3.3.4.

During any frame, the ST may make at most two rate requests (for each priority, i.e. low and high priority traffic).

The ST shall combine all of its rate and volume bandwidth requirements into one or more bandwidth request messages. The bandwidth request message format is described in clause 7.5.4. The ST shall send each bandwidth request message to the SAM via the SAM/ST interface (see BSM RSM-A, TS 102 189-3 [6]). The SAM will return each message with a 4-byte integrity check. The network shall discard all bandwidth request messages which do not contain a valid integrity check.

The ST shall utilise either a slotted aloha contention channel or a previously assigned (dedicated) rate or volume time slot to make the request to the satellite. The rule for using previously assigned bandwidth for bandwidth requests is defined in clause 6.3.3.1.

The network shall respond to each bandwidth request message with bandwidth assignment messages and/or negative acknowledgement messages rejecting the request.

Each bandwidth assignment contains the assigned dedicated resources to be used by the ST. Each assignment contains an assignment integrity check. The ST shall pass each assignment to the SAM for permission to use the assigned resource.

An ST shall be able to use all assignments which are received 24 ms prior to the start of the uplink frame for which the assignment is made. An ST shall transmit NULL packets in any such assignment, which it does not use for traffic or signalling. An ST may use any assignments received between 24 ms prior to the start of frame and just prior to the actual assigned time slot. However, an ST shall generate an alarm to the network for all assignment messages which are received subsequent to 24 ms prior to the start of the frame for which the assignment is made.

6.3.3.1 Volume request protocol

A pair of volume requests is associated with every combination of destination region ID and priority. An allocation timer instance is associated with each such volume request pair. For each such pair of requests, the allocation timer's timeout value is initialized to BODAllocationMinTimer (see clause 8). The allocation timer's timeout value for each request pair is adjusted between this value and BODAllocationMaxTimer (see clause 8) according to the following protocol:

- 1) When a new queue is created and it is the first queue created for a destination region/priority pair, the allocation timer for the destination region/priority pair is initialized to BODAllocationMinTimer (see clause 8). When a new queue is created and other queues already exist for this destination region/priority pair, the new queue is subject to the current value of allocation timer.
- 2) When a new volume request is transmitted from the request pair for a specific combination of destination region ID and priority, the allocation timer is started as long as it is not already running. If the timer is already running when the request is transmitted, it indicates that there is already a pending request from this pair, and so this newly transmitted request must be a follow-up request to that pending request. In such a case, the timer continues to run for the pending request. When the last allocation is received for that request, the timer is reinitialized to the current timeout value and restarted, for it is now time for the follow-up request to receive allocations. It is important to note that the allocation timer's timeout value does not depend on whether or not the current request is a follow-up request. The timeout value of the allocation timer for each request pair is adjusted by an independent method that is described in the following points.
- 3) If the ST receives a bandwidth assignment message containing an assignment corresponding to a volume request, it shall stop the allocation timer for that volume request. The allocation timer's timeout value shall be reduced by BODAllocationStepTimer (see clause 8), unless it is already at the value BODAllocationMinTimer (see clause 8).
- 4) If the allocation timer expires and the ST has not received either an assignment or a negative acknowledgement, the ST shall increase the value of the allocation timer by BODAllocationStepTimer, unless it has already reached the value BODAllocationMaxTimer (see clause 8). The ST shall then re-evaluate the bandwidth requirement for that destination region ID/priority pair and transmit a bandwidth request message with the new requirement.
- 5) If the ST receives a negative acknowledgement, the ST shall behave as per the cause code, see clause 7.5.6.
- 6) If the ST receives a ULPC status message indicating a R/S failure (see clause 7.5.3.1.5) for the transmitted packet containing the bandwidth request message, the ST may then re-evaluate the bandwidth requirement for that destination region ID and transmit a bandwidth request message with the new requirement immediately. The allocation timer shall be stopped and restarted using the most recently used value for that destination region ID.
- 7) As more data arrives in a destination region/priority queue, the ST shall request follow-up bandwidth to service the new data in that queue. The ST shall set the follow-up bit in the bandwidth request data field and may use one of the assigned slots to send a bandwidth request message for additional slots and shall start its allocation timer. Other rate and volume bandwidth requests may be aggregated on the same bandwidth request message using different bandwidth request data fields.

- 8) An ST may have at most two outstanding requests per destination region ID/priority pair outstanding at any time.
- 9) The ST may request up to BODMaximumBODRequestSize (see clause 8) slots in a single volume request message per destination region ID/ priority pair.
- 10) An ST may receive explicit negative acknowledgements for volume request. The ST shall react based on the cause code as specified in clause 7.5.6.

6.3.3.1.1 Mapping of downlink destination ID into destination region IDs

The downlink destination ID field is an information element in every MAC header as described in clause 7.3.1.4. Each downlink cell has a downlink destination ID. The downlink destination ID field is defined in BSM RSM-A TS 102 188-6 [4]. The network maps downlink destination IDs to destination region IDs based on network congestion. Thus several destination IDs may be mapped to a single destination region ID if traffic in these downlink cells cause mutual congestion. Most downlink cells are not congested and do not cause mutual congestion to each other. These downlink destination IDs are all mapped to a default destination region ID value called the wildcard destination region ID. The ST shall aggregate volume traffic by destination region ID and priority rather than on downlink destination ID. This mapping is transmitted by the network.

The mapping of downlink destination IDs into destination region IDs may change at any time. This is expected to be an infrequent event and the following rules are designed to allow an ST to implement an efficient remapping procedure.

Following any change to the mapping, the ST shall map all subsequent packet arrivals using the new mapping. The ST shall map any packets that were queued up prior to the receipt of the remapping using either the new mapping or the previous (old) mapping provided that all such packets are preserved and are transmitted (or retransmitted) using one of these two mappings.

6.3.3.2 Rate request protocol

Rate requests shall be used for connection oriented traffic. (i.e. all CR traffic as well as the constant rate portion of CRWB traffic). The rate requests specifies the number of slots in each uplink frame that a ST requires to meet the aggregate rate for all connection-oriented traffic with the same priority.

- 1) The ST shall start a response timer with a value BODResponseTimer (see clause 8) when it transmits a bandwidth request message containing a rate request for each rate request. It shall set the RETRY counter to BODRateRequestRetries (see clause 8).
- 2) If the ST Response timer expires, the ST shall do the following. If the RETRY counter is non-zero, the ST shall transmit another bandwidth request message with the rate request, restart the response timer and decrement the RETRY counter. If the RETRY counter is zero, the ST shall declare failure to the connection management entity and abandon the attempt to obtain a rate assignment. If the ST has entered CC transition mode (refer to clause 7.5.2.2.10), the ST shall suspend transmitting bandwidth request messages as per the protocol, and shall not declare failure to the connection management module.
- 3) If the network does not have available bandwidth, it shall transmit a negative acknowledgement message with the appropriate cause code. The ST shall react based on the cause code as specified in clause 7.5.6.
- 4) If the ST receives bandwidth assignments for the rate requests, the ST shall reset the RETRY counter to BODRateRequestRetries. The ST shall restart the response timer for each assignment it receives. If the response timer expires while the connection is active, the ST shall handle it as specified in 2) above.

The network may assign bandwidth for the rate requests every frame or may make an assignment which is valid for multiple frames (see clause 7.5.5.1.5).

If the requesting ST receives an assignment valid for multiple frames, the ST shall use the multiple frame assignment until one of the following occurs:

- The multiple frame assignment expires in which case the ST must stop using the assignment.
- The ST receives an assignment that replaces the multiple frame assignment in which case the ST abandons the multiple frame assignment and uses the replacement.

If the ST misses an assignment for a frame (e.g. due to rain fade), then it shall not transmit for that frame. The ST shall wait until it receives a bandwidth assignment message that specifies it is a rate assignment to resume transmission. If the ST receives the assignment valid for multiple frames then it shall stop the response timer and restart the response timer after finishing the multiple frame allocation.

6.3.3.3 Rate modification procedure

The ST shall re-evaluate the aggregate rate requirement for both low and high priority rates every uplink frame. If the aggregate rate is changed, either due to a new connection becoming active or due to termination of an existing connection, the ST shall transmit a new bandwidth request message, requesting the rate modification to the new aggregate rate. The ST shall set the request action information element of the bandwidth request message as described in clause 7.5.4.4.4.

The network shall respond with a bandwidth assignment message or a negative acknowledgement message. The ST shall assume the rate modification was successful only when it receives the first bandwidth assignment message with the new rate.

- 1) The ST shall start a response timer with a value BODResponseTimer when it transmits a bandwidth request message containing a rate modification for each rate request. It shall set the RETRY counter to BODRateRequestRetries.
- 2) If the ST Response timer expires, the ST shall do the following. If the RETRY counter is non-zero, the ST shall transmit another bandwidth request message with the rate modification, restart the response timer and decrement the RETRY counter. If the RETRY counter is zero, the ST shall declare failure to the connection management entity and abandon the attempt to modify the rate. If the ST has entered CC transition mode (refer to clause 7.5.2.2.10), the ST shall suspend transmitting bandwidth request messages as per the protocol, and shall not declare failure to the connection management module.
- 3) If the ST is requesting more rate bandwidth and network does not have available bandwidth, it shall transmit a negative acknowledgement message with the appropriate cause code. The ST shall react based on the cause code as specified in clause 7.5.6.
- 4) If the ST receives bandwidth assignments for the modified rate, the ST shall reset the RETRY counter to BoDRateRequestRetries. The ST shall assume that the rate modification procedure has been successful.

6.3.3.4 Rate de-allocation procedure

The network shall continue to assign bandwidth to the ST for the aggregate rate until the ST transmits a bandwidth request message with the request action information element (see clause 7.5.4.4.4) set to cancel or de-allocate the existing rate. There is no explicit response from the network for the de-allocation request. The ST should monitor the bandwidth assignment messages and check whether the assignment has been stopped. The assigned rates for each priority are independent.

The following is the protocol for rate de-allocation:

- 1) The ST shall transmit a bandwidth request message requesting rate de-allocation and start the response timer.
- 2) If the network receives the rate de-allocation message, it shall delete the request from its internal queue and stop making the rate assignments for the ST.
- 3) The ST shall continue to monitor all bandwidth assignment messages for the rate assignment. While the deallocation request is pending, failure to receive a bandwidth assignment message with the previously requested rate for two consecutive frames shall be interpreted by the ST to indicate a successful deallocation. The ST shall not restart response timer on receipt of a bandwidth assignment message which continues to assign the rate.
- 4) If the response timer expires and deallocation is still not successful, i.e. the ST is still receiving rate assignments; it shall send another bandwidth request message for the rate deallocation and restart the response timer. This shall continue indefinitely until the condition described in the step 3 has been achieved.

6.3.4 Bandwidth management procedures

The ST classifies the data transiting over the air-interface into different flows, each being associated with certain User Data Transport Service (UDTS) to be used for that flow. It is possible that the multiple flows share the same UDTS.

The RSM-A system defines a fixed set of UDTS: Constant Rate (CR), Constant Rate With Burst (CRWB), Low Volume Low Latency (LVLL), High Priority Burst (HPB), Ack Return, and Normal Priority Burst (NPB). Based on combination of UDTS and the dynamics like queue size and priority, SDUs are mapped onto different Packet Delivery Service (PDS) using either dedicated and/or contention channels at the MAC layer.

Several "instances" of a single burst UDTS may be available, each instance being independently configurable to provide differentiated servicing within the ST. Each UDTS instance is associated with a group of queues within the ST, referred to as the "service queue group" of the UDTS instance. In addition, each UDTS instance is associated with a configurable parameter "serviceWeight", and each queue in the service queue group shares this parameter. In other words, each service queue group is associated with such a weight parameter. Such parameter helps specify the relative weighting across the multiple instances of the single burst UDTS. The possible UDTSs and the associated queue resources are described below. Note that there are other queues within the ST (other than those mentioned below) that are used for carrying internally sourced messages including bandwidth requests, management messages, and address resolution requests. All such internally sourced messages are generally queued separately from user data.

If the MAC receives an SDU with an associated UDTS, for which the mapped PDS (both primary and alternate) does not exist, the MAC shall drop the SDU.

6.3.4.1 Description of UDTS

6.3.4.1.1 Constant Rate (CR)

This UDTS offers a constant bit rate service in terms of packets per frame.

A single instance of the CR UDTS is available. Within this instance, there are multiple queues, one for each connection. Classification returns the connection number, which is used to identify the specific queue within the queue group of the CR UDTS.

6.3.4.1.2 Constant Rate With Burst (CRWB)

This UDTS offers a minimum bit-rate service with surplus demand being handled using the Bandwidth on Demand capability of the system.

Up to four instances of carriage of the burst portion of CRWB UDTS may be defined. The instances differ in the values of the burst threshold and the burst limit applicable to each connection associated with the instance. Each connection mapped to a CRWB UDTS instance is queued separately. Classification returns the connection number used to identify the specific queue within the queue group of the CRWB UDTS instance, from which the instance can also be determined.

6.3.4.1.3 High Priority Burst/Normal Priority Burst

The high priority burst and normal priority burst UDTSs use the bandwidth on demand capability of the RSM-A system to deliver data. The priority refers to the service priority of the packet.

Up to four different instances of any combination of HPB and NPB UDTSs may be defined. The different instances of a burst UDTS differ among themselves in the relative bandwidth available to each instance. Each instance of a burst UDTS is associated with a queue group, with separate queues for traffic destined to each downlink region. Classification returns the UDTS instance of the packet, and the Destination MAC Address of the next-hop ST is used to determine the destination downlink region and thus the specific queue for the packet.

6.3.4.1.4 Low Volume Low Latency (LVLL)

This UDTS is for use for small transactions where the QoS is primarily determined by the latency of transfer for small sets of data.

Only one instance of the LVLL UDTS is available, and one queue is used for all LVLL traffic, regardless of the destination downlink region of the packets mapped to the LVLL service. Special handling is given to the queue used for LVLL. If a packet mapped to LVLL service is received and the LVLL queue is full, the packet is diverted to a pre-configured burst UDTS instance. Within the UDTS instance the packet is placed in the specific queue pertaining to the destination downlink region of the packet.

6.3.4.1.5 Ack-Return UDTS

The envisioned use of the Ack-Return UDTS is for carrying TCP spoofer-sourced PBP acknowledgement packets. One instance of the Ack-Return UDTS is available, and in BoD mode one queue is used for all traffic mapped to this UDTS, regardless of the destination downlink region of the packets mapped to it.

In HVUL mode, no special queue for the Ack-Return UDTS is present. Instead, any data mapped to the Ack-Return UDTS is treated as belonging to a pre-configured burst UDTS, and placed in the appropriate queue depending on the destination downlink region.

6.3.4.2 Description of PDS

The RSM-A Air interface defines the following Packet Delivery Services which may be used for packet delivery.

6.3.4.2.1 High priority rate/Low priority rate

This refers to the resources associated with a negotiated connection between the ST and the NCC to a particular destination ST. A rate PDS is created when a connection is successfully setup. Subsequently, a constant number of slots are allocated on an uplink frame by uplink frame basis by the spacecraft. Refer to clause 6.3.3 for details.

Note that low priority rate is not currently used in the RSM-A system i.e. there is no defined mapping from any UDTS to low priority rate. Support for low-priority rate in the ST is optional.

6.3.4.2.2 High priority volume/Normal priority volume

These are associated with dynamic resources obtained via the bandwidth on demand protocol with no pre-authorization or clearance from the NCC. The BoD protocol is executed frame by frame with the spacecraft which makes allocations on a per-uplink frame basis based on the existing demand as reported by the ST. Refer to clause 6.3.3 for details.

6.3.4.2.3 Slotted Aloha (SA)

This PDS is associated with certain shared uplink channels on which the ST is permitted to use a slotted aloha protocol to transmit individual RSM-A packets.

6.3.4.2.4 Persistent Aloha (PA)

This PDS is associated with certain shared uplink channels on which the ST is permitted to execute the Persistent Aloha (PA) protocol. There are two types of PA channels. Successful transmission on a PA-1spnf channel causes the same slot number on the same PA channel to be reserved for the ST n uplink frames later, where $n = N_{ulpc}$ (see clause 8). Successful transmission on a PA-1spf channel is similar to PA-1spnf, where $n = 1$. The term PA is used to refer to both PA-1spf and PA-1spnf. Where there are specific differences between the two protocols the terms PA-1spnf and PA-1spf are used. PA-1spnf is described in clause 6.3.5.3 and PA-1spf is described in clause 6.3.5.4. Note that channels with rate equal to 128 kbps shall not be used for PA.

6.3.4.3 UDTs to PDS mapping

The mapping of UDTs to PDS follows a basic pattern. For each UDT, there is a primary PDS (which is used by default) and possibly a secondary PDS, which is used if the primary PDS is not available or there is too much backlogged demand. Some UDTs may get converted to other UDTs as part of the mapping depending on the configuration of the ST and the radio-resources available. Also, under specific conditions, packets marked for a given UDT are allowed to pre-empt Packet Transmission Opportunities (PTOs) which were originally intended to service for packets associated with other UDTs.

The following clauses detail the UDTs to PDS mapping algorithm.

6.3.4.3.1 Constant Rate UDTs mapping

Constant Rate uses the high priority rate PDS only as the primary PDS. There is no secondary PDS. Constant Rate packets are not allowed to pre-empt PTOs from other PDSs.

For each CR queue an associated parameter called `maxQueueDepth` is defined. If the arriving packet, if queued, would cause the size of the associated constant rate queue to be greater than the `maxQueueDepth`, the arriving packet is discarded. Otherwise it is queued and serviced using high priority rate PDS.

6.3.4.3.2 High Priority Burst/Normal Priority Burst UDTs mapping

Burst services are in two priorities, normal and high. Each has associated queues. There are a total of four groups of possible queues for a burst UDT, each with an associated instance id and priority - each queue may be marked either as high-priority or as normal priority. Each queue group has an associated weight (`serviceWeight`) which is used to service the queue once the volume PTOs are available. However volume requests are made for the aggregate demand.

High priority burst is serviced by the high priority volume PDS and normal priority burst is serviced by the normal priority volume PDS. If the ST is programmed for HVUL mode, there is only one volume PDS available, which services them both.

It is possible to configure one of the burst queues of an ST to use one slot per frame Persistent Aloha (PA1spf). Note that only one queue (to a specific downlink destination region), and not an entire burst UDT instance may be configured to use PA1spf. This queue will be serviced using PA1spf PDS if PA1spf is available, and will use volume PDS otherwise.

6.3.4.3.3 Constant Rate with Burst mapping

CRWB uses the associated connection (as identified by the classifier) for its primary PDS and either the HPV or the LPV PDS in BoD Mode or the volume PDS in HVUL mode as its secondary PDS. Whether HPV or LPV PDS is used in BoD Mode is decided by configuration.

For each CRWB queue, there is an associated parameter called the `maxQueueDepth`. If the new packet would cause the queue size to cross the `maxQueueDepth`, it is dropped. If the new packet does not cause the queue size to cross the `maxQueueDepth`, but does cause it to cross the configured parameter `volumeBoDTriggerThreshold`, the ST has to request volume bandwidth to carry an amount of data equal to the difference between `volumeBoDTriggerThreshold` and the instantaneous queue depth in one or more subsequent volume requests. These parameters are defined in clause 8.

NOTE: CRWB queues, regardless of the fact that they may be served by two PDSs, are always served in a FIFO manner.

6.3.4.3.4 Low Volume Low Latency mapping

LVLL uses slotted Aloha PDS as the primary PDS.

Each LVLL queue has an associated `maxQueueDepth`. If the queue size crosses the `maxQueueDepth`, the additional packets are serviced using the configured burst service i.e. HPB or NPB by remapping to the queue for the configured burst UDT instance, if allowed by the queue management rules of the appropriate queue. (These remapped packets are then serviced based on the burst UDTs to PDS mapping rules).

If the rate allocation is such that the SA PTOs cannot be used i.e. retuning to the contention channels is not possible, the LVLL shall be transmitted by pre-empting the PTOs meant for the rate queue. Volume PTOs shall be used to service LVLL packets if the number of volume allocations in a given uplink frame are larger than the number of packets in the volume queues - this is known as backfill. Similarly excess rate PTOs may also be backfilled.

6.3.4.3.5 Ack Return UDTs mapping

There is one associated queue for the Ack Return UDTs. Ack Return UDTs by default is serviced by PA-1spnf Persistent Aloha. If PA-1spnf channels are not available, the Ack-Return queue is serviced just as another LVLL queue. Note that in general Ack-Return takes priority over LVLL, and thus when PA is not available, Ack-Return packets are preferentially serviced, using any available SA PTOs, over LVLL packets.

Table 6.1: UDTs to PDS mapping table

UDTs	PDS			
	Rate	Volume (HPV/LPV)	SA	PA
CR	Always	-	-	-
CRWB	Primary (for data up to the burst threshold)	Secondary (for any excess beyond the burst threshold but within the burst limit)	-	-
Burst (HPB/NPB)	-	Always	-	-
LVLL	Pre-emption allowed (when re-tuning to contention channel not possible) and backfill allowed	Secondary (for any excess beyond the queue threshold by remapping to a burst UDTs instance), pre-emption and backfill allowed	Primary	Backfill of excess PA (PA-1spnf or PA-1spnf) PTOs allowed
Ack-Return	Pre-emption allowed (when re-tuning to contention channel not possible and backfill allowed if PA-1spnf not available)	Secondary (for any excess beyond the queue threshold by remapping to a burst UDTs instance), pre-emption and backfill allowed if PA-1spnf not available	Primary if PA-1spnf not available	PA-1spnf Primary

6.3.4.4 Management Transport Services (MTS)

The Management Transport Services (MTS) are offered to packets which are generated by the entities in the ST M-plane. Consequently, the MTS are only associated with the SLC-M-SAP; i.e. the management plane service access point that the data link layer offers to the local management IP layer.

Five types of MTS are offered- Very High priority, High priority, Medium priority, Low priority, and Supervisory. Very High priority MTS is meant to be used for latency sensitive management protocols, and to this end uses contention PDS. High priority, Medium priority and Low priority MTS all use volume PDS, and differ in their queue servicing priority and drop-class used. All three are subject to token bucket regulation, unlike Very High priority MTS that is not regulated by any token bucket.

Supervisory MTS uses a separate supervisory SA contention channel for transport. This service is not regulated by any token bucket.

The mapping of MTS to PDS is defined in table 6.2. Note that all MTSs are allowed to backfill user data rate and volume assignments.

Table 6.2: Mapping of MTS to PDS

MTS	PDS			
	Rate	Volume (HPV/LPV)	SA	PA
Very High Priority	Unrestricted pre-emption	Unrestricted pre-emption	Primary PDS - not subject to management bandwidth usage token bucket	Unrestricted pre-emption of PA-1spf or PA-1spnf
High Priority	pre-emption subject to token bucket as below; backfill allowed	Primary PDS		-
Medium Priority	pre-emption subject to token bucket as below; backfill allowed	Primary PDS		-
Low Priority	pre-emption subject to token bucket as below; backfill allowed	Primary PDS		-
Supervisory	-	-	Primary PDS - not subject to management bandwidth usage token bucket; Supervisory SA channel used	-

6.3.4.5 Queue servicing and flow control procedures

6.3.4.5.1 Servicing of rate queues

The ST schedules packets from rate based queues with the goal of minimizing the jitter experienced by data in each queue. The available rate PTOs should be distributed among all active connections such that each connection experiences minimal jitter.

Each rate PTO is uniquely assigned to a rate queue. If a packet is not available on that queue, the PTO becomes available for use by other services. Any service that may use an excess rate PTO may use it. It is also possible for a rate PTO to be pre-empted for use by another service, as mentioned previously.

6.3.4.5.2 Servicing of volume queues

Scheduling of burst traffic to use volume PDS is performed with the goal of weighting the volume PTOs among the burst queues competing for the same downlink region that have outstanding data. This weighting needs to be respected at the time of scheduling burst data. In BoD mode, the available HPV PTOs are allocated to the various queues in the following order of priority:

- First the internal MTS queues are served until the allocation is exhausted.
- Then the user queues for the burst UDTs mapped to use HPV PDS (including any CRWB queues exceeding their burst threshold) are serviced in proportion of the configured service weights of the UDTs instances, until the allocation is exhausted.

Similarly, the available LPV PTOs are allocated to the various candidate queues (i.e. all queues associated with burst UDTs instances configured to use LPV PDS, including any CRWB queues exceeding their burst thresholds) in proportion of the configured service weights of the UDTs instances.

In HVUL mode, the available volume PTOs are allocated to the various queues in the following order of priority:

- First the internal queues are served (up to the downlink limit) until the allocation is exhausted.
- Then the LVLL queue is served until the allocation is exhausted.
- Then the user queues for the burst UDTs are serviced in proportion of the configured service weights of the UDTs instances (up to the downlink limits) until the allocation is exhausted.

Note that an ST operating in HVUL mode must limit the number of packets scheduled for each downlink region up to the downlink limit for the region (excluding LVLL data).

Any excess volume PTOs may be used by the services that are allowed to do so. It is also possible for a volume PTO to be pre-empted for use by another service.

6.3.4.5.3 Queue servicing regulation procedures

Usage of PDS by some of the UDTS is limited through certain queue servicing regulation procedures, to impose some policy-based constraints on resource usage by the ST. Also, because there are multiple UDTS available simultaneously in the ST and common resources are shared between the different UDTS, certain queue servicing procedures are in place to prevent one UDTS from constantly pre-empting another kind of UDTS and thus leading to "unfairness" in utilization.

These queue servicing regulation procedures use a token bucket mechanism with the token bucket size and token bucket fill-rate being configured by the NCC. The fill-rate is defined in terms of a `SatellitePacketRefillSize` (SPRS) and a `RefillTimePeriod` (RTP); the ratio `SPRS/RTP` determines the fill-rate for the token bucket in terms of packets per uplink frame. The bucket size is defined in terms of a `maxBurstSize`. The parameters are defined in clause 8.

Before servicing a packet a check is performed against the token bucket regulating this servicing. A packet is serviced only if the check determines that the packet is conformant. A packet is conformant if sufficient tokens exist in the token bucket at the instant when the packet is to be serviced. The number of tokens, N , in the bucket is updated every RTP uplink frames as follows:

$$N_{\text{new}} = \text{Min} \{ N_{\text{old}} + \text{SPRS}, \text{maxBurstSize} \}$$

One token corresponds to one RSM-A packet, and as many RSM-A packets may be serviced as the number of tokens in the bucket. After servicing the queue the number of tokens in the bucket is decremented by the number of packets serviced.

For all but the `highPriorityVolume` token bucket and the `highPlusLowPriorityVolume` token bucket (see table 6.3) the above discussion applies directly. For the `highPriorityVolume` and the `highPlusLowPriorityVolume` token buckets (collectively referred to as the volume token buckets) "queue servicing" for purposes of discussion above should be interpreted as meaning the process of making BoD requests for queued data. That is to say, volume token buckets are consulted at the time of making a BoD request. Only if tokens are available in the applicable token bucket(s), can a request be made (of up to the number of packets equivalent to the number of tokens in the bucket(s)).

Usage of LPV is regulated by the `highPlusLowPriorityVolume` token bucket. Enough tokens must be available in this token bucket for a low priority BoD request of certain size to be made; if not the request size must be limited to the number of tokens available in this token bucket. Once a request is made the `highPlusLowPriorityVolume` token bucket must be decremented by size of the request made. Usage of HPV on the other hand is regulated by both volume token buckets. Enough tokens must be available separately in each volume token bucket for a high priority BoD request of certain size to be made, and if not the request size must be limited to the minimum of tokens available in the two token buckets. Note that both token buckets must be decremented when a high priority BoD request is made.

The different queue servicing decisions that the ST has to take are outlined in the table 6.3.

Table 6.3: Token buckets to be used for queue servicing

TOKEN BUCKET	USAGE - BoD mode	USAGE - HVUL mode
High Priority Volume	The usage of HPV is limited by this token bucket. ST can only make a high priority BoD request for upto the minimum of the HighPriorityVolume token bucket and the HighPlusLowPriorityVolume token bucket.	Not applicable
High Plus Low PriorityVolume	The usage of HPV and LPV is limited by this token bucket. ST can only make a high priority BoD request for upto the minimum of the HighPriorityVolume token bucket and the HighPlusLowPriorityVolume token bucket. ST can only make a low priority BoD request if enough tokens are available in this token bucket.	Not applicable
Data Contention	The usage of contention PTOs by LVLL user data traffic is limited by this token bucket.	Not applicable
Excess Transmission	In Bod mode, LVLL PDUs can use excess volume and rate PTOs if the aggregate generation rate does not violate this token bucket as shown above.	In HVUL mode this is applicable only to LVLL queues. Excess PTOs are any PTO unused by any other service.
Normal Pre-emption	LVLL PDUs may pre-empt volume PTOs as long as the rate at which LVLL traffic is generated does not violate this token bucket. Note that LVLL PDUs may always be transmitted in unused volume PTOs. Since Ack-Return is treated as an LVLL queue when PA is unavailable, this token bucket regulates pre-emption of volume PTOs by Ack-return packets when PA is not available.	Same as BoD mode
Pre-emption User Traffic For Blocked LVLL	If the ST is currently servicing rate and this prevents it from tuning to a contention channel, LVLL traffic may pre-empt the rate PTOs, as long as the rate at which LVLL traffic is generated does not violate this token bucket. Note that LVLL PDUs may always be transmitted in unused rate PTOs as discussed in the first item. This token bucket also regulates pre-emption of rate PTOs by Ack-return, when PA is not available.	If the ST has allocated sufficient rate capacity that fewer than 2 PTOs are available, LVLL traffic may pre-empt the rate PTOs, as long as the rate at which LVLL traffic is generated does not violate this token bucket. Note that LVLL PDUs may always be transmitted in unused rate PTOs as discussed in the first item.
Pre-emption Internal Traffic For Blocked Volume	If the ST is currently servicing only rate PDS and additional volume PDS is not possible, internal management traffic is allowed to pre-empt rate, as long as rate at which the internal management traffic PDU is generated does not violate this token bucket.	If the ST has allocated sufficient rate capacity that fewer than 2 PTOs are available, internal management traffic is allowed to pre-empt rate as long as rate at which the internal management traffic PDU is generated does not violate this token bucket.

6.3.5 Contention channel access procedures

Contention channels are provided by the network to be used by the STs to transmit small bursts of data or control information without first reserving bandwidth through the BoD mechanism. All contention channels are 512 kbps carriers for normal operations or 128 kbps carriers for ST-200s in fallback mode.

6.3.5.1 General

6.3.5.1.1 Types of access protocols

The RSM-A system supports three contention access protocols. Table 6.4 describes these three access protocols and the corresponding usage of each. Information as to which type of access protocol is used on a given channel is dynamically broadcast by the system as part of the TIP, NIP or MIP packet contents.

Table 6.4: Contention access protocols

Access Protocol	Usage	comments
Slotted Aloha (SA)	Shared by all STs in an uplink cell or specific channel groups. Used for BoD, management signalling, and user data.	Similar to standard slotted Aloha. Two types of SA channels are defined: Supervisory, Data/Control.
Persistent Aloha one slot per n frames (PA-1spnf)	Shared by all STs in an uplink cell that are configured to use PA-1spnf.	Differs from SA in that successful transmission by an ST causes the same slot number to be reserved for this same ST, $n = N_{ulpc}$ UL frames later.
Persistent Aloha-one slot per frame (PA-1spf)	Shared by all STs in an uplink cell that are configured to use PA-1spf.	Differs from SA in that successful transmission by an ST causes (with certain caveats) the same slot number, each UL frame thereafter for the next N_{ulpc} UL frames, to be reserved for this same ST.

6.3.5.1.2 Success or failure indication

The success or failure of a transmission is indicated in the ULPC packet that is transmitted from the network at every uplink frame boundary. If an ST has transmitted a packet in a given slot in a particular uplink frame, the information as to whether that packet was received successfully at the satellite or not is given in the ULPC packet sent by the network for that uplink frame. This ULPC packet is received at the ST within 6 uplink frames, following the frame of the original ST transmission. The packet contains a Reed-Solomon (RS) pass/fail indication for each uplink slot within the block decoder subfield as described in clause 7.5.3.2.5.

6.3.5.1.3 Retransmission

The MAC layer shall not perform retransmission of failed packets generated by Bandwidth Control Protocol (BCP). All such packet transmission failures are indicated to the BCP. Data SDUs may be retransmitted once, if so enabled, by buffering them for potential SA transmission.

6.3.5.1.4 Mapping transmission probability to potential contention transmission opportunity

The slot selection algorithm of each contention access protocol depends on a transmission probability, P . P will always belong to the set $\{2^{-n}, n \in I, n \geq 0\}$ and has the meaning given in table 6.5. For Slotted Aloha (SA) channel types, "free slot" in table 6.5 refers to a slot for which it is possible to tune to a contention channel without causing an outage to any reserved slot that was granted to the ST (including any "seized" Persistent Aloha (PA) slot). For PA channel types, "free slot" is further restricted by the set of slots on the selected PA channel that are open for contention (i.e. not "seized" by another ST). "Unconditionally free slot" in table 6.5 refers to a slot for which not only are the above conditions satisfied, but also for which it is possible to tune to the contention channel without causing an outage to any potential contention transmission opportunity that was already selected for a different contention channel type. "Contention" in this table refers indiscriminately to PA, PA-1spf, or any of the SA types; the appropriate contention access protocol type and transmission probability variable should be substituted when applying this table to the slot selection algorithm section of each particular contention access protocol. The transmission probability variable with respect to SA is P_{SA} (separate values of this variable will be required per SA type supported by the ST). The transmission probability variable with respect to either PA or PA-1spf is P_{PA} .

SA-supervisory channel transmissions shall take priority over PA and SA-data/control transmissions; then the ST may calculate potential contention transmission opportunities, as applicable, in the following order: PA, then SA-data/control. In the event that selected potential contention transmission opportunities of different contention types conflict with each other, the ST may give priority to PA transmission opportunities over SA transmission opportunity. Alternatively, ordering may be based on P-values, where a channel type with a smaller P-value takes precedence to a channel type with a larger P-value.

Table 6.5: Transmission probability definition

P value	Meaning
1	All free slots in the current uplink frame are selected as potential contention transmission opportunities.
1/2 (1/4, 1/8, 1/16) ($P=1/2$ or $1/4$ in fallback mode on a 128 kbps channel)	For every 2 (4, 8, 16) consecutive slots of the current uplink frame, if there exists at least one free slot in the set of 2 (4, 8, 16) slots, then one potential contention transmission opportunity is chosen randomly from the subset of free slots within the set of 2 (4, 8, 16) slots. (If the subset of unconditionally free slots is not null, the ST may opt to choose randomly from the subset of unconditionally free slots instead. The same option applies to all subsequent entries in this table).
1/32 ($P=1/8$ in fallback mode on a 128 kbps channel)	If at least one free slot exists in the current uplink frame, then one potential contention transmission opportunity is randomly chosen from the subset of free slots in that frame.
1/64 (1/128, 1/256 etc.) ($P=1/16, 1/32...$ in fallback mode on a 128 kbps channel)	Either (a) One uplink frame, out of the next 2 (4, 8 etc.) frames is chosen as a potential frame to contain a contention transmission opportunity. When the reserved slot schedule is known for that uplink frame, then if there exists at least one free slot in that frame, one potential contention transmission opportunity is randomly chosen from the subset of free slots in that frame. or (b) with probability 1/2 (1/4, 1/8 etc.) the upcoming uplink frame is chosen as a potential SA transmission opportunity, in which case, if there exists at least one free slot in a frame, then one potential SA transmission opportunity is randomly chosen from the subset of free slots in that frame. NOTE: P-values are defined in clause 6.3.5.2.6.

6.3.5.2 Slotted-Aloha channel access

The implementation of the SA protocol in the ST shall be such that, while the ST is only transmitting packets on SA channels, i.e. during a period wherein the ST has no rate or volume time slot assignments, no time slot or group of time slots within the uplink frame shall have higher utilization for SA transmission than any other slot or group of slots with the exception of time slot 31.

6.3.5.2.1 Types of Slotted Aloha channels

The RSM-A system supports two types of slotted Aloha channels. Table 6.6 describes these two SA types and the corresponding usage of each. Information as to which SA type adheres to a given channel is dynamically broadcast by the system, as part of the TIP, MIP, or dynamic contention channel assignment message contents. An ST shall support both types of contention channels.

Table 6.6: Slotted Aloha channel types

SA Channel Type	Usage
Supervisory contention channel	No security check, shared by all STs in an uplink cell; only for management signalling needed as a precursor to getting security keys (e.g. registration, authentication, security resynchronization requests).
Data/Control contention channel	Used for bandwidth request messages, management signalling, and user data (LVLL traffic). Either (1) shared by all STs in an uplink cell ; can be temporary or permanent, or (2) assigned to specific channel groups and usable by STs belonging to those channel groups only; permanent only.

6.3.5.2.2 State machine definitions

The following definitions are needed to properly interpret the SA State Machine:

packet: a single packet or a packet couplet that is to be transmitted in a single code block

buffered for SA transmission: the packet in question is to be transmitted on the next selected SA transmission opportunity

eligible for SA transmission: the packet in question is eligible to be transmitted on a future SA transmission opportunity

buffered for potential SA transmission: same as "eligible for SA transmission"

6.3.5.2.3 State machine

The core of the Slotted-Aloha access protocol is illustrated by the state machine in figure 6.1. An ST shall have, at most, one instantiation of this state machine per SA type. When a packet is buffered for SA transmission, the ST enters a state of waiting for transmission of this packet on the next selected SA transmission opportunity. The SA channel selection and slot selection processes are given in the next two clauses. Once the packet is transmitted in the selected SA slot, if there are no additional packets buffered for SA transmission, the ST goes back to the idle state, awaiting another packet to be buffered for SA transmission. Otherwise, the ST remains in the state of waiting for transmitting the next packet.

If retransmission is configured and supported by the ST, the SDU shall be buffered for at least 6 frames after initial transmission of its last SLC-PDU. If any of the corresponding ULPC status messages indicate that an initial transmission for any of the SLC-PDUs for that SDU has failed, then the ST shall enqueue that SDU again for SA transmission. Each SDU shall be retransmitted not more than once. If the ST does not receive the ULPC status message within 6 uplink frames of the initial transmission of the last SLC-PDU, then the ST should drop the SDU.

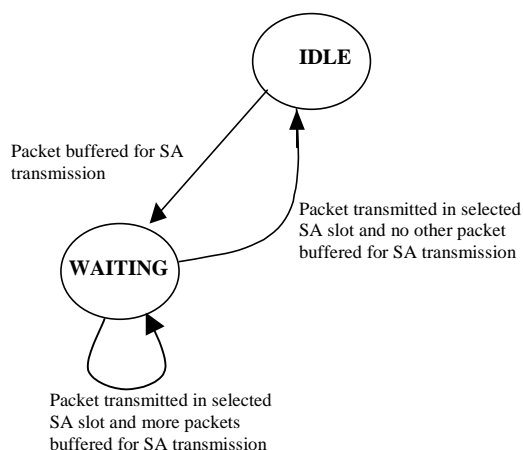

Figure 6.1: State machine for Slotted Aloha

The "feeder" mechanism by which a packet may be buffered for SA transmission is illustrated in figure 6.2. Each packet that is to be potentially transmitted using Slotted Aloha goes through this sequence of events. When a packet arrives that is eligible for SA transmission, it is buffered for possible SA transmission. There are a number of factors that may prevent this packet from being buffered for transmission in the next selected SA transmission opportunity. Such factors are implementation dependent and are outside the scope of the air interface specification. Nonetheless, for illustrative purposes, a few examples of possible factors are given below:

- the packet is enqueued behind another packet of equal or higher priority;
- the packet is held back until just before the next selected SA transmission opportunity to allow for the potential arrival, in the meantime, of a higher priority packet;
- the ST has exceeded configured SA usage limits defined by number of tokens assigned (specified in units of number of packets and uplink frames) for all SA channel types;
- the packet requires a greater degree of time randomization than is provided by the SA slot selection process.

After being buffered for potential SA transmission, two outcomes are possible:

- 1) all constraining factors are removed, at which point the packet is buffered for transmission; or
- 2) prior to all constraining factors being removed, the packet is cleared from the queue of packets eligible for SA transmission. This might happen, for example, if the packet was deleted due to becoming stale prior to being buffered for SA transmission or if the packet was transmitted in a non-SA slot prior to being buffered for SA transmission. Such events that might cause the packet to be thus cleared are implementation specific and are outside the scope of the air interface specification.

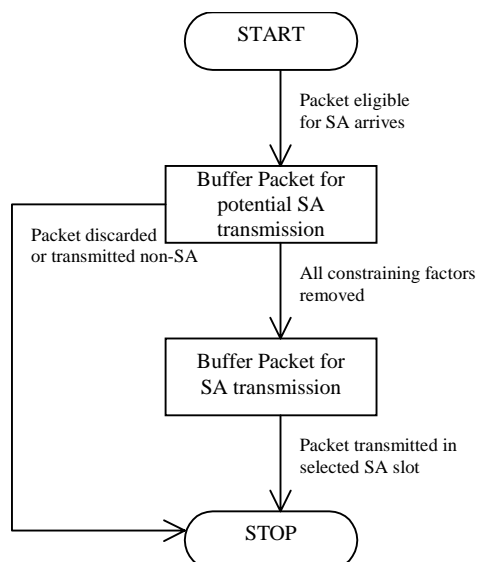

Figure 6.2: Slotted Aloha "Feeder" mechanism

6.3.5.2.4 Mapping transmission probability to potential SA transmission opportunity

See clause 6.3.5.1.4. The SA slot selection algorithm depends on a transmission probability, P_{SA} . P_{SA} will always belong to the set $\{2^{-n}, n \in I, n \geq 0\}$ and has the meaning given in table 6.7. "SA" in table 6.7 refers to either of the SA types.

6.3.5.2.5 Channel selection

In the event that multiple channels of an SA channel type are offered to the ST, the ST shall randomly choose one channel out of the set of possible channels on which to transmit a packet that is being buffered for SA transmission. The random choosing of a channel must take place, at the least, every time there is a change to the set of possible channels.

6.3.5.2.6 Slot selection

The selection of potential SA transmission opportunities given a transmission probability was presented above in clause 6.3.5.1.4. This clause will give the algorithm by which the slotted-Aloha transmission probability, P_{SA} , is determined for data only, control only and data/control SA channel types. P_{SA} is a function of two other variables, P_c and P_d , and is given by $P_{SA} = \min(P_c, P_d)$. P_c and P_d belonging to the ordered set $\{P_{max}, P_{max}/2, P_{max}/4 \dots P_{min}\}$ when operating in normal mode. When operating in fallback mode however, P_{SA} is given by $P_{SA} = \min[1, 4 \times \min(P_c, P_d)]$. P_{max} is a configurable parameter belonging to the set $\{2^{-n}, n \in \{0, 1, \dots, 5\}\}$. P_{min} is a configurable parameter belonging to the set $\{2^{-n}, n \in \{5, 6, \dots, 12\}\}$.

P_c controls the SA transmission probability for a given ST based on the past the history of the SA used by that ST. The ST maintains a single value, P_c ; per SA channel type without respect to which an SA channel of an SA channel type is used during that history:

- The initial value of P_c is P_{max} .
- P_c can be modified, at most, one time per uplink frame.
- For every SA uplink frame transmission failure, the ST must halve P_c within 96 ms, subject to the P_{min} limit. In this context, "SA frame transmission failure" means that at least one SA packet that was transmitted in a frame resulted in a Reed-Solomon fail.

- For every SA frame transmission success, the ST may double P_c , subject to the P_{max} limit. In this context, "SA frame transmission success" means that every SA packet that was transmitted in a frame resulted in a Reed-Solomon pass.
- For every $\max[6, 1/(32 \times P_c)]$ frame that passes without a modification to P_c , the P_c may double P_c , subject to the P_{max} limit.

NOTE: The failure/success is detected with the arrival of the ULPC status message at most 6 uplink frames later. In the time period between making a transmission and getting the result, the value of P_c is unchanged except by other ULPC frames based on previous transmissions. The ST can make multiple transmissions per uplink frame; each transmission will be governed by the same value of P_c .

P_d controls the SA transmission probability for a given ST based on a average loading of the SA. The ST maintains a single value of P_d per SA channel type without respect to the history of which channel per SA type the ST tracks over time:

- The loading for a given frame, j , is measured as the number of slots in that frame that have successful transmissions in them: $L_{j=n_success}$ (hence L_j assumes integer values from 0 through 32, except when operating in fallback mode on a 128 kbps channel in which case its range varies from 0 through 8).
- The average loading for a given channel type at any given frame T is given by: $L_c = (L_c^{old} + L_0)/2$ where L_c^{old} is the average loading calculated last time, and L_0 is the measured loading of the most recent uplink frame for which ULPC status information was received by the ST.
- When operating in fallback mode on a 128 kbps channel, the measured loading of the most recent uplink frame is scaled up by a factor of 4, before being used in the formula given above for computing L_c .
- At initialization, when L_c^{old} is unknown, it shall be set to zero in the computation of L_c .
- The function $P_d(L_c)$ is defined as follows when the contention channel in use is a 512 kbps channel, for $0 \leq L_c \leq 32$:

$$P_d(0 \leq L_c \leq 7) = P_{max};$$

$$P_d(7 < L_c \leq 11) = 1/32;$$

$$P_d(11 < L_c \leq 32) = P_{min}.$$

For supervisory SA channel type, value of P_{SA} is fixed at 1/32 and is not changed irrespective of frame transmission success, failure or channel loading.

6.3.5.3 Persistent Aloha channel access procedure

6.3.5.3.1 Introduction

The PA access protocol differs from SA in that successful transmission by an ST on a PA channel causes the same slot number, on the same PA channel, to be reserved for the ST in subsequent uplink frames. PA-1spnf reserves the same slot N_{ulpc} UL frames later, for this same ST. N_{ulpc} is a systemwide configurable parameter. Unlike SA, there is no supervisory PA channel type. Whereas the SA protocol was designed for rapid transmission of packets of infrequent, random, uncorrelated arrival, PA was designed for capacity-efficient transmission of infrequent but periodic arrival of packets such as TCP ACKs or PBP ACKs. PA-1spf is a separate, although similar, PA protocol. While much of the PA-1spnf protocol applies to PA-1spf if the differences are described in clause 6.3.5.4.

NOTE: The variable N_{ulpc} defines the number of frames, following a successful transmission on a certain slot of a PA-1spnf channel, after which the same slot on the same channel is reserved for the same ST. The value of N_{ulpc} will normally be set longer than the round trip time; thus, the value of N_{ulpc} should allow an ST to learn the status of an earlier transmission on the PA-1spnf channel before the next transmission opportunity occurs (i.e. before the potentially reserved PA-1spnf slot occurs).

By way of introduction, it should be noted that PA-1spnf is used principally to service packets in the Ack-Return UDTS queue only. It is possible, however, for excess (unused) PA-1spnf PTOs to be used for servicing other user data packets and internal packets. It is also possible for some internal packets to pre-empt PA-1spnf PTOs. Frequently there may be conditions under which the PA-1spnf channel may become unavailable. An example is when it is impossible for the ST to tune to the PA-1spnf contention channel because of other allocations. Whenever PA-1spnf is deemed unavailable, the Ack-Return queue is serviced as another LVLL queue. The exact situations that lead to PA-1spnf being marked unavailable are given later.

6.3.5.3.2 State machine

The following definitions are needed to properly interpret the PA-1spnf State Machine.

Term	Meaning
Packet	A single RSM-A packet, or a packet couplet that is to be transmitted in a single code block
Unreserved PA-1spnf slot	A PA-1spnf slot that is not reserved for any particular ST but rather is available to all STs in an UL cell on a contention basis. In particular: slot x of frame y on PA-1spnf channel z, where it can be positively identified through a ULPC message that there was NOT a successful transmission in slot x of frame y-N_ulpc on channel z.
free PA slot	A PA-1spnf slot that is both unreserved and does not conflict with a BoD rate/volume allocation
PACTO	"PA-1spnf contention transmission opportunity - An UL slot, chosen randomly from the set of free PA-1spnf slots, which the ST may use to transmit a packet in contention with other STs in the UL cell.
seized slot	A PA slot that is reserved for an ST's use due to successful transmission in that slot N-ulpc frames previously. More precisely: slot x of frame y on PA-1spnf channel z, where (a) the ST transmitted a packet on slot x of frame y-N_ulpc on channel z and (b) received confirmation from an ULPC message, prior to the start of frame y, that the transmission in frame y-N_ulpc was successful.
buffered for PA-1spnf transmission	The packet in question is to be transmitted on the PACTO or seized slot
eligible for PA-1spnf contention	The packet in question is eligible to be transmitted on a future PACTO (see note)
buffered for potential PA-1spnf contention	Same as "eligible for PA-1spnf contention"
PA-eligible packet	Same as "packet eligible for PA-1spnf contention"
Burst data	Connectionless user data and/or control data that that is not eligible for SA transmission; bandwidth to service this data is obtained via BoD volume. This includes the portion of CRWB data serviced by BoD volume.
PA-1spnf availability evaluation	The task of performing an evaluation to determine if a PACTO may be scheduled over the upcoming PA-1spnf scheduling period. PA-1spnf availability evaluation may be periodic with the caveat that PA-1spnf evaluation must be performed at least once per uplink frame period.
PA-1spnf slot retention evaluation	The task of evaluating whether a seized PA slot may be retained or not. PA-1spnf slot retention evaluation must be performed at least once per uplink frame period.
PA-1spnf scheduling period	The time period (range of slots) over which a PACTO may be scheduled as a result of the current availability evaluation of PA-1spnf. The PA-1spnf scheduling period specifies the range of slots for which ULPC status is available, and for which it is safe to schedule a PACTO such that no conflict with a possible BoD rate/volume allocation occurs.

NOTE: The set of packets that can be transmitted in a PA-1spnf seized slot is broader than the set of packets that are eligible for PA-1spnf contention and may include non eligible packets such as NULL packets and internal packets that can pre-empt the seized PA-1spnf slot.

The protocol state machine is shown in figure 6.3.

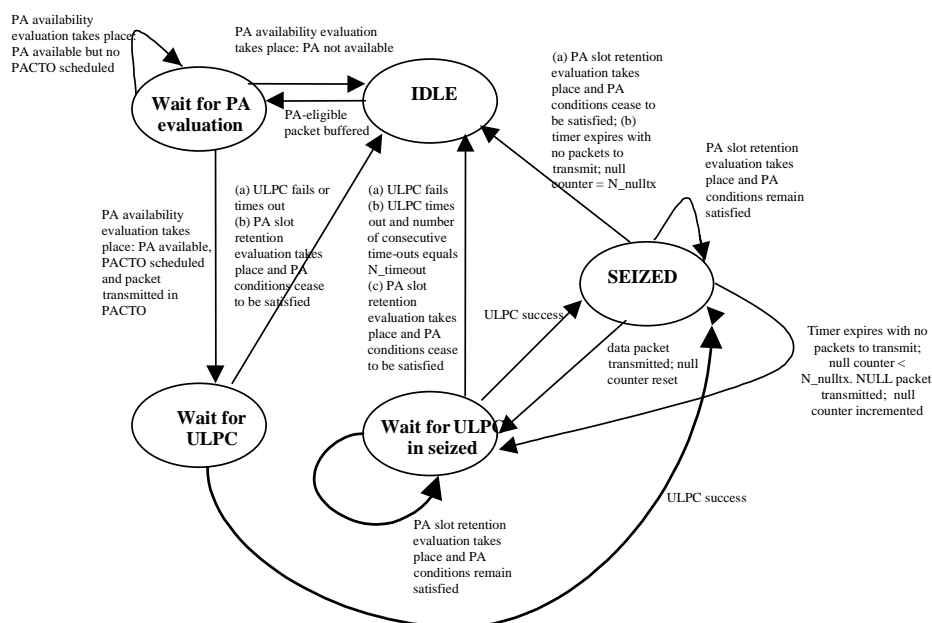

Figure 6.3: Protocol state machine for Persistent Aloha

The conditions under which the ST attempts to schedule a PA-1spnf contention transmission opportunity for a PA-1spnf -eligible packet are as follows:

- There is no burst data on queue at the ST.
- There are no outstanding BoD volume requests.
- No BoD volume slots have been allocated to the ST during the upcoming BoD cycle.
- The number of consecutive PACTO failures is less than three.
- At least one PA-1spnf channel is offered to the ST.
- The average loading, L_f (see below) of at least one PA-1spnf channel that the ST is monitoring is less than a configured parameter L_{fmax} .

An ST "schedules" a PA-1spnf Contention Transmission opportunity by selecting a range of slots (the PA-1spnf scheduling period) and executing the slot-selection algorithm to identify a slot for transmission. The slots have to be chosen out of a finite range. The range of slots may be taken across multiple evaluation periods. The range may not include any slots that may conflict with a present or future BoD rate/volume allocation. The ULPC status must be available for this range.

Each of the above conditions shall be evaluated at the time of making a PA-1spnf availability evaluation. If any of the above conditions is not satisfied, then PA-1spnf is deemed unavailable and the ST shall serve the Ack-Return queue just as another LVLL queue (i.e. using SA contention as the primary PDS), until the time of the next PA-1spnf availability evaluation.

On the other hand, if all the conditions above are met at the time of PA-1spnf availability evaluation, the ST shall attempt to schedule a PA-1spnf Contention Transmission Opportunity (PACTO) during the upcoming PA scheduling period according to rules specified in clause 6.3.5.3.4.

If, due to probabilistic or deterministic slot-selection factors (see clause 6.3.5.3.4), a PACTO cannot be scheduled during the upcoming PA-1spnf scheduling period, then no action is taken until the time of the next PA-1spnf evaluation and the rules specified above shall be applied afresh. No state is kept as to what did or did not transpire at the time of any previous PA evaluation.

If, however, a PACTO is scheduled during the upcoming PA-1spnf scheduling period, then the packet is buffered for transmission on the PACTO and shall be transmitted irrespective of the above-specified conditions at the instant of transmission.

Once the packet is transmitted on a PACTO, the ST waits to see if the transmission on the UL was indicated to be a success or a failure by the corresponding ULPC packet.

- If the ULPC packet indicates that the previous transmission failed, or if the ST does not receive and process the ULPC packet within N_{ulpc} frames of the original transmission, then the ST increments the counter for the number of successive failures and goes back to idle state.
- If the ULPC packet indicates that the previous transmission was successful, the ST goes to the "seized" state and sets the "number of successive failures" counter to 0. The ST accounts the same slot of the same channel N_{ulpc} frames after the successful transmission to be reserved for its own use. It can transmit a data packet in that slot or a NULL packet if there is no data to be sent. Not more than N_{nulltx} consecutive seized PA-1spnf slots can be filled with NULL packets. After this, the ST has to give the slot up if it has no data to transmit. The ST cannot transmit a NULL packet if there are data packets waiting to be transmitted. N_{nulltx} is an ST configurable parameter.
- The ST releases its slot by not transmitting in it. This is broadcast in the next ULPC packet corresponding to this frame, and other STs can now use this slot for initial access.
- After each transmission in a seized slot, the ST goes into a state of "waiting for ULPC in seized". This state is analogous to the "waiting for ULPC" state except that the handling of a non-receipt of ULPC packet (within N_{ulpc} frames of the original transmission), i.e. a ULPC timeout is different. In this state a ULPC timeout is not considered a failure of transmission unless the number of consecutive ULPC timeouts reaches $N_{timeout}$, where $N_{timeout}$ is a configurable parameter. After each success indication, the counter for the number of consecutive ULPC timeouts is set to zero and the ST returns to the "seized" state. The only state information that is kept from one such cycle to the next is the number of consecutive NULL-packet transmissions so as to ensure that this number does not exceed the N_{nulltx} parameter. On the other hand, if any ULPC indicated a failure or if the counter of consecutive ULPC timeouts reaches $N_{timeout}$, the ST sets the counter to zero, releases the seized slot and returns to the IDLE state. However, the "number of successive failures" counter shall not be incremented.

While in the "seized" state or the states of "Waiting for ULPC," the ST continues to ensure, at least once every frame that the following conditions continue to be satisfied:

- The PA-1spnf channel on which the ST transmitted remains in the set of PA-1spnf channels offered to the ST (i.e. via a channel information element of a MIP).
- The seized PA-1spnf slot does not conflict with a BoD rate/volume slot allocated to the ST.

These conditions constitute the PA-1spnf slot retention evaluation. If any of these conditions cease to be satisfied while waiting for pass/fail indication or while in the "seized" state, the ST goes back to the Idle state. The ST must release the seized slot at the same time.

6.3.5.3.3 Channel selection

In the event that multiple PA-1spnf channels are offered to the ST, the ST shall randomly choose at least one channel out of the set of possible channels on which to monitor ULPC messages and attempt to schedule a PACTO. When PA-1spnf is in the Idle state, then the random choosing of a channel must take place, at the least, every time there is a change to the set of possible channels. For all other states, the ST need not re-randomize as long as the channel the ST has been monitoring, or on which it is transmitting, remains in the set of PA-1spnf channels made available to the ST. In the event that a PA-1spnf channel is removed from PA-1spnf service, and an ST has either seized or is awaiting seizure of a slot on that channel, the ST shall return to the IDLE state.

Whichever PA-1spnf channel(s) the ST chooses to monitor, the ST shall continuously monitor the ULPC packets for that channel(s) while in the IDLE state; otherwise, when a PA-1spnf -eligible packet arrives at the ST, the ST would have to wait potentially several frames before successfully scheduling a PACTO.

6.3.5.3.4 Slot selection algorithm for PACTO

An ST attempts to schedule a PACTO only under the conditions outlined in clause 6.3.5.3.2. The period of time covered by the scheduling attempt is the upcoming PA-1spnf scheduling period.

In order to attempt to schedule a PACTO, the ST must first know the loading on the PA-1spnf channel(s) as determined by ULPC packets. These packets are used for two purposes in scheduling a PACTO. First, these packets are used to determine the probability of scheduling a PACTO or even if the channel is available for PA-1spnf. For this purpose, ULPC packets are evaluated on a UL-frame-by-UL-frame basis. This will be described in more detail below.

Second, ULPC packets are monitored to determine which slots of a particular PA channel are unreserved (and therefore can be used as a potential PACTO) during the upcoming PA-1spnf scheduling period.

The ST maintains the last N_{ulpc} ULPC packets successfully received by it. The ULPC information is stored associated with the frame number and the channel number to which it corresponds. It is possible that this ULPC history be discontinuous since ULPC packets may be lost or dropped. The way ULPC information is used for scheduling a PACTO is described below.

In particular, let the upcoming PA-1spnf scheduling period span slot x of UL frame M to slot y of UL frame M . Then the set of unreserved slots from which a PACTO is potentially chosen is the set of slots for which ULPC did indicate an R/S fail in the span of slot x of frame $M-N_{ulpc}$ through slot y of frame $M-N_{ulpc}$ for the channel under consideration. If R/S pass/fail cannot be discerned for any portion of this span (e.g. a ULPC packet was not received or monitored, for the channel under consideration) then the ST must exclude those slots from the potential set of unreserved slots. The set of free PA-1spnf slots is the subset of unreserved PA-1spnf slots that does not conflict with a BoD rate/volume allocation that was granted to the ST.

Once the set of free PA-1spnf slots is known and the probability, P_{PA} , of scheduling a PACTO is known (see below), then the attempt to schedule a PACTO shall take place in the following manner:

- Let X be the total number of slots in the upcoming PA-1spnf scheduling period; let z be the PA-1spnf channel on which the ST will attempt to schedule a PACTO.
- With probability $\min(1, X \times P_{PA})$ let the upcoming PA-1spnf scheduling period is chosen to contain a PACTO.
- If the upcoming PA-1spnf scheduling period was chosen to contain a PACTO and the set of free PA-1spnf slots on channel z is not NULL, then randomly choose one free PA-1spnf slot from the set of free PA slots on channel z to be the PACTO for the upcoming PA-1spnf scheduling period, else return to the "wait for PA-1spnf evaluation" state to await the next PA-1spnf evaluation time.

The PA probability, P_{PA} , is a function of two other variables, P_e and P_f , and is given by $P_{PA} = \min(P_e, P_f)$. P_e and P_f are bounded by P_{emin} and P_{emax} , the values of which are defined in table 6.7.

P_e controls the PA-1spnf transmission probability for a given ST based on past history of PA-1spnf used by that ST. The ST maintains a single value of P_e without respect to which PA-1spnf channel is used during that history. P_e is set at initialization to P_{emax} .

- If the number of consecutive failures is 0 then $P_e = P_{emax}$.
- If the number of consecutive failures is 1 or 2 then $P_e = P_{emin}$.
- If the number of consecutive failures is 3, then P_e is not applicable; the PA-1spnf conditions are not satisfied and the ST shall serve the PA-1spnf-eligible queue as an LVLL queue.
- ST shall decrement the "number of consecutive failures" counter if at least 20 frames pass without a transmission in a PACTO until that counter reaches 0.

P_f controls the PA-1spnf transmission probability for a given ST based on an average loading, L_f , of PA-1spnf. The ST maintains a single value of P_f without regard to the PA-1spnf channel that it is monitoring.

The loading for a given frame, j , is measured as the number of slots in that frame that have successful transmissions in them: $L_j = n_{\text{success}}$:

- The average loading at any given frame T is given by: $L_f = (L_f^{\text{old}} + L_0) / 2$, where L_f^{old} is the average loading calculated last time, and L_0 is the measured loading of the most recent frame for which ULPC status information was received by the ST.
- At initialization, for the purposes of channel loading computation, L_f^{old} is assumed to be zero, subject to the condition that if the resultant value is less than $0,7 \times L_{\text{fmax}}$, then L_f shall be reset to a value in the range $0,7 \times L_{\text{fmax}} \leq L_f \leq L_{\text{fmax}}$.
- The function $Pf(L_f)$ is as follows:
 - For $L_f < 0,7 \times L_{\text{fmax}}$ $Pf = Pf_{\text{max}}$;
 - For $0,7 \times L_{\text{fmax}} \leq L_f < L_{\text{fmax}}$ $Pf = Pf_{\text{min}}$;
 - For $L_f \geq L_{\text{fmax}}$ Pf is not applicable; PA-1spnf is unavailable.

6.3.5.4 Persistent Aloha channel access procedure-one slot per frame

6.3.5.4.1 Introduction

One-slot-per-frame PA-1spf is a contention access protocol that may be offered by the RSM-A system in addition to regular PA-1spnf. That is, the protocol is supported by the RSM-A system, but PA-1spf channels will be offered in a UL cell only if there is sufficient demand to warrant allocating UL bandwidth to PA-1spf. Whereas PA-1spnf was designed for capacity-efficient transmission of infrequent but periodic arrival of packets such as PBP ACKs (from spoofed TCP connection), PA-1spf was designed for capacity-efficient transmission of more frequent quasiperiodic arrival of packets such as TCP ACKs from nonspoofed TCP connections.

PA-1spf is similar to PA-1spnf in that once the first contention transmission is successful, further transmission slots are reserved for, or "seized" by, the ST by virtue of the previous successful transmission. PA-1spf differs from PA-1spnf in that once an ST seizes a slot position in a UL frame, that slot position is reserved for the ST in all subsequent frames, not just once every N_{ulpc} frames as in the PA-1spnf case, until the ST releases the slot.

PA-1spnf and PA-1spf cannot be active simultaneously in an ST. If an ST supports both the PA-1spnf and PA-1spf protocols, and data is present that is eligible to use either protocol, it is up to the discretion of the ST to determine which protocol takes precedence over the other. However, if data is present that is eligible for PA-1spf but not eligible for PA-1spnf, then, according to the conditions of clause 6.3.5.3, PA cannot be active. The reverse does not hold true (the presence of data that is PA-1spnf -eligible but is not PA-1spf-eligible does not inhibit the use of PA-1spf).

The protocol description of PA-1spf is almost identical to that of PA-1spnf. Only the differences between the two protocols are given below:

NOTE: All configurable parameters are independent between PA-1spnf and PA-1spf except for N_{ulpc} .

6.3.5.4.2 State machine

All of the state machine definitions for PA-1spf are identical to those for the PA-1spnf State Machine except for the following:

unreserved PA-1spf slot: An ST shall declare a slot x of frame y on PA-1spf channel z unreserved if and only if all slots x in frames $y - N_{\text{ulpc}}$ through $y - 1$, inclusive, are unreserved.

seized slot: A PA-1spf slot that is reserved for an ST's use due to successful transmission in that slot on a previous frame (as detailed below). More precisely, slot x of frame y on PA-1spf channel z , where, in the event that the last transmission was on a PACTO, (a) the ST transmitted a packet on slot x of frame $y-N_{ulpc}$ on channel z and (b) received confirmation from an ULPC message, prior to the start of frame y that the transmission in frame $y-N_{ulpc}$ was successful; or where, subsequent to seizing a slot, (a) the ST transmitted a packet on slot x of frame $y-1$ on channel z and (b) in the event that the ST transmitted a packet on slot x of frame $y-N_{ulpc}$, the ST received confirmation from an ULPC message, prior to the start of frame y that the transmission in frame $y-N_{ulpc}$ was successful. The ST shall not consider a slot as seized if a ULPC status message is not received for any of the preceding $N_{ulpc}-1$ frames.

eligible for PA-1spf contention: The packet in question is eligible to be transmitted on a future PACTO (note that the set of packets that can be transmitted in a PA-1spf seized slot is broader than the set of packets that are eligible for PA-1spf contention and may include non eligible packets such as NULL packets and PA-eligible and SA-eligible control or user packets that can pre-empt the seized PA-1spf slot).

The protocol state machine is shown in figure 6.3.

The conditions under which the ST attempts to schedule a PA-1spf contention transmission opportunity for a PA-1spf-eligible packet rather than make a BoD request are identical to those for PA-1spf eligibility.

Once the packet is transmitted on a PA-1spf channel PACTO, the ST shall wait to receive the R/S pass/fail indication on the corresponding ULPC packet.

- If the ULPC packet indicates that the previous transmission failed, or if the ST does not receive and process the ULPC packet within N_{ulpc_frames} of the original transmission, then the ST increments the counter for the number of successful failures and goes back to idle state.
- The ST shall monitor the ULPC messages for frame $y+1-N_{ulpc}$ through frame $y-1$. If a successful transmission was indicated for slot x of channel z of any frame in this range of frames, then the ST must go back to the IDLE state after processing the ULPC message for frame y , even if the ULPC for frame y indicated its own transmission was successful. In addition, the counter for the number of successive failures is incremented.
- If the ULPC packet indicates that the previous transmission was successful, and no successful transmissions were indicated for frame $y+1-N_{ulpc}$ through frame $y-1$, the ST goes to the "seized" state and sets the "number of successive failures" counter to 0. The ST accounts the same slot of the same channel N_{ulpc} frames after the successful PACTO transmission, and each subsequent frame thereafter, to be reserved for its own use. It can transmit a data packet in that slot or a NULL packet if there is no data to be sent. Not more than N_{1spf_nulltx} consecutive seized PA-1spf slots can be filled with NULL packets. After this, the ST has to give the slot up if it has no data to transmit. The ST cannot transmit a NULL packet if there are data packets waiting to be transmitted. N_{1spf_nulltx} is an ST configurable parameter.
- The ST releases its slot by not transmitting in it. This is broadcast in the next ULPC packet corresponding to this frame and other STs can now use this slot for initial access.
- For the first $N_{ulpc}-1$ transmissions in a seized slot, the ST remains in the seized state without transitioning to the "Wait for ULPC" state. This is due to the fact that any ULPC for frames $y+1$ through $Y-1+N_{ulpc}$ have no bearing on this ST. After each subsequent transmission in a seized slot of frame y_{new} , the ST goes back into a state of waiting for the ULPC packet of frame $y_{new}+1-N_{ulpc}$. After each success indication, the ST returns to the "seized" state. The only state information that is kept from one such cycle to the next is the number of consecutive NULL-packet transmissions so as to ensure that this number does not exceed the N_{1spf_nulltx} parameter. On the other hand, if any ULPC indicated a failure or if the ULPC packet for frame $y_{new}+1-N_{ulpc}$ is not received by the start of frame $y_{new}+1$, the ST releases the seized slot and returns to the IDLE state. However, the "number of successive failures" counter does not need to be incremented.

While in the "seized" state or the state of "Waiting for ULPC," the ST shall continue to ensure, at least once every BoD cycle, that the same conditions continue to be satisfied as per the PA-1spf protocol.

6.3.5.4.3 Channel selection

In the event that multiple PA-1spf channels are offered to the ST, the ST shall randomly choose at least one channel out of the set of possible channels on which to monitor ULPC messages and attempt to schedule a PACTO. The same rules apply as those listed for the PA-1spf protocol in clause 6.3.5.3.3.

6.3.5.4.4 Slot selection algorithm for PACTO

Except for the definition of an unreserved PA-1spf slot, the slot selection algorithm is identical to that for the PA-1spnf protocol as described in clause 6.3.5.3.4.

6.3.5.5 Variables

Table 6.7: Variables for contention channel access

Variable	Purpose	Computed/Updated
$P_{SA} / P_{PA} / P_{PA1spf}$	To control the transmission probability for a given ST in a given channel for any available slot, using SA/PA-1spnf/PA-1spf	$\min(P_c, P_d) / \min(P_e, P_f) / \min(P_b, P_g)$
P_c	To control the transmission probability for a given ST in a given SA channel for any available slot based on past history	Maintained by ST. Value is between P_{min} and P_{max} , divided by 2, for failure. Multiplied by 2 for success or for passage of time
P_e / P_b	To control the transmission probability for a given ST in a given SA/PA-1spnf / PA-1spf channel for any available slot	Maintained by ST. Value is between P_{emin}/P_{ebmin} and P_{emax}/P_{ebmax} , set to min for failure; set to max for success or for passage of time
$P_d / P_f / P_g$	To control the transmission probability for a given ST in a given SA/PA-1spnf / PA-1spf channel for any available slot based on loading	Maintained by ST. Computed as a function of a weighted moving average load, $L_d/L_f/L_g$, over the last N_{ulpc} frames
$P_{max} / P_{emax} / P_{bmax} / P_{fmax}$	To bound the maximum transmission probability for SA/PA-1spnf / PA-1spf	Configured(dynamically via System Profile MIP) / (1/32) / (1/32) / (1/32)
$P_{min} / P_{emin} / P_{bmin} / P_{fmin}$	To bound the minimum transmission probability for SA/PA-1spnf / PA-1spf	Configured(dynamically via System Profile MIP) / (1/256) / (1/256) / (1/256)
L_{fmax} / L_{gmax}	To cause a PA-1spnf / PA-1spf channel to be unavailable to an ST if the weighted average loading on that channel is too high	Configured (statically via DLL mechanism)

6.3.6 Packet filtering procedures

6.3.6.1 Packet discrimination procedure

STs shall receive all the data transmitted in the microcell to which it belongs. A ST is assigned a unique RSM-A Destination MAC Address for each virtual port and management port (within the satellite network), on which it shall be capable of receiving dedicated traffic. STs shall also be capable of receiving system multicast and user multicast information. These are identified by well-defined MGID numbers. The ST has to receive and interpret all messages which are addressed using the well defined MGIDs. For all packets, if the frame header is present, and the application ID indicates the TP diag function, then the normal delivery is overridden, and the packet is delivered instead to the TP diag function.

The ST identification field defined in clause 7.3.2 is used to identify multicast as well as unicast user data and signalling traffic to a ST.

See the figure 6.4, Packet filtering tree, for a flowchart of the discrimination procedure.

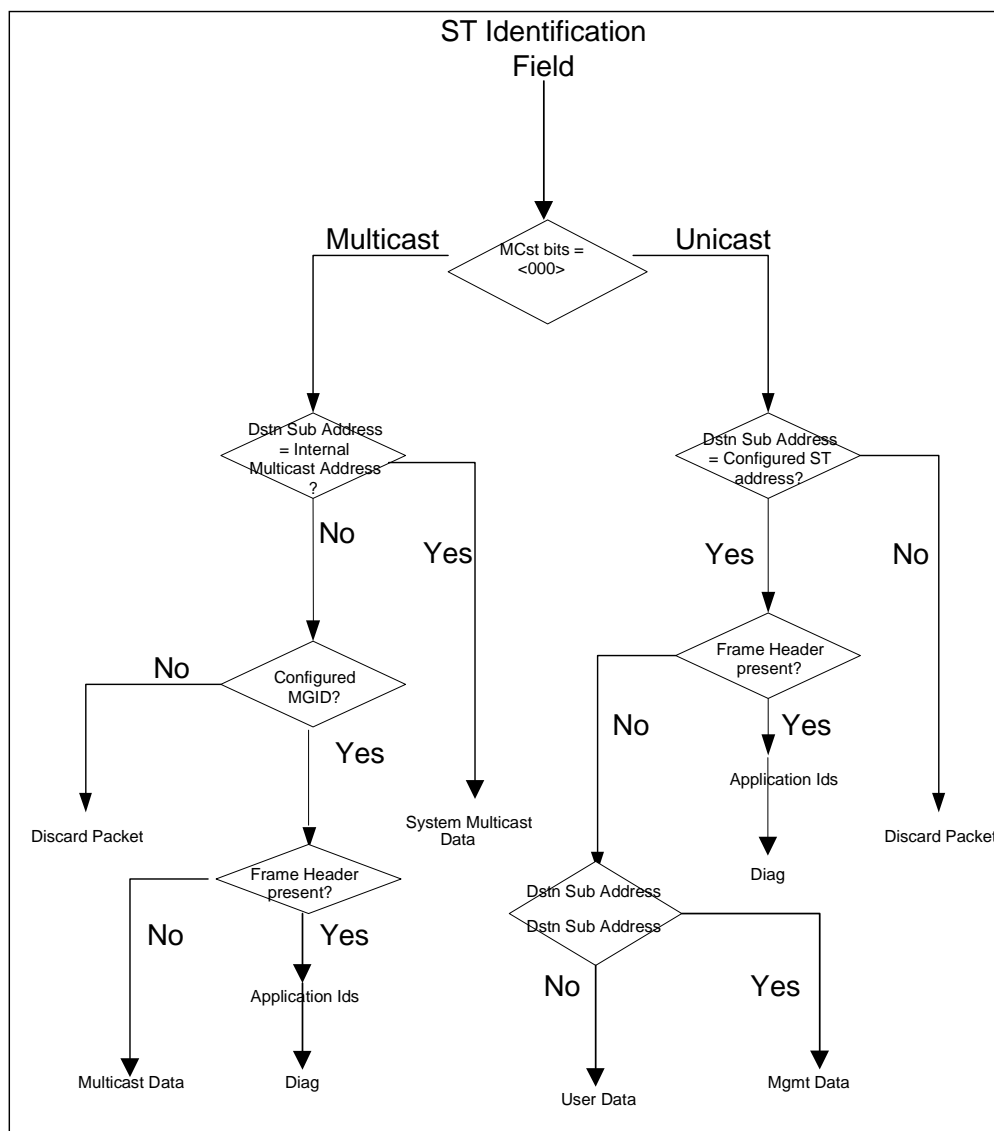

Figure 6.4: Packet filtering tree

6.3.6.1.1 Data packets

The Data packets addressed to a ST may be either user data (which may be multicast or unicast) or ST management data.

6.3.6.1.2 Signalling packets

Signalling packets, like Transmission information packet, ULPC Status packet etc are multicast in the cell and are identified by reserved Multicast Group IDs (MGID), refer to clause 7.5 for the list of all the signalling packets.

7 Message functional definition and contents

7.1 General

7.1.1 Packet order of presentation

The order of presentation or transmission of both uplink and downlink RSM-A packets by the STs is in consecutive byte number, starting with byte 0 (header) and ending with byte 107. The STs transmit order of presentation of the bits within each byte of a packet is MSB first (bit 7) and LSB last (bit 0). The packets are transmitted in order as shown by the direction of transmission in figure 7.1.

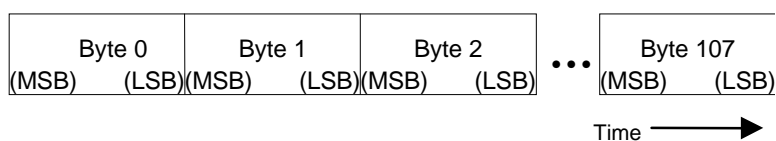

Figure 7.1: Packet byte and bit order of presentation

7.1.2 Order of bits within a field

The order of bits within a field shall be "big-endian" as illustrated in figure 7.2.

(MSB) Bit 7	Bit 6	Bit 5	Bit 4	Bit 3	Bit 2	Bit 1	(LSB) Bit 0	Byte
								N
				2^7	2^6	2^5	2^4	N+1
2^3	2^2	2^1	2^0					N+2
								N+3

Figure 7.2: Order of bits within a field

7.2 MAC block format

7.2.1 MAC downlink block format

A downlink MAC block consists of two RSM-A packets as shown in figure 7.3.

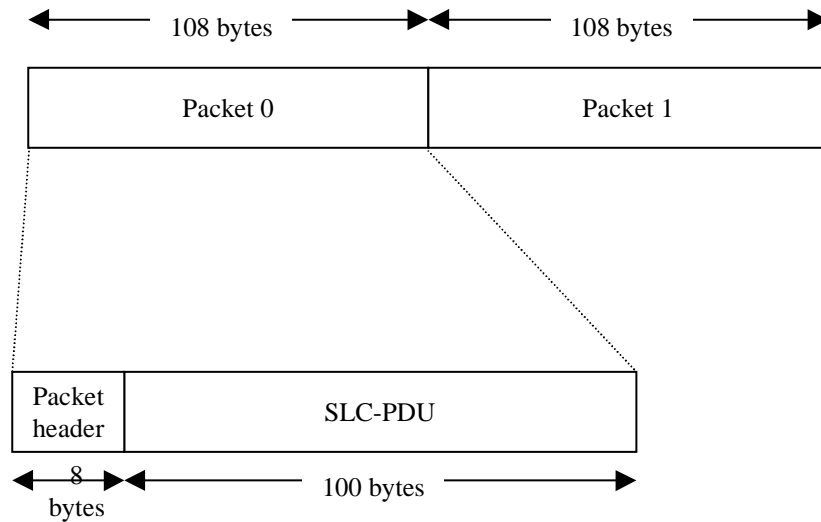

Figure 7.3: Downlink MAC block format

Each RSM-A packet consists of a MAC RSM-A packet header and an SLC-PDU. The MAC packet header is described in clause 7.3.

7.2.2 MAC uplink block format

An uplink MAC block consists of two RSM-A packets. Plus an Access Control Field (ACF).

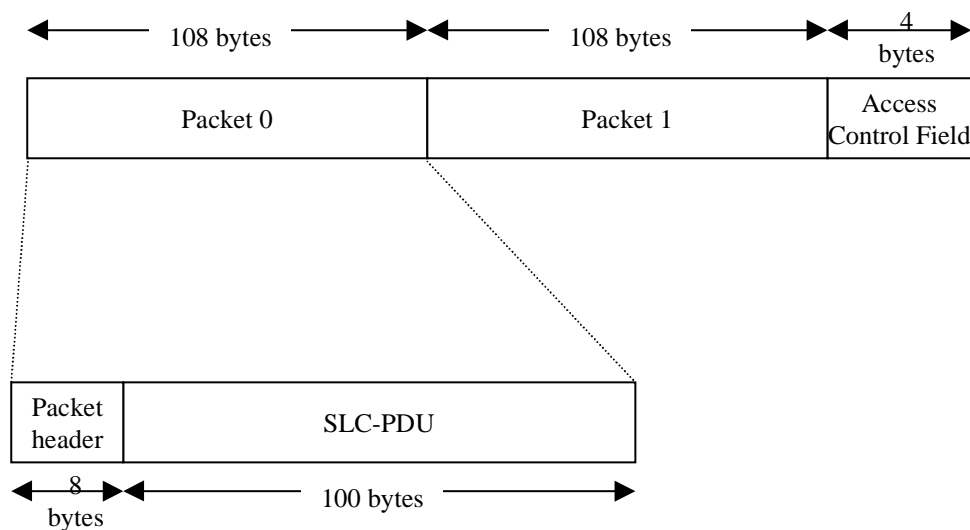

Figure 7.4: Uplink MAC block format

Each RSM-A packet consists of a MAC RSM-A packet header and an SLC-PDU. The MAC packet header is described in clause 7.3.

During block assembly, the MAC shall request an ACF from the SAM as specified in BSM RSM-A interface specification, SMAC/SLC layer, TS 102 189-3 [6].

If at the time of transmission opportunity, there is only one RSM-A packet to transmit, the ST shall complete the MAC block using a NULL packet for packet 1. The NULL packet format is described in clause 7.4.7.

7.3 Packet header format

The RSM-A packet header consists of 2 parts, the Satellite Routing Field and the ST Identification Field, as shown in figure 7.5.

(MSB) Bit 7	Bit 6	Bit 5	Bit 4	Bit 3	Bit 2	Bit 1	(LSB) Bit 0	Byte
Satellite Routing Field								0
								1
ST Identification Field								2
								...
								7

Figure 7.5: RSM-A packet header format

7.3.1 Satellite routing field

The first 2 bytes of the packet structure shown in figure 7.6. Satellite Routing Field Format is used to indicate to the satellite payload the destination where the packet is to be routed.

(MSB) Bit 7	Bit 6	Bit 5	Bit 4	Bit 3	Bit 2	Bit 1	(LSB) Bit 0	Byte
Cong	Drop Class		Dest.Type			(MSB)		0
Downlink Destination ID (LSB)								1

Figure 7.6: Satellite routing field format

The satellite payload may modify the Satellite Routing Field when it delivers ST generated packet to the downlink (either spot or shaped beams). If the Destination Type sub-field specifies Multicast Replication Group, the Payload replaces all of the Satellite Routing Field sub-fields (except the Drop Class and Dest Type sub-fields) with values configured for the specified Multicast Replication Group for each copy of the packet forwarded. Each copy of the packet contains the original Drop Class sub-fields, ST Identification field, and Data Payload fields.

7.3.1.1 Congestion bit field

On the uplink, the ST shall set this bit to "0".

On the downlink, the congestion bit is set to 1 to indicate that there is congestion in the downlink microcell for the specific polarity in which the message is being received.

Table 7.1: Congestion bit field

Link	Byte 0, Bit 7	Description
Uplink	0	Sub-field not used
Downlink	N/A	This field is ignored for all MAC messages
Downlink	0	No congestion
Downlink	1	Congestion (queue exceeds a pre-configured congestion threshold)

7.3.1.2 Drop class field

The Drop Class sub-field is set by the packet originator (e.g. STs or satellite) and used by the network. Drop class ranges from 0 to 3. "0" is the highest priority and, thus, has the least chance of being dropped by the network. All MAC messages shall use drop class "0".

Table 7.2: Drop class field values

Byte 0, Bit 6	Byte 0, Bit 5	Description
0	0	Drop class 0
0	1	Drop class 1
1	0	Drop class 2
1	1	Drop class 3

7.3.1.3 Destination type field

The Destination Type sub-field is set (table 7.3) by the STs for specifying uplink packet type, downlink transmission mode, or uplink destination. The uplink packet type option is null packet. The downlink transmission mode options are spot beam, shaped beam, or multicast. The CONUS broadcast beam is only one of the possible shaped beam patterns. The uplink destination option is the network.

The ST originated null packets and network packets are terminated by the network and do not get forwarded to downlink. The ST originated multicast replication group packets are terminated by the network and cause the creation of multiple "replicated" packets on the downlink.

The Destination Type field is set (table 7.3) by the network for network generated packets. It specifies downlink packet type or downlink transmission mode. The downlink packet type option is null packet or replicated packet, and the downlink transmission mode options are spot beam, cellcast, or shaped beam.

If an ST receives a packet with destination type subfield binary value of 00 or 11 then the ST shall drop the packet.

Table 7.3: Destination type field values

Byte 0, Bit 4	Byte 0, Bit 3	ST originated packet description	Network originated packet description
0	0	Null Packet	Null Packet
0	1	Spot or Shaped Beam	Spot, Cellcast, or Shaped Beam
1	0	Multicast Replication Group	Replicated by the Network
1	1	Network	Not Used

7.3.1.4 Downlink destination ID field

The interpretation of the Downlink Destination ID field is conditioned on the value of the Destination Type field. Refer also to TS 102 188-6 [4].

If the destination type field is "00" then the downlink destination ID is encoded as all zeros.

If the Destination Type field is encoded as "01", then the Downlink Destination ID field shall be as defined in TS 102 188-6 [4].

The ST shall filter, based upon downlink destination IDs the ST is configured to accept, all received packets bearing a destination type sub-field specifying either "spot/cellcast/shaped beam" or "replicated by network". The satellite shall discard any packet received with both a destination type sub-field specifying "spot/cellcast/shaped beam" and a cell number sub-field specifying a reserved value.

Figure 7.7: Void

Table 7.4: Void

On the uplink, if the Destination Type field is encoded as "10", the Downlink Destination ID field specifies the Multicast Replication Group Number (0 to 511) that the network uses to replicate the packet. All other values are reserved.

On the downlink, if the Destination Type field is encoded as "10", then the Downlink Destination ID field is as defined in TS 102 188-6 [4].

If the Destination Type field is encoded as "11", the network consumes the packet. The packet type is further defined by the Downlink Destination ID fields as shown in table 7.5.

Table 7.5: Cell number field values

Cell Number Sub-field	Description
0	NOCC to network signalling (not used by STs)
512	Bandwidth request message from ST to network
All other values	Reserved

7.3.2 ST Identification field

Bytes 2 through 7 of the packet structure contain terminal address information as shown in figure 7.8.

(MSB) Bit 7	Bit 6	Bit 5	Bit 4	Bit 3	Bit 2	Bit 1	(LSB) Bit 0	Byte
								2
Destination Sub-Address								3
					Aloha	SLC mode		4
								5
Source ID								6
								7

Figure 7.8: ST Identification field format

7.3.2.1 Destination Sub-Address field

If the three high-order bits of the Destination Sub-Address field (the Mcst sub-field) are zero, the remaining 18 bits of the Destination Sub-Address field represent a Multicast Group Number. Otherwise, the Destination Sub-Address is the address of an ST, an ST port or the network. The Destination Sub-Address of an ST or an ST port is only unique within a specific downlink microcell and its polarization.

The Multicast Group Number is unique system-wide. Table 7.6 shows the Multicast Group Number assignments. The first 39 332 values are reserved for internal system use. The NCC dynamically assigns and releases the remaining group numbers as requested for user multicasts. Note that user multicasts may use the network's multicast replication, shaped beam, both, or neither.

Table 7.6: Multicast group number assignments

Multicast group number	Description
0 to 127	Internal system use for Transmission Information packet messages (see note)
128 to 255	Internal system use for ULPC Status messages (see note)
256 to 383	Internal system use for Uplink Indirect Management Information packet messages (see note)
384 to 511	Internal system use for Bandwidth Assignment messages (see note)
512 to 639	Internal system use for Dynamic Contention channel assignment messages (see note)
640 to 767	Internal system use for negative acknowledgement messages (see note)
768	Reserved for Internal system use
769	Internal system use for NCC Services
769	Internal system use for NCC Routing
769	Internal system use for ST State
769	Internal system use for BC Congestion
769	Internal system use for BOD/HVUL Region Mapping
769	Internal system use for DAMR Information
769	Internal system use for System Profile
769	Internal system use for ST Registration
769	Internal system use for Channel Information
769	Internal system use for DPC
769	Internal system use for DLL Announcement
769	General Use (all other purposes addressed to all STs without advance configuration)
770	Internal system use for Registration Traffic
771 to 920	Internal system use for DLL Range (Configuration and Operational Software DLL)
921	Internal system use for HVUL
922	Internal system use for PIM-SIM
923	Internal system use for Congestion Testing
924 to 1023	System Reserve (Spare)
1 024 to 1055	Internal system use for SSTs (Management and DPC)
1 056 to 8 000	Internal system use for NSP/BBS ST Management
8 001	Internal system use for Commissioning software DLL
8 002	Internal system use for Shaped Beam Availability test
8 003	Internal system use for Over the Air IDU Replacement
8 004 to 39 332	System Reserve (Spare)
39 333	Dynamically assigned to users
...	Dynamically assigned to users
2 ¹⁸ to 1	Dynamically assigned to users
NOTE:	The ST shall filter these MGIDs with the cellcast/microcast logic specified below.

For multicast group numbers from 0 to 767 the lower 7-bits of the multicast group number can be used to signify which of the microcells per uplink cell are sent system information packets in cellcast or microcast modes. A value of X=0 signifies that the system information packet is sent in cellcast mode only. A value of X=1 signifies that the system information packet is sent in microcast mode.

Microcell #7 (center microcell) shall never use cellcast and microcast at the same time, only one or the other. For microcells #1 to #6, more than one microcell may use microcast packets at the same time. The microcell numbering is defined in BSM RSM-A TS 102 188-1 [1].

The lower 7-bits in of the multicast group number in packet header bytes 2 to 4 have the following meaning:

- 1 1 1 1 1 1 1 = All STs must process microcast system information packets.
- XXXXXX1 = Microcell #1 STs must process microcast system information packets.
- XXXXX1X = Microcell #2 STs must process microcast system information packets.
- XXXX1XX = Microcell #3 STs must process microcast system information packets.
- XXX1XXX = Microcell #4 STs must process microcast system information packets.
- XX1XXXX = Microcell #5 STs must process microcast system information packets.
- X1XXXXX = Microcell #6 STs must process microcast system information packets.
- 1XXXXXX = Microcell #7 STs must process microcast system information packets.
- 0 0 0 0 0 0 0 = Microcell #0 or all STs within the uplink cell must process cellcast system information packets.
- XXXXXX0 = Microcell #1 STs must process cellcast system information packets.
- XXXXX0X = Microcell #2 STs must process cellcast system information packets.
- XXXX0XX = Microcell #3 STs must process cellcast system information packets.
- XXX0XXX = Microcell #4 STs must process cellcast system information packets.
- XX0XXXX = Microcell #5 STs must process cellcast system information packets.
- X0XXXXX = Microcell #6 STs must process cellcast system information packets.
- 0XXXXXX = Microcell #7 STs must process cellcast system information packets.

7.3.2.2 Aloha field

The Aloha field is a bit that indicates whether the uplink packet is being sent in an Aloha (contention) slot ("1") or in an assigned rate/volume slot ("0") according to table 7.7. This bit is only defined in the uplink. This bit is "do not care" in the downlink and should be left in its uplink state or set to zero for packets generated by the network. The exception is that for uplink and downlink null packets, the Aloha bit is set to "1".

Table 7.7: Aloha field

Link	Byte 4, Bit 2	Description
Uplink	0	Rate or volume channel
	1	Contention channel
Downlink	1	Null packets
	X	ST originated packets
	0	Network originated packets
	1	Null packet

7.3.2.3 SLC mode field

The SLC mode field is a 2-bit field that indicates the SLC mode (see table 7.8).

If an ST receives a packet with an SLC mode field set to a mode which it does not support then it shall drop the packet.

Table 7.8: SLC mode field values

Bit	Description
00	Transparent
01	SLC header present - unacknowledged mode
10	Reserved for Network
11	spare

7.3.2.4 Source ID field

The Source ID field always identifies the sending ST or network (table 7.9) uniquely systemwide. Note that the Source ID is a "flat" identifier that does not correspond to the address that would be used to send a data packet to this ST. The purpose of the Source ID is to authoritatively identify the sending entity for billing and monitoring purposes. However, a receiving ST may use this field to identify the source for the purpose of associating the incoming packet with a current Segmentation and Reassembly (SAR), compression, or ST-to-ST link protocol state.

Table 7.9: Reserved source ID values

ID (hex)	Description
000000 to 00003F	Reserved for network
000040	Reserved for registration messages
1FFFF0	Reserved for transmission information packet and ULPC status messages
1FFFF0 to 1FFFFF	Reserved for satellite sourced messages

7.4 SLC packet data unit format

The ST shall build 100 byte SLC-PDUs as per clause 5.

7.4.1 SLC unack mode header format

The SLC in unacked mode uses four different header formats for data transmission. The header format used for transmission depends on the length of the data packet and the packet type being transmitted. Each header format is described below. A data packet that meets the segmentation criteria is fragmented. Segmentation Criteria are defined in clause 5.6.

The four packet types are:

- unfragmented (Whole) data packet;
- first segment of fragmented data packet;
- middle segment of fragmented data packet;
- last segment fragmented data of packet.

An ST shall only include SLC extension headers, frame headers and security headers on unfragmented data packets and first segment of fragmented data packet.

7.4.1.1 Header for unfragmented (whole) data packet

The header for unfragmented data packet (figure 7.9) consists of the following fields.

(MSB) Bit 7	Bit 6	Bit 5	Bit 4	Bit 3	Bit 2	Bit 1	(LSB) Bit 0	Byte
Session Number						First	Last	0
Packet Sequence Number								1
Cmp	Frm	Sec	CRC Type		Spare		E	2
Bytes in Last Segment								3

Figure 7.9: Header for unfragmented packet

7.4.1.2 Header for first segment data packet

The header for first segment of data packet consists of the following fields.

(MSB) Bit 7	Bit 6	Bit 5	Bit 4	Bit 3	Bit 2	Bit 1	(LSB) Bit 0	Byte
Session Number						First	Last	0
Packet Sequence Number								1
Cmp	Frm	Sec	CRC Type		Spare		E	2

Figure 7.10: Header for first segment data packet

7.4.1.3 Header for middle segment data packet

The header for middle segment data packet consists of the following fields.

(MSB) Bit 7	Bit 6	Bit 5	Bit 4	Bit 3	Bit 2	Bit 1	(LSB) Bit 0	Byte
Session Number						First	Last	0
Packet Sequence Number								1

Figure 7.11: Header "middle" segment

The Sending ST uses this packet type when sending the middle segment of a fragmented user data packet to the Receiving ST.

7.4.1.4 Header for last segment data packet

The header for last segment data packet consists of the following fields.

(MSB) Bit 7	Bit 6	Bit 5	Bit 4	Bit 3	Bit 2	Bit 1	(LSB) Bit 0	Byte
Session Number						First	Last	0
Packet Sequence Number								1
Bytes in Last Segment								2

Figure 7.12: Header last segment

7.4.2 SLC ack mode header format

Void

7.4.3 SLC header field definitions

7.4.3.1 Session number field

The Session Number field contains the session number of the SAR session assigned by the Transmitting ST when a session is created. The ST initiating the packet shall set the session number.

7.4.3.2 First and last bits fields

The First bit field specifies whether this packet is the first segment of a fragmented data packet. The Last bit field specifies whether this packet is the last segment of a fragmented data packet.

For the following packet types, the First and Last bits are set as follows.

Table 7.10: SLC-unacknowledged mode data packet types

Data packet type	First bit value	Last bit value
Unfragmented	1	1
First segment of fragmented data packet	1	0
Any middle segment of fragmented data packet	0	0
Last segment of fragmented data packet	0	1

7.4.3.3 Packet sequence number field

The Packet Sequence Number field is an 8-bit field, which specifies the sequence number of the SAR data packet.

7.4.3.4 Cmp field

The Cmp bit field specifies whether or not the SAR data is compressed.

The Cmp bit field is set as follows:

- Cmp bit field is set to "1" indicating this packet is compressed.
- Cmp bit field is set to "0" indicating this packet is not compressed.

7.4.3.5 Frm field

The Frm bit field specifies whether or not there is a frame header present following the SLC header.

The frame header is an application specific header, which might be used to provide additional information.

The Frm bit field is set as follows:

- Frm bit field is set to "1" indicating this packet has a frame header present.
- Frm bit field is set to "0" indicating this packet has no frame header present.

7.4.3.6 Sec field

The Sec bit field specifies whether there is a Security header present in the first segment of a fragmented data packet.

The Sec bit field is set as follows:

- Sec bit field is set to "1" indicating this packet has a security header present.
- Sec bit field is set to "0" indicating this packet has no security header present.

7.4.3.7 CRC type field

The CRC Type field specifies whether or not there is a CRC field present appended to the end of the data field and its size.

Table 7.11: CRC type field encoding

CRC type	interpretation
0	No CRC appended
1	16 bit CRC appended
2	32 bit CRC appended
3	64 bit CRC appended

7.4.3.8 Bytes in last segment field

The Bytes in Last Segment field specifies the number of bytes in the Data field, padding bytes if any included by the security header of this packet, and all headers present and the CRC field. It should be interpreted as a positive integer format.

7.4.3.9 E bit field

The E bit, if set, indicates the presence of the SLC extension header.

The E bit subfield is set as follows:

- E bit subfield is set to "1" indicating this packet has an SLC extension header present.
- E bit subfield is set to "0" indicating this packet has no SLC extension header present.

7.4.4 SLC extension header format

The SLC extension header format is shown in figure 7.13.

(MSB) Bit 7	Bit 6	Bit 5	Bit 4	Bit 3	Bit 2	Bit 1	(LSB) Bit 0	Byte
Length of Extension Header (conditional) = N								4
Type of Extension Header (conditional)								5
Value part of extension header (optional)								6...N +3

Figure 7.13: SLC extension header format

7.4.4.1 Extension header length field

This field indicates the length of the extension header, including the current octet in octets. It is to be interpreted as an integer in unsigned format.

7.4.4.2 Extension header type

The extension header type is an 8 bit value, which indicates the type of extension header.

Table 7.12: Extension header type subfield values

extension header type value	extension header type
0x01	Destination MAC Address of sender
all other values	reserved

7.4.4.3 Extension header value

The extension header value is an optional variable length field. It shall be padded out to the length as indicated in the length field. The presence or absence of this field shall be deduced from the type. If the type is set to 0x01, the contents shall be taken as the Destination MAC Address of the sender, starting from the highest order bytes. The total length of the header value shall be four.

An ST shall be able to read the E-bit subfield and if set to "1", read the extension header length subfield. An ST may not be able to read the extension header type or value, but shall be able to read any data field or CRC field present in the packet following the extension header value.

7.4.5 Frame header format

The frame header format is shown in figure 7.14.

(MSB) Bit 7	Bit 6	Bit 5	Bit 4	Bit 3	Bit 2	Bit 1	(LSB) Bit 0	Byte
Frame Header Value (8 bits)								0

Figure 7.14: Frame header

The frame header allows for conducting tests and for sending non-standard protocols in the future.

If an ST receives a packet with frame header value set to a reserved value or a value not recognized by the ST, then the ST shall ignore the frame header.

Table 7.13: Frame header value

Frame Header Value	Description
00000110	Diagnostic test controller satellite delay test (clause 5.8.4)
00000111	Diagnostic test controller SLC peer-to-peer delay test (clause 5.8.3)
All other values	Reserved

7.4.6 Security header format

The security header is shown in figure 7.15.

(MSB) Bit 7	Bit 6	Bit 5	Bit 4	Bit 3	Bit 2	Bit 1	(LSB) Bit 0	Byte
A/B	Pad Count (2 to 0)			Initial Vector (27 to 24)				0
Initial Vector (23 to 16)								1
Initial Vector (15 to 8)								2
Initial Vector (7 to 0)								3

Figure 7.15: Security header

7.4.6.1 A/B field

Refer to the BSM RSM-A, TS 102 189-3 [6] for details.

7.4.6.2 Pad count field

The pad count subfield identifies the number of padding bytes that were added to the user data to pad to 64-bit boundary.

7.4.6.3 Initial vector field

The initial vector subfield is a number generated at the source ST so that the encryption algorithm generates different bits even when the real data is identical, making it much more difficult for anyone to break the encryption mechanism. Refer to BSM RSM-A, TS 102 189-3 [6] for details.

7.4.7 Null packet format

The STs shall transmit null uplink RSM-A packets, shown in figure 7.16, to the satellite whenever necessary to fill a MAC block. The ST shall transmit null packets as required for synchronization probes, and uplink power control calibration probes. The ST shall always transmit a "0" for byte 0, bit 7. The network may transmit either a "0" or a "1" for byte 0, bit 7.

(MSB) Bit 7	Bit 6	Bit 5	Bit 4	Bit 3	Bit 2	Bit 1	(LSB) Bit 0	Packet Byte #
0 or 1	1	1	0	0	1	1	0	0
0	1	0	0	1	1	1	1	1
1	0	0	1	0	1	1	1	2
0	0	0	1	0	1	0	1	3
1	1	0	0	1	1	0	0	4
1	1	0	0	1	1	0	1	5
0	0	0	1	1	0	1	0	6
1	1	1	0	1	1	0	0	7
0	0	0	0	0	0	0	0	8
all "0"s								9
•••								•••
0	0	0	0	0	0	0	0	107

Figure 7.16: Null packet format prior to scrambling

7.5 MAC/SLC message types

Table 7.14 lists the MAC/SLC message types, and their direction, i.e., from ST to network or from network to ST. Transmission information packet, uplink power control status, bandwidth request, network information packet and indirect MIP messages are all MAC message types where the Destination MAC Address identifies the message type. See clause 7.3.2.1. The SLC Test message is an SLC message type where the Destination MAC Address identifies a multicast group or a specific terminal and the required frame header identifies the message type. See clause 7.4.5. Unrecognized messages shall be ignored upon receipt.

Table 7.14: MAC/SLC message types

Message type	Description	Direction	Reference Location
Transmission Information Packet (TIP) message	Contains information on downlink power control, satellite ephemeris, and dedicated contention channels.	Nwk -> ST	Clause 7.5.2
Uplink Power Control Status message	Contains information on uplink power control needed for the uplink power control algorithm.	Nwk -> ST	Clause 7.5.3
Bandwidth Request message	Used by the ST to request uplink volume or rate bandwidth resources.	ST ->Nwk	Clause 7.5.4
Network Information Packet messages (NIP)	Bandwidth assignment message.	Nwk -> ST	Clause 7.5.5
	Negative acknowledgements message.	Nwk -> ST	Clause 7.5.6
	Dynamic contention channel assignments message.	Nwk -> ST	Clause 7.5.7
	Sent by one ST to another to inject test data over link.	ST -> ST	Clause 7.5.9
SLC Test message	This set of messages contains fields that contain information needed by STs for accessing the network or accessing management functions. The open architecture of this message supports many information types in various orderings based on the current need for sending information to STs. Examples include the IP address of the NCC servers (including the Registration server), the ST addresses of the SSTs serving the NCC servers, and the interim addresses to be used by STs before they are registered. The MIP packets are classified as indirect MIP and direct MIP packet. The satellite multicasts indirect MIP at regular interval of time until stopped by NCC. The direct MIP is sent directly to the intended ST transparently through payload just like a normal RSM-A packet.	Nwk -> ST	
Management Information Packet (MIP) messages			

7.5.1 Common field definitions

7.5.1.1 Spare fields

All spare fields shall be encoded as all zeros unless otherwise specified. Spare fields in received messages shall be ignored.

7.5.1.2 Carrier mode field

The carrier mode field indicates the uplink carrier mode as shown in table 7.15.

Table 7.15: Carrier mode bit assignment

Bit 7	Bit 6	Carrier mode
0	0	128 kbps
0	1	512 kbps
1	0	2 Mbps
1	1	16 Mbps

All fields shall use binary coding unless otherwise stated.

7.5.1.3 Rate

The Rate field represents the least significant bit of the carrier mode where 0 indicates 128 kbps and 1 indicates 512 kbps.

7.5.1.4 D/C field

The D/C field indicates the data/control mode for the contention channel where "00" represents "Control or Data", and "11" represents "Supervisory". The other two values are reserved. An ST shall not use contention channels, for which the D/C field value is "01" or "10".

Contention channels with the data/control mode of "control or data" may have a rate of 128 kbps or 512 kbps. Contention channels with the data/control mode of "Supervisory" shall have a rate of 512 kbps. An ST shall ignore any contention channel assignment which has a rate which is not in accordance with these rules.

7.5.1.5 Sub band designator

The sub band designator field is a 4-bit field. The values shall be as defined in BSM RSM-A TS 102 188-5 [3].

7.5.1.6 Carrier designator

The carrier designator field is a 7-bit field. The values shall be as defined in BSM RSM-A TS 102 188-5 [3].

7.5.1.7 Channel Group ID

The channel group ID is a 15 bit number identifying the channel group. All STs belong to channel group ID "000000000000000" and shall be able to access all contention channel which as so designated.

7.5.1.8 Bandwidth Control ST ID

The Bandwidth Control ST ID (BCSTID) is a 21-bit field. See clause 4.2.5.

7.5.1.9 A/B key

If this field is set to 0 use Key A, and if it is set to 1 the Key B is used. The ST obtains this information from the NCC when the BR session key is provided/updated.

7.5.1.10 Bandwidth control message common fields

The bandwidth control messages have five common fields as shown in table 7.16.

Table 7.16: Bandwidth control message common field format

Byte/bit	bit 7	bit 6	bit 5	bit 4	bit 3	bit 2	Bit 1	bit 0
8	message Type (2 bits)		IF Ver	Number of assignments/acknowledgements/spare (5 bits)				
9	Uplink Frame number (8 bits)							
10	number of contention channels/Spare (5 bits)					Spare (3 bits)		

7.5.1.10.1 Message type

This 2-bit field identifies one of the four different types of bandwidth control messages that ST may receive from the network.

Table 7.17: Packet type

Bits 7 6	Value	Description
0 0	0	Bandwidth assignment message
0 1	1	Negative acknowledgement message
1 0	2	Dynamic contention channel assignment message
1 1	3	reserved

7.5.1.10.2 IF version

This field represents the interface version number. In the current version it is to be set to zero.

7.5.1.10.3 Number assignments/acknowledgements/spare (5 bits)

If the message type is "assignment message" this field is the number of assignments which are included in the message. The maximum number of assignments is 9 and the minimum is 1. If the message type is "acknowledgement message" then this field is the number of acknowledgements which are included in the message. The minimum number of acknowledgements is 1 and the maximum number is 16. If the message type is "contention assignment message" then this field is spare.

If ST receives a message with number of assignments/acknowledgements field set to an out-of-range value then ST shall drop this message.

7.5.1.10.4 Uplink frame number

This field indicates the frame number for which the assignments contained in the packet are valid. The ST shall not use the time slots per the new assignment for transmission prior to the frame indicated by this field. The uplink frame number uses the TOD [12, 5] format specified in BSM RSM-A TS 102 188-6 [4].

7.5.1.10.5 Number of contention channels/spare

If the message type is "Bandwidth assignment message" or "negative acknowledgement message" this field is spare. If the message type is "dynamic contention channel assignment message" then this field is the number of dynamic contention channels which are allocated by this message. This is a value between 1 and 20.

7.5.1.11 TOD check

The TOD check field is the TOD frame count of the satellite master clock at the time the message is generated by the Satellite. The TOD check uses format TOD [36, 5] as defined in BSM RSM-A TS 102 188-6 [4].

7.5.1.11.1 Uplink frame number TOD check relationship

The relationship between TOD check and uplink frame number in the same bandwidth assignment message is shown in figure 7.17. The uplink frame number is equal to $N+5$ for all assignment messages processed during BC frame N.

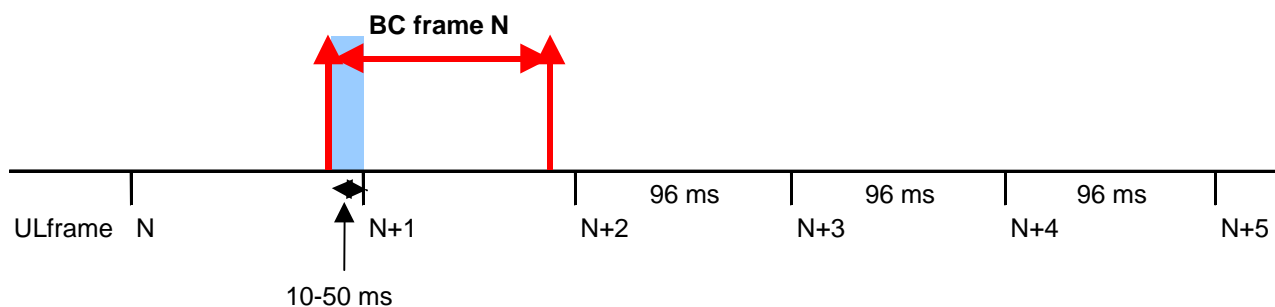

Figure 7.17: Relationship between uplink frame number and TOD check

7.5.1.12 Padding byte

Padding bytes shall be set to zero upon transmission and shall be ignored upon receipt.

7.5.2 Transmission Information Packet message

The transmission information packets are generated by the satellite and sent to STs within the entire coverage area.

The transmission information packets are sent in multicast replication mode or when weather permitting in cellcast mode.

The satellite static delay of the transmission information packet as defined with respect to the LHCP timing beacon epoch shall be less than or equal to 50 ms. This delay is computed assuming that the fast packet switch latency timeout is configured to 4 ms and excludes queuing delay.

The satellite shall send transmission information packets to downlink microcells corresponding to each uplink cell at the rate of once per superframe.

The transmission information packet format shall be as defined in figure 7.18.

Byte #	MSB bit 7	bit 6	bit 5	bit 4	bit 3	Bit2	bit 1	LSB bit 0
8	Spare	FS1	FS2	Satellite Network ID				
9	Spare			CM	TM	CP	TP	
10	Current PTP Slot number (1 Byte)							
11	Transition PTP Slot number (1 Byte)							
12	TDM Frame Transition superframe number							
13								
14								
15								
16	TDM Frame Transition D/L frame number							
17	Future Spare 1							
18								
19								
20								
21	Future Spare 2							
22								
23								
24								
25								
26								
27								
28								
29								
30								
31								
32								
33								
34								

Byte #	MSB bit 7	bit 6	bit 5	bit 4	bit 3	Bit2	bit 1	LSB bit 0
35	TOD to UTC Offset (2 bytes)							
36								
37	Absolute Superframe Count							
38								
39								
40								
41	X Range (4 bytes)							
42								
43								
44								
45	Y Range (4 bytes)							
46								
47								
48								
49	Z Range (4 bytes)							
50								
51								
52								
53	X Range Rate (4 bytes)							
54								
55								
56								
57	Y Range Rate (4 bytes)							
58								
59								
60								
61	Z Range Rate (4 bytes)							
62								
63								
64								
65	Spare (4 bits)				Nb cont (4-bits)			
66	Spare	Rate	D/C (2-bit)		Sub-band designator (4-bit)			
67	Spare	Carrier designator (7-bit)						
68	Spare							
69	Channel Group ID (15-bit)							
70	Spare	Rate	D/C (2-bit)		Sub-band designator (4-bit)			
71	Spare	Carrier designator (7-bit)						
72	Spare							
73	Channel Group ID (15-bit)							
74	Spare	Rate	D/C (2-bit)		Sub-band designator (4-bit)			
75	Spare	Carrier designator (7-bit)						
76	Spare							
77	Channel Group ID (15-bit)							
78	Spare	Rate	D/C (2-bit)		Sub-band designator (4-bit)			
79	Spare	Carrier designator (7-bit)						
80	Spare							
81	Channel Group ID (15-bit)							
82	Spare	Rate	D/C (2-bit)		Sub-band designator (4-bit)			
83	Spare	Carrier designator (7-bit)						
84	Spare							
85	Channel Group ID (15-bit)							
86	Spare	Rate	D/C (2-bit)		Sub-band designator (4-bit)			
87	Spare	Carrier designator (7-bit)						
88	Spare							
89	Channel Group ID (15-bit)							
90	Spare	Rate	D/C (2-bit)		Sub-band designator (4-bit)			
91	Spare	Carrier designator (7-bit)						
92	Spare							
93	Channel Group ID (15-bit)							

Byte #	MSB bit 7	bit 6	bit 5	bit 4	bit 3	Bit2	bit 1	LSB bit 0
94	Spare	Rate	D/C (2-bit)		Sub-band designator (4-bit)			
95	Spare	Carrier designator (7-bit)						
96	Spare	Channel Group ID (16-bit)						
97								
98	Spare							
•••								
107								

Figure 7.18: Transmission Information Packet (TIP) message format

7.5.2.1 Packet header field values

The network shall use the following values for the packet header subfields, which are used for the TIP message.

7.5.2.2 Transmission information packet message field definition

7.5.2.2.1 Satellite Network ID

The satellite network ID is a unique identifier of the RSM-A satellite network. The range of values are given by table 7.18.

Table 7.18: satellite number subfield

values	Satellite Number
00000	Reserved
00001	1
00010	2
00011	3

7.5.2.2.2 CM bit

The CM bit indicates the current broadcast mode where 0 represents 1/3 rate and 1 represents 1/4 rate.

7.5.2.2.3 TM bit

The TM bit indicates the transition broadcast mode where 0 represents 1/3 rate and 1 represents 1/4 rate.

7.5.2.2.4 CP bit

The CP bit indicates the Bandwidth control entity, to which the ST shall address bandwidth request messages, where 0 represents CC1 and 1 represents CC2.

7.5.2.2.5 TP bit

The TP bit indicates the new transition control entity where 0 represents CC1 and 1 represents CC2. If TP = CP then no transition is planned. If TP does not equal CP, then a transition from the bandwidth control computer indicated by CP to the bandwidth control computer indicated by TP is planned. An ST shall enter CC transition mode whenever TP does not equal CP.

A transition shall always take place in frame zero of a superframe and the CP and TP bits will be set equal in the TIP message in the same superframe.

7.5.2.2.6 Current PTP slot number

The current (transition) PTP slot number field is an integer value indicating the current slot number of the first PTP burst in the current frame structure. Valid numbers configurable in the satellite range from 2 to 137. However, the network shall not set the current (transition) PTP slot number field to a value higher than 134 when the current (transition) broadcast mode is 1/4 rate. If the current (transition) PTP slot number field is ever set to a value greater than 134, while the current (transition) broadcast mode is 1/4 rate, the ST shall assume the current (transition) PTP slot number is 2 until it receives a TIP with a value equal to or less than 134. See BSM RSM-A TS 102 188-6 [4] for exact value for every configuration.

7.5.2.2.7 Transition PTP slot number

The transition PTP slot number field is an integer value indicating the transition slot number of the first PTP burst in the transition frame structure. Valid numbers range from 2 to 137. See BSM RSM-A TS 102 188-6 [4] for exact value for every configuration.

7.5.2.2.8 TDM frame transition superframe number

The TDM frame transition superframe number uses format TOD[39,8] (see BSM RSM-A TS 102 188-6 [4]) and is the absolute downlink superframe count at which the TDM frame format transitions to the configuration specified by the TM (transition broadcast modulation mode) and Transition PTP slot number fields. If the value of TDM frame transition superframe number is less than or equal to the value of the current absolute superframe count then no transition is planned. If the value of TDM frame transition superframe number is greater than the value of the current absolute superframe count then a transition is planned in the downlink superframe equal to this value. At all times the terminal shall use the current values specified by the CM field and the Current PTP slot number field. The Satellite shall update the TM and Transition PTP slot number fields when a transition is planned, and shall update the CM and Current PTP slot number fields when the transition takes place.

7.5.2.2.9 TDM frame transition downlink frame number

The TDM frame transition downlink frame number field indicates the downlink frame number (0 through to 255) within the specified superframe that the TDM frame format transition will occur. This field uses format TOD [7, 0] (see BSM RSM-A TS 102 188-6 [4]). This field shall be encoded as "0000 0001".

7.5.2.2.10 Future spare 1 and protocol switch

7.5.2.2.10.1 FS1 bit spare

The FS1 bit in octet 8 is used as a protocol switch to indicate the satellite coding definition for the Future Spare 1 field. If FS1 is zero, the satellite may encode arbitrary bits into bytes 17 to 20, and the ST shall ignore this field. If FS1 is one, then the Future Spare 1 field shall have a definition to be specified in the future. An ST which supports only the basic capabilities set as defined in annex D, may ignore these bits.

7.5.2.2.10.2 Future spare 1

See FS1 bit.

7.5.2.2.11 Future spare 2 and protocol switch

7.5.2.2.11.1 FS2 bit

The FS2 bit in octet 8 is used as a protocol switch to indicate the satellite coding definition for the Future Spare 2 fields. If FS1 is zero, the satellite may encode arbitrary bits into bytes 21 to 34, and the ST shall ignore the Future Spare 2 field. If FS1 is one, then the Future Spare field shall have a definition to be specified in the future. An ST which supports only the basic capabilities set as defined in annex D may ignore these bits.

7.5.2.2.11.2 Future spare 2

See FS2 bit.

7.5.2.2.12 TOD to UTC offset

The TOD-to-UTC offset is a 16 bit number representing the offset between the satellite TOD count relative to UTC. LSB resolution is 768 ms (RSM-A superframe). MSB is a sign bit where "1" is "plus" and "0" is "minus". Refer to BSM RSM-A TS 102 188-6 [4] for usage.

7.5.2.2.13 Absolute superframe count

The Absolute superframe count is a 32 bit number representing the payload TOD with a resolution of 768 ms using the format TOD [39, 8]. See BSM RSM-A TS 102 188-6 [4].

7.5.2.2.14 Ephemeris data

This ephemeris information in the transmission information packet shall be computed relative to UTC (not TOD). (See BSM RSM-A TS 102 188-6 [4]).

Ephemeris Data fields are used to indicate the range and range rate. The 32 bit range numbers (bytes 41 through 52) are fixed point representation of the range such that the LSB is 0.1 meter. The 32 bit range rate numbers (bytes 53 through 64) are fixed point representation of the range rate such that the LSB is 1 micrometer/sec. The coordinate reference frame is WGS84 (see bibliography).

7.5.2.2.15 Nb cont

The NB cont field uses Byte 65, bits 3 through 0. The Nb cont field is the number of static contention channels which are allocated by this message. The value "0000" indicates that there is no contention channels allocated. There cannot be more than 8 contention channels allocated by this message.

7.5.2.2.16 Dedicated contention channel information

Bytes 66 through 97 are used to provide information on Nb cont contention channels. Each subfield which is used to define each channel is described in clause 7.5.1.

7.5.3 ULPC status message format

The Uplink Power Control function is used to control ST transmit power to attain the following objectives:

- Assure adequate margins against interference and atmospheric effects to meet the uplink packet loss rate and power control error objectives.
- Compensate for the ST RF imperfections such as power versus frequency variation.

The ULPC process is distributed between the satellite and STs. The STs adjust their transmit uplink power per carrier frequency based on beacon power measurements and satellite power measurement feedback of uplinked packets. Thus, the satellite is responsible for maintaining a stable beacon signal over time, and performing power and early/late measurements on uplinked packets.

In order to assist STs with adjusting transmitted uplink signal power and uplink signal timing, the satellite shall measure the received quality of uplink frames and feed back the following set of metrics via uplink power control status packets:

- Noise measurement of the noise estimation period in each uplink frame.
- Signal-to-noise measurement of each time slot in each uplink.
- Block decoder error values of the first code block of each time slot in each uplink frame.
- Early/late timing indication of the burst of each time slot in the uplink frame.

The satellite shall transmit the uplink power control status packets in cellcast mode.

The uplink power control status packets shall be formatted as defined in figure 7.19 through to figure 7.22.

There is one packet format per carrier mode.

(MSB)	bit 7	bit 6	bit 5	bit 4	bit 3	bit 2	bit 1	(LSB)	Byte #	
	Carrier Mode		sub band designator (4 bits)				carrier designator		8	
	Carrier designator (7 bits)				(MSB) Uplink Frame Number (LSB)				9	
(MSB)	Superframe Number							(LSB)	10	
(MSB)	Noise Measurement of 1st 2 Mbps bandwidth composing this 16 Mbps							(LSB)	11	
(MSB)	Noise Measurement of 2nd 2 Mbps bandwidth composing this 16 Mbps							(LSB)	12	
(MSB)	Noise Measurement of 3rd 2 Mbps bandwidth composing this 16 Mbps							(LSB)	13	
(MSB)	Noise Measurement of 4th 2 Mbps bandwidth composing this 16 Mbps							(LSB)	14	
(MSB)	Noise Measurement of 5th 2 Mbps bandwidth composing this 16 Mbps							(LSB)	15	
(MSB)	Noise Measurement of 6th 2 Mbps bandwidth composing this 16 Mbps							(LSB)	16	
(MSB)	Noise Measurement of 7th 2 Mbps bandwidth composing this 16 Mbps							(LSB)	17	
(MSB)	Noise Measurement of 8th 2 Mbps bandwidth composing this 16 Mbps							(LSB)	18	
(MSB)	SNR - TS 0							(LSB)	(MSB)	19
Decoder Metric -TS 0		(LSB)	E/L TS 0	(MSB)	SNR - TS 1					20
		(LSB)	(MSB)	Decoder Metric - TS 1	(LSB)	E/L TS 1				21
(MSB)	SNR - TS 02						(LSB)	(MSB)	22	
Decoder Metric -TS 2		(LSB)	E/L TS 2	(MSB)	SNR - TS 3					23
		(LSB)	(MSB)	Decoder Metric - TS 3	(LSB)	E/L TS 3				24
(MSB)	SNR - TS 30						(LSB)	(MSB)	64	
Decoder Metric -TS 30		(LSB)	E/L TS 30	(MSB)	SNR - TS 31					65
		(LSB)	(MSB)	Decoder Metric - TS 31	(LSB)	E/L TS 31				66
	All Zero Pattern								67	
									...	
									107	

Figure 7.19: 16 Mbps carrier mode ULPC status message format

(MSB)	bit 7	bit 6	bit 5	bit 4	bit 3	bit 2	bit 1	(LSB)	Byte #
	Carrier Mode		Sub band designator				carrier designator		8
	Carrier designator (7 bits)				(MSB) Uplink Frame Number (LSB)				9
(MSB)	Superframe Number							(LSB)	10
(MSB)	Noise Measurement of this 2 Mbps carrier							(LSB)	11
	0	0	0	0	0	0	0	0	12
	0	0	0	0	0	0	0	0	13
	0	0	0	0	0	0	0	0	14
	0	0	0	0	0	0	0	0	15
	0	0	0	0	0	0	0	0	16
	0	0	0	0	0	0	0	0	17
	0	0	0	0	0	0	0	0	18
(MSB)	SNR - TS 0						(LSB)	(MSB)	19
Decoder Metric -TS 0		(LSB)	E/L TS 0	(MSB)	SNR - TS 1				20
		(LSB)	(MSB)	Decoder Metric - TS 1	(LSB)	E/L TS 1			21
(MSB)	SNR - TS 02						(LSB)	(MSB)	22
Decoder Metric -TS 2		(LSB)	E/L TS 2	(MSB)	SNR - TS 3				23
		(LSB)	(MSB)	Decoder Metric - TS 3	(LSB)	E/L TS 3			24
(MSB)	SNR - TS 30						(LSB)	(MSB)	64
Decoder Metric -TS 30		(LSB)	E/L TS 30	(MSB)	SNR - TS 31				65
		(LSB)	(MSB)	Decoder Metric - TS 31	(LSB)	E/L TS 31			66
	All Zero Pattern								67
									...
									107

Figure 7.20: 2 Mbps carrier mode ULPC status message format

(MSB)	bit 7	bit 6	bit 5	bit 4	bit 3	bit 2	bit 1	(LSB)	bit 0	Byte #			
Carrier Mode		Sub band designator (LSB)				carrier designator					8		
Carrier designator (7 bits) (LSB)					(MSB) Uplink Frame Number (LSB)						9		
(MSB)	Superframe Number							(LSB)			10		
(MSB)	Noise Measurement over 2 Mbps bandwidth that contains this 512 kbps carrier							(LSB)			11		
(MSB)	SNR - TS 0						(LSB)	(MSB)			12	Carrier k	
Decoder Metric -TS 0		(LSB)	E/L TS 0	(MSB)	SNR - TS 1					13			
		(LSB)	(MSB)	Decoder Metric - TS 1		(LSB)	E/L TS 1			14			
(MSB)	SNR - TS 02						(LSB)	(MSB)			15		
Decoder Metric -TS 2		(LSB)	E/L TS 2	(MSB)	SNR - TS 3					16			
		(LSB)	(MSB)	Decoder Metric - TS 3		(LSB)	E/L TS 3			17			
								(LSB)	(MSB)			57	
Decoder Metric -TS 30		(LSB)	E/L TS 30	(MSB)	SNR - TS 31					58			
		(LSB)	(MSB)	Decoder Metric - TS 31		(LSB)	E/L TS 31			59			
(MSB)	SNR - TS 0						(LSB)	(MSB)			60	Carrier k+1	
Decoder Metric -TS 0		(LSB)	E/L TS 0	(MSB)	SNR - TS 1					61			
		(LSB)	(MSB)	Decoder Metric - TS 1		(LSB)	E/L TS 1			62			
(MSB)	SNR - TS 02						(LSB)	(MSB)			63		
Decoder Metric -TS 2		(LSB)	E/L TS 2	(MSB)	SNR - TS 3					64			
		(LSB)	(MSB)	Decoder Metric - TS 3		(LSB)	E/L TS 3			65			
								(LSB)	(MSB)			105	
Decoder Metric -TS 30		(LSB)	E/L TS 30	(MSB)	SNR - TS 31					106			
		(LSB)	(MSB)	Decoder Metric - TS 31		(LSB)	E/L TS 31			107			

Figure 7.21: 512 kbps carrier mode ULPC status message format

(MSB)	bit 7	bit 6	bit 5	bit 4	bit 3	bit 2	bit 1	(LSB)	bit 0	Byte #			
Carrier Mode		Sub band designator				carrier designator					8		
Carrier designator					(MSB) Uplink Frame Number (LSB)						9		
(MSB)	Superframe Number							(LSB)			10		
(MSB)	Noise Measurement over 2 Mbps bandwidth that contains this 128 kbps							(LSB)			11		
(MSB)	SNR - TS 0						(LSB)	(MSB)			12	Carrier k	
Decoder Metric -TS 0		(LSB)	E/L TS 0	(MSB)	SNR - TS 1					13			
		(LSB)	(MSB)	Decoder Metric - TS 1		(LSB)	E/L TS 1			14			
(MSB)	SNR - TS 02						(LSB)	(MSB)			15		
Decoder Metric -TS 2		(LSB)	E/L TS 2	(MSB)	SNR - TS 3					16			
		(LSB)	(MSB)	Decoder Metric - TS 3		(LSB)	E/L TS 3			17			
								(LSB)	(MSB)			21	
Decoder Metric -TS 6		(LSB)	E/L TS 6	(MSB)	SNR - TS 7					22			
		(LSB)	(MSB)	Decoder Metric - TS 7		(LSB)	E/L TS 7			23			
All Zero Pattern (shown below)										24			
										...			
										59			
(MSB)	SNR - TS 0						(LSB)	(MSB)			60	Carrier k+1	
Decoder Metric -TS 0		(LSB)	E/L TS 0	(MSB)	SNR - TS 1					61			
		(LSB)	(MSB)	Decoder Metric - TS 1		(LSB)	E/L TS 1			62			
(MSB)	SNR - TS 02						(LSB)	(MSB)			63		
Decoder Metric -TS 2		(LSB)	E/L TS 2	(MSB)	SNR - TS 3					64			
		(LSB)	(MSB)	Decoder Metric - TS 3		(LSB)	E/L TS 3			65			
								(LSB)	(MSB)			69	
Decoder Metric -TS 6		(LSB)	E/L TS 6	(MSB)	SNR - TS 7					70			
		(LSB)	(MSB)	Decoder Metric - TS 7		(LSB)	E/L TS 7			71			
All Zero Pattern										72			
										...			
										107			

Figure 7.22: 128 kbps carrier mode ULPC status message format

7.5.3.1 ULPC status message field definition

The ULPC status message header contains three bytes (Bytes 8 to 10) of information that is applicable to all of the uplink carrier modes.

7.5.3.1.1 Carrier groupings

If the carrier mode is either the 128 kbps or 512 kbps, the carrier pairing is used as described in table 7.19. In this case, the reported carrier designator is the smaller of the two that are paired.

Table 7.19: Carrier grouping

Adjacent Uplink Carriers Pairs for 512 kbps (Standard Slot) or 128 kbps (Long Slot) Mode
0, 1
2, 3
4, 5
• • •
90, 91
92, 93
94, 95

NOTE: The carrier sub-field contained in bytes 8 and 9 represent the lower-numbered carrier of the pair of adjacent carriers. There is no pairing for the 2 Mbps and 16 Mbps standard slot modes.

7.5.3.1.2 Uplink frame number field

The uplink frame number field is the relative uplink frame number using format TOD [7, 5] (BSM RSM-A TS 102 188-6 [4]) for which uplink power control status is being reported. The uplink frame number is the same for all time slot measurements reported by this message.

7.5.3.1.3 Superframe number field

The superframe number field is the 8 lsbs of the absolute superframe count using format TOD [15, 8] (see BSM RSM-A TS 102 188-6 [4]) for which uplink power control status is being reported. The superframe number is the same for all time slot measurements reported by this message.

7.5.3.1.4 Noise measurement field

The uplink noise measurement subfield correlates with carrier bandwidth as defined in BSM RSM-A TS 102 188-6 [4]. This 8-bit value can be used to obtain an estimate of the noise density at the satellite. The uplink noise measurement subfield is an integer with a value between 0 and 255. Its use is described in BSM RSM-A TS 102 188-6 [4].

7.5.3.1.5 Time slot measurement field

The uplink power control status packet message contains one set of measurements per time slot per carrier.

The satellite measures the signal to noise ratio reported in the SNR subfield, block decoder errors reported in the block decoder subfield, and early/late timing arrival indication of the uplink burst in the E/L subfield. There are 12 bits for each measurement set as defined in table 7.20.

Table 7.20: Number of bits per time slot measurement

SNR	Block Decoder	E/L
7 bits	4 bits	1 bit

The SNR subfield is an integer value between 0 and 127.

The block decoder subfield is defined in table 7.21.

Table 7.21: Block decoder

Block decoder subfield	RS indication
1111	RS failure
All other values	RS pass

More detailed definition of the SNR and block decoder subfield are given in BSM RSM-A TS 102 188-5 [3].

Only the "1111" value is to be interpreted as a RS fail indication. All other values are to be interpreted as a RS pass indication.

A value for E/L subfield of "0" indicates that the corresponding uplink burst arrived early within the uplink time slot and a value of "1" indicates that the corresponding uplink burst arrived late within the uplink time slot.

The use of these parameters is further described in BSM RSM-A TS 102 188-5 [3].

7.5.4 Bandwidth request message

The ST MAC layer shall use the bandwidth request packet for rate or volume requests. The ST may combine rate and volume request messages within a single packet. However, each request within a bandwidth request packet shall be treated independently. The ST sets the appropriate fields and formats them. The packet format for a bandwidth request is given in table 7.22.

Table 7.22: Bandwidth Request Packet

Byte/bit	Bit 7	Bit 6	Bit 5	Bit 4	Bit 3	Bit 2	Bit 1	Bit 0
8	Authorization information							
12	Spare							
13	Spare							
15	Spare							
16	Frame count							
19	Spare							
20	Bandwidth Request Header							
25	Spare							
26	Bandwidth Request Data # 1							
32	Bandwidth Request Data # 2							
38	Bandwidth Request Data # 3							
44	Bandwidth Request Data # 4							
50	Bandwidth Request Data # 5							
56	Spare							
63	Spare							
64	Integrity Check (4 bytes)							
67	Spare							
68	Spare							
95	Spare							
96	Padding bytes							
107	Spare							

7.5.4.1 Authorization information

This 5-byte field is reserved for a future application. The ST shall encode this field with all zeros and the network shall ignore it.

7.5.4.2 Frame Count

The ST shall encode the frame count with the uplink frame count at the time the message is generated, just prior to sending it to the SAM for validation as described in BSM RSM-A SMAC/SLC interface specification TS 102 189-3 [6]. This uses format TOD [36, 5] as described in BSM RSM-A TS 102 188-6 [4].

7.5.4.3 Bandwidth Request Header

This 6-byte field is detailed in the table 7.23.

Table 7.23: Bandwidth Request Header

Byte/Bit	Bit 7 (MSB)	Bit 6	Bit 5	Bit 4	Bit 3	Bit 2	Bit 1	Bit 0 (LSB)
0	Spare (3 bits)			BCSTID (21 bits)				
1								
2								
3	Uplink cell ID (8 bits)							
4	Spare	Num Requests (3 bits)		Spare	A/B key	IF V	BC	
5	AA	carrier mode		Spare (5 bits)				

7.5.4.3.1 Uplink Cell ID

This 8-bit field contains the uplink cell ID.

7.5.4.3.2 Number of Requests

This 3-bit field represents the number of bandwidth requests that are contained within one message. If the BCS receives one of the reserved values in number of requests field then it shall drop the bandwidth request packet.

Table 7.24: Number of requests

Bits	6	5	4	Value	Description
	0	0	0	0	Reserved
	0	0	1	1	One BW request in the packet
	0	1	0	2	Two requests in the packet
	0	1	1	3	Three requests in the packet
	1	0	0	4	Four requests in the packet
	1	0	1	5	Five requests in the packet
	1	1	0	6	Reserved
	1	1	1	7	Reserved

7.5.4.3.3 Void

7.5.4.3.4 IF V

This field specifies the interface version that supports up to two versions of the request format. For the current version, the IF V field shall be set to zero. If the BCS receives bandwidth request packet with IF V field set to "1" then it shall drop the bandwidth request packet.

Table 7.25: IF version

Bit 1	Description
0	Version 0 of the request format
1	Reserved for future use

7.5.4.3.5 BC

Depending on the uplink cell to which the ST belongs, it sets the BC bit. This is provided to the ST in the TIP.

Table 7.26: BC bit

Bit 0	Description
0	Bandwidth Control 1
1	Bandwidth Control 2

7.5.4.3.6 AA bit

The AA (aloha or assignment) bit identifies whether the bandwidth request message is sent by the ST via a contention (aloha) channel or on an assigned (for rate or volume) time slot.

Table 7.27: AA bit definition

Bit 7	Description
0	Request is sent via the contention channel
1	Request is sent using an assigned time slot

7.5.4.4 Bandwidth request data

Five bandwidth request data messages can be packed in a single request packet. Each of the bandwidth request message is 6 bytes in length. The request data format is shown in table 7.28.

Table 7.28: Bandwidth request data

Byte	Bit 7	bit 6	Bit 5	bit 4	bit 3	bit 2	bit 1	bit 0
0	Follow-up bit	Sub band Designator/Spare (4 bit)						
1	Destination Region ID (11-bit)							
2	Spare (3-bit)			Request action				
3	Number Slots (11-bit)							
4	Carrier Designator/Spare (7-bit)							
5	Request ID (9-bit)							

7.5.4.4.1 Follow-up bit

The ST shall set this bit to 1 to identify explicitly to the network that this is a follow-up request going to the same destination. For a new or original request, this bit is set to 0.

7.5.4.4.2 Sub band designator/Spare

The ST shall set this field to the sub band designator for the sub band in which the ST is requesting resource if the request action is "Test request", otherwise the ST shall set this field as spare.

7.5.4.4.3 Destination region ID

This 11-bit field identifies the destination region. The ST shall set this field for volume requests only. For the rate request, this field is set to all ones by the ST and ignored by the network. The ST shall set this field to indicate shaped beam if it is sending Volume shaped beam traffic. The ST shall set this to wildcard if it is configured to aggregate all traffic to a clustered set of downlink cells into a single BC request.

7.5.4.4.4 Request action

The request action specifies the type of request that the ST may originate. The field indicates if the request being originated is a new rate request or a volume request, a modification of the existing rate request, a de-allocation of an existing request, or if it is the initiation of a test request.

Table 7.29: Request action

Bit 4	Bit 3	Value	Description
0	0	0	Rate request/volume request - Initiate a new request (rate or volume - see note).
0	1	1	Rate modification - Change the existing rate request (only for rate)
1	0	2	Rate de-allocation - Cancel or de-allocate the existing rate request (only for rate)
1	1	3	Test request (only for volume) NOTE: Rate requests and Volume requests can be distinguished by the Request ID field as defined in clause 7.5.4.4.7.

7.5.4.4.5 Number of slots

The 11-bit field represents the number of slots a ST may request in a given request. The Satellite will add 1 to the value specified in this field for rate and volume requests. For rate requests, this number specifies the number of slots required in every frame. The ST will enter a number in the valid range of 0 to 31 for rate requests. For volume requests, this field specifies the total number of slots required to service a particular burst of traffic. The valid range is 0-2 047. However, it may be limited to a maximum value that is configurable by the NCC.

7.5.4.4.6 Carrier designator/spare

The ST shall set these seven bits to the carrier designator (see BSM RSM-A TS 102 188-5 [3]) of the uplink channel in which the ST is requesting bandwidth if the request action is "test request". Otherwise this field is spare.

7.5.4.4.7 Request ID

This 9-bit request ID field is associated with each individual request. If this field is set to 0, it indicates low priority rate request. If this is set to 1, it indicates high priority request. Low priority volume request will have values in pairs such as 2 to 3, 4 to 5, 6 to 7, up to 256 to 257. High priority volume requests can have values in pairs from 258 to 259, 260 to 261, etc. 510 to 511. For volume requests of a given destination and priority, a unique request ID pair is assigned by the ST. If the original request is assigned 2, the subsequent follow-up request can be assigned the request ID of 3, the following request for the same destination and priority is assigned 2 again. Thus the values in each of the pair is toggled to represent the successive requests for the given priority and destination. Note that if the request action indicates a test request the request ID can only be for volume; request ID 0 and 1 are not valid codings if the request action indicates test request.

Table 7.30: Request ID

Request ID	Description
0	Low Priority Rate
1	High Priority Rate
2 to 3	Low Priority Volume for Destination A
4 to 5	Low Priority Volume for Destination B
..	
256 to 257	Low Priority Volume for Destination Z
258 to 259	High Priority Volume for Destination 1
260 to 261	High Priority Volume for Destination 2
..	
510 to 511	High Priority Volume for Destination #N

7.5.4.5 Integrity check

This 4-byte field contains the Message Integrity Check code that SAM assigns to each Bandwidth Request message that the ST originates. See BSM RSM-A, SMAC/SLC interface specification TS 102 189-3 [6].

7.5.5 Bandwidth assignment message

Table 7.31: Bandwidth assignment message format

Byte/Bit	Bit 7	Bit 6	Bit 5	Bit 4	Bit 3	Bit 2	Bit 1	Bit 0
8	Bandwidth Control message common fields (see clause 7.5.1)							
9								
10								
11	Assignment field# 1							
19	Assignment field # 2/padding							
20								
28	Assignment field # 3/padding							
29								
37	Assignment field # 4/padding							
38								
46	Assignment field # 5/padding							
47								
55	Assignment field # 6/padding							
56								
64	Assignment field # 7/padding							
65								
73	Assignment field # 8/pading							
74								
82	Assignment field # 9/padding							
83								
91	Padding bytes							
92								
103	TOD check (see clause 7.5.1)							
104								
107								

7.5.5.1 Assignment field

The assignment field that actually contains the channel numbers, slot numbers and total number of slots assigned to the particular ST is detailed in table 7.32. In case there is no assignment field, this field shall be padded out with zeros.

The assignment field of the assignment packet is a 9-byte field and details the exact assignment such as the slot numbers, and the channel number that the given ST is authorised to transmit.

Table 7.32: Assignment field format

Byte/Bit	Bit 7	Bit 6	Bit 5	Bit 4	Bit 3	Bit 2	Bit 1	Bit 0
0	Spare (3-bit)			BCSTID (21-bit)				
1								
2								
3	A/B key	TSMF	spare	Start index (5-bit)				
4	Number of consecutive indices (5-bit)				Last	Carrier mode		
5	Number of frames (3-bit)			Spare	Sub-band designator (4-bit)			
6	carrier designator (7-bit)							Req ID
7	Request ID (9-bit)							
8	Assignment Integrity Check (8-bit)							

7.5.5.1.1 TSMF

The TSMF bit identifies the time slot mapping function which the ST shall use to determine the actual time slots, which are assigned to it, from the start position and number of consecutive positions fields. If this bit is "0", the ST shall use the time slot mapping function defined in annex A. The value "1" is reserved.

7.5.5.1.2 Start index

This field indicates the starting index, that is assigned to the given ST. Range of values is 0-31. Start index is defined in annex A.

7.5.5.1.3 Number of consecutive indices

This 5-bit field represents the number of consecutive indices beginning from the start index number that the ST is assigned for future transmission in the indicated frame or frames. The ST shall derive the actual time slot assignment using the start index and number of consecutive indices values using the time slot mapping function given in annex A.

7.5.5.1.4 Last

This bit indicates that the given assignment is the last assignment for the requested volume bandwidth. All of the allocations have already been made, and ST shall remove this request as it has already been serviced. If ST has more data to send, it can use one of the allocated slots to make a new request.

7.5.5.1.5 Number of frames

This field specifies the duration for which the assignment is valid. Occasionally, the ST may not receive allocations every frame. During these periods, the ST shall continue to use the channel and the slots that were assigned for the specified number of frames, as an exception. Normally, the ST shall receive the allocations every frame. For rate assignments, this field would be set for $n=0, 1, 2, 3, 4, 5, 6, 7$ to indicate values of $2^n=1, 2, 4, 8, 16, 32, 64$ or 128 frames respectively.

7.5.5.1.6 Request ID

This identifies the request for which the assignment is being sent. Refer to the request ID field in the BW request header format. See clause 7.5.4.4.7. The Source ID and Request ID pair are unique in a given bandwidth assignment packet.

7.5.5.1.7 Assignment integrity check

The 8-bit field is given by the BCS. The ST shall pass the packet to the SAM. The SAM then verifies authenticity of the assignment messages received from the satellite for this ST. This is done for all assignment messages received, for both rate and volume. Refer to the BSM RSM-A, TS 102 189-3 [6].

7.5.6 Negative acknowledgement message

The format for the negative acknowledgement message is defined in table 7.33.

Table 7.33: Negative Acknowledgement message definition

Byte/Bit	Bit 7	Bit 6	Bit 5	Bit 4	Bit 3	Bit 2	Bit 1	Bit 0
8	Bandwidth Control message common fields (see clause 7.5.1)							
9								
10								
11 15	Acknowledgement field# 1							
16 20	Acknowledgement field # 2/pad							
21 25	Acknowledgement field # 3/pad							
26 30	Acknowledgement field #4/pad							
31 35	Acknowledgement field #5/pad							
36 40	Acknowledgement field #6/pad							
41 45	Acknowledgement field #7/pad							
46 50	Acknowledgement field # 8/pad							
51 55	Acknowledgement field # 9/pad							
56 60	Acknowledgement field # 10/pad							
61 65	Acknowledgement field # 11/pad							
66 70	Acknowledgement field # 12/pad							
71 75	Acknowledgement field # 13/pad							
76 80	Acknowledgement field # 14/pad							
81 85	Acknowledgement field # 15/pad							
86 90	Acknowledgement field # 16/pad							
91 103	Padding bytes							
104 107	TOD check (see clause 7.5.1)							

7.5.6.1 Acknowledgement fields 1-16

The detail format of the acknowledgement is shown in table 7.34. If there is no valid acknowledgement message, this field is set to all zeros.

Table 7.34: Acknowledgement field format

Byte/Bit	Bit 7	Bit 6	Bit 5	Bit 4	Bit 3	Bit 2	Bit 1	Bit 0
0	spare (3-bit)			BCSTID (21 bits)				
1								
2								
3	Cause Code (4 bits)				Spare (3-bit)			
4	Request ID (9 bits)							

7.5.6.1.1 Cause code

The cause code is defined in table 7.35.

Table 7.35: Cause code definition

Cause code	NACK reason	Possible explanation	ST action
RATE REQUEST			
0001	No bandwidth	Network reconfiguration Fragmented channels.	ST shall increment RETRY_COUNT. If the count is less than MAX_NO_RETRY, ST shall reissue the request. Otherwise ST shall declare failure to CM entity.
1010	Rate request of specified priority already exists	Previous rate request of same priority that ST believes was deleted is still active at BCS.	ST shall execute rate-change procedure.
1011	Invalid number of slots specified in request message	Configuration error.	ST shall increment RETRY_COUNT. If the count is less than MAX_NO_RETRY, ST shall reissue the request. Otherwise ST shall declare failure to CM entity.
1100	Total number of rate slots to this ST exceeds maximum for specified channel rate	Previous rate request of same priority that ST believes was deleted is still active at BCS.	ST shall increment RETRY_COUNT. If the count is less than MAX_NO_RETRY, ST shall reissue the request. Otherwise ST shall declare failure to CM entity.
1101	Bad packet header - UL beam, number of requests, interface version	Configuration error.	ST shall increment RETRY_COUNT. If the count is less than MAX_NO_RETRY, ST shall reissue the request. Otherwise ST shall declare failure to CM entity.
All other values		Unexpected cause code for this request type.	ST shall ignore NACK.
RATE MODIFICATION REQUEST			
1110	No existing request found of specified priority from this ST	ST's rate was deleted and a rate change was sent before the ST detected its allocations ceased. Rate was deleted for one of the following reasons: 1) NCC deleted ST's rate because keep-alives were not received. 2) ST's rate removed because of LPR pre-emption. 3) ST's rate removed because old channel did not have enough slots and no new channels were available.	ST shall declare failure to CM entity.
1011	Invalid number of slots specified in request message	Configuration error.	ST shall increment RETRY_COUNT. If the count is less than MAX_NO_RETRY, ST shall reissue the request. Otherwise ST shall declare failure to CM entity.

Cause code	NACK reason	Possible explanation	ST action
1100	Total number of rate slots to this ST exceeds maximum for specified channel rate	Previous rate request of same priority that ST believes was deleted is still active at BCS.	ST shall increment RETRY_COUNT. If the count is less than MAX_NO_RETRY, ST shall reissue the request. Otherwise ST shall declare failure to CM entity.
1101	Bad packet header - UL beam, number of requests, interface version	Configuration error.	ST shall increment RETRY_COUNT. If the count is less than MAX_NO_RETRY, ST shall reissue the request. Otherwise ST shall declare failure to CM entity.
All other values	-	Unexpected cause code for this request type.	ST shall ignore NACK.
RATE DE-ALLOCATION			
1110	No existing request found of specified priority from this ST	ST's rate was deleted and a rate deallocation request was sent before the ST detected its allocations ceased. 1) NCC deletes ST's rate because keep-alive messages were not received. 2) ST's rate removed because of LPR pre-emption. 3) ST's rate removed because old channel did not have enough slots and no new channels were available.	ST shall declare success to CM entity.
All other values	-	Unexpected cause code for this request type.	ST shall ignore NACK.
VOLUME REQUEST			
0001	No bandwidth (admit thresholds exceeded for specified UL beam and channel rate)	Temporary congestion at BCS caused by too many unallocated volume slots for given UL and channel rate.	The ST shall restart the allocation timer at its current value. ST shall evaluate the queue on expiry of the allocation timer and issue a new volume Request.
All other values	-	Unexpected cause code for this request type.	ST shall ignore NACK.

7.5.6.1.2 Request ID

This identifies the request for which the assignment is being sent. Refer to the request ID field in clause 7.5.4.4.7.

7.5.7 Dynamic contention channel assignment message

The dynamic contention channel assignment message is shown in table 7.36. This message contains the details about the various contention channels that can be used by the ST to transmit bandwidth requests or other control or user data.

Table 7.36: Dynamic contention channel assignment message definition

Byte/bit	bit 7	bit 6	bit 5	bit 4	bit 3	bit 2	Bit 1	bit 0
8	Bandwidth Control message common fields (see clause 7.5.1)							
9								
10								
11 14	Dynamic contention assignment field# 1/pad							
15 18	Dynamic contention assignment field# 2/pad							
19 22	Dynamic contention assignment field# 3/pad							
23 26	Dynamic contention assignment field# 4/pad							
27 30	Dynamic contention assignment field# 5/pad							
31 34	Dynamic contention assignment field# 6/pad							
35 38	Dynamic contention assignment field# 7/pad							
39 42	Dynamic contention assignment field# 8/pad							
43 46	Dynamic contention assignment field# 9/pad							
47 50	Dynamic contention assignment field# 10/pad							
51 54	Dynamic contention assignment field# 11/pad							
55 58	Dynamic contention assignment field# 12/pad							
59 62	Dynamic contention assignment field# 13/pad							
63 66	Dynamic contention assignment field# 14/pad							
67 70	Dynamic contention assignment field# 15/pad							
71 74	Dynamic contention assignment field# 16/pad							
75 78	Dynamic contention assignment field# 17/pad							
79 82	Dynamic contention assignment field# 18/pad							
83 86	Dynamic contention assignment field# 19/pad							
87 90	Dynamic contention assignment field# 20/pad							
91 103	Padding bytes							
104 107	TOD check (see clause 7.5.1)							

7.5.7.1 Dynamic contention assignment field definition

The details of the contention field format is shown in table 7.37.

Table 7.37: Dynamic contention assignment field format

Byte/bit	bit 7	bit 6	bit 5	bit 4	bit 3	bit 2	bit 1	bit 0
0	Spare	Rate	D/C (2-bit)		Sub-band designator (4-bit)			
1	Spare	carrier designator (7-bit)						
2	Spare	Spare						
3								

The D/C field for dynamic contention assignments shall always designate the data/control mode as "control or data".

7.5.8 Void

7.5.9 SLC test messages

The SLC test message format is shown in figure 7.23.

(MSB) Bit 7	Bit 6	Bit 5	Bit 4	Bit 3	Bit 2	Bit 1	(LSB) Bit 0	Byte
Version Number (4 bits)				R/C	Message type (3 bits)			0
Sequence Number (16 bits)								1
								2
Test Id (4 bits)				Packet type (4 bits)				3
Time Sent								4.. 12
Time Received								13..21
Return MAC Address								22..25
Transaction ID				Number of destination addresses				26
List of recipients (up to 15 address of 32 bits each)								27.. 86
Padding bytes								87..to end of message

Figure 7.23: SLC Test message format

7.5.9.1 Version Number

This field shall be set to "0000". The ST shall ignore all received test messages with versions greater than "0000".

7.5.9.2 R/C

This field determines whether the ST is to collect the diagnostics information or send it back. If this bit is set to "1" the receiving ST shall send the packet back to the originating ST. If this bit is set to "0", the receiving ST shall collect the diagnostics information.

7.5.9.3 Message type

SLC test message type field is coded as per table 7.38.

Table 7.38: SLC test message type field definition

Message type	Definition
000	SLC peer-to-peer delay test
001	Satellite delay test
All other values	reserved

7.5.9.4 Sequence number

The sequence number field is an optional field. A sequence number may be associated with each message within a flow. The sequence number starts from zero and is incremented for each message within that flow. If this field is not used then the ST shall code it as all zeros.

7.5.9.5 Test Id

For each individual test, a new test-id is created by the initiating ST.

7.5.9.6 Packet type

The packet type field identifies the packet type as defined in table 7.39.

Table 7.39: packet type field definition

Packet type	Definition
0000	Satellite loopback packet
0001	Satellite connectivity QoS packet
0010	Specified channel test packet
0011	Background QoS packet
All other values	reserved

7.5.9.7 Time sent

The time sent field coding is conditional on the value of the message type field. When the message type is peer-to-peer delay test, this field is coded as per clause 7.5.9.7.1. When the message type is satellite delay test, this field is coded as per clause 7.5.9.7.2.

7.5.9.7.1 SLC peer-to-peer delay timestamp

The time sent field has two subfields: the downlink frame number and the slant path delay. The downlink frame number is the absolute downlink TOD [39, 0] at the time the diagnostic message is generated prior to calculation of CRC. The slant path delay, t_{SP} , is defined in BSM RSM-A TS 102 188-6 [4]. The resolution of the delta offset is 1 ms.

(MSB) Bit 7	Bit 6	Bit 5	Bit 4	Bit 3	Bit 2	Bit 1	(LSB) Bit 0	Byte
downlink frame number								0
								1
								2
								3
Slant path delay								4
Spare								5
Spare								6
Spare								7
Spare								8

Figure 7.24: Time sent format

7.5.9.7.2 Satellite delay timestamp

The time sent field has one subfield called the uplink timeslot number. The uplink timeslot number is the absolute uplink TOD [39,0] at the transmitter at the start of the time slot used for the transmission where the lsb is 3 ms. It is equivalent to the downlink TOD[39,0] counter + t_{SP} . See BSM RSM-A TS 102 188-6 [4].

(MSB) Bit 7	Bit 6	Bit 5	Bit 4	Bit 3	Bit 2	Bit 1	(LSB) Bit 0	Byte
uplink timeslot number								0
								1
								2
								3
Spare								4
								5
								6
								7
Spare								8

Figure 7.25: Time sent format

7.5.9.8 Time received

The time received field coding is conditional on the value of the message type field. When the message type is peer-to-peer delay test, this field is coded as per clause 7.5.9.8.1. When the message type is satellite delay test, this field is coded as per clause 7.5.9.8.2.

7.5.9.8.1 SLC peer-to-peer delay timestamp

The time received field has two subfields. The downlink frame number is the downlink TOD[39,0] counter at the receiver ST after calculation of CRC. The slant path delay, t_{SP} , is defined in BSM RSM-A TS 102 188-6 [4]. The resolution of the delta offset is 1 ms.

(MSB) Bit 7	Bit 6	Bit 5	Bit 4	Bit 3	Bit 2	Bit 1	(LSB) Bit 0	Byte
downlink frame number								0
								1
								2
								3
Slant path delay								4
Spare								5
Spare								6
Spare								7
Spare								8

Figure 7.26: Time received format

7.5.9.8.2 Satellite delay timestamp

The time received field has one subfield called the downlink frame number. The downlink frame number is the absolute downlink TOD [39, 0] at the received for the downlink frame in with the message was received where the lsb is 3 ms. It is equivalent to the downlink TOD [39, 0] counter + t_{SP} . See BSM RSM-A TS 102 188-6 [4].

(MSB) Bit 7	Bit 6	Bit 5	Bit 4	Bit 3	Bit 2	Bit 1	(LSB) Bit 0	Byte
downlink frame number								0
								1
								2
								3
Spare								4
Spare								5
Spare								6
Spare								7
Spare								8

Figure 7.27: Time sent format

7.5.9.9 Return MAC address±

The return MAC address is the source ST's Destination MAC Address.

7.5.9.10 Number of designated addresses

The number of designated addresses field indicates the number of recipients which are listed in the list of recipients field. Up to 15 recipients can be addressed for a multicast test.

7.5.9.11 List of recipients

This field provides a list of recipients in case the transmission is multicast. The recipients shall be identified by their ST Site IDs. When there are less than 15 recipients, unused bits in this field shall be coded all zeros.

7.5.9.12 Padding bytes

The number of padding bytes to be added to the end of the message shall equal TestMsgLength in bytes. See clause 8. The maximum SLC-PDU is 64 000 bytes. The Padding bytes field shall be truncated if necessary so that the maximum SLC-PDU length will not be exceeded after all necessary headers and CRC fields are added.

When the message type field is satellite delay test, the TestMsgLength shall be ignored and no padding bytes shall be added.

8 Configurable parameters

8.1 SLC un-ack mode configurable parameters

The SAR configurable parameters are for both the Sending ST and the Receiving ST. These parameters assist the SAR's segmentation process and reassembly process on any given RSM-A system terminal.

8.1.1 Timers

Timers used in SLC-unack mode are defined in table 8.1.

Table 8.1: Timers description in SLC-unack mode

Timer	Started	Stopped	Action at expiry	Value
Reassembly_timer	When first segment of a packet is received Restarted on receiving the next segment of a segmented packet.	Stopped on receiving the last segment of a fragmented packet.	All the segments of partially received packets are discarded.	5 000 ms

8.2 SLC ack-mode configurable parameters

Void

8.3 SLC CRC configurable parameters

Thresholds are used to determine which CRC to apply to data. These parameters are configurable and are listed in table 8.2.

Table 8.2: CRC threshold parameters

Parameter	Default value
TH1	0
TH2	4 094
TH3	32 764

8.4 MAC configurable parameters

8.4.1 Bandwidth control parameters

The following timers are used by the ST during the handshake with the network.

Table 8.3: Bandwidth control protocol timers

Timer	Started	Stopped	Action at expiry	Value
Response Timer	When the rate request is initially sent. It is also restarted on every cell-cast message where an allocation is received from the network for the existing rate-request. It is also restarted after sending rate deallocation request	On receipt of rate denied message or on successful completion of rate deallocation procedure	Re-send the rate request over to network and restart the timer. After MAX_NO_RETRY expires, abort attempt. If CC transition is detected (refer to clause 7.5.2.2.10), take no further action. If CC transition is not ongoing, declare failure to CM. If this timer is started after sending a rate deallocation request then retransmit rate deallocation request and restart this timer	10 frames
Allocation Timer	When a volume request is initially sent over to the network or each time a non-final partial allocation is received	When an allocation arrives from the network via the cellcast message	Increment the current value of the allocation timer by bcp_alloc_step and retransmit the BoD request	Bounded by bcp_alloc_min and bcp_alloc_max. Increased by bcp_alloc_step for each failure and decreased by bcp_alloc_step for each success. Default values: bcp_alloc_min=10 frames bcp_alloc_step=2 frames bcp_alloc_max=30 frames

The following configurable parameters are used for controlling the operation of the Bandwidth control procedures.

Table 8.4: Bandwidth control procedure variable definitions

Variable	Purpose
BOD Allocation Min Timer	Used in computation of timeout for BOD volume requests, as defined in clause 6.3.3.1. The timeout is lower bounded by this parameter.
BOD Allocation Max Timer	Used in computation of timeout for BOD volume requests, as defined in clause 6.3.3.1. The timeout is upper bounded by this parameter.
BOD Allocation Step Timer	Used in computation of timeout for BOD volume requests, as defined in clause 6.3.3.1. On each successive timeout, the timeout value is incremented by this parameter.
BODMaximumBODRequestSize	The maximum amount of data for which an allocation can be requested in a single BOD volume request.
BOD Response Timer	The timeout value for waiting for a response to a BOD rate request.
BOD Rate Request Retries	The maximum number of retries allowed for a BOD rate request.

8.4.2 Contention access protocol parameters

The following configurable parameters govern operation of the contention channel access protocols.

Table 8.5: Contention access protocol variable definitions

Variable	Purpose
N_ulpc	Configurable system wide parameter which defines the frame periodicity of seized slots using PA-1spnf protocol.
N_timeout	Maximum number of consecutive ULPC timeouts allowed on a seized PA-1spnf slot, after which the slot must be released.
Pmax	Used in computation of transmission probabilities for SA access, as defined in clause 6.3.5.2.6. The transmission probability is upper bounded by this parameter.
Pmin	Used in computation of transmission probabilities for SA access, as defined in clause 6.3.5.2.6. The transmission probability is lower bounded by this parameter.
N_nulltx	Defines maximum consecutive NULL packets that may be transmitted on a seized PA-1spnf slot.
Lfmax	Used in computation of PA-1spnf channel loading, as defined in clause 6.3.5.3.4. A PA-1spnf channel is considered unavailable if the channel loading equals or exceeds this parameter.
N_1spf_nulltx	Defines maximum consecutive NULL packets that may be transmitted on a seized PA-1spf slot.
Lgmax	Used in computation of PA-1spf channel loading, as defined in clause 6.3.5.4.4. A PA-1spf channel is considered unavailable if the channel loading equals or exceeds this parameter.

8.4.3 Miscellaneous MAC parameters

The following configurable parameters govern miscellaneous aspects of the MAC:

Table 8.6: Miscellaneous MAC parameters

Variable	Purpose
maxQueueDepth	Parameter that defines the maximum amount of data (in number of RSM-A packets) that can be queued in a CR/CRWB/LVLL/Ack-Return queue. Any SDU that if enqueued would cause the associated maxQueueDepth to be exceeded is either dropped (for CR/CRWB) or remapped to the alternate UDTs instance (for LVLL/Ack-Return).
serviceWeight	Parameter that defines the relative weight of a HPB/NPB/CRWB queue used when servicing HPB/NPB/CRWB queues using available Volume PTOs.
volumeBoDTriggerThreshold	Parameter that defines a threshold queue depth for a CRWB queue which if exceeded results in a volume request being made for the amount of data exceeding this threshold.
SatellitePacketRefillSize (SPRS)	For a token bucket the number of tokens to add to the bucket every RTP time period.
RefillPeriod (RTP)	For a token bucket the time period to periodically add SPRS amount of tokens to the bucket.
maxBurstSize	For a token bucket the maximum amount of tokens that may be stored in the token bucket.

Annex A (normative): Uplink Frame, Beams and Channels

A.1 Uplink frame structure, beams and channels

This clause summaries the up-link frame structure and beams and channels, which will help in understanding the bandwidth control (that deals primarily with the managing the uplink channels and time slots) aspects. In case of disagreement, BSM RSM-A TS 102 188-2 [2] and TS 102 188-6 [4] are the normative documents.

The ST may operate in one of the four uplink carrier modes: 128K, 512K, 2MB and 16MB. The uplink frame duration is 96 ms and is divided into 32 time slots of 3ms each. The ST shall transmit one burst within a time slot. The number of MAC blocks, which the ST maps into a burst, varies for different carrier modes. A burst contains one MAC block for 512K channel, 4 MAC blocks on a 2-MB channel, and 32 MAC blocks for 16MB channel.

The ST receives index assignments from the BCS in the bandwidth assignment message that are consecutive. Each assignment contains two fields: a start index and a number of consecutive indices. The start index is a binary value, which varies from 0 to 31. The number of consecutive indices is an integer, which varies from 1 (coding of "00000") to 32 (coding of "11111"). The ST shall use these values in the time slot mapping function below to determine the actual time slots, which are assigned to the ST. This is true for all forms of assignments from the network, i.e. MIP assignments, HVUL assignments and BC assignments. Once the set of time slots is known, the ST shall map MAC blocks into these assignments such that the RSM-A packets are transmitted in order. In other words, the packets sent using the assigned time slots shall arrive at the destination ST in the correct order.

The conversion is as follows. If an index x has been assigned to the ST, and k is the uplink cell ID (see BSM RSM-A TS 102 188-1 [1]) then the time slot assignment, y , is determined using the time slot mapping function f_2 for carrier mode of 128 kbps and f_1 for all other carrier modes.

For a 128 kb/s channel: $y = f_2(x)$ where $f_2(a)$ is the entry in the array f_2 corresponding to the index a .
Note that $0 \leq y \leq 7$.

For any other channel $y = f_1((x+k) \bmod 32)$ where $f_1(a)$ is the entry in the array f_1 corresponding to index a .
Note that $0 \leq y \leq 31$.

The time slot mapping functions are the ordered arrays:

$$f_1[] = \{0,16,8,24, 4,20,12,28,1,17,9,25,5,21,13,29, 2,18,10,26,6,22,14,30,3,19,11,27, 7,23,15,31\}$$

for the 512kb/s and higher carrier modes; and

$$f_2[] = \{0,4,2,6,1,5,3,7\}$$

for the 128kb/s carrier mode.

Annex B (informative): Message sequence diagrams

B.1 Message sequence diagrams

The following clause illustrates the various scenarios of the bandwidth-on-demand protocol.

B.1.1 Rate request - Positive response

The Rate request protocol is described in clause 6.3.3.2.

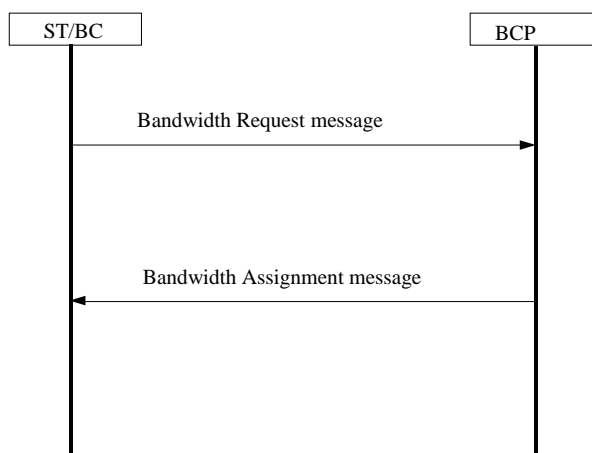

Figure B.1: Rate request - Positive response

The ST MAC informs the upper layer about the granted assignment. The ST shall transmit the data in the newly allotted slots in the frame number, for which the new assignment is valid.

B.1.2 Rate request - Negative response

The network may respond with a negative acknowledgement for one of the following reasons:

- The request packet received from the ST is invalid (invalid number of requests or interface version or too many slots requested, request already exists).
- The network cannot allocate the requested bandwidth.

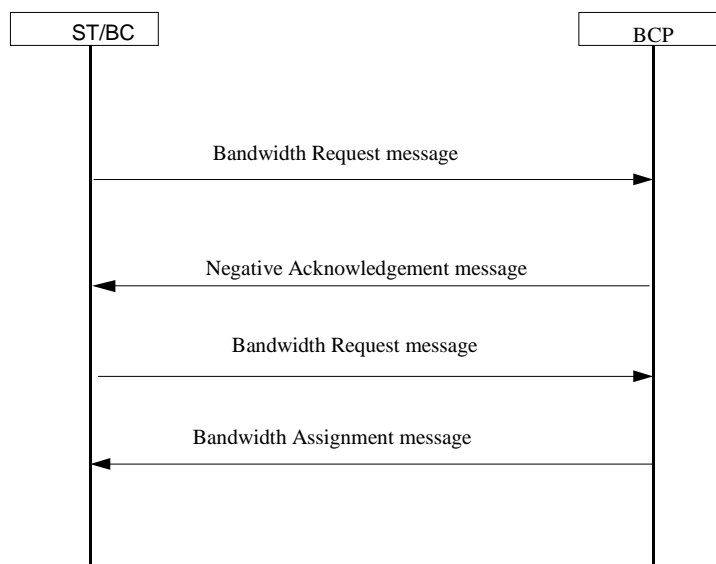

Figure B.2: Negative response due to an invalid request header in the packet

Each step is explained in the following list:

- 1) The network discovers that the packet has been formatted incorrectly, i.e. the number of requests field is incorrectly filled, or the interface version specified is invalid and the network sends a Negative Acknowledgement message.
- 2) The MAC sub-layer of the ST receives the Negative Acknowledgement message with cause: Bad packet header. The ST shall cancel the timer.
- 3) The MAC sub-layer issues a corrected rate request.
- 4) The network receives the correctly formatted Bandwidth request message and allocates the requested bandwidth and sends the assignment via the Bandwidth Assignment message. The ST processes the Bandwidth Assignment message and identifies the assignments addressed to it. It cancels the timer.

B.1.2.1 Rate request - Negative response due to insufficient bandwidth

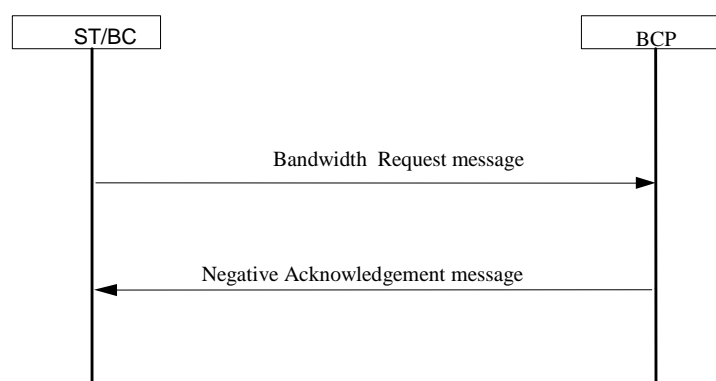

Figure B.3: Negative Response due to insufficient bandwidth

- 1) The network can not allocate the requested bandwidth and sends a Negative Acknowledgement message with cause: No bandwidth.
- 2) The ST receives the Negative Acknowledgement message.
- 3) The MAC sub-layer shall convey this "Rate denied" information to upper layer, the connection management entity in the ST.
- 4) The MAC sub-layer shall delete all queued data for this connection and clear it.

B.1.3 Message corruption/Lost

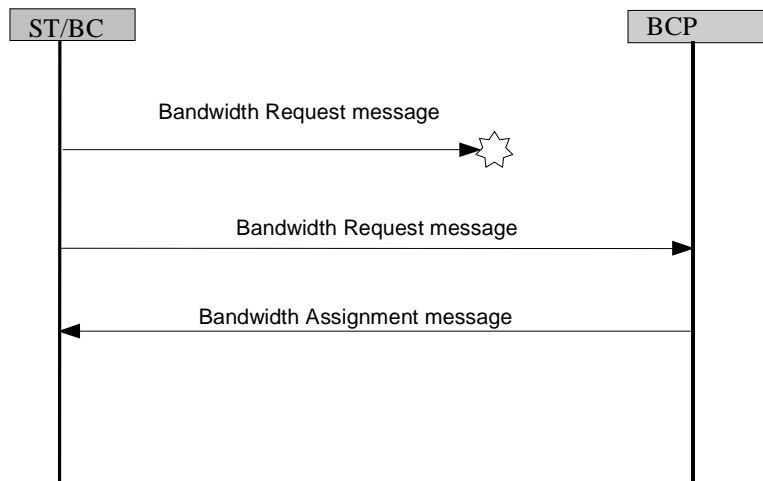

Figure B.4: Message corruption/lost during transmission

B.1.4 Rate request - Changes in the traffic pattern

See clause 6.3.3.3.

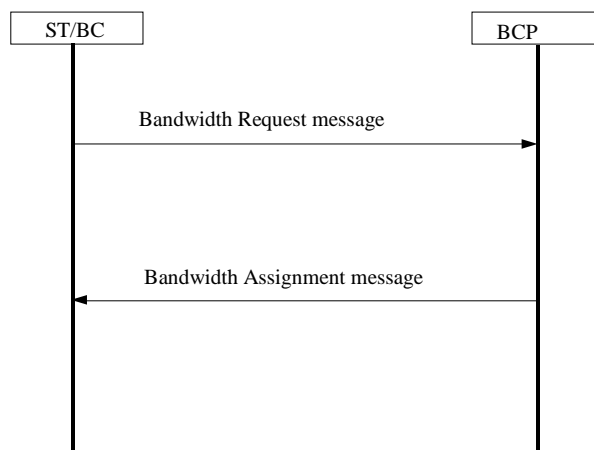

Figure B.5: Rate request - rate change request

B.1.5 Rate de-allocation

See clause 6.3.3.4.

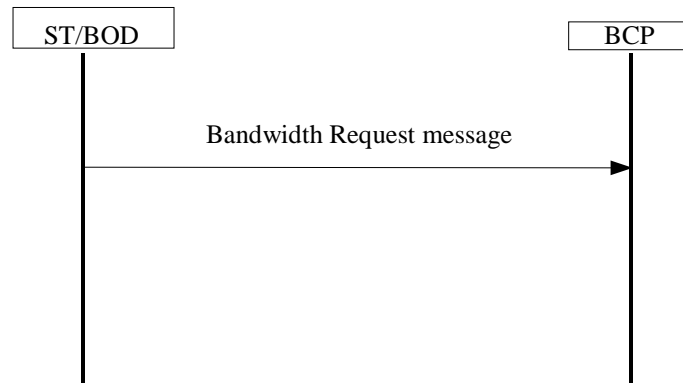

Figure B.6: Rate de-allocation

B.1.6 Volume request

See clause 6.3.3.1.

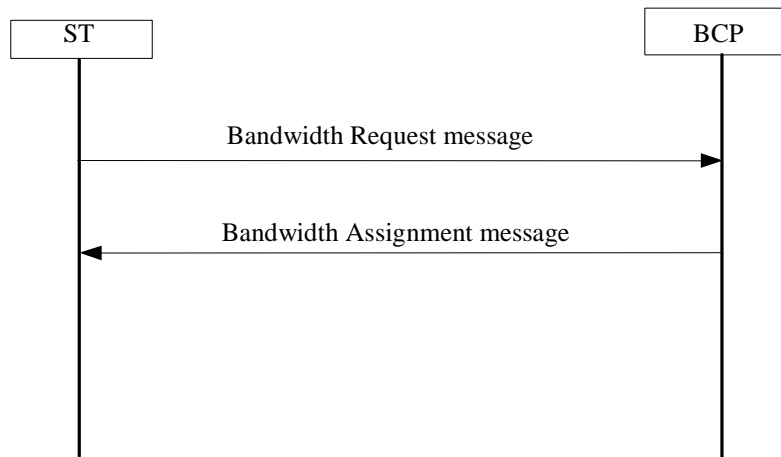

Figure B.7: Volume request

B.1.7 Volume request - partial assignment

See clause 6.3.3.1.

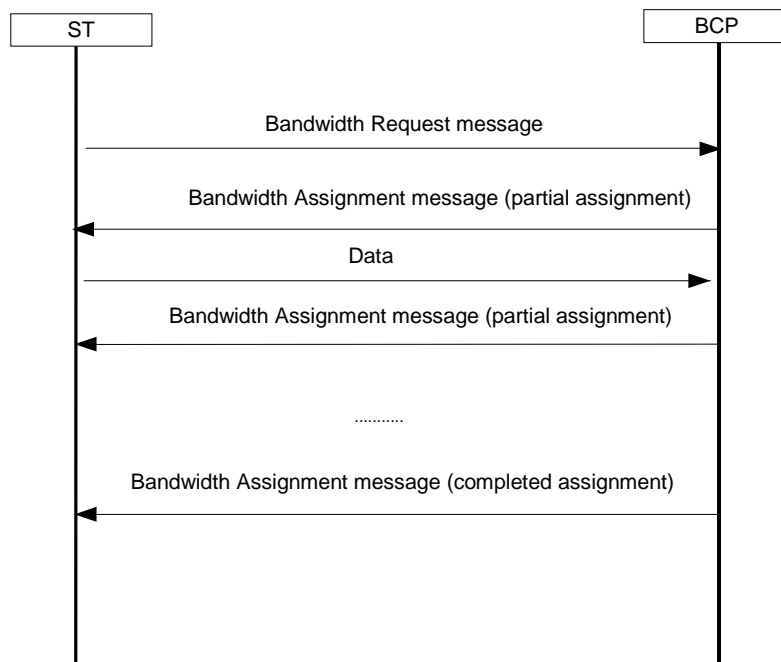

Figure B.8: Partial allocations

Annex C (informative):
Void

Annex D (normative): Satellite terminal capability

D.1 ST basic capability set

The basic capability set for the ST is given in table D.1.

Table D.1: Basic required capability set of an ST

Capability	Description
Link Protocol	SLC Unacknowledged mode only
Compression	No SLC compression
CRC	All four options supported
Link layer data confidentiality	ST should support but not a basic capability, if supported. ST shall pad all encrypted SDUs out to multiple of 8 octets prior to encryption
User Data Transport Services (UDTS) supported	Constant Rate (CR), Constant Rate with Burst (CRWB), Low Volume Low Latency (LVLL), High Priority Burst, Ack Return and Normal Priority Burst
Packet Delivery Service (PDS)	High priority Rate, High Priority Volume, Normal Priority Volume, Slotted Aloha (SA), Persistent aloha (PA)
Extension header	ST shall recognize E bit read length and skip. ST is not required to read the extension header
SAR	ST shall support up to at least two segments in one packet
SA	ST shall support supervisory and data/control SA channel types and shall treat all other code points as data/control
PA	ST shall support PA, ST may support PA-1spf
Retransmission	ST may support up to one retransmission of data packets only on the SA channel. ST shall not retransmit BoD packets or management packets
Uplink Channel Rate	ST shall support rates up to 512 kbps, and may support rates up to 16 Mbps
Multicast	ST shall receive multicast packets and should source multicast packets
Diagnostic Support	As defined in clause 5.8

Annex E (informative): CRC Examples

An implementation of the CRC calculation given in clause 5.4 will calculate the CRC values given in table E.1.

Table E.1: Examples of CRC values

Input data	CRC type	CRC value (hexadecimal)
1 byte of 0x61 (note 1)	CRC-ST-16	0f 46
1 byte of 0x61 (note 1)	CRC-ST-32	ef 74 60 bc
1 byte of 0x61 (note 1)	CRC-ST-64	00 00 00 00 00 00 cf bb
50 bytes of 0x41 (note 2)	CRC-ST-16	37 bc
50 bytes of 0x41 (note 2)	CRC-ST-32	6a 19 f3 a2
50 bytes of 0x41 (note 2)	CRC-ST-64	88 88 7b 53 e5 cd 88 83
1000 bytes of 0x5a (note 3)	CRC-ST-16	db 65
1000 bytes of 0x5a (note 3)	CRC-ST-32	fc 5b 98 87
1000 bytes of 0x5a (note 3)	CRC-ST-64	8b 48 44 74 bc ef c1 fb
NOTE 1: The value 0x61 is the ASCII representation for the letter "a". This input is one byte representing one instance of ASCII value.		
NOTE 2: The value 0x41 is the ASCII representation for the letter "A". This input represents a string consisting of that letter appearing 50 times.		
NOTE 3: The value 0x5a is the ASCII representation for the letter "Z". This input represents a string consisting of that letter appearing 1 000 times.		

Annex F (informative): Bibliography

ETSI TS 102 188-3: "Satellite Earth Stations and Systems (SES); Regenerative Satellite Mesh - A (RSM-A) air interface; Physical layer specification; Part 3: Channel coding".

ETSI TS 102 188-4: "Satellite Earth Stations and Systems (SES); Regenerative Satellite Mesh - A (RSM-A) air interface; Physical layer specification; Part 4: Modulation".

ETSI TR 101 984: "Satellite Earth Stations and Systems (SES); Broadband Satellite Multimedia; Services and Architectures".

MIL-STD-2401: United States Military Standard, WGS84, "DEPARTMENT OF DEFENSE WORLD GEODETIC SYSTEM (WGS)", 11 January 1994.

History

Document history		
V1.1.1	March 2004	Publication
V1.1.2	July 2004	Publication