

# ETSI TS 102 192-2 V1.1.1 (2004-08)

---

*Technical Specification*

## **Electromagnetic compatibility and Radio spectrum Matters (ERM); International Technical Characteristics and Test Methods; Part 2: Cordless audio and Consumer radio microphones in the 25 MHz to 3 GHz Frequency Range**

---



---

Reference

DTS/ERM-TG17-006-2

---

Keywords

Audio, radio, radio mic, testing

**ETSI**

650 Route des Lucioles  
F-06921 Sophia Antipolis Cedex - FRANCE

Tel.: +33 4 92 94 42 00 Fax: +33 4 93 65 47 16

Siret N° 348 623 562 00017 - NAF 742 C  
Association à but non lucratif enregistrée à la  
Sous-Préfecture de Grasse (06) N° 7803/88

---

**Important notice**

Individual copies of the present document can be downloaded from:

<http://www.etsi.org>

The present document may be made available in more than one electronic version or in print. In any case of existing or perceived difference in contents between such versions, the reference version is the Portable Document Format (PDF). In case of dispute, the reference shall be the printing on ETSI printers of the PDF version kept on a specific network drive within ETSI Secretariat.

Users of the present document should be aware that the document may be subject to revision or change of status. Information on the current status of this and other ETSI documents is available at

<http://portal.etsi.org/tb/status/status.asp>

If you find errors in the present document, send your comment to:

[editor@etsi.org](mailto:editor@etsi.org)

---

**Copyright Notification**

No part may be reproduced except as authorized by written permission.  
The copyright and the foregoing restriction extend to reproduction in all media.

© European Telecommunications Standards Institute 2004.  
All rights reserved.

**DECT™**, **PLUGTESTS™** and **UMTS™** are Trade Marks of ETSI registered for the benefit of its Members.  
**TIPHON™** and the **TIPHON logo** are Trade Marks currently being registered by ETSI for the benefit of its Members.  
**3GPP™** is a Trade Mark of ETSI registered for the benefit of its Members and of the 3GPP Organizational Partners.

# Contents

Intellectual Property Rights .....	6
Foreword.....	6
1 Scope .....	7
2 References .....	7
3 Definitions, symbols and abbreviations .....	8
3.1 Definitions .....	8
3.2 Symbols.....	9
3.3 Abbreviations .....	9
4 Functional characteristics .....	10
4.1 Cordless audio .....	10
4.2 Consumer radio microphones.....	10
4.3 In-ear monitoring.....	10
4.4 In-vehicle cordless.....	10
4.5 Personal cordless .....	10
4.6 Broadband multi channel systems .....	10
5 General .....	10
5.1 Presentation of equipment for testing purposes.....	10
5.1.1 Choice of model for performance testing .....	11
5.1.2 Definitions of alignment and switching ranges.....	11
5.1.3 Void .....	11
5.1.4 Choice of frequencies .....	11
5.1.5 Testing of single channel equipment .....	11
5.1.6 Testing of two channel equipment.....	12
5.1.7 Testing of multi-channel equipment (more than two channels).....	12
5.1.8 Testing of equipment with an external frequency control.....	12
5.1.9 Testing of equipment with an integral antenna .....	12
5.1.9.1 Equipment with a permanent internal RF port .....	12
5.1.9.2 Equipment with a temporary RF port.....	12
5.2 Mechanical and electrical design.....	13
5.2.1 General.....	13
5.2.2 Controls .....	13
5.2.3 Testing with integral antenna.....	13
5.2.4 Marking .....	13
5.2.4.1 Equipment identification .....	13
5.2.4.2 Regulatory marking.....	13
5.3 Interpretation of the measurement results .....	13
6 Test conditions, power sources and ambient conditions .....	14
6.1 Normal and extreme test-conditions.....	14
6.2 Test power source.....	14
6.3 Normal test conditions.....	14
6.3.1 Normal temperature and humidity .....	14
6.3.2 Normal test power source voltage.....	14
6.3.2.1 Mains voltage .....	14
6.3.2.2 Void.....	15
6.3.2.3 Other power sources.....	15
6.4 Extreme test conditions .....	15
6.4.1 Extreme temperatures .....	15
6.4.1.1 Procedures for tests at extreme temperatures .....	15
6.4.2 Extreme test power source voltages.....	15
6.4.2.1 Mains voltage .....	15
6.4.2.2 Void.....	15
6.4.2.3 Void.....	15
6.4.2.4 Other power sources.....	15

7	General conditions.....	16
7.1	Normal test modulation.....	16
7.2	Test fixture.....	17
7.3	Test site and general arrangements for radiated measurements.....	17
7.4	Modes of operation of the transmitter.....	17
7.5	Arrangement for test signals at the input of the transmitter.....	18
8	Methods of measurement and limits for transmitter parameters.....	18
8.1	Frequency stability.....	18
8.1.1	Definition.....	18
8.1.2	Method of measurement (analogue modulation).....	18
8.1.3	Method of measurement (digital modulation).....	18
8.1.4	Limit.....	18
8.2	Rated output power.....	19
8.2.1	Definition.....	19
8.2.2	Method of measurement for equipment with integral antenna.....	19
8.2.2.1	Method of measurement under normal test conditions.....	19
8.2.3	Limit.....	19
8.3	Necessary bandwidth.....	19
8.3.1	Definition.....	19
8.3.2	Measurement of Necessary Bandwidth (BN) for analogue modulation.....	20
8.3.3	Measurement of Necessary Bandwidth (BN) for digital modulation.....	20
8.3.4	Limits.....	21
8.3.5	Edge of band limits.....	21
8.4	Spurious emissions.....	22
8.4.1	Definitions.....	22
8.4.2	Method of measurement.....	22
8.4.3	Limits.....	23
8.4.4	Measuring receiver.....	23
8.5	Cordless audio transmitter shutoff.....	23
8.5.1	Definition.....	23
8.5.2	Method of measurement.....	24
8.5.3	Limits.....	24
9	Receiver.....	24
9.1	Spurious emissions.....	24
9.1.1	Definitions.....	24
9.1.2	Method of measuring the power level in a specified load.....	24
9.1.3	Method of measuring the effective radiated power of the enclosure.....	25
9.1.4	Method of measuring the radiated power.....	25
9.1.5	Limits.....	25
10	Measurement uncertainty.....	26
<b>Annex A (normative): EMC requirements.....</b>		<b>27</b>
<b>Annex B (normative): Measurement of Necessary Bandwidth (BN).....</b>		<b>28</b>
<b>Annex C (informative): Receiver parameters.....</b>		<b>29</b>
C.1	Blocking or desensitization.....	29
C.1.1	Definition.....	29
C.1.2	Method of measurement.....	29
C.1.2.1	Measurement procedure.....	29
C.1.2.2	Definitions.....	29
C.1.2.3	Limits for applications below 1 GHz.....	30
C.1.2.4	Limits for applications above 1 GHz.....	30
C.2	Frequency mask for the receiver part.....	30
C.2.1	Definition.....	30
C.2.2	Method of measurement.....	30
C.2.3	Typical values for receivers.....	31
C.2.3.1	Typical values for receivers with analogue modulation.....	31
C.2.3.2	Typical values for receivers with digital modulation.....	31

**Annex D (informative): Bibliography.....32**  
History .....33

---

## Intellectual Property Rights

IPRs essential or potentially essential to the present document may have been declared to ETSI. The information pertaining to these essential IPRs, if any, is publicly available for **ETSI members and non-members**, and can be found in ETSI SR 000 314: "*Intellectual Property Rights (IPRs); Essential, or potentially Essential, IPRs notified to ETSI in respect of ETSI standards*", which is available from the ETSI Secretariat. Latest updates are available on the ETSI Web server (<http://webapp.etsi.org/IPR/home.asp>).

Pursuant to the ETSI IPR Policy, no investigation, including IPR searches, has been carried out by ETSI. No guarantee can be given as to the existence of other IPRs not referenced in ETSI SR 000 314 (or the updates on the ETSI Web server) which are, or may be, or may become, essential to the present document.

---

## Foreword

This Technical Specification (TS) has been produced by ETSI Technical Committee Electromagnetic compatibility and Radio spectrum Matters (ERM).

The present document is part 2 of a multi-part deliverable covering the International Technical Characteristics and Test Methods, as identified below:

Part 1: "Wireless/Radio Microphones in the 25 MHz to 3 GHz Frequency Range";

**Part 2: "Cordless audio and Consumer radio microphones in the 25 MHz to 3 GHz Frequency Range".**

The present document was submitted to GSC9 (Seoul, 9 to 13 May 2004) where interested PSOs were requested to take the necessary action to transpose it into their own deliverables for application as appropriate.

---

# 1 Scope

The present document covers the minimum characteristics considered necessary in order to make the best use of the available frequencies. It does not necessarily include all the characteristics that may be required by a user, nor does it necessarily represent the optimum performance achievable.

The present document applies to cordless audio and in ear monitoring equipment using either 300 kHz bandwidth analogue modulation or 300 kHz, 600 kHz or 1 200 kHz digital modulation. The frequency bands for this equipment may differ from country to country as specified in their national regulations. All equipment is intended to be used with integral antennas.

The present document does not apply to broadband modulation such as spread spectrum techniques.

Consumer audio equipment intended for audio and voice operating below 50 MHz and using narrow band modulation are excluded from the present document.

Electromagnetic Compatibility (EMC) requirements are covered by the present document in annex A.

The types of equipment covered by the present document are examples as follows:

- cordless headphones;
- cordless loudspeakers;
- consumer radio microphones;
- in-ear monitoring;
- in-vehicle cordless;
- personal cordless;
- broadband multi channel audio systems.

---

# 2 References

The following documents contain provisions which, through reference in this text, constitute provisions of the present document.

- References are either specific (identified by date of publication and/or edition number or version number) or non-specific.
- For a specific reference, subsequent revisions do not apply.
- For a non-specific reference, the latest version applies.

Referenced documents which are not found to be publicly available in the expected location might be found at <http://docbox.etsi.org/Reference>.

- [1] ITU-R Radio Regulations (Appendix 3 to WRC2000): "Table of maximum permitted spurious emission power levels".
- [2] ITU-R Recommendation BS.559-2: "Objective measurement of radio-frequency protection ratios in LF, MF and HF broadcasting".
- [3] ETSI TR 100 028 (all parts): "Electromagnetic compatibility and Radio spectrum Matters (ERM); Uncertainties in the measurement of mobile radio equipment characteristics".
- [4] EN 60244-13: "Methods of measurement for radio transmitters - Part 13: Performance characteristics for FM sound broadcasting".

- [5] ANSI C63.5: "American National Standard for Calibration of Antennas Used for Radiated Emission Measurements in Electromagnetic Interference (EMI)".
- [6] ETSI EN 301 489-1: "Electromagnetic compatibility and Radio spectrum Matters (ERM); ElectroMagnetic Compatibility (EMC) standard for radio equipment and services; Part 1: Common technical requirements".
- [7] ETSI EN 301 489-9: "Electromagnetic compatibility and Radio spectrum Matters (ERM); ElectroMagnetic Compatibility (EMC) standard for radio equipment and services; Part 9: Specific conditions for wireless microphones, similar Radio Frequency (RF) audio link equipment, cordless audio and in-ear monitoring devices
- [8] Code of Federal Regulations: "Title 47: telecommunication; Chapter 1: Federal Communications Commission; Part 15: radio frequency devices".
- [9] ETSI TR 100 027: "Electromagnetic compatibility and Radio spectrum Matters (ERM); Methods of measurement for private mobile radio equipment".
- [10] ITU-R Recommendation BS.412-9: "Planning standards for terrestrial FM sound broadcasting at VHF".
- [11] CEPT/ERC/REC 74-01E: "Spurious emissions".
- [12] ETSI TS 102 192-1: "Electromagnetic compatibility and Radio spectrum Matters (ERM); International Technical Characteristics and Test Methods; Part 1: Wireless/Radio Microphones in the 25 MHz to 3 GHz Frequency Range".

---

## 3 Definitions, symbols and abbreviations

### 3.1 Definitions

For the purposes of the present document, the following terms and definitions apply:

**alignment range:** see clause 5.1.2

**artificial antenna:** tuned reduced-radiating dummy load equal to the nominal impedance specified by the applicant

**carrier power** (of a radio transmitter): average power supplied to the antenna transmission line by a transmitter during one radio frequency cycle taken under the condition of no modulation

**channel bandwidth:** frequency band of defined width including safety margin for operation on adjacent channels, located symmetrically around the carrier frequency

**class of emission:** the set of characteristics of an emission, designated by standard symbols, e.g. type of modulation of the main carrier, modulating signal, type of information to be transmitted, and also, if appropriate, any additional signal characteristics

**dBc:** decibels relative to the unmodulated carrier power of the emission

NOTE: In the cases which do not have a carrier, for example in some digital modulation schemes where the carrier is not accessible for measurement, the reference level equivalent to dBc is decibels relative to the mean power  $P$ .

**enclosure port:** physical boundary of the apparatus through which electromagnetic fields may radiate or impinge

NOTE: In the case of integral antenna equipment, this port is inseparable from the antenna port.

**integral antenna:** antenna, with or without a connector, designed as, and declared as by the manufacturer, an indispensable part of the equipment

**mean power** (of a radio transmitter): average power supplied to the antenna transmission line by a transmitter during an interval of time sufficiently long compared with the lowest frequency encountered in the modulation taken under normal operating conditions



**necessary bandwidth:** for a given class of emission, the width of the frequency band which is just sufficient to ensure the transmission of information at the rate and with the quality required under specified conditions

**out-of-band emissions:** emission on a frequency or frequencies immediately outside the necessary bandwidth which results from the modulation process, but excluding spurious emissions

**peak envelope power (of a radio transmitter):** average power supplied to the antenna transmission line by a transmitter during one radio frequency cycle at the crest of the modulation envelope taken under normal operating conditions

**port:** any connection point on or within the Equipment Under Test (EUT) intended for the connection of cables to or from that equipment

**radiated measurements:** measurements that involve the absolute measurement of a radiated electromagnetic field

**spurious emissions:** emission on a frequency or frequencies which are outside the necessary bandwidth and the level of which may be reduced without affecting the corresponding transmission of information. Spurious emissions include harmonic emissions, parasitic emissions, intermodulation products and frequency conversion products, but exclude out-of-band emissions

**switching range:** see clause 5.1.2

**unwanted emissions:** consist of spurious emissions and out-of-band emissions

## 3.2 Symbols

For the purposes of the present document, the following symbols apply:

$\lambda$	wavelength in metres
$\mu\text{F}$	micro Farad
$\mu\text{W}$	micro Watt
$\Omega$	ohm

## 3.3 Abbreviations

For the purposes of the present document, the following abbreviations apply:

ac	alternating current
B	Channel Bandwidth
BN	Necessary Bandwidth
CW	continuous wave
dBc	dB relative to the carrier level
dc	direct current
erp	effective radiated power
fc	carrier frequency
fo	operating frequency
GHz	Giga Hertz
kHz	kilo Hertz
MHz	Mega Hertz
DAC	Digital Analogue Converter
EUT	Equipment Under Test
HF	High Frequency
LF	Low Frequency
MF	Medium Frequency
PPM	Parts per million
PRBS	Pseudo Random Binary Sequence
RBW	Resolution Bandwidth
RF	Radio Frequency
SRD	Short Range Devices
mW	milli Watt
R	distance (see annex A)
Tx	Transmitter

## 4 Functional characteristics

### 4.1 Cordless audio

Cordless audio equipment encompasses e.g. radio linked headphones and loudspeakers. The transmitters may be installed in a building, fitted in a vehicle or body worn. The term cordless is also used to describe infra red and other non-RF "wireless" links, but in the context of the present document it is restricted to RF operating systems only. Stereo equipment can be designed for required channel bandwidths of 200 kHz or less but only with a high cost penalty, however consumer wideband (multi channel) audio equipment and stereo equipment using e.g. Zenith-GE pilot tone systems or digital modulation may need wider bandwidths as defined in the present document.

Other equipment that may be connected to cordless audio equipment shall fulfil the standards applicable to that equipment (if any).

### 4.2 Consumer radio microphones

Consumer radio microphones are intended for non-professional and consumer applications. Part 1 of the present document deals with professional radio microphones.

### 4.3 In-ear monitoring

In-ear monitoring equipment is used by stage and studio performers to receive personal fold back (monitoring) of the performance. This can be just their own voice or a complex mix of sources. This equipment is usually stereo or 2 channel audio.

Other equipment that may be connected to in-ear monitoring equipment shall fulfil the standards applicable to that equipment (if any).

### 4.4 In-vehicle cordless

In-vehicle systems are used for private listening in automobiles and other methods of transport (where permitted).

### 4.5 Personal cordless

Personal cordless transmitters are to enable the body worn personal stereo equipment to be wire free.

### 4.6 Broadband multi channel systems

Broadband multi channel systems are used for the transmission of high quality digital audio. These can be e.g. surround sound systems, compressed audio or uncompressed audio.

---

## 5 General

### 5.1 Presentation of equipment for testing purposes

Each equipment submitted for performance testing shall fulfil the requirements of the present document on all channels over which it is intended to operate.

The applicant shall complete the appropriate application form when submitting equipment for testing.

The applicant shall state the channel bandwidth(s) within which the equipment is designed to operate.

The applicant shall also supply all relevant interface information and any tools and test fixtures to allow:

- direct current (dc) power connection;
- analogue audio connection;
- the deviation limiting of the transmitter; and
- the setting of any input audio level controls and input signal level for normal operation, for a sinusoidal input signal of 500 Hz. The manufacturer shall specify the settings of any other controls necessary to avoid invalidating the test measurements.

Besides the technical documentation, the applicant should also supply an operating manual, identical in content to that supplied with the production model(s) available to the public, for the device(s).

To simplify and harmonize the testing procedures between different test engineers, measurements shall be performed, according to the present document, on samples of equipment defined in clauses 5.1.1 to 5.1.9.2.

These clauses are intended to give confidence that the requirements set out in the present document have been met without the necessity of performing measurements on all channels.

### 5.1.1 Choice of model for performance testing

The applicant shall provide one sample of each model to be tested.

The equipment tested shall be representative in all technical respects of a production model.

### 5.1.2 Definitions of alignment and switching ranges

The alignment range is defined as the frequency range over which the receiver and the transmitter can be programmed and/or re-aligned to operate with a single oscillator frequency multiplication, without any physical change of components other than:

- programmable read only memories supplied by the manufacturer or the manufacturer's nominee;
- crystals;
- frequency setting elements (for the receiver and transmitter). These elements shall not be accessible to the end user and shall be declared by the applicant in the application form.

The switching range is the maximum frequency range over which the receiver or the transmitter can be operated without re-programming or realignment.

The applicant shall, when submitting equipment for test, state the alignment ranges for the receiver and transmitter. The applicant shall also state the switching range of the receiver and the transmitter (which may differ).

### 5.1.3 Void

### 5.1.4 Choice of frequencies

The frequencies for testing shall be chosen by the applicant.

### 5.1.5 Testing of single channel equipment

Full tests shall be carried out on a channel within  $B/2$  of the centre frequency of the alignment range on one sample of the equipment ( $B$  = declared channel bandwidth).

### 5.1.6 Testing of two channel equipment

One sample shall be submitted to enable tests to be carried out on both channels.

The frequency of the upper channel shall be within B/2 of the highest frequency of the switching range. The frequency of the lower channel shall be within B/2 of the lowest frequency of the switching range. In addition, the average of the frequencies of the two channels shall be within B/2 of the centre frequency of the alignment range.

Full tests shall be carried out on both channels.

### 5.1.7 Testing of multi-channel equipment (more than two channels)

One sample of the equipment shall be submitted to enable tests to be carried out on three channels. The centre frequency of the switching range of the sample shall correspond to the centre frequency of the alignment range.

Full tests shall be carried out on a frequency within B/2 of the centre, lowest and highest frequencies of the switching range.

### 5.1.8 Testing of equipment with an external frequency control

One sample shall be submitted to enable tests to be performed across the entire frequency band allowed by the frequency control setting.

The following tests shall be performed at either edge of the tuneable range of the equipment:

- clause 8.1: Frequency error;
- clause 8.2: Carrier power;
- clause 8.3: Channel bandwidth.

The following tests shall be performed with the frequency set to the middle of the tuneable range of the equipment:

- clause 8.4: Spurious emissions;
- clause 8.5: Transmitter shutoff.

### 5.1.9 Testing of equipment with an integral antenna

To facilitate relative measurements, use may be made of a test fixture as described in clause 7.2, or the equipment may be supplied with a permanent internal or temporary internal/external RF port.

#### 5.1.9.1 Equipment with a permanent internal RF port

The way to access a permanent internal RF port shall be stated by the applicant with the aid of a diagram. The fact that use has been made of a permanent internal RF port shall be recorded in the test report.

#### 5.1.9.2 Equipment with a temporary RF port

The applicant shall submit two sets of equipment to the test laboratory, one fitted with a temporary 50  $\Omega$  RF connector with the antenna disconnected and the other with the antenna connected. Each equipment shall be used for the appropriate tests.

The way the temporary RF port is implemented shall be stated by the applicant with the aid of a diagram. The fact that use has been made of the temporary RF port to facilitate measurements shall be stated in the test report. The addition of a temporary RF port should not influence the performance of the EUT.

## 5.2 Mechanical and electrical design

### 5.2.1 General

The equipment submitted by the applicant shall be designed, constructed and manufactured in accordance with sound engineering practice, and with the aim of minimizing harmful interference to other equipment and services and minimizing risk of physical injury to the user when in use or having to gain access to batteries or controls.

### 5.2.2 Controls

Those controls that, if maladjusted, might increase the interfering potentialities of the equipment shall only be accessible by partial or complete disassembly of the device and requiring the use of special tools.

### 5.2.3 Testing with integral antenna

Testing of equipment with integral antenna only applies to that equipment together with the antenna originally provided by the manufacturer.

### 5.2.4 Marking

The equipment shall be marked in a visible place. This marking shall be legible and durable.

#### 5.2.4.1 Equipment identification

The marking shall include as a minimum:

- the name of the applicant or his trademark;
- the type designation.

#### 5.2.4.2 Regulatory marking

The equipment shall be marked, where applicable, in accordance with the local regional or national requirements.

## 5.3 Interpretation of the measurement results

The interpretation of the results recorded in the appropriate test report for the measurements described in the present document shall be as follows:

- The measured value related to the corresponding limit shall be used to decide whether an equipment meets the requirements of the present document.
- The measurement uncertainty value for the measurement of each parameter shall be separately included in the test report.
- The recorded value of the measurement uncertainty shall be, for each measurement, equal to or lower than the figures applicable to the test.

---

## 6 Test conditions, power sources and ambient conditions

### 6.1 Normal and extreme test-conditions

Type tests shall be made under normal test conditions, and also, where stated, under extreme test conditions.

The test conditions and procedures shall be as specified in clauses 6.2 to 6.4.2.4.

### 6.2 Test power source

During type tests the power source of the equipment shall be replaced by a test power source, capable of producing normal and extreme test voltages as specified in clauses 6.3.2 and 6.4.2. The internal impedance of the test power source shall be low enough for its effect on the test results to be negligible. For the purpose of the tests, the voltage of the power source shall be measured at the input terminals of the equipment.

For battery-operated equipment, the battery shall be removed and the test power source shall be suitably decoupled and applied as close to the equipment battery terminals as practicable. For radiated measurements any external power leads should be arranged so as not to affect the measurements. If necessary the external power supply may be replaced with the equipment's own internal batteries at the required voltage, this shall be stated on the test report.

If the equipment is provided with a power cable or power socket, the test voltage shall be that measured at the point of connection of the power cable to the equipment.

During tests the power source voltages shall be within a tolerance of  $\leq \pm 1$  % relative to the voltage at the beginning of each test. The value of this tolerance can be critical for certain measurements. Using a smaller tolerance provides a better uncertainty value for these measurements. If internal batteries are used, at the end of each test the voltage shall be within a tolerance of  $\leq \pm 1$  % relative to the voltage at the beginning of each test.

### 6.3 Normal test conditions

#### 6.3.1 Normal temperature and humidity

The normal temperature and humidity conditions for tests shall be any convenient combination of temperature and humidity within the following ranges:

- temperature: +15°C to +35°C;
- relative humidity: 20 % to 75 %.

When it is impracticable to carry out the tests under the conditions stated above, a note to this effect, stating the actual temperature and relative humidity during the tests, shall be added to the test report.

#### 6.3.2 Normal test power source voltage

##### 6.3.2.1 Mains voltage

The normal test voltage for equipment to be connected to the mains shall be the nominal mains voltage. For the purpose of the present document, the nominal voltage shall be the declared mains voltage, or any of the declared mains voltages, for which the equipment was designed.

### 6.3.2.2 Void

### 6.3.2.3 Other power sources

For operation from other power sources or types of battery (primary or secondary), the normal test voltage shall be that declared by the equipment manufacturer, in equipment handbook and approved by the test engineer. The values shall be stated in the test report.

## 6.4 Extreme test conditions

### 6.4.1 Extreme temperatures

For tests at extreme temperatures, measurements shall be made in accordance with the procedures specified in clause 6.4.1.1, at:

- a)  $-10^{\circ}\text{C}$  and  $+45^{\circ}\text{C}$ , for in-vehicle equipment;
- b)  $+5^{\circ}\text{C}$  and  $+45^{\circ}\text{C}$ , for all other types of equipment.

#### 6.4.1.1 Procedures for tests at extreme temperatures

Before measurements are made the equipment shall have reached thermal balance in the test chamber. The equipment shall be switched off during the temperature stabilizing period. If the thermal balance is not checked by measurements, a temperature-stabilizing period of at least one hour shall be allowed.

The sequence of measurements shall be chosen and the humidity content in the test chamber shall be controlled so that excessive condensation does not occur.

Before tests at the higher temperatures, the equipment shall be placed in the test chamber and left until thermal balance is attained. The equipment shall then be switched on for one minute in the transmit condition, after which the equipment shall meet the specified requirements.

For tests at the lower extreme temperature the equipment shall be left in the test chamber until thermal balance is attained, then switched to the standby or receive condition for one minute after which the equipment shall meet the specified requirements.

### 6.4.2 Extreme test power source voltages

#### 6.4.2.1 Mains voltage

The extreme test voltages for equipment to be connected to an ac mains source shall be the nominal mains voltage  $\pm 10\%$ .

The frequency of the test power source corresponding to the ac mains shall be the nominal mains frequency  $\pm 1\text{Hz}$ .

#### 6.4.2.2 Void

#### 6.4.2.3 Void

#### 6.4.2.4 Other power sources

For equipment using other power sources, or capable of being operated from a variety of power sources, the extreme test voltages shall be those agreed between the equipment applicant and the testing engineer and shall be recorded with the results.

## 7 General conditions

### 7.1 Normal test modulation

The normal test modulation to produce the declared nominal deviation shall be a sinusoidal tone of 500 Hz, set at an input audio level to the transmitter as defined by the manufacturer.

In the case of systems with a digital audio input this test signal has to be presented via a suitable test fixture.

The applicant shall provide details on the interface and test fixture used for the test.

For the purpose of determining the transmitter necessary bandwidth, coloured noise according to ITU-R Recommendation BS.559-2 [2] shall be used, according to the method laid down in clause 8.3.2. The resulting spectral distribution is shown in figure 1. This noise may be generated by a white noise source followed by a passive filter shown in figure 2.

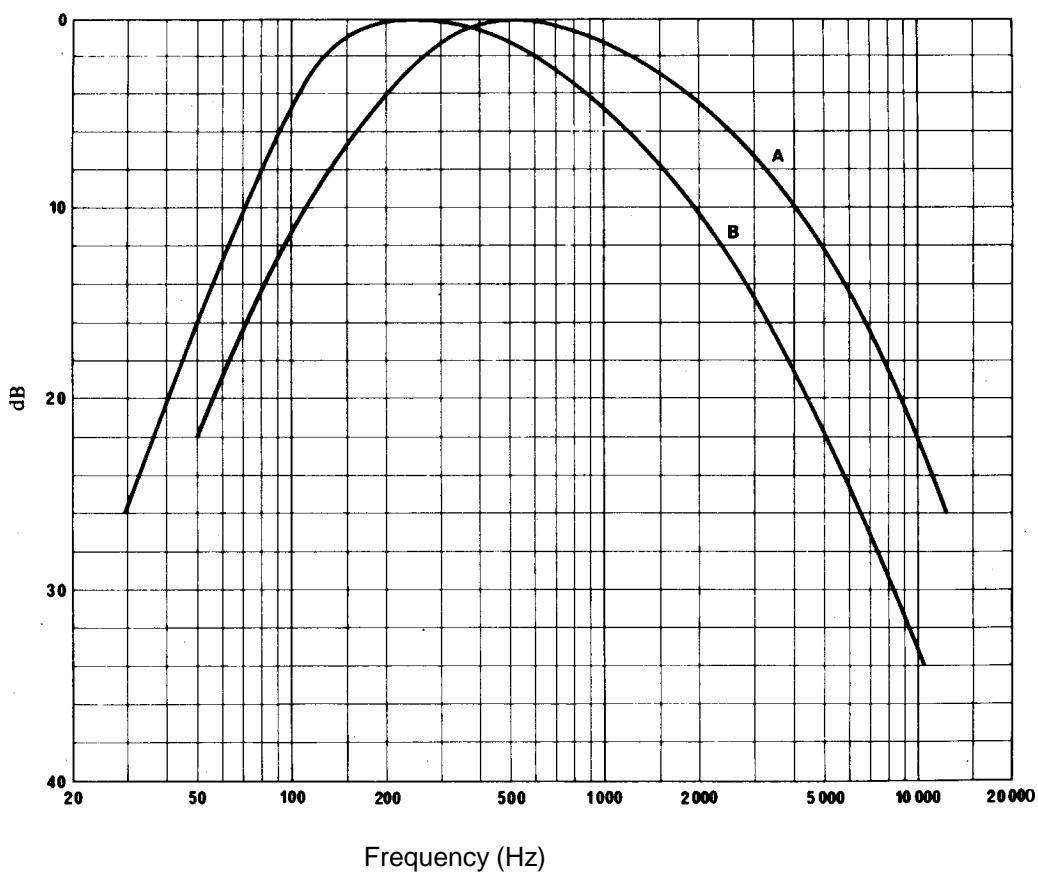

Curve A = Frequency spectrum of standardized noise (measured with one-third octave filters).  
 Curve B = Frequency response characteristics of filter circuit.

**Figure 1: Spectral distribution for determining transmitter necessary bandwidth**



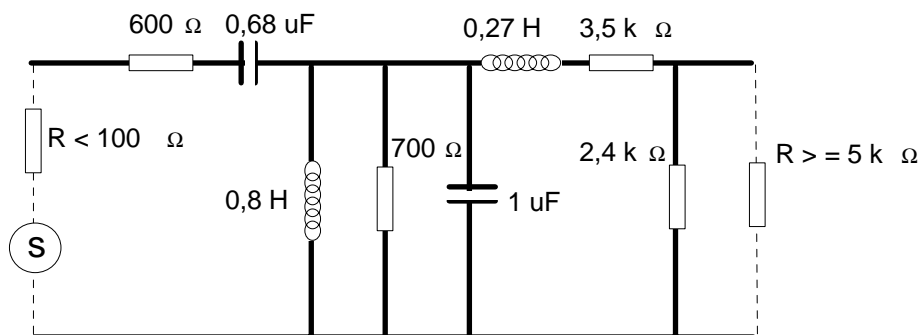

Figure 2: Filter circuit

## 7.2 Test fixture

The applicant may be required to supply a test fixture suitable to allow relative measurements to be made on the submitted sample, particularly in the case of digital equipment.

In all cases, the test fixture shall provide:

- a connection to an external power supply;
- an analogue audio interface (in the case of digital systems this can be a complex interface).

In addition, the test fixture for integral antenna equipment shall contain a radio frequency coupling device associated with an integral antenna equipment for coupling the integral antenna to an RF port at the working frequencies of the EUT. This allows certain measurements to be performed using the conducted measurement methods. Only relative measurements may be performed and only those at or near frequencies for which the test fixture has been calibrated.

The performance characteristics of the test fixture shall be agreed upon with the test engineer and shall conform to the following basic parameters:

- the circuitry associated with the RF coupling shall contain no active or non-linear devices;
- the coupling loss shall not influence the measuring results;
- the coupling loss shall be independent of the position of the test fixture and be unaffected by the proximity of surrounding objects or people;
- the coupling loss shall be reproducible when the EUT is removed and replaced;
- the coupling loss shall remain substantially constant when the environmental conditions are varied.

## 7.3 Test site and general arrangements for radiated measurements

For guidance on radiation test sites, see annex A. Detailed descriptions of the radiated measurement arrangements are included in annex A.

## 7.4 Modes of operation of the transmitter

For the purpose of the measurements according to the present document there should preferably be a facility to operate the transmitter in an unmodulated state. The method of achieving an unmodulated carrier frequency or special types of modulation patterns may also be decided by agreement between the applicant and the testing engineer. It shall be described in the test report. It may involve suitable temporary internal modifications of the EUT. Should it not be possible to produce an unmodulated signal, the peak envelope power is to be measured. The manufacturer shall specify in accordance with clauses 8.2 and 8.3.

## 7.5 Arrangement for test signals at the input of the transmitter

For the purpose of the present document, the appropriate audio frequency input signal to produce the applicant declared nominal deviation shall be supplied by a generator at the correct impedance applied at the connections of the stated audio input, unless otherwise stated.

For digital systems a nominal input level, as specified in clause 7.1, shall be supplied by a generator at the correct impedance applied at the connections of the stated audio input of the test fixture. The proper settings and format for the generator shall be agreed upon between the applicant and the testing engineer.

## 8 Methods of measurement and limits for transmitter parameters

All tests shall be carried out under normal conditions unless otherwise stated.

### 8.1 Frequency stability

#### 8.1.1 Definition

The frequency stability of the transmitter is the difference between the spontaneous and/or environmentally caused frequency change within a given time interval.

#### 8.1.2 Method of measurement (analogue modulation)

The carrier frequency shall be measured with the transmitter placed in a test fixture (see clause 7.2) connected to an artificial antenna. For equipment with an external frequency control the nominal frequencies are taken as the measured frequency under normal test conditions at each end of the tuning range (see clause 8.3.4).

The measurement shall be made under normal test conditions (see clause 6.3), and extreme test conditions (clauses 6.4.1 and 6.4.2 applied simultaneously).

#### 8.1.3 Method of measurement (digital modulation)

In the case of transmitters that are incapable of producing an unmodulated carrier, the mean of two frequency measurements taken at the same level on the upper and lower sides of the modulation envelope shall be taken as the measurement. The measurements shall be made at both ends of the tuning range.

The measurement shall be made under normal test conditions (see clause 6.3), and extreme test conditions (clauses 6.4.1 and 6.4.2 applied simultaneously).

#### 8.1.4 Limit

The limits for the frequency error over the normal and extreme temperature range can be identified as follows:

**Table 1: Limits on frequency error**

Frequencies below 1 GHz	Frequencies above 1 GHz
±60 ppm	±35 ppm

## 8.2 Rated output power

### 8.2.1 Definition

The rated output power is the power that the transmitter shall deliver at its antenna port under the applicants specified conditions of operation. For the purposes of the present document this shall be quoted as mean power.

### 8.2.2 Method of measurement for equipment with integral antenna

#### 8.2.2.1 Method of measurement under normal test conditions

On a test site , the sample shall be placed on the support in the following position:

- for equipment with an internal antenna, it shall stand vertically, with that axis vertical which is closest to vertical in normal use;
- for equipment with rigid external antenna, the antenna shall be vertical;
- for equipment with a non-rigid external antenna, with the antenna extended vertically upwards by a non-conducting support.

The transmitter shall be switched on, with modulation, and the test receiver shall be tuned to the frequency of the signal being measured. The test antenna shall be oriented for vertical polarization and shall be raised or lowered through the specified height range until a maximum signal level is detected on the test receiver. The test antenna shall then be oriented for horizontal polarization and raised or lowered through the specified height range until a maximum signal level is detected on the test receiver. For transmitters that are incapable of producing an unmodulated carrier (CW), the transmitter peak power shall be measured, using a spectrum analyser that is able to display the peak enveloped power either via a special function calculation, a correction factor to be used or by any other means. The applicant shall state the method used.

The transmitter shall be rotated horizontally through 360° until the highest maximum signal is received.

NOTE: This maximum may be a lower value than the value obtainable at heights outside the specified limits.

The transmitter shall be replaced by a substitution antenna, as defined in clause A.1.3 and the test antenna raised or lowered as necessary to ensure that the maximum signal is still received. The input signal to the substitution antenna shall be adjusted in level until an equal or a known related level to that detected from the transmitter is obtained in the test receiver.

The carrier power is equal to the power supplied to the substitution antenna, increased by the known relationship if necessary.

A check should be made in the horizontal plane of polarization to ensure that the value obtained above is the maximum. If larger values are obtained, this fact should be recorded in the test report.

### 8.2.3 Limit

The carrier power shall be in line with regional or national requirements.

## 8.3 Necessary bandwidth

### 8.3.1 Definition

For a given *class of emission*, the width of the frequency band which is just sufficient to ensure the transmission of information at the rate and with the quality required under specified conditions. The necessary bandwidth of the transmitter shall be measured under the conditions laid down in clauses 8.3.2 and 8.3.3.

### 8.3.2 Measurement of Necessary Bandwidth (BN) for analogue modulation

With a weighted noise source to ITU-R Recommendation BS.559-2 [2], band-limited to 15 kHz as described in EN 60244-13 [4], the audio input level to the EUT shall be adjusted to give the manufacturer's declared nominal deviation as measured by a deviation meter. If no nominal deviation is declared the stated 500 Hz nominal audio input level shall be used for the weighted noise input level. The audio input level shall be increased until a maximum peak deviation reading is obtained on a deviation meter.

The input level is then increased by 10 dB. The transmitter RF output spectrum shall be measured, using a spectrum analyser with the following settings:

**Table 2: Necessary bandwidth, measurement parameters**

	Frequencies below 1 GHz	Frequencies above 1 GHz
Centre frequency	fc: transmitter (TX) nominal frequencies	
Dispersion (span)	fc – 1 MHz to fc + 1 MHz	fc – 3 MHz to fc + 3 MHz
Resolution bandwidth (RBW)	1 kHz	1 kHz
Video bandwidth (VBW)	1 kHz	1 kHz
Analyser detector mode	peak	
Analyser display mode	peak hold	
NOTE 1:	If the transmitter incorporates any ancillary coding or signalling channels (e.g. pilot-tones), these should be enabled prior to any spectral measurements.	
NOTE 2:	If the transmitter incorporates more than one audio input, e.g. stereo systems, the second and subsequent channels should be simultaneously driven from the same noise source, attenuated to a level of -16 dB relative to the primary input.	
NOTE 3:	The reference level of the spectrum analyser shall be referred to as the unmodulated (CW) level. Equipment that cannot be put in this position shall use the peak power level as derived with e.g. a spectrum analyser special function calculation, a correction factor to declare or by any other means. The applicant shall state the method used.	

### 8.3.3 Measurement of Necessary Bandwidth (BN) for digital modulation

In case of digital systems the applicant and the test engineer shall agree on the test method and parameters to use.

Either a suitable interface from analogue domain to digital domain should be supplied, or the settings for obtaining maximum digital modulation should be agreed.

In case of S/PDIF inputs these include the settings of the full scale input for the DAC, the sampling rate or in case of other input e.g. I2S or other the maximum utilization for the DAC should be agreed between the applicant and the test engineer. The levels used must be properly identified in the test report. In case of a standard digital input the input signal shall be a PRBS signal which causes maximum utilization of the DAC (full scale).

In case of an interface from analogue to digital domain or vice-versa the tests can be handled further if like the system was an analogue system as in 8.3.2.

Proper description of the interface and levels used need to be agreed with the testing engineer and stated in the test report

**Table 3: Necessary bandwidth, measurement parameters**

	Frequencies below 1 GHz	Frequencies above 1 GHz
Centre frequency	fc: transmitter (TX) nominal frequencies	
Dispersion (span)	fc – 1 MHz to fc + 1 MHz	fc – 3 MHz to fc + 3 MHz
Resolution bandwidth (RBW)	1 kHz	1 kHz
Video bandwidth (VBW)	1 kHz	1 kHz
Analyser detector mode	peak	
Analyser display mode	peak hold	

NOTE : The reference level of the spectrum analyser shall be referred to as the unmodulated (CW) level. Equipment that cannot be put in this position shall use the peak power level as derived with e.g. a spectrum analyser special function calculation, a correction factor to declare or by any other means. The applicant shall state the method used.

### 8.3.4 Limits

The transmitter output spectrum shall be within the mask defined in figure 3 or 4 where B is the channel bandwidth.

The manufacturer shall advise the channel bandwidth B to the test engineer and it shall be recorded in the testreport.

### 8.3.5 Edge of band limits

At no time, any part of the occupied bandwidth mask shall fall above the values in the table

**Table 4: Edge of band spectrum limits**

	For equipment below 1 GHz	For equipment above 1 GHz
At the allocated frequency band edges, the measured level with an average detector shall be below:	-46 dBc	-50 dBc

For switched frequency equipment the switching range shall be limited so that this condition is met allowing for the maximum frequency error measured under normal or extreme test conditions in clause 8.1.

For equipment with an external frequency control the tuning range shall be limited so that this condition is met allowing for the maximum frequency error measured under normal or extreme test conditions in clause 8.1

The modes of operation as stated in clause 7.4 apply.

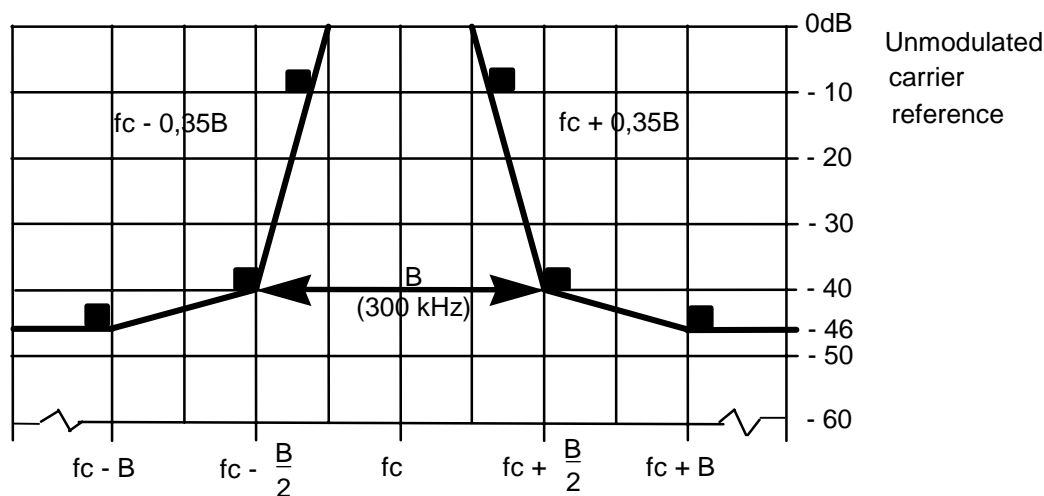

fc = Transmitter carrier frequency

**Figure 3: Spectral mask for analogue or digital modulation with B = 300 kHz**

The measurement of Tx broadband noise floor shall be carried out in accordance with clause 8.3.2. The -46 dBc point shall be  $\pm 300$  kHz from  $f_c$  measured with an average detector.

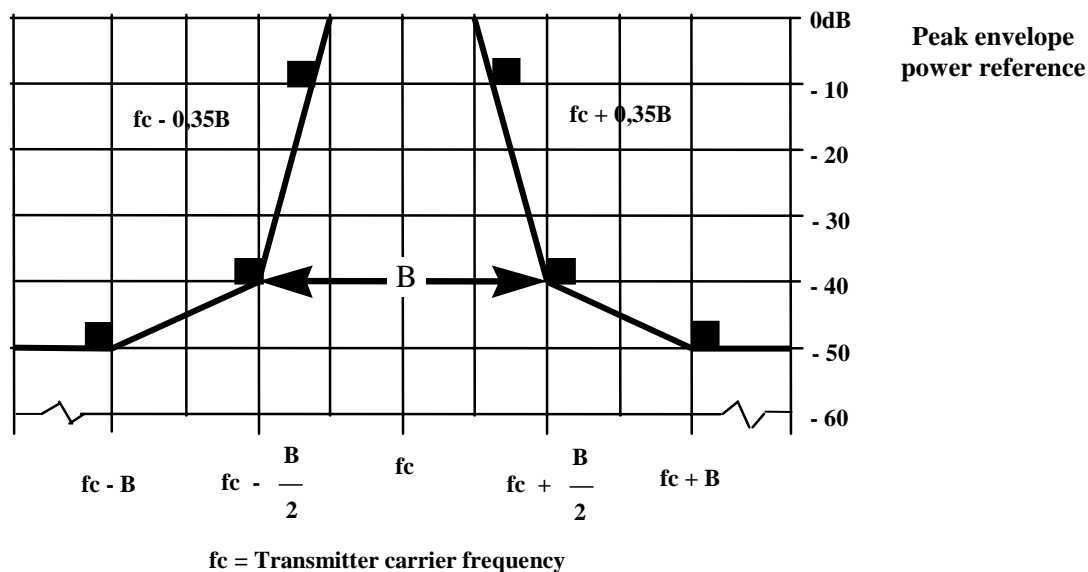

**Figure 4: Scaleable spectral mask for digital modulation with  $B = 600$  kHz, 1 200 kHz**

The measurement of Tx broadband noise floor shall be carried out in accordance with clause 8.3.2. The -50 dBc point shall be  $\pm B$  kHz from  $f_c$  measured with an average detector.

## 8.4 Spurious emissions

### 8.4.1 Definitions

See clause 3.

### 8.4.2 Method of measurement

On a test site, the sample shall be placed at the specified height on a non-conducting support. The transmitter shall be operated at the power as specified under clause 8.2. Radiation of any spurious components shall be detected by the test antenna and receiver, over the frequency range specified below, excluding a band of frequencies of  $2 \times$  Bandwidth  $B$  centred on the channel on which the transmitter is intended to operate.

NOTE: The exclusion band is covered by measurements carried out in clause 8.3.3.

The measuring receiver shall be tuned over the frequency range:

**Table 5: Test receiver frequency range**

Fundamental frequency range	lower frequency	upper frequency
9 kHz to 100 MHz	9 kHz	1 GHz
100 MHz to 300 MHz	9 kHz	10 <sup>th</sup> harmonic
300 MHz to 600 MHz	30 MHz	3 GHz
600 MHz to 5,2 GHz	30 MHz	5 <sup>th</sup> harmonic

The test should include the entire harmonic band and not be truncated at the precise upper frequency limit stated.

At each frequency at which a component is detected, the sample shall be rotated to obtain maximum response and the effective radiated power of that component determined by a substitution measurement.

If the transmitter allows for stand-by operation the tests shall be repeated with the transmitter in standby mode.

### 8.4.3 Limits

The power of the spurious emissions shall not exceed the limits of table 6 (ITU) or the relevant FCC part 15 section [8].

**ITU requirements [1]:**

**Table 6: ITU limits**

Mean power	Limits
of the transmitter	Mean power absolute levels (dBm) or relative levels (dBc) below the mean power supplied to the antenna port in the reference bandwidth
short range devices below 100 mW	$56 \log(P)$ , or 40 dBc, whichever is less stringent. NOTE: Within the band 108 MHz to 137 MHz the limits shall be -50 dBc, without exceeding the absolute mean power of 25 $\mu$ W (-16 dBm).

**FCC part 15 requirements [8]:**

NOTE: This measurement is made at a measurement distance of either 1 or 3 meters on an Open Air Test Site (OATS) or in an RF anechoic chamber according to ANSI C63.5 [5].

The relevant section has to be referred to in the FCC part 15 subpart C (intentional radiators) standard [8].

The general requirements on radiated emission as in section 15.209 apply.

For operation in e.g. 902-928 MHz, section 15.249 applies.

For other operating frequencies, the relevant applicable sections have to be referred to.

### 8.4.4 Measuring receiver

The term measuring receiver refers to either a selective voltmeter or a spectrum analyser. The bandwidth of the measuring receiver is given in table 7.

**Table 7: Reference bandwidth**

Frequency being measured	Measuring receiver bandwidth
25 MHz to <30 MHz	9 to 10 kHz
30 MHz to <1 000 MHz	100 to 120 kHz
>1 000 MHz	1 MHz

## 8.5 Cordless audio transmitter shutoff

### 8.5.1 Definition

The transmitter shall have a built in timer facility that automatically switches off the RF carrier after a period of no input audio signal or no utilization of the system. If the transmitter is built-in into a larger set such as a DVD player, a TV set or other, the applicant shall state in which conditions of the host set the RF carrier will switch off.

In case of consumer radio microphones etc. that operate on a battery, this requirement is not required since it is common that a user switches off the device when not in use.

## 8.5.2 Method of measurement

The output of the transmitter shall be connected to a power meter with an audio input signal applied. When the audio signal is removed or the host set switch-off condition is initiated, a timer is started and the power level recorded. When the switch -off occurs the elapsed time period and new power levels are noted.

## 8.5.3 Limits

The carrier output power shall be reduced by  $\geq 30$  dB, less than 5 minutes after the input audio signal is removed or the condition for the host set to go to switch-off is initiated.

# 9 Receiver

## 9.1 Spurious emissions

### 9.1.1 Definitions

Spurious emissions from the receiver are radio frequency emissions at any frequency, generated by the equipment, antenna, aerial amplifier, down converters or filter.

Manufacturers shall provide a representative sample of the receiver system. The level of spurious emissions shall be measured by either:

- a) the power level from an external RF port; and
- b) their effective radiated power when radiated by the cabinet and structure of the equipment (cabinet radiation);  
or
- c) their effective radiated power when radiated by the cabinet and the integral antenna, in the case of equipment fitted with such an antenna and no external RF port.

### 9.1.2 Method of measuring the power level in a specified load

This method applies only to equipment with an external RF port.

The external RF port of the receiver under test shall be connected to a measuring receiver (see clause 8.4.4). The receiver under test shall be switched on, and the measuring receiver shall be tuned over the frequency range.

(The test should include the entire harmonic band and not be truncated at the precise upper frequency limit stated.)

**Table 8: testreceiver freq. range**

<b>Fundamental frequency range</b>	<b>lower frequency</b>	<b>upper frequency</b>
9 kHz to 100 MHz	9 kHz	1 GHz
100 MHz to 300 MHz	9 kHz	10 <sup>th</sup> harmonic
300 MHz to 600 MHz	30 MHz	3 GHz
600 MHz to 5,2 GHz	30 MHz	5 <sup>th</sup> harmonic

At each frequency at which a spurious component is detected, the power level shall be recorded as the spurious level delivered into the specified load.



### 9.1.3 Method of measuring the effective radiated power of the enclosure

On a test site, the equipment shall be placed at the specified height on a non-conducting support and in the position closest to normal use as declared by the manufacturer. The receiver antenna connector shall be connected to an artificial antenna.

The test antenna shall be oriented for vertical polarization and the length of the test antenna shall be chosen to correspond to the instantaneous frequency of the measuring receiver (see clause 8.4.4). The output of the test antenna shall be connected to a measuring receiver. The receiver shall be switched on and the measuring receiver shall be tuned over the frequency range as specified in clause 9.1.2. At each frequency at which a spurious component is detected, the test antenna shall be raised and lowered through the specified range of height until a maximum signal level is detected by the measuring receiver. When a full anechoic test site is used there is no need to vary the height of the antenna. The receiver shall then be rotated through 360° in the horizontal plane until the maximum signal level is detected by the measuring receiver. The maximum signal level detected by the measuring receiver shall be noted.

The receiver shall be replaced by a substitution antenna.

The substitution antenna shall be oriented for vertical polarization and the length of the substitution antenna shall be adjusted to correspond to the frequency of the spurious component detected.

The substitution antenna shall be connected to a calibrated signal generator.

The frequency of the calibrated signal generator shall be set to the frequency of the spurious component detected.

The input attenuator setting of the measuring receiver shall be adjusted in order to increase the sensitivity of the measuring receiver, if necessary.

The test antenna shall be raised and lowered through the specified range of height to ensure that the maximum signal is received. The input signal to the substitution antenna shall be adjusted to the level that produces a level detected by the measuring receiver, that is equal to the level noted while the spurious component was measured, corrected for the change of input attenuator setting of the measuring receiver. The input level to the substitution antenna shall be recorded as power level, corrected for the change of input attenuator setting of the measuring receiver.

The measurement shall be repeated with the test antenna and the substitution antenna oriented for horizontal polarization.

The measure of the effective radiated power of the spurious components is the larger of the two power levels recorded for each spurious component at the input to the substitution antenna, corrected for the gain of the antenna if necessary.

### 9.1.4 Method of measuring the radiated power

This method applies only to equipment with an integral antenna.

The method of measurement shall be performed according to clause 9.1.3, except that the receiver input shall be connected to the integral antenna and not to an artificial antenna.

### 9.1.5 Limits

The power of the spurious emissions shall not exceed the limits of table 9 or the values indicated in FCC part 15 [8].

#### CEPT/ERC/REC 74-01E limits [11]:

Refer to table 2.1 on limits for the Land Mobile service and maritime mobile service (VHF) of the CEPT/ERC/REC 74-01E document [11].

**Table 9: CEPT limits for receiver spurious emissions**

Receivers and idle/standby transmitters	- 57 dBm $9 \text{ kHz} \leq f \leq 1 \text{ GHz}$
	- 47 dBm $1 \text{ GHz} < f$

**FCC part 15 limits [8]:**

Subpart B on un-intentional radiators is applicable.

The section 15.109 on radiated emission limits from 30 MHz to above 960 MHz applies.

The section 15.107 on conducted limits from 150 kHz to 30 MHz applies.

The section 15.111 on antenna power conduction limits from 30 MHz to 960 MHz applies.

## 10 Measurement uncertainty

The accumulated measurement uncertainties of the test system in use for the parameters to be measured shall not exceed those given in table 9. This is in order to ensure that the measurements remain within an acceptable standard.

Uncertainty values for the RF parameters are valid to 2 GHz unless otherwise stated.

For the test methods, according to the present document the uncertainty figures shall be calculated according to the methods described in the TR 100 028 [3] and shall correspond to an expansion factor (coverage factor)  $k = 1,96$  or  $k = 2$  (which provide confidence levels of respectively 95 % and 95,45 % in case where the distributions characterizing the actual measurement uncertainties are normal (Gaussian)).

Table 9 is based on such expansion factors.

The particular expansion factor used for the evaluation to above measurement uncertainty shall be stated.

**Table 10: Measurement uncertainty**

Parameter	Uncertainty
RF frequency	$<\pm 1 \times 10^{-7}$
Audio output power	$<\pm 0,5$ dB
Radiated RF power	$<\pm 6$ dB
Conducted RF power variations using a test fixture	$<\pm 0,75$ dB
Maximum frequency deviation:	
- within 300 Hz and 6 kHz of audio frequency	$<\pm 5$ %
- within 6 kHz and 25 kHz of audio frequency	$<\pm 3$ dB
Deviation limitation	$<\pm 5$ %
Radiated emission of transmitter, valid up to 12,75 GHz	$<\pm 6$ dB
Radiated emission of receiver, valid up to 12,75 GHz	$<\pm 6$ dB
Transmitter switch off time	$<\pm 5$ %

---

## Annex A (normative): EMC requirements

For EMC generic and specific requirements please refer to TS 102 192-1 [12] annexes B and C.

The information is based upon reference EN 301 489 part 1 [6] and part 9 [7].

For cordless audio and consumer radio microphones the mfg. can choose to meet the performance class 2 (domestic entertainment) or 3 (general consumer) as mentioned in TS 102 192-1 [12] clause C3 of part 1. The chosen class shall be stated to the engineer for testing and noted in the testreport.

## Annex B (normative): Measurement of Necessary Bandwidth (BN)

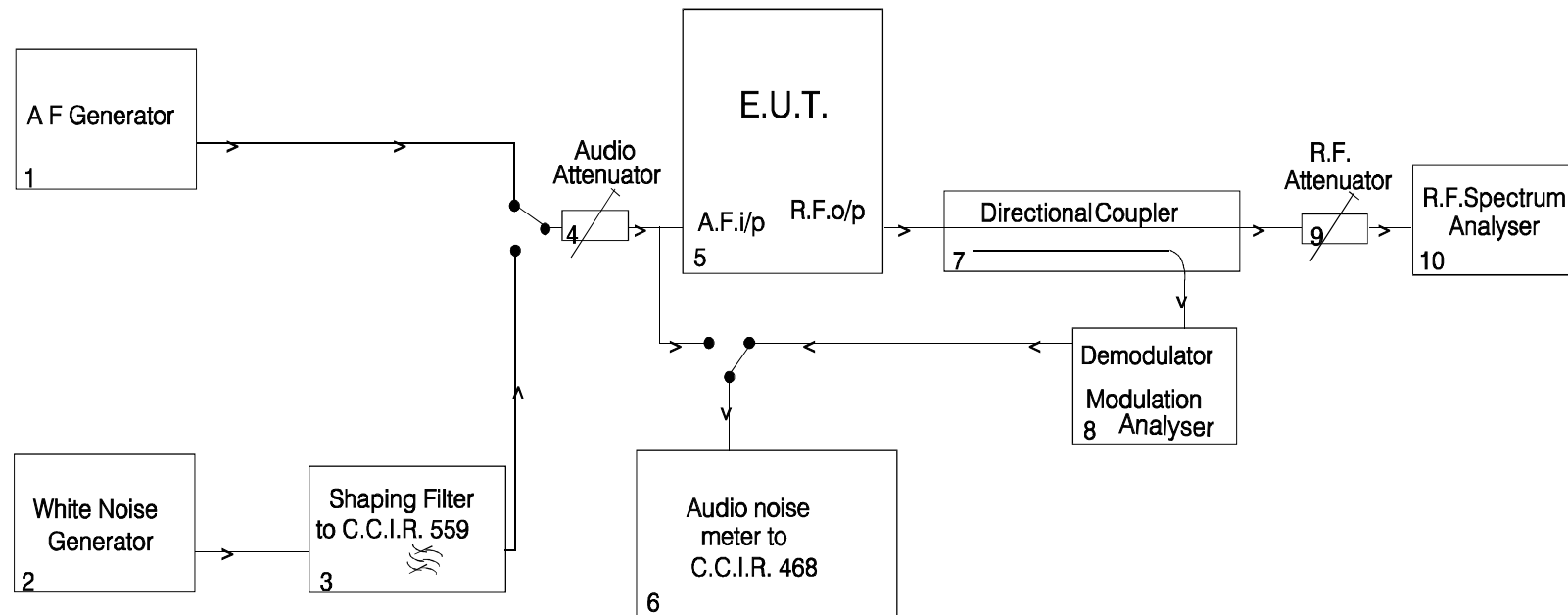

NOTE 1: If the EUT incorporates ancillary coding or signalling channels, for example, pilot tone, etc. these should be switched on prior to measuring the transmitter RF output spectrum.

NOTE 2: In the case of digital systems it is necessary to add test fixtures for the conversion of the audio input/output signals.

**Figure B.1**

---

## Annex C (informative): Receiver parameters

The following information serves the purpose to give guidance to manufacturers on the design for the receiver part. The aim is to have as much as possible efficient use of the wireless application with the highest spectral efficiency. This annex can be used by regulatory authorities to make spectrum sharing studies.

---

### C.1 Blocking or desensitization

#### C.1.1 Definition

Blocking immunity is a measure of the capability of the receiver to receive a wanted modulated signal without exceeding a given degradation due to the presence of an unwanted unmodulated input signal at any frequency within a defined distance. The spurious response frequencies are excluded.

It is specified as the ratio in decibels of the level of the unwanted signal to a specified level of the wanted signal at the receiver input for which a defined degradation of the received signal occurs.

#### C.1.2 Method of measurement

The method of measurement is derived from TR 100 027 [9] with some minor adaptations.

##### C.1.2.1 Measurement procedure

- a) The wanted signal and the unwanted signal should be connected to the receiver input via a combining network. The wanted signal can be either generated by the transmitter, which belongs to the receiver under test, but with a power regulator or damping network at the RF output or it can be represented by a signal generator capable to produce an appropriate modulated signal. The wanted signal has *nominal test modulation*.

The unwanted signal is an unmodulated RF sine wave represented by a generator.

- b) Initially the unwanted signal should be switched off and the level of the wanted signal has to be adjusted to the *blocking reference signal level* measured at the receiver input.
- c) The frequency of the unwanted signal is set according the tables below (clause C.1.2.3 or C.1.2.4). Frequencies of spurious responses are excluded. The level of the unwanted signal has to be increased until the *defined signal degradation* at the receiver's output is observed. This level should be recorded for calculation of the blocking ratio.

##### C.1.2.2 Definitions

**nominal test modulation:** for equipment with analogue audio inputs on the transmitter side the nominal test modulation is a 1 kHz sine wave with nominal input level.

For equipment with digital inputs only at the transmitter side the manufacturer shall specify the input signal. In all cases the modulated spectrum shall be within the spectrum mask according the declared bandwidth.

**blocking reference signal level:** level of the wanted signal at which the blocking measurement takes place. The blocking reference signal level shall either be defined by the manufacturer or be defined as 3 dB higher than the *reference sensitivity level*. The manufacturer shall declare either the blocking reference signal level or the *reference sensitivity level*.

**reference sensitivity level:** RF level at the input of the receiver (using nominal test modulation without any unwanted signal) at which the *defined signal degradation* at the receiver output can be observed.

**defined signal degradation:** in analogue modulated systems the defined signal degradation is either 14 dB SINAD ratio at the receiver output or a reduction of 3 dB audio output power, whichever occurs first. In digital modulated systems the manufacturer shall define or describe the limit of signal degradation.

### C.1.2.3 Limits for applications below 1 GHz

The limit values for the applications below 1 GHz should be higher or equal to the values given in table 9.

**Table C1: Blocking limits at frequencies below 1 GHz**

Class	Blocking (dB)		
	$\pm(1 \text{ MHz} + 2 \text{ B})$	$\pm 5 \text{ MHz}$	$\pm 10 \text{ MHz}$
1	50	60	70
2	30	40	50

### C.1.2.4 Limits for applications above 1 GHz

The limit values for the applications above 1 GHz should be higher or equal to the values given in table 10.

**Table C2: Blocking limits at frequencies above 1 GHz**

Class	Blocking (dB)		
	$\pm(1 \text{ MHz} + 2 \text{ B})$	$\pm 5 \text{ MHz}$	$\pm 10 \text{ MHz}$
1	50	60	70

---

## C.2 Frequency mask for the receiver part

### C.2.1 Definition

The frequency mask for the receiver is giving information on the bandwidth and selectivity behaviour of the receiver. Depending on the application, analogue/digital with  $B = 300 \text{ kHz}$  or wideband digital with  $B = 600 \text{ kHz}$  or  $1\,200 \text{ kHz}$ , the receiver mask can be different.

### C.2.2 Method of measurement

The measuring method is similar to TR 100 027 [9], adjacent channel selectivity measurement (clause 8.1.3). Some minor modifications are in place as described below:

- Analogue modulation:
  - use test modulation A-M1 and A-M3 as described in TR 100 027 [9], clauses 3.1 and 8.1.3.1;
  - for the wanted signal definition, the wanted signal level is defined as the reference sensitivity level + 3 dB.
- Digital modulation:
  - use test modulation as described in TR 100 027 [9], clauses 3.1 and 8.1.3.2;
  - the wanted signal level is described as the reference sensitivity + 3 dB;
  - digital systems can however deviate from this method. In this case the applicant shall state the criteria used.

## C.2.3 Typical values for receivers

Figure C.1 gives a graphical indication of the adjacent channel selectivity and i.e. displays the frequency mask. The curve is based upon discrete filters. Modern receiver architectures allow for more possibilities to achieve the required selectivity. This mask is intended for monophonic operation.

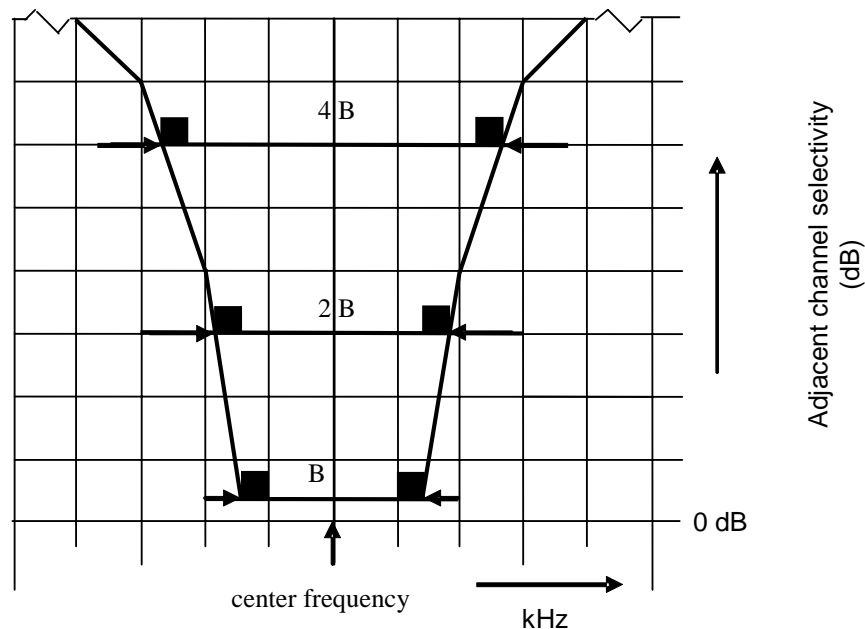

**Figure C.1: Receiver frequency mask**

For spectrum compatibility studies on analogue receivers intended for monophonic and stereophonic operation similar as those used for FM broadcasting ( $B = 300$  kHz), ITU-R Recommendation BS.412-9 [10] can be used as a guideline for calculations.

### C.2.3.1 Typical values for receivers with analogue modulation

The values are applicable for receivers that will match transmitters with defined bandwidth  $B = 300$  kHz and measured in monophonic mode.

**Table C3**

Class	Adjacent channel selectivity (dB)	
	2B (600 kHz)	4B (1 200 kHz)
1	45	60
2	15	30

### C.2.3.2 Typical values for receivers with digital modulation

Due to limited experience with products the values are under consideration.

---

## Annex D (informative): Bibliography

IEC 60489-3: "Methods of measurement for radio equipment used in the mobile services; part 3: Receivers for A3E or F3E emissions".



---

## History

<b>Document history</b>		
V1.1.1	August 2004	Publication