

ETSI TS 102 250-4 V2.3.1 (2019-11)



**Speech and multimedia Transmission Quality (STQ);
QoS aspects for popular services in mobile networks;
Part 4: Requirements for Quality of Service
measurement equipment**

Reference

RTS/STQ-00224-4m

Keywords

3G, GSM, network, QoS, service, speech

ETSI

650 Route des Lucioles
F-06921 Sophia Antipolis Cedex - FRANCE

Tel.: +33 4 92 94 42 00 Fax: +33 4 93 65 47 16

Siret N° 348 623 562 00017 - NAF 742 C
Association à but non lucratif enregistrée à la
Sous-Préfecture de Grasse (06) N° 7803/88

Important notice

The present document can be downloaded from:

<http://www.etsi.org/standards-search>

The present document may be made available in electronic versions and/or in print. The content of any electronic and/or print versions of the present document shall not be modified without the prior written authorization of ETSI. In case of any existing or perceived difference in contents between such versions and/or in print, the prevailing version of an ETSI deliverable is the one made publicly available in PDF format at www.etsi.org/deliver.

Users of the present document should be aware that the document may be subject to revision or change of status.

Information on the current status of this and other ETSI documents is available at

<https://portal.etsi.org/TB/ETSIDeliverableStatus.aspx>

If you find errors in the present document, please send your comment to one of the following services:

<https://portal.etsi.org/People/CommitteeSupportStaff.aspx>

Copyright Notification

No part may be reproduced or utilized in any form or by any means, electronic or mechanical, including photocopying and microfilm except as authorized by written permission of ETSI.

The content of the PDF version shall not be modified without the written authorization of ETSI.

The copyright and the foregoing restriction extend to reproduction in all media.

© ETSI 2019.

All rights reserved.

DECT™, **PLUGTESTS™**, **UMTS™** and the ETSI logo are trademarks of ETSI registered for the benefit of its Members.

3GPP™ and **LTE™** are trademarks of ETSI registered for the benefit of its Members and of the 3GPP Organizational Partners.

oneM2M™ logo is a trademark of ETSI registered for the benefit of its Members and of the oneM2M Partners.

GSM® and the GSM logo are trademarks registered and owned by the GSM Association.

Contents

Intellectual Property Rights	6
Foreword.....	6
Modal verbs terminology.....	6
Introduction	6
1 Scope	7
2 References	7
2.1 Normative references	7
2.2 Informative references.....	8
3 Definition of terms, symbols and abbreviations.....	8
3.1 Terms.....	8
3.2 Symbols.....	8
3.3 Abbreviations	8
4 Overview	9
4.1 General Aspects.....	9
4.2 Considerations on trigger points.....	10
5 General requirements	11
5.1 General requirement for data logging.....	11
5.2 Overview	11
5.3 Required information for logging.....	11
5.3.1 Information on Measurement Setup.....	11
5.3.1.1 General Information	11
5.3.1.2 Information on User Equipment in use	12
5.3.1.3 Information on Store-And-Forward Setups.....	12
5.3.1.4 Information on Data Test Setups.....	13
5.3.2 Measurement Data	13
5.3.3 Status Information	13
5.3.4 Trigger Points	13
5.3.5 QoS Parameters	13
5.4 Test-UE	13
5.5 Antennas.....	13
5.6 Controller/processor/storage.....	14
5.7 Man Machine Interface (MMI)	14
5.7.1 Local Controlled Systems.....	14
5.7.2 Remote Controlled Systems.....	14
5.8 Time sources	14
5.9 Environmental conditions.....	14
6 Fixed QoS Test-equipment (FQT)	15
6.1 General	15
6.2 Controller	15
6.3 Time-sources	15
6.4 Environmental conditions.....	15
6.5 FQT for Telephony Measurements.....	15
6.5.1 Common Aspects.....	15
6.5.2 Telephony Speech.....	15
6.5.3 Telephony Video	16
6.6 FQT for store-and-forward services	16
6.6.1 Overview and Common Aspects	16
6.7 FQT for Data Measurements	16
7 Mobile QoS Test-equipment (MQT).....	16
7.1 General	16
7.2 Controller	16
7.3 Geographical positioning	17

7.3.1	Format of geographical co-ordinates	17
7.3.2	Accuracy	17
7.4	Time-sources	17
7.5	Environmental conditions.....	17
7.6	MQT for Telephony Measurements	17
7.6.1	Common Aspects.....	17
7.6.2	Telephony Speech.....	18
7.6.3	Telephony Video:	18
7.7	MQT for store-and-forward services.....	18
7.8	MQT for Data Measurements.....	18
7.8.1	Common Aspects.....	18
7.8.2	MQT for FTP.....	18
7.8.3	MQT for E-Mail	18
7.8.4	MQT for HTTP.....	18
7.8.5	MQT for WAP.....	19
7.8.6	MQT for streaming services	19
8	Mobile based measurement equipment	19
Annex A (informative): QoS parameter export.....		20
A.1	Overview	20
A.2	XML Bodies	20
A.2.1	<measurement>	20
A.2.2	Configuration	22
A.2.2.1	<fileversion>.....	22
A.2.2.2	<system>.....	22
A.2.2.3	<source>	22
A.2.2.4	<setting>	23
A.2.2.5	<configuration>	23
A.2.3	Measurement Results	24
A.2.3.1	<sequence>	24
A.2.3.2	<trigger>	24
A.2.3.3	<reftrigger>.....	25
A.2.3.4	<qsi>	25
A.2.3.5	<value>	26
A.2.4	Data Dictionary	27
A.2.4.1	Overview	27
A.2.4.2	GPS.....	27
A.2.4.3	GSM.....	28
A.2.4.4	UMTS	29
A.2.4.5	Layer 3 Message PDU Types	31
A.2.4.6	HSDPA	33
A.2.4.7	HSUPA	34
A.3	Schema	38
A.4	Example.....	38
Annex B (informative): RF COMBINER.....		39
B.1	What is blocking?.....	39
B.2	Which parameters have an impact on the effect of blocking?.....	39
B.3	The Standards.....	39
B.4	The Situation	40
B.4.1	One test mobile transmits, the other one receives	40
B.4.2	Antennas on the roof of a car	40
B.4.3	Conclusion.....	40
B.5	Possible Solutions	41
B.5.1	Overview - Attenuators	41
B.5.2	Recommendations	41

B.5.2.1	Benchmarking tests	41
B.5.2.2	Coverage tests	41
B.5.3	Other equipment involved	41
B.5.3.1	Scanners	41
B.5.3.2	GPS receiver 1,2/1,5 GHz	41
B.5.3.3	Risk for Scanner and GPS receiver	41
B.5.4	Mixed Service GSM/WCDMA	41
Annex C (informative):	Bibliography	42
History		43

Intellectual Property Rights

Essential patents

IPRs essential or potentially essential to normative deliverables may have been declared to ETSI. The information pertaining to these essential IPRs, if any, is publicly available for **ETSI members and non-members**, and can be found in ETSI SR 000 314: "*Intellectual Property Rights (IPRs); Essential, or potentially Essential, IPRs notified to ETSI in respect of ETSI standards*", which is available from the ETSI Secretariat. Latest updates are available on the ETSI Web server (<https://ipr.etsi.org/>).

Pursuant to the ETSI IPR Policy, no investigation, including IPR searches, has been carried out by ETSI. No guarantee can be given as to the existence of other IPRs not referenced in ETSI SR 000 314 (or the updates on the ETSI Web server) which are, or may be, or may become, essential to the present document.

Trademarks

The present document may include trademarks and/or tradenames which are asserted and/or registered by their owners. ETSI claims no ownership of these except for any which are indicated as being the property of ETSI, and conveys no right to use or reproduce any trademark and/or tradename. Mention of those trademarks in the present document does not constitute an endorsement by ETSI of products, services or organizations associated with those trademarks.

Foreword

This Technical Specification (TS) has been produced by ETSI Technical Committee Speech and multimedia Transmission Quality (STQ).

The present document is part 4 of a multi-part deliverable. Full details of the entire series can be found in part 1 [2].

Modal verbs terminology

In the present document "**shall**", "**shall not**", "**should**", "**should not**", "**may**", "**need not**", "**will**", "**will not**", "**can**" and "**cannot**" are to be interpreted as described in clause 3.2 of the [ETSI Drafting Rules](#) (Verbal forms for the expression of provisions).

"**must**" and "**must not**" are **NOT** allowed in ETSI deliverables except when used in direct citation.

Introduction

All the defined quality of service parameters and their computations are based on field measurements. That indicates that the measurements were made from users point of view (full End-to-end perspective, taking into account the needs of testing).

It is assumed that the end user can handle his user equipment and the services he wants to use (operability is not evaluated at this time). For the purpose of measurement it is assumed that:

- the service is not barred for any reason;
- routing is defined correctly without errors; and
- the target subscriber equipment is ready to process the service request.

Speech and video quality values measured should only be applied by calls ended successfully for statistical analysis.

However, measured values from calls ended unsuccessfully (dropped) should be available for additional evaluations and therefore, need to be stored.

Further preconditions may apply when reasonable.

1 Scope

The present document defines the minimum requirements of QoS measurement equipment for digital wireless networks in the way that the values and trigger-points needed to compute the QoS parameter as defined in ETSI TS 102 250-2 [3] can be measured following the procedures defined in ETSI TS 102 250-3 [4].

Test-equipment fulfilling the specified minimum requirements, will allow performing the proposed measurements in a reliable and reproducible way.

2 References

2.1 Normative references

References are either specific (identified by date of publication and/or edition number or version number) or non-specific. For specific references, only the cited version applies. For non-specific references, the latest version of the reference document (including any amendments) applies.

Referenced documents which are not found to be publicly available in the expected location might be found at <https://docbox.etsi.org/Reference>.

NOTE: While any hyperlinks included in this clause were valid at the time of publication ETSI cannot guarantee their long term validity.

The following referenced documents are necessary for the application of the present document.

- [1] ETSI TS 100 910: "Digital cellular telecommunications system (Phase 2+); Radio Transmission and Reception (3GPP TS 05.05)".
- [2] ETSI TS 102 250-1: "Speech and multimedia Transmission Quality (STQ); QoS aspects for popular services in mobile networks; Part 1: Assessment of Quality of Service".
- [3] ETSI TS 102 250-2: "Speech and multimedia Transmission Quality (STQ); QoS aspects for popular services in mobile networks; Part 2: Definition of Quality of Service parameters and their computation".
- [4] ETSI TS 102 250-3: "Speech and multimedia Transmission Quality (STQ); QoS aspects for popular services in mobile networks; Part 3: Typical procedures for Quality of Service measurement equipment".
- [5] ETSI TS 102 250-5: "Speech and multimedia Transmission Quality (STQ); QoS aspects for popular services in mobile networks; Part 5: Definition of typical measurement profiles".
- [6] Void.
- [7] Void.
- [8] ETSI ETS 300 607-1: "Digital cellular telecommunications system (Phase 2) (GSM); Mobile Station (MS) conformance specification; Part 1: Conformance specification; (GSM 11.10-1 version 4.28.1)".
- [9] ETSI TS 125 101: "Universal Mobile Telecommunications System (UMTS); User Equipment (UE) radio transmission and reception (FDD) (3GPP TS 25.101)".
- [10] ETSI TS 127 007: "Digital cellular telecommunications system (Phase 2+); Universal Mobile Telecommunications System (UMTS); LTE; AT command set for User Equipment (UE) (3GPP TS 27.00)".
- [11] ETSI TS 127 005: "Digital cellular telecommunications system (Phase 2+); Universal Mobile Telecommunications System (UMTS); LTE; Use of Data Terminal Equipment - Data Circuit terminating Equipment (DTE-DCE) interface for Short Message Service (SMS) and Cell Broadcast Service (CBS) (3GPP TS 27.005)".

- [12] ETSI EN 300 392-5: "Terrestrial Trunked Radio (TETRA); Voice plus Data (V+D) and Direct Mode Operation (DMO); Part 5: Peripheral Equipment Interface (PEI)".
- [13] Void.

2.2 Informative references

References are either specific (identified by date of publication and/or edition number or version number) or non-specific. For specific references, only the cited version applies. For non-specific references, the latest version of the referenced document (including any amendments) applies.

NOTE: While any hyperlinks included in this clause were valid at the time of publication, ETSI cannot guarantee their long term validity.

The following referenced documents are not necessary for the application of the present document but they assist the user with regard to a particular subject area.

- [i.1] ETSI TR 102 581: "Speech Processing, Transmission and Quality Aspects (STQ); A Study on the Minimum Additional Required Attenuation on the Antenna Path of the Field Test Equipment".

3 Definition of terms, symbols and abbreviations

3.1 Terms

Void.

3.2 Symbols

Void.

3.3 Abbreviations

For the purposes of the present document, the following abbreviations apply:

3GPP	3 rd Generation Partnership Project
CI	Cell Identity
CTR	Controller
FQT	Fixed QoS Test equipment
FTP	File Transfer Protocol
GPS	General Positioning System
GSM	Global System for Mobile communication
HTTP	HyperText Transfer Protocol
IMAP	Internet Message Access Protocol
IMEI	International Mobile Equipment Identity
IMSI	International Mobile Station Identifier
IP	Internet Protocol
ISDN	International Subscriber Digital Network
LAC	Location Area Code
LC	Local Control
MCC	Mobile Country Code
MMI	Man Machine Interface
MNC	Mobile Network Code
MQT	Mobile QoS Test equipment
MQT-LC	Mobile QoS Test equipment Local Control
MQT-RC	Mobile QoS Test equipment Remote Control
MSC	Mobile Switching Centre
MSN	Mobile Station Number

PC	Personal Computer
PDN	Packet Data Network
PMN	Public Mobile Network
POP3	Post Office Protocol version 3
PROC	Processor
PSTN	Public Switching Telephone Network
PWR	Power Supply
QoS	Quality of Service
QSI	Quality Sequence Indicator
RC	Remote Control
RF	Radio Frequency
RNC	Radio Network Controller
SIM	Subscriber Identity Module
SMS	Short Message Service
SMSC	Short Message Service Centre
SMTP	Simple Mail Transfer Protocol
TCP	Transmission Control Protocol
TETRA	TErrestrial Trunked RAdio
TS	TimeSlot
UE	User Equipment
UMTS	Universal Mobile Telecommunications System
UTC	Coordinated Universal Time
WAP	Wireless Application Protocol
WCDMA	Wide band Code Division Multiple Access
WGS-84	World Geodetic System 1984
XML	eXtended Mark-up Language

4 Overview

4.1 General Aspects

All tests are based on emulation of a typical user using services provided in a public mobile network (PMN). All of the services to be tested (see ETSI TS 102 250-2 [3]) can be emulated by the Mobile QoS Test-equipment (MQT) which can be installed in a vehicle, can be carried around by a pedestrian or is installed for semi-stationary use (e.g. office environment).

Test scenarios need to distinguish the following principal user cases.

- 1) User-to-user services (typically telephony).
- 2) Store-and-forward services (e.g. SMS).
- 3) Information services (e.g. accessing the internet or FTP download).
- 4) Push services.

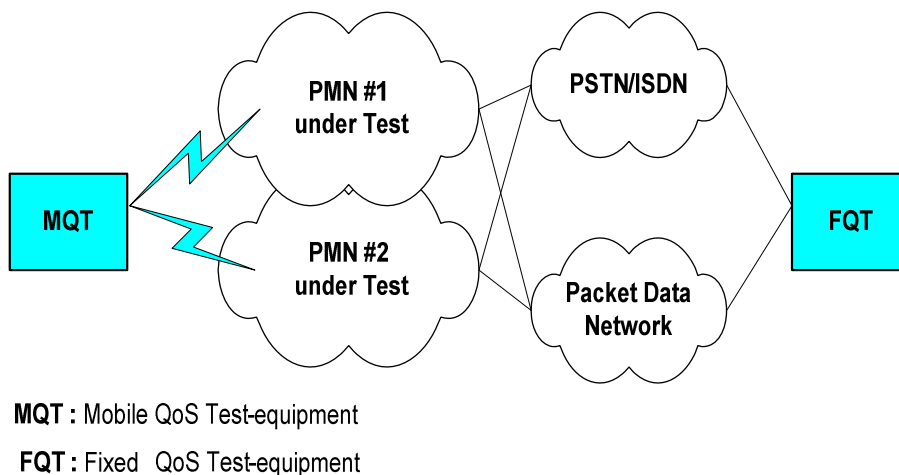

Figure 1: QoS test scenario overview

Some of the services require test-equipment connected to a non-mobile network emulating the counterpart of the typical mobile user or the host offering the service. This part will be called Fixed QoS Test-equipment (FQT). The FQT may be connected via a public network (PSTN, ISDN, PDN) or via a network internal connection point (e.g. at MSC). The FQT for type 3) and 4) services could be composed as a (virtual) Internet Service Provider.

Below, requirements will be described on a per scenario basis. Those requirements not belonging to a specific scenario, e.g. antenna requirements will be grouped together.

Depending on how far the MQT can be automated, the following subtypes are distinguished:

- MQT-LC: local control and operation; or
- MQT-RC: remote control and operation.

Although the same type of classification (-LC or -RC) can be made for FQT, most of the FQT are remote controlled.

4.2 Considerations on trigger points

Without loss of generality it can be assumed that any feasible test equipment will contain some kind of communication terminal (UE) which may be a special type (e.g. a Trace Phone) or a standard UE. Also, it can be assumed that each such device will provide information from different communication layers, from Application Layer (close to the user interface) down to lower layers, e.g. operating-system events, TCP/IP layer, or Layer 3 signalling information, which is used as trigger points for QOS PARAMETERS processing.

When considering the event chain, action is typically triggered by some emulated user action which finally causes some action on the air interface. This process of event propagation is deterministic, allowing some kind of mapping between layers, in the limits of available information, but will inevitably be associated with some communication and processing delay in each stage.

Therefore, choice of the layer to get trigger point information from determines the view expressed in a QOS PARAMETERS. Generally, choosing lower-level events such as Layer 3 gives a more network-centric view, while events on higher levels tend to produce views more user-related. From this, the following guidelines result:

- Within the same QoS PARAMETERS, the source layer for events used as trigger points should be the same.
- In benchmarking, all networks under test should be tested using the same type of UE, and QOS PARAMETERS for all networks under test should use trigger points from the same layer.
- When changing the source layer for a given trigger point, changes in QOS PARAMETERS should be expected, and respective calibration measurements should be taken to assess influence on QOS PARAMETERS both quantitatively and qualitatively.

5 General requirements

5.1 General requirement for data logging

The measurement system shall provide means to collect and store reliably all relevant measurement data. Additionally all configuration parameters have to be stored to be able to reproduce the test.

The system has to provide means to detect and sort out invalid measurement cycles to avoid misrepresenting statistics. The evaluation of the measured values is typically done during post processing. Measurement cycles which are removed from the measured data have to be reported.

5.2 Overview

The typical components of the Mobile QoS Test-equipment (MQT) will be as illustrated in Figure 2.

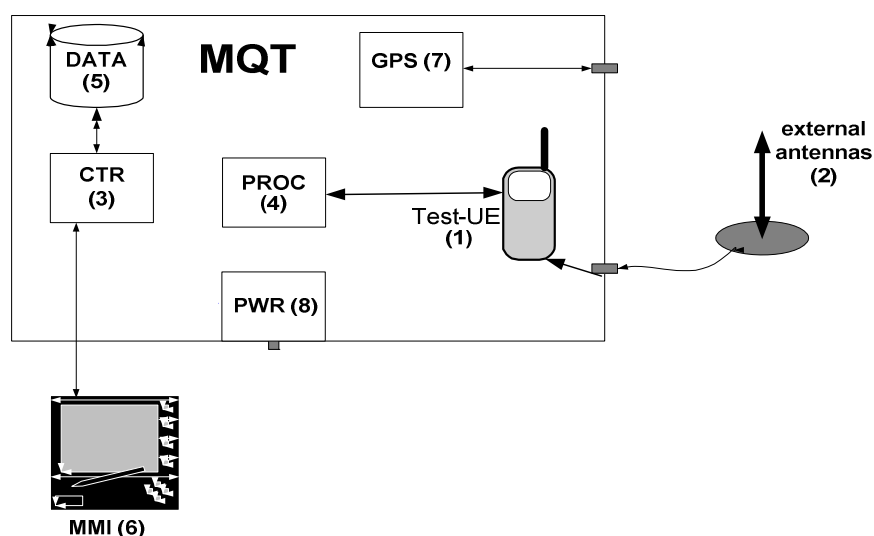

- | | | |
|-----|-------------|---|
| (1) | Test-UE: | User equipment emulating the typical user device (1...n). |
| (2) | Antenna: | Test-UE antenna or external antenna. |
| (3) | Controller: | Controls all the active parts in MQT. |
| (4) | Processor: | Controlling the Test-UE and Pre-processing measurement data.
Optionally the tasks of the processor can be moved into controller. |
| (5) | Storage: | Storage of measurement data and programs. |
| (6) | MMI: | Man Machine Interface for control and configuration of a MQT-LC or for diagnostics in case of a MQT-RC. |
| (7) | PS: | Positioning System (GPS or Indoor Navigation). |
| (8) | PWR: | Power Supply. |

Figure 2: Typical components of the mobile QoS test-equipment (MQT)

5.3 Required information for logging

5.3.1 Information on Measurement Setup

5.3.1.1 General Information

Measurement setup needs to be reproduced if necessary. This requires that the configuration of the measurement equipment, with which the measurement has been done needs to be recorded.

NOTE: However, the measurement results not only depend on the configuration of the measurement equipment, also other circumstances like day of the week and time of day influence the measurement results considerably.

The following list is considered to be a required minimum.

Information automatically collected:

- Versions of measurement equipment:
 - Hardware Version.
 - Software Version of Measurement Application.
 - Operating System Version (Operation System and Service Pack).
- Date, time of day (UTC time + time zone).

Manually entered information:

- User.
- Comment.
- Any other information on test case control parameters, which is required to re-run the test case under the same conditions, but cannot be collected automatically.

5.3.1.2 Information on User Equipment in use

For the setup of the User Equipment in use, the following list of parameters is required as a minimum:

Information automatically collected:

- Type of User Equipment.
- Firmware version.
- Unique UE ID (e.g. IMEI, Serial Number, MAC, etc.).
- IMSI (configuration of SIM card can have a significant influence on the measurement result).
- Software Version of driver for operating system, if used.
- All settings of the control software.

Manually entered information:

- Antenna:
 - Type.
 - Extra attenuation.
 - Total Cable loss (Cables, RF combiners, etc.).

5.3.1.3 Information on Store-And-Forward Setups

The following information has to be logged:

- Number of Service Centre.
- Access Parameters.
- Transmitted Message, Video and/or Audio.
- Timeout Values.

5.3.1.4 Information on Data Test Setups

For Data Tests the following list represents the minimum required parameters.

Information automatically collected:

- Any stack parameter configuration or difference to the standard of the used operating system, e.g. information about TCP stack parameter changes.
- Servers.
- All settings of the control software concerning the Data Test Setup, e.g. FTP Settings.

5.3.2 Measurement Data

Each measured item has to be stored with the corresponding timestamp.

Additional to the trigger points as specified in ETSI TS 102 250-2 [3], the measurement equipment shall collect the following list of data:

- Network ID (MCC, MNC, CI, LAC), respective data items with a rate sufficient to track the User Equipments behaviour.

5.3.3 Status Information

The system has to record information about the status and progress of the current measurement.

5.3.4 Trigger Points

The system has to record all necessary trigger points. See ETSI TS 102 250-2 [3].

5.3.5 QoS Parameters

If possible, QoS Parameters shall be calculated during the measurement and be shown on the MMI.

For test cases on distributed systems the calculation process for QoS Parameters has to be done in a post process.

5.4 Test-UE

Basic requirements on the Test-UE:

- Compliant to corresponding specifications (e.g. 3GPP, TETRA).
- For usage of the AT interface for trigger point measurements, the UE has to conform to the corresponding specifications, e.g. ETSI TS 127 007 [10] and ETSI TS 127 005 [11] for 3GPP, and ETSI EN 300 392-5 [12] for TETRA.
- Remote controllable to initiate the QoS tests with required parameter settings.
- Test UE delivers the necessary data, which is required for the QoS test.
- For benchmark tests only User Equipments with the same capabilities can be used. (e.g. max. number of TS allowed, best type of speech codec, etc.).
- Depending on the test case additional requirements may be relevant.

5.5 Antennas

Depending on the test case, the Test-UE's own antenna or an external antenna has to be used.

Where applicable, the antennas have to be arranged in a well-defined fixed way with a minimum distance to each other reducing RF-influence on an acceptable level in an equal radio environment. The coupling loss between 2 UEs should be minimum 40,5 dB (as specified in clause 2 of ETSI TS 100 910 [1]).

NOTE 1: Certain types of system integration will not allow satisfying these requirements, due to the limitation of space (e.g. backpack system). However, the antennas should be mounted on pre-determined points of the system which guarantee a minimum RF-influence.

External antennas are typically used for measurements in vehicles (car, train, ship). Two RF scenarios can be defined for vehicles:

- 1) User with car kit and external antenna:
 - Car mounted antenna with no extra attenuation has to be used.
- 2) User without car kit, using the User Equipment only (In-car use):
 - Internal antenna of User Equipment can be used.

NOTE 2: Simulation without body loss.

or

- External antenna connected with an overall attenuation of approximately 13 dB (cable loss plus extra attenuation) should be used.

NOTE 3: More information about antenna attenuation is to be found in ETSI TR 102 581 [i.1].

5.6 Controller/processor/storage

The performance of the unit should be high enough and have no measurable impact on the correctness of the data collection. If the unit runs out of any resources it shall inform the user on the MMI.

5.7 Man Machine Interface (MMI)

5.7.1 Local Controlled Systems

The MMI has to allow full operation of the system by the operator. The main functionalities can be monitored and the operator is alerted in case of main failures. Some basic failure diagnostic is possible.

5.7.2 Remote Controlled Systems

An MMI can be connected to perform basic tests and some failure diagnostics. Unattended systems should provide means to generate alarms upon operational faults in the system.

5.8 Time sources

The clocks on the measurement systems have to be synchronized periodically. The required accuracy of the timestamps of the measurement item is:

- Relative: 20 ms.
- Absolute: 250 ms.

5.9 Environmental conditions

The measurement system has to meet at least the minimal environmental conditions requirements defined in clauses 6.4 and 7.5.

6 Fixed QoS Test-equipment (FQT)

6.1 General

Depending on the test-scenarios defined in clause 4 of the present document, there will be different requirements for the FQT and MQT.

6.2 Controller

The performance of the unit should be high enough and have no measurable impact on the correctness of the data collection.

6.3 Time-sources

See clause 5.8.

6.4 Environmental conditions

The FQT has to meet the following environmental conditions:

- Temperature: 5 °C to 40 °C.
- Humidity: maximum 90 %.

6.5 FQT for Telephony Measurements

6.5.1 Common Aspects

For the user-to-user services different FQTs can be used. Also the connection point to the network can vary between an ISDN or PSTN line and a direct link at the MSC/RNC.

However, the used type of server and the connection have to be stored in the final measurement result.

The topology of the distributed system (MQT and FQT) results in the necessity of merging the measurement results made on the FQT and on the MQT. The result will be merged on the time base.

A unique identifier has to be included in measurement files to be able to identify what files belong to the same measurements. This identifier has to be generated automatically by the measurement system.

6.5.2 Telephony Speech

Calculating Telephony QoS parameters including speech quality requires a counterpart on the fixed network. This is typically a PC which is connected to the PSTN. An application on the PC answers the incoming calls from the MQT or generates calls to the MQT.

A FQT application for Telephony Speech Service handles the CS connections of the speech calls, like an answering machine. It controls 1 to n MSN(s). Each MSN has its own profile for incoming or outgoing calls. The FQT application has to have the following capabilities:

- Auto answering of incoming calls.
- Speech Quality Assessment of the incoming speech calls (uplink).
- Providing speech samples for the downlink.
- Generating MT calls.

6.5.3 Telephony Video

For telephony video different types of connection points are available:

- ISDN line/direct connection at MSC/RNC.
- UMTS User Equipment with video telephony application.
- UMTS User Equipment used as modem with a video telephony stack on the PC.

A FQT application for Telephony Video handles the CS connections of the video calls. It controls 1 to n connection points. Each connection point has its own profile for incoming calls. The FQT application has to have the following capabilities:

- Auto answering of incoming video calls.
- Providing speech/video samples for the downlink.

6.6 FQT for store-and-forward services

6.6.1 Overview and Common Aspects

Store and forward services typically transports information between two User Equipments. Therefore the typical difference between MQT and FQT does not apply for store-and-forward services. The quality of store-and-forward services depend on one side on the RF coverage and on the other side, much more than other services, on the network internal infrastructure like the SMSC.

The measurement system shall be able to measure all specified QoS Parameters using User Equipments only.

A general problem is that the A-party does not get a confirmation if the message was received successfully to the B-party. Also the network internal infrastructure can change the order of messages. The B-party of the measurement system has to be able to handle this effect.

6.7 FQT for Data Measurements

The FQT is the measurement server as the physical machine plus the service application.

It shall serve the service requests from the MQT in order to achieve the QoS parameter defined ETSI TS 102 250-2 [3]. The server has to support the user profiles defined in ETSI TS 102 250-5 [5].

It has to be ensured, that the highest possible throughput on the measurement server is higher than the expected throughput for the measurements.

7 Mobile QoS Test-equipment (MQT)

7.1 General

Depending on the test-scenarios defined in clause 4 of the present document, there will be different requirements for the MQT.

7.2 Controller

The performance of the unit should be high enough and have no measurable impact on the correctness of the data collection.

7.3 Geographical positioning

7.3.1 Format of geographical co-ordinates

Geographical data (position, speed, and heading) shall be collected during a mobile measurement. The geographical position can be retrieved by the following alternatives:

- Geographical information shall be taken from GPS whenever possible.
- If no GPS signal is available other tools have to be used, e.g. navigation on a geo-referenced bitmap.

The format of geographical co-ordinates can be as follows:

- Out-door: WGS-84.
- In-door: Fixed reference points on a geographical referenced map and WGS-84 positions calculated by the software.

7.3.2 Accuracy

The accuracy of the geographical positioning has to meet the following requirements:

- Outdoor: < 15 m.
- Indoor: < 10 m.

7.4 Time-sources

See clause 5.8.

7.5 Environmental conditions

The FQT has to meet at least the following environmental conditions:

- Temperature: 5 °C to 40 °C.
- Humidity: maximum 90 %.

Information about the necessary power supply has to be available.

7.6 MQT for Telephony Measurements

7.6.1 Common Aspects

For the user-to-user services different MQTs can be used. The topology of the distributed system (MQT and FQT) results in the necessity of merging the measurement results made on the MQT and on the FQT. The result will be merged on the time base.

Due to the fact, that these systems will operate in moving vehicles or are carried around, they have to be ruggedly constructed. However, all local laws concerning industrial and/or road safety regulations have to be satisfied.

The manufacturer shall provide a system manual, which shows the setup of the system. For easy identifying, elements of the system have to be labelled. Labels on all cables and connectors shall simplify the operation of the system.

7.6.2 Telephony Speech

The MQT for Speech has to provide software, which provides the means to generate the necessary calls or to answer automatically incoming calls from the FQT.

The received speech sample is measured via the analogue output of the User Equipment, as consequence the hardware setup of the system has to include the necessary electrical adaptation between certain User Equipments and the controller (soundcard).

The call generator of the MQT shall establish speech call as specified in ETSI TS 102 250-5 [5].

The hardware setup of such a system is essential for the correctness of the measured QoS Parameters. The system includes a UE specific part, which is responsible for the electrical adaptation of the audio output of the handset to the input of the soundcard of the controller.

7.6.3 Telephony Video:

The MQT for Video has to provide a call generator, which generates automatically calls as specified in ETSI TS 102 250-5 [5] or to answer automatically incoming calls from the FQT. The system has to be capable to provide the following measurement methods:

- Video Telephony using the User Equipments application; or
- Video Telephony using a Video Telephony Stack on the PC.

7.7 MQT for store-and-forward services

See clause 6.6.

7.8 MQT for Data Measurements

7.8.1 Common Aspects

Data Measurements require a client on the MQT side for the different applications. These clients can be either part of the MQT application or an external application, remote controlled by the MQT. However, the MQT has to log the type and configuration of the client used for the measurement.

7.8.2 MQT for FTP

The used FTP client has to support the following points:

- Active/Passive Mode.
- Common Firewall support.
- Downloading from subdirectories.
- Uploading to subdirectories.

7.8.3 MQT for E-Mail

The E-Mail Client has to support POP3 and SMTP or IMAP for sending and receiving E-Mails.

7.8.4 MQT for HTTP

The used HTTP client (browser) has to support all common HTTP versions. The client has to download an implemented static version of one of the ETSI reference webpages:

<http://portal.etsi.org/TBSiteMap/STQ/HTLMReferenceWebPage.aspx>. For details see [i.1].

7.8.5 MQT for WAP

The WAP client shall support all common WAP versions. The used WAP version has to be logged.

7.8.6 MQT for streaming services

The MQT has to support the required streaming clients.

8 Mobile based measurement equipment

The functionalities of the MQT as described in the clause 7 can also be realized on a single mobile phone. In such mobile based measurement equipment different types of QoS tests can run and test results can be logged for post processing. Mobile based measurement equipment may be controlled by an application, remotely or may be operated by a person.

This type of equipment is for further study.

Annex A (informative): QoS parameter export

A.1 Overview

Goal of this file format is to have a common interface to be able to interchange measurement result between systems of different vendors. Data should be provided on the highest possible level of granularity to support the QoS Parameters defined in ETSI TS 102 250-1 [2] and ETSI TS 102 250-2 [3] by keeping the possibility to select by time, geographical position and operator information.

The file format is XML. The present document describes the used XML bodies and tags.

All relevant IDs for trigger points and QoS Parameters can be found in ETSI TS 102 250-1 [2].

A.2 XML Bodies

A.2.1 <measurement>

This is the root of the XML document.

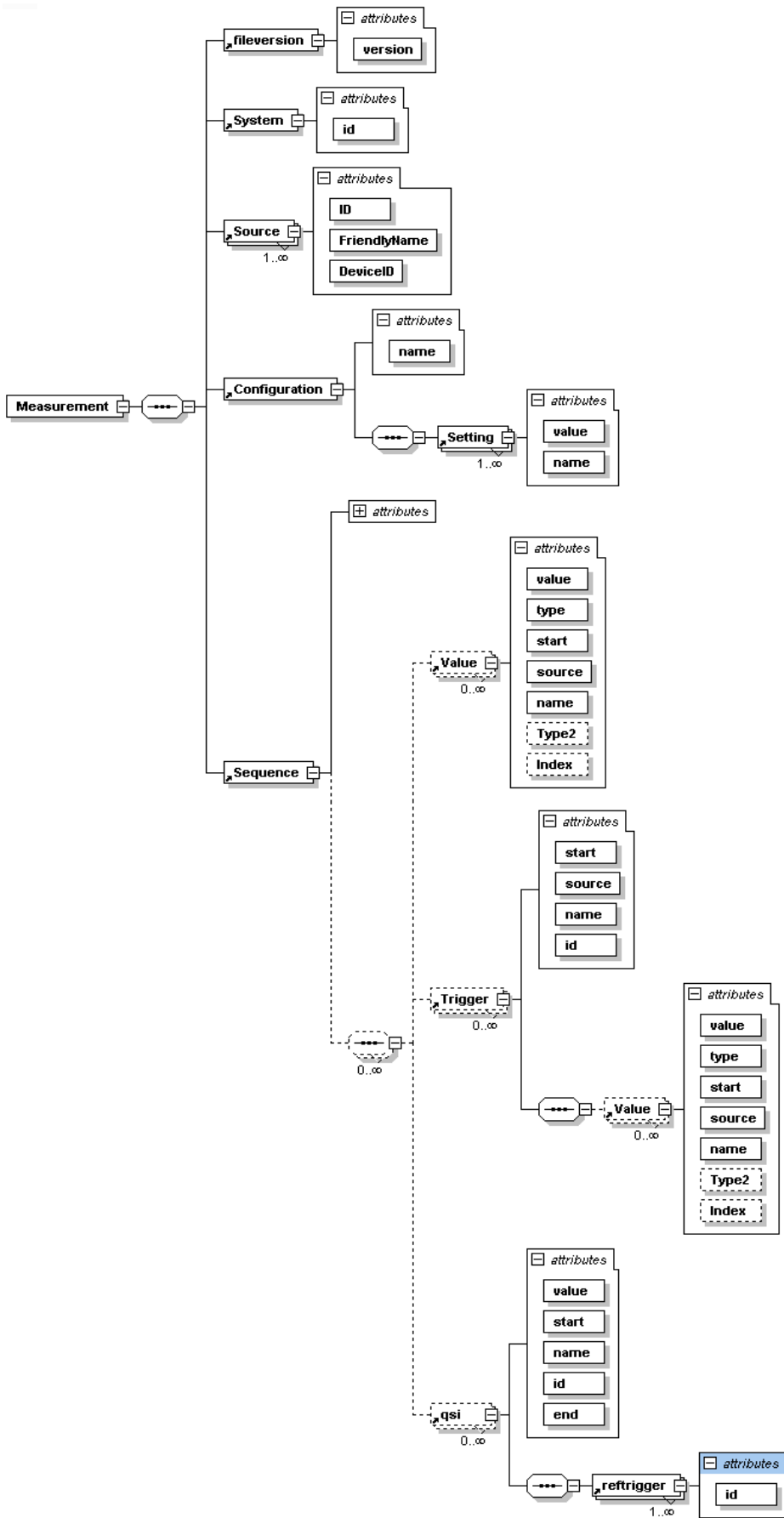

Figure A.1

A.2.2 Configuration

A.2.2.1 <fileversion>

Version of the file definition.

Version	Version number of the document ETSI TS 102 250-4. E.g. 1.2.1.
---------	---

EXAMPLE: <fileversion version = "1.2.1"/>

XML Schema:

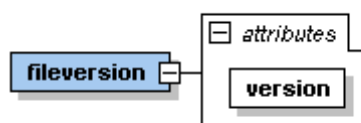

Figure A.2

A.2.2.2 <system>

Name of the measurement system

Id	A unique id of the measurement system.
----	--

EXAMPLE: <system id = "A Measurement System"/>

XML Schema:

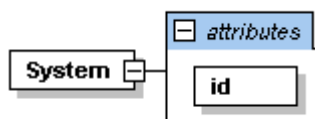

Figure A.3

A.2.2.3 <source>

A source can be any source of measurement data.

Id	A unique id of the data source within the XML file.
FriendlyNam	The friendly name of the device.
DeviceID	Unique Device ID, e.g. IMEI/IMSI.

EXAMPLE: <source id = "1" FriendlyName = "Mobile A" DeviceID="1234567890" >

XML Schema:

Figure A.4

A.2.2.4 <setting>

A setting is one special parameter of the measurement setup of a logical part of the system.

Name	Name of the Setting.
Value	Value of Setting.

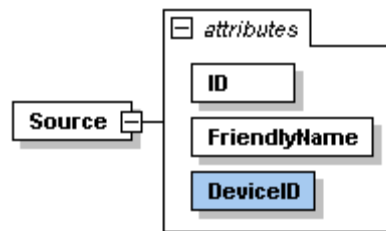
EXAMPLE: `<Setting name="POST_ATTACH_PAUSE" value="15 000"/>`

XML Schema:

See clause A.2.2.5.

A.2.2.5 <configuration>

The configuration container holds all settings concerning a logical part of the system.

Name	Name of the Settings Container.
------	---------------------------------

EXAMPLE: `< configuration name="Service"/>`

XML Schema:

Figure A.5

A.2.3 Measurement Results

A.2.3.1 <sequence>

A sequence contains all relevant data which is necessary for one measurement cycle. The tag is mandatory.

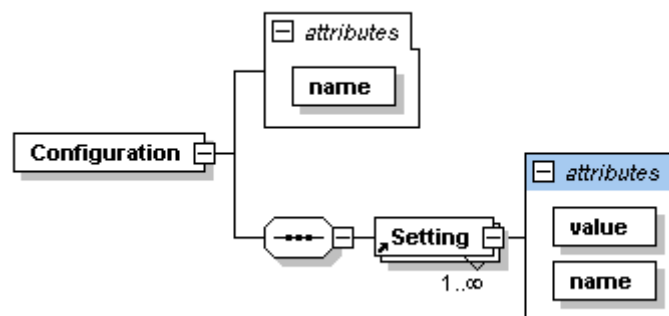
Start	Start time of sequence.
End	End time of sequence.
Id	Id of sequence.

EXAMPLE: `<Sequence start="2007-01-25T15:18:25.405+01:00" end="2007-01-25T15:23:35.982+01:00" id="0005883"/>`

XML Schema:

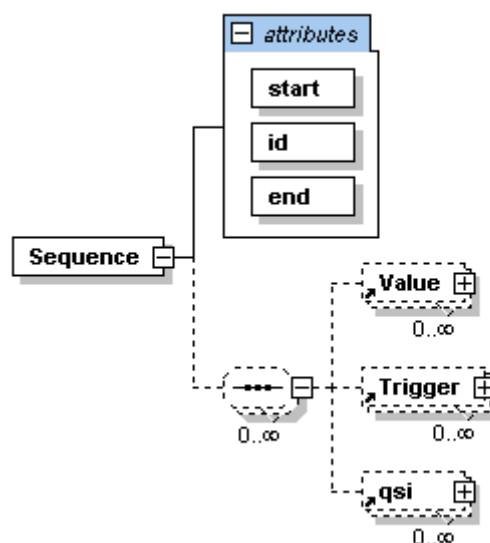

Figure A.6

A.2.3.2 <trigger>

A trigger point as defined in ETSI TS 102 250-1 [2]. The tag is mandatory.

Start	Time when trigger occurred.
Name	Trigger Name, as specified in [2].
Id	Id of trigger.
Source	ID of source.

EXAMPLE: `<Trigger name="attach attempt" start="2007-01-25T14:19:16.222" id="ID-0-51" source="1"/>`

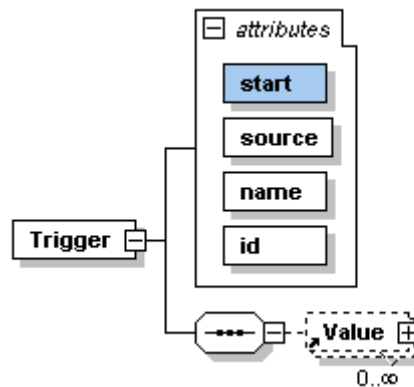
XML Schema:**Figure A.7****A.2.3.3 <reftrigger>**

A reference to an already reported trigger point. This allows to report the full information of the trigger point once, and to refer to this report later. The tag is optional.

Id	Id of trigger.
----	----------------

EXAMPLE: `<REFTRIGGER ID=" ID-1-53" />`

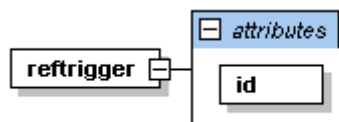
XML Schema:**Figure A.8****A.2.3.4 <qsi>**

A Quality Sequence Indicator is a quality of service parameter of the test sequence, as defined in ETSI TS 102 250-1 [2]. The tag is optional.

Start	Start time of qsi calculation.
End	End time of qsi calculation.
Name	Name, as specified in [2].
Id	Id of qsi.
Value	Value of QSI.

EXAMPLE: `<QSI name="CCR" start="2007-01-25T14:19:16.222" end="2007-01-25T14:19:19.358" value="0" id="ID-1-53"/>`

XML Schema:

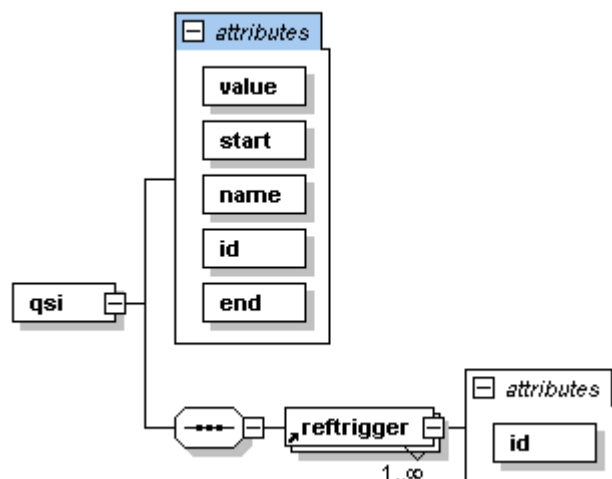

Figure A.9

A.2.3.5 <value>

A measurement value can be any value, which was measured during the measurement cycle. The tag is optional.

Start	Timestamp.
Name	Value Name.
Value	Value of value.
Type	Type of value attribute.
Type2	Optional attribute, which may be necessary for interpreting the value.
Source	ID of source.
Index	Index of an Array.

Type	Description
NUMBER	Number without unit for general purpose
BLOB	Binary Dump, The values is a HEX dump, e.g.: A1B204
STRING	Text for general purpose
BOOL	Boolean

EXAMPLE 1: `<Value name="GSM_MOBILE~SERVERREPORT~MCC " start="2007-01-25T14:18:26.647" value="262" type="NUMBER" source="1" />`

EXAMPLE 2: `<Value name="GPS_SYSTEM~LLAPOSITION~LONGITUDE" start="2007-01-25T14:18:26.647" value="11.6" type="NUMBER" source="1"/>`

XML Schema:

Figure A.10

A.2.4 Data Dictionary

A.2.4.1 Overview

The following data dictionary defines measurement values which can be added to the export file. If a one of these values becomes a trigger point, it should not be removed from the list. The trigger point should be defined as additional information.

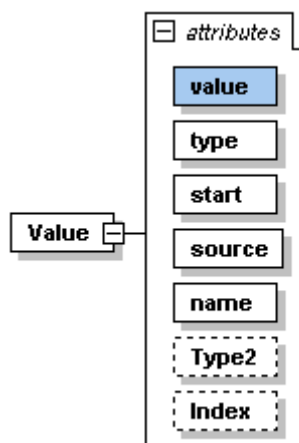
Other, not defined, values may be exported as well. Their names have to be marked clearly by the prefix USERData~. E.g. USERData~newvalue1.

NOTE: If the vendor e.g. wants to add a version, it can create an item:

- USERData~Version.

A.2.4.2 GPS

Name	Unit	Remarks
GPS_SYSTEM~LLAPOSITION~LATITUDE	°	Latitude (WGS84)
GPS_SYSTEM~LLAPOSITION~LONGITUDE	°	Longitude (WGS84)
GPS_SYSTEM~LLAPOSITION~ALTITUDE	M	Altitude
GPS_SYSTEM~LLAPOSITION~GPS_DISTANCE	M	Driven Distance
GPS_SYSTEM~SPEEDINFO~SPEED	km/h	Speed
GPS_SYSTEM~SPEEDINFO~HEADING	°	Heading

A.2.4.3 GSM

Name	Unit	Remarks
GSM_MOBILE~SERVERREPORT~BCCH	ChanNr	BCCH
GSM_MOBILE~SERVERREPORT~BSIC	---	BSIC
GSM_MOBILE~SERVERREPORT~RxLevF	Step	Rx Lev Full
GSM_MOBILE~SERVERREPORT~RxLevS	Step	Rx Lev Sub
GSM_MOBILE~SERVERREPORT~RxQualF	---	Rx Qual Full
GSM_MOBILE~SERVERREPORT~RxQualS	---	Rx Qual Sub
GSM_MOBILE~SERVERREPORT~C1	---	C1 Criteria
GSM_MOBILE~SERVERREPORT~C2	---	C2 Criteria
GSM_MOBILE~SERVERREPORT~SVR_AVG_C_I	dB	Average C/I
GSM_MOBILE~SERVERREPORT~CELLBARFLAG	---	Cellbar Flag
GSM_MOBILE~SERVERREPORT~MCC	---	MCC
GSM_MOBILE~SERVERREPORT~MNC	---	MNC
GSM_MOBILE~SERVERREPORT~LAC	---	LAC
GSM_MOBILE~SERVERREPORT~CI	---	Cell Identity
GSM_MOBILE~SERVERREPORT~TIMESLOT	---	Used Timeslot
GSM_MOBILE~SERVERREPORT~TIMINGADVANCE	Step	Timing Advance
GSM_MOBILE~SERVERREPORT~TSC	---	Trainings Sequence
GSM_MOBILE~SERVERREPORT~TXPOWER	---	Tx Power
GSM_MOBILE~SERVERREPORT~DTX	---	DTX On/Off
GSM_MOBILE~SERVERREPORT~HOPPING	---	Hopping On/Off
GSM_MOBILE~SERVERREPORT~TRAFFICCHANNEL	---	Used Traffic Channel, if Hopping is off
GSM_MOBILE~SERVERREPORT~MAIO	---	MAIO
GSM_MOBILE~SERVERREPORT~HSN	---	HSN
GSM_MOBILE~SERVERREPORT~SERVINGCELL	---	Name of the serving cell
GSM_MOBILE~SERVERREPORT~FER_Full	%	FER Full
GSM_MOBILE~SERVERREPORT~FER_Sub	%	FER Sub
GSM_MOBILE~PACKET_SERVERREPORT~P_SVR_RA_COLOUR	---	RA Color
GSM_MOBILE~PACKET_SERVERREPORT~P_SVR_RXLEVEL	Step	GPRS Rx Lev
GSM_MOBILE~PACKET_SERVERREPORT~P_SVR_C31	---	C31 Criteria
GSM_MOBILE~PACKET_SERVERREPORT~P_SVR_C32	---	C32 Criteria
GSM_MOBILE~PACKET_SERVERREPORT~P_SVR_N_BCCH	---	BCCH of neighbour, Array for n neighbours
GSM_MOBILE~PACKET_SERVERREPORT~P_SVR_N_NCC	---	BCC of neighbour, Array for n neighbours
GSM_MOBILE~PACKET_SERVERREPORT~P_SVR_N_BCC	---	NCC of neighbour, Array for n neighbours
GSM_MOBILE~PACKET_SERVERREPORT~P_SVR_N_RA_COLOUR	---	RA Color of neighbour, Array for n neighbours
GSM_MOBILE~PACKET_SERVERREPORT~P_SVR_N_RX_LEVEL	Step	GPRS RxLev of neighbour, Array for n neighbours
GSM_MOBILE~PACKET_SERVERREPORT~P_SVR_N_C31	---	C31 Criteria of neighbour, Array for n neighbours
GSM_MOBILE~PACKET_SERVERREPORT~P_SVR_N_C32	---	C32 Criteria of neighbour, Array for n neighbours

Name	Unit	Remarks
GSM_MOBILE~PACKET_SERVERREPORT~P_SVR_N_GPRS_RX_LEV_ACCESS_MIN	Step	GPRS_RX_LEV_ACCESS_MIN of neighbour, Array for n neighbours
GSM_MOBILE~PACKET_SERVERREPORT~P_SVR_N_GPRS_MS_TXPWR_MAX_CCH	---	GPRS_MS_TXPWR_MAX_CCH of neighbour, Array for n neighbours
GSM_MOBILE~PACKET_SERVERREPORT~P_SVR_N_HCS_THR	Step	HCS_THR of neighbour, Array for n neighbours
GSM_MOBILE~PACKET_SERVERREPORT~P_SVR_N_PRIORITY_CLASS	---	PRIORITY_CLASS of neighbour, Array for n neighbours
GSM_MOBILE~PACKET_SERVERREPORT~P_SVR_N_PSI1_REPEAT_PERIOD	---	PSI1_REPEAT_PERIOD of neighbour, Array for n neighbours
GSM_MOBILE~PACKET_SERVERREPORT~P_SVR_N_PBCCH_LOCATION	---	PBCCH_LOCATION of neighbour, Array for n neighbours
GSM_MOBILE~PACKET_SERVERREPORT~P_SVR_N_GPRS_INDICATOR	---	GPRS_INDICATOR of neighbour, Array for n neighbours
GSM_MOBILE~PACKET_SERVERREPORT~P_SVR_N_PBCCH_Indicator	---	PBCCH_Indicator of neighbour, Array for n neighbours
GSM_MOBILE~PACKET_SERVERREPORT~P_SVR_N_GPRS_PENALTY_TIME	---	GPRS_PENALTY_TIME of neighbour, Array for n neighbours
GSM_MOBILE~PACKET_SERVERREPORT~P_SVR_N_GPRS_RESELECT_OFFSET	---	GPRS_RESELECT_OFFSET of neighbour, Array for n neighbours
GSM_MOBILE~PACKET_SERVERREPORT~P_SVR_N_GPRS_TEMPORARY_OFFSET	---	GPRS_TEMPORARY_OFFSET of neighbour, Array for n neighbours
GSM_MOBILE~MEASUREMENTREPORT~MMR_N_BCCH	---	BCCH of neighbour, Array for n neighbours
GSM_MOBILE~MEASUREMENTREPORT~MMR_N_RXLEV	Step	Rx Lev of neighbour, Array for n neighbours
GSM_MOBILE~MEASUREMENTREPORT~MMR_N_BSIC	---	BSIC of neighbour, Array for n neighbours
GSM_MOBILE~MEASUREMENTREPORT~MMR_N_C1	---	C1 Criteria of neighbour, Array for n neighbours
GSM_MOBILE~MEASUREMENTREPORT~MMR_N_C2	---	C2 Criteria of neighbour, Array for n neighbours
GSM_MOBILE~MEASUREMENTREPORT~NEIGHBOURCELL	---	Name of neighbour, Array for n neighbours
GSM_MOBILE~LAYER3~L3MESSAGE	---	Byte Stream of message

A.2.4.4 UMTS

Name	Unit	Remarks
UMTS_MOBILE~UMTS_MOBILE_LAYER_1~UMTS_MOBILE_LAYER_1_RSCP_CPICH	dBm	RSCP
UMTS_MOBILE~UMTS_MOBILE_LAYER_1~UMTS_MOBILE_LAYER_1_RSSI_UTRA	dBm	RSSI
UMTS_MOBILE~UMTS_MOBILE_LAYER_1~UMTS_MOBILE_LAYER_1_EcNo_CPICH	dB	Ec/No of CPICH
UMTS_MOBILE~UMTS_MOBILE_LAYER_1~	dBm	Tx Power

Name	Unit	Remarks
UMTS_MOBILE_LAYER_1_Tx_POWER		
UMTS_MOBILE~UMTS_MOBILE_LAYER_1~ UMTS_MOBILE_LAYER_1_TCH_BLER	%	TrCH BLER
UMTS_MOBILE~UMTS_MOBILE_LAYER_1~ UMTS_MOBILE_LAYER_1_UL_INTERFERENCE	dBm	UL Interference
UMTS_MOBILE~UMTS_MOBILE_LAYER_1~ UMTS_MOBILE_LAYER_1_DF_DL	SF	Spreading Factor Downlink
UMTS_MOBILE~UMTS_MOBILE_LAYER_1~ UMTS_MOBILE_LAYER_1_DF_UL	SF	Spreading Factor Uplink
UMTS_MOBILE~UMTS_MOBILE_LAYER_1~ UMTS_MOBILE_LAYER_1_UL_ARFCN		UARFCN UL
UMTS_MOBILE~UMTS_MOBILE_LAYER_1~ UMTS_MOBILE_LAYER_1_DL_ARFCN		UARFCN DL
UMTS_MOBILE~UMTS_MOBILE_LAYER_1~ UMTS_MOBILE_LAYER_1_SC	---	Scrambling Code from 0...8191.
UMTS_MOBILE~UMTS_MOBILE_LAYER_1~ UMTS_MOBILE_LAYER_1_HSDPA	---	HSDPA is active
UMTS_MOBILE~UMTS_MOBILE_LAYER_1~ UMTS_MOBILE_LAYER_1_HSUPA	---	HSUPA is active
UMTS_MOBILE~UMTS_MOBILE_LAYER_1~ UMTS_MOBILE_LAYER_1_NODEB	---	Name of current best Node B
UMTS_MOBILE~UMTS_MOBILE_LAYER_3~ UMTS_MOBILE_L3_RRC_STATE	---	"Unknown", "CELL FACH", "CELL DCH", "CELL PCH", "URA PCH"
UMTS_MOBILE~UMTS_MOBILE_LAYER_3~ UMTS_MOBILE_L3_SC_NAME	---	Name of the cell
UMTS_MOBILE~UMTS_MOBILE_LAYER_3~ UMTS_MOBILE_L3_CELL_ID	---	16 bit cell ID
UMTS_MOBILE~UMTS_MOBILE_LAYER_3~ UMTS_MOBILE_L3_CELL_ID_28BIT	---	28 bit cell ID
UMTS_MOBILE~UMTS_MOBILE_LAYER_3~ UMTS_MOBILE_L3_LAC	---	LAC
UMTS_MOBILE~UMTS_MOBILE_LAYER_3~ UMTS_MOBILE_L3_MNC	---	MNC
UMTS_MOBILE~UMTS_MOBILE_LAYER_3~ UMTS_MOBILE_L3_MCC	---	MCC
UMTS_MOBILE~UMTS_MOBILE_LAYER_3~ UMTS_MOBILE_L3_URA_ID	---	URA ID
UMTS_MOBILE~UMTS_MOBILE_AS~ UMTS_MOBILE_AS_SC_NAME	---	Name of the cell
UMTS_MOBILE~UMTS_MOBILE_AS~ UMTS_MOBILE_AS_COUNT	---	when in CELL_DCH
UMTS_MOBILE~UMTS_MOBILE_AS~ UMTS_MOBILE_AS_DL_UARFCN		UARFCN
UMTS_MOBILE~UMTS_MOBILE_AS~AS_SC	---	Scrambling Code, Array for n members of the active set

Name	Unit	Remarks
UMTS_MOBILE~UMTS_MOBILE_AS~AS_Eclo	dB	Ec/No, Array for n members of the active set
UMTS_MOBILE~UMTS_MOBILE_AS~AS_RSCP	dBm	RSCP, Array for n members of the active set
UMTS_MOBILE~UMTS_MOBILE_AS~AS_NODEB	---	Name of Node B, Array for n members of the active set
UMTS_MOBILE~UMTS_MOBILE_NS~UMTS_MOBILE_NS_COUNT	---	Number of cells in neighbour set
UMTS_MOBILE~UMTS_MOBILE_NS~NS_SC_0	---	Scrambling Code, Array for n members of the neighbour set
UMTS_MOBILE~UMTS_MOBILE_NS~NS_Eclo_0	dB	Ec/No, Array for n members of the neighbour set
UMTS_MOBILE~UMTS_MOBILE_NS~NS_RSCP_0	dBm	RSCP, Array for n members of the neighbour set
UMTS_MOBILE~UMTS_MOBILE_NS~NS_STATE_0	---	Current State of neighbour. Array for n members of the neighbour set. Possible values: "Active", "Serving", "Monitored", "Detected", "Undetected", "Not Listed or Detected"
UMTS_MOBILE~UMTS_MOBILE_NS~NS_NODEB_0	---	Name of Node B, Array for n members of the neighbour set
UMTS_MOBILE~UMTS_MOBILE_NS~NS_UARFCN_0	---	UARFCN of Node B, Array for n members of the neighbour set
UMTS_MOBILE~UMTS_MOBILE_FINGER_INFO~UMTS_MOBILE_FINGER_INFO_1_Eb_lo	dB	Ec/No of finger, Array for n fingers
UMTS_MOBILE~UMTS_MOBILE_FINGER_INFO~UMTS_MOBILE_FINGER_INFO_1_SC	---	Scrambling Code of Finger, Array for n fingers
UMTS_MOBILE~UMTS_MOBILE_FINGER_INFO~UMTS_MOBILE_FINGER_INFO_1_TO	---	Offset of finger, Array for n fingers
UMTS_MOBILE~UMTS_MOBILE_RRC_MSG~UMTS_MOBILE_RRC_MSG_CONTENT	---	See clause A.2.4.3

A.2.4.5 Layer 3 Message PDU Types

The attribute Type2 of the value tag has to be set to one of the following values:

Type of PDU	Type 2
umts_r6_DL_DCCH_Message_PDU	1
umts_r6_UL_DCCH_Message_PDU	2
umts_r6_DL_CCCH_Message_PDU	3

Type of PDU	Type 2
umts_r6_UL_CCCH_Message_PDU	4
umts_r6_PCCH_Message_PDU	5
umts_r6_DL_SHCCH_Message_PDU	6
umts_r6_UL_SHCCH_Message_PDU	7
umts_r6_BCCH_FACH_Message_PDU	8
umts_r6_BCCH_BCH_Message_PDU	9
umts_r6_MCCH_Message_PDU	10
umts_r6_MSCH_Message_PDU	11
umts_r6_HandoverToUTRANCommand_PDU	12
umts_r6_InterRATHandoverInfo_PDU	13
umts_r6_InterRATHandoverInfo_r3_add_ext_IEs_PDU	14
umts_r6_RRCConnectionSetupComplete_r3_add_ext_IEs_PDU	15
umts_r6_UECapabilityInformation_r3_add_ext_IEs_PDU	16
umts_r6_UE_CapabilityContainer_IEs_PDU	17
umts_r6_UE_RadioAccessCapabilityInfo_PDU	18
umts_r6_UL_PhysChCapabilityFDD_r6_PDU	19
umts_r6_TFC_Subset_ID_With3b_PDU	20
umts_r6_TFC_Subset_ID_With5b_PDU	21
umts_r6_TFC_Subset_ID_With10b_PDU	22
umts_r6_DL_CCTrChTPCList_PDU	23
umts_r6_Event1b_r6_PDU	24
umts_r6_MasterInformationBlock_PDU	25
umts_r6_SysInfoType1_PDU	26
umts_r6_SysInfoType2_PDU	27
umts_r6_SysInfoType3_PDU	28
umts_r6_SysInfoType4_PDU	29
umts_r6_SysInfoType5bis_PDU	30
umts_r6_SysInfoType6_PDU	31
umts_r6_SysInfoType7_PDU	32
umts_r6_SysInfoType8_PDU	33
umts_r6_SysInfoType9_PDU	34
umts_r6_SysInfoType10_PDU	35
umts_r6_SysInfoType11_PDU	36
umts_r6_SysInfoType12_PDU	37
umts_r6_SysInfoType13_PDU	38
umts_r6_SysInfoType13_1_PDU	39
umts_r6_SysInfoType13_2_PDU	40
umts_r6_SysInfoType13_3_PDU	41
umts_r6_SysInfoType13_4_PDU	42
umts_r6_SysInfoType14_PDU	43
umts_r6_SysInfoType15_PDU	44
umts_r6_SysInfoType15_1_PDU	45
umts_r6_SysInfoType15_2_PDU	46
umts_r6_SysInfoType15_3_PDU	47
umts_r6_SysInfoType15_4_PDU	48
umts_r6_SysInfoType15_5_PDU	49

Type of PDU	Type 2
umts_r6_SysInfoType16_PDU	50
umts_r6_SysInfoType17_PDU	51
umts_r6_SysInfoType18_PDU	52
umts_r6_SysInfoTypeSB1_PDU	53
umts_r6_SysInfoTypeSB2_PDU	54
umts_r6_MBMS_PREFERRED_FREQ_REQUEST_r6_PDU	55
umts_r6_ToTargetRNC_Container_PDU	56
umts_r6_TargetRNC_ToSourceRNC_Container_PDU	57
umts_r6_SRNC_RelocationInfo_v3h0ext_IEs_PDU	58

A.2.4.6 HSDPA

Name	Unit	Remarks
UMTS_MOBILE~UMTS_HSDPA_DECODE_SUM~UMTS_MOBILE_HSDPA_DEMOD_VALIDS	%	Decode Success Rate
UMTS_MOBILE~UMTS_HSDPA_DECODE_SUM~UMTS_MOBILE_HSDPA_DSCH_PASSED	%	DSCH Passed Rate
UMTS_MOBILE~UMTS_HSDPA_DECODE_SUM~UMTS_MOBILE_HSDPA_DSCH_FAILED	%	DSCH Failed Rate
UMTS_MOBILE~UMTS_HSDPA_DECODE_SUM~UMTS_MOBILE_HSDPA_DSCH_DTX	%	DSCH DTX Rate
UMTS_MOBILE~UMTS_HSDPA_DECODE_SUM~UMTS_MOBILE_HSDPA_RE_TRANSMISSION	%	Retransmission Rate
UMTS_MOBILE~UMTS_HSDPA_DECODE_SUM~UMTS_MOBILE_HSDPA_QPSK	%	SCCH QPSK Rate
UMTS_MOBILE~UMTS_HSDPA_DECODE_SUM~UMTS_MOBILE_HSDPA_16QAM	Bits	SCCH 16QAM Rate
UMTS_MOBILE~UMTS_HSDPA_DECODE_SUM~UMTS_MOBILE_HSDPA_MAX_TBS	Bits	Max Transport Block Size
UMTS_MOBILE~UMTS_HSDPA_DECODE_SUM~UMTS_MOBILE_HSDPA_MIN_TBS	Bits	Min Transport Block Size
UMTS_MOBILE~UMTS_HSDPA_DECODE_SUM~UMTS_MOBILE_HSDPA_AVG_TBS	---	Average Transport Block Size
UMTS_MOBILE~UMTS_HSDPA_DECODE_SUM~UMTS_MOBILE_HSDPA_MAX_CHAN	---	SCCH Max # Codes
UMTS_MOBILE~UMTS_HSDPA_DECODE_SUM~UMTS_MOBILE_HSDPA_MIN_CHAN	---	SCCH Min # Codes
UMTS_MOBILE~UMTS_HSDPA_DECODE_SUM~UMTS_MOBILE_HSDPA_AVG_CHAN	---	SCCH Average # Codes
UMTS_MOBILE~UMTS_HSDPA_DECODE_SUM~UMTS_MOBILE_HSDPA_SCCH_TP	kbit/s	SCCH Throughput When Served
UMTS_MOBILE~UMTS_HSDPA_DECODE_SUM~UMTS_MOBILE_HSDPA_SCCH_TP_SCHEDULED	kbit/s	SCCH Throughput When Scheduled

Name	Unit	Remarks
UMTS_MOBILE~UMTS_HSDPA_DECODE_SUM~ UMTS_MOBILE_HSDPA_SCCH_TP_MAC	kbit/s	MAC Throughput
UMTS_MOBILE~UMTS_HSDPA_DECODE_SUM~ UMTS_MOBILE_HSDPA_SCCH_BLER	%	BLER
UMTS_MOBILE~UMTS_HSDPA_ACK_NACK_STAT~ UMTS_MOBILE_HSDPA_ACK_NACK_SAMPLES		Count of ACK/NACK Samples
UMTS_MOBILE~UMTS_HSDPA_ACK_NACK_STAT~ UMTS_MOBILE_HSDPA_ACK_PERCENTAGE	%	ACK Rate
UMTS_MOBILE~UMTS_HSDPA_ACK_NACK_STAT~ UMTS_MOBILE_HSDPA_NACK_PERCENTAGE	%	NACK Rate
UMTS_MOBILE~UMTS_HSDPA_ACK_NACK_STAT~ UMTS_MOBILE_HSDPA_DTX_PERCENTAGE	%	DTX Rate
UMTS_MOBILE~UMTS_HSDPA_CQI_STAT_2~ UMTS_MOBILE_HSDPA_CQI2_SAMPLES	---	Count of CQI Samples
UMTS_MOBILE~UMTS_HSDPA_CQI_STAT_2~ UMTS_MOBILE_HSDPA_CQI2_TIME_SPAN	Ms	Time Span of measurement
UMTS_MOBILE~UMTS_HSDPA_CQI_STAT_2~ UMTS_MOBILE_HSDPA_CQI2_MIN	---	Min. CQI
UMTS_MOBILE~UMTS_HSDPA_CQI_STAT_2~ UMTS_MOBILE_HSDPA_CQI2_MAX	---	Max. CQI
UMTS_MOBILE~UMTS_HSDPA_CQI_STAT_2~ UMTS_MOBILE_HSDPA_CQI2_MIN_CODE	---	Min. number of Codes
UMTS_MOBILE~UMTS_HSDPA_CQI_STAT_2~ UMTS_MOBILE_HSDPA_CQI2_MAX_CODE	---	Max. number of Codes
UMTS_MOBILE~UMTS_HSDPA_CQI_STAT_2~ UMTS_MOBILE_HSDPA_CQI2_TP	kbit/s	Requested Throughput
UMTS_MOBILE~UMTS_HSDPA_CQI_STAT_2~ UMTS_MOBILE_HSDPA_CQI2_AVG	---	Average CQI
UMTS_MOBILE~UMTS_HSDPA_CQI_STAT_2~ UMTS_MOBILE_HSDPA_CQI2_AVG_CODE	---	Average number of Codes
UMTS_MOBILE~UMTS_HSDPA_CQI_STAT_2~ UMTS_MOBILE_HSDPA_CQI2_QPSK	%	Requested QPSK Rate
UMTS_MOBILE~UMTS_HSDPA_CQI_STAT_2~ UMTS_MOBILE_HSDPA_CQI2_16QAM	%	Requested 16QAM Rate

A.2.4.7 HSUPA

Name	Unit	Remarks
UMTS_MOBILE~UMTS_HSUPA_EDPCH_SUMMERY~ UMTS_MOBILE_HSUPA_HAPPY_RATE	%	HappyRate
UMTS_MOBILE~RN_UMTS_MOBILE_HSUPA_EDCH_SUMME RY_EV~UMTS_MOBILE_HSUPA_CHANBIT_RATE	kbit/s	Channelbit Rate

Name	Unit	Remarks
UMTS_MOBILE~RN_UMTS_MOBILE_HSUPA_EDCH_SUMME RY_EV~UMTS_MOBILE_HSUPA_TBS_RATE	kbit/s	TBS Bit Rate
UMTS_MOBILE~RN_UMTS_MOBILE_HSUPA_EDCH_SUMME RY_EV~UMTS_MOBILE_HSUPA_1ST_TX_TBS_RATE	kbit/s	1st Tx TBS Bit Rate
UMTS_MOBILE~UMTS_HSUPA_EDPCH_SUMMERY~ UMTS_MOBILE_HSUPA_TTI	---	TTI, 2 ms or 10 ms
UMTS_MOBILE~UMTS_HSUPA_EDPCH_SUMMERY~ UMTS_MOBILE_HSUPA_MIN_RE_TX	%	Min. Retransmission
UMTS_MOBILE~UMTS_HSUPA_EDPCH_SUMMERY~ UMTS_MOBILE_HSUPA_MAX_RE_TX	%	Max. Retransmission
UMTS_MOBILE~UMTS_HSUPA_EDPCH_SUMMERY~ UMTS_MOBILE_HSUPA_AVG_RE_TX	%	Avg. Retransmission
UMTS_MOBILE~UMTS_HSUPA_EDPCH_SUMMERY~ UMTS_MOBILE_HSUPA_MIN_NDATA	---	Min. Channelbits
UMTS_MOBILE~UMTS_HSUPA_EDPCH_SUMMERY~ UMTS_MOBILE_HSUPA_MAX_NDATA	---	Max. Channelbits
UMTS_MOBILE~UMTS_HSUPA_EDPCH_SUMMERY~ UMTS_MOBILE_HSUPA_AVG_NDATA	---	Avg. Channelbits
UMTS_MOBILE~RN_UMTS_MOBILE_HSUPA_EDCH_SUMME RY_EV~UMTS_MOBILE_HSUPA_MIN_TBS	---	Min. TBS
UMTS_MOBILE~RN_UMTS_MOBILE_HSUPA_EDCH_SUMME RY_EV~UMTS_MOBILE_HSUPA_MAX_TBS	---	Max. TBS
UMTS_MOBILE~RN_UMTS_MOBILE_HSUPA_EDCH_SUMME RY_EV~UMTS_MOBILE_HSUPA_AVG_TBS	---	Avg. TBS
UMTS_MOBILE~UMTS_HSUPA_CELLS~ UMTS_MOBILE_HSUPA_CS_NUMBER	---	# of Cells in the Cell Set
UMTS_MOBILE~UMTS_HSUPA_CELLS~ UMTS_MOBILE_HSUPA_CS_COMB_ACK_TP	kbit/s	Comb. Ack'd Throughput
UMTS_MOBILE~UMTS_HSUPA_CELLS~ UMTS_MOBILE_HSUPA_CS_SCH_COMB_ACK_TP	kbit/s	Scheduled Throughput
UMTS_MOBILE~UMTS_HSUPA_CELLS~ UMTS_MOBILE_HSUPA_CS_COMB_ACK	%	Comb. ACK Rate
UMTS_MOBILE~UMTS_HSUPA_CELLS~ UMTS_MOBILE_HSUPA_CS_COMB_NACK	%	Comb. NACK Rate
UMTS_MOBILE~UMTS_HSUPA_CELLS~ UMTS_MOBILE_HSUPA_CS_NS_ACK_RATE	%	NS ACK Rate
UMTS_MOBILE~UMTS_HSUPA_CELLS~ UMTS_MOBILE_HSUPA_CS_COMB_HIGH_SUCCESS	%	Comb. HIGH Success Rate
UMTS_MOBILE~UMTS_HSUPA_CELLS~ UMTS_MOBILE_HSUPA_CS_COMB_UP	%	Comb. UP Rate
UMTS_MOBILE~UMTS_HSUPA_CELLS~ UMTS_MOBILE_HSUPA_CS_COMB_DOWN	%	Comb. DOWN Rate
UMTS_MOBILE~UMTS_HSUPA_CELLS~ UMTS_MOBILE_HSUPA_CS_COMB_HOLD	%	Comb. HOLD Rate
UMTS_MOBILE~UMTS_HSUPA_CELLS~	---	Min. SG Index

Name	Unit	Remarks
UMTS_MOBILE_HSUPA_CS_MIN_SG_INDEX		
UMTS_MOBILE~UMTS_HSUPA_CELLS~UMTS_MOBILE_HSUPA_CS_MAX_SG_INDEX	---	Max. SG Index
UMTS_MOBILE~UMTS_HSUPA_CELLS~UMTS_MOBILE_HSUPA_CS_AVG_SG_INDEX	---	Avg. SG Index
UMTS_MOBILE~UMTS_HSUPA_CELLS~UMTS_MOBILE_HSUPA_CS_MIN_LUPR_INDEX	---	Min. LUPR Index
UMTS_MOBILE~UMTS_HSUPA_CELLS~UMTS_MOBILE_HSUPA_CS_MAX_LUPR_INDEX	---	Max. LUPR Index
UMTS_MOBILE~UMTS_HSUPA_CELLS~UMTS_MOBILE_HSUPA_CS_AVG_LUPR_INDEX	---	Avg. LUPR Index
UMTS_MOBILE~UMTS_HSUPA_CELLS~UMTS_MOBILE_HSUPA_CS_DTX	%	DTX Rate
UMTS_MOBILE~UMTS_HSUPA_CELLS~UMTS_MOBILE_HSUPA_CS_HAPPY	%	Happy Rate
UMTS_MOBILE~UMTS_HSUPA_CELLS~UMTS_MOBILE_HSUPA_CS_MIN_RE_TX_COUNT	---	Min. Retransmission Count
UMTS_MOBILE~UMTS_HSUPA_CELLS~UMTS_MOBILE_HSUPA_CS_MAX_RE_TX_COUNT	---	Max. Retransmission Count
UMTS_MOBILE~UMTS_HSUPA_CELLS~UMTS_MOBILE_HSUPA_CS_AVG_RE_TX_COUNT	---	Avg. Retransmission Count
UMTS_MOBILE~UMTS_HSUPA_CELLS~UMTS_MOBILE_HSUPA_CS_LTD_PWR	---	Ltd. by Power Rate
UMTS_MOBILE~UMTS_HSUPA_CELLS~UMTS_MOBILE_HSUPA_CS_LTD_SG	---	Ltd. by SG Rate
UMTS_MOBILE~UMTS_HSUPA_CELLS~UMTS_MOBILE_HSUPA_CS_LTD_BUFFER	---	Ltd. by Buffer Occ. Rate
UMTS_MOBILE~UMTS_HSUPA_CELLS~UMTS_MOBILE_HSUPA_CS_LTD_MUX	%	Non-Serving HOLD Rate
UMTS_MOBILE~UMTS_HSUPA_CELLS~UMTS_MOBILE_HSUPA_CS_LTD_HARQ	%	Non-Serving DOWN Rate
UMTS_MOBILE~UMTS_HSUPA_CELLS~HSUPA_RLS_SC_0	---	Serving Cell SC
UMTS_MOBILE~UMTS_HSUPA_CELLS~RLS_ID_0	---	Serving Cell RLS IDX
UMTS_MOBILE~UMTS_HSUPA_CELLS~RLS_RSCP_0	dBm	Serving Cell RSCP
UMTS_MOBILE~UMTS_HSUPA_CELLS~RLS_EcIo_0	dB	Serving Cell Ec/Io
UMTS_MOBILE~UMTS_HSUPA_CELLS~RLS_ACKD_TP_0	kbit/s	Serving Cell ACK'd Throughput
UMTS_MOBILE~UMTS_HSUPA_CELLS~RLS_ACK_0	---	Serving Cell ACK Rate
UMTS_MOBILE~UMTS_HSUPA_CELLS~RLS_NACK_0	---	Serving Cell NACK Rate
UMTS_MOBILE~UMTS_HSUPA_CELLS~RLS_HICH_SUC_0	---	Serving Cell HICH Success Rate
UMTS_MOBILE~UMTS_HSUPA_CELLS~RLS_UP_0	---	Serving Cell UP Rate
UMTS_MOBILE~UMTS_HSUPA_CELLS~RLS_DOWN_0	---	Serving Cell DOWN Rate
UMTS_MOBILE~UMTS_HSUPA_CELLS~RLS_HOLD_0	---	Serving Cell HOLD Rate
UMTS_MOBILE~UMTS_HSUPA_CELLS~RLS_MIN_AG_0	---	Serving Cell Min. AG Value
UMTS_MOBILE~UMTS_HSUPA_CELLS~RLS_MAX_AG_0	---	Serving Cell Max. AG Value
UMTS_MOBILE~UMTS_HSUPA_CELLS~RLS_AVG_AG_0	---	Serving Cell Avg. AG Value

Name	Unit	Remarks
UMTS_MOBILE~UMTS_HSUPA_CELLS~HSUPA_RLS_SC_1	---	Non-serving CellSC, Array of 0..3 cells
UMTS_MOBILE~UMTS_HSUPA_CELLS~RLS_ID_1	---	Non-serving CellRLSIDX, Array of 0..3 cells
UMTS_MOBILE~UMTS_HSUPA_CELLS~RLS_RSCP_1	dBm	Non-serving CellRSCP, Array of 0..3 cells
UMTS_MOBILE~UMTS_HSUPA_CELLS~RLS_Eclo_1	dB	Non-serving CellEclo, Array of 0..3 cells
UMTS_MOBILE~UMTS_HSUPA_CELLS~RLS_ACKD_TP_1	kbit/s	Non-serving CellACKdThroughput, Array of 0..3 cells
UMTS_MOBILE~UMTS_HSUPA_CELLS~RLS_ACK_1	---	Non-serving CellACKRate, Array of 0..3 cells
UMTS_MOBILE~UMTS_HSUPA_CELLS~RLS_NACK_1	---	Non-serving CellNACKRate, Array of 0..3 cells
UMTS_MOBILE~UMTS_HSUPA_CELLS~RLS_HICH_SUC_1	---	Non-serving CellHICHSuccessRate, Array of 0..3 cells
UMTS_MOBILE~UMTS_HSUPA_CELLS~RLS_UP_1	---	Non-serving CellUPRate, Array of 0..3 cells
UMTS_MOBILE~UMTS_HSUPA_CELLS~RLS_DOWN_1	---	Non-serving CellDOWNRate, Array of 0..3 cells
UMTS_MOBILE~UMTS_HSUPA_CELLS~RLS_HOLD_1	---	Non-serving CellHOLDRate, Array of 0..3 cells
UMTS_MOBILE~UMTS_HSUPA_RETX_STATISTIC~UMTS_MOBILE_HSUPA_1_RX	%	Rate of n th Transmission was successful, Array of 0...15

A.3 Schema

The schema representation contained in an ASCII file (ETSIQoSExport.xsd contained in archive ts_10225004v020301p0.zip) which accompanies the present document.

A.4 Example

```

<Measurement xmlns:xsi="http://www.w3.org/2001/XMLSchema-instance"
xsi:noNamespaceSchemaLocation="ETSIQoSExport.xsd">
  <fileversion version="1.2.1"/>
  <System id="any"/>
  <Source FriendlyName="Etna" ID="1" DeviceID="MOB_1234567890"/>
  <Source FriendlyName="GPS" ID="0" DeviceID="GPS_1234567890"/>
  <Configuration name="Network">
    <Setting name="Desired Operator" value="26202"/>
    <Setting name="Desired APN" value="web.vodafone.de"/>
    <Setting name="Force APN" value="0"/>
    <Setting name="Network Type" value="UMTS first, CS and PS"/>
    <Setting name="Net Type" value="umts_pref"/>
    <Setting name="MIN_NET_AVAIL_TIME" value="75"/>
    <Setting name="TO_SI_13" value="30"/>
  </Configuration>
  <Sequence start="2007-01-25T15:18:25.405+01:00" end="2007-01-25T15:23:35.982+01:00" id="0005883">
    <Value name="USERData~aslkdhl" start="2007-01-25T14:18:25.572" value="11.58" type="NUMBER"
source="0"/>
    <Value name="GPS_SYSTEM~LLAPOSITION~LONGITUDE" start="2007-01-25T14:18:25.572"
value="11.58" type="NUMBER" source="0"/>
    <Value name="GPS_SYSTEM~LLAPOSITION~LATITUDE" start="2007-01-25T14:18:25.572"
value="48.11" type="NUMBER" source="0"/>
    <Trigger name="TRG001" start="2007-01-25T14:18:57.582" id="ID-0-29" source="1">
      <Value name="GSM_MOBILE~SERVERREPORT~MCC" start="2007-01-25T14:18:26.647"
value="262" type="NUMBER" source="1"/>
      <Value name="GSM_MOBILE~SERVERREPORT~MNC" start="2007-01-25T14:18:26.647"
value="2" type="NUMBER" source="1"/>
      <Value name="GSM_MOBILE~SERVERREPORT~LAC" start="2007-01-25T14:18:26.647"
value="12" type="NUMBER" source="1"/>
      <Value name="GSM_MOBILE~SERVERREPORT~CI" start="2007-01-25T14:18:26.647"
value="1" type="NUMBER" source="1"/>
      <Value name="GSM_MOBILE~SERVERREPORT~RxLevF" start="2007-01-25T14:18:57.572"
value="-103" type="NUMBER" source="1"/>
    </Trigger>
    <Trigger name="TRG002" start="2007-01-25T14:18:58.582" id="ID-0-30" source="1">
      <Value name="GSM_MOBILE~SERVERREPORT~MCC" start="2007-01-25T14:18:26.647"
value="262" type="NUMBER" source="1"/>
      <Value name="GSM_MOBILE~SERVERREPORT~MNC" start="2007-01-25T14:18:26.647"
value="2" type="NUMBER" source="1"/>
      <Value name="GSM_MOBILE~SERVERREPORT~LAC" start="2007-01-25T14:18:26.647"
value="12" type="NUMBER" source="1"/>
      <Value name="GSM_MOBILE~SERVERREPORT~CI" start="2007-01-25T14:18:26.647"
value="1" type="NUMBER" source="1"/>
      <Value name="GSM_MOBILE~SERVERREPORT~RxLevF" start="2007-01-25T14:18:57.572"
value="-93" type="NUMBER" source="1"/>
    </Trigger>
    <qsi name="QOS PARAMETERSxxx" start="2007-01-25T14:18:57.582" end="2007-01-25T14:18:59.665"
value="2.083" id="ID-0-31">
      <reftrigger id="ID-0-29"/>
      <reftrigger id="ID-0-30"/>
    </qsi>
    <Value name="GPS_SYSTEM~LLAPOSITION~LONGITUDE" start="2007-01-25T14:18:59.572"
value="11.6" type="NUMBER" source="0"/>
    <Value name="GPS_SYSTEM~LLAPOSITION~LATITUDE" start="2007-01-25T14:18:59.572"
value="48.1" type="NUMBER" source="0"/>
    <Value name="GSM_MOBILE~MEASUREMENTREPORT~MMR_N_BCCH" start="2007-01-25T14:18:59.572"
value="120" type="NUMBER" source="0" Index="0"/>
    <Value name="UMTS_MOBILE~UMTS_MOBILE_RRC_MSG~UMTS_MOBILE_RRC_MSG_CONTENT"
start="2007-01-25T14:18:59.572" value="01030ABC" type="BLOB" source="0" Type2="1"/>
  </Sequence>
</Measurement>

```

Annex B (informative): RF COMBINER

B.1 What is blocking?

Definition (ETSI ETS 300 607-1 [8]).

Blocking is a measure of the ability of the receiver to receive a wanted input signal in the presence of an unwanted input signal, without exceeding a given degradation. The degradation is measured in reduction of sensitivity of the receiver (up to complete loss). In case of GSM, the effect only happens if the two test mobiles use the same time slot or fractions of it.

B.2 Which parameters have an impact on the effect of blocking?

- **The selectivity of the receiver (Hardware)**

Minimum requirements for selectivity are defined in the corresponding standards. Better selectivity of a receiver increases the costs of the receiver.

- **The level of the unwanted signal**

- **The level of the wanted signal**

The wanted signal is transmitted from the base station to the test mobile. The level of the received signal depends on propagation.

B.3 The Standards

Rx blocking analysis for ETSI ETS 300 607-1 [8].

Frequency	Blocking Level GSM900 in dB	Blocking Level GSM1800 in dB
835 MHz to < 915 MHz	0	
> 1 000 MHz to 12,75 GHz	-23	
100 KHz to 1 705 MHz		0
> 1 920 MHz to 1 980 MHz		-10

Rx blocking analysis for WCDMA TS 125 101 [9], table 7.7 Out of Band blocking (extract).

Parameter	Unit	Frequency Range 3
DPCH_Ec	dBm/3,84 MHz	-114
I _{or}	dBm/3,84 MHz	-103,7
I blocking (CW)	dBm	-15
F _{uw}	MHz	1 < f < 2 025 2 255 < f < 1 2750
UE transmitted mean power	dBm	20/18 (for Power class 3/2)

Possible interactions:

Receiver Wanted Signal	Transmitter Unwanted Signal	Rec. blocking at dBm	Transmit. Pwr. dBm	Min att. no blocking dB
GSM 900	GSM 900	0	33	33
GSM 900	GSM 1800	-23	30	53
GSM 900	UMTS	-23	18	41
GSM 1800	GSM 900	0	33	33
GSM 1800	GSM 1800	-10	30	40
GSM 1800	UMTS	-10	18	28
UMTS	GSM 900	-15	33	48
UMTS	GSM 1800	-15	30	45
UMTS	UMTS	-15	18	33

B.4 The Situation

B.4.1 One test mobile transmits, the other one receives

The two are connected to the same combiner. Will there be any problems? The combiner isolates the two test mobiles by 20 dB and attenuates the wanted (and the transmitting) signal by 8 dB. In order to prevent blocking, the isolation between the units, using the same time slot, should be higher than 53 dB. When the wanted signal is weak the receiver will show blocking effects. The weak wanted signal will be suppressed by the strong unwanted and reception will no longer be possible. If another channel with sufficient radio level (RxLev) is available, then the test mobile may change the serving cell. If there is no stronger wanted signal available, then the call will drop.

B.4.2 Antennas on the roof of a car

Since the same technical specification of the receiver is applicable, the problem of potential blocking remains basically the same. In order to be on the safe side, the distance between two test mobiles should be 5 m to 10 m (Interpreting the standards, the 53 dB). If the distance between two antennas is greater than approximately 1 m, then the isolation of the test mobiles will be higher than the isolation by means of a combiner.

But if there is no combiner used then the wanted and transmitted signals are not attenuated.

(Worst case: weak wanted signal, high transmitting power unwanted signal and overlapping GSM time slots). In WCDMA technology the necessary isolation has to be 48 dB (2,5 m to 5 m). There is no time slot overlap.

B.4.3 Conclusion

In the real world, distances of approximately 5 m between antennas are not practicable. Even at higher cost, etc.

B.5 Possible Solutions

B.5.1 Overview - Attenuators

Depending on the purpose of the test (urban vs. rural, coverage vs. benchmarking), the method chosen for combining the test mobiles should be different. In case of benchmarking tests in urban areas, the use of combiners might not significantly influence the results due to the small cell design, resulting in very high dynamics of the network and many handovers. In rural areas, the range of the system is a dominant issue. Additional loss of the wanted signal in a combiner leads to a considerable risk of losing calls. This is due to the combination of a weak wanted signal with the high output power of the transmitting test mobile.

Refer to ETSI TR 102 581 [i.1] for recommendations regarding the usage of attenuators.

B.5.2 Recommendations

B.5.2.1 Benchmarking tests

The most reliable results will be obtained if no combiners are used. However, when using combiners in an urban environment, no significant influence is to be expected.

B.5.2.2 Coverage tests

The use of combiners and/or attenuators is not recommended (8 dB attenuation reduces the coverage down to 25 % to 50 %). In order to avoid time slot collisions, only one network should be tested at any one time.

B.5.3 Other equipment involved

B.5.3.1 Scanners

Although scanners delivered have an outstanding dynamic range, the filters used have limitations. This makes the scanner vulnerable to blocking.

B.5.3.2 GPS receiver 1,2/1,5 GHz

GPS receivers usually use high gain antennas. This fact makes them sensitive for blocking (the distance between the satellite and the GPS receiver is approximately 20 000 km).

B.5.3.3 Risk for Scanner and GPS receiver

Malfunction of scanner and GPS might be possible, depending on the transmit power of the test equipment. Antennas for scanners and GPS receiver should be spaced to the practical maximum.

B.5.4 Mixed Service GSM/WCDMA

Separate antennas for GSM and WCDMA are recommended, with maximum possible spacing.

Annex C (informative): Bibliography

Void.

History

Document history		
V1.1.1	October 2003	Publication
V1.2.1	July 2007	Publication
V1.3.1	March 2009	Publication
V2.2.1	April 2011	Publication
V2.3.1	November 2019	Publication