

# ETSI TS 102 442-5 V1.1.1 (2006-11)

---

*Technical Specification*

**Satellite Earth Stations and Systems (SES);  
Satellite Component of UMTS/IMT-2000;  
Multimedia Broadcast/Multicast Services;  
Part 5: Performances over the radio Interface**

---



---

Reference

DTS/SES-00250-5

---

Keywords

broadcast, IMT-2000, performance, satellite,  
service, UMTS

**ETSI**

650 Route des Lucioles  
F-06921 Sophia Antipolis Cedex - FRANCE

Tel.: +33 4 92 94 42 00 Fax: +33 4 93 65 47 16

Siret N° 348 623 562 00017 - NAF 742 C  
Association à but non lucratif enregistrée à la  
Sous-Préfecture de Grasse (06) N° 7803/88

---

**Important notice**

Individual copies of the present document can be downloaded from:

<http://www.etsi.org>

The present document may be made available in more than one electronic version or in print. In any case of existing or perceived difference in contents between such versions, the reference version is the Portable Document Format (PDF). In case of dispute, the reference shall be the printing on ETSI printers of the PDF version kept on a specific network drive within ETSI Secretariat.

Users of the present document should be aware that the document may be subject to revision or change of status. Information on the current status of this and other ETSI documents is available at

<http://portal.etsi.org/tb/status/status.asp>

If you find errors in the present document, please send your comment to one of the following services:

[http://portal.etsi.org/chaicor/ETSI\\_support.asp](http://portal.etsi.org/chaicor/ETSI_support.asp)

---

**Copyright Notification**

No part may be reproduced except as authorized by written permission.  
The copyright and the foregoing restriction extend to reproduction in all media.

© European Telecommunications Standards Institute 2006.  
All rights reserved.

**DECT™**, **PLUGTESTS™** and **UMTS™** are Trade Marks of ETSI registered for the benefit of its Members.  
**TIPHON™** and the **TIPHON logo** are Trade Marks currently being registered by ETSI for the benefit of its Members.  
**3GPP™** is a Trade Mark of ETSI registered for the benefit of its Members and of the 3GPP Organizational Partners.

# Contents

Intellectual Property Rights .....	4
Foreword.....	4
Introduction .....	4
1 Scope .....	6
2 References .....	6
3 Definitions and abbreviations.....	6
3.1 Definitions .....	6
3.2 Abbreviations .....	7
4 Performance requirement .....	7
4.1 General .....	7
4.2 Demodulation of FACH in static propagation conditions .....	7
4.2.1 Minimum requirement .....	7
4.3 Demodulation of FACH in multi-path fading conditions.....	8
4.3.1 ITU Models A, B, C.....	8
4.3.1.1 Minimum requirement - LOS.....	8
4.3.1.2 Minimum requirement – NLOS .....	9
4.3.2 Combined satellite and transparent IMR .....	10
4.3.3 Combined satellite and regenerative IMR .....	13
4.3.4 IMR only.....	14
4.3.5 Aeronautical.....	14
4.4 Demodulation of FACH in satellite diversity mode .....	15
4.4.1 Minimum requirement .....	15
4.5 Detection of Broadcast Channel (BCH) .....	16
4.5.1 Minimum requirement .....	16
4.6 Demodulation of Paging Channel (PCH) .....	17
4.6.1 Minimum requirement .....	17
<b>Annex A (normative): Measurement channels.....</b>	<b>19</b>
A.1 General .....	19
A.2 Downlink reference measurement channel .....	19
A.2.1 DL reference measurement channel (8 kbps) .....	19
A.2.2 DL reference measurement channel (32 kbps) .....	20
A.2.3 DL reference measurement channel (64 kbps) .....	21
A.2.4 DL reference measurement channel (128 kbps) .....	22
A.2.5 DL reference measurement channel (256 kbps) .....	23
A.2.6 DL reference measurement channel (384 kbps) .....	24
A.3 DL reference parameters for PCH tests.....	25
<b>Annex B (normative): Propagation conditions.....</b>	<b>26</b>
B.1 Propagation conditions .....	26
B.1.1 Static propagation condition.....	26
B.1.2 Multi-path fading propagation conditions .....	26
B.1.2.1 Satellite channels .....	26
B.1.2.2 Combined Satellite and IMR channels.....	27
<b>Annex C (informative): Bibliography.....</b>	<b>28</b>
History .....	29

---

## Intellectual Property Rights

IPRs essential or potentially essential to the present document may have been declared to ETSI. The information pertaining to these essential IPRs, if any, is publicly available for **ETSI members and non-members**, and can be found in ETSI SR 000 314: "*Intellectual Property Rights (IPRs); Essential, or potentially Essential, IPRs notified to ETSI in respect of ETSI standards*", which is available from the ETSI Secretariat. Latest updates are available on the ETSI Web server (<http://webapp.etsi.org/IPR/home.asp>).

Pursuant to the ETSI IPR Policy, no investigation, including IPR searches, has been carried out by ETSI. No guarantee can be given as to the existence of other IPRs not referenced in ETSI SR 000 314 (or the updates on the ETSI Web server) which are, or may be, or may become, essential to the present document.

---

## Foreword

This Technical Specification (TS) has been produced by ETSI Technical Committee Satellite Earth Stations and Systems (SES).

The present document is part 5 of a multi-part deliverable covering Satellite Earth Stations and Systems (SES); Satellite Component of UMTS/IMT-2000; Multimedia Broadcast/Multicast Services, as identified below:

- Part 1: "Services definitions";
- Part 2: "Architecture and functional description";
- Part 3: "Introduction in the Radio Access Network (RAN)";
- Part 4: "Interworking with terrestrial UMTS networks";
- Part 5: "Performances over the radio interface";**
- Part 6: "Security".

---

## Introduction

S-UMTS stands for the Satellite component of the Universal Mobile Telecommunication System. S-UMTS systems will complement the terrestrial UMTS (T-UMTS) and inter-work with other IMT-2000 family members through the UMTS core network. S-UMTS will be used to deliver 3<sup>rd</sup> generation mobile satellite services (MSS) utilizing either low (LEO) or medium (MEO) earth orbiting, or geostationary (GEO) satellite(s). S-UMTS systems are based on terrestrial 3GPP specifications and will support access to GSM/UMTS core networks.

NOTE 1: The term T-UMTS will be used in the present document to further differentiate the Terrestrial UMTS component.

Due to the differences between terrestrial and satellite channel characteristics, some modifications to the terrestrial UMTS (T-UMTS) standards are necessary. Some specifications are directly applicable, whereas others are applicable with modifications. Similarly, some T-UMTS specifications do not apply, whilst some S-UMTS specifications have no corresponding T-UMTS specification.

- Since S-UMTS is derived from T-UMTS, the organization of the S-UMTS specifications closely follows the original 3<sup>rd</sup> Generation Partnership Project (3GPP) structure.

An S-UMTS system is defined by the combination of a family of S-UMTS specifications and 3GPP specifications, as follows:

- If an S-UMTS specification exists it takes precedence over the corresponding 3GPP specification (if any). This precedence rule applies to any references in the corresponding 3GPP specifications.

NOTE 2: Any references to 3GPP specifications within the S-UMTS specifications are not subject to this precedence rule. For example, an S-UMTS specification may contain specific references to the corresponding 3GPP specification.

- If an S-UMTS specification does not exist, the corresponding 3GPP specification may or may not apply. The exact applicability of the complete list of 3GPP specifications shall be defined at a later stage.

---

# 1 Scope

The scope of the present document is to establish UE minimum performances for Satellite Multimedia Broadcast/Multicast Service.

The present document is applicable to UE that conform to TS 101 851 parts [1] to [3] and to RF characteristics specified in TS 125 101 [4].

The UE shall meet the specified performances for all S-MBMS services supported.

---

# 2 References

The following documents contain provisions which, through reference in this text, constitute provisions of the present document.

- References are either specific (identified by date of publication and/or edition number or version number) or non-specific.
- For a specific reference, subsequent revisions do not apply.
- For a non-specific reference, the latest version applies.

Referenced documents which are not found to be publicly available in the expected location might be found at <http://docbox.etsi.org/Reference>.

NOTE: While any hyperlinks included in this clause were valid at the time of publication ETSI cannot guarantee their long term validity.

- [1] ETSI TS 101 851-1: "Satellite Earth Stations and Systems (SES); Satellite Component of UMTS/IMT2000; G-family; Part 1: Physical channels and mapping of transport channels into physical channels (S-UMTS-A 25.211)".
  - [2] ETSI TS 101 851-2: "Satellite Earth Stations and Systems (SES); Satellite Component of UMTS/IMT2000; G-family; Part 2: Multiplexing and channel coding (S-UMTS-A 25.212)".
  - [3] ETSI TS 101 851-4: "Satellite Earth Stations and Systems (SES); Satellite Component of UMTS/IMT2000; G-family; Part 4: Physical layer procedures (S-UMTS-A 25.214)".
  - [4] ETSI TS 125 101: "Universal Mobile Telecommunications System (UMTS); User Equipment (UE) radio transmission and reception (FDD) (3GPP TS 25.101)".
- 

# 3 Definitions and abbreviations

## 3.1 Definitions

For the purposes of the present document, the terms and definitions given in [2] and the following apply:

**Block Error Rate:** error rate of the transport (data) blocks passed by the physical layer to MAC layer for a given transport channel (i.e. physical layer error rate)

**Transmission Time Interval:** interval of time over which a transport block is transmitted; multiple transport blocks may be transmitted in a transmission time interval per transport channel

## 3.2 Abbreviations

For the purposes of the present document, the following abbreviations apply:

AWGN	Additive White Gaussian Noise
BCH	Broadcast CHannel
BER	Bit Error Ratio
BER	Block Error Rate
BLER	BLOCK Error Ratio
DL	DownLink
FACH	Forward Access CHannel
IMR	Intermediate Module Repeater
LOS	Line Of Sight
NA	Not Applicable
NLOS	No Line Of Sight
PCH	Paging Channel
P-CPICH	Primary-Common Pilot CHannel
S-CCPCH	Secondary-Common Control Physical CHannel
S-MBMS	Satellite-Multimedia Broadcast/Multicast Service
TFCI	Transport Format Combination Indicator
TFCS	Transport Format Combination Set
TrCH	Transport CHannel
TTI	Transmission Time Interval
UE	User Equipment

---

## 4 Performance requirement

### 4.1 General

The performance requirements for the UE in this clause are specified for the measurement channels specified in annex A, the propagation conditions specified in annex B.

### 4.2 Demodulation of FACH in static propagation conditions

The receive characteristic of the Forward Access CHannel (FACH) in the static environment is determined by the BLOCK Error Ratio (BLER). BLER is specified for each individual data rate of the FACH. FACH is mapped into the Secondary Common Control Physical CHannel (S-CCPCH).

#### 4.2.1 Minimum requirement

For the parameters specified in table 4.1 the average downlink  $\frac{SCCPCH_{-}E_c}{I_{or}}$  power ratio shall be below the specified value for the BLER shown in table 4.7. These requirements are applicable for TFCS size 16.

**Table 4.1: FACH parameters in static propagation conditions**

Parameter	Unit	Test 1	Test 2	Test 3	Test 4	Test 5	Test 6
Phase reference		P-CPICH					
$\hat{I}_{or}/I_{oc}$	dB	-1					
$I_{oc}$	dBm/3,84 MHz	-60					
Information Data Rate	kbps	8	32	64	128	256	384

Table 4.2: FACH requirements in static propagation conditions

Test Number	$\frac{SCCPCH\_E_c}{I_{or}}$	BLER
1	-19,6 dB	$10^{-2}$
2	-15,8 dB	$10^{-2}$
3	-12,8 dB	$10^{-2}$
4	-10,3 dB	$10^{-2}$
5	-7,5 dB	$10^{-2}$
6	-5,3 dB	$10^{-2}$

## 4.3 Demodulation of FACH in multi-path fading conditions

Demodulation performance requirements are specified in both LOS view of the satellite signal, i.e. in presence of Rice channel at 3 km/h and 250 km/h and NLOS view of the satellite signal, Rayleigh channel at 3 km/h and 50 km/h.

### 4.3.1 ITU Models A, B, C

#### 4.3.1.1 Minimum requirement - LOS

$$\frac{SCCPCH\_E_c}{I_{or}}$$

For the parameters specified in table 4.3 the average downlink  $\frac{SCCPCH\_E_c}{I_{or}}$  power ratio shall be below the specified value for the BLER shown in tables 4.4, 4.5 and 4.6. These requirements are applicable for TFCS size 16.

Table 4.3: FACH parameters in ITU A, B, C LOS propagation conditions

Parameter	Unit	Test 1	Test 2	Test 3	Test 4	Test 5	Test 6
Phase reference		P-CPICH					
$\hat{I}_{or}/I_{oc}$	dB	-3	-3	-3	9	9	9
$I_{oc}$	dBm/3,84 MHz	-60					
UE speed	km/h	3					
Information Data Rate	kbps	8	32	64	128	256	384
Parameter	Unit	Test 7	Test 8	Test 9	Test 10	Test 11	Test 12
Phase reference		P-CPICH					
$\hat{I}_{or}/I_{oc}$	dB	-3	-3	-3	9	9	9
$I_{oc}$	dBm/3,84 MHz	-60					
UE speed	Km/h	250					
Information Data Rate	kbps	8	32	64	128	256	384

Table 4.4: FACH requirements in ITU A LOS propagation conditions

Test Number	$\frac{SCCPCH\_E_c}{I_{or}}$	BLER	Test Number	$\frac{SCCPCH\_E_c}{I_{or}}$	BLER
1	-16,6 dB	$10^{-2}$	7	-15,4 dB	$10^{-2}$
2	-12,8 dB	$10^{-2}$	8	-12,2 dB	$10^{-2}$
3	-9,8 dB	$10^{-2}$	9	-9,1 dB	$10^{-2}$
4	-19,5 dB	$10^{-2}$	10	-18,9 dB	$10^{-2}$
5	-16,4 dB	$10^{-2}$	11	-16,1 dB	$10^{-2}$
6	-14 dB	$10^{-2}$	12	-13,6 dB	$10^{-2}$



**Table 4.5: FACH requirements in ITU B LOS propagation conditions**

Test Number	$\frac{SCCPCH - E_c}{I_{or}}$	BLER	Test Number	$\frac{SCCPCH - E_c}{I_{or}}$	BLER
1	-16,1 dB	$10^{-2}$	7	-14,8 dB	$10^{-2}$
2	-12,3 dB	$10^{-2}$	8	-11,6 dB	$10^{-2}$
3	-9,3 dB	$10^{-2}$	9	-8,6 dB	$10^{-2}$
4	-19,2 dB	$10^{-2}$	10	-18,4 dB	$10^{-2}$
5	-15,8 dB	$10^{-2}$	11	-15,7 dB	$10^{-2}$
6	-13,3 dB	$10^{-2}$	12	-13,1 dB	$10^{-2}$

**Table 4.6: FACH requirements in ITU C LOS propagation conditions**

Test Number	$\frac{SCCPCH - E_c}{I_{or}}$	BLER	Test Number	$\frac{SCCPCH - E_c}{I_{or}}$	BLER
1	-14,8 dB	$10^{-2}$	7	-13 dB	$10^{-2}$
2	-11 dB	$10^{-2}$	8	-10,1 dB	$10^{-2}$
3	-8 dB	$10^{-2}$	9	-7,2 dB	$10^{-2}$
4	-18,2 dB	$10^{-2}$	10	-17,3 dB	$10^{-2}$
5	-14,1 dB	$10^{-2}$	11	-14,3 dB	$10^{-2}$
6	-11 dB	$10^{-2}$	12	-11 dB	$10^{-2}$

#### 4.3.1.2 Minimum requirement – NLOS

$$\frac{SCCPCH - E_c}{I_{or}}$$

For the parameters specified in table 4.7 the average downlink  $\frac{SCCPCH - E_c}{I_{or}}$  power ratio shall be below the specified value for the BLER shown in tables 4.8, 4.9 and 4.10. These requirements are applicable for TFCS size 16.

**Table 4.7: FACH parameters in ITU A NLOS propagation conditions**

Parameter	Unit	Test 1	Test 2	Test 3	Test 4	Test 5	Test 6
Phase reference		P-CPICH					
$\hat{I}_{or}/I_{oc}$	dB	9					
$I_{oc}$	dBm/3,84 MHz	-60					
UE speed	Km/h	3					
Information Data Rate	kbps	8	32	64	128	256	384
Parameter	Unit	Test 7	Test 8	Test 9	Test 10	Test 11	Test 12
Phase reference		P-CPICH					
$\hat{I}_{or}/I_{oc}$	dB	9					
$I_{oc}$	dBm/3,84 MHz	-60					
UE speed	Km/h	50					
Information Data Rate	kbps	8	32	64	128	256	384

**Table 4.8: FACH requirements in ITU A NLOS propagation conditions**

Test Number	$\frac{SCCPCH - E_c}{I_{or}}$	BLER	Test Number	$\frac{SCCPCH - E_c}{I_{or}}$	BLER
1	-15,8 dB	$10^{-2}$	7	-24,3 dB	$10^{-2}$
2	-11,4 dB	$10^{-2}$	8	-19,7 dB	$10^{-2}$
3	-8 dB	$10^{-2}$	9	-16,7 dB	$10^{-2}$
4	-10,5 dB	$10^{-2}$	10	-17,8 dB	$10^{-2}$
5	-1,6 dB	$10^{-2}$	11	-12 dB	$10^{-2}$
6	NA	$10^{-2}$	12	-6,5 dB	$10^{-2}$

**Table 4.9: FACH requirements in ITU B NLOS propagation conditions**

Test Number	$\frac{SCCPCH-E_c}{I_{or}}$	BLER	Test Number	$\frac{SCCPCH-E_c}{I_{or}}$	BLER
1	-17,2 dB	$10^{-2}$	7	-24,6 dB	$10^{-2}$
2	-12,7 dB	$10^{-2}$	8	-20,1 dB	$10^{-2}$
3	-9,3 dB	$10^{-2}$	9	-17,1 dB	$10^{-2}$
4	-11,3 dB	$10^{-2}$	10	-17,8 dB	$10^{-2}$
5	-3,1 dB	$10^{-2}$	11	-9,8 dB	$10^{-2}$
6	-0,4 dB	$10^{-2}$	12	-7,1 dB	$10^{-2}$

**Table 4.10: FACH requirements in ITU C NLOS propagation conditions**

Test Number	$\frac{SCCPCH-E_c}{I_{or}}$	BLER	Test Number	$\frac{SCCPCH-E_c}{I_{or}}$	BLER
1	-18 dB	$10^{-2}$	7	-24 dB	$10^{-2}$
2	-13,7 dB	$10^{-2}$	8	-19,7 dB	$10^{-2}$
3	-10,1 dB	$10^{-2}$	9	-16,5 dB	$10^{-2}$
4	-11,3 dB	$10^{-2}$	10	-16,4 dB	$10^{-2}$
5	-5,1 dB	$10^{-2}$	11	-10 dB	$10^{-2}$
6	-1,6 dB	$10^{-2}$	12	-7,1 dB	$10^{-2}$

### 4.3.2 Combined satellite and transparent IMR

For the parameters specified in tables 4.11, 4.13, 4.15, 4.17, 4.19, 4.21 the average downlink  $\frac{SCCPCH-E_c}{I_{or}}$  power ratio shall be below the specified value for the BLER shown in tables 4.12, 4.14, 4.16, 4.18, 4.20, and 4.22.

**Table 4.11: FACH parameters in combined satellite and transparent IMR propagation conditions; S-Case 1**

Parameter	Unit	Test 1	Test 2	Test 3	Test 4	Test 5	Test 6
Phase reference		P-CPICH					
$\hat{I}_{or}/I_{oc}$	dB	9					
$I_{oc}$	dBm/3,84 MHz	-60					
Information Data Rate	kbps	8	32	64	128	256	384

**Table 4.12: FACH requirements in combined satellite and transparent IMR propagation conditions; S-Case 1**

Test Number	$\frac{SCCPCH-E_c}{I_{or}}$	BLER
1	-18,5 dB	$10^{-2}$
2	-13,8 dB	$10^{-2}$
3	-10,3 dB	$10^{-2}$
4	-11,9 dB	$10^{-2}$
5	-5,1 dB	$10^{-2}$
6	-1,9 dB	$10^{-2}$

**Table 4.13: FACH parameters in combined satellite and transparent IMR propagation conditions; S-Case 2**

Parameter	Unit	Test 7	Test 8	Test 9	Test 10	Test 11	Test 12
Phase reference		P-CPICH					
$\hat{I}_{or}/I_{oc}$	dB	-3	-3	-3	3	6	6
$I_{oc}$	dBm/3,84 MHz	-60					
Information Data Rate	kbps	8	32	64	128	256	384

**Table 4.14: FACH requirements in combined satellite and transparent IMR propagation conditions; S-Case 2**

Test Number	$\frac{SCCPCH-E_c}{I_{or}}$	BLER
7	-9,6 dB	$10^{-2}$
8	-5,1 dB	$10^{-2}$
9	-1,8 dB	$10^{-2}$
10	-1,9 dB	$10^{-2}$
11	NA	$10^{-2}$
12	NA	$10^{-2}$

**Table 4.15: FACH parameters in combined satellite and transparent IMR propagation conditions; S-Case 3**

Parameter	Unit	Test 13	Test 14	Test 15	Test 16	Test 17	Test 18
Phase reference		P-CPICH					
$\hat{I}_{or}/I_{oc}$	dB	-3	-3	-3	3	6	6
$I_{oc}$	dBm/3,84 MHz	-60					
Information Data Rate	kbps	8	32	64	128	256	384

**Table 4.16: FACH requirements in combined satellite and transparent IMR propagation conditions; S-Case 3**

Test Number	$\frac{SCCPCH-E_c}{I_{or}}$	BLER
13	-14 dB	$10^{-2}$
14	-10,2 dB	$10^{-2}$
15	-7 dB	$10^{-2}$
16	-5,4 dB	$10^{-2}$
17	-4 dB	$10^{-2}$
18	-3,7 dB	$10^{-2}$

**Table 4.17: FACH parameters in combined satellite and transparent IMR propagation conditions; S-Case 4**

Parameter	Unit	Test 19	Test 20	Test 21	Test 22	Test 23	Test 24
Phase reference		P-CPICH					
$\hat{I}_{or}/I_{oc}$	dB	9					
$I_{oc}$	dBm/3,84 MHz	-60					
Information Data Rate	kbps	8	32	64	128	256	384

**Table 4.18: FACH requirements in combined satellite and transparent IMR propagation conditions; S-Case 4**

Test Number	$\frac{SCCPCH\_E_c}{I_{or}}$	BLER
19	-19,2 dB	$10^{-2}$
20	-16,8 dB	$10^{-2}$
21	-12,5 dB	$10^{-2}$
22	-11,4 dB	$10^{-2}$
23	-2,5 dB	$10^{-2}$
24	-1,4 dB	$10^{-2}$

**Table 4.19: FACH parameters in combined satellite and transparent IMR propagation conditions; S-Case 5**

Parameter	Unit	Test 25	Test 26	Test 27	Test 28	Test 29	Test 30
Phase reference		P-CPICH					
$\hat{I}_{or}/I_{oc}$	dB	9					
$I_{oc}$	dBm/3,84 MHz	-60					
Information Data Rate	kbps	8	32	64	128	256	384

**Table 4.20: FACH requirements in combined satellite and transparent IMR propagation conditions; S-Case 5**

Test Number	$\frac{SCCPCH\_E_c}{I_{or}}$	BLER
25	-18,7 dB	$10^{-2}$
26	-	$10^{-2}$
27	-11,9 dB	$10^{-2}$
28	-	$10^{-2}$
29	-	$10^{-2}$
30	-1,7 dB	$10^{-2}$

**Table 4.21: FACH parameters in combined satellite and transparent IMR propagation conditions; S-Case 6**

Parameter	Unit	Test 31	Test 32	Test 33	Test 34	Test 35	Test 36
Phase reference		P-CPICH					
$\hat{I}_{or}/I_{oc}$	dB	-3	-3	-3	3	6	6
$I_{oc}$	dBm/3,84 MHz	-60					
Information Data Rate	kbps	8	32	64	128	256	384

**Table 4.22: FACH requirements in combined satellite and transparent IMR propagation conditions; S-Case 6**

Test Number	$\frac{SCCPCH\_E_c}{I_{or}}$	BLER
31	-10,9 dB	$10^{-2}$
32	-8,6 dB	$10^{-2}$
33	-4,7 dB	$10^{-2}$
34	-2,9 dB	$10^{-2}$
35	NA	$10^{-2}$
36	NA	$10^{-2}$

### 4.3.3 Combined satellite and regenerative IMR

For the parameters specified in table 23, the average downlink  $\frac{SCCPCH\_E_c}{I_{or}}$  power ratio shall be below the specified value for the BLER shown in table 24.

**Table 4.23: FACH parameters in combined satellite and regenerative IMR propagation conditions; Soft combining**

Parameter	Unit	Test 1	Test 2	Test 3	Test 4	Test 5	Test 6	Test 7	Test 8
Phase reference		P-CPICH							
Cell path loss difference	DB	4							
Propagation environment		Pedestrian A		Vehicular A		Pedestrian A		Vehicular A	
UE Speed	km/h	3	50	3	50	3	50	3	50
Information Data Rate	Kbps	64	64	64	64	128	128	128	128

**Table 4.24: FACH requirements in combined satellite and regenerative IMR propagation conditions; Soft combining**

Test Number	$\frac{SCCPCH\_E_c}{I_{or}}$	BLER
1	-2,5 dB	$10^{-2}$
2	-7,7 dB	$10^{-2}$
3	-3,6 dB	$10^{-2}$
4	-7,2 dB	$10^{-2}$
5	-	$10^{-2}$
6	-4,8 dB	$10^{-2}$
7	-0,6 dB	$10^{-2}$
8	-4,3 dB	$10^{-2}$

### 4.3.4 IMR only

In case of IMR signal reception without view of satellite signal, which means propagation environment fully terrestrial, 3GPP MBMS requirements apply.

### 4.3.5 Aeronautical

For the parameters specified in table 4.25 the average downlink  $\frac{SCCPCH\_E_c}{I_{or}}$  power ratio shall be below the specified value for the BLER shown in table 4.26. These requirements are applicable for TFCS size 16.

**Table 4.25: FACH parameters in aeronautic propagation conditions**

Parameter	Unit	Test 1	Test 2	Test 3	Test 4	Test 5	Test 6
Phase reference		P-CPICH					
$\hat{I}_{or}/I_{oc}$	dB	9					
$I_{oc}$	dBm/3,84 MHz	-60					
Information Data Rate	kbps	8	32	64	128	256	384
Parameter	Unit	Test 7	Test 8	Test 9	Test 10	Test 11	Test 12
Phase reference		P-CPICH					
$\hat{I}_{or}/I_{oc}$	dB	-3					
$I_{oc}$	dBm/3,84 MHz	-60					
Information Data Rate	kbps	8	32	64	128	256	384

**Table 4.26: FACH requirements in aeronautic propagation conditions**

Test Number	$\frac{SCCPCH-E_c}{I_{or}}$	BLER	Test Number	$\frac{SCCPCH-E_c}{I_{or}}$	BLER
1	-26,3 dB	$10^{-2}$	7	-14,3 dB	$10^{-2}$
2	-23,4 dB	$10^{-2}$	8	-11,4 dB	$10^{-2}$
3	-20 dB	$10^{-2}$	9	-8 dB	$10^{-2}$
4	-17,8 dB	$10^{-2}$	10	-5,9 dB	$10^{-2}$
5	-15 dB	$10^{-2}$	11	-3 dB	$10^{-2}$
6	-12,8 dB	$10^{-2}$	12	-0,8 dB	$10^{-2}$

## 4.4 Demodulation of FACH in satellite diversity mode

### 4.4.1 Minimum requirement

$$\frac{SCCPCH-E_c}{I_{or}}$$

For the parameters specified in table 4.27 the average downlink  $\frac{SCCPCH-E_c}{I_{or}}$  power ratio shall be below the specified value for the BLER shown in tables 4.28, 4.29 and 4.30. These requirements are applicable for TFCS size 16.

**Table 4.27: FACH parameters during satellite diversity (ITU A NLOS)**

Parameter	Unit	Test 1	Test 2	Test 3	Test 4	Test 5
Phase reference		P-CPICH				
$\hat{I}_{or1}/I_{oc}$ and $\hat{I}_{or2}/I_{oc}$	dB	9				
$I_{oc}$	dBm/3,84 MHz	-60				
UE speed	Km/h	3				
Information Data Rate	kbps	8	32	64	128	384
Parameter	Unit	Test 6	Test 7	Test 8	Test 9	Test 10
Phase reference		P-CPICH				
$\hat{I}_{or1}/I_{oc}$ and $\hat{I}_{or2}/I_{oc}$	dB	9				
$I_{oc}$	dBm/3,84 MHz	-60				
UE speed	Km/h	50				
Information Data Rate	kbps	8	32	64	128	384

**Table 4.28: FACH requirements during satellite diversity (ITU A NLOS)**

Test Number	$\frac{SCCPCH-E_c}{I_{or}}$	BLER	Test Number	$\frac{SCCPCH-E_c}{I_{or}}$	BLER
1	-21,5 dB	$10^{-2}$	6	-26,7 dB	$10^{-2}$
2	-16,5 dB	$10^{-2}$	7	-22 dB	$10^{-2}$
3	-13,7 dB	$10^{-2}$	8	-19,5 dB	$10^{-2}$
4	-13,8 dB	$10^{-2}$	9	-18,2 dB	$10^{-2}$
5	-5,1 dB	$10^{-2}$	10	-10 dB	$10^{-2}$

**Table 4.29: FACH requirements during satellite diversity (ITU B NLOS)**

Test Number	$\frac{SCCPCH-E_c}{I_{or}}$	BLER	Test Number	$\frac{SCCPCH-E_c}{I_{or}}$	BLER
1	-22,3 dB	$10^{-2}$	6	-26,8 dB	$10^{-2}$
2	-17,3 dB	$10^{-2}$	7	-22 dB	$10^{-2}$
3	-14,4 dB	$10^{-2}$	8	-19,5 dB	$10^{-2}$
4	-14 dB	$10^{-2}$	9	-18,2 dB	$10^{-2}$
5	-6 dB	$10^{-2}$	10	-10,1 dB	$10^{-2}$

**Table 4.30: FACH requirements during satellite diversity (ITU C NLOS)**

Test Number	$\frac{SCCPCH - E_c}{I_{or}}$	BLER	Test Number	$\frac{SCCPCH - E_c}{I_{or}}$	BLER
1	-22,4 dB	10 <sup>-2</sup>	6	-25,6 dB	10 <sup>-2</sup>
2	-17,2 dB	10 <sup>-2</sup>	7	-20,9 dB	10 <sup>-2</sup>
3	-14,5 dB	10 <sup>-2</sup>	8	-18,3 dB	10 <sup>-2</sup>
4	-8,7 dB	10 <sup>-2</sup>	9	-16,6 dB	10 <sup>-2</sup>
5	-6,4 dB	10 <sup>-2</sup>	10	-9,3 dB	10 <sup>-2</sup>

## 4.5 Detection of Broadcast Channel (BCH)

### 4.5.1 Minimum requirement

For the parameters specified in tables 4.31, 4.32, 4.33 and 4.34 the average  $\frac{PCCPCH - E_c}{I_{or}}$  shall be below the specified value for the BLER shown in table 4.35. These requirements are applicable for TFCS size 16.

**Table 4.31: BCH parameters in static and aeronautical propagation conditions**

Parameter	Unit	Test 1	Test 20
Phase reference		P-CPICH	
$\hat{I}_{or}/I_{oc}$	dB	-1	-3
$I_{oc}$	dBm/3,84 MHz	-60	
Propagation condition	kbps	Static	Aeronautic
UE speed	km/h	-	800

**Table 4.32: BCH parameters in ITU A, B, C LOS propagation conditions**

Parameter	Unit	Test 2	Test 3	Test 4	Test 5	Test 6	Test 7
Phase reference		P-CPICH					
$\hat{I}_{or}/I_{oc}$	dB	-3					
$I_{oc}$	dBm/3,84 MHz	-60					
Propagation condition	kbps	ITU A LOS		ITU B LOS		ITU C LOS	
UE speed	Km/h	3	250	3	250	3	250

**Table 4.33: BCH parameters in ITU A, B, C NLOS propagation conditions**

Parameter	Unit	Test 8	Test 9	Test 10	Test 11	Test 12	Test 13
Phase reference		P-CPICH					
$\hat{I}_{or}/I_{oc}$	dB	-3					
$I_{oc}$	dBm/3,84 MHz	-60					
Propagation condition	kbps	ITU A NLOS		ITU B NLOS		ITU C NLOS	
UE speed	Km/h	3	50	3	50	3	50

Table 4.34: BCH parameters in combined satellite and IMR propagation conditions

Parameter	Unit	Test 14	Test 15	Test 16	Test 17	Test 18	Test 19
Phase reference		P-CPICH					
$\hat{I}_{or}/I_{oc}$	dB	-3	-3	-3	6	-3	-3
$I_{oc}$	dBm/3,84 MHz	-60					
Propagation condition	kbps	SCase1	SCase2	SCase3	SCase4	SCase5	SCase6

Table 4.35: BCH requirements

Test Number	$\frac{PCCPCH\_E_c}{I_{or}}$	BLER	Test Number	$\frac{PCCPCH\_E_c}{I_{or}}$	BLER
1	-18,7 dB	$10^{-2}$	11	-11,5 dB	$10^{-2}$
2	-15,8 dB	$10^{-2}$	12	-6,8 dB	$10^{-2}$
3	-14,8 dB	$10^{-2}$	13	-12,6 dB	$10^{-2}$
4	-15,3 dB	$10^{-2}$	14	-17,5 dB	$10^{-2}$
5	-13,8 dB	$10^{-2}$	15	-8,9 dB	$10^{-2}$
6	-13,7 dB	$10^{-2}$	16	-13,2 dB	$10^{-2}$
7	-11,6 dB	$10^{-2}$	17	-12,1 dB	$10^{-2}$
8	-3 dB	$10^{-2}$	18	-	$10^{-2}$
9	-11 dB	$10^{-2}$	19	-11,2 dB	$10^{-2}$
10	-4,3 dB	$10^{-2}$	20	-14,2 dB	$10^{-2}$

## 4.6 Demodulation of Paging Channel (PCH)

### 4.6.1 Minimum requirement

Table 4.36: PCH parameters in static and aeronautical propagation conditions

Parameter	Unit	Test 1	Test 20
Phase reference		P-CPICH	
$\hat{I}_{or}/I_{oc}$	dB	-1	-3
$I_{oc}$	dBm/3,84 MHz	-60	
Propagation condition	kbps	Static	Aeronautic
UE speed	km/h	-	800

Table 4.37: PCH parameters in ITU A, B, C LOS propagation conditions

Parameter	Unit	Test 2	Test 3	Test 4	Test 5	Test 6	Test 7
Phase reference		P-CPICH					
$\hat{I}_{or}/I_{oc}$	dB	-3					
$I_{oc}$	dBm/3,84 MHz	-60					
Propagation condition	kbps	ITU A LOS		ITU B LOS		ITU C LOS	
UE speed	Km/h	3	250	3	250	3	250



**Table 4.38: PCH parameters in ITU A, B, C NLOS propagation conditions**

Parameter	Unit	Test 8	Test 9	Test 10	Test 11	Test 12	Test 13
Phase reference		P-CPICH					
$\hat{I}_{or}/I_{oc}$	dB	-3					
$I_{oc}$	dBm/3,84 MHz	-60					
Propagation condition	kbps	ITU A NLOS		ITU B NLOS		ITU C NLOS	
UE speed	Km/h	3	50	3	50	3	50

**Table 4.39: PCH parameters in combined satellite and IMR propagation conditions**

Parameter	Unit	Test 14	Test 15	Test 16	Test 17	Test 18	Test 19
Phase reference		P-CPICH					
$\hat{I}_{or}/I_{oc}$	dB	-3	-3	-3	6	-3	-3
$I_{oc}$	dBm/3,84 MHz	-60					
Propagation condition	kbps	SCase1	SCase2	SCase3	SCase4	SCase5	SCase6

**Table 4.40: PCH requirements**

Test Number	$\frac{SCCPCH_{-}E_c}{I_{or}}$	BLER	Test Number	$\frac{SCCPCH_{-}E_c}{I_{or}}$	BLER
1	-15,9 dB	$10^{-2}$	11	-7 dB	$10^{-2}$
2	-12,8 dB	$10^{-2}$	12	-3,3 dB	$10^{-2}$
3	-11,7 dB	$10^{-2}$	13	-8,4 dB	$10^{-2}$
4	-12,2 dB	$10^{-2}$	14	-13,9 dB	$10^{-2}$
5	-10,5 dB	$10^{-2}$	15	-5,8 dB	$10^{-2}$
6	-10,1 dB	$10^{-2}$	16	-9,9 dB	$10^{-2}$
7	-7,9 dB	$10^{-2}$	17	-9,2 dB	$10^{-2}$
8	-	$10^{-2}$	18	-	$10^{-2}$
9	-6,4 dB	$10^{-2}$	19	-8,3 dB	$10^{-2}$
10	-0,4 dB	$10^{-2}$	20	-11,4 dB	$10^{-2}$

---

## Annex A (normative): Measurement channels

### A.1 General

The measurement channels in this annex are defined to derive the requirements in clause 4. The measurement channels represent example configuration of radio access bearers for different rates.

---

### A.2 Downlink reference measurement channel

#### A.2.1 DL reference measurement channel (8 kbps)

This test service concerns broadcasting of basic audio service. The parameters for the 8 kbps audio broadcast service are specified in table A.1. The channel coding for information is shown in figure A.1.

**Table A.1: Parameters for 8 kbps test service**

Parameter	
Information bit rate	8 kbps
S-CCPCH	15 ksps
Slot Format #i	2
TFCI	On
TFCI/Pilot to Data fields Power offsets	0 dB
Puncturing	2,17 %
Transport Channel Number	1
Transport Block Size	160 bits
Transport Block Set Size	160 bits
Transmission Time Interval	20 ms
Type of Error Protection	Convolution Coding
Coding Rate	1/3
Rate Matching attribute	256
Size of CRC	16
Position of TrCH in radio frame	Fixed

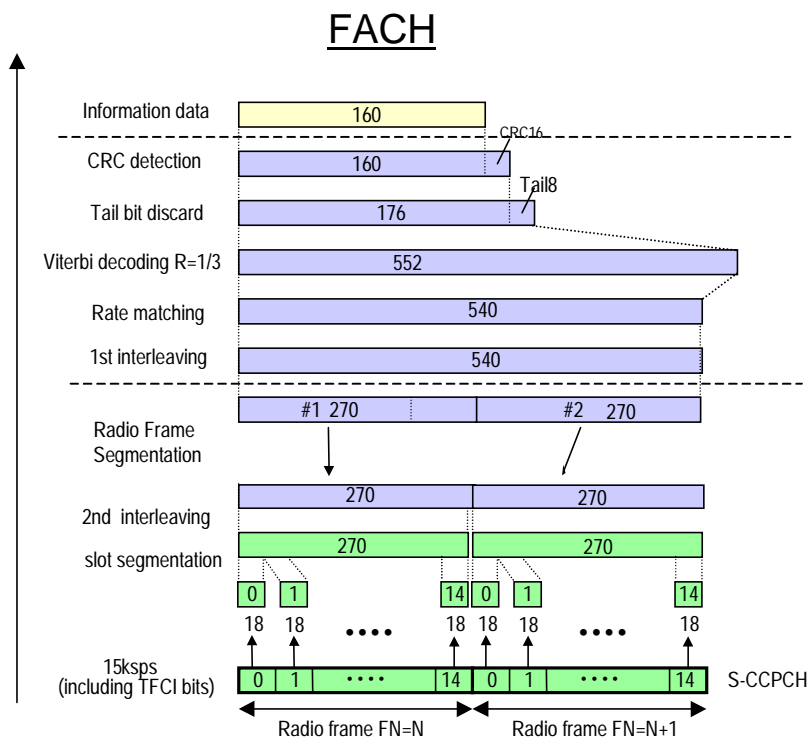

**Figure A.1: Channel coding and multiplexing example for 8 kbps data**

## A.2.2 DL reference measurement channel (32 kbps)

The parameters for the 32 kbps data service are specified in table A.2. The channel coding for information is shown in figure A.2 .

**Table A.2: Parameters for 32 kbps test service**

Parameter	
Information bit rate	32 kbps
S-CCPCH	60 ksp
Slot Format #i	8
TFCI	On
TFCI/Pilot to Data fields Power offsets	0 dB
Repetition	9,31 %
Transport Channel Number	1
Transport Block Size	640
Transport Block Set Size	640
Transmission Time Interval	20 ms
Type of Error Protection	Turbo Coding
Coding Rate	1/3
Rate Matching attribute	256
Size of CRC	16
Position of TrCH in radio frame	Fixed

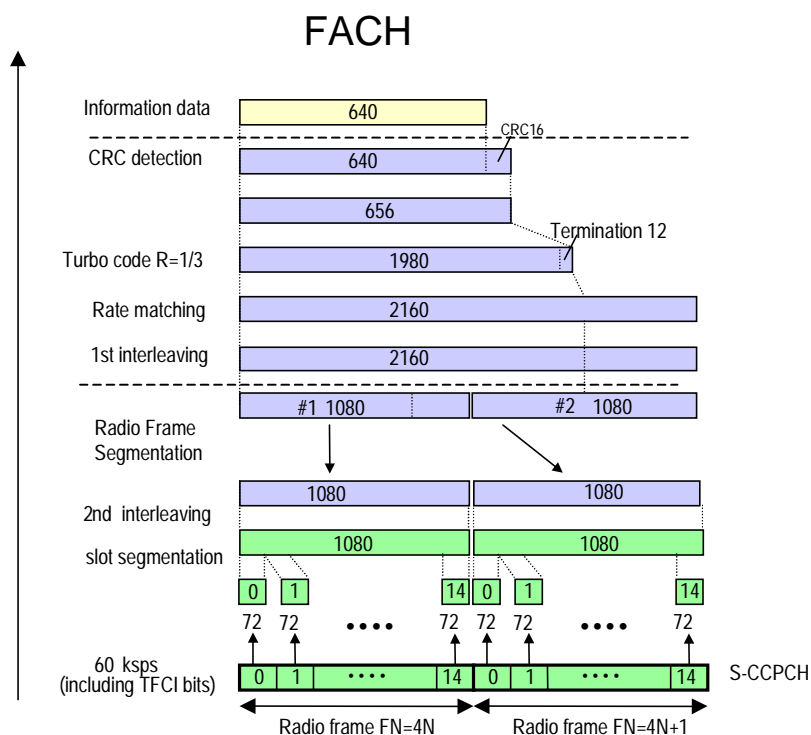

**Figure A.2: Channel coding and multiplexing example for 32 kbps data**

### A.2.3 DL reference measurement channel (64 kbps)

The parameters for the 64 kbps data service are specified in table A.3. The channel coding for information is shown in figure A.3.

**Table A.3: Parameters for 64 kbps test service**

Parameter	
Information bit rate	64 kbps
S-CCPCH	120 kbps
Slot Format #i	10
TFCI	On
TFCI/Pilot to Data fields Power offsets	0 dB
Repetition	11,1 %
Transport Channel Number	1
Transport Block Size	1280
Transport Block Set Size	1280
Transmission Time Interval	20 ms
Type of Error Protection	Turbo Coding
Coding Rate	1/3
Rate Matching attribute	256
Size of CRC	16
Position of TrCH in radio frame	Fixed

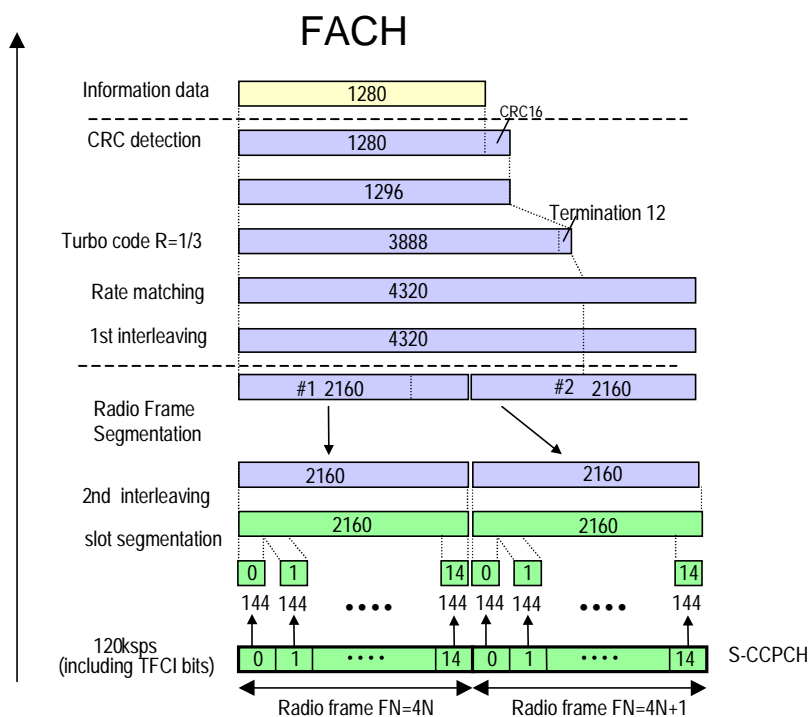

**Figure A.3: Channel coding and multiplexing example for 64 kbps data**

## A.2.4 DL reference measurement channel (128 kbps)

The parameters for the 128 kbps data service are specified in table A.4. The channel coding for information is shown in figure A.4.

**Table A.4: Parameters for 128 kbps test service**

Parameter	
Information bit rate	128 kbps
S-CCPCH	240 kpsps
Slot Format #i	12
TFCI	On
TFCI/Pilot to Data fields Power offsets	0 dB
Repetition	21,58 %
Transport Channel Number	1
Transport Block Size	10 240
Transport Block Set Size	10 240
Transmission Time Interval	80 ms
Type of Error Protection	Turbo Coding
Coding Rate	1/3
Rate Matching attribute	256
Size of CRC	16
Position of TrCH in radio frame	Fixed

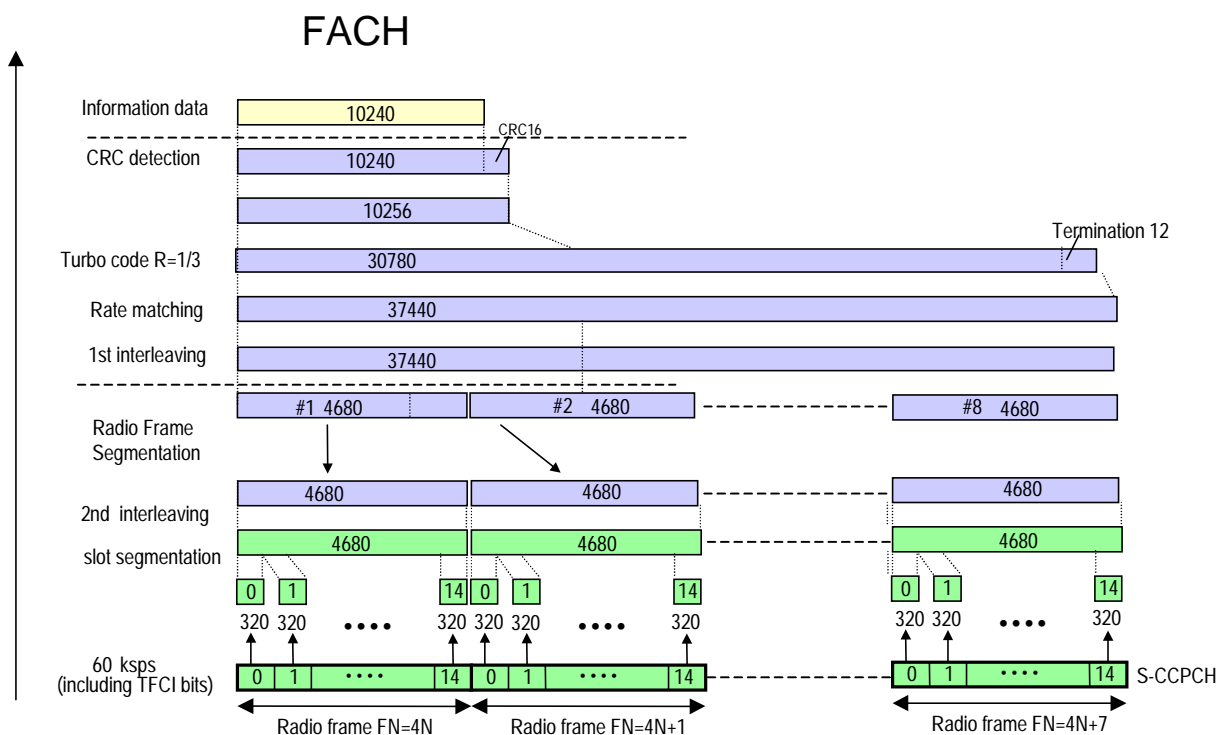

**Figure A.4: Channel coding and multiplexing example for 128 kbps data**

## A.2.5 DL reference measurement channel (256 kbps)

The parameters for the 256 kbps data service are specified in table A.5. The channel coding for information is shown in figure A.5.

**Table A.5: Parameters for 256 kbps test service**

Parameter	
Information bit rate	256 kbps
S-CCPCH	480 kbps
Slot format #i	14
TFCI	On
TFCI/pilot to data fields power offsets	0 dB
Repetition	22,5 %
Transport channel number	1
Transport block size	2 560
Transport block set size	2 560
Transmission time interval	10 ms
Type of error protection	Turbo Coding
Coding rate	1/3
Rate matching attribute	256
Size of CRC	16
Position of TrCH in radio frame	fixed

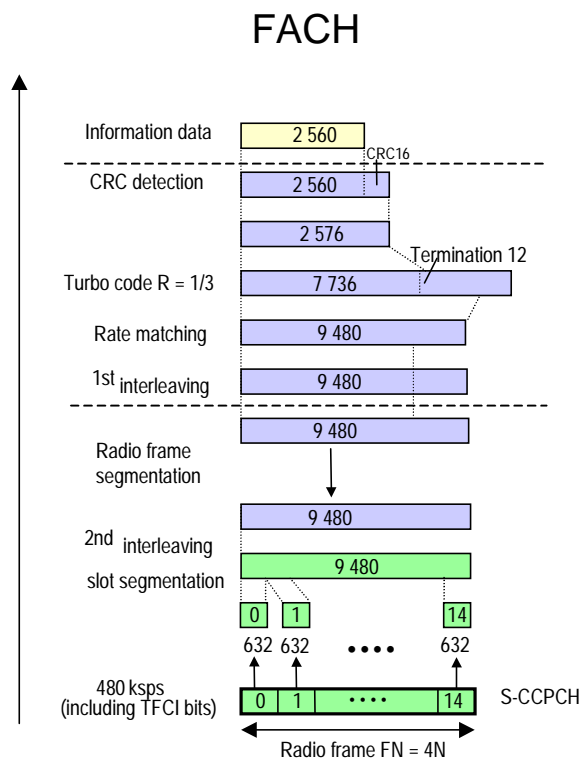

**Figure A.5: Channel coding and multiplexing example for 256 kbps data**

## A.2.6 DL reference measurement channel (384 kbps)

The parameters for the 384 kbps data service are specified in table A.6. The channel coding for information is shown in figure A.6.

**Table A.6: Parameters for 384 kbps test service**

Parameter	
Information bit rate	384 kbps
S-CCPCH	480 kbps
Slot Format #i	15
TFCI	On
TFCI/Pilot to Data fields Power offsets	0 dB
Puncturing	20,1 %
Transport Channel Number	1
Transport Block Size	3840
Transport Block Set Size	3840
Transmission Time Interval	10 ms
Type of Error Protection	Turbo Coding
Coding Rate	1/3
Rate Matching attribute	256
Size of CRC	16
Position of TrCH in radio frame	fixed

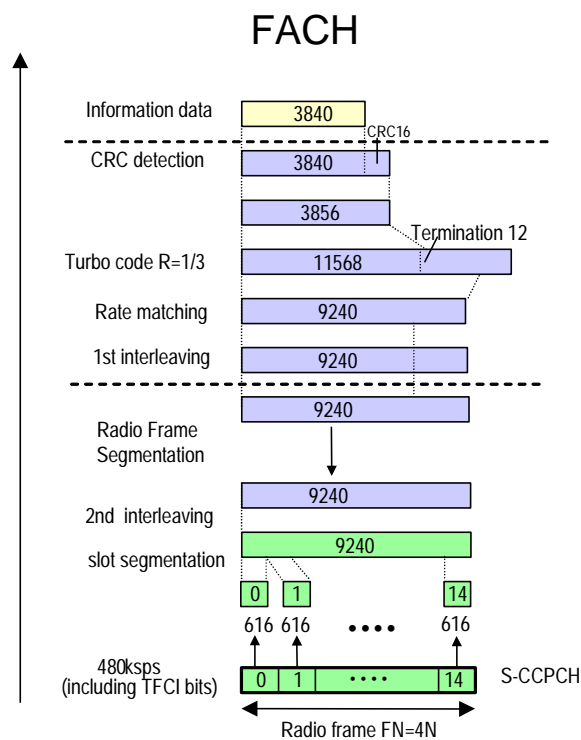

Figure A.6: Channel coding and multiplexing example for 384 kbps data

## A.3 DL reference parameters for PCH tests

The parameters for the PCH test service are specified in table A.7.

Table A.7: Parameters for PCH test service

Parameter	
Information bit rate	24 kbps
S-CCPCH	30 ksps
Slot Format #i	4
TFCI	OFF
TFCI/Pilot to Data fields Power offsets	0 dB
Repetition	13,6 %
Transport Channel Number	1
Transport Block Size	240
Transport Block Set Size	240
Transmission Time Interval	10 ms
Type of Error Protection	Convolution Coding
Coding Rate	1/2
Rate Matching attribute	256
Size of CRC	16
Position of TrCH in radio frame	fixed



## Annex B (normative): Propagation conditions

### B.1 Propagation conditions

#### B.1.1 Static propagation condition

The propagation for the static performance measurement is an Additive White Gaussian Noise (AWGN) environment. No fading and multi-paths exist for this propagation model.

#### B.1.2 Multi-path fading propagation conditions

##### B.1.2.1 Satellite channels

**Table B.1: Channel model A (10 % delay spread values)**

Tap number	Relative tap delay value (ns)	Tap amplitude distribution	Parameter of amplitude distribution (dB)	Average amplitude with respect to free space propagation	Rice factor (dB)	Doppler spectrum
1	0	LOS: Rice NLOS: Rayleigh	$10 \log c$ $10 \log P_m$	0,0 -7,3	10 -	Rice Classic
2	100	Rayleigh	$10 \log P_m$	-23,6	-	Classic
3	180	Rayleigh	$10 \log P_m$	-28,1	-	Classic

**Table B.2: Channel model B (50 % delay spread values)**

Tap number	Relative tap delay value (ns)	Tap amplitude distribution	Parameter of amplitude distribution (dB)	Average amplitude with respect to free space propagation	Rice factor (dB)	Doppler spectrum
1	0	LOS: Rice NLOS: Rayleigh	$10 \log c$ $10 \log P_m$	0,0 -9,5	7 -	Rice Classic
2	100	Rayleigh	$10 \log P_m$	-24,1	-	Classic
3	250	Rayleigh	$10 \log P_m$	-25,1	-	Classic

**Table B.3: Channel model C (90 % delay spread values)**

Tap number	Relative tap delay value (ns)	Tap amplitude distribution	Parameter of amplitude distribution (dB)	Average amplitude with respect to free space propagation	Rice factor (dB)	Doppler spectrum
1	0	LOS: Rice NLOS: Rayleigh	$10 \log c$ $10 \log P_m$	0,0 -12,1	3 -	Rice Classic
2	60	Rayleigh	$10 \log P_m$	-17,0	-	Classic
3	100	Rayleigh	$10 \log P_m$	-18,3	-	Classic
4	130	Rayleigh	$10 \log P_m$	-19,1	-	Classic
5	250	Rayleigh	$10 \log P_m$	-22,1	-	Classic

## B.1.2.2 Combined Satellite and IMR channels

Table B.4: Path delay profiles; Combined Satellite and IMRs test cases

S-Case 1 speed 3 km/h		S-Case 2 speed 3 km/h		S-Case 3 speed 120 km/h		S-Case 4 speed 250 km/h		S-Case 5 speed 120 km/h		S-Case 6 speed 250 km/h	
Relative Delay [ns]	Average Power [dB]	Relative Delay [ns]	Average Power [dB]	Relative Delay [ns]	Average Power [dB]	Relative Delay [ns]	Average Power [dB]	Relative Delay [ns]	Average Power [dB]	Relative Delay [ns]	Average Power [dB]
0	0	0	0	0	0	0	0	0	-3	0	-3
1 042	-10	1 042	0	260	-3	260	-3	260	-3	260	-3
		26 563	0	521	-6	521	-6	521	-9	521	-9
				781	-9	781	-9	1 042	-3	1 042	-3
								1 302	-3	1 302	-3
								1 562	-3	1 562	-3
								1 823	0	1 823	0
								2 083	0	2 083	0

---

## Annex C (informative): Bibliography

- ETSI TS 101 851-3: "Satellite Earth Stations and Systems (SES); Satellite Component of UMTS/IMT2000; G-family; Part 3: Spreading and modulation (S-UMTS-A 25.213)".
- ETSI TR 102 277: "Satellite Earth Stations and Systems (SES); Satellite Component of UMTS/IMT-2000; W-CDMA Radio Interface for Multimedia Broadcast/Multicast Service (MBMS)".
- ETSI TS 121 905: "Vocabulary for 3GPP Specifications".
- ETSI TS 125 306: "Universal Mobile Telecommunications System (UMTS); UE Radio Access capabilities (3GPP TS 25.306)".
- ETSI TS 102 442-3: "Satellite Earth Stations and Systems (SES); Satellite Component of UMTS/IMT-2000; Multimedia Broadcast/Multicast Services; Part 3: Introduction in the Radio Access Network (RAN)".

---

## History

<b>Document history</b>		
V1.1.1	November 2006	Publication