

# ETSI TS 102 516 V1.1.1 (2006-04)

---

*Technical Specification*

**Methods for Testing and Specification (MTS);  
Internet Protocol Testing (IPT): IPv6 Core Protocol;  
Conformance Abstract Test Suite (ATS) and partial Protocol  
Implementation eXtra Information for Testing (PIXIT) proforma**

---



---

**Reference**

---

DTS/MTS-IPT-006-IPv6-CoreATS

---

---

**Keywords**

---

IP, IPv6, testing, TTCN

---

**ETSI**

650 Route des Lucioles  
F-06921 Sophia Antipolis Cedex - FRANCE

---

Tel.: +33 4 92 94 42 00 Fax: +33 4 93 65 47 16

Siret N° 348 623 562 00017 - NAF 742 C  
Association à but non lucratif enregistrée à la  
Sous-Préfecture de Grasse (06) N° 7803/88

---

**Important notice**

---

Individual copies of the present document can be downloaded from:

<http://www.etsi.org>

The present document may be made available in more than one electronic version or in print. In any case of existing or perceived difference in contents between such versions, the reference version is the Portable Document Format (PDF). In case of dispute, the reference shall be the printing on ETSI printers of the PDF version kept on a specific network drive within ETSI Secretariat.

Users of the present document should be aware that the document may be subject to revision or change of status. Information on the current status of this and other ETSI documents is available at

<http://portal.etsi.org/tb/status/status.asp>

If you find errors in the present document, please send your comment to one of the following services:

[http://portal.etsi.org/chaicor/ETSI\\_support.asp](http://portal.etsi.org/chaicor/ETSI_support.asp)

---

**Copyright Notification**

---

No part may be reproduced except as authorized by written permission.  
The copyright and the foregoing restriction extend to reproduction in all media.

© European Telecommunications Standards Institute 2006.  
All rights reserved.

**DECT**<sup>TM</sup>, **PLUGTESTS**<sup>TM</sup> and **UMTS**<sup>TM</sup> are Trade Marks of ETSI registered for the benefit of its Members.  
**TIPHON**<sup>TM</sup> and the **TIPHON logo** are Trade Marks currently being registered by ETSI for the benefit of its Members.  
**3GPP**<sup>TM</sup> is a Trade Mark of ETSI registered for the benefit of its Members and of the 3GPP Organizational Partners.

# Contents

Intellectual Property Rights .....	5
Foreword.....	5
1 Scope .....	6
2 References .....	6
3 Definitions and abbreviations.....	7
3.1 Definitions .....	7
3.2 Abbreviations .....	7
4 Abstract Test Method (ATM).....	8
4.1 Configuration CF01.....	8
4.2 Configuration CF02.....	9
4.3 Configuration CF03.....	9
5 Untestable and not implemented Test Purposes (TP).....	10
5.1 Untestable TP .....	10
5.2 Not implemented TP .....	11
6 ATS conventions .....	11
7 PCTR conformance .....	12
8 PIXIT conformance.....	12
9 ATS Conformance.....	12
<b>Annex A (normative): Abstract Test Suite (ATS) .....</b>	<b>13</b>
A.1 The ATS in TTCN-3 core (text) format .....	13
<b>Annex B (normative): Partial PIXIT proforma.....</b>	<b>14</b>
B.1 Identification summary.....	14
B.2 ATS summary .....	14
B.3 Test laboratory.....	14
B.4 Client identification.....	15
B.5 SUT .....	15
B.6 Protocol layer information.....	15
B.6.1 Protocol identification .....	15
B.6.2 Generic Setup .....	16
B.6.3 Default Values .....	16
B.6.4 Unknown IDs .....	17
B.6.5 Addresses .....	17
B.6.5.1 IUT Addresses .....	17
B.6.5.2 Tester Addresses.....	18
B.6.5.2.1 Host 1 (HS_01) .....	18
B.6.5.2.2 Host 2 (HS_02) .....	19
B.6.5.2.3 Host 3 (HS_03) .....	19
B.6.5.2.4 Router 1 (RT_01).....	19
B.6.5.2.5 Router 3 (RT_03).....	19
B.6.6 Timer .....	20
<b>Annex C (normative): PCTR proforma .....</b>	<b>21</b>
C.1 Identification summary.....	21
C.1.1 Protocol conformance test report.....	21

C.1.2	IUT identification .....	21
C.1.3	Testing environment.....	22
C.1.4	Limits and reservation .....	22
C.1.5	Comments.....	22
C.2	IUT Conformance status .....	23
C.3	Static conformance summary .....	23
C.4	Dynamic conformance summary.....	23
C.5	Static conformance review report.....	23
C.6	Test campaign report.....	24
C.7	Void.....	31
C.8	Observations.....	31
History	.....	32

---

## Intellectual Property Rights

IPRs essential or potentially essential to the present document may have been declared to ETSI. The information pertaining to these essential IPRs, if any, is publicly available for **ETSI members and non-members**, and can be found in ETSI SR 000 314: *"Intellectual Property Rights (IPRs); Essential, or potentially Essential, IPRs notified to ETSI in respect of ETSI standards"*, which is available from the ETSI Secretariat. Latest updates are available on the ETSI Web server (<http://webapp.etsi.org/IPR/home.asp>).

Pursuant to the ETSI IPR Policy, no investigation, including IPR searches, has been carried out by ETSI. No guarantee can be given as to the existence of other IPRs not referenced in ETSI SR 000 314 (or the updates on the ETSI Web server) which are, or may be, or may become, essential to the present document.

---

## Foreword

This Technical Specification (TS) has been produced by ETSI Technical Committee Methods for Testing and Specification (MTS).

---

# 1 Scope

The present document specifies the Abstract Test Suite (ATS) for the core functions of the Internet Protocol, Version 6, as defined in the specifications [11] through to [21]. The ATS is based on the requirements defined in the IPv6 requirements catalogue (TS 102 514 [2]) and the IPv6 test purposes (TS 102 515 [3]) and written according to the guidelines of TS 102 514 [1], ISO/IEC 9646-2 [5] and ETS 300 406 [9].

The objective of the present document is to provide a basis for conformance tests for IPv6 equipment giving a high probability of inter-operability between different manufacturer's IPv6 equipments.

Annex A provides the Tree and Tabular Combined Notation (TTCN-3) part of the ATS.

Annex B provides the Partial Protocol Implementation Extra Information for Testing (PIXIT) Proforma of the ATS.

Annex C provides the Protocol Conformance Test Report (PCTR) Proforma of the ATS.

---

# 2 References

The following documents contain provisions which, through reference in this text, constitute provisions of the present document.

- References are either specific (identified by date of publication and/or edition number or version number) or non-specific.
- For a specific reference, subsequent revisions do not apply.
- For a non-specific reference, the latest version applies.

Referenced documents which are not found to be publicly available in the expected location might be found at <http://docbox.etsi.org/Reference>.

- [1] ETSI TS 102 351: "Methods for Testing and Specification (MTS); Internet Protocol Testing (IPT); IPv6 Testing: Methodology and Framework".
- [2] ETSI TS 102 514: "Methods for Testing and Specification (MTS); Internet Protocol Testing (IPT); IPv6 Core Protocol; Requirements Catalogue".
- [3] ETSI TS 102 515: "Methods for Testing and Specification (MTS); Internet Protocol Testing (IPT); IPv6 Core Protocol; Conformance Test Suite Structure and Test Purposes (TSS&TP)".
- [4] ISO/IEC 9646-1: "Information technology - Open Systems Interconnection - Conformance testing methodology and framework - Part 1: General concepts".
- [5] ISO/IEC 9646-2: "Information technology - Open Systems Interconnection - Conformance testing methodology and framework - Part 2: Abstract Test Suite specification".
- [6] ISO/IEC 9646-4: "Information technology - Open Systems Interconnection - Conformance testing methodology and framework - Part 4: Test realization".
- [7] ISO/IEC 9646-5: "Information technology - Open Systems Interconnection - Conformance testing methodology and Framework - Part 5: Requirements on test laboratories and clients for the conformance assessment process".
- [8] ISO/IEC 9646-6: "Information technology - Open Systems Interconnection - Conformance testing methodology and framework - Part 6: Protocol profile test specification".
- [9] ETSI ETS 300 406: "Methods for Testing and Specification (MTS); Protocol and profile conformance testing specifications; Standardization methodology".
- [10] ETSI ES 201 873-1: "Methods for Testing and Specification (MTS); The Testing and Test Control Notation version 3; Part 1: TTCN-3 Core Language".

- [11] IETF RFC 1981: "Path MTU Discovery for IP version 6".
- [12] IETF RFC 2374: "An IPv6 Aggregatable Global Unicast Address Format".
- [13] IETF RFC 2460: "Internet Protocol, Version 6 (IPv6) Specification".
- [14] IETF RFC 2461: "Neighbor Discovery for IP Version 6 (IPv6)".
- [15] IETF RFC 2462: "IPv6 Stateless Address Autoconfiguration".
- [16] IETF RFC 2463: "Internet Control Message Protocol (ICMPv6) for the Internet Protocol Version 6 (IPv6) Specification".
- [17] IETF RFC 2675: "IPv6 Jumbograms".
- [18] IETF RFC 2711: "IPv6 Router Alert Option".
- [19] IETF RFC 2894: "Router Renumbering for IPv6".
- [20] IETF RFC 3484: "Default Address Selection for Internet Protocol version 6 (IPv6)".
- [21] IETF RFC 3513: "Internet Protocol Version 6 (IPv6) addressing Architecture".

---

## 3 Definitions and abbreviations

### 3.1 Definitions

For the purposes of the present document, the following terms and definitions apply:

**abstract test case:** Refer to ISO/IEC 9646-1 [4].

**Abstract Test Method (ATM):** Refer to ISO/IEC 9646-1 [4].

**Abstract Test Suite (ATS):** Refer to ISO/IEC 9646-1 [4].

**Implementation Under Test (IUT):** Refer to ISO/IEC 9646-1 [4].

**Lower Tester (LT):** Refer to ISO/IEC 9646-1 [4].

**Test Purpose (TP):** Refer to ISO/IEC 9646-1 [4].

### 3.2 Abbreviations

For the purposes of the present document, the following abbreviations apply:

ATM	Abstract Test Method
ATS	Abstract Test Suite
ETS	Executable Test Suite
IETF	Internet Engineering Task Force
IPv4	Internet Protocol version 4
IPv6	Internet Protocol version 6
IUT	Implementation Under Test
MAC	Medium Access Control
MOT	Means Of Testing
MTC	Main Test Component
PCO	Point of Control and Observation
PCTR	Protocol Conformance Test Report
PDU	Protocol Data Unit
PICS	Protocol Implementation Conformance Statement
PIXIT	Protocol Implementation eXtra Information for Testing
PTC	Parallel Test Component

RC	Requirements Catalogue
RQ	Requirement
SUT	System Under Test
TC	Test Case
TP	Test Purpose
TSS	Test Suite Structure
UDP	User Datagram Protocol
UT	Upper Tester

---

## 4 Abstract Test Method (ATM)

This clause describes the ATM used to test the IPv6 core functions as defined in the RFC specifications [11] through to [21]. The three following configurations have been developed to test the two different types of IUT, hosts and routers. Either a simple one-to-one connection between tester and IUT is established which serves as Point of Control and Observation (PCO) or the IUT is connected to two Parallel Test Components (PTCs) that act as router or host respectively.

### 4.1 Configuration CF01

This figure shows the configuration CF01. This is the basic configuration for router or host tests. PTC01 simulates a router.

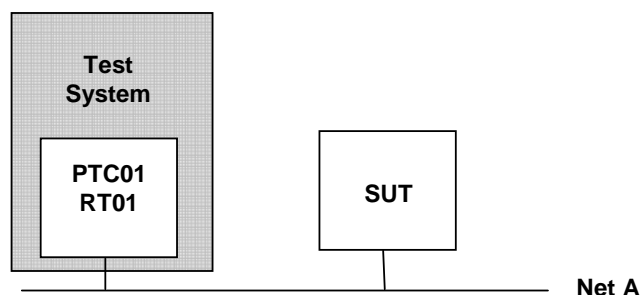

Figure 1: CF01



## 4.2 Configuration CF02

This figure shows CF02. The IUT is a router. PTC01 and PTC02 simulate hosts. CF02\_HS01 is used in the case where only 1 interface of the IUT is tested.

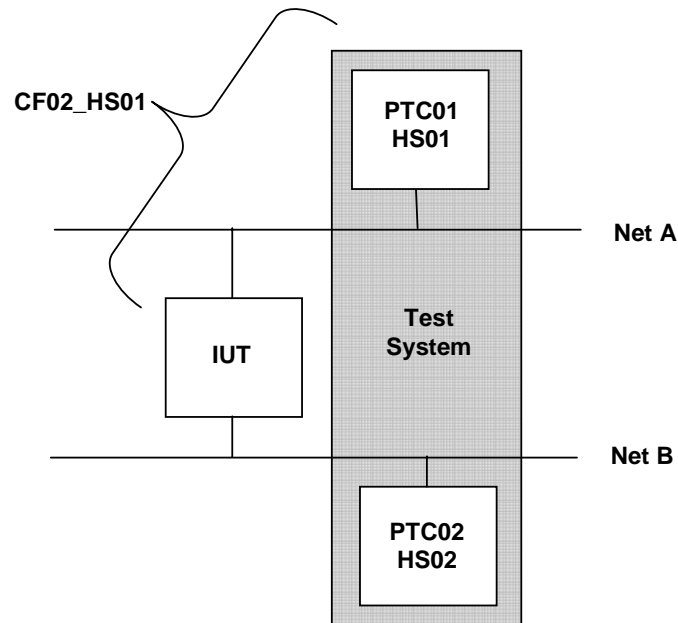

Figure 2: CF02

## 4.3 Configuration CF03

This figure shows CF03. The IUT is a host. PTC01 and PTC02 simulate routers. HS01 and HS03 are shown in cloud symbols because their protocol behaviour is simulated by PTC01 and PTC02 respectively. At start time of a test case PTC1 RT01 is considered to be the default router of the host acting as IUT. CF03\_RT01 shall be used in the case where only the interface between RT01 and the IUT is tested.

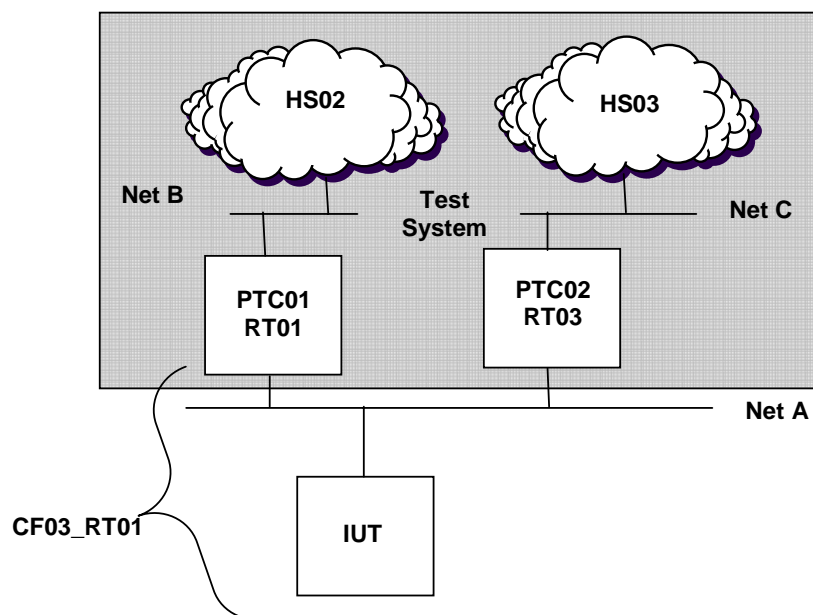

Figure 3: CF03

## 5 Untestable and not implemented Test Purposes (TP)

The ATS is comprised of 273 TC. Those were derived from a total of 396 TP.

### 5.1 Untestable TP

This clause gives a list of 80 TP, which are not implemented in the ATS due to the chosen ATM or other restrictions:

TP\_COR\_1092\_01, TP\_COR\_1089\_01, TP\_COR\_1034\_01, TP\_COR\_1008\_01, TP\_COR\_1814\_01,  
 TP\_COR\_1086\_01, TP\_COR\_1122\_01, TP\_COR\_9012\_01, TP\_COR\_1272\_01, TP\_COR\_9016\_01,  
 TP\_COR\_9017\_01, TP\_COR\_9018\_01, TP\_COR\_9019\_01, TP\_COR\_8009\_01, TP\_COR\_1225\_01,  
 TP\_COR\_1276\_01, TP\_COR\_8013\_01, TP\_COR\_1282\_01, TP\_COR\_1282\_02, TP\_COR\_1256\_01,  
 TP\_COR\_1257\_01, TP\_COR\_1263\_01, TP\_COR\_1250\_01, TP\_COR\_1292\_01, TP\_COR\_1471\_01,  
 TP\_COR\_1472\_01, TP\_COR\_1416\_01, TP\_COR\_1416\_02, TP\_COR\_1416\_03, TP\_COR\_1416\_04,  
 TP\_COR\_1458\_01, TP\_COR\_1448\_01, TP\_COR\_1444\_01, TP\_COR\_1442\_01, TP\_COR\_8579\_01,  
 TP\_COR\_8492\_01, TP\_COR\_8493\_01, TP\_COR\_8232\_01, TP\_COR\_8565\_01, TP\_COR\_8583\_01,  
 TP\_COR\_8387\_01, TP\_COR\_8402\_01, TP\_COR\_8586\_01, TP\_COR\_8210\_01, TP\_COR\_8246\_01,  
 TP\_COR\_8160\_01, TP\_COR\_8169\_01, TP\_COR\_8168\_01, TP\_COR\_8805\_01, TP\_COR\_8338\_02,  
 TP\_COR\_8338\_03, TP\_COR\_8338\_05, TP\_COR\_8338\_06, TP\_COR\_8108\_01, TP\_COR\_1294\_01,  
 TP\_COR\_1245\_01, TP\_COR\_1248\_01, TP\_COR\_1299\_01, TP\_COR\_9027\_01, TP\_COR\_1304\_01,  
 TP\_COR\_8578\_01, TP\_COR\_8530\_01, TP\_COR\_8125\_01, TP\_COR\_8126\_01, TP\_COR\_8128\_01,  
 TP\_COR\_8243\_01, TP\_COR\_8133\_01, TP\_COR\_8379\_01, TP\_COR\_8384\_01, TP\_COR\_8382\_01,  
 TP\_COR\_1435\_01, TP\_COR\_8577\_01, TP\_COR\_8435\_01, TP\_COR\_8512\_01, TP\_COR\_8516\_01,  
 TP\_COR\_8235\_01, TP\_COR\_8574\_01, TP\_COR\_8326\_01, TP\_COR\_8297\_01, TP\_COR\_8188\_01

## 5.2 Not implemented TP

A number of 42 TP have not been implemented, as the dynamic behaviour that validates their test purpose is already implemented in one or more TC. Table 1 gives the relation between the non-implemented TP and the TC that cover(s) its purpose:

**Table 1: List of not implemented TP**

TP not implemented	TC that covers the dynamic behaviour
TP_COR_8814_01	TC_COR_8813_01
TP_COR_1455_01	TC_COR_1085_01
TP_COR_1244_01	TC_COR_1235_01
TP_COR_1239_01	TC_COR_1210_02
TP_COR_8148_01	TC_COR_1280_01
TP_COR_1419_01	TC_COR_1417_01
TP_COR_1459_01	TC_COR_1468_01
TP_COR_1453_01	TC_COR_1085_01
TP_COR_1453_02	TC_COR_1011_01
TP_COR_1453_03	TC_COR_1020_01
TP_COR_1447_01	TC_COR_1058_01
TP_COR_1447_02	TC_COR_1058_02
TP_COR_8415_01	TC_COR_8146_01
TP_COR_8483_01	TC_COR_8482_01
TP_COR_8491_01	TC_COR_8146_01
TP_COR_8494_01	TC_COR_8464_01
TP_COR_8499_01	TC_COR_8147_01
TP_COR_8504_01	TC_COR_8434_01
TP_COR_8511_01	TC_COR_8434_01, TC_COR_8504_01
TP_COR_8366_01	TC_COR_8507_01
TP_COR_8162_01	TC_COR_8159_01, TC_COR_8179_01, TC_COR_8180_01
TP_COR_8444_01	TC_COR_8179_01
TP_COR_8452_01	TC_COR_8159_01
TP_COR_8171_01	TC_COR_8461_01
TP_COR_8172_01	TC_COR_8470_01
TP_COR_8410_01	TC_COR_8567_01
TP_COR_8587_01	TC_COR_8592_01
TP_COR_8118_01	TC_COR_8513_01
TP_COR_8113_01	TC_COR_8146_01
TP_COR_8149_01	TC_COR_8146_01
TP_COR_1228_01	Several TC test the behaviour implicitly
TP_COR_1303_01	TC_COR_1298_01
TP_COR_8543_01	TC_COR_8349_01
TP_COR_1042_01	TC_COR_1443_01
TP_COR_8107_01	Several TC test the behaviour implicitly
TP_COR_1419_03	TC_COR_1417_02
TP_COR_1443_03	TC_COR_1443_02
TP_COR_8330_01	TC_COR_8586_01
TP_COR_8299_01	TC_COR_9034_01
TP_COR_8315_01	TC_COR_9034_02
TP_COR_8315_02	TC_COR_9034_01
TP_COR_8550_01	TC_COR_8183_01

---

## 6 ATS conventions

The complete description of the ATS conventions is found in TS 102 5141 [1].

---

## 7 PCTR conformance

A test laboratory, when requested by a client to produce a PCTR, is required, as specified in ISO/IEC 9646-5 [7], to produce a PCTR conformant with the PCTR template given in annex B of ISO/IEC 9646-5 [7].

Furthermore, a test laboratory, offering testing for the ATS specification contained in annex C, when requested by a client to produce a PCTR, is required to produce a PCTR conformant with the PCTR proforma contained in annex A.

A PCTR which conforms to this PCTR proforma specification shall preserve the content and ordering of the clauses contained in annex A. Clause A.6 of the PCTR may contain additional columns. If included, these shall be placed to the right of the existing columns. Text in italics may be retained by the test laboratory.

---

## 8 PIXIT conformance

A test realizer, producing an executable test suite for the Abstract Test Suite (ATS) specification contained in annex C, is required, as specified in ISO/IEC 9646-4 [6], to produce an augmented partial PIXIT proforma conformant with this partial PIXIT proforma specification.

An augmented partial PIXIT proforma which conforms to this partial PIXIT proforma specification shall, as a minimum, have contents which are technically equivalent to annex B. The augmented partial PIXIT proforma may contain additional questions that need to be answered in order to prepare the Means Of Testing (MOT) for a particular Implementation Under Test (IUT).

A test laboratory, offering testing for the ATS specification contained in annex C, is required, as specified in ISO/IEC 9646-5 [7], to further augment the augmented partial PIXIT proforma to produce a PIXIT proforma conformant with this partial PIXIT proforma specification.

A PIXIT proforma which conforms to this partial PIXIT proforma specification shall, as a minimum, have contents which are technically equivalent to annex B. The PIXIT proforma may contain additional questions that need to be answered in order to prepare the test laboratory for a particular IUT.

---

## 9 ATS Conformance

The test realizer, producing a Means Of Testing (MOT) and Executable Test Suite (ETS) for the present document, shall comply with the requirements of ISO/IEC 9646-4 [6]. In particular, these concern the realization of an Executable Test Suite (ETS) based on each ATS. The test realizer shall provide a statement of conformance of the MOT to the present document.

An ETS which conforms to the present document shall contain test groups and test cases which are technically equivalent to those contained in the ATS in annex C. All sequences of test events comprising an abstract test case shall be capable of being realized in the executable test case. Any further checking which the test system might be capable of performing is outside the scope of the present document and shall not contribute to the verdict assignment for each test case.

Test laboratories running conformance test services using this ATS shall comply with ISO/IEC 9646-5 [7].

A test laboratory which claims to conform to this ATS specification shall use an MOT which conforms to this ATS.

---

## Annex A (normative): Abstract Test Suite (ATS)

### A.1 The ATS in TTCN-3 core (text) format

This ATS has been produced using the Testing and Test Control Notation (TTCN-3) according to ES 201 873-1 [10].

The TTCN-3 core (text) representation corresponding to this ATS is contained in several ASCII files contained in archive ts\_102516v010101p0.zip which accompanies the present document.

---

## Annex B (normative): Partial PIXIT proforma

Notwithstanding the provisions of the copyright clause related to the text of the present document, ETSI grants that users of the present document may freely reproduce the PIXIT proforma in this annex so that it can be used for its intended purposes and may further publish the completed PIXIT.

The PIXIT Proforma is based on ISO/IEC 9646-6 [8]. Any needed additional information can be found in there.

---

### B.1 Identification summary

**Table B.1**

PIXIT Number:	
Test Laboratory Name:	
Date of Issue:	
Issued to:	

---

### B.2 ATS summary

**Table B.2**

Protocol Specification:	
Protocol to be tested:	
ATS Specification:	
Abstract Test Method:	

---

### B.3 Test laboratory

**Table B.3**

Test Laboratory Identification:	
Test Laboratory Manager:	
Means of Testing:	
SAP Address:	

---

## B.4 Client identification

Table B.4

Client Identification:	
Client Test manager:	
Test Facilities required:	

---

## B.5 SUT

Table B.5

Name:	
Version:	
SCS Number:	
Machine configuration:	
Operating System Identification:	
IUT Identification:	
PICS Reference for IUT:	
Limitations of the SUT:	
Environmental Conditions:	

---

## B.6 Protocol layer information

### B.6.1 Protocol identification

Table B.6

Name:	
Version:	
PICS References:	

## B.6.2 Generic Setup

**Table B.7: Generic Setup**

Name	Type	Comments	Value
PX_IUT_ROLE	Router/Host	Is the IUT a router or a host?	
PX_TEST_CAMPAIGN	CampaignType	Selects only TCs that can be run in a campaign.	
PX_CONFIGURATION_ID	ConfigId	The id of the current configuration/topology.	
PX_UTS_AVAILABLE	BOOLEAN	Specifies if Upper Tester Server is available or not.	
PX_MAC_LAYER	e_atm, e_eth	Transport layer is ATM or Ethernet?	
PX_MAC_OPTION_LEN	Integer	Length of Source Link-Layer and Target Link-Layer options	
PX_T_BUILD_GLA	Integer	What time does the IUT need to build its global address?	

## B.6.3 Default Values

**Table B.8: Default Values**

Name	Type	Comments	Value
PX_DAD_DUP_ADDR_DETECT_TRANSMITS_IUT	Integer	Number of DAD packet retransmissions	
PX_MAX_UNICAST_SOLICIT_IUT	Integer	Number of NUD Neighbor Solicitation retransmissions	



## B.6.4 Unknown IDs

**Table B.9: Unknown IDs**

Name	Type	Comments	Value
PX_UNRECOGNIZED_EXT_HEADER_ID	Integer	Id of an IPv6 extension header that the IUT does not recognize.	
PX_NEXT_HEADER_STOPS_PACKET_PROCESSING	Integer	Id of an IPv6 extension header that stops packet processing.	
PX_UNRECOGNIZED_ROUTING_TYPE	Integer	Id of a routing type that the IUT does not recognize.	
PX_UNKNOWN_ICMP_MESSAGE_TYPE	Integer	An ICMPv6 message type that is greater than 129 and unknown to the implementation.	
PX_UNKNOWN_NBRADVOPT_ID	Integer	A Neighbor Advertisement option id that is unknown to the implementation.	
PX_UNKNOWN_NBRSOLOPT_ID	Integer	A Neighbor Solicitation option id that is unknown to the implementation.	
PX_UNKNOWN_RTRSOLOPT_ID	Integer	A Router Solicitation option id that is unknown to the implementation.	
PX_UNKNOWN_REDIRECTOPT_ID	Integer	A Redirect option id that is unknown to the implementation.	
PX_SKIP_OVER_HOP_BY_HOP_OPTION	Integer	A hop by hop option id that is unknown to the implementation ('skip over' type).	
PX_SKIP_OVER_DESTINATION_OPTION	Integer	A destination option id that is unknown to the implementation ('skip over' type).	
PX_DISCARD_PACKET_HOP_BY_HOP_OPTION	Integer	A hop by hop option id that is unknown to the implementation ('discard' type).	
PX_DISCARD_PACKET_DESTINATION_OPTION	Integer	A destination option id that is unknown to the implementation ('discard' type).	
PX_DISCARD_PACKET_HOP_BY_HOP_OPTION_TYPE_10	Integer	A destination option id that is unknown to the implementation ('discard and always send ICMP Parameter Problem message' type).	
PX_DISCARD_PACKET_DESTINATION_OPTION_TYPE_10	Integer	A destination option id that is unknown to the implementation ('discard and always send ICMP Parameter Problem message' type).	
PX_DISCARD_PACKET_HOP_BY_HOP_OPTION_TYPE_11	Integer	A destination option id that is unknown to the implementation ('discard and, if not multicast, send ICMP Parameter Problem message' type).	
PX_DISCARD_PACKET_DESTINATION_OPTION_TYPE_11	Integer	A destination option id that is unknown to the implementation ('discard and, if not multicast, send ICMP Parameter Problem message' type).	

## B.6.5 Addresses

### B.6.5.1 IUT Addresses

**Table B.10: IUT Addresses – Net A**

Name	Type	Comments	Value
PX_LLA_IUT_A	IPv6 Address	Link Local Address of IUT sending in netA	
PX_GLA_IUT_A	IPv6 Address	Global Address of IUT sending in netA	
PX_SOL_NODE_MCA_IUT_A	IPv6 Address	Solicited-Node Multicast Address of IUT sending in netA	
PX_MAC_UCA_IUT_A	MAC Address	Unicast MAC Address of IUT sending in netA	
PX_MAC_SOL_NODE_MCA_IUT_A	MAC Address	MAC Solicited-Node Multicast Address of IUT sending in netA	

**Table B.11: IUT Addresses – Net B**

Name	Type	Comments	Value
PX_LLA_IUT_B	IPv6 Address	Link Local Address of IUT sending in netB	
PX_GLA_IUT_B	IPv6 Address	Global Local Address of IUT sending in netB	
PX_SOL_NODE_MCA_IUT_B	IPv6 Address	Solicited-Node Multicast Address of IUT sending in netB	
PX_MAC_UCA_IUT_B	MAC Address	Unicast MAC Address of IUT sending in netB	
PX_MAC_SOL_NODE_MCA_IUT_B	MAC Address	MAC Solicited-Node Multicast Address of IUT sending in netB	

**Table B.12: IUT Addresses – Other**

Name	Type	Comments	Value
PX_MAC_BROADCAST_IUT	MAC Address	Mac Broadcast Address of Implementation Under Test	
PX_ANYCAST_IUT	IPv6 Address	Anycast Address that is known to the implementation	
PX_ANYCAST_NOT_IUT	IPv6 Address	Anycast Address that is not known to the implementation	
PX_MAC_ANYCAST_IUT	MAC Address	Mac Anycast Address of Router Under Test	
PX_MAC_ANYCAST_NOT_IUT	MAC Address	Mac Anycast Address of Test Node	
PX_MAC_SOL_ANYCAST_NOT_IUT	MAC Address	Mac Anycast Address of Test Node	
PX_UNICAST_NOT_IUT	IPv6 Address	Unicast Address that is not of the implementation.	
PX_UNICAST_PROXY_IUT	IPv6 Address	Unicast Address for which the NUT proxies.	
PX_UNICAST_UNREACHABLE_IUT	IPv6 Address	Unicast Address to which the IUT cannot deliver packets due to reasons other than congestion.	
PX_UNICAST_UNREACHABLE_NO_ENTRY_IUT	IPv6 Address	Unicast Address to which the IUT cannot deliver packets due to lack of entry in routing table.	
PX_UNICAST_UNREACHABLE_ADMINISTRATIVE_PROHIBITION_IUT	IPv6 Address	Unicast Address to which the IUT cannot deliver packets due to administrative prohibition.	
PX_UNICAST_UNREACHABLE_OTHER_IUT	IPv6 Address	Unicast Address to which the IUT cannot deliver packets due to other reason.	
PX_UNICAST_UNREACHABLE_NO_UPPER_LAYER_PEER_IUT	IPv6 Address	Unicast Address to which the IUT cannot deliver packets due to lack of upper layer peer.	
PX_UNICAST_PROXY_SOLNODE_IUT	IPv6 Address	Solicited Node Multicast Address of PX_UNICAST_PROXY_IUT.	

## B.6.5.2 Tester Addresses

### B.6.5.2.1 Host 1 (HS\_01)

**Table B.13: Addresses HS\_01**

Name	Type	Comments	Value
PX_MAC_UCA_HS01	MAC Address	First unicast MAC Address	
PX_MAC_UCA_HS01_2	MAC Address	Second unicast MAC Address	
PX_MAC_SOL_NODE_MCA_HS01	MAC Address	MAC Solicited-Node Multicast Address	
PX_LLA_HS01	IPv6 Address	Link Local Address	
PX_GLA_HS01	IPv6 Address	Global Address	
PX_SOL_NODE_MCA_HS01	IPv6 Address	Solicited-Node Multicast Address	

## B.6.5.2.2 Host 2 (HS\_02)

Table B.14: Addresses HS\_02

Name	Type	Comments	Value
PX_MAC_UCA_HS02	MAC Address	Unicast MAC Address	
PX_MAC_SOL_NODE_MCA_HS02	MAC Address	MAC Solicited-Node Multicast Address	
PX_LLA_HS02	IPv6 Address	Link Local Address	
PX_GLA_HS02	IPv6 Address	Global Address	
PX_SOL_NODE_MCA_HS02	IPv6 Address	Solicited-Node Multicast Address	

## B.6.5.2.3 Host 3 (HS\_03)

Table B.15: Addresses HS\_03

Name	Type	Comments	Value
PX_MAC_UCA_HS03	MAC Address	Unicast MAC Address	
PX_MAC_SOL_NODE_MCA_HS03	MAC Address	MAC Solicited-Node Multicast Address	
PX_LLA_HS03	IPv6 Address	Link Local Address	
PX_GLA_HS03	IPv6 Address	Global Address	
PX_SOL_NODE_MCA_HS03	IPv6 Address	Solicited-Node Multicast Address	

## B.6.5.2.4 Router 1 (RT\_01)

Table B.16: Addresses RT\_01 – Net A

Name	Type	Comments	Value
PX_MAC_UCA_RT01_A	MAC Address	Unicast MAC Address Net A	
PX_MAC_SOL_NODE_MCA_RT01_A	MAC Address	MAC Solicited-Node Multicast Address Net A	
PX_LLA_RT01_A	IPv6 Address	Link Local Address Net A	
PX_GLA_RT01_A	IPv6 Address	Global Address Net A	
PX_SOL_NODE_MCA_RT01_A	IPv6 Address	Solicited-Node Multicast Address Net A	

Table B.17: Addresses RT\_01 – Net B

Name	Type	Comments	Value
PX_MAC_UCA_RT01_B	MAC Address	Unicast MAC Address Net B	
PX_MAC_SOL_NODE_MCA_RT01_C	MAC Address	MAC Solicited-Node Multicast Address Net B	
PX_LLA_RT01_B	IPv6 Address	Link Local Address Net B	
PX_GLA_RT01_B	IPv6 Address	Global Address Net B	
PX_SOL_NODE_MCA_RT01_B	IPv6 Address	Solicited-Node Multicast Address Net B	

## B.6.5.2.5 Router 3 (RT\_03)

Table B.18: Addresses RT\_03 – Net A

Name	Type	Comments	Value
PX_MAC_UCA_RT03_A	MAC Address	Unicast MAC Address Net A	
PX_MAC_SOL_NODE_MCA_RT03_A	MAC Address	MAC Solicited-Node Multicast Address Net A	
PX_LLA_RT03_A	IPv6 Address	Link Local Address Net A	
PX_GLA_RT03_A	IPv6 Address	Global Address Net A	
PX_SOL_NODE_MCA_RT03_A	IPv6 Address	Solicited-Node Multicast Address Net A	

Table B.19: Addresses RT\_03 – Net C

Name	Type	Comments	Value
PX_MAC_UCA_RT03_C	MAC Address	Unicast MAC Address Net C	
PX_MAC_SOL_NODE_MCA_RT03_C	MAC Address	MAC Solicited-Node Multicast Address Net C	
PX_LLA_RT03_C	IPv6 Address	Link Local Address Net C	
PX_GLA_RT03_C	IPv6 Address	Global Address Net C	
PX_SOL_NODE_MCA_RT03_C	IPv6 Address	Solicited-Node Multicast Address Net C	

## B.6.6 Timer

Table B.20: Timer

Name	Type	Comments	Value
PX_TIMER_PRECISION	Float	Precision of timers in percentage (default is 5 percent).	
PX_REACHABLE_TIME	Integer	The value to be placed in the Reachable Time field in the Router Advertisement messages sent by the router.	
PX_ADVERTISEMENT_RETRANS_TIMER	Integer	The value to be placed in the Retrans Timer field in the Router Advertisement messages sent by the router.	
float PX_MAX_RTR_ADV_INTERVAL	Float	The maximum time allowed between sending unsolicited multicast Router Advertisements from the interface, in seconds.	
PX_MIN_RTR_ADV_INTERVAL	Float	The minimum time allowed between sending unsolicited multicast Router Advertisements from the interface, in seconds.	
PX_ICMP_ERROR_MESSAGE_RATE_LIMIT	Float	The minimum time allowed between sending ICMPv6 error messages, in seconds.	
PX_TDONE	Float	Time to control PTC.stop.	
PX_TAC	Float	Time to control the reception of a message.	
PX_TNOAC	Float	Time to control that IUT sends nothing.	
PX_TWAIT	Float	Time to control that IUT reacts prior to Upper Tester action.	
PX_TSYNC_TIME_LIMIT	Float	Default time limit for a sync client to reach a synchronization point	
PX_TSHUT_DOWN_TIME_LIMIT	Float	Default time limit for a sync client to finish its execution of the shutdown default	

---

## Annex C (normative): PCTR proforma

Notwithstanding the provisions of the copyright clause related to the text of the present document, ETSI grants that users of the present document may freely reproduce the PCTR proforma in this annex so that it can be used for its intended purposes and may further publish the completed PCTR.

The PCTR proforma is based on ISO/IEC 9646-6 [8]. Any needed additional information can be found in there.

---

### C.1 Identification summary

#### C.1.1 Protocol conformance test report

**Table C.1**

PCTR Number:	
PCTR Date:	
Corresponding SCTR Number:	
Corresponding SCTR Date:	
Test Laboratory Identification:	
Test Laboratory Manager:	
Signature:	

#### C.1.2 IUT identification

**Table C.2**

Name:	
Version:	
Protocol specification:	
PICS:	
Previous PCTR if any:	

### C.1.3 Testing environment

**Table C.3**

PIXIT Number:	
ATS Specification:	
Abstract Test Method:	
Means of Testing identification:	
Date of testing:	
Conformance Log reference(s):	
Retention Date for Log reference(s):	

### C.1.4 Limits and reservation

Additional information relevant to the technical contents or further use of the test report, or the rights and obligations of the test laboratory and the client, may be given here. Such information may include restriction on the publication of the test report.

.....

.....

.....

.....

.....

.....

.....

### C.1.5 Comments

Additional comments may be given by either the client or the test laboratory on any of the contents of the PCTR, for example, to note disagreement between the two parties.

.....

.....

.....

.....

.....

.....

.....

## C.2 IUT Conformance status

This IUT has or has not been shown by conformance assessment to be non conforming to the specified protocol specification.

*Strike the appropriate words in this sentence. If the PICS for this IUT is consistent with the static conformance requirements (as specified in clause C.3) and there are no "FAIL" verdicts to be recorded (in clause C.6) strike the words "has or", otherwise strike the words "or has not".*

## C.3 Static conformance summary

The PICS for this IUT is or is not consistent with the static conformance requirements in the specified protocol.

*Strike the appropriate words in this sentence.*

## C.4 Dynamic conformance summary

The test campaign did or did not reveal errors in the IUT.

*Strike the appropriate words in this sentence. If there are no "FAIL" verdicts to be recorded (in clause C.6t) strike the words "did or" otherwise strike the words "or did not".*

Summary of the results of groups of test:

.....  
.....  
.....  
.....  
.....  
.....  
.....  
.....  
.....  
.....  
.....

## C.5 Static conformance review report

If clause C.3 indicates non-conformance, this clause itemizes the mismatches between the PICS and the static conformance requirements of the specified protocol specification.

.....  
.....  
.....  
.....  
.....  
.....  
.....  
.....  
.....  
.....

## C.6 Test campaign report

Table C.4

ATS Reference	Selected?	Run?	Verdict	Observations
<b>1. Node tests (NT)</b>				
1.1 Generate IPv6 packets (GIP)				
1.1.2 Generate IPv6 Header(GIH)				
TC_COR_1000_01				
1.1.3 Discover PMTU(DPMTU)				
TC_COR_1806_01				
TC_COR_1821_01				
TC_COR_1823_01				
1.2 Process IPv6 packets (PIP)				
1.2.1 Process Extension Headers (PEH)				
TC_COR_1010_01				
TC_COR_1011_01				
TC_COR_1016_01				
TC_COR_1093_01				
TC_COR_9030_01				
1.2.1.1 Process Fragment Packets (PFP)				
TC_COR_1082_01				
TC_COR_1083_01				
TC_COR_1085_01				
1.2.1.2 Process Routing Header (PRH)				
TC_COR_1040_01				
TC_COR_1041_01				
TC_COR_1052_01				
TC_COR_1053_01				
TC_COR_1055_01				
TC_COR_1056_01				
TC_COR_1058_01				
TC_COR_1058_02				
1.2.1.3 Process Hop-By-Hop Header (PHBHH)				
TC_COR_8813_01				
TC_COR_1018_01				
1.2.1.4 Process Extension Header Options (PEHO)				
TC_COR_1018_02				
TC_COR_1019_01				
TC_COR_1019_02				
TC_COR_1020_01				
TC_COR_1020_02				
TC_COR_9002_01				
TC_COR_9002_02				
TC_COR_1021_01				
TC_COR_1021_02				
TC_COR_9003_01				
TC_COR_9003_02				
1.3 Initialize (INI)				
1.3.2 Configure Address (CA)				
1.3.2.2 Stateless Autoconfiguration (SLAC)				
TC_COR_1231_01				
1.3.2.5 Detect Duplicate Address (DAD)				
TC_COR_1210_01				
TC_COR_1210_02				
TC_COR_1235_01				
TC_COR_1280_01				
1.5 ICMPv6 Functions (ICF)				
1.5.2 Process ICMPv6 Messages (PIM)				
TC_COR_1412_01				
TC_COR_1417_01				
TC_COR_1421_01				
TC_COR_1424_01				
TC_COR_1425_01				



ATS Reference	Selected?	Run?	Verdict	Observations
TC_COR_1426_01				
1.5.2.1 Process ICMPv6 Information Messages (PIIM)				
1.5.2.1.1 Process Echo Reply Message (PERPM)				
TC_COR_1468_01				
1.5.2.1.2 Process Echo Request Message (PERQM)				
TC_COR_1463_01				
TC_COR_1465_01				
1.5.3 Generate ICMPv6 Messages (GIM)				
1.5.3.3 Determine ICMPv6 Message Source Address (DIMSA)				
TC_COR_1406_01				
TC_COR_1407_01				
TC_COR_1407_02				
1.6 Neighbour Discovery (ND)				
1.6.2 Address Resolution (AR)				
TC_COR_8146_01				
TC_COR_8416_01				
TC_COR_8417_01				
TC_COR_8418_01				
TC_COR_8482_01				
1.6.2.1 Address Resolution Behavior (ARB)				
TC_COR_8434_01				
TC_COR_8457_01				
TC_COR_8458_01				
TC_COR_8459_01				
TC_COR_8460_01				
TC_COR_8462_01				
TC_COR_8463_01				
TC_COR_8594_01				
1.6.3 Neighbor Unreachability Detection (NUD)				
TC_COR_8363_01				
TC_COR_8470_01				
TC_COR_8461_01				
TC_COR_8465_01				
TC_COR_8475_01				
TC_COR_8513_01				
TC_COR_8514_01				
TC_COR_8515_01				
TC_COR_8147_01				
TC_COR_8464_01				
1.6.3.1.3 Invalid Reachability Indications (IRI)				
TC_COR_8501_01				
TC_COR_8500_01				
1.6.3.2 Neighbor Reachability Probing (NRP)				
TC_COR_8503_01				
TC_COR_8509_01				
TC_COR_8510_01				
TC_COR_8510_02				
1.6.4 Next Hop Determination (NHD)				
TC_COR_8507_01				
TC_COR_8364_01				
TC_COR_8365_01				
TC_COR_8367_01				
1.6.5 Using Options in Neighbor Discovery Messages (UONDM)				
TC_COR_8567_01				
TC_COR_8572_01				
TC_COR_8573_01				
1.6.6 Process Neighbor Discovery Messages (PND)				
TC_COR_8591_01				
TC_COR_8592_01				
1.6.6.1 Process Neighbor Solicitation (PND)				
TC_COR_8159_01				
TC_COR_8179_01				
TC_COR_8180_01				
TC_COR_8163_01				

ATS Reference	Selected?	Run?	Verdict	Observations
TC_COR_8177_01				
TC_COR_8103_05				
1.6.6.1.2 Process Proxy NS (PPNS)				
TC_COR_8488_01				
1.6.6.1.5 Process Field Anomalies in NS (NSFA)				
TC_COR_8386_01				
TC_COR_8388_01				
TC_COR_8389_01				
TC_COR_8390_01				
TC_COR_8391_01				
TC_COR_8392_01				
TC_COR_8393_01				
TC_COR_8395_01				
TC_COR_8436_01				
1.6.6.1.6 Process Option Anomalies in NS (NSOA)				
TC_COR_8396_01				
TC_COR_8394_01				
TC_COR_8397_01				
TC_COR_8398_01				
TC_COR_8399_01				
TC_COR_8400_01				
1.6.6.2 Process Neighbor Advertisement (PNA)				
TC_COR_8522_01				
1.6.6.2.1 Process Solicited Neighbor Advertisement (PSNA)				
TC_COR_8407_01				
1.6.6.2.3 Discover Neighbor by NA (DNNA)				
TC_COR_8102_01				
TC_COR_8103_01				
1.6.6.2.4 Process Field Anomalies in NA (PFANA)				
TC_COR_8167_01				
TC_COR_8401_01				
TC_COR_8403_01				
TC_COR_8404_01				
TC_COR_8405_01				
TC_COR_8406_01				
1.6.6.2.5 Process Option Anomalies in NA (POANA)				
TC_COR_8408_01				
TC_COR_8411_01				
TC_COR_8412_01				
TC_COR_8413_01				
TC_COR_8414_01				
1.6.6.3 Process Router Solicitation (PRA)				
1.6.6.3.1 Discover Neighbor by RS (DNRS)				
TC_COR_8103_02				
1.6.6.4 Process Router Advertisement (PRA)				
1.6.6.4.1 Discover Neighbor by RA (DNRA)				
TC_COR_8359_01				
TC_COR_8361_01				
1.6.6.4.4 Process Field Anomalies in RA (PFARA)				
TC_COR_8139_01				
TC_COR_8244_01				
TC_COR_8245_01				
TC_COR_8247_01				
TC_COR_8248_01				
TC_COR_8249_01				
1.6.6.4.5 Process Option Anomalies in RA (PAORA)				
TC_COR_8251_01				
TC_COR_8250_01				
TC_COR_8205_01				
TC_COR_8209_01				
1.6.6.5 Process Redirect Message (PRM)				
TC_COR_8580_01				
1.6.6.5.1 Discover Neighbor by Redirect Message (DNRM)				
TC_COR_8101_01				

ATS Reference	Selected?	Run?	Verdict	Observations
TC_COR_8103_04				
1.6.7 Generate Neighbor Discovery Messages (GNDM)				
1.6.7.1 Generate Neighbor Solicitation (GNS)				
TC_COR_8454_01				
1.6.7.1.1 Generate Neighbor Solicitation Header (GNSH)				
TC_COR_8150_01				
1.6.7.1.2 Generate Neighbor Solicitation Option (GNSO)				
TC_COR_8155_01				
TC_COR_8156_01				
1.6.7.1.3 Generate NS for Address Resolution (GNSAR)				
TC_COR_8423_01				
1.6.7.2 Generate Neighbor Advertisement (GNA)				
1.6.7.2.2 Form Neighbor Advertisement Header (FNAH)				
TC_COR_8161_01				
1.8 Jumbograms (JG)				
1.8.3 Process Jumbograms (PJG)				
TC_COR_8806_01				
TC_COR_8809_01				
TC_COR_8810_01				
TC_COR_8811_01				
TC_COR_8812_01				

ATS Reference	Selected?	Run?	Verdict	Observations
<b>2. Host (HS)</b>				
2.3 Initialize (INI)				
TC_COR_8338_01				
TC_COR_8338_04				
2.3.2 Configure Address (CA)				
2.3.2.6 Assign Global Address (GA)				
2.3.2.6.1 Use of M-bit (UMB)				
TC_COR_1298_01				
2.3.2.6.3 Process the Prefix Information Option (PFX)				
TC_COR_1305_01				
TC_COR_1306_01				
TC_COR_1307_01				
TC_COR_1309_01				
TC_COR_1310_01				
2.6 Neighbour Discovery (ND)				
2.6.6 Process Neighbor Discovery Messages (PND)				
2.6.6.1.4 Process NS for Address Resolution (PNSAR)				
TC_COR_8446_01				
2.6.6.3.3 Host Processing of RS (HPRS)				
TC_COR_8233_01				
2.6.6.4.1 Discover Neighbor by RA (DNRA)				
TC_COR_8103_03				
2.6.6.4.3 Host Processing of RA (HPRA)				
TC_COR_8385_01				
TC_COR_8231_01				
TC_COR_8346_01				
TC_COR_8348_01				
TC_COR_8349_01				
TC_COR_8343_01				
TC_COR_8345_01				
TC_COR_8360_01				
TC_COR_8362_01				
TC_COR_8358_01				
2.6.6.4.5 Process Option Anomalies in RA (POARA)				
TC_COR_8224_01				
TC_COR_8221_01				
2.6.6.5.3 Host Processing of Redirect Message (HPRM)				
TC_COR_8557_01				
TC_COR_8558_01				
TC_COR_8556_01				
TC_COR_8560_01				
TC_COR_8561_01				
TC_COR_8559_01				
TC_COR_8533_01				
2.6.6.5.4 Process Field Anomalies in Redirect Message (PFARM)				
TC_COR_8528_01				
TC_COR_8529_01				
TC_COR_8531_01				
TC_COR_8532_01				
TC_COR_8534_01				
TC_COR_8535_01				
TC_COR_8536_01				
TC_COR_8537_01				
TC_COR_8539_01				
TC_COR_8545_01				
2.6.6.5.5 Process Option Anomalies in Redirect Message (POARM)				
TC_COR_8538_01				
TC_COR_8218_01				
TC_COR_8540_01				
TC_COR_8541_01				
TC_COR_8542_01				

ATS Reference	Selected?	Run?	Verdict	Observations
<b>3. Router (RT)</b>				
3.2 Process IPv6 packets (PIP)				
3.2.1.2 Process Routing Header (PRH)				
TC_COR_1059_01				
3.3 Initialize (INI)				
3.3.2 Configure Address (CA)				
TC_COR_1246_01				
3.3.2.2 Stateless Autoconfiguration (SAC)				
TC_COR_1229_01				

ATS Reference	Selected?	Run?	Verdict	Observations
3.5 ICMPv6 Functions (ICF)				
3.5.2 Process ICMPv6 Messages (PIM)				
TC_COR_1416_05				
TC_COR_1416_06				
TC_COR_1416_07				
TC_COR_1416_08				
TC_COR_1417_02				
TC_COR_1421_02				
TC_COR_1424_02				
TC_COR_1425_02				
TC_COR_1426_02				
3.5.3.2.2 Generate Time Exceeded Message (GTEM)				
TC_COR_1449_01				
TC_COR_1450_01				
3.5.3.2.3 Generate Message Too Big Message (GMTBM)				
TC_COR_1443_01				
TC_COR_1443_02				
TC_COR_1443_04				
3.5.3.2.4 Generate Destination Unreachable Message (GTEM)				
TC_COR_1432_01				
3.5.3.2.4.1 Destination Unreachable Code Field Value (DUCFV)				
TC_COR_1436_01				
TC_COR_1437_01				
TC_COR_1438_01				
TC_COR_1441_01				
3.6 Neighbour Discovery (ND)				
3.6.6.1.4 Process NS for Address Resolution (PNSAR)				
TC_COR_8445_01				
3.6.6.3 Process Router Solicitation (PRS)				
TC_COR_9033_01				
TC_COR_9033_02				
TC_COR_9034_01				
TC_COR_9034_02				
3.6.6.3.1 Discover Neighbor by RS (DNRS)				
TC_COR_8327_01				
3.6.6.3.2 Router Processing of RS (RPRS)				
TC_COR_8112_01				
TC_COR_8229_01				
TC_COR_8319_01				
TC_COR_8320_01				
TC_COR_8321_01				
3.6.6.3.4 Process Field Anomalies in RS (PFARS)				
TC_COR_8131_01				
TC_COR_8234_01				
TC_COR_8236_01				
TC_COR_8237_01				
TC_COR_8238_01				
3.6.6.3.5 Process Option Anomalies in RS (POARS)				
TC_COR_8204_01				
TC_COR_8215_01				
TC_COR_8222_01				
TC_COR_8227_01				
TC_COR_8239_01				
TC_COR_8240_01				
TC_COR_8241_01				
3.6.6.5.2 Router Processing of Redirect Message (RPRM)				
TC_COR_8552_01				
3.6.7 Generate Neighbor Discovery Messages (GNDM)				
3.6.7.2 Generate Neighbor Advertisement (GNA)				
TC_COR_8201_01				
3.6.7.2.1.2 Generate Unsolicited Proxy NA (GUPNA)				
TC_COR_8486_01				
3.6.7.4 Generate Router Advertisement (GRA)				
TC_COR_8111_01				

ATS Reference	Selected?	Run?	Verdict	Observations
3.6.7.4.1 Form Router Advertisement Header (FRAH)				
TC_COR_8135_01				
3.6.7.4.2 Form Router Advertisement Options (FRAO)				
TC_COR_8253_01				
3.6.7.4.2.1 RA MTU Option (RAMTUO)				
TC_COR_8223_01				
3.6.7.4.2.2 RA Source Link-layer Address Option (RASLAO)				
TC_COR_8200_01				
3.6.7.4.2.3 RA Prefix Information Option (RAPIO)				
TC_COR_8302_01				
3.6.7.4.3 Router Advertisement Behavior (RAB)				
TC_COR_8309_01				
3.6.7.4.3.1 Startup Router Advertisement Behavior (SRAB)				
TC_COR_8303_01				
3.6.7.4.3.1.2 AdvDefaultLifetime (ADL)				
TC_COR_8284_01				
TC_COR_8286_01				
3.6.7.4.3.1.3 AdvManagedFlag (AMF)				
TC_COR_8265_01				
3.6.7.4.3.1.4 AdvOtherConfigFlag (AOCF)				
TC_COR_8268_01				
TC_COR_8269_01				
3.6.7.4.3.1.5 AdvReachableTime (ART)				
TC_COR_8274_01				
TC_COR_8275_01				
3.6.7.4.3.1.6 AdvRetransTimer (ADRT)				
TC_COR_8277_01				
TC_COR_8278_01				
3.6.7.4.3.1.7 MaxRtrAdvInterval (MAXRAI)				
TC_COR_8259_01				
TC_COR_8260_01				
3.6.7.4.3.1.8 MinRtrAdvInterval (MINRAI)				
TC_COR_8262_01				
TC_COR_8263_01				
3.6.7.5 Generate Redirect Message (GRM)				
TC_COR_8182_01				
TC_COR_8183_01				
TC_COR_8551_01				
3.6.7.5.1 Generate Redirect Options (GRO)				
TC_COR_8191_01				
TC_COR_8217_01				
TC_COR_8544_01				
TC_COR_8544_02				

---

## C.7 Void

## C.8 Observations

Additional information relevant to the technical content of the PCTR is given here.

.....

.....

.....

.....

.....

---

## History

<b>Document history</b>		
V1.1.1	April 2006	Publication