

**Electromagnetic compatibility and
Radio spectrum Matters (ERM);
Conformance testing for the
Peer-to-Peer Digital Private Mobile Radio;
Part 4: Abstract Test Suite (ATS)**



Reference

DTS/ERM-TGDMMR-269-4

Keywords

ATS, digital, mobile, radio, testing

ETSI

650 Route des Lucioles
F-06921 Sophia Antipolis Cedex - FRANCE

Tel.: +33 4 92 94 42 00 Fax: +33 4 93 65 47 16

Siret N° 348 623 562 00017 - NAF 742 C
Association à but non lucratif enregistrée à la
Sous-Préfecture de Grasse (06) N° 7803/88

Important notice

Individual copies of the present document can be downloaded from:

<http://www.etsi.org>

The present document may be made available in more than one electronic version or in print. In any case of existing or perceived difference in contents between such versions, the reference version is the Portable Document Format (PDF). In case of dispute, the reference shall be the printing on ETSI printers of the PDF version kept on a specific network drive within ETSI Secretariat.

Users of the present document should be aware that the document may be subject to revision or change of status. Information on the current status of this and other ETSI documents is available at

<http://portal.etsi.org/tb/status/status.asp>

If you find errors in the present document, please send your comment to one of the following services:

http://portal.etsi.org/chaicor/ETSI_support.asp

Copyright Notification

No part may be reproduced except as authorized by written permission.
The copyright and the foregoing restriction extend to reproduction in all media.

© European Telecommunications Standards Institute 2008.
All rights reserved.

DECT™, **PLUGTESTS™**, **UMTS™**, **TIPHON™**, the TIPHON logo and the ETSI logo are Trade Marks of ETSI registered for the benefit of its Members.

3GPP™ is a Trade Mark of ETSI registered for the benefit of its Members and of the 3GPP Organizational Partners.

Contents

Intellectual Property Rights	5
Foreword.....	5
1 Scope	6
2 References	6
2.1 Normative references	7
2.2 Informative references.....	7
3 Definitions and abbreviations.....	7
3.1 Definitions.....	7
3.2 Abbreviations	8
4 Test configuration	8
4.1 dPMR test configuration	9
4.1.1 Lower tester dPMR messages	10
4.1.1.1 Lower Tester Port 1 PDU messages.....	10
4.1.1.2 Lower Tester test adapter configuration messages.....	10
4.1.2 Upper Tester command and confirmation messages	11
5 ATS conventions	11
5.1 Naming conventions.....	11
5.2 Implementation conventions	12
5.2.1 Templates.....	12
5.3 Test Case (TC) identifier.....	12
5.4 Test suite documentation.....	13
Annex A (informative): On Upper Tester, SUT Emulation and Simulation.....	14
A.1 Specifying an Upper Tester Server	14
A.1.1 The UTC in the dPMR test system.....	14
A.2 Using the ATS for Testing with an Emulated SUT.....	14
A.3 Test case simulation	15
Annex B (normative): Abstract Test Suite (ATS).....	16
B.1 The ATS in TTCN-3 core (text) format	16
B.2 The ATS in TTCN-3 tabular format.....	16
Annex C (normative): Partial PIXIT proforma for dPMR.....	17
C.1 Identification summary.....	17
C.2 ATS summary	17
C.3 Test laboratory.....	17
C.4 Client identification.....	18
C.5 SUT	18
C.6 Protocol layer information.....	18
C.6.1 Protocol identification	18
C.6.2 IUT information	18
Annex D (normative): PCTR proforma for dPMR.....	19
D.1 Identification summary.....	19
D.1.1 Protocol conformance test report.....	19
D.1.2 IUT identification	19

D.1.3	Testing environment.....	20
D.1.4	Limits and reservation.....	20
D.1.5	Comments.....	20
D.2	IUT Conformance status	20
D.3	Static conformance summary	21
D.4	Dynamic conformance summary.....	21
D.5	Static conformance review report.....	21
D.6	Test campaign report.....	22
D.7	Observations.....	25
Annex E (informative):	Bibliography.....	26
History		27

Intellectual Property Rights

IPRs essential or potentially essential to the present document may have been declared to ETSI. The information pertaining to these essential IPRs, if any, is publicly available for **ETSI members and non-members**, and can be found in ETSI SR 000 314: "*Intellectual Property Rights (IPRs); Essential, or potentially Essential, IPRs notified to ETSI in respect of ETSI standards*", which is available from the ETSI Secretariat. Latest updates are available on the ETSI Web server (<http://webapp.etsi.org/IPR/home.asp>).

Pursuant to the ETSI IPR Policy, no investigation, including IPR searches, has been carried out by ETSI. No guarantee can be given as to the existence of other IPRs not referenced in ETSI SR 000 314 (or the updates on the ETSI Web server) which are, or may be, or may become, essential to the present document.

Foreword

This Technical Specification (TS) has been produced by ETSI Technical Committee Electromagnetic compatibility and Radio spectrum Matters (ERM).

The present document is part 4 of a multi-part deliverable covering the Electromagnetic compatibility and Radio spectrum Matters (ERM); Conformance testing for the Peer-to-Peer Digital Private Mobile Radio, as identified below:

- Part 1: "Protocol Implementation Conformance Statement (PICS) proforma";
- Part 2: "Test Suite Structure and Test Purposes (TSS&TP) specification";
- Part 3: "Requirements catalogue";
- Part 4: "Abstract Test Suite (ATS)";**
- Part 5: "Interoperability Test Suite Structure and Test Purposes (TSS&TP) specification";
- Part 6: "Test descriptions (TD)".

1 Scope

The present document contains the Abstract Test Suite (ATS) to test the dPMR Call Control (CCL) and Data Link Layer (DLL).

The objective of the present document is to provide a basis for conformance tests for ERM dPMR equipment giving a high probability of air interface inter-operability between different manufacturer's ERM dPMR equipment.

The ISO standard for the methodology of conformance testing (ISO/IEC 9646-1 [4]) and the ETSI rules for conformance testing (ETS 300 406 [7]) are used as a basis for the test methodology.

- Clause 4 describes the Test Configuration used to test the dPMR Dynamic Link Layer (DLL) and the Call Control Layer (CCL).
- Clause 5 describes the ATS conventions, which are intended to give a better understanding of the ATS.
- Annex A provides guidelines for upper tester implementation as well as testing with an emulated and simulated SUT.
- Annex B provides the TTCN-3 part of the ATS.
- Annex C provides the Partial Protocol Implementation Extra Information for Testing (PIXIT) Proforma of dPMR.
- Annex D provides the Protocol Conformance Test Report (PCTR) Proforma of dPMR.

2 References

References are either specific (identified by date of publication and/or edition number or version number) or non-specific.

- For a specific reference, subsequent revisions do not apply.
- Non-specific reference may be made only to a complete document or a part thereof and only in the following cases:
 - if it is accepted that it will be possible to use all future changes of the referenced document for the purposes of the referring document;
 - for informative references.

Referenced documents which are not found to be publicly available in the expected location might be found at <http://docbox.etsi.org/Reference>.

For online referenced documents, information sufficient to identify and locate the source shall be provided. Preferably, the primary source of the referenced document should be cited, in order to ensure traceability. Furthermore, the reference should, as far as possible, remain valid for the expected life of the document. The reference shall include the method of access to the referenced document and the full network address, with the same punctuation and use of upper case and lower case letters.

NOTE: While any hyperlinks included in this clause were valid at the time of publication ETSI cannot guarantee their long term validity.

2.1 Normative references

The following referenced documents are indispensable for the application of the present document. For dated references, only the edition cited applies. For non-specific references, the latest edition of the referenced document (including any amendments) applies.

- [1] ETSI TS 102 490 (V1.3.1): "Electromagnetic compatibility and Radio spectrum Matters (ERM); Peer-to-Peer Digital Private Mobile Radio using FDMA with a channel spacing of 6,25 kHz with e.r.p. of up to 500 mW".
- [2] ETSI TS 102 587-1: "Electromagnetic compatibility and Radio spectrum Matters (ERM); Conformance testing for the Peer-to-Peer Digital Private Mobile Radio; Part 1: Protocol Conformance Implementation Statement (PICS) proforma DMR PICS proforma".
- [3] ETSI TS 102 587-2: "Electromagnetic compatibility and Radio spectrum Matters (ERM); Conformance testing for the Peer-to-Peer Digital Private Mobile Radio; Part 2: Test Suite Structure and Test Purposes (TSS & TP) specification".
- [4] ISO/IEC 9646-1: "Information technology - Open Systems Interconnection - Conformance testing methodology and framework - Part 1: General concepts".
- [5] ISO/IEC 9646-6: "Information technology - Open Systems Interconnection - Conformance testing methodology and framework - Part 6: Protocol profile test specification".
- [6] ISO/IEC 9646-7: "Information technology - Open Systems Interconnection - Conformance testing methodology and framework - Part 7: Implementation Conformance Statements".
- [7] ETSI ETS 300 406: "Methods for testing and Specification (MTS); Protocol and profile conformance testing specifications; Standardization methodology".
- [8] ETSI ES 201 873-1: "Methods for Testing and Specification (MTS); The Testing and Test Control Notation version 3; Part 1: TTCN-3 Core Language".
- [9] Void.
- [10] ETSI ES 201 873-5: "Methods for Testing and Specification (MTS); The Testing and Test Control Notation version 3; Part 5: TTCN-3 Runtime Interface (TRI)".
- [11] ETSI ES 201 873-6: "Methods for Testing and Specification (MTS); The Testing and Test Control Notation version 3; Part 6: TTCN-3 Control Interface (TCI)".

2.2 Informative references

The following referenced documents are not essential to the use of the present document but they assist the user with regard to a particular subject area. For non-specific references, the latest version of the referenced document (including any amendments) applies.

- [i.1] ETSI EG 202 568 (V1.1.3): "Methods for Testing and Specification (MTS); Internet Protocol Testing (IPT); Testing: Methodology and Framework".

3 Definitions and abbreviations

3.1 Definitions

For the purposes of the present document, the terms and definitions given in ISO/IEC 9646-7 [6], TS 102 587-1 [2], TS 102 587-2 [3] and the following apply:

lower DLL: all functions which are not part of upper DLL functions, like framing, interleaving and bit ordering

upper DLL: DLL functions for DLL PDU management and DLL signalling

3.2 Abbreviations

For the purposes of the present document, the abbreviations given in ISO/IEC 9646-1 [4], ISO/IEC 9646-7 [6] and the following apply:

ATS	Abstract Test Suite
BER	Bit Error Rate
CCL	Call Control Layer
CRC	Cyclic Redundancy Checksum for data error detection
DLL	Data Link Layer
dPMR	Digital Private Mobile Radio
IUT	Implementation Under Test
MTC	Main Test Component
PCTR	Protocol Conformance Test Report
PDU	Protocol Data Unit
PICS	Protocol Implementation Conformance Statement
PIXIT	Partial Protocol Implementation Extra Information for Testing
PTC	Parallel Test Component
RF	Radio Frequency
SUT	System Under Test
TC	Test Case
TP	Test Purpose
TRI	TTCN-3 Runtime Interface
TSS	Test Suite Structure
TTCN	Testing and Test Control Notation
TTCN-3	Testing and Test Control Notation version 3
Tx	Transmission
UTC	Upper Tester Client
UTS	Upper Tester Server

4 Test configuration

This clause describes the Test Configuration used to test the dPMR Call Control Layer (CCL) and the dPMR Upper Data Link Layer (DLL).

Figure 1 shows the dPMR protocol stack used to define the Test Configuration.

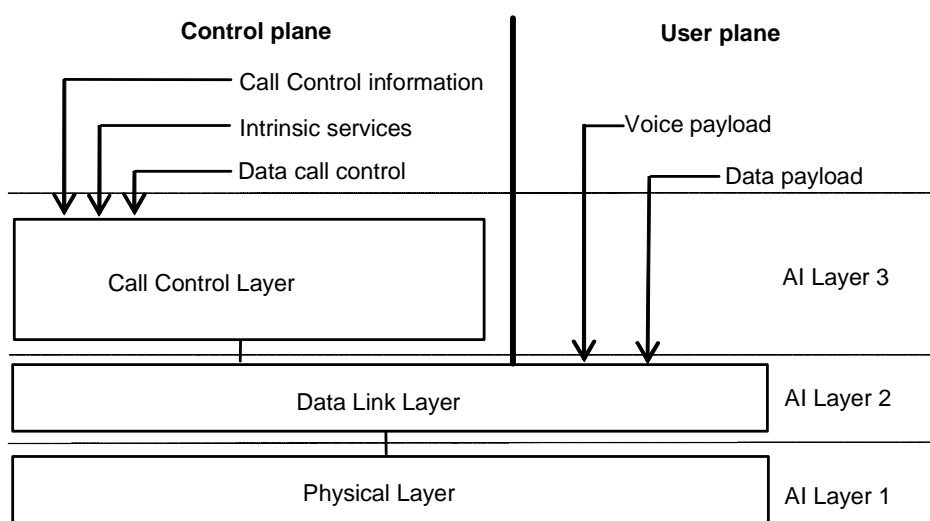

Figure 1: dPMR protocol stack

4.1 dPMR test configuration

Figure 2 illustrates the dPMR Test Configuration for testing a real product implementing the dPMR base standard. More information for this architecture is provided below. The test system architecture is based on the general TTCN test system architecture specified in ES 201 873-5 [10] and ES 201 873-6 [11].

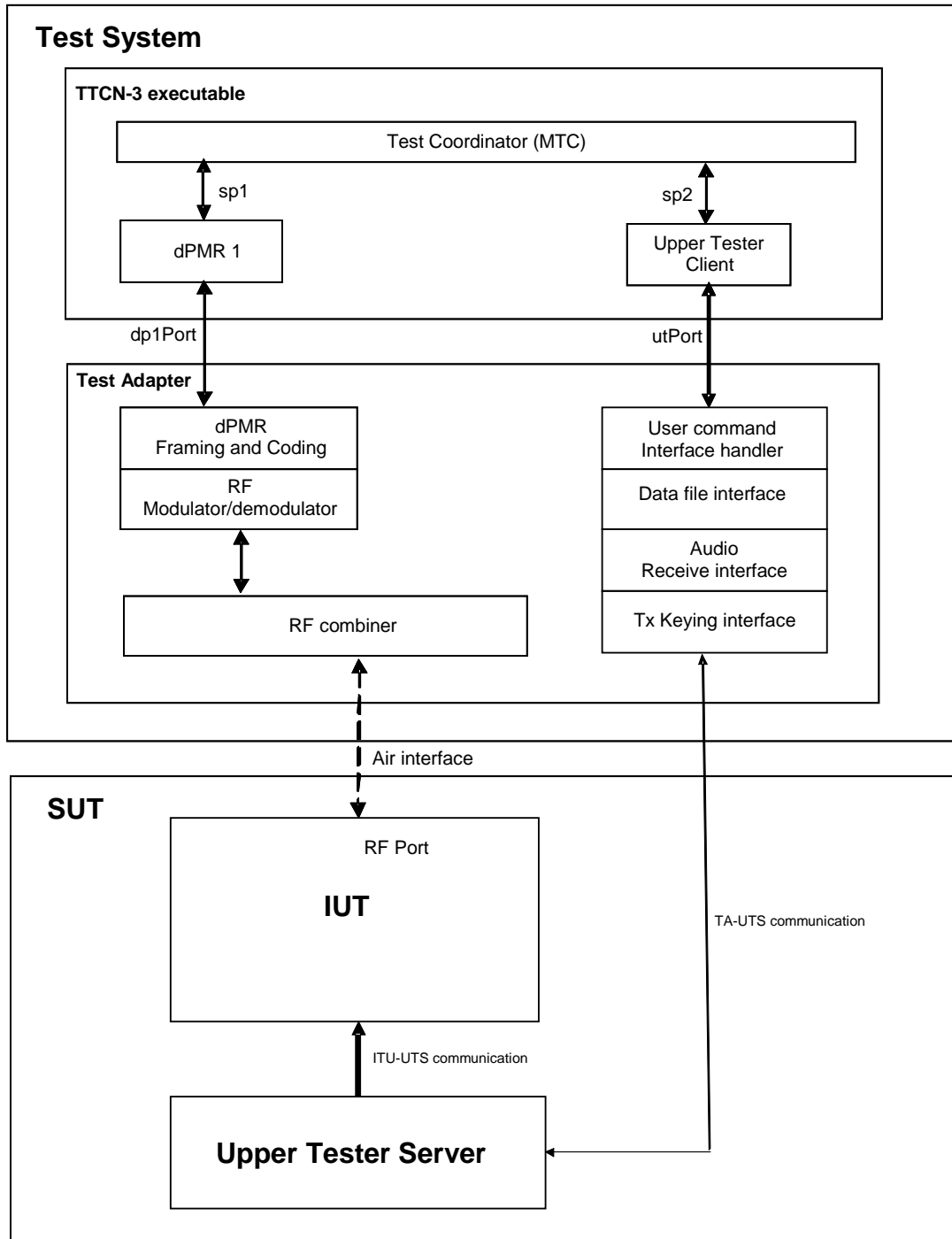

Figure 2: dPMR Test Configuration

The Test Adapter (TA) implements the dPMR framing and coding block, the physical layer, and the transport part between Upper Tester Client (UTC) and Upper Tester Server (UTS). Framing and coding handles the adding/removal of CRC, dividing/collecting fields, interleaving, and scrambling. The actual implementation of the dPMR framing and coding block is outside the scope of the present document and not part of the ATS development.

TTCN-3 dPMR test components implement the Lower Tester (LT), i.e. the Upper DLL and CCL of dPMR equipment.

The tasks of the different TTCN-3 components in figure 2 are:

- The Main Test Component (MTC) plays the role of a test coordinator, i.e. creating, synchronizing, and terminating dPMR and UTC test components used in the test cases. The communication between the MTC and the PTCs is done via synchronization ports sp1 and sp2.
- dPMR 1 is the Parallel Test Component (PTC) that plays the role of the Lower tester. It uses the dp1 port to send and receive dPMR PDUs. The dPMR PDUs supported by dPMR 1 is defined in table 1.
- UTC is the test component that communicates with the UTS which interacts with the specific IUT interfaces. All communication between the Upper Tester Client and Server is done via the utp port. Via the utp port the Upper Tester Client sends commands to the Test Adapter and receives indication messages from the IUT via the UTS, e.g. a command to enter a specific string to the Tx Keying interface or an indication from the Receive audio interface. All the commands and indications are listed in table 3.
- All PTCs also interact with the TA to configure their respective PDU transport. Table 2 shows the list of Configuration Messages that can be used to configure the TA.

4.1.1 Lower tester dPMR messages

4.1.1.1 Lower Tester Port 1 PDU messages

The lower tester port dp1Port supports exchange of the PDUs in table 1.

Table 1: dPMR PDUs exchanged over dp1Port

dPMR PDU	Direction
HeaderFrame	Rx/Tx
AckFrame	Rx/Tx
PayloadTransmission	Rx/Tx
PayloadTransmissionWithoutHeader	Rx/Tx
CallSetUpOrServiceRequest	Rx/Tx
Acknowledgement	Rx/Tx
StatusReqAck	Rx/Tx
Disconnect	Rx/Tx
PacketDataTransmission	Rx/Tx

When receiving parts of dPMR PDUs, the test adapter shall re-assemble these parts and shall deliver only complete dPMR PDUs to the TTCN.

4.1.1.2 Lower Tester test adapter configuration messages

The lower tester port taPort allows for the Test Adapter to be configured.

Table 2: dPMR Test Adapter configuration messages exchanged over taPort

Configuration command	Parameter
TaRequest	ChannelNumber PoliteLvl SignalLevel ColourCode
TaConfirm	TA_Success Observation

4.1.2 Upper Tester command and confirmation messages

Upper Tester command messages can be used for configuration of the IUT as well as requesting the test operator to execute a specific action.

Table 3: Upper Tester command and confirmation messages exchanged via the upper tester port (utPort)

UT	Parameters
UtRequest	ChannelNumber PoliteLvl DialString Common_ID UtActParams
UtConfirm	UT_Success Observation

5 ATS conventions

The ATS conventions are intended to give a better understanding of the ATS but they also describe the conventions made for the development of the ATS. These conventions shall be considered during any later maintenance or further development of the ATS.

The ATS conventions contain two clauses, the naming conventions and the implementation conventions. The naming conventions describe the structure of the naming of all ATS elements. The implementation conventions describe the functional structure of the ATS.

To define the ATS, the guidelines of the document ETS 300 406 [7] are considered.

5.1 Naming conventions

The naming convention is based on the following underlying principles:

- in most cases, identifiers should be prefixed with a short alphabetic string (specified in table 4) indicating the type of TTCN-3 element it represents;
- suffixes shall not be used;
- prefixes should be separated from the body of the identifier with an underscore ("_");

EXAMPLE 1: `c_sixteen, t_waitMax.`

- only module names, test case identifiers, data type names and module parameters should begin with an upper-case letter. All other names (i.e. the part of the identifier following the prefix) should begin with a lower-case letter;
- the start of second and subsequent words in an identifier should be indicated by capitalizing the first character. Underscores should not be used for this purpose.

EXAMPLE 2: `f_authenticateUser().`

Table 4 specifies the naming guidelines for each element of the TTCN-3 language indicating the recommended prefix, suffixes (if any) and capitalization.

Table 4: TTCN-3 naming convention

Language element	Naming convention	Prefix	Example	Notes
Module	Use upper-case initial letter	none	DPMR_TypesAndValues	
Item group within a module	Use lower-case initial letter	none	messageGroup	
Data type	Use upper-case initial letter	none	SetupContents	
Message template	Use lower-case initial letter	m_	m_setupInit m_setupBasic	Note 1
Message template with wildcard or matching expression	Use lower-case initial letters	mw_	mw_anyUserReply	Note 2
Port instance	Use lower-case initial letter	none	signallingPort	
Test component ref	Use lower-case initial letter	none	userTerminal	
Constant	Use lower-case initial letter	c_	c_maxRetransmission	
External constant	Use lower-case initial letter	cx_	cx_macId	
Function	Use lower-case initial letter	f_	f_authentication()	
External function	Use lower-case initial letter	fx_	fx_calculateLength()	
Altstep (incl. Default)	Use lower-case initial letter	a_	a_receiveSetup()	
Test case	Use all upper-case letters	TC_	TC_BS_DLL_TACT_BV_001	
Variable (local)	Use lower-case initial letter	v_	v_macId	
Variable (defined within a component)	Use lower-case initial letters	vc_	vc_systemName	
Timer (local)	Use lower-case initial letter	t_	t_wait	
Timer (defined within a component)	Use lower-case initial letters	tc_	tc_authMin	
Module parameter	Use all upper-case letters	none	PX_MAC_ID	
Parameterization	Use lower-case initial letter	p_	p_macId	
Enumerated Value	Use lower-case initial letter	e_	e_syncOk	
NOTE 1: This prefix must be used for all template definitions which do <i>not</i> assign or refer to templates with wildcards or matching expressions, e.g. templates specifying a constant value, parameterized templates without matching expressions, etc.				
NOTE 2: This prefix must be used in identifiers for templates which either assign a wildcard or matching expression (e.g. ?, *, value list, if present, pattern, etc) or reference another template which assigns a wildcard or matching expression.				

5.2 Implementation conventions

5.2.1 Templates

- Templates should be identified with names rather than numbers.
- Templates should not modify other modified templates. Base templates which are modified must be identified in their naming.
- Templates should be specified separately for use in sending and receiving operations. The prefixes as described above must be used in identifiers for templates which either assign a wildcard or matching expression (e.g. ?, *, value list, if present, pattern, etc) or reference another template which assigns a wildcard or matching expression.
- Template definitions should avoid using matching attributes such as "*" or "?" for complete structured values, e.g. record or set of values.
- PIXIT parameter values should be passed as parameters into templates.

5.3 Test Case (TC) identifier

The identifier of the test case is built in the same way as for the test purpose described in TS 102 587-2 [3], with the exception that "TP" is replaced by "TC". This naming convention is proposed in EG 202 568 [i.1].

EXAMPLE: The TP TP_PMR_0824_02 is given the TC Id TC_PMR_0824_02.

5.4 Test suite documentation

In order to allow browsing of the dPMR TTCN-3 ATS without the use of a specific TTCN-3 test development environment, the TTCN ATS is made available in HTML format with hyperlinks between entities in the ATS. The documentation in the ATS makes use of special comment tags used by the tool that converts the ATS to the HTML format. These tags are defined in clause 9 of EG 202 568 [i.1] and the tags shown in table 5.

Table 5: TTCN-3 comment tags

Tag	Description
@author	Specifies the names of the authors or an authoring organization which either has created or is maintaining a particular piece of TTCN-3 code.
@desc	Describes the purpose of a particular piece of TTCN-3 code. The description should be concise yet informative and describe the function and use of the construct.
@remark	Adds extra information, such as the highlighting of a particular feature or aspect not covered in the description.
@img	Associates images with a particular piece of TTCN-3 code.
@see	Refers to other TTCN-3 definitions in the same or another module.
@url	Associates references to external files or web pages with a particular piece of TTCN-3 code, e.g. a protocol specification or standard.
@return	Provides additional information on the value returned by a given function.
@param	Documents the parameters of parameterized TTCN-3 definitions.
@version	States the version of a particular piece of TTCN-3 code.

Annex A (informative): On Upper Tester, SUT Emulation and Simulation

A.1 Specifying an Upper Tester Server

In order to completely automate conformance and interoperability testing, the upper interface of the IUT needs to be accessible to TTCN-3 test cases. The specification of this upper interface is not standardized by the dPMR base specification, e.g. there are no primitives defined for requesting the dPMR stack to send a specific burst or to check if one has been received. Consequently, implementations of this interface are vendor specific and may even vary between different IUTs.

In conformance testing methodology the tight integration problem can be resolved by implementing an Upper Tester Server (UTS) in the SUT, i.e. outside of the test system. The purpose of the UTS is to play the role of a dPMR application which interacts with the dPMR stack. It is, however, controlled by the test system with the Upper Tester Client test component via a message channel. Therefore, another task of the UTS is to convert the messages sent by UTC into concrete dPMR interface calls and vice versa. This allows a fairly generic design and encoding of a protocol between the UTS and UTC.

A.1.1 The UTC in the dPMR test system

In the test system the UTC is assigned in each test case an own utp port. During the execution of a test case commands are sent to the UTS in the SUT via the utp port. These commands:

- indicate the reception of an dPMR call;
- configure the SUT.

Further on the commands could:

- indicate the start and end of a test case;
- reset the UTS in case of test case errors.

The commands that are used are listed in clause 4.1.2.

A.2 Using the ATS for Testing with an Emulated SUT

The delivered dPMR test system can also be used with emulated SUTs, e.g. for in-house testing. Here:

- IUT is a software application - usually not running in target hardware but in an emulation environment.
- A protocol, e.g. TCP/IP or a serial interface, and a wired connection replaces the RF parts in the Test Adapter, i.e. the air interface would be circumvented
- The ATS would not require changes, because it is independent of the actual dPMR message transport.
- Upper Tester Server may need to be adapted to fit the emulated SUT.

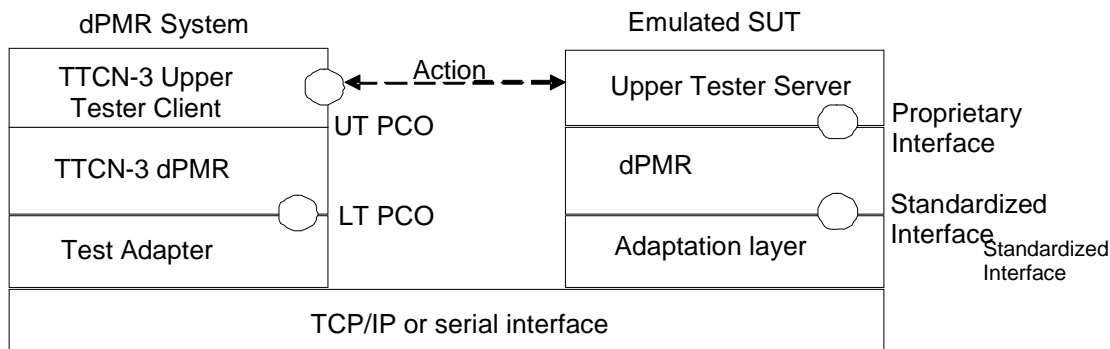

Figure A.1: Testing Architecture with Emulated SUT

A.3 Test case simulation

The test cases in the dPMR test suite can be simulated, by execution of the compiled test case against a System Under Test (SUT) implementation.

The TTCN-3 simulation executes a selected TTCN-3 test case (ETS) against a System Under Test (SUT) executable that implements the expected behaviour of a conforming IUT using TTCN-3. The two executable programs connect, e.g. via a socket connection and exchange BER encoded data messages. Figure A.2 illustrates a simulation configuration.

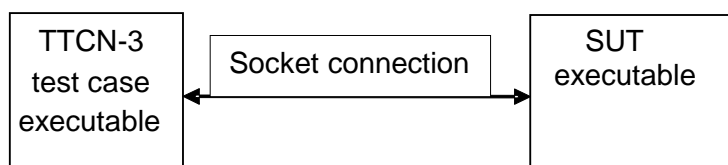

Figure A.2: TTCN test case simulation configuration

The SUT executable is also a generated from a TTCN-3 specification using the same data type definitions as the dPMR test suite specification. The SUT specification also may need to be modified to match the test case selected for simulation.

Simulation of the test cases will improve the quality of the dPMR TTCN-3 test suite detecting a number of errors not detected by static analysis. The types of errors detected include:

- Synchronization errors between parallel test components, e.g. causing that the test case execution never terminates.
- Program flow errors in test components, e.g. loops with incorrect termination conditions or missing "repeat" statements causing the premature termination of the test case execution.
- Use of incorrect test configuration.
- Incorrect or missing handling of messages from the SUT, causing the test case to fail the IUT even if the IUT satisfies the conformance requirement.
- Missing verdict assignments.

The goal of validation with simulation is usually to ensure that test cases pass when executed against a conformant IUT.

Annex B (normative): Abstract Test Suite (ATS)

NOTE: Where an ETSI Abstract Test Suite (in TTCN-3) is published in both core and tabular format these two forms are considered to be equivalent. In the event that there appears to be syntactical or semantic differences between the two then the problem is resolved and the erroneous format (whichever it is) is corrected.

B.1 The ATS in TTCN-3 core (text) format

This ATS has been produced using the Testing and Test Control Notation (TTCN) according to ES 201 873-1 [8].

The TTCN-3 core (text) representation corresponding to this ATS is contained in archive `ts_10258704v010101p0.zip` which accompanies the present document.

Where an ETSI Abstract Test Suite (in TTCN-3) is published in both core and tabular format these two forms shall be considered equivalent. In the event that there appears to be syntactical or semantic differences between the two then the problem shall be resolved and the erroneous format (whichever it is) shall be corrected.

B.2 The ATS in TTCN-3 tabular format

This ATS has been produced using the Testing and Test Control Notation (TTCN) according to ES 201 873-2 [8].

The TTCN-3 Tabular representation of this ATS is contained in archive `ts_10258704v010101p0.zip` which accompanies the present document.

Where an Suite (in TTCN-3) is published in both core and tabular ETSI Abstract Test format these two forms shall be considered equivalent. In the event that there appears to be syntactical or semantic differences between the two then the problem shall be resolved and the erroneous format (whichever it is) shall be corrected.

Annex C (normative): Partial PIXIT proforma for dPMR

Notwithstanding the provisions of the copyright clause related to the text of the present document, ETSI grants that users of the present document may freely reproduce the partial PIXIT proforma in this annex so that it can be used for its intended purposes and may further publish the completed partial PIXIT.

The PIXIT Proforma is based on ISO/IEC 9646-6 [5]. Any needed additional information can be found in the present document.

C.1 Identification summary

Table C.1

PIXIT Number:	
Test Laboratory Name:	
Date of Issue:	
Issued to:	

C.2 ATS summary

Table C.2

Protocol Specification:	TS 102 490 [1]
Protocol to be tested:	
ATS Specification:	TS 102 587-4
Test Configuration:	TS 102 587-4, clause 4

C.3 Test laboratory

Table C.3

Test Laboratory Identification:	
Test Laboratory Manager:	
Means of Testing:	
SAP Address:	

C.4 Client identification

Table C.4

Client Identification:	
Client Test manager:	
Test Facilities required:	

C.5 SUT

Table C.5

Name:	
Version:	
SCS Number:	
Machine configuration:	
Operating System Identification:	
IUT Identification:	
PICS Reference for IUT:	
Limitations of the SUT:	
Environmental Conditions:	

C.6 Protocol layer information

C.6.1 Protocol identification

Table C.6

Name:	TS 102 490 [1]
Version:	
PICS References:	

C.6.2 IUT information

For all relevant IUT information see clause B.1.1.

Annex D (normative): PCTR proforma for dPMR

Notwithstanding the provisions of the copyright clause related to the text of the present document, ETSI grants that users of the present document may freely reproduce the PCTR proforma in this annex so that it can be used for its intended purposes and may further publish the completed PCTR.

The PCTR proforma is based on ISO/IEC 9646-6 [5]. Any needed additional information can be found in the present document.

D.1 Identification summary

D.1.1 Protocol conformance test report

Table D.1

PCTR Number:	
PCTR Date:	
Corresponding SCTR Number:	
Corresponding SCTR Date:	
Test Laboratory Identification:	
Test Laboratory Manager:	
Signature:	

D.1.2 IUT identification

Table D.2

Name:	
Version:	
Protocol specification:	
PICS:	
Previous PCTR if any:	

D.1.3 Testing environment

Table D.3

PIXIT Number:	
ATS Specification:	
Test Configuration:	
Means of Testing identification:	
Date of testing:	
Conformance Log reference(s):	
Retention Date for Log reference(s):	

D.1.4 Limits and reservation

Additional information relevant to the technical contents or further use of the test report, or the rights and obligations of the test laboratory and the client, may be given here. Such information may include restriction on the publication of the report.

.....

.....

.....

.....

.....

D.1.5 Comments

Additional comments may be given by either the client or the test laboratory on any of the contents of the PCTR, for example, to note disagreement between the two parties.

.....

.....

.....

.....

.....

D.2 IUT Conformance status

This IUT has or has not been shown by conformance assessment to be non-conforming to the specified protocol specification.

Strike the appropriate words in this sentence. If the PICS for this IUT is consistent with the static conformance requirements (as specified in clause D.3) and there are no "FAIL" verdicts to be recorded (in clause D.6) strike the words "has or", otherwise strike the words "or has not".

D.3 Static conformance summary

The PICS for this IUT is or is not consistent with the static conformance requirements in the specified protocol.

Strike the appropriate words in this sentence.

D.4 Dynamic conformance summary

The test campaign did or did not reveal errors in the IUT.

Strike the appropriate words in this sentence. If there are no "FAIL" verdicts to be recorded (in clause D.6) strike the words "did or" otherwise strike the words "or did not".

Summary of the results of groups of test:

.....
.....
.....
.....
.....
.....
.....
.....
.....
.....
.....

D.5 Static conformance review report

If clause D.3 indicates non-conformance, this clause itemizes the mismatches between the PICS and the static conformance requirements of the specified protocol specification.

.....
.....
.....
.....
.....
.....
.....
.....
.....
.....
.....

D.6 Test campaign report

Table D.4

ATS Reference	Selected?	Run?	Verdict	Observations (Reference to any observations made in clause D.7)
1.1 'All Call' (ref. 5.1.1)				
TP_PMR_0824_01				
TP_PMR_0858_01				
TP_PMR_0858_02				
TP_PMR_1317_01				
TP_PMR_1317_02				
TP_PMR_1317_03				
TP_PMR_1317_04				
1.2 'Channel Access' (ref. 5.1.2)				
TP_PMR_1004_01				
TP_PMR_1005_01				
TP_PMR_1007_01				
TP_PMR_1007_02				
TP_PMR_1007_03				
TP_PMR_1008_01				
TP_PMR_1009_01				
TP_PMR_1010_01				
TP_PMR_1011_01				
TP_PMR_1012_01				
TP_PMR_1012_02				
TP_PMR_1012_03				
1.3 'Framing' (ref. 5.1.3)				
TP_PMR_0401_01				
TP_PMR_0401_02				
TP_PMR_0401_03				
TP_PMR_0403_01				
TP_PMR_0403_02				
TP_PMR_0403_03				
TP_PMR_0404_01				
TP_PMR_0404_02				
TP_PMR_0404_03				
TP_PMR_0405_01				
TP_PMR_0405_02				
TP_PMR_0406_01				
TP_PMR_0406_02				
TP_PMR_0406_03				
TP_PMR_0406_04				
TP_PMR_0407_01				
TP_PMR_0407_02				
TP_PMR_0407_03				
TP_PMR_0407_04				
TP_PMR_0408_01				
TP_PMR_0811_01				
TP_PMR_0811_02				
TP_PMR_0811_03				
TP_PMR_0811_04				
TP_PMR_0811_05				
TP_PMR_0811_06				
TP_PMR_0811_07				
TP_PMR_0811_08				
TP_PMR_0811_09				
TP_PMR_0811_10				
TP_PMR_0811_11				
TP_PMR_0811_12				
TP_PMR_0811_13				

ATS Reference	Selected?	Run?	Verdict	Observations (Reference to any observations made in clause D.7)
TP_PMR_0811_14				
TP_PMR_0811_15				
TP_PMR_0811_16				
TP_PMR_0812_01				
TP_PMR_0812_02				
TP_PMR_0812_03				
TP_PMR_0812_04				
TP_PMR_0812_05				
TP_PMR_0812_06				
TP_PMR_0812_07				
TP_PMR_0812_08				
TP_PMR_0812_09				
TP_PMR_0812_10				
TP_PMR_0812_11				
TP_PMR_0812_12				
TP_PMR_0812_13				
TP_PMR_0812_14				
TP_PMR_0812_15				
TP_PMR_0812_16				
1.3.1 'End Frame' (ref. 5.1.3.1)				
Void				
1.3.2 'Header frames' (ref. 5.1.3.2)				
TP_PMR_0816_01				
1.3.2.1 'Call information field' (ref. 5.1.3.2.1)				
Void				
1.3.3 'Packet data frame' (ref. 5.1.3.3)				
Void				
1.3.4 'Superframe' (ref. 5.1.3.4)				
1.3.4.1 'Type 1 data' (ref. 5.1.3.4.1)				
TP_PMR_0807_01				
TP_PMR_0831_01				
TP_PMR_0831_02				
TP_PMR_0832_01				
TP_PMR_0832_02				
TP_PMR_0833_01				
TP_PMR_0833_02				
TP_PMR_0834_01				
TP_PMR_0834_02				
1.3.4.2 'Type 2 data' (ref. 5.1.3.4.2)				
TP_PMR_0806_01				
TP_PMR_0825_01				
TP_PMR_0825_02				
TP_PMR_0827_01				
TP_PMR_0827_02				
TP_PMR_0829_01				
TP_PMR_0829_02				
TP_PMR_0830_01				
TP_PMR_0830_02				
1.3.4.3 'Voice' (ref. 5.1.3.4.3)				
TP_PMR_0801_01				
1.4 'Late entry' (ref. 5.1.4)				
TP_PMR_0802_01				
TP_PMR_0802_02				
TP_PMR_0802_03				
TP_PMR_0802_04				
1.5 'Powersave' (ref. 5.1.5)				
TP_PMR_1101_01				
TP_PMR_1102_01				
TP_PMR_1103_01				
1.6 'Talking party ID' (ref. 5.1.6)				
TP_PMR_0803_01				

ATS Reference	Selected?	Run?	Verdict	Observations (Reference to any observations made in clause D.7)
1.7 'Slow User Data' (ref. 5.1.7)				
TP_PMR_0836_01				
TP_PMR_0836_02				
2 'CSF' (ref. 5.2)				
2.1 'Broadcast call' (ref. 5.2.1)				
TP_PMR_0838_01				
2.2 'Dialling plan' (ref. 5.2.2)				
TP_PMR_1310_01				
TP_PMR_1310_02				
TP_PMR_1310_03				
TP_PMR_1310_04				
TP_PMR_1403_01				
TP_PMR_1403_02				
TP_PMR_1416_01				
TP_PMR_1417_01				
TP_PMR_1417_02				
TP_PMR_1418_01				
TP_PMR_1418_02				
TP_PMR_1418_03				
TP_PMR_1418_04				
TP_PMR_1420_01				
TP_PMR_1420_02				
TP_PMR_1420_03				
TP_PMR_1420_04				
TP_PMR_1420_05				
TP_PMR_1420_06				
TP_PMR_1420_07				
TP_PMR_1421_01				
TP_PMR_1423_01				
TP_PMR_1424_01				
2.3 'Individual short data message' (ref. 5.2.3)				
2.3.1 'ISDM free text message' (ref. 5.2.3.1)				
TP_PMR_0852_01				
TP_PMR_0853_01				
2.3.2 'ISDM precoded message' (ref. 5.2.3.2)				
TP_PMR_0850_01				
TP_PMR_0851_01				
2.3.3 'ISDM short file transfer' (ref. 5.2.3.3)				
TP_PMR_0855_01				
TP_PMR_0856_01				
TP_PMR_0857_01				
2.3.4 'ISDM status message' (ref. 5.2.3.4)				
TP_PMR_0846_01				
TP_PMR_0847_01				
2.4 'OACSU' (ref. 5.2.4)				
TP_PMR_0840_01				
TP_PMR_0840_02				
TP_PMR_0840_03				
2.5 'Short appended data' (ref. 5.2.5)				
TP_PMR_0837_01				Not testable
TP_PMR_0844_01				Not testable
2.6 'Slow user data' (ref. 5.2.6)				
TP_PMR_0843_01				
2.7 'Type 3 data' (ref. 5.2.7)				
TP_PMR_0808_01				
TP_PMR_0817_01				
TP_PMR_0818_01				
TP_PMR_0819_01				
TP_PMR_0820_01				
TP_PMR_0821_01				
TP_PMR_0822_01				

ATS Reference	Selected?	Run?	Verdict	Observations (Reference to any observations made in clause D.7)
3 'ISF' (ref. 5.3)				
TP_PMR_0804_01				
TP_PMR_0805_01				

D.7 Observations

Additional information relevant to the technical content of the PCTR is given here.

TP_PMR_0837_01 and TP_PMR_0844_01 are not testable due to restrictions of the test system.

.....

.....

.....

.....

.....

.....

.....

.....

.....

.....

.....

.....

.....

.....

.....

Annex E (informative): Bibliography

- ETSI ES 201 873-2: "Methods for Testing and Specification (MTS); The Testing and Test Control Notation version 3; Part 2: TTCN-3 Tabular presentation Format (TFT)".

History

Document history		
V1.1.1	July 2008	Publication