

**Methods for Testing and Specification (MTS);
Internet Protocol Testing (IPT): IPv6 Mobility;
Conformance Abstract Test Suite (ATS)
and partial Protocol Implementation eXtra
Information for Testing (PIXIT) proforma**



Reference

RTS/MTS-IPT-016[2]-IPV6-MobATS

Keywords

IP, IPv6, testing, TTCN, mobility

ETSI

650 Route des Lucioles
F-06921 Sophia Antipolis Cedex - FRANCE

Tel.: +33 4 92 94 42 00 Fax: +33 4 93 65 47 16

Siret N° 348 623 562 00017 - NAF 742 C
Association à but non lucratif enregistrée à la
Sous-Préfecture de Grasse (06) N° 7803/88

Important notice

Individual copies of the present document can be downloaded from:

<http://www.etsi.org>

The present document may be made available in more than one electronic version or in print. In any case of existing or perceived difference in contents between such versions, the reference version is the Portable Document Format (PDF). In case of dispute, the reference shall be the printing on ETSI printers of the PDF version kept on a specific network drive within ETSI Secretariat.

Users of the present document should be aware that the document may be subject to revision or change of status. Information on the current status of this and other ETSI documents is available at

<http://portal.etsi.org/tb/status/status.asp>

If you find errors in the present document, please send your comment to one of the following services:

http://portal.etsi.org/chaicor/ETSI_support.asp

Copyright Notification

No part may be reproduced except as authorized by written permission.
The copyright and the foregoing restriction extend to reproduction in all media.

© European Telecommunications Standards Institute 2008.
All rights reserved.

DECT™, PLUGTESTS™, UMTS™, TIPHON™, the TIPHON logo and the ETSI logo are Trade Marks of ETSI registered for the benefit of its Members.

3GPP™ is a Trade Mark of ETSI registered for the benefit of its Members and of the 3GPP Organizational Partners.

Contents

Intellectual Property Rights	5
Foreword.....	5
1 Scope	6
2 References	6
2.1 Normative references	6
2.2 Informative references.....	7
3 Definitions and abbreviations.....	7
3.1 Definitions.....	7
3.2 Abbreviations	8
4 Abstract Test Method (ATM).....	8
4.1 CF_MOB_01 mobility config for HA under test	8
4.2 CF_MOB_02 mobility config for MN under test.....	9
4.3 CF_MOB_03 mobility config for CN under test.....	10
5 Untestable and not implemented Test Purposes (TP).....	10
5.1 Untestable TP	10
5.2 Not implemented TP	10
6 ATS conventions	10
6.1 Security test cleanup.....	11
7 PCTR conformance	11
8 PIXIT conformance.....	11
9 ATS conformance	12
Annex A (normative): Abstract Test Suite (ATS)	13
A.1 The ATS in TTCN-3 core (text) format	13
Annex B (normative): Partial PIXIT proforma	14
B.1 Identification summary.....	14
B.2 ATS summary	14
B.3 Test laboratory.....	14
B.4 Client identification.....	15
B.5 SUT	15
B.6 Protocol layer information.....	15
B.6.1 Protocol identification	15
B.6.2 Default Values.....	16
B.6.3 Unknown IDs	16
B.6.4 Addresses	16
B.6.4.1 IUT Addresses	16
B.6.4.2 Tester Addresses.....	17
B.6.4.2.1 Router 2 (RT_02).....	17
B.6.4.2.2 Router 4 (RT_04).....	17
B.6.4.2.3 Mobile Node (MN01)	17
B.6.5 Timer	17
B.6.6 Security Parameters.....	17
Annex C (normative): PCTR proforma	18
C.1 Identification summary.....	18

C.1.1	Protocol conformance test report.....	18
C.1.2	IUT identification	18
C.1.3	Testing environment.....	19
C.1.4	Limits and reservation	19
C.1.5	Comments.....	19
C.2	IUT Conformance status	20
C.3	Static conformance summary	20
C.4	Dynamic conformance summary.....	20
C.5	Static conformance review report.....	20
C.6	Test campaign report.....	21
C.7	Void.....	24
C.8	Observations.....	24
	History	25

Intellectual Property Rights

IPRs essential or potentially essential to the present document may have been declared to ETSI. The information pertaining to these essential IPRs, if any, is publicly available for **ETSI members and non-members**, and can be found in ETSI SR 000 314: "*Intellectual Property Rights (IPRs); Essential, or potentially Essential, IPRs notified to ETSI in respect of ETSI standards*", which is available from the ETSI Secretariat. Latest updates are available on the ETSI Web server (<http://webapp.etsi.org/IPR/home.asp>).

Pursuant to the ETSI IPR Policy, no investigation, including IPR searches, has been carried out by ETSI. No guarantee can be given as to the existence of other IPRs not referenced in ETSI SR 000 314 (or the updates on the ETSI Web server) which are, or may be, or may become, essential to the present document.

Foreword

This Technical Specification (TS) has been produced by ETSI Technical Committee Methods for Testing and Specification (MTS).

1 Scope

The present document specifies the Abstract Test Suite (ATS) for the mobility functions of the Internet Protocol, Version 6, as defined in the specifications [11] through to [14]. The ATS is based on the requirements defined in the IPv6 requirements catalogue TS 102 559 [2], the IPv6 test purposes TS 102 595 [3] and written according to the guidelines of TS 102 351 [1], ISO/IEC 9646-2 [5] and ETS 300 406 [9].

The objective of the present document is to provide a basis for conformance tests for IPv6 equipment giving a high probability of inter-operability between different manufacturer's IPv6 equipments.

Annex A provides the Tree and Tabular Combined Notation (TTCN-3) part of the ATS.

Annex B provides the Partial Protocol Implementation Extra Information for Testing (PIXIT) Proforma of the ATS.

Annex C provides the Protocol Conformance Test Report (PCTR) Proforma of the ATS.

NOTE: Annex B provides only the PIXIT items relevant for the mobility functions of IPv6. It is therefore necessary to also fill the core PIXIT item in TS 102 516 [15] to gain all PIXIT values needed to run the mobility test campaign.

2 References

References are either specific (identified by date of publication and/or edition number or version number) or non-specific.

- For a specific reference, subsequent revisions do not apply.
- Non-specific reference may be made only to a complete document or a part thereof and only in the following cases:
 - if it is accepted that it will be possible to use all future changes of the referenced document for the purposes of the referring document;
 - for informative references.

Referenced documents which are not found to be publicly available in the expected location might be found at <http://docbox.etsi.org/Reference>.

For online referenced documents, information sufficient to identify and locate the source shall be provided. Preferably, the primary source of the referenced document should be cited, in order to ensure traceability. Furthermore, the reference should, as far as possible, remain valid for the expected life of the document. The reference shall include the method of access to the referenced document and the full network address, with the same punctuation and use of upper case and lower case letters.

NOTE: While any hyperlinks included in this clause were valid at the time of publication ETSI cannot guarantee their long term validity.

2.1 Normative references

The following referenced documents are indispensable for the application of the present document. For dated references, only the edition cited applies. For non-specific references, the latest edition of the referenced document (including any amendments) applies.

- [1] ETSI TS 102 351: "Methods for Testing and Specification (MTS); Internet Protocol Testing (IPT); IPv6 Testing: Methodology and Framework".
- [2] ETSI TS 102 559: "Methods for Testing and Specification (MTS); Internet Protocol Testing (IPT); IPv6 Mobility; Requirements Catalogue".

- [3] ETSI TS 102 595: "Methods for Testing and Specification (MTS); Internet Protocol Testing (IPT); IPv6 Mobility; Conformance Test Suite Structure and Test Purposes (TSS&TP)".
- [4] ISO/IEC 9646-1: "Information technology - Open Systems Interconnection - Conformance testing methodology and framework - Part 1: General concepts".
- [5] ISO/IEC 9646-2: "Information technology - Open Systems Interconnection - Conformance testing methodology and framework - Part 2: Abstract Test Suite specification".
- [6] ISO/IEC 9646-4: "Information technology - Open Systems Interconnection - Conformance testing methodology and framework - Part 4: Test realization".
- [7] ISO/IEC 9646-5: "Information technology - Open Systems Interconnection - Conformance testing methodology and framework - Part 5: Requirements on test laboratories and clients for the conformance assessment process".
- [8] ISO/IEC 9646-6: "Information technology - Open Systems Interconnection - Conformance testing methodology and framework - Part 6: Protocol profile test specification".
- [9] ETSI ETS 300 406: "Methods for Testing and Specification (MTS); Protocol and profile conformance testing specifications; Standardization methodology".
- [10] ETSI ES 201 873-1: "Methods for Testing and Specification (MTS); The Testing and Test Control Notation version 3; Part 1: TTCN-3 Core Language".
- [11] IETF RFC 2473: "Generic Packet Tunneling in IPv6 Specification".
- [12] IETF RFC 3775: "Mobility Support in IPv6".
- [13] IETF RFC 3776: "Using IPsec to Protect Mobile IPv6 Signaling Between Mobile Nodes and Home Agents".
- [14] IETF RFC 4068: "Fast Handovers for Mobile IPv6".
- [15] ETSI TS 102 516: "Methods for Testing and Specification (MTS); Internet Protocol Testing (IPT); IPv6 Core Protocol; Conformance Abstract Test Suite (ATS) and partial Protocol Implementation eXtra Information for Testing (PIXIT) proforma".

2.2 Informative references

The following referenced documents are not essential to the use of the present document but they assist the user with regard to a particular subject area. For non-specific references, the latest version of the referenced document (including any amendments) applies.

Not applicable.

3 Definitions and abbreviations

3.1 Definitions

For the purposes of the present document, the following terms and definitions apply:

abstract test case: Refer to ISO/IEC 9646-1 [4].

Abstract Test Method (ATM): Refer to ISO/IEC 9646-1 [4].

Abstract Test Suite (ATS): Refer to ISO/IEC 9646-1 [4].

Implementation Under Test (IUT): Refer to ISO/IEC 9646-1 [4].

Test Purpose (TP): Refer to ISO/IEC 9646-1 [4].

3.2 Abbreviations

For the purposes of the present document, the following abbreviations apply:

ATM	Abstract Test Method
ATS	Abstract Test Suite
CN	Correspondent Node
ESP	Encapsulation Security Payload
ETS	Executable Test Suite
HA	Home Agent
IETF	Internet Engineering Task Force
IPSEC	Security Architecture for the Internet Protocol
IPv6	Internet Protocol version 6
IUT	Implementation Under Test
MAC	Medium Access Control
MN	Mobile Node
MNUT	Mobile Node Under Test
MOT	Means Of Testing
PCTR	Protocol Conformance Test Report
PICS	Protocol Implementation Conformance Statement
PIXIT	Protocol Implementation eXtra Information for Testing
RT	Router
SUT	System Under Test
TC	Test Case
TP	Test Purpose
TSS	Test Suite Structure

4 Abstract Test Method (ATM)

This clause describes the ATM used to test the IPv6 mobility functions as defined in the RFC specifications [11] through to [14]. The three following configurations have been developed to test the three different types of IUT, home agents (HA), mobile nodes (MN) and correspondent nodes (CN).

4.1 CF_MOB_01 mobility config for HA under test

PTC01 simulates RT01, HS02 and MN. PTC02 simulates RT03 and HS03/CN. MNOffHome and MNAtHome are mutually exclusive. CF_MOB_01 is initialized with MNOffHome; this allows in the preamble to start to send Binding Update Off Home. In the postamble, in order to empty the HA Binding cache, MNOffHome is not used anymore and MNAtHome is created. MNAtHome empties then the HA Binding cache.

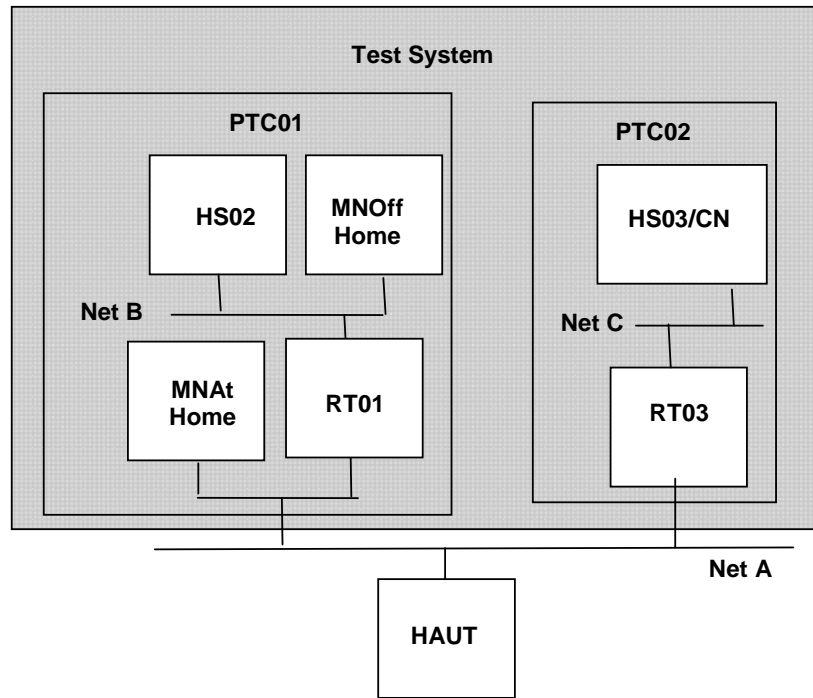

Figure 1: CF_MOB_01

4.2 CF_MOB_02 mobility config for MN under test

PTC01 simulates the home net. PTC02 simulates the visited net. PTC01 and PTC02 send messages mutually exclusive. In the case where MNUT is in the visited net, RT02 proxies all communication (the tunneled HOT/HOTI) between MNUT and its HA.

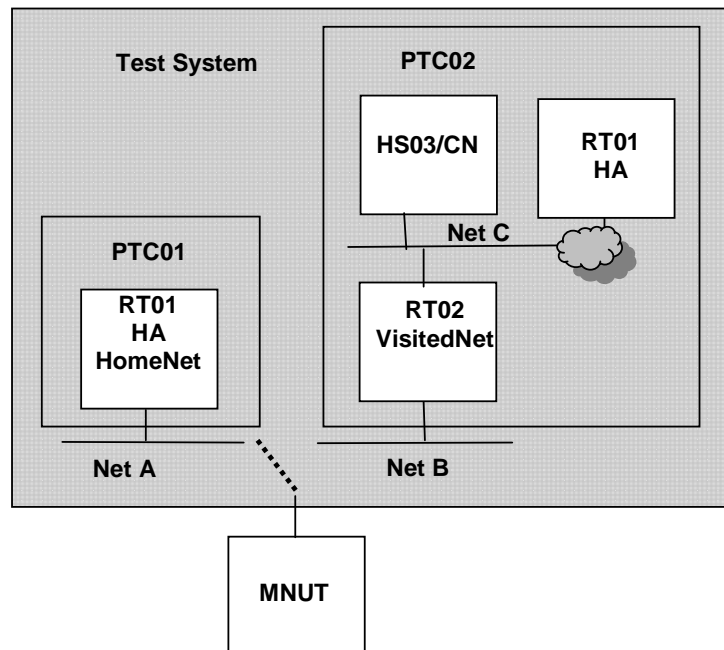

Figure 2: CF_MOB_02

4.3 CF_MOB_03 mobility config for CN under test

PTC04 simulates home net and visited net. Communication between MNAtHome and CNUT (e.g. HOTI, MNAtHome deregisters from CNUT in the postamble) passes through the HA. Communication between MNOffHome and CNUT passes through RT04.

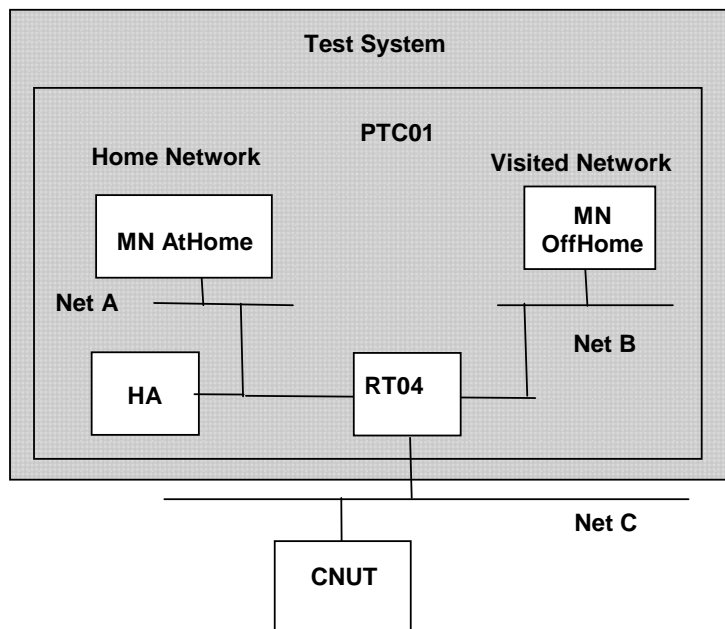

Figure 3: CF_MOB_03

5 Untestable and not implemented Test Purposes (TP)

The ATS comprises 141 TC. Those were derived from a total of 161 TP.

5.1 Untestable TP

This clause gives a list of 19 TP, which are not implemented in the ATS due to the chosen ATM or other restrictions:

TP_MOB_1315_01, TP_MOB_1483_01, TP_MOB_1562_01, TP_MOB_1634_01, TP_MOB_1636_01,
 TP_MOB_1638_01, TP_MOB_1639_01, TP_MOB_1645_01, TP_MOB_1661_01, TP_MOB_1674_01,
 TP_MOB_1674_02, TP_MOB_1764_01, TP_MOB_1764_02, TP_MOB_1764_03, TP_MOB_3021_01,
 TP_MOB_3029_01, TP_MOB_3053_01, TP_MOB_3053_02, TP_MOB_3058_01

5.2 Not implemented TP

TP TP_MOB_1631_01 has not been implemented, as the dynamic behaviour that validates its test purpose is already implemented in TC_MOB_1615_01.

6 ATS conventions

Clause 6.1 describes the cleanup procedures used in this ATS.

Descriptions of the ATS conventions are found in TS 102 351 [1]. The ATS implementation details for the IPv6 core test suite, including mapping procedures and ATS value conventions are found in TS 102 516 [15].

6.1 Security test cleanup

In the case where IKEv2 is used to negotiate the security associations, an INFORMATIONAL exchange with a Delete Payload is executed as shown in figure 4.

In the case where security associations are configured manually, the security association has to be deleted manually after a test case.

MSC IKEv2_TestCleanup

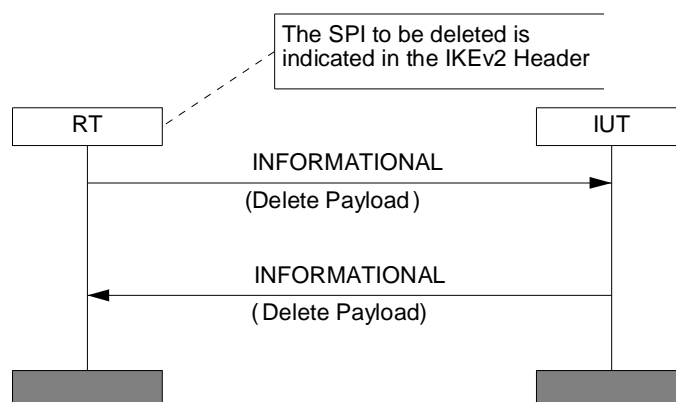

Figure 4: IKEv2 test cleanup

7 PCTR conformance

A test laboratory, when requested by a client to produce a PCTR, is required, as specified in ISO/IEC 9646-5 [7], to produce a PCTR conformant with the PCTR template given in annex B of ISO/IEC 9646-5 [7].

Furthermore, a test laboratory, offering testing for the ATS specification contained in annex C, when requested by a client to produce a PCTR, is required to produce a PCTR conformant with the PCTR proforma contained in annex A.

A PCTR which conforms to this PCTR proforma specification shall preserve the content and ordering of the clauses contained in annex A. Clause A.6 of the PCTR may contain additional columns. If included, these shall be placed to the right of the existing columns. Text in italics may be retained by the test laboratory.

8 PIXIT conformance

A test realizer, producing an executable test suite for the Abstract Test Suite (ATS) specification contained in annex C, is required, as specified in ISO/IEC 9646-4 [6], to produce an augmented partial PIXIT proforma conformant with this partial PIXIT proforma specification.

An augmented partial PIXIT proforma which conforms to this partial PIXIT proforma specification shall, as a minimum, have contents which are technically equivalent to annex B. The augmented partial PIXIT proforma may contain additional questions that need to be answered in order to prepare the Means Of Testing (MOT) for a particular Implementation Under Test (IUT).

A test laboratory, offering testing for the ATS specification contained in annex C, is required, as specified in ISO/IEC 9646-5 [7], to further augment the augmented partial PIXIT proforma to produce a PIXIT proforma conformant with this partial PIXIT proforma specification.

A PIXIT proforma which conforms to this partial PIXIT proforma specification shall, as a minimum, have contents which are technically equivalent to annex B. The PIXIT proforma may contain additional questions that need to be answered in order to prepare the test laboratory for a particular IUT.

9 ATS conformance

The test realizer, producing a Means Of Testing (MOT) and Executable Test Suite (ETS) for the present document, shall comply with the requirements of ISO/IEC 9646-4 [6]. In particular, these concern the realization of an Executable Test Suite (ETS) based on each ATS. The test realizer shall provide a statement of conformance of the MOT to the present document.

An ETS which conforms to the present document shall contain test groups and test cases which are technically equivalent to those contained in the ATS in annex C. All sequences of test events comprising an abstract test case shall be capable of being realized in the executable test case. Any further checking which the test system might be capable of performing is outside the scope of the present document and shall not contribute to the verdict assignment for each test case.

Test laboratories running conformance test services using this ATS shall comply with ISO/IEC 9646-5 [7].

A test laboratory which claims to conform to this ATS specification shall use an MOT which conforms to this ATS.

Annex A (normative): Abstract Test Suite (ATS)

A.1 The ATS in TTCN-3 core (text) format

This ATS has been produced using the Testing and Test Control Notation (TTCN-3) according to ES 201 873-1 [10].

The TTCN-3 core (text) representation corresponding to this ATS is contained in several ASCII files contained in archive ts_102596v010200p0.zip which accompanies the present document.

Annex B (normative): Partial PIXIT proforma

Notwithstanding the provisions of the copyright clause related to the text of the present document, ETSI grants that users of the present document may freely reproduce the PIXIT proforma in this annex so that it can be used for its intended purposes and may further publish the completed PIXIT.

The PIXIT Proforma is based on ISO/IEC 9646-6 [8]. Any needed additional information can be found in there.

B.1 Identification summary

Table B.1: Identification summary

PIXIT Number:	
Test Laboratory Name:	
Date of Issue:	
Issued to:	

B.2 ATS summary

Table B.2: ATS summary

Protocol Specification:	
Protocol to be tested:	
ATS Specification:	
Abstract Test Method:	

B.3 Test laboratory

Table B.3: Test laboratory

Test Laboratory Identification:	
Test Laboratory Manager:	
Means of Testing:	
SAP Address:	

B.4 Client identification

Table B.4: Client identification

Client Identification:	
Client Test manager:	
Test Facilities required:	

B.5 SUT

Table B.5: SUT

Name:	
Version:	
SCS Number:	
Machine configuration:	
Operating System Identification:	
IUT Identification:	
PICS Reference for IUT:	
Limitations of the SUT:	
Environmental Conditions:	

B.6 Protocol layer information

NOTE: The tables below provide only the PIXIT items relevant for the mobility functions of IPv6. It is therefore necessary to also fill the core PIXIT item in TS 102 516 [15] to gain all PIXIT values needed to run the mobility test campaign.

B.6.1 Protocol identification

Table B.6: Protocol identification

Name:	
Version:	
PICS References:	

B.6.2 Default Values

Table B.7: Default Values

Name	Type	Comments	Value
PX_MAX_MULTICAST_SOLICIT_IUT	Integer	Number of AR Neighbor Solicitation retransmissions	
PX_FBU_RETRIES	Integer	Number of Fast Binding Update retransmissions	

B.6.3 Unknown IDs

Table B.8: Unknown IDs

Name	Type	Comments	Value
PX_UNKNOWN_MHTYPE	Integer	A mobile header type that is unknown to the implementation.	

B.6.4 Addresses

B.6.4.1 IUT Addresses

Table B.9: IUT Addresses - Other

Name	Type	Comments	Value
PX_MOBILENODE_HOMEADDR_NOBINDING	IPv6 Address	A unicast home address for which no binding exists in IUT.	
PX_LINK_LOCAL_MULTICAST_ADDRESS	IPv6 Address	A multicast address with link local scope.	
PX_LINK_GLOBAL_MULTICAST_ADDRESS	IPv6 Address	A multicast address with link global scope.	
PX_ALTERNATE_CARE_OF_ADDRESS	IPv6 Address	Alternate care-of address of IUT. It is configured via router advertisements.	
PX_SECOND_HOME_ADDRESS	IPv6 Address	second home address of the IUT	
PX_NAR_MAC	MAC Address	Link-layer address of the new access point.	
PX_NAR_UNKNOWN_MAC	MAC Address	Link-layer address of an unknown access point.	
PX_NAR_SAME_INTERFACE_MAC	MAC Address	Link-layer address indicating endpoint on the same interface.	
PX_NAR_DIFFERENT_INTERFACE_MAC	MAC Address	Link-layer address indicating endpoint on a different interface.	
PX_NAR_NO_SUPPORT_INTERFACE_MAC	MAC Address	Link-layer address indicating endpoint that does not support fast handover.	
PX_NAR_GLA	MAC Address	A unicast global address of the new access point.	
PX_NEW_COA	IPv6 Address	A unicast global address as the new Care-of Address.	
PX_UNACCEPTABLE_CARE_OF_ADDRESS	IPv6 Address	An unacceptable Care-of Address.	

B.6.4.2 Tester Addresses

B.6.4.2.1 Router 2 (RT_02)

Table B.10: Addresses RT_01

Name	Type	Comments	Value
PX_MAC_UCA_RT02_B	MAC Address	Unicast MAC Address Net B	
PX_MAC_UCA_RT02_C	MAC Address	Unicast MAC Address Net C	

B.6.4.2.2 Router 4 (RT_04)

Table B.11: Addresses RT_04

Name	Type	Comments	Value
PX_MAC_UCA_RT04_C	MAC Address	Unicast MAC Address Net C	

B.6.4.2.3 Mobile Node (MN01)

Table B.12: Addresses MN01

Name	Type	Comments	Value
PX_MAC_UCA_MN01	MAC Address	Unicast MAC Address Net C	

B.6.5 Timer

Table B.13: Timer

Name	Type	Comments	Value
PX_MAX_MOBILE_PREFIX_ADVERTISEMENT_INTERVAL	Float	The maximum Mobile Prefix Advertisement Interval, in seconds.	
PX_PREFIX_ADV_TIMEOUT	Float	The Prefix Advertisement timeout, in seconds.	

B.6.6 Security Parameters

Table B.14: Security parameters

Name	Type	Comments	Value
PX_USE_IPSEC_FOR_MIP	e_securityOn or e_securityOff	Shall IPSEC be tested?	
PX_IP_SEC_PROTOCOL	e_esp or e_ah	Which protocol (ESP or AH) shall be used?	
PX_IP_SEC_PROTOCOL_MODE	e_transportMode or e_tunnelMode	Which protocol mode (tunnel or transport) shall be used?	
PX_ENCRYPTION_ALGO	EncryptionAlgo	Which Algorithm shall be used for Encryption?	
PX_INTEGRITY_ALGO	IntegrityAlgo	Which Algorithm shall be used for Encryption?	
PX_SA_RRP_OUT_SPI	Integer	Which SPI value shall be used for Return routability Procedure outbound traffic?	
PX_SA_RRP_IN_SPI	Integer	Which SPI value shall be used for Return routability Procedure inbound traffic?	
PX_SA_CNMN_OUT_SPI	Integer	Which SPI value shall be used for outbound traffic to Mobile Node?	
PX_SA_CNMN_IN_SPI	Integer	Which SPI value shall be used for inbound traffic from Mobile Node?	
PX_ESP_ENCR_KEY	octetstring	Encryption Key	
PX_INTEGRITY_KEY	octetstring	Integrity Key	

Annex C (normative): PCTR proforma

Notwithstanding the provisions of the copyright clause related to the text of the present document, ETSI grants that users of the present document may freely reproduce the PCTR proforma in this annex so that it can be used for its intended purposes and may further publish the completed PCTR.

The PCTR proforma is based on ISO/IEC 9646-6 [8]. Any needed additional information can be found in there.

C.1 Identification summary

C.1.1 Protocol conformance test report

Table C.1: Protocol conformance test report

PCTR Number:	
PCTR Date:	
Corresponding SCTR Number:	
Corresponding SCTR Date:	
Test Laboratory Identification:	
Test Laboratory Manager:	
Signature:	

C.1.2 IUT identification

Table C.2: IUT identification

Name:	
Version:	
Protocol specification:	
PICS:	
Previous PCTR if any:	

C.1.3 Testing environment

Table C.3: Testing environment

PIXIT Number:	
ATS Specification:	
Abstract Test Method:	
Means of Testing identification:	
Date of testing:	
Conformance Log reference(s):	
Retention Date for Log reference(s):	

C.1.4 Limits and reservation

Additional information relevant to the technical contents or further use of the test report, or the rights and obligations of the test laboratory and the client, may be given here. Such information may include restriction on the publication of the test report.

.....

.....

.....

.....

.....

.....

C.1.5 Comments

Additional comments may be given by either the client or the test laboratory on any of the contents of the PCTR, for example, to note disagreement between the two parties.

.....

.....

.....

.....

.....

.....

C.6 Test campaign report

Table C.4: Test campaign report

ATS Reference	Selected?	Run?	Verdict	Observations
Group 1 IPv6 Mobility - RFC3775				
Group 1.1 Overview of Mobile IPv6 Security				
Group 1.1.1 Return Routability Procedure				
TC_MOB_1048_01				
TC_MOB_1050_01				
TC_MOB_1052_01				
Group 1.1.2 Authorizing Binding Management Messages				
TC_MOB_1063_01				
Group 1.1.3 Updating Node Keys and Nonces				
TC_MOB_1075_01				
TC_MOB_1075_02				
Group 1.2 New IPv6 Protocol, Message Types, and Destination Option				
Group 1.2.1 Home Address Option				
TC_MOB_1208_01				
TC_MOB_1209_01				
Group 1.3 Modifications to IPv6 Neighbor Discovery				
Group 1.3.1 Modified Router Advertisement Message Format				
TC_MOB_1293_01				
Group 1.3.2 New Advertisement Interval Option Format				
TC_MOB_1310_01				
TC_MOB_1310_02				
Group 1.3.3 New Home Agent Information Option Format				
TC_MOB_1328_01				
TC_MOB_1328_02				
Group 1.4 Correspondent Node Operation				
Group 1.4.1 Processing Mobility Headers				
TC_MOB_1399_01				
TC_MOB_1399_02				
TC_MOB_1399_03				
TC_MOB_1399_04				
TC_MOB_1399_05				
TC_MOB_1399_06				
TC_MOB_1401_01				
TC_MOB_1404_01				
TC_MOB_1404_02				
TC_MOB_1404_03				
TC_MOB_1404_04				
TC_MOB_1404_05				
TC_MOB_1404_06				
TC_MOB_1408_01				
TC_MOB_1408_02				
TC_MOB_1408_03				
TC_MOB_1408_04				
TC_MOB_1408_05				
TC_MOB_1408_06				
Group 1.4.2 Packet Processing				
Group 1.4.2.1 Receiving Packets with Home Address Option				
TC_MOB_1411_01				
TC_MOB_1413_01				
TC_MOB_1414_01				
TC_MOB_1415_01				
Group 1.4.3 Sending Binding Error Messages				
TC_MOB_1426_01				
Group 1.4.4 Return Routability Procedure				
Group 1.4.4.1 Receiving Home Test Init Messages				
TC_MOB_1430_01				
Group 1.4.4.2 Receiving Care-of Test Init Messages				
TC_MOB_1431_01				
Group 1.4.5 Processing Bindings				

ATS Reference	Selected?	Run?	Verdict	Observations
Group 1.4.5.1 Receiving Binding Updates				
TC_MOB_1432_01				
TC_MOB_1432_02				
TC_MOB_1433_01				
TC_MOB_1433_02				
TC_MOB_1436_01				
TC_MOB_1437_01				
TC_MOB_1439_01				
TC_MOB_1440_01				
TC_MOB_1441_01				
TC_MOB_1442_01				
TC_MOB_1443_01				
TC_MOB_1445_01				
TC_MOB_1446_01				
TC_MOB_1447_01				
Group 1.4.5.2 Requests to Delete a Binding				
TC_MOB_1465_01				
TC_MOB_1465_02				
Group 1.4.5.3 Sending Binding Acknowledgements				
TC_MOB_1470_01				
TC_MOB_1481_01				
Group 1.5 Home Agent Operation				
Group 1.5.1 Processing Bindings				
Group 1.5.1.1 Primary Care-of Address Registration				
TC_MOB_1432_03				
TC_MOB_1441_02				
TC_MOB_1442_02				
TC_MOB_1493_01				
TC_MOB_1496_01				
TC_MOB_1502_01				
TC_MOB_1510_01				
TC_MOB_1510_02				
TC_MOB_1512_01				
TC_MOB_1513_01				
TC_MOB_1518_01				
Group 1.5.1.2 Primary Care-of Address De-Registration				
TC_MOB_1526_01				
TC_MOB_1529_01				
Group 1.5.2 Packet Processing				
Group 1.5.2.1 Intercepting Packets for a Mobile Node				
TC_MOB_1537_01				
TC_MOB_1538_01				
TC_MOB_1547_01				
Group 1.5.2.2 Processing Intercepted Packets				
TC_MOB_1551_01				
TC_MOB_1552_01				
TC_MOB_1555_01				
TC_MOB_1557_01				
Group 1.5.2.4 Handling ReverseTunneled Packets				
TC_MOB_1568_01				
Group 1.5.3 Dynamic Home Agent Address Discovery				
Group 1.5.3.1 Receiving Router Advertisement messages				
TC_MOB_1576_01				
TC_MOB_1582_01				
TC_MOB_1588_01				
Group 1.5.4 Sending Prefix Information to the Mobile Node				
Group 1.5.4.1 Scheduling Prefix Deliveries				
TC_MOB_1591_01				
TC_MOB_1594_01				
TC_MOB_1595_01				
TC_MOB_1601_01				
TC_MOB_1601_02				
TC_MOB_1601_03				
TC_MOB_1602_01				

ATS Reference	Selected?	Run?	Verdict	Observations
Group 10.6 Mobile Node Operation				
Group 10.6.1 Packet Processing				
Group 1.6.1.1 Sending Packets While Away From Home				
TC_MOB_1615_01				
TC_MOB_1820_01				
TC_MOB_1619_01				
Group 1.6.1.2 Interaction With Outbound IPsec Processing				
TC_MOB_1625_01				
Group 1.6.1.3 Receiving Packets While Away From Home				
TC_MOB_1633_01				
TC_MOB_1633_02				
TC_MOB_1633_03				
TC_MOB_1633_04				
Group 1.6.1.5 Receiving Binding Error Messages				
TC_MOB_1648_01				
Group 1.6.2 Home Agent and Prefix Management				
Group 1.6.2.1 Dynamic Home Agent Address Discovery				
TC_MOB_1655_01				
Group 1.6.2.2 Sending Mobile Prefix Solicitations				
TC_MOB_1661_01				
Group 1.6.2.3 Receiving Mobile Prefix Advertisements				
TC_MOB_1669_01				
TC_MOB_1670_01				
TC_MOB_1671_01				
TC_MOB_1672_01				
Group 1.6.3 Movement				
Group 1.6.3.1 Using Multiple Care-of Addresses				
TC_MOB_1690_01				
Group 1.6.3.2 Returning Home				
TC_MOB_1695_01				
TC_MOB_1698_01				
TC_MOB_1702_01				
TC_MOB_1704_01				
Group 1.6.4 Return Routability Procedure				
Group 1.6.4.1 Receiving Test Messages				
TC_MOB_1716_01				
TC_MOB_1716_02				
TC_MOB_1716_03				
TC_MOB_1716_04				
TC_MOB_1720_01				
TC_MOB_1720_02				
TC_MOB_1720_03				
Group 1.6.5 Processing Bindings				
Group 1.6.5.1 Sending Binding Updates To The Home Agent				
TC_MOB_1730_01				
TC_MOB_1739_01				
TC_MOB_1742_01				
Group 1.6.5.2 Receiving Binding Acknowledgements				
TC_MOB_1765_01				
TC_MOB_1765_02				
TC_MOB_1769_01				
TC_MOB_1769_02				
Group 1.6.5.3 Receiving Binding Refresh Requests				
TC_MOB_1776_02				
Group 2 IPv6 Mobility - RFC4086				
Group 2.1 Protocol Operation of Network-initiated Handover				
TC_MOB_3018_01				
Group 2.2 Protocol Details				
TC_MOB_3022_01				
TC_MOB_3024_01				
TC_MOB_3025_01				
TC_MOB_3025_02				
TC_MOB_3030_01				
TC_MOB_3030_02				

ATS Reference	Selected?	Run?	Verdict	Observations
TC_MOB_3031_01				
TC_MOB_3031_02				
TC_MOB_3035_01				
TC_MOB_3035_02				
TC_MOB_3036_01				
TC_MOB_3036_02				
TC_MOB_3037_01				
TC_MOB_3039_01				
TC_MOB_3043_01				
TC_MOB_3046_01				
TC_MOB_3048_01				
TC_MOB_3223_01				

C.7 Void

C.8 Observations

Additional information relevant to the technical content of the PCTR is given here.

.....

.....

.....

.....

.....

History

Document history		
V1.1.1	May 2007	Publication
V1.2.0	April 2008	Publication