

# ETSI TS 102 658 V2.2.3 (2012-04)



**Electromagnetic compatibility  
and Radio spectrum Matters (ERM);  
Digital Private Mobile Radio (dPMR) using  
FDMA with a channel spacing of 6,25 kHz**

---

**Reference**

RTS/ERM-TGDMR-310

---

**Keywords**

air interface, digital, FDMA, PMR, protocol, radio

**ETSI**

---

650 Route des Lucioles  
F-06921 Sophia Antipolis Cedex - FRANCE

Tel.: +33 4 92 94 42 00 Fax: +33 4 93 65 47 16

Siret N° 348 623 562 00017 - NAF 742 C  
Association à but non lucratif enregistrée à la  
Sous-Préfecture de Grasse (06) N° 7803/88

---

**Important notice**

Individual copies of the present document can be downloaded from:

<http://www.etsi.org>

The present document may be made available in more than one electronic version or in print. In any case of existing or perceived difference in contents between such versions, the reference version is the Portable Document Format (PDF). In case of dispute, the reference shall be the printing on ETSI printers of the PDF version kept on a specific network drive within ETSI Secretariat.

Users of the present document should be aware that the document may be subject to revision or change of status. Information on the current status of this and other ETSI documents is available at

<http://portal.etsi.org/tb/status/status.asp>

If you find errors in the present document, please send your comment to one of the following services:

[http://portal.etsi.org/chaicor/ETSI\\_support.asp](http://portal.etsi.org/chaicor/ETSI_support.asp)

---

**Copyright Notification**

No part may be reproduced except as authorized by written permission.  
The copyright and the foregoing restriction extend to reproduction in all media.

© European Telecommunications Standards Institute 2012.  
All rights reserved.

**DECT™**, **PLUGTESTS™**, **UMTS™** and the ETSI logo are Trade Marks of ETSI registered for the benefit of its Members.  
**3GPP™** and **LTE™** are Trade Marks of ETSI registered for the benefit of its Members and of the 3GPP Organizational Partners.  
**GSM®** and the GSM logo are Trade Marks registered and owned by the GSM Association.

# Contents

Intellectual Property Rights .....	12
Foreword.....	12
1 Scope .....	13
2 References .....	14
2.1 Normative references .....	14
2.2 Informative references.....	14
3 Definitions, symbols and abbreviations .....	15
3.1 Definitions.....	15
3.2 Symbols.....	17
3.3 Abbreviations .....	17
4 Overview .....	19
4.1 Protocol architecture.....	19
4.1.1 Air Interface Physical Layer (layer 1).....	20
4.1.2 Air Interface Data Link Layer (layer 2).....	20
4.1.3 Air Interface Call Control Layer (layer 3) .....	21
4.1.4 Architectural Configurations .....	21
4.1.4.1 Peer-to-Peer Direct Network (Mode 1).....	21
4.1.4.2 Centralized Repeater Network (Mode 2) .....	22
4.1.4.3 Managed Centralized Repeater Network (Mode 3).....	22
4.1.4.3.1 Beacon Channel.....	22
4.1.4.3.2 Traffic Channel.....	22
4.1.5 Channel Access Mechanisms.....	23
4.1.5.1 Random Access (Mode 1, Mode 2).....	23
4.1.5.2 Regulated Random Access (Mode 3).....	23
4.1.5.3 Polling.....	23
4.1.5.4 Beacon Signal .....	23
4.2 FDMA Structure.....	24
4.2.1 Overview of transmission and burst structure.....	24
4.2.2 Transmission format .....	24
4.2.2.1 Traffic Channel Message Frame .....	24
4.2.2.2 Traffic Channel Payload Frame .....	25
4.2.2.2.1 Traffic Channel Superframe .....	25
4.2.2.3 Traffic Channel Packet Data Header Frame.....	25
4.2.2.4 Traffic Channel End Frame.....	26
4.2.2.5 Beacon SYScast Frame .....	26
4.2.2.6 Appended Data Frame.....	26
4.2.3 Transmission sequences.....	26
4.2.3.1 Traffic Channel Voice or data payload item transmission .....	26
4.2.3.2 Traffic Channel Call set up, service request, etc .....	27
4.2.3.3 Traffic Channel Acknowledgement: .....	27
4.2.3.4 Traffic Channel Status request acknowledgements:.....	27
4.2.3.5 Traffic Channel Disconnection: .....	27
4.2.3.6 Traffic Channel Preservation Message.....	28
4.2.3.7 Mode 3 Beacon Channel .....	28
4.2.3.8 Mode 1 Call Exchange .....	28
4.2.3.8.1 Mode 1 Voice Call.....	28
4.2.3.8.2 Mode 1 Data Call.....	30
4.2.3.9 Mode 2 Call Exchange .....	31
4.2.3.10 Co-channel BS networks .....	31
4.2.3.11 Mode 3 Operation .....	32
4.3 Addressing.....	34
4.4 Unified Data Transport Mechanism .....	34
4.5 Complementary Data.....	34
4.5.1 Support for Voice and Data call services.....	35

4.5.2	Transport of complementary data for MS control.....	35
5	Frame coding.....	35
5.1	Payload Frame [T].....	37
5.2	Message_Frame [BT].....	37
5.2.1	Communications_Start Header [T].....	38
5.2.1.1	Concatenated Superframe to a Communications_Start Header[T] .....	38
5.2.2	Connection_Request Header [T].....	40
5.2.2.1	Called Party Check [T].....	40
5.2.2.2	Repeat Last Ack (RLA) [T] .....	41
5.2.2.3	Short Data Delivery Header message [T].....	41
5.2.2.4	Call Diversion [T] .....	42
5.2.3	Disconnect_Request Header [T].....	42
5.2.4	T_ACK B_ACK Message [T] .....	42
5.2.4.1	Message Information for acknowledgements.....	43
5.2.5	Maintenance_Message [T].....	43
5.2.5.1	Idle Message [T] .....	44
5.2.5.2	Preservation message .....	44
5.2.5.3	Guard_Message [T].....	45
5.2.6	System_Request Header [T] .....	45
5.2.7	ACK header response to a System Request [T].....	46
5.2.8	System Delivery Header [T] .....	46
5.2.9	Status Polling Response Message [T].....	46
5.2.10	Status Polling Request Message [T] .....	47
5.2.11	BS_Command header(U) and response(D) [T].....	47
5.2.12	BS_Access header(U) and response(D) [T].....	47
5.2.13	Broadcast Messages [B] [T].....	48
5.2.13.1	Broadcast Aloha Message [B].....	48
5.2.13.2	Broadcast Announcements [B].....	49
5.2.13.2.1	Broadcast Announcement - Call Timers [B] .....	50
5.2.13.2.2	Broadcast Announcement - Vote Now [B].....	50
5.2.13.2.3	Broadcast Announcement - Mass Registration [B] .....	51
5.2.13.2.4	Broadcast Announcement - Real Time [B].....	51
5.2.13.3	Move Channel Broadcast [BT] .....	52
5.2.13.4	Goto Channel Broadcast [BT].....	52
5.2.13.5	Ambience Listening [T] .....	52
5.2.14	AHOY / Random Access Request Message [B].....	53
5.2.14.1	B_AHOY Message Downlink [B] .....	54
5.2.14.2	Random Access Request Uplink [B].....	56
5.2.15	UDT Header messages [B] .....	57
5.3	End_Frame .....	58
5.4	Packet Data Header [T] .....	59
5.5	Field Descriptions.....	59
5.5.1	Active ACTIVE [B].....	60
5.5.2	Appended_Data [BT].....	60
5.5.3	ARQ [T].....	60
5.5.4	Backoff [B] .....	61
5.5.5	Call Timers [BT].....	61
5.5.6	Communication format [BT] .....	62
5.5.7	Communication Mode [BT].....	62
5.5.8	COMP [B].....	63
5.5.9	Continuation_Flag [T] .....	63
5.5.10	Day of Week (DAYSOFF_WEEK) [B].....	63
5.5.11	Digits [BT].....	64
5.5.12	Emergency Priority [BT] .....	64
5.5.13	End_Type [T].....	64
5.5.14	Frame numbering [T].....	65
5.5.15	Frequency Definitions FR, FT, SEP, BAND [BT] .....	65
5.5.16	Guard_Kind [T] .....	66
5.5.17	Long [B] .....	66
5.5.18	Mask [B] .....	66
5.5.19	Message Information [BT].....	66

5.5.19.1	Message Information for Powersave [T].....	67
5.5.19.2	Message Information for Types 1 and 2 data [T].....	67
5.5.19.3	Message Information for Type 3 (packet) data [T] .....	68
5.5.19.4	Message Information for system transactions [T].....	68
5.5.19.5	Message Information for B_ACK T_ACK acknowledgements [BT] .....	69
5.5.19.6	Message Information for Broadcast headers [BT] .....	69
5.5.19.7	Message Information for BS Command headers [T] .....	69
5.5.19.8	Message Information for additional services [B] .....	70
5.5.20	Message_Type [BT] .....	70
5.5.21	Month B_MONTH .....	70
5.5.22	NRand_Wait [B].....	71
5.5.23	Preservation_Message PM [T].....	71
5.5.24	POL_FMT [BT].....	72
5.5.25	Reason [BT].....	72
5.5.26	Reg [B] .....	75
5.5.27	Reserved [BT].....	75
5.5.28	Service Function [B].....	75
5.5.29	SLD format [T].....	76
5.5.29.1	SLOW Data in the voice superframe .....	76
5.5.29.2	SLOW Data field use with Type 1 or 2 data.....	76
5.5.30	Status .....	77
5.5.30.1	Status for Mode 1 and Mode 2 systems [T] .....	77
5.5.30.2	Status for Mode 3 systems[B].....	77
5.5.31	SYMB [BT] .....	77
5.5.32	SYScast [B] .....	77
5.5.32.1	SYScast1 [B].....	77
5.5.32.2	SYScast2 or SYScast3 [B].....	78
5.5.32.2.1	SYScast2 or SYScast3 Call Timer MS to MS [B].....	78
5.5.32.2.2	Call Timer for line connected calls and packet data [B].....	78
5.5.32.2.3	SYScast2 or SYScast3 Real Time [B].....	78
5.5.32.2.4	SYScast2 or SYScast3 Common Frame Counter [B].....	79
5.5.32.2.5	SYScast2, SYScast3 Calling Party Address [B].....	79
5.5.33	System Identity Code [B] .....	80
5.5.34	Tx_Wait [T].....	80
5.5.35	UAD [BT].....	80
5.5.36	UDT_Format [BT].....	81
5.5.37	Version [BT].....	81
5.5.38	Vote Now Advice Parameters [B] .....	81
5.5.39	Withdrawn W [B] .....	81
5.6	Appended_Data Messages [BT].....	82
5.6.1	Appended_Data MS ID Format .....	82
5.6.2	Appended_Data Binary Format .....	82
5.6.3	Appended_Data BCD Format.....	83
5.6.4	Appended_Data (ISO 7 bit character set Format).....	83
5.6.5	Appended_Data (ISO 8 bit character set format).....	83
5.6.6	Appended_Data NMEA (EN 61162-1 [1]) format .....	84
5.6.7	Appended_Data IPV4 format .....	84
5.6.8	Appended_Data IPV6 format .....	85
5.6.9	Appended_Data Filler.....	85
6	Synchronisation.....	86
6.1	Frame synchronization .....	86
6.1.1	FS1.....	86
6.1.2	FS2.....	86
6.1.3	FS3.....	86
6.1.4	FS4.....	86
6.1.5	Colour Code.....	86
6.1.5.1	Colour Code for Mode 1 and Mode 2 Systems .....	87
6.1.5.2	Colour Code for Mode 3 Systems .....	87
6.1.5.2.1	Colour Code Determined by Frequency .....	87
6.1.5.2.2	Colour Code Determined by Frequency and System Identity Code .....	87
6.1.6	Preamble .....	89

7	Interleaving and FEC coding.....	89
7.1	CRC addition.....	89
7.2	Hamming code .....	89
7.3	Scrambling .....	90
7.4	Interleaving.....	90
7.5	FEC coding of CCH (superframe).....	91
7.6	FEC coding of MI (message info') and HI (header info') .....	91
7.7	FEC coding of END information .....	92
7.8	FEC coding of Appended Data.....	92
8	Bearer Services, tele-services and supplementary services.....	92
8.1	Call types.....	93
8.1.1	Individual call .....	93
8.1.2	Group call .....	93
8.2	Addressing.....	94
8.3	Colour Codes.....	94
8.4	Messages .....	94
8.4.1	Downlink Traffic Channel messages .....	94
8.4.2	Uplink Traffic Channel messages.....	95
8.4.3	Downlink Beacon messages .....	95
8.4.4	Uplink Beacon messages .....	96
9	Packet data.....	96
9.1	Format .....	96
9.2	Receiving party .....	97
9.3	Packet frame coding .....	98
9.4	Data frame size.....	98
9.5	Valid data length .....	99
9.6	Data checksum .....	99
9.7	Standard Packet Exchange Format.....	100
10	Call procedures.....	101
10.1	Call procedures for Mode 1 .....	102
10.1.1	Common procedures for Mode 1 Voice and Data calls .....	102
10.1.1.1	Mode 1 Call set up. ....	102
10.1.2	Mode 1 Voice calls .....	104
10.1.2.1	Mode 1 Voice Call in progress.....	104
10.1.2.2	Mode 1 Voice Call with Slow Data .....	105
10.1.2.3	Mode 1 Voice Call with Attached Data .....	105
10.1.2.4	Mode 1 Voice Call Termination.....	105
10.1.3	Mode 1 Data Calls .....	106
10.1.3.1	Mode 1 T1 and T2 Data calls .....	106
10.1.3.2	Mode 1 T3 (Packet) Data Calls.....	107
10.1.3.3	Mode 1 Individual Status polling .....	110
10.1.3.4	Mode 1 Short Data Delivery .....	111
10.1.4	Mode 1 Traffic Channel Powersave .....	113
10.1.4.1	Transmitted format.....	113
10.1.4.2	Receive format .....	114
10.2	Call procedures for Mode 2.....	114
10.2.1	Mode 2 MS to MS Call set up. ....	115
10.2.2	Mode 2 MS to MS Voice Calls.....	116
10.2.3	Mode 2 Data Calls .....	117
10.2.3.1	Mode 2 T1 and T2 Data Calls .....	117
10.2.3.2	Mode 2 T3 (Packet) Data Calls.....	118
10.2.3.3	MS to MS Status request and responses.....	118
10.2.3.4	MS to MS Short Data.....	119
10.2.4	Mode 2 MS Mode 2 Call Diversion.....	121
10.2.4.1	Setting the diversion.....	122
10.2.4.2	Cancelling the diversion.....	122
10.2.5	Mode 2 Connection to line connected destinations.....	122
10.2.5.1	Voice Call Connection_Request message.....	125
10.2.5.2	Call Matrix for calls to line connected destinations .....	125
10.2.6	Mode 2 calls from line connected sources .....	126

10.2.6.1	Call Matrix for calls from line connected destinations .....	126
10.2.7	Mode 2 Co-channel repeater networks .....	126
10.2.7.1	MS originated repeater polling.....	126
10.2.7.1.1	Description of the messages .....	128
10.2.7.2	BS originated repeater polling.....	128
10.2.7.2.1	Description of the messages .....	129
10.2.7.3	Access and Response timing .....	130
10.3	Call Procedures for Mode 3.....	130
10.3.1	Mode 3 UDT Mechanism .....	131
10.3.1.1	Format of the Appended_Data .....	133
10.3.1.2	UDT Structure.....	134
10.3.1.2.1	UDT Content for Services Carried on the Downlink channel .....	134
10.3.1.2.2	UDT Mechanism for the Uplink channel .....	135
10.3.1.3	Single Part and Multi-part call set-up .....	135
10.3.1.4	MS behaviour to B_AHOY messages.....	135
10.3.2	Mode 3 call examples .....	136
10.3.2.1	An individual voice call example.....	136
10.3.2.2	A Mode 3 talkgroup call example .....	137
10.3.2.3	Mode 3 Short Data call example .....	138
10.3.2.4	Mode 3 Call to PABX/PSTN example .....	138
10.3.2.5	Mode 3 Call from the PABX/PSTN example .....	139
10.3.2.6	Mode 3 transport of complementary data example .....	140
10.3.2.7	Mode 3 transport of complementary data and an extended address example .....	140
10.3.2.8	Mode 3 Refusal of Service .....	141
10.3.3	Mode 3 Detailed Call procedures .....	142
10.3.3.1	Mode 3 Procedures common to Voice calls and Data Calls.....	142
10.3.3.1.1	Availability of requesting MS .....	142
10.3.3.1.2	Call Cancellation .....	142
10.3.3.1.3	Acknowledgements sent to calling MS .....	142
10.3.3.1.4	Maintenance of call progress waiting timers .....	143
10.3.3.1.5	Traffic Channel Assignment .....	143
10.3.4	Mode 3 Voice Call Procedures .....	144
10.3.4.1	Voice Call Procedures for the BS .....	144
10.3.4.1.1	BS Response to single-part voice call set-up.....	145
10.3.4.1.2	BS Response to multi-part voice call set-up.....	145
10.3.4.1.3	Acknowledgements sent by the BS to the calling MS (voice).....	145
10.3.4.1.4	Voice Radio Check.....	146
10.3.4.1.5	Availability Check for Voice Calls connected through Gateways .....	146
10.3.4.2	Voice Call Procedures for MS .....	146
10.3.4.2.1	Initiating a single-part voice call service .....	147
10.3.4.2.2	Response to the single-part individual voice service request .....	147
10.3.4.2.3	Initiating a multi-part voice call service .....	148
10.3.4.2.4	Response to the multi-part voice service request.....	148
10.3.4.2.5	Acknowledgements received by the calling MS (voice) .....	148
10.3.4.2.6	Availability Check to the called MS (voice) .....	149
10.3.4.2.7	Traffic Channel Allocation.....	149
10.3.4.3	Procedures for the Voice Traffic Channel .....	149
10.3.4.3.1	BS Procedures for the Voice Traffic Channel .....	150
10.3.4.3.2	MS Procedures for the Voice Traffic Channel .....	151
10.3.5	Mode 3 Data Call Procedures .....	152
10.3.5.1	Data Call Procedures for the BS .....	153
10.3.5.1.1	BS Response to single-part data call set-up.....	153
10.3.5.1.2	BS Response to multi-part data call set-up.....	153
10.3.5.1.3	Acknowledgements sent by the BS to the calling MS (data).....	153
10.3.5.1.4	Radio Check for Data .....	154
10.3.5.1.5	Availability Check for Data Calls connected through Gateways .....	154
10.3.5.2	Data Call Procedures for MS .....	154
10.3.5.2.1	Initiating a single-part data call service.....	155
10.3.5.2.2	Response to the single-part data call service request.....	155
10.3.5.2.3	Initiating a multi-part data call service .....	156
10.3.5.2.4	Response to the multi-part data service request.....	156
10.3.5.2.5	Acknowledgements received by the calling MS (data) .....	156

10.3.5.2.6	Availability Check to the called MS (data) .....	156
10.3.5.2.7	Traffic Channel Allocation .....	157
10.3.5.3	Procedures for the Data Traffic Channel.....	157
10.3.5.3.1	BS Procedures for the Data Traffic Channel .....	157
10.3.5.3.2	MS Procedures for the Data Traffic Channel .....	158
10.3.5.4	Mode 3 Short Data Message Procedure .....	159
10.3.5.4.1	Short Data Procedures for the BS .....	161
10.3.5.4.2	Short Data Message procedures for MS .....	162
10.3.5.4.3	Initiating a Short Data Message service .....	163
10.3.5.4.4	Response to a random access short data message.....	163
10.3.5.4.5	Acknowledgements received by the calling MS.....	164
10.3.5.4.6	Timeout waiting for further signalling .....	164
10.3.5.4.7	MS receiving a short data message.....	164
10.3.5.5	Mode 3 Short Data Polling Service.....	164
10.3.5.5.1	Short Data Polling Procedures for the BS .....	165
10.3.5.5.2	Short Data Polling Message procedures for MS.....	166
10.3.5.5.3	Initiating a Short Data Polling service.....	167
10.3.5.5.4	Response to a random access short data polling message .....	167
10.3.5.5.5	Final Acknowledgement transmitted by the calling MS.....	167
10.3.5.5.6	Timeout waiting for further signalling .....	168
10.3.5.5.7	MS receiving a B_AHOY poll for a short polling message .....	168
10.3.5.6	Mode 3 Status Call Service .....	168
10.3.5.6.1	Status Service Delivery Procedure .....	168
10.3.5.7	Mode 3 Call Diversion .....	171
10.3.5.7.1	Call Diversion Service.....	171
10.3.5.7.2	Call set-up to an MS that has a Diverted address .....	174
10.3.5.8	Mode 3 MS Stun/Revive Procedures .....	174
10.3.5.8.1	MS Stun/Revive without authentication.....	175
10.3.5.9	Mode 3 MS Kill .....	176
10.3.5.9.1	Kill procedures for the BS .....	176
10.3.5.9.2	Kill procedure with ESN check for the MS .....	177
10.3.6	Message Address Matrix for Mode 3 Call services .....	177
10.3.6.1	Call Services that require the allocation of a Traffic Channel.....	178
10.3.6.1.1	MS to MS or talkgroup Voice, T1, T2, T3 data call.....	178
10.3.6.1.2	MS call to PSTN, PABXI and other extended addresses .....	178
10.3.6.1.3	Call from PSTN, PABX, or other line connected address to MS or talkgroup.....	179
10.3.6.2	Call Services that only require the Beacon Channel .....	180
10.3.6.2.1	MS Short Data Call to MS or talkgroup .....	180
10.3.6.2.2	Short Data Call from PSTN, PABX, LINEI, DISPATI to MS or talkgroup .....	180
10.3.6.2.3	Short Data Call from MS to PSTN, PABX, LINEI, DISPATI.....	180
10.3.6.2.4	Short Data Polling from MS to MS .....	181
10.3.6.2.5	Short Data MS Polling from a gateway .....	181
10.3.6.2.6	Status Transport from MS to MS or talkgroup .....	181
10.3.6.3	Complementary data .....	182
10.3.6.4	Other Mode 3 Services.....	182
10.3.6.4.1	Call Diversion Service.....	182
10.3.6.4.1.1	Set Call Diversion.....	182
10.3.6.4.1.2	Clear Call Diversion .....	183
10.3.6.4.1.3	Call to an MS that has a diverted address .....	183
10.3.6.4.2	Registration .....	183
10.3.6.4.3	Serial Number Check .....	184
10.3.6.4.4	MS Stun/Revive.....	184
10.3.6.4.5	MS Kill .....	184
11	Channel coding process.....	184
11.1	Voice superframe .....	184
11.1.1	Voice + Attached data call.....	185
11.2	Type 1 data superframe .....	187
11.3	Type 2 Data superframe .....	189
11.4	Type 3 (Packet) Data frame.....	191
11.5	Messages .....	193
11.6	End frames.....	194



11.7	SYScast Frames.....	195
11.8	Appended Data Frames .....	196
12	Channel access .....	197
12.1	Channel access for Mode 1 [M1] .....	199
12.1.1	Listen Before Transmit (LBT) [M1].....	199
12.1.2	Hang time messages and timers [M1].....	199
12.1.2.1	Definition [M1] .....	199
12.1.2.2	Action by receiving stations [M1].....	200
12.1.2.3	Call duration timers [M1].....	200
12.1.2.3.1	Item Duration Timer for Voice Calls [M1] .....	200
12.1.2.3.2	Item Duration Timer for Data Calls [M1] .....	200
12.1.3	Transmit admit criteria [M1] .....	200
12.1.3.1	Channel "Politeness" [M1].....	200
12.1.3.2	General Timing [M1] .....	201
12.1.3.3	Transmission re-tries [M1].....	201
12.1.3.4	Emergency channel access procedures [M1] .....	201
12.1.3.4.1	Emergency Break-in requests [M1].....	201
12.2	Channel access for Mode 2 [M2] .....	202
12.2.1	Listen Before Transmit (LBT) [M2].....	203
12.2.2	Hang time messages and timers [M2].....	203
12.2.2.1	Definition [M2] .....	203
12.2.2.2	Action by receiving stations [M2].....	204
12.2.2.3	Call duration timers [M2].....	204
12.2.2.3.1	Item Duration Timer for Voice Calls [M2] .....	204
12.2.2.3.2	Item Duration Timer for Data Calls [M2] .....	204
12.2.2.3.3	Maximum call duration timer for Mode 2 calls .....	204
12.2.3	Transmit admit criteria [M2] .....	205
12.2.3.1	Channel "Politeness" [M2].....	205
12.2.3.2	General Timing [M2] .....	205
12.2.3.3	Transmission re-tries [M2].....	206
12.2.3.4	Emergency channel access procedures [M2] .....	206
12.2.3.4.1	Emergency Break-in requests [M2].....	206
12.3	Channel access for Mode 3 [M3] .....	207
12.3.1	Mode 3 Channel Structure .....	207
12.3.2	Introduction to the Beacon Structure [M3] .....	208
12.3.2.1	Beacon Timing [M3].....	208
12.3.3	Network architecture [M3] .....	209
12.3.3.1	Network functions.....	209
12.3.3.1.1	Establishing service .....	209
12.3.3.1.2	Network Identifier .....	209
12.3.3.2	MS Location by Registration .....	209
12.3.4	Trunking methods [M3].....	209
12.3.5	Beacon Channel Formats [M3].....	209
12.3.5.1	Use of the SYScast Frames .....	210
12.3.5.1.1	SYC1 SYScast Frame.....	210
12.3.5.1.2	SYC2 or SYSC3 SYScast Frame .....	210
12.3.5.2	Beacon Frame Structure .....	211
12.3.5.2.1	Frames on the Beacon downlink channel .....	211
12.3.5.2.2	Frames on the Beacon uplink channel .....	211
12.3.6	Channel Access for a Beacon Channel .....	212
12.3.6.1	Basic Structure .....	212
12.3.6.1.1	Channel Structure .....	212
12.3.6.1.2	Physical Channel Addressing .....	212
12.3.6.1.3	Sub-Division of the MS population.....	212
12.3.7	Random Access Procedures .....	214
12.3.7.1	The Random Access Principle .....	214
12.3.7.1.1	Random Access Control .....	214
12.3.7.1.2	Action after receiving an acknowledgement .....	220
12.3.7.1.3	MS Arriving on a Beacon Channel.....	220
12.3.8	Beacon Channel Acquisition and Retention .....	220
12.3.8.1	MS Parameter.....	221

12.3.8.2	Beacon Channel Acquisition Procedures .....	221
12.3.8.2.1	Entry into Beacon Acquisition Procedures .....	222
12.3.8.2.2	Identifying a Candidate Beacon Channel .....	222
12.3.8.2.3	Confirmation - Monitoring the BS downlink channel signal quality .....	226
12.3.8.3	MS Leaving a Beacon Channel .....	226
12.3.8.3.1	Leaving a Beacon Channel Whilst Waiting for Signalling .....	226
12.3.8.4	Registration, Power Save, and Authentication Procedures .....	227
12.3.8.4.1	General .....	227
12.3.8.4.2	Registration Procedures .....	229
12.3.9	Mass re-registration .....	231
12.3.9.1	Procedure for MS on receipt of Mass Re-registration Broadcast .....	231
12.3.9.2	De-registration .....	232
12.3.10	Beacon Power Save .....	233
12.3.10.1	Overview .....	233
12.3.10.2	Power Save Procedures .....	233
12.3.10.2.1	Basic Power Save Procedures .....	233
12.3.11	Electronic Serial Number Check Procedures .....	235
12.3.11.1	Format of the Electronic Serial Number (ESN) .....	236
12.3.11.2	ESN Procedures for the BS to authenticate an MS .....	236
12.3.11.3	ESN Procedures for the MS .....	237
12.4	Traffic Channel Access for Mode 3 .....	237
12.4.1	Preservation of the traffic channel [M3] .....	238
12.4.2	Reassignment of the traffic channel for an emergency call .....	238
13	Timers, constants levels and addresses .....	239
13.1	Timers .....	239
13.2	Constants .....	240
13.3	Levels .....	241
13.4	Gateways/Identifiers .....	241
13.5	Message Matrix's .....	242
14	Physical Layer .....	243
14.1	General parameters .....	243
14.1.1	Frequency range .....	243
14.1.2	RF carrier bandwidth .....	243
14.1.3	Transmit frequency error .....	243
14.1.4	Time base clock drift error .....	243
14.2	Modulation .....	244
14.2.1	Symbols .....	244
14.2.2	4FSK generation .....	244
14.2.2.1	Deviation index .....	244
14.2.2.2	Square root raised cosine filter .....	245
14.2.2.3	4FSK Modulator .....	246
<b>Annex A (normative):</b>	<b>Standard User Interface .....</b>	<b>247</b>
A.1	Numbering and dialling plan .....	247
A.1.1	Introduction to the numbering and dialling plan .....	247
A.1.2	Subscriber mapping .....	248
A.1.2.1	User Interface - Air Interface .....	248
A.1.2.1.1	Mapping for MS address space .....	249
A.1.2.1.1.1	The concept of the wildcard character .....	249
A.1.2.1.1.2	The concept of stored parameters .....	249
A.1.2.1.1.3	The concept of ad-hoc arrangement .....	249
A.1.2.1.1.4	The rules for the sender .....	249
A.1.2.1.1.5	The rules for the recipient .....	250
A.1.2.1.1.6	Mapping of dialled strings to the AI address space .....	250
A.1.2.2	Addresses .....	251
A.1.2.3	Conversion rules .....	251
A.1.2.3.1	MS addresses .....	251
A.1.2.3.2	Limiting the length of the destination address .....	252
A.1.2.3.3	All talkgroup address .....	252
A.1.3	User dialling plan .....	252

A.1.3.1	User numbering .....	252
A.1.3.1.1	Dialling method.....	252
A.1.3.1.2	Call Type determination.....	252
A.1.3.1.3	Call modifier strings.....	252
A.1.3.2	Dialled digits to address mapping.....	253
A.1.3.3	Storage requirements .....	253
A.1.3.3.1	MS individual address.....	253
A.1.3.3.2	Dialled Talkgroups.....	253
A.1.3.3.3	All MSs .....	253
A.1.3.3.4	Non-dialable numbers .....	254
A.1.3.3.5	Talkgroup recognition.....	254
A.1.3.3.5.1	All numeric talkgroups .....	254
A.1.3.3.5.2	Talkgroups defined by wildcards.....	254
A.1.3.3.5.3	MS receives a talkgroup call .....	254
A.1.3.4	Dialling procedures.....	255
A.1.3.4.1	MS calls .....	255
A.1.3.4.1.1	Seven digit dialling.....	255
A.1.3.4.1.2	Abbreviated dialling .....	255
A.1.3.4.1.3	Masked dialling .....	255
A.1.3.4.2	Gateway Calls .....	256
A.1.3.4.2.1	Telephone call .....	256
A.1.3.4.2.2	PABX call.....	256
A.1.3.4.2.3	IP call.....	257
A.1.3.4.3	Call modifiers.....	257
A.1.3.4.3.1	Broadcast call .....	257
A.1.3.4.3.2	Priority call .....	258
A.1.3.4.3.3	Emergency Call .....	258
A.1.3.4.3.4	Status poll call .....	258
A.1.3.4.3.5	Status delivery call .....	258
A.1.3.4.3.6	Divert own call .....	258
A.1.3.4.3.7	Force talkgroup service .....	258
A.1.3.4.4	Call set-up abandon or call complete .....	258
A.1.3.4.4.1	Call set-up abandon or call complete - Mode 1 .....	258
A.1.3.4.4.2	Call set-up abandon or call complete - Mode 2 .....	259
A.1.3.4.4.3	Call set-up abandon or call complete - Mode 3 .....	259

## **Annex B (informative): Beacon Channel Hunting Procedures .....260**

B.1	Introduction .....	260
B.1.1	Resuming a Beacon hunt channel.....	262
B.1.2	Commanded Beacon hunt channel .....	262
B.1.2.1	Conditions to enter a Commanded Beacon hunt.....	262
B.1.2.2	Nominated Channel for the Single Channel Hunt.....	262
B.1.2.3	Short Hunt Sequence .....	263
B.1.2.3.1	Conditions to enter a Short Channel Hunt.....	263
B.1.2.4	Comprehensive Hunt Sequence .....	263
B.1.2.4.1	Conditions to enter a Comprehensive Channel Hunt .....	263
B.1.2.5	Receiver Sensitivity During Beacon Channel Acquisition .....	264
History	.....	265

---

## Intellectual Property Rights

IPRs essential or potentially essential to the present document may have been declared to ETSI. The information pertaining to these essential IPRs, if any, is publicly available for **ETSI members and non-members**, and can be found in ETSI SR 000 314: *"Intellectual Property Rights (IPRs); Essential, or potentially Essential, IPRs notified to ETSI in respect of ETSI standards"*, which is available from the ETSI Secretariat. Latest updates are available on the ETSI Web server (<http://ipr.etsi.org>).

Pursuant to the ETSI IPR Policy, no investigation, including IPR searches, has been carried out by ETSI. No guarantee can be given as to the existence of other IPRs not referenced in ETSI SR 000 314 (or the updates on the ETSI Web server) which are, or may be, or may become, essential to the present document.

---

## Foreword

This Technical Specification (TS) has been produced by ETSI Technical Committee Electromagnetic compatibility and Radio spectrum Matters (ERM).

---

# 1 Scope

The present document covers digital Private Mobile Radio (dPMR) equipment using FDMA technology with channel spacing of 6,25 kHz supporting voice and data applications capable of operating in the existing licensed land mobile service frequency bands below 1 000 MHz.

The present document includes the baseband signal processing parameters of the physical layer and the protocol structure at the air interface. The protocol supports different levels of functionality from peer to peer mode to managed base station access mode:

- |        |  |
|--------|--|
| Mode 1 | Peer to peer (direct mode) operation without Base Stations or infrastructure.                          |
| Mode 2 | dPMR systems incorporating one or more Base Stations for repeating or providing system gateways.       |
| Mode 3 | dPMR systems operating under a managed access mode in systems incorporating one or more Base Stations. |

All three modes of operation of the present air interface are designed to be compliant with the appropriate harmonized standard for spectrum use, EN 301 166-2 [4]. A polite spectrum access protocol for sharing the physical channel has also been specified.

---

## 2 References

References are either specific (identified by date of publication and/or edition number or version number) or non-specific. For specific references, only the cited version applies. For non-specific references, the latest version of the reference document (including any amendments) applies.

Referenced documents which are not found to be publicly available in the expected location might be found at <http://docbox.etsi.org/Reference>.

NOTE: While any hyperlinks included in this clause were valid at the time of publication ETSI cannot guarantee their long term validity.

### 2.1 Normative references

The following referenced documents are necessary for the application of the present document.

- [1] IEC EN 61162-1 (2010): "Maritime navigation and radiocommunication equipment and systems - Digital interfaces - Part 1: Single talker and multiple listeners".
- [2] ISO/IEC 646 (1991): "Information technology - ISO 7-bit coded character set for information interchange".
- [3] ISO/IEC 8859-series (1998 - 2001): "Information technology - 8-bit single-byte coded graphic character sets".
- [4] ETSI EN 301 166-2: "Electromagnetic compatibility and Radio spectrum Matters (ERM); Land Mobile Service; Radio equipment for analogue and/or digital communication (speech and/or data) and operating on narrow band channels and having an antenna connector; Part 2: Harmonized EN covering essential requirements of article 3.2 of the R&TTE Directive".

### 2.2 Informative references

The following referenced documents are not necessary for the application of the present document but they assist the user with regard to a particular subject area.

- [i.1] ETSI ETS 300 230: "Radio Equipment and Systems (RES); Land mobile service; Binary Interchange of Information and Signalling (BIIS) at 1 200 bit/s (BIIS 1 200)".
- [i.2] MPT 1327 (June 1997): "A Signalling Standard for Trunked Private Land Mobile Radio Systems".

---

## 3 Definitions, symbols and abbreviations

### 3.1 Definitions

For the purposes of the present document, the following terms and definitions apply:

**active\_hang\_time:** time during which a Mode 2 BS preserves the channel for the parties involved in a call

**Appended\_Data:** message carrying principally data that is formatted according to the present document

**Base Station (BS):** fixed end equipment that is used to obtain dPMR services

**beacon channel:** channel that carries synchronous beacon frames timed from a BS

**bearer service:** type of telecommunication service that provides the capability for the information transfer between user network interfaces, involving only low layer functions (layers 1 to 3 of the OSI model)

NOTE: Confirmed Data and Unconfirmed Data are examples of bearer services.

**burst:** smallest predefined block of continuous bits containing information or signalling

NOTE: The burst may include a guard time at the beginning and end of the burst used for power ramp-up and ramp-down.

**call:** complete sequence of related transactions between MS

NOTE: Transactions may be one or more bursts containing specific call related information

**Caller Line Identity (CLI):** ability to see who is calling you before answering the telephone

**call\_hang\_time:** time during which a Mode 1 or Mode 2 channel is available for an emergency pre-emption

**complementary service:** dPMR service that enables complementary data to be passed between MS and BS as part of the call set-up phase of another service (such as voice)

**Control plane (C-plane):** part of the protocol stack dedicated to control and data services

**downlink:** transmission from BS to MS(s)

**extended address:** address of an entity that is not a native MS/BS individual/group identity

**feature:** attribute intrinsic to a station, e.g. MS has an address

**intrinsic service:** service which is inherent within a voice or data service

**late entry:** where receiving stations that have missed the start of a transmission are able to recover all information about the call from subsequent message frames

**line connected:** call whereby one end of the call is connected to the radio system that does not use the dPMR Air Interface

NOTE: Examples may be connection to the PSTN or a PABX.

**logical channel:** distinct data path between logical endpoints

**Manufacturers ID (MID):** 8 bit identifier assigned to a particular manufacturer

**Mobile Station (MS):** physical grouping that contains all of the mobile equipment that is used to obtain dPMR mobile services

**mode:** class of operation of a dPMR system

**multi-part call set-up:** call set-up procedure whereby the full information to be exchanged between entities cannot be accommodated in a single message frame

NOTE: The UDT procedure is invoked to transfer the address information using UDT signalling. UDT is also invoked to transport complementary and user data between dPMR entities.

**network personalization:** configuration parameters appropriate to network configuration programmed into an MS that may be set by an external agency but not by the user of an MS

**payload:** part of a data stream representing the user information

**peer-to-peer mode:** mode of operation where MS may communicate outside the control of a network

NOTE: This is communication technique where any MS may communicate with one or more other MS(s) without the need for any additional equipment (e.g. BS).

**personalization:** address and configuration information that characterizes a particular dPMR MS

NOTE: This information may be implanted by the installer before putting an MS into service.

**physical channel:** FDMA transmission

**polite protocol:** Listen Before Transmit (LBT) protocol

NOTE: This is a medium access protocol that implements a LBT function in order to ensure that the channel is free before transmitting.

**prefix:** most significant digit of an MS address in the user domain

**radio frequency channel:** radio frequency carrier (RF carrier)

NOTE: This is a specified portion of the RF spectrum. The RF carrier separation is 6,25 kHz.

**Received Signal Strength Indication (RSSI):** root mean squared value of the signal received at the receiver antenna

**signalling:** exchange of information specifically concerned with the establishment and control of connections, and with management, in a telecommunication network

**simplex:** mode of working by which information can be transferred in both directions but not at the same time

NOTE: Simplex is also known as half duplex.

**superframe:** four concatenated FDMA frames

NOTE: A superframe has a length of 320 ms.

**supplementary service:** supplementary service modifies or supplements a tele-service or bearer service

NOTE: Consequently, it cannot be offered to a user as a standalone service. It is offered together with or in association with a tele-service or bearer service. The same supplementary service may be common to a number of telecommunication services. Late entry is an example of supplementary service.

**talkgroup:** collection of MSs that have the same group address

**traffic channel:** channel in which control/payload frames are exchanged asynchronously

**telecommunication service:** offered by a dPMR entity in order to satisfy a specific telecommunication requirement

**tele-service:** type of telecommunication service that provides the complete capability, including terminal equipment functions, for communication between users

NOTE: Individual voice calls and talkgroup voice calls are examples of tele-services.

**uplink:** transmission from MS to BS

**user numbering:** decimal representation of dPMR air interface addresses, as seen by the user, i.e. user visible numbering



**User plane (U-plane):** part of the protocol stack dedicated to user voice services

**vocoder socket:** 216 bits vocoder payload

**wildcard:** character in the user domain that represents all digits 0 to 9

## 3.2 Symbols

For the purposes of the present document, the following symbols apply:

$B_2$	algorithm that converts MS dialable talkgroup addresses between the User Interface and the Air Interface
dBm	absolute power level relative to 1 mW, expressed in dB
dBp	Power relative to the average power transmitted over a burst in decibel
Hz	frequency
Eb	Energy per bit
ms	milli-seconds
No	Noise per Hz
ppm	parts per million

## 3.3 Abbreviations

For the purposes of the present document, the following abbreviations apply:

4FSK	Four-level Frequency Shift Keying
ACK	ACKnowledgment
AI	Air Interface
ANNS	ANNouncement parameterS
ANT	ANnouncement Type
ARQ	Automatic Retransmission reQuest
BAND	Band
BCD	Binary Coded Decimal
BER	Bit Error Rate
BRCST	Broadcast
BS	Base Station
BS/RPT	Base Station/Repeater
BSID	Base Station IDentity
CC	Colour Code
CCH	Control CHannel
CCL	Call Control Layer
CFC	Common Frame Counter
CLI	Caller Line Identity
CM	Communications Mode
COCHIn	CO-CHannel Identity n (n = 1 to 15)
COG	Course Over Ground
COMP	COMPLEMENTary data service
Cont	Continuation flag
C-plane	Control-plane
CRC	Cyclic Redundancy Checksum

NOTE: For data error detection.

DET	DETail
DISPAT	DISPATcher
DLL	Data Link Layer
DN	Nth Packet Data Frame
DP	Data Position
dPMR	digital Private Mobile Radio
EDEG	Longitude Degrees
EF	Emergency Flag
EMINF	Longitude Minutes

EP	Emergency Priority
ESN	Electronic Serial Number
ET	End Type
EW	East/West Flag
FDMA	Frequency Division Multiple Access
FEC	Forward Error Correction
FIFO	First In First Out
FMT	Format
FN	Frame Numbering
FR	Receive Frequency
FS	Frame Synchronisation
FSK	Frequency Shift Keying
FT	Transmit frequency
GBSID	Global Base Station IDentity
GPI	Group Identity
GPS	Global Position System
GTC	Go To Channel
HEAD	Header
HI	Header Information
HT	Header Type
ID	IDentifier
IPI	Internet Protocol Identity
LBT	Listen Before Transmit
LEN	Length
LINEI	Line Identity
LSB	Least Significant Bit
MI	Message Information
MID	Manufacturer's ID
MMI	Man Machine Interface
MPT	Ministry of Post and Telecommunications
MS	Mobile Station
MSB	Most Significant Bit
MSI	Mobile Station Identity
MSs	Multiplicity of mobile or handportable Stations
MT	Message Type
NACK	Negative ACKnowledgment
NDEG	Latitude Degrees
NMEA	National Marine & electronics Association
NMINF	Latitude Minutes
NS	North/South Flag
NW	Wait Number
OACSU	Off Air Call Set Up
PABX	Private Automatic Branch eXchange
PABXI	Private Automatic Branch Exchange Identity
PAR	Parameter data
PARMS	PARaMeterS
PDF	Packet Data Format
PDU	Packet Data Unit
PL	Physical Layer
PM	Preservation Message
PR	Preservation
PSTN	Public Switched Telephone Network
PSTNI	Public Switched Telephone Network Identity
PTT	Push-To-Talk
QACK	Queue wait ACKnowledgment

NOTE: The call is in a queue. More signalling to follow.

REGI	Registration Identity
RF	Radio Frequency
RLA	Repeat Last Ack
RLAI	Repeat Cast Ack Identifier

RQ	Request
RRC	Raised Root Cosine
RSSI	Received Signal Strength Indication
RSSI	Relative Signal Strength Indication
RSVD	ReSerVeD
RTFMT	Real Time Format
SDM	Short Data Service
SDMI	Short Data Service Identity
SEP	Separation
SLD	SLOW Data
SOG	Speed Over Ground
SYMB	SYMBOL
SYNC	SYNChronization
TBD	To Be Decided
TC	Traffic Channel
TCH	Traffic CHannel
TGI	Talk Group Identity
UDT	Unified Data Transport
UDTD	Unified Data Downlink
UDTU	Unified Data Uplink
U-plane	User-plane
UTC	Universal Time Coordinated
VFRMS	Vote FRaMeSets
VSYS	Vote SYStem identity code
WACK	Wait ACKnowledgement

NOTE: More signalling to follow.

WU Wake Up

## 4 Overview

The present document describes a narrow band Digital Private Mobile Radio system which employs a Frequency Division Multiple Access (FDMA) technology with an RF carrier bandwidth of 6,25 kHz.

The present document describes the Physical Layer (PL) and the Data Link Layer (DLL) of the Air Interface (AI) as well as the standardized services and facilities of the radio. Radio equipments which conform to the present document shall be interoperable at the PL and DLL with equipment from other manufacturers.

Where manufacturers have declared compliance to the "Standard User Interface", the MMI shall also comply with the relevant requirements of annex A.

The present document does not provide the specification or operational detail for system implementations which include but are not limited to, vocoder, security, data, and other interfaces.

### 4.1 Protocol architecture

The purpose of this clause is to provide a model where the different functions and processes are identified and allocated to different layers in the protocol stack.

The protocol stack in this clause and all other related clauses describe and specify the interfaces, but this stack does not imply or restrict any implementation.

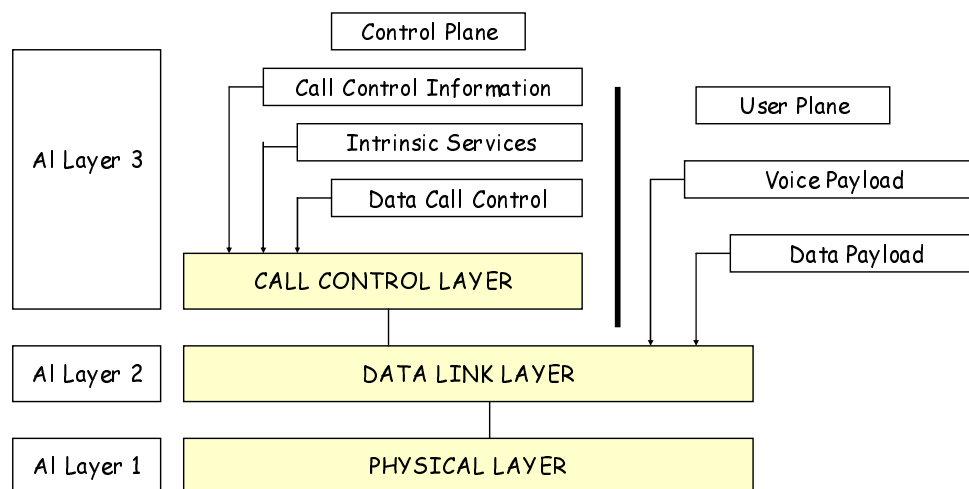
The protocol architecture which is defined herein follows the generic layered structure, which is accepted for reference description and specification of layered communication architectures.

The standard defines the protocols for the following 3 layered model as illustrated in figure 4.1.

The base of the protocol stack is the Physical Layer (PL) which is the layer 1.

The Data Link Layer (DLL), which is the layer 2, shall handle sharing of the medium by a number of users. At the DLL, the protocol stack shall be divided vertically into two parts, the User plane (U-plane), for transporting information without addressing capability (e.g. voice or data stream), and the Control plane (C-plane) for signalling with addressing capability, as illustrated by figure 4.1.

The Call Control Layer (CCL), which is layer 3, lies in the C-plane and is responsible for control of the call (addressing, facilities, etc.), provides the services supported by the radio, and supports the Data Service. U-plane access at layer 2 (DLL) supports the voice service.



**Figure 4.1: dPMR protocol stack**

#### 4.1.1 Air Interface Physical Layer (layer 1)

The Air Interface layer 1 shall be the physical interface. It shall deal with the physical transmission or burst, composed of bits, which is to be sent and/or received. The Physical Layer is described in clause 12. The Air Interface layer 1 shall contain the following functions:

- modulation and demodulation;
- transmitter and receiver switching;
- RF characteristics;
- bits and symbol definition;
- frequency and symbol synchronization;
- transmission or burst building.

#### 4.1.2 Air Interface Data Link Layer (layer 2)

The Air Interface layer 2 shall handle logical connections and shall hide the physical medium from the upper layers. The Data Link Layer is described in clauses 11 to 14.

The main functions are as follows:

- channel coding (FEC, CRC);
- interleaving, de-interleaving and bit ordering;
- acknowledgement and retry mechanism;
- media access control and channel management;
- framing, superframe building and synchronization;

- burst and parameter definition;
- link addressing (source and/or destination);
- interfacing of voice applications (vocoder data) with the PL;
- data bearer services;
- exchanging signalling and/or user data with the CCL.

### 4.1.3 Air Interface Call Control Layer (layer 3)

Air Interface layer 3 (CCL) is applicable only to the C-plane, and shall be an entity for the services and facilities supported by the radio on top of the layer 2 functionality.

The CCL provides the following functions:

- establishing, maintaining and terminating of calls;
- individual or talkgroup call transmission and reception;
- destination addressing;
- support of intrinsic services (late entry, call divert, etc.);
- data call control.

### 4.1.4 Architectural Configurations

A network of MS and/or BS shall be configured into one of three modes, Mode 1, Mode 2 or Mode 3. Within a network all entities shall be configured with the matching mode.

#### 4.1.4.1 Peer-to-Peer Direct Network (Mode 1)

A Peer-to-Peer Direct Network illustrated in figure 4.2 is characterized by multiple MS communicating with each other directly on a single frequency channel (i.e.  $MS f_{TX} = MS f_{RX} = f_1$ ).

Peer-to-Peer operation on a given channel is governed by the MS on that channel. There is no 'Master-Slave' relationship on such a channel and each MS is responsible for adhering to the channel access rules. Peer-to-Peer communication is directly between the MS.

Signalling between entities is asynchronous using a traffic channel.

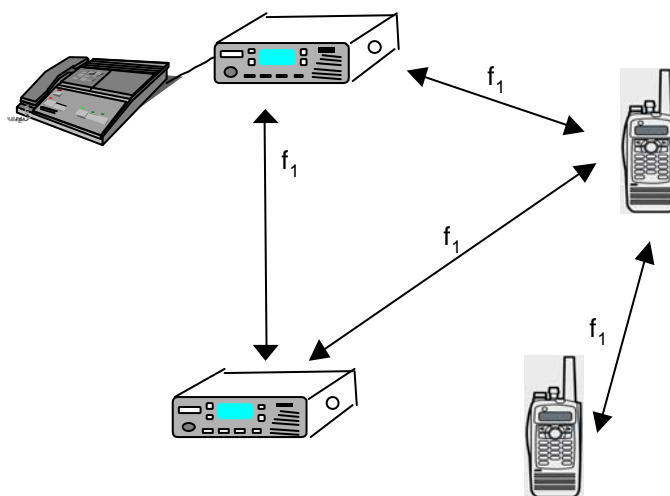
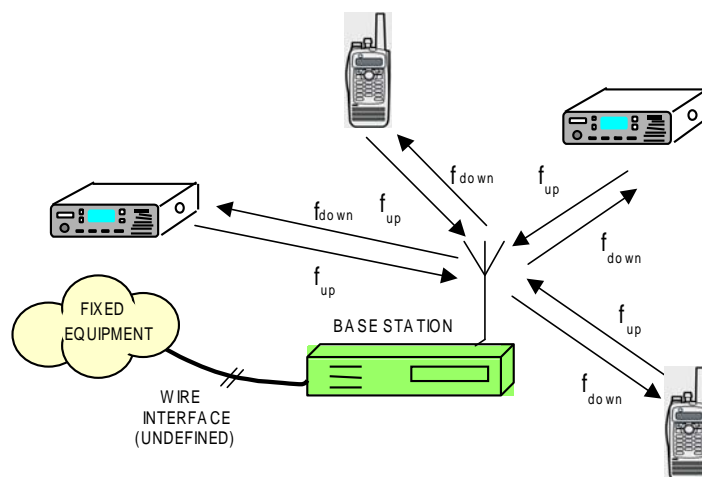


Figure 4.2: Peer-to-Peer Direct Network (Mode 1)

#### 4.1.4.2 Centralized Repeater Network (Mode 2)

A Centralized BS Network illustrated in figure 4.3 is characterized by multiple MS communicating with a BS on up-link and down-link channels (i.e.  $MS f_{tx} = BS f_{rx} = f_{uplink}$ ,  $MS f_{rx} = BS f_{tx} = f_{downlink}$ ). All Centralized communication is via the BS. For polite operation, the BS is required to indicate on the down-link when the up-link is busy.

Signalling between entities is asynchronous using a traffic channel.



**Figure 4.3: Centralized Repeater Network (Mode 2)**

#### 4.1.4.3 Managed Centralized Repeater Network (Mode 3)

A Managed Centralized BS Network illustrated in figure 4.4 is characterized by multiple MS communicating with a BS on up-link and down-link channels (i.e.  $MS f_{tx} = BS f_{rx} = f_{uplink}$ ,  $MS f_{rx} = BS f_{tx} = f_{downlink}$ ). There is a 'Master-Slave' relationship on such a channel where the BS is considered the Master and the MS are considered the Slaves. All Centralized communication is via the BS.

A Mode 3 physical channel may be operating as a beacon channel or a traffic channel.

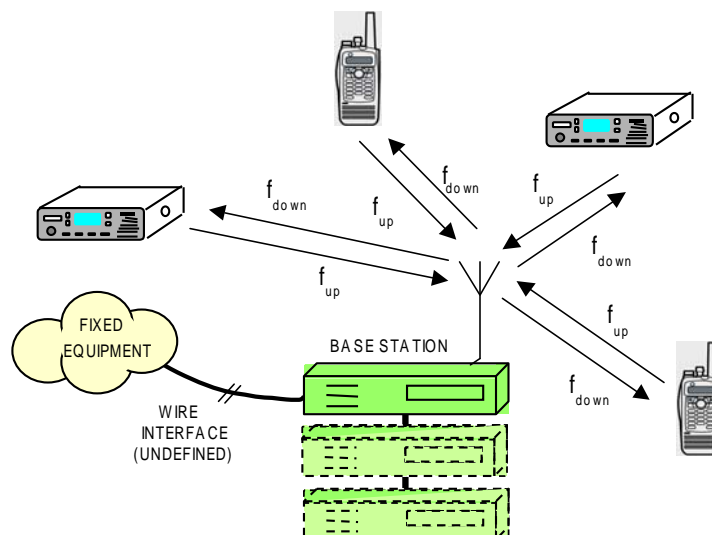
##### 4.1.4.3.1 Beacon Channel

Signalling between entities is synchronous. Frames are transmitted by the BS to provide MS bit and slot timing. All call set-ups use a beacon channel.

By default, MS employ Random Access to access the channel, however the channel access rules may be modified at any time by the BS regulating channel access or implementing the role of a polling station. The BS is required to implement intelligent signalling functions such as indicating on the down-link when the up-link is busy.

##### 4.1.4.3.2 Traffic Channel

For some services (such as voice) the BS and MS either switches to traffic channel operation or transfers the call to an alternative BS that is activated as a traffic channel.



**Figure 4.4: Managed Centralized Repeater Network (Mode 3)**

## 4.1.5 Channel Access Mechanisms

### 4.1.5.1 Random Access (Mode 1, Mode 2)

By default, MS employ a Random Access method to access channels. This method provides a polite and organized protocol for MS to access the channel by ensuring that:

- a) MS refrain from accessing a channel which is already in use.
- b) MS access a channel in a way which minimizes collisions (resulting from simultaneous transmissions).
- c) Collisions are resolved in an orderly manner.
- d) Emergency calls are given priority over non-emergency calls.

### 4.1.5.2 Regulated Random Access (Mode 3)

MS channel access on a given channel shall be regulated by a Managed Repeater (Mode 3). Channel access is regulated while a payload transaction is not in progress in order to provide a Centralized control of the channel access. This Centralized control is a particularly useful mechanism for improving the throughput of heavily utilized channels.

### 4.1.5.3 Polling

For Polling applications, MS channel access is in response to transmissions generated by a Central entity (i.e. the Polling Station).

Polling is applicable both to Peer-to-Peer and Centralized operation, and where employed, the role of Polling Station is either implemented by an MS (Peer-to-Peer operation) or the BS (Centralized operation).

### 4.1.5.4 Beacon Signal

A Mode 3 BS shall transmit a Beacon Signal on a given channel in order to provide one or more of the following features:

- a) Mark the presence of a system.
- b) Radiate system parameters.
- c) Provide timing information (common clock, timeslot timing, frame timing etc.).
- d) Provide signal strength information.

- e) Invite MS to instigate a call service.

## 4.2 FDMA Structure

### 4.2.1 Overview of transmission and burst structure

The described solution is based on a FDMA structure.

The physical resource available to the radio system is an allocation of the radio spectrum.

A transmission or burst is a period of RF carrier that is modulated by a data stream. The physical channel of an FDMA transmission is required to support the logical channels.

A logical channel is defined as a logical communication pathway between two or more parties. The logical channels represent the interface between the protocol and the radio subsystem. The logical channels may be separated into two categories:

- traffic channels carrying control frames, speech or data payload (Mode 1, Mode 2, Mode 3); and
- beacon channels (Mode 3).

**NOTE:** A Mode 3 system employs a beacon channel for call set-up and beacon transactions. For some services (such as voice calls) the beacon channel may revert to a traffic channel or the beacon channel may transfer the call to a separate physical traffic channel for the duration of the call.

All traffic channel transmissions are asynchronous, since there is no entity to provide frame or slot timing.

All beacon channel transmissions are synchronous and rely on a BS to provide slot timing.

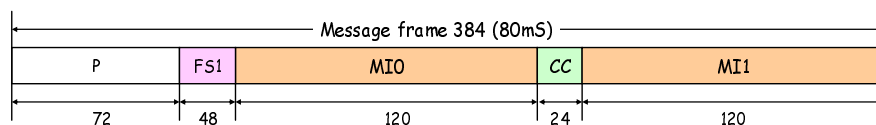
Peer-to-peer, uplink, and downlink messages are distinguished by a two bit Communications Format field that is carried in all message frames.

### 4.2.2 Transmission format

dPMR transmissions follow the formats in these clauses.

#### 4.2.2.1 Traffic Channel Message Frame

The traffic channel message frame illustrated in figure 4.5 is of 80 ms (384 bits) in length.



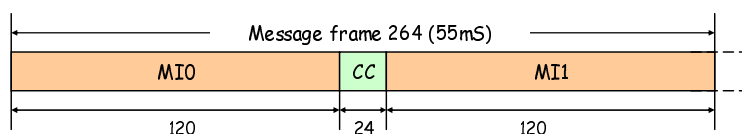
- P: Preamble, minimum of 72 bits  
 FS1: 48 bit Frame Sync 1 sequence  
 MIO: Message 0, 120 bits  
 CC: Colour Code, 24 bits  
 MI1: Message 1, 120 bits

**Figure 4.5: Traffic Channel Message Frame**

**NOTE:** The Communications\_Start Header Frame is a type of Message Frame. See clause 5.2.1.

A beacon channel message frame has a very similar structure illustrated in figure 4.6.

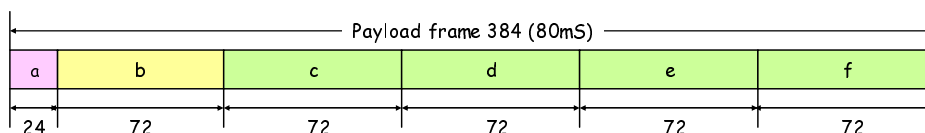




**Figure 4.6: Beacon Channel Message Frame**

#### 4.2.2.2 Traffic Channel Payload Frame

An FDMA traffic channel payload transmission illustrated in figure 4.7 is made up of 80 ms payload frames, each comprising 384 bits.

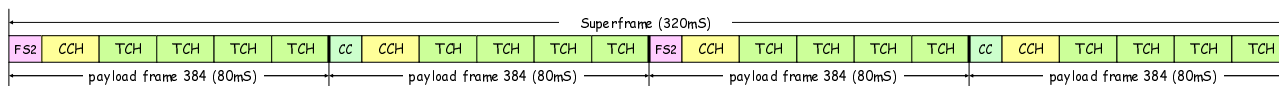


- a: 24 bits FrameSync2 (FS2) or Colour Code (CC) bits
- b: 72 bits Control Channel (CCH) data
- c: 72 bits Traffic channel (TCH)
- d: 72 bits TCH
- e: 72 bits TCH
- f: 72 bits TCH

**Figure 4.7: Payload Frame**

#### 4.2.2.2.1 Traffic Channel Superframe

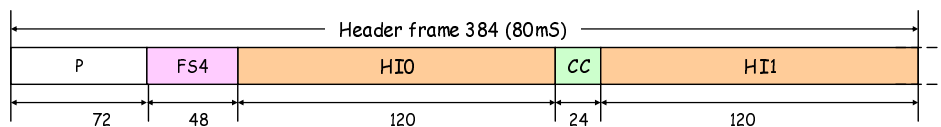
Four 80 ms payload frames illustrated in figure 4.8 are concatenated to form a superframe of 320 ms.



**Figure 4.8: Superframe**

#### 4.2.2.3 Traffic Channel Packet Data Header Frame

The Header frame illustrated in figure 4.9 is of 80 ms (384 bits) in length.

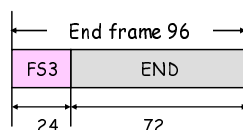


- P: Preamble, minimum of 72 bits
- FS4: 48 bit Frame Sync 4 sequence
- HIO: Header Information 0, 120 bits
- CC: Colour Code, 24 bits
- HI1: Header Information 1, 120 bits

**Figure 4.9: Packet Data Header Frame**

#### 4.2.2.4 Traffic Channel End Frame

The End frame illustrated in figure 4.10 is a shortened 96 bit frame.



FS3: Frame sync, 24 bits

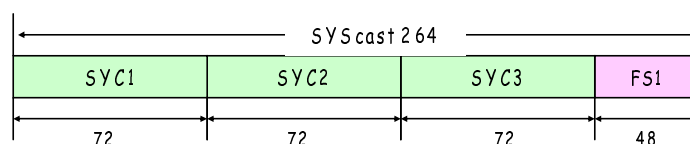
END: End data, 72 bits

NOTE: Type 3 data transmissions (packet data) use a different framing structure.

**Figure 4.10: End Frame**

#### 4.2.2.5 Beacon SYScast Frame

The SYScast frame illustrated in figure 4.11 is transmitted by a Mode 3 beacon BS.



SYC1: SYScast1, 72 bits

SYC2: SYScast2, 72 bits

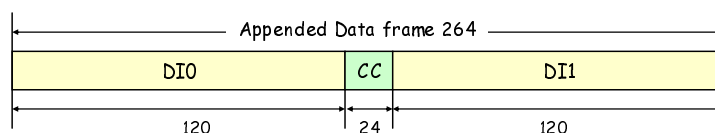
SYC3: SYScast3, 72 bits

FS1: Frame sync, 48 bits

**Figure 4.11: SYScast Frame**

#### 4.2.2.6 Appended Data Frame

The Appended Data frame is illustrated in figure 4.12



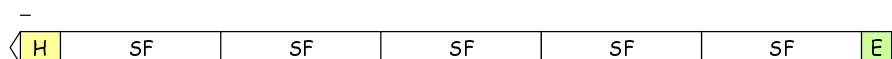
**Figure 4.12: Appended Data Frame**

### 4.2.3 Transmission sequences

#### 4.2.3.1 Traffic Channel Voice or data payload item transmission

The sequence is illustrated in figure 4.13. These transmissions are always started with a Header frame containing a preamble (for bit synchronization) and a frame synch (for frame synchronization). The Header is followed by a series of Superframes that contain both the payload (voice or data) and the information about the call such that receiving stations can implement late entry. A call always consists of an integral number of superframes and is terminated by an End frame.

For receiving stations, purpose and content of any transmission can be determined by the Message Information (MI0 and MI1).

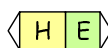


H: Header frame  
 SF: Superframe  
 E: End frame

**Figure 4.13: Voice or Data Payload continuous transmission**

#### 4.2.3.2 Traffic Channel Call set up, service request, etc

The transmission illustrated in figure 4.14 may be sent by Mode 1 and Mode 2 systems on a traffic channel at the start of a call. They are a concatenation of a Header frame and an End frame. Their purpose is to inform the receiving station of the call, type of call or information required.



**Figure 4.14: Call Set-up**

The transmission may be sent for an individual call manually as a kind of 'polling call' to check if the called party is listening on the same channel.

These transmissions may be sent automatically by as the first part of an OACSU sequence or for initiating an individual data call.

#### 4.2.3.3 Traffic Channel Acknowledgement:

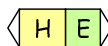
Traffic channel acknowledgements are sent in response to applicable messages back to the originator. Acknowledgements are a type of Header that contains information such as confirmation of received data, errors in received data, etc.



**Figure 4.15: Acknowledgement**

#### 4.2.3.4 Traffic Channel Status request acknowledgements:

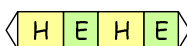
Traffic channel status request acknowledgements illustrated in figure 4.16 are sent by Mode 1 and Mode 2 systems. As the status information is contained within the End frame then the response of a receiving station to a status request call shall be a Header + End frame pair.



**Figure 4.16: Status Request Acknowledgement**

#### 4.2.3.5 Traffic Channel Disconnection:

Sending stations can signal that all exchanges of a call have been completed by transmitting a disconnection request. This is a Header + End frame pair that is repeated illustrated in figure 4.17.



**Figure 4.17: Disconnection**

These transmissions may be sent manually as confirmation to the called party that the communication is complete.

These transmissions may also be sent automatically to the called party to indicate that an individual data call is completed.

### 4.2.3.6 Traffic Channel Preservation Message

These messages are transmitted by a Mode 2 or Mode 3 traffic channel BS to preserve the channel between MS items.

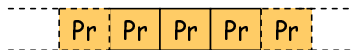


Figure 4.18: Preservation Frames

### 4.2.3.7 Mode 3 Beacon Channel

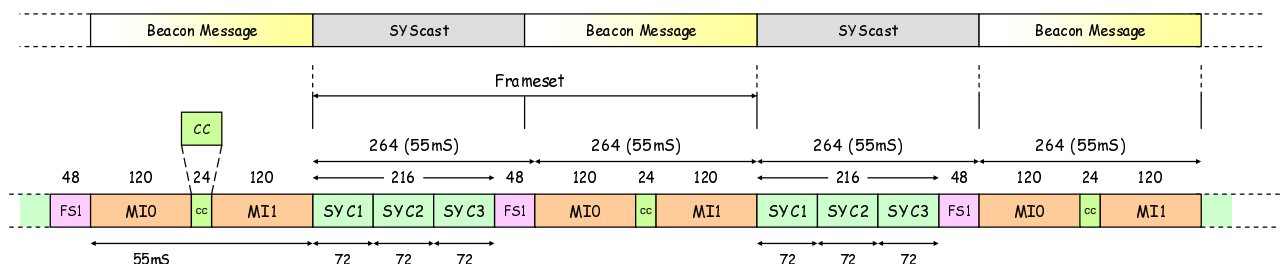


Figure 4.19: Beacon Channel

The Beacon Channel transmission is synchronous with a slot size of 264 bits. The slots alternate between beacon messages and SYScast broadcasts. One SYScast concatenated with a beacon message is a frameset.

### 4.2.3.8 Mode 1 Call Exchange

#### 4.2.3.8.1 Mode 1 Voice Call

Figure 4.20 illustrates a Mode 1 voice call. This example shows the MS behaviour for a call to an MS talkgroup. The same behaviour may apply to an individual call where the calling party does not wish to first determine if the recipient of the call is in radio contact.

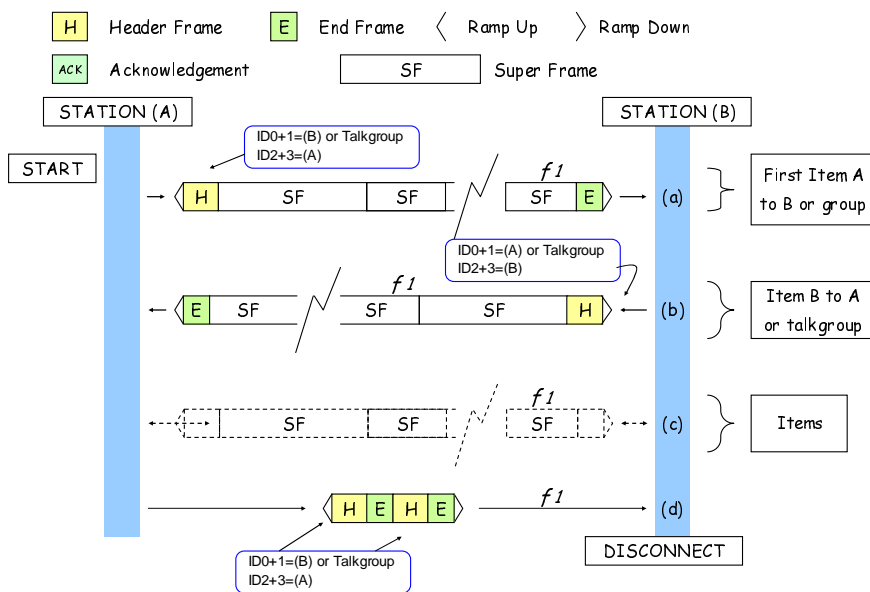


Figure 4.20: Mode 1 voice call message exchange

In this example:

The initial transmission from MS(A) is subject to polite access rules. If access is permitted then:

- The sending station sends its first payload item to the talkgroup or individual recipient.
- A payload item is returned to the sender.
- Payload items continue.
- When call is complete - if the call was to an individual MS either party may clear the call down; if the call was to a talkgroup only the initial calling party shall be permitted clear the call.

NOTE 1: The disconnect message at point (d) is optional.

Figure 4.21 illustrates an individual Mode 1 voice call with called party check. For this option, the calling party wishes to first determine if the recipient of the call is in radio contact before the call proceeds.

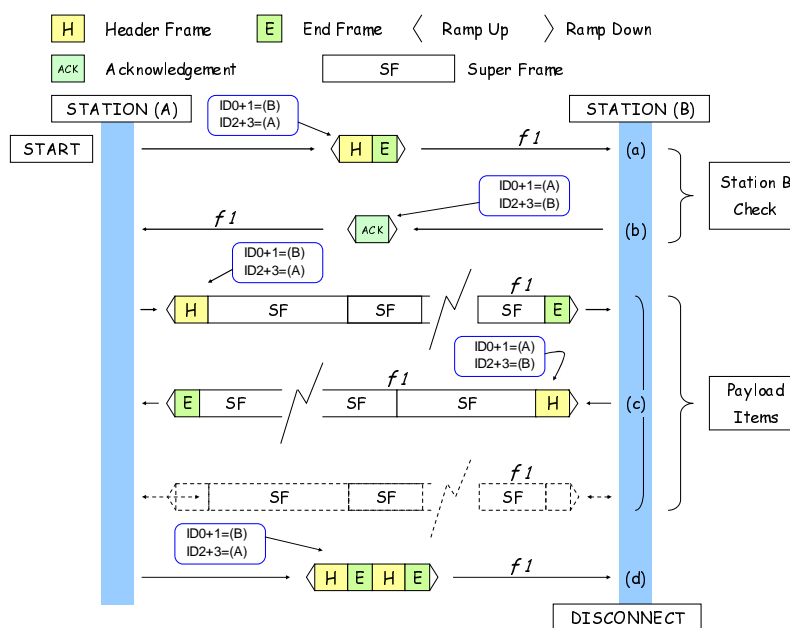


Figure 4.21: Mode 1 voice call exchanges with called party check

In this example:

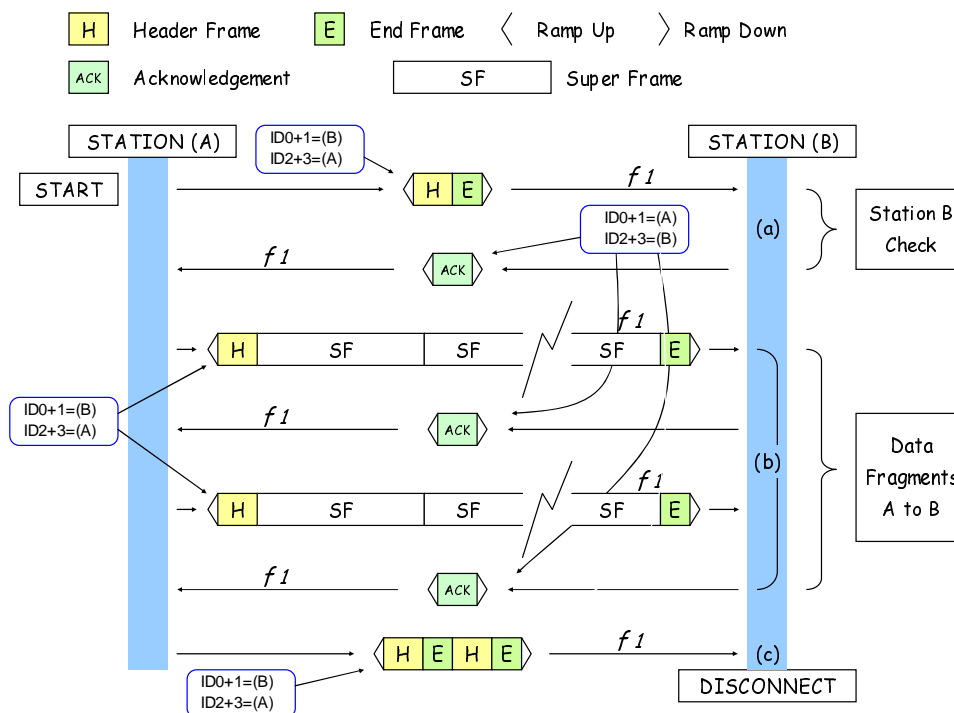
The initial transmission from MS(A) is subject to polite access rules. If access is permitted then:

- The sending station uses the call set-up (Header and End frames) to establish that the receiving station is within range and not busy.
- When the receiving station has acknowledged with a T\_ACK the sending station commences to send the first voice payload item.
- Voice payload items continue.
- When call is complete either party (but in this case the calling party) may end the call by sending a disconnect request to show that the transaction is complete.

NOTE 2: The disconnect message at point (d) is optional.

## 4.2.3.8.2 Mode 1 Data Call

Figure 4.22 shows an example of the exchanges involved in the call set-up and exchanges of an individual data call.



**Figure 4.22: Mode 1 Individual data call exchanges**

In this case:

The initial transmission from MS(A) is subject to polite access rules. If access is permitted then:

- The sending station uses the call set-up (Header and End frames) to establish that the receiving station is within range and not busy. The receiving station acknowledges with a T\_ACK.
- The sending station commences to send the data in 4 superframe bursts. After each burst the receiving station decodes and error checks the data and if there are no uncorrectable errors a positive ACK is sent. If errors are detected then a negative ACK would be sent and the sending station would repeat that transmission.
- When all the data has been transmitted and positively acknowledged the sending station sends a disconnect request to show that the transaction is complete.

### 4.2.3.9 Mode 2 Call Exchange

An example of a Mode 2 voice call message exchange is illustrated in figure 4.23. All Centralized communication is via the BS in Mode 2 systems.

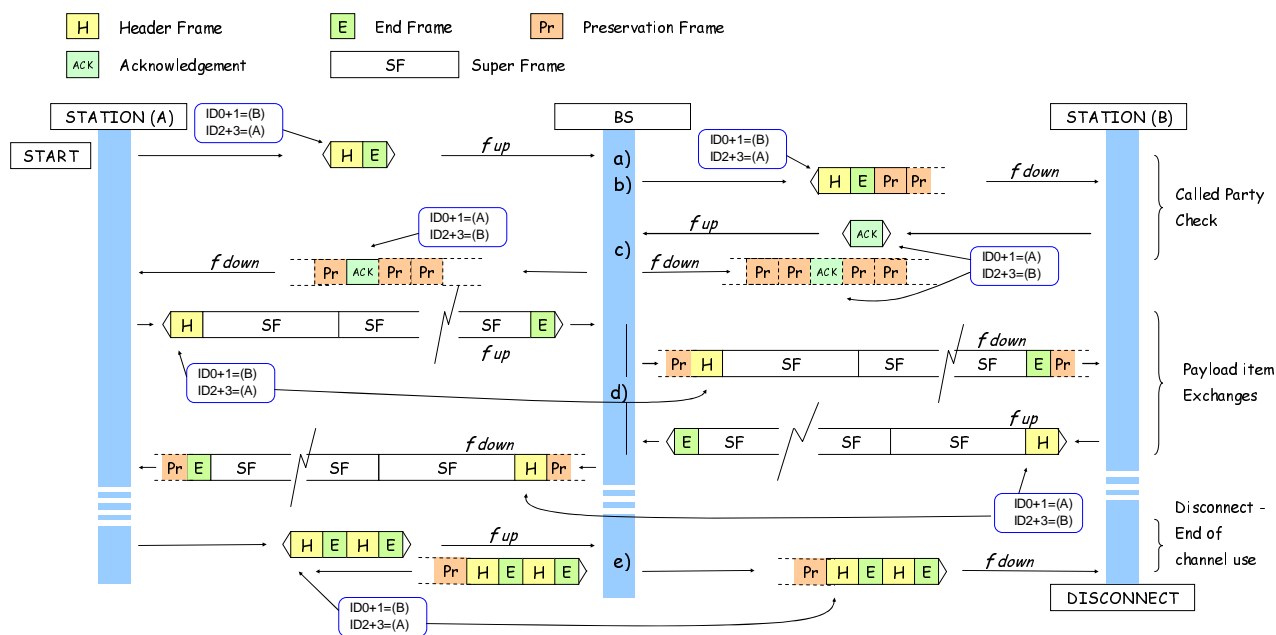


Figure 4.23: Mode 2 Voice Call Example

In this example:

The initial transmission from MS(A) is subject to polite access rules. If access is permitted then:

- The sending station uses the call set-up (Header and End frames) to the BS on the uplink channel to establish that the receiving station is within range and not busy.
- The BS retransmits the call set-up on the downlink channel to the receiving station. The BS then protects the traffic channel against access by MS not involved in the call by transmitting preservation frames.
- When the receiving station has acknowledged with a T\_ACK, the T\_ACK is repeated by the BS to the sending station.
- The MS exchange voice payload items.
- When the call is ended MS(A) clears the call by transmitting Disconnect + END frame pairs. The message is retransmitted by the BS. The BS then returns to idle.

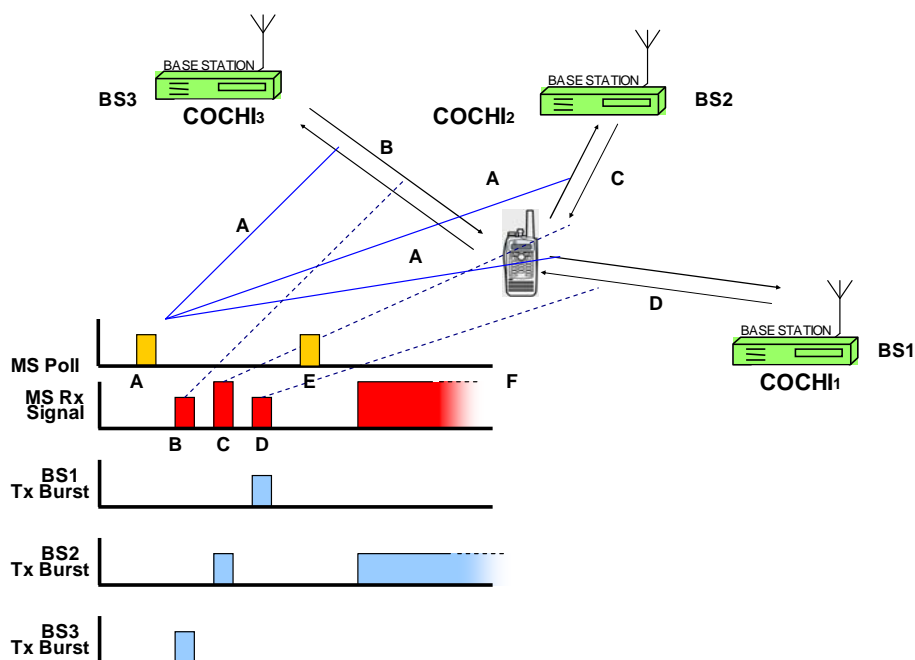
NOTE 1: There is an inherent delay between information received by the BS on the uplink channel and the BS retransmitting the information on the downlink channel.

NOTE 2: In the gap between transmission items, the Base Station transmits preservation frames to preserve the channel for the call.

NOTE 3: During the call, the retransmission from the BS is continuous. Preservation frames are transmitted when there are no MS originated messages to transmit. Unless an MS is transmitting, frames may be received that are directed to the other party. This is illustrated in figure 4.23 in the gaps between the payload items.

### 4.2.3.10 Co-channel BS networks

Where geographical radio coverage is extended by multiple co-channel BSs, the system may operate by using a poll and vote call sequence. In all cases it is the MS that makes the assessment of the received signals to select the optimum BS.



**Figure 4.24: Co-channel Base Station networks**

A network employing three co-channel BSs is illustrated in figure 4.24. An MS wishes to select the BS that will provide the best signal quality for the call.

Referring to the illustration in figure 4.24:

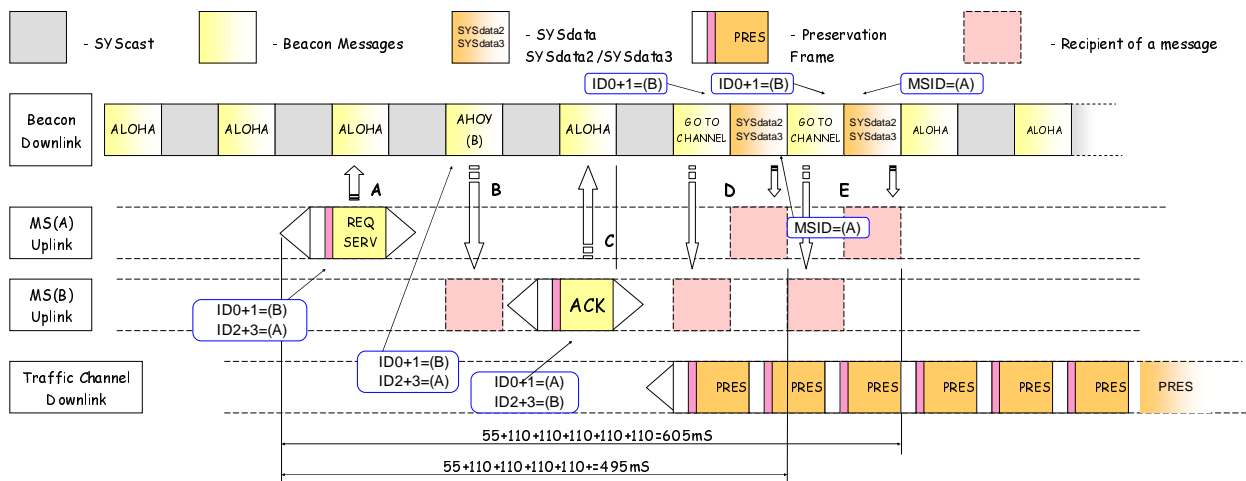
- a) The MS makes an initial polling call to all BSs within range.
- b) The BS with the highest assigned co-channel address (COCHI3 in this example) sends a response to the poll message. The timing of the poll message is determined by the particular COCHI index number.
- c) The BS assigned as COCHI2 sends a response to the poll message.
- d) The BS assigned as COCHI1 sends a response to the poll message.
- e) The MS assesses the signal quality of each of the poll responses. In this example, BS2 has the best signal quality. The MS then sends an acknowledgement to the gateway address COCHI2.
- f) BS2 then asserts its carrier transmitting protection frames until the MS transmits its first call set-up or payload burst.

#### 4.2.3.11 Mode 3 Operation

When idle, MSs listen to a beacon channel. All call services originate on this beacon with an exchange of call set-up messages. For some services such as voice, the MS participants in the call are transferred to a traffic channel for the transaction. When the call is complete the MSs return to the beacon channel.

An example of a Mode 3 call set-up is illustrated in figure 4.25. MS(A) and MS(B) is initially tuned to the Beacon Channel. This example illustrates a voice call set-up where the call is transferred to a traffic channel for the transaction.





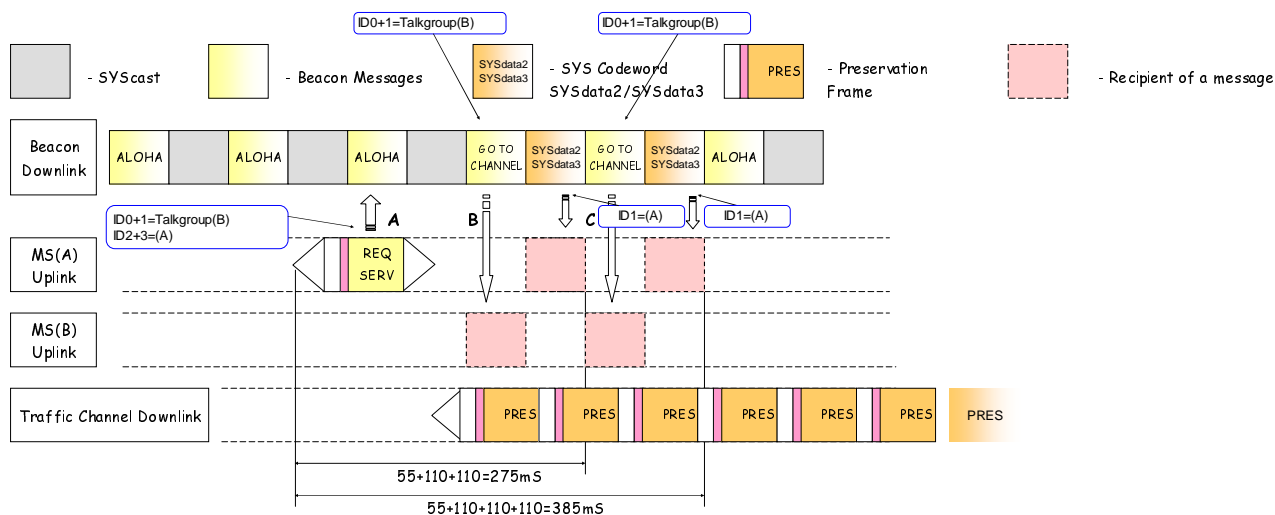
**Figure 4.25: Mode 3 Beacon Channel Individual Voice Call Set-up**

In this example:

The initial request for a transmission from MS(A) is subject to fully managed access rules. If access is permitted then:

- The calling MS sends a service request to the beacon.
- The beacon sends an AHOY message to MS(B) to determine if MS(B) is in radio contact.
- MS(B) sends an acknowledgement to the beacon.
- The beacon sends a Goto Channel message to MS(B) to direct the MS to a traffic channel for the transaction. The system activates the traffic channel. The Goto Channel message contains the uplink and downlink frequencies of the traffic channel. The calling party address is sent in the SYScast that immediately follows the Goto Channel message.
- Since the Goto Channel and SYScast message is not acknowledged, the BS may repeat this message to the MSs.

An example of a group call set-up is illustrated in figure 4.26.



**Figure 4.26: Talkgroup Voice Call-Setup**

In this example:

The initial request for a transmission from MS(A) is subject to fully managed access rules. If access is permitted then:

- a) The calling MS sends a service request to the beacon.
- b) The beacon sends a Goto Channel message to MS(B) (MS(B) is part of the talkgroup) to direct the MSs to a traffic channel for the transaction. The system activates the traffic channel. The Goto Channel message contains the uplink and downlink frequencies of the traffic channel. The calling party address MS(A) is sent in the SYScast that immediately follows the Goto Channel message.
- c) Since the Goto Channel and SYScast message is not acknowledged, the BS may repeat the message to the MSs.

## 4.3 Addressing

All entities defined in the present document shall be assigned a unique individual IDentity. MSs may also be assigned one or more group identities to form a talkgroup. MSs and talkgroups use a 24 bit Identity.

Other entities connecting to MS and BS conforming to the present document may employ different addressing formats. As an example, PSTN destinations may be described by a string of numeric digits. An IP address may be defined by a 32 bit (IPV4) or a 128 bit address (IPV6). In the present document, these destinations are defined as extended addresses.

When many different types of entity are linked in a system conforming to the present document, a way of identifying these entities is essential. The present document uses Gateway Addresses that identify both destinations and certain intrinsic call services. A table listing these addresses is illustrated in clause 13.4.

## 4.4 Unified Data Transport Mechanism

A dPMR network supports a wide range of facilities. To support these facilities, the transporting of data is a very common necessity. For example, although Short Data is a primary Mode 2 and Mode 3 data service, there are many instances where data needs to be transported to support other facilities. (For example when an MS dials a PABX or PSTN destination, the dialled digits are uploaded to the BS. This extended addressing is transported between MS and BS using the UDT. In addition, as part of the call set-up the MS may exchange complementary information. Complementary information is user data that may be passed between MS and other entities as part of another call service. To reduce the dPMR complexity, all short data, extended addressing and complementary data transport between MS and BS share this common method - the Unified Data Transport mechanism.

The UDT defines Appended\_Data messages that contain principally data that may be concatenated to other message frames.

In Mode 1 and Mode 2 systems Appended\_Data Messages may be concatenated to Connection\_Request messages. Mode 3 systems concatenate Appended\_Data carrying short data, extended addresses and complementary data to a UDT Header message.

The data in these Appended\_Data messages are coded in a uniform way and support dPMR addresses, binary, BCD, 7 bit text, 8 bit octets, EN 61162-1 [1] and IP addressing. The format of Appended\_Data messages is described in clause 5.6.

## 4.5 Complementary Data

In Mode 3 systems, a feature of the Unified Data Transport mechanism is complementary data. In Mode 3 systems, complementary data may be passed from MS to BS or from BS to MS. The data sent by the UDT mechanism and the recipient is able to determine the format of the received data (binary, BCD, text, etc.).

### 4.5.1 Support for Voice and Data call services

Complementary data may be invoked by an MS to send this data as part of another user call service. However it shall be noted that the motive for the MS to send the data and the use that the BS puts to this data is outside the scope of the present document.

**EXAMPLE:** A system is designed such that An MS uses the complementary data feature to send its GPS location as part of all voice call set-ups.

### 4.5.2 Transport of complementary data for MS control

The present document prescribes a number of facilities that use complementary data. These include:

- a) MS stun/unstun.
- b) MS Electronic serial number check.
- c) MS Kill.

The use of complementary data to provide these facilities simplifies the protocol. MS stun, ESN check and Kill is described in the Channel Access clause 12.

---

## 5 Frame coding

The following clauses contain descriptions of the Frames and fields contained within them. The structure of the frame definition represented by the tables is as follows:

- the FIELD column gives the name or description of the field;
- the LENGTH and TRANSFER column defines the length of the field in bits;
- the MEANING contains further description of the field;
- the FEC field provides the pointer to the clauses that describe the FEC;
- the ALIAS contains a shorthand for the field;
- MNEMONIC is a description of the particular value of a field or alias.

If a field is marked RSVD, all bits of the reserved field shall be set to 0<sub>2</sub>.

If a field is marked SPARE, the bits are not used by this protocol and may be set to any value.

If a field is marked N/A that means the field is not applicable for that particular message. The field shall be set to all zeros.

The differing frame structures are identified by one of four synchronization fields FS1, FS2, FS3 and FS4.

The organization of the frames is illustrated in figures 5.1 and 5.2.

The four structures that are defined for a dPMR traffic channel illustrated in figure 5.1. Traffic channels are exclusively used in Mode 1 and Mode 2 systems. Mode 3 systems use a beacon channel for call set-up. Traffic channels carry voice and data payload in a Mode 3 system.

The Packet\_Data header shares the same CRC and FEC as a Message\_Frame but is separately identified by a different synchronization sequence.

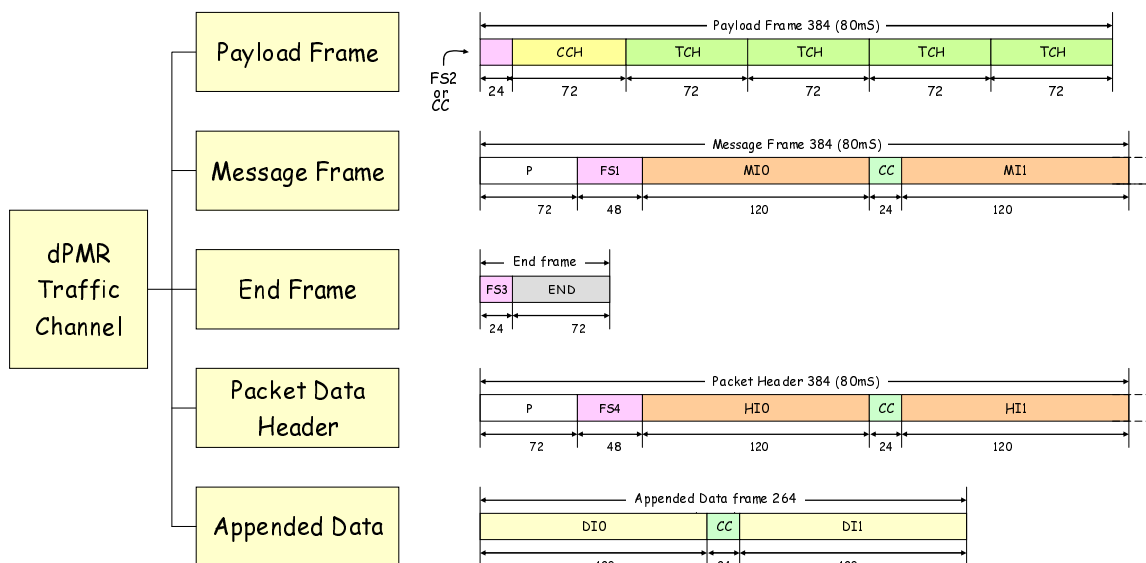


Figure 5.1: dPMR Traffic Channel Frame Structures

Four structures make up a dPMR beacon frame used for Mode 3 systems illustrated in figure 5.2.

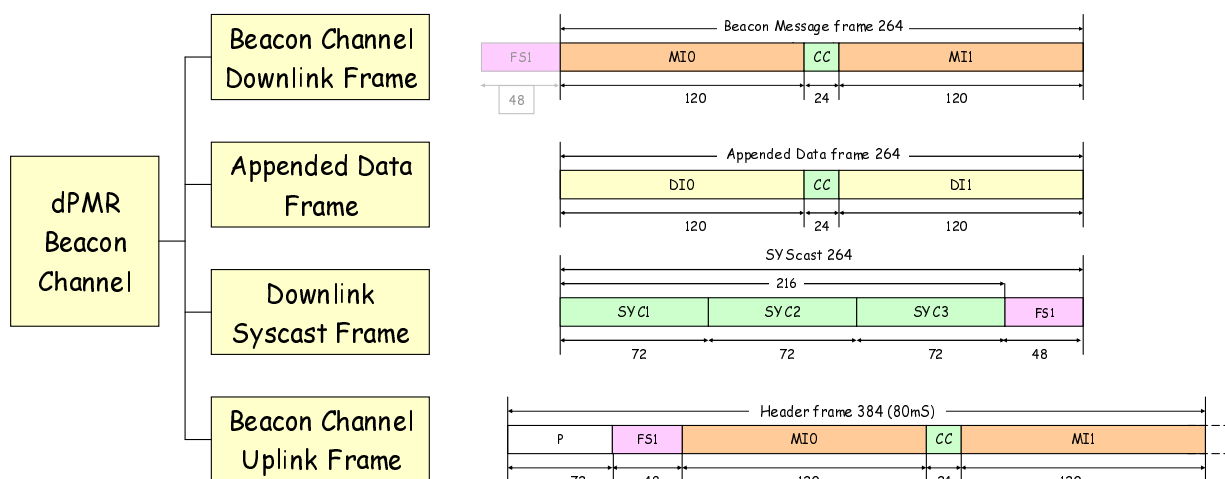


Figure 5.2: Beacon Message Frames

A Mode 3 Beacon Channel downlink is a continuous transmission therefore the preamble field is not needed. Hence a message frame is constructed as illustrated in the Beacon Message Downlink Frame in figure 5.2. Figure 5.3 illustrates how a SYScast frame is concatenated with a beacon message to position the FS1 field in the correct position for the receiving MSs.

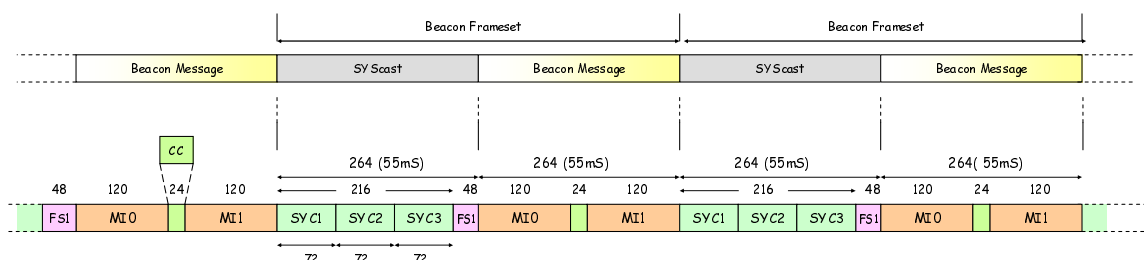


Figure 5.3: Beacon Frameset Example

In clauses 5.1 to 5.6, the headings prefixed by a [T] and/or a [B] to indicate if that particular message is valid for a [T]raffic channel and/or a [B]eacon channel.

## 5.1 Payload Frame [T]

The content of a payload frame is illustrated in table 5.1.

**Table 5.1: Payload frame.**

Alias	Length	Meaning
FS2 or CC	24	Frame sync 2 or Colour Code
TCH	72	Payload
TCH	72	Payload
TCH	72	Payload
TCH	72	Payload

## 5.2 Message\_Frame [BT]

The content for the Message\_Frame is illustrated in table 5.2.

**Table 5.2: Message\_Frame content**

Alias	Field	Length	CRC + FEC	Transfer
P	Preamble	$\geq 72$	none	72
FS1	Frame Sync	48	none	48
MI0	MT	Message_Type	clause 7.6	120
	PARMS	Parameters for this Message Type		
	CRC+FEC	CRC (8 bits) and FEC(40 bits)		
CC	Colour Code	24	clause 6.1.5	24
MI1	MT	Message_Type	clause 7.6	120
	PARMS	Parameters for this Message Type		
	CRC+FEC	CRC (8 bits) and FEC(40 bits)		

The MI0 and MI1 fields are transmitted as duplicates. Where Message\_Frames are illustrated by the tables in the following clauses, it is therefore only necessary to show one of the MI fields

The purpose of the messages is defined by the Message\_Type (MT). For each Message\_Type (MT) defined in the present document, the parameters (PARMS) are specified in clauses 5.2.1 to 5.2.15.

Table 5.3: Message\_Type

Alias	Length	Value	Uplink/ Downlink	Traffic/ Beacon	Meaning
MT	4	0000 <sub>2</sub>	U/D	T	Communications_Start header (a superframe follows)
		0001 <sub>2</sub>	U/D	T	Connection_Request header (an END frame follows)
		0010 <sub>2</sub>	U/D	T	Disconnect_Request header (an END frame follows)
		0011 <sub>2</sub>	U/D	BT	T_ACK B_ACK (this a single frame, ACK or NACK is differentiated by the MI bits setting)
		0100 <sub>2</sub>	D	T	Traffic Channel Maintenance
			U		
		0101 <sub>2</sub>	U	T	ACK header reply to a system request(a superframe follows)
		0110 <sub>2</sub>	D	T	System Delivery Header(a superframe follows)
		0111 <sub>2</sub>	U/D	T	Status Polling Response header (an END frame follows)
		1000 <sub>2</sub>	U/D	T	Status Polling Request header
		1001 <sub>2</sub>	U/D	T	BS_Command header(U) and response(D)
		1010 <sub>2</sub>	U/D	T	BS_Access header(U) and response(D)
		1011 <sub>2</sub>	D	BT	Broadcast
		1100 <sub>2</sub>	D	B	Beacon Ahoy (B_AHOY)
			U		Beacon Random Access Request (B_RAND)
1101 <sub>2</sub>	-	-	Reserved		
1110 <sub>2</sub>	U/D	B	UDT_Header		
1111 <sub>2</sub>	U/D	B	UDT_Appended Data		

NOTE: BS\_Command header and response, and BS\_Access header and response are used for transactions directly between MS and BS.

## 5.2.1 Communications\_Start Header [T]

This is a Message\_Frame identified by MT = 0000<sub>2</sub>.The header is transmitted at the start of a traffic channel transmission item. A payload superframe is concatenated to this header.

Table 5.4: Communications\_Start Header

Alias	Alias	Alias	Length	Value	Meaning
MT			4	0000 <sub>2</sub>	Message type = Communications Start Header
PARMS	ID0 + 1		24		Called Station ID or gateway
	ID2 + 3		24		Calling Station ID or gateway
	M		3		Communications Mode
	V		2		Version
	F		2		Comms Format
	EP		1		Emergency Priority
	PM		1	N/A	Not Applicable for this particular message
	MI	MI_TYPE		3	
MI_DET			8		Message Detail

### 5.2.1.1 Concatenated Superframe to a Communications\_Start Header[T]

The structure of a superframe is illustrated in figure 5.4.

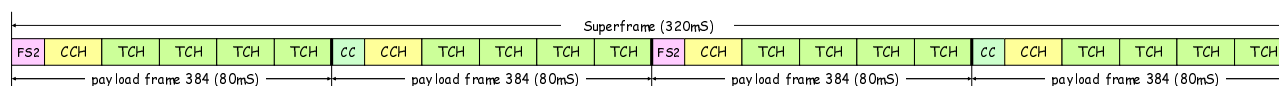


Figure 5.4: Superframe Structure

The content for the four frames that make up a superframe are illustrated in tables 5.5 to 5.8.

**Table 5.5: Superframe content, payload frame 1**

FRAME 1						
Alias	Meaning	Length	FEC	Transfer	Rate	
FS2	Frame Sync	24	None	24		
CCH	FN	Frame Number	See Clause 7.5	72	25 bps	
	ID0	Called ID (most sig' 12 bits)			38 bps	
	M	Communications Mode			38 bps	
	V	Version			25 bps	
	F	Comms format			25 bps	
	EP	Emergency Priority			12 bps	
	RSVD	Reserved				
	SLD	Slow Data			225 bps	
		CRC			7	
		FEC			24	
TCH	Payload	72 x 4		288		

**Table 5.6: Superframe content, payload frame 2**

FRAME 2						
Alias	Meaning	Length	FEC	Transfer	Rate	
CC	Colour Code	24	c	24		
CCH	FN	Frame Number	See Clause 7.5	72	25 bps	
	ID1	Called ID (least sig' 12 bits)			38 bps	
	M	Communications Mode			38 bps	
	V	Version			25 bps	
	F	Comms Format			25 bps	
	EP	Emergency Priority			12 bps	
	RSVD	Reserved				
	SLD	Slow Data			225 bps	
		CRC			7	
		FEC			24	
TCH	Payload	72 x 4		288		

**Table 5.7: Superframe content, payload frame 3**

FRAME 3						
Alias	Meaning	Length	FEC	Transfer	Rate	
FS2	Frame Sync	24	None	24		
CCH	FN	Frame Number	See Clause 7.5	72	25 bps	
	ID2	Calling ID (most sig' 12 bits)			38 bps	
	M	Communications Mode			38 bps	
	V	Version			25 bps	
	F	Comms Format			25 bps	
	EP	Emergency Priority			12 bps	
	RSVD	Reserved				
	SLD	Slow Data			225 bps	
		CRC			7	
		FEC			24	
TCH	Payload	72 x 4		288		

Table 5.8: Superframe content, payload frame 4

FRAME 4						
Alias	Meaning		Length	FEC	Transfer	Rate
CC	Colour Code		24	Clause 6.1.5	24	
CCH	FN	Frame Number	2	See Clause 7.5	72	25 bps
	ID3	Calling ID (least sig 12 bits)	12			38 bps
	M	Communications Mode	3			38 bps
	V	Version	2			25 bps
	F	Comms_Format	2			25 bps
	EP	Emergency Priority	1			12 bps
	RSVD	Reserved	1			
	SLD	Slow_Data	18			225 bps
		CRC	7			
	FEC	24				
TCH	Payload		72 x 4		288	

## 5.2.2 Connection\_Request Header [T]

This is a Message\_Frame identified by  $MT = 0001_2$ .

Table 5.9: Connection\_Request Header Message

Alias	Alias	Alias	Length	Value	Meaning
MT			4	$0001_2$	Message Type = Connection_Request Header
PARMS	ID0 + 1		24		Called Station ID or gateway
	ID2 + 3		24		Calling Station ID or gateway
	M		3		Communications Mode
	V		2		Version
	F		2		Comms Format
	EP		1		Emergency Priority
	PM		1	N/A	Not Applicable for this particular message
	MI	MI_TYPE		3	
MI_DET			8		

### 5.2.2.1 Called Party Check [T]

A Called\_Party Check Header message is used in Mode 1 and Mode 2 systems and is identified as a Connection\_Request message with M in the range  $000_2$  to  $101_2$ .

Table 5.10: Called Party Check

Alias	Alias	Alias	Length	Value	Meaning
MT			4	$0001_2$	Message Type = Connection_Request Header
PARMS	ID0 + 1		24		Called Station ID or gateway
	ID2 + 3		24		Calling Station ID or gateway
	M		3	$000_2$ to $101_2$	Communications Mode
	V		2		Version
	F		2		Comms Format
	EP		1		Emergency Priority
	PM		1	N/A	Not Applicable for this particular message
	MI	MI_TYPE		3	
MI_DET			8		



### 5.2.2.2 Repeat Last Ack (RLA) [T]

A Repeat\_Last\_Ack Header message is identified as a Connection\_Request message with  $ID2 + 3 = RLAI$ .

**Table 5.11: Repeat\_Last\_Ack Header message**

Alias	Alias	Alias	Length	Value	Meaning
MT			4	$0001_2$	Message Type = Connection_Request Header
PARMS	ID0 + 1		24		Called Station ID
	ID2 + 3		24		RLAI
	M		3	N/A	Communications Mode - Not Applicable for this particular message (see note)
	V		2		Version
	F		2		Comms Format
	EP		1	N/A	Emergency Priority
	PM		1	N/A	Not Applicable for this particular message
	MI	MI_TYPE		3	N/A
MI_DET			8	N/A	Not Applicable for this particular message
NOTE: N/A fields are set to zero.					

If an MS receives a Repeat\_Last\_Ack + END message, the MS shall send verbatim the acknowledgement that was previously sent.

### 5.2.2.3 Short Data Delivery Header message [T]

A Short Data Delivery Header message is used in Mode 1 and Mode 2 systems and is identified as a Connection\_Request message with  $M = 110_2$  and  $MI\_TYPE = 000_2$ .

**Table 5.12: Short Data Delivery Header message**

Alias	Alias	Alias	Value	Length	Meaning	
MT			$0001_2$	4	Message Type = Connection_Request	
PARMS	ID0 + 1			24	Called MS talkgroup or gateway	
	ID2 + 3			24	Calling MS ID	
	M		$110_2$	3	Service requested is defined by MI_TYPE	
	V		N/A	2	Not Applicable for this particular message	
	F		$01_2$	2	Comms Format = Peer to peer	
	EP		$0_2$	1	Non emergency service	
			$1_2$		Emergency Service	
	PM		N/A	1	Not Applicable for this particular message	
	MI	MI_TYPE		$000_2$	3	Service Requested is Short Data
		MI_DET	UAD		2	Appended Short Data. Number of appended UDTs required to transport short data
SYMB					6	Number of symbols in the short data

### 5.2.2.4 Call Diversion [T]

A Call Diversion header message is used in Mode 2 systems and is identified as a Connection\_Request message with  $M = 110_2$  and  $MI\_TYPE = 011_2$ .

**Table 5.13: Call Diversion header message**

Alias	Alias	Alias	Length	Value	Meaning
MT			4	$0001_2$	Message Type = Connection_Request Header
PARMS	ID0 + 1		24	DIVERTI	Gateway ID DIVERTI
	ID2 + 3		24		Calling Station MS ID
	M		3	$110_2$	Service requested is defined by MI_TYPE
	V		2	N/A	Not Applicable for this particular message
	F		2	$10_2$	Comms Format = uplink
	EP		1	N/A	Not Applicable for this particular message
	PM		1	N/A	Not Applicable for this particular message
	MI	MI_TYPE		3	$011_2$
MI_DET			2	$00_2$	UAD Number of Appended_Data messages = 1
			6	SYMB	N/A for call diversion

NOTE: The UDT Appended\_Data uses UDT\_FORMAT =  $000_2$  (Address format) holding the MS ID.

### 5.2.3 Disconnect\_Request Header [T]

This is a Message\_Frame identified by  $MT = 0010_2$ .

**Table 5.14: Disconnect\_Header Request Message**

Alias	Alias	Alias	Length	Value	Meaning
MT			4	$0010_2$	Mess_Type = Disconnect_Header
PARMS	ID0 + 1		24		Called Station ID or gateway
	ID2 + 3		24		Calling Station MS ID or gateway
	M		3		Communications Mode
	V		2		Version
	F		2		Comms Format
	EP		1		Emergency Priority
	PM		1	N/A	Not Applicable for this particular message
	MI	MI_TYPE		3	N/A
MI_DET			8	N/A	Not Applicable for this particular message

### 5.2.4 T\_ACK B\_ACK Message [T]

This is a Message\_Frame identified by  $MT = 0011_2$ . Acknowledgements may be transmitted by BS or MS. T\_ACK messages shall be transmitted on a Traffic Channel. B\_ACK messages shall be transmitted on a Beacon Channel.

The T\_ACK B\_ACK frame is illustrated in table 5.15. The use of T\_ACK B\_ACK frames is normally applicable only to individually addressed messages but there are exceptions described in clause 10.3.

When referencing acknowledgements in the present document a suffix 'D' or 'U' may be added to the ACK alias to indicate if the message is a Downlink message or Uplink message.

Table 5.15: T\_ACK B\_ACK frame content

Alias	Alias	Alias	Length	Value	Meaning
MT			4	0011 <sub>2</sub>	Mess_Type = T_ACK B_ACK
PARMS	ID0 + 1		24		Station ID or gateway address that originated the message for which this acknowledgement is being sent
	ID2 + 3		24		Station ID or gateway that is sending this Acknowledgement
	M		3		Communications Mode
	V		2		Version
	F		2		Comms Format
	EP		1		Emergency Priority
	PM		1	N/A	Not Applicable for this particular message
	MI	MI_TYPE		3	
MI_DET			8		Reason

#### 5.2.4.1 Message Information for acknowledgements

Table 5.16: Acknowledgement types

Alias	MI_TYPE	Definition	
B_ACK B_NACK B_WACK B_QACK	000 <sub>2</sub>	Acknowledgement - Acknowledgement type defined by REASON	Acknowledgements transmitted on a Beacon Channel
T_ACK	001 <sub>2</sub>	ACK (Rx OK)	Acknowledgements transmitted on a Traffic Channel
	010 <sub>2</sub>	NACK (data error, resend request)	
	011 <sub>2</sub>	NACK (request denied)	
	Other	Reserved	

Table 5.17: Acknowledgement Information

MI_DET	Definition
0	Reserved
1 to 255	ACK / NACK status (reason see clause 5.5.25)

#### 5.2.5 Maintenance\_Message [T]

This is a Message\_Frame identified by MT = 0100<sub>2</sub>.

The message is transmitted by a BS to provide traffic channel call maintenance. Maintenance messages are not acknowledged. The function that maintenance messages provide are:

- a) An Idle Message.
- b) A Preservation Message.
- c) Guard Message.

For this class of message MI\_TYPE = 010<sub>2</sub> to 111<sub>2</sub> is reserved.

This message shall not be transmitted by an MS.

### 5.2.5.1 Idle Message [T]

An idle message illustrated in table 5.18 may be transmitted by a Mode 2 BS when there are no calls active on the channel (the BS may also elect to de-key its transmitter when idle).

**Table 5.18: Mode 2 Idle\_Message**

Alias	Alias	Alias	Length	Value	Meaning
MT			4	0100 <sub>2</sub>	Mess_Type = Maintenance
PARMS	ID0 + 1		24	24 x 0 <sub>2</sub>	Station ID = DUMMY1
	ID2 + 3		24	BSIn	Station ID = Identity of the BS
	M		3	N/A	Not Applicable for this particular message
	V		2	N/A	Not Applicable for this particular message
	F		2	11 <sub>2</sub>	Comms Format = BS downlink
	EP		1	N/A	Not Applicable for this particular message
	PM		1	0 <sub>2</sub>	Channel is not preserved
	MI	MI_TYPE		3	000 <sub>2</sub>
MI_DET			8	N/A	Not Applicable for this particular message

### 5.2.5.2 Preservation message

The Preservation\_Message illustrated in table 5.19 preserves the channel during a call in the gaps between MS items.

**Table 5.19: Preservation\_Message**

Alias	Alias	Alias	Length	Value	Meaning
MT			4	0100 <sub>2</sub>	Mess_Type = Maintenance
PARMS	ID0 + 1		24		MSID or talkgroup occupying the channel (NOTE 1)
	ID2 + 3		24		MSID or Gateway occupying the channel. (NOTE 1)
	M		3	000 <sub>2</sub>	See note
	V		2		Version
	F		2	11 <sub>2</sub>	Comms Format = BS downlink
	EP		1	0 <sub>2</sub>	Channel is occupied by a non emergency service
				1 <sub>2</sub>	Channel is occupied by an emergency service
	PM		1	1 <sub>2</sub>	Channel is Preserved
	MI	MI_TYPE		3	000 <sub>2</sub>
MI_DET			8	00000000 <sub>2</sub>	See note

NOTE 1: ID0 + 1 and ID2 + 3 are the addresses of the legitimate occupiers of the channel.  
 NOTE 2: PM = 1<sub>2</sub> identifies the message as Preservation. The fields M, MI\_TYPE and MI\_DET are not applicable for this message.

### 5.2.5.3 Guard\_Message [T]

A Guard message may be transmitted by a Mode 2 or Mode 3 BS when there is an active call on the channel. A Guard message is a Maintenance\_Message with fields set as table 5.20.

**Table 5.20: Mode 2 Mode 3 Guard\_Message**

Alias	Alias	Alias	Length	Value	Meaning		
MT			4	0100 <sub>2</sub>	Mess_Type = Maintenance		
PARMS	ID0 + 1		24	Target	MSID or talkgroup occupying the channel		
	ID2 + 3		24	Source	MSID or Gateway		
	M		3	N/A	Not Applicable for this particular message		
	V		2	N/A	Not Applicable for this particular message		
	F		2	11 <sub>2</sub>	Comms Format = BS downlink		
	EP		1	N/A	Not Applicable for this particular message		
	PM		1	0 <sub>2</sub>	Channel is not preserved		
	MI	Guard_Kind	MI_TYPE	3	001 <sub>2</sub>	Guard	Guard Message
			4		RSVD	Reserved	
					0000 <sub>2</sub>	Reserved	
				0001 <sub>2</sub>	DIS_PTT	Disable Target MS or Talkgroup PTT	
				0010 <sub>2</sub>	EN_PTT	Enable Target MS or Talkgroup PTT	
				0011 <sub>2</sub>	ILLEGALLY PARKED	Clear down from the payload channel, MS whose address does not match Source or Target Address	
	0100 <sub>2</sub> to 1111 <sub>2</sub>	Reserved					

### 5.2.6 System\_Request Header [T]

This is a Message\_Frame identified by MT = 0100<sub>2</sub>. System\_Request messages shall only be transmitted by MS in Mode 2 systems.

**Table 5.21: System\_Request header content**

Alias	Alias	Alias	Length	Value	Meaning		
MT			4	0100 <sub>2</sub>	Mess_Type = System_Request header		
PARMS	ID0 + 1		24		Called Station ID or gateway		
	ID2 + 3		24		Calling Station ID or gateway		
	M		3		Communications Mode		
	V		2		Version		
	F		2		Comms Format		
	EP		1		Emergency Priority		
	PM		1	N/A	Not Applicable for this particular message		
	MI	MI_TYPE		3		Message information Type	
		MI_DET		8		Message Information	

## 5.2.7 ACK header response to a System Request [T]

This is a Message\_Frame identified by MT = 0101<sub>2</sub>. ACK to System\_Requests are transmitted by BS in Mode 2 systems.

**Table 5.22: ACK to a System Request header content**

Alias	Alias	Alias	Length	Value	Meaning
MT			4	0101 <sub>2</sub>	Mess_Type = ACK response to a System Request
PARMS	ID0 + 1		24		Called Station ID or gateway
	ID2 + 3		24		Calling Station ID or gateway
	M		3		Communications Mode
	V		2		Version
	F		2		Comms Format
	EP		1		Emergency Priority
	PM		1	N/A	Not Applicable for this particular message
	MI	MI_TYPE		3	
MI_DET			8		Message Information

## 5.2.8 System Delivery Header [T]

This is a Message\_Frame identified by MT = 0110<sub>2</sub>. The message is a System Delivery Header.

**Table 5.23: ACK to a System Request header content**

Alias	Alias	Alias	Length	Value	Meaning
MT			4	0110 <sub>2</sub>	Mess_Type = System_Delivery header
PARMS	ID0 + 1		24		Called Station ID or gateway
	ID2 + 3		24		Calling Station ID or gateway
	M		3		Communications Mode
	V		2		Version
	F		2		Comms Format
	EP		1		Emergency Priority
	PM		1	N/A	Not Applicable for this particular message
	MI	MI_TYPE		3	
MI_DET			8		Message Information

## 5.2.9 Status Polling Response Message [T]

This is a Message\_Frame identified by MT = 0111<sub>2</sub>.

**Table 5.24: Status Polling Response message**

Alias	Alias	Alias	Value	Length	Meaning
MT			0111 <sub>2</sub>	4	Message Type = Status_Response Header
PARMS	ID0 + 1			24	Called Station or gateway
	ID2 + 3			24	Calling Station ID or gateway
	M		N/A	3	Not Applicable for this particular message
	V		N/A	2	Not Applicable for this particular message
	F			2	Comms Format
	EP		N/A	1	Not Applicable for this particular message
	PM		N/A	1	Not Applicable for this particular message
	MI	MI_TYPE		N/A	3
MI_DET			N/A	8	Not Applicable for this particular message

## 5.2.10 Status Polling Request Message [T]

This is a Message\_Frame identified by MT = 1000<sub>2</sub>.

**Table 5.25: Status Polling Request header**

Alias	Alias	Alias	Value	Length	Meaning	
MT			1000 <sub>2</sub>	4	Message Type = Status_Request Header	
PARMS	ID0 + 1			24	Called Station or gateway	
	ID2 + 3			24	Calling Station or gateway	
	M		N/A	3	Not Applicable for this particular message	
	V		N/A	2	Not Applicable for this particular message	
	F			2	Comms Format	
	EP		N/A	1	Not Applicable for this particular message	
	PM		N/A	1	Not Applicable for this particular message	
	MI	MI_TYPE		N/A	3	Not Applicable for this particular message
		MI_DET		N/A	8	Not Applicable for this particular message

## 5.2.11 BS\_Command header(U) and response(D) [T]

This is a Message\_Frame identified by MT = 1001<sub>2</sub>.

**Table 5.26: BS\_Command header and response**

Alias	Alias	Alias	Value	Length	Meaning	
MT			1001 <sub>2</sub>	4	Message Type = BS_Command header and response	
PARMS	ID0 + 1			24	Called Station or gateway	
	ID2 + 3			24	Calling Station ID or gateway	
	M		N/A	3	Not Applicable for this particular message	
	V		N/A	2	Not Applicable for this particular message	
	F			2	Comms Format	
	EP		N/A	1	Not Applicable for this particular message	
	PM		N/A	1	Not Applicable for this particular message	
	MI	MI_TYPE		N/A	3	Not Applicable for this particular message
		MI_DET		N/A	8	Not Applicable for this particular message

## 5.2.12 BS\_Access header(U) and response(D) [T]

This is a Message\_Frame identified by MT = 1010<sub>2</sub>.

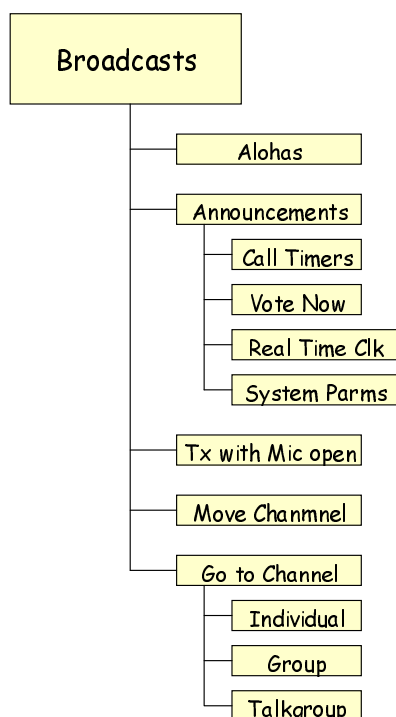
**Table 5.27: BS\_Access header and response**

Alias	Alias	Alias	Value	Length	Meaning	
MT			1010 <sub>2</sub>	4	Message Type = BS_Access header and response	
PARMS	ID0 + 1			24	Called Station or gateway	
	ID2 + 3			24	Calling Station or gateway	
	M		N/A	3	Not Applicable for this particular message	
	V		N/A	2	Not Applicable for this particular message	
	F			2	Comms Format	
	EP		N/A	1	Not Applicable for this particular message	
	PM		N/A	1	Not Applicable for this particular message	
	MI	MI_TYPE		000 <sub>2</sub>	3	No Appended_Data
				001 <sub>2</sub>		An Appended_Data message is concatenated to this header
				other		Reserved
	MI_DET		N/A	8	Not Applicable for this particular message	

NOTE: The BS\_Access response message transmitted by a BS may itself demand an acknowledgement.

### 5.2.13 Broadcast Messages [B] [T]

This is a Message\_Frame transmitted by a BS and identified by  $MT = 1011_2$ . These messages are unacknowledged. The structure is illustrated in figure 5.5.



**Figure 5.5: Broadcast Structure**

Broadcast messages are divided into the functionality of Aloha, Announcements, Move messages, Goto Channel messages, and Ambience listening activation messages, by the MI\_TYPE field as illustrated in table 5.28.

**Table 5.28: Types of Broadcast**

Alias	Length	Value	Meaning
MI_TYPE	3	000 <sub>2</sub>	Broadcast = Aloha
		001 <sub>2</sub>	Broadcast = Announcement
		010 <sub>2</sub>	Broadcast = Move
		011 <sub>2</sub>	Broadcast = Goto_Channel
		100 <sub>2</sub>	Broadcast = Ambience Listening
		101 <sub>2</sub>	Reserved
		110 <sub>2</sub>	Reserved
		111 <sub>2</sub>	Reserved

#### 5.2.13.1 Broadcast Aloha Message [B]

The Aloha message (B\_ALOHA) is transmitted by a Mode3 BS to all MS or a sub-set of MS defined by the contents of the Aloha.



Table 5.29: Aloha Message Content

Alias	Alias	Alias	Length	Value	Meaning	
MT			4	1011 <sub>2</sub>	Message Type = Broadcast	
PARMS	ID0 + 1		24		MS ID or DUMMYI	
	SYS		14		System Identity Code	
	RSVD		10	10 x 0 <sub>2</sub>	Reserved	
	MASK		5			
	NRAND_WAIT		4		Wait between random access attempts	
	MI_TYPE		3	000 <sub>2</sub>	Broadcast = Aloha	
	MI_DET	SF		2		Service_Function
		BACKOFF		4		Backoff Number for random access
		ACTIVE		1	0 <sub>2</sub>	Radio site is isolated
					1 <sub>2</sub>	Radio site is connected to the network
REG			1	0 <sub>2</sub>	Registration Not Required	
			1 <sub>2</sub>	Registration Required		

### 5.2.13.2 Broadcast Announcements [B]

Announcements are transmitted by a Mode 3 BS to all MS or a sub-set of MS. Announcements are defined by MI\_TYPE = 001<sub>2</sub>.

Table 5.30: Broadcast Announcements

Alias	Alias	Alias	Alias	length	value	Meaning	
MT				4	1011 <sub>2</sub>	Message type = Broadcast	
PARMS	ANT			4	0000 <sub>2</sub>	Announcement Type = Timers	
					0001 <sub>2</sub>	Announcement Type = Vote Now	
					0010 <sub>2</sub>	Announcement Type = Mass Reg	
					0011 <sub>2</sub>	Announce Real Time	
					others	Reserved	
	ANNS			53		Announcement Parameters	
	MI	MI_DET	MI_TYPE		3	001 <sub>2</sub>	Call Information = Announcement
			RSVD		2	00 <sub>2</sub>	Reserved
			BACKOFF		4		Backoff Number
			ACTIVE		1	0 <sub>2</sub>	Radio site is isolated
						1 <sub>2</sub>	Radio site is connected to the network
			REG		1	0 <sub>2</sub>	Registration Not Required
		1 <sub>2</sub>		Registration Required			

## 5.2.13.2.1 Broadcast Announcement - Call Timers [B]

The Broadcast announcement - call timers is defined by Announcement Type (ANT) = 0000<sub>2</sub>. The timer parameters are defined in Announcement Parameters (ANNS).

Table 5.31: Broadcast Timers and Time

Alias	Alias	Length	Value	Meaning
ANNS	T_MS-MS_TMR	6	0	MS uses its Internal Timer for MS-MS calls
			1 to 62	Call_Timer for MS-MS calls (see note 2)
			63	MS-MS Call_Timer is Infinity
	T_EMERG_TMR	6	0	MS uses its Internal Emergency Timer
			1 to 62	Call_Timer for Emergency Calls (see note 2)
			63	Emergency Call_Timer is Infinity
	T_DATA_TMR	6	0	MS uses its Internal Packet Timer
			1 to 62	Call_Timer for Packet Data (see note 2)
			63	Packet Call_Timer is Infinity
	T_MS-LINE_TMR	6	0	MS uses its Internal Timer for line connected calls
			1 to 62	Call_Timer for Line Connected calls (see note 2)
			63	Line Connected Call_Timer is Infinity
	B_MONTH	4	1 to 12	Month (or 0 if month is not being broadcast) see note 1
B_DAY	5	1 to 31	Day of the Month (or 0 if date is not being broadcast)	
DAYOF_WEEK	3	1 to 7	Day of Week (see note 1) (or 0 if not being broadcast)	
B_HOURS	5	0 to 23	Hours (or 24 if hours is not being broadcast)	
B_MINS	6	0 to 59	Minutes (or 60 if minutes is not being broadcast)	
B_SECS	6	0 to 59	Seconds (or 60 if seconds is not being broadcast)	
NOTE 1: The field meaning of B_MONTH and DAYOF_WEEK values are specified in tables 5.79 and 5.57.				
NOTE 2: The timers are tokens. See table 5.49 described in clause 5.5.5.				

## 5.2.13.2.2 Broadcast Announcement - Vote Now [B]

The Vote Now announcement is defined by Announcement Type (ANT) = 0001<sub>2</sub>. The vote now parameters are defined in Announcement Parameters (ANNS).

Table 5.32: Broadcast Vote Now

Alias	Alias	Length	Value	Meaning
ANNS	FR	15		Receive Frequency
	SEP	1		Channel Separation
	BAND	4		Frequency Band
	VSYS	14		System Identity Code of the system being assessed
	VFRMS	3		Number of framesets BS will allocate for vote now
	FT	15		Transmit Frequency
	RSVD	1	0 <sub>2</sub>	Reserved

VSYS and VFRMS are described in clause 5.5.38.

## 5.2.13.2.3 Broadcast Announcement - Mass Registration [B]

The Mass Registration announcement is defined by Announcement Type (ANT) = 0010<sub>2</sub>. The mass registration parameters are defined in Announcement Parameters (ANNS).

**Table 5.33: Broadcast Mass Registration**

Alias	Alias	Length	Value	Meaning
ANNS	ID0 + 1	24		MS ID or DUMMYI
	RSVD	20	20 x 0 <sub>2</sub>	Reserved
	MASK	5		Aloha Mask
	REG_W	4		Registration Window

**Table 5.34: Registration Window**

Alias	Length	Value	Meaning
REG_W	4	0	<Cancel Mass Registration>
		1	0,5 s
		2	1 s
		3	2 s
		4	5 s
		5	10 s
		6	20 s
		7	30 s
		8	100 s
		9	300 s
		10	1 000 s
		11	3 000 s
		12	10 000 s
		13	30 000 s
		14	100 000 s
		15	200 000 s

## 5.2.13.2.4 Broadcast Announcement - Real Time [B]

Real time parameters are transmitted in the real time broadcast. The offset to calculate local time is UTC Hours + (Offset for local time mod 24) + ½ (if add 30 minute offset = 1<sub>2</sub>).

**Table 5.35: Broadcast - Real Time**

Alias	Alias	Length	Value	Meaning	
ANNS	B_MONTH	4	1 to 12	Month (0 <sub>2</sub> if not broadcast)	
	B_DAY	5	1 to 31	Day of Month (0 <sub>2</sub> if not broadcast)	
	DAYSOF_WEEK	3	1 to 7	Day (0 <sub>2</sub> if not broadcast)	
		5	0 to 23	UTC Hours (or 24 if not broadcast)	
		6	0 to 59	UTC Minutes (or 60 if not broadcast)	
		6	0 to 59	UTC Seconds	
		5	0 to 23	Offset for local time	
		1	0 <sub>2</sub>	No 30 minute offset	
			1 <sub>2</sub>	Add 30 minute offset	
		RSVD	18	18 x 0 <sub>2</sub>	Reserved

### 5.2.13.3 Move Channel Broadcast [BT]

The Move message is transmitted by a BS to all MS or a sub-set of MS defined by ID0+1 (MS ID) and MASK. The message directs applicable MS to move to a new physical radio channel. The current state of the MS is retained. The receive and transmit frequency to which the MS shall move is defined in the FT, FR, SEP and BAND fields. Applicable MS are only individual MSIDs. Group IDs are NOT applicable for this message.

**Table 5.36: Move Frame Content**

Alias	Alias	Alias	Alias	Length	Value	Meaning	
MT				4	1011 <sub>2</sub>	Message type = Broadcast	
PARMS		ID0 + 1		24		MS ID	
		FT		15		Transmit Frequency	
		FR1		9		Receive Frequency (most significant 9 bits)	
		MASK1		3		MASK(most significant 3 bits)	
		FR2		6		Receive Frequency (least significant 6 bits)	
	MI	MI	MI_TYPE		3	010 <sub>2</sub>	Broadcast = Move
			SEP		1		Channel Separation
			BAND		4		Frequency Band
			MASK2		2		MASK (least significant 2 bits)
RSVD				1	0 <sub>2</sub>	Reserved	

### 5.2.13.4 Goto Channel Broadcast [BT]

The Goto Channel message is transmitted by a BS to an MS or talkgroup to retune to a traffic channel for the transaction to take place. The receive and transmit frequency to which the MS shall tune is defined in the FT, FR, SEP and BAND fields. The calling party address (or gateway) shall be transmitted in a SYScast2/SYScast3 that immediately follows the Goto Channel message (see clause 5.5.32.2.5).

**Table 5.37: Goto Channel Message Content**

Alias	Alias	Alias	Alias	Length	Value	Meaning	
MT				4	1011 <sub>2</sub>	Message type = Broadcast	
PARMS		ID0 + 1		24		Called party. MS ID, talkgroup or Gateway	
		FT		15		Transmit Frequency	
		FR1		9		Receive Frequency (most significant 9 bits)	
		M		3		Communication Mode	
		FR2		6		Receive Frequency (least significant 6 bits)	
	MI	MI	MI_TYPE		3	011 <sub>2</sub>	Message Info = Goto Channel
			SEP		1		Channel Separation
			BAND		4		Frequency Band
			EF	1	0 <sub>2</sub>		Call is not an Emergency call
					1 <sub>2</sub>		Emergency Call
			BRCST	1	0 <sub>2</sub>		Goto Channel is not a Broadcast
1 <sub>2</sub>						Goto Channel is a Broadcast	
RSVD		1	0 <sub>2</sub>	Reserved			

### 5.2.13.5 Ambience Listening [T]

Ambience Listening is a Mode 2 broadcast that directs an MS to transmit a single voice item for a predetermined time. The broadcast shall only be directed to an MS individual ID. If the MS supports ambience listening the MS shall respond by transmitting a single voice payload item for a period defined by TX\_ATMR (see table 5.39). The broadcast shall only be transmitted by a BS from the gateway IDs DISPAT(n), LINE(n), GBSID or BSID(n).

The Ambience Listening broadcast frame is illustrated in table 5.38.

Table 5.38: Ambience Listening

Alias	Alias	Alias	Length	Value	Meaning	
MT			4	1011 <sub>2</sub>	Message Type = Broadcast	
PARMS	ID0 + 1		24		Called MS ID	
	ID2 + 3		24		Calling Gateway	
	M		3	000 <sub>2</sub>	Voice Communications (no user data)	
	V		2		00 <sub>2</sub> for standard TCH	
	F		2	11 <sub>2</sub>	BS Downlink	
	EP			1	0 <sub>2</sub>	Non Emergency Service
					1 <sub>2</sub>	Emergency Service
	PM		1	0 <sub>2</sub>	Not applicable for this particular message	
	MI_TYPE		3	100 <sub>2</sub>	Broadcast = Ambience Listening	
	MI_DET	TX_ATMR		4		MS Item time
RSVD			4	0000 <sub>2</sub>	Reserved	

The MI\_DET bits define the item period illustrated in table 5.39.

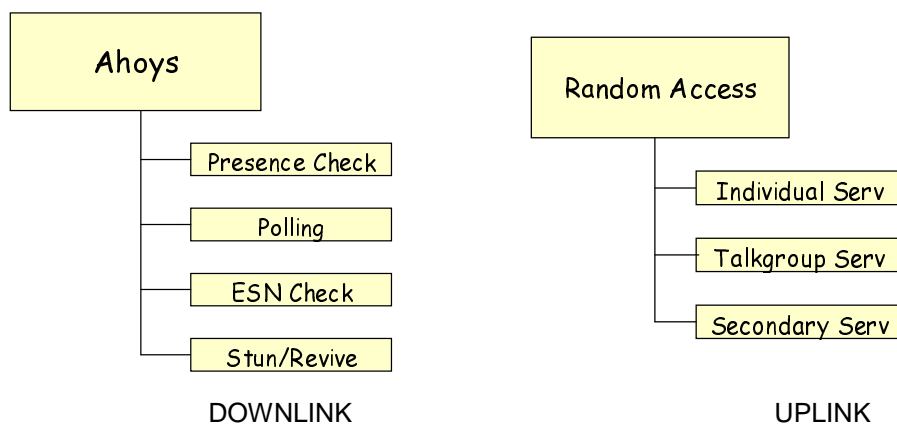
Table 5.39: TX\_ATMR for Ambience Listening

Alias	Alias	Length	Value	Meaning
MI	MI_TYPE	3	100 <sub>2</sub>	MI for Tx with mic open
	MI_DET TX_ATMR	4	0000 <sub>2</sub>	Reserved
			0001 <sub>2</sub>	5 s
			0010 <sub>2</sub>	10 s
			0011 <sub>2</sub>	20 s
			0100 <sub>2</sub>	30 s
			0101 <sub>2</sub>	60 s
			0110 <sub>2</sub>	120 s
			0111 <sub>2</sub>	180 s
			1000 <sub>2</sub> to 1111 <sub>2</sub>	Reserved
Reserved	4	0000 <sub>2</sub>		

After transmitting the Ambience Broadcast, the BS shall transmit preservation frames to protect the uplink channel. If the BS does not receive the expected voice item from the MS, the BS shall discontinue transmitting preservation frames and return to the idle state.

#### 5.2.14 AHOY / Random Access Request Message [B]

This is a Message\_Frame identified by MT = 1100<sub>2</sub>. The structure is illustrated in figure 5.6.



**Figure 5.6: Ahoy/Random Access Structure**

The meaning of this message is different for downlink and uplink messages.

The AHOY downlink message may be transmitted by BS to determine if an MS is in radio contact or to request that the MS send a message.

The uplink message is transmitted by MS making random access service requests.

#### 5.2.14.1 B\_AHOY Message Downlink [B]

The AHOY message is transmitted by a BS to an MS or group of MS to:

- a) determine if the called party MS is in contact;
- b) invite a calling party MS to send complementary data for a call set-up; or
- c) invite a calling party MS to send its short data for as part of a short data transaction.

The message content is illustrated in table 5.40.

Table 5.40: B\_AHOY message content

Alias	Alias	Alias	Value	Length	Meaning			
MT			1100 <sub>2</sub>	4	Message Type = AHOY (BS downlink)			
PARMS	ID0 + 1			24	Target MS ID or DUMMYI (see Note 1)			
	ID2 + 3			24	Source MS ID or Gateway			
	M			000 <sub>2</sub>	3	Service supported is a Voice Call		
				001 <sub>2</sub>		Service supported is a Voice Call + slow data		
				010 <sub>2</sub>		Service supported is a T1 Data Call		
				011 <sub>2</sub>		Service supported is a T2 Data Call		
				100 <sub>2</sub>		Service supported is a T3 Packet Data Call		
				101 <sub>2</sub>		Service supported is Voice + Attached_Data		
				110 <sub>2</sub>		Service supported is defined by MI_TYPE		
				111 <sub>2</sub>		Cancel the call service		
	V			00 <sub>2</sub>	2	TCH is standard (non zero for custom)		
	F			11 <sub>2</sub>	2	Comms Format = BS Downlink		
	EP			0 <sub>2</sub>	1	Non emergency service		
				1 <sub>2</sub>		Emergency Service		
	W			0 <sub>2</sub>	1	The following slot is available for random access		
				1 <sub>2</sub>		The following slot is withdrawn from random access		
	MI	MI_TYPE		000 <sub>2</sub>	3	Service Supported is Short Data		
				001 <sub>2</sub>		Service Supported is Status Transport		
				010 <sub>2</sub>		Data Polling Service		
				011 <sub>2</sub>		Call Diversion Service		
				100 <sub>2</sub>		Complementary Data Service		
				101 <sub>2</sub>		Registration Service		
				110 <sub>2</sub>		Reserved		
				111 <sub>2</sub>		Reserved for Powersave		
		MI_DET Note 2				2	Number of UAD needed in the response to this message	
					00 <sub>2</sub>	2	RSVD	Reserved
					0 <sub>2</sub>	1	LONG	PABX/PSTN dialled string is 1 to 16 digits. or IPV4
1 <sub>2</sub>					PABX/PSTN dialled string is 17 to 32 digits or IPV6			
0 <sub>2</sub>					1	COMP	Complementary Data is not being requested	
1 <sub>2</sub>							Complementary Data is being requested	
0 <sub>2</sub>	1	PRIORITY	Normal Priority call					
1 <sub>2</sub>			High Priority Call					
0 <sub>2</sub>	1	BRCST	Non Broadcast Service					
1 <sub>2</sub>			Broadcast Service					
NOTE 1: The Target MS ID is the recipient MS for this message. DUMMYI is used where the AHOY message is used solely for the purpose of withdrawing the following slot from random access. If this particular case an acknowledgement to this message is not expected.								
NOTE 2: For the Status Delivery Service, MI_DET=STATUSM3.								

## 5.2.14.2 Random Access Request Uplink [B]

Random Access Requests are sent by MS to request a particular service. The message content is illustrated in table 5.41.

**Table 5.41: B\_RAND random access message content**

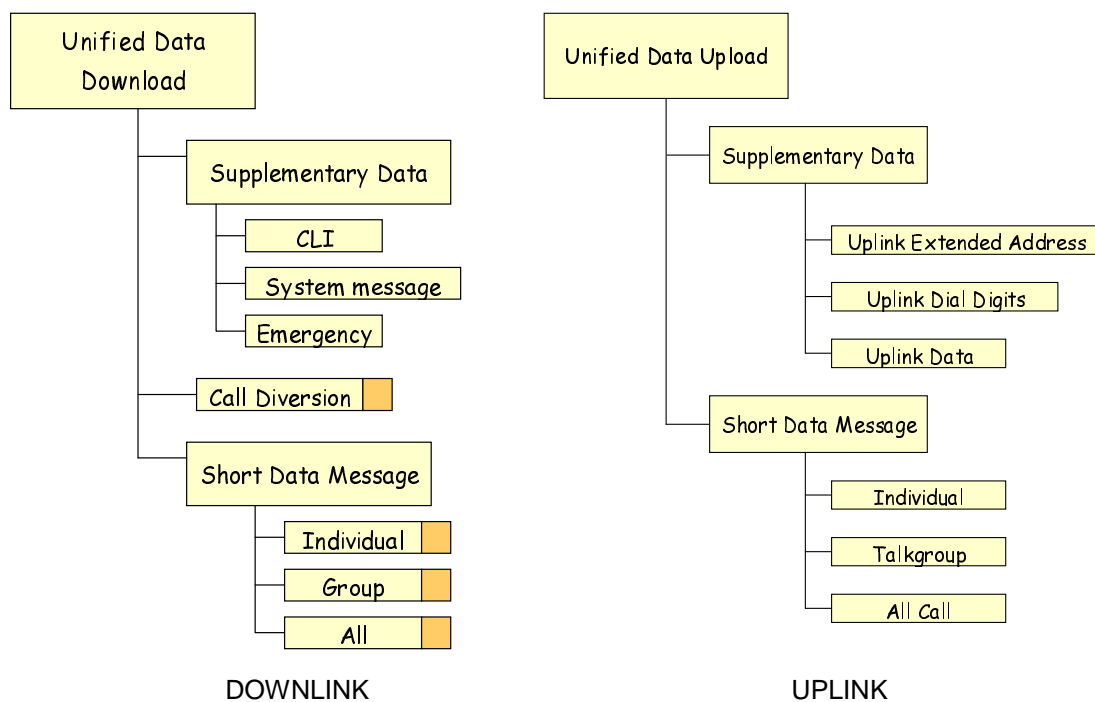
Alias	Alias	Alias	Value	Length	Meaning		
MT			1100 <sub>2</sub>	4	Message Type = B_RAND (BS uplink)		
PARMS	ID0 + 1			24	Called MS, talkgroup, or gateway		
	ID2 + 3			24	Calling MS ID		
	M			000 <sub>2</sub>	3	Service requested is a Voice Call	
				001 <sub>2</sub>		Service requested is a Voice Call + slow data	
				010 <sub>2</sub>		Service requested is a T1 Data Call	
				011 <sub>2</sub>		Service requested is a T2 Data Call	
				100 <sub>2</sub>		Service requested is a T3 Packet Data Call	
				101 <sub>2</sub>		Service requested is Voice + Attached Data	
				110 <sub>2</sub>		Service requested is defined by MI_TYPE	
				111 <sub>2</sub>		Cancel the call service	
	V		00 <sub>2</sub>	2	TCH is standard (non zero for custom)		
	F		10 <sub>2</sub>	2	Comms Format = BS Uplink		
	EP			0 <sub>2</sub>	1	Non emergency service	
				1 <sub>2</sub>		Emergency Service	
	PM		N/A	1	Not Applicable for this particular message		
	MI	MI_TYPE		000 <sub>2</sub>	3	Service Requested is Short Data	
				001 <sub>2</sub>		Service Requested is Status Transport	
				010 <sub>2</sub>		Data Polling Service	
				011 <sub>2</sub>		Call Diversion Service	
				100 <sub>2</sub>		Complementary Data Service	
				101 <sub>2</sub>		Service Request is Registration	
				110 <sub>2</sub>		Reserved	
				111 <sub>2</sub>		Reserved for Powersave	
		MI_DET Note 3				2	UAD1
					2	UAD2	Appended Complementary Data. Number of appended UDTs required to transport the complementary data
0 <sub>2</sub>					1	LONG	PABX/PSTN dialled string is 1 to 16 digits or IPV4
1 <sub>2</sub>							PABX/PSTN dialled string is 17 to 32 digits or IPV6
0 <sub>2</sub>					1	COMP	Complementary Data service not required for this call
1 <sub>2</sub>							Complementary Data service is required for this call
0 <sub>2</sub>					1	PRIORITY	Normal Priority call (see note 2)
1 <sub>2</sub>							High Priority Call
0 <sub>2</sub>					1	BRCST	Non Broadcast Service
1 <sub>2</sub>							Broadcast Option (see note 1)

NOTE 1: The broadcast option is only applicable for the talkgroup service.  
NOTE 2: If EP = 1<sub>2</sub> indicating an emergency service, the PRIORITY flag in MI\_DET = 0<sub>2</sub>.  
NOTE 3: For the Status Delivery Service, MI\_DET=STATUSM3.



## 5.2.15 UDT Header messages [B]

This is a Message\_Frame identified by MT = 1110<sub>2</sub>. The structure is illustrated in figure 5.7.



**Figure 5.7: UDT Header**

UDT Header messages may be transmitted both on the uplink and downlink for Mode 3 systems. The message is illustrated in table 5.42. Between 1 and 4 Appended\_Data messages may be concatenated to the UDT header. The number of UDT Appended\_Data Messages is indicated by the Appended\_Data (UAD) field. The format of the data carried in the Appended\_Data messages is defined in UDT\_FORMAT. If this UDT header + Appended\_Data is carrying user data (short data) and the short data is formatted BCD, 7 bit, or 8 bit, the SYMB field contains the number of user symbols in the Appended\_Data (see note).

NOTE: If the number of symbols = 64, SYMB = 00 0000<sub>2</sub>.

Table 5.42: UDT Header Message

Alias	Alias	Alias	Value	Length	Meaning		
MT			1110 <sub>2</sub>	4	Message Type = UDT Header		
PARMS	ID0 + 1			24	Target MS ID or Gateway		
	ID2 + 3			24	Source MS ID or Gateway		
	UDT_FORMAT			000 <sub>2</sub>	3	MS ID	
				001 <sub>2</sub>		Binary	
				010 <sub>2</sub>		4 bit BCD	
				011 <sub>2</sub>		ISO 7 bit character set	
				100 <sub>2</sub>		ISO 8 bit character set (ISO/IEC 8859 [3])	
				101 <sub>2</sub>		NMEA location coded (EN 61162-1 [1])	
				110 <sub>2</sub>		IPV4	
				111 <sub>2</sub>		IPV6	
	V		N/A	2	N/A for a UDT Header		
	F			2	Comms Format Uplink/Downlink		
	EP			0 <sub>2</sub>	1	Non Emergency	
				1 <sub>2</sub>		This message is supporting a call service with emergency priority	
	COMP			1 <sub>2</sub>	1	This UDT is a Header where the Appended_Data is carrying Complementary Data supporting another Mode 3 service	
0 <sub>2</sub>				This UDT is a Header where the Appended_Data is carrying Data for a user initiated service (Short Data/ Data Polling)			
MI	MI_TYPE		N/A	3	Service that this UDT header is supporting (see note)		
			MI_DET		2	UAD	Number of Appended_Data messages appended to this UDT header
					6	SYMB	Number of symbols to be transported if this header is transporting short data

NOTE: For a list of services, refer to clause 5.5.19.8.

## 5.3 End\_Frame

The content for the end frame is illustrated in table 5.43.

The END0 and END1 fields are transmitted as duplicates. Where End\_Frames are illustrated by the tables in these clauses, it is only necessary to show one of the END fields.

Table 5.43: End frame content

Alias	Meaning	Length	FEC	Transfer
FS3	Frame Sync	24	none	24
END0	ET	End type	Clause 7.7	72
	ARQ	Ack request		
	Tx_WAIT	Tx_Wait		
	STAT	Status message		
	RSVD	Reserved		
	CRC + FEC			
END1	ET	End type	Clause 7.7	72
	ARQ	Ack request		
	Tx_WAIT	Tx_Wait		
	STAT	Status message		
	RSVD	Reserved		
	CRC + FEC			

## 5.4 Packet Data Header [T]

The packet data header is illustrated in table 5.44. It has to signify that the framing and coding structure following is of a different format than a message frame. This is signalled to receiving stations by the use of a different synchronization sequence (FS4) in exactly the same way as in ETS 300 230 [i.1] for example. However, for receiving stations, the purpose and content of any transmission can be determined by the Header Information (HI0 and HI1).

**Table 5.44: Packet data header frame content**

Alias	Field	Length	FEC	Transfer
P	Preamble	$\geq 72$	none	72
FS4	Frame Sync	48	none	48
HI0	HT	Header type	Clause 7.6	120
	ID0+1	Called station ID		
	ID2+3	Own ID		
	M	Communication Mode		
	V	Version		
	F	Comms format		
	EP	Emergency Priority		
	PM	N/A		
	MI	Message Information		
	CRC + FEC	8 + 40		
CC	Colour Code	24	Clause 6.1.5	24
HI1	HT	Header type	Clause 7.6	120
	ID0+1	Called station ID		
	ID2+3	Own ID		
	M	Communication Mode		
	V	Version		
	F	Comms format		
	EP	Emergency Priority		
	PM	N/A		
	MI	Message Information		
	CRC + FEC	8 + 40		

Alias	Length	Value	Meaning
PARMS	HT		Header type
	ID0+1	24	Called station ID
	ID2+3	24	Own ID
	M	3	Communication Mode
	V	2	Version
	F	2	Comms format
	EP	1	Emergency Priority
	PM	N/A	Not Applicable for this message
	MI	11	Message Information

## 5.5 Field Descriptions

The following clauses contain descriptions of the fields contained within frames, and provide a description of what the elements represent in relation to their bit representation. The structure of the tables is as follows:

- the Field element column gives the name of the field;
- the Length column defines the length of the field in bits;
- the Value column denotes fixed values or a range of values;
- the Meaning column defines the meaning of the field against each of its bit represented values;
- the Alias column is a shorthand for the field;

- the Mnemonic is a description of the particular value of a field or alias.

### 5.5.1 Active ACTIVE [B]

On a BS downlink channel, the active field indicates if the radio site is isolated from the network or has an active connection to the network.

**Table 5.45: Active Field**

Alias	Length	Value	Meaning
ACTIVE	1	0 <sub>2</sub>	The radio site BS is isolated from the network
		1 <sub>2</sub>	The radio site is connected to the network

### 5.5.2 Appended\_Data [BT]

If the Complementary Data Service has been invoked as an option with other voice or data services, the Appended Complementary Data field is used to pass the number of Appended\_Data UDTs needed to upload the Complementary Data.

If the Short Data Service has been invoked, the Appended Short Data field is used by an MS to pass the number of Appended\_Data UDTs needed to upload the Short Data.

**Table 5.46: Appended Complementary Data field**

Field	Length	Alias	Value	Meaning
Appended_Data	2	UAD	00 <sub>2</sub>	Number of Appended_Data UDTs needed to transfer the data = 1
			01 <sub>2</sub>	Number of Appended_Data UDTs needed to transfer the data = 2
			10 <sub>2</sub>	Number of Appended_Data UDTs needed to transfer the data = 3
			11 <sub>2</sub>	Number of Appended_Data UDTs needed to transfer the data = 4

### 5.5.3 ARQ [T]

Table 5.47 describes the ARQ field. This field is part of an END frame.

**Table 5.47: ARQ**

Alias	Length	Value	Meaning
ARQ	2	00 <sub>2</sub>	No ACK request to called station
		01 <sub>2</sub>	ACK request to called station
		10 <sub>2</sub>	Reserved
		11 <sub>2</sub>	Reserved

## 5.5.4 Backoff [B]

The Backoff field is illustrated in table 5.48.

**Table 5.48: Backoff Number**

Alias	Length	Value	Meaning
BACKOFF	4	0	0 - Reserved
		1	Backoff Frameset length = 1
		2	Backoff Frameset length = 2
		3	Backoff Frameset length = 3
		4	Backoff Frameset length = 4
		5	Backoff Frameset length = 5
		6	Backoff Frameset length = 8
		7	Backoff Frameset length = 11
		8	Backoff Frameset length = 15
		9	Backoff Frameset length = 20
		10	Backoff Frameset length = 26
		11	Backoff Frameset length = 33
		12	Backoff Frameset length = 41
		13	Backoff Frameset length = 50
		14	Backoff Frameset length = 70
15	Backoff Frameset length = 100		

## 5.5.5 Call Timers [BT]

The Call timers specified in this clause use tokens to extend the real time Values from what could be expressed using a purely binary representation.

**Table 5.49: Call Timer Tokens**

Alias	Value	Length	Meaning
T_MS-MS T_EMERG_T T_PACKET T_MS-LINE_TMR T_DATA_TMR	0	6	MS uses its Internal Timers for the appropriate call type
	1 to 10		Call Timer in seconds
	11 to 20		Call timer in increments of 5 s from - 11 = 15 s to 20 = 60 s
	21 to 28		Call timer in increments of 15 s from - 21 = 75 s to 28 = 180 s
	29 to 40		Call timer in increments of 30 s from - 29 = 3,5 minutes to 40 = 9 minutes
	41 to 51		Call timer in increments of 1 minute from - 41 = 10 minutes to 51 = 20 minutes
	52 to 62		Call timer in increments of 5 minutes from - 52 = 25 minutes to 62 = 75 minutes
	63		Call timer is infinity

## 5.5.6 Communication format [BT]

The communications format [F] field illustrated in table 5.50 is transmitted in Mode 1 traffic channel header frames, packet data header frames and communications start header frames to indicate the source of the message.

**Table 5.50: Communication format for Mode 1**

Alias	Length	Value	Meaning
F	2	00 <sub>2</sub>	Call ALL (Broadcast)
		01 <sub>2</sub>	Peer-to-peer communication (MS to MS)
		10 <sub>2</sub>	Reserved
		11 <sub>2</sub>	Reserved

The communications format [F] field illustrated in table 5.51 is transmitted in Mode 2 traffic channel header frames, packet data header frames and communications start header frames to indicate the source of the message.

**Table 5.51: Communication format for Mode 2**

Alias	Length	Value	Meaning
F	2	00 <sub>2</sub>	(Broadcast) BS Downlink
		01 <sub>2</sub>	(Broadcast) BS Uplink
		10 <sub>2</sub>	BS uplink
		11 <sub>2</sub>	BS downlink

NOTE: Not all messages carry the Communications Format (F) field. In particular, some of the Broadcast (MT = 1011<sub>2</sub>) messages do not carry this field. Broadcasts are only transmitted on the downlink though so there is no ambiguity.

The communications format [F] field illustrated in table 5.52 is transmitted in Mode 3 beacon channel frames.

**Table 5.52: Communication format for Mode 3 Beacon Channel**

Alias	Length	Value	Meaning
F	2	00 <sub>2</sub>	Reserved
		01 <sub>2</sub>	Reserved
		10 <sub>2</sub>	BS uplink
		11 <sub>2</sub>	BS downlink

The communications format [F] field illustrated in table 5.53 is transmitted in Mode 3 traffic channel frames.

**Table 5.53: Communication format for Mode 3**

Alias	Length	Value	Meaning
F	2	00 <sub>2</sub>	(Broadcast) BS Downlink
		01 <sub>2</sub>	(Broadcast) BS Uplink
		10 <sub>2</sub>	BS uplink
		11 <sub>2</sub>	BS downlink

## 5.5.7 Communication Mode [BT]

The communications Mode [M] field illustrated in table 5.54 is used to:

- indicate the content of traffic channel payload to the recipient(s); or
- indicate a service, for a call set-up. There are more services available than will fit in the M field. For services that are not defined in table 5.54 (M=000<sub>2</sub> to 101<sub>2</sub>), M is set to 110<sub>2</sub> and the service is defined by MI\_TYPE.

**Table 5.54: Communications Mode**

Alias	Length	Value	Meaning
M	3	000 <sub>2</sub>	Voice communication (no user data in SLD field)
		001 <sub>2</sub>	Voice + slow data (user data in SLD field)
		010 <sub>2</sub>	Data communication type 1 (Payload is user data without FEC)
		011 <sub>2</sub>	Data communication type 2 (Payload is user data with FEC)
		100 <sub>2</sub>	Data communication type 3 (Packet data, ARQ method)
		101 <sub>2</sub>	Voice and attached data (Type 2)
		110 <sub>2</sub>	Service requested is defined by MI_TYPE
		111 <sub>2</sub>	Reserved

### 5.5.8 COMP [B]

The COMPLEMENTARY field is use in the UDT mechanism to indicate if the data being carried in Appended\_Data is user data (for instance in a short data service) or the Appended\_Data is supporting another dPMR service.

**Table 5.55: COMP**

Alias	Length	Value	Meaning
COMP	2	0 <sub>2</sub>	The Appended_Data that is part of this message exchange is supporting extended or user data
		1 <sub>2</sub>	The Appended_Data that is part of this message exchange is supporting complementary data sent or received as part of a call set-up for another service

### 5.5.9 Continuation\_Flag [T]

Table 5.56 illustrated describes the Continuation\_Flag CONT field.

**Table 5.56: Continuation Flag**

Alias	Value	Meaning
CONT	0 <sub>2</sub>	User data continues after the following byte
	1 <sub>2</sub>	User data is terminated by the following byte

### 5.5.10 Day of Week (DAYSOF\_WEEK) [B]

**Table 5.57: DAYSOF\_WEEK field**

Alias	Length	Value	Meaning
DAYSOF_WEEK	3	000 <sub>2</sub>	<Days of Week not broadcast>
		001 <sub>2</sub>	Sunday
		010 <sub>2</sub>	Monday
		011 <sub>2</sub>	Tuesday
		100 <sub>2</sub>	Wednesday
		101 <sub>2</sub>	Thursday
		110 <sub>2</sub>	Friday
		111 <sub>2</sub>	Saturday

### 5.5.11 Digits [BT]

The DIAL\_DIGITS Alias represents dialled digits coded as table 5.58.

**Table 5.58: Digits**

Alias	Length	Value	Alias	Meaning
DIAL_DIGITS	4	0000 <sub>2</sub>	Digit '0'	
		0001 <sub>2</sub>	Digit '1'	
		0010 <sub>2</sub>	Digit '2'	
		0011 <sub>2</sub>	Digit '3'	
		0100 <sub>2</sub>	Digit '4'	
		0101 <sub>2</sub>	Digit '5'	
		0110 <sub>2</sub>	Digit '6'	
		0111 <sub>2</sub>	Digit '7'	
		1000 <sub>2</sub>	Digit '8'	
		1001 <sub>2</sub>	Digit '9'	
		1010 <sub>2</sub>	Digit '*'	* character
		1011 <sub>2</sub>	Digit '#'	# character
		1100 <sub>2</sub>	Spare	
		1101 <sub>2</sub>	Spare	
1110 <sub>2</sub>	Spare			
1111 <sub>2</sub>	Digit 'DIAL_NULL'	End of Dialed String		

If dialled digits are transported between entities as part of a PABX or PSTN call setup the number of dialled digits shall be determined as follows:

- The sending entity shall fill unused BCD digits in the Appended\_Data message(s) with DIAL\_NULL (1111<sub>2</sub>).
- The receiving entity shall then count the dialled digits until DIAL\_NULL is encountered.

### 5.5.12 Emergency Priority [BT]

The emergency priority [EP] field illustrated in table 5.59 is transmitted in traffic channel header frames, packet data header frames and communications start header frames to indicate if the call has emergency priority.

**Table 5.59: Priority**

Alias	Length	Value	Meaning
EP	1	0 <sub>2</sub>	Normal Priority
		1 <sub>2</sub>	Emergency Priority

### 5.5.13 End\_Type [T]

Table 5.60 illustrated below describes the End\_Type field. This field is part of an END frame.

**Table 5.60: End type**

Alias	Length	Value	Meaning
ET	2	00 <sub>2</sub>	Normal end frame
		01 <sub>2</sub>	End frame with status message
		10 <sub>2</sub>	Reserved
		11 <sub>2</sub>	Reserved



### 5.5.14 Frame numbering [T]

The frame numbering field illustrated in table 5.61 is used in traffic channel superframes to indicate the particular superframe being transmitted.

**Table 5.61: Frame numbering**

Alias	Length	Value	meaning
FN	2	00 <sub>2</sub>	frame 1
		01 <sub>2</sub>	frame 2
		10 <sub>2</sub>	frame 3
		11 <sub>2</sub>	frame 4

### 5.5.15 Frequency Definitions FR, FT, SEP, BAND [BT]

The tables in this clause describes the coding for the transmit and receive frequency.

**Table 5.62: Coding for BAND**

Alias	Value	Range
BAND	0000 <sub>2</sub>	0 MHz to 100 MHz
	0001 <sub>2</sub>	80 MHz to 180 MHz
	0010 <sub>2</sub>	160 MHz to 260 MHz
	0011 <sub>2</sub>	240 MHz to 340 MHz
	0100 <sub>2</sub>	320 MHz to 420 MHz
	0101 <sub>2</sub>	400 MHz to 500 MHz
	0110 <sub>2</sub>	480 MHz to 580 MHz
	0111 <sub>2</sub>	560 MHz to 660 MHz
	1000 <sub>2</sub>	640 MHz to 740 MHz
	1001 <sub>2</sub>	700 MHz to 800 MHz
	1010 <sub>2</sub>	750 MHz to 850 MHz
	1011 <sub>2</sub>	800 MHz to 900 MHz
	1100 <sub>2</sub>	850 MHz to 950 MHz
	1101 <sub>2</sub>	900 MHz to 1 000 MHz
	1110 <sub>2</sub>	Reserved
	1111 <sub>2</sub>	Custom

**Table 5.63: Coding for Separation SEP**

Alias	Length	Value	Meaning
SEP	1	0 <sub>2</sub>	Channel Frequency Separation is 3,125 kHz
		1 <sub>2</sub>	Channel Frequency Separation is 5,000 kHz

**Table 5.64: Frequency FR FT**

Alias	Length	Value	Meaning
FR FT	15	000 0000 0000 0000 <sub>2</sub>	Receive Frequency is coded as - f = BAND + (SEP x FR)
		000 0000 0000 0001 <sub>2</sub>	
		000 0000 0000 0010 <sub>2</sub>	Transmit Frequency is coded as - f = BAND + (SEP x FT)
		000 0000 0000 0011 <sub>2</sub>	
		.....	

## 5.5.16 Guard\_Kind [T]

**Table 5.65: Guard\_Kind field Definition**

Alias	Length	Value	Alias	Remark
Guard_Kind (MI_DET)	4	0000 <sub>2</sub>	DIS_PTT	Disable Target MS or Talkgroup PTT
		0001 <sub>2</sub>	EN_PTT	Enable Target MS or Talkgroup PTT
		0010 <sub>2</sub>	Illegally_Parked	Clear down from the payload channel, MS whose address does not match Source or Target Address
		0011 <sub>2</sub> to 1111 <sub>2</sub>	RSVD	Reserved

## 5.5.17 Long [B]

The LONG field is illustrated in table 5.66.

**Table 5.66: Long**

Alias	Length	Value	Meaning
LONG	1	0 <sub>2</sub>	For a call to the PABX/PSTN the number of dialled string is 1 to 16 digits
			For a call to an IP destination the format is IPV4
		1 <sub>2</sub>	For a call to the PABX/PSTN the number of dialled string is 17 to 32 digits
			For a call to an IP destination the format is IPV6

## 5.5.18 Mask [B]

The Mask field is illustrated in table 5.67. For a description of the Mask field see clause 12.3.6.1.3.

**Table 5.67: Mask**

Alias	Length	Value	Meaning
Mask	5	0 to 24	Value in the range 0 to 24 (decimal)

## 5.5.19 Message Information [BT]

Table 5.68 illustrates the Message\_Information field. 11 bits of the Message Frame/Packet Header Frame are allocated for Message Information (MI) data, three bits indicate the type of data (MI\_TYPE) and 8 bits contain the detail (MI\_DET). If MI\_TYPE=111<sub>2</sub> then the message is a powersave header otherwise the message is a normal header.

**Table 5.68: Message Information**

Alias	Alias	Length	Value	Meaning
MI	MI_TYPE	3	000 <sub>2</sub> to 110 <sub>2</sub>	Message is a normal header
			111 <sub>2</sub>	Message is Powersave header
	MI_DET	8		Message Detail

If powersave frames precede a normal header frame for powersave purposes, MI\_TYPE = 111<sub>2</sub> replaces the MI\_TYPE value in the normal header frame. The other fields may remain as the normal header.

Message\_Information is used to give additional information about the message. It has different content and purpose depending on the message or call type. Table 5.69 outlines the various uses of Message\_Information and the related clauses that define that use.

**Table 5.69: Use of Message information (MI)**

Use	Purpose	Clause	MI_TYPE
Powersave	Indicate normal or powersave message type	5.5.19.1	MI_TYPE=111 <sub>2</sub>
T1 or T2 Data	Indicate the type of data (complementary service)	5.5.19.2	MI_TYPE = 000 <sub>2</sub> to 110 <sub>2</sub>
T3 Data (Packet)	Indicate data frame size and number of frames	5.5.19.3	
System Transactions		5.5.19.4	
Acknowledgements	Indicate ACK or NACK and reason	5.5.19.5	
Broadcast Headers		5.5.19.6	
System request System response Delivery Header	MI_Type defines the purpose MI_Detail is not used and set to 0000 0000 <sub>2</sub>		
BS Command Headers		5.5.19.7	
AHOY Headers		5.5.19.8	

### 5.5.19.1 Message Information for Powersave [T]

Powersave messages are only transmitted by Mode 1 MS and Mode 2 MS/BS.

For powersave wake-up headers, the WU bits indicate how many (powersave-1) frames follow the current one (i.e. counting down to zero).

**Table 5.70: MI bits for powersave**

Alias	Alias	Length	Value	Meaning
MI	MI_TYPE	3	111 <sub>2</sub>	Powersave header
	RSVD	4	0000 <sub>2</sub>	Reserved
	WU	4	1111 <sub>2</sub>	Extended Header frame 15
			-- ↓ -- 0001 <sub>2</sub>	Extended Header frame 1
			0000 <sub>2</sub>	Normal header frame

### 5.5.19.2 Message Information for Types 1 and 2 data [T]

Message Information bits for type 1 and 2 data is illustrated in table 5.71.

**Table 5.71: MI bits for type 1 and 2 data**

Alias	Alias	Length	Value	Meaning
MI	MI_TYPE	3	001 <sub>2</sub>	MI for Types 1 and 2 data
	TFormat	4	0000 <sub>2</sub>	Status message
			0001 <sub>2</sub>	Pre-coded message
			0010 <sub>2</sub>	Free text message (radio generated data)
			0011 <sub>2</sub>	Short file transfer
			0100 <sub>2</sub>	User defined data 1
			0101 <sub>2</sub>	User defined data 2
			0110 <sub>2</sub>	User defined data 3
			0111 <sub>2</sub>	User defined data 4
			1000 <sub>2</sub> to 1111 <sub>2</sub>	Reserved
Reserved	4	0000 <sub>2</sub>		

### 5.5.19.3 Message Information for Type 3 (packet) data [T]

Message Information bits for Packet data format (Type 3) is illustrated in table 5.72.

**Table 5.72: MI bits for type 3 data**

Alias	Alias	Length	Value	Meaning
MI	MI_TYPE	3	011 <sub>2</sub>	MI for type 3 data
	pdS	4	0000 <sub>2</sub>	Frame time 80 ms    Data size 288 bits
			0001 <sub>2</sub>	Frame size 160 ms    Data size 672 bits
			0010 <sub>2</sub>	Frame size 240 ms    Data size 1 056 bits
			0011 <sub>2</sub>	Frame size 320 ms    Data size 1 400 bits
			0100 <sub>2</sub> to 1111 <sub>2</sub>	Reserved
	pdM	4	0000 <sub>2</sub>	1 frame
			0001 <sub>2</sub>	2 frames
			0010 <sub>2</sub>	3 frames
			0011 <sub>2</sub>	4 frames
			0100 <sub>2</sub>	5 frames
			0101 <sub>2</sub>	6 frames
			0110 <sub>2</sub>	7 frames
			0111 <sub>2</sub>	8 frames
	1000 <sub>2</sub> to 1111 <sub>2</sub>	Reserved		

### 5.5.19.4 Message Information for system transactions [T]

The Message Information for System request/answer/delivery header is illustrated in table 5.73.

**Table 5.73: MI bits for System transactions**

Alias	Alias	Length	Value	Meaning
MI	MI_TYPE	3	000 <sub>2</sub>	
			001 <sub>2</sub>	
			010 <sub>2</sub>	
			011 <sub>2</sub>	
			100 <sub>2</sub>	
			101 <sub>2</sub>	
			110 <sub>2</sub>	
			111 <sub>2</sub>	Reserved for Powersave
	MI_DET	8		

### 5.5.19.5 Message Information for B\_ACK T\_ACK acknowledgements [BT]

The Message Information for an Acknowledgement frame is illustrated in table 5.74.

**Table 5.74: MI bits for Acknowledgement types**

Alias	Alias	Value	Length	Definition	
MI_TYPE	B_ACK B_NACK B_WACK B_QACK	000 <sub>2</sub>	3	Acknowledgement - Acknowledgement type defined by REASON	Acknowledgements transmitted on a Beacon Channel
	T_ACK	001 <sub>2</sub>		ACK (Rx OK)	Acknowledgements transmitted on a Traffic Channel
		010 <sub>2</sub>		NACK (data error, resend request)	
		011 <sub>2</sub>		NACK (request denied)	
		Other		Reserved	
MI_DET		0000 0000 <sub>2</sub>	Reason not Specified		
	REASON	1 to 255	8	ACK / NACK status (rejection reason defined by user or by REASON)	REASON, (see clause 5.5.25)

If the reason for the acknowledgement is not specified, REASON = 0000 0000<sub>2</sub>. For a non-zero REASON, the reason for the acknowledgement is specified in clause 5.5.25.

### 5.5.19.6 Message Information for Broadcast headers [BT]

The Message Information for a Broadcast header frame is illustrated in table 5.75.

**Table 5.75: MI bits for broadcast headers**

MI_TYPE	Mnemonic	Meaning
000 <sub>2</sub>	Aloha	Broadcast = Aloha
001 <sub>2</sub>	Announcement	Broadcast = Announcement
010 <sub>2</sub>	Move	Broadcast = Move
011 <sub>2</sub>	Goto Channel	Broadcast = Goto_Channel
100 <sub>2</sub>	Ambience Listening	Broadcast = Ambience Listening
101 <sub>2</sub>		Reserved
110 <sub>2</sub>		Reserved
111 <sub>2</sub>		Reserved

### 5.5.19.7 Message Information for BS Command headers [T]

The Message Information for a BS Command Header frames is illustrated in table 5.76.

**Table 5.76: MI bits for BS command headers**

MI_TYPE	Mnemonic	Meaning
000 <sub>2</sub>		Reserved
001 <sub>2</sub>		Reserved
010 <sub>2</sub>		Reserved
011 <sub>2</sub>		Reserved
100 <sub>2</sub>		Reserved
101 <sub>2</sub>		Reserved
110 <sub>2</sub>		Reserved
111 <sub>2</sub>		Reserved for Powersave

Table 5.77: MI bits for Tech status requests

Alias	Alias	Length	Value	Meaning
MI	MI_TYPE	3	000 <sub>2</sub>	
	MI_DET Parameter	3	000 <sub>2</sub>	
			001 <sub>2</sub>	
			010 <sub>2</sub>	
			011 <sub>2</sub>	
			100 <sub>2</sub>	
			101 <sub>2</sub> to 111 <sub>2</sub>	
Reserved	5	00000 <sub>2</sub>		

### 5.5.19.8 Message Information for additional services [B]

The Message Information for additional Beacon frames that cannot be described by the M field is illustrated in table 5.78.

Therefore the M field and the MI\_TYPE field combine to fully define the service. If M = 110<sub>2</sub> then table 5.78 applies.

Table 5.78: MI bits for Beacon Frames (M=110<sub>2</sub>)

MI_TYPE	Mnemonic	Meaning
000 <sub>2</sub>	Short Data	Service Requested is Short Data
001 <sub>2</sub>	Status Transport	Service Requested is Status Transport
010 <sub>2</sub>	Data Polling	Data Polling Service
011 <sub>2</sub>	Call Diversion	Call Diversion Service
100 <sub>2</sub>	Complementary Service	Complementary Service
101 <sub>2</sub>	Registration or authentication Service	Registration or authentication Service
110 <sub>2</sub>	Reserved	Reserved
111 <sub>2</sub>	Powersave	Reserved for Powersave

### 5.5.20 Message\_Type [BT]

Table 5.3 in clause 5.2 describes the Message\_Type field.

### 5.5.21 Month B\_MONTH

Table 5.79: B\_MONTH field

Alias	Length	Value	Meaning
B_MONTH	4	0000 <sub>2</sub>	<Month not broadcast>
		0001 <sub>2</sub>	January
		0010 <sub>2</sub>	February
		0011 <sub>2</sub>	March
		0100 <sub>2</sub>	April
		0101 <sub>2</sub>	May
		0110 <sub>2</sub>	June
		0111 <sub>2</sub>	July
		1000 <sub>2</sub>	August
		1001 <sub>2</sub>	September
		1010 <sub>2</sub>	October
		1011 <sub>2</sub>	November
1100 <sub>2</sub>	December		

## 5.5.22 NRand\_Wait [B]

The Nrand\_Wait field is illustrated in table 5.80. The Beacon shall specify using NRand\_Wait, the delay (in framesets) an MS shall wait before deciding to retransmit and choose another slot from a new random-access-frame.

**Table 5.80: NRand\_Wait**

Alias	Length	Value	Meaning
NRand_Wait	4	0 to 15	Beacon response to a Random Access Request 0 = response in the next -frame 1 - MS shall wait for 1 frameset 2 - MS shall wait for 2 framesets 3 - MS shall wait for 3 framesets 4 - MS shall wait for 4 framesets 5 - MS shall wait for 5 framesets 6 - MS shall wait for 6 framesets 7 - MS shall wait for 7 framesets 8 - MS shall wait for 8 framesets 9 - MS shall wait for 9 framesets 10 - MS shall wait for 10 framesets 11 - MS shall wait for 11 framesets 12 - MS shall wait for 12 framesets 13 - MS shall wait for 13 framesets 14 - MS shall wait for 15 framesets 15 - MS shall wait for 24 framesets

## 5.5.23 Preservation\_Message PM [T]

The PM field identifies the message as a Preservation\_Message. Preservation\_Messages are transmitted by BS on a traffic channel to indicate to MS not involved in the call that the channel is busy.

**Table 5.81: Protection Message Status**

Alias	Length	Value	Meaning
PM	1	0 <sub>2</sub>	The BS is idle or the PM field is not applicable for this message
		1 <sub>2</sub>	The BS is announcing a Preservation

## 5.5.24 POL\_FMT [BT]

Specifies the format of polled data from the Short Data Polling procedures.

**Table 5.82: POL\_FMT field [B]**

Alias	Length	Value	Meaning
POL_FMT	4	0000 <sub>2</sub>	Binary
		0001 <sub>2</sub>	MS Addresses
		0010 <sub>2</sub>	4 bit BCD
		0011 <sub>2</sub>	ISO 7 bit character set (ISO/IEC 646 [2])
		0100 <sub>2</sub>	ISO 8 bit character set (ISO/IEC 8859 [3])
		0101 <sub>2</sub>	NMEA location information (EN 61162-1 [1])
		0110 <sub>2</sub>	Reserved
		0111 <sub>2</sub>	Reserved
		1000 <sub>2</sub>	Reserved
		1001 <sub>2</sub>	Reserved
		1010 <sub>2</sub>	Reserved
		1011 <sub>2</sub>	Reserved
		1100 <sub>2</sub>	Reserved
		1101 <sub>2</sub>	Reserved
		1110 <sub>2</sub>	Reserved
		1110 <sub>2</sub>	Reserved

## 5.5.25 Reason [BT]

The Reason field is illustrated in tables 5.83 to 5.88. Separate tables are illustrated for the classifications T\_ACK, T\_NACK, B\_ACK, B\_NACK, B\_QACK, and B\_WACK. Undefined values of REASON are Reserved.

Reason Codes in acknowledgement messages from MS may be retransmitted on the BS downlink

**Table 5.83: Answer Response T\_ACK [T]**

Alias	Length	Value	Mnemonic	Meaning
		Acknowledgement Transmitted by the sender Message Accepted by the recipient		
REASON	8	0100 0100 <sub>2</sub> to 0100 0111 <sub>2</sub>	Message_Accepted	Message accepted by recipient - Proceed Reason is user specified



Table 5.84: Answer Response T\_NACK

Alias	Length	Value	Mnemonic	Meaning
REASON	8	<b>Message/Service rejected by BS</b>		
		0010 0001 <sub>2</sub>	Not_Supported	System does not support this service
		0010 0010 <sub>2</sub>	Perm_User_Refused	Request refused because service has not been authorized for this user (permanent) (Meaning of permanent is manufacturer specific)
		0010 0011 <sub>2</sub>	Temp_User_Refused	Request refused because service is not currently authorized for this user (temporary) (Meaning of temporary is manufacturer specific)
		0010 0100 <sub>2</sub>	Transient_Sys_Refused	Request refused because the service is not available to this network at this time
		0010 0101 <sub>2</sub>	NoregMSaway_Refused	Request refused because called party is not in radio contact
		<b>Message/Service sent by MS or BS rejected by MS</b>		
		0011 1100 <sub>2</sub>	MSNot_Supported	MS does not support this service or feature
		0011 0001 <sub>2</sub> to 0011 0011 <sub>2</sub>	Custom_Refused	Request refused due to custom-defined reason

Table 5.85: Answer Response B\_ACK [B]

Alias	Length	Value	Mnemonic	Meaning
REASON	8	<b>Acknowledgement Transmitted by a Beacon Message Accepted by the MS</b>		
		0111 0000 <sub>2</sub>	Message_Accepted	Message accepted by Beacon - Proceed
		0111 0001 <sub>2</sub>	Store_Forward	Call is placed in store and forward buffer for onward transmission when the called MS registers.
		0111 0010 <sub>2</sub>	Reg_Accepted	Request from MS to register has been accepted
		0111 0011 <sub>2</sub>	Call-Back	Called Party will call back
		<b>Acknowledgement Transmitted by an MS Message Accepted by the BS</b>		
		0111 0100 <sub>2</sub>	MS_Accepted	Message accepted by MS
		0111 0101 <sub>2</sub>	CallBack	Called MS is indicating to the Beacon that it will call back later

Table 5.86: Answer Response B\_NACK

Alias	Length	Value	Mnemonic	Meaning
REASON	8	<b>Message/Service rejected by network (BS)</b>		
		0101 0001 <sub>2</sub>	Not_Supported	Network does not support this service
		0101 0010 <sub>2</sub>	Perm_User_Refused	Request refused because service has not been authorized for this user (permanent) (Meaning of permanent is manufacturer specific)
		0101 0011 <sub>2</sub>	Temp_User_Refused	Request refused because service is not currently authorized for this user (temporary) (Meaning of temporary is manufacturer specific)
		0101 0100 <sub>2</sub>	Transient_Sys_Refused	Request refused because the service is not available to this network at this time
		0101 0101 <sub>2</sub>	NoregMSaway_Refused	Request refused because called party is not in radio contact (and is not registered with the network)
		0101 0110 <sub>2</sub>	MSaway_Refused	Request refused because called party is not in radio contact (but is registered with the network)
		0101 0111 <sub>2</sub>	Div_Cause_Fail	Call cannot be processed because the MS has diverted its calls
		0101 1000 <sub>2</sub>	SYSbusy_Refused	Request refused because the network is experiencing congestion (Network Overload)
		0101 1001 <sub>2</sub>	SYS_NotReady	Request refused because the network is not ready (try later)
		0101 1010 <sub>2</sub>	Call_Cancel_Refused	Request to cancel a call has been refused i.e. the call may still mature
		0101 1011 <sub>2</sub>	Reg_Refused	Request from an MS to register has been refused
		0101 1100 <sub>2</sub>	Reg_Denied	Request from an MS to register has been denied
		0101 1101 <sub>2</sub>	IP_Connection_failed	Request from an MS to inform IP connection advice failed
		0101 1110 <sub>2</sub>	MS Busy but call not queued	Called party is busy and the BS has not queued the call
		<b>Message/Service rejected by MS</b>		
		0110 1100 <sub>2</sub>	MSNot_Supported	MS does not support this service or feature
		0110 1101 <sub>2</sub>	LineNot_Supported	Request refused because service is not supported by the called party (Line)
		0110 1110 <sub>2</sub>	StackFull_Refused	Request refused because the called party's internal call stack is full and is not employing a FIFO
		0110 1111 <sub>2</sub>	EuiBusy_Refused	Request refused because called party ancillary equipment is busy
		0110 0000 <sub>2</sub>	Recipient_Refused	Request refused by called party user
0110 0001 <sub>2</sub>	Custom_Refused	Request refused due to custom-defined reason		

**Table 5.87: Answer Response B\_QACK [B]**

Alias	Length	Value	Mnemonic	Meaning
				Acknowledgement Transmitted by a Beacon
REASON	8	1000 0000 <sub>2</sub>	Queued-for-channel	Message accepted and queued by the beacon: more signalling to follow
		1000 0001 <sub>2</sub>	Queued-for-busy	Message accepted and queued by the beacon because the called party is busy: more signalling to follow

**Table 5.88: Answer Response B\_WACK [B]**

Alias	Length	Value	Mnemonic	Meaning
				Acknowledgement Transmitted by a Beacon
REASON	8	1100 0000 <sub>2</sub>	Wait	Message accepted by Beacon - more signalling to follow

### 5.5.26 Reg [B]

The Reg field is illustrated in table 5.89.

**Table 5.89: Reg**

Alias	Length	Value	Meaning
Reg	1	0 <sub>2</sub>	MSs are not required to register
		1 <sub>2</sub>	MSs are required to register

### 5.5.27 Reserved [BT]

Entities shall set any reserved field to zero's.

**Table 5.90: Reserved**

Alias	Length	Value	Meaning
RSVD	length	0 <sub>2</sub>	Fields that are reserved

### 5.5.28 Service Function [B]

The Service\_Function field is illustrated in table 5.91.

**Table 5.91: Service Function**

Alias	Length	Value	Meaning
SF	2	00 <sub>2</sub>	Random Access invited for all Services
		01 <sub>2</sub>	Random Access Invited for Services that require a payload channel Random Access Invited for registration requests
		10 <sub>2</sub>	Random Access Invited for Services that do not require a payload channel Random Access Invited for registration requests
		11 <sub>2</sub>	Random Access invited for random access registration requests only

## 5.5.29 SLD format [T]

### 5.5.29.1 SLD in the voice superframe

This is the normal use of the slow data field and 2 bytes of user data can be included within each frame of the voice superframe.

In this case the communication Mode is set to  $001_2$  (see clause 5.5.7).

Each byte of user data is preceded by a continuation flag (CONT) to inform the receiving party if the subsequent byte is the last.

**Table 5.92: SLD in voice superframe**

Alias	Alias	Length	Value	Meaning
SLD	CONT	1	$0_2$	User data continues after the following byte
			$1_2$	User data is terminated by the following byte
	user data	8		User Data
	CONT	1	$0_2$	User data continues after the following byte
			$1_2$	User data is terminated by the following byte
	user data	8		User Data

### 5.5.29.2 SLD Data field use with Type 1 or 2 data

When Type 1 or 2 data is transmitted, the SLD field is used to convey information of data format, position and continuation, etc. The SLD field is also used when a voice transmission has data attached to the end of the transmission.

**Table 5.93: SLD with type 1 or 2 data**

Alias	Alias	Length	Value	Meaning
SLD	RSVD	5	$00000_2$	Reserved
	DP (data position)	2	$00_2$	There is no data in this frame
			$01_2$	Reserved
			$10_2$	Reserved
			$11_2$	There is data in this frame
	Format	4	$0000_2$	Status message
			$0001_2$	Precoded message
			$0010_2$	Free text message (radio generated data)
			$0011_2$	Short file transfer
			$0100_2$	User defined data 1
			$0101_2$	User defined data 2
			$0110_2$	User defined data 3
			$0111_2$	User defined data 4
			$1000_2$ to $1111_2$	Reserved
	CONT	1	$0_2$	Data continues after this frame
			$1_2$	Data finishes at this frame
Data length	6	value		

## 5.5.30 Status

### 5.5.30.1 Status for Mode 1 and Mode 2 systems [T]

Table 5.94 illustrated describes the STAT field. This field is part of an END frame.

**Table 5.94: Status for Mode 1 and Mode 2 Systems**

Alias	Length	Value	Meaning
STAT	5	0 to 31	Status message

### 5.5.30.2 Status for Mode 3 systems[B]

Table 5.95 illustrated describes the STATUSM3 field.

**Table 5.95: Status for Mode 3 Systems**

Alias	Length	Value	Meaning
STATUSM3	8	0 to 199	Status message
		200 to 255	Reserved

## 5.5.31 SYMB [BT]

The SYMB field contains the number of symbols that are transported in a short data message call.

**Table 5.96: SYMB**

Alias	Length	Value	Meaning
SYMB	6	00 0001 <sub>2</sub> to 11 1111 <sub>2</sub>	Number of data symbols to transport for a Short data Message service is 1 to 31
		00 0000 <sub>2</sub>	Number of data symbols to transport for a Short data Message service is 64

## 5.5.32 SYScast [B]

The SYSCAST is identified as SYScast1, SYScast2 and SYScast3 depending when the field is transmitted during the SYScast frame. SYScast message are transmitted by a Beacon. The SYScast1 message is used to transmit registration requirements and the SYScast2 and SYScast3 fields may carry a variety of broadcast information permitted in the present document.

### 5.5.32.1 SYScast1 [B]

**Table 5.97: SYScast1 - System Identity Code**

Alias	Alias	Length	Value	Meaning
SYC1	Reg	1	0 <sub>2</sub>	The system does not require MS to register before access
			1 <sub>2</sub>	The system requires MS to register before access
	RSVD	2	00 <sub>2</sub>	Reserved
	SYScode	14		System Identity Code

## 5.5.32.2 SYScast2 or SYScast3 [B]

Table 5.98: SYScast2 or SYScast3 System Broadcasts

Alias	Alias	Length	Value	Meaning
SYC2 SYC3	SYTYPE	3	000 <sub>2</sub>	Call timer for MS to MS calls - Voice
			001 <sub>2</sub>	Call timer for MS to line connected calls - Voice
			010 <sub>2</sub>	Real Time
			011 <sub>2</sub>	Calling Party Address (MSB)
			100 <sub>2</sub>	Calling Party Address (LSB)
			101 <sub>2</sub>	
			110 <sub>2</sub>	
			111 <sub>2</sub>	Common Frame Counter
	SYDATA	14		Meaning depends on SYTYPE

## 5.5.32.2.1 SYScast2 or SYScast3 Call Timer MS to MS [B]

Table 5.99: SYScast2 or SYScast3 Call timer 1

Alias	Alias	Alias	Length	Value	Meaning
SYC2 SYC3	SYTYPE		3	000 <sub>2</sub>	Call_Timer for MS to MS connected voice calls
		RSVD	2	00 <sub>2</sub>	Reserved
	SYDATA	T_MS-MS_TMR	6	0	MS uses its Internal Timer for MS-MS calls
				1 to 62	Call_Timer for MS-MS calls (see note)
				63	MS-MS Call_Timer is Infinity
		T_EMERG_T	6	0	MS uses its Internal Emergency Timer
				1 to 62	Call_Timer for Emergency Calls (see note)
				63	Emergency Call_Timer is Infinity

NOTE: The values are tokens that are translated to real time by the table 5.49 described in clause 5.5.5.

## 5.5.32.2.2 Call Timer for line connected calls and packet data [B]

Table 5.100: SYScast2 or SYScast3 call timer 2

Alias	Alias	Alias	Length	Value	Meaning
SYC2 SYC3	SYTYPE		3	001 <sub>2</sub>	Call_Timer for Packet, and Line connected voice calls
		RSVD	2	00 <sub>2</sub>	Reserved
	SYDATA	T_DATA_TMR	6	0	MS uses its Internal Packet Timer
				1 to 62	Call_Timer for Packet Data (see note)
				63	Packet Call_Timer is Infinity
		T_MS-LINE_TMR	6	0	MS uses its Internal Timer for line connected calls
				1 to 62	Call_Timer for Line Connected calls (see note)
				63	Line Connected Call_Timer is Infinity

NOTE: The values are tokens that are translated to real time by the table 5.49 described in clause 5.5.5.

## 5.5.32.2.3 SYScast2 or SYScast3 Real Time [B]

Table 5.101 illustrates how a beacon may synchronize MS clocks. There are not enough bits in this message to transmit the full UTC time and date. The message is split by the RTFMT field. If RTFMT = 0<sub>2</sub> then day of week and UTC hours is broadcast. Designers may which to transmit this message only occasionally. If RTFMT = 1<sub>2</sub> the UTC minutes and seconds are broadcast.

**Table 5.101: SYScast2 or SYScast3 real time**

Alias	Alias	Alias	Length	Value	Meaning
SYC2 SYC3	SYTYPE		3	010 <sub>2</sub>	Real Time
		RTFMT	1	0 <sub>2</sub>	
	SYDATA		5	0 0000 <sub>2</sub>	Reserved
		DAYSOFF_WEEK	3	0 to 7	Day of Week (see table 5.57)
			5	0 to 23	UTC hours (or 24 if not broadcast)

Alias	Alias	Alias	Length	Value	Meaning
SYC2 SYC3	SYTYPE		3	010 <sub>2</sub>	Real Time
		RTFMT	1	1 <sub>2</sub>	
	SYDATA		1	0 <sub>2</sub>	Reserved
			6	0 to 59	UTC minutes (or 60 if not broadcast)
			6	0 to 59	UTC seconds (or 60 if not broadcast)

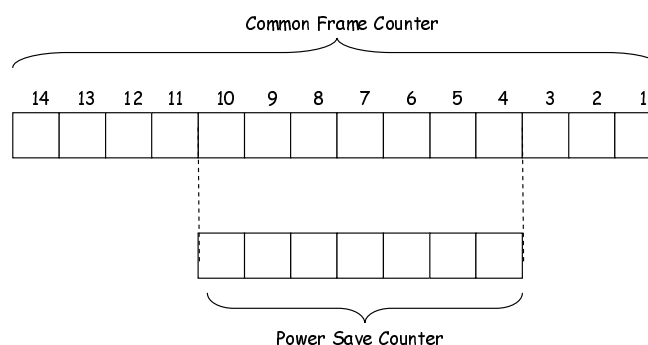
#### 5.5.32.2.4 SYScast2 or SYScast3 Common Frame Counter [B]

The Common Frame counter illustrated in table 5.102 is a binary counter that increments by one every time a Beacon Frameset is transmitted. If for some reason the BS suspends the transmission of beacon frames, the BS shall attempt to maintain the common slot counter value as if frames had been transmitted.

**Table 5.102: Common Frame Counter**

Alias	Alias	Alias	Length	Value	Meaning
SYC2	SYTYPE		3	111 <sub>2</sub>	Common Frame Counter Type
SYC3	SYDATA	CFC	14		Common Frame Counter

A sub-set of the common frame counter is used for power save as illustrated in figure 5.8. The power save counter increments by one every eight framesets.

**Figure 5.8: Power Save Counter**

#### 5.5.32.2.5 SYScast2, SYScast3 Calling Party Address [B]

This SYScast shall be transmitted immediately following a Goto Channel message to carry the calling party address. SYScast2 shall carry the most significant 10 bits and the SYScast3 shall carry the least significant 14 bits of the calling party address.

**Table 5.103: SYScast2 Calling Party Address**

Alias	Alias	Alias	Length	Value	Meaning
SYC2	SYTYPE		3	011 <sub>2</sub>	SYScast2 carries the Calling Party Address (part)
	SYDATA	RSVD	4	0000 <sub>2</sub>	
		MS ID(msb)	10		Most significant 10 bits of Calling Party Address or Gateway

**Table 5.104: SYScast3 Calling Party Address**

Alias	Alias	Alias	Length	Value	Meaning
SYC3	SYTYPE		3	100 <sub>2</sub>	SYScast3 carries the Calling Party Address (part)
	SYDATA	MS ID(lsb)	14		Least significant 14 bits of Calling Party Address or Gateway

### 5.5.33 System Identity Code [B]

The System Identity Code field is illustrated in table 5.105.

**Table 5.105: System Identity Code**

Alias	Length	Value	Meaning
B_SYScore	14		System identity Code transmitted by a Beacon

### 5.5.34 Tx\_Wait [T]

Table 5.106 illustrated above describes the Tx\_Wait field. This field is part of an END frame.

The Tx\_Wait time is implemented by the called station(s) such that other MS who have a break-in request for an emergency call pre-keyed by the user may transmit during the specified time.

**Table 5.106: Tx\_Wait time**

Alias	Length	Value	Meaning
Tx_Wait	4	0000 <sub>2</sub>	No specified time
		0001 <sub>2</sub>	40 ms (half a frame) see note
		0010 <sub>2</sub>	80 ms (one frame)
		0011 <sub>2</sub>	160 ms (two frames)
		0100 <sub>2</sub>	320 ms (one superframe)
		0101 <sub>2</sub> to 1111 <sub>2</sub>	Reserved
NOTE: The value 0001 <sub>2</sub> is only applicable for mode 1 MS.			

### 5.5.35 UAD [BT]

The UAD is a field in bursts that have Appended\_Data concatenated to a message frame. The field indicates the number of Appended\_Data messages in the burst.

**Table 5.107: UAD field**

Alias	Length	Value	Meaning
UAD	2	00 <sub>2</sub>	One Appended_Data message
		01 <sub>2</sub>	Two Appended_Data messages
		10 <sub>2</sub>	Three Appended_Data messages
		11 <sub>2</sub>	Four Appended_Data messages



### 5.5.36 UDT\_Format [BT]

Specifies the format of the user or complementary data carried in UDT Header frames for the UDT mechanism.

**Table 5.108: UDT\_Format field**

Alias	Length	Value	Meaning
UDT_FORMAT	3	000 <sub>2</sub>	MS ID
		001 <sub>2</sub>	Binary
		010 <sub>2</sub>	4 bit BCD
		011 <sub>2</sub>	ISO 7 bit character set (ISO/IEC 646 ([2]))
		100 <sub>2</sub>	ISO 8 bit character set (ISO/IEC 8859 [3])
		101 <sub>2</sub>	NMEA location coded (EN 61162-1 [1])
		110 <sub>2</sub>	IPV4
		111 <sub>2</sub>	IPV6

NOTE: If the Appended\_Data message is carrying PABX or PTSN dialled digits, there is no necessity for a specific field that indicates the number of dialled digits. The sender marks the end of the dialled string by a DIAL\_NULL symbol (11112).

### 5.5.37 Version [BT]

The version [V] field illustrated in table 5.104 is transmitted in certain frames to indicate if a message is standard content compliant with the present document.

**Table 5.109: Version**

Alias	Length	Value	Meaning
V	2	00 <sub>2</sub>	Standard TS102 658 content
		01 <sub>2</sub>	TBD
		10 <sub>2</sub>	TBD
		11 <sub>2</sub>	Manufacturer Specific

### 5.5.38 Vote Now Advice Parameters [B]

**Table 5.110: Vote Now Advice Parameters**

Alias	Length	Value	Meaning
VSYS	14		System Identity Code of the beacon being assessed
VFRMS	5		Number of framesets BS will allocate for vote now

### 5.5.39 Withdrawn W [B]

On a Mode 3 BS downlink channel, specifies if the message frame following this message is withdrawn for random access. If the message is appended Data, the W field is only relevant in the second and fourth Appended\_Data message. The first and third Appended\_Data message shall set W = RSVD.

**Table 5.111: Withdrawn frame**

Alias	Length	Value	Meaning
W	1	0 <sub>2</sub>	The following beacon message frame is available for random access
		1 <sub>2</sub>	The following beacon message frame is withdrawn and not available for random access

On a BS Uplink, if a message contains a W field, the value shall be set to  $0_2$ .

## 5.6 Appended\_Data Messages [BT]

Appended\_Data messages are message frames that carry either user data or intrinsic data that is supporting a call set-up. If the Appended\_Data is transmitted by a Mode 3 BS concatenated to a UDT header, The W field is only valid in the second and fourth Appended\_Data message. In this case the W field in the first and third Appended\_Data codeword shall be set to  $0_2$ .

### 5.6.1 Appended\_Data MS ID Format

The UDT\_FMT field (FMT in the figures) specifies the information format. Appended\_Data is 24 bit address coded. One Appended\_Data frame may be concatenated to a UDT Appended\_Data header. Up to two MS IDs may be transported. If only one address is carried in the message, that address shall be carried in ADDRESS1 and ADDRESS2 shall be set to all  $0_2$ s. For MSID format the SYMB field in the UDT header is set to  $00\ 0000_2$ .

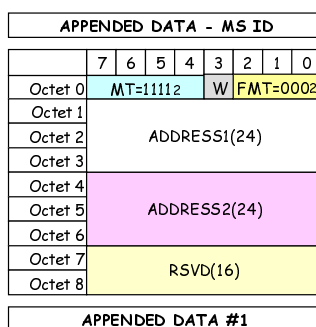


Figure 5.8: Appended\_Data (MS ID)

### 5.6.2 Appended\_Data Binary Format

The UDT\_FMT field (FMT in figure 5.9) specifies the information format). Appended\_Data is binary coded. Up to four Appended\_Data message frames may be concatenated to a UDT header frame. Up to 256 bits may be transported. For binary format transport the SYMB field in the UDT header is set to  $00\ 0000_2$ . If variable length binary data is being transported, the last bit of the user data may identified as follows:

- A  $0_2$  is appended to the user data and the remaining bits to fill an Appended\_Data frame are set to  $1_2$ . The call set-up header and appended frames are then transmitted.
- The receiver may identify the end of user data by counting backwards until the first  $0_2$  is reached. That point is one bit past the user data.

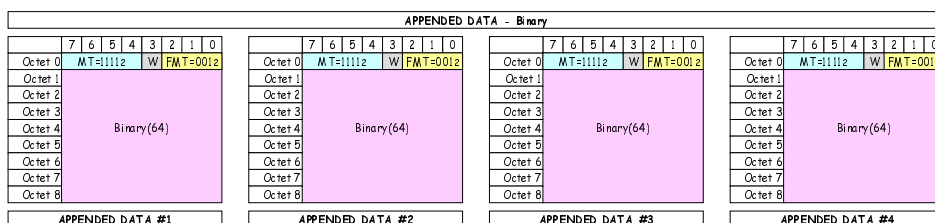


Figure 5.9: Appended\_Data (Binary)

### 5.6.3 Appended\_Data BCD Format

The UDT\_FMT field (FMT in figure 5.10) specifies the information format). Appended\_Data is BCD coded. Up to four Appended\_Data message frames may be concatenated to a UDT header frame. Up to 64 BCD digits may be transported. For a short data message the SYMB field in the UDT header message specifies the number of 4 bit nibbles carried (except for 64 nibbles where SYMB = 00 0000<sub>2</sub>). For PABX and PSTN calls set-up, this message type carries the dialled string. In this case the sender marks the end of the dialled string and irrelevant digits by DIAL\_NULL symbols (1111<sub>2</sub>).

APPENDED DATA - BCD																																											
	7	6	5	4	3	2	1	0			7	6	5	4	3	2	1	0			7	6	5	4	3	2	1	0			7	6	5	4	3	2	1	0					
Octet 0	MT=1111 <sub>2</sub>				W	FMT=010 <sub>2</sub>					Octet 0	MT=1111 <sub>2</sub>				W	FMT=010 <sub>2</sub>					Octet 0	MT=1111 <sub>2</sub>				W	FMT=010 <sub>2</sub>					Octet 0	MT=1111 <sub>2</sub>				W	FMT=010 <sub>2</sub>				
Octet 1	Digit(4)				Digit(4)					Octet 1	Digit(4)				Digit(4)					Octet 1	Digit(4)				Digit(4)					Octet 1	Digit(4)				Digit(4)								
Octet 2	Digit(4)				Digit(4)					Octet 2	Digit(4)				Digit(4)					Octet 2	Digit(4)				Digit(4)					Octet 2	Digit(4)				Digit(4)								
Octet 3	Digit(4)				Digit(4)					Octet 3	Digit(4)				Digit(4)					Octet 3	Digit(4)				Digit(4)					Octet 3	Digit(4)				Digit(4)								
Octet 4	Digit(4)				Digit(4)					Octet 4	Digit(4)				Digit(4)					Octet 4	Digit(4)				Digit(4)					Octet 4	Digit(4)				Digit(4)								
Octet 5	Digit(4)				Digit(4)					Octet 5	Digit(4)				Digit(4)					Octet 5	Digit(4)				Digit(4)					Octet 5	Digit(4)				Digit(4)								
Octet 6	Digit(4)				Digit(4)					Octet 6	Digit(4)				Digit(4)					Octet 6	Digit(4)				Digit(4)					Octet 6	Digit(4)				Digit(4)								
Octet 7	Digit(4)				Digit(4)					Octet 7	Digit(4)				Digit(4)					Octet 7	Digit(4)				Digit(4)					Octet 7	Digit(4)				Digit(4)								
Octet 8	Digit(4)				Digit(4)					Octet 8	Digit(4)				Digit(4)					Octet 8	Digit(4)				Digit(4)					Octet 8	Digit(4)				Digit(4)								
APPENDED DATA #1										APPENDED DATA #2										APPENDED DATA #3										APPENDED DATA #4													

Figure 5.10: UDT Appended\_Data (BCD)

### 5.6.4 Appended\_Data (ISO 7 bit character set Format)

The UDT\_FMT field (FMT in figure 5.11) specifies the information format). Appended\_Data is coded ISO 7 bit character set (ISO/IEC 646 [2]). Up to four Appended\_Data frames may be concatenated to a UDT Appended\_Data header. Up to 36 ISO 7 bit characters may be transported. The SYMB field in the UDT header message specifies the number of 7 bit text symbols that are transported.

APPENDED DATA ISO 7 bit Char																																											
	7	6	5	4	3	2	1	0			7	6	5	4	3	2	1	0			7	6	5	4	3	2	1	0			7	6	5	4	3	2	1	0					
Octet 0	MT=1111 <sub>2</sub>				W	FMT=011 <sub>2</sub>					Octet 0	MT=1111 <sub>2</sub>				W	FMT=011 <sub>2</sub>					Octet 0	MT=1111 <sub>2</sub>				W	FMT=011 <sub>2</sub>					Octet 0	MT=1111 <sub>2</sub>				W	FMT=011 <sub>2</sub>				
Octet 1	Digit(7)									Octet 1	Digit(7)									Octet 1	Digit(7)									Octet 1	Digit(7)												
Octet 2	Digit(7)									Octet 2	Digit(7)									Octet 2	Digit(7)									Octet 2	Digit(7)												
Octet 3	Digit(7)									Octet 3	Digit(7)									Octet 3	Digit(7)									Octet 3	Digit(7)												
Octet 4	Digit(7)				Digit(7)					Octet 4	Digit(7)				Digit(7)					Octet 4	Digit(7)				Digit(7)					Octet 4	Digit(7)				Digit(7)								
Octet 5	Digit(7)---									Octet 5	Digit(7)---									Octet 5	Digit(7)---									Octet 5	Digit(7)---												
Octet 6	Digit(7)									Octet 6	Digit(7)									Octet 6	Digit(7)									Octet 6	Digit(7)												
Octet 7	Digit(7)									Octet 7	Digit(7)									Octet 7	Digit(7)									Octet 7	Digit(7)												
Octet 8	Digit(7)							1		Octet 8	Digit(7)							1		Octet 8	Digit(7)							1		Octet 8	Digit(7)							1					
APPENDED DATA #1										APPENDED DATA #2										APPENDED DATA #3										APPENDED DATA #4													

Figure 5.11: UDT Appended\_Data (ISO 7 bit)

### 5.6.5 Appended\_Data (ISO 8 bit character set format)

The UDT\_FMT field (FMT in figure 5.12) specifies the information format). Appended\_Data is coded ISO 8 bit character format (ISO/IEC 8859 [3]). Up to four Appended\_Data frames may be concatenated to a UDT Appended\_Data header. Up to 32 ISO 8 bit characters may be transported. The SYMB in the UDT header specifies the number of 8 bit symbols that are transported.

APPENDED DATA - ISO 8 bit Char																																											
	7	6	5	4	3	2	1	0			7	6	5	4	3	2	1	0			7	6	5	4	3	2	1	0			7	6	5	4	3	2	1	0					
Octet 0	MT=1111 <sub>2</sub>				W	FMT=100 <sub>2</sub>					Octet 0	MT=1111 <sub>2</sub>				W	FMT=100 <sub>2</sub>					Octet 0	MT=1111 <sub>2</sub>				W	FMT=100 <sub>2</sub>					Octet 0	MT=1111 <sub>2</sub>				W	FMT=100 <sub>2</sub>				
Octet 1	Digit(8)									Octet 1	Digit(8)									Octet 1	Digit(8)									Octet 1	Digit(8)												
Octet 2	Digit(8)									Octet 2	Digit(8)									Octet 2	Digit(8)									Octet 2	Digit(8)												
Octet 3	Digit(8)									Octet 3	Digit(8)									Octet 3	Digit(8)									Octet 3	Digit(8)												
Octet 4	Digit(8)									Octet 4	Digit(8)									Octet 4	Digit(8)									Octet 4	Digit(8)												
Octet 5	Digit(8)									Octet 5	Digit(8)									Octet 5	Digit(8)									Octet 5	Digit(8)												
Octet 6	Digit(8)									Octet 6	Digit(8)									Octet 6	Digit(8)									Octet 6	Digit(8)												
Octet 7	Digit(8)									Octet 7	Digit(8)									Octet 7	Digit(8)									Octet 7	Digit(8)												
Octet 8	Digit(8)									Octet 8	Digit(8)									Octet 8	Digit(8)									Octet 8	Digit(8)												
APPENDED DATA #1										APPENDED DATA #2										APPENDED DATA #3										APPENDED DATA #4													

Figure 5.12: UDT Appended\_Data (ISO 8 bit)

## 5.6.6 Appended\_Data NMEA (EN 61162-1 [1]) format

The UDT\_FMT field (FMT in figure 5.13) specifies the information format). Appended\_Data is with essential data elements for NMEA formatted (EN 61162-1 [1]) coordinates. Up to two Appended\_Data frames may be concatenated to a UDT Appended\_Data header. For NMEA format the SYMB field in the UDT header is set to 00 0000<sub>2</sub>.

Table 5.112 describes the fields.

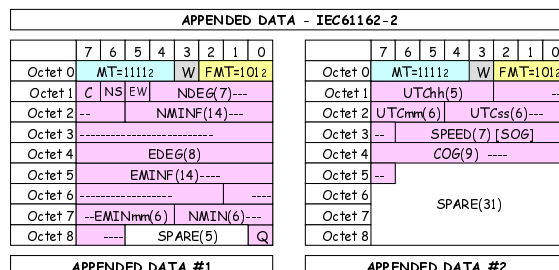


Figure 5.13: UDT Appended\_Data EN61162-1 Format

Table 5.112: NMEA fields

Alias	Length	Value	Description
C	1	0 <sub>2</sub>	Data is not encrypted
		1 <sub>2</sub>	Data is encrypted
NS	1	0 <sub>2</sub>	Latitude Direction - South
		1 <sub>2</sub>	Latitude Direction - North
EW	1	0 <sub>2</sub>	Longitude Direction - West
		1 <sub>2</sub>	Longitude Direction - East
NDEG	7		Latitude Degrees (00 to 89)
NMINF	14		Latitude Fractions of minutes (0000 to 9 999)
EDEG	8		Longitude Degrees (000 to 179)
EMINF	14		Longitude Fractions of minutes (0000 to 9 999)
EMINmm	6		Longitude Minutes (00 to 59)
NMINmm	6		Latitude Minutes (00 to 59)
Spare	5		
Q	1	0 <sub>2</sub>	GPS Quality Indicator - No fix
		1 <sub>2</sub>	GPS Quality Indicator - Fix Valid
UTC <sub>hh</sub>	5		UTC time hours (00 to 23)
UTC <sub>mm</sub>	6		UTC time minutes (00 to 59)
UTC <sub>ss</sub>	6		UTC time seconds (00 to 59)
SPEED [SOG]	7		Speed in knots (0 to 127)
COURSE [COG]	9		Course over ground (0 to 360 °)
Spare	40		

## 5.6.7 Appended\_Data IPV4 format

Figure 5.14 illustrates the IPV4 format. For IPV4 format the SYMB field in the UDT header is set to 00 0000<sub>2</sub>.

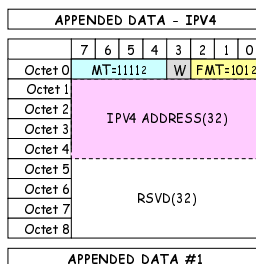


Figure 5.14: UDT Appended\_Data IPV4 Format

### 5.6.8 Appended\_Data IPV6 format

Figure 5.15 illustrates the IPV6 format. For IPV6 format the SYMB field in the UDT header is set to 00 0000<sub>2</sub>.

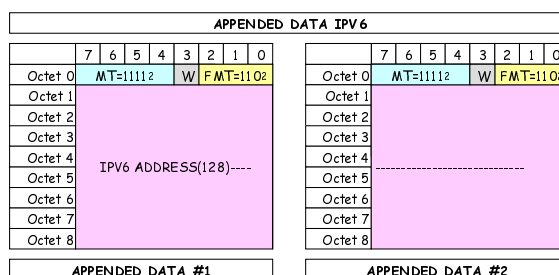


Figure 5.15: UDT Appended\_Data IPV6 Format

### 5.6.9 Appended\_Data Filler

Figure 5.16 illustrates the filler. For Mode 3 systems, if a UDT downlink Header contains an odd number of Appended\_Data messages, a "filler" data codeword shall be appended to the burst. The UDT\_FORMAT field is set to the UDT\_FORMAT in the Appended\_Data message that immediately preceded the filler.

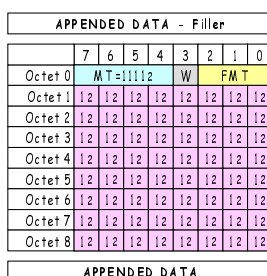


Figure 5.16: Appended\_Data Filler

---

## 6 Synchronisation

### 6.1 Frame synchronization

#### 6.1.1 FS1

The Frame Sync 1 sequence transmitted by MS and contained in the non packet data header frame (Header 1) is a 48 bit sequence that shall have the following value:

Binary: 0101 0111 1111 1111 0101 1111 0111 0101 1101 0101 0111 0111<sub>2</sub>.

Hex: 57 FF 5F 75 D5 77<sub>16</sub>.

#### 6.1.2 FS2

The Frame Sync 2 sequence transmitted by MS and contained in the superframe (frames 1 and 3) is a 24 bit sequence that shall have the following value:

Binary: 0101 1111 1111 0111 0111 1101<sub>2</sub>.

Hex: 5F F7 7D<sub>16</sub>.

#### 6.1.3 FS3

The Frame Sync 3 sequence transmitted by MS and contained in the End frame is a 24 bit sequence that shall have the following value:

Binary: 0111 1101 1101 1111 1111 0101<sub>2</sub>.

Hex: 7D DF F5<sub>16</sub>.

#### 6.1.4 FS4

The Frame Sync 4 sequence transmitted by MS and contained in the Packet Data header frame (Header 2) is a 48 bit sequence that shall have the following value:

Binary: 1111 1101 0101 0101 1111 0101 1101 1111 0111 1111 1101 1101<sub>2</sub>.

Hex: FD 55 F5 DF 7F DD<sub>16</sub>.

NOTE: FS4 is a symbol-wise complement of FS1. The frame sync correlator will find a positive result for FS1 and an equal but negative result for FS4 when running a single correlator.

#### 6.1.5 Colour Code

The Colour Code contained in the superframe (frames 2 and 4) and the message frames is a 24 bit code sequence.

Colour Codes may be individually assigned for each radio channel separately for spectrum management purposes or to differentiate different systems sharing a physical radio channel(s).

Alternatively, where no specific Colour Code has been programmed for a channel, for Mode 1 and Mode 2 systems the algorithm specified in clause 6.1.5.1 shall apply, or for Mode 3 systems the algorithm specified in clause 6.1.5.2 shall apply.

### 6.1.5.1 Colour Code for Mode 1 and Mode 2 Systems

MS and BS shall determine the Colour Code applicable from the channel centre transmit frequency. In this case, as dPMR may be operated both in existing 12,5 kHz channel rasters and in 6,25 kHz channel rasters, the Colour Code shall be calculated as follows:

For 12,5 kHz channel rasters:

$$\text{CC number} = 64 \times (f \text{ modulo } 0,4) \text{ where } f \text{ is the channel freq in MHz.}$$

For 6,25 kHz channel rasters:

$$\text{CC number} = [64 \times (f \text{ modulo } 0,4)] - 0,5 \text{ where } f \text{ is the channel freq in MHz.}$$

Both algorithms result in integer values of CC from 0 to 63.

(f modulo 0,4) is calculated as follows:

- a) the frequency 'f' in MHz is divided by 0,4;
- b) the part to the right of the decimal point of the result from a) is retained.

### 6.1.5.2 Colour Code for Mode 3 Systems

Mode 3 systems shall support the two methods for determining the Colour Code. All MS and BS in a particular system shall employ the same method.

#### 6.1.5.2.1 Colour Code Determined by Frequency

MS and BS shall determine the Colour Code applicable from the channel centre transmit frequency using the algorithm specified for Mode 1 and Mode 2 (see clause 6.1.5.1).

#### 6.1.5.2.2 Colour Code Determined by Frequency and System Identity Code

MS and BS shall determine the Colour Code applicable from the channel centre transmit frequency and the System Identity Code (see clause 5.5.33) for that radio site. In this case, as dPMR may be operated both in existing 12,5 kHz channel rasters and in 6,25 kHz channel rasters, the Colour Code shall be calculated as follows:

SYS\_CC = The least significant six bits of the System Identity Code

For 12,5 kHz channel rasters:

$$\text{CC number} = (64 \times (f \text{ modulo } 0,4)) \text{ exclusive\_or } \text{SYS\_CC} \text{ where } f \text{ is the channel freq in MHz.}$$

For 6,25 kHz channel rasters:

$$\text{CC number} = [(64 \times (f \text{ modulo } 0,4)) \text{ exclusive\_or } \text{SYS\_CC}] - 0,5 \text{ where } f \text{ is the channel freq in MHz.}$$

Both algorithms result in integer values of CC from 0 to 63.

**Table 6.1: Colour Code**

Code number	Colour Code (Bits)	Colour Code (Hex)
0	0101 0111 0101 1111 0111 0111 <sub>2</sub>	57 5F 77 <sub>16</sub>
1	0101 0111 0111 0101 0111 0111 <sub>2</sub>	57 75 77 <sub>16</sub>
2	0101 0111 1101 1101 0111 0101 <sub>2</sub>	57 DD 75 <sub>16</sub>
3	0101 0111 1111 0111 0111 0101 <sub>2</sub>	57 F7 75 <sub>16</sub>
4	0101 0101 0101 0111 0111 1101 <sub>2</sub>	55 57 7D <sub>16</sub>
5	0101 0101 0111 1101 0111 1101 <sub>2</sub>	55 7D 7D <sub>16</sub>
6	0101 0101 1101 0101 0111 1111 <sub>2</sub>	55 D5 7F <sub>16</sub>
7	0101 0101 1111 1111 0111 1111 <sub>2</sub>	55 FF 7F <sub>16</sub>
8	0101 1111 0101 0101 0101 1111 <sub>2</sub>	5F 55 5F <sub>16</sub>
9	0101 1111 0111 1111 0101 1111 <sub>2</sub>	5F 7F 5F <sub>16</sub>

Code number	Colour Code (Bits)	Colour Code (Hex)
10	0101 1111 1101 0111 0101 1101 <sub>2</sub>	5F D7 5D <sub>16</sub>
11	0101 1111 1111 1101 0101 1101 <sub>2</sub>	5F FD 5D <sub>16</sub>
12	0101 1101 0101 1101 0101 0101 <sub>2</sub>	5D 5D 55 <sub>16</sub>
13	0101 1101 0111 0111 0101 0101 <sub>2</sub>	5D 77 55 <sub>16</sub>
14	0101 1101 1101 1111 0101 0111 <sub>2</sub>	5D DF 57 <sub>16</sub>
15	0101 1101 1111 0101 0101 0111 <sub>2</sub>	5D F5 57 <sub>16</sub>
16	0111 0111 0101 1101 1101 0111 <sub>2</sub>	77 5D D7 <sub>16</sub>
17	0111 0111 0111 0111 1101 0111 <sub>2</sub>	77 77 D7 <sub>16</sub>
18	0111 0111 1101 1111 1101 0101 <sub>2</sub>	77 DF D5 <sub>16</sub>
19	0111 0111 1111 0101 1101 0101 <sub>2</sub>	77 F5 D5 <sub>16</sub>
20	0111 0101 0101 0101 1101 1101 <sub>2</sub>	75 55 DD <sub>16</sub>
21	0111 0101 0111 1111 1101 1101 <sub>2</sub>	75 7F DD <sub>16</sub>
22	0111 0101 1101 0111 1101 1111 <sub>2</sub>	75 D7 DF <sub>16</sub>
23	0111 0101 1111 1101 1101 1111 <sub>2</sub>	75 FD DF <sub>16</sub>
24	0111 1111 0101 0111 1111 1111 <sub>2</sub>	7F 57 FF <sub>16</sub>
25	0111 1111 0111 1101 1111 1111 <sub>2</sub>	7F 7D FF <sub>16</sub>
26	0111 1111 1101 0101 1111 1101 <sub>2</sub>	7F D5 FD <sub>16</sub>
27	0111 1111 1111 1111 1111 1101 <sub>2</sub>	7F FF FD <sub>16</sub>
28	0111 1101 0101 1111 1111 0101 <sub>2</sub>	7D 5F F5 <sub>16</sub>
29	0111 1101 0111 0101 1111 0101 <sub>2</sub>	7D 75 F5 <sub>16</sub>
30	0111 1101 1101 1101 1111 0111 <sub>2</sub>	7D DD F7 <sub>16</sub>
31	0111 1101 1111 0111 1111 0111 <sub>2</sub>	7D F7 F7 <sub>16</sub>
32	1101 0111 0101 0101 1111 0111 <sub>2</sub>	D7 55 F7 <sub>16</sub>
33	1101 0111 0111 1111 1111 0111 <sub>2</sub>	D7 7F F7 <sub>16</sub>
34	1101 0111 1101 0111 1111 0101 <sub>2</sub>	D7 D7 F5 <sub>16</sub>
35	1101 0111 1111 1101 1111 0101 <sub>2</sub>	D7 FD F5 <sub>16</sub>
36	1101 0101 0101 1101 1111 1101 <sub>2</sub>	D5 5D FD <sub>16</sub>
37	1101 0101 0111 0111 1111 1101 <sub>2</sub>	D5 77 FD <sub>16</sub>
38	1101 0101 1101 1111 1111 1111 <sub>2</sub>	D5 DF FF <sub>16</sub>
39	1101 0101 1111 0101 1111 1111 <sub>2</sub>	D5 F5 FF <sub>16</sub>
40	1101 1111 0101 1111 1101 1111 <sub>2</sub>	DF 5F DF <sub>16</sub>
41	1101 1111 0111 0101 1101 1111 <sub>2</sub>	DF 75 DF <sub>16</sub>
42	1101 1111 1101 1101 1101 1101 <sub>2</sub>	DF DD DD <sub>16</sub>
43	1101 1111 1111 0111 1101 1101 <sub>2</sub>	DF F7 DD <sub>16</sub>
44	1101 1101 0101 0111 1101 0101 <sub>2</sub>	DD 57 D5 <sub>16</sub>
45	1101 1101 0111 1101 1101 0101 <sub>2</sub>	DD 7D D5 <sub>16</sub>
46	1101 1101 1101 0101 1101 0111 <sub>2</sub>	DD D5 D7 <sub>16</sub>
47	1101 1101 1111 1111 1101 0111 <sub>2</sub>	DD FF D7 <sub>16</sub>
48	1111 0111 0101 0111 0101 0111 <sub>2</sub>	F7 57 57 <sub>16</sub>
49	1111 0111 0111 1101 0101 0111 <sub>2</sub>	F7 7D 57 <sub>16</sub>
50	1111 0111 1101 0101 0101 0101 <sub>2</sub>	F7 D5 55 <sub>16</sub>
51	1111 0111 1111 1111 0101 0101 <sub>2</sub>	F7 FF 55 <sub>16</sub>
52	1111 0101 0101 1111 0101 1101 <sub>2</sub>	F5 5F 5D <sub>16</sub>
53	1111 0101 0111 0101 0101 1101 <sub>2</sub>	F5 75 5D <sub>16</sub>
54	1111 0101 1101 1101 0101 1111 <sub>2</sub>	F5 D D5F <sub>16</sub>
55	1111 0101 1111 0111 0101 1111 <sub>2</sub>	F5 F7 5F <sub>16</sub>
56	1111 1111 0101 1101 0111 1111 <sub>2</sub>	FF 5D 7F <sub>16</sub>
57	1111 1111 0111 0111 0111 1111 <sub>2</sub>	FF 77 7F <sub>16</sub>
58	1111 1111 1101 1111 0111 1101 <sub>2</sub>	FF DF 7D <sub>16</sub>
59	1111 1111 1111 0101 0111 1101 <sub>2</sub>	FF F5 7D <sub>16</sub>
60	1111 1101 0101 0101 0111 0101 <sub>2</sub>	FD 55 75 <sub>16</sub>
61	1111 1101 0111 1111 0111 0101 <sub>2</sub>	FD 7F 75 <sub>16</sub>



Code number	Colour Code (Bits)	Colour Code (Hex)
62	1111 1101 1101 0111 0111 0111 <sub>2</sub>	FD D7 77 <sub>16</sub>
63	1111 1101 1111 1101 0111 0111 <sub>2</sub>	FD FD 77 <sub>16</sub>

## 6.1.6 Preamble

The preamble consists of a minimum of 72 bits and shall have the form 5F 5F 5F 5F 5F 5F 5F 5F 5F<sub>16</sub>. If a preamble pattern longer than 72 bits is used then the repeated 5F<sub>16</sub> pattern (0101 1111<sub>2</sub>) shall be maintained.

# 7 Interleaving and FEC coding

## 7.1 CRC addition

Table 7.1: CRC coding

Use	CRC	Polynomial
Frame (CCH)	CRC7	$X^7 + X^3 + 1$
Message (MI and Header (HI))	CRC8	$X^8 + X^2 + X^1 + 1$

## 7.2 Hamming code

A shortened Hamming code (12,8) is employed and the generator matrix is illustrated in table 7.2.

$X^7, X^6, X^5, X^4, X^3, X^2, X^1$  and 1 are Identity bits (8 bit): C3, C2, C1 and C0 are Parity bits (4 bit).

Table 7.2: Generator matrix

	12	11	10	9	8	7	6	5	4	3	2	1
	$X^7$	$X^6$	$X^5$	$X^4$	$X^3$	$X^2$	$X^1$	1	C3	C2	C1	C0
1	1	0	0	0	0	0	0	0	1	1	1	0
2	0	1	0	0	0	0	0	0	0	1	1	1
3	0	0	1	0	0	0	0	0	1	0	1	0
4	0	0	0	1	0	0	0	0	0	1	0	1
5	0	0	0	0	1	0	0	0	1	0	1	1
6	0	0	0	0	0	1	0	0	1	1	0	0
7	0	0	0	0	0	0	1	0	0	1	1	0
8	0	0	0	0	0	0	0	1	0	0	1	1

Shortened Hamming code (12,8) Polynomial:  $X^4 + X + 1$ .

## 7.3 Scrambling

The scrambling polynomial is  $X^9 + X^5 + 1$  with an initial preset value of all "1"s.

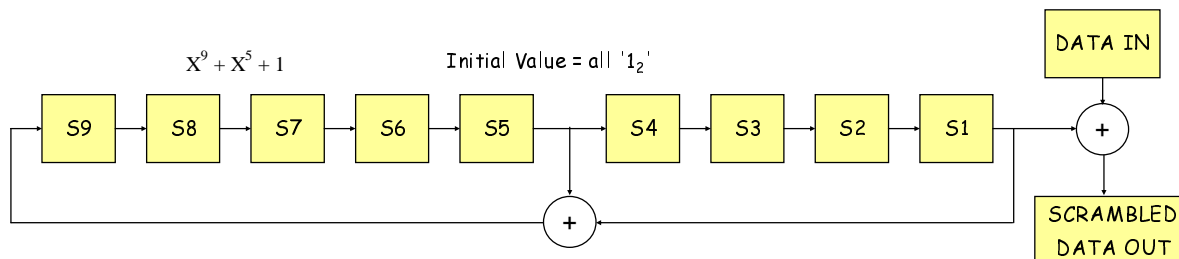


Figure 7.1: Scrambling format

## 7.4 Interleaving

There are two interleaving matrices, one for the TCH and one for the MI/HI field.

TCH interleave structure matrix:

Table 7.3: TCH Interleaving matrix

	1	2	3	4	5	6
1	1	13	25	37	49	61
2	2	14	26	38	50	62
3	3	15	27	39	51	63
4	4	16	28	40	52	64
5	5	17	29	41	53	65
6	6	18	30	42	54	66
7	7	19	31	43	55	67
8	8	20	32	44	56	68
9	9	21	33	45	57	69
10	10	22	34	46	58	70
11	11	23	35	47	59	71
12	12	24	36	48	60	72

The Interleave Structure Matrix Map.

Use of the interleaving matrix [12 x 6]:

- Transmit data is input to the matrix in vertical columns from top left to lower right. Data is output from the matrix in horizontal rows from top left to lower right.
  - If the input to the transmit interleaver is a vector of length 72, bit ordered as [1,2,3,4,5,6.....72] the output is a vector ordered as [1,13,25,37,49,61.....72].
- Receive data is input to the matrix in horizontal rows from top left to lower right. Data is output from the matrix in vertical columns from top left to lower right.
  - If the input to the receive de-interleaver is a vector of length 72, bit ordered as [1,2,3,4,5,6.....72] the output is a vector ordered as [1,7,13,19,25,31.....72].

**Table 7.4: MI and HI field Interleaving matrix**

	1	2	3	4	5	6	7	8	9	10
1	1	13	25	37	49	61	73	85	97	109
2	2	14	26	38	50	62	74	86	98	110
3	3	15	27	39	51	63	75	87	99	111
4	4	16	28	40	52	64	76	88	100	112
5	5	17	29	41	53	65	77	89	101	113
6	6	18	30	42	54	66	78	90	102	114
7	7	19	31	43	55	67	79	91	103	115
8	8	20	32	44	56	68	80	92	104	116
9	9	21	33	45	57	69	81	93	105	117
10	10	22	34	46	58	70	82	94	106	118
11	11	23	35	47	59	71	83	95	107	119
12	12	24	36	48	60	72	84	96	108	120
NOTE: Applied in the Header M10/M11 and H10/HI1.										

The Interleave Structure Matrix Map [12 x 10].

Use of the interleaving matrix:

- Transmit data is input to the matrix in vertical columns from top left to lower right. Data is output from the matrix in horizontal rows from top left to lower right.
  - If the input to the transmit interleaver is a vector of length 72, bit ordered as [1,2,3,4,5,6.....120] the output is a vector ordered as [1,13,25,37,49,61.....120].
- Receive data is input to the matrix in horizontal rows from top left to lower right. Data is output from the matrix in vertical columns from top left to lower right.
  - If the input to the receive de-interleaver is a vector of length 72, bit ordered as [1,2,3,4,5,6.....120] the output is a vector ordered as [1,11,22,33,44,55.....120].

## 7.5 FEC coding of CCH (superframe)

There are a total of 41 bits of CCH data.

The 7 bit CRC checksum is added using the polynomial given in clause 7.1 giving a total of 48 bits.

These 48 bits are now separated into 6 bytes. Each byte is now coded by a shortened 12,8 Hamming Code (see clause 7.2) giving 6 x 12 bit blocks.

To protect against burst interference, these 6 x 12 bit blocks are now interleaved using the 12 x 6 TCH interleaving matrix given in table 7.4.

Then the interleaved CCH data is scrambled using the polynomial given in clause 7.3.

## 7.6 FEC coding of MI (message info') and HI (header info')

There are a total of 72 bits of MI/HI data.

The 8 bit CRC checksum is added using the polynomial given in clause 7.1 giving a total of 80 bits.

These 80 bits are now separated into 10 bytes. Each byte is now coded by a shortened 12,8 Hamming Code (see clause 7.2) giving 10 x 12 bit blocks.

To protect against burst interference, these 10 x 12 bit blocks are now interleaved using the 12 x 10 HI interleaving matrix given in clause 7.4.

Then the interleaved MI/HI data is scrambled using the polynomial given in clause 7.3.

## 7.7 FEC coding of END information

There are a total of 17 bits of END information.

The 7 bit CRC checksum is added using the polynomial given in clause 7.1 giving a total of 24 bits.

These 24 bits are now separated into 3 bytes. Each byte is now coded by a shortened 12,8 Hamming Code (see clause 7.2) giving 3 x 12 bit blocks. These 36 bits are now repeated and the total 72 bits are scrambled using the polynomial described in clause 7.3.

## 7.8 FEC coding of Appended Data

There are a total of 72 bits of Appended Data.

The 8 bit CRC checksum is added using the polynomial given in clause 7.1 giving a total of 80 bits.

These 80 bits are now separated into 10 bytes. Each byte is now coded by a shortened 12,8 Hamming Code (see clause 7.2) giving 10 x 12 bit blocks.

To protect against burst interference, these 10 x 12 bit blocks are now interleaved using the 12 x 10 HI interleaving matrix given in clause 7.4.

Then the interleaved Appended Data is scrambled using the polynomial given in clause 7.3.

---

# 8 Bearer Services, tele-services and supplementary services

**Table 8.1: Mode 1 Mode 2 Services**

Bearer services	Tele-services	Supplementary services
Voice	Individual Call	Late Entry
		OACSU
		Cancel call set-up
		PTT call
		Slow user data
		Short Attached_Data
	Talking Party Identification	
	Call to a talkgroup	Late Entry
		All Call
		PTT Call
		Slow user data
		Short Attached_Data
Broadcast Call		
Talking Party Identification		
Type 3 data	IP over dPMR	-
	Individual Data Message	
Type 2 data	IP over dPMR	-
	Individual Data Message	
	Data Message to a talkgroup	
Type 1 data	IP over dPMR	-
	Individual Data Message	
	Data Message to a talkgroup	
Status Polling	Individual Status Polling	
Short Data	Short Data Delivery	

Table 8.2: Mode 3 Services

Bearer services	Tele-services	Supplementary services
Voice	Individual Call	Late Entry
		OACSU
		Cancel call set-up
		PTT call
		Slow user data
		Short Attached_Data
	Call to a talkgroup	Talking Party Identification
		Call Diversion
		Call Back
		Late Entry
		All Call
		PTT Call
Type 3 data	IP over dPMR	-
	Individual Data Message	
Type 2 data	IP over dPMR	-
	Individual Data Message	
	Data Message to a talkgroup	
Type 1 data	IP over dPMR	-
	Individual Data Message	
	Data Message to a talkgroup	
Status Polling	Individual Status Polling	
Short Data	Individual Short Data Delivery	
	Short Data Delivery to a talkgroup	
Short Data Polling	Short Data Polling	

## 8.1 Call types

### 8.1.1 Individual call

An individual call is a call made to a unique address that is not identified as a group address within an MS that is part of a system.

For equipment compliant with the Standard User Interface, an individual call is a call made to a dialable address as defined in clause A.1.2.1.1.1 that does not contain any "wildcard" characters as defined in clause A.1.2.1.1.1.

### 8.1.2 Group call

A group call is a call made to an address that is identified as a group address within one or more MSs that is part of a system.

For equipment compliant with the Standard User Interface, a group call is a call made to a dialable address as defined in clause A.1.2.1.1.1 using "wildcard" characters to define talkgroups.

## 8.2 Addressing

MS, BS and Gateway addresses that do not require extended addressing is based on an allocation of 24 bits.

For equipment compliant with the Standard User Interface radios shall use a 7 digit addressing scheme that is encoded into the 24 bit address field as detailed in annex A.

## 8.3 Colour Codes

Colour Codes can be individually assigned by channel for spectrum management purposes or to differentiate independent co-channel networks.

Where no specific Colour Code has been programmed for a channel, MS shall determine the Colour Code applicable for the frequency by the algorithm defined in clause 6.1.5 for Mode 1 and Mode 2 systems or clause 6.1.5.2 for Mode 3 systems.

## 8.4 Messages

### 8.4.1 Downlink Traffic Channel messages

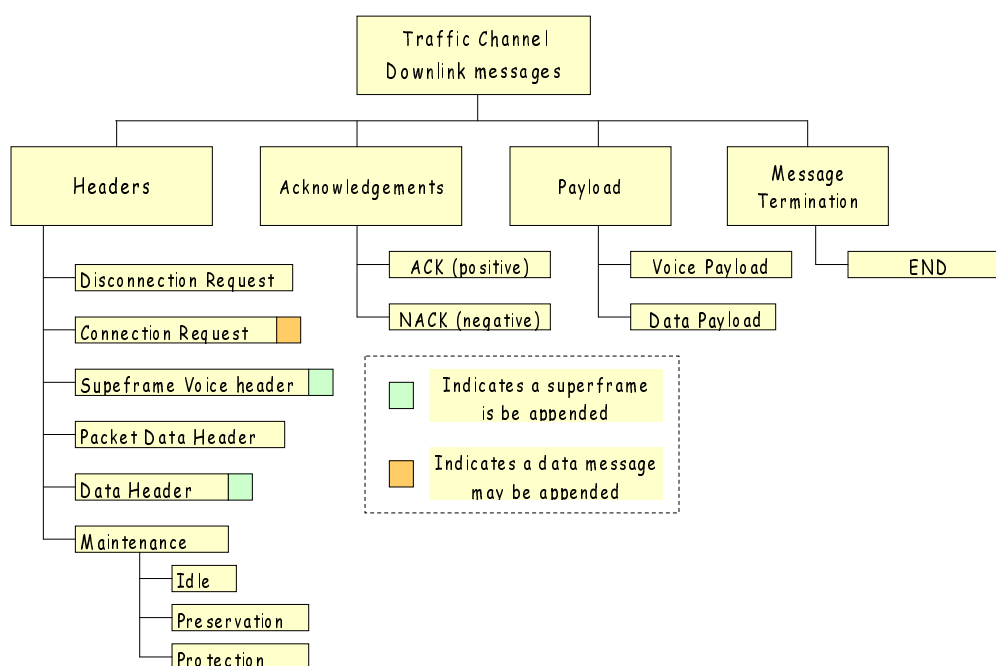


Figure 8.1: Downlink Traffic Channel Messages

### 8.4.2 Uplink Traffic Channel messages

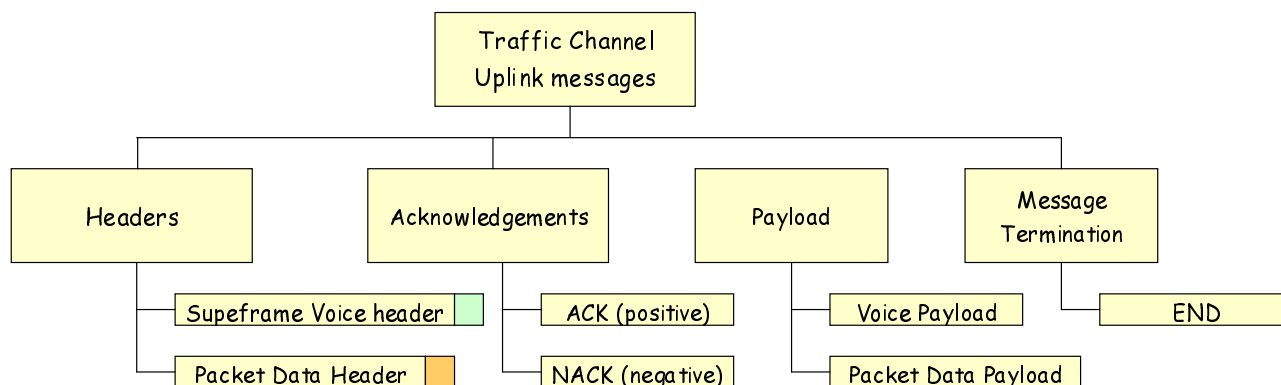


Figure 8.2: Uplink Traffic Channel Messages

### 8.4.3 Downlink Beacon messages

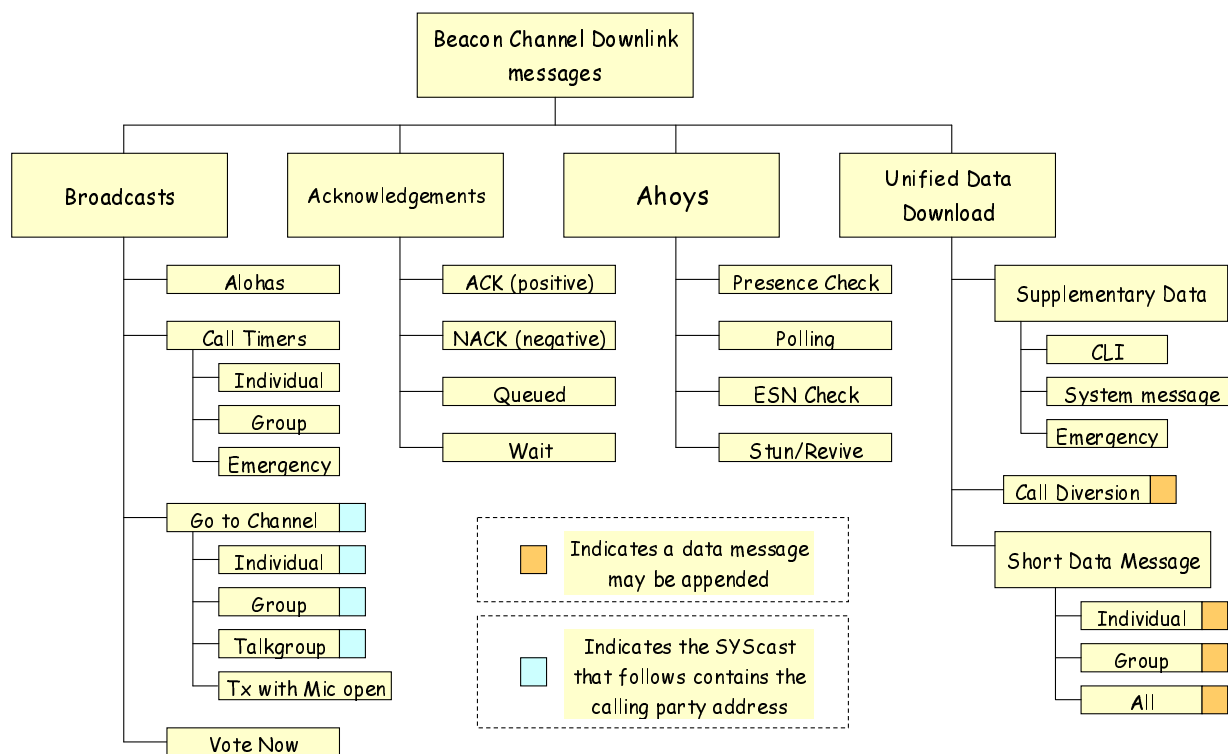


Figure 8.3: Downlink Beacon Messages

### 8.4.4 Uplink Beacon messages

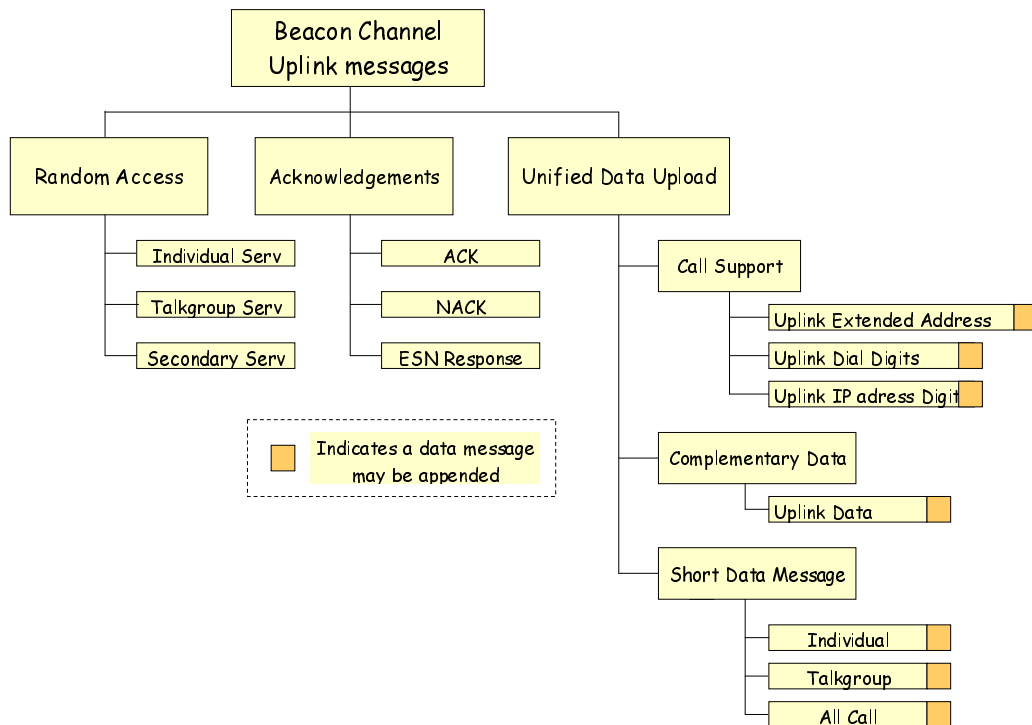


Figure 8.4: Uplink Beacon Messages

## 9 Packet data

### 9.1 Format

Packet data uses a different format to the normal communications frame format. The use of frame sync 4 (FS4) indicates that the frames following are in the PDF format.

The basic PDF format is illustrated in figure 9.1.

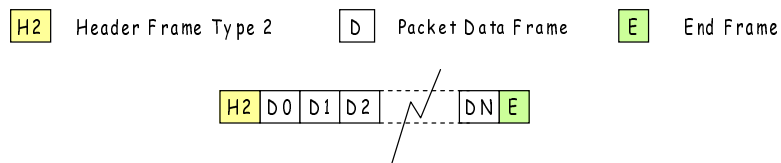


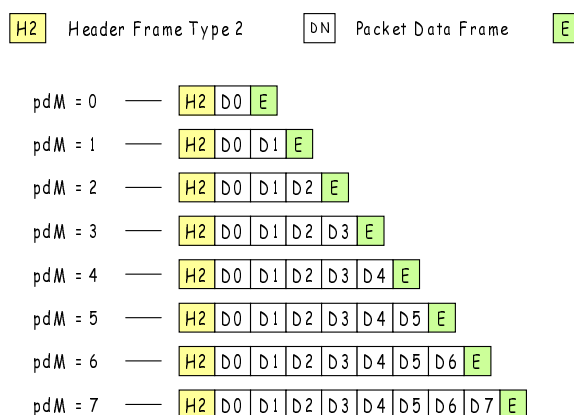
Figure 9.1: PDF format

Total length of a data frame  $D(N) = 80 \times (pdS + 1)$  ms.

The value of pdS transmitted indicates the number of 80 ms frames.

Figure 9.2 illustrates concatenated PDF frames.





**Figure 9.2: PDF frames**

The value of pdM transmitted indicates the number of 320 ms frames.

The maximum transmission time of a single packet occurs when pdS = 3 and pdM = 7.

i.e. Header2 + (PDF max x pdM max) + END.

= 80 + (320 x 8) + 20 ms.

= 2 660 ms.

## 9.2 Receiving party

For an individual call, the receiving party shall signal to the transmitting party whether the data has been received without errors.

Where there were no errors in any of the received packet frames, the response shall be an ACK frame with the Acknowledgement type (in the MI data) set to 001<sub>2</sub>.

Where errors are detected in any of the received packet frames, the response shall be an acknowledgement with the Acknowledgement type (in the MI data) set to 010<sub>2</sub>. This is a NACK frame. The information bits in the MI data denote the number of the packet frame from which retransmission shall commence. The NACK retransmit values are given in table 9.1.

**Table 9.1: NACK retransmit values**

Type	Information		
	Reserved	Retransmit Pointer	Meaning
010 <sub>2</sub>	0 0000 <sub>2</sub>	000 <sub>2</sub>	Retransmit from frame 0
		001 <sub>2</sub>	Retransmit from frame 1
		010 <sub>2</sub>	Retransmit from frame 2
		011 <sub>2</sub>	Retransmit from frame 3
		100 <sub>2</sub>	Retransmit from frame 4
		101 <sub>2</sub>	Retransmit from frame 5
		110 <sub>2</sub>	Retransmit from frame 6
		111 <sub>2</sub>	Retransmit from frame 7

## 9.3 Packet frame coding

Packet Data Frame format.

**Table 9.2: Packet Data Frame Format**

CC	PAR	DATA
24 bits	72 bits	288 bits (pdS = 0), 672 (pdS = 1), 1 056 (pdS=2), 1 440 (pdS = 3)

**Table 9.3: Packet data frame coding**

		Tx frame	Info bits	FEC	Transfer bits		
CC	Colour Code	ALL	24	Clause 6.1.5	24		
PAR	Parameter		(41)	CRC 7 bit (12, 8) Short Hamming Interleave 12 x 6	72		
N	Packet frame number	ALL	3				
LEN	Data length (BYTE) *1	ALL	8				
DUMMY	DUMMY BITS	ALL	14				
CRC-D	CRC for DATA field	ALL	16	NONE	Scramble		
DATA	User data	pdS = 0	ALL			288	288
		pdS = 1	ALL			672	672
		pdS = 2	ALL			1 056	1 056
		pdS = 3	ALL	1 440	1 440		

DUMMY bits in the data frame are all set to zero.

N: Number of each individual packet frame transmitted in this item counting from 0 up to the value given by pdM in the Packet data Header.

Data length 3 bit.

Definition.

**Table 9.4: Number of Packet Frames**

field	value	length	meaning
N	0 to 7 (dec)	3	Frame Number

## 9.4 Data frame size

The data frame size is declared in the Header frame MI field pdS. (See table 5.5.19.3).

The length of a packet data transmission shall always be an integral number of 80 ms units (i.e. same as the normal FDMA frames).

**Table 9.5: Data Frame Size**

pdS = 0 total length = 80 ms / 384 bits.

CC	PAR	Data
		288 bits (36 bytes)

pdS = 1 total length = 160 ms / 768 bits.

CC	PAR	Data
		672 bits (84 bytes)

pdS = 2 total length = 240 ms / 1 152 bits.

CC	PAR	Data
		1 056 bits (132 bytes)

pdS = 3 total length = 320 ms / 1 536 bit.

CC	PAR	Data
		1 440 bits (180 bytes)

## 9.5 Valid data length

The transmitting party shall signal the actual length of the valid data contained in each packet using the LEN parameter. Any unused bytes of each packet shall be completed with null data (all zeroes).

LEN Data length (BYTE).

Data length 8 bits.

Definition.

**Table 9.6: Valid Data Length**

0 to 36	(dec)	Data length (BYTE)	36 bytes = 288 bits, for pdS = 0
0 to 84	(dec)	Data length (BYTE)	84 bytes = 672 bits, for pdS = 1
0 to 132	(dec)	Data length (BYTE)	132 bytes = 1 056 bits, for pdS = 2
0 to 180	(dec)	Data length (BYTE)	180 bytes = 1 440 bits, for pdS = 3
Other	(dec)	Reserved	

## 9.6 Data checksum

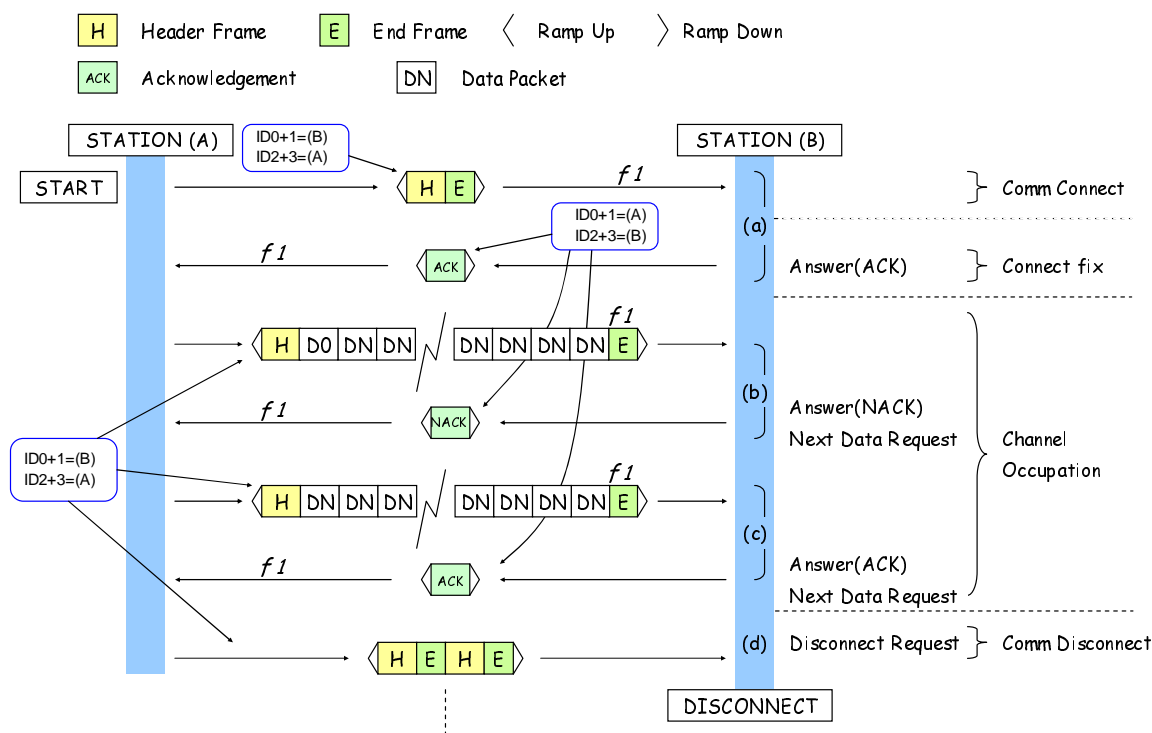
A 16 bit CRC checksum is calculated from the contents of the data field (including any dummy bits used) in each packet frame, CRC-D.

The Generated Polynomial uses  $X^{16} + X^{12} + X^5 + 1$ .

This CRC-D checksum is used in the parameter field (PAR) of the packet data frame.

## 9.7 Standard Packet Exchange Format

A packet data call is illustrated in figure 9.3.



**Figure 9.3: Packet exchanges**

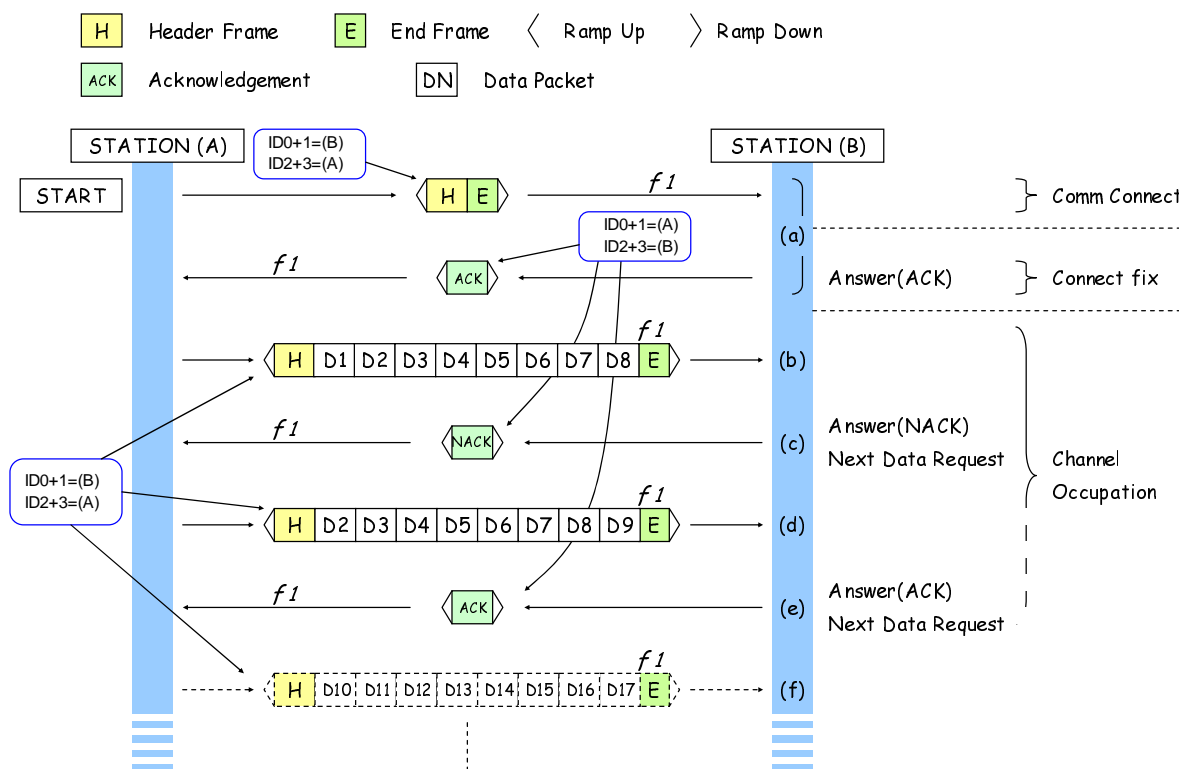
Station 'A' is conducting a packet data transaction with station 'B'. Station 'A' fragments its data message into suitable packets and chooses the most suitable value for pS (packet size) and pM (data packets per transmission item).

Referring to figure 9.3:

- Station 'A' attempts to establish a connection by transmitting a type 3 header frame/END. Station 'B' responds with a positive acknowledgement. If 'A' receives the acknowledgement the connection is established;
- Station 'A' transmits the item and appends pM packets to the header. Station 'B' acknowledges that the packets were received without any uncorrectable errors;
- Assuming that station 'A' received the positive acknowledgement, station 'A' transmits the next item. Again the item is acknowledged;
- When that data has been completely transmitted, station A send the disconnect request. Since the disconnect is not acknowledged, the header/end is repeated.

If a transmission item from station 'A' contains errors in some packets, the whole item does not need to be retransmitted. If station 'B' receives a transmitted item containing an error in one of the data packets, 'B' will send NACK to 'A' in response to the item. The NACK from station 'B' contains a field which indicates the packet that contains the first error detected.

Figure 9.4 illustrates a packet data call with an error.



**Figure 9.4: Packet retractions**

Referring to figure 9.4:

- Station 'A' attempts to establish a connection by transmitting a type 3 header frame/END. Station 'B' responds with a positive acknowledgement. Station 'A' receives the acknowledgement and the connection was established.
- Station 'A' transmits the item and appends 8 (pdM=0111<sub>2</sub>) packets to the header.
- Station 'B' received the header and D0 correctly but D1 was received with errors. Station 'B' therefore transmitted a NACK (Type=010<sub>2</sub>, Information = 0 asking for a retransmission from data packet #1.
- Station 'A' transmits the item from data packet #1.
- When that data has been completely transmitted, station 'A' send the disconnect request. Since the disconnect is not acknowledged, the header/end is repeated.

If Station 'A' has sent a packet and does not receive any acknowledgement, station 'A' may send a Repeat\_Last\_Ack + END message instead of repeating the packet data item. If station B receives a Repeat\_Last\_Ack + END message, it shall send verbatim the acknowledgement that was previously sent.

## 10 Call procedures

The facilities described for dPMR are related to user initiated call procedures, e.g. talkgroup speech call, individual speech call, data call etc. The services defined for dPMR contains intrinsic (embedded) signalling or procedures which may support user initiated call procedures. Some services are visible to users others are not and will be processed by the MS or BS itself.

The individual call service provides voice call or data call service between two parties. Only the parties engaged in the call can hear each other. The individual call is initiated at the user level by selecting the desired individual called party ID via a predefined selection procedure and then activating a mechanism to initiate the call.

The group call service provides voice call or data call service between one individual user and a predetermined group of MS. All parties in the talkgroup can hear each other. The talkgroup call is initiated at the user level by selecting the desired talkgroup ID via a predefined selection procedure and then activating a mechanism to initiate the call.

For a voice call, dPMR MSs shall employ a traffic channel transmit TimeOut timer (TV\_Item) which limits the time of a single transmission item. This timer shall be set to the value TV\_Item whenever the PTT key is pressed and counts down to zero. For a data call, dPMR MSs shall have a traffic channel transmit TimeOut timer (TD\_Item) which limits the maximum time of a single data transmission item.

If the transmit TimeOut timer expires during a voice transmission, then the MS shall stop transmitting after the end of the current superframe plus the END frame, and may not re-transmit until PTT has been released and pressed again. If the transmit TimeOut timer expires during a data transmission, then the MS shall stop transmitting immediately (see note).

NOTE: MS are configured with the parameter TD\_Item timer and are therefore able determine a data frame length that ensures the TimeOut timer will not expire.

A Mode 1 system can support a range of services including MS to MS individual calls for voice, status, and data, and calls to talkgroups.

A Mode 2 or Mode 3 system can allocate resources for additional services including calls to and from line connected destinations, and complementary services.

Complementary data may be sent between MS and the network during the call set-up phase using the Complementary Data Transfer Service to poll for, or deliver additional information using a Unified Data Transport method. Examples include:

- the uplink of dialling digits for calls to the PSTN, PABX extensions;
- the transport of MS location information using data collected from EN 61162-1 [1] compatible devices;
- the transport of any complementary user or system data;
- the downlink of CLI information for calls from PSTN and PABX gateways to the called MS(s).

## 10.1 Call procedures for Mode 1

This clause defines the following facilities for Mode 1 equipment. MS may support:

- a) MS to MS Individual Voice Call Service;
- b) MS to talkgroup Voice Call Service;
- c) MS to MS Individual T1, T2 and T3 Data Call Service;
- d) MS from MS Individual status polling;
- e) MS to MS Individual Short Data Delivery Service;
- f) MS to talkgroup Short Data Delivery Service.

In addition a power save feature is specified.

### 10.1.1 Common procedures for Mode 1 Voice and Data calls

#### 10.1.1.1 Mode 1 Call set up.

Individual Mode 1 calls may be preceded by a called party check illustrated in figure 10.1.

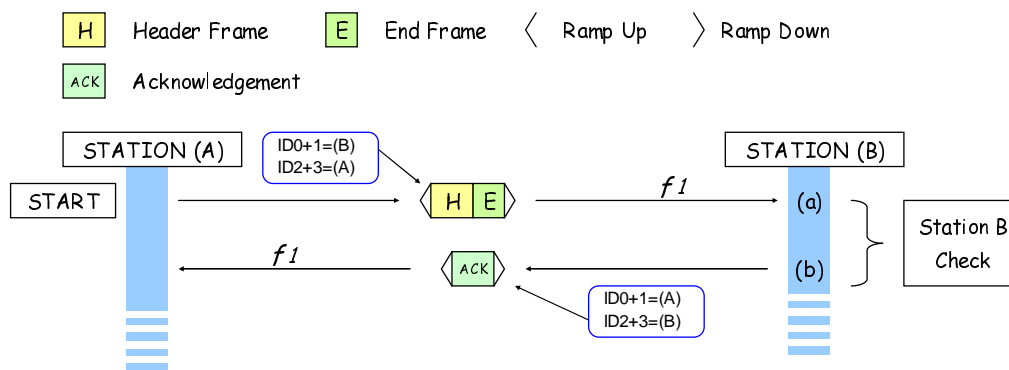


Figure 10.1: Mode 1 Called Party Check

The called party check consists of a Connection\_Request Header + End\_Message pair described in tables 10.1 and 10.2.

The calling party (STATION A) sends a Connection Request Header with its individual address in ID2+3 and the called party address (STATION B) in ID0+1. The called party sends an acknowledgement to the called party. The acknowledgement message ID0+1 contains the calling party address (STATION A) and ID2+3 contains the called party address (STATION B).

Table 10.1: Connection\_Request Header for a Mode\_1 Called Party Check

Alias	Alias	Alias	Value	Length	Meaning
MT			0001 <sub>2</sub>	4	Message Type = Connection_Request Header
PARMS	ID0 + 1			24	Called Station individual MS ID
	ID2 + 3			24	Calling Station ID
	M			3	Communications Mode
	V			2	Version (00 <sub>2</sub> for standard TCH)
	F		01 <sub>2</sub>	2	Comms Format = peer to peer
	EP			1	Priority (0 <sub>2</sub> for normal priority 1 <sub>2</sub> for emergency)
	PM		N/A	1	Not Applicable for this particular message
MI	MI_TYPE		N/A	3	Called Party Check = 000 <sub>2</sub>
	MI_DET		N/A	8	Not Applicable for this particular message

The M field indicates the service that will form the content of the payload (voice/data, etc.).

The V field indicates if the payload is dPMR standard traffic channel content.

The EP field = 0<sub>2</sub> for a normal priority call or 1<sub>2</sub> for an emergency call.

Table 10.2: END message fields for a Mode 1 called party check

Alias	Length	Value	Meaning
ET	2	00 <sub>2</sub>	End type = Normal End Frame
ARQ	2	01 <sub>2</sub>	ACK requested
Tx_WAIT	4	value	Tx_Wait
STAT	5	N/A	Not Applicable for this particular message
RSVD	4	0000 <sub>2</sub>	Reserved

Called parties receiving a Connection\_Request shall respond with a T\_ACK frame. If the called party wishes to accept the call and is able to support the call service being checked, the T\_ACK frame shall set the MI\_TYPE = 001<sub>2</sub> as illustrated in table 10.3.

**Table 10.3: MI Parameters in a T\_ACK for a called party check**

Alias	Length	Value	Meaning
MI_TYPE	3	001 <sub>2</sub>	ACK Connection_Request accepted. Call may proceed
		011 <sub>2</sub>	NACK Connection_Request Denied or the called party does not support the call service requested

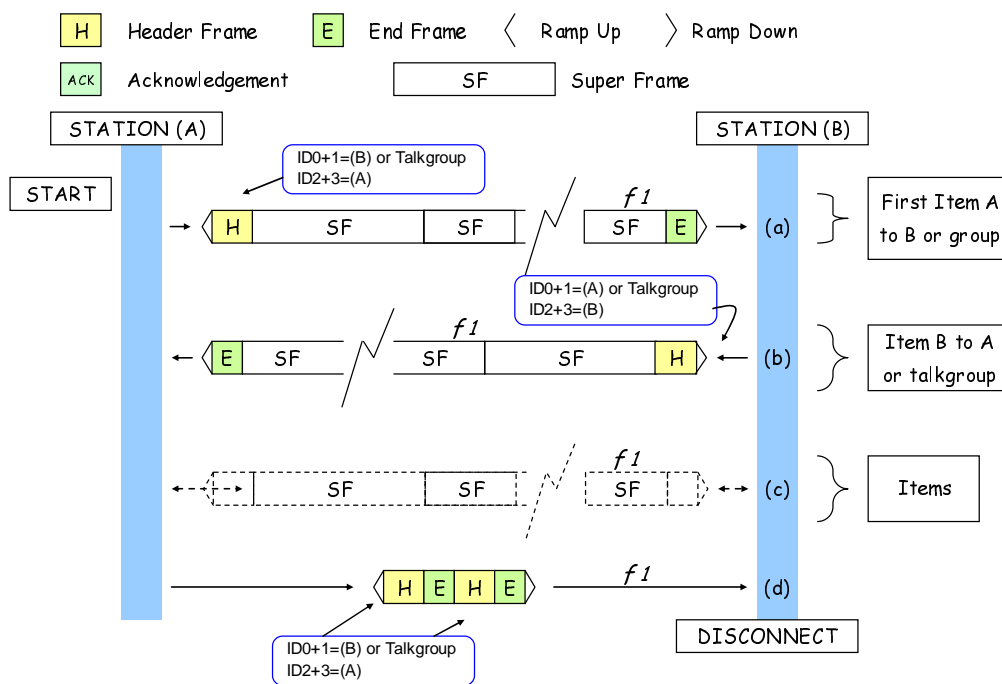
If the T\_ACK response is NACK, the calling party shall abandon the call and return to the idle state. If the T\_ACK response is ACK the connection request is confirmed.

If the calling party does not receive an acknowledgement the connection request may be repeated up to NM1\_Rep times.

### 10.1.2 Mode 1 Voice calls

#### 10.1.2.1 Mode 1 Voice Call in progress

The voice call traffic channel exchanges (following any call set up procedures, if used) are a series of asynchronous transmission items comprising Communication\_Start Header Message, 'n' Payload+Superframes and an End\_Message frame.



**Figure 10.2: Mode 1 voice call exchanges**

Figure 10.2 illustrates a Mode 1 voice call. In this case the MS has chosen not to precede the call with a called party check. The first Communications\_Start header transmitted however inherently provides a logical connection for the call.

The parameters for the Communications\_Start Header are described in table 10.4. It is not permitted to change the M, V or P fields after the first message that activated the connection for the call.

The called party shall determine the requested call service from the called party check or first item from the calling party.



**Table 10.4: Communications\_Start Header for a Mode\_1 voice call**

Alias	Alias	Alias	Value	Length	Meaning
MT			0000 <sub>2</sub>	4	Message Type = Communications_Start Header
PARMS	ID0 + 1			24	Called Station individual MS ID or talkgroup
	ID2 + 3			24	Calling Station ID
	M			3	Communications Mode (000 <sub>2</sub> or 001 <sub>2</sub> )
	V			2	Version (00 <sub>2</sub> for standard TCH content)
	F		01 <sub>2</sub>	2	Comms Format = peer to peer
	EP			1	Priority (0 <sub>2</sub> for normal priority 1 <sub>2</sub> for emergency)
	PM		N/A	1	Not Applicable for this particular message
	MI	MI_TYPE		N/A	3
MI_DET			N/A	8	Not Applicable for this particular message

The M field indicates if there is slow data in the SLD field.

The V field indicates if the payload is dPMR standard traffic channel content.

The payload superframe that is concatenated to the Communications\_Start Header is formatted as described in clause 5.2.1.1.

The END message is described in table 10.5.

**Table 10.5: END message for a Mode 1 voice item**

Alias	Length	Value	Meaning
ET	2	00 <sub>2</sub>	End type = Normal End Frame
ARQ	2	00 <sub>2</sub>	No ACK requested
Tx_WAIT	4	value	Tx Wait
STAT	5	N/A	Not Applicable for this particular message
RSVD	4	0000 <sub>2</sub>	Reserved

### 10.1.2.2 Mode 1 Voice Call with Slow Data

The Superframe CCH contains a SLD field that is available to carry slow data with the voice payload. The SLD fields may contain user data. To signify that slow data is being carried, the communications Mode (M) field in the Communications\_Start header is set to 001<sub>2</sub> instead of 000<sub>2</sub>. The construction of this superframe is described in clause 11.1.

### 10.1.2.3 Mode 1 Voice Call with Attached Data

If MS release the PTT before a superframe has completed the remaining TCH frames may carry attached data. The construction of such superframes is described in clause 11.1.1.

### 10.1.2.4 Mode 1 Voice Call Termination

For an individual call, when the communication exchanges are complete the caller or the called party may optionally transmit a disconnect request by a repeated Disconnect\_Request header + End message pair. The fields M, V, F, and P shall remain the values from the Communications\_Start Header. The END message shall set the fields as the END message to the values described in table 10.5.

For a call to a talkgroup, when the communication exchanges are complete only the caller may optionally transmit a disconnect request by a repeated Disconnect\_Request header + End message pair. The called party or parties shall not be permitted to send a disconnect request to end a talkgroup call.

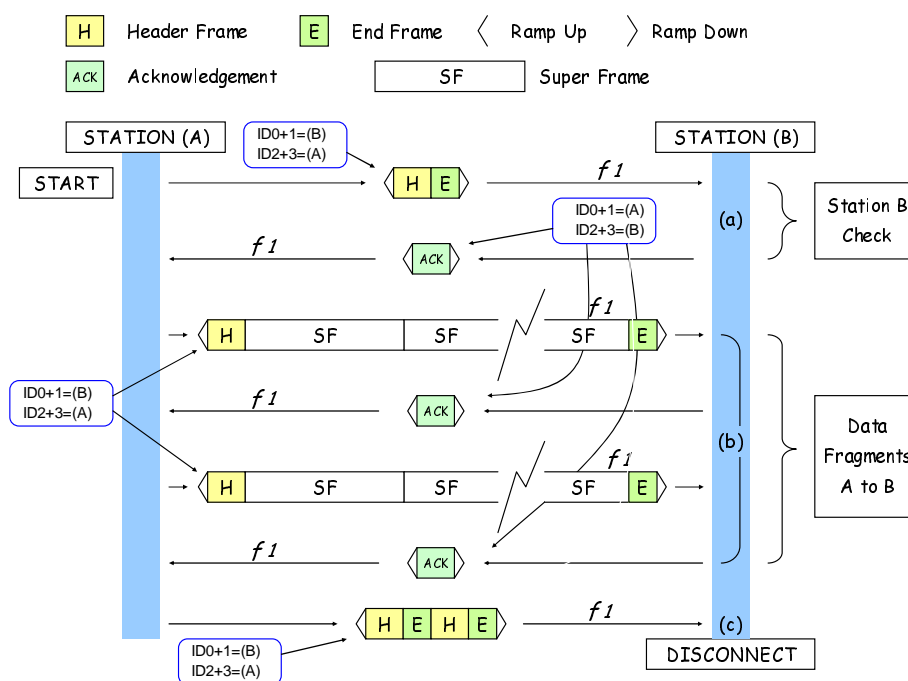
### 10.1.3 Mode 1 Data Calls

The data call traffic channel exchanges (following any call set up procedures, if used) are a series of asynchronous transmissions comprising Communications\_Start Header message, 'n' Payload\_Superframes and an End\_Message frame.

#### 10.1.3.1 Mode 1 T1 and T2 Data calls

The data type and length of each transmitted block is given in the SLD field of the Payload Superframe Communications\_Start header. The data length can vary for each block. In cases where the use of large data blocks results in T\_NACK responses, MS may choose to reduce the block data length to reduce the size of data block transmitted until the responses are predominately T\_ACKs indicating the block was received with either no errors or correctable errors. If the sending MS does not receive an acknowledgement, the data item may be repeated or the sender may send a RLA (Repeat Last Ack) message.

A typical individual data call is illustrated in figure 10.3.



**Figure 10.3: T1 and T2 Data Calls**

In this example, the calling party has chosen to start the call with a called party check. The called party only sends a positive acknowledgement to the called party check if it is able to receive this type of call. In the case of an individual data call, each data block transmitted shall be acknowledged positively before subsequent blocks are transmitted.

For a talkgroup call, the data blocks may be transmitted as one item (subject to the not exceeding the TD\_Item timer). Talkgroup items shall not be acknowledged. When all data blocks have been transmitted (and acknowledged as appropriate) the calling station shall send a disconnect request of a repeated Disconnect\_Header message + End message pair. The disconnect message shall not be acknowledged.

Each T1 superframe can carry up to 288 bits. A T2 superframe has the capacity for up to 160 data bits.

**Table 10.6: Communications\_Start Header for a T1 and T2 call**

Alias	Alias	Alias	Alias	Value	Length	Meaning
MT				0000 <sub>2</sub>	4	Message Type = Communications_Start Header
PARMS	ID0 + 1				24	Called Station individual MS ID or talkgroup
	ID2 + 3				24	Calling Station ID
	M				3	Communications Mode (010 <sub>2</sub> or 011 <sub>2</sub> )
	V			N/A	2	Not Applicable for this particular message
	F			01 <sub>2</sub>	2	Comms Format = peer to peer
	EP				1	Priority (0 <sub>2</sub> for normal priority 1 <sub>2</sub> for emergency)
	PM			N/A	1	Not Applicable for this particular message
	MI	MI_TYPE			001 <sub>2</sub>	3
MI_DET		TFormat	value		4	Format of the T1/T2 data
		RSVD	0000 <sub>2</sub>		4	Reserved

Table 10.6 describes the fields for the Communications\_Start header.

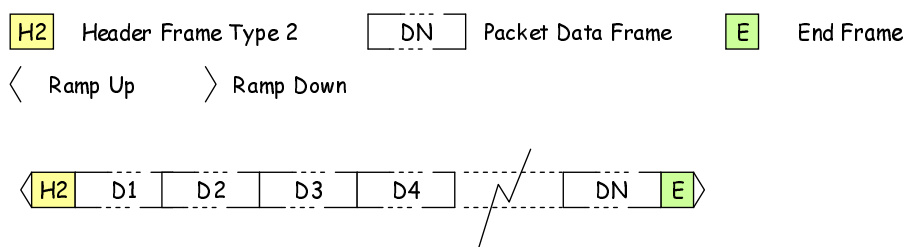
The M field determine if type 1 or type 2 data is being transported. M = 010<sub>2</sub> indicates type 1 data - payload is user data without FEC, M = 011<sub>2</sub> indicates type 2 data - payload is user data with FEC. Construction of T1/T2 superframes are described in clauses 11.2 and 11.3.

The message information (MI) is split into 2 fields. The most significant four bits of MI carry the format of the TCH data. (see clause 5.5.19.2).

### 10.1.3.2 Mode 1 T3 (Packet) Data Calls

Packet data uses a different format to the normal communications frame format. The use of frame sync 4 (FS4) indicates to a recipient of a message that the frames following are in a packet data format.

The basic packet data format is illustrated in figure 10.4.

**Figure 10.4: Packet Data Format**

The Message Information field in a Header Frame type 2 (H2) contains a parameter pdS that indicates the number of bits carried in each packet data frame (DN in figure 10.4).

The value of pdS transmitted indicates the number of 80 ms frames in a data packet frame.

Total length of a packet data frame  $D(N) = 80 \times (pdS + 1)$  ms.

Figure 10.5 illustrates concatenated Packet Data Frames:

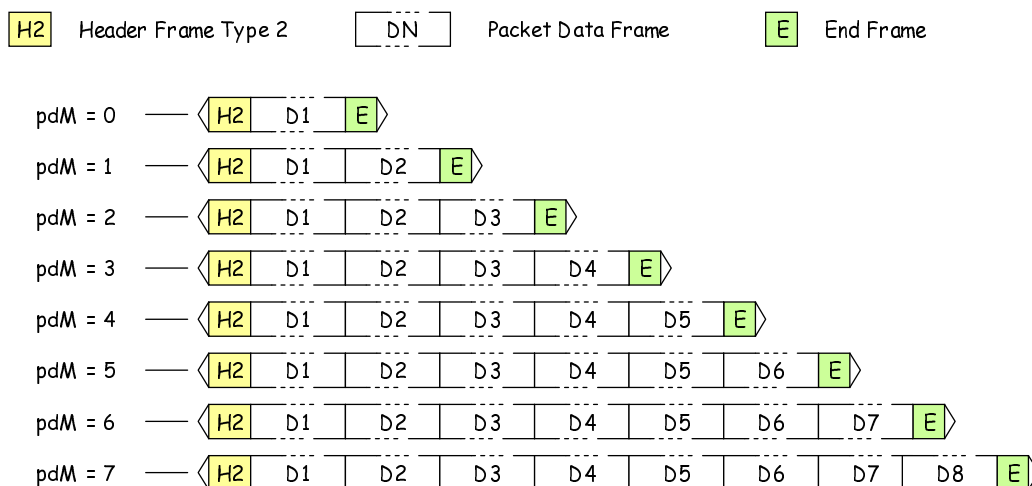


Figure 10.5: Packet Data frames

The value - pdM indicates the number of packet data frames.

The maximum transmission time of a single packet occurs when pdS = 3 and pdM = 7.

i.e. Header2 + (80 x [pdS+1]) max x pdM max) + END.

$$= 80 + (320 \times 8) + 20 \text{ ms.}$$

$$= 2\ 660 \text{ ms.}$$

T3 (Packet) data calls are by definition always individual calls as each packet is acknowledged. MS may choose to initiate a called party check before the first packet item is transmitted.

A packet data call is illustrated in figure 10.6.

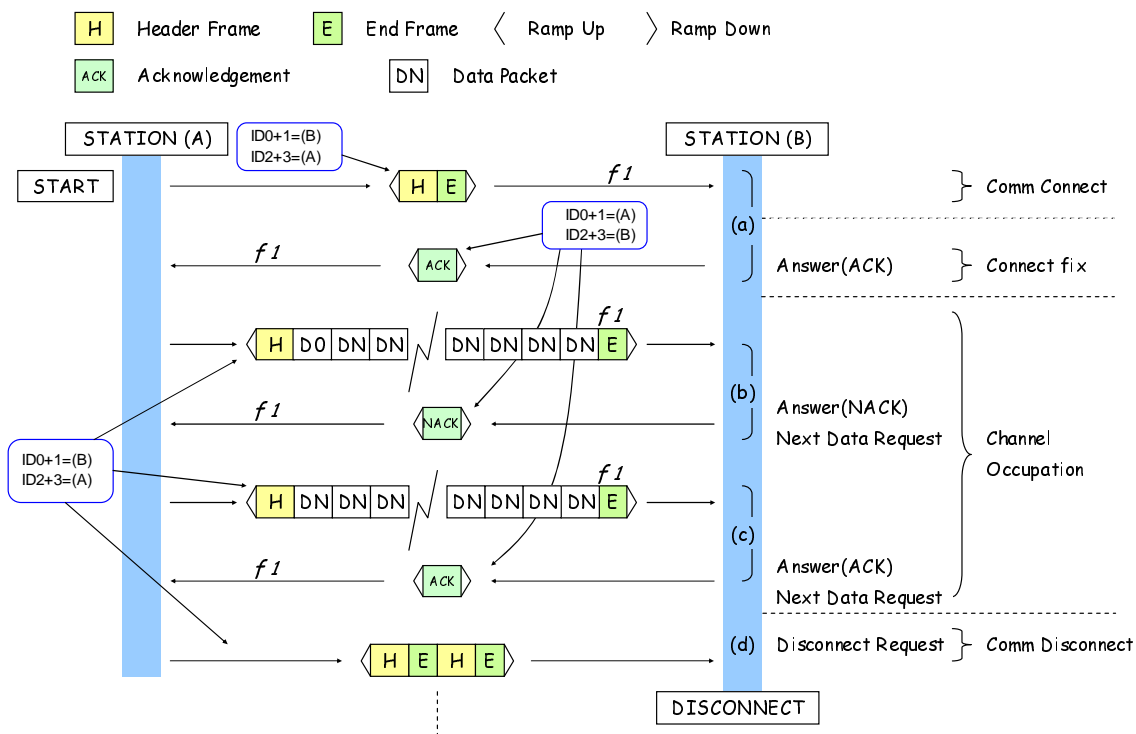


Figure 10.6: T3 (Packet) Data Call

Station 'A' is conducting a packet data transaction with station 'B'. Station 'A' fragments its data message into suitable packets and chooses the most suitable value for pdS (packet size) and pdM (data packets per transmission item).

Referring to figure 10.6:

- a) Station 'A' chooses to send a called party check before sending the first packet by transmitting a Called Party Check frame MT = 0001<sub>2</sub> header frame/END. Station 'B' responds with a positive acknowledgement.
- b) Station 'A' transmits the item and appends pdM packets to the header. Station 'B' acknowledges that the packets were received without any uncorrectable errors.
- c) Assuming that station 'A' received the positive acknowledgement, station 'A' transmits the next item. Again the item is acknowledged.
- d) When that data has been completely transmitted, station 'A' send the disconnect request. Since the disconnect is not acknowledged, the header/end is repeated. That ends the transaction.

If a transmission item from station 'A' contains errors in some packets, the whole item does not need to be retransmitted. If station 'B' receives a transmitted item containing an error in one of the data packets, 'B' shall send a NACK to 'A' in response to the item. The NACK from station 'B' contains the Message\_Information field that indicates the packet that contains the first error detected.

Construction of T3 superframes is described in clause 11.4.

Figure 10.7 illustrates a packet data call with an error.

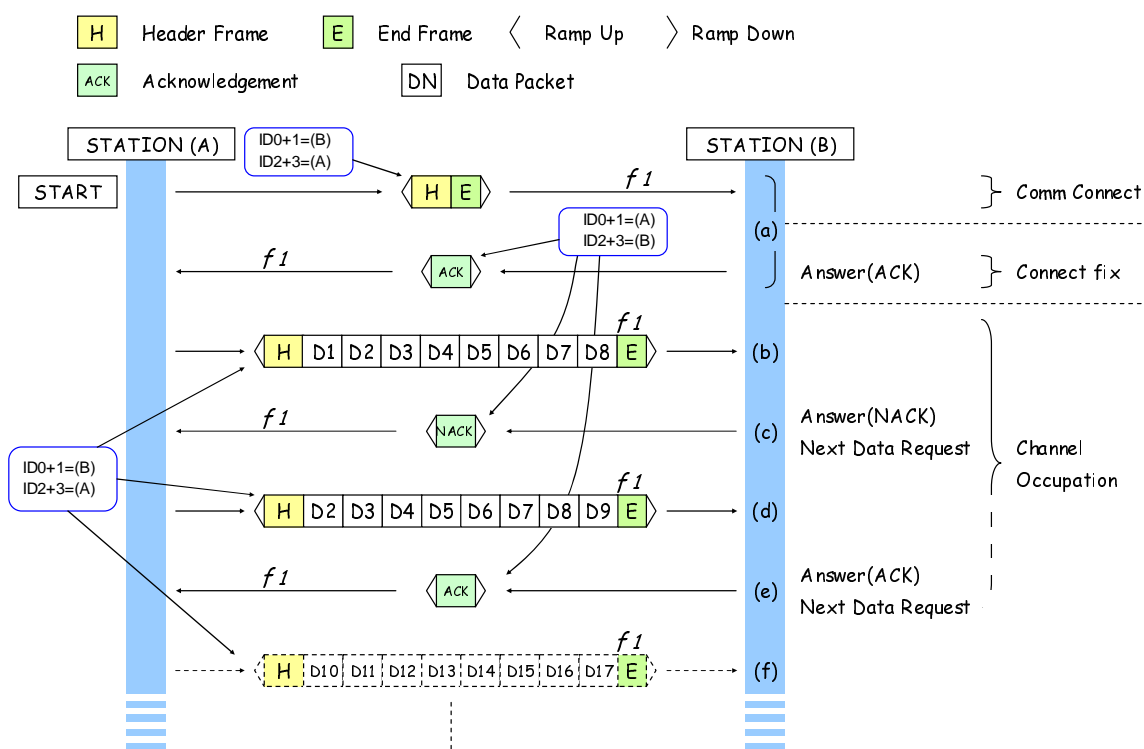


Figure 10.7: Packet Retransmissions

Referring to figure 10.7:

- Station 'A' chooses to send a called party check before sending the first packet by transmitting a Called Party Check frame (MT = 0001<sub>2</sub>) header frame + END. Station 'B' responds with a positive acknowledgement.
- Station 'A' transmits the item and appends 8 (pdM=0111<sub>2</sub>) packets to the header.
- Station 'B' received the header and D0 correctly but D1 was received with errors. Station 'B' therefore transmitted a NACK (Type=010<sub>2</sub>, Information = 0<sub>2</sub>) asking for a retransmission from data packet #1.
- Station 'A' transmits the item from data packet #1.
- When that data has been completely transmitted, station 'A' sends the disconnect request. Since the disconnect is not acknowledged, the header + end is repeated.

In the event of a T\_NACK response to a data block, the calling party shall decode the T\_NACK to ascertain the frame from which a retransmission should occur. The data length may vary for each packet. In cases where the use of large data packets results in NACK responses, MS may choose to reduce the block data length to reduce the size of data block transmitted until the responses are predominately T\_ACKs.

If the sending MS does not receive an acknowledgement, the data item may be repeated or the sender may send an RLA (Repeat Last Ack) message.

### 10.1.3.3 Mode 1 Individual Status polling

Individual MS may be polled for their current status.

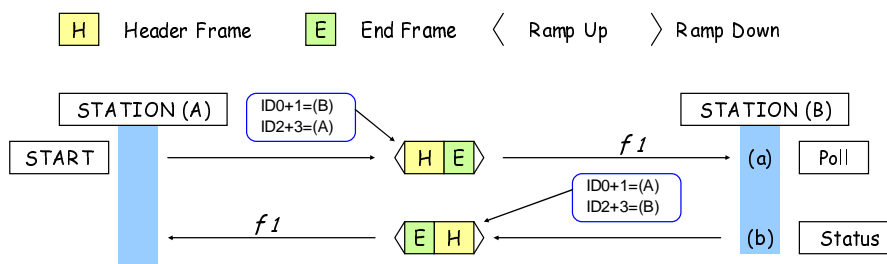


Figure 10.8: Status Polling

Figure 10.8 illustrates a status polling transaction.

A Status Polling Request header + END pair with the Message\_Type set to 'Status Polling Request' (1000<sub>2</sub>) is transmitted by the calling party as described by table 10.7. The End\_Message frame illustrated in table 10.8 of this pair shall set the acknowledgement (ARQ) field to 01<sub>2</sub> that signifies an acknowledgement with status is required.

Table 10.7: Mode 1 Status Polling Request header

Alias	Alias	Alias	Value	Length	Meaning
MT			1000 <sub>2</sub>	4	Message Type = Status Polling Request Header
PARMS	ID0 + 1			24	Called Station individual MS ID
	ID2 + 3			24	Calling Station ID
	M		N/A	3	Not Applicable for this particular message
	V		N/A	2	Not Applicable for this particular message
	F		01 <sub>2</sub>	2	Comms Format = peer to peer
	EP		N/A	1	Not Applicable for this particular message
	PM		N/A	1	Not Applicable for this particular message
MI	MI_TYPE		N/A	3	Call information Type
	MI_DET		N/A	8	Call Information

**Table 10.8: END (for Mode 1 status request)**

Alias	Length	Value	Meaning
ET	2	00 <sub>2</sub>	End type = Normal End Frame
ARQ	2	01 <sub>2</sub>	ACK requested
Tx_WAIT	4	value	Tx_Wait
STAT	5	N/A	Not Applicable for this particular message
RSVD	4	0000 <sub>2</sub>	Reserved

The response to this status request is A Status\_Response header + END pair The End Type (ET) in the END frame is set to 01<sub>2</sub> that signifies that end frame contains valid status data. These messages are illustrated in tables 10.9 and 10.10.

The called party shall set the 5 bits of status data as required.

**Table 10.9: Mode 1 Status Polling Response header**

Alias	Alias	Alias	Value	Length	Meaning
MT			0111 <sub>2</sub>	4	Message Type = Status Polling Response Header
PARMS	ID0 + 1			24	MS ID that originated the message for which this response is being sent
	ID2 + 3			24	MS ID that is sending this response
	M		N/A	3	Not Applicable for this particular message
	V		N/A	2	Not Applicable for this particular message
	F		01 <sub>2</sub>	2	Comms Format = peer to peer
	EP		N/A	1	Not Applicable for this particular message
	PM		N/A	1	Not Applicable for this particular message
	MI	MI_TYPE		N/A	3
MI_DET			N/A	8	Not Applicable for this particular message

**Table 10.10: Mode 1 END (for status response)**

Alias	Length	Value	Meaning
ET	2	01 <sub>2</sub>	End type = End frame with status message
ARQ	2	00 <sub>2</sub>	ACK not requested
TX_WAIT	4	0000 <sub>2</sub>	Not Applicable for this particular message
STAT	5	value	Status value returned to the polling entity
RSVD	4	0000 <sub>2</sub>	Reserved

#### 10.1.3.4 Mode 1 Short Data Delivery

An MS may send a short data message to an MS or talkgroup. A short data transaction to an individual MS is illustrated in figure 10.9. The UDT protocol enables the sender to define the format of the data including binary, BCD, text, byte and NMEA. These formats are described in clause 5.6.

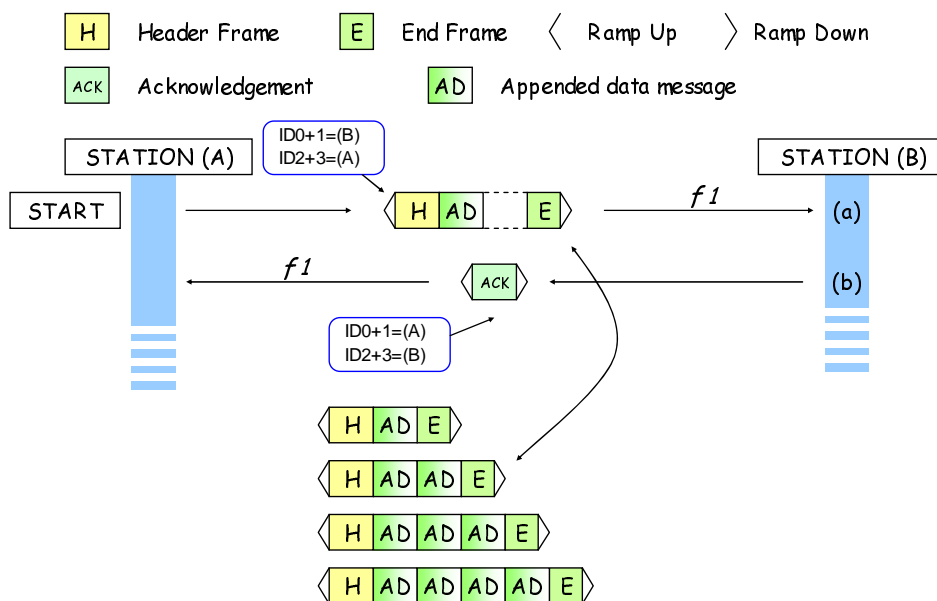


Figure 10.9: Mode 1 Short Data transaction

Referring to figure 10.9:

- a) Station 'A' builds the burst from a Connection\_Request header with between 1 to 4 Appended\_Data data messages illustrated at (c) and an END message. The format of the Appended\_Data is coded using the UDT format;
- b) Station 'B' responds with a positive acknowledgement.

If the short data is to a talkgroup, an acknowledgement shall not transmitted by the recipient(s).

A short data message does not create a logical connection so there is no need to send a disconnect.

The Connection\_Request is coded as table 10.11.

Table 10.11: Short\_Data Header

Alias	Alias	Alias	Value	Length	Meaning
MT			0001 <sub>2</sub>	4	Message Type = Connection_Request
PARMS	ID0 + 1			24	Called MS talkgroup or gateway
	ID2 + 3			24	Calling MS ID
	M		110 <sub>2</sub>	3	Service requested is defined by MI_TYPE
	V		N/A	2	Not Applicable for this particular message
	F		01 <sub>2</sub>	2	Comms Format = Peer to peer
	EP		0 <sub>2</sub>	1	Non emergency service
			1 <sub>2</sub>		Emergency Service
	PM		N/A	1	Not Applicable for this particular message
	MI	MI_TYPE		000 <sub>2</sub>	3
MI_DET			UAD	2	Appended Short Data. Number of appended UDTs required to transport short data
			SYMB	6	Number of symbols in the short data (see note)

NOTE: The field UAD defines the number of UDT Appended\_Data messages concatenated to the Short\_Data header (00<sub>2</sub> to 11<sub>2</sub> represents one to four Appended\_Data messages). The SYMB field is applicable for BCD, 7 bit text and 8 bit octet formatted data. If address, binary, EN 61162-1 [1] or IP address is transported SYMB = 00 0000<sub>2</sub>. For BCD, 7 bit, 8 bit data format, SYMB is coded to the number of symbols to be transmitted unless the number of symbols is 64 when SYMB = 00 0000<sub>2</sub>.



### 10.1.4 Mode 1 Traffic Channel Powersave

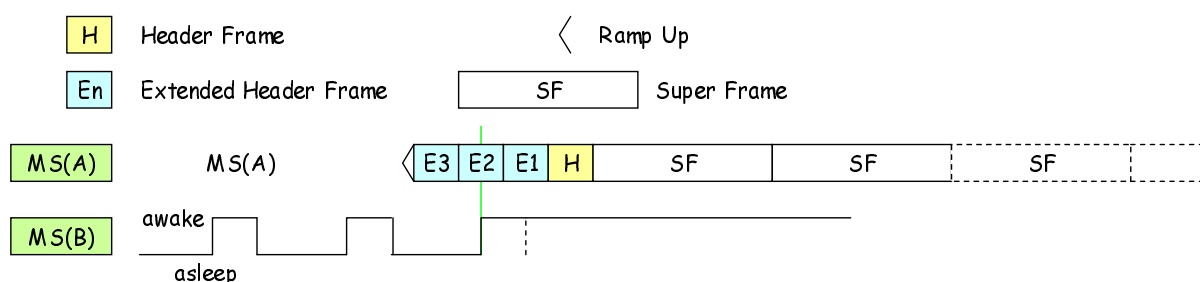
Traffic Channel power Save is applicable to Mode 1 and Mode 2 systems.

MS are permitted to alternate between "awake" (where the MS is able to receive messages) and "asleep". Therefore any transmission by other MS in the same fleet (or talkgroup as appropriate) needs to be preceded by an extra period that is longer than the "sleep" time.

The extra period before the normal transmission starts comprises multiple repeated headers up to a maximum of NMax1\_Rep. The permitted sleep time is directly related to the number of extended headers used. (see clause 13.2).

The choice of powersave settings is a balance between call set-up time and battery economy.

Extended\_Headers are transmitted with a sequence number N\_PSave that counts down as each Extended\_Header is transmitted. If an MS awakes and decodes an appropriate header (addressed to that MS) during the awake period, the MS is able to determine if this is an extended header, and if so, which extended header number in the sequence. From this, the MS is able to ascertain exactly when the normal header starts.



**Figure 10.10: Powersave Example**

In the example illustrated in figure 10.10, three extended powersave headers are transmitted. MS(B) only has to wake up for 1/3 of the time in order to receive one of the powersave headers. The transmission from MS(A) is detected by MS(B) which has woken in time to fully decode the E1 extended header. MS(B) then remains awake for the following transmission of Header (H) and payload superframes, etc.

#### 10.1.4.1 Transmitted format

Powersave is implemented by using a call set-up procedure of multiple repeated header frames called Powersave\_Header frames. Each of these Powersave\_Header frames are numbered and count down to zero, so that MSs sampling the channel can calculate exactly when the payload frames or signalling will commence.

In the case of repeated headers for powersave use, the preamble used by each header shall be fixed at 72 bits.

These powersave wake-up headers shall be coded according to table 10.12.

The 11 bits of Message Information (MI) illustrated in table 10.12 are used as follows:

MI\_TYPE = 111<sub>2</sub> (powersave wake-up header).

MI Information uses that least significant 4 bits to portray when the normal header frame occurs.

**Table 10.12: Powersave wake up header numbering**

field		Length	Value	Meaning
MI	MI_TYPE	3	111 <sub>2</sub>	MI_TYPE = Wakeup Header
	Reserved	4	0000 <sub>2</sub>	
	N_PSave	4	1111 <sub>2</sub>	Powersave Header frame 15
			0001 <sub>2</sub>	Powersave Header frame 1
			0000 <sub>2</sub>	Normal header frame

MS may be programmed to use up to 15 powersave header frames for wake-up purposes. This results in a maximum response time of 1,2 s.

**Table 10.13: Powersave header coding**

MT	Comm Mode	Powersave Header		Powersave Header	Normal Header	Super Frame
		MI	MI			
0000 <sub>2</sub>	000 <sub>2</sub>	MI	MI	MI	MI	
0001 <sub>2</sub>	001 <sub>2</sub>	Type 111 <sub>2</sub>	Type 111 <sub>2</sub>	Type 111 <sub>2</sub>	Type 000 <sub>2</sub>	
1000 <sub>2</sub>	001 <sub>2</sub>	N_PSave 0111 <sub>2</sub>	N_PSave 0110 <sub>2</sub>	N_PSave 0001 <sub>2</sub>	Info XXXX XXXX <sub>2</sub>	
0000 <sub>2</sub>	010 <sub>2</sub>	↑	↑	↑	MI	
0001 <sub>2</sub>	011 <sub>2</sub>	↑	↑	↑	001 <sub>2</sub> + Data Type	
1000 <sub>2</sub>	101 <sub>2</sub>	↑	↑	↑		
0000 <sub>2</sub>	100 <sub>2</sub>	↑	↑	↑	MI	
0001 <sub>2</sub>	100 <sub>2</sub>	↑	↑	↑	011 <sub>2</sub> + pdS pdM	
1000 <sub>2</sub>	100 <sub>2</sub>	↑	↑	↑		
0100 <sub>2</sub>	011 <sub>2</sub>	↑	↑	↑	MI	
0110 <sub>2</sub>	011 <sub>2</sub>	↑	↑	↑	Type XXX <sub>2</sub>	
					Info XXXX XXXX <sub>2</sub>	

#### 10.1.4.2 Receive format

MS in standby (sleep) are programmed to wake-up and monitor the channel at regular intervals. Each wake-up shall have a minimum duration of  $T_{ch\_chk}$  (see clause 13.1). The intervals between successive wake-ups shall be dependent on the number of repeated header frames used in powersave wake-up according to clause 10.1.4.1.

The maximum sampling interval between wake-ups shall be  $T_{sam} = (n - 1) \times 80$  ms where  $T_{sam}$  is the sampling interval and  $n$  is the number of powersave wake-up headers. (see clause 13.1 for the  $T_{sam}$  value).

If the MS wakes and there is no activity on the channel for the duration of  $T_{ch\_chk}$  it may return to sleep.

If the MS wakes and decodes dPMR activity but the called station ID in the Header\_Message frame does not match the MS individual ID or one of the MS talkgroup IDs, the MS may return to sleep.

If the MS wakes and decodes dPMR activity and the called station ID in the Header\_Message frame matches the MS individual ID or one of the MS talkgroup IDs, the MS is able to calculate from the MI information bits the point in time when the payload item or signalling will begin. Upon completion of the payload item or signalling the MS may return to sleep.

## 10.2 Call procedures for Mode 2

This clause defines the following facilities for Mode 2 equipment:

- MS to/from MS, Gateway, Individual Voice Call Service;
- MS, Gateway to Talkgroup Voice Call Service;
- MS to/from MS or Gateway Individual T1, T2, T3 Data Call Service;
- MS to/from MS or Gateway Individual Short Data Delivery Service;
- MS or Gateway to Talkgroup Short Data Delivery Service;
- MS or Gateway from individual MS status polling;
- Call diversion.

NOTE: Gateway includes PABX, PSTN, LINE(n), DISPAT(n), and IPI.

In addition Mode 2 supports co-channel repeater networks.

### 10.2.1 Mode 2 MS to MS Call set up.

Individual Mode 2 calls may be preceded by a called party check. The called party check consists of a Connection\_Request Header + End\_Message pair illustrated in table 10.14.

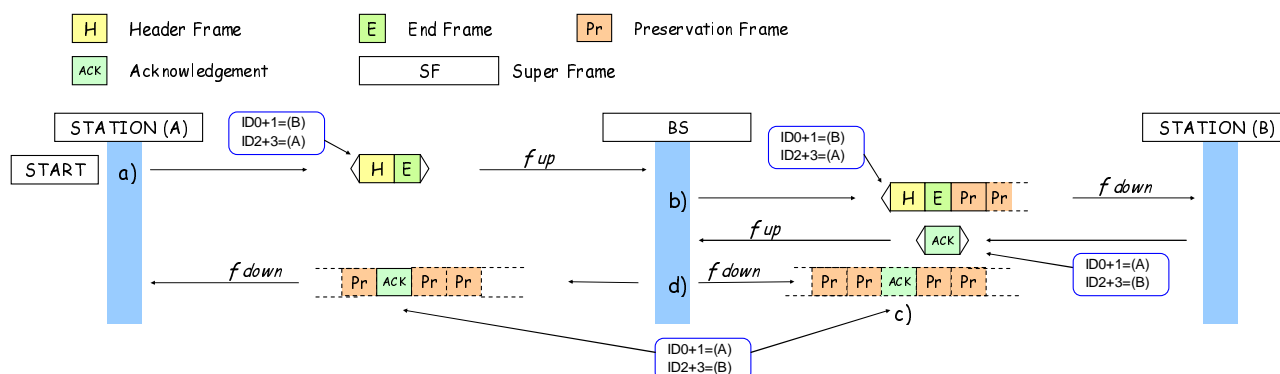


Figure 10.11: MS to MS call set up sequence

The calling party (STATION A) sends a Connection Request Header to the BS with its individual address in ID2+3 and the called party address (STATION B) in ID0+1. The BS retransmits this message verbatim (with the exception of the F bits) to the called party (STATION B). The called party sends an acknowledgement to the called party. The acknowledgement transmitted by the called party (STATION B) has ID0+1 set to the calling party address (STATION A) and ID2+3 set to the called party address (STATION B). THE BS retransmits the acknowledgement verbatim (with the exception of the F bits) to the calling party.

Table 10.14: Connection\_Request Header for a Mode 2 called party check

Alias	Alias	Alias	Value	Length	Meaning
MT			0001 <sub>2</sub>	4	Message Type = Connection_Request Header
PARMS	ID0 + 1			24	Called Station individual ID
	ID2 + 3			24	Calling Station ID
	M			3	Communications Mode
	V			2	Version
	F		10 <sub>2</sub>	2	Comms Format = BS Uplink
			11 <sub>2</sub>		Comms Format = BS Downlink
	EP			1	Priority (0 <sub>2</sub> for normal priority 1 <sub>2</sub> for emergency)
	PR		0 <sub>2</sub>	1	Preservation
MI	MI_TYPE	N/A	3	Not Applicable for this particular message	
	MI_DET	N/A	8	Not Applicable for this particular message	

The M field indicates the service that will form the content of the payload (voice/data, etc). The F field indicates if the message originated from the MS (uplink) or the BS (downlink).

The V field indicates if the payload is dPMR standard traffic channel content.

The EP field = 0<sub>2</sub> for a normal priority call or 1<sub>2</sub> for an emergency call.

Gaps in the MS payload item on the uplink shall be filled with Preservation frames on the downlink to inform MS not involved in the call that the BS is busy.

The BS stores any T\_ACK response on the uplink until the end of the current Preservation\_Frame when BS is able to seamlessly insert the T\_ACK frame, then transmit the remaining hangtime Preservation\_Frames.

### 10.2.2 Mode 2 MS to MS Voice Calls

Figure 10.12 illustrates a Mode 2 repeater system at the start of a call. The BS is initially idle. (In this particular example, when the BS is idle the BS carrier drops). The MS seizes the BS by transmitting the first item. The BS becomes active and the item is retransmitted by the BS with a delay that permits the BS to apply FEC on this uplink item. At the end of the item the BS echo's the End\_Frame then starts to transmit Preservation\_Frames. The Preservation\_Frames contain the ID of the called and calling party.

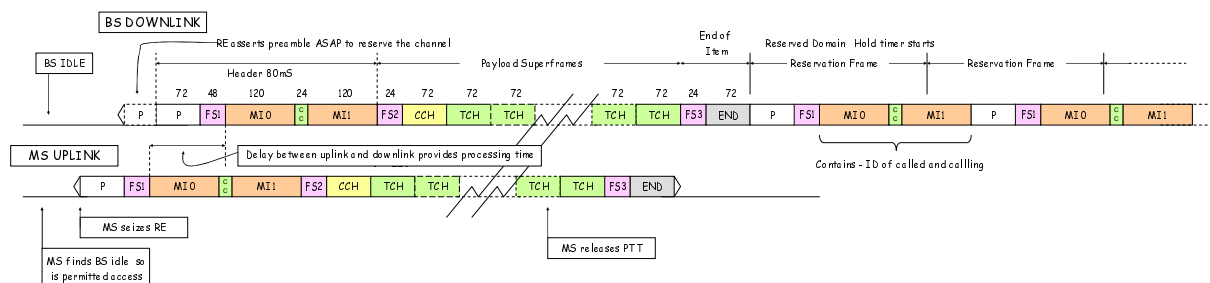


Figure 10.12: Mode 2 Repeater System

The recipient of the item listening to the BS knows that it is party to the call, so is permitted to transmit. If the call was to a talkgroup, joining MS (who may have just switched on for example) will be able to ascertain that they are permitted access by decoding the contents of any of the Header Frames, the Payload Superframes or the Preservation Frames.

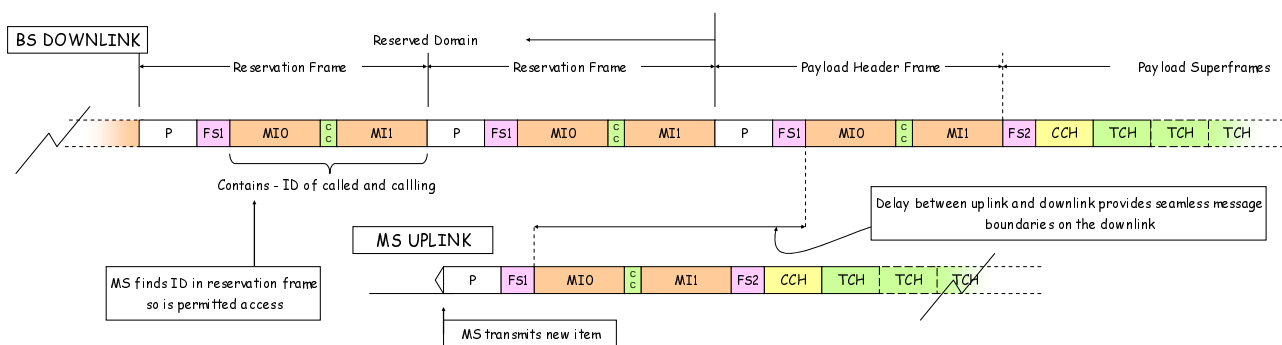


Figure 10.13: Start of New Transmission Item

Figure 10.13 illustrates the MS behaviour at the start of new MS transmission item when the BS is active transmitting Preservation\_Frames from a previous transmission item. The BS buffers MS uplink bits until the end of the current Preservation\_Frame when BS is able to seamlessly transmit the new Payload\_Header\_Frame for the new item.

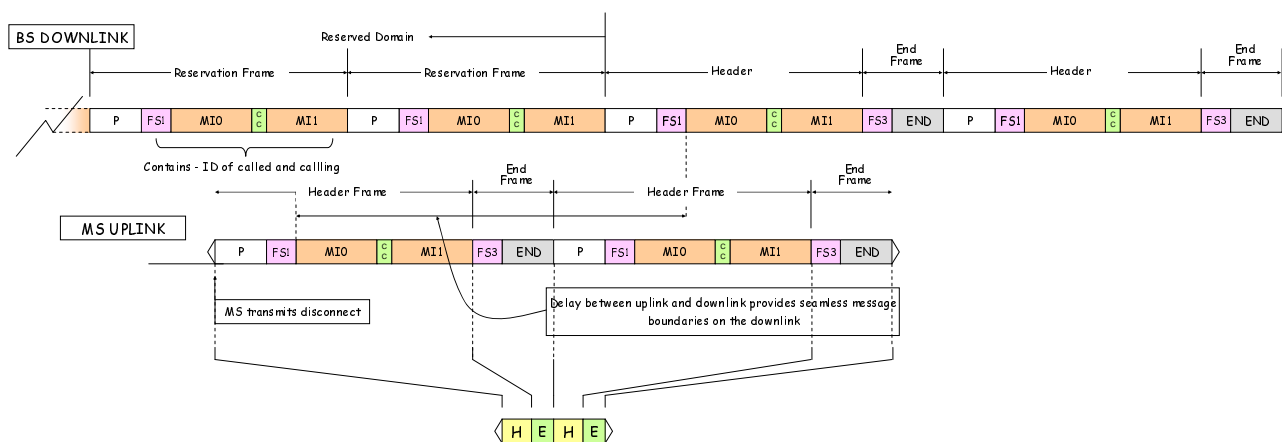


Figure 10.14: End of the call

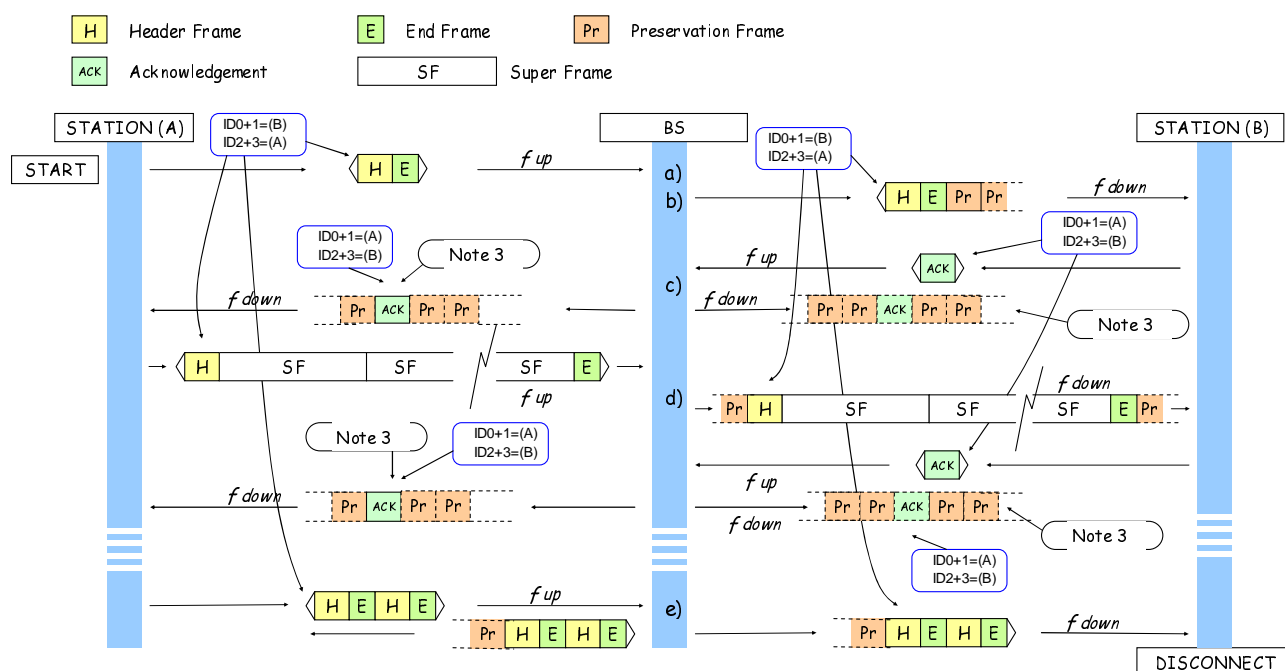
Figure 10.14 illustrates the behaviour at the end of the call. If the MS chooses to send a disconnect, the BS buffers MS uplink bits until the end of the current Preservation\_Frame when BS is able to seamlessly transmit the Header + End, Header +\_End sequence. The BS then reverts to idle.

## 10.2.3 Mode 2 Data Calls

### 10.2.3.1 Mode 2 T1 and T2 Data Calls

The data call traffic channel exchanges (following any called party check procedures, if used) are a series of asynchronous transmission items comprising Communication\_Start Header Message, 'n' Payload+Superframes and an End\_Message frame.

An example of a Mode 2 individual data call is illustrated in figure 10.15.



**Figure 10.15: Mode 2 Individual data call exchanges**

In this example the initial transmission from MS(A) is subject to polite access rules. If access is permitted then:

- The sending station uses the call set-up (Header and End frames) to the BS on the uplink frequency to establish that the receiving station is within range and not busy.
- The BS retransmits the call set-up on the downlink frequency to the receiving station. The BS protects the traffic channel against access by MS not involved in the call by transmitting preservation frames.
- When the receiving station has acknowledged with a T\_ACK, the T\_ACK is repeated by the BS to the sending station. The sending station commences to send the data in 4 superframe bursts. After each burst the receiving station decodes and error checks the data and if there are no errors a positive T\_ACK is sent. If errors are detected then a negative T\_ACK would be sent and the sending station would repeat that transmission.
- The BS retransmits the T\_ACK on the downlink.
- When all the data has been transmitted and positively acknowledged the sending station sends a disconnect request through the BS to show that the transaction is complete. The BS then drops its carrier.

NOTE 1: There is an inherent delay between information received by the BS on the uplink channel and the BS retransmitting the information on the downlink channel.

NOTE 2: In the gap between transmission items, the Base Station transmits preservation frames to preserve the system for the call.

NOTE 3: During the call the transmission from the BS is continuous. Preservation frames are transmitted when there are no MS originated messages to transmit. Unless an MS is transmitting, frames may be received that are directed to the other party. This is illustrated in figure 4.23 in the acknowledgement frames.

For a data call to a talkgroup, acknowledgements are not transmitted.

If the sending MS does not receive an acknowledgement, the data item may be repeated or the sender may send an RLA (Repeat Last Ack) message.

### 10.2.3.2 Mode 2 T3 (Packet) Data Calls

T3 (Packet) data calls are always individual calls as each packet is acknowledged. MS may choose to send a called party check before the first packet data item is transmitted. The BS protects the traffic channel against access by MS not involved in the call by transmitting preservation frames. The packet items follows the same format as clause 10.1.3.2. Uplink and Downlink headers are distinguished by the F field ( $10_2$  for uplink and  $11_2$  for downlink).

### 10.2.3.3 MS to MS Status request and responses

The request consists of a Status\_Request + End frame pair. The polled party receiving a status request shall reply with a Status\_Response message.

The BS shall protect the traffic channel by inserting preservation frames immediately after the Status\_Request + End frame pair has been re-transmitted on the downlink preserving the channel for the polled party acknowledgement. The BS may also protect the traffic channel as soon as the initial message at the start of the transaction on the uplink is detected. The BS buffers any status response from the polled party until the end of the current Preservation\_Frame when BS is able to seamlessly transmit the H+E frame pair of the status response. At the end of the transaction the BS shall return to idle.

An example of a Mode 2 Status Request transaction is illustrated in figure 10.16.

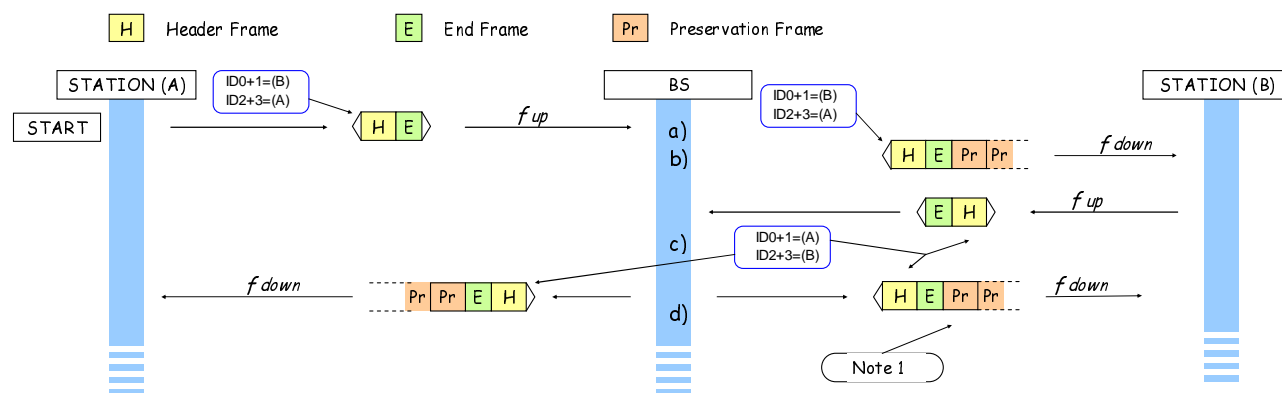


Figure 10.16: Mode 2 Status Polling

In this example:

- The requesting station sends a Status Polling Request Header + END pair as described by tables 10.15 and 10.16 with the Message\_Type set to 'Status Polling Request' ( $1000_2$ ). The END shall set the acknowledgement (ARQ) field to  $012$  that signifies an acknowledgement is required (that contains the status value);
- The BS retransmits the status request Header + END on the downlink to the polled station B substituting the Comms Format = downlink. The BS protects the traffic channel against access by MS not involved in the transaction by transmitting preservation frames (although not shown in this example preservation frames may be transmitted by the BS as soon as the start of the transaction is detected by the BS);
- Station B responds with the status by transmitting a Status\_Response\_Header + END pair as described in tables 10.17 and 10.18;
- The BS retransmits the status on the downlink to the requesting B substituting the Comms Format = downlink. When the transaction is complete the BS reverts to idle.

NOTE: During the transaction the transmission from the BS is continuous. Preservation frames are transmitted when there are no MS originated messages to retransmit.

**Table 10.15: Mode 2 Status Polling Request header**

Alias	Alias	Alias	Value	Length	Meaning
MT			1000 <sub>2</sub>	4	Message Type = Status Polling Request Header
PARMS	ID0 + 1			24	Called Station individual MS ID
	ID2 + 3			24	Calling Station ID
	M		N/A	3	Not Applicable for this particular message
	V		N/A	2	Not Applicable for this particular message
	F		10 <sub>2</sub>	2	Comms Format = uplink
	EP		N/A	1	Not Applicable for this particular message
	PM		N/A	1	Not Applicable for this particular message
	MI	MI_TYPE		N/A	3
MI_DET			N/A	8	Call Information

**Table 10.16: END (for Mode 2 status request)**

Alias	Length	Value	Meaning
ET	2	00 <sub>2</sub>	End type = Normal End Frame
ARQ	2	01 <sub>2</sub>	ACK requested
Tx_WAIT	4	value	Tx Wait
STAT	5	N/A	Not Applicable for this particular message
RSVD	4	0000 <sub>2</sub>	Reserved

**Table 10.17: Mode 2 Status Polling Response header**

Alias	Alias	Alias	Value	Length	Meaning
MT			0111 <sub>2</sub>	4	Message Type = Status Polling Response Header
PARMS	ID0 + 1			24	MS ID that originated the message for which this response is being sent
	ID2 + 3			24	MS ID that is sending this response
	M		N/A	3	Not Applicable for this particular message
	V		N/A	2	Not Applicable for this particular message
	F		10 <sub>2</sub>	2	Comms Format = uplink
	EP		N/A	1	Not Applicable for this particular message
	PM		N/A	1	Not Applicable for this particular message
	MI	MI_TYPE		N/A	3
MI_DET			N/A	8	Not Applicable for this particular message

**Table 10.18: Mode 2 END (for status response)**

Alias	Length	Value	Meaning
ET	2	01 <sub>2</sub>	End type = End frame with status message
ARQ	2	00 <sub>2</sub>	ACK not requested
TX_WAIT	4	0000 <sub>2</sub>	Not Applicable for this particular message
STAT	5	value	Status value returned to the polling entity
RSVD	4	0000 <sub>2</sub>	Reserved

#### 10.2.3.4 MS to MS Short Data

An MS may send a short data message to an MS or talkgroup. The UDT protocol enables the sender to define the format of the data including binary, BCD, text, byte and NMEA. These formats are described in clause 5.6.

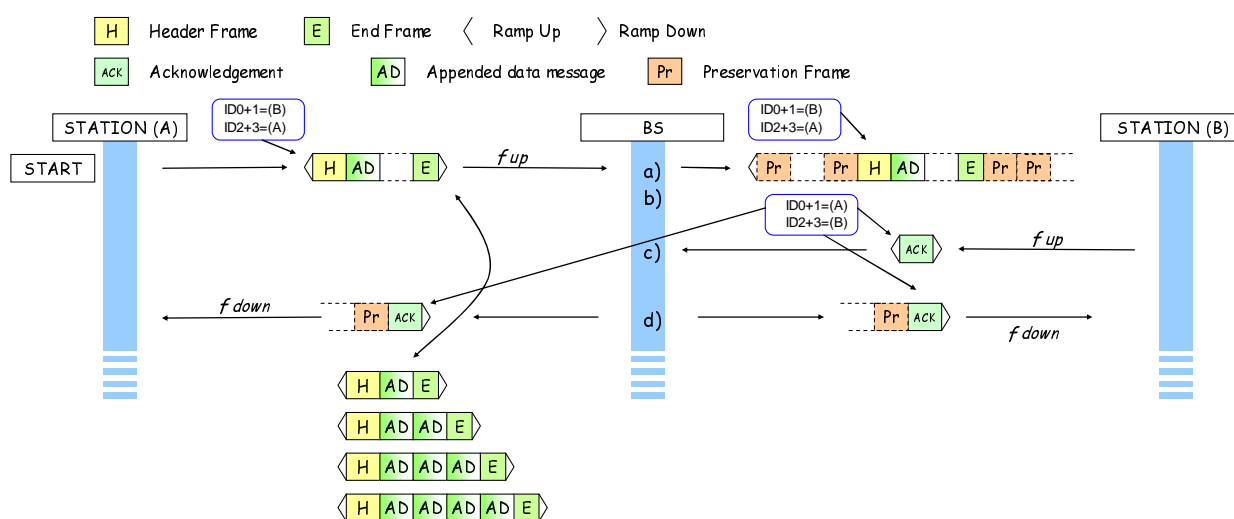
If the short data destination is a talkgroup, an acknowledgement is not transmitted by the recipient(s) (and the ARQ field in the END frame is set to 00<sub>2</sub>).

A short data message does not create a logical connection so there is no need to send a disconnect.

The burst sequence is a Connection\_Request header + 1 to 4 Appended\_Data messages + END frame.

Referring to figure 10.17:

- Station 'A' builds the burst from a Connection\_Request Header + between 1 and 4 concatenated Appended\_Data data messages + an END message. The format of the Appended\_Data is coded using the UDT format. This is transmitted to the BS.
- The BS protects the channel by transmitting preservation frames when the uplink burst is first detected. The BS retransmits the burst (substituting the Comms format = downlink). The BS then resumes preservation frames to protect the channel for the acknowledgement.
- Station 'B' acknowledges receipt of the short data.
- The acknowledgement is retransmitted back to the sending station. The BS then resumes idle.



**Figure 10.17: Mode 2 Short Data Transaction**

The Connection\_Request from the calling MS is coded as table 10.19. The BS shall retransmit the burst on the downlink substituting  $F = 11_2$  for the downlink. The BS shall insert preservation frames on the downlink until the transaction is complete then the BS shall revert to idle.



Table 10.19: Mode 2 Short\_Data Header (Uplink)

Alias	Alias	Alias	Value	Length	Meaning
MT			0001 <sub>2</sub>	4	Message Type = Connection_Request
PARMS	ID0 + 1			24	Called MS talkgroup or gateway
	ID2 + 3			24	Calling MS ID
	M		110 <sub>2</sub>	3	Service requested is defined by MI_TYPE
	V		N/A	2	Not Applicable for this particular message
	F		10 <sub>2</sub>	2	Comms Format = Uplink
	EP		0 <sub>2</sub>	1	Non emergency service
			1 <sub>2</sub>		Emergency Service
	PM		N/A	1	Not Applicable for this particular message
	MI	MI_TYPE		000 <sub>2</sub>	3
MI_DET			UAD	2	Appended Short Data. Number of appended UDTs required to transport short data
			SYMB		6

NOTE: The field UAD defines the number of UDT Appended\_Data messages concatenated to the Short\_Data header (00<sub>2</sub> to 11<sub>2</sub> represents one to four Appended\_Data messages). The SYMB field is applicable for BCD, 7 bit text and 8 bit octet formatted data. If address, binary, EN 61162-1 [1] or IP address is transported SYMB = 00 0000<sub>2</sub>. For BCD, 7 bit, 8 bit data format, SYMB is coded to the number of symbols to be transmitted unless the number of symbols is 64 when SYMB = 00 0000<sub>2</sub>.

## 10.2.4 Mode 2 MS Mode 2 Call Diversion

An MS may divert calls from its individual MSID to another destination. The destination shall be a diverted individual MS ID. This transaction is a call between the MS initiating the diversion and the BS. The MS uses the UDT protocol for this service.

If the MS has an active diversion for a particular MS, the BS shall transpose the MS ID with the diverted MSID between the uplink and downlink messages.

The MS uses the UDT protocol to pass the diverted address to the BS.

Figure 10.18 illustrates the transaction between an MS and the BS to set or clear a call diversion.

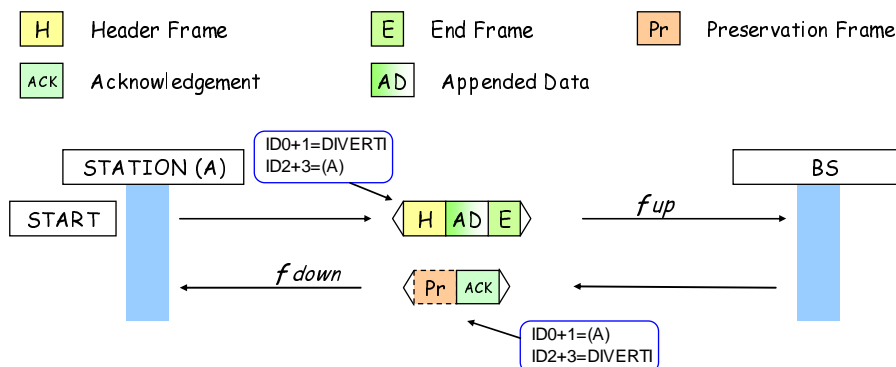


Figure 10.18: Call Diversion

The BS shall only accept a diversion to an individual MS ID. Only the MS that set the diversion shall be permitted to clear it using the AI. The BS may clear the diversion at any time. The method and reason is outside the scope of the present document.

If the BS supports call diversion and is able to accept the Set/Clear diversion, the response is ACK else the response is NACK.

If the BS is not able to respond to the call diversion request immediately, the BS may send preservation frames prior to the acknowledgement message.

The normal Connection\_Request header fields for a set call diversion in the uplink burst are illustrated in table 10.16.

**Table 10.20: Connection\_Request for a Set/Clear Call Diversion**

Alias	Alias	Alias	Length	Value	Meaning
MT			4	0001 <sub>2</sub>	Message Type = Connection_Request Header
PARMS	ID0 + 1		24	DIVERTI	Gateway ID DIVERTI
	ID2 + 3		24		Calling Station MS ID
	M		3	110 <sub>2</sub>	Service requested is defined by MI_TYPE
	V		2	N/A	Not Applicable for this particular message
	F		2	10 <sub>2</sub>	Comms Format = uplink
	EP		1	N/A	Not Applicable for this particular message
	PM		1	N/A	Not Applicable for this particular message
	MI	MI_TYPE		3	011 <sub>2</sub>
MI_DET			2	00 <sub>2</sub>	UAD Number of Appended_Data messages = 1
			6	SYMB	N/A for call diversion

NOTE: The UDT Appended\_Data uses UDT\_FORMAT = 000<sub>2</sub> Address format is MS ID.

The Appended\_Data message for call diversion is illustrated in table 10.21. If the diversion is successful the BS shall respond with ACK. If diversion is unsuccessful or unsupported the BS shall respond with NACK.

**Table 10.21: Appended\_Data for call diversion**

Alias	Length	Value	Meaning
MT	4	1111 <sub>2</sub>	Message Type = Appended_Data
W	1	0 <sub>2</sub>	N/A for Mode 2 messages
UDT_FORMAT	3	000 <sub>2</sub>	UDT format is MSID
ADDRESS1	24	DIV	Diversion_Address
ADDRESS2	24	24 x 0 <sub>2</sub>	N/A for call diversion
RSVD	16	16 x 0 <sub>2</sub>	Reserved

#### 10.2.4.1 Setting the diversion

The ADDRESS1 field in the Appended\_Data message contains the Diversion\_Address. If a new call diversion is requested from an MS that already has a call diversion set, the new diversion address shall overwrite the previous call diversion address.

#### 10.2.4.2 Cancelling the diversion

The ADDRESS1 field in the Appended\_Data message contains the Calling MS ID that set the call diversion.

### 10.2.5 Mode 2 Connection to line connected destinations

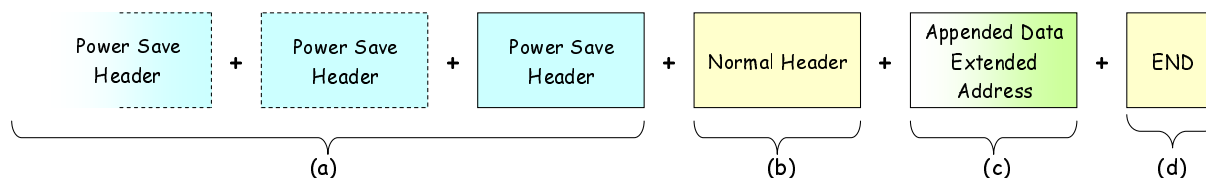
MS may make calls to and from line connected destinations. Line connected destination may be identified by a 24 bit address or may require extended addressing information (such as PABX/PSTN/IP). Table 10.22 illustrates the gateway addresses that require extended addressing.

**Table 10.22: Matrix for Mode 2 calls to line connected destinations**

Type of Call	Gateway	Extended Addressing	Format of Extended Addressing
Call to the system line connected dispatcher	LINEIn n = 1 to 4	No	
Call to the system dispatched	DISPATIn n = 1 to 4	No	
Call to the PABX	PABXI	Yes	BCD terminated in DIAL_NULL
Call to the PSTN	PSTNI	Yes	BCD terminated in DIAL_NULL
Call to an IP Destination	IPI	Yes	IPV4 or IPV6

Table 10.22 illustrates the destinations that do not require extended addressing only requiring the gateway address. For destinations that do require extended addressing, this extended addressing is dialling information using BCD digits for PABX and PSTN, or an IPV4/IPV6 address for an IP destination. Destinations that use BCD coding and '\*' and '#' characters, the digits symbol table in clause 5.5.11 describes the alphabet.

The method by which an MS builds the burst for a Connection Request is uniform and logical. The steps are illustrated in figure 10.19.

**Figure 10.19: Burst build-up for a line connected call**

The steps to build a call set-up burst are:

- If necessary powersave messages preceded a normal Connection\_Request header.
- The Connection\_Request header contains fields that define the call service requested and if Appended\_Data message(s) are necessary. The called ID field contains a gateway ID that indicates the type of line connected equipment that the MS wishes to connect to. Valid gateway IDs are PABXI, PSTNI, LINEI(n), IPI.
- If the call set-up requires extended address information (such as dialled digits for PSTN), that extended information is encapsulated in an Appended\_Data message.
- Finally the END message completes the call set-up burst.

For a call to a PABX/PSTN destination the format of the Extended Address in an Appended\_Data message is BCD.

For a call to an IP destination the format of the Extended Address in an Appended\_Data message is IPV4 or IPV6.

Calls set-up to line connected destinations shall begin with a Connection Request using a Connection\_Request header. For destinations requiring extended addressing, the Connection\_Request header is the header to a UDT Appended\_Data message. The Appended\_Data messages are described in clause 5.6.

The call set-up to establish a connection between an MS and a line type entity that does not use extended addressing is illustrated in figure 10.20.

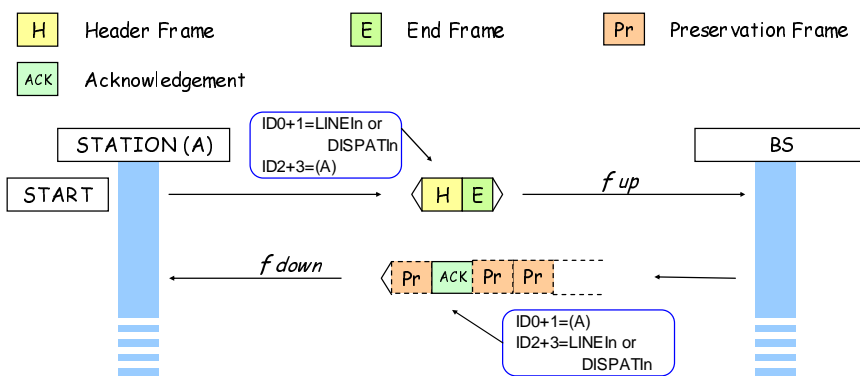


Figure 10.20: Call to LINEIn or DISPATIn Gateway

If the call destination requires extended addressing an Appended\_Data message is concatenated to the Connection\_Request Header. An example of a complete call to a PABX/PSTN destination that requires extended addressing is illustrated in figure 10.21.

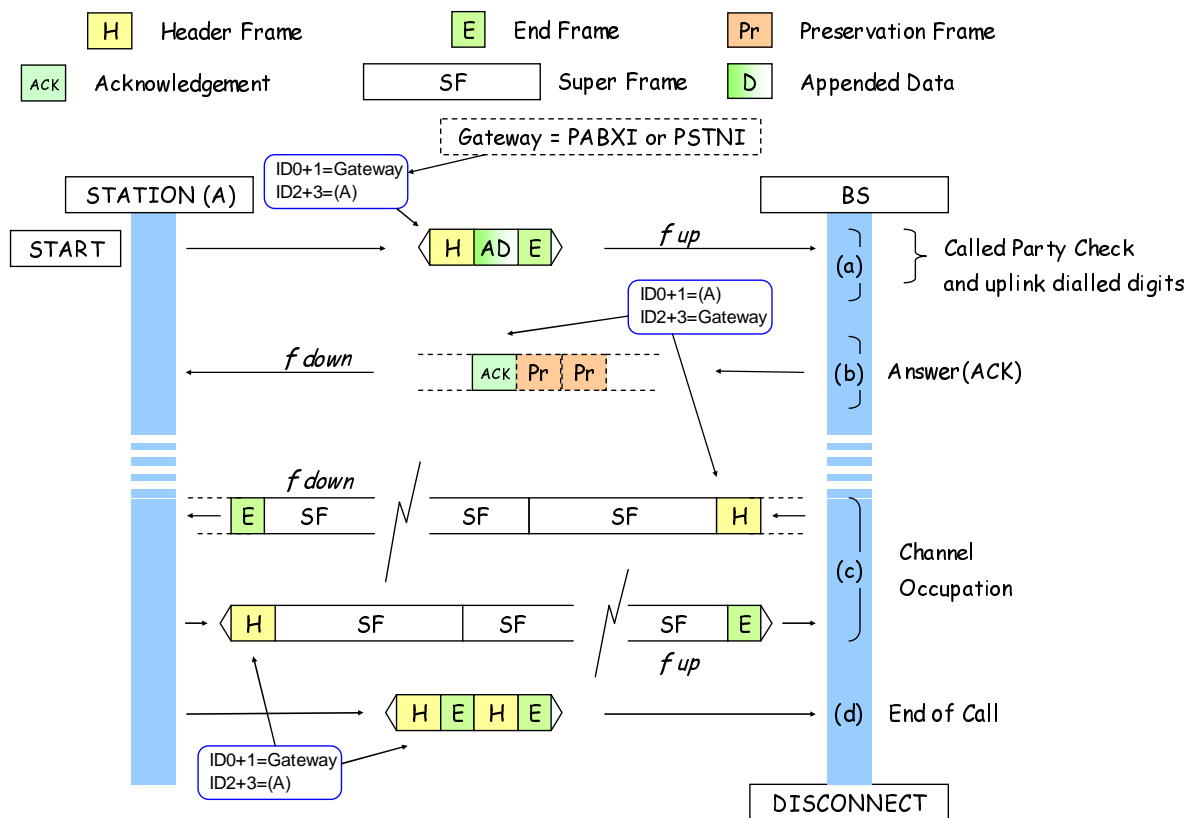


Figure 10.21: Call to PSTN/PABX

Referring to figure 10.21 the call set-up procedure is:

The calling MS selects the destination PABX extension or PSTN number.

- a) The MS sends a called Connection\_Request header setting the destination ID to the gateway address. The destination ID is PABXI for a PABX extension or PSTNI for a PSTN destination. This step creates the call connection. The channel is protected by preservation frames transmitted by the BS. The dialled digits are carried in the Appended\_Data message.
- b) A positive acknowledgement is sent from the BS.
- c) During channel occupation the voice path from the gateway to the MS is continuous. The voice path from the MS to the gateway is active when the MS is transmitting a voice item.

- d) The MS has disconnected the call. If the BS is able to detect the line connected party has hung up, the BS shall send the disconnect message.

When the BS receives the connection request it shall protect the channel by transmitting Preservation frames on the downlink. When the BS has processed the uplink burst, the BS shall acknowledge the call by transmitting an appropriate acknowledgement. If the BS is able to connect the call requested, the acknowledgement shall be ACK. If the BS is unable to connect the call the acknowledgement shall be a NACK and the BS shall enter the idle state.

The payload and disconnect messages shall use the called party = gateway ident to identify the users of the channel.

### 10.2.5.1 Voice Call Connection\_Request message

The normal Connection\_Request header fields in the MS uplink burst are set as table 10.23.

**Table 10.23: Connection\_Request for call to a line connected destination**

Alias	Alias	Alias	Length	Value	Meaning	
MT			4	0001 <sub>2</sub>	Message Type = Connection_Request Header	
PARMS	ID0 + 1		24		Gateway ID PABXI, PSTNI, LINEIn, DISPATIn	
	ID2 + 3		24		Calling Station MS ID	
	M		3		Call Service - Voice/data etc	
	V		2		Payload TCH content (if standard = 00 <sub>2</sub> )	
	F		2	10 <sub>2</sub>	Comms Format = uplink	
	EP		1	0 <sub>2</sub>	Normal Priority = 0 <sub>2</sub> Emergency Priority = 1 <sub>2</sub>	
	PM		1	N/A	Not Applicable for this particular message	
	MI	MI_TYPE		3	000 <sub>2</sub>	Appended_Data messages not required
					001 <sub>2</sub>	Appended_Data Message(s) needed for this call
					010 <sub>2</sub> to 110 <sub>2</sub>	Reserved
					111 <sub>2</sub>	Not a normal frame. This is a powersave frame
MI_DET			1	00 <sub>2</sub>	UAD	Number of Appended_Data messages needed to transport dialling digits
		6	N/A		Not Applicable for this particular message	

For a call to LINEI(n) or DISPATI(n) the Appended\_Data message is not required. For a call to the PSTN/PABX the Appended\_Data message(s) carry the dialled digits.

### 10.2.5.2 Call Matrix for calls to line connected destinations

Table 10.24 illustrates the fields for a Connection\_Request header for line connected destinations described in the present document.

**Table 10.24: Message matrix for calls to line connected destinations**

Call to	ID0 + 1	MI_TYPE	MI_DET		Appended_Data
			UAD	Dialled Digits	
Line(n)	LINEIn	000 <sub>2</sub>	00 <sub>2</sub>		No
Dispatcher(n)	DISPATIn	000 <sub>2</sub>	00 <sub>2</sub>		No
PABX	PABXI	001 <sub>2</sub>	00 <sub>2</sub>	Digits = 1 to 16	Yes UDP_FORMAT = 010 <sub>2</sub>
PSTN	PSTNI		01 <sub>2</sub>	Digits = 17 to 32	
			00 <sub>2</sub>	Digits = 1 to 16	
		01 <sub>2</sub>	Digits = 17 to 32		
IP (IPV4)	IPI	001 <sub>2</sub>	00 <sub>2</sub>		Yes UDP_FORMAT = 111 <sub>2</sub>
IP (IPV6)			01 <sub>2</sub>		

## 10.2.6 Mode 2 calls from line connected sources

Individual Mode 2 calls may be preceded by a called party check. For a line originated call the calling party type is set to the gateway ID. If the full address of the calling party is required (for instance the CLI of an inbound PSTN call), the extended address may be passed to the called party MS or talkgroup. Figure 10.22 illustrates such a call to an individual MS ID. If extended addressing is used to inform the MS the full called party address, the Connection\_Request header is the header to a UDT Appended\_Data message. The Appended\_Data messages are described in clause 5.6. The same downlink burst may be used for a call to a talkgroup but the called party check would not be acknowledged.

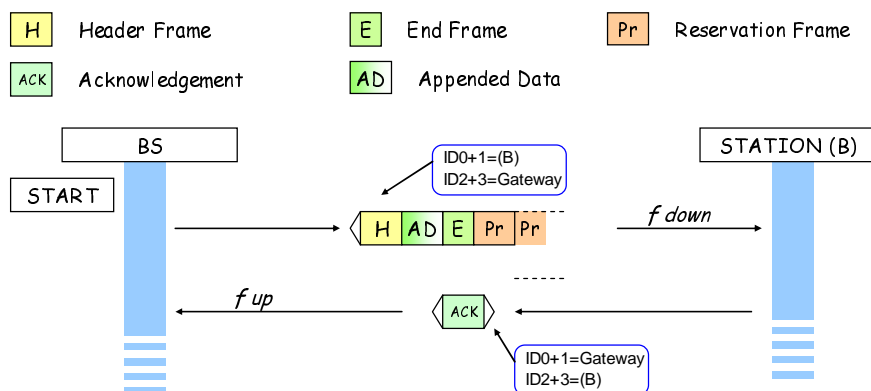


Figure 10.22: Call from a line connected source

### 10.2.6.1 Call Matrix for calls from line connected destinations

Table 10.25 illustrates the fields for a Connection\_Request header for calls to MS destinations from a line connected caller described in the present document.

Table 10.25: Call matrix for calls from line connected destinations

Call from	ID0 + 1	ID2 + 3	MI_TYPE	MI_DET		Appended_Data
				UAD	CLI Digits	
Line(n)	MS ID or talkgroup	LINEIn	000 <sub>2</sub>	00 <sub>2</sub>		No
Dispatcher(n)		DISPATIn	000 <sub>2</sub>	00 <sub>2</sub>		No
PABX (No CLI)		PABXI	000 <sub>2</sub>	00 <sub>2</sub>		No
PABX (CLI)			001 <sub>2</sub>	00 <sub>2</sub>	Digits = 1 to 16	Yes UDP_FORMAT = 010 <sub>2</sub>
PSTN (No CLI)		PSTNI	000 <sub>2</sub>	00 <sub>2</sub>		
PSTN (CLI)			001 <sub>2</sub>	00 <sub>2</sub>	Digits = 1 to 16	Yes UDP_FORMAT = 010 <sub>2</sub>
IP (IPv4)		IPI	001 <sub>2</sub>	00 <sub>2</sub>	Digits = 17 to 32	
IP (IPv6)				01 <sub>2</sub>	Digits = 17 to 32	

## 10.2.7 Mode 2 Co-channel repeater networks

Such co-channel BS networks are accessed using the BS\_Access Header Type. In all cases it is the MS that shall make the assessment of the received signals to select the optimum BS. This polling for best repeater shall be made prior to any call set up procedure.

### 10.2.7.1 MS originated repeater polling

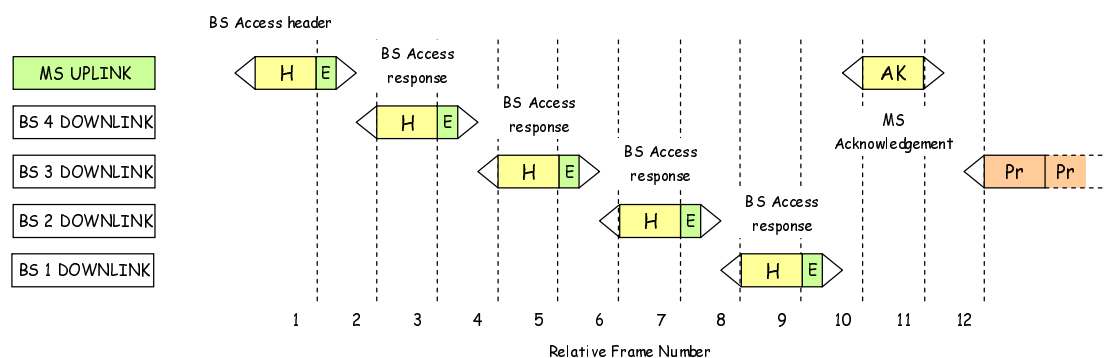
A co-channel network consists of a number of base station covering a wider geographical area than is possible with a single repeater. Clearly only one repeater may be transmitting a signal at any one time, therefore when idle all repeaters are de-keyed.

An MS shall select a repeater that provides the best signal quality before initiating the call to the called party. To identify separate BSs in the co-channel network, each BS is given a gateway address for the purposes of co-channel operation. Fifteen co channel addresses are defined in the present document - COCHI1 to COCHI15.

Figure 10.23 illustrates a four repeater Mode 2 network. MS may choose to select the repeater that provides the best grade of service by the following process:

- MS shall transmit a BS\_Access H + End frame (Message type =  $1010_2$ , MI\_TYPE= $000_2$ ) to Gateway ID COCHI0. Each repeater receiving this call shall respond in sequence with a BS\_Access response (MI\_TYPE =  $000_2$ ) + End that is transmitted after a time delay calculated from its own COCHI<sub>n</sub>. The MS with the highest COCHI<sub>n</sub> shall transmit its polling response first, then the other repeaters counting down in turn.
- The MS shall then evaluate the quality of each received response and use the best signal to identify the repeater that it shall use. (MS may use RSSI or other method to measure the quality of the responses).
- MS shall determine from any received replies when the final (COCHI = 1) transmission in the sequence will occur, and the downlink channel may be assumed to be free. The BS originated BS\_Access Header demands an acknowledgement. The MS selects the COCH BS that will be used for the call and sends an acknowledgement with ID1 + 0 set to the co-channel gateway address that will be used for the call. (In this example BS3 has been selected).
- The selected BS then asserts its carrier and transmits preservation frames until the MS makes its call set-up or payload transmission. (or the BS hang\_timer expires).

The call set up and call exchanges are then exactly as for normal repeater calls.



**Figure 10.23: MS polling of a 4 repeater network**

In a co-channel network, each call shall be preceded by the BS selection. It shall not be possible to seize a BS without this selection process. If the BS times out and becomes idle (de-keys), the selection process shall be repeated.

**NOTE:** The BS hang\_time is configurable. For co-channel networks designers may choose to set a BS hang\_time that is different for certain call services. For example voice services may have a longer BS hang\_time than data services.

When the selected BS asserts its carrier and transmits Preservation frames, the address of the called party is not known. The Preservation messages shall therefore contain the address of the calling party and DUMMYI until the BS is able to determine the called party address(or gateway) whereupon it shall substitute the legitimate users of the channel.

### 10.2.7.1.1 Description of the messages

The initial BS\_Access\_Header is illustrated in table 10.26 followed by the BS\_Access Response and T\_ACK message.

**Table 10.26: BS\_Access Header, Response and T\_ACK for Co Channel Access**

Alias	Alias	Alias	Value	Length	Meaning
MT			1010 <sub>2</sub>	4	Message Type = BS_Access header and response
PARMS	ID0 + 1			24	Gateway COCHIO
	ID2 + 3			24	Calling MS ID
	M		N/A	3	Not Applicable for this particular message
	V		N/A	2	Not Applicable for this particular message
	F		10 <sub>2</sub>	2	Comms Format = BS Uplink
	EP		N/A	1	Not Applicable for this particular message
	PM		N/A	1	Not Applicable for this particular message
	MI	MI_TYPE	000 <sub>2</sub>	3	No Appended_Data
other			Reserved		
MI_DET		N/A	8	Not Applicable for this particular message	

Alias	Alias	Alias	Value	Length	Meaning
MT			1010 <sub>2</sub>	4	Message Type = BS_Access header and response
PARMS	ID0 + 1			24	MS ID
	ID2 + 3			24	Gateway COCHIn
	M		N/A	3	Not Applicable for this particular message
	V		N/A	2	Not Applicable for this particular message
	F		11 <sub>2</sub>	2	Comms Format = BS Downlink
	EP		N/A	1	Not Applicable for this particular message
	PM		N/A	1	Not Applicable for this particular message
	MI	MI_TYPE	000 <sub>2</sub>	3	No Appended_Data
other			Reserved		
MI_DET		N/A	8	Not Applicable for this particular message	

Alias	Alias	Alias	Value	Length	Meaning
MT			0011 <sub>2</sub>	4	Mess_Type = T_ACK
PARMS	ID0 + 1			24	Gateway address of the chosen BS
	ID2 + 3			24	MSID
	M		N/A	3	Not Applicable for this particular message
	V		N/A	2	Not Applicable for this particular message
	F		10 <sub>2</sub>	2	Comms Format = BS Uplink
	EP		N/A	1	Not Applicable for this particular message
	PM		N/A	1	Not Applicable for this particular message
	MI	MI_TYPE	001 <sub>2</sub>	3	ACK (Rx OK)
MI_DET			8	Reason	

### 10.2.7.2 BS originated repeater polling

An individual call to an MS may originate from a line connected source. In this case the network shall determine the best BS for the call by polling the called party from each BS in turn.

Figure 10.24 illustrates a four repeater Mode 2 network.

The repeater with the highest COCHIn shall transmit a BS\_Access response +End frame (MI\_TYPE = 000<sub>2</sub>). The other BS shall transmit a BS\_Access response after a time delay calculated from its own COCHIn in turn.

MS shall determine from any received replies when the final (COCHI = 1) transmission in the sequence will occur, and the downlink channel may be assumed to be free. The BS originated BS\_Access Header demands an acknowledgement.



The called party MS shall then evaluate the quality of each received response and use the best signal to identify the repeater that it shall use. (MS may use RSSI other method to measure the quality of the responses).

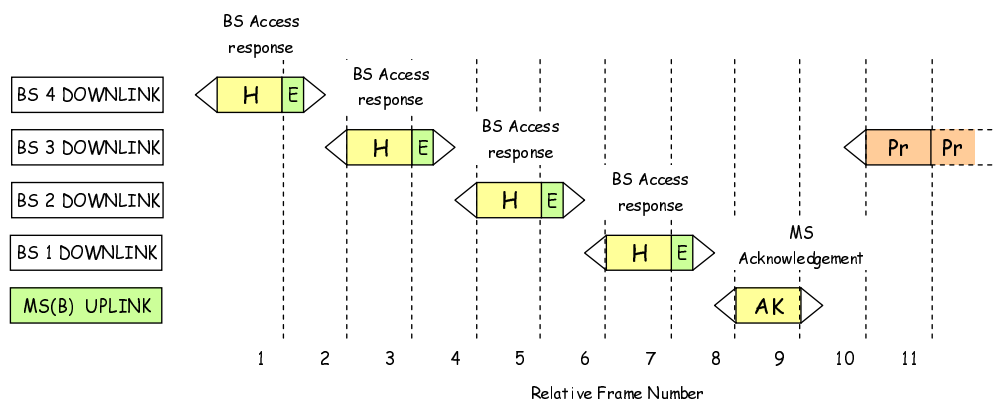


Figure 10.24: BS originated co-channel call set-up

The MS selects the COCH BS that will be used for the call and sends an acknowledgement with ID1 + 0 set to the co-channel gateway address that will be used for the call. (In this example BS3 has been selected).

The selected BS then asserts its carrier and transmits preservation frames identifying the legitimate users of the channel as the called party MSID and the gateway ID of the call originator (e.g. PABXI).

10.2.7.2.1 Description of the messages

The initial BS\_Access\_Response is illustrated in table 10.27 followed by the T\_ACK message.

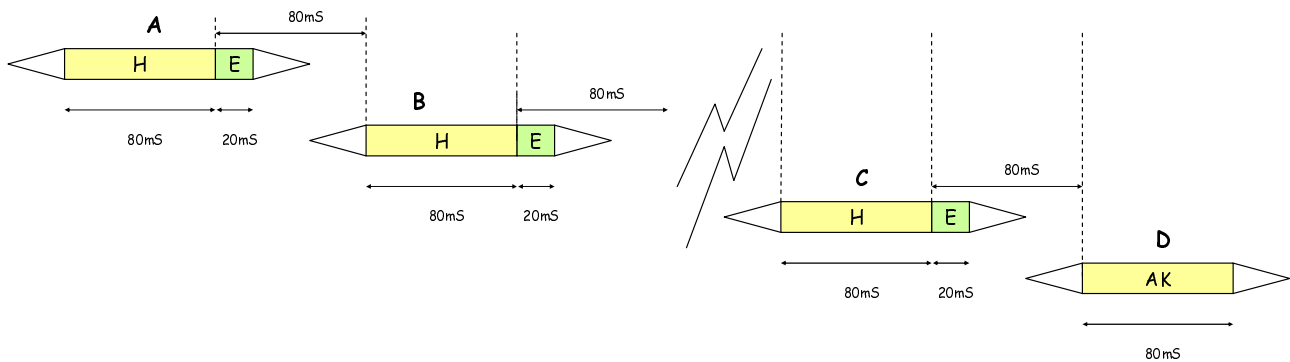
Table 10.27: BS\_Access Response and T\_ACK for Co Channel Access

Alias	Alias	Alias	Value	Length	Meaning
MT			1010 <sub>2</sub>	4	Message Type = BS_Access header and response
PARMS	ID0 + 1			24	MS ID
	ID2 + 3			24	Gateway COCHIn
	M		N/A	3	Not Applicable for this particular message
	V		N/A	2	Not Applicable for this particular message
	F		11 <sub>2</sub>	2	Comms Format = BS Downlink
	EP		N/A	1	Not Applicable for this particular message
	PM		N/A	1	Not Applicable for this particular message
MI	MI_TYPE	000 <sub>2</sub>	3	No Appended_Data	
		other		Reserved	
	MI_DET	N/A	8	Not Applicable for this particular message	

Alias	Alias	Alias	Value	Length	Meaning
MT			0011 <sub>2</sub>	4	Mess_Type = T_ACK
PARMS	ID0 + 1			24	Gateway address of the chosen BS
	ID2 + 3			24	MSID
	M		N/A	3	Not Applicable for this particular message
	V		N/A	2	Not Applicable for this particular message
	F		10 <sub>2</sub>	2	Comms Format = BS Uplink
	EP		N/A	1	Not Applicable for this particular message
	PM		N/A	1	Not Applicable for this particular message
MI	MI_TYPE	001 <sub>2</sub>	3	ACK (Rx OK)	
	MI_DET		8	Reason	

### 10.2.7.3 Access and Response timing

Figure 10.25 illustrates the timing from which each message in the co-channel network polling sequence is timed.



**Figure 10.25: Co-Channel BS/MS timing**

'A' is the first message from which the timing for subsequent messages shall be timed.

For MS originated repeater polling 'A' is the BS Access Header on the uplink. 'B' is the BS Access response with the highest COCHIn in the network. 'C' is the BS with ID COCHI1 and 'D' is the acknowledgement from MS(A).

For BS originated polling 'A' is the BS Access response with the highest COCHIn in the network. 'B' is COCHIn-1, 'C' is the BS with ID COCHI1 and 'D' is the acknowledgement from MS(B).

Although Mode 2 operation is asynchronous, for the purposes of co-channel polling, messages shall be timed into slots equal to a message frame as illustrated in figure 10.25.

**NOTE:** In a practical environment an MS listening to the BS Access Response messages, not all messages may be received because one or more BSs may be out of range. The BS is however able to calculate when the acknowledgement is sent from the COCHIn embedded in the message if it receives any one of the BS responses.

## 10.3 Call Procedures for Mode 3

The channel access mechanism for Mode 3 systems is described in clause 12.3. Channel access is synchronous and aligned to a beacon channel frame structure.

Access to Mode 3 Services from MS shall be by random access using the random access protocol described in clause 12.3.7. The B\_RAND random access frame contains all parameters necessary to signify the particular Mode 3 service requested.

Mode 3 equipment may support the following facilities:

- a) MS to/from MS or Gateway Individual Voice Call Service;
- b) MS or Gateway Voice Call Service to talkgroup;
- c) MS to/from MS or Gateway Individual Data Call Service;
- d) MS or Gateway Data Call Service to talkgroup;
- e) MS to/from MS/Gateway Individual Short Data Delivery Service;
- f) MS or Gateway Short Data Delivery Service to talkgroup;
- g) MS from MS or Gateway Individual data polling;
- h) Call Diversion Service;
- i) MS stun Service;

- j) MS kill service;
- k) Complementary Data Transfer Service.

NOTE: Gateway includes PABX, PSTN, LINE(n), DISPAT(n), IPI.

In addition the following intrinsic services support Mode 3 systems:

- a) MS location service for multi-site systems by registration (see clause 12.3.8.4);
- b) MS/BS authentication Service;
- c) UDT to support voice and data call facilities.

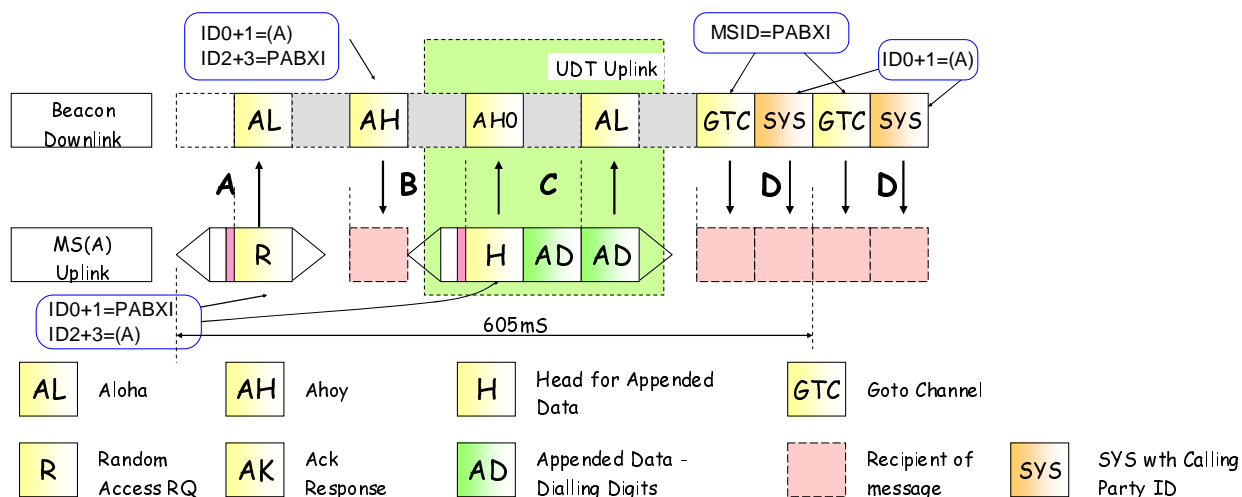
### 10.3.1 Mode 3 UDT Mechanism

To support Mode 3 Services and Facilities, the UDT is extensively used. UDT is used for:

- a) Complementary Data Transfer Service;
- b) Uplink transport of destination extended addresses that are connected through system gateways;
- a) Uplink of PSTN and PABX dialling digits from MS;
- b) Uplink of an MS address;
- c) Uplink of MS NMEA (EN 61162-1 [1]) location information;
- d) Downlink remote addresses that are connected through system gateways;
- e) Downlink CLI information from PABX/PSTN networks;
- f) Downlink NMEA (EN 61162-1 [1]) MS location;
- g) Short Data Transfer Delivery Service;
- h) Short Data Polling Service;
- i) Uplink diverted address digits for the Call Diversion Service.

To support these services the Mode 3 complementary data transport mechanism may be invoked to enhance the services.

For an MS call to an MS, talkgroup All-MS and simple gateways such as LINEIn and DISPATIn, the full source and destination address is encapsulated in the B\_RANDOM frame so a single-part call set-up procedure shall be invoked. For calls to some destinations however, the full destination address cannot be accommodated in one frame. One such example is a call to the PSTN where the destination is a number of dialled digits. For such cases the particular class of destination (PSTN, PABX, IP) is specified by a Gateway Ident which substitutes the called party address in the frame. For these destinations connected through a gateway (such as PSTN) that require extended addressing, a multi-part call procedure sets an appropriate gateway address as the destination in the B\_RANDOM frame. The BS then demands the extended addressing information (such as dialled digits) from the calling MS using the Unified Data Transport Service.



**Figure 10.26: Example of Multi-part call procedure**

Figure 10.26 shows an example of a call to a PABX extension:

- "A" is the random access B\_RAND frame. The destination address is set to PABXI indicating a multi-part call set-up for a call service to the PABX.
- "B" is a B\_AHOY frame to ask the calling MS for the PABX extension digits.
- The UDT uplink channel "C" contains a header and an Appended\_Data frame containing the PABX extension digits.
- The BS sends the Goto Channel frames to the MS at "D".

The format for the data transfer is the same for transfers using the downlink channel and the uplink channel. The header frame for UDT is illustrated in table 10.28. This frame carries source and destination addresses, the format of the data being carried (UDT\_Format), and if the UDT burst is carrying complementary data. Up to four Appended\_Data frames may be concatenated to the UDT header to carry the data. All Appended\_Data frames are transmitted consecutively.

Table 10.28: UDT Header

Alias	Alias	Alias	Value	Length	Meaning	
MT			1110 <sub>2</sub>	4	Message Type = UDT Header	
PARMS	ID0 + 1			24	Target MS ID or Gateway	
	ID2 + 3			24	Source MS ID or Gateway	
	UDT_FORMAT			000 <sub>2</sub>	3	MS ID
				001 <sub>2</sub>		Binary
				010 <sub>2</sub>		4 bit BCD
				011 <sub>2</sub>		ISO 7 bit character set
				100 <sub>2</sub>		ISO 8 bit character set (ISO/IEC 8859 [3])
				101 <sub>2</sub>		NMEA location coded (EN 61162-1 [1])
				110 <sub>2</sub>		IPV4
				111 <sub>2</sub>		IPV6
	V			N/A	2	N/A for a UDT Header
	F				2	Comms Format Uplink/Downlink
	EP			0 <sub>2</sub>	1	Non Emergency
				1 <sub>2</sub>		Emergency for the call this message is supporting
	COMP			1 <sub>2</sub>	1	This UDT is a Header where the Appended_Data is carrying Complementary Data supporting another Mode 3 service
0 <sub>2</sub>				This UDT is a Header where the Appended_Data is carrying Data for a user initiated service (Short Data/ Data Polling		
MI	MI_TYPE		N/A	3	Not Applicable for this particular message	
		MI_DET		2	UAD Number of Appended_Data messages concatenated to this UDT header	
				6	SYMB Number of symbols to be transported if this header is transporting short data	

The UAD field indicates the number of UDT frames that are appended to this header.

### 10.3.1.1 Format of the Appended\_Data

The format of the Appended\_Data is specified in annex B. The formats specified in the present document are:

- a) Address format - the appended frame(s) contain dPMR IDs;
- b) Binary Format - the appended frame(s) contain binary data;
- c) BCD format - the appended frames contain digit coded data;
- d) 7 bit text coded - the Appended\_Data is text coded using ISO 7 bit character set (ISO/IEC 646 [2]);
- e) 8 bit character coded - the Appended\_Data is character coded using ISO 8 bit character set (ISO/IEC 8859 [3]);
- f) NMEA (EN 61162-1 [1]) location format - the Appended\_Data is coded specifically for NMEA (EN 61162-1 [1]) position data;
- g) IPV4 or IPV6 address.

There are many examples of calls where the final destination address (such as PSTN dialled digits) cannot be carried in a single message. The UDT provides a common structure for transporting both user short data and addressing information between BS and MS(s). If a destination address is transported this way it is called an extended address.

### 10.3.1.2 UDT Structure

#### 10.3.1.2.1 UDT Content for Services Carried on the Downlink channel

The UDT downlink channel mechanism may be invoked as part of a dPMR service. The UDT header frame contains all parameters for an MS or talkgroup UDT. The data to be downloaded is held in the BS and the fields formed as table 10.29.

**Table 10.29: UDT Downlink channel field examples**

Service	Operation	Service	COMP	UDT-Format	Target address or gateway	Source or gateway address	MS Response to Head+Data
Voice Call from PSTN to Individual MS	Send CLI information from PSTN	Individual Voice Call Service	02	BCD	MS Address	PSTNI	ACK, NACK
Voice Call from PABX to Individual MS	Send CLI information from PABX	Individual Voice Call Service	0 <sub>2</sub>	BCD	MS Address	PABXI	ACK, NACK
Voice Call from PSTN to Talkgroup	Send CLI information from PSTN	Talkgroup Voice Call Service	0 <sub>2</sub>	BCD	Talkgroup	PSTNI	No
Voice Call from PABX to Talkgroup	Send CLI information from PABX	Talkgroup Voice Call Service	0 <sub>2</sub>	BCD	Talkgroup	PABXI	No
Voice Call from MS to Individual MS	Send NMEA information from Source MS	Individual Voice Call Service	1 <sub>2</sub>	NMEA	Destination MS Address	Source MS	ACK, NACK
Voice Call from MS to Individual MS	Send complementary text as part of call set-up	Individual Voice Call Service	1 <sub>2</sub>	7 bit txt	MS Address	Source MS	ACK, NACK
Short Data call from MS to MS	Short Data Downlink Phase	Individual Short Data	0 <sub>2</sub>	UDT_Format	Destination MS Address	Source MS	ACK, NACK
Short Data call from Dispatcher to MS	Short Data Downlink Phase	Individual Short Data	0 <sub>2</sub>	UDT_Format	Destination MS Address	DISPATI	ACK, NACK

### 10.3.1.2.2 UDT Mechanism for the Uplink channel

The UDT uplink channel mechanism may be invoked as part of a dPMR service. The UDT head frame contains all parameters for the UDT. The data to be uploaded is set as table 10.30. This table is not exhaustive and many other arrangements are possible to support Mode 3 services.

**Table 10.30: UDT Uplink channel field examples**

Service	Operation	Service	COMP	Format	Target address or gateway	Source address or gateway
Voice Call from Individual MS to PSTN	Send PSTN dialling information from MS	Individual Voice Call Service	0 <sub>2</sub>	BCD	PSTNI	MS Address
Voice Call from Individual MS to PABX	Send PABX dialling information from MS	Individual Voice Call Service	0 <sub>2</sub>	BCD	PABXI	MS Address
Voice Call from MS to Individual MS	Uplink NMEA information from Source MS	Individual Voice Call Service	1 <sub>2</sub>	NMEA	Destination MS	MS Address
Short Data call from MS to MS	Short Data Uplink Phase	Individual Short Data	0 <sub>2</sub>	UDT_Format	Destination MS	Source MS
NMEA polling from a gateway	Short Data Uplink Phase	Short data polling service	0 <sub>2</sub>	NMEA	A BS Gateway	Polled MS
Call Diversion Service	Diversion Uplink phase	Call Diversion service	0 <sub>2</sub>	value	DIVERTI	MS

### 10.3.1.3 Single Part and Multi-part call set-up

A fundamental characteristic of the UDT mechanism is that a call set-up may require a number of message exchanges between MS and BS.

A single part call set-up is a call where the initial message from the calling party is able to fully specify the destination address.

A multi-part call set-up requires at least two message exchanges to transport addresses or user information between the entities involved in the call transaction.

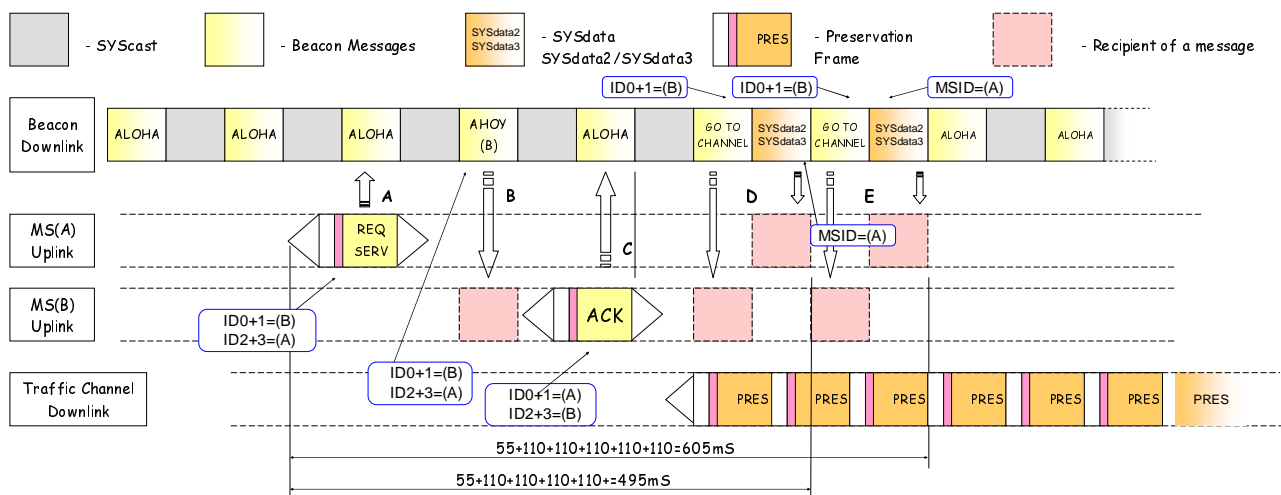
### 10.3.1.4 MS behaviour to B\_AHOY messages

B\_AHOY messages may be transmitted by a Mode 3 BS to ascertain if an MS is in radio contact and able to receive the call service specified by the B\_AHOY messages. Mode 3 systems may also send called party checks to talkgroups. If an MS receives an AHOY called party check to one of its talkgroups, it shall acknowledge the message. In practice, it is understood that multiple MS may respond to such a message and the acknowledgement will most likely be undecodeable. Mode 3 networks may cover a wide geographical area using many radio sites. If such a Mode 3 network supports wide area talkgroup calls, and a B\_AHOY is transmitted on these radio sites, the lack of a response would indicate that there are no talkgroups registered with that particular site. The system may then remove that site from the call thus saving spectrum usage.

## 10.3.2 Mode 3 call examples

### 10.3.2.1 An individual voice call example

Two MS, MS(A) and MS(B) are active listening to the beacon. MS(A) requests a voice service to MS(B). Before a traffic channel is assigned, the system checks that the MS(B) is in radio contact and wishes to accept the call. If MS(B) sends a positive acknowledgement response (indicating that MS(B) will accept the call), the system allocates a traffic channel for the call. The address of the called party was encapsulated in the random access request so this is a single part call set-up.



**Figure 10.27: Individual Call Set-up example**

Referring to figure 10.27, some key aspects are described. When a beacon has no calls in progress, it shall transmit system management or system broadcast messages to all MSs listening to the beacon.

- MS(A) makes a Service Request at point "A" aligning its timing to the beacon downlink channel (see figure 12.7).
- The beacon sends an AHOY message (point "B") addressed to MS(B) that demands an acknowledgement response.
- MS(B) responds with a positive acknowledgement at point "C".
- At point "D", the beacon sends a Goto Channel message addressed to MS(B). The calling party, MS(A) is directed to the traffic channel by the SYScast2/SYScast3 that immediately follows the Goto Channel message. A logical channel field in the Goto Channel message directs MS(B) to a particular physical channel; MS(B) may wish to wait for the SYScast2/SYScast3 to be received so that the address of the calling party MS(A) may be retrieved and indicated to the called party MS(B).
- The Goto Channel message is not acknowledged so the message is repeated for reliability at "E". A beacon may transmit the repeated Goto Channel message consecutively, or wait for a few framesets before repeating the Goto Channel message.

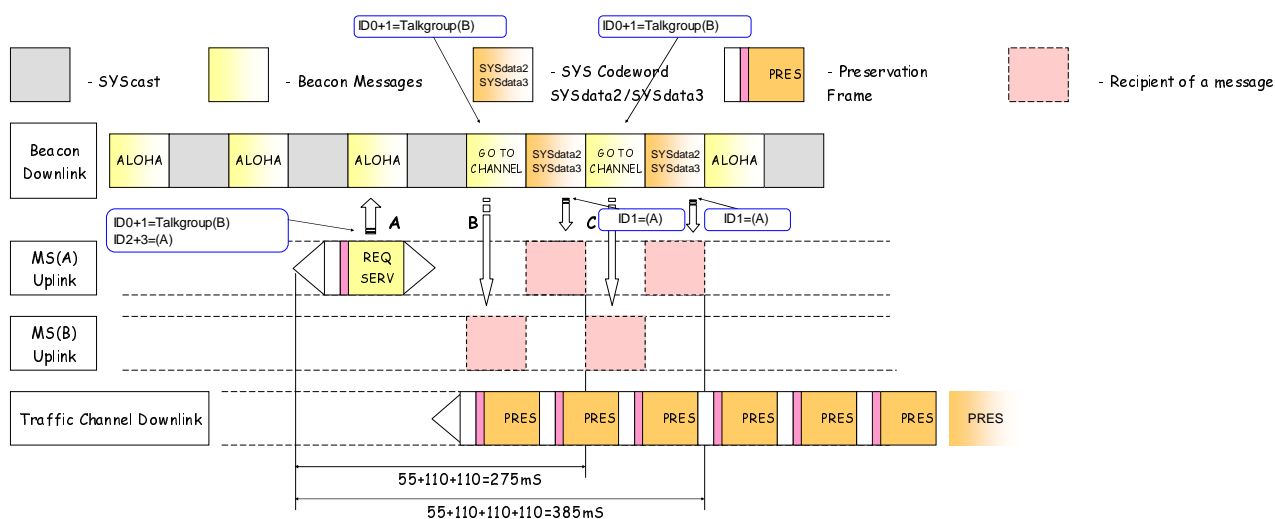
NOTE 1: The traffic channel is not time aligned with the beacon channel. In addition note that the traffic channel operation is asynchronous.

NOTE 2: Since each frame takes 55 ms, the best case performance for a Mode 3 individual call set-up is (30 ms MSramp + 15 ms MSpreamble + 10 ms MSsync + [8 × 55] ms) = 495 ms.



### 10.3.2.2 A Mode 3 talkgroup call example

For a talkgroup call, the intermediate step of checking if MS(B) is in radio contact is not required.



**Figure 10.28: Group Call set-up example**

Figure 10.28 illustrates a call set-up for a talkgroup call. MS(B) is a party to that talkgroup. For a talkgroup call, the intermediate step of checking if MS(B) is in radio contact is not relevant.

- MS(A) makes a Service Request at point "A" aligning its timing to the beacon downlink channel (see figure 12.7).
- At point "B", the beacon sends a Goto Channel message addressed to MS(B)(member of the talkgroup). The calling party, MS(A) is directed to the traffic channel by the SYScast2/SYScast3 that immediately follows the Goto Channel message. A logical channel field in the Goto Channel message directs the MSs involved in the talkgroup to a particular physical channel. Members of the talkgroup may wish to wait for the SYScast2/SYScast3 to be received so that the address of the calling party may be retrieved and indicated to the called parties (members of the talkgroup).
- The Goto Channel message is not acknowledged so the message is repeated for reliability at "C". A beacon may transmit the repeated Goto Channel message consecutively, or wait for a few framesets before repeating the Goto Channel message.

**NOTE:** The best case performance for a Mode 3 talkgroup call set-up is (30 ms ramp + 15 ms preamble + 10 ms sync + [4 x 55 ms]) = 275 ms.

### 10.3.2.3 Mode 3 Short Data call example

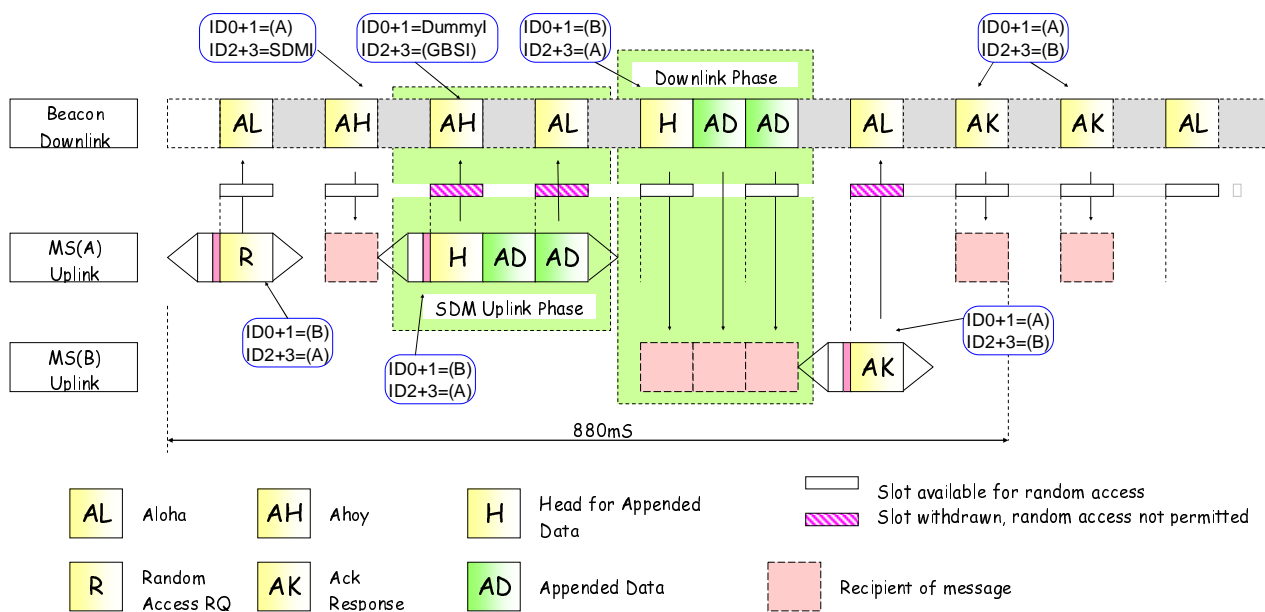


Figure 10.29: A Short Data call

Figure 10.29 is just one example showing how the Short Data service makes use of the UDT mechanism. The Short Data employs a store and forward technique and the procedures are fully described in clause 10.3.5.4.

However the UDT segments are highlighted to show the upload and download phases that are described in these clauses. In this example the UDT elements consist of a Header + two appended frames.

The transaction requires a number of message exchanges between the calling party and the Beacon so this is a multi-part call set-up.

### 10.3.2.4 Mode 3 Call to PABX/PSTN example

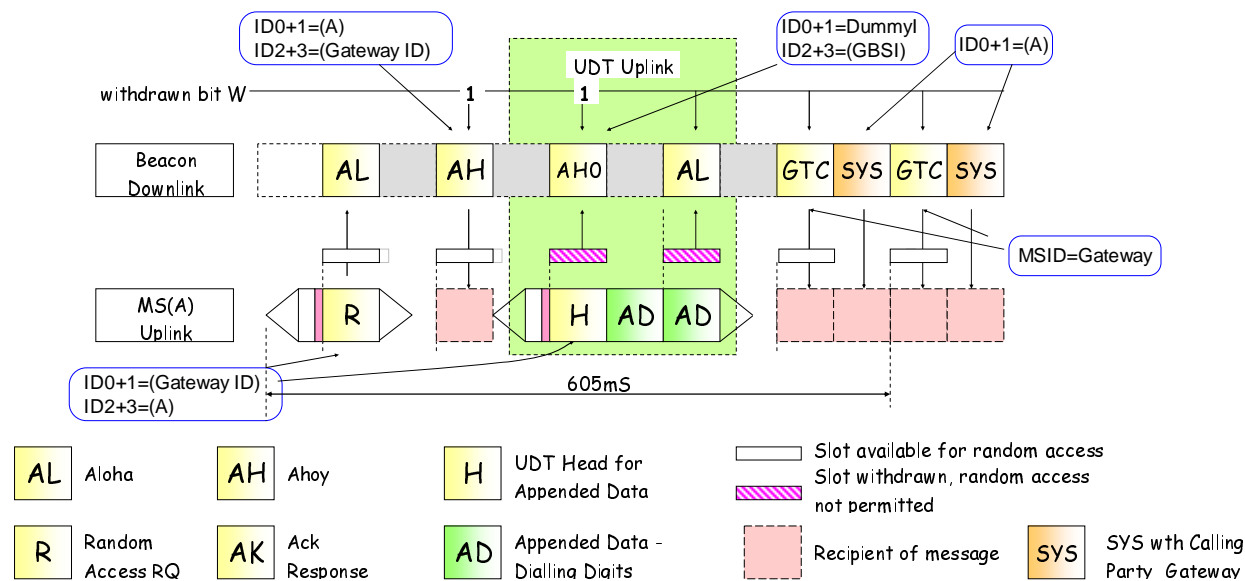


Figure 10.30: MS to PABX/PSTN Call using the UDT Mechanism

Figure 10.30 illustrates a call set-up for a call from an MS to the PABX/PSTN. Calls to these destinations are characterized by the necessity of passing the dialled destination to the system. The UDT mechanism provides an unambiguous transfer. In this example the UDT consists of a Header + two appended frames. In this example the UDT consists of a Header + two appended frames for up to 32 dialled digits.

The MS makes the call set-up request by transmitting a random access request to addressed PABX or PSTNI. The LONG parameter indicates that two Appended\_Data messages are needed to uplink the dialled digits. The BS sends an AHOY message to the MS inviting the MS to uplink the dialled digits. The response from the MS consists of two BCD Appended\_Data message concatenated to a UDT header. The AHOY contains the withdrawn bit W which is set to indicates to listening MS not involved in the call that the message frame is withdrawn for random access. The figure shows that two message frames shall be withdrawn. One way to achieve this is for the BS to transmit a second dummy AHOY addressed to DUMMYI - an MS address that is reserved. This is another example is a multi-part call set-up.

NOTE 1: The GTC message carries the ID of the Gateway and the frequency of the traffic channel. The appended SYcast2/SYScast2 carries the address of the calling party (MS(A)).

NOTE 2: The AHOY message carries the W bit that withdraws the uplink slot containing the UDT Header. The AH0 is an AHOY message to DUMMYI that does not expect a response but withdraws the slot for the second Appended\_Data message.

### 10.3.2.5 Mode 3 Call from the PABX/PSTN example

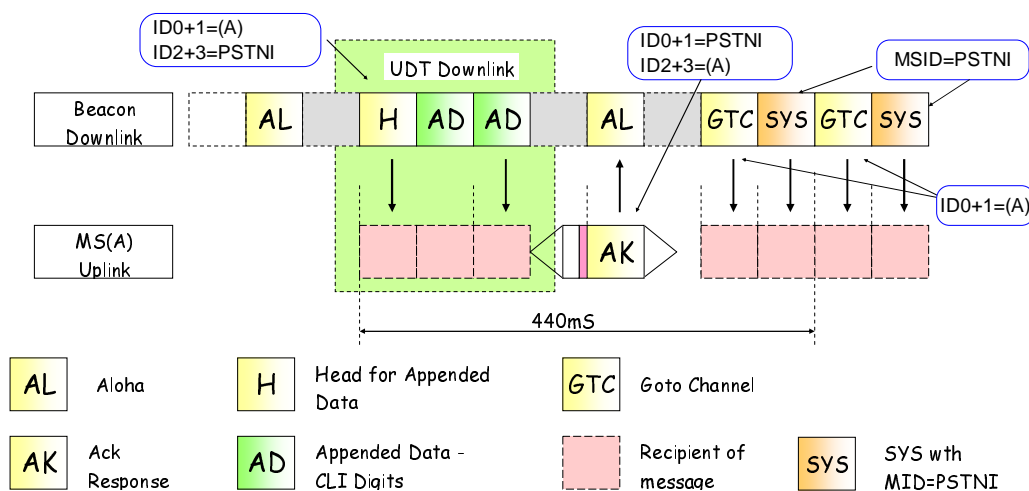


Figure 10.31: Call from the PSTN using the UDT Mechanism

Figure 10.31 illustrates a call from the PSTN, another example of a multi-part call set-up. The BS has elected to download the CLI information to the recipient as part of this call set-up. The Service\_Type field is passed in the header therefore the recipient MS knows the call is uplink and the call is from the PSTN. Since the Service\_Type is known to the recipient, a secondary feature of the UDT mechanism is that it may serve as a radio check. Only if the MS responds with a positive (B\_ACK) acknowledgement does the call mature. The particular message frame that the MS acknowledgement is expected is withdrawn by setting the withdrawn bit W in the second Appended\_Data message to 1<sub>2</sub>.

### 10.3.2.6 Mode 3 transport of complementary data example

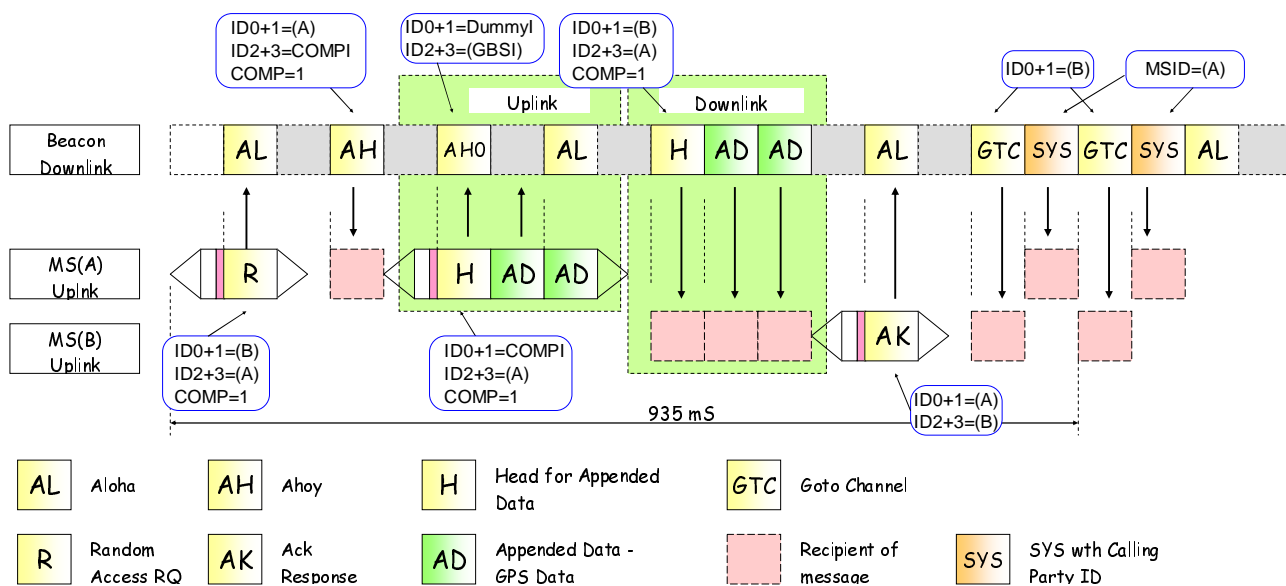


Figure 10.32: UDT mechanism carrying complementary data

Figure 10.32 illustrates how complementary data may be carried as part of multi-part call set-up. MS(A) wishes to send its GPS position as part of a voice call set-up. MS therefore indicates that complementary data is available by setting COMP = 1<sub>2</sub> in the random access call set up. The BS uploads the complementary data and passes the data to the recipient. The UDT download/acknowledgement also serves as the radio check.

NOTE: The AHOY message carries the W bit that withdraws the uplink slot containing the UDT Header. The AH0 is an AHOY message to DUMMYI that does not expect a response but withdraws the slot for the second Appended\_Data message. The second downlink Appended\_Data message sets the W bit to withdraw the slot for the acknowledgement.

### 10.3.2.7 Mode 3 transport of complementary data and an extended address example.

UDT is versatile enough to support a wide range of extended destination address and complementary data. In this example illustrated in figure 10.33, an MS wishes to set up a packet data call to an IPV4 destination and as part of the call set-up wishes to sent this text message "/CGI/code.cgi" to the network.

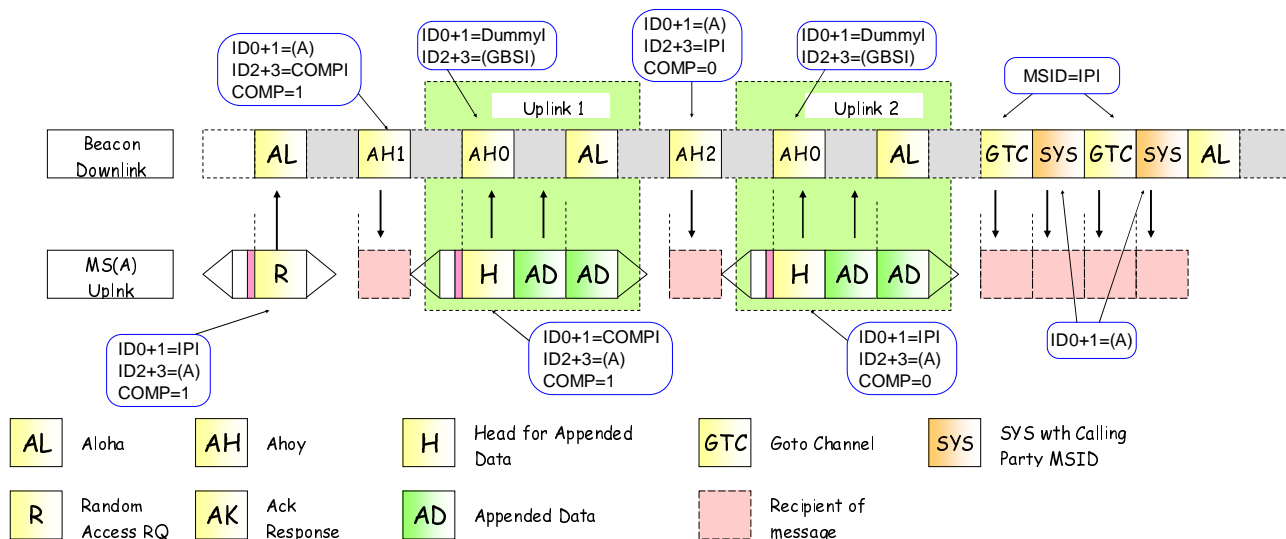


Figure 10.33: Call to an Extended Address with Complementary Data

The random access request from the MS contains the fields to achieve this call set-up. The destination address is set to IPI, LONG = 0<sub>2</sub> indicating IPV4. COMP = 1<sub>2</sub> advising the BS that complementary data is requested for this call. In the first part of the uplink phase, the BS sends an AHOY (AH1 in the figure) requesting the complementary data. The response from the MS is UDT Header + Appended\_Data (the text "/CGI/code.cgi") + filler. The BS then send an AHOY (AH2) requesting the extended address. The response from the MS is UDT Header + Appended\_Data (IP address) + filler. Finally the Goto Channel message is sent to the MS directing the call to a working channel.

NOTE: The AHOY message carries the W bit that withdraws the uplink slot containing the UDT Header. The AH0 is an AHOY message to DUMMYI that does not expect a response but withdraws the slot for the second Appended\_Data message.

### 10.3.2.8 Mode 3 Refusal of Service

An MS requests a call service by transmitting a random access message. This service call request may be

- a) accepted and the call proceeds to a completion; or
- b) the call or service is refused by the BS. The particular service requested by the mS may not be supported by the BS or the BS may not wish to accept service from this particular MS;
- c) the call may be refused by the called party because the called party does not support the particular service or call, or the called party does not wish to accept the call from that calling party or accept any calls.

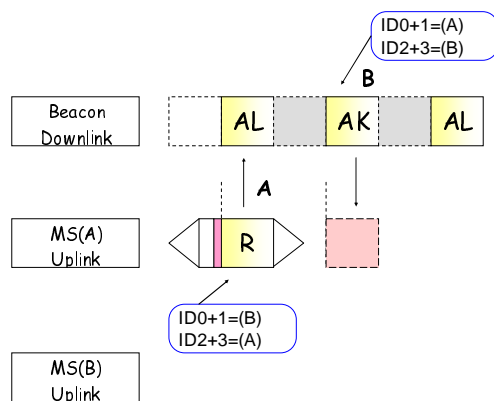


Figure 10.34: Call is refused by the BS

Figure 10.34 illustrates a call request that is refused by the BS:

- a) At [A], MS(A) makes a random access call request.
- b) At [B] The BS refuses the call by sending an N\_ACK acknowledgement.

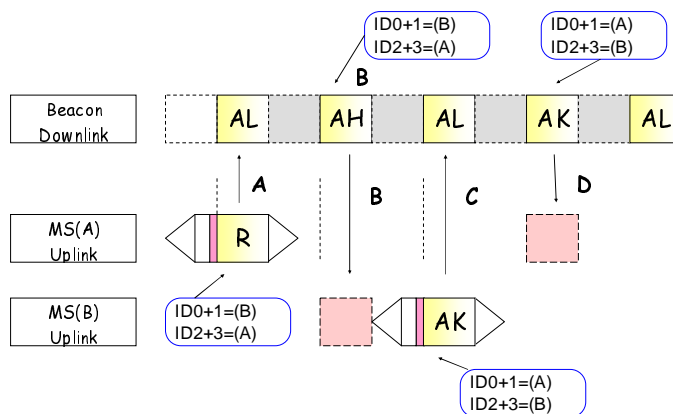


Figure 10.35: Call is refused by the Called Party

Figure 10.35 illustrates a call that is refused by the called party:

- a) At [A] MS(A) makes an individual call request addressed to MS(B).
- b) At [B] the BS sends an AHOY message to check if MS(B) is in radio contact and wishes to accept the call.
- c) At [C], MS(B) sends a B\_NACK indicating that MS(B) cannot accept or does not wish to accept the call. MS(B) knows the address of the calling party because the calling party ID is indicated by ID2+3 of the AHOY message.
- d) At [D] the B\_NACK is passed to MS(A) and the call is terminated.

### 10.3.3 Mode 3 Detailed Call procedures

The procedures for Voice calls are specified in clause 10.3.4 and data procedures on clause 10.3.5. The procedures include:

- a) Call Set-up:
  - 1) Random Access Call Request.
  - 2) Possible AHOY/UDT procedure to provide extended addressing for calls through gateways.
  - 3) Availability check to called party.
  - 4) Goto Channel frames.
- b) Call Management on the traffic channel:
  - 1) Call maintenance.
  - 2) Call clear-down.

#### 10.3.3.1 Mode 3 Procedures common to Voice calls and Data Calls

##### 10.3.3.1.1 Availability of requesting MS

An MS requests a call service by transmitting a random access service request. While the call set-up is in progress, the BS may check that the requesting MS is still in radio contact at any time by sending a B\_AHOY frame addressed to it. The B\_AHOY frame demands a response from the calling MS.

##### 10.3.3.1.2 Call Cancellation

If a Voice call service request has initiated, but the call is cancelled before the Random Access frame has been transmitted to the BS, the MS shall return to the idle state.

If an MS has initiated a voice call service and the call has not matured (by the transmission of Goto Channel Frames) the call may be cancelled by the calling party initiating a Call Cancel Service request. This is a random access service request ( $M=111_2 = \text{Cancel Call Request}$ ). The BS response to a call cancel request shall be B\_ACKD (Reason=Message accepted).

##### 10.3.3.1.3 Acknowledgements sent to calling MS

From the point at which an MS has requested a particular service, the BS may send acknowledgement Frames to indicate to the calling MS the progress of the service request.

- a) The BS may send Frames that complete or terminate the call service request as follows:
  - 1) The BS may send B\_NACKD to indicate to the calling MS that the call has failed. The B\_NACKD frame contains a Reason code to indicate to the caller why the service request failed.

- 2) The BS may send a UDT header + appended UDT frame to indicate that the call is diverted. From the BS perspective the service transaction is completed. The MS may choose to indicate the diverted address to the caller and return to the idle state, or automatically make a new service request with the diverted address as the destination.
  - 3) The BS may send B\_ACKD(Reason=Callback) to inform the calling MS that the caller has indicated they will call back.
- b) The BS may send progress Frames to the calling MS as a valid response to the random access request as follows:
- 1) B\_WACKD - An intermediate acknowledgement, more signalling to follow.
  - 2) B\_QACKD - The BS has queued the call because the resource requested or called party is busy, more signalling to follow.
  - 3) B\_AHOY - The BS has sent a B\_AHOY frame with the calling MS address in either the Source or Target address field.

### 10.3.3.1.4 Maintenance of call progress waiting timers

#### 10.3.3.1.4.1 Call waiting timer for the calling MS

From the point at which an MS has requested a particular service, the BS may send acknowledgement frames to indicate to the calling MS the progress of the service request. If the calling MS receives an acknowledgement to its random access request, it shall start one of two timers. The timer TP\_Timer shall be started for any random access service request that requires the allocation of a traffic channel. The timer TNP\_Timer shall be started for a call that only uses the BS for the call. If, while the timer is running the MS receives another acknowledgement frame, the timer shall be refreshed. If the timer expires, the MS may assume that the BS has abandoned the call and the MS shall return to the idle state.

The BS shall maintain an identical timer. If the BS receives a random access request for a call that requires the allocation of a traffic channel, it shall start timer TP\_Timer. A call that only requires the BS shall start timer TNP\_Timer. The BS may send a further acknowledgement to the calling MS and refresh its timer. If the timer expires, the BS shall abandon that call service.

#### 10.3.3.1.4.2 Call waiting timer for the called MS

If an MS receives an individually addressed B\_AHOY frame with an M field indicating a traffic channel will be assigned for the call, the MS shall start timer T\_Pending.

While T\_Pending is running, if the MS receives a talkgroup voice Goto Channel or Data talkgroup Goto Channel frame, the frame shall be discarded. If the timer T\_Pending expires and the MS has not been directed to a traffic channel, the MS may assume that the BS has abandoned the call that was indicated in the B\_AHOY frame.

If while T\_Pending is running, the BS transmits another individually addressed B\_AHOY frame for the same call service, the MS shall send an acknowledgement and refresh timer T\_Pending.

If while T\_Pending is running, the BS transmits an individually addressed B\_AHOY call cancellation frame M = 111<sub>2</sub>, the message shall be acknowledged, T\_Pending timer shall be suspended and the MS shall return to the idle state.

If the timer T\_Pending expires before the BS has transmitted applicable Goto Channel message(s) directing the MS to a traffic channel, the BS shall abandon the call.

### 10.3.3.1.5 Traffic Channel Assignment

The BS shall assign a traffic channel for the call by transmitting applicable Goto Channel Frames for the service supported (individual MS or talkgroup).

The Goto Channel frames may be single frame or a frame concatenated with an Appended\_Data message. If the Goto Channel message is concatenated with an Appended\_Data message and is repeated, at least one SYScast message shall be transmitted between the repeated Goto Channel messages.

A Goto Channel frame may be transmitted by the system on a traffic channel to swap the call to a replacement channel.

If a particular talkgroup call is active on a traffic channel, the BS may continue to transmit appropriately addressed Goto Channel frames at regular intervals to permit late joining MSs (MSs who may have just arrived on the control channel) to join that talkgroup call.

### 10.3.4 Mode 3 Voice Call Procedures

Voice calls require a traffic channel over which the call is conducted. Calls may be transacted between the entities in table 10.31.

**Table 10.31: Voice Call Services**

Mode	Originator		Recipient
Voice	MS	-	MS or Talkgroup
	MS	-	All MS (Broadcast)
	MS	-	Line Connected destination through a Gateway: PABX Extension PSTN destination Other gateway equipped for voice
	Line Connected source via a Gateway: PABX Extension PSTN destination Other gateways equipped for voice	-	MS or Talkgroup or All MS

The called party MS ID in the Random Access Service Request shall determine if the caller has selected a Mode 3 service to an individual MS or a talkgroup.

The Service\_Options frame in the Random Access Service Request shall activate options for the Voice Call Service Request:

- Emergency service:
  - Emergency calls shall take precedence over all other calls. Emergency call may be pre-emptive causing another call to be cleared down if the resource requested for the emergency call is not available.
- Complementary Data Transfer Service requested for this call:
  - Information may be sent to the called party as part of and to support another call service. For instance for a call from the PSTN a short text message could be passed to the called party as part of a voice call set-up.
- Broadcast service:
  - The Broadcast Call Voice service provides a one-way voice call from any user to a predetermined talkgroup. Recipients of a broadcast shall not be permitted to transmit.
- Priority:
  - The priority option permits the originator to select one of three levels of priority. The BS may manage and manipulate a call queue to cause calls with a higher priority to mature faster. The procedures the BS may employ are not prescribed in the present document.

#### 10.3.4.1 Voice Call Procedures for the BS

An MS requests a Mode 3 voice service by generating a random access request frame with the Target Address set to one of the following:

- a) An individual MS address (single-part call set-up).
- b) A group MS address (single-part call set-up).



- c) A gateway address that indicates a multi-part call set-up.

When the BS responds to the random access request, it shall start a timer (TP\_Timer). This timer shall be refreshed if the BS sends further call related Frames B\_WACKD, B\_QACKD or B\_AHOY, to the calling party.

#### 10.3.4.1.1 BS Response to single-part voice call set-up

When a random access voice service frame is received on the BS, the BS shall send a response in accordance with the random access procedures prescribed in clause 12.3.7.

The frames that represent a valid response to the voice call single-part service random access request are:

- a) An acknowledgement frame B\_NACKD, B\_QACKD, B\_WACKD, B\_ACKD(reason=callback).
- b) A UDT Head + appended frame(s) (voice call is diverted) UDT Header Frames ID = DIVERTI (conveying a diverted address) COMP = 0<sub>2</sub>.
- c) A B\_AHOY frame (called party radio check) if the call is to an individual MS address.
- d) A Goto Channel frame(s) for this call.

#### 10.3.4.1.2 BS Response to multi-part voice call set-up

For calls to extended addresses, the MS requests multi-part addressing by generating a voice call random access request with the Destination Address field set to a gateway address (PABXI, PSTNI, etc) and the LONG field to indicate if the number of Appended\_Data messages are required to transport the extended address from the MS. For calls to the PABX/PSTN one appended UDT can carry up to 16 dialled digits (LONG = 0<sub>2</sub>), and for the number of dialled digits = 17 to 32 (LONG = 1<sub>2</sub>).

The Frames that shall represent a valid response to the voice call multi-part part voice service random access request are:

- a) An acknowledgement frame B\_NACKD, B\_WACKD(reason=Wait), B\_QACKD.
- b) A B\_AHOY frame for the calling MS to send the extended address information.
- c) A B\_AHOY frame for the calling MS to send complementary data (see clause 4.5).

For b) The BS shall then invoke the UDT procedure by sending a B\_AHOY to the calling MS to send the extended address information. For a call to the PABX or PSTN the extended address information shall be BCD digits. The LONG field in the B-AHOY frame shall be copied from the LONG field received from the MS B\_RAND frame. If the BS does not successfully receive the UDT from the MS, the BS may repeat the B\_AHOY, or transmit a B\_NACKD to indicate failure of the call.

For c) The BS shall then invoke the UDT procedure by sending a B\_AHOY to the calling MS to send the complementary data. The format of the complementary data is specified in the UDT. If the BS does not successfully receive the UDT from the MS, the BS may repeat the B\_AHOY, or transmit a B\_NACKD to indicate failure of the call, or continue with the call set-up and abandon the complementary data.

#### 10.3.4.1.3 Acknowledgements sent by the BS to the calling MS (voice)

The BS may send acknowledgement Frames following the random access voice service request to indicate the progress of the call, to terminate the call or indicate call-back. If the BS sends a frame to indicate the progress of a call it shall start a waiting timer TP\_Timer. (The calling party MS maintains a similar timer):

- a) Progress Frames are:
  - 1) B\_WACKD: Intermediate acknowledgement. More Frames to follow;
  - 2) B\_QACKD: Called MS engaged in another call;
  - 3) B\_QACKD: Call is queued because the resource is in use at the moment;
  - 4) B\_AHOY: containing the calling party MS address.

- b) Termination Frames are selected from an appropriate Reason field in a B\_NACKD frame (see clause 5.5.25).
  - 1) B\_NACKD.
- c) Call-Back Frames indicate to the calling MS that the voice call service has been accepted by the called party for call back.
  - 1) B\_ACKD(reason=CallBack).
- d) If the BS has previously accepted a call diversion indicating that this type of service request should be directed to another called party, the BS shall invoke the UDT and send a UDT Head + Appended\_Data to the calling party. UDT Header Frames Source Address=DIVERTI (conveying a diverted address) COMP = 0<sub>2</sub>.

#### 10.3.4.1.4 Voice Radio Check

For calls to individual MS, the BS shall check that the called party is in radio contact and shall accept the call before a traffic channel is allocated.

The BS may check availability of the called party by:

- a) Sending a B\_AHOY frame to that called party.
- b) Sending a UDT header with complementary data (if the complementary data service is active for this call).

If a response is not received from the called party the BS may repeat the B\_AHOY.

The availability check demands a response from the called party:

- If the response is B\_NACKU, the BS shall send an appropriate call failed response to the calling MS and echo the Reason in the B\_NACKU frame.
- If the response is B\_ACKU(Reason=CallBack), the BS shall send an appropriate CallBack response to the calling MS.
- If the response is B\_ACKU(Reason=Message\_Accepted), the BS shall progress the service request and allocate a traffic channel by transmitting appropriate Goto Channel frames.

#### 10.3.4.1.5 Availability Check for Voice Calls connected through Gateways

For calls connected through gateways the BS equipment may wait until the destination is ready before allocating the traffic channel. For example a BS may wait until the PSTN handset has been answered before sending Goto Channel frames.

#### 10.3.4.2 Voice Call Procedures for MS

An MS is able to request a voice call service to another individual MS or a talkgroup using a single-part service request. For a voice service requested to extended addresses through a gateway the MS requests a multi-part service request. For multi-part service requests the MS sets the gateway address as the called party. The full destination address is then uploaded from the MS to the BS by the UDT procedure.

An MS requests a voice service by sending a B\_RAND random access request complying with the random access procedures in clause 12.3.7. The fields in the random access request are set appropriately as prescribed in table 10.32.

Table 10.32: B\_RAND fields for a Voice Call Service

Alias	Alias	Alias	Value	Length	Meaning		
MT			1100 <sub>2</sub>	4	Message Type = B_RAND (BS uplink)		
	ID0 + 1			24	Called MS, talkgroup, or gateway		
PARMS	ID2 + 3			24	Calling MS ID		
	M		000 <sub>2</sub>	3	Service requested is a Voice Call		
			001 <sub>2</sub>		Service requested is a Voice Call + slow data		
			101 <sub>2</sub>		Service requested is Voice + Appended_Data		
			111 <sub>2</sub>		Cancel the call service		
	V		00 <sub>2</sub>	2	TCH is standard (non zero for custom)		
	F		10 <sub>2</sub>	2	Comms Format = BS Uplink		
	EP		0 <sub>2</sub>	1	Non emergency service		
			1 <sub>2</sub>		Emergency Service		
	PM		N/A	1	Not Applicable for this particular message		
	MI	MI_TYPE		000 <sub>2</sub>	3	N/A for a voice call service	
		MI_DET		00 <sub>2</sub>	2	UAD1	Appended Short Data. Number of appended UDTs required to transport the short data
					2	UAD2	Appended Complementary Data. Number of appended UDTs required to transport the complementary data
				0 <sub>2</sub>	1	LONG	PABX/PSTN dialled string is 17 digits to 32 digits. or IPV6
				1			PABX/PSTN dialled string is 1 digits to 16 digits. or IPV4
				0 <sub>2</sub>	1	COMP	Complementary Data service not required for this call
				1 <sub>2</sub>			Complementary Data service is required for this call
0 <sub>2</sub>				1	PRIORITY	Normal Priority call	
1 <sub>2</sub>						High Priority Call	
0 <sub>2</sub>				1	BRCST	Non Broadcast Service	
1 <sub>2</sub>	Broadcast Option						

#### 10.3.4.2.1 Initiating a single-part voice call service

For a voice service request to an individual MS or talkgroup, the destination address is completely expressed by the Called MS Address field in the random access frame B\_RAND. The M field specifies the voice call options when a traffic channel is allocated.

#### 10.3.4.2.2 Response to the single-part individual voice service request

MS shall accept the following Frames as valid response to the single-part voice service request:

- an acknowledgement B\_WACKD, B\_QACKD, B\_NACKD, B\_ACKD(reason=callback);
- for an individual call service request, a B\_AHOY called party radio check;
- a UDT header + appended UDT frame. UDT Header Source\_Address=DIVERTI (conveying a diverted address) COMP = 0<sub>2</sub>;
- a Goto Channel frame;
- if COMP = 1<sub>2</sub> a B\_AHOY to upload the complementary data from the calling MS.

### 10.3.4.2.3 Initiating a multi-part voice call service

For a voice service request to a gateway, the destination type (PABX, PSTN, etc) the gateway address is (PABXI, PSTNI etc) is stored in the Called MS Address field in the random access frame B\_RANDOM. The M field specifies the voice call options when a traffic channel is allocated.

### 10.3.4.2.4 Response to the multi-part voice service request

MS shall accept the following Frames as valid response to the multi-part voice service request:

- a) an acknowledgement B\_WACKD, B\_QACKD, B\_NACKD;
- b) a B\_AHOY frame to upload the extended address:
  - 1) for a call to the PABX/PSTN a B\_AHOY from PABXI/PSTNI to upload the dialled digits;
  - 2) if the Service\_Options SUPED\_SV = 1<sub>2</sub> a B\_AHOY from COMPLI to upload the complementary data from the calling MS.

For b), if the Voice Call Service Request requires extended address information and the calling MS has selected the Complementary Data in the Service\_Options, the BS uploads the information in two steps. The order in which the information is uploaded is not prescribed because the B\_AHOY specifically indicates which UDT uplink procedure has been invoked by setting appropriate unambiguous Gateway fields in the B\_AHOY frame. The gateway fields for B\_AHOY Frames to support voice services are prescribed in table 10.32.

**Table 10.33: B\_AHOY fields for multi-part voice call set-up**

Action	Gateway address	Remark
MS send PSTN digits	PSTNI	The calling party shall send BCD dialled digits
MS sends PABX digits	PABXI	The calling party shall send BCD dialled digits
MS sends complementary data	COMPLI	The format of the data shall be determined by the calling party

### 10.3.4.2.5 Acknowledgements received by the calling MS (voice)

At some time after sending the voice service request random access frame the calling MS may receive an acknowledgement. On receiving the acknowledgement, the MS shall start or restart a waiting timer, TP\_Timer. (The BS maintains a similar timer).

The MS shall take the actions prescribed:

- a) Progress Frames for a single-part voice call Service Request are:
  - 1) B\_WACKD: Intermediate acknowledgement. More Frames to follow. The MS shall start TP\_Timer for further signalling and may indicate a possible delay to the calling MS.
  - 2) B\_QACKD: Called MS engaged in another call. The MS shall start TP\_Timer for further signalling.
  - 3) B\_QACKD: Call is queued because the resource is in use at the moment. The MS shall start TP\_Timer for further signalling and may indicate a possible delay to the calling MS.
  - 4) B\_AHOY: containing the calling party MS address.

NOTE: (The MS may choose to differentiate between 1), 2) and 3) by providing the calling MS with a visual or audible indication for each of the conditions).

- b) Termination Frames are selected from an appropriate Reason field in a B\_NACKD frame (see clause 5.5.25):
  - 1) B\_NACKD: Call refused and terminated. The B\_NACKD frame provides a versatile range of Reason codes to indicate to the calling party why the Service request was terminated. The calling party shall return to the idle state.

- c) Call-Back frame to indicate to the calling MS that the voice call service has been accepted by the called party for call back. Service concluded. The calling party shall return to the idle state:
  - 1) B\_ACKD(reason=CallBack).
- d) If the BS has previously accepted a call diversion indicating that this type of service request be directed to another called party, a UDT Head + Appended\_Data indicating the diverted address.

#### 10.3.4.2.6 Availability Check to the called MS (voice)

For an individual MS address call set-up, the called MS shall receive a radio check to which it shall respond with an appropriate acknowledgement:

- The called party shall respond B\_NACKU, if it cannot accept the call (the BS shall send an appropriate call failed response to the calling MS).
- The called party shall respond B\_ACKU(Reason=CallBack), if the called MS wishes to return the call at some future time (the BS shall send an appropriate CallBack response to the calling MS).
- The calling party shall respond B\_ACKU(Reason=Message\_Accepted), if the call is accepted (the BS shall progress the service request and allocate a traffic channel by transmitting appropriate Goto Channel Frames).

#### 10.3.4.2.7 Traffic Channel Allocation

MS shall check the address fields received in Goto Channel frames and SYScast2/SYScast3 frames (that carry the calling party address). If it is determined that the Goto Channel frame is applicable then it shall retune to the indicated traffic channel to commence the Voice Service.

- a) For Private Voice Goto Channel frame:
  - a) If an MS receives an Goto Channel frame where ID0+1 matches the MSID individual address, then that frame is applicable
  - b) If an MS receives a SYcast2/SYScast3 frame (that carries a calling party address), where MSID matches the MS individual address, then that frame is applicable.
- b) Group Voice Goto Channel frame:
  - 1) If an MS receives a Goto Channel frame where ID0+1 matches one of the MS talkgroup addresses, then that frame is applicable.
  - 2) If an MS receives a SYcast2/SYScast3 frame (that carries a calling party address), where MSID matches the MS individual address then that frame is applicable.
  - 3) If an MS receives a Goto Channel frame where ID0+1 = ALLI then that frame is applicable.
  - 4) If an MS receives a Goto Channel frame where ID0+1 = ALLTALK10 then that frame is applicable.
  - 5) If an MS receives a Goto Channel frame where ID0+1 = ALLTALKn where n is the prefix of the called party (see clauses A.1.2.3.3 and 13.4) then that frame is applicable.

#### 10.3.4.3 Procedures for the Voice Traffic Channel

MSs are directed to a voice traffic channel by an applicable Goto Channel/SYScast2/SYScast3 frame transmitted on the beacon channel. When the voice call is terminated, MS returns to the beacon channel and the traffic channel is returned to idle for reassignment to another call.

A voice call may extend over several MS PTT items for the duration of the call (unless the call is terminated prematurely by the expiry of the voice traffic channel timer).

### 10.3.4.3.1 BS Procedures for the Voice Traffic Channel

A traffic channel shall carry one voice call at any one time. When the traffic channel is assigned for a call, the voice channel traffic timer shall be initialized as follows:

- For an individual MS/MS or MS/talkgroup normal or high priority call T\_MS-MS\_TMR.
- For a gateway individual MS or talkgroup normal or high priority call T\_MS-LINE\_TMR.
- For an emergency call T\_EMERG\_TMR.

#### 10.3.4.3.1.1 Traffic Channel MS radio check

The BS may poll an individual MS on the traffic channel to check if the MS is active on the traffic channel by transmitting a Connection\_Request header. This is identical to the Mode 2 called party check described in clause 10.2.1.

The response is T\_ACK.

The BS may also poll a talkgroup to check if at least one member of the talkgroup is active on the traffic channel by transmitting the called party check to the talkgroup.

The response is ACK. If more than one MS makes a response to this frame, it is likely that the BS will be unable to decode it because of collisions. The purpose of this procedure is to determine if any talkgroups are active, therefore the BS may use the presence of the burst for the result of the talkgroup radio check.

#### 10.3.4.3.1.2 Disabling/enabling a users PTT

The BS may at any time send a Guard message (Guard\_Type=DIS\_PTT) addressed to an individual MS, talkgroup, or All Unit ID to disable the PTT. Since the T\_PROTECT frame is unacknowledged the frame may be repeated at layer 2.

The BS may also at any time send a Guard message (Guard\_Type=EN\_PTT) addressed to an individual MS, talkgroup, or All Unit ID to enable the PTT. Since the Guard message is unacknowledged the frame may be repeated.

#### 10.3.4.3.1.3 Swapping the call to a replacement voice traffic channel



**Figure 10.36: Message Content swapping a call to a replacement voice traffic channel**

The BS may send Goto Channel/SYScast2/SYScast3 Frames on the traffic channel as illustrated in figure 10.36 to move MS already active to an alternative voice traffic channel. If MS had previously received a Guard(Guard\_Type=DIS\_PTT to disable their PTT, the PTT shall be re-enabled on the replacement voice traffic channel unless the call service was a broadcast when called party(s) shall retain their PTT status (enable/disable) from the original call.

#### 10.3.4.3.1.4 Removing MS from the traffic channel that are not legitimate parties

The BS may transmit Guard(Illegally\_Parked) messages on the traffic channel at any time to clear down any MSs that are listening to the channel and are not part of the current call. The BS sets ID2+3 in the Guard Message to the calling party ID ( from the SYScast2 SYScast3), and ID0+1 to the called party or talkgroup ID0+1 from the Goto Channel message.

#### 10.3.4.3.1.5 Clearing down the voice call

The BS shall clear the parties involved in the traffic voice call if:

- The relevant overall traffic call timer T\_MS-MS\_TMR, T\_MS-LINE\_TMR or T\_EMERG\_TMR expires.
- The BS receives an applicable Disconnect\_Request header + END frame.
- The BS detects by any other means that the call has ended (e.g. PSTN destination on hook).
- The M3N\_PreserveV preservation frames counter expires.

The BS shall clear down the call by transmitting Disconnect\_Request header + END frame(s). Since this frame is not acknowledged it may be repeated.

#### 10.3.4.3.1.6 Clearing down a particular MS or talkgroup

The BS may selectively clear an individual MS by transmitting a Disconnect\_Request header with ID0 + 1 addressed to the particular MS ID to be cleared down.

A Disconnect\_Request header with ID2 + 3 addressed to the particular MS ID to be cleared down.

The BS may clear a talkgroup by transmitting a Disconnect\_Request header with ID0 + 1 addressed to the talkgroup to be cleared down.

### 10.3.4.3.2 MS Procedures for the Voice Traffic Channel

#### 10.3.4.3.2.1 MS receives an MS radio check

If an MS receives a Connection\_Request header addressed to its individual address then it shall respond with ACK.

If an MS receives a Connection\_Request header to the talkgroup address previously transmitted in the Goto Channel frame that directed this MS to the traffic channel then it shall respond with an ACK.

#### 10.3.4.3.2.2 Disabling/enabling a users PTT

If the MS receives a Guard(Guard\_Type=DIS\_PTT) addressed to its individual address, or to its talkgroup address previously transmitted in the Goto Channel frame directing the MS to the traffic channel, or All Unit ID, the MS shall disable its PTT.

If the MS receives a Guard(Guard\_Type=EN\_PTT) addressed to its individual address, or to its talkgroup address previously transmitted in the Goto Channel frame, or All Unit ID, the MS shall re-enable its PTT unless this MS was the recipient of a broadcast call.

#### 10.3.4.3.2.3 MS receives a Goto Channel frame(s)

If an MS receives an applicable Goto Channel/SYScast2/SYScast3 addressed to its individual address, or to the talkgroup address previously transmitted in the Goto Channel/SYScast2/SYScast3 frames directing the MS to the traffic channel, then the MS shall retune to the new traffic channel. If the PTT was disabled prior to receiving the Goto Channel frame, the PTT shall be re-enabled unless this MS was the recipient of a broadcast call set-up or a call to All-Unit ID.

#### 10.3.4.3.2.4 End of call

The MS shall signify the end of the call by:

- a) if the MS is the calling party to the call or if the MS is the recipient of an individual call, the MS shall signify the end of the call by transmitting a number of Disconnect\_Request header + END headers. The MS shall send the Disconnect\_Request header +END frames consecutively addressed to the parties involved in the call, then return to the beacon channel acquisition procedures (it is suggested that the BS initially sampled is the BS that transferred the call to the traffic channel); or
- b) if the MS is the called party in a talkgroup, the MS shall leave the channel without sending any Disconnect\_Requests header + END headers, but immediately return to the beacon channel acquisition procedures (it is suggested that the BS initially sampled is the BS that transferred the call to the traffic channel).

#### 10.3.4.3.2.5 MS receives an individually addressed Disconnect Request

If an MS receives a Disconnect\_Request header + END frame directed to the individual MS ID (ID0 + 1 = MSID) then it shall return to the beacon channel acquisition procedures (it is suggested that the BS sampled is the BS that transferred the call to the traffic channel). If an MS receives a Disconnect\_Request header + END frame directed to the individual MS ID (ID2 + 3 = MSID) then it shall return to the beacon channel acquisition procedures.

#### 10.3.4.3.2.6 MS receives a Disconnect Request addressed to a talkgroup

If an MS receives a Disconnect\_Request header + END frame directed to the active MS talkgroup (ID0 + 1 = talkgroup) then it shall return to the beacon channel acquisition procedures (it is suggested that the BS sampled is the BS that transferred the call to the traffic channel).

#### 10.3.4.3.2.7 MS receives a Guard message(s)

If an MS receives a Guard(Illegally\_Parked) message where:

- a) ID2+3 from the Guard Message is equal to the MSID; or
- b) ID0+1 from the Guard Message is equal to the MSID or the MS's active talkgroup ID;

then that MS is considered to be a legitimate user of the channel, otherwise the MS shall leave the traffic channel without making any further transmissions.

#### 10.3.4.3.2.8 Time out on the Traffic Channel

An MS shall maintain a number of timers while active on a voice traffic channel.

- a) Inactivity timer:
  - An MS shall measure the length of time the MS is unable to detect adequate signal quality. If the MS fails to detect adequate signal quality for a continuous time TV\_Inactive, the MS shall assume that the call has ended and return to the beacon channel acquisition procedures without sending any call termination signalling (it is suggested that the BS sampled is the BS that transferred the call to the traffic channel).
- b) Item Duration timer:
  - An MS shall maintain a maximum item duration timer. If the MS reaches the maximum item duration TV\_Item, the MS shall disable the PTT and wait until the user releases the PTT before re-enabling the PTT.
- c) An overall traffic call timer:
  - If the overall voice traffic call timer T\_MS-MS\_TMR, T\_MS-LINE\_TMR or T\_EMERG\_TMR expires, the MS shall transmit a number (N\_Maint) of P\_MAINT frames consecutively then return to the beacon channel acquisition procedures (it is suggested that the BS sampled is the BS that transferred the call to the traffic channel).

### 10.3.5 Mode 3 Data Call Procedures

Data calls require a traffic channel over which the call is conducted. Calls may be transacted between the entities in table 10.34.

**Table 10.34: Data Call Services**

Mode	Originator		Recipient
Data	MS	-	MS or talkgroup
	MS	-	All MS (Broadcast)
	MS	-	Line Connected destination through a Gateway: Data Gateway Other gateway equipped for data
	Line Connected source via a Gateway: Data Gateway Other gateway equipped for data	-	MS or talkgroup or All MS



### 10.3.5.1 Data Call Procedures for the BS

An MS requests a Mode 3 service by generating a random access request frame with the Target Address set to:

- a) An individual MS address (single-part call set-up).
- b) A talkgroup MS address (single-part call set-up).
- c) A gateway address that indicates a multi-part call set-up.

When the BS responds to the random access request, it shall start a timer (TP\_Timer). This timer shall be refreshed if the BS sends further call progress frames to the calling party.

#### 10.3.5.1.1 BS Response to single-part data call set-up

When a random access data frame is received by the beacon, the BS shall send a response in accordance with the random access procedures prescribed in clause 12.3.7.

The frames that represent a valid response to the data call single-part service random access request are:

- a) An acknowledgement frame B\_NACKD, B\_QACKD, B\_WACKD.
- b) A UDT Head + Appended\_Data(s) (data call is diverted) UDT Header Frames Source\_Address=DIVERTI (conveying a diverted address) Complementary Flag = 1<sub>2</sub> and UDT\_Response = 0<sub>2</sub>.
- c) A B\_AHOY frame (called party radio check).
- d) A B\_AHOY frame to upload complementary data from calling MS.
- e) A Goto Channel frame(s) for this call.

#### 10.3.5.1.2 BS Response to multi-part data call set-up

For calls to extended addresses, the MS requests multi-part addressing by generating a voice call random access request with the Destination Address field set to a gateway address (PABXI, PSTNI, etc) and the LONG field to indicate if the number of Appended\_Data messages are required to transport the extended address from the MS. For calls to the PABX/PSTN one appended UDT can carry up to 16 dialled digits (LONG = 0<sub>2</sub>), and for the number of dialled digits = 17 to 32 (LONG = 1<sub>2</sub>). For calls to an IP destination one appended UDT can carry an IPV4 address (LONG = 0<sub>2</sub>), and for IPV6 (LONG = 1<sub>2</sub>).

The frames that shall represent a valid response to the voice call multi-part part voice service random access request are:

- a) An acknowledgement frame B\_NACKD, B\_WACKD(reason=Wait).
- b) A B\_AHOY frame from PABXI,PSTNI,IPI for the calling MS to send the extended address information.
- c) A B\_AHOY frame from COMPI for the calling MS to send complementary data (see clause 4.5).

For b) The BS shall then invoke the UDT procedure by sending a B\_AHOY to the calling MS to send the extended address information. For a call to the PABX or PSTN the extended address information shall be BCD digits. The LONG Flag field in the B\_AHOY frame shall be copied from the LONG Flag field received from the MS B\_RAND frame. For an IP destination the extended address information shall be an IPV4 or IPV6 address.

For c) The BS shall then invoke the UDT procedure by sending a B\_AHOY to the calling MS to send the complementary data. The format of the complementary data is specified in the UDT.

If the BS does not successfully receive the UDT from the MS, the BS may repeat the B\_AHOY or transmit a B\_NACKD to indicate failure of the call.

#### 10.3.5.1.3 Acknowledgements sent by the BS to the calling MS (data)

The BS may send acknowledgement Frames following the random access data service request to indicate the progress of the call, to terminate the call. If the BS sends a frame to indicate the progress of a call it shall start a waiting timer TP\_Timer. (The calling party MS maintains a similar timer).

- a) Progress Frames are:
  - 1) B\_WACKD: Intermediate acknowledgement. More frames to follow;
  - 2) B\_QACKD: Called MS engaged in another call;
  - 3) B\_QACKD: Call is queued because the resource is in use at the moment;
  - 4) B\_AHOY: containing the calling party MS address.
- b) Termination Frames are selected from an appropriate Reason field in a B\_NACKD frame):
  - 1) B\_NACKD.
- c) If the beacon has previously accepted a call diversion indicating that this type of service request be directed to another called party, the BS shall invoke the UDT and send a UDT Head + Appended\_Data to the calling party.

#### 10.3.5.1.4 Radio Check for Data

For calls to individual MS, the BS shall check that the called party is in radio contact and wishes to accept the call before a traffic channel is allocated. The radio check may also indicate that the called party data terminal equipment is ready.

The BS may check availability of the called party by:

- a) Sending a B\_AHOY frame to that called party.
- b) Sending a Multi-frame UDT with complementary data (if the complementary data service is active for this call).

If a response is not received from the calling party the BS may repeat the B\_AHOY.

The availability check demands a response from the called party:

- If the response is B\_NACKU, the BS shall send an appropriate call failed response to the calling MS and echo the Reason in the B\_NACKD frame.
- If the response is B\_ACKU(Reason=Message\_Accepted), the BS shall progress the service request and allocate a traffic channel by transmitting appropriate Goto Channel Frames.

#### 10.3.5.1.5 Availability Check for Data Calls connected through Gateways

For calls connected through gateways the beacon equipment may wait until the destination is ready before allocating the traffic channel. For example a beacon waits until PSTN equipment has linked the data terminal before sending Goto Channel frames.

#### 10.3.5.2 Data Call Procedures for MS

An MS is able to request a data call service to another individual MS or a talkgroup using a single-part service request. For a data service requested to extended addresses through a gateway the MS requests a multi-part service request. For multi-part service requests the MS sets the gateway address as the called party. The full destination address is then provided by the MS to the BS by the UDT procedure.

An MS requests a data service by sending a, random access request complying with the random access procedures in clause 12.3.7. The fields in the random access request are set as prescribed in table 10.35.

Table 10.35: B\_RAND fields for a Data Call Service

Alias	Alias	Alias	Value	Length	Meaning		
MT			1100 <sub>2</sub>	4	Message Type = B_RAND (BS uplink)		
	ID0 + 1			24	Called MS, talkgroup, or gateway		
PARMS	ID2 + 3			24	Calling MS ID		
	M		010 <sub>2</sub>	3	Service requested is a T1 Data Call		
			011 <sub>2</sub>		Service requested is a T2 Data Call		
			100 <sub>2</sub>		Service requested is a T3 Packet Data Call		
			111 <sub>2</sub>		Cancel the call service		
	V		00 <sub>2</sub>	2	TCH is standard (non zero for custom)		
	F		10 <sub>2</sub>	2	Comms Format = BS Uplink		
	EP		0 <sub>2</sub>	1	Non emergency service		
			1 <sub>2</sub>		Emergency Service		
	PM		N/A	1	Not Applicable for this particular message		
	MI	MI_TYPE		000 <sub>2</sub>	3	Not Applicable for this particular message	
		MI_DET		00 <sub>2</sub>	2	UAD1	Appended Short Data. Number of appended UDTs required to transport the short data
					2	UAD2	Appended Complementary Data. Number of appended UDTs required to transport the complementary data
				0 <sub>2</sub>	1	LONG	PABX/PSTN dialled string is 1 to 16 digits. or IPV4
				1 <sub>2</sub>			PABX/PSTN dialled string is 17 to 32 digits or IPV6
				0 <sub>2</sub>	1	COMP	Complementary Data service not required for this call
1 <sub>2</sub>				Complementary Data service is required for this call			
0 <sub>2</sub>				1	PRIORITY	Normal Priority call	
1 <sub>2</sub>						High Priority Call	
0 <sub>2</sub>				1	BRCST	Non Broadcast Service	
1 <sub>2</sub>	Broadcast Option						

### 10.3.5.2.1 Initiating a single-part data call service

For a data service request to an individual MS or talkgroup, the destination address is completely expressed by the Target Address field in the random access frame. The Service\_Type specifies if the data call service is addressed to an individual address or a talkgroup.

### 10.3.5.2.2 Response to the single-part data call service request

MS shall accept the following Frames as valid response to the single-part data service request:

- an acknowledgement B\_WACKD, B\_QACKD, B\_NACKD;
- for an individual call service request, a B\_AHOY called party radio check;
- a Goto Channel frame;
- if the COMP = 1<sub>2</sub> a B\_AHOY to upload the complementary data from the calling MS;
- a UDT Head + appended frames UDT Header Frames Source\_Address=DIVERTI, COMP = 0<sub>2</sub>.

### 10.3.4.2.3 Initiating a multi-part data call service

For a voice service request to a gateway, the destination type (PABX, PSTN, IP etc) the gateway address is (PABXI, PSTNI, IPI etc) is stored in the Called MS Address field in the random access frame B\_RANDOM. The M field specifies the voice call options when a traffic channel is allocated. The Service\_Type specifies if the data call service is addressed to an individual address or a talkgroup.

### 10.3.5.2.4 Response to the multi-part data service request

MS shall accept the following Frames as valid response to the multi-part data service request:

- a) an acknowledgement B\_WACKD, B\_QACKD, B\_NACKD;
- b) a B\_AHOY frame to upload the extended address:
  - 1) for a call to the PABX/PSTN a B\_AHOY to upload the dialled digits;
  - 2) for a call to an IP destination a B\_AHOY from IPI to upload the IP address;
  - 3) if COMP = 1<sub>2</sub> a B\_AHOY from COMPI to upload the complementary data from the calling MS.

NOTE: For b), if the Data Call Service Request requires extended address information and the calling MS has selected the Complementary Data in the Service option, the BS uploads the information in two steps. The order in which the information is uploaded is not prescribed because the B\_AHOY specifically indicates which UDT uplink procedure has been invoked by setting appropriate unambiguous fields in the B\_AHOY frame.

### 10.3.5.2.5 Acknowledgements received by the calling MS (data)

At some time after sending the data service request random access frame the calling MS may receive an acknowledgement. On receiving the acknowledgement, the MS shall start or restart a waiting timer, TP\_Timer. (The BS maintains a similar timer).

The MS shall take the actions prescribed:

- a) Progress Frames for a single-part data call Service Request are:
  - 1) B\_WACKD: Intermediate acknowledgement. More Frames to follow. The MS shall start TP\_Timer for further signalling and may indicate a possible delay to the calling MS;
  - 2) B\_QACKD (Reason=1000 0001<sub>2</sub>): Called MS engaged in another call. The MS shall start TP\_Timer for further signalling and may indicate a possible delay to the calling MS;
  - 3) B\_QACKD (Reason=1000 0000<sub>2</sub>): Call is queued because the resource is in use at the moment. The MS shall start TP\_Timer for further signalling and may indicate a possible delay to the calling MS. The MS may choose to differentiate between 1), 2) and 3) by providing the calling MS with a particular indication for each of the conditions;
  - 4) B\_AHOY: containing the calling party MS address.
- b) Termination Frames are selected from an appropriate Reason field in a B\_NACKD frame:
  - 1) B\_NACKD: Call refused and terminated. The B\_NACKD frame provides a versatile range of Reason codes to indicate to the calling party why the Service request was terminated. The calling party shall return to the idle state.

### 10.3.5.2.6 Availability Check to the called MS (data)

For an individual MS address call set-up, the called MS shall receive a radio check to which it will respond with an appropriate acknowledgement:

- The called party shall respond B\_NACKU, if it cannot accept the call or its data terminal equipment is not ready (the BS shall send an appropriate call failed response to the calling MS).

- The calling party shall respond B\_ACKU (Reason=Message\_Accepted), if the call is accepted (the BS shall progress the service request and allocate a traffic channel by transmitting appropriate Goto Channel frames).

### 10.3.5.2.7 Traffic Channel Allocation

MS shall check the address fields received in Data Goto Channel frames and SYScast2/SYScast3 frames (that carry the calling party address). If it is determined that the Goto Channel frame is applicable then it shall retune to the indicated physical traffic channel to commence the Data Service.

- a) For an individual MS Data Goto Channel frame:
  - a. If an MS receives a Goto Channel frame where ID0+1 matches the MSID individual address, then that frame is applicable.
  - b. If an MS receives a SYScast2/SYScast3 frame (that carries the calling party address), where MSID matches the MS individual address, then that frame is applicable
- b) Talkgroup Data Goto Channel frame:
  - 1) If an MS receives a talkgroup Goto Channel frame where ID0+1 matches one of the MS talkgroup addresses, then that frame is applicable.
  - 2) If an MS receives a SYScast2/SYScast3 frame (that carries the calling party address), where MSID matches the MS individual address, then that frame is applicable.
  - 3) If an MS receives a Goto Channel frame where ID0+1 = ALLI then that frame is applicable;
  - 4) If an MS receives a Goto Channel frame where ID0+1 = ALLTALK10 then that frame is applicable;
  - 5) If an MS receives a Goto Channel frame where ID0+1 = ALLTALKn where n is the prefix of the called party (see clauses A.1.2.3.3 and 13.4) then that frame is applicable.

### 10.3.5.3 Procedures for the Data Traffic Channel

MSs are directed to a Data traffic channel by the beacon. When the Data call is terminated by either the BS or MS, the MS shall return to the beacon. When a physical channel has been assigned, data Frames of arbitrary length are transferred over the dPMR Air Interface using the data procedures described in clause 10.2.3. A Data call may continue unless the call is terminated by a) the MS or b) the BS or c) terminated prematurely as a result of the expiry of an overall traffic channel call timer). In the Mode 3 environment however, additional call maintenance Frames may be transmitted by the BS.

#### 10.3.5.3.1 BS Procedures for the Data Traffic Channel

If a new physical channel is allocated by an applicable Goto Channel/SYScast2/SYScast frame, the MS shall start the Data traffic timer T\_DATA\_TMR for T1, T2 and T3 data.

##### 10.3.5.3.1.1 MS radio check

The BS may poll an individual MS on the traffic channel to check if the MS is active on the traffic channel by transmitting a Connection\_Request header + END. This is identical to the Mode 2 called party check described in clause 10.2.1.

The response is T\_ACK.

The BS may also poll a talkgroup to check if at least one member of the talkgroup is active on the traffic channel by transmitting a Connection\_Request + END to a talkgroup.

The response is T\_ACK. If more than one MS makes a response to this frame, it is likely that the BS will be unable to decode it because of collisions. The purpose of this procedure is to determine if any talkgroups are active therefore the BS may use the presence of the burst for the result of the talkgroup radio check.

### 10.3.5.3.1.2 Disabling/enabling a users transmission

The BS may at any time send a Guard(Guard\_Type=DIS\_PTT) addressed to an individual MS, talkgroup, or All Unit ID to disable all MS transmissions for the remainder of the call. Since the Guard message is unacknowledged the message may be repeated.

The BS may also at any time send a Guard(Guard\_Type=EN\_PTT) addressed to an individual MS, talkgroup, or All Unit ID to enable the users transmission. Since the Guard message is unacknowledged the frame may be repeated.

### 10.3.5.3.1.3 Swapping the call to a replacement Data Traffic Channel



**Figure 10.37: Message Content swapping a call to a replacement data traffic channel**

The BS may send Goto Channel/SYScast2/SYScast3 Frames on the traffic channel as illustrated in figure 10.37 to move MS already active to an alternative data traffic channel. If MS had previously received a GUARD to disable its transmissions, the transmissions shall be re-enabled on the replacement data traffic channel.

### 10.3.5.3.1.4 Clearing down the Data Channel

The BS shall clear down the parties involved in all traffic channel calls if:

- the relevant overall traffic channel call timer T\_DATA\_TMR expires;
- the BS receives an applicable Disconnect\_Request Header + END frame;
- the BS detects by any other means that the call has ended;
- the M3N\_PreserveD preservation frames counter for T1 and T2 data or M3N\_PreserveP frames counter for T3 data expires.

The BS shall clear down the data call by transmitting Disconnect\_Request header + END frame(s). Since this frame is not acknowledged it may be repeated.

### 10.3.5.3.1.5 Clearing down a particular MS or talkgroup

The BS is able to clear down the parties involved in a data call if:

- the BS receives an applicable Disconnect\_Request header + END frame;
- the BS detects by any other means that the data call has ended.

The BS response to an applicable Disconnect\_Request header is T\_ACK.

The BS may selectively clear an MS by transmitting a Disconnect\_Request header addressed to the individual MS ID.

## 10.3.5.3.2 MS Procedures for the Data Traffic Channel

### 10.3.5.3.2.1 MS receives an MS radio check

If an MS receives a Connection\_Request header to its individual address, then it shall respond with a T\_ACK.

If an MS receives a Connection\_Request header to its talkgroup address previously transmitted in the Goto Channel frame that directed this MS to the traffic channel then it shall respond with a T\_ACK.

### 10.3.5.3.2.2 Disabling/enabling a user transmission

If the MS receives a Guard(Guard\_Type=DIS\_PTT) addressed to its individual address, or to its talkgroup address previously transmitted in the Goto Channel frame, or All Unit ID, the MS shall disable its transmissions.

If the MS receives a Guard(Guard\_Type=EN\_PTT) addressed to its individual address, to its talkgroup address previously transmitted in the Goto Channel frame, or All Unit ID, the MS shall re-enable its transmissions.

#### 10.3.5.3.2.3 MS receives a Goto Channel frame(s)

If an MS receives an applicable Goto Channel/SYScast2/SYScast3 addressed to its individual address, or to the talkgroup address previously transmitted in the Goto Channel/SYScast2/SYScast3 frames directing the MS to the traffic channel, then the MS shall retune to the new traffic channel. If the PTT was disabled prior to receiving the Goto Channel frame, the PTT shall be re-enabled unless this MS was the recipient of a broadcast call set-up or a call to All-Unit ID.

#### 10.3.5.3.2.4 End of call

The MS shall signify the end of the call by:

- a) if the MS is the calling party to the call or if the MS is the recipient of an individual call, the MS shall signify the end of the call by transmitting a number of Disconnect\_Request header + END headers. The MS shall send the Disconnect\_Request header + END frames consecutively addressed to the parties involved in the call, then return to the beacon channel acquisition procedures (it is suggested that the BS initially sampled is the BS that transferred the call to the traffic channel); or
- b) if the MS is the called party in a talkgroup, the MS shall leave the channel without sending any Disconnect\_Requests header + END headers, but immediately return to the beacon channel acquisition procedures (it is suggested that the BS initially sampled is the BS that transferred the call to the traffic channel).

#### 10.3.5.3.2.5 MS receives a Disconnect\_Request header

If an MS receives an applicable Disconnect\_Request header + END frame then it shall abandon the traffic channel and enter control channel acquisition procedures. An applicable Disconnect\_Request header is a message where ID0 + 1 matches the MS ID, ID0 + 1 matches the active talkgroup, or ID2 + 3 matches the MS ID.

#### 10.3.5.3.2.6 Time-out on the Traffic Channel

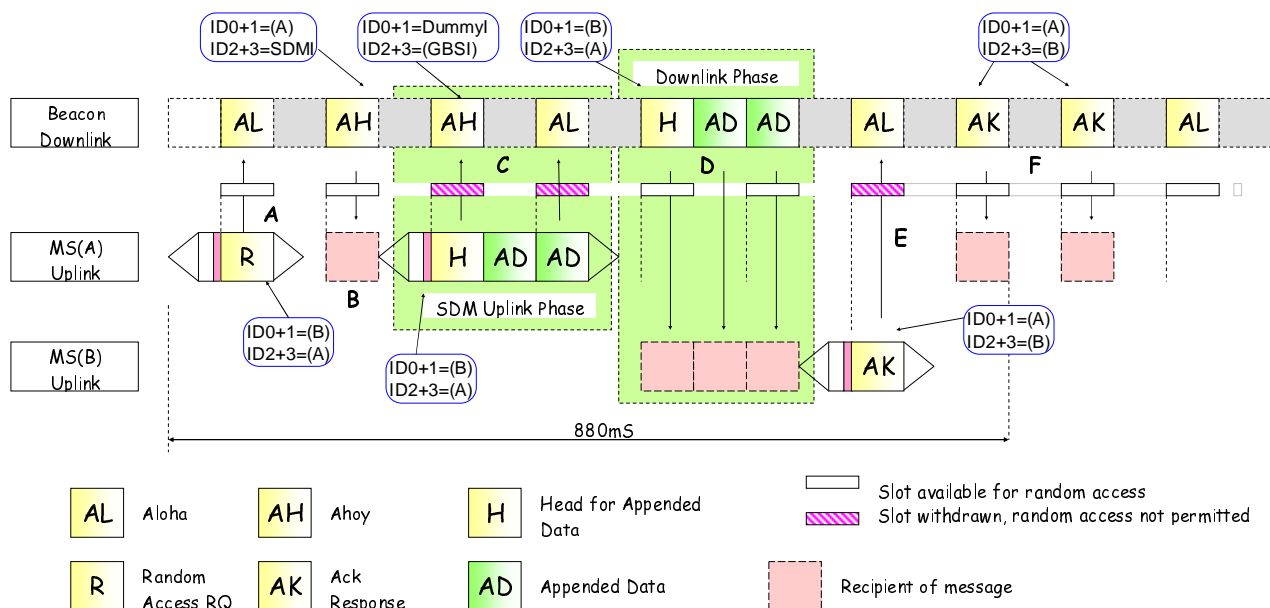
An MS shall maintain a number of timers while active on a data traffic channel.

- a) Inactivity timer:
  - An MS shall measure the length of time the MS is unable to detect adequate signal quality. If the MS fails to detect adequate signal quality for a continuous time TD\_Inactive, the MS shall assume that the call has ended and return to the beacon channel acquisition procedures without sending any call termination signalling (it is suggested that the BS sampled is the BS that transferred the call to the traffic channel).
- b) Item Duration timer:
  - An MS shall maintain the maximum item duration timer TD\_Item. If the MS reaches the maximum item duration TD\_Item, the MS shall discontinue the item and indicate to the application layer that the item was not successfully transmitted.
- c) An overall traffic channel call timer:
  - If the overall data traffic channel call timer T\_DATA\_TMR expires, the MS shall transmit a Disconnect\_Request Header + END frames then return to the beacon channel acquisition procedures (it is suggested that the BS sampled is the BS that transferred the call to the traffic channel) If the MS was sending data frames when the overall data traffic call timer expires, the MS shall indicate to the application layer prior to transmitting the Disconnect\_Request Header + END frames.

### 10.3.5.4 Mode 3 Short Data Message Procedure

The Short Data Message service enables data to be transmitted between dPMR entities using the beacon channel. Up to 256 bits of data may be transported using this service in a number of formats including binary, BCD, 7 bit text, 8 bit characters, and NMEA (EN 61162-1 [1]).

The Short Data Message procedure uses the multi-part call set-up. An MS may send a Short Data Message to an MS, a talkgroup, the PSTN or PABX, a line connected gateway, a dispatcher gateway, or all MS (if the BS permits it). The BS may also transmit a short data message from a gateway addressed to an individual MS or talkgroup.



**Figure 10.38: Short Data Message transfer**

Figure 10.38 shows an example of a short data message transfer from MS to MS.

- MS(A) calculates the number of appended UDTs needed to transmit the short data. In this example, two appended UDTs are required;
- "A" is the random access B\_RAND frame. The called party is MS(B) and M/MI\_TYPE is set to 'Short Data'. UAD1 is set to the number of data frames needed to transport the short data;
- "B" is a B\_AHOY frame that request MS(A) to transport the short data using the UDT mechanism;
- "C" is the uplink phase consisting of a Multi-frame UDT header + Appended\_Data;
- "D" is the downlink phase consisting of a Multi-frame UDT header + Appended\_Data;
- "E" is the acknowledgement from MS(B);
- "F" is the final acknowledgement to the calling party MS(A). Note that the acknowledgement is repeated for reliability.

For a call to an extended address destination the BS uses the UDT mechanism to transport the extended address information. In this case the uplink phase shall use two UDT procedures. The B\_AHOY frame indicates which UDT uplink transport is requested by unambiguous fields in the B\_AHOY frame.

The maximum number of bits that may be transported by the short data message service is limited by the maximum number of Appended\_Data messages. The Mode 3 protocol permits up to four Appended\_Data messages.

For a short data message service to a talkgroup, the called party(s) shall not send a response. The BS may repeat the downlink phase to improve the probability of a successful message transfer. The BS shall send a final acknowledgement to the calling unit even though the receipt of the short data message is not certain.



### 10.3.5.4.1 Short Data Procedures for the BS

An MS requests a Mode 3 short data message service by generating a random access request frame with the Target Address set to:

- a) an individual MS address;
- b) a talkgroup MS address;
- c) a gateway address (a UDT to transport the extended destination address from the MS).

When the BS responds to the random access request, it shall start a timer (TNP\_Timer). This timer shall be refreshed if the BS sends further call progress messages to the calling party.

#### 10.3.5.4.1.1 BS Response to a call to an individual MS or talkgroup

When a random access short message service frame is received by the BS, the BS shall send a response in accordance with the random access procedures prescribed in clause 12.3.7.

The Frames that represent a valid response to the short data message service random access request to an MS or talkgroup are:

- a) an acknowledgement frame B\_NACKD, B\_QACKD, B\_WACKD;
- b) a UDT Head + Appended\_Data messages(s) (short data call is diverted);
- c) a B\_AHOY frame from SDMI instructing the calling MS to transport its short data message using the UDT mechanism;
- d) a B\_AHOY frame from COMPI instructing the calling MS to transport complementary data using the UDT mechanism;
- e) for a call to an extended address, A B\_AHOY frame from PABXI/PSTNI instructing the calling party to send its extended address (such as PSTN, PABX etc) using the UDT mechanism.

NOTE: c), d) and e) may be performed in any order.

#### 10.3.5.4.1.2 BS Response to a call to an extended address destination

When a random access short message service frame is received on the BS, the BS shall send a response in accordance with the random access procedures prescribed in clause 12.3.7.

The frames that represent a valid response to the short data message service random access request to an extended address are:

- a) an acknowledgement frame B\_QACKD, B\_WACKD;
- b) a B\_AHOY frame from SDMI instructing the calling MS to transport its short data message using the UDT mechanism;
- c) a B\_AHOY frame from COMPI instructing the calling MS to transport complementary data using the UDT mechanism.

NOTE: b) and c) may be performed in any order.

The gateway Frames for B\_AHOY Frames to support short data message services are prescribed in table 10.36.

**Table 10.36: B\_AHOY fields for short data message service to a gateway**

Action	Gateway address	Remark
Send PSTN digits for the short data destination	PSTNI	The calling party shall uplink BCD dialled digits
Send PABX digits for the short data destination	PABXI	The calling party shall uplink BCD dialled digits

- a) B\_NACKD: Call refused and terminated. The calling party shall return to the idle state;
- b) if the BS has previously accepted a call diversion indicating that this type of service request be directed to another called party, a UDT Head + Appended\_Data indicating the diverted address.

#### 10.3.5.4.1.3 Availability Check to the called MS (short data)

For calls to individual MS, the BS may check that the called party is in radio contact before downloading the short data.

The BS may check availability of the called party by:

- a) Sending a B\_AHOY frame to that called party.
- b) Sending a Multi-frame UDT with complementary data (if the complementary data service is active for this call).

If a response is not received from the called party the BS may repeat the B\_AHOY.

The availability check demands a response from the called party:

- If the response is B\_NACKU, the BS shall abandon the short message call send an appropriate call failed response to the calling MS and echo the Reason in the B\_NACKD frame.
- If the response is B\_ACKU (Reason=Message\_Accepted), the BS shall progress the service request and download the short data message using the UDT mechanism.

#### 10.3.5.4.1.4 Final acknowledgement to the calling party

In the downlink phase, the BS downloads the short data message to the called party. If the recipient is an individual MS an acknowledgement shall be received on the BS. For a short data message service to a talkgroup, the downlink phase may be repeated but no acknowledgement shall be expected.

The BS shall send an appropriate acknowledgement to the calling party to indicate the outcome of the short data transfer request.

#### 10.3.5.4.2 Short Data Message procedures for MS

An MS requests a short data message call service to another individual MS or a talkgroup or gateway using a multi-part service request. For calls to an extended address the transport of the extended address and the short data message is uploaded by two separate UDT transfers.

An MS requests a short data service by sending a B\_RAND random access request complying with the random access procedures in clause 12.3.7. The Fields in the random access request are passed from the application layers - set appropriately as prescribed in table 10.37.

Table 10.37: B\_RAND fields for a Short Data Message Service

Alias	Alias	Alias	Value	Length	Meaning		
MT			1100 <sub>2</sub>	4	Message Type = B_RAND (BS uplink)		
PARMS	ID0 + 1			24	Called MS, talkgroup or gateway		
	ID2 + 3			24	Calling MS ID		
	M		110 <sub>2</sub>	3	Service requested is defined by MI_TYPE		
			111 <sub>2</sub>		Cancel the call service		
	V		00 <sub>2</sub>	2	TCH is standard (non zero for custom)		
	F		10 <sub>2</sub>	2	Comms Format = BS Uplink		
	EP		0 <sub>2</sub>	1	Non emergency service		
			1 <sub>2</sub>		Emergency Service		
	PM		N/A	1	Not Applicable for this particular message		
	MI	MI_TYPE		000 <sub>2</sub>	3	Service Requested is Short Data	
		MI_DET			2	UAD1	Appended Short Data. Number of appended UDTs required to transport the short data
					2	UAD2	Appended Complementary Data. Number of appended UDTs required to transport the complementary data
				0 <sub>2</sub>	1	LONG	PABX/PSTN dialled string is 1 to 16 digits. or IPV4
				1 <sub>2</sub>			PABX/PSTN dialled string is 17 to 32 digits. or IPV6
				0 <sub>2</sub>	1	COMP	Complementary Data service not required for this call
1 <sub>2</sub>				Complementary Data service is required for this call			
0 <sub>2</sub>				1	PRIORITY	Normal Priority call	
1 <sub>2</sub>						High Priority Call	
0 <sub>2</sub>				1	BRCST	Non Broadcast Service	
1 <sub>2</sub>	Broadcast Option						

#### 10.3.5.4.3 Initiating a Short Data Message service

For a short data message service request to an individual MS or talkgroup, the destination address is completely expressed by the ID0 + 1 field in the B\_RAND random access frame. For calls to a gateway addresses the Target\_address or Gateway field in the B\_RAND is set to the gateway address.

The MS shall attempt access until it receives a valid response, or the service is cancelled by the user, or the attempt fails by sending the maximum number of random access Frames or the random access timer expires.

#### 10.3.5.4.4 Response to a random access short data message

The calling MS shall accept the following Frames a valid response to the SDM random access request:

- an acknowledgement frame B\_NACKD, B\_QACKD, B\_WACKD;
- a UDT Head + appended data message(s) (short data call is diverted);
- a B\_AHOY frame from SDMI instructing the calling MS to transport its short data message using the UDT mechanism;
- a B\_AHOY frame from COMPI instructing the calling MS to transport complementary data using the UDT mechanism;
- for a call to an extended address, A B\_AHOY frame from PABXI/PSTNI instructing the calling party to send its extended address using the UDT mechanism.

NOTE: c), d) and e) may be performed in any order.

### 10.3.5.4.5 Acknowledgements received by the calling MS

When the B\_RAND frame has been transmitted by the calling party, an initial response may be received by the calling party as specified in clause 10.3.5.4.4.

At any time further Frames may be sent to the calling party as follows:

- a) a B\_NACKD at any time to indicate the call has failed. The Reason field shall be set to indicate the reason for the call failure;
- b) a B\_WACKD if more signalling will follow;
- c) after the short data message has been successfully transported, B\_ACKD frame.

If a B\_NACKD is received, the calling MS shall abandon the short data message call and return to the idle state.

Any applicable call progress acknowledgements received shall restart the TNP\_timer.

### 10.3.5.4.6 Timeout waiting for further signalling

An MS waiting for further signalling shall abandon the short data message service and return to the idle state if the TNP\_Timer expires.

### 10.3.5.4.7 MS receiving a short data message

If an MS receives a multi frame UDT Head frame with the Target Address matching its individual address, it shall respond with an appropriate acknowledgement. The Appended\_Data field in the UDT header indicates the number of appended UDT messages.

If an MS receives a multi UDT Header message with the Target Address matching a talkgroup, it shall accept the information contained in the Appended\_Data message, but shall transmit no response.

### 10.3.5.5 Mode 3 Short Data Polling Service

The Short Data Polling Message service enables data to be polled from MS using the control channel. Up to 256 bits of data may be transported using this service formatted in a number of formats including binary, BCD, ISO 7 bit text (ISO/IEC 646 [2]), ISO 8 bit characters (ISO/IEC 8859 [3]), and NMEA (EN 61162-1 [1]) formatted location data.

NOTE: Calling and polled MSs pre-arrange the number of appended UDTs required to transport the polled data.

The Short Data Message polling procedure uses the single-part call set-up.

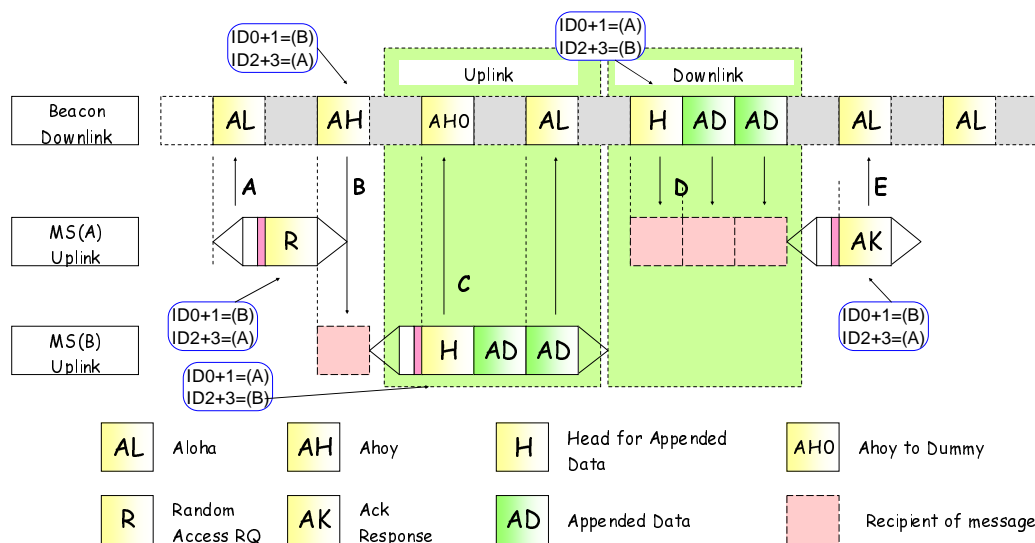
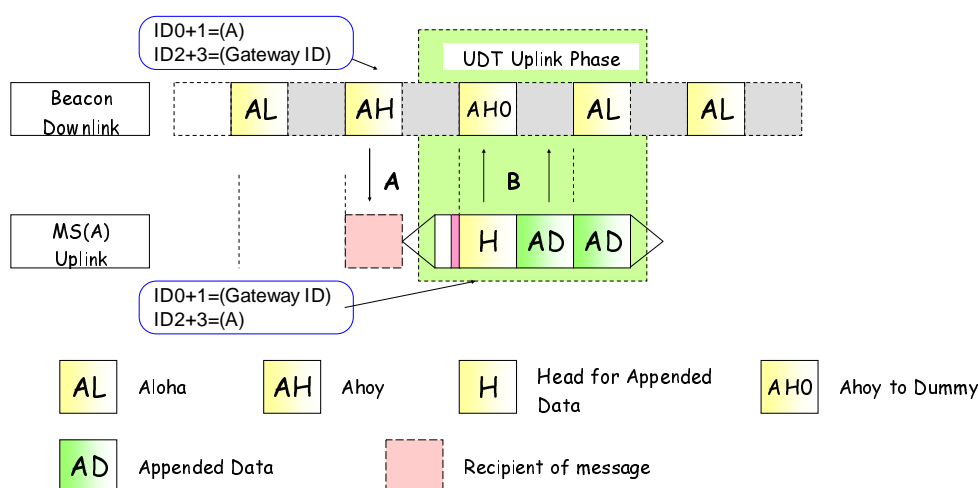


Figure 10.39: Example of a Short Data Polling transfer

Figure 10.39 shows an example of a short data polling service:

- MS(A) specifies the number of appended UDTs for the polled short data. In this example, one appended UDT is required;
- "A" is the random access B\_RAND frame. The target address is set to the polled party, M/MI\_TYPE set to 'Short Data Polling' (010<sub>2</sub>) and the Appended\_Short\_Data field to the number of data frames to transport the polled short data;
- "B" is a B\_AHOY frame that requests MS(B) to transport the short data using the UDT mechanism;
- "C" is the uplink phase consisting of a UDT header + Appended\_Data;
- "D" is the downlink phase consisting of a UDT header + Appended\_Data;
- "E" is the final acknowledgement from MS(A).

The maximum number of bits that may be transported by the short data message polling service is limited by the maximum number of Appended\_Data UDTs. The Mode 3 protocol permits up to four Appended Data frames concatenated to a UDT header.



**Figure 10.40: Example of short data polling from a gateway**

Figure 10.40 shows a short data polling transfer from a gateway to an MS. The BS requests the short data by transmitting a B\_AHOY frame addressed to MS(A). MS(A) responds with the UDT head + short data.

### 10.3.5.5.1 Short Data Polling Procedures for the BS

An MS requests a Mode 3 short data polling message service by generating a random access request frame with the Target Address set to an individual address.

When the BS responds to the random access request, it shall start a timer (TNP\_Timer). This timer shall be refreshed if the BS sends further call progress frames to the calling party.

#### 10.3.5.5.1.1 BS Response to a poll request from an MS

When a random access short data poll service frame is received on the BS, the BS shall send a response in accordance with the random access procedures prescribed in clause 12.3.7.

The Frames that represent a valid response to the short data polling service random access request to an MS or talkgroup are:

- an acknowledgement frame B\_NACKD, B\_QACKD, B\_WACKD;
- a B\_AHOY frame from SDMI instructing the polled MS to transport complementary data using the UDT mechanism.

NOTE: If the polled MS has diverted its calls the response is B\_NACKD (Reason= Div\_Cause\_Fail).

#### 10.3.5.5.1.2 Availability Check to the called MS (short data poll)

The BS may check that the called party is in radio contact before polling the MS for the short data.

The BS may check availability of the polled party by sending a B\_AHOY frame addressed to the polled MS individual address. If a response is not received from the calling party the BS may repeat the B\_AHOY.

The availability check demands a response from the called party:

- a) If the response is B\_NACKU, the BS shall abandon the short message polling transaction, send an appropriate call failed response to the calling MS and echo the Reason in the B\_NACKU frame.
- b) If the response is B\_ACKU (Reason=Message\_Accepted), the BS shall progress the service request and poll the MS for the short data using the UDT mechanism.

#### 10.3.5.5.1.3 Delivery of the polled data to the calling party

In the downlink phase, the BS downloads the short data polled message to the calling party using the UDT mechanism.

The calling MS shall send an appropriate acknowledgement to the BS to indicate the outcome of the short data polling request.

#### 10.3.5.5.1.4 Final acknowledgement by the calling party to the BS

The final phase of the polling transaction is the acknowledgement from the calling MS that the polled data was successfully received. If the BS does not receive a response, it may repeat the downlink phase described in clause 10.3.5.5.1.3.

#### 10.3.5.5.1.5 Short Data Polling procedures from a BS gateway

The short polling service initiated through a gateway is illustrated in figure 10.40. The BS transmits a B\_AHOY frame addressed to an individual MS. The B\_AHOY frame demands a response:

- a) If the response is B\_NACKU, the BS shall abandon the short message polling transaction.
- b) If the response is a multi-frame UDT containing the polled data, the transaction is complete.

#### 10.3.5.5.2 Short Data Polling Message procedures for MS

An MS requests a short data polling call service to another individual MS, using a single-part service request.

An MS requests a short data service by sending a B\_RANDOM random access request complying with the random access procedures in clause 12.3.7. The fields in the random access request are passed from the application layer and set appropriately as prescribed in table 10.38.

Table 10.38: B\_RAND fields for a Short Data Polling Service

Alias	Alias	Alias	Value	Length	Meaning		
MT			1100 <sub>2</sub>	4	Message Type = B_RAND (BS uplink)		
PARMS	ID0 + 1			24	Called MS		
	ID2 + 3			24	Calling MS ID		
	M		110 <sub>2</sub>			Service requested is defined by MI_TYPE	
			111 <sub>2</sub>			Cancel the call service	
	V		00 <sub>2</sub>	2	TCH is standard (non zero for custom)		
	F		10 <sub>2</sub>	2	Comms Format = BS Uplink		
	EP		0 <sub>2</sub>	1	Non emergency service		
			1 <sub>2</sub>		Emergency Service		
	PM		N/A	1	Not Applicable for this particular message		
		MI_TYPE		010 <sub>2</sub>		Data Polling Service	
		MI_DET			2	UAD1	Appended Short Data. Number of appended UDTs required to transport the short data
					2	UAD2	Appended Complementary Data. Number of appended UDTs required to transport the complementary data
			0 <sub>2</sub>	1	1	LONG	PABX/PSTN dialled string is 1 to 16 digits. or IPV4
			1 <sub>2</sub>				PABX/PSTN dialled string is 17 to 32 digits. or IPV6
			0 <sub>2</sub>	1	1	COMP	Complementary Data service not required for this call
	1 <sub>2</sub>		Complementary Data service is required for this call				
	0 <sub>2</sub>		1	1	PRIORITY	Normal Priority call	
	1 <sub>2</sub>					High Priority Call	
	0 <sub>2</sub>		1	1	BRCST	Non Broadcast Service	
	1 <sub>2</sub>					Broadcast Option	

### 10.3.5.5.3 Initiating a Short Data Polling service

For a short data polling service request to an individual MS, the polling MS address is completely expressed by the Target Address field in the B\_RAND random access frame. The M=110<sub>2</sub>/MI\_TYPE=010<sub>2</sub> specifies the Short Data Polling service.

The MS shall attempt access until it receives a valid response, or the service is cancelled by the user, or the attempt fails by sending the maximum number of random access frames or the random access timer expires.

### 10.3.5.5.4 Response to a random access short data polling message

The calling MS shall accept the following Frames a valid response to the SDM random access request:

- An acknowledgement frame B\_NACKD, B\_QACKD, B\_WACKD.
- A B\_AHOY frame from SDMI instructing the polled MS to transport its short data message using the UDT mechanism.

### 10.3.5.5.5 Final Acknowledgement transmitted by the calling MS

In the downlink phase, the BS downloads the short data polled message to the calling party. Valid responses to the BS are:

- An acknowledgement frame B\_NACKU indicating the transaction has failed.
- An acknowledgement frame B\_ACKU indicating the transaction was successful.

#### 10.3.5.5.6 Timeout waiting for further signalling

An MS waiting for further signalling shall abandon the short data polling service and return to the idle state if the TNP\_Timer expires.

#### 10.3.5.5.7 MS receiving a B\_AHOY poll for a short polling message

If an MS receives a B\_AHOY frame with the Target Address matching its individual address and the Service\_Type = Short Data Polling Service it shall respond with:

- a) A UDT Header frame with the Target Address matching its calling party (source) address from the B\_AHOY frame. The Appended\_Frames field in the UDT header indicates the number of appended UDT frames.
- b) A B\_NACKU frame if the polled MS does not wish to accept the polling request.

### 10.3.5.6 Mode 3 Status Call Service

The Status Message service enables data to be transmitted between dPMR entities on the beacon channel. Seven bits of data may be transported using this service. The status delivery service transports a status message from the initiator to a recipient. The status polling service enables an initiator to request a status message from an addressed entity. Seven bits are transported representing 256 status messages. Each status message has a user-defined meaning.

Status messages addressed from MS to the beacon are system messages.

#### 10.3.5.6.1 Status Service Delivery Procedure

The Status Message procedure employs a store and forward mechanism. An MS may send a Status Message to an individual MS, the PSTN or PABX, a line connected gateway, a dispatcher gateway or the BS. The BS may also transmit a short data message from a gateway or special ID addressed to an individual MS.

##### 10.3.5.6.1.1 Status Service Delivery Procedures for the BS

An MS initiates a Status Service by random access addressed to:

- a) An individual MS address (single-part call set-up).
- b) A gateway address that indicates a multi-part call set-up.
- c) The BS.

When the BS responds to the random access request it shall start timer (TNP\_Timer). This timer shall be refreshed if the BS sends further call progress messages to the calling party.

##### 10.3.5.6.1.1.1 BS Response to a single part Status Service Delivery call set-up

On receipt of the random access service request the BS shall transmit either:

- a) An acknowledgement frame B\_NACKD, B\_WACKD (Reason=Wait), B\_ACKD addressed to the calling MS.
- b) A B\_AHOY frame addressed to the called party for this call to pass the status to the called MS.
- c) A UDT Head + Appended\_Data frame(s) status message service is diverted. If the BS has previously accepted a call diversion indicating that this type of service request be directed to another called party, the BS shall invoke the UDT and send a UDT Head + Appended\_Data to the calling party.



#### 10.3.5.6.1.1.2 BS Response to a multi part Status Service Delivery call set-up

For calls to extended addresses, the MS requests multi-part addressing by generating a status call random access request with the Destination Address field set to a gateway address (PABXI, PSTNI, etc) and the LONG Flag field to indicate the number of digits for the extended address. For the number of dialled digits = 1 to 16 the LONG Flag field shall be set to 0<sub>2</sub>. For the number of dialled digits = 17 to 32 the LONG Flag field shall be set to 1<sub>2</sub>. The Frames that shall represent a valid response to the multi-part Status service random access request are:

- a) An acknowledgement frame B\_NACKD, B\_WACKD(reason=Wait).
- b) A B\_AHOY frame from PABXI/PSTNI for the calling MS to send the extended address information.
- c) A B\_AHOY frame from COMPI for the calling MS to send complementary data (see clause 4.5).

For b) The BS shall then invoke the UDT procedure by sending a B\_AHOY to the calling MS to send the extended address information. For a call to the PABX or PSTN the extended address information shall be BCD digits. The LONG Flag field in the B\_AHOY frame shall be copied from the LONG Flag field received from the MS B\_RAND frame. If the BS does not successfully receive the UDT from the MS, the BS may repeat the B\_AHOY, or transmit a B\_NACKD to indicate failure of the call.

For c) The BS shall then invoke the UDT procedure by sending a B\_AHOY to the calling MS to send the complementary data. The format of the complementary data is specified in the UDT. If the BS does not successfully receive the UDT from the MS, the BS may repeat the B\_AHOY, transmit a B\_NACKD to indicate failure of the call or continue with the call set-up and abandon the complementary data.

#### 10.3.5.6.1.1.3 Acknowledgements sent on the BS to the calling MS (status)

The BS may send acknowledgement Frames following the random access Status service request to indicate the progress of the call, or terminate the call. If the BS sends a frame to indicate the progress of a call it shall start a waiting timer TNP\_Timer. (The calling party MS maintains a similar timer).

- a) Progress Frames may be:
  - 1) B\_WACKD: Intermediate acknowledgement. More Frames to follow.
  - 2) B\_QACKD: Called MS engaged in another call.
  - 3) B\_QACKD: Call is queued because the resource is in use at the moment.
- b) Termination Frames are selected from an appropriate Reason field in a B\_NACKD frame (see clause 5.5.25):
  - 1) B\_NACKD.

#### 10.3.5.6.1.1.4 Delivery of the status to the called party

The BS delivers the status to the called MS by transmitting a B\_AHOY frame containing the Status field. The status message may have originated from another MS, a gateway or the BS. The B\_AHOY frame demands a response from the called MS. If the response is B\_ACKU or B\_NACKU, the BS shall send an equivalent acknowledgement to the calling party. If no response is received the BS may repeat the B\_AHOY or abandon the service and indicate the failure to the called party by transmitting a B\_NACKD.

#### 10.3.5.6.1.1.5 Call Time Out

The BS shall maintain a timeout defining the maximum time it shall store a status message request waiting for the called MS or BS resource to become free.

#### 10.3.5.6.1.2 Status Service Delivery Procedures for MS

An MS requests a status message call service to another individual MS using a single part service request or gateway using a multi-part service request. For calls to an extended address the sending of the extended address is by a UDT transfer.

An MS requests a status service by sending a B\_RAND random access request complying with the random access procedures in clause 12.3.7. The fields in the random access request are passed from the application layer - set appropriately as prescribed in table 10.39.

**Table 10.39: B\_RAND fields for a Status Message Service**

Alias	Alias	Alias	Value	Length	Meaning
MT			1100 <sub>2</sub>	4	Message Type = B_RAND (BS uplink)
PARMS	ID0 + 1			24	Called MS or talkgroup
	ID2 + 3			24	Calling MS ID
			110 <sub>2</sub>		Service requested is defined by MI_TYPE
			111 <sub>2</sub>		Cancel the call service
	V		00 <sub>2</sub>	2	TCH is standard (non zero for custom)
	F		10 <sub>2</sub>	2	Comms Format = BS Uplink
	EP		0 <sub>2</sub>	1	Non emergency service
			1 <sub>2</sub>		Emergency Service
	PM		N/A	1	Not Applicable for this particular message
		MI_TYPE	001 <sub>2</sub>	3	Service Requested is Status Transport
	MI_DET		8	STATUSM3   Status Value	

#### 10.3.5.6.1.2.1 Initiating a Status Message service

For a status message service request to an individual MS, the destination address is completely expressed by the Target Address field in the B\_RAND random access frame. The M/MI\_TYPE specifies the Status Message call service. For calls to a gateway addresses ID0 + 1 in the B\_RAND is set to the gateway address.

The MS shall attempt access until it receives a valid response, or the service is cancelled by the user, or the attempt fails by sending the maximum number of random access frames or the random access timer expires.

#### 10.3.5.6.1.2.2 Response to a random access status message service request

The calling MS shall accept the following Frames a valid response to the status service random access request:

- An acknowledgement frame B\_NACKD, B\_QACKD, B\_WACKD.
- A UDT Head + appended frame(s) (short data call is diverted).
- A B\_AHOY frame to the called MS containing the status frame.
- For a call to an extended address, A B\_AHOY frame from PABXI/PSTNI instructing the calling party to send its extended address using the UDT mechanism.

#### 10.3.5.6.1.2.3 Acknowledgements received by the calling MS

When the B\_RAND frame has been transmitted by the calling party, an initial response may be received by the calling party as specified in clause 10.3.5.6.1.1.3.

At any time further frames may be sent to the calling party as follows:

- A B\_NACKD at any time to indicate the call has failed. The Reason field shall be set to indicate the reason for the call failure.
- A B\_WACKD if more signalling will follow.
- After the status message has been successfully transported, a B\_ACKD frame.

If a B\_NACKD is received, the calling MS shall abandon the status message call and return to the idle state.

If a B\_WACKD is received the MS shall start/restart the TNP\_Timer and wait for further signalling.

Any acknowledgement or valid B\_AHOY frame received shall restart the TNP\_timer.

#### 10.3.5.6.1.2.4 Timeout waiting for further signalling

An MS waiting for further signalling shall abandon the status message service and return to the idle state if the TNP\_Timer expires.

#### 10.3.5.6.1.2.5 MS receiving a status message

If an MS receives a B\_AHOY message with the Target Address matching its individual address, it shall respond with an appropriate acknowledgement. The Service\_Options field contains the status message.

### 10.3.5.7 Mode 3 Call Diversion

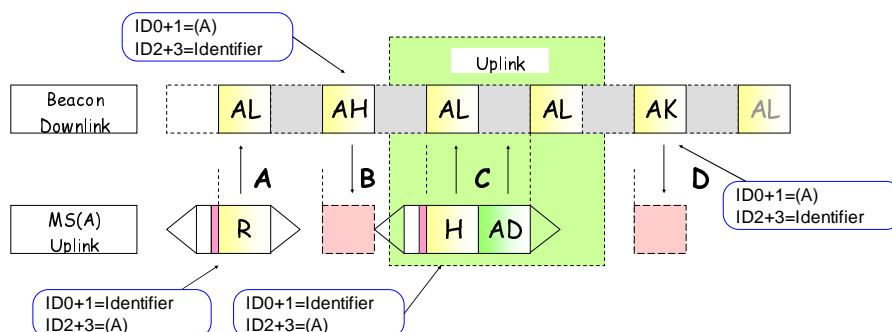
#### 10.3.5.7.1 Call Diversion Service

The call diversion service supports a self initiated diversion - that is an MS may request that all future services be redirected to an alternative destination. Requests are applicable to:

- Voice call service.
- Data service.
- Short data message delivery service.
- Status message service.

Applicable Services may be redirected to another MS, a talkgroup, or an extended address through a gateway.

The "Set Diversion" call diversion service uses a multi-part call set-up and the diversion address is sent by the caller using the UDT mechanism. This is recognized by the DIVONOFF field in the diversion service request set to "Set Call Diversion" (=1<sub>2</sub>).



**Figure 10.41: Example of a Call Diversion Call**

- MS(A) defines the number of appended UDTs needed to transport the diverted address to the BS. In this example, one appended UDT is required.
- "A" is the random access B\_RAND frame. The Service\_Type set to 'Call Diversion Service' and the Appended\_Short\_Data frame to the number of UDT appended messages to transport the diverted address to the BS. ID0+1 is an Identifier set to one of - MSI for a diversion to an individual MS, GPI for a diversion to a talkgroup, PSTNI for a diversion to a PSTN destination, PABXI for a diversion to a PABX destination, IPI for a diversion to an IP address.
- "B" is a B\_AHOY frame that requests MS(A) to transport the diversion address using the UDT mechanism.
- "C" is the uplink phase consisting of a Multi-frame UDT header + Appended\_Data transporting the diverted address to the BS.
- "D" is the acknowledgement from the beacon.

If the Service\_Options field DIVONOFF in the call diversion Service request is set to "Clear Diversion" then a single part call set-up with the Target Address set to DIVERTI.

## 10.3.5.7.1.1 MS Procedures for the Call Diversion Service

An MS requests the call diversion service using a random access service request.

If the MS wishes to divert its calls, the DIVONOFF field in the Service\_Options is set to "Set Diversion (=1<sub>2</sub>)". A multi-part service request is invoked. The fields in the random access request are passed from the application layer - set appropriately as prescribed in table 10.40.

If the MS wishes to cancel a previously set diversion, a single part B RAND is sent to DIVERTI with the DIVONOFF field in the Service\_Options is set to "Clear Diversion (=0<sub>2</sub>)".

**Table 10.40: B RAND fields for a Call Diversion Service**

Alias	Alias	Alias	Value	Length	Meaning		
MT			1100 <sub>2</sub>	4	Message Type = B RAND (BS uplink)		
PARMS	ID0 + 1		Identifier	24	Diversion Gateway		
	ID2 + 3			24	Calling MS ID		
		M	110 <sub>2</sub>	3	Service requested is defined by MI_TYPE		
			111 <sub>2</sub>		Cancel the call service requested		
	V		N/A	2	Not Applicable for this particular message		
	F		10 <sub>2</sub>	2	Comms Format = BS Uplink		
	EP		0 <sub>2</sub>	1	Non emergency service		
			1 <sub>2</sub>		Emergency Service		
	PM		N/A	1	Not Applicable for this particular message		
		MI_DET	MI_TYPE	011 <sub>2</sub>		Call Diversion Service	
			0 <sub>2</sub>	1	DIV_V	Do not Divert Voice Calls	
						Divert Voice Calls	
			0 <sub>2</sub>	1	DIV_D	Do not Divert Data Calls	
						Divert Data Calls	
				2	UAD2	Appended Complementary Data. Number of appended UDTs required to transport the complementary data	
			0 <sub>2</sub>	1	LONG	PABX/PSTN dialled string is 1 to 16 digits. or IPV4	
						PABX/PSTN dialled string is 17 to 32 digits. or IPV6	
			0 <sub>2</sub>	1	COMP	Complementary Data service not required for this call	
						Complementary Data service is required for this call	
	0 <sub>2</sub>		1	PRIORITY	Normal Priority call		
					High Priority Call		
	0 <sub>2</sub>		1	DIVONOFF	Clear Call Diversion		
		Set Call Diversion					

If DIVONOFF=1<sub>2</sub>, the alias DIV\_V, DIV\_D that are set to Active (1<sub>2</sub>): define which services shall be diverted for this call diversion service request.

If DIVONOFF=0<sub>2</sub>, the alias DIV\_V, DIV\_D that are set to Active (1<sub>2</sub>): define which services shall have the call diversion cancelled.

**Table 10.41: Field definitions for the Call Diversion Service**

Diversion Address	Target Address or Gateway	LONG
Individual MS Address	MSI	0 <sub>2</sub>
talkgroup Address	GPI	0 <sub>2</sub>
PSTN Address (1 to 16 dialled digits)	PSTNI	0 <sub>2</sub>
PSTN Address (17 to 32 dialled digits)	PSTNI	1 <sub>2</sub>
PABX Address(1 to 16 dialled digits)	PABXI	0 <sub>2</sub>
PABX Address (17 to 32 dialled digits)	PABXI	1 <sub>2</sub>

#### 10.3.5.7.1.2 BS Procedures for the Call Diversion Service

An MS initiates a Set Call Diversion Service by random access addressed to the gateway identifier appropriate to the diverted destination - individual MS address, talkgroup, PSTN, PABX, IP. The set call diversion service uses the multi-part call set-up. When the BS responds to the random access request it shall start timer (TNP\_Timer). This timer shall be refreshed if the BS sends further call progress Frames to the calling party.

An MS initiates a Clear Call Diversion Service by random access addressed to the gateway identifier DIVERTI. The clear call diversion service uses the single-part call set-up. When the BS responds to the random access request it shall start timer (TNP\_Timer). This timer shall be refreshed if the BS sends further call progress Frames to the calling party.

The BS shall refuse a call diversion request that is not achievable. An example of an impossible diversion request is a diversion from a talkgroup to an individual destination.

##### 10.3.5.7.1.2.1 BS Response to a multi-part Set Call Diversion Service call set-up

To set call diversion service, the MS generates a random access diversion service request with the B\_RAND fields set as table 10.40 and the DIVONOFF field set to Set Call Diversion (=1<sub>2</sub>).

The frames that shall represent a valid response to the set call diversion service multi-part random access request are:

- a) An acknowledgement frame B\_NACKD, B\_WACKD(reason=Wait).
- b) A B\_AHOY frame for the calling MS to send the diverted address using the UDT mechanism.

For b) The BS shall invoke the UDT procedure by sending a B\_AHOY to the calling MS to send the diverted address information. For a call diversion to the PABX or PSTN the diverted address information shall be BCD digits. The LONG Flag field in the B\_AHOY frame shall be copied from the LONG Flag field received from the MS B\_RAND frame. If the BS does not successfully receive the UDT from the MS, the BS may repeat the B\_AHOY, or transmit a B\_NACKD to indicate failure of the call.

The gateway fields for B\_AHOY Frames to upload the diverted address is prescribed in table 10.42.

**Table 10.42: B\_AHOY fields for the Set Call Diversion Service**

Action	Gateway Address	Remark
Send the individual MS Address	MSI	The calling party shall send the MS Individual diversion address
Send the talkgroup Address	GPI	The calling party shall send the MS talkgroup diversion address
Send PSTN digits	PSTNI	The calling party shall send BCD dialled digits
Send PABX digits	PABXI	The calling party shall send BCD dialled digits
Send the IP address	IPI	The calling party shall send the IP address

##### 10.3.5.7.1.2.2 BS Response to a single-part Clear Call Diversion Service set-up

For the clear call diversion service, the MS generates a random access diversion service request with the B\_RAND fields set as table 10.40 and the DIVONOFF field set to Clear Call Diversion (=0<sub>2</sub>).

The frames that shall represent a valid response to the clear call diversion service multi-part random access request are:

- a) An acknowledgement frame B\_NACKD indicating that the service request has not succeeded.
- b) B\_WACKD(reason=Wait) further signalling to follow.
- c) An acknowledgement B\_ACKD indicating that the service request has succeeded.

#### 10.3.5.7.1.2.3 MS Sends the Diversion Address

After the MS has made a call diversion service request, the BS sends a B\_AHOY frame to which the MS shall respond with a UDT Header + Appended\_Data frame(s) using the UDT mechanism. The UDT header shall contain the destination address type (MS, PSTN etc.) and the appended frame(s) shall contain the diversion address.

The fields for the UDT uplink Header are specified in table 10.43.

**Table 10.43: Field Definitions for the Call Diversion UDT Header**

Diversion Address	UDT Uplink Channel Header Field			
	UDT Format	Appended Frames	Target Address or Gateway	Source Address or Gateway
Individual MS	MS ID - 000 <sub>2</sub>	00 <sub>2</sub>	MSI	MS ID
Talkgroup	MS ID - 000 <sub>2</sub>	00 <sub>2</sub>	GPI	MS ID
PSTN destination	BCD - 010 <sub>2</sub>	1 digits to 16 digits - 00 <sub>2</sub> 17 digits to 32 digits - 01 <sub>2</sub>	PSTNI	MS ID
PABX destination	BCD - 010 <sub>2</sub>	1 digits to 16 digits - 00 <sub>2</sub> 17 digits to 32 digits - 01 <sub>2</sub>	PABXI	MS ID
IP destination	IP - 110 <sub>2</sub> or 111 <sub>2</sub>	IPV4 IPV6	IPI	MS ID

#### 10.3.5.7.2 Call set-up to an MS that has a Diverted address

An MS makes a service access request by random access. If the destination address selected is an individual MS address and the BS determines that calls to this address are diverted, the BS shall acknowledge the random access request with a B\_WACK, ID0 + 1 = Calling MS, ID2 + 3 = DIVERTI to indicate to the calling party that the call is diverted. The BS shall then connect the call to the diverted address for the selected service. For calls diverted to an individual MS, an MS presence check shall be performed.

#### 10.3.5.8 Mode 3 MS Stun/Revive Procedures

MS may be denied access to most call services using the stun mechanism. If an MS has been disabled by a stun procedure, the MS may not request nor receive any user initiated services on the network that performed the procedure. However hunting and registration, authentication, stun/unstun and registration services shall remain active.

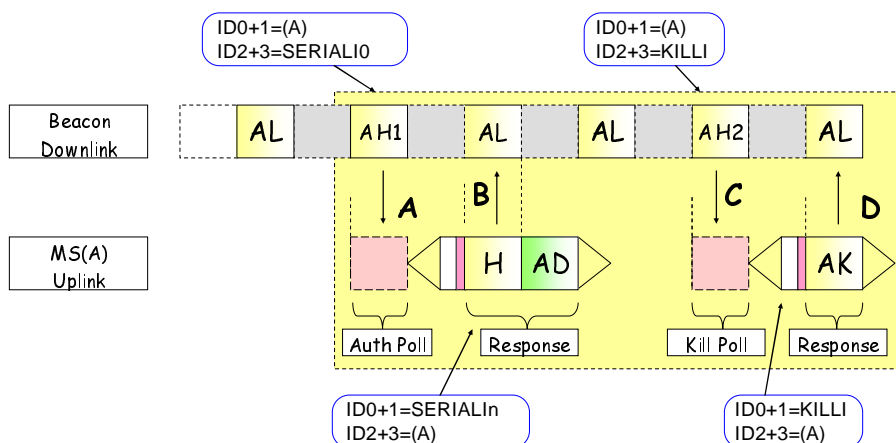
In the present document, MS shall only be stunned/revived from a BS gateway STUNI as described in clause 10.3.5.8.1.1.



### 10.3.5.9 Mode 3 MS Kill

MS may be completely and permanently disabled using the kill mechanism. If a MS has been killed by a kill procedure, the MS shall lose all dPMR functionality. An MS may not be revived from the kill state by any AI generated message.

In the present document, MS shall only be killed from a BS gateway KILLI. To protect the MS from accidentally being disabled, the kill procedure includes an authentication step. The BS shall check and confirm the ESN of the MS before the BS sends the specific message (B\_AHOY) that directs the MS to be permanently disabled.



**Figure 10.43: MS Kill (with Authentication)**

Figure 10.43 illustrates the mechanism for MS kill:

- The BS sends a B\_AHOY (AH1) at "A" to poll the MS for its ESN.
- At "B" The MS responds with its ESN. (see clause 12.3.11.3 for the Head + Appended data content).
- At "C" the BS sends the B\_AHOY to Kill the MS.
- The MS sends ACKU ("D"). Following the acknowledgement the MS disables all dPMR functionality.

A situation may exist where the final acknowledgement C\_ACKU was sent by the MS (and the MS disabled all functionality) but the acknowledgement was not received by the BS. In this case, repeating the kill procedure from step "A" would not result in any response from the MS. The BS shall be able to deal with this situation.

#### 10.3.5.9.1 Kill procedures for the BS

The kill procedure is split into two phases. The first phase consists of an authentication check as described in clause 12.3.11. The BS shall only initiate the second phase if the authentication check is successful. If the authentication phase is unsuccessful the kill procedure shall be abandoned.

In the second phase, the Beacon transmits a B\_AHOY (AH2 in figure 10.43) with the information elements as illustrated in table 10.45.

**Table 10.45: B\_AHOY information elements for Kill**

Alias	Alias	Value	Length	Meaning
ID0 + 1			24	Target MS
ID2 + 3		KILLI	24	Gateway = KILLI
M		110 <sub>2</sub>	3	110 <sub>2</sub> Service is defined by MI_TYPE
V		00 <sub>2</sub>	2	N/A
F		11 <sub>2</sub>	2	Downlink
EP		0 <sub>2</sub>	1	N/A
PM		0 <sub>2</sub>	1	N/A
MI_TYPE		100 <sub>2</sub>	3	Complementary Service
MI_DET		0000 0000 <sub>2</sub>	8	N/A



- a) If the final acknowledgement transmitted by the MS is B\_ACKU(Reason=Message\_Accepted) the BS shall assume that the kill procedure was successful;
- b) If the final acknowledgement transmitted by the MS is B\_NACKU (Reason=MSNot\_Supported) the BS shall identify that the kill was unsuccessful.

### 10.3.5.9.2 Kill procedure with ESN check for the MS

If the MS does not support kill, it shall respond with C\_NACKU (Reason=MSNot\_Supported).

The kill procedure is split into two phases. The first phase is an authentication check. If the MS receives a B\_AHOY for an authentication check, the MS shall respond as described in clause 12.3.11 and start the frameset counter N\_kill\_cnr.

If the frameset counter N\_kill\_cnr expires before the B\_AHOY for the second phase has been received, the MS shall respond B\_NACKU (Reason=MSNot\_Supported).

Figure 10.44 illustrates the operation of N\_kill\_cnr. In this example the BS has started the second phase of the kill procedure before the framset\_counter N\_kill\_cnr has expired. If kill is supported the MS shall respond with B\_ACKU(Reason=Message\_Accepted) and then become permanently disabled.

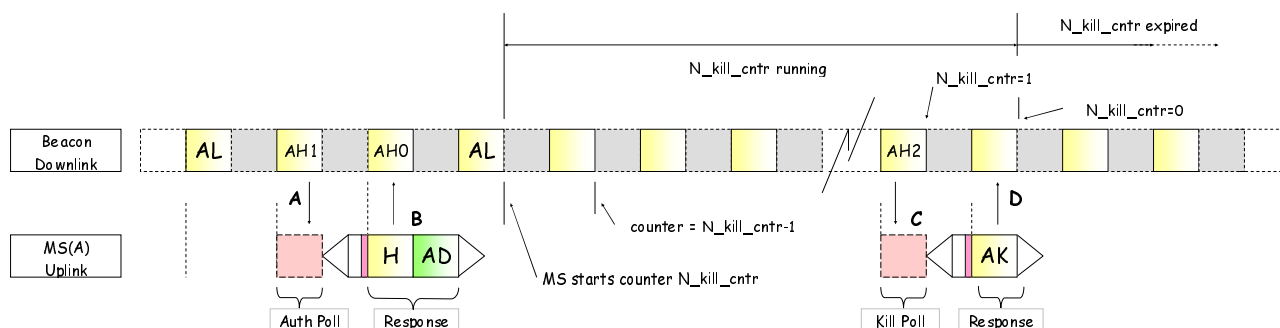


Figure 10.44: Example of successful kill procedure

In the second example illustrated in figure 10.45, the BS has attempted the second phase of the kill procedure after the N\_kill\_cnr has expired. In this case the MS shall respond with B\_NACKU (Reason=Recipient\_refused) and take no further action.

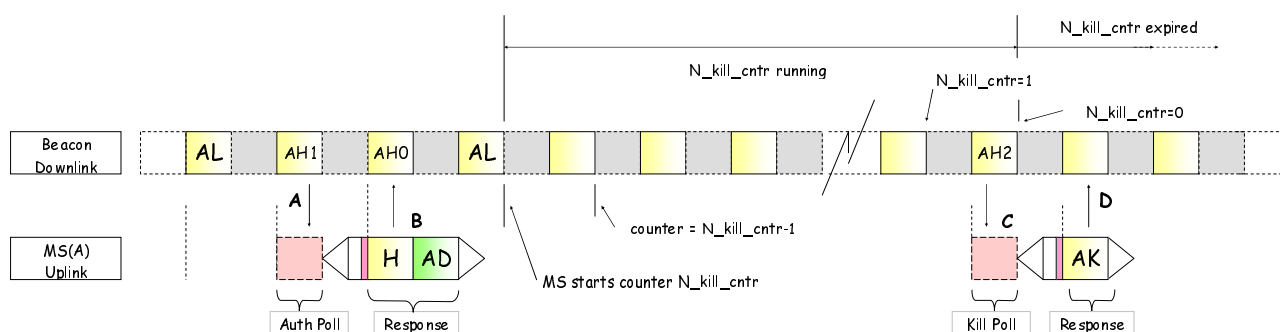


Figure 10.45: Example of unsuccessful kill procedure

## 10.3.6 Message Address Matrix for Mode 3 Call services

The tables in this clause specify the contents in the fields of messages frames.

- (A) is the address of the calling party MS;
- (B) is the address of the called party MS or talkgroup.

### 10.3.6.1 Call Services that require the allocation of a Traffic Channel

#### 10.3.6.1.1 MS to MS or talkgroup Voice, T1, T2, T3 data call

Table 10.46 illustrates a call initiated from MS(A) to MS(B) or a talkgroup(B).

**Table 10.46: Calls from MS to MS or talkgroup (M = 000<sub>2</sub> to 101<sub>2</sub>)**

M=000 <sub>2</sub> - Service requested is a voice call						
M=001 <sub>2</sub> - Service requested is Voice Call + Slow Data						
M=010 <sub>2</sub> - Service requested is a T1 data call						
M=011 <sub>2</sub> - Service requested is a T2 data call						
M=100 <sub>2</sub> - Service requested is a T3 data call						
M=101 <sub>2</sub> - Service requested is a Voice + embedded data call						
Beacon	Message Frame	ID0+1	ID2+3 or MSID	M	MI_TYPE	MI_DET
From (A) to BS	B_RAND[U]	(B)	(A)	M	N/A	N/A
From BS to (B)	B_AHOY[D]	(B)	(A)	M	N/A	N/A
From BS to (A)	B_AHOY[D]	(A)	(B)	M	N/A	N/A
From BS to (A)	B_ACK[D]	(A)	(B)	M	See clause 5.5.19.5	Reason clause 5.5.25
From (A) to BS	B_ACK[U]	(B)	(A)	M		
From BS to (B)	B_ACK[D]	(B)	(A)	M		
From (B) to BS	B_ACK[U]	(A)	(B)	M		
From BS to (B)	Goto Channel[D]	(B)				
From BS to (A)	SYScast2/3[D]		(A)			

Traffic	Message Frame	ID0+1	ID2+3	M	MI_TYPE	MI_DET
From BS	Preservation	(B)	(A)	000 <sub>2</sub>	000 <sub>2</sub>	0000 0000 <sub>2</sub>
From MS(A) to BS	Disconnect Request{U}	(B)	(A)	M	000 <sub>2</sub>	0000 0000 <sub>2</sub>
From MS(B) to BS Note	Disconnect Request[U]	(A)	(B)	M	000 <sub>2</sub>	0000 0000 <sub>2</sub>
From BS	Disconnect Request[D]	Called Party or talkgroup	Calling Party (Originator of the call)	M	000 <sub>2</sub>	0000 0000 <sub>2</sub>
NOTE: If (B) is a talkgroup, the members of the talkgroup do not send this message when the call is ended. (See clause 10.3.4.3.2.4).						

#### 10.3.6.1.2 MS call to PSTN, PABXI and other extended addresses

Table 10.47 illustrates a call initiated from MS(A) to a line connected destination. Where extended addressing is required. The table illustrates PSTNI but this also applies to other extended addresses where the extended address is transported using the UDT.

**Table 10.47: Voice Call from MS to PSTN (M = 000<sub>2</sub> to 101<sub>2</sub>)**

M=000 <sub>2</sub> - Service requested is a voice call						
M=001 <sub>2</sub> - Service requested is Voice Call + Slow Data						
M=010 <sub>2</sub> - Service requested is a T1 data call						
M=011 <sub>2</sub> - Service requested is a T2 data call						
M=100 <sub>2</sub> - Service requested is a T3 data call						
M=101 <sub>2</sub> - Service requested is a Voice + embedded data call						
Beacon	Message Frame	ID0+1	ID2+3 or MSID	M	MI_TYPE	MI_DET
From (A) to BS	B_RAND[U]	PSTNI	(A)	M	N/A	LONG See 5.2.14.2
From BS to (A)	B_AHOY[D]	(A)	PSTNI	M	N/A	LONG See 5.2.14.1
From (A) to BS	HEAD[U] Note	PSTNI	(A)	UDT Format 010 <sub>2</sub>	N/A	See 5.2.15
From BS to (A)	B_ACK[D]	(A)	PSTNI	M	See clause 5.5.19.5	Reason clause 5.5.25
From (A) to BS	B_ACK[U]	PSTNI	(A)	M		
From BS	Goto Channel[D]	PSTNI				
From BS to (A)	SYScast2/3[D]		(A)			
NOTE: The B_Head+appended data contain the PSTN dialled digits.						

Traffic	Message Frame	ID0+1	ID2+3	M	MI_TYPE	MI_DET
From BS	Preservation[D]	(A)	PSTNI	000 <sub>2</sub>	000 <sub>2</sub>	0000 0000 <sub>2</sub>
From MS(A) to BS	Disconnect Request[U]	PSTNI	(A)	M	000 <sub>2</sub>	0000 0000 <sub>2</sub>
From BS to (A)	Disconnect Request[D]	PSTNI	(A)	M	000 <sub>2</sub>	0000 0000 <sub>2</sub>

### 10.3.6.1.3 Call from PSTN, PABX, or other line connected address to MS or talkgroup

Table 10.48 illustrates a call from the PSTN to a MS or talkgroup. The call set-up is also applicable for other line connected addresses. If the call set-up does not transport the PSTN number to the MS then the BS sends a B\_AHOY. Alternatively, if the BS is able to determine and wishes to send the PSTN number then the BS sends a HEAD + appended data containing the PSTN digits.

**Table 10.48: Voice Call from PSTN to MS or talkgroup**

M=000 <sub>2</sub> - Service requested is a voice call						
M=001 <sub>2</sub> - Service requested is Voice Call + Slow Data						
M=010 <sub>2</sub> - Service requested is a T1 data call						
M=011 <sub>2</sub> - Service requested is a T2 data call						
M=100 <sub>2</sub> - Service requested is a T3 data call						
M=101 <sub>2</sub> - Service requested is a Voice + embedded data call						
Beacon	Message Frame	ID0+1	ID2+3	M	MI_TYPE	MI_DET
From BS to (B)	B_AHOY[D] note 1	(B)	PSTNI	M	N/A	N/A
From BS to (B)	HEAD+data[D] note 2	(B)	PSTNI	UDT Format 010 <sub>2</sub>		
From (B) to BS	B_ACK[U]	PSTNI	(B)	M	See clause 5.5.19.5	Reason
From BS to (B)	Goto Channel[D]	(B)				
From BS	SYScast2/3[D]		PSTNI			
NOTE 1: This call set-up does not transport the PSTN number to the MS.						
NOTE 2: The HEAD+appended data contains the PSTN number.						

Traffic	Message Frame	ID0+1	ID2+3	M	MI_TYPE	MI_DET
From BS	Preservation[D]	(B)	PSTNI	000 <sub>2</sub>	000 <sub>2</sub>	0000 0000 <sub>2</sub>
From MS(B) to BS Note	Disconnect Request[U]	(B)	PSTNI	M	000 <sub>2</sub>	0000 0000 <sub>2</sub>
From BS to (B)	Disconnect Request[D]	(B)	PSTNI	M	000 <sub>2</sub>	0000 0000 <sub>2</sub>

NOTE: If (B) is a talkgroup, the members of the talkgroup do not send this message when the call is ended.  
(see clause 10.3.4.3.2.4).

### 10.3.6.2 Call Services that only require the Beacon Channel

#### 10.3.6.2.1 MS Short Data Call to MS or talkgroup

Table 10.49 illustrates a Short Data call initiated from MS(A) to MS(B) or a talkgroup(B).

**Table 10.49: Short Data Call from MS to Ms or talkgroup**

Beacon	Message Frame	ID0+1	ID2+3	M	MI_TYPE	MI_DET
From (A) to BS	B_RAND[U]	(B)	(A)	110 <sub>2</sub>	000 <sub>2</sub>	See clause 5.2.14.2
From BS to (A)	B_AHOY[D]	(A)	SDMI	110 <sub>2</sub>	000 <sub>2</sub>	See clause 5.2.14.1
From BS to (A)	B_ACK[D]	(A)	(B)	110 <sub>2</sub>	See clause 5.5.19.5	Reason
From (A) to BS	B_ACK[U]	(B)	(A)	110 <sub>2</sub>		
From BS to (B)	B_ACK[D]	(B)	(A)	110 <sub>2</sub>		
From (B) to BS	B_ACK[U]	(A)	(B)	110 <sub>2</sub>		
From (A) to BS	HEAD+data[U]	(B)	(A)	UDT Format 010 <sub>2</sub>	000 <sub>2</sub>	See clause 5.2.15
From BS to (B)	HEAD+data[D]	(B)	(A)	UDT Format 010 <sub>2</sub>	000 <sub>2</sub>	

#### 10.3.6.2.2 Short Data Call from PSTN, PABX, LINEI, DISPATI to MS or talkgroup

Table 10.50 illustrates a Short Data call initiated from the PSTN to MS(B) or a talkgroup(B). The call is also applicable for PABXI, LINEI and DISPATI.

**Table 10.50: Short Data Call from PSTN to MS or talkgroup**

Beacon	Message Frame	ID0+1	ID2+3	M	MI_TYPE	MI_DET
From BS to (B)	B_AHOY[D]	(B)	PSTNI	110 <sub>2</sub>	000 <sub>2</sub>	See clause 5.2.14.1
From BS to (B)	B_ACK[D]	(B)	PSTNI	110 <sub>2</sub>	See clause 5.5.19.5	Reason
From (B) to BS	B_ACK[U]	PSTNI	(B)	110 <sub>2</sub>		Reason
From BS to (B)	HEAD+data[D]	(B)	PSTNI	UDT Format 010 <sub>2</sub>	000 <sub>2</sub>	See clause 5.2.15

#### 10.3.6.2.3 Short Data Call from MS to PSTN, PABX, LINEI, DISPATI

Table 10.51 illustrates a Short Data call initiated from an MS to the PSTN. The call is also applicable for PABXI, LINEI and DISPATI.

**Table 10.51: Short Data Call from MS to PSTN**

Beacon	Message Frame	ID0+1	ID2+3	M	MI_TYPE	MI_DET
From (A) to BS	B RAND[U]	PSTNI	(A)	110 <sub>2</sub>	000 <sub>2</sub>	See clause 5.2.14.2
From BS to (A)	B_AHOY[D] Note 1	(A)	PSTNI	110 <sub>2</sub>	000 <sub>2</sub>	See clause 5.2.14.1
From BS to (A)	B_AHOY[D] Note 2	(A)	SDMI	110 <sub>2</sub>	000 <sub>2</sub>	
From BS to (A)	B_ACK[D]	(A)	PSTNI	110 <sub>2</sub>	See clause 5.5.19.5	Reason
From (A) to BS	B_ACK[U]	PSTNI	(A)	110 <sub>2</sub>		Reason
From (A) to BS	HEAD+data[U]	PSTNI	(A)	UDT Format	000 <sub>2</sub>	See clause 5.2.15

NOTE 1: B\_AHOY to request uplink the dialled digits.  
NOTE 2: B\_AHOY to request uplink the SDM data.

#### 10.3.6.2.4 Short Data Polling from MS to MS

Table 10.52 illustrates Short Data is polled from an MS to an MS.

**Table 10.52: Short Data Polling from MS to MS**

Beacon	Message Frame	ID0+1	ID2+3	M	MI_TYPE	MI_DET
From (A) to BS	B RAND[U]	(B)	(A)	110 <sub>2</sub>	010 <sub>2</sub>	See clause 5.2.14.2
From BS to (B)	B_AHOY[D] Note 1	(B)	(A)	110 <sub>2</sub>	010 <sub>2</sub>	See clause 5.2.14.1
From (B) to BS	HEAD+data[U]	(A)	(B)	UDT Format	010 <sub>2</sub>	
From BS to (A)	HEAD+data[D]	(A)	(B)	UDT Format	010 <sub>2</sub>	See clause 5.2.15
From (A) to BS	B_ACK[U]	(B)	(A)	110 <sub>2</sub>	See clause 5.5.19.5	Reason

NOTE: B\_AHOY to request uplink the Short Data (format of the short data not part of the present document).

#### 10.3.6.2.5 Short Data MS Polling from a gateway

Table 10.53 illustrates a Short Data Poll initiated from a Gateway Identifier.

**Table 10.53: Short Data Polling from MS to Gateway Identifier**

Beacon	Message Frame	ID0+1	ID2+3	M	MI_TYPE	MI_DET
From BS to (B)	B_AHOY[D] Note	(B)	Identifier	110 <sub>2</sub>	010 <sub>2</sub>	See 5.2.14.1
From (B) to BS	HEAD+data[U]	Identifier	(B)	UDT Format	010 <sub>2</sub>	See 5.2.15

NOTE: B\_AHOY to request uplink the Short Data (format of the short data not part of the present document).

The identifier may be PSTNI, PABXI, IPI, etc.

#### 10.3.6.2.6 Status Transport from MS to MS or talkgroup

Table 10.52 illustrates a Short Data call initiated from an MS to the PSTN. The call is also applicable for PABXI, LINEI and DISPATI.

**Table 10.54: Status Transport Call from MS to MS or talkgroup**

Beacon	Message Frame	ID0+1	ID2+3	M	MI_TYPE	MI_DET
From (A) to BS	B_RAND[U]	(B)	(A)	110 <sub>2</sub>	001 <sub>2</sub>	Status
From BS to (B)	B_AHOY[D]	(B)	(A)	110 <sub>2</sub>	001 <sub>2</sub>	Status
From BS to (A)	B_ACK[D]	(A)	(B)	110 <sub>2</sub>	See clause 5.5.19.5	Reason
From (B) to BS	B_ACK[U]	(A)	(B)	110 <sub>2</sub>		Reason

### 10.3.6.3 Complementary data

Complementary data transport is used to:

- transport data between MS and BS for electronic serial number check;
- transport data for MS stun and revive;
- transport data for MS Kill;
- transport data as part of another call service. For a call that is initiated by an MS, Complementary Data may be requested by setting COMP=1 in the random access request. Complementary data may be transported from MS or to MS. The format of the complementary data transported shall be agreed between MS and BS that is not part of the present document. The format agreed between MS and BS is not part of the present document.

**Table 10.55: Complementary Data as part of call set-up**

Beacon	Message Frame	ID0+1	ID2+3	M	MI_TYPE	MI_DET
Complementary Data from MS to BS						
Form BS to (A)	B_AHOY[D]	(A)	COMP1	110 <sub>2</sub>	100 <sub>2</sub>	See clause 5.2.14.1 COMP=1 <sub>2</sub>
From (A) to BS	HEAD+data[D]	COMP1	(A)	UDT Format	100 <sub>2</sub>	See clause 5.2.15 COMP=1 <sub>2</sub>
Complementary Data from BS to MS						
From BS to (B)	HEAD+data[D]	(B)	(A)	UDT Format	100 <sub>2</sub>	See clause 5.2.15 COMP=1 <sub>2</sub>
From (B) to BS	B_ACK[U]	(A)	(B)	110 <sub>2</sub>	100 <sub>2</sub>	Reason

### 10.3.6.4 Other Mode 3 Services

#### 10.3.6.4.1 Call Diversion Service

##### 10.3.6.4.1.1 Set Call Diversion

The service requested is Call Diversion therefore M=110<sub>2</sub> and MI\_TYPE=011<sub>2</sub>. Calls may be diverted to another MS, a talkgroup, or extended address. The Identifier illustrated in table 10.56 is set to one of MSI, GPI, PSTNI, PABXI or IPI to indicate the diverted destination type. The address of the destination is imparted in the appended data to the HEAD message

**Table 10.56: Set Call Diversion Service**

Identifier		Divert Calls to				
MSI		An Individual MS				
GPI		A talkgroup				
PSTNI		A PSTN Destination				
PABXI		A PABX Destination				
IPI		A IP Destination				
Beacon	Message Frame	ID0+1	ID2+3 or MSID	M	MI_TYPE	MI_DET
From (A) to BS	B_RAND[U]	Identifier	(A)	110 <sub>2</sub>	011 <sub>2</sub>	N/A or LONG
From BS to (A)	B_AHOY[D]	(A)	Identifier	110 <sub>2</sub>	011 <sub>2</sub>	See 5.2.14.1
From (A) to BS	HEAD+data[U]	Identifier	(A)	UDT Format	011 <sub>2</sub>	See 5.2.15
From BS to (A)	B_ACK[D]	(A)	Identifier	110 <sub>2</sub>	011 <sub>2</sub>	Reason

## 10.3.6.4.1.2 Clear Call Diversion

**Table 10.57: Clear Call Diversion Service**

Beacon	Message Frame	ID0+1	ID2+3 or MSID	M	MI_TYPE	MI_DET
From (A) to BS	B_RAND[U]	DIVERTI	(A)	110 <sub>2</sub>	011 <sub>2</sub>	N/A
From BS to (A)	B_ACK[D]	(A)	DIVERTI	110 <sub>2</sub>	011 <sub>2</sub>	Reason

## 10.3.6.4.1.3 Call to an MS that has a diverted address

**Table 10.58: Call to an MS with a diverted address**

Beacon	Message Frame	ID0+1	ID2+3 or MSID	M	MI_TYPE	MI_DET
From (A) to BS	B_RAND[U]	MS or talkgroup	(A)	M	MI_TYPE	0000 0000 <sub>2</sub>
From BS to (A)	B_WACK[D]	(A)	DIVERTI	M	MI_TYPE	Reason

Following the B\_WACK, the call shall process the selected service to the diverted address. If the diverted address is an individual MS, an MS presence check shall be performed.

## 10.3.6.4.2 Registration

**Table 10.59: Registration Service**

Beacon	Message Frame	ID0+1	ID2+3	M	MI_TYPE	MI_DET
From (A) to BS	B_RAND[U]	REGI	(A)	110 <sub>2</sub>	101 <sub>2</sub>	Status
From BS to (A)	B_ACK[D]	(A)	REGI	110 <sub>2</sub>	101 <sub>2</sub>	Reason
Serial Number Check as part of Registration						
Form BS to (A)	B_AHOY[D]	(A)	SERIALIO	110 <sub>2</sub>	100 <sub>2</sub> Note	See clause 5.2.14.1
From (A) to BS	HEAD+data[U]	SERIALIn	(A)	UDT Format	100 <sub>2</sub> Note	See clause 5.2.15
NOTE: For the serial number check, MI_TYPE=100 <sub>2</sub> .						

## 10.3.6.4.3 Serial Number Check

Table 10.60: Serial Number Check

Beacon	Message Frame	ID0+1	ID2+3 or MSID	M	MI_TYPE	MI_DET
From BS to (A)	B_AHOY[D]	(A)	SERIALIO	110 <sub>2</sub>	100 <sub>2</sub>	See clause 5.2.14.1
From (A) to BS	HEAD+data[U]	SERIALIn	(A)	110 <sub>2</sub>	100 <sub>2</sub>	See clause 5.2.15

## 10.3.6.4.4 MS Stun/Revive

Table 10.61: MS Stun/Revive

Beacon	Message Frame	ID0+1	ID2+3	M	MI_TYPE	MI_DET
From BS to (A)	B_AHOY[D]	(A)	STUNI	110 <sub>2</sub>	100 <sub>2</sub>	See clause 5.2.14.1
Form (A) to BS	B_ACK[U]	STUNI	(A)	110 <sub>2</sub>	100 <sub>2</sub>	Reason

## 10.3.6.4.5 MS Kill

Table 10.62: MS Kill with ESN check

Beacon	Message Frame	ID0+1	ID2+3	M	MI_TYPE	MI_DET
From BS to (A)	B_AHOY[D]	(A)	SERIALIO	110 <sub>2</sub>	100 <sub>2</sub>	See clause 5.2.14.1
From (A) to BS	HEAD+data[U]	SERIALIn	(A)	UDT Format	100 <sub>2</sub>	See clause 5.2.15
From BS to (A)	B_AHOY[D]	(A)	KILLI	100 <sub>2</sub>	001 <sub>2</sub>	See clause 5.2.14.1
Form (A) to BS	B_ACK[U]	KILLI	(A)	100 <sub>2</sub>	001 <sub>2</sub>	Reason

---

## 11 Channel coding process

### 11.1 Voice superframe

Construction of the voice superframe starts with CCH control channel data.

Frame Numbering (FN) is from 00<sub>2</sub> to 11<sub>2</sub> (1 to 4).

FN is followed by 12 bits of the called station address or own ID as follows:

The called station ID and own ID make a total of 48 bits. These bits are split into 12 bit blocks and one block is included in each of the 4 frames of the superframe:

- FN 00<sub>2</sub> shall include the upper 12 bits of the called station ID.
- FN 01<sub>2</sub> shall include the lower 12 bits of the called station ID.
- FN 10<sub>2</sub> shall include the upper 12 bits of the own ID.
- FN 11<sub>2</sub> shall include the lower 12 bits of the own ID.

The Communications Mode value is added according to the table in clause 5.5.7. For example, if slow data (SLD) is being included within the voice superframe then Communications Mode value is set to 001<sub>2</sub>.



The two version bits are added according to clause 5.5.37.

The communications format bits are now added according to clause 5.5.6. Occasionally they may be set to  $00_2$  (all call) but this is a special case, similar to a broadcast.

The next bit is the Emergency Priority according to clause 5.5.12.

The next bit is the Preservation message according to clause 5.5.23. This bit will be used by BS downlinks only and MS shall set this to 0:

- If the Communications Mode is set to  $000_2$  the 18 bits of slow user data (SLD) field are set to zero and added.
- If the Communications Mode is set to  $001_2$  the 18 bits of slow user data (SLD) are added (clause 5.5.29.1).
- If the Communications Mode is set to  $101_2$  the slow user data (SLD) field is assembled according to clause 5.5.29.2 and appended.

This gives the total of 41 bits of CCH data.

The 7 bit CRC checksum is added using the polynomial given in clause 7.1 giving a total of 48 bits.

These 48 bits are now separated into 6 bytes. Each byte is now coded by a shortened 12,8 Hamming Code (clause 7.2) giving 6 x 12 bit blocks.

To protect against burst interference, these 6 x 12 bit blocks are now interleaved using the 12 x 6 TCH interleaving matrix given in table 7.3.

Then the interleaved CCH data is scrambled using the polynomial given in clause 7.3.

The frame is completed by prefixing with either the 24 bits of FS2 (frame numbers  $00_2$  or  $10_2$ ) or the 24 bits of Colour Code (frame numbers  $01_2$  or  $11_2$ ).

Finally the 4 x 72 bit blocks of Forward Error corrected vocoder data (TCH) are appended.

If the PTT is released before the end of the current superframe, then the superframe shall be completed using silence data for the TCH ("silence data" is the vocoder output data when no sound is input).

In the case of a voice + data and the voice transmission ends before the end of the current superframe, the current frame shall be completed using silence data for the TCH ("silence data" is the vocoder output data when no sound is input). After completion of the current frame, subsequent frames in the superframe are available for data and coded according to clause 11.3. DP in the SLD field shall indicate if the frame contains voice or data information (clause 5.5.29.1).

### 11.1.1 Voice + Attached data call

In each transmitted item the format is always that of a series of complete superframes (SF) with Header and End frames as illustrated in figure 11.1.

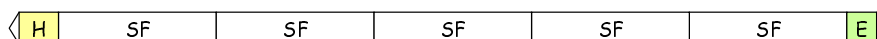


Figure 11.1: Transmitted Item

Within each superframe, there are 4 payload frames.

For this example illustrated in figure 11.2, we shall assume that the PTT is released in frame 2 and the voice codec data stops. 36 bytes of data with FEC (type 2) shall be attached. As each frame has a capacity of 20 bytes of type 2 data, both frames 3 and 4 shall be required.

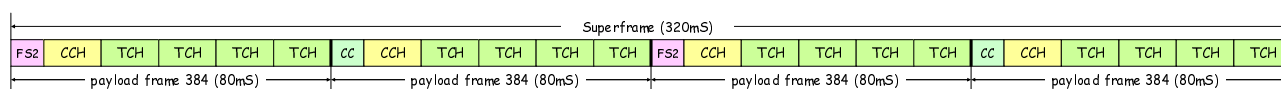


Figure 11.2: Transmitted Item Example

The SLD field in each of these frames is composed as illustrated in figure 11.3:

Frame 1: with voice payload

Reserved	DP	Format	Cont.	Data length (bytes)
00000 <sub>2</sub>	00 <sub>2</sub>	4 bits	1 <sub>2</sub>	000000 <sub>2</sub>

Frame 2: with voice payload ending in this frame

Reserved	DP	Format	Cont.	Data length (bytes)
00000 <sub>2</sub>	00 <sub>2</sub>	4 bits	1 <sub>2</sub>	000000 <sub>2</sub>

Frame 3: with data payload starting in this frame

Reserved	DP	Format	Cont.	Data length (bytes)
00000 <sub>2</sub>	11 <sub>2</sub>	4 bits	0 <sub>2</sub>	010100 <sub>2</sub> (20 bytes in this frame)

Frame 4: with data payload ending in this frame

Reserved	DP	Format	Cont.	Data length (bytes)
00000 <sub>2</sub>	11 <sub>2</sub>	4 bits	1 <sub>2</sub>	010000 <sub>2</sub> (16 bytes in this frame)

**Figure 11.3: Frame Construction**

Notes for TCH payload:

- In frame two, the voice codec data ends when the PTT is released. "Silence data" is used to complete the TCH payload of frame 2 as previously stated.
- In frame four, the 16 bytes of data is not enough to complete the frame. Therefore 4 bytes of dummy data (i.e. zeros) is attached to complete the TCH payload of frame 4. The TCH payload is coded according to clause 9.3. The receiving party knows that there are 4 bytes of dummy data as the SLD data length field indicates that only 16 of the 20 bytes are valid data.

**Table 11.1: CM, SLD, MI use**

Communication mode	SLD field (CCH) see clause 5.5.29	MI field (Header) see clause 5.5.19
000 <sub>2</sub> Voice Comm	ALL "0 <sub>2</sub> " (No user data)	Header Type
001 <sub>2</sub> Voice + User SLD	User Slow Data (clause 5.5.29.1)	Header Type
010 <sub>2</sub> Data Type 1	TCH data information (clause 5.5.29.2)	Header Type (see note) / Data Format
011 <sub>2</sub> Data Type 2	TCH data information (clause 5.5.29.2)	Header Type (see note) / Data Format
100 <sub>2</sub> Data Type 3	-----	Header Type (see note) / pdS, pdM
101 <sub>2</sub> Voice and attached Data Type 2	TCH data information	Header Type

NOTE: Use Extended Header (clause 11.1).

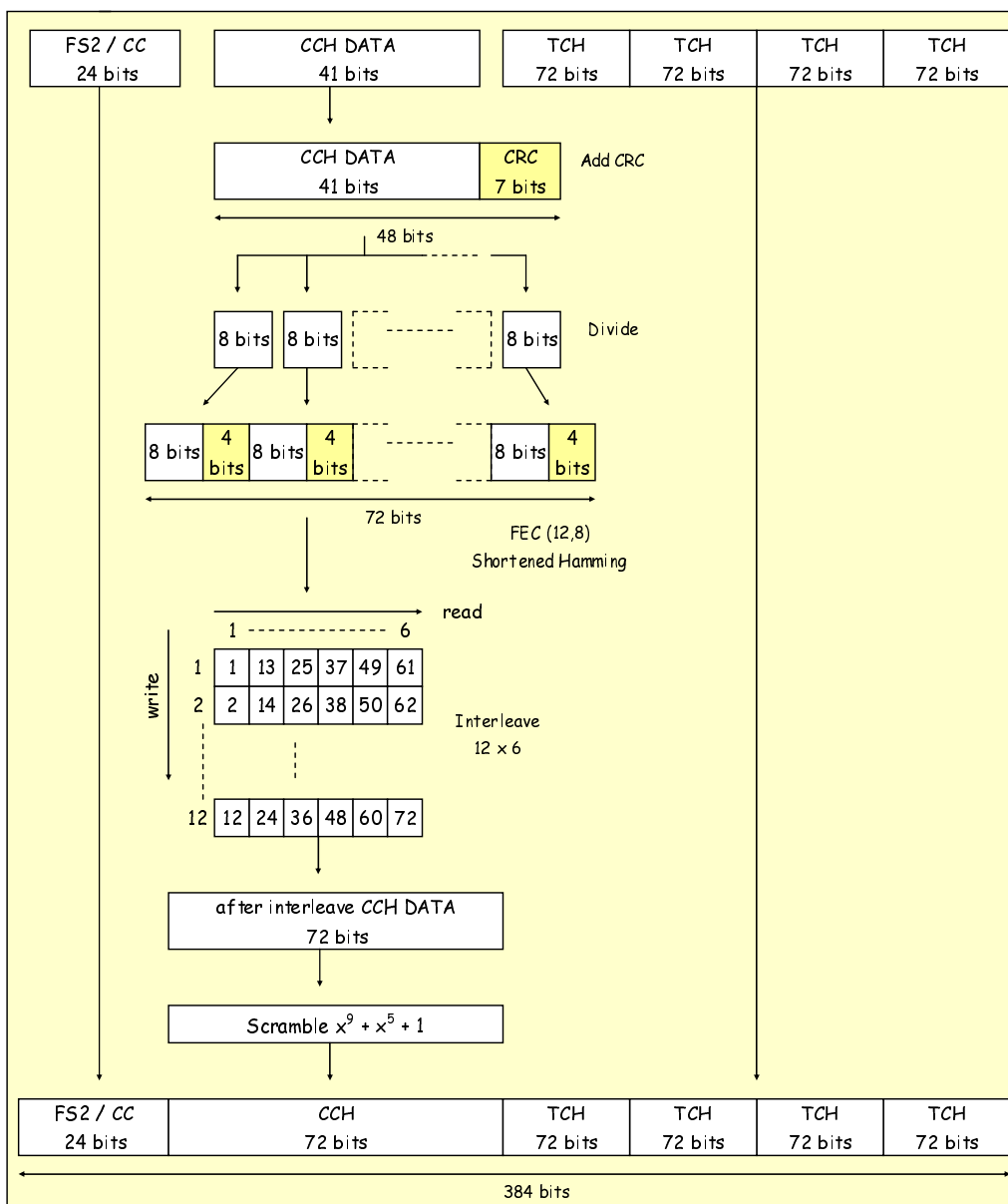


Figure 11.4: Voice frame coding

## 11.2 Type 1 data superframe

A characteristic of a type 1 data superframe is that no error correction is applied to the user data.

Construction of the type 1 data superframe starts with CCH control channel data.

Frame Numbering (FN) is from  $00_2$  to  $11_2$  (1 to 4).

FN is followed by 12 bits of the called station address or own ID as follows:

- The called station ID and own ID make a total of 48 bits. These bits are split into 12 bit blocks and one block is included in each of the 4 frames of the superframe:
  - FN  $00_2$  shall include the upper 12 bits of the called station ID.
  - FN  $01_2$  shall include the lower 12 bits of the called station ID.
  - FN  $10_2$  shall include the upper 12 bits of the own ID.

- FN  $11_2$  shall include the lower 12 bits of the own ID.

The Communications Mode,  $010_2$  is added (clause 5.5.7).

The 2 version bits are added according to clause 5.5.37.

The communications format bits are now added according to clause 5.8. Occasionally they may be set to  $00_2$  (all call) but this is a special case, similar to a broadcast.

The next bit is the Emergency Priority according to clause 5.5.12.

The next bit is the Preservation message according to clause 5.5.23. This bit will be used by BS downlinks only and MS shall set this to 0.

Then there are the 18 bits of the slow user data field (SLD). These bits are set according to clause 5.5.29.2 depending on the data to be transmitted.

This gives the total of 41 bits of CCH data.

The 7 bit CRC checksum is added using the polynomial given in clause 7.1 giving a total of 48 bits.

These 48 bits are now separated into 6 bytes. Each byte is now coded by a shortened 12,8 Hamming Code (clause 7.2) giving 6 x 12 bit blocks.

To protect against burst interference, these 6 x 12 bit blocks are now interleaved using the 12 x 6 TCH interleaving matrix given in table 7.4.

Next the 288 bit block of uncorrected user data are attached.

Finally the interleaved CCH data and attached data blocks are scrambled using the polynomial given in clause 7.3.

The frame is completed by prefixing with either the 24 bits of FS2 (frame numbers  $00_2$  or  $10_2$ ) or the 24 bits of Colour Code (frame numbers  $01_2$  or  $11_2$ ).

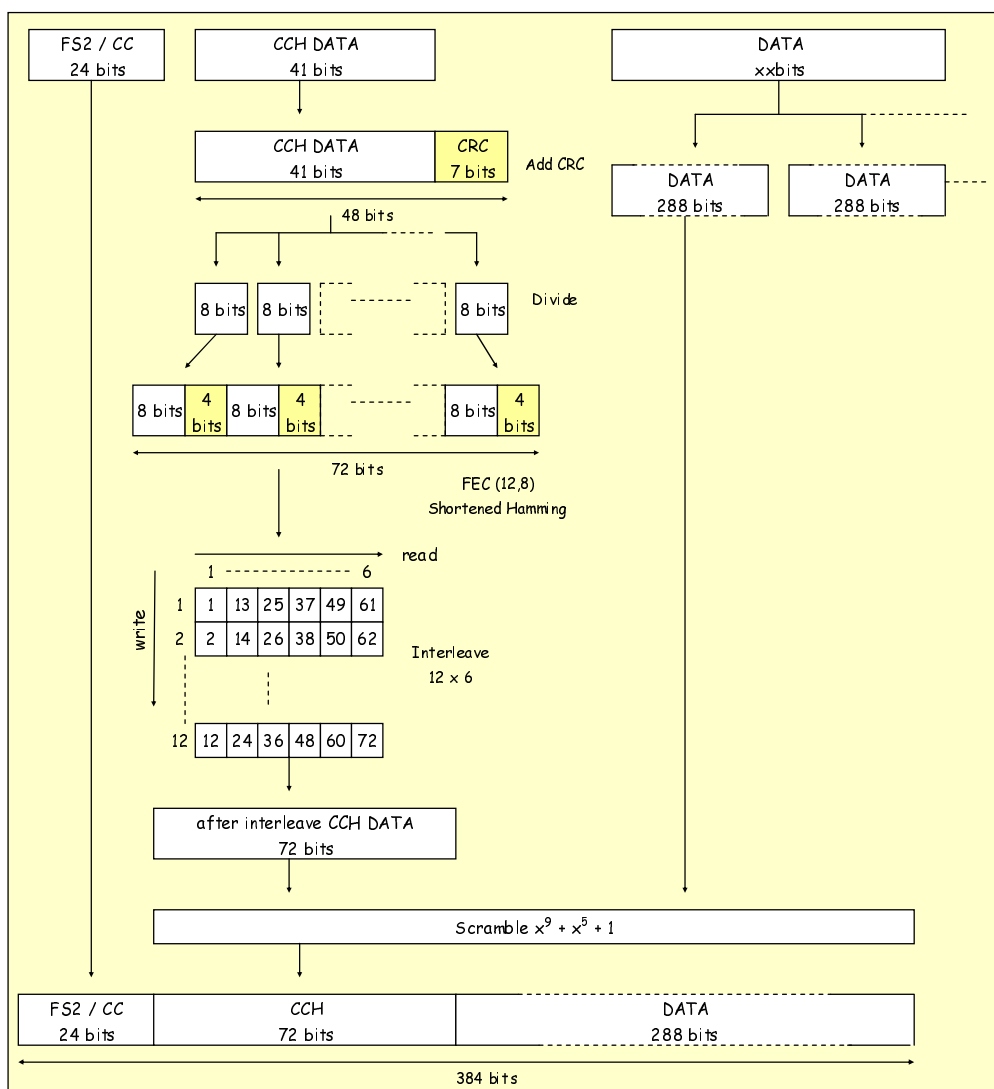


Figure 11.5: Type 1 data frame coding

### 11.3 Type 2 Data superframe

Construction of the type 2 data superframe starts with CCH control channel data.

Frame numbering (FN) is from  $00_2$  to  $11_2$  (1 to 4).

FN is followed by 12 bits of the called station address or own ID as follows:

- The called station ID and own ID make a total of 48 bits. These bits are split into 12 bit blocks and one block is included in each of the 4 frames of the superframe:
  - FN  $00_2$  shall include the upper 12 bits of the called station ID.
  - FN  $01_2$  shall include the lower 12 bits of the called station ID.
  - FN  $10_2$  shall include the upper 12 bits of the own ID.
  - FN  $11_2$  shall include the lower 12 bits of the own ID.

The Communications Mode,  $011_2$  is added (clause 5.5.7).

The 2 version bits are added according to clause 5.5.37.

The communications format bits are now added according to clause 5.5.6. Occasionally they may be set to  $00_2$  (all call) but this is a special case, similar to a broadcast.

The next bit is the Emergency Priority according to clause 5.5.12.

The next bit is the Preservation message according to clause 5.5.23. This bit will be used by BS downlinks only and MS shall set this to 0.

Finally there are the 18 bits of the slow user data field (SLD). These bits are set according to clause 5.5.29.2 depending on the data to be transmitted.

This gives the total of 41 bits of CCH data.

The 7 bit CRC checksum is added using the polynomial given in clause 7.1 giving a total of 48 bits.

These 48 bits are now separated into 6 bytes. Each byte is now coded by a shortened 12,8 Hamming Code (clause 7.2) giving  $6 \times 12$  bit blocks.

To protect against burst interference, these  $6 \times 12$  bit blocks are now interleaved using the  $12 \times 6$  TCH interleaving matrix given in clause 7.4.

The user data is broken down into 5 byte blocks (40 bits) to which 1 bit of null data (i.e. set to  $0_2$ ) is attached. Four of these 41 bit blocks shall be allocated to each frame.

The 7 bit CRC checksum is added to each 41 bit block using the polynomial given in clause 7.1 giving a total of 48 data bits.

These 48 data bits are now separated into 6 bytes. Each byte is now coded by a shortened 12,8 Hamming Code (clause 7.2) giving  $6 \times 12$  bit blocks.

To protect against burst interference, these  $6 \times 12$  bit blocks are now interleaved using the  $12 \times 6$  TCH interleaving matrix given in table 7.4.

Next four of the 72 bit coded data blocks are concatenated to the interleaved CCH data and scrambled using the polynomial given in clause 7.3.

The frame is completed by prefixing with either the 24 bits of FS2 (frame numbers  $00_2$  or  $10_2$ ) or the 24 bits of Colour Code (frame numbers  $01_2$  or  $11_2$ ).

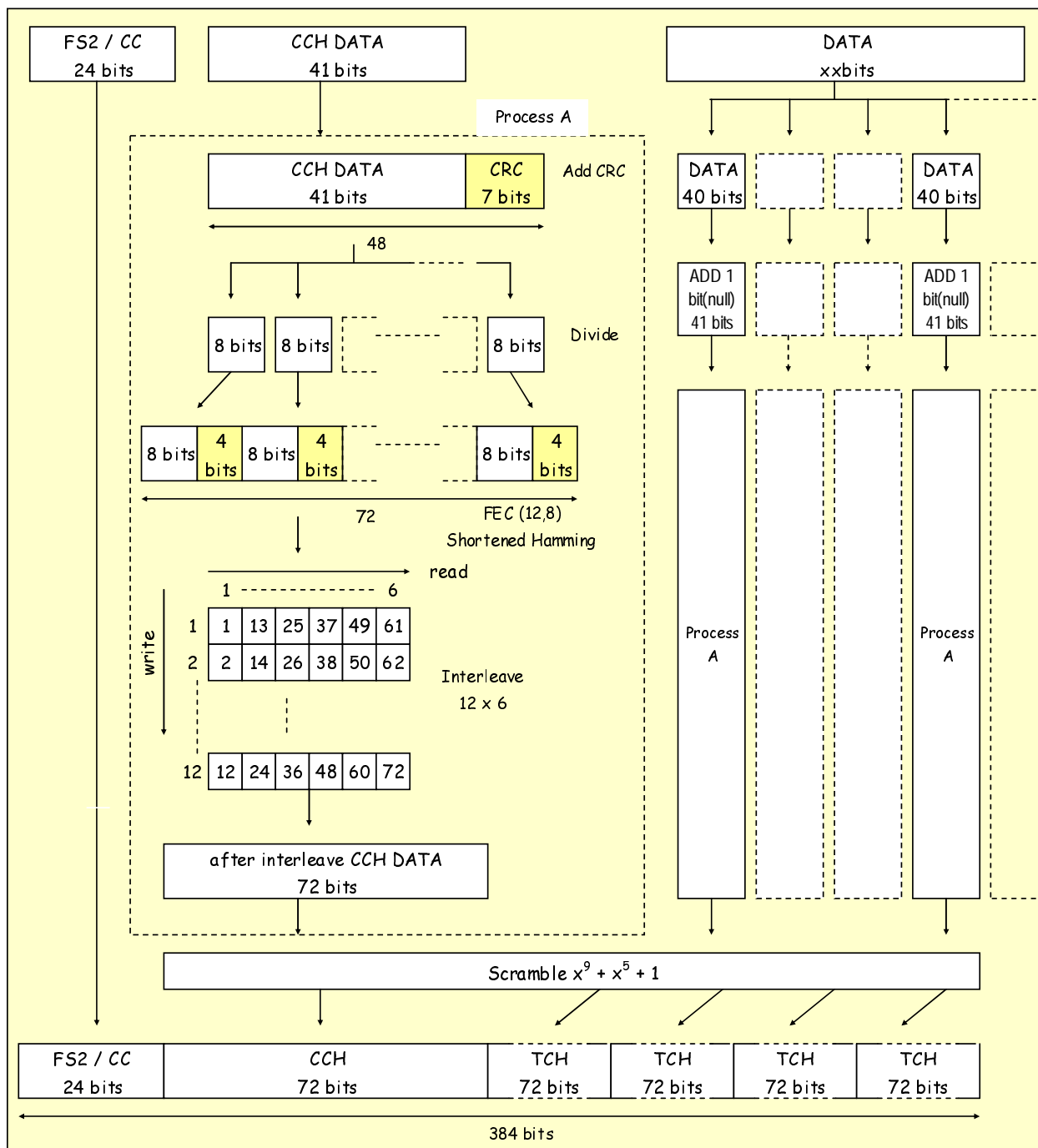


Figure 11.6: Type 2 data0 frame coding

## 11.4 Type 3 (Packet) Data frame

Construction of the type 3 Packet starts with the PAR (parameter) data.

The packet burst can consist of up to 8 data frames. The current data frame number (N) is from  $000_2$  to  $111_2$ .

N is followed by 8 bits that give the total number of data bytes contained in the current burst.

This is followed by 14 dummy bits that are set to zero.

The next 16 bits are the CRC for the data field contained in this burst.

The 7 bit CRC checksum is added to these 41 bits using the polynomial given in clause 7.1 giving a total of 48 bits.

These 48 data bits are now separated into 6 bytes. Each byte is now coded by a shortened 12,8 Hamming Code (clause 7.2) giving 6 x 12 bit blocks.

To protect against burst interference, these 6 x 12 bit blocks are now interleaved using the 12 x 6 TCH interleaving matrix given in clause 7.4.

Next the associated data frames are concatenated to the interleaved PAR data and scrambled using the polynomial given in clause 7.3.

The frame is completed by prefixing the 24 bits of Colour Code.

NOTE: The packet data format used in these frames is indicated by the Message Information (MI) contained in the Packet data Header. See clause 9.3.

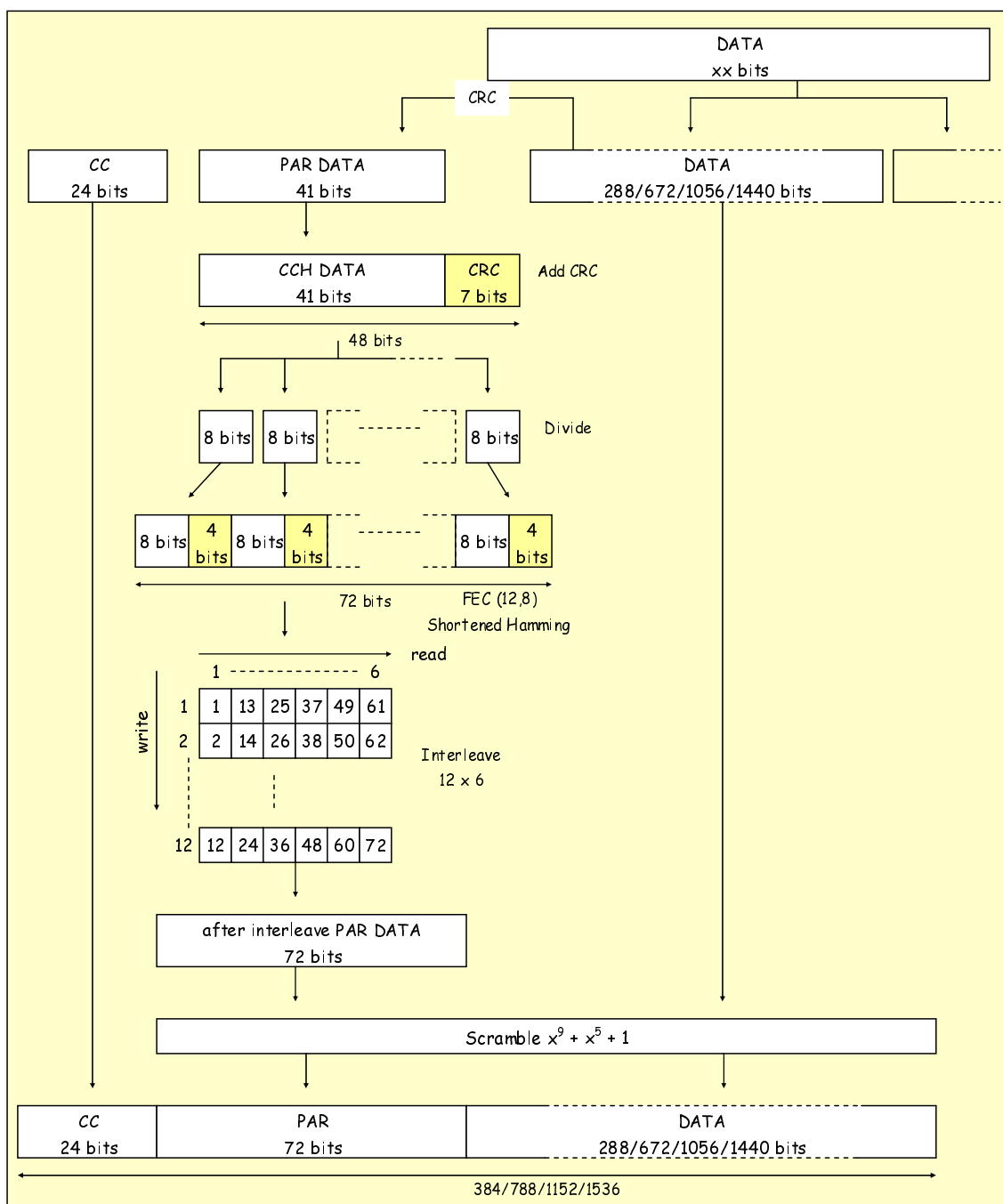


Figure 11.7: Packet data frame coding



## 11.5 Messages

Construction of a Message starts with the Message Information (MI) bits.

First there are 4 bits allocated to Message Type (MT) which is selected according to clause 5.5.20.

MT is followed by the 24 bits of the called station ID. To this the 24 bits of the own ID is added.

The Communications Mode value is added according to the table in clause 5.5.7.

The 2 version bits are added according to clause 5.5.37.

The communications format bits are now added according to clause 5.5.6. Occasionally they may be set to 00<sub>2</sub> (all call) but this is a special case, similar to a broadcast.

The next bit is the Emergency Priority according to clause 5.5.12.

The next bit is the Preservation message according to clause 5.5.23. This bit will be used by BS downlinks only and MS shall set this to 0.

Finally there are the 11 bits of Message Information (MI) that are made up of 3 MI Type bits and 8 MI\_Detail bits as described in clause 5.5.19 (see table 11.1).

This gives the total of 72 bits of MI data.

The 8 bit CRC checksum is added using the polynomial given in clause 7.1 giving a total of 80 bits.

These 80 bits are now separated into 10 bytes. Each byte is now coded by a shortened 12,8 Hamming Code (clause 7.2) giving 10 x 12 bit blocks.

To protect against burst interference, these 10 x 12 bit blocks are now interleaved using the 12 x 10 MI interleaving matrix given in clause 7.4.

Then the interleaved MI data is scrambled using the polynomial given in clause 7.3.

The 24 bit Colour Code is concatenated to the MI data and then the MI data is repeated after the CC.

The message is completed by prefixing with the 48 bit FS1 synchronization sequence (see note 1) and then prefixing the synchronization sequence with a minimum of 72 bits of preamble.

**Table 11.1: Use of Message Information**

Use	Purpose	Clause
Powersave	Indicate normal or extended header type	5.5.19.1
T1 or T2 Data	Indicate the type of data (complementary service)	5.5.19.2
T3 Data (Packet)	Indicate data frame size and number of frames	5.5.19.3
Acknowledgements	Indicate ACK or NACK and reason	5.5.19.5
System request System response Delivery Header	MI Type defines the purpose MI_Detail is not used and set to 0000 0000 <sub>2</sub>	5.5.19.4
Broadcast		5.5.19.6
BS Command Header	MI type defines the purpose MI_Detail may give extra parameters	5.5.19.7
Ahoys		5.5.19.8

NOTE 1: In the case where this is a Packet Data header, the 48 bit FS4 synchronization sequence is used, H10 replaces M10, H11 replaces M11 and HT replaces MT. Normally receiving stations determine the call type from the Header Information but techniques such as determination by FS type (as used by ETS 300 230 [i.1], MPT 1327 [i.2] and others) are equally valid.

NOTE 2: The preamble and FS1 is not present for a beacon channel message frame.

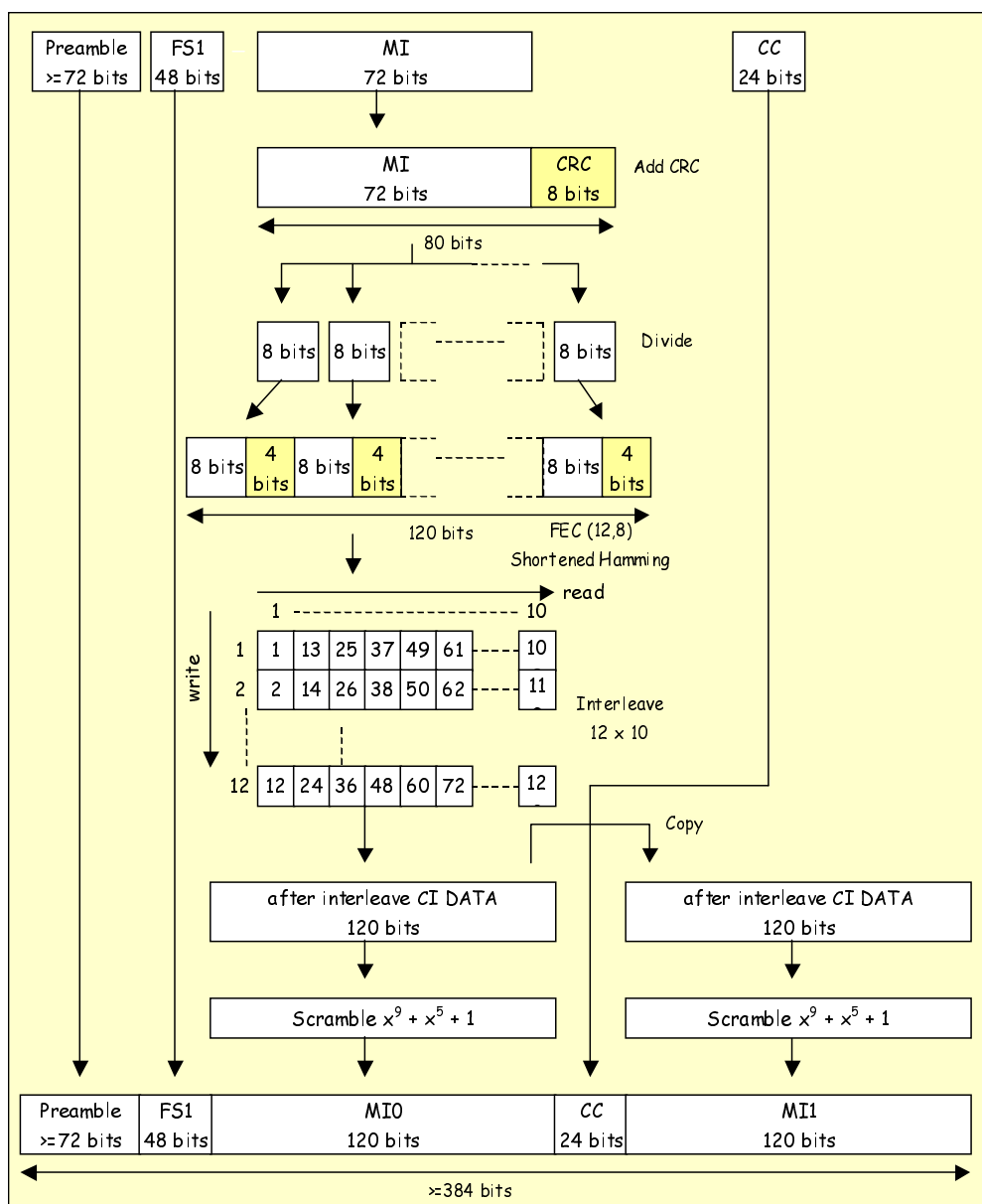


Figure 11.8: Message coding

## 11.6 End frames

Construction of the End frame starts with the 17 bits of End data.

The end data starts with the End Type (ET) which is either  $00_2$  (normal end frame) or  $01_2$  (end frame with status message).

The next 2 bit are the acknowledgement request (ARQ).  $00_2$  signifies that no acknowledgement is requested and  $01$  requires an acknowledgement.

The next 4 bits define any Tx\_Wait time (WAIT) using the values given in clause 5.5.34.

5 bit of status message shall then follow if ET has been set to  $01_2$  (or 5 bits of dummy data if ET =  $00_2$ ).

Finally the 4 reserved bits are set to  $0000_2$ .

The 7 bit CRC checksum is added using the polynomial given in clause 7.1 giving a total of 24 bits.

These 24 bits are now separated into 3 bytes. Each byte is now coded by a shortened 12,8 Hamming Code (clause 7.2) giving 3 x 12 bit blocks. These 36 bits are now repeated and the total 72 bits are scrambled using the polynomial given in clause 7.3. For each scrambler block the scrambler is re-initialised therefore the two scrambled END DATA blocks are bit exact copies.

Finally the 24 bit FS3 synchronization sequence is prefixed to these end data bits.

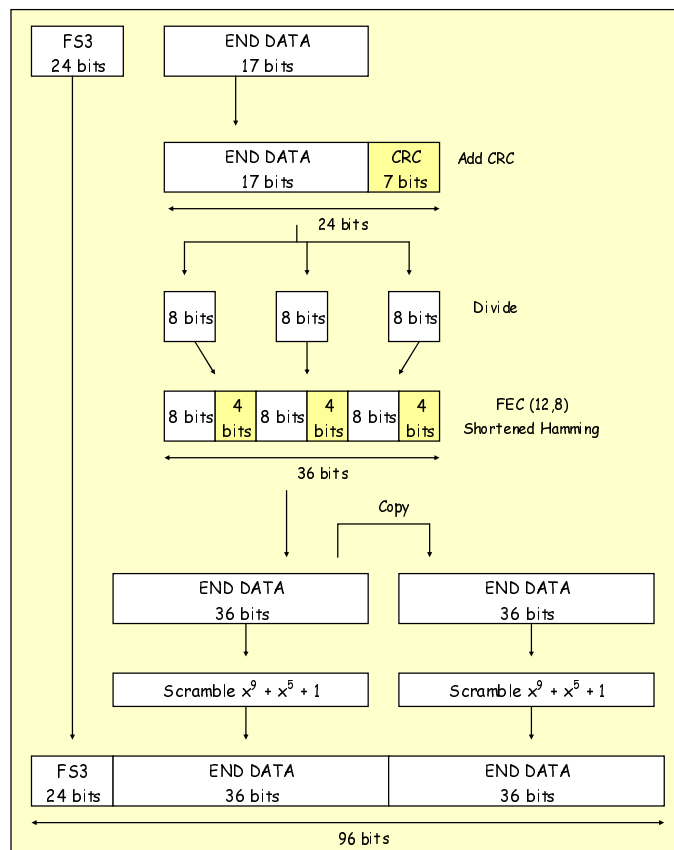


Figure 11.9: End frame coding

## 11.7 SYScast Frames

SYScast frames are transmitted by a Mode 3 Beacon Channel.

Construction of the SYScast frame starts with the 17 bits of SYScast1, SYScast2 and SYScast 3 data.

The SYScast1, SYScast2 and SYScast3 fields are defined in clause 5.5.32.

For each SYScast frame:

- The 7 bit CRC checksum is added using the polynomial given in clause 7.1 giving a total of 24 bits.
- These 24 bits are now separated into 3 bytes. Each byte is now coded by a shortened 12,8 Hamming Code (clause 7.2) giving 3 x 12 bit blocks.
- The 36 bits are now repeated to give a total of 72 bits.
- To protect against burst interference, these 6 x 12 bit blocks are interleaved using the 12 x 6 TCH interleaving matrix given in clause 7.4.
- The three 72 bit SYScast1, SYScast2 and SYScast3 blocks are then concatenated to produce a 216 bit block.
- The 216 bit block is scrambled using the polynomial given in clause 7.3

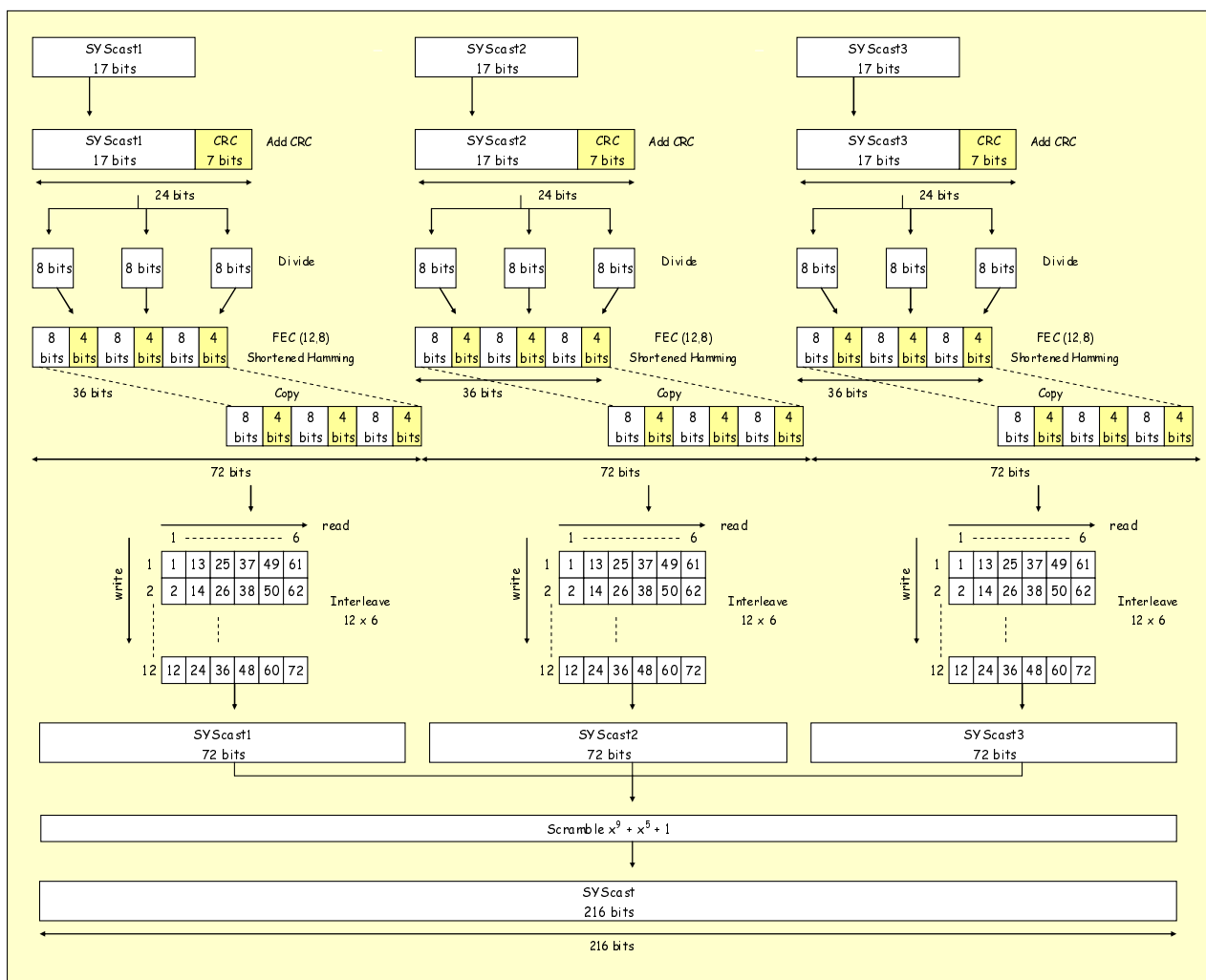


Figure 11.10: SYScast frame coding

## 11.8 Appended Data Frames

Construction of a Message starts with the 72 Appended Data bits.

The 8 bit CRC checksum is added using the polynomial given in clause 7.1 giving a total of 80 bits.

These 80 bits are now separated into 10 bytes. Each byte is now coded by a shortened 12,8 Hamming Code (clause 7.2) giving 10 x 12 bit blocks.

To protect against burst interference, these 10 x 12 bit blocks are now interleaved using the 12 x 10 interleaving matrix given in clause 7.4.

Then the interleaved appended data is scrambled using the polynomial given in clause 7.3.

The 24 bit Colour Code is concatenated to the appended data and then the appended data is repeated after the CC.

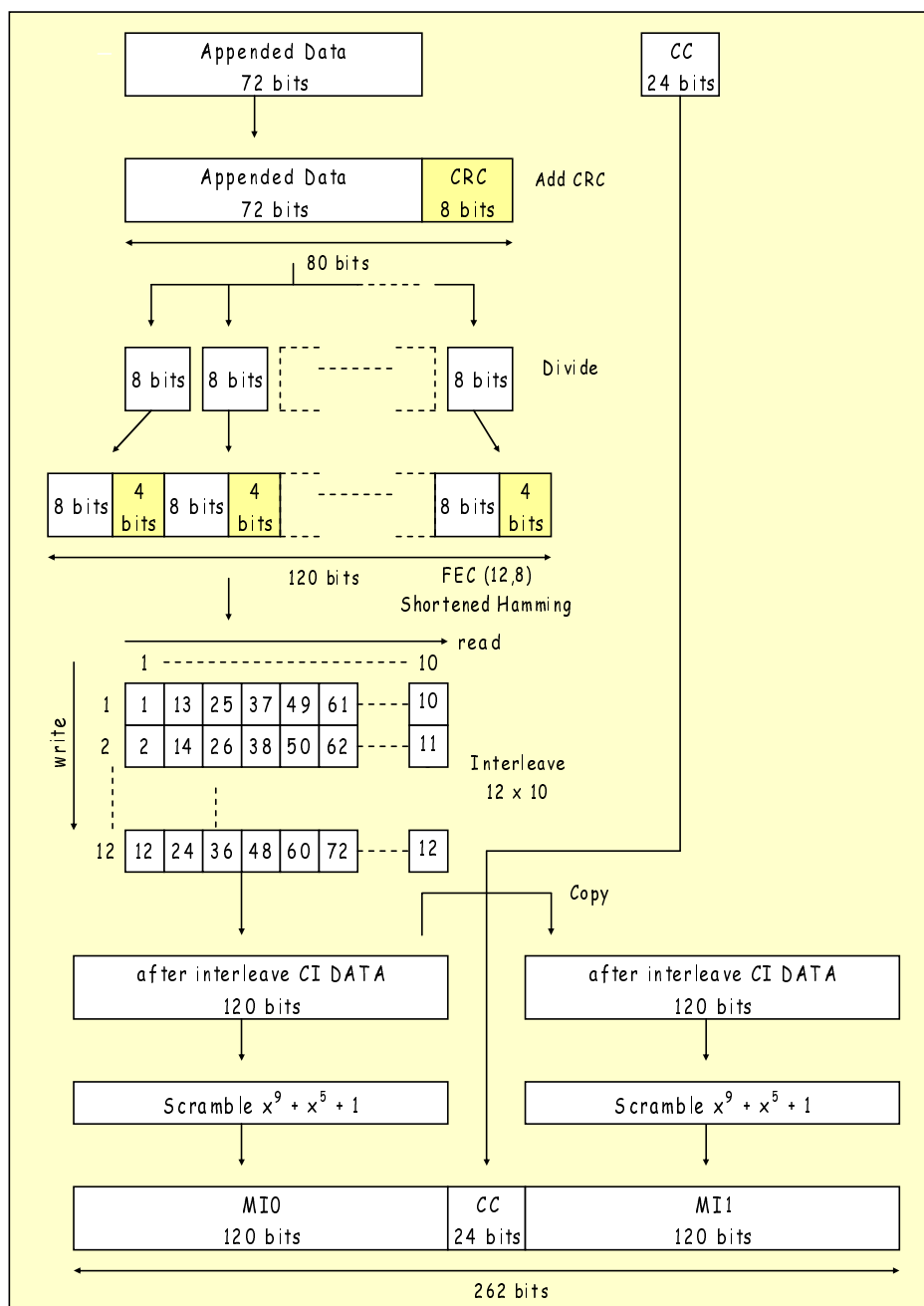


Figure 11.11: Appended Data frame coding

## 12 Channel access

Systems compliant with the present document may operate in one of three Modes. Mode 1 systems are peer-to-peer described in clause 12.1. Clause 12.2 describes Mode 2 centralized repeater systems. Mode 3 systems are fully managed systems intended for a high throughput of traffic supporting a number of traffic channels. In addition to describing the basic channel access for Mode 3 systems, the additional services needed for effective system management are also described in clause 12.3.

Where an MS has been solicited to transmit a response, the preamble at the start of the transmission shall be timed to conform with figure 12.1. Figure 12.1 shows the case where MS(A) (or BS) has transmitted a message that solicits a response from MS(B). The MS transmitting the response shall send its first bit of preamble not earlier than 30 ms and not later than 35 ms from the last bit of the message that solicited the response. The diagram does not imply any limitation on the start of the MS Tx RF power ramp which does not need to have attained full power for the first 24 bits of the preamble.

The response shall be sent irrespective of whether the channel is "Idle" or "Busy".

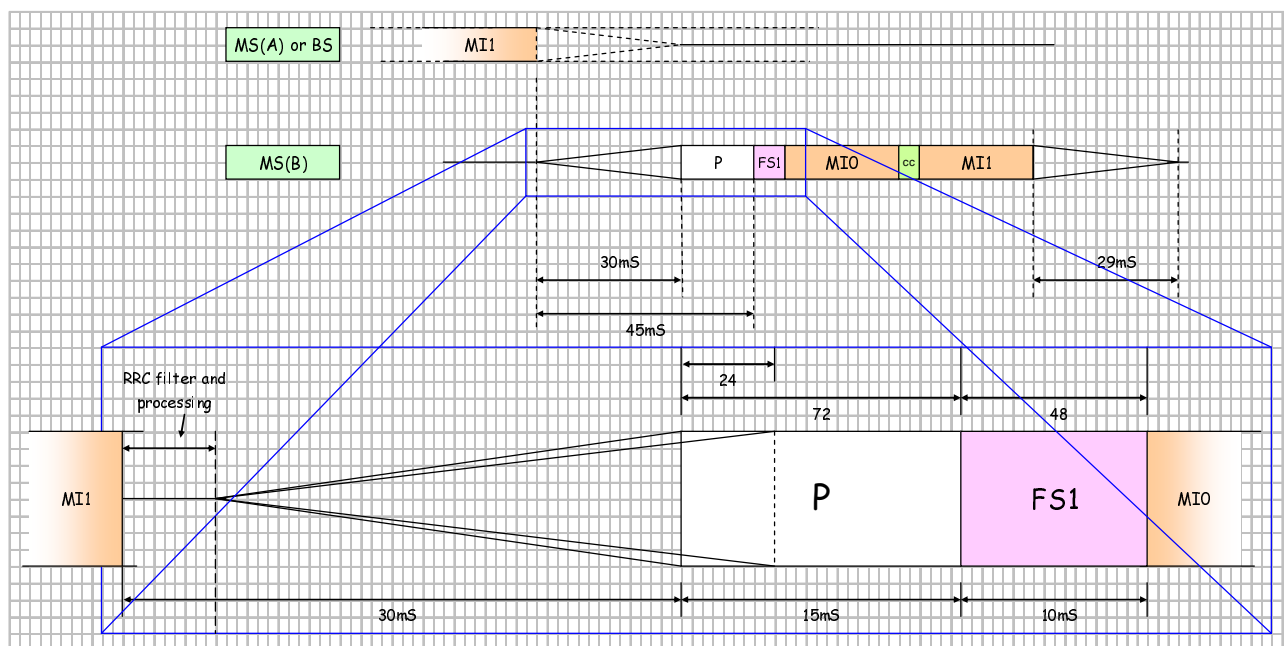


Figure 12.1: Preamble Timing

Referring to figure 12.1, if the MS transmitting the message selects earliest permissible timing, when the MS has transmitted its response, the MS shall ramp down the transmitter and in time to be able to decode a new message within 30 ms of the last MS transmitted message bit.

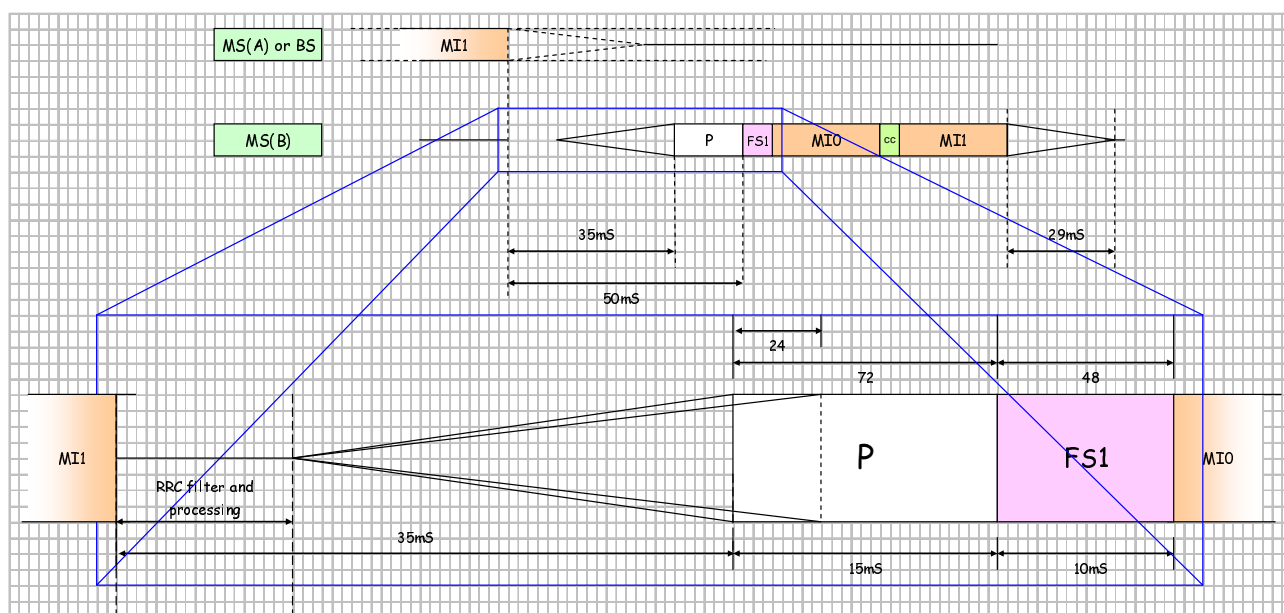


Figure 12.2: Message Profile for latest timing

Referring to figure 12.2, if the MS transmitting the message selects latest permissible timing, when the MS has transmitted its response, the MS shall ramp down the transmitter and in time to be able to decode a new message within 25 ms of the last transmitted message bit.

Although there is no limitation of the power ramp, figures 12.1 and 12.2 illustrate a practical implementation. Due to realistic receiver RRC filter and processing delays, the ramp may not start immediately. In a Mode 3 system illustrated in figure 12.3, if the MS wishes to transmit a random access message or the Beacon has solicited a response, the MS transmitting the response shall send its first bit of preamble not earlier than 30ms and not later than 35ms from the last bit of the Beacon Message. This timing is identical to the timing for the solicited message case described and illustrated in figures 12.1 and 12.2.

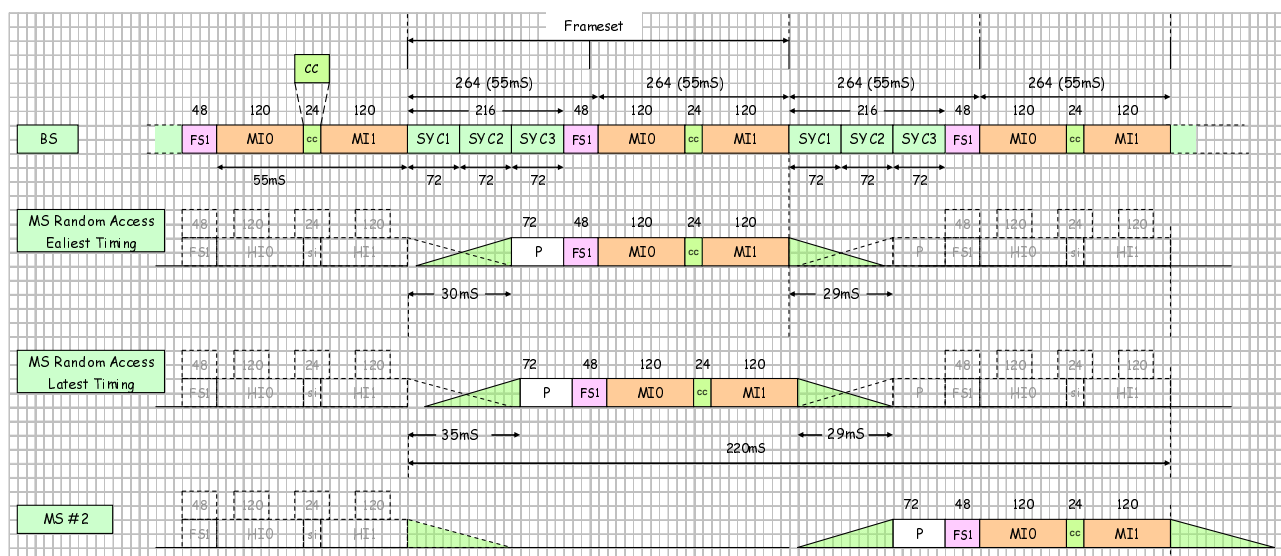


Figure 12.3: Message Timing Profile for Mode 3

## 12.1 Channel access for Mode 1 [M1]

In Mode 1, MS are operating in a peer to peer (direct Mode) environment. A base station may also be part of a Mode 1 system where they are used as a simple base station without repeater function but for the purposes of describing the protocol in the present document such equipment shall be described as MS.

Mode 1 operation would normally be simplex. Where a BS is operated in a two frequency dispatcher environment, the system may also be semi-duplex.

A single traffic channel carrying speech or data information is used and all exchanges are asynchronous.

### 12.1.1 Listen Before Transmit (LBT) [M1]

When accessing a traffic channel to transmit, an MS shall take account of the following types of activity which may already be present on the channel:

- 6,25 kHz FDMA activity;
- other digital protocol activity;
- analogue activity.

When determining whether activity is present on a channel, the MS shall monitor the RSSI level. If after a maximum period of time ( $T_{ch\_chk}$ ) the RSSI level has not exceeded a configurable (within a predefined range) threshold  $RSSI_{LO}$ , then the radio shall assume that activity is not present on the channel.

If the RSSI level does exceed the  $RSSI_{LO}$  threshold, then the MS shall assume that activity is present on the channel and it shall attempt to identify that it is compliant with the present document.

If the MS does identify the channel as compliant with the present document, the MS shall attempt to identify the Colour Code. If the Colour Code received differs from the Colour Code expected by the MS (see clause 6.1.5) then the MS shall assume that the activity is not applicable to this MS.

### 12.1.2 Hang time messages and timers [M1]

#### 12.1.2.1 Definition [M1]

A voice call consists of a series of speech items separated by gaps known as "call hang\_time periods". A talkgroup data call consists of one or more data items.

As the protocol is inherently asynchronous, these gaps are of random duration but it is possible for an MS involved in a talkgroup call to define a minimum call hang\_time period using the Tx\_Wait parameter transmitted at the end of each item in the END frame. The Tx\_Wait timer commences immediately after the last bit of the END frame of the transmission that announces a Tx\_Wait period.

### 12.1.2.2 Action by receiving stations [M1]

When a transmitting MS involved in a talkgroup call announces a non zero Tx\_Wait time then the next item shall not be permitted to start during this Tx\_Wait time irrespective of any polite or impolite criteria employed.

During the TX\_Wait period, MS shall monitor the channel for a possible break-in request.

Where an MS receives an emergency break-in request during the announced Tx\_Wait time then the MS shall generate a suitable audible prompt to the user to leave the channel free for the station that has requested the channel.

### 12.1.2.3 Call duration timers [M1]

#### 12.1.2.3.1 Item Duration Timer for Voice Calls [M1]

For a voice call, MSs shall maintain a traffic channel transmit TimeOut timer (TV\_Item) which limits the time of a single voice transmission item. This timer shall be set to the value of TV\_Item seconds whenever the PTT key is pressed and counts down to zero.

If the transmit TimeOut timer expires, then the MS shall complete the current superframe, transmit an END frame then stop transmitting. The MS may not re-transmit until PTT has been released and pressed again.

#### 12.1.2.3.2 Item Duration Timer for Data Calls [M1]

MSs shall maintain a data maximum item duration timer TD\_Item. If the MS reaches the maximum item duration TD\_Item, the MS shall discontinue the item immediately and indicate to the application layer that the item was not successfully transmitted.

### 12.1.3 Transmit admit criteria [M1]

#### 12.1.3.1 Channel "Politeness" [M1]

While an MS is party to a voice call, it may transmit irrespective of whether the channel is "Idle" or "Busy" with 6,25 kHz FDMA activity pertaining to the same voice call but may not transmit if a Tx\_Wait time has been invoked and the timer is running. However, for all other situations including data transmissions, MSs shall be configurable to employ the following levels of "politeness" on a channel:

- a) Polite to own Talkgroup: The MS shall refrain from transmitting on a channel while the channel is "Busy" with other 6,25 kHz FDMA activity from MSs within its own talkgroup. For all other types of activity already present on the channel, the MS shall transmit regardless.
- b) Polite to own Colour Code: The MS shall refrain from transmitting on a channel while the channel is "Busy" with other 6,25 kHz FDMA activity from MSs using the same Colour Code. For all other types of activity already present on the channel, the MS shall transmit regardless.
- c) Impolite: The radio shall transmit on a channel regardless of any other activity (either 6,25 kHz FDMA or otherwise) already present on the channel.

On a given channel, not all features may be supported the same level of politeness. So for example, voice transmissions may be configured to be "impolite" while packet data transmissions are configured to be "polite".



### 12.1.3.2 General Timing [M1]

Where an MS has been solicited to transmit a response, it shall conform to the timing specified in clause 12.

If an MS is soliciting a response and does not receive it, there are two possibilities:

- a) The message that solicited the response was not received by the called party.
- b) The message that solicited the response was received by the polled party, an acknowledgement was sent by the polled party but the acknowledgement was not received by the calling party.

If a repeat message is sent by the calling party, any repeat message shall be delayed to account for case b) above.

### 12.1.3.3 Transmission re-tries [M1]

Certain transmissions solicit responses and where these responses are not received (e.g. due to collisions, interference etc.) the transmitting entity may repeat the original transmission NM1\_Rep times.

### 12.1.3.4 Emergency channel access procedures [M1]

In systems where emergency channel access is required, it shall be implemented as follows:

- a) MS shall be specifically configured to permit emergency calls.
- b) If the channel is idle, an MS may make an emergency call. While an emergency call is in progress the MS engaged in the call shall set Tx\_Wait = 0.
- c) An active emergency call shall not be interrupted by a new emergency call.
- d) If, at the time emergency access is required the channel is occupied by a normal priority call, emergency channel access shall be by means of a pre-keyed break in request which shall be transmitted during the Tx\_Wait delay announced by the last END frame.
- e) MS who were previously involved in a call shall continue to decode the message information (MI) of the frames received and shall not transmit as they are no longer party to this call. Such MS may also provide some indication to the user that the channel has been pre-empted for an emergency call. MS that have been pre-empted and idle MSs (not involved in the call) shall monitor the channel and be inhibited from transmitting until they are able to determine the emergency call has ended by the following:
  - 1) the MS monitoring the channel decode a disconnect message ending the emergency call; or
  - 2) MS have not decoded an item from the emergency call for T\_Emer\_Barr seconds.

#### 12.1.3.4.1 Emergency Break-in requests [M1]

When a transmitting station engaged in a normal priority call has announced a non-zero Tx\_Wait time (thus inviting emergency break-in request), then this period is available for emergency break-in requests from stations that are not involved in the call;

- a) Break-in requests are permitted for normal priority talkgroup calls. They shall not be permitted for individual calls or All Calls.
- b) A user that wishes to break-in to the channel shall have pre-keyed a break-in request on their MS. That MS shall not transmit the request until the start of the announced Tx\_Wait time. The break-in request transmission shall be of the 'connection request' format using one header and one end frame. The Header Type is set to 0001<sub>2</sub> (Connection\_Request) and the Called Station ID is set to the new destination MS ID. The P bit shall be set to Emergency (P = 1<sub>2</sub>).
- c) An emergency call shall not break-in to an existing emergency call.

Although an emergency call shall not break-in to an existing emergency call, An MS may monitor the channel for the emergency call to complete then make a pre-keyed break in request. If more than one MS is trying to access the channel using a break-in request then there is a strong chance a collision will occur.

## 12.2 Channel access for Mode 2 [M2]

In Mode 2, MS are operating in a centralized repeater network.

Mode 2 operation is normally semi-duplex for MS and duplex for BS repeaters. MS cannot directly hear transmissions from other MS directly since they are listening to the BS downlink channel. MS transmissions are retransmitted by the BS on the downlink channel after appropriate FEC and CRC processing. This causes an inherent delay to the retransmission by the BS.

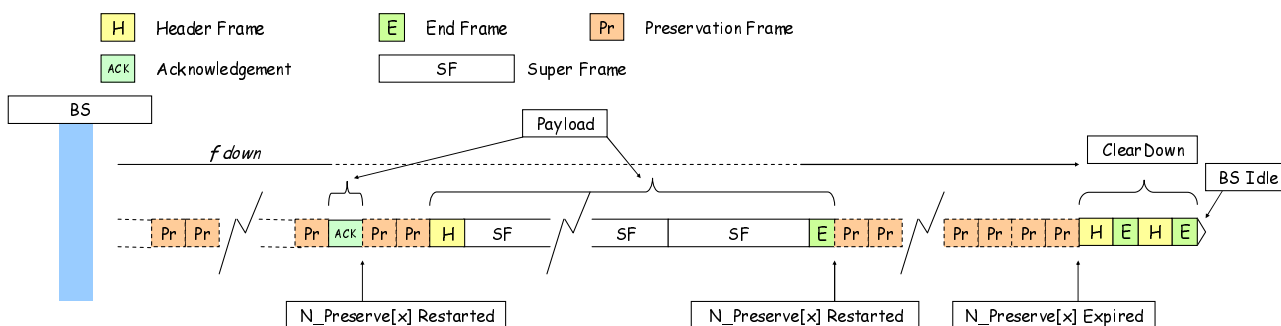
A single traffic channel carrying speech or data information is used for Mode 2 transactions and all access to the BS is asynchronous. BS may also use the traffic channel to broadcast information. BS shall use the downlink traffic channel for the purposes of:

- preserving the channel during call set-up;
- preserving the channel between items during the carrier hang\_time;
- marking the channel for MS to identify the current users of the system;
- identifying the particular BS.

Effective management of Mode 2 systems relies on MS polite access. MS that are listening on the BS downlink channel are able to determine if a call is in progress. MS would normally be aware if they were party to a call, but there are instances where an MS may have just joined a channel and be party to an on-going group call. The protocol is able to deal with this because the Preservation Frames contain the addresses of the parties legitimately occupying the channel.

When the BS is not engaged in a call it is idle. When idle, the BS may either de-key its carrier or transmit IDLE messages. If a BS chooses to transmit IDLE messages, MS are able to use the received RSSI to determine the quality of the link.

The use of preservation frames to provide effective Mode 2 management is illustrated in figure 12.4.



**Figure 12.4: Use of Preservation Frames**

When the BS is idle MS may access the channel to start a call. When the BS becomes active the maximum call timer  $M2\_CallV$  is started.

M2 systems shall only use polite criteria apart from emergency break in requests described in clause 12.2.3.4. As soon as a BS becomes active with a call and there are no payload frames to transmit, the BS shall transmit preservation frames. Preservation frame contain the addresses of the parties occupying the channel. MS not party to the call shall use polite criteria and not transmit while this call is active.

During the call, MS transmit items that the BS then retransmits on the downlink channel. Between items the BS transmits preservation frames to preserve the channel for parties to the call. The preservation frames shall be displaced by the next item re-transmitted. The channel shall remain preserved for the call unless:

- parties stop transmitting items and a preservation timer  $N\_Preserve[x]$  expires;
- a disconnect message is received by the BS and the disconnect has been completely retransmitted to MS;
- a call timeout has occurred. The timer  $M2\_CallV$  expires.

When the preservation state is no longer in force the channel shall revert to idle.

Referring to figure 12.4:

- a) the N\_Preserve[x] timer is started when the BS becomes active, If there is no payload for the BS to immediately retransmit, the BS transmits preservation frames;
- b) the N\_Preserve[x] timer is paused at the point a new payload item is started;
- c) the N\_Preserve[x] timer is restarted at the point a payload item is complete;
- d) if the N\_Preserve[x] timer expires, the BS stops sending preservation frames and clears the call by transmitting Disconnect\_Request header + END frame(s). Following the Disconnect frames the BS returns to idle.

## 12.2.1 Listen Before Transmit (LBT) [M2]

When accessing a traffic channel to transmit, an MS shall take account of the following types of activity which may already be present on the downlink channel:

- 6,25 kHz FDMA activity;
- other digital protocol activity;
- analogue activity.

When determining whether activity is present on a channel, the MS shall monitor the RSSI level. If after a maximum period of time (M2T\_ch\_chk) the RSSI level has not exceeded a configurable (within a predefined range) threshold RSSI\_LO, then the radio shall assume that activity is not present on the channel.

If the RSSI level does exceed the RSSI\_LO threshold, then the MS shall assume that activity is present on the channel and it shall attempt to identify that it is compliant with the present document.

If the MS does identify the channel as compliant with the present document, the MS shall attempt to identify the Colour Code. If the Colour Code received differs from that personalized in the MS then the MS shall assume that the activity is not applicable to this MS. When idle, a Mode 2 BS may de-key its transmitter or transmit idle messages inviting access.

## 12.2.2 Hang time messages and timers [M2]

### 12.2.2.1 Definition [M2]

A voice call consists of a series of speech items separated by gaps known as "call\_hang\_time periods". A talkgroup data call consists of one or more data items. As the protocol is inherently asynchronous, these gaps on the uplink channel are of random duration but it is possible for an MS involved in a talkgroup call to define a minimum call\_hang\_time period using the Tx\_Wait parameter transmitted at the end of each item in the END frame. Tx\_Wait commences immediately after the END frame of the transmission that announces a Tx\_Wait period.

On the downlink channel, after the item from the MS has been re-transmitted to the listener the BS shall insert preservation frames in the gaps to preserve the channel for the parties involved in the call. BS shall operate with an active\_hang\_time that is configurable and during the active\_hang\_time period the BS shall transmit N\_Preserve[x] preservation frames. If a new item is not received by the BS after N\_Preserve[x] frames have been transmitted, the BS shall become idle. Five N\_Preserve[x] values are defined as follows:

- a) for a voice call, the carrier hang\_time is N\_PreserveV preservation frames;
- b) for an emergency voice call, the carrier hang\_time is N\_PreserveE preservation frames;
- c) for a data call, the carrier hang\_time is N\_PreserveD preservation frames;
- d) for a packet data call, the carrier hang\_time is N\_PreserveP preservation frames; for a packet data call the carrier hang\_time between the packet data message and the acknowledgement is N\_PreservePI preservation frames.

NOTE: Packet data is a connectionless call. Setting the value of N\_PreserveP=0 causes the BS to immediately become idle when the acknowledgement to a packet has been retransmitted by the BS.

Carrier\_hang\_time shall not be implemented following the downlink transmission of any of the following:

- Disconnect request.
- BS/RPT Command header responses.
- Repeater Access header responses.
- Status responses.
- BS broadcast information.
- Packet data transmissions.

Where the logical channel connecting the called party is not the traffic channel downlink (in the case for example of a call to a line connected destination), the BS shall transmit preservation frames for the duration of the connection.

### 12.2.2.2 Action by receiving stations [M2]

When a transmitting MS involved in a group or talkgroup call announces a non zero Tx\_Wait time, that parameter is retransmitted by the BS on the downlink. The next item shall not be permitted to start during this Tx\_Wait time irrespective of any polite or impolite criteria employed.

During the TX\_Wait period, MS shall monitor the channel for a possible break-in request.

Where an MS receives an emergency break-in request during the announced Tx\_Wait time then the MS shall generate a suitable audible prompt to the user to leave the channel free for the station that has requested the channel.

### 12.2.2.3 Call duration timers [M2]

#### 12.2.2.3.1 Item Duration Timer for Voice Calls [M2]

For a voice call, MSs shall maintain a traffic channel transmit TimeOut timer (TV\_Item) which limits the time of a single voice transmission item. This timer shall be set to the value of TV\_Item seconds whenever the PTT key is pressed and counts down to zero.

If the transmit TimeOut timer expires, then the MS shall complete the current superframe, transmit an END frame then stop transmitting. The MS may not re-transmit until PTT has been released and pressed again.

#### 12.2.2.3.2 Item Duration Timer for Data Calls [M2]

MSs shall maintain a data maximum item duration timer TD\_Item. If the MS reaches the maximum item duration TD\_Item, the MS shall discontinue the item immediately and indicate to the application layer that the item was not successfully transmitted.

#### 12.2.2.3.3 Maximum call duration timer for Mode 2 calls

At the start of a normal priority voice call, an emergency priority voice call or a data call the BS shall set one of the timers M2\_CallV, M2\_CallE or M2\_CallD. If during the call the maximum duration call timer expires the BS shall return to idle.

## 12.2.3 Transmit admit criteria [M2]

### 12.2.3.1 Channel "Politeness" [M2]

While an MS is party to a voice call, it may transmit irrespective of whether the channel is "Idle" or "Busy" with 6,25 kHz FDMA activity pertaining to the same voice call but may not transmit if a Tx\_Wait time has been invoked and the timer is running. However, for all other situations including data transmissions, MSs shall be configurable to employ the following levels of "politeness" on a channel:

- Polite to own Talkgroup: The MS shall refrain from transmitting on a channel while the channel is "Busy" with other 6,25 kHz FDMA activity from MSs within its own talkgroup. For all other types of activity already present on the channel, the MS shall transmit regardless.
- Polite to own Colour Code: The MS shall refrain from transmitting on a channel while the channel is "Busy" with other 6,25 kHz FDMA activity from MSs using the same Colour Code. For all other types of activity already present on the channel, the MS shall transmit regardless.

On a given channel, not all features may be supported the same level of politeness. So for example, voice transmissions may be configured to be "polite to own talkgroup" while packet data transmissions are configured to be "polite to own Colour Code".

### 12.2.3.2 General Timing [M2]

The MS timing shall be as specified in clause 12.

Where an MS has been solicited to transmit a response, it shall be noted that the message from the MS is re-transmitted by the BS on the downlink (apart from the F field in the message). The message is therefore delayed reaching the called party. An acknowledgement from the called party back to the sender is similarly delayed. The delay is variable caused by:

- the design of the BS - how the BS buffers the information on the uplink and processes CRC and FEC;
- the timing that enables the uplink message to displace Preservation\_Messages.

MS waiting for a response shall be configured with a timer (M2T\_ack) that expires when there is no possibility that an acknowledgment message would ever be received. Timings for such a response are illustrated in figure 12.5. MS(A) has transmitted a message that solicits a response from MS(B). There is a delay between the BS receiving the message and re-transmitting the message on the downlink. At this point, the BS protects the channel by transmitting Preservation\_Messages. When MS(B) transmits the response on the uplink, the BS shall process that message then seamlessly displace Preservation\_Messages and insert the response message on the downlink. This causes a further delay transmitting the response.

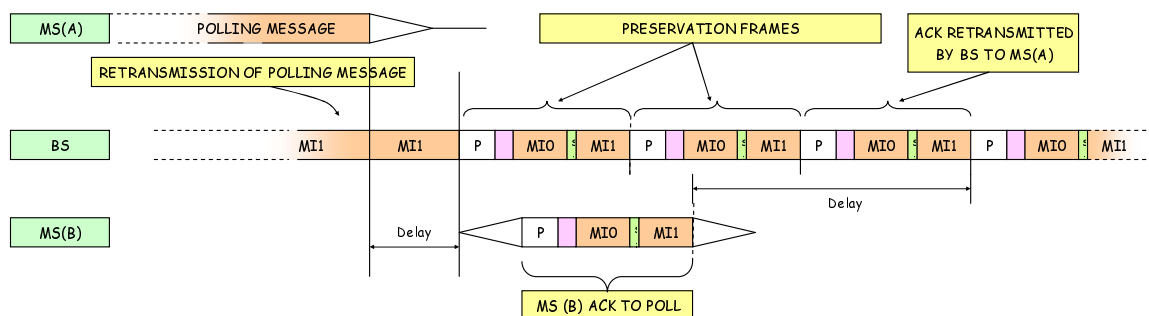


Figure 12.5: Mode 2 Response Timing

The response shall be sent irrespective of whether the channel is "Idle" or "Busy".

If an MS is soliciting a response and does not receive it, there are two possibilities:

- 1) The message that solicited the response was not received by the called party.
- 2) The message that solicited the response was received by the polled party, an acknowledgement was sent by the polled party but the acknowledgement was not received by the calling party.

If a repeat message is sent by the calling party, any repeat message shall be delayed to account for case b) above.

### 12.2.3.3 Transmission re-tries [M2]

Certain transmissions solicit responses and where these responses are not received (e.g. due to collisions, interference, etc.) the transmitting entity may repeat the original transmission NM1\_Rep times.

### 12.2.3.4 Emergency channel access procedures [M2]

For Mode 2 systems preservation frames are inserted by the BS in the period between items. Normal and emergency priority calls are identified in preservation frames therefore MS not involved in a call can always determine the priority of the current call.

In systems where emergency channel access is required, it shall be implemented as follows:

- a) MS shall be specifically configured to permit emergency calls.
- b) If the channel is idle, an MS may make an emergency call. While an emergency call is in progress the MS engaged in the call shall set Tx\_Wait = 0. At the start of the call the BS shall start maximum call timer M2\_CallE. If the timer M2\_CallE expires the BS shall return to idle.
- c) An active emergency call shall not be interrupted by a new emergency call.
- d) If, at the time emergency access is required the channel is occupied by a normal priority call, emergency channel access shall be by means of a pre-keyed break in request which shall be transmitted during the Tx\_Wait delay announced by the last END frame.
- e) MS who were previously involved in a call shall continue to decode the message information (MI) of the frames received and shall not transmit as they are no longer party to this call. Such MS may also provide some indication to the user that the channel has been pre-empted for an emergency call. MS that have been pre-empted and idle MSs (not involved in the call) shall monitor the channel and be inhibited from transmitting until they are able to determine the emergency call has ended by the following:
  - 1) the MS monitoring the channel decode a disconnect message ending the emergency call; or
  - 2) MS have not decoded an item from the emergency call for T\_Emer\_Barr seconds.

#### 12.2.3.4.1 Emergency Break-in requests [M2]

When a transmitting station engaged in a normal priority call has announced a non-zero Tx\_Wait time (thus inviting emergency break-in request), then this period is available for emergency break-in requests from stations that are not involved in the call.

- a) Break-in requests are permitted for normal priority talkgroup calls. They shall not be permitted for individual calls or All Calls.
- b) A user that wishes to break-in to the channel shall have pre-keyed a break-in request on their MS. That MS shall not transmit the request until the start of the announced Tx\_Wait time (during the preservation frame). The break-in request transmission shall be of the 'connection request' format using one header and one end frame. The Header Type is set to 0001<sub>2</sub> (Connection\_Request) and the Called Station ID is set to the new destination. The P bit shall be set to Emergency (P = 1<sub>2</sub>).
- c) An emergency call shall not break-in to an existing emergency call.

- d) Preservation frames subsequent to this emergency break in request shall use the called and calling party IDs of the break in request MS, with the P field set to 1<sub>2</sub> and the PM field set to 1<sub>2</sub>.
- e) MS who were previously involved in a call shall continue to decode the message information (MI) from the preservation and other message frames and shall not transmit as they are no longer party to this call. Such MS may also provide some indication to the user that the channel has been pre-empted for an emergency call.

Although an emergency call shall not break-in to an existing emergency call, An MS may monitor the channel for the emergency call to complete then make a pre-keyed break in request. If more than one MS is trying to access the channel using a break-in request then there is a strong chance a collision will occur.

## 12.3 Channel access for Mode 3 [M3]

In Mode 3, MS are operating in a centralized managed repeater network. This Mode of operation yields the highest performance and throughput.

Mode 3 radio systems are characterized by regulating channel access by means of a beacon channel. Beacon channel packets generated by a Mode 3 BS transmit on the downlink path that all MSs listen to when not involved in a call. MSs request access to the system by managed random access. For services such as a voice call service, the call set-up is done by an exchange of messages on the beacon channel that result in the MSs being directed to a traffic channel. When the call is complete, the MSs return to the beacon channel. One beacon can support a large number of traffic channels. There are a number of Mode 3 services (such as short data messaging) that only require the beacon channel.

Mode 3 operation would normally be semi-duplex for MS and duplex for BS repeaters. Common to Mode 2, Mode 3 MS cannot directly hear transmissions from other MS directly since they are listening to the BS downlink channel.

The channel access procedure described for Mode 1 and Mode 2 system have no meaning for Mode 3. In Mode 3 systems, access to system resources is managed by the beacon channel.

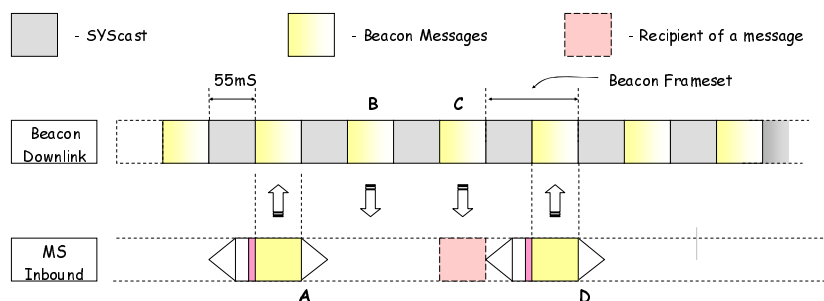
### 12.3.1 Mode 3 Channel Structure

The logical channels are separated into two categories:

- a beacon channel carrying slotted signalling (in framesets); and
- traffic channels (beacon/payload) carrying speech or data information. Traffic channel access is described in clause 12.4.

MSs operate in half duplex Mode. BSs are full duplex.

A generalized diagram of exchanges between the BS Beacon channel and MS is illustrated in figure 12.6 where the beacon messages and SYScasts are illustrated.



**Figure 12.6: Key points for a Mode 3 beacon channel**

Key points particular to Mode 3 operation illustrated by figure 12.6 includes the following:

- While the beacon channel is keyed up, the downlink channel is continuously transmitted in order to:
  - a) Maintain frameset timing.

- b) Manage MS access.
- c) Broadcast system information.
- The message frames in the uplink channel are time aligned with the downlink channel.
- Referring to figure 12.6, a random access burst on the uplink channel labelled "A" shall be acknowledged by a message frame on the downlink channel. This acknowledgement may be transmitted in frameset "B".
- For an MS response to an applicable message received from the beacon, the MS shall transmit its frame in the next frameset following the end of the applicable beacon frame. i.e. a frame from the beacon in frameset "C" that requires a response from an MS shall be acknowledged on the beacon channel in frameset "D".
- The MS response at "D" cannot collide with another random access burst because the message frame is protected by setting the W bit in the message "C" to withdrawn. MS shall check that the random access frame it has chosen is not withdrawn before making a random access attempt.

### 12.3.2 Introduction to the Beacon Structure [M3]

These clauses outline some key aspects of the Mode 3 protocol by reference to examples. The Mode 3 protocol manages MS access and service provision by means of a beacon channel. MSs request service by means of random access. The beacon downlink channel may be:

- a) continuously transmitting framesets that invite MS access, broadcast of system parameters to, and managing the resources that are available to MS; allocating a separate traffic channel resource for a call where appropriate;
- b) transmitting information as a) but reverting to a traffic channel when other traffic channels are not available.

#### 12.3.2.1 Beacon Timing [M3]

The timing of BS and MS is illustrated in figure 12.7.

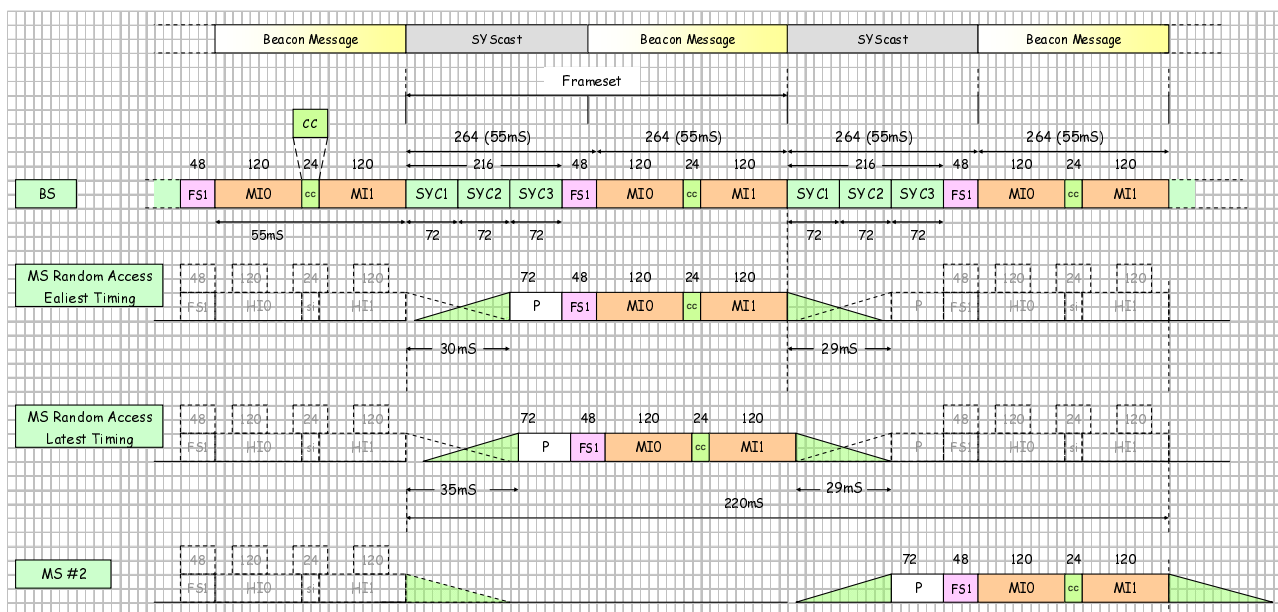


Figure 12.7: Beacon Timing

Beacon messages and SYScast messages are transmitted alternately. MS transmissions are time aligned. The MS timing is specified in clause 12. Two MS transmissions (from MS #1 and MS #2) are illustrated in figure 12.7. The timing constraints ensure that MS transmissions in adjacent framesets do not overlap.

SYScast messages are transmitted by the BS to broadcast information about the system to which MS are listening. If there are more bits to send than may be contained within a beacon message, SYScast frames may be displaced by data frames that are appended to a message frame to provide the additional bits.



### 12.3.3 Network architecture [M3]

#### 12.3.3.1 Network functions

In addition to the normal call handling functions required to provide the telecommunication services identified above, a number of standard network procedures are needed for the efficient operation of the system and to provide an acceptable grade of service to the users.

##### 12.3.3.1.1 Establishing service

A notable feature of a Mode 3 system is that physical channel acquisition is performed automatically when an MS is powered up. The user does not need to manually select physical channels. The relevant physical channel is stored in the MS or a search is performed to find an applicable Mode 3 beacon. If the MS is directed to a traffic channel, the applicable traffic channel is transmitted to the MS by a GoTo Channel frame that specifies the physical channel.

##### 12.3.3.1.2 Network Identifier

All Mode 3 beacons carry a network and radio site identifier. This identifier, the System Identity Code (SYScode) is transmitted frequently by the beacon in the SYScast1 frame. The SYScode is composed of MODEL, NET and SITE information. Within a particular network, the NET remains a constant. Within a particular radio network, each beacon station is designated a different SITE parameter. MSs use the NET to determine if they are authorized to attempt to become active on that network.

#### 12.3.3.2 MS Location by Registration

The coverage area of a Mode 3 network is divided into a number of Location Areas (dPMRLAs). A dPMRLA corresponds to a single radio site or a small number of radio sites structured as dPMRLAs.

Implicit registration is the network functionality that registers the location of the MS without need for an explicit registration frame. Implicit registration can be attained by any uplink beacon frame that conveys the MS individual identity, e.g. call request, service answer response.

It is possible that due to adverse conditions the registration information held by the network and that held by the MS may not be the same. To restore and maintain the registration records:

- a) The system shall update its registration records from MS random access call requests (The network may however deny the service requested by the MS for other reasons).
- b) Responses from MS (resulting from a radio check for example) implicitly update the system registration records.

### 12.3.4 Trunking methods [M3]

Mode 3 systems implement the "message trunking" method.

Message trunking is a traffic (beacon/payload) channel allocation strategy in which the traffic channel is continuously allocated for the whole duration of a call, which may include several separate call items or transactions (i.e. PTT activation by separate terminals). The traffic channel is only de-allocated when the call is explicitly cleared by the call owner in the case of a group call, either party hanging up during an individual call or if a traffic channel inactivity timer expires. The BS may also clear the call at any time but the BS shall be confident that all parties in the call are able to hear the particular frame that clears down the call.

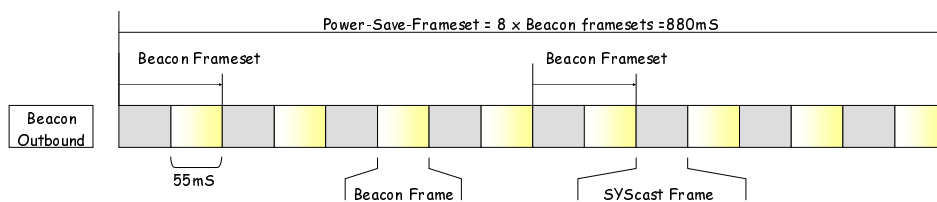
When a traffic channel has been allocated the users will experience the minimum delay for each transmission item since there is no queuing for the allocation of channel resources. The absence of any perceptible delay when the PTT is activated ensures that a conversation can proceed without interruption. This strategy is likely to minimize the processing and signalling overheads in the network infrastructure.

### 12.3.5 Beacon Channel Formats [M3]

A beacon shall employ one physical channel.

When idle, MSs shall listen to the beacon downlink channel.

Signalling on the beacon downlink channel is nominally continuous.



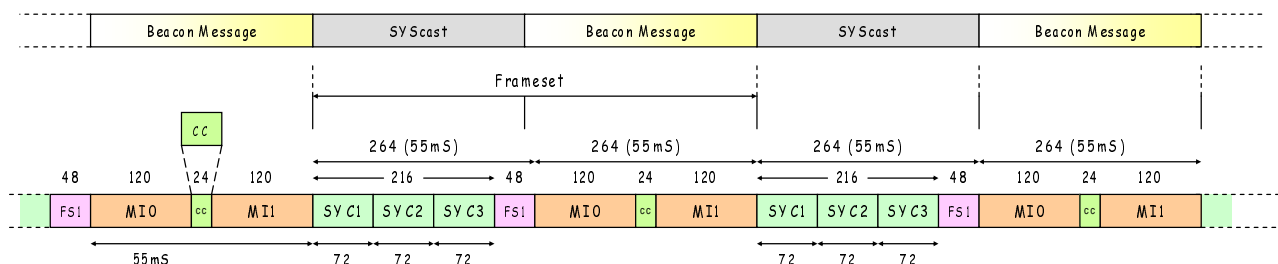
**Figure 12.8: Beacon frames and Framesets**

Figure 12.8 illustrates Beacon Frames, Beacon Framesets and Power-Save-Framesets.

A Beacon Frameset encompasses a SYScast Frame followed by a Beacon Frame.

A power\_save-frame is defined by transmission of 8 consecutive Beacon Framesets. A power\_save frame is transmitted by a Beacon every 880 ms. Power save is described in clause 12.3.10.

### 12.3.5.1 Use of the SYScast Frames



**Figure 12.9: Beacon Channel Downlink**

A Beacon downlink channel is illustrated in figure 12.6. The SYScast frames carry system information that is broadcast to MS. SYScast frames may be displaced by appended data frames. Appended data frames are used to transport information that cannot be sent by a single beacon message frame.

#### 12.3.5.1.1 SYC1 SYScast Frame

The SYSC1 frame carries the Reg and SYSCode.

The Reg field carries a flag that specifies if this particular system requires MS to register before becoming active.

The SYSCode is the ID of the Beacon and described in clause 12.3.8.2.2.2.

#### 12.3.5.1.2 SYC2 or SYSC3 SYScast Frame

SYScast2 and SYScast3 frames are available in a SYScast frame. If the Mode 3 system employs power save, one of the SYScast2 frames shall carry a common frameset counter. This counter is further described in the powersave clause 12.3.10. SYScast2 or SYScast3 frames may also carry a range of broadcast information including:

- broadcast of real time;
- network timers.
- the calling party address following a Goto Channel message

## 12.3.5.2 Beacon Frame Structure

### 12.3.5.2.1 Frames on the Beacon downlink channel

The frames sent by a Beacon on the downlink channel are classified as illustrated in table 12.1.

**Table 12.1 Beacon Downlink Frames**

Class	Mnemonic	frame Descriptor	Description
Broadcast	B_GTC	Beacon Go To Channel	Transfer MS to a traffic channel for a Voice or data transaction
	B_MOVE	Beacon Move to a new physical channel	MSs shall move to an alternative BS
	B_ALOHA	Beacon Aloha	To Manage Random Access
	B_BCAST	Beacon Announcements	Frames intended for all MSs listening to this BS
Ahoys	B_AHOY	Beacon Ahoy	Sent to an individually addressed MS and demand a response
Acknowledgements	B_xACKD	Beacon Acknowledgements	A response to Frames from the MS that demand a response: B_ACKD, B_NACKD, B_WACKD, B_QACKD
Unified Data Downlink	B_UDTD	Beacon Short System Message Downlink (see note)	System frame addressed to an individually addressed MS and demand a response
		Short Data Message Downlink	Short data message addressed to a group
NOTE: Short System Message to be defined.			

### 12.3.5.2.2 Frames on the Beacon uplink channel

The frames sent by an MS on the Beacon uplink channel are classified as illustrated in figure 12.2.

**Table 12.2: Beacon Uplink Frames**

Class	Mnemonic	frame Descriptor	Description
Random Access	B_RAND	Beacon Random Access	Random Access Requests
Acknowledgements	B_xACKU	Beacon Acknowledgements	A response to Frames from the BS that demand a response B_ACKU, B_NACKU
Unified Data Uplink	B_UDTU	Beacon Short System Message Uplink (see note)	System frame addressed to an individually addressed MS or the BS as a response to an Ahoy frame from the BS
		Beacon Short Data Message Uplink	Short Data Message addressed to an individually addressed MS, or the BS as a response to an Ahoy frame from the BS
NOTE: Short System Message to be defined.			

## 12.3.6 Channel Access for a Beacon Channel

### 12.3.6.1 Basic Structure

#### 12.3.6.1.1 Channel Structure

Mode 3 MS require a Beacon BS to regulate channel access by a fully managed synchronous frameset structure.

The Beacon BS shall provide the following services:

- a) Management and control of channel access by MS using a slotted random backoff mechanism.
- b) Processing service requests to and from MS and optionally to and from line connected entities.
- c) Allocating traffic channel resources to calls.
- d) Broadcast of system information to MS.
- e) MS location management by registration.
- f) Provision of complementary services such as beacon short data polling and transfer.
- g) Beacon power save.

#### 12.3.6.1.2 Physical Channel Addressing

The Mode 3 protocol supports a number of different physical channel strategies to accommodate operation in physical radio channels that may be dedicated, in blocks or allocated on an ad-hoc basis by an external agency. Physical radio channels are specified by a mechanism whereby the absolute transmitter and receiver frequencies are specified in the fields of frames that are passed between dPMR entities at the air interface.

#### 12.3.6.1.3 Sub-Division of the MS population

Certain messages transmitted by the BS may be directed to and applicable only to a sub-set of the MS population. Examples are Aloha (B\_ALOHA) Frames and Broadcast (B\_BCAST) Frames. Applicable Frames contain a 24 bit address fields and a 5 bit (Mask) number field. The sub-set division is achieved by using the address qualifier (Mask) from the frame. This parameter instructs an MS to compare the "Mask" least significant bits of its individual address with the "Mask" least significant bits of the address field from the frame (containing the MASK) to determine if that frame is applicable.

An MS shall note the population subdivision contained in each applicable frame that it receives. For Mask = 0 to 24, the frame is applicable to the unit if the "Mask" least significant bits of the Aloha address match the "Mask" least significant bits of its individual address.

In this way, the MS population is effectively divided into  $2^{\text{Mask}}$  subsets:

- If Mask = 0 then no address bits are compared, so there is no subdivision.
- If Mask = 1 then only MS whose least significant individual address bit matches the least significant individual address bit from the frame received shall consider the frame to be applicable to that particular MS.

This process continues up to Mask = 24. In this case the frame is only applicable to one MS.

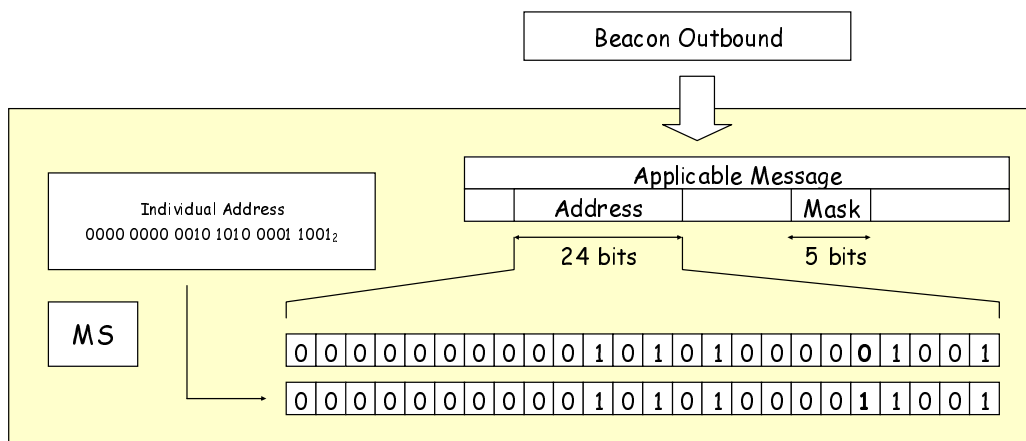


Figure 12.10: Example of frame containing the "Mask" field

Figure 12.10 illustrates an MS personalized with the address 0000 0000 0010 1010 0001 1001<sub>2</sub>.

A frame is received that contains a Mask field. The MS shall therefore determine if that frame is applicable or the frame shall be discarded.

EXAMPLE 1: The Mask field contains the value 0 0100<sub>2</sub>.

The value of the Mask is 4 therefore the MS compares the 4 least significant bits of the address field in the frame received with the 4 least significant bits of the MS individual address.

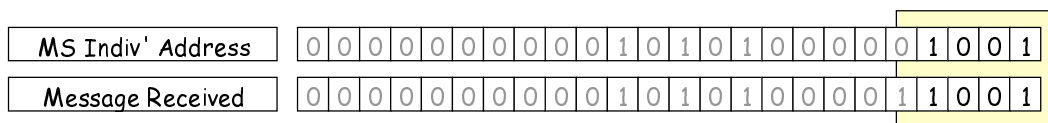


Figure 12.11: Applicable frame defined by Address and Mask

The least significant 4 bits are compared as illustrated in figure 12.11. In this case the bits match so this IS an applicable frame for this particular MS. (If Mask were any value from 0 to 4 the frame would still be applicable.)

EXAMPLE 2: The Mask field contains the value 0 0101<sub>2</sub>.

The value of the Mask is 5 therefore the MS compares the 5 least significant bits of the address field in the frame received with the 5 least significant bits of the MS individual address.

The least significant 5 bits are compared as illustrated in figure 12.12. In this case the bits do NOT match so this frame shall be discarded by this particular MS. (If Mask were any value from 5 to 24 the frame would still be discarded).

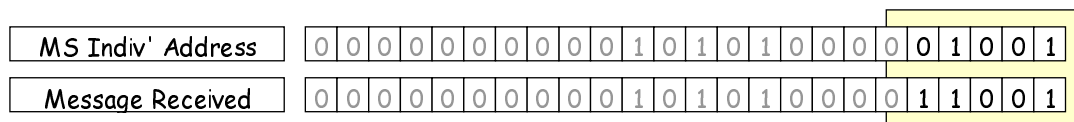


Figure 12.12: Non-Applicable frame defined by Address and Mask

## 12.3.7 Random Access Procedures

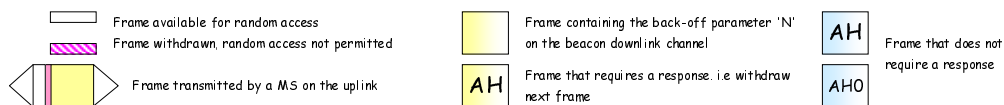
These clauses define the random access protocol, which is based on slotted aloha that is used to:

- control the collision of simultaneous random access attempts from different MSs;
- manage the BS to minimize access delays;
- ensure system stability; and
- maintain optimum throughput under heavy traffic loads.

Random access is the only access method permitted for MS on a Mode 3 beacon BS.

### 12.3.7.1 The Random Access Principle

The figures in the random access procedure clauses adopt the conventions illustrated in figure 12.13.



**Figure 12.13: Conventions used in the figures**

Frames transmitted on the BS on the downlink channel are divided between those that invite random access (such as Aloha's) and those that withdraw one or more framesets for the purpose of preventing random access in frames where an explicit acknowledgement message from an MS had been expected on the uplink channel (see clause 12.3.7.1.1.3).

#### 12.3.7.1.1 Random Access Control

The Beacon downlink channel creates an environment where BS access may be managed and controlled. This protocol specifies a specific B\_ALOHA frame that contains the fields BACKOFF, MASK, and Service\_Function (SF), to manage and control random access. Other Frames transmitted on the BS also contain the BACKOFF field.

All MS initiated services are by random access. If an MS wishes to make a random access attempt, the MS may send the random access service request frame so long as:

- access is not inhibited by Mask (see clause 12.3.7.1.1.1);
- access is not inhibited by the Service\_Function (see clause 12.3.7.1.1.2); or
- the frameset chosen is not withdrawn (see clause 12.3.7.1.1.3).

##### 12.3.7.1.1.1 Sub dividing the MS population

B\_ALOHA Frames contain an address field and a Mask field. The procedure described in clause 12.3.6.1.3 is therefore applied.

An MS shall note the population subdivision contained in each Aloha frame that it receives. When attempting random access, the MS shall check if the population subdivision is applicable to it using the qualifier (Mask) and the address field from the Aloha frame. For Mask = 0 to 24, the frame is applicable to the MS if the "Mask" least significant bits of the Aloha address match the "Mask" least significant bits of its individual address.

The subdivision is applied to subsequent framesets that do not contain the Mask field, until updated or changed by the next Aloha frame.

In this way, the MS population is effectively divided into  $2^{\text{Mask}}$  subsets:

- If Mask = 0 then no address bits are compared, so there is no subdivision (under normal traffic loading, this will usually be the case).
- If Mask = 1 then only units whose least significant individual address bit matches the Aloha address may send non-emergency random access Frames. Thus the MS population has been divided into two subsets.

- This process continues up to Mask = 24. In this case only one MS shall be permitted to make a random access attempt. (unless the MS requested an emergency service whereupon the MS may make a random access attempt for all values of Mask except Mask = 24).

When an MS becomes active on a Beacon, including when returning from a traffic channel, it shall either assume that the population is not subdivided (i.e. that the last B\_ALOHA frame was applicable to all MSs) or wait for a B\_ALOHA frame before attempting random access.

#### 12.3.7.1.1.2 Checking the Service\_Function

For service requests except emergency:

- An MS shall use the Service\_Function from the B\_ALOHA frame. An MS shall not choose a frameset for random access unless the random access attempt is for a service type invited by the Service\_Function field.

**Table 12.3: Service\_Function**

Alias	Value	Meaning
SF	00 <sub>2</sub>	Random Access invited for all Services
	01 <sub>2</sub>	Random Access Invited for Services that require a traffic channel Random Access Invited for registration requests
	10 <sub>2</sub>	Random Access Invited for Services that do not require a traffic channel Random Access Invited for registration requests
	11 <sub>2</sub>	Random Access invited for random access registration requests only

- The Service\_Function shall apply until the Service\_Function is updated by a subsequent B\_ALOHA frame.

For emergency service requests the MS is not required to check the Service\_Function.

#### 12.3.7.1.1.3 Withdrawing framesets from Random-Access

The Beacon BS may transmit a frame on the downlink channel that solicits a response from a specified MS. For a single message that demands a response, the response shall be expected in the following frameset. For a message that consists of multiple concatenated frames the response shall be expected in the frameset following the last frame of the multi-frame message. In order to prevent a collision occurring between this solicited response and a random access transmission from a different MS, the BS withdraws this frame, thereby prohibiting any random access transmissions in the given frameset. MSs intending to make a random access attempt in a particular frame shall determine that the frame is not withdrawn. Frames that may solicit a response from an MS contain a flag (W) that indicates if the following frameset is withdrawn. This, therefore implies that an MS intending to transmit a message frame by random access in a given frameset shall successfully decode the message frame from the previous beacon message. Only if the previous message did not withdraw the following frameset would random access be permitted.

The following BS originated messages implicitly withdraw the following frameset for random access:

- AHOY(single frame withdrawn bit  $W=1_2$ ) addressed to an individual MS ID;
- AHOY(multi frame) that has appended data where the last message would cause a collision in the following frameset. (Appended\_Data messages transmitted on the downlink contain a withdrawn bit W that indicates the following frameset is withdrawn. If the withdrawn flag (W) is  $= 1_2$  the following frameset is withdrawn.

In the example in figure 12.14, when the BS transmits a frame that requires a response, that frame withdraws the following BS beacon frame for random access.

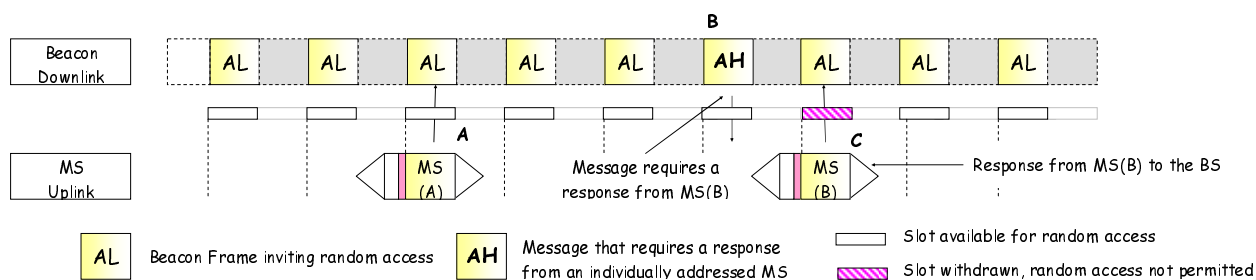


Figure 12.14: Withdrawn Framesets Example

The Beacon transmits Frames inviting random access:

- Aloha Frames invite random access. Therefore an MS is permitted to transmit a random access frame. Aloha frames do not mark a withdrawn frameset.
- At point "B", the BS transmits an AHOY frame to an individual MS that demands a response. The AHOY is a message frame that implicitly withdraws the following frameset. The result is that the following message frame "C" is withdrawn - i.e. not available for random access. The BS withdraws that frameset because the frame "B" requires response from a specific MS(B).
- At point "C", MS(B) transmits its acknowledgment frame.

If the frameset chosen for the random access attempt is not available because the frameset is withdrawn, the MS shall choose another frameset for a subsequent random access attempt using the random backoff procedures specified in clause 12.3.7.1.1.6.

A second example illustrated in figure 12.15. This is a specific example of a BS sending a UDT Header + two Appended\_Data messages to an individual MS. The message requires an acknowledgement at "B" therefore that frameset shall be withdrawn from random access. MS's listening to the Beacon shall be able to ascertain if a frameset is withdrawn by examination of the previous message. In this case the message is the Appended\_Data - in particular the second Appended\_Data message that sets the W bit to withdraw the frameset in which the acknowledgement from the MS is expected. UDT downlink transactions shall always consist of either HEAD+AD+AD or HEAD+AD+AD+AD+AD to ensure that slot timing is maintained. The W bit is applicable in the second or fourth appended data message.

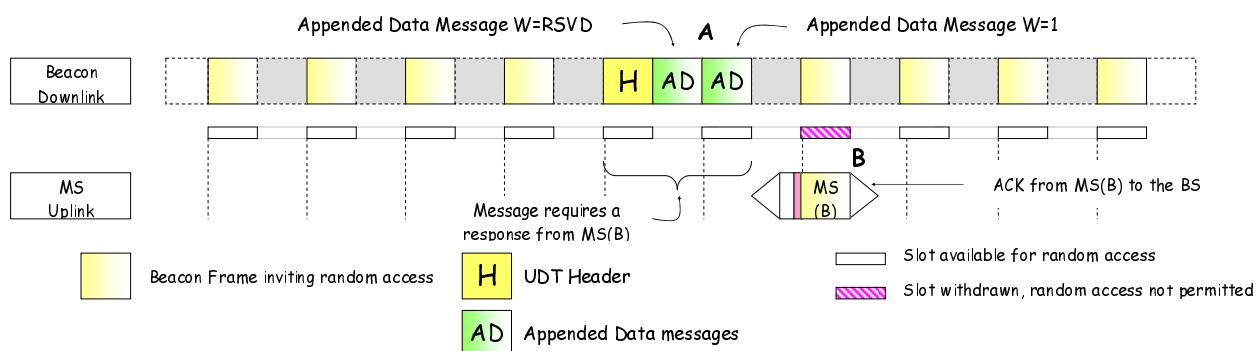


Figure 12.15: Withdrawn Framesets Example #2

In the third example illustrated in figure 12.16, an AHOY message has been transmitted by the BS to request an individual MS to uplink a HEAD message concatenated with four appended data messages as part of a UDT transaction:

- At point "A" an AHOY ( $ID_0+1=MS(B)$  ID,  $ID_2+3=$ calling party ID,  $W=1_2$ ) has requested an uplink consisting of a HEAD + four appended data messages. It can be seen from the figure that three slots must be withdrawn from random access to prevent a possible collision. The AHOY message sets the W bit to  $1_2$  to withdraw the following slot.
- At points "B" and "C" the BS transmits AHOY ( $ID_0+1=DUMMYI$ ,  $ID_2+3=BSID$ ,  $W=1_2$ ) whose purpose is to withdraw two more slots for the uplink.



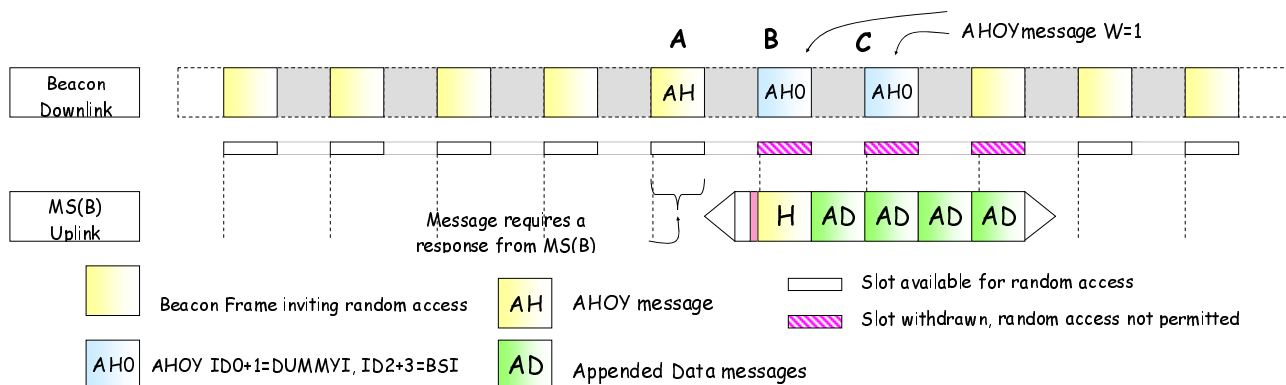


Figure 12.16: Withdrawn Framesets Example #3

The fourth example illustrated in figure 12.17 shows part of a UDT transaction where the BS is transmitting a UDT head + appended data to a group of MS. No acknowledgement is expected therefore no slots need to be withdrawn. The W bit in the second appended data message is set to 0<sub>2</sub>.

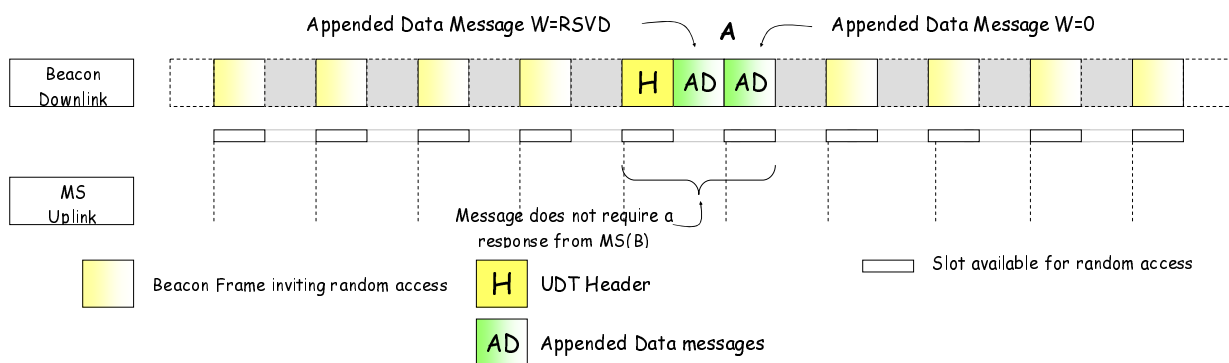


Figure 12.17: Withdrawn Framesets Example #4

12.3.7.1.1.4 BS responses to Random Access attempts

After receiving a random access frame, the BS shall send a response. Valid responses are specified in the clauses detailing the registration and call procedures. The response may be sent in the frameset following the random access frame or it may be delayed. The BS shall use a Nrand\_Wait field in the B\_ALOHA frame to specify the delay (in RA\_Framesets) an MS shall wait before choosing another frameset using a random backoff timer for a repeat random access attempt.

12.3.7.1.1.5 Noting the response delay

An MS shall note the delay parameter Nrand\_Wait from each B\_ALOHA RA\_Frameset it receives and shall use table 12.4 to derive from it the number of RA\_Frames, Nwait, by which the BSs response to a random access frame may be delayed. (Nwait = 0 means that the response is expected by the MS in the frameset following the random access frame.) At the start of a session, until it receives an Aloha RA\_Frame, the unit shall assume a default value of Nwait = Ndefault\_NW.

Table 12.4: System Response delays indicated by the delay parameter Nrand\_Wait

Nrand_Wait	Nwait(RA_Framesets)	Nrand_Wait	Nwait(RA_Framesets)
0	0	8	8
1	1	9	9
2	2	10	10
3	3	11	11
4	4	12	12
5	5	13	13
6	6	14	15
7	7	15	24

### 12.3.7.1.1.6 Random Backoff

This clause specifies the method to manage the BSs receipt of random access Frames. A Mode 3 system periodically broadcasts a random back-off timer (specified in beacon frames).

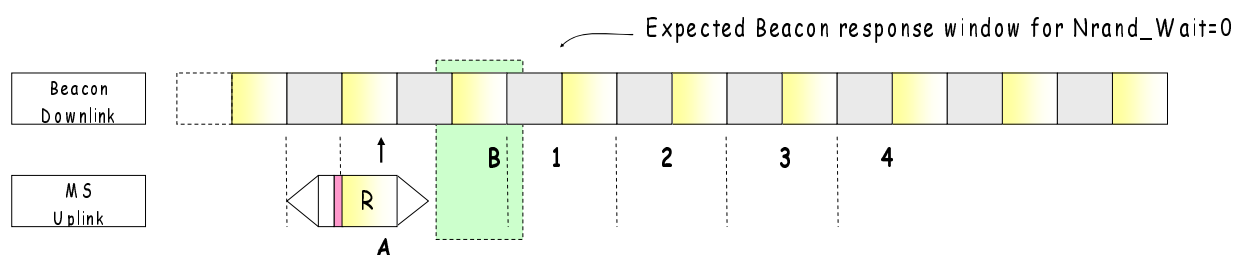
When an MS initiates a call, the MS may send its first random access frame in the next frameset (subject to Mask, Service\_Function and withdrawn frameset specified in clauses 12.3.7.1.1 a), b) and c)).

The MS shall invoke the random backoff procedures specified in this clause if:

- The MS could not make its random access attempt because access was inhibited by Mask.
- The MS could not make its random access attempt because access was inhibited by the Service\_Function.
- The MS could not make its random access attempt because the frameset was withdrawn.
- The MS did make a random access attempt but that attempt was unsuccessful (the BS did not respond before the expiry of Nrand\_Wait).

If the MS makes a random access attempt and is unsuccessful, the MS shall choose a frameset for its next random access attempt by choosing a random number between the limits of one and the BACKOFF parameter using a statistically uniform distribution.

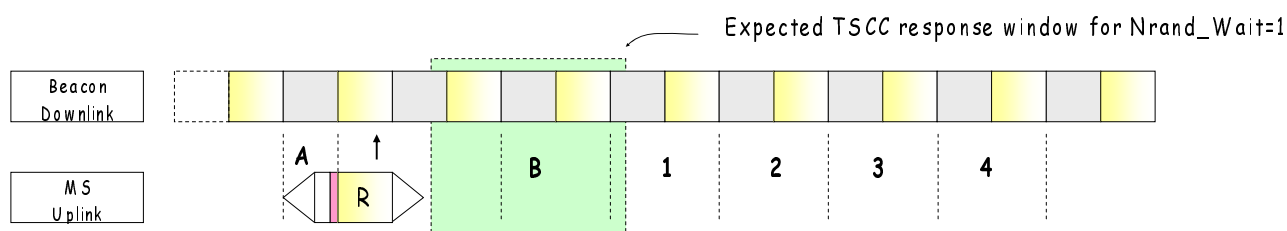
Figure 12.18 illustrates a BS using parameters Nrand\_Wait=0. The most recent value of BACKOFF received=4.



**Figure 12.18: Random Backoff Example #1**

- At "A" the MS makes a random access attempt. Nrand\_Wait=0 indicates that the BS shall respond in the next frameset at "B".
- After frameset "B" a response has not been received, therefore the MS chooses one of the framesets 1, 2, 3, 4 randomly for its next access attempt.

Figure 12.19 illustrates a BS using parameters Nrand\_Wait=1. The most recent value of back-off received=4.



**Figure 12.19: Random backoff Example #2**

- The MS makes a random access attempt. Nrand\_Wait=1 indicates that the BS shall respond in one of the next two framesets at "B".
- After frameset "B" a response has not been received, therefore the MS chooses one of the framesets 1, 2, 3, 4 randomly for its next access attempt.

A number of downlink channel Frames including an Aloha frame contain the BACKOFF field.

The BACKOFF may be altered by the BS and broadcast to MS to respond to varying load conditions presented to the system throughout the course of operation. If the system has a light traffic load, the BACKOFF may be small, so decreasing random access latency. If the traffic load increases a longer backoff may be warranted to spread competing of random access attempts from different MSs by the BS transmitting a larger backoff number. This traffic load may be estimated from historical usage or may be calculated from the burst traffic being received at that time.

The BACKOFF parameter may change while the MS is already making random access attempts. When the MS has chosen a random frameset, that frameset shall be preserved for the duration of the current random access attempt. Any new value of backoff parameter from the BS shall be noted by the MS and shall be employed if the MS needs to choose a new random frameset for its next random access attempt.

For Frames that contain the BACKOFF field, the number of backoff RA\_Framesets is coded, so that more backoff RA\_Framesets can be realized than a pure binary representation would permit. The explicit numbers of RA\_Framesets resulting from the back-off number is indicated by table 12.5.

**Table 12.5: Number of backoff framesets indicated by the Backoff Number**

Backoff Number	Back-off Framesets	Backoff Number	Back-off Framesets
0	Reserved	8	15
1	1	9	20
2	2	10	26
3	3	11	33
4	4	12	41
5	5	13	50
6	8	14	70
7	11	15	100

Note that:

- a) A B\_ALOHA frame with M=24 invites access only for one specific individual MS.
- b) In the example in figure 12.14, if an MS had chosen the frameset "C" for a random access attempt, that MS would be able to determine that the frameset was not available for random access because the frameset was withdrawn by decoding the W bit from the previous beacon message and noting that the frameset the MS had chosen was withdrawn. The MS would abandon that random access attempt, and choose another candidate frameset using the random backoff parameter.
- c) The MS shall rely on the W bit to determine if the following random-access frameset is withdrawn. If the MS does not successfully receive the preceding beacon message, the MS shall assume the frameset is withdrawn and abandon that particular random access attempt.

#### 12.3.7.1.1.8 Retry decision and time-outs

After sending a random access frame, an MS shall wait to receive a response from the BS. Various frames shall be accepted as a valid response (as specified in the clauses detailing the registration and call procedures).

The MS shall abandon its access attempt if it has sent the maximum permitted number of random access for the particular service requested and received no valid response. This number depends on the service and priority of service being requested:

- For non-emergency random access requests, it is Nrand\_NR.
- For emergency random access requests, it is Nrand\_NE.

The MS shall also operate a time-out Trand\_TC that defines the maximum time it waits trying to achieve random access, and abandon the attempt if this time-out expires.

If the unit's access attempt fails as a result of Trand\_TC timeout then:

- a) if the MS has not transmitted a frame, it shall return to the idle state (and may indicate the failure to the user);
- b) otherwise, (the MS has made at least one random access attempt) if the Trand\_TC timer expires while the MS is waiting Nwait+1 for the last random access attempt, the MS shall complete the Nwait+1 RA\_Frames before abandoning its random access.

### 12.3.7.1.2 Action after receiving an acknowledgement

The MS shall not re-transmit any further random access frame when an appropriate acknowledgement has been received from the BS. Various Frames that are acceptable in addition to specific acknowledgement Frames are indicated in the procedures specified in the present document. An applicable BS response to a random access request shall start an MS timer. This timer may be restarted by the reception of a further applicable acknowledgement frame from the BS. Two values are specified for this timer. One value TP\_Timer shall be used if the random access service requires a traffic channel (for example a speech or data service). The second value TNP\_Timer shall be used for services that only make use of the BS resource (for example Registration, Short Data service).

### 12.3.7.1.3 MS Arriving on a Beacon Channel

Channel access regulation for trunked systems is implemented by a BS transmitting signalling on the downlink channel with periodic Frames that define regulated channel access.

When an MS tunes to a new channel where the recent history of channel activity is unknown, the MS shall establish that the BS is identified as one that the MS is permitted to access.

- a) the MS shall wait until it receives a Colour Code field, and SYSCode field. The MS shall check that this particular channel is transmitting a Colour Code that is expected by the MS after applying the appropriate algorithm specified in clause 6.1.5; and
- b) the MS shall check the SYSCode being transmitted by the BS. If the MS is authorized to access this BS, the MS shall wait for an applicable B\_ALOHA frame before it attempts access by random access procedures defined in these clauses.

## 12.3.8 Beacon Channel Acquisition and Retention

Unless assigned to a traffic channel (including immediately after switch-on), the MS shall attempt to find a BS beacon appropriate to the MSs selected network. The search for a BS may be performed by a general hunt through all likely channels or by reference to parameters stored within the MS. A framework for MS hunting is described in annex B.

An MS shall not make any transmissions on a beacon BS unless it is active on that channel. It shall not become active until it has received a SYSCode that authorizes the MS to access that BS.

If an MS is hunting over a number of candidate channels, it shall leave the selected channel as soon as it becomes evident that the MS shall not be permitted service.

The discipline for MSs whilst active a BS and the circumstances which may result in a search for a new BS are the subjects of clause 12.3.8.2.

In particular:

- the method by which the MS searches for an appropriate BS;
- the criteria to which a BS shall be considered appropriate by the MS - authorization;
- procedures for returning to the BS acquisition procedures.

The methods specified in this clause recognize that designers of networks may choose from a variety of beacon channel.

The beacon channel acquisition and retention procedures specified in the present document may result in the MS encountering a variety of beacon channel situations, including:

- a) receiving a BS which suffers short-term interruptions (radio fading and multi-path reception);
- b) suffering long-term interruptions to BS reception during which no appropriate BS can be received by the MS (moving out of range of the network);
- c) being in a location where it is possible for more than one BS to be received from the selected network, involving the unit in a choice;
- d) being instructed to leave a BS;

- e) being instructed to leave or being barred from access to, a BS as a result of a network load sharing arrangement;
- f) Being instructed to sample an alternative BS on an adjacent radio site (Vote Now).

Procedures have been specified in the present document to indicate to MS when they may sample an adjacent radio site for a BS that may provide an improved grade of service for the MS user. This is achieved on the BS transmitting a frame that invites all MS to leave the BS momentarily. During this sample time the BS can discontinue call transactions. Notwithstanding this, manufacturers may devise their own procedures that will allow an MS to leave the current BS to sample for an alternative BS. However it shall be noted that if the MS leaves the BS on its own volition the MS may miss a BS transaction specifically addressed to that MS.

### 12.3.8.1 MS Parameter

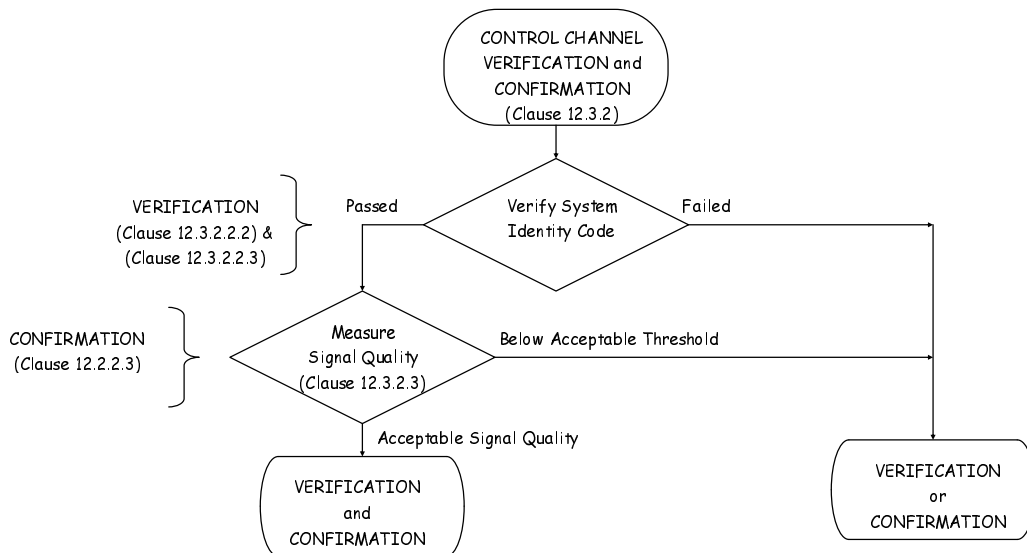
In order to satisfy the procedures specified in this clause, the MS shall retain certain parameters for each selected network when the MS is switched off. Other parameters shall be discarded when the MS is switched off. Table 12.6 lists the behaviour of each applicable parameter. MS parameters that are not listed in table 12.6 shall assume that it shall be discarded when the MS is switched off.

**Table 12.6: MS Parameter Volatility for Beacon Channel Acquisition and Retention**

Parameter	Clause	Fixed during MS Personalization. Retained when MS is switched off	Changes during operation and retained when MS is switched off	Changes during operation and discarded when MS is switched off
MODEL	12.3.8.2.2.2	Y		
NET	12.3.8.2.2.2	Y		
dPMRLA	12.3.8.2.2.2	Y		
Acquisition Authorization Data	12.3.8.2.2.3	Y See note		
Logical Channel Hunt List	See annex B	Y		
Additions to the hunt list from Announcements received			Y	
Any parameter not listed				Y
NOTE:	Length of authorization data is dependent on MODEL. Huge - 10 bits, Large - 8 bits, Small - 5 bits, Tiny - 3 bits.			

### 12.3.8.2 Beacon Channel Acquisition Procedures

Beacon Channel acquisition consists of the steps of checking the SYSCode (verification) and, if successful measuring the signal quality (confirmation) as illustrated in figure 12.20.



**Figure 12.20: Verification and Confirmation Steps**

### 12.3.8.2.1 Entry into Beacon Acquisition Procedures

The Beacon acquisition procedures enable an MS that is not assigned to a traffic channel to attempt to select a suitable BS. Beacon acquisition is a procedure that consists of hunting for candidate BSs and attempting to verify that the MS is authorized to become active on that selected BS.

The MS shall enter into the BS acquisition procedures under the following circumstances:

- immediately after switch-on;
- a user-initiated change of selected network;
- when it has relinquished the current BS under the procedures specified in clause 12.3.8.3;
- when it has received an applicable Disconnect\_Request frame on a traffic channel;
- when it has sent Disconnect\_Request Header Frames or timed-out on a traffic channel;
- when it has received a call T\_AHOY(M=Cancel Call Service) frame on a traffic channel which requires it to vacate that channel.

At all times during the BS acquisition procedures the MS shall mute its received audio and transmission shall be inhibited.

A framework for BS beacon channel hunting is provided in annex B.

### 12.3.8.2.2 Identifying a Candidate Beacon Channel

When an MS is searching for a suitable beacon channel, the MS shall examine any signal detected for conformity with BS structure. The MS shall accept as a candidate BS any channel on which a BS FS1 synchronization sequence is detected.

The method by which the MS identifies candidate BSs during hunting is not detailed in the present document. In particular no maximum time allowance for this procedure is specified, although attention is drawn to the necessity of completing tests as quickly as possible, notably on channels which can be easily rejected as BS candidates (e.g. invalid parameters from the SYSCode), since the overall speed of the hunt (and thus efficiency of service to the user) depends on the rapidity with which these tests can be carried out.

#### 12.3.8.2.2.1 Checking the System Identity Code

When the MS has identified a candidate Beacon, it shall examine the values of the SYSCode fields from the BS Frames that transmit the SYSCode field and the Colour Code.

The time which the MS may continue to search for a value of SYSCode field and frames that contain the Colour Code for verification is not specified since this depends on the regularity by which the BS transmits these parameters.

When the MS checked the Colour Code and has selected the SYSCode field for verification, it shall decide if it is authorized to acquire the BS (see clause 12.3.8.2.2.3). If acquisition is permitted then the MS shall become active on that BS and start the signal quality checking procedures specified in clause 12.3.8.2.3.

Whilst active on a BS, after verification but prior to confirmation, the MS shall not transmit any random access frames, but it shall comply with any applicable frames received, as required, provided that to do so does not involve transmitting to the BS.

#### 12.3.8.2.2.2 Structure of the System Identity Code (SYSCode)

dPMR trunked networks may range from tiny systems consisting of a very small number of sites to very large systems covering a wide geographic area. To accommodate this wide range of networks, dPMR specifies four network Models, each with characteristics appropriate to each Model.

**Table 12.7: Network Model**

Network Model	Model Coding	Number of Networks	Number of Sites per Network	dPMRLA
Tiny	00 <sub>2</sub>	512	8	1 to 3
Small	01 <sub>2</sub>	128	32	1 to 5
Large	10 <sub>2</sub>	16	256	1 to 8
Huge	11 <sub>2</sub>	4	1 024	1 to 10

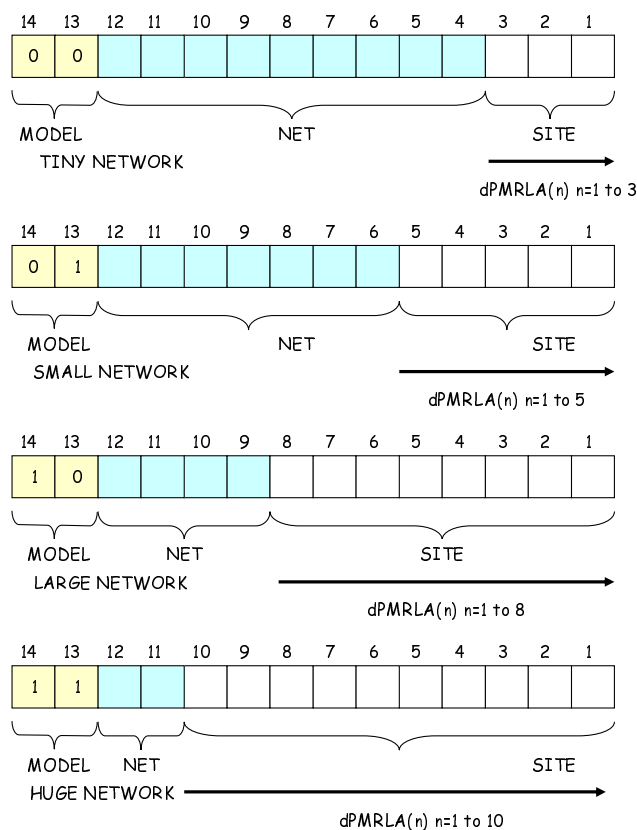
In order to identify the network and site to MSs, a Beacon frequently transmits a SYSCode in the SYScast1 message. MSs shall examine the SYSCode to determine if they are permitted to become or remain active on the BS. The SYSCode fields are structured as follows.

**Table 12.8: Network Model Description**

Parameter	Descriptor and section	Description
MODEL	Network Model	Tiny, Small, Large, Huge
NET	Network Identity	Identifies a particular dPMR trunked network
SITE		The SITE parameter identifies a particular radio site within a network

A bit specific representation of the Syscode field is illustrated in figure 12.21. The MODEL defines the length of the NET and SITE fields. Table 12.7 illustrates the effect of this partition. It is likely that in a particular geographical area a large number of small networks may be employed but only a small number of large networks. The MODEL parameter enables a number of differing archetypal networks to be defined.

**NOTE:** The dPMRLA parameter illustrated in figure 12.21 is used for registration. The registration protocol is specified in clause 12.3.8.4.2).



**Figure 12.21: Allocation of NET and SITE fields in SYSCode**

#### 12.3.8.2.2.3 BS Authorization Procedure

The MS shall read the SYSCode being transmitted by the beacon BS:

- a) Checking the MODEL:
  - The MS shall compare the MODEL transmitted in the SYSCode on the BS with the MODEL stored in MS fixed non-volatile storage. If there is no match then the MS unit shall assume that it is not authorized to acquire the BS under test.
- b) Checking the NET:
  - If the MS has successfully verified a) above then:
    - The MS shall compare the NET transmitted in the SYS code on the BS with the NET stored in MS fixed non-volatile storage. If there is no match then the MS unit shall assume that it is not authorized to acquire the BS under test.
- c) Checking the SITE\_Acquisition Authorization Data:
  - If the MS has successfully verified a) and b) above then:
    - The MS shall first check if it has stored any SITE acquisition authorization parameters. If no SITE acquisition authorization parameters are stored then no checking of SITE acquisition authorization shall be performed. However if the MS holds at least one parameter, each value stored shall be compared with the SITE parameter transmitted in the SYSCode on the BS. If there are no matches then the MS unit shall assume that it is not authorized to acquire the BS under test.



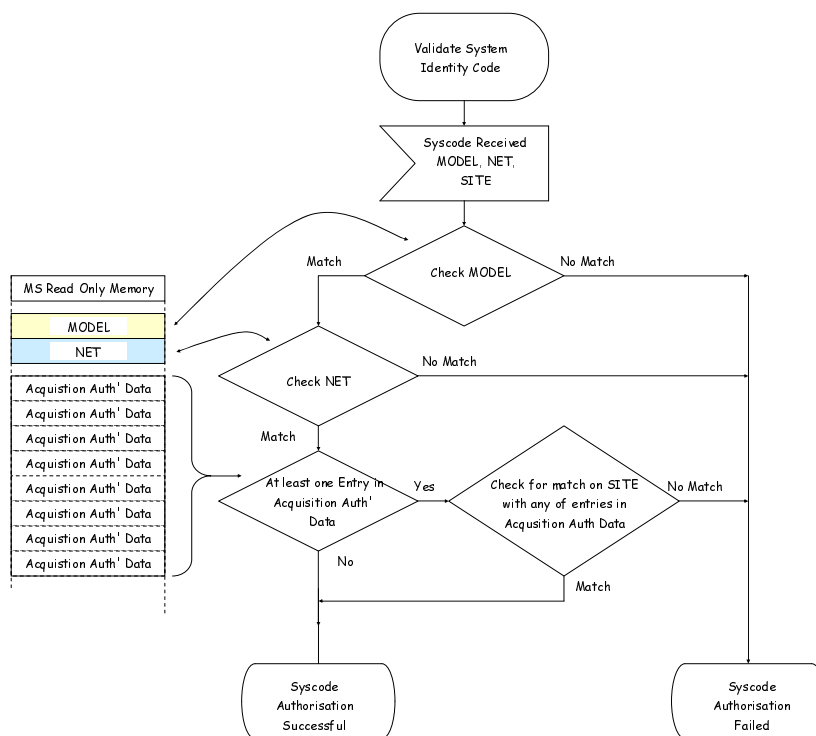


Figure 12.22: Checking the SYScode

Figure 12.22 illustrates the Beacon Authorization procedure specified in clause 12.3.8.2.2.3 a), b), c) and d).

12.3.8.2.2.4 Checking the SYS\_AREA field

If the MS has successfully verified the SYScode (according to clause 12.3.8.2.2.3), then it shall examine the SYS\_AREA field from the SYScode. The SYS\_AREA is formed by applying a mask to the Site field of width specified by dPMRLA.

The SYS\_AREA field is then compared with a list in the light of denied registrations applicable to the selected network held by the MS. (That list is discarded when the MS is switched off. See clause 12.3.8.2.2.3 and clause 12.3.8.4.1.3.)

If the value of the SYS\_AREA field under examination matches with any of the records of denied registrations applicable to the selected network, then the MS unit shall not be authorized to acquire the BS under test.

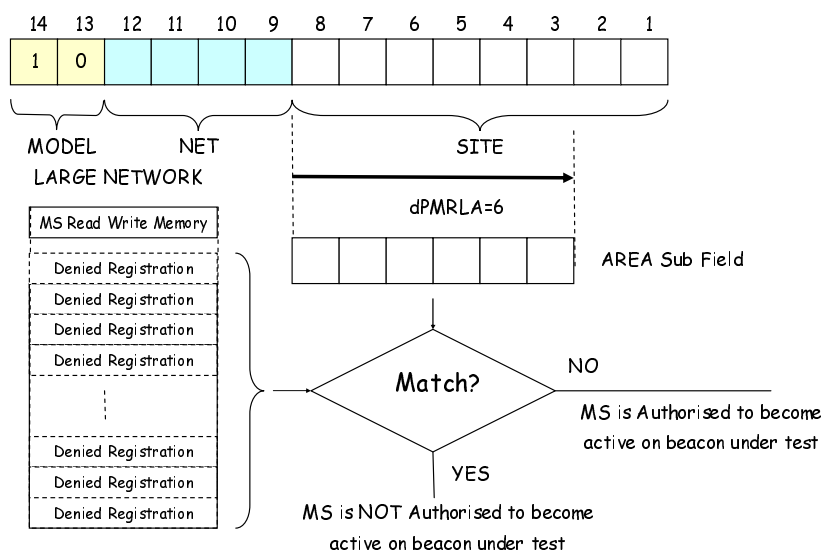


Figure 12.23: SYS\_AREA field from the SYScode

**EXAMPLE:** A large network has MS personalized with dPMRLA=6. The MS retrieves the SYS\_AREA field from the SYSCode and compares that result with each entry in the list of denied registrations. If there is a match in any one of the entries then the MS shall not be authorized to acquire the BS under test.

#### 12.3.8.2.2.4.1 Lifetime of SYS\_AREA entries in the denied registration list

The entire denied registration list is discarded when the MS is switched off (see clause 12.3.8.4.1.3).

If the timer T\_DENREG is non-zero, individual entries in the denied registration list shall have a limited lifetime. In this case the MS maintains a timer for each of the entries. If the timer for a particular SYS\_AREA expires, that SYS\_AREA shall be removed from the list.

#### 12.3.8.2.3 Confirmation - Monitoring the BS downlink channel signal quality

While idle on a beacon channel the MS shall determine the downlink channel signal quality. This may be for example the examination of the error rate, from measurement of the RF signal strength.

The MS shall hold two thresholds of signal quality:

- a) One threshold shall be used while the MS is hunting for a BS prior to confirmation (see clause 12.3.8.2).
- b) The second threshold shall be used after verification and confirmation and the MS is idle on the BS.
- c) When an MS enters a call set-up phase, it shall suspend signal quality measurement of the BS.

#### 12.3.8.3 MS Leaving a Beacon Channel

When active, the MS shall monitor the BS and return to hunting procedures if any of these conditions are met:

- a) After confirmation, the bit error rate exceeds the minimum prescribed in clause 12.3.8.2.3.
- b) The value of SYSCode received differs from the value verified during acquisition authorization for N<sub>SYSErr</sub> consecutive occurrences.
- c) No decodeable beacon Frames are received by the MS for T<sub>Nosig</sub> seconds.
- d) The user initiates a change of selected network.
- e) A B\_MOVE frame applicable to the MS is received. In this case the MS shall note the values of the transmit and receive frequencies from the B\_MOVE frame.
- f) The MS receives N\_ACK(Reason=Denied) as a result of sending a random access registration frame. In the case of a random access registration request, the MS shall assume the hunt stage that it was last engaged in prior to the registration attempt.
- g) After SYSCode confirmation, the MS receives N\_ACK(Reason=failed) as a result of random access registration procedures. In this case the MS shall assume the hunt stage that it was last engaged in prior to the registration attempt.
- h) After confirmation, the MS has timed out after a random access registration procedure due to Nrand<sub>NR</sub> being reached or Trand<sub>TC</sub> being exceeded. In this case the MS shall assume the hunt stage that it was last engaged in prior to the registration attempt.
- i) After confirmation, the MS has timed-out after a random access attempt for a service request, except registration, due to Nrand<sub>NR</sub> or Nrand<sub>NE</sub> being reached or Trand<sub>TC</sub> being exceeded.

##### 12.3.8.3.1 Leaving a Beacon Channel Whilst Waiting for Signalling

An MS waiting for signalling shall leave the BS on which it is currently active when any of the following events as listed in clause 12.3.8.3 occur - b), c) and e). In such circumstances the MS shall retain its state of waiting for signalling during any hunting procedures and subsequent BS confirmation tests. Any timers relevant to the waiting state shall be maintained.

## 12.3.8.4 Registration, Power Save, and Authentication Procedures

### 12.3.8.4.1 General

The procedures defined in this clause support the registration, authentication and power-save activation services. Messages exchanged between the BS and MS contain device addresses that either identify a specific device (such as an MS), or a gateway (see clause A.4) that indicates the service being supported. For clarity the service, the services and addresses are illustrated in table 12.9.

**Table 12.9: Services - addresses cross reference**

Service	PDU	Source	Source Address ID2 + 3	Destination Address ID0 + 1	Notes
Registration	Random Access Request	MS	MS ID	REGI	
	Acknowledgment	BS	REGI	MS ID	B_ACKD, B_NACKD, B_WACKD
Serial Number Check as part of registration	B_AHOY	BS	SERIALIO	MS ID	
	Acknowledgment HEAD + Appended data	MS	MS ID (head)	SERIALIn (head)	Appended data contains the ESN and signature

#### 12.3.8.4.1.1 Introduction

Registration is a method of recording the area or group of geographic areas where an MS is likely to be located within a wide area network. This information avoids searching for MSs throughout the whole network, consequently reducing call set-up time and BS loading.

A secondary feature is that it provides a means of restricting the service to individual MSs to specific BSs by allowing the network to deny other registration requests (see clause 12.3.8.4.2.5).

The registration strategy describes two types of registration. The first of these is explicit registration, where registration is achieved by means of an MS random access procedure. The second is implicit registration, where registration is achieved as the result of any Frames exchanged between a BS and an MS.

Explicit registration also enables MS to request power save. Power save is prescribed in clause 12.3.10.

#### 12.3.8.4.1.2 The Principle

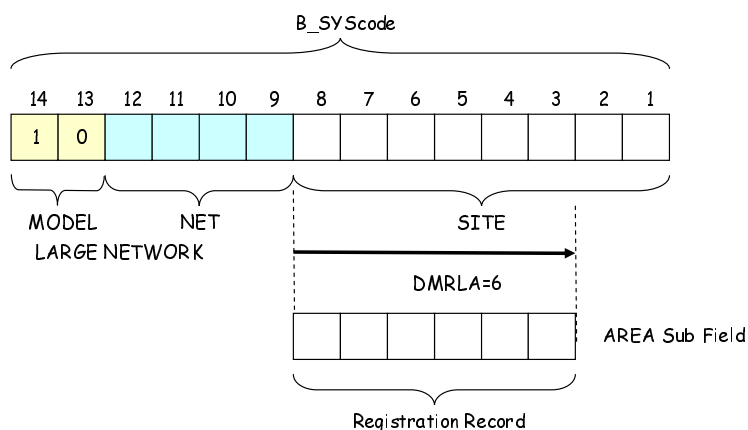
The principle of registration requires that the MS shall only retain a valid registration record where it has received confirmation that it is the same record as that currently held within the network. If an MS fails to receive a response to a registration request, this could be due to:

- the registration request not being received by the network, in which case the network shall regard the previous successful registration by the unit as the currently-valid registration record;
- the registration request being accepted by the network but the service answer response not being received by the MS, in which case the network shall regard the unsuccessful registration by the unit as the currently-valid registration record.

Accordingly, in such cases the MS is not able to confirm whether the network holds a valid record for the unit and if it does, whether it is the previous registration or the present registration. The MS shall therefore only replace its current registration record when a successful registration is confirmed by a suitable service answer response to the registration service random access request from the BS.

The registration record shall be extracted from the SYSCode using the following procedure:

- The MS extracts the SITE parameter from the SYSCode.
- The MS then extracts the SYS\_AREA information from the SITE parameter by masking the most significant bits (MSBs) with dPMRLA.



**Figure 12.24: Extraction of the registration record from the SYScode**

**EXAMPLE:** Figure 12.24 illustrates a Large Network. The SITE parameter for a Large Network has a field length of 8 bits. dPMRLA in this example=6, therefore the most significant 6 bits become the registration record.

#### 12.3.8.4.1.3 MS Parameter Volatility

In order to satisfy the procedures specified in this clause and annex B, the MS shall retain certain parameters for each selected network when the MS is switched off. Other parameter shall be discarded when the MS is switched off. Table 12.10 lists the behaviour of each applicable parameter.

**Table 12.10: MS Parameter Volatility for Registration**

Parameter	Clause	Fixed during MS Personalization. Retained when MS is switched off	Changes during operation and retained when MS is switched off	Changes during operation and discarded when MS is switched off
The Current Registration Record	12.3.8.4.2		Y	
List of Denied Registrations	12.3.8.2.2.4 see note 1			Y
NOTE 1: At least 8 different values of SYS_AREA field from the received SYScode verified when acquiring the BS on which a registration attempt by the MS has been denied. These are managed as a FIFO list: when the MS has a full list of entries, any further addition to the list displaces the earliest entry.				
NOTE 2: Individual entries in the Denied Registrations list are deleted by expiry of the denied registrations timer T_DENREG (see clauses 12.3.8.2.2.4.1 and 12.3.8.4.2.5).				

#### 12.3.8.4.1.4 Action on confirmation of a BS

An MS shall not make any attempt at random access until BS confirmation has been achieved.

When an MS confirms a BS it shall either:

- if the Reg field (carried in B\_ALOHA Frames and in the SYScast) is zero, the MS shall not seek to register by random access nor shall it create or alter any registration record. The MS shall note that registration is not required and that it is free to initiate calls;
- if the verified SYS\_AREA field from the SYScode matches any entry in the list of denied registrations then the MS shall not be authorized to acquire the BS under test. The MS shall resume hunting; or
- if the MS does not hold a successful registration record for the verified SYS\_AREA, the MS shall attempt to register by random access.

Once confirmed on a BS, the MS shall not transmit any frame other than:

- registration service random access request frame; or
- an acknowledgement to an authentication challenge as specified in clause 12.3.11.3;

until it holds a successful registration record relating to the verified SYS\_AREA unless Reg = 0.

If the MS holds a successful registration record relating to the verified SYS\_AREA code, it is free to transmit any frame conforming to the requirements of the present document.

#### 12.3.8.4.2 Registration Procedures

The procedures for explicit MS registration are prescribed in these clauses. An example of a registration is illustrated in figure 12.25.

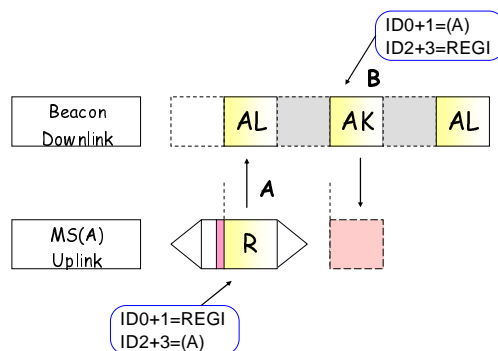


Figure 12.25: Registration Exchange

##### 12.3.8.4.2.1 Registration by Random Access

When an MS determines that it is required to register, it shall attempt to do so by random access using the procedures defined in clause 12.3.7. If the random access timeout B\_RandTC expires and the MS has not sent a random access registration request, the MS shall enter the BS channel acquisition procedures.

The B\_RAND for a registration are set as prescribed in table 12.11.

Table 12.11: B\_RAND fields for a Registration Request

Alias	Alias	Alias	Alias	Value	Length	Meaning	
MT				1100 <sub>2</sub>	4	Message Type = B_RAND (BS uplink)	
PARMS	ID0 + 1				24	REGI gateway	
	ID2 + 3				24	Calling MS ID	
				110 <sub>2</sub>	3	Service requested is defined by MI_TYPE	
	V			N/A	2	Not Applicable for this particular message	
	F			10 <sub>2</sub>	2	Comms Format = BS Uplink	
	EP			0 <sub>2</sub>	1	Non emergency service	
	PM			N/A	1	Not Applicable for this particular message	
	MI	MI_DET	MI_TYPE		101 <sub>2</sub>	3	Service Requested is Registration
			RSVD		N/A	4	Not Applicable for this particular message
			PowerSave_RQ	000 <sub>2</sub>	3	Power Save not requested	
other				Power Save requested			
Reg_Dereg			0 <sub>2</sub>	1	MS is attempting to de-register		
	1 <sub>2</sub>	MS is attempting to register					

Immediately upon sending the registration request by random access, the MS shall delete its current SYS\_AREA code retained from its previous registration.

Valid BS responses to the random access request are B\_WACKD(Reason=Wait) more signalling to follow, B\_ACKD(Reason=Reg\_Accepted), B\_NACKD(Reason=Reg\_Refused), B\_NACKD(Reason=Reg\_Denied), or B\_AHOY(Source Address or Gateway=SERIALI0) (see clause 12.3.11).

NOTE: SERIALI0 is the serial number identifier (see clause 13.4).

### 12.3.8.4.2.2 Intermediate Acknowledgement

If the BS cannot respond immediately to the random access request, it can send a B\_WACKD(Reason=Wait) to the MS. This acknowledgement shall start timer TNP\_Timer in accordance with clause 12.3.7.1.2. If further signalling is not received after the expiry of the timer, the MS shall comply with the procedures in clause 12.3.8.4.2.7.

### 12.3.8.4.2.3 Registration accepted

The registration attempt shall be considered successful on receipt of B\_ACK(Reason=Reg\_Accepted). The MS shall record the SYS\_AREA information from the BS SYScore. The MS shall replace any old registration record with the new record extracted from the SYScore.

### 12.3.8.4.2.4 Registration Refused

The registration attempt shall be considered to have been unsuccessful if the MS receives B\_NACKD(Reason=Reg\_Failed).

The MS shall resume hunting, and after confirming a BS and receiving a suitable B\_ALOHA frame, shall recommence a random access registration attempt.

Until a successful registration is achieved, the MS shall not attempt to transmit other than random access registration service requests.

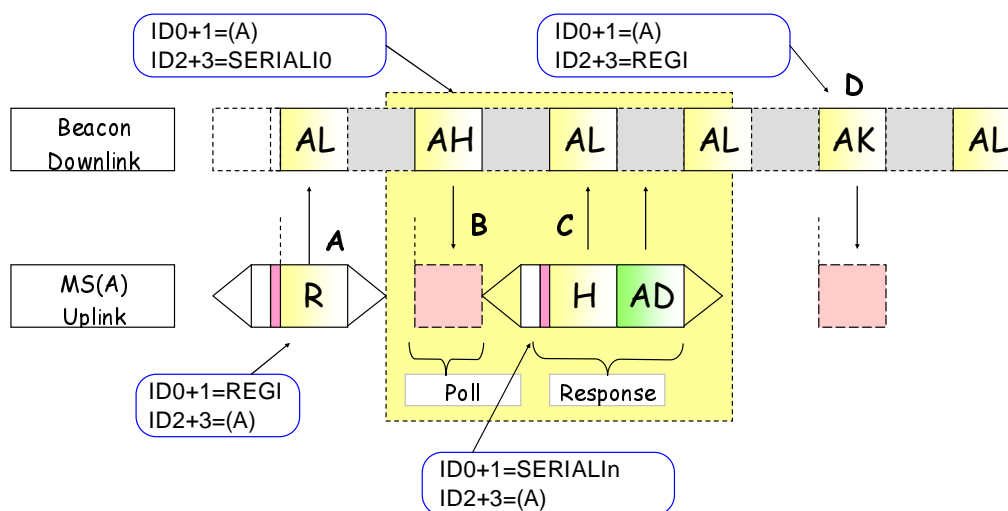
### 12.3.8.4.2.5 Registration Denied

The registration attempt shall be considered denied if the MS receives B\_NACKD(Reason=Reg\_Denied). The MS shall add the SYS\_AREA code to the list of denied registration records and enter the BS acquisition procedures.

If T\_DENREG is non-zero the MS shall start a timer equal to the value of T\_DENREG for that entry in the denied registration list.

### 12.3.8.4.2.6 Serial Number Check

The BS may apply an intermediate step of authenticating the MS during the registration procedure.



**Figure 12.26: Registration with serial check**

Figure 12.26 illustrates an MS registration procedure with the optional steps "B" and "C":

- At "A" the MS makes a random access registration attempt.
- The AH frame at "B" is the acknowledgement to the random access and polls the MS for its Electronic Serial Number. The timer TNP\_Timer timer is started.
- "C" is the MS response to the BS containing the Serial Number.

- d) The final B\_ACKD(Reason=Reg\_Accepted) or B\_NACKD (depending on the result of the serial number check).

The specific authentication procedures are prescribed in clause 12.3.11.

#### 12.3.8.4.2.7 Registration Attempt Times Out

If the MS times out from waiting for further signalling for the registration (expiry of timer TNP\_Timer), it shall enter the BS acquisition procedures.

#### 12.3.8.4.2.8 Registration Demand Received During Random Access Registration

The beacon BS shall avoid conflict in the protocol. If, while waiting for a response to a random access registration request frame, the MS receives a B\_BCAST(Announcement\_type=MassReg) frame applicable to the MS, the MS shall note the fields from the B\_BCAST and initiate the procedure specified in clause 12.3.9.1 then continue with its registration request in accordance with the random access procedures.

#### 12.3.8.4.2.9 No answer response Received after the maximum number of random access attempts

If no response is received within WAIT+1 framesets after the MS has transmitted Nrand\_NR random access attempts, the MS shall make no consequential changes to its registration record.

#### 12.3.8.4.2.10 Registration Action on Switch-on or equivalent

If an MS determines that the BS requires MS to register, the MS shall register by random access on switch on or change of selected network.

### 12.3.9 Mass re-registration

A wide area network relies on the integrity of the registration records for MS location management. It is possible that the records may be suspect for many reasons including loss of connections between the various beacons in a network. This clause describes a mechanism whereby a BS may re-establish those registration records from the MS that are currently confirmed on that BS. A broadcast frame is transmitted on the BS that causes all applicable MS that are confirmed to re-register by random access. If this re-registration procedure is activated it is essential to avoid congestion from the increased random access activity that would result. To manage this process therefore, a REG\_WINDOW field is transmitted in the broadcast frame that permits MS to make their random access registration attempt over an extended period of time.

An MS shall note the delay parameter REG\_WINDOW from the B\_BCAST(Announcement\_type=MassReg) frame it receives and shall use table 12.12 to derive from it a time window to make a random access registration attempt.

The Mass registration may be used to demand a registration from a specific MS by setting the MS address in the Mass Registration Broadcast frame to the individual address of an MS and setting the Mask = 24.

#### 12.3.9.1 Procedure for MS on receipt of Mass Re-registration Broadcast

When confirmed on a BS an MS shall make use of information B\_BCAST(Announcement\_type=MassReg). This frame may be transmitted on the BS to cause all MS or a subset of the MS population to re-register by random access.

An MS shall note the population subdivision contained in each B\_BCAST(Announcement\_type=MassReg) frame that it receives (as prescribed in clause 12.3.6.1.3) using the qualifier (Mask) and the address field from the B\_BCAST frame. For Mask = 0 to 24, the frame is applicable to the MS if the "Mask" least significant bits of the B\_BCAST address field match the "Mask" least significant bits of its individual address.

Table 12.12: REG\_WINDOW lookup for Mass-Registration

REG_WINDOW	Treg_Window	REG_WINDOW	Treg_Window
0	Cancel Mass Reg	8	100
1	.5	9	300
2	1	10	1 000
3	2	11	3 000
4	5	12	10 000
5	10	13	30 000
6	20	14	100 000
7	30	15	200 000

If the MS determines that the B\_BCAST(Announcement\_type=MassReg) frame is applicable, the MS shall:

- examine the REG\_WINDOW field from the B\_BCAST(Announcement\_type=MassReg). If the REG\_WINDOW field is non-zero, the MS shall derive the window size TREG\_WINDOW (in seconds) for a Random Access Registration attempt using table 12.12;
- choose a random number (using a statistically uniform distribution) from zero to TREG\_WINDOW;
- count real time seconds until the random value is reached;
- make a random access registration attempt using the procedures prescribed in clause 12.3.8.4. If the MS is in power save Mode, the PowerSave\_RQ field in the Service\_Options of the registration service request shall be set to maintain the power save Mode currently in operation;
- also count real time seconds until the TREG\_WINDOW frameset is reached. If the MS receives other applicable B\_BCAST(Announcement\_type=MassReg) containing a non zero REG\_WINDOW field before REG\_WINDOW is reached the MS shall ignore that B\_BCAST frame;
- if Power Save is in operation, the BS shall ensure that the Mass-Registration is transmitted in the wake period.

If the MS is confirmed on a BS and the MS receives other applicable B\_BCAST(Announcement\_type=MassReg) containing a zero REG\_WINDOW field the mass re-registration procedure and any pending random access attempt shall be cancelled. If such a broadcast is received when the random access procedure is in progress that random access procedure shall be completed before the mass re-registration procedure is cancelled.

If the MS leaves the currently confirmed BS, and successfully confirms a different BS, any Mass-registration procedure shall be cancelled.

### 12.3.9.2 De-registration

When an MS is switched off, or a user initiated change of system is invoked, the MS may first attempt to de-register from the current system. It shall attempt to do so by random access using the procedures defined in clause 12.3.7. In the Service\_Options of the registration service request the fields shall be set to IP\_Inform=0<sub>2</sub>, Reg\_Dereg=0<sub>2</sub> and PowerSave\_RQ=000<sub>2</sub>.

When an MS switch-off or change of network is performed, the MS shall start a timer T\_Dereg.

Immediately upon sending the de-registration request by random access, the MS shall discard its current SYS\_AREA code retained from its previous registration.

The only valid BS response to the de-register random access request shall be B\_ACKD(Reason=Reg\_Accepted). If the acknowledgement is received, the MS shall complete the switch off or change of network.

If timer T\_Dereg expires, the MS shall abandon the de-registration procedure and complete the action of switch-off or change of network.

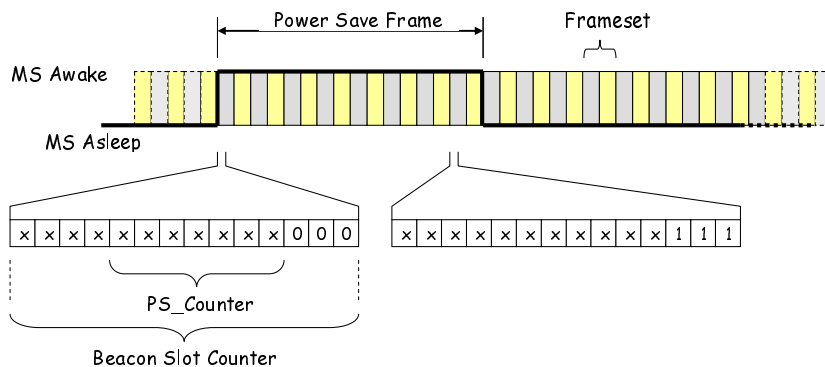


## 12.3.10 Beacon Power Save

### 12.3.10.1 Overview

Mode 3 systems may support a synchronous power saving feature.

An MS can synchronize to the timing parameters that have been exchanged with the BS and adopt a periodic sleep cycle. Calls to that MS shall be synchronized to the wake-up periods (power save frames) that are agreed between MS and the BS.



**Figure 12.27: Power Save Frame Structure**

The power save frames are defined by the PS\_Counter field, a sub-set of the Beacon\_Frameset\_Counter broadcast in a SYSCast2 message. A sleeping MS shall wake for a designated power save frame. If the BS has a frame or transaction for the sleeping MS, that frame shall be queued until a designated power save frame is transmitted on the BS. MS or other entity that initiates a transaction to a sleeping MS (or group of MSs) shall be queued on the BS until the designated power save frame has been reached. Figure 12.27 illustrates a power save frame. There are eight framesets available to signal MS during a designated power save frame:

- The MS and BS shall have previously synchronized a particular wake frame.
- The BS knows when a particular MS has woken and is able to receive signalling addressed to that MS. If several MSs are in a fleet and are party to a group call, all MSs in that particular group may share the same wakeup frame. The way in which the BS manages the power save and allocates particular wakeup frames is not prescribed in the present document.
- Different MSs sharing a common BS may have differing power save and the BS/MSs shall be able to deal with this.
- The SYSCast2 that carries the Power Save Counter does not have to be continuously transmitted. When MS have received a Power Save SYSCast2, they are able to calculate power save frames from that point. MS may then refresh by occasional appropriate SYSCast2 Frames.

### 12.3.10.2 Power Save Procedures

#### 12.3.10.2.1 Basic Power Save Procedures

For an MS to activate power save, it registers with the BS. In the registration service request the MS may ask for power save it wishes to employ, by sending a non-zero three bit PowerSave\_RQ field with a number between 1 and 7. A registration service request with a zero PowerSave\_RQ indicates that no power save is required or a previous power save is cancelled. The BS responds positively if it supports power save for that request, with a PowerSave\_Offset field (length 7) in the range 0 to 1, 0 to 3, 0 to 7, 0 to 15, 0 to 31, 0 to 63 or 0 to 127.

**Table 12.13: Power Save fields during MS registration**

Power Save	PowerSave_RQ	PowerSave_Offset
OFF	0	0
1:2	1	0 to 1
1:4	2	0 to 3
1:8	3	0 to 7
1:16	4	0 to 15
1:32	5	0 to 31
1:64	6	0 to 63
1:128	7	0 to 127

A PowerSave\_RQ=1 indicates the MS shall sleep for one Power Save Frame and awake for the second. A "2" indicate 1 awake and 3 sleeping. A "3" indicates 1 in 8 awake and so on. In this example the greatest power save would be "7" indicating 1 in 128 awake as illustrated in table 12.13.

The BS responds with an acknowledgement containing a PowerSave\_Offset field (the Response\_Info field in the acknowledgement frame) that indicates the power save frame number that the BS shall send signalling to that particular MS. The BS may therefore average out signalling across all power save frames for differing fleets (or differing groups). The frame number is read by the MS and a mask applied according to the power save request. The answer gives the power save frame number for that power save value asked for in the registration request. The MS can then calculate when to wake for incoming traffic.

**EXAMPLE:** An MS requests a power save of 4 by setting the value of PowerSave\_RQ = 2 in the registration service request. The BS responds with Powersave\_Offset = 2.

The PS\_Counter is counting up continuously. Suppose the PS\_Counter at this moment = 65<sub>decimal</sub>.

**Table 12.14: Power Save Example - MS state**

PS_Counter	Count	Mask Counter with PowerSave RQ								MS state
		0	1	0	0	0	0	1	0	
...	.....	.	.	.	.	.	.	.	.	...
65	010 0001 <sub>2</sub>	0	1	0	0	0	0	0	1	- Sleep
66	010 0010 <sub>2</sub>	0	1	0	0	0	0	1	0	- Wake
67	010 0011 <sub>2</sub>	0	1	0	0	0	0	1	1	- Sleep
68	010 0100 <sub>2</sub>	0	1	0	0	0	1	0	0	- Sleep
69	010 0101 <sub>2</sub>	0	1	0	0	0	1	0	1	- Sleep
70	010 0110 <sub>2</sub>	0	1	0	0	0	1	1	0	- Wake
...	.....	.	.	.	.	.	.	.	.	....

Table 12.14 illustrates how a BS determines when an MS is awake. The BS applies a mask of length PowerSave\_RQ. In this example the mask leaves two bits. When the masked PS\_Counter equals the PowerSave\_Offset the BS may signal the MS.

MS can sample a relevant SYScast2 message at any time, read the Common\_Frameset Counter and determine when the wake frame will be transmitted. The MS may then sleep until a point at which its wake frame is scheduled. A frame addressed to the MS by its individual address shall cause the MS to awaken for T\_Awake seconds. Each MS individually addressed or applicable group address frame transmitted on the BS or MS shall refresh T\_Awake. If no Frames have been transmitted or received by the MS when T\_Awake expires the MS shall return to its sleeping state retaining its previous power save settings.

If an MS awakes and receives an applicable B\_AHOY frame that will result in a traffic channel being assigned, the MS shall stay awake for a time T\_Pending for the Channel Grant Frames to be transmitted. When that call is completed and the MS returns to the BS, the MS shall wait for T\_Awake seconds and then return to the sleeping state.

If while awake, the MS receives a B\_MOVE frame, the MS shall retain its T\_Awake timer and return to its sleeping state after T\_Awake expires, unless the move to the replacement BS causes the MS to re-register when new power save fields shall be exchanged.

In example #1 illustrated in figure 12.28 displays a power save of 4:1 in operation. MS(A) and MS(B) are part of the same fleet and share the same powersave offset. When MS(A) is awake, MS(B) is awake. MS(A) makes a random access request at "A". The BS is aware that the powersave awake window is open and therefore sends a B\_AHOY to MS(B) at point "B". MS(B) is awake, responds and the call completes.

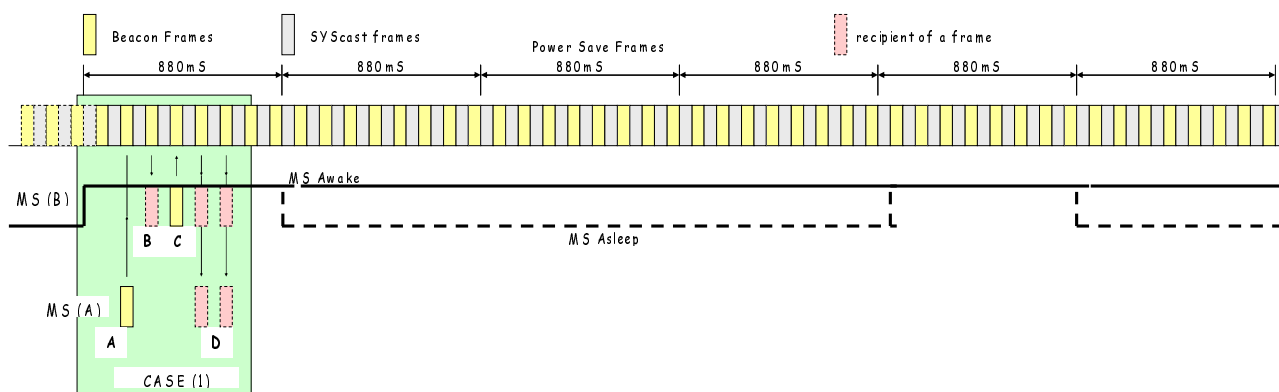


Figure 12.28: Power Save Frame Example #1

Example #2 illustrated in figure 12.29 shows MS(A) making a random access call set-up to MS(B) at point "E". The beacon is aware of the power save window and realizes that a B\_AHOY to MS(B) would be futile since MS(B) window has closed. The beacon therefore sends an ACKQ message to MS(A) to queue the call. When the beacon knows the next awake window has been reached the beacon sends the B\_AHOY to MS(B) at point "G". MS(B) acknowledges it is awake and available to receive the call at point "H" and the call set-up completes.

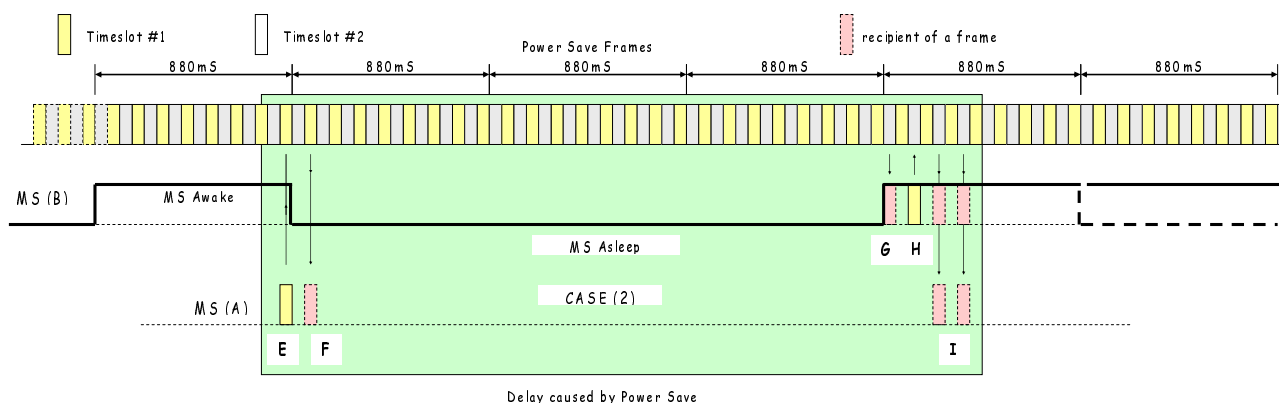
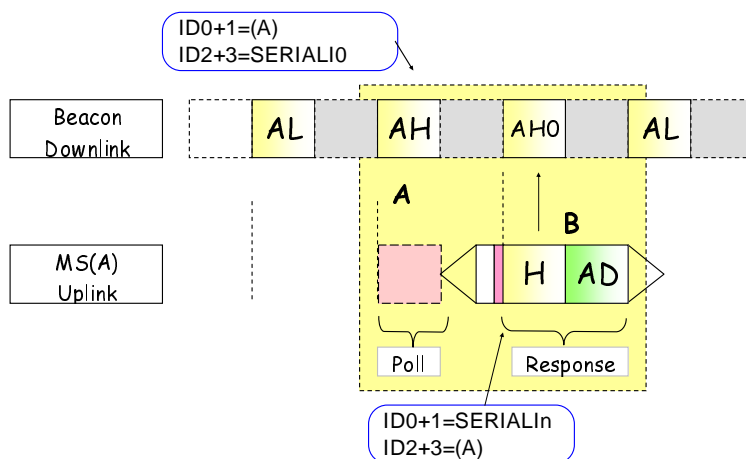


Figure 12.29: Power Save Frame Example #2

### 12.3.11 Electronic Serial Number Check Procedures

An Electronic Serial Number (ESN) check is a procedure to verify that an MS is genuine. An MS shall be assigned a unique ESN by the manufacturer. The MS manufacturer shall ensure that:

- The method of implanting the ESN shall only be known to the manufacturer.
- Any attempt to tamper with the ESN (other than by the manufacturer) shall render the MS inoperable.
- Any attempt to remove the device containing the ESN shall render the MS inoperable.
- The algorithm by which the ESN signature is generated shall not be implanted in the MS.



**Figure 12.30: Serial Number Check**

Figure 12.30 illustrates the mechanism. The BS polls the MS for its serial number by sending a B\_AHOY frame from the Gateway SERIALI0. The serial number is signed by an algorithm. The algorithm is not part of the present document.

NOTE: A serial number check may be invoked as part of an MS registration procedure.

### 12.3.11.1 Format of the Electronic Serial Number (ESN)

The format of the ESN is illustrated in table 12.15.

**Table 12.15: Format of the ESN**

Length	Coding	Meaning
16	4 characters Hexadecimal	Product Code or Model Number
8	2 characters Hexadecimal	Version Number
30	Binary	ESN
10	See Note	ESN signature

NOTE: The format of the ESN signature is not part of the present document

### 12.3.11.2 ESN Procedures for the BS to authenticate an MS

The BS polls an MS by transmitting a B\_AHOY frame to an individual MS address and fields as illustrated in table 12.16. The called party shall be the individual MS ID. The calling party address is the gateway address SERIALI0.

The BS response is a HEAD + Appended data. The BS therefore transmits a dummy AHOY(AH0) in the frameset following the AHOY to withdraw the following frame from random access.

**Table 12.16: B\_AHOY fields for serial number poll**

Alias	Alias	Value	Length	Meaning
MT		1100 <sub>2</sub>	4	Message_Type = AHOY
ID0 + 1			24	Target MS
ID2 + 3		SERIALI0	24	Gateway = SERIALI0
M		110 <sub>2</sub>	3	110 <sub>2</sub> Service is defined by MI_TYPE
V		00 <sub>2</sub>	2	N/A
F		11 <sub>2</sub>	2	Downlink
W		1 <sub>2</sub>	1	Withdraw the following slot from random access
PM		0 <sub>2</sub>	1	N/A
MI_TYPE		100 <sub>2</sub>	3	Complementary Service
MI_DET		0000 0000 <sub>2</sub>	2	N/A

### 12.3.11.3 ESN Procedures for the MS

If an MS receives an applicable B\_AHOY frame from SERIALI0 for a serial number check it shall transmit the signed electronic serial number back to the BS by a B\_HEAD + Appended data frame. The destination address shall be SERIALIn. In order that the BS may check the validity of the ESN, an ESN CRC is transmitted in MI\_DET. The ESN CRC algorithm is not part of the present document.

**Table 12.17: Serial number response frame - HEAD**

Alias	Alias	Value	Length	Meaning
MT		1110 <sub>2</sub>	4	Message_Type = HEAD
ID0 + 1		SERIALIn	24	Gateway = SERIALIn
ID2 + 3			24	MSID
UDT_FORMAT		001 <sub>2</sub>	3	110 <sub>2</sub> = Binary format
V		N/A	2	N/A
F		10 <sub>2</sub>	2	Uplink
EP		0 <sub>2</sub>	1	N/A
COMP		0 <sub>2</sub>	1	
	MI_TYPE	N.A	3	Not Applicable for this particular message
	MI_DET	00 <sub>2</sub>	2	UAD Number of Data messages appended to this UDT header=1
		00 0000 <sub>2</sub>	6	SYMB Number of symbols to be transported=64

**Table 12.18: Serial number response frame - Appended Data**

Length	Coding	Meaning
16	4 characters Hexadecimal	Product Code or Model Number
8	2 characters Hexadecimal	Version Number
30	Binary	ESN
10	See Note	ESN signature
NOTE: The format of the ESN signature is not part of the present document.		

The MS serial number is returned in the appended data frame. In order to validate the serial number a Serial Number signature is passed to the BS. The algorithm for calculating the Serial number signature is not part of the present document.

## 12.4 Traffic Channel Access for Mode 3

MSs are directed to a traffic channel for the duration of the call. When the call is completed all parties return to the beacon channel, the traffic channel BS returns to idle and becomes available for assignment of a new call.

### 12.4.1 Preservation of the traffic channel [M3]

The traffic channel access is asynchronous and the operation/access is very similar to Mode 2. When a traffic channel is assigned, the BS shall transmit preservation frames. Payload items shall displace preservation frames in the same manner as Mode 2 operation.

BS shall use the downlink traffic channel for the purposes of:

- a) preserving the channel between items during the carrier hang\_time;
- b) marking the channel for MS to identify the current users of the channel.

The MS involved in the call have exclusive use of the traffic channel. However MS not involved in the call be stranded on the channel from a previous call. If a MS is able to determine that it is not party to the present call the MS shall leave the traffic channel and return to the beacon channel without making any further transmissions whatsoever.

During the call, MS transmit items that the BS then retransmits on the downlink channel. Between items the BS transmits preservation frames to identify the parties in the call. The preservation frames shall be displaced by the next item re-transmitted. The channel shall remain preserved for the call unless:

- 1) parties stop transmitting items and a preservation timer N\_Preserve[x] expires;
- 2) a disconnect message is received by the BS and the disconnect has been completely retransmitted to MS;
- 3) a call timeout has occurred.

The preservation timer has the same functionality as Mode 2 illustrated in figure 12.4.

### 12.4.2 Reassignment of the traffic channel for an emergency call

In a Mode 3 system there is no concept of emergency break in on the traffic channel. Emergency calls are handled by the beacon channel. Mode 3 system may use pre-emption to permit a traffic channel to be reassigned for an emergency call when there is an existing non-emergency call using that traffic channel. For Mode 3 systems therefore the Tx\_Wait time parameter shall be set to 0.

The steps to remove an existing call from a Mode 3 traffic channel for reassignment for an emergency call are - as soon as the BS identifies that a traffic channel must be reassigned:

- a) If an MS is not transmitting payload:
  - The traffic channel BS sends disconnect messages on the traffic channel to clear down the existing users of the channel.
- b) If an MS is transmitting payload:
  - The BS send PTT disable frames to stop all listening MS from transmitting a new item.
  - When the BS detects that the MS transmitting payload has released its PTT, the BS sends disconnect messages to clear down the existing users of the channel.

The BS then reassigns the channel for the emergency call.

This clause lists the timers and constants for dPMR BS and MS.

Where indicated, a value shall be chosen from within the specified range. For other timers and constants, a default value may be specified and the value of these timers and constants shall be configurable within the dPMR entity (MS or BS).

## 13 Timers, constants levels and addresses

### 13.1 Timers

Table 13.1: Timers

Mnemonic		Value	Description
<b>Mode 1</b>			
T_ch_chk	-	100 ms	Mode 1 Channel check timer
T_ack:	-	3 s	Mode 1 Acknowledgement response time
<b>Mode 2</b>			
TX_ATMR		5 s to 180 s	Ambience Listening timer. (See table 5.39)
M2T_ch_chk	-	100 ms	Mode 2 Channel check timer
M2T_ack	-	3 s	Mode 2 acknowledgement response time
M2_CallV	-	10 s to 600 s	Mode 2 maximum call timer for normal priority voice calls
M2_CallE	-	10 s to 1200 s	Mode 2 maximum call timer for emergency priority voice calls
M2_CallD	-	10 s to 600 s	Mode 2 maximum call timer for T1 T2 data calls
<b>Mode 3</b>			
Trand_TC	-	2 s to 60 s	Timeout for MS attempting Random Access
T_Nosig	-	1 s to 15 s	Timeout for entering hunting procedures if the Beacon is no longer received
T_EMERG_TMR	-	Token	See table 5.49 described in clause 5.5.5
T_DATA_TMR	-	Token	See table 5.49 described in clause 5.5.5
T_MS-MS_TMR	-	Token	See table 5.49 described in clause 5.5.5
T_MS-LINE_TMR	-	Token	See table 5.49 described in clause 5.5.5
TP_Timer	-	4 s to 60 s	Timeout for a calling MS waiting for a call that requires a payload channel
TNP_Timer	-	2 s to 20 s	Timeout for a calling MS waiting for a call that does not require a payload channel
T_Awake	-	0,1 s to 60 s	Time MS stays awake after receiving a message (in steps of 0,1 s)
TV_Item	-	10 s to 60 s	Payload Voice Maximum Item Timer
TV_Inactive	-	0 s to 20 s	Payload Voice Inactivity Timer
TD_Inactive	-	0 s to 20 s	Payload Data inactivity Timer
TD_Item	-	1 s to 60 s	Payload Packet Data Maximum Item Timer
T_Pending	-	2 s to 60 s	Timeout for called MS after receiving AHOY
T_dereg	-	0,2 s to 2 s	Timer to de-register before abandon in 0,1 second steps
T_BS_Inactive	-	1 s to 300 s	Timer to hibernate if no inbound activity on an unregulated Beacon
T_DENREG	-	0	The denied registration timer is inactive
		1 s to 1 000 s	Denied registration lifetime in steps of 10 s (e.g. 1 = 10 s, 2 = 20 s, etc.)
T_MS_Timing	-	30 ms to 35 ms	Range of MS timing for MS transmissions

## 13.2 Constants

**Table 13.2: Layer 3 Constants**

Mnemonic		Value	Description
<b>Mode 1</b>			
NM1_Rep	-	4	Number of times a message attempts for a Mode 1 service
Nmax1_Rep	-	0 or (2 to 15)	Number of Extended headers for powersave
<b>Mode 2</b>			
NM2_Rep	-	4	Number of times a message attempts for a Mode 2 service
Nmax2_Rep	-	0 or (2 to 15)	Number of Extended headers for powersave
N_PreserveV	-	0 to 100	Number of preservation frames to transmit before the BS reverts to idle from inactivity for a normal priority voice call
N_PreserveE	-	0 to 255	Number of preservation frames to transmit before the BS reverts to idle from inactivity for an emergency priority voice call
N_PreserveD	-	0 to 50	Number of preservation frames to transmit before the BS reverts to idle from inactivity for a data or status request call
N_PreserveP	-	0 to 50	Number of preservation frames to transmit before the BS reverts to idle from inactivity for a packet data call
N_Preserve_PI	-	0 to 10	Number of preservation frames to transmit before the BS reverts to idle for an packet data acknowledgement
<b>Mode 3</b>			
Ndefault_NW	-	5	Nrand_Wait at MS switch on
Nrand_NR	-	6	Number of random access attempts for a normal and high priority service
Nrand_NE	-	10	Number of random access attempts for a emergency priority service
N_Discon	-	4	Number of Disconnect + End messages transmitted by an MS to clear down the payload channel
Nmax_Ch	-	50	Minimum Number of channels in Short Hunt List
Nlow_Comp_Ch	-	See BAND, SEP,	Lowest channel frequency in use by the network
Nhigh_Comp_Ch	-	FR, FT	Highest channel frequency in use by the network
Comp_Flag	-	True/False	Suppress Comprehensive Hunt (see annex D)
NSYSerr	-	1 to 3	Number of B_SYS codes received that differ from the value verified
dPMRLA	-	0 to 10	Length of SYS_AREA information field from the B_SYScode
N_kill_cntr	-	10	Number of framesets between an authentication check and a kill procedure
M3N_PreserveV	-	0 to 100	Number of preservation frames to transmit before the BS clears down the call and reverts to idle for a normal priority voice call
M3N_PreserveE	-	0 to 255	Number of preservation frames to transmit before the BS clears down the call and reverts to idle from inactivity for an emergency priority voice call
M3N_PreserveD	-	0 to 50	Number of preservation frames to transmit before the BS clears down the call and reverts to idle from inactivity for a data or status request call
M3N_PreserveP	-	0 to 50	Number of preservation frames to transmit before the BS clears down the call and reverts to idle from inactivity for a packet data call
M3N_Preserve_PI	-	0 to 10	Number of preservation frames to transmit before the BS goes to idle for an packet data acknowledgement



## 13.3 Levels

**Table 13.3: Layer 3 signal levels**

Mnemonic		Value	Description
L_Upper_Short	-	Units and values are manufacturer specific	The threshold of signal quality above which will be sampled first in a short hunt
L_Lower_Short	-		The threshold of signal quality below which the MS shall be unable to become active
L_Squelch	-		Signal level (or equivalent) below which physical channels are to be rejected because the received signal quality is inadequate
RSSI_LO			-105 dBm $\pm$ 3 dB

## 13.4 Gateways/Identifiers

**Table 13.4: Gateways/Identifiers**

dPMR ID	Alias	Meaning
00 0000 <sub>16</sub>	DUMMYI	An address that is reserved shall not be assigned to any entity
00 0001 <sub>16</sub> to DF 6767 <sub>16</sub>	MSID and talkgroups	Address space for MSIDs and talkgroups
DF 6768 <sub>16</sub> to F8 339B <sub>16</sub>	RSVD	Reserved
F8 339C <sub>16</sub> to F8 33A5 <sub>16</sub>	ALLTALK <sub>n</sub>	All Talkgroup prefix (n=0 to 9)
F8 33A6 <sub>16</sub>	ALLTALK10	All Talkgroups, All prefix's
F8 33A7 <sub>16</sub> to FF FDBF <sub>16</sub>	RSVD	Reserved
FF FDC0 <sub>16</sub>	PSTNI	Gateway address for services to the PSTN
FF FDC1 <sub>16</sub>	PABXI	Gateway address for services to the PABX
FF FDC2 <sub>16</sub>	LINEIn	Address for services to a Line Gateway (n = 1 to 4)
FF FDC3 <sub>16</sub>		
FF FDC4 <sub>16</sub>		
FF FDC5 <sub>16</sub>		
FF FDC6 <sub>16</sub>	IPI	Address for services to an IP Gateway
FF FDC7 <sub>16</sub>	COMPI	Address used to identify an complementary data service
FF FDC8 <sub>16</sub>	SDMI	Address used to identify a short data service
FF FDC9 <sub>16</sub>	REGI	Address used to identify a registration service
FF FDCA <sub>16</sub>	TGI	Address used to identify the totality of talkgroup addresses
FF FDCB <sub>16</sub>	DIVERTI	Address used to identify a call diversion
FF FDCC <sub>16</sub>	GBSI	Global BS Address (totality of all BS)
FF FDCE <sub>16</sub>	DISPATIn	Address of the system dispatchers (n = 1 to 4)
FF FDCE <sub>16</sub>		
FF FDCF <sub>16</sub>		
FF FDD0 <sub>16</sub>		
FF FDD1 <sub>16</sub>	STUNI	MS Stun/Unstun Identifier
FF FDD2 <sub>16</sub>	RLAI	Repeat Last Ack Identifier
FF FDD3 <sub>16</sub>	GPI	Talkgroup Identifier
FF FDD4 <sub>16</sub> to FF FDDF <sub>16</sub>	BSIn	Address of a BS (n = 1 to 12)
FF FDE0 <sub>16</sub>	COCHI0	Polling identifier ID for Co-Channel Systems
FF FDE1 <sub>16</sub> to FF FDEF <sub>16</sub>	COCHIn	BS IDs for Polled BS in a Co-Channel network (n = 1 to 15)


dPMR ID	Alias	Meaning
FF FDF0 <sub>16</sub>	ALLI	Totality of all MSID and talkgroup IDs
FF FDF1 <sub>16</sub>	DYNADDI	Identifier to add dynamically assigned talkgroups
FF FDF2 <sub>16</sub>	DYNSUBI	Identifier to delete dynamically assigned talkgroups
FF FDF3 <sub>16</sub>	KILLI	Identifier for the Kill procedure
FF FDF4 <sub>16</sub> to FF FDF5 <sub>16</sub>	RSVD	Reserved
FF FE00 <sub>16</sub>	SERIALI0	Source ID for Electronic Serial Number (ESN) Check
FF FE01 <sub>16</sub> to FF FEFF <sub>16</sub>	SERIALIn	MID Manufacturers ID for ESN check (see note)
FF FF00 <sub>16</sub> to FF FFFF <sub>16</sub>	RSVD	Reserved
NOTE: SERIALIn has 254 values. Each value is assigned to a manufacturer and is unique to each manufacturer. If an MS is polled for its ESN the polling BS uses SERIALI0. The MS response is SERIALIn (n = 1 to 255) for manufacturer 1 to 255. The code that is assigned to a particular manufacturer is not specified in the present document.		

## 13.5 Message Matrix's

Table 13.5: Message Description Matrix

MT	Uplink/ Downlink	Description	Beacon Channel		
			Traffic Channel		M3
			M1	M2/ M3	
0000 <sub>2</sub>	U/D	Communication_Start header	Y	Y	
0001 <sub>2</sub>	U/D	Connection_Request header	Y	Y	
0010 <sub>2</sub>	U/D	Disconnect_Request header	Y	Y	
0011 <sub>2</sub>	U/D	B_ACK T_ACK (this a single frame, ACK or NACK is differentiated by the MI bits setting)	Y	Y	Y
0100 <sub>2</sub>	D	Traffic Channel Maintenance		Y	
	U	System_Request header (an END frame follows)			
0101 <sub>2</sub>	U	ACK header reply to a system request(a superframe follows)			
0110 <sub>2</sub>	D	System Delivery Header(a superframe follows)			
0111 <sub>2</sub>	U/D	Status_Response header (an END frame follows)	Y	Y	
1000 <sub>2</sub>	U/D	Status_Request header	Y	Y	
1001 <sub>2</sub>	U/D	BS_Command header and response			
1010 <sub>2</sub>	U/D	BS_Access header and response		Y	
1011 <sub>2</sub>	D	Broadcast			Y
1100 <sub>2</sub>	D	Beacon Ahoy (B_Ahoy)			Y
	U	Beacon Random Access Request			Y
1101 <sub>2</sub>	U/D	Beacon ACK (B_ACK)			Y
1110 <sub>2</sub>	U/D	UDT_Header			Y
1111 <sub>2</sub>	U/D	UDT_Appended Message	Y	Y	Y

Table 13.6: Call Service Matrix

M	MI_TYPE	Value	Call Service	M1	M2	M3
Y		000 <sub>2</sub>	Service Requested is a voice call	Y	Y	Y
Y		001 <sub>2</sub>	Service Requested is a Voice Call + Slow Data	Y	Y	Y
Y		010 <sub>2</sub>	Service Requested is a T1 data call	Y	Y	Y
Y		011 <sub>2</sub>	Service Requested is a T2 data call	Y	Y	Y
Y		100 <sub>2</sub>	Service Requested is a T3 data call	Y	Y	Y
Y		101 <sub>2</sub>	Service Requested is a Voice + embedded data call	Y	Y	Y
Y		110 <sub>2</sub>	Service Requested is defined by MI_TYPE	-	-	-
Y		111 <sub>2</sub>	Cancel the call service			Y
	Y	000 <sub>2</sub>	Service Requested is Short Data	Y	Y	Y
	Y	001 <sub>2</sub>	Service Requested is Status Delivery			Y
	Y	010 <sub>2</sub>	Service Requested is Data Polling			Y
	Y	011 <sub>2</sub>	Service Requested is Call Diversion			Y
	Y	100 <sub>2</sub>	Complementary Data Service			Y
	Y	101 <sub>2</sub>	Registration and Authentication Service			Y
	Y	110 <sub>2</sub>	Reserved			
	Y	111 <sub>2</sub>	Reserved for Powersave	Y	Y	

## 14 Physical Layer

### 14.1 General parameters

The radio shall comply with the essential requirements as stated in EN 301 166-2 [4].

#### 14.1.1 Frequency range

#### 14.1.2 RF carrier bandwidth

The radio system operates within a 6,25 kHz RF carrier bandwidth.

#### 14.1.3 Transmit frequency error

The maximum transmit frequency error from the assigned RF carrier centre shall be within  $\pm 625$  Hz as stated in EN 301 166-2 [4].

#### 14.1.4 Time base clock drift error

The maximum time base clock drift error shall be  $\pm 2$  ppm. This error is the amount of clock drift that is acceptable during a transmission.

## 14.2 Modulation

### 14.2.1 Symbols

The modulation sends 2 400 symbols/sec with each symbol conveying 2 bits of information. The maximum deviation,  $D$ , of the symbol is defined as:

$$D = 3h / 2T$$

Where:

- $h$  is the deviation index defined for the particular modulation; and
- $T$  is the symbol time (1 / 2 400) in seconds.

### 14.2.2 4FSK generation

This clause describes the characteristics of the constant-envelope modulation, entitled 4FSK.

#### 14.2.2.1 Deviation index

The deviation index,  $h$ , for 4FSK is defined to be 0,29. This yields a symbol deviation of 1 050 Hz at the symbol centre. The mapping between symbols and bits is given in table 14.1.

Information Bits Symbol Mapping to 4FSK Deviation.

**Table 14.1: FSK symbol mapping**

Information Bits		Symbol	4FSK Deviation
Bit 1	Bit 0		
0 <sub>2</sub>	1 <sub>2</sub>	+3	+1 050 Hz
0 <sub>2</sub>	0 <sub>2</sub>	+1	+350 Hz
1 <sub>2</sub>	0 <sub>2</sub>	-1	-350 Hz
1 <sub>2</sub>	1 <sub>2</sub>	-3	-1 050 Hz

14.2.2.2 Square root raised cosine filter

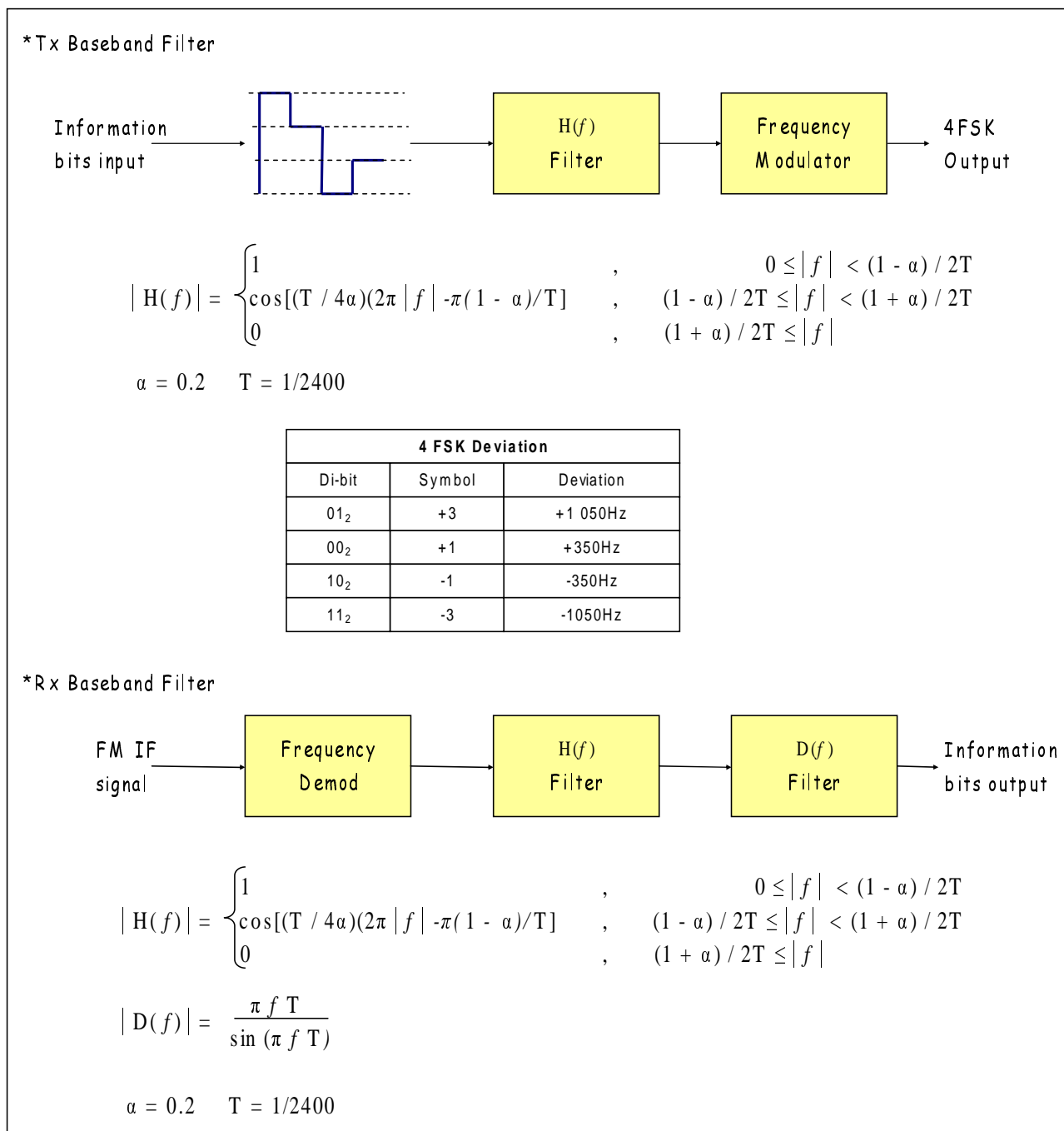


Figure 14.0

### 14.2.2.3 4FSK Modulator

The 4FSK modulator consists of a Square Root Raised Cosine Filter, cascaded with a frequency modulator as illustrated in figure 14.1. The Square Root Raised Cosine Filter is described in clause 14.2.2.2.

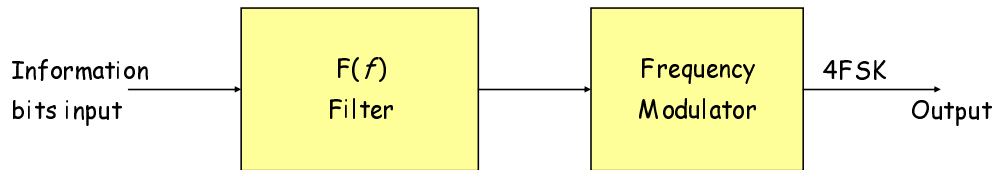


Figure 14.1: 4FSK Modulator

## 14.3 Transmit Power Ramping

The instantaneous power levels shall be constrained to the mask specified in figure 14.2. The mask ensures that MS transmissions do not overlap in a synchronous environment such as a Mode 3 Beacon channel.

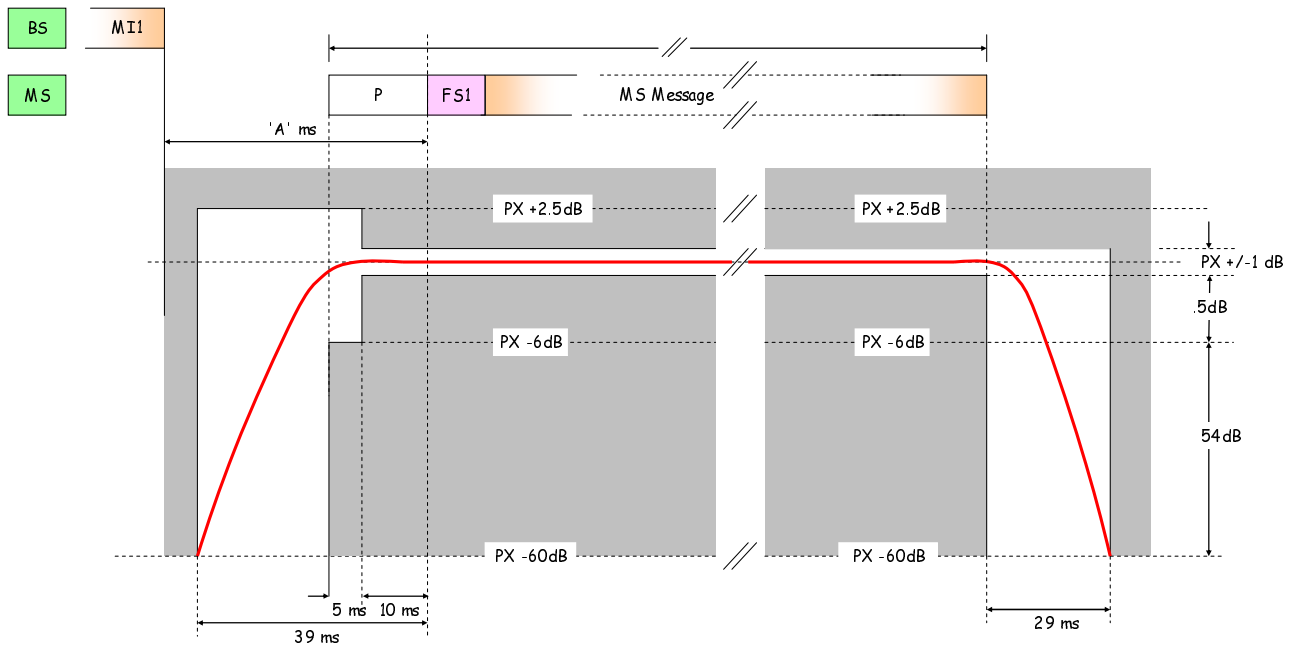


Figure 14.2: MS Power Ramp

Clause 12 defines the MS timing. The MS transmitting the response shall send its first bit of preamble not earlier than 30 ms and not later than 35 ms ( $T_{MS\_Timing}$ ) from the last bit of the message that solicited the response.

Referring to figure 14.2:

- if the MS has selected earliest bit timing then  $A = 45$  ms;
- if the MS has selected latest bit timing then  $A = 50$  ms;
- if the MS has selected a value  $T_{MS\_timing}$  between the earliest and latest permissible timing then  $A = 80 - T_{MS\_Timing}$  ms.

---

## Annex A (normative): Standard User Interface

It is recognized that manufacturers of MSs may wish to exercise design independence in their products and, accordingly, the requirements of these annexes are only applicable to equipment where the manufacturer has declared compliance with the "Standard User Interface".

---

### A.1 Numbering and dialling plan

#### A.1.1 Introduction to the numbering and dialling plan

This annex is intended to:

- a) define the user visible numbering (User Interface domain);
- b) dialling in an MS for accessing other MS(s) over the AI; and
- c) to describe how the visible user numbering and dial strings may be mapped on to the AI.

The Man Machine Interface (MMI) issues have been addressed in these annex only to the extent of those strictly related to numbering and dialling.

It should be ensured in the MS implementation, that no non-deterministic user input results in an ambiguous call set-up attempt over the Air Interface. For example, if a user inputs a dialled string of digits that is not assigned to any of the presented dialling algorithms, then the MS should not try to establish the call and appropriate feedback or alert should be given to the user.

As not to restrict manufacturer's independence, it is envisaged that dialling selection may be initiated in many ways. Some methods are:

- a) direct number entry via a keypad;
- b) mode selection buttons; and
- c) soft key menu selection.

The dialling method may vary according to the MS terminal type. This annex is applicable to MSs with a basic CCITT number keypad, as illustrated in figure A.1 and/or with a display capable of displaying the decimal numbers "0" to "9" and the keys "\*" and "#". However, manufacturers may employ other keypad layouts.

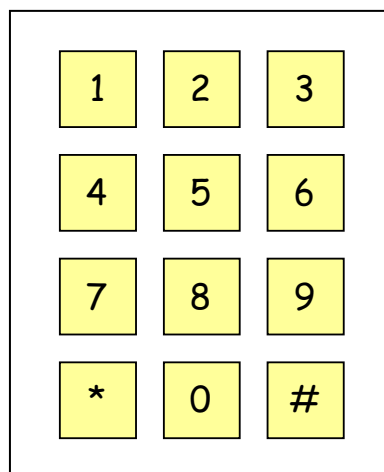


Figure A.1: CCITT keypad layout

The primary use for the keypad is to enable the user to select the destination address, the type of service, and to initiate calls from the MS. Certain other services may be requested by dialling "call modifier" strings prior to entering the destination address:

- a) the user dials digits; and
- b) user initiates call.

User input in case of establishing a call is defined for the purposes of this annex as two sequential events:

The call initiation is the event, which terminates the user input related to the digits and normally causes a call set-up. The call initiation event itself may be either when the user presses the "#" key or Push-To-Talk (PTT) or other method that may be manufacturer or implementation specific.

**NOTE:** This definition of the user input for call establishment is valid only for the cases when a user dials a number using the number keypad or selects a number e.g. from a list of predefined numbers. There may be methods to combine all the three events so that e.g. PTT causes a call establishment using a predefined dialling algorithm to a predefined address requiring no explicit dialling event.

Manufacturers may implement barring of certain types of call or restrict calls to certain addresses. However, such constraints are outside the scope of this annex.

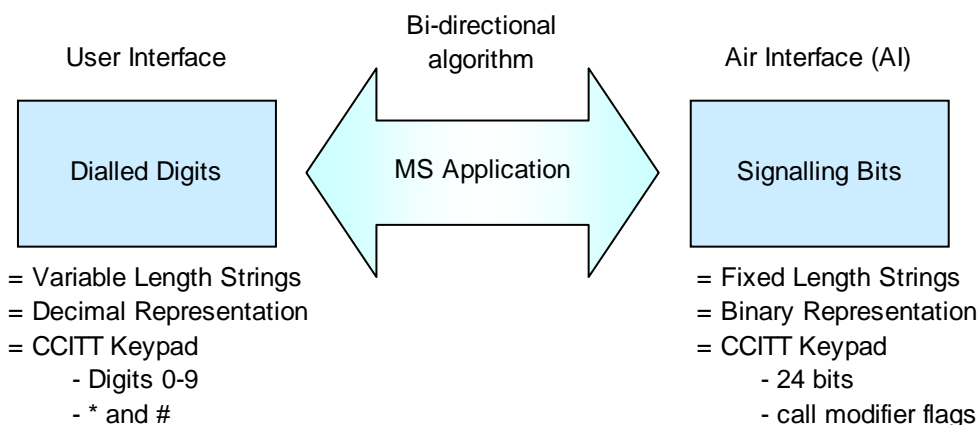
The MS may contain predefined parameters prescribing the minimum and maximum length of the user dial string. By limiting the length of the dialled string the address range the MS is able to dial is restricted. The minimum length parameter may be set according to the user needs, e.g. to disable accidental 1-digit dialling.

The (User Interface) address that an individual MS is assigned (its own address) may be defined by the dialled digits another MS would dial to reach that MS rather than the Air Interface binary number. If the algorithm specified in this annex were implemented, an MS individual address would be fully specified by seven decimal digits. Similarly, if an MS was personalized with one or more talkgroup addresses, they may be specified at the user interface by seven decimal digits.

## A.1.2 Subscriber mapping

### A.1.2.1 User Interface - Air Interface

Dialled digits are represented in decimal notation and utilize the numbers "0" to "9" and the keys "\*" and "#". For an MS fitted with a keypad, the "#" key may initiate a call (although other initiate methods may be implemented by a manufacturer). Dialled digits that represent a destination address are translated to a form for the Air Interface by a coding algorithm. This is illustrated in figure A.2.



**Figure A.2: Number conversion**



Address fields in the Air-Interface domain structure has a length of 24 bits.

The content of a 24-bit AI MS address field may represent:

- a) an MS individual address;
- b) an MS talkgroup address.

The Air Interface provides call services for voice and data. The AI also permits the call services to be modified. The application that converts the User Interface to the Air Interface recognizes the "call modifier" and request the lower layers to set appropriate bits in the messages carried between the entities. At the User Interface, the "call modifier" is indicated by preceding the destination address digits with additional "call modifier" digits.

#### A.1.2.1.1 Mapping for MS address space

Each call is made to a numeric or non-numeric address (with "wildcards"). The mapping between the User-Interface domain and the Air Interface uses a reversible coding algorithm.

MS are able to establish the call type from analysis of the decoded Air Interface address. There are a number of methods by which an MS may distinguish between talkgroup and individual calls and these are described in the following clauses.

##### A.1.2.1.1.1 The concept of the wildcard character

The MS may discriminate a talkgroup call from an individual call by the use of the "wildcard".

In the User Interface domain structure, if the dialled string represents an MS address, and contains a "\*" in any of the four least significant characters, then that MS address represents a talkgroup of MSs. The "\*" character is the "wildcard" and represents all numeric values in that digit position, as defined in examples 1 to 3.

EXAMPLE 1: The user dials "012345\*" means that the MS is addressing 10 separate MSs whose individual addresses are "0123450", "0123451", "0123452", "0123453", "0123454", "0123455", "0123456", "0123457", "0123458", and "0123459".

EXAMPLE 2: The user dials "01234\*6" means the MS is addressing 10 separate MSs whose individual addresses are "0123406", "0123416", "0123426", "0123436", "0123446", "0123456", "0123466", "0123476", "0123486", and "0123496".

EXAMPLE 3: Wildcards may be combined. The user dials "01234\*\*" represents 100 MSs in the range "0123400" to "0123499".

For operators who have no interest in this method of defining talkgroups, the "wildcard" feature may be disabled by MS programming.

##### A.1.2.1.1.2 The concept of stored parameters

The MS equipment may contain predefined parameters prescribing the MS addresses that can be interpreted as talkgroup addresses. These addresses may be stored as a list programmed during manufacture or before connecting an MS into service.

##### A.1.2.1.1.3 The concept of ad-hoc arrangement

The MS equipment may simply rely on a range of addresses that all equipment is known to be talkgroup addresses.

##### A.1.2.1.1.4 The rules for the sender

The MS codes the dialled user digits to a 24 bit Air Interface address by using the reversible algorithm  $B_2$ .

### A.1.2.1.1.5 The rules for the recipient

These rules determine whether a call is to a talkgroup or individual address and will be accepted by an MS. (All reference to MS in this clause refer to the recipient.)

MS receives a dPMR call.

MS uses the reverse of the  $B_2$  function specified in clause A.1.2.1.1.6.1 to translate the AI talkgroup address to the User Interface domain.

IF digits (User Interface)

contains a "\*" in any of the least significant four characters.

THEN

each digit received is compared with each corresponding digit of the MS individual address except where the received digit is a "\*". If there is a match on all applicable digits then this MS is party to the talkgroup call.

ELSE

(consists of numeric characters only).

THEN

EITHER

The string of digits received is compared with each corresponding string of talkgroup digits that the MS has stored (specifically indicating a talkgroup).

If there is a match then this MS is party to the talkgroup call.

OR

The string of digits received is compared with each corresponding string of individual address digits that the MS has stored.

If there is a match then this MS is party to the individual call.

ENDIF

### A.1.2.1.1.6 Mapping of dialled strings to the AI address space

An MS address is a 7-character numeric string in the range "0000001" to "999\*\*\*\*", these characters are mapped to the Air Interface domain structure bits by the reversible function  $B_2$ .

Addresses may consist of all numeric characters (but the MS shall be able to ascertain the address is a talkgroup address rather than an individual address). Alternatively any of the last four characters may contain one or more "\*" characters that explicitly signifies the address is a talkgroup address.

#### A.1.2.1.1.6.1 Mapping of numeric dialled strings to the AI address space

**Table A.1: Dialable address mapping by  $B_2$**

Character							$B_2$	Air Interface ID
1	2	3	4	5	6	7		24 bits
$K_1$	$K_2$	$K_3$	$K_4$	$K_5$	$K_6$	$K_7$		

$K_1$ ,  $K_2$  and  $K_3$  represent decimal symbols in the range 0 to 9.

$K_4$ ,  $K_5$ ,  $K_6$  and  $K_7$  represent symbols to base 11 using the digits 0,1,2,3,4,5,6,7,8,9,\*.

The "\*" is a symbol that has the value of 10.

The six least significant user dialled digits  $K_2$  to  $K_7$  in the range "000001" to "999999" are converted to the 20 least significant 20 bits of the AI ID using true decimal to binary conversion. The most significant user dialled digit  $K_1$  is converted to the most significant 4 bits of the AI ID using a true decimal to binary conversion.

$$B_2 = \sum K_1 \times 1\,464\,100, K_2 \times 146\,410, K_3 \times 14\,641, K_4 \times 1\,331, K_5 \times 121, K_6 \times 11, K_7$$

**Figure A.3: B2 Algorithm**

The following steps are needed to convert the dialled digits to an ID in the AI domain:

- a) take the first digit (0 to 9) and multiply by 1 464 100;
- b) take the second digit (0 to 9), multiply by 146 410;
- c) take the third digit (0 to 9) and multiply by 14 641;
- d) take the fourth digit (0 to 9) or \* (\* has a value of 10) and multiply by 1 331;
- e) take the fifth digit (0 to 9) or \* (\* has a value of 10) and multiply by 121;
- f) take the sixth digit (0 to 9) or \* (\* has a value of 10) and multiply by 11;
- g) take the seventh digit (0 to 9) or \* (\* has a value of 10);
- h) add c) to i); and
- i) convert the sum to a 24-bit binary number.

Examples are illustrated in table A.2.

**Table A.2: Examples of address translation**

User-Interface	Air-Interface (Hex)	Air Interface (Binary)
1234567	1B 91 FD <sub>16</sub>	0001 1011 1001 0001 1111 1101 <sub>2</sub>
468956*	68 BF 08 <sub>16</sub>	0110 1000 1011 1111 0000 1000 <sub>2</sub>
012345*	02 C0 0A <sub>16</sub>	0000 0010 1100 0000 0000 1010 <sub>2</sub>
0123460	02 C0 0B <sub>16</sub>	0000 0010 C000 0000 0000 1011 <sub>2</sub>
999****	DF 67 67 <sub>16</sub>	1101 1111 0110 0111 0110 0111 <sub>2</sub>

## A.1.2.2 Addresses

An MS is pre-programmed with at least one individual identity.

An MS is permitted to have multiple individual identities and one or more talkgroup identities.

Where an MS has more than one individual identity then one of these shall be assigned as the primary individual identity. This primary individual identity is the one that shall be used for all forms of abbreviated or masked dialling.

An MS may contain a list of talkgroup identities, which may be pre-programmed or dynamically updated (manually or over the AI).

The User Interface domain maps to the AI address space by the  $B_2$  algorithm.

## A.1.2.3 Conversion rules

### A.1.2.3.1 MS addresses

An MS address in the User-Interface structure is defined as 7 characters of which for an individual MS address contain the characters "0" to "9". For a talkgroup address the three most significant contain the characters "0" to "9" and least significant four characters contain the characters "0" to "9" or "\*".

### A.1.2.3.2 Limiting the length of the destination address

The MS equipment may contain predefined parameters prescribing the minimum and maximum length of the user dial string. By limiting the length of the dialled string, the address range that the MS is able to dial is restricted.

### A.1.2.3.3 All talkgroup address

The All Call dialled string "n\*\*\*\*\*" (All Call within a prefix) is mapped as illustrated in table A.3.

**Table A.3: Mapping of prefixed All Call to the AI**

User dialled string	Air Interface ID (see table 13.4)	Meaning
"0*****"	F8 339C <sub>16</sub>	All Talkgroup ID0
"1*****"	F8 339D <sub>16</sub>	All Talkgroup ID1
etc.	etc.	etc.
"9*****"	F8 33A5 <sub>16</sub>	All Talkgroup ID9

The All Call dialled string: "\*\*\*\*\*" is mapped to the All Talkgroup ID10 and addresses all MSs irrespective of their prefix.

**Table A.4: Mapping of all prefix call to the AI**

User dialled string	Air Interface ID	Meaning
"*****"	F8 33A6 <sub>16</sub>	All Talkgroup ID10

## A.1.3 User dialling plan

### A.1.3.1 User numbering

All dialled strings, as defined in the clause A.1.3.4 of the present document, are read from left to right and are dialled in the sequence in which they are read. Throughout this clause all representations of dialled strings are underlined.

MSs may only be required to dial sufficient numbers of characters unambiguously define the destination and service required.

#### A.1.3.1.1 Dialling method

To maximize channel utilization, the user should enter a string of digits and then press a button to initiate the call.

The "#" key or a dedicated "send" key is used to initiate the call. The "#" key has an additional purpose of modifying the call type or priority.

#### A.1.3.1.2 Call Type determination

Underlying signalling and system functionality is hidden from the user. MSs determine the call type and function from the length and content of the dialled string.

#### A.1.3.1.3 Call modifier strings

Dialled strings that commence with a hash "#" provide secondary uses for the keypad.

Secondary dialling functions may be as follows:

- a) Status Call.
- b) Broadcast Call.

Secondary dialling is achieved by the use of call modifier strings in front of the dialled number. These call modifier sequences utilize the "#" and "\*" keys.

### A.1.3.2 Dialled digits to address mapping

The User-Interface employs 11 symbols "0" to "9" and "\*" and "#".

In the User-Interface domain structure, if the string represents an MS address, and contains a "\*" in any of the four least significant characters, then that MS address represents a talkgroup of MSs.

The length of destination MS address dialled digits is in the range from 1 to 7, and is interpreted as the right most digits of the recipient's number. The MSs individual address is used as a base address, and the right-most digits of that number are replaced by the user dialled digits, as illustrated in example 1 and 2. The resulting number is then converted to the AI ID using the algorithm prescribed in clause A.1.2.1.1.6.

EXAMPLE 1: An MS whose individual address is "1234567" (in the user domain), dials "43".

MS source address	1	2	3	4	5	6	7
Dialled destination						4	3
Full destination address, see note	1	2	3	4	5	4	3
NOTE: Destination address after processing.							

EXAMPLE 2: This example is a call to a talkgroup, described in clause A.2.1.2.1.

MS source address	1	2	3	4	5	6	*
Dialled destination							*
Full destination address, see note	1	2	3	4	5	6	*
NOTE: Destination address after processing.							

### A.1.3.3 Storage requirements

#### A.1.3.3.1 MS individual address

An MS is allocated a numeric address in the range in the range "0000001" to "9999999", see note. MSs may be programmed with more than one individual address.

NOTE: The addresses "1000000", "2000000", "3000000", "4000000", "5000000", "6000000", "7000000", "8000000", and "9000000" are not valid.

#### A.1.3.3.2 Dialled Talkgroups

Talkgroups may be both all numeric numbers, or contain a "\*" in any of the least significant four digits.

xxxxxx\* is valid

xxxxx\*\* is valid

xxxx\*\*\* is valid

xxx\*\*\*\* is valid

All other combinations in the least significant four digits of the dialled string such as xxxxx\*x are invalid

#### A.1.3.3.3 All MSs

All units respond to All MSs address "\*\*\*\*\*#".

All units with prefix "n" respond to the prefixed All MS address "n\*\*\*\*\*#" with n = 0 to 9.

See clause A.1.2.3.3 of the present document for the mapping of MS dialled digits "n\*\*\*\*\*#" and "\*\*\*\*\*#".

#### A.1.3.3.4 Non-dialable numbers

MS Address's "0000000", "1000000", "2000000", "3000000", "4000000", "5000000", "6000000", "7000000", "8000000", "9000000" are not dialable. If the user inputs a dialled string of digits that is not assigned to any of the dialling algorithms, then the MS should not try to establish the call and appropriate feedback given to the user.

#### A.1.3.3.5 Talkgroup recognition

##### A.1.3.3.5.1 All numeric talkgroups

Each MS has storage allocated for numeric talkgroup addresses. The table is populated during MS personalization by the user. The sender (MS) may use entries in this table to establish that the destination address is a talkgroup rather than an individual address.

The talkgroup table contains entries consisting of the full talkgroup address consisting of 7 characters as illustrated in the example.

EXAMPLE: The sender (MS) whose individual address is "1234561" has the destination "1234567" stored in its talkgroup table. The user enters a single digit "7" as the destination address. The full destination address is formed from the dialled digit(s) and the MS own individual address.

MS source address	1	2	3	4	5	6	1
Dialled destination							7
Full (Talkgroup), see note	1	2	3	4	5	6	7
NOTE: Destination address after processing.							

The talkgroup table is searched for a match. In this example there is a match so the destination address is a talkgroup address

##### A.1.3.3.5.2 Talkgroups defined by wildcards

The dialled string is examined by the initiating MS. If the destination is identified as a talkgroup because the address contains a "wildcard" character in one of the four least significant digits then call set-up procedure is to a talkgroup as illustrated in the example. Abbreviated dialling minimizes the number of dialled digits. An advantage of using "wildcard" to define talkgroups is that no pre-arrangement is necessary, i.e. there is no need for a talkgroup table or other MS configuration to recognize an address as a talkgroup.

EXAMPLE:

MS source address	1	2	3	4	5	6	1
Dialled destination							*
Full destination address, see note	1	2	3	4	5	6	*
NOTE: Destination address after processing.							

##### A.1.3.3.5.3 MS receives a talkgroup call

The recipient MS applies the reverse  $B_2$  to recover the dialled digits  $K_1$  to  $K_7$ .

- a) If the received digits contain a "\*" in the digits  $K_4$  to  $K_7$  then:
- each digit is compared in turn with the corresponding digit of the MS individual identity looking for a match. If an "\*" is encountered then a match for that digit is assumed.
  - If the received digits are all numeric then:
    - the digits  $K_1$  to  $K_7$  are compared with each of the entries in the talkgroup table looking for a match (after each entry in the table has been expanded to the full 7 address digits as described in clause A.1.3.3.5.1).

There shall be a match between the received digit and an entry in the talkgroup table for the MS to respond to the talkgroup call.

## A.1.3.4 Dialling procedures

### A.1.3.4.1 MS calls

#### A.1.3.4.1.1 Seven digit dialling

The user may enter the whole seven digit address to complete the dialled string prior to transmission.

These seven digits may also contain wildcards.

#### A.1.3.4.1.2 Abbreviated dialling

Where abbreviated keypad dialling is used in the MS, the MS should insert the more significant characters from the MS individual address to complete the dialled string prior to transmission.

Those digits entered may also include wildcards.

If all digits are not dialled the more significant digits from the MS individual address are copied to the dialled string to build a seven digit address so:

For the MS individual address "2112345":

- a) if the user dials 6#, the destination address shall be **2112346**;
- b) if the user dials 56#, the destination address shall be **2112356**;
- c) if the user dials 958#, the destination address shall be **2112958**;
- d) if the user dials 1385#, the destination address shall be **2111385**;
- e) if the user dials 13\*5#, the destination address shall be **21113\*5** (talkgroup).

(The **bold** characters represent those that have been copied from the MS individual address).

At the Air Interface the calling party address is transferred to the called party. The abbreviated dialling may be applied to display only an abbreviated calling party address on the display of the called party.

- a) The calling party dials a single digit "2".
- b) The MS inserts the more significant digits from its individual address to complete the dialled string prior to transmission - i.e. the destination address becomes "1234562".
- c) The called and calling party addresses are passed across the Air Interface.
- d) The "B" party decodes the called party address and there is a match and the "B" party receives the call.
- e) The "B" party decodes the calling party address and may display only an abbreviated digit(s). In this case a single digit "1".

The abbreviated display is sufficient for the "B" party to know who has called because the "B" party could call the "A" party by the same abbreviated dialling.

By using abbreviated dialling, the dPMR dialling plan is appropriate for the smallest and largest fleets.

#### A.1.3.4.1.3 Masked dialling

The number of digits of a dialling string that can be entered may be restricted by MS programming to restrict the number range accessible from the user interface. For example the user interface could mask the most significant digit of an address to prevent the MS from reaching other MSs outside its own prefix.

Where masked dialling is used in the MS, the MS shall insert the characters from its own individual address that correspond to the each of the blocked positions to complete the dialled string prior to transmission.

Masked dialling may also be used in conjunction with abbreviated dialling.

Those digits entered may also include wildcards.

EXAMPLE:

For the MS individual address of 3456789.

The dialling string entry mask is [X] [X] [X] [X] [ ] [ ] [ ] [ ].

The user may only enter digits in those positions not marked with an X.

- If the user enters 888# then the resulting dialling string is be 3456888.
- If the user enters 8# then the resulting dialling string is be 3456788.
- If the user enters 88\*# then the resulting dialling string is be 345688\* (Talkgroup call).

#### A.1.3.4.2 Gateway Calls

Mode 2 and Mode 3 systems supports calls through gateways to and from line connected destinations. The dialled strings to address these destinations is described in this clause.

##### A.1.3.4.2.1 Telephone call

PSTN telephone numbers may be dialled using two alternative methods.

###### A.1.3.4.2.1.1 Telephone numeric padding format

PSTN telephone numbers are called by entering the "9" or a "0" followed by a 7 to 20 digit telephone number followed by the "#" character to indicate that dialling is complete and that the call is to be initiated.

EXAMPLE 1: "91234530#" should initiate a telephone call to the telephone subscriber "1234530". Likewise dialling "001256484530#" should dial telephone subscriber "01256484530".

Telephone numbers can be of length 7 to 20 digits and can have any digit 0 to 9 in any position in the dialled string.

Any telephone numbers that are outside this range (e.g. four digit PSTN numbers) should require to be padded with leading digits to a length that can be dialled. This padding may be stripped by the telephone interconnect (at the physical gateway) to ensure correct dialling.

If the first dialled digit is the "#" key and the key is held for more than **DIALn** seconds, the international dialling symbol "+" shall be inserted into the dialled string, replacing the "\*" character. For an MS employing a display, the "+" character shall be shown.

EXAMPLE 2: "+441253123456#" should initiate a telephone call to the U.K. The number is compiled as follows:  
 "+" international gateway  
 "44" U.K  
 "1253" National Code  
 "123456" Local Number.

###### A.1.3.4.2.1.2 Telephone star modifier format

PSTN telephone numbers are called by entering "\*9" or "\*0" followed by a 3 to 20 digit telephone number followed by the "#" character to indicate that dialling is complete and that the call is to be initiated.

EXAMPLE: "\*9845#" should initiate a PSTN telephone call to the telephone subscriber "845". Likewise dialling "\*035276#" should dial telephone subscriber "35276".

Telephone numbers can be of length 3 to 20 digits and can have any digit 0 to 9 in any position in the dialled string.

##### A.1.3.4.2.2 PABX call

PABX telephone numbers may be dialled using two alternative methods.



#### A.1.3.4.2.2.1 PABX numeric padding format

PABX numbers are called by entering "8" followed by a 7 to 20 digit extension number followed by the "#" character to indicate that dialling is complete and that the call is to be initiated.

EXAMPLE: "81234530#" should initiate a PABX call to the extension "1234530". Likewise dialling "81256484530#" should dial PABX extension "1256484530".

Extension numbers can be of length 7 digits to 20 digits and can have any digit 0 to 9 in any position in the dialled string.

Any extension numbers that are outside this range (e.g. three digit PABX numbers) should require to be padded with leading digits to a length that can be dialled. This Padding should have to be stripped by the PABX interconnect to ensure correct dialling. In addition part of the dialled string may also define a particular PABX. It is the responsibility of the PABX gateway to route the call correctly.

#### A.1.3.4.2.2.2 PABX star modifier format

PABX numbers are called by entering "\*8" followed by a 3 digits to 20 digits extension number followed by the "#" character to indicate that dialling is complete and that the call is to be initiated.

EXAMPLE: "\*8234#" should initiate a PABX call to the extension "234". Likewise dialling "\*81234#" should dial PABX extension "1234".

Extension numbers can be of length 3 digits to 20 digits and can have any digit 0 to 9 in any position in the dialled string.

#### A.1.3.4.2.3 IP call

IP addresses are called by entering "\*7" followed by an IPV4 or IPV6 dotted address followed by the "#" character to indicate that dialling is complete and that the call is to be initiated. Since the dot cannot be dialled the "\*" key is a substitute for the dots.

EXAMPLE: "\*7213\*48\*132\*2#" should call IP address "213.48.132.2".

### A.1.3.4.3 Call modifiers

Functions such as the modification of call requests to change to type of service request, and the implementation of other facilities (status, broadcast, etc), are initiated using the syntax in the following clauses. The call modifier is defined by the dialled string by adding extra digits to the dialled destination in the form.

# <call modifier code> \* destination as defined in clauses A.1.3.4.3.1 to A.1.3.4.3.7.

**Table A.5: Summary of call modifiers**

Dialled Digits	Call Modifier
#1*nn...#	Broadcast call, clause A.1.3.4.3.1
#8*nn...#	Priority call, clause A.1.3.4.3.2
#9*nn...#	Emergency call, clause A.1.3.4.3.3
#7*nn...#	Status Poll call, clause A.1.3.4.3.4
#0ss*nn...#	Status delivery call, clause A.1.3.4.3.5
#41*nn...#	Divert Own call, clause A.1.3.4.3.6
#6*nnn..#	Force talkgroup service, clause A.1.3.4.3.7

#### A.1.3.4.3.1 Broadcast call

The MS shall set-up a broadcast call to the destination talkgroup nn by dialling "#1\*nn#".

The broadcast call shall be a normal talkgroup call but with the Communications Format set to 'Call All' (Broadcast).

EXAMPLE 1: "#1\*112345\*#" should make a broadcast talkgroup call to MS address "112345\*#".

NOTE: The dialled string "#1\*nnn". "#" will generate an error if the address is not a talkgroup address.

EXAMPLE 2: If the MS calling party address is "1234567". "#1\*\*#" should make a broadcast talkgroup call to "123456\*" (i.e. to "1234560", "1234561", etc. "1234569").

#### A.1.3.4.3.2 Priority call

The MS may set up a high priority call to the destination address nn by dialling "#8\*nn#".

EXAMPLE 1: To make a high priority call from MS 1122345 to MS 1122346 dial "#8\*6#".

EXAMPLE 2: To make a high priority talkgroup call from MS 1122345 to MSs fleet 112234\* dial "#8\*\*#".

EXAMPLE 3: To make a high priority individual call to PABX extension 234 using start modifier format dial "#8\*\*8234#".

#### A.1.3.4.3.3 Emergency Call

The MS may set-up an emergency priority call to the destination address nn dialling "#9\*nn#".

EXAMPLE 1: To make an emergency call from MS 1122345 to talkgroup MSs 11223\*6 dial "#9\*\*6#".

EXAMPLE 2: To make an emergency call to telephone number 456 (using telephone star modifier format) dial "#9\*\*9456#".

EXAMPLE 3: To make an emergency call to telephone number 01772123456 (using telephone numeric padding format) dial "#9\*901772123456#".

#### A.1.3.4.3.4 Status poll call

The string "#0ss\*nnn#" causes the MS to set up a status poll to the destination address nnn.

#### A.1.3.4.3.5 Status delivery call

The string "#0ss\*nnn#" causes the MS to set up a status call to the destination address nnn. The status digits "ss" are numeric in the range 0 to 31.

Entry of a status value of greater than 31 shall generate an error warning to the user.

#### A.1.3.4.3.6 Divert own call

The string "#41\*nn#" instructs a repeater BS to offer the number "nn..n" back to any caller who is attempting to make a call to the originating MS as an alternative destination for the call. The number to which calls are to be diverted, and which follows the code, should be any number which the user is able to dial between 0 and 99.

The MS should instruct the repeater BS to cancel the diverted state dialling "#41#" or "#41\*#".

#### A.1.3.4.3.7 Force talkgroup service

The string "#6\*nnn.#" causes the MS to set up a talkgroup call to destination talkgroup nnn. where nnn. is a numeric string of length from 1 to 7 digits.

EXAMPLE: To make a talkgroup call from MS 1122345 to talkgroup MSs 1122356 dial "#6\*1122356#". In this case dialling "#6\*56#" would achieve the same result.

#### A.1.3.4.4 Call set-up abandon or call complete

"##" may be dialled after digits and a terminator have been entered on the keyboard. The MS behaviour is different for modes 1, 2 and 3.

##### A.1.3.4.4.1 Call set-up abandon or call complete - Mode 1

If the MS has not transmitted a call request, it shall abandon the call, otherwise the MS shall comply with the procedures specified in clause 10.1.2.4.

#### A.1.3.4.4.2 Call set-up abandon or call complete - Mode 2

If the MS has not transmitted a call request, it shall abandon the call, otherwise the MS shall comply with the End of Call procedures specified in clause 10.2.2.

#### A.1.3.4.4.3 Call set-up abandon or call complete - Mode 3

If the MS has cancelled the call after a call service request, the MS shall comply with the call cancellation procedures specified in clause 10.3.3.1.2. If the MS is engaged in a call having been assigned a traffic channel for the call, and the call is complete the MS shall comply with the procedure specified in clause 10.3.4.3.2.4.

---

# Annex B (informative): Beacon Channel Hunting Procedures

## B.1 Introduction

In order to locate a valid Beacon, the MS hunts through a list of candidate physical channels until an appropriate Beacon is selected and confirmed. This Beacon hunting may involve a variety of hunting sequences depending on the circumstances of the hunt. This annex shows a framework for MS hunting strategy.

The MS may use information from any of the messages that contain the SYSCode field to use for verification tests specified in clause 12.3.8.2.2.1.

The Beacon Channel Hunting Procedure stages are:

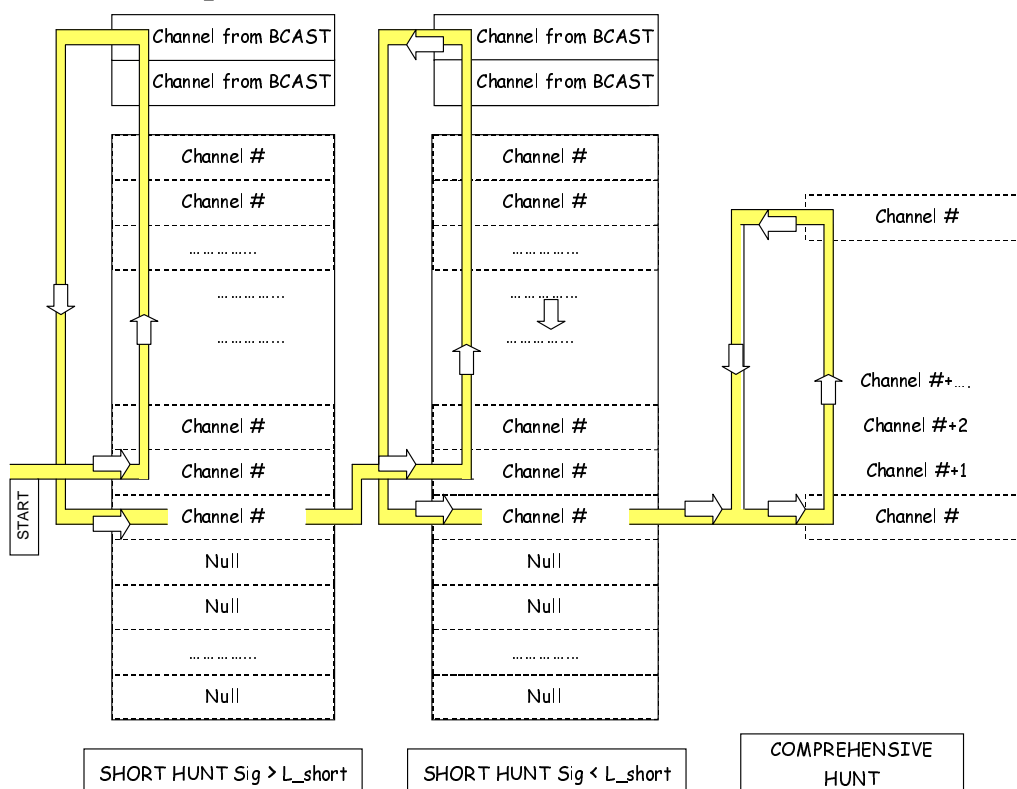
- a) The "resuming a Beacon hunt channel" allows an MS, after a period of activity on a traffic channel, to resume the Beacon on which it was last confirmed prior to the payload Goto Channel message.
- b) The "commanded Beacon hunt channel" is employed when an MS is directed on the Beacon to a particular Beacon (from an applicable B\_MOVE or Disconnect\_Request message) or seeks to regain a Beacon after a period of inactivity on the selected network (due to being switched off or a user-initiated change of selected network when details of the last confirmed Beacon channel has been stored by the MS in non-volatile storage).

"Short Hunt Sequence": A hunting sequence, which samples all physical channel frequencies likely to be employed as Beacons by the selected network. A list of Nmax\_Ch likely logical candidate physical channel frequency pairs is held in MS fixed non-volatile storage for the selected network. The MS should have the storage for up to 64 values of the logical physical channel information element defining the extent of the "short hunt sequence". Unused storage locations are marked such that the MS may ignore them. Particular Physical channel numbers may be stored in the list numerous times to provide a bias to that particular Beacon.

- a) "Comprehensive Hunt Sequence". A hunting sequence, that samples all possible physical channel numbers in use by the network. This hunting sequence provides a contingency to allow Beacons to be acquired even when physical channel numbers not normally employed for this purpose are in use. The "comprehensive hunt sequence" may be temporarily suspended to sample likely physical channels or repeat a "short hunt sequence". The lowest Low\_Comp\_Ch and highest High\_Comp\_Ch is held in the MS fixed non-volatile storage.

NOTE 1: The "Comprehensive Hunt Sequence" may be suppressed by network personalization.

When carrying out a "resuming a Beacon hunt channel" or "commanded Beacon hunt channel" the hunting procedure is considered complete when the MS has tuned directly to the physical channel and has carried out the appropriate verification and confirmation procedures specified in clause 12.3.8.2.



**Figure B.1: Physical Channel Hunting**

Figure B.1 shows a possible implementation of the "Short Hunt Sequence" and "Comprehensive Hunt" Sequence. If the MS needs to search for an appropriate Beacon, this process searches the most likely physical channel candidates first. This example of a possible implementation carries out the short hunt twice, the first loop being exercised looking for a Beacon whose signal strength exceeds a defined value ( $L_{SigShort}$ ).

A hunting sequence may be considered complete when either:

- a physical channel is found that satisfies the Beacon verification and confirmation tests specified in clause 12.3.8.2. (The hunting procedure was successful);
- all physical channel numbers within the scope of the hunting sequence have been tested without a physical channel being found which satisfies the Beacon confirmation tests specified in clause 12.3.8 (the hunting sequence failed).

The MS carries out the hunting procedure in the order described in this clause. If a hunting sequence is unsuccessfully completed, then the MS starts the next hunting sequence. The final hunting sequence is the "comprehensive hunt sequence". If this hunting sequence cannot be completed, the MS stays in this hunting sequence until a Beacon is confirmed. However, the foregoing provisions of this clause may be relaxed in the following circumstances:

- the "comprehensive hunt sequence" may be suppressed by MS personalization for a network;
- an MS in a "comprehensive hunt sequence" may elect to perform complete hunting sequences of any other type, returning to the "comprehensive hunt sequence" in the event of failure to confirm an appropriate Beacon;
- an MS may elect to sample any physical channel that may satisfy the Beacon verification and confirmation tests specified in clause 12.3.8.2.

Where a hunting stage involves more than one physical channel the order in which physical channels are sampled is not specified. However, in order to guard against bias towards certain physical channels, MSs should ensure randomness in the order in which physical channels are sampled by one of the following:

- hunting physical channel numbers sequentially (e.g. from lowest to highest number) but beginning the hunting stage at a random position in the sequence of physical channel numbers;
- hunting physical channel numbers in a random fashion.

The procedures defined in the present document are intended to provide a comprehensive range of methods that may be used as a basis for the design of MSs.

NOTE 2: The specified mechanism is a framework for MSs. The use of additional or differing procedures is not prohibited provided that they satisfy the verification and confirmation procedures defined in the present document.

EXAMPLE: An MS locating a physical channel which satisfies the Beacon confirmation tests specified in clause 12.3.8.2 may continue the hunt in anticipation that an alternative Beacon may be found with a higher received signal quality or level. Also, MSs need not limit the hunting procedures to the receiver sensitivity threshold levels specified and may conduct additional hunts at other levels.

## B.1.1 Resuming a Beacon hunt channel

When "resuming a Beacon hunt channel" the MS retunes to the logical physical channel number of the Beacon on which it was last confirmed. The MS should be capable of receiving on the Beacon outbound channel, which it is resuming within two framesets of the following instants:

- a) the end of any Disconnect\_Request Header message, which requires the MS to cease activity on the traffic channel to which it is currently tuned;
- b) the end of the last Disconnect\_Request Header message sent by the MS on a traffic channel;
- c) the end of any Guard message (Guard\_Kind=Illegally\_Parked received on a traffic channel where either MS ID in the Guard message does NOT match one of the MS IDs from the Goto Channel message that directed the MS to the traffic channel;
- d) the operation of the any user initiated "call end request" by the user during a group call when the MS was not the call originator of the call.

Before confirming the Beacon the MS should verify any SYSCode received on the channel in accordance with the procedures of clause 12.3.8.2.2.1. In the event of the SYSCode fails the verification procedures, the hunting sequence is considered unsuccessfully completed and the MS enters the "short hunt sequence".

## B.1.2 Commanded Beacon hunt channel

### B.1.2.1 Conditions to enter a Commanded Beacon hunt

A "single channel hunt" applies when the MS is directed to a Beacon other than the one on which it was last confirmed, or when it is switched on whilst still retaining valid network information from previous activity on the selected network, or the user initiates a change of selected network and the MS still retains valid information of previous activity on the new selected network. The MS should be able to receive the nominated physical channel within 3 framesets of the following instants:

- a) the end of any valid B\_MOVE message that is applicable to the MS;
- b) the MS being switched on, provided that the unit holds a valid record of the channel number on which the MS was most recently confirmed;
- c) a change of selected network being initiated by the user, provided that the MS holds a valid record of the channel number on which the MS was most recently confirmed on the new selected network.

### B.1.2.2 Nominated Channel for the Single Channel Hunt

The nominated channel is:

- a) the channel number held in the MSs read/write storage as the Beacon on which the unit was most recently confirmed on the selected network.

The MS does not make any transmissions on a Beacon until it has confirmed the channel in accordance with the procedure specified in clause 12.3.8.2.2.3. In the event of a failure of the Beacon to meet the channel confirmation criteria the hunting sequence is considered unsuccessfully completed. Upon unsuccessful completion of the "commanded Beacon hunt channel" the MS enters the "short hunt sequence".

### B.1.2.3 Short Hunt Sequence

A "Short Hunt Sequence" samples all physical channels most likely to be employed as Beacons by the selected network. There are many strategies that may be employed but all will search from a shortlist of candidates as follows:

- a) A list of likely physical channels specified by an external agency will be stored in MS fixed non-volatile storage.
- b) The MS may modify the scope of the shortlist of physical channels from information broadcast from the network and held in its non-volatile storage as follows:
  - 1) by adding to the compass of the hunting sequence channel numbers received in B\_BCAST (Announce/Withdraw) message from the selected network;
  - 2) by removing from the compass of the hunting sequence channel numbers received in B\_BCAST (Announce/Withdraw) messages from the selected network.

One strategy illustrated in figure B.1 entails hunting the list of physical channel numbers sequentially (e.g. from the randomly chosen list position to the highest then circling to the lowest list position) but beginning the hunting stage at a random position in the sequence of physical channel numbers. The shortlist is sampled twice, the first loop being exercised looking for a Beacon whose signal strength exceeds a defined value (L\_Short).

Another possible strategy entails hunting the complete shortlist of physical channel numbers sequentially (e.g. from lowest list position to highest list position) recording the signal strength and/or BER. After sampling all channels in the list the MS chooses the most appropriate Beacon.

#### B.1.2.3.1 Conditions to enter a Short Channel Hunt

An MS enters the "short hunt sequence":

- a) immediately after switch-on, provided that the MS holds no valid information of previous activity on the selected network;
- b) when the user indicates a change of selected network, provided that the MS holds no valid information of previous activity on the selected network.

The MS may enter the "short hunt sequence" at any time during the "comprehensive hunt sequence", at the MSs discretion.

The MS should not make any transmissions on a Beacon located during the "short hunt sequence" until it has verified and confirmed the channel in accordance with the procedures specified in clause 12.3.8.2.

Upon unsuccessful completion of the "short hunt sequence" the MS enters the "comprehensive hunt sequence", except when the "comprehensive hunt sequence" has been suppressed by MS personalization for a network.

### B.1.2.4 Comprehensive Hunt Sequence

The "comprehensive hunt sequence" includes every channel within the range set by the lowest and highest channel numbers set by the network personalization, held in the MSs fixed non-volatile storage.

#### B.1.2.4.1 Conditions to enter a Comprehensive Channel Hunt

An MS enters the "comprehensive hunt sequence" when a "short hunt sequence" has been unsuccessfully completed.

An MS may repeat the "comprehensive hunt stage" until such a time as a physical channel which satisfies the Beacon confirmation tests specified in clause 12.3.8.2 is found.

The MS will not make any transmissions on a Beacon located during the "comprehensive hunt sequence" until it has confirmed the channel in accordance with the procedures specified in clause 12.3.8.2.

At any time during the "comprehensive hunt sequence" an MS may undertake a "short hunt sequence", or sample any physical channels that the MS is able to determine may be successful, returning to the "comprehensive hunt sequence" in the event that these choices is unsuccessful.

The possibility to suppress the "comprehensive hunt sequence" by MS network personalization. In this case the MS will remain in the "short hunt sequence" with the acquisition threshold set to a level  $L_{\text{Squelch}}$  until such time as a channel which satisfies the Beacon confirmation tests specified in clause 12.3.8.2.

### B.1.2.5 Receiver Sensitivity During Beacon Channel Acquisition

The MS should not attempt to become active on any physical channel for which the received signal level (or signal quality) is less than the specified acquisition threshold.

The acquisition threshold  $L_{\text{Short}}$  is set to a signal level within the range  $L_{\text{Upper\_Short}}$  to  $L_{\text{Lower\_Short}}$  at the input of the receiver (or an equivalent if the receiver measures signal quality).

$L_{\text{Squelch}}$  is set at a level determined by the MS manufacturer which enables unsuitable physical channels to be rejected on which the received signal is inadequate for a suitable grade of service (or an equivalent if the receiver measures signal quality).

NOTE: The MS may be unable to determine the received signal level but may use other methods such as bit error measurements to determine the signal quality.



---

## History

<b>Document history</b>		
V1.1.1	December 2008	Publication
V1.2.1	September 2009	Publication
V2.1.1	June 2010	Publication
V2.2.3	April 2012	Publication