



**Environmental Engineering (EE);
Metrics and Measurement Method for Energy Efficiency of
Wireless Access Network Equipment;
Part 2: Energy Efficiency - dynamic measurement method**

Reference

RTS/EE-EEPS13

Keywords

energy efficiency, LTE

ETSI

650 Route des Lucioles
F-06921 Sophia Antipolis Cedex - FRANCE

Tel.: +33 4 92 94 42 00 Fax: +33 4 93 65 47 16

Siret N° 348 623 562 00017 - NAF 742 C
Association à but non lucratif enregistrée à la
Sous-Préfecture de Grasse (06) N° 7803/88

Important notice

The present document can be downloaded from:

<http://www.etsi.org/standards-search>

The present document may be made available in electronic versions and/or in print. The content of any electronic and/or print versions of the present document shall not be modified without the prior written authorization of ETSI. In case of any existing or perceived difference in contents between such versions and/or in print, the only prevailing document is the print of the Portable Document Format (PDF) version kept on a specific network drive within ETSI Secretariat.

Users of the present document should be aware that the document may be subject to revision or change of status.

Information on the current status of this and other ETSI documents is available at

<https://portal.etsi.org/TB/ETSIDeliverableStatus.aspx>

If you find errors in the present document, please send your comment to one of the following services:

<https://portal.etsi.org/People/CommiteeSupportStaff.aspx>

Copyright Notification

No part may be reproduced or utilized in any form or by any means, electronic or mechanical, including photocopying and microfilm except as authorized by written permission of ETSI.

The content of the PDF version shall not be modified without the written authorization of ETSI.

The copyright and the foregoing restriction extend to reproduction in all media.

© ETSI 2018.

All rights reserved.

DECT™, **PLUGTESTS™**, **UMTS™** and the ETSI logo are trademarks of ETSI registered for the benefit of its Members.

3GPP™ and **LTE™** are trademarks of ETSI registered for the benefit of its Members and of the 3GPP Organizational Partners.

oneM2M™ logo is a trademark of ETSI registered for the benefit of its Members and of the oneM2M Partners.

GSM® and the GSM logo are trademarks registered and owned by the GSM Association.

Contents

Intellectual Property Rights	5
Foreword.....	5
Modal verbs terminology.....	5
Introduction	5
1 Scope	6
2 References	6
2.1 Normative references	6
2.2 Informative references.....	7
3 Definition of terms and abbreviations	7
3.1 Terms.....	7
3.2 Abbreviations	8
4 Assessment method	9
5 Reference configurations and Measurement requirements	9
5.1 Reference configurations.....	9
5.2 Measurement and test equipment requirements	10
5.3 BS Configuration.....	11
5.4 Transmit Signal and RF output power.....	11
5.5 UE Emulator requirements and settings	11
5.6 Environmental conditions.....	12
5.7 Power supply	12
6 Energy Efficiency Performance	12
6.1 Energy Efficiency Performance KPI Definition.....	12
6.2 Energy Efficiency Performance Measurement.....	13
6.2.1 Measurement Lab Setup	13
6.2.2 UE Distribution.....	13
6.2.3 Data Traffic Model	14
6.2.4 Measurement Time Definition.....	15
6.2.5 Low traffic model	15
6.2.6 Medium traffic model	15
6.2.7 Busy-hour traffic model.....	15
6.2.8 Data Volume Measurement	15
6.2.9 Power and Energy Consumption Measurement.....	16
6.2.10 Energy Consumption measurement	16
6.2.11 Base Station Energy Efficiency KPI.....	17
6.2.12 UE quality of service KPI.....	17
7 Uncertainty	17
8 Measurement report.....	17
Annex A (normative): Test Reports	18
A.1 General information to be reported	18
A.2 Base Station Energy Performance report	19
Annex B (normative): Reference parameters for LTE system	20
Annex C (normative): Data Traffic Model	21
C.1 Data Traffic Model.....	21
C.2 Measured data for BS Energy Performance KPI calculation	22
Annex D (normative): Uncertainty assessment	23

D.1	General requirements	23
D.2	Components contributing to uncertainty	23
D.2.1	Contribution of the measurement system	23
D.2.2	Measurement equipment (dynamic)	24
D.2.3	Attenuators, cables (dynamic)	24
D.2.4	UE emulator (dynamic)	24
D.3	Contribution of physical parameters	24
D.3.1	Impact of environmental parameters (dynamic)	24
D.3.2	Impact of path loss(dynamic)	24
D.3.3	Data volume (dynamic)	25
D.3.4	Variance of device under test	25
D.4	Uncertainty assessment	25
D.4.1	Combined and expanded uncertainties	25
D.4.2	Cross correlation of uncertainty factors	25
D.4.3	Maximum expanded uncertainty	26
Annex E (informative):	Bibliography	27
History		28

Intellectual Property Rights

Essential patents

IPRs essential or potentially essential to normative deliverables may have been declared to ETSI. The information pertaining to these essential IPRs, if any, is publicly available for **ETSI members and non-members**, and can be found in ETSI SR 000 314: "*Intellectual Property Rights (IPRs); Essential, or potentially Essential, IPRs notified to ETSI in respect of ETSI standards*", which is available from the ETSI Secretariat. Latest updates are available on the ETSI Web server (<https://ipr.etsi.org/>).

Pursuant to the ETSI IPR Policy, no investigation, including IPR searches, has been carried out by ETSI. No guarantee can be given as to the existence of other IPRs not referenced in ETSI SR 000 314 (or the updates on the ETSI Web server) which are, or may be, or may become, essential to the present document.

Trademarks

The present document may include trademarks and/or tradenames which are asserted and/or registered by their owners. ETSI claims no ownership of these except for any which are indicated as being the property of ETSI, and conveys no right to use or reproduce any trademark and/or tradename. Mention of those trademarks in the present document does not constitute an endorsement by ETSI of products, services or organizations associated with those trademarks.

Foreword

This Technical Specification (TS) has been produced by ETSI Technical Committee Environmental Engineering (EE).

The present document is part 2 of a multi-part deliverable covering Metrics and Measurement Method for Energy Efficiency of Wireless Access Network Equipment, as identified below:

ETSI ES 202 706-1: "Power Consumption - Static Measurement Method";

ETSI TS 102 706-2: "Energy Efficiency - dynamic measurement method".

Modal verbs terminology

In the present document "**shall**", "**shall not**", "**should**", "**should not**", "**may**", "**need not**", "**will**", "**will not**", "**can**" and "**cannot**" are to be interpreted as described in clause 3.2 of the [ETSI Drafting Rules](#) (Verbal forms for the expression of provisions).

"**must**" and "**must not**" are **NOT** allowed in ETSI deliverables except when used in direct citation.

Introduction

Energy efficiency is one of the critical factors of the modern telecommunication systems. The energy consumption of the access network is the dominating part of the wireless telecom network energy consumption. Therefore, the core network and the service network are not considered in the present document. In a radio access network, the energy consumption of the Base Station is dominating (depending on technology often also referred to as BTS, NodeB, eNodeB, etc. and in the present document denoted as BS). The energy consumption of Radio Network Control nodes (RNC or BSC) are covered in ETSI ES 201 554 [6].

The present document defines the dynamic measurement method for evaluation energy efficiency:

- BS efficiency under dynamic load conditions: the BS capacity under dynamic traffic load provided within a defined coverage area and the corresponding energy consumption is measured for given reference configurations.

ETSI ES 202 706-1 [1.6] defines daily average power consumption of the base station.

1 Scope

The present document covers the following radio access technology:

- LTE.

The methodology described in the present document is to measure base station dynamic energy efficiency. Within the present document, it is referred to dynamic measurement.

The results based on dynamic measurements of the BS provide energy efficiency information for BS with dynamic load.

Energy consumption of terminal (end-user) equipment is outside the scope of the present document however, how a user equipment (UE) affects a base station energy performance will be considered for further study.

The scope of the present document is not to define target values for the power consumption nor the energy efficiency of equipment.

The results should only be used to assess and compare the energy efficiency of base stations.

Wide Area Base Stations are covered in this version of the present document.

2 References

2.1 Normative references

References are either specific (identified by date of publication and/or edition number or version number) or non-specific. For specific references, only the cited version applies. For non-specific references, the latest version of the referenced document (including any amendments) applies.

Referenced documents which are not found to be publicly available in the expected location might be found at <https://docbox.etsi.org/Reference/>.

NOTE: While any hyperlinks included in this clause were valid at the time of publication, ETSI cannot guarantee their long term validity.

The following referenced documents are necessary for the application of the present document.

- [1] ETSI TS 125 104: "Universal Mobile Telecommunications System (UMTS); Base Station (BS) radio transmission and reception (FDD) (3GPP TS 25 104)".
- [2] ETSI EN 300 132-1: "Environmental Engineering (EE); Power supply interface at the input to Information and Communication Technology (ICT) equipment; Part 1: Operated by Alternating Current (AC) source".
- [3] ETSI EN 300 132-2: "Environmental Engineering (EE); Power supply interface at the input to telecommunications and datacom (ICT) equipment; Part 2: Operated by -48 V direct current (dc)".
- [4] ETSI TS 136 211: "LTE; Evolved Universal Terrestrial Radio Access (E-UTRA); Physical channels and modulation (3GPP TS 36.211)".
- [5] ETSI TS 136 104: "LTE; Evolved Universal Terrestrial Radio Access (E-UTRA); Base Station (BS) radio transmission and reception (3GPP TS 36.104)".
- [6] ETSI ES 201 554: "Environmental Engineering (EE); Measurement method for Energy efficiency of Mobile Core network and Radio Access Control equipment".
- [7] ETSI EN 300 132-3: "Environmental Engineering (EE); Power supply interface at the input to telecommunications equipment; Part 3: Operated by rectified current source, alternating current source or direct current source up to 400 V".

- [8] 3GPP TR 36 873: "3rd Generation Partnership Project; Technical Specification Group radio Access Network; Study on 3D channel model for LTE".
- [9] ETSI TS 136 141: "LTE; Evolved Universal Terrestrial Radio Access (E-UTRA); Base Station (BS) conformance testing (3GPP TS 36.141)".

2.2 Informative references.

References are either specific (identified by date of publication and/or edition number or version number) or non-specific. For specific references, only the cited version applies. For non-specific references, the latest version of the referenced document (including any amendments) applies.

NOTE: While any hyperlinks included in this clause were valid at the time of publication, ETSI cannot guarantee their long term validity.

The following referenced documents are not necessary for the application of the present document but they assist the user with regard to a particular subject area.

- [i.1] IEC/ISO Guide 98-3: "Evaluation of measurement data - Guide to the expression of uncertainty in measurement", (2008 or equivalent GUM:2008/JCGM 100:2008).

NOTE: Available at http://www.bipm.org/utis/common/documents/jcgm/JCGM_100_2008_E.pdf.

- [i.2] ETSI TS 145 005: "Digital cellular telecommunications system (Phase 2+); Radio transmission and reception (3GPP TS 45.005)".
- [i.3] ISO/IEC 17025: "General requirements for the competence of testing and calibration laboratories".
- [i.4] IEC 62018: "Power consumption of information technology equipment - Measurement methods".

NOTE: Equivalent to CENELEC EN 62018.

- [i.5] ETSI TS 102 706 (V1.2.1): "Environmental Engineering (EE); Measurement Method for Energy Efficiency of Wireless Access Network Equipment".
- [i.6] ETSI ES 202 706-1: "Environmental Engineering (EE); Metrics and measurement method for energy efficiency of wireless access network equipment; Part 1: Power Consumption - Static Measurement Method".

3 Definition of terms and abbreviations

3.1 Terms

For the purposes of the present document, the following terms apply:

Base Station (BS): radio access network component which serves one or more radio cells and interfaces the user terminal (through air interface) and a wireless network infrastructure

BS test control unit: unit which can be used to control and manage BS locally in a lab

busy hour load: period during which occurs the maximum total load in a given 24-hour period

distributed BS: BS architecture which contains remote radio heads (i.e. RRH) close to antenna element and a central element connecting BS to network infrastructure

efficiency: throughout the present document the term efficiency is used as the relation between the useful output (telecom service, etc.) and energy consumption of the BS

integrated BS: BS architecture in which all BS elements are located close to each other; for example, in one single cabinet

NOTE: The integrated BS architecture may include Tower Mount Amplifier (TMA) close to antenna.

low load: lowest generated traffic during the dynamic measurement period

medium load: medium load between the lowest and buy hour load generate during the dynamic measurement period

power saving feature: software/hardware feature in a BS which contributes to decrease power consumption

static measurement: power consumption measurement performed with different radio resource configurations with pre-defined and fixed load levels

UE group: group of UEs whose path losses to the BS are identical

Wide Area Base stations: Base Stations that are characterized by requirements derived from Macro Cell scenarios with a BS to UE minimum coupling loss equals to 70 dB and having a rated output power (PRAT) above 38 dBm, where the Rated output power, PRAT, of the BS is the mean power level per carrier for BS operating in single carrier, multi-carrier, or carrier aggregation configurations that the manufacturer has declared to be available at the antenna connector during the transmitter ON period according to 3GPP standardization, ETSI TS 136 104 [5] and ETSI TS 125 104 [1]

3.2 Abbreviations

For the purposes of the present document, the following abbreviations apply:

AC	Alternating Current
BS	Base Station
BSC	Base Station Controller
BTS	Base Transceiver Station
BW	Bandwidth
CPICH	Common Pilot CHannel
DC	Direct Current
DL	DownLink
DUT	Device Under Test
EC	Energy for Central part
EPRE	Emitted Power per Resource Element
ERRH	Energy for Remote Radio Part
GSM	Global System for Mobile communication
GUM	Guide to the expression of Uncertainty in Measurement
HSPA	High Speed Packet Access
HW	HardWare
JCGM	Joint Committee for Guides in Metrology
KPI	Key Performance Indicator
LTE	Long Term Evolution
MIMO	Multiple Input Multiple Output
NIST	National Institute of Standards and Technology
PBCH	Packet Broadcast Control Channel
PC	Power for Central part
PCM	Pulse Code Modulation
PDCCH	Physical Downlink Control CHannel
PDF	Proportional Distribution Function
PDSCH	Physical Downlink Shared CHannel
PSS	Primary Synchronizing Signal
REG	Resource Element Group
RF	Radio Frequency
RNC	Radio Network Controller
RRH	Remote Radio Head
RS	Reference Signals
RX	Receiver
SDH	Synchronous Digital Hierarchy
SIMO	Single Input Multiple Output
SSS	Secondary Synchronizing Signal
SW	SoftWare
TMA	Tower Mount Amplifier
TX	Transmitter

UE User Equipment
UL UpLink

4 Assessment method

The assessment method is covering the BS equipment dynamic efficiency for which the present document defines reference BS equipment configurations and reference load levels to be used when measuring BS efficiency.

The assessment procedure contains the following tasks:

- 1) Identification of equipment under test:
 - 1.1 Identify BS basic parameters (Table A.1).
 - 1.2 List BS configuration (annexes A and B).
 - 1.3 List traffic load(s) for measurements (annex C).
 - 1.4 List of used power saving features and capacity enhancement features.
- 2) Efficiency measurement under dynamic load conditions, Measure BS equipment delivered task in terms of bits and the consumed energy under required conditions (see clause 6).
- 3) Collect and report the efficiency measurement results.

5 Reference configurations and Measurement requirements

5.1 Reference configurations

Reference configurations are defined for LTE in annex B.

These configurations include integrated and distributed BS, mast head amplifiers, remote radio heads, RF feeder cables, number of carriers, number of sectors, power range per sector, frequency range, diversity, MIMO.

The BS shall be tested with its intended commercially available configuration at temperatures defined in clause 5.6 "Environmental conditions". It shall be clearly reported in the measurement report if the BS cannot be operated without additional air-conditioning at the defined temperatures.

Appropriate transmission e.g. a transport function or other providing capacity corresponding to the BS capacity, shall be included in the BS configuration during testing. The configurations include:

- 1) UL diversity (this is a standard feature in all BS. Therefore, it is considered sufficient that the test is performed on the main RX antenna only. The diversity RX shall be active during the measurement without connection to the test signal).
- 2) DL diversity (not considered in HSPA. LTE: Transmission mode 3 "Open loop spatial multiplexing" shall be according to ETSI TS 136 211 [4] (2×2 DL MIMO)).

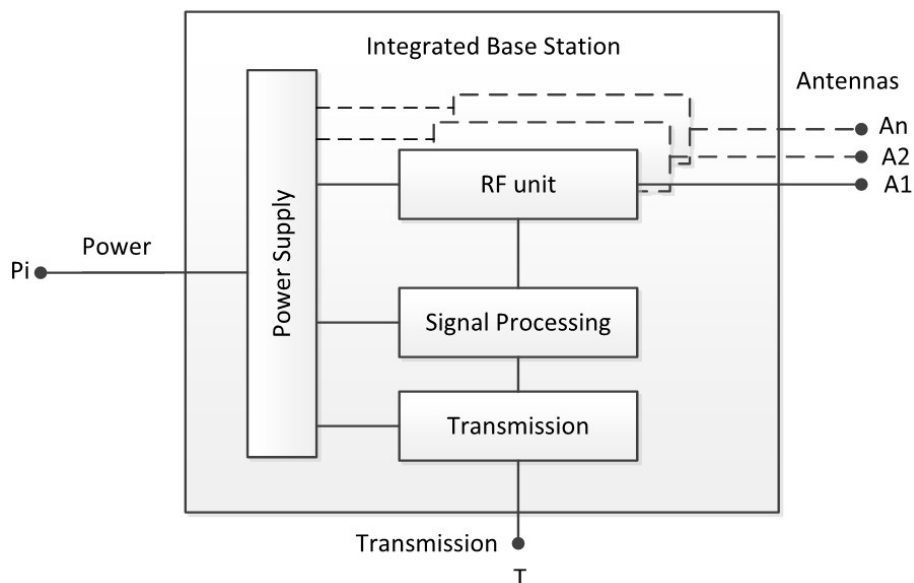

Figure 1: Integrated BS model

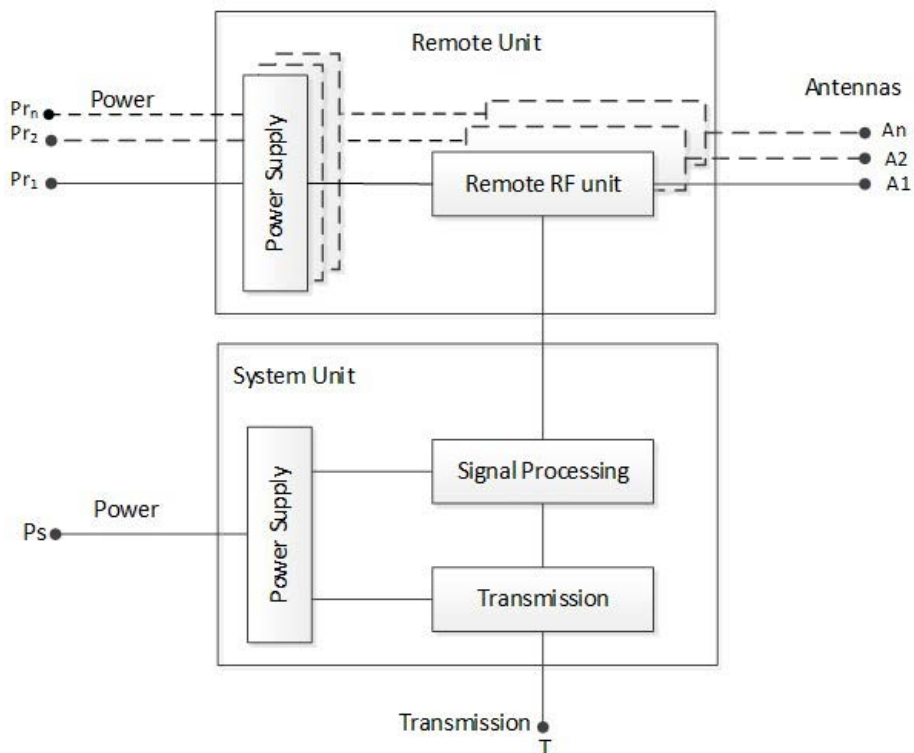

Figure 2: Distributed BS model

5.2 Measurement and test equipment requirements

The measurement of the power consumption shall be performed by either measuring the power supply voltage and true effective current in parallel and calculate the resulting power consumption (applicable only for DC) or with a wattmeter (applicable for both AC and DC). The measurements can be performed by a variety of measurement equipment, including power clamps, or power supplies with in-built power measurement capability.

All measurement equipment shall be calibrated and shall have data output interface to allow long term data recording and calculation of the complete power consumption over a dedicated time.

The measurement equipment shall comply with following attributes:

- Input power:
 - Resolution: ≤ 10 mA; ≤ 100 mV; ≤ 100 mW.
 - DC current: ± 1 %.
 - DC voltage: ± 1 %.
 - AC power: ± 1 %.
 - An available current crest factor of 5 or more.
 - The test instrument shall have a bandwidth of at least 1 kHz.

NOTE: Additional information on accuracy can be found in IEC 62018 [i.4].

- RF output power accuracy: $\pm 0,4$ dB.

5.3 BS Configuration

The BS shall be tested under normal test conditions according to the information accompanying the equipment. The BS, test configuration and mode of operation (baseband, control and RF part of the BS as well as the software and firmware) shall represent the normal intended use and shall be recorded in the test report.

The BS shall be tested with its typical configuration. In case of multiple configurations, a configuration with 3 sectors shall be used.

EXAMPLE: A typical wide area BS configuration consists of three sectors and shall therefore be tested in a three-sector configuration. If a BS is designed for dual or single sector applications, it shall be tested in its designed configuration.

The connection to the simulator via the BS controller interface shall be an electrical or optical cable-based interface (e.g. PCM, SDH, and Ethernet) which is commercially offered along with the applied BS configuration.

Additional power consuming features like battery loading shall be switched off.

The used power saving features and SW version shall be listed in the measurement report.

The measurement report shall mention the configuration of the BS for example the type of RF signal combining (antenna network combining, air combining or multi-carrier).

5.4 Transmit Signal and RF output power

The maximum RF transmit power that the base station under test is capable of shall be reported.

The base station under test shall control the RF transmit signal to fulfil the traffic profiles as listed in annexes A and B.

The power amplifier(s) of the BS shall support the same crest factor (peak to average ratio) and back-off as applied in the commercial product.

All relevant requirements from 3GPP specifications for the LTE air-interface shall be fulfilled.

5.5 UE Emulator requirements and settings

UE power consumption is not considered in the present document. However, UE category and performance has a significant impact on the base station energy efficiency. To assess energy efficiency of the BS, the UE capabilities represented by the UE emulator shall be used as following:

- The UE emulator shall provide the total capacity (number of simultaneous UEs as defined in annex C, max data rate, etc.) to load the BS per test specifications.

- The UE emulator shall be capable of Supporting LTE release 12.
- Multiband radio interface support 400 - 4 000 MHz.
- Simulation capacity of 1 000 UE.
- Full stack E2E UE simulation.
- Capability of Mobility simulation.
- Fading simulation capability (according to 3GPP models).
- Possibility to control every UE position (pathloss), data traffic, fading and other radio channel behaviour individually.
- Logging of UE performance.

The used UE emulator type shall be recorded in detail for the test protocol. This shall include HW and S/W versions.

5.6 Environmental conditions

For the BS efficiency measurements, the environmental conditions under which the BS shall be tested are defined as follows.

Table 1: BS environmental conditions

Condition	Minimum	Maximum
Barometric pressure	86 kPa (860 mbar)	106 kPa (1 060 mbar)
Relative Humidity	20 %	85 %
Vibration	Negligible	
Temperature	+25 °C	
Temperature accuracy	±2 °C	

The BS efficiency measurements shall be performed when stable temperature conditions inside the equipment are reached. For this purpose, the BS shall be placed in the environmental conditions for minimum two hours with a minimum operation time of one hour before doing the measurements.

5.7 Power supply

For measurements of the BS power consumption the following operating voltage value shall be used (for non-standard power supply voltages one should use operating voltage with $\pm 2,5$ % tolerances).

Nominal value and operating value for AC testing shall be according to [2] and for DC testing to [3] & [7].

The frequency of the power supply corresponding to the AC mains shall be according to [2].

6 Energy Efficiency Performance

6.1 Energy Efficiency Performance KPI Definition

For dynamic measurement, the BS shall be operated in a test and measuring environment as illustrated in Figure 3.

For equipment efficiency measurements the following items are specified for each system in annexes B and C:

- Reference configuration (annex B).
- Frequency bands (annex B).
- Traffic load levels (annex C).

- Traffic case (annex C).

Power Savings features and other radio and traffic related features implemented in BS can be used during the testing. Such features shall be listed in the measurement report.

The BS is powered by a DC or AC power supply. The control unit itself is connected to the core network. The core network can be either a real network element or a core network emulator.

6.2 Energy Efficiency Performance Measurement

6.2.1 Measurement Lab Setup

Figure 3 shows the test setup using a UE emulator and a channel emulator connected to the BS under test. A traffic generator is used to generate both data traffic requested by the UEs and measuring the received data by the UEs during the measurement period.

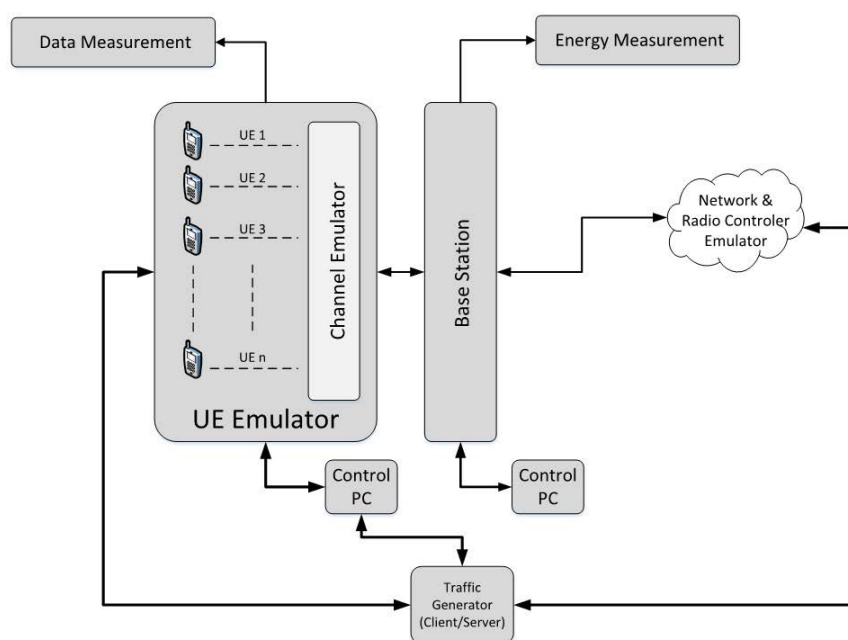

NOTE: BS as defined in Figure 1 (integrated BS) or Figure 2 (distributed BS). AC supply to be used for BS with build in AC power supply, otherwise default DC supply voltage as specified in clause 5.7.

Figure 3: Test setup for dynamic measurement with integrated BS and UE emulator

The BS shall be operated and controlled via the controller units as illustrated in Figure 3 in conjunction with the UE distribution and the traffic models and reference parameters given in annexes B and C.

A channel emulator is used either by an in-built channel emulator in the UE emulator or as a standalone channel emulator. It is used for emulating fading over the radio channels between UEs and the BS. The fading models shall be according the models specified in 3GPP TR 36 873 [8].

6.2.2 UE Distribution

The UEs are distributed in three different path loss regions, low path loss, medium path loss and high path loss regions. The number of allocated UEs in each region are according to Table C.1. The path loss value for each region is also according Table C.1.

The number of UEs for low, medium, and busy-hour traffic loads are different and are according to Table C.1.

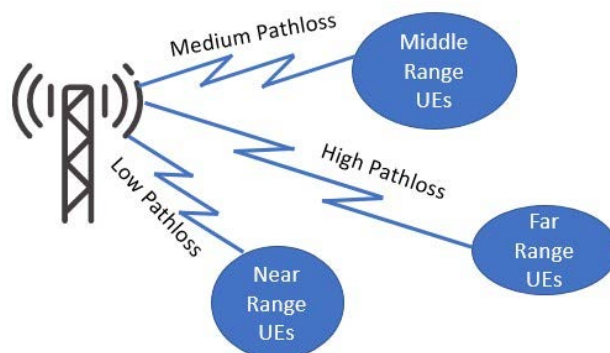

Figure 4: UE distribution in three different pathloss areas

6.2.3 Data Traffic Model

The traffic model used for BS energy efficiency measurement in the present document is based on artificially generated data traffic by a traffic generator. This traffic generator is either inbuilt in the UE emulator used in the test setup or is a standalone traffic generator. The following requirements shall be fulfilled for the data traffic model in the present document.

- The data traffic model shall be based on TCP protocol.
- Measurement results shall be repeatable within a given confidence interval of 95 %.
- The total number of delivered files, file types and data volume per UE is defined in annex C.
- An inter arrival time shall be applied before requesting a new file by each UE. When this time is elapsed, a UE will request the next file. This time could be different for different UEs, load scenarios and file sizes and is defined in annex C.
- An idle state time shall be applied when all the UEs have finished requesting data and the BS enters the idle state. This idle state time is defined according to annex C.
- Startup procedure: in order to reduce the time to reach stable conditions, it is recommended that each emulated UE shall start requesting files individually, with a start-up delay between each UE file request start.

Figure 5 shows a sketch over how different files in a random way are transmitted to each UE. At the start of the test each UE starts to be connected randomly and independent of each other (No UE starts at the same time). The data traffic model used in the present document is based on transmitting three different file sizes denoted as small, medium, and large file sizes. The size of these files is defined in annex C. The number of files to be requested by each UE is fixed and is different for small, medium, and large file sizes which are specified in annex C.

During the measurement, each UE starts requesting a predefined fixed number of files from a bucket of files assigned to this UE. The number of these files are defined in annex C and are denoted as "S" for small files, "M" for medium files and "L" for large files. Each UE continues requesting files until there is no file left to be requested in the bucket assigned to this UE.

When there is no file left to be sent by BS to the UEs i.e. all the files have been requested and received by the UEs, the BS enters an idle state for a specific idle time according to annex C.

After this idle time has elapsed the measurement will be stopped and the energy consumption, the received data by the UEs and the total measurement time will be collected.

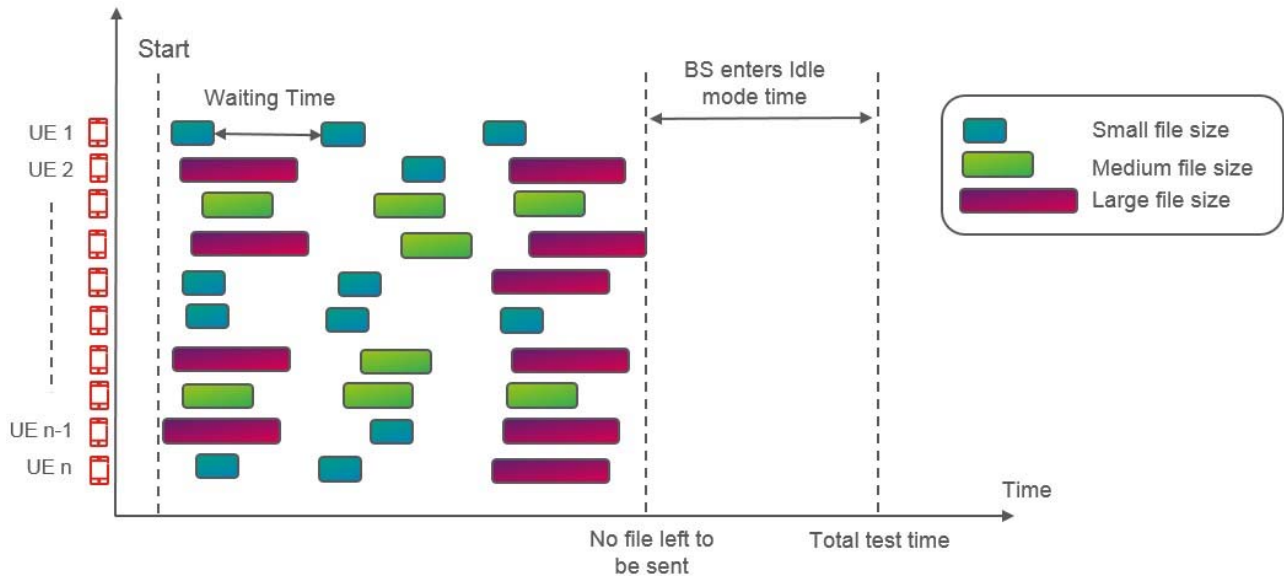

Figure 5: Data traffic flow to each UE

6.2.4 Measurement Time Definition

The total measurement time is dependent on the time when all UEs have received their requested files sent by the base station plus the idle state time of the BS. This measurement time is denoted as $T_{measurement}$ and it is the time between the start of the measurement and the time when the measurement has stopped.

The measured time for low, medium and busy-hour traffic loads are: $T_{measurement-low}$, $T_{measurement-medium}$, and $T_{measurement-busy-hour}$ respectively.

6.2.5 Low traffic model

For low load traffic level, the number of used UEs is the lowest. Time between requesting each file by each UE, file sizes and file count is specified in annex C.

6.2.6 Medium traffic model

For medium load traffic level, the number of UEs is at the medium level. Time between requesting each file by each UE, file sizes and file count is defined in annex C.

6.2.7 Busy-hour traffic model

For the busy-hour traffic level the number of used UEs is highest. Time between requesting each file by each UE, file sizes and file count is defined in annex C.

6.2.8 Data Volume Measurement

All received data by the UEs during each measurement period for each traffic level shall be measured. The measured data is the net data volume and shall not contain any duplicated or retransmitted data. The data shall be generated as described in clause 6.2.3 and annex C. The measured data will be used for calculation of BS efficiency KPI and is in bits.

Since the time period for the three load levels in a real network under a 24-hours period is different, three weighting factors are applied to the measurement results to reflect the time ratio of low load, medium load and busy-hour load levels in a 24-hours period respectively.

These weighting factors are denoted as W_{low} for low traffic, W_{medium} for medium traffic and $W_{busy-hour}$ for busy-hour traffic level and they are defined in annex C.

The measured data volume in bits for low load level is denoted as $DV_{measured-low}$.

The measured data volume in bits for medium load level is denoted as $DV_{measured-medium}$.

The measured data volume in bits for busy-hour load level is denoted as $DV_{measured-busy-hour}$.

The total data volume for 24-hours period is calculated as following:

$$DV_{total} = \left(DV_{low} \times \frac{W_{low}}{T_{measurement\ low}} \right) + \left(DV_{medium} \times \frac{W_{medium}}{T_{measurement\ medium}} \right) + \left(DV_{busy\ hour} \times \frac{W_{busy\ hour}}{T_{measurement\ busy\ hour}} \right) [bits] \quad (6.1)$$

The three load levels shall be measured at middle frequency channel.

6.2.9 Power and Energy Consumption Measurement

The energy consumption measurements shall be performed when the stable temperature conditions inside the equipment are reached. For this purpose, the BS shall be placed in the environmental conditions for minimum two hours with a minimum operation time of one hour before starting the measurements.

Measurement results shall be captured earliest when the equipment including the selected load is in stable operating conditions.

The RF output powers as well as the corresponding power consumptions of the BS shall be measured and collected during the whole measurement period according to the traffic model described in clause 6.2.3 and annex C.

The test models as well as the different traffic loads are defined in clause 6.2.3 and annex C.

The power consumption of the BS shall be given in Watts in accordance with the accuracies and the resolutions given in clause 5.7.

The measurement expanded uncertainty shall be assessed according to annex D.

6.2.10 Energy Consumption measurement

The energy consumption of the base station under test shall be calculated during the whole measurement period. The total energy consumption of the base station will be the sum of weighted energy consumption for each traffic level i.e. low, medium and busy-hour traffic.

Since the time period for the three load levels in a real network under a 24-hours period is different, three weighting factors are applied to the measurement results to reflect the low load, medium load and busy-hour load levels in a 24-hours period respectively.

These weighting factors are denoted as W_{low} for low traffic, W_{medium} for medium traffic and $W_{busy-hour}$ for busy-hour traffic level and they are defined in annex C.

To calculate the energy consumption, the power consumption of the BS is sampled continuously (interval time Δt_m : 0,5 seconds or shorter) over the complete measurement period for each traffic level. For the integrated BS,

$P_{i,equipment}^{traffic_scenario}$ is the measured power value for the i^{th} sampled measurement during the measurement period. The energy

$E_{equipment}^{traffic_scenario}$ which is the energy consumption of the BS during the measurement is calculated as follows:

$$E_{equipment}^{traffic_scenario\ x} = \sum_{k=1}^n (\Delta t_m \cdot P_{k,equipment}^{traffic_scenario\ x}) [Wh] \quad (6.2)$$

For the distributed BS, $E_{C,equipment}$ and $ERRH_{equipment}$ [Wh] are the energy consumption of the central and the remote parts in the dynamic method defined as:

$$E_{RRH,equipment}^{traffic_scenario\ x} = \sum_{k=1}^n (\Delta t_m \cdot P_{k,RRH,equipment}^{traffic_scenario\ x}) [Wh] \quad (6.3)$$

$$E_{C,equipment}^{traffic_scenario\ x} = \sum_{k=1}^n (\Delta t_m \cdot P_{k,C,equipment}^{traffic_scenario\ x}) [Wh] \quad (6.4)$$

Where $n = \frac{T_{measurement}}{\Delta t_m}$, and $T_{measurement}$ is the measurement time for each traffic level and Δt_m is the sampling period.

The measured energy consumption in Wh for low load level is denoted as $E_{equipment}^{measured-traffic_scenario_low}$.

The measured energy consumption in Wh for medium load level is denoted as $E_{equipment}^{measured-traffic_scenario_medium}$.

The measured energy consumption in Wh for busy-hour load level is denoted as $E_{equipment}^{measured-traffic_scenario_busy-hour}$.

The total energy consumption for 24-hours period is calculated as following:

$$E_{total\ equipment} = \left(E_{low} \times \frac{W_{low}}{T_{measurement\ low}} \right) + \left(E_{medium} \times \frac{W_{medium}}{T_{measurement\ medium}} \right) + \left(E_{busy\ hour} \times \frac{W_{busy\ hour}}{T_{measurement\ busy\ hour}} \right) [Wh] \quad (6.5)$$

For the calculation of the total energy consumption for distributed BS similar calculation as above for radio remote part and the central equipment part formulas (6.2) to (6.6) can be used. The sum of each part and then summing up these two parts to obtain the total energy consumption for a distributed BS.

6.2.11 Base Station Energy Efficiency KPI

The base station energy efficiency KPI is an indicator for showing how a base station in a energy efficient way is doing work in terms of delivering useful bits to the UEs served by the base station. A base station is more energy efficient when doing more work with the same energy, doing the same work with less energy or in the best case doing more work with less energy. The base station energy efficiency KPI is the ratio of delivered bits and consumed energy and is consisting of delivered useful bits in the numerator and consumed energy in the denominator.

$$BSEP = \frac{DV_{total}}{E_{equipment}^{total}} \left[\frac{bits}{Wh} \right] \quad (6.6)$$

Where DV_{total} is the total delivered bits during the measurement for all three traffic levels according to clause 6.2.6 and $E_{equipment}^{total}$ is the total consumed energy during the measurement period for delivering DV_{total} according to clause 6.2.8.

6.2.12 UE quality of service KPI

The final report shall include UE quality of service KPI as throughput. For every transmitted file an average throughput for that file shall be calculated. Average throughput of a file is calculated as file size divided by file transmission time. Transmission time starts when a UE requests a file and ends when the complete files is received.

For each load level average UE throughput shall be reported for all UEs. 95 % percentile shall also be provided, see annex A.

7 Uncertainty

The measurement expanded uncertainty shall be assessed according to annex D.

8 Measurement report

The results of the assessments shall be reported accurately, clearly, unambiguously and objectively, and in accordance with any specific instructions in the required method(s).

A list of reference parameters, measurement conditions, test results, uncertainty analysis (cf. annex D) and derived calculation results which shall be reported according to annex A. The report shall contain a full list of equipment, interfaces and detailed of test setup realized to perform the measurement in line with Figure 3.

Further guidelines on the test report can be found in clause 5.10 of ISO/IEC 17025 [i.3].

Annex A (normative): Test Reports

A.1 General information to be reported

Table A.1: Test general information

Items	Remarks
1) Test report reference and version	
2) Date of the test	
3) Standard Used as test methodology	
4) Location of the test	
5) Name of test organization and person responsible	
6) Tested equipment	
6.1) Tested HW unit names and serial numbers	
6.2) Software version of tested equipment	
7) List of used measurements equipment including type, serial number and calibration information	

Table A.2: BS reference parameters to be reported

Parameter	Value	Unit
1) BS configuration		
1.1) Number of sectors		
1.2) Nominal max RF output power per sector		W
1.3) Number of carriers per sector		
1.3.1) Number of carriers the BS is able to support		
1.3.2) Number of carriers, for which the HW was enabled (independent whether or not the carriers were used for the test)		
1.3.3) Number of carriers used during the test		
1.4) TX diversity		
1.5) RX diversity (number)		
1.6) Type of RF signal combining		
1.7) Remote Radio Head (Yes/No)		
2) Frequency		
2.1) Downlink band		MHz
2.2) Uplink band		MHz
2.3) Channel bandwidth		MHz
3) Environment		
3.1) Temperature range		°C
3.2) Type of air filter		
4) Features		
4.1) Power saving features		
4.2) Coverage and capacity features		
4.3) Downlink ciphering used? (Y/N)		

A.2 Base Station Energy Performance report

Table A.3: Measurements conditions and results to be reported for BS Energy Performance

Parameter	Test case 25 °C	Unit
1) Test environment		
1.1) Temperature during test (measured)		°C
1.2) Pressure (measured)		kPa
1.3) Relative humidity (measured)		%
2) Frequency used during test		
2.1) Downlink Centre frequency of middle channel		MHz
2.2) Uplink Centre frequency of middle channel		MHz
3) Supply voltage		
3.1) DC voltage (measured)		V
3.2) AC voltage (measured, phase to neutral)		V
3.3) AC Frequency (measured)		Hz
4) Dynamic energy consumption (measured)		
4.1) Low traffic level		Wh
4.2) Medium traffic level		Wh
4.3) Busy-hour traffic level		Wh
5) Accumulated measured data volume		
5.1) Low traffic level		bits
5.2) Medium traffic level		bits
5.3) Busy-hour traffic level		bits

Table A.4: Calculated results to be reported for BS Energy Performance

Parameter	Value	Unit
1) Total delivered data in bits during the test		bits
2) Total energy consumption		Wh
3) Coverage		km ²
4) Base Station Energy Performance (BSEP)		bits/Wh
5) Average UE throughput		kbps
6) Expanded uncertainty		%

The measurement report shall include the uncertainty Table following the template defined in Table D.1.

Table A.5: UE Emulator reporting table

Item	Value	Remarks	Unit
Additional Antenna attenuator for DL test		Value of sensitivity and power correction attenuators as specified in section UE requirements	dB
Additional Antenna attenuator for UL test		Value of sensitivity and power correction attenuators as specified in section UE requirements	dB
UE Category	4	This category is fixed for purpose of testing	
UE emulator version			
UE Emulator Model			
UE Manufacturer			
Maximum specified DL data rate		According to manufacturer data sheet	kbps
Maximum specified UL data rate		According to manufacturer data sheet	kbps
Serial number			
UE emulator SW version			
Other		Any other information/parameter that is needed to reproduce the measurement shall be stated	

Annex B (normative): Reference parameters for LTE system

Reference configurations for LTE shall be:

- Only normal cyclic prefix is used.
- RF output power: 2 x 40 W.
- PBCH shall be transmitted.
- PDCCH REG EPRE and PDSCH PRB P_A shall be used as defined in TM1.1 [9].
- Usage of PDSCH PRBs and PSS & SSS & PBCH can overlap for medium load and busy hour load.
- PDCCH CCE allocation can be selected freely for medium load and busy hour load.
- Number of sectors and transmitters:
 - 111 (1 TX, 2 RX-paths per sector, SIMO);
 - 111 (1 carrier, 2 TX, 2 RX-paths per sector, MIMO).

RF bands are specified in ETSI TS 136 104 [5] The amount of available bandwidth varies for different frequencies. Table B.1 proposes the default bandwidth setting for different bands. Carrier bandwidth shall be chosen according to the Table B.1.

Table B.1: Bandwidth and Duplex mode for different E-UTRA operating bands supported by current standard version

E-UTRA operating band	1	2	3	4	7	9	10	11	20	22	23	24	25	30	32
Duplex mode	FDD	FDD	FDD	FDD	FDD	FDD	FDD	FDD	FDD	FDD	FDD	FDD	FDD	FDD	FDD
Test BW (MHz)	20	20	20	20	20	20	20	20	20	20	20	20	20	20	20

- Power for RS: 15 dBm.
- RF output power level:
 - Power Range applicable to the "Wide Area BS" class as defined in ETSI TS 136 104 [5].
 - Maximum nominal RF output power at antenna connector according to product specification and according to the load levels (Output power at antenna connector = load model-based percentage * Maximum nominal RF output power) measured at the antenna connector according to ETSI TS 136 141 [9].
- Power Input:
 - -48 V DC, 230 V AC.

Frequency bands for LTE:

The frequency band shall be as defined in ETSI TS 145 005 [i.2] and according to equipment specifications. For measurement centre frequency of the specified band is used.

Annex C (normative): Data Traffic Model

C.1 Data Traffic Model

The UEs shall be distributed based on the path loss distribution according to Tables C.2, C3 and C4 for low, medium and busy-hour traffic model. Three file sizes are requested by UEs. These three files are different for different traffic load levels according to Tables C.2, C3 and C4. There is a time applied between each requested file by UEs. This inter arrival time is different for different file sizes and is depicted in Tables C.2, C.3 and C.4.

Since the time period for the three load levels in a real network under a 24-hours period is different, three weighting factors are applied to the measurement results to reflect the time ratio of low load, medium load and busy-hour load levels in a 24-hours period respectively. These weighting factors are denoted as W_{low} for low traffic, W_{medium} for medium traffic and $W_{busy-hour}$ for busy-hour traffic level and they are defined in Table C.1 for low, medium and busy-hour traffic levels respectively.

In addition to the path loss settings the minimum power received by the UE shall be specified (as it was in ETSI ES 202 706-1 [i.6] (V1.4.1)):

LTE: RS = 15 dBm

Table C.1: Total number of UEs and Weighting factor

Traffic load level	Low	Medium	Busy-hour
Total number UEs	18	24	40
Weighting Factor	$W_{low} = 8$	$W_{medium} = 10$	$W_{busy-hour} = 6$

Table C.2: Traffic model parameters for Low Load level

Low Load Level									
Path loss [dB]	85			110			130		
File size [kByte]	0,1	1	10	0,1	1	10	0,1	1	10
% of file distribution	50 %	22 %	28 %	50 %	22 %	28 %	50 %	22 %	28 %
Inter Arrival Time [ms]	4	20	200	4	20	200	4	20	200
# UEs per files size	1	1	1	7	2	3	1	1	1
# UEs per path loss	3			12			3		
% of UEs per path loss	17 %			66 %			17 %		

Table C.3: Traffic model parameters for Medium Load Level

Medium Load Level									
Path loss [dB]	85			110			130		
File size [kByte]	0,1	1	250	0,1	1	250	0,1	1	250
% of file distribution	50 %	25 %	25 %	50 %	25 %	25 %	50 %	25 %	25 %
Inter arrival time [ms]	4	20	200	4	20	200	4	20	200
# UEs per path files size	1	1	1	10	4	4	1	1	1
# UEs per path loss	3			18			3		
% of UEs per path loss	12,5 %			75 %			12,5 %		

Table C.4: Traffic model parameters for Busy-hour Load Level

Busy-hour Load Level									
Path loss [dB]	85			110			130		
File size [kByte]	0,1	1	250	0,1	1	250	0,1	1	250
% of file distribution	44 %	28 %	28 %	50 %	25 %	25 %	50 %	25 %	25 %
Inter arrival time [ms]	4	20	200	4	20	200	4	20	200
# UEs per path files size	2	2	2	14	7	7	2	2	2
# UEs per path loss	6			28			6		
% of UEs per path loss	15 %			70 %			15 %		

C.2 Measured data for BS Energy Performance KPI calculation

To calculate the BS Energy Performance KPI, the equations specified in clause 6.2 shall be applied. Table C.5 gives data needed for calculation the BS EE KPI.

Table C.5: Data required for calculation of BSEP

Traffic load levels	Low	Medium	Busy-hour
Weighting factor	$W_{low} = 8$	$W_{medium} = 10$	$W_{busy-hour} = 6$
Measured time	$T_{measured-low}$	$T_{measured-medium}$	$T_{measured-busy-hour}$
Measured data volume [bits]	$DV_{measured-low}$	$DV_{measured-medium}$	$DV_{measured-busy-hour}$
Measured Energy Consumption [Wh]	$E_{equipment}^{measured-traffic_scenario_low}$	$E_{equipment}^{measured-traffic_scenario_medium}$	$E_{equipment}^{measured-traffic_scenario_busy_hour}$

Annex D (normative): Uncertainty assessment

D.1 General requirements

The assessment of uncertainty in the measurement of the dynamic efficiency of a base station shall be based on the general rules provided by the IEC/ISO Guide 98-3 [i.1] "Evaluation of measurement data - Guide to the expression of uncertainty in measurement" that is publicly available at:

- http://www.bipm.org/utis/common/documents/jcgm/JCGM_100_2008_E.pdf.

Uncertainty factors are grouped into two categories according to the method used to estimate their numerical value:

- Type A: those which are evaluated by statistical means.
- Type B: those which are evaluated by other means, usually by scientific judgment using information available.

When a *Type A* analysis is performed, the standard uncertainty u_i shall be derived from the estimate from statistical observations.

When *Type B* analysis is performed, the standard uncertainty u_i is derived from the parameter $a = (a_+ - a_-)/2$, where a_+ is the upper limit and a_- is the lower limit of the measured quantity, and taking into account the distribution law of measured quantity, as follows:

- Normal law: $u_i = a/k$ where k is a coverage factor.
- U-shaped (asymmetric) law: $u_i = a/\sqrt{2}$.
- Rectangular law: $u_i = a/\sqrt{3}$ (default value to be used in the absence of any other information).
- Triangular law: $u_i = a/\sqrt{6}$ (not used in the present document).

D.2 Components contributing to uncertainty

D.2.1 Contribution of the measurement system

The factors contributing to uncertainty are schematically shown in the uncertainty trees (Figure D.1).

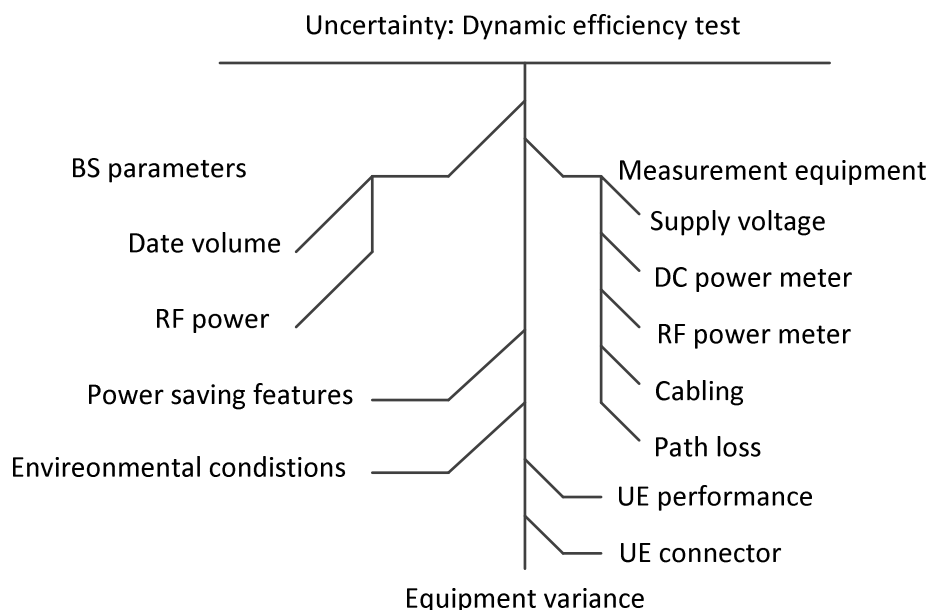

Figure D.1: Uncertainty tree - dynamic efficiency test

D.2.2 Measurement equipment (dynamic)

The uncertainty contributed by the measurement equipment, e.g. voltmeter, power meter, RF power meter shall be assessed with reference to its calibration certificates. The uncertainty due to the measurement device shall be evaluated assuming a type B normal probability distribution.

D.2.3 Attenuators, cables (dynamic)

The uncertainty contributed by the attenuator, shall be assessed with reference to its calibration certificates. The uncertainty due to the attenuator shall be evaluated assuming a Type B normal probability distribution.

D.2.4 UE emulator (dynamic)

The uncertainty contributed by the UE emulator, shall be assessed with reference to its calibration certificates. The uncertainty due to the UE emulator shall be evaluated assuming a Type B normal probability distribution.

D.3 Contribution of physical parameters

D.3.1 Impact of environmental parameters (dynamic)

The impact of environmental parameters (mainly temperature) is assessed considering temperature variation during the measurement period. It has to be assured that the DUT has reached stable conditions as defined in clause 5.6. The uncertainty shall be evaluated assuming a Type B rectangular probability distribution.

D.3.2 Impact of path loss(dynamic)

The contribution due to the path loss, radio effects, etc are controlled during the tests and the resulting error is less than $\pm x$ %. The uncertainty shall be evaluated assuming a Type B rectangular probability distribution. Path loss uncertainty is a result of attenuator and cable uncertainty as described under clause D.2.3.

D.3.3 Data volume (dynamic)

The uncertainty contributed by the traffic monitoring, shall be assessed with reference to its calibration certificates. The uncertainty due to the traffic monitoring shall be evaluated assuming a Type B normal probability distribution.

D.3.4 Variance of device under test

Based on component variances the individual base stations will have a certain deviation from the nominal value. The tested base station shall represent the nominal performance. The product to product efficiency spread is not considered in this uncertainty analysis but additional results on product efficiency spread might be provided.

D.4 Uncertainty assessment

D.4.1 Combined and expanded uncertainties

The contributions of each component of uncertainty shall be registered with their name, probability distribution, sensitivity coefficient and uncertainty value. The results shall be recorded in a table of the following form. The combined uncertainty shall then be evaluated according to the following formula:

$$u_c = \sqrt{\sum_{i=1}^m c_i^2 \cdot u_i^2} \quad (\text{D.1})$$

where c_i is the weighting coefficient.

The expanded uncertainty shall be evaluated using a confidence interval of 95 % using the templates defined in Table D.1 for dynamic measurements.

Table D.1: Uncertainty analysis for dynamic efficiency assessment

ERROR SOURCES	Description (clause)	Uncertainty Value (%)	Probability Distribution	Divisor	c_i	Standard Uncertainty (%)
Measurement Equipment						
Supply voltage	D.2.2		Normal	1	1	
Power consumption / DC power meter	D.2.2		Normal	1	1	
RF power / RF power meter	D.2.2		Normal	1	1	
Cabling, Attenuators	D.2.3		Normal	1	1	
Data volume	D.2.4		Normal	1	1	
User equipment	D.2.4		Rectangular	$\sqrt{3}$	1	
Physical Parameters						
Environment conditions (T)	D.3.1	5 %	Rectangular	$\sqrt{3}$	0,5	
Impact of path loss	D.3.3		xx	xx	xx	
BS parameters						
Equipment variance	D.3.4	-	Gaussian			
Combined standard uncertainty			$u_c = \sqrt{\sum_{i=1}^m c_i^2 \cdot u_i^2}$			
Expanded uncertainty (confidence interval of 95 %)			Normal			$u_e = 1,96 u_c$

D.4.2 Cross correlation of uncertainty factors

Cross correlations of above uncertainty factors are not considered if not otherwise stated.

D.4.3 Maximum expanded uncertainty

The expanded uncertainty with a confidence interval of 95 % shall not exceed 20 % for dynamic tests.

If the expanded uncertainty is exceeding this target, then the uncertainty shall be added to the measured results.

Annex E (informative): Bibliography

- NIST Technical Note 1297: "Guidance for evaluating and expressing the uncertainty of NIST measurement results".

History

Document history		
V1.1.1	August 2009	Publication as ETSI TS 102 706
V1.2.1	October 2011	Publication as ETSI TS 102 706
V1.3.1	July 2013	Publication as ETSI TS 102 706
V1.4.1	December 2014	Publication as ETSI ES 202 706
V1.5.1	November 2018	Publication