



**Intelligent Transport Systems (ITS);
RTTT;**

**Test specifications for High Data Rate (HDR) data
transmission equipment operating in the 5,8 GHz ISM band;
Part 2: Application Layer;
Sub-Part 3: Abstract Test Suite (ATS)
and partial PIXIT proforma**

ReferenceRTS/ITS-0020033

Keywordsapplication, ATS, DSRC, ITS, layer 7, PIXIT,
protocol, testing, TTCN

ETSI650 Route des Lucioles
F-06921 Sophia Antipolis Cedex - FRANCE

Tel.: +33 4 92 94 42 00 Fax: +33 4 93 65 47 16

Siret N° 348 623 562 00017 - NAF 742 C
Association à but non lucratif enregistrée à la
Sous-Préfecture de Grasse (06) N° 7803/88

Important notice

Individual copies of the present document can be downloaded from:

<http://www.etsi.org>

The present document may be made available in more than one electronic version or in print. In any case of existing or perceived difference in contents between such versions, the reference version is the Portable Document Format (PDF). In case of dispute, the reference shall be the printing on ETSI printers of the PDF version kept on a specific network drive within ETSI Secretariat.

Users of the present document should be aware that the document may be subject to revision or change of status. Information on the current status of this and other ETSI documents is available at

<http://portal.etsi.org/tb/status/status.asp>

If you find errors in the present document, please send your comment to one of the following services:

http://portal.etsi.org/chaicor/ETSI_support.asp

Copyright Notification

No part may be reproduced except as authorized by written permission.
The copyright and the foregoing restriction extend to reproduction in all media.

© European Telecommunications Standards Institute 2012.
All rights reserved.

DECT™, **PLUGTESTS™**, **UMTS™** and the ETSI logo are Trade Marks of ETSI registered for the benefit of its Members.
3GPP™ and **LTE™** are Trade Marks of ETSI registered for the benefit of its Members and
of the 3GPP Organizational Partners.
GSM® and the GSM logo are Trade Marks registered and owned by the GSM Association.

Contents

Intellectual Property Rights	4
Foreword.....	4
1 Scope	5
2 References	5
2.1 Normative references	5
2.2 Informative references.....	6
3 Definitions and abbreviations.....	6
3.1 Definitions.....	6
3.2 Abbreviations	6
4 Abstract Test Method (ATM).....	7
4.1 Protocol layer architecture.....	7
4.2 Test system architecture	7
4.2.1 The TTCN-3 test architecture	7
4.2.2 The HDR Application Layer test architecture	8
4.2.3 Port mapping.....	9
4.2.3.1 Mapping rules for the llc port.....	9
4.2.3.2 Mapping rules for APDUs	9
4.3 Type of SUT.....	10
5 Untestable test purposes	10
6 The ATS development process.....	10
6.1 Requirements and Test Purposes.....	10
6.2 Test case grouping.....	10
6.3 Test case identifier.....	10
6.4 ATS Library	11
6.5 TTCN-3 naming conventions.....	11
6.6 PICS information.....	12
6.7 Test Suite documentation	12
6.8 ATS archive.....	13
Annex A (normative): Partial PIXIT proforma	14
A.1 Introduction	14
A.2 PIXIT items	14
Annex B (informative): TTCN-3 library modules.....	16
B.1 Electronic annex, zip file with TTCN-3 code	16
B.2 Electronic annex, zip file with HTML documentation.....	16
History	17

Intellectual Property Rights

IPRs essential or potentially essential to the present document may have been declared to ETSI. The information pertaining to these essential IPRs, if any, is publicly available for **ETSI members and non-members**, and can be found in ETSI SR 000 314: "*Intellectual Property Rights (IPRs); Essential, or potentially Essential, IPRs notified to ETSI in respect of ETSI standards*", which is available from the ETSI Secretariat. Latest updates are available on the ETSI Web server (<http://ipr.etsi.org>).

Pursuant to the ETSI IPR Policy, no investigation, including IPR searches, has been carried out by ETSI. No guarantee can be given as to the existence of other IPRs not referenced in ETSI SR 000 314 (or the updates on the ETSI Web server) which are, or may be, or may become, essential to the present document.

Foreword

This Technical Specification (TS) has been produced by ETSI Technical Committee Intelligent Transport System (ITS).

The present document is part 2, sub-part 3 of a multi-part deliverable covering the test specifications for High Data Rate (HDR) Dedicated Short Range Communication (DSRC).

Full details of the entire series can be found in part 2-1 [2].

1 Scope

The present document contains the Abstract Test Suite (ATS) and partial PIXIT proforma to test the Application layer of ES 200 674-1 [1].

The objective of this abstract test specification is to provide test scripts for testing conformance of DSRC-HDR equipment specified in [1] giving a high probability of inter-operability between different manufacturer's equipment.

All formal test scripts provided in the present test specification are based on TS 102 708-2-2 [3].

The ISO standard for the methodology of conformance testing (ISO/IEC 9646-1 [4], ISO/IEC 9646-2 [5] and ISO/IEC 9646-5 [6]), ETS 300 406 [7] and ES 201 873-1 [8] specifying the TTCN-3 core language are used as a basis for the test methodology.

2 References

References are either specific (identified by date of publication and/or edition number or version number) or non-specific. For specific references, only the cited version applies. For non-specific references, the latest version of the reference document (including any amendments) applies.

Referenced documents which are not found to be publicly available in the expected location might be found at <http://docbox.etsi.org/Reference>.

NOTE: While any hyperlinks included in this clause were valid at the time of publication, ETSI cannot guarantee their long term validity.

2.1 Normative references

The following referenced documents are necessary for the application of the present document.

- [1] ETSI ES 200 674-1: "Intelligent Transport Systems (ITS); Road Transport and Traffic Telematics (RTTT); Dedicated Short Range Communications (DSRC); Part 1: Technical characteristics and test methods for High Data Rate (HDR) data transmission equipment operating in the 5,8 GHz Industrial, Scientific and Medical (ISM) band".
- [2] ETSI TS 102 708-2-1: "Intelligent Transport Systems (ITS); RTTT; Test specifications for High Data Rate (HDR) data transmission equipment operating in the 5,8 GHz ISM band; Part 2: Application Layer; Sub-Part 1: Protocol Implementation Conformance Statement (PICS) proforma specification".
- [3] ETSI TS 102 708-2-2: "Intelligent Transport Systems (ITS); RTTT; Test specifications for High Data Rate (HDR) data transmission equipment operating in the 5,8 GHz ISM band; Part 2: Application Layer; Sub-Part 2: Test Suite Structure and Test Purposes (TSS&TP)".
- [4] ISO/IEC 9646-1 (1994): "Information technology - Open Systems Interconnection - Conformance testing methodology and framework - Part 1: General concepts".
- [5] ISO/IEC 9646-2 (1994): "Information technology - Open Systems Interconnection - Conformance testing methodology and framework - Part 2: Abstract Test Suite specification".
- [6] ISO/IEC 9646-5 (1994): "Information technology - Open Systems Interconnection - Conformance testing methodology and framework - Part 5: Requirements on test laboratories and clients for the conformance assessment process".
- [7] ETSI ETS 300 406: "Methods for testing and Specification (MTS); Protocol and profile conformance testing specifications; Standardization methodology".
- [8] ETSI ES 201 873-1: "Methods for Testing and Specification (MTS); The Testing and Test Control Notation version 3; Part 1: TTCN-3 Core Language".

- [9] ETSI ES 201 873-5: "Methods for Testing and Specification (MTS); The Testing and Test Control Notation version 3; Part 5: TTCN-3 Runtime Interface (TRI)".
- [10] ETSI ES 201 873-6: "Methods for Testing and Specification (MTS); The Testing and Test Control Notation version 3; Part 6: TTCN-3 Control Interface (TCI)".

2.2 Informative references

The following referenced documents are not necessary for the application of the present document but they assist the user with regard to a particular subject area.

- [i.1] ETSI TS 102 708-1-3: "Intelligent Transport Systems (ITS); RTTT; Test specifications for High Data Rate (HDR) data transmission equipment operating in the 5,8 GHz ISM band; Part 1: Data Link Layer; Sub-Part 3: Abstract Test Suite (ATS) and partial PIXIT proforma".

3 Definitions and abbreviations

3.1 Definitions

For the purposes of the present document, the terms and definitions given in ES 200 674-1 [1], ISO/IEC 9646-1 [4], ISO/IEC 9646-2 [5], ES 201 873-1 [8] and the following apply:

abstract test case: Refer to ISO/IEC 9646-1 [4].

Abstract Test Method (ATM): Refer to ISO/IEC 9646-1 [4].

Abstract Test Suite (ATS): Refer to ISO/IEC 9646-1 [4].

Implementation Under Test (IUT): Refer to ISO/IEC 9646-1 [4].

Lower Tester (LT): Refer to ISO/IEC 9646-1 [4].

Test Purpose (TP): Refer to ISO/IEC 9646-1 [4].

3.2 Abbreviations

For the purposes of the present document, the abbreviations given in ES 200 674-1 [1], ISO/IEC 9646-1 [4], ISO/IEC 9646-2 [5], ES 201 873-1 [8] and the following apply:

AL	Application Layer
ATS	Abstract Test Suite
DLL	Data Link Layer
IUT	Implementation Under Test
LLC	Link Layer Control
OBU	On Board Unit
PDU	Protocol Data Unit
PICS	Protocol Implementation Conformance Statement
PIXIT	Partial Protocol Implementation Extra Information for Testing
RSU	Road Side Unit
SUT	System under Test
TC	Test Case
TP	Test Purpose
TS	Test System
TSS	Test Suite Structure
TTCN	Testing and Test Control Notation
TTCN-3	Testing and Test Control Notation version 3

4 Abstract Test Method (ATM)

This clause describes the ATM used to test TS 102 708-2-2 [3].

4.1 Protocol layer architecture

The implementation under test is the Application layer of ES 200 674-1 [1]. The System under test includes also the PHY layer and the LLC layer, which are necessary to perform the IUT tests.

The tester executes the TTCN-3 scripts of the present Test Specification, running on an emulated PHY layer.

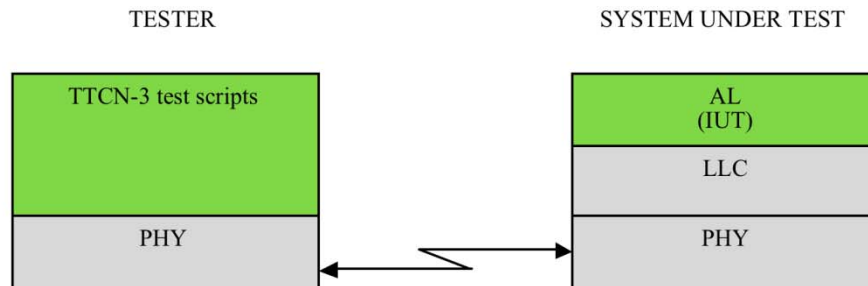

Figure 1: Protocol layer architecture

Table 1 shows the Application Test Suite Structure (TSS) including its subgroups defined for the conformance testing.

Table 1: Test suite structure for DSRC-HDR application layer

Group	Type of system under test (SUT)	Behaviour
Kernel unit	On Board Unit	Valid behaviour
		Invalid behaviour
Read access	Road Side Unit	Valid behaviour
	On Board Unit	Valid behaviour
Write access	On Board Unit	Invalid behaviour
		Valid behaviour
	Road Side Unit	Valid behaviour
	Road Side Unit	Valid behaviour
Optional functionality	On Board Unit	Invalid behaviour
		Valid behaviour
	Road Side Unit	Valid behaviour
	Road Side Unit	Valid behaviour
Security	On Board Unit	Invalid behaviour
		Valid behaviour
	Road Side Unit	Valid behaviour
	Road Side Unit	Invalid behaviour
Integrity constraints	On Board Unit	Invalid behaviour

4.2 Test system architecture

4.2.1 The TTCN-3 test architecture

An abstract architecture for a test system (TS) implementing a TTCN-3 ATS is displayed in figure 2 and also stated in ES 201 873-5 [9].

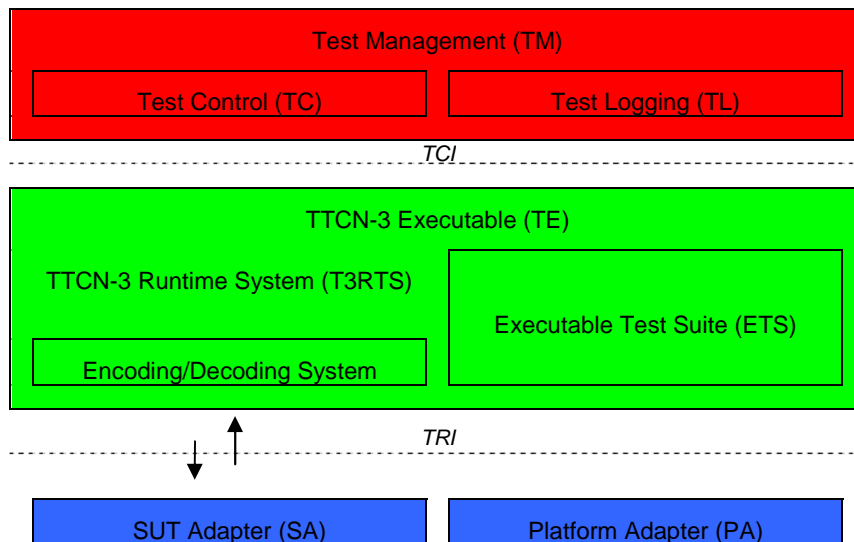

Figure 2: The TTCN-3 Abstract Test System Architecture

A TS has two interfaces, the TTCN-3 Control Interface (TCI) and the TTCN-3 Runtime Interface (TRI), which specify the interface between Test Management (TM) and TTCN-3 Executable (TE) entities, and TE, SUT Adapter (SA) and Platform Adapter (PA) entities, respectively. Out of these two interfaces the TRI has been standardized in ES 201 873-5 [9], whereas the specification and implementation of the TCI is in ES 201 873-6 [10].

The part of TS that deals with interpretation and execution of TTCN-3 modules, i.e. the Executable Test Suite (ETS), is shown as part of the TTCN-3 Executable (TE). This ETS corresponds either to the executable code produced by a TTCN-3 compiler or a TTCN-3 interpreter from the TTCN-3 ATS in a TS implementation. The remaining part of the TS, which deals with any aspects that cannot be concluded from information being present in the TTCN-3 ATS alone, can be decomposed into Test Management (TM), SUT Adapter (SA) and Platform Adapter (PA) entities. In general, these entities cover a TS user interface, test execution control, test event logging, communication of test data with the SUT, and timer implementation.

4.2.2 The HDR Application Layer test architecture

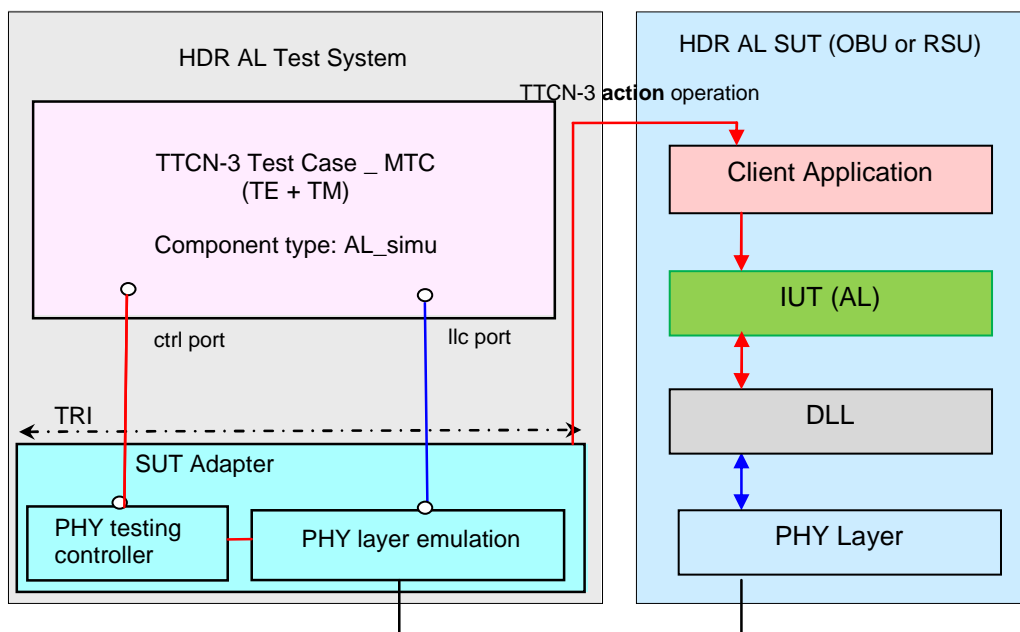

Figure 3: The HDR Application Layer Test System Architecture

The HDR AL Test System Architecture, as described in figure 3, shows the interaction between the test case execution (TE) and the test adapter, as required to cover the test purpose requirements.

LLC frames, sent to the SUT and received from the SUT are handled by the SA in order to fit the TTCN-3 types (see port mapping in the clause 4.2.3). Actually, the application layer (AL) requires changing the LLC address field, so that the TE needs to handle the complete LLC frame as in LLC testing, and not only the Information field where the AL messages are included. As consequence, the TE uses the same port type as the DLL ATS: the llc port.

As in the DLL ATS the TTCN-3 does not manage the values of some fields of the frames, which require dynamic bitwise computation, like for instance the frame flags and the Frame Check Sequence fields. As consequence, the llc port does only manage frames without flags and FCS.

Flags and FCS shall be autonomously and correctly managed by the "PHY layer emulation".

Some test cases require to trigger some actions in the IUT, which result in sending the expected frames to the tester. Triggering these action is realized in TTCN-3 by using the **action** operation (see in ES 201 873-1 [8]). According to the TTCN-3 standards, the **action** operation can result in different types of behaviour. For the best automatization of the test system, it is recommend to use the **action** operation to trigger the IUT for sending the required frames. At a minimum, the TTCN-3 test system shall generate text windows to invite the test operator to activate the necessary procedures in the IUT for sending the required frames.

4.2.3 Port mapping

4.2.3.1 Mapping rules for the llc port

Only one TTCN-3 types is sent and received over the llc port:

- the Lpdu type.

Table 2: Lpdu type mapping

TTCN-3 type	LLC frame field
LlcAddressField	LLC Address Field of the LPDU
Apdu	Information Field of the LPDU, containing the AL messages.

4.2.3.2 Mapping rules for APDUs

In the ATS, the information field containing APDU is using a regular TTCN-3 type: Apdu.

This type declares a message type structure that is defined with ASN.1 in the base standard ES 200 674-1 [1]. The ASN.1 definitions are mapped one to one to standard TTCN-3 type definitions.

The encoding rules of ES 200 674-1 [1], clause 11.4, map all ASN.1 types onto string types resulting in octetstring (Byte aligned). Thus, the usage of ASN.1 specific encoding rules is not necessary.

As a consequence, using TTCN-3 types with Byte aligned bitstring encoding ensures a correct construction of the APDUs.

As far as possible, the same type identifiers were used in the TTCN-3 type definitions as in the ASN.1 type definitions of ES 200 674-1 [1].

As the hyphen character (-) is not allowed in TTCN-3, it was either removed or replaced with a "_" in the TTCN-3 identifiers. If different names are used, table 3 shows the type identifiers mapping between the ATS and ES 200 674-1 [1].

Table 3: Adu type mapping

TTCN-3 type	ASN.1 type of ES 200 674-1 [1]
RequestPdu	Request-PDU
ResponsePdu	Response-PDU
RespondingModeValue	3 MSB bits of RespondingMode
RespondingModeReserved	5 MSB bits of RespondingMode (reserved)
OpenMessage	Open-Rq
CloseMessage	Close-Rq

4.3 Type of SUT

Two types of systems under test (SUT) are distinguished, i.e. on board units (OBUs) and road side units (RSUs).

5 Untestable test purposes

This clause gives a list of TP, which are not implemented in the ATS due to the chosen ATM or other restrictions.

Table 4: Untestable TP

Test Case Name	Reason
void	

6 The ATS development process

6.1 Requirements and Test Purposes

For each test purpose there is a table defined in clause 5 of TS 102 708-2-2 [3]. The requirements applicable to this TP are given by a reference to ES 200 674-1 [1]. There are no explicit formulations of requirements.

6.2 Test case grouping

The ATS structure is based on the structuring of Test Purposes in clause 4 of TS 102 708-2-2 [3].

6.3 Test case identifier

The test case names are built in the TSS&TP document (Part 2 of the present document) according to the following scheme.

Table 5: TC identifier naming convention scheme

TC <st> <pl> <g> <x> <nn>		
<st> = side type	OBU	On Board Unit
	RSU	Road Side Unit
<pl> = protocol layer	AL	Application Layer
<g> test group	KU	Kernel Unit
	RA	Read Access
	WA	Write Access
	OF	Optional Functionality
	IC	Integrity Constraints
	SC	Security
<x> = type of testing	BV	Valid Behaviour Tests
	BI	Invalid Behaviour Tests
<nn>	> 0	sequential number

The present document covers only OBU and RSU test cases for the Application Layer (AL). Data Link Layer (DLL) tests are part of TS 102 708-1-3 [i.1]. Hence, there is no group in the test cases that explicitly identifies the Application Layer. Names of the single test case, however, are the same as the TSS&TP ones.

EXAMPLE: TC_OBU_AL_KU_BV_01.

6.4 ATS Library

For this ATS the TTCN-3 library modules are basically organized as:

- 1) LibCommon modules (only a sub-part of the modules of this library is used);
- 2) AL test suite modules.

Table 6 shows the organisation of the ATS as library of modules.

Table 6: Library of modules

Module Class	Module Id	Description
LibCommon	LibCommon_BasicTypesAndValues	Basic type and value definitions (integer and Boolean)
	LibCommon_DataStrings	Bit and Octet string types
ITS_L7	ITS_L7_types	Type definitions
	ITS_L7_pics	PICS definitions
	ITS_L7_pixits	PIXIT definitions
	ITS_L7_configuration	Definitions of test configurations (ports and components)
	ITS_L7_templates	TTCN-3 template definitions
	ITS_L7_extFunctions	External functions
	ITS_L7_functions	Functions
	ITS_L7_testcases	Test cases
	ITS_L7_control	TTCN-3 control part

6.5 TTCN-3 naming conventions

The naming conventions applied to the ATS are based on the following underlying principles:

- the names of TTCN-3 objects being associated with standardized data types (e.g. in the base protocols) reflect the names of these data types as close as possible (of course not conflicting with syntactical requirements or other conventions being explicitly stated);
- the subfield names of TTCN-3 objects being associated with standardized data type are similar to corresponding element names in the base standards (to be recognizable in the local context);
- in most other cases, identifiers are prefixed with a short alphabetic string (specified in table 3) indicating the type of TTCN-3 element it represents;

- prefixes are separated from the body of the identifier with an underscore ("_");
- test case names, module names, data type names and module parameters begin with an uppercase letter. All other names (i.e. the part of an identifier following the prefix) begin with a lowercase letter.

Table 7 specifies the naming guidelines for each element of the TTCN-3 language indicating the used prefix and capitalization style.

Table 7: TTCN-3 naming conventions

Language element	Naming convention	Prefix
Module	Uppercase initial character	none
TSS grouping	All uppercase characters	none
Basic common data types (e.g. bit string types of fixed length)	Uppercase initial character	none
Other Data types	Uppercase initial character	none
Port instance	Lowercase initial character	none
Test component ref	Lowercase initial character	none
Function	Lowercase initial character	f_
External function	Lowercase initial character	xf_
Test case	Naming as specified in clause 6.3	TC_
Variable (local)	Lowercase initial character	v_
Timer (local)	Lowercase initial character	t_
Module parameter	Use initial uppercase letters	PX
Parameterization	Lowercase initial character	p_
Enumerated Value	Lowercase initial character	e_
Message template	Lowercase initial character, followed by message type in uppercase characters	m_
Message template with wildcard or matching expression	Lowercase initial character	mw_

6.6 PICS information

Test purposes, which form the base test specification for this ATS, contain selection criteria using PICS parameters. Actually a major part of the features described in the PICS are likely to be supported, even if the PICS status is "optional". Thus the selection criteria will not be applied as a condition for the execution of the test case.

Test operators will be able to execute all test cases. Possible Fail verdicts will anyway lead the test operator to analyze the traces of the test case execution. Fail verdicts resulting from a feature not supported by the IUT, will appear obviously in the traces.

This approach enables test case users to execute test cases, which are then not locked by the test selection mechanism.

6.7 Test Suite documentation

In order to allow browsing of the ITS_L7 ATS without the use of a specific TTCN-3 test development environment, the TTCN ATS is made available in HTML format with hyperlinks between entities in the ATS. The documentation in the ATS makes use of special comment tags used by the tool that converts the ATS to the HTML format. These tags are defined in table 8.

Table 8: TTCN-3 comment tags

Tag	Description
@author	Specifies the names of the authors or an authoring organization which either has created or is maintaining a particular piece of TTCN-3 code.
@purpose	Describes the purpose of a particular piece of TTCN-3 code. The description should be concise yet informative and describe the function and use of the construct.
@remark	Adds extra information, such as the highlighting of a particular feature or aspect not covered in the description.
@see	Refers to other TTCN-3 definitions in the same or another module.
@return	Provides additional information on the value returned by a given function.
@param	Documents the parameters of parameterized TTCN-3 definitions.
@version	States the version of a particular piece of TTCN-3 code.

6.8 ATS archive

Annex B contains the ATS archive (.zip file expanding to text files with TTCN-3 code).

Annex A (normative): Partial PIXIT proforma

Notwithstanding the provisions of the copyright clause related to the text of the present document, grants that users of the present document may freely reproduce the PIXIT proforma in this annex so that it can be used for its intended purposes and may further publish the completed PIXIT proforma.

A.1 Introduction

This partial PIXIT proforma contained in the present document is provided for completion, when the related Abstract Test Suite is to be used against the Implementation Under Test (IUT).

The completed partial PIXIT will normally be used in conjunction with the completed PICS, as it adds precision to the information provided by the PICS.

A.2 PIXIT items

According to the interworking type of ATS defined in the present document, the PIXIT are divided in SIP-related PIXIT and IMS-related PIXIT.

NOTE: The Default values may not be applicable for certain PIXITs.

Table A.1: Test timer PIXITS

Identifier	Type	Description	Default value
PXT_TAC	float	Guard timer to control a reaction from the IUT to a stimulus sent by the tester (e.g. a message).	0,5
PXT_TNOAC	float	Timer to control a non-reaction from the IUT to a stimulus sent by the tester (e.g. a message). On expiry of this timer, it is considered that, as it is expected in the test purpose, the IUT has not responded to the stimulus.	1,0
PXT_TWAIT	float	Wait for an implicit send. This guard timer is used to limit the time where the tester is waiting for the response of the IUT that is triggered out by an action from the test operator. On expiry of this timer, it is considered that the action will not succeed, and thus the test case will be terminated.	60,0
PXT_T_GUARD	float	Guard timer used in the TTCN-3 control part.	60,0

Table A.2: Application Layer PIXITS

Identifier	Type	Description	Default value
PXT_AP_INVOCATION_ID	Integer (10 bits)	Integer value representing the AP invocation identifier as defined by the applicant. This value is then mapped on to the 10 LSB bits of the LaID field	255
PXT_CALLING_AP_TITLE	Octetstring (size 4)	Value representing the calling AP title as defined by the applicant. This value is then sent in the RequestPDU header. This parameter represent the RSU SNr, as Tester, and is relevant for testing OBU	
PXT_INVALID_CALLING_AP_TITLE	Octetstring (size 4)	Value representing an invalid calling AP title	
PXT_CALLED_AP_TITLE	Octetstring (size 5)	Octetstring (size 5) value representing the called AP title as defined by the applicant. This value is then sent in the ResponsePDU header. This parameter represent the OBU SNr, as Tester, and is relevant for testing RSU	

Identifier	Type	Description	Default value
PXT_DEFAULT_RESP_MODE	Bitstring (size 3)	Bitstring (size 3) value representing the response mode default value. This value is used as part of the responding mode parameter in the RequestPDU header. This default value shall be '000'B	'000'B
PXT_MASTER_CORE_LENGTH_MAX	Integer (size 1)	Maximum length of Master Core memory for Read	5
PXT_MASTER_CORE	ReadData	Content of Master Core memory	'0011223344'O
PXT_APPL_CORE_LENGTH_MAX	Integer	Maximum length of Application Core memory for Read	5
PXT_APPL_CORE	ReadData	Content of Application Core memory	'1122334455'O
PXT_APPL_RECORD_LENGTH_MAX	Integer (size 1)	Maximum length of Application Core memory for Read	5
PXT_APPL_RECORD	ReadData	Content of Application Record memory	'2233445566'O
PXT_ACTION_WRITE_MODE	WriteDataT oExternalRq Mode (3 elements)	Action-Rq write valid mode	
PXT_ACTION_WRITE_ADDRESS	WriteDataT oExternalRq Mode (3 elements)	Action-Rq write valid address	
PXT_ACTION_WRITE_ADDRESS_W RONG	WriteDataT oExternalRq Mode (3 elements)	Action-Rq write invalid address	
PXT_ACTION_WRITE_TIME	Integer (3 elements)	Action-Rq write time	
PXT_ACTION_WRITE_LENGTH	Integer (3 elements)	Action-Rq write length of data	
PXT_ACTION_WRITE_DATA	WriteData (3 elements)	Action-Rq write data	
PXT_ACTION_READ_LENGTH	Integer (3 elements)	Action-Rs length	
PXT_ACTION_READ_DATA	ReadData (3 elements)	Action-Rs read data	
PXT_PASSWORD_LENGTH	Integer (size 1)	Length of Password	8
PXT_PASSWORD	DataString	Password	
PXT_ACTION_WRITE_MODE_PW	BitString (size 8)	Action-Rq write mode address for password protected access valid	'00000000'B
PXT_ACTION_WRITE_ADDRESS_PW	BitString (size 8)	Action-Rq write address for password protected access valid	'11111111'B
PXT_ACTION_WRITE_TIME_PW	Integer (size 1)	Action-Rq write time for password protected access	0
PXT_ACTION_WRITE_LENGTH_PW	Integer (size 1)	Action-Rq write length of data for password protected access	1
PXT_ACTION_WRITE_DATA_PW	WriteData	Action-Rq write data for password protected access	'ff'O
PXT_ACTION_READ_LENGT_PW	Integer (size 1)	Action-Rs length for password protected access	1
PXT_ACTION_READ_DATA_PW	ReadData	Action-Rs read data for password protected access	'ee'O
PXT_TBA_RANDOM_NUMBER LENG TH_MIN	Integer (size 1)	GetTBArandom-Rq minimum length of random number	4
PXT_TBA_RANDOM_NUMBER LENG TH_MAX	Integer (size 1)	GetTBArandom-Rq maximum length of random number	8
PXT_CREDENTIAL_RETRIEVE DIRE CTIVE	CredentialID ataRetrieve Directive	Selector for method to retrieve data used to calculate credentials	e_readApplCoreRq
PXT_CREDENTIAL_RETRIEVE OFFS ET	Integer (size 1)	Offset and length to retrieve data used to calculate credentials	0
PXT_CREDENTIAL_RETRIEVE LEN GTH	Integer (size 1)	Offset and length to retrieve data used to calculate credentials	8
PXT_CALCULATED_CREDENTIALS	DataString (size 4)	Credentials in Get Credentials Response	'CAFEDCA'O

Annex B (informative): TTCN-3 library modules

B.1 Electronic annex, zip file with TTCN-3 code

The TTCN-3 library modules, which form parts of the present technical standard, are contained in archive `ts_1027080203v010201_ttcn3.zip` which is contained in the archive `ts_1027080203v010201p0.zip` which accompanies the present document.

B.2 Electronic annex, zip file with HTML documentation

The HTML documentation, which forms parts of the present technical standard, is contained in archive `ts_1027080203v010201_t3doc.zip` which is contained in the archive `ts_1027080203v010201p0.zip` which accompanies the present document. Start the `index.htm` file in any preferred web browser.

History

Document history		
V1.1.1	March 2010	Publication
V1.2.1	March 2012	Publication