



**Intelligent Transport Systems (ITS);
Testing;
Conformance test specifications for
Decentralized Environmental Notification
Basic Service (DEN);
Part 3: Abstract Test Suite (ATS) and
Protocol Implementation eXtra Information for Testing (PIXIT)**

Reference

RTS/ITS-00174

Keywords

ATS, ITS, PIXIT, testing

ETSI

650 Route des Lucioles
F-06921 Sophia Antipolis Cedex - FRANCE

Tel.: +33 4 92 94 42 00 Fax: +33 4 93 65 47 16

Siret N° 348 623 562 00017 - NAF 742 C
Association à but non lucratif enregistrée à la
Sous-Préfecture de Grasse (06) N° 7803/88

Important notice

The present document can be downloaded from:
<http://www.etsi.org/standards-search>

The present document may be made available in electronic versions and/or in print. The content of any electronic and/or print versions of the present document shall not be modified without the prior written authorization of ETSI. In case of any existing or perceived difference in contents between such versions and/or in print, the only prevailing document is the print of the Portable Document Format (PDF) version kept on a specific network drive within ETSI Secretariat.

Users of the present document should be aware that the document may be subject to revision or change of status. Information on the current status of this and other ETSI documents is available at
<https://portal.etsi.org/TB/ETSIDeliverableStatus.aspx>

If you find errors in the present document, please send your comment to one of the following services:
<https://portal.etsi.org/People/CommiteeSupportStaff.aspx>

Copyright Notification

No part may be reproduced or utilized in any form or by any means, electronic or mechanical, including photocopying and microfilm except as authorized by written permission of ETSI.

The content of the PDF version shall not be modified without the written authorization of ETSI.
The copyright and the foregoing restriction extend to reproduction in all media.

© European Telecommunications Standards Institute 2017.
All rights reserved.

DECT™, **PLUGTESTS™**, **UMTS™** and the ETSI logo are Trade Marks of ETSI registered for the benefit of its Members.
3GPP™ and **LTE™** are Trade Marks of ETSI registered for the benefit of its Members and of the 3GPP Organizational Partners.
GSM® and the GSM logo are Trade Marks registered and owned by the GSM Association.

Contents

Intellectual Property Rights	5
Foreword.....	5
Modal verbs terminology.....	5
1 Scope	6
2 References	6
2.1 Normative references	6
2.2 Informative references.....	6
3 Definitions and abbreviations.....	7
3.1 Definitions	7
3.2 Abbreviations	7
4 Abstract Test Method (ATM).....	8
4.1 Abstract protocol tester	8
4.2 Test Configuration.....	8
4.3 Test architecture	8
4.4 Ports and ASPs (Abstract Services Primitives)	9
4.4.1 Introduction.....	9
4.4.2 Primitives of the denmPort	10
4.4.3 Primitives of the utPort	10
4.5 Executing DEN tests in secured mode	10
4.6 ETSI test adapter	10
5 Untestable Test Purposes.....	11
6 ATS conventions	11
6.1 Introduction	11
6.2 Testing conventions.....	11
6.2.1 Testing states	11
6.2.1.1 Initial state.....	11
6.2.1.2 Final state	11
6.2.2 Message types - ASN.1 definitions.....	11
6.3 Naming conventions.....	12
6.3.1 General guidelines	12
6.3.2 ITS specific TTCN-3 naming conventions	13
6.3.3 Usage of Log statements.....	14
6.3.4 Test Case (TC) identifier	14
Annex A (normative): TTCN-3 library modules.....	15
A.1 TTCN-3 files and other related modules.....	15
Annex B (normative): Partial PIXIT pro forma for DEN.....	16
B.1 Partial cancellation of copyright.....	16
B.2 Introduction	16
B.3 Identification summary.....	16
B.4 ATS summary	16
B.5 Test laboratory.....	17
B.6 Client identification.....	17
B.7 SUT	17
B.8 Protocol layer information.....	18
B.8.1 Protocol identification	18
B.8.2 IUT information	18

Annex C (normative):	PCTR pro forma for DEN	19
C.1	Partial cancellation of copyright	19
C.2	Introduction	19
C.3	Identification summary	19
C.3.1	Protocol conformance test report	19
C.3.2	IUT identification	19
C.3.3	Testing environment	20
C.3.4	Limits and reservation	20
C.3.5	Comments	20
C.4	IUT Conformance status	21
C.5	Static conformance summary	21
C.6	Dynamic conformance summary	21
C.7	Static conformance review report	21
C.8	Test campaign report	22
C.9	Observations	23
History		24

Intellectual Property Rights

IPRs essential or potentially essential to the present document may have been declared to ETSI. The information pertaining to these essential IPRs, if any, is publicly available for **ETSI members and non-members**, and can be found in ETSI SR 000 314: "*Intellectual Property Rights (IPRs); Essential, or potentially Essential, IPRs notified to ETSI in respect of ETSI standards*", which is available from the ETSI Secretariat. Latest updates are available on the ETSI Web server (<https://ipr.etsi.org>).

Pursuant to the ETSI IPR Policy, no investigation, including IPR searches, has been carried out by ETSI. No guarantee can be given as to the existence of other IPRs not referenced in ETSI SR 000 314 (or the updates on the ETSI Web server) which are, or may be, or may become, essential to the present document.

Foreword

This Technical Specification (TS) has been produced by ETSI Technical Committee Intelligent Transport Systems (ITS).

The present document is part 3 of a multi-part deliverable covering Conformance test specifications for Decentralized Environmental Notification Basic Service (DEN) as identified below:

Part 1: "Test requirements and Protocol Implementation Conformance Statement (PICS) pro forma";

Part 2: "Test Suite Structure and Test Purposes (TSS & TP)";

Part 3: "Abstract Test Suite (ATS) and Protocol Implementation eXtra Information for Testing (PIXIT)".

The development of ITS test specifications follows the guidance provided in the ETSI EG 202 798 [i.1]. Therefore, the ATS documentation outlined in the present document is also based on the guidance provided in ETSI EG 202 798 [i.1].

Modal verbs terminology

In the present document "**shall**", "**shall not**", "**should**", "**should not**", "**may**", "**need not**", "**will**", "**will not**", "**can**" and "**cannot**" are to be interpreted as described in clause 3.2 of the [ETSI Drafting Rules](#) (Verbal forms for the expression of provisions).

"**must**" and "**must not**" are **NOT** allowed in ETSI deliverables except when used in direct citation.

1 Scope

The present document contains the Abstract Test Suite (ATS) for Decentralized Environmental Notification Basic Service (DEN) as defined in ETSI EN 302 637-3 [1] in compliance with the relevant requirements and in accordance with the relevant guidance given in ISO/IEC 9646-7 [i.7].

The objective of the present document is to provide a basis for conformance tests for Decentralized Environmental Notification Basic Service (DEN) equipment giving a high probability of interoperability between different manufacturers' equipment.

The ISO standards for the methodology of conformance testing (ISO/IEC 9646-1 [i.4] and ISO/IEC 9646-2 [i.5]) as well as the ETSI rules for conformance testing (ETSI ETS 300 406 [i.8]) are used as a basis for the test methodology.

2 References

2.1 Normative references

References are either specific (identified by date of publication and/or edition number or version number) or non-specific. For specific references, only the cited version applies. For non-specific references, the latest version of the referenced document (including any amendments) applies.

Referenced documents which are not found to be publicly available in the expected location might be found at <http://docbox.etsi.org/Reference>.

NOTE: While any hyperlinks included in this clause were valid at the time of publication, ETSI cannot guarantee their long term validity.

The following referenced documents are necessary for the application of the present document.

- [1] ETSI EN 302 637-3 (V1.2.2): "Intelligent Transport Systems (ITS); Vehicular Communications; Basic Set of Applications; Part 3: Specifications of Decentralized Environmental Notification Basic Service".
- [2] ETSI TS 102 869-1 (V1.5.1): "Intelligent Transport Systems (ITS); Testing; Conformance test specifications for Decentralized Environmental Notification Basic Service (DEN); Part 1: Test requirements and Protocol Implementation Conformance Statement (PICS) pro forma".
- [3] ETSI TS 102 869-2 (V1.5.1): "Intelligent Transport Systems (ITS); Testing; Conformance test specifications for Decentralized Environmental Notification Basic Service (DEN); Part 2: Test Suite Structure and Test Purposes (TSS & TP)".
- [4] ETSI TS 102 894-2 (V1.2.1): "Intelligent Transport Systems (ITS); Users and applications requirements; Part 2: Applications and facilities layer common data dictionary".

2.2 Informative references

References are either specific (identified by date of publication and/or edition number or version number) or non-specific. For specific references, only the cited version applies. For non-specific references, the latest version of the referenced document (including any amendments) applies.

NOTE: While any hyperlinks included in this clause were valid at the time of publication, ETSI cannot guarantee their long term validity.

The following referenced documents are not necessary for the application of the present document but they assist the user with regard to a particular subject area.

- [i.1] ETSI EG 202 798 (V1.1.1): "Intelligent Transport Systems (ITS); Testing; Framework for conformance and interoperability testing".

- [i.2] ETSI TS 103 096-3 (V1.3.1): "Intelligent Transport Systems (ITS); Testing; Conformance test specifications for ITS Security; Part 3: Abstract Test Suite (ATS) and Protocol Implementation eXtra Information for Testing (PIXIT)".
- [i.3] ETSI TR 103 099 (V1.4.1): "Intelligent Transport Systems (ITS); Architecture of conformance validation framework".
- [i.4] ISO/IEC 9646-1 (1994): "Information technology -- Open Systems Interconnection -- Conformance testing methodology and framework -- Part 1: General concepts".
- [i.5] ISO/IEC 9646-2 (1994): "Information technology -- Open Systems Interconnection -- Conformance testing methodology and framework -- Part 2: Abstract Test Suite specification".
- [i.6] ISO/IEC 9646-6 (1994): "Information technology -- Open Systems Interconnection -- Conformance testing methodology and framework -- Part 6: Protocol profile test specification".
- [i.7] ISO/IEC 9646-7 (1995): "Information technology -- Open Systems Interconnection -- Conformance testing methodology and framework -- Part 7: Implementation Conformance Statements".
- [i.8] ETSI ETS 300 406 (1995): "Methods for testing and Specification (MTS); Protocol and profile conformance testing specifications; Standardization methodology".
- [i.9] ETSI ES 201 873-1 (V4.5.1): "Methods for Testing and Specification (MTS); The Testing and Test Control Notation version 3; Part 1: TTCN-3 Core Language".
- [i.10] ETSI ES 201 873-7 (V4.5.1): "Methods for Testing and Specification (MTS); The Testing and Test Control Notation version 3; Part 7: Using ASN.1 with TTCN-3".

3 Definitions and abbreviations

3.1 Definitions

For the purposes of the present document, the terms and definitions given in ETSI EN 302 637-3 [1], ISO/IEC 9646-1 [i.4] and ISO/IEC 9646-7 [i.7] apply.

3.2 Abbreviations

For the purposes of the present document, the following abbreviations apply:

ASN.1	Abstract Syntax Notation One
ATM	Abstract Test Method
ATS	Abstract Test Suite
BV	valid test events for Behaviour tests
CAN	Controller Area Network
DEN	Decentralized Environmental Notification Basic Service
DENM	Decentralized Environmental Notification Message
DRCX	DENM Reception
EG	ETSI Guide
EN	European Norm
ES	ETSI Standard
EXTI	Expiration Time
GNSS	Global Navigation Satellite System
ISO	International Organization for Standardization
ITS	Intelligent Transport Systems
IUT	Implementation Under Test
LDM	Local Dynamic Map
MSGF	Message Format
MTC	Main Test Component
PCTR	Protocol Conformance Test Report

PETY	Periodicity
PICS	Protocol Implementation Conformance Statement
PIXIT	Partial Protocol Implementation eXtra Information for Testing
PX	Pixit
SA	System Adaptor
SAP	Service Access Point
SCS	System Conformance Statement
SCTR	Static Conformance Test Report
SLCI	Specific Location Container Information
SSCI	Specific Situation Container Information
SSP	Specific Service Permission
SUT	System Under Test
TC	Test Case
TDEV	Two different events
TI	Timer tests
TNEV	Termination/Negation of an Event
TP	Test Purposes
TS	Technical Specification
TSS	Test Suite Structure
TTCN	Testing and Test Control Notation

4 Abstract Test Method (ATM)

4.1 Abstract protocol tester

The abstract protocol tester used by this test suite is described in figure 1. The test system simulates valid and invalid protocol behaviour, and analyses the reaction of the IUT.

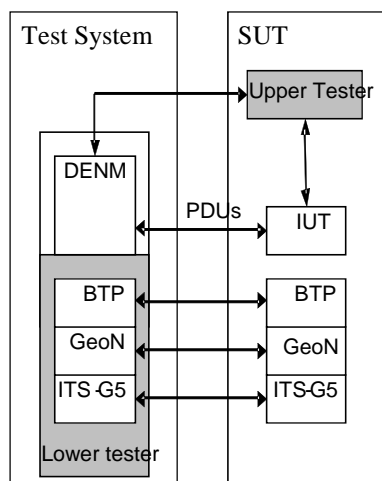

Figure 1: Abstract protocol tester - DEN

4.2 Test Configuration

This test suite uses a unique test configuration in order to cover the different test scenarios. In this configuration, the tester simulates one ITS station implementing the DEN protocol.

4.3 Test architecture

The present document implements the general TTCN-3 test architecture described in ETSI EG 202 798 [i.1], clauses 6.3.2 and 8.3.1.

Figure 2 shows the test architecture used in for the DEN ATS. The DEN test component requires using only the Main Test Component (MTC). The MTC communicates with the DEN SUT over the denmPort. The denmPort is used to exchange DEN protocol messages between the DEN test component and the DEN IUT.

The Upper tester entity in the SUT enables triggering DEN functionalities by simulating primitives from application or LDM entities. It is required to trigger the DEN layer in the SUT to send DEN messages, which are resulting from upper layer primitives. Furthermore, receiving DEN messages may result for the DEN layer in sending primitives to the upper layer (sending Data to LDM, for instance).

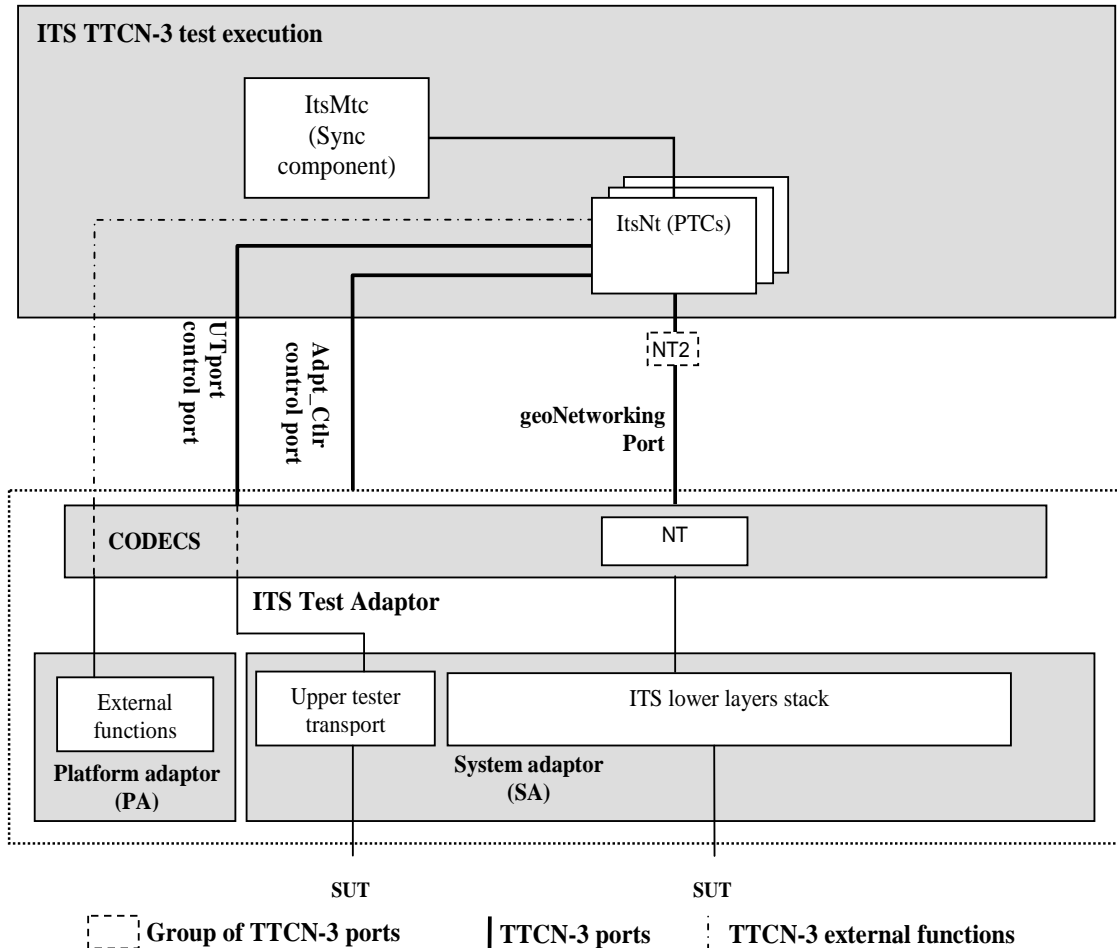

Figure 2: Test system architecture

4.4 Ports and ASPs (Abstract Services Primitives)

4.4.1 Introduction

Two ports are used by the DEN ATS:

- The denmPort, of type DenmPort.
- The utPort of type UpperTesterPort.

4.4.2 Primitives of the denmPort

Two types of primitives are used in the denmPort:

- The DenmInd primitive, containing the received messages of type DenmPdu, and a timestamp corresponding to the receipt time.
- The DenmReq primitive containing the sent messages of type DenmPdu.

The DenmPdu type is declared in the DENM.asn ASN.1 module, following the ASN.1 definition from ETSI EN 302 637-3 [1].

```
DenmPdu ::= SEQUENCE {
    header    ItsPduHeader,
    denm     DecentralizedEnvironmentalNotificationMessage
}
```

4.4.3 Primitives of the utPort

This port uses two types of primitives:

- The UtInitialize primitive used to initialize IUT.
- The UtTrigger primitive used trigger upper layer events in IUT.

4.5 Executing DEN tests in secured mode

All the DEN tests, with the exception of the SSP tests, can be executed with security enabled or with security disabled. The choice of running the DEN tests in secured or non-secured mode has no impact on the result of the DEN tests because the test verdicts assess DEN protocol behaviour only.

The SSP tests can only be executed in secured mode.

The choice of running the DEN tests in secured or non-secured mode can be controlled via the test suite parameter PICS_IS_IUT_SECURED, see table A.3/1 of ETSI TS 102 869-1 [2].

Before running the DEN tests in secured mode, the following steps need to be executed:

- security certificates need to be generated for the tester as well as for the IUT, see ETSI TS 103 096-3 [i.2], clause 5.3.2.5;
- security certificates need to be installed onto the IUT, see ETSI TS 103 096-3 [i.2], clause 5.3.2.6;
- in case of usage of the ETSI test adapter, the following test adapter parameters need to be configured:

Test adapter parameter	Default value	Comment
TsSecuredRootPath	data/certificates	The path to the location where all certificates (tester and IUT certificates) are installed
TsSecuredConfigId	void	Name of the subfolder in TsSecuredRootPath in order to organize multiple IUTs
UtSecuredMode	FALSE	To use upper-tester interface in non-secured mode

4.6 ETSI test adapter

All information of the ETSI test adapter is described in ETSI TR 103 099 [i.3].

5 Untestable Test Purposes

Table 1 gives a list of TPs, which are not implemented in the ATS due to the chosen ATM or other restrictions.

Table 1: Untestable TP

Test purpose	Reason
TP/DEN/EVGN/BV-08	In order to achieve the situation of sequenceNumber wrap-around, 65 535 DENMs would need to be generated. With 10 DENMs sent per second, the test would need an execution time of 1,8 hours

6 ATS conventions

6.1 Introduction

The ATS conventions are intended to give a better understanding of the ATS but they also describe the conventions made for the development of the ATS. These conventions shall be considered during any later maintenance or further development of the ATS.

The ATS conventions contain two clauses, the testing conventions and the naming conventions. The testing conventions describe the functional structure of the ATS. The naming conventions describe the structure of the naming of all ATS elements.

To define the ATS, the guidelines of the document ETSI ETS 300 406 [i.8] were considered.

6.2 Testing conventions

6.2.1 Testing states

6.2.1.1 Initial state

All test cases start with the function `f_prInitialState`. This function brings the IUT in an "initialized" state by invoking the upper tester primitive `UtInitialize`.

6.2.1.2 Final state

All test cases end with the function `f_poDefault`. This function brings the IUT back in an "idle" state. As no specific actions are required for the idle state in ETSI EN 302 637-3 [1], the function `f_poDefault` does not invoke any action.

As necessary, further actions may be included in the `f_poDefault` function.

6.2.2 Message types - ASN.1 definitions

ASN.1 definitions from ETSI EN 302 637-3 [1] are directly imported in TTCN-3 using the ASN.1 import method specified in ETSI ES 201 873-7 [i.10].

The following example shows the TTCN-3 import statement used to import ASN.1 definitions in the TTCN-3 modules:

```
import from DENM_PDU_Descriptions language "ASN.1:1997" all;
```

Generic ASN.1 definitions (message header, station Id, etc.), are defined in the Common Data Dictionary ETSI TS 102 894-2 [4] ASN.1 module. Thus the DEN ASN.1 modules shall import these definitions from the Common Data Dictionary ETSI TS 102 894-2 [4] ASN.1 module (see the following ASN.1 import statement extracted from the DEN ASN.1 module):

```
IMPORTS
    ItsPduHeader, StationID, ...
FROM ITS-Container {
    itu-t(0) identified-organization(4) etsi(0) itsDomain(5) wgl(1) ts(102894) cdd(2) version(1)
};
```

6.3 Naming conventions

6.3.1 General guidelines

The naming convention is based on the following underlying principles:

- in most cases, identifiers should be prefixed with a short alphabetic string (specified in table 2) indicating the type of TTCN-3 element it represents;
- suffixes should not be used except in those specific cases identified in table 2;
- prefixes and suffixes should be separated from the body of the identifier with an underscore ("_");

EXAMPLE 1: `c_sixteen`, `t_wait`.

- only module names, data type names and module parameters should begin with an upper-case letter. All other names (i.e. the part of the identifier following the prefix) should begin with a lower-case letter;
- the start of second and subsequent words in an identifier should be indicated by capitalizing the first character. Underscores should not be used for this purpose.

EXAMPLE 2: `f_initialState`.

Table 2 specifies the naming guidelines for each element of the TTCN-3 language indicating the recommended prefix, suffixes (if any) and capitalization.

Table 2: ETSI TTCN-3 generic naming conventions

Language element	Naming convention	Prefix	Example identifier
Module	Use upper-case initial letter	none	IPv6Templates
Group within a module	Use lower-case initial letter	none	messageGroup
Data type	Use upper-case initial letter	none	SetupContents
Message template	Use lower-case initial letter	m_	m_setupInit
Message template with wildcard or matching expression	Use lower-case initial letters	mw_	mw_anyUserReply
Signature template	Use lower-case initial letter	s_	s_callSignature
Port instance	Use lower-case initial letter	none	signallingPort
Test component instance	Use lower-case initial letter	none	userTerminal
Constant	Use lower-case initial letter	c_	c_maxRetransmission
Constant (defined within component type)	Use lower-case initial letter	cc_	cc_minDuration
External constant	Use lower-case initial letter	cx_	cx_macId
Function	Use lower-case initial letter	f_	f_authentication()
External function	Use lower-case initial letter	fx_	fx_calculateLength()
Altstep (incl. Default)	Use lower-case initial letter	a_	a_receiveSetup()
Test case	Use ETSI numbering	TC_	TC_COR_0009_47_ND
Variable (local)	Use lower-case initial letter	v_	v_macId
Variable (defined within a component type)	Use lower-case initial letters	vc_	vc_systemName
Timer (local)	Use lower-case initial letter	t_	t_wait
Timer (defined within a component)	Use lower-case initial letters	tc_	tc_authMin
Module parameters for PICS	Use all upper case letters	PICS_	PICS_DOOROPEN
Module parameters for other parameters	Use all upper case letters	PX_	PX_TESTER_STATION_ID
Formal Parameters	Use lower-case initial letter	p_	p_macId
Enumerated Values	Use lower-case initial letter	e_	e_syncOk

6.3.2 ITS specific TTCN-3 naming conventions

Next to such general naming conventions, table 3 shows specific naming conventions that apply to the ITS TTCN-3 test suite.

Table 3: ITS specific TTCN-3 naming conventions

Language element	Naming convention	Prefix	Example identifier
ITS Module	Use upper-case initial letter	Its"IUTname" _	ItsDenm_
Module containing types and values	Use upper-case initial letter	Its"IUTname" _TypesAndValues	ItsDenm _TypesAndValues
Module containing Templates	Use upper-case initial letter	Its"IUTname" _Templates	ItsDenm _Templates
Module containing test cases	Use upper-case initial letter	Its"IUTname" _TestCases	ItsDenm _TestCases
Module containing functions	Use upper-case initial letter	Its"IUTname" _Functions	ItsDenm _Functions
Module containing external functions	Use upper-case initial letter	Its"IUTname" _ExternalFunctions	ItsDenm _ExternalFunctions
Module containing components, ports and message definitions	Use upper-case initial letter	Its"IUTname" _Interface	ItsDenm _Interface
Module containing main component definitions	Use upper-case initial letter	Its"IUTname" _TestSystem	ItsDenm _TestSystem
Module containing the control part	Use upper-case initial letter	Its"IUTname" _TestControl	ItsDenm _TestControl

6.3.3 Usage of Log statements

All TTCN-3 log statements use the following format using the same order:

- Three asterisks.
- The TTCN-3 test case or function identifier in which the log statement is defined.
- One of the categories of log: INFO, WARNING, ERROR, PASS, FAIL, INCONC, TIMEOUT.
- Free text.
- Three asterisks.

EXAMPLE 1: `log("*** f_awaitDenMessageOut: INFO: Timeout while awaiting the reception of a message ***");`

Furthermore, the following rules are applied for the DEN ATS:

Log statements are used in the body of the functions, so that invocations of functions are visible in the test logs:

- All TTCN-3 setverdict statements are combined (as defined in ETSI ES 201 873-1 V4.5.1 [i.9]) with a log statement following the same above rules (see example 2).

EXAMPLE 2: `setverdict (pass, "*** f_utInitializeIut: PASS: IUT initialized ***");`

6.3.4 Test Case (TC) identifier

Table 4 shows the test case naming convention, which follows the same naming convention as the test purposes.

Table 4: TC naming convention

Identifier:	TC <root> <gr> <x> <nn>		
	<root> = root	DEN	
	<gr> = group	MSGF	Message Format
		EVGN	Event Generation
		SSCI	Specific Situation Container Information
		SLCI	Specific Location Container Information
		PETY	Periodicity
		TDEV	Two different events
		EXTI	Expiration Time
		EUPD	Event Update
		TNEV	Termination/Negation of an Event
		DRCX	DENM Reception
	<x> = type of testing	BV	Behaviour: Valid event tests
		BO	Behaviour: Inopportune event tests
		TI	Timer tests
	<nn> = sequential number		01 to 99

EXAMPLE: TP identifier: TP/DEN/MSGF/BV/01
TC identifier: TC_DEN_MSGF_BV_01

Annex A (normative): TTCN-3 library modules

A.1 TTCN-3 files and other related modules

This test suite has been produced using the Testing and Test Control Notation (TTCN) according to ETSI ES 201 873-1 [i.9].

ETSI EN 302 637-3 [1], ETSI TS 102 869-1 [2] and ETSI TS 102 869-2 [3] have been applied to develop this test suite.

This test suite has been compiled error-free using two different commercial TTCN-3 compilers.

The TTCN-3 and other related modules are contained in archive `ts_10286903v010501p0.zip` which accompanies the present document.

Annex B (normative): Partial PIXIT pro forma for DEN

B.1 Partial cancellation of copyright

Notwithstanding the provisions of the copyright clause related to the text of the present document, ETSI grants that users of the present document may freely reproduce the Partial PIXIT pro forma in this annex so that it can be used for its intended purposes and may further publish the completed Partial PIXIT.

B.2 Introduction

The PIXIT pro forma is based on ISO/IEC 9646-6 [i.6].

B.3 Identification summary

The Identification summary shall be as specified in table B.1.

Table B.1: Identification summary

PIXIT Number:	
Test Laboratory Name:	
Date of Issue:	
Issued to:	

B.4 ATS summary

The ATS summary shall be as specified in table B.2.

Table B.2: ATS summary

Protocol Specification:	ETSI EN 302 637-3 [1]
Protocol to be tested:	DEN (Decentralized Environmental Notification Messages)
ATS Specification:	ETSI TS 102 869-3
Abstract Test Method:	Clause 4

B.5 Test laboratory

The Test laboratory info shall be specified as in table B.3.

Table B.3: Test laboratory info

Test Laboratory Identification:	
Test Laboratory Manager:	
Means of Testing:	
SAP Address:	

B.6 Client identification

The Client identification shall be specified as in table B.4.

Table B.4: Client identification

Client Identification:	
Client Test manager:	
Test Facilities required:	

B.7 SUT

SUT shall be specified as in table B.5.

Table B.5: SUT

Name:	
Version:	
SCS Number:	
Machine configuration:	
Operating System Identification:	
IUT Identification:	
PICS Reference for IUT:	
Limitations of the SUT:	
Environmental Conditions:	

B.8 Protocol layer information

B.8.1 Protocol identification

Protocol identification shall be as specified in table B.6.

Table B.6: Protocol identification

Name:	ETSI EN 302 637-3 [1]
Version:	
PICS References:	ETSI TS 102 869-1 [2]

B.8.2 IUT information

DEN PIXITs shall be as in table B.7.

Table B.7: DEN PIXITs

Identifier	Description	
PX_IUT_STATION_ID	Comment	Station Id sent by the IUT
	Type	Integer
	Default value	1
PX_IUT_STATION_TYPE	Comment	Station Type sent by the IUT
	Type	Integer
	Default value	1
PX_TESTER_STATION_ID	Comment	Station Id sent by the tester
	Type	Integer
	Default value	111 111
PX_TESTER_STATION_TYPE	Comment	Station Type sent by the tester
	Type	Integer
	Default value	1
PX_TS_LATITUDE	Comment	The Latitude of the tester (microdegrees)
	Type	Integer
	Default value	436 175 790
PX_TS_LONGITUDE	Comment	The Longitude of the tester (microdegrees)
	Type	Integer
	Default value	70 546 480
PX_TIME_DELTA	Comment	Tolerance to be applied when checking timestamps (ms)
	Type	Integer
	Default value	1 000
PX_GNSS_SCENARIO_SUPPORT	Comment	Does the IUT support GNSS scenarios?
	Type	Boolean
	Default value	FALSE
PX_CERT_FOR_TS	Comment	The certificate identifier that the tester (TS) shall use in case of secured IUT
	Type	Charstring
	Default value	"CERT_TS_A_AT"

Annex C (normative): PCTR pro forma for DEN

C.1 Partial cancellation of copyright

Notwithstanding the provisions of the copyright clause related to the text of the present document, ETSI grants that users of the present document may freely reproduce the PCTR pro forma in this annex so that it can be used for its intended purposes and may further publish the completed PCTR.

C.2 Introduction

The PCTR pro forma is based on ISO/IEC 9646-6 [i.6].

C.3 Identification summary

C.3.1 Protocol conformance test report

A protocol conformance test report shall be as in table C.1.

Table C.1: Protocol conformance test report

PCTR Number:	
PCTR Date:	
Corresponding SCTR Number:	
Corresponding SCTR Date:	
Test Laboratory Identification:	
Test Laboratory Manager:	
Signature:	

C.3.2 IUT identification

An IUT shall be identified as specified in table C.2.

Table C.2: IUT identification

Name:	
Version:	
Protocol specification:	
PICS:	
Previous PCTR if any:	

C.3.3 Testing environment

The testing environment shall be as specified in table C.3.

Table C.3: Testing environment

PIXIT Number:	
ATS Specification:	
Abstract Test Method:	
Means of Testing identification:	
Date of testing:	
Conformance Log reference(s):	
Retention Date for Log reference(s):	

C.3.4 Limits and reservation

Additional information relevant to the technical contents or further use of the test report, or the rights and obligations of the test laboratory and the client, may be given here. Such information may include restriction on the publication of the report.

.....

.....

.....

.....

.....

.....

C.3.5 Comments

Additional comments may be given by either the client or the test laboratory on any of the contents of the PCTR, for example, to note disagreement between the two parties.

.....

.....

.....

.....

.....

.....

C.4 IUT Conformance status

This IUT has or has not been shown by conformance assessment to be non-conforming to the specified protocol specification.

Strike the appropriate words in this sentence. If the PICS for this IUT is consistent with the static conformance requirements (as specified in clause C.3 in the present document) and there are no "FAIL" verdicts to be recorded (in clause C.6 in the present document) strike the words "has or", otherwise strike the words "or has not".

C.5 Static conformance summary

The PICS for this IUT is or is not consistent with the static conformance requirements in the specified protocol.

Strike the appropriate words in this sentence.

C.6 Dynamic conformance summary

The test campaign did or did not reveal errors in the IUT.

Strike the appropriate words in this sentence. If there are no "FAIL" verdicts to be recorded (in clause C.6 of the present document) strike the words "did or" otherwise strike the words "or did not".

Summary of the results of groups of test:

.....
.....
.....
.....
.....
.....
.....
.....
.....
.....
.....
.....
.....
.....
.....
.....
.....

C.7 Static conformance review report

If clause C.3 indicates non-conformance, this clause itemizes the mismatches between the PICS and the static conformance requirements of the specified protocol specification.

.....
.....
.....
.....
.....
.....
.....

C.8 Test campaign report

Table C.4: Test cases

ATS Reference	Selected?	Run?	Verdict	Observations (Reference to any observations made in clause C.7)
TC_DEN_MSGF_BV_01	Yes/No	Yes/No		
TC_DEN_MSGF_BV_02	Yes/No	Yes/No		
TC_DEN_EVGN_BV_01	Yes/No	Yes/No		
TC_DEN_EVGN_BV_02	Yes/No	Yes/No		
TC_DEN_EVGN_BV_03	Yes/No	Yes/No		
TC_DEN_EVGN_BV_04	Yes/No	Yes/No		
TC_DEN_EVGN_BV_05	Yes/No	Yes/No		
TC_DEN_EVGN_BV_07	Yes/No	Yes/No		
TC_DEN_EVGN_BV_08	Yes/No	Yes/No		Untestable, see clause 5
TC_DEN_EVGN_BV_10	Yes/No	Yes/No		
TC_DEN_EVUP_BV_01	Yes/No	Yes/No		
TC_DEN_EVUP_BV_02	Yes/No	Yes/No		
TC_DEN_EVUP_BV_03	Yes/No	Yes/No		
TC_DEN_EVUP_BV_04	Yes/No	Yes/No		
TC_DEN_EVTR_BV_01	Yes/No	Yes/No		
TC_DEN_EVTR_BV_02	Yes/No	Yes/No		
TC_DEN_EVTR_BV_03	Yes/No	Yes/No		
TC_DEN_EVTR_BV_04	Yes/No	Yes/No		
TC_DEN_EVTR_BV_05	Yes/No	Yes/No		
TC_DEN_EVTR_BO_06	Yes/No	Yes/No		
TC_DEN_EVTR_BO_07	Yes/No	Yes/No		
TC_DEN_EVRP_TI_01	Yes/No	Yes/No		
TC_DEN_EVRP_BV_02	Yes/No	Yes/No		
TC_DEN_EVRP_BV_03	Yes/No	Yes/No		
TC_DEN_EVRP_BV_04	Yes/No	Yes/No		
TC_DEN_EVRP_BV_05	Yes/No	Yes/No		
TC_DEN_EVRP_BV_06	Yes/No	Yes/No		
TC_DEN_EVRP_BV_08	Yes/No	Yes/No		
TC_DEN_EVRP_BV_09	Yes/No	Yes/No		
TC_DEN_EVRP_BV_10	Yes/No	Yes/No		
TC_DEN_EVRP_BV_11	Yes/No	Yes/No		
TC_DEN_MSRV_BV_01	Yes/No	Yes/No		
TC_DEN_MSRV_BV_02	Yes/No	Yes/No		
TC_DEN_MSRV_BO_03	Yes/No	Yes/No		
TC_DEN_MSRV_BO_04	Yes/No	Yes/No		
TC_DEN_MSRV_BO_05	Yes/No	Yes/No		
TC_DEN_MSRV_BO_06	Yes/No	Yes/No		
TC_DEN_MSRV_BV_07	Yes/No	Yes/No		
TC_DEN_MSRV_BV_08_01	Yes/No	Yes/No		
TC_DEN_MSRV_BV_08_02	Yes/No	Yes/No		
TC_DEN_MSRV_BV_09_01	Yes/No	Yes/No		
TC_DEN_MSRV_BV_09_02	Yes/No	Yes/No		
TC_DEN_MSRV_BV_10	Yes/No	Yes/No		
TC_DEN_PAR_BV_01	Yes/No	Yes/No		
TC_DEN_PAR_BV_02	Yes/No	Yes/No		
TC_DEN_SSP_BV_01	Yes/No	Yes/No		
TC_DEN_SSP_BV_01	Yes/No	Yes/No		

ATS Reference	Selected?	Run?	Verdict	Observations (Reference to any observations made in clause C.7)
TC_DEN_KAFW_BV_01	Yes/No	Yes/No		
TC_DEN_KAFW_BV_02	Yes/No	Yes/No		
TC_DEN_KAFW_TI_03	Yes/No	Yes/No		
TC_DEN_KAFW_BV_04	Yes/No	Yes/No		
TC_DEN_KAFW_BV_05	Yes/No	Yes/No		
TC_DEN_KAFW_BV_06	Yes/No	Yes/No		
TC_DEN_KAFW_BV_07	Yes/No	Yes/No		
TC_DEN_KAFW_BV_08	Yes/No	Yes/No		
TC_DEN_KAFW_BV_09	Yes/No	Yes/No		
TC_DEN_KAFW_BV_10	Yes/No	Yes/No		

C.9 Observations

Additional information relevant to the technical content of the PCTR is given here.

.....

.....

.....

.....

.....

.....

.....

.....

.....

.....

.....

.....

.....

.....

.....

.....

.....

.....

.....

.....

.....

.....

.....

History

Document history		
V1.1.1	March 2011	Publication
V1.2.1	August 2013	Publication
V1.3.1	May 2014	Publication
V1.4.1	July 2015	Publication
V1.5.1	March 2017	Publication