



**Digital Enhanced Cordless Telecommunications (DECT);
Ultra Low Energy (ULE);
Machine to Machine Communications;
Part 1: Home Automation Network (phase 1)**

Reference

RTS/DECT-ULE270-1

Keywords

access, data, DECT, environment, IMT-2000,
intelligent homes & buildings, internet,
interoperability, interworking, M2M, mobility,
packet mode, profile, radio, synchronization,
TDD, TDMA

ETSI

650 Route des Lucioles
F-06921 Sophia Antipolis Cedex - FRANCE

Tel.: +33 4 92 94 42 00 Fax: +33 4 93 65 47 16

Siret N° 348 623 562 00017 - NAF 742 C
Association à but non lucratif enregistrée à la
Sous-Préfecture de Grasse (06) N° 7803/88

Important notice

The present document can be downloaded from:
<http://www.etsi.org/standards-search>

The present document may be made available in electronic versions and/or in print. The content of any electronic and/or print versions of the present document shall not be modified without the prior written authorization of ETSI. In case of any existing or perceived difference in contents between such versions and/or in print, the only prevailing document is the print of the Portable Document Format (PDF) version kept on a specific network drive within ETSI Secretariat.

Users of the present document should be aware that the document may be subject to revision or change of status. Information on the current status of this and other ETSI documents is available at
<http://portal.etsi.org/tb/status/status.asp>

If you find errors in the present document, please send your comment to one of the following services:
<https://portal.etsi.org/People/CommitteeSupportStaff.aspx>

Copyright Notification

No part may be reproduced or utilized in any form or by any means, electronic or mechanical, including photocopying and microfilm except as authorized by written permission of ETSI.

The content of the PDF version shall not be modified without the written authorization of ETSI.
The copyright and the foregoing restriction extend to reproduction in all media.

© European Telecommunications Standards Institute 2015.
All rights reserved.

DECT™, **PLUGTESTS™**, **UMTS™** and the ETSI logo are Trade Marks of ETSI registered for the benefit of its Members.
3GPP™ and **LTE™** are Trade Marks of ETSI registered for the benefit of its Members and of the 3GPP Organizational Partners.
GSM® and the GSM logo are Trade Marks registered and owned by the GSM Association.

Contents

Intellectual Property Rights	13
Foreword.....	13
Modal verbs terminology.....	13
Introduction	13
1 Scope	15
2 References	15
2.1 Normative references	15
2.2 Informative references.....	16
3 Definitions, symbols and abbreviations	17
3.1 Definitions	17
3.2 Symbols.....	20
3.3 Abbreviations	21
4 Description of services	23
4.1 DECT Ultra Low Energy	23
4.1.1 Introduction.....	23
4.2 ULE phase 1	23
4.2.1 Definition of ULE phase 1	23
4.2.2 Example of applications covered by ULE phase 1	24
4.2.3 Physical layer, radio properties and spectrum use	24
4.2.4 Coexistence with other DECT services	24
4.3 Example scenarios for DECT ULE phase 1	24
4.3.1 Security applications (fire and burglary alarms).....	24
4.3.2 Global Home control and domotic scenario.....	25
4.3.3 Energy and appliances management scenario.....	25
4.4 Requirement specification for ULE phase 1	26
4.4.1 ULE phase 1 device types.....	26
4.4.1.0 General	26
4.4.1.1 PP type I: "sensor"	26
4.4.1.1.1 General description.....	26
4.4.1.1.2 Requirements and functionalities for type I devices.....	26
4.4.1.2 PP type II: "fast actuator"	27
4.4.1.2.1 General description.....	27
4.4.1.2.2 Requirements and functionalities for type II devices	27
4.4.1.3 PP type III: "slow actuator"	27
4.4.1.3.1 General description.....	27
4.4.1.3.2 Requirements and functionalities for type III devices	27
4.4.1.4 ULE phase 1 compliant RFP	27
4.4.1.4.1 General description.....	27
4.4.1.4.2 Requirements and functionalities for ULE phase 1 RFP	27
4.4.2 U-plane interworking and protocol architecture	28
4.4.2.1 ULE phase 1 protocol architecture.....	28
4.4.3 Performance Objectives	28
4.5 Technical features implemented by ULE phase 1	29
4.5.0 General.....	29
4.5.1 MAC/PHY layer	29
4.5.2 DLC layer	30
4.5.3 NWK layer.....	30
4.5.4 Interworking and Application layer	30
4.5.5 Security	31
4.5.6 Management entity	31
5 Service and feature definitions	31
5.1 ULE Phase 1	31
5.1.1 PHL service definitions	31
5.1.2 MAC service definitions	31

5.1.3	DLC service definitions	33
5.1.4	NWK feature definitions.....	34
5.1.5	Application feature definitions	35
5.1.6	Management Entity (ME) definitions	35
5.1.7	U-plane service and interworking definitions	35
5.1.8	ULE 1 device types definitions.....	35
6	Profile specific requirements.....	36
6.1	General	36
6.2	Specific conventions.....	36
6.2.1	Use of symbols in support status tables	36
6.3	DECT ULE phase 1 device types	36
6.3.1	Types of devices supported by the present document.....	36
6.3.2	Specific procedures for specific device types	37
6.4	Physical layer (PHL) requirements.....	38
6.4.1	Physical layer (PHL) services	38
6.4.2	Modulation schemes	38
6.4.3	PHL service to procedure mapping.....	38
6.5	MAC layer requirements	39
6.5.1	MAC layer services	39
6.5.2	MAC service to procedure mapping	39
6.6	DLC layer	43
6.6.1	DLC layer services.....	43
6.6.2	DLC service to procedure mapping	44
6.7	NWK layer	45
6.7.1	General.....	45
6.7.2	NWK features	45
6.7.3	NWK features to procedures mapping.....	46
6.8	Application Layer.....	48
6.8.1	Application features	48
6.8.2	Application features to procedures mapping.....	48
6.9	Distributed communications.....	48
6.10	Management Entity (ME).....	49
6.10.1	Management Entity (ME) services	49
6.10.2	Management Entity (ME) mode to procedures mapping	49
6.11	U-plane services and interworking requirements	49
6.11.1	U-plane and interworking services	49
6.11.2	U-plane and interworking service to procedure mapping	49
7	Profile specific procedures description	50
8	Physical Layer (PHL) procedures	50
8.1	Supported Modulation types and schemes	50
8.1.1	GFSK modulation.....	50
8.1.2	Modulation scheme 1a	50
8.2	Supported Physical Packets	50
8.2.1	Physical Packet P32	50
8.2.2	Use of Physical Packet P32	50
8.2.3	Physical Packet P00	51
8.2.4	Transmission and use of Physical Packet P00	51
8.2.5	Reception of Physical Packet P00.....	51
8.3	General PHL procedures	51
8.3.1	General radio requirements.....	51
8.3.2	Radio receiver sensitivity.....	51
8.3.3	Z-field	51
8.3.4	Sliding collision detection	51
8.3.5	Physical channel availability.....	51
8.3.6	Synchronization window	52
8.3.7	Minimum Normal Transmit Power (NTP).....	52
8.3.8	Power management.....	52
8.3.9	Fast hopping radio	52
9	Management Entity (ME) procedures	52

9.1	ULE phase 1 Management	52
9.1.1	ULE phase 1 connection and resources management	52
9.1.2	Stay alive procedure.....	52
9.2	Channel selection and collision avoidance procedures.....	53
9.2.1	Overall architecture of ULE channel selection processes	53
9.2.2	Process M0 (RFP side pre-selection process)	53
9.2.3	Broadcast mechanism	53
9.2.4	Process M1 (PP side channel selection process).....	53
9.2.5	Setup attempt and evaluation of responses	54
9.2.6	Process M2 (collision handling/collision avoidance process).....	54
10	MAC layer procedures	54
10.1	General	54
10.1.1	Frame and multiframe structure.....	54
10.1.2	Bit mappings.....	54
10.1.3	E/U mux modes and B-field identification (BA) bits	55
10.1.3.0	General	55
10.1.3.1	E/U mux modes and B-field identification (BA) bits for C/O bearers	55
10.1.3.2	E/U mux modes and B-field identification (BA) bits for C/L (dummy) bearers.....	55
10.1.4	Scrambling	55
10.1.5	Error control.....	55
10.1.6	RFP idle receiver scan sequence.....	55
10.1.7	Identities	56
10.2	Time multiplexers.....	56
10.2.1	A-field Multiplexer	56
10.2.1.1	Tail Multiplexer (T-MUX).....	56
10.2.1.2	A-tail identifications.....	56
10.2.2	B-field control Multiplexer (E/U-MUX)	56
10.2.2.1	B-field control Multiplexer (E/U-MUX), basic modes	56
10.2.2.1.1	U-type Multiplexer for C/O bearers	56
10.2.2.1.2	E-type Multiplexer "all MAC control" for C/O bearers	56
10.2.2.1.3	E-type Multiplexer "no-B field" for C/O bearers	56
10.2.2.1.4	E-type Multiplexer "all MAC control" for C/L (dummy) bearers	57
10.2.2.1.5	E/U-Mux priority schema	57
10.2.2.1.6	B-field identifications (basic)	57
10.2.2.2	B-field control Multiplexer (E/U-MUX), C _F modes	57
10.2.2.2.1	E-type Multiplexer, all modes (over C/O bearers)	57
10.2.2.2.2	E/U-Mux priority schema	58
10.2.2.2.3	B-field identifications (C _F)	58
10.3	Downlink broadcast (A-field).....	58
10.3.0	General.....	58
10.3.1	N _T messages.....	58
10.3.2	Q _T messages.....	58
10.3.2.1	Q _T - static system information.....	58
10.3.2.2	Q _T - FP capabilities	58
10.3.2.2.1	Standard FP Capabilities	58
10.3.2.2.2	Extended FP Capabilities.....	59
10.3.2.2.3	Extended FP Capabilities part 2	60
10.3.2.3	Q _T - SARI list contents.....	60
10.3.2.4	Multiframe number (A-field)	60
10.3.3	Reception of downlink broadcast (A-field)	60
10.4	Paging broadcast	61
10.4.0	General.....	61
10.4.1	Paging message formats.....	61
10.4.1.0	General	61
10.4.1.1	Full page message format.....	61
10.4.1.2	Short page message format	61
10.4.1.3	Zero length page message format.....	61
10.4.1.4	MAC layer information in zero and short length paging messages.....	62
10.4.1.4.0	General	62
10.4.1.4.1	RFP status.....	62
10.4.2	MAC layer information messages procedures	63

10.4.2.0	General	63
10.4.2.1	Blind slot information for circuit mode service	63
10.4.2.2	Bearer handover/replacement information	63
10.4.2.3	Other bearer position	63
10.4.2.4	Recommended other bearer position	63
10.4.2.5	Dummy or C/L bearer position	63
10.4.2.6	C/L bearer position	63
10.4.2.7	RFP-status and Modulation Types	63
10.4.2.8	Blind slot information for packet mode service	64
10.4.3	Paging Procedures	64
10.4.3.1	LCE Paging	64
10.4.4	Paging detection	64
10.4.4.1	Normal duty cycle	64
10.5	ULE Dummy Bearer Procedures	64
10.5.0	General	64
10.5.1	N _S channel	64
10.5.2	Q _C channel	64
10.5.3	M _U channel	65
10.5.4	Reception of Messages	65
10.5.5	Operation in unlocked mode	65
10.6	ULE Paging Procedures	65
10.6.0	General	65
10.6.1	P _U Paging Message Formats	65
10.6.1.0	General	65
10.6.1.1	P _U Message General format	65
10.6.1.2	Control fields SFa/SFb	66
10.6.1.3	CA field	66
10.6.1.4	Subfield A data	66
10.6.1.5	Subfield B data	67
10.6.2	Paging Descriptors for ULE Paging	67
10.6.2.1	Basic concepts of the ULE paging system	67
10.6.2.2	Basic operation of the descriptors	67
10.6.2.3	Allocation of descriptors	68
10.6.2.4	Format for descriptors in ULE phase 1	68
10.6.2.5	Descriptors in ULE phase 1	69
10.6.2.5.1	Descriptor codes	69
10.6.2.5.2	Descriptor detailed descriptions	69
10.6.2.5.3	Additional conventions for ULE phase 1 descriptors	70
10.6.3	The CA mask mechanism	70
10.6.3.0	General	70
10.6.3.1	CA mask and CA groups	71
10.6.3.2	Subscription to CA groups	71
10.6.3.3	Action after receiving the CA signal	71
10.7	Connection Management	71
10.7.1	Logical Connection Setup	71
10.7.1.0	General	71
10.7.1.1	ULE logical connection setup - explicit procedure	71
10.7.1.2	ULE logical connection setup - procedure for ancillary connections	71
10.7.1.3	ULE logical connection setup - implicit procedure	72
10.7.2	Logical Connection Release	72
10.7.2.0	General	72
10.7.2.1	ULE logical connection release - explicit procedure	72
10.7.2.2	ULE logical connection release - procedure for ancillary connections	72
10.7.2.3	ULE logical connection release - implicit procedure	72
10.7.2.4	ULE logical connection release - abnormal procedure	73
10.7.3	Connection Suspend and Resume	73
10.7.3.1	General	73
10.7.3.2	Suspend	73
10.7.3.2.0	General	73
10.7.3.2.1	Entering in suspended state	73
10.7.3.3	Resume	73
10.7.3.3.0	General	73

10.7.3.3.1	Resuming a suspended connection	74
10.7.4	Other Connection Modification	74
10.7.4.0	General	74
10.7.4.1	Void.....	74
10.7.4.2	Connection modification to change service type, slot type, modulation type or adaptive code rate	74
10.7.4.2.1	Connection modification to change MAC service type	74
10.7.4.2.2	Connection modification to change slot type	75
10.7.4.2.3	Connection modification to change maximum MAC packet lifetime	75
10.7.4.2.4	Connection modification to change the modulation scheme and adaptive code rate.....	76
10.7.4.2.5	Use of ATTRIBUTES_T.req/cfm in connection modification.....	76
10.8	Other MAC control procedures	77
10.8.1	Quality control	77
10.8.1.1	RFPI handshake	77
10.8.1.2	PT frequency correction.....	77
10.8.1.3	Bearer quality report	77
10.8.1.4	A-CRC handshake.....	77
10.8.2	Physical channel selection	77
10.8.2.1	Channel selection for the ULE packet data connection.....	77
10.8.2.2	Exceptional cases	77
10.8.2.3	Channel selection for the Service Call and other circuit mode connections	77
10.8.3	A-field MAC Bearer replacement procedure (M _T).....	78
10.8.4	Dummy bearer replacement procedure	78
10.8.4.0	General	78
10.8.4.1	Quality control	78
10.8.4.2	Requirements	78
10.9	A-field (M _T) Advanced Connection control procedures.....	79
10.9.1	General.....	79
10.9.2	PT initiated A-field advanced bearer setup.....	79
10.9.2.0	General	79
10.9.2.1	M _T access request message	79
10.9.2.2	M _T Attributes_T.req/cfm message	80
10.9.3	A-field connection/bearer release	81
10.9.3.0	General	81
10.9.3.1	M _T message	81
10.9.4	A-field bearer handover request.....	81
10.9.4.0	General	81
10.9.4.1	M _T message	81
10.9.5	A-field connection handover request	82
10.9.5.0	General	82
10.9.5.1	M _T message	82
10.10	A-field (M _T) Expedited operations for Advanced Connection control.....	82
10.10.1	General.....	82
10.10.2	M _T advanced control messages for expedited operations	83
10.10.2.1	Supported M _T messages	83
10.10.2.2	G _{FA} transmission	83
10.10.2.3	Reason codes in "expedited release" and "ready for release" messages.....	83
10.10.2.3.1	Reason codes in "expedited release" message	83
10.10.2.3.2	Reason codes in "ready for release" message	84
10.10.2.4	Operation codes in "Null or G _{FA} channel transmission" message	85
10.10.3	Expedited procedures.....	85
10.10.3.0	General	85
10.10.3.1	Procedure for Single-burst setup and release	85
10.10.3.2	Procedure for Multi-burst setup	85
10.10.3.3	Announcement "Ready for Release"	86
10.10.3.4	General Expedited Release procedure.....	86
10.10.3.5	Single-message expedited release procedure	86
10.10.3.6	Abnormal expedited release procedure	86
10.10.4	Expedited procedures use cases	86
10.10.4.1	General use cases	86
10.10.4.1.1	Single Packet Data Transfer - Success	86
10.10.4.1.2	Single Packet Data Transfer: error/abnormal cases	87

10.10.4.1.3	Multi Packet Data Transfer.....	89
10.10.4.2	C-plane related use cases	98
10.10.4.2.1	Multi Packet Data Transfer: FP requested C-plane traffic only - Success.....	98
10.10.4.3	Stay alive related use cases	99
10.10.4.3.1	PT initiated stay alive with transmission of G_{FA} from FT	99
10.10.4.3.2	PT initiated stay alive - the FT changes the procedure to start a C-plane procedure.....	100
10.10.4.3.3	PT initiated stay alive - the FT changes the procedure to send U-plane data	101
10.10.4.4	Failure and Retransmission Use cases.....	102
10.10.4.4.1	Setup Failure and Retransmission Examples.....	102
10.10.4.4.2	Release Failure and Retransmission Examples	104
10.10.4.4.3	Errors when in TBC "connected" state.....	106
10.10.4.4.4	Intrusion and interference use cases	107
10.10.4.4.5	Errors in release procedures	109
10.10.4.5	Data transfer use cases showing the response to the BCK bit and to transitions between BA codes	110
10.10.4.5.1	Multi Packet Data Transfer: FP traffic only (3 U-plane packets) - Success	110
10.10.4.5.2	Multi Packet Data Transfer: FP traffic only (3 U-plane packets) - Retransmission	110
10.10.4.5.3	Multi Packet Data Transfer: FP traffic only (2 U-plane packets) - running empty	111
10.10.4.5.4	Multi Packet Data Transfer: FP traffic only (3 U-plane packets) - Retransmit after 'no advance' (due to congestion).....	112
10.10.4.5.5	Multi Packet Data Transfer: FP and PP send 2 packets each - Congestion in 'Ready for Release' transfer (I).....	113
10.10.4.5.6	Multi Packet Data Transfer: FP and PP send 2 packets each - Congestion in 'Ready for Release' transfer (II)	114
10.10.4.5.7	Multi Packet Data Transfer: FP sends 2 packets and PP sends 3 packets - Congestion in 'Ready For Release' transfer (I)	115
10.10.4.5.8	Multi Packet Data Transfer: FP sends 2 packets and PP sends 3 packets - Congestion in 'Ready For Release' transfer (II)	116
10.10.5	Use of reason codes in "expedited release" and "ready for release" messages	117
10.10.5.1	Use of reason code "normal bearer release"	117
10.10.5.2	Use of reason code "base station busy"	118
10.10.5.3	Use of reason code "unacceptable PMID / Unregistered PMID"	118
10.10.5.4	Use of reason code "switch to circuit mode"	118
10.10.5.5	Use of reason code "Stay in LCE paging detection mode"	119
10.10.5.6	Use of reason code "Stay in higher paging detection mode"	121
10.10.5.7	Use of reason code "Setup again after n frames"	123
10.10.5.8	Use of reason code "No such connection / virtual circuit"	124
10.11	Slot types and slot use	124
10.11.1	Full Slot	124
10.11.1.1	General	124
10.11.1.2	Use of full slot in C/O bearers.....	125
10.11.1.3	Use of full slot in C/L dummy bearers	125
10.11.2	Short Slot	125
10.11.2.1	General	125
10.11.2.2	Use of short slot in C/O bearers	125
10.12	I channel services	125
10.12.1	Protected I channel error_correct service.....	125
10.12.1.0	General	125
10.12.1.1	Unilateral jump	125
10.12.1.2	Bearer reset	125
10.12.2	Lifetime management with TWO separate maximum MAC packet lifetimes.....	125
10.12.2.0	General	125
10.12.2.1	Operation of the counters	126
10.13	G_{FA} channel	126
10.13.1	G_{FA} channel data	126
10.13.1.1	G_{FA} channel transmission.....	126
10.13.1.2	G_{FA} channel reception	126
10.14	C channel operation.....	127
10.14.1	C_S channel.....	127
10.14.2	C_F channel.....	127
10.14.2.0	General	127
10.14.2.1	Priority schema of the C_F channel	127

10.15	MAC Encryption control.....	128
10.15.0	General.....	128
10.15.1	Encryption process - initialization and synchronization	128
10.15.2	Encryption mode control	129
10.15.2.1	General	129
10.15.2.2	M _T message	130
10.15.2.3	Procedure for enabling encryption	130
10.15.2.3.1	Prerequisite.....	130
10.15.2.3.2	Procedure.....	130
10.15.2.4	Procedure for disabling encryption	130
10.15.2.4.1	Prerequisite.....	130
10.15.2.4.2	Procedure.....	130
10.15.3	Handover encryption process.....	131
10.16	Enhanced security procedures	131
10.16.1	Re-keying.....	131
10.16.2	Early Encryption.....	131
10.16.3	DSC Encryption.....	131
10.16.4	AES/DSC2 Encryption	131
11	DLC layer procedures	131
11.1	LU14 Enhanced Frame RELay service with CCM (EFREL-CCM)	131
11.2	LU10 Enhanced Frame RELay service (EFREL)	132
11.2.0	General.....	132
11.2.1	Window size	132
11.2.2	SDU transmission and delivery mode.....	133
11.3	FU10 framing (FU10a, FU10d).....	133
11.3.0	General.....	133
11.3.1	FU10a	133
11.3.2	FU10d.....	133
11.3.2.1	General	133
11.3.2.2	Transport of FU10d frames over G _{FA} channel	133
11.3.2.3	Insertion of FU10d frames in FU10a frames of the opposite link.....	133
11.4	Class A operation	134
11.4.0	General.....	134
11.4.1	Class A link establishment.....	134
11.4.1.0	General	134
11.4.1.1	Associated procedures.....	136
11.4.1.1.1	Timer P<DL.07> management	136
11.4.1.1.2	Re-transmission counter management	136
11.4.1.1.3	Multiple frame operation variables management	136
11.4.1.1.4	Lower Layer Management Entity (LLME) establishment of a MAC connection	136
11.4.1.2	Exceptional cases	138
11.4.1.2.1	Timer P<DL.07> expiry	138
11.4.1.2.2	Receipt of a request for link release	138
11.4.1.2.3	Receipt of an indication for a connection release	138
11.4.2	Class A Acknowledged Information transfer.....	138
11.4.2.0	General	138
11.4.2.1	Acknowledgement with an I_frame	138
11.4.2.2	Acknowledgement with a RR_frame	139
11.4.2.3	Class A acknowledged information transfer with segment reassemble	140
11.4.2.4	Associated procedures.....	140
11.4.2.4.1	Timer <DL.04> management	140
11.4.2.4.2	Re-transmission counter management	141
11.4.2.4.3	Multiple frame operation variables management	141
11.4.2.5	Exceptional cases	141
11.4.2.5.1	Timer <DL.04> expiry	141
11.4.2.5.2	Receipt of a request for link release	141
11.4.2.5.3	Receipt of an indication for a connection release	141
11.4.2.5.4	DLC wants to make a connection handover	141
11.4.3	Class A link release.....	142
11.4.3.0	General	142
11.4.3.1	Associated procedures.....	142

11.4.3.1.1	LLME U-plane release	142
11.4.3.1.2	LLME release a MAC connection.....	142
11.4.4	Class A link re-establishment	142
11.4.5	Handling of NWK layer messages longer than 63 octets.....	142
11.5	U-plane frame transmission procedures	142
11.5.1	DLC U-plane transmission Class 1	142
11.5.1.1	General	142
11.5.1.2	Sending side procedure	142
11.5.1.3	Receiving side procedure	143
11.6	Lc frame delimiting and sequencing service	143
11.6.1	C _S channel fragmentation and recombination.....	143
11.6.2	C _F channel fragmentation and recombination.....	143
11.6.3	Selection of logical channels (C _S and C _F).....	143
11.7	Broadcast Lb service	143
11.7.1	Normal broadcast.....	143
11.8	LU13 Enhanced Frame RELay service with CRC (EFREL-CRC)	145
11.9	Encryption switching.....	145
11.9.1	MAC layer encryption switching.....	145
11.9.1.0	General	145
11.9.1.1	Associated procedure	145
11.9.1.1.1	Providing Encryption key to the MAC layer.....	145
11.9.1.2	Exceptional cases	146
11.9.1.2.1	Encryption fails	146
11.9.1.2.2	Connection handover of ciphered connections.....	146
11.9.2	CCM encryption switching.....	146
11.10	CCM/AES encryption	146
11.10.1	CCM Authenticated Encryption	146
11.10.2	CCM activation at Virtual Call setup.....	146
11.10.3	Cipher keys for CCM.....	146
12	NWK layer procedures.....	147
12.1	Simplified NWK layer control procedures for ULE.....	147
12.1.0	General.....	147
12.1.1	General pre-requisites.....	147
12.1.2	Creation of the ULE PVC and states	147
12.1.2.0	General	147
12.1.2.1	State diagram.....	147
12.1.2.2	Creation of the transaction	148
12.1.3	Allowed CC Operations over the ULE transaction.....	148
12.1.3.0	General	148
12.1.3.1	Service Change "NWK resume"	149
12.1.3.1.0	General	149
12.1.3.1.1	Pre-requisite:	149
12.1.3.1.2	Coding of the operation messages	149
12.1.3.1.3	Actions after a successfully CC Service Change "NWK resume" operation.....	150
12.1.3.1.4	Exception case for "NWK resume" operation when already Resumed	151
12.1.3.2	Service Change "NWK suspend"	151
12.1.3.2.0	General	151
12.1.3.2.1	Pre-requisite:	151
12.1.3.2.2	Coding of the operation messages	151
12.1.3.2.3	Actions after a successful CC Service Change "NWK suspend" operation	152
12.1.3.2.4	Exception case for "NWK suspend" operation when already Suspended	152
12.1.3.3	Service Change "other"	152
12.1.3.3.0	General	152
12.1.3.3.1	Pre-requisite:	152
12.1.3.3.2	Coding of the operation messages	153
12.1.3.4	Allowed parameters in any service change operation	153
12.1.3.5	Default parameters	155
12.1.3.6	Initiating part of the Service Change operations	156
12.3.1.6.0	General	156
12.1.3.6.1	Rule for handling collisions.....	156
12.1.3.7	Independence of other CC transactions.....	156

12.1.3.8	Default MAC parameters for implicitly created MBC	156
12.1.3.9	Paging descriptors in suspend and resume states	156
12.1.3.10	Negotiation rules	156
12.2	Other NWK layer procedures	157
12.2.1	Service call setup	157
12.2.1.0	General	157
12.2.1.1	Prerequisites	158
12.2.1.2	Procedure	158
12.2.2	Storing the Derived Cipher Key for CCM (DCK-CCM)	158
12.3	Terminal capabilities and FP broadcasts	159
12.3.1	Terminal capability indication	159
12.3.2	FP broadcasts	160
12.3.2.1	Higher layer information FP broadcast	160
12.3.2.1.0	General	160
12.3.2.1.1	Higher layer information in standard FP broadcast (Qh = 3)	161
12.3.2.1.2	Higher layer information in Extended FP broadcast (Qh = 4)	161
12.3.2.1.3	Extended Higher Layer capabilities part 2 (Qh = 11)	161
13	Services and Interworking procedures	162
13.1	Interworking specific procedures	162
13.2	Other Interworking procedures	162
13.2.1	Transport of IWU-to-IWU data	162
13.2.1.1	General requirements	162
13.2.1.2	Prerequisites	163
13.2.1.3	Procedure	163
14	Application procedures	163
14.0	General	163
14.1	Easy Pairing procedures	163
14.1.1	Searching mode request	163
Annex A (normative): Parameters and Information Elements		165
A.1	Constants, variables and operating parameters	165
A.1.1	Operating parameters	165
A.1.1.1	Channel selection algorithms	165
A.1.1.2	MAC layer	165
A.1.1.3	DLC layer	165
A.2	Coding of Information Elements	165
A.2.1	Coding of the Information Element << ULE-MAC-CONFIGURATION-INFO >>	165
A.2.2	Coding of the Information Element <<IWU-ATTRIBUTES>>	166
A.2.3	Coding of the Information Element <<IWU-to-IWU>>	168
A.2.3.0	General	168
A.2.3.1	IWU-to-IWU information field (octets 4 to L+2) for Protocol Discriminator value "ULE Configuration and Control"	168
A.2.3.2	Discriminator Specific Contents (octets 5 to L+2) for Discriminator type "Proprietary ULE protocols "	169
A.2.3.3	Discriminator Specific Contents (octets 5 to L+2) for Discriminator type "ULE Common Control Protocol "	169
Annex B (normative): U-plane services and interworking procedures		171
B.1	Scope of this annex	171
B.2	Transparent U-plane Interworking	171
B.2.1	U-plane procedures	171
B.2.2	C-plane procedures	171
Annex C (informative): Guidelines and examples		172
C.1	Channel selection algorithms	172
C.1.1	Example of Implementation of Process M0	172
C.1.1.0	General	172
C.1.1.1	Technical principles and objectives	172

C.1.1.2	Possible implementation	172
C.1.1.3	Alternative implementation	173
C.2	ULE Paging Mechanism	174
C.2.1	Examples of ULE Paging Mechanism.....	174
C.2.1.0	General.....	174
C.2.1.1	Example 1	174
C.2.1.2	Example 2	174
History	177

Intellectual Property Rights

IPRs essential or potentially essential to the present document may have been declared to ETSI. The information pertaining to these essential IPRs, if any, is publicly available for **ETSI members and non-members**, and can be found in ETSI SR 000 314: "*Intellectual Property Rights (IPRs); Essential, or potentially Essential, IPRs notified to ETSI in respect of ETSI standards*", which is available from the ETSI Secretariat. Latest updates are available on the ETSI Web server (<http://ipr.etsi.org>).

Pursuant to the ETSI IPR Policy, no investigation, including IPR searches, has been carried out by ETSI. No guarantee can be given as to the existence of other IPRs not referenced in ETSI SR 000 314 (or the updates on the ETSI Web server) which are, or may be, or may become, essential to the present document.

Foreword

This Technical Specification (TS) has been produced by ETSI Technical Committee Digital Enhanced Cordless Telecommunications (DECT).

The present document is based on ETSI EN 300 175, parts 1 [1] to 8 [8], ETSI EN 300 444 [9] and ETSI EN 301 649 [i.4]. Further details of the DECT system may be found in ETSI TR 101 178 [i.1].

The present document has been developed in accordance to the rules of documenting a profile specification as described in ISO/IEC 9646-6 [i.2].

The present document is part 1 of a multi-part deliverable covering Machine to Machine Communications based on DECT Ultra Low Energy (ULE) as identified below:

Part 1: "Home Automation Network (phase 1)";

Part 2: "Home Automation Network (phase 2)".

The present document defines the functionality for phase 1 of DECT Ultra Low Energy (ULE), Home Automation Network (HAN). Further phases with additional functionality will be defined in the future by other parts of this multi-part deliverable.

Modal verbs terminology

In the present document "**shall**", "**shall not**", "**should**", "**should not**", "**may**", "**need not**", "**will**", "**will not**", "**can**" and "**cannot**" are to be interpreted as described in clause 3.2 of the [ETSI Drafting Rules](#) (Verbal forms for the expression of provisions).

"**must**" and "**must not**" are **NOT** allowed in ETSI deliverables except when used in direct citation.

Introduction

DECT Ultra Low Energy (ULE) provides bi-directional radio communication with medium range, data protection, and Ultra Low Power consumption between different types of Portable Devices and Radio Fixed Parts.

DECT ULE is based on the DECT base standard ETSI EN 300 175 parts 1 [1] to 8 [8], and the DECT Packet Radio Service (DPRS) ETSI EN 301 649 [i.4]. However DECT ULE includes substantial differences with its parent technology in order to achieve Ultra Low Power consumption.

The maximum radio coverage range of DECT ULE will be the same as standard DECT technology. Smaller coverage may be defined for specific applications due to power consumption and spectrum use considerations.

DECT ULE has been designed to be coexistent with other DECT applications (including GAP or NG-DECT). Different types of DECT devices may be used over the same spectrum, and mixed devices supporting DECT ULE and other DECT applications may be built. It is foreseen that the majority of DECT ULE RFPs and some DECT ULE PPs will be mixed devices.

From the point of view of DECT standardization DECT ULE is an Application Profile (AP) based on the DECT base standard (ETSI EN 300 175, parts 1 [1] to 8 [8]). This application profile (AP) may reuse definitions and procedures defined in other DECT applications profiles when needed or convenient. This is the case, for instance, of the DECT Generic Access Profile (GAP) ETSI EN 300 444 [9], and the DECT Packet Radio Service (DPRS) ETSI EN 301 649 [i.4]

All DECT devices claiming to be compliant with this Application Profile will offer at least the basic services defined as mandatory. In addition to that, optional features can be implemented to offer additional DECT ULE services.

The aim of the DECT ULE standard is to guarantee a sufficient level of interoperability and to provide an easy route for development of DECT ULE applications. The DECT ULE standard also guarantees compatibility between DECT ULE applications and existing DECT applications (such as GAP or NG-DECT) running over the same spectrum and even in the same device.

The following three types of PP devices are part of DECT ULE phase 1. Additional device types may be added in further ULE phases:

- **Fast Actuator type PP**
Devices optimized for fast response times (both ways) and significant FP to PP traffic. Typical applications are, for instance, electricity control elements. Fast actuators are normally line powered.
- **Slow Actuator type PP**
Devices optimized for medium response times and significant Fixed Part to Portable Part traffic. Typical applications are, for instance, thermostats and related control elements. Slow actuators are normally battery powered.
- **Sensor type PP**
Devices characterized by long sleep times, traffic dominated by Portable Part to Fixed Part direction and optimized for minimal battery consumption. Sensors are typically battery powered and are still able to provide fast response times from Portable Part to Fixed Part. Typical applications are, for instance, command elements in electricity control, smoke detectors and motion detectors.

1 Scope

The present document specifies the first set of functionalities of the ETSI radio technology named DECT Ultra Low Energy (ULE).

The set of features defined in the present document is named "Home Automation Network (HAN), phase 1", and is primarily targeted to provide a global M2M solution within domestic scenarios. However, this does not prevent the use of the present document in other scenarios.

DECT Ultra Low Energy (ULE) Part 1 (the present document) provides the following basic functionalities:

- New MAC layer procedures optimized for ULE:
 - Ultra-fast "expedited" MAC procedures allowing combined transmission of signalling and data packet in the very first frame.
 - Unlocked, ultra low duty cycle operation for battery powered Portable Part devices.
 - New Channel selection processes with channel pre-selection and management algorithms for collision prevention and collision avoidance.
 - U-plane protected service I_{PQR} with automatic retransmission (ARQ) capabilities.
- New DLC service (LU14) incorporating CCM authenticated encryption.
- Network (NWK) Layer Connection Oriented model including CC (Call Control) and MM (Mobility Management) entities.
- State of the art Security.

2 References

2.1 Normative references

References are either specific (identified by date of publication and/or edition number or version number) or non-specific. For specific references, only the cited version applies. For non-specific references, the latest version of the reference document (including any amendments) applies.

Referenced documents which are not found to be publicly available in the expected location might be found at <http://docbox.etsi.org/Reference>.

NOTE: While any hyperlinks included in this clause were valid at the time of publication, ETSI cannot guarantee their long term validity.

The following referenced documents are necessary for the application of the present document.

- [1] ETSI EN 300 175-1: "Digital Enhanced Cordless Telecommunications (DECT); Common Interface (CI); Part 1: Overview".
- [2] ETSI EN 300 175-2: "Digital Enhanced Cordless Telecommunications (DECT); Common Interface (CI); Part 2: Physical layer (PHL)".
- [3] ETSI EN 300 175-3: "Digital Enhanced Cordless Telecommunications (DECT); Common Interface (CI); Part 3: Medium Access Control (MAC) layer".
- [4] ETSI EN 300 175-4: "Digital Enhanced Cordless Telecommunications (DECT); Common Interface (CI); Part 4: Data Link Control (DLC) layer".
- [5] ETSI EN 300 175-5: "Digital Enhanced Cordless Telecommunications (DECT); Common Interface (CI); Part 5: Network (NWK) layer".
- [6] ETSI EN 300 175-6: "Digital Enhanced Cordless Telecommunications (DECT); Common Interface (CI); Part 6: Identities and addressing".

- [7] ETSI EN 300 175-7: "Digital Enhanced Cordless Telecommunications (DECT); Common Interface (CI); Part 7: Security features".
- [8] ETSI EN 300 175-8: "Digital Enhanced Cordless Telecommunications (DECT); Common Interface (CI); Part 8: Speech and audio coding and transmission".
- [9] ETSI EN 300 444: "Digital Enhanced Cordless Telecommunications (DECT); Generic Access Profile (GAP)".
- [10] ETSI EN 300 176-1: "Digital Enhanced Cordless Telecommunications (DECT); Test specification; Part 1: Radio".
- [11] ETSI TS 102 527-3: "Digital Enhanced Cordless Telecommunications (DECT); New Generation DECT; Part 3: Extended Wideband Speech Services".
- [12] ISO/IEC 8073 (1997): "Information technology -- Open Systems Interconnection -- Protocol for providing the connection-mode transport service".

2.2 Informative references

References are either specific (identified by date of publication and/or edition number or version number) or non-specific. For specific references, only the cited version applies. For non-specific references, the latest version of the reference document (including any amendments) applies.

NOTE: While any hyperlinks included in this clause were valid at the time of publication, ETSI cannot guarantee their long term validity.

The following referenced documents are not necessary for the application of the present document but they assist the user with regard to a particular subject area.

- [i.1] ETSI TR 101 178: "Digital Enhanced Cordless Telecommunications (DECT); A high Level Guide to the DECT Standardization".
- [i.2] ISO/IEC 9646-6: "Information technology -- Open Systems Interconnection -- Conformance testing methodology and framework -- Part 6: Protocol profile test specification".
- [i.3] ISO/IEC 9646-7: "Information technology -- Open Systems Interconnection -- Conformance testing methodology and framework -- Part 7: Implementation Conformance Statements".
- [i.4] ETSI EN 301 649: "Digital Enhanced Cordless Telecommunications (DECT); DECT Packet Radio Service (DPRS)".
- [i.5] ETSI TS 102 527-1: "Digital Enhanced Cordless Telecommunications (DECT); New Generation DECT; Part 1: Wideband Speech".
- [i.6] IETF RFC 3610: "Counter with CBC-MAC (CCM)".
- [i.7] FIPS Publication 197 (2001): "Advanced Encryption Standard (AES)", National Institute of Standards and Technology (NIST).
- [i.8] draft-ietf-6lo-dect-ule-00: "Transmission of IPv6 Packets over DECT Ultra Low Energy".

NOTE: Available at : <https://tools.ietf.org/html/draft-ietf-6lo-dect-ule-00>.

- [i.9] ETSI TS 102 939-2: "Digital Enhanced Cordless Telecommunications (DECT); Ultra Low Energy (ULE); Machine to Machine Communications; Part 2: Home Automation Network (phase 2)".
- [i.10] ETSI TS 102 527-5: "Digital Enhanced Cordless Telecommunications (DECT); New Generation DECT; Part 5: Additional feature set nr. 1 for extended wideband speech services".
- [i.11] ETSI EN 301 908-10: "Electromagnetic compatibility and Radio spectrum Matters (ERM); Base Stations (BS), Repeaters and User Equipment (UE) for IMT-2000 Third-Generation cellular networks; Part 10: Harmonized EN for IMT-2000, FDMA/TDMA (DECT) covering essential requirements of article 3.2 of the R&TTE Directive".

3 Definitions, symbols and abbreviations

3.1 Definitions

For the purposes of the present document, the following terms and definitions apply:

Access Rights Identity (ARI): globally unique identity that shows the access rights related to a service provider

NOTE: See ETSI EN 300 175-6 [6].

attach: process whereby a PP within the coverage area of a FP to which it has access rights, notifies this FP that it is operative

authentication: process whereby a DECT PT, FT or subscriber is positively verified to be a legitimate user of a particular DECT system

bearer service: type of telecommunication service that provides a defined capability for the transmission of signals between user-network interfaces

C-plane: control plane of the DECT protocol stacks, which contains all of the internal DECT protocol control, but may also include some external user information

NOTE: The C-plane stack always contains protocol entities up to and including the NWK layer.

call: all of the NWK layer processes involved in one NWK layer peer-to-peer association

Cipher Block Chaining Message Authentication Code (CBC-MAC): cryptographic technique for constructing a message authentication code from a block cipher

Counter with CBC-MAC (CCM): authenticated encryption algorithm designed to provide both authentication and confidentiality

DECT network: network that uses the DECT air i/f to interconnect a local network to one or more portable applications. The logical boundaries of the DECT network are defined to be at the top of the DECT NWK layer

expedited (messages, procedures, operations): MAC C/O operations (messages, procedures, operations) intended for ultra fast setup and release of bearers, allowing in most cases reduction in the number of messages and early or late U-plane transmission compared to regular procedures

Fixed Part (DECT Fixed Part) (FP): physical grouping that contains all of the elements in the DECT network between the local network and the DECT air i/f

NOTE: A DECT FP contains the logical elements of at least one FT, plus additional implementation specific elements.

Fixed radio Termination (FT): logical group of functions that contains all of the DECT processes and procedures on the fixed side of the DECT air i/f

NOTE: A FT only includes elements that are defined in the DECT Common Interface (CI) standard. This includes radio transmission elements together with a selection of layer 2 and layer 3 elements.

geographically unique identity: related to FP identities, PARIs and RFPIs, it indicates that two systems with the same PARI, or respectively two RFPs with the same RFPI, cannot be reached or listened to at the same geographical position

NOTE: For PARI and RFPI, see abbreviations clause.

global network: telecommunication network capable of offering a long distance telecommunication service

NOTE: The term does not include legal or regulatory aspects, nor does it indicate if the network is a public or a private network.

globally unique identity: identity is unique within DECT (without geographical or other restrictions)

handover: process of switching a call in progress from one physical channel to another physical channel

NOTE: Handover may be intra-cell handover or inter-cell handover.

Home Automation Network (HAN): network that connects all sensors and actors in a house or apartment, providing interoperability for devices of different vendors and typically has a connection to the Internet. The Home Automation Network is used for various applications, from Home Automation and Security to Climate Control and Energy Management

inter-cell handover: switching of a call in progress from one cell to another cell

internal general call: internal call setup by a PP to ring all other PPs (i.e. excluding the initiator) and FP (when capable of)

NOTE: This is typically useful in residential environments when transferring a call.

internal handover: handover processes that are completely internal to one FT Internal handover reconnects the call at the lower layers, while maintaining the call at the NWK layer

NOTE: The lower layer reconnection can either be at the Data Link Control (DLC) layer (connection handover) or at the Medium Access Control (MAC) layer (bearer handover).

inter-operability: capability of FPs and PPs, that enable a PP to obtain access to teleservices in more than one Location Area (LA) and/or from more than one operator (more than one service provider)

InterWorking Unit (IWU): unit that is used to interconnect sub networks

NOTE: The IWU will contain the interworking functions necessary to support the required sub-network interworking.

intra-cell handover: switching of a call in progress from one physical channel of one cell to another physical channel of the same cell

link: association between two DLC layer entities

NOTE: This can either be one DLC C-plane association or one DLC U-plane association. Usually, but not necessarily, one DLC Link is mapped to one Logical connection.

locally unique identity: unique identity within one FP or LA, depending on application

Location Area (LA): domain in which a PP may receive (and/or make) calls as a result of a single location registration

location registration: process whereby the position of a DECT PT is determined to the level of one LA, and this position is updated in one or more databases

NOTE: These databases are not included within a DECT FT.

logical connection: association between two instances of the MAC MBC that can be used by higher layers to exchange U-plane or C-plane data

logical connection establishment: procedure to create a logical connection

NOTE: The logical connection establishment is instantiated by the DLC upon request of the NWK layer.

logical connection release: procedure to release a logical connection

NOTE: The logical connection release is usually instantiated by the DLC upon request of the NWK layer, but under certain circumstances it could also be initiated by the ME.

MAC connection (connection): association between one source MAC Multiple Bearer Control (MBC) entity and one destination MAC MBC entity

NOTE: This provides a set of related MAC services (a set of logical channels), and it can involve one or more underlying MAC bearers.

machine to machine solution: combination of devices, software and services that operate with little or no human interaction

Message Authentication Code (CCM): short piece of information generated by a cryptographic function used to authenticate and to protect the data integrity of a message

Message Integrity Code (CCM): alternative name for the Message Authentication Code

multiframe: repeating sequence of 16 successive Time Division Multiple Access (TDMA) frames, that allows low rate or sporadic information to be multiplexed (e.g. basic system information or paging)

New Generation DECT: further development of the DECT standard introducing wideband speech, improved data services, new slot types and other technical enhancements

outgoing call: call originating from a PP

Packet Data Protocol (PDP): terminology used in GPRS and 3GPP that refers to any of the data protocols transported over the radio packet service (IP, X.25, etc.)

PDP context: terminology used in GPRS and 3GPP to denote the context associated to a packet data connection

NOTE: It is equivalent to "virtual circuit".

Permanent Virtual Circuit (PVC): virtual circuit that can be established and cleared only by configuration

physical connection: association between two sets of TBCS at MAC layer including the underlying bearers that belong to a single logical connection

physical connection establishment: procedure to activate all bearers and TBCs related to a single logical connection

NOTE: The physical connection establishment is always under control of the Management Entity (ME).

physical connection release: procedure to release all bearers and TBCs associated with a Logical connection

NOTE: Physical Connection release is always under control of the Management Entity (ME).

Portable Part (DECT Portable Part) (PP): physical grouping that contains all elements between the user and the DECT air i/f

NOTE 1: PP is a generic term that may describe one or several physical pieces.

NOTE 2: A DECT PP is logically divided into one PT plus one or more PAs.

Portable radio Termination (PT): logical group of functions that contains all of the DECT processes and procedures on the portable side of the DECT air i/f

NOTE: A PT only includes elements that are defined in the DECT Common Interface standards (ETSI EN 300 175 parts 1 [1] to 8 [8]). This includes radio transmission elements (layer 1) together with a selection of layer 2 and layer 3 elements.

Radio Fixed Part (RFP): one physical sub-group of a FP that contains all the radio end points (one or more) that are connected to a single system of antennas

registration: ambiguous term that should always be qualified. See either location registration or subscription registration

resume: procedure to re-establish the physical connection for a logical connection in suspended state

resumed state: state of an established Logical connection, open at MB, DLC and NWK, with active TBCs and physical layer

roaming: movement of a PP from one FP coverage area to another FP coverage area, where the capabilities of the FPs enable the PP to make or receive calls in both areas

NOTE: Roaming requires the relevant FPs and PP to be inter-operable.

RS: value used to establish authentication session keys

subscription registration: infrequent process whereby a subscriber obtains access rights to one or more FPs

NOTE: Subscription registration is usually required before a setting any virtual call.

suspend: procedure to release the physical connection without releasing the logical connection

suspended state: state of an established logical connection open at MBC, DLC and NWK but with no associated TBCs and physical layer resources

TDMA frame: time-division multiplex of 10 ms duration, containing 24 successive full slots

NOTE: A TDMA frame starts with the first bit period of full slot 0 and ends with the last bit period of full slot 23.

Ultra Low Energy (ULE): packet data technology based on DECT intended for M2M communications and optimized for ultra low power consumption under low or moderate data rate and traffic conditions

Virtual Call (VC): any packet-mode user connection that can be setup and released by means of NWK layer C-plane procedures

NOTE 1: A Virtual Call is the packet-mode equivalent of a circuit-mode call.

NOTE 2: Virtual Call is the DECT terminology for what in GPRS and UMTS is called "PDP context".

virtual circuit: any packet-mode user connection able to transport the user packet data protocol. Each virtual circuit provides an independent and isolated context for each subscriber data session and is mapped to one DLC Link and to one MAC Logical connection

NOTE 1: Virtual circuits could be of two types: Virtual Calls (VC) and Permanent Virtual Circuits (PVC).

NOTE 2: A Permanent Virtual Circuit is the packet-mode equivalent of a circuit-mode leased line. A PVC is a degenerated case of a VC.

3.2 Symbols

For the purposes of the present document, the following symbols apply:

B_S	Slow Broadcast channel
B_U	ULE Broadcast channel
C	for conditional to support (process mandatory)
C	higher layer control Channel (see C_S and C_F)
C_F	higher layer signalling Channel (Fast)
C_S	higher layer signalling Channel (Slow)
G_F	higher layer information control channel (fast) (a logical channel to the MAC layer)
G_{FA}	higher layer information control channel (slow) (a logical channel to the MAC layer)
I	for out-of-scope (provision optional, process optional) not subject for testing
I	higher layer Information channel (see I_N and I_P)
i/f	interface
I_N	higher layer Information channel (unprotected)
I_P	higher layer Information channel protected (in general, any variant)
I_{PF}	higher layer Information channel (protected) transported multiplexed with signalling in the E+U
I_{PM}	higher layer Information channel, multi-subfield (protected) B-field with error detection only
I_{PMR}	higher layer Information channel, multi-subfield (protected) B-field with MOD-2 protected
I_{PQ}	higher layer Information channel (protected) with single subfield format and error detection only
I_{PQR}	higher layer Information channel (protected) with single subfield format and error correction
L_c	DLC layer C-plane protocol entity
N	identities channel
M_T	MAC control channel on A-tail field, or one message on such channel
M_U	MAC control channel on B-field for ULE
N_S	split identities channel on B-field for ULE
N_T	identities information channel or one message in such channel
O	optional to support

NOTE: Provision optional, process mandatory, see clause 6.2.1.

O.x	option comprising number of items
Q _C	Compound System Information Channel of B-field for ULE
Q _H	Q field header
Q _T	system information and Multiframe marker
RR	frame type of the DLC C-plane entity
SI _p	higher layer connectionless channel (protected)
X	excluded, not allowed

3.3 Abbreviations

For the purposes of the present document, the following abbreviations apply:

AC	Authentication Code
ACK	ACKnowledgement
AES	Advanced Encryption Standard
AP	Application Profile
ARI	Access Rights Identity
ARQ	Automatic Retransmission reQuest
BA (bits)	B-field identification bits, the bits from the A-field header that provide indication for the content of the B-field of one MAC layer packet
BCK	bit used for I _p channel flow control in MAC I _p error correction services
C/L	ConnectionLess
CA	Channel Active
CBC-MAC	Cipher Block Chaining Message Authentication Code
CC	Call Control, a NWK layer functional grouping
CCM	Counter with CBC-MAC
CHO	Connection HandOver
CI	Common Interface
CLMS	ConnectionLess Message Service
C-plane	Control plane
CRC	Cyclic Redundancy Check
DCK	Derived Cipher Key
DECT	Digital Enhanced Cordless Telecommunications
DF	DECT Forum
DLC	Data Link Control
DPRS	Data Packet Radio service
DSAA	DECT Standard Authentication Algorithm
DSAA2	DECT Standard Authentication Algorithm #2
DSC	DECT Standard Cipher (algorithm)
DSC2	DECT Standard Cipher #2 (algorithm)
E+U	Mode of the B-field E/U multiplexer carrying U-plane data and signalling
ECN	Exchanged Connection Number
EFREL	Enhanced Frame RELay service
EMC	Equipment Manufacturer's Code
FCNT	Frame CouNTER
FLEN	Frame LENgth
FMID	Fixed part MAC IDentity
FP	Fixed Part
FT	Fixed radio Termination
GAP	Generic Access Profile
GFSK	Gaussian Frequency Shift Keying
GPRS	General Packet Radio Service
HAN	Home Automation Network
HD	High Definition
HLM	High Level Modulation
HTTP	HyperText Transfer Protocol
IE	Information Element
IETF	Internet Engineering Task Force
i/f	interface

IWU	InterWorking Unit
KSG	Key Stream Generator
L	Length
LA	Location Area
LAPC	DLC layer C-plane protocol entity
LBN	Logical Bearer Number
Lc	DLC layer C-plane protocol entity
LCE	Link Control Entity
LLME	Lower Layer Management Entity
LLN	Logical Link Number
LSB	Least Significant Bit
LSIG	LSIG Link SIGNature
LU	DECT DLC U-Plane Service
M	for mandatory to support (provision mandatory, process mandatory, see clause 6.2.1).
M	MAC control channel
M0	RFP channel pre-selection algorithm for ULE
M1	PP channel selection algorithm for ULE
M2	PP collision handling and avoidance algorithm for ULE
MAC	Medium Access Control
MAC	Message Authentication Code (CCM)
MBC	Multi Bearer Control
MCEI	MAC Connection Endpoint Identifier
ME	Management Entity
MF	Multi Frame
MFN	MultiFrame Number
MIC	Message Integrity Code (CCM)
MM	Mobility Management
MOD	MODulus
MTU	Maximum Transmission Unit
MUX	time MULTipleXors
N	identities channel
N/A	not-applicable

NOTE: In the given context the specification makes it impossible to use this capability, see clause 6.2.1.

NG-DECT	New Generation DECT
NLF	New Link Flag
NTP	Normal Transmitted Power
NWK	NetWorK
P	Paging channel
PAP	PAP Public Access Profile
PARI	Primary Access Rights Identity
PDP	Packet Data Protocol
PDU	Protocol Data Unit
PHL	PHysical Layer
PHY	PHYSical
PIN	Personal Identity Number
PMID	Portable part MAC IDentity
PP	DECT Portable Part
PP	Portable Part
PSCN	Primary receiver Scan Carrier Number
PSTN	Public Switched Telephone Network
P _T	one P-channel message
PT	Portable radio Termination
P _U	ULE Paging channel on B-field
PVC	Permanent Virtual Circuit
RES	RESponse
RFC	Request For Comment
RFP	Radio Fixed Part
RFPI	Radio Fixed Part Identity
RN	Received sequence Number
RSSI	Radio Signal Strength Indicator

Rx	Receiver side
SAP	Service Access Point
SAPI	Service Access Point Identifier
SARI	Secondary Access Rights Identity
SDU	Service Data Unit
SIP	Session Initiation Protocol
SN	Slot Number
TBC	Traffic Bearer Control
TDMA	Time Division Multiple Access
Tx	Transmitter side
UAK	User Authentication Key
ULE	Ultra Low Energy
UMTS	Universal Mobile Telecommunication System
UPI	User Personal Identification
U-plane	User-plane
VC	Virtual Call

4 Description of services

4.1 DECT Ultra Low Energy

4.1.1 Introduction

Digital Enhanced Cordless Telecommunications (DECT) technology was launched in 1987 and has since then developed into one of the most reliable and flexible digital radio access standard for cordless communication. DECT has been a continuously evolving technology and new versions of the core technology such as New Generation DECT- (NG-DECT) have already surfaced. It has added features such as HD voice, VoIP and other internet based services over the standard DECT protocol.

DECT ULE is based on the proven and established DECT standard. ULE has all the traditional strengths of DECT (interference free, license free, security, authentication, long range, ready internet, etc.). With re-designed hardware and software components DECT ULE is optimized for low data rate application and ultra-low power consumption. DECT ULE is compatible with DECT voice applications, such as GAP [9] or NG-DECT, allowing the support of both services in the same system and the design of mixed mode PPs or RFPs.

DECT ULE is designed to maintain a good Quality of Service (which is a unique feature of ULE compared to other low power wireless standards). The low energy (ULE) version positions DECT in new and rapidly growing market segments beyond the traditional DECT telephony market, such as the wireless Machine-to-Machine (M2M) market - a rapidly growing segment.

DECT Ultra Low Energy is the DECT base specification for the low power applications. DECT ULE includes powerful mechanisms providing context control, mobility management and security, and takes advantage of powerful features of the DECT common interface to offer a high performance data transport mechanism.

The present document defines the base functions for DECT ULE and the specific functions for "Home Automation Network (phase 1)". The present document provides a selection of features, operation modes and interworking functions and defines an interoperability profile.

4.2 ULE phase 1

4.2.1 Definition of ULE phase 1

DECT ULE phase 1 is defined as a specific DECT ULE capability set that provides solutions intended primarily, but not necessarily, for Home Automation scenarios.

DECT ULE phase 1 device types are described in clause 4.3.1. All these device types may also implement other DECT functionalities. For example, an ULE compliant RFP may, at the same time, be a GAP or an NG-DECT RFP.

4.2.2 Example of applications covered by ULE phase 1

Examples of the applications that can be built with DECT ULE phase 1 (the present document) are the following:

- **Actuator devices**
Devices with fast response time requirements and traffic usually FT initiated, such as electricity plugs, electric control elements, alarm centrals and other control elements.
- **Slow Actuator devices**
Devices with medium response time requirements and traffic usually FT initiated, commonly used, for instance, in heating and air conditioning systems.
- **Sensor devices**
Devices with long sleep times, very demanding power consumption requirements, fast response time requirements for PP originated events and slow response time requirements for FP initiated actions. Typical examples are switches and push buttons, command modules, thermostats, smoke detectors and motion detectors.

This list is not exhaustive and further applications may be developed by device vendors based on the present document.

4.2.3 Physical layer, radio properties and spectrum use

The maximum radio coverage range of DECT ULE will be as wide as standard DECT technology. Smaller coverage may be defined for specific applications due to power consumption and spectrum use considerations.

Due to the nature of DECT ULE applications, it is foreseen that most of them would operate, however not necessarily, over unlicensed or license exempt spectrum. The standard DECT frequency allocation (1 880 - 1 900 MHz) will be used in EU area for operation of ULE phase 1 devices. Further bands, licensed or unlicensed, may be identified in the future.

4.2.4 Coexistence with other DECT services

DECT ULE has been designed to be coexistent with other DECT applications (including GAP or NG-DECT). Different types of DECT devices may be used over the same spectrum, and mixed devices supporting DECT ULE and other DECT applications may be built. It is foreseen that the majority of DECT ULE RFPs and some DECT ULE PPs will be mixed devices.

4.3 Example scenarios for DECT ULE phase 1

4.3.1 Security applications (fire and burglary alarms)

Figure 1 shows a typical security application scenario. External communications (via PSTN or internet) may be part of the scenario and easily implemented due to the usual PSTN or internet connectivity of most DECT RFPs.

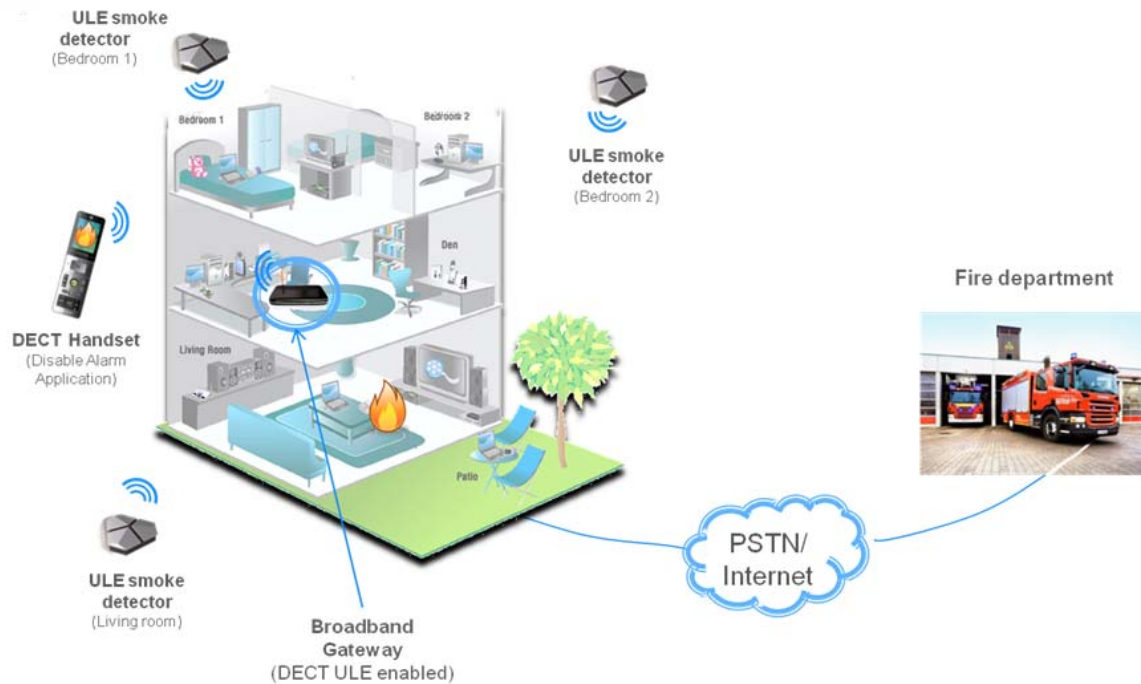

Figure 1: Security application scenario (fire and burglary alarms)

4.3.2 Global Home control and domotic scenario

Figure 2 shows a Home control and domotic scenario. Sensor type and actuator type ULE devices are combined with specific application logic to perform a potentially large number of functions in a home scenario. DECT advanced voice terminals such as the ones compliant to New Generation DECT parts 3 [11] or 5 [i.10], and external connectivity via internet may also be part of the solution.



Figure 2: Global Home control and domotic scenario

4.3.3 Energy and appliances management scenario

Energy control is a target application of DECT ULE phase 1. Figure 3 shows an energy and appliances management scenario in a domestic environment. Sensor type and actuator type ULE devices are used to perform multiple energy control related functions. Interconnection to utility companies via internet may be part of the solution.

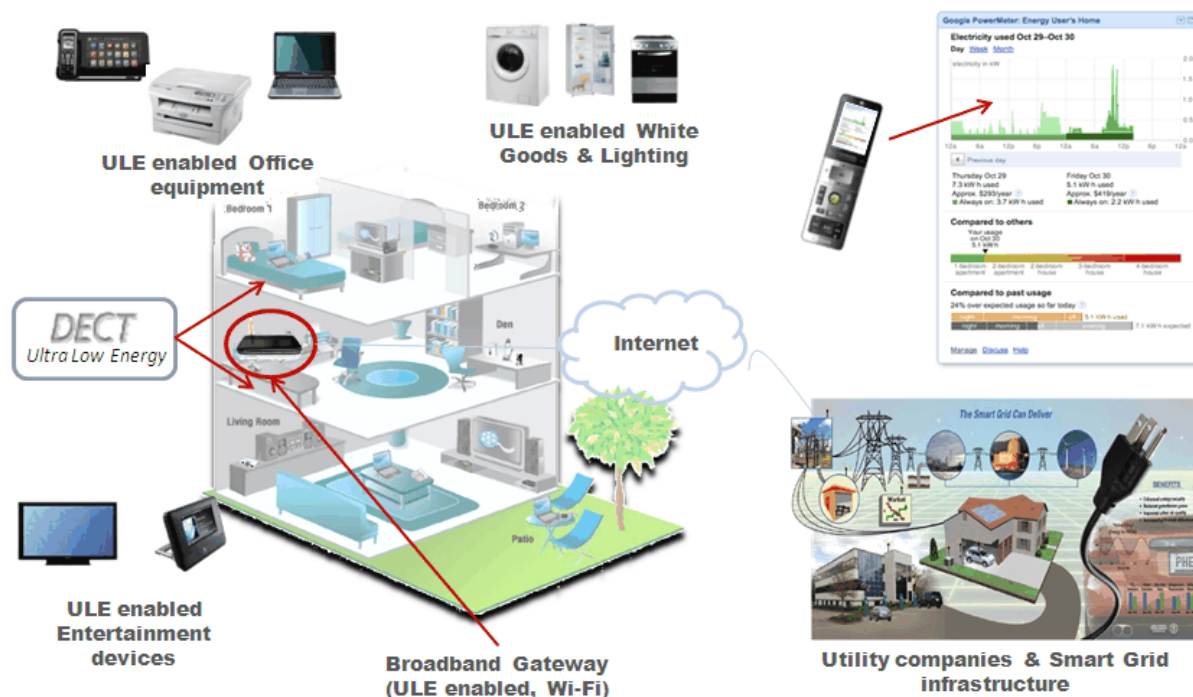

Figure 3: Energy and appliances management scenario

4.4 Requirement specification for ULE phase 1

4.4.1 ULE phase 1 device types

4.4.1.0 General

ULE phase 1 supports the following types of devices:

- RFP with support of ULE phase 1
- PP type I: "sensor"
- PP type II: "fast actuator"
- PP type III: "slow actuator"

4.4.1.1 PP type I: "sensor"

4.4.1.1.1 General description

ULE PP devices, generally battery powered, with long sleep times and strong power saving requirements.

Typical examples are sensors (all types), Smoke Detectors, Motion Detectors, temperature sensor, switches and press buttons, command modules, etc.

4.4.1.1.2 Requirements and functionalities for type I devices

ULE type I "sensor" PPs has the following requirements and specific functionalities:

- Ultra low power consumption
- Unlocked "deep sleep" operation
- Ultra low paging cycles (type Ia) or no paging cycle at all (type Ib)
- Fast response times when activated due to an event at the PP side

4.4.1.2 PP type II: "fast actuator"

4.4.1.2.1 General description

ULE PP devices, generally line powered, with not so strong power saving requirements, but requiring fast response times as response to FP side requests.

Typical examples are electric control modules (actuators) driving powers circuits, air conditioning equipment, alarm bells and control modules, etc.

4.4.1.2.2 Requirements and functionalities for type II devices

ULE type II "fast actuator" PPs have the following requirements and specific functionalities:

- Locked operation
- Normal or fast paging cycles
- High paging capacity
- Fast response times as response to paging commands from the FP side

4.4.1.3 PP type III: "slow actuator"

4.4.1.3.1 General description

ULE PP devices, battery or powered, with power saving requirements, but with traffic dominated by the FP to PP direction, and requiring medium response times to FP side requests.

Typical examples are control modules (actuators) for heating (hot water circuit radiator) and air conditioning equipment.

4.4.1.3.2 Requirements and functionalities for type III devices

ULE type III "slow actuator" PPs have the following requirements and specific functionalities:

- Locked or un-locked operation
- Normal to slow paging cycles
- Medium paging capacity
- Medium response times to paging commands from the FP side

4.4.1.4 ULE phase 1 compliant RFP

4.4.1.4.1 General description

DECT Radio Fixed Parts supporting the functionalities described in the present document.

The RFP may typically support other DECT services such as GAP or New Generation DECT (any phase), however this is not mandatory.

4.4.1.4.2 Requirements and functionalities for ULE phase 1 RFP

ULE phase 1 RFP has the following requirements and specific functionalities:

General coexistence requirement:

- It should be possible the implementation of RFP supporting at the same time, ULE phase 1 and a DECT voice service (GAP or New Generation DECT).

Specific ULE phase 1 requirement:

- All RFPs compliant with the present document shall be able to support the three described types of ULE PPs.

4.4.2 U-plane interworking and protocol architecture

4.4.2.1 ULE phase 1 protocol architecture

Figure 4 shows the protocol architecture of DECT ULE phase 1.

An external protocol (application layer) is transported over LU14 by means of an Interworking layer. The DECT C-plane may be activated as response to external application protocol when needed.

In ULE phase 1, the only Interworking defined provides the transparent transport of the external protocol packet and the DECT C-plane is used to configure interworking parameters. Other more complex interworkings may be defined in further phases and releases.



Figure 4: Reference model of the ULE U-plane and C-plane

4.4.3 Performance Objectives

Table 1 shows the performance objectives of DECT ULE phase 1.

Table 1: Performance objectives

Performance	Value	Notes
Maximum data rate for full-slot devices	24 kbit/s	
Maximum data rate for double-slot devices	64 kbit/s	
Response time for a PP => FP transmission when the PP was in locked state	20 ms	
Response time for a PP => FP transmission when the PP was in deep sleep (unlocked) state (sensor type device)	30 ms	
Response time for a FP => PP transmission (fast actuator type device)	50 m	
Paging cycle for sensor type devices	Configurable: 160 ms to 60 min plus infinite	
Paging cycle for slow actuator devices	Configurable: 160 ms to 10 min	
Paging cycle for fast actuator devices	Configurable: 10 ms to 160 ms	
Stay alive cycle	Configurable: 640 ms to 60 min plus infinite	

Table 2: Void

4.5 Technical features implemented by ULE phase 1

4.5.0 General

DECT Ultra Low Energy (ULE) Part 1 (the present document) provides the basic functionalities described in clauses 4.5.1 to 4.5.6.

4.5.1 MAC/PHY layer

C/O MAC service with capability of suspend/resume via expedited operations:

- Advanced connection setup
- Advanced connection release
- Full slot
- Short slot
- MAC format I_{PQ}

Expedited ULE C/O operations:

- Ultra-fast "expedited" procedures optimized for ULE and allowing combined transmission of signalling and data packet in the very first frame
- Expedited Access Request, Ready for Release and Release commands
- Expedited operations optimized for short burst data transfer
- Expedited operations optimized for multi-burst data transfer
- Optional use of short slots (P00) for power saving when no data is transported on B-field
- Management algorithms for channel selection and handling access collisions

Transport of higher layer signalling:

- Transport of channel C_S over A-field of ULE C/O bearers
- Transport of channel C_F (optional) over B-field of ULE C/O bearers
- Transport of channel G_{FA} over A-field of ULE C/O bearers

Dedicated ULE "dummy" C/L channel using the B-field of regular dummy bearer containing:

- Aids for fast re-synchronization
- General static broadcast information
- Channel selection information
- Dedicated ULE paging channels
- Provision for connectionless downlink channels (in further phases)
- Capability for changing the position of the dummy bearer

Unlocked, ultra low duty cycle operation for battery powered Portable Part devices:

- PP may enter in "deep sleep" state between activity cycles with near all circuits switched off (with loss of synchronization to the base)

- Provisions for Fast Locking so the Portable Part devices can remain in long sleep cycles and regain the timing information of the DECT network quickly

New paging channels specific for ULE over extended dummy bearer:

- Implementing a wide range of modes from fast to ultra-slow paging
- Separate channels from existing DECT LCE paging over A-field
- High capacity: a large number of sensor, fast and slow actuator devices can be paged
- Provision for future broadcast channels

U-plane handling:

- MAC MOD-2 protected channel operation (service I_{PQR} error_correct)

"Stay-alive" handshake procedures.

4.5.2 DLC layer

DLC C-plane:

- C-plane DLC (LAPC) as in existing DECT

DLC U-plane:

- New DLC service LU14 adding a CCM authenticated encryption layer based on existing service LU10:
 - Provides sequence numbering and control, flow control, Tx/Rx window handling, and segmentation and re-assembling, of higher layer packets
 - See also security description
- Class 1 transmission protocol
- New channel GFA for DLC control

4.5.3 NWK layer

- Connection Oriented model including CC (Call Control) and MM (Mobility Management) entities:
 - Configurable Virtual Circuits (= PDP Context) created at the beginning and kept for long time.
 - No NWK layer operations required during regular packet handling.
- DECT CC message and operations support:
 - Simplified NWK CC procedures for Virtual Circuit control with optimized state machine.
- DECT MM message and operations support:
 - Location update, authentication, etc.
 - Some restrictions (e.g. inter-cell handover) are applicable in phase 1.
- Additional IEs for negotiation of higher layer (application) protocol.

4.5.4 Interworking and Application layer

Transparent interworking allowing the use of external protocols with packet size of up to 500 octets.

4.5.5 Security

NWK layer authentication algorithm DSAA2 based on AES [i.7] with key length 128 bits (see ETSI EN 300 175-7 [7]):

- Provides both PT and FT mutual authentication and Cipher Key generation.
- Split into two security processes in NWK side allowing geographic distribution in home/visited domains.

New authenticated encryption based on CCM operating at DECT DLC layer:

- Strong packet encryption mechanism providing packet sequence integrity based on AES algorithm with key length 128 bits and dynamic key generated by the DSAA2 authentication algorithms.
- Based on RFC 3610 [i.6] and AES [i.7] with key length 128 bits.
- Provides simultaneously strong encryption and continuous mutual authentication without the need of running NWK layer transactions.

4.5.6 Management entity

Management entity processes for:

- Channel selection
- Handling of collisions
- Handling of other errors
- Rules for resume
- Rules for suspend, sending Ready for Release, Release, etc.

5 Service and feature definitions

5.1 ULE Phase 1

5.1.1 PHL service definitions

For the purpose of the present document, the following definitions shall apply:

GFSK modulation [ULE1-P.1]: 2 level Gaussian frequency Shift Key (GFSK) modulation as defined by ETSI EN 300 175-2 [2], clause 5.

Physical Packet P32 [ULE1-P.2]: Physical packet P32 (full slot) as defined by ETSI EN 300 175-2 [2], clause 4.4.2.

Physical Packet P00 [ULE1-P.3]: Physical packet P00 (short slot) as defined by ETSI EN 300 175-2 [2], clause 4.4.1.

General PHL [ULE1-P.4]: General Physical layer procedures applicable to all ULE terminals.

ULE Transmitted power [ULE1-P.5]: Physical layer procedures defining the transmitted power applicable to all ULE terminals.

Fast hopping radio [ULE1-P.6]: Radio transceiver able to perform frequency change during the interval between two consecutive Physical Packets P32 (full slot).

5.1.2 MAC service definitions

For the purpose of the present document, the following definitions shall apply:

General [ULE1-M.1]: set of basic requirements regarding data formats, multiplexing, CRC usage, scanning and locking, which are prerequisites to communication between peer MAC entities.

A-field continuous broadcast [ULE1-M.2]: simplex service from FT to PT whereby the FT maintains at least one bearer with continuous transmissions. The PT can use the information carried in this bearer to lock to the FT and to obtain knowledge about the FT (service similar to GAP-M.2).

A-field paging broadcast [ULE1-M.3]: service whereby the identities of specific PTs can be broadcasted by the FT. This service is normally used by the FT to request a specific PT to setup a link to the FT (service similar to GAP-M.3).

B-field continuous ULE broadcast [ULE1-M.4]: simplex service from FT to PT whereby the FT broadcasts additional information, specific for the ULE service, using part of the B-field of the same bearer(s) used for service ULE.M.3. The PT can use the information carried in this bearer to lock to the FT and to obtain knowledge about the FT.

B-field paging broadcast [ULE1-M.5]: service whereby the identities of specific PTs can be broadcasted by the FT using ULE specific broadcast procedures and broadcast channels over B-field. This service is normally used by the FT to request a specific PT to setup a link to the FT.

Basic connection control [ULE1-M.6]: MAC control procedures using the basic control set, providing means for setting-up and releasing a basic connection. Basic connections used in the present document are single bearer, full slot, no C_F and may transport an U-plane with $I_{NA_minimum_delay}$ data service (i.e. speech), or no U-plane at all (service calls). Only one basic connection may exist between a FT and particular PT.

A-field advanced connection control [ULE1-M.7]: MAC control procedures providing complete MAC support of single bearer connections using the advanced connection control set. MAC connections used in ULE use advanced control set (advanced connections) and may coexist with other advanced or basic connections for voice service between the same PT-FT pair. Several advanced connections may exist, however only one of them is controllable using ULE expedited operations.

Expedited operations for advanced connection control [ULE1-M.8]: MAC control using expedited messages and procedures optimized for ultra low efficiency and power consumption. Expedited operations are used for ULE suspend and resume procedures.

Full slot [ULE1-M.9]: support of the physical packet P32 and appropriate D-field mapping according to modulation type (D32a for GFSK modulation).

$I_{PQR_error_correction}$ MAC service type [ULE1-M.10]: $I_{p_error_correction}$ symmetric or asymmetric service as defined in ETSI EN 300 175-3 [3], clauses 5.6.2.1 (type 4: $I_{p_error_correction}$ symmetric) and 5.6.2.2. (type 8: $I_{p_error_correction}$ asymmetric) with multi-subfield protected B-field as defined in ETSI EN 300 175-3 [3], clause 6.2.1.3.3 and Mod-2-protected channel operation as defined by ETSI EN 300 175-3 [3], clause 10.8.2.

Short slot [ULE1-M.11]: support of the physical packet P00 and appropriate D-field mapping according to modulation type (D00a for GFSK modulation).

G_{FA} channel [ULE1-M.12]: simplex channel transported in the A-field that is used to provide control and carry acknowledgements for DLC entities.

C_S higher layer signalling [ULE1-M.13]: low rate connection oriented data service with ARQ using the C_S channel to transfer higher layer signalling data.

C_F higher layer signalling [ULE1-M.14]: high rate connection oriented data service with ARQ using the C_F channel to transfer higher layer signalling data.

Quality control [ULE1-M.15]: provides means for monitoring and controlling the radio link quality.

ULE physical channel selection [ULE1-M.16]: defines the policy for the dynamic selection of a channel, caused by the fact that an old one has to be changed or a new one is needed. Detection of bad quality on the physical channel in use (i.e. due to weak signals or interference), detection of a RFP with a stronger signal than the one of the own RFP, detection of local congestion are all criteria that can be used to select the channel.

Secondary Access Rights Identity (SARI) support [ULE1-M.17]: ability to support, in addition to the primary Access Rights Identity (ARI), secondary ARIs that the FT broadcasts less frequently than PARIs. These may be used to reflect an inter-operators agreement allowing a portable to access more than one operator or services through FT (service similar to GAP-M.13).

ULE bearer replacement intra-cell [ULE1-M.18]: bearer quality maintenance procedure by setting up a replacement bearer in the same RFP. Opposing to conventional voice channel handover, there is no requirement of using identical LBN and maintaining identical data on both bearers. Furthermore, the old bearer is released, before the setup of the new one.

Dummy bearer replacement [ULE1-M.19]: bearer quality maintenance procedure by setting up a replacement for the dummy bearer in the same cluster. The old dummy bearer is released after the setup of the new one.

Bearer handover inter-cell [ULE1-M.20]: connection quality maintenance by setting up replacement bearers in a different RFP belonging to the same cluster. Opposing to conventional voice channel handover, there is no the requirement of using identical LBN and maintaining identical data on both bearers. Furthermore, the old bearer is released, before the setup of the new one.

Connection handover [ULE1-M.21]: connection quality maintenance by setting up replacement bearers in the same or a different cluster, each with identical LBN and maintaining identical data bearers with identical LBN. Subsequently the old bearers are released.

Encryption activation [ULE1-M.22]: service providing means for enabling the encryption whereby on demand all higher layer data is transferred across the DECT air interface in an encrypted form. Always initiated by the PT. A connection release automatically disables ciphering (service similar to GAP-M.7).

Encryption deactivation [ULE1-M.23]: service providing means for disabling the encryption whereby on demand all higher layer data is transferred across the DECT air interface in an encrypted form. A connection release automatically disables ciphering (service similar to GAP-M.14).

Re-keying [ULE1-M.24]: mechanism to change the cipher key during an ongoing virtual call or PVC.

Early encryption [ULE1-M.25]: mechanism to activate encryption immediately after connection establishment.

DSC encryption [ULE1-M.26]: encryption using the DSC algorithm.

AES/DSC2 encryption [ULE1-M.27]: encryption using the DSC2 algorithm, based on AES, with Cipher Key of 128 bits.

5.1.3 DLC service definitions

For the purpose of the present document, the following definitions shall apply:

LU14 Enhanced Frame RELay service with CCM encryption (EFREL-CCM) [ULE1-D.1]: an enhanced frame relay service accessed through the LU14 SAP. LU14 adds CCM encryption on top of LU10. LU14 encrypts the external message using CCM with AES algorithm and 128 bit key, adds a Message Integrity Code (MIC) of 32 bytes, and transfers the resulting structure to the LU10 SAP. All other properties of LU10 apply (except the option of operating with infinite size SDU that is not possible here).

LU13 Enhanced Frame RELay service with CRC (EFREL-CRC) [ULE1-D.2]: an enhanced frame relay service accessed through the LU13 SAP. LU13 adds a CRC at SDU level, providing additional residual error detection capability, and transfers the resulting structure to the LU10 SAP. All other properties of LU10 apply (except the option of operating with infinite size SDU that is not possible here).

LU10 Enhanced Frame RELay service (EFREL) [ULE1-D.3]: an enhanced frame relay service accessed through the LU10 SAP. The LU10 shall operate on a generic field of user data that shall be transferred into and out of the DLC U-plane as a single SDU. This SDU is assumed to contain one external frame, but the operation of LU10 shall be independent of the actual contents of the SDU. LU10 shall provide mechanisms that offer reliable transport of the generic SDUs, and that preserve the SDU boundaries.

FU10a [ULE1-D.4]: offers a defined fixed length frame structure and buffering functions for transmission of U-plane data to the MAC layer (at the transmit side) or accepts data from the MAC layer (at the receiving side) on demand and with minimum delay. Frame type FU10a is used for the forward path of unidirectional links. Bi-directional links may be implemented using two unidirectional links.

FU10d [ULE1-D.5]: frame structure and buffering functions for transmission of higher layer U-plane control data from the DLC to the MAC layer channel (at the transmit side) or for accepting data from the MAC layer (at the receiving side). Used to carry acknowledgements or negative acknowledgement for connections. Frame type FU10d is used for the backward control path of unidirectional links: it contains a single receive sequence number for the forward link. FU10d is transported by MAC channel G_{FA} using M_T control messages over A-field. There are two FU10d frame formats depending on the transporting message.

Data Link Service (LAPC + Lc) class A service [ULE1-D.6]: single frame acknowledged C-plane data link service providing a data link between one FT and one PT. The higher layer information is segmented (if necessary) and transmitted in numbered frames. The Lc service, upon which LAPC is defined, provides frame delimiting, transparency and frame synchronization (Service equivalent to GAP-D.1 with modifications).

DLC Transmission Class 1 [ULE1-D.7]: U-Plane DLC Transmission Protocol providing variable throughput service, with removal and notification of all errors detected at the MAC layer, resequencing and flow control.

Lc Service [ULE1-D.8]: service providing channel dependant fragmentation, recombination, frame synchronization and frame delimiting transparency. Fragmentation is obtained by means of dividing a LAPC data unit into more than one service data units for delivery to the MAC layer C logical channel, whilst recombination is obtained by means of joining several service units received from the MAC layer C logical channel into a LAPC data unit. Allows the LLME to select the logical channel for Lc operation on a frame-by-frame basis.

broadcast Lb service [ULE1-D.9]: simplex point-to-multipoint transmission using simple fixed length DLC frames providing a restricted broadcast service in direction FP to PP(s) (Service equivalent to GAP-D.3).

encryption activation [ULE1-D.10]: transporting the NWK layer encryption request and the cipher key to the MAC layer, thereby enabling the encryption process in the MAC layer (Service equivalent to GAP-D.6).

encryption deactivation [ULE1-D.11]: transporting the NWK layer encryption deactivation request to the MAC layer, thereby disabling the encryption process in the MAC layer (Service equivalent to GAP-D.9).

CCM/AES encryption [ULE-D.12]: Encryption mechanism operating at DLC layer based on CCM with AES algorithm and Cipher Key of 128 bits.

5.1.4 NWK feature definitions

For the purpose of the present document, the following definitions shall apply:

ULE NWK control [ULE1-N.1]: simplified NWK layer control procedures for ULE.

ULE Service Call [ULE1-N.2]: call with only C-plane initiated by a DECT PT for entering of FT related service and adjustment procedures.

authentication of PP [ULE1-N.3]: process by which the identity of a DECT PP is checked by the FP.

authentication of user [ULE1-N.4]: process by which the identity of a user of a DECT PP is checked by the FP. The User Personal Identification (UPI), a personal identification of 0 to 8 digits, manually entered by the user, is used for user authentication.

location registration [ULE1-N.5]: facility whereby a PP can be registered with a FP or a cluster of FPs such that incoming calls, radio pages or messages may be routed to it.

on-air key allocation [ULE1-N.6]: capability to transform Authentication Code (AC) into User Authentication Key (UAK) using the key allocation procedure.

identification of PP [ULE1-N.7]: ability for the FP to request and PP to provide specific identification parameters.

service class indication/assignment [ULE1-N.8]: assignment by the FP to PP of the service class and indication to the FP by the PP of the contents of its service class.

encryption activation FT initiated [ULE1-N.9]: activation of the encryption process requested by FT.

subscription registration procedure on-air [ULE1-N.10]: standardized procedure for loading subscription registration data into a PP in real time over the air-interface.

link control [N.11]: ability to request, accept, maintain and release a data link for the purposes of a NWK layer procedure.

terminate access rights FT initiated [ULE1-N.12]: ability of the FP to delete a subscription in the PP.

authentication of FT [ULE1-N.13]: process by which the identity of a FP is checked by the PP.

encryption activation PT initiated [ULE1-N.14]: activation of the encryption process suggested by PT. The real time start of ciphering is done in the MAC layer and is always initiated by the PT.

encryption deactivation FT initiated [ULE1-N.15]: deactivation of the encryption process requested by FT. The real time stop of ciphering is done in the MAC layer and is always initiated by the PT.

encryption deactivation PT initiated [ULE1-N.16]: deactivation of the encryption process suggested by PT. The real time stop of ciphering is done in the MAC layer and is always initiated by the PT.

Enhanced Security [ULE1-N.17]: mechanism to enhance DECT security by introduction of early encryption and the possibility of re-keying during an ongoing call.

AES/DSAA2 authentication [ULE1-N.18]: authentication using the DECT Authentication Algorithm #2 (DSAA2), based on AES, and including type 2 (see ETSI EN 300 175-7 [7]) air i/f procedures.

5.1.5 Application feature definitions

For the purpose of the present document, the following definitions shall apply:

AC to bitstring mapping [ULE1.A.1]: mapping of the AC into a bitstring.

Multiple subscription registration [ULE1.A.2]: ability of PP to store more than one subscription.

Easy pairing registration [ULE1.A.3]: ability to register a PP that is not registered to a FP by pressing a physical or logical button on the PP and on the FP.

5.1.6 Management Entity (ME) definitions

For the purpose of the present document, the following definitions shall apply:

ULE phase 1 Management [ULE1-ME.1]: inter and intra DECT protocol layers management of the phase 1 of the ULE protocol requirements that does incorporate a C-plane providing some MM and CC capabilities.

ULE Physical Channel Selection [ULE1-ME.2]: management processes and algorithms in charge of physical channel selection in DECT ULE devices.

5.1.7 U-plane service and interworking definitions

For the purpose of the present document, the following definitions shall apply:

Transparent U-plane Interworking [ULE1-I.1]: provides the transparent transport of external protocol packets. C-plane configuration of the external protocol and MTU size are provided.

5.1.8 ULE 1 device types definitions

For the purpose of the present document, the following definitions shall apply:

RFP with support of ULE phase 1 [ULE1-TYP.1]: A DECT RFP with support of ULE phase 1 specification. Other DECT services, such as GAP or NG-DECT, may also be supported in the same RFP.

PP type I "sensor" with paging support [ULE1-TYP.2]: ULE PP device type, generally battery powered, with long sleep times and strong power saving requirements. The device may be pageable using a very slow or ultra slow paging cycle.

PP type I "sensor" without paging support [ULE1-TYP.3]: ULE PP device type, generally battery powered, with long sleep times and strong power saving requirements. The device does not listen to any paging channel in normal conditions.

PP type II "fast actuator" [ULE1-TYP.4]: ULE PP device type, generally line powered, with not so strong power saving requirements, but requiring fast response times as response to FP side orders.

PP type III "slow actuator" [ULE1-TYP.5]: ULE PP devices, battery or powered, with power saving requirements, but with traffic dominated by order from the FP and requiring medium response times as response to FP side orders.

6 Profile specific requirements

6.1 General

The tables below define the status of all protocol elements (i.e. features, services and procedures), which can be: mandatory, optional, conditional under the provision of another protocol element, outside the scope of the present document, or not applicable. The status is identified by the status designations defined in clause 6.2.1, and is described separately for FT and PT.

All optional elements shall be process mandatory according to the procedures described in the present document.

Protocol elements defined as mandatory, optional or conditional in this clause are further defined in the referenced DECT specification, or, if needed, in clause 7 of the present document.

In any case, the requirements of the test specification ETSI EN 300 176-1 [10] shall be met by all equipment conforming to the present document.

6.2 Specific conventions

6.2.1 Use of symbols in support status tables

The symbols defined in this clause are applied for procedures, features, and services in the present document if not explicitly otherwise stated. The interpretation of status columns in all tables is as follows:

- "M" (provision mandatory, process mandatory) means that the indicated feature service or procedure shall be implemented as described in the present document, and may be subject to testing.
- "O" (provision optional, process mandatory) means that the indicated feature, service or procedure may be implemented, and if implemented, the feature, service or procedure shall be implemented as described in the present document, and may be subject to testing.
- "N/A" (not-applicable) means that, in the given context the specification, the use of the indicated feature, service or procedure is meaningless or out of scope.
- "Cxxx" (conditional) indicates that the status is given by a conditional expression defined at the bottom of the table.
- "I" (irrelevant) means that the implementation status of the indicated feature, service or procedure is out of the scope (provision optional, process optional) of the present document.

NOTE: The used notation is based on the notation proposed in ISO/IEC 9646-7 [i.3].

6.3 DECT ULE phase 1 device types

6.3.1 Types of devices supported by the present document

The identified types of DECT ULE phase 1 devices are described in table 3. Additional device types may be added to further releases of the present document.

Table 3: Types of DECT ULE phase 1 devices

Item	Name of service	Reference	Support status in a ULE system	
			PT	FT
ULE1-TYP.1	RFP with support of ULE phase 1	5.1.8	-	M
ULE1-TYP.2	PP type I "sensor" with paging support	5.1.8	C301	-
ULE1-TYP.3	PP type I "sensor" without paging support	5.1.8	C301	-
ULE1-TYP.4	PP type II "fast actuator"	5.1.8	C301	-
ULE1-TYP.5	PP type III "slow actuator"	5.1.8	C301	-
C301: At least one device type shall be used.				
NOTE: The reference column refers to the relevant clause in the present document.				

6.3.2 Specific procedures for specific device types

All services, features and procedures described in the present document are applicable to all kinds of device types, except when otherwise stated.

The present document defines only one type of RFP [ULE1-TYP.1]. Therefore, the support status of all services, features and procedures for FP is as given in tables 5 to 19.

In regard to PP device types, most of services, features and procedures have the same support status for all kinds of devices. There are a few exceptions whose support status varies depending on the PP type. The status support of these procedures is given in table 4.

Table 4: Specific procedures for specific device types

Device type	Service or feature	Procedure	Reference	Status	
				PT	FT
PP type I "sensor" with paging [ULE1-TYP.2]:	B-field Continuous ULE broadcast [ULE1-M.4]	Operation in unlocked mode	10.5.5	M	-
	B-field paging broadcast [ULE1-M.5]	P _U Paging Message Formats	10.6.1	M	-
		Paging Descriptors for ULE Paging	10.6.2	M	-
		CA mask mechanism	10.6.3	M	-
PP type I "sensor" without paging support [ULE1-TYP.3]:	B-field Continuous ULE broadcast [ULE1-M.4]	Operation in unlocked mode	10.5.5	M	
	B-field paging broadcast [ULE1-M.5]	P _U Paging Message Formats	10.6.1	O	-
		Paging Descriptors for ULE Paging	10.6.2	O	-
		CA mask mechanism	10.6.3	O	-
PP type II "fast actuator" [ULE1-TYP.4]:	B-field Continuous ULE broadcast [ULE1-M.4]	Operation in unlocked mode	10.5.5	O	-
	B-field paging broadcast [ULE1-M.5]	P _U Paging Message Formats	10.6.1	M	-
		Paging Descriptors for ULE Paging	10.6.2	M	-
		CA mask mechanism	10.6.3	O	-
PP type III "slow actuator" [ULE1-TYP.5]:	B-field Continuous ULE broadcast [ULE1-M.4]	Operation in unlocked mode	10.5.5	M	-
	B-field paging broadcast [ULE1-M.5]	P _U Paging Message Formats	10.6.1	M	-
		Paging Descriptors for ULE Paging	10.6.2	M	-
		CA mask mechanism	10.6.3	O	-

Device type	Service or feature	Procedure	Reference	Status	
				PT	FT
NOTE: The reference column refers to the relevant clause in the present document.					

6.4 Physical layer (PHL) requirements

6.4.1 Physical layer (PHL) services

DECT Ultra Low Energy, phase 1 devices shall support the Physical layer (PHL) services described in table 5.

Table 5: Physical layer service support

Item	Name of service	Reference	Support status	
			PT	FT
ULE1-P.1	GFSK modulation	5.1.1	M	M
ULE1-P.2	Physical Packet P32	5.1.1	M	M
ULE1-P.3	Physical Packet P00	5.1.1	M	M
ULE1-P.4	General PHL	5.1.1	M	M
ULE1-P.5	ULE Transmitted Power	5.1.1	M	M
ULE1-P.6	Fast hopping radio	5.1.1	O	O
NOTE: The reference column refers to the relevant clause in the present document.				

6.4.2 Modulation schemes

The following modulation schemes given in table 6 and defined in annex D of ETSI EN 300 175-2 [2] shall be supported.

Table 6: Allowed combinations of modulation schemes

Modulation scheme	S-field	A-field	B + Z-field	Support status
1a	GFSK	GFSK	GFSK	M

6.4.3 PHL service to procedure mapping

The Physical layer (PHL) service to procedure mapping given in table 7 shall apply.

Table 7: PHL service to procedure mapping

Service	Procedure	Reference	Status	
			PT	FT
ULE1-P.1 GFSK modulation		5.1.1	M	M
	GFSK modulation	8.1.1	M	M
	Modulation scheme 1a	8.1.2	M	M
ULE1-P.2 Physical Packet P32		5.5.1	M	M
	Physical Packet P32	8.2.1	M	M
	Use of Physical Packet P32	8.2.2	M	M
ULE1-P.3 Physical Packet P00		5.5.1	M	M
	Physical Packet P00	8.2.3	M	M
	Transmission and use of Physical Packet P00	8.2.4	O	O
	Reception of Physical Packet P00	8.2.5	M	M
ULE1-P.4 General PHL		5.5.1	M	M
	General radio requirements	8.3.1	M	M
	Radio receiver sensitivity	8.3.2	M	M
	Z-field	8.3.3	M	M
	Sliding collision detection	8.3.4	M	M
	Physical channel availability	8.3.5	M	M
	Synchronization window	8.3.6	M	M

Service	Procedure	Reference	Status	
			PT	FT
ULE1-P.5 ULE Transmitted Power		5.5.1	M	M
	Minimum Normal Transmit Power (NTP)	8.3.7	M	M
	ULE Transmitted Power management	8.3.8	O	O
ULE1-P.6 Fast hopping radio		5.5.1	O	O
	Fast hopping radio	8.3.9	M	M

NOTE: The reference column refers to the relevant clause in the present document except otherwise noted.

6.5 MAC layer requirements

6.5.1 MAC layer services

DECT Ultra Low Energy, phase 1 devices shall support the MAC layer services given in table 8.

Table 8: MAC service support

Item	Name of service	Reference	Support status	
			PT	FT
ULE1-M.1	General	5.1.2	M	M
ULE1-M.2	A-field Continuous broadcast	5.1.2	M	M
ULE1-M.3	A-field Paging broadcast	5.1.2	M	M
ULE1-M.4	B-field Continuous ULE broadcast	5.1.2	M	M
ULE1-M.5	B-field paging broadcast	5.1.2	M	M
ULE1-M.6	Basic connection control	5.1.2	M	M
ULE1-M.7	A-field advanced connection control	5.1.2	M	M
ULE1-M.8	Expedited operations (advanced connection control)	5.1.2	M	M
ULE1-M.9	Full slot	5.1.2	M	M
ULE1-M.10	Short slot	5.1.2	M	M
ULE1-M.11	$I_{PQR_error_correction}$ MAC service type	5.1.2	M	M
ULE1-M.12	G_{FA} channel	5.1.2	M	M
ULE1-M.13	C_S higher layer signalling	5.1.2	M	M
ULE1-M.14	C_F higher layer signalling	5.1.2	O	O
ULE1-M.15	Quality control	5.1.2	M	M
ULE1-M.16	ULE Physical channel selection	5.1.2	M	M
ULE1-M.17	SARI support	5.1.2	M	O
ULE1-M.18	ULE Bearer replacement (intra-cell)	5.1.2	M	M
ULE1-M.19	Dummy Bearer replacement	5.1.2	M	M
ULE1-M.20	Bearer handover inter-cell	5.1.2	I	I
ULE1-M.21	Connection handover	5.1.2	I	I
ULE1-M.22	Encryption activation	5.1.2	M	M
ULE1-M.23	Encryption deactivation	5.1.2	C801	C801
ULE1-M.24	Re-keying	5.1.2	C802	C802
ULE1-M.25	Early encryption	5.1.2	C803	C803
ULE1-M.26	DSC encryption	5.1.2	M	M
ULE1-M.27	AES/DSC2 encryption	5.1.2	O	O

C801: IF ULE1-N.15 or ULE1-N.16 then M else I.
C802: IF NWK layer procedure "Re-keying during a call " THEN M ELSE I.
C803: IF NWK layer procedure "Early encryption " THEN M ELSE I.

NOTE 1: The reference column refers to the relevant clause in the present document.
NOTE 2: See also the DLC service ULE1-D.12 (CCM/AES encryption).

6.5.2 MAC service to procedure mapping

The MAC layer service to procedure mapping given in table 9 shall apply.

Table 9: MAC service to procedure mapping

Service	Procedure	Reference	Status	
			PT	FT
ULE1-M.1 General		5.1.2	M	M
	Frame and Multiframe structure	10.1.1	M	M
	Bit mappings	10.1.2	M	M
	E/U mux modes and B-field identification (BA) bits	10.1.3	M	M
	Scrambling	10.1.4	M	M
	Error control	10.1.5	M	M
	RFP idle receiver scan sequence	10.1.6	M	M
	Identities	10.1.7	M	M
	A-field Multiplexer (T-MUX)	10.2.1	M	M
	B-field control Multiplexer (E/U-MUX), basic modes	10.2.2.1	M	M
	B-field control Multiplexer (E/U-MUX), C _F modes	10.2.2.2	O	O
ULE1-M.2 A-field Continuous broadcast		5.1.2	M	M
	Downlink broadcast (A-field)	10.3	M	M
	Q _T - static system information	10.3.2.1	M	M
	Q _T - FP capabilities	10.3.2.2	M	M
	Reception of downlink broadcast (A-field)	10.3.3	M	M
	Higher layer information FP broadcast	12.3.2	M	M
ULE1-M.3 A-field Paging broadcast		5.1.2	M	M
	Paging messages on A-field	10.4.1	M	M
	MAC layer information messages procedures	10.4.2	M	M
	LCE paging procedure	10.4.3.1	O	O
	MAC layer information in zero and short length paging messages	10.4.1.4	M	M
ULE1-M.4 B-field Continuous ULE broadcast		5.1.2	M	M
	N _S channel	10.5.1	M	M
	Q _C channel	10.5.2	M	M
	M _J channel	10.5.3	M	M
	Reception of Messages	10.5.4	M	M
	Operation in unlocked mode	10.5.5	C900	N/A
ULE1-M.5 B-field Paging broadcast		5.1.2	M	M
	P _J Paging Message Formats	10.6.1	C900	M
	Paging Descriptors for ULE Paging	10.6.2	C900	M
	CA mask mechanism	10.6.3	C900	M
ULE1-M.6 Basic connection control		5.1.2	M	M
	Logical connection setup - procedure for ancillary connections	10.7.1.2	M	M
	Logical connection release - procedure for ancillary connections	10.7.2.2	M	M
	Setup of basic connection, basic bearer setup (A-field)	10.4 [9]	M	M
	Connection/bearer release (M _T)	10.5 [9]	M	M
	Bearer handover request (basic)	10.6 [9]	M	M
	Connection handover request (basic)	10.7 [9]	M	O
ULE1-M.7 A-field Advanced connection control		5.1.2	M	M
	Logical connection setup - explicit procedure	10.7.1.1	O	O
	Logical connection setup - implicit procedure	10.7.1.3	M	M
	Logical connection release - explicit procedure	10.7.2.1	O	O
	Logical connection release - implicit procedure	10.7.2.3	M	M

Service	Procedure	Reference	Status	
			PT	FT
	Logical connection release - abnormal procedure	10.7.2.4	M	M
	Connection Suspend and Resume	10.7.3	M	M
	Connection modification to change MAC service type	10.7.4.2.1	O	O
	Connection modification to change slot type	10.7.4.2.2	I	I
	Connection modification to change maximum MAC packet lifetime	10.7.4.2.3	O	O
	Connection modification to change the modulation scheme and adaptive code rate	10.7.4.2.4	I	I
	Use of ATTRIBUTES_T.req/cfm in connection modification	10.7.4.2.5	C901	C901
	PT initiated A-field advanced bearer setup (M_T)	10.9.2	C902	C902
	Connection/bearer release (M_T)	10.9.3	C903	C903
	A-field bearer handover request (advanced)	10.9.4	O	O
	A-field connection handover request (advanced)	10.9.5	I	I
ULE1-M.8 Expedited operations (advanced connection control)		5.1.2	M	M
	General	10.10.1	M	M
	M_T advanced control messages for expedited operations - Supported M_T messages	10.10.2.1	M	M
	M_T advanced control messages for expedited operations - G_{FA} transmission	10.10.2.2	M	M
	M_T advanced control messages for expedited operations - Reason codes in "expedited release" and "ready for release" messages	10.10.2.3	M	M
	M_T advanced control messages for expedited operations - Operation codes in "Null or G_{FA} channel transmission" message	10.10.2.4	M	M
	Expedited procedures - Procedure for Single-burst setup and release	10.10.3.1	M	M
	Expedited procedures - Procedure for Multi burst setup	10.10.3.2	M	M
	Expedited procedures - Announcement "Ready for Release"	10.10.3.3	M	M
	Expedited procedures - General Expedited Release procedure	10.10.3.4	M	M
	Expedited procedures - Single-message expedited release procedure	10.10.3.5	M	M
	Expedited procedures - Abnormal expedited release procedure	10.10.3.6	M	M
	Use cases - General Use cases	10.10.4.1	M	M
	Use cases - C-plane related use cases	10.10.4.2	O	O
	Use cases - Stay alive related use cases	10.10.4.3	M	M
	Use cases - Failure and Retransmission Use cases	10.10.4.4	M	M
	Use cases - Data transfer use cases showing the response to the BCK bit and to transitions between BA codes	10.10.4.5	M	M
	Use of reason code "normal bearer release"	10.10.5.1	M	M
	Use of reason code "base station busy"	10.10.5.2	O	O

Service	Procedure	Reference	Status	
			PT	FT
	Use of reason code "unacceptable PMID / Unregistered PMID"	10.10.5.3	M	M
	Use of reason code "switch to circuit mode"	10.10.5.4	M	M
	Use of reason code "Stay in LCE paging detection mode"	10.10.5.5	M	M
	Use of reason code "Stay in higher paging detection mode"	10.10.5.6	M	M
	Use of reason code "Setup again after <i>n</i> frames"	10.10.5.7	M	M
	Use of reason code "No such connection / virtual circuit"	10.10.5.8	M	M
ULE-M.9 Full slot		5.1.2	M	M
	D-field mapping for the full slot structure (physical packet P32)	6.2.1.1.2 [3]	M	M
	B-field mapping for the full slot structure (physical packet P32)	6.2.1.3.1.2 [3]	M	M
	Use of full slot in C/O bearers	10.11.1.1	M	M
	Use of full slot in C/L dummy bearers	10.11.1.2	M	M
ULE-M.10 Short slot		5.1.2	M	M
	D-field mapping for the short slot structure (physical packet P00)	6.2.1.1.3 [3]	M	M
	B-field mapping for the short slot structure (physical packet P00)	6.2.1.3.1.3 [3]	M	M
	Use (transmission) of short slot in C/O bearers	10.11.2	O	O
	Reception of short slot in C/O bearers	10.11.2	M	M
ULE-M.11 I _{PQR} _error_correction MAC service type		5.1.2	M	M
	Type 4: I _p _error_correction symmetric MAC service	5.6.2.1 [3]	M	M
	Single-subfield protected B-field	6.2.1.3.4 [3]	M	M
	MOD-2 protected channel operation	10.8.2 [3]	M	M
	Protected I channel error_correct mode	10.12.1	M	M
	Lifetime management with TWO separate maximum MAC packet lifetimes	10.12.2	M	M
ULE1-M.12 G _{FA} channel			M	M
	G _{FA} channel transmission	10.13.1	M	M
	G _{FA} channel data reception	10.13.2	M	M
ULE1-M.13 C _S higher layer signalling		5.1.2	M	M
	C _S channel data	10.14.1	M	M
ULE1-M.14 C _F higher layer signalling		5.1.2	O	O
	C _F channel data	10.14.2	M	M
	Priority schema of the C _F channel	10.14.2.1	M	M
	B-field control Multiplexer (E/U-MUX), C _F modes	10.2.2.2	M	M
ULE1-M.15 Quality control		5.1.2	M	M
	RFPI handshake	10.8.1.1	M	M
	PT frequency correction procedure	10.8.1.2	O	O
	Bearer quality report	10.8.1.3	M	M
	A-CRC handshake	10.8.1.4	M	M
ULE1-M.16 ULE Physical channel selection		5.1.2	M	M
	Channel selection for the ULE packet data connection	10.8.2.1	M	M
	Overall architecture	9.2.1	M	M
	Process M0 (RFP side pre-selection process)	9.2.2	M	M
	Broadcast mechanism	9.2.3	M	M
	Process M1 (PP side channel selection process)	9.2.4	M	M

Service	Procedure	Reference	Status	
			PT	FT
	Setup attempt and evaluation of responses	9.2.5	M	M
	Process M2 (collision handling/collision avoidance process)	9.2.6	M	M
	Exceptional cases	10.8.2.2	M	M
	Channel selection for the Service Call and other circuit mode connections	10.8.2.3	M	M
ULE1-M.17 SARI support		5.1.2	M	O
	Downlink broadcast	10.3.2.3	M	M
ULE1-M.18 ULE Bearer replacement (intra-cell)		5.1.2	M	M
	A-field MAC Bearer replacement procedure (M_T)	10.8.3	M	M
	A-field bearer handover request (M_T advanced)	10.9.4	O	O
ULE1-M.19 ULE Dummy Bearer replacement		5.1.2	M	M
	Dummy bearer replacement procedure	10.8.4	M	M
ULE1-M.20 Bearer handover inter-cell		5.1.2	I	I
	A-field bearer handover request	10.9.4	I	I
ULE1-M.21 Connection handover		5.1.2	I	I
	A-field connection handover request	10.9.5	I	I
ULE1-M.22 Encryption activation		5.1.2	M	M
	Encryption process - initialization and synchronization	10.15.1	M	M
	Encryption mode control; General	10.15.2.1	M	M
	Encryption mode control; M_T message	10.15.2.2	M	M
	Procedure for enabling encryption	10.15.2.3	M	M
	Encryption activation in resume operations	10.15.2.5	M	M
	Encryption handover control	10.15.3	M	M
ULE1-M.23 Encryption deactivation		5.1.2	C801	C801
	Encryption mode control; General	10.15.2.1	M	M
	Encryption mode control; M_T message	10.15.2.2	M	M
	Procedure for disabling encryption	10.15.2.4	M	M
ULE1-M.24 Re-keying		5.1.2	C802	C802
	Re-keying	10.16.1	M	M
ULE1-M.25 Early encryption		5.1.2	C803	C803
	Early encryption	10.16.2	M	M
ULE1-M.26 DSC encryption		5.1.2	M	M
	DSC encryption	10.16.3	M	M
ULE1-M.27 AES/DSC2 encryption		5.1.2	O	O
	AES/DSC2 encryption	10.16.4	M	M
C801:	IF ULE1-N.15 or ULE1-N.16 then M else I.			
C802:	IF NWK layer procedure "Re-keying during a call " THEN M ELSE I.			
C803:	IF NWK layer procedure "Early encryption " THEN M ELSE I.			
C900:	Status given in table 4 of clause 6.3.			
C901:	IF procedures "Connection modification to change MAC service type" OR "Connection modification to change slot type" OR "Connection modification to change maximum MAC packet lifetime" THEN M ELSE O.			
C902:	IF procedure "Logical connection setup - general procedure " THEN M ELSE O.			
C903:	IF procedure "Logical connection release - explicit procedure" THEN M ELSE O.			
NOTE:	The reference column refers to the relevant clause in the present or in the referenced document.			

6.6 DLC layer

6.6.1 DLC layer services

DECT Ultra Low Energy, phase 1 devices shall support the DLC services given in table 10.

Table 10: DLC service status

Item no.	Name of service	Reference	Status	
			PT	FT
ULE1-D.1	LU14 Enhanced Frame RELay service with CCM (EFREL-CCM)	5.1.3	M	M
ULE1-D.2	LU13 Enhanced Frame RELay service with CRC (EFREL-CRC)	5.1.3	O	O
ULE1-D.3	LU10 Enhanced Frame RELay service (EFREL)	5.1.3	M	M
ULE1-D.4	FU10a	5.1.3	M	M
ULE1-D.5	FU10d	5.1.3	M	M
ULE1-D.6	Data Link Service (LAPC + Lc) class A service	5.1.3	M	M
ULE1-D.7	DLC Transmission Class 1	5.1.3	M	M
ULE1-D.8	Lc Frame delimiting and sequencing service	5.1.3	M	M
ULE1-D.9	Broadcast Lb service	5.1.3	O	O
ULE1-D.10	Encryption activation	5.1.3	M	M
ULE1-D.11	Encryption deactivation	5.1.3	C1001	C1001
ULE1-D.12	CCM/AES encryption	5.1.3	M	M
C1001: IF feature ULE1-N.15 (Encryption deactivation FT initiated) OR ULE1-N.14 (Encryption deactivation PT initiated) THEN M ELSE I.				
NOTE: The reference column refers to the relevant clause in the present document.				

6.6.2 DLC service to procedure mapping

The DLC layer service to procedure mapping given in table 11 shall apply.

Table 11: DLC service to procedure mapping

Service	Procedure	Reference	Status	
			PT	FT
ULE1-D.1 LU14 Enhanced Frame RELay service with CCM (EFREL-CCM)		5.1.3	M	M
	LU14 Enhanced Frame RELay service with CCM (EFREL-CCM)	11.1	M	M
ULE1-D.2 LU13 Enhanced Frame RELay service with CRC (EFREL-CRC)		5.1.3	O	O
	LU13 Enhanced Frame RELay service with CRC (EFREL-CRC)	11.8	M	M
ULE1-D.3 LU10 Enhanced Frame RELay service (EFREL)		5.1.3	M	M
	LU10 Enhanced Frame RELay service (EFREL)	11.2	M	M
ULE1-D.4 FU10a		5.1.3	M	M
	FU10a frame operation	11.3.1	M	M
ULE1-D.5 FU10d		5.1.3	M	M
	FU10d frame operation: general	11.3.2.1	M	M
	Transport of FU10d frames over G _{FA} channel	11.3.2.2	M	M
	Insertion in FU10a frames of the opposite link	11.3.2.3	O	O
ULE1-D.6 Data Link Service (LAPC + Lc) class A service		5.1.3	M	M
	Class A link establishment	11.4.1	M	M
	Class A acknowledged information transfer	11.4.2	M	M
	Class A link release	11.4.3	M	M
	Class A link re-establishment	11.4.4	M	M
Handling of NWK layer messages longer than 63 octets	11.4.5	O	O	
ULE1-D.7 DLC Transmission Class 1		5.1.3	M	M
	General	11.5.1.1	M	M
	Sending side procedure	11.5.1.2	M	M
	Receiving side procedure	11.5.1.3	M	M

Service	Procedure	Reference	Status	
			PT	FT
ULE1-D.8 Lc Frame delimiting and sequencing service		5.1.3	M	M
	C _S channel fragmentation and recombination	11.6.1	M	M
	C _F channel fragmentation and recombination	11.6.2	C1101	C1101
	Selection of logical channels (C _S and C _F)	11.6.3	C1101	C1101
ULE1-D.9 Broadcast Lb service		5.1.3	O	O
	Normal operation	11.7.1	M	M
ULE1-D.10 Encryption activation		5.1.3	M	M
	MAC encryption switching	11.9.1	M	M
	CCM encryption switching	11.9.2	M	M
ULE1-D.11 Encryption deactivation		5.1.3	C1001	C1001
	Encryption switching	11.9	M	M
ULE1-D.12 CCM/AES encryption		5.1.3	M	M
	CCM Authenticated Encryption	11.10.1	M	M
	CCM activation at Virtual Call setup	11.10.2	M	M
	Cipher keys for CCM	11.10.3	M	M
C1001: IF feature ULE1-N.15 (Encryption deactivation FT initiated) OR ULE1-N.14 (Encryption deactivation PT initiated) THEN M ELSE I.				
C1101: IF ULE1-M.14 (C _F higher layer signalling) THEN M ELSE I.				
NOTE: The reference column refers to the relevant clause in the present or in the referenced document.				

6.7 NWK layer

6.7.1 General

The NWK layer provisions shall include the following entities:

- Call Control (CC).
- Mobility Management (MM).
- Link Control Entity (LCE).
- ConnectionLess Message Service (CLMS).

DECT ULE phase 1 requires a NWK layer.

6.7.2 NWK features

DECT Ultra Low Energy, phase 1 devices shall support the NWK layer features given in table 12.

Table 12: NWK features status

Feature supported				
Features			Status	
Item no.	Name of feature	Reference	PT	FT
ULE1-N.1	ULE NWK control	5.1.4	M	M
ULE1-N.2	ULE Service Call	5.1.4	M	M
ULE1-N.3	Authentication of PP	5.1.4	M	M
ULE1-N.4	Authentication of user	5.1.4	O	O
ULE1-N.5	Location registration	5.1.4	M	M
ULE1-N.6	On air key allocation	5.1.4	M	M
ULE1-N.7	Identification of PP	5.1.4	M	O
ULE1-N.8	Service class indication/assignment	5.1.4	M	O
ULE1-N.9	Encryption activation FT initiated	5.1.4	M	M
ULE1-N.10	Subscription registration procedure on-air	5.1.4	M	M
ULE1-N.11	Link control	5.1.4	M	M
ULE1-N.12	Terminate access rights FT initiated	5.1.4	M	O
ULE1-N.13	Authentication of FT	5.1.4	O	O

Feature supported				
Features			Status	
Item no.	Name of feature	Reference	PT	FT
ULE1-N.14	Encryption activation PT initiated	5.1.4	O	O
ULE1-N.15	Encryption deactivation FT initiated	5.1.4	O	O
ULE1-N.16	Encryption deactivation PT initiated	5.1.4	O	O
ULE1-N.17	Enhanced security	5.1.4	M	M
ULE1-N.18	AES/DSAA2 authentication	5.1.4	M	M

NOTE: The reference column refers to the relevant clause in the present document.

6.7.3 NWK features to procedures mapping

The NWK layer feature to procedure mapping given in table 13 shall apply.

Table 13: NWK feature to procedure mapping

Feature/Procedure mapping					
Feature	Procedure	Reference	PT	Status	
				R/B	FT
ULE1-N.1 ULE NWK control		5.1.4	M	M	
	General pre-requisites	12.1.1	M	M	
	Creation of the ULE PVC and states	12.1.2	M	M	
	Allowed CC Operations over the ULE transaction	12.1.3	M	M	
	Service Change "NWK resume"	12.1.3.1	M	M	
	Service Change "NWK suspend"	12.1.3.2	M	M	
	Service Change "other"	12.1.3.3	M	M	
	Allowed parameters in any service change operation	12.1.3.4	M	M	
	Default parameters	12.1.3.5	M	M	
	Initiating part of the Service Change operations	12.1.3.6	M	M	
	Independence of other CC transactions.	12.1.3.7	M	M	
	Default MAC parameters for implicitly created MBC	12.1.3.8	M	M	
Paging descriptors in suspend and resume states	12.1.3.9	M	M		
ULE1-N.2 ULE Service call		5.1.4	M	M	
	Service call setup	12.2.1	M	M	
	Normal call release	8.7 [9]	M	M	
	Abnormal call release	8.8 [9]	M	M	
	Transport of IWU-to-IWU data	13.2.1	O	O	
ULE1-N.3 Authentication of the PP		5.1.4	M	M	
	Authentication of PP using DSAA	8.24 [9]	M	M	
	Authentication of PP using DSAA2	8.45.7 [9]	C1301	C1301	
	Storing the Derived Cipher Key (DCK)	8.27 [9]	M	M	
	Storing the Derived Cipher Key for CCM (DCK-CCM)	12.2.2	M	M	
ULE1-N.4 Authentication of the user		5.1.4	O	O	
	Authentication of user using DSAA	8.25 [9]	M	M	
	Authentication of user using DSAA2	8.45.8 [9]	C1301	C1301	
ULE1-N.5 Location registration		5.1.4	M	M	
	Location registration	8.28 [9]	M	M	
	Location update	8.29 [9]	M	O	
	Terminal Capability indication	12.3.1	M	M	
ULE-N.6 On air key allocation		5.1.4	M	M	
	Key allocation using DSAA	8.32 [9]	M	M	
	Key allocation using DSAA2	8.45.9 [9]	C1301	C1301	
ULE1-N.7 Identification of PP		5.1.4	M	O	
	Identification of PT	8.22 [9]	M	M	
ULE1-N.8 Service class indication/assignment		5.1.4	M	O	
	Obtaining access rights	8.30 [9]	M	M	

Feature/Procedure mapping					
Feature	Procedure	Reference	Status		
			PT	FT	
				R/B	
	Terminal Capability indication	12.3.1	M	M	
	Authentication of PP using DSAA	8.24 [9]	M	M	
	Authentication of PP using DSAA2	8.45.7 [9]	C1301	C1301	
ULE1-N.9 Encryption activation FT initiated		5.1.4	M	M	
	Cipher-switching initiated by FT using DSC	8.33 [9]	M	M	
	Cipher-switching initiated by FT using DSC2	8.45.10 [9]	C1303	C1303	
	Storing the Derived Cipher Key (DCK)	8.27 [9]	M	M	
ULE1-N.10 Subscription registration user procedure on-air		5.1.4	M	M	
	Obtaining access rights	8.30 [9]	M	M	
	Terminal Capability indication	12.3.1	M	M	
ULE1-N.11 Link control		5.1.4	M	M	
	Indirect FT initiated link establishment	8.35 [9]	O	O	
	Direct PT initiated link establishment	8.36 [9]	M	M	
	Link release "normal"	8.37 [9]	M	M	
	Link release "abnormal"	8.38 [9]	M	M	
	Link release "maintain"	8.39 [9]	M	M	
ULE1-N.12 Terminate access rights FT initiated		5.1.4	M	O	
	FT terminating access rights	8.31 [9]	M	M	
	Authentication of FT using DSAA	8.23 [9]	O	M	
	Authentication of FT using DSAA2	8.45.6 [9]	C1302	C1301	
ULE1-N.13 Authentication of FT		5.1.4	O	O	
	Authentication of FT using DSAA	8.23 [9]	M	M	
	Authentication of FT using DSAA2	8.45.6 [9]	C1301	C1301	
ULE1-N.14 Encryption activation PT initiated		5.1.4	O	O	
	Cipher-switching initiated by PT using DSC	8.34 [9]	M	M	
	Cipher-switching initiated by PT using DSC2	8.45.11 [9]	C1303	C1303	
	Storing the DCK	8.27 [9]	M	M	
ULE1-N.15 Encryption deactivation FT initiated		5.1.4	O	O	
	Cipher-switching initiated by FT using DSC	8.33 [9]	M	M	
	Cipher-switching initiated by FT using DSC2	8.45.10 [9]	C1303	C1303	
ULE1-N.16 Encryption deactivation PT initiated		5.1.4	O	O	
	Cipher-switching initiated by PT using DSC	8.34 [9]	M	M	
	Cipher-switching initiated by PT using DSC2	8.45.11 [9]	C1303	C1303	
ULE1-N.17 Enhanced security		5.1.4	M	M	
	Encryption of all calls	8.45.1 [9]	M	M	
	Re-keying during a call	8.45.2 [9]	O	O	
	Early encryption	8.45.3 [9]	O	O	
	Subscription requirements	8.45.4 [9]	M	M	
	Behaviour against legacy devices	8.45.5 [9]	O	O	
ULE1-N.18 AES/DSAA2 authentication		5.1.4	M	M	
	Authentication of FT using DSAA2 (see note)	8.45.6 [9]	O	O	
	Authentication of PP using DSAA2	8.45.7 [9]	M	M	
	Authentication of user using DSAA2	8.45.8 [9]	O	O	
	Key allocation using DSAA2	8.45.9 [9]	M	M	
	Cipher-switching initiated by FT using DSC2	8.45.10 [9]	C1303	C1303	
	Cipher-switching initiated by PT using DSC2	8.45.11 [9]	C1304	C1304	
	Storing the Derived Cipher Key (DCK)	8.27 [9]	M	M	

Feature/Procedure mapping					
Feature	Procedure	Reference	Status		
			PT	FT	
				R/B	
	Storing the Derived Cipher Key for CCM (DCK-CCM)	12.2.2	M	M	
C1301:	IF feature ULE1-N.18 THEN M ELSE I.				
C1302:	IF feature ULE1-N.18 and THEN O ELSE I.				
C1303:	IF MAC service ULE1-M.27 THEN M ELSE I.				
C1304:	IF (feature ULE1-N.15 or feature ULE1-N.16) and MAC service ULE1-M.27 THEN M ELSE I.				
NOTE:	The reference column refers to the relevant clause in the present or in the referenced document.				

6.8 Application Layer

6.8.1 Application features

DECT Ultra Low Energy, phase 1 devices shall support the application features given in table 14.

Table 14: Application features status

Item no.	Feature supported		Status	
	Name of feature	Reference	PT	FT
ULE1.A.1	AC to bitstring mapping	5.1.5	M	M
ULE1.A.2	Multiple subscription registration	5.1.5	O	N/A
ULE1.A.3	Easy pairing registration	5.1.5	O	O
NOTE:	The reference column refers to the relevant clause in the present document.			

6.8.2 Application features to procedures mapping

The Application layer feature to procedure mapping given in table 15 shall apply.

Table 15: Application feature to procedure mapping

Feature/Procedure mapping			Status	
Feature	Procedure	Ref.	PT	FT
AC to bitstring mapping [ULE1.A.1]			M	M
	AC to bitstring mapping	14.2 [9]	M	M
Multiple subscription registration [ULE1.A.2]			O	N/A
	Subscription control	14.1 [9]	M	N/A
Easy pairing registration [ULE1.A.3]			O	O
	Registration mode automatic access	7.10.1.3.1 [11]	M	N/A
	Base station limited registration mode	7.10.1.2.2 [11]	N/A	M
	Searching mode request	14.1.1	M	N/A
	Base station name selection	7.10.1.3.2 [11]	O	O
	Registration user feedback	7.10.1.3.3 [11]	O	O
NOTE:	The reference column refers to the relevant clause in the present or in the referenced document.			

6.9 Distributed communications

The distributed communication mode (PP-PP communication) is not currently supported by ULE technology.

6.10 Management Entity (ME)

6.10.1 Management Entity (ME) services

ULE phase 1 devices, shall support the ME services given in table 16.

Table 16: Management Entity Requirements

Feature supported			Status	
Feature	Name of feature	Ref.	PT	FT
ULE1-ME.1	ULE phase 1 Management	5.1.6	M	M
ULE1-ME.2	ULE Physical Channel Selection	5.1.6	M	M
NOTE: The reference column refers to the relevant clause in the present document.				

6.10.2 Management Entity (ME) mode to procedures mapping

The ME service to procedure mapping given in table 17 shall apply.

Table 17: Management Entity mode to procedures mapping

Feature/Procedure mapping			Status	
Service	Procedure	Reference	PT	FT
ULE phase 1 Management [ULE1-ME.1]		5.1.6	M	M
	ULE phase 1 connection and resources management	9.1.1	M	M
	Stay alive procedure	9.1.2	O	O
ULE Physical Channel Selection [ULE1-ME.2]		5.1.6	M	M
	Overall architecture of ULE channel selection processes	9.2.1	M	M
	Process M0 (RFP side pre-selection process)	9.2.2	M	M
	Broadcast mechanism	9.2.3	M	M
	Process M1 (PP side channel selection process)	9.2.4	M	M
	Setup attempt and evaluation of responses	9.2.5	M	M
	Process M2 (collision handling/collision avoidance process)	9.2.6	M	M
NOTE: The reference column refers to the relevant clause in the present document.				

6.11 U-plane services and interworking requirements

6.11.1 U-plane and interworking services

DECT Ultra Low Energy, phase 1 devices shall support the U-plane and interworking services given in table 18.

Table 18: U-plane services and interworking

Item	Name of service	Reference	Support status	
			PT	FT
ULE1-I.1	Transparent U-plane Interworking	5.1.7	M	M
NOTE: The reference column refers to the relevant clause in the present document.				

6.11.2 U-plane and interworking service to procedure mapping

The U-plane and interworking service to procedure mapping given in table 19 shall apply.

Table 19: U-plane and interworking service to procedure mapping

Service	Procedure	Reference	Status	
			PT	FT
ULE1-I.1 Transparent U-plane Interworking		5.1.2	M	M
	U-plane procedures	B.2.1	M	M
	C-plane procedures	B.2.2	M	M
	Transport of IWU-to-IWU data	13.2.1	O	O
NOTE: The reference column refers to the relevant clause in the present document.				

7 Profile specific procedures description

All profile specific procedures are described in clauses 8 to 13 of the present document, organized by layers.

This clause may be used for the definition of general profile specific procedures or general requirements in further releases of the present document.

8 Physical Layer (PHL) procedures

8.1 Supported Modulation types and schemes

8.1.1 GFSK modulation

All equipment compliant with the present document shall support GFSK modulation, as defined by ETSI EN 300 175-2 [2], clause 5.4.

8.1.2 Modulation scheme 1a

All equipment compliant with the present document shall support the modulation scheme configuration 1a, as defined by ETSI EN 300 175-2 [2], clause 5.4 and table D.1.

8.2 Supported Physical Packets

8.2.1 Physical Packet P32

All equipment compliant with the present document shall support the Physical Packet P32, as defined by ETSI EN 300 175-2 [2], clause 4.4.2.

8.2.2 Use of Physical Packet P32

All equipment compliant with the present document shall use the Physical Packet P32 for all ULE connection oriented services transmissions, except within the exceptions listed in clause 8.2.4, where Packet P00 may be also used.

NOTE 1: Equipment compliant with the present document may also implement other DECT applications. In such a case other packets may be used for non ULE services.

All FPs compliant with the present document shall use the Physical Packet P32 for the transmission of the dummy bearer and shall not use Packet P00 in any case.

The provision given in the previous paragraph shall be respected, even if the FP supports simultaneously other DECT non-ULE services, and even if multiple dummy bearers are temporally or permanently broadcasted.

NOTE 2: However, it should be assumed that FPs may have mechanisms to completely deactivate the ULE capabilities. In such a case the device is no longer compliant with the present document and dummy bearer over P00 may be used.

8.2.3 Physical Packet P00

All equipment compliant with the present document shall support the reception and may support the transmission of Physical Packet P00, as defined by ETSI EN 300 175-2 [2], clause 4.4.1.

8.2.4 Transmission and use of Physical Packet P00

All equipment compliant with the present document may optionally use the Physical Packet P00 for transmission of connection oriented service packets with empty B fields in the specific cases described in clause 10.11.2.2 of the present document "Use of short slots for packets containing "no B-field".

All equipment compliant with the present document shall not use the Physical Packet P00 in any other case.

8.2.5 Reception of Physical Packet P00

All equipment compliant with the present document shall support the reception of Physical Packet P00 for connection oriented service packets with empty B fields in the specific cases described in clause 10.11.2.2 of the present document "Use of short slots in C/O bearers".

8.3 General PHL procedures

8.3.1 General radio requirements

The radio requirements specified in ETSI EN 300 175-2 [2] shall apply.

For equipment operating in the European Union, using the original DECT band (1 880 MHz to 1 900 MHz), the test requirements are specified in ETSI EN 300 176-1 [10].

For equipment operating in the European Union, using the IMT-2000, FDMA/TDMA bands, the test requirements are specified in ETSI EN 301 908-10 [i.11].

8.3.2 Radio receiver sensitivity

The radio receiver sensitivity shall be -86 dBm, or better.

8.3.3 Z-field

The Z-field shall be transmitted by RFPs and PTs.

8.3.4 Sliding collision detection

PT and FT shall be able to detect sliding collision on received packets.

Minimum criteria for sliding collision are defined as S- or Z-field failure. Early sliding collision detection may be supported by other means e.g. signal strength measurements in the guard band.

The Z-field is defined to have failed if the received X- and Z-fields are not identical.

S-field failure is defined with some tolerance in order not to restrict the physical implementation of the word synchronization detector.

S-field failure may be indicated if there are 1 or more bit errors in bits s12 to s31 (errors in bits s0 to s11 shall be ignored). In all cases, S-field failure shall be indicated if 3 or more bit errors occur in bits s16 to s31.

When protected B-field format is used, B field CRC criteria may be used for detecting sliding collisions.

8.3.5 Physical channel availability

A FP shall be able to receive and transmit on all DECT frequencies f0 to f9 and at least half of the slot pairs 0 to 11.

A PP shall be able to receive and transmit on all DECT frequencies f0 to f9, and shall be able to lock on any slot number 0 to 11, and receive and transmit at least on every slot pair that is not directly neighboured to the slot the PP is locked to, or to a slot on which a traffic bearer is active at the PP.

8.3.6 Synchronization window

Related to its reference timer, the PP synchronization window shall be at least ± 4 bits for bearers to the RFP to which the reference timer is synchronized, and at least ± 10 bits for other bearers.

8.3.7 Minimum Normal Transmit Power (NTP)

The NTP shall be greater than 80 mW per simultaneously active transmitter as shown by the test verdict criteria and declaration of ETSI EN 300 176-1 [10], clause 10.2.3.

8.3.8 Power management

To fight mutual interference between data terminals operating in different local DECT networks when using for the transmission most of the slots from a frame, control of the transmission power is recommended.

If transmission power control procedure is implemented, the requirements in ETSI EN 300 175-2 [2], annex E shall fully apply.

8.3.9 Fast hopping radio

The radio transceiver shall be able to perform any frequency change during the interval between two consecutive Physical Packets P32 (full slot).

9 Management Entity (ME) procedures

9.1 ULE phase 1 Management

9.1.1 ULE phase 1 connection and resources management

The management entity rules for the present document are based on the following elements:

- Simplified Network Layer CC model based on PVC (Permanent Virtual Circuit) controllable by means of Service Change operations, as described in feature [ULE1-N.1] ULE phase 1 NWK control.
- Use of two mechanisms of Suspend and Resume: Network layer suspend and resume, as described in clause 12.1, and MAC layer suspend and resume, as described in clause 10.7.3.
- Network layer Suspend and Resume is used to control the NWK layer state of the Virtual Circuit, which may be changed between two states: suspended and resumed.
- DLC link and MAC MBC are automatically created by changing the NWK layer state. This mechanism, called "implicit connection setup" is specific of ULE.
- In normal operation mode (NWK resumed, link and MBC created), data can be exchanged using specific MAC layer procedures. MBC is preserved and remains in suspended (MAC suspended) state at the end of the activity.
- Specific "expedited" MAC procedures for optimized transfer of ULE data, with minimum overhead, and ultra fast response time.

More specific ME rules may be added to further releases of the present document.

9.1.2 Stay alive procedure

ULE phase 1 may use a stay alive procedure, to control the integrity of the connection and the existence of the other peer.

No specific stay alive procedure is defined in the present document. Therefore, the design of the stay alive procedure is left to the implementer.

The expected response after a failure, or a multiple failure, of the stay alive handshake is notification to higher layers and release of the MBC and DLC link, moving the NWK state to "NWK suspend".

9.2 Channel selection and collision avoidance procedures

9.2.1 Overall architecture of ULE channel selection processes

DECT ULE devices shall implement the Physical channel selection procedures as described in ETSI EN 300 175-3 [3], clause 11.12. The processes and mechanisms described in ETSI EN 300 175-3 [3], clause 11.12.2 shall be implemented.

9.2.2 Process M0 (RFP side pre-selection process)

DECT ULE RFPs shall implement the process M0 (RFP side pre-selection process) as described in ETSI EN 300 175-3 [3], clause 11.12.3.

Implementation at PP side consists in the understanding of the RFP algorithm.

The guidelines given in ETSI EN 300 175-3 [3], clause 11.12.3 should be followed.

The following additional provisions shall apply:

- The value of m is $m = 2$.
- In order to compile the list of candidate channels, the RFP shall routinely scan all DECT channels (except those impossible to receive by physical limitations) and compute their RSSI.
- In order to consider a given channel as candidate for setup, both simplex bearers of it shall be measured in at least one frame, and the worst (highest) RSSI value shall be used.

The following additional guidelines are given:

- Due to the need to have the RFP receiver listening for possible setups according to the scan sequence, for single transceiver systems, it is assumed that the scan of the uplink simplex bearer will be done, in practice, listening to the scan sequence frequency.
- The scan of the downlink bearers of the channels may be done with the same criteria (listening according to RFP scan sequence), or with a different cycle (implementation choice).
- The measurement of the RSSI should be done assuming that the slot to be used on the transmission will be a full slot.
- Other mechanisms, such as multi-transceiver RFP, are possible.
- As general rule, the unnecessary restriction of the offered channels by reserving fixed slots for other services is not recommended.

A possible implementation of algorithm M0 is provided in clause C.1.

9.2.3 Broadcast mechanism

DECT ULE RFPs shall implement the transmitter part and DECT ULE PPs shall implement the receiver part the broadcast mechanism described in ETSI EN 300 175-3 [3], clause 11.12.4.

The following additional provisions shall apply:

- The value of m , the time difference between frame that carries the broadcast and the access frame for which the channel selection information refers, shall be equal to 2. Therefore all channel selection information shall refer to frame $N+2$.

9.2.4 Process M1 (PP side channel selection process)

DECT ULE PPs and FPs shall implement the process M1 (PP side channel selection process) as described in ETSI EN 300 175-3 [3], clause 11.12.5.

Implementation at RFP side consists in the understanding of the PP setup process.

The following additional provisions and notes shall apply:

- For PPs without power consumption limitations (fast actuators) higher numbers of n may be used.
- It is allowed to receive and decode the content of channel selection information in the dummy bearer in frames $N+1$ or $N+2$, in order to quickly react to the event of repetition of algorithm M1 due to no validation of any candidate channel.
- PP devices without power consumption limitations (fast actuators) may be continuously scanning the dummy bearer channel selection info and continuously performing the RSSI validation in order to be ready for a fast response to an event (paging or PP side event) requiring setup.
- The measurement of the RSSI shall be done taken into account the slot type that will be used in the transmission.

9.2.5 Setup attempt and evaluation of responses

PPs shall perform the access request and evaluation or responses as defined in ETSI EN 300 175-3 [3], clause 11.12.6.

Implementation at RFP side consists in the understanding of the PP response.

The following additional provisions shall apply:

- The differentiation of error responses compatible and not compatible with collision is optional. If this differentiation is not implemented all error cases shall be followed by execution of algorithm M2.
- In case or impossibility of access due to repetitive lack of channels in the information provided by the base, or impossibility to validate the channels provided, the PP is allowed to perform a regular DECT scan and use regular DECT channel selection mechanisms.

9.2.6 Process M2 (collision handling/collision avoidance process)

DECT ULE PPs and FPs shall implement the process M2 (PP side collision handling/collision avoidance process) as described in ETSI EN 300 175-3 [3], clause 11.12.7.

Implementation at RFP side consists in the understanding of the PP response under potential collision conditions.

The following additional provisions and notes shall apply:

- The value of the parameter b in the equation A (defined in clause 11.12.7.1 of ETSI EN 300 175-3 [3]) shall be as defined in clause A.1.1.1 of the present document.

NOTE: All other parameters of the equations are defined by ETSI EN 300 175-3 [3], clause A.2.1.

10 MAC layer procedures

10.1 General

10.1.1 Frame and multiframe structure

The FT and PT shall support frame and multiframe structures as defined in ETSI EN 300 175-3 [3], clause 4.2.

10.1.2 Bit mappings

The FT and PT shall support the D-field mappings as defined in ETSI EN 300 175-3 [3], clause 6.2.1.1 for full slot, Physical Packet P32, GFSK modulation and modulation schema 1a (clause 6.4.1, table 5 and clause 6.4.2, table 6).

The FT and PT shall support the D-field mappings as defined in ETSI EN 300 175-3 [3], clause 6.2.1.1 for short slot, Physical Packet P00, GFSK modulation and modulation schema 1a (clause 6.4.1, table 5 and clause 6.4.2, table 6).

The FT and PT shall support the A-field mappings as defined in ETSI EN 300 175-3 [3], clause 6.2.1.2 for the supported Physical Packets (clause 6.4.1, table 5) and modulation schema (clause 6.4.2, table 6).

The FT and PT shall support the B-field mappings as defined in ETSI EN 300 175-3 [3], clause 6.2.1.3 for the supported Physical Packets (clause 6.4.1, table 5) modulation and modulation schema (clause 6.4.2, table 6) and for the E/U mux modes described in clause 10.1.3.

10.1.3 E/U mux modes and B-field identification (BA) bits

10.1.3.0 General

NOTE: See also clause 10.2.2 for detailed provisions regarding the E/U multiplexer modes.

10.1.3.1 E/U mux modes and B-field identification (BA) bits for C/O bearers

The FT and PT shall support the following E/U mux modes and associated B-field identifications (BA bits a4, a5 and a6) as defined in ETSI EN 300 175-3 [3], clause 7.1.4 for traffic C/O bearers:

- BA = "000"B: U-type, I_p packet number 0;
- BA = "001"B: U-type, I_p packet number 1;
- BA = "111"B: no B-field, (shall only be used for connection oriented bearers);
- BA = "110"B: E-type, all MAC control.

The I_{PF} channel should not be used in ULE connections.

The FT and PT may optionally support the following E/U mux additional modes and associated B-field identifications (BA bits a4, a5 and a6) as defined in ETSI EN 300 175-3 [3], clause 7.1.4 for traffic C/O bearers:

- BA = "010"B: E-type, all C_F , packet number 0;
- BA = "011"B: E-type, all C_F , packet number 1;
- BA = "100"B: E-type, not all C_F , packet number 0;
- BA = "101"B: E-type, not all C_F , packet number 1.

10.1.3.2 E/U mux modes and B-field identification (BA) bits for C/L (dummy) bearers

The FT and PT shall support the following E/U mux modes and associated B-field identifications (BA bits a4, a5 and a6) as defined in ETSI EN 300 175-3 [3], clause 7.1.4 for dummy C/L bearers:

- BA = "110"B: E-type, all MAC control.

10.1.4 Scrambling

The FT and PT shall support scrambling as defined in ETSI EN 300 175-3 [3], clause 6.2.4.

The dummy C/L bearer containing the special B-field ULE dummy structure shall not be scrambled.

The previous provision applies even if there are several ULE dummy bearers.

Other C/L bearers not containing the special B-field ULE dummy structure, if used, shall be normally scrambled as defined in ETSI EN 300 175-3 [3], clause 6.2.4.

10.1.5 Error control

The FT and PT shall support R-CRC and X-CRC generation as defined in ETSI EN 300 175-3 [3], clause 6.2.5.

FT and PT shall support 16-Bit R-CRC as defined in ETSI EN 300 175-3 [3], clause 6.2.5.2.

10.1.6 RFP idle receiver scan sequence

The FT shall support primary scan as defined in ETSI EN 300 175-3 [3], clause 11.8.

10.1.7 Identities

The provisions of ETSI EN 300 175-3 [3], clause 11.7 and ETSI EN 300 175-6 [6] shall be implemented with respect to the structure and use of identities.

10.2 Time multiplexers

10.2.1 A-field Multiplexer

10.2.1.1 Tail Multiplexer (T-MUX)

The FT and PT shall support T-MUX as defined in ETSI EN 300 175-3 [3], clause 6.2.2.1.

10.2.1.2 A-tail identifications

The FT and PT shall understand all A-field tail identifications (bits a_0 to a_2) as defined in ETSI EN 300 175-3 [3], clause 7.1.2. The value 101 - "escape" need not be understood. To distinguish a connectionless bearer from a non-connectionless bearer the N_T message send on a connectionless bearer shall carry the value "Identity information (N_T) on connectionless bearer" (010) and the value "Identity information (N_T)" (011) in all other cases.

10.2.2 B-field control Multiplexer (E/U-MUX)

10.2.2.1 B-field control Multiplexer (E/U-MUX), basic modes

10.2.2.1.1 U-type Multiplexer for C/O bearers

The FT and PT shall support the following U-type multiplexer modes as defined in ETSI EN 300 175-3 [3], clause 6.2.2.2 for traffic C/O bearers:

- BA = "000"B: U-type, I_p packet number 0;
- BA = "001"B: U-type, I_p packet number 1.

10.2.2.1.2 E-type Multiplexer "all MAC control" for C/O bearers

The FT and PT shall support the following E-type multiplexer mode as defined in ETSI EN 300 175-3 [3], clauses 6.2.2.2 and 6.2.2.3:

- BA = "110"B: E-type, all MAC control.

The following restrictions apply:

- Channel G_F does not need to be supported.
- MAC control messages for controlling channel I_{PF} do not need to be supported.

The FT and PT shall support the E-type mode "all MAC control" as defined in ETSI EN 300 175-3 [3], clause 6.2.2.3 (tables 6.24 to 6.33) for the supported D-field mappings (defined in clause 6.2, table 11) and modulation type (defined in clause 5.1, table 7).

10.2.2.1.3 E-type Multiplexer "no-B field" for C/O bearers

The FT and PT shall support the following E-type multiplexer mode as defined in ETSI EN 300 175-3 [3], clauses 6.2.2.2 and 6.2.2.3:

- BA = "111"B: no B-field

NOTE: This BA code and mux mode should only be used over C/O bearers.

In general, the BA coding and multiplexer mode "no-B field" has to be understood as transmission of an unprotected filling pattern over the B-field (format similar to MAC service C_F). However, in some specific cases (and only in them) it is allowed the transmission of a short slot instead (optional, transmission choice). Such cases are described in clause 10.11.2.2. ULE Receivers shall be aware of such optional behaviour.

10.2.2.1.4 E-type Multiplexer "all MAC control" for C/L (dummy) bearers

The FT and PT shall support the following E-type multiplexer mode as defined in ETSI EN 300 175-3 [3], clauses 6.2.2.2 and 6.2.2.3, over dummy C/L bearers:

- BA = "110"B: E-type, all MAC control.

The following restrictions apply:

- The repertory of possible MAC control messages is reduced according to the C/L type of the bearer.
- Channel G_F does not need to be supported.
- MAC control messages for controlling channel I_{PF} do not need to be supported.

In ULE RFPs, the use of "no B-field" mode and the use of short slots over dummy bearers is not allowed.

The FT and PT shall support the E-type mode "all MAC control" as defined in ETSI EN 300 175-3 [3], clause 6.2.2.3 (tables 6.24 to 6.33) for the supported D-field mappings (defined in clause 6.5.2, table 9 of the present document) and modulation type (defined in clause 6.4.1, table 5 of the present document).

10.2.2.1.5 E/U-Mux priority schema

The FT and PT shall support the priority schema as defined in ETSI EN 300 175-3 [3], clause 6.2.2.4 with the following restrictions:

- I_{PF} channel modes and I_{PF} segmentation control are not applicable.
- C_F channel modes are not applicable.

10.2.2.1.6 B-field identifications (basic)

The FT and PT shall use and understand all B-field identifications (bits a_4 to a_6) as defined in ETSI EN 300 175-3 [3], clause 7.1.4 with the following restrictions:

- Codes for E-mux with C_F channel ("010", "011", "100" and "101") are not applicable.
- Code "110" is only understood as "E-type all MAC control".
- Code "111" is only understood as "no B-field".

10.2.2.2 B-field control Multiplexer (E/U-MUX), C_F modes

10.2.2.2.1 E-type Multiplexer, all modes (over C/O bearers)

The FT and PT shall support E-type mode multiplexer as defined in ETSI EN 300 175-3 [3], clauses 6.2.2.2 and 6.2.2.3, including the modes "E-type all C_F ", and "E-type not all C_F " over traffic C/O bearers.

The FT and PT shall support all E-type modes as defined in ETSI EN 300 175-3 [3], clause 6.2.2.3 (tables 6.24 to 6.33) for the supported D-field mappings (defined in clause 6.5.2, table 9 of the present document) and modulation type (defined in clause 6.4.1, table 5 of the present document).

The following modes shall be supported:

- BA = "010"B: E-type, all C_F , packet number 0;
- BA = "011"B: E-type, all C_F , packet number 1;
- BA = "100"B: E-type, not all C_F , packet number 0;

- BA = "101"B: E-type, not all C_F , packet number 1.

NOTE: It is not allowed the transmission of C_F over the dummy bearer.

10.2.2.2.2 E/U-Mux priority schema

The FT and PT shall support the priority schema as defined in ETSI EN 300 175-3 [3], clause 6.2.2.4 with the following restriction:

- I_{PF} channel modes and I_{PF} segmentation control are not applicable.

10.2.2.2.3 B-field identifications (C_F)

The FT and PT shall use and understand all B-field identifications (bits a_4 to a_6) as defined in ETSI EN 300 175-3 [3], clause 7.1.4 with the following restrictions:

- Code "110" is only understood as "E-type all MAC control".
- Code "111" is only understood as "no B-field".

10.3 Downlink broadcast (A-field)

10.3.0 General

The procedure shall be performed as defined in ETSI EN 300 444 (GAP) [9], clause 10.2 and ETSI EN 300 175-3 [3], clause 9.1.1.

10.3.1 N_T messages

The same message defined in ETSI EN 300 444 (GAP) [9], clause 10.2.1 shall be used.

10.3.2 Q_T messages

10.3.2.1 Q_T - static system information

The FT shall be capable of sending and the PT shall be capable of receiving and processing the Q_T static system information message as defined in ETSI EN 300 175-3 [3], clause 7.2.3.2, with the following contents as defined below.

The same contents defined in ETSI EN 300 444 (GAP) [9], clause 10.2.3 shall be supported.

10.3.2.2 Q_T - FP capabilities

10.3.2.2.1 Standard FP Capabilities

The FP shall indicate its standard capabilities using the fixed part capabilities Q_T message as described in ETSI EN 300 175-3 [3], clause 7.2.3.4, with contents as defined in table 20 below. The PT shall be able to receive and understand this message.

Table 20: Values used within Standard FP capabilities

MAC message	Field within the message	Standard values within the MAC message	Normative action/comment
<< FP capabilities >>	< Q _H >	3	
	< a ₁₂ >	1	Extended FP info (Q _H = 4)
	< a ₁₅ >	[0, 1]	Double slot (optional)
	< a ₁₇ >	1	Full slot (mandatory to support)
	< a ₂₃ >	1	Basic A-field setup, mandatory
	< a ₂₄ >	[0, 1]	Advanced A-field setup. See note 1 (optional)
	< a ₂₆ >	[0, 1]	C _F messages, if PT supports only C _S messages it may ignore this value.
	< a ₃₀ >	1	I _{p_error_correction} (mandatory to support)
NOTE 1: The bit < a ₂₄ > shall only be set if the messages for A-field advanced bearer setup (M _T) and release are supported. Refer to clauses 10.9.2 and 10.9.3. It shall not be set if only the implicit connection setup and release as described in clause 10.9.6 is supported.			
NOTE 2: For the higher layer capabilities, bits < a ₃₂ to a ₄₇ >, see clause 12.3.2.1.1.			

The MAC extended fixed part information message shall be used and, therefore, bit a₁₂ of the fixed part information field shall be set to 1.

Higher layer information: The management entity in the FP supplies the MAC layer with a 16-bit SDU via the Management Entity (ME) SAP. The content of that SDU is placed in bits < a₃₂ > to < a₄₇ > of the Q_T message. At the PT the MAC layer passes the 16 bits out through the ME SAP to the management entity.

For the setting of the higher layer information bits see clause 12.3.2.1.1.

10.3.2.2.2 Extended FP Capabilities

The FP shall indicate its extended capabilities using the Extended fixed part capabilities Q_T message as described in ETSI EN 300 175-3 [3], clause 7.2.3.5, with contents as defined in table 21 below. The PT shall be able to receive and understand this message.

Table 21: Values used within Extended FP capabilities

MAC message	Field within the message	Standard values within the MAC message	Normative action/comment
<< FP capabilities >>	< Q _H >	4	
	< a ₂₂ >	1	I _{PQ} services supported.
	< a ₂₃ >	1	Extended FP capabilities Part 2.
NOTE: For the higher layer capabilities, bits < a ₂₅ to a ₄₇ >, see clause 12.3.2.1.2.			

The MAC extended fixed part capability part 2, information message shall be used and, therefore, bit a₂₃ of the extended FP capability field shall be set to 1.

Higher layer information: The management entity in the FP supplies the MAC layer with a 23-bit SDU via the Management Entity (ME) SAP. The content of that SDU is placed in bits < a₂₅ > to < a₄₇ > of the Q_T message. At the PT the MAC layer passes the 24 bits out through the ME SAP to the management entity.

For the setting of the higher layer information bits see clause 12.3.2.1.2.

10.3.2.2.3 Extended FP Capabilities part 2

The use of Extended FP Capabilities part 2 is needed in all cases due to the position of the bits <a39 - a41> in the Extended higher layer capabilities broadcast, which defines the support of ULE (see clause 12.3.2.1.3). All bits in the MAC layer part of the broadcast are optional and will be set to describe the support of optional features, or services other than ULE Phase 1. Due to the probable coexistence with NG-DECT services in the same RFP, it should be assumed that most RFPs may broadcast some of them.

The FP shall indicate its extended capabilities using the Extended fixed part capabilities part 2 Q_T message as described in ETSI EN 300 175-3 [3], clause 7.2.3.11, with contents as defined in table 22 below. The PT shall be able to receive and understand this message.

Table 22: Values used within Extended FP capabilities part 2

MAC message	Field within the message	Standard values within the MAC message	Normative action/comment
<< FP capabilities >>	< Q_H >	C (hex)	
	< a_{12} >	[0, 1]	Long slot support ($j = 640$).
NOTE: For the higher layer capabilities, bits < a_{24} to a_{47} >, see clause 12.3.2.1.3.			

Higher layer information: The management entity in the FP supplies the MAC layer with a 24-bit SDU via the Management Entity (ME) SAP. The content of that SDU is placed in bits <a24> to <a47> of the Q_T message. At the PT the MAC layer passes the 24 bits out through the ME SAP to the management entity.

For the setting of the higher layer information bits see clause 12.3.2.1.3.

10.3.2.3 Q_T - SARI list contents

The FT may send and the PT shall be capable of receiving and processing (if broadcast by the FT) the Q_T SARI message as defined in ETSI EN 300 175-3 [3], clause 7.2.3.6, with same contents as defined by ETSI EN 300 444 (GAP) [9], clause 10.2.4.

This is relevant if the N_T message indicates SARI support.

10.3.2.4 Multiframe number (A-field)

Q_T message carries the multiframe number which is used in the encryption algorithm. Both, FT and PT, shall be able to transmit and respectively retrieve the information carried in this message with contents as defined in table 23 below.

Table 23: Values used within Q_T multiframe number message

MAC message	Field within the message	Standard values within the MAC message	Normative action/comment
<< multiframe number >>	< Q header >	6	
	< spare >	111100001111B	
	< multi frame number >	All	The number of the multiframe, modulo 2^{**24} .

10.3.3 Reception of downlink broadcast (A-field)

DECT ULE PPs are not required to listen to downlink broadcast channels (over A-field) in all states. They will listen to these channels only in specific situations.

The following channels are considered downlink broadcasts for this description:

- N_T : Identities Information
- Q_T : Static System Information
- Q_T : FP capabilities

- Q_T : SARI contents

Specifically, ULE PPs shall listen to downlink broadcasts in the following cases:

- During initial registration process.
- During the VC setup process.
- PPs supporting at the same time DECT voice services (GAP or NG-DECT) shall listen to the Q_T broadcast as required by such profiles.

NOTE: In general, ULE PPs will not be listening to downlink broadcasts channels in regular operation, idle state (registered, idle locked or unlocked -depending on the type of PP- and with a suspended VC opened towards a RFP).

10.4 Paging broadcast

10.4.0 General

Clause 10.4 refers to the LCE paging capability using A-field messages. Refer to clause 10.6 for ULE paging using B-field channels.

10.4.1 Paging message formats

10.4.1.0 General

The FT and PT shall support full, short and zero length paging message formats as defined in ETSI EN 300 175-3 [3], clause 7.2.4.

10.4.1.1 Full page message format

The values used in a full-page message shall be as given in table 24.

Table 24: Values used within full-page message format

MAC message	Field within the message	Standard values within the MAC message	Normative action/comment
<< P_T full page format >>	< P_T -header extend flag > (a_8)	0,1	$a_8 = 1$ means another page message shall start in the next frame in this multiframe that is permitted to contain a P_T type.
	< BS SDU length indication > (a_9 to a_{11})	010	Full-page message shall be used to carry LCE resume page message.
	< BS channel data > (a_{12} to a_{47})	All	The content of the BS channel data is defined by the LCE-message definition.

10.4.1.2 Short page message format

The same values defined in ETSI EN 300 444 GAP) [9], clause 10.3.1 shall be supported.

10.4.1.3 Zero length page message format

The same values defined in ETSI EN 300 444 GAP) [9], clause 10.3.2 shall be supported.

10.4.1.4 MAC layer information in zero and short length paging messages

10.4.1.4.0 General

The MAC layer information types given in table 25 and defined by ETSI EN 300 175-3 [3], clause 7.2.4.3 shall be supported (understood) by a PT.

Table 25: Types of MAC layer paging information to be supported by a PT

a ₃₂	a ₃₃	a ₃₄	a ₃₅	MAC information type
0	0	0	1	Blind slot information for circuit mode service.
0	0	1	0	Other bearer.
0	0	1	1	Recommended other bearer.
0	1	0	1	Dummy or C/L bearer position.
1	0	0	1	Bearer handover/replacement information.
1	0	1	0	RFP-status and Modulation Types (see clause 10.4.1.4.1). (The Modulation Types replaces the spare bits.)
1	1	0	0	C/L bearer position
1	1	1	1	Blind slot information for packet mode service. (This replaces the Modulation Types information.)

10.4.1.4.1 RFP status

Figure 5 shows the format of the MAC layer paging information when bits a₃₂ to a₃₅ are set to "RFP-status and Modulation Types".

Figure 5: RFP status

RFP status		Modulation Types			
		A-field		(B + Z)-fields	
a ₃₆	a ₃₉	a ₄₀	a ₄₃	a ₄₄	a ₄₇

Bits a₃₆ to a₃₉ (see figure 5) allows the transmission of RFP status information. The following codes given in table 26 shall be supported.

Table 26: RFP status

RFP status	Meaning
0xxx	RFP clear for data.
1xxx	RFP busy for data (see note).
NOTE: "RFP busy for data" means that the RFP recommends PTs not to send access request messages for ULE service towards this RFP.	

Bits a₄₀ to a₄₃ (see figure 5) define the modulation schemes supported in the A-field, in addition to the default one. Since no other A-field modulation schemes are used in the present document, the listening and understanding of the flags is irrelevant. They shall be coded by the transmitter as shown in table 27.

Table 27: RFP status A-field modulation scheme

a ₄₀	a ₄₁	a ₄₂	a ₄₃	A-field modulation scheme
0	0	0	0	Only 2-level modulation supported.

Bits a₄₄ to a₄₇ (see figure 5) define the modulation schemes supported in the (B + Z)-fields, in addition to the default one. All HLM modes in B-field are for further study and are not used by the current revision of the present document. However they may be added in future revisions or used by other services implemented in the RFP. All RFPs implementing the present document shall support at least the 2-level modulation and shall code the bit a₄₇ accordingly. This is shown in table 28.

Table 28: RFP status B+Z field modulation scheme (mandatory coding for all types of RFP implementing the present document)

a ₄₄	a ₄₅	a ₄₆	a ₄₇	(B + Z)-fields modulation scheme
X	X	X	1	2-level modulation supported.

For the usual case of RFP supporting only the present document, or the present document plus other 2-level modulation service, the coding of the bits shall be as shown in table 29.

Table 29: RFP status B+Z field modulation scheme (coding for RFP supporting only 2-level modulation services)

a ₄₄	a ₄₅	a ₄₆	a ₄₇	(B + Z)-fields modulation scheme
1	1	1	1	only 2-level modulation supported.

10.4.2 MAC layer information messages procedures

10.4.2.0 General

The MAC layer information message procedures are defined in the clauses below. Each supported message shall be broadcasted at least once every 10 s.

In regard to the support status of the different codes, the provisions of ETSI EN 300 444 [9], clause 10.3.1 shall apply.

10.4.2.1 Blind slot information for circuit mode service

The provisions of ETSI EN 300 444 (GAP) [9], clause 10.3.3 shall apply.

10.4.2.2 Bearer handover/replacement information

The provisions of ETSI EN 300 444 (GAP) [9], clause 10.3.4 shall apply.

10.4.2.3 Other bearer position

The RFP is recommended to broadcast the "other bearer" information indicating the position of a 2nd dummy bearer or traffic bearer, if such bearer exists.

10.4.2.4 Recommended other bearer position

The RFP is recommended to broadcast the "recommended other bearer" information indicating the position of another bearer. This message shall not be sent unless the bearer that it is sent on will be released in less than or equal to 4 multiframe.

10.4.2.5 Dummy or C/L bearer position

The RFP shall announce the dummy bearer position, if a dummy bearer exists.

10.4.2.6 C/L bearer position

The RFP shall announce the connectionless downlink bearer position, if such a bearer exists. The bearer position shall be announced 1 Multi-Frame (4 MF in case of low duty cycle) in advance of transmission of C/L data via this bearer.

10.4.2.7 RFP-status and Modulation Types

The RFP should send the RFP-status information "RFP busy-for-data/not-busy-for-data" as soon as possible after a detection of a change in RFP-status, i.e. in the first allowed frame after the change. It is recommended that the RFP periodically sends the RFP-status information. It is not recommended to send this message very often when the status changes frequently, because the other messages may be delayed too long. A practical limit may be to send this information not more than once a second.

RFPs which are capable of Higher Layer Modulation shall transmit this message to announce this capability, otherwise the peer will assume that only default modulation is available. For the present document, this is 2-level modulation.

10.4.2.8 Blind slot information for packet mode service

The RFP shall announce the slots which are blocked for packet mode service. The coding of the message is identical to clause 10.4.2.1 Blind slot information for circuit mode service, except that the MAC layer information type bits are coded as '1111'B (0FH).

ULE PPs shall use this information for ULE mode setups.

The same provisions and procedure given by ETSI EN 300 444 (GAP) [9], clause 10.3.3 for the voice service shall be followed, but applied to the ULE service.

10.4.3 Paging Procedures

10.4.3.1 LCE Paging

The procedure shall be performed as defined by ETSI EN 300 175-3 [3], clauses 9.1.3.1 and 9.1.3.2.2.

This procedure includes transmission and reception of Zero length, short and full page messages.

In the LCE procedure, the B_S channel SDU is provided by the DLC layer.

The procedure is compatible with normal, high and low duty cycle paging detection modes in the PT.

10.4.4 Paging detection

10.4.4.1 Normal duty cycle

The procedure shall be performed as defined by ETSI EN 300 175-3 [3], clause 9.1.3.2.1.

The PT shall be in the state "Normal Idle Locked mode" as defined in ETSI EN 300 175-3 [3], clause 11.3.3.1. In this mode, the PT shall receive any B_S channel transmitted in frame 0 and additional frames that are commanded by the extend flag.

The normal duty cycle detection state applies to LCE paging procedures.

10.5 ULE Dummy Bearer Procedures

10.5.0 General

The procedures described in clauses 10.5 shall be performed as defined in ETSI EN 300 175-3 [3], clause 9.5.

10.5.1 N_S channel

The FT shall send the N_S message in all frames where a ULE Dummy Bearer is active and the PT shall be capable of receiving and processing the N_S split identities message as defined in ETSI EN 300 175-3 [3], clause 7.3.5.

This message contains the RFPI of the RFP constructed in an identical manner to the information sent in an N_T message as defined in ETSI EN 300 175-3 [3], clause 7.2.2 but in this message it is separated into two fields as defined in ETSI EN 300 175-3 [3], clause 9.5.

10.5.2 Q_C channel

The FT shall send the Q_C message in all frames where a ULE Dummy Bearer is active and the PT shall be capable of receiving and processing the Q_C compound system information message as defined in ETSI EN 300 175-3 [3], clause 7.3.5.

This message contains information constructed in an identical manner to the information sent in Q_T messages.

Specifically the SN and PSCN fields as in Q_0 messages, see ETSI EN 300 175-3 [3], clause 7.2.3.2 and the multiframe number as in Q_6 messages, see ETSI EN 300 175-3 [3], clause 7.2.3.7. In addition this message also contains frame number, preamble pattern and ULE Dummy Bearer specific synchronization pattern as defined in ETSI EN 300 175-3 [3], clause 9.5.

10.5.3 M_U channel

The FT shall send one M_U message in every frame where a ULE Dummy Bearer is active and the PT shall be capable of receiving and processing the M_U ULE MAC control channel message as defined in ETSI EN 300 175-3 [3], clause 7.3.5.

The message contains MAC layer information specific to ULE devices and shall be as defined in ETSI EN 300 175-3 [3], clause 9.5.

10.5.4 Reception of Messages

DECT ULE PTs are not required to listen for N_S , Q_C or M_U messages at any mandated rate, the PTs will listen when there is a requirement for the PT to gain lock to a specific FT at which point the N_S , Q_C and M_U messages shall be collected and the information understood to enable the PT to lock to the desired FT.

All the information necessary to allow a PT to lock to the desired FT is contained in the N_S , Q_C and M_U messages included in a single slot transmission so they may all be collected in a single reception.

10.5.5 Operation in unlocked mode

Operation in unlocked mode refers to the operation mode when the PP losses the locked state to the RFP during idle time.

The PP shall be capable to get synchronization again to the RFP, when required, by using the information provided in the channels N_S and Q_C .

The PP shall be capable to react properly to a possible change in slot and/or carrier of the dummy bearer during the inactivity time.

The exact re-synchronization algorithm is left to the implementer.

10.6 ULE Paging Procedures

10.6.0 General

Clause 10.6 refers to ULE specific paging capability using B-Field channels over the ULE dummy bearer. Refer to clause 10.4 for LCE paging using A-field tail.

10.6.1 P_U Paging Message Formats

10.6.1.0 General

The FT and PT shall support the ULE Dummy Bearer paging format as defined in ETSI EN 300 175-3 [3], clause 7.3.5. The FT shall send a P_U message in all frames where a ULE Dummy Bearer is active and the PT shall be capable of receiving and processing the P_U ULE Paging channel message.

The FT and PT shall support the internal format for channel P_U in subfields 1 and 3 as defined in ETSI EN 300 17583 [3], clause 9.5.

10.6.1.1 P_U Message General format

The P_U Message (see figure 6) is spread across two subfields of the ULE Dummy Bearer: the subfield 1 carries 44 bits and the subfield 3 carries 56 bits as shown below. The 44 bits in subfield 1 are subdivided into a control field (comprised of the SFa and SFb mask fields), the CA field and the subfield A data. The 56 bits in subfield 3 carry the subfield B data.

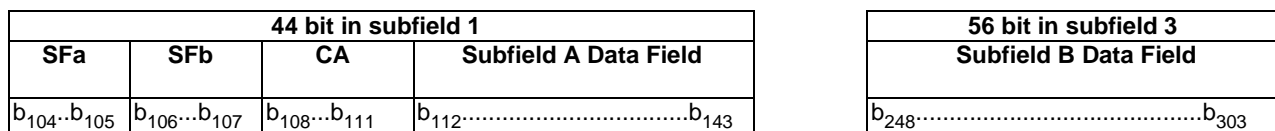

Figure 6: General P_U message format

The detailed format is defined in ETSI EN 300 175-3 [3], clauses 9.5.1.2 (subfield 1) and 9.5.1.4 (subfield 3).

10.6.1.2 Control fields SFa/SFb

These subfields define the internal format of the data subfields A and B. The coding is defined in ETSI EN 300 175-3 [3], clause 9.5.1.2. PT and FT conforming to the present document shall support the codings given in tables 30 and 31:

Table 30: Supported codes in SFa control subfield

SFa		Associated data b ₁₁₂ to b ₁₄₃
b ₁₀₄	b ₁₀₅	
0	0	No information
0	1	Subfield A Data carries paging information (bit-map scheme)
1	0	Subfield A Data carries paging information (index scheme)
1	1	Not supported

Table 31: Supported codes in SFb control subfield

SFb		Associated data b ₁₁₂ to b ₁₄₃
b ₁₀₆	b ₁₀₇	
0	0	No information
0	1	Subfield B Data carries paging information (bit-map scheme)
1	0	Subfield B Data carries paging information (index scheme)
1	1	Not supported

10.6.1.3 CA field

The CA mask consists of 4 bits transmitted always in bitmask format in bits b₁₀₈..b₁₁₁ on channel P_U, subfield 1. They define four groups named "CA groups". Bit 108 transmit the CA signal for CA group 1 and bit 111 for CA group 4. These bits are used by the CA mechanism whose operation is described in clause 10.6.3.

Table 32 shows the position and meaning of the CA bits.

Table 32: CA mask field meaning

CA				Meaning
b ₁₀₈	b ₁₀₉	b ₁₁₀	b ₁₁₁	
CA 1	CA 2	CA 3	CA 4	CA signal for each CA group

10.6.1.4 Subfield A data

The internal format of the Subfield A data is defined in ETSI EN 300 175-3 [3], clause 9.5.1.2, table 9.10.

PT and FT shall support both the bit-map format and the index format.

When the index format is used, the implementation shall be able to recognize the bit b₁₄₃ and to discard the index X₄ when b₁₄₃ is set to "1". However they do not need to understand any special format in index X₄.

Bit b₁₄₂ is not used by the present document. It shall be set to '0' by the FP and shall be ignored by the PT.

Only 7 bits of addressing are used by the present document. Therefore, bits b133 and b134 in index X4 shall always be set to '0' and shall be ignored by the PT.

10.6.1.5 Subfield B data

The internal format of the Subfield B data is defined in ETSI EN 300 175-3 [3], clause 9.5.1.4, table 9.14.

PT and FT shall support both the bit-map format and the index format.

When the index format is used, the implementation shall be able to recognize the bit b303 and to discard the index X10 when b303 is set to "1". However they do not need to understand any special format in index X10.

Bit b302 is not used by the present document. It shall be set to '0' by the FP and shall be ignored by the PT.

Only 7 bits of addressing are used by the present document. Therefore the two most significant bits in all indices shall always be set to '0' by the FT and shall be ignored by the PT.

10.6.2 Paging Descriptors for ULE Paging

10.6.2.1 Basic concepts of the ULE paging system

The following concepts are defined:

Repetition rate: interval in frames between two transmissions of a paging signal.

Offset: a starting point defined by a frame and multiframe of a paging sequence.

Paging sequence: a series defined by an offset and a repetition rate where a paging signal can be transmitted.

Paging ID: a numeric value that combined with a sequence defines a paging signal. Paging IDs are numeric values between 0 and 510. All values may be transmitted using the index format. Values between 0 and 87 may also be transmitted in bitmap format. Value 511 is reserved and is used to indicate that an index may be ignored.

Paging signal: a combination of a paging ID and a sequence that, when happens, activates a paging action defined by a descriptor.

Descriptor: a record in the << ULE-MAC-CONFIGURATION-INFO >> IE that identifies a paging signal (by its sequence and paging ID) and defines the action to be performed when the signal appears. It may also define the action to be done when the signal does not appear (default negative action), the action to be done when it appears but set to "0" (explicit negative action) and the instructions for the paging reception.

Positive action: action to be performed when a paging signal is received with either the paging ID value coded in an index or a "1" coded in the Paging ID position in bitmask format.

Explicit negative action: action to be performed when a paging signal is received with a "0" coded in the Paging ID position in bitmask format.

Default negative action: action to be performed when a paging signal is not received.

Paging reception mode: instructions about how the paging should be received.

10.6.2.2 Basic operation of the descriptors

The ULE Dummy Bearer paging channel (P_U channel) is used to pass transient information from the FT to the PT. This information are the paging IDs and may be exchanged in either bit-map or index formats. The receiver combines these paging IDs with the paging sequence to identify paging signals. The definition of each paging signal (paging ID and sequence elements) is given in the descriptors, which also define the actions to be performed.

The descriptors are records sent in the << ULE-MAC-CONFIGURATION-INFO >> information element during VC configuration (see clause 12.1 for the associated NWK layer procedures).

In the present document only one type of descriptors is used coding the positive action "resume" (or setup service call if the VC is suspended). However several descriptors (of the only type) may be used with different Paging IDs, repetition rate and sequence offset in order to synthesize a more complex sequence.

The mandatory number of descriptors that shall be supported by all pageable devices (any PP type except [ULE1-TYP.3]) is TWO. Support of higher number of descriptors is optional.

NOTE 1: The << ULE-MAC-CONFIGURATION-INFO >> information element allows multiple descriptors to be carried in the same information element. However, a NWK layer message has a physical size limit of 63 octets. Any NWK layer message bigger than 63 octets will require the use of extension mechanisms which are not mandatory in the standard, and therefore are not always supported.

NOTE 2: The standard allows for multiple descriptors to be assigned, either by sending multiple descriptors in the same information element, or by sending additional descriptor(s) at later time(s) when using the "append" code of the information element's control field.

NOTE 3: It is possible to assign more than 2 paging descriptors if this has been agreed by prior-negotiation. The mechanism for this negotiation is not described in the present document, but could, for example, be performed by the application layer protocol.

NOTE 4: If the FT uses the Service Change procedure and attempts to assign more paging descriptors than the PT supports, then the PT can reject the Service Change (using {CC-SERVICE-REJECT}). However, this should be an exception case and is not intended for ad-hoc negotiation.

NOTE 5: If the PT initiated the Service Change procedure, and the FT attempts to assign more paging descriptors than the PP supports (in the {CC-SERVICE-ACCEPT} message, then there is no opportunity for the PT to reject this. In this case, the PT may not be able to use all the assigned paging descriptors.

10.6.2.3 Allocation of descriptors

The descriptors are generated by the FT and sent to the PT by means of the << ULE-MAC-CONFIGURATION-INFO >> information element during VC configuration (see clause 12.1). It is the sole responsibility of the FT the choice of paging IDs and sequences and the control of the coherence of all paging parameters in the system.

Clause 12.1 describes which Network Layer procedures may be used for sending descriptors.

The << ULE-MAC-CONFIGURATION-INFO >> information element allows the sending of new descriptors to be added to the existing ones, or it can indicate that all descriptors sent earlier should be deleted and replaced with any subsequent descriptors. This is handled with the Control field. Both modes shall be supported.

For simple examples of the usage of this mechanism, see clause C.2.1 of the present document.

10.6.2.4 Format for descriptors in ULE phase 1

Descriptors may potentially have different formats, with potentially different sizes (number of octets). However only one type of descriptor and one format are used in ULE phase 1. This is the "format A" with the following structure (IE header is also shown).

Bit:	8	7	6	5	4	3	2	1	Octet:
	<< ULE-MAC-CONFIGURATION-INFO >>								1
	Length of Contents (L)								2
	1	Coding standard	Control						3

Descriptor format A

	Descriptor type and command		CA	k
	Spare (0000)		Repetition	k+1
	0 spare	Start MFN4		k+2
	Start MFN		Start FCNT	k+3
	0/1	Paging ID (7 bits)		k+4

Figure 6a: Descriptor "format A"

The meaning of the different fields and the allowable values in "format A" are described in table 32a.

Table 32a: Descriptor fields in descriptor "format A"

Field	Description	Range
Descriptor type and command	Defines the descriptor type and action. See clause 10.6.2.5 for allowed values and actions	
CA	These 4 bits control the subscription to the groups of the CA mechanism (see clause 10.6.3) Bit 4 subscribes the PT to CA group 4 and bit 1 to CA group 1. A PP may be subscribed to one, more than one, or may not be subscribed to any CA group. Subscription to more than one CA groups is commanded by setting several CA bits to "1" in the descriptor. See clauses 10.6.3.1 and 10.6.3.2	0-1
Start_MFN	Multi-Frame Number of the starting point of the paging sequence	0 - 2 047
Start_FCNT	Frame number of the starting point of the paging sequence	0 - 15
Repetition	Repetition rate (interval in frames between two windows for transmission of the paging signal in the sequence)	$2^0 - 2^{15}$
Paging ID	The Paging ID. The paging signal defined by the descriptor is given by the paging ID combined with the paging sequence Only 7 bits are used in ULE phase 1 with a theoretical range of 0..127. However value 127 is reserved and shall not be used. Values 0..87 can be addressed when using the bit-map scheme, and values 0..126 can be addressed when using the index scheme	0 - 126

10.6.2.5 Descriptors in ULE phase 1**10.6.2.5.1 Descriptor codes**

The only descriptor used in the present document has the following code, meaning and format:

Channel Descriptor Type and command (octet k):

Bits	8 7 6 5 4 3 2 1	Meaning	Format
	0 0 1 0 x x x x	ULE resume paging	"format A"

NOTE: Bits 1 to 4 are used by the CA field and are not part of the "descriptor type and command" in "format A".

10.6.2.5.2 Descriptor detailed descriptions**10.6.2.5.2.0 General**

See conventions and definitions in clause 10.6.2.1.

10.6.2.5.2.1 ULE resume paging descriptor

- Code = 0 0 1 0 (the octet carries CA subscription info in bits 1 - 4).
- Paging format = format A (see clause 10.6.2.4), 5 bytes.
- Positive action = VC resume or Service call setup if VC is not active (NWK resumed).
- Default negative action = no action, continue listening to paging in next occurrence.
- Explicit negative action =
 - If the PT is sensor type: no action, the PT may enter in deep sleep mode for a time equal to the wake-up timer (see note). The PP is assumed not continue listening to the paging until expiration of the timer.
 - If the PT is a fast actuator: no action, continue listening to paging in next occurrence.
 - If the PT is a slow actuator: no action, the PT may enter in deep sleep mode for a time equal to the wake-up timer (see note). The PP is assumed not continue listening to the paging until expiration of the timer.
- Paging reception mode =
 - If the PT is sensor type: the receiver is not required to listen for paging in all occurrences specified by periodicity x offset in the descriptor. Receiver is assumed to listen only from time to time, asynchronously, according to the wake up timer (whose value and tolerance are known by the FP, but not the listening time).
 - If the PT is a fast actuator: the receiver should listen for paging in all occurrences specified by the sequence in the descriptor.
 - If the PT is a slow actuator: the receiver is not required to listen for paging in all occurrences specified by periodicity x offset in the descriptor. Receiver is assumed to listen only from time to time, asynchronously, according to the wake up timer (whose value and tolerance are known by the FP, but not the listening time).

NOTE: the wake up timer is a configuration parameter known by both peers. The mechanism for setting this parameter is out of the scope of the present document.

10.6.2.5.3 Additional conventions for ULE phase 1 descriptors

10.6.2.5.3.1 Coding of bit 8 in octet k+4

When sending the << ULE-MAC-CONFIGURATION-INFO >> to a ULE phase 1 PT, the following convention shall be used for the coding of the bit 8 in octet K+4.

- If there is only one descriptor in the IE, this bit shall be set to '1'.
- If there are two or more descriptors in the IE, the bit shall be set to '0' in all descriptors except the last one and shall be set to '1' in the last one.

NOTE: This coding is an implementation convention and does not follow the standard DECT rule for coding of IEs. It tries to mimic the rule for coding of extension octets, however octet k+4 is not really an extension octet.

10.6.3 The CA mask mechanism

10.6.3.0 General

The CA mechanism is an additional paging feature that allows the early detection of no activity in the paging channel.

10.6.3.1 CA mask and CA groups

The CA mask consists of 4 bits transmitted always in bitmask format on the P_U channel. They are transmitted on fixed positions on bits 108 to 111 in subfield SF1 of the channel. They define four groups named "CA groups". Bit 108 transmit the CA signal for CA group 1 and bit 111 for CA group 4.

10.6.3.2 Subscription to CA groups

Any PT may be subscribed to none, one or several of the CA groups. The subscription to the CA groups is controlled by means of the 4 bits "CA" inserted by the FT in the first octet of the "ULE resume paging" descriptor defined in clause 10.6.2.5.

Each bit set to "1" subscribes the PP to a CA group. Bit 4 in the first octet of the descriptor subscribes the PP to CA group 4 and bit 1 to CA group 1.

A PT may be subscribed to one, more than one, or may not be subscribed to any CA group. Subscription to more than one CA groups is commanded by setting several CA bits to "1" in the descriptor.

In case of multiple descriptors carrying the CA field with different content, a logic sum (OR) will be done between the same bits on multiple descriptors.

10.6.3.3 Action after receiving the CA signal

If a PP is subscribed to a single CA group, a "0" transmitted in the respective CA bit of the paging channel indicates that there is not any paging signal of any type intended for this PP and therefore, the portable does not need to continue decoding the rest of the paging bits. Furthermore, the PP should act as if an "explicit negative action" signal is received. In practice this means that a sensor type PPs may start the sleep cycle.

If a PP is subscribed to more than one CA group, then a "0" should be transmitted in all the CA bits for which the PP is subscribed to consider that there is not a paging signal for such PP and assume that an "explicit negative signal" has been received. In any other case, the PP should evaluate the content of the paging channel.

If a PP is not subscribed to any CA group, the PP should ignore the CA bits and decode the paging channel normally.

10.7 Connection Management

10.7.1 Logical Connection Setup

10.7.1.0 General

Logical Connection Setup is the procedure of creation of MBC. Depending on the procedure, it may be immediately followed by a Physical connection setup or not.

10.7.1.1 ULE logical connection setup - explicit procedure

The creation of an MBC shall be performed as described in ETSI EN 300 175-3 [3], clause 10.2.4.1, with the following specific provisions:

- Connection shall be advanced, full slot.
- ECN number shall be set to "7".

The connections created with this ECN shall be "Expedited" as defined in ETSI EN 300 175-3 [3], clause 10.2.5.

Initial Physical Connection setup as immediate result of the creation of the MBC shall be performed as described in clause 10.9.2. Subsequent Physical Connection setup (resume) shall be performed using expedited procedures (see clause 10.10).

10.7.1.2 ULE logical connection setup - procedure for ancillary connections

The creation of an MBC for an ancillary connection, such as that required by the feature [ULE1-N.2] (Service Call) is done as described in ETSI EN 300 175-3 [3], clause 10.2.4, with the following specific provisions:

- Connection shall be basic, full slot.

Therefore the procedure is identical to the one used in GAP (ETSI EN 300 444 [9]).

The ancillary connection is not controllable by means of "Expedited" operations as defined in ETSI EN 300 175-3 [3], clause 10.2.5 and in clause 10.10 of the present document.

10.7.1.3 ULE logical connection setup - implicit procedure

It is possible to create a pair of MBCs for the ULE connection without any exchange of air interface messages by means of the mechanism described in clause 12.1.3.1.3.2, case b). In order to do that, another MBC, generally associated to a circuit mode service, should exist in order to transport the NWK layer messages. This mechanism is called implicit creation of the MBC pair. After an implicit creation of the MBCs, the procedure is not necessarily immediately followed by a Physical connection setup.

10.7.2 Logical Connection Release

10.7.2.0 General

Logical Connection Release is the procedure of removal of an MBC. This procedure is preceded by either a NWK layer release procedure, by a NWK layer suspend procedure or by a handshake failure.

The NWK layer release procedure and the NWK layer suspend procedure will cause DLC layer to send a MAC_DIS-req primitive to MBC (and also the clearing of the DLC U-plane and C-plane instances as well).

The stay alive procedure may also cause the ME to send a MAC_DIS-req primitive to MBC.

Logical connection release will also cause a Physical Connection release, if the connection is active.

The procedures described in the clauses below are possible.

10.7.2.1 ULE logical connection release - explicit procedure

The following procedure shall be performed:

- If the connection was active, the procedure A-field connection/bearer release as defined in clause 10.9.3 shall be executed.

NOTE: It is assumed that a NWK layer RELEASE procedure has been previously executed between both peers in order to release the logical connection.

- If the connection was suspended, releasing explicitly the logical connection requires resuming the connection, executing the NWK layer RELEASE procedure, and then executing the A-field connection/bearer release as defined in clause 10.9.3.

10.7.2.2 ULE logical connection release - procedure for ancillary connections

This procedure shall be used to release the MBC for an ancillary basic connection, such as that required by the feature [ULE1-N.2] (Service Call).

The same procedure described in ETSI EN 300 444 (GAP) [9], clause 10.5 shall be performed. The procedure releases at the same time the bearer and the connection.

NOTE: An ancillary connection does not support MAC suspend/resume. Therefore, its MBC may only be in active state.

10.7.2.3 ULE logical connection release - implicit procedure

The execution of the NWK layer procedure "NWK suspend" as described in clause 12.1.3.2, when the NWK messages are carried by a different MBC to the one associated to the CC entity, and when the associated MBC is in "MAC suspend" state, causes the release of the MBC at both peers without any further signalling operation.

This procedure is called "logical connection release - implicit procedure" and is the connection release normally used in ULE.

The NWK layer procedure is described in clause 12.1.3.2. The implicit release procedure is the case A described in clause 12.1.3.2.3.2.

10.7.2.4 ULE logical connection release - abnormal procedure

Abnormal release of the connection at all levels may also be done by the Management Entity as result of failure of stay-alive procedures. In such a case, the procedure is implicit and there is no exchange of air i/f messages.

10.7.3 Connection Suspend and Resume

10.7.3.1 General

The suspend/resume process used in ULE is entirely handled at MAC layer and under control by the Management Entity in response to instantaneous traffic need. The suspend/resume process is the DECT packet handling mechanism over the MAC C/O service.

The suspend/resume process happens at an imaginary plane in between the MAC TBC (also called lower-MAC) and the MAC MBC (also called higher-MAC). This applies to both U-plane and C-plane transmissions.

MBC and higher layers are active and, in general, not aware of the suspend/resume state. However they may contribute to trigger the suspend/resume process by sending traffic (U-plane or C-plane) to the lower layers, which would be detected by the Management Entity and would trigger the proper action at MAC layer.

Packet handling Suspend/resume process is part of the MAC C/O service.

10.7.3.2 Suspend

10.7.3.2.0 General

Suspend is defined as the process of releasing the physical connection without releasing the logical connection. Therefore in suspend state:

- There are not physical bearers active at the physical layer.
- There is not active TBC entity.
- There is a MBC associated to the connection.
- All higher layer entities (DLC and above) associated to the connection are active, and, in general are not aware of the suspend state at lower MAC layer.

10.7.3.2.1 Entering in suspended state

A connection enters in suspend state by releasing its bearer at MAC layer without an explicit process of connection release.

The previous principle applies independently of the process for the bearer release, that may be normal (as described in clause 10.9), expedited (as describe in clause 10.10) or even due to errors, abnormal operations or timeouts.

An ULE connection also enters in suspends state (and shall not be completely released) by abnormal loss of the bearer.

NOTE: In this case, the stay-alive procedure (see clause 9.1.2) will be in charge of debugging the situation.

The explicit process of connection release is normally done by a NWK layer procedure. In the present document the procedure is the NWK layer Service Change "suspend" (see clause 12.1.3.2). This procedure moves the NWK state to "NWK suspend" (see clause 12.1.2) and releases the MBC (MAC connection).

The ME handshake procedure (see clause 9.1.2) may also release the MAC connection.

10.7.3.3 Resume

10.7.3.3.0 General

Resume is the process of activating the physical layer for an existing connection in suspended state.

A connection in resumed state behaves as a normal DECT connection and includes at least a TBC entity. However the connection is still identified as packet-mode at MBC level, which would trigger the proper action at MBC level (pass to suspend state) after the release of the bearer and TBC.

The provisions of ETSI EN 300 175-3 [3], clause 10.3.1.1 shall apply.

10.7.3.3.1 Resuming a suspended connection

For devices compliant with the present document the resume process is performed by executing a bearer setup process with any of the following two options:

- Any Advanced connection setup (as described in clause 10.9) with the ECN number belonging to an existing suspended connection between the PT - FT pair.

NOTE 1: Therefore any setup process with a different ECN should be understood as the setup of a separate connection (if supported).

- Any expedited bearer setup as described in clause 10.10.3 of the present document.
 - Expedited bearer setups (any) shall be understood as a resume process to an existing connection with ECN = 7.

NOTE 2: Therefore expedited operations cannot be used for initial setup, or when there is no a suspended connection.

All devices compliant with the present document shall use the ECN = 7 for the DECT ULE service and shall not reuse such value for any other service. Expedited operations shall be used only for controlling the ULE connection.

NOTE 3: However, it is possible to have other DECT services (voice or data) over the same FT - PT pair with different ECN values.

NOTE 4: It is also possible to have other packet mode services over the same FT - PT pair, however they should be handled with regular advanced connection control messages (clause 10.9) and not with expedited messages (clause 10.10).

10.7.3.3.1.1 FT initiated resume

Resuming a connection from the FT side shall be performed using indirect setup via B-field paging. For ULE PPs, a dedicated paging channel inside the B-field of the dummy bearer(s) is used for triggering the resume process from FT side (indirect setup). See clause 10.6 for description of the B-field resume paging procedures.

10.7.4 Other Connection Modification

10.7.4.0 General

Clause 10.7.4 describes additional connection modification procedures (other than suspend and resume) that may be supported by ULE devices.

10.7.4.1 Void

10.7.4.2 Connection modification to change service type, slot type, modulation type or adaptive code rate

10.7.4.2.1 Connection modification to change MAC service type

The MAC connection modification procedure to change the service type is needed to change the actual service type of a logical connection to a new one due to the result of the NWK service negotiation defined by clause 12.5 or service changes defined in clauses 12.6 and 12.7.

The connection modification procedure to change the service type between the following service types defined by ETSI EN 300 175-3 [3], clauses 5.6.2.1 and 5.6.2.2:

- $I_{PM_error_correct}$;
- $I_{PQ_error_correct}$.

The connection modification procedure to change the service type is only needed, if other MAC service types than $I_{PQ_error_correct}$ are supported.

The connection modification procedure to change the service type shall be performed as defined by ETSI EN 300 175-3 [3], clause 10.3.2.1. The attributes_request and attributes_confirm message exchanged for this procedure shall be the ATTRIBUTES_T.req/cfm message as defined by ETSI EN 300 175-3 [3], clause 7.2.5.3.8.

The connection modification to change service type shall be only performed following a NWK layer Service Change negotiation.

10.7.4.2.2 Connection modification to change slot type

The MAC connection modification procedure to change the slot type is needed to change the slot type of a logical connection to a new one due to the result of the NWK service negotiation defined by clause 12.5 or service changes defined in clauses 12.6 and 12.7.

The connection modification procedure is in charge to change the slot type between the following slot types defined by ETSI EN 300 175-3 [3], clause 6.2.1.1:

- Full slot (physical packet P32);
- Double slot (physical packet P80);
- Long slot (physical packet P64);
- Long slot (physical packet P67).

The connection modification procedure to change the slot type is optional to support, and has only sense if multiple MAC slots are supported.

The connection modification procedure to change the slot type shall be performed as defined by ETSI EN 300 175-3 [3], clause 10.3.2. The attributes_request and attributes_confirm message exchanged for this procedure shall be the ATTRIBUTES_T.req/cfm message as defined by ETSI EN 300 175-3 [3], clause 7.2.5.3.8.

The connection modification to change slot type shall be only performed following a NWK layer Service Change negotiation to change slot (see clause 12.6.2).

10.7.4.2.3 Connection modification to change maximum MAC packet lifetime

The MAC connection modification procedure to change the maximum MAC TBC packet lifetime is needed to change this parameter which influences the $I_p_error_correct$ operation. The following provisions shall apply:

The connection modification procedure to change the maximum MAC packet lifetime shall be performed as defined by ETSI EN 300 175-3 [3], clause 10.3.2. The attributes_request and attributes_confirm message exchanged for this procedure shall be the ATTRIBUTES_T.req/cfm message as defined by ETSI EN 300 175-3 [3], clause 7.2.5.3.8, with the following modifications:

- The values coded in bits a_{29} to a_{31} of the ATTRIBUTES_T.req/cfm message shall be coded as shown in table 32b.

Table 32b

Ser type/max life for MAC MOD-2 protected services in ULE			Meaning
a_{29}	a_{30}	a_{31}	
0	0	0	no lifetime is set (infinite)
0	0	1	lifetime = 1 frame (no retransmission allowed)
0	1	0	lifetime = 3 frames
0	1	1	lifetime = 5 frames
1	0	0	lifetime = 7 frames
1	0	1	lifetime = 10 frames
1	1	0	lifetime = 14 frames
1	1	1	lifetime = 20 frames

NOTE 1: This convention is specific for ULE and supersedes the standard DECT coding defined by table 7.32a of ETSI EN 300 175-3 [3].

NOTE 2: There is no need to run a NWK layer service negotiation to change the MAC maximum TBC packet lifetime.

- In case of divergences between req and cfm messages, the value provided by the FT shall apply.

10.7.4.2.4 Connection modification to change the modulation scheme and adaptive code rate

The use of HLM or encoded protected MAC service in DECT ULE is for further study.

10.7.4.2.5 Use of ATTRIBUTES_T.req/cfm in connection modification

This clause applies to all connection modification cases covered by clause 10.8.2.

The ATTRIBUTES_T.req/cfm message as defined by ETSI EN 300 175-3 [3], clause 7.2.5.3.8 shall be used for connection modification to change service type and/or modulation scheme.

The message shall be supported if any connection modification case covered by clause 10.7.2 has to be implemented.

The values used in the ATTRIBUTES_T.req/cfm messages given in table 33 and defined in clause 7.2.5.3.8 of ETSI EN 300 175-3 [3] shall be supported by the PT and the FT.

Table 33: Values used within ATTRIBUTES_T.req/cfm messages

MAC message	Field within the message	Standard values within the MAC message	Normative action/comment
<< M _T message >>	< M _T header >	0001	"Advanced connection control".
	< Command >	6	"Attributes_T.request".
		7	"Attributes_T.confirm".
	< ECN >	7	ECN = 7 reserved for ULE.
	< LBN >	1 to 15	Any value shall be supported. Value shall match the LBN of the bearer that carries the message.
	< up/down/ss/sm >	"11"B	Symmetric single bearer connection.
	< service type >	7	I _{PQR-error-correct} mandatory to support.
	< max. lifetime >	1 to 7	Values 1 to 7 (in the message) mandatory to support (they code lifetime values from 1 to 20).
	< slot type >	0, 2, 3, 4	Full slot (code = '0'B) mandatory to support. Double, long 640 and long 672 slots optional.
	< C _F >	[0, 1]	C _F support is optional.
	< extended (B + Z) field mod. type >	0	(extended (B + Z) field not used).
	< adaptive code rate >	0	No coding used (see note 2).
	< A-field modulation type >	3	Default modulation scheme is 2-level modulation. All others schemas are for further study.
	< (B + Z) field mod. type >	3	Default modulation scheme is 2-level modulation. All others schemas are for further study (see note 1).

NOTE 1: Modulation fields other default modulation schema are for further study.
NOTE 2: Use of encoded protected services and adaptive code rate is for further study.

10.8 Other MAC control procedures

10.8.1 Quality control

10.8.1.1 RFPI handshake

RFPI handshake procedure shall be performed as defined in ETSI EN 300 175-3 [3], clause 11.5.1.

10.8.1.2 PT frequency correction

PT frequency correction procedure shall be performed as defined in ETSI EN 300 175-3 [3], clause 11.5.2.2.

10.8.1.3 Bearer quality report

Receiver side will send bits Q1 (or BCK) and Q2 reporting quality of received bearers. Report shall be done in bits a_3 and a_7 of a field in the reverse bearer of the duplex pair.

The bit Q1 shall be set as defined in ETSI EN 300 175-3 [3], clause 10.8.1.3.4. The bit Q2 shall be set as described in ETSI EN 300 175-3 [3], clause 10.8.1.3.3. In $I_{p_error_correct}$ services, the bit Q2 shall be set as defined in ETSI EN 300 175-3 [3], clause 10.8.2.4.1, and the bit BCK, set as defined in ETSI EN 300 175-3 [3], clause 10.8.2.4.2, shall be sent in the place of bit Q1.

FT and PT should use the information of the received bits Q1 and Q2 to take the decision to perform bearer replacement procedures.

FT may use the information of the Q1 and Q2-bits sent by the PT, to decide whether to switch antenna or not.

10.8.1.4 A-CRC handshake

When a TBC is in active connected state, if no correct A-CRC is received (in regard to the active FT identity) for a time equal to maximum MAC packet lifetime, the bearer shall be released. The abnormal expedited release procedure (clause 10.10.3.6) shall be used in this case.

NOTE: The normal reaction on the release of a bearer because of A-CRC handshake failure will be setup a new bearer over a new TBC.

10.8.2 Physical channel selection

10.8.2.1 Channel selection for the ULE packet data connection

The ULE specific channel selection mechanisms, as described in clause 9.2, shall be used for the channel selection of the ULE packet data connection (MBC resume procedure), except in the exceptional cases listed in clause 10.8.2.2. Such channel selection procedures, combined with expedited setup procedures (clause 10.10) shall be the normal operation procedures for all types of ULE Portable Parts. This rule applies in all cases, including PP types that may be continuously locked to the RFP such as PPs type II "fast actuator" [ULE1-TYP.4].

10.8.2.2 Exceptional cases

Regular DECT channel selection procedures (as described in ETSI EN 300 175-5 [5], clause 11.4) may only be used for channel selection for the ULE packet data connection, on an exceptional basis, in the following cases:

- In the initial setup of the connection, when explicit procedures are used (see clause 10.7.7.1.1).
- When using regular advanced (non expedited) bearer setup procedure.
- In case or impossibility of access due to repetitive lack of channels in the information provided by the base, or repeated impossibility to validate the channels provided by the RFP.

10.8.2.3 Channel selection for the Service Call and other circuit mode connections

The setup of the Service Call (feature [ULE1-N.2]), or other circuit-mode connections that may exist in the system, shall be done using regular DECT channel selection procedures as described in ETSI EN 300 175-5 [5], clause 11.4.

10.8.3 A-field MAC Bearer replacement procedure (M_T)

The PT shall be able to perform bearer replacement, by setting up new TBCs within the same logical connection. The following rules shall apply:

- The bearer replacement shall be always implemented by dropping the existing bearer before establishing the new one.
- There should not be more than one bearer over the air at any time.
- Bearer replacement shall be performed in case of transmission errors prior to achieving the expedited "connected" state (see present document, clause 10.10.4.1.2.3).
- Bearer replacement, at a position other than an SDU boundary, is optional, and may be supported by some implementations.
- This procedure only applies to ULE packet mode connections.

The quality criteria that cause a bearer replacement are left to the implementer.

10.8.4 Dummy bearer replacement procedure

10.8.4.0 General

The FT shall be able to control the quality and to move the position of the dummy bearer as response to quality issues.

The rules described in the clauses below shall be followed.

10.8.4.1 Quality control

The FT shall be able to periodically measure the background RSSI level on the dummy bearer channel. To do that, it is allowed to interrupt the transmission of the dummy bearer from time to time.

This interruption of transmission has some implications on system operation:

- A ULE PP device might try to lock to the FP on this frame, resulting in it missing the dummy bearer broadcast.
- The ULE FP is unable to broadcast any paging information in this frame.

The detrimental effect of the above points can be mitigated somewhat by appropriate design. For example:

- The frequency of the FP's RSSI scan can be limited.
- The PP sync algorithm can take into account that some frames might be missing.
- The FP can avoid allocating this frame for paging broadcast schedules.

The details and use of any such mitigation strategies are left to the implementation.

10.8.4.2 Requirements

- The bearer replacement shall consist of raising a new dummy bearer on a new channel, before releasing the old one.
- The old dummy bearer shall be released latest four multiframe after raising the new replacement dummy bearer.
- The number of physical channel changes for the dummy bearer shall not exceed 5 changes per any one minute interval (see ETSI EN 300 175-3 [3], clause 5.7).
- It is not allowed to miss transmissions in frames 0, 8 and 14 of a multiframe (see ETSI EN 300 175-3 [3], clause 6.2.2.1.1).

- The FP shall broadcast the position of the new dummy bearer using the A-field MAC layer information for Pt message, with the coding for "dummy or C/L bearer position" (see ETSI EN 300 175-3 [3], clause 7.2.4.3.4).
- Modification of frequency should be avoided if possible, for example by moving to a different slot on the same frequency. However, this should only occur if allowed by channel selection algorithm.
- The FP shall miss at most one downlink transmission in any one second interval.

NOTE: ETSI EN 300 175-3 [3], clause 5.7 describes the normal procedures for dummy bearer replacement.

10.9 A-field (M_T) Advanced Connection control procedures

10.9.1 General

A-field MAC advanced control procedures are used for the setup, release and handover of ULE connections. They may be used in any case (including initial setup, resume, suspend and complete release), however expedited operations (clause 10.10) are assumed to be normally used in suspend and resume by efficiency reasons.

The following procedures are available:

- PT initiated A-field advanced bearer setup.
- A-field connection/bearer release.
- A-field bearer handover request (optional).
- A-field connection handover request (for further study).

10.9.2 PT initiated A-field advanced bearer setup

10.9.2.0 General

The connection setup procedure shall be performed as defined in ETSI EN 300 175-3 [3], clauses 10.2.4.1 and 10.2.4.2 or 10.2.4.3.

The connection setup procedure described in ETSI EN 300 175-3 [3], clause 10.2.4.2 shall be used in the following cases:

- PT initiated setup (all cases).
- FT initiated indirect setup (via paging).

The bearer setup procedure shall be performed in all cases as defined in ETSI EN 300 175-3 [3], clause 10.5.1.2.

The exchange of the messages "Attributes_T.req" and "Attributes_T.cfm" is mandatory in all cases. The PT shall send the "Attributes_T.req" message after reception of the "Bearer.cfm" as described in ETSI EN 300 175-3 [3], clause 10.5.1.2.1.

In the case of FT initiated (indirect) setup, the LCE paging code = "110"B shall be used in the initial setup of the call and LCE = "111"B in the case of resume of an existing connection.

NOTE: It is expected that the use of this procedure and the LCE = "111"B code for resume will be an infrequent use case since resume will be generally performed using expedited procedures (see clause 10.10).

10.9.2.1 M_T access request message

The values used in the MAC control (M_T) message given in table 34 and defined in clause 7.2.5.3 of ETSI EN 300 175-3 [3] shall be supported by the PT and the FT.

Table 34: Values used within M_T message

MAC message	Field within the message	Standard values within the MAC message	Normative action/comment
<<M _T message>>	<M _T header>	1	"Advanced connection control".
	<Command>	0	"Access_request".
		4	"Bearer_confirm".
		5	"Wait".
		6	"Attributes_T_request" (see note).
		7	"Attributes_T_confirm" (see note).
	<FMID>	All	
<PMID>	All	See clause 13.4 of ETSI EN 300 444 [9].	

NOTE: For values in the Attributes_T req/cfm message, see table 35.

10.9.2.2 M_T Attributes_T.req/cfm message

The values used in the ATTRIBUTES_T.req/cfm messages given in table 35 and defined in clause 7.2.5.3.8 of ETSI EN 300 175-3 [3] shall be supported by the PT and the FT.

Table 35: Values used within ATTRIBUTES_T.req/cfm messages

MAC message	Field within the message	Standard values within the MAC message	Normative action/comment
<< M _T message >>	< M _T header >	0001	"Advanced connection control".
	< Command >	6	"Attributes_T.request".
		7	"Attributes_T.confirm".
	< ECN >	7	ECN = 7 for ULE connection. Other values allowed for other applications.
	< LBN >	1 to 15	LBN = 15 shall be used for initial setup. Other values allowed in case of bearer replacement.
	< up/down/ss/sm >	"11"B	Symmetric single bearer connection.
	< service type >	7	I _{PQR_error_correct}
	< max. lifetime >	1 to 7	Values 1 to 7 mandatory to support
	< slot type >	0	Full slot Mandatory. Other slots optional.
	< C _F >	[0, 1]	Support of C _F optional.
	< extended (B + Z) field mod. type >	0	(extended (B + Z) field not used).
	< adaptive code rate >	0	No coding used (see note 2).
	< A-field modulation type >	3	Default modulation scheme to use for bearer setup is 2-level modulation.
	< (B + Z) field mod. type >	3	Default modulation scheme to use for bearer setup is 2-level modulation (see note 1).

NOTE 1: Modulation schemas other default modulation schema are for further study.
NOTE 2: Use of encoded protected services and adaptive code rate is for further study.

10.9.3 A-field connection/bearer release

10.9.3.0 General

The procedure (see figure 7) shall be performed as defined in ETSI EN 300 175-3 [3], clauses 10.4 and 10.7.2.1.

The procedure may be used if the connection is either, basic or advanced. The proper value shall be inserted in the M_T header.

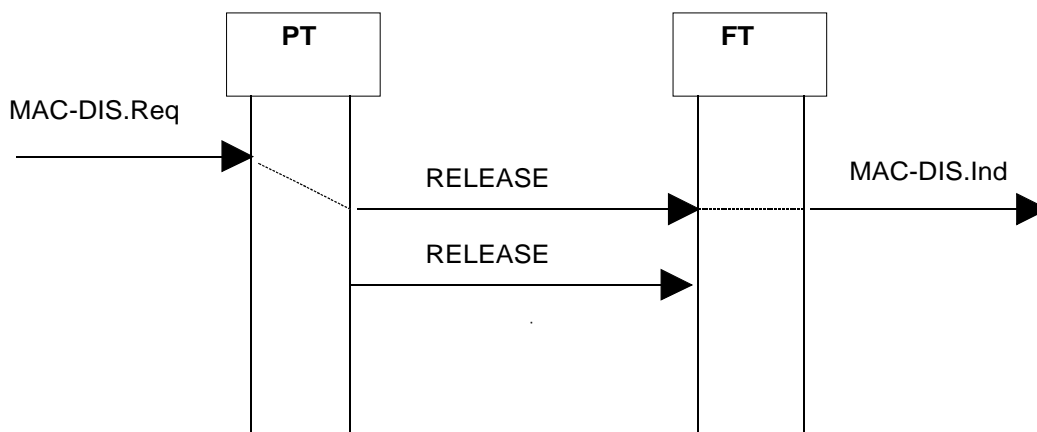

Figure 7: Bearer release

10.9.3.1 M_T message

The values used in the MAC control (M_T) message given in table 36 and defined in clause 7.2.5.2 ETSI EN 300 175-3 [3] shall be supported by the PT and the FT.

Table 36: Values used within M_T message

MAC message	Field within the message	Standard values within the MAC message	Normative action/comment
<< M_T message>>	< M_T header>	0	Basic connection control
		1	Advanced connection control
	<Command>	15	Release
	<FMID>	All	Basic connections only
	<LBN>	All	Advanced connection control only
	<reason>	All	Advanced connection control only
	<PMID>	All	See clause 13.4 of ETSI EN 300 444 [9]

10.9.4 A-field bearer handover request

10.9.4.0 General

The procedure shall be performed as defined in ETSI EN 300 175-3 [3], clauses 10.6.2 and 10.5.1.1.

The procedure is equivalent for intra- and inter-cell handover.

The procedure may be used if the connection is either, basic or advanced. The proper value for the M_T header shall be used.

The FT should not release the old bearer within 10 ms after the establishment of the new bearer.

10.9.4.1 M_T message

The values used in the MAC control (M_T) message given in table 37 and defined in clause 7.2.5.2 of ETSI EN 300 175-3 [3] shall be supported by the PT and the FT.

Table 37: Values used within M_T message

MAC message	Field within the message	Standard values within the MAC message	Normative action/comment
<<M _T message>>	<M _T header>		
		1	"Advanced connection control".
	<Command>	1	"Bearer_handover_request".
		4	"Bearer_confirm".
		5	"Wait".
	<FMID>	All	
<PMID>	All	See clause 13.4 of ETSI EN 300 444 [9].	

10.9.5 A-field connection handover request

10.9.5.0 General

The procedure shall be performed as defined in ETSI EN 300 175-3 [3], clauses 10.2.4.2 and 10.5.1.1.

The procedure may be used if the connection is either, basic or advanced. The proper value for the M_T header shall be used.

The procedure is equivalent for intra- and inter-cell handover.

10.9.5.1 M_T message

The values used in the MAC control (M_T) message given in table 38 and defined in clause 7.2.5.3 ETSI EN 300 175-3 [3] shall be supported by the PT and the FT.

Table 38: Values used within M_T message

MAC message	Field within the message	Standard values within the MAC message	Normative action/comment
<<M _T message>>	<M _T header>		
		1	"Advanced connection control".
	<Command>	2	"Connection_handover_request". PT shall capable to send. FT shall be capable to process.
		4	"Bearer_confirm".
		5	"Wait".
	<FMID>	All	
<PMID>	All	See clause 13.4 of ETSI EN 300 444 [9].	

10.10 A-field (M_T) Expedited operations for Advanced Connection control

10.10.1 General

The expedited bearer setup procedures are optimized advanced M_T setup procedures intended for ultra fast setup of bearers, allowing in most cases reduction in the number of messages and early U-plane transmission compared to regular procedures.

Expedited messages are only used for resume (bearer setup of existing MAC connections) or suspend (bearer release without clearing the connection at MBC level).

Expedited bearer setup procedures are only defined as PT initiated. However, once initiated by the PT, FT may change the continuation of the procedure.

Expedited messages may coexist with other advanced connection control set messages.

10.10.2 M_T advanced control messages for expedited operations

10.10.2.1 Supported M_T messages

The PT and FT shall support the following M_T advanced control messages from the Advanced connection control part 2 set (see ETSI EN 300 175-3 [3], clauses 7.2.5.12.1 and 7.2.5.12.2):

- "Expedited Access Request" (command "0000"B)
- "Expedited Access Request ready for release" (command "0001"B)
- "Null or G_{FA} channel transmission" (command "0010"B)
- "Ready for release with G_{FA} transmission" (command "1110"B)
- "Expedited Release with G_{FA} transmission" (command "1111"B)

The PT and FT shall support the following M_T advanced control messages from the Advanced connection control set (see ETSI EN 300 175-3 [3], clauses 7.2.5.3.1 and 7.2.5.3.6):

- "Bearer confirm" (command "0100"B)

10.10.2.2 G_{FA} transmission

The PT and FT shall include a G_{FA} message indicating last valid DLC RN (positive ACK) in all transmissions of "expedited release" and "ready for release" messages.

10.10.2.3 Reason codes in "expedited release" and "ready for release" messages

10.10.2.3.1 Reason codes in "expedited release" message

The reason codes given in table 39 shall be supported by both peers in the "expedited release" message.

Table 39: Supported "reason codes" in "expedited release" message

Reason code						Meaning	Info field
a ₂₂	a ₂₃	a ₂₄	a ₂₅	a ₂₆	a ₂₇		
0	0	0	0	0	1	Normal bearer release (see note 1)	Not used, note 9
0	0	1	0	1	0	base station busy (see note 2)	Not used, note 9
0	0	1	1	0	1	unacceptable PMID / Unregistered PMID (see note 3)	Not used, note 9
0	0	1	1	1	1	Stay in LCE paging detection mode (see note 5)	Code indicating paging mode and timer information, see note 5
0	1	0	0	0	0	switch to circuit mode (see note 4)	See note 10
0	1	0	0	0	1	Stay in higher paging detection mode (see note 6)	Code indicating paging mode and timer information, see note 6
0	1	0	0	1	0	setup again after <i>n</i> frames (see note 7)	Code indicating number of frames for the setup attempt, note 7
0	1	0	1	0	0	No such connection / virtual circuit, (see note 8)	Not used, note 9

NOTE 1: This is the 'normal' release reason code for a release of packet mode connections.

NOTE 2: The applicable procedure is defined in clause 10.10.5.1 of the present document.

NOTE 3: This reason code shall be used as response to Expedited access requests attempts when the PT is not registered at the RFP. See also clause 10.10.5.2 in the present document.

NOTE 4: The applicable procedure is defined in clause 10.10.5.3 of the present document.

NOTE 5: The exact meaning of the info field is defined in ETSI EN 300 175-3 [3], clause 7.2.5.12.5.2. The applicable procedure is defined in clause 10.10.5.5 of the present document.

NOTE 6: The exact meaning of the info field is defined in ETSI EN 300 175-3 [3], clause 7.2.5.12.5.3. The applicable procedure is defined in clause 10.10.5.6 of the present document.

NOTE 7: The exact meaning of the info field is defined in ETSI EN 300 175-3 [3], clause 7.2.5.12.5.4. The applicable procedure is defined in clause 10.10.5.7 of the present document.

NOTE 8: This reason code shall be used as response to Expedited access requests attempts when there is no associated context (suspended MAC connection / suspended link / Virtual call) for the initiating PT. See also clause 10.10.5.8 in the present document.

NOTE 9: Unused bits in 'info' field shall be set to '0'.

NOTE 10: The contents and meaning of this info field are described in clause 10.10.5.4 of the present document.

The procedures described in clause 10.10.5 shall be followed for the use of reason codes other than "Normal bearer release".

10.10.2.3.2 Reason codes in "ready for release" message

The reason codes given in table 40 shall be supported by both peers in the "ready for release" message.

Table 40: Supported "reason codes" in "ready for release" message

Reason code						Meaning	Info field
a ₂₂	a ₂₃	a ₂₄	a ₂₅	a ₂₆	a ₂₇		
0	0	0	0	0	1	Normal bearer release (see note 1)	Not used, note 9
0	0	1	0	1	0	base station busy (see note 2)	Not used, note 9
0	0	1	1	0	1	unacceptable PMID / Unregistered PMID (see note 3)	Not used, note 9
0	0	1	1	1	1	Stay in LCE paging detection mode (see note 5)	Code indicating paging mode and timer information, see note 5
0	1	0	0	0	0	switch to circuit mode (see note 4)	See note 10
0	1	0	0	0	1	Stay in higher paging detection mode (see note 6)	Code indicating paging mode and timer information, see note 6
0	1	0	0	1	0	setup again after <i>n</i> frames (see note 7)	Code indicating number of frames for the setup attempt, note 7
0	1	0	1	0	0	No such connection / virtual circuit, (see note 8)	Not used, note 9

NOTE 1: This is the 'normal' release reason code for a release of packet mode connections.
NOTE 2: The applicable procedure is defined in clause 10.10.5.1 of the present document.
NOTE 3: This reason code shall be used as response to Expedited access requests attempts when the PT is not registered at the RFP. See also clause 10.10.5.2 in the present document.
NOTE 4: The applicable procedure is defined in clause 10.10.5.3 of the present document.
NOTE 5: The exact meaning of the info field is defined in ETSI EN 300 175-3 [3], clause 7.2.5.12.5.2. The applicable procedure is defined in clause 10.10.5.5 of the present document.
NOTE 6: The exact meaning of the info field is defined in ETSI EN 300 175-3 [3], clause 7.2.5.12.5.3. The applicable procedure is defined in clause 10.10.5.6 of the present document.
NOTE 7: The exact meaning of the info field is defined in ETSI EN 300 175-3 [3], clause 7.2.5.12.5.4. The applicable procedure is defined in clause 10.10.5.7 of the present document.
NOTE 8: This reason code shall be used as response to Expedited access requests attempts when there is no associated context (suspended MAC connection / suspended link / Virtual call) for the initiating PT. See also clause 10.10.5.8 in the present document.
NOTE 9: Unused bits in 'info' field shall be set to '0'.
NOTE 10: The contents and meaning of this info field are described in clause 10.10.5.4 of the present document.

The procedures described in clause 10.10.5 shall be followed for the use of reason codes other than "Normal bearer release".

10.10.2.4 Operation codes in "Null or G_{FA} channel transmission" message

The following operation code shall be supported by both peers in the "Null or G_{FA} channel transmission" message.

- "01"B: G_{FA} channel

NOTE: See ETSI EN 300 175-3 [3], clause 7.2.5.12.5.

10.10.3 Expedited procedures

10.10.3.0 General

The expedited procedures described in the clauses below shall be supported.

10.10.3.1 Procedure for Single-burst setup and release

The PT and FT shall support the Procedure for Single-burst setup and release as defined by ETSI EN 300 175-3 [3], clause 10.5.1.8.2.

10.10.3.2 Procedure for Multi-burst setup

The PT and FT shall support the Procedure for Multi-burst setup as defined by ETSI EN 300 175-3 [3], clause 10.5.1.8.3, including the modification single-burst setup > Multi burst setup and the FT response table defined by ETSI EN 300 175-3 [3], clauses 10.5.1.8.3.2 and 10.5.1.8.3.3.

10.10.3.3 Announcement "Ready for Release"

The PT and FT shall support the Procedure for announcement "Ready for Release" as defined by ETSI EN 300 175-3 [3], clause 10.5.1.8.4, including the protection as defined by ETSI EN 300 175-3 [3], clause 10.5.1.8.4.1.

10.10.3.4 General Expedited Release procedure

The PT and FT shall support the General Expedited Release procedure as defined by ETSI EN 300 175-3 [3], clause 10.7.3.2.

10.10.3.5 Single-message expedited release procedure

The PT and FT shall support the Single-message expedited release procedure as defined by ETSI EN 300 175-3 [3], clause 10.7.3.3.1.

10.10.3.6 Abnormal expedited release procedure

The PT and FT shall support the Abnormal expedited release procedure as defined by ETSI EN 300 175-3 [3], clause 10.7.3.3.2.

10.10.4 Expedited procedures use cases

10.10.4.1 General use cases

10.10.4.1.1 Single Packet Data Transfer - Success

Description:

- Single-packet Data Transfer is designed to be as fast and simple as possible. It can even contain no data at all, and serve as a data pull request (PP->FP) only.
- Single-packet Data Transfer will normally be preceded by a regular advanced connection which has negotiated service and slot type, and which has been suspended before. By default the single-packet data transfer uses IP error correct MAC service, single subfield protection, and full slot. The first messages do contain data.

NOTE: The first IP packet transmitted on a new MAC packet mode connection has IP packet number 1.

Figure 8 shows a single packet transfer from PP to FP.

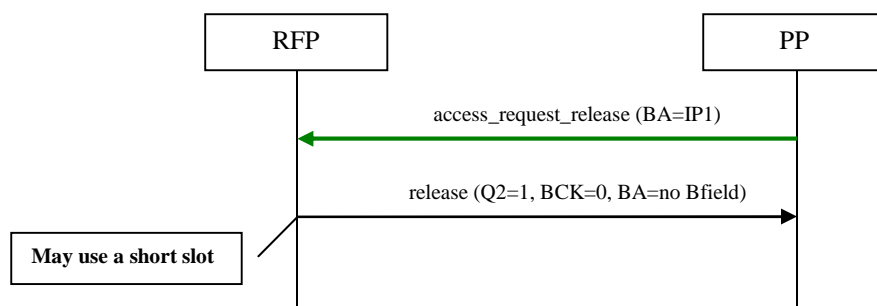

Figure 8: Single Frame Data Transfer - Success

- There may be cases whether neither the PP, nor the FP has data to send (e.g. when the PP just polls the FP to see whether it has data, but the FP does not have any data). In this case, the flowchart would look exactly as shown in figure 8, only that the BA bits of the expedited_access_request_ready_for_release message would be 'no Bfield'.

- This use case may happen as response to paging (indirect FT initiated setup) only in the event that the FT has no data to be sent downstream and PT has no data, or has a single packet ready to be sent upstream (the reason of the FT paging would be just a polling or an "stay-alive" checking). In the most usual case when the reason of the paging is sending data downstream, the use case is executed as shown in clause 10.10.4.1.3.1 (transfer of a single packet downstream) or further use cases in clause 10.10.4.1.3 (transfer of multiple packets).

10.10.4.1.2 Single Packet Data Transfer: error/abnormal cases

10.10.4.1.2.1 Error in B-field CRC

Description:

- MAC signalling procedure is OK (A-field received and message decoded), but due to a corrupted B-field the IP packet has not been received.
- In this case, the PP should understand that the packet has not been accepted and should try to retransmit it.
- The bearer is released and the PP has to repeat access request (on a different slot/carrier).
- The release reason may be "normal release" since the A-field was received OK, or "setup again in k frames" in order to trigger a subsequent setup process.
 - If normal release reason is sent, the PP will reattempt the setup immediately.

The use case is shown in figure 9.

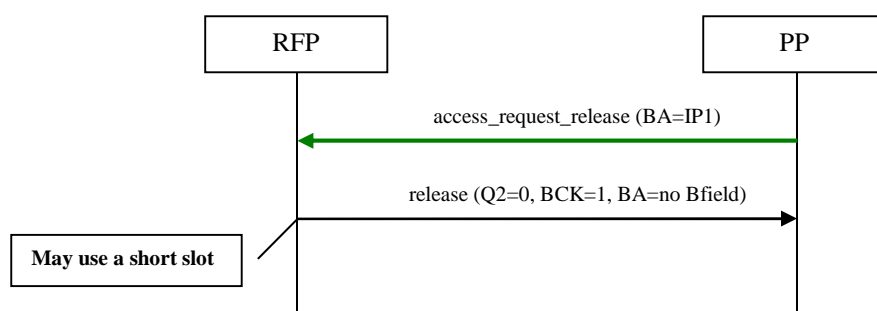

Figure 9: Single Frame Data Transfer - A-field OK, B-field CRC Error

10.10.4.1.2.2 No advance of BCK

Description:

- MAC signalling procedure is OK (A-field received and message decoded). B-field CRCs have been received OK. However received side cannot process the IP packet (for instance due to overflow or to implementation constrains) and send BCK without advancing.
- In this case, the PP should understand that the packet has not been accepted and should try to retransmit it (on a separate bearer setup attempt).
- Otherwise, it is similar to previous case.

The use case is shown in figure 10.

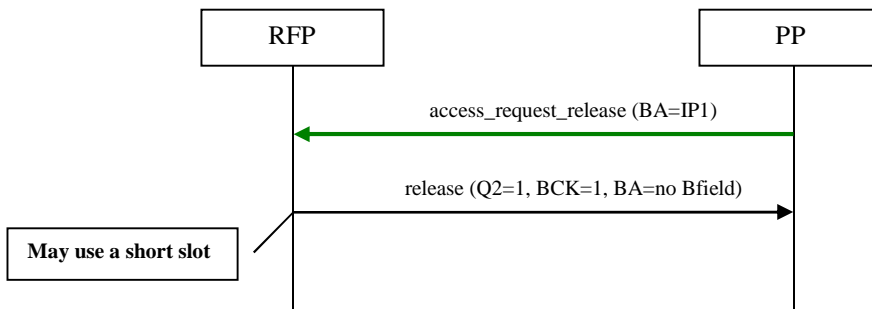

Figure 10: Single Frame Data Transfer - B-field CRC OK, but no advance of BCK

10.10.4.1.2.3 Error in the procedure - Retries

Description:

- Error in the setup procedure.

Possible causes of the error:

- Collision: there may be collision between multiple ULE transmitters trying to access at the same time.
- Radio interference or fading.

The use case is shown in figure 11.

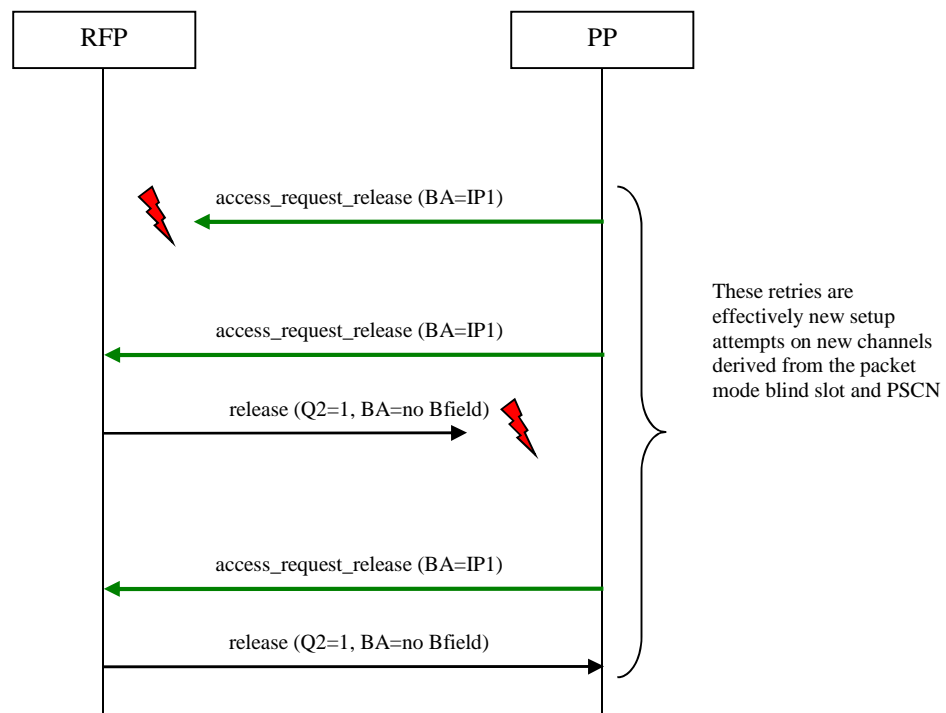

Figure 11: Single Frame Data Transfer - Retries

10.10.4.1.2.4 The FP cannot accept the setup procedure

Description:

- The FP cannot accept the setup procedure.

Possible reasons:

- The FP refuses the setup due to temporary congestion or other implementation reason:
 - the release reason "repeat again in k frames" may be used.
- The FP does not know the PP (PP not registered):
 - the release reason "unacceptable PMID / Unregistered PMID" may be used.
- The FP knows the PP, but there is not a VC active:
 - the release reason "No such connection / virtual circuit" may be used.

The last two cases may happen, for instance, after a reset or a power loss of the RFP. A proper release reason will help the PP to handle the error case (starting the right NWK procedure).

In all cases, the U-plane packet cannot be accepted. But the information is needed in order to instruct the PP how to handle the case and continue the procedure:

- In general, the PP will have to start NWK layer procedures (CC or MM).

Q2 and BCK settings (in release message):

- Q2 shall be set according to real CRC decoding (so it will send quality feedback to the PP).
- For BCK, the recommended practice is setting it as BCK = 1 (repetition).

The use case is shown in figure 12.

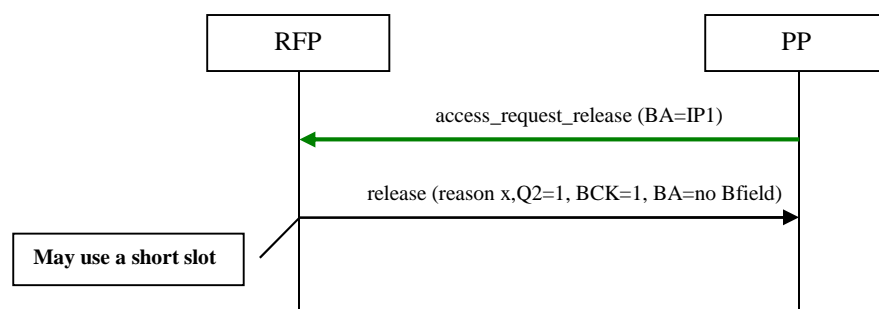

Figure 12: Single Frame Data Transfer - Abnormal release sent by the FP

10.10.4.1.3 Multi Packet Data Transfer

10.10.4.1.3.0 General

Description:

- Multi-packet Data Transfer will normally be preceded by a regular advanced connection which has negotiated service and slot type, and which has been suspended before. By default the multi-packet data transfer uses IP error correct MAC service, single subfield protection, and full slot. The first messages do contain data.
- The first IP packet transmitted on a new MAC packet mode connection has IP packet number 1.
- For the release of a packet mode connection the following applies:
 - One peer knows first that both ends have successfully transferred their data, when:
 - Its own 'ready_for_release' command that it sent with valid IP data was acknowledged by the other end (using the Q2 bit).
 - It has received an error free ready_for_release command from the other end.

- The peer that knows first that both ends have successfully received their data starts sending the 'release' command. This 'release' message may use a short slot.
- A two-message release procedure (general expedited release) is used, to reduce the active transmitter time in the ULE device.
- FT initiated (indirect) setups, when the FP has data to be sent, are always implemented as a multi-burst data transfer with two release messages, even if only a single packet FT => PT is exchanged (see use case 10.10.4.1.3.1).

10.10.4.1.3.1 FT initiated (indirect) setup. only one packet FT => PT sent

Description:

- The FT has a single U-plane packet to be sent downstream. The PT has no data to be sent upstream.
- The initial setup message should be "Expedited_access_request_ready_for_release" with BA code = "no B-field" (see ETSI EN 300 175-3 [3], clause 10.5.1.8.5).

The use case is shown in figure 13.

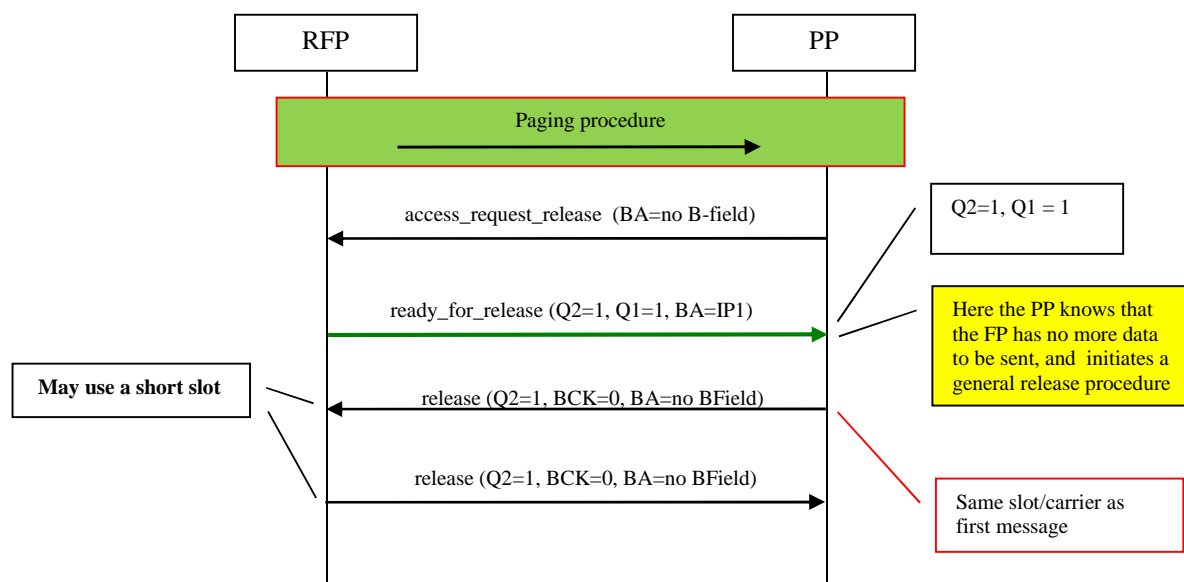

Figure 13: FT initiated (indirect) setup. only one packet FT => PT sent

10.10.4.1.3.2 Multi Packet Data Transfer: Two-way single packet

Description:

- This example shows the simplest multi packet transfer. PP and RFP have 1 IP packet each.
- A two-way single packet transfer FT initiated looks exactly the same with the only difference of the paging procedure.

The use case is shown in figure 14.

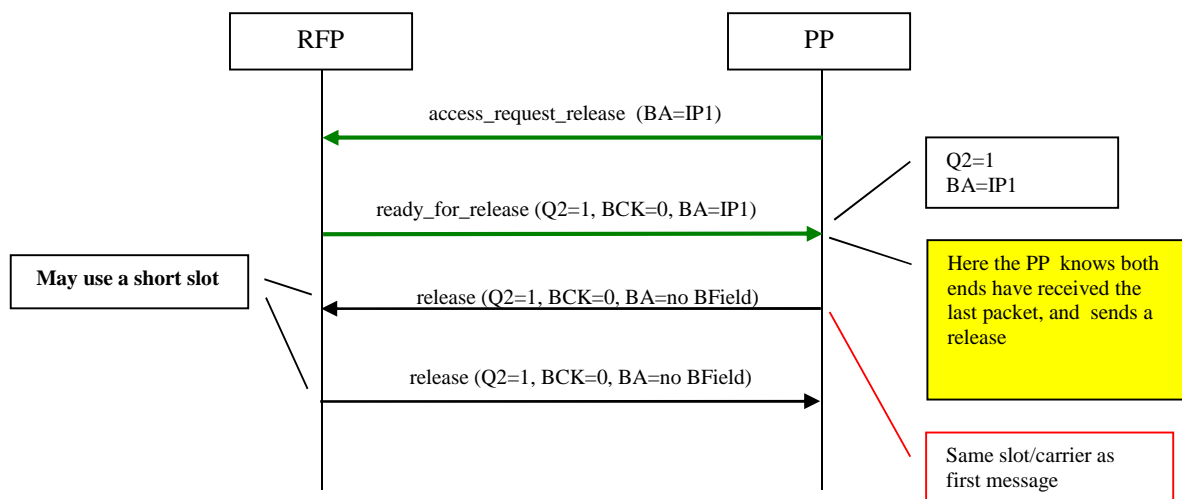

Figure 14: Two-way Single Packet Data Transfer

10.10.4.1.3.3 Multi Packet Data Transfer: PP sends 4, FP sends 1, showing the "connected" state point

Description:

- This example shows a multi packet transfer. PP has more data to send than RFP (PP sends 4 IP packets, FP sends 1 IP packets).
- The use case shows when the TBC connected state is reached.

The use case is shown in figure 15.

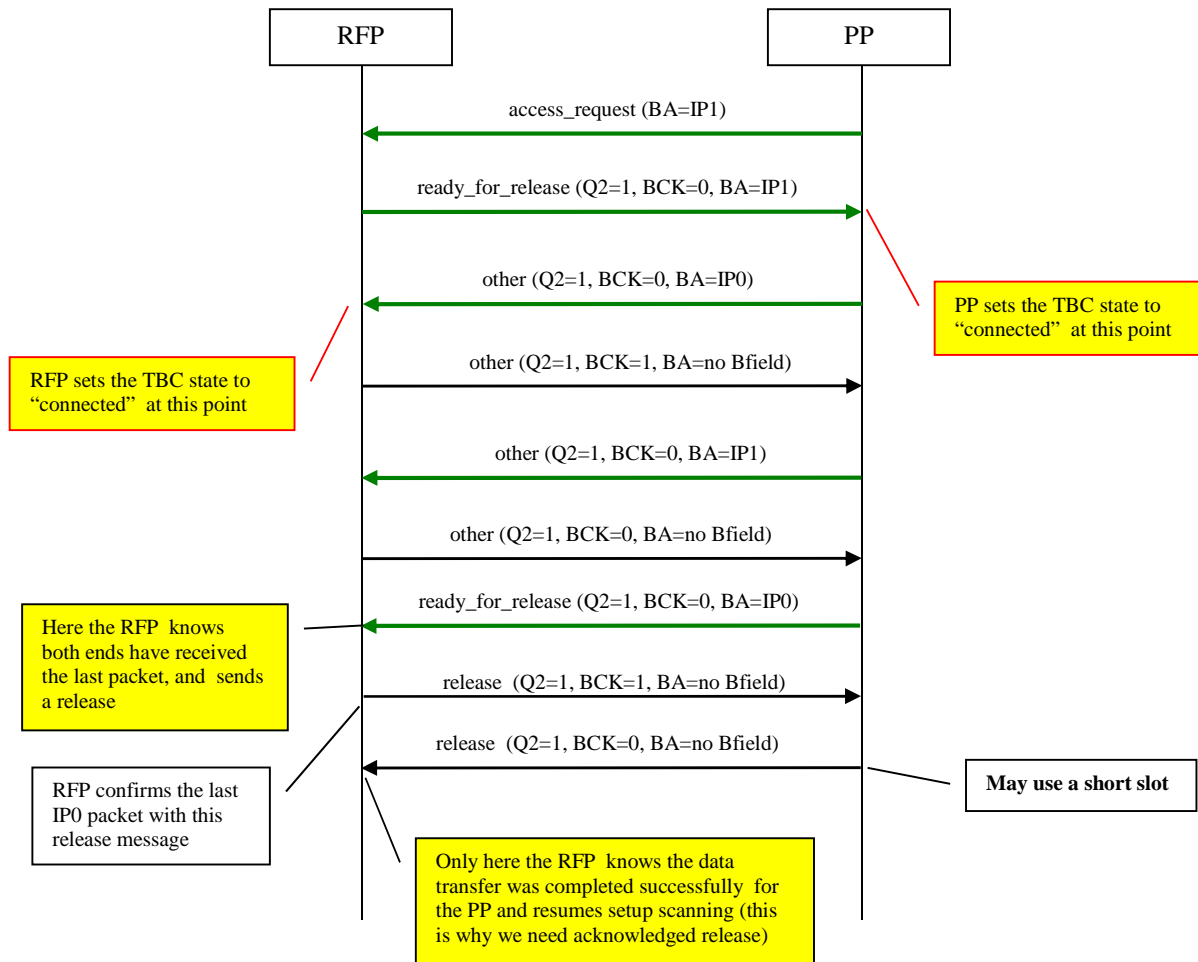

Figure 15: Multi Packet Data Transfer - Success

NOTE 1: See ETSI EN 300 175-3 [3], clause 10.5.1.8.7 for description on when the TBC connected state is reached.

NOTE 2: The general policy is sending ready for release only once (as the diagram). However, the ready_for_release should be ACK OK (Q2 = 1). Otherwise it should be repeated.

NOTE 3: The ready for release effect cannot be cancelled. However if the RFP receives data to be sent downstream and wish to transmit further data, it may use the "setup again" code in the release message.

10.10.4.1.3.4 Multi Packet Data Transfer: PP sends 1, FP sends 4

Description:

- This example shows a multi packet transfer. RFP has more data to send than PP (PP sends 1 IP packet, FP sends 4 IP packets).

The use case is shown in figure 16.

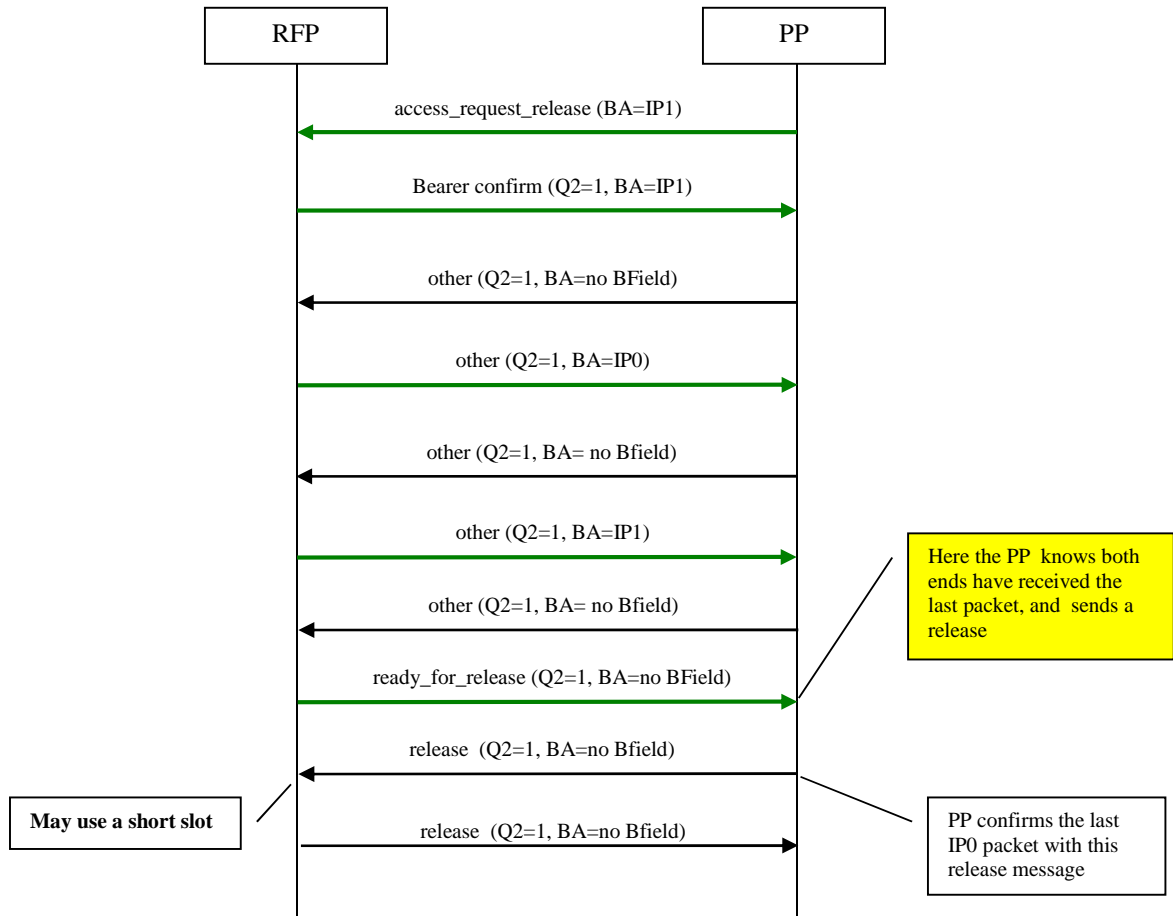

Figure 16: Multi Packet Data Transfer - Success

NOTE: When the PP has no data to send at all, this flowchart would look exactly the same with the difference that that the BA bits of the expedited_access_request_ready_for_release message would be 'no Bfield'.

10.10.4.1.3.5 Multi Packet Data Transfer: PP sends 2, FP sends 2

Description:

- This example shows a multi-burst transfer. PP and RFP have 2 IP packets each to send.

The use case is shown in figure 17.

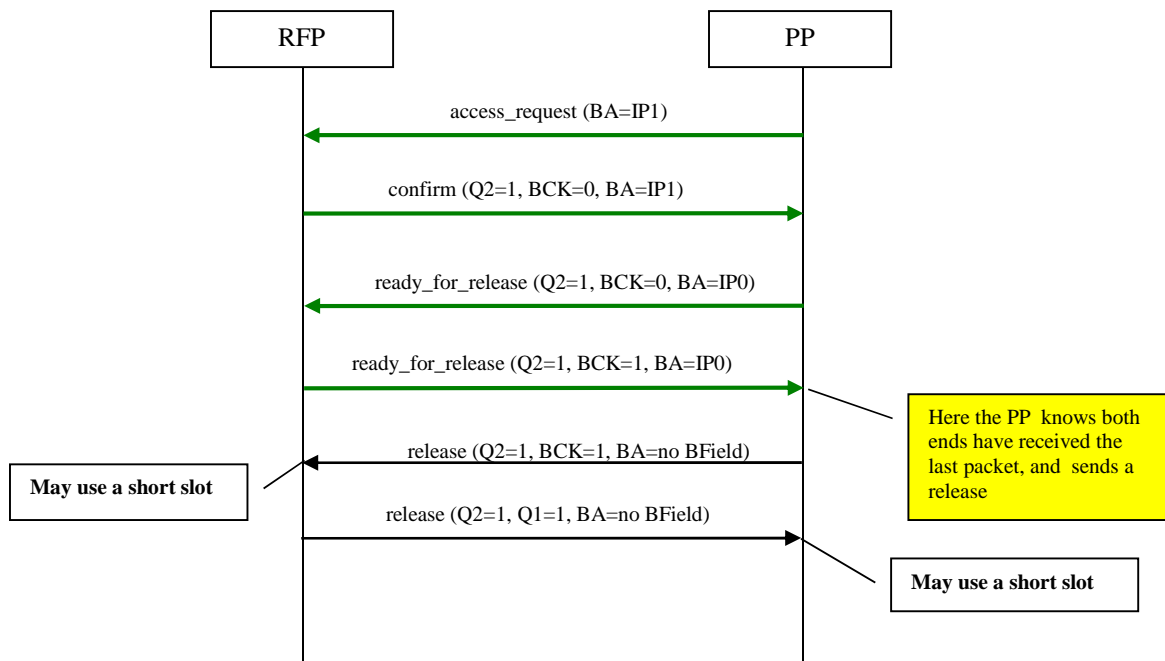

Figure 17: Multi Packet Data Transfer: PP sends 2, FP sends 2 - Success

10.10.4.1.3.6 Multi Packet Data Transfer: PP sends 2, FP sends 2 - Error in one release message

Description:

- This example shows a multi-burst transfer. PP and RFP have 2 IP packets each to send.
- There is an error in one release message.

The use case is shown in figure 18.

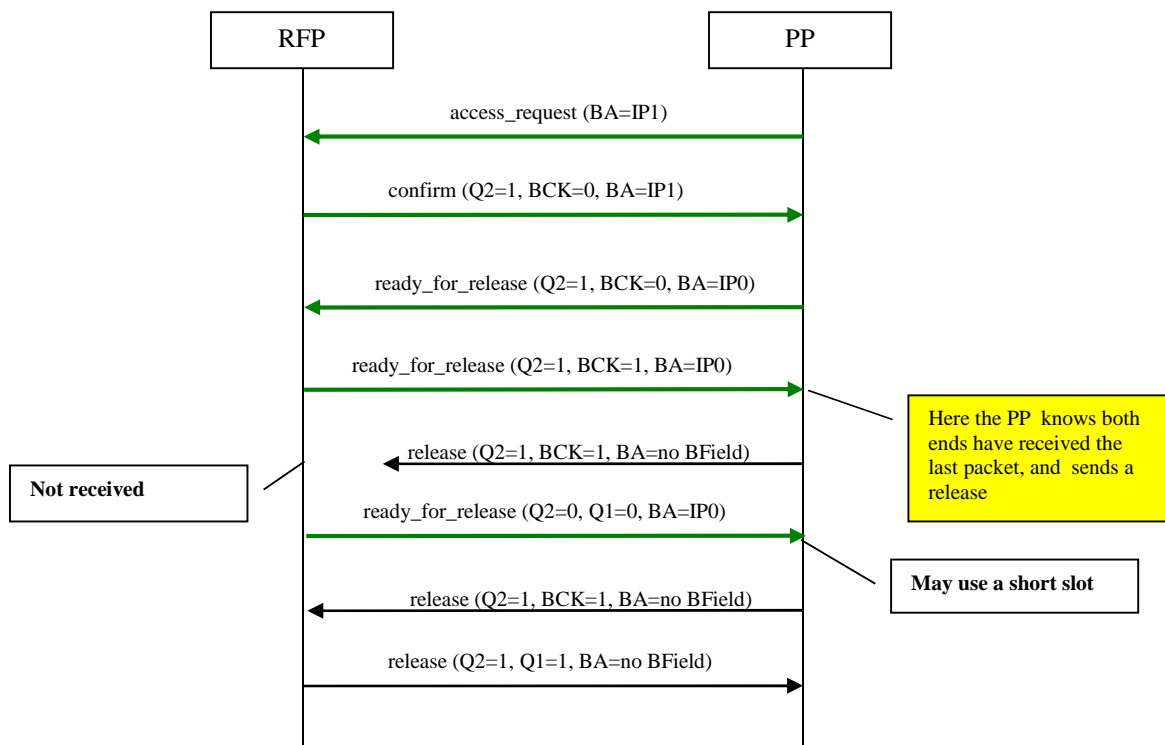

Figure 18: Multi Packet Data Transfer: PP sends 2, FP sends 2 - Success - Error in one release message

10.10.4.1.3.7 Multi Packet Data Transfer: FP traffic only (3 U-plane packets) - Success

The use case is shown in figure 19.

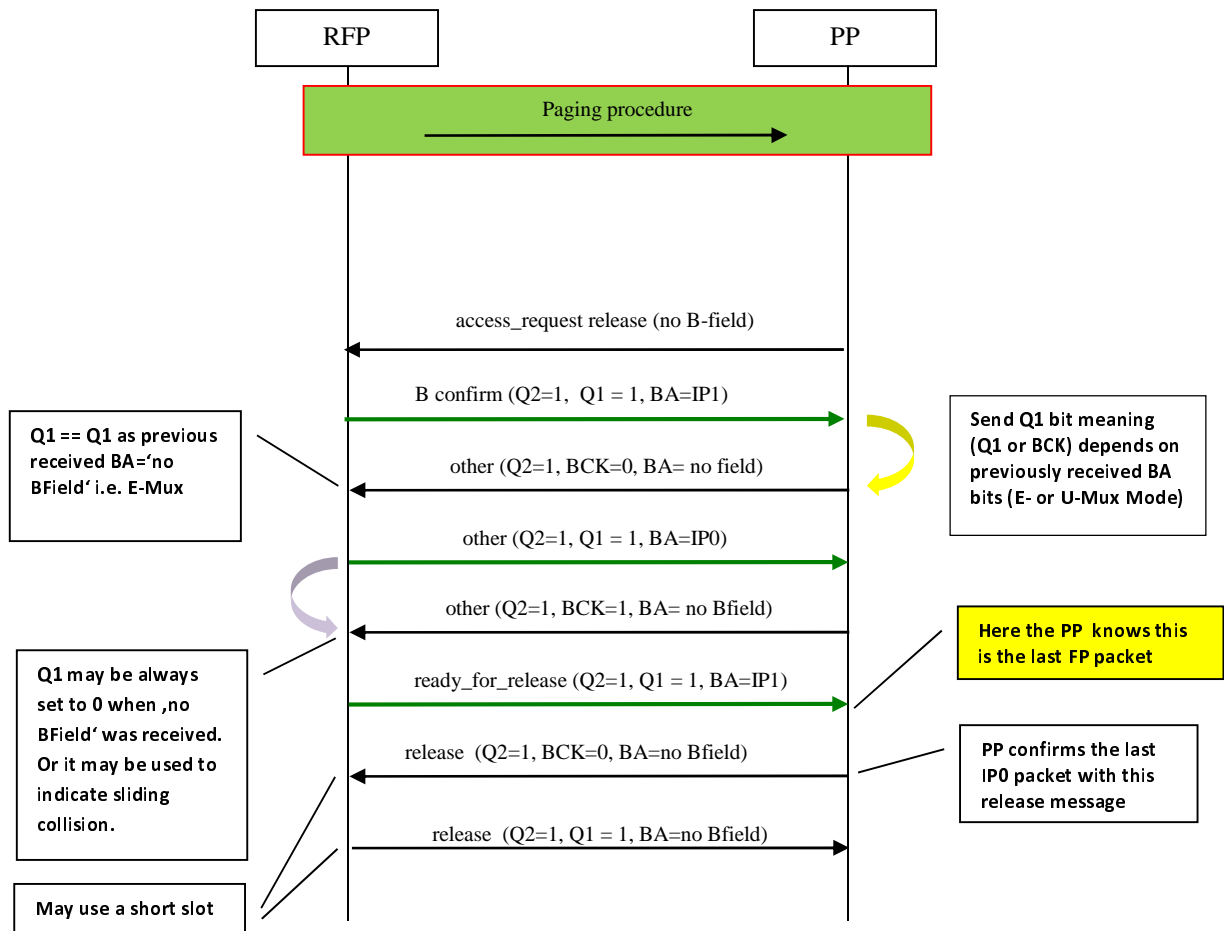

Figure 19: Multi Packet Data Transfer - FP traffic only (3) - Success

The PP will start the procedure with:

- Access Request Release: if it has nothing to be sent upstream.
- Access Request: if it has something to be sent.

10.10.4.1.3.8 Multi Packet Data Transfer: FP traffic only (3 U-plane packets) - Retransmit

The use case is shown in figure 20.

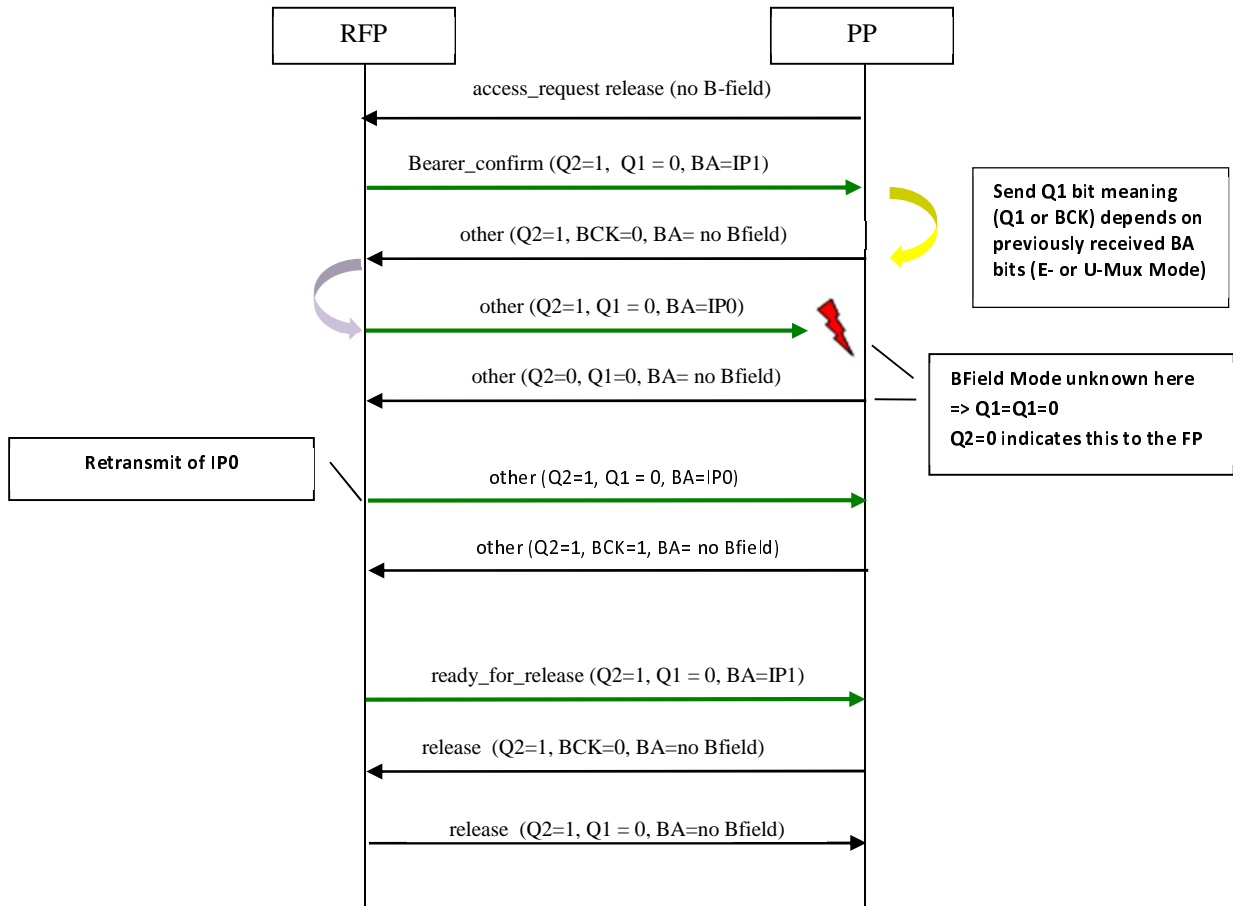

Figure 20: Multi Packet Data Transfer - FP traffic only (3) - Retransmit

The PP will start the procedure with:

- Access Request Release: if it has nothing to be sent upstream.
- Access Request: if it has something to be sent.

10.10.4.1.3.9 Multi Packet Data Transfer: FP traffic only (3 U-plane packets) - running empty in the middle

The use case is shown in figure 21.

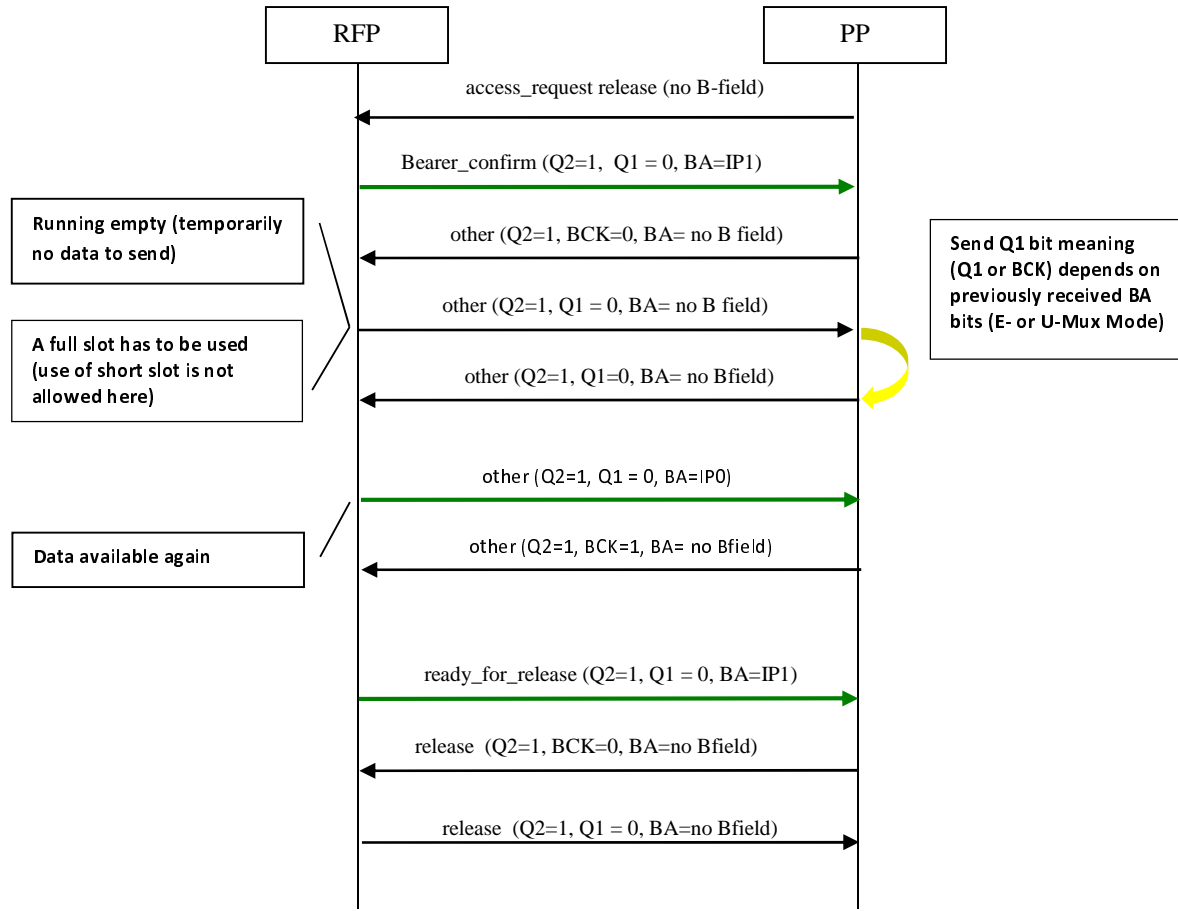

Figure 21: Multi Packet Data Transfer - FP traffic only (3 U-plane packets) - running empty in the middle

10.10.4.1.3.10 Multi Packet Data Transfer: FP traffic only (3 U-plane packets) - Retransmit due to congestion

The use case is shown in figure 22.

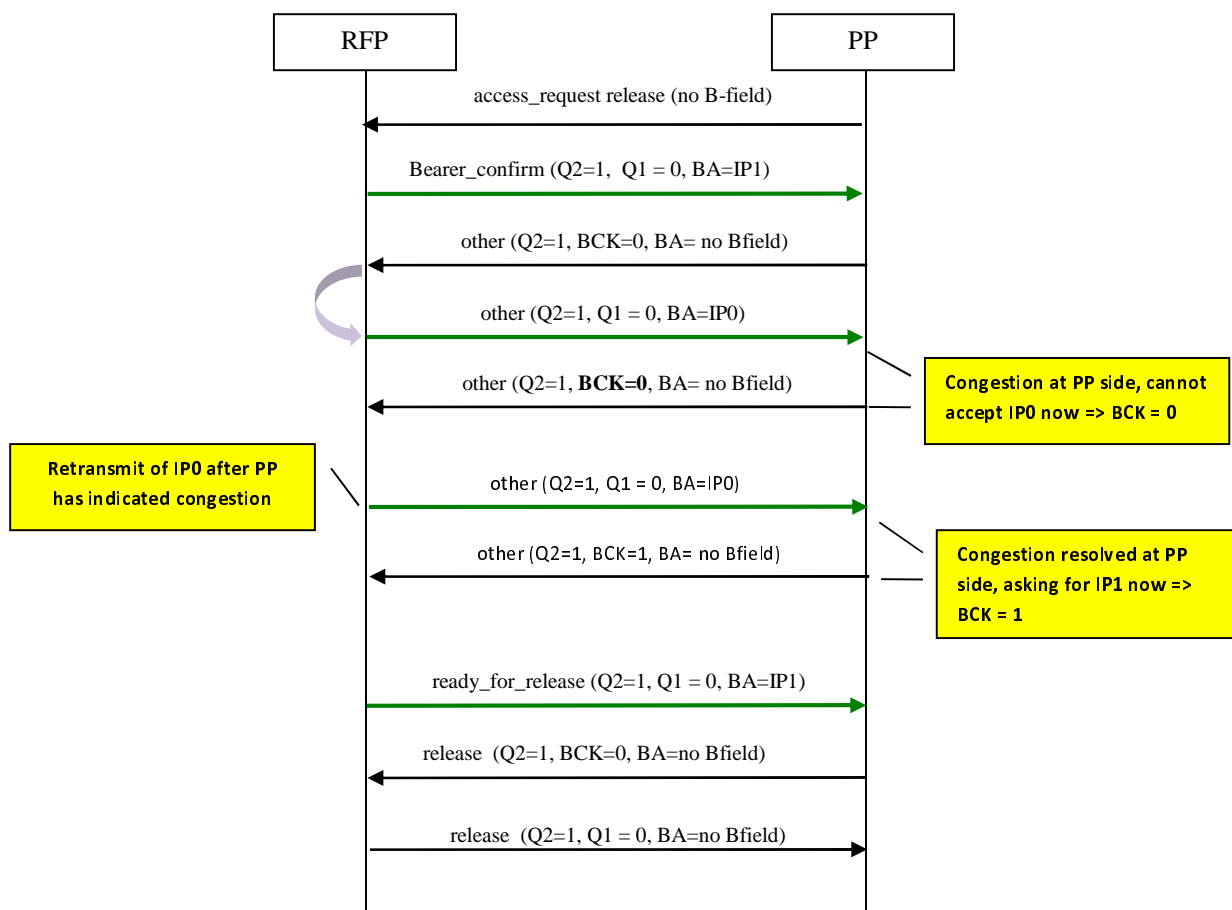

Figure 22: Multi Packet Data Transfer - FP traffic only (3 U-plane packets) - Retransmit due to congestion

10.10.4.2 C-plane related use cases

10.10.4.2.1 Multi Packet Data Transfer: FP requested C-plane traffic only - Success

Description:

- FP requested setup to execute a C-plane procedure.
- In the example, there is C-plane traffic only:
 - For practical purposes, it may be assumed that the C-plane operation requested by the FP is an MM authentication.

The use case is shown in figure 23.

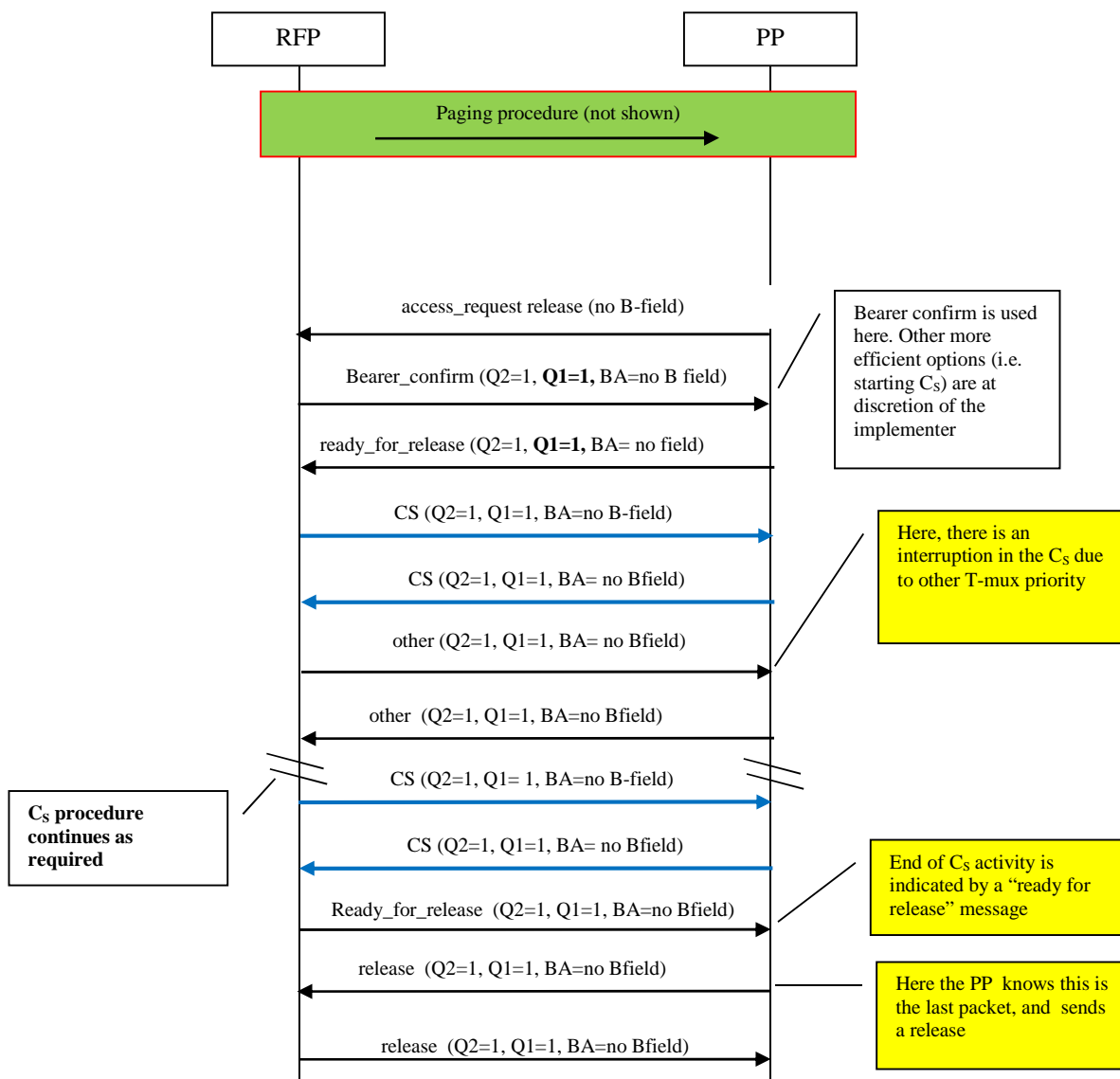

Figure 23: Multi Packet Data Transfer - FP req. C-plane traffic only - Success

10.10.4.3 Stay alive related use cases

10.10.4.3.1 PT initiated stay alive with transmission of G_{FA} from FT

Description:

- Stay alive handshake designed as a short single-burst transfer process, but without U-plane.

Successfully handshake requires correct reception of release with Q2=1 and any of the following reason codes in the release message:

- Normal bearer release.
- Stay in higher paging detection mode (paging mode and timer in info field), the PP shall obey the command.
- Setup again after n frames (in that case the PP shall obey the instructions for the setup).

The procedure does not qualify for the handshake and the PP will move to an intermediate state (and repeat again the handshake attempt) if:

- No reception of release.
- Bad Q2 report (Q2 = 0) received (with the release message).
- Reception of release reason "base station busy".

The procedure does not qualify for the handshake and the PP will move directly to loss of handshake state if:

- No such connection / virtual circuit.
- Unacceptable PMID / Unregistered PMID.

The use case is shown in figure 24.

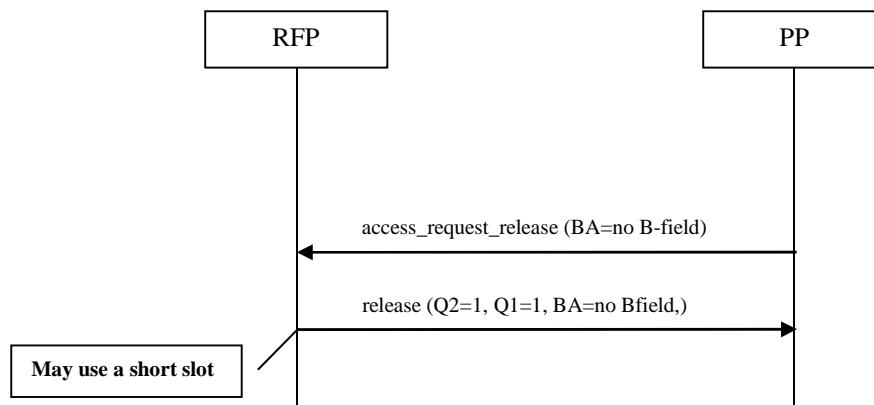

Figure 24: Stay alive - PT initiated- Success

NOTE: A DLC ACK message is transmitted via the G_{FA} channel in the FT => PT message.

10.10.4.3.2 PT initiated stay alive - the FT changes the procedure to start a C-plane procedure

Description:

- It starts as a stay alive handshake. The FP decides to keep the bearer by changing the procedure to a multi-burst setup. This is done by replying "bearer confirm" to the setup. Instead of sending U-plane packets, the FP starts a C_S transmission.
- The procedure continues as 10.10.4.2.1 "Multi burst data transfer: FP requested C-plane traffic only -Success".
- The procedure qualifies as a handshake.

The use case is shown in figure 25.

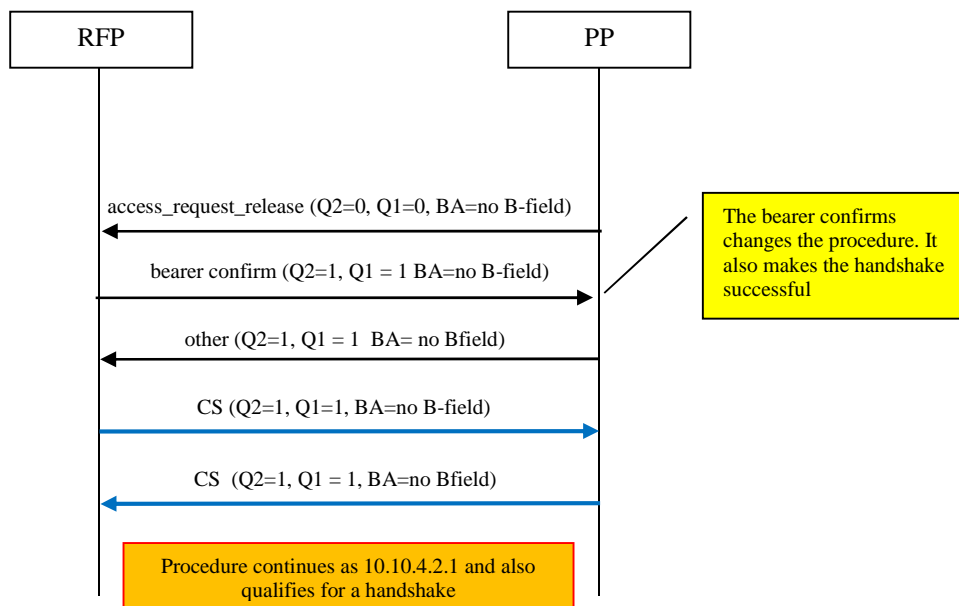

Figure 25: Stay alive - PT initiated- Success and the FT changes the procedure to start C-plane procedures

NOTE: A DLC ACK command is transmitted via the G_{FA} channel in the two last releases (both ways allowed) after the termination of the C-plane procedure.

10.10.4.3.3 PT initiated stay alive - the FT changes the procedure to send U-plane data

Description:

- It starts as a stay alive. The FP decides to keep the bearer changing the procedure to multi-burst. This is done by replying "bearer confirm" to the setup. The procedure continues as a multi-burst transfer.
- It also qualifies as a handshake. The reception of the "bearer confirm" makes the handshake successful.

The use case is shown in figure 26.

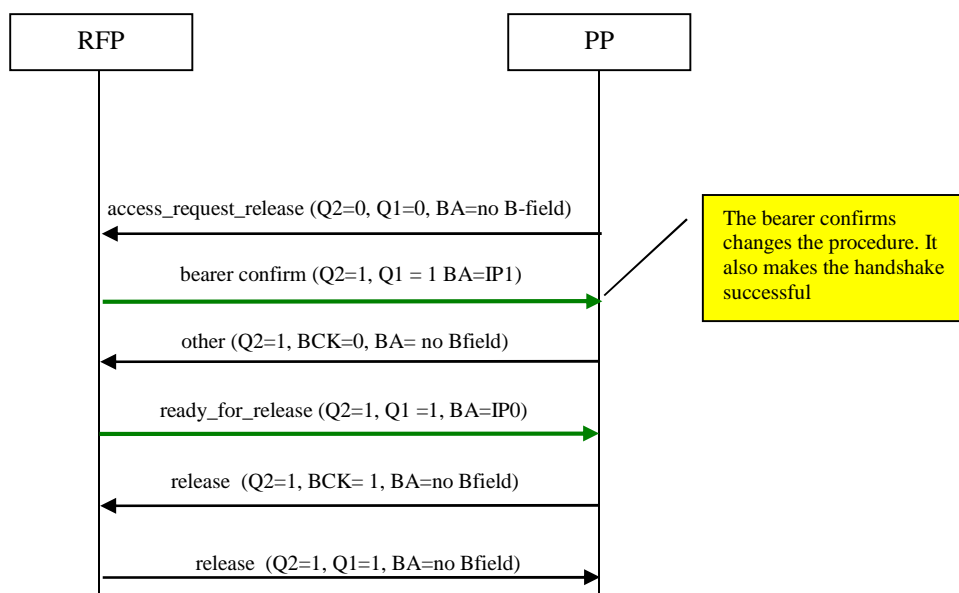

Figure 26: Stay alive - PT initiated- Success and the FT changes the procedure to send two U-plane packets

10.10.4.4 Failure and Retransmission Use cases

10.10.4.4.1 Setup Failure and Retransmission Examples

10.10.4.4.1.0 General

This clause shows some scenarios where the packet mode connection setup fails, and where re-transmission is applied. The BA header codes and Q bit settings are omitted mostly for clarity reasons.

In the scenarios described below the red lightning indicates that the message was not received error free.

10.10.4.4.1.1 Error in access message

In case of error in the reception of the Access request message (A field cannot be decoded by the FP) the expected FP response is no action.

The use case is shown in figure 27.



Figure 27: Packet Mode Connection setup fail (access message wrong)

10.10.4.4.1.2 Error in confirmation message

In this scenario the first message FP => PP is lost. The PP then does not send anything anymore, and starts a new setup attempt on a new channel. The FP starts an unacknowledged release procedure.

The use case is shown in figure 28.

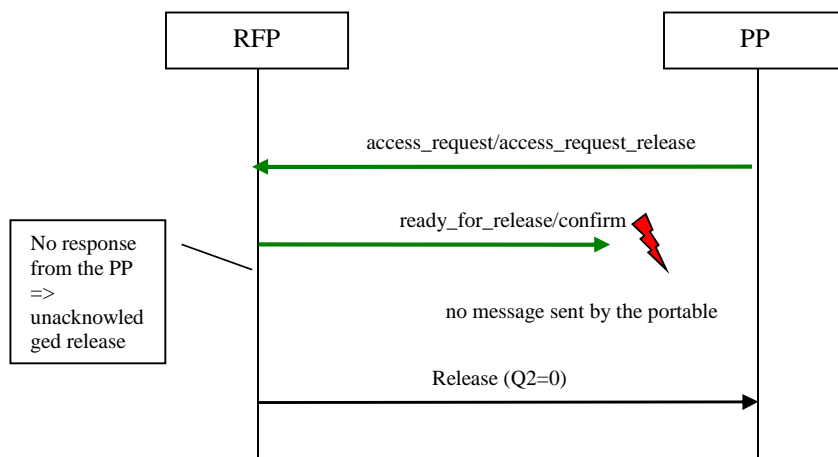

Figure 28: Packet Mode Connection setup fail (confirm message wrong)

10.10.4.4.1.3 Error in "other" message

In this scenario the 3rd message is not received in the RFP. Again in that case the FP starts an unacknowledged release procedure.

The use case is shown in figure 29.

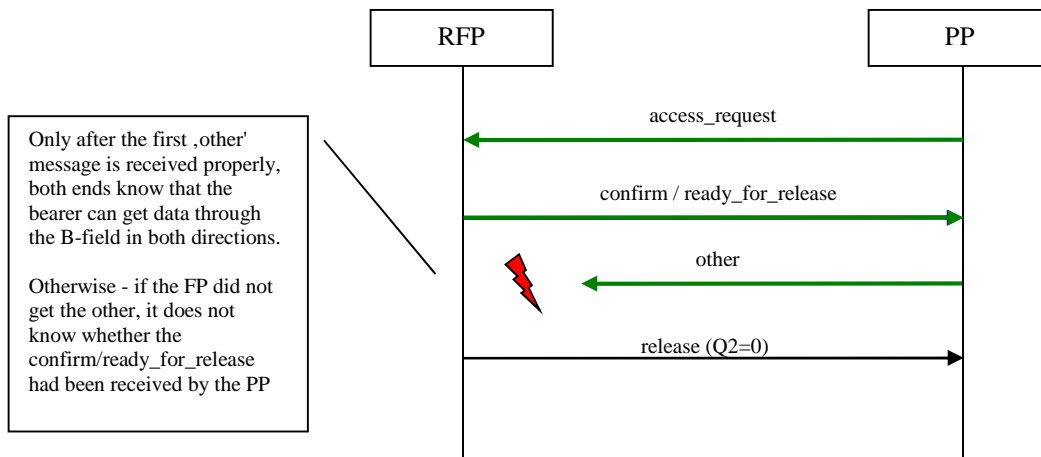

Figure 29: Packet Mode Connection setup fails (other message wrong)

Only one release message shall be sent. There is no timing to send this release (it is sent in next frame). This response will be mandatory.

10.10.4.4.1.4 Error in the second "other" message

Description:

- There is a retransmission of the second 'other' message (4th message).

The use case is shown in figure 30.

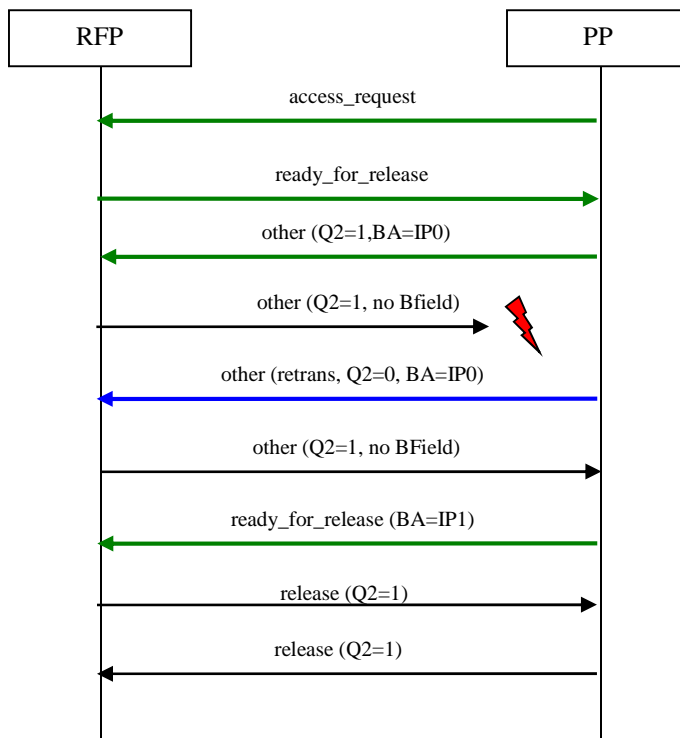

Figure 30: Packet Mode Connection success (2nd other message retransmitted)

10.10.4.4.2 Release Failure and Retransmission Examples

10.10.4.4.2.1 Error in the "release" message

Description:

- This flowchart shows a single two-way packet transfer, were the first release message is not received. As this is a 'multi packet data transfer', and this release message is the 3rd message, the packet mode connection is considered to be failed. The FP starts an unacknowledged release procedure.

The use case is shown in figure 31.

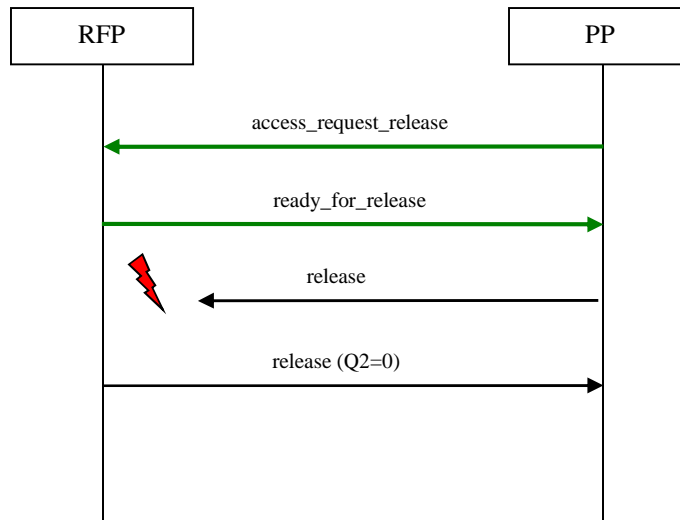

Figure 31: Two-way Single Packet Mode Connection (1st release message wrong)

10.10.4.4.2.2 Error in the second "release" message

Description:

- In the scenario described below it is the second release message that is not received. Here the release message is re-transmitted.
- RFP shall be able to receive the retransmitted release message.

The use case is shown in figure 32.

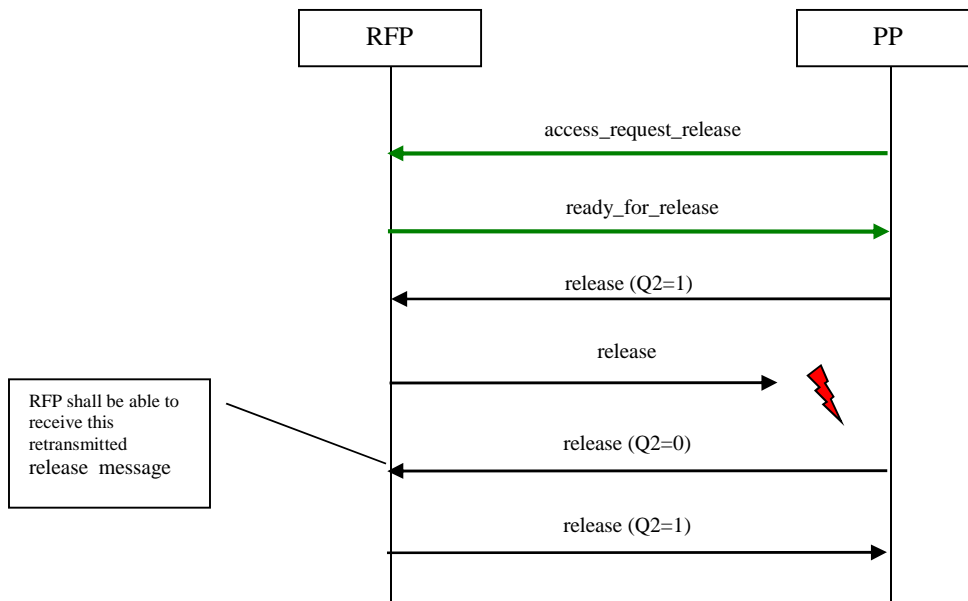

Figure 32: Two-way Single Packet Mode Connection (release retransmitted)

10.10.4.4.2.3 Error in the "release" message causing a retransmission of the "ready for release"

The following two flowcharts (figures 33 and 34) show re-transmission of the "ready for release" message.

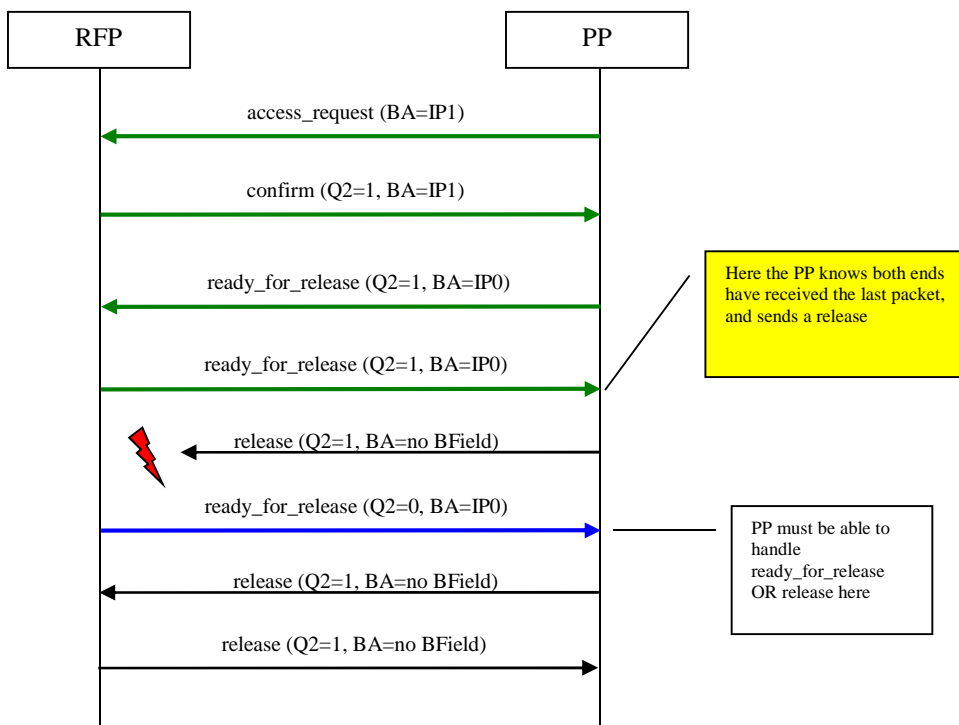

Figure 33: Multi Packet Data Transfer - Error in the "release" message causing a retransmission of the "ready for release"

Upon receiving the "ready_for_release" message, the PP knows that both ends have received the last packet, and therefore sends a release. If the RFP does not receive the "release" message and therefore sends again a "ready_for_release" (in blue in figure 33), the PP shall be able to handle it and release here (i.e. sending back to the RFP a "release" message).

10.10.4.4.2.4 Error in a "ready for release" message causing its retransmission

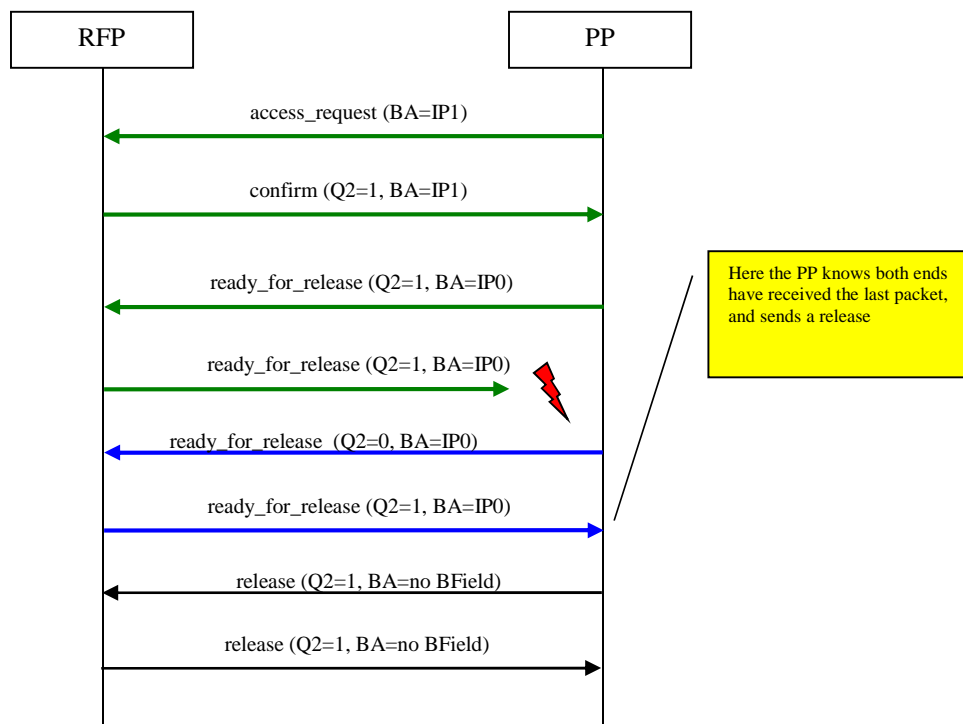

Figure 34: Multi Packet Data Transfer for "DF Sweet Spot" (ready for release retransmit case 2)

As shown in figure 34, the PP does not receive Q2 feedback to a "ready_for_release" message and therefore retransmits the message (in blue). Upon receiving back from the RFP another "ready_for_release" message (in blue), the PP knows that both ends have received the last packet, and therefore sends a "release" message.

10.10.4.4.3 Errors when in TBC "connected" state

10.10.4.4.3.1 Retransmission abandoned and abnormal release of the TBC due to multiple errors

Description

- This use case shows how data retransmission is abandoned when the data is not going for 3 re-transmissions.

The use case is shown in figure 35.

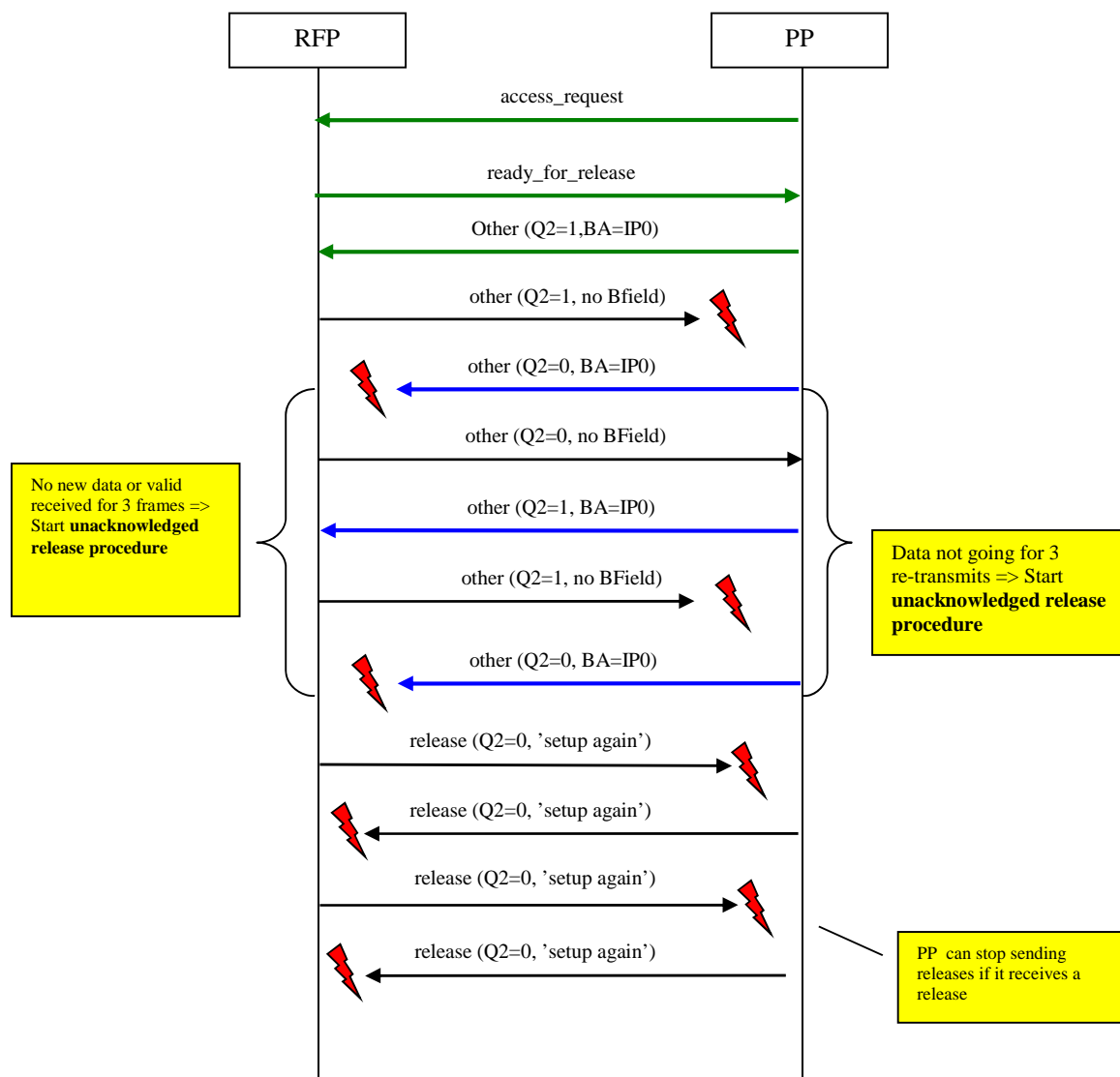

Figure 35: Packet Mode Connection fails (retransmission abandoned)

10.10.4.4.4 Intrusion and interference use cases

10.10.4.4.4.1 Intrusion of a Ready for release with wrong identity intrusion, continuing transmission

Description:

- This use case shows the behaviour when a wrong identity is received on one of the messages. This can happen if the chosen channel is hijacked by a foreign DECT device. The end that receives the wrong identity starts an unacknowledged release procedure. The packet mode connection is deemed to fail.

The use case is shown in figure 36.

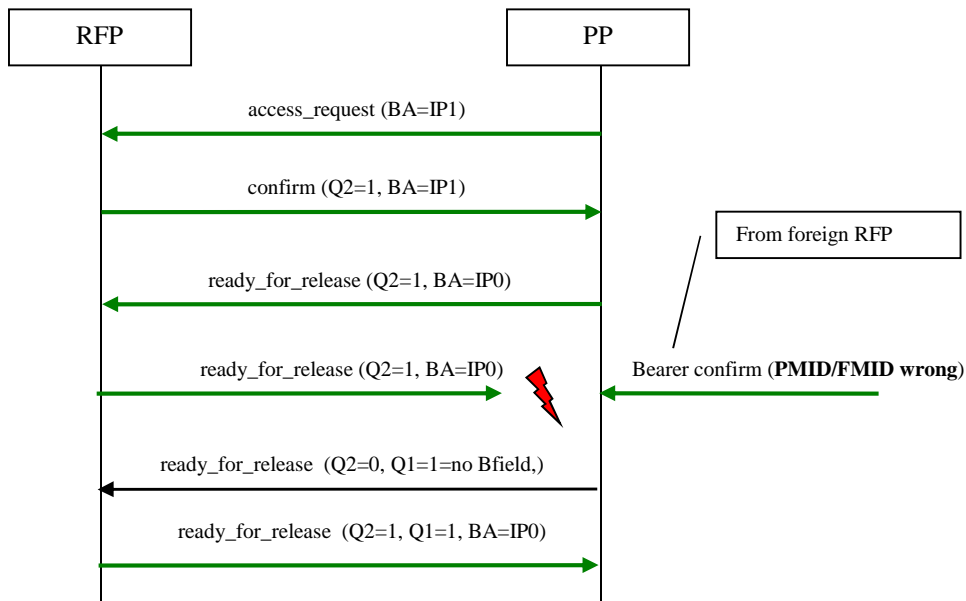

Figure 36: Intrusion of a Ready for release with wrong identity intrusion, continuing transmission

10.10.4.4.4.2 Intrusion of a Ready for release with wrong identity intrusion, causing its retransmission

Description:

- This use case shows the behaviour when a wrong identity is received on one of the messages. This can happen if the chosen channel is hijacked by a foreign DECT device. The end that receives the wrong identity starts an unacknowledged release procedure. The packet mode connection is deemed to fail.

The use case is shown in figure 36.

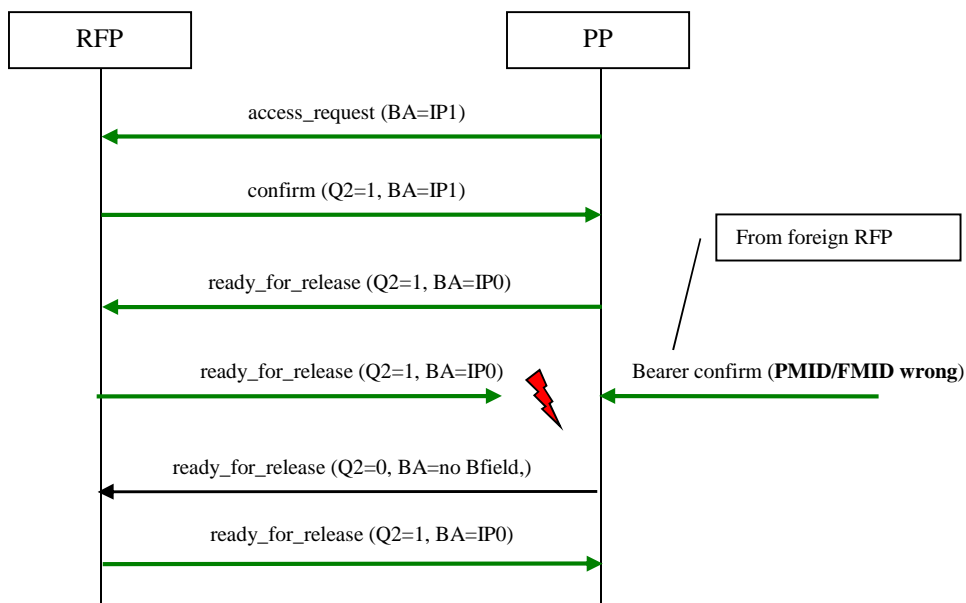

Figure 37: Intrusion of a Ready for release with wrong identity intrusion, causing its retransmission

The bearer when TBC is in connected state should not be aborted after a single intrusion. The case is handled as not reception of the frame. The TBC will be aborted after three errors.

10.10.4.4.5 Errors in release procedures

10.10.4.4.5.1 Multiple errors in release: abandoned release retransmission

General remark:

- In any case one should bear in mind that these are all exceptional error cases only.

The release retransmission is shown in figure 38.

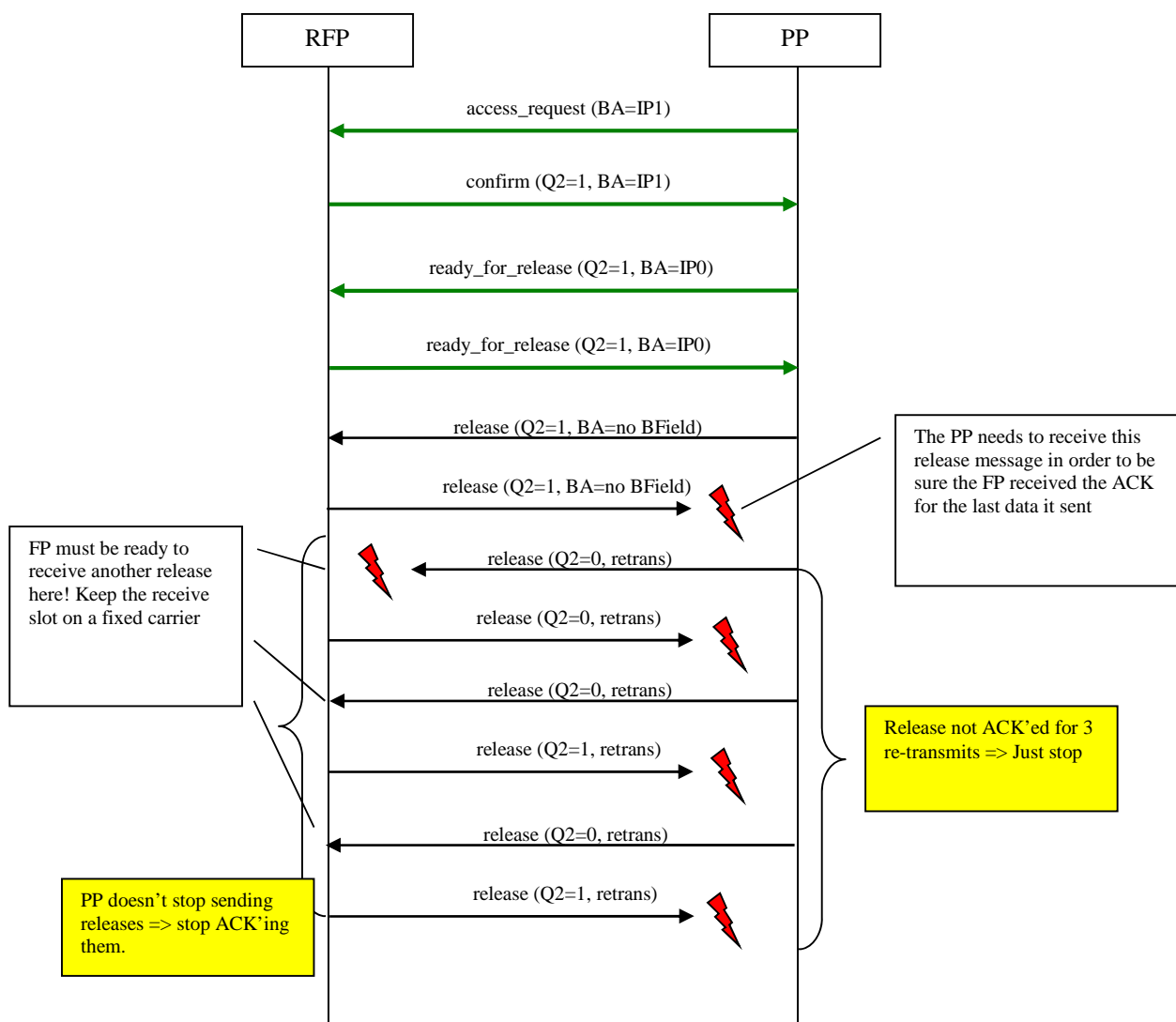

Figure 38: Multi Packet Data Transfer - Abandoned release retransmission (option 1)

The above mechanism is based on the following principles:

- The peer that knows all data has been passed (the one that receives the second `ready_for_release` message) starts sending release messages.
- If it does not get anything back, it stops after 3 retransmissions.
- If it gets a release back the procedure ends.

- If it gets another ready_for_release, the release message retransmit counter is restarted. In case of continuous problems i.e. when ready_for_release is received again and again, the procedure then would end when the other side abandons sending the ready_for_release.

10.10.4.5 Data transfer use cases showing the response to the BCK bit and to transitions between BA codes

10.10.4.5.1 Multi Packet Data Transfer: FP traffic only (3 U-plane packets) - Success

The release retransmission is shown in figure 39.

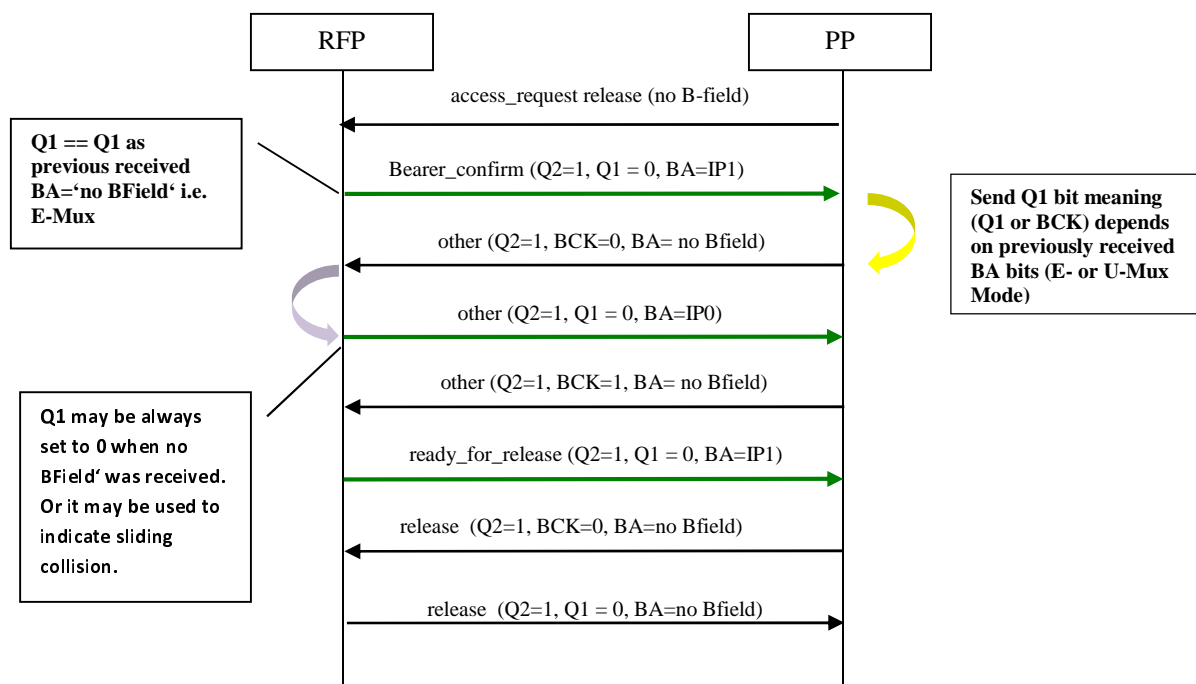

Figure 39: Multi Packet Data Transfer - FP traffic only (3) - Success

10.10.4.5.2 Multi Packet Data Transfer: FP traffic only (3 U-plane packets) - Retransmission

The release retransmission is shown in figure 40.

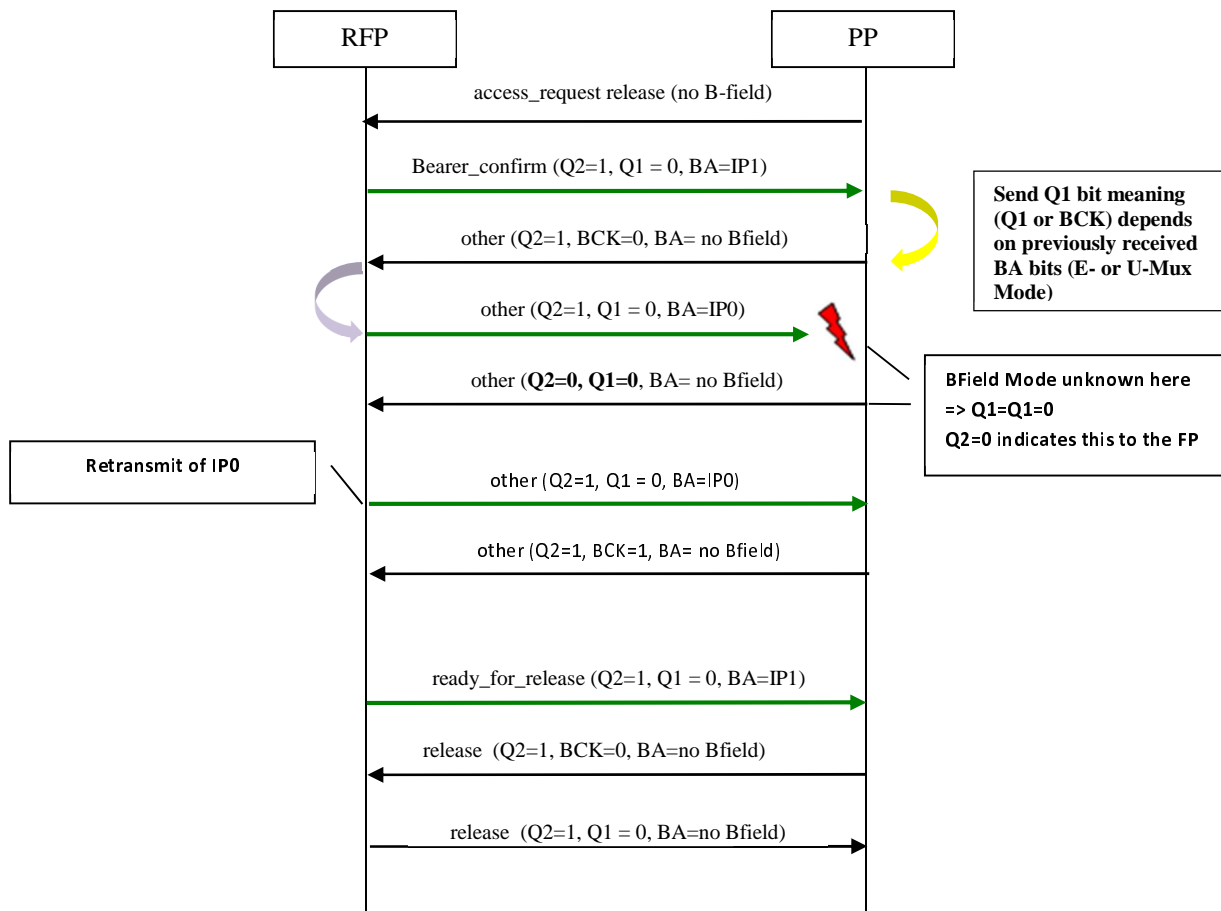

Figure 40: Multi Packet Data Transfer - FP traffic only (3) - Retransmission

10.10.4.5.3 Multi Packet Data Transfer: FP traffic only (2 U-plane packets) - running empty
 The release retransmission is shown in figure 41.

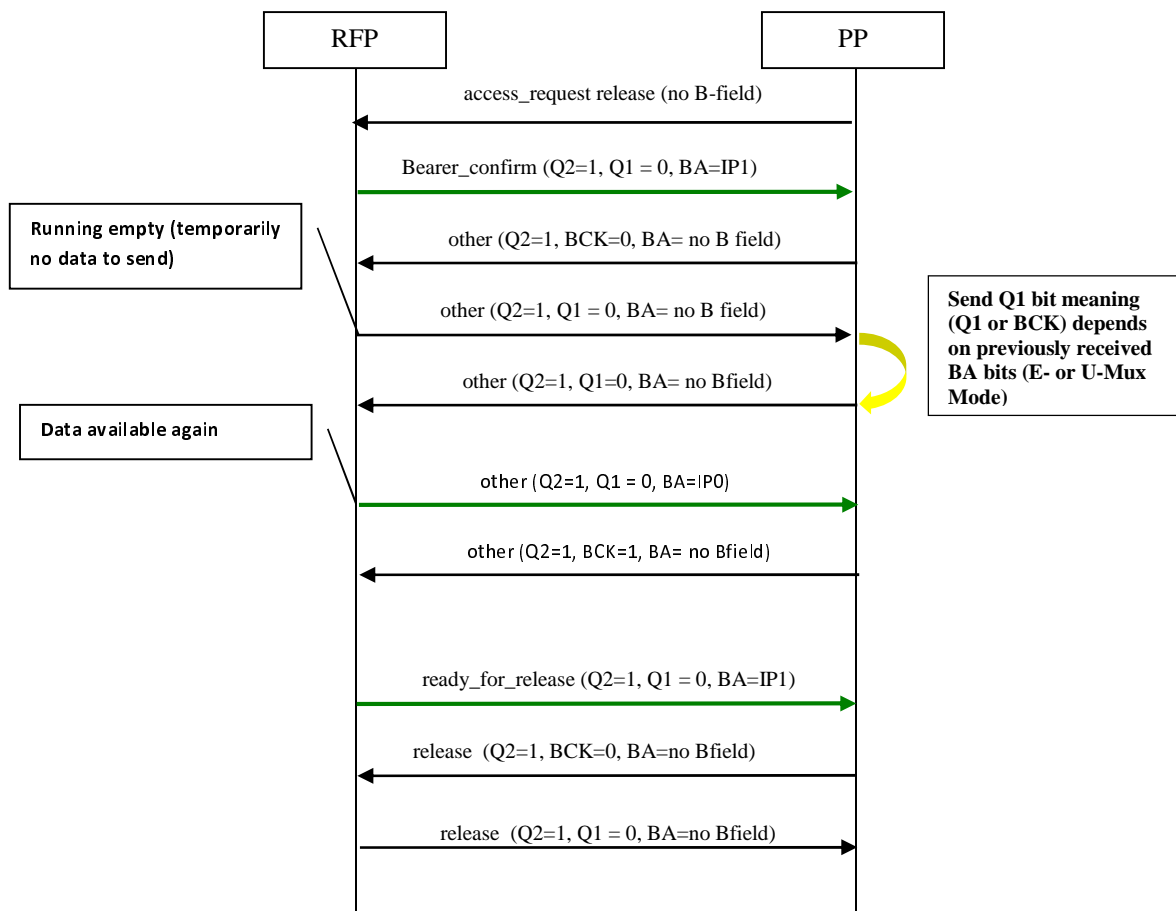

Figure 41: Multi Packet Data Transfer - FP traffic only (3) - running empty

10.10.4.5.4 Multi Packet Data Transfer: FP traffic only (3 U-plane packets) - Retransmit after 'no advance' (due to congestion)

The release retransmission is shown in figure 42.

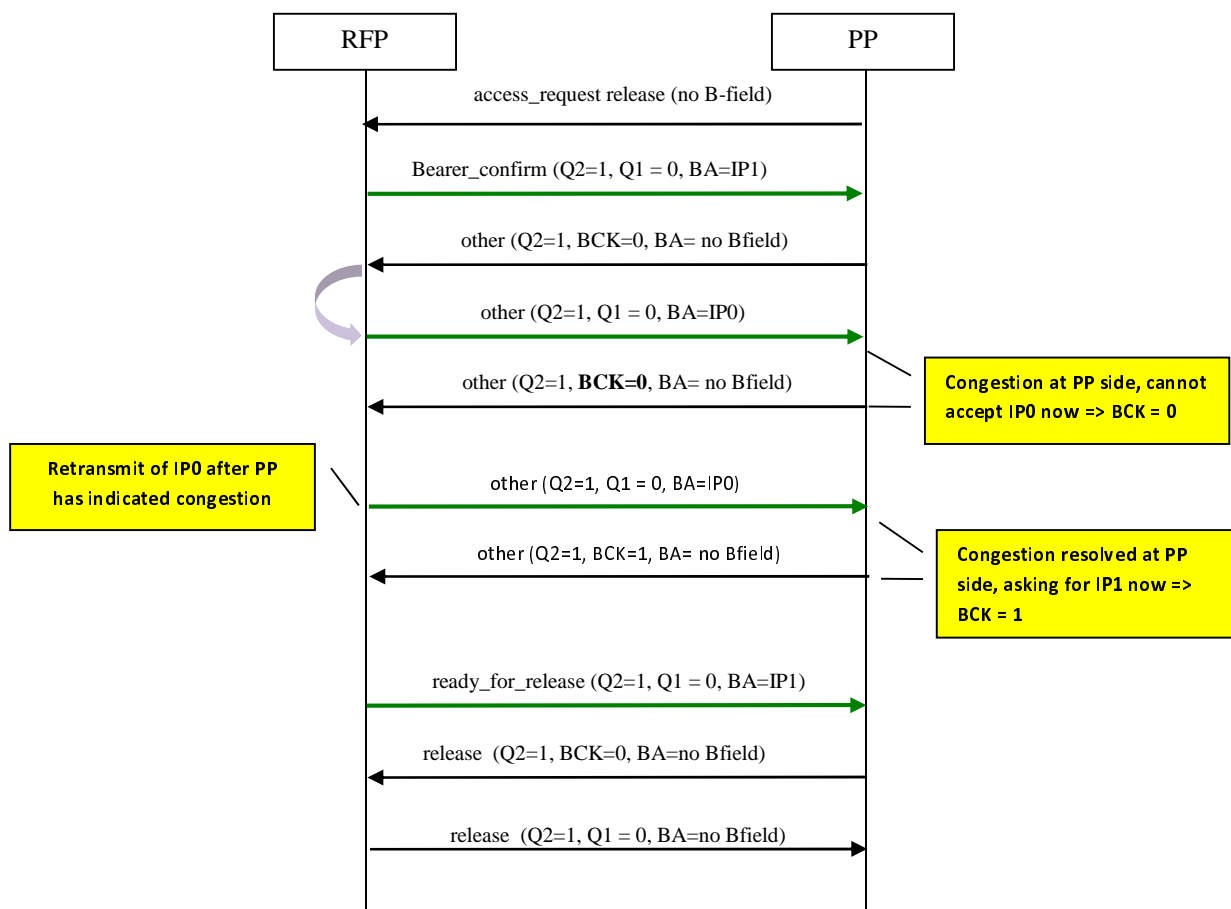

Figure 42: Multi Packet Data Transfer - FP traffic only (3) - Retransmit due to congestion

10.10.4.5.5 Multi Packet Data Transfer: FP and PP send 2 packets each - Congestion in 'Ready for Release' transfer (I)

There may be some special difficulties with 'no advance' scenarios during the MAC expedited connection release phase. This scenario and the following give some focus on this.

As a general rule:

- For the release of a packet mode connection the following applies:
 - One peer knows first that both ends have successfully transferred their data, when:
 - Its own 'ready_for_release' command that it sent with valid IP data was acknowledged by the other end (using the Q2 bit).
 - It has received an error free ready_for_release command from the other end.
 - There is no congestion ('no advance' scenario) pending on either end.
 - The peer that knows first, that both ends have successfully received their data starts sending the 'release' command. This release message may use a short slot.
 - A crossed (acknowledged) release procedure is used, to reduce the active transmitter time in the ULE device.
- So as long as a 'no advance' scenario is pending no end is allowed to start the acknowledged release.
- Both sides should take into account the MAC maximum packet lifetime as upper limit for the retransmissions.

The use case is shown in figure 43.

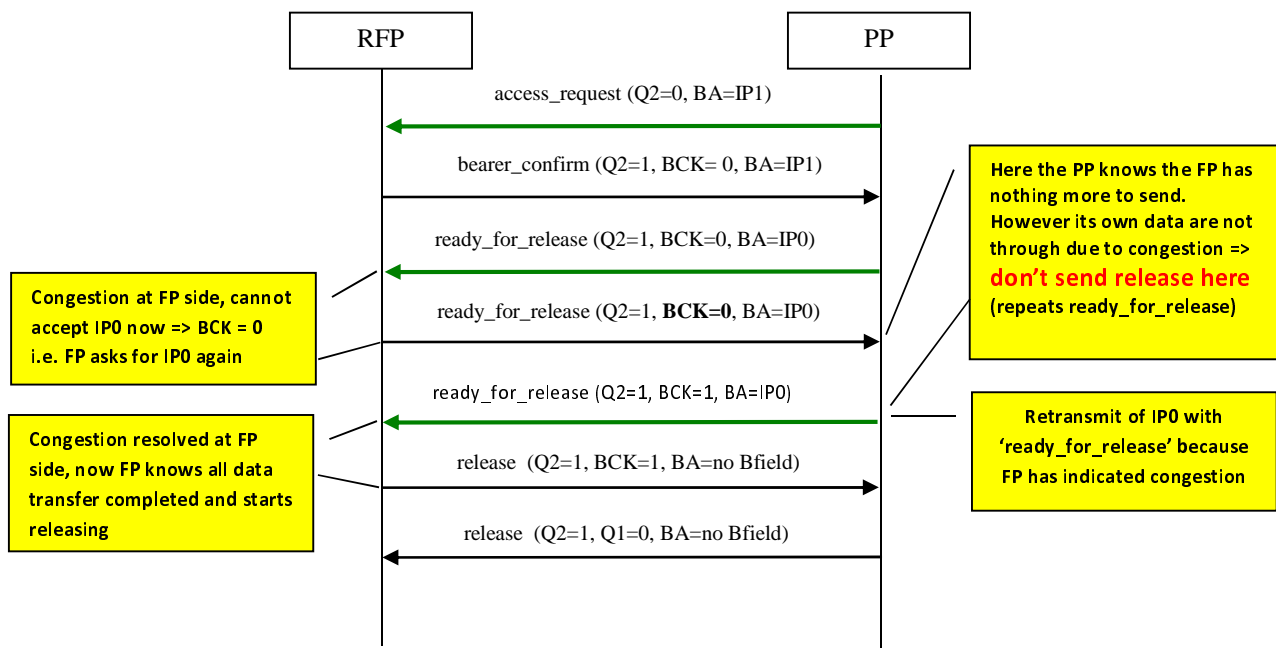

Figure 43: Multi Packet Data Transfer: FP and PP send 2 packets each - Congestion in 'Ready For Release' transfer (I)

10.10.4.5.6 Multi Packet Data Transfer: FP and PP send 2 packets each - Congestion in 'Ready for Release' transfer (II)

Description:

- Use case: Multi Packet Data Transfer: FP and PP send 2 packets each. Congestion in 'Ready For Release' transfer II (later phase).

The use case is shown in figure 44.

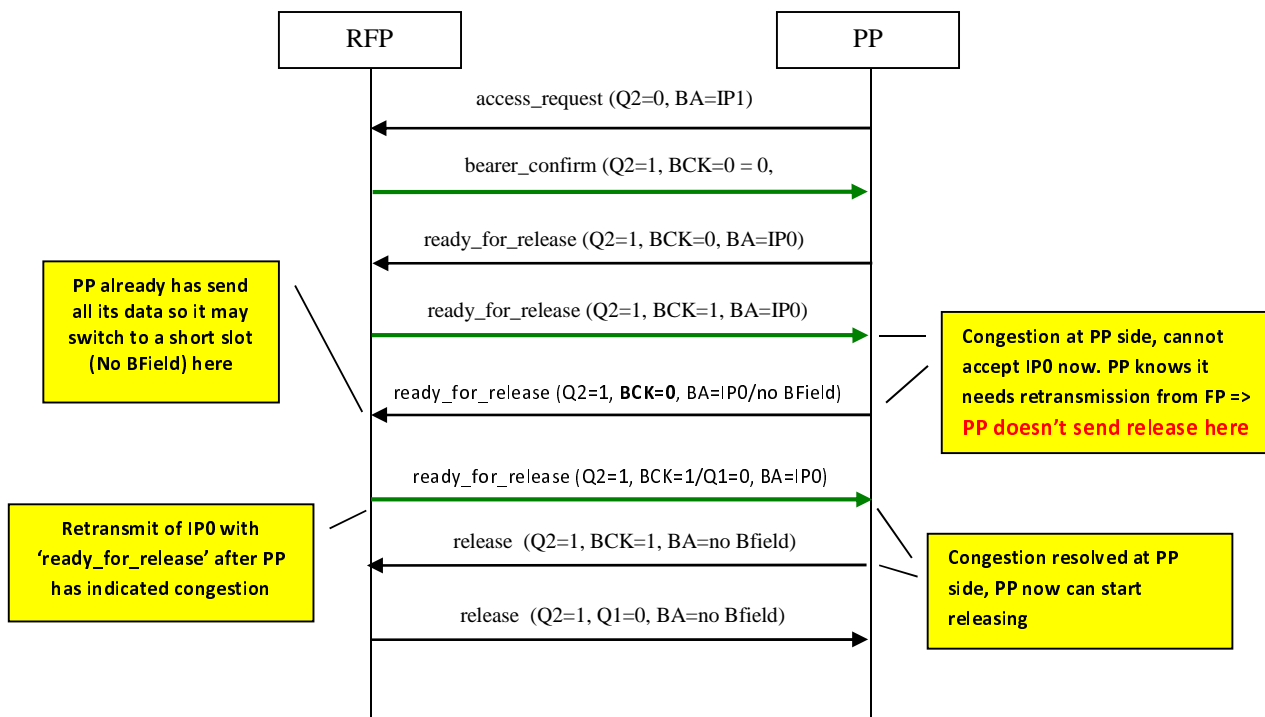

Figure 44: Multi Packet Data Transfer: FP and PP send 2 packets each - Congestion in 'Ready For Release' transfer II

10.10.4.5.7 Multi Packet Data Transfer: FP sends 2 packets and PP sends 3 packets - Congestion in 'Ready For Release' transfer (I)

The use case is shown in figure 45.

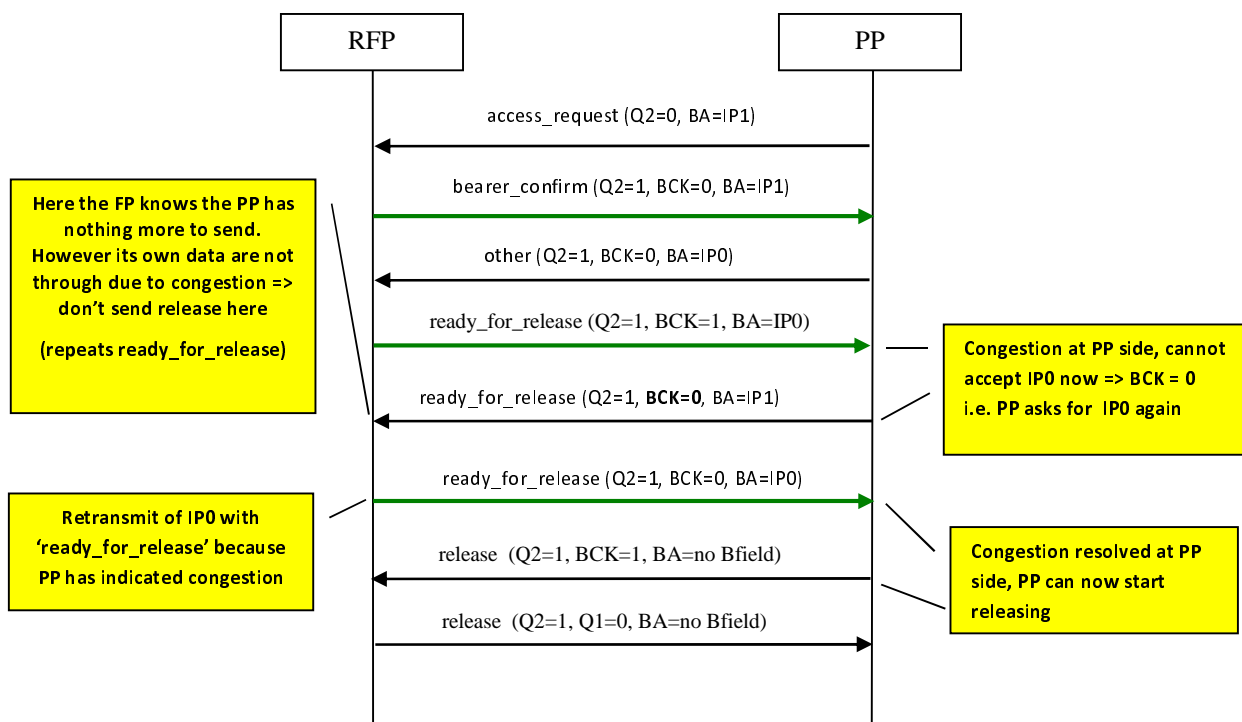

Figure 45: Multi Packet Data Transfer: FP sends 2 packets and PP sends 3 packets - Congestion in 'Ready For Release' transfer (I)

10.10.4.5.8 Multi Packet Data Transfer: FP sends 2 packets and PP sends 3 packets - Congestion in 'Ready For Release' transfer (II)

Description:

- Multi Packet Data Transfer: FP send 2 packets and PP sends 3 packets. Congestion in 'Ready for Release' transfer II (later phase).

The use case is shown in figure 46.

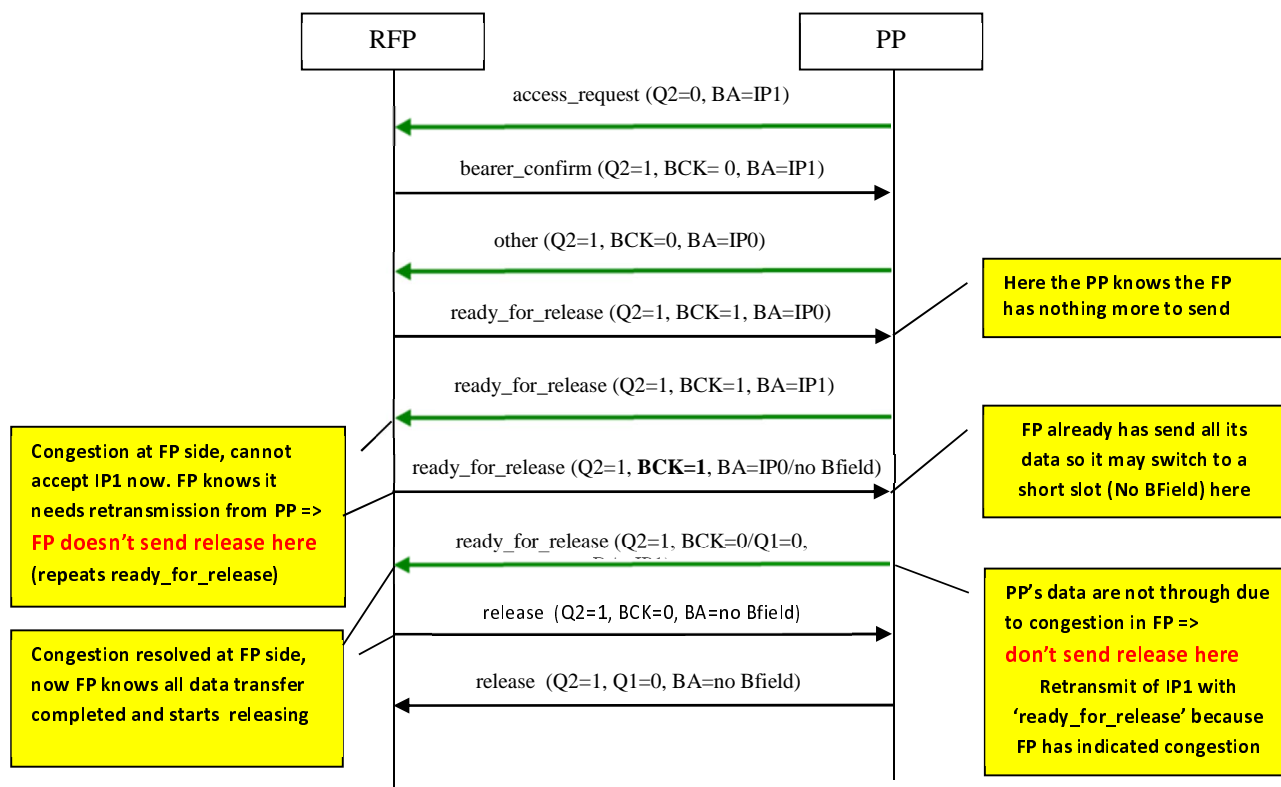

Figure 46: Multi Packet Data Transfer: FP send 2 packets and PP sends 3 packets - Congestion in 'Ready For Release' transfer II (later phase)

10.10.5 Use of reason codes in "expedited release" and "ready for release" messages

10.10.5.1 Use of reason code "normal bearer release"

This is the normal situation at the end of a ULE packet transmission, the release reason is "normal bearer release" which instructs the PT to return to Idle (see figure 47).

This reason code shall be used by both, the FT and the PT, unless there is a reason for using any other code.

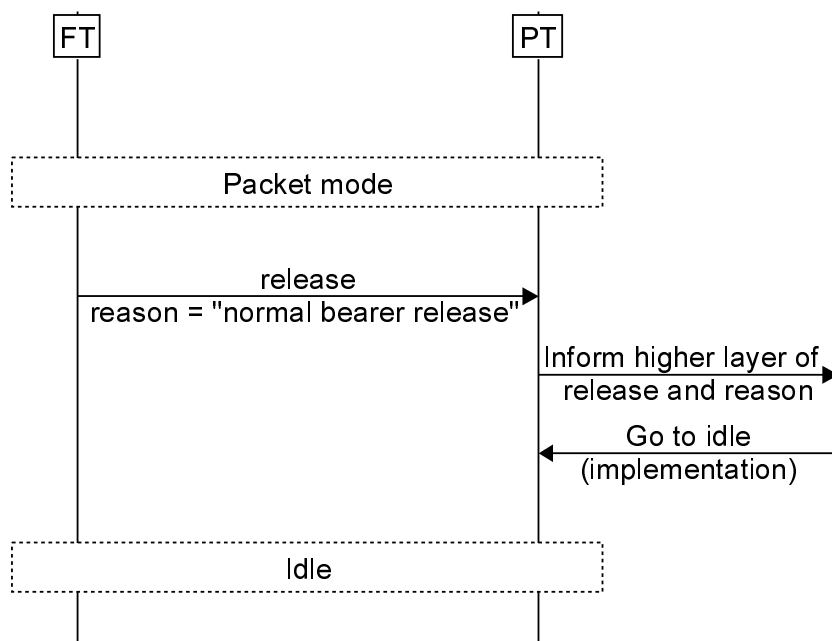

Figure 47: Use of reason code "normal bearer release"

10.10.5.2 Use of reason code "base station busy"

The release reason "base station busy" indicates that the RFP is too busy to continue handling the connection with PT. Oppositely to the reason code "Setup again after n frames", no explicit action is mandated.

It is expected that the PT will retry the access (including new channel selection process) after a timer. The value of such timer is left to the implementer.

10.10.5.3 Use of reason code "unacceptable PMID / Unregistered PMID"

The release reason "unacceptable PMID / Unregistered PMID" is used to indicate to the PT that the PT is not registered in the RFP. This can be the result of an abnormal situation, such as the reset of the RFP.

The expected response shall be the PT to execute Mobility Management procedures in order to register again the PT in the RFP. After MM, CC Service Change may be executed in order to resume the connection. See clause 12.1.3.1.

10.10.5.4 Use of reason code "switch to circuit mode"

The release reason "switch to circuit mode" is used to request to the PT that a circuit mode connection should be started. The requested circuit mode service is indicated by the info field as shown in table 41. In figure 48, the PT behaviour at the end of the ULE service call is shown as returning to idle but the actual action is controlled by the PT application.

Table 41: Info field for Release Reason code "switch to circuit mode"

Info field (bits a17 to a21)					Requested action
a17	a18	a19	a20	a21	
0	0	0	0	0	Reserved for only MAC setup
0	0	0	0	1	Start ULE service call
0	0	0	1	0	Start Location registration
0	0	0	1	1	Reserved for start GAP voice call (outgoing)
0	0	1	0	0	Reserved for LCE procedures
0	0	1	0	1	} reserved
to					
1	1	1	1	1	}

In all cases, the MAC setup shall be basic connection (full slot).

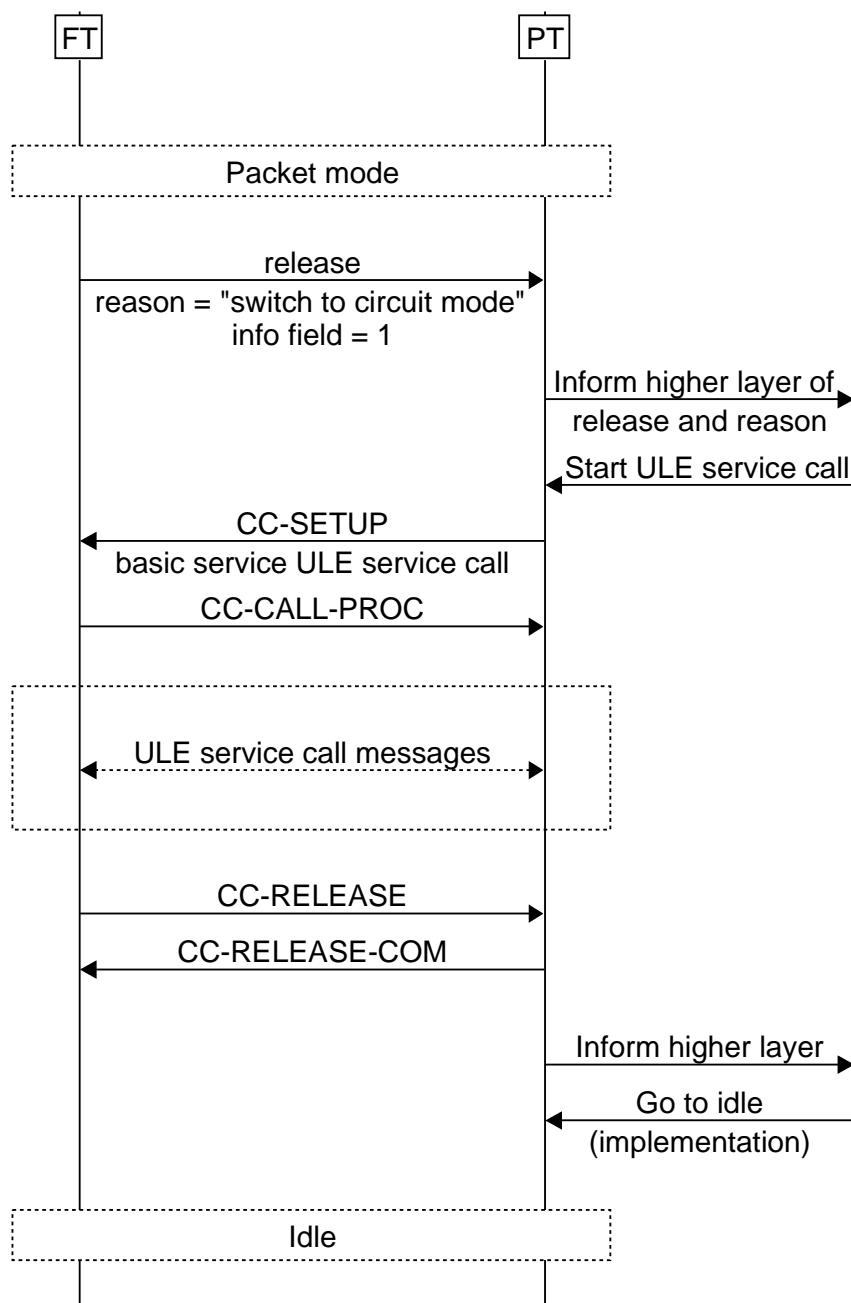

Figure 48: Use of reason code "switch to circuit mode" and setup ULE service call

10.10.5.5 Use of reason code "Stay in LCE paging detection mode"

The release reason "stay in LCE paging detection mode" is used to instruct the PT to enter a mode where it can listen for LCE paging. Being able to respond to LCE paging lets the FT initiate circuit mode transactions, the example given here is of deregistration of a ULE node.

Both, normal and fast LCE paging may be supported. The duration of the listening to LCE paging state and the paging cycle (normal or high) is given in the info field. The coding of the info field is defined in ETSI EN 300 175-3 [3], clause 7.2.5.12.5.2.

Figure 49 shows the message sequence if the PT finds an LCE page before the listening period times out.

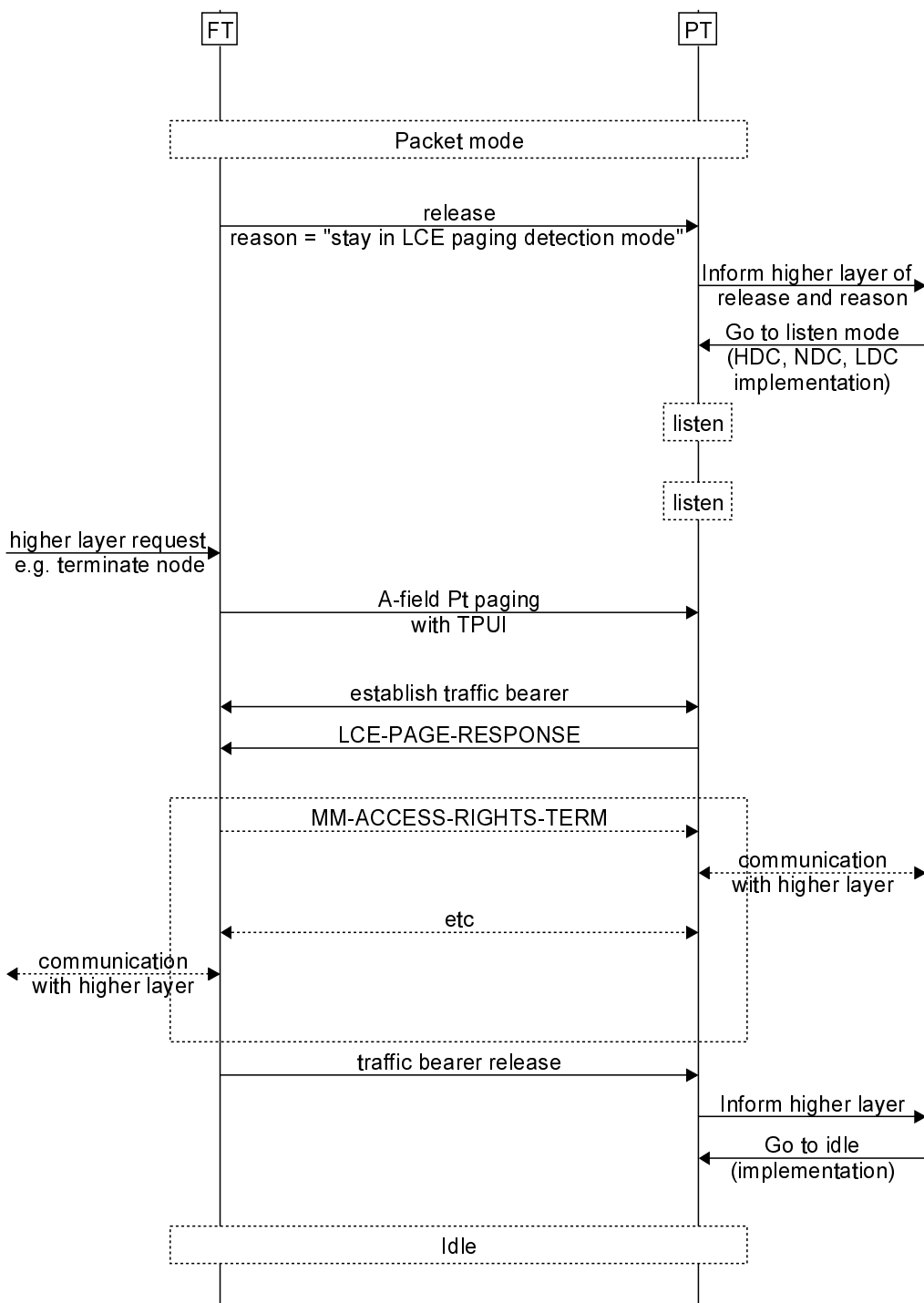

Figure 49: Use of reason code "Stay in LCE paging detection mode": LCE paging

If the PT does not receive an LCE page before the timeout period it should stop listening and return to idle. This use case is shown in figure 50.

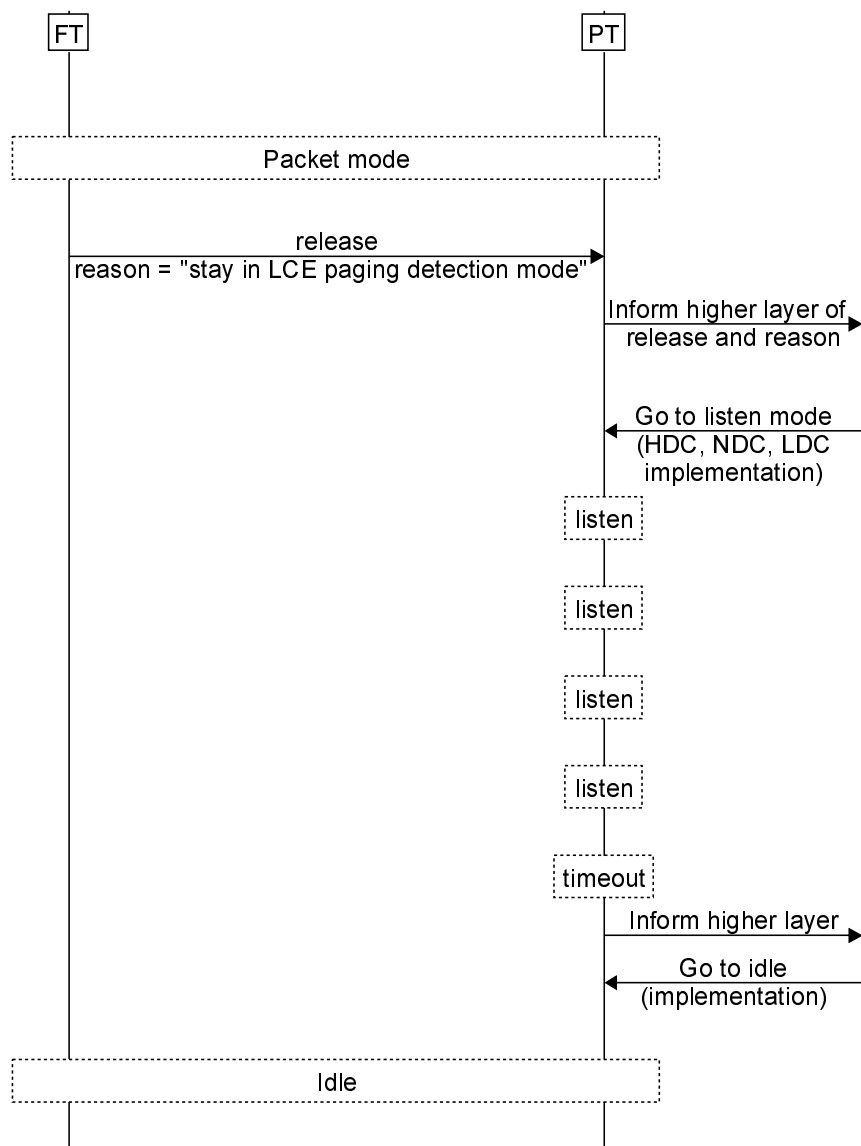

Figure 50: Use of reason code "Stay in LCE paging detection mode": timer expiration

10.10.5.6 Use of reason code "Stay in higher paging detection mode"

The release reason "stay on higher paging detection mode" is used to cause the PT to stay listening for a ULE page message with a different paging cycle from the standard one. This feature is used in slow paging cycle devices, such as PP type 1 (sensors), when the FT may have the need to send data to such PP sooner than the regular paging cycle.

The duration of the higher paging detection mode is given in the info field. The coding of the info field is defined in ETSI EN 300 175-3 [3], clause 7.2.5.12.5.3.

In a use case similar to the one described in clause 10.10.5.7 ("Setup again after n frames'), when the FT is not in a position to immediately service the PT (for instance because the application needs time to respond), the FT may use "Stay in higher paging detection mode" as a release reason instead of Setup again after n frames". After the application response, the FT can page the PT which will then raise a bearer. If there is no application response there will be no page and the PT does not waste energy or bandwidth by raising an unneeded bearer. The listening period is specified in the information field of the release reason and is counted in paging cycles of the paging descriptor (in paging cycles of the fastest descriptor if more than one has been allocated). The use case is shown in figure 51.

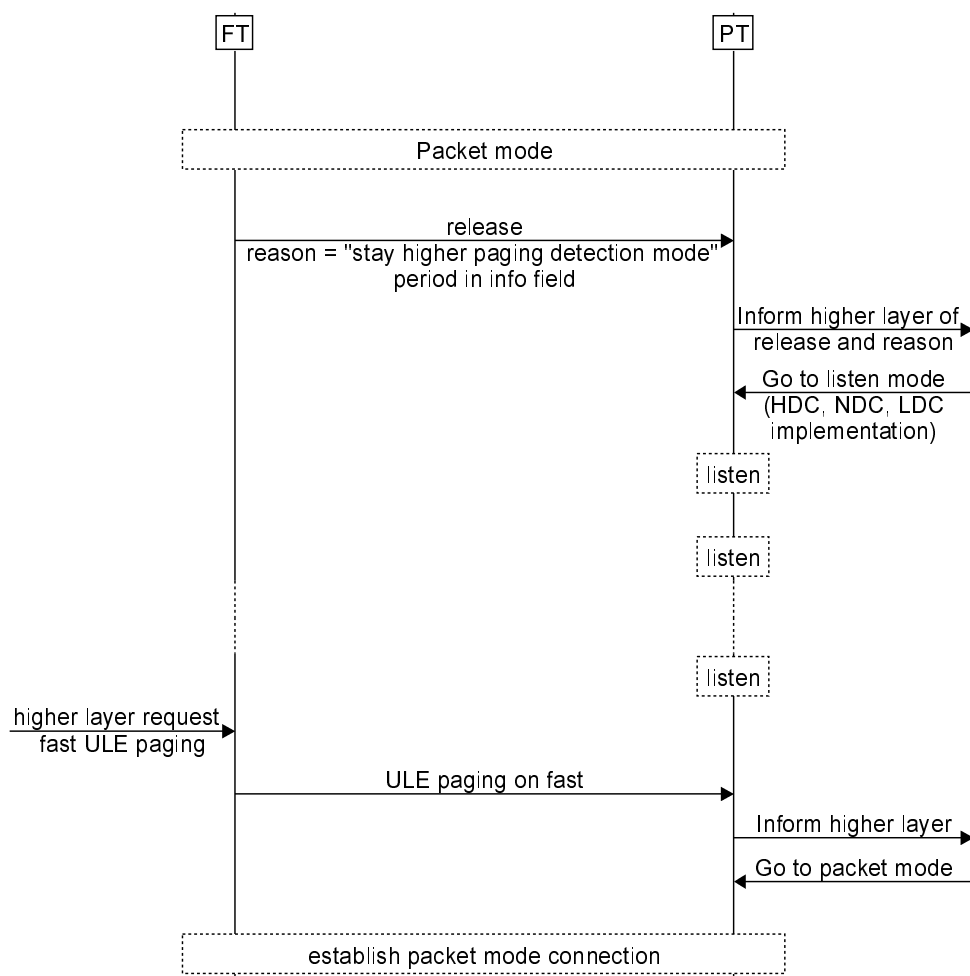

Figure 51: Use of reason code "Stay in higher paging detection mode": paging event

If the PT does not receive a ULE page before the timeout period it should stop listening and return to idle. The use case is shown in figure 52.

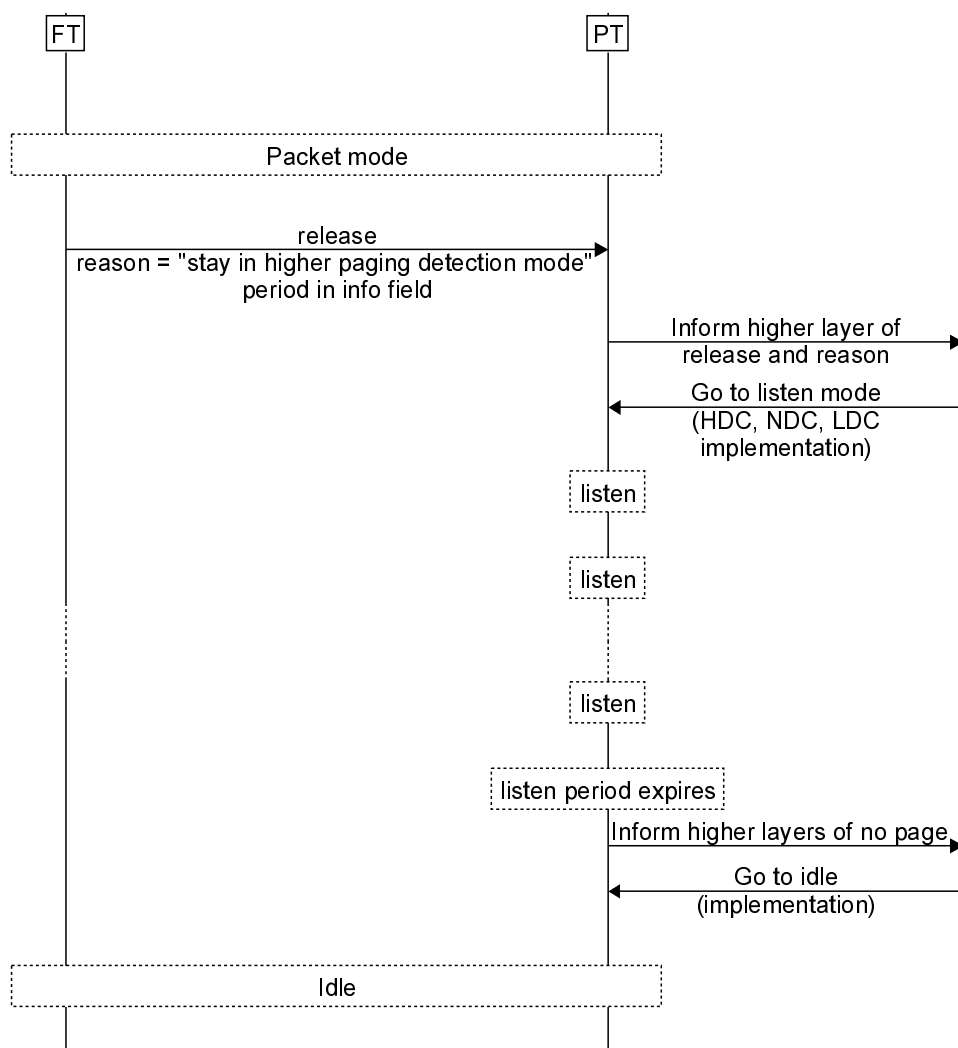

Figure 52: Use of reason code "Stay in higher paging detection mode": timer expiration

10.10.5.7 Use of reason code "Setup again after n frames"

The release reason "set up again" is used to instruct the PT to attempt to establish a ULE packet mode connection at some future time. It could be used if the FT is too busy to deal with the original packet mode connection or if it cannot respond to the PT immediately (a delay in the application layer). The delay before re-establishing is specified in the information field of the release reason.

The delay value is coded as defined in ETSI EN 300 175-3 [3], clause 7.2.5.12.5.4. The maximum value is 31 frames.

The standard rules for ULE channel selection shall apply. The PT may start looking the channel selection info in the dummy bearer just before the expiration of the timer in order to perform the setup after n frames.

It is not possible to guarantee that the call will be raised after exactly N frames, it will depend on the availability of slots among other things; the value of n should be considered as a minimum time: a call will not be raised before n frames have passed. Additionally, the value should be treated as a suggestion from the FT thus allowing the PT to independently determine how many frames to wait.

NOTE: The action of the PT during the wait period is essentially an implementation decision however it may depend on the length of the suggested delay. If the delay is short it may not be possible or advisable to loose and regain sync, for a longer delay it may be worthwhile for the PT to enter a lower power state.

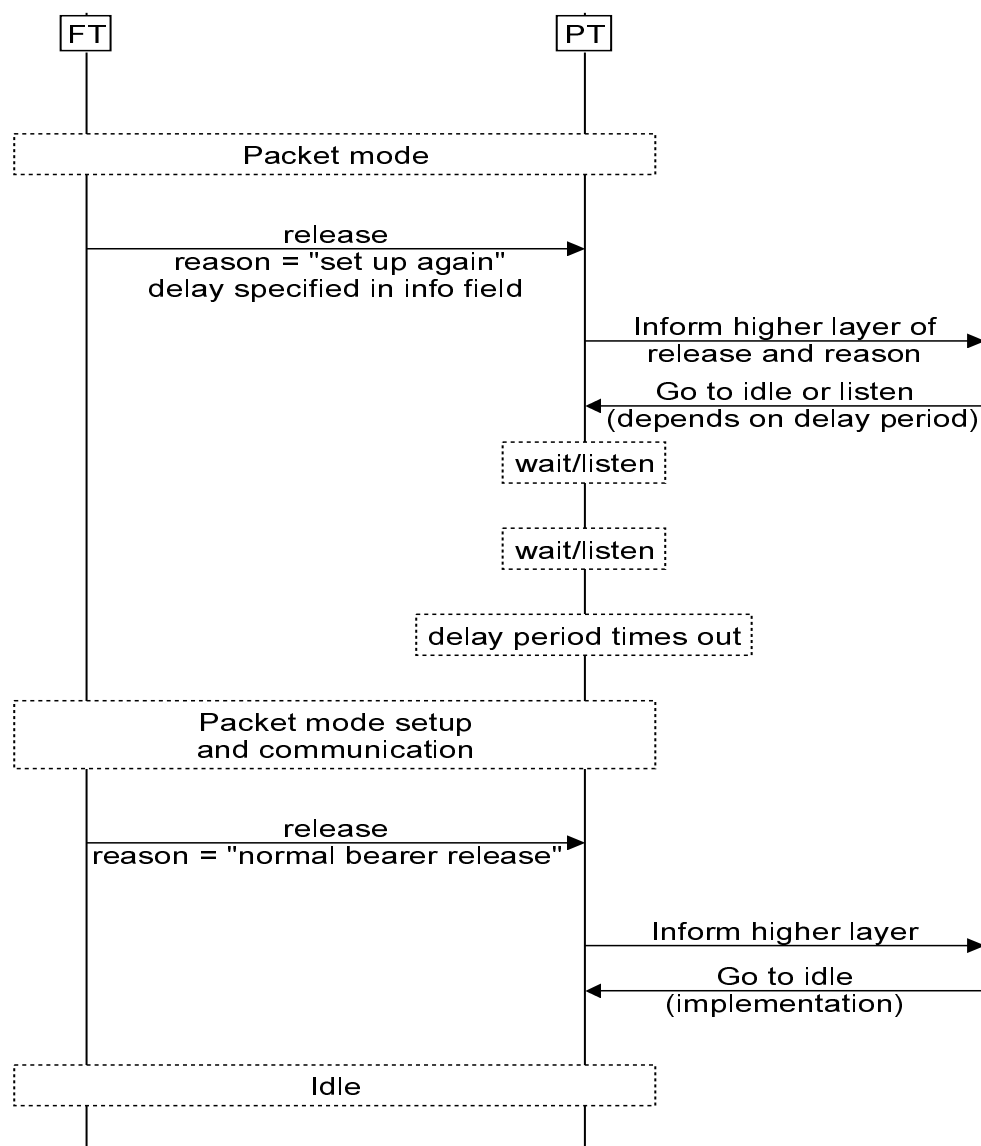

Figure 53: Use of reason code "Setup again"

10.10.5.8 Use of reason code "No such connection / virtual circuit"

The release reason "No such connection / virtual circuit" is used to indicate that the PT is known at the RFP (PP registered), however the NWK layer PVC is not in active state and the DLC link and MAC MBC are not created. Therefore, expedited operations cannot be used yet and any attempt to setup a bearer with expedited procedures shall result on a M_T Release response with this Reason code.

The expected response from the PT is to execute NWK C-plane procedures in order to resume the NWK transaction and re-create the link and the MBC. The Service change procedures described at clause 12.1.3.1 shall be used.

10.11 Slot types and slot use

10.11.1 Full Slot

10.11.1.1 General

The D-field mapping for the full slot structure (physical packet P32), as defined by ETSI EN 300 175-3 [3], clause 6.2.1.1.2 shall be supported.

The B-field mapping for the full slot structure (physical packet P32), as defined by ETSI EN 300 175-3 [3], clause 6.2.1.3.1.2 shall be supported.

10.11.1.2 Use of full slot in C/O bearers

Full slot shall be used for C/O bearers, unless another slot type is explicitly requested (e.g. using Advanced Connection control procedures). Additionally, a short slot may also be used in some cases, see clause 10.11.2.2.

10.11.1.3 Use of full slot in C/L dummy bearers

Full slot shall be used in the dummy C/L bearers in all cases.

10.11.2 Short Slot

10.11.2.1 General

The D-field mapping for the short slot structure (physical packet P00), as defined by ETSI EN 300 175-3 [3], clause 6.2.1.1.3 shall be supported in both PT and FT, at least in receiving mode. Use (transmission) of the slot is optional at both sides.

10.11.2.2 Use of short slot in C/O bearers

In order to further save energy, it is allowed to transmit as short slots frames that do not carry any B-field (BA code = no B-field) in certain cases.

The use of short slots is optional at sending side (transmitter choice). However its understanding by the receiving side is mandatory.

The rules given in ETSI EN 300 175-3 [3], clause 10.5.1.8.9 shall apply in full extend and shall be fulfilled.

In addition to that, the following additional rule shall apply:

- After using a short slot, it is not allowed to roll back to full slot. Therefore all subsequent transmissions shall be short slots and no further U-plane may be send by the peer over that TBC.

10.12 I channel services

10.12.1 Protected I channel error_correct service

10.12.1.0 General

The FT and PT shall support protected I channel operation in error_correct mode as defined in ETSI EN 300 175-3 [3], clause 10.8.2.

The I_p _error_correct mode shall apply to the I_p service $I_{pQR_error_correct}$.

10.12.1.1 Unilateral jump

FT and PT shall support unilateral data jump procedure according to ETSI EN 300 175-3 [3], clause 10.8.2.5.2.

10.12.1.2 Bearer reset

FT and PT shall support bearer reset according to ETSI EN 300 175-3 [3], clause 10.8.2.5.3.

10.12.2 Lifetime management with TWO separate maximum MAC packet lifetimes

10.12.2.0 General

The FT and PT shall operate with TWO separate maximum MAC packet lifetimes, differentiating the maximum lifetime at the bearer (at TBC level) and the maximum lifetime at the MAC layer, as described in ETSI EN 300 175-3 [3], clauses 10.8.2.2.1.2 and 10.8.2.2.1.3.

The detailed provisions given in ETSI EN 300 175-3 [3], clause 10.8.2.2.1.3 shall apply.

The operation of the counters shall be as described in clause 10.12.2.1 of the present document.

The following specific provisions apply:

- The default value for the overall MAC layer maximum lifetime, defined in table 57 of clause 12.1.3.5 shall initially be used and shall remain in use unless it is changed by a CC Service Change procedure.
- If it is required to change the maximum packet lifetime value at the MAC layer then the NWK layer IE << TRANSIT-DELAY >> shall be used. This IE shall be sent using the CC Service Change "other" procedure, as described in clause 12.1.3.3 of the present document.
- The default value for the TBC maximum lifetime, defined in table 58 of clause 12.1.3.8 shall initially be used and shall remain in use unless it is changed by a MAC connection modification procedure.
- If it is required to change the maximum packet lifetime value at the TBC then the MAC control message "ATTRIBUTES_T" shall be used, as described in clause 10.7.4.2.3 of the present document.
- When the maximum TBC lifetime expires, in addition to stopping further re-transmissions over the same TBC, the bearer shall be released and (if allowed by the overall packet lifetime) a new bearer shall be established (bearer replacement) where further re-transmissions may happen. The process of setting up the new TBC (bearer replacement) may start before the expiration of the TBC lifetime.

10.12.2.1 Operation of the counters

The overall MAC packet lifetime counter shall be started for the packet with the defined maximum value when it is delivered to the MAC layer for transmission and shall be decreased with absolute TDMA frames (every 10 ms), irrespective of if there is an active TBC or not. In other words, it shall count during suspension times or during idle periods of time due to execution of channel selection or back off algorithms.

Nevertheless, in applications with ultra slow paging cycles, it is allowed not to take in consideration the delay due the paging mechanism.

The TBC packet lifetime counter starts to count with the first transmission over the TBC. Thereafter, the TBC packet lifetime counter is decreased with absolute TDMA frames (every 10 ms) for each retransmission by the TBC.

10.13 G_{FA} channel

10.13.1 G_{FA} channel data

10.13.1.1 G_{FA} channel transmission

The transmitter side of FT and PT shall support the G_{FA} channel transmission as defined in ETSI EN 300 175-3 [3], clause 5.3.1.3 over the following M_T messages:

- ready for release with G_{FA} transmission
- expedited_release with G_{FA} transmission
- Null or G_{FA} channel transmission

10.13.1.2 G_{FA} channel reception

The receiver side of FT and PT shall support the of G_{FA} channel reception, as defined in ETSI EN 300 175-3 [3], clause 5.3.1.3 and shall understand the frame format FU10d when transmitted over the G_{FA} channel.

The receiver side (FT or PT) shall be able to understand G_{FA} channel messages when transmitted over the following M_T messages:

- ready for release with G_{FA} transmission
- expedited_release with G_{FA} transmission
- Null or G_{FA} channel transmission

10.14 C channel operation

10.14.1 C_S channel

FT and PT shall support C_S channel data transmission and reception as defined in ETSI EN 300 175-3 [3], clauses 10.8.1 and 10.8.1.1.

10.14.2 C_F channel

10.14.2.0 General

FT and PT shall support C_F channel data transmission and reception as defined in ETSI EN 300 175-3 [3], clauses 10.8.1 and 10.8.1.2. However, the priority of C_F channel over U-plane shall be ruled as defined in the next clause.

For ULE devices, the use of C_F channel and its priority is negotiated by means of the NWK layer IE <Connection Attributes>, see ETSI EN 300 175-5 [5], clause 7.7.11, that is performed during call setup and optionally at any time (CC-Service Change).

Once such negotiation has been performed, the use of C_F and the C_F setting in MAC control messages (Attributes) should follow the decision taken at NWK layer.

Before such negotiation is done, or in absence of it, the use of C_F is controlled by a flag in MAC "Attributes" command. For indirect FT initiated setup, the code "0101" in LCE paging "field 2: setup info" (see ETSI EN 300 175-5 [5], clause 8.2.2), indicates to the PT that may start using channel C_F. In such case, the NWK layer call setup may be performed over C_F.

In absence of "Attributes" exchange, or the reception of the setup info code "0101" in LCE paging, the initial NWK layer call setup shall be performed over C_S, switching to C_F only after NWK layer negotiation.

The suspension and resume of any ULE connection does not change the setting of C_F. Both peers shall use C_F, or not, as before the suspension.

A FT or PT that has indicated that it supports C_F channel (see clause 10.3.2.2.1 for the FT and 12.3 for the PT), shall accept the setting of C_F in the NWK layer negotiation.

If C_F channel is active, all C-plane transmission shall take place preferably on the C_F channel. However, it is allowed to use C_S channel if C_F channel has priority D (lowest) and there is no interruption in the U plane data flow.

10.14.2.1 Priority schema of the C_F channel

This clause defines the relative priority of the C_F channel over U-plane (I-channels) and other B-field control channels in ULE connections.

In ULE, it is possible to select the priority level of C_F channel by means of the NWK layer IE <Connection Attributes> (see ETSI EN 300 175-5 [5], clause 7.7.11). The setting is done by means of octets 6 and 6a.

The priority schema of the different B-field channels shall be as defined in ETSI EN 300 175-3 [3], clause 6.2.2.4 (Priority scheme in E or E+U mode) with the following exceptions and specific provisions:

- The priority of all channels except C_F channel shall be as defined in the clause 6.2.2.4 of ETSI EN 300 175-3 [3].
- The priority of channel C_F and its retransmissions depends on the negotiated value of the fields "C_F channel attributes" in the Information Element <Connection Attributes> (see ETSI EN 300 175-5 [5], clause 7.7.11):
 - a) C_F channel attribute = "101" = Priority A (highest):

- Channel C_F has always priority over U-plane data. The priority of C_F versus U plane and other channels is exactly as described in ETSI EN 300 175-3 [3], clause 6.2.2.4. C_F channel may use all duplex bearers in a multibearer connection and always with priority over U plane.
- b) C_F channel attribute = "100" = Priority B:
 - It shall not be used.
- c) C_F channel attribute = "010" = Priority C:
 - Channel C_F has less priority than U-plane data (as priority D), until a time limit of 250 ms. If there is C_F data buffered and waiting for transmission longer than 250 ms, then the priority is changed to priority B (priority over U plane in one bearer).
- d) C_F channel attribute = "001" = Priority D (lowest):
 - Channel C_F has always less priority than U-plane data. The priorities of C_F channel retransmissions and fresh data are reduced to priorities 9 and 10 in the list described in ETSI EN 300 175-3 [3], clause 6.2.2.4. C_F channel may only be transmitted if there is no U plane data to fill in all bearers.
- e) C_F channel attribute = "000" = no C_F channel:
 - There is no C_F channel. All higher layers C-plane traffic is routed through the C_S channel.

10.15 MAC Encryption control

10.15.0 General

The following clauses refer to the Encryption process performed at MAC layer as defined in ETSI EN 300 175-7 [7], clauses 6.4.4 and 6.4.5. Refer to clause 11.10 for the CCM encryption operating at DLC layer.

10.15.1 Encryption process - initialization and synchronization

The procedure shall be performed as defined by ETSI EN 300 444 (GAP) [9], clause 10.13.

10.15.2 Encryption mode control

10.15.2.1 General

The procedure shall be performed as defined in ETSI EN 300 444 (GAP) [9], clause 10.14 and ETSI EN 300 175-7 [7], clause 6.4.6.

Figure 54 summarizes the sequence and timing of MAC encryption control procedures.

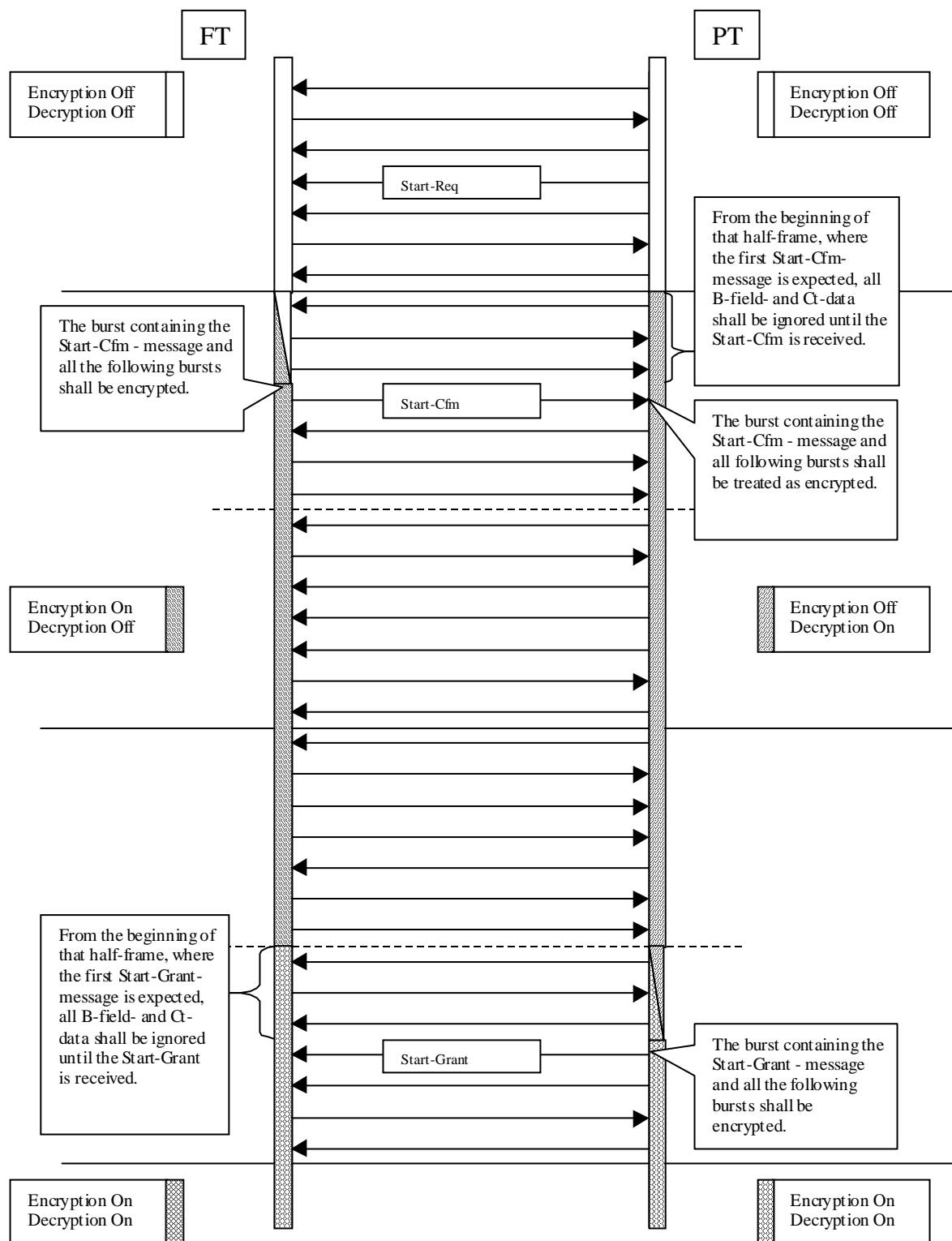

Figure 54: MAC Encryption control procedures

10.15.2.2 M_T message

The provisions of ETSI EN 300 444 (GAP) [9], clause 10.14.1 shall apply.

10.15.2.3 Procedure for enabling encryption

10.15.2.3.1 Prerequisite

In order to execute the MAC procedure for enabling encryption, it is a prerequisite that the NWK layer procedure Cipher-switching has been previously successfully executed with the Y/N value in <<Cipher-info>> indicating Cipher activation ("1").

Any of the following NWK layer procedures qualifies for the prerequisite:

- Cipher-switching initiated by FT using DSC (clause 12.23.11)
- Cipher-switching initiated by PT using DSC (clause 12.23.12)
- Cipher-switching initiated by FT using DSC2 (clause 12.24.10)
- Cipher-switching initiated by PT using DSC2 (clause 12.24.11)

The use of DSC or DSC2 produces should be consistent with the cipher supported by the system.

The MAC procedure may only be executed within a timer equivalent to <MM_cipher.1>: (defined in ETSI EN 300 175-5 [5], annex A) after the transmission of the {CIPHER-REQUEST} message in the NWK layer procedure. Otherwise the MAC shall not perform the MAC layer procedure, the receiving entity of any MAC layer procedure attempt shall reject the command, and the encryption state shall be kept unchanged.

10.15.2.3.2 Procedure

The connection shall be in active state (it should be resumed if suspended).

The PT-MAC shall start the encryption switching process on one bearer as described in ETSI EN 300 175-7 [7], clause 6.4.6.3.

10.15.2.4 Procedure for disabling encryption

10.15.2.4.1 Prerequisite

In order to execute the MAC procedure for disabling encryption, it is a prerequisite that the NWK layer procedure Cipher-switching has been previously successfully executed with the Y/N value in <<Cipher-info>> indicating Cipher deactivation ("0").

Any of the following NWK layer procedures qualifies for the prerequisite:

- Cipher-switching initiated by FT using DSC (clause 12.23.11)
- Cipher-switching initiated by PT using DSC (clause 12.23.12)
- Cipher-switching initiated by FT using DSC2 (clause 12.24.10)
- Cipher-switching initiated by PT using DSC2 (clause 12.24.11)

The use of DSC or DSC2 produces should be consistent with the cipher in use.

The MAC procedure may only be executed within a timer equivalent to <MM_cipher.1>: (defined in ETSI EN 300 175-5 [5], annex A) after the transmission of the {CIPHER-REQUEST} message in the NWK layer procedure. Otherwise the MAC shall not perform the MAC layer procedure, the receiving entity of any MAC layer procedure attempt shall reject the command, and the encryption state shall be kept unchanged.

10.15.2.4.2 Procedure

The connection shall be in active state (it should be resumed if suspended).

The PT-MAC shall start the encryption switching process on one bearer as described in ETSI EN 300 175-7 [7], clause 6.4.6.4.

10.15.3 Handover encryption process

The handover encryption process is only used for circuit mode connections.

For the ULE packet mode connection, bearer replacement shall be performed. See clause 10.20.

For the handover encryption process of circuit-mode connections, the procedure shall be performed as defined in ETSI EN 300 175-7 [7], clause 6.4.7

10.16 Enhanced security procedures

10.16.1 Re-keying

The procedure shall be performed as specified in ETSI EN 300 175-7 [7], clause 6.4.6.5.

10.16.2 Early Encryption

The procedure shall be performed as specified in ETSI EN 300 175-7 [7], clause 6.4.6.

10.16.3 DSC Encryption

The procedures specified in ETSI EN 300 175-7 [7], clause 6.4 shall apply with the following specific requirements:

- The DECT Standard Cipher (DSC) algorithm (see ETSI EN 300 175-7 [7], annex J) shall be used in the Key Stream Generator (KSG).
- The Cipher Key used by the KSG shall have 64 bits. When the DSAA2 authentication algorithm is used, the 64 least significant bits of the DCK generated by DSAA2 shall be used as Cipher Key for the KSG.

10.16.4 AES/DSC2 Encryption

The procedures specified in ETSI EN 300 175-7 [7], clause 6.4 shall apply with the following specific requirements:

- The DECT Standard Cipher #2 (DSC2) algorithm (see ETSI EN 300 175-7 [7], annex M) shall be used in the Key Stream Generator (KSG).
- The Cipher Key used by the KSG shall have 128 bits.

NOTE: This is the size of the DCK generated by DSAA2.

11 DLC layer procedures

11.1 LU14 Enhanced Frame RELay service with CCM (EFREL-CCM)

The procedure shall be performed as defined in ETSI EN 300 175-4 [4], clause 11.16 with the following specific provisions:

- The packet received from the U-plane application layer shall be the LU14 SDU.
- The LU14 SDU shall be encrypted using CCM as described in Service [ULE1-D.13], the CCM MIC shall be added, and the resulting packet shall be sent to the LU10 SAP to be further processed as described in Service [ULE1-D.3].
- The reverse procedure shall be done at the receiving side.

- The received packet shall be only revealed and delivered to higher layers if the CCM MIC is decoded and checked correctly. In case of wrong CCM MIC, the packet shall be discarded and an error notification shall be sent to higher layer.
- The standard delivery mode (see LU10 description) shall be used.
- The maximum LU14 SDU size that shall be supported is defined in clause B.2.1.
- The maximum SDU size in use at a given time may be configured by means of C-plane procedures. See clause B.2.1.
- All provisions applicable to the LU10 processing, underlying layers and the transport protocol are given in Service [ULE1-D.2].
- Only one instance of LU14 shall be supported between the same PT-FT pair:
 - The support of multiple instances of LU14 is for further study.

11.2 LU10 Enhanced Frame RELay service (EFREL)

11.2.0 General

The procedure shall be performed as defined in ETSI EN 300 175-4 [4], clause 11.12 with the following specific provisions:

- The SDU shall be segmented into fixed length segments, where the segment length shall depend on the PDU structure chosen (see clause 11.3).
- The following MAC service shall be used: $I_{PQR_error_correction}$.
- The transmission class 1 shall be used.
- Modulus shall be 512 for the send sequence number and 256 for the receive sequence number. The bit 9th of sending Sequence Number shall be provided and properly coded, however the receiving side may ignore this bit for DLC transmission protocol purposes since the window size is always ≤ 128 . The 9th bit shall be, however, used by the CCM decoder as explicit part of the CCM sequence number.
- The 9th bit shall never be coded in the receive sequence number. If FU10d full format is used, the bit shall always be coded to "0".
- Implementations shall support a maximum LU10 SDU size equal to the maximum LU14 or LU13 SDU size plus 4 octets.
- Window size shall be managed as defined in clause 11.2.1.
- SDU handling shall be as defined in clause 11.2.2.

NOTE: The maximum LU10 SDU size is always equal to the maximum LU13 or LU14 SDU size plus 4 octets.

11.2.1 Window size

The window size can be negotiated in the range of 8 to 128 by the NWK-layer.

The default value for the window size is 16.

This default value will be used in absence or failure of NWK-Layer negotiation.

Any ULE device shall support at least the following values for the window size: 8, 16 and 32.

The window size in use at a given time may be negotiated by means of C-plane procedures. See clause 12.1.3 in the present document.

11.2.2 SDU transmission and delivery mode

The standard delivery mode shall be used in all cases.

The option of transporting parts of several SDUs in one PDU shall not be used. Only one segment of one SDU shall be carried in each PDU.

11.3 FU10 framing (FU10a, FU10d)

11.3.0 General

The procedure shall be performed as defined in ETSI EN 300 175-4 [4], clause 12.11 with the specific provisions given in clauses 11.3.1 and 11.3.2.

11.3.1 FU10a

FU10a frames as defined in see ETSI EN 300 175-4 [4], clause 12.11 shall be used for the forward path of unidirectional links. Bi-directional links may be implemented using two unidirectional links for each direction. FU10a is the standard frame for carrying data in ULE.

Modulus shall be 512 for the send sequence number. The bit 9th of sending Sequence Number shall be provided and properly coded, even if it is not needed by the DLC transmission protocol due to the window size. The receiving side of the DLC transmission protocol may ignore this bit. The 9th bit shall be, however, used by the CCM decoder as explicit part of the CCM sequence number.

The option of transporting parts of several SDUs in one PDU shall not be used. Only one segment of one SDU shall be carried in each PDU.

11.3.2 FU10d

11.3.2.1 General

FU10d frames as defined in see ETSI EN 300 175-4 [4], clause 12.11, with total length shall be used for the backward control path.

Both the shortened and the full format shall be supported:

- Shortened format shall be used when the frame is transported over G_{FA} channel, messages M_T "Expedited Release" and "Expedited Ready for Release".
- Full format shall be used when the frame is transported over G_{FA} channel, message M_T "Null or G_{FA} packet", and using the insertion facility described in clause 11.3.2.1.

When full format is used, the N/A bit shall always be coded to "1" (positive ACK).

The 9th bit shall never be coded in the receive sequence number. If FU10d full format is used, the bit shall always be coded to "0".

11.3.2.2 Transport of FU10d frames over G_{FA} channel

The transport of FU10d frame over channel G_{FA} shall be supported in all cases:

- Shortened format shall be used when the frame is transported over messages M_T "Expedited Release" and "Expedited Ready for Release".
- Full format shall be used the frame is transported over message M_T "Null or G_{FA} packet".

11.3.2.3 Insertion of FU10d frames in FU10a frames of the opposite link

The FT and PT shall support the transport of FU10d frames by insertion in the frame FU10a of the opposite link using the procedure described in ETSI EN 300 175-4 [4], clause 12.11.2.3.

The sending side can take dynamically the decision on how to transport the FU10d frames according to traffic and use of the M_T channel by the connection.

NOTE: As general rule, if a suitable M_T message with G_{FA} transport capability has to be sent due to MAC control reasons, this should be the preferred mechanism for sending the FU10d frame. The use of the insertion mechanisms is only recommended in case of long bursts with the tail channel used by channels or operations which do not allow G_{FA} transport.

11.4 Class A operation

11.4.0 General

The class A link operation can be either PT or FT initiated. To simplify the description this clause considers only the PT initiated procedures; for the FT initiated procedures, "PT" shall be replaced with "FT" and vice versa. This is valid for the entire clause 11.4 and the associated clauses.

11.4.1 Class A link establishment

11.4.1.0 General

The procedure shall be performed as defined in ETSI EN 300 175-4 [4], clause 9.2.3.1. The following text together with the associated clauses define the mandatory requirements with regard to the present document.

If, class B acknowledged transfer is requested but not supported (B acknowledged transfer is not required to be supported for ULE) by the receiving side, the I_frame requesting class B operation shall be treated as though it was a class A frame, see ETSI EN 300 175-4 [4], clause 9.2.4.3.1 b). Figure 55 shows a class A link establishment while tables 42 and 43 show the I_frame and RR_response fields.

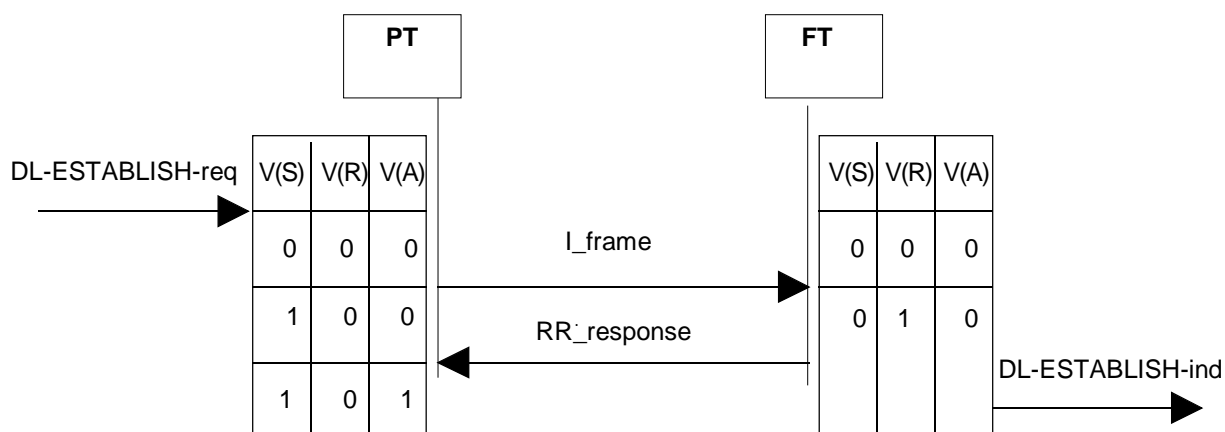

Figure 55: Class A link establishment

Table 42: Values used within the I-frame

Field	Parameter within the field	Standard values within the field/parameter	Normative action/comment
<<Address-field>>	<NLF>	1	New link
	<LLN>	1	Class A operation
	<SAPI>	0	Connection oriented
	<C/R>	0	PT command
	<RES>	1	
<<Control-field>>	<N(R)>	0	$N(R) = V(R)$
	<P>	0	Ignore
	<N(S)>	0	$N(S) = V(S)$
<<Length-indicator-field>>		0	No higher layer information
		1..63	Higher layer info length
	<M>	All	
	<N>	1	No extended length field. If "0" the frame may be discarded
<<Information field>>		All appropriate	Higher layer information. If field indicates "0" shall be omitted. This field shall be used to carry the {LCE-PAGE-RESPONSE} message in case of FT initiated indirect link establishment
<<Fill field>>		11110000B	Ignore. 0 to 4 such octets may be included in case for the C_S logical channel, as the Frame Length (FLEN) mod 5 = 0. If indicates "0", no <Fill field> is required
<<Checksum field1>>		All	The contents shall be calculated using two elements: LSIG see ETSI EN 300 175-4 [4], clause 10.3.1; underlying checksum calculation based on ISO/IEC 8073 [12]
<<Checksum field2>>		All	See above

Table 43: Values used within the {RR-Frame} S-format message

Field	Parameter within the field	Standard values within the field/parameter	Normative action/comment
<<Address-field>>	<NLF>	1	New link
	<LLN>	1	Class A operation
	<SAPI>	0	Connection oriented
	<C/R>	0	FT response
	<RES>	1	
<<Control-field>>	<N(R)>	1	$N(R) = V(R)$
	<P/F>	0	Ignore
	<SS>	0	
	<***>	1	constant
<<Length-indicator-field>>		0	No higher layer information
	<M>	0	
	<N>	1	No extended length field. If "0" the frame may be discarded
<<Checksum field1>>		All	
<<Checksum field2>>		All	

11.4.1.1 Associated procedures

11.4.1.1.1 Timer P<DL.07> management

<DL.07>: class A establishment timer;

value: refer to ETSI EN 300 175-4 [4], annex A;

start: a Class A link establishment I_frame is transmitted;

stop: on receipt of: a Class A errorless RR_response with the New Link Flag (NLF) bit set to "1"; a DL_RELEASE-req primitive indicating "abnormal"; a MAC_DIS-ind primitive.

11.4.1.1.2 Re-transmission counter management

Clauses 9.2.3.1 and 9.2.3.6 of ETSI EN 300 175-4 [4] shall apply.

Each LAPC entity shall maintain an internal Re-transmission count variable determining the maximum number of re-transmissions of an I_frame. The default value shall be 3.

For Class A operations the Re-transmission counter shall be reset any time a new I_frame has been sent.

11.4.1.1.3 Multiple frame operation variables management

Clause 7.5.2 of ETSI EN 300 175-4 [4] shall apply.

For the DLC layer acknowledged transfer to be performed the V(S), V(A), and V(R) operation variables together with their appropriate management shall be supported.

The allowed values of all state variables for a given class of operation shall always be defined by the modulus operation. For Class A operation, the modulus equals 2.

11.4.1.1.4 Lower Layer Management Entity (LLME) establishment of a MAC connection

The procedure shall be performed as defined in ETSI EN 300 175-4 [4], clause 10.2 and ETSI EN 300 175-3 [3], clause 8.1.1. The following text together with the associated clauses define the mandatory requirements with regard to the present document.

For a link to be established a suitable MAC connection is needed. If such one does not exist the LLME shall request it. Figure 56 shows the establishment of a MAC connection while table 44 and table 45 show the MAC_CON-req and MAC_CON-cfm_fields.

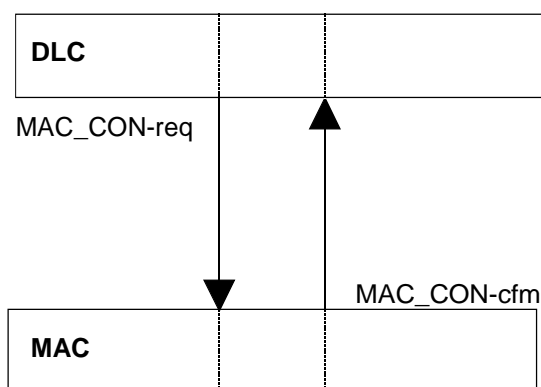

Figure 56: Establishment of a MAC connection initiating side

Table 44: Values used within the MAC_CON-req primitive

Parameter	Information within the parameter	Normative action/comment
<<MCEI>>	MAC Connection Endpoint Identifier	Refer to ETSI EN 300 175-4 [4], clause 10.2.4.4
<<PMID>>	Portable part MAC Identity (PMID)	
<<CHO flag>>	N	N = Normal connection Y (connection required for Connection handover) is for further study
<<Old MCEI>>	Not used	Only needed for Connection handover and Basic type connections
<< C _F required >>	0, 1	C _F is optional.
<<Slot type>>	full slot	
<<Service type>>	I _{PQR_error_correction}	Mandatory
<< up/down/sm/ss >>	ss	11 (single bearer connection)
<<connection type>>	Advanced	
<< ECN >>	7	DLC requests a specific ECN value (expedited connection) See also ETSI EN 300 175-4 [4], clause 10.2.4.2

Table 45: Values used within the MAC_CON-cfm primitive

Parameter	Information within the parameter	Normative action/comment
<<MCEI>>	MAC Connection Endpoint Identifier	Refer to ETSI EN 300 175-4 [4], clause 10.2.4.4
<<Connection type>>	Advanced	The type of the established connection
<< ECN >>	7	MAC confirms the ECN = 7 (expedited connection) See also ETSI EN 300 175-4 [4], clause 10.2.4.2

As shown in figure 57, the receiving side shall be informed about the action that has taken place in case it was successful by a MAC_CON-ind primitive whose fields are show in table 46.

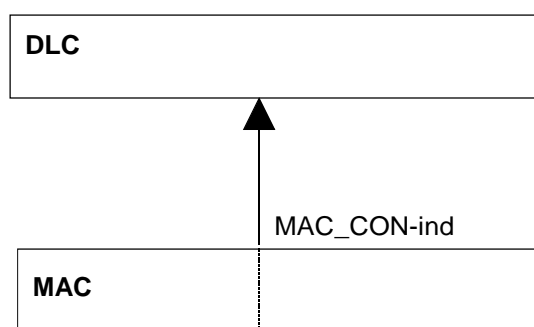

Figure 57: Establishment of a MAC connection receiving side

Table 46: Values used within the MAC_CON-ind primitive

Parameter	Information within the parameter	Normative action/comment
<<MCEI>>	MAC Connection Endpoint Identifier	Refer to ETSI EN 300 175-4 [4], clause 10.2.4.4
<<PMID>>	PMID	
<<CHO flag>>	N	N = Normal connection Y (connection required for Connection handover) is for further study
<< C _F required >>	0, 1	C _F is optional
<<Slot type>>	full slot	
	I _{PQR_error_correction}	Mandatory
<< up/down/sm/ss >>	ss	11 (single bearer connection)
<< Connection type >>	Advanced	
<< ECN >>	7	MAC indicates that this is an ECN = 7 expedited connection (see also ETSI EN 300 175-4 [4], clause 10.2.4.2)

11.4.1.2 Exceptional cases

11.4.1.2.1 Timer P<DL.07> expiry

If an RR response is received with the NLF bit set to "0" or containing errors the LAPC entity shall discard it. If the peer finds errors in the I_frame, response shall not be generated. In both cases timer P<DL.07> shall expire. An action shall be taken according to ETSI EN 300 175-4 [4], clause 9.2.3.1.

11.4.1.2.2 Receipt of a request for link release

If DL_RELEASE-req primitive is received timer P<DL.07> shall be stopped. Class A link release procedure shall be performed (see clause 9.3).

11.4.1.2.3 Receipt of an indication for a connection release

Timer P<DL.07> shall be stopped, all outstanding data shall be discarded, and, the NWK layer shall be informed for the MAC failure by DL_RELEASE-ind primitive.

11.4.2 Class A Acknowledged Information transfer

11.4.2.0 General

The procedure shall be performed as defined in ETSI EN 300 175-4 [4], clauses 9.2.3.2 to 9.2.3.6.

The following cases, depending on the frame which confirms the reception of the frame-request, shall be supported:

- acknowledgement with an I_frame (see clause 11.4.2.1);
- acknowledgement with an RR_frame (see clause 11.4.2.2).

11.4.2.1 Acknowledgement with an I_frame

Acknowledgement with an I_frame is shown in figure 58.

NOTE 1: During the calculation of the variable's values the assumptions have been made that the I_frame sent by PT is not used for acknowledgement of previous received I_frames and, both frames are not re-transmission.

NOTE 2: A Class A acknowledged information transfer procedure is considered as successful for the Initiator when in case N(S) is sent and N(R) is received the next equation is valid: $(N(S)+1) \bmod 2 = N(R)$.

NOTE 3: The I_frame sent by the FT is assumed to be acknowledged as well (not indicated in the figure).

NOTE 4: The case when FT initiates differs only in the notations.

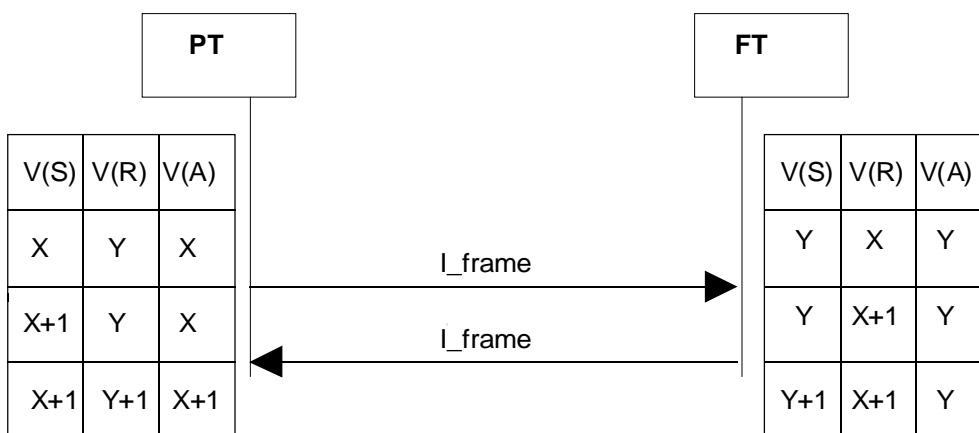

Figure 58: Class A acknowledge information transfer by I_frame, PT initiated

Table 47 shows the fields (with the associated values) sent with an I_frame.

Table 47: Values used within the I-Frame sent by the PT(FT)

Field	Parameter within the field	Standard values within the field/parameter	Normative action/comment
<<Address-field>>	<NLF>	0	
	<LLN>	1	Class A operation
	<SAPI>	0	Connection oriented
	<C/R>	0	From PT
		1	From FT
	<RES>	1	
<<Control-field>>	<N(R)>	=V(R)	In I_frame transmitter
	<P>	0	Ignore
	<N(S)>	=V(S)	In I_frame transmitter
<<Length-indicator-field>>		1..63	Higher layer info length
	<M>	All	
	<N>	1	No extended length field. If "0" the frame may be discarded
<<Information field>>		All relevant	Higher layer information
<<Fill field>>		11110000B	Ignore. 0 to 4 such octets may be included in case for the C _S logical channel
<<Checksum field1>>		All	
<<Checksum field2>>		All	

11.4.2.2 Acknowledgement with a RR_frame

Acknowledgement with an I_frame is shown in figure 59.

NOTE 1: During the calculation of the variable's values an assumption has been made that the I_frame sent by PT is not used for acknowledgement of previous received I_frames and is not a re-transmission.

NOTE 2: A Class A acknowledged information transfer procedure is considered as successful for the Initiator when in case N(S) is sent and N(R) is received the next equation is valid: $(N(S)+1) \bmod 2 = N(R)$.

NOTE 3: The case when FT initiates differs only in the notations.

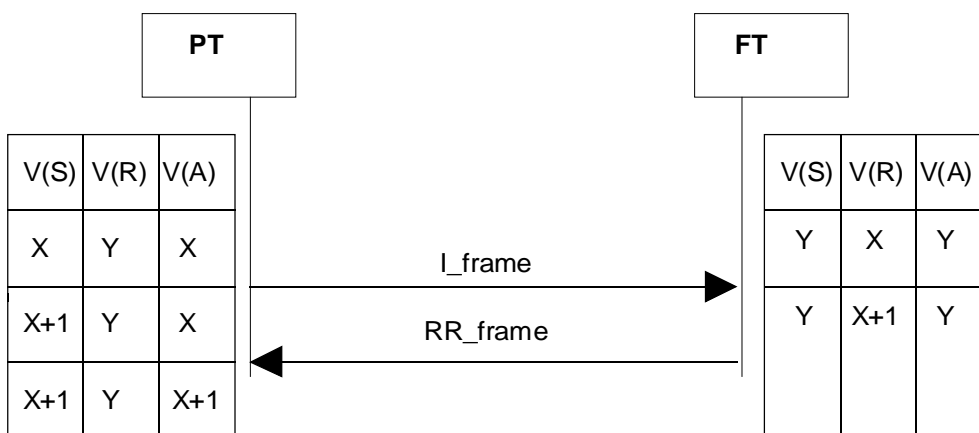

Figure 59: Class A acknowledge information transfer by RR_frame

The values used within the {I-Frame} shall be the same as in the case Acknowledgement with an I_frame and shown in table 47.

Table 48 shows the fields (with the associated values) sent with an RR-frame.

Table 48: Values used within the {RR-Frame} S-format message

Field	Parameter within the field	Standard values within the field/parameter	Normative action/comment
<<Address-field>>	<NLF>	0	
	<LLN>	1	Class A operation
	<SAPI>	0	Connection oriented
	<C/R>	0	From FT
		1	From PT
<<Control-field>>	<N(R)>	= V(R)	In RR-frame transmitter
	<P/F>	0	Ignore
	<SS>	0	
	<***>	1	Constant
<<Length-indicator-field>>		0	No higher layer information
	<M>	0	
	<N>	1	No extended length field. If "0" the frame may be discarded
<<Checksum field1>>		All	
<<Checksum field2>>		All	

11.4.2.3 Class A acknowledged information transfer with segment reassemble

If procedure 11.4.5 "Handling of NWK layer messages longer than 63 octets" is not supported the following provisions shall apply:

If an implementation supporting longer messages wants to access an implementation which does not support segmentation, the last shall act as follows:

- acknowledge the receipt of each error free, in sequence segment;
- do not store any segment after the first;
- deliver to its own NWK layer only the first segment.

11.4.2.4 Associated procedures

11.4.2.4.1 Timer <DL.04> management

DL.04>: re transmission timer;

value: refer to ETSI EN 300 175-4 [4], annex A;
 start: a I_frame is transmitted;
 stop: on receipt of: an acknowledgement for that frame; a DL_RELEASE-req primitive indicating "abnormal"; a MAC_DIS-ind primitive.

11.4.2.4.2 Re-transmission counter management

Clause 11.4.1.1.2 shall apply.

11.4.2.4.3 Multiple frame operation variables management

Clause 11.4.1.1.3 shall apply.

11.4.2.5 Exceptional cases

11.4.2.5.1 Timer <DL.04> expiry

The procedure described in clause 9.2.3.6 of ETSI EN 300 175-4 [4] shall apply.

An errored or erroneous I-frame shall be discarded and therefore shall not generate peer response. The procedure is shown in figure 60 below.

An errored or erroneous frame-acknowledgement shall be discarded and timer <DL.04> shall not be stopped.

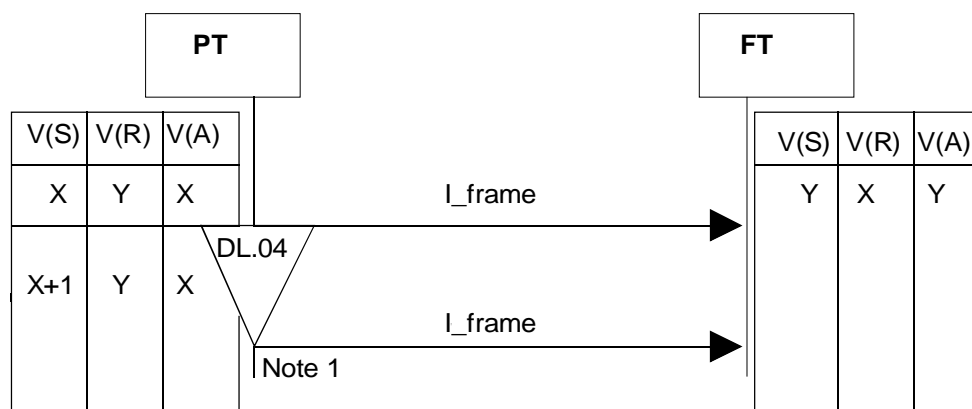

NOTE 1: The I_frame is re-transmitted only if N250<max. value.

NOTE 2: During the calculation of the variable's values an assumption has been made that the I_frames sent are not used for acknowledgement of previous received I_frames and the first one is not a re-transmission.

NOTE 3: The case when FT initiates differs only in the notations.

NOTE 4: The contents of the retranslated frame will be exactly the same as the first one.

Figure 60: Timer <DL.04> expiry

The values used within the {I-Frame} shall be the same as in the case acknowledgement with an I_frame described in table 47.

11.4.2.5.2 Receipt of a request for link release

On receipt of a DL_RELEASE-req after an I-frame has been transmitted timer <DL.04> shall be stopped and class A link release procedure (see clause 9.3) shall be performed.

11.4.2.5.3 Receipt of an indication for a connection release

On receipt of an indication from the MAC layer for a release meaning either a bearer release started by the MAC layer or a bearer release resulting from a link release initiated by the peer, the timer <DL.04> shall be stopped and class A Link release procedure (see clause 9.3) shall be performed.

11.4.2.5.4 DLC wants to make a connection handover

See class A basic connection handover procedure given in clause 9.7.

11.4.3 Class A link release

11.4.3.0 General

The procedure shall be performed as defined in ETSI EN 300 175-4 [4], clauses 9.2.3.7, 9.2.7.1.2, 10.2.2 and 10.4.1, ETSI EN 300 175-3 [3], clause 8.1.6, and ETSI EN 300 175-5 [5], clause 17.9.

The procedure for Class A link release is initiated on receipt of a DL_RELEASE-req primitive (see clauses 8.37 and 8.38) or a MAC_DIS-ind primitive.

On receipt of a MAC_DIS-ind primitive DLC shall release the link.

A link release procedure is qualified as "normal" if no outstanding I-frames or outstanding DL_DATA-req primitives have been discarded before the link has been released.

Even if in the DL_RELEASE-req primitive a "normal" link release has been requested, the DLC layer might be unable to process all outstanding data. If any outstanding I-frames or DL_DATA-req primitives were or have to be discarded the release is qualified as "abnormal" and the resulting "abnormal" release mode shall be indicated in the DL_RELEASE-cfm and DL_RELEASE-ind primitives respectively.

11.4.3.1 Associated procedures

11.4.3.1.1 LLME U-plane release

The procedure shall be performed as defined in ETSI EN 300 175-4 [4], clause 10.4.2.

11.4.3.1.2 LLME release a MAC connection

The procedure shall be performed as defined in of ETSI EN 300 175-4 [4], clause 10.2 and ETSI EN 300 175-3 [3], clause 8.1.6.

11.4.4 Class A link re-establishment

The procedure shall be performed as defined in of ETSI EN 300 175-4 [4], clause 9.2.3.8 and ETSI EN 300 175-5 [5], clause 17.8.

A class A link may be re-established at any time using the procedure for class A link establishment, (see clause 11.4.1). All outstanding DL_DATA primitives and I-frames shall be discarded, and all link variables shall be reset.

Alternatively an implementation is permitted to release the link after receipt of an I-frame with NLF flag set to "1".

A link shall not be re-established whilst in the "RELEASE-PENDING" state, see ETSI EN 300 175-5 [5], clause 14.2.7.

11.4.5 Handling of NWK layer messages longer than 63 octets

Both PT and FT shall be able to handle NWK layer messages longer than 63 octets. Messages longer than 63 octets shall be segmented at DLC sending side and re-assembled in DLC receiving side as specified in ETSI EN 300 175-4 [4], clause 7.7.2.

11.5 U-plane frame transmission procedures

11.5.1 DLC U-plane transmission Class 1

11.5.1.1 General

The general provisions given in ETSI EN 300 175-4 [4], clause 14.3.1 and clause 14.3.3 shall be followed.

11.5.1.2 Sending side procedure

The procedure shall be performed as defined in ETSI EN 300 175-4 [4], clause 14.3.3.1.

11.5.1.3 Receiving side procedure

The procedure shall be performed as defined in ETSI EN 300 175-4 [4], clause 14.3.3.2 with the following specific provisions:

- The value of timer L(R) shall be set as equal to the MAC packet lifetime.
- Timer L(R) shall be running with the absolute TDMA frame counter. This timer shall not be stopped if the connection is suspended.

11.6 Lc frame delimiting and sequencing service

11.6.1 C_S channel fragmentation and recombination

The procedure shall be performed as defined in ETSI EN 300 175-4 [4], clauses 6.1.2, 6.1.3, 6.1.4 and 6.1.4.2.

The complete frame shall be fragmented into 5 octet fragments.

11.6.2 C_F channel fragmentation and recombination

The C_F channel shall be operated according to the procedures defined in ETSI EN 300 175-4 [4], clauses 6.1.2, 6.1.3, 6.1.4 and 6.1.4.1.

The complete frame shall be fragmented into 8 octet fragments.

11.6.3 Selection of logical channels (C_S and C_F)

The selection of the C_F instead of the C_S channel for Lc operation, shall be done according to the conditions defined in ETSI EN 300 175-4 [4], clause 10.2.5.

If both sides have indicated that they support C_F channel (see clause 10.3.2.2.1 for the FT and clause 12.3 for the PT) all C-plane transmission shall take place on the C_F channel.

11.7 Broadcast Lb service

11.7.1 Normal broadcast

The procedure shall be performed as defined in ETSI EN 300 175-4 [4], clauses 6.2.1, 8.3.3.1, 9.4.1.1 and 9.4.1.2 and ETSI EN 300 175-3 [3], clause 8.2.1.

Short frame format (frame length = 3) and full frame format (frame length = 5) are required to be supported.

The procedure is shown in figure 61 while tables 49 to 52 show the message fields.

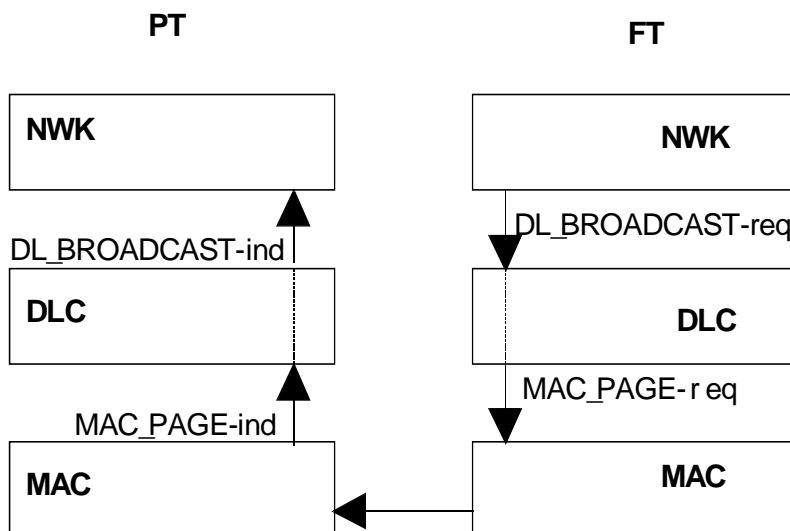

Figure 61: Normal broadcast

Table 49: Information used within the DL_BROADCAST-req primitive

Parameter	Information within the parameter	Normative action/comment
<< Cluster address list >>	All cluster/an integer	
<< Message unit length >>	3, 5 octets	Short and full frame format are required to be supported. (It is assumed that the RFP will support some NG-DECT service that may use full format paging)
<< Message unit >>	From the NWK layer	

Table 50: Information used within the MAC_PAGE-req primitive

Parameter	Information within the parameter	Normative action/comment
<< cluster ID >>	All clusters/an integer	
<< page type >>	Normal	"fast" (LCE paging) is not required to be supported
<< length of page field >>	0, 20 or 36	zero length, short and full paging formats
<< long flag >>	N/A	Long paging formats (length of page field > 36) does not need to be supported.
<< SDU >>	The data from the << Message unit >> received in the DL_BROADCAST-req primitive.	

Table 51: Information used within the MAC_PAGE-ind primitive

Parameter	Information within the parameter	Normative action/comment
<< length of page field >>	20 or 36	
<< long flag >>	N/A	Long paging formats (length of page field > 36) does not need to be supported.
<< SDU >>	The LCE page SDU	

Table 52: Information used within the DL_BROADCAST-ind primitive

Parameter	Information within the parameter	Normative action/comment
<< Message unit length >>	3, 5 octets	Short and full formats
<< Message unit >>	The data from the << SDU >> from the MAC_PAGE-ind primitive.	

11.8 LU13 Enhanced Frame RELay service with CRC (EFREL-CRC)

The procedure shall be performed as defined in ETSI EN 300 175-4 [4], clause 11.15 with the following specific requirements:

- The packet received from the U-plane application layer shall be the LU13 SDU.
- A 32 bit CRC shall be added at the end of the LU13 SDU as described in ETSI EN 300 175-4 [4], clause 11.15.2, second bullet. The 32 bit CRC shall be identical to the B-CRC defined in ETSI EN 300 175-3 [3], clause 6.2.5.5.
- Only the 32 bit CRC option defined in ETSI EN 300 175-4 [4] is supported.
- The reverse procedure shall be done at the receiving side.
- In case of wrong CRC decoding, the packet shall be discarded and an error notification shall be sent to higher layer.
- The standard delivery mode (see LU10 description) shall be used.
- The maximum LU13 SDU size that shall be supported is defined in clause B.2.1.
- The maximum SDU size in use at a given time may be configured by means of C-plane procedures (see clause B.2.1).
- All provisions applicable to the LU10 processing, underlying layers and the transport protocol are given in Service [ULE1-D.3].
- Only one instance of LU13 shall be supported between the same PT-FT pair:
 - The support of multiple instances of LU13 is for further study.

11.9 Encryption switching

11.9.1 MAC layer encryption switching

11.9.1.0 General

This procedure refers to the activation or deactivation of the MAC layer encryption (see for instance ETSI EN 300 175-3 [3], clause 6.2.3). For activation of the CCM encryption, see clause 11.9.2.

The procedure shall be performed as defined in ETSI EN 300 175-4 [4], clause 10.6, ETSI EN 300 175-7 [7], clauses 6.5.3 and 6.4.6 and ETSI EN 300 175-3 [3], clause 6.2.3.

The procedure for encryption deactivation is not required to be supported since a new connection is always established in clear mode. Therefore any connection or link release implies encryption deactivation.

The encryption deactivation is mandatory only if service [ULE1-D.11] is supported.

11.9.1.1 Associated procedure

11.9.1.1.1 Providing Encryption key to the MAC layer

On receipt of the DCK in a DL-ENC_KEY-req primitive the DLC shall transmit it to the MAC layer.

A record shall be kept for the active (the one used for the current encryption) DCK for use in case of connection handover.

11.9.1.2 Exceptional cases

11.9.1.2.1 Encryption fails

An encryption attempt which fails means the desired "Crypted" mode is not achieved. If the MAC fails to switch from clear to encrypted mode the connection is released and the DLC layer is informed by a MAC_DIS-ind primitive. At the peer side this indication shall arrive as a result of the connection release.

11.9.1.2.2 Connection handover of ciphered connections

Connection handover is for further study and not supported by this revision of the present document.

11.9.2 CCM encryption switching

When a DLC LU14 instance (DLC layer U-plane service with CCM) is created, a valid derived cipher key stored under the cipher key nr. associated to CCM should exist. Such derived cipher key has had to be created using a MM process:

- The key shall be automatically retrieved from NWK layer MM and transferred to the CCM engine associated to the LU14 instance for use as encryption key.
- If the key is not available, the LU14 instance cannot be created.

LU14 links shall be CCM encrypted from the first SDU.

When the DLC service operates in both ways (consisting either on a bi-directional link or two unidirectional links), the same key shall be used in both directions.

There is not a procedure for CCM encryption de-activation.

There is not a procedure for CCM re-keying. If this is required, the link may be dropped and a new one may be set up.

11.10 CCM/AES encryption

11.10.1 CCM Authenticated Encryption

The procedure shall be performed as described in ETSI EN 300 175-7 [7], clause 6.6.2.

The Initialization Vector shall be computed as described in ETSI EN 300 175-7 [7], clause 6.6.2.3.

11.10.2 CCM activation at Virtual Call setup

The CCM Authenticated Encryption shall start automatically when a LU14 DLC link is created. This happens when a Virtual call invoking this service is setup or resumed at NWK layer.

All LU14 U-plane transfer shall be CCM encrypted starting by the first SDU.

An unused Derived Cipher Key (DCK) generated by a PT authentication process and identified as a CCM Key, should exist before the creation of an LU14 instance. Otherwise the link setup and the associated Virtual Call setup should fail.

- The provisions given in ETSI EN 300 175-7 [7], clause 6.3.7.1 shall apply in this case.
- CCM sequence number shall be handled as described in ETSI EN 300 175-7 [7], clause 6.6.2.4. Both, the CCM sequence number and the DLC sending sequence number shall be set to "0" at the activation of the LU14 instance after the NWK layer Virtual Call setup or resume procedure.

CCM Sequence resetting and re-keying procedures without creating a new link are for further study.

11.10.3 Cipher keys for CCM

Keys used by CCM shall be Derived Cipher Keys (DCK) of 128 bits and are generated by a PT authentication process, as described in ETSI EN 300 175-7 [7], clause 6.2.3.

The Derived Key to be used for CCM shall use the <Cipher Key nr> = "9". This value shall be used in IE <<Auth-type>> and <<Cipher-Info>> associated to CCM keys.

The provisions for single use of the Keys given in ETSI EN 300 175-7 [7], clause 6.2.3.1 shall apply.

12 NWK layer procedures

12.1 Simplified NWK layer control procedures for ULE

12.1.0 General

In ULE phase 1, a simplified CC control model is used. Such model is based on the concept of a PVC (Permanent Virtual Circuit) controllable by means of Service Change operations.

NOTE: These procedures may be reused in further ULE phases.

12.1.1 General pre-requisites

The CC transaction value number 5, FT initiated, is reserved and shall not be used by any other service. This transaction number represents the ULE PVC.

ULE PT and FT shall support a DECT MAC service call with capacity to carry C-plane NWK messages. However, it does not need to be necessarily the same MAC connection that carries the ULE traffic. Network messages to control ULE PVC may be carried over any circuit mode MAC connection, such as the one used to set up a Service Call.

12.1.2 Creation of the ULE PVC and states

12.1.2.0 General

When a ULE phase 1 PP is registered to a ULE phase 1 RFP, a CC transaction with transaction value 5 (FT initiated) is automatically created without any CC operation (see clause 12.1.2.2).

Such CC transaction may only have two states:

- Connected and NWK suspended
- Connected and NWK resumed

NOTE: The states "NWK suspended" and "NWK resumed" refer to the NWK layer suspend and resume mechanism (as described in ETSI EN 300 175-5 [5], clause 9.6.4) and should not be confused with the MAC suspension and resume. Since both types of operations are used in the present document, the terms "NWK suspend" or "NWK resume" are used when referring to the NWK operations, except when it can be easily inferred from the context.

When the state is "NWK suspended", there is neither link nor MBC associated to the CC transaction.

When the state is "NWK resumed", there is a DLC LU link and a MAC MBC associated to the CC transaction. NWK resumed stated does not imply physical layer activity since the MAC MBC may be either MAC suspended or MAC resumed.

12.1.2.1 State diagram

Figure 62 shows the two possible states of the transaction and the possible operations.

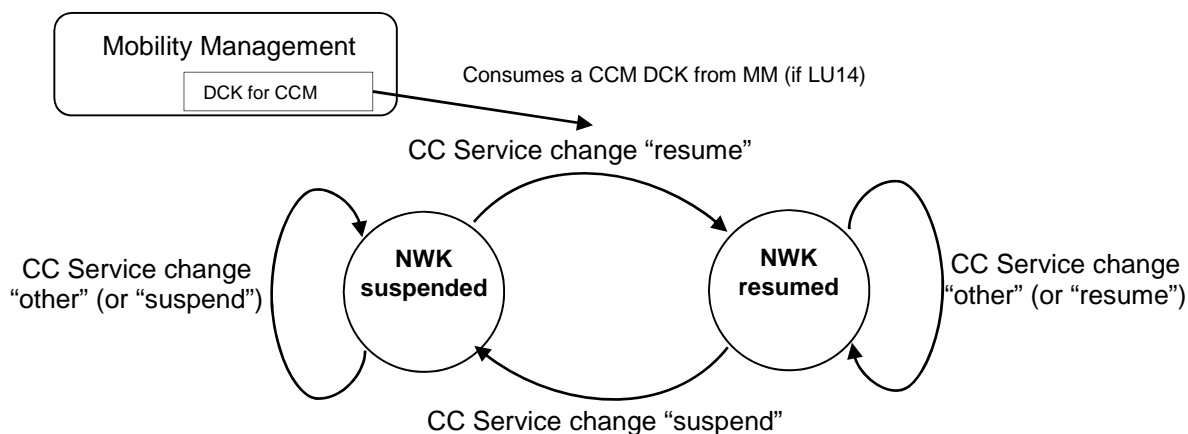

Figure 62: States and allowed transitions of the CC transaction

The ULE transaction only supports the following CC operations:

- "Service Change" by means of the message {CC Service Change} and its two possible replies {CC-Service Accept} and {CC-Service Reject};
- {IWU-INFO}.

Any other CC message over this transaction shall be ignored.

Only the following three "Service Change" operations are possible:

- Service Change "NWK resume"
- Service change "NWK suspend"
- Service change "other"

12.1.2.2 Creation of the transaction

The transaction is always created (at subscription registration) with the state NWK suspended. Transition between states is done by means of Service change CC operations as described in clause 12.1.3.

When the transaction is created, the default parameters given in clause 12.1.3.8 shall apply.

NOTE 1: The PVC is created without the need for explicit CC-SETUP transaction, and is automatically allocated a Transaction Value of 5. For the purposes of the Transaction Identifier Flag, the PVC is regarded as FT-initiated. This is just a matter of convention.

NOTE 2: The special Transaction Value 5 is only used for messages relating to the PVC, e.g. when {CC-SERVICE-CHANGE} is used to modify the PVC.

NOTE 3: The normal state of the transaction in normal ULE operation is NWK resumed.

12.1.3 Allowed CC Operations over the ULE transaction

12.1.3.0 General

The ULE transaction only supports the following CC operations:

- "Service Change" by means of the message {CC Service Change} and its two possible replies {CC-Service Accept} and {CC-Service Reject};
- {IWU-INFO} (see 13.2.1).

Any other CC message over this transaction shall be ignored.

For "Service Change" the following three operations are possible:

- Service Change "NWK resume"
- Service change "NWK suspend"
- Service change "other"

Each operation shall use the message {CC Service Change} and one of its possible replies {CC-Service Accept} (if successful) and {CC-Service Reject} (if unsuccessful).

The operations Service Change "NWK resume" and Service Change "NWK suspend" change the state of the CC transaction between the two possible states. They may also transfer parameters.

The operation Service Change "other" does not change the state and only transfers parameters.

For ULE phase 1, the PVC's "Service Change" messages shall be transported over the C-plane of an existing DECT link. Furthermore, ULE phase 1 restricts the type and state of the DECT link used for this purpose, as defined below:

- The link shall have an existing CC transaction, for example ULE Service Call, or voice call.
- The state of the existing CC transaction shall not be "NULL (T-00 or F-00) or "RELEASE PENDING" (T-19 or F-19) (see ETSI EN 300 175-5 [5] clause 9 for details of the CC state machine states).

These "Service Change" messages shall use the special Transaction Value of 5, as described in 12.1.2.2.

Messages pertaining to the underlying link shall use their own Transaction Identifier, according to the normal rules, e.g. the CC-SETUP and CC-RELEASE for the ULE Service Call shall use the Transaction Value of the ULE Service Call and not the PVC's special value of 5.

12.1.3.1 Service Change "NWK resume"

12.1.3.1.0 General

This operation changes the state of the CC transaction from "NWK suspended" to "NWK resumed".

This operation should always be invoked for any ULE activation (since the ULE CC transaction is always created in suspended state).

NOTE: See clause 12.1.3.1.4 for an exception case where a "NWK resume" Service Change is received in the "NWK resumed" state.

12.1.3.1.1 Pre-requisite:

The following pre-requisite applies if the required DLC service is LU14:

- A suitable (unused) Derived Cipher key for CCM shall exist before the completion of the CC Service Change operation (i.e. before the responding side sends the {CC-Service-Accept} response). Such Derived Cipher Key will be the key for LU14 and is consumed in the operation.

In the case of FP-initiated "NWK resume", the FP shall ensure that a valid cipher key exists before sending the {CC-Service-Request} message.

In the case of PP-initiated "NWK resume", the FP shall ensure that a valid cipher key exists before responding with the {CC-Service-Accept} message. If required, the FP shall generate the Derived Cipher Key for CCM by invoking of the Authenticate PP procedure (see ETSI EN 300 444 (GAP) [9], clauses 8.24 and 8.45.7).

If the CCM Derived Cipher key does not exist and cannot be generated, the resume operation shall fail (the response {CC-Service Reject} shall be used) and the state shall remain as "NWK suspended".

12.1.3.1.2 Coding of the operation messages

This operation is coded as follows:

- Initiating message {CC Service Change}

- Possible replies {CC-Service Accept} and {CC-Service Reject}
- Transaction value: 5, FT originated
- The IEs << SERVICE-CHANGE-INFO >> and << CONNECTION-IDENTITY >> shall be included and coded as described in table 53.

Table 53: Specific mandatory IEs and their values used within the {CC-SERVICE-CHANGE} and {CC-SERVICE-ACCEPT} message

Information element	Field within the information element	Standard values within the field/information element	Normative action/comment
Protocol Discriminator Transaction Identifier		'0011'B	Call control
	Flag	0 - 1	The transaction is assumed to be FT originated
	Transaction value	'101'B	"5"
<< PORTABLE IDENTITY >>			Only required for {CC-SERVICE-CHANGE} message.
	< Type >	0	International Portable User Identity (IPUI)
	< PUT >	all	Area dependent
	< PUN >	all	Area dependent
<< SERVICE-CHANGE-INFO >>			Only required for {CC-SERVICE-CHANGE} message.
	< Ext3 >	1	Octet 3a not used
	< Coding standard >	'00'B	DECT standard coding.
	< M >	0/1	Initiating/Receiving side is master.
	< Change Mode >	'1001'B	"Resume"
	< A >	'000'B	Not Applicable
	< R >	0	Do not reset state variables, this parameter may be ignored
	< B >	'000'B	Not Applicable
<< CONNECTION-IDENTITY >>			
	< U Plane link identity >	0	unnumbered U-plane link
	< Connection identity >	'1111'B	ECN = 7

In addition to the specific mandatory IEs mentioned above, the message may also carry any of the IEs allowed in clause 12.1.3.4.

12.1.3.1.3 Actions after a successfully CC Service Change "NWK resume" operation

12.1.3.1.3.1 DLC layer

After a successfully CC Service Change "NWK resume" operation, a DLC U-plane link (LU) shall be created at both peers. The LU shall be LU13 or LU14 according to the parameter currently set for the transaction. Since the default parameter is LU14 (see clause 12.1.3.5) the LU shall be LU14 unless the LU parameter has been changed by means of a previous or a simultaneous insertion of the IE <<Call attributes>>.

The DLC and CCM sequence numbers shall be initialized to "0" as indicated in ETSI EN 300 175-4 [4], clause 11.16.2.5.

The Derived Cipher key for CCM generated by the MM (which should exist) shall be used in the LU14 (and is consumed in the operation).

12.1.3.1.3.2 MAC layer

A MAC MBC with ECN = 7 and suitable for expedited operations shall be created or associated to the transaction.

- If such MBC (ECN = 7) exists, it shall be associated to the transaction with its existing MAC parameters.
- If such MBC (ECN = 7) does not exist, it is created at both sides with the default parameters given in clause 12.1.3.8, without the exchange of any MAC message.

The mechanism described as case b) is named "logical connection setup - implicit procedure" (see also clause 10.7.1.3).

NOTE: This is the normal MBC creation mechanism in ULE phase 1.

12.1.3.1.4 Exception case for "NWK resume" operation when already Resumed

The Service Change "NWK resume" message shall not be sent when the state is already "NWK resumed". However, in some scenarios a device could receive a Service Change "NWK resume" when it was already in the "NWK resumed" state. For example, there was a mismatch in the state between FP and PP; one side was in "NWK Suspended" state and the other side was in "NWK resumed" state. Such a scenario would only normally occur as an error condition.

In this exception case, the responding side shall reject the Service Change by sending the {CC-Service Reject} message with the Information Element <<RELEASE REASON>> and the release reason code "Unexpected Message" ('01'H).

Since the Service Change was rejected, both sides shall remain in their present states.

The receipt of a {CC-Service Reject} message with the Information Element <<RELEASE REASON>> and the release reason code "Unexpected Message" ('01'H) shall be understood to mean that the peer was not in a suitable state to accept the Service Change "NWK resume". The receiver of this message may subsequently use the Service Change "NWK suspend" operation to ensure both sides are in "NWK suspended" state, thus re-synchronizing the states.

12.1.3.2 Service Change "NWK suspend"

12.1.3.2.0 General

This operation changes the state of the CC transaction from "NWK resumed" to "NWK suspended".

This operation may be invoked only if needed.

NOTE 1: A possible reason for the use of the "NWK suspend" operation is the need to reset the DLC link.

NOTE 2: See clause 12.1.3.2.4 for an exception case where a "NWK suspend" Service Change is received in the "NWK suspended" state.

12.1.3.2.1 Pre-requisite:

Not applicable.

12.1.3.2.2 Coding of the operation messages

This operation is coded as follows:

- Initiating message {CC Service Change}
- Possible replies {CC-Service Accept} and {CC-Service Reject}
- Transaction value: 5, FT originated
- The IEs << SERVICE-CHANGE-INFO >> shall be included and coded as described in table 54.

Table 54: Specific mandatory IEs and their values used within the {CC-SERVICE-CHANGE} and {CC-SERVICE-ACCEPT} message

Information element	Field within the information element	Standard values within the field/information element	Normative action/comment
Protocol Discriminator Transaction Identifier		'0011'B	Call control
	Flag	0 - 1	The transaction is assumed to be FT originated
	Transaction value	'101'B	"5"
<< PORTABLE IDENTITY >>			Only required for {CC-SERVICE-CHANGE} message
	< Type >	0	International Portable User Identity (IPUI)
	< PUT >	all	Area dependent
	< PUN >	all	Area dependent

Information element	Field within the information element	Standard values within the field/information element	Normative action/comment
<< SERVICE-CHANGE-INFO >>			Only required for {CC-SERVICE-CHANGE} message
	< Ext3 >	1	Octet 3a not used
	< Coding standard >	'00'B	DECT standard coding.
	< M >	0/1	Initiating/Receiving side is master.
	< Change Mode >	'1000'B	"Suspend"
	< A >	'000'B	Not Applicable
	< R >	0	Do not reset state variables, this parameter may be ignored
	< B >	'000'B	Not Applicable

In addition to the specific mandatory IEs mentioned above, the message may also carry any of the IEs allowed in clause 12.1.3.4.

NOTE: When additional IEs are exchanged, and the operation is successful, the parameters carried in these IEs are immediately set into the transaction, even if the resulting state is "NWK suspended". Some of such parameters will only be used after a subsequent resume.

12.1.3.2.3 Actions after a successful CC Service Change "NWK suspend" operation

12.1.3.2.3.1 DLC layer

DLC LU entity is released.

12.1.3.2.3.2 MAC layer

Case A: If the CC message was carried by a different MBC to the one associated to the transaction:

- The CC operation is completed and the MAC MBC associated to the transaction (with ECN = 7) is released at both peers without any further signalling operation.

NOTE: This is the normal intended operation in ULE phase 1.

Case B: If the CC message was carried by the same MBC that is associated to the transaction:

- The CC operation is completed, and then the MAC bearer is released using MAC normal release (not expedited) procedures.

12.1.3.2.4 Exception case for "NWK suspend" operation when already Suspended

In some scenarios a device could receive a Service Change "NWK suspend" message when it was already in the "NWK suspended" state. For example, there was a mismatch in the state between FP and PP; one side was in "NWK Suspended" state and the other side was in "NWK resumed" state. Such a scenario would only normally occur as an error condition.

A Service Change "NWK suspend" message may be sent intentionally by a device even though it is already in "NWK suspended" state. For example in order to ensure both sides are in "NWK suspended" state, thus re-synchronizing the states.

In this exception case, the responding side shall accept the Service Change by sending the {CC-Service Accept} message and the operation will proceed as normal.

12.1.3.3 Service Change "other"

12.1.3.3.0 General

At any state, it is possible to perform service change operations that are neither suspend nor resume. They are used to configure parameters of the PVC. The transaction state remains unchanged.

12.1.3.3.1 Pre-requisite:

Not applicable.

12.1.3.3.2 Coding of the operation messages

This operation is coded as follows:

- Initiating message {CC Service Change}
- Possible replies {CC-Service Accept} and {CC-Service Reject}.
- Transaction value: 5, FT originated
- The IEs << SERVICE-CHANGE-INFO >> shall be included and coded as described in table 55.

Table 55: Specific mandatory IEs and their values used within the {CC-SERVICE-CHANGE} and {CC-SERVICE-ACCEPT} message

Information element	Field within the information element	Standard values within the field/information element	Normative action/comment
Protocol Discriminator Transaction Identifier		'0011'B	Call control
	Flag	0 - 1	The transaction is assumed to be FT originated
	Transaction value	'101'B	"5"
<< PORTABLE IDENTITY >>			Only required for {CC-SERVICE-CHANGE} message
	< Type >	0	International Portable User Identity (IPUI)
	< PUT >	all	Area dependent
	< PUN >	all	Area dependent
<< SERVICE-CHANGE-INFO >>			Only required for {CC-SERVICE-CHANGE} message
	< Ext3 >	1	Octet 3a not used
	< Coding standard >	'00'B	DECT standard coding
	< M >	0/1	Initiating/Receiving side is master
	< Change Mode >	'0000'B	"none" The "none" value is used when there is no state change
	< A >	'000'B	Not Applicable
	< R >	0	Do not reset state variables, this parameter may be ignored
	< B >	'000'B	Not Applicable

In addition to the specific mandatory IEs mentioned above, the message may also carry any of the IEs allowed in clause 12.1.3.4.

12.1.3.4 Allowed parameters in any service change operation

The parameters described below may be inserted in any service change operation. In all cases they will be transmitted in addition to the mandatory IEs.

All IEs shall always be transmitted over the air in the standard DECT order, as indicated in ETSI EN 300 175-5 [5], clause 6.3.1.

For FT initiated operations, the PT shall repeat the parameters sent by the FT. If the FT is trying to set an optional value of a parameter that the PT does not support, it is allowed for the PT to reject the operation. The release reason IE with the code '06'H (service not implemented) shall be inserted in the {Service Reject} message.

For PT initiated operations, the parameters sent in the PT => FT direction have the nature of suggestion. The FT has the choice to reject the operation and start an FT initiated Service Change with its own parameters. The release reason IE may be inserted in the {Service Reject} message.

If the << ULE-MAC-CONFIGURATION-INFO >> IE is used in a request message sent by the PT, it shall be coded with control = 0 and no descriptors shall be sent.

After a successfully operation, the parameters carried in these IEs are immediately set into the transaction, even if the resulting state is "NWK suspended". However some of such parameters will only be used after a subsequent resume.

Before or in absence of any Service change operation changing parameters, the default parameters given in clause 12.1.3.5 shall apply.

The optional parameters that can be used in a CC-SERVICE-CHANGE and CC-SERVICE-ACCEPT message are shown in table 56.

Table 56: Optional parameters that may be used in the {CC-SERVICE-CHANGE} and {CC-SERVICE-ACCEPT} message in any CC Service change operation

Information element	Field within the information element	Standard values within the field/information element	Normative action/comment
<< ULE-MAC-CONFIGURATION-INFO >>	Control	0-1	0=de-allocates all channels, 1= append new channel Control value =0 shall also be used in the PT=>FT message
	Paging descriptors	All	All values may be used. Paging descriptors shall be inserted only in the message sent in FT => PT direction
<< TRANSIT-DELAY >>	Overall DECT system maximum Delay	Any	Overall DECT system maximum delay is not used and shall be ignored. It is recommended to code it with the same value as next parameter" overall MAC layer maximum lifetime"
	overall MAC layer maximum lifetime	1-1 008 frames	Codes the overall MAC layer maximum lifetime
<< WINDOW-SIZE >>	Window size value (PT => FT, used for both directions)	8 - 128	The same window size is used in both directions. All other parameters in the IE are not used Only values 8, 16 and 32 are mandatory to support. All others are optional
<< IWU-ATTRIBUTES >>	Coding Standard	'01'B	Profile defined coding
	Profile	'1000'B	ULE profile
	Negotiation indicator	'100'B	Exchanged parameter negotiation
	Profile subtype	'0000'B	ULE Part 1 transparent Interworking
	IWU function at FP	'0000001'B	transparent routing
	ULE Application Protocol Identifier	'0000000'B '0000001'B '0000110'B '1xxxxx'B	undefined protocol ULE Functional application protocol #1 6LoWPAN protocol Proprietary ULE protocols
	ULE Application Protocol Version	all	Coding specified by the application protocol
	Maximum MTU/SDU size	8 - 65532 octets (coded as 16383)	Maximum size of the SDU (and MTU) All values above 500 are optional to support
	EMC	all	EMC code for discriminating proprietary protocols
<< CALL-ATTRIBUTES >>	Coding Standard	0	DECT standard coding
	NWK layer attributes	'0100'B (ULE part 1)	ULE part 1
	C-plane class	'010'B, (Class A link), or '111'B (no C-plane)	No C-plane mandatory (see note) Class A link, optional
	C-Plane routing	'0000'B (Cs only),, '0010'B C _F (preferred), '1111'B (no C-plane routing)	No C-plane mandatory (see note). Cs and C _F optional
	U-Plane symmetry	1	Symmetric
	LU identification	'0001101'B (LU13), '0001110'B (LU14)	LU14 mandatory, LU13 optional (except for markets where LU14 is not allowed)
	U-Plane Class	'010'B	Class 1
FU-Type symmetry	1	Symmetric	

Information element	Field within the information element	Standard values within the field/information element	Normative action/comment
	U-Plane frame type and options (if LU is LU13)	'1001'B (FU10a/d, CRC 32 bit)	FU10a/FU10d CRC-32 bit (only combination supported)
	U-Plane frame type and options (if LU is LU14)	'1001'B (FU10a/d)	FU10a/FU10d (only combination supported)

NOTE: No C-plane refers to the case when the MAC connection associated to the PVC does not have the capability to transport C-plane higher layer messages and does not have its own DLC C-plane entity. In such a case, the C-plane higher layer messages may be transported over other MAC connections (that may be associated to other CC transactions). This is the normal mode in ULE phase 1.

12.1.3.5 Default parameters

The ULE PVC transactions are created with the default parameters defined in table 57, which shall apply unless changed by any Service Change operation.

Table 57: Default parameters for ULE PVC transactions

Information element	Field within the information element	Default values	Normative action/comment
<< ULE-MAC-CONFIGURATION-INFO >>	Paging descriptors	No paging descriptor allocated	
<< TRANSIT-DELAY >>	Overall DECT system maximum Delay	Not applicable	
	Overall MAC layer maximum lifetime	25	25 frames = 250 ms.
<< WINDOW-SIZE >>	Window size value (PT => FT, used for both directions)	16	The same window size is used in both directions. All other parameters in the IE are not used
<< IWU-ATTRIBUTES >>	Coding Standard	'01'B	Profile defined coding
	Profile	'10000'B	ULE profile
	Negotiation indicator	'100'B	Exchanged parameter negotiation
	Profile subtype	'0000'B	ULE Part 1 transparent Interworking
	Reserved bits	'0000000'B	shall be coded to '0'
	ULE Application Protocol Identifier	'0000000'B	undefined protocol
	ULE Application Protocol Version	'0'	Coding specified by the application protocol
	Maximum MTU/SDU size	32 octets (coded as 8)	Maximum size of the SDU (and MTU). Default value shall be understood as bidirectional
<< CALL-ATTRIBUTES >>	Coding Standard	0	DECT standard coding
	NWK layer attributes	'0100'B (ULE part 1)	ULE part 1
	C-plane class	'111'B (no C-plane)	No C-plane is the default value for ULE phase 1
	C-Plane routing	"1111'B (no C-plane routing)	No C-plane routing is the default value for ULE phase 1
	U-Plane symmetry	1	Symmetric
	LU identification	'0001110'B (LU14)	LU14 is the default value for ULE phase 1
	U-Plane Class	'010'B	Class 1
	FU-Type symmetry	1	Symmetric
	U-Plane frame type and options (if LU is LU14)	'1001'B (FU10a/d)	FU10a/FU10d (only combination supported)

12.1.3.6 Initiating part of the Service Change operations

12.3.1.6.0 General

Service change operations may be initiated by any of the peers.

12.1.3.6.1 Rule for handling collisions

In case of collision of PT initiated and FT initiated operations, the FT shall reject the colliding PT initiated operation. The release reason IE with the code '0C'H (collision) shall be inserted in the {Service Reject} message.

The PT shall continue processing the FT initiated operation.

12.1.3.7 Independence of other CC transactions.

The standard DECT rules apply regarding the use of Service Change CC operations and MM states.

Service change CC operations related to the ULE PVC (transaction 5 FT initiated) are orthogonal to the states of other CC transactions that may exist in the PT-FT pair.

12.1.3.8 Default MAC parameters for implicitly created MBC

When a pair of MAC MBCs is created without exchange of MAC signalling, as result of the procedure described in clause 12.1.3.1.3.2, case b), the default MAC parameters described in table 58 shall be used.

Table 58: Default MAC parameters in MBCs created without exchange of MAC messages after a Service Change Resume operation

MAC parameter	Default initial value	comment
Type of connection	Advanced	
ECN	7	
LBN	Not applicable	The MBC is always created in MAC suspended state
Up/down/sm/ss	'11'B	Symmetric single bearer
Ser type	IPQR	MAC IPQR error correct
TBC Max lifetime	7	Lifetime = 7 frames
Slot type	Full	Full slot
C _F	0	C _F not used
A-field modulation	2-level	2-level GFSK
B+Z field modulation	2-level	2-level GFSK

12.1.3.9 Paging descriptors in suspend and resume states

Paging descriptors for B_U paging configured by means of << ULE-MAC-CONFIGURATION-INFO >> apply even in NWK suspend state.

Paging commands received over B_U when the PP is in "NWK resumed" state trigger a MAC resume using expedited procedures as described in clause 10.10.

Paging commands received over B_U when the PP is in "NWK suspended" state shall be understood as orders to set up the Service Call and performing a Service Change "resume" operation.

NOTE: MM procedures may also be executed, if needed, in order to generate a fresh key for CCM.

12.1.3.10 Negotiation rules

The following negotiation rules apply when exchanging parameters via any CC Service Change operation:

<< ULE-MAC-CONFIGURATION-INFO >>

The descriptors are always set by the FT.

<< TRANSIT-DELAY >>,

<Overall MAC layer maximum lifetime>

The initiating side may propose a new value. The other side may accept it, or reply with the default value in the response message.

<< WINDOW-SIZE >>

The initiating side may propose a new value. The other side shall accept it if it is in the range 8-32. Otherwise it may reply with the default value in the response message. The value in the response message shall be the one to be used.

<< IWU-ATTRIBUTES >>**<ULE Application Protocol Identifier>**

FT shall accept any value proposed by the PT.

PT shall only accept values it really supports.

< ULE Application Protocol Version >

Any value shall be accepted.

< Maximum MTU/SDU size >

FT shall accept any value proposed by the PT if it is ≤ 500 octets. If the PT proposes a higher value and the FT does not support it, it may reply with 500 and this will be the used value.

PT shall accept any value proposed by the FT that the PT may support. If this is not the case, the PT may reply with the highest value it may support (depending on the implemented application protocols).

< EMC >

Any value shall be accepted.

<< CALL-ATTRIBUTES >>**< C-plane class >, < C-plane routing >,**

It is allowed to reply with the mandatory value (no C-plane), and this will be the value to be used.

< LU identification >

It is allowed to reply with the mandatory value (LU14), and this will be the value to be used.

12.2 Other NWK layer procedures

12.2.1 Service call setup

12.2.1.0 General

NOTE: The ULE Service Call is modelled on the NG-DECT List Access Service Call, and will use CC-CALL-PROC rather than CC-CONNECT, since a U-plane connection is not required for the ULE Service Call.

12.2.1.1 Prerequisites

The service call shall be established only over a (circuit mode) basic MAC connection. The NWK messages associated to this call shall be routed over its own (basic connection) MBC.

12.2.1.2 Procedure

The GAP outgoing call request procedure shall be used as defined in ETSI EN 300 444 [9], clause 8.2, with the differences in the { CC-SETUP } message given in table 59 below

Table 59: Values used within the {CC-SETUP} message for service call

Information element	Field within the information element	Standard values within the field/information element	Normative action/comment
<<Basic service>>	<Call class>	'0011'B	ULE Service call setup
	<Basic Service>	'0000'B	Basic speech default setup attributes

The FT shall respond to the { CC-SETUP } message with a { CC-CALL-PROC } message rather than a { CC-CONNECT } message.

NOTE: A ULE Service Call does not normally enter the "ACTIVE" state (F-10 or T-10), but stays in "CALL PROCEEDING" (F-03 or T-03). This is analogous to the NG-DECT List Access Service Call.

12.2.2 Storing the Derived Cipher Key for CCM (DCK-CCM)

This procedure is required by the DLC Service [ULE1-D.12] "CCM/AES encryption". It is related, but not exactly the same, to the procedure "Storing the Derived Cipher Key (DCK)" (clause 8.27 of ETSI EN 300 444 (GAP) [9]).

In order to generate a Derived Cipher Key for CCM, the authentication of PT procedure of the feature [ULE1-N.3] ("Authentication of the PP") is executed with the modification noted in table 60 to the { AUTHENTICATION-REQUEST } message.

The procedure may be either Authentication of PP using DSAA (clause 8.24 of [9]) or Authentication of PP using DSAA2 (clause 8.45.7 of [9]). The strongest security is achieved with the Authentication of PP using DSAA2.

This procedure may be executed using either DSAA or DSAA2 algorithms. The procedure for authentication of PT shall be executed as described in clause 8.24 of [9] when DSAA is used or as described in clause 8.45.7 of [9] when DSAA2 is used. The strongest security is achieved with the Authentication of PP using DSAA2.

The authentication algorithm shall be the same in use for the execution of the FT authentication procedures.

The modification given in table 60 shall apply in the message { AUTHENTICATION-REQUEST } sent by the FT.

Table 60: Replacement to {AUTHENTICATION-REQUEST} for storing the DCK for CCM (DCK-CCM)

Information element	Field within the information element	Standard values within the field/information element	Normative action/comment
<<Auth-type>>	<UPC>	1	Store the new DCK
	<Cipher key number>	9	See ETSI EN 300 175-7 [7], clause 6.2.3

For the other contents of the { AUTHENTICATION-REQUEST } message, refer to table 39 of [9] if DSAA is used or to table 82 of [9] (clause 8.45.7) if DSAA2 is used.

12.3 Terminal capabilities and FP broadcasts

12.3.1 Terminal capability indication

The PP shall be able to send the <<Terminal capability>> information element and the FP shall be able to receive it at least in {ACCESS-RIGHTS-REQUEST} and when location registration is supported in the {LOCATE-REQUEST}.

Terminal capability indication shall be done as defined in clause 8.17 of ETSI EN 300 444 [9] (GAP) with the content in the <<Terminal capability>> information element as defined in table 61.

Table 61: Values used within the <<TERMINAL CAPABILITY>> information element

Information element	Field within the information element	Standard values within the field/information element	Normative action/comment
<<Terminal capability>>	<Slot type capability>	"xxx1xxx"B	Full slot supported (all others optional)
	<Profile indicator_1>	'xxxxXx"B X = [0,1]	GAP and/or PAP supported or not supported (see note 1)
	<Profile indicator_4>	"xxxXxxx"B X = [0,1]	Support or not support of C _F channel (see note 1)
	<Profile indicator_4>	"xx1xxxx"B	I _{PQ} services supported
	<Profile indicator_5>	"xxxxx1"B	2-level modulation scheme supported (B+Z field)
	<Profile indicator_5>	"xx1xxxx"B	2-level modulation scheme supported (A field)
	<Profile indicator_6>	"xXxxxx"B X = [0,1]	PT with fast hopping radio or not (see note 1)
	<Profile indicator_7>	"xxXxxxx"B X = [0,1]	Support or no support of "Re-keying" and "default cipher key early encryption mechanism" (see notes 1 and 2)
	<Profile indicator_7>	"xxxxXx"B X = [0,1]	Support or no support of NG-DECT Part 1: Wideband voice supported (ETSI TS 102 527-1 [i.5] and note 1)
	<Profile indicator_7>	"xxxxXXx"B X = [0x,11]	Support or no support of NG-DECT Part 3: Extended wideband speech services supported (ETSI TS 102 527-3 [11] and note 1)
	<Profile indicator_9>	"xxXXXx"B XXX = [011], note 4	Support for DECT ULE. See notes 3, 4, 5 and 6
	DSAA2 (Octet 5)	[0,1]	Support (or not support) of the DSAA2 (see ETSI EN 300 175-7 [7] and notes 1 and 2)
	DSC2 (Octet 5)	[0,1]	Support (or not support) of the DSC2 (see ETSI EN 300 175-7 [7] and note 1)
<p>NOTE 1: This bit is only set if the corresponding capability is supported.</p> <p>NOTE 2: This capability is assumed as the default value (see table 62) if the <<TERMINAL-CAPABILITY>> information element is omitted.</p> <p>NOTE 3: Bits 3-5 of 'Profile indicator_9' indicate the supported ULE version; 001 indicates ULE Phase 1 (revision v1.1.1); 011 indicates ULE Phase 1 (revision v1.2.1 or later), 101 indicates support of phase 2 and 111 is reserved for indicating support of Phase 3.</p> <p>NOTE 4: PPs compliant with the present documents will always set '011'B (support of ULE Phase 1 revision v1.2.1 or later). However FPs shall understand all codes.</p> <p>NOTE 5: Phases 2 and 3 PPs are assumed to be backcompatible with the present document. When observing these codes, the FP shall assume that the PP will behave as a Phase 1 (revision v1.2.1 or later) PP.</p> <p>NOTE 6: Phase 1 revision v1.1.1 PPs have some limitations compared to Phase 1 revision v1.2.1 or later PPs. The FP should be able to understand and handle properly such limitations.</p>			

The values given in table 62 shall be assumed as default if the related fields in the <<TERMINAL CAPABILITY>> information element are not present.

Table 62: Values assumed as terminal capabilities

Information element	Field within the information element	Standard values within the field/information element	Normative action/comment
<<Terminal capability>>	<Slot type capability>	"xxx1xxx"B	Full slot supported
	<Profile indicator_1>	'xxxxx0x"B	GAP and/or PAP not supported
	<Profile indicator_4>	"xxx0xxx"B	No support of C _F channel
	<Profile indicator_6>	"x0xxxx"B	PT without fast hopping radio
	<Profile indicator_7>	"xx0xxxx"B	No support of "Re-keying" and "default cipher key early encryption mechanism"
	<Profile indicator_7>	"xxxxx0x"B	No support of NG-DECT Part 1: Wideband voice (ETSI TS 102 527-1 [i.5])
	<Profile indicator_7>	"xxxx00x"B	No support of NG-DECT Part 3: Extended Wideband voice (ETSI TS 102 527-3 [11])
	DSAA2 (Octet 5)	0	No support of the DSAA2 (see ETSI EN 300 175-7 [7])
	DSC2 (Octet 5)	0	No support of the DSC2 (see ETSI EN 300 175-7 [7])

12.3.2 FP broadcasts

12.3.2.1 Higher layer information FP broadcast

12.3.2.1.0 General

The FP and PT shall support the broadcast of Higher Layer capabilities as part of Q_T MAC broadcast messages (see clause 10.3.2.2).

The broadcast attributes are a small set of NWK layer and DLC layer capabilities (jointly known as "higher layer capabilities") that shall be broadcast regularly as part of the MAC layer broadcast service (see ETSI EN 300 175-5 [5], annex F).

RFPs belonging to the same LA shall broadcast the same values of higher layer attributes (see ETSI EN 300 175-5 [5], annex F) at any given time.

FP and PT shall support the values of "Higher Layer capabilities" information attributes given in clauses 12.3.2.1.1 and 12.3.2.1.3.

The PP shall be capable to read and interpret at least the broadcast attributes codings during locking procedure. In the locked state the PP may assume them as static.

12.3.2.1.1 Higher layer information in standard FP broadcast (Qh = 3)

The Higher Layer capabilities Fixed Part Information fields given in table 63 shall be used to indicate the support of the indicated features. Most bits are not specific of ULE part 1, but will be set in most RFPs due to the coexistence with voice services.

Table 63: Higher layer information attributes in standard FP broadcast (Qh = 3)

BIT Number	Attribute	Value	Note
< a ₃₂ >	ADPCM/G.726 Voice service	[0,1]	If voice services are supported
< a ₃₃ >	GAP and/or PAP basic speech	[0,1]	If voice services are supported
< a ₃₆ >	DECT Standard Authentication (DSAA) required	1	Mandatory to support
< a ₃₇ >	DECT Standard Cipher (DSC) supported	1	Mandatory to support
< a ₃₈ >	Location registration supported	1	See location update procedure, clause 8.29 of ETSI EN 300 444 [9] (GAP)
< a ₄₀ >	Non-static FP	[0,1]	A FP which is mounted on a moving vehicle
< a ₄₄ >	Access Rights requests supported	[0,1]	The FP can toggle this bit to enable or disable on air subscription (see annex A)
< a ₄₆ >	Connection handover supported	[0,1]	Shall be understood as referring to voice services

12.3.2.1.2 Higher layer information in Extended FP broadcast (Qh = 4)

No Extended higher layer capabilities bits are used by the present document.

12.3.2.1.3 Extended Higher Layer capabilities part 2 (Qh = 11)

The Extended Higher Layer capabilities, part 2, Fixed Part Information fields given in table 64 shall be used to indicate the support of ULE part 1 (bit < a₃₉ >) as well as other services and optional features that may be supported by the RFP.

Table 64: Extended Higher Layer Capabilities part 2 interpretation by the PP

BIT Number	Attribute	Value	Note
< a ₂₄ >	NG-DECT Wideband voice supported	[0, 1]	See ETSI TS 102 527-1 [i.5] (see notes 1 and 2)
< a ₂₉ >	NG-DECT extended wideband voice services supported	[0, 1]	Support or not support of ETSI TS 102 527-3 [11] (see notes 1 and 2)
< a ₃₉ - a ₄₁ >	Support for DECT ULE	[110], note 5	Support of ULE Phase 1 revision v1.2.1 (the present document) or later. See notes 4, 5, 6 and 7
< a ₄₂ >	Support of 'Re-keying' and 'early encryption'	[0, 1]	Support (or not support) of the 'Re-keying' and 'default cipher key mechanism early encryption' procedures (related to feature [ULE1-N.17])
< a ₄₃ >	DSAA2 supported	[0, 1]	Support (or not support) of the DSAA2 (see ETSI EN 300 175-7 [7])
< a ₄₄ >	DSC2 supported	[0, 1]	Support (or not support) of the DSC2 (see ETSI EN 300 175-7 [7] and note 3)
<p>NOTE 1: Value refers to the value to be set by FPs complying with the present document. PPs may need to understand other values due to the compatibility with GAP and NG-DECT Part 1 FPs.</p> <p>NOTE 2: All equipment compliant with the present document shall broadcast and shall understand the "Extended Higher layer capabilities (part 2)".</p> <p>NOTE 3: The support of the DECT Standard Cipher #2 (DSC2) requires the support of the DECT Standard Authentication Algorithm #2 (DSAA2).</p> <p>NOTE 4: Bits a₃₉ - a₄₁ of 'Extended Higher Layer Capabilities Part 2' indicate the supported ULE version; 100 indicates support of ULE Phase 1 revision v1.1.1; 110 indicates support of ULE Phase revision v1.2.1 or later, 101 indicates support of ULE Phase 2 and 111 is reserved for indicating support of ULE Phase 3.</p> <p>NOTE 5: FPs compliant with the present documents will always set '110'B (support of ULE Phase 1 revision v1.2.1 or later). However PPs shall understand all codes.</p> <p>NOTE 6: Phase 2 and Phase 3 FPs are assumed to be backward compatible with Phase 1. When observing the codes indicating support of Phase 2 or Phase 3, a PP compliant with the present document may assume that the FP will be able to identify the PP phase (by means of terminal capability) and behave as a "Phase 1 revision v1.2.1 or later" FP.</p> <p>NOTE 7: "Phase 1 revision v1.1.1" FPs have some limitations compared to "Phase 1 revision v1.2.1 or later" FPs. The PP should be able to understand and handle properly such limitations.</p>			

13 Services and Interworking procedures

13.1 Interworking specific procedures

The different types of Interworking options supported by the present document are listed and described in annex B (normative). The U-plane and C-plane procedures that are specific for each Interworking type are defined in the applicable clause of annex B.

13.2 Other Interworking procedures

13.2.1 Transport of IWU-to-IWU data

13.2.1.1 General requirements

For ULE phase 1, the IWU-to-IWU messages shall be transported over the C-plane of an existing DECT link. Furthermore, ULE phase 1 restricts the type and state of the DECT link used for this purpose, as defined below:

- The link shall have an existing CC transaction, for example ULE Service Call, or voice call.
- The state of the existing CC transaction shall not be "NULL (T-00 or F-00) or "RELEASE PENDING" (T-19 or F-19) (see ETSI EN 300 175-5 [5] clause 9 for details of the CC state machine states).

These IWU-to-IWU messages shall use the special Transaction Value of 5, as described in clause 12.1.2.2.

NOTE: Messages pertaining to the CC transaction associated to the existing underlying link will use their own Transaction Identifier, according to the normal rules, e.g. the CC-SETUP and CC-RELEASE for the ULE Service Call will use the Transaction Value of the ULE Service Call and not the PVC's special value of 5.

This procedure may be used to transport data between ULE applications peer-to-peer (i.e. FP to PP) in both directions.

13.2.1.2 Prerequisites

For ULE phase 1, the IWU-to-IWU messages shall be transported over the C-plane of an existing DECT link, as defined in clause 13.2.1.1.

13.2.1.3 Procedure

Data shall be sent using an <<IWU-to-IWU>> Information Element (see table 65) contained within an IWU-INFO call control message. The general format of the <<IWU-to-IWU>> message is shown in clause A.3.

The actual payload data for this message is defined on a ULE Application Protocol specific basis, and is not defined in the present document.

Table 65: Values used within the <<IWU-to-IWU>> information element

Information element	Field within the information element	Standard values within the field/IE	Normative action/comment
Protocol Discriminator		'0011'B	Call Control
Transaction Identifier	Flag	0 - 1	The transaction is assumed to be FT originated
	Transaction value	'101'B	"5"
<<IWU-to-IWU>>	<Length of content>	L	Length of content
	<S/R bit>	1	Transmission of message
	<Protocol Discriminator>	05H	ULE Configuration and Control
	IWU-TO-IWU INFORMATION	...	Payload data format is protocol specific, and is not defined in the present document.

14 Application procedures

14.0 General

Clause 14 specifies the additional application layer procedures, messages and information elements required in ULE Phase 1, which are not described in ETSI EN 300 444 [9] (GAP) or ETSI TS 102 527-3 [11] (NG-DECT), or incorporating modifications to the description given in these specifications.

NOTE: The main functional application is out of the scope of the present document.

14.1 Easy Pairing procedures

14.1.1 Searching mode request

The access rights procedure triggering by the user on the PP causes it to actively search for a FP broadcasting 'Access Rights requests supported' capability bit (Higher layer capabilities bit $a_{44} = 1$, see ETSI EN 300 175-5 [5], clause F.1 and ETSI EN 300 444 [9], annex A (informative): PP locking procedure for on-air subscription procedure). The searching mode shall be limited by the timer P<AP.02>.

When a FP is found in subscription mode, the PP shall start the access rights procedure using the '0000' value for the authentication code. If the FP rejects the access rights, the PP may prompt the user to enter the PIN code, or may use a pre-programmed PIN code which could be entered at the FP. The PP may then initiate a new access rights request with the same FP using the supplied PIN entered value for the authentication code.

NOTE: When performing easy pairing registration, it is assumed that the PP is in close proximity to the FP, and therefore the PP will receive a stronger signal from that FP. The PP can use RSSI readings to speed up the search for the desired FP. For example:

- 1) Measure the RSSI level on each channel.
- 2) Synchronize on the FP with the highest RSSI value.

- 3) Wait for the a₄₄ bit to check if it is set.
- 4a) If a₄₄ is set, start the access rights procedure.
- 4b) If a₄₄ is not set, put the RFPI on a barred list and go to step 2 (or 1) to find other FP.

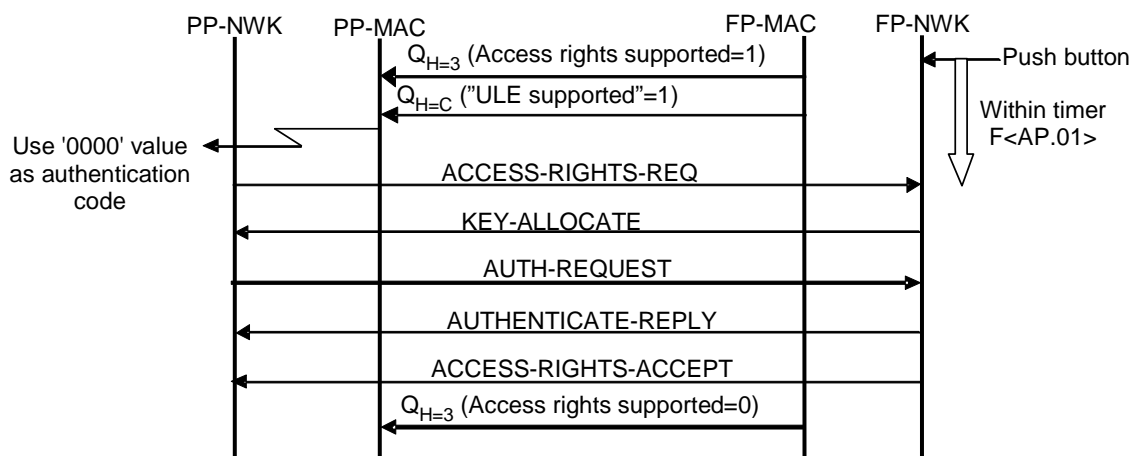

Figure 63: Easy pairing when PIN is set to default '0000' value

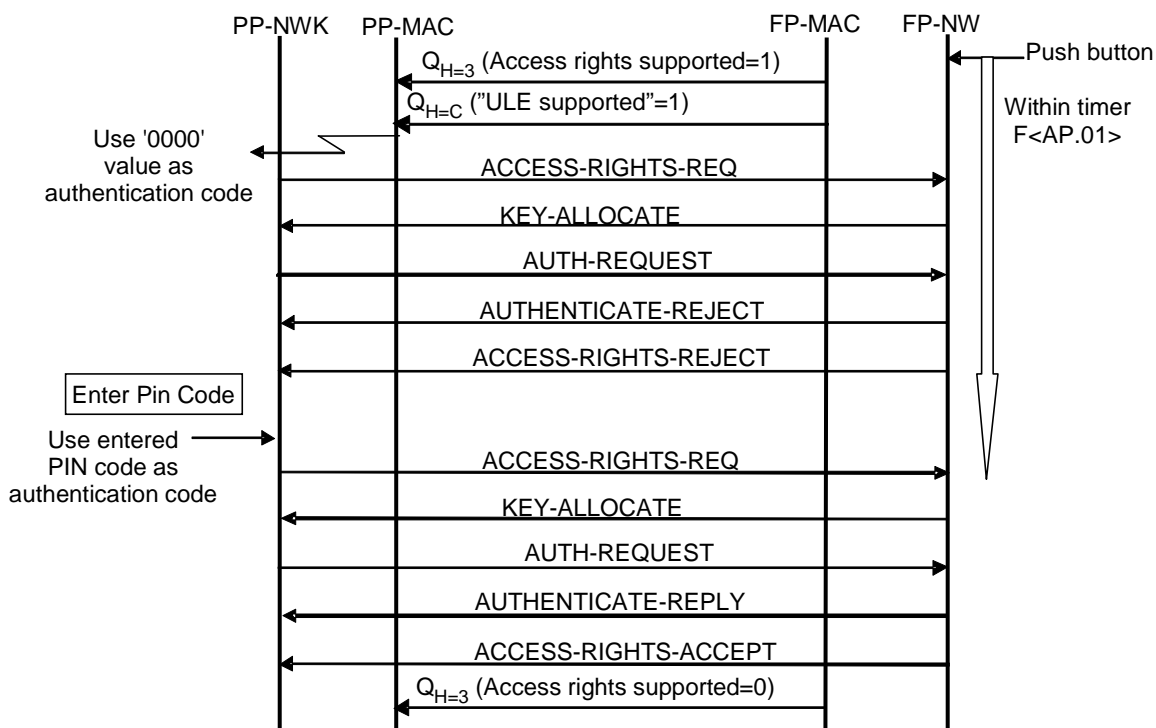

Figure 64: Easy pairing when PIN is not set to default '0000' value: switching back to PIN entry

In figure 63 and figure 64 above, the $Q_{(H=C)}$ message "ULE supported" refers to the any of the ULE capability bits (a39-a41) in the Extended Higher Layer Capabilities Part 2 message.

Annex A (normative): Parameters and Information Elements

A.1 Constants, variables and operating parameters

A.1.1 Operating parameters

A.1.1.1 Channel selection algorithms

b (a parameter of the channel selection algorithm M2): 6

m (delay between frame carrying the M_U channel selection information and the access frame): 2 frames

A.1.1.2 MAC layer

Several MAC layer parameters are negotiable by means of MAC or NWK messages. Their default values are provided in clauses 12.1.3.8 and 12.1.3.5.

A.1.1.3 DLC layer

Maximum SDU size with mandatory support at FP side: 500 octets

NOTE: Other DLC parameters are negotiable by means of NWK messages. Their default values are provided in clause 12.1.3.5.

A.2 Coding of Information Elements

A.2.1 Coding of the Information Element << ULE-MAC-CONFIGURATION-INFO >>

The purpose of the << ULE-MAC-CONFIGURATION-INFO >> element is to transport one or more descriptors. The descriptors are records that identify a paging signal (by its sequence and paging ID) and define the action to be performed when the signal appears. See clauses 10.6.2.1. and 10.6.2.2 for a general description of the paging descriptors.

The format of the descriptors used by the present document is shown in figure A.1 (see also clause 10.6.2):

Bit:	8	7	6	5	4	3	2	1	Octet:
	<< ULE-MAC-CONFIGURATION-INFO >>								1
	Length of Contents (L)								2
	1	Coding standard			Control				3

Descriptor format A

	Descriptor type and command		CA		k
	Spare (0000)		Repetition		k+1
	0 spare	Start MFN4			k+2
	Start MFN		Start FCNT		k+3
	0/1	Paging ID (7 bits)			k+4

Figure A.1: <<ULE-MAC-CONFIGURATION-INFO>> information element coding

The coding of the initial octets 1 - 2 is given by ETSI EN 300 175-5 [5]. The coding of octet 3 is as follows:

Reserved bit (octet 3):

Bits	8	Meaning
	1	shall be set to '1'

The value '0' is reserved for further expansion and shall not be used

Coding standard (octet 3):

Bits	7 6	Meaning
	0 0	DECT ULE ETSI TS 102 939 (any part of this multi-part deliverable)

All other values are reserved

Control (octet 3):

Bits	5 4 3 2 1	Meaning
	0 0 0 0	Replace all descriptors
	0 0 0 1	Appends new descriptors.

All other values are reserved.

NOTE 1: If any change to a PT's existing paging descriptors is required, the existing channel descriptions may be removed and replaced by new ones by using a "Replace all descriptors" command. If only adding additional channels is required, the control command "Append new descriptors" may be used.

NOTE 2: Code '0000'B "Replacing all descriptors" may also be used to clear all descriptors by not including any new descriptor in the IE.

NOTE 3: Code '0000'B may also be used when the insertion of descriptors is meaningless.

For the content of the additional octets of the <<ULE-MAC-CONFIGURATION-INFO>> carrying the descriptors, see clauses 10.6.2.4 and 10.6.2.5.

A.2.2 Coding of the Information Element <<IWU-ATTRIBUTES>>

The <<IWU-ATTRIBUTES>> Information Element (see figure A.2) may be used during the execution of the CC Service Change procedure in order to negotiate various attributes relating to the IWU.

The base standard ETSI EN 300 175-5 [5] defines the basic structure of the IE, and the present document describes the profile-specific structure.

Bit:	8	7	6	5	4	3	2	1	Octet:
	0	<< IWU-ATTRIBUTES >>							1
	Length of Contents (L)								2
	1	0	1	Profile					3
	1	Negotiation indicator			Profile subtype				4
	1	IWU function at FP							5
	0	Maximum MTU/SDU size PT => FT (most significant 7 bits)							6
	0/1	Maximum MTU/SDU size PT => FT (least significant 7 bits)							6a
	0	Maximum MTU/SDU size FT => PT (most significant 7 bits)							6b
	1	Maximum MTU/SDU size FT => PT (least significant 7 bits)							6c
	0	ULE Application Protocol Identifier							7
	0/1	ULE Application Protocol Version							7a
	0	EMC or extended Application Protocol Identifier							7b
	0	EMC or extended Application Protocol Identifier (continued)							7c
	1	EMC or extended Application Protocol Identifier (continued)							7d
		...							
	0	ULE Application Protocol Identifier							k
	0/1	ULE Application Protocol Version							ka
	0	EMC or extended Application Protocol Identifier							kb

	0	EMC or extended Application Protocol Identifier (continued)	kc
	1	EMC or extended Application Protocol Identifier (continued)	kd

Figure A.2: ULE specific <<IWU-ATTRIBUTES>> information element coding

Coding Standard (octet 3):

Bits 7 6 **Meaning**
 0 1 Profile Defined Coding

Profile (octet 3):

Bits 5 4 3 2 1 **Meaning**
 1 0 0 0 0 ULE profile

Negotiation indicator (octet 4):

Bits 7 6 5 **Meaning**
 0 0 0 Negotiation not possible
 1 0 0 Exchanged parameter negotiation
 0 1 0 Peer attribute negotiation
 1 1 0 Exchanged attribute negotiation and Peer attribute negotiation
 All other values reserved.

Profile subtype (octet 4):

Bits 4 3 2 1 **Meaning**
 0 0 0 0 ULE Part 1 transparent Interworking
 All other values reserved.

IWU functionality at FP (octet 5):

Bits 6 5 4 3 2 1 **Meaning**
 0 0 0 0 0 0 undefined
 0 0 0 0 0 1 Transparent routing
 All other values reserved.

Maximum MTU/SDU size PT => FT (or bidirectional) (octets 6 and 6a):

This 14-bit word represents the natural binary coding of the maximum MTU/SDU length, in units of four bytes (32 bits) to be used in PT => FT direction. The sending side shall not send MTU/SDU bigger than this value. The least significant bit shall be in position 1 of octet 6.

Maximum MTU/SDU size FT => PT (octets 6b and 6c, optional):

This 14-bit word represents the natural binary coding of the maximum MTU/SDU length, in units of four bytes (32 bits) to be used in FT => PT direction. The sending side shall not send MTU/SDU bigger than this value. The least significant bit shall be in position 1 of octet 6b.

If octets 6b and 6c are not present, the MTU/SDU size value defined for PT => FT direction shall be also used if FT => PT direction.

NOTE 1: In the Interworking type "transparent interworking" the size of the SDU is equal to the size of the external MTU.

ULE Application Protocol Identifier (octet 7, k):

Bits 7 6 5 4 3 2 1 **Meaning**
 0 0 0 0 0 0 0 undefined protocol
 0 0 0 0 0 0 1 ULE Functional application protocol #1
 0 0 0 0 1 1 0 6LoWPAN [i.8]

1 x x x x x Proprietary ULE protocols
All other values reserved.

NOTE 2: When the coding for Proprietary ULE protocols is used, the bits 1 to 6 may be freely coded by the vendor to specify different proprietary protocols or any other use. The FP and PP may also use proprietary messaging to negotiate the protocol used.

ULE Application Protocol Version (octet 7a, ka):

Bits 1-7 form a version number which may be used to further identify the ULE Application Protocol. A value of 0 shall be used when there is no specific requirement to specify the version.

EMC or extended Application Protocol Identifier (octet 7b-7d, kb-kd, optional):

If bit 7 of the Application Protocol Identifier is set to '1' (proprietary application protocol) these three octets are used to code the EMC field that may be used to discriminate between different proprietary protocols. The EMC is a 16 bit number, which is inserted into the 'EMC field' as follows:

Octet 7b, kb: 7 most significant bits of EMC (LSB inserted into bit 1 of 7b,kb)

Octet 7c, kc: next 7 most significant bits of EMC (LSB inserted into bit 1 of 7c,kc)

Octet 7d, kd: least significant 2 bits (LSB inserted into bit 1 of 7d,kd)

NOTE 3: The use of standard IE coding rules allow the octet group 7, k to be ended at the end of 7a, ka. This means that the addition of the EMC is optional in the IE, and may be omitted, if not required by the specified ULE Application Protocol.

If bit 7 of the Application Protocol Identifier is set to '0' the three octets 7b, 7c and 7d (or kb, kc, kd) are used to extend the Application Protocol Identifier, that has now 4 octets with a total of 4 x 7 bits. Most significant 7 bits are coded in octet 7 (or k) and LSB in octet 7d (or kd).

NOTE 4: A total of 20 bits are usable since bit 1 of octet 7 (or k) has to be set to '0'.

A.2.3 Coding of the Information Element <<IWU-to-IWU>>

A.2.3.0 General

The <<IWU-to-IWU>> Information Element (figure A.3) may be used to transport data between ULE applications peer-to-peer (i.e. FP to PP) in both directions.

The base standard ETSI EN 300 175-5 [5] defines the basic structure of the IE. The actual payload data for the <IWU-to-IWU INFORMATION> is ULE Protocol specific.

Bit:	8	7	6	5	4	3	2	1	Octet:
	0	<< IWU-TO-IWU >>							1
	Length of Contents (L)								2
	1	S/R	Protocol Discriminator						3
									4
	IWU-TO-IWU INFORMATION								
									L+2

Figure A.3: IWU-TO-IWU information element

A.2.3.1 IWU-to-IWU information field (octets 4 to L+2) for Protocol Discriminator value "ULE Configuration and Control"

When the Protocol Discriminator value is "ULE Configuration and Control" the format of the <IWU-to-IWU INFORMATION> is as given in figure A.4.

The format of the "Discriminator Specific Contents" (octet 6 and following) depends of the discriminator type.

- For discriminator type "ULE Common Control Protocol", the format is defined in clause A.2.3.3. the present document.

- For discriminator type "reserved for ULE Functional Application Protocol #1" and for discriminators for proprietary ULE protocols, the format is not defined in the present document.

Bit:	8	7	6	5	4	3	2	1	Octet:
	1	Discriminator type							4
									5
	Discriminator Specific Contents								
									L+2

Figure A.4: IWU-to-IWU information field (octets 4 to L+2) for Protocol Discriminator value "ULE Configuration and Control"

Discriminator type (octet 4):

Bits 7 6 5 4 3 2 1 Meaning

0 0 0 0 0 0 0 ULE Common Control Protocol (see note 1)

0 0 0 0 0 0 1 reserved for ULE Functional Application Protocol #1 (see note 2)

1 x x x x x x Proprietary ULE protocols

All other values reserved.

NOTE 1: The ULE Common Control Protocol is further defined in clause A.2.3.3.

NOTE 2: The code '0000001'B is reserved for ULE Functional Application Protocol #1.

A.2.3.2 Discriminator Specific Contents (octets 5 to L+2) for Discriminator type "Proprietary ULE protocols "

When the Protocol Discriminator value is "Proprietary ULE protocols " the format of the <IWU-to-IWU INFORMATION> is as given in figure A.5.

The actual content of the "ULE Proprietary contents" is not defined in the present document.

Bit:	8	7	6	5	4	3	2	1	Octet:
	Proprietary Discriminator								5
	Proprietary Discriminator (continued)								6
									7
	ULE Proprietary contents								
									L+2

Figure A.5: Discriminator Specific Contents (octets 5 to L+2) for Discriminator type "Proprietary ULE protocols"

The Proprietary discriminator consists of 2 octets (octets 5 and 6) and contains the EMC, with the most significant byte in octet 5 and the least significant byte in octet 6 (see figure A.5).

A.2.3.3 Discriminator Specific Contents (octets 5 to L+2) for Discriminator type "ULE Common Control Protocol "

Bit:	8	7	6	5	4	3	2	1	Octet:
	1	Op-code							5
									6
	Op-code specific contents								
									L+2

Figure A.6: Discriminator Specific Contents (octets 5 to L+2) for Discriminator type " ULE Common Control Protocol"

Op-code (octet 5, bits 1-7):**Bits 7 6 5 4 3 2 1 Meaning**

0 0 0 0 0 0 0 MAC Release Reason Emulation (see note)
All other values reserved

NOTE: Op-code values are currently not used in the present document. The only defined value is used by ETSI TS 102 939-2 [i.9].

Annex B (normative): U-plane services and interworking procedures

B.1 Scope of this annex

This annex defines the Interworking conventions and procedures for the different Interworking options that are supported by the present document. Currently only the transparent U-plane interworking (service [ULE1-I.1]) is supported. This interworking service may be used for the transport of several application protocols:

B.2 Transparent U-plane Interworking

B.2.1 U-plane procedures

The external protocol packet or datagram shall be mapped into a DLC LU13 or LU14 SDU.

The maximum value of the size of the external packet, and therefore the SDU, may be configured by means of C-plane procedures (see clause B.2.2).

The default value for the maximum SDU size is defined in clause 12.1.3.5 of the present document.

Additionally, the following requirements apply regarding the maximum SDU size that shall be supported:

FT requirement:

- *Receive direction:* FT shall support at least a Maximum SDU size of 500 octets. By negotiation with the PT, it is possible to support higher or lower values than 500 octets.
- *Transmit direction:* there is no minimum requirement. The Maximum SDU size shall not exceed the Maximum SDU size supported by the PT in receive direction. This is a result of the negotiation with the PT.

PT requirement:

- *Receive direction:* PT shall support at least a Maximum SDU size of 32 octets. By negotiation with the FT, it is possible to support higher values than 32 octets.
- *Transmit direction:* there is no minimum requirement. The Maximum SDU size shall not exceed the Maximum SDU size supported by the FT in receive direction. This is a result of the negotiation with the FT.

B.2.2 C-plane procedures

The parameters of the transported protocol may be configured by means of NWK layer procedures. The NWK layer information element << IWU-ATTRIBUTES >> provides the transport of the required parameters.

Multiple application protocols may be transported over ULE transparent Interworking. The negotiation of the transported protocol may be done by means of the CC Service Change procedure including the << IWU-ATTRIBUTES >> Information Element. This procedure also allows configuring the maximum MTU size used by each application protocol. The highest value of maximum MTU size shall also be used as maximum SDU size for the DLC layer.

See clause A.2.2 for the composition of the << IWU-ATTRIBUTES >> IE used with the transparent U-plane Interworking.

Annex C (informative): Guidelines and examples

C.1 Channel selection algorithms

C.1.1 Example of Implementation of Process M0

C.1.1.0 General

This annex describes a possible implementation of the algorithm for process M0.

C.1.1.1 Technical principles and objectives

The process M0 algorithm is based on an adaptive variable RSSI threshold level (the RFP threshold level) used to evaluate if a channel is free for use.

The objective of the proposed architecture is to balance the goal of pre-selecting the less interfered available channels with the need of offering multiple options for the process M1 in order to reduce the probability of collision.

C.1.1.2 Possible implementation

The different RSSI levels that the RFP may measure for a given channel are classified in "bins" separated 6 dB, in a similar way to the standard DECT channel selection algorithm.

An adaptive variable threshold level is used to evaluate if a channel is free for use and announcement in the next broadcast opportunity related to the channel frequency. Channels with RSSI below the threshold will be announced as usable and channels above such level will not.

The adaptive variable RSSI threshold level may be as low as the background noise level, if at such level the RFP may find an "enough" number of candidate channels. The value of what is "enough" is part of the design and, in this example, is defined by a table (see table C.1, column 3).

If this is not the case, the RFP, will progressively raise the RFP threshold level in order to increase the chance of getting a sufficient number of candidate channels (for the next frame).

The raise of the RFP threshold level will be progressive. It is proposed a rate of one bin step (6 dB) per frame. However slower rates may also be investigated.

If more channels than the "enough" target are found, the RFP will (for next frame) progressively decrease the RSSI threshold value, until the value matches the "enough" target. Reduction in the threshold value will also be done at the same rate as the rise.

If the number of channels that passes the RSSI criteria matches exactly the target, the threshold level will remain unchanged.

In any case, the real number of channels matching the threshold evaluation will be announced in the M_U broadcast (irrespective of if it is lower or higher than the target for the threshold bin).

The number of "target" channels varies for each bin. It is higher for low interference levels and is reduced when the RFP is forced to increase the threshold level due to higher interference. By doing that, the algorithm is accepting higher collision probabilities (due to the reduction in the offer) in turn of lower interference levels. Thus, it is implementing the first goal given in ETSI EN 300 175-3 [3] guidelines.

For each threshold level, the algorithm defines also the PP threshold value. This is the value that should be transmitted in the info 1 field of channel M_U . In the proposed sketch, the value of the PP threshold is calculated as a function of the FP threshold level adding a margin of some dB. The value of the margin decreases with the threshold level. For specification purposes, the resulting value is also tabulated in the table.

A possible design for the algorithm is given in table C.1.

Table C.1: A possible design of the algorithm M0 in tabulated format

"bin" nr.	RFP threshold RSSI level (dBm)	Target number of offered channels (see note 1)	PP threshold (dBm) (to be transmitted to the PPs)
	(see note 2)		
10	-33 dBm	1	-33 dBm (+0 dB)
9	-39 dBm	2	-39 dBm (+0 dB)
8	-45 dBm	2	-45 dBm (+0 dB)
7	-51 dBm	3	-45 dBm (+6 dB)
6	-57 dBm	3	-51 dBm (+6 dB)
5	-63 dBm	3	-57 dBm (+6 dB)
4	-69 dBm	4	-57 dBm (+12 dB)
3	-75 dBm	4	-63 dBm (+12 dB)
2	-81 dBm	4	-69 dBm (+12 dB)
1	-87 dBm	4	-69 dBm (+18 dB)
0	-93 dBm	4	-69 dBm (+24 dB)
NOTE 1: The target number of channels refers to the available channels (channels that match the threshold criteria) within the 12 channels possible in each M_U announcement.			
NOTE 2: This design sketch does not enter to evaluate the convenience of operation above -33 dBm.			

C.1.1.3 Alternative implementation

An alternative implementation that provides smoother transitions in the threshold RSSI level in turn of a more complex implementation is given in table C.2. The design is identical to previous example; however the number of available channels used to decide if the threshold level should be moved up or down is based on the total pool of DECT channels (120 channels assuming 10 frequencies).

For the preparation of each M_U announcement, the RFP computes the channels that should be in the announcement (by comparing the 12 channels in the future scan sequence with the threshold level), but also compares the whole pool of channels (120) with the threshold to see if the threshold itself should be raised or reduced.

The result is a more stable threshold level. For instance, if the overall number of channels that would pass the threshold is i.e. 36, the threshold will remain at -69 dBm, even if in a given frame there are no channels passing the criteria.

Table C.2: Alternative design of the algorithm M0 in tabulated format

"bin" nr.	RFP threshold RSSI level (dBm)	Target number of offered channels (see note 1)	PP threshold (dBm) (to be transmitted to the PPs)
	(see note 2)		
10	-33 dBm	10	-33 dBm (+0 dB)
9	-39 dBm	15	-39 dBm (+0 dB)
8	-45 dBm	20	-45 dBm (+0 dB)
7	-51 dBm	25	-45 dBm (+6 dB)
6	-57 dBm	30	-51 dBm (+6 dB)
5	-63 dBm	34	-57 dBm (+6 dB)
4	-69 dBm	36	-57 dBm (+12 dB)
3	-75 dBm	38	-63 dBm (+12 dB)
2	-81 dBm	40	-69 dBm (+12 dB)
1	-87 dBm	41	-69 dBm (+18 dB)
0	-93 dBm	42	-69 dBm (+24 dB)
NOTE 1: The target number of channels refers to the available channels (channels that match the threshold criteria) within the whole pool of DECT channels assuming 10 frequencies (120 channels).			
NOTE 2: This design sketch does not enter to evaluate the convenience of operation above -33 dBm.			

C.2 ULE Paging Mechanism

C.2.1 Examples of ULE Paging Mechanism

C.2.1.0 General

This annex gives details of how the flexible ULE paging channel (channel B_U) mechanism can be used to set up simple scenarios.

C.2.1.1 Example 1

Only one channel defined giving access to up to 88 devices in every frame. Each PT is given the parameters shown in table C.3 as the parameters of a << ULE-MAC-CONFIGURATION-INFO >> information element, then in every frame the B_U channel data transmitted in the ULE dummy P_U channel is described in table C.4, this is arbitrarily given the channel designation 0100b for the Channel Active field, the two SubField Use fields (SFa and SFb) indicate paging information only. Because the channel is paging information the bit set in BitOffset determines which PT responds.

Table C.3: Example 1; Single Paging Channel Descriptor Parameters

Field	Value
DescriptorType	ULE resume paging
Start_MFN	0
Start_FCNT	0
ChannelPeriodicity	2 ⁰
ChannelActive	0100
BitOffset	0 - 87

Table C.4: Example 1; First Channel ULE Dummy B_U Channel Values

Sub Field	Value
CA (ChannelActive)	0100
SFa	01
SFb	01
BitOffset	0 - 87

C.2.1.2 Example 2

Three channels defined for paging, all of them in bitmask format. Each PT is given the set of parameters from some/none/all of the following tables of parameters of << ULE-MAC-CONFIGURATION-INFO >> information elements (tables C.5 to C.10) depending on which channels that particular PT needs to receive. If the PT is not given any, it will not receive any paging message.

Table C.5: Example 2; First Paging Channel Descriptor Parameters

Field	Value
DescriptorType	ULE resume paging
Start_MFN	0
Start_FCNT	0
ChannelPeriodicity	2 ¹
ChannelActive	0001
BitOffset	0 - 87

Table C.6: Example 2; First Paging Channel ULE Dummy B_U Channel Values

Sub Field	Value
CA (ChannelActive)	1011
SFa	01
SFb	01
BitOffset	0 - 87

So this gives paging access to 88 identities once every 2 frames.

Table C.7: Example 2; Second Paging Channel Descriptor Parameters

Field	Value
DescriptorType	ULE resume paging
Start_MFN	0
Start_FCNT	1
ChannelPeriodicity	2 ²
ChannelActive	1000
BitOffset	0 - 87

Table C.8: Example 2; Second Paging Channel ULE Dummy B_U Channel Values

Sub Field	Value
CA (ChannelActive)	1011
SFa	01
SFb	01
BitOffset	0 - 87

So this gives paging access to 88 identities once every (2²) or 4 frames.

Table C.9: Example 2; Third Paging Channel Descriptor Parameters

Field	Value
DescriptorType	ULE resume paging
Start_MFN	0
Start_FCNT	3
ChannelPeriodicity	2 ³
ChannelActive	0010
BitOffset	0 - 87

Table C.10: Example 2; Third Paging Channel ULE Dummy B_U Channel Values

Sub Field	Value
CA (ChannelActive)	1011
SFa	01
SFb	01
BitOffset	0 - 87

So this gives paging access to 88 identities once every (2³) or 8 frames.

This scheme gives the ULE dummy bearer sub field usage as shown in table C.11.

Table C.11: Example 2; ULE Dummy B_U Channel Usage

Multi-frame 0																
FCNT	0	1	2	3	4	5	6	7	8	9	10	11	12	13	14	15
First Paging Channel (Fast Page)	X		X		X		X		X		X		X		X	
Second Paging Channel (Slow Page)		Y				Y				Y				Y		
Third Paging Channel (Slow Page)				Z								Z				
Multi-frame 1																
FCNT	0	1	2	3	4	5	6	7	8	9	10	11	12	13	14	15
Channel 0 (Fast Page)	X		X		X		X		X		X		X		X	
Channel 1 (Slow Page)		Y				Y				Y				Y		
Channel 2 (Slow Page)				Z								Z				

NOTE: The CA Channel Active field shown in each B_U channel table has the value '1011'B. This indicates that these three channels are actively sending paging data so any device that has been informed it should receive these channels knows there is data to check so it will ensure it receives the messages in the next frame in which they are sent.

History

Document history		
V1.1.1	April 2013	Publication
V1.2.1	March 2015	Publication