

ETSI TS 102 941 V1.3.1 (2019-02)



TECHNICAL SPECIFICATION

**Intelligent Transport Systems (ITS);  
Security;  
Trust and Privacy Management**

---

Reference

RTS/ITS-00552

---

Keywords

interoperability, ITS, management, security

**ETSI**

650 Route des Lucioles  
F-06921 Sophia Antipolis Cedex - FRANCE

Tel.: +33 4 92 94 42 00 Fax: +33 4 93 65 47 16

Siret N° 348 623 562 00017 - NAF 742 C  
Association à but non lucratif enregistrée à la  
Sous-Préfecture de Grasse (06) N° 7803/88

---

**Important notice**

The present document can be downloaded from:

<http://www.etsi.org/standards-search>

The present document may be made available in electronic versions and/or in print. The content of any electronic and/or print versions of the present document shall not be modified without the prior written authorization of ETSI. In case of any existing or perceived difference in contents between such versions and/or in print, the prevailing version of an ETSI deliverable is the one made publicly available in PDF format at [www.etsi.org/deliver](http://www.etsi.org/deliver).

Users of the present document should be aware that the document may be subject to revision or change of status.

Information on the current status of this and other ETSI documents is available at

<https://portal.etsi.org/TB/ETSIDeliverableStatus.aspx>

If you find errors in the present document, please send your comment to one of the following services:

<https://portal.etsi.org/People/CommiteeSupportStaff.aspx>

---

**Copyright Notification**

No part may be reproduced or utilized in any form or by any means, electronic or mechanical, including photocopying and microfilm except as authorized by written permission of ETSI.

The content of the PDF version shall not be modified without the written authorization of ETSI.

The copyright and the foregoing restriction extend to reproduction in all media.

© ETSI 2019.

All rights reserved.

**DECT™**, **PLUGTESTS™**, **UMTS™** and the ETSI logo are trademarks of ETSI registered for the benefit of its Members.

**3GPP™** and **LTE™** are trademarks of ETSI registered for the benefit of its Members and of the 3GPP Organizational Partners.

**oneM2M™** logo is a trademark of ETSI registered for the benefit of its Members and of the oneM2M Partners.

**GSM®** and the GSM logo are trademarks registered and owned by the GSM Association.

# Contents

Intellectual Property Rights .....	5
Foreword.....	5
Modal verbs terminology.....	5
1 Scope .....	6
2 References .....	6
2.1 Normative references .....	6
2.2 Informative references.....	7
3 Definition of terms, symbols, abbreviations and notation.....	8
3.1 Terms.....	8
3.2 Symbols.....	8
3.3 Abbreviations .....	8
3.4 Notation.....	9
4 ITS authority hierarchy .....	9
5 Privacy in ITS.....	10
6 Trust and privacy management .....	11
6.1 ITS-S Security Lifecycle .....	11
6.1.1 ITS-S Life-cycle management .....	11
6.1.2 Manufacture.....	12
6.1.3 Enrolment .....	12
6.1.4 Authorization .....	13
6.1.5 Maintenance.....	14
6.1.6 End of life .....	14
6.2 Public Key Infrastructure .....	14
6.2.0 General.....	14
6.2.0.1 Messages format .....	14
6.2.0.2 Signed and encrypted data structures .....	16
6.2.1 CA certificate request .....	17
6.2.2 Enrolment/Authorization assumption and requirements.....	20
6.2.3 Message Sequences.....	23
6.2.3.1 Introduction.....	23
6.2.3.2 Enrolment Management.....	23
6.2.3.2.0 Overview .....	23
6.2.3.2.1 Enrolment request.....	24
6.2.3.2.2 Enrolment response .....	26
6.2.3.3 Authorization Management.....	28
6.2.3.3.0 Overview .....	28
6.2.3.3.1 Authorization request .....	29
6.2.3.3.2 Authorization response.....	34
6.2.3.4 Authorization Validation protocol .....	35
6.2.3.4.0 Overview .....	35
6.2.3.4.1 Authorization validation request .....	36
6.2.3.4.2 Authorization validation response .....	37
6.3 Generation, distribution and use of Trust information lists .....	39
6.3.1 Generation and distribution of CTL by TLM .....	39
6.3.2 Generation and distribution of CTL by RCA.....	40
6.3.3 Generation and distribution of CRL by RCA .....	41
6.3.4 Specification of Full CTL and Delta CTL .....	41
6.3.5 Transmission of CTL and CRL.....	42
6.3.6 CTL and CRL use by ITS-Ss.....	42
7 Security association and key management between ITS Stations.....	43
7.0 Introduction .....	43
7.1 Broadcast SAs .....	43

7.2	Multicast SAs .....	43
7.3	Unicast SAs .....	44
<b>Annex A (normative): ITS security management messages specified in ASN.1.....</b>		<b>46</b>
A.1	ITS trust and privacy messages specified in ASN.1.....	46
A.2	Security management messages structures.....	46
A.2.1	Security data structures .....	46
A.2.2	Security Management messages for CA.....	47
A.2.3	Security Management messages for ITS-S_WithPrivacy.....	49
A.2.4	Security Management messages for ITSS_NoPrivacy.....	51
A.2.5	Enrolment and authorization data types .....	52
A.2.5.1	Enrolment .....	52
A.2.5.2	Authorization .....	53
A.2.5.3	AuthorizationValidation .....	54
A.2.6	Offline message structures .....	56
A.2.7	Trust lists data types.....	56
<b>Annex B (normative): Service specific parameters (SSPs) definition .....</b>		<b>59</b>
B.1	Overview .....	59
B.2	CTL SSPs definition.....	59
B.3	CRL SSPs definition .....	60
B.4	Certificate request messages SSPs definition.....	60
B.5	Security Management certificate permissions.....	61
<b>Annex C (informative): Communication profiles for security credential provisioning services (EC request, AT request) .....</b>		<b>62</b>
C.0	General .....	62
C.1	Communication profiles description .....	63
<b>Annex D (normative): Communication profiles for CTL and CRL .....</b>		<b>67</b>
D.1	CTL request and response protocol.....	67
D.2	CRL request and response protocol.....	67
D.3	Broadcast communication of CTL/CRL .....	68
<b>Annex E (informative): Encryption of a message from a sender to a receiver .....</b>		<b>69</b>
<b>Annex F (informative): Bibliography.....</b>		<b>71</b>
<b>Annex G (informative): Change history .....</b>		<b>72</b>
History .....		73

---

## Intellectual Property Rights

### Essential patents

IPRs essential or potentially essential to normative deliverables may have been declared to ETSI. The information pertaining to these essential IPRs, if any, is publicly available for **ETSI members and non-members**, and can be found in ETSI SR 000 314: *"Intellectual Property Rights (IPRs); Essential, or potentially Essential, IPRs notified to ETSI in respect of ETSI standards"*, which is available from the ETSI Secretariat. Latest updates are available on the ETSI Web server (<https://ipr.etsi.org/>).

Pursuant to the ETSI IPR Policy, no investigation, including IPR searches, has been carried out by ETSI. No guarantee can be given as to the existence of other IPRs not referenced in ETSI SR 000 314 (or the updates on the ETSI Web server) which are, or may be, or may become, essential to the present document.

### Trademarks

The present document may include trademarks and/or tradenames which are asserted and/or registered by their owners. ETSI claims no ownership of these except for any which are indicated as being the property of ETSI, and conveys no right to use or reproduce any trademark and/or tradename. Mention of those trademarks in the present document does not constitute an endorsement by ETSI of products, services or organizations associated with those trademarks.

---

## Foreword

This Technical Specification (TS) has been produced by ETSI Technical Committee Intelligent Transport Systems (ITS).

---

## Modal verbs terminology

In the present document "**shall**", "**shall not**", "**should**", "**should not**", "**may**", "**need not**", "**will**", "**will not**", "**can**" and "**cannot**" are to be interpreted as described in clause 3.2 of the [ETSI Drafting Rules](#) (Verbal forms for the expression of provisions).

"**must**" and "**must not**" are **NOT** allowed in ETSI deliverables except when used in direct citation.

---

# 1 Scope

The present document specifies the trust and privacy management for Intelligent Transport System (ITS) communications. Based upon the security services defined in ETSI TS 102 731 [1] and the security architecture defined in ETSI TS 102 940 [5], it identifies the trust establishment and privacy management required to support security in an ITS environment and the relationships that exist between the entities themselves and the elements of the ITS reference architecture defined in ETSI EN 302 665 [2].

The present document identifies and specifies security services for the establishment and maintenance of identities and cryptographic keys in an Intelligent Transport System (ITS). Its purpose is to provide the functions upon which systems of trust and privacy can be built within an ITS.

---

## 2 References

### 2.1 Normative references

References are either specific (identified by date of publication and/or edition number or version number) or non-specific. For specific references, only the cited version applies. For non-specific references, the latest version of the referenced document (including any amendments) applies.

Referenced documents which are not found to be publicly available in the expected location might be found at <https://docbox.etsi.org/Reference>.

NOTE: While any hyperlinks included in this clause were valid at the time of publication, ETSI cannot guarantee their long term validity.

The following referenced documents are necessary for the application of the present document.

- [1] ETSI TS 102 731: "Intelligent Transport Systems (ITS); Security; Security Services and Architecture".
- [2] ETSI EN 302 665: "Intelligent Transport Systems (ITS); Communications Architecture".
- [3] ETSI TS 103 097: "Intelligent Transport Systems (ITS); Security; Security header and certificate formats".
- [4] ETSI TS 102 942: "Intelligent Transport Systems (ITS); Security; Access control".
- [5] ETSI TS 102 940: "Intelligent Transport Systems (ITS); Security; ITS communications security architecture and security management".
- [6] ISO/IEC 8824-1:2015: "Information technology -- Abstract Syntax Notation One (ASN.1): Specification of basic notation".
- [7] Recommendation ITU-T X.696 (08/2014): "Information Technology-Specification of Octet Encoding Rules (OER)".
- [8] Void.
- [9] ETSI TS 102 943: "Intelligent Transport Systems (ITS); Security; Confidentiality services".
- [10] ETSI EN 302 637-2: "Intelligent Transport Systems (ITS); Vehicular Communications; Basic Set of Applications; Part 2: Specification of Cooperative Awareness Basic Service".
- [11] ETSI EN 302 637-3: "Intelligent Transport Systems (ITS); Vehicular Communications; Basic Set of Applications; Part 3: Specifications of Decentralized Environmental Notification Basic Service".
- [12] ETSI TS 103 301: "Intelligent Transport Systems (ITS); Vehicular Communications; Basic Set of Applications; Facilities layer protocols and communication requirements for infrastructure services".

- [13] NIST FIPS PUB 198-1: "The Keyed-Hash Message Authentication Code (HMAC)".
- [14] Void.
- [15] IETF RFC 4862: "IPv6 Stateless Address Autoconfiguration".
- [16] ETSI EN 302 636-6-1: "Intelligent Transport Systems (ITS); Vehicular Communications; GeoNetworking; Part 6: Internet Integration; Sub-part 1: Transmission of IPv6 Packets over GeoNetworking Protocols".
- [17] Void.
- [18] ETSI EN 302 636-4-1: "Intelligent Transport Systems (ITS); Vehicular communications; GeoNetworking; Part 4: Geographical addressing and forwarding for point-to-point and point-to-multipoint communications; Sub-part 1: Media-Independent Functionality".
- [19] ETSI TS 102 965: "Intelligent Transport Systems (ITS); Application Object Identifier (ITS-AID); Registration".
- [20] IEEE 802.11™: "IEEE Standard for Information technology -- Telecommunications and information exchange between systems -- Local and metropolitan area networks-Specific requirements -- Part 11: Wireless LAN Medium Access Control (MAC) and Physical Layer (PHY) Specifications".

## 2.2 Informative references

References are either specific (identified by date of publication and/or edition number or version number) or non-specific. For specific references, only the cited version applies. For non-specific references, the latest version of the referenced document (including any amendments) applies.

NOTE: While any hyperlinks included in this clause were valid at the time of publication, ETSI cannot guarantee their long term validity.

The following referenced documents are not necessary for the application of the present document but they assist the user with regard to a particular subject area.

- [i.1] ISO/IEC 15408-2: "Information technology - Security techniques - Evaluation criteria for IT security; Part 2: Security functional components".
- [i.2] ETSI TR 102 638: "Intelligent Transport Systems (ITS); Vehicular Communications; Basic Set of Applications; Definitions".
- [i.3] IETF RFC 4046: "Multicast Security (MSEC) Group Key Management Architecture".
- [i.4] IETF RFC 4301: "Security Architecture for the Internet Protocol".
- [i.5] IETF RFC 4302: "IP Authentication Header".
- [i.6] IETF RFC 4303: "IP Encapsulating Security Payload (ESP)".
- [i.7] IETF RFC 5246: "The Transport Layer Security (TLS) Protocol Version 1.2".
- [i.8] IETF RFC 3547: "The Group Domain of Interpretation".
- [i.9] IETF RFC 3830: "MIKEY: Multimedia Internet KEYing".
- [i.10] IETF RFC 4535: "GSAKMP: Group Secure Association Key Management Protocol".
- [i.11] IETF RFC 4306: "Internet Key Exchange (IKEv2) Protocol", December 2005.
- [i.12] IETF RFC 4877: "Mobile IPv6 Operation with IKEv2 and the Revised IPsec Architecture".
- [i.13] ETSI TS 102 723-8: "Intelligent Transport Systems (ITS); OSI cross-layer topics; Part 8: Interface between security entity and network and transport layer".

[i.14] CVRIA: "Connected Vehicle Reference Implementation Architecture".

NOTE: Available at <http://www.iteris.com/cvria/>.

[i.15] ISO 21210-2010: "Intelligent Transport Systems (ITS) - Communications access for land mobiles (CALM) - Ipv6 networking".

## 3 Definition of terms, symbols, abbreviations and notation

### 3.1 Terms

For the purposes of the present document, the terms given in ETSI TS 102 731 [1], ETSI TS 102 940 [5], ISO/IEC 15408-2 [i.1] and the following apply:

**delta CTL:** partial CTL that only contains CTL entries that have been updated since the issuance of the prior, base CTL

### 3.2 Symbols

Void.

### 3.3 Abbreviations

For the purposes of the present document, the abbreviations given in ETSI TS 103 097 [3], ETSI TS 102 940 [21], ETSI EN 302 636-4-1 [18] and the following apply:

AA	Authorization Authority
AES	Advanced Encryption Standard
ASN	Abstract Syntax Notation
AT	Authorization Ticket
CA	Certification Authority
CBC-MAC	Cipher Block Chaining Message Authentication Code
CCH	Control CHannel
CCM	Counter with CBC-MAC
CCMS	Cooperative-ITS Certificate Management System
COER	Canonical Octet Encoding Rule
CPOC	C-ITS Point Of Contact
CRL	Certificate Revocation List
CTL	Certificate Trust List
CVRIA	Connected Vehicle Reference Implementation Architecture
DC	Distribution Centre
DEN	Decentralized Environmental Notification
DENM	Decentralized Environmental Notification Message
EA	Enrolment Authority
EC	Enrolment Credential
ECC	Elliptic Curve Cryptography
ECTL	European Certificate Trust List
EV	Electric Vehicle
FIPS	Federal Information Processing Standard
GET	command HTTP GET
GN/BTP	GeoNetworking/Basic Transport Protocol
GN6	GeoNetworking-IPv6
HMAC	keyed-Hash Message Authentication Code
HTTP	Hyper Text Transfer Protocol
IETF	Internet Engineering Task Force
IP	Internet Protocol
ITS-AID	ITS Application ID



ITU-T	International Telecommunication Union - Telecommunication Standardization Sector
KDF	Key Derivation Function
LTE	Long Term Evolution (4G)
MSB	Most Significant Bit
MSEC	Multicast SECURITY
OBD	On-Board Diagnosis
PA	Policy Authority
PDU	Protocol Data Unit
PII	Personally Identifiable Information
POP	Proof Of Possession
PSID	Provider Service Identifier
RCA	Root Certification Authority
RFC	Request For Comment
SA	Security Association
SCH	Service CHannel
SLAAC	StateLess Address Auto Configuration
SM	Security Management
SSP	Service Specific Permissions
TCP	Transmission Control Protocol
TLM	Trust List Manager
TLS	Transport Layer Security
URL	Uniform Resource Locator
V2I	Vehicle-to-Infrastructure
WLAN	Wireless Local Area Network
XOR	eXclusive OR function

### 3.4 Notation

The requirements identified in the present document include:

- a) mandatory requirements strictly to be followed in order to conform to the present document. Such requirements are indicated by clauses without any additional marking;
- b) requirements strictly to be followed if applicable to the type of ITS Station concerned.

Such requirements are indicated by clauses marked by "[CONDITIONAL]"; and where relevant is marked by an identifier of the type of ITS-S for which the clauses are applicable as follows:

- [Itss\_WithPrivacy] is used to denote requirements applicable to ITS-S for which pseudonymity has to be assured and re-identification by the AA is not allowed. This includes for instance personal user vehicle ITS-S or personal ITS-S Portable.
- [Itss\_NoPrivacy] is used to denote requirements applicable to ITS-S for which pseudonymity does not have to be assured and are allowed to be re-identified by the AA. This may be for instance fixed or mobile RSUs or special vehicles.

---

## 4 ITS authority hierarchy

Trust and privacy management requires secure distribution and maintenance (including revocation when applicable) of trust relationships, which may be enabled by specific security parameters that include enrolment credentials that provide 3<sup>rd</sup> party certificates of proof of identity or other attributes such as pseudonym certificates. Public key certificates and Public Key Infrastructure (PKI) are used to establish and maintain trust between the ITS-S and other ITS-S and authorities.

ETSI TS 102 731 [1] specifies requirements on security management services and security management roles such as EAs and AAs. The ITS security architecture is defined in ETSI TS 102 940 [5] and covers both the secured Communication Architecture, the architecture of the ITS-S Communication security system and the Security Management System architecture.

The present document assumes the definition of the security management entities specified in ETSI TS 102 940 [5] and the top-level entities for the management of multiple Root CAs collaborating within a single Trust Model. For ease of reading and for further specification of trust and privacy management the relevant tables from ETSI TS 102 940 [5] are copied here.

**Table 1: Functional element roles of the PKI**

Functional element	Description
<b>Root Certification Authority</b>	The Root CA is the highest level CA in the certification hierarchy. It provides EA and AA with proof that it may issue enrolment credentials, respectively authorization tickets
<b>Enrolment Authority</b>	Security management entity responsible for the life cycle management of enrolment credentials. Authenticates an ITS-S and grants it access to ITS communications
<b>Authorization Authority</b>	Security management entity responsible for issuing, monitoring the use of authorization tickets. Provides an ITS-S with authoritative proof that it may use specific ITS services
<b>Distribution Centre (optional)</b>	Provides to ITS-S the updated trust information necessary for performing the validation process to control that received information is coming from a legitimate and authorized ITS-S or a PKI certification authority by publishing the CTL and CRL
<b>Sending ITS-S</b>	Acquires rights to access ITS communications from Enrolment Authority Negotiates rights to invoke ITS services from Authorization Authority Sends single-hop and relayed broadcast messages
<b>Relaying ITS-S</b>	Receives broadcast message from the sending ITS-S and forwards them to the receiving ITS-S if required
<b>Receiving ITS-S</b>	Receives broadcast messages from the sending or relaying ITS-S
<b>Manufacturer</b>	Installs necessary information for security management in ITS-S at production
<b>Operator</b>	Installs and updates necessary information for security management in ITS-S during operation

**Table 2: Functional element roles of the top-level trust management**

Functional element	Description
<b>Policy Authority</b>	Policy authority is a role composed by the representatives of public and private stakeholders (e.g. Authorities, Road Operators, Vehicle Manufacturers, etc.) participating to the C-ITS trust model. It designates and authorizes the TLM and the CPOC to operate in the C-ITS Trust system. It decides if root CAs are trustable and approves/removes the Root CAs operation in C-ITS trust domain by notifying the TLM about approved/revoked Root CAs certificates
<b>Central Point of Contact (optional)</b>	The CPOC is a unique entity appointed by the Policy Authority. It has responsibility to establish and contribute to ensure communication exchange between the Root CAs, to collect the Root CA certificates and provide them to the Trust List Manager (TLM). The CPOC is also responsible for distributing the ECTL to any interested entities in the trust model
<b>Trust List Manager</b>	Trust List Manager is responsible for creating the list of root CA certificates and TLM certificates and signing it. The signed list issued by the TLM is called the ECTL

## 5 Privacy in ITS

ISO/IEC 15408-2 [i.1] identifies 4 key attributes that relate to privacy:

- anonymity;
- pseudonymity;
- unlinkability; and
- unobservability.

Anonymity alone is insufficient for protection of an ITS user's privacy and unsuitable as a solution for ITS, as one of the main requirements of ITS is that the ITS-S should be observable in order to provide improved safety. Consequently, pseudonymity and unlinkability offer the appropriate protection of the privacy of a sender of basic ITS safety messages (CAM and DENM). Pseudonymity ensures that an ITS-S may use a resource or service without disclosing its identity but can still be accountable for that use [i.1]. Unlinkability ensures that an ITS-S may make multiple uses of resources or services without others being able to link them together [i.1].

Pseudonymity shall be provided by using temporary identifiers in ITS safety messages, and never transmitting the station's canonical identifier in communications between ITS stations. Unlinkability can be achieved by limiting the amount of detailed immutable (or slowly changing) information carried in the ITS safety message, thus preventing the possible association of transmissions from the same vehicle over a long time period (such as two similar transmissions broadcast on different days).

ITS Privacy is provided in two dimensions:

- i) privacy of ITS registration and authorization tickets provisioning:
  - ensured by permitting knowledge of the canonical identifier of an ITS-S to only a limited number of authorities (EAs);
  - provided by the separation of the duties and roles of PKI authorities into an entity verifying the canonical identifier known as the Enrolment Authority (EA) and an entity responsible for authorizing and managing services known as the Authorization Authority (AA);
- ii) privacy of communications between ITS-Ss.

Separation of duties for enrolment (identification and authentication) and for authorization has been shown in ETSI TS 102 731 [1] as an essential component of privacy management and provides protection against attacks on a user's privacy. However, it is possible for the EA role to be delegated to the manufacturer and for the EA and AA roles to be assumed by a single authority.

When the same operational authority manages both the EA and AA, it shall guarantee privacy of requesting ITS-S i.e. providing all the technical and organizational measures to ensure that ITS identity information held by the EA is kept separately to avoid re-identification of pseudonym certificates (ATs).

When dedicated authorities are used only for certificates provisioning to ITS-S which do not have privacy requirements such as Road-Side Units, the EA and AA may not provide technical and operational separation.

---

## 6 Trust and privacy management

### 6.1 ITS-S Security Lifecycle

#### 6.1.1 ITS-S Life-cycle management

The ITS-S Security Lifecycle includes the following stages (see Figure 1):

- initial ITS-S configuration during manufacture;
- enrolment;
- authorization;
- operation and maintenance;
- end of life.

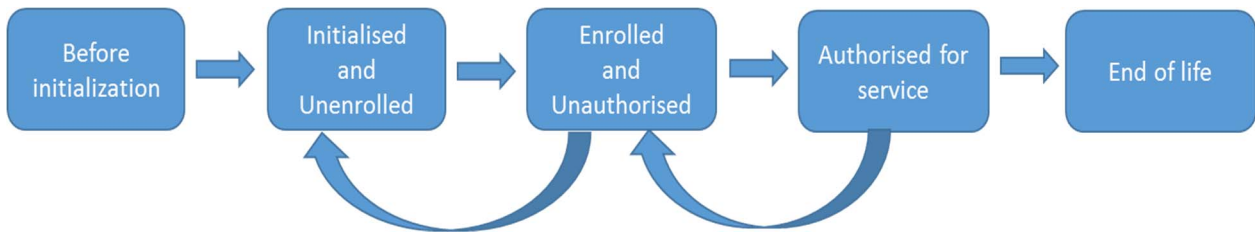

**Figure 1: ITS Station Security Life Cycle**

## 6.1.2 Manufacture

As part of the ITS-S manufacturing process, the following information elements associated with the identity of the station shall be established within the ITS-S itself and within the Enrolment Authority (EA):

- In the ITS-S, the following information elements shall be established using a physically secure process. The specification of this physically secure process is out of scope for the present document:
  - a canonical identifier which is globally unique (see note 1);
  - contact information for the EA and AA which will issue certificates for the ITS-S:
    - network address;
    - public key certificate;
  - the set of current known trusted AA certificates which the ITS-S may use to trust communications from other ITS-S;
  - a public/private key pair for cryptographic purposes (canonical key pair); and
  - the trust anchor (Root CA) public key certificate and the DC network address;
  - in case of a multiple root CAs architecture as specified in [5], the TLM public key certificate and the CPOC network address.

NOTE 1: The management of the canonical identifier and the means to guarantee uniqueness are not addressed in the present document.

- In the EA, the following three items of information shall be established, all associated with each other (see note 2):
  - the permanent canonical identifier of the ITS-S;
  - the profile information for the ITS-S that may contain an initial list of maximum appPermissions (ITS-AIDs with SSPs), region restrictions and assurance level which may be modified over time;
  - the public key from the key pair belonging to the ITS-S (canonical public key).

NOTE 2: The process for establishing this information within the ITS-S and the EA is beyond the scope of the present document.

## 6.1.3 Enrolment

The ITS-S requests its enrolment certificate from the EA (see clause 6.2.3.2).

The state transitions for enrolment are shown in Figure 2.

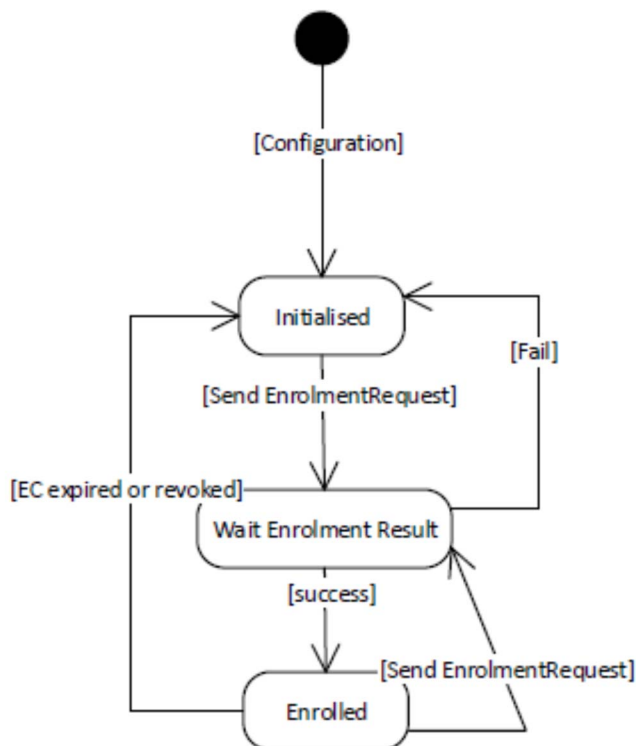

**Figure 2: Simplified state machine for the enrolment process**

After a successful enrolment process, the ITS-S shall possess an enrolment credential that shall be used in subsequent authorization requests.

For renewing the Enrolment Certificate at the EA, the ITS-S shall send an EnrolmentRequest signed by the previous valid enrolment credential issued by this EA.

#### 6.1.4 Authorization

Having received the enrolment credentials (i.e. in state "Enrolled" as shown in Figure 2), the ITS-S is able to request its authorization ticket(s) from the AA (see clause 6.2.3.3).

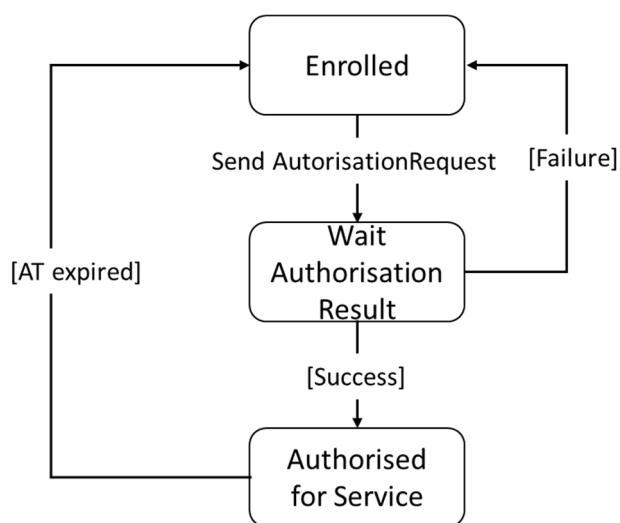

**Figure 3: Simplified state machine for the authorization process**

NOTE 1: This state machine only considers one instance of Authorization Request for one service (or class of services). Eventually, an ITS-S may perform several Authorization Requests to fill a pool of ATs stored in ITS-S memory (depending of the policy). The management of the pool of ATs within an ITS-S is out of the scope of the present document.

When in the state "Authorized for service" the ITS-S has a set of authorization tickets to allow signed transmission of messages to any other ITS-S that do not reveal the canonical identity nor the enrolment credential of the transmitting ITS-S.

NOTE 2: It is assumed that the ITS service requesting the use of a secure message transfer service only reveals PII in the payload if the release of that PII has been consented by the sending party.

NOTE 3: The ITS-S in state Authorized for Service may still have the possibility to obtain or update its pool of Authorization Tickets by sending Authorization requests (not representing on the Figure 3).

When the complete set of authorization tickets is exhausted, the ITS-S cannot sign transmission of messages to others ITS-S and is back to the state Enrolled.

NOTE 4: In this state diagram, it is assumed that revocation of authorization tickets is not possible as passive revocation is preferred (the ITS-S receives ATs of limited validity period and of limited allowed preloading period, renewing them frequently so that compromised ITS-S can be evicted from the ITS network by not reissuing them new ATs).

## 6.1.5 Maintenance

If an EA or AA is added to or removed from the system, the Root CA shall inform enrolled ITS-Ss of this change.

When multiple Root CAs are used in the same Trust Domain (as specified in ETSI TS 102 940 [5]), the trust relationship between the different PKIs may be managed by a Trusted Third Party (Trust List Manager). If a Root CA is added or removed from the system, the TLM should inform enrolled ITS-Ss of this change.

The process for updating the trust information lists such as the CTL and the CRL and for publishing these lists by the associated trust authority is specified in clause 6.3 and include different possible methods for updating the enrolled ITS-Ss:

- requesting CRL and CTL from the distribution centre associated to the root CA;
- sending a trust information list (CRL or CTL) across a wireless interface e.g. using a RSU able to transmit the CRL/CTL on ITS G5; or
- providing information to a trusted maintenance entity to enable it to update an individual ITS-S in a controlled environment.

## 6.1.6 End of life

In case of the device's end of life or following a compromise (revocation decided by its issuing EA), the ITS Station should be revoked and removed from operation in the ITS G5 communication network by means of a passive revocation mechanism, i.e. the EA shall reject the authorization of all the next Authorization Ticket requests for this specific ITS-S.

## 6.2 Public Key Infrastructure

### 6.2.0 General

#### 6.2.0.1 Messages format

All the security management messages (SM\_PDU) specified in the present document shall follow the message format shown in Figure 5.

Each SM-PDU message shall be encoded into an `EtsiTs103097Data-Encrypted`, `EtsiTs103097Data-Signed` or an `EtsiTs103097Data-SignedAndEncrypted` structure, depending on the specific message. This outermost structure shall contain an `EtsiTS102941Data` which in turn contains the content of the specific message.

Figure 4 shows an example of the use of above structures to provide enrolment/authorization requests and responses between an ITS-S and a Certification Authority. The same diagram applies for authorization validation requests and responses exchanged between Certification Authorities (EA and AA) as specified in clause 6.2.3.4.

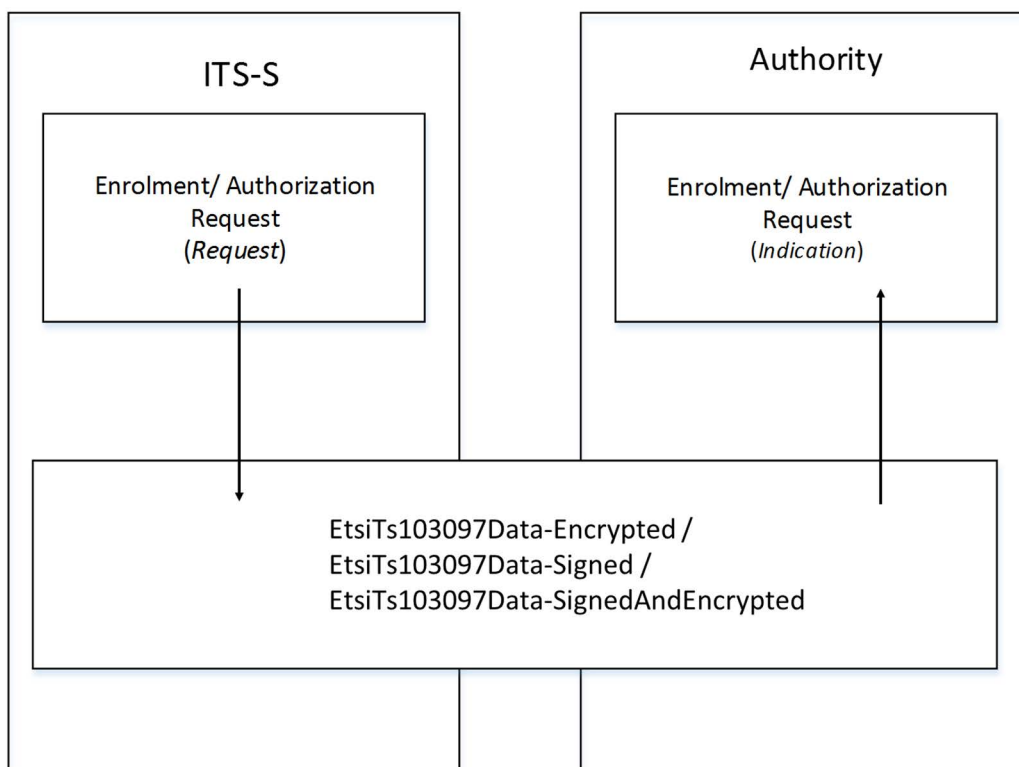

**Figure 4: Illustration of using Security Management PDU structure**

This outermost data structure `EtsiTs103097Data-Encrypted`, `EtsiTs103097Data-Signed` or `EtsiTs103097Data-SignedAndEncrypted` structure shall encapsulate an `EtsiTS102941Data` as shown in Figure 5. Specification of all containers and enclosed data structures are given in annex A.

`EtsiTs103097Data-Encrypted / EtsiTs103097Data-Signed / EtsiTs103097Data-SignedAndEncrypted`

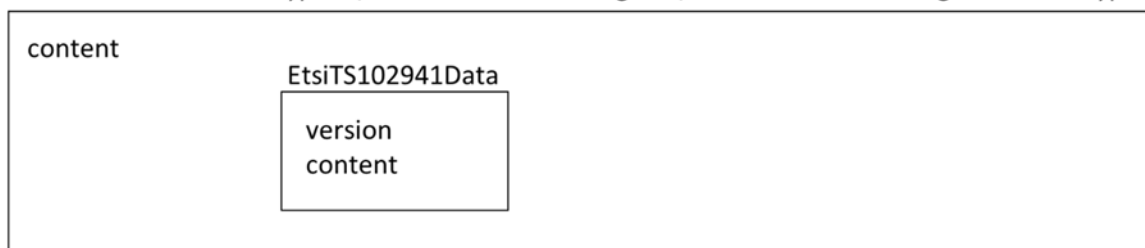

**Figure 5: Generic Security Management PDU structure**

Each of the SM\_PDU is containing an `EtsiTS102941Data` as specified in clause A.2.1:

```
EtsiTS102941Data ::= SEQUENCE {
    version Version (v1),
    content EtsiTS102941DataContent
}
EtsiTS102941DataContent ::= CHOICE {
...}
```

In the present document, the version of `EtsiTS102941Data` structure shall be set to version v1 (integer value 1).

Data structures in the present document are defined using Abstract Syntax Notation 1 (ASN.1) and shall be encoded using the Canonical Octet Encoding Rules (COER) as defined in Recommendation ITU-T X.696 [7].

The ASN.1 representation of Security Management PDUs shall be as specified in the annex A of the present document.

### 6.2.0.2 Signed and encrypted data structures

The present document assumes the definition of the data structures specified in ETSI TS 103 097 [3].

Especially the following TS103097 data structures shall be used for encrypted/signed messages specified in the present document:

- `EtsiTs103097Data-Signed;`
- `EtsiTs103097Data-Encrypted;`
- `EtsiTs103097Data-SignedAndEncrypted;`
- `EtsiTs103097Data-SignedExternalPayload.`

All signed data structures contain a `headerInfo` which itself includes a PSID/ ITS-AID. This PSID/ITS-AID is mandatory and shall be used for certificate management with value as assigned in ETSI TS 102 965 [19].

For all messages that are using the `EtsiTs103097Data-SignedAndEncrypted` structure as outermost message format, the `EtsiTs103097Data-SignedAndEncrypted` structure shall be built using the security profile for signed and encrypted messages defined in [3] and shall be composed of an `EtsiTs103097Data-Encrypted` structure containing an encrypted `EtsiTs103097Data-Signed` structure, containing a `EtsiTs102941 Data` structure, containing a version and an `EtsiTs102941DataContent` structure corresponding to the specific message (see clauses 6.2.3.2 to 6.2.3.4).

For all request and responses messages used for the provisioning of EC or ATs to an ITS-S, the following generic request and responses messages are used as depicted in Figure 6 and Figure 7.

For each generation of a REQUEST message, the request initiator shall generate a new AES symmetric key `k` which is used to encrypt the inner message as shown in Figure 6.

The `EtsiTs103097Data-Encrypted` structure shall be used to encapsulate all this message data using encryption option 1: encryption is done using the recipient public encryption key corresponding to the recipient's certificate. The field `recipients` shall contain **one single** `RecipientInfo` of type `certRecipInfo`.

The request initiator shall store the encryption symmetric key (`k`) in memory until it receives and processes the corresponding RESPONSE message as this key is to be used to decrypt the response (session encryption key). See clause 7.3.



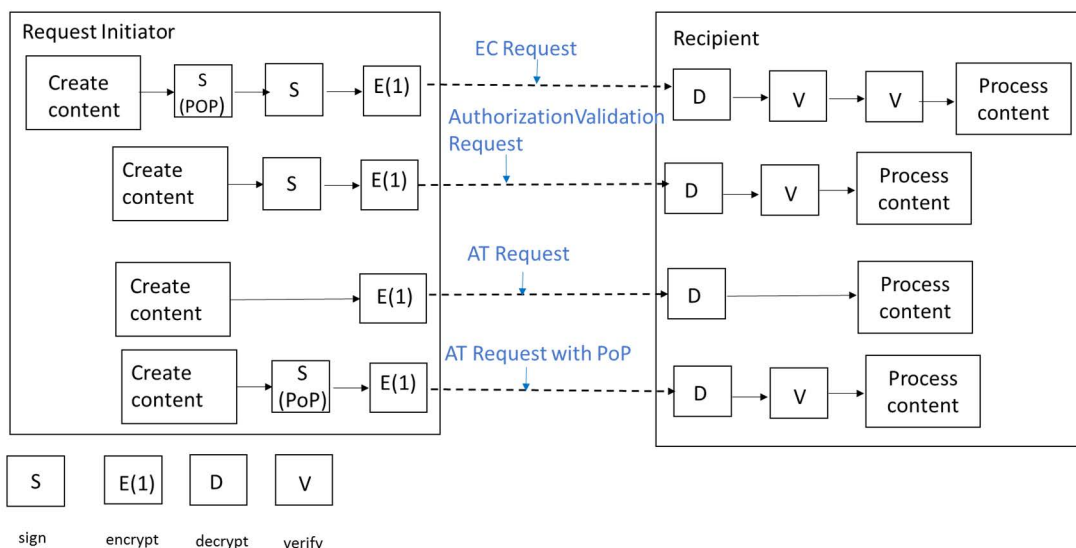

E(1): use EtsiTs103097Data-Encrypted with option 1 (using the recipient public encryption key corresponding to the recipient's certificate): the field recipients shall contain one single RecipientInfo of type certRecipInfo

NOTE: The AT Request depicted in Figure 6 uses different authentication mechanisms. See clause 6.2.3.3.1 for details.

**Figure 6: Generic REQUEST message**

For generating the RESPONSE message, the Recipient of the request shall use an outermost EtsiTs103097Data-Encrypted structure that encapsulates the response message as shown in Figure 7 using encryption option 2: the AES symmetric key used to encrypt the corresponding request is reused to encrypt the response, with the pskRecipInfo option in the RecipientInfo that indicates the use of a pre-shared symmetric key.

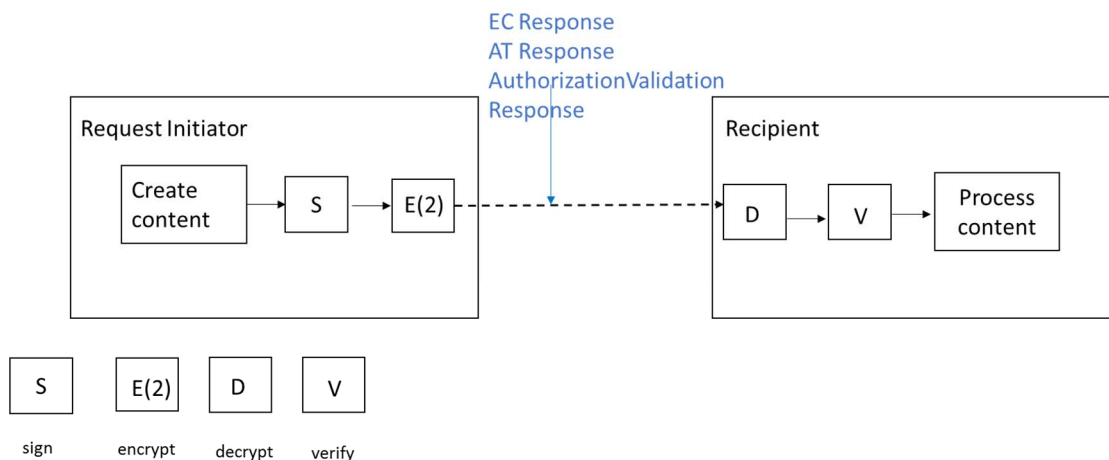

E(2): use EtsiTs103097Data-Encrypted with option 2. The key used to encrypt the corresponding request is reused to encrypt the response using one single RecipientInfo of type pskRecipInfo.

**Figure 7: Generic RESPONSE message**

An algorithm for encryption of a message from a sender to a receiver (Recipient) is given in annex E.

## 6.2.1 CA certificate request

The CACertificateRequest message defines a standalone certificate request, which shall be used to transport SubCA (i.e. EA or AA) certificate request to the RCA (across the interface at reference point S<sub>9</sub> or S<sub>10</sub> as specified in ETSI TS 102 940 [5]).

For the initial application of a SubCA to the RCA, the SubCA needs to submit an application form containing organization identity and other registration information specified in the respective policy. The details of this application form and process are out of the scope of the present document.

The SubCA shall transfer the signed certificate request (`CACertificateRequest`) by an off-band mechanism to the RCA entity: for initial application of the subCA, the subCA shall use a separate communication channel with the RCA (electronic communication means) other than the channel used for transmitting the application form and documents to the RCA. The application form should include the digital fingerprint of the `CACertificateRequest` in printable format. For rekeying, an application form is not needed because the RCA has a trust relation after the initial request.

NOTE 1: The digital fingerprint of the `CACertificateRequest` is computed using an ETSI TS 103 097 [3] approved hash algorithm.

For the initial application of a Sub CA to the RCA for issuance of its certificate, the SubCA shall generate its key pairs and the `CACertificateRequest` shall be signed with the private key corresponding to the verification public key provided by the Sub-CA for certification, to prove possession of the private key.

After approval of the application form and associated documents supplied by the SubCA and validation of the integrity and authenticity of the certificate request transmitted by the SubCA, the RCA shall generate the certificate of the SubCA, which is provided as a response to the `CACertificateRequest`: the certificate issued by the RCA to the SubCA shall follow the requirements of CA certificate as defined in ETSI TS 103 097 [3].

For the subsequent applications of the SubCA for requesting new certificate to the RCA, the SubCA shall generate its new key pairs. Then the CA certificate request shall be signed with the new private key corresponding to the verification public key (inner signature) and the whole request shall be signed with the current valid private key (outer signature) to ensure the integrity and authenticity of the request. If the current private key has reached its end of validity period or is revoked, the SubCA shall restart the initial certificate application process.

The content of the `CACertificateRequest` message shall be as described in Figure 8.

The specification of the `CACertificateRequest` message using ASN.1 [6], [7] shall be as specified in clause A.2.6.

For the initial application to the RCA, an EA or AA shall follow this process to create a `CaCertificateRequestMessage`:

- An ECC private key is randomly generated, the corresponding public key (`verificationKey`) is provided to be included in the `CaCertificateRequest`.
- An ECC encryption private key is randomly generated, the corresponding public key (`encryptionKey`) is provided to be included in the `CACertificateRequest`.
- An `EtsiTs102941Data` structure is built, containing:
  - `version` is set to v1 (integer value set to 1);
  - a `CaCertificateRequest` is built with:
    - `publicKeys` shall contain `verification_key` and `encryption_key`;
    - `requestedSubjectAttributes` shall contain the requested certificates attributes as specified in ETSI TS 103 097 [3], clause 7.2.4.
- An `EtsiTs103097Data-Signed` structure is built, containing: `hashId`, `tbsData`, `signer` and `signature`:
  - the `hashId` shall indicate the hash algorithm to be used as specified in ETSI TS 103 097 [3];
  - in `tbsData`:
    - the `payload` shall contain the previous `EtsiTs102941Data` structure;

- in the headerInfo:
  - the `psid` shall be set to "secured certificate request" as assigned in ETSI TS 102 965 [19];
  - the `generationTime` shall be present;
  - all other components of the component `tbsdata.headerInfo` not used and absent;
- the `signer` is set to 'self'.
- the signature over the `tbsData` computed using the private key corresponding to the new `verificationKey` to be certified (i.e. the request is self-signed).

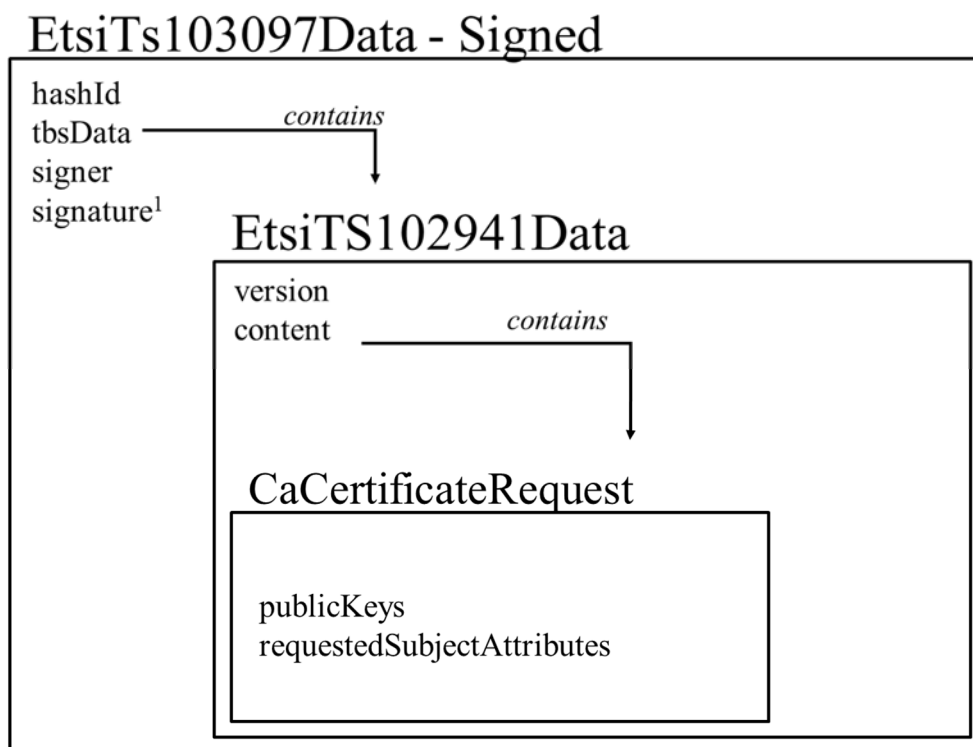

NOTE: <sup>1</sup> Signature computed using the private key corresponding to the verification public key to be certified.

**Figure 8: CA Certificate Request message for initial creation**

For the re-keying application to the RCA, an EA or AA shall follow this process to create a `CaCertificateRekeyingMessage`:

- An `EtsiTs103097Data-Signed` structure is built, containing: `hashId`, `tbsData`, `signer` and `signature`:
  - the `hashId` shall indicate the hash algorithm to be used as specified in ETSI TS 103 097 [3];
  - in the `tbsData`:
    - the `payload` shall contain the previous `CaCertificateRequestMessage` structure;
    - in the headerInfo:
      - the `psid` shall be set "secured certificate request" as assigned in ETSI TS 102 965 [19];
      - the `generationTime` shall be present;
      - all other components of the component `tbsdata.headerInfo` not used and absent;

- the `signer` declared as a `digest`, containing the `hashedId8` of the EA or AA certificate;
- the `signature` over `tbsData` computed using the currently valid private key corresponding to the AA or EA certificate (outer signature).

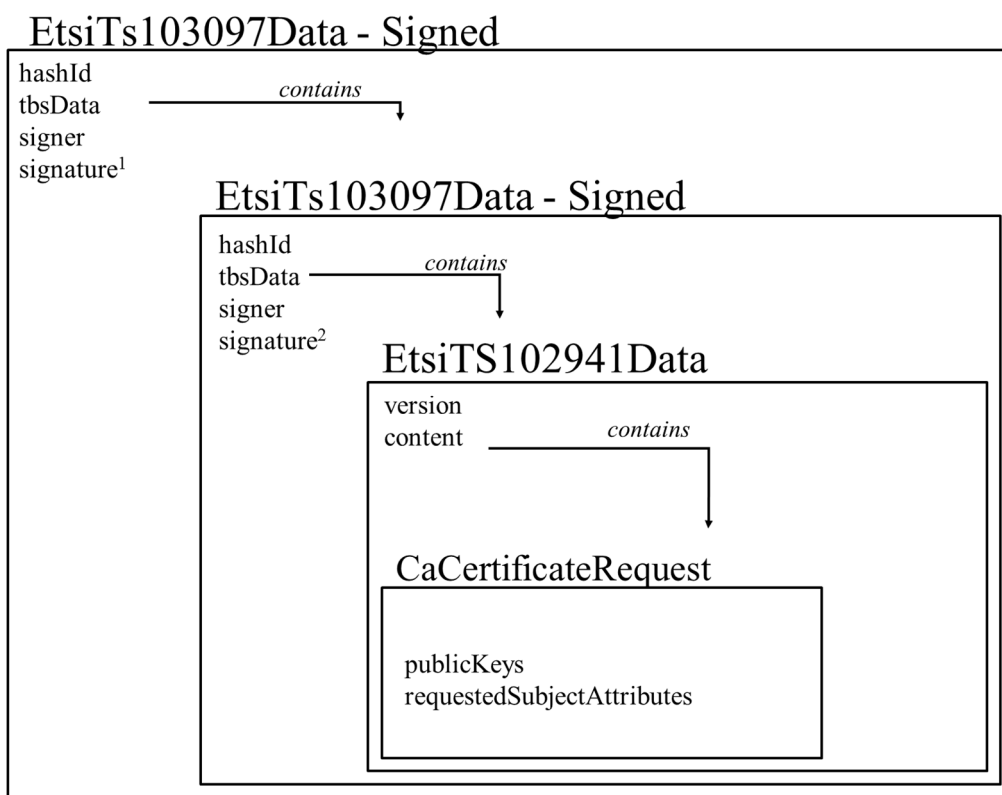

NOTE: <sup>1</sup> Signature computed using the currently valid private key corresponding to the AA or EA certificate.  
<sup>2</sup> Signature computed using the private key corresponding to the verification public key to be certified.

**Figure 9: CA certificate Request message for certificate re-keying**

NOTE 2: If the SubCA certificate contains an encryption public key, a proof of possession for this private key may be provided by the requesting SubCA. The method for establishing this proof of possession between the SubCA and the RCA is beyond the scope of the present document.

## 6.2.2 Enrolment/Authorization assumption and requirements

The present document assumes the ITS security reference model that is described in ETSI TS 102 940 [5].

For obtaining security credentials from the PKI, the ITS station has to set up a communication with the Certificate Authority (EA or AA). The ITS station may use different communication types for the provisioning of certificates, such as for instance:

- An ITS G5 communication via a roadside station.
- A WLAN consumer network using IEEE 802.11 [20] protocol (via a public or private hotspot or a home network).
- A Cellular network link (3G, 4G or LTE).
- A wired or wireless connection at EV Charging station.
- Using the Vehicle On-Board Diagnostic (OBD) port and a diagnostic system at the Service Garage or inspection workshop.

Figure 10 and Figure 11 present two possible options for ITS-S communication with the PKI, in order to support the security management services as specified in ETSI TS 102 940 [5] and shown in clause 4 above.

This functional model extends the ITS Communication security model specified in ETSI TS 102 940 [5] with the different communication paths. It introduces functional entities as defined in Table 3 and specifies the communication paths needed to support the ITS-S communication via a cellular network (Figure 10) or via an ITS G5 access network to the ITS infrastructure (Figure 11).

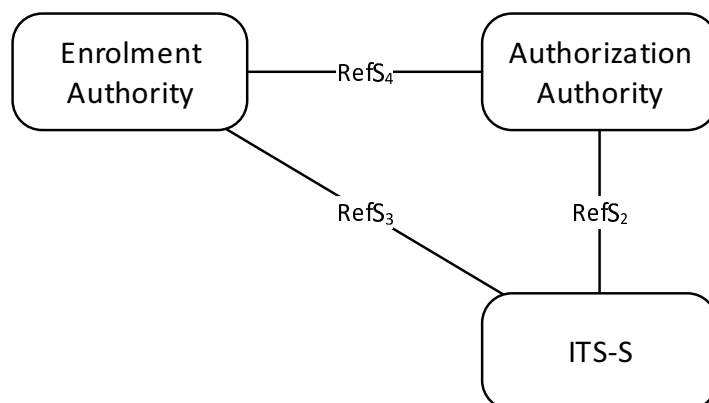

**Figure 10: Communication with PKI using a cellular network connection**

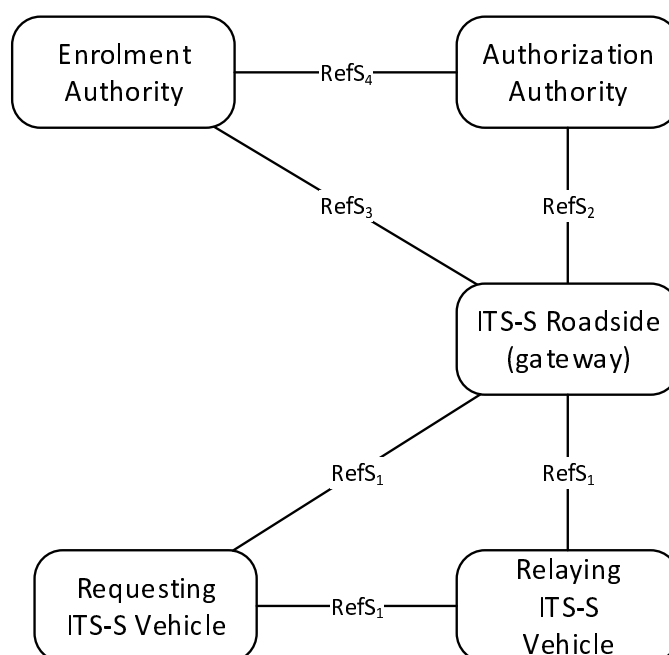

**Figure 11: Communication with PKI using a V2I connection**

In Figure 11, the model specified in ETSI TS 102 940 [5] is refined by considering one ITS-S sending the certificate request message, one roadside ITS-S for relaying the message via the infrastructure network to the recipient Certificate Authority and the receiving Certificate Authority (EA or AA). The certificate request message shall be sent in one-hop or multi-hops using the GeoNetworking protocol specified in ETSI EN 302 636-4-1 [18].

**Table 3: Functional element roles**

Functional element	Role
Enrolment Authority	See definition of functional elements, as specified in ETSI TS 102 940 [5]
Authorization Authority	
Requesting ITS-S	
Relaying ITS-S	
ITS-S Roadside Gateway	Receives broadcast messages from mobile ITS-S and relays certificate requests and responses to/from the Receiving Certificate Authority within the PKI

The model depicted in Figure 11 assumes that a mobile ITS-S has the capabilities to transmit security management messages such as defined in clauses 6.2.3.2, 6.2.3.3 and 6.2.3.4 through the ITS G5 communication interface (Reference Point S<sub>1</sub>). For that scenario, a communication bandwidth should be made available to the requesting ITS-S on an allocated G5 channel for security management purpose (e.g. CCH, SCH1 or SCH2).

The present document specifies messages format for certificate provisioning that is agnostic to the underlying communication path and communication media.

The term message refers to the Security Management PDUs which are processed by the Security Management Functional entity specified in ETSI TS 102 940 [5], clause 5. There is no application payload in these messages provided by the ITS Applications layer. The generation and processing of Security Management Messages in the ITS-S should be executed in a trusted software platform environment.

Several communication profiles are possible as described in annex C.

For all the communication profiles which are using IP protocol, HTTP/1.1 over TCP/IP shall be used in end-to-end communication paths, over the reference points S<sub>2</sub> and S<sub>3</sub>. (directly or after forwarding via reference points S<sub>1</sub>). No supplementary cryptographic layer such as TLS is required.

The term message refers to the Security Management PDUs which are processed by the Security Management Functional entity specified in ETSI TS 102 940 [5] clause 5. There is no application payload in these messages provided by the ITS Applications layer. The generation and processing of Security Management Messages in the ITS-S shall be executed in a trusted software platform environment.

NOTE 1: The present document does not specify the interface between Security Entity and the ITS-S communication layers and does not specify the interface between the Security Entity and the Facilities layer, i.e. mechanism for transferring Security Management PDUs via the SF-SAP. It does not specify the way the communication profile parameters are provided to the ITS-S communication stacks.

If an ITS station needs to provide pseudonym change management for privacy protection (e.g. vehicle ITS-S or personal ITS-S Portable), the following requirements shall be satisfied:

- [Itss\_WithPrivacy] if the requesting ITS-S uses an Ipv6 communication link to request a CCMS service, the ITS-S shall support temporary pseudonyms instead of permanent identifiers such as defined in ETSI TS 102 731 [1] and further specified in [5] and shall use automatically configured Ipv6 address using Stateless Address Autoconfiguration (SLAAC) as specified in IETF RFC 4862 [15].
- [Itss\_WithPrivacy] upon notification of an ID Change, the ITS-S Ipv6 layer shall modify the MAC address of each virtual interface which implies a change in the Ipv6 addresses associated to the virtual interfaces.
- [Itss\_WithPrivacy] in case the ITS-S communication profile used is based on Ipv6 over GeoNetworking (GN<sub>6</sub>), the ITS-S shall provide support for pseudonym change as specified in ETSI EN 302 636-6-1 [16], clause 11. This function enables change of the GN\_Addr and the change of MAC address implies creation of a new temporary Ipv6 address for the ITS-S originating the connection with the CCMS service. For security protection of Ipv6 over GeoNetworking traffic, the ITS-S should protect integrity & authenticity of packets by signature as presented in ETSI EN 302 636-6-1 [16], clause G.1.
- [Itss\_WithPrivacy] the ITS-S security entity shall perform an ID change (as specified in ETSI TS 102 940 [5]) each time before sending an AT request to the Authorization Authority (i.e. change the used Ipv6 address, MAC address, etc.) if no previous Authorization request is waiting for the response. Otherwise the ITS-S shall block ID Change until it receives the corresponding response from the AA or after a maximum time limit.

NOTE 2: The security entity uses the ID Change service in order to force ITS-S' IPv6 address change. To this end, it is not mandatory to change the AT prior to use the ID Change service. When no AT change occurs, the HashedId8 passed with the ID\_Change should contain a random value (SN-IDCHANGE-EVENT as specified in ETSI TS 102 723-8 [i.13]).

## 6.2.3 Message Sequences

### 6.2.3.1 Introduction

The overall ITS-S initialization sequence to achieve ITS secured message transfer on ITS G5 is given in Figure 12. The messages are specified in details in clauses 6.2.3.2, 6.2.3.3 and 6.2.3.4.

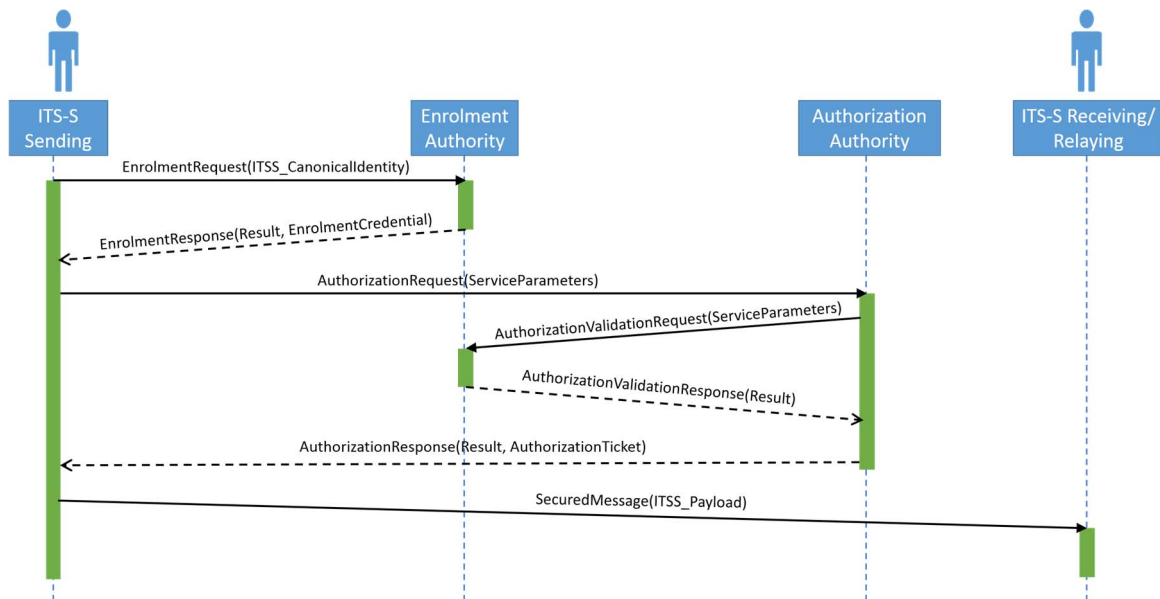

Figure 12: Sequence to achieve signed message transfer between ITS-Ss

### 6.2.3.2 Enrolment Management

#### 6.2.3.2.0 Overview

The Enrolment Request message shall be sent by an ITS-S to the Enrolment Authority (EA) across the interface at reference point S<sub>3</sub> (see Figure 8 in ETSI TS 102 940 [5]) to request an enrolment certificate to be used in a subsequent authorization request. Figure 13 shows an example of a message sequence for a successful or unsuccessful enrolment request.

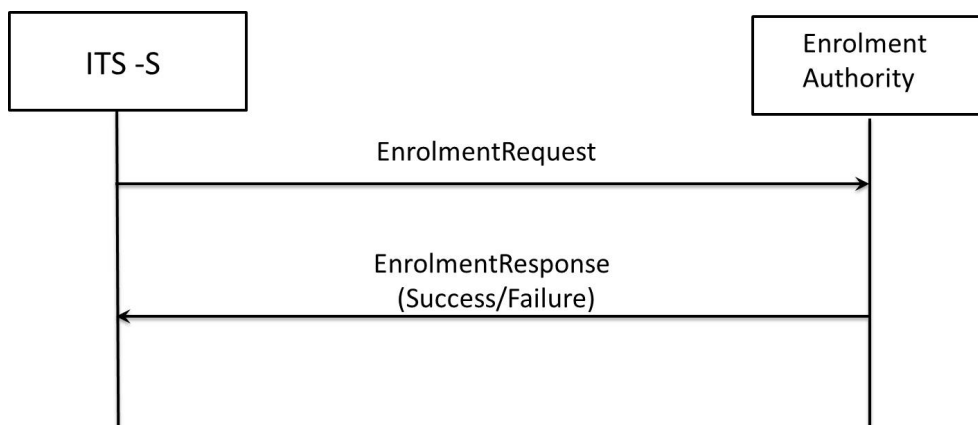

Figure 13: Message sequence for enrolment request and response

### 6.2.3.2.1 Enrolment request

The following functional requirements are defined on the state machine of Figure 2 (sender ITS-S for the enrolment process):

- The EnrolmentRequest message shall be encrypted using a ETSI TS 103 097 [3] approved encryption algorithm and the public key provided by the enrolment authority.
- For each enrolment request, the ITS-S shall generate a new verification key pair corresponding to an approved signature algorithm as specified in ETSI TS 103 097 [3].
- The contents of the EnrolmentRequest message shall be as described in Figure 14. The specification of the ITS-S EnrolmentRequest message using ASN.1 [6], [7] shall be as specified in clause A.2.

To create an enrolment request, an ITS-S shall follow this process:

- An ECC private key is randomly generated, the corresponding public key (verificationKey) is provided to be included in the EC.
- An InnerECRequest structure is built, containing:
  - the identifier of the requesting ITS-S (itsId): this identifier shall be set to the canonical identifier of the ITS-S for the initial enrolment with the recipient EA. For a re-enrolment of the ITS-S, the requesting ITS-S shall use the identifier of its current valid Enrolment Credential (EC identifier) which is computed as the HashedID8 of the Enrolment Credential (as specified in ETSI TS 103 097 [3]);
  - the certificateFormat which specifies the version used for the certificate format specification. In the present document, the certificate format shall be set to ts103097v131 (integer value 1);
  - the verificationKey for the EC;
  - the desired attributes (requestedSubjectAttributes);
  - the requestedSubjectAttributes shall not contain a certIssuePermissions field and the fields validityPeriod and region are optional because the EA already knows the ITS-S and can set duration and region restrictions on its own.
- For the proof of possession of the verification key pair, an EtsiTs103097Data-Signed structure (InnerECRequestSignedForPOP) is built containing: hashId, tbsData, signer and signature:
  - the hashId shall indicate the hash algorithm to be used as specified in ETSI TS 103 097 [3];
  - in the tbsData:
    - the payload shall contain the previous InnerECRequest structure;
    - in the headerInfo:
      - the psid shall be set to "secured certificate request" as assigned in ETSI TS 102 965 [19];
      - the generationTime shall be present;
      - all other component of the component tbsdata.headerInfo not used and absent;
  - the signer is set to 'self';
  - the signature over the tbsData computed using the private key corresponding to the new verificationKey to be certified (i.e. the request is self-signed) to prove possession of the generated verification key pair.
- An EtsiTs102941Data structure is built, with:
  - version is set to v1 (integer value set to 1);
  - the content is set to the previous signed data structure (InnerECRequestSignedForPOP).



- An `EtsiTs1030971Data-Signed` structure is built containing: `hashId`, `tbsData`, `signer` and `signature`:
  - the `hashId` shall indicate the hash algorithm to be used as specified in ETSI TS 103 097 [3];
  - in the `tbsData`:
    - the `payload` field shall contain the previous `EtsiTs102941Data` structure;
    - in the `headerInfo`:
      - the `psid` shall be set to "secured certificate request" as assigned in ETSI TS 102 965 [19];
      - the `generationTime` shall be present;
      - all other components of the component `tbsData.headerInfo` not used and absent;
  - the `signer` declared as `self` when the `itsId` is set to canonical identifier in the initial request or declared as `digest`, containing the `HashedId8` of the EC when the `itsId` is set to the EC identifier in a successive re-keying request. In the latter case, the digest of the `SignerIdentifier` shall match with the digest in the `itsId`;
  - the `signature` computed using the canonical private key if the `itsId` is set to canonical identifier or the current valid EC private key corresponding to the verification public key.
- An `EtsiTs103097Data-Encrypted` structure is built, with:
  - the component `recipients` containing one instance of `RecipientInfo` of choice `certRecipInfo`, containing:
    - the `hashedId8` of the EA certificate in `recipientId`; and
    - the encrypted data encryption key in `encKey`; the public key to use for encryption is the `encryptionKey` found in the `EACertificate` referenced in `recipientId`;
  - the component `ciphertext` containing the encrypted representation of the `EtsiTs1030971Data-Signed` structure.

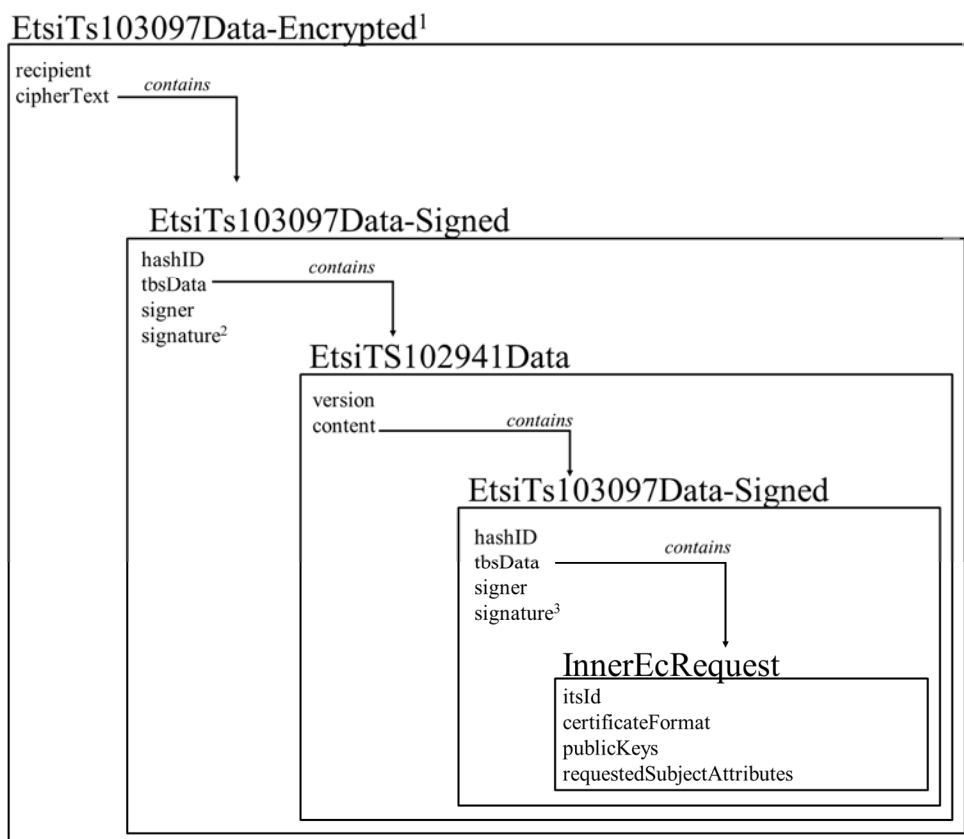

- NOTE: <sup>1</sup> Encryption is done with ECIES using the public encryption key of the EA.
- <sup>2</sup> In the outer signed data structure, the signature is computed using either the canonical private key if the itsId is set to the canonical identifier or the current valid private key corresponding to the EC's verification public key if the itsId is set to the EC identifier.
- <sup>3</sup> In the inner signed data structure (InnerECRequestSignedForPOP), the signature is computed on InnerECRequest with the private key corresponding to the new verificationKey to prove possession of the generated verification key pair.

**Figure 14: EnrolmentRequest message**

#### 6.2.3.2.2 Enrolment response

The EnrolmentResponse message shall be sent by the EA to the ITS-S across the interface at reference point S<sub>3</sub> in response to a received EnrolmentRequest message.

The EnrolmentResponse message shall be encrypted using an ETSI TS 103 097 [3] approved algorithm and the encryption shall be done with the same AES key as the one used by the ITS-S requestor for the encryption of the EnrolmentRequest message.

The contents of the EnrolmentResponse message shall be as described in Figure 15. The specification of the ITS-S EnrolmentResponse message using ASN.1 [6], [7] shall be as specified in clause A.2.

To read an EnrolmentResponse message, the ITS-S shall receive an EtsiTs103097Data-Encrypted structure, containing an EtsiTs103097Data-Signed structure, containing an EtsiTs102941Data, containing an InnerECResponse structure.

The outermost structure is an EtsiTs103097Data-Encrypted structure containing:

- the component recipients containing one instance of RecipientInfo of choice pskRecipInfo, which contains the HashedId8 of the SymmetricEncryptionKey structure containing the symmetric key used by the ITS-S to encrypt the EnrolmentRequest message to which the response is built;
- the component ciphertext, once decrypted, contains an EtsiTs103097Data-Signed structure.

If the ITS-S has been able to decrypt the content, this expected EtsiTs103097Data-Signed structure shall contain `hashId`, `tbsData`, `signer` and `signature`:

- the `hashId` shall indicate the hash algorithm to be used as specified in ETSI TS 103 097 [3];
- in the `tbsData`:
  - the payload shall contain the `EtsiTS102941Data` structure;
  - in the `headerInfo`:
    - the `psid` shall be set to "secured certificate request" as assigned in ETSI TS 102 965 [19];
    - the `generationTime` shall be present;
    - all other components of the component `tbsData.headerInfo` not used and absent;
- the `signer` declared as a digest, containing the `HashedId8` of the EA certificate;
- the `signature` over `tbsData` computed using the EA private key corresponding to its `publicVerificationKey` found in the referenced EA certificate.

The `EtsiTS102941Data` shall contain:

- the `version` set to `v1` (integer value set to 1);
- the `content` set to `InnerECResponse`.

The `InnerECResponse` shall contain:

- the `requestHash` is the left-most 16 octets of the SHA256 digest of the topmost `EtsiTs103097Data-Encrypted` structure received in the request;
- a `responseCode` indicating the result of the request;
- if `responseCode` is 0, indicating a positive response, then a certificate is returned;
- if `responseCode` is different than 0, indicating a negative response, then no certificate will be returned.

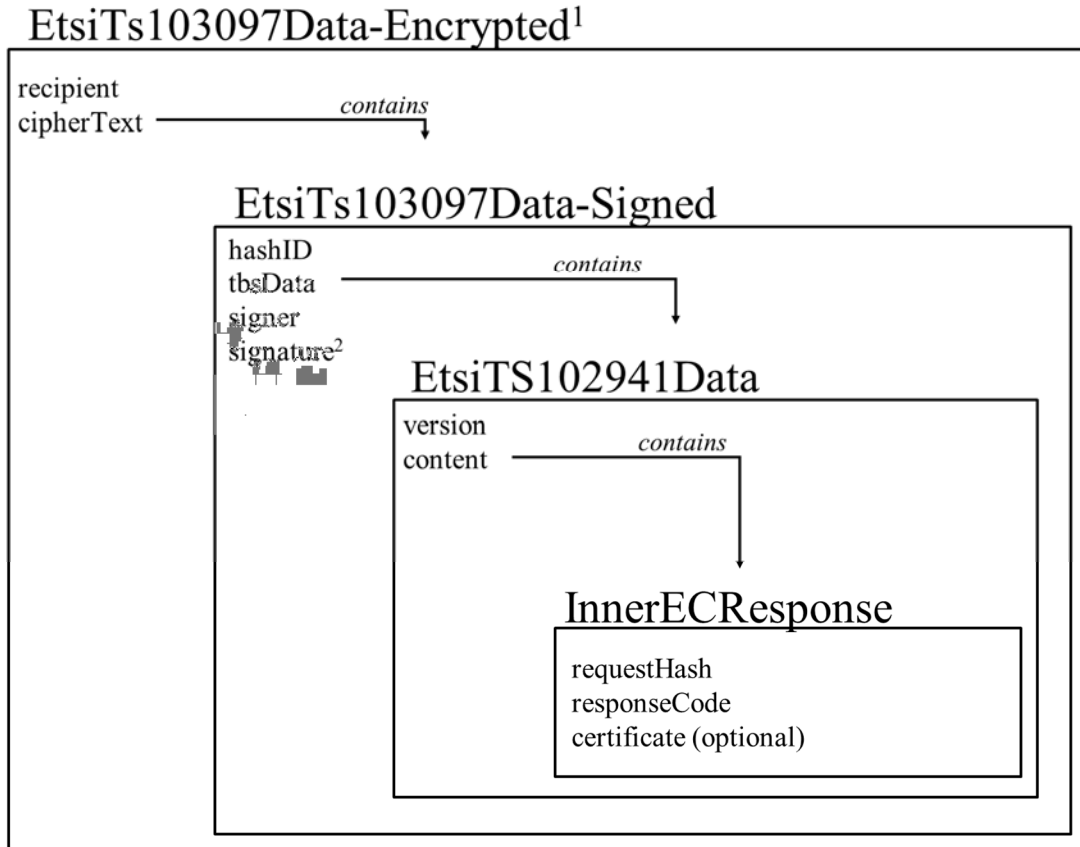

NOTE: <sup>1</sup> Encryption is done with the AES key used in ECIES for the encryption of the ECREquest.  
<sup>2</sup> Signature computed using the private key corresponding to the EA certificate's verification public key.

**Figure 15: EnrolmentResponse message**

### 6.2.3.3 Authorization Management

#### 6.2.3.3.0 Overview

The Authorization Request message shall be sent by an ITS-S to the Authorization Authority (AA) across the interface at reference point S<sub>2</sub> (see clause 6.2.2) to request an authorization ticket to be used in subsequent ITS communications. Figure 16 shows an example of a message sequence for a successful or unsuccessful authorization request.

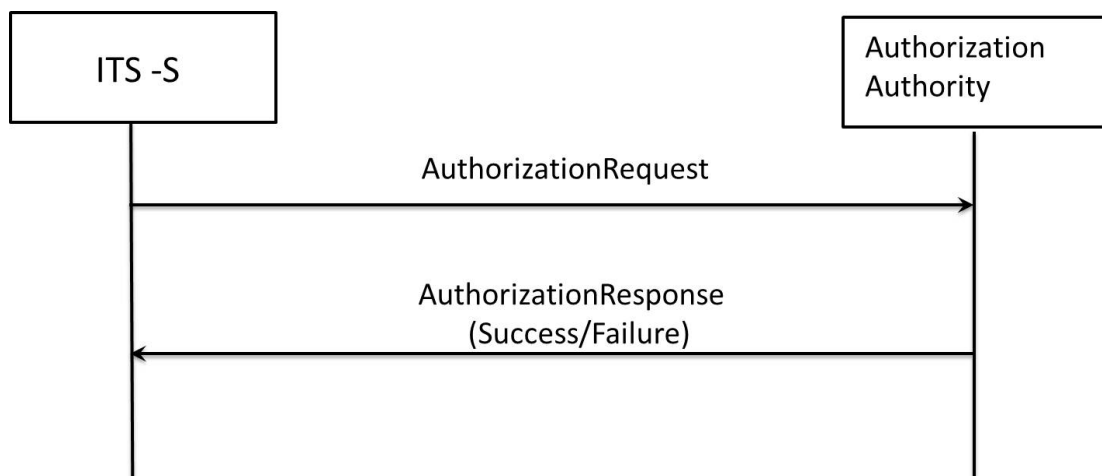

**Figure 16: Message sequence for authorization request and response**

All messages supporting the authorization process will satisfy the following security and privacy requirements:

- integrity, data origin authenticity, and confidentiality shall be ensured;
- authorization and access control: only registered and authenticated ITS stations shall get Authorization Tickets that enable them to access to cooperative ITS services.

For ITS-S that need privacy protection such as ITS-S vehicles or personal devices, the following requirements apply:

- pseudonymity of the ITS-S requester towards external attackers and against the Authorization Authority should be ensured;
- unlinkability of the ITS-S requesting Authorization Tickets: several successive requests should not be linked to the same ITS-S requester or linked between them.

#### 6.2.3.3.1 Authorization request

The following functional requirements are defined on the state machine of Figure 3 (sender ITS-S for the authorization process):

- The AuthorizationRequest message shall be encrypted using an ETSI TS 103 097 [3] approved encryption algorithm and the public key provided by the authorization authority.
- For each authorization request, the ITS-S shall generate a new verification key pair corresponding to an approved signature algorithm as specified in ETSI TS 103 097 [3].
- The contents of the Authorization Request message shall be as described in Figure 17.
- The complete nested data structure of the Authorization Request message is specified in Figure 17. The specification of the content of the ITS-S Authorization Request message using ASN.1 [6], [7] shall be as specified in clause A.2.

To create an authorization request, the ITS-S shall follow this process:

- An ECC private key is randomly generated, the corresponding public key (`verificationKey`) is provided to be included in the AT.
- Optionally, an ECC encryption private key is randomly generated, the corresponding public key (`encryptionKey`) is provided to be included in the AT.
- A random 32 octets long secret key (`hmac-key`) is generated.
- A tag using the HMAC-SHA256 function is computed using the previously generated `hmac-key`, on the concatenation of the serialization of `verificationKey` and `encryptionKey` elements (`encryptionKey` is optional); this tag is truncated to the leftmost 128 bits and named `keyTag` (see FIPS 198-1 [13]). By including the tag in the `SharedATRequest` structure the integrity as well as the non-repudiation of the `verificationKey` and `encryptionKey` elements is ensured. The use of an HMAC function ensures that the tag can only be verified by the instances that are in possession of the `hmac-key`. By this means the AA can verify that the HMAC value of the public keys match the given `keyTag` and the EA is not able to draw conclusions on the keys requested by the ITS-S.
- A `SharedATRequest` structure is built, with:
  - the `eaId` identifying the EA certificate of the EA that can be contacted for validation;
  - the calculated `keyTag`;
  - the `certificateFormat` which specifies the version used for the certificate format specification. In the present document, the certificate format shall be set to `ts103097v131` (integer value 1);
  - the desired attributes (`requestedSubjecAttributes`).

- An `EtsiTs103097Data-SignedExternalPayload` structure is built containing: `hashId`, `tbsData`, `signer` and `signature`:
  - the `hashId` shall indicate the hash algorithm to be used as specified in ETSI TS 103 097 [3];
  - in the `tbsData`:
    - the payload shall contain an `extDataHash` with the hash of `SharedATRequest`;
    - in the `headerInfo`:
      - the `psid` shall be set to "secured certificate request" as assigned in ETSI TS 102 965 [19];
      - the `generationTime` shall be present;
    - all other components of the component `tbsdata.headerInfo` not used and absent;
  - the `signer` declared as a `digest` referencing the `hashedId8` of the EC certificate;
  - the `signature` over `tbsData` computed using the private key corresponding to the EC's verification public key.
- [Itss\_WithPrivacy] An `EtsiTs103097Data-Encrypted` structure (`encryptedEcSignature`) is built with:
  - the component `recipients` with one instance of `RecipientInfo` of choice `certRecipInfo`, containing:
    - the `HashedId8` of the EA certificate in `recipientId`; and
    - the encrypted data encryption key in `encKey`; the public key to use for encryption is the `encryptionKey` found in the EA certificate referenced in `recipientId`;
  - the component `ciphertext` containing the encrypted representation of the `EtsiTs103097Data-SignedExternalPayload` structure;
  - [Itss\_NoPrivacy] For special purpose ITS-Ss which do not require privacy and are allowed to be re-identified by the AA, the message structure shall omit the encryption of the signer information and signature by omitting the previous step.
- An `InnerATRequest` structure is built, containing:
  - the `publicKeys`: a `verificationKey` requested for certification and an optional `encryptionKey` to be placed in the same certificate;
  - the generated `hmac-key`;
  - the `SharedATRequest` structure;
  - [Itss\_WithPrivacy] the encrypted detached signature containing the `EtsiTs103097Data-Encrypted` structure (`encryptedEcSignature`);
  - [Itss\_NoPrivacy] the not encrypted detached signature containing the `EtsiTs103097Data-SignedExternalPayload`.
- An `EtsiTs102941Data` structure is built, with:
  - the `version` set to `v1` (integer value set to 1);
  - the `content` set to the previous `InnerATRequest` structure.

The POP signature is optional. That is why there is two types of messages for the authorization request provided in the ASN.1 module present in clause A.2: `AuthorizationRequestMessage` and `AuthorizationRequestMessageWithPop`. The use of this signature is recommended since it is an important security mechanism to ensure the trustworthiness of the ITS-S. It ensures that the requesting ITS-S is in possession of the corresponding private key. If present, this `EtsiTs103097Data-Signed` contains a signature providing a proof of possession of the ITS-S verification key that is provided to the AA for certification. This component is an `EtsiTs103097Data-Signed` structure containing (see Figure 18) the `hashId`, the `tbsData`, the `signer` and `signature`:

- The `hashId` shall indicate the hash algorithm to be used as specified in ETSI TS 103 097 [3].
- In the `tbsData`:
  - the payload shall contain the previous `EtsiTs102941Data` structure;
  - in the `headerInfo`:
    - the `psid` shall be set to "secured certificate request" as assigned in ETSI TS 102 965 [19];
    - the `generationTime` in the `headerInfo` shall be present;
    - all other components of the component `tbsdata.headerInfo` not used and absent.
- The `signer` declared as self.
- The signature over `tbsData` computed using the private key corresponding to the verification public key `verificationKey` to be certified and provided in the `ATRequest`.
- An `EtsiTs103097Data-Encrypted` structure is built, with:
  - the component `recipients` containing one instance of `RecipientInfo` of choice `certRecipInfo`, containing:
    - the `hashedId8` of the AA certificate in `recipientId`; and
    - the encrypted data encryption key in `encKey`, the public key to use for encryption is the `encryptionKey` found in the AA certificate referenced in `recipientId`;
  - the component `ciphertext` containing the encrypted representation of the previous `EtsiTs103097Data-Signed` structure if the POP signature is present otherwise the `EtsiTs103097Data` unsecured envelope containing the `EtsiTs102941Data` structure.

The `requestedSubjecAttributes` shall not contain a `certIssuePermissions` attribute, but shall contain an `appPermissions` attribute.

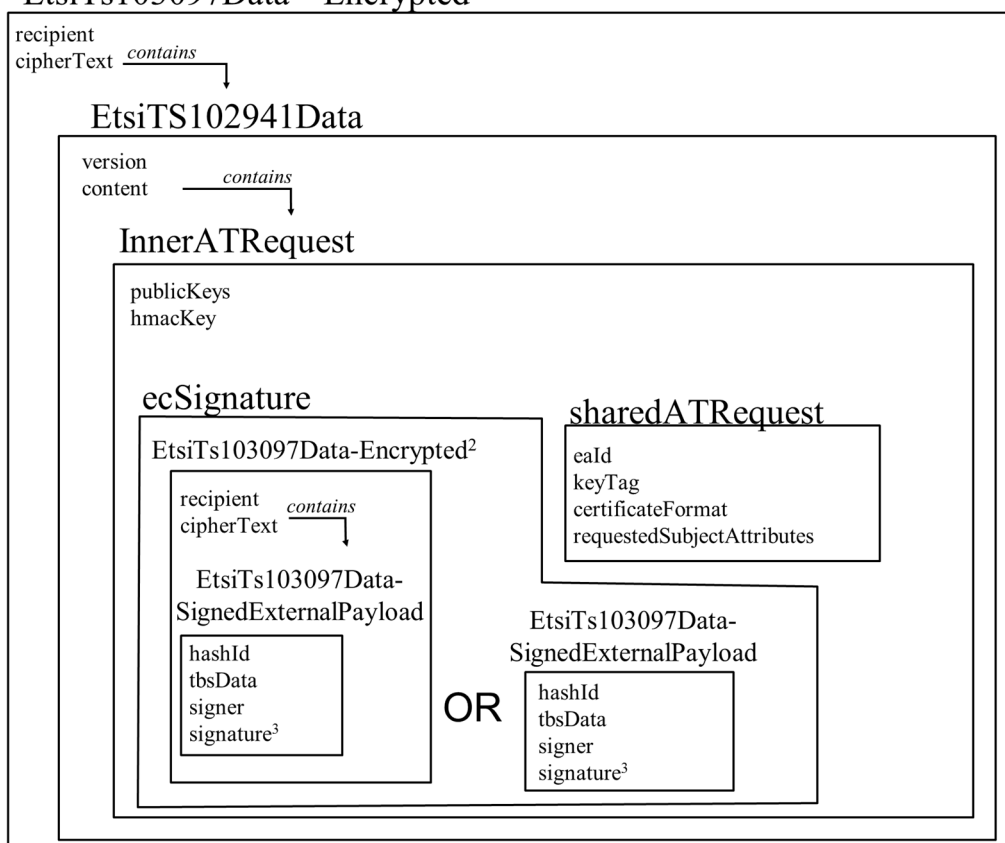
EtsiTs103097Data – Encrypted<sup>1</sup>

- NOTE: <sup>1</sup> Encryption is done with ECIES using the public encryption key of the AA.  
<sup>2</sup> Encryption is done with ECIES using the public encryption key of the EA.  
<sup>3</sup> Signature computed using currently valid private key corresponding to the EC's verification public key.

**Figure 17: AuthorizationRequest message**

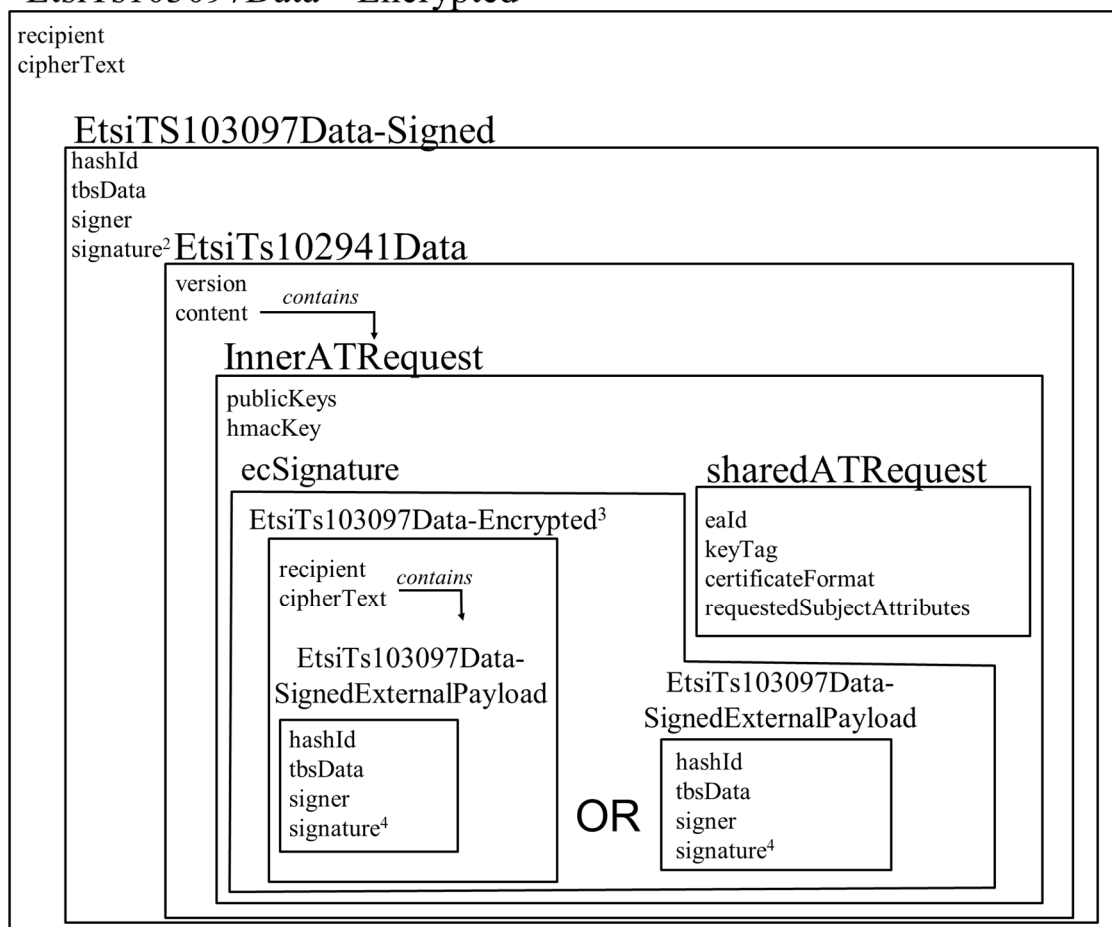

EtsiTs103097Data – Encrypted<sup>1</sup>

- NOTE:
- <sup>1</sup> Encryption is done with ECIES using the public encryption key of the AA.
  - <sup>2</sup> Signature computed using the private key corresponding to the verification public key to be certified.
  - <sup>3</sup> Encryption is done with ECIES using the public encryption key of the EA.
  - <sup>4</sup> Signature computed using currently valid EC private key corresponding to the verification public key.

**Figure 18: AuthorizationRequestMessageWithPop**

When receiving an `AuthorizationRequest` or an `AuthorizationRequestMessageWithPop` message, the AA shall make the following verifications before preparing and sending the corresponding `AuthorizationResponse` (see Figure 12):

- AA shall decrypt the `AuthorizationRequest` using the encryption private key corresponding to the recipient certificate (`certRecipInfo` specified in the message `Recipients` field).
- AA shall verify the inner signature (if the POP is present).
- AA shall verify the HMAC-SHA256 value on the concatenation of the serialization of `publicKeys` using the received `hmacKey` to check the request authenticity.
- If the result is equal to the `keyTag` in the received request, the AA shall request to the EA identified by its certificate digest (`eaId`) the authorization validation for the requested AT. If result is not equal, the AA shall return an `AuthorizationResponse` with negative response code (different than 0).
- After receiving a positive `AuthorizationValidationResponse` from the EA, the AA shall be authorized to issue the requested AT. Otherwise it shall return a negative response code in the `AuthorizationResponse`.

### 6.2.3.3.2 Authorization response

The `AuthorizationResponse` message shall be sent by the AA to the ITS-S across the interface at reference point  $S_2$  in response to a received `AuthorizationRequest` message.

The `AuthorizationResponse` message shall be encrypted using an ETSI TS 103 097 [3] approved algorithm and the encryption shall be done with the same AES key as the one used by the ITS-S requestor for the encryption of the `AuthorizationRequest` message.

The complete nested data structure of the `AuthorizationResponse` message is specified in Figure 19. The specification of the ITS-S `AuthorizationResponse` message using ASN.1 [6], [7] shall be as specified in clause A.2.

To read an authorization response, the ITS-S shall receive an `EtsiTs103097Data-Encrypted` structure, containing an `EtsiTs103097Data-Signed` structure, containing an `EtsiTs102941Data` structure, containing an `authorizationResponse` structure:

- The outermost structure is an `EtsiTs103097Data-Encrypted` structure with:
  - the component `recipients` containing one instance of `RecipientInfo` of choice `pskRecipInfo`, which contains the `HashedId8` of the `SymmetricEncryptionKey` structure containing the symmetric key used by the ITS-S to encrypt the `AuthorizationRequest` message to which the response is built;
  - the component `ciphertext`, once decrypted, contains an `EtsiTs103097Data-Signed` structure.

If the ITS-S has been able to decrypt the content, this expected `EtsiTs103097Data-Signed` structure shall contain `hashId`, `tbsData`, `signer` and `signature`:

- The `hashId` shall indicate the hash algorithm to be used as specified in ETSI TS 103 097 [3]:
  - in the `tbsData`:
    - the payload shall contain an `EtsiTs102941Data` structure;
    - in the `headerInfo`:
      - the `psid` shall be set to "secured certificate request" as assigned in ETSI TS 102 965 [19];
      - the `generationTime` shall be present;
      - all other components of the component `tbsdata.headerInfo` not used and absent;
  - the `signer` as a `digest` referencing the `hashedId8` of AA certificate;
  - the `signature` over `tbsData` computed using the AA private key corresponding to its public verification key found in the AA certificate.

The `authorizationResponse` shall contain:

- The `requestHash` is the left-most 16 octets of the SHA256 digest of the COER representation of the topmost `EtsiTs103097Data-Encrypted` structure of the received request (see Figure 17 and Figure 18);
- A `responseCode` indicating the result of the request.
- If `responseCode` is 0, indicating a positive response, then a certificate is returned.
- If `responseCode` is different than 0, indicating a negative response, then no certificate will be returned.

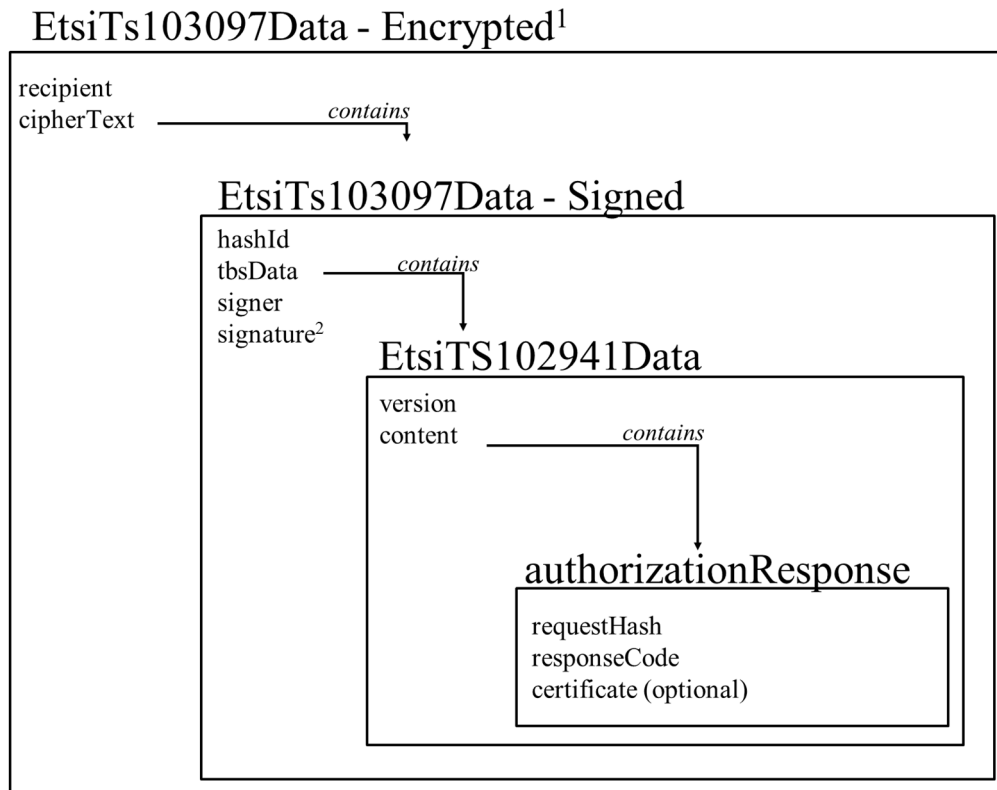

NOTE: <sup>1</sup> Encryption is done with the AES key used for the encryption of the ATRequest.  
<sup>2</sup> Signature computed using the verification private key associated with the AA certificate.

**Figure 19: AuthorizationResponse message**

#### 6.2.3.4 Authorization Validation protocol

##### 6.2.3.4.0 Overview

The *AuthorizationValidation Request* message shall be sent by the Authorization Authority (AA) to the Enrolment Authority (EA) across the interface at reference point S<sub>4</sub> (see Figure 8 in ETSI TS 102 940 [5]) to request the validation of the Authorization Ticket (AT) request receiving from an ITS-S.

Figure 20 shows an example of a message sequence for a successful or unsuccessful AT validation request.

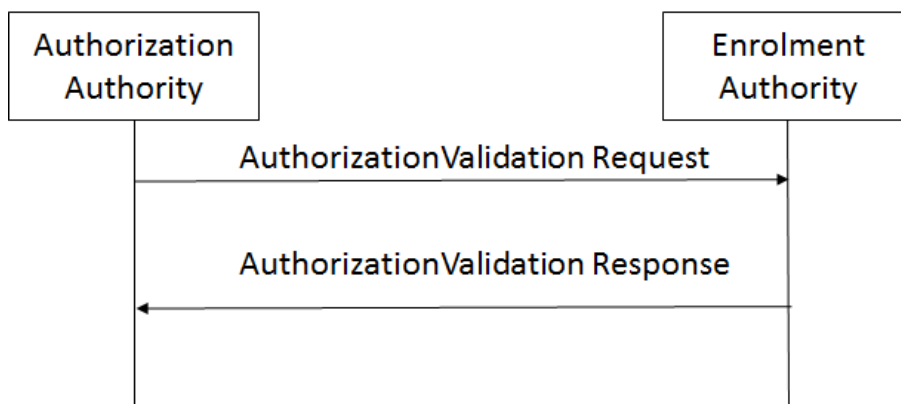

**Figure 20: Message sequence for an authorization validation request**

### 6.2.3.4.1 Authorization validation request

The following functional requirements are defined on the communication flow of Figure 20.

The `AuthorizationValidationRequest` message shall be encrypted using a ETSI TS 103 097 [3] approved encryption algorithm and the public key provided by the enrolment authority.

The contents of the `AuthorizationValidationRequest` message shall be as described in Figure 21.

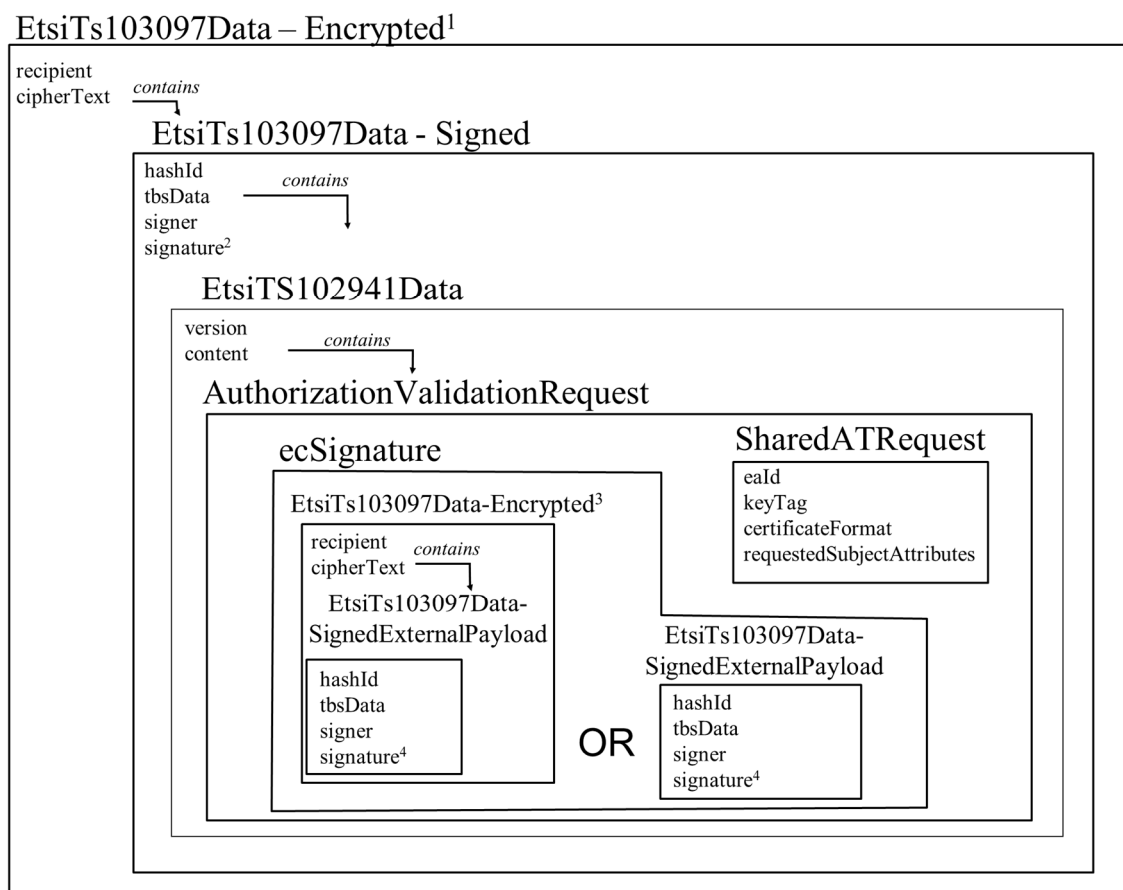

- NOTE:
- <sup>1</sup> Encryption is done with ECIES using the public encryption key of the EA.
  - <sup>2</sup> Signature computed using the private key corresponding to the AA certificate's verification public key.
  - <sup>3</sup> Encryption is done with ECIES using the public encryption key of the EA.
  - <sup>4</sup> Signature computed using current valid EC verification private key.

**Figure 21: AuthorizationValidationRequest message**

The specification of the ITS-S `AuthorizationValidationRequest` message using ASN.1 [6], [7] shall be as specified in clause A.2.

To create an `AuthorizationValidationRequest`, the AA shall follow this process:

- An `AuthorizationValidationRequest` structure is built, with:
  - in the component `sharedAtRequest`, the `sharedAtRequest` component from the `InnerAtRequest` received in the `AuthorizationRequestMessage` or `AuthorizationRequestMessageWithPop`;
  - in the component `ecSignature`, the `ecSignature` component from the `InnerAtRequest` received in the `AuthorizationRequestMessage` or `AuthorizationRequestMessageWithPop`.

- An `EtsiTs102941Data` structure is built, with:
  - the version set to `v1` (integer value set to 1);
  - the content set to the previous data structure (`AuthorizationValidationRequest`).
- An `EtsiTs103097Data-Encrypted` with:
  - the component `recipients` with one instance of `RecipientInfo` of choice `certRecipInfo`, containing:
    - the `hashedId8` of the EA certificate in `recipientId`; and
    - the encrypted data encryption key in `encKey`; the public key to use for encryption is the `encryptionKey` found in the EA certificate referenced in `recipientId`;
  - the component `ciphertext` containing the encrypted representation of the `EtsiTs103097Data-Signed` structure.
- An `EtsiTs103097Data-Signed` structure is built containing `hashId`, `tbsData`, `signer` and `signature`:
  - the `hashId` shall indicate the hash algorithm to be used as specified in ETSI TS 103 097 [3];
  - in the `tbsData`:
    - the payload shall contain the previous `EtsiTs102941Data` structure;
    - in the `headerInfo`:
      - the `psid` shall be set to "secured certificate request" as assigned in ETSI TS 102 965 [19];
      - the `generationTime` shall be present;
      - all other components of the component `tbsdata.headerInfo` not used and absent;
    - the `signer` declared as a `digest` referencing the `hashedId8` of the AA certificate;
    - the `signature` over `tbsData` computed using the AA private key corresponding to its public verification key found in the AA certificate.

#### 6.2.3.4.2 Authorization validation response

The `AuthorizationValidationResponse` message shall be sent by the EA to the AA across the interface at reference point `S4` in response to a received `AuthorizationValidationRequest` message.

The following functional requirements are defined on the communication flow of Figure 20.

The `AuthorizationValidationResponse` message shall be encrypted using an ETSI TS 103 097 [3] approved algorithm and the response encryption key provided in the `AuthorizationValidationRequest` message.

The complete nested data structure of the `AuthorizationValidationResponse` message is specified in Figure 22. The specification of the ITS-S `AuthorizationValidationRequest` message using ASN.1 [6], [7] shall be as specified in clause A.2.

To read an authorization validation response, the AA shall receive an `EtsiTs103097Data-Encrypted` structure, containing an `EtsiTs103097Data-Signed` structure, containing an `EtsiTs102941Data` structure, containing an `AuthorizationValidationResponse` structure.

To create an `AuthorizationValidationResponse` message, an EA shall follow this process:

- An `AuthorizationValidationResponse` structure is built, containing:
  - the `requestHash` is the left-most 16 octets of the SHA256 digest of the topmost `EtsiTs103097Data-Encrypted` structure received in the `AuthorizationValidationRequest`;
  - a `responseCode` the response code applying to the request, based on EA internal verification results;
  - if `responseCode` is 0, in the field `confirmedSubjectAttributes`, the attributes the EA wishes to confirm, except for `certIssuePermissions` which is not allowed to be present;
  - if `responseCode` is different than 0, no component `confirmedSubjectAttributes`.
- An `EtsiTs102941Data` structure is built, with:
  - the version set to v1 (integer value set to 1);
  - the content set to the previous data structure (`AuthorizationValidationResponse`).
- An `EtsiTs103097Data-Encrypted` with:
  - the component `recipients` containing one instance of `RecipientInfo` of choice `pskRecipInfo`, which contains the `HashedId8` of the `SymmetricEncryptionKey` structure containing the symmetric key used by the ITS-S to encrypt the `AuthorizationValidationRequest` message to which the response is built;
  - the component `ciphertext` containing the encrypted representation of the `EtsiTs103097Data-Signed`.
- An `EtsiTs103097Data-Signed` structure is built containing `hashId`, `tbsData`, `signer` and `signature`:
  - the `hashId` shall indicate the hash algorithm to be used as specified in ETSI TS 103 097 [3];
  - in the `tbsData`:
    - the payload shall contain the previous `EtsiTs102941Data` structure;
    - in the `headerInfo`:
      - the `psid` shall be set to "secured certificate request" as assigned in ETSI TS 102 965 [19];
      - the `generationTime` shall be present;
      - all other components of the component `tbsdata.headerInfo` not used and absent;
  - the `signer` declared as a `digest` referencing the `hashedId8` of the EA certificate;
  - the `signature` over `tbsData` computed using the EA private key corresponding to its public verification key found in the referenced EA certificate.

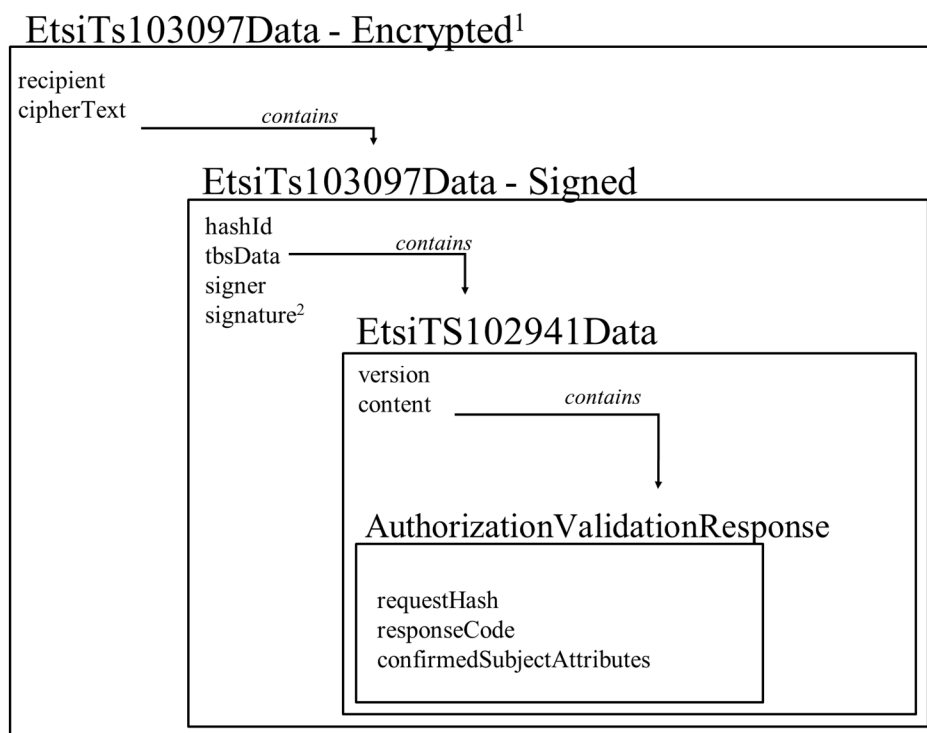

NOTE: <sup>1</sup> Encryption is done with the AES key used for the encryption of the AuthorizationValidationRequest.  
<sup>2</sup> Signature computed using the private key corresponding to the EA certificate's verification public key.

**Figure 22: AuthorizationValidationResponse**

A successful response shall contain a subject assurance, a start date and an end date, which shall be in the produced AT certificate. The subject assurance is defined in ETSI TS 103 097 [3].

## 6.3 Generation, distribution and use of Trust information lists

### 6.3.1 Generation and distribution of CTL by TLM

The Trust List Manager (TLM) is a superior entity in the C-ITS trust model. It is responsible for approving or rejecting the insertion of a Root CA certificate in the Certificate Trust List (CTL) in accordance with the Policy Authority (PA) as specified in ETSI TS 102 940 [5].

NOTE: In the planned deployment of C-ITS in Europe, the CTL issued by the TLM is called ECTL (European Certificate Trust List).

The TLM shall update and publish the Certificate Trust List (CTL) using the Full CTL format specified in clause 6.3.4. Especially, the update and distribution of CTL information to all C-ITS entities is needed to support the following use cases:

- add a new Root CA;
- update trust information of a Root CA, i.e. renewing the Root CA certificate, removing expired Root CA certificate;
- delete a Root CA certificate (revoked);
- update the TLM certificate after a renewal process (creation of new key and generation of TLM certificates);
- update the CPOC access point (URL) to enable secure distribution of TLM contact details.

The CTL issued by the TLM shall be signed using the TLM verification key and time-stamped using a time-stamp counter (ctlSequence) which is specified as a monotonically increasing counter, with increased value of 1 and maximum value 255. The list is valid when received and shall contain a validity end (nextUpdate).

The CTL issued by the TLM shall contain only the following information:

- TLM certificate and link certificate (optional);
- Root CA certificates and link certificates (optional);
- CPOC access point.

For each update of the CTL, the TLM shall also generate the Delta CTL list using the formats specified in clause 6.3.4. The sequence number of the Full CTL (ctlSequence) shall be identical to the sequence number of the Delta CTL.

The full and delta CTL should be published via the C-ITS Point Of Contact (CPOC).

## 6.3.2 Generation and distribution of CTL by RCA

The Root CA is the root of trust for the PKI hierarchy. The RCA is responsible of managing and providing trust information about all its subordinate authorities (EAs, AAs), e.g. CA certificates and access points (URL) as specified in ETSI TS 102 940 [5].

The RCA shall update and publish the Certificate Trust List (CTL) using the Full CTL format specified in clause 6.3.4. Especially, the update and distribution of CTL information to all C-ITS entities is needed to support the following use cases:

- add a new trusted EA or AA;
- update EA certificates (renewing the EA certificate, removing expired EA certificate) and access points (URL);
- update AA certificates (renewing the AA certificate, removing expired AA certificate) and access points (URL);
- update DC access point to enable secure distribution of RCA contact details.

The CTL issued by the RCA shall be signed using the private key corresponding to the RCA certificate's verification public key and time-stamped using a time-stamp counter (ctlSequence) which is specified as a monotonically increasing counter, with increased value of 1 and maximum value 255. The list is valid when received and shall contain a validity end (nextUpdate).

The CTL issued by a RCA may contain the following information:

- EA certificates and access points;
- AA certificates and access point;
- DC access point.

The CTL issued by a RCA shall not contain the following information: the TLM certificate and associated linked certificate (optional) and the Root CAs certificates.

For each update of the CTL, the RCA shall also generate the Delta CTL list using the formats specified in clause 6.3.4. The sequence number of the Full CTL (ctlSequence) shall be identical to the sequence number of the Delta CTL.

The full and delta CTL should be published via the Distribution Centre (DC) associated to the RCA.



### 6.3.3 Generation and distribution of CRL by RCA

A Certificate Revocation List (CRL) is issued and signed by the RCA verification key. It contains the CA certificates identifiers (HashedID8) that are no longer worthy of being trusted. It is accessible through a defined DC associated to the RCA.

NOTE: The CRL may contain revoked Root CA certificates.

The CRL issued by a Root CA shall not contain RCA certificates identifiers of other RCAs.

The RCA shall update the CRL by adding the identifiers of the revoked CA certificates and removing the identifiers of the expired ones.

The generated CRL CA shall be signed and time-stamped (`thisUpdate`) and shall use the CRL data structure as specified in clause A.2.7.

The RCA shall publish and distribute the updated CRL CA via a Distribution Centre (DC).

### 6.3.4 Specification of Full CTL and Delta CTL

The CTL messages are split in two different message types depending of the issuer category: the `TlmCertificateTrustListMessage` shall be issued by a TLM entity and an `RcaCertificateTrustListMessage` shall be issued by a Root CA.

The `signer` in the `SignedData` shall contain the certificate of the CTL issuer.

The CTL data structure as specified in clause A.2.7 takes into account the need for transmitting the Full CTL list over any kind of medium (providing that message fragmentation is supported) and the possible transmission of a small size format for transmission over ITS G5 (Delta CTL).

A `ToBeSignedTlmCtl` or `ToBeSignedRcaCtl` shall be of type `FullCtl` or `DeltaCtl`. Both types use the same common format `CtlFormat`.

The type `CtlFormat` shall have the following components:

- `version` indicates the version of the CTL Format. For this version of the Technical Specification the version is set to 1;
- `nextUpdate` indicates the time when a next update of the CTL is expected, and consequently the time after which the CTL is to be considered expired;
- `isFullCtl` is a flag indicating if the list is a full or delta list;
- `ctlSequence` indicated the sequence number of the list and is monotonically increased with steps of one unit, and clipped around 255;
- `ctlCommands` contains the CTL commands add or delete, add is of type `CtlEntry`, and indicates that the entry shall be trusted; delete is of type `CtlDelete`, and indicates explicitly that an entry that was previously trusted is not trustable anymore and shall be removed.

A `ToBeSignedCtl` of type `FullCtl` shall have `isFullCtl` set to `TRUE` and shall contain only `ctlCommands` of type `CtlEntry`, generating the full list of trustable entries.

A `ToBeSignedCtl` of type `DeltaCtl` shall have `isFullCtl` set to `FALSE`, and shall contain `ctlCommands` of type `CtlEntry` to indicate trust in new or updated entries, and `ctlCommands` of type `CtlDelete` to indicate that trust in previous entries has been revoked, and that such entries shall be considered deleted from the full List. A `ToBeSignedCtl` of type `DeltaCtl` shall always be generated with respect to the previous full list, i.e. the full list with `ctlSequence` with one unit less than the current.

Note that a full list and a delta list may exist in parallel, e.g. a full list of `ctlSequence` 5 may coexist with a delta list of `ctlSequence` 5, generated with respect to the Full List of `ctlSequence` of 4.

A `CtlEntry` shall provide either a `rca`, `ea`, `aa`, `dc` or `tlm` entry of type respectively `RootCaEntry`, `EaEntry`, `AaEntry`, `DcEntry`, `TlmEntry`.

A `CtlDelete` shall provide either the `cert` to revoke a `CtlEntry` entry corresponding to a certificate (i.e. `rca`, `ea`, `aa`, `t1m`) using its `HashedId8` or the `dc` to delete a `CtlEntry` entry corresponding to a distribution centre using its URL.

`RootCAEntry` shall contain a Root CA certificate and optionally a link certificate.

`EaEntry` shall contain an EA certificate, the URL for the connection by the AA, and optionally the URL for the connection by the ITS-Station.

`AaEntry` shall contain an AA certificate, and optionally the URL for the connection by the ITS-Station.

`T1mEntry` shall contain the TLM Certificate which is a self-signed certificate, optionally the TLM link certificate and the CPOC URL for the connection by the all the entities of C-ITS trust domain.

`DcEntry` shall contain the URL of the Distribution Centre and a list of certificate digests (`HashedId8`).

The CTL issued by a RCA shall contain one or multiple `DcEntry` with elements as follows:

- URL of Distribution Centre concerned;
- the RCA(s) certificate digests that publish via the Distribution Centre. This list of certificate digests may not be exhaustive.

A CTL issued by a RCA shall have at least one `DC` entry where its certificate is contained in the list of certificate digests.

### 6.3.5 Transmission of CTL and CRL

Different methods for updating the enrolled ITS-Ss may be used as specified in clause 6.1.5. Communication profiles for transmitting the CTL or CRL CA to enrolled ITSs are specified in annex D.

For broadcasting a CTL issued by TLM over ITS-G5, an ITS-S shall re-transmit the received `T1mCertificateTrustListMessage` defined in clause A.2 without modifications. The CTL transmitted issued by the TLM shall contain a `DeltaCtl` (the value of `CtlFormat` shall be set to `DeltaCtl`). The communication profile for CTL broadcast communication is specified in clause D.3.

For broadcasting a CTL issued by RCA over ITS-G5, an ITS-S shall re-transmit the received `RcaCertificateTrustListMessage` defined in clause A.2 without modifications. The CTL transmitted issued by a RCA shall contain a `DeltaCtl` (the value of `CtlFormat` shall be set to `DeltaCtl`). The communication profile for CTL broadcast communication is specified in clause D.3.

For broadcasting a CRL over ITS-G5, an ITS-S shall re-transmit the received `CertificateRevocationListMessage` defined in annex A without modifications.

The communication profile for CRL broadcast communication is specified in clause D.3.

### 6.3.6 CTL and CRL use by ITS-Ss

Upon the reception of the CTL or the CRL, the ITS-S verifies that it is signed by the associated RCA.

The ITS-S uses the CTL to update its trust information list in terms of trust anchors. This information allows to build a candidate certificate chain only based on declared `issuer` component as specified in ETSI TS 103 097 [3].

The ITS-S extracts the list of revoked CA certificates from the CRL and utilizes this information while performing the validation of the certification path.

---

# 7 Security association and key management between ITS Stations

## 7.0 Introduction

A detailed set of use case examples for ITS applications is presented in ETSI TR 102 638 [i.2]. In addition, ETSI TS 102 940 [5] categorizes the application communication (addressing) patterns used as:

- Broadcast;
- Multicast;
- Unicast.

In contrast to the strictly safety-related broadcast applications (CAM and DENM), multicast and unicast applications are assumed to be offered by several providers and, possibly, to be commercially sensitive. Therefore, the requirements depend heavily on the specific application and the respective business model.

With the exception of broadcast applications, all other multicast and unicast communications can use either asymmetric or symmetric key systems to provide for Security Association (SA) lifecycle and the related key management (registration, key establishment, updates and removal).

Unicast and multicast applications shall use link layer encryption and regular changes of the ITS MAC addresses to protect the privacy of the ITS-S (and its user) as well as all higher layer information from radio channel eavesdropping. Further details can be found in ETSI TS 102 942 [4] and ETSI TS 102 943 [9].

## 7.1 Broadcast SAs

Broadcast applications such as CA basic service, DEN basic service or Infrastructure messages service specified in [10], [11] and [12] require authentication, authorization and integrity but not confidentiality. Senders of CAM and DENM shall obtain this service by signing with an authorization ticket using the mechanisms specified in ETSI TS 103 097 [3] clauses 7.1 (Security profile for CAMs), 7.2 (Security profile for DENMs) or 7.3 (Generic profile for other broadcast messages) respectively.

To enable broadcast message signature verification, a receiving ITS-S or a relaying ITS-S shall have the capabilities to construct the certificate chain from the certificate of the Sending ITS-S up to a trust anchor. A trust anchor is either a trusted root certificate or any other CA certificate that is known to be trustworthy from the receiving or relaying ITS-S.

A receiving or relaying ITS-S shall have the capabilities to cryptographically verify the constructed certificate chain.

A receiving or relaying ITS-S shall have the capabilities to cryptographically verify the signature of the broadcasted message.

## 7.2 Multicast SAs

Multicast applications such as public transport information and Point of Interest notification services require secure group communications with message authentication, authorization and encryption depending on that group's particular security policy.

The following specifications assume that the ITS-S is using an IP-based multicast communication.

An ITS-S may join a multicast group using an authorization ticket (see clause 6.2.3.3) followed, possibly, by further registration steps.

The key management for multicast applications can be controlled by the multicast service provider or a separate security manager. Such key management may be application-specific or it may use a standard multicast key management system such as the IETF Multicast Security (MSEC) Group Key Management Architecture [i.3], [i.8], [i.9] and [i.10].

For other use cases using communications that are not IP-based, ETSI TS 103 097 [3] provides data structures that may be used to establish SA in a multicast group.

For key establishment, the multicast group leader should generate a fresh symmetric key *k*, use it to encrypt the first multicast message (with AES-CCM), then encrypt *k* for each recipient with the corresponding recipient key.

The structure `EtsiTs103097Data-Encrypted` can be used to encapsulate all this data in the following way:

- The field `recipients` shall contain one or more `RecipientInfos`, one for each key used to encrypt the symmetric key *k*.
- Each `RecipientInfo` shall be of type `certRecipInfo` or `signedDataRecipInfo`:
  - `certRecipInfo` shall be used if the symmetric key *k* is encrypted with a public encryption key present in a certificate.
  - `signedDataRecipInfo` shall be used if the symmetric key *k* is encrypted with an encryption key present in a previously received `SignedData` structure.
- The field `ciphertext` shall contain the encrypted message.

After each recipient in the multicast group receives the encrypted data structure, it shall decrypt the key *k* and the encrypted multicast message. This key may be reused to encrypt further confidential multicast messages, with the `pskRecipInfo` option in the `RecipientInfo` that indicates the use of a pre-shared symmetric key. However, the AES-CCM nonce shall be chosen randomly and shall never be reused with the same key.

If the multicast group already has a pre-shared key obtained through another key establishment protocol, the group can use this key with the structure `EtsiTs103097Data-Encrypted` and the `pskRecipInfo` option in the `RecipientInfo`.

The structure `EtsiTs103097Data-SignedAndEncrypted` can be used if authentication is also required in the key establishment step and/or the multicast group communication.

NOTE: The detailed requirements and the protocols for secure group communications with message authentication, authorization and encryption will be later specified in ETSI TS 102 943 [9].

## 7.3 Unicast SAs

Unicast applications such as automatic access control, parking management and media downloading services require secure unicast communications with message authentication, authorization and encryption.

The following specifications assume that the ITS-S is using an IP-based unicast communication.

An ITS-S may join such services using its authorization ticket followed, possibly, by further registration protocol steps.

Unicast key management may be application-specific or it may use a standard key management systems such as network layer security using Ipsec as defined by the IETF RFC 4301 [i.4], IETF RFC 4877 [i.12], IETF RFC 4306 [i.11], IETF RFC 4302 [i.5] and IETF RFC 4303 [i.6]. Also, security in the transport layer can be provided using methods such as the IETF Transport Layer Security (TLS) [i.7].

For other use cases such as the Trust and Privacy management services specified in the present document, other unicast solutions using the ETSI ITS security standards for ITS G5 communications shall be considered (ETSI TS 103 097 [3]).

For non-IP unicast SA, it is possible to proceed in the same way as multicast SA to establish a shared key. The SA initiator should generate a fresh symmetric key *k*, use it to encrypt the first confidential message, then encrypt *k* for the recipient with the corresponding recipient key. The structure `EtsiTs103097Data-Encrypted` shall be used to encapsulate all this data in the following way:

- The field `recipients` shall contain one `RecipientInfo` of type `certRecipInfo` or `signedDataRecipInfo` depending on which recipient key is used.
- The field `ciphertext` shall contain the encrypted message.

After the recipient receives the encrypted data structure, it shall decrypt the key  $k$  and the encrypted message. This key may be reused to encrypt further confidential messages, with the `pskRecipInfo` option in the `RecipientInfo` that indicates the use of a pre-shared symmetric key. However, the AES-CCM nonce shall be chosen randomly and shall never be reused with the same key.

If the units involved in a unicast communication already have a pre-shared key obtained through another key establishment protocol, the units can use this key with the structure `EtsiTs103097Data-Encrypted` and the `pskRecipInfo` option in the `RecipientInfo`.

The structure `EtsiTs103097Data-SignedAndEncrypted` can be used if authentication is also required in the key establishment step and/or the unicast communication.

NOTE: The detailed requirements and the protocols for Secure unicast communications with message authentication, authorization and encryption will be later specified in ETSI TS 102 943 [9].

---

# Annex A (normative): ITS security management messages specified in ASN.1

---

## A.1 ITS trust and privacy messages specified in ASN.1

The ASN.1 [6] modules in this annex specify data types for ITS trust and privacy services together with useful ASN.1 value notations. Security Management Messages specified in the present document shall comply with the structures specified here but the definitive encoding of messages in an implementation of the present document is specified in clause 6.2.0.

---

## A.2 Security management messages structures

### A.2.1 Security data structures

```
EtsiTs102941BaseTypes
{ itu-t(0) identified-organization(4) etsi(0) itsDomain(5) wg5(5) ts(102941) baseTypes(3)
  version2(2) }
```

```
DEFINITIONS AUTOMATIC TAGS ::=
BEGIN
```

```
IMPORTS
```

```
  HashedId8, Time32, PublicEncryptionKey, PublicVerificationKey, Signature
```

```
FROM
```

```
  IEEE1609dot2BaseTypes { iso(1) identified-organization(3) ieee(111)
    standards-association-numbered-series-standards(2) wave-stds(1609)
    dot2(2) base(1) base-types(2) major-version-2(2) }
```

```
  CertificateId, SubjectAssurance, SequenceOfPsidSsp, SequenceOfPsidGroupPermissions,
  ValidityPeriod, GeographicRegion
```

```
FROM
```

```
  IEEE1609dot2 { iso(1) identified-organization(3) ieee(111)
    standards-association-numbered-series-standards(2) wave-stds(1609) dot2(2) base (1)
    schema (1) major-version-2(2) }
```

```
  EtsiTs103097Data, EtsiTs103097Data-Encrypted, EtsiTs103097Data-Signed,
  EtsiTs103097Data-SignedExternalPayload
```

```
FROM
```

```
  EtsiTs103097Module { itu-t(0) identified-organization(4) etsi(0) itsDomain(5) wg5(5)
    ts(103097) securedMessageV1(0) }
```

```
;
```

```
CertificateFormat ::= INTEGER {
  ts103097v131 (1)
} (1..255)
```

```
CertificateSubjectAttributes ::= SEQUENCE {
  id          CertificateId OPTIONAL,
  validityPeriod      ValidityPeriod OPTIONAL,
  region           GeographicRegion OPTIONAL,
  assuranceLevel     SubjectAssurance OPTIONAL,
  appPermissions    SequenceOfPsidSsp OPTIONAL,
  certIssuePermissions  SequenceOfPsidGroupPermissions OPTIONAL,
  ...
} (WITH COMPONENTS { ..., appPermissions PRESENT } |
  WITH COMPONENTS { ..., certIssuePermissions PRESENT })
```

```
EcSignature ::= CHOICE {
  encryptedEcSignature EtsiTs103097Data-Encrypted{EtsiTs103097Data-
    SignedExternalPayload},
```

```

    ecSignature          EtsiTs103097Data-SignedExternalPayload
  }

PublicKeys ::= SEQUENCE {
  verificationKey      PublicVerificationKey,
  encryptionKey        PublicEncryptionKey OPTIONAL
}

Version ::= INTEGER {v1(1)}

EtsiTs103097Data-Unsecured {ToBeSentDataContent} ::= EtsiTs103097Data (WITH COMPONENTS
  {...,
  content (WITH COMPONENTS {
    unsecuredData (CONTAINING ToBeSentDataContent)
  })
})

EtsiTs103097Data-Encrypted-Unicast {ToBeEncryptedDataContent} ::= EtsiTs103097Data-
  Encrypted { EtsiTs103097Data-Unsecured{ToBeEncryptedDataContent}}
(WITH COMPONENTS {...,
  content (WITH COMPONENTS {
    encryptedData (WITH COMPONENTS {...,
      recipients (SIZE(1))
    })
  })
})

EtsiTs103097Data-SignedAndEncrypted-Unicast {ToBesignedAndEncryptedDataContent} ::=
  EtsiTs103097Data-Encrypted {EtsiTs103097Data-Signed
  {ToBesignedAndEncryptedDataContent}}
(WITH COMPONENTS {...,
  content (WITH COMPONENTS {
    encryptedData (WITH COMPONENTS {...,
      recipients (SIZE(1))
    })
  })
})

END

```

## A.2.2 Security Management messages for CA

```

/*****
  This file contains the EtsiTs102941Messages module containing all possible PKI
  messages.
  It should be used when all PKI messages needs to be implemented (for example, for CA
  development)
*****/
EtsiTs102941MessagesCa
  { itu-t(0) identified-organization(4) etsi(0) itsDomain(5) wg5(5) ts(102941)
  messagesCa(0) version2(2)}

DEFINITIONS AUTOMATIC TAGS ::=
BEGIN

IMPORTS

EtsiTs103097Data-Signed,
--EtsiTs103097Data-Encrypted,
EtsiTs103097Data-SignedExternalPayload
--EtsiTs103097Data-SignedAndEncrypted
FROM EtsiTs103097Module
{ itu-t(0) identified-organization(4) etsi(0) itsDomain(5) wg5(5) ts(103097)
  securedMessageV1(0)}

Version,
EtsiTs103097Data-Encrypted-Unicast,
EtsiTs103097Data-SignedAndEncrypted-Unicast

```

```

FROM EtsiTs102941BaseTypes
{ itu-t(0) identified-organization(4) etsi(0) itsDomain(5) wg5(5) ts(102941) baseTypes(3)
version2(2) }

InnerEcRequestSignedForPop, InnerEcResponse
FROM EtsiTs102941TypesEnrolment
{ itu-t(0) identified-organization(4) etsi(0) itsDomain(5) wg5(5) ts(102941) enrolment(4)
version2(2) }

InnerAtRequest, InnerAtResponse
FROM EtsiTs102941TypesAuthorization
{ itu-t(0) identified-organization(4) etsi(0) itsDomain(5) wg5(5) ts(102941)
authorization(5) version2(2) }

ToBeSignedCrl, ToBeSignedTlmCtl, ToBeSignedRcaCtl
FROM EtsiTs102941TrustLists
{ itu-t(0) identified-organization(4) etsi(0) itsDomain(5) wg5(5) ts(102941)
trustLists(6) version2(2) }

AuthorizationValidationRequest, AuthorizationValidationResponse
FROM EtsiTs102941TypesAuthorizationValidation
{ itu-t(0) identified-organization(4) etsi(0) itsDomain(5) wg5(5) ts(102941)
authValidation(7) version2(2) }

CaCertificateRequest
FROM EtsiTs102941TypesCaManagement
{ itu-t(0) identified-organization(4) etsi(0) itsDomain(5) wg5(5) ts(102941)
caManagement(8) version2(2) }

;

/*****
-- Messages
*****/
EnrolmentRequestMessage ::= EtsiTs103097Data-SignedAndEncrypted-Unicast {EtsiTs102941Data
(WITH COMPONENTS{..., content (WITH COMPONENTS{enrolmentRequest PRESENT}})}}
EnrolmentResponseMessage ::= EtsiTs103097Data-SignedAndEncrypted-Unicast
{EtsiTs102941Data (WITH COMPONENTS{..., content (WITH COMPONENTS{enrolmentResponse
PRESENT}})}}
AuthorizationRequestMessage ::= EtsiTs103097Data-Encrypted-Unicast {EtsiTs102941Data
(WITH COMPONENTS{..., content (WITH COMPONENTS{authorizationRequest PRESENT}})}}
AuthorizationRequestMessageWithPop ::= EtsiTs103097Data-SignedAndEncrypted-Unicast
{EtsiTs102941Data (WITH COMPONENTS{..., content (WITH COMPONENTS{authorizationRequest
PRESENT}})}}
AuthorizationResponseMessage ::= EtsiTs103097Data-SignedAndEncrypted-Unicast
{EtsiTs102941Data (WITH COMPONENTS{..., content (WITH COMPONENTS{authorizationResponse
PRESENT}})}}
CertificateRevocationListMessage ::= EtsiTs103097Data-Signed{EtsiTs102941Data (WITH
COMPONENTS{..., content (WITH COMPONENTS{certificateRevocationList PRESENT}})}}
TlmCertificateTrustListMessage ::= EtsiTs103097Data-Signed{EtsiTs102941Data (WITH
COMPONENTS{..., content (WITH COMPONENTS{certificateTrustListTlm PRESENT}})}}
RcaCertificateTrustListMessage ::= EtsiTs103097Data-Signed{EtsiTs102941Data (WITH
COMPONENTS{..., content (WITH COMPONENTS{certificateTrustListRca PRESENT}})}}
AuthorizationValidationRequestMessage ::= EtsiTs103097Data-SignedAndEncrypted-Unicast
{EtsiTs102941Data (WITH COMPONENTS{..., content (WITH
COMPONENTS{authorizationValidationRequest PRESENT}})}}
AuthorizationValidationResponseMessage ::= EtsiTs103097Data-SignedAndEncrypted-Unicast
{EtsiTs102941Data (WITH COMPONENTS{..., content (WITH
COMPONENTS{authorizationValidationResponse PRESENT}})}}
CaCertificateRequestMessage ::= EtsiTs103097Data-Signed {EtsiTs102941Data(WITH
COMPONENTS{..., content (WITH COMPONENTS{caCertificateRequest PRESENT}})}}
CaCertificateRekeyingMessage ::= EtsiTs103097Data-Signed {EtsiTs103097Data-Signed
{EtsiTs102941Data(WITH COMPONENTS{..., content (WITH COMPONENTS{caCertificateRequest
PRESENT}})}}}

/*****
-- EtsiTs102941Data
*****/

EtsiTs102941Data ::= SEQUENCE {

```



```

    version Version (v1),
    content EtsiTs102941DataContent
  }

EtsiTs102941DataContent ::= CHOICE {
  enrolmentRequest          InnerEcRequestSignedForPop,
  enrolmentResponse        InnerEcResponse,
  authorizationRequest      InnerAtRequest,
  authorizationResponse    InnerAtResponse,
  certificateRevocationList ToBeSignedCrl,
  certificateTrustListTlm   ToBeSignedTlmCtl,
  certificateTrustListRca   ToBeSignedRcaCtl,
  authorizationValidationRequest AuthorizationValidationRequest,
  authorizationValidationResponse AuthorizationValidationResponse,
  caCertificateRequest      CaCertificateRequest,
  ...
}

END

```

### A.2.3 Security Management messages for ITS-S\_WithPrivacy

```

*****
  This file contains the EtsiTs102941MessagesItss module providing the ITS-S subset
  of messages defined in the module EtsiTs102941MessagesCA
  It should never be imported together with the module EtsiTs102941MessagesCA.
  Use the EtsiTs102941MessagesCA if all possible PKI message types are needed.

```

```

  This module blocks the usage of unencrypted EC signature for AA requests.
  *****/

```

```

EtsiTs102941MessagesItss
  { itu-t(0) identified-organization(4) etsi(0) itsDomain(5) wg5(5) ts(102941)
  messagesItss(1) version2(2) }

DEFINITIONS AUTOMATIC TAGS ::=
BEGIN

IMPORTS

EtsiTs103097Data-Signed
--EtsiTs103097Data-Encrypted,
--EtsiTs103097Data-SignedAndEncrypted
FROM EtsiTs103097Module
{ itu-t(0) identified-organization(4) etsi(0) itsDomain(5) wg5(5) ts(103097)
  securedMessageV1(0) }

EtsiTs103097Data-Encrypted-Unicast,
EtsiTs103097Data-SignedAndEncrypted-Unicast,
Version
FROM EtsiTs102941BaseTypes
{ itu-t(0) identified-organization(4) etsi(0) itsDomain(5) wg5(5) ts(102941) baseTypes(3)
  version2(2) }

InnerEcRequestSignedForPop, InnerEcResponse
FROM EtsiTs102941TypesEnrolment
{ itu-t(0) identified-organization(4) etsi(0) itsDomain(5) wg5(5) ts(102941) enrolment(4)
  version2(2) }

InnerAtRequest, InnerAtResponse
FROM EtsiTs102941TypesAuthorization
{ itu-t(0) identified-organization(4) etsi(0) itsDomain(5) wg5(5) ts(102941)
  authorization(5) version2(2) }

ToBeSignedCrl, ToBeSignedTlmCtl, ToBeSignedRcaCtl
FROM EtsiTs102941TrustLists
{ itu-t(0) identified-organization(4) etsi(0) itsDomain(5) wg5(5) ts(102941)
  trustLists(6) version2(2) }

```

```

;

/*****
-- Messages
*****/

EnrolmentRequestMessage ::= EtsiTs103097Data-SignedAndEncrypted-Unicast {EtsiTs102941Data
(WITH COMPONENTS{..., content (WITH COMPONENTS{enrolmentRequest PRESENT}})}}
EnrolmentResponseMessage ::= EtsiTs103097Data-SignedAndEncrypted-Unicast
{EtsiTs102941Data (WITH COMPONENTS{..., content (WITH COMPONENTS{enrolmentResponse
PRESENT}})}}
AuthorizationRequestMessage ::= EtsiTs103097Data-Encrypted-Unicast {EtsiTs102941Data
(WITH COMPONENTS{..., content (WITH COMPONENTS{authorizationRequest PRESENT}})}}
AuthorizationRequestMessageWithPop ::= EtsiTs103097Data-SignedAndEncrypted-Unicast
{EtsiTs102941Data (WITH COMPONENTS{..., content (WITH COMPONENTS{authorizationRequest
PRESENT}})}}
AuthorizationResponseMessage ::= EtsiTs103097Data-SignedAndEncrypted-Unicast
{EtsiTs102941Data (WITH COMPONENTS{..., content (WITH COMPONENTS{authorizationResponse
PRESENT}})}}
CertificateRevocationListMessage ::= EtsiTs103097Data-Signed{EtsiTs102941Data (WITH
COMPONENTS{..., content (WITH COMPONENTS{certificateRevocationList PRESENT}})}}
TlmCertificateTrustListMessage ::= EtsiTs103097Data-Signed{EtsiTs102941Data (WITH
COMPONENTS{..., content (WITH COMPONENTS{certificateTrustListTlm PRESENT}})}}
RcaCertificateTrustListMessage ::= EtsiTs103097Data-Signed{EtsiTs102941Data (WITH
COMPONENTS{..., content (WITH COMPONENTS{certificateTrustListRca PRESENT}})}}

/*****
-- EtsiTs102941Data
*****/

EtsiTs102941Data ::= SEQUENCE {
    version Version (v1),
    content EtsiTs102941DataContent
}

EtsiTs102941DataContent ::= CHOICE {
    enrolmentRequest                InnerEcRequestSignedForPop,
    enrolmentResponse                InnerEcResponse,
    authorizationRequest             InnerAtRequest,
    authorizationResponse            InnerAtResponse,
    certificateRevocationList        ToBeSignedCrl,
    certificateTrustListTlm          ToBeSignedTlmCtl,
    certificateTrustListRca          ToBeSignedRcaCtl,
    ...
} (WITH COMPONENTS{...,
    authorizationRequest (WITH COMPONENTS{...,
        ecSignature (WITH COMPONENTS{...,
            encryptedEcSignature PRESENT
        })
    })
})

END

```

## A.2.4 Security Management messages for ITSS\_NoPrivacy

```

/*****
  This file contains the EtsiTs102941MessagesItss-OptionalPrivacy module providing the
  same subset of messages as the EtsiTs102941MessagesItss module.
  It should never be used together with the EtsiTs102941MessagesCA and
  EtsiTs102941MessagesItss

  This module allows the usage of unencrypted EC signature for AA requests.
  *****/
EtsiTs102941MessagesItss-OptionalPrivacy
  { itu-t(0) identified-organization(4) etsi(0) itsDomain(5) wg5(5) ts(102941)
  messagesItssOp(2) version2(2) }

DEFINITIONS AUTOMATIC TAGS ::=
BEGIN

IMPORTS

EtsiTs103097Data-Signed
--EtsiTs103097Data-Encrypted,
--EtsiTs103097Data-SignedAndEncrypted
FROM EtsiTs103097Module
{ itu-t(0) identified-organization(4) etsi(0) itsDomain(5) wg5(5) ts(103097)
  securedMessageV1(0) }

EtsiTs103097Data-Encrypted-Unicast,
EtsiTs103097Data-SignedAndEncrypted-Unicast,
Version
FROM EtsiTs102941BaseTypes
{ itu-t(0) identified-organization(4) etsi(0) itsDomain(5) wg5(5) ts(102941) baseTypes(3)
  version2(2) }

InnerEcRequestSignedForPop, InnerEcResponse
FROM EtsiTs102941TypesEnrolment
{ itu-t(0) identified-organization(4) etsi(0) itsDomain(5) wg5(5) ts(102941) enrolment(4)
  version2(2) }

InnerAtRequest, InnerAtResponse
FROM EtsiTs102941TypesAuthorization
{ itu-t(0) identified-organization(4) etsi(0) itsDomain(5) wg5(5) ts(102941)
  authorization(5) version2(2) }

ToBeSignedCrl, ToBeSignedTlmCtl, ToBeSignedRcaCtl
FROM EtsiTs102941TrustLists
{ itu-t(0) identified-organization(4) etsi(0) itsDomain(5) wg5(5) ts(102941)
  trustLists(6) version2(2) }

;

/*****
-- Messages
*****/

EnrolmentRequestMessage ::= EtsiTs103097Data-SignedAndEncrypted-Unicast {EtsiTs102941Data
(WITH COMPONENTS{..., content (WITH COMPONENTS{enrolmentRequest PRESENT}})}}
EnrolmentResponseMessage ::= EtsiTs103097Data-SignedAndEncrypted-Unicast
{EtsiTs102941Data (WITH COMPONENTS{..., content (WITH COMPONENTS{enrolmentResponse
PRESENT}})}}
AuthorizationRequestMessage ::= EtsiTs103097Data-Encrypted-Unicast {EtsiTs102941Data
(WITH COMPONENTS{..., content (WITH COMPONENTS{authorizationRequest PRESENT}})}}
AuthorizationRequestMessageWithPop ::= EtsiTs103097Data-SignedAndEncrypted-Unicast
{EtsiTs102941Data (WITH COMPONENTS{..., content (WITH COMPONENTS{authorizationRequest
PRESENT}})}}
AuthorizationResponseMessage ::= EtsiTs103097Data-SignedAndEncrypted-Unicast
{EtsiTs102941Data (WITH COMPONENTS{..., content (WITH COMPONENTS{authorizationResponse
PRESENT}})}}
CertificateRevocationListMessage ::= EtsiTs103097Data-Signed{EtsiTs102941Data (WITH
COMPONENTS{..., content (WITH COMPONENTS{certificateRevocationList PRESENT}})}}

```

```
TlmCertificateTrustListMessage ::= EtsiTs103097Data-Signed{EtsiTs102941Data (WITH
COMPONENTS{..., content (WITH COMPONENTS{certificateTrustListTlm PRESENT}})}}
RcaCertificateTrustListMessage ::= EtsiTs103097Data-Signed{EtsiTs102941Data (WITH
COMPONENTS{..., content (WITH COMPONENTS{certificateTrustListRca PRESENT}})}}
```

```
/******
-- EtsiTs102941Data
*****/
```

```
EtsiTs102941Data ::= SEQUENCE {
    version Version (v1),
    content EtsiTs102941DataContent
}
```

```
EtsiTs102941DataContent ::= CHOICE {
    enrolmentRequest          InnerEcRequestSignedForPop,
    enrolmentResponse         InnerEcResponse,
    authorizationRequest      InnerAtRequest,
    authorizationResponse     InnerAtResponse,
    certificateRevocationList  ToBeSignedCrl,
    certificateTrustListTlm    ToBeSignedTlmCtl,
    certificateTrustListRca    ToBeSignedRcaCtl,
    ...
}
```

```
END
```

## A.2.5 Enrolment and authorization data types

### A.2.5.1 Enrolment

```
EtsiTs102941TypesEnrolment
{ itu-t(0) identified-organization(4) etsi(0) itsDomain(5) wg5(5) ts(102941)
enrolment(4) version2(2)}
```

```
DEFINITIONS AUTOMATIC TAGS ::=
BEGIN
```

```
IMPORTS
```

```
EtsiTs103097Certificate,
EtsiTs103097Data-Signed
FROM EtsiTs103097Module
{ itu-t(0) identified-organization(4) etsi(0) itsDomain(5) wg5(5) ts(103097)
securedMessageV1(0)}
```

```
CertificateFormat, CertificateSubjectAttributes, EcSignature, HashedId8, PublicKeys,
Version
FROM EtsiTs102941BaseTypes
{ itu-t(0) identified-organization(4) etsi(0) itsDomain(5) wg5(5) ts(102941) baseTypes(3)
version2(2) }
```

```
;
```

```
/******
-- EnrolmentRequest/Response
*****/
```

```
EnrolmentResponseCode ::= ENUMERATED {
    ok(0),
    cantparse, -- valid for any structure
    badcontenttype, -- not encrypted, not signed, not enrolmentrequest
    imnotintherecipient, -- the "recipients" doesn't include me
    unknowncryptionalgorithm, -- either kexalg or contentencryptionalgorithm
    decryptionfailed, -- works for ECIES-HMAC and AES-CCM
    unknownnits, -- can't retrieve the ITS from the itsId
    invalidsignature, -- signature verification of the request fails
```

```

invalidencryptionkey, -- signature is good, but the responseEncryptionKey is bad
baditsstatus, -- revoked, not yet active
incompletelerequest, -- some elements are missing
deniedpermissions, -- requested permissions are not granted
invalidkeys, -- either the verification_key of the encryption_key is bad
deniedrequest, -- any other reason?
... }

```

```
InnerEcRequestSignedForPop ::= EtsiTs103097Data-Signed{InnerEcRequest}
```

```

InnerEcRequest ::= SEQUENCE {
    itsId                               OCTET STRING,
    certificateFormat                   CertificateFormat,
    publicKeys                          PublicKeys,
    requestedSubjectAttributes          CertificateSubjectAttributes (WITH
COMPONENTS{..., certIssuePermissions ABSENT}),
    ...
}

```

```

InnerEcResponse ::= SEQUENCE {
    requestHash                         OCTET STRING (SIZE(16)),
    responseCode                        EnrolmentResponseCode,
    certificate                          EtsiTs103097Certificate OPTIONAL,
    ...
}
(WITH COMPONENTS { responseCode (ok), certificate PRESENT }
 | WITH COMPONENTS { responseCode (ALL EXCEPT ok), certificate ABSENT }
)

```

```
END
```

## A.2.5.2 Authorization

```

EtsiTs102941TypesAuthorization
{ itu-t(0) identified-organization(4) etsi(0) itsDomain(5) wg5(5) ts(102941)
authorization(5) version2(2)}

```

```

DEFINITIONS AUTOMATIC TAGS ::=
BEGIN

```

```
IMPORTS
```

```

EtsiTs103097Certificate,
EtsiTs103097Data-Signed
FROM EtsiTs103097Module
{ itu-t(0) identified-organization(4) etsi(0) itsDomain(5) wg5(5) ts(103097)
securedMessageV1(0)}

```

```

CertificateFormat, CertificateSubjectAttributes, EcSignature, HashedId8, PublicKeys,
Version
FROM EtsiTs102941BaseTypes
{ itu-t(0) identified-organization(4) etsi(0) itsDomain(5) wg5(5) ts(102941) baseTypes(3)
version2(2) }

```

```
;
```

```

/*****
-- AuthorizationRequest/Response
*****/

```

```

AuthorizationResponseCode ::= ENUMERATED {
    ok(0),
    -- ITS->AA
    its-aa-cantparse, -- valid for any structure
    its-aa-badcontenttype, -- not encrypted, not signed, not authorizationrequest
    its-aa-imnottherecipient, -- the "recipients" of the outermost encrypted data doesn't
include me
    its-aa-unknowncryptionalgorithm, -- either kexalg or contentcryptionalgorithm
    its-aa-decryptionfailed, -- works for ECIES-HMAC and AES-CCM
}

```

```

its-aa-keysdontmatch, -- HMAC keyTag verification fails
its-aa-incompletrequest, -- some elements are missing
its-aa-invalidencryptionkey, -- the responseEncryptionKey is bad
its-aa-outofsyncrequest, -- signingTime is outside acceptable limits
its-aa-unknownea, -- the EA identified by eaId is unknown to me
its-aa-invalididea, -- the EA certificate is revoked
its-aa-deniedpermissions, -- I, the AA, deny the requested permissions
-- AA->EA
aa-ea-cantreachea, -- the EA is unreachable (network error?)
-- EA->AA
ea-aa-cantparse, -- valid for any structure
ea-aa-badcontenttype, -- not encrypted, not signed, not authorizationrequest
ea-aa-imnotthereipient, -- the "recipients" of the outermost encrypted data doesn't
include me
ea-aa-unknowncryptionalgorithm, -- either kexalg or contentencryotionalgorithm
ea-aa-decryptionfailed, -- works for ECIES-HMAC and AES-CCM
-- TODO: to be continued...
invalidaa, -- the AA certificate presented is invalid/revoked/whatever
invalidaasignature, -- the AA certificate presented can't validate the request
signature
wrongea, -- the encrypted signature doesn't designate me as the EA
unknownits, -- can't retrieve the EC/ITS in my DB
invalidsignature, -- signature verification of the request by the EC fails
invalidencryptionkey, -- signature is good, but the key is bad
deniedpermissions, -- permissions not granted
deniedtoomanycerts, -- parallel limit
... }

```

```

InnerAtRequest ::= SEQUENCE {
    publicKey          PublicKeys,
    hmacKey            OCTET STRING (SIZE(32)),
    sharedAtRequest    SharedAtRequest,
    ecSignature        EcSignature,
    ...
}

SharedAtRequest ::= SEQUENCE {
    eaId              HashedId8,
    keyTag            OCTET STRING (SIZE(16)),
    certificateFormat CertificateFormat,
    requestedSubjectAttributes CertificateSubjectAttributes (WITH COMPONENTS{...,
certIssuePermissions ABSENT}),
    ...
}

InnerAtResponse ::= SEQUENCE {
    requestHash       OCTET STRING (SIZE(16)),
    responseCode      AuthorizationResponseCode,
    certificate        EtsiTs103097Certificate OPTIONAL,
    ...
}
(WITH COMPONENTS { responseCode (ok), certificate PRESENT }
| WITH COMPONENTS { responseCode (ALL EXCEPT ok), certificate ABSENT }
)

```

END

### A.2.5.3 AuthorizationValidation

```

EtsiTs102941TypesAuthorizationValidation
{ itu-t(0) identified-organization(4) etsi(0) itsDomain(5) wg5(5) ts(102941)
authValidation(7) version2(2) }

```

```

DEFINITIONS AUTOMATIC TAGS ::=
BEGIN

```

```

IMPORTS

```

```

EtsiTs103097Certificate
FROM EtsiTs103097Module
{ itu-t(0) identified-organization(4) etsi(0) itsDomain(5) wg5(5) ts(103097)
securedMessageV1(0)}

CertificateFormat, CertificateSubjectAttributes, EcSignature, HashedId8, PublicKeys,
Version
FROM EtsiTs102941BaseTypes
{ itu-t(0) identified-organization(4) etsi(0) itsDomain(5) wg5(5) ts(102941) baseTypes(3)
version2(2) }

SharedAtRequest
FROM EtsiTs102941TypesAuthorization
{ itu-t(0) identified-organization(4) etsi(0) itsDomain(5) wg5(5) ts(102941)
authorization(5) version2(2)}

;

/*****
-- AuthorizationValidationRequest/Response
*****/

AuthorizationValidationResponseCode ::= ENUMERATED {
    ok(0),
    cantparse, -- valid for any structure
    badcontenttype, -- not encrypted, not signed, not permissionsverificationrequest
    imnotintherecipient, -- the "recipients" of the outermost encrypted data doesn't include
me
    unknownencryptionalgorithm, -- either kexalg or contentencryptionalgorithm
    decryptionfailed, -- works for ECIES-HMAC and AES-CCM
    invalidaa, -- the AA certificate presented is invalid/revoked/whatever
    invalidaasignature, -- the AA certificate presented can't validate the request
signature
    wrongea, -- the encrypted signature doesn't designate me as the EA
    unknownits, -- can't retrieve the EC/ITS in my DB
    invalidsignature, -- signature verification of the request by the EC fails
    invalidencryptionkey, -- signature is good, but the responseEncryptionKey is bad
    deniedpermissions, -- requested permissions not granted
    deniedtoomanycerts, -- parallel limit
    deniedrequest, -- any other reason?
    ... }

AuthorizationValidationRequest ::= SEQUENCE {
    sharedAtRequest          SharedAtRequest,
    ecSignature              EcSignature,
    ...
}

AuthorizationValidationResponse ::= SEQUENCE {
    requestHash              OCTET STRING (SIZE(16)),
    responseCode             AuthorizationValidationResponseCode,
    confirmedSubjectAttributes CertificateSubjectAttributes (WITH COMPONENTS{...,
certIssuePermissions ABSENT}) OPTIONAL,
    ...
}
(WITH COMPONENTS { responseCode (ok), confirmedSubjectAttributes PRESENT }
| WITH COMPONENTS { responseCode (ALL EXCEPT ok), confirmedSubjectAttributes ABSENT }
)

END

```

## A.2.6 Offline message structures

```

EtsiTs102941TypesCaManagement
  { itu-t(0) identified-organization(4) etsi(0) itsDomain(5) wg5(5) ts(102941)
  caManagement(8) version2(2)}

DEFINITIONS AUTOMATIC TAGS ::=
BEGIN

IMPORTS

EtsiTs103097Certificate, EtsiTs103097Data-Signed
FROM
EtsiTs103097Module
{itu-t(0) identified-organization(4) etsi(0) itsDomain(5) wg5(5) ts(103097)
securedMessageV1(0)}

PublicKeys, CertificateSubjectAttributes
FROM EtsiTs102941BaseTypes
{ itu-t(0) identified-organization(4) etsi(0) itsDomain(5) wg5(5) ts(102941) baseTypes(3)
version2(2)}

;

/*****
-- CA certificate request
*****/

CaCertificateRequest ::= SEQUENCE {
    publicKeys          PublicKeys,
    requestedSubjectAttributes CertificateSubjectAttributes,
    ...
}

END

```

## A.2.7 Trust lists data types

```

EtsiTs102941TrustLists
  { itu-t(0) identified-organization(4) etsi(0) itsDomain(5) wg5(5) ts(102941)
  trustLists(6) version2(2)}

DEFINITIONS AUTOMATIC TAGS ::=
BEGIN

IMPORTS

EtsiTs103097Certificate, EtsiTs103097Data-SignedAndEncrypted, EtsiTs103097Data-Signed
FROM
EtsiTs103097Module
{itu-t(0) identified-organization(4) etsi(0) itsDomain(5) wg5(5) ts(103097)
securedMessageV1(0)}

HashedId8, Time32, Version --, CertificateAuthorityConstraints
FROM EtsiTs102941BaseTypes
{itu-t(0) identified-organization(4) etsi(0) itsDomain(5) wg5(5) ts(102941) baseTypes(3)
version2(2)}

;

/*****
-- CRL
*****/

ToBeSignedCrl ::= SEQUENCE {
    version      Version,
    thisUpdate   Time32,
    nextUpdate   Time32,

```



```

    entries SEQUENCE OF CrlEntry,
    ...
}

CrlEntry ::= HashedId8

/*****
-- TLM CTL
*****/

ToBeSignedTlmCtl ::= CtlFormat (FullCtl | DeltaCtl) (WITH COMPONENTS {...,
    ctlCommands ( WITH COMPONENT(
        ( WITH COMPONENTS {...,
            add ( WITH COMPONENTS {...,
                ea ABSENT,
                aa ABSENT
            })
        })
    ))
})

/*****
-- RCA CTL
*****/

ToBeSignedRcaCtl ::= CtlFormat (FullCtl | DeltaCtl) ( WITH COMPONENTS {...,
    ctlCommands ( WITH COMPONENT(
        ( WITH COMPONENTS {...,
            add ( WITH COMPONENTS {...,
                rca ABSENT,
                tlm ABSENT
            })
        })
    ))
})

/*****
-- CTL
*****/

FullCtl ::= CtlFormat ( WITH COMPONENTS {...,
    isFullCtl ( TRUE ),
    ctlCommands ( WITH COMPONENT(
        ( WITH COMPONENTS {...,
            delete ABSENT
        })
    ))
})

DeltaCtl ::= CtlFormat (WITH COMPONENTS {...,
    isFullCtl(FALSE)
})

CtlFormat ::= SEQUENCE {
    version      Version,
    nextUpdate   Time32,
    isFullCtl    BOOLEAN,
    ctlSequence  INTEGER (0..255),
    ctlCommands  SEQUENCE OF CtlCommand,
    ...
}

CtlCommand ::= CHOICE {
    add      CtlEntry,
    delete   CtlDelete,
    ...
}

CtlEntry ::= CHOICE {

```

```
rca    RootCaEntry,
ea     EaEntry,
aa     AaEntry,
dc     DcEntry,
tlm    TlmEntry,
...
}

CtlDelete ::= CHOICE {
  cert HashedId8,
  dc    DcDelete,
  ...
}

TlmEntry ::= SEQUENCE {
  selfSignedTLMCertificate EtsiTs103097Certificate,
  linkTLMCertificate       EtsiTs103097Certificate OPTIONAL,
  accessPoint              Url
}

RootCaEntry ::= SEQUENCE {
  selfsignedRootCa      EtsiTs103097Certificate,
  linkRootCaCertificate EtsiTs103097Certificate OPTIONAL
}

EaEntry ::= SEQUENCE {
  eaCertificate      EtsiTs103097Certificate,
  aaAccessPoint      Url,
  itsAccessPoint     Url OPTIONAL
}

AaEntry ::= SEQUENCE {
  aaCertificate EtsiTs103097Certificate,
  accessPoint  Url
}

DcEntry ::= SEQUENCE {
  url  Url,
  cert SEQUENCE OF HashedId8
}

DcDelete ::= Url

Url ::= IA5String

END
```

## Annex B (normative): Service specific parameters (SSPs) definition

### B.1 Overview

Service permissions are indicated by a pair of identifiers within a certificate, the ITS-AID and the SSP. The ITS-Application Identifier (ITS-AID) as given in ETSI TS 102 965 [19] indicates the overall type of permissions being granted.

The Service Specific Permissions (SSP) is a field that indicates specific sets of permissions within the overall permissions indicated by the ITS-AID. The originating ITS-S shall provide SSP information in its certificate for all generated signed messages.

The SSP information for Security Management messages is constructed in a common way, containing 1 or more octets depending of the actual service. For each octet, the most significant bit (MSB) shall be the leftmost bit. The transmission order shall always be the MSB first.

The first octet shall control the SSP version and be interpreted in the following way:

- 0: No version, length 1 octet; the value shall only be used for testing purposes.
- 1: First version, SSP contains information as defined in the present document.
- 2 to 255: Reserved for future usage.

### B.2 CTL SSPs definition

The interpretation of the CTL SSP octet scheme is defined as depicted in Figure B.1.

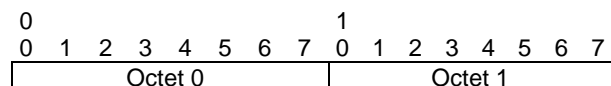

**Figure B.1: The CTL SSP schema**

The SSP for the CTL service shall be of 2 octets length, corresponding to the scheme defined in Table B.1.

**Table B.1: Octet Scheme for CTL SSPs**

Octet #	Description
0	SSP version control
1	Service-specific parameters

The service specific parameter bits shall be as defined in Table B.2.

**Table B.2: CTL service-specific permissions**

Bit position	Permission	Bit Value
0 (80h)	The certificate can be used to sign CTL containing the TLM entries	0: certificate not allowed to sign 1: certificate allowed to sign
1 (40h)	The certificate can be used to sign CTL containing the Root CA entries	0: certificate not allowed to sign 1: certificate allowed to sign
2 (20h)	The certificate can be used to sign CTL containing the EA entries	0: certificate not allowed to sign 1: certificate allowed to sign
3 (10h)	The certificate can be used to sign CTL containing the AA entries	0: certificate not allowed to sign 1: certificate allowed to sign
4 (08h)	The certificate can be used to sign CTL containing the DC entries	0: certificate not allowed to sign 1: certificate allowed to sign
5 to 7	unused	

According to clauses 6.3.1 and 6.3.2 of the present document, only combinations of SSPs defined in the Table B.3 shall be allowed.

**Table B.3: Allowed combinations of CTL SSPs**

CTL type	Allowed CTL entries	Value
TLM CTL (ECTL)	<ul style="list-style-type: none"> <li>• TLM certificate entries;</li> <li>• Root CA entries;</li> <li>• DC entry (for CPOC access point).</li> </ul>	C8h
RootCA CTL	<ul style="list-style-type: none"> <li>• EA entries;</li> <li>• AA entries;</li> <li>• DC access point entries.</li> </ul>	38h

## B.3 CRL SSPs definition

The interpretation of the CRL SSP octet scheme is defined as depicted in Figure B.2.

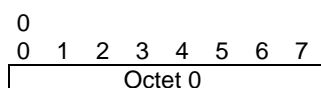
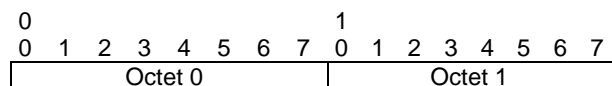

**Figure B.2: The CRL SSP schema**

The SSP for the CTL service shall be of 1 octet length, containing the SSP version control only.

## B.4 Certificate request messages SSPs definition

The interpretation of the Certificate Request SSP octet scheme is defined as depicted in Figure B.3.



**Figure B.3: The Security Management SSP schema**

The SSP for the Security Management service shall be of 2 octets length, corresponding to the scheme defined in Table B.4.

**Table B.4: Octet Scheme for Security Management SSPs**

Octet #	Description
0	SSP version control
1	Service-specific parameters

The service specific parameter shall be as defined in Table B.5.

**Table B.5: Security Management service-specific permissions**

Bit position	Permission	Bit Value
0 (80h)	The certificate can be used to sign the Enrolment Request messages	0: certificate not allowed to sign 1: certificate allowed to sign
1 (40h)	The certificate can be used to sign the Authorization Request messages	0: certificate not allowed to sign 1: certificate allowed to sign
2 (20h)	The certificate can be used to sign the AuthorizationValidation Request messages	0: certificate not allowed to sign 1: certificate allowed to sign
3 (10h)	The certificate can be used to sign the Authorization Response messages	0: certificate not allowed to sign 1: certificate allowed to sign

Bit position	Permission	Bit Value
4 (08h)	The certificate can be used to sign the Authorization Validation Response messages	0: certificate not allowed to sign 1: certificate allowed to sign
5 (04h)	The certificate can be used to sign the Enrolment Response messages	0: certificate not allowed to sign 1: certificate allowed to sign
6 (02h)	The certificate can be used to sign the CA Certificate Request messages	0: certificate not allowed to sign 1: certificate allowed to sign
7 (01h)	Unused	

## B.5 Security Management certificate permissions

The overall allowance of certificate permissions for Security Management purpose is defined in Table B.6.

**Table B.6: SM\_PDU certificate permissions**

ITS Entity	Certificate	CTL SSP					CRL	Secured Certificate Request SSP						
		TLM entry (bit 0)	RootCA entry (bit 1)	EA entry (bit 2)	AA entry (bit 3)	DC entry (bit 4)		Enr Req (bit 0)	Auth Req (bit 1)	Auth Valid Req (bit 2)	Auth Resp (bit 3)	Auth Valid Resp (bit 4)	Enr Resp (bit 5)	CA Cert Req (bit 6)
TLM	TLM	A	A	-	-	A	-	-	-	-	-	-	-	-
RootCA	Root	-	-	A	A	A	A	I	I	I	I	I	I	I
EA	EA	-	-	-	-	-	-	I	I	-	-	A	A	A
AA	AA	-	-	-	-	-	-	-	-	A	A	-	-	A
ITS-S	EC	-	-	-	-	-	-	A	A	-	-	-	-	-
	AT	-	-	-	-	-	-	-	-	-	-	-	-	-

A Certificate may contain correspondent application permission.  
I Certificate may contain correspondent certificate issuing permission.  
- Certificate shall not contain correspondent permission.

All issuing permissions, described in Table B.6, shall be included in the `certIssuePermissions` field of the certificate with `EndEntityType` equal to 'app', permitting to include these permissions into the `appPermissions` field of subordinated certificates.

## Annex C (informative): Communication profiles for security credential provisioning services (EC request, AT request)

### C.0 General

All the messages exchanged are sent as HTTP POST requests. HTTP/1.1 is used.

Parameters for the POST requests and responses are described in the tables below containing the corresponding messages descriptions.

**Table C.1: Enrolment Credential Request**

**POST** `http://<ea_access_point>`

Inputs:

- Content-type: application/x-its-request
- Content: binary encoded EnrolmentRequestMessage object

Outputs:

- Content-type: application/x-its-response
- Content: binary encoded EnrolmentResponseMessage object

**Table C.2: Request Authorization Ticket (AT)**

**POST** `http://<aa_access_point>`

Inputs:

- Content-type: application/x-its-request
- Content: binary encoded AuthorizationRequestMessage object

Outputs:

- Content-type: application/x-its-response
- Content: binary encoded AuthorizationResponseMessage object

**Table C.3: Request Authorization Ticket (AT) with PoP**

**POST** `http://<aa_access_point>`

Inputs:

- Content-type: application/x-its-request
- Content: binary encoded AuthorizationRequestMessageWithPop object

Outputs:

- Content-type: application/x-its-response
- Content: binary encoded AuthorizationResponseMessage object

**Table C.4: Validate Authorization Ticket (AT) request**

<p><b>POST</b> <a href="http://&lt;ea_access_point&gt;">http://&lt;ea_access_point&gt;</a></p> <p>Inputs:</p> <ul style="list-style-type: none"> <li>• Content-type: application/x-its-request</li> <li>• Content: binary encoded AuthorizationValidationRequestMessage object</li> </ul> <p>Outputs:</p> <ul style="list-style-type: none"> <li>• Content-type: application/x-its-response</li> <li>• Content: binary encoded AuthorizationValidationResponseMessage object</li> </ul>
---

## C.1 Communication profiles description

This annex follows the CVRIA approach ([i.14]) for the specification of the layered sets of communications protocols that are required to support communications between the ITS-S and other ITS stations and PKI authorities.

Figure C.1, Figure C.2, Figure C.3 and Figure C.4 specify the communication protocols of the requesting ITS-S for different communication media (cellular networks or ITS G5 access network).

Figure C.1 specifies the communication protocols that should be used between the ITS-S and the PKI authorities when a cellular network connection is used. It shows the mapping to ITS-S Communication layers such as specified in ETSI EN 302 665 [2]. This figure specifies the reference points  $S_2$  and  $S_3$  in the model of Figure 10.

ETSI ITS communications architecture			Requesting ITS-S
Management	Security	ITS Applications	ITS-S Certificate Reloading application
		Security Management	Enrolment Credential / Authorization Ticket Request ASN.1 OER
		Facilities	HTTP
		Networking & Transport	TCP IPv6
		Access	Cellular (2G/3G/LTE)

**Figure C.1: Communication protocols between Requesting ITS-S and PKI authorities using cellular networks**

Figure C.2, Figure C.3 and Figure C.4 depict the possible communication stacks of the requesting ITS-S when communication is based on ITS G5 media. These figures specify alternative communication profiles available on ITS G5 and the required security services that should be applied for message authentication. These figures specify the reference points  $S_1$  between the requesting ITS-S and the Relaying ITS-S or the ITS-S Roadside Gateway shown in Figure 11.

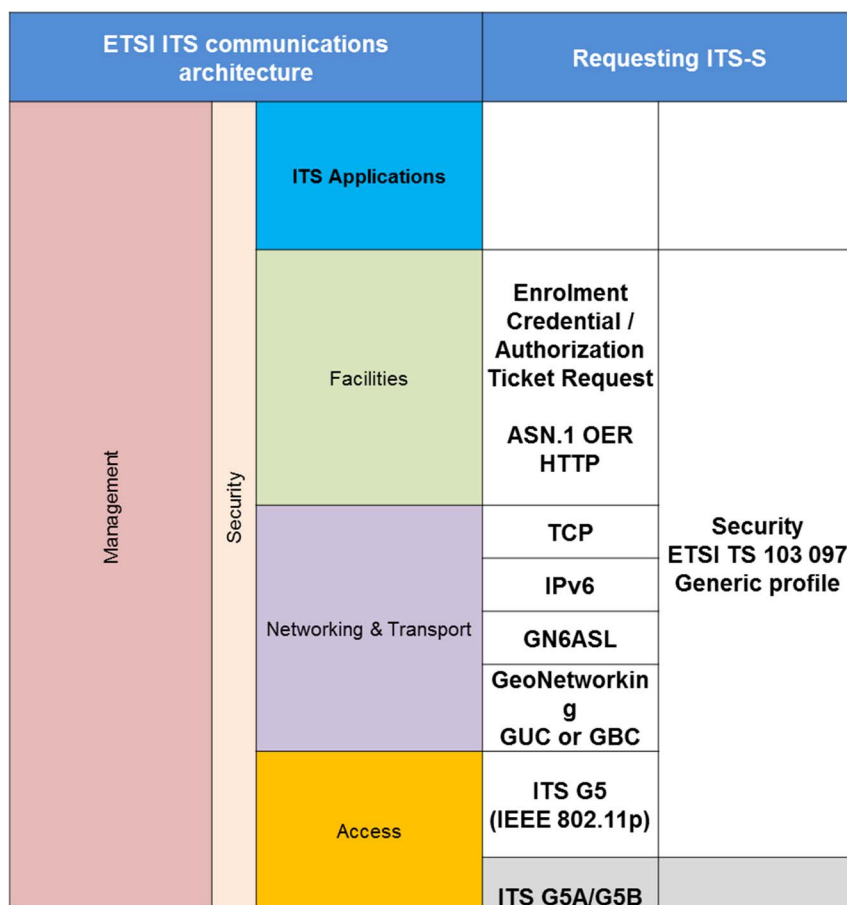

**Figure C.2: Communication protocols of the Requesting ITS-S Vehicle and ITS-S Roadside Gateway using Ipv6 over GeoNetworking**

NOTE 1: With respect to Figure C.2, the protocol layers include GN6ASL as specified in ETSI EN 302 636-6-1 [16] and the Ipv6 (and mobility extensions as defined in [i.15]).

NOTE 2: Security management services may use any service channel (SCH) available in the ITS G5A, except the CCH channel reserved for safety messages or other supplementary ITS channels when available (G5B, G5D).



ETSI ITS communications architecture		Requesting ITS-S	
Management	Security	ITS Applications	
		Facilities	Enrolment Credential / Authorization Ticket Request ASN.1 OER
		Networking & Transport	BTP
			GeoNetworking GUC or GBC
		Access	ITS G5 (IEEE 802.11p)
ITS G5A/G5B			
		Security ETSI TS 103 097 Generic profile	

Figure C.3: Communication protocols between Requesting ITS-S Vehicle and ITS-S Roadside Gateway using GN/BTP protocol

ETSI ITS communications architecture		Requesting ITS-S	
Management	Security	ITS Applications	
		Facilities	Enrolment Credential / Authorization Ticket Request ASN.1 OER HTTP
		Networking & Transport	TCP
			IPv6
		Access	ITS G5 (IEEE 802.11p)
ITS G5A/G5B			
		Security ETSI TS 103 097 Generic profile	

Figure C.4: Communication protocols of the Requesting ITS-S Vehicle and ITS-S Roadside Gateway using Ipv6 over G5

Figure C.5 specifies the communication path and the communication protocols used between the requesting ITS-S and the PKI when V2I communication is based on Ipv6 over GeoNetworking, for sending a service request to the CCMS, for instance requesting a EC (or AT) certificate to the EA (or AA).

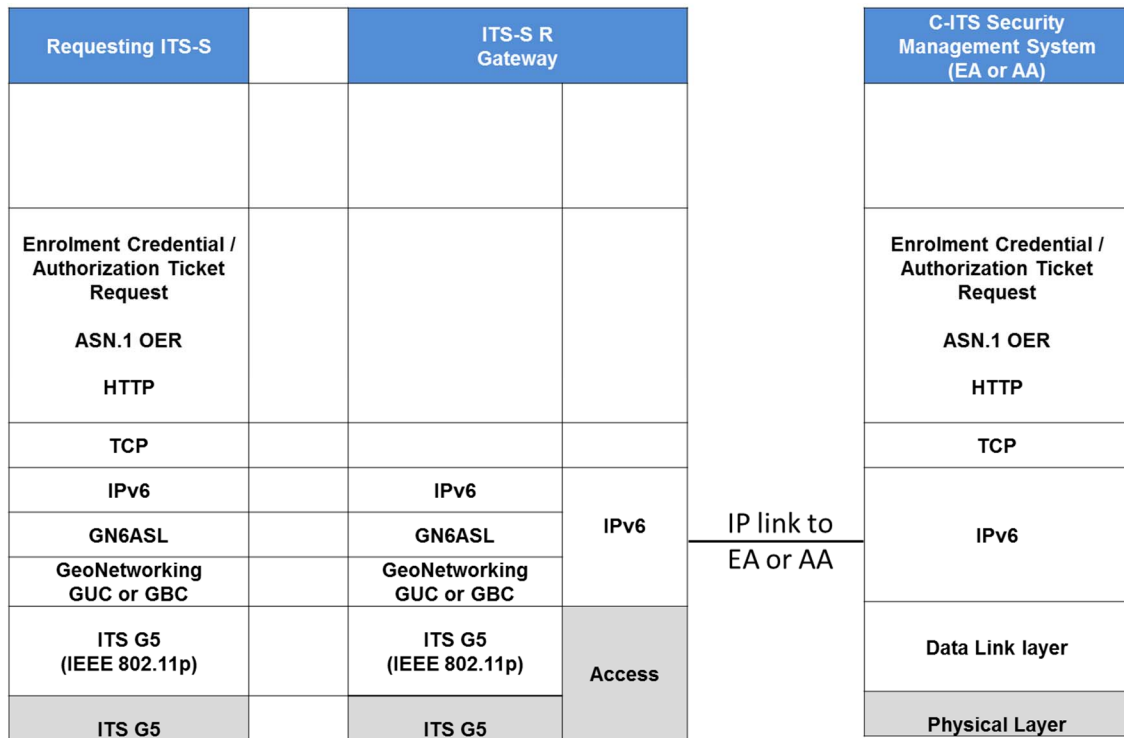

Figure C.5: Communication path between requesting ITS-S and PKI authorities

## Annex D (normative): Communication profiles for CTL and CRL

### D.1 CTL request and response protocol

In order to obtain the CTL from a Distribution Centre, an ITS-S may contact the DC using an HTTP GET as specified in Table D.1 using the Certificate Identifier of its Root CA (HashedID8) or the Certificate Identifier of a trusted Root CA included in the ECTL.

**Table D.1: Get CTL**

<p>GET <a href="http://dc_access_point/getctl/HashedId8/ctlSequence">http://dc_access_point/getctl/HashedId8/ctlSequence</a></p> <p>The abs_path part of the HTTP request is built by taking the DC access point (from the CTL or from an ad-hoc configuration), appending "/getctl/" and the uppercase hexadecimal representation of HashedId8, then appending the /ctlSequence if necessary.</p> <p>Where the last part /ctlSequence may be missing.</p> <p>If /ctlSequence is specified, the DC shall provide the deltaCTL of sequence ctlSequence issued by the entity identified by HashedId8.</p> <p>If /ctlSequence is ABSENT, the DC shall provide the latest fullCTL issued by the entity identified by HashedId8.</p> <p>Inputs:</p> <ul style="list-style-type: none"> <li>• No inputs</li> </ul> <p>Outputs:</p> <ul style="list-style-type: none"> <li>• Content-type: application/x-its-ctl</li> <li>• Content: binary encoded CTL object issued by the entity identified by HashedId8</li> </ul>
---

The format of CTL is described in clause A.2.7 Trust lists data types.

### D.2 CRL request and response protocol

In order to obtain the CRL from a Distribution Centre, an ITS-S may contact the DC using an HTTP GET as specified in the Table D.2 using the Certificate Identifier of its Root CA (HashedID8) or the Certificate Identifier of a trusted Root CA included in the ECTL.

**Table D.2: Get CRL**

<p>GET <a href="http://dc_access_point/getcrl/HashedId8">http://dc_access_point/getcrl/HashedId8</a></p> <p>The abs_path part of the HTTP request is built by taking the DC access point (from the CTL or from an ad-hoc configuration), appending "/getcrl/", and the uppercase hexadecimal representation of HashedId8.</p> <p>Inputs:</p> <ul style="list-style-type: none"> <li>• No inputs</li> </ul>
--

Outputs:

- Content-type: application/x-its-crl
- Content: binary encoded CRL object issued by the entity identified by HashedId8

The format of CRL is described in clause A.2.7 Trust lists data types.

## D.3 Broadcast communication of CTL/CRL

This clause specifies the communication profile which may be used for transmitting the trust information list such as the CRL or CTL on ITS G5.

To provide a CTL/ CRL broadcasting service over G5, the RSU shall provide a proxy application which periodically transmits updated trust list information issued by the Distribution Centre. The Trust List message shall be sent in one-hop (SHB packets) using the GeoNetworking protocol specified in ETSI EN 302 636-4-1 [18].

The size of CRL/CTL messages to be transmitted should be small, using the CRL/ DeltaCTL format structures as specified in clause A.2.3. No data segmentation/reassembling is provided in the lower or upper protocol layers depicted in Figure D.1.

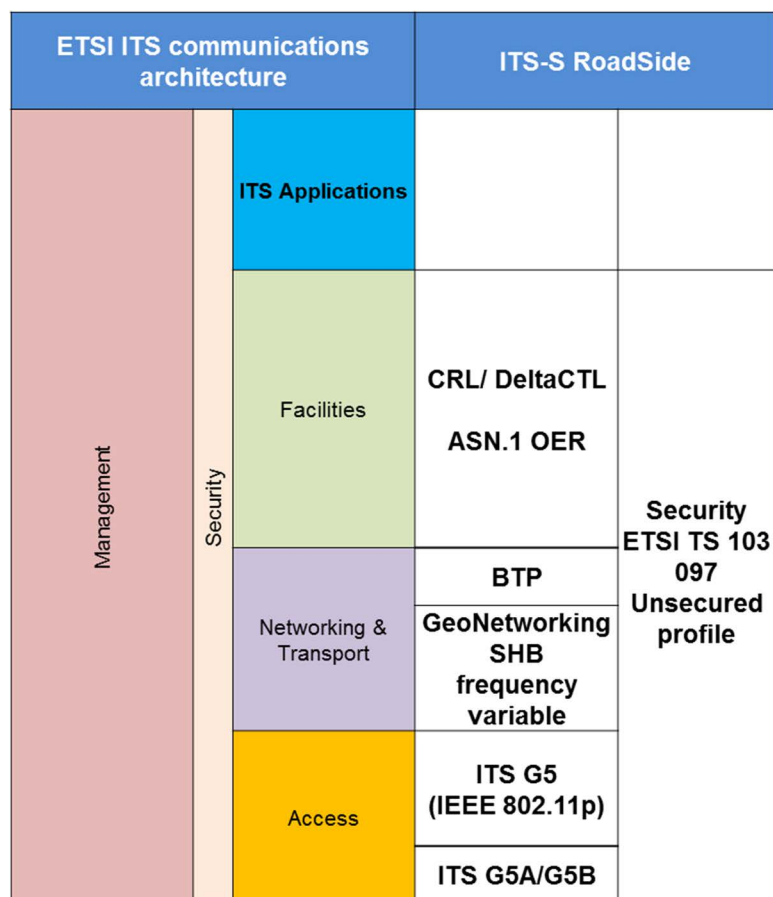

Figure D.1: Communication protocols for CRL/CTL transmission using GN/BTP protocol over G5

## Annex E (informative): Encryption of a message from a sender to a receiver

This annex describes cryptographic operations to be implemented to encrypt a message using mechanisms compliant with the present document. Message encryption is used for example to encrypt EC requests or AT requests.

The message is encrypted with a freshly generated symmetric key (AES-CCM key). Then, this symmetric key is encrypted with the public key of the receiver (using ECIES) and transmitted alongside the encrypted message.

Detailed description:

### Parameters

- Key Derivation Function (KDF). Here:  $KDF(S) = \text{SHA256}(S \parallel \text{counter})$ .
- Symmetric encryption algorithm for ECIES. Here a XOR function is used ( $E(m, k) = m \oplus k$ ,  $E^{-1}(c, k) = c \oplus k$ ). This should not be confused with AES-CCM which is used for message encryption.
- Message Authentication Code (MAC). Here:  $MAC(m, km) = \text{HMAC}(m, km)$ .
- Elliptic curve parameters (p: curve prime, G: base point, q: base point order, O point at infinity).
- $\parallel$ : concatenation.

### Encryption

#### Input

- m: Message of the sender.  
Kr: Encryption public key of the receiver.

#### Output

- C: Encryption of the message m with AES-CCM concatenated with CCM authentication tag.  
V: ECIES ephemeral public key.  
c: encryption of the AES-CCM key used to encrypt m.  
t: ECIES authentication tag.

### Algorithm

- 1) The sender encrypts the message with AES-CCM:
  - a) Sender generates a random AES key A (16 octets).
  - b) Sender chooses a random nonce n, 12 octets.
  - c) Sender encrypts the message m with AES-CCM mode using the key A and the nonce n. The output is the value C that consists of the encrypted message followed by the encrypted authentication value.
- 2) The sender encrypts the key A with ECIES:
  - a) Sender generates an ephemeral private key r in  $[1, q-1]$ , and the associated public key  $V=r.G$ , 33 octets if compressed.
  - b) Sender derives a shared secret S from receiver encryption public key Kr:  $S = P_x$ , where  $P_x$  is the x-coordinate of the point  $P = r.Kr = (P_x, P_y)$ . (verify that  $P \neq O$ , if not, back to previous step).
  - c) Sender then derives a set of keys ke and km with derivation algorithm:  $(ke \parallel km) = KDF(S)$ , ke is 16 octets long, km is 32 octets long.

- d) Sender encrypts the AES key:  $c=E(A, ke)$ ,  $c$  is 16 octets long.
  - e) Sender produces a tag on the encrypted message:  $t=MAC(c, km)$ ,  $t$  is 16 octets long.
- 3) Sender transmits to the receiver a message containing:
- The identifier for the recipient's certificate ( $cert\_id$ ), 8 octets.
  - The encrypted message  $C$ .
  - The encryption parameters (algorithm identifier  $aes\_128\_ccm$ , nonce  $n$ ), 13 octets.
  - The ephemeral public key ( $V$ ).
  - The encrypted key ( $c$ ) with the associated tag ( $t$ ).

## Decryption

### Input

- $kr$ : Private key of the receiver.
- $n$ : Nonce used for AES-CCM.
- $C$ : Output of the AES-CCM encryption: encrypted message || CCM tag.
- $V$ : ECIES ephemeral public key.
- $c$ : encryption of the AES-CCM key used to encrypt  $m$ .
- $t$ : ECIES authentication tag.

### Output

- $m$ : Message of the sender or *failed* if any of the checks fails.

### Algorithm

- 1) ECIES decryption to get the AES-CCM key  $A$ :
  - a) Receiver derives a shared secret  $S=P_x$ , with  $(P_x, P_y)=kr.V$  or outputs *failed* if  $s.V = O$ .
  - b) Receiver derives the keys  $(ke || km)=KDF(S)$ .
  - c) Receiver checks that the tag  $t=MAC(c, km)$ , if not, receiver outputs *failed*.
  - d) Receiver decrypts the key  $A = E^{-1}(c, ke) = c \oplus ke$ .
- 2) AES-CCM decryption and verification of the message:
  - a) Receiver decrypts the encrypted message part of  $C$  using AES-CCM with the key  $A$ .
  - b) Receiver checks the validity of the authentication tag computed on the plaintext, if it is not valid, receiver outputs *failed*.

NOTE: It is important that the nonce of CCM should be carefully chosen to never be used more than once for a given key.  
To avoid timing attacks, the output of decryption should be given after performing all the computations even if it outputs failed.

---

## Annex F (informative): Bibliography

- 26<sup>th</sup> International Conference on Computer Communication and Networks (ICCCN), July 2017: "Securing PKI Requests for C-ITS Systems", JP. Monteuis, Badis Hammi, Eduardo Sallés, Houda Labiod, Rémi Blancher, Erwan Abalea, Brigitte Lonc.
- ISE Project (SystemX): "PKI system requirements specification, v1.1", (PUBLIC); March 2015.
- ISE Project (SystemX): "PKI architecture and technical specifications, v1.1", (PUBLIC), July 2015.
- SCOOP@F technical specifications Release 2: Deliverable 2.4.4.6: "PKI architecture and technical specifications", May 2016.

NOTE: Available at <http://www.scoop.developpement-durable.gouv.fr/en/technical-specifications-a22.html>.

---

## Annex G (informative): Change history

<b>Date</b>	<b>Version</b>	<b>Information about changes</b>
June 2012	1.1.1	First version of the TS
April 2018	1.2.1	Revised to add new roles in Security architecture and align to ETSI TS 103 097 ASN.1 format
January 2019	1.2.2	Revised to add corrections and clarifications provided for the ETSI ITS CMS6 – Security plugtest



---

# History

<b>Document history</b>		
V1.1.1	June 2012	Publication
V1.2.1	May 2018	Publication
V1.3.1	February 2019	Publication