



**Intelligent Transport Systems (ITS);
Testing;
Conformance test specifications for
Signal Phase And Timing (SPAT) and Map (MAP);
Part 3: Abstract Test Suite (ATS) and Protocol Implementation
eXtra Information for Testing (PIXIT)**

Reference

DTS/ITS-00136

Keywords

ATS, ITS, PIXIT, testing

ETSI

650 Route des Lucioles
F-06921 Sophia Antipolis Cedex - FRANCE

Tel.: +33 4 92 94 42 00 Fax: +33 4 93 65 47 16

Siret N° 348 623 562 00017 - NAF 742 C
Association à but non lucratif enregistrée à la
Sous-Préfecture de Grasse (06) N° 7803/88

Important notice

The present document can be downloaded from:
<http://www.etsi.org/standards-search>

The present document may be made available in electronic versions and/or in print. The content of any electronic and/or print versions of the present document shall not be modified without the prior written authorization of ETSI. In case of any existing or perceived difference in contents between such versions and/or in print, the only prevailing document is the print of the Portable Document Format (PDF) version kept on a specific network drive within ETSI Secretariat.

Users of the present document should be aware that the document may be subject to revision or change of status. Information on the current status of this and other ETSI documents is available at
<http://portal.etsi.org/tb/status/status.asp>

If you find errors in the present document, please send your comment to one of the following services:
<https://portal.etsi.org/People/CommitteeSupportStaff.aspx>

Copyright Notification

No part may be reproduced or utilized in any form or by any means, electronic or mechanical, including photocopying and microfilm except as authorized by written permission of ETSI.

The content of the PDF version shall not be modified without the written authorization of ETSI.
The copyright and the foregoing restriction extend to reproduction in all media.

© European Telecommunications Standards Institute 2015.
All rights reserved.

DECT™, **PLUGTESTS™**, **UMTS™** and the ETSI logo are Trade Marks of ETSI registered for the benefit of its Members.
3GPP™ and **LTE™** are Trade Marks of ETSI registered for the benefit of its Members and of the 3GPP Organizational Partners.
GSM® and the GSM logo are Trade Marks registered and owned by the GSM Association.

Contents

Intellectual Property Rights	5
Foreword.....	5
Modal verbs terminology.....	5
1 Scope	6
2 References	6
2.1 Normative references	6
2.2 Informative references.....	7
3 Definitions and abbreviations.....	7
3.1 Definitions.....	7
3.2 Abbreviations	7
4 Abstract Test Method (ATM).....	8
4.1 Abstract protocol tester	8
4.2 Test Configuration.....	8
4.3 Test architecture	8
4.4 Ports and ASPs (Abstract Services Primitives)	9
4.4.1 Introduction.....	9
4.4.2 Primitives of the mapSpatPort	9
4.4.3 Primitives of the utPort	10
5 Untestable Test Purposes.....	10
6 ATS conventions	10
6.1 Introduction	10
6.2 Testing conventions.....	11
6.2.1 Testing states	11
6.2.1.1 Initial state.....	11
6.2.1.2 Final state	11
6.2.2 Message types - ASN.1 definitions.....	11
6.3 Naming conventions.....	11
6.3.1 Introduction.....	11
6.3.2 General guidelines	11
6.3.3 ITS specific TTCN-3 naming conventions	12
6.3.4 Usage of Log statements.....	13
6.3.5 Test Case (TC) identifier	13
Annex A (normative): TTCN-3 library modules.....	14
A.1 Electronic annex, zip file with TTCN-3 code	14
Annex B (normative): Partial PIXIT pro forma for MAP SPAT	15
B.1 Partial cancellation of copyright.....	15
B.2 Introduction	15
B.3 Identification summary.....	15
B.4 ATS summary	15
B.5 Test laboratory.....	15
B.6 Client identification.....	16
B.7 SUT	16
B.8 Protocol layer information.....	16
B.8.1 Protocol identification	16
B.8.2 IUT information	17

Annex C (normative):	PCTR pro forma for MAP SPAT	18
C.1	Partial cancellation of copyright	18
C.2	Introduction	18
C.3	Identification summary	18
C.3.1	Protocol conformance test report	18
C.3.2	IUT identification	18
C.3.3	Testing environment	18
C.3.4	Limits and reservation	19
C.3.5	Comments	19
C.4	IUT Conformance status	19
C.5	Static conformance summary	19
C.6	Dynamic conformance summary	19
C.7	Static conformance review report	20
C.8	Test campaign report	20
C.9	Observations	21
History		22

Intellectual Property Rights

IPRs essential or potentially essential to the present document may have been declared to ETSI. The information pertaining to these essential IPRs, if any, is publicly available for **ETSI members and non-members**, and can be found in ETSI SR 000 314: "*Intellectual Property Rights (IPRs); Essential, or potentially Essential, IPRs notified to ETSI in respect of ETSI standards*", which is available from the ETSI Secretariat. Latest updates are available on the ETSI Web server (<http://ipr.etsi.org>).

Pursuant to the ETSI IPR Policy, no investigation, including IPR searches, has been carried out by ETSI. No guarantee can be given as to the existence of other IPRs not referenced in ETSI SR 000 314 (or the updates on the ETSI Web server) which are, or may be, or may become, essential to the present document.

Foreword

This Technical Specification (TS) has been produced by ETSI Technical Committee Intelligent Transport Systems (ITS).

The present document is part 3 of a multi-part deliverable covering Conformance test specification for Signal Phase And Timing (SPAT) and Map (MAP) as identified below:

Part 1: "Test requirements and Protocol Implementation Conformance Statement (PICS) pro forma";

Part 2: "Test Suite Structure and Test Purposes (TSS & TP)";

Part 3: "Abstract Test Suite (ATS) and Protocol Implementation eXtra Information for Testing (PIXIT)".

The development of ITS test specifications follows the guidance provided in the ETSI EG 202 798 [i.1]. Therefore, the ATS documentation outlined in the present document is also based on the guidance provided in ETSI EG 202 798 [i.1].

Modal verbs terminology

In the present document "**shall**", "**shall not**", "**should**", "**should not**", "**may**", "**need not**", "**will**", "**will not**", "**can**" and "**cannot**" are to be interpreted as described in clause 3.2 of the [ETSI Drafting Rules](#) (Verbal forms for the expression of provisions).

"**must**" and "**must not**" are **NOT** allowed in ETSI deliverables except when used in direct citation.

1 Scope

The present document contains the Abstract Test Suite (ATS) for MAP-SPAT Messages (MAP-SPAT) as defined in SAE J2735 [1] in compliance with the relevant requirements and in accordance with the relevant guidance given in ISO/IEC 9646-7 [5].

The objective of the present document is to provide a basis for conformance tests for MAP-SPAT Messages (MAP-SPAT) equipment giving a high probability of interoperability between different manufacturers' equipment.

The ISO standard for the methodology of conformance testing (ISO/IEC 9646-1 [2] and ISO/IEC 9646-2 [3]) as well as the ETSI rules for conformance testing (ETSI ETS 300 406 [6]) are used as a basis for the test methodology.

2 References

2.1 Normative references

References are either specific (identified by date of publication and/or edition number or version number) or non-specific. For specific references, only the cited version applies. For non-specific references, the latest version of the reference document (including any amendments) applies.

Referenced documents which are not found to be publicly available in the expected location might be found at <http://docbox.etsi.org/Reference>.

NOTE: While any hyperlinks included in this clause were valid at the time of publication, ETSI cannot guarantee their long term validity.

The following referenced documents are necessary for the application of the present document.

- [1] SAE J2735 (2015-04-30): "Dedicated Short Range Communications (DSRC) Message Set Dictionary™".
- [2] ISO/IEC 9646-1 (1994): "Information technology - Open Systems Interconnection - Conformance testing methodology and framework - Part 1: General concepts".
- [3] ISO/IEC 9646-2 (1994): "Information technology -- Open Systems Interconnection -- Conformance testing methodology and framework -- Part 2: Abstract Test Suite specification".
- [4] ISO/IEC 9646-6 (1994): "Information technology -- Open Systems Interconnection -- Conformance testing methodology and framework -- Part 6: Protocol profile test specification".
- [5] ISO/IEC 9646-7 (1995): "Information technology -- Open Systems Interconnection -- Conformance testing methodology and framework -- Part 7: Implementation Conformance Statements".
- [6] ETSI ETS 300 406 (1995): "Methods for testing and Specification (MTS); Protocol and profile conformance testing specifications; Standardization methodology".
- [7] ETSI ES 201 873-1 (V4.5.1): "Methods for Testing and Specification (MTS); The Testing and Test Control Notation version 3; Part 1: TTCN-3 Core Language".
- [8] ETSI ES 201 873-7 (V4.5.1): "Methods for Testing and Specification (MTS); The Testing and Test Control Notation version 3; Part 7: Using ASN.1 with TTCN-3".
- [9] ETSI TS 103 191-1 (V1.1.1): "Intelligent Transport Systems (ITS); Testing; Conformance test specifications for Signal Phase And Timing (SPAT) and Map (MAP); Part 1: Test requirements and Protocol Implementation Conformance Statement (PICS) pro forma".
- [10] ETSI TS 102 894-2 (V1.2.1): "Intelligent Transport Systems (ITS); Users and applications requirements; Part 2: Applications and facilities layer common data dictionary".

2.2 Informative references

References are either specific (identified by date of publication and/or edition number or version number) or non-specific. For specific references, only the cited version applies. For non-specific references, the latest version of the reference document (including any amendments) applies.

NOTE: While any hyperlinks included in this clause were valid at the time of publication, ETSI cannot guarantee their long term validity.

The following referenced documents are not necessary for the application of the present document but they assist the user with regard to a particular subject area.

[i.1] ETSI EG 202 798 (V1.1.1): "Intelligent Transport Systems (ITS); Testing; Framework for conformance and interoperability testing".

3 Definitions and abbreviations

3.1 Definitions

For the purposes of the present document, the terms and definitions given SAE J2735 [1], ISO/IEC 9646-1 [2] and in ISO/IEC 9646-7 [5] apply.

3.2 Abbreviations

For the purposes of the present document, the following abbreviations apply:

ASN	Abstract Syntax Notation
ATM	Abstract Test Method
ATS	Abstract Test Suite
BI	Invalid Syntax or Behaviour Tests
BV	Valid Behaviour Tests
ES	ETSI Standard
ISO	International Organization for Standardization
ITS	Intelligent Transport Systems
IUT	Implementation Under Test
MAP	MapData Messages
MSD	Message Dissemination
MSP	Message Processing
MTC	Main Test Component
PCTR	Protocol Conformance Test Report
PICS	Protocol Implementation Conformance Statement
PIXIT	Partial Protocol Implementation eXtra Information for Testing
PX	Pixit
SAE	Society of Automotive Engineers
SAP	Service Access Point
SCS	System Conformance Statement
SCTR	System Conformance Test Report
SPAT	Signal Phase And Timing Messages
SUT	System Under Test
TC	Test Case
TP	Test Purposes
TSS	Test Suite Structure
TTCN	Testing and Test Control Notation

4 Abstract Test Method (ATM)

4.1 Abstract protocol tester

The abstract protocol tester used by this test suite is described in figure 1. The test system simulates valid and invalid protocol behaviour, and analyses the reaction of the IUT.

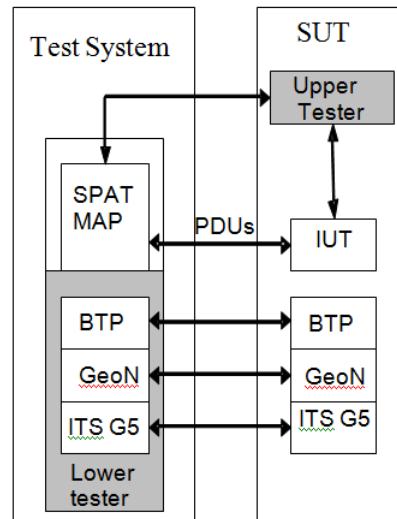

Figure 1: Abstract protocol tester – MAP SPAT

4.2 Test Configuration

This test suite uses a unique test configuration in order to cover the different test scenarios. In this configuration, the tester simulates one ITS station implementing the MAP SPAT protocol.

4.3 Test architecture

The present document implements the general TTCN-3 test architecture described in ETSI EG 202 798 [i.1], clauses 6.3.2 and 8.3.1.

Figure 2 shows the test architecture used in for the MAP SPAT ATS. The MAP SPAT test component requires using only the Main Test Component (MTC). The MTC communicates with the MAP SPAT SUT over the MapSpatPort. The MapSpatPort is used to exchange MAP SPAT protocol messages between the MAP SPAT test component and the MAP SPAT IUT.

The Upper tester entity in the SUT enables triggering MAP SPAT functionalities by simulating primitives from application. It is required to trigger the MAP SPAT layer in the SUT to send SPAT messages, which are resulting from upper layer primitives. Furthermore, receiving MAP messages may result for the MAP SPAT layer in sending primitives to the upper layer.

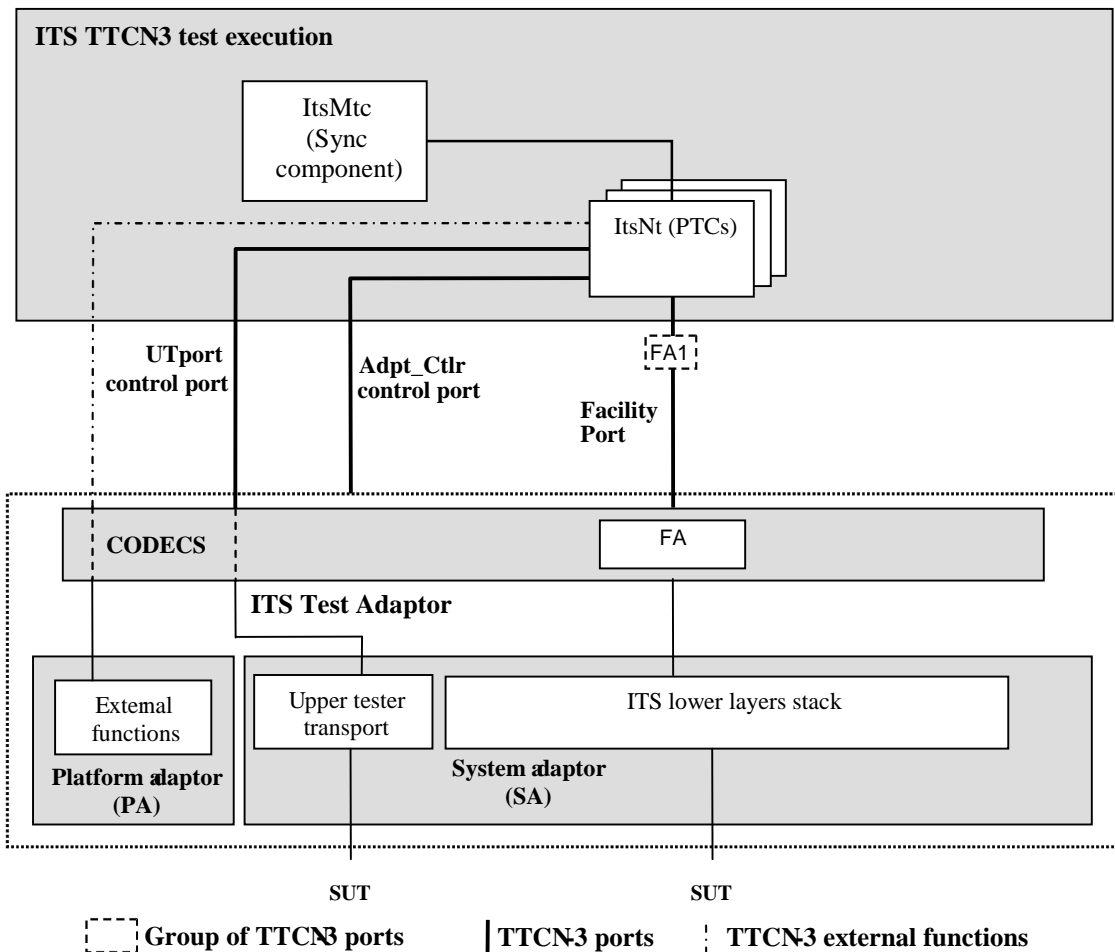

Figure 2: Test system architecture

4.4 Ports and ASPs (Abstract Services Primitives)

4.4.1 Introduction

Two ports are used by the MAP SPAT ATS:

- The mapSpatPort, of type MapSpatPort.
- The utPort, of type UpperTesterPort.

4.4.2 Primitives of the mapSpatPort

Four types of primitives are used in the mapSpatPort:

- The MapInd primitive used to receive messages of type MapMsg (MAP_PDU + RawData).
- The SpatInd primitive used to receive messages of type SpatMsg (SPAT_PDU + RawData).
- The MapReq primitive used to send messages of type MAP_PDU.
- The SpatReq primitive used to send messages of type SPAT_PDU.

These four primitives use the MAP_PDU type and the SPAT_PDU type, which is declared in the MAP_SPAT_ETSI.asn ASN.1 module, following the ASN.1 definition from SAE J2735 [1].

MAP-PDU ::= SEQUENCE

```
{
  header ItsPduHeader,
  mapData MapData
}
```

SPAT-PDU ::= SEQUENCE

```
{
  header ItsPduHeader,
  spatData SPAT
}
```

4.4.3 Primitives of the utPort

This port uses six types of primitives:

- The UtInitialize primitive used to initialize IUT.
- The UtMapSpatTrigger primitive used to trigger upper layer events in IUT.
- The UtInitializeResult primitive used to receive upper layer result of initialization in IUT.
- The UtMapSpatTriggerResult primitive used to receive upper layer result of triggering MAP-SPAT in IUT.
- The UtMapEventInd primitive used to receive upper layer event of MAP_PDU in IUT.
- The UtMapEventInd primitive used to receive upper layer event of SPAT_PDU in IUT.

5 Untestable Test Purposes

Table 1 gives a list of TPs, which are not implemented in the ATS due to the chosen ATM or other restrictions.

Table 1: Untestable TPs

Test purpose	Reason
None	

6 ATS conventions

6.1 Introduction

The ATS conventions are intended to give a better understanding of the ATS but they also describe the conventions made for the development of the ATS. These conventions shall be considered during any later maintenance or further development of the ATS.

The ATS conventions contain two clauses, the testing conventions and the naming conventions. The testing conventions describe the functional structure of the ATS. The naming conventions describe the structure of the naming of all ATS elements.

To define the ATS, the guidelines of the document ETSI ETS 300 406 [6] was considered.

6.2 Testing conventions

6.2.1 Testing states

6.2.1.1 Initial state

All test cases start with the function `f_prInitialState`. This function brings the IUT in an "initialized" state by invoking the upper tester primitive `UtInitialize`.

6.2.1.2 Final state

All test cases end with the function `f_poDefault`. This function brings the IUT back in an "idle" state. As no specific actions are required for the idle state in SAE J2735 [1], the function `f_poDefault` does not invoke any action.

As necessary, further actions may be included in the `f_poDefault` function.

6.2.2 Message types - ASN.1 definitions

ASN.1 definitions from SAE J2735 [1] are directly imported in TTCN-3 using the ASN.1 import method specified in ETSI ES 201 873-7 [8].

The following example shows the TTCN-3 import statement used to import ASN.1 definitions in the TTCN-3 modules:

```
import from DSRC language "ASN.1:1997" all;
```

Generic ASN.1 definitions (message header, station Id, etc.), are defined in the Common Data Dictionary ETSI TS 102 894-2 [10] ASN.1 module. Thus the MAP SPAT ASN.1 modules need to import these definitions from the Common Data Dictionary ETSI TS 102 894-2 [10] ASN.1 module (see the following ASN.1 import statement extracted from the MAP-SPAT-ETSI ASN.1 module):

```
IMPORTS
  MapData, SPAT FROM DSRC
  ItsPduHeader FROM ITS-Container
```

6.3 Naming conventions

6.3.1 Introduction

This test suite follows the naming convention guidelines provided in the ETSI EG 202 798 [i.1].

6.3.2 General guidelines

The naming convention is based on the following underlying principles:

- in most cases, identifiers should be prefixed with a short alphabetic string (specified in table 2) indicating the type of TTCN-3 element it represents;
- suffixes should not be used except in those specific cases identified in table 2;
- prefixes and suffixes should be separated from the body of the identifier with an underscore ("_");

EXAMPLE 1: `c_sixteen`, `t_wait`.

- only module names, data type names and module parameters should begin with an upper-case letter. All other names (i.e. the part of the identifier following the prefix) should begin with a lower-case letter;
- the start of second and subsequent words in an identifier should be indicated by capitalizing the first character. Underscores should not be used for this purpose.

EXAMPLE 2: `f_initialState`.

Table 2 specifies the naming guidelines for each element of the TTCN-3 language indicating the recommended prefix, suffixes (if any) and capitalization.

Table 2: ETSI TTCN-3 generic naming conventions

Language element	Naming convention	Prefix	Example identifier
Module	Use upper-case initial letter	none	IPv6Templates
Group within a module	Use lower-case initial letter	none	messageGroup
Data type	Use upper-case initial letter	none	SetupContents
Message template	Use lower-case initial letter	m_	m_setupInit
Message template with wildcard or matching expression	Use lower-case initial letters	mw_	mw_anyUserReply
Signature template	Use lower-case initial letter	s_	s_callSignature
Port instance	Use lower-case initial letter	none	signallingPort
Test component instance	Use lower-case initial letter	none	userTerminal
Constant	Use lower-case initial letter	c_	c_maxRetransmission
Constant (defined within component type)	Use lower-case initial letter	cc_	cc_minDuration
External constant	Use lower-case initial letter	cx_	cx_macId
Function	Use lower-case initial letter	f_	f_authentication()
External function	Use lower-case initial letter	fx_	fx_calculateLength()
Altstep (incl. Default)	Use lower-case initial letter	a_	a_receiveSetup()
Test case	Use ETSI numbering	TC_	TC_COR_0009_47_ND
Variable (local)	Use lower-case initial letter	v_	v_macId
Variable (defined within a component type)	Use lower-case initial letters	vc_	vc_systemName
Timer (local)	Use lower-case initial letter	t_	t_wait
Timer (defined within a component)	Use lower-case initial letters	tc_	tc_authMin
Module parameters for PICS	Use all upper case letters	PICS_	PICS_DOOROPEN
Module parameters for other parameters	Use all upper case letters	PX_	PX_TESTER_STATION_ID
Formal Parameters	Use lower-case initial letter	p_	p_macId
Enumerated Values	Use lower-case initial letter	e_	e_syncOk

6.3.3 ITS specific TTCN-3 naming conventions

Next to such general naming conventions, table 3 shows specific naming conventions that apply to the ITS TTCN-3 test suite.

Table 3: ITS specific TTCN-3 naming conventions

Language element	Naming convention	Prefix	Example identifier
ITS Module	Use upper-case initial letter	Its"IUTname" _	ItsMapSpat_
Module containing types and values	Use upper-case initial letter	Its"IUTname" _TypesAndValues	ItsMapSpat_TypesAndValues
Module containing Templates	Use upper-case initial letter	Its"IUTname" _Templates	ItsMapSpat_Templates
Module containing test cases	Use upper-case initial letter	Its"IUTname" _TestCases	ItsMapSpat_TestCases
Module containing functions and external functions	Use upper-case initial letter	Its"IUTname" _Functions	ItsMapSpat_Functions
Module containing main component definitions components, ports and message definitions	Use upper-case initial letter	Its"IUTname" _TestSystem	ItsMapSpat_TestSystem
Module containing the control part	Use upper-case initial letter	Its"IUTname" _TestControl	ItsMapSpat_TestControl

6.3.4 Usage of Log statements

All TTCN-3 log statements use the following format using the same order:

- Three asterisks.
- The TTCN-3 test case or function identifier in which the log statement is defined.
- One of the categories of log: INFO, WARNING, ERROR, PASS, FAIL, INCONC, TIMEOUT.
- Free text.
- Three asterisks.

EXAMPLE 1: `log("*** TC_MAP_SPAT_MSD_BV_01: INFO: Initial conditions: First MAP message received ***");`

Furthermore, the following rules are applied for the MAP SPAT ATS:

- Log statements are used in the body of the functions, so that invocations of functions are visible in the test logs.
- All TTCN-3 setverdict statements are combined (as defined in ETSI ES 201 873-1 [7]) with a log statement following the same above rules (see example 2).

EXAMPLE 2: `setverdict(pass, "*** TC_MAP_SPAT_MSD_BV_01: PASS: MAP message received with DSRCmsgSubID = 0***").`

6.3.5 Test Case (TC) identifier

Table 4 shows the test case naming convention, which follows the same naming convention as the test purposes.

Table 4: TC naming convention

Identifier	TP_<root>_<gr>_<x>_<nn>		
	<root> = root	MAP_SPAT	
	<gr> = group	MSD	Message Dissemination
		MSP	Message Processing
	<x> = type of testing	BV	Valid Behaviour tests
		BI	Invalid Syntax or Behaviour Tests
	<nn> = sequential number		01 to 99

EXAMPLE: TP identifier: TP/MAP-SPAT/MSD/BV/01
TC identifier: TC_MAP_SPAT_MSD_BV_01.

Annex A (normative): TTCN-3 library modules

A.1 Electronic annex, zip file with TTCN-3 code

This ATS has been produced using the Testing and Test Control Notation (TTCN) according to ETSI ES 201 873-1 [7].

This test suite has been compiled error-free using two different commercial TTCN-3 compilers.

The TTCN-3 library modules, which form parts of the present document, are contained in the archive `ts_10319103v010101.zip` which accompanies the present document.

Annex B (normative): Partial PIXIT pro forma for MAP SPAT

B.1 Partial cancellation of copyright

Notwithstanding the provisions of the copyright clause related to the text of the present document, ETSI grants that users of the present document may freely reproduce the Partial PIXIT pro forma in this annex so that it can be used for its intended purposes and may further publish the completed Partial PIXIT.

B.2 Introduction

The PIXIT pro forma is based on ISO/IEC 9646-6 [4]. Any needed additional information can be found in ISO/IEC 9646-6 [4].

B.3 Identification summary

Table B.1

PIXIT Number:	
Test Laboratory Name:	
Date of Issue:	
Issued to:	

B.4 ATS summary

Table B.2

Protocol Specification:	SAE J2735 [1]
Protocol to be tested:	MAP-SPAT Messages (MAP-SPAT)
ATS Specification:	ETSI TS 103 191-3
Abstract Test Method:	Clause 4

B.5 Test laboratory

Table B.3

Test Laboratory Identification:	
Test Laboratory Manager:	
Means of Testing:	
SAP Address:	

B.6 Client identification

Table B.4

Client Identification:	
Client Test manager:	
Test Facilities required:	

B.7 SUT

Table B.5

Name:	
Version:	
SCS Number:	
Machine configuration:	
Operating System Identification:	
IUT Identification:	
PICS Reference for IUT:	
Limitations of the SUT:	
Environmental Conditions:	

B.8 Protocol layer information

B.8.1 Protocol identification

Table B.6

Name:	SAE J2735 [1]
Version:	
PICS References:	ETSI TS 103 191-1 [9]

B.8.2 IUT information

Table B.7: MAP SPAT pixits

Identifier	Description	
PX_MSG_ISSUE_REVISION	Comment	MsgCount fo MAP message sending
	Type	MsgCount
	Default value	10
PX_INTERSECTIONSTATE_REVISION	Comment	MsgCount for IntersectionState sending
	Type	MsgCount
	Default value	20
PX_STATUS	Comment	Status for IntersectionState sending
	Type	IntersectionStatusObject
	Default value	'1000'O
PX_INTERSECTION_ID	Comment	Id for IntersectionReferenceID sending
	Type	IntersectionId
	Default value	'ABAB'O
PX_SIGNAL_GROUP_ID	Comment	SignalGroup for MovementState sending
	Type	SignalGroupId
	Default value	128

Annex C (normative): PCTR pro forma for MAP SPAT

C.1 Partial cancellation of copyright

Notwithstanding the provisions of the copyright clause related to the text of the present document, ETSI grants that users of the present document may freely reproduce the PCTR pro forma in this annex so that it can be used for its intended purposes and may further publish the completed PCTR.

C.2 Introduction

The PCTR pro forma is based on ISO/IEC 9646-6 [4]. Any needed additional information can be found in ISO/IEC 9646-6 [4].

C.3 Identification summary

C.3.1 Protocol conformance test report

Table C.1

PCTR Number:	
PCTR Date:	
Corresponding SCTR Number:	
Corresponding SCTR Date:	
Test Laboratory Identification:	
Test Laboratory Manager:	
Signature:	

C.3.2 IUT identification

Table C.2

Name:	
Version:	
Protocol specification:	
PICS:	
Previous PCTR if any:	

C.3.3 Testing environment

Table C.3

PIXIT Number:	
ATS Specification:	
Abstract Test Method:	
Means of Testing identification:	
Date of testing:	
Conformance Log reference(s):	
Retention Date for Log reference(s):	

C.3.4 Limits and reservation

Additional information relevant to the technical contents or further use of the test report, or the rights and obligations of the test laboratory and the client, may be given here. Such information may include restriction on the publication of the report.

.....

.....

.....

.....

.....

C.3.5 Comments

Additional comments may be given by either the client or the test laboratory on any of the contents of the PCTR, for example, to note disagreement between the two parties.

.....

.....

.....

.....

.....

.....

C.4 IUT Conformance status

This IUT has or has not been shown by conformance assessment to be non-conforming to the specified protocol specification.

Strike the appropriate words in this sentence. If the PICS for this IUT is consistent with the static conformance requirements (as specified in clause C.3 in the present document) and there are no "FAIL" verdicts to be recorded (in clause C.6 in the present document) strike the words "has or", otherwise strike the words "or has not".

C.5 Static conformance summary

The PICS for this IUT is or is not consistent with the static conformance requirements in the specified protocol.

Strike the appropriate words in this sentence.

C.6 Dynamic conformance summary

The test campaign did or did not reveal errors in the IUT.

Strike the appropriate words in this sentence. If there are no "FAIL" verdicts to be recorded (in clause C.6 of the present document) strike the words "did or" otherwise strike the words "or did not".

Summary of the results of groups of test:

.....

.....

.....

C.7 Static conformance review report

If clause C.3 indicates non-conformance, this clause itemizes the mismatches between the PICS and the static conformance requirements of the specified protocol specification.

.....

.....

.....

.....

.....

.....

.....

.....

.....

.....

.....

.....

.....

.....

.....

.....

.....

.....

.....

.....

.....

.....

.....

.....

C.8 Test campaign report

Table C.4: test cases

ATS Reference	Selected?	Run?	Verdict	Observations (Reference to any observations made in clause C.7)
TC_MAP_SPAT_MSD_BV_01	Yes/No	Yes/No		
TC_MAP_SPAT_MSD_BV_02	Yes/No	Yes/No		
TC_MAP_SPAT_MSD_BV_03	Yes/No	Yes/No		
TC_MAP_SPAT_MSD_BV_04	Yes/No	Yes/No		
TC_MAP_SPAT_MSD_BV_05	Yes/No	Yes/No		
TC_MAP_SPAT_MSD_BV_06	Yes/No	Yes/No		
TC_MAP_SPAT_MSD_BV_08	Yes/No	Yes/No		
TC_MAP_SPAT_MSD_BV_09	Yes/No	Yes/No		
TC_MAP_SPAT_MSD_BV_10	Yes/No	Yes/No		
TC_MAP_SPAT_MSD_BV_11	Yes/No	Yes/No		
TC_MAP_SPAT_MSD_BV_12	Yes/No	Yes/No		
TC_MAP_SPAT_MSD_BV_15	Yes/No	Yes/No		
TC_MAP_SPAT_MSD_BV_16	Yes/No	Yes/No		
TC_MAP_SPAT_MSP_BV_01	Yes/No	Yes/No		
TC_MAP_SPAT_MSP_BV_02	Yes/No	Yes/No		

C.9 Observations

Additional information relevant to the technical content of the PCTR is given here.

.....

.....

.....

.....

.....

.....

.....

.....

.....

.....

.....

.....

.....

.....

.....

.....

.....

.....

.....

.....

.....

.....

History

Document history		
V1.1.1	September 2015	Publication