



Lawful Interception (LI); Part 1: Internal Network Interface X1 for Lawful Interception

Reference

RTS/LI-00161-1

Keywords

interface, lawful interception

ETSI

650 Route des Lucioles
F-06921 Sophia Antipolis Cedex - FRANCE

Tel.: +33 4 92 94 42 00 Fax: +33 4 93 65 47 16

Siret N° 348 623 562 00017 - NAF 742 C
Association à but non lucratif enregistrée à la
Sous-Préfecture de Grasse (06) N° 7803/88

Important notice

The present document can be downloaded from:

<http://www.etsi.org/standards-search>

The present document may be made available in electronic versions and/or in print. The content of any electronic and/or print versions of the present document shall not be modified without the prior written authorization of ETSI. In case of any existing or perceived difference in contents between such versions and/or in print, the only prevailing document is the print of the Portable Document Format (PDF) version kept on a specific network drive within ETSI Secretariat.

Users of the present document should be aware that the document may be subject to revision or change of status.

Information on the current status of this and other ETSI documents is available at

<https://portal.etsi.org/TB/ETSIDeliverableStatus.aspx>

If you find errors in the present document, please send your comment to one of the following services:

<https://portal.etsi.org/People/CommiteeSupportStaff.aspx>

Copyright Notification

No part may be reproduced or utilized in any form or by any means, electronic or mechanical, including photocopying and microfilm except as authorized by written permission of ETSI.

The content of the PDF version shall not be modified without the written authorization of ETSI.

The copyright and the foregoing restriction extend to reproduction in all media.

© ETSI 2018.

All rights reserved.

DECT™, **PLUGTESTS™**, **UMTS™** and the ETSI logo are trademarks of ETSI registered for the benefit of its Members.

3GPP™ and **LTE™** are trademarks of ETSI registered for the benefit of its Members and of the 3GPP Organizational Partners.

oneM2M logo is protected for the benefit of its Members.

GSM® and the GSM logo are trademarks registered and owned by the GSM Association.

Contents

Intellectual Property Rights	5
Foreword.....	5
Modal verbs terminology.....	5
1 Scope	6
2 References	6
2.1 Normative references	6
2.2 Informative references.....	7
3 Definitions and abbreviations.....	7
3.1 Definitions.....	7
3.2 Abbreviations	8
4 Overview	9
4.1 Reference model.....	9
4.2 Reference model for X1: requesting and responding	9
4.3 Overview of security	10
4.4 Relationship to other standards	10
4.5 Release management.....	10
5 Basic concepts	11
5.1 The lifecycle of a Task	11
5.1.1 Start and end of a Task	11
5.1.2 Identification of a Task.....	11
5.1.3 Destinations	11
5.2 The lifecycle of an X1 request/response.....	11
5.2.1 Identification of X1 request/response	11
5.2.2 Responding to the request.....	11
5.2.3 Behaviour if a response is not received	12
5.3 Warnings and Faults.....	12
6 Message Structure and Data Definitions	12
6.1 X1 Message details.....	12
6.2 Message definitions: starting, modifying and stopping tasks	13
6.2.1 ActivateTask	13
6.2.1.1 Summary	13
6.2.1.2 TaskDetails.....	14
6.2.2 ModifyTask.....	16
6.2.3 DeactivateTask	16
6.2.4 DeactivateAllTasks.....	16
6.3 Message definitions: creating, modifying and removing Destinations.....	17
6.3.1 CreateDestination	17
6.3.1.1 Summary	17
6.3.1.2 DestinationDetails.....	17
6.3.2 ModifyDestination.....	18
6.3.3 RemoveDestination.....	18
6.3.4 RemoveAllDestinations	19
6.4 Message details: Getting information from NE.....	19
6.4.1 Introduction.....	19
6.4.2 GetTaskDetails	19
6.4.2.1 Summary	19
6.4.2.2 TaskStatus	20
6.4.3 GetDestinationDetails.....	20
6.4.3.1 Summary	20
6.4.3.2 DestinationStatus	21
6.4.4 GetNEStatus	21
6.4.4.1 Summary	21
6.4.5 GetAllDetails	22

6.4.5.1	Summary	22
6.4.6	ListAllDetails.....	22
6.4.6.1	Summary	22
6.5	Message details: Reporting issues from the NE	23
6.5.1	Introduction.....	23
6.5.2	ReportTaskIssue on given XID.....	23
6.5.2.1	Summary	23
6.5.2.2	Task report types	23
6.5.3	ReportDestinationIssue on given DID	24
6.5.3.1	Summary	24
6.5.4	ReportNEIssue	24
6.6	Message details: Pings and Keepalives	25
6.6.1	Ping.....	25
6.6.2	Keepalive	25
6.7	Protocol error details	26
7	Transport and Encoding	27
7.1	Introduction	27
7.2	Profile A	28
7.2.1	Encoding	28
7.2.2	Transport layer.....	28
7.2.2.1	HTTPS and HTTP.....	28
7.2.2.2	How HTTP is used.....	28
7.2.2.3	Profile.....	28
8	Security.....	29
8.1	Introduction	29
8.2	Transport Security	29
8.2.1	Summary.....	29
8.2.2	Profile	29
8.2.3	Key generation, deployment and storage.....	29
8.2.4	Authentication.....	29
8.3	Additional security measures (beyond transport layer)	30
Annex A (normative): Requirements		31
A.1	Basic requirements	31
A.1.1	Existing standards.....	31
A.2	Protocol & Architecture requirements.....	31
A.3	Security requirements.....	32
A.4	Other requirements	33
A.4.1	Performance statistics (For Further Study).....	33
A.4.2	Capability detection.....	34
A.4.3	Remote triggering.....	34
A.4.4	Requirements to be handled by the transport layer	34
Annex B (normative): Use of extensions		35
B.1	Introduction	35
B.2	Extension definitions.....	35
Annex C (informative): Change request history.....		36
History		37

Intellectual Property Rights

Essential patents

IPRs essential or potentially essential to normative deliverables may have been declared to ETSI. The information pertaining to these essential IPRs, if any, is publicly available for **ETSI members and non-members**, and can be found in ETSI SR 000 314: "*Intellectual Property Rights (IPRs); Essential, or potentially Essential, IPRs notified to ETSI in respect of ETSI standards*", which is available from the ETSI Secretariat. Latest updates are available on the ETSI Web server (<https://ipr.etsi.org/>).

Pursuant to the ETSI IPR Policy, no investigation, including IPR searches, has been carried out by ETSI. No guarantee can be given as to the existence of other IPRs not referenced in ETSI SR 000 314 (or the updates on the ETSI Web server) which are, or may be, or may become, essential to the present document.

Trademarks

The present document may include trademarks and/or tradenames which are asserted and/or registered by their owners. ETSI claims no ownership of these except for any which are indicated as being the property of ETSI, and conveys no right to use or reproduce any trademark and/or tradename. Mention of those trademarks in the present document does not constitute an endorsement by ETSI of products, services or organizations associated with those trademarks.

Foreword

This Technical Specification (TS) has been produced by ETSI Technical Committee Lawful Interception (LI).

The present document is part 1 of a multi-part deliverable covering the internal network interfaces for Lawful Interception as identified below:

Part 1: "Internal Network interface X1 for Lawful Interception";

Part 2: "Internal Network interface X2 for Lawful Interception";

Part 3: "Internal Network interface X3 for Lawful Interception".

Modal verbs terminology

In the present document "**shall**", "**shall not**", "**should**", "**should not**", "**may**", "**need not**", "**will**", "**will not**", "**can**" and "**cannot**" are to be interpreted as described in clause 3.2 of the [ETSI Drafting Rules](#) (Verbal forms for the expression of provisions).

"**must**" and "**must not**" are **NOT** allowed in ETSI deliverables except when used in direct citation.

1 Scope

The present document defines an electronic interface for the exchange of information relating to the establishment and management of Lawful Interception. Typically, this interface would be used between a central LI administration function and the network internal interception points.

Typical reference models for LI define an interface between law enforcement agencies (LEAs) and communication service providers (CSPs), called the handover interface. They also define an internal network interface within the CSP domain between administration and mediation functions for lawful interception and network internal functions, which facilitates the interception of communication. This internal network interface typically consists of three sub-interfaces; administration (called X1), transmission of intercept related information (X2) and transmission of content of communication (X3). The present document specifies the administration interface X1.

2 References

2.1 Normative references

References are either specific (identified by date of publication and/or edition number or version number) or non-specific. For specific references, only the cited version applies. For non-specific references, the latest version of the referenced document (including any amendments) applies.

Referenced documents which are not found to be publicly available in the expected location might be found at <https://docbox.etsi.org/Reference/>.

NOTE: While any hyperlinks included in this clause were valid at the time of publication, ETSI cannot guarantee their long term validity.

The following referenced documents are necessary for the application of the present document.

- [1] ETSI TS 133 107: "Universal Mobile Telecommunications System (UMTS); LTE; Digital cellular telecommunications system (Phase 2+) (GSM); 3G security; Lawful interception architecture and functions (3GPP TS 33.107)".
- [2] IETF RFC 4122: "A Universally Unique Identifier (UUID) URN Namespace".
- [3] W3C Recommendation 28 October 2004: "XML Schema Part 2: Datatypes Second Edition".
- [4] ETSI TS 103 280: "Lawful Interception (LI); Dictionary for common parameters".
- [5] Recommendation ITU-T E.212: "The international identification plan for public networks and subscriptions".
- [6] ETSI TS 123 003: "Digital cellular telecommunications system (Phase 2+) (GSM); Universal Mobile Telecommunications System (UMTS); Numbering, addressing and identification (3GPP TS 23.003)".
- [7] IETF RFC 3261: "SIP: Session Initiation Protocol".
- [8] IETF RFC 3966: "The tel URI for Telephone Numbers".
- [9] IETF RFC 3508: "H.323 Uniform Resource Locator (URL) Scheme Registration".
- [10] IETF RFC 7542: "The Network Access Identifier".
- [11] IETF RFC 2865: "Remote Authentication Dial In User Service (RADIUS)".
- [12] IETF RFC 2818: "HTTP over TLS".
- [13] IETF RFC 7230: "Hypertext Transfer Protocol (HTTP/1.1): Message Syntax and Routing".
- [14] IETF RFC 5246: "The Transport Layer Security (TLS) Protocol Version 1.2".

- [15] IETF RFC 6176: "Prohibiting Secure Sockets Layer (SSL) Version 2.0".
- [16] IETF RFC 7525: "Recommendations for Secure Use of Transport Layer Security (TLS) and Datagram Transport Layer Security (DTLS)".
- [17] IETF RFC 6125: "Representation and Verification of Domain-Based Application Service Identity within Internet Public Key Infrastructure Using X.509 (PKIX) Certificates in the Context of Transport Layer Security (TLS)".
- [18] IETF RFC 4519: "Lightweight Directory Access Protocol (LDAP): Schema for User Applications".

2.2 Informative references

References are either specific (identified by date of publication and/or edition number or version number) or non-specific. For specific references, only the cited version applies. For non-specific references, the latest version of the referenced document (including any amendments) applies.

NOTE: While any hyperlinks included in this clause were valid at the time of publication, ETSI cannot guarantee their long term validity.

The following referenced documents are not necessary for the application of the present document but they assist the user with regard to a particular subject area.

[i.1] OWASP TLS Cheat Sheet.

NOTE: Available at https://www.owasp.org/index.php/Transport_Layer_Protection_Cheat_Sheet.

[i.2] ETSI TR 103 308: "CYBER; Security baseline regarding LI and RD for NFV and related platforms".

[i.3] ETSI GS NFV-SEC 009: "Network Functions Virtualisation (NFV); NFV Security; Report on use cases and technical approaches for multi-layer host administration".

[i.4] ETSI GS NFV-SEC 012: "Network Functions Virtualisation (NFV) Release 3; Security; System architecture specification for execution of sensitive NFV components".

[i.5] OWASP XML Security Cheat Sheet.

NOTE: Available at https://www.owasp.org/index.php/XML_Security_Cheat_Sheet.

3 Definitions and abbreviations

3.1 Definitions

For the purposes of the present document, the following terms and definitions apply:

destination: point to which IRI and/or CC is delivered by the NE

Destination Identifier (DID): identifier to uniquely identify a Destination internally to the X1 interface

protocol error: error at the X1 protocol level (rather than any fault with ADMF or NE)

NOTE: In the present document, the term "error" in general refers to a protocol error, whereas issues with systems not behaving correctly are called "faults".

task: continuous instance of interception at a single NE carried out against a set of target identifiers, identified by an X1 Identifier, starting from an activate command and ending with a deactivate command or terminating fault

terminating fault: fault signalled from NE to ADMF which terminates the specific Task

X1: LI interfaces internal to the CSP for management tasking

X2: LI interfaces internal to the CSP for IRI delivery

X3: LI interfaces internal to the CSP for CC delivery

X1 Identifier (XID): identifier to uniquely identify a Task internally to the X1 interface

X1 Transaction ID: identifier used to identify a specific request/response pair

3.2 Abbreviations

For the purposes of the present document, the following abbreviations apply:

ADMF	ADMinistration Function
AVP	Attribute-Value Pair
CC	Content of Communication
CIDR	Classless Inter Domain Routing
CSP	Communication Service Provider
DID	Destination IDentifier
FQDN	Full Qualified Domain Name
FTP	File Transfer Protocol
GTP-C	GPRS Tunnel Protocol (Control plane)
GTP-U	GPRS Tunnel Protocol (User plane)
HI	Handover Interface
HTML	HyperText Markup Language
HTTP	HyperText Transfer Protocol
HTTPS	HTTP over TLS
IMEI	International Mobile Equipment Identity
IMPI	IP Multimedia Private Identity
IMPU	IP Multimedia PUBlic identity
IMSI	International Mobile Station Identity
IP	Internet Protocol
IRI	Intercept Related Information
LEA	Law Enforcement Agency
LEMF	Law Enforcement Monitoring Facility
LI	Lawful Interception
MAC	Media Access Control
NAI	Network Access Identifier
NAT	Network Address Translation
NE	Network Element

NOTE: The element or function performing the interception.

NFV	Network Functions Virtualisation
OWASP	Open Web Application Security Project
RADIUS	Remote Authentication Dial In User Service
SGSN	Serving GPRS Support Node
SIP	Session Initiation Protocol
SNMP	Simple Network Management Protocol
TCP	Transmission Control Protocol
TISPAN	Telecommunication and Internet converged Services and Protocols for Advanced Networking
TLS	Transport Layer Security
TPM	Trusted Platform Module
UDP	User Datagram Protocol
UID	Unique IDentifier
URI	Uniform Resource Identifier
UTF	UCS Transformation Formats
UUID	Universally Unique IDentifier
XID	X1 IDentifier
XML	eXtended Markup Language
XSD	XML Schema Definition

4 Overview

4.1 Reference model

The X1 interface is based on communication between two entities; the CSP Administration Function (ADMF), and the Network Element (NE) performing interception. The X1 reference model is shown in figure 1.

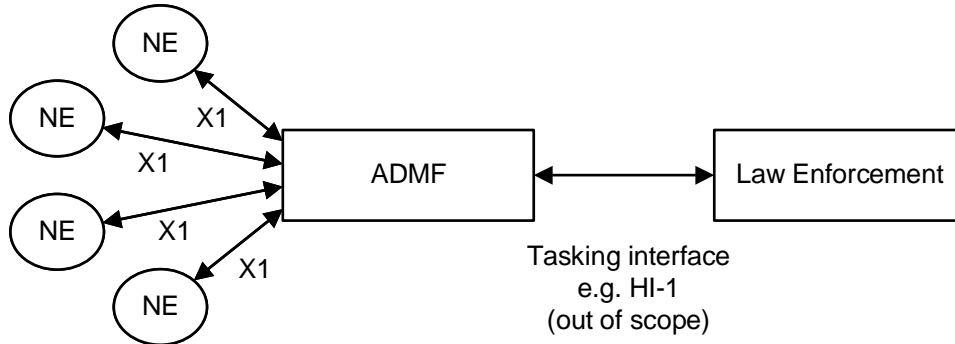

Figure 1: X1 reference model

Only one ADMF shall make changes by X1 to a given NE. This is called the ADMF which is "responsible" for that NE.

Onward delivery of information from the NE is called X2 (for IRI) and X3 (for CC). The choice of protocols for X2 and X3 are out of scope of the present document.

Some deployments may involve multiple ADMFs for redundancy or other purposes; where multiple ADMFs are required, the NE shall be implemented such that it presents itself as a separate NE to each ADMF.

ADMF and NE shall implement time synchronization where possible; in situations where it is not possible, the ADMF shall maintain knowledge of the timing offset between the ADMF and NE.

NOTE: The present document may be used in direct delivery scenarios, in which the NE delivers directly to the LEMF. Any consequences of using direct delivery are out of scope of the present document.

4.2 Reference model for X1: requesting and responding

X1 transactions consist of a request followed by a response.

Requests may be sent in either direction i.e. with the ADMF or NE initiating the request. The side initiating the request is called the "Requester"; this term is used when it is not specified whether it is the ADMF or NE making the request. The other side is called the "Responder".

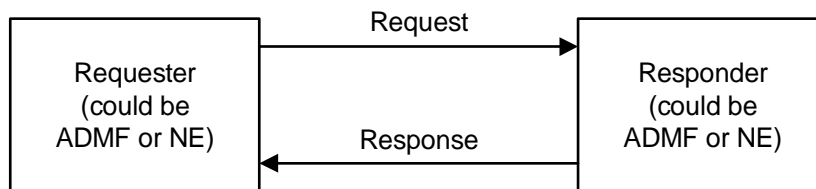

Figure 2: Showing generic terminology

It is likely that in most situations, the ADMF will initiate the message i.e. to distribute information or request status. However, it is possible that the NE will initiate the request in order to deliver fault reports, etc.

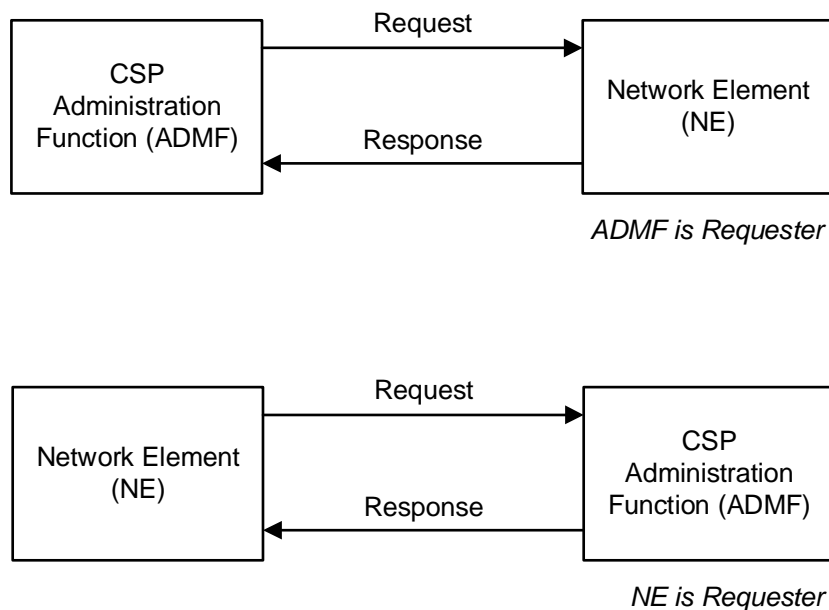

Figure 3: Showing two situations with either ADMF or NE as the requester

4.3 Overview of security

Security is based on creating public/private keys for the ADMF and each NE for which it is responsible. All transactions over X1 are performed using the security procedures in clause 8, which provide assurance that communication only takes place between an NE and ADMF which have been populated with the relevant key material.

NE implementers are strongly discouraged from exposing additional interfaces for controlling the LI functionality of the NE other than by X1 e.g. via a local administrative interface at the NE. If such additional interfaces exist, any such action performed on the NE shall be captured on the NE audit/logging, and any consequences of such actions shall be able to be seen and controlled by the ADMF that is responsible for the NE i.e. the ADMF shall be able to use the X1 interface to stop or undo any changes made over a local administrative interface. There may be broader consequences that are not covered by the present document if an NE is tasked independently of the X1 interface (e.g. security concerns).

4.4 Relationship to other standards

The present document forms part of a family of internal interface documents covering all of X1, X2 and X3 which are handled as separate standards.

Some models of LI (e.g. ETSI TS 133 107 [1]) define interfaces between ADMF and functions which perform mediation and delivery of content and IRI, (e.g. X1_2 and X1_3 defined by ETSI TS 133 107 [1]). The present document is designed to fulfil the requirements for X1_1 as defined in ETSI TS 133 107 [1].

4.5 Release management

This clause describes the release management requirements. The requirements are:

- The version of the present document is defined as <major>.<minor>.<patch>.
- The major version should be incremented when making a backwards incompatible change.
- The minor version should be incremented when adding backwards compatible functionality.
- The patch version should be incremented when fixing a backwards compatible bug.

Once a major version has been incremented, the previous major version will be supported for 2 years after publication of the new version. Change requests issued to a version that is no longer supported will need to be issued for the latest supported major version.

5 Basic concepts

5.1 The lifecycle of a Task

5.1.1 Start and end of a Task

A Task relates to a single target identifier, and goes from the point an ActivateTask Request is sent by the ADMF to the time a DeactivateTask Request is sent by the ADMF, or a "terminating fault" occurs.

The present document does not define which situations are categorized as "terminating faults". Local recovery procedures should be followed before a Task is ended with a "terminating fault". In general, irrecoverable failures with an interception, or major security issues at an NE should be considered terminating faults, and certain outcomes with keepalives are also terminating faults (where defined in clause 6.6.2).

5.1.2 Identification of a Task

Each Task on X1 is uniquely identified by an X1 Identifier (XID) and it is handled independently of all others. The ADMF shall assign the XID as a version 4 UUID as per IETF RFC 4122 [2]. The ADMF is responsible for correlating the XID to any LI instance identifiers used to communicate with Law Enforcement.

In addition, the XID is released once the Task has ended.

5.1.3 Destinations

Intercepted traffic is delivered by the NE to a Destination. Each Destination is uniquely identified by a Destination Identifier (DID), and is handled independently from details of the Task. Each Task is associated with one or more Destinations. Prior to associating a Task with a given DID, it is required that a Destination with the DID has already been created (as described in clause 6.3) but there is no requirement that a connection has been successfully established for that DID. Checks regarding availability and status of downstream delivery of information are outside the scope of the present document.

5.2 The lifecycle of an X1 request/response

5.2.1 Identification of X1 request/response

Each request and response shall be identified by an X1TransactionID. The requester (may be ADMF or NE) shall assign an X1TransactionID as a version 4 UUID as per IETF RFC 4122 [2].

5.2.2 Responding to the request

The response shall be sent without undue delay and shall be sent within TIME1 of receiving the request. TIME1 shall be configurable and by default TIME1 shall be five seconds. TIME2, the time a requester waits for a response, shall be configurable, it shall be at least twice TIME1 and by default shall be fifteen seconds.

An error response shall be sent if the request is not compliant syntactically (it does not match the schema) or semantically (it is not compliant or consistent with the existing state of the NE e.g. activating an existing XID).

If the request is compliant, one of the following responses shall be sent:

- "OK - Acknowledged and Completed" response shall be sent if the request is fully understood, compliant and the request has been successfully completed. If the request was a request for information then all the information shall be delivered together as part of the "OK - Acknowledged and Completed" response. The NE and ADMF shall be designed so that information requested (status and Task information) is in a data store which is readily available without undue delay and within TIME1.
- If the action requested cannot be completed within TIME1, an "OK - Acknowledged" response shall be sent. A status report shall be sent by the NE as soon as the action is completed or if it is unsuccessful (see clause 6.5.2.2). This status report shall be sent as a new request/response pair, using the same XID but the status report shall have its own X1TransactionID. The "OK - Acknowledged" response shall only be used for responding to requests which are Activating, Modifying or Deleting Tasks and Destinations (those in clauses 6.2 and 6.3) and they shall not be used to respond to other request types.

5.2.3 Behaviour if a response is not received

If the requester has not received a response after TIME2 (as defined in clause 5.2.2), or if a status report on the completion of the whole request following an "OK - Acknowledge" has not been received in a timely fashion, the requester may assume that either the request or response failed to get through. For example, the requester may consider requesting the status of the XID in question to see whether the prior request has been actioned (e.g. ActivateTask, ModifyTask, DeactivateTask or DeactivateAllTasks) or the requester may re-send the original request (as a new request, with a new X1TransactionID).

5.3 Warnings and Faults

The present document uses the term "error" to mean a protocol error within the X1 protocol as defined in clause 6.7.

All other problems are categorized as warnings or faults:

- Warnings are one-off problems i.e. sent by the NE and then not referred to again over X1. Warnings shall not be used for issues which are affecting traffic (i.e. losing content or intercept-related information). For example, warnings may include resources being nearly exhausted but not yet traffic-affecting. Warnings should include that keys/certificates are about to expire.
- Faults are problems which the NE will continue to be aware of and which the NE is trying to manage and/or rectify. Any issue which loses traffic is categorized as a fault.

Warnings are reported using issue-reporting messages (clause 6.5) but then are not included in any future Status-Getting messages (see clause 6.4). The NE shall log any warnings for audit reasons.

The NE shall remember which of the XIDs are in fault and whether the NE itself is in a fault situation. An issue report (see clause 6.5) is required at the start of the fault. The NE shall report faults when responding to the Status-Getting message defined in clause 6.4. The NE shall also indicate that a fault has been cleared (see clauses 6.5.2 and 6.5.3) unless otherwise configured.

6 Message Structure and Data Definitions

6.1 X1 Message details

X1 messages contain information as defined in table 1 (the information is Mandatory, Optional or Conditional as shown in the last column).

Table 1: Message details

Field	Description	Format	Mandatory (M), Optional (O) or Conditional (C)
ADMF Identifier	Identifies the ADMF uniquely to the NE. Required to match the details provided by the ADMF's X.509 certificate (see clause 8)	Token as per [3], section 3.4.2. Definition and assignment of identifiers is a deployment issue	M
NE Identifier	Uniquely identifies the NE to the ADMF. Required to match the details provided by the NE's X.509 certificate (see clause 8)	Token as per [3], section 3.4.2. Definition and assignment of identifiers is a deployment issue	M
MessageTimestamp	Timestamp indicating the time the message was sent by the requester	See ETSI TS 103 280 [4] Qualified Microsecond Date Time	M
Version	Version of the present document used for encoding the message	See clause 4.5	M
X1TransactionID	Used to correlate Request and Response. Shall be omitted for "TopLevelError" situations as defined below this table but otherwise is mandatory	An ID as defined in clause 5.2	C

In addition to the information in the table above, the X1 Request shall indicate the type of request being made (see clauses 6.2 to 6.6), and contain the appropriate request parameters for that type of request.

If the X1 Request could not be parsed, then the response shall be constructed with an ADMF and NE Identifier (extracting the identifier of the Requester from the X.509 certificate if necessary), MessageTimestamp and Version, and a "TopLevelError" flag but no other information.

If the request could be parsed then the response shall indicate the type of response being returned (see clauses 6.2 to 6.6) and contain the appropriate response parameters for that type of response.

A "RequestContainer" is used to contain one or more requests. All requests in a container are delivered at the same time, from the same Requester and to the same Responder. There is no implication about which order they are processed; for this reason, the ADMF should avoid sending ActivateTask and ModifyTask messages for the same XID in the same RequestContainer. A "ResponseContainer" is used to contain all the responses to the requests in the container. The ordering of these responses does not have a meaning. All responses are sent at the same time, from the same Responder and to the same Requester. The RequestContainer and ResponseContainer shall be used even if there is one request and one response.

For each "OK - Acknowledged" response received for the requests transported by a "RequestContainer", the requester should implement logic to assure the related status report is received and the transaction is completed or initiate a recovery procedure.

6.2 Message definitions: starting, modifying and stopping tasks

6.2.1 ActivateTask

6.2.1.1 Summary

DIRECTION: ADMF to NE.

USAGE: Used by the ADMF to add a new Task to an NE.

Table 2: ActivateTaskRequest

Field	Description	Format	M/C/O
TaskDetails	Target and interception details	See clause 6.2.1.2	M

Table 3: ActivateTaskResponse

Field	Description	Format	M/C/O
OK or Error	The general errors in clause 6.7 apply. Also, it is an error if the XID is already present at the NE	See clause 6.7	M

6.2.1.2 TaskDetails

The TaskDetails structure shall include the following.

Table 4: TaskDetails

Field	Description	Format	M/C/O
XID	Uniquely identifies the Task. There may be more than one different Task relating to the same target identifier (two distinct XIDs). The X1 interface supports delivery of this situation (i.e. it is not considered an error on the X1 interface).	UUIDv4 (see clause 5.1).	M
TargetIdentifiers	List of criteria which are used to identify the traffic to be intercepted. Where multiple criteria are present, all criteria are required to be matched. If an NE cannot target based on the criteria specified (e.g. due to an unsupported format or inappropriate combination of identifiers) the NE shall reject the request with an appropriate error. It is an implementation decision which identifiers and combinations of identifiers are supported.	Each TargetIdentifier given follows one of the formats given in table 5.	M
DeliveryType	Statement of whether to deliver X2 and/or X3.	Enumerated value - one of "X2Only", "X3Only" and "X2andX3".	M
ListOfDIDs	Details of where to send the intercepted traffic. It is an implementation decision for the NE to determine how to duplicate traffic if multiple destinations are specified, or if multiple destinations are supported.	List of Destination Identifiers (DID) referencing the desired delivery destination records.	M
TaskDetailsExtensions	One or more extension placeholders; each may be populated by a list of elements defined by external specifications.	See annex B.	O

If a Task is specific with an invalid combination of DeliveryType and Destinations (e.g. "X2andX3" delivery specified, but only an X2 Destination given), then the NE shall reject the ActivateTaskRequest with an appropriate error.

The list of permissible TargetIdentifier formats is given in table 5.

Table 5: TargetIdentifier Formats

Format Name	Description	Format
E164Number	E.164 Number in fully international format, written as decimal digits	Given in ETSI TS 103 280 [4] InternationalE164 format
IMSI	International Mobile Subscriber Identity, following the Recommendation ITU-T E.212 [5] numbering scheme, written as decimal digits	Given in ETSI TS 103 280 [4] IMSI format
IMEI	International Mobile station Equipment Identity, following the numbering plan defined in ETSI TS 123 003 [6], written as decimal digits without the (Luhn) check digit	Given in ETSI TS 103 280 [4] IMEI format
MACAddress	A MAC address	Given in ETSI TS 103 280 [4] MACAddress format
IPv4Address	An IPv4 address	Given in ETSI TS 103 280 [4] IPv4Address format
IPv6Address	IPv6 address	Given in ETSI TS 103 280 [4] IPv6Address format
IPv4CIDR	IPv4CIDR, written in dotted decimal notation followed by CIDR notation	Given in ETSI TS 103 280 [4] IPv4CIDR format
IPv6CIDR	IPv6CIDR written as eight groups of four hexadecimal digits separated by a colon, followed by CIDR notation	Given in ETSI TS 103 280 [4] IPv6CIDR format
TCPPort	TCP Port number, written in decimal notation	Given in ETSI TS 103 280 [4] TCPPort format
TCPPortRange	Range of TCP Ports, written as decimal numbers separated by a colon	Given in ETSI TS 103 280 [4] TCPPortRange format
UDPPort	UDP Port number, written in decimal notation	Given in ETSI TS 103 280 [4] UDPPort format
UDPPortRange	Range of UDP Ports, written as decimal numbers separated by a colon	Given in ETSI TS 103 280 [4] UDPPortRange format
EmailAddress	Email address following W3C HTML 5 Recommendation	Given in ETSI TS 103 280 [4] EmailAddress format
SIP-URI	SIP-URI according to the SIP URI scheme given in IETF RFC 3261 [7]	Given in ETSI TS 103 280 [4] SIPURI format
TEL-URI	TEL-URI according to the TEL URI scheme (see IETF RFC 3966 [8]) Implementers should consider whether the value could be sent as an E.164 number (or one of the related types) instead	Given in ETSI TS 103 280 [4] TELURI format
H323-URI	H323 URI according to the H323 URI scheme (see IETF RFC 3508 [9])	Given in H323Uri format (see XSD schema)
IMPU	IP Multimedia Public Identity, as per ETSI TS 123 003 [6]	Given in IMPU format (see XSD schema)
IMPI	IP Multimedia Private Identity, as per ETSI TS 123 003 [6]	Given in IMPI format (see XSD schema)
NAI	Network Access Identifier following IETF RFC 7542 [10] format	Given in NAI format (see XSD schema)
RADIUS	Any Radius attribute that uniquely identifies the subscriber within the specific CSP (see note 1)	Given as binary octets containing RADIUS AVP following IETF RFC 2865 [11] clause 5 (see note 2)
GTPUTunnelId	GTP-U Tunnel Identifier	Given as a 32-bit integer
GTPCTunnelId	GTP-C Tunnel Identifier	Given as a 32-bit integer
CallPartyRole	Identifies the role of a party in a call. Intended for use in conjunction with e.g. E164Number	One of the values "Originating", "Terminating", "ForwardedTo"
NonLocalIdentifier	Identifies whether the identifier is local or non-local. Intended for use in conjunction with e.g. E164Number	One of the values "Local" or "NonLocal"
TargetIdentifierExtension	Identifier defined by an external specification	See annex B

Format Name	Description	Format
NOTE 1:	Future versions of the present document may need to consider temporary identifiers including pseudonyms or short-term identifiers which have been derived from the permanent identifiers.	
NOTE 2:	Depending on NE implementation, this may not be exactly the same binary representation used to match traffic e.g. for case-insensitive matching.	

6.2.2 ModifyTask

DIRECTION: ADMF to NE.

USAGE: Used by the ADMF to modify an existing Task on the NE. All details for the Task shall be given (i.e. the modified details and the information that is unchanged) to totally replace the previous Task details.

Depending on the NE implementation, it may not be possible to modify some or all of the Task details. If the NE cannot modify one or more of the elements in the ModifyTaskRequest, it shall reject the entire ModifyTaskRequest with an appropriate error response.

The length of time an NE requires to make the changes requested in the ModifyTaskRequest message is an implementation detail, but the expectation is that changes are made without undue delay.

Table 6: ModifyTaskRequest

Field	Description	Format	M/C/O
Task details	Target and interception details (same as for ActivateTaskRequest)	See clause 6.2.1.2	M

Table 7: ModifyTaskResponse

Field	Description	Format	M/C/O
OK or Error	The general errors in clause 6.7 apply. Also, it is an error if the XID is not already present	See clause 6.7	M

6.2.3 DeactivateTask

DIRECTION: ADMF to NE.

USAGE: Used by the ADMF to deactivate (permanently stop and remove) a Task on the NE.

There is no concept of suspension or temporary deactivation. To stop a Task "temporarily", ADMFs shall deactivate the Task and then activate a new Task.

Table 8: DeactivateTaskRequest

Field	Description	Format	M/C/O
XID	See clause 5.1	See clause 5.1	M

Table 9: DeactivateTaskResponse

Field	Description	Format	M/C/O
OK or Error	The general errors in clause 6.7 apply. Also, it is an error if the XID is not already present at the NE	See clause 6.7	M

6.2.4 DeactivateAllTasks

DIRECTION: ADMF to NE.

USAGE: If enabled, the DeactiveAllTasks command shall perform a "DeactiveTask" command for all Tasks on the NE.

Table 10: DeactivateAllTasksRequest

Field	Description	Format	M/C/O
There shall be no request parameters			

Table 11: DeactivateAllTasksResponse

Field	Description	Format	M/C/O
OK or Error	The general errors in clause 6.7 apply. See below regarding whether "DeactivateAllTasks" is enabled; if Disabled then DeactivateAllTasks always triggers an error response of type "DeactivateAllTasks message is not enabled"	See clause 6.7	M

The DeactiveAllTasks request shall be supported by all implementations of the present document. It should be agreed in advance as to whether the DeactivateAllTasks request is enabled or disabled. By default (if there has been no agreement in advance) then DeactivateAllTasks is enabled.

6.3 Message definitions: creating, modifying and removing Destinations

6.3.1 CreateDestination

6.3.1.1 Summary

DIRECTION: ADMF to NE.

USAGE: Used by the ADMF to add a new Destination to the NE.

Table 12: CreateDestinationRequest

Field	Description	Format	M/C/O
Destination details	Details of the new destination	See clause 6.3.1.2	M

Table 13: CreateDestinationResponse

Field	Description	Format	M/C/O
OK or Error	The general errors in clause 6.7 apply. Also, it is an error if the DID is already present at the NE	See clause 6.7	M

6.3.1.2 DestinationDetails

DestinationDetails relate to the delivery of information from the NE to a Destination. Any further onward forwarding of data is handled by other administrative, mediation or delivery functions (out of scope of the present document).

The DestinationDetails structure is defined as follows.

Table 14: DestinationDetails

Field	Description	Format	M/C/O
DID	Destination Identifier which uniquely identifies the destination	UUIDv4 (see clause 5.1)	M
FriendlyName	A human-readable name associated with the delivery destination	Free-text string	O
DeliveryType	Statement of whether to deliver X2 and/or X3 to this destination	Enumerated value - one of "X2Only", "X3Only" and "X2andX3"	M
DeliveryAddress	One of the values from table 15	As defined in table 15	M

The DeliveryAddress structure is defined as follows.

Table 15: DeliveryAddress

Field	Description	Format	M/C/O
IPAddressAndPort	This covers both IPv4 and IPv6 and contains a single IP Address and Port	IPAddressAndPort from ETSI TS 103 280 [4]	O
E164Number	E.164 destination	InternationalE164 (see ETSI TS 103 280 [4])	O
URI	URI destination (e.g. an FQDN or other form of URI)	anyURI (see [3], section 3.2.17)	O
EmailAddress	Email address of the destination	EmailAddress (see ETSI TS 103 280 [4])	O
NOTE: Once X2 and X3 are complete, this table will be updated and some items (e.g. FTP and email address) may be removed from the list of delivery address details.			

6.3.2 ModifyDestination

DIRECTION: ADMF to NE.

USAGE: Used by the ADMF to modify an existing Destination on the NE. All details for the Destination shall be given (i.e. the modified details and the information that is unchanged) to totally replace the previous Destination details.

Depending on the NE implementation, it may not be possible to modify some or all Destination details while the Destination is in use. If the NE cannot modify one or more of the elements in the ModifyDestinationRequest, it shall reject the entire ModifyDestinationRequest with an appropriate error response.

The length of time an NE requires to make the changes requested in the ModifyDestinationRequest message is an implementation detail, but the expectation is that changes are made without undue delay.

Table 16: ModifyDestinationRequest

Field	Description	Format	M/C/O
DestinationDetails	Updated details for the destination	See clause 6.3.1.2	M

Table 17: ModifyDestinationResponse

Field	Description	Format	M/C/O
OK or Error	The general errors in clause 6.7 apply. Also, it is an error if the DID is not present	See clause 6.7	M

6.3.3 RemoveDestination

DIRECTION: ADMF to NE.

USAGE: Used by the ADMF to remove a Destination from the NE.

A Destination may only be removed if it is not referenced by any Tasks. An NE shall respond with an appropriate error if the ADMF attempts to remove a Destination that is referenced by a Task.

Table 18: RemoveDestinationRequest

Field	Description	Format	M/C/O
DID	See clause 5.1	See clause 5.1	M

Table 19: RemoveDestinationResponse

Field	Description	Format	M/C/O
OK or Error	The general errors in clause 6.7 apply. Also, it is an error if the XID is not already present at the NE	See clause 6.7	M

6.3.4 RemoveAllDestinations

DIRECTION: ADMF to NE.

USAGE: To completely and permanently remove all Destinations on the NE.

Table 20: RemoveAllDestinationsRequest

Field	Description	Format	M/C/O
There shall be no message parameters			

Table 21: RemoveAllDestinationsResponse

Field	Description	Format	M/C/O
OK or Error	The general errors in clause 6.7 apply. See below regarding whether "RemoveAllDestinations" is enabled; if Disabled then RemoveAllDestinations always triggers an error response	See clause 6.7	M

The RemoveAllDestinations request shall be supported by all implementations of the present document.

It shall be agreed in advance as to whether the RemoveAllDestinations request is enabled or disabled. By default (if there has been no agreement in advance) then RemoveAllDestinations is enabled.

If RemoveAllDestinations is disabled, then a RemoveAllDestinations request shall always trigger an ErrorResponse indicating "RemoveAllDestinations request is not enabled".

If RemoveAllDestinations is enabled, then a RemoveAllDestinations request shall remove all Destinations on that NE, or it shall trigger an error for the general error conditions listed in clause 6.7. Since a RemoveDestination request can only be issued against destinations that are not in use, an NE shall respond with an error if the ADMF sends a RemoveAllDestinations request while any of the Destinations are referenced by Tasks.

6.4 Message details: Getting information from NE

6.4.1 Introduction

This clause defines messages for the ADMF to request status information from the NE. This is distinct from "Reporting Issues" where the NE pushes information to the ADMF (see clause 6.5).

The following requests and responses shall be supported:

- GetTaskDetails: to request details of a single Task.
- GetDestinationDetails: to request details of a single Destination.
- GetNEStatus: to request status of the NE itself.
- GetAllDetails: requests details of all Tasks, Destinations and the status of the NE itself.
- ListAllDetails: requests the XIDs of all Tasks and DIDs of all Destinations (i.e. not all the details).

6.4.2 GetTaskDetails

6.4.2.1 Summary

DIRECTION: ADMF to NE.

USAGE: Used by the ADMF to retrieve the details of a particular Task.

Table 22: GetTaskDetailsRequest

Field	Description	Format	M/C/O
XID	See clause 5.1	See clause 5.1	M

Table 23: GetTaskDetailsResponse

Field	Description	Format	M/C/O
TaskResponseDetails	The Task details are as per clause 6.2.1.2, additionally containing a TaskStatus structure as per clause 6.4.2.2, unless there is an error, in which case see clause 6.7. If the XID is not present, this is an error (the appropriate error code shall be used, see clause 6.7).	See clauses 6.2.1.2 and 6.4.2.2	M

6.4.2.2 TaskStatus

The TaskStatus contains information about a Task as collected internally by the NE.

Table 24: TaskStatus

Field	Description	Format	M/C/O
ProvisioningStatus	Indicates whether the Task has been provisioned ("complete"), has failed to provision ("failed") or whether it is awaiting provisioning ("awaitingProvisioning")	One of the values "awaitingProvisioning", "failed" or "complete"	M
ListOfFaults	List of all active faults on that Task. If there are no faults, the field shall be omitted	List of ErrorInformation structures (see clause 6.7)	C
TimeOfLastIntercept	Time of last traffic intercepted if any (omit only if none seen so far) This time may also be updated periodically (instead of per packet) if required due to performance reasons	See ETSI TS 103 280 [4] Qualified Microsecond Date Time	C
AmountOfX2Data	Data transmitted over X2 since the creation of the Task in bytes, summed across all Destinations. If given, shall be correct at the time given in TimeOfLastIntercept	Integer	C
AmountOfX3Data	Data transmitted over X3 since the creation of the Task in bytes, summed across all Destinations. If given, shall be correct at the time given in TimeOfLastIntercept	Integer	C
TimeOfLastModification	Time of the last modification to the Task (omit only if unmodified)	See ETSI TS 103 280 [4] Qualified Microsecond Date Time	C
NumberOfModifications	Number of successful modifications since start	Integer	C

For any of the following fields: TimeOfLastIntercept, AmountOfX2Data, AmountOfX3Data, TimeOfLastModification and NumberOfModifications, if a field is not implemented by an NE, the field shall always be omitted.

6.4.3 GetDestinationDetails

6.4.3.1 Summary

DIRECTION: ADMF to NE.

USAGE: Used by the ADMF to retrieve the details of a particular Destination.

Table 25: GetDestinationRequest

Field	Description	Format	M/C/O
DID	See clause 5.1	See clause 5.1	M

Table 26: GetDestinationResponse

Field	Description	Format	M/C/O
DestinationResponseDetails	The destination details are as per table 14, additionally containing a DestinationStatus structure as per clause 6.4.3.2, unless there is an error, in which case see clause 6.7. If the DID is not present, this is an error (the appropriate error code shall be used, see clause 6.7).	See clauses 6.3.1.2 and 6.4.3.2.	M

6.4.3.2 DestinationStatus

The DestinationStatus relates only to the status of the delivery Destination as seen by the NE.

Table 27: DestinationStatus

Field	Description	Format	M/C/O
DestinationStatus	Status of Destination (or two destinations, if X2 and X3 are sent separately). Indicating whether the destination is active and working, or whether there is a delivery fault and traffic being lost. It is possible in the DeliveryFault state that some traffic is still being delivered - the determining factor is that issues with delivery to this destination is causing some traffic to be lost.	One of "ActiveAndWorking" or "DeliveryFaults"	M
ListOfFaults	List of all active faults on that Destination.	List of ErrorInformation structures (see clause 6.7)	M

6.4.4 GetNEStatus

6.4.4.1 Summary

DIRECTION: ADMF to NE.

USAGE: Used by the ADMF to determine the status of the NE.

Table 28: GetNEStatusRequest

Field	Description	Format	M/C/O
There shall be no request parameters			

Table 29: GetNEStatusResponse

Field	Description	Format	M/C/O
NEStatusDetails	The NEStatusDetails for the NE. The NE Status shall be one of "OK" i.e. no NE faults, or "Faults" i.e. NE losing traffic (these are separate from delivery faults which are reported per XID). Additionally, a list of currently unresolved faults (list of ErrorInformation items) shall be included (previous warnings are not included here).	Enumerated NEStatus value - one of "OK" or "Faults". List of ErrorInformation structures (see clause 6.7).	M

6.4.5 GetAllDetails

6.4.5.1 Summary

DIRECTION: The GetAllDetails command goes from ADMF to NE.

USAGE: For the ADMF to determine the details of all Tasks, Destinations and the status of the NE itself.

Table 30: GetAllDetailsRequest

Field	Description	Format	M/C/O
There shall be no request parameters			

Table 31: GetAllDetailsResponse

Field	Description	Format	M/C/O
NEStatusDetails	The NEStatusDetails for the NE. The NEStatus shall be one of "OK" i.e. no NE faults, or "Faults" i.e. NE losing traffic (these are separate from delivery faults which are reported per XID). Additionally, a list of currently unresolved faults (list of ErrorInformation items) shall be included (previous warnings are not included here).	Enumerated NEStatus value - one of "OK" or "Faults" List of ErrorInformation structures (see clause 6.7)	M
ListOfTaskResponseDetails	The response shall include TaskResponseDetails structures for all Tasks present on the NE. If there are no Tasks, an empty list shall be returned - this is not an error.	See clauses 6.2.1.2 and 6.4.2.2	M
ListOfDestinationResponseDetails	The response shall include DestinationResponseDetails structures for all destinations present on the NE. If there are no destinations, an empty list shall be returned - this is not an error.	See clauses 6.3.1.2 and 6.4.3.2	M

6.4.6 ListAllDetails

6.4.6.1 Summary

DIRECTION: ADMF to NE.

USAGE: Used by the ADMF to retrieve the list of all XIDs and DIDs (i.e. a list of identifiers) but no details.

Table 32: ListAllInterceptionsRequest

Field	Description	Format	M/C/O
There shall be no request parameters			

Table 33: ListAllInterceptionsResponse

Field	Description	Format	M/C/O
ListOfXIDs	A list of all XIDs on the NE. If there are none, then an empty list is returned; this is not an error	List of XIDs	M
ListOfDIDs	A list of all DIDs on the NE. If there are none, then an empty list is returned; this is not an error	List of DIDs	M

6.5 Message details: Reporting issues from the NE

6.5.1 Introduction

This clause defines request types for the NE to report issues to the ADMF. It is distinct from "Getting Status", in which the ADMF retrieves information from the NE (see clause 6.4).

Issues may be:

- Relating to a particular XID (including delivery issues with that XID).
- Relating to a particular DID.
- Relating to the whole NE.

6.5.2 ReportTaskIssue on given XID

6.5.2.1 Summary

DIRECTION: NE to ADMF.

USAGE: The NE shall send a ReportTaskIssue request when it becomes aware of an issue (warning or fault) relating specifically to a particular XID. It shall also be used to follow up on an "OK - Acknowledged" response, to signal that a request has been completed (clause 5.2) successfully or unsuccessfully.

Faults and warnings are defined in clause 5.3; see also clause 5.1 about terminating and non-terminating faults.

If a non-terminating fault becomes terminating, the NE shall send another ReportTaskIssue.

If a non-terminating fault is cleared, the NE shall send another ReportTaskIssue indicating the fault is cleared.

Table 34: ReportTaskIssueRequest

Field	Description	Format	M/C/O
XID	See clause 5.1	See clause 5.1	M
TaskReportType	Type of Issue	See clause 6.5.2.2	M
TaskIssueErrorCode	Error code associated with the issue, if appropriate	See clause 6.7	O
TaskIssueDetails	Further description of issue if appropriate	Free text	O

Table 35: ReportTaskIssueResponse

Field	Description	Format	M/C/O
OK or Error	The general errors in clause 6.7 apply	See clause 6.7	M

It is possible that the ADMF is not aware of the XID which is referenced in the NE message. The ADMF shall not send an error back to the NE in this situation: it is for the ADMF to decide how to handle this (e.g. GetAllDetails or Deactivate the XID in question are possible approaches).

6.5.2.2 Task report types

The TaskReportType shall be one of the following:

- All clear: non-terminating fault resolved.
- Warning: not traffic-affecting.
- Non-terminating fault (currently unable to collect traffic but not terminating).

- Terminating fault. The message is used by the NE to indicate that the Task has experienced a terminating fault and has been deactivated.
- Actioned: Request has been fully actioned and was successful (to follow up on "OK - Acknowledged" response from clause 5.2).
- Failed: Request has been fully actioned but was unsuccessful (to follow up on "OK - Acknowledged" response from clause 5.2). This is a terminating fault.

6.5.3 ReportDestinationIssue on given DID

6.5.3.1 Summary

DIRECTION: NE to ADMF.

USAGE: The NE shall send a ReportDestinationIssue request when it becomes aware of an issue (warning or fault) relating specifically to a particular DID.

Faults and warnings are defined in clause 5.3; see also clause 5.1 about terminating and non-terminating faults.

If a non-terminating fault becomes terminating, the NE shall send another ReportDestinationIssue.

If a non-terminating fault is cleared, the NE shall send another ReportDestinationIssue indicating the fault is cleared.

Table 36: ReportDestinationIssueRequest

Field	Description	Format	M/C/O
DID	See clause 5.1	See clause 5.1	M
DestinationReportType	Type of Issue	Same as TaskReportType, see clause 6.5.2.2	M
DestinationIssueErrorCode	Error code for the issue, if appropriate	See clause 6.7	O
DestinationIssueDetails	Further description of issue if appropriate	Free text	O

Table 37: ReportDestinationIssueResponse

Field	Description	Format	M/C/O
OK or Error	The general errors in clause 6.7 apply	See clause 6.7	M

6.5.4 ReportNEIssue

DIRECTION: NE to ADMF.

USAGE: The NE shall send a ReportNEIssue request when it becomes aware of an issue (warning or fault) relating to the whole NE.

NE issues can relate to:

- Any hardware issue on NE (storage nearly full, power issue).
- Current security issue on NE.
- Any issues with logging or audit material.
- Any report from manual changes to NE configuration.

Table 38: ReportNEIssueRequest

Field	Description	Format	M/C/O
NEIssueDetails	Description of issue being reported, including type of message (Warning, Fault Cleared, Fault Report) and description	ErrorInformation structure (see clause 6.7)	M

Table 39: ReportNEIssueResponse

Field	Description	Format	M/C/O
OK or Error	The general errors in clause 6.7 apply	See clause 6.7	M

6.6 Message details: Pings and Keepalives

6.6.1 Ping

DIRECTION: Either direction.

USAGE: At any time from the ADMF or NE, to get a response over the X1 interface (does not test X2 or X3 or onward delivery).

Table 40: PingRequest

Field	Description	Format	M/C/O
There shall be no request parameters			

Table 41: PingResponse

Field	Description	Format	M/C/O
OK or Error	The OK response has no other content. The general errors in clause 6.7 apply.	See clause 6.7	M

6.6.2 Keepalive

DIRECTION: The Keepalive command goes from ADMF to NE.

USAGE: See below.

Table 42: KeepaliveRequest

Field	Description	Format	M/C/O
There shall be no request parameters			

Table 43: KeepaliveResponse

Field	Description	Format	M/C/O
OK or Error	The OK message has no other content. The general errors in clause 6.7 apply.	See clause 6.7	M

The Keepalive functionality shall be supported by NE and ADMF. It is for prior agreement to determine whether Keepalives are enabled or disabled. By default (with no prior agreement) they are enabled. It is intended as a means for the NE application to assert that the ADMF application is still operational, and remove all tasking information as a security measure if it is not.

If Keepalives are enabled, the ADMF shall send out a Keepalive message at least every TIME_P1 (by default TIME_P1 is 1 minute) if no other X1 request has been sent to the NE.

If Keepalives are enabled, the NE shall respond with an OK for each Keepalive; if the NE has not seen a Keepalive message for TIME_P2 (by default TIME_P2 is 1 hour) then the NE shall perform a DeactivateAllTasks command i.e. deactivate all XIDs on the NE. The NE implementation shall reset the timer whenever any X1 Request is received from the ADMF (including a Keepalive Request).

6.7 Protocol error details

If the Responder is unable to perform an action requested as part of a Request Message, then it shall respond to that Request Message with an Error Response.

An ErrorResponse is a response which has the information from clause 6.1, but the response body has an error code from the list below and a free text field for further information. It has the following structure.

Table 44: ErrorResponse

Field	Description	Format	M/C/O
RequestMessageType	Indicates the type of Request Message that the Error Response message is a response to	One of the following: "ActivateTask", "ModifyTask", "DeactivateTask", "DeactivateAllTasks", "GetTaskDetails", "CreateDestination", "ModifyDestination", "RemoveDestination", "RemoveAllDestinations", "GetDestinationDetails", "GetNEStatus", "GetAllDetails", "ListAllDetails", "ReportTaskIssue", "ReportDestinationIssue", "ReportNEIssue", "Ping", "Keepalive"	M
ErrorInformation	Error code and optional description for the error	ErrorInformation as defined in table 45	M

Table 45: ErrorInformation

Field	Description	Format	M/C/O
ErrorCode	Integer code indicating the type of error (see table 46)	Integer	M
ErrorDescription	Free text field giving further details of the error. Implementers are encouraged to avoid placing sensitive information (such as personally identifiable information or sensitive details of the network) in error messages.	UTF-8 string	C

The ErrorResponse is used only as a response to a request which could not be actioned or understood. It is different from reporting on the status of the Task which are called "faults" and "warnings" but not "protocol errors".

Table 46: Error codes

Error Code	Error Description	Suggested Information elements
General message errors		
1000	Generic error	Details of the error
1010	Syntax / schema error	Details of the schema or syntax error
1020	Unsupported version	Version supported by the issuing system
1030	ADMF Identifier does not match certificate details	None
1040	Unexpected ADMF Identifier	None
1050	NE Identifier does not match certificate details	None
1060	Unexpected NE Identifier	None
Identifier errors		
2010	XID already exists on NE	XID in question
2020	XID does not exist on NE	XID in question
2030	DID already exists on the NE	DID in question
2040	DID does not exist on the NE	DID in question
ActivateTask / ModifyTask errors		
3000	Generic ActivateTask failure	Details of why the Task cannot be activated
3001	Generic ModifyTask failure	Details of why the Task cannot be modified
3010	Unsupported TargetIdentifier type	Details of the unsupported TargetIdentifier type
3020	Unsupported combination of TargetIdentifiers	Details of the unsupported combination
3030	Multiple destinations not supported	None
3040	Invalid combination of DeliveryType and Destinations specified	None
DeactivateTask failures		
4000	Generic DeactivateTask failure	Details of why the Task cannot be deactivated
DeactivateAllTasks failures		
5000	Generic DeactivateAllTasks failure	Details of why all Tasks cannot be removed
5010	DeactivateAllTasks not enabled	None
CreateDestination / ModifyDestination failures		
6000	Generic CreateDestination failure	Details of why the Destination cannot be created
6001	Generic ModifyDestination failure	Details of why the Destination cannot be modified
6020	Unsupported DeliveryAddress type	Details of the DeliveryAddress type requested
RemoveDestination failures		
7000	Generic RemoveDestination failure	Details of why the Destination cannot be removed
7010	Destination in use	Details of the Task(s) referencing the Destination if possible
RemoveAllDestinations failures		
8000	Generic RemoveAllDestinations failure	Details of why all Destinations cannot be removed
8010	Destinations in use	Details of which Destinations are in use, and (if possible) by which Tasks
8020	RemoveAllDestinations not enabled	None
Status / fault codes		
9000	Error cleared	Nature of the error which has now cleared
9010	Generic warning	Details of the warning
9020	Generic non-terminating fault	Details of the fault
9030	Terminating fault	Details of the fault
9040	Request actioned	X1TransactionID of the request now actioned

Implementers shall use the most specific error code available.

7 Transport and Encoding

7.1 Introduction

The present document defines a single profile for transport and encoding of X1 messages.

7.2 Profile A

7.2.1 Encoding

XML encoding shall be used. An XSD schema is provided contained in an archive which accompanies the present document. In the event of a discrepancy between the XSD schema and the present document, the present document shall be considered authoritative.

The attached samples provide an informative example for implementations of the present document. The samples do not form part of the normative specification.

7.2.2 Transport layer

7.2.2.1 HTTPS and HTTP

HTTPS shall be used as per IETF RFC 2818 [12]. The details relating to HTTP are given in this clause and the details relating to TLS are specified in clause 8.2.

In this clause, the term HTTP is used (it is implicit that it is in fact HTTPS i.e. that the HTTP is used over TLS).

7.2.2.2 How HTTP is used

The ADMF and NE shall both run HTTP clients and servers:

- For messages where the ADMF is the requester, the ADMF shall use its HTTP client and the NE shall use its HTTP server.
- For messages where the NE is the requester, the NE shall use its HTTP client and the ADMF shall use its HTTP server.

Details in the request:

- Each "RequestContainer" shall be sent as a HTTP request. It shall be a "POST" message (regardless of which type of X1 request it is) and the message body shall contain the RequestContainer as described in clause 6.

Details in the response:

- Each "ResponseContainer" message shall be sent as a HTTP response.
- The response shall indicate HTTP level errors within the range of HTTP error codes. If the HTTP level transaction is successful, then the response shall be a 200 OK message, with the ResponseContainer contained within the message body.
- HTTP error codes shall only be used to indicate HTTP-level errors, and shall not be used to indicate errors with the X1 responses themselves. X1-level errors shall be indicated by correct use of the appropriate X1 ErrorResponse, encoded and returned as a HTTP 200 OK response.

7.2.2.3 Profile

The following profile shall be used:

HTTP version 1.1 shall be used as per IETF RFC 7230 [13] and related specifications.

NOTE: HTTP/1.1 defaults to the use of "persistent connections" (see IETF RFC 7230 [13], section 6.3). Implementers are encouraged to support the use of persistent connections.

HTTP Pipelining shall not be used.

A Requester may issue multiple HTTP requests in parallel over multiple HTTP connections. However, such implementations should be aware that there is no guarantee of the order in which these requests are processed by the Responder. If such ordering is important to the Requester, it is responsible for ensuring the requests are sent out in the correct order, and for waiting for the response to each request before issuing the next one. Transfer Coding shall not be applied to the HTTP Request or Response (see IETF RFC 7230 [13], section 4).

By default, port 443 shall be used. If this is already in use, then the NE and ADMF shall be able to be configured with a port number, which shall be agreed prior to use of the standard.

By default, the HTTP path for X1 request messages shall be "/X1/ADMF" for the ADMF and "/X1/NE" for the NE. An exception to the default shall only be made with strict agreement between NE and ADMF; however, implementers shall ensure that an X1 implementation can be configured with a different path if required.

8 Security

8.1 Introduction

This clause details security measures to be implemented for the X1 interface. Other security aspects related to the NE (e.g. secure storage of information, access control) are out of scope of the present document.

8.2 Transport Security

8.2.1 Summary

TLS shall be used which provides authentication and authorization, integrity and confidentiality as well as replay protection between the TLS endpoints.

8.2.2 Profile

TLS shall be followed as defined in IETF RFC 5246 [14], and SSL2.0 shall not be used as described in IETF RFC 6176 [15].

IETF RFC 7525 [16] shall be followed.

8.2.3 Key generation, deployment and storage

Apart from requirements given in clauses 8.2.1 and 8.2.2, aspects concerning the generation, distribution, storage and revocation of key material and certificates are out of scope of the present document. Implementations are encouraged to support best practice e.g. the guidance given in OWASP TLS Cheat Sheet section 2.6 [i.1].

NOTE: It is assumed that the NE and ADMF are in a physically secure environment. For future uses e.g. NFV then this assumption would no longer be valid. Further details would then need to be added about the security of storage of key or certificate material e.g. TPM, Secure enclaves. See ETSI TR 103 308 [i.2], ETSI GS NFV-SEC 009 [i.3] and ETSI GS NFV-SEC 012 [i.4].

8.2.4 Authentication

Implementations shall perform mutual authentication using X.509 certificates following IETF RFC 6125 [17].

X1 implementations shall check that the UID part of the Subject field in the certificate (see IETF RFC 4519 [18]) provided matches the Sender or Receiver ID (whichever is provided by the other party in the communication). If a Responder receives an X1 message where these values do not match, it shall respond with an X1 error message indicating that the Requester is not authorized. If the Requester receives a response where these values do not match, then it shall disregard the response and log an appropriate error message.

8.3 Additional security measures (beyond transport layer)

It will be important to follow general security best practice (e.g. use of firewalls and/or access lists to prevent denial-of-service attacks). This is out of scope of the present document. However, implementers are specifically encouraged to follow XML best practices outlined in the OWASP XML Security Cheat Sheet [i.5].

The present document does not recommend that message-layer encryption or message-level message authentication codes are used in addition to the provisions in this clause. Of course, there may be threat models in which additional encryption may be thought to be useful. The present document does not forbid adding message-layer encryption e.g. by encrypting the whole of the payloads of the request and response messages. The details of the changes needed to do this are outside the scope of the present document.

Annex A (normative): Requirements

A.1 Basic requirements

A.1.1 Existing standards

The interface should use already existing mechanisms and standards if possible.

- R1) Future proof:** Changes can be made and new features can be added. A version structure will allow for co-existence of different versions.
- R2) Open structure:** The interface will have an open structure that will allow for extensions. Though it should be as strict as possible to make implementations as interoperable as possible. Extensions should not have any negative impact on security and other requirements.
- R3) Security:** Authentication, integrity protection and confidentiality shall be supported from end to end.
- R4) Authenticity:** The authenticity of a message can be checked in a standalone environment (e.g. no connection to an online server needed, root certificate can be enough).
- R5) Legal framework:** The present document contains a technical specification which is independent of national legislation. It does not supersede national legislation or approved practices.
- R6) Direct delivery:** Some network elements support direct delivery of IRI and CC without any additional mediation function. The interface should also support administration of these network elements.
- R7) Core functionality:** It shall be possible to provision (create, modify and delete) interceptions including all necessary parameters (e.g. CC/IRI-destination) on network nodes. It shall be possible to retrieve details of a single or all interceptions provisioned on a network node.
- R8) Administration:** It shall be possible to administrate LI relevant configuration on network nodes (e.g. update of security certificates).

A.2 Protocol & Architecture requirements

The following protocol and architecture requirements are listed:

- R9) Node Scope:** The X1 architecture and protocol shall support administration of all nodes involved in capture and control of target intercept traffic including intercept nodes and mediation functions. This shall include both on-switch and off switch probe scenarios.
- R10) Basic functionality:** The basic message exchange protocol shall be able to carry both generic LI parameters (e.g. those obtained from X1 E-warrant interface) and Interception Node manufacturer specific parameters.
- R11) Extensible:** The basic message exchange protocol shall allow limited extensibility to support parameter not currently supported by the base protocol. This extensibility shall be limited to encourage future extension of the standardized basic functionality in future versions of the X1 standard.
- R12) Flexibility:** The X1 architecture and message exchange technique shall be flexible to allow implementation in both existing and future national and international operator network architectures. As a minimum it shall be compatible with 3GPP, TISPAN / NTECH, NFV SEC, ETSI TC LI, ANSI and other international network architecture and handover standards.
- R13) One-to-many:** The architecture and message protocol shall support both one-to-one and one-to-many LI end point configurations (i.e. it shall be possible to provision 100s of end points simultaneously and efficiently).

- R14) Backwards compatibility:** The X1 architecture and protocol shall be backwards compatible with existing LI devices where possible. Specifically the standardized X1 shall not place significantly more performance or load impacts than existing proprietary approaches on LI nodes.

There is no specific requirement to retro-fit this X1 standards onto existing IP or legacy circuit switched nodes, although the standards does not prohibit such retrofitting where practical. Parallel running of X1 and legacy or proprietary interfaces shall be supported where practical. The X1 architecture shall permit different versions of X1 to be running on different components and (as far as is practical) the functionality from the older version shall still continue to work (though features introduced in the new versions shall cause errors to be sent).

- R15) Lightweight:** Many LI devices (e.g. Switches / Routers) currently use lightweight protocols such as SNMP, and have limited processing power and/or limited application layer intelligence. The protocol shall be designed to support such lightweight devices.
- R16) Permanent and dynamic connections:** The X1 architecture and message exchange technique shall support both permanent connection and dynamic link/connection scenarios.
- R17) Direct delivery:** Support situation where interception is delivered direct to LEMF without further CSP mediation. No need to explicitly draw this out but do allow enough information over X1 to support this situation.
- R18) Delay:** The X1 architecture and message exchange technique shall by design not introduce undue delay compared with existing proprietary X1 implementations.
- R19) Dynamic Triggering and HI1:** The X1 architecture and message exchange technique shall be compatible and interoperable with both ETSI TC LI HI1 and Dynamic Triggering standards.

A.3 Security requirements

- R20) Authentication:** The X1 architecture and message exchange technique shall provide both authentication of physical end points and authentication of the software application receiving the message.
- NOTE: Requirement is limited to authenticating the LI function identity and not authenticating the software version or integrity.
- R21) Authorization:** The X1 architecture and message exchange technique shall provide both authorization of physical end points and authorization of the software application receiving the message.
- R22) Accounting and audit:** The X1 architecture and message exchange technique shall include sufficient information to enable Accounting & Auditing functions in the ADMF and NE.
- R23) Integrity protection:** The X1 message exchange technique shall provide integrity protection for all messages exchanged between nodes in the X1 architecture. Use of Integrity protection shall be mandatory.
- R24) Confidentiality protection:** The X1 message exchange technique shall provide confidentiality protection for all messages exchanged between nodes in the X1 architecture.
- R25) Replay protection:** The X1 message exchange technique shall provide replay protection for all messages exchanged between nodes in the X1 architecture.
- R26) Standalone interface:** The X1 architecture and message exchange technique shall be designed as a standalone physically dedicated LI interface. The design and selection of the protocol shall where possible ensure vulnerabilities in non-LI interfaces on the same node shall not impact LI interfaces and security.
- R27) Hardened Protocol:** The X1 message exchange technique shall use a harden protocol containing minimal options or extensions which are not specifically required by X1.
- R28) Minimum Security Level:** The X1 architecture and message exchange techniques shall provide a minimum level of security (including cypher suites and key length), which shall be supported by all nodes. At least two algorithms shall be specified. The protocol and algorithms shall be resistant to bid down attack.

- R29) Underlying Infrastructure Trust:** The X1 architecture and message exchange techniques shall assume by default that the underlying network communication links and infrastructure are untrusted.
- R30) Firewall and NAT Transversal:** The X1 message exchange technique shall be compatible with existing operator firewall and NAT transversal architectures. The message exchange technique shall not require unrestricted opening of common ports (e.g. port 80 or 21). The message exchange technique shall not prohibit the development of future X1 aware firewall filtering to provide rejection of malicious X1 message at operator security gateways.
- R31) Certificate and Key Management:** The X1 architecture and message exchange techniques shall include (where applicable) Certificate and Key Management mechanisms. In addition mechanisms for Certificate / Key revocation shall be provided.
- R32) Single Node Compromise:** The X1 architecture and message exchange techniques shall ensure that a vulnerability or weak implementation in one node does not adversely affect other nodes. Specifically it shall not be possible to attack one interception node by using recovered plan text or other security parameters from a vulnerable one.
- R33) Node Administration:** The X1 architecture and message exchange techniques shall ensure by design that within node implementations, non-LI super-users can be prevented from making LI related parameters changes without authority from and knowledge of the LI administrator.
- R34) Encryption of target information:** It shall be possible to use encrypted target information only by use of encrypted targets and encryption keys. In case of encrypted information it shall be possible to change encrypted target information and encryption keys periodically without interruption of any active interception.

A.4 Other requirements

A.4.1 Performance statistics (For Further Study)

Performance requirements include:

- In general or per LI measure.
- Activity: Amount of intercepted traffic? Maximum and average bandwidth? Minutes of intercepted voice? Count of intercepted messages? Time of last activity?
- Maximum number of parallel interceptions (e.g. in busy hours).
- Maximum number of parallel intercepted accounts/connections with same target identifier (e.g. in case of IMEI duplicates).

The performance requirements are derived from measures of the amount and rate of Lawful Interception. Clearly this will vary but some guidelines are as follows:

- Considerations of the bandwidth of intercepted traffic are in general not relevant to X1 (except perhaps for a NE to report that bandwidth is exceeding certain parameters).
- Number of targets on cover at any given time:
 - This number is usually very small compared to the total number of users and for the purposes of the present document will be considered as tens or hundreds at most.
- Are there situations where a single target on cover causes a lot of X1 messages. Consider the following ways this could happen:
 - Can a single target cause a large number of target identifiers to be tasked (consider roaming)?
 - Can one have a large number of HI-1 messages for each target identifier (frequent changing of parameters?).

- For a single ADMF-NE link, can one have lots of X1 messages for a given HI-1 message arriving at the ADMF?
- How many different NEs can each ADMF have to talk to?

A.4.2 Capability detection

Automatic capability detection is not covered in the present document.

A.4.3 Remote triggering

Remote triggering is defined as a system where a trustworthy node contains the target list. Instead of maintaining a list of intercepted targets on a (less trustworthy) network node, the start of all communication (calls, data session, etc.) could be reported to another (trustworthy) node which checks for intercepted targets and dynamically triggers interceptions on the first node.

Remote triggering is not covered in the present document.

A.4.4 Requirements to be handled by the transport layer

- R35)** Ability to send frequent messages from ADMF to NE to add/delete, with an OK/not OK response.
- R36)** Ability to send frequent list messages, with a status update response.
- R37)** Ability to send occasional urgent messages from NE as error messages, with a "received OK" response.
- R38)** Reliable transport - need to know if message failed to get through.
- R39)** Able to be secured using standard techniques. Discuss whether there are concerns about what has to be opened in various firewalls to let it through.
- R40)** Simple and lightweight, suitable for use on standard network equipment in broadband (e.g. router) and mobile communications (e.g. SGSN).
- R41)** Helpful (non-essential) if it is able to group multiple messages together so that one security check is not needed for each message (this can be handled by a grouping function within our message layer though nicer not to).
- R42)** No unnecessary buffering or delays of some messages compared to others, though perhaps does not need to guarantee the order of delivery of messages.
- R43)** No QoS - the interface will not prioritize or buffer any information. Needs to deliver messages to end point, which can either accept the message (and buffer/prioritize if it chooses) or reject.
- R44)** Every message requires a response:
 - Helpful if it can relay an immediate "don't understand" response as a reply to a message i.e. without understanding its contents.
 - Need to be able to respond quickly with errors e.g. parsing errors.
 - Need to be able to respond quickly with an OK message.

No messages to be stalled/buffered or rejected by the transport layer because the receiving application layer is busy creating a response.

Annex B (normative): Use of extensions

B.1 Introduction

The present document defines a number of extension points, including in the TaskDetails structure (see clause 6.2.1.2), and TargetIdentifier format (see table 5). This clause defines how extensions are to be used in table 4 and table 5.

B.2 Extension definitions

Where a feature or information element already exists in the present document, it shall be used in preference to any extended field. Extensions shall not be drafted as an alternative or re-formatting of functionality or information that already exists within the present document.

An extension shall be a structure (e.g. a complexType in XSD) defined in a separate schema, and shall contain at a minimum the following elements.

Table B.1: Extension fields

Field	Description	Format	M/C/O
Owner	Human-readable indication of the entity responsible for the definition and maintenance of the extension	UTF-8 string	M

The extensions shall be defined in a namespace belonging to the entity responsible for drafting and maintaining the extension. It shall not be defined in the namespace of the present document.

Annex C (informative): Change request history

Status of the present document: ETSI TS 103 221-1 Part 1: Internal Network Interface X1 for Lawful Interception		
TC LI Approval Date	Version	Remarks
October 2017	1.1.1	First publication XSD schema is provided in TS_103_221_01_v010101.xsd contained in archive ts_10322101v010101p0.zip which accompanies the present document
February 2018	1.2.1	Included Change Request: TS103221-1CR01r1 (cat F) Warning and Faults Reporting This CR was approved by TC LI#47 (5-7 February 2018, New Delhi) No changes in XML Schema. Version 1.2.1 prepared by Martin Kissel (Telefónica) (rapporteur)
June 2018	1.3.1	Included Change Request: TS103221-1CR02r2 (cat F) X1 response/request lifecycle This CR was approved by TC LI#48 (26-28 June 2018, Bergen) No changes in XML Schema. Version 1.3.1 prepared by Martin Kissel (Telefónica) (rapporteur)

History

Document history		
V1.1.1	October 2017	Publication
V1.2.1	March 2018	Publication
V1.3.1	September 2018	Publication