



TECHNICAL SPECIFICATION

**Speech and multimedia Transmission Quality (STQ);  
Reference benchmarking,  
background traffic profiles and KPIs;  
Part 1: Reference benchmarking, background traffic profiles  
and KPIs for VoIP and FoIP in fixed networks**

---

Reference

RTS/STQ-266-1

---

Keywords

KPI, QoS

**ETSI**

650 Route des Lucioles  
F-06921 Sophia Antipolis Cedex - FRANCE

Tel.: +33 4 92 94 42 00 Fax: +33 4 93 65 47 16

Siret N° 348 623 562 00017 - NAF 742 C  
Association à but non lucratif enregistrée à la  
Sous-Préfecture de Grasse (06) N° 7803/88

---

**Important notice**

The present document can be downloaded from:

<http://www.etsi.org/standards-search>

The present document may be made available in electronic versions and/or in print. The content of any electronic and/or print versions of the present document shall not be modified without the prior written authorization of ETSI. In case of any existing or perceived difference in contents between such versions and/or in print, the only prevailing document is the print of the Portable Document Format (PDF) version kept on a specific network drive within ETSI Secretariat.

Users of the present document should be aware that the document may be subject to revision or change of status.

Information on the current status of this and other ETSI documents is available at

<https://portal.etsi.org/TB/ETSIDeliverableStatus.aspx>

If you find errors in the present document, please send your comment to one of the following services:

<https://portal.etsi.org/People/CommiteeSupportStaff.aspx>

---

**Copyright Notification**

No part may be reproduced or utilized in any form or by any means, electronic or mechanical, including photocopying and microfilm except as authorized by written permission of ETSI.

The content of the PDF version shall not be modified without the written authorization of ETSI.

The copyright and the foregoing restriction extend to reproduction in all media.

© ETSI 2018.

All rights reserved.

**DECT™**, **PLUGTESTS™**, **UMTS™** and the ETSI logo are trademarks of ETSI registered for the benefit of its Members.

**3GPP™** and **LTE™** are trademarks of ETSI registered for the benefit of its Members and of the 3GPP Organizational Partners.

**oneM2M** logo is protected for the benefit of its Members.

**GSM®** and the GSM logo are trademarks registered and owned by the GSM Association.

# Contents

Intellectual Property Rights .....	5
Foreword.....	5
Modal verbs terminology.....	5
Introduction .....	5
1 Scope .....	6
2 References .....	6
2.1 Normative references .....	6
2.2 Informative references.....	7
3 Definitions and abbreviations.....	8
3.1 Definitions.....	8
3.2 Abbreviations .....	8
4 Management Summary.....	10
4.1 Introduction .....	10
4.2 Scope of functionality .....	10
5 Technical concept.....	11
5.1 Voice over IP.....	11
5.2 Call set-up delay and Session initiation call set-up delay.....	12
5.3 Call set-up time (post dialling delay) .....	14
5.4 Premature release probability (call failure rate; telephony service non accessibility).....	16
5.5 Telephony Cut-off Call Ratio [%] (Call drop rate) .....	16
5.6 Media establishment delay .....	17
5.7 Level of active speech signal in receive direction .....	17
5.8 Noise level in receive direction .....	18
5.9 Signal to noise ratio in receive direction .....	18
5.10 Speech signal attenuation (or gain) .....	18
5.11 Talker echo delay .....	18
5.12 Double talk performance .....	18
5.13 Interrupted voice transmission .....	19
5.14 Listening speech quality .....	20
5.14.1 General aspects of Listening Speech Quality.....	20
5.14.2 General aspects of voice channel test calls .....	20
5.14.3 Connections without parallel data transfer.....	22
5.14.3.1 Connections with one voice channel .....	22
5.14.3.2 Multiple voice channel access.....	24
5.14.4 Connections with parallel data transfer.....	27
5.14.4.0 Introduction.....	27
5.14.4.1 Quality measurement of one voice channel and parallel data transfer .....	28
5.14.4.2 Parallel quality measurement of one voice channel and data transmission speed.....	31
5.14.4.3 Quality measurement of multiple voice channels and data transfer .....	33
5.14.4.4 Parallel quality measurement of multiple voice channels and data transmission speed.....	34
5.15 Listening speech quality stability .....	37
5.16 End-to-end audio delay .....	37
5.17 End -to-end audio delay variation .....	38
5.18 Frequency response in receive direction .....	39
5.19 Fax transmission with Recommendations ITU-T T.30 and T.38 .....	39
5.19.1 General considerations.....	39
5.19.2 Fax set-up duration .....	41
5.19.3 Fax transmission duration.....	41
5.19.4 Fax failure ratio.....	42
5.19.5 Test case descriptions .....	42
5.19.5.1 Quality measurement of one fax channel .....	42
5.19.5.2 Quality measurement of one fax channel and parallel data transfer.....	43
5.20 Early media listening speech quality .....	50

5.20.1	Introduction.....	50
5.20.2	Early media generated by the called party .....	50
5.21	Jitter Buffer and IP prioritization response time.....	51
5.21.1	Jitter Buffer and IP prioritization response time without data transfer .....	51
5.21.2	Jitter Buffer and IP prioritization response time with data transfer .....	52
5.22	Stability of the de-jitter buffer delay adjustments for VBD calls during IP data transfer.....	53
6	Internet related performance measurement methods of data transmission and voice transmission .....	56
6.1	Internet related performance measurement method of data transmission, general requirements .....	56
6.1.1	Introduction.....	56
6.2	Functional architecture of the Measurement System.....	56
6.2.0	Introduction.....	56
6.2.1	Controller FE .....	57
6.2.2	Collector FE.....	57
6.2.3	Measurement Agent FE .....	57
6.2.4	Measurement Peer FE.....	57
6.2.5	Common remarks.....	57
6.2.6	Security Considerations .....	57
6.3	Workflow .....	58
6.3.1	General requirements.....	58
6.3.2	Initial conditions .....	58
6.3.3	Measurement procedure.....	58
6.3.3.0	Introduction .....	58
6.3.3.1	Phase 1: Initialization.....	59
6.3.3.2	Phase 2: Downlink pre-test .....	60
6.3.3.3	Phase 3: Latency test.....	60
6.3.3.4	Phase 4: Downlink subtest .....	61
6.3.3.5	Phase 5: Uplink pre-test .....	61
6.3.3.6	Phase 6: Uplink subtest .....	62
6.3.3.7	Phase 7: Finalization .....	63
6.4	Measurement of Data .....	63
6.5	QoS IP transmission layer parameter tests .....	64
6.5.0	Introduction.....	64
6.5.1	VoIP (Voice over IP).....	64
6.5.2	TCP Parameters .....	65
6.5.3	UDP Parameters.....	65
6.5.4	Web Page .....	66
6.5.5	Unmodified content .....	66
6.5.6	Transparent connection.....	66
6.5.7	DNS .....	67
6.5.8	Traceroute.....	67
<b>Annex A (informative):</b>	<b>Bibliography.....</b>	<b>68</b>
History .....		69

---

## Intellectual Property Rights

### Essential patents

IPRs essential or potentially essential to normative deliverables may have been declared to ETSI. The information pertaining to these essential IPRs, if any, is publicly available for **ETSI members and non-members**, and can be found in ETSI SR 000 314: "*Intellectual Property Rights (IPRs); Essential, or potentially Essential, IPRs notified to ETSI in respect of ETSI standards*", which is available from the ETSI Secretariat. Latest updates are available on the ETSI Web server (<https://ipr.etsi.org/>).

Pursuant to the ETSI IPR Policy, no investigation, including IPR searches, has been carried out by ETSI. No guarantee can be given as to the existence of other IPRs not referenced in ETSI SR 000 314 (or the updates on the ETSI Web server) which are, or may be, or may become, essential to the present document.

### Trademarks

The present document may include trademarks and/or tradenames which are asserted and/or registered by their owners. ETSI claims no ownership of these except for any which are indicated as being the property of ETSI, and conveys no right to use or reproduce any trademark and/or tradename. Mention of those trademarks in the present document does not constitute an endorsement by ETSI of products, services or organizations associated with those trademarks.

---

## Foreword

This Technical Specification (TS) has been produced by ETSI Technical Committee Speech and multimedia Transmission Quality (STQ).

The present document is part 1 of a multi-part deliverable covering the Reference benchmarking, background traffic profiles and KPIs as identified below:

- Part 1: "Reference benchmarking, background traffic profiles and KPIs for VoIP and FoIP in fixed networks";**
- Part 2: "Reference benchmarking and KPIs for High speed internet";
- Part 3: "Reference benchmarking, background traffic profiles and KPIs for UMTS and VoLTE";
- Part 4: "Reference benchmarking for IPTV, Web TV and RCS-e Video Share".

---

## Modal verbs terminology

In the present document "**shall**", "**shall not**", "**should**", "**should not**", "**may**", "**need not**", "**will**", "**will not**", "**can**" and "**cannot**" are to be interpreted as described in clause 3.2 of the [ETSI Drafting Rules](#) (Verbal forms for the expression of provisions).

"**must**" and "**must not**" are **NOT** allowed in ETSI deliverables except when used in direct citation.

---

## Introduction

The present document describes possible key performance indicators for VoIP and FoIP as well as framework requirements for reference benchmarking particularly with regard to background traffic.

---

# 1 Scope

The present document:

- identifies and defines possible key performance indicators for voice and fax telephony services;
- defines benchmarking methods for the spectrum of potential applications.

The offer of new NGN services requires new KPIs, QoS measurement and benchmarking methods which are needed to ensure the quality of new services. To ensure the comparability of test results, reference benchmarking methods and background traffic load profiles are needed.

The scope of the defined testing procedures is the evaluation of the network access by VoIP and FoIP fixed-network services. The measurements are conducted stationary between a subscriber access-point to a measurement point emulating an idealized termination point in the core network. All access technologies offered by the operator under test are considered. In this context the measurements and key performance indicators determinations are performed by analysing signals accessible on the network.

The present document is the first part of the multi-part deliverable which consists of four parts.

The present document contains possible KPIs for VoIP and FoIP as well as framework requirements for reference benchmarking particularly with regard to background traffic profiles.

---

## 2 References

### 2.1 Normative references

References are either specific (identified by date of publication and/or edition number or version number) or non-specific. For specific references, only the cited version applies. For non-specific references, the latest version of the referenced document (including any amendments) applies.

Referenced documents which are not found to be publicly available in the expected location might be found at <https://docbox.etsi.org/Reference/>.

NOTE: While any hyperlinks included in this clause were valid at the time of publication, ETSI cannot guarantee their long term validity.

The following referenced documents are necessary for the application of the present document.

- [1] Recommendation ITU-T E.800 (09-2008): "Definitions of terms related to quality of service".
- [2] Recommendation ITU-T P.863 (09-2014): "Perceptual objective listening quality assessment".
- [3] ETSI TS 101 563 (V1.3.1): "Speech and multimedia Transmission Quality (STQ); IMS/PES/VoLTE exchange performance requirements".
- [4] Recommendation ITU-T Q.543 (03-1993): "Digital exchange performance design objectives".
- [5] ETSI ES 202 765-2 (V1.2.1): "Speech and multimedia Transmission Quality (STQ); QoS and network performance metrics and measurement methods; Part 2: Transmission Quality Indicator combining Voice Quality Metrics".
- [6] Recommendation ITU-T G.131 (11-2003): "Talker echo and its control".
- [7] ETSI ES 203 021-3 (V2.1.2): "Access and Terminals (AT); Harmonized basic attachment requirements for Terminals for connection to analogue interfaces of the Telephone Networks; Update of the technical contents of TBR 021, EN 301 437, TBR 015, TBR 017; Part 3: Basic Interworking with the Public Telephone Networks".
- [8] ETSI TBR 003 (Edition 1) (11-1995): "Integrated Services Digital Network (ISDN); Attachment requirements for terminal equipment to connect to an ISDN using ISDN basic access".

- [9] ETSI TBR 004 (Edition 1) (11-1995): "Integrated Services Digital Network (ISDN); Attachment requirements for terminal equipment to connect to an ISDN using ISDN primary rate access".
- [10] ETSI EN 300 175-8: "Digital Enhanced Cordless Telecommunications (DECT); Common Interface (CI); Part 8: Speech and audio coding and transmission".
- [11] Recommendation ITU-T O.41 (10-1994): "Psophometer for use on telephone-type circuits".
- [12] Recommendation ITU-T P.56 (12-2011): "Objective measurement of active speech level".
- [13] Recommendation ITU-T P.501 (03-2017): "Test signals for use in telephony".
- [14] ETSI ES 202 737 (V1.4.1): "Speech and multimedia Transmission Quality (STQ); Transmission requirements for narrowband VoIP terminals (handset and headset) from a QoS perspective as perceived by the user".
- [15] ETSI ES 202 739 (V1.4.1): "Speech and multimedia Transmission Quality (STQ); Transmission requirements for wideband VoIP terminals (handset and headset) from a QoS perspective as perceived by the user".
- [16] Recommendation ITU-T P.340 (05-2000): "Transmission characteristics and speech quality parameters of hands-free terminals".
- [17] Recommendation ITU-T P.502 (05-2000): "Objective test methods for speech communication systems using complex test signals".
- [18] IETF RFC 4122 (07-2005): "A Universally Unique Identifier (UUID) URN Namespace".
- [19] Recommendation ITU-T P.863.1 (09-2014): "Application guide for Recommendation ITU-T P.863".
- [20] Recommendation ITU-T E.458 (02-1996): "Figure of merit for facsimile transmission performance".
- [21] Recommendation ITU-T E.453 (08-1994): "Facsimile image quality as corrupted by transmission-induced scan line errors".
- [22] ETSI TS 102 250-2 (V2.3.1): "Speech and multimedia Transmission Quality (STQ); QoS aspects for popular services in mobile networks; Part 2: Definition of Quality of Service parameters and their computation".
- [23] IETF RFC 7594 (2015): "A Framework for Large-Scale Measurement of Broadband Performance (LMAP)".
- [24] Recommendation ITU-T Y.1541: "Network performance objectives for IP-based services".

## 2.2 Informative references

References are either specific (identified by date of publication and/or edition number or version number) or non-specific. For specific references, only the cited version applies. For non-specific references, the latest version of the referenced document (including any amendments) applies.

NOTE: While any hyperlinks included in this clause were valid at the time of publication, ETSI cannot guarantee their long term validity.

The following referenced documents are not necessary for the application of the present document but they assist the user with regard to a particular subject area.

- [i.1] Recommendation ITU-T Q.3960: "Framework of Internet related performance measurements".
- [i.2] ETSI ETR 138 (12-1997): "Network Aspects (NA); Quality of service indicators for Open Network Provision (ONP) of voice telephony and Integrated Services Digital Network (ISDN)".
- [i.3] ETSI EG 202 425 (V1.1.1): "Speech Processing, Transmission and Quality Aspects (STQ); Definition and implementation of VoIP reference point".

- [i.4] ETSI EG 202 057-2: "Speech and multimedia Transmission Quality (STQ); User related QoS parameter definitions and measurements; Part 2: Voice telephony, Group 3 fax, modem data services and SMS".
- [i.5] ETSI TR 103 138: "Speech and multimedia Transmission Quality (STQ); Speech samples and their use for QoS testing".
- [i.6] IEC 61260:1995: "Electroacoustics - Octave-band and fractional-octave-band filters".
- [i.7] Recommendation ITU-T T.30 (09-2005): "Procedures for document facsimile transmission in the general switched telephone network".
- [i.8] Recommendation ITU-T T.38 (09-2010): "Procedures for real-time Group 3 facsimile communication over IP networks".
- [i.9] Recommendation ITU-T T.24: "Standardized digitized image set".
- [i.10] Recommendation ITU-T G.168 (04/15): "Digital network echo cancellers".
- [i.11] Recommendation ITU-T V.25: "Automatic answering equipment and general procedures for automatic calling equipment on the general switched telephone network including procedures for disabling of echo control devices for both manually and automatically established calls".

---

## 3 Definitions and abbreviations

### 3.1 Definitions

For the purposes of the present document, the following terms and definitions apply:

**benchmark:** evaluation of performance value/s of a parameter or set of parameters for the purpose of establishing value/s as the norm against which future performance achievements may be compared or assessed

NOTE: The definition is taken from Recommendation ITU-T E.800 [1].

### 3.2 Abbreviations

For the purposes of the present document, the following abbreviations apply:

AB	Direction of call establishment User B to user A
ACK	ACKnowledgemen
AGCF	Access Gateway Control Function
AGW	Access Gateway
ANS	Answer Tone
AS	Application Server
BA	Direction of call establishment User A to user B
BRI	Basic Rate Interface
BST	Broadband Speed Test
CED	Called station identification tone
CFR	Call Failure Rate
CI	Common Interface
CLI	Calling Line Identification
CNG	Calling Tone
CPE	Customer Premises Equipment
CSCF	Call Session Control Function
CSS	Composite Source Signal
DL	DownLink
DNS	Domain Name System
DSS1	Digital Subscriber Signalling System No. 1
DTMF	Dual-Tone Multi-Frequency signalling
ECM	Error Correction Mode



ERP	Ear Reference Point
FE	Functional Entity
FM	Feature Manager
FoIP	Fax over IP
FOM	Figure Of Merit
FTP	File Transfer Protocol
HTTP	Hypertext Transfer Protocol
HTTPS	Hypertext Transfer Protocol Secure
HW/SW	Hardware/Software
IAD	Integrated Access Device
IEC	International Electrotechnical Commission
IETF	Internet Engineering Task Force
IMAP	Internet Message Access Protocol
IMAPS	Internet Message Access Protocol Secure
IMCP	Internet Message Control Protocol
IMS	Internet Multimedia Subsystem
IP	Internet Protocol
IPTV	Internet Protocol TeleVision
ISDN	Integrated Services Digital Network
ITU-T	International Telecommunication Union - Telecommunication standardization sector
IVR	Interactive Voice Response
KB	Kilo Byte
KPI	Key Performance Indicator
LTE	Long Term Evolution
MA	Measurement Agent
MGC	Media Gateway Controller
MGW	Media Gateway
MMTel	MultiMedia Telephony service
MOS	Mean Opinion Score
MOS-LQO	MOS Listening Quality Objective
MP	Measurement Peer
MRP	Mouth Reference Point
MSAN	Multi-Service Access Nodes
NGN	New Generation Network
NTP	Network Time Protocol
OS	Operating System
OVL	OverLoad Point
PCMA	Pulse Code Modulation A-Law
P-CSCF	Proxy Call Session Control Function
PES	PSTN Emulation Subsystem
PRI	Primary Rate Interface
PSTN	Public Switched Telephone Network
PT	Protocol
QoS	Quality of Service
RDP	Remote Desktop Protocol
RFC	Request for Comments
RSSI	Received Signal Strength Indicator
RTCP	RealTime Control Protocol
RTP	Real Time Protocol
RTSP	Real-Time Streaming Protocol
S-CSCF	Service Call Session Control Function
SDP	Session Description Protocol
SIP	Session Initiation Protocol
SMTP	Simple Mail Transfer Protocol
SMTSPS	Simple Mail Transfer Protocol Secure
SNR	Speech signal level/noise level
SSH	Secure Shell
SSL	Secure Sockets Layer
SWB	Super Wide Band
TCP	Transmission Control Protocol
TE	Terminal Equipment
TELR	Talker Echo Loudness Rating

TLS	Transport Layer Security
TOR	Terminal Owing Region
TR	Technical Report
TV	TeleVision
UA	User Agent
UAS	User Agent Server
UDP	User Datagram Protocol
UE	User Equipment
UL	UpLink
UMTS	Universal Mobile Telecommunications System
UNiA	User Network interface A
UNiB	User Network interface B
UUID	Universally Unique Identifier

NOTE: As described in IETF RFC 4122 [18].

VBD	Voice Band Data
VGW	Voice Gateway
VoIP	Voice over IP
VoLTE	Voice over LTE

---

## 4 Management Summary

### 4.1 Introduction

The spectrum of potential applications of a benchmarking platform requires measurements including but not limited to the following: analogue (a/b), ISDN, VoIP (including SIP trunking) and high-speed internet.

The performance data which are collected will be relevant for a real-world environment encompassing a mix of technologies. The scope of the defined testing procedures is the evaluation of the network access by VoIP and FoIP fix-network services. The measurements are conducted stationary between a subscriber access-point to a measurement point emulating an idealized termination point in the core network.

### 4.2 Scope of functionality

A benchmarking platform can be distributed across a larger region or an entire country. In this case several server systems should be also part of the setup, including: a business intelligence platform; a data warehouse, a management system and a system for evaluating of media (e.g. video, audio and voice) quality.

The measurement systems at the user premises are connected electrically to ISDN ports via a VGW (IAD) or directly to a CPE or Ethernet port (e.g. MMTel fixed access).

The test system (QoS control and data server) is connected through ISDN connections (via IMS PES with AGCF (or PSTN or ISDN Access) or IMS PES with VGW) or MMTel (IMS) fixed access lines for voice quality measurements.

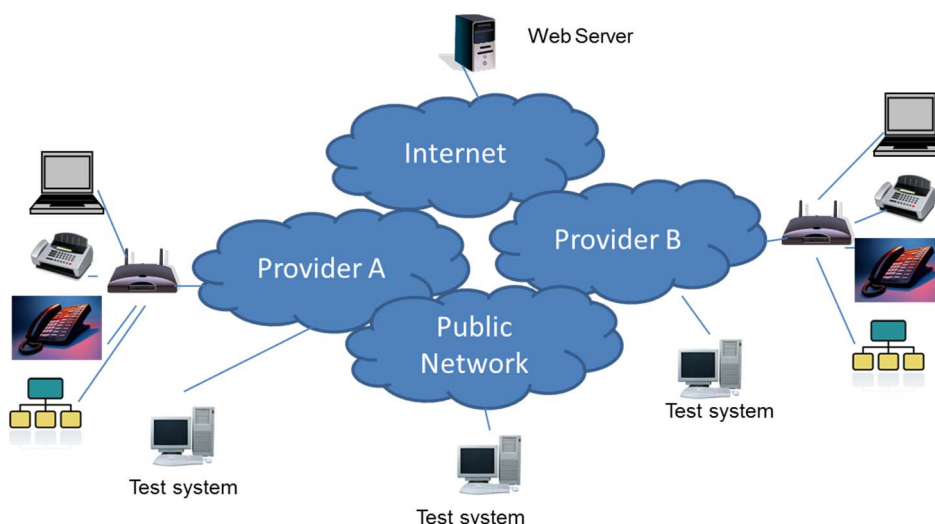

**Figure 1: Setup of the benchmarking platform**

## 5 Technical concept

### 5.1 Voice over IP

The conduction of voice quality measurements is following the descriptions that can be found in ETSI EG 202 057-2 [i.4], Recommendation ITU-T Q.543 [4], ETSI TS 101 563 [3] and ETSI TS 102 250-2 [22], clauses 6.6.3.1 and 6.6.3.2.

The access points of the test equipment which are used for inserting or retrieving the signals needed for determining the speech quality parameters shall conform to the reference characteristics as laid down in the following relevant standards:

- ETSI EG 202 425 [i.3] for VoIP access;
- ETSI ES 203 021-3 [7] for analogue access;
- ETSI TBR 3 [8] for ISDN BRI access;
- ETSI TBR 4 [9] for ISDN PRI access;
- ETSI EN 300 175-8 [10]: "Digital Enhanced Cordless Telecommunications (DECT); Common Interface (CI); Part 8: Speech and audio coding and transmission".

The properties of the test equipment shall be known and the values measured for each parameter shall be corrected accordingly by the impairments introduced by the test equipment. Especially any delay introduced by the test equipment shall be known and the measurement results shall be corrected by the delay introduced by the test equipment.

The simultaneous transmission of voice and data through uploads, downloads or IPTV use is an additional user related scenario. For this reason voice quality measurements have been included where in parallel to the voice connection active upload and download of data is simulated. This provides information about any potential prioritization of voice data when the entire bandwidth is being utilized.

The KPI listed in table 1 are recorded as part of the voice quality measurements.

**Table 1: Overview of KPI for voice quality measurements**

1.	call set-up delay [4] and session initiation call set-up delay [3]
2.	call set-up time (Post Dialling Delay) [5]
3.	Premature release probability (Call Failure Rate), see clause 5.4
4.	Telephony Cut-off Call Ratio [%] (Call drop rate), see clause 5.5
5.	Media establishment delay, see clause 5.6
6.	Level of active speech signal, see clause 5.7
7.	Noise level, see clause 5.8
8.	Signal to Noise ratio, see clause 5.9
9.	Speech signal attenuation, see clause 5.10
10.	Talker echo delay, see clause 5.11
11.	Double talk, see clause 5.12
12.	Interrupted voice transmission, see clause 5.13
13.	Listening speech quality, see clause 5.14
14.	Listening speech quality stability, see clause 5.15
15.	End-to-end audio delay, see clause 5.16
16.	End-to-end audio delay variation, see clause 5.17
17.	Frequency response, see clause 5.18
18.	Fax transmission T.30 (Fax, bit rate $\leq$ 14,4 kbit/s and Fax, bit rate $\geq$ 14,4 kbit/s) see clause 5.19
19.	Early media, see clause 5.20
20.	Jitter Buffer and IP periodization response time, see clause 5.21

## 5.2 Call set-up delay and Session initiation call set-up delay

The testing methodology for the call set-up delay is described in ETSI TS 101 563 [3].

Call set-up delay is defined as the interval from the instant when the signalling information required for outgoing circuit selection is received from the incoming signalling system until the instant when the corresponding signalling information is passed to the outgoing signalling system.

For SIP (e.g. SIP Trunking, IMS) Session initiation call set-up delay is defined as the interval from the instant when the INVITE signalling information is received from the calling user on the originating Gm interface until the instant when the corresponding INVITE signalling information is passed on the terminating Gm interface to the called user.

Figure 2 depicts some of the call set up measurement options between AGCF/VGW and the Gm Interface.

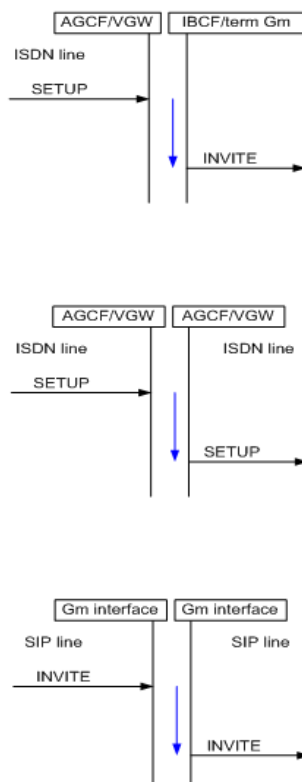

**Figure 2: Call set-up delay and Session initiation call set-up delay: en-bloc sending is used**

Table 2 gives an overview of the call set-up delay configuration options.

**Table 2: Call set-up delay configurations**

	From	To
<b>Call set up delay and Session initiation call set-up delay</b>	MMTel (IMS) fixed access	MMTel (IMS) fixed access
	MMTel (IMS) fixed access	IMS PES with AGW (PSTN or ISDN Access)
	MMTel (IMS) fixed access	IMS PES with VGW
	IMS PES with AGW (PSTN or ISDN Access)	MMTel (IMS) fixed access
	IMS PES with AGW (PSTN or ISDN Access)	IMS PES with AGW (PSTN or ISDN Access)
	IMS PES with AGW (PSTN or ISDN Access)	IMS PES with VGW
	IMS PES with VGW	IMS PES with VGW
	IMS PES with VGW	IMS PES with AGW (PSTN or ISDN Access)
	IMS PES with VGW	IMS PES with VGW

NOTE: The Call set-up delay values are specified in ETSI TS 101 563 [3].

Figure 3 illustrates the session processing model used by the AGCF and VGW functional entities.

An AGCF is modelled as comprising H.248 Media Gateway Controller (MGC), Feature Manager (FM), and SIP UA functionality. An AGCF interfaces to a Media Gateway (MGW) and also to the S-CSCF (via P1 and Mw reference points respectively).

A functional modelling of the VGW contains an entity similar to H.248 Media Gateway Controller, a Feature Manager, a SIP UA, and MGW functionality. The VGW interfaces to the P-CSCF using the Gm reference point.

The SIP UA functionality provides the interface to the other components of the IMS-based architecture. It is involved in registration and session processing as well as in event subscription/notification procedures with application servers.

The MGC functionality enables the session processing functionality to interface with existing line signalling such as analogue signalling or DSS1.

Session and registration processing in the AGCF or VGW involves two halves: H.248 based MGC processing and SIP User Agent (UA) processing (see figure 3). MGC processing focuses on the interactions with the media gateway functions, while SIP UA processing focuses on the interactions with the IMS components. The Feature Manager (FM) coordinates the two processing activities.

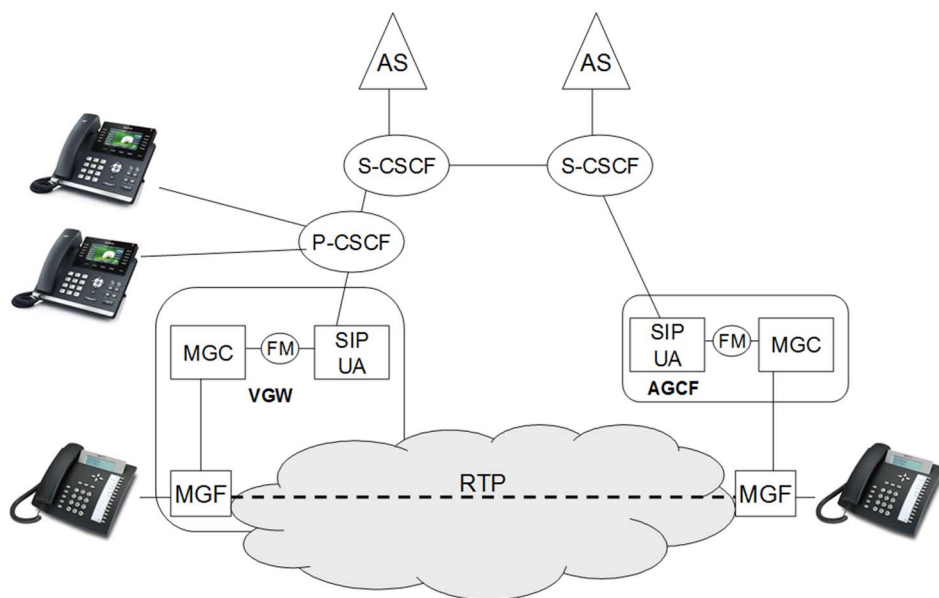

Figure 3: AGCF/VGW session processing models

### 5.3 Call set-up time (post dialling delay)

**Call set-up time:** the period starting when the address information required for setting up a call is received by the network (e.g. recognized on the calling user's access line) and finishing when the called party busy tone or ringing tone or answer signal is received by the calling party (e.g. recognized on the calling user's access line) (see ETSI ETR 138 [i.2]).

To determine the call setup time in an ISDN implementation, the time in seconds from the sending of the DSS1 SETUP signal through the "A" side (calling number + "Sending complete" information) until the receipt of the DSS1 CONNECT signal is measured on the "A" side is measured, or the time in seconds from the sending of the DSS1 SETUP signal through the "A" side (calling number + "Sending complete" information) until the receipt of the DSS1 ALERTING signal is measured on the "A" side is measured. In figures 4 and 5, this time is indicated by the green arrow.

For ANALOGUE SUBSCRIBER LINES the Post Dialling Delay shall be used. It is the time interval between the end of dialling by the caller and the reception back by him of the appropriate ringing tone or recorded announcement.

To determine the call setup time in a VoIP implementation, the time in seconds from the sending of the INVITE signal through the "A" side until the receipt of the 200 OK signal is measured on the "A" side is measured, or the time in seconds from the sending of the INVITE signal through the "A" side until the receipt of the 180 Ringing signal on the "A" side is recorded. In figures 6 and 7, this time is indicated by the grey arrow.

Table 3 gives an overview of the call set-up time configurations options.

**Table 3: Call set-up time configurations**

	From	To
<b>Call set up time</b>	MMTel (IMS) fixed access	MMTel (IMS) fixed access
	MMTel (IMS) fixed access	IMS PES with AGW (PSTN or ISDN Access)
	MMTel (IMS) fixed access	IMS PES with VGW
	IMS PES with AGW (PSTN or ISDN Access)	MMTel (IMS) fixed access
	IMS PES with AGW (PSTN or ISDN Access)	IMS PES with AGW (PSTN or ISDN Access)
	IMS PES with AGW (PSTN or ISDN Access)	IMS PES with VGW
	IMS PES with VGW	IMS PES with VGW
	IMS PES with VGW	IMS PES with AGW (PSTN or ISDN Access)
	IMS PES with VGW	IMS PES with VGW

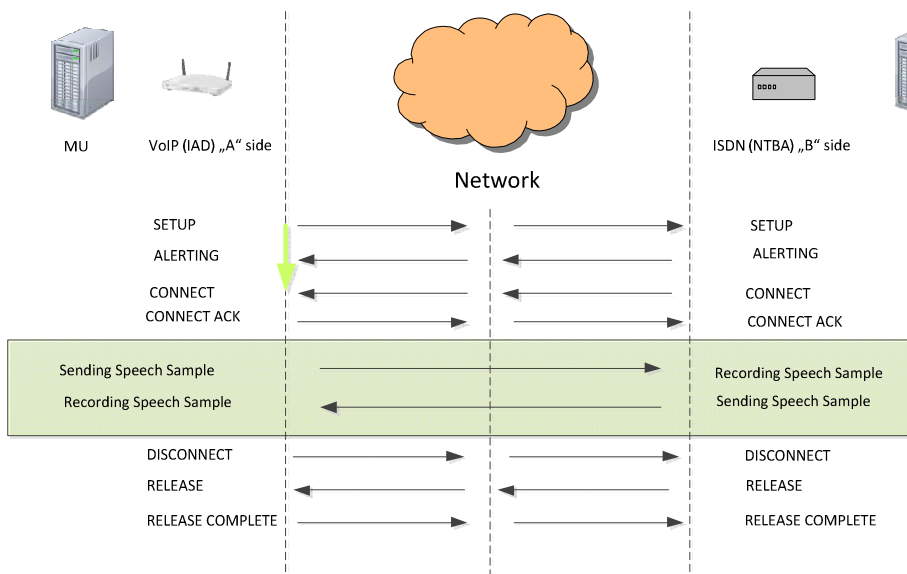

**Figure 4: Measurement of the call setup duration, option A with CONNECT**

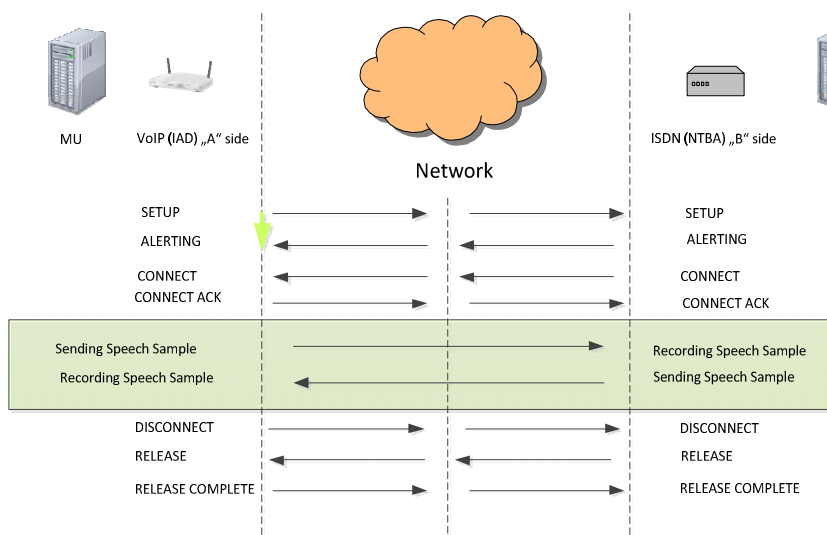

**Figure 5: Measurement of the call setup duration, option B with ALERTING**

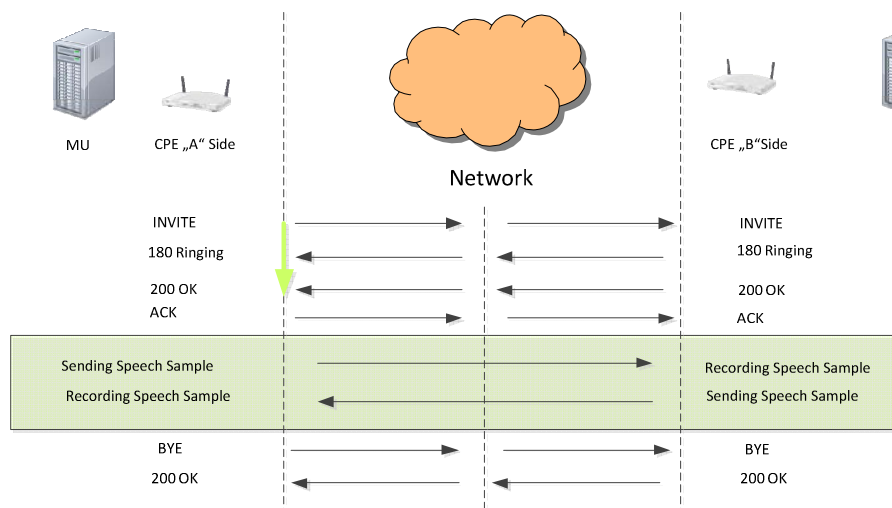

**Figure 6: VoIP Measurement of the call setup duration, option A with 200 OK**

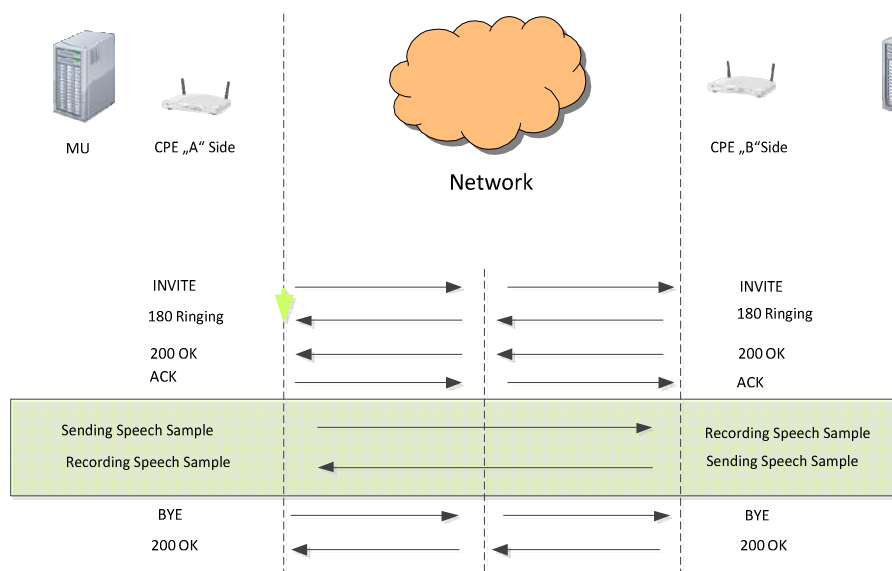

**Figure 7: VoIP Measurement of the call setup duration, option B with 180 Ringing**

## 5.4 Premature release probability (call failure rate; telephony service non accessibility)

Premature release probability (call failure rate (CFR) is based on the measurement of the number of released communications in comparison with the number of established communications. Released communications are defined as communications released before voluntary action from one of the ends of the transmission. See ETSI TS 102 250-2 [22] for the formula.

## 5.5 Telephony Cut-off Call Ratio [%] (Call drop rate)

The Cut-off Call Ratio (Call drop rate) is the percentage of number of calls that are dropped after connection to the system or network has been established. See ETSI TS 102 250-2 [22] for the formula.

In a ISDN implementation a call is completely established with the Connect message [22] and is considered dropped if the call is not ended intentionally. See figure 8 for details.

In a SIP implementation a call is completely established with the arrival of the INVITE 200 OK on the caller side and is considered dropped if the call is not terminated intentionally. See figure 9 for details.



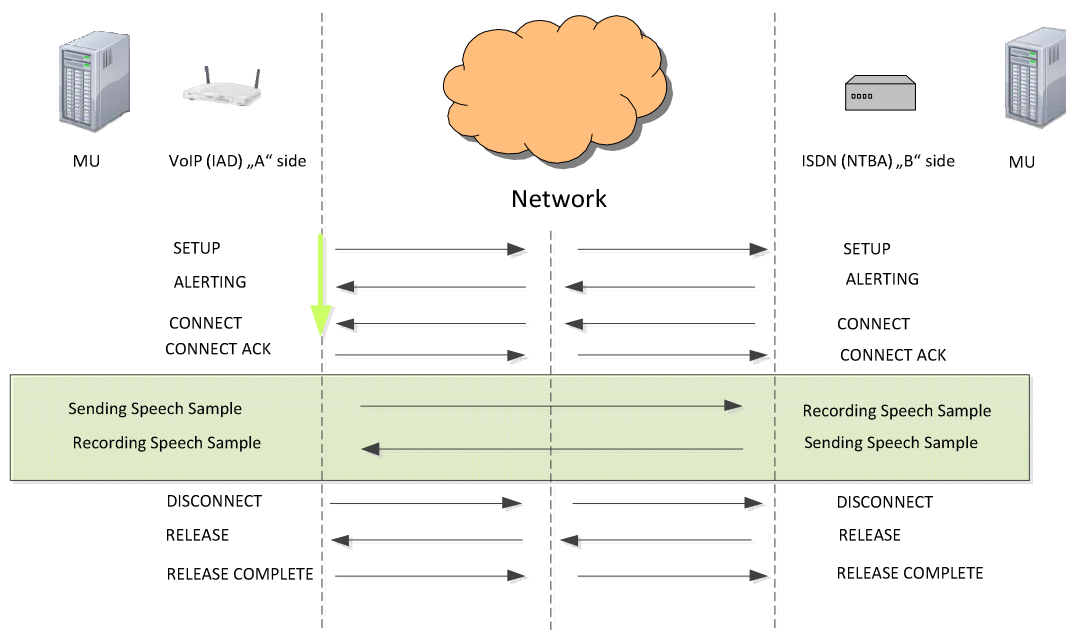

**Figure 8: Determination of the call drop ratio**

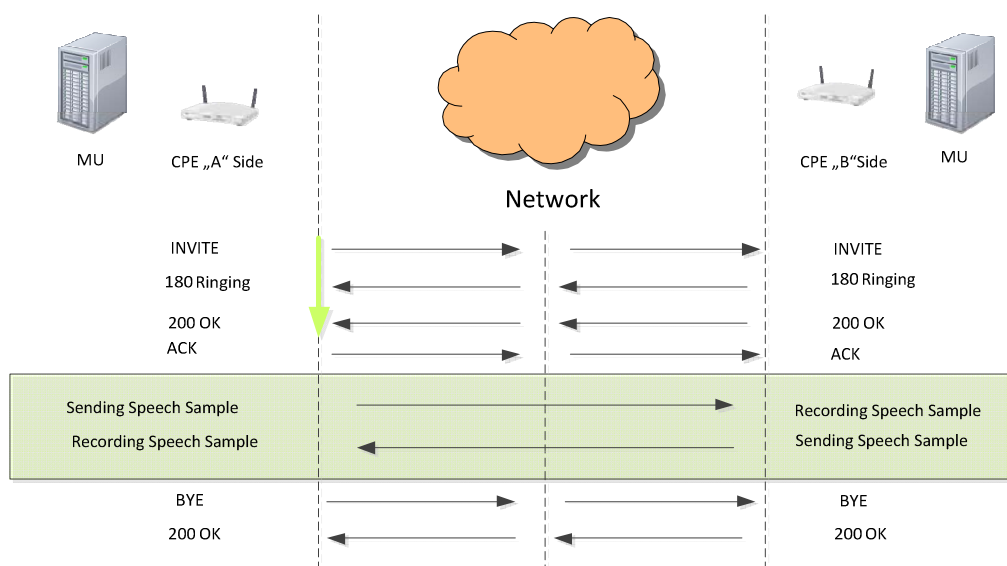

**Figure 9: VoIP: determination of the call drop ratio**

## 5.6 Media establishment delay

The Media establishment delay determines on one of the two access of the communication, between off hook of the called and the beginning of voice signal receive. The detailed testing method is described in ETSI ES 202 765-2 [5].

## 5.7 Level of active speech signal in receive direction

A typical method for the measurement of this parameter, based on a sample by sample approach and a moving threshold between noise and speech, is given in Recommendation ITU-T P.56 [12].

## 5.8 Noise level in receive direction

Level of noise determined in receive direction in the non-speech segments of a speech sample. For the actual measurement the noise in between speech signals (idle noise) is analysed. The analysis window length needs to be adapted accordingly.

The noise level is measured in the frequency range from 100 Hz to 4 kHz in narrowband and from 100 Hz to 8 kHz in wideband. The analysis window is applied directly to the end of a speech signal until the start of the following speech signal. The averaging time is determined by the length of this segment.

In narrowband, the noise level is measured in dBm0p (*psophometric* weighting, see Recommendation ITU-T O.41 [11]). In wideband the noise level is determined in dBm0 (A).

## 5.9 Signal to noise ratio in receive direction

The noise to signal ratio in receive direction is defined as the difference between the active speech level and the level of noise in receive direction (Speech signal level/noise level = SNR).

The signal level is the average level of the complete speech signal. The signal level is measured using a speech level voltmeter according to Recommendation ITU-T P.56 [12]. This level is the speech signal level.

The noise level in receive direction is determined as described in clause 5.8.

The weighted noise signal level is referenced to the speech signal level.

## 5.10 Speech signal attenuation (or gain)

The speech signal attenuation is the difference between the active speech level at the receiving and at the sending point.

## 5.11 Talker echo delay

In telecommunications, the term talker echo describes delayed and undesired feedback from the send signal into the receive path. The so-called echo source is the reflection point between send and receive directions. Talker echo delay is the round-trip delay of the echo path. The impact of user perception of talker echo in conjunction with delay is explained in Recommendation ITU-T G.131 [6]. The detailed test description is to be found in ETSI ES 202 765-2 [5].

In general the test of talker echo delay can be based on cross correlation between the speech signal inserted and the echo signal received. The measurement is corrected by delays which are caused by the test equipment. The maximum of the cross-correlation function is used for the determination. However, it shall be noted that such measurements can only be made in case the echo signal is sufficiently high to allow a reliable calculation of the cross correlation.

NOTE: In case the talker echo is received at a very low level, the echo loss might be artificially decreased in order to allow for the calculation of talker echo delay.

## 5.12 Double talk performance

This parameter looks into the situation when the talk spurts of both partners of a conversation overlap for a period of time. Degradations due to bad double talk performance can be perceived as very annoying because this impairment has a potential to frequently interrupt the flow of the conversation.

During double talk the speech is mainly determined by two parameters: Impairment caused by echo during double talk and level variation between single and double talk (attenuation range).

In order to allow for sufficient quality under double talk conditions the Talker Echo Loudness Rating (TELR) should be high and the attenuation inserted should be as low as possible. Connections which do not allow double talk in any case should provide a good echo attenuation which is realized by a high attenuation range in this case.

The most important parameters determining the speech quality during double talk are (see Recommendations ITU-T P.340 [16] and P.502 [17]):

- Attenuation range in send direction during double talk  $A_{H,S,dt}$ .
- Attenuation range in receive direction during double talk  $A_{H,R,dt}$ .
- Echo attenuation during double talk.

The categorization of a connection is based on the three categories defined in the following clauses and this categorization is given by the "worst" of the three parameters, e.g. if  $A_{H,S,dt}$  provides 2a,  $A_{H,R,dt}$  2b and echo loss 1, the categorization of the terminal is 2b.

### Test Signal

The test signal to determine the attenuation range during double talk is the double talk speech sequence as defined in clause 7.3.5 of Recommendation ITU-T P.501 [13] as shown in figure 10. The competing speaker is always inserted as the double talk sequence  $s_{dt}(t)$  either in send or receive and is used for analysis.

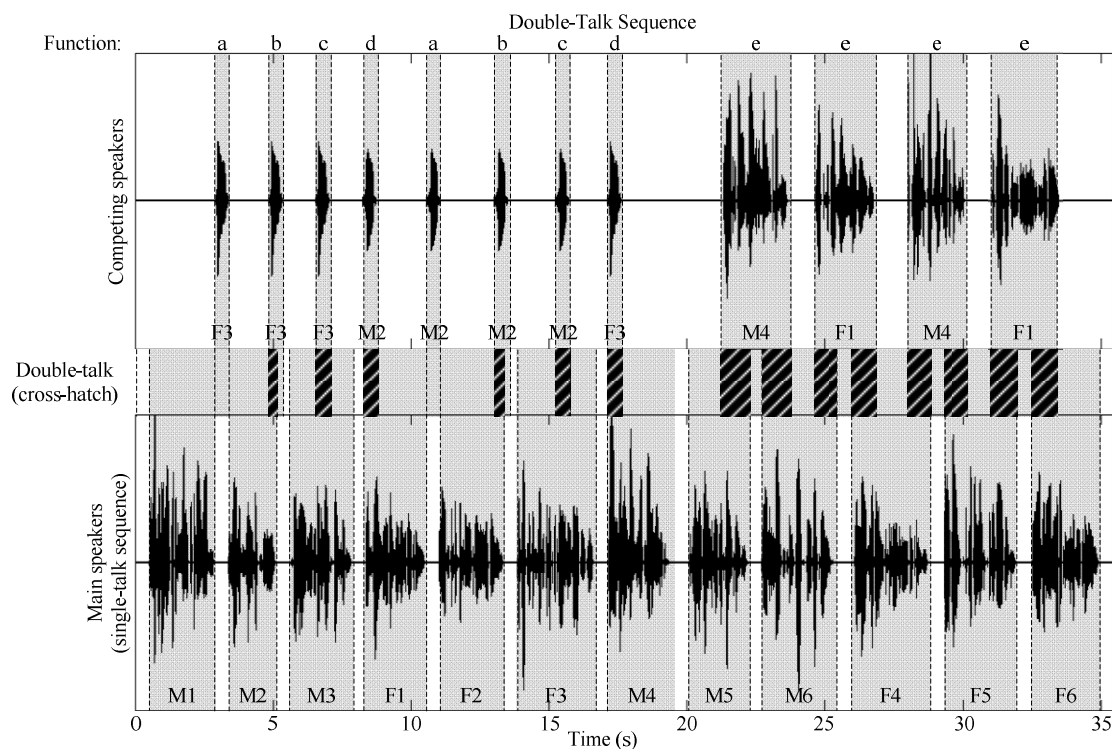

**Figure 10: Double talk test sequence with overlapping speech sequences in send and receive direction**

### Measurement method

The attenuation range during double talk is determined as described in Appendix III of Recommendation ITU-T P.502 [17]. The double talk performance is analysed for all sequences of the competing speaker. The requirement has to be met for each word and sentence produced by the competing speaker.

## 5.13 Interrupted voice transmission

A call is defined as interrupted if the duration of the interruption of the voice transmission is  $> 1$  s and the call connection is maintained.

## 5.14 Listening speech quality

### 5.14.1 General aspects of Listening Speech Quality

The listening speech quality represents the intrinsic quality of speech signal as perceived by the user at the receiving end. This indicator takes into account the impairments introduced by the transmission system. The MOS-LQO score is obtained by comparing speech samples:

- the original undistorted reference speech signal;
- the degraded signal received at the local end, where the measurement is applied.

Recommendation ITU-T P.863 [2] recommends two samples from each of two male and two female speakers, i.e. eight sentence pairs. Some applications may only permit shorter test durations. Typically, test sentence material in subjective tests has a 0,5 second silence lead in, two sentences, and then a 0,5 s silence at the end of the signal. Further information can be found in ETSI TR 103 138 [i.5] and Recommendation ITU-T P.863.1 [19].

To ensure comparable voice quality results it shall be ensured that the test equipment uses the codec described in the first line of the m line in the SDP Part which is the preconfigured codec by the network operator.

### 5.14.2 General aspects of voice channel test calls

For the **all voice channel tests**, an aligned structure of the voice call shall be used. In this call sentence pairs (male/female) fulfilling the requirements of Recommendation ITU-T P.863.1 [19] shall be transmitted from A to B and from B to A. Speech files especially tested for the use with Recommendation ITU-T P.863 [2] are published in Recommendation ITU-T P.501 [13], annex C, where samples in different languages are covered.

In principle all voice channel tests consist of three parts:

- Channel Convergence Quality test;
- Listening Speech Quality test;
- DTMF test.

Which parts are actually used and how they are structured is defined for the individual test cases in the clauses below.

The **Channel Convergence quality test** starts with a listening speech quality test from B to A after the connection is established. This initial test provides information about the listening quality during convergence of the channel.

For the analysis of the initial listening speech quality during convergence of the channel the method according to Recommendation ITU-T P.863 [2] in SWB mode based **on only two sentences** (one female voice and one male voice) is used. For this purpose a male voice (e.g. "Four hours of steady work faced us") and a female voice (e.g. "The hogs were fed chopped corn and garbage") can be selected from the test sentences provided in Recommendation ITU-T P.501 [13], annex C.

After convergence of the channel the regular **Listening Speech quality test** starts and is using Recommendation ITU-T P.863 [2] in SWB mode based on eight sentences (two male and two female voices, two sentences each).

Usually, the listening speech quality tests should start 10 seconds after the connection is established. This 10 s pause is recommended for converging the speech processing components and building up the IP-buffer at receiving side and can be used for the Channel Convergence quality test as described above. It is assumed that the convergence has finished after 10 s. In the event of a proven shorter convergence, the pause can be shorter.

In case the channel can be assumed as converged from the beginning, and/or the separation of the Channel Convergence quality is not of interest, the Listening Quality test can start at any time after the connection is established.

Within the Listening Speech quality test, for example the following English samples can be selected from the test sentences provided in Recommendation ITU-T P.501 [13], annex C:

- *Female 1:*
  - These days a chicken leg is a rare dish.

- The hogs were fed with chopped corn and garbage.
- *Female 2:*
  - Rice is often served in round bowls.
  - A large size in stockings is hard to sell.
- *Male 1:*
  - The juice of lemons makes fine punch.
  - Four hours of steady work faced us.
- *Male 2:*
  - The birch canoe slid on smooth planks.
  - Glue the sheet to the dark blue background.

If a global application is of interest, optionally the male and female tests sentences of other languages provided in Recommendation ITU-T P.501 [13], annex C can be used.

After conducting all evaluations, the derived MOS scores for each sample in the listening test are averaged over all received and scored samples separately for each direction A-B and B-A.

**DTMF Test:** DTMF tones are often used for remote controlling equipment and need to be tested in an established voice channel too for correct transmission. It is recommended to test DTMF before or after the Listening Speech quality test but in each case after the channel has converged. The DTMF Test should consist of DTMF tones (70 ms signal, 70 ms pause) and shall contain the tones 0, 1, 2, 3, 4, 5, 6, 7, 8, 9, A, B, C, D, \*, #.

**Technical comments:**

- If the interrupted voice transmission time is > 1 s and the call connection is maintained, the call is rated as interrupted (see clause 5.13).
- If all 8 sentences (4 samples) are sent within one file, the score calculation according to Recommendation ITU-T P.863 [2] shall be performed separately for each sample (2 sentences per sample).
- In case the sampling frequency at the input measuring interface is 8 kHz - as it usual for ISDN and narrowband applications - the input speech signal used shall be band limited at 3 800 kHz (see ETSI TR 103 138 [i.5]).
- When the sampling frequency at the input measuring interface is 16 kHz as required for wideband telephony the input speech signal used shall be band limited between 100 Hz and 7 600 kHz with a band pass filter providing a minimum of 24 dB/Oct. filter roll off, when feeding into the receive direction (see ETSI TR 103 138 [i.5]).
- The input test signal levels are referred to the average level of the (band limited in receive direction) test signal, averaged over the complete test sequence unless specified otherwise. It is recommended to adjust the active speech level to -26 dB OVL as specified in ETSI TR 103 138 [i.5].
- DTMF Tone duration: Where the DTMF signalling tone duration is controlled automatically by the transmitter, the duration of any individual DTMF tone combination sent shall not be less than 65 ms. The time shall be measured from the time when the tone reaches 90 % of its steady-state value, until it has dropped to 90 % of its steady-state value. For correct operation of supplementary services such as CLI and Direct Dialling In, DTMF tone bursts should not be longer than 75 ms in the present document.
- DTMF Pause duration: Where the DTMF signalling pause duration is controlled automatically by the transmitter the duration of the pause between any individual DTMF tone combination shall not be less than 65 ms. The time shall be measured from the time when the tone has dropped to 10 % of its steady-state value, until it has risen to 10 % of its steady-state value in the present document.

## 5.14.3 Connections without parallel data transfer

### 5.14.3.1 Connections with one voice channel

For the **single voice channel Test**, a test call consisting of the three following parts should be used:

- Channel Convergence Quality test.
- Listening Speech Quality test.
- DTMF test.

Figures 11 to 13 depict the detailed description of the single **voice channel test**. The general technical aspects are described in clause 5.14.2.

Table 4 gives an overview of the connection options without parallel data transfer.

**Table 4: Connection options without parallel data transfer**

	From	To
<b>Connections without parallel data transfer</b>	MMTel (IMS) fixed access	MMTel (IMS) fixed access
	MMTel (IMS) fixed access	IMS PES with AGW (PSTN or ISDN Access)
	MMTel (IMS) fixed access	IMS PES with VGW
	IMS PES with AGW (PSTN or ISDN Access)	MMTel (IMS) fixed access
	IMS PES with AGW (PSTN or ISDN Access)	IMS PES with AGW(PSTN or ISDN Access)
	IMS PES with AGW (PSTN or ISDN Access)	IMS PES with VGW
	IMS PES with VGW	IMS PES with VGW
	IMS PES with VGW	IMS PES with AGW (PSTN or ISDN Access)
	IMS PES with VGW	IMS PES with VGW

The derived MOS scores in the listening test are averaged over all received and scored samples separately for each direction A-B and B-A.

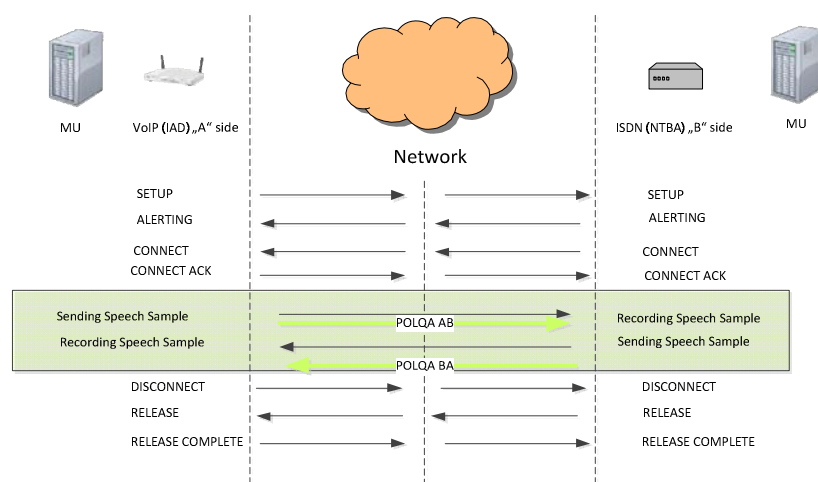

**Figure 11: Measurement of voice quality**

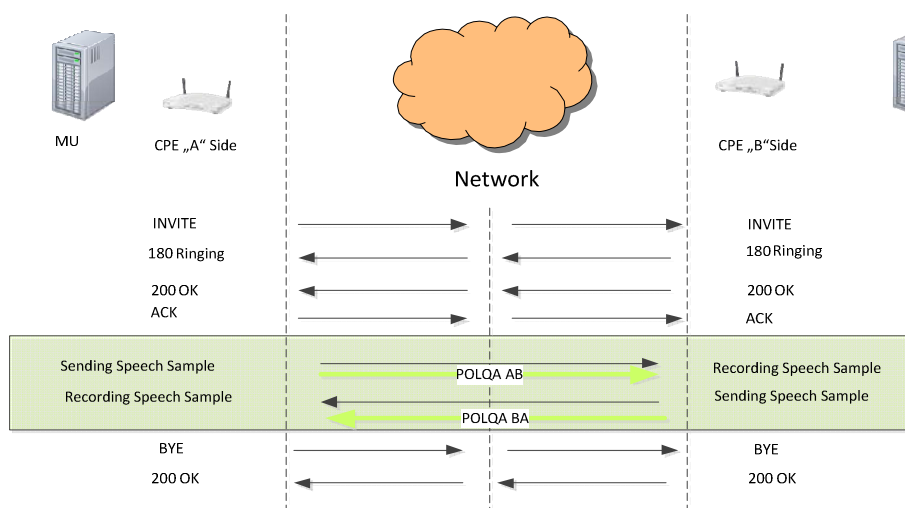

Figure 12: VoIP Measurement of voice quality, MMTel fixed to MMTel fixed

Relative Time	Test equipment A	NETWORK		Test equipment B
<b>CALL A to B</b>				
T0 - 2	SETUP / INVITE	→		→
	ALERTING / 180 Ringing	←		←
T0	CONNECT / 200 OK	←		←
	CONNECT ACK/ ACK	→		→
Start Convergence Quality test				
T0	Start Audio Receive BA_1 (female & male)	←		←
	End Audio Receive BA_1	←		←
Stop Convergence Quality test				
Listening Speech Quality test				
T0 + 10 s	Start Audio Send AB_1 (female 1)	→		→
	End Audio Send AB_1 (female 1)	→		→
	Start Audio Send AB_2 (female 2)	→		→
	End Audio Send AB_2 (female 2)	→		→
	Start Audio Send AB_3 (male 1)	→		→
	End Audio Send AB_3 (male 1)	→		→
	Start Audio Send AB_4 (male 2)	→		→
	End Audio Send AB_4 (male 2)	→		→
	Start Audio Receive AB_1 (female 1)			
	End Audio Receive AB_1 (female 1)			
	Start Audio Receive AB_2 (female 2)			
	End Audio Receive AB_2 (female 2)			
	Start Audio Receive AB_3 (male 1)			
	End Audio Receive AB_3 (male 1)			
	Start Audio Receive AB_4 (male 2)			
	End Audio Receive AB_4 (male 2)			

Relative Time	Test equipment A		NETWORK		Test equipment B
1 s	Pause				
	Start Audio Receive BA_1 (female 1)	←		←	Start Audio Send BA_1 (female 1)
	End Audio Receive BA_1 (female 1)	←		←	End Audio Send BA_1 (female 1)
	Start Audio Receive BA_2 (female 2)	←		←	Start Audio Send BA_2 (female 2)
	End Audio Receive BA_2 (female 2)	←		←	End Audio Send BA_2 (female 2)
	Start Audio Receive BA_3 (male 1)	←		←	Start Audio Send BA_3 (male 1)
	End Audio Receive BA_3 (male 1)	←		←	End Audio Send BA_3 (male 1)
	Start Audio Receive BA_4 (male 2)	←		←	Start Audio Send BA_4 (male 2)
	End Audio Receive BA_4 (male 2)	←		←	End Audio Send BA_4 (male 2)
1 s	Pause				
	Start DTMF Send AB_1	→		→	Start DTMF Receive AB_1
	End DTMF Send AB_1	→		→	End DTMF Receive AB_1
	Start DTMF Receive BA_1	←		←	Start DTMF Send BA_1
	End DTMF Receive BA_1	←		←	End DTMF Send BA_1
	DISCONNECT / BYE	→		→	DISCONNECT /BYE
	RELEASE / 200 OK	←		←	RELEASE / 200 OK
	RELEASE COMPLETE	→		→	RELEASE COMPLETE

Figure 13: Single voice channel test

### 5.14.3.2 Multiple voice channel access

In the case of multiple voice channel access or SIP trunking, during the complete testing phase the first call (**single voice channel test**) from user A to user B is active (see figure 14).

The **single voice channel test** consists of the following parts:

- Convergence Quality test.
- Listening Speech Quality test.
- DTMF test.

The result of each part shall be listed in the test report.

Figure 15 depicts the detailed description of the single **voice channel test for the multiple voice channel access**.

The four speech files should be repeated during the call is active. For n channels n -1 cycles (duration of one cycle is approximately **80 seconds**) are recommended (e.g. for 4 channels the duration is approximately 360 seconds).

Parallel to the **single voice channel test** additional calls should be established (**multiple voice channel test**). The **multiple voice channel test** consists of the following parts:

- Convergence Quality test.
- Listening Speech Quality test.

Figure 16 depicts the detailed description of the **multiple voice channel access**. The general aspects for the **multiple voice channel tests** are given in clause 5.14.2.

Figure 14 depicts an example of multiple voice channel access test for five channels.



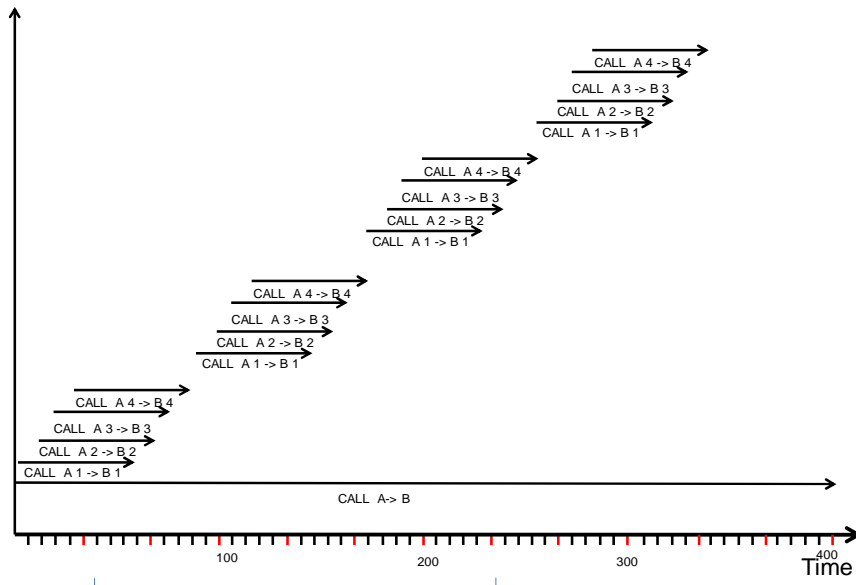

Figure 14: Example of multiple voice channel access test

Relative Time	Test equipment A		NETWORK		Test equipment B
T0 - 2	SETUP / INVITE	→		→	SETUP / INVITE
	ALERTING / 180 Ringing	←		←	ALERTING / 180 Ringing
T0	CONNECT / 200 OK	←		←	CONNECT / 200 OK
	CONNECT ACK/ ACK	→		→	CONNECT ACK/ ACK
	Start Convergence Quality test				
T0	Start Audio Receive BA_1 (female & male)	←		←	Start Audio Send BA_1 (male & female)
	End Audio Receive BA_1	←		←	End Audio Send BA_1
	Stop Convergence Quality test				
	Listening Speech Quality test				
T0 + 10 s	Start Audio Send AB_1 (female 1)	→		→	Start Audio Receive AB_1 (female 1)
	End Audio Send AB_1 (female 1)	→		→	End Audio Receive AB_1 (female 1)
	Start Audio Send AB_2 (female 2)	→		→	Start Audio Receive AB_2 (female 2)
	End Audio Send AB_2 (female 2)	→		→	End Audio Receive AB_2 (female 2)
	Start Audio Send AB_3 (male 1)	→		→	Start Audio Receive AB_3 (male 1)
	End Audio Send AB_3 (male 1)	→		→	End Audio Receive AB_3 (male 1)
	Start Audio Send AB_4 (male 2)	→		→	Start Audio Receive AB_4 (male 2)
	End Audio Send AB_4 (male 2)	→		→	End Audio Receive AB_4 (male 2)
1s	Pause				
	Start Audio Receive BA_1 (female 1)	←		←	Start Audio Send BA_1 (female 1)
	End Audio Receive BA_1 (female 1)	←		←	End Audio Send BA_1 (female 1)
	Start Audio Receive BA_2 (female 2)	←		←	Start Audio Send BA_2 (female 2)
	End Audio Receive BA_2 (female 2)	←		←	End Audio Send BA_2 (female 2)
	Start Audio Receive BA_3 (male 1)	←		←	Start Audio Send BA_3 (male 1)
	End Audio Receive BA_3 (male 1)	←		←	End Audio Send BA_3 (male 1)
	Start Audio Receive BA_4 (male 2)	←		←	Start Audio Send BA_4 (male 2)
	End Audio Receive BA_4 (male 2)	←		←	End Audio Send BA_4 (male 2)
1s	Pause				
	Start DTMF Send AB_1	→		→	Start DTMF Receive AB_1
	End DTMF Send AB_1	→		→	End DTMF Receive AB_1
	Start DTMF Receive BA_1	←		←	Start DTMF Send BA_1
	End DTMF Receive BA_1	←		←	End DTMF Send BA_1
	The four speech files are repeated during the call is active				
	Start DTMF Send AB_1	→		→	Start DTMF Receive AB_1
	End DTMF Send AB_1	→		→	End DTMF Receive AB_1
	Start DTMF Receive BA_1	←		←	Start DTMF Send BA_1
	End DTMF Receive BA_1	←		←	End DTMF Send BA_1
	DISCONNECT / BYE	→		→	DISCONNECT / BYE
	RELEASE / 200 OK	←		←	RELEASE / 200 OK
	RELEASE COMPLETE	→		→	RELEASE COMPLETE

Figure 15: Single voice channel test for multiple voice channel access

Relative Time	Test equipment A		NETWORK		Test equipment B
T0 - 2	SETUP / INVITE	→		→	SETUP / INVITE
	ALERTING / 180 Ringing	←		←	ALERTING / 180 Ringing
T0	CONNECT / 200 OK	←		←	CONNECT / 200 OK
	CONNECT ACK/ ACK	→		→	CONNECT ACK/ ACK
Start Convergence Quality test					
T0	Start Audio Receive BA_1 (female & male)	←		←	Start Audio Send BA_1 (male & female)
	End Audio Receive BA_1	←		←	End Audio Send BA_1
Stop Convergence Quality test					
Listening Speech Quality test					
T0 + 10 s	Start Audio Send AB_1 (female 1)	→		→	Start Audio Receive AB_1 (female 1)
	End Audio Send AB_1 (female 1)	→		→	End Audio Receive AB_1 (female 1)
	Start Audio Send AB_2 (female 2)	→		→	Start Audio Receive AB_2 (female 2)
	End Audio Send AB_2 (female 2)	→		→	End Audio Receive AB_2 (female 2)
	Start Audio Send AB_3 (male 1)	→		→	Start Audio Receive AB_3 (male 1)
	End Audio Send AB_3 (male 1)	→		→	End Audio Receive AB_3 (male 1)
	Start Audio Send AB_4 (male 2)	→		→	Start Audio Receive AB_4 (male 2)
	End Audio Send AB_4 (male 2)	→		→	End Audio Receive AB_4 (male 2)
1 s	Pause				
	Start Audio Receive BA_1 (female 1)	←		←	Start Audio Send BA_1 (female 1)
	End Audio Receive BA_1 (female 1)	←		←	End Audio Send BA_1 (female 1)
	Start Audio Receive BA_2 (female 2)	←		←	Start Audio Send BA_2 (female 2)
	End Audio Receive BA_2 (female 2)	←		←	End Audio Send BA_2 (female 2)
	Start Audio Receive BA_3 (male 1)	←		←	Start Audio Send BA_3 (male 1)
	End Audio Receive BA_3 (male 1)	←		←	End Audio Send BA_3 (male 1)
	Start Audio Receive BA_4 (male 2)	←		←	Start Audio Send BA_4 (male 2)
	End Audio Receive BA_4 (male 2)	←		←	End Audio Send BA_4 (male 2)
	DISCONNECT / BYE	→		→	DISCONNECT / BYE
	RELEASE / 200 OK	←		←	RELEASE / 200 OK
	RELEASE COMPLETE	→		→	RELEASE COMPLETE

Figure 16: Multiple voice channel test

## 5.14.4 Connections with parallel data transfer

### 5.14.4.0 Introduction

The data traffic should be parameterized according to respective typical service usages. This refers to the overall load as well as to the composition with respect to the number of sockets and temporal shape. The use of multiple parallel socket connections may be required either to reach the desired load, or to meet the desired structure of traffic.

The transferred data shall consist of randomly generated data with high entropy. It is not expected that the (pseudo) random number generator meets cryptographic requirements. However it should effectively avoid data compression during the transmission.

5.14.4.1 Quality measurement of one voice channel and parallel data transfer

In the case when the access link is used for voice and data application the voice quality measurement sequence with parallel upload/download shall be used. Table 5 gives an overview about the connections options with parallel data transfer, figures 17 and 18 depict the measurement of voice quality with parallel data load.

**Table 5: Connection options with parallel data transfer**

	From		To	
	Voice	Data	Voice	Data
<b>Connections with parallel data transfer</b>	MMTel (IMS) fixed access	User data server or user data application	MMTel (IMS) fixed access	Webserver
	MMTel (IMS) fixed access	User data server or user data application	IMS PES with AGW (PSTN or ISDN Access)	Webserver
	MMTel (IMS) fixed access	User data server or user data application	IMS PES with VGW	Webserver
	IMS PES with VGW	User data server or user data application	IMS PES with VGW	Webserver
	IMS PES with VGW	User data server or user data application	IMS PES with AGW (PSTN or ISDN Access)	Webserver
	IMS PES with VGW	User data server or user data application	MMTel (IMS) fixed access	Webserver

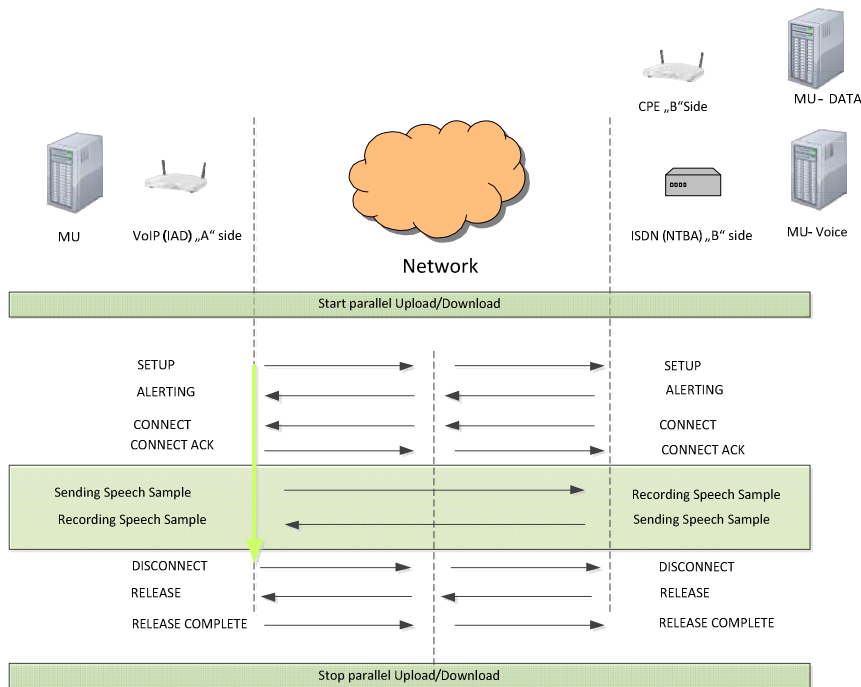

**Figure 17: Measurement of voice quality with parallel data load**

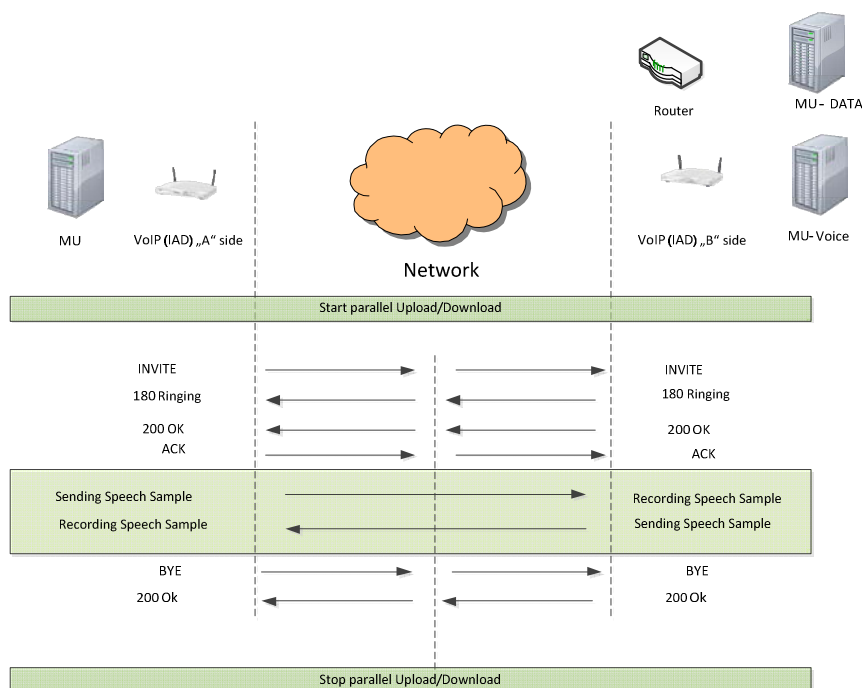

**Figure 18: VoIP measurement of voice quality with parallel data load**

During the parallel download and upload the data size should be between 80 % and 100 % of the nominal data capacity of the link or respectively the maximal data capacity which can be provided during the voice transmission.

For data transfer the following constants are used:

- $n$  number of parallel TCP connections for one direction ( $1 \leq n \leq 10$ ); default:  $n = 3$ .
- In case of use of fixed-size chunks, the initial size of data block sent during the test is  $s = 4,096$  Bytes.
- $t$  duration of tests, approximately  $t = 80$  s.

Several parallel data streams are initiated with a number of  $n$  parallel TCP connections with an upload and download of data files from the data-reference system. The upload shall start before the call setup starts, the download before the voice quality measurement starts.

After time  $t$ , each TCP connection shall be resetted.

As an option the server can continuously send data streams consisting of fixed-size chunks of size  $s$  (randomly generated data with high entropy). The data should be transferred between client and server over the TCP port 443 using TLS or SSL in order to avoid interference with firewalls as much as possible. The ports for communication and data transfers between the different servers themselves shall be configurable.

Parallel to the data transmission the **single voice channel test** should be established. For this, the up- and download is started before at least six seconds the speech quality measurement and also will continue for at least six seconds after the end of the speech quality measurements in order to ensure full utilization of the bandwidth during the measurement phase. The structure is shown in figures 19 and 20.

The **single voice channel test** consists of the following parts as described and explained in clause 5.14.2:

- Convergence Quality test.
- Listening Speech Quality test.
- DTMF test.

Figure 13 depicts the detailed description of the single **voice channel test**.

Relative Time	Test equipment A		NETWORK		Test equipment B Data Reference System
Start download and upload procedure					
T0 - 10 s	Start TCP upload connection 1	→		→	
	Start TCP upload connection 2	→		→	
	Start TCP upload connection 3	→		→	
Single voice Channel test					
T0 - 5 s	SETUP / INVITE	→		→	SETUP / INVITE
	Start TCP download connection 1	←		←	
	Start TCP download connection 2	←		←	
	Start TCP download connection 3	←		←	
	ALERTING / 180 Ringing	←		←	ALERTING / 180 Ringing
T0	CONNECT / 200 OK	←		←	CONNECT / 200 OK
	CONNECT ACK / ACK	→		→	CONNECT ACK / ACK
Start Convergence Quality test					
T0	Start Audio Receive BA_1 (female & male)	←		←	Start Audio Send BA_1 (male & female)
Stop Convergence Quality test					
Listening Speech Quality test					
T0 + 10 s	Start Audio Send AB_1 (female 1)	→		→	Start Audio Receive AB_1 (female 1)
.....continued .....					
	DISCONNECT / BYE	→		→	DISCONNECT / BYE
	RELEASE / 200 OK	←		←	RELEASE / 200 OK
	RELEASE COMPLETE	→		→	RELEASE COMPLETE
Stop download and upload procedure					

Figure 19: Detailed download and upload procedure for automatically controlled test sequence

Relative Time	Test equipment A		NETWORK		Test equipment B Data Reference System
Start download and upload procedure					
T0 - 10 s	Start TCP upload connection 1	→		→	
	Start TCP upload connection 2	→		→	
	Start TCP upload connection 3	→		→	
	Start TCP download connection 1	←		←	
	Start TCP download connection 2	←		←	
	Start TCP download connection 3	←		←	
Single voice Channel test					
T0 - 5 s	SETUP / INVITE	→		→	SETUP / INVITE
	ALERTING / 180 Ringing	←		←	ALERTING / 180 Ringing
T0	CONNECT / 200 OK	←		←	CONNECT / 200 OK
	CONNECT ACK / ACK	→		→	CONNECT ACK / ACK
Start Convergence Quality test					
T0	Start Audio Receive BA_1 (female & male)	←		←	Start Audio Send BA_1 (male & female)
1 s	Stop Convergence Quality test				
Listening Speech Quality test					
T0 + 10 s	Start Audio Send AB_1 (female 1)	→		→	Start Audio Receive AB_1 (female 1)
.....continued .....					
	DISCONNECT / BYE	→		→	DISCONNECT / BYE
	RELEASE / 200 OK	←		←	RELEASE / 200 OK
	RELEASE COMPLETE	→		→	RELEASE COMPLETE
Stop download and upload procedure					

Figure 20: Detailed download and upload procedure for manually controlled tests sequence

The download and upload (see figures 19 and 20) is based on several parallel data streams initiated with TCP with data files from the data-reference system. This ensures that the maximum data transfer rate during the entire measurement period can be achieved. In the determination of the time window, the effects of TCP congestion control were (overload control) taken into account. Initiating several parallel data streams at the same time is reducing the effect of the TCP/IP configuration of the measurement unit to the measurement.

The download and upload procedure shall be repeated while the voice call measurements are active.

#### 5.14.4.2 Parallel quality measurement of one voice channel and data transmission speed

During the parallel download and upload the data size should be between 80 % and 100 % of the nominal data capacity of the link or respectively the maximal data capacity which can be provided during the voice transmission, see figure 22.

For the data transfer the following constants are used:

- $n$  number of parallel TCP connections for one direction ( $1 \leq n \leq 10$ ); default:  $n = 3$ .
- In case of use of fixed-size chunks, the initial size of data block sent during the test is  $s = 4,096$  Bytes.
- $t$  duration of tests, approximately  $t = 80$  s.

Several parallel data streams are initiated with a number of  $n$  parallel TCP connections with an upload and download of data files from the data-reference system. The upload shall start before the call setup starts, the download before the voice quality measurement starts. After time  $t$ , each TCP connection shall be reseted.

As an option the server can continuously send data streams consisting of fixed-size chunks of size  $s$  (randomly generated data with high entropy). The data should be transferred between client and server over the TCP port 443 using TLS or SSL in order to avoid interference with firewalls as much as possible. The ports for communication and data transfers between the different servers themselves shall be configurable.

For each TCP connection  $k$ ,  $1 \leq k \leq n$ , the client records the relative time " $t$ " and the amount of data received from time from 0 to  $t$ .

After completion of all tests, the client sends the results and data collected to the data server. Both datasets are then compared by the data server to check the quality and integrity of the result. All tests, successful or unsuccessful, are stored by the data server.

The values presented which are measured every 500 ms shall include the minimum, the average and the maximum values.

Table 5 gives an overview of the connection options with parallel data transfer.

Parallel to the data transmission the **single voice channel test** should be established, see figure 21.

The **single voice channel test** consists of the following parts as described in clause 5.14.2:

- Convergence Quality test.
- Listening Speech Quality test.
- DTMF test.

The result of each part shall be listed in the test report.

Figure 13 depicts the detailed description of the single **voice channel test**.

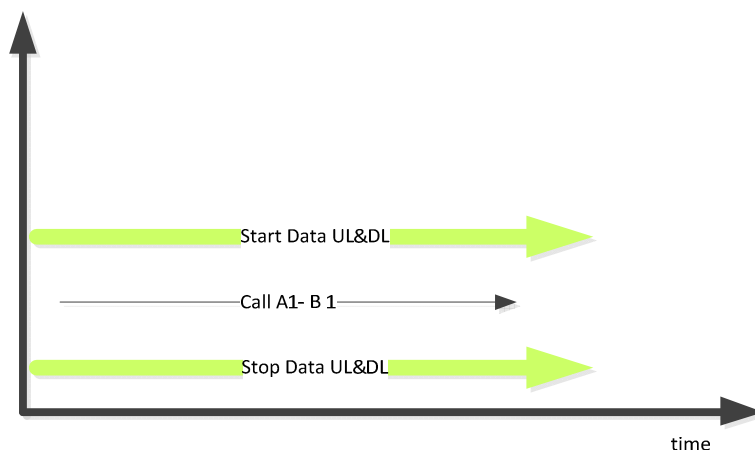

Figure 21: Parallel measurement of the quality of one voice channel and data transmission speed

Relative Time	Test equipment A		NETWORK		Test equipment B Data Reference System
T0 - 12 s	Ping	→		→	
Start download and upload procedure					
T0 - 10 s	Start TCP upload connection 1	→		→	
	Start TCP upload connection 2	→		→	
	Start TCP upload connection 3	→		→	
	Start TCP download connection 1	←		←	
	Start TCP download connection 2	←		←	
	Start TCP download connection 3	←		←	
The calculation of the throughput values for up/down stream starts					
T0 - 5	SETUP / INITE	→		→	SETUP / INITE
	ALERTING / 180 Ringing	←		←	ALERTING / 180 Ringing
T0	CONNECT / 200 OK	←		←	CONNECT / 200 OK
	CONNECT ACK / ACK	→		→	CONNECT ACK / ACK
Start Convergence Quality test					
T0	Start Audio Receive BA_1 (male & female)	←		←	Start Audio Send BA_1 (male & female)
	End Audio Receive BA_1	←		←	End Audio Send BA_1
Stop Convergence Quality test					
Listening Speech Quality test					
T0 + 10 s	Start Audio Send AB_1 (female 1)	→		→	Start Audio Receive AB_1 (female 1)
	End Audio Send AB_1 (female 1)	→		→	End Audio Receive AB_1 (female 1)
	Start Audio Send AB_2 (female 2)	→		→	Start Audio Receive AB_2 (female 2)
	End Audio Send AB_2 (female 2)	→		→	End Audio Receive AB_2 (female 2)
	Start Audio Send AB_3 (male 1)	→		→	Start Audio Receive AB_3 (male 1)
	End Audio Send AB_3 (male 1)	→		→	End Audio Receive AB_3 (male 1)
	Start Audio Send AB_4 (male 2)	→		→	Start Audio Receive AB_4 (male 2)
	End Audio Send AB_4 (male 2)	→		→	End Audio Receive AB_4 (male 2)



Relative Time	Test equipment A		NETWORK		Test equipment B Data Reference System
1 s	Pause				
	Start Audio Receive BA_1 (female 1)	←		←	Start Audio Send BA_1 (female 1)
	End Audio Receive BA_1 (female 1)	←		←	End Audio Send BA_1 (female 1)
	Start Audio Receive BA_2 (female 2)	←		←	Start Audio Send BA_2 (female 2)
	End Audio Receive BA_2 (female 2)	←		←	End Audio Send BA_2 (female 2)
	Start Audio Receive BA_3 (male 1)	←		←	Start Audio Send BA_3 (male 1)
	End Audio Receive BA_3 (male 1)	←		←	End Audio Send BA_3 (male 1)
	Start Audio Receive BA_4 (male 2)	←		←	Start Audio Send BA_4 (male 2)
	End Audio Receive BA_4 (male 2)	←		←	End Audio Send BA_4 (male 2)
1 s	Pause				
	Start DTMF Send AB_1	→		→	Start DTMF Receive AB_1
	End DTMF Send AB_1	→		→	End DTMF Receive AB_1
	Start DTMF Receive BA_1	←		←	Start DTMF Send BA_1
	End DTMF Receive BA_1	←		←	End DTMF Send BA_1
	DISCONNECT / BYE	←		←	DISCONNECT / BYE
	RELEASE / 200 OK	→		→	RELEASE /200 OK
	RELEASE COMPLETE	←		←	RELEASE COMPLETE
	The data transmission of data streams is stopped				
	The calculation of the throughput values for up/down stream				

**Figure 22: Detailed listening speech quality, DTMF procedure and UL/DL procedure**

#### 5.14.4.3 Quality measurement of multiple voice channels and data transfer

In the case of multiple voice channel access or SIP Trunking, during the complete testing phase the first call from user A to user B is active. During the parallel download and upload the data size should be between 80 % and 100 % of the nominal data capacity of the link or respectively the maximal data capacity which can be provided during the voice transmission, see figure 23.

For the data transfer the following constants are used:

- n number of parallel TCP connections for one direction ( $1 \leq n \leq 10$ ); default:  $n = 3$ .
- In case of use of fixed-size chunks, the initial size of data block sent during the test is  $s = 4,096$  Bytes.
- t duration of tests: The download and upload procedure shall be repeated during the voice call measurement procedure is active.

Several parallel data streams are initiated with a number of n parallel TCP connections with an upload and download of data files from the data-reference system. The upload shall start before the call setup starts, the download before the voice quality measurement starts. After time t, each TCP connection shall be reseted.

As an option the server can continuously sent data streams consisting of fixed-size chunks of size s (randomly generated data with high entropy). The data should be transferred between client and server over the TCP port 443 using TLS or SSL in order to avoid interference with firewalls as much as possible. The ports for communication and data transfers between the different servers themselves shall be configurable.

Parallel to the data transmission the **single voice Channel and multiple voice Channel test** should be established.

The **single voice Channel test** consists of the following parts:

- Convergence Quality test.

- Listening Speech Quality test.
- DTMF test.

Figure 15 depicts the detailed description of the **Single Voice Channel test for the multiple voice channel access**, where a part of transmitted speech samples are repeated multiple times.

The test sequence shall be performed in both directions ( $UNI_A$  to  $UNI_B$  and  $UNI_B$  to  $UNI_A$ ).

The four speech files should be repeated during the call is active. For  $n$  channels  $n - 1$  cycles (approximately 80 seconds) are recommended (e.g. for 4 channels the duration is approximately 360 seconds), see also figure 15.

**Parallel to the single voice channel test** additional calls should be established (**Multiple Voice Channel test**, as described in clause 5.14.2). The call establishment time between the **multiple** voice Channels should be 1 second (the load is 0,5 calls per second).

The **multiple voice Channel test** consists of the following parts:

- Convergence Quality test.
- Listening Speech Quality test.

Figure 16 depicts the detailed description of the **multiple voice channel access**.

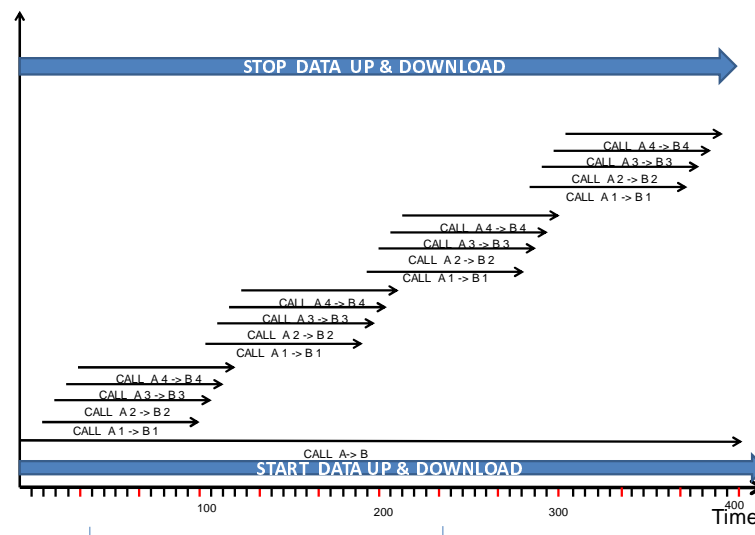

Figure 23: Multiple voice channel access test

#### 5.14.4.4 Parallel quality measurement of multiple voice channels and data transmission speed

In the case of multiple voice channel access or SIP Trunking, during the complete testing phase the first call from user A to user B is active. During the parallel download and upload the data size should be between 80 % and 100 % of the nominal data capacity of the link or respectively the maximal data capacity which can be provided during the voice transmission, see figures 24 and 25. For the data transfer the following constants are used:

- $n$  number of parallel TCP connections for one direction ( $1 \leq n \leq 10$ ); default:  $n = 3$ .
- In case of use of fixed-size chunks, the initial size of data block sent during the test is  $s = 4,096$  Bytes.
- $t$  duration of tests: The download and upload procedure shall be repeated during the voice call measurement procedure is active.

Several parallel data streams are initiated with a number of  $n$  parallel TCP connections with an upload and download of data files from the data-reference system. The upload shall start before the call setup starts, the download before the voice quality measurement starts. After time  $t$ , each TCP connection shall be resetted.

As an option the server can continuously send data streams consisting of fixed-size chunks of size  $s$  (randomly generated data with high entropy). The data should be transferred between client and server over the TCP port 443 using TLS or SSL in order to avoid interference with firewalls as much as possible. The ports for communication and data transfers between the different servers themselves shall be configurable.

For each TCP connection  $k$ ,  $1 \leq k \leq n$ , the client records the relative time " $t$ " and the amount of data received from time 0 to  $t$ .

After completion of all tests, the client sends the results and data collected to the Data Server. Both datasets are then compared by the Data Server to check the quality and integrity of the result. All tests, successful or unsuccessful, are stored by the Data Server.

The values presented which are measured each 500 ms shall include the minimum, the average and the maximum values.

Parallel to the data transmission the **single voice Channel and multiple voice Channel test** should be established. The **single voice Channel test** consists of the following parts:

- Convergence Quality test.
- Listening Speech Quality test.
- DTMF test.

The four speech files should be repeated during the call is active. For  $n$  channels  $n-1$  cycles (approximately 80 seconds) are recommended (e.g. for 4 channels the duration is 360 seconds), see also figure 15.

**Parallel to the single voice channel test** additional calls should be established (**multiple voice Channel test**).

The **multiple voice Channel test** consists of the following parts:

- Convergence Quality test.
- Listening Speech Quality test.

Figure 16 depicts the detailed description of the **multiple voice channel access**.

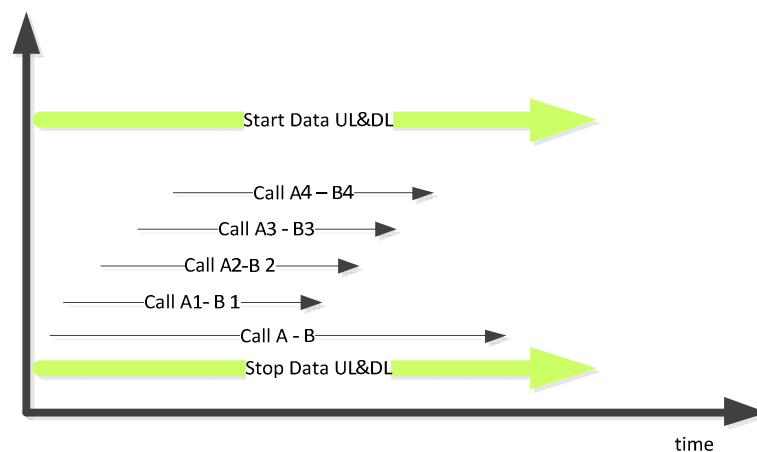

**Figure 24: Parallel quality measurement of multiple voice channels and data transmission speed**

Relative Time	Test equipment A		NETWORK		Test equipment B Data Reference System
T0 - 12 s	Ping	→		→	
Start download and upload procedure					
T0 - 10 s	Start TCP upload connection 1	→		→	
	Start TCP upload connection 2	→		→	
	Start TCP upload connection 3	→		→	
	Start TCP download connection 1	←		←	
	Start TCP download connection 2	←		←	
	Start TCP download connection 3	←		←	
The calculation of the throughput values for up/down stream starts					
T0 - 5	SETUP / INITE	→		→	SETUP / INITE
	ALERTING / 180 Ringing	←		←	ALERTING / 180 Ringing
T0	CONNECT / 200 OK	←		←	CONNECT / 200 OK
	CONNECT ACK / ACK	→		→	CONNECT ACK / ACK
Start Convergence Quality test					
T0	Start Audio Receive BA_1 (male & female)	←		←	Start Audio Send BA_1 (male & female)
	End Audio Receive BA_1	←		←	End Audio Send BA_1
Stop Convergence Quality test					
Listening Speech Quality test					
T0 + 10 s	Start Audio Send AB_1 (female 1)	→		→	Start Audio Receive AB_1 (female 1)
	End Audio Send AB_1 (female 1)	→		→	End Audio Receive AB_1 (female 1)
	Start Audio Send AB_2 (female 2)	→		→	Start Audio Receive AB_2 (female 2)
	End Audio Send AB_2 (female 2)	→		→	End Audio Receive AB_2 (female 2)
	Start Audio Send AB_3 (male 1)	→		→	Start Audio Receive AB_3 (male 1)
	End Audio Send AB_3 (male 1)	→		→	End Audio Receive AB_3 (male 1)
	Start Audio Send AB_4 (male 2)	→		→	Start Audio Receive AB_4 (male 2)
	End Audio Send AB_4 (male 2)	→		→	End Audio Receive AB_4 (male 2)
Pause					
	Start Audio Receive BA_1 (female 1)	←		←	Start Audio Send BA_1 (female 1)
	End Audio Receive BA_1 (female 1)	←		←	End Audio Send BA_1 (female 1)
	Start Audio Receive BA_2 (female 2)	←		←	Start Audio Send BA_2 (female 2)
	End Audio Receive BA_2 (female 2)	←		←	End Audio Send BA_2 (female 2)
	Start Audio Receive BA_3 (male 1)	←		←	Start Audio Send BA_3 (male 1)
	End Audio Receive BA_3 (male 1)	←		←	End Audio Send BA_3 (male 1)
	Start Audio Receive BA_4 (male 2)	←		←	Start Audio Send BA_4 (male 2)
	End Audio Receive BA_4 (male 2)	←		←	End Audio Send BA_4 (male 2)

Relative Time	Test equipment A		NETWORK		Test equipment B Data Reference System
	Pause				
	Start DTMF Send AB_1	→		→	Start DTMF Receive AB_1
	End DTMF Send AB_1	→		→	End DTMF Receive AB_1
	Start DTMF Receive BA_1	←		←	Start DTMF Send BA_1
	End DTMF Receive BA_1	←		←	End DTMF Send BA_1
	DISCONNECT / BYE	←		←	DISCONNECT / BYE
	RELEASE / 200 OK	→		→	RELEASE /200 OK
	RELEASE COMPLETE	←		←	RELEASE COMPLETE
	The data transmission of data streams is stopped				
	The calculation of the throughput values for up/down stream				

Figure 25: Detailed listening speech quality, DTMF procedure and UL/DL procedure

## 5.15 Listening speech quality stability

The listening speech quality stability should be analysed all along the duration of the call.

This indicator takes into account the degradations generated on the signal by the transmission links.

Several measurements of MOS-LQO score performed with Recommendation ITU-T P.863 [2] are performed in series within the same call.

The detailed testing method is described in Recommendation ITU-T G.131 [6].

## 5.16 End-to-end audio delay

This parameter represents the global delay from one user to the other one. This indicator takes into account the transmission delay of networks but also processing delay in sending and receiving terminals. The end-to-end delay can be measured acoustically from mouth to ear, from one access point to the other one, see figures 26 and 27. The delay can be calculated based on cross correlation between the signal at the MRP (at one access) and the signal at the ERP (at the other access) using the test methods as described e.g. in ETSI ES 202 737 [14] and ETSI ES 202 739 [15].

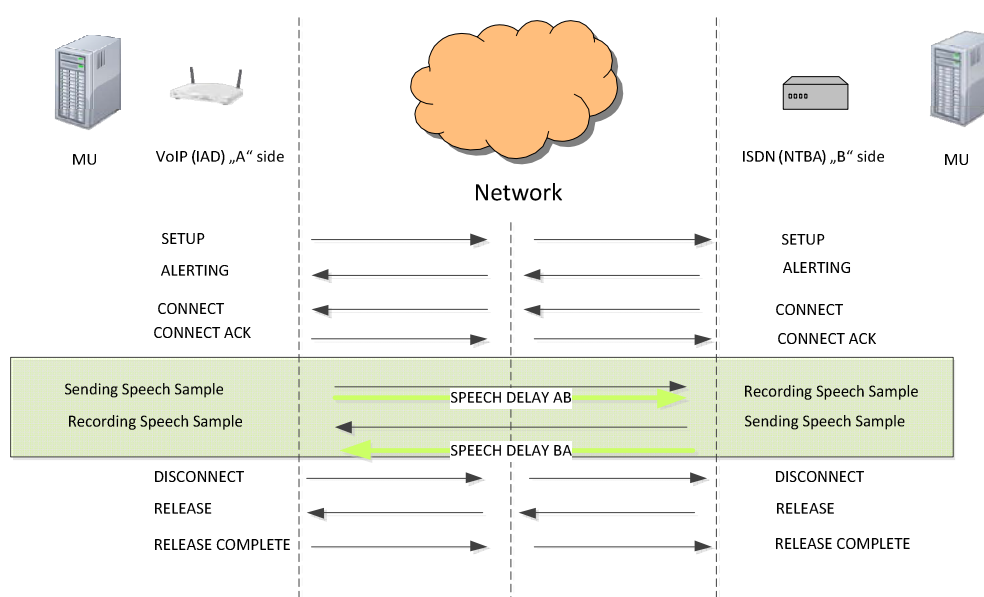
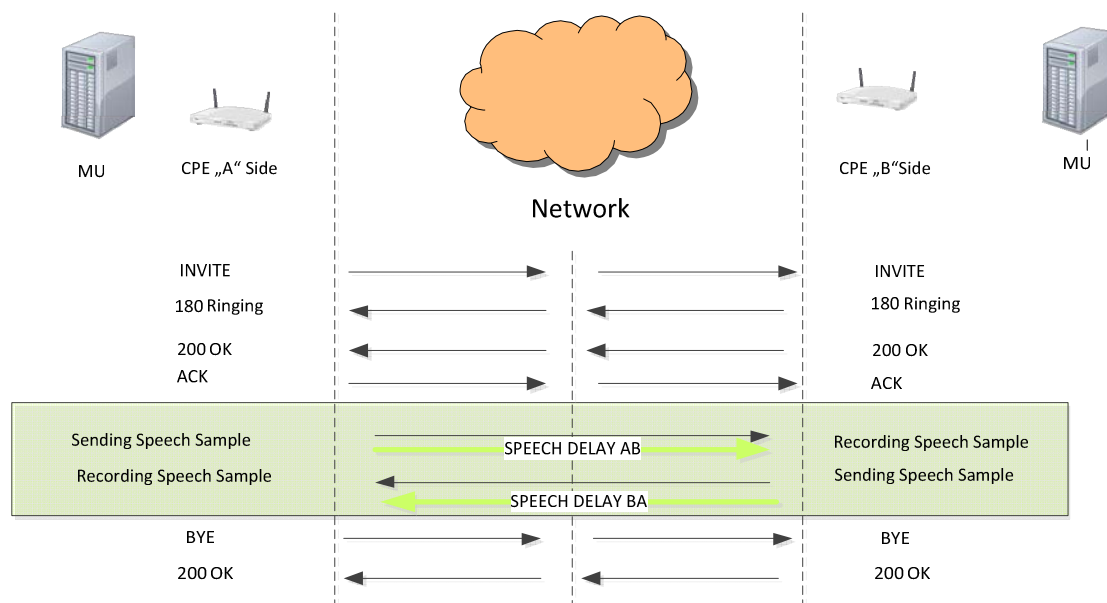

Figure 26: Measurement of the speech delay



**Figure 27: VoIP measurement of the speech delay**

Electrically the end-to-end delay can be measured based on cross correlation between the signal at the electrical measurement point at one access and the signal at the electrical measurement point at the other access.

The test signal consists of a series of CSS-signals using a nominal network level of -16 dBm0 as described in Recommendation ITU-T P.501 [13]. The test signal consists of the voiced part as described in Recommendation ITU-T P.501 [13] followed by a pseudo random noise sequence with a periodicity of minimum 500 ms (described also in ETSI ES 202 737 [14] and ETSI ES 202 739 [15]).

**NOTE:** If the expected delay is higher than 500 ms a pseudo random sequence with a higher periodicity should be used.

## 5.17 End -to-end audio delay variation

The test signal consists of a series of CSS-signals using a nominal network level of -16 dBm0 with a total duration of 120 s. The pause of the CSS-sequence should be 150 ms. The delay of every CSS-signal should be measured.

The delay variation for each CSS-signal  $D(i)$  compared to the first CSS signal (as described in Recommendation ITU-T P.501 [13]) of the analysis period is calculated:

$$D(i) = T1 - Ti$$

With:

- $T1$  - Delay of the first CSS
- $Ti$  - Delay CSS number  $i$

## 5.18 Frequency response in receive direction

Narrowband telephony should transmit signals between 300 Hz and 3 400 Hz. Wideband telephony should transmit signals between 50 Hz and 7 000 Hz. The objective of this measurement is to see which bandwidth is used, and also to see whether a partial and unwanted bandwidth limitation is present. The frequency response is the gain (or attenuation) of the speech spectrum after transmission. The test signal used for the measurements shall be the British-English single talk sequence described in clause 7.3.2 of Recommendation ITU-T P.501 [13]. The test signal level is -16 dBm0. The level is averaged over the complete test signal. For determining the frequency response in wideband the sensitivity frequency response is determined in 1/12<sup>th</sup> octave bands, as given by IEC 61260 [i.6] for frequencies of 100 Hz and 8 kHz, inclusive. In narrowband it is determined for frequencies from 200 Hz to 4 kHz. In each 1/12<sup>th</sup> octave band, the level of the measured signal is referred to the level of the reference signal averaged over the complete test sequence length. The sensitivity is determined in dBV/V.

## 5.19 Fax transmission with Recommendations ITU-T T.30 and T.38

### 5.19.1 General considerations

This test applies to Fax bit rates  $\leq 14,4$  kbit/s and Fax bit rates  $\geq 14,4$  kbit/s in accordance with Recommendation ITU-T T.30 [i.7] and Recommendation ITU-T T.38 [i.8]. Figure 28 gives an overview about the Fax stack for FoIP.

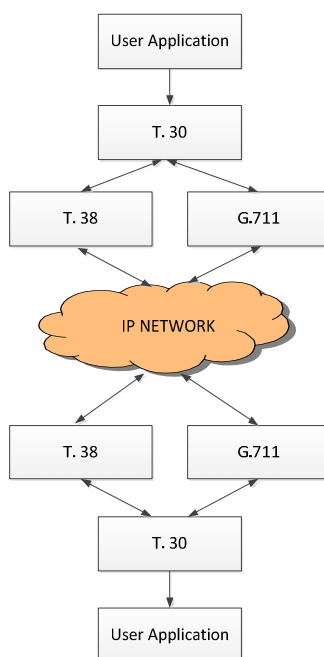

**Figure 28: FAX Stack for FoIP**

Following is the electronic version of the test pages related to the test case descriptions. The files consist of five test pages which are available as electronic attachments to Recommendation ITU-T T.24 [i.9] or in the ITU test signal database: <http://www.itu.int/net/itu-t/sigdb/menu.aspx>. (The figures from the text of the Recommendation are not suitable for testing purposes). For all text pages the version with 400 dpi resolution shall be selected for the electronic processing of the fax simulation.

- F03\_400
- F04\_400
- F07\_400
- F09\_400

- F20\_400

A Fax benchmarking test with parallel data transfer shall contain at least the following six test pages which are available as electronic attachments to Recommendation ITU-T T.24 [i.9] or in the ITU test signal database:

<http://www.itu.int/net/itu-t/sigdb/menu.aspx>. For all text pages the version with 400 dpi resolution shall be selected for the electronic processing of the fax simulation.

- F03\_400
- F04\_400
- F07\_400
- F09\_400
- F18\_400
- F20\_400

For long term evaluation at least the following test pages shall be used which are available as electronic attachments to Recommendation ITU-T T.24 [i.9] or in the ITU test signal database: <http://www.itu.int/net/itu-t/sigdb/menu.aspx>.

- F01\_400
- F03\_400
- F04\_400
- F05\_400
- F06\_400
- F07\_400
- F09\_400
- F20\_400
- F18\_400
- EDUC
- AERIAL2
- CMPND3

The test pages defined shall be recorded and classified according to the following definitions.

The Complete/incomplete transmission of page, received pages shall be stored with test # as name:

- 1) Nominal bit rate of transmission.
- 2) Figure of Merit (FOM) as defined in Recommendation ITU-T E.458 [20]. There will be only one FOM value reported per Fax transmission, independent of the number of pages.
- 3) Duration of transmission of test page in seconds.
- 4) Visual inspection of received page for visible errors and missing information.



**Table 6: From Recommendation ITU-T E.458 [20] - Definition of Figure of Merit**

Transaction type	Complete	Maximum speed	Image quality
I	Yes	Yes	ERROR-FREE
II	Yes	Yes	ERRORED
III	Yes	Yes	SEVERELY ERRORED
IV	Yes	No	ERROR-FREE
V	Yes	No	ERRORED
VI	Yes	No	SEVERELY ERRORED
VII	No	Not applicable	Not applicable

NOTE 1: ERROR-FREE, ERRORED and SEVERELY ERRORED transactions are as defined in Recommendation ITU-T E.453 [21].

NOTE 2: If the transaction is incomplete, it is categorized as Type VII irrespective of the speed and image quality of the completed pages.

**Table 7: From Recommendation ITU-T E.453 [21] - Image quality categories**

<b>error-free page</b>	No degradation by network impairments
<b>errored page</b>	Information conveyed
<b>severely-errored page</b>	Part of information missing

### 5.19.2 Fax set-up duration

To determine the fax set-up duration, the time in seconds is measured from the sending of the dialling information by the "A" side to the start of transmission of the fax page on the "A" side (see green arrow in figure 29).

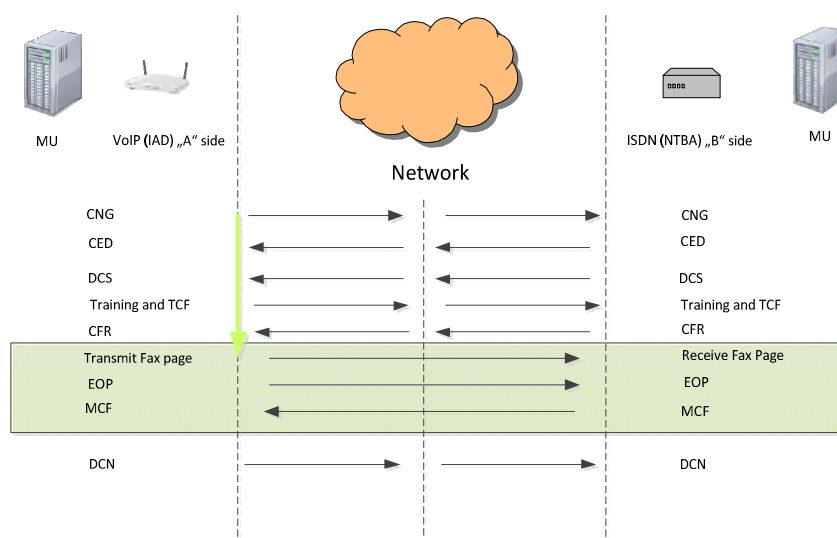
**Figure 29: Fax setup duration**

### 5.19.3 Fax transmission duration

This value measured shows the transmission time of a fax page in seconds.

The fax transmission duration is defined in the context of the present document as the time that elapses from the start of transmission of the fax page by the "A" side until the complete transfer of the fax page to the "B" side (see green arrow in figure 30).

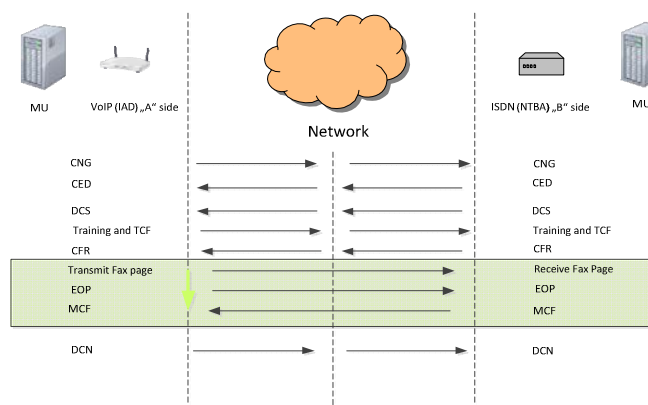
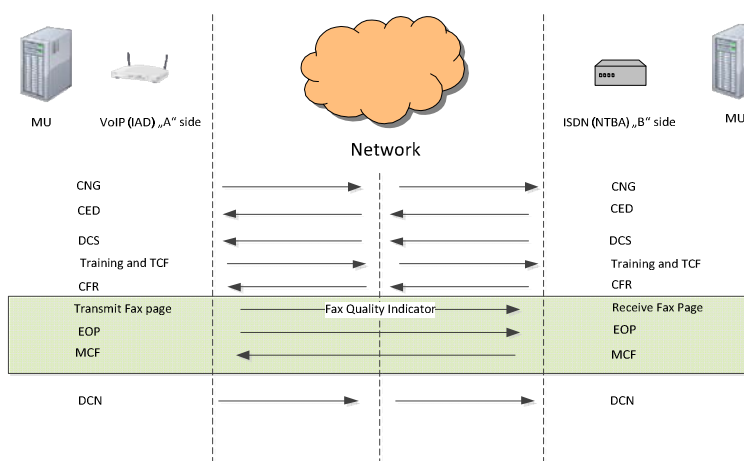

**Figure 30: Fax transmission duration**

### 5.19.4 Fax failure ratio

The fax failure ratio is defined as the ratio of failed fax transmissions and all fax transmissions initiated, see figure 31.

A fax transmission is considered to have failed if the fax connection setup or the fax transmission is unsuccessful, or if fax connection setup and fax were not completed within 180 seconds.



**Figure 31: Fax failure ratio**

### 5.19.5 Test case descriptions

#### 5.19.5.1 Quality measurement of one fax channel

Table 8 gives an overview about the connections options without parallel data transfer. Figure 32 gives an overview a detailed overview of a single FAX channel test.

Table 8: Transmission options without additional data traffic

No.	From				PT assig.	To			
	G.711 Modem Type	ECM	Page resolution	IP Gateway		IP Gateway	ECM	Page resolution	G.711 Modem Type
1	V.34 Data rate 33,6 kbit/s	True	200x100 dpi	AGW / MSAN / VGW	G.711, VBD with G711, T.38	AGW / MSAN/ VGW	True	200x100 dpi	V.34 Data rate 33,6 kbit/s
2	V.17 Data rate 14,4 kbit/s	True	200x100 dpi	AGW / MSAN / VGW	G.711, VBD with G711, T.38	AGW / MSAN/ VGW	True	200x100 dpi	V.17 Data rate 14,4 kbit/s
3	V.17 Data rate 14,4 kbit/s	False	200x100 dpi	AGW / MSAN / VGW	G.711, VBD with G711, T.38	AGW / MSAN/ VGW	False	200x100 dpi	V.17 Data rate 14,4 kbit/s

Relative Time	Test equipment A		NETWORK		Test equipment B
T0 - 2	SETUP / INVITE	→		→	SETUP / INVITE
	ALERTING / 180 Ringing	←		←	ALERTING / 180 Ringing
T0	CONNECT / 200 OK	←		←	CONNECT / 200 OK
	CONNECT ACK/ ACK	→		→	CONNECT ACK/ ACK
Start Fax Transmission					
T0	Start Fax Send AB_1 (F09_400)	→		→	Start Fax Receive AB_1 (F09_400)
	End Fax Send AB_1 (F09_400)	→		→	End Fax Send AB_1 (F09_400)
	Start Fax Send AB_2 (F03_400)	→		→	Start Fax Receive AB_2 (F03_400)
	End Fax Send AB_2 (F03_400)	→		→	End Fax Receive AB_2 (F03_400)
	Start Fax Send AB_3 (F04_400)	→		→	Start Fax Receive AB_3 (F04_400)
	End Fax Send AB_3 (F04_400)	→		→	End Fax Send AB_3 (F04_400)
	Start Fax Send AB_4 (F07_400)	→		→	Start Fax Receive AB_4 (F07_400)
	End Fax Send AB_4 (F07_400)	→		→	End Fax Receive AB_4 (F07_400)
	Start Fax Send AB_5 (F20_400)	→		→	Start Fax Receive AB_5 (F20_400)
	End Fax Send AB_5 (F20_400)	→		→	End Fax Receive AB_5 (F20_400)
End Fax Transmission					
	DISCONNECT / BYE	→		→	DISCONNECT / BYE
	RELEASE / 200 OK	←		←	RELEASE / 200 OK
	RELEASE COMPLETE	→		→	RELEASE COMPLETE

Figure 32: Single FAX channel test

### 5.19.5.2 Quality measurement of one fax channel and parallel data transfer

The data traffic should be parameterized according to respective typical service usages. This refers to the overall load as well as to the composition with respect to the number of sockets and temporal shape. The use of multiple parallel socket connections may be required either to reach the desired load, or to meet the desired structure of traffic.

The transferred data shall consist of randomly generated data with high entropy. It is not expected that the (pseudo) random number generator meets cryptographic requirements. However it should effectively avoid data compression during the transmission.

In the case of multiple voice and data channel access or SIP Trunking, when the access link is used for voice, fax and data application the fax quality measurement sequence with parallel upload/download shall be used. Table 9 gives an overview about the connections options with parallel data transfer.

For data transfer the following constants are used:

- $n$  number of parallel TCP connections for one direction ( $1 \leq n \leq 10$ ); default:  $n = 3$ .
- In case of use of fixed-size chunks, the initial size of data block sent during the test is  $s = 4,096$  Bytes.

Several parallel data streams are initiated with a number of  $n$  parallel TCP connections with an upload and download of data files from the data-reference system. The upload shall start before the call setup starts, the download before the voice quality measurement starts. After time  $t$ , each TCP connection shall be reseted.

As an option the server can continuously send data streams consisting of fixed-size chunks of size  $s$  (randomly generated data with high entropy). The data should be transferred between client and server over the TCP port 443 using TLS or SSL in order to avoid interference with firewalls as much as possible. The ports for communication and data transfers between the different servers themselves shall be configurable. Figure 33 gives an overview about the quality measurement of one Fax channel and parallel data load, figure 34 gives an overview about the detailed download and upload procedure for automatically controlled test sequence and figure 35 gives an overview about detailed download and upload procedure for manually controlled test sequence. Figures 36 through 42 depict the different scenarios.

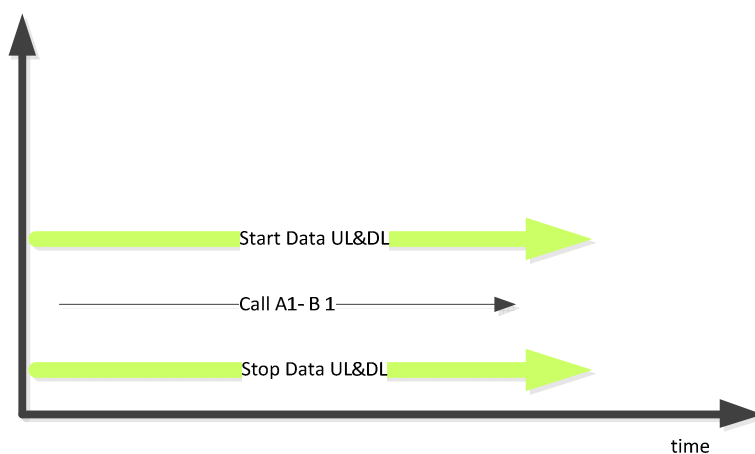

**Figure 33: Quality measurement of one Fax channel and parallel data load**

Start download and upload procedure					
T0 - 10 s	Start TCP upload connection 1	→		→	
	Start TCP upload connection 2	→		→	
	Start TCP upload connection 3	→		→	
<b>FAX Test</b>					
T0 - 5 s	SETUP / INVITE	→		→	SETUP / INVITE
	Start TCP download connection 1	←		←	
	Start TCP download connection 2	←		←	
	Start TCP download connection 3	←		←	
	ALERTING / 180 Ringing	←		←	ALERTING / 180 Ringing
T0	CONNECT / 200 OK	←		←	CONNECT / 200 OK
	CONNECT ACK / ACK	→		→	CONNECT ACK / ACK
Start Fax Transmission					
	Start Fax Send AB_1 (F09_400)	→		→	Start Fax Receive BA_1 (F09_400)
.....continued .....					
	End Fax Send AB_6 (F20_400)	→		→	End Fax Receive AB_6 (F20_400)
End Fax Transmission					
	DISCONNECT / BYE	→		→	DISCONNECT / BYE
	RELEASE / 200 OK	←		←	RELEASE / 200 OK
	RELEASE COMPLETE	→		→	RELEASE COMPLETE
Stop download and upload procedure					

Figure 34: Detailed download and upload procedure for automatically controlled test sequence

Relative Time	Test equipment A		NETWORK		Test equipment B Data Reference System
Start download and upload procedure					
T0 - 10 s	Start TCP upload connection 1	→		→	
	Start TCP upload connection 2	→		→	
	Start TCP upload connection 3	→		→	
	Start TCP download connection 1	←		←	
	Start TCP download connection 2	←		←	
	Start TCP download connection 3	←		←	
<b>FAX Test</b>					
T0 - 5 s	SETUP / INVITE	→		→	SETUP / INVITE
	ALERTING / 180 Ringing	←		←	ALERTING / 180 Ringing
T0	CONNECT / 200 OK	←		←	CONNECT / 200 OK
	CONNECT ACK / ACK	→		→	CONNECT ACK / ACK
Start Fax Transmission					
	Start Fax Send AB_1 (F09_400)	→		→	Start Fax Receive BA_1 (F09_400)
.....continued .....					
	End Fax Send AB_6 (F20_400)	→		→	End Fax Receive AB_6 (F20_400)
End Fax Transmission					
	DISCONNECT / BYE	→		→	DISCONNECT / BYE
	RELEASE / 200 OK	←		←	RELEASE / 200 OK
	RELEASE COMPLETE	→		→	RELEASE COMPLETE
Stop download and upload procedure					

Figure 35: Detailed download and upload procedure for manually controlled tests sequence

Table 9: Transmission options with additional data traffic

No.	From				PT assig.	To			
	G.711 Modem Type	ECM	Page resolution	IP Gateway		IP Gateway	ECM	Page resolution	G.711 Modem Type
1	V.34 Data rate 33,6 kbit/s	True	200x100 dpi	AGW / MSAN/ VGW	G.711, VBD with G711, T.38	AGW / MSAN/ VGW	True	200x100 dpi	V.34 Data rate 33,6 kbit/s
2	V.17 Data rate 14,4 kbit/s	True	200x100 dpi	AGW / MSAN / VGW	G.711, VBD with G711, T.38	AGW / MSAN/ VGW	True	200x100 dpi	V.17 Data rate 14,4 kbit/s
3	V.17 Data rate 14,4 kbit/s	False	200x100 dpi	AGW / MSAN/ VGW	G.711, VBD with G711, T.38	AGW / MSAN/ VGW	False	200x100 dpi	V.17 Data rate 14,4 kbit/s

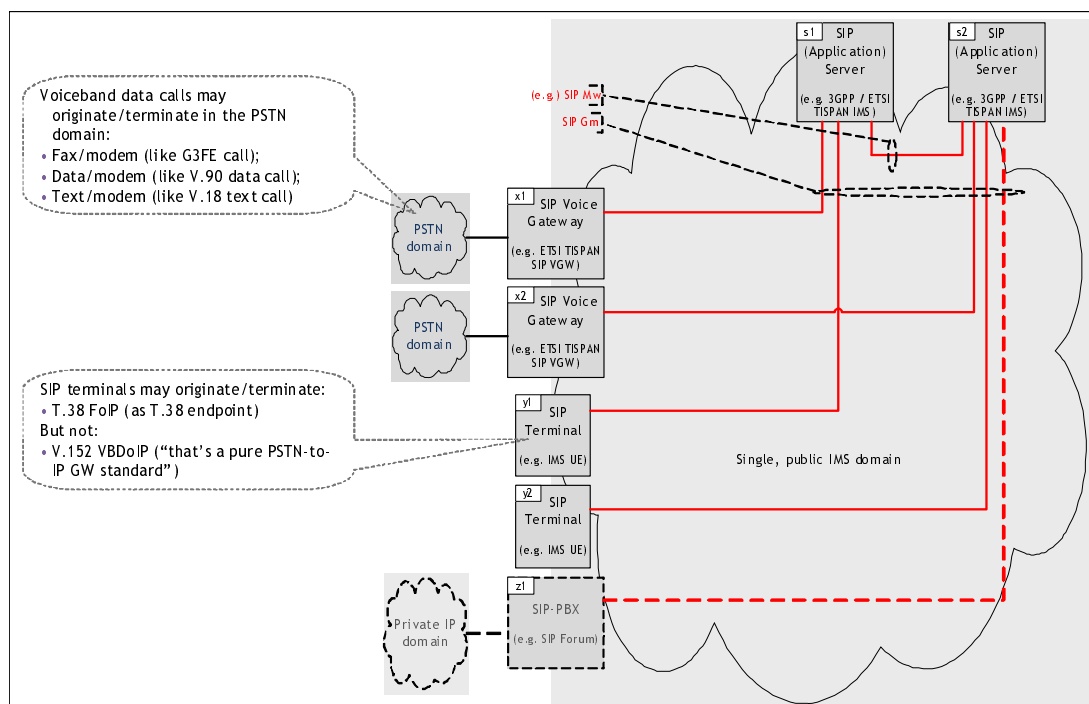

Figure 36: Mix of SIP VGWs (IMS-based PES) & SIP UEs (IMS)

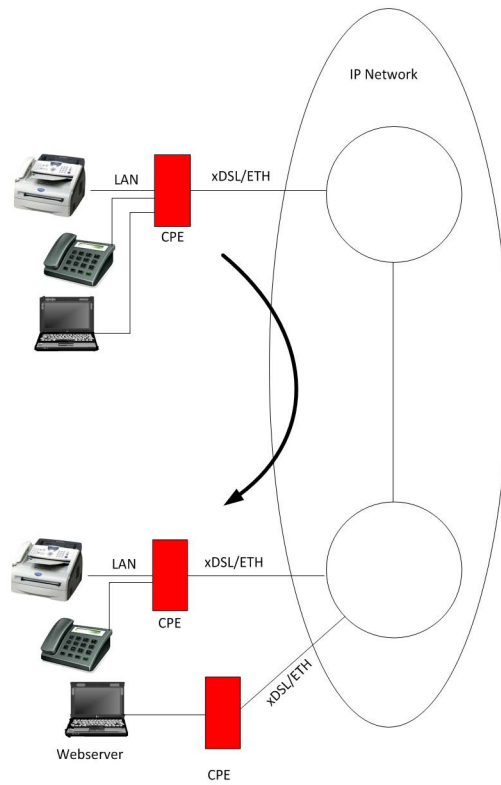

Figure 37: Call between two MMTel (IMS) Fax UE with additional data traffic

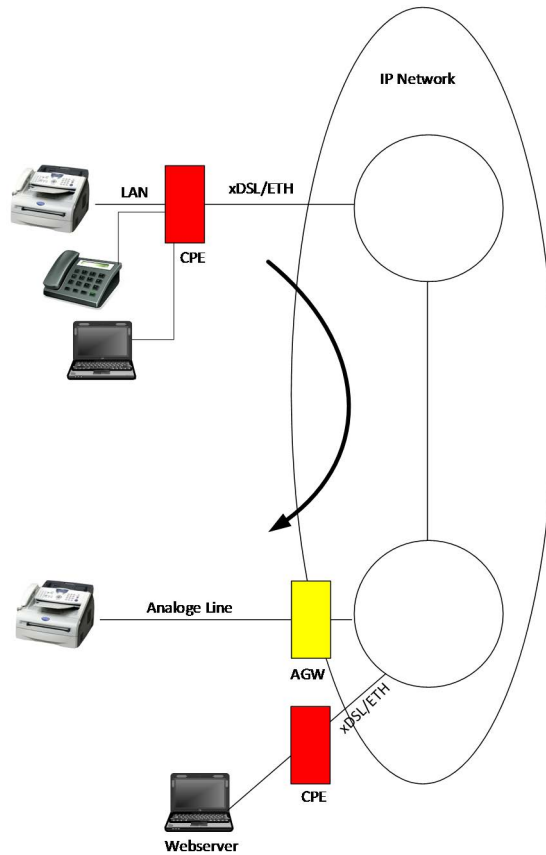

Figure 38: Call between MMTel (IMS) Fax UE with additional data traffic and AGW Fax UE

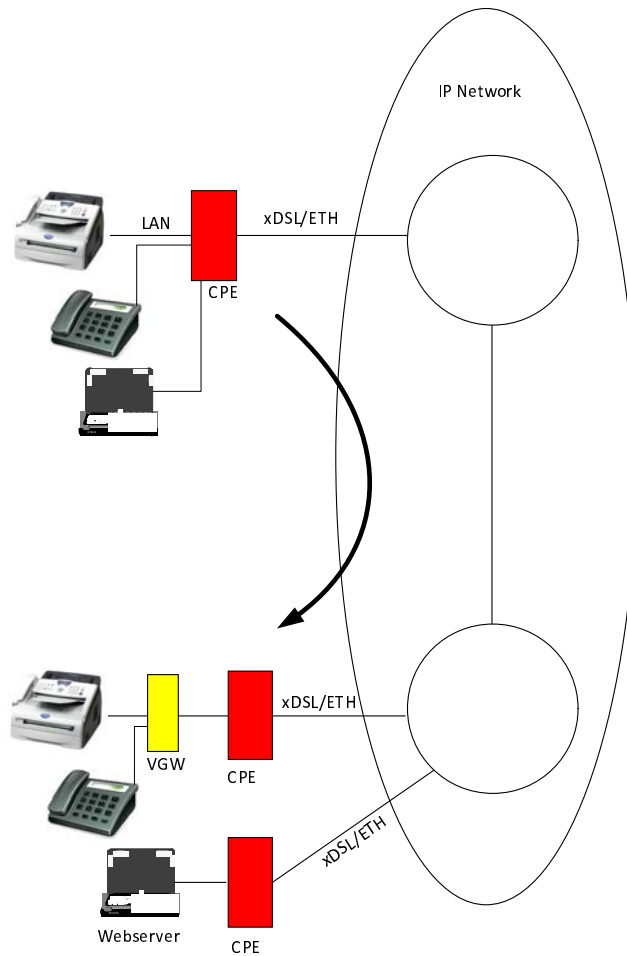

Figure 39: Call between MMTel (IMS) Fax UE with additional data traffic and VGW Fax UE

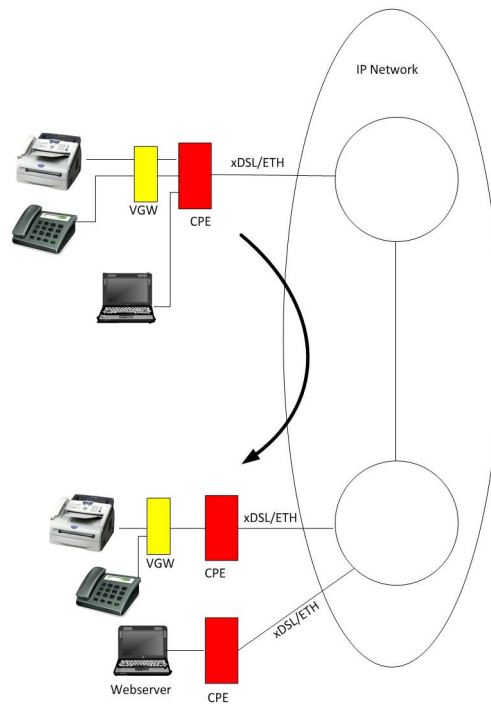

Figure 40: Call between two VGW Fax UE with additional data traffic



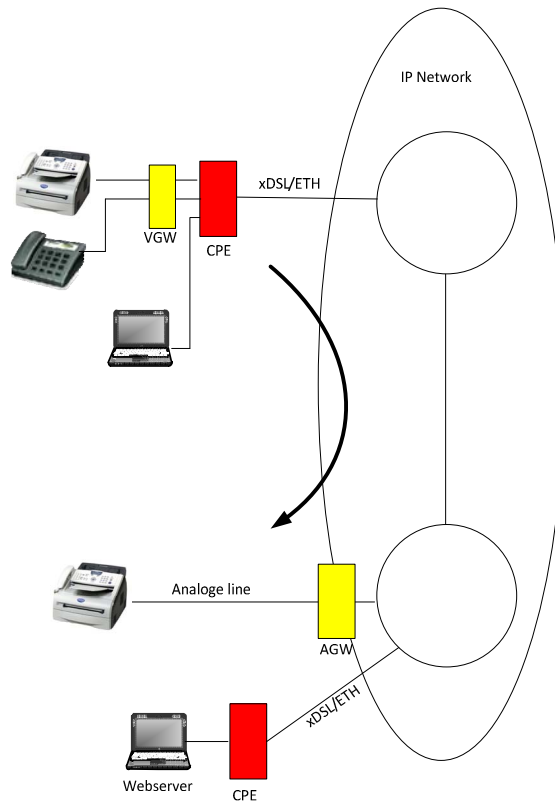

Figure 41: Call between VGW Fax UE with additional data traffic and AGW Fax UE

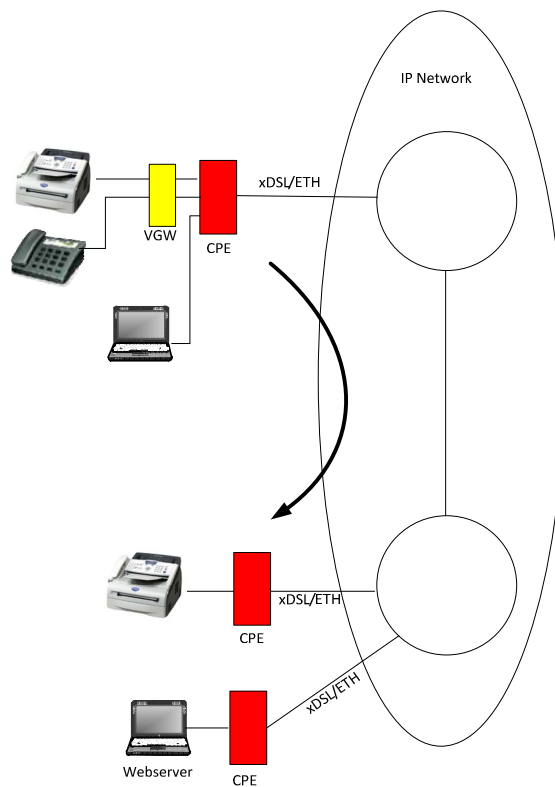

Figure 42: Call between VGW Fax UE with additional data traffic and MMTel (IMS)

## 5.20 Early media listening speech quality

### 5.20.1 Introduction

Early media refers to media (e.g. audio and video) which are exchanged before a particular session is accepted by the called user (in terms of the signalling). Within a dialogue, early media occurs from the moment the initial INVITE is sent until the User Agent Server (UAS) generates a final response. It may be unidirectional or bidirectional, and can be generated by the caller, the called party, or both. Typical examples of early media generated by the called party are ringing tone and announcements (e.g. queuing status). Early media generated by the caller typically consists of voice commands or dual tone multi-frequency (DTMF) tones to drive interactive voice response (IVR) systems. See figure 43.

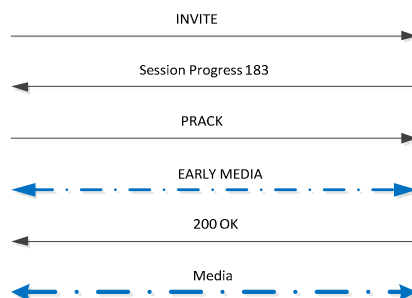

Figure 43: Early media SIP overview

### 5.20.2 Early media generated by the called party

To test the early media, the listening speech quality test from B to A after the '183 Session Progress' message is sent. In case of IMS implementations the '183 Session Progress' should contain the P-Early - media header.

In case that the called user is an ISDN user an ALERTING with Progress Indicator #8 or a progress message with the progress indicator should be sent.

For the synchronization of the voice samples a 700 Hz tone (100 ms signal) as trigger event can be used.

The principle of testing 'early media' is the same as defined for the Convergence Quality test according to clause 5.14.2. However, only one speech sample (male/female voice) has to be transmitted from the called party to the calling party emulating the 'early media' transfer. The general technical aspects for this speech samples are the same as defined in clause 5.14.2.

The call flow and the application of the early media test are shown in figures 44, 45 and 46.

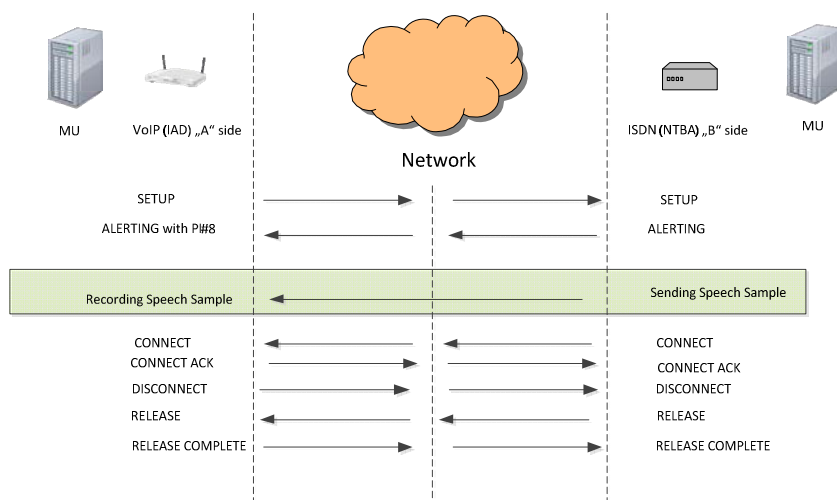

Figure 44: Early media ISDN case A

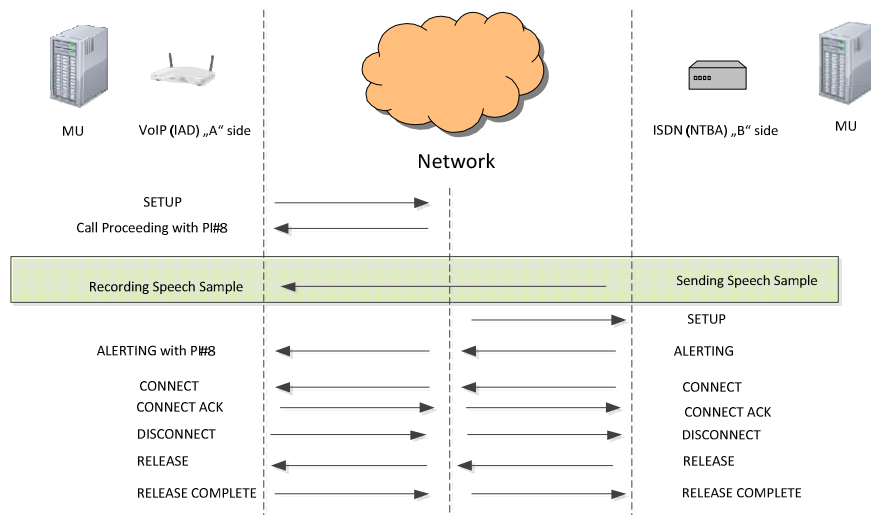

Figure 45: Early media ISDN case B

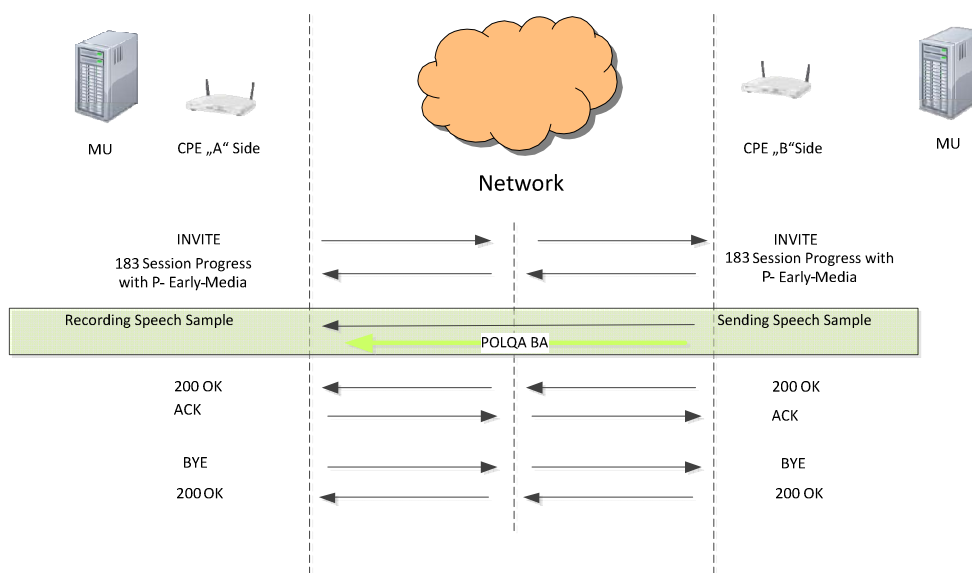

Figure 46: Early media SIP

## 5.21 Jitter Buffer and IP prioritization response time

### 5.21.1 Jitter Buffer and IP prioritization response time without data transfer

To test the jitter buffer and IP prioritization response time the test starts directly with a Listening Speech Quality test from the called party to the calling party directly after the connection is established. After the call is released the tests is repeated in the opposite direction.

However, only one speech sample (male/female voice) has to be transmitted from the called party to the calling party emulating the 'early media' transfer. The general technical aspects for this speech samples are the same as defined in clause 5.14.2.

The call flow and the application of the early media test are shown in figure 47.

Relative Time	Test equipment A		NETWORK		Test equipment B
<b>CALL A to B</b>					
T0 - 2	SETUP / INVITE			→	SETUP / INVITE
	ALERTING / 180 Ringing	←		←	ALERTING / 180 Ringing
T0	CONNECT / 200 OK	←		←	CONNECT / 200 OK
	CONNECT ACK/ ACK	→		→	CONNECT ACK/ ACK
T0	Start Audio Receive BA_1 (male & female)	←		←	Start Audio Send BA_1 (male & female)
	End Audio Receive BA_1	←		←	End Audio Send BA_1
	DISCONNECT / BYE	→		→	DISCONNECT / BYE
	RELEASE / 200 OK	←		←	RELEASE / 200 OK
	RELEASE COMPLETE	→		→	RELEASE COMPLETE
<b>CALL B to A</b>					
T0 - 2	SETUP / INVITE	←		←	SETUP / INVITE
	ALERTING / 180 Ringing	→		→	ALERTING / 180 Ringing
T0	CONNECT / 200 OK	→		→	CONNECT / 200 OK
	CONNECT ACK/ ACK	←		←	CONNECT ACK/ ACK
T0	Start Audio Send AB_1 (male & female) Start Audio Receive AB_1	→		→	Start Audio Receive AB_1 (female & female) Start Audio Send AB_1
	End Audio Receive BA_1	→		→	End Audio Send AB_1
	DISCONNECT / BYE	→		→	DISCONNECT / BYE
	RELEASE / 200 OK	←		←	RELEASE / 200 OK
	RELEASE COMPLETE	→		→	RELEASE COMPLETE

Figure 47: Jitter Buffer and IP prioritization response time tests

## 5.21.2 Jitter Buffer and IP prioritization response time with data transfer

To test the jitter buffer and IP prioritization response time the test starts with a Listening Speech Quality test from the called party to the calling party. After the call is released the tests is repeated in the opposite direction. The flow of the voice call is the same as in clause 5.21.1, there is just a surrounding and background data transfer active as shown in figure 48.

Relative Time	Test equipment A		NETWORK		Test equipment B
Start download and upload procedure					
T0 - 10 s	Start using multiple socket upload connection 1	→		→	
	Start using multiple socket upload connection 2	→		→	
	Start using multiple socket upload connection 3	→		→	
	Start using multiple socket download connection 1	←		←	
	Start using multiple socket download connection 2	←		←	
	Start using multiple socket download connection 3	←		←	
<b>CALL A to B</b>					
T0 - 5	SETUP / INVITE	→		→	SETUP / INVITE
	ALERTING / 180 Ringing	←		←	ALERTING / 180 Ringing
T0	CONNECT / 200 OK	←		←	CONNECT / 200 OK
	CONNECT ACK/ ACK	→		→	CONNECT ACK/ ACK
T0	Start Audio Receive BA_1 (male & female)	←		←	Start Audio Send BA_1 (male & female)
	End Audio Receive BA_1	←		←	End Audio Send BA_1
	DISCONNECT / BYE	→		→	DISCONNECT / BYE
	RELEASE / 200 OK	←		←	RELEASE / 200 OK
	RELEASE COMPLETE	→		→	RELEASE COMPLETE
<b>CALL B to A</b>					
T12	SETUP / INVITE	←		←	SETUP / INVITE
	ALERTING / 180 Ringing	→		→	ALERTING / 180 Ringing
T14	CONNECT / 200 OK	→		→	CONNECT / 200 OK
	CONNECT ACK/ ACK	←		←	CONNECT ACK/ ACK
T14	Start Audio Send AB_1 (male & female)	→		→	Start Audio Receive AB_1 (male & female)
	End Audio Receive AB_1	→		→	End Audio Send AB_1
	DISCONNECT / BYE	→		→	DISCONNECT / BYE
	RELEASE / 200 OK	←		←	RELEASE / 200 OK
	RELEASE COMPLETE	→		→	RELEASE COMPLETE
Stop download and upload procedure					

**Figure 48: Jitter Buffer and IP prioritization response time test with data transfer**

## 5.22 Stability of the de-jitter buffer delay adjustments for VBD calls during IP data transfer

### Measurement method

These tests should ensure that the de-jitter buffer located at each end of a connection keeps the E2E audio delay constant after the detection of a VBD call and that there are no delay variations besides a possible drift during a parallel IP Data transfer. The IP traffic generator at the called side, should be connected with a separate data access as shown in figure 52.

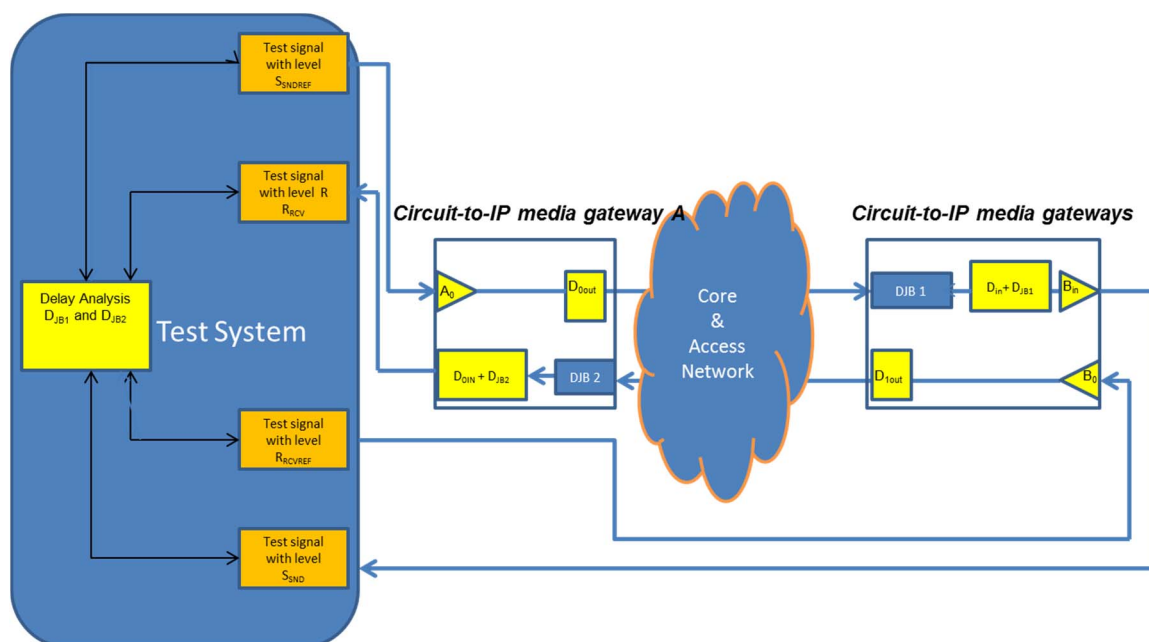

Figure 49: Test configuration A calls B

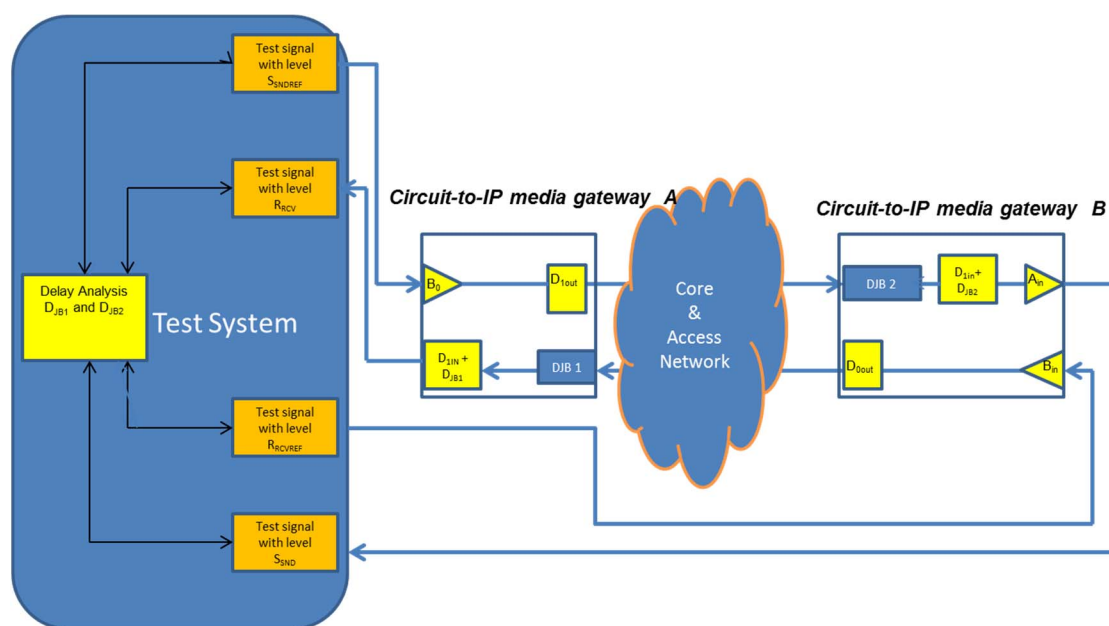

Figure 50: Test configuration B calls A

$A_0$  - output level interface A

$A_{in}$  - input level interface A

$B_{in}$  - input level interface B

$B_0$  - output level interface B

DV(i) – Delay variation

Used signals:

C16 Signal of Test 2A (Recommendation ITU-T G.168 [i.10]), average level -16 dBm0 Gaussian white noise signal which is used to identify the echo-path impulse response.

ANS 2 100 Hz sine (Recommendation ITU-T V.25 [i.11]). The duration of the tone is set to  $T1 = 1,35$  s.

<b>Measurement procedure</b>	I) <ul style="list-style-type: none"> <li>• Establishing a call from A to B</li> <li>• Apply signal ANS to Interface B</li> <li>• Apply signal C16-signals to Interface A with parallel upload of IP data transmission traffic as shown in figure 51</li> <li>• Determine the delay variation DV(i) for each CSS after sending ANS (from A)</li> <li>• Apply signal C16-signals to Interface B with parallel download of IP data transmission traffic as shown in figure 51</li> <li>• Determine the delay variation DV(i) for each CSS after sending ANS (from B)</li> </ul> II) <ul style="list-style-type: none"> <li>• Establishing a new call from B to A</li> <li>• Apply signal ANS to Interface A</li> <li>• Apply signal C16-signals to Interface B with parallel download of IP data transmission traffic as shown in figure 51</li> <li>• Determine the delay variation DV(i) for each CSS after sending ANS (from B)</li> <li>• Apply signal C16-signals to Interface A with parallel upload of IP data transmission traffic as shown in figure 51</li> <li>• Determine the delay variation DV(i) for each CSS after sending ANS (from A)</li> </ul>
<b>Requirement</b>	$ DV(i)  < 0,02 \text{ ms}$ ; Delay Variation for De-jitter buffer Fixed
<b>FAX test sequences: Calling tone (CNG) Conditions</b>	
<b>Called station identification (CED) Conditions</b>	CED (ANS) 2 100 Hz $\pm$ 15 Hz sine (Recommendation ITU-T V.25 [i.11]) Duration 3 s (Recommendation ITU-T G.168 [i.10], clause 6.4.2.11 Test No. 10 - Facsimile test) The amplitude of the tone is <b>-12 dBm0</b>

The test signal consists of a series of C16 signals using a nominal network level of -16 dBm0 with a total duration of 65 s. The pause between the of the C16-sequence should be 150 ms.

The delay variation for each CSS-signal D(i) compared to the first CSS signal (as described in Recommendation ITU-T P.501 [13]) of the analysis period is calculated:

$$DV(i) = T(i-1) - T(i)$$

With:

- T1 - Delay of the first CSS
- Ti - Delay CSS number i

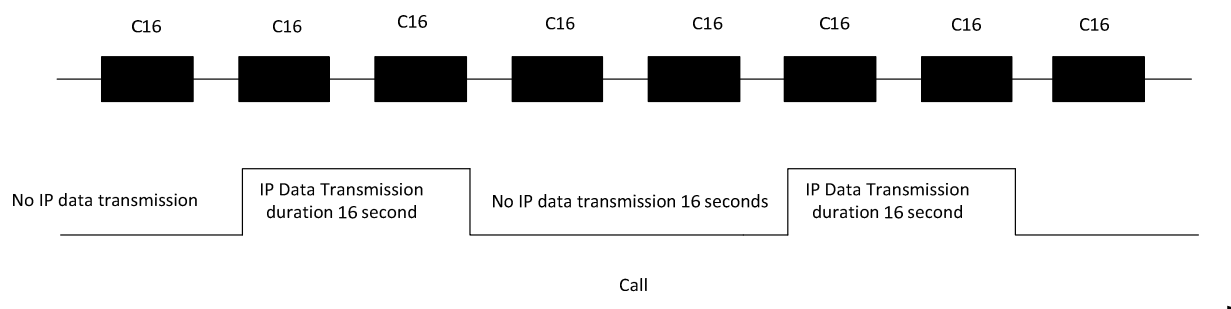

**Figure 51: Test Sequence to measure the stability of Jitter buffer adjustment**

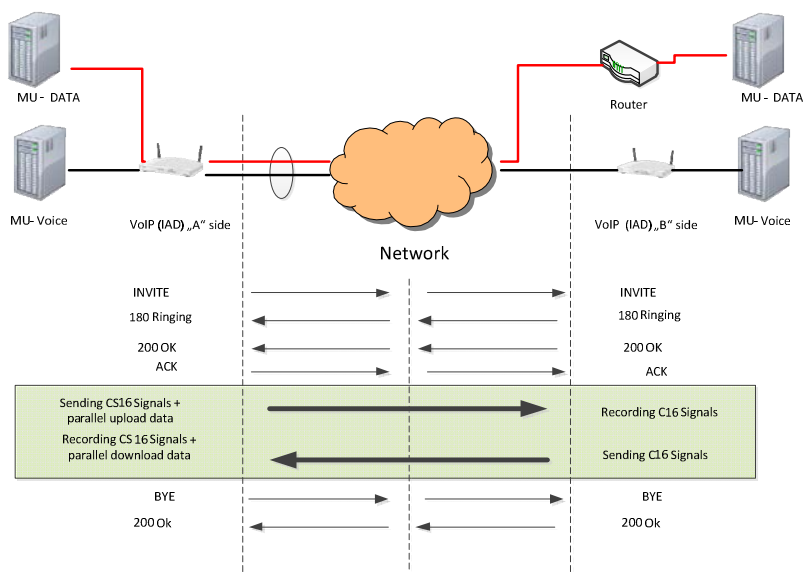

Figure 52: Test configuration to measure the stability of Jitter buffer adjustment VoIP

## 6 Internet related performance measurement methods of data transmission and voice transmission

### 6.1 Internet related performance measurement method of data transmission, general requirements

#### 6.1.1 Introduction

The Internet related performance measurement method of data transmission speed and transit time Test is based on Recommendation ITU-T Q.3960 [i.1].

## 6.2 Functional architecture of the Measurement System

### 6.2.0 Introduction

The measurement system should be composed of the Functional Entities (FE) in figure 53. Note that this functional architecture does not impose any particular implementation constraints and different FEs can be mapped to one or many software/hardware nodes.

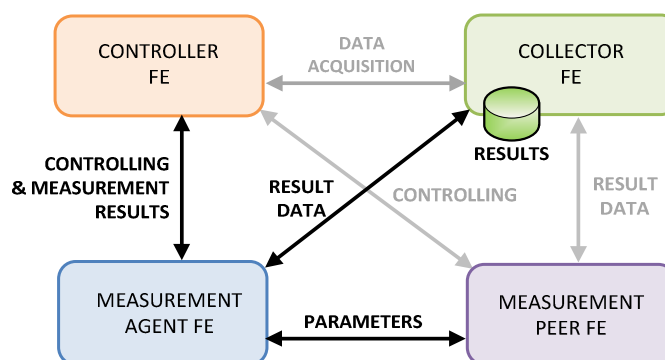

Figure 53: The functional architecture of the basic measurement system



## 6.2.1 Controller FE

The Controller is a FE that is able to control the testing mechanisms on a particular MA. The Controller should allow the specification of test scripts defining the measurement workflow (i.e. different stages and testing procedures involved) to later trigger the execution of the relevant Test Scenarios on that particular MA. The specification process may demand the acquisition of existing data from the Collector.

Furthermore, the Controller provides the user with the measurement environment and tools to execute the test throughout a web page or a HTTP/s access. It should be capable of hosting and serving the required scripts and contents to be used during the test. Additionally it will provide users with an interface to access measurement results.

## 6.2.2 Collector FE

The Collector is a FE that gathers, process and store measurement results and other statistical data from all Measurement Agents connected to the Controller, and from the Measurement Peers in case they are specifically deployed for the specific Test Scenario. It should be capable of handling properly secured transmission of data.

## 6.2.3 Measurement Agent FE

The Measurement Agent (MA) is a FE that has the functionality to execute the test scripts defined in the Controller, obtain the test results and upload the relevant result data to the Collector.

The Measurement Agent may well admit two different configurations.

Option a) involves a Terminal Equipment (TE, including but not limited to computer, smartphone, tablet, etc.) physically controlled and generally owned by the user.

This Terminal Equipment should have an active Internet connection and a web-browser in order to access the web-site hosted at the Controller, or an app to access the test in case of a portable device.

The TE should be also capable of establishing secure communications to the Collector, for the safe transfer of results and other statistical data.

Option b) involves the same TE and the existence of a MA in the form of a middlebox (probe) or additional hardware integrated in the TE.

The local Measurement Peer also requires any hardware and software that enables the remote management and configuration of the device without requiring any specific operation from the customer.

## 6.2.4 Measurement Peer FE

The Measurement Peer (MP) is a FE which is able to respond on testing messages sent from MA and possibly collect measurement data to be uploaded to the collector. Additionally, it may provide resource usage monitoring capabilities so that the Controller could schedule tests as to prevent any foreseeing interference impacting tests results.

## 6.2.5 Common remarks

All the functional entities should ensure that no interference among concurrent activities is affecting the test result by proper dimensioning in terms of HW/SW and link capacity. Furthermore, the recipient of the result should be notified of the conditions required to ensure a reliable measurement and the possible measurement errors due to unfulfillment of such conditions (including but not limited to cross traffic, background applications, OS and applications configuration, etc.).

## 6.2.6 Security Considerations

Tests may raise different security and confidentiality concerns about the data collected either from the TE and/or the MA (including but not limited to user identity, location, IP address, etc.). Specific measures to secure every data transfer, authenticate different FEs and anonymize specific collected data are described in IETF RFC 7594 [23]. In any case, adopted security and privacy threat mitigations shall be deployed according to every national regulation.

## 6.3 Workflow

### 6.3.1 General requirements

The test aims at delivering an accurate measurement of the maximum bandwidth available over a given internet connection. It may be the case that the maximum data rate per socket connection is limited. Therefore multiple parallel data streams (multiple sockets), running within a given time window should be used.

In order to prevent data compression by the network under test, the transferred data consist of randomly generated data with high entropy. It is recommended to verify that no or only negligible data compression takes place by respective validation tests prior to the actual measurement.

In order to increase the probability that the test can be performed even within networks protected by firewalls and proxy servers, the data should be transferred over HTTP or HTTPS (i.e. TLS or SSL connection).

### 6.3.2 Initial conditions

The test methodology defines a set of variables and constants that need to be assigned prior to the execution of the measurement algorithm or during the test execution. Some of these values are open to selection within a range, according to the specific considerations of each implementation or the current network conditions at the time the test is being executed.

**Table 10: Indicative Measurement Parameters**

	Parameter	Unit	Range	Default value
n	Number of parallel connections	#	$1 \leq n \leq 10$	$n = 3$
Tp	Duration of pre-test	s	$0 \leq T_p \leq 5$	$T_p = 2 \text{ s}$
Td	Duration of the downlink subtest	s	$5 \leq T_d \leq 15$	$T_d = 7 \text{ s}$
Tu	Duration of the uplink subtest	s	$5 \leq T_u \leq 15$	$T_d = 7 \text{ s}$
To	Timeout value	s	$5 \leq T_o \leq 10$	$T_o = 5 \text{ s}$
p	Number of 'pings' during delay subtest	#	$5 \leq p \leq 20$	$p = 10$
Tl	Maximum elapsed time before the first ping starts	ms	$200 \leq T_l \leq 1\,000$	$T_l = 500 \text{ ms}$
z	Reference size of data block (chunk size)	KB	Minimum 1 kbyte	$z = 4 \text{ KBytes}$
NOTE: All the values in the table are indicative.				

### 6.3.3 Measurement procedure

#### 6.3.3.0 Introduction

This clause defines the main phases of the testing procedure, once the Measurement Agent has obtained the test code from the Controller and the location or locations of the measurement peers.

The Measurement Peer (MP) is determined directly in Controller by geo-locating the Measurement Agent (MA) and determining his closest access to the Internet. In case of executing the Internet resource speed test, the Measurement Peer can be either selected by default or letting the user chose a destination within a list of Internet resources.

The following set of graphics state the basic exchange of information between the Measurement Agent (MA) and the selected Measurement Peer (MP) for each of the cases (The same procedure is defined for both the Network Internet speed test and the Internet resource speed test).

The test follows the procedure outlined below. The test consists of seven phases which are carried out one after each other, i.e. phase  $m$  starts after phase  $m-1$  has finished without any pause in-between. That means that the phases do not overlap.

To ensure comparable data transmission speed test conditions in mobile networks, a pre-load should be initiated. With the pre-load, the mobile networks are set in a defined initial state i.e. CELL\_DCH in UMTS and connected in LTE.

If the downlink and uplink pre-tests procedures are not implemented (Phases 2 and 5), the Measurement Agent shall open a uplink and downlink connection using a number of multiple sockets.

For the latency calculation (IMCP Echo Request/Echo Reply method) the echo receiver processing delay shall be taken into account.

The workflow of the measurement system is shown in figure 54.

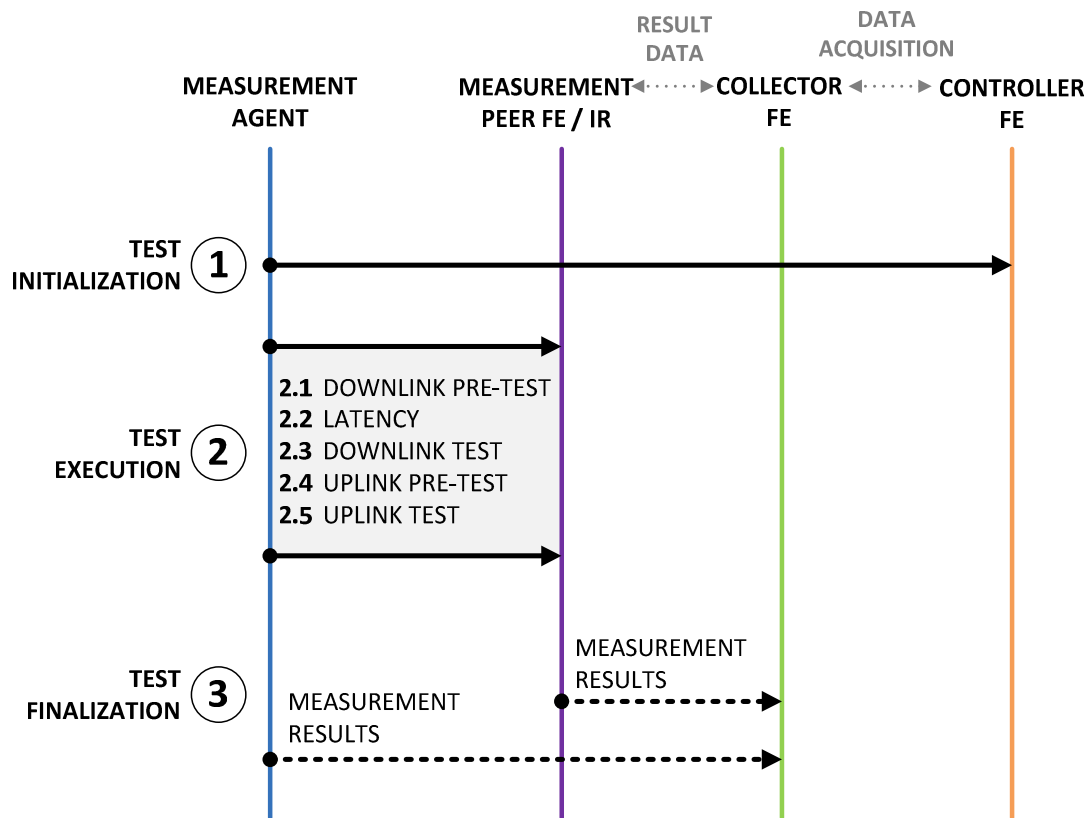

Figure 54: The workflow of the measurement system

### 6.3.3.1 Phase 1: Initialization

The Measurement Agent tries to connect to the Controller, as option can be used HTTP and/or HTTPS using port 443 over TLS or SSL. In order to pass through certain firewalls, which might block unencrypted data transmissions, HTTPS might be necessary. The data streams themselves are optionally unencrypted. In order for the computational cost of encryption not to deteriorate the measurement results, encryption and authentication parameters should be chosen as low as possible.

After establishing a proper connection, Measurement Agent and Measurement Peer exchange the information, which is required for running the test.

The Controller determines the Measurement Peer to be used. It then generates a token consisting of the following components e.g.:

- a unique test ID;
- the time at which the measurement is allowed to start;
- the period of time during which access to the Measurement Peer is allowed (a string representing number of seconds);
- the maximum number of permitted parallel connections from the Measurement Agent to the Measurement Peer (a string representing a positive integer).

The Controller then transmits the token as well as all the additional test parameters (e.g. IP address of the Measurement Peer, public IP address of the Measurement Agent, number of used multiple socket connections, etc.) to the Measurement Agent. The token is used for identifying the test session.

### 6.3.3.2 Phase 2: Downlink pre-test

The downlink pre-test for fixed wired high speed internet connections is optional.

In Phase 2, the Measurement Agent opens  $n$  connections to the assigned Measurement Peer. Within each connection, the Measurement Agent requests and the Measurement Peer sends a data block of size  $z$ . While the duration of the pre-test has not exceeded  $T_p$ , the Measurement Agent requests a data block of double size compared to the last iteration step. The transfer of the last data block will be finished even if the duration has already exceeded  $T_p$ . At the end of the pre-test, all connections are left optionally open for further use.

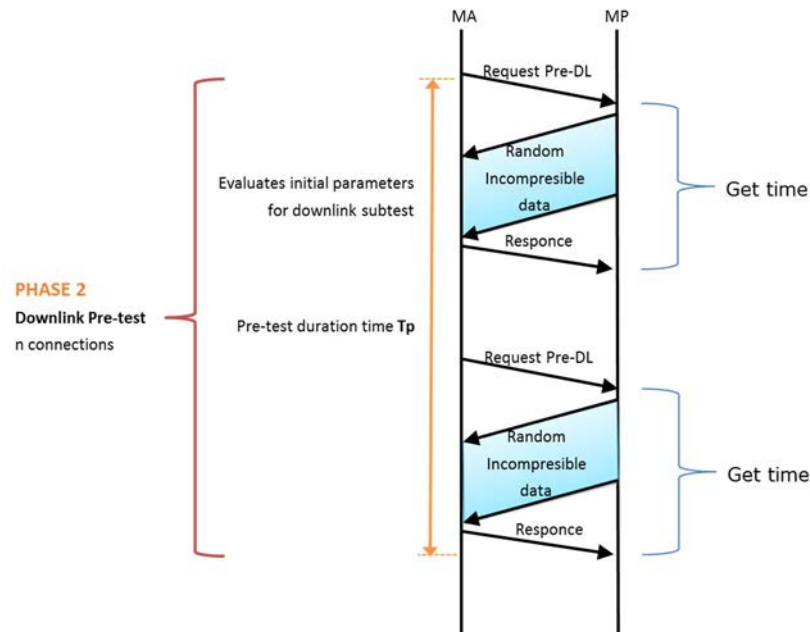

Figure 55: Sample diagram of phase 2 of measurement algorithm

### 6.3.3.3 Phase 3: Latency test

During this phase, the Measurement Agent sends  $p$  "pings" in short intervals to the Measurement Peer to test the latency of the connection. One "ping" consists of the transmission of short strings via one of the connections to the Measurement Peer, which returns short strings as acknowledgement. The Measurement Agent measures the time between sending and receiving the return message, while the Measurement Peer additionally measures the time between sending its return message and the Measurement Agent's reception response. The Measurement Agent stores all measurements.

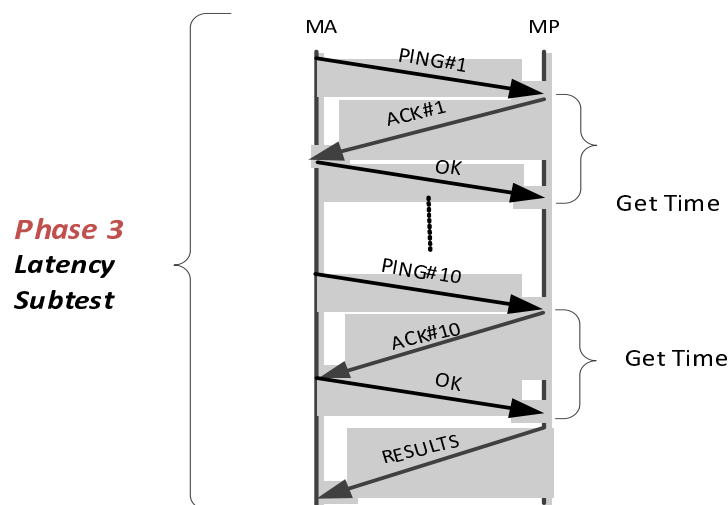

Figure 56: Sample diagram of phase 3 of measurement algorithm

### 6.3.3.4 Phase 4: Downlink subtest

Within each of the  $n$  connections opened during phase 2, the Measurement Agent simultaneously requests and the Measurement Peer continuously sends data streams consisting of fixed-size chunks of size  $s$  (randomly pre-generated data with high entropy).

As an option, the Collector can continuously send data streams on  $n$  connections consisting data files from the data-reference system. All transmissions start at the same time, which is denoted as relative time 0. For each connection the Measurement Agent records the elapsed time and the amount of data received.

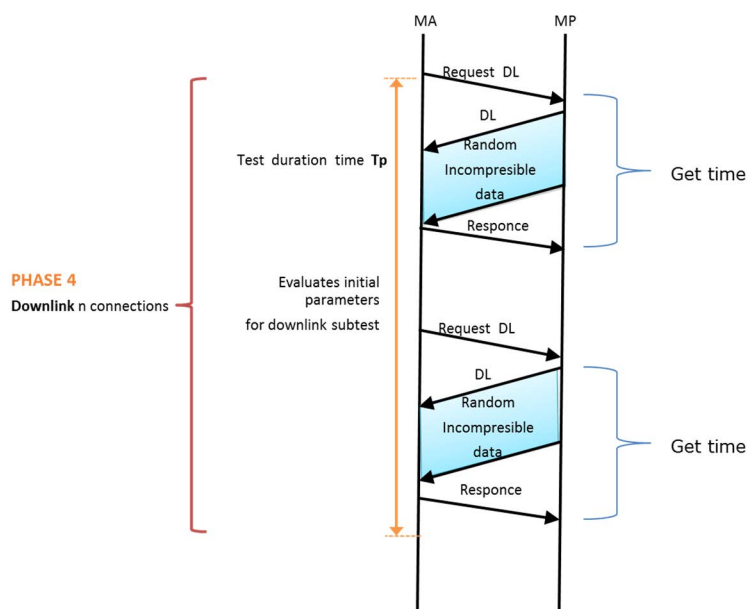

Figure 57: Sample diagram of phase 4 of measurement algorithm

### 6.3.3.5 Phase 5: Uplink pre-test

The uplink pre-test for fixed wired high speed internet connections is optional.

In Phase 5, the Measurement Agent opens  $n$  connections to the assigned Measurement Peer. Within each connection, the Measurement Agent sends a data block of size  $z$  (randomly pre-generated data with high entropy). While the duration of the pre-test has not exceeded  $T_p$ , the Measurement Agent sends a data block of double size compared to the last iteration step. The transfer of the last data block will be finished even if the duration has already exceeded  $T_p$ . At the end of the pre-test, the connections are left open for further use.

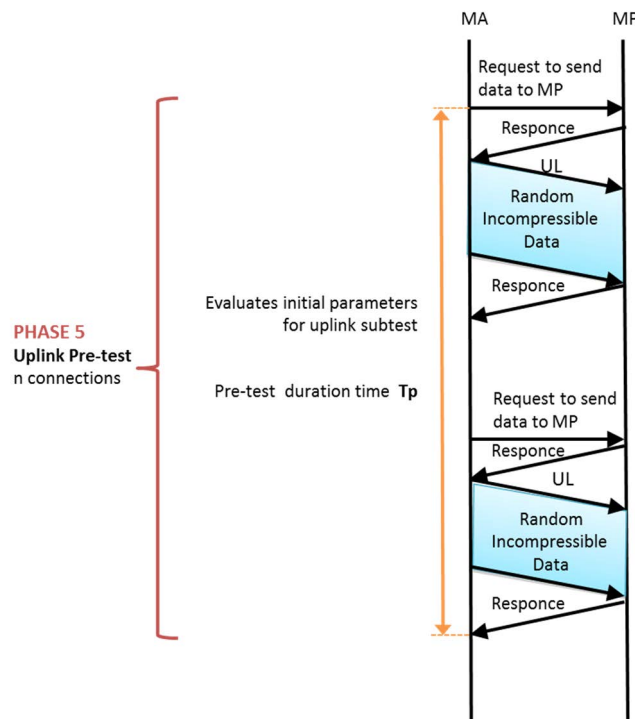

Figure 58: Sample diagram of phase 5 of measurement algorithm

### 6.3.3.6 Phase 6: Uplink subtest

Within each of the  $n$  connections opened during phase 5, the Measurement Agent continuously sends data streams. As an option can be used fixed-size chunks. As an option, the Measurement Agent can continuously send data streams on  $n$  connections consisting of a data file with randomly generated data with high entropy. All transmissions start at the same time, which is denoted as relative time 0. For each connection, the Measurement Peer gives feedback to the Measurement Agent by sending the elapsed time and the amount of data received.

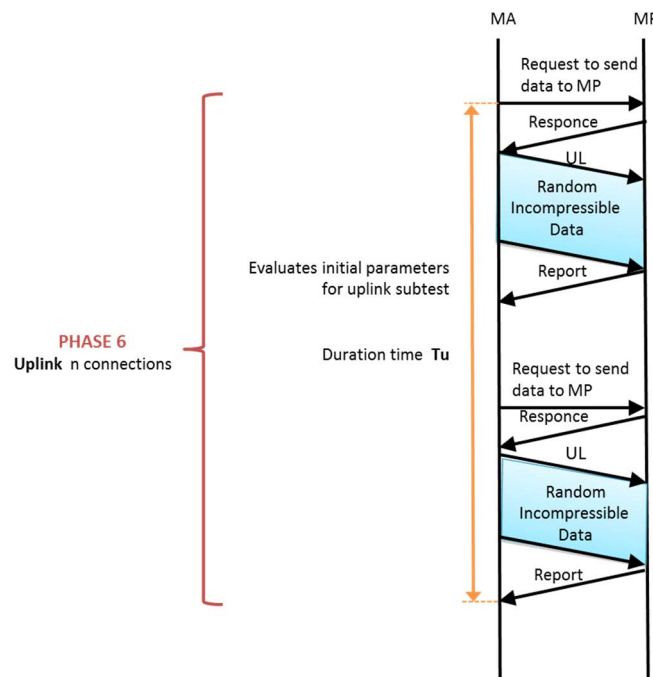

Figure 59: Sample diagram of phase 6 of measurement algorithm

### 6.3.3.7 Phase 7: Finalization

After finishing all tests, the Measurement Agent sends the collected data to the Collector. All results and additional information on the Measurement Agent are transferred directly to the Collector. Both datasets are then compared by the Collector to check the quality and integrity of the result. All tests, successful or unsuccessful, are stored by the Collector.

## 6.4 Measurement of Data

According to IETF RFC 7594 [23] the reporting by the MA shall be encrypted to maintain confidentiality, so that only the authorized Collector can decrypt the results to prevent the leakage of confidential or private information. Reporting shall also be authenticated (to ensure that it comes from a trusted MA and that the MA reports to a genuine Collector) and not vulnerable to tampering (which can be ensured through integrity and replay checks). It shall not be possible to fool an MA by injecting falsified data and the results shall also be stored and processed securely after collection and analysis.

As far as it is available, the following information is stored for each completed test:

- Test UUID.
- Date and time.
- Latency.
- Uplink capacity.
- Downlink capacity.
- Encryption used: HTTPS over TLS.
- Number of concurrent connections.
- Client public IP.
- Client phone status and radio technology (e.g. UMTS, LTE, etc.) and quality (e.g. RSSI) Geo-location and tracking accuracy as well as movement during the test (lat, long, timestamp, accuracy, altitude, speed, bearing, location provider).
- The presented values which are measured shall have the minimum, the mean, the median and the max values.

Detailed download & upload procedure					
Duration Time (example)	Test equipment A		NETWORK		Test equipment B Data Reference System BST
	Phase 1: Initialization	→ ←		→ ←	
2 s	Phase 2: Downlink pre-test	←		←	
2,5 s	Phase 3: Latency test	→		→	
7 s	Phase 4: Downlink				
	Start using multiple socket connection 1	←		←	
	Start using multiple socket connection 2	←		←	
	Start using multiple socket connection 3	←		←	
2 s	Phase 5: Uplink pre-test	→		→	
7 s	Phase 6: Uplink	→		→	
	Start using multiple socket connection 1	→		→	
	Start using multiple socket connection 2	→		→	
	Start using multiple socket connection 3	→		→	
	Phase 7: Finalization	→ ←		→ ←	

**Figure 60: Detailed download & upload procedure**

An example of the detailed description of the Communication protocol can be found in clause 8 of [i.1].

## 6.5 QoS IP transmission layer parameter tests

### 6.5.0 Introduction

During the transmission the IP traffic from the user is passing several Firewalls und Session Border Controllers which are in some cases not transparent. To ensure a transparent E2E transmission the following tests should be executed.

**Table 11: Transparent E2E transmission tests**

1.	VoIP.
2.	TCP Port- TCP is an important connection oriented Internet protocol. It is used for example for web pages or e-mail.
3.	UDP Ports: UDP is an important connectionless Internet protocol. It is used for real-time communications, e.g. for VoIP and video.
4.	Web Page - It is verified, if the page can be transferred and how long the download of the page takes.
5.	Unmodified content- This test downloads a test web ressource (e.g. image) and checks if it was modified during transport.
6.	Transparent connection This test checks if a request is modified by a proxy or other middlebox.
7.	DNS- DNS is a fundamental Internet service. It is used to translate domain names to IP addresses. Depending on the test it is checked if the service is available, if the answers are correct and how fast the server responds.
8.	Traceroute.

#### 6.5.1 VoIP (Voice over IP)

To ensure a transparent E2E transmission of VoIP, the following Quality of Service (QoS) parameters defined in Recommendation ITU-T Y.1541 [24] should be tested with a simulated VoIP call.



**Table 12: Network performance objectives test for VoIP**

<b>Simulated VoIP call</b>		
1.	Sample rate	8 000, bits per sample: 8
2.	Call duration	8 000 ms
3.	Packet interval:	20 ms
4.	Payload type: PCMA	PCMA
5.	Target port:	5 060
<b>Incoming voice stream, measured values</b>		
6.	max. jitter:	ms
7.	mean jitter:	ms
8.	max. delta:	ms
9.	packets received:	400
10.	packet lost percentage:	%
11.	sequence errors:	number of sequence errors
<b>Outgoing voice stream</b>		
12.	max. jitter:	ms
13.	mean jitter:	ms
14.	max. delta:	ms
15.	packets received:	400
16.	packet lost percentage:	%
17.	sequence errors:	number of sequence errors

## 6.5.2 TCP Parameters

TCP is an important connection oriented Internet protocol. It is used for example for web pages or e-mail. To ensure a transparent E2E transmission the following TCP port tests should be executed.

**Table 13: TCP port tests**

1.	Web site protocol (HTTP alternate, TCP port 8080 incoming)
2.	Secure control of communication sessions (SIP over TLS, TCP port 5061 incoming)
3.	Peer to peer file sharing (BitTorrent, TCP port 6881 outgoing)
4.	Secure e-mail retrieval and storage (IMAPS, TCP port 993 outgoing)
5.	Web site protocol (HTTP, TCP port 80 outgoing)
6.	Secure e-mail retrieval and storage (IMAPS, TCP port 585 outgoing)
7.	Online anonymity (TOR, TCP port 9001 outgoing)
8.	File transfer protocol (FTP, TCP port 21 outgoing)
9.	Control of communication sessions (SIP, TCP port 5060 outgoing)
10.	E-mail transmission (SMTP, TCP port 587 outgoing)
11.	Secure e-mail retrieval (POP3S, TCP port 995 outgoing)
12.	Control of streaming of audio and visual media (RTSP, TCP port 554 outgoing)
13.	Name resolving for computers and services (DNS, TCP port 53 outgoing)
14.	E-mail retrieval and storage (IMAP, TCP port 143 outgoing)
15.	E-mail retrieval (POP3, TCP port 110 outgoing)
16.	Secure e-mail transmission (SMTPS, TCP-Port 465 ausgehend)
17.	E-mail transmission (SMTP, TCP port 25 outgoing)
18.	Secure logins and file transfers (SSH, TCP port 22 outgoing)

## 6.5.3 UDP Parameters

UDP is an important connectionless Internet protocol. It is used for real-time communications, e.g. for VoIP and video. To ensure a transparent E2E transmission the following UDP port tests should be executed.

**Table 14: UDP port tests**

1.	Microsoft Terminal Server (RDP, UDP port 3389 incoming)
2.	Streaming of audio and visual media (RTP, UDP port 5004 incoming)
3.	Control of streaming of audio and visual media (RTSP, UDP port 554 outgoing)
4.	Voice over Internet (VoIP, UDP port 7078 outgoing)
5.	Time synchronization (NTP, UDP port 123 outgoing)
6.	Time synchronization (NTP, UDP port 123 outgoing)
7.	Name resolving for computers and services (DNS, UDP port 53 outgoing)
8.	Online gaming (Steam gaming, UDP port 27015 outgoing)
9.	Voice over Internet (VoIP, UDP port 7082 outgoing)
10.	Streaming of audio and visual media (RTP, UDP port 5004 outgoing)
11.	Control of communication sessions (SIP, UDP port 5060 outgoing)
12.	Establishment and usage of secure services (ISAKMP, UDP port 500 outgoing)
13.	Quality of service for streaming of audio and visual media (RTCP, UDP port 5005 outgoing)

### 6.5.4 Web Page

The website test downloads a reference web page (mobile Kepler page by ETSI). It is verified, if the page can be transferred and how long the download of the page takes.

### 6.5.5 Unmodified content

This test downloads a test web resource (e.g. image) and checks if it was modified during transport.

EXAMPLE:

Target: 'http://webtest.nettest.at/qostest/reference01.jpg'

Range: bytes=1000000-1004999

Duration: 0,1 s

Length: 5 000

Status code: 206

Hash: fc563e1e80b8cb964d712982fa2143c8

Header:

Connection: keep-alive

Content-Length: 5 000

Content-Range: bytes 1000000-1004999/9982005

Content-Type: image/jpeg

Date: Fri, 07 Jul 2017 14:16:41 GMT

ETag: "54974579-985035"

Last-Modified: Sun, 21 Dec 2014 22:11:05 GMT

Server: nginx

X-Android-Received-Millis: 1499437001400

X-Android-Response-Source: NETWORK 206

X-Android-Sent-Millis: 1499437001341

### 6.5.6 Transparent connection

This test checks if a request is modified by a proxy or other middlebox

**Table 15: Transparent port test**

1.	Port: 45963, Request: GET / HTTP/7.9
2.	Port: 80, Request: GET
3.	Port: 25, Request: SMTP Transparent
4.	Port: 23329, Request: GET
5.	Port: 80, Request: GET / HTTP/7.9

## 6.5.7 DNS

DNS is a fundamental Internet service. It is used to translate domain names to IP addresses. Depending on the test it is checked if the service is available, if the answers are correct and how fast the server responds.

**Table 16: DNS test**

1.	google.com
2.	youtube.com
3.	facebook.com
4.	baidu.com
5.	wikipedia.org
6.	yahoo.com
7.	google.co.in
8.	reddit.com
9.	qq.com
10.	amazon.com
11.	taobao.com
12.	twitter.com
13.	vk.com
14.	instagram.com
15.	google.de
16.	google.co.uk
17.	google.fr
18.	google.ru
19.	yandex.ru
20.	ebay.com
21.	google.ca
22.	microsoft.com
23.	t-online.de
24.	spiegel.de
25.	telekom.com
26.	rtr.at
27.	whatsapp.com
28.	google.at
29.	orf.at
30.	telekom.at

## 6.5.8 Traceroute

Traceroute is a tool for displaying the route across IP based networks.

---

## Annex A (informative): Bibliography

- Recommendation ITU-T P.800.1 (07-2006): "Mean Opinion Score (MOS) terminology".
- ETSI TS 103 189 (V1.2.1): "Core Network and Interoperability Testing (INT); Assessment of end-to-end Quality for VoLTE and RCS".

---

## History

<b>Document history</b>		
V1.1.1	November 2015	Publication
V1.2.1	March 2018	Publication