

ETSI TS 103 247 V1.1.1 (2015-09)



**Access, Terminals, Transmission and Multiplexing (ATTM);
Singlemode Optical Fibre System Specifications
for Home Cabling**

Reference

DTS/ATTM-02008-2

Keywords

cable, fibre, network, optical

ETSI

650 Route des Lucioles
F-06921 Sophia Antipolis Cedex - FRANCE

Tel.: +33 4 92 94 42 00 Fax: +33 4 93 65 47 16

Siret N° 348 623 562 00017 - NAF 742 C
Association à but non lucratif enregistrée à la
Sous-Préfecture de Grasse (06) N° 7803/88

Important notice

The present document can be downloaded from:
<http://www.etsi.org/standards-search>

The present document may be made available in electronic versions and/or in print. The content of any electronic and/or print versions of the present document shall not be modified without the prior written authorization of ETSI. In case of any existing or perceived difference in contents between such versions and/or in print, the only prevailing document is the print of the Portable Document Format (PDF) version kept on a specific network drive within ETSI Secretariat.

Users of the present document should be aware that the document may be subject to revision or change of status. Information on the current status of this and other ETSI documents is available at
<http://portal.etsi.org/tb/status/status.asp>

If you find errors in the present document, please send your comment to one of the following services:
<https://portal.etsi.org/People/CommitteeSupportStaff.aspx>

Copyright Notification

No part may be reproduced or utilized in any form or by any means, electronic or mechanical, including photocopying and microfilm except as authorized by written permission of ETSI.

The content of the PDF version shall not be modified without the written authorization of ETSI.
The copyright and the foregoing restriction extend to reproduction in all media.

© European Telecommunications Standards Institute 2015.
All rights reserved.

DECT™, **PLUGTESTS™**, **UMTS™** and the ETSI logo are Trade Marks of ETSI registered for the benefit of its Members.
3GPP™ and **LTE™** are Trade Marks of ETSI registered for the benefit of its Members and of the 3GPP Organizational Partners.
GSM® and the GSM logo are Trade Marks registered and owned by the GSM Association.

Contents

Foreword.....	5
Modal verbs terminology.....	5
Introduction	5
1 Scope	7
2 References	7
2.1 Normative references	7
2.2 Informative references.....	9
3 Definitions and abbreviations.....	10
3.1 Definitions.....	10
3.2 Abbreviations	10
4 HAN architecture evolution	12
4.1 Introduction	12
4.2 HAN architectures.....	13
4.2.1 Different architecture.....	13
4.2.2 Single format HAN.....	13
4.2.3 Multi format HAN.....	14
4.2.3.1 A mid-term architecture: the Multiformat Active Star.....	14
4.2.3.2 A longer-term architecture: the Multiformat Passive Star.....	15
5 HAN performances.....	18
5.1 HAN optical power budget.....	18
5.1.1 Introduction.....	18
5.1.2 Transmission system requirements	18
5.1.2.1 Assumptions.....	18
5.1.2.2 Active star architecture.....	19
5.1.2.3 CWDM passive star architecture.....	20
5.1.3 Attenuation requirements for passive optical network.....	21
5.1.4 Optical budget deterioration	22
5.1.4.1 Definitions of requirements.....	22
5.1.4.2 BOL (Begin-Of-Life).....	23
5.1.4.3 EOL (End-Of-Life)	23
6 Home area network cabling.....	23
6.1 Introduction	23
6.2 Optical fibre.....	23
6.3 Cables	23
6.3.1 Generalities	23
6.3.2 Dimensional and colour requirements	24
6.3.3 Mechanical requirements	24
6.3.4 Environmental requirements	24
6.4 Optical connector	24
6.5 Optical non-wavelength-selective splitter	25
6.6 Optical WDM (Wavelength-Division-Multiplexer)	25
7 Reliability	25
7.1 Reliability of active devices	25
7.2 Reliability of passive components.....	25
8 Installation.....	25
9 Energy efficiency	25
Annex A (informative): Optical Telecommunication Outlet - wall socket	27
A.1 Introduction	27
A.2 Connection type.....	27

A.3	Optical connections in wall outlet	27
A.4	Interfaces - External sockets.....	28
A.5	Interfaces - Internal sockets.....	28
A.6	Wall socket plugs versions	28
A.7	Sustainability requirements	29
A.8	Examples of optical fibre wall outlet.....	29
Annex B (informative): Residential PON example.....		30
B.1	Residential network evolution.....	30
B.2	Architecture 1 - centralized mode according to Recommendation ITU-T G.9960 (G.hn) - P2MP	30
B.3	Architecture 2 - peer to peer-mode according to Recommendation ITU-T G.9960 (G.hn) - MP2MP	32
B.4	Architecture 3 - G.hn with RF Video Overlay	33
B.5	Residential network performances	33
B.5.1	Optical power budget	33
B.5.2	Transmission system requirements.....	33
Annex C (informative): Multiformat active star example		34
C.1	Introduction	34
C.2	First option: electrical multiplex on an optical path.....	34
C.3	Second option: hybrid electrical / optical multiplex.....	39
Annex D (informative): Multiformat passive star example		43
D.1	Introduction	43
D.2	The demonstrated configuration.....	44
D.3	Implementing the applications	47
D.3.1	Residential PON ("PON-like") application	47
D.3.2	"LAN-like" application	47
D.3.3	RoF application	48
D.3.4	TV broadcast application.....	48
D.3.5	Point to point application	49
D.3.6	Simultaneous running applications.....	49
Annex E (informative): Example of an optical fibre home cabling system.....		51
E.1	Introduction	51
E.2	Installation of an optical fibre home cabling system.....	51
E.3	Connection of the optical TO to the end user equipment.....	52
	History	53

Intellectual Property Rights

IPRs essential or potentially essential to the present document may have been declared to ETSI. The information pertaining to these essential IPRs, if any, is publicly available for **ETSI members and non-members**, and can be found in ETSI SR 000 314: "*Intellectual Property Rights (IPRs); Essential, or potentially Essential, IPRs notified to ETSI in respect of ETSI standards*", which is available from the ETSI Secretariat. Latest updates are available on the ETSI Web server (<http://ipr.etsi.org>).

Pursuant to the ETSI IPR Policy, no investigation, including IPR searches, has been carried out by ETSI. No guarantee can be given as to the existence of other IPRs not referenced in ETSI SR 000 314 (or the updates on the ETSI Web server) which are, or may be, or may become, essential to the present document.

Foreword

This Technical Specification (TS) has been produced by ETSI Technical Committee Access, Terminals, Transmission and Multiplexing (ATTM).

Modal verbs terminology

In the present document "**shall**", "**shall not**", "**should**", "**should not**", "**may**", "**need not**", "**will**", "**will not**", "**can**" and "**cannot**" are to be interpreted as described in clause 3.2 of the [ETSI Drafting Rules](#) (Verbal forms for the expression of provisions).

"**must**" and "**must not**" are **NOT** allowed in ETSI deliverables except when used in direct citation.

Introduction

Singlemode non-dispersion shifted optical fibres with step-index according to CENELEC EN 60793-2-50 [5] with cladding diameter of 125 μm (referred to as SM in the present document) are mostly deployed in telecommunication networks. The rise of available transmission [bandwidth](#) per fiber is even significantly faster than e.g. the increase of storage capacity of electronic memory chips, or the increase of computation power of microprocessors. The main advantages of SM are:

- SM is the current communication wireline with the biggest bandwidth (up to 160 Gbit/s)
- SM is the current optical waveguide with the lowest optical losses (< 0,25 dB/km at 1 550 nm, see figure 1)
- SM is the waveguide with the best possibilities for wavelength multiplexing
- SM optical connections have the best developed theory for optical interface with narrow uncertainties
- There are reasonable compatibilities for connecting SM fibres of different types (considering losses)
- Complete immunity to electromagnetic interference (EMI)
- Compared with electrical cables, fiber-optic cables are very lightweight

For all these reasons, SM is potentially the best and most sustainable solution for all telecommunication networks.

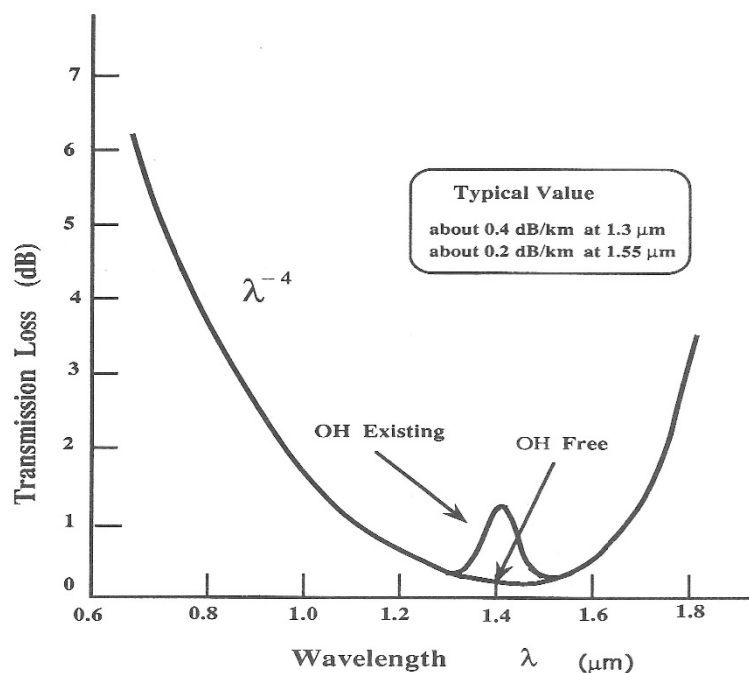

Figure 1: Singlemode fibre attenuation versus wavelength

The home network should not represent a bottleneck for the expected evolution for services such as the introduction of High Definition quality IPTV, multi-room/multi-vision configuration, using different channels seen in different rooms with up to 3 Set Top Boxes (STBs) and high quality video communication via the TV set. More in general, with the "Connected Home", several devices are connected together: the home network can be used, for example, to share multimedia contents not necessarily delivered in real time by access network, but with the paradigm of "download and play" this content can be stored in a device inside the house and use it afterwards. However, this residential network cabling should be easy, fast and cheap to deploy.

The home network should be able to manage multiformat and multiservice characteristics of the information delivered by different service providers.

1 Scope

The present document specifies the SM cabling system for multiformat and multiservices optical home area network (HAN) for interoperability among different suppliers. The system comprises of the active optical elements, the cables, connectors and wall plugs.

2 References

2.1 Normative references

References are either specific (identified by date of publication and/or edition number or version number) or non-specific. For specific references, only the cited version applies. For non-specific references, the latest version of the reference document (including any amendments) applies.

Referenced documents which are not found to be publicly available in the expected location might be found at <http://docbox.etsi.org/Reference>.

NOTE: While any hyperlinks included in this clause were valid at the time of publication, ETSI cannot guarantee their long term validity.

The following referenced documents are necessary for the application of the present document.

- [1] Directive 2002/95/EC of the European Parliament and of the Council of 27 January 2003 on the restriction of the use of certain hazardous substances in electrical and electronic equipment.
- [2] IEEE 802.3: "LAN/MAN CSMA/CD (Ethernet) Access Method".
- [3] CENELEC EN 50399: "Common test methods for cables under fire conditions - Heat release and smoke production measurement on cables during flame spread test - Test apparatus, procedures, results".
- [4] ETSI TS 101 791: "Transmission and Multiplexing (TM); Dense wavelength division multiplexing devices; Common requirements and conformance testing".
- [5] CENELEC EN 60793-2-50: "Optical fibres - Part 2-50: Product specifications - Sectional specification for category B singlemode fibres".
- [6] CENELEC EN 60825-1: "Safety of laser products - Part 1: Equipment classification and requirements".
- [7] CENELEC EN 60875-1: "Fibre optic interconnecting devices and passive components - Non-wavelength-selective fibre optic branching devices - Part 1: Generic specification".
- [8] CENELEC EN 61753-031-2/Ed2: "Fibre optic interconnecting devices and passive components - Performance standard - Part 031- 2: Non-connectorised single-mode 1×N and 2×N non-wavelength-selective branching devices for Category C - Controlled environment".
- [9] CENELEC EN 62074-1: "Fibre optic interconnecting devices and passive components - Fibre optic WDM devices - Part 1: Generic specification".
- [10] CENELEC EN 61754-series: "Fibre optic connector interfaces".
- [11] CENELEC EN 61755 series: " Fibre optic connector optical interfaces".
- [12] EU: "Code of Conduct on Energy Consumption of Broad Band Equipment", version 3 18 November 2008.
- [13] IEC 60884-1: "Plugs and socket-outlets for household and similar purposes - Part 1: General requirements".

- [14] ISO/IEC 8802-3: "Information technology -- Telecommunications and information exchange between systems -- Local and metropolitan area networks -- Specific requirements -- Part 3: Carrier sense multiple access with collision detection (CSMA/CD) access method and physical layer specifications".
- [15] CENELEC EN 60950-1: "Information technology equipment - Safety - Part 1: General requirements".
- [16] Recommendation ITU-T G.671: "Transmission media and optical systems characteristics - Characteristics of optical components and subsystems, Transmission characteristics of optical components and subsystems".
- [17] Recommendation ITU-T G.9960 (G.hn).
- [18] Recommendation ITU-T K.21: "Resistibility of telecommunication equipment installed in customer premises to overvoltages and overcurrents".
- [19] ETSI ETS 300 019-2-3: "Equipment Engineering (EE); Environmental conditions and environmental tests for telecommunications equipment; Part 2-3: Specification of environmental tests; Stationary use at weatherprotected locations".
- [20] CENELEC EN 50173-1: " Information technology - Generic cabling systems - Part 1: General requirements and office areas".
- [21] CENELEC EN 61755-1: " Fibre optic connector optical interfaces - Part 1: Optical interfaces for single mode non-dispersion shifted fibres - General and guidance".
- [22] CENELEC EN 60794-2 series: "Optical fibre cables; part 2: Indoor cables - Sectional specification".
- [23] CEN EN 13501-6: "Fire Classification of Construction Products and Building elements - Part 6: Classification using test data from reaction to fire tests on electric cables".
- [24] CENELEC EN 60794-1-21: "Optical fibre cables - Part 1-21: Generic specification - Basic optical cable test procedures - Mechanical Tests Methods".
- [25] CENELEC EN 60332-1-2: "Tests on electric and optical fibre cables under fire conditions - Part 1-2: Test for vertical flame propagation for a single insulated wire or cable - Procedure for 1 kW pre-mixed flame".
- [26] CENELEC EN 50267-2-3: Common test methods for cables under fire conditions - Tests on gases evolved during combustion of materials from cables - Part 2-3: Procedures - Determination of degree of acidity of gases for cables by determination of the weighted average of pH and conductivity".
- [27] CENELEC EN 61754-20: "Fibre optic interconnecting devices and passive components - Fibre optic connector interfaces - Part 20: Type LC connector family".
- [28] CENELEC EN 61754-4: "Fibre optic interconnecting devices and passive components - Fibre optic connector interfaces - Part 4: Type SC connector family".
- [29] CENELEC EN 61754-29: "Fibre optic interconnecting devices and passive components - Fibre optic connector interfaces - Part 29: Type BLINK connector series".
- [30] CENELEC EN 61754-30: " Fibre optic interconnecting devices and passive components - Fibre optic connector interfaces - Part 30: Type CLIK connector series".
- [31] CENELEC EN 61755-1: "Fibre optic connector optical interfaces - Part 1: Optical interfaces for single mode non-dispersion shifted fibres - General and guidance".
- [32] CENELEC EN 61755-2-1: "Fibre optic connector optical interfaces - Part 2-1: Optical interface standard single mode non-angled physically contacting fibres".
- [33] CENELEC EN 61755-2-2: "Fibre optic connector optical interfaces - Part 2-2: Optical interface standard single mode angled physically contacting fibres".

- [34] CENELEC EN 61755-3-1: "Fibre optic connector optical interfaces - Part 3-1: Optical interface, 2,5 mm and 1,25 mm diameter cylindrical full zirconia PC ferrule, single mode fibre".
- [35] CENELEC EN 61755-3-2: "Fibre optic connector optical interfaces - Part 3-2: Optical interface, 2,5 mm and 1,25 mm diameter cylindrical full zirconia ferrules for 8 degrees angled-PC single mode fibres".
- [36] CENELEC EN 61300-3-6:" Fibre optic interconnecting devices and passive components - Basic test and measurement procedures - Part 3-6: Examinations and measurements - Return loss".
- [37] CENELEC EN 61300-3-34: "Fibre optic interconnecting devices and passive components - Basic test and measurement procedures - Part 3-34: Examinations and measurements - Attenuation of random mated connectors".
- [38] CENELEC EN 61300-3-4: "Fibre optic interconnecting devices and passive components - Basic test and measurement procedures - Part 3-4: Examinations and measurements - Attenuation".
- [39] CENELEC EN 55022: "Limits and methods of measurement of radio disturbance characteristics of information technology equipment".
- [40] CENELEC EN 55024: "Information technology equipment - Immunity characteristics - Limits and methods of measurement".
- [41] CENELEC EN 61753-031-2: "Fibre optic interconnecting devices and passive components - Performance standard - Part 031-2: Non-connectorized single-mode 1×N and 2×N non-wavelength-selective branching devices for Category C - Controlled environment".
- [42] Directive 2012/27/EU of the European Parliament and of the Council of 25 October 2012 on energy efficiency, amending Directives 2009/125/EC and 2010/30/EU and repealing Directives 2004/8/EC and 2006/32/EC Text with EEA relevance 2012/27/EU.
- [43] Code of Conduct for Broadband Equipment version 3, 18 November 2008.
- [44] Recommendation ITU-T G.657: " Characteristics of a bending-loss insensitive single-mode optical fibre and cable for the access network".
- [45] Recommendation ITU G.652: "Characteristics of a single-mode optical fibre and cable".
- [46] EN 60794-1-22: "Optical fibre cables - Part 1-22: Generic specification - Basic optical cable test procedures - Environmental Tests Methods".

2.2 Informative references

References are either specific (identified by date of publication and/or edition number or version number) or non-specific. For specific references, only the cited version applies. For non-specific references, the latest version of the reference document (including any amendments) applies.

NOTE: While any hyperlinks included in this clause were valid at the time of publication, ETSI cannot guarantee their long term validity.

The following referenced documents are not necessary for the application of the present document but they assist the user with regard to a particular subject area.

- [i.1] IEEE 802.3u: "Local and Metropolitan Area Networks-Supplement - Media Access Control (MAC) Parameters, Physical Layer, Medium Attachment Units and Repeater for 100Mb/s Operation, Type 100BASE-T (Clauses 21-30)".
- [i.2] IEEE 802.3x: "IEEE Standards for Local and Metropolitan Area Networks: Specification for 802.3 Full Duplex Operation".
- [i.3] IEEE 802.1Q: "IEEE Standard for Local and Metropolitan Area Networks - Virtual Bridged Local Area Networks".
- [i.4] IEEE 802.1p: "IEEE Standard for Local and Metropolitan Area Networks - Supplement to Media Access Control (MAC) Bridges: Traffic Class Expediting and Dynamic Multicast Filtering".

- [i.5] IEEE 802.1D: "IEEE Standard for Local and metropolitan area networks: Media Access Control (MAC) Bridges".

3 Definitions and abbreviations

3.1 Definitions

For the purposes of the present document, the terms and definitions given in Recommendation ITU G.671 [16] and the following apply:

access point: physical point where terminal equipment can be connected on physical interface (Home Network Extender) like RJ45®, etc.

global link: transmission link between transmitter and receiver of two connected systems

global link loss: loss of the global link comprising loss of the permanent link and all additional optical elements losses

home network extender: access point located in each room and capable to give access to the multiformat services at the customer by multiplexing (uplink) and demultiplexing (down link)

Home Area Network (HAN): network of optical fibres in homes that considers convergence of communication multiformat services and extends an access from a carrier's central office, broadcast terrestrial, cable or satellite TV or other networks (ICT, BCT, CCCB, etc.)

multiformat: different format of signal (Ethernet, broadcasted TV, Phone, etc.)

multiformat link: link capable to transport over a single medium multiformat signals from the multiformat switch to the extender

multiformat switch: active equipment able to multiplex multiformat signals

multiservice: several services like telephone, TV, Internet, etc.

permanent link: part of the transmission link comprising fixed cabling (fibre and permanent optical elements) with one connector at each end

permanent link loss: loss of the permanent link comprising fibre and permanent optical elements losses

point-to-point link: direct link from one physical point to another physical point
Point-to-MultiPoint link: link from one physical point to several physical points

multiPoint-to-multipoint link: link from several physical points to several physical points

triple play services: triple-play service scenario is one in which voice, video and data are all provided in a single access subscription

3.2 Abbreviations

For the purposes of the present document, the following abbreviations apply:

ACS	Auto Configuration Server
AP	Access Point
APC	Angled Physical Contact
BCT	Broadcast and Communications Technology
BIDI	Bidirectional
BO	Broadcast Outlet
BOL	Begin-Of-Life
CATV	Cable TV
CCCB	Commands, Controls and Communications in Buildings
CPE	Customer Premises Equipment
CPR	Construction Product Regulation
CWDM	Coarse Wavelength Division Multiplexing
DFB	Distributed feedback

DIY	Do It Yourself
DVB	Digital Video Broadcasting
DVB-S	Digital Video Broadcasting - Satellite
DVB-T	Digital Video Broadcasting - Terrestrial
DWDM	Dense Wavelength Division Multiplexing
EMI	Electro Magnetic Interference
EOL	End-Of-Life
Ext	Extender
FMT	Fibre Management Tray
FSAN	Full Service Access Network
FTTH	Fiber To The Home
GL	Global Link
GOF	Glass Optical Fibre
GPON	Gigabit Passive Optical Network
GTW	Gateway
HAN	Home Area Network
HD	Home Distributor
HDMI	High Definition Multimedia Interface
HG	Home Gateway
ICT	Information and Communications Technology
IP	Internet Protocol
IPTV	Internet Protocol Television
LAN	Local Area Network
LC	Lucent Connector
LD	Laser Diode
LNB	Low Noise Block
MAC	Media Access Control
MC	Mediaconverters
MS	Multiformat Switch
MTBF	Mean Time Between Failures
OFE	Optical FrontEnd
ONT	Optical Network termination
OTO	Optical Telecommunication Outlet
P2P	Point-to-Point
PC	Physical Contact
PCI	Peripheral Component Interconnect
PD	Photo Diode
PF	Perfluorinated
PIN	Positive Intrinsic Negative
PL	Permanent Link
POF	Plastic Optical Fibre
PON	Passive Optical Network
PVC	PolyVinyl Chloride
QoE	Quality of Experience
QoS	Quality of Service
RF	Radio Frequency
RoF	Radio over Fibre
RoHS	Restriction of the Use of Certain Hazardous Substances
SC	Subscriber Connector
SEF	Subscriber Entry Facilities
SFP	Small Form-factor Pluggable
SM	Single Mode
STB	Set Top Box
SW	Switch
TDMA	Time division multiple access
TO	Telecommunications Outlet
TOS	Type of Service
TV	Television
TVoIP	Television over IP
TX	Tranceiver
UHF	Ultra High Frequency
UTP5	Unshielded Twisted Pair (Category 5)

UWB	Ultra Wide Band
VAC	Volts Alternating Current
VCSEL	Vertical Cavity Surface Emitting Laser
VDSL2	Very high bit-rate Digital Subscriber Line
VLAN	Virtual Local Area Network
WDM	Wavelength Division Multiplexing

4 HAN architecture evolution

4.1 Introduction

HAN includes active and passive networks deployed at the customer's site (apartment or building) between the Home Distributor (HD) and the end-user devices (TV, PC, telephone, surveillance, etc.).

The Home Distributor is located at the SEF (Subscriber Entrance Facilities) and includes the ENTI (External Network Testing Interface) and active equipments (CPE as Customer Premises Equipment) like Home Gateway (HG), Multifunction Switch (MS), etc.

The HD is connected with optical links to optical TO/BO (Telecommunications Outlet/Broadcast Outlet) where the end-user devices are connected via converters or extenders if needed.

The inputs to STB from terrestrial TV and satellite TV should be copper or fibre cables.

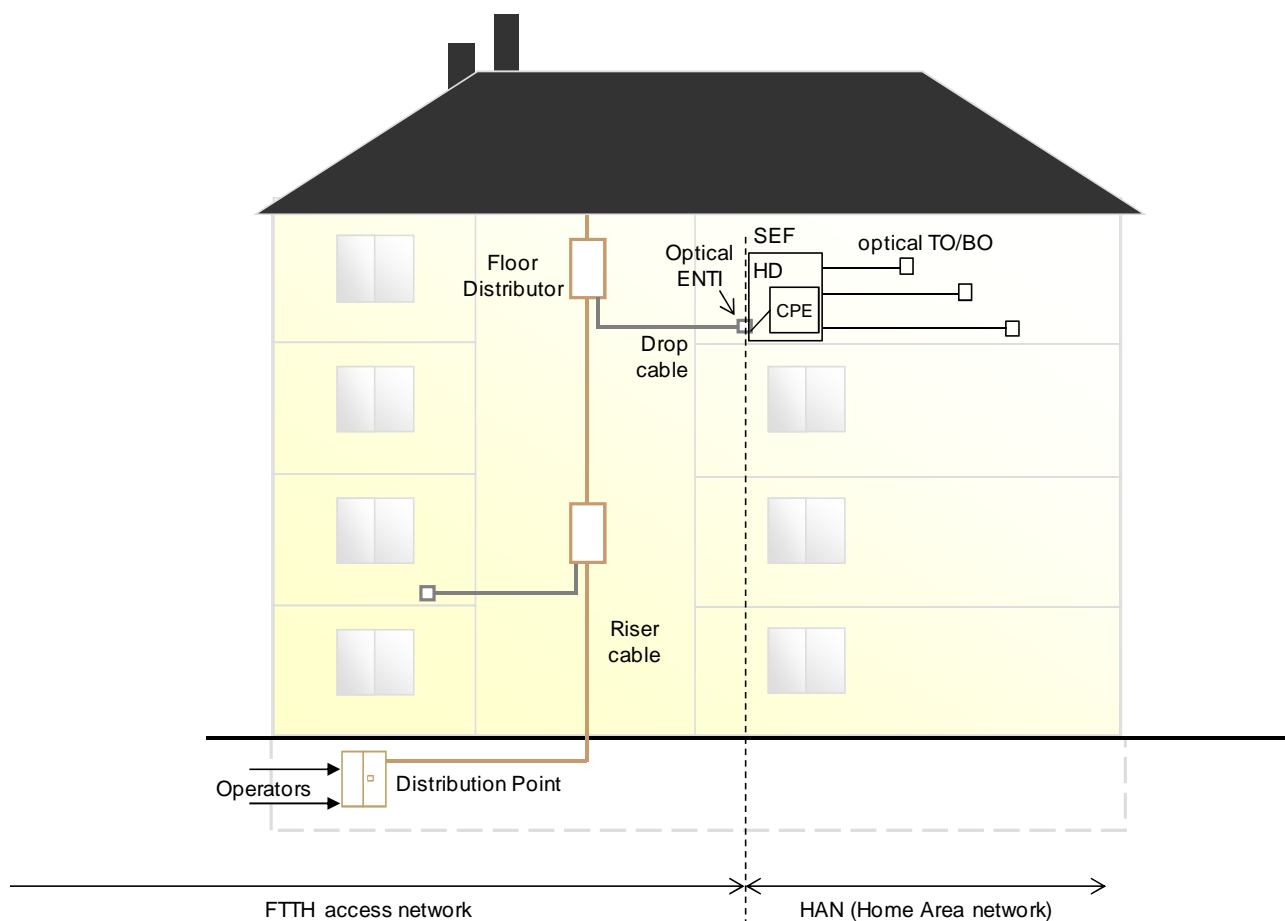

Figure 2: FTTH and HAN cabling system scope

Increasing the bit rate to meet the requirements related to the richness of the contents and high interactivity, and taking into account the heterogeneity of the signals to be delivered are the two major challenges which drive the HAN evolutions.

Data exchanges (traffic) have drastically increased in the Home Area Network (HAN) these last years and this expansion is expected to indubitably go on for a long time. First, because significant progress has been accomplished during the last years in the access networks: with continuously increasing bit rate on copper networks thanks to xDSL technologies, or as well with the Fiber-To-The-Home (FTTH) deployments, it is now possible to deliver rich contents up to the user's door. The second reason is the steadily increasing number of interconnected devices inside the home, implementing multi-Gigabit interfaces such as USB-3 (4,8 Gbit/s) or Thunderbolt (10 Gbit/s).

However, besides the need for high capacity, another major challenge lies in the great heterogeneity of signals to be delivered in the home. Actually, the HAN is the convergence point of many competing worlds, as computer, telecommunication, consumer electronics and several types of signals have to be considered: IP data for triple play services, Radio Frequency (RF) signals for broadcast TV (terrestrial, satellite or cable TV), specific formats as High Definition Multimedia Interface (HDMI) signals or related to various very high bit rate interfaces for example. Today, separate network segments are used in the home, each carrying one type of service (Ethernet cables for IP data, coaxial cable for broadcasted terrestrial or satellite TV, HDMI cables for high definition digital video). This situation is expected to be soon unacceptable by the customer, and the only solution is a structured home network able to carry all these signals on a unique convergent infrastructure. In addition, to guarantee effectiveness, safety and comfort in use, the medium used to realize the HAN is expected to be integrated inside the walls of the home: singlemode optical fiber then appears as a very good candidate to implement such a multiformat and future-proof network, as its performances allows facing further evolutions of HAN requirements.

4.2 HAN architectures

4.2.1 Different architecture

Today, the HAN architecture is a single format active star network dedicated to services based on Ethernet or IP technology. Two other multiformat architectures, taking into account additional types of signals encountered in the home, are described in the present document: the first one, a mid-term approach, is based on multiformat active star architecture, while the second one is a longer term solution based on a passive star and CWDM technology.

4.2.2 Single format HAN

Most home networks are presently based on a single format active star. A Home Gateway typically placed at the apartment entrance, where the external access network is terminated with the ENTI (External Network Testing Interface), acts as a central switch, being the node of an active star. Customer's premises are connected to this Home Gateway through point-to-point (P2P) links (or wireless links), as shown at figure 3. Only one type of data, based on Ethernet or IP protocols, is supported by this single format network.

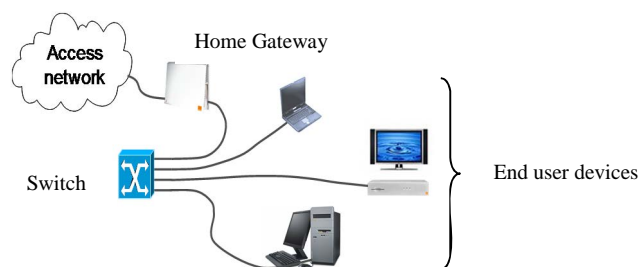

Figure 3: Point-to-Point IP architecture

4.2.3 Multi format HAN

4.2.3.1 A mid-term architecture: the Multiformat Active Star

Only a multiformat Home Area Network, able to deliver several types of signals, makes possible the convergence of all services on a unique physical infrastructure. The first proposed solution, a mid-term solution, is based on a multiformat active star topology. In this configuration shown in figure 4, all types of signals converge to a central node, named the Multiformat Switch (MS): IP data coming from the access network or home devices, RF signals as broadcasted TV coming from the roof antenna or the satellite dish and radio programs. These signals are separately processed and then multiplexed at each port of the MS. The multiplex is then transmitted to each room by point to point multiformat links. In each room, a remote device named "extender" acts as a multiformat link and demultiplexes the different signals, which can then be delivered using an appropriate interface. The one or two meters final link from the extender to the terminal device should use any convenient medium, for example wireless, coaxial, Ethernet cable or plastic fibre. A similar process is applied for the uplink.

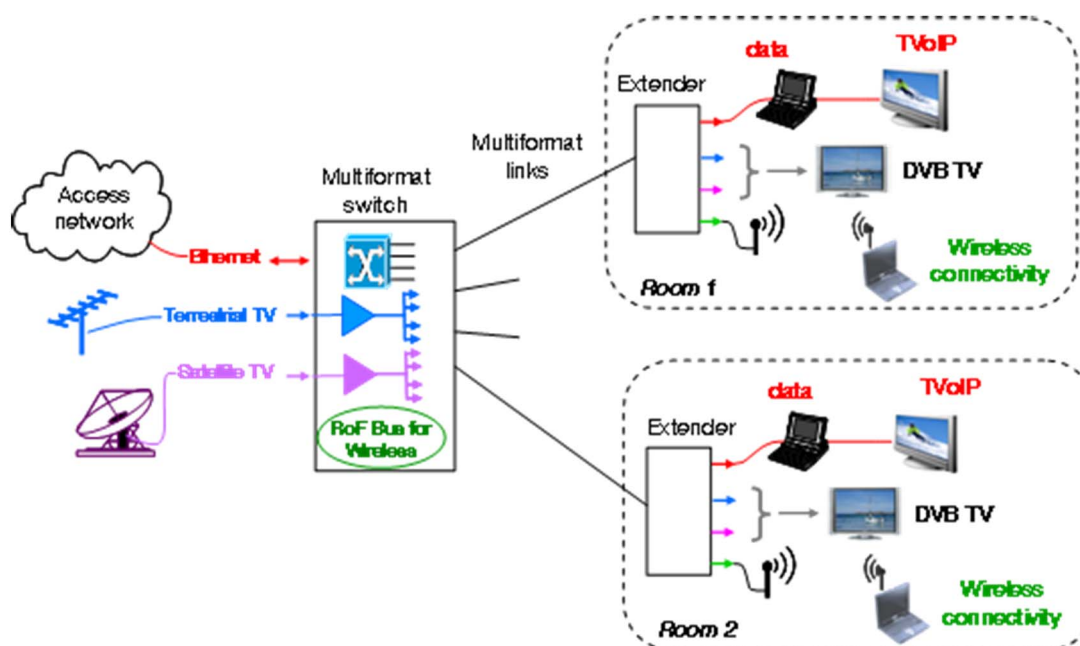

Figure 4: Point-to-Point multiformat active star architecture

Two solutions are possible to achieve the multiplex of the different types of signals. If there is no electrical spectrum overlapping between these signals, a simple multiplexing in the electrical domain can be done. The electrical multiplex is then used to modulate a laser located at each port of the MS. An example is given at figure 5, combining 100 Mbit/s Ethernet (Fast Ethernet), terrestrial TV (DVB-T), satellite TV (DVB-S) and a RF signal for wireless final connection.

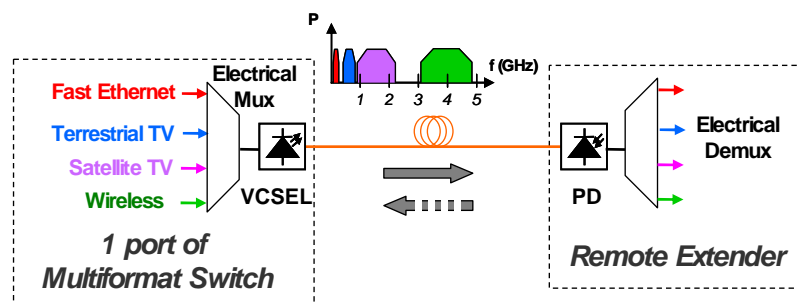

Figure 5: Multiformat link based on electrical multiplexing

With this simple solution, evolution towards 1 Gbit/s Ethernet is not possible, as spectrums of Gigabit Ethernet and terrestrial TV would overlap. One solution then consists in combining optical and electrical multiplexing: the RF signals remain multiplexed in the electrical domain before modulating a laser. Gigabit (or more) Ethernet is applied to another laser, the two optical signals being then combined by an optical mux. Two options again are possible: in the first one (figure 6), one fibre is dedicated only to Ethernet signals, using bidirectional transmission at two different wavelengths, while a second fibre is dedicated to the transmission of the RF multiplex. In the second option (figure 7), only one fibre is used, thanks to additional optical mux/demux.

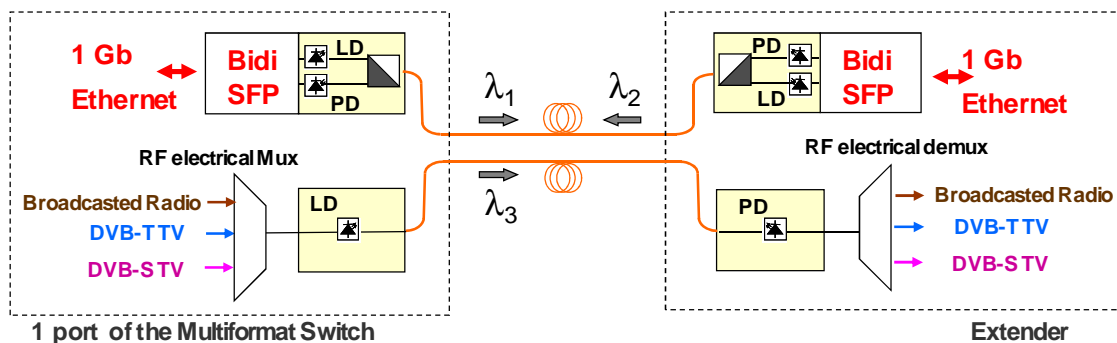

Figure 6: Multifformat link based on hybrid electrical / optical multiplexing (bifibre configuration)

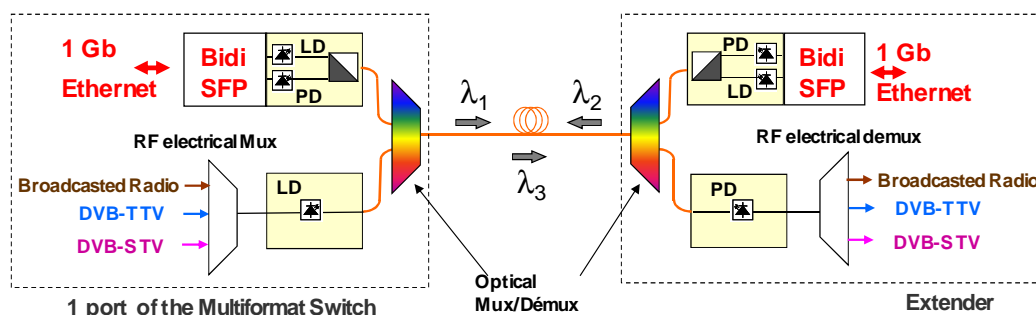

Figure 7: Multifformat link based on hybrid electrical / optical multiplexing (single fibre configuration)

With these two options, evolution towards higher Ethernet bit rates (for example 10 Gbit/s) is simple, and has been demonstrated, as only the Ethernet signal is present in this channel.

4.2.3.2 A longer-term architecture: the Multifformat Passive Star

The previously described solution, the multifformat active star, which has been widely demonstrated, is close to an industrial development. However, it could be only the first step as capacity and multiplexing possibilities remain limited on point to point links. Actually, the active central node, being not transparent, is a blocking point for optical signals, and optical multiplexing and demultiplexing shall be achieved at each port of the MS. This leads to the proliferation of optical devices and a drastic system cost increase. A second architecture, a longer term solution based on an optical passive star, allows overcoming this issue. In this configuration, the network is centered on a passive $N \times N$ splitter, which provides a broadcast architecture. Thanks to this splitter, a signal transmitted by any connected device is broadcasted to all the device receivers. The CWDM (coarse WDM) technology is then used to separate the various types of signals: the home network terminations (extenders) in the different rooms integrate optical "add and drop" (A&D) filters allowing the injection or the selection of one wavelength to connect to the desired application. Instead of standard optical bandpass filters, A&D modules are preferred as they give the possibility of cascading different applications connected at one unique optical outlet, and thus to access to several services in each room. This CWDM broadcast & select architecture provides not only an enormous capacity and an efficient separation between incompatible signals, but also a great flexibility, as many different logical topologies should be emulated simultaneously on such an infrastructure (figure 8).

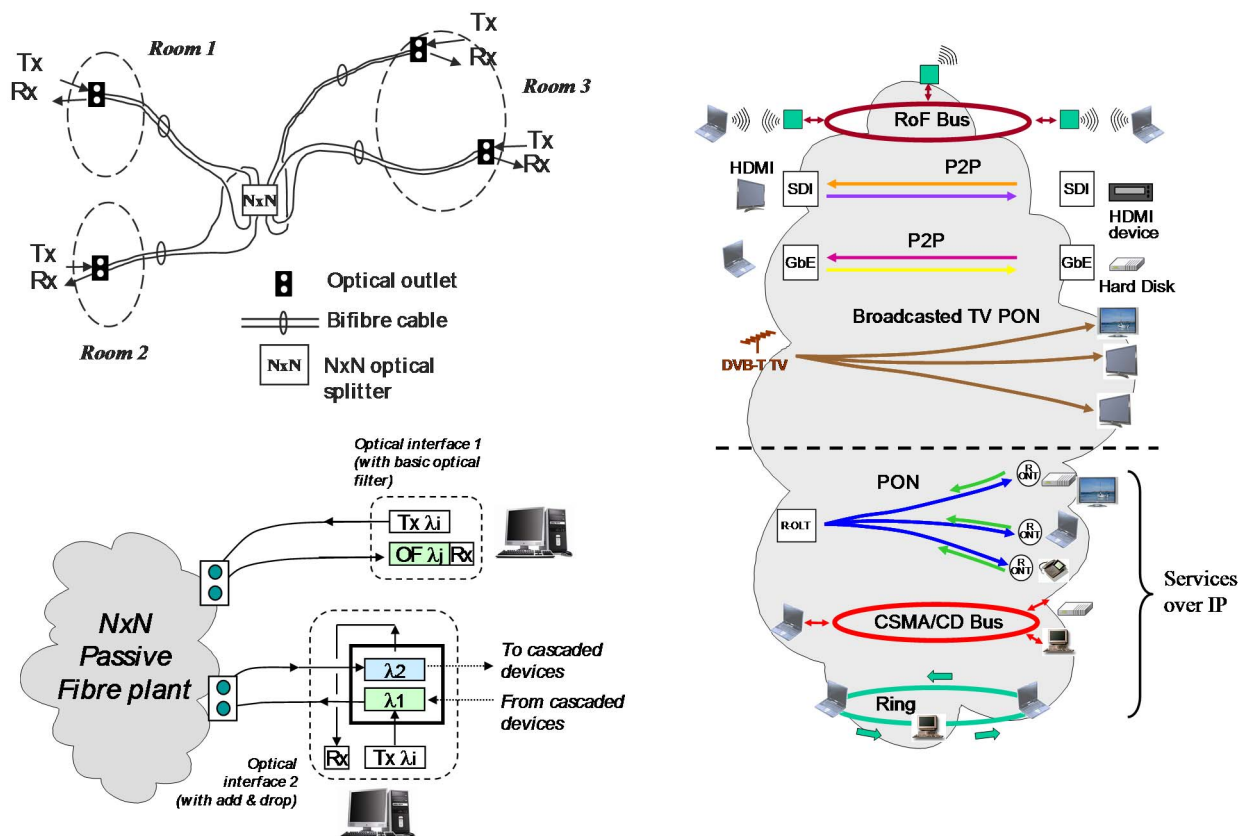

Figure 8: The multifformat passive star solution (CWDM Broadcast & Select architecture)

The most basic application to be run in a HAN is to ensure data exchanges between devices at IP level for triple play services (data, voice and TV over IP). These exchanges are based on P2P links in usual active star configurations, but this option is not fitted to a CWDM approach on an $N \times N$ passive optical plant as it results in a waste of the wavelength resource, each bidirectional P2P link requiring two wavelengths. This solution shall be dedicated to a few links requiring a very high bit rate and an excellent Quality of Service (QoS) between two identified devices. Protocols and topologies designed for shared medium applications are then preferred.

Two options can be considered:

- "PON-like" protocol (figure 9): this solution transposes in the HAN context Point to multipoint ($1 \times N$) protocols implemented in Passive Optical Network (PON) access network. The gateway acts then as a HAN Optical Line Termination (HAN-OLT), premises being connected using HAN Optical Network Terminations (HAN-ONT). A PON can be implemented on an $N \times N$ passive infrastructure using only two wavelengths, one for downstream, one for upstream. Increasing the number of access point (AP) is very easy: PON are presently sized with up to 128 ONT. PON mechanisms guarantee a perfect QoS with coexisting real time and best effort traffic, as PON allows resource reservation. The main issue is to reduce the cost of PON equipments by a major simplification thanks to relaxed specifications compared to the access network context.

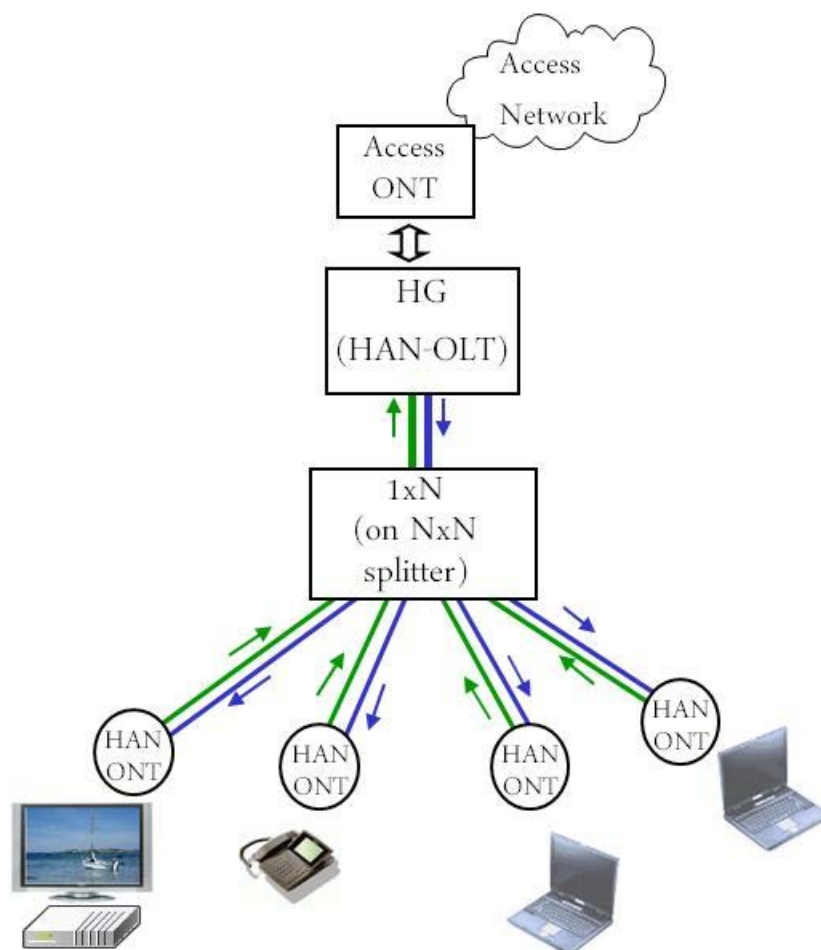

Figure 9: 1 × N PON-like architecture

- "LAN-like" protocol (figure 10): this solution reuses Multipoint to multipoint ($N \times N$) protocols deriving from the BUS concept developed early for Local Access Networks (LAN). This option can be easily implemented on an $N \times N$ passive architecture as this latter is an optical bus. Thus, simple Medium Access Control (MAC) like CSMA/CD can be reused. The advantage is the implementation simplicity: only one wavelength is required. The home gateway is on the same hierarchical level than other premises and the network manages itself. The drawback is that such protocols have been designed for best effort traffic and QoS still has to be demonstrated for real time traffic in the specific HAN context.

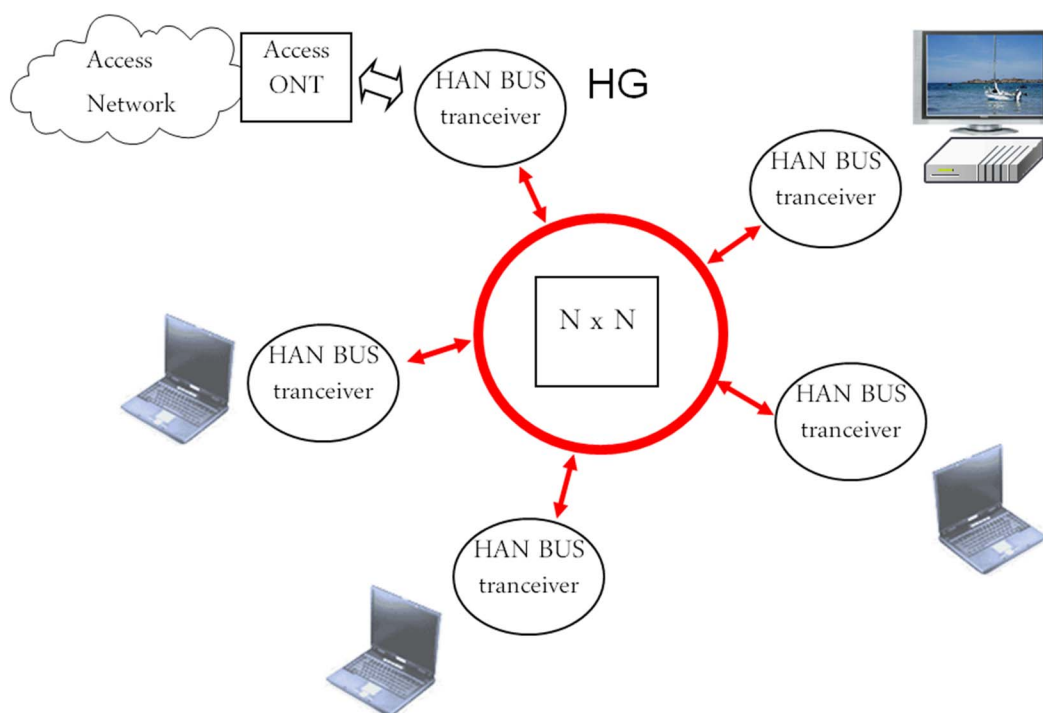

Figure 10: $N \times N$ LAN-like architecture

5 HAN performances

5.1 HAN optical power budget

5.1.1 Introduction

Optical power budget is related to the requirements of the transmission systems, i.e. optical transmitters and detectors as well as of the passive optical network components, i.e. fibres, cables, splices and connectors used.

5.1.2 Transmission system requirements

5.1.2.1 Assumptions

Two multiformat architectures have been described in clause 4.2.3: the active star, centred on a multiformat switch, and the passive CWDM star, centred on a passive $N \times N$ optical splitter. Figure 11 and figure 12 show possible implementations for these two architectures. This clause proposes to set the elements to calculate attenuation of the part of the home network corresponding to the permanent link, and provide indications to evaluate the optical budget for the global link. Concerning the optical connections, it is assumed that:

- an optical connection is composed of two joined connectors;
- the interface between the permanent link and the additional elements of the global link takes the form of an optical connection. In the proposed calculations, even if the connectors terminating the permanent link then appear on the following figures, their attenuation is not taken into account in the permanent link losses, as a connector does not represent a complete connection. The corresponding connection loss will be integrated in a next step when computing the total losses of the global link;
- if optical connections appear in the permanent link core (for example in the multiformat passive star), their attenuation is obviously taken into account in the permanent link losses.

5.1.2.2 Active star architecture.

In this case, only Point to Point links between the ports of the multiformat switch and the extenders located in the different rooms are considered. As shown at figure 11, optical patch cords may be used at the home distributor side to connect the ports of the switch to the fiber installed in the walls, the same solution being applied to connect the optical room outlets to the extender ports. The permanent link is composed of two connectors (C_{FMT} and C_{room} on the figure at each side of the link) and of the fiber length installed in the walls between these two connectors. Remembering the assumptions in clause 5.1.1, the optical attenuation of this permanent part of the network can be simply expressed as:

$$Att_{PL} = L \times A_f \text{ (permanent link)} \tag{equation 1}$$

where L is the length of the link in km, A_f the attenuation of the fiber per km.

When considering the total attenuation between a transmitter and a receiver, it is necessary to add the attenuation of four connections (C_{FMT} , C_{room} , C_{sw} and C_{ext} connections on figure 11), and the total attenuation can be now expressed as:

$$Att_{GL} = 4A_c + L \times A_f \text{ (between Tx and Rx)} \tag{equation 2}$$

Where A_c is the attenuation of one connection.

The optical budget of the link is of course dependent on the optical power P_{TX} generated by the transmitter and the sensibility S_{RX} of the receiver. These two parameters also strongly depend on transmission parameters such as the component technology, the type of transmitted signal (digital or RF) and the used modulation. In addition, a margin (M) can be introduced to take into account the performance degradation of the elements composing the link. The optical link budget is then expressed as:

$$B = (P_{TX} - S_{RX}) - 4A_c - L \times A_f - M \tag{equation 3}$$

and shall be greater than zero for proper operation.

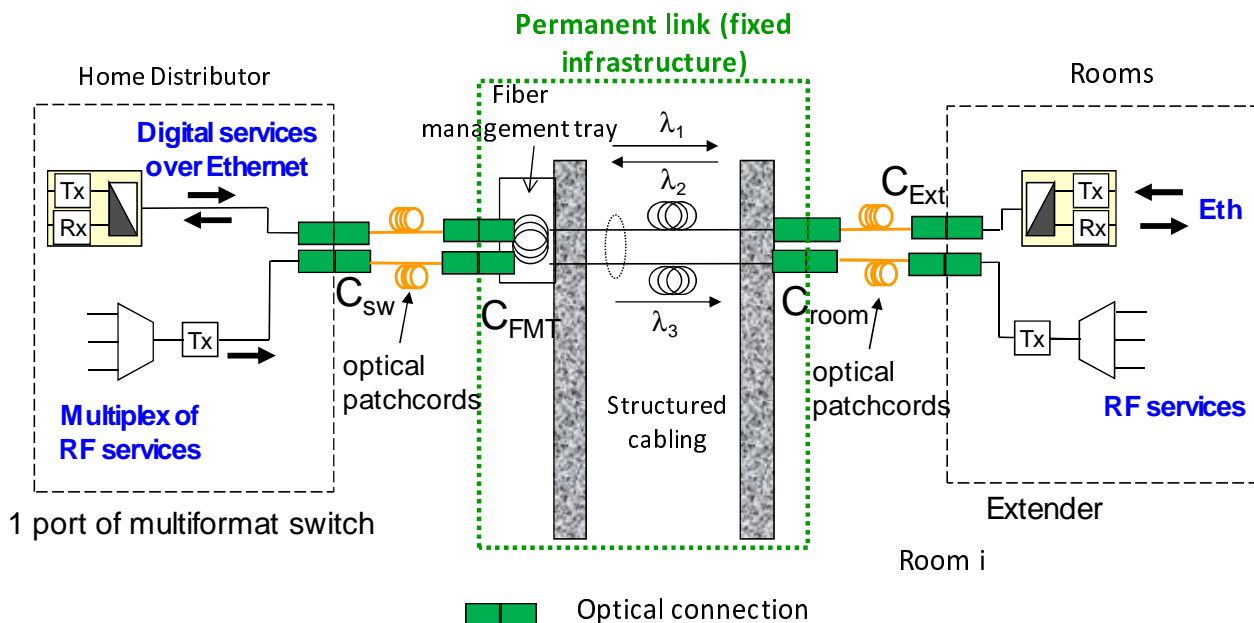

Figure 11: Possible implementation for active star based multiformat home network

5.1.2.3 CWDM passive star architecture

Figure 12 shows a possible implementation of a CWDM passive star architecture. With the same remarks as in clause 5.1.1.1 the permanent link is considered to include now:

- The P2P link corresponding to the uplink between an extender and the $N \times N$ splitter, including one C_{FMT} connection, which is now considered as an internal element of the permanent link (corresponding attenuation: $A_c + L \times A_f$).
- The P2P link corresponding to the downlink between the $N \times N$ splitter and an extender, including one C_{FMT} connection for the same reasons (corresponding attenuation: $A_c + L \times A_f$).
- The $N \times N$ splitter: the corresponding attenuation is $A_{split} + A_{ins} + 2A_c$, where A_{split} corresponds to the power splitting (equal to $10 \log N$), A_{ins} is the additional loss introduced by the splitter, and $2 A_c$ corresponds to the attenuation of the $C_{splitter}$ connections at the input and output ports of the splitter).
- The two patch cords used to connect the ports of the splitter to the fiber coming from the different rooms: their attenuation is considered negligible, the connection attenuation being already taken into account in the previous terms.

The optical attenuation of this permanent link can now be expressed as:

$$Att_{PL} = (A_c + L \times A_f) + (A_c + L \times A_f) + (A_{split} + A_{ins} + 2A_c)$$

or

$$Att_{PL} = 4 A_c + 2L \times A_f + 10 \log N + A_{ins} \quad (\text{permanent link}) \quad (\text{equation 4})$$

To define the total attenuation between a transmitter and a receiver, it is necessary to take into account the two C_{room} connections, corresponding to the interfaces between the uplink and the permanent link and between the downlink and the permanent link. It also is necessary to consider additional elements: as mentioned in clause 4.2.3, A&D modules shall be used at the transmission side if several services at different wavelengths are injected into the same optical outlet in a room. In the same way at the receiver side, one Add & Drop element shall be inserted per service selected at one optical outlet. A configuration example is given, corresponding to the minimum additional losses, with only one service injected at the transmission side, and only one service dropped at the receiver end. In this case, Add & Drop elements at the transmission side are not needed, only one is needed to drop the right wavelength at the reception side. This minimum additional attenuation is then:

A_c (corresponding to C_{Ext} at the transmission side) + $2 A_c$ (C_{Ext} and $C_{A\&D}$ at the receiver side) + $A_{A\&D}$ (one Add & Drop losses at the receiver side).

The minimum total attenuation is then in this case:

$$Att_{GL} = 6 A_c + 2L \times A_f + 10 \log N + A_{ins} + (A_c + 2 A_c + A_{A\&D})$$

or

$$Att_{GL} = 9 A_c + 2L \times A_f + 10 \log N + A_{ins} + A_{A\&D} \quad (\text{minimum attenuation between Tx and Rx}) \quad (\text{equation 5})$$

With the same notations and remarks as in clause 5.1.1.1, the optical budget of the link may then be expressed as:

$$B = (P_{TX} - S_{RX}) - 9 A_c - 2L \times A_f - 10 \log N - A_{ins} - A_{A\&D} - M \quad (\text{equation 6})$$

and shall be greater than zero for proper operation.

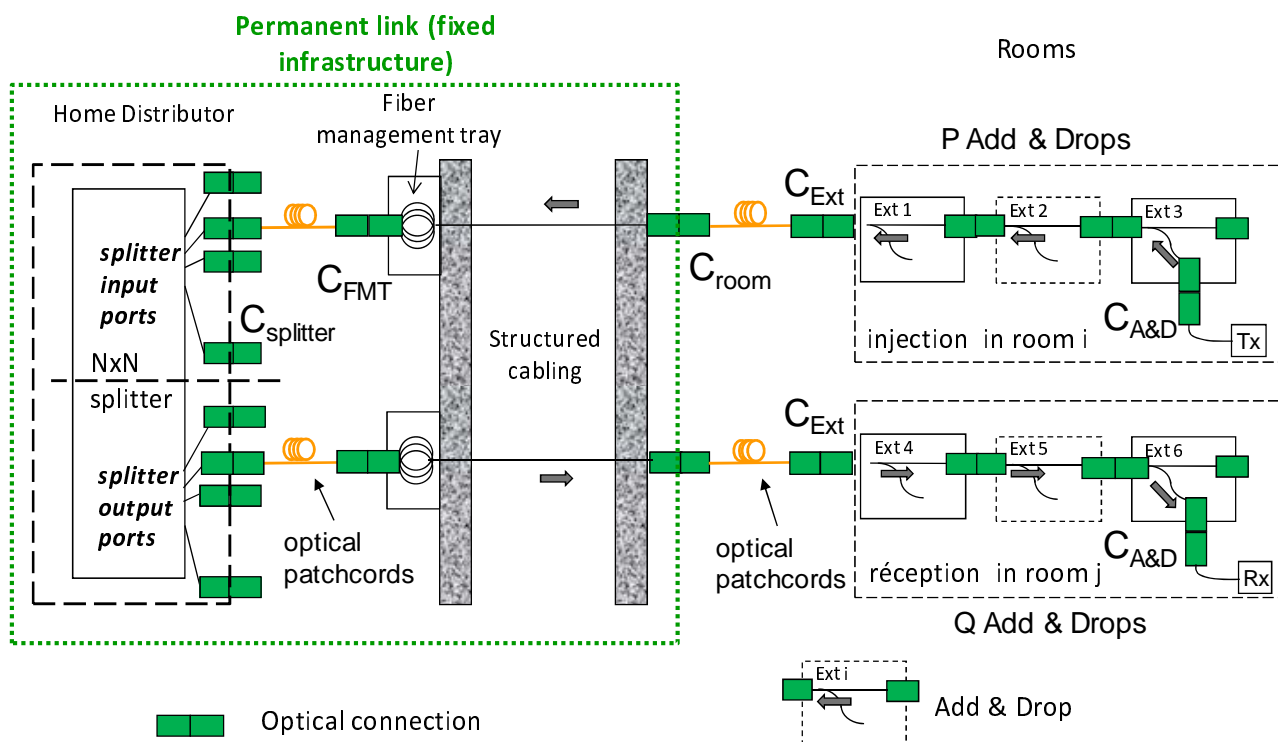

Figure 12: Possible implementation for CWDM passive star based multifformat home network

5.1.3 Attenuation requirements for passive optical network

Optical fibre attenuation requirements are well defined in CENELEC EN 60793-2-50 [5] (see clause 6.1) for fibre types used in passive optical network cabling as specified for the applications. These requirements are different from those specified for cabled fibre. The requirements for the applications according to the present document are given in table 1.

Table 1

Attenuation coefficient from 1 310 nm to 1 625 nm	dB/km	≤ 0,40
Attenuation coefficient at 1 383 nm ± 3 nm	dB/km	≤ 0,40
Attenuation coefficient at 1 550 nm	dB/km	≤ 0,30
Macrobending loss at 1 550 nm, 10 turns on a 15 mm radius mandrel	dB	≤ 0,25

Construction of optical cables for these applications is based on CENELEC EN 60794-2 series [22], optical cables for indoor applications. Optical cabled fibre attenuation requirements are defined in CENELEC EN 50173-1 [20]. The requirement for these applications is shown in table 2.

Table 2

Attenuation coefficient from 1 310 nm to 1 625 nm	dB/km	≤ 1,0
---	-------	-------

Optical connections (connectors) attenuation requirements are defined in CENELEC EN 61755-1 [21]. For the applications according to the present document the attenuation values in table 3 are required.

Table 3

Attenuation	Mean (dB)	97 % (dB)
Class C	≤ 0,25	≤ 0,50

The return loss of the optical connections is another important transmission parameter for the optical network. The requirements for connections for all transmission wavelengths used for this application are given in table 4.

Table 4

Return loss	dB
APC connections	≥ 60
PC connections	≥ 45

Mechanical splice is a temporary connection of two fibres. Therefore it can be used for special circumstances and it is not advisable to use it generally. The requirements for all wavelengths are given in table 5.

Table 5

Attenuation	Mean (dB)	97 % (dB)
Mechanical splice	≤ 0,50	≤ 1,00

The return loss of these optical connections is important transmission parameter for the optical network. The requirements for connections used for this application are given in table 6.

Table 6

Return loss	(dB)
Mechanical splice	≥ 60

Fusion splice is a permanent connection of two fibres not to be disconnecting. The requirements are given in table 7.

Table 7

Attenuation	Mean (dB)	97 % (dB)
Fusion splice	≤ 0,10	≤ 0,20

The return loss requirements are given below.

Table 8

Return loss	(dB)
Fusion splice	≥ 60

Optical splitter used in this home network shall be according to CENELEC EN 61753-031-2 [8]. The attenuation and uniformity requirements are defined in table 9.

Table 9

Type	Attenuation	Uniformity
1X2	ffs	ffs
1X4	ffs	ffs
1X8	ffs	ffs

5.1.4 Optical budget deterioration

5.1.4.1 Definitions of requirements

International standardization defines requirements for transmission values such as attenuation and return loss. These requirements have different understanding depending on standardization body. IEC as component standardization body considers these values as BOL (Begin-Of-Life) while the system standardization body ITU considers these values as EOL (End-Of-Life).

Extrapolating the BOL values to estimated/calculated EOL values should be done by a specific reliability test schedules with carefully selected test severities. These test schedules are unfortunately depending on the component type and design and their results cannot be extrapolated without taking into account specific design features.

5.1.4.2 BOL (Begin-Of-Life)

The international standardization documents give specific values that can be met during and after exposure to environmental perturbations at BOL (Begin-Of-Life).

5.1.4.3 EOL (End-Of-Life)

System designers and network carriers prefer to have in the passive optical components specification a single value that is met under all conditions without additional margin for environmental effects or aging over its total lifetime and is called EOL (End-Of-Life) characteristics.

6 Home area network cabling

6.1 Introduction

HAN cabling depends on optical network architecture and topology. Generally the network cabling can be distinguished according to its functionality such as:

- Cables for IT services
- Cables for P2P applications
- Cables for P2MP applications
- Cables for satellite and terrestrial TV services
- Cables for work area cords to be terminated with optical connectors
- Cables to be installed in ducts
- Cables to be installed without ducts

Home area network cabling belongs to indoor cable applications and as such shall follow the requirements of CPR (Construction Product Regulation) as defined in European Union.

6.2 Optical fibre

Optical fibre as transmission media in the homes is a singlemode fibre according to CENELEC EN 60793-2-50 [5] or Recommendation ITU G.652 [45] and ITU-T 657 [44]. Preferably singlemode fibre category CENELEC EN 60793-2-50 [5] sub-category B6 (Recommendation ITU-T G.657 [44]), with improved bending loss performance in case of low bends shall be used.

6.3 Cables

6.3.1 Generalities

The cables shall be according to CENELEC EN 60794-2 [22] and include 1 fibre to 4 fibres.

The cable design shall allow an easy access to the fibres. With this cable the termination of the cable with connector shall be using fusion or mechanical splice.

Material used in the cable manufacturing shall meet health requirements.

Material shall be compliant with requirements defined in REACH regulation.

The optical cable shall be flame retardant.

Optical cable shall be compliant with CEN EN 13501 [23] (Euro classes of cables).

6.3.2 Dimensional and colour requirements

The dimensional and colour requirements for the cables are defined in table 10.

Table 10

Sheath	Unit	requirement
Nominal diameter	mm	2 to 3
colour		grey

6.3.3 Mechanical requirements

The mechanical requirements for the cables are defined in table 11.

Table 11

	Standard	Unit	Severity
Tensile load	CENELEC EN 60794-1-21 [24], E1	N	400
Crush	CENELEC EN 60794-1-21 [24], E3	N	400
Kink	CENELEC EN 60794-1-21 [24], E10	mm	10
Bend	CENELEC EN 60794-1-21 [24], E11	mm	60

6.3.4 Environmental requirements

The environmental requirements for the cables are defined in table 12.

Table 12

	Standard	Unit	Severity
Temperature behaviour	CENELEC EN 60794-1-22 [46], F1	° C	-10 to +60
Flame propagation	CENELEC EN 60332-1-2 [25]	-	for further study
Acidity	CENELEC EN 50267-2-3 [26]	-	for further study
Smoke density	CENELEC EN 50399 [3]	-	for further study

6.4 Optical connector

The mechanical interface of the Singlemode fibre optic connector hardware shall be according to CENELEC EN 61754 [10] series:

- CENELEC EN 61754-20 [27]: LC type optical connector (recommended)
- CENELEC EN 61754-4 [28]: SC type optical connector
- CENELEC EN 61754-29 [29]: BLINK type optical connector (see annex E)
- CENELEC EN 61754-30 [30]: CLIK type optical connector (see annex B)

For the whole installation, only one connector type should be used.

The BLINK type optical connector provides an integrated laser and dust protection in the connector and adapter as well as an automatic self-release mechanism.

The optical interface of the Singlemode fibre optic connections shall be according to Grade C defined in CENELEC EN 61755-1 [31], CENELEC EN 61755-2-1 [32] and CENELEC EN 61755-2-2 [33].

The optical interface of the Singlemode fibre optic connector shall be according to CENELEC EN 61755-3-1 [34] and CENELEC EN 61755-3-2 [35].

The return loss of the optical APC connection shall be ≥ 60 dB measured with method 2 of CENELEC EN 61300-3-6 [36].

The optical performance shall be tested for the type approval according to CENELEC EN 61300-3-34 [37]. The optical performance shall be tested for each lot according to CENELEC EN 61300-3-4 [38].

The mechanical and environmental requirements for connectors shall be tested according to ETSI ETS 300 019-2-3 [19].

6.5 Optical non-wavelength-selective splitter

The optical splitter used in HAN shall be non-connectorized single-mode $1 \times N$ and $2 \times N$ non-wavelength-selective power splitter for Category C - Controlled environment according to CENELEC EN 60875-1 [7] and CENELEC EN 61753-031-2 [41] as well as according to Recommendation ITU G.671 [16] for optical branching component (wavelength non-selective).

6.6 Optical WDM (Wavelength-Division-Multiplexer)

The optical splitter used in HAN shall be non-connectorized single-mode WDM devices for Category C - Controlled environment according to CENELEC EN 62074-1 [9] as well as according to ETSI TS 101 791 [4] (DWDM devices).

7 Reliability

7.1 Reliability of active devices

The MTBF of the active devices in the home network shall be 5 years. This shall be demonstrated by design requirements and testing results.

7.2 Reliability of passive components

The reliability of passive components such as fibres, cables and passive components shall be demonstrated by materials used, design requirements and testing results.

8 Installation

Optical fibre cables used in home network are designed so that normal installation practices and equipment can be used wherever possible. They do, however, generally have a strain limit rather lower than metallic conductor cables and, in some circumstances, special care and arrangements are needed to ensure successful installation.

It is important to pay particular attention to the cable manufacturer's recommendations and stated physical limitations and not exceed the given cable tensile load ratings for the outdoor and indoor cable as well as their different bend radius requirements. Damage to a cable caused by mechanical overloading during installation should not be immediately apparent but can lead to failure later in its service life.

Several installation configurations can be considered:

- the cable can be installed in existing ducts (empty or already used by a copper/electrical cable);
- installed along the wall or plinths by stapling or gluing.

In the case of a visible home-cabling the constraints applied on the cable could be more severe (several corners and doors).

9 Energy efficiency

In terms of energy efficiency, the directive 2012/27/EU of the European Parliament and of the Council of 25 October 2012 [42] is taken into account.

Ultimately SM transceivers are integrated in the user equipments thus reducing the number of power supplies hence the overall electrical consumption.

An alternative to this is to power up the media converter by means of USB interface or Power over Ethernet (PoE) on the RJ45[®] interface. Energy efficiency targets are set out in the EU "Code of Conduct on Energy Consumption of Broad Band Equipment" version 3 18 November 2008 [12].

The maximum power consumption shall be < 1 W in full operation per port for 100 Mbit/s SM transceiver; < 3,5 W in full operation 100 Mbit/s media converter; < 3,5 W in full operation per port for 1 Gbit/s media converter. The target is to achieve as low power consumption as possible. The targets outlined here are the 2011 targets of the EU Code of Conduct on Energy Consumption of Broad Band Equipment.

The devices should offer a standby mode and they shall enter this mode after a configurable period without any traffic.

The maximum power consumption in standby mode shall be < 0,5 W.

The Power Mode Transition Time (the time transition from the standby mode to active mode when traffic is detected) shall be < 1 s.

Annex A (informative): Optical Telecommunication Outlet - wall socket

A.1 Introduction

The equipment described in this part permits the usage of SM in residential environments, especially enabling SM cables insertion into existing ducts. The wall outlet is a passive element in HAN.

The Wall socket is usually the interface between FTTH and HAN and is a passive device (terminates on an optical connector). They are also FTTH networks where the wall socket integrates a primary active converter with switching function translating the signal from fibre onto copper cables.

The design of the wall socket should fulfil the following requirements:

- to accommodate X splices and Y splice protectors,
- to store the fibre overlengths,
- to avoid bend radii less than 15 mm.

A.2 Connection type

The fibre connection at the wall outlet can be:

- pre-terminated cable assemblies;
- spliced pigtailed;
- field-mountable connector.

A.3 Optical connections in wall outlet

Optical connections in wall outlet should fulfil the requirements of the Grade C according to CENELEC EN 61755-1 [31], CENELEC EN 61755-2-1 [32] and CENELEC EN 61755-2-2 [33]:

- Environmental protection: the wall outlet functions as a physical protection for fibre, cable, splice and optical connector.
- Housing: wall outlet functions as a housing for optical connector, adapter and fibre management system.
- Sealing: wall outlet seals the incoming and outgoing cables.
- Protection: wall outlet contains means for protection of mechanical accidental wall outlet damage.
- Operational environment: wall outlet should be designed for normal temperature range between 5 °C and 40 °C and relative humidity range between 10 % and 80 %.
- Cable routing: wall outlet contains means for routing of minimum one incoming cable to the specified numbers of outputs.
- Re-entry: wall outlet should be re-opened when necessary without interruption or disturbance of the traffic of the live circuits.
- Blowing microduct: wall outlet should have means for installations by blowing using microducts.
- Testing: fully equipped wall outlet should be tested at temperature range between -5 °C and 55 °C and relative humidity 85 % for 96 hours. The optical attenuation and return loss should be measured during the test. There should be no optical transmission disturbance during and after the test.

A.4 Interfaces - External sockets

The wall plug should have one external energy socket according to specific country standard according to IEC 60884-1 [13] for general requirements.

The wall plug should have one or two RJ45[®] ports: 10/100/(1000 optional) BaseT/TX Ethernet ports.

The BaseT/TX Ethernet interface should be compliant to the ISO/IEC 8802-3 [14] standard.

The BaseT/TX Ethernet interface should be autosensing for rate and type of UTP5 cables (straight and crossed).

A.5 Interfaces - Internal sockets

The wall plug should have one or two or three SM interfaces (each interface for a couple of SMs in order to allow a bi-directional communication).

The optical interface should be compliant with CENELEC EN 61755 [11] series and according to the transceivers already available on the market today (e.g. SFP).

The installation procedure should be "easy" in order to simplify the connection to the electrical wiring, e.g. using a single device that replaces the existing one and requires just the connection of energy and SM cabling.

A.6 Wall socket plugs versions

Four versions can be considered.

All versions should include one energy socket.

- a) Version 1 (basic) with one RJ45[®] (External) and one SM fibre interface (Internal).
- b) Version 2 (pass-through) with one RJ45[®] (External) and two SM fibres interfaces (Internal).
- c) Version 3 (optical splitter) with one RJ45[®] (External) and three SM fibres interfaces (Internal).
- d) Version 4 (switch) with two RJ45[®] (External) two SM interfaces (Internal).

Other wall socket versions should be considered, e.g. without external energy socket.

An internal switch should be required for Ethernet packet management on all versions of the equipment.

The switch should be compliant with IEEE 802.3 [2] 10BaseT and IEEE 802.3u [i.1] 100BaseTX Ethernet specifications.

The switch should be compliant with IEEE 802.3x [i.2] Full duplex and Flow Control specifications.

The switch should support auto MDI/MDI-X function.

The internal switch should be transparent for tagged frames (e.g. TOS or VLAN tags).

An internal switch with VLAN management should be adopted for the version 2, 3 and 4 of the equipment. In addition to the previous points:

- a) It should be compliant with IEEE 802.1Q [i.3] VLAN management specifications;
- b) It should be compliant with IEEE 802.1p [i.4] MAC layer QoS specifications;
 - i) Configuration options should include VLANs assignment and QoS parameters;
 - ii) Device configuration reset should be possible (and should be reasonably easy).
- c) It should be managed via RJ45[®] ports or via SM ports with a layer 2 protocol:
 - i) In alternative, it should be managed with web interface (or Telnet).

- d) It should be compliant with IEEE 802.1D [i.5] Spanning Tree for complex network topologies.

The equipment should be compliant with CENELEC EN 60950-1 [15] ("Information technology equipment - Safety Part 1: General requirements") in order to guarantee safety requirements for RJ45[®] external interfaces.

The equipment should be compliant with Recommendation ITU-T K.21 [18] ("Resistibility of telecommunication equipment installed in customer premises to overvoltages and overcurrents").

The equipment should be Class 1 compliant for 100 Mbit/s solutions and Class 1M compliant for 1 Gbit/s solutions according to CENELEC EN 60825-1 [6] ("Safety of laser products. Equipment classification, requirements and user's guide").

The equipment should have an adequate mechanical robustness in order to comply with the tests defined for the Class 3.2 in ETSI ETS 300 019-2-3 [19].

The equipment should be compliant with CENELEC EN 55022 [39] - class B limits ("Information technology equipment. Radio disturbance characteristics. Limits and methods of measurement").

The equipment should be compliant with CENELEC EN 55024 [40] ("Information technology equipment. Immunity characteristics. Limits and methods of measurement").

A.7 Sustainability requirements

The equipment should:

- a) Minimize the number of used materials;
- b) Use recycled materials;
- c) Be manufactured with "lead-free" solder;
- d) Avoid using hazardous materials as per the RoHS Directive [1], with specific reference to PVC for coatings.

The equipment should be compliant with Code of Conduct for Broadband Equipment version 3 18 November 2008 [43] for issues concerning energy consumption (C.1.2 table for Home Network Infrastructure Devices).

A.8 Examples of optical fibre wall outlet

Here are examples of passive optical wall outlets that could have the wall plug integrating the SM/Ethernet bridge as presented in clause 4. Each country can fit it according to national guides.



Figure A.1: Example of Integrated Wall Plug

Annex B (informative): Residential PON example

B.1 Residential network evolution

Residential network according to the present document is a passive network deployed at the customer's site (apartment or building) between the Residential Gateway/Integrated Access Device/Optical Network Termination/Optical Network Unit and the end-user devices (TV, PC, telephone, surveillance, etc.).

B.2 Architecture 1 - centralized mode according to Recommendation ITU-T G.9960 (G.hn) - P2MP

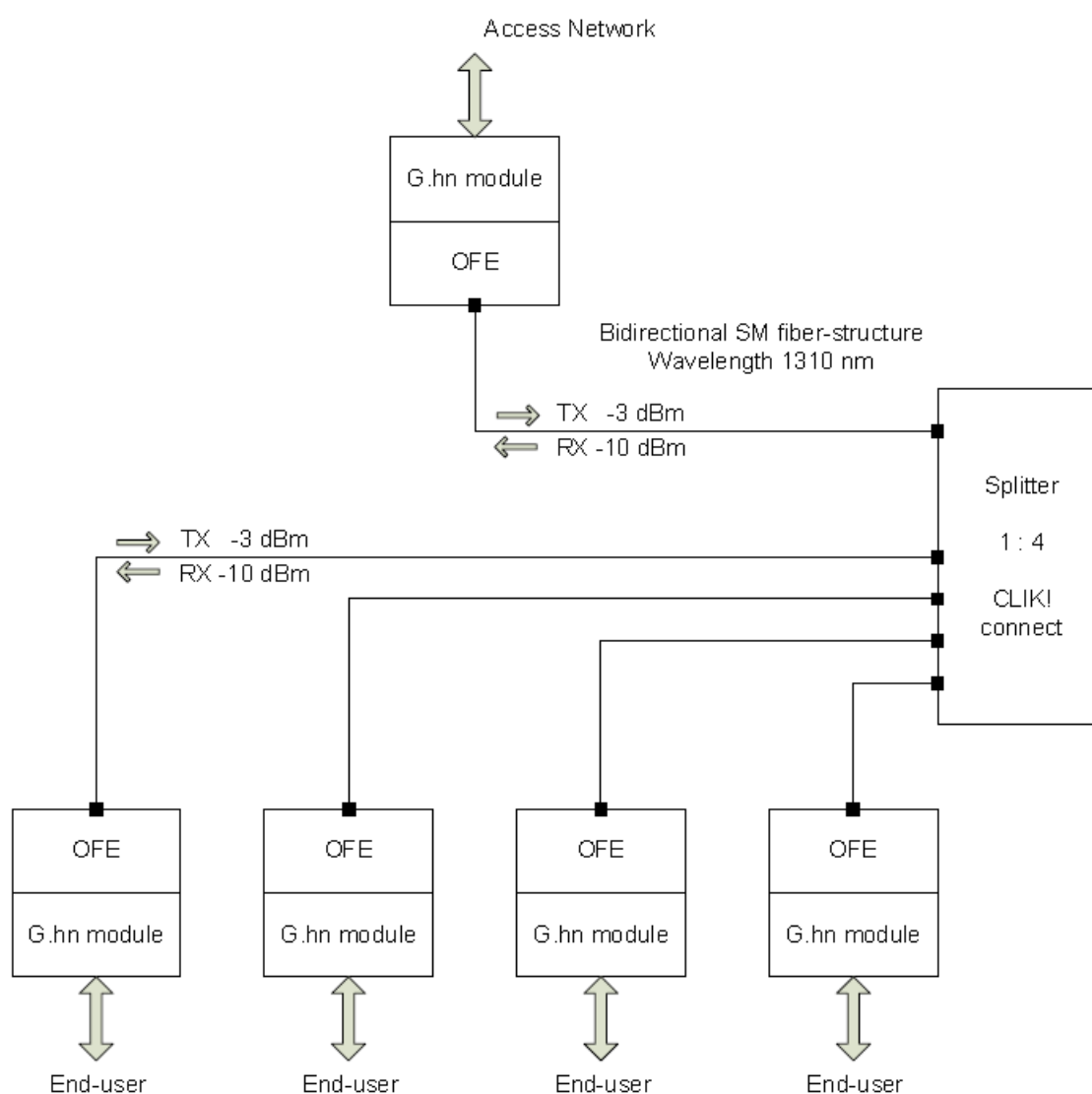

Figure B.1: Centralized mode example

On the access network a RG/IAD/ONT/ONU with for instance GbE interface is located. The G.hn module is connected to a 1: N Splitter (1 : 2; 1 : 4; 1 : 8, etc. are possible) using an optical Frontend (OFE). The N splitter ports are connected to N G.hn modules using N OFEs.

The OFE can be realized as BIDI modules working for example at 1 300 nm.

This setup does not allow the direct communication between customers (Splitter ports). The communication between the customers (Splitter ports) can only be realized via the uplink-port (the 1 in 1 : N; northbound port in figure B.1).

In figure B.2 a realization example with 2 OFEs and 2 G.hn modules is shown. Because the BIDI module is not equipped with an CLIK connector, the additional adapter is necessary. In the future, the BIDI module should also have an CLIK connector.

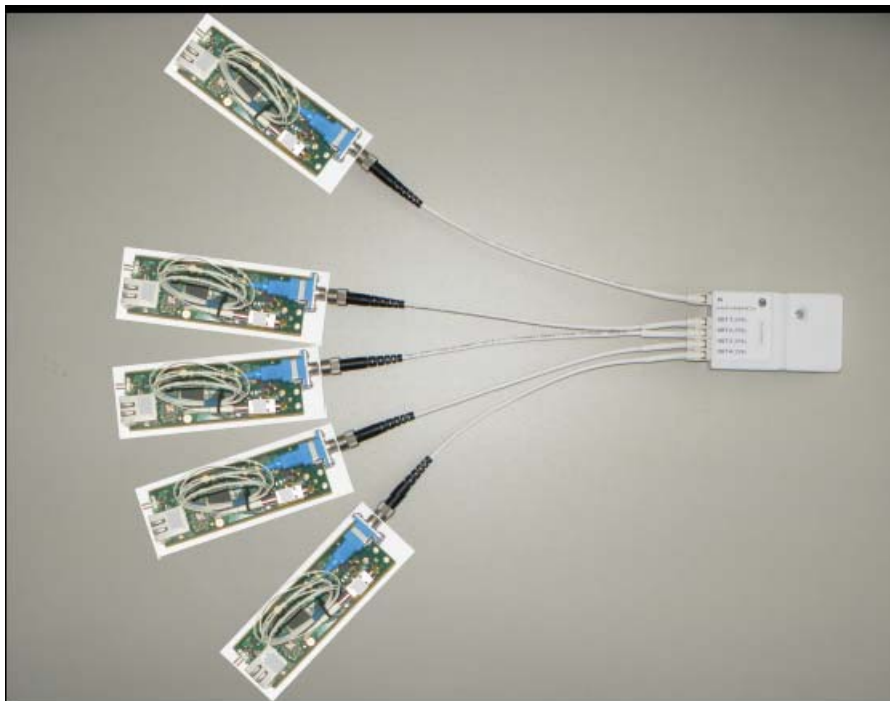

Figure B.2: Centralized mode subsystem example

B.3 Architecture 2 - peer to peer-mode according to Recommendation ITU-T G.9960 (G.hn) - MP2MP

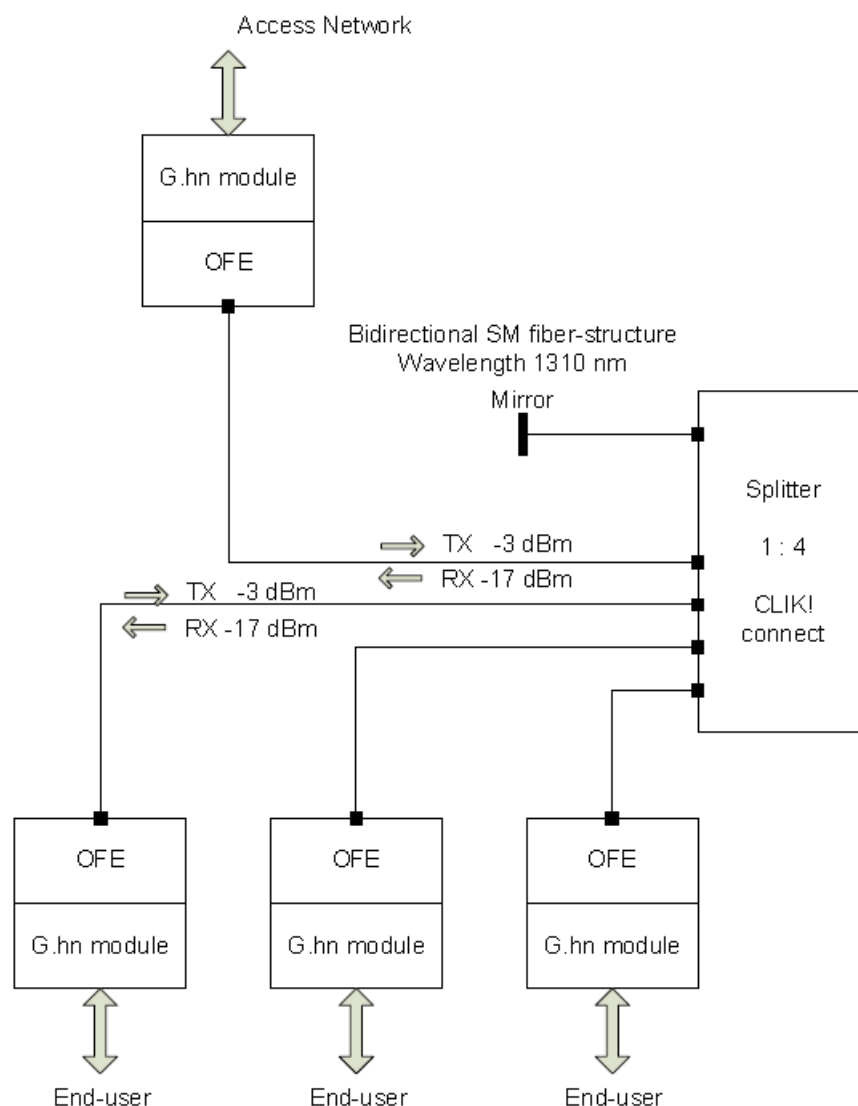

Figure B.3: Peer-to-peer mode example

On the access network a RG/IAD/ONT/ONU with for instance GbE interface is located as shown in figure B.3. The G.hn module is connected to a 1 : N Splitter. (1 : 2; 1 : 4; 1 : 8, etc. are possible) using an optical Frontend (OFE). The N - 1 splitter ports are connected to N - 1 G.hn modules using N - 1 OFEs. The common port of the 1 : N splitter (1 in 1 : N) is equipped with an mirror.

The OFE can be realized as BIDI modules working for example at 1 300 nm.

This setup does allow direct communication between customers (Splitter ports).

In figure B.4 a realization example with 2 OFEs and 2 G.hn modules is shown. Because the BIDI module is not equipped with an CLIK connector, the additional adapter is necessary. In the future, the BIDI module should also have an CLIK connector. In this example, the common mode of the splitter (1 in 1:N) is equipped with an mirror. In the future, this mirror can be integrated in the splitter.

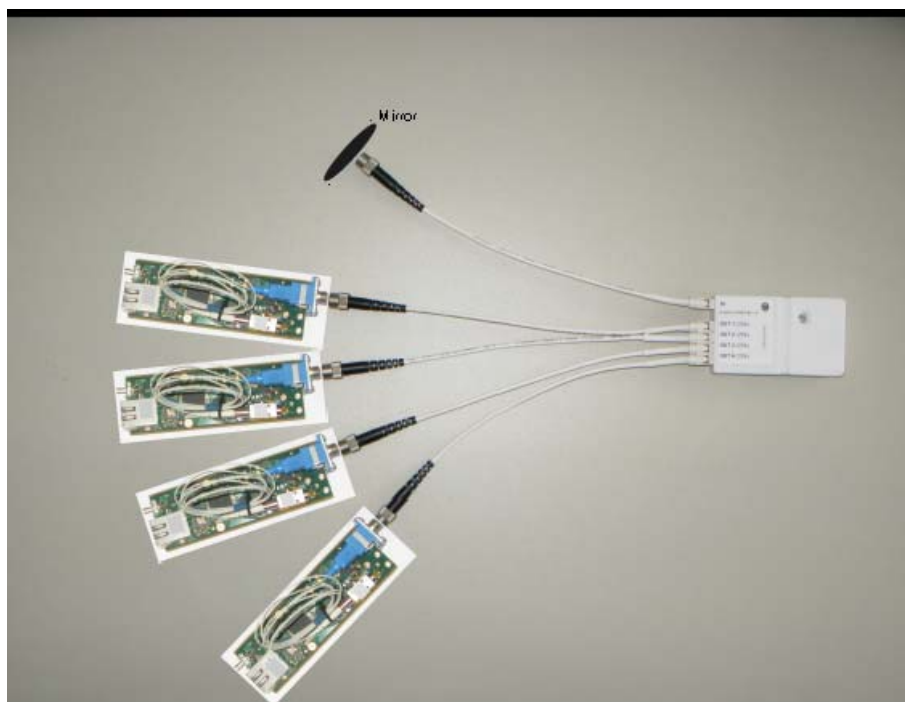

Figure B.4: Peer-to-peer mode subsystem example

B.4 Architecture 3 - G.hn with RF Video Overlay

With an additional splitter, a TV distribution system can be realized. There it is possible to transport TV signals (for example from SAT-LNB) in parallel to network data (G.hn) using the same infrastructure. For this, additional optical components are necessary.

B.5 Residential network performances

B.5.1 Optical power budget

Optical power budget is related to the requirements of the transmission systems, i.e. optical transmitters and detectors as well as of the passive optical network components, i.e. fibres, cables, splices and connectors used.

B.5.2 Transmission system requirements

For the realization of such a system, TDMA based technology should be used. The preferred technology is G.hn. Because of the small attenuation of the optical links inside a home, the optical receivers do not necessarily require a high dynamic range.

Annex C (informative): Multiformat active star example

C.1 Introduction

During the last years, several configurations of multiformat active star home networks have been demonstrated, derived from the architecture described in clause 4.2.3.1 of the present document. Amongst them, two representative configurations should be focussed on, based respectively on electrical multiplexing, and hybrid electrical/optical multiplexing.

C.2 First option: electrical multiplex on an optical path

If there is no electrical spectrum overlapping between the transmitted signals, a simple electrical multiplexing should be used to combine these signals on the point to point links connecting the ports of the multiformat switch and the extenders. An example is shown at figure C.1, in which four signals are taken into account: 100 Mbit/s Ethernet, UWB radio for wireless final connectivity (the lower band going from 3,1 GHz to 4,7 GHz), digital terrestrial and satellite TV. Before achieving the electrical multiplexing, it is important to adjust the level of the different incoming signals, to guarantee an optimal modulation of the laser used in this transmitter. The multiplex then modulates an optical transmitter. For the applications requiring symmetric traffic or upstream data transmission, the uplink processes in a symmetric way, using another fibre.

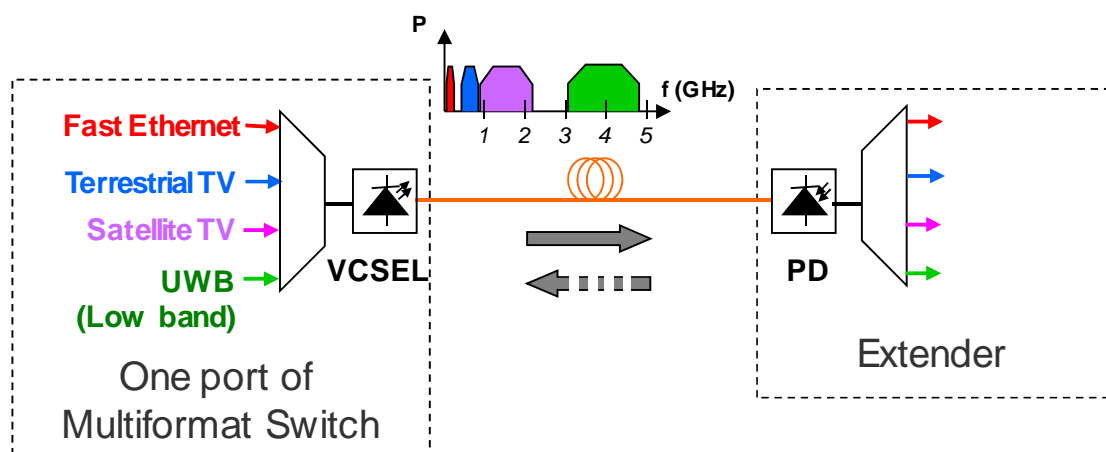

Figure C.1: Electrical multiplex of the different signals

The same process should be done for the different ports of the multiformat switch. Each port is connected to an extender. The complete setup is described in figure C.2. The multiformat switch integrates an Ethernet switch, each port of this switch is dedicated to a port of the multiformat switch. A RoF bus (a RF combiner) is connected in a similar way, it ensures the transparency for RoF signals and for protocols used by the radio layer. TV signals coming from the roof antenna (terrestrial TV) or from the satellite dish (satellite TV) are simply replicated and distributed to the different ports of the multiformat switch. It should be noted that an uplink may be necessary to transmit signals coming from the satellite demodulator to control the LNB located near the satellite dish.

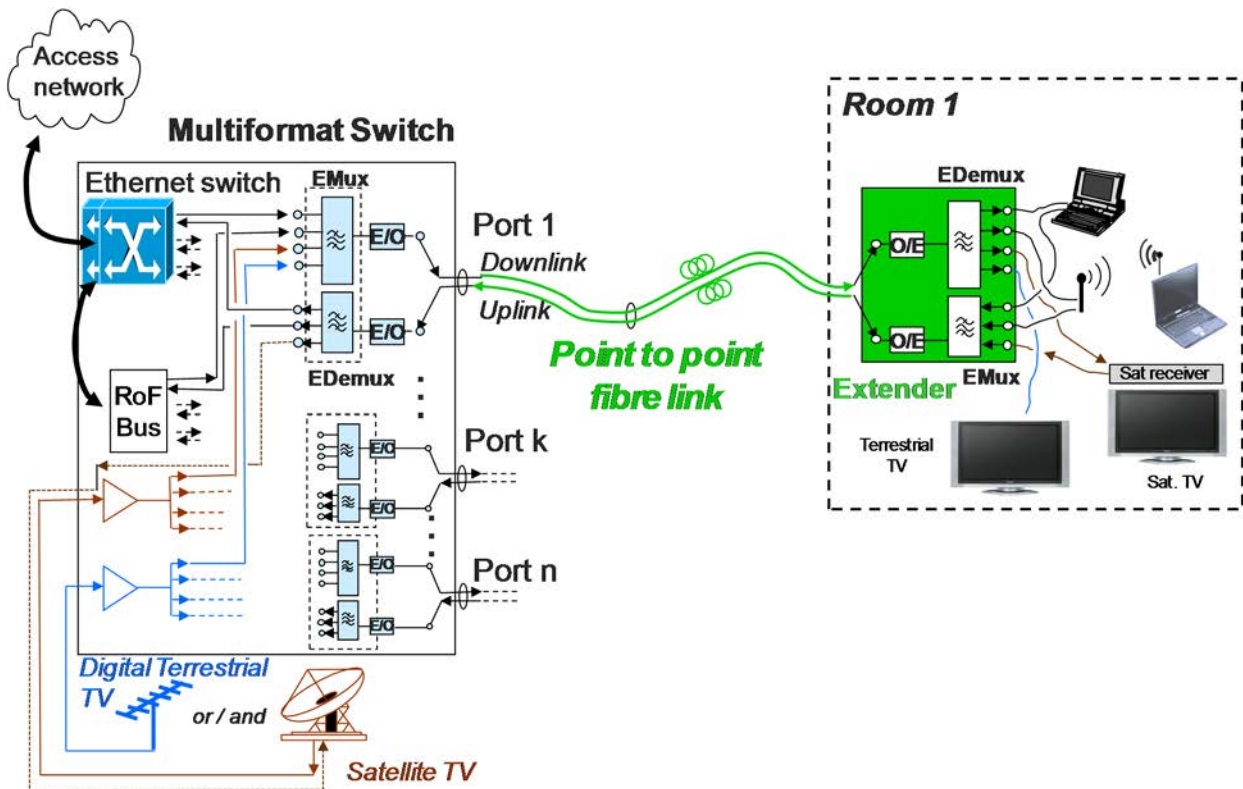

Figure C.2: Network architecture

In a first step, the proposed solution combining Fast Ethernet, RoF (3,1 GHz to 4,7 GHz UWB) and digital terrestrial TV signals has been implemented, in order to demonstrate the feasibility of the proposed solution. The result of the electrical multiplexing is shown in figure C.3. Though single-mode or multimode silica fibre is recommended, the concept using perfluorinated plastic fibre (PF POF) for cost and "Do It Yourself" (DIY) reasons has been demonstrated to be feasible. The performances of this fibre are compatible with the multiplex transmission requirements. This fibre is optimized at 850 nm, thus allowing for the use of low cost vertical cavity surface emitting lasers (VCSEL) and photodiodes. The fibre electrical bandwidth is limited to 300 MHz/km, but this corresponds to 3 GHz to 6 GHz for distances between 50 m and 100 m that are typical of home networks.

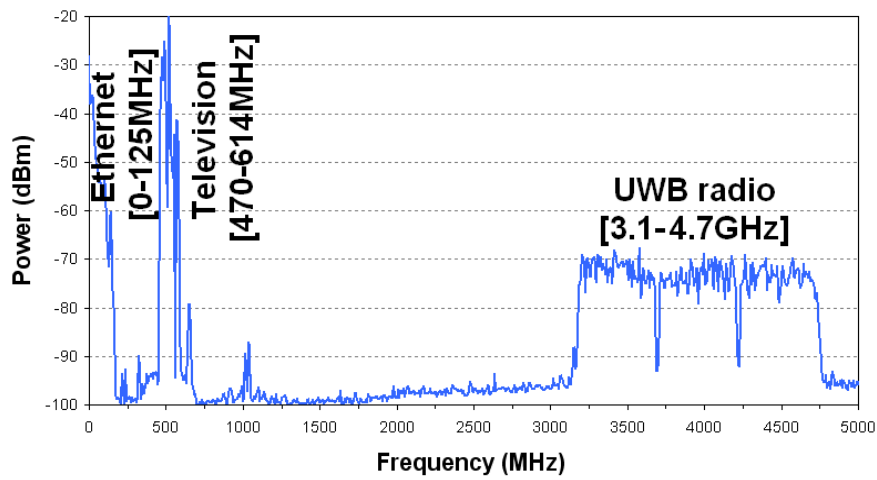
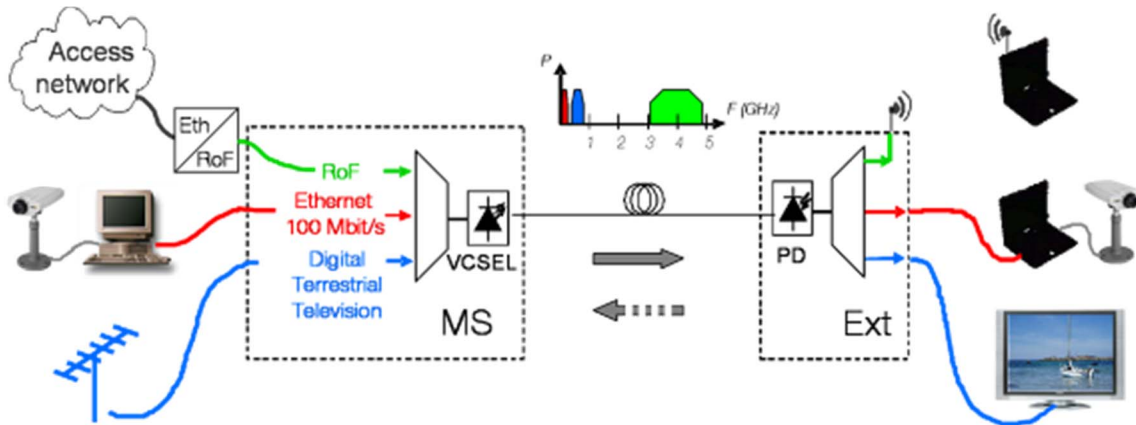

Figure C.3: Electrical multiplex of Fast Ethernet, DVB-T and UWB

The realized setup, achieved for full duplex transmission with two fibres (one for downlink and one for uplink), is reported in figure C.4. When looking at the multiformat switch, for the downlink, the three electrical signals should be adapted in amplitude and in their impedance so to harmonize their levels. In particular the uplink and downlink pairs of the Ethernet are separated and symmetrised by means of a balun (balanced unbalanced). The digital terrestrial TV signal coming from the antenna is adapted to 50 Ω and suitably amplified. Finally, the UWB is separated in downlink and uplink by means of a circulator.

The three signals are then multiplexed together and directly modulate a VCSEL typically used for digital communications.

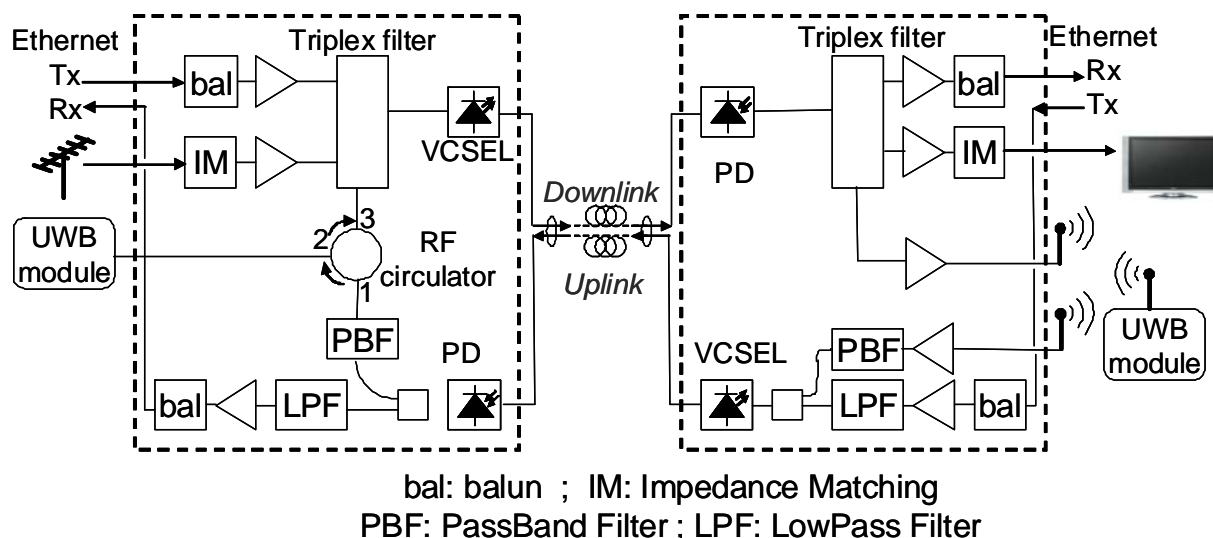

Figure C.4: Realized setup

In the uplink of the multiformat switch, the optical signal is detected by a low cost GaAs PIN photodiode packaged with a transimpedance amplifier. As there is no uplink for the digital terrestrial TV signal, the Ethernet and UWB can be separated by an RF coupler. Then, suitable filters are used to suppress spurious signals. At the user side, the setup is symmetric with respect to the multiformat switch. The optical signals are transported on two different fibres for uplink and downlink. Lengths up to 50 m have been tested for the three services.

A multiformat switch and an extender have been packaged to demonstrate the solution. The extender and the switch are shown respectively at the left and right side of figure C.5. UWB antennas clearly appear on the extender. A detailed top view of the extender is shown in figure C.6.

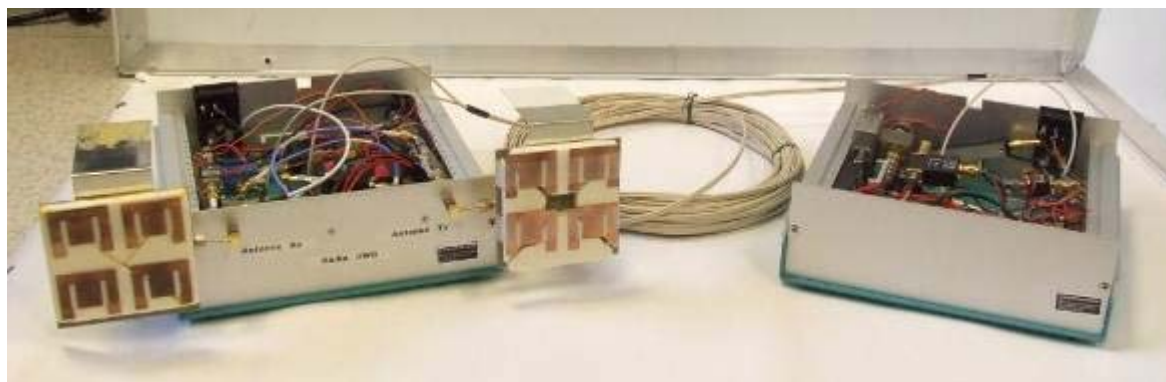

Figure C.5: Packaging of the multiformat switch (right) and of the extender (left)



Figure C.6: Detailed top view of the extender

For demonstration, the services run on the system as shown in figure C.7. The 100 Mbit/s Ethernet baseband signal was illustrated using a bidirectional link between two laptops equipped with webcams for videoconferencing (red link on the figure), the final connectivity being achieved with cat5 cable. RoF signals carried a connection to the access network, providing also a bidirectional wireless link for Internet browsing (green link). Digital terrestrial TV was also transmitted in the multiplex, the whole TV UHF spectrum being available at the TV set, through a coaxial cable, for an easy zapping. Figure C.8 and figure C.9 show the right part of the demo of figure C.7. Figure C.8 shows the extender, the TV set and the laptop connected with wires, while figure C.9 shows the third device, the laptop connected through a wireless link.

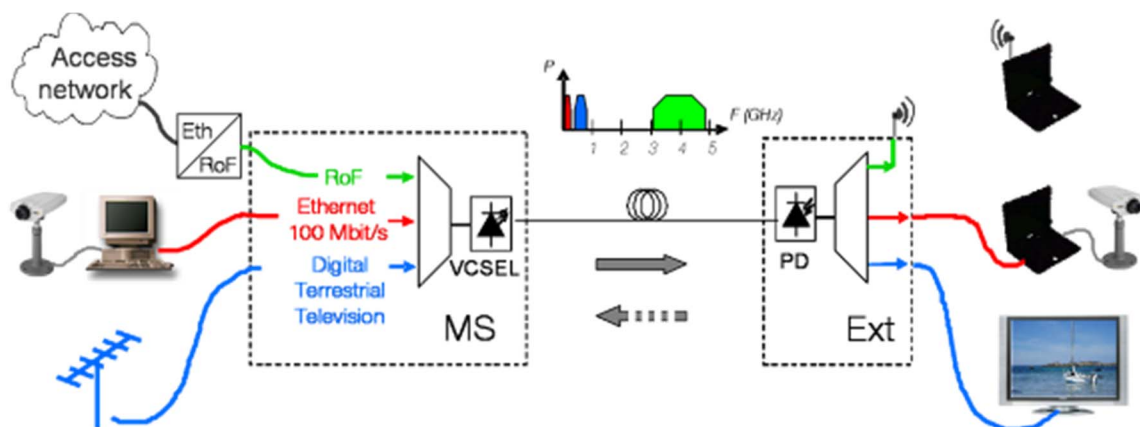

Figure C.7: Services run on the demo



Figure C.8: The extender and connected devices (view 1)



Figure C.9: The extender and connected devices (view 2)

C.3 Second option: hybrid electrical / optical multiplex

As explained in clause 4.2.3.1 of the present document, Ethernet bit rate is limited to 100 Mbit/s if only electrical multiplexing is used. Increasing this bit rate to 1 Gbit/s leads to spectrum overlapping between Ethernet and terrestrial TV signals. To face this bit rate increase, optical multiplexing should be introduced. Figure C.10 shows an example of implementation. Gigabit Ethernet is transmitted in both directions on one fibre, while the RF electrical multiplex combining the other signals is transmitted on a second fibre. The advantage of this solution lies in the possibility of increasing later the Ethernet to 10 Gbit/s without difficulty. Using an additional optical mux/demux at each side of the link makes it possible to implement a single fibre configuration.

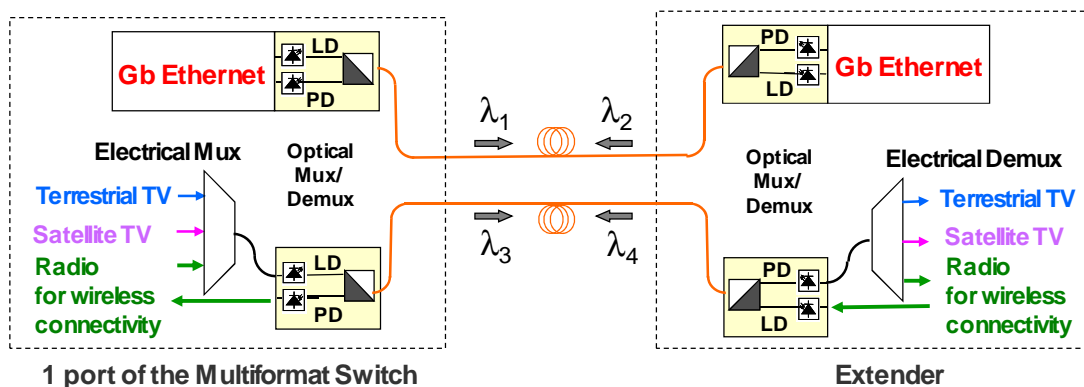

Figure C.10: hybrid electrical / optical multiplexing

This solution has been implemented with two services: 1 Gbit/s Ethernet and terrestrial TV. Bifibre and single fibre implemented demo configurations are shown respectively on figure C.11 and figure C.12.

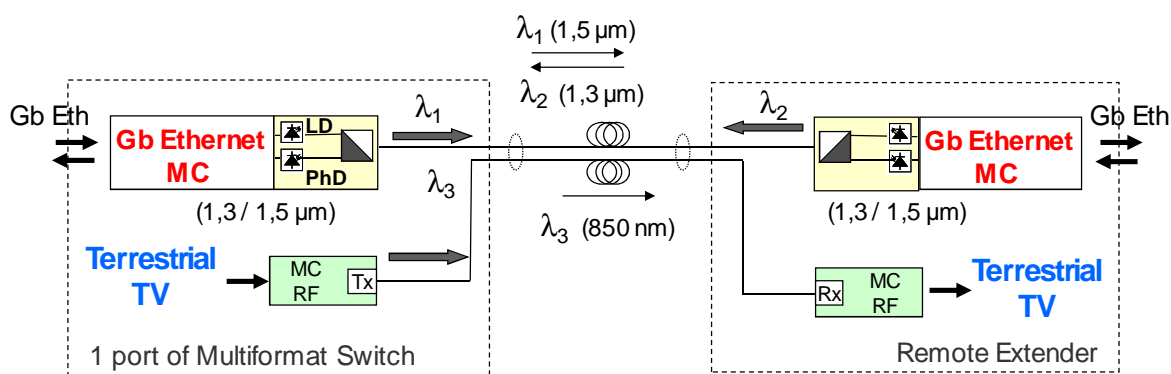

Figure C.11: bifibre demo configuration

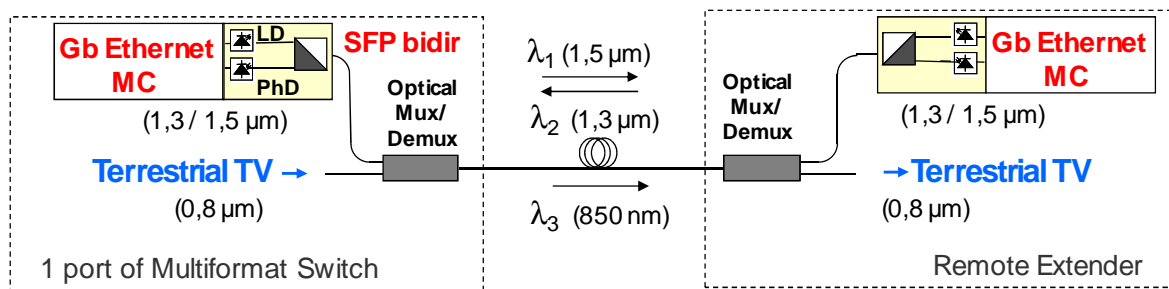

Figure C.12: single fibre demo configuration

In the complete setup configuration, this multiplexing process should be achieved for the different ports of the multifomat switch. As in the previous case, a Gigabit Ethernet switch has been used, each of its ports being dedicated to a port of the multifomat switch. To replicate the terrestrial TV signal, two options are possible. In the first one (figure C.13), the electrical TV signal is amplified and split in the electrical domain, several RF mediaconverters (MC) are then used for the electrical to optical conversion at each port of the electrical splitter. In the second one (figure C.14), only one RF mediaconverter is used to convert the electrical RF signal to an optical signal, which is then replicated using an optical splitter.

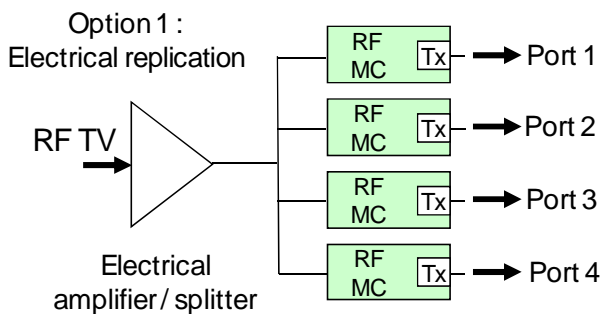

Figure C.13: TV signal replication using electrical splitting

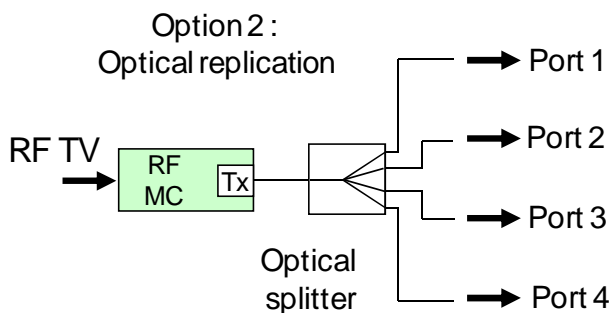

Figure C.14: TV signal replication using optical splitting

The complete setup is depicted in figure C.15. For the demo, the second option was chosen, with an optical splitter to replicate for the TV signal. An eight port multiformat switch was realized but, for realistic use case, only four ports were opticalized. Figure C.16 shows the realized multiformat switch.

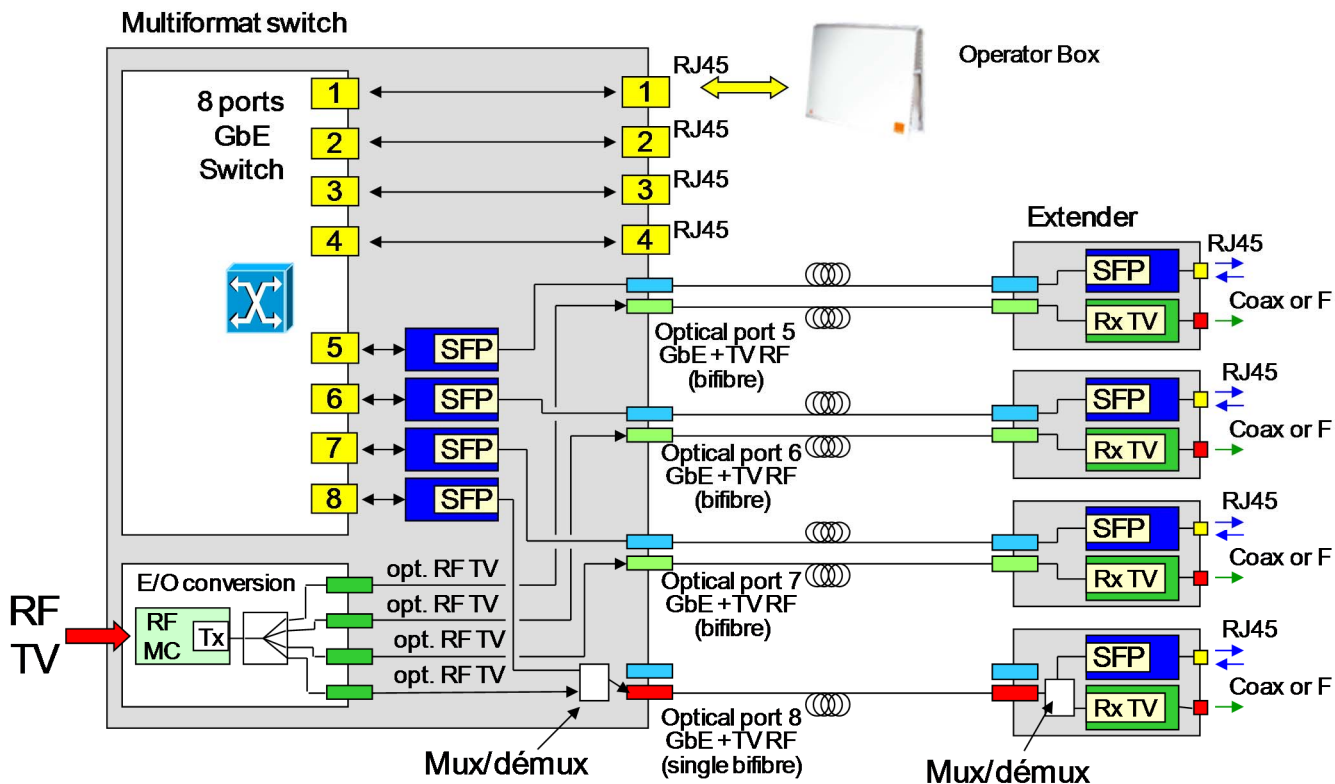

Figure C.15: complete setup configuration



Figure. C.16: Pictures of the multiformat switch

D.2 The demonstrated configuration

The CWDM passive star architecture is already described in clause 4.2.3.2; therefore, the demo configuration is focussed on hereafter. The services that were selected to demonstrate this architecture are listed below, and illustrated in figure D.2:

- **RoF transmission:** a Residential PON ("PON-like" application): deriving from the access domain, this transport solution uses the mechanisms developed in the access PONs to share a passive infrastructure between several users. The gateway is then a Home Network Optical Line Termination (HN-OLT). Premises are connected using Home Network Optical Network Termination (HN-ONT). Real time traffic and best effort traffic coexist with a good QoS, as PON allows resource reservation. Increasing the number of connected devices is very easy, as PON are presently sized with up to 128 ONT. In our B&S CWDM solution, two wavelengths are necessary to implement a PON on the transparent infrastructure: one for upstream, and one for downstream traffic.
- **Residential LAN ("LAN-like" application):** with this solution derived from LAN and Ethernet context, all premises are connected to an optical bus, using optical transceivers. The gateway is on the same hierarchical level than other premises and the network manages itself. The advantage is the simplicity of the Medium Access Control (MAC), e.g. CSMA/CD. The drawback is that this type of network has been designed for best effort traffic and no QoS is currently considered. But, considering the short transmission distances, the limited number of nodes compared to the LAN context and taking into account the increasing speed of transceivers, the ability of such a network to transport simultaneously real time and best effort traffic should be possible. As the best solution to implement an optical bus is the passive optical $N \times N$ star, this approach is well suited to the transparent optical plant we use for the demo. Another advantage is that only one wavelength is necessary for this application.
- **Point to point links:** this topology is not well adapted to the B&S CWDM architecture, for it requires two wavelengths, one for each transmission direction, only to connect two devices between each other. However, it is useful to be able to offer such links, for instance to interconnect two devices for very high bit rate and high QoS services. In the frame of the demo, Fast Ethernet and Gigabit Ethernet point to point links are implemented.
- **wireless connectivity** is often preferred for its convenience, data have to be transported to radio access points. The best solution is to achieve the transmission in the radio native format, in order to simplify the radio access points, and to be transparent regarding the protocols used by the radio application.
- **TV broadcasting:** the possibility to broadcast TV programs from the TV antenna (or satellite dish) to the TV sets inside the home should be a significant advantage for the user. One wavelength may then be used and, for terrestrial TV for example, the whole RF TV spectrum supporting all the programs is then transmitted to each TV set.

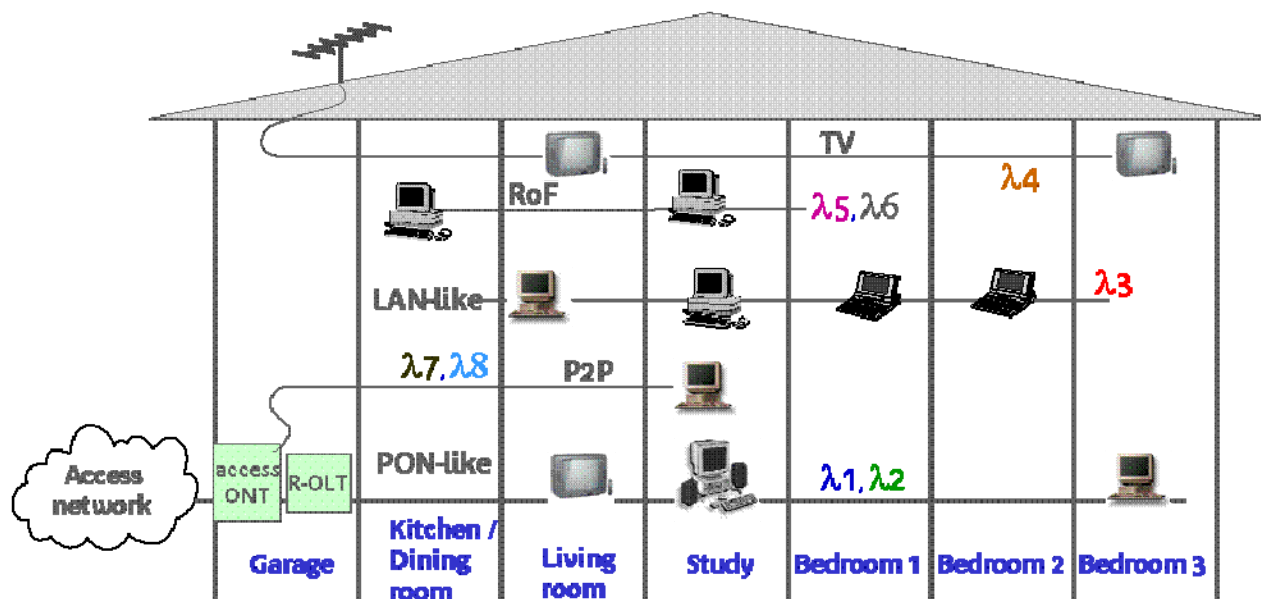

Figure D.2: The different services implemented on the demo

The different implemented wavelengths were chosen in the coarse WDM (CWDM) grid, except for the RoF transmission, for which two very close wavelengths have been selected from the DWDM grid, only to demonstrate this possibility. The wavelength allocation is given in figure D.3.

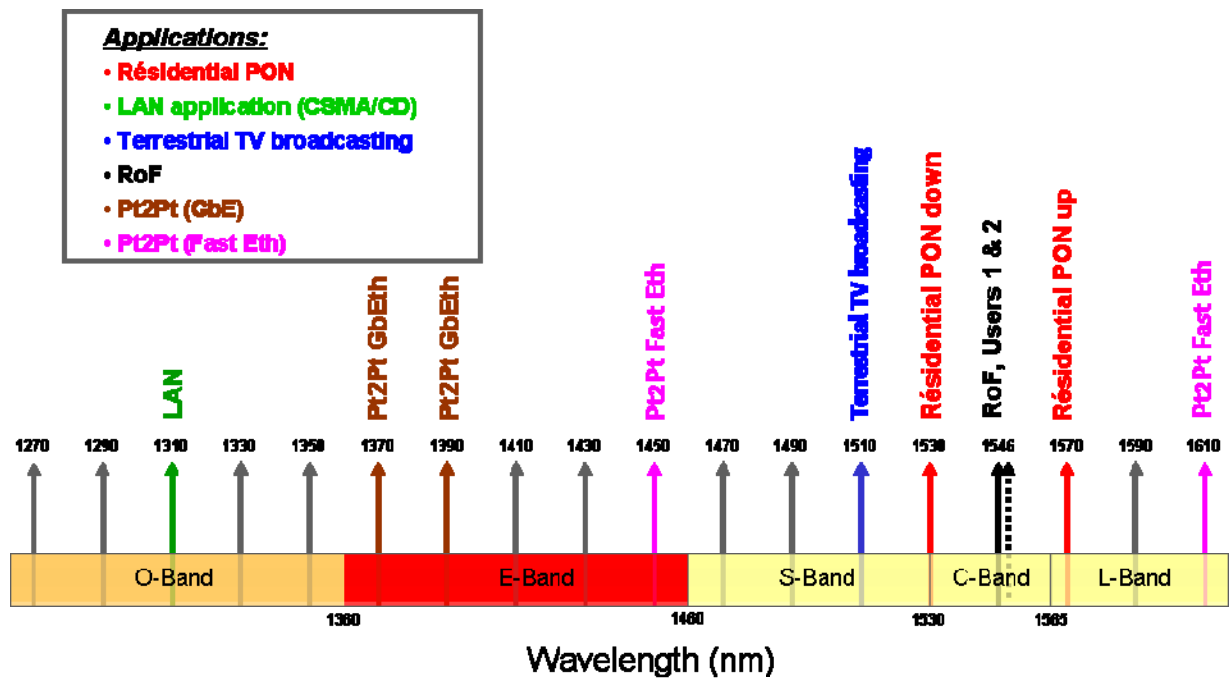

Figure D.3: Wavelength allocation

The demo was achieved using the single-mode passive infrastructure, organized around a 16×16 splitter (figure D.4).

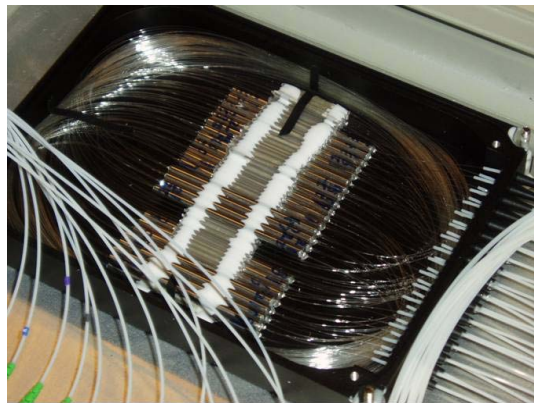

Figure D.4: Picture of the 16×16 optical splitter

Add & drop modules were packaged and used for inserting or extracting applications to or from the home network. As depicted in figure D.5, figure D.6 and figure D.7, add & drops should be cascaded to connect several services to one optical outlet in a room.



Figure D.5: Packaging of the add & drop modules

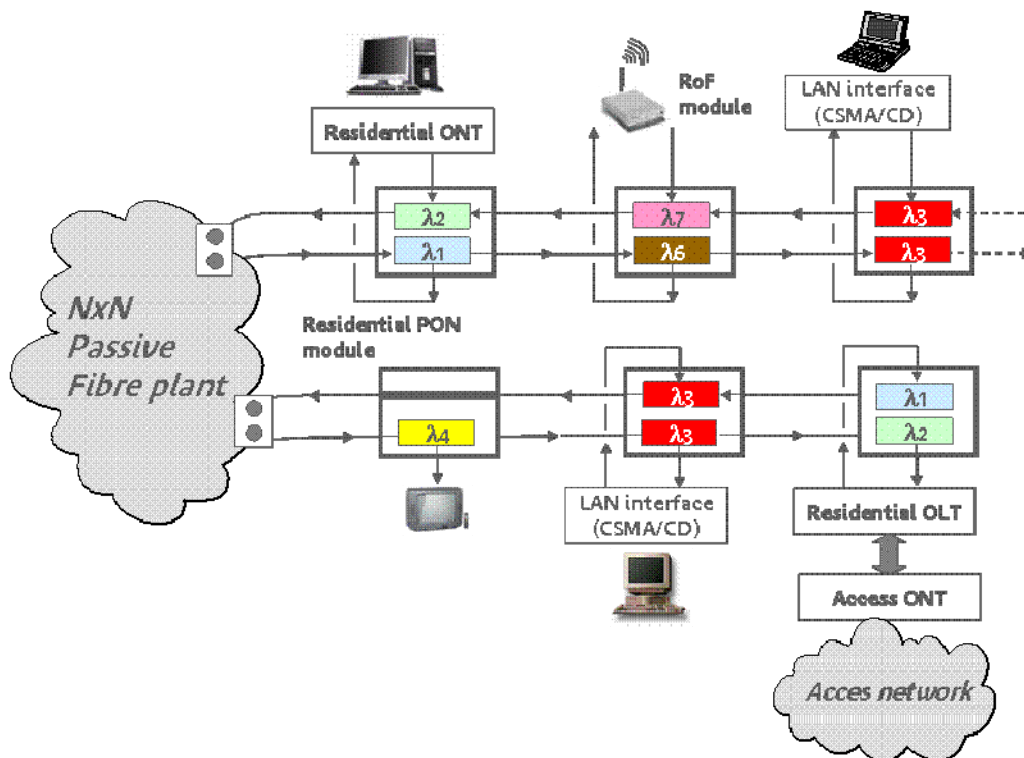

Figure D.6: Principle of cascading add & drop modules

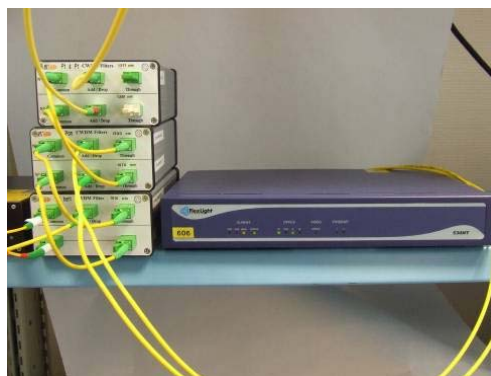

Figure D.7: A cascade of add & drop modules

D.3 Implementing the applications

D.3.1 Residential PON ("PON-like") application

As it was not possible to develop a specific Home Network PON, a PON system dedicated for access network application was used. One difficulty is that access PONs are designed to work in a single fibre configuration, with wavelengths specified by the FSAN standardization group, and most of the systems cannot work in a CWDM environment. Generally, there is no possibility to access to the optical components, which is a major difficulty to adapt them to the demonstration. This system uses DFB lasers for both transmission directions, in the 1,5 μm window. With some slight modifications, it was possible to adapt this system to the bi fibre configuration of the demonstration. As two wavelengths are necessary for implementing this PON system, 1 570 nm and 1 530 nm were selected for downstream and upstream transmission respectively, as shown in figure D.8.

The demonstration is interconnected with a distant service platform, the delivering of Internet applications and video over IP programs through the PON-like application was demonstrated successfully.

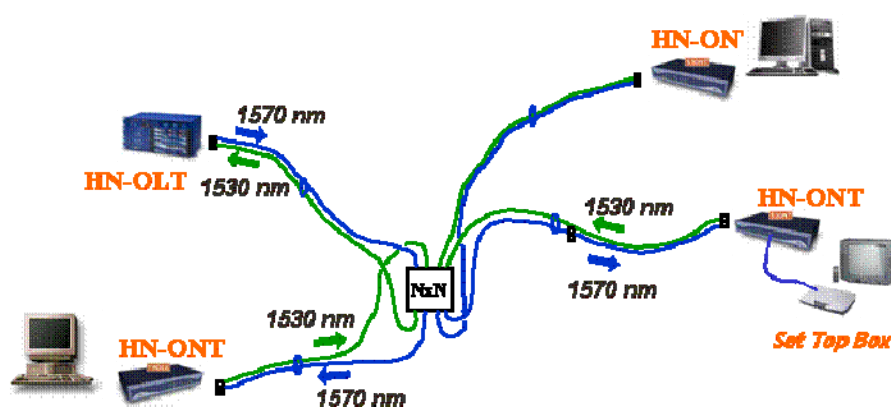

Figure D.8: Implementation of PON-like application

D.3.2 "LAN-like" application

This application runs on an optical bus, with only one wavelength. As today Ethernet networks are generally based on point to point links in an active star configuration (switched Ethernet), it was not easy to find products compatible with the bus topology, in other terms working with the CSMA/CD medium access control. Only one company was able to provide such prototypes, at a bit rate of 100 Mbit/s. Some negotiations were necessary to modify these prototypes to cope with the requirements related to CWDM environment. Wide spectrum Fabry-Perot lasers were replaced by DFB lasers, at a wavelength of 1 310 nm. These prototypes were designed as Ethernet cards to be inserted on the PCI bus in PC (figure D.9). Three cards were used to interconnect three PC through our transparent optical architecture, as shown in figure D.10.



Figure D.9: CSMA/CD prototypes

To test this application, files were transferred from PC to PC, while movies were played, from one of the PC acting as a video server.

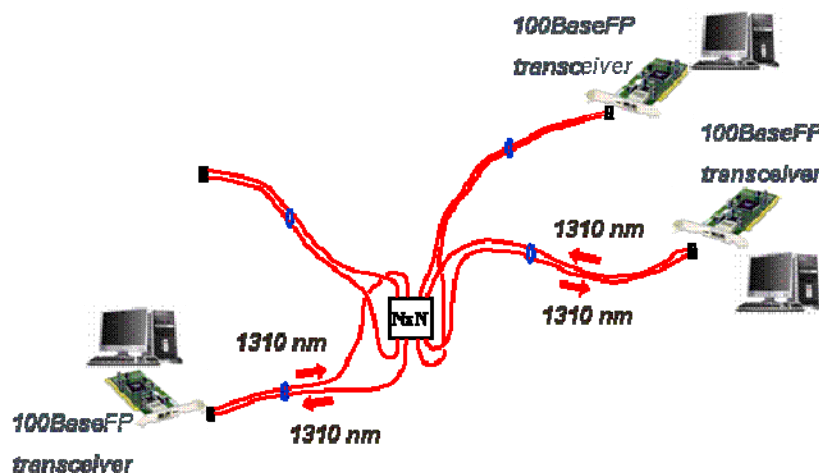

Figure D.10: "LAN-like" application implementation

D.3.3 RoF application

With the RoF technology, radio signals are transported in their native format on optical fibre. Thus, a RoF system achieves a transparent interconnection of radio cells, their association being equivalent to a unique cell with a wider coverage. Ultra Wide Band (UWB) was the technology chosen for this demonstration. As RoF products for the home network do not exist, this application was implemented using commercially available components. The dimensioning was made on the basis of the common cable lengths in a home network, and taking into account the losses introduced by a 16×16 splitter. The RoF application was implanted in the demonstration, according to the scheme in figure D.11. A communication between two devices using an UWB interface has been considered. One of these devices was a video server, the other one being a PC. Rather than using two wavelengths selected in the CWDM grid, two very close channels, 1 549,76 nm and 1 550,33 nm, were selected only to show the compatibility of this approach with Dense WDM (DWDM), the two wavelengths being in the same CWDM channel. The separation of 1 nm between the two wavelengths prevents from problems due to optical beat interference.

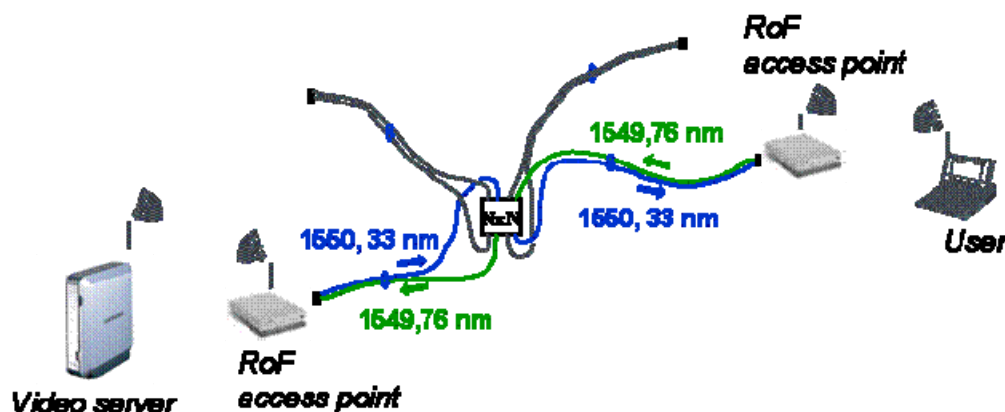

Figure D.11: RoF application implementation

D.3.4 TV broadcast application

The aim of this application was to demonstrate the possibility of broadcasting the whole TV terrestrial spectrum to a large number of TV sets, from the antenna located on the roof of the house. The requirements for transmitting these signals were strong, in terms of optical budget, which had to be compatible with our passive architecture (figure D.12), and laser linearity. One transmitter and some receiver modules have been developed according to our specifications. It should be noted that this application is unidirectional.

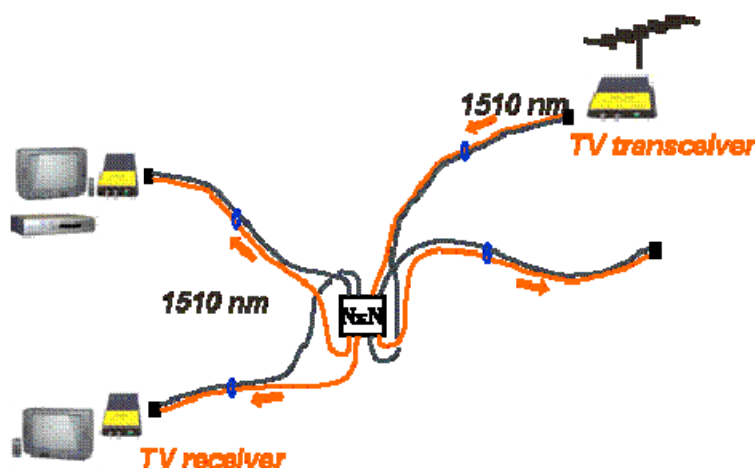

Figure D.12: TV broadcast implementation

The broadcast of terrestrial TV has been validated on the demonstration, using the wavelength of 1 510 nm. With a 16×16 splitter, the optical budget provides about 5 dB margin, which is sufficient to insert the TV add & drop module in a cascade of filtering modules (from the 1st to the 5th rank). With a 32×32 splitter, this module should be inserted in the first rank of the cascade to ensure the required power level at the receiver end.

D.3.5 Point to point application

This application is the simplest to implement, even if it is not the more advantageous one, in terms of wavelength waste, as it requires one channel for each direction. So, a point to point bidirectional link uses two wavelengths. But this can be a relevant solution if two devices have to be interconnected with a very high bit rate with strong QoS requirements. Two point to point bidirectional links were implemented in the demonstration, one at 100 Mbit/s (Fast Ethernet), the other one at 1 Gbit/s (Gigabit Ethernet). They also contribute to prove the huge potential in terms of capacity for the demonstrated solution. One implementation example is given in figure D.13, for a bidirectional Gigabit Ethernet link. A traffic analyser exhibiting SFP cages was used to generate Gigabit Ethernet frames, and CWDM SFP modules with the desired wavelengths were inserted in these cages. According to the SFP modules characteristics (transmitted power, sensitivity) and the application bit rate, the optical budget provides different margin levels, which generally remains widely sufficient for an easy implementation.

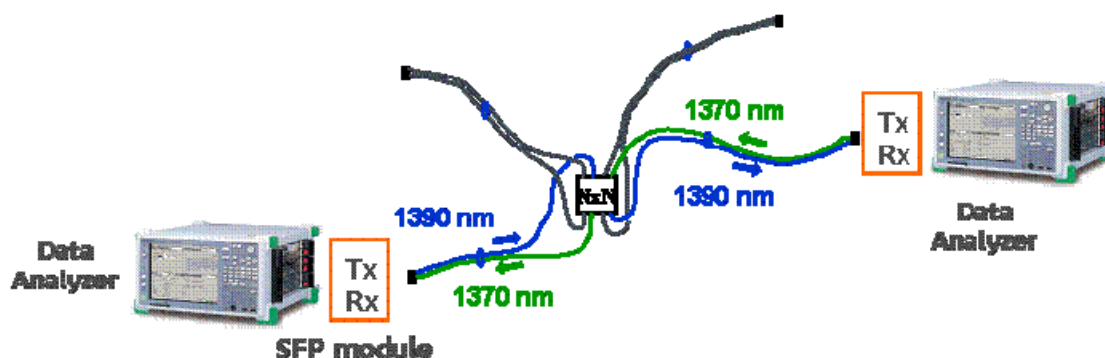

Figure D.13: Point to Point application implementation

D.3.6 Simultaneous running applications

All the previous described applications were run simultaneously using the CWDM technology. An optical spectrum measured with an optical spectrum analyser is depicted in figure D.14. It shows the wavelength allocation for the different implemented applications.

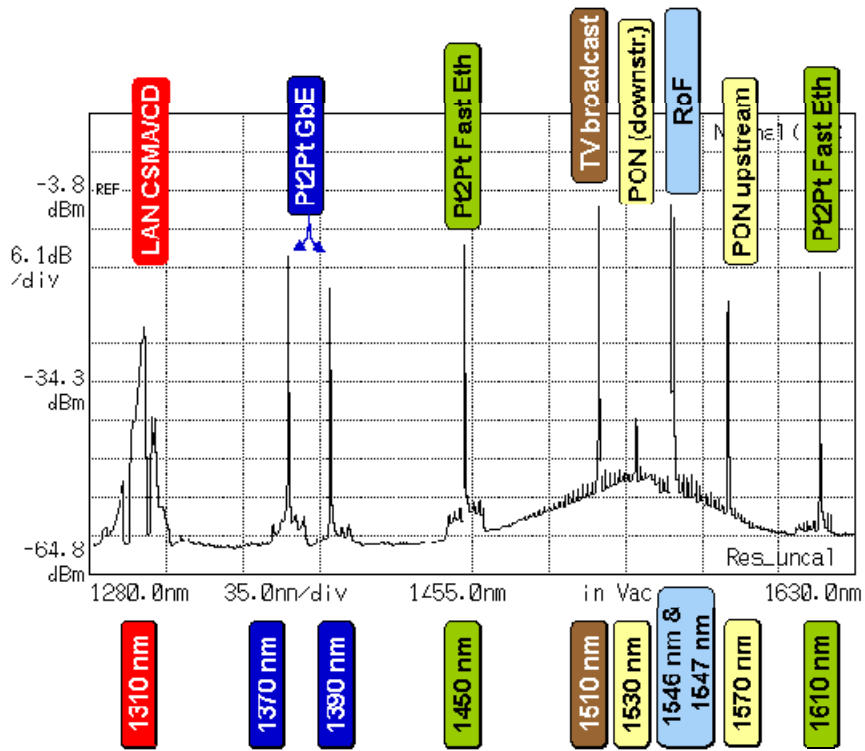

Figure D.14: Wavelength allocation for the different applications

Annex E (informative): Example of an optical fibre home cabling system

E.1 Introduction

This annex describes an example of a pre-assembled optical fibre home system for HAN including an optical TO (OTO) and an adapter for BLINK type connectors that comprises special features for the user handling.

E.2 Installation of an optical fibre home cabling system

The optical fibre home cabling system allows an easy and fast installation of fibers in HAN. A defined length of bend-insensitive cabled fibers is already connected to the optical TO by the manufacturer. The free cable end is pulled through the duct and connected in the HD. Afterwards the optical TO is fixed at the wall. A realization example is shown in figure E.1.



Figure E.1: Optical fibre home cabling system

The optical fibre home cabling system is terminated with the connector interfaces BLINK, LC or SC. In this example, a dedicated adapter is used with the interface of the BLINK type on one side and the LC type on the second side (see figure E.2). The connector interface of the BLINK type is specified in CENELEC EN 61754-29 [29] and the LC type in CENELEC EN 61754-20 [27].



Figure E.2: Adapter with BLINK and LC type adapter sides

The dedicated adapter (figure E.2) is assembled into the optical TO, so that the BLINK type adapter side is externally accessible (see figure E.3). Internally in the optical TO, the fibers of the cable are connected to pigtails with LC type adapter side. The optical TO is able to manage up to four fibers.

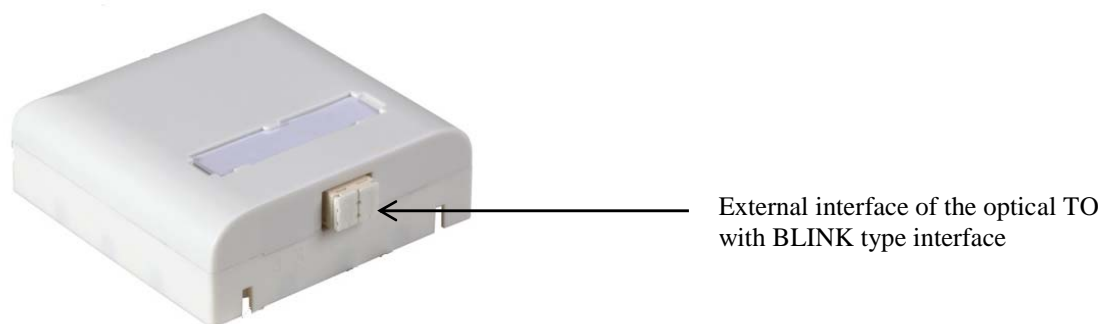

Figure E.3: Optical TO with BLINK type interface

E.3 Connection of the optical TO to the end user equipment

At the external interface of the optical TO, cables with BLINK type connectors can be plugged in by the user to connect the end user equipment. Figure E.4 shows an indoor cable with terminated BLINK type connector.

The BLINK type connector offers special features for the user handling. The automatic self-release mechanism prevents damages of the connectors, cables, fibers and optical TO, when the users handle the cables with less care and pull at the cables with high force. Moreover, the BLINK type connector provides a protection cap for laser, end-face and dust protection.

These features support to prevent interruption of the network connection as well as avoid time consuming and costly repair.



Figure E.4: Indoor cable with terminated BLINK type connector

Summarized, the BLINK type connector provides the following features:

- an integrated laser and dust protection in the connector and adapter;
- an integrated optical end face protection at the connector;
- an automatic self-release mechanism.

History

Document history		
V1.1.1	September 2015	Publication