

ETSI TS 103 397 V1.1.2 (2020-03)



**Core Network and Interoperability Testing (INT);
VoLTE and ViLTE interconnect, interworking and
roaming test specification with QoS/QoE
(3GPP™ Release 12)**

Reference

RTS/INT-00164

Keywords

QoE, QoS, ViLTE, VoLTE

ETSI

650 Route des Lucioles
F-06921 Sophia Antipolis Cedex - FRANCE

Tel.: +33 4 92 94 42 00 Fax: +33 4 93 65 47 16

Siret N° 348 623 562 00017 - NAF 742 C
Association à but non lucratif enregistrée à la
Sous-Préfecture de Grasse (06) N° 7803/88

Important notice

The present document can be downloaded from:

<http://www.etsi.org/standards-search>

The present document may be made available in electronic versions and/or in print. The content of any electronic and/or print versions of the present document shall not be modified without the prior written authorization of ETSI. In case of any existing or perceived difference in contents between such versions and/or in print, the prevailing version of an ETSI deliverable is the one made publicly available in PDF format at www.etsi.org/deliver.

Users of the present document should be aware that the document may be subject to revision or change of status.

Information on the current status of this and other ETSI documents is available at

<https://portal.etsi.org/TB/ETSIDeliverableStatus.aspx>

If you find errors in the present document, please send your comment to one of the following services:

<https://portal.etsi.org/People/CommitteeSupportStaff.aspx>

Copyright Notification

No part may be reproduced or utilized in any form or by any means, electronic or mechanical, including photocopying and microfilm except as authorized by written permission of ETSI.

The content of the PDF version shall not be modified without the written authorization of ETSI.

The copyright and the foregoing restriction extend to reproduction in all media.

© ETSI 2020.

All rights reserved.

DECT™, **PLUGTESTS™**, **UMTS™** and the ETSI logo are trademarks of ETSI registered for the benefit of its Members.

3GPP™ and **LTE™** are trademarks of ETSI registered for the benefit of its Members and of the 3GPP Organizational Partners.

oneM2M™ logo is a trademark of ETSI registered for the benefit of its Members and of the oneM2M Partners.

GSM® and the GSM logo are trademarks registered and owned by the GSM Association.

Contents

Intellectual Property Rights	5
Foreword.....	5
Modal verbs terminology.....	5
Introduction	5
1 Scope	6
2 References	6
2.1 Normative references	6
2.2 Informative references.....	9
3 Definition of terms, symbols and abbreviations.....	9
3.1 Terms.....	9
3.2 Symbols.....	9
3.3 Abbreviations	9
4 General principles of interconnection of VoLTE-based networks	11
4.0 Overview	11
4.1 E2E scenarios in terms of interworking, interconnection and roaming.....	12
4.2 Interconnection and roaming scenarios test selection description (Excel file).....	13
4.2.0 General.....	13
4.2.1 First step- "Identification of the Networks"	13
4.2.2 Second step - Selection Expression	13
4.2.3 Third step- Access and End Devices Types.....	15
4.2.4 Fourth step- activation	16
4.2.5 Fifth step - Selection of roaming scenarios (not contained in the Excel file)	17
5 IMS Roaming and Interconnection options (for information).....	21
6 VoLTE interconnect and roaming tests.....	24
6.1 Test Suite Structure (TSS).....	24
6.2 VoLTE Consideration	24
6.2.1 EPC Consideration.....	24
6.2.2 EPC Configuration Requirements.....	25
6.3 Device and U/ISIM consideration	25
6.3.1 Multi-Mode and Multi-band Terminal.....	25
6.3.2 General Requirements for VoLTE Terminal	25
6.3.2.0 Overview	25
6.3.2.1 RAN Features.....	26
6.3.2.2 IMS function on control plane	26
6.3.2.3 IMS function on media plane	26
6.3.2.4 Services Requirements	26
7 Test purposes.....	27
7.0 General	27
7.1 Testing of SIP protocol requirements.....	27
7.1.1 Test purposes for Basic call, Successful	27
7.1.2 Test purposes for Basic call, DTMF Transport.....	49
7.1.3 Test purposes for Basic call, Fax transmission	50
7.1.4 SIP-I Tests	53
7.1.5 Codec negotiation	61
7.1.6 Resource Reservation	65
7.1.7 Test purposes for SIP-SIP, Basic call, Unsuccessful	67
7.1.7.1 NNI	67
7.1.7.2 SIP-I.....	73
7.1.8 Test purposes for Supplementary services.....	78
7.1.8.1 Test purposes for OIP.....	78
7.1.8.2 Test purposes for OIR	83
7.2 Video Call	86

7.2.1	Testing of SIP protocol requirements	86
7.2.1.1	Test purposes for Basic call, Successful	86
8	QoS/QoE/Test requirements.....	91
8.0	General	91
8.1	Call set-up time (post dialling delay)	92
8.2	Listening speech quality	92
8.2.1	Connections with one voice channel.....	92
8.2.2	General aspects of Listening Speech Quality.....	94
8.2.3	General aspects of voice channel test calls	94
8.3	End-to-end audio delay	97
8.4	End-to-end audio delay variation	97
8.5	Early media call flow options and listening speech quality.....	97
8.5.1	Introduction.....	97
8.5.1.0	General	97
8.5.1.1	Call Flow 1	98
8.5.1.2	Call Flow 2.....	99
8.5.2	Early media listening speech quality convergence quality test.....	100
8.6	Fax Transmission	101
8.7	ViLTE KPI	101
Annex A (informative):	Examples of Codecs which can be used in the case of interworking/roaming	104
Annex B (informative):	Examples for grouped tests.....	108
Annex C (informative):	Bibliography.....	110
History		111

Intellectual Property Rights

Essential patents

IPRs essential or potentially essential to normative deliverables may have been declared to ETSI. The information pertaining to these essential IPRs, if any, is publicly available for **ETSI members and non-members**, and can be found in ETSI SR 000 314: "*Intellectual Property Rights (IPRs); Essential, or potentially Essential, IPRs notified to ETSI in respect of ETSI standards*", which is available from the ETSI Secretariat. Latest updates are available on the ETSI Web server (<https://ipr.etsi.org/>).

Pursuant to the ETSI IPR Policy, no investigation, including IPR searches, has been carried out by ETSI. No guarantee can be given as to the existence of other IPRs not referenced in ETSI SR 000 314 (or the updates on the ETSI Web server) which are, or may be, or may become, essential to the present document.

Trademarks

The present document may include trademarks and/or tradenames which are asserted and/or registered by their owners. ETSI claims no ownership of these except for any which are indicated as being the property of ETSI, and conveys no right to use or reproduce any trademark and/or tradename. Mention of those trademarks in the present document does not constitute an endorsement by ETSI of products, services or organizations associated with those trademarks.

Foreword

This Technical Specification (TS) has been produced by ETSI Technical Committee Core Network and Interoperability Testing (INT).

The test case list and test selection are contained in archive ts_103397v010102p0.zip which accompanies the present document.

Modal verbs terminology

In the present document "**shall**", "**shall not**", "**should**", "**should not**", "**may**", "**need not**", "**will**", "**will not**", "**can**" and "**cannot**" are to be interpreted as described in clause 3.2 of the [ETSI Drafting Rules](#) (Verbal forms for the expression of provisions).

"**must**" and "**must not**" are **NOT** allowed in ETSI deliverables except when used in direct citation.

Introduction

Voice over LTE (VoLTE) and Video over LTE (ViLTE) are services which deliver voice and video communication over packet-based networks. VoLTE/ViLTE services can be provided by either traditional fixed or by mobile telecom operators who have implemented the LTE technology as access technology to its core IP network.

1 Scope

The present document enables interested parties to verify the VoLTE and ViLTE interworking, interconnection and roaming of networks by providing e2e scenarios based on an identification and selection of various criteria:

- Identification of the Networks
- Selection of Expression
- Determination of Access and end Device Types
- Selection of roaming scenarios

Additionally the present document provides a series of test suites for Quality of Service (QoS) and Quality of Experience (QoE) based on KPI for voice quality measurements and KPI for video quality measurements.

2 References

2.1 Normative references

References are either specific (identified by date of publication and/or edition number or version number) or non-specific. For specific references, only the cited version applies. For non-specific references, the latest version of the referenced document (including any amendments) applies.

Referenced documents which are not found to be publicly available in the expected location might be found at <https://docbox.etsi.org/Reference>.

NOTE: While any hyperlinks included in this clause were valid at the time of publication, ETSI cannot guarantee their long term validity.

The following referenced documents are necessary for the application of the present document.

- [1] ETSI TS 129 165: "Digital cellular telecommunications system (Phase 2+); Universal Mobile Telecommunications System (UMTS); LTE; Inter-IMS Network to Network Interface (NNI) (3GPP TS 29.165 Release 12)".
- [2] ETSI TS 124 229: "Digital cellular telecommunications system (Phase 2+); Universal Mobile Telecommunications System (UMTS); LTE; IP multimedia call control protocol based on Session Initiation Protocol (SIP) and Session Description Protocol (SDP); Stage 3 (3GPP TS 24.229 Release 12)".
- [3] IETF RFC 4566 (2006): "SDP: Session Description Protocol".
- [4] IETF RFC 3261 (2002): "SIP: Session Initiation Protocol".
- [5] IETF RFC 3264 (2002): "An Offer/Answer Model with the Session Description Protocol (SDP)".
- [6] IETF RFC 3312 (2002): "Integration of Resource Management and Session Initiation Protocol (SIP)".
- [7] ETSI TS 124 607: "Digital cellular telecommunications system (Phase 2+); Universal Mobile Telecommunications System (UMTS); LTE; Originating Identification Presentation (OIP) and Originating Identification Restriction (OIR) using IP Multimedia (IM) Core Network (CN) subsystem; Protocol specification (3GPP TS 24.607 Release 12)".
- [8] IETF RFC 5009 (September 2007): "Private header (P-Header) extension to the Session Initiation Protocol (SIP) for authorization of Early Media".
- [9] Recommendation ITU-T V.152 (09- 2010): "Procedures for supporting Voice-Band Data over IP Networks".

- [10] Recommendation ITU-T T.38 (11-2015): "Procedures for real-time Group 3 facsimile communication over IP networks".
- [11] Recommendation ITU-T Q.1912.5: "Interworking between session initiation protocol (SIP) and bearer independent call control protocol or ISDN user part".
- [12] ETSI TS 183 036: "Telecommunications and Internet converged Services and Protocols for Advanced Networking (TISPAN); ISDN/SIP interworking; Protocol specification".
- [13] IETF RFC 4733: "RTP Payload for DTMF Digits, Telephony Tones and Telephony Signals".
- [14] IETF RFC 4028: "Session Timers in the Session Initiation Protocol (SIP)".
- [15] ETSI TS 103 222-1 (V1.3.1): "Speech and multimedia Transmission Quality (STQ); Reference benchmarking, background traffic profiles and KPIs; Part 1: Reference benchmarking, background traffic profiles and KPIs for VoIP and FoIP in fixed networks".
- [16] ETSI TS 101 563 (V1.3.1): "Speech and multimedia Transmission Quality (STQ); IMS/PES/VoLTE exchange performance requirements".
- [17] Recommendation ITU-T Q.543 (03-1993): "Digital exchange performance design objectives".
- [18] ETSI ES 202 765-2 (V1.2.1): "Speech and multimedia Transmission Quality (STQ); QoS and network performance metrics and measurement methods; Part 2: Transmission Quality Indicator combining Voice Quality Metrics".
- [19] ETSI TS 102 250-2 (V2.6.1): "Speech and multimedia Transmission Quality (STQ); QoS aspects for popular services in mobile networks; Part 2: Definition of Quality of Service parameters and their computation".
- [20] Recommendation ITU-T P.863 (03-2018): "Perceptual objective listening quality assessment".
- [21] Recommendation ITU-T P.863.1 (06-2019): "Application guide for Recommendation ITU-T P.863".
- [22] Recommendation ITU-T P.501 (03-2017): "Test signals for use in telephony".
- [23] ETSI ES 202 737 (V1.4.1): "Speech and multimedia Transmission Quality (STQ); Transmission requirements for narrowband VoIP terminals (handset and headset) from a QoS perspective as perceived by the user".
- [24] ETSI ES 202 739 (V1.4.1): "Speech and multimedia Transmission Quality (STQ); Transmission requirements for wideband VoIP terminals (handset and headset) from a QoS perspective as perceived by the user".
- [25] ETSI TS 101 585 (V1.2.1): "Core Network and Interoperability Testing (INT); IMS interconnection tests at the Ic Interface; Test Suite Structure and Test Purposes (TSS&TP)".
- [26] GSMA PRD IR.67: "DNS/ENUM Guidelines for Service Providers & GRX/IPX".
- [27] ETSI ES 203 021-3 (V2.1.2): "Access and Terminals (AT); Harmonized basic attachment requirements for Terminals for connection to analogue interfaces of the Telephone Networks; Update of the technical contents of TBR 021, EN 301 437, TBR 015, TBR 017; Part 3: Basic Interworking with the Public Telephone Networks".
- [28] Recommendation ITU-T Q.4016 (01-2018): "Testing specification of call establishment procedures based on SIP/SDP and H.248 for a real-time fax over IP service2".
- [29] ETSI TS 126 114 (V13.6.0): "Universal Mobile Telecommunications System (UMTS); LTE; IP Multimedia Subsystem (IMS); Multimedia telephony; Media handling and interaction (3GPP TS 26.114 version 13.6.0 Release 13)".
- [30] ETSI TS 126 103 (V13.3.0): "Digital cellular telecommunications system (Phase 2+) (GSM); Universal Mobile Telecommunications System (UMTS); Speech codec list for GSM and UMTS (3GPP TS 26.103 version 13.3.0 Release 13)".

- [31] ETSI ES 202 667 (V1.1.5): "Speech and multimedia Transmission Quality (STQ); Audiovisual QoS for communication over IP networks".
- [32] Recommendation ITU-T P.910 (April 2008): "Subjective video quality assessment methods for multimedia applications".
- [33] Recommendation ITU-T P.911: "Subjective audiovisual quality assessment methods for multimedia applications".
- [34] IETF RFC 3761 (2004): "The E.164 to Uniform Resource Identifiers (URI) Dynamic Delegation Discovery System (DDDS) Application (ENUM)".
- [35] GSMA IR.65 V.28 (May 2018): "IMS Roaming and Interworking Guidelines".
- [36] ETSI TS 123 002: "Digital cellular telecommunications system (Phase 2+); Universal Mobile Telecommunications System (UMTS); LTE; Network architecture (3GPP TS 23.002 version 12.7.0 Release 12)".
- [37] ETSI TS 129 235 (V12.1.0): "Digital cellular telecommunications system (Phase 2+) (GSM); Universal Mobile Telecommunications System (UMTS); LTE; Interworking between SIP-I based circuit-switched core network and other networks (3GPP TS 29.235 version 12.1.0 Release 12)".
- [38] ETSI TS 123 231 (V12.0.0): "Digital cellular telecommunications system (Phase 2+) (GSM); Universal Mobile Telecommunications System (UMTS); SIP-I based circuit-switched core network; Stage 2 (3GPP TS 23.231 version 12.0.0 Release 12)".
- [39] ETSI TS 129 231 (V12.0.0): "Digital cellular telecommunications system (Phase 2+) (GSM); Universal Mobile Telecommunications System (UMTS); Application of SIP-I Protocols to Circuit Switched (CS) core network architecture; Stage 3 (3GPP TS 29.231 version 12.0.0 Release 12)".
- [40] ETSI TS 123 228 (V8.12.0): "Digital cellular telecommunications system (Phase 2+) (GSM); Universal Mobile Telecommunications System (UMTS); LTE; IP Multimedia Subsystem (IMS); Stage 2 (3GPP TS 23.228 version 8.12.0 Release 8)".
- [41] ETSI TS 129 162 (V12.7.0): "Digital cellular telecommunications system (Phase 2+) (GSM); Universal Mobile Telecommunications System (UMTS); LTE; Interworking between the IM CN subsystem and IP networks (3GPP TS 29.162 version 12.7.0 Release 12)".
- [42] ETSI TS 183 043: "Telecommunications and Internet converged Services and Protocols for Advanced Networking (TISPAN); IMS-based PSTN/ISDN Emulation; Stage 3 specification".
- [43] ETSI TS 129 163 (V12.14.0): "Digital cellular telecommunications system (Phase 2+) (GSM); Universal Mobile Telecommunications System (UMTS); LTE; Interworking between the IP Multimedia (IM) Core Network (CN) subsystem and Circuit Switched (CS) networks (3GPP TS 29.163 version 12.14.0 Release 12)".
- [44] Recommendation ITU-T Q.761: "Signalling System No. 7 - ISDN User Part functional description".
- [45] Recommendation ITU-T Q.764: "Q.764: Signalling System No. 7 - ISDN User Part signalling procedures".
- [46] ETSI TS 124 605 (V12.5.0): "Digital cellular telecommunications system (Phase 2+); Universal Mobile Telecommunications System (UMTS); LTE; Conference (CONF) using IP Multimedia (IM) Core Network (CN) subsystem; Protocol specification (3GPP TS 24.605 version 12.5.0 Release 12)".

2.2 Informative references

References are either specific (identified by date of publication and/or edition number or version number) or non-specific. For specific references, only the cited version applies. For non-specific references, the latest version of the referenced document (including any amendments) applies.

NOTE: While any hyperlinks included in this clause were valid at the time of publication, ETSI cannot guarantee their long term validity.

The following referenced documents are not necessary for the application of the present document but they assist the user with regard to a particular subject area.

- [i.1] ETSI EG 202 057-2 (V1.3.2): "Speech and multimedia Transmission Quality (STQ); User related QoS parameter definitions and measurements; Part 2: Voice telephony, Group 3 fax, modem data services and SMS".
- [i.2] ETSI TR 103 138 (V1.4.1): "Speech and multimedia Transmission Quality (STQ); Speech samples and their use for QoS testing".
- [i.3] ETSI EG 202 425 (V1.1.1): "Speech Processing, Transmission and Quality Aspects (STQ); Definition and implementation of VoIP reference point".

3 Definition of terms, symbols and abbreviations

3.1 Terms

Void

3.2 Symbols

Void

3.3 Abbreviations

For the purposes of the present document, the following abbreviations apply:

3GPP	3 rd Generation Partnership Project
ACM	Accumulated Call Meter
ACR	Anonymous Communication Rejection
ACR-CB	Anonymous Call Rejection and Call Barring
AGCF	Access Gateway Control Function
AMR	Adaptative Multi-Rate
AMR-NB	Adaptive Multi Rate - NarrowBand
AMR-WB	Adaptive Multi Rate - Wide Band
ANM	ANswer Message
APN	Access Point Name
ATP	Access Transport Parameter
ATS	Abstract Test Suite
BCALL	Basic CALL
BICC	Bearer Independant Call Control
CB	Communication Barring
CCBS	Completion of Communications to Busy Subscriber
CCNR	Completion of Communications by No Reply
CD	Communication Deflection
CDIV	Communication DIVersion
CDP	Charging Determinating Point
CDR	Communication Data Record
CFB	Communication Forwarding Busy

CFNL	Communication Forwarding Not Logged in
CFNR	Communication Forwarding No Reply
CFU	Communication Forwarding Unconditional
CONF	CONFerence
CPG	Call Progress Message
CS	Circuit-Switched
CSCF	Call Session Control Function
CSFB	Circuit Switched Fall Back
CUG	Closed User Group
CW	Communication Waiting
DRX	Discontinuous Reception
DTMF	Dual Tone Multi Frequency
ECM	EPS Connection Management
ECT	Explicit Communication Transfer
ENUM	Telephone Number Mapping
FFS	For Further Study
GBR	Gross Bit Rate
GRX/IPX	GPRS Roaming eXchange/IP eXchange
GW	GateWay
HEVC	High Efficiency Video Coding
HLC	High Layer Compatibility
HOLD	communication HOLD
HPLMN	Home Public Land Mobile Network
HPMN	Home Public Mobile Network
IAM	Initial Address Message
IBCF	Interconnect Border Control Function
II-NNI	Inter-IMS Network to Network Interface
IPTV	Internal Protocol TeleVision
ISDN	Integrated Services Digital Network
ISIM	Inter-System Interface Mobility Management
IUT	Implementation Under Test
IVR	Interactive Voice Response
JPEG	Joint Photographic Expert Group
LBO	Local Break Out
LI	Lawful Interception
LLC	Low Layer Compatibility
LPC	Linear Predictive Coding
MBR	Maximum BitRate
MCID	Malicious Communication Identification
MGCF	Media Gateway Control Function
MPV	Management Protocol Version
MTBF	Mean Time Between Failure
MWI	Message Waiting Indication
NDUB	Network Determined User Busy
NNI	Network to Network Interface
OIP	Originating Identification Presentation
OIR	Originating Identification presentation Restriction
OMR	Optimal Media Routeing
OVL	OVER-Load point
PASP	Public Answering Safety Point
PBX	Private Branch eXchange
PCMA	Pulse-Code-Modulation- A law
PCMU	Pulse Code Modulation μ -law
PCRF	Policy and Charging Rule Function
PDD	Post Dial Delay
PDN	Public Data Network
PGW	Packet GateWay
PICS	Protocol Implementation Conformance Statement
PRACK	Provisional Response Acknowledgement
PS	Packet Switched
PSTN	Public Switched Telephone Network
QCELP	Qualcomm Code-Excited Linear Prediction

QCI	QoS Class Identifier
QCIF	Quarter Common Intermediate Format
QoS	Quality of Service
R-NNI	Roaming Network to Network Interface
RTCP	Real Time Control Protocol
SDU	Service Data Unit
SIP	Session Initiation Protocol
SIP-I	Session Initiation Protocol - ISUP (SIP with encapsulated ISUP)
SRVCC	Single Radio Voice Call Continuity
SWB	Super Wide Band
TBR	Technical Basis for Regulation
TIP	Terminating Identification Presentation
TIR	Terminating Identification Restriction
TMF	Management Task Force
TP	Test Purpose
TRFO	Transcoder free operation
TSS	Test Suite Structure
UAC	User Agent Client
UDUB	User Determined User Busy
UUS	The User-to-User Signalling supplementary service
VGW	Voice GateWay
VoPS	IMS Voice over PS session
VPLMN	Visited Public Land Mobile Network
VPMN	Visited Public Mobile Network
XCAP	eXtended Camel Application Part

4 General principles of interconnection of VoLTE-based networks

4.0 Overview

Voice over LTE (VoLTE) and Video over LTE (ViLTE) services deliver voice and video communication over packet-based networks which include LTE technology on the access layer. It means that VoLTE/ViLTE services can be provided by either traditional fixed or mobile telecom operators who have implemented LTE technology as access technology to its core IP network.

VoLTE/ViLTE services are so-called "managed" voice and video services which are based on standardized SIP/IMS signalling and provided by telecom operators, while Over The Top (OTT) applications are services in the Internet provided by independent third party, without standardized signalling protocols, traffic prioritization and guaranteed quality of services.

The IMS platform is used as a service control layer which is used for managing VoLTE/ViLTE sessions. The reference architecture of the IP Multimedia Core Network Subsystem described in ETSI TS 123 002 [36] is shown in figure 4.0-1.

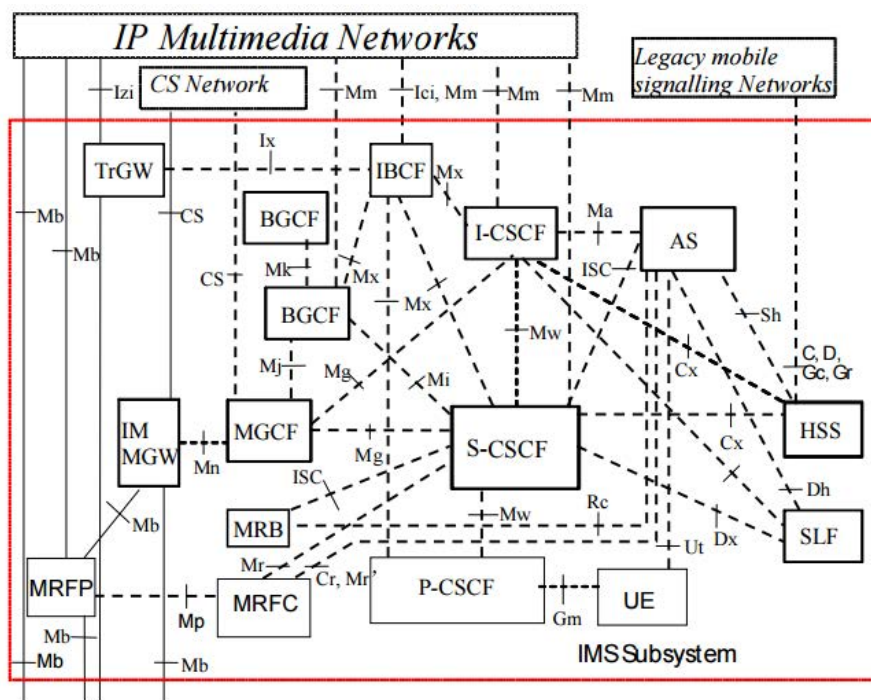

Figure 4.0-1: Reference Architecture of the IP Multimedia Core Network Subsystem

VoLTE/ViLTE interconnection implies interconnection of IMS platforms for providing VoLTE/ViLTE and legacy e2e sessions.

Some of the types of interconnection between IMS-based telecom operators:

- Interconnection for delivering sessions amongst users of different operators (hereafter Interworking scenarios);
- Interconnection for providing roaming of users of the Home networks in Visited networks (hereafter Roaming scenarios).

There are also options for interconnection between the VoLTE/ViLTE and IMS-based networks with existing legacy networks (e.g. PSTN, PLMN).

The ENUM/DNS translation mechanism as specified in IETF RFC 3761 [34] can be used by all IMS nodes that require E.164 address to SIP URI resolution and subsequently, the GSMA published PRD IR.67 [26] "DNS and ENUM Guidelines for Service Providers and GRX/IPX Providers".

4.1 E2E scenarios in terms of interworking, interconnection and roaming

The tests shall be executed according to the tests case selection expression and the type of end devices which are contained in the excel test list attached to the present document. The excel list is a normative part of this ETSI standard. The interconnection and roaming scenarios should be selected depending on the network infrastructure and company strategy.

The reference configuration depicted in figure 4.1-1 shall be used to perform an interconnection test between two network operators. Depicted is the reference point to observe the message flow at the 'Ic' interface between the two networks.

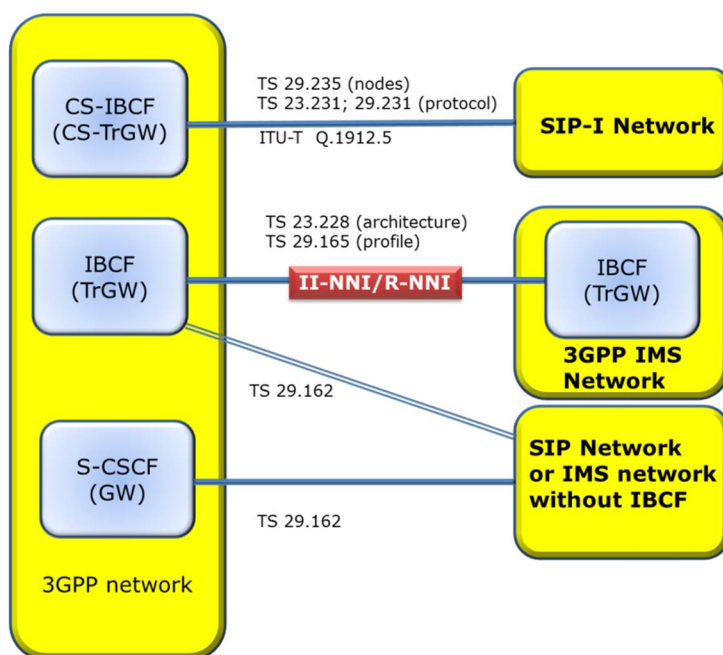

Figure 4.1-1: Reference configuration for the interconnection test

4.2 Interconnection and roaming scenarios test selection description (Excel file)

4.2.0 General

The interconnection and roaming test scenarios selection procedure is divided in five steps.

4.2.1 First step- "Identification of the Networks"

During the first step the table "Identification of the Networks" should be completed.

Table 4.2.1-1: Identification of the Networks, with examples

	Network A	Network B
Network under Test identification	Telekom Austria	Deutsche Telekom
Responsibility		
Name:	Martin Brand	Gerhard Ott
Telephone number:		
Facsimile number:		
Additional information:		
Product Supplier	Nokia	Huawei
Date of the statement:		
Dates of Testing (from .. to ..)		

4.2.2 Second step - Selection Expression

During the second step the Selection Expression form sheet should be completed. The Selection Expression depicted in table 4.2.2-1 was developed to select the scope of the compatibility test between network operator A and network operator B. By doing that, test purposes are selected automatically. The table shall be filled out (yes/no). This table can be used as a PICS form as used in a conformance test.

Table 4.2.2-1: Selection expression applicable in the Test Purposes

SELECTION EXPRESSION		Support Network A	Support Network B
Network capabilities			
SE 1:	The originating network (Network A) sends the P-Charging-Vector header?		
SE 2:	The originating network (Network A) sends a subset of parameters in the P-Charging-Vector header?		
SE 3:	The P-Early-Media header is supported?		
SE 4:	Overlap procedure using multiple INVITE method is supported?		
SE 5:	Overlap sending using in-dialog method is supported?		
SE 6:	Network A supports the PSTN XML schema?		
SE 7:	The resource reservation procedure is supported?		
SE 8:	Does the network perform the "Fall back" procedure (PSTN or MGCF)?		
SE 9:	The network is untrusted?		
SE 10:	Originating network does not have a number portability data base, the number portability look up is done in the interconnected network?		
SE 11:	The network supports the REFER method?		
SE 12:	The Network supports the 3 party call control procedure (REFER interworking)?		
SE 13:	The Number Portability is supported?		
SE 14:	Carrier Selection is performed?		
SE 15:	The Network is a Long distance carrier?		
SE 16:	SIP Support of Charging is supported?		
SE 17:	The interworking ISUP - SIP I is performed in the network?		
Supplementary services			
SE 18:	The network supports the Originating Identification Presentation (OIP)?		
SE 19:	The network supports the "Special arrangement" procedure for the originating user?		
SE 20:	The network supports the Originating Identification Restriction (OIR)?		
SE 21:	The Network supports the Terminating Identification Presentation (TIP)?		
SE 22:	The network supports the "Special arrangement" procedure for the terminating user?		
SE 23:	The Network supports the Terminating Identification Restriction (TIR)?		
SE 24:	The Network supports the session HOLD procedure?		
SE 25:	The network supports Communication Forwarding Unconditional (CFU)?		
SE 26:	The network supports Communication Forwarding Busy (CFB)?		
SE 27:	The network supports Communication Forwarding No Reply (CFNR)?		
SE 28:	The Network supports Communication Forwarding Not Logged in (CFNL)?		
SE 29:	The Network supports Communication Deflection?		
SE 30:	The Network supports the CDIV Notification procedure?		
SE 31:	The Network supports conference (CONF)?		
SE 32:	The Network supports the Communication Barring procedure (CB) - (Black list for incoming calls)?		
SE 33:	The Network supports the Anonymous Communication Rejection (ACR)?		
SE 34:	The Network supports the Closed User Group (CUG)?		
SE 35:	The Network supports the Communication Waiting (CW) service?		
SE 36:	The Network supports the T _{AS-CW} timer?		
SE 37:	The Network supports Explicit Communication Transfer (ECT)?		
SE 38:	The network supports Malicious Communication Identification (MCID)?		
SE 39:	The Network supports Message Waiting Indication (MWI)?		
SE 40:	The Network supports Completion of Communications to Busy Subscriber (CCBS)?		
SE 41:	The Network supports Completion of Communications by No Reply (CCNR)?		
Terminal capabilities			
SE 42:	Void		
SE 43:	The End device supports Fax transmission via G.711 codec?		

SELECTION EXPRESSION	Support Network A	Support Network B
SE 44: The End device supports Fax transmission via V.152 codec?		
SE 45: The End device supports Fax transmission via m-line T.38 codec?		
SE 46: A SIP end device is used supporting an ISDN user equipment and the PSTN XML Schema is used?		
SE 47: End device is located in the PSTN or PLMN?		
SE 48: The terminating UE supports the from-change tag procedure and sends a second user identity in an UPDATE request after the dialogue is confirmed?		
SE 49: The end device performs ECT using the 'Blind/assured transfer'?		
SE 50: The end device performs ECT using the 'Consultative transfer'?		
SE 51: The end device supports the Resource reservation procedure?		
PSTN/PLMN Supplementary services		
SE 52: CLIP/CLIR is supported in the PSTN/PLMN part of the network?		
SE 53: COLP/COLR is supported in the PSTN/PLMN part of the network?		
SE 54: HOLD is supported in the PSTN/PLMN part of the network?		
SE 55: CDIV is supported in the PSTN/PLMN part of the network?		
SE 56: CONF/3PTY is supported in the PSTN/PLMN part of the network?		
SE 57: ACR is supported in the PSTN/PLMN part of the network?		
SE 58: CUG is supported in the PSTN/PLMN part of the network?		
SE 59: CW is supported in the PSTN/PLMN part of the network?		
SE 60: ECT is supported in the PSTN/PLMN part of the network?		
SE 61: MCID is supported in the PSTN/PLMN part of the network?		
SE 61A: Call Completion is supported in the PSTN/PLMN part of the network?		
SE 62: SUB is supported in the PSTN/PLMN part of the network?		
SE 63: UUS is supported in the PSTN/PLMN part of the network?		
SE 64: TP is supported in the PSTN/PLMN part of the network?		
DTMF transmission		
SE 65: The Network supports DTMF transmission in the RTP stream		
SE 65: The Network supports DTMF transmission indicating in the SDP offer in the RTP stream		
SE 67: The Network supports DTMF transmission by the SIP INFO/NOTIFY Method for DTMF tone generation		

4.2.3 Third step- Access and End Devices Types

During the third step the **Access and End Devices Types** form sheet should be completed. With the specified Test Purposes in the present document, the compatibility between the interconnected networks and the used access and end devices Selection Expression shall be assured. Each Test Purpose can be performed by using a physical end device to assure end-to-end compatibility between the two interconnected networks.

Table 4.2.3-1: Overview of Accesses and end devices types

List of Type of End devices in both networks		
	Network A	Network B
	Telekom Austria	Deutsche Telekom
SIP-VoIP		x
POTS		x
ISDN		
GSM		
VoUMTS		
VoLTE		
PSTN	x	x

Highlight color	Explanation	Reference
	The user equipment is a SIP hardphone or a SIP soft client on a PC in the fixed network The user equipment is a 4G mobile device in an LTE network The user equipment is a 3G mobile device in an UMTS network	TS 124 229
	The user equipment is an integrated end device in the fixed network - access via a legacy analogue device	TS 183 043
	The user equipment is an integrated end device in the fixed network - access via a legacy ISDN device	TS 183 036
	The user equipment is a 2G mobile device in an GSM network. SS7 / SIP interworking applies The user equipment is located in a fixed SS7 network (analogue or ISDN)	ITU-T Q.761 - Q764 TS129 163 ITU-T Q.1912.5

4.2.4 Fourth step- activation

In the fourth step in the Test list (table 4.2.4-1) activate the filter "Selected" in row "G" (deactivate the "no" entry). In addition to hide the title of the test case deselect also the "empty" entry.

Table 4.2.4-1: Test list - example

IMS interconnection tests at the Ic Interface; Test Suite Structure and Test Purposes (TSS&TP)									
Test case number	Test name	Dir	Originating end device	Terminating end device	Selected	Executed	Verdict	Observation	
BCALL									
BCALL/successful									
SS_bcall_002_a_pstn_sip	Basic call normal call clearing from the calling user.	NA -> NB	PSTN	SIP-VoIP	yes	no		2	
SS_bcall_002_a_pstn_pots	Basic call normal call clearing from the calling user.	NA -> NB	PSTN	POTS	yes	no		2	
SS_bcall_002_a_pstn_pstn	Basic call normal call clearing from the calling user.	NA -> NB	PSTN	PSTN	yes	no		2	
SS_bcall_002_b_sip_pstn	Basic call normal call clearing from the calling user.	NB -> NA	SIP-VoIP	PSTN	yes	yes			
SS_bcall_002_b_pots_pstn	Basic call normal call clearing from the calling user.	NB -> NA	POTS	PSTN	yes	yes			
SS_bcall_002_b_pstn_pstn	Basic call normal call clearing from the calling user.	NB -> NA	PSTN	PSTN	yes	yes			
SS_bcall_003_a_pstn_sip	Request line in the INVITE.	NA -> NB	PSTN	SIP-VoIP	yes	yes			
SS_bcall_003_a_pstn_pots	Request line in the INVITE.	NA -> NB	PSTN	POTS	yes	yes			

4.2.5 Fifth step - Selection of roaming scenarios (not contained in the Excel file)

According to the general principles described in step 3 (Overview of Access and end devices types), four key e2e interworking scenarios can be identified (see also table 4.2.5-1):

- VoLTE – IMS interconnection scenarios.
- VoLTE – Legacy network scenarios.
- VoLTE - VoLTE and ViLTE - ViLTE interconnection scenarios.
- VoLTE - VoLTE and ViLTE - ViLTE roaming scenarios.

As for the roaming scenarios the identical interworking are used, the execution of the complete interconnection test list (see step 4) is not useful. For the applicable roaming scenario(s) the two first test cases (SS_bcall_NNI_01 and SS_bcall_NNI_02) for different roaming scenario and codecs should be repeated.

For a simplified execution of the tests, the test cases can be grouped. An example of a VoLTE - 2G/3G interconnection scenario is depicted in annex B.

Table 4.2.5-1: E2E scenarios in terms of interconnection and roaming

No.	Scenario	Description	Roaming options	Calling options
VoLTE - IMS interworking scenarios				
1	Scenario 1	The user UE1 (a) is in the IMS network A , UE2 (a) in HPMN (a).		The test shall be performed in both directions
2	Scenario 1A	The user UE 1 (a) is in the IMS network A , UE2 (a) in HPMN (a) with CSFB (circuit switched fallback). See note 1.		The test shall be performed in both directions
3	Scenario 1B	The user UE1 (a) is in the IMS network A , UE2 (a) in HPMN (a) is moving from 4G to 3G coverage with SRVCC.		The test shall be performed in both directions
4	Scenario 1C	The user UE1 (a) is in the IMS network A , UE2 (a) roamed in VPMN (b).	<ul style="list-style-type: none"> • Local Breakout VPMN Routing architecture (LBO-VR) • LBO Home Routing architecture (LBO-HR) • S8HR VoLTE Roaming architecture 	The test shall be performed in both directions
5	Scenario 1D	The user UE1 (a) is in the IMS network A , UE2 (a) roamed in VPMN (b) moving from 4G to 3G coverage with SRVCC.	<ul style="list-style-type: none"> • Local Breakout VPMN Routing architecture (LBO-VR) • LBO Home Routing architecture (LBO-HR) • S8HR VoLTE Roaming architecture 	The test shall be performed in both directions
VoLTE - Legacy network scenarios				
6	Scenario 2	User UE1 (a) is in the legacy network A , UE2 (a) is in HPMN (a).		The test shall be performed in both directions
7	Scenario 2A	User UE1 (a) is in the legacy network A , UE2 (a) is in HPMN (a), with CSFB (circuit switched fallback). See note 2.		The test shall be performed in both directions
8	Scenario 2B	User UE1 (a) is in the legacy network A , UE2 (a) is in HPMN (a), roamed in VPMN (b) moving from 4G to 3G coverage with SRVCC.		The test shall be performed in both directions
9	Scenario 3	User UE1(a) is in the legacy network A , UE2 (a) is in VPMN (b).	<ul style="list-style-type: none"> • Local Breakout VPMN Routing architecture (LBO-VR) • LBO Home Routing architecture (LBO-HR) • S8HR VoLTE Roaming architecture 	
VoLTE - VoLTE and ViLTE - ViLTE interconnections scenarios				
10	Scenario 4	UE1 (a) is in HPMN (a), UE2 (b) is in HPMN (b).		
11	Scenario 4A	UE1 (a) is in HPMN (a), UE2 (b) is in HPMN (b) with CSFB (circuit switched fallback). See note 3.		
12	Scenario 4B	UE1 (a) is in HPMN (a), UE2 (b) is in HPMN (b) moving from 4G to 3G coverage with SRVCC.		
13	Scenario 4C	UE1 (a) is in HPMN (a) with CSFB (circuit switched fallback). UE2 (b) is in HPMN (b).		
14	Scenario 4D	UE1 (a) is in HPMN (a) moving from 4G to 3G coverage with SRVCC, UE2 (b) is in HPMN (b).		

No.	Scenario	Description	Roaming options	Calling options
VoLTE - VoLTE and ViLTE - ViLTE roaming scenarios				
15	Scenario 5	UE1 (a) is in HPMN (a), UE3 (a) roamed in VPMN (b).	<ul style="list-style-type: none"> Local Breakout VPMN Routing architecture (LBO-VR) LBO Home Routing architecture (LBO-HR) S8HR VoLTE Roaming architecture 	User A is calling user B User B is calling user A
16	Scenario 5A	UE1 (a) is in HPMN (a), UE3 (a) roamed in VPMN (b) with CSFB (circuit switched fallback). See note 4.		User A is calling user B User B is calling user A
17	Scenario 5B	UE1 (a) is in HPMN (a), UE3 (a) roamed in VPMN (b) moving from 4G to 3G coverage with SRVCC.	<ul style="list-style-type: none"> Local Breakout VPMN Routing architecture (LBO-VR) LBO Home Routing architecture (LBO-HR) S8HR VoLTE Roaming architecture 	User A is calling user B User B is calling user A
18	Scenario 5C	UE1 (a) in HPMN (a) with CSFB (circuit switched fallback), UE3 (a) roamed in VPMN (b).	Roaming options: <ul style="list-style-type: none"> Local Breakout VPMN Routing architecture (LBO-VR) LBO Home Routing architecture (LBO-HR) S8HR VoLTE Roaming architecture 	User A is calling user B User B is calling user A
19	Scenario 5D	UE1 (a) is in HPMN (a) moving from 4G to 3G coverage with SRVCC , UE3 (a) roamed in VPMN (b).	Roaming options: <ul style="list-style-type: none"> Local Breakout VPMN Routing architecture (LBO-VR) LBO Home Routing architecture (LBO-HR) S8HR VoLTE Roaming architecture 	User A is calling user B User B is calling user A
20	Scenario 6	UE1 (a) Calls UE3 (a), both Roamed in VPMN (b).	<ul style="list-style-type: none"> Local Breakout VPMN Routing architecture (LBO-VR) LBO Home Routing architecture (LBO-HR) S8HR VoLTE Roaming architecture 	User A is calling user B User B is calling user A
21	Scenario 6A	UE1 (a) Calls UE3 (a), both Roamed in VPMN (b), UE1 (a) with CSFB (circuit switched fallback). See note 5.	<ul style="list-style-type: none"> Local Breakout VPMN Routing architecture (LBO-VR) LBO Home Routing architecture (LBO-HR) S8HR VoLTE Roaming architecture 	User A is calling user B User B is calling user A
22	Scenario 6B	UE1 (a) Calls UE3 (a), both Roamed in VPMN (b), UE1 (a) is moving from 4G to 3G coverage with SRVCC.	<ul style="list-style-type: none"> Local Breakout VPMN Routing architecture (LBO-VR) LBO Home Routing architecture (LBO-HR) S8HR VoLTE Roaming architecture 	User A is calling user B User B is calling user A
23	Scenario 6C	UE1 (a) Calls UE3 (a), both Roamed in VPMN (b), UE2 (a) is moving from 4G to 3G coverage with SRVCC.	<ul style="list-style-type: none"> Local Breakout VPMN Routing architecture (LBO-VR) LBO Home Routing architecture (LBO-HR) S8HR VoLTE Roaming architecture 	User A is calling user B User B is calling user A
24	Scenario 7	UE1 (a) roamed in VPMN (b), UE2 (b) roamed in VPMN (a).	<ul style="list-style-type: none"> Local Breakout VPMN Routing architecture (LBO-VR) LBO Home Routing architecture (LBO-HR) S8HR VoLTE Roaming architecture 	User A is calling user B User B is calling user A

No.	Scenario	Description	Roaming options	Calling options
25	Scenario 7A	UE1 (a) roamed in VPMN (b), UE2 (b) roamed in VPMN (a), UE1 (a) with CSFB (circuit switched fallback).	<ul style="list-style-type: none"> Local Breakout VPMN Routing architecture (LBO-VR) LBO Home Routing architecture (LBO-HR) S8HR VoLTE Roaming architecture 	User A is calling user B User B is calling user A
26	Scenario 7B	UE1 (a) roamed in VPMN (b), UE2 (b) roamed in VPMN (a) and UE2 (b) is moving from 4G to 3G coverage with SRVCC.	<ul style="list-style-type: none"> Local Breakout VPMN Routing architecture (LBO-VR) LBO Home Routing architecture (LBO-HR) S8HR VoLTE Roaming architecture 	
27	Scenario 7C	UE1 (a) roamed in VPMN (b), UE2 (b) roamed in VPMN (a), and UE1 (a) is moving from 4G to 3G coverage with SRVCC.	<ul style="list-style-type: none"> Local Breakout VPMN Routing architecture (LBO-VR) LBO Home Routing architecture (LBO-HR) S8HR VoLTE Roaming architecture 	
28	Scenario 8	The VoLTE subscriber UE1 (a) in the HPMN (a) is calling the 2G/3G user UE2 (b) in HPMN (b).		User A is calling user B User B is calling user A
29	Scenario 9	The VoLTE subscribers UE1 (a) and UE 2(a) are subscribed in the HPMN (a). Subscribers UE1 (a) is roaming in 2G/3G VPMN (b).		User A is calling user B User B is calling user A
30	Scenario 10	The VoLTE subscribers UE1 (a) and UE 2(a) are subscribed in the HPMN (a). Subscribers UE1 (a) and UE2 (a) are roaming in 2G/3G VPMN (b).		User A is calling user B User B is calling user A
NOTE 1: Occurs only in the case if VoPS is not supported in the HMPMN's LTE Networks.				
NOTE 2: Occurs only in the case if VoPS is not supported in the HMPMN's LTE N/W.				
NOTE 3: Occurs only in the case if VoPS is not supported in HPMN.				
NOTE 4: Occurs only in the case if VoPS is not supported in HPMN.				
NOTE 5: Occurs only in the case if VoPS is not supported in VPMN of UE1.				

5 IMS Roaming and Interconnection options (for information)

According to GSMA IR.65 "IMS Roaming and Interworking Guidelines" [35], there are different possible options for IMS interconnection which should meet the following requirements:

- 1) Routing of media for voice & video over IMS when call originator is Roaming shall be at least as optimal as that of current Circuit Switched (CS) domain.
- 2) The charging model for roaming used in CS domain shall be maintained in VoIMS.
- 3) Allow the HPMN to decide, based on service and commercial considerations & regulatory obligations, to enforce the routing of the originated traffic to itself (home routing).

UE has obtained IP connectivity in the visited network and can have access to home's IMS services via one of the following options:

- **Option 1:** Target IMS roaming solution, IMS is required in both VPLMN and HPLMN.

UE has obtained IP connectivity from the visited network and is connected to the P-CSCF in the visited network which establishes connections using the home IMS platform; traffic is routed directly by the visited network.

- **Option 2:** Data local breakout, but IMS home routed, IMS is not needed in VPLMN.

UE has obtained IP connectivity from the visited network and is connected to the P-CSCF in the visited network which itself is connected to the home IMS platform; traffic is routed via the home network.

- **Option 3:** UE has obtained IP connectivity from the home network and is directly connected to the home IMS platform; traffic is routed via the home network. Data and IMS are both home routed, IMS is not needed in VPLMN.

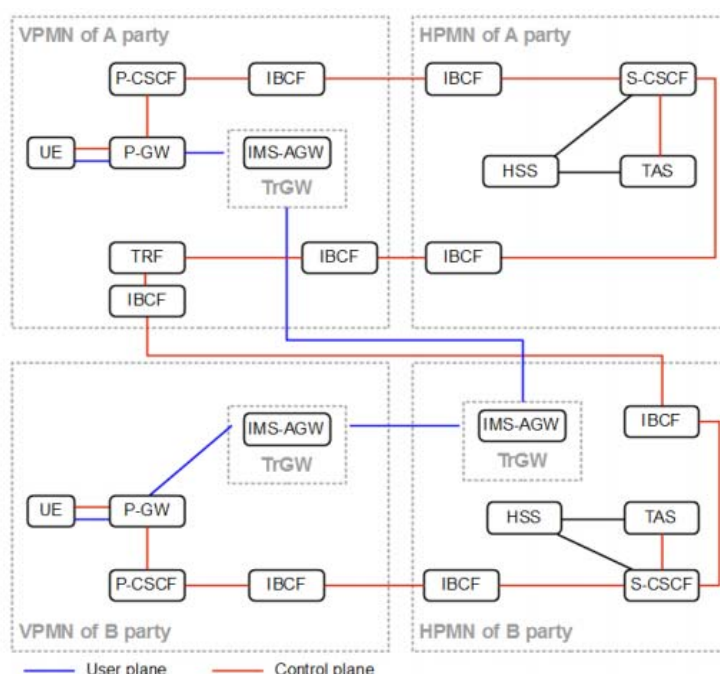

**Figure 5-1: Local Breakout VPMN Routing architecture (LBO-VR)
(Reference IR.65 [35])**

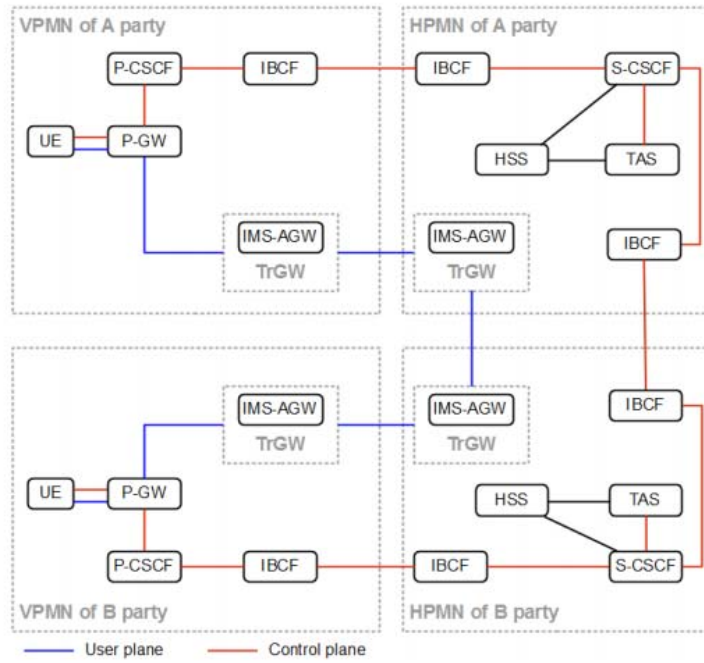

Figure 5-2: LBO Home Routing architecture (LBO-HR)
(Reference IR.65 [38])

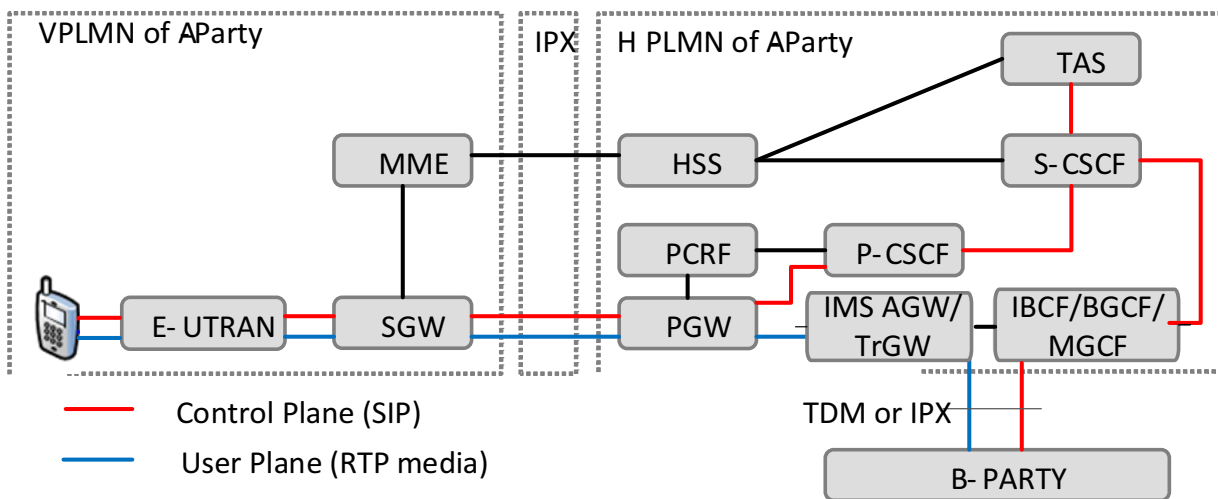

Figure 5-3: S8HR VoLTE Roaming architecture
(Reference IR.65 [35])

For S8HR VoLTE Roaming architecture, regulatory requirements (Legal Interception and Emergency Calling) have triggered additional specification work currently being performed in 3GPP.

Table 5-1: Comparison of VoLTE Roaming Architecture

	Option 1 LBO-VR (Target IMS roaming solution, IMS is required in both VPLMN and HPLMN)	Option 2, LBO-HR (Data local breakout, but IMS home routed, IMS is not needed in VPLMN)	Option 3 S8HR Data and IMS are both home routed, IMS is not needed in VPLMN
HPLMN with VoLTE implementation	Required	Required	Required
VPLMN with VoLTE implementation	Required	Not required	Not required
IMS service over GRX	Not required	Required	Required
Charging depending on Evolved Packet Core (EPC)	Optional (Charge on IMS service layer)	Required	Required
Policy and charging control mode	HPLMN hPCRF can control the VPLMN vPCRF via S9 Interface (S9 interface is optional)	HPLMN hPCRF controls VPLMN vPCRF via S9 Interface or via roaming agreement and support of common QCI	HPLMN hPCRF controls HPLMN PGW, 2/3G and 4G (e.g Web browsing) data roaming via S8
Single Radio Voice Call Continuity (SRVCC) support capability	Fully Supported	Supported	Partially supported
VoLTE local emergency call	Supported	Supported	Not supported
VoLTE local LI	Supported	Supported	Not supported (LI will be possible at the S-GW)
LBO with Optimal Media Routeing (OMR)	Supported	Not supported	Not supported

6 VoLTE interconnect and roaming tests

6.1 Test Suite Structure (TSS)

BCALL	Successful NNI	SS_bcall_NNI_xxx		
	DTMF	SS_DTMF_xxx		
	Fax transmission	SS_bcall_FAX_xxx see note 2		
	Successful SIP-I	SS_bcall_SIP-I_xxx		
	Codec_Negotiation	SS_codec_xxx		
	Resource_Reservation	SS_resource_xxx		
	Unsuccessful NNI	SS_unsucc_NNI_NNI_xxx		
	Unsuccessful SIP-I	SS_unsucc_NNI_SIP-I_xxx		
	Successful Video	SS_bcall_video_xxx		
SIP-SIP	Service	OIP	SS_oip_NNI_xxx	
		OIP	SS_oip_SIP-I_xxx	
		OIR	SS_oir_NNI_xxx	
		OIR	SS_oir_SIP-I_xxx	
		TIP	SS_tip_xxx see note 1	
		TIR	SS_tir_xxx see note 1	
		HOLD	SS_hold_xxx see note 1	
		CFU	SS_cfu_xxx see note 1	
		CFB	SS_cfb_xxx see note 1	
		CFNR	SS_cfnr_xxx see note 1	
		CFNL	SS_cfnl_xxx see note 1	
		CD	SS_cd_xxx see note 1	
		CONF	SS_conf_xxx see note 1	
		ACR-CB	SS_acr-cb_xxx see note 1	
		CUG	SS_cug_xxx see note 1	
		CW	SS_cw_xxx see note 1	
		ECT	SS_ect_xxx see note 1	
		MCID	SS_mcid_xxx see note 1	
		MWI	SS_mwi_xxx see note 1	
		CC	SS_cc_xxx see note 1	
		SIP-I	UUS	SS_uus_xxx see note 1
			SUB	SS_sub_xxx see note 1
			TP	SS_tp_xxx see note 1
		NubP	SS_NP_xxx see note 1	
		ACCOUNTING	SS_acc_xxx see note 1	
		CS	SS_csel_xxx see note 1	
		EmC	SS_ecall_xxx see note 1	
SIP_charging	SS_sipc_xxx see note 1			
NOTE 1: The tests are specified in ETSI TS 101 585 [25].				
NOTE 2: This clause contains three basic fax transmission tests without QoS requirements for the case when both networks are supporting the same transmission capabilities.				

The "minimal requirements" for fax support between SIP enabled devices for real-time fax over IP are described in Recommendation ITU-T Q.4016 [28].

6.2 VoLTE Consideration

6.2.1 EPC Consideration

An EPC network should support general VoLTE related functions, for example, basic voice and video call:

- Visited network MME shall support VoLTE capability indication to UE, "IMS voice over PS" in order to select voice solution.
- Visited network MME may support the Sv interface and eSRVCC handover control function.
- SAE-GW shall support the establishment of dedicated bearer with QCI=8/9, QCI=1 and QCI=2.

- SAE-GW shall support IPv6 PDN type.
- P-GW shall support the P-CSCF discovery function and allocating P-CSCF IP address to UE.
- PCRF shall guarantee end-to-end QoS by interworking with IMS and AF via Rx interface.

6.2.2 EPC Configuration Requirements

MME:

- MME in the visited network shall configure PLMN for inbound roamer, so that the inbound roamer can be attached to the network.
- MME in the visited network shall configure "IMS voice over PS" for inbound roamer.
- LBO VR: MME in the visited network shall be able to resolve IMS APN to PGW address in visited network.
- S8HR: MME in the visited network shall resolve IMS APN into PGW address in home network instead of visit network. If home network cannot resolve IMS APN to P-GW, manually configured to the MME in visited network.

6.3 Device and U/SIM consideration

6.3.1 Multi-Mode and Multi-band Terminal

To meet the requirements for domestic frequency access and international roaming, five radio modes including LTE FDD, TD-LTE, TD-SCDMA, WCDMA, and GSM should be supported. The multi-mode and multi-band requirements are as follow:

- GSM: Band3, Band8 and Band2 are mandatory. Besides, Band5 is recommended.
- TD-SCDMA: Band34 and Band39 are mandatory.
- TD-LTE: Band39, Band40 and Band41 (at least supporting 2 575 to 2 635 MHz) are mandatory. If the terminals support Band 41 without Band 38, it shall support the frequency mutual identification via mFBI.
- WCDMA: Band1, Band2 and Band5 are mandatory.
- LTE FDD: Band3 and Band7 are mandatory. Besides, Band1, Band17, Band4 and Band20 are recommended.

Additionally, compatible bands based on bilateral/multi-lateral discussions may be supported by the Device. Other multi-mode and multi-band terminals could also be introduced in according to trial demand.

6.3.2 General Requirements for VoLTE Terminal

6.3.2.0 Overview

To achieve excellent user experience, VoLTE terminals shall have performance requirements that are comparable with the commercially available terminals in the following aspects:

- operation system;
- hardware;
- software;
- MTBF;
- standby time;
- communication duration.

Regarding the outbound roaming requirement, VoLTE handsets should support CSFB from LTE to WCDMA/GSM and support four kinds of functions for VoLTE:

- RAN Features;
- IMS function on control plane;
- IMS function on media plane;
- Service Requirements.

6.3.2.1 RAN Features

- Support SPS, TTI-Bundling, RoHC, Connected-DRX and its combinations; Support interoperation from LTE to GSM via eSRVCC, aSRVCC, mid-call SRVCC; Support SRVCC related measurement capability and capability report.
- Support UE-based Fast Return to LTE after SRVCC CS Call ends.
- Support IPv4, IPv6 and IPv4v6 dual-stacks.
- Support multi-PDN connections; Delete IMS PDN when moving out of VoLTE coverage.
- Support EPS bearer combinations for VoLTE service; support End to End QoS.

6.3.2.2 IMS function on control plane

- Support the standard SIP/IMS protocol in order to inter-work with the global IMS networks.
- Support derivation of IMS identifiers from USIM ,if ISIM is not introduced.
- Support IMS Exceptions Handling.
- Support RTP/RTCP.
- Support the IMS authorization and authentication, etc.
- Support Early Media.
- Support Precondition.
- Support upgrade and downgrade between voice and video call.
- Support Supplementary Service configuration via Ut/XCAP.

6.3.2.3 IMS function on media plane

- Audio Codec: Entities in the IMS core network that terminate the user plane supporting speech communication and supporting TFO and/or TrFO shall support AMR speech codec modes 12.2, 7.4, 5.9 and 4.75; Entities in the IMS core network that terminate the user plane supporting wideband speech communication and supporting TFO and/or TrFO shall support AMR-WB speech codec modes 12.65, 8.85 and 6.60.
- Video Codec: H.264 640*480@30fps; 720P@30fps is recommended.
- Quality Enhanced Features: Noise Suppression, Echo Cancellation, Jitter Buffer, Lip Sync.

6.3.2.4 Services Requirements

- Voice Call:
 - Support standard Voice call & HD Voice call.
 - Support Voice domain transition between VoLTE and CSFB.

- Support Voice Continuity among different scenarios.
- Support SilentRedial.
- Message:
 - Support SMS over IP, SMS over CS.
 - Support MMS.
- Video Call:
 - Support video call when UE within VoLTE coverage.
- Supplementary Services:
 - Supported Enhanced Conference call.
 - Support IMS Supplementary Services.
- IMS Emergency Service.

7 Test purposes

7.0 General

The application usage procedures in the ATS shall be compliant with ETSI TS 129 165 [1], ETSI TS 124 229 [2] and IETF RFC 3261 [4]. The validation of the registration procedure is out of scope of the present document.

7.1 Testing of SIP protocol requirements

7.1.1 Test purposes for Basic call, Successful

Test case number	SS_bcall_NNI_001	
Test case group	BCALL/successful	
Reference	IETF RFC 3261 [4]	
SELECTION EXPRESSION		
Test purpose	<p>Basic call normal call clearing from the called user. Ensure that the UE can successfully activate the voice call via dedicated voice bearer. The test call is successful in the case if the Call setup time does not exceed the values listed in table 7.1.1-1 and call is stable in unanswered and answered phases, the call remains in intelligible/high quality conversation phase for 80 seconds. The Voice Quality test procedures are described in clause 8.2. The test scenarios are listed in table 4.2.5-1. The call is released from the called user.</p>	
Configuration		
SIP Parameter		
Message flow		
SIP (Network A)	Interconnection Interface	SIP (Network B)
	INVITE →	
	← 100 Trying	
	← 180 Ringing	
	← 200 OK INVITE	
	ACK →	
	Communication	
	← BYE	
	200 OK BYE →	

Comments	<ul style="list-style-type: none"> • UE1 (a) establishes call to UE2 (b). • Call answered and held for 80 seconds. • Quality assessed. • Repeat this test in reverse direction.
-----------------	---

Test case number	SS_bcall_NNI_002																											
Test case group	BCALL/successful																											
Reference	IETF RFC 3261 [4]																											
SELECTION EXPRESSION																												
Test purpose	<p>Basic call normal call clearing from the calling user.</p> <p>Ensure that the UE can successfully activate the voice call via dedicated voice bearer.</p> <p>The test call is successful in the case if the Call setup time does not exceed the values listed in table 7.1.1-1 and the call is stable in unanswered and answered phases, the call remains in intelligible/high quality conversation phase for 80 seconds. The Voice Quality test procedures are described in clause 8.2.</p> <p>The test scenarios are listed in table 4.2.5-1.</p> <p>The call is released from the calling user.</p>																											
Configuration																												
SIP Parameter																												
Message flow	<table border="0" style="width: 100%; border-collapse: collapse;"> <thead> <tr> <th style="text-align: left; width: 30%;">SIP (Network A)</th> <th style="text-align: center; width: 40%;">Interconnection Interface</th> <th style="text-align: right; width: 30%;">SIP (Network B)</th> </tr> </thead> <tbody> <tr> <td></td> <td style="text-align: center;">INVITE →</td> <td></td> </tr> <tr> <td></td> <td style="text-align: center;">← 100 Trying</td> <td></td> </tr> <tr> <td></td> <td style="text-align: center;">← 180 Ringing</td> <td></td> </tr> <tr> <td></td> <td style="text-align: center;">← 200 OK INVITE</td> <td></td> </tr> <tr> <td></td> <td style="text-align: center;">ACK →</td> <td></td> </tr> <tr> <td></td> <td style="text-align: center;">Communication</td> <td></td> </tr> <tr> <td></td> <td style="text-align: center;">BYE →</td> <td></td> </tr> <tr> <td></td> <td style="text-align: center;">← 200 OK BYE</td> <td></td> </tr> </tbody> </table>	SIP (Network A)	Interconnection Interface	SIP (Network B)		INVITE →			← 100 Trying			← 180 Ringing			← 200 OK INVITE			ACK →			Communication			BYE →			← 200 OK BYE	
SIP (Network A)	Interconnection Interface	SIP (Network B)																										
	INVITE →																											
	← 100 Trying																											
	← 180 Ringing																											
	← 200 OK INVITE																											
	ACK →																											
	Communication																											
	BYE →																											
	← 200 OK BYE																											
Comments	<ul style="list-style-type: none"> • UE1 (a) establishes call to UE2 (b). • Call answered and held for 80 seconds. • Quality assessed. <p>Repeat this test in reverse direction.</p>																											

Table 7.1.1-1: Call setup time (post dialling delay, PDD [18])

Meaning of timers	Parameter Recommendation ITU-T Q.543 [17] Detailed description	IMS, PES equivalent	Reference Load A		Reference Load B	
			Mean Value	95 % probability of not exceeding	Mean Value	95 % probability of not exceeding
VoLTE -VoLTE [16] IMS to VoLTE						
Call setup time: The definition of Call setup time for VoLTE is defined in ETSI TS 102 250-2 [19].						
			≤ 1 950 ms	≤ 2 100 ms	≤ 2 250 ms	≤ 2 400 ms See note 1 See note 2 See note 3
VoLTE to IMS (See note 4)						
Call setup time (post dialling delay, PDD [18]) To determine the call setup time in a VoIP implementation, the time in seconds from the sending of the INVITE signal through the "A" side until the receipt of the 200 OK signal is measured on the "A" side is measured, or the time in seconds from the sending of the INVITE signal through the "A" side until the receipt of the 180 Ringing signal on the "A" side is recorded.						
			≤ 420 ms	≤ 580 ms	≤ 750 ms	≤ 900 ms See note 4
IMS - IMS						
Call setup time (post dialling delay, PDD [18])						
			≤ 350 ms	≤ 500 ms	≤ 650 ms	≤ 800 ms
NOTE 1: Paging Cycle 1,28 s. NOTE 2: S1-Control plane delay: 2 ms - 15 ms (S1 is the interface between eNode Bs and MME and S-GW). NOTE 3: The maximum value should not exceed 5,9 second [16]. NOTE 4: The values are based on the condition that the originating VoLTE - UE is in the state ECM Connected. In the case when the VoLTE - UE is in the state ECM Idle, the time duration is about 100 ms higher.						

Test case number	SS_bcall_NNI_003							
Test case group	BCALL/successful							
Reference	Clause 8 / [1]							
SELECTION EXPRESSION								
Test purpose	Request line in the INVITE. Ensure that the Request line in the INVITE contains in the user part the telephone number of the destination user equipment formatted as a 'tel' URI in the global number format and the host portion is set to the host name of the interconnected network. The user URI parameter is present and set to 'phone'.							
Configuration								
SIP Parameter	INVITE Request line Address of user B @ network B;user=phone							
Message flow	<table style="width:100%; border:none;"> <tr> <td style="width:33%; text-align:center; vertical-align:middle;">SIP (Network A)</td> <td style="width:33%; text-align:center; vertical-align:middle;">Interconnection Interface INVITE →</td> <td style="width:33%; text-align:center; vertical-align:middle;">SIP (Network B)</td> </tr> <tr> <td colspan="3" style="text-align:center;">Apply post test routine</td> </tr> </table>		SIP (Network A)	Interconnection Interface INVITE →	SIP (Network B)	Apply post test routine		
SIP (Network A)	Interconnection Interface INVITE →	SIP (Network B)						
Apply post test routine								
Comments	Establish a communication from Network A to Network B. Check: The user part is in the format of a tel URI in global number format. Check: The host portion is set to the host name of the interconnected network. Check: The user parameter is set to phone. Repeat this test in reverse direction. Repeat this test with all chosen end devices.							

Test case number	SS_bcall_NNI_004							
Test case group	BCALL/successful							
Reference	Clause 5.10 / [2]							
Testspec Reference								
SELECTION EXPRESSION	SE 1							
Test purpose	P-Charging-Vector header in the INVITE. Ensure that the P-Charging-Vector header is present in the INVITE establishes a communication between a user of network A and a user of network B and the 'icid-value' and the 'orig-ioi' parameter is present.							
Configuration								
SIP Parameter	INVITE P-Charging-Vector: icid-value; orig-ioi							
Message flow	<table style="width:100%; border:none;"> <tr> <td style="width:33%; text-align:center; vertical-align:middle;">SIP (Network A)</td> <td style="width:33%; text-align:center; vertical-align:middle;">Interconnection Interface INVITE →</td> <td style="width:33%; text-align:center; vertical-align:middle;">SIP (Network B)</td> </tr> <tr> <td colspan="3" style="text-align:center;">Apply post test routine</td> </tr> </table>		SIP (Network A)	Interconnection Interface INVITE →	SIP (Network B)	Apply post test routine		
SIP (Network A)	Interconnection Interface INVITE →	SIP (Network B)						
Apply post test routine								
Comments	Establish a communication from Network A to Network B. Check: The P-Charging-Vector header contains the icid-value parameter. Check: The P-Charging-Vector header contains the orig-ioi parameter. Repeat this test in reverse direction.							

Test case number	SS_bcall_NNI_005						
Test case group	BCALL/successful						
Reference	Clause 5.10 / [2]						
Testspec Reference							
SELECTION EXPRESSION	SE 2						
Test purpose	P-Charging-Vector header in the INVITE, subset. Ensure that the P-Charging-Vector header is present in the INVITE establishes a communication between a user of network A and a user of network B and a subset of the parameters is present.						
Configuration							
SIP Parameter	INVITE P-Charging-Vector: icid-value; orig-ioi						
Message flow	<table style="width: 100%; border: none;"> <tr> <td style="text-align: center; width: 33%;">SIP (Network A)</td> <td style="text-align: center; width: 33%;">Interconnection Interface INVITE →</td> <td style="text-align: center; width: 33%;">SIP (Network B)</td> </tr> <tr> <td colspan="3" style="text-align: center;">Apply post test routine</td> </tr> </table>	SIP (Network A)	Interconnection Interface INVITE →	SIP (Network B)	Apply post test routine		
SIP (Network A)	Interconnection Interface INVITE →	SIP (Network B)					
Apply post test routine							
Comments	Establish a communication from Network A to Network B. Check: The P-Charging-Vector header contains the icid-value parameter. Check: The P-Charging-Vector header contains the orig-ioi parameter (optional). Repeat this test in reverse direction.						

Test case number	SS_bcall_NNI_006						
Test case group	BCALL/successful						
Reference	Clause 8 / [8]						
SELECTION EXPRESSION	[Network A] SE 3						
Test purpose	P-Early-Media header support indication in the initial INVITE request. Ensure that the support of the P-Early. Media header is indicated in the initial INVITE request. A P-Early-Media header is present set to 'supported'.						
Configuration							
SIP Parameter	INVITE P-Early-Media: supported SDP						
Message flow	<table style="width: 100%; border: none;"> <tr> <td style="text-align: center; width: 33%;">SIP (Network A)</td> <td style="text-align: center; width: 33%;">Interconnection Interface INVITE →</td> <td style="text-align: center; width: 33%;">SIP (Network B)</td> </tr> <tr> <td colspan="3" style="text-align: center;">Apply post test routine</td> </tr> </table>	SIP (Network A)	Interconnection Interface INVITE →	SIP (Network B)	Apply post test routine		
SIP (Network A)	Interconnection Interface INVITE →	SIP (Network B)					
Apply post test routine							
Comments	Establish a communication from Network A to Network B. Check: Is a P-Early-Media header present in the INVITE request? Repeat this test in reverse direction.						

Test case number	SS_bcall_NNI_007													
Test case group	BCALL/successful													
Reference	Clause 8 / [8]													
SELECTION EXPRESSION	[Network A] SE 3 AND [Network B] SE3													
Test purpose	<p>P-Early-Media header supported in early dialogue. Ensure that an early dialogue is established by sending a 183 Session Progress or 180 Ringing from Network B and the P-Early-Media header is present authorizes early media. The Early media voice quality test procedures are described clause 8.2.</p>													
Configuration														
SIP Parameter	INVITE P-Early-Media: supported SDP 183 P-Early-Media: [any value authorizes early media] SDP OR 180 P-Early-Media: [any value authorizes early media] SDP													
Message flow	<table style="width: 100%; border-collapse: collapse;"> <tr> <td style="text-align: center; width: 33%;">SIP (Network A)</td> <td style="text-align: center; width: 33%;">Interconnection Interface</td> <td style="text-align: center; width: 33%;">SIP (Network B)</td> </tr> <tr> <td></td> <td style="text-align: center;">INVITE →</td> <td></td> </tr> <tr> <td>CASE A</td> <td style="text-align: center;">← 183 Session Progress</td> <td></td> </tr> <tr> <td>CASE B</td> <td style="text-align: center;">← 180 Ringing</td> <td></td> </tr> </table> <p style="text-align: center;">Apply post test routine</p>		SIP (Network A)	Interconnection Interface	SIP (Network B)		INVITE →		CASE A	← 183 Session Progress		CASE B	← 180 Ringing	
SIP (Network A)	Interconnection Interface	SIP (Network B)												
	INVITE →													
CASE A	← 183 Session Progress													
CASE B	← 180 Ringing													
Comments	Establish a communication from Network A to Network B. Check: Is a 183 or 180 send from Network B to establish an early dialogue? Check: Is an SDP present in the 183 as a SDP answer? Check: A bearer transmission is possible in backward directions. NOTE 1: The absence of the direction parameter of an 'a' line represents the default value 'sendrecv'. NOTE 2: The presence of the P-Early-Media header in the INVITE request indicates the support of "early media Authorization" in the originating Network. NOTE 3: The presence of the P-Early-Media header in the 183 or 180 indicates the support of the P-Early-Media header and authorizes the media in the early dialogue. Repeat this test in reverse direction. Repeat this test by a call setup to an announcement application.													

Test case number	SS_bcall_NNI_008												
Test case group	BCALL/successful												
Reference	Clause 8 / [8]												
SELECTION EXPRESSION	[Network A] SE 3 AND [Network B] SE 3 AND (SE 25 OR SE 26 OR SE 27 OR SE 28 OR SE 29).												
Test purpose	P-Early-Media header supported early dialogue with 181. Ensure that an early dialogue is established by sending a 181 Call Is Being Forwarded from Network B and the P-Early-Media header is present authorizes early media. The Call is forwarded in network B.												
Configuration	Subscription options: <ul style="list-style-type: none"> Originating user receives notification that his communication has been diverted = Yes 												
SIP Parameter	INVITE P-Early-Media: supported SDP 181 P-Early-Media: [any value authorizes early media]												
Message flow	<table border="0" style="width: 100%; text-align: center;"> <tr> <td style="width: 30%;">SIP (Network A)</td> <td style="width: 35%;">Interconnection Interface</td> <td style="width: 35%;">SIP (Network B)</td> </tr> <tr> <td></td> <td>INVITE</td> <td></td> </tr> <tr> <td></td> <td>← 180 Call Is Being Forwarded →</td> <td></td> </tr> <tr> <td></td> <td>Apply post test routine</td> <td></td> </tr> </table>	SIP (Network A)	Interconnection Interface	SIP (Network B)		INVITE			← 180 Call Is Being Forwarded →			Apply post test routine	
SIP (Network A)	Interconnection Interface	SIP (Network B)											
	INVITE												
	← 180 Call Is Being Forwarded →												
	Apply post test routine												
Comments	Establish a communication from Network A to Network B. Check: Is a 181 sent from Network B to establish an early dialogue? Check: Is an SDP present in the 181 as a SDP answer? Check: Is a bearer transmission possible in backward direction? (Optional). See notes 1 and 2. NOTE 1: The presence of the P-Early-Media header in the INVITE request indicates the support of "early media Authorization" in the originating Network. NOTE 2: The presence of the P-Early-Media header in the 181 indicates the support of the P-Early-Media header and authorizes the media in the early dialogue. Repeat this test in reverse direction.												

Test case number	SS_bcall_NNI_009	
Test case group	BCALL/successful	
Reference	Clause 8 / [8]	
SELECTION EXPRESSION	[Network A] SE 3 AND [Network B] SE 3 AND SE 35	
Test purpose	P-Early-Media header supported early dialogue with 182. Ensure that an early dialogue is established by sending a 182 Queued from Network B and the P-Early-Media header is present authorizes early media. The Call is a waiting call in network B.	
Configuration		
SIP Parameter	INVITE P-Early-Media: supported SDP 182 P-Early-Media: [any value authorizes early media]	
Message flow	Interconnection Interface	SIP (Network B)
SIP (Network A)	INVITE →	
	← 182 Call Is Being Forwarded →	
	Apply post test routine	
Comments	Establish a communication from Network A to Network B. Check: Is a 181 sent from Network B to establish an early dialogue? Check: Is an SDP present in the 182 as a SDP answer? Check: Is a bearer transmission possible in backward direction? (Optional). NOTE 1: The presence of the P-Early-Media header in the INVITE request indicates the support of "early media Authorization" in the originating Network. NOTE 2: The presence of the P-Early-Media header in the 182 indicates the support of the P-Early-Media header and authorizes the media in the early dialogue. Repeat this test in reverse direction.	

Test case number	SS_bcall_NNI_010	
Test case group	BCALL/successful	
Reference	Clause 5.10 / [2]	
SELECTION EXPRESSION		
Test purpose	Record-route header in the INVITE. Ensure that if the Record-Route header is present in the INVITE establishes a communication between a user of network A and a user of network B the topmost header is set to the IBCF of network A.	
Configuration		
SIP Parameter	INVITE Record-Route: <Address of IBCF in network A>	
Message flow	Interconnection Interface	SIP (Network B)
SIP (Network A)	INVITE →	
	Apply post test routine	
Comments	Establish a communication from Network A to Network B. Check: If present the topmost Record-Route header or entry contains the address of the IBCF of network A. Repeat this test in reverse direction. Repeat this test with all chosen end devices.	

Test case number	SS_bcall_NNI_011										
Test case group	BCALL/successful										
Reference	Clause 5.10 / [2]										
SELECTION EXPRESSION											
Test purpose	Via header in the INVITE. Ensure that the Via header is present in the INVITE establishes a communication between a user of network A and a user of network B and the topmost header is set to the IBCF of network A and contains a branch parameter.										
Configuration											
SIP Parameter	INVITE Via: <Address of IBCF in network A>; branch=[any value]										
Message flow	<table style="width: 100%; border: none;"> <tr> <td style="text-align: center; width: 33%;">SIP (Network A)</td> <td style="text-align: center; width: 33%;">Interconnection Interface</td> <td style="text-align: center; width: 33%;">SIP (Network B)</td> </tr> <tr> <td></td> <td style="text-align: center;">INVITE →</td> <td></td> </tr> <tr> <td></td> <td colspan="2" style="text-align: center;">Apply post test routine</td> </tr> </table>		SIP (Network A)	Interconnection Interface	SIP (Network B)		INVITE →			Apply post test routine	
SIP (Network A)	Interconnection Interface	SIP (Network B)									
	INVITE →										
	Apply post test routine										
Comments	Establish a communication from Network A to Network B. Check: The topmost Via header contains the Address of IBCF in network A and a branch parameter. Repeat this test in reverse direction. Repeat this test with all chosen end devices.										

Test case number	SS_bcall_NNI_012													
Test case group	BCALL/successful													
Reference	Clause 5.10 / [2]													
SELECTION EXPRESSION														
Test purpose	Record-Route header in the 180 Ringing. Ensure if a Record-Route header was present in the initial INVITE that the Record-Route header is present in the 180 Ringing provisional response as the first response from network B upon a connection establish setup from network A.													
Configuration														
SIP Parameter	INVITE Record-Route 180: Record-Route													
Message flow	<table style="width: 100%; border: none;"> <tr> <td style="text-align: center; width: 33%;">SIP (Network A)</td> <td style="text-align: center; width: 33%;">Interconnection Interface</td> <td style="text-align: center; width: 33%;">SIP (Network B)</td> </tr> <tr> <td></td> <td style="text-align: center;">INVITE →</td> <td></td> </tr> <tr> <td></td> <td style="text-align: center;">← 180 Ringing</td> <td></td> </tr> <tr> <td></td> <td colspan="2" style="text-align: center;">Apply post test routine</td> </tr> </table>		SIP (Network A)	Interconnection Interface	SIP (Network B)		INVITE →			← 180 Ringing			Apply post test routine	
SIP (Network A)	Interconnection Interface	SIP (Network B)												
	INVITE →													
	← 180 Ringing													
	Apply post test routine													
Comments	Establish a communication from Network A to Network B. Check: If the Record-Route header is present is in the 180 Ringing. The Record-Route header is optional. Repeat this test in reverse direction. Repeat this test with all chosen end devices.													

Test case number	SS_bcall_NNI_013												
Test case group	BCALL/successful												
Reference	Clause 5.10 / [2]												
SELECTION EXPRESSION													
Test purpose	Route header in the BYE of the originating user. Ensure that if a Record-Route header was present in the initial INVITE the Route header may be present in the BYE request sent from the originating user equipment in network A the topmost Route header or entry is set to the IBCF of network B.												
Configuration													
SIP Parameter	BYE: Route: <Address of IBCF in network B>;lr...												
Message flow	<table style="width: 100%; border: none;"> <tr> <td style="width: 33%; text-align: center;">SIP (Network A)</td> <td style="width: 33%; text-align: center;">Interconnection Interface A confirmed session already exists</td> <td style="width: 33%; text-align: center;">SIP (Network B)</td> </tr> <tr> <td></td> <td style="text-align: center;">BYE →</td> <td></td> </tr> <tr> <td></td> <td style="text-align: center;">← 200 OK BYE</td> <td></td> </tr> <tr> <td></td> <td style="text-align: center;">Apply post test routine</td> <td></td> </tr> </table>	SIP (Network A)	Interconnection Interface A confirmed session already exists	SIP (Network B)		BYE →			← 200 OK BYE			Apply post test routine	
SIP (Network A)	Interconnection Interface A confirmed session already exists	SIP (Network B)											
	BYE →												
	← 200 OK BYE												
	Apply post test routine												
Comments	Establish a communication from Network A to Network B. Check: Is the Route header present in the BYE, the topmost header or entry is set to the address of the IBCF of network B. Repeat this test in reverse direction. Repeat this test with all chosen end devices.												

Test case number	SS_bcall_NNI_014												
Test case group	BCALL/successful												
Reference	Clause 5.10 / [2]												
SELECTION EXPRESSION													
Test purpose	Route header in the BYE of the terminating user. Ensure that if a Record-Route header was present in the initial INVITE the Route header may be present in the BYE request sent from the terminating user equipment in network B the topmost Route header or entry is set to the IBCF of network A.												
Configuration													
SIP Parameter	BYE: Route: <Address of IBCF in network A>;lr,												
Message flow	<table style="width: 100%; border: none;"> <tr> <td style="width: 33%; text-align: center;">SIP (Network A)</td> <td style="width: 33%; text-align: center;">Interconnection Interface A confirmed session already exists</td> <td style="width: 33%; text-align: center;">SIP (Network B)</td> </tr> <tr> <td></td> <td style="text-align: center;">← BYE</td> <td></td> </tr> <tr> <td></td> <td style="text-align: center;">200 OK BYE →</td> <td></td> </tr> <tr> <td></td> <td style="text-align: center;">Apply post test routine</td> <td></td> </tr> </table>	SIP (Network A)	Interconnection Interface A confirmed session already exists	SIP (Network B)		← BYE			200 OK BYE →			Apply post test routine	
SIP (Network A)	Interconnection Interface A confirmed session already exists	SIP (Network B)											
	← BYE												
	200 OK BYE →												
	Apply post test routine												
Comments	Establish a communication from Network A to Network B. Check: If the Route header present in the BYE, the topmost header or entry is set to the address of the IBCF of network A. Repeat this test in reverse direction. Repeat this test with all chosen end devices.												

Test case number	SS_bcall_NNI_015																		
Test case group	BCALL/successful																		
Reference	Clause 5.10 / [2]																		
SELECTION EXPRESSION																			
Test purpose	Route header in the ACK. Ensure that if a Record-Route header was present in the initial INVITE the Route header may be present in ACK from network A upon a connection establishment from network A is completed the topmost Route header or entry is set to the IBCF of network B.																		
Configuration																			
SIP Parameter	ACK: Route: <Address of IBCF in network B>;lr,																		
Message flow	<table style="width: 100%; border: none;"> <tr> <td style="text-align: center; vertical-align: top;">SIP (Network A)</td> <td style="text-align: center; vertical-align: top;">Interconnection Interface</td> <td style="text-align: center; vertical-align: top;">SIP (Network B)</td> </tr> <tr> <td></td> <td style="text-align: center;">INVITE →</td> <td></td> </tr> <tr> <td></td> <td style="text-align: center;">← 180 Ringing</td> <td></td> </tr> <tr> <td></td> <td style="text-align: center;">← 200 OK INVITE</td> <td></td> </tr> <tr> <td></td> <td style="text-align: center;">ACK →</td> <td></td> </tr> <tr> <td></td> <td style="text-align: center;">Apply post test routine</td> <td></td> </tr> </table>	SIP (Network A)	Interconnection Interface	SIP (Network B)		INVITE →			← 180 Ringing			← 200 OK INVITE			ACK →			Apply post test routine	
SIP (Network A)	Interconnection Interface	SIP (Network B)																	
	INVITE →																		
	← 180 Ringing																		
	← 200 OK INVITE																		
	ACK →																		
	Apply post test routine																		
Comments	Establish a communication from Network A to Network B. Check: Is the Route header present in the ACK, the topmost header or entry is set to the address of the IBCF of network B. Repeat this test in reverse direction. Repeat this test with all chosen end devices.																		

Test case number	SS_bcall_NNI_016									
Test case group	BCALL/successful									
Reference	[4] and [5]									
SELECTION EXPRESSION										
Test purpose	Handling of SDP parameters in the INVITE. Ensure that call establishment and the correct handling of the SDP parameters of the INVITE message defined as: TYPE_SDP is performed correctly. Ensure that in the active call state the voice/data transfer on the media channels is performed correctly (e.g. testing QoS parameters). In case when the parameter in the SDP rtpmap:<dynamic-PT> is used the codecs in table 7.1.1-1 applies.									
Configuration										
SIP Parameter	INVITE: Content-Type: application/sdp m=audio <Port number> RTP/AVP TYPE_SDP= PIXIT (table 7.1.1-1) or m= Image <Port number> Udptl or Tcptl TYPE_SDP= PIXIT (table 7.1.1-1) a=TYPE_SDP= PIXIT (table 1) b=TYPE_SDP= PIXIT (table 1)									
Message flow	<table style="width: 100%; border: none;"> <tr> <td style="text-align: center; vertical-align: top;">SIP (Network A)</td> <td style="text-align: center; vertical-align: top;">Interconnection Interface</td> <td style="text-align: center; vertical-align: top;">SIP (Network B)</td> </tr> <tr> <td></td> <td style="text-align: center;">INVITE →</td> <td></td> </tr> <tr> <td></td> <td style="text-align: center;">Apply post test routine</td> <td></td> </tr> </table>	SIP (Network A)	Interconnection Interface	SIP (Network B)		INVITE →			Apply post test routine	
SIP (Network A)	Interconnection Interface	SIP (Network B)								
	INVITE →									
	Apply post test routine									
Comments	Establish a communication from Network A to Network B. Check: Is the preferred codec set to TYPE_SDP? Check: If present: Is the a line set to TYPE_SDP? Check: If present: Is the b line set to TYPE_SDP? Check: Is the codec list consistent with the attribute(s) (bandwidth) regarding the media description? Repeat this test in reverse direction. Repeat this test with all chosen end devices.									

Test case number	SS_bcall_NNI_017						
Test case group	BCALL/successful						
Reference	[4] and [5]						
SELECTION EXPRESSION							
Test purpose	The SDP answer is sent in the 200 OK. Ensure that the call establishment performed correctly. The initial INVITE contains an SDP with the offer 1 according table 7.1.1-1. Ensure that answer related to the SDP offer is contained in the 200 OK INVITE message. Ensure that in the confirmed state the voice transfer on the media and B-channels is performed correctly.						
Configuration							
SIP Parameter							
Message flow	<table style="width: 100%; border: none;"> <tr> <td style="text-align: center; width: 30%;">SIP (Network A)</td> <td style="text-align: center; width: 40%;">Interconnection Interface</td> <td style="text-align: center; width: 30%;">SIP (Network B)</td> </tr> <tr> <td></td> <td style="text-align: center;"> INVITE (SDP1) → ← 180 Ringing ← 200 OK INVITE (SDP2) ACK → </td> <td></td> </tr> </table>	SIP (Network A)	Interconnection Interface	SIP (Network B)		INVITE (SDP1) → ← 180 Ringing ← 200 OK INVITE (SDP2) ACK →	
SIP (Network A)	Interconnection Interface	SIP (Network B)					
	INVITE (SDP1) → ← 180 Ringing ← 200 OK INVITE (SDP2) ACK →						
Apply post test routine							
Comments	Establish a communication from Network A to Network B. Check: Is the SDP answer contained in the 200 OK INVITE? NOTE: An SDP answer could be present in a provisional response. See note Repeat this test in reverse direction. Repeat this test with all chosen end devices.						

Test case number	SS_bcall_NNI_018						
Test case group	BCALL/successful						
Reference	[4] and [5]						
SELECTION EXPRESSION							
Test purpose	First response 200 OK INVITE. Ensure that call establishment and the correctly if the called user answers with a 200 OK message.						
Configuration							
SIP Parameter							
Message flow	<table style="width: 100%; border: none;"> <tr> <td style="text-align: center; width: 30%;">SIP (Network A)</td> <td style="text-align: center; width: 40%;">Interconnection Interface</td> <td style="text-align: center; width: 30%;">SIP (Network B)</td> </tr> <tr> <td></td> <td style="text-align: center;"> INVITE → ← 200 OK INVITE ACK → </td> <td></td> </tr> </table> <p style="text-align: center;">Apply post test routine</p>	SIP (Network A)	Interconnection Interface	SIP (Network B)		INVITE → ← 200 OK INVITE ACK →	
SIP (Network A)	Interconnection Interface	SIP (Network B)					
	INVITE → ← 200 OK INVITE ACK →						
Comments	Establish a communication from Network A to Network B. Check: Is it possible to confirm a session without early dialogue? Repeat this test in reverse direction. Repeat this test with all chosen end devices.						

Table 7.1.1-2

TYPE_SDP				b= line	a= line
VA	<media>	m= line <transport>	<fmt-list>	<modifier>:<bandwidth-value> (see note)	rtpmap:<dynamic-PT> <encoding name>/<clock rate>/[encoding parameters]
VA_01	audio	RTP/AVP	0	N/A or up to 64 kbit/s	N/A or rtpmap 0 PCMU/8000
VA_02	audio	RTP/AVP	Dynamic PT	N/A or up to 64 kbit/s	rtpmap:<dynamic-PT> PCMU/8000
VA_03	audio	RTP/AVP	8	N/A or up to 64 kbit/s	N/A or rtpmap 8 PCMA/8000
VA_04	audio	RTP/AVP	Dynamic PT	N/A or up to 64 kbit/s	rtpmap:<dynamic-PT> PCMA/8000
VA_05	audio	RTP/AVP	Dynamic PT	N/A or up to 64 kbit/s	rtpmap:<dynamic-PT> CLEARMODE
VA_06	audio	RTP/AVP	Dynamic PT		rtpmap:<dynamic-PT> AMR-WB/16000/1
VA_07	audio	RTP/AVP	Dynamic PT	N/A or up to 64 kbit/s	rtpmap:<dynamic-PT> AMR/8000/1

NOTE: <bandwidth value> for <modifier> of AS is evaluated to be B kbit/s.

Test case number	SS_bcall_NNI_019																																												
Test case group	BCALL/successful																																												
Reference	Clause 4.9, N / [2]																																												
SELECTION EXPRESSION	[Network A] SE 47 AND [Network A] SE 4 AND [Network B] SE 4																																												
Test purpose	Overlap sending, the Multiple INVITE method is used. Ensure that call establishment using overlap sending is performed correctly. Ensure that in the confirmed state the voice transfer on the media and B-channels is performed correctly.																																												
Configuration																																													
SIP Parameter																																													
Message flow	<table border="0" style="width: 100%; border-collapse: collapse;"> <thead> <tr> <th style="text-align: left; width: 30%;">SIP (Network A)</th> <th style="text-align: center; width: 40%;">Interconnection Interface</th> <th style="width: 10%;"></th> <th style="text-align: right; width: 20%;">SIP (Network B)</th> </tr> </thead> <tbody> <tr> <td></td> <td style="text-align: center;">INVITE(CSq 1)</td> <td style="text-align: center;">→</td> <td></td> </tr> <tr> <td></td> <td style="text-align: center;">INVITE(CSq 2)</td> <td style="text-align: center;">→</td> <td></td> </tr> <tr> <td style="text-align: center;">←</td> <td style="text-align: center;">484 Address Incomplete(CSq 1) ACK</td> <td style="text-align: center;">→</td> <td></td> </tr> <tr> <td></td> <td style="text-align: center;">INVITE(CSq 3)</td> <td style="text-align: center;">→</td> <td></td> </tr> <tr> <td style="text-align: center;">←</td> <td style="text-align: center;">484 Address Incomplete(CSq 2) ACK</td> <td style="text-align: center;">→</td> <td></td> </tr> <tr> <td></td> <td style="text-align: center;">.....</td> <td></td> <td></td> </tr> <tr> <td></td> <td style="text-align: center;">INVITE(CSq 4)</td> <td style="text-align: center;">→</td> <td></td> </tr> <tr> <td style="text-align: center;">←</td> <td style="text-align: center;">484 Address Incomplete(CSq 3) ACK</td> <td style="text-align: center;">→</td> <td></td> </tr> <tr> <td style="text-align: center;">←</td> <td style="text-align: center;">180 Ringing(CSq 4)</td> <td></td> <td></td> </tr> <tr> <td></td> <td style="text-align: center;">Apply post test routine</td> <td></td> <td></td> </tr> </tbody> </table>	SIP (Network A)	Interconnection Interface		SIP (Network B)		INVITE(CSq 1)	→			INVITE(CSq 2)	→		←	484 Address Incomplete(CSq 1) ACK	→			INVITE(CSq 3)	→		←	484 Address Incomplete(CSq 2) ACK	→						INVITE(CSq 4)	→		←	484 Address Incomplete(CSq 3) ACK	→		←	180 Ringing(CSq 4)				Apply post test routine		
SIP (Network A)	Interconnection Interface		SIP (Network B)																																										
	INVITE(CSq 1)	→																																											
	INVITE(CSq 2)	→																																											
←	484 Address Incomplete(CSq 1) ACK	→																																											
	INVITE(CSq 3)	→																																											
←	484 Address Incomplete(CSq 2) ACK	→																																											
																																												
	INVITE(CSq 4)	→																																											
←	484 Address Incomplete(CSq 3) ACK	→																																											
←	180 Ringing(CSq 4)																																												
	Apply post test routine																																												
Comments	Establish a communication from ISDN to SIP using the overlap operation in ISDN. Check: All INVITE requests contain the same Call ID and From header values. SIP answers with 180 Ringing. Repeat this test in reverse direction.																																												

Test case number	SS_bcall_NNI_020																																											
Test case group	BCALL/successful																																											
Reference	Clause 4.9, N / [2]																																											
SELECTION EXPRESSION	[Network A] SE 47 AND [Network A] SE 5 AND [Network B] SE 5																																											
Test purpose	<p>Overlap sending, the in-Dialogue method is used. Ensure that call establishment using overlap sending is performed correctly. Ensure that in the confirmed state the voice transfer on the media and B-channels is performed correctly.</p>																																											
Configuration																																												
SIP Parameter	INVITE 2: Supported: 100rel 183: Require: 100rel INFO: Content-Type: application/x-session-info SubsequentDigit: <additional digits>																																											
Message flow	<table border="0" style="width: 100%; border-collapse: collapse;"> <thead> <tr> <th style="text-align: left; width: 30%;">SIP (Network A)</th> <th style="text-align: center; width: 40%;">Interconnection Interface</th> <th style="text-align: right; width: 30%;">SIP (Network B)</th> </tr> </thead> <tbody> <tr> <td></td> <td style="text-align: center;">INVITE(CSq 1) 1</td> <td style="text-align: right;">→</td> </tr> <tr> <td style="text-align: left;">←</td> <td style="text-align: center;">484 Address Incomplete(CSq 1)</td> <td></td> </tr> <tr> <td></td> <td style="text-align: center;">ACK</td> <td style="text-align: right;">→</td> </tr> <tr> <td></td> <td style="text-align: center;">INVITE(CSq 2) 2</td> <td style="text-align: right;">→</td> </tr> <tr> <td style="text-align: left;">←</td> <td style="text-align: center;">183 Session Progress(CSq 2)</td> <td></td> </tr> <tr> <td></td> <td style="text-align: center;">PRACK</td> <td style="text-align: right;">→</td> </tr> <tr> <td style="text-align: left;">←</td> <td style="text-align: center;">200 OK PRACK</td> <td></td> </tr> <tr> <td></td> <td style="text-align: center;">INFO</td> <td style="text-align: right;">→</td> </tr> <tr> <td style="text-align: left;">←</td> <td style="text-align: center;">200 OK INFO</td> <td></td> </tr> <tr> <td></td> <td style="text-align: center;">.....</td> <td></td> </tr> <tr> <td></td> <td style="text-align: center;">INFO</td> <td style="text-align: right;">→</td> </tr> <tr> <td style="text-align: left;">←</td> <td style="text-align: center;">200 OK INFO</td> <td></td> </tr> <tr> <td style="text-align: left;">←</td> <td style="text-align: center;">180 Ringing(CSq 2)</td> <td></td> </tr> </tbody> </table> <p style="text-align: center;">Apply post test routine</p>		SIP (Network A)	Interconnection Interface	SIP (Network B)		INVITE(CSq 1) 1	→	←	484 Address Incomplete(CSq 1)			ACK	→		INVITE(CSq 2) 2	→	←	183 Session Progress(CSq 2)			PRACK	→	←	200 OK PRACK			INFO	→	←	200 OK INFO					INFO	→	←	200 OK INFO		←	180 Ringing(CSq 2)	
SIP (Network A)	Interconnection Interface	SIP (Network B)																																										
	INVITE(CSq 1) 1	→																																										
←	484 Address Incomplete(CSq 1)																																											
	ACK	→																																										
	INVITE(CSq 2) 2	→																																										
←	183 Session Progress(CSq 2)																																											
	PRACK	→																																										
←	200 OK PRACK																																											
	INFO	→																																										
←	200 OK INFO																																											
																																											
	INFO	→																																										
←	200 OK INFO																																											
←	180 Ringing(CSq 2)																																											
Comments	Establish a communication from ISDN to SIP using the overlap operation in ISDN. Check: All INVITE requests contains the same Call ID and From header values. Check: The 183 session Progress that establishes an early dialogue contains a Require header set to 100rel. Check: All INFO requests contain the Content-Type header set to 'application/x-session-info'. Check: All INFO requests contains the 'SubsequentDigit:' MIME body containing the additional digits. The UE B answers with 180 Ringing response after the INVITE was received. Repeat this test in reverse direction.																																											

Test case number	SS_bcall_NNI_021	
Test case group	BCALL/successful	
Reference	Clause 5.1.1.1.2 / [12]	
SELECTION EXPRESSION	[Network A] (SE 46 OR SE 47) AND [Network A] SE 6	
Test purpose	PSTN XML BearerCapability element in the INVITE. User A is located in network A and an ISDN end device is used. Ensure that the INVITE request contains a PSTN XML MIME body and a BearerCapability element as indicated in table 7.1.1-2 is present.	
Configuration	User A is an ISDN access either in the PSTN or the SIP - ISDN interworking according ETSI TS 124 605 [46] applies.	
SIP Parameter	INVITE: Content-Type: application/vnd.etsi.pstn+xml Content-Disposition: signal;handling=optional <?xml version="1.0" encoding="utf-8"?> PSTN BearerCapability BCoctet3 CodingStandard>00< InformationTransferCabability> ITC_value < < BCoctet4 TransferMode>00< InformationTransferRate>10000< BCoet5 Layer1Identification>01< UserInfoLayer1Protocol>00011<	
Message flow	<div style="display: flex; justify-content: space-between; align-items: center;"> <div style="text-align: center;">SIP (Network A)</div> <div style="text-align: center;"> Interconnection Interface INVITE → Apply post test routine </div> <div style="text-align: center;">SIP (Network B)</div> </div>	
Comments	Check: Is a PSTN XML MIME body contained in the INVITE request? Check: Is the BearerCapability element present? Check: Is the InformationTransferCabability element set as indicated in table 7.1.1-1? Check: Is the InformationTransferCabability element value consistent with the codec list in the SDP? Check: Is the InformationTransferCabability element value consistent with the bandwidth information in the SDP? Repeat this test in reverse direction.	

Table 7.1.1-3: PSTN XML BearerCapability

ITC_value	BC Information transfer capability	XML InformationTransferCabability
ITC_VA_1	Speech	00000
ITC_VA_2	3,1 kHz audio	10000
ITC_VA_3	unrestricted digital information	01000

Test case number	SS_bcall_NNI_022	
Test case group	BCALL/successful	
Reference	Clause 5.1.1.1.2 / [12]	
SELECTION EXPRESSION	[Network A] (SE 46 OR SE 47) AND [Network A] SE 6	
Test purpose	PSTN XML HighLayerCapability element in the INVITE. User A is located in network A and an ISDN end device is used. Ensure that the INVITE request contains a PSTN XML MIME body and a HighLayerCapability element is present.	
Configuration	User A is an ISDN access either in the PSTN or the SIP - ISDN interworking according ETSI TS 124 605 [46] applies.	
SIP Parameter	INVITE: Content-Type: application/vnd.etsi.pstn+xml Content-Disposition: signal;handling=optional <?xml version="1.0" encoding="utf-8"?> PSTN HighLayerCompatibility HLOctet3 CodingStandard>00< Interpretation>100< PresentationMethod>01< HLOctet4 HighLayerCharacteristics>[any value]<	
Message flow	<div style="display: flex; justify-content: space-between; align-items: center;"> <div style="text-align: center;">SIP (Network A)</div> <div style="text-align: center;">Interconnection Interface INVITE →</div> <div style="text-align: center;">SIP (Network B)</div> </div> <p style="text-align: center;">Apply post test routine</p>	
Comments	Check: Is a PSTN XML MIME body contained in the INVITE request? Check: Is the HighLayerCapability element present? Repeat this test in reverse direction.	

Test case number	SS_bcall_NNI_023	
Test case group	BCALL/successful	
Reference	Clause 5.1.1.1.2 / [12]	
SELECTION EXPRESSION	[Network A] (SE 46 OR SE 47) AND [Network A] SE 6	
Test purpose	PSTN XML Progress Indicator element in the INVITE. User A is located in network A and an ISDN end device is used. Ensure that the INVITE request contains a PSTN XML MIME body and at least one Progress Indicator element is present.	
Configuration	User A is an ISDN access either in the PSTN or the SIP - ISDN interworking according ETSI TS 124 605 [46] applies.	
SIP Parameter	INVITE: Content-Type: application/vnd.etsi.pstn+xml Content-Disposition: signal;handling=optional <?xml version="1.0" encoding="utf-8"?> PSTN ProgressIndicator ProgressOctet3 CodingStandard>00< Location>yyyy< ProgressOctet4 ProgressDescription>0000110< <i>ProgressIndicator</i> <i>ProgressOctet3</i> <i>CodingStandard>00<</i> <i>Location>0000<</i> <i>ProgressOctet4</i> <i>ProgressDescription>[any value]<</i>	
Message flow	<div style="display: flex; justify-content: space-between; align-items: center;"> <div style="text-align: center;"> SIP (Network A) </div> <div style="text-align: center;"> Interconnection Interface INVITE → Apply post test routine </div> <div style="text-align: center;"> SIP (Network B) </div> </div>	
Comments	Check: Is a PSTN XML MIME body contained in the INVITE request? Check: Is a ProgressIndicator element present and the ProgressDescription element is set to '0000110'? Check: Is optional a second ProgressIndicator element present and the ProgressDescription element is set to any value not #2 and not #8? Repeat this test in reverse direction.	

Test case number	SS_bcall_NNI_024												
Test case group	BCALL/successful												
Reference	Clause 5.1.2.2 / [12]												
SELECTION EXPRESSION	[Network B] (SE 46 OR SE 47) AND [Network B] SE 6												
Test purpose	PSTN XML ProgressIndicator element in the 180. User B is located in network B and an ISDN end device is used. Ensure that the 180 Ringing response contains a PSTN XML MIME body and at least one ProgressIndicator element is present.												
Configuration	User B is an ISDN access either in the PSTN or the SIP - ISDN interworking according ETSI TS 124 605 [46] applies.												
SIP Parameter	180: Content-Type: application/vnd.etsi.pstn+xml Content-Disposition: signal;handling=optional <?xml version="1.0" encoding="utf-8"?> PSTN ProgressIndicator ProgressOctet3 CodingStandard>00< Location>yyyy< ProgressOctet4 ProgressDescription>0000111< ProgressIndicator ProgressOctet3 CodingStandard>00< Location>0000< ProgressOctet4 ProgressDescription>[any value]<												
Message flow	<table style="width: 100%; border: none;"> <tr> <td style="text-align: center; width: 33%;">SIP (Network A)</td> <td style="text-align: center; width: 33%;">Interconnection Interface</td> <td style="text-align: center; width: 33%;">SIP (Network B)</td> </tr> <tr> <td></td> <td style="text-align: center;">INVITE →</td> <td></td> </tr> <tr> <td></td> <td style="text-align: center;">← 180 Ringing</td> <td></td> </tr> <tr> <td></td> <td style="text-align: center;">Apply post test routine</td> <td></td> </tr> </table>	SIP (Network A)	Interconnection Interface	SIP (Network B)		INVITE →			← 180 Ringing			Apply post test routine	
SIP (Network A)	Interconnection Interface	SIP (Network B)											
	INVITE →												
	← 180 Ringing												
	Apply post test routine												
Comments	Check: Is a PSTN XML MIME body contained in the 180 Ringing response? Check: Is a ProgressIndicator element present and the ProgressDescription element is set to '0000110'? Check: Is optional a second ProgressIndicator element present and the ProgressDescription element is set to any value not #2 and not #8? Repeat this test in reverse direction.												

Test case number	SS_bcall_NNI_025																			
Test case group	BCALL/successful																			
Reference	Clause 5.1.2.3 / [12]																			
SELECTION EXPRESSION	[Network B] (SE 46 OR SE 47) AND [Network B] SE 6.																			
Test purpose	PSTN XML ProgressIndicator element in the 200. User B is located in network B and an ISDN end device is used. Ensure that the 200 OK INVITE response contains a PSTN XML MIME body and at least one ProgressIndicator element is present.																			
Configuration	User B is an ISDN access either in the PSTN or the SIP - ISDN interworking according ETSI TS 124 605 [46] applies.																			
SIP Parameter	200: Content-Type: application/vnd.etsi.pstn+xml Content-Disposition: signal;handling=optional <?xml version="1.0" encoding="utf-8"?> PSTN ProgressIndicator ProgressOctet3 CodingStandard>00< Location>yyyy< ProgressOctet4 ProgressDescription>0000111<																			
Message flow	<table style="width: 100%; border-collapse: collapse;"> <thead> <tr> <th style="text-align: left; width: 33%;">SIP (Network A)</th> <th style="text-align: center; width: 33%;">Interconnection Interface</th> <th style="text-align: right; width: 33%;">SIP (Network B)</th> </tr> </thead> <tbody> <tr> <td></td> <td style="text-align: center;">INVITE →</td> <td></td> </tr> <tr> <td style="text-align: left;">←</td> <td style="text-align: center;">180 Ringing</td> <td></td> </tr> <tr> <td style="text-align: left;">←</td> <td style="text-align: center;">200 OK INVITE</td> <td></td> </tr> <tr> <td></td> <td style="text-align: center;">ACK →</td> <td></td> </tr> <tr> <td></td> <td colspan="2" style="text-align: center;">Apply post test routine</td> </tr> </tbody> </table>		SIP (Network A)	Interconnection Interface	SIP (Network B)		INVITE →		←	180 Ringing		←	200 OK INVITE			ACK →			Apply post test routine	
SIP (Network A)	Interconnection Interface	SIP (Network B)																		
	INVITE →																			
←	180 Ringing																			
←	200 OK INVITE																			
	ACK →																			
	Apply post test routine																			
Comments	Check: Is a PSTN XML MIME body contained in the 200 OK INVITE response? Check: Is a ProgressIndicator element present and the ProgressDescription element is set to '0000110'? Repeat this test in reverse direction.																			

Test case number	SS_bcall_NNI_026							
Test case group	BCALL/successful							
Reference	Clause 5.1.1.1.2 / [12]							
SELECTION EXPRESSION	[Network A] (SE 46 OR SE 47) AND [Network A] SE 6.							
Test purpose	PSTN XML BearerCapability Fallback connection type element in the INVITE. User A is located in network A and an ISDN end device is used. Ensure that the INVITE request contains a PSTN XML MIME body and one BearerCapability element is present the InformationTransferCabability element is set to '00000' and one InformationTransferCabability element is set to '10001'.							
Configuration	User A is an ISDN access either in the PSTN or the SIP - ISDN interworking according ETSI TS 124 605 [46] applies.							
SIP Parameter	INVITE: Content-Type: application/vnd.etsi.pstn+xml Content-Disposition: signal;handling=optional <?xml version="1.0" encoding="utf-8"?> PSTN BearerCapability BCoetct3 CodingStandard>00< InformationTransferCabability>00000< BearerCapability BCoetct3 CodingStandard>00< InformationTransferCabability>10001<							
Message flow	<table style="width: 100%; border: none;"> <tr> <td style="text-align: center; width: 33%;">SIP (Network A)</td> <td style="text-align: center; width: 33%;">Interconnection Interface</td> <td style="text-align: center; width: 33%;">SIP (Network B)</td> </tr> <tr> <td></td> <td style="text-align: center;">INVITE →</td> <td></td> </tr> </table>		SIP (Network A)	Interconnection Interface	SIP (Network B)		INVITE →	
SIP (Network A)	Interconnection Interface	SIP (Network B)						
	INVITE →							
Apply post test routine								
Comments	Check: Is a PSTN XML MIME body contained in the INVITE request? Check: Is the first BearerCapability InformationTransferCabability element set as indicated to '00000'? Check: Is the second BearerCapability InformationTransferCabability element set as indicated to '10001'? Check: Is the InformationTransferCabability element value consistent with the codec list in the SDP? Check: Is the InformationTransferCabability element value consistent with the bandwidth information in the SDP? Repeat this test in reverse direction.							

Test case number	SS_bcall_NNI_027																		
Test case group	BCALL/successful																		
Reference	Clause 5.1.2.3 / [12]																		
SELECTION EXPRESSION	[Network B] (SE 46 OR SE 47) AND [Network B] SE 6.																		
Test purpose	Fall back does not occur. User B is located in network B and an ISDN end device is used. The Fallback connection type was requested in the initial INVITE request. Ensure that the 200 OK INVITE response contains a PSTN XML MIME body and a BearerCapability element is present the InformationTransferCabability element set to '10001'.																		
Configuration	User B is an ISDN access either in the PSTN or the SIP - ISDN interworking according ETSI TS 124 605 [46] applies.																		
SIP Parameter	200: Content-Type: application/vnd.etsi.pstn+xml Content-Disposition: signal;handling=optional <?xml version="1.0" encoding="utf-8"?> PSTN BearerCapability BCoctet3 CodingStandard>00< InformationTransferCabability>10001<																		
Message flow	<table style="width: 100%; border: none;"> <tr> <td style="text-align: center; vertical-align: top;">SIP (Network A)</td> <td style="text-align: center; vertical-align: top;">Interconnection Interface</td> <td style="text-align: center; vertical-align: top;">SIP (Network B)</td> </tr> <tr> <td></td> <td style="text-align: center;">INVITE →</td> <td></td> </tr> <tr> <td></td> <td style="text-align: center;">← 180 Ringing</td> <td></td> </tr> <tr> <td></td> <td style="text-align: center;">← 200 OK INVITE</td> <td></td> </tr> <tr> <td></td> <td style="text-align: center;">ACK →</td> <td></td> </tr> <tr> <td></td> <td colspan="2" style="text-align: center;">Apply post test routine</td> </tr> </table>	SIP (Network A)	Interconnection Interface	SIP (Network B)		INVITE →			← 180 Ringing			← 200 OK INVITE			ACK →			Apply post test routine	
SIP (Network A)	Interconnection Interface	SIP (Network B)																	
	INVITE →																		
	← 180 Ringing																		
	← 200 OK INVITE																		
	ACK →																		
	Apply post test routine																		
Comments	<p>Check: Is a PSTN XML MIME body contained in the 200 OK INVITE response?</p> <p>Check: Is a BearerCapability element present, the InformationTransferCabability element set to '10001'?</p> <p>Check: Is the InformationTransferCabability element value consistent with the codec list in the SDP?</p> <p>Check: Is the InformationTransferCabability element value consistent with the bandwidth information in the SDP?</p> <p>Repeat this test in reverse direction.</p>																		

Test case number	SS_bcall_NNI_028																		
Test case group	BCALL/successful																		
Reference	Clause 5.1.2.3 / [12]																		
SELECTION EXPRESSION	[Network B] (SE 46 OR SE 47) AND [Network B] SE 6																		
Test purpose	Fall back occurs. User B is located in network B and an ISDN end device is used. The Fallback connection type was requested in the initial INVITE request. Ensure that the 200 OK INVITE response contains a PSTN XML MIME body and a BearerCapability element is present the InformationTransferCabability element set to '00000'. A PSTN XML MIME ProgressIndicator body is present, the ProgressDescription is set to '0000101'.																		
Configuration	User B is an ISDN access either in the PSTN or the SIP - ISDN interworking according ETSI TS 124 605 [46] applies.																		
SIP Parameter	200: Content-Type: application/vnd.etsi.pstn+xml Content-Disposition: signal;handling=optional <?xml version="1.0" encoding="utf-8"?> PSTN BearerCapability BCoetct3 CodingStandard>00< InformationTransferCabability>00000< ProgressIndicator ProgressOctet4 ProgressDescription>0000101< OR No PSTN XML element																		
Message flow	<table style="width: 100%; border: none;"> <tr> <td style="text-align: center; width: 30%;">SIP (Network A)</td> <td style="text-align: center; width: 40%;">Interconnection Interface</td> <td style="text-align: center; width: 30%;">SIP (Network B)</td> </tr> <tr> <td></td> <td style="text-align: center;">INVITE →</td> <td></td> </tr> <tr> <td></td> <td style="text-align: center;">← 180 Ringing</td> <td></td> </tr> <tr> <td></td> <td style="text-align: center;">← 200 OK INVITE</td> <td></td> </tr> <tr> <td></td> <td style="text-align: center;">ACK →</td> <td></td> </tr> <tr> <td></td> <td colspan="2" style="text-align: center;">Apply post test routine</td> </tr> </table>	SIP (Network A)	Interconnection Interface	SIP (Network B)		INVITE →			← 180 Ringing			← 200 OK INVITE			ACK →			Apply post test routine	
SIP (Network A)	Interconnection Interface	SIP (Network B)																	
	INVITE →																		
	← 180 Ringing																		
	← 200 OK INVITE																		
	ACK →																		
	Apply post test routine																		
Comments	<p>Check: Is a PSTN XML MIME body contained in the 200 OK INVITE response? OR If no PSTN XML MIME body contained in the 200 OK INVITE response? No further checks!</p> <p>Check: Is a BearerCapability element present, the InformationTransferCabability element set to '00000'?</p> <p>Check: Is a ProgressIndicator element present, the ProgressDescription is set to '0000101'?</p> <p>Check: Is the InformationTransferCabability element value consistent with the codec list in the SDP?</p> <p>Check: Is the InformationTransferCabability element value consistent with the bandwidth information in the SDP?</p> <p>Repeat this test in reverse direction.</p>																		

Test case number	SS_bcall_NNI_029	
Test case group	BCALL/successful	
Reference	[46]	
SELECTION EXPRESSION	[Network B] SE 17b	
Test purpose	Handling of multiple early dialogues. Ensure that in case of forking in Network B the early dialogues are handled in a proper way. When a 200 OK INVITE is received, the remaining early dialogues shall be cancelled.	
Configuration	User B has registered three end devices under the same identity.	
SIP Parameter		
Message flow		
SIP (Network A)	Interconnection Interface	SIP (Network B)
	INVITE	→
	←	180 Ringing 1
	←	180 Ringing 2
	←	180 Ringing 3
	←	200 OK INVITE 3
	ACK	→
	Communication	
CASE A	←	BYE 3
		200 OK BYE 3 →
CASE B		BYE 3 →
	←	200 OK BYE 3
Comments	Establish a communication from Network A to Network B. Check: Ensure that several provisional responses with different 'To' tags are sent from Network B to Network A. Repeat this test in reverse direction.	

7.1.2 Test purposes for Basic call, DTMF Transport

Test case number	SS_DTMF_1
Test case group	BCALL/successful
Reference	Clause 5.1.2.3 / [13]
SELECTION EXPRESSION	SE 35 SE 36 SE 37
Test purpose	Transmission of DTMF Ensure that the ability of transmission of DTMF can be performed by the originating and destination user. The transmission can be done by: <ul style="list-style-type: none"> • DTMF in the RTP stream • Either by indicating in the SDP offer in the RTP stream • Or by the SIP INFO/NOTIFY Method for DTMF tone generation DTMF Test: The DTMF Test should consist DTMF tones (70 ms signal, 100 ms pause) and shall contain the tones 0, 1, 2, 3, 4, 5, 6, 7, 8, 9, A, B, C, D, *, #. The transmission shall be tested in both directions.

Configuration SIP Parameter	INVITE: CASE A m=audio <Port> RTP/AVP <dynamic-PT> CASE B m=audio <Port> RTP/AVP <dynamic-PT> a=rtpmap <dynamic-PT> telephone-event/8000 a=rtpmap <dynamic-PT> 0-15 CASE C INFO Content-Type: application/dtmf 'x' or INFO Content-Type: application/dtmf-relay Signal=x Duration=y																																	
Message flow SIP (Network A)	<table border="0" style="width: 100%; text-align: center;"> <thead> <tr> <th style="width: 30%;"></th> <th style="width: 40%;">Interconnection Interface</th> <th style="width: 30%;"></th> </tr> </thead> <tbody> <tr> <td></td> <td>INVITE</td> <td>→</td> </tr> <tr> <td></td> <td>← 180 Ringing</td> <td></td> </tr> <tr> <td></td> <td>← 200 OK INVITE</td> <td></td> </tr> <tr> <td></td> <td>ACK</td> <td>→</td> </tr> <tr> <td>CASE A</td> <td>RTP DTMF inband</td> <td></td> </tr> <tr> <td>CASE B</td> <td>RTP DTMF events</td> <td></td> </tr> <tr> <td></td> <td>INFO</td> <td>→</td> </tr> <tr> <td>CASE C</td> <td>← 200 OK INFO</td> <td></td> </tr> <tr> <td></td> <td>INFO</td> <td>→</td> </tr> <tr> <td>CASE D</td> <td>← 200 OK INFO</td> <td></td> </tr> </tbody> </table> <p style="text-align: center;">Apply post test routine</p>		Interconnection Interface			INVITE	→		← 180 Ringing			← 200 OK INVITE			ACK	→	CASE A	RTP DTMF inband		CASE B	RTP DTMF events			INFO	→	CASE C	← 200 OK INFO			INFO	→	CASE D	← 200 OK INFO	
	Interconnection Interface																																	
	INVITE	→																																
	← 180 Ringing																																	
	← 200 OK INVITE																																	
	ACK	→																																
CASE A	RTP DTMF inband																																	
CASE B	RTP DTMF events																																	
	INFO	→																																
CASE C	← 200 OK INFO																																	
	INFO	→																																
CASE D	← 200 OK INFO																																	
Comments	Establish a communication from Network A to Network B Check: Case B: Is the dynamic payload type 'telephone-event' present in the SDP offer? Check: Case B: Is the dynamic payload type 'telephone-event' covered in the RTP stream if the Telephone event occurs? Check: Case C: Does the Content-Type header field in the INFO request conveying the DTMF signal set to 'application/dtmf'? Check: Case C: does the MIME body of the INFO request covering the TMF signal contain the events regarding the used content type? Check: Case D: Does the Content-Type header field in the INFO request conveying the DTMF signal set to 'application/dtmf-relay'? Check: Case C: Does the MIME body of the INFO request covering the TMF signal contain the events and duration regarding the used content type? Repeat this test in reverse direction.																																	

7.1.3 Test purposes for Basic call, Fax transmission

This clause contains three basic fax transmission tests without QoS requirements for the case when both networks are supporting the same transmission capabilities.

The "minimal requirements" for fax support between SIP enabled devices for real-time fax over IP are described in Recommendation ITU-T Q.4016 [28].

Test case number	SS_bcall_FAX_1									
Test case group	BCALL/successful									
Reference	[4] and [5]									
SELECTION EXPRESSION	[Network A] SE 45 AND [Network B] SE 45									
Test purpose	Fax transmission using the G.711 codec. Ensure that a Fax transmission is possible from Network A to Network B and the relevant codec is the G.711 codec. Ensure in the active call state the property of Fax transmission. The call establishment procedures based on SIP/SDP and H.248 for a real-time fax over IP service are described in Recommendation ITU-T Q.4016 [28].									
Configuration										
SIP Parameter	INVITE: SDP m=audio <Port> RTP/AVP 8 OR <dynamic-PT> a=rtpmap 8 OR <dynamic-PT> PCMA/8000 m=audio <Port> RTP/AVP 8/0 180/200 OK INVITE: SDP m=audio <Port> RTP/AVP 8									
Message flow	<table style="width: 100%; border: none;"> <tr> <td style="text-align: center; vertical-align: top;">SIP (Network A)</td> <td style="text-align: center; vertical-align: top;">Interconnection Interface</td> <td style="text-align: center; vertical-align: top;">SIP (Network B)</td> </tr> <tr> <td></td> <td style="text-align: center;"> INVITE (SDP1) → ← 180 Ringing ← 200 OK INVITE (SDP2) ACK → </td> <td></td> </tr> <tr> <td colspan="3" style="text-align: center;">Apply post test routine</td> </tr> </table>	SIP (Network A)	Interconnection Interface	SIP (Network B)		INVITE (SDP1) → ← 180 Ringing ← 200 OK INVITE (SDP2) ACK →		Apply post test routine		
SIP (Network A)	Interconnection Interface	SIP (Network B)								
	INVITE (SDP1) → ← 180 Ringing ← 200 OK INVITE (SDP2) ACK →									
Apply post test routine										
Comments	Establish a communication from Network A to Network B. Check: Is the SDP answer contained in the 200 OK INVITE? Check: Is Fax transmission successful? Repeat this test in reverse direction.									

Test case number	SS_bcall_FAX_2									
Test case group	BCALL/successful									
Reference	[5] and [9]									
SELECTION EXPRESSION	[Network A] SE 44 AND [Network A] SE 44									
Test purpose	Fax transmission using the V.152 codec. Ensure that a Fax transmission is possible from Network A to Network B and the relevant codec is the V.152 codec. Ensure in the active call state the property of Fax transmission. The call establishment procedures based on SIP/SDP and H.248 for a real-time fax over IP service are described in Recommendation ITU-T Q.4016 [28].									
Configuration										
SIP Parameter	INVITE: SDP m=audio <Port> RTP/AVP 8 <dynamic-PT> a=rtpmap <dynamic-PT> PCMA/8000 a=gpm; vbd=yes 180/200 OK INVITE: SDP m=audio <Port> RTP/AVP <dynamic-PT> a=rtpmap <dynamic-PT> PCMA/8000 a=gpm; vbd=yes									
Message flow	<table style="width: 100%; border: none;"> <tr> <td style="text-align: center; vertical-align: top;">SIP (Network A)</td> <td style="text-align: center; vertical-align: top;">Interconnection Interface</td> <td style="text-align: center; vertical-align: top;">SIP (Network B)</td> </tr> <tr> <td></td> <td style="text-align: center;"> INVITE (SDP1) → ← 180 Ringing ← 200 OK INVITE (SDP2) ACK → </td> <td></td> </tr> <tr> <td colspan="3" style="text-align: center;">Apply post test routine</td> </tr> </table>	SIP (Network A)	Interconnection Interface	SIP (Network B)		INVITE (SDP1) → ← 180 Ringing ← 200 OK INVITE (SDP2) ACK →		Apply post test routine		
SIP (Network A)	Interconnection Interface	SIP (Network B)								
	INVITE (SDP1) → ← 180 Ringing ← 200 OK INVITE (SDP2) ACK →									
Apply post test routine										
Comments	Establish a communication from Network A to Network B. Check: Contains the SDP offer in the initial INVITE a voice band data codec? Check: Contains the SDP answer in the 180 or 200 OK INVITE a voice band data codec? Check: Is Fax transmission successful? Repeat this test in reverse direction.									

Test case number	SS_bcall_FAX_3									
Test case group	BCALL/successful									
Reference	[5] and [10]									
SELECTION EXPRESSION	[Network A] SE 45 AND [Network B] SE 45									
Test purpose	<p>Fax transmission using the T.38 in an audio m-line codec. Ensure that a Fax transmission is possible from Network A to Network B and the relevant codec is the T.38 in an 'audio' m-line codec. Ensure in the active call state the property of Fax transmission. The call establishment procedures based on SIP/SDP and H.248 for a real-time fax over IP service are described in Recommendation ITU-T Q.4016 [28].</p>									
Configuration										
SIP Parameter	<p>INVITE: SDP m=audio <Port> RTP/AVP 8 OR <dynamic-PT> a=rtpmap 8 OR <dynamic-PT> PCMA/8000 m=image <Port> udptl t38</p> <p>180/200 OK INVITE: SDP m=image <Port> udptl t38</p>									
Message flow	<table style="width: 100%; border: none;"> <tr> <td style="text-align: center; vertical-align: middle;">SIP (Network A)</td> <td style="text-align: center; vertical-align: middle;">Interconnection Interface</td> <td style="text-align: center; vertical-align: middle;">SIP (Network B)</td> </tr> <tr> <td></td> <td style="text-align: center;"> INVITE (SDP1) → ← 180 Ringing ← 200 OK INVITE (SDP2) ACK → </td> <td></td> </tr> <tr> <td colspan="3" style="text-align: center;">Apply post test routine</td> </tr> </table>	SIP (Network A)	Interconnection Interface	SIP (Network B)		INVITE (SDP1) → ← 180 Ringing ← 200 OK INVITE (SDP2) ACK →		Apply post test routine		
SIP (Network A)	Interconnection Interface	SIP (Network B)								
	INVITE (SDP1) → ← 180 Ringing ← 200 OK INVITE (SDP2) ACK →									
Apply post test routine										
Comments	<p>Establish a communication from Network A to Network B.</p> <p>Check: Contains the SDP offer in the initial INVITE a T.38 codec in an 'audio' line?</p> <p>Check: Contains the SDP answer in the 180 or 200 OK INVITE a T.38 codec in an 'audio' line?</p> <p>Check: Is Fax transmission successful?</p> <p>Repeat this test in reverse direction.</p>									

7.1.4 SIP-I Tests

Test case number	SS_bcall_SIP-I_01												
Test case group	BCALL/successful												
Reference	Clause 7.1 / [11]												
SELECTION EXPRESSION	[Network A] SE 17 AND [Network A] SE 47												
Test purpose	SIP-I support, Basic call, IAM present in the INVITE request. Ensure that when a call initiated in the PSTN or the PLMN and the ISUP - SIP-I interworking is applicable in the originating network, an ISUP IAM is encapsulated in the initial INVITE request. Ensure that all the mandatory parameters in the IAM are present and the values are valid and the Transmission medium requirement parameter is consistent with the SDP.												
Configuration													
SIP Parameter	INVITE: Content-Type: multipart/mixed;boundary=[any boundary name] --[any boundary name] Content-Type: application/isup;version=itu-t92 Content-Disposition: signal;handling=required IAM Nature of connection indicators Forward call indicators Calling party's category Transmission medium requirement Called party number <i>Calling party number (optional)</i> <i>Optional forward call indicators (optional)</i> <i>Hop counter (optional)</i> <i>User service information (optional)</i> <i>Access transport (optional)</i> --[any boundary name]--												
Message flow	<table style="width: 100%; border: none;"> <tr> <td style="text-align: center; width: 33%;">SIP (Network A)</td> <td style="text-align: center; width: 34%;">Interconnection Interface</td> <td style="text-align: center; width: 33%;">SIP (Network B)</td> </tr> <tr> <td></td> <td style="text-align: center;">INVITE(IAM) →</td> <td></td> </tr> <tr> <td></td> <td style="text-align: center;">← 100 Trying</td> <td></td> </tr> <tr> <td></td> <td style="text-align: center;">Apply post test routine</td> <td></td> </tr> </table>	SIP (Network A)	Interconnection Interface	SIP (Network B)		INVITE(IAM) →			← 100 Trying			Apply post test routine	
SIP (Network A)	Interconnection Interface	SIP (Network B)											
	INVITE(IAM) →												
	← 100 Trying												
	Apply post test routine												
Comments	Establish a communication from Network A to Network B. Check: Is an ISUP IAM encapsulated in the INVITE request? Check: Are all the mandatory ISUP parameters present in the IAM and are the values valid? Check: Are the values of the optional parameters in the encapsulated IAM valid? Check: Is the 'm' line with corresponding attributes in the SDP consistent with the Transmission medium requirement parameter? Check: Is the Transmission medium requirement value consistent with the bandwidth information in the SDP? Repeat this test with all possible IAM USI and ATP combinations as indicated in table 7.1.4-1. Repeat this test in reverse direction.												

Table 7.1.4-1: IAM Parametrization

ITC_value	IAM USI	ATP
ITC_VA_1	Speech	HLC: telephony
ITC_VA_2	3,1 kHz audio	No HLC
ITC_VA_3	3,1 kHz audio	HLC: facsimile group 2/3
ITC_VA_4	3,1 kHz audio	LLC: 3,1 kHz audio, voice band data via modem, synchronous mode, user rate 2,4 kbit/s
ITC_VA_5	unrestricted digital information	HLC: facsimile group 4
ITC_VA_6	unrestricted digital information	HLC: facsimile group 4, LLC: telematic_term
ITC_VA_7	Speech	No HLC
ITC_VA_8	unrestricted digital information	No HLC

Test case number	SS_bcall_SIP-I_02																																										
Test case group	BCALL/successful																																										
Reference	Clause 7.2.1 / [11]																																										
SELECTION EXPRESSION	[Network A] SE 4 AND SE 17 AND [Network A] SE 47																																										
Test purpose	<p>SIP-I support, Basic call, overlap signalling. Ensure that when overlap signalling applies in the ISUP -SIP-I interworking in the originating network, several INVITE requests with the same Cal-ID and From tag are sent from Network A to Network B. Ensure that the original IAM is encapsulated in any INVITE request.</p>																																										
Configuration																																											
SIP Parameter																																											
Message flow																																											
SIP (Network A)	<table style="width: 100%; border-collapse: collapse;"> <thead> <tr> <th style="width: 30%;"></th> <th style="width: 40%; text-align: center;">Interconnection Interface</th> <th style="width: 30%;"></th> </tr> </thead> <tbody> <tr> <td></td> <td style="text-align: center;">INVITE(1)</td> <td style="text-align: right;">→</td> </tr> <tr> <td style="text-align: right;">←</td> <td style="text-align: center;">484 Address Incomplete(1)</td> <td></td> </tr> <tr> <td></td> <td style="text-align: center;">ACK</td> <td style="text-align: right;">→</td> </tr> <tr> <td></td> <td style="text-align: center;">INVITE(2)</td> <td style="text-align: right;">→</td> </tr> <tr> <td style="text-align: right;">←</td> <td style="text-align: center;">484 Address Incomplete(2)</td> <td></td> </tr> <tr> <td></td> <td style="text-align: center;">ACK</td> <td style="text-align: right;">→</td> </tr> <tr> <td></td> <td style="text-align: center;">INVITE(3)</td> <td style="text-align: right;">→</td> </tr> <tr> <td style="text-align: right;">←</td> <td style="text-align: center;">484 Address Incomplete(3)</td> <td></td> </tr> <tr> <td></td> <td style="text-align: center;">ACK</td> <td style="text-align: right;">→</td> </tr> <tr> <td></td> <td style="text-align: center;">.</td> <td></td> </tr> <tr> <td></td> <td style="text-align: center;">INVITE(4)</td> <td style="text-align: right;">→</td> </tr> <tr> <td style="text-align: right;">←</td> <td style="text-align: center;">180 Ringing(4)</td> <td></td> </tr> <tr> <td></td> <td style="text-align: center;">Apply post test routine</td> <td></td> </tr> </tbody> </table>		Interconnection Interface			INVITE(1)	→	←	484 Address Incomplete(1)			ACK	→		INVITE(2)	→	←	484 Address Incomplete(2)			ACK	→		INVITE(3)	→	←	484 Address Incomplete(3)			ACK	→		.			INVITE(4)	→	←	180 Ringing(4)			Apply post test routine	
	Interconnection Interface																																										
	INVITE(1)	→																																									
←	484 Address Incomplete(1)																																										
	ACK	→																																									
	INVITE(2)	→																																									
←	484 Address Incomplete(2)																																										
	ACK	→																																									
	INVITE(3)	→																																									
←	484 Address Incomplete(3)																																										
	ACK	→																																									
	.																																										
	INVITE(4)	→																																									
←	180 Ringing(4)																																										
	Apply post test routine																																										
Comments	<p>Establish a communication from Network A to Network B using the overlap procedure in Network A.</p> <p>Check: Are the INVITE requests sent with the same From tag and the Call-ID?</p> <p>Check: After the 180 applies, are all previous INVITE transactions are terminated with a 484 final response?</p> <p>Check: Is the encapsulated IAM present in the initial INVITE request also encapsulated in any following INVITE request required for the call setup?</p> <p>Repeat this test in reverse direction.</p>																																										

Test case number	SS_bcall_SIP-I_03	
Test case group	BCALL/successful	
Reference	Clause 6.5 / [11]	
SELECTION EXPRESSION	[Network B] SE 17 AND [Network B] SE 47	
Test purpose	<p>SIP-I support, Basic call, ACM present in the 180 response.</p> <p>Ensure that on receipt of a 180 Ringing provisional response and an SIP-I - ISUP interworking is applicable in the terminating network the Backward call indicators parameter in the encapsulated ACM is present and the values are valid.</p> <p>Ensure that the values of the optional parameters in the encapsulated ACM are valid.</p>	
Configuration		
SIP Parameter	<p>180:</p> <p>Content-Type: multipart/mixed;boundary=[any boundary name]</p> <p>--[any boundary name]</p> <p>Content-Type: application/isup;version=itu-t92</p> <p>Content-Disposition: signal;handling=required</p> <p>ACM</p> <p>Backward call indicators</p> <p>Called party's status indicator= subscriber free</p> <p>--[any boundary name]--</p>	
Message flow		
SIP (Network A)	<p>Interconnection Interface</p> <p>INVITE →</p> <p>← 100 Trying</p> <p>← 180 Ringing(ACM)</p> <p>Apply post test routine</p>	SIP (Network B)
Comments	<p>Establish a communication from Network A to Network B.</p> <p>Check: Is an ISUP ACM message encapsulated in the 180 Ringing provisional response?</p> <p>Check: Is the mandatory Backward call indicators parameter present in the encapsulated ISUP ACM and are the values valid?</p> <p>Check: Are the values of optional parameters in the encapsulated ISUP ACM valid?</p> <p>Check: If an SDP answer is present in the 180, are the codec and the bandwidth information in the 'a' attributes consistent with Transmission medium requirement in the encapsulated IAM of the INVITE request?</p> <p>Check: Can be a ringing tone heard from the terminating side?</p> <p>Check: Can the ringing tone be heard from the terminating side?</p> <p>Repeat this test in reverse direction.</p>	

Test case number	SS_bcall_SIP-I_04 (36)	
Test case group	BCALL/successful	
Reference	Clause 6.5 / [11]	
SELECTION EXPRESSION	[Network B] SE 17 AND [Network B] SE 47	
Test purpose	<p>SIP-I support. Basic call, early ACM present in the 183 response.</p> <p>Ensure that on receipt of a 183 Session Progress provisional response and an SIP-I - ISUP interworking is applicable in the terminating network the Backward call indicators parameter in the encapsulated ACM is present and the value of the Called party's status indicator is set to 'no indication'.</p> <p>Ensure that the values of the optional parameters in the encapsulated ACM are valid.</p>	
Configuration	Select a proper destination that sends an early ACM in the PSTN/PLMN e.g. announcement.	
SIP Parameter	<p>183:</p> <p>Content-Type: multipart/mixed;boundary=[any boundary name]</p> <p>--[any boundary name]</p> <p>Content-Type: application/isup;version=itu-t92</p> <p>Content-Disposition: signal;handling=required</p> <p>ACM</p> <p>Backward call indicators</p> <p>Called party's status indicator= no indication</p> <p>Optional backward call indicator</p> <p>Inband info or appropriate pattern is now available</p> <p>Access Transport (optional)</p> <p>Progress Indicator</p> <p>Progress description = Destination address is non ISDN</p> <p>Optional Backward call indicators</p> <p><i>In-band information or an appropriate pattern is now available</i></p> <p>(optional) Access transport = PI # 2 destination address is non-ISDN</p> <p>--[any boundary name]--</p>	
Message flow		
SIP (Network A)	<p>Interconnection Interface</p> <p>INVITE →</p> <p>← 100 Trying</p> <p>← 183 Session Progress(ACM)</p> <p>Apply post test routine</p>	SIP (Network B)
Comments	<p>Establish a communication from Network A to Network B.</p> <p>Check: Is an ISUP ACM message encapsulated in the 183 Session Progress provisional response?</p> <p>Check: Is the mandatory Backward call indicators parameter present in the encapsulated ISUP ACM and are the values valid?</p> <p>Check: Is the Called party's status indicator in the encapsulated ISUP ACM set to 'no indication'?</p> <p>Check: Are the values of optional parameters in the encapsulated ISUP ACM valid?</p> <p>Check: Can be an early media (e.g. announcement) heard from the terminating side?</p> <p>Repeat this test in reverse direction.</p>	

Test case number	SS_bcall_SIP-I_05
Test case group	BCALL/successful
Reference	Clause 6.6 / [11]
SELECTION EXPRESSION	[Network B] SE 17 AND [Network B] SE 47.
Test purpose	<p>SIP-I support. Basic call, CPG present in a 180 response. Ensure that on receipt of a 180 Ringing provisional response and an SIP-I - ISUP interworking is applicable in the terminating network the Event indicator in the encapsulated CPG is present and set to 'ALERTING'. Ensure that the values of the optional parameters in the encapsulated CPG are valid.</p>
Configuration	Select a proper destination that sends at first an early ACM and after then a CPG 'ALERTING' in the PSTN/PLMN (e.g. PBX).
SIP Parameter	<p>180: Content-Type: multipart/mixed;boundary=[any boundary name] --[any boundary name] Content-Type: application/isup;version=itu-t92 Content-Disposition: signal;handling=required</p> <p>CPG Event indicator = ALERTING Optional Access transport = PI # 2 termination address is non-ISDN</p> <p>--[any boundary name]--</p>
Message flow	
SIP (Network A)	Interconnection Interface INVITE → SIP (Network B) ← 100 Trying ← 183 Session Progress(ACM) ← 180 Ringing(CPG) Apply post test routine
Comments	<p>Establish a communication from Network A to Network B. Check: Is an ISUP CPG message encapsulated in the 180 Ringing provisional response? Check: Is the mandatory Event indicator present in the encapsulated ISUP CPG set to 'ALERTING'? Check: Are the values of optional parameters in the encapsulated ISUP CPG valid? Repeat this test in reverse direction.</p>

Test case number	SS_bcall_SIP-I_06	
Test case group	BCALL/successful	
Reference	Clause 6.7 / [11]	
SELECTION EXPRESSION	[Network B] SE 17 [Network B] AND SE 47	
Test purpose	<p>SIP-I support. Basic call, ANM present in a 200 OK INVITE response. Ensure that on receipt of a 200 OK INVITE final response and an SIP-I - ISUP interworking is applicable in the terminating network the ISUP ANM is encapsulated in the 200 OK. Ensure that the values of the optional parameters in the encapsulated ANM are valid.</p>	
Configuration		
SIP Parameter	<p>200 OK:</p> <p style="padding-left: 40px;">Content-Type: multipart/mixed;boundary=[any boundary name]</p> <p style="padding-left: 40px;">--[any boundary name]</p> <p style="padding-left: 40px;">Content-Type: application/isup;version=itu-t92</p> <p style="padding-left: 40px;">Content-Disposition: signal;handling=required</p> <p style="text-align: center;">ANM</p> <p style="padding-left: 40px;">--[any boundary name]--</p>	
Message flow		
SIP (Network A)	<p>Interconnection Interface</p> <p>INVITE →</p> <p>← 100 Trying</p> <p>← 180 Ringing(ACM)</p> <p>← 200 OK INVITE(ANM)</p> <p>ACK →</p> <p>Apply post test routine</p>	SIP (Network B)
Comments	<p>Establish a confirmed communication from Network A to Network B</p> <p>Check: Is an ISUP ANM encapsulated in the 200 OK INVITE?</p> <p>Check: Are the values of optional parameters in the encapsulated ISUP ANM valid?</p> <p>Check: Ensure the property of speech.</p> <p>Check: Are the codec and the bandwidth information in the 'a' attributes consistent with Transmission medium requirement in the encapsulated IAM of the INVITE request?</p> <p>Repeat this test in reverse direction.</p>	

Test case number	SS_bcall_SIP-I_07	
Test case group	BCALL/successful	
Reference	Clauses 5.4.3.4 and 6.11.2 / [11]	
SELECTION EXPRESSION	[Network A] SE 17 [Network A] AND SE 47	
Test purpose	<p>SIP-I support. Basic call, REL present in a BYE request sent from the originating network.</p> <p>Ensure that a ISUP REL message is encapsulated in a BYE request sent in the release procedure initiated from the originating user when ISUP - SIP-I interworking is applicable in the originating network.</p> <p>Ensure the validity of the cause indicator in the encapsulated REL.</p> <p>Ensure that the ISUP RLC is encapsulated in the 200 OK BYE.</p>	
Configuration		
SIP Parameter	<p>BYE:</p> <p>Content-Type: multipart/mixed;boundary=[any boundary name]</p> <p>--[any boundary name]</p> <p>Content-Type: application/isup;version=itu-t92</p> <p>Content-Disposition: signal;handling=required</p> <p>REL</p> <p>Cause value:</p> <p>--[any boundary name]--</p> <p>200 OK BYE</p> <p>Content-Type: multipart/mixed;boundary=[any boundary name]</p> <p>--[any boundary name]</p> <p>Content-Type: application/isup;version=itu-t92</p> <p>Content-Disposition: signal;handling=required</p> <p>RLC</p> <p>--[any boundary name]--</p>	
Message flow		
SIP (Network A)	Interconnection Interface	SIP (Network B)
	INVITE →	
	← 100 Trying	
	← 180 Ringing	
	← 200 OK INVITE	
	ACK →	
	Communication	
	BYE(REL) →	
	← 200 OK BYE(RLC)	
Comments	<p>Establish a confirmed communication from Network A to Network B</p> <p>The originating user terminates the communication.</p> <p>Check: Is the ISUP REL encapsulated in the BYE request?</p> <p>Check: Are the cause indicators in the encapsulated ISUP REL valid?</p> <p>Check: If a Reason header is present in the BYE request, is the 'cause' value of Reason header equal to the 'Cause value' in the encapsulated REL?</p> <p>Check: Is the ISUP RLC encapsulated in the 200 OK BYE?</p> <p>Repeat this test in reverse direction.</p>	

Test case number	SS_bcall_SIP-I_08	
Test case group	BCALL/successful	
Reference	Clauses 5.4.3.4 and 6.11.2 / [11]	
SELECTION EXPRESSION	[Network B] SE 17 [Network B] AND SE 47	
Test purpose	<p>SIP-I support. Basic call, REL present in a BYE request sent from the terminating network.</p> <p>Ensure that a ISUP REL message is encapsulated in a BYE request sent in the release procedure initiated from the terminating user when SIP-I - ISUP interworking is applicable in the terminating network.</p> <p>Ensure the validity of the cause indicator in the encapsulated REL.</p> <p>Ensure that the ISUP RLC is encapsulated in the 200 OK BYE.</p>	
Configuration		
SIP Parameter	<p>BYE:</p> <p>Content-Type: multipart/mixed;boundary=[any boundary name]</p> <p>--[any boundary name]</p> <p>Content-Type: application/isup;version=itu-t92</p> <p>Content-Disposition: signal;handling=required</p> <p>REL</p> <p>Cause value:</p> <p>--[any boundary name]--</p> <p>200 OK BYE</p> <p>Content-Type: multipart/mixed;boundary=[any boundary name]</p> <p>--[any boundary name]</p> <p>Content-Type: application/isup;version=itu-t92</p> <p>Content-Disposition: signal;handling=required</p> <p>RLC</p> <p>--[any boundary name]--</p>	
Message flow		
SIP (Network A)	Interconnection Interface	SIP (Network B)
	INVITE →	
	← 100 Trying	
	← 180 Ringing	
	← 200 OK INVITE	
	ACK →	
	Communication	
	← BYE(REL)	
	200 OK BYE(RLC) →	
Comments	<p>Establish a confirmed communication from Network A to Network B.</p> <p>The terminating user terminates the communication.</p> <p>Check: Is the ISUP REL encapsulated in the BYE request?</p> <p>Check: Are the cause indicators in the encapsulated ISUP REL valid?</p> <p>Check: If a Reason header is present in the BYE request, is the 'cause' value of Reason header equal to the 'Cause value' in the encapsulated REL?</p> <p>Check: Is the ISUP RLC encapsulated in the 200 OK BYE?</p> <p>Repeat this test in reverse direction.</p>	

7.1.5 Codec negotiation

Test case number	SS_codec_001																
Test case group	BCALL/Codec_Negotiation																
Reference	[3], [4] and [5]																
SELECTION EXPRESSION																	
Test purpose	<p>Session update requested by the calling user. During the session, the calling user decides to change the characteristics of the media session. This is accomplished by sending a re-INVITE or UPDATE containing a new media description. This re-INVITE or UPDATE references the existing dialogue so that the other party knows that it has to modify an existing session instead of establishing a new session. The other party sends a 200 (OK) to accept the change. The requestor responds to the 200 (OK) with an ACK. In case when the parameter in the SDP rtpmap:<dynamic-PT> is used the codecs in table 7.1.5-1 applies.</p>																
Configuration																	
SIP Parameter	SDP1: codec x chosen from table 7.1.5-1 SDP3: codec y chosen from table 7.1.5-1																
Message flow	<table border="0" style="width: 100%; border-collapse: collapse;"> <thead> <tr> <th style="text-align: left; width: 30%;">SIP (Network A)</th> <th style="text-align: center; width: 40%;">Interconnection Interface</th> <th style="text-align: right; width: 30%;">SIP (Network B)</th> </tr> </thead> <tbody> <tr> <td></td> <td colspan="2" style="text-align: center;">A confirmed session already exists (SDP 1)</td> </tr> <tr> <td>CASE A</td> <td style="text-align: center;"> ← INVITE(SDP3) 200 OK INVITE(SDP4) ACK </td> <td style="text-align: center;"> → → </td> </tr> <tr> <td>CASE B</td> <td style="text-align: center;"> ← UPDATE(SDP3) 200 OK UPDATE(SDP4) </td> <td style="text-align: center;"> → [5] </td> </tr> <tr> <td></td> <td colspan="2" style="text-align: center;">Apply post test routine</td> </tr> </tbody> </table>		SIP (Network A)	Interconnection Interface	SIP (Network B)		A confirmed session already exists (SDP 1)		CASE A	← INVITE(SDP3) 200 OK INVITE(SDP4) ACK	→ →	CASE B	← UPDATE(SDP3) 200 OK UPDATE(SDP4)	→ [5]		Apply post test routine	
SIP (Network A)	Interconnection Interface	SIP (Network B)															
	A confirmed session already exists (SDP 1)																
CASE A	← INVITE(SDP3) 200 OK INVITE(SDP4) ACK	→ →															
CASE B	← UPDATE(SDP3) 200 OK UPDATE(SDP4)	→ [5]															
	Apply post test routine																
Comments	Establish a communication from Network A to Network B using SDP1 chosen from the table 7.1.5-1. Check: The calling user changes the media description using INVITE request containing SDP 3 codec chosen from table 7.1.5-1 different to SDP1. Check: Is the codec list consistent with the attribute(s) (bandwidth) regarding the media description? Repeat this test in reverse direction.																

Test case number	SS_codec_002																												
Test case group	BCALL/Codec_Negotiation																												
Reference	[3], [4] and [5]																												
SELECTION EXPRESSION																													
Test purpose	<p>Session update requested by the called user. During the session, the called user decides to change the characteristics of the media session. This is accomplished by sending a re-INVITE containing a new media description. This re- INVITE references the existing dialogue so that the other party knows that it has to modify an existing session instead of establishing a new session. The other party sends a 200 (OK) to accept the change. The requestor responds to the 200 (OK) with an ACK. In case when the parameter in the SDP rtpmap:<dynamic-PT> is used the codecs in table 7.1.2-1 applies.</p>																												
Configuration																													
SIP Parameter	SDP1: codec x chosen from table 7.1.2-1 SDP2: codec y chosen from table 7.1.2-1																												
Message flow	<table border="0" style="width: 100%; text-align: center;"> <thead> <tr> <th style="width: 30%;">SIP (Network A)</th> <th style="width: 40%;">Interconnection Interface</th> <th style="width: 30%;">SIP (Network B)</th> </tr> </thead> <tbody> <tr> <td colspan="3">A confirmed session already exists (SDP 1)</td> </tr> <tr> <td></td> <td>INVITE(SDP3) →</td> <td></td> </tr> <tr> <td>←</td> <td>200 OK INVITE(SDP4)</td> <td></td> </tr> <tr> <td></td> <td>ACK →</td> <td></td> </tr> <tr> <td colspan="3">CASE B</td> </tr> <tr> <td></td> <td>UPDATE(SDP3) →</td> <td></td> </tr> <tr> <td>←</td> <td>200 OK UPDATE(SDP4)</td> <td></td> </tr> <tr> <td></td> <td>Apply post test routine</td> <td></td> </tr> </tbody> </table>		SIP (Network A)	Interconnection Interface	SIP (Network B)	A confirmed session already exists (SDP 1)				INVITE(SDP3) →		←	200 OK INVITE(SDP4)			ACK →		CASE B				UPDATE(SDP3) →		←	200 OK UPDATE(SDP4)			Apply post test routine	
SIP (Network A)	Interconnection Interface	SIP (Network B)																											
A confirmed session already exists (SDP 1)																													
	INVITE(SDP3) →																												
←	200 OK INVITE(SDP4)																												
	ACK →																												
CASE B																													
	UPDATE(SDP3) →																												
←	200 OK UPDATE(SDP4)																												
	Apply post test routine																												
Comments	Establish a connection from SIP UE 1 to SIP UE 2 using SDP1 chosen from the table 7.1.2-1. Check: The called user changes the media description using INVITE request containing SDP 2 codec chosen from table 7.1.2-1 different to SDP1. Check: Is the codec list consistent with the attribute(s) (bandwidth) regarding the media description? Repeat this test in reverse direction.																												

Test case number	SS_codec_003																			
Test case group	BCALL/Codec_Negotiation																			
Reference	[3], [4] and [5]																			
SELECTION EXPRESSION																				
Test purpose	<p>The SDP answer is contained in a 200 OK final response. Ensure that the call establishment performed correctly.</p> <ul style="list-style-type: none"> The initial INVITE contains an SDP with the offer 1. Ensure that answer related to the SDP offer is contained in the 200 OK INVITE message. <p>The test call is successful in the case if the Call setup time does not exceed the values listed in table 7.1.1-1 and call is stable in unanswered and answered phases, the call remains in intelligible/high quality conversation phase for 80 seconds. The Voice Quality test procedures are described clause 8.2.</p>																			
Configuration																				
SIP Parameter	INVITE: SDP offer 200: SDP answer																			
Message flow	<table border="0" style="width: 100%; text-align: center;"> <thead> <tr> <th style="width: 30%;">SIP (Network A)</th> <th style="width: 40%;">Interconnection Interface</th> <th style="width: 30%;">SIP (Network B)</th> </tr> </thead> <tbody> <tr> <td></td> <td>INVITE(SDP1) →</td> <td></td> </tr> <tr> <td>←</td> <td>180 Ringing</td> <td></td> </tr> <tr> <td>←</td> <td>200 OK INVITE(SDP2)</td> <td></td> </tr> <tr> <td></td> <td>ACK →</td> <td></td> </tr> <tr> <td></td> <td>Apply post test routine</td> <td></td> </tr> </tbody> </table>		SIP (Network A)	Interconnection Interface	SIP (Network B)		INVITE(SDP1) →		←	180 Ringing		←	200 OK INVITE(SDP2)			ACK →			Apply post test routine	
SIP (Network A)	Interconnection Interface	SIP (Network B)																		
	INVITE(SDP1) →																			
←	180 Ringing																			
←	200 OK INVITE(SDP2)																			
	ACK →																			
	Apply post test routine																			
Comments	Establish a communication from Network A to Network B. Check: Is the SDP offer contained in the initial INVITE request? Check: Is the SDP answer contained in the 200 OK INVITE final response? NOTE: An SDP answer could be present in a provisional response. Repeat this test in reverse direction.																			

Table 7.1.5-1

VARIABLE	PT	Encoding	Media type	Clock rate	Channels	Supported in network A	Supported in network B
VA_01	0	PCMU	A	8 000	1		
VA_02	3	GSM	A	8 000	1		
VA_03	4	G723	A	8 000	1		
VA_04	5	DVI4	A	8 000	1		
VA_05	6	DVI4	A	16 000	1		
VA_06	7	LPC	A	8 000	1		
VA_07	8	PCMA	A	8 000	1		
VA_08	9	G722	A	8 000	1		
VA_09	10	L16	A	44 100	2		
VA_10	11	L16	A	44 100	1		
VA_13	12	QCELP	A	8 000	1		
VA_12	13	CN	A	8 000	1		
VA_13	14	MPA	A	90 000			
VA_14	15	G728	A	18 000	1		
VA_15	16	DVI4	A	11 025	1		
VA_16	17	DVI4	A	22 050	1		
VA_17	18	G729	A	8 000	1		
VA_18	Dyn	G726-40	A	8 000	1		
VA_19	Dyn	G726-32	A	8 000	1		
VA_20	Dyn	G726-24	A	8 000	1		
VA_21	Dyn	G726-16	A	8 000	1		
VA_22	Dyn	G729D	A	8 000	1		
VA_23	Dyn	G729E	A	8 000	1		
VA_24	Dyn	GSM-EFR	A	8 000	1		
VA_25	25	CelB	V	90 000			
VA_26	26	JPEG	V	90 000			
VA_27	28	Nv	V	90 000			
VA_28	31	H261	V	90 000			
VA_29	32	MPV	V	90 000			
VA_30	33	MP2T	V	90 000			
VA_31	34	H263	V	90 000			
VA_32	Dyn	H263-1998	V	90 000			
VA_33	Dyn	AMR	A	8 000	1		
VA_34	Dyn	AMR-WB	A	16 000	1		
VA_35	Dyn	telephone-event	A	8 000	1		

Test case number	SS_codec_004
Test case group	BCALL/Codec_Negotiation
Reference	[3], [4] and [5]
SELECTION EXPRESSION	
Test purpose	<p>The SDP answer is contained in a 200 OK final response.</p> <p>Ensure that the call establishment to a 4 G subscriber roaming in a 3G network is performed correctly. The used codecs are listed in ETSI TS 126 103 [30]. Examples of Codecs which should be tested in the case of interworking/roaming are contained in table A.1 and table A.2.</p> <p>The test call is successful in the case if the call remains in intelligible/high quality conversation phase for 80 seconds. The Voice Quality test procedures are described clause 8.2.</p>
Configuration	
SIP Parameter	INVITE: SDP offer 200: SDP answer
Message flow	<div style="display: flex; justify-content: space-between; align-items: center;"> <div style="text-align: center;"> <p>SIP (Network A)</p> </div> <div style="text-align: center;"> <p>Interconnection Interface</p> </div> <div style="text-align: center;"> <p>SIP (Network B)</p> </div> </div> <div style="text-align: center; margin-top: 10px;"> <p>← INVITE(SDP1) →</p> <p>← 180 Ringing →</p> <p>← 200 OK INVITE(SDP2) →</p> <p>ACK →</p> <p>Apply post test routine</p> </div>
Comments	

Test case number	SS_codec_005
Test case group	BCALL/Codec_Negotiation
Reference	[3], [4] and [5]
SELECTION EXPRESSION	
Test purpose	<p>The SDP answer is contained in a 200 OK final response.</p> <p>Ensure that the call establishment in when user A and user B are subscribed to the same VoLTE Network N1 and user A and B are roaming in a 3G/2G Network N2. The used codecs are listed in ETSI TS 126 103 [30]. Examples of Codecs which should be tested in the case of interworking/roaming are contained in table A.3.</p> <p>The test call is successful in the case if the call remains in intelligible/high quality conversation phase for 80 seconds. The Voice Quality test procedures are described clause 8.2.</p>
Configuration	
SIP Parameter	INVITE: SDP offer 200: SDP answer
Message flow	<div style="display: flex; justify-content: space-between; align-items: center;"> <div style="text-align: center;"> <p>SIP (Network A)</p> </div> <div style="text-align: center;"> <p>Interconnection Interface</p> </div> <div style="text-align: center;"> <p>SIP (Network B)</p> </div> </div> <div style="display: flex; justify-content: center; align-items: center; margin-top: 10px;"> <div style="text-align: center; margin-right: 10px;">←</div> <div style="text-align: center; margin-right: 10px;">←</div> <div style="text-align: center; margin-right: 10px;">→</div> <div style="text-align: center; margin-right: 10px;">→</div> </div> <div style="display: flex; justify-content: center; align-items: center; margin-top: 5px;"> <div style="text-align: center; margin-right: 10px;">←</div> <div style="text-align: center; margin-right: 10px;">←</div> <div style="text-align: center; margin-right: 10px;">→</div> <div style="text-align: center; margin-right: 10px;">→</div> </div> <div style="display: flex; justify-content: center; align-items: center; margin-top: 5px;"> <div style="text-align: center; margin-right: 10px;">←</div> <div style="text-align: center; margin-right: 10px;">←</div> <div style="text-align: center; margin-right: 10px;">→</div> <div style="text-align: center; margin-right: 10px;">→</div> </div> <div style="text-align: center; margin-top: 5px;"> <p>180 Ringing</p> <p>200 OK INVITE(SDP2)</p> <p>ACK</p> </div> <div style="text-align: center; margin-top: 5px;"> <p>INVITE(SDP1)</p> </div>
Comments	Apply post test routine

7.1.6 Resource Reservation

Test case number	SS_resource_001																											
Test case group	BCALL/Resource_Reservation																											
Reference	[3], [4], [5] and [6]																											
SELECTION EXPRESSION	(([Network A] SE 7 AND [Network B] SE 7) AND ([User A] SE 42 AND [User B] SE 42).																											
Test purpose	<p>Resource reservation successful, segmented status.</p> <p>Ensure that the network is able to reserve resources for quality of service when requested from the initiating user.</p> <ul style="list-style-type: none"> • In the INVITE the UE requests to establish QoS preconditions for all the media streams. • In the 183 Session Progress the UAS supports the QoS preconditions and requests that UAC sends a confirmation when the QoS preconditions are met. • The UPDATE includes in the SDP the information about the successful QoS bidirectional mode, due to the successful bidirectional PDP context established. • 200 OK UPDATE the SDP contains an indication that the UE successfully reserved the QoS in the send and receive directions. 																											
Configuration																												
SIP Parameter	<p>INVITE: Supported: 100rel precondition SDP1: m=audio <Port number> RTP/AVP <codec> a=curr:qos local none a=curr:qos remote none a=des:qos mandatory/optional local sendrecv a=des:qos none remote sendrecv</p> <p>183 Session Progress: Supported/Require: 100rel precondition SDP2: m=audio <Port number> RTP/AVP <codec> a=curr:qos local none a=curr:qos remote none a=des:qos mandatory/optional local sendrecv a=des:qos mandatory/optional remote sendrecv</p> <p>UPDATE SDP3: m=audio <Port number> RTP/AVP <codec> a=curr:qos local sendrecv a=curr:qos remote none a=des:qos mandatory/optional local sendrecv a=des:qos mandatory/optional remote sendrecv</p> <p>200 OK UPDATE SDP4: a=curr:qos local sendrecv a=curr:qos remote sendrecv a=des:qos mandatory/optional local sendrecv a=des:qos mandatory/optional remote sendrecv</p>																											
Message flow	<table style="width: 100%; border-collapse: collapse;"> <thead> <tr> <th style="text-align: left; width: 30%;">SIP (Network A)</th> <th style="text-align: center; width: 40%;">Interconnection Interface</th> <th style="text-align: right; width: 30%;">SIP (Network B)</th> </tr> </thead> <tbody> <tr> <td></td> <td style="text-align: center;">INVITE(SDP1) →</td> <td></td> </tr> <tr> <td style="text-align: center;">←</td> <td style="text-align: center;">183 Session Progress(SDP2)</td> <td style="text-align: center;">→</td> </tr> <tr> <td></td> <td style="text-align: center;">PRACK →</td> <td></td> </tr> <tr> <td style="text-align: center;">←</td> <td style="text-align: center;">200 OK PRACK</td> <td></td> </tr> <tr> <td></td> <td style="text-align: center;">Resource reservation</td> <td></td> </tr> <tr> <td></td> <td style="text-align: center;">UPDATE(SDP3) →</td> <td></td> </tr> <tr> <td style="text-align: center;">←</td> <td style="text-align: center;">200 OK UPDATE(SDP4)</td> <td></td> </tr> <tr> <td></td> <td style="text-align: center;">Apply post test routine</td> <td></td> </tr> </tbody> </table>	SIP (Network A)	Interconnection Interface	SIP (Network B)		INVITE(SDP1) →		←	183 Session Progress(SDP2)	→		PRACK →		←	200 OK PRACK			Resource reservation			UPDATE(SDP3) →		←	200 OK UPDATE(SDP4)			Apply post test routine	
SIP (Network A)	Interconnection Interface	SIP (Network B)																										
	INVITE(SDP1) →																											
←	183 Session Progress(SDP2)	→																										
	PRACK →																											
←	200 OK PRACK																											
	Resource reservation																											
	UPDATE(SDP3) →																											
←	200 OK UPDATE(SDP4)																											
	Apply post test routine																											

Comments	<p>Establish a communication from Network A to Network B.</p> <p>Check: Is the quality of service for the current state local and remote set to 'none' indicated in the SDP in the INVITE?</p> <p>Check: Is the quality of service for the desired state local and remote set to 'mandatory' and 'sendrecv' in the 183?</p> <p>Check: Is the quality of service for the current state local set to 'sendrecv' indicated in the SDP in the UPDATE?</p> <p>Check: Is the quality of service for the current state local and remote set to 'sendrecv' indicated in the SDP in the 200 OK UPDATE?</p> <p>Check: Is the codec in the codec list consistent with the attribute(s) (bandwidth) regarding the media description? At least a G.711 codec is required.</p> <p>Repeat this test in reverse direction.</p> <p>NOTE: This test case is applicable with an VoLTE originator and termination.</p>
-----------------	--

Test case number	SS_resource_002																		
Test case group	BCALL/Resource_Reservation																		
Reference	[3], [4], [5] and [6]																		
SELECTION EXPRESSION	(Network A] SE 7 AND ([User A] SE 42 AND NOT [User B] SE 42)																		
Test purpose	<p>Resource reservation not supported.</p> <p>Ensure that the network is able to reserve resources for quality of service when requested from the initiating user. The terminating user does not support the precondition procedure.</p> <ul style="list-style-type: none"> • In the INVITE the UE requests to establish QoS preconditions for all the media streams. • In the 183 Session Progress: no support by the terminating UA is indicated. <p>Or</p> <p>In the 180 Ringing: no support by the terminating UA is indicated.</p> <p>Or</p> <p>In the 200 OK INVITE: no support by the terminating UA is indicated.</p>																		
Configuration																			
SIP Parameter	<p>INVITE: Supported: 100rel precondition SDP1: m=audio <Port number> RTP/AVP <codec> a=curr:qos local none a=curr:qos remote none a=des:qos mandatory/optional local sendrecv a=des:qos none remote sendrecv</p> <p>183 Session Progress: SDP2: m=audio <Port number> RTP/AVP <codec> Or</p> <p>180 Ringing: SDP2: m=audio <Port number> RTP/AVP <codec> Or</p> <p>200 OK: SDP2: m=audio <Port number> RTP/AVP <codec></p>																		
Message flow	<table style="width: 100%; border-collapse: collapse;"> <thead> <tr> <th style="width: 30%; text-align: left;">SIP (Network A)</th> <th style="width: 40%; text-align: center;">Interconnection Interface</th> <th style="width: 30%; text-align: right;">SIP (Network B)</th> </tr> </thead> <tbody> <tr> <td></td> <td style="text-align: center;">INVITE(SDP1)</td> <td style="text-align: right;">→</td> </tr> <tr> <td>CASE A</td> <td style="text-align: center;">← 183 Session Progress(SDP2)</td> <td></td> </tr> <tr> <td>CASE B</td> <td style="text-align: center;">← 180 Ringing(SDP2)</td> <td></td> </tr> <tr> <td>CASE C</td> <td style="text-align: center;">← 180 Ringing ← 200 OK INVITE(SDP2) ACK</td> <td style="text-align: right;">→</td> </tr> <tr> <td></td> <td style="text-align: center;">Apply post test routine</td> <td></td> </tr> </tbody> </table>	SIP (Network A)	Interconnection Interface	SIP (Network B)		INVITE(SDP1)	→	CASE A	← 183 Session Progress(SDP2)		CASE B	← 180 Ringing(SDP2)		CASE C	← 180 Ringing ← 200 OK INVITE(SDP2) ACK	→		Apply post test routine	
SIP (Network A)	Interconnection Interface	SIP (Network B)																	
	INVITE(SDP1)	→																	
CASE A	← 183 Session Progress(SDP2)																		
CASE B	← 180 Ringing(SDP2)																		
CASE C	← 180 Ringing ← 200 OK INVITE(SDP2) ACK	→																	
	Apply post test routine																		
Comments																			

7.1.7 Test purposes for SIP-SIP, Basic call, Unsuccessful

7.1.7.1 NNI

Test case number	SS_unsucc_NNI__001
Test case group	BCALL/unsuccessful
Reference	[4]
SELECTION EXPRESSION	
Test purpose	Called number is not allocated in the assumed network. Ensure that, when calling to unallocated number, the network initiate call clearing to the calling user with a 404 Not Found message.
Configuration	
SIP Parameter	
Message flow	
SIP (Network A)	Interconnection Interface INVITE → ← 404 Not Found ACK →
SIP (Network B)	
Comments	Establish a communication from Network A to Network B, called user number is not allocated in Network B. Check: Is a 404 Not Found sent from Network B to Network A? Repeat this test in reverse direction. Repeat this test with all chosen end devices.

Test case number	SS_unsucc_NNI__002
Test case group	BCALL/unsuccessful
Reference	[4]
SELECTION EXPRESSION	
Test purpose	The network B is unable to process the request. Ensure that the call will be released if the Service is unavailable. The network initiates call clearing to the calling user with a 503 Service unavailable message.
Configuration	
SIP Parameter	
Message flow	
SIP (Network A)	Interconnection Interface INVITE → ← 503 Service unavailable ACK →
SIP (Network B)	
Comments	Establish a communication from Network A to Network B, Network B is unable to process the request. Check: Is a 503 Service unavailable sent from Network B to Network A? Repeat this test in reverse direction. Repeat this test with all chosen end devices.

Test case number	SS_unsucc_NNI__003
Test case group	BCALL/unsuccessful
Reference	[4]
SELECTION EXPRESSION	
Test purpose	The called user is network determined busy. Ensure that, when the called user is busy, the network initiates call clearing to the calling user with a 486 Busy Here message.
Configuration	
SIP Parameter	
Message flow	
SIP (Network A)	Interconnection Interface INVITE → ← 486 Busy Here ACK →
SIP (Network B)	
Comments	Establish a communication from Network A to Network B, user B is network determined user busy. Check: Is a 486 Busy Here sent from Network B to Network A? Repeat this test in reverse direction.

Test case number	SS_unsucc_NNI_004												
Test case group	BCALL/unsuccessful												
Reference	[4]												
SELECTION EXPRESSION													
Test purpose	The called user is user determined busy. Ensure that, when the called user is busy, the user initiates call clearing to the calling user with a 486 Busy Here message.												
Configuration													
SIP Parameter													
Message flow	<table style="width: 100%; border: none;"> <tr> <td style="text-align: left; width: 30%;">SIP (Network A)</td> <td style="text-align: center; width: 40%;">Interconnection Interface</td> <td style="text-align: right; width: 30%;">SIP (Network B)</td> </tr> <tr> <td></td> <td style="text-align: center;">INVITE →</td> <td></td> </tr> <tr> <td></td> <td style="text-align: center;">← 486 Busy Here</td> <td></td> </tr> <tr> <td></td> <td style="text-align: center;">ACK →</td> <td></td> </tr> </table>	SIP (Network A)	Interconnection Interface	SIP (Network B)		INVITE →			← 486 Busy Here			ACK →	
SIP (Network A)	Interconnection Interface	SIP (Network B)											
	INVITE →												
	← 486 Busy Here												
	ACK →												
Comments	Establish a communication from Network A to Network B, user B is user determined user busy. Check: Is a 486 Busy Here sent from Network B to Network A? Repeat this test in reverse direction.												

Test case number	SS_unsucc_NNI_005												
Test case group	BCALL/unsuccessful												
Reference	[4]												
SELECTION EXPRESSION													
Test purpose	The called user is not available on the called number. Ensure that when the number is changed, the network initiate call clearing to the calling user with a 410 Gone message.												
Configuration													
SIP Parameter													
Message flow	<table style="width: 100%; border: none;"> <tr> <td style="text-align: left; width: 30%;">SIP (Network A)</td> <td style="text-align: center; width: 40%;">Interconnection Interface</td> <td style="text-align: right; width: 30%;">SIP (Network B)</td> </tr> <tr> <td></td> <td style="text-align: center;">INVITE →</td> <td></td> </tr> <tr> <td></td> <td style="text-align: center;">← 410 Gone</td> <td></td> </tr> <tr> <td></td> <td style="text-align: center;">ACK →</td> <td></td> </tr> </table>	SIP (Network A)	Interconnection Interface	SIP (Network B)		INVITE →			← 410 Gone			ACK →	
SIP (Network A)	Interconnection Interface	SIP (Network B)											
	INVITE →												
	← 410 Gone												
	ACK →												
Comments	Establish a communication from Network A to Network B, user B is not allocated in Network B. Check: Is a 410 Gone sent from Network B to Network A? Repeat this test in reverse direction.												

Test case number	SS_unsucc_NNI_006												
Test case group	BCALL/unsuccessful												
Reference	[4]												
SELECTION EXPRESSION													
Test purpose	The number of the called user is incomplete. Ensure that the call will be released when the called number is incomplete. The network initiates call clearing to the calling user with 484 Not Found message.												
Configuration													
SIP Parameter													
Message flow	<table style="width: 100%; border: none;"> <tr> <td style="text-align: left; width: 30%;">SIP (Network A)</td> <td style="text-align: center; width: 40%;">Interconnection Interface</td> <td style="text-align: right; width: 30%;">SIP (Network B)</td> </tr> <tr> <td></td> <td style="text-align: center;">INVITE →</td> <td></td> </tr> <tr> <td></td> <td style="text-align: center;">← 484 Address Incomplete</td> <td></td> </tr> <tr> <td></td> <td style="text-align: center;">ACK →</td> <td></td> </tr> </table>	SIP (Network A)	Interconnection Interface	SIP (Network B)		INVITE →			← 484 Address Incomplete			ACK →	
SIP (Network A)	Interconnection Interface	SIP (Network B)											
	INVITE →												
	← 484 Address Incomplete												
	ACK →												
Comments	Establish a communication from Network A to Network B, the called number is incomplete. Check: Is a 484 Address Incomplete sent from Network B to Network A? Repeat this test in reverse direction.												

Test case number	SS_unsucc_NNI__007																														
Test case group	BCALL/unsuccessful																														
Reference	[3], [4] and [5]																														
SELECTION EXPRESSION																															
Test purpose	<p>Session update requested by the calling user is unsuccessful, existing session remains unchanged.</p> <p>During the session, the calling user decides to change the characteristics of the media session. This is accomplished by sending a re-INVITE containing a new media description. This re-INVITE references the existing dialogue so that the other party knows that it has to modify an existing session instead of establishing a new session. Ensure that if the other party does not accept the change, it sends an error response such as 488 Not Acceptable Here, which also receives an ACK. The session remains unchanged.</p>																														
Configuration																															
SIP Parameter	INVITE : codec not supported in Network B.																														
Message flow	<table border="0" style="width: 100%; border-collapse: collapse;"> <thead> <tr> <th style="text-align: left; width: 30%;">SIP (Network A)</th> <th style="text-align: center; width: 40%;">Interconnection Interface</th> <th style="text-align: right; width: 30%;">SIP (Network B)</th> </tr> </thead> <tbody> <tr> <td></td> <td style="text-align: center;">INVITE</td> <td style="text-align: right;">→</td> </tr> <tr> <td style="text-align: left;">←</td> <td style="text-align: center;">180 Ringing</td> <td></td> </tr> <tr> <td style="text-align: left;">←</td> <td style="text-align: center;">200 OK INVITE</td> <td></td> </tr> <tr> <td></td> <td style="text-align: center;">ACK</td> <td style="text-align: right;">→</td> </tr> <tr> <td></td> <td style="text-align: center;">Communication</td> <td></td> </tr> <tr> <td></td> <td style="text-align: center;">INVITE</td> <td style="text-align: right;">→</td> </tr> <tr> <td style="text-align: left;">←</td> <td style="text-align: center;">488 Not Acceptable Here</td> <td></td> </tr> <tr> <td></td> <td style="text-align: center;">ACK</td> <td style="text-align: right;">→</td> </tr> <tr> <td></td> <td style="text-align: center;">Apply post test routine</td> <td></td> </tr> </tbody> </table>	SIP (Network A)	Interconnection Interface	SIP (Network B)		INVITE	→	←	180 Ringing		←	200 OK INVITE			ACK	→		Communication			INVITE	→	←	488 Not Acceptable Here			ACK	→		Apply post test routine	
SIP (Network A)	Interconnection Interface	SIP (Network B)																													
	INVITE	→																													
←	180 Ringing																														
←	200 OK INVITE																														
	ACK	→																													
	Communication																														
	INVITE	→																													
←	488 Not Acceptable Here																														
	ACK	→																													
	Apply post test routine																														
Comments	<p>Establish a communication from Network A to Network B. User A in Network A attempts to change the session by sending a SDP offer to the UE in Network B. Network B does not support the codec sent in the offer. Check: Is a 488 Not Acceptable Here sent from Network B to Network A? Repeat this test in reverse direction.</p>																														

Test case number	SS_unsucc_NNI__008																														
Test case group	BCALL/unsuccessful																														
Reference	[3], [4] and [5]																														
SELECTION EXPRESSION																															
Test purpose	<p>Session update requested by the called user is unsuccessful, existing session remains unchanged.</p> <p>During the session, the called user decides to change the characteristics of the media session. This is accomplished by sending a re-INVITE containing a new media description. This re-INVITE references the existing dialogue so that the other party knows that it has to modify an existing session instead of establishing a new session. Ensure that if the other party does not accept the change, it sends an error response such as 488 Not Acceptable Here, which also receives an ACK. The session remains unchanged.</p> <p>The 488 Not Acceptable Here may be sent by a simulation equipment.</p>																														
Configuration																															
SIP Parameter	INVITE : codec not supported in Network A.																														
Message flow	<table border="0" style="width: 100%; border-collapse: collapse;"> <thead> <tr> <th style="text-align: left; width: 30%;">SIP (Network A)</th> <th style="text-align: center; width: 40%;">Interconnection Interface</th> <th style="text-align: right; width: 30%;">SIP (Network B)</th> </tr> </thead> <tbody> <tr> <td></td> <td style="text-align: center;">INVITE</td> <td style="text-align: right;">→</td> </tr> <tr> <td style="text-align: left;">←</td> <td style="text-align: center;">180 Ringing</td> <td></td> </tr> <tr> <td style="text-align: left;">←</td> <td style="text-align: center;">200 OK INVITE</td> <td></td> </tr> <tr> <td></td> <td style="text-align: center;">ACK</td> <td style="text-align: right;">→</td> </tr> <tr> <td></td> <td style="text-align: center;">Communication</td> <td></td> </tr> <tr> <td style="text-align: left;">←</td> <td style="text-align: center;">INVITE</td> <td></td> </tr> <tr> <td></td> <td style="text-align: center;">488 Not Acceptable Here</td> <td style="text-align: right;">→</td> </tr> <tr> <td style="text-align: left;">←</td> <td style="text-align: center;">ACK</td> <td></td> </tr> <tr> <td></td> <td style="text-align: center;">Apply post test routine</td> <td></td> </tr> </tbody> </table>	SIP (Network A)	Interconnection Interface	SIP (Network B)		INVITE	→	←	180 Ringing		←	200 OK INVITE			ACK	→		Communication		←	INVITE			488 Not Acceptable Here	→	←	ACK			Apply post test routine	
SIP (Network A)	Interconnection Interface	SIP (Network B)																													
	INVITE	→																													
←	180 Ringing																														
←	200 OK INVITE																														
	ACK	→																													
	Communication																														
←	INVITE																														
	488 Not Acceptable Here	→																													
←	ACK																														
	Apply post test routine																														
Comments	<p>Establish a communication from Network A to Network B.</p> <p>User B in Network B attempts to change the session by sending a SDP offer to the UE in Network A</p> <p>Network A does not support the codec sent in the offer.</p> <p>Check: Is a 488 Not Acceptable Here sent from Network B to Network A?</p> <p>Repeat this test in reverse direction.</p>																														

Test case number	SS_unsucc_NNI__009																					
Test case group	BCALL/unsuccessful																					
Reference	[4]																					
SELECTION EXPRESSION																						
Test purpose	<p>Call clearing due to no answer from the called user initiated by the calling user.</p> <p>Ensure that when there is no answer from the called user, the calling user initiates call clearing to the called user with CANCEL or BYE.</p>																					
Configuration																						
SIP Parameter																						
Message flow	<table border="0" style="width: 100%; border-collapse: collapse;"> <thead> <tr> <th style="text-align: left; width: 30%;">SIP (Network A)</th> <th style="text-align: center; width: 40%;">Interconnection Interface</th> <th style="text-align: right; width: 30%;">SIP (Network B)</th> </tr> </thead> <tbody> <tr> <td></td> <td style="text-align: center;">INVITE</td> <td style="text-align: right;">→</td> </tr> <tr> <td style="text-align: left;">←</td> <td style="text-align: center;">180 Ringing</td> <td></td> </tr> <tr> <td></td> <td style="text-align: center;">CANCEL/BYE</td> <td style="text-align: right;">→</td> </tr> <tr> <td style="text-align: left;">←</td> <td style="text-align: center;">200 OK CANCEL/BYE</td> <td></td> </tr> <tr> <td style="text-align: left;">←</td> <td style="text-align: center;">487 Request Terminated</td> <td></td> </tr> <tr> <td></td> <td style="text-align: center;">ACK</td> <td style="text-align: right;">→</td> </tr> </tbody> </table>	SIP (Network A)	Interconnection Interface	SIP (Network B)		INVITE	→	←	180 Ringing			CANCEL/BYE	→	←	200 OK CANCEL/BYE		←	487 Request Terminated			ACK	→
SIP (Network A)	Interconnection Interface	SIP (Network B)																				
	INVITE	→																				
←	180 Ringing																					
	CANCEL/BYE	→																				
←	200 OK CANCEL/BYE																					
←	487 Request Terminated																					
	ACK	→																				
Comments	<p>Check: Is a CANCEL or BYE request is sent by the from the originating user?</p> <p>Check: Is a 487 Request Terminating sent by the terminating user?</p> <p>Check: Are the media streams terminated after the 200 OK CANCEL/BYE was sent?</p> <p>Repeat this test in reverse direction.</p>																					

Test case number	SS_unsucc_NNI__010												
Test case group	BCALL/unsuccessful												
Reference	[3], [4] and [5]												
SELECTION EXPRESSION													
Test purpose	Codec not supported by the called user. The initial INVITE contains an SDP with codecs that are not supported by the called user. Ensure that, when the called user does not accept the Media session, the called user initiates call clearing to the calling user with 488 Not Acceptable Here or 606 Not Acceptable, which also receives an ACK.												
Configuration													
SIP Parameter	INVITE : codec not supported at user (Network B).												
Message flow	<table border="0" style="width: 100%; border-collapse: collapse;"> <thead> <tr> <th style="text-align: left; width: 30%;">SIP (Network A)</th> <th style="text-align: center; width: 40%;">Interconnection Interface</th> <th style="text-align: right; width: 30%;">SIP (Network B)</th> </tr> </thead> <tbody> <tr> <td></td> <td style="text-align: center;">INVITE →</td> <td></td> </tr> <tr> <td>CASE A</td> <td style="text-align: center;">← 488 Not Acceptable Here ACK →</td> <td></td> </tr> <tr> <td>CASE B</td> <td style="text-align: center;">← 606 Not Acceptable ACK →</td> <td></td> </tr> </tbody> </table>	SIP (Network A)	Interconnection Interface	SIP (Network B)		INVITE →		CASE A	← 488 Not Acceptable Here ACK →		CASE B	← 606 Not Acceptable ACK →	
SIP (Network A)	Interconnection Interface	SIP (Network B)											
	INVITE →												
CASE A	← 488 Not Acceptable Here ACK →												
CASE B	← 606 Not Acceptable ACK →												
Comments	Establish a call setup from Network A to Network B. User B in Network B does not support the codec offered in the SDP received from Network A. Check: Is a 488 Not Acceptable Here or 606 Not Acceptable sent from Network B to Network A. Repeat this test in reverse direction.												

Test case number	SS_unsucc_NNI__011																					
Test case group	BCALL/unsuccessful																					
Reference	[4]																					
SELECTION EXPRESSION																						
Test purpose	Call clearing due to no answer from the called user initiated by the originating network. Ensure that when there is no answer from the called user, the originating network initiates the call clearing after timeout of SIP timer C and sends a CANCEL or BYE to the called user.																					
Configuration																						
SIP Parameter																						
Message flow	<table border="0" style="width: 100%; border-collapse: collapse;"> <thead> <tr> <th style="text-align: left; width: 30%;">SIP (Network A)</th> <th style="text-align: center; width: 40%;">Interconnection Interface</th> <th style="text-align: right; width: 30%;">SIP (Network B)</th> </tr> </thead> <tbody> <tr> <td></td> <td style="text-align: center;">→ INVITE →</td> <td></td> </tr> <tr> <td></td> <td style="text-align: center;">← 180 Ringing Start timer C</td> <td></td> </tr> <tr> <td></td> <td style="text-align: center;">Timeout timer C</td> <td></td> </tr> <tr> <td></td> <td style="text-align: center;">← CANCEL/BYE →</td> <td></td> </tr> <tr> <td></td> <td style="text-align: center;">← 200 OK CANCEL/BYE</td> <td></td> </tr> <tr> <td></td> <td style="text-align: center;">← 487 Request Terminated ACK →</td> <td></td> </tr> </tbody> </table>	SIP (Network A)	Interconnection Interface	SIP (Network B)		→ INVITE →			← 180 Ringing Start timer C			Timeout timer C			← CANCEL/BYE →			← 200 OK CANCEL/BYE			← 487 Request Terminated ACK →	
SIP (Network A)	Interconnection Interface	SIP (Network B)																				
	→ INVITE →																					
	← 180 Ringing Start timer C																					
	Timeout timer C																					
	← CANCEL/BYE →																					
	← 200 OK CANCEL/BYE																					
	← 487 Request Terminated ACK →																					
Comments	Check: Is a CANCEL or BYE request sent by the originating network? Check: Is a 487 Request Terminating send from the terminating user? Check: Are the media streams terminated after the 200 OK CANCEL/BYE was sent? Repeat this test in reverse direction.																					

Test case number	SS_unsucc_NNI__011A															
Test case group	BCALL/unsuccessful															
Reference	[14]															
SELECTION EXPRESSION	[Network A] SE 17a AND [Network B] SE 17a.															
Test purpose	Negotiation of session timer. Ensure that the interconnected networks are able to negotiate the session time to refresh the session. If the session refresh duration is too short for one of the involved entities, a 422 Session Interval Too Small unsuccessful final response is sent in backward direction to update the session duration time. A new INVITE is sent and a Min-SE header present proposes a longer session duration.															
Configuration	The session time in Network B is smaller than the session time used in Network A.															
Comment	This test case is only applicable if the session refresh time is different in Network A and Network B. This situation is also load dependent.															
SIP Parameter	INVITE 1: Supported: timer Session-Expires: x 422: Min-SE. x + y INVITE 2 Session-Expires: x + y															
Message flow	<table border="0" style="width: 100%; border-collapse: collapse;"> <thead> <tr> <th style="text-align: left; width: 30%;">SIP (Network A)</th> <th style="text-align: center; width: 40%;">Interconnection Interface</th> <th style="text-align: right; width: 30%;">SIP (Network B)</th> </tr> </thead> <tbody> <tr> <td></td> <td style="text-align: center;">INVITE 1</td> <td style="text-align: right;">→</td> </tr> <tr> <td style="text-align: left;">←</td> <td style="text-align: center;">422 Session Interval Too Small ACK</td> <td style="text-align: right;">→</td> </tr> <tr> <td></td> <td style="text-align: center;">INVITE 2</td> <td style="text-align: right;">→</td> </tr> <tr> <td style="text-align: left;">←</td> <td style="text-align: center;">180 Ringing</td> <td></td> </tr> </tbody> </table> <p style="text-align: center;">Apply post test routine</p>	SIP (Network A)	Interconnection Interface	SIP (Network B)		INVITE 1	→	←	422 Session Interval Too Small ACK	→		INVITE 2	→	←	180 Ringing	
SIP (Network A)	Interconnection Interface	SIP (Network B)														
	INVITE 1	→														
←	422 Session Interval Too Small ACK	→														
	INVITE 2	→														
←	180 Ringing															
Comments	Establish a communication setup from Network A to Network B. Check: Is the supported header in the initial INVITE set to 'timer'. Check: Is a 422 Session Interval Too Small sent by the terminating Network? Check: Is the Session-Expires header in the second initial INVITE request sent from Network A set to the value indicated in the 422 final response? Repeat this test in reverse direction.															

7.1.7.2 SIP-I

Test case number	SS_unsucc_SIP-I_01													
Test case group	BCALL/unsuccessful													
Reference	Clause 6.11.2 / [11]													
SELECTION EXPRESSION	[Network B] SE 17 AND [Network B] SE 47.													
Test purpose	SIP-I support. Called number is not allocated in the PSTN/PLMN network. Ensure that, when calling to an unallocated number in the PSTN/PLMN part of network B and ISUP - SIP-I interworking applies in Network B, the network initiate call clearing to the calling user with a 404 Not Found message. A ISUP REL message is encapsulated and the Cause value indicator is set to '1'.													
Configuration	The called user number is not assigned to the PSTN/PLMN part in Network B.													
SIP Parameter	404: Reason: Q.850;cause=1 (optional) Content-Type: multipart/mixed;boundary=[any boundary name] --[any boundary name] Content-Type: application/isup;version=itu-t92 Content-Disposition: signal;handling=required REL Cause value: 1 --[any boundary name]--													
Message flow	<table style="width: 100%; border: none;"> <tr> <td style="width: 30%;">SIP (Network A)</td> <td style="width: 40%; text-align: center;">Interconnection Interface</td> <td style="width: 30%; text-align: right;">SIP (Network B)</td> </tr> <tr> <td></td> <td style="text-align: center;">INVITE →</td> <td></td> </tr> <tr> <td></td> <td style="text-align: center;">← 404 Not Found(REL)</td> <td></td> </tr> <tr> <td></td> <td style="text-align: center;">ACK →</td> <td></td> </tr> </table>		SIP (Network A)	Interconnection Interface	SIP (Network B)		INVITE →			← 404 Not Found(REL)			ACK →	
SIP (Network A)	Interconnection Interface	SIP (Network B)												
	INVITE →													
	← 404 Not Found(REL)													
	ACK →													
Comments	Establish a communication from Network A to Network B, called user number is not allocated in the PSTN/PLMN part of Network B. Check: Is a 404 Not Found sent from Network B to Network A? Check: is a ISUP REL encapsulated and the Cause value indicator is set to '1'? Check: If a Reason header is present, is the cause value equal to the value in the Cause value of the encapsulated ISUP REL? Repeat this test in reverse direction.													

Test case number	SS_unsucc_SIP-I_02												
Test case group	BCALL/unsuccessful												
Reference	Clause 6.11.2 / [11]												
SELECTION EXPRESSION	[Network B] SE 17 AND [Network B] SE 47.												
Test purpose	SIP-I support. The called user is busy. Ensure that, when the called user in the PSTN/PLMN part of Network B and ISUP - SIP-I interworking applies in Network B is busy, the network initiates call clearing to the calling user with a 486 Busy Here message. A ISUP REL message is encapsulated and the Cause value indicator is set to '17'.												
Configuration	The called user is busy in the PSTN/PLMN part in Network B.												
SIP Parameter	486: Reason: Q.850;cause=17 (optional) Content-Type: multipart/mixed;boundary=[any boundary name] --[any boundary name] Content-Type: application/isup;version=itu-t92 Content-Disposition: signal;handling=required REL Cause value: 17 --[any boundary name]--												
Message flow	<table style="width: 100%; border: none;"> <tr> <td style="text-align: left; width: 33%;">SIP (Network A)</td> <td style="text-align: center; width: 33%;">Interconnection Interface</td> <td style="text-align: right; width: 33%;">SIP (Network B)</td> </tr> <tr> <td></td> <td style="text-align: center;">INVITE →</td> <td></td> </tr> <tr> <td></td> <td style="text-align: center;">← 486 Busy Here(REL)</td> <td></td> </tr> <tr> <td></td> <td style="text-align: center;">ACK →</td> <td></td> </tr> </table>	SIP (Network A)	Interconnection Interface	SIP (Network B)		INVITE →			← 486 Busy Here(REL)			ACK →	
SIP (Network A)	Interconnection Interface	SIP (Network B)											
	INVITE →												
	← 486 Busy Here(REL)												
	ACK →												
Comments	Establish a communication from Network A to Network B, user B in the PSTN/PLMN part of Network B is busy. Check: Is a 486 Busy Here sent from Network B to Network A? Check: Is a ISUP REL encapsulated and the Cause value indicator is set to '17'? Check: If a Reason header is present, is the cause value equal to the value in the Cause value of the encapsulated ISUP REL? Repeat this test in reverse direction.												

Test case number	SS_unsucc_SIP-I_3												
Test case group	BCALL/unsuccessful												
Reference	Clause 6.11.2 / [11]												
SELECTION EXPRESSION	[Network B] SE 17 AND [Network B] SE 47.												
Test purpose	SIP-I support. The called user rejects the call. Ensure that, when the called user in the PSTN/PLMN part of Network B and ISUP - SIP-I interworking applies in Network B rejects the communication setup, the network initiates call clearing to the calling user with a 480 Temporarily Unavailable final response. A ISUP REL message is encapsulated and the Cause value indicator is set to '21'.												
Configuration													
SIP Parameter	480: Reason: Q.850;cause=21 (optional) Content-Type: multipart/mixed;boundary=[any boundary name] --[any boundary name] Content-Type: application/isup;version=itu-t92 Content-Disposition: signal;handling=required REL Cause value: 21 --[any boundary name]--												
Message flow	<table style="width: 100%; border: none;"> <tr> <td style="text-align: center; width: 30%;">SIP (Network A)</td> <td style="text-align: center; width: 40%;">Interconnection Interface</td> <td style="text-align: center; width: 30%;">SIP (Network B)</td> </tr> <tr> <td></td> <td style="text-align: center;">INVITE</td> <td style="text-align: center;">→</td> </tr> <tr> <td></td> <td style="text-align: center;">← 480 Temporarily Unavailable (REL)</td> <td></td> </tr> <tr> <td></td> <td style="text-align: center;">ACK</td> <td style="text-align: center;">→</td> </tr> </table>	SIP (Network A)	Interconnection Interface	SIP (Network B)		INVITE	→		← 480 Temporarily Unavailable (REL)			ACK	→
SIP (Network A)	Interconnection Interface	SIP (Network B)											
	INVITE	→											
	← 480 Temporarily Unavailable (REL)												
	ACK	→											
Comments	Establish a communication from Network A to Network B, user B in the PSTN/PLMN part of network B rejects the communication setup. Check: Is a 480 Temporarily Unavailable sent from Network B to Network A? Check: is a ISUP REL encapsulated and the Cause value indicator is set to '21'? Check: If a Reason header is present, is the cause value equal to the value in the Cause value of the encapsulated ISUP REL? Repeat this test in reverse direction.												

Test case number	SS_unsucc_SIP-I_04																																								
Test case group	BCALL/unsuccessful																																								
Reference	Clause 7.7.1 / [11]																																								
SELECTION EXPRESSION	[Network A] SE 17 AND [Network B] SE 47.																																								
Test purpose	<p>SIP-I support. Call clearing due to no answer from the called user initiated by the calling user.</p> <p>Ensure when the early dialogue is not confirmed by the called user, the calling user located in the PSTN/PLMN part of Network A and ISUP - SIP-I interworking applies in Network A initiates call clearing to the called user with CANCEL or BYE. An ISUP REL message is encapsulated in the BYE request and the Cause value indicator is set to '16'.</p>																																								
Configuration																																									
SIP Parameter	<pre> 480: Reason: Q.850;cause=16 (optional) Content-Type: multipart/mixed;boundary=[any boundary name] --[any boundary name] Content-Type: application/isup;version=itu-t92 Content-Disposition: signal;handling=required REL Cause value: 16 --[any boundary name]-- </pre>																																								
Message flow	<table border="0" style="width: 100%; border-collapse: collapse;"> <thead> <tr> <th style="text-align: left; width: 30%;">SIP (Network A)</th> <th style="text-align: center; width: 40%;">Interconnection Interface</th> <th style="text-align: right; width: 30%;">SIP (Network B)</th> </tr> </thead> <tbody> <tr> <td></td> <td style="text-align: center;">INVITE</td> <td style="text-align: right;">→</td> </tr> <tr> <td></td> <td style="text-align: center;">← 180 Ringing</td> <td></td> </tr> <tr> <td>CASE A</td> <td></td> <td></td> </tr> <tr> <td></td> <td style="text-align: center;">CANCEL</td> <td style="text-align: right;">→</td> </tr> <tr> <td></td> <td style="text-align: center;">← 200 OK CANCEL</td> <td></td> </tr> <tr> <td></td> <td style="text-align: center;">← 487 Request Terminated</td> <td></td> </tr> <tr> <td></td> <td style="text-align: center;">ACK</td> <td style="text-align: right;">→</td> </tr> <tr> <td>CASE B</td> <td></td> <td></td> </tr> <tr> <td></td> <td style="text-align: center;">BYE(REL)</td> <td style="text-align: right;">→</td> </tr> <tr> <td></td> <td style="text-align: center;">← 200 OK BYE(RLC)</td> <td></td> </tr> <tr> <td></td> <td style="text-align: center;">← 487 Request Terminated</td> <td></td> </tr> <tr> <td></td> <td style="text-align: center;">ACK</td> <td style="text-align: right;">→</td> </tr> </tbody> </table>		SIP (Network A)	Interconnection Interface	SIP (Network B)		INVITE	→		← 180 Ringing		CASE A				CANCEL	→		← 200 OK CANCEL			← 487 Request Terminated			ACK	→	CASE B				BYE(REL)	→		← 200 OK BYE(RLC)			← 487 Request Terminated			ACK	→
SIP (Network A)	Interconnection Interface	SIP (Network B)																																							
	INVITE	→																																							
	← 180 Ringing																																								
CASE A																																									
	CANCEL	→																																							
	← 200 OK CANCEL																																								
	← 487 Request Terminated																																								
	ACK	→																																							
CASE B																																									
	BYE(REL)	→																																							
	← 200 OK BYE(RLC)																																								
	← 487 Request Terminated																																								
	ACK	→																																							
Comments	<p>Establish a communication from Network A to Network B, user B does not confirm the communication.</p> <p>The originating user in the PSTN/PLMN part of Network A terminates the early dialogue.</p> <p>Check: Is a CANCEL or BYE request is sent from the originating network?</p> <p>Check: Is a ISUP REL encapsulated in a BYE request?</p> <p>Check: Is the Cause value of the encapsulated REL set to '16'?</p> <p>Check: If a Reason header is present, is the cause value equal to the value in the Cause value of the encapsulated ISUP REL?</p> <p>Check: Is a 487 Request Terminating send from the terminating user?</p> <p>Check: Are the media streams terminated after the 200 OK CANCEL/BYE was sent?</p>																																								
NOTE:	A ISUP REL is not encapsulated in a CANCEL request. Repeat this test in reverse direction.																																								

Test case number	SS_unsucc_SIP-I_04																																							
Test case group	BCALL/unsuccessful																																							
Reference	Clause 7.7.1 / [11]																																							
SELECTION EXPRESSION	[Network A] SE 17 AND [Network B] SE 47.																																							
Test purpose	<p>SIP-I support. Call clearing due to no answer from the called user initiated by the originating network.</p> <p>Ensure when the early dialogue is not confirmed by the called user, the originating network initiate the call clearing after timeout of ISUP timer T9 if the calling user is located in the PSTN/PLMN part of Network A and ISUP - SIP-I interworking applies in Network A and the originating network sends a CANCEL or BYE to the called user. An ISUP REL message is encapsulated in the BYE request and the Cause value indicator is set to '19'.</p>																																							
Configuration																																								
SIP Parameter	<pre> 480: Reason: Q.850;cause=19 (optional) Content-Type: multipart/mixed;boundary=[any boundary name] --[any boundary name] Content-Type: application/isup;version=itu-t92 Content-Disposition: signal;handling=required REL Cause value: 19 --[any boundary name]-- </pre>																																							
Message flow	<table border="0" style="width: 100%; border-collapse: collapse;"> <thead> <tr> <th style="text-align: left; width: 30%;">SIP (Network A)</th> <th style="text-align: center; width: 40%;">Interconnection Interface</th> <th style="text-align: right; width: 30%;">SIP (Network B)</th> </tr> </thead> <tbody> <tr> <td></td> <td style="text-align: center;">→ INVITE →</td> <td></td> </tr> <tr> <td></td> <td style="text-align: center;">← 180 Ringing ←</td> <td></td> </tr> <tr> <td></td> <td style="text-align: center;">Start timer T9</td> <td></td> </tr> <tr> <td></td> <td style="text-align: center;">Timeout T9</td> <td></td> </tr> <tr> <td>CASE A</td> <td style="text-align: center;">← CANCEL ←</td> <td style="text-align: right;">→</td> </tr> <tr> <td></td> <td style="text-align: center;">← 200 OK CANCEL ←</td> <td style="text-align: right;">→</td> </tr> <tr> <td></td> <td style="text-align: center;">← 487 Request Terminated ←</td> <td style="text-align: right;">→</td> </tr> <tr> <td></td> <td style="text-align: center;">ACK</td> <td style="text-align: right;">→</td> </tr> <tr> <td>CASE B</td> <td style="text-align: center;">← BYE(REL) ←</td> <td style="text-align: right;">→</td> </tr> <tr> <td></td> <td style="text-align: center;">← 200 OK BYE(RLC) ←</td> <td style="text-align: right;">→</td> </tr> <tr> <td></td> <td style="text-align: center;">← 487 Request Terminated ←</td> <td style="text-align: right;">→</td> </tr> <tr> <td></td> <td style="text-align: center;">ACK</td> <td style="text-align: right;">→</td> </tr> </tbody> </table>	SIP (Network A)	Interconnection Interface	SIP (Network B)		→ INVITE →			← 180 Ringing ←			Start timer T9			Timeout T9		CASE A	← CANCEL ←	→		← 200 OK CANCEL ←	→		← 487 Request Terminated ←	→		ACK	→	CASE B	← BYE(REL) ←	→		← 200 OK BYE(RLC) ←	→		← 487 Request Terminated ←	→		ACK	→
SIP (Network A)	Interconnection Interface	SIP (Network B)																																						
	→ INVITE →																																							
	← 180 Ringing ←																																							
	Start timer T9																																							
	Timeout T9																																							
CASE A	← CANCEL ←	→																																						
	← 200 OK CANCEL ←	→																																						
	← 487 Request Terminated ←	→																																						
	ACK	→																																						
CASE B	← BYE(REL) ←	→																																						
	← 200 OK BYE(RLC) ←	→																																						
	← 487 Request Terminated ←	→																																						
	ACK	→																																						
Comments	<p>Establish a communication from Network A to Network B, user B does not answer the communication setup. The ISUP timer T9 in the PSTN/PLMN expires.</p> <p>Check: Is a CANCEL or BYE request is sent by the originating network? Check: Is a ISUP REL encapsulated in a BYE request? Check: Is the Cause value of the encapsulated REL set to '19'? Check: If a Reason header is present, is the cause value equal to the value in the Cause value of the encapsulated ISUP REL?</p> <p>Check: Is a 487 Request Terminating send from the terminating user? Check: Are the media streams terminated after the 200 OK CANCEL/BYE was sent?</p> <p>NOTE: A ISUP REL is not encapsulated in a CANCEL request. Repeat this test in reverse direction.</p>																																							

7.1.8 Test purposes for Supplementary services

7.1.8.1 Test purposes for OIP

Test case number	SS_oip_NNI_001
Test case group	SIP-SIP/Service/OIP
Reference	Clause 5.2.6.3 / [2]
SELECTION EXPRESSION	
Test purpose	<p>No P-Preferred-Identity received. The terminating user receives the default public user identity of the originating user.</p> <p>In case the preconditions are fulfilled to provide the terminating UE with originating identification information without preventing the presentation, ensure that no identity information in the P-Preferred-Identity header is provided by the originating UE, the terminating user receives a P-Asserted-Identity based on the default public user identity associated with the originating UE identifies the originator of the session.</p>
Configuration	
SIP Parameter	INVITE P-Asserted-Identity= default public user identity
Message flow	<p style="text-align: center;"> SIP (Network A) Interconnection Interface SIP (Network B) INVITE → Apply post test routine </p>
Comments	<p>Check: Is the P-Asserted-Identity set to the default public user identity?</p> <p>Check: Is optional a second P-Asserted-Identity header present as a 'tel' URI with a public user identity?</p> <p>Check: Is the user parameter in the P-Asserted-Identity header set to phone?</p> <p>Repeat this test in reverse direction. Repeat this test with all relevant end devices.</p>

Test case number	SS_oip_NNI_002
Test case group	SIP-SIP/Service/OIP
Reference	Clause 5.2.6.3 / [2]
SELECTION EXPRESSION	
Test purpose	<p>P-Preferred-Identity received, no match with the set of registered public identities. The terminating user receives the default public user identity of the originating user.</p> <p>In case the preconditions are fulfilled to provide the terminating UE with originating identification information without preventing the presentation, ensure that an identity information in the P-Preferred-Identity header is provided by the originating UE, does not match with the set of registered public identities of the originating UE the terminating user receives a P-Asserted-Identity based on the default public user identity associated with the originating UE identifies the originator of the session.</p>
Configuration	
SIP Parameter	INVITE P-Asserted-Identity= default public user identity
Message flow	<p style="text-align: center;"> SIP (Network A) Interconnection Interface SIP (Network B) INVITE → Apply post test routine </p>
Comments	<p>Check: Is the P-Asserted-Identity set to the default public user identity?</p> <p>Check: Is optional a second P-Asserted-Identity header present as a 'tel' URI with a public user identity?</p> <p>Check: If the user parameter is set to phone?</p> <p>Check: Is the P-Preferred-Identity header not present?</p> <p>Repeat this test in reverse direction. Repeat this test with all relevant end devices.</p>

Test case number	SS_oip_NNI_003	
Test case group	SIP-SIP/Service/OIP	
Reference	Clause 5.2.6.3 / [2]	
SELECTION EXPRESSION		
Test purpose	<p>P-Preferred-Identity received, match with the set of registered public identities. The terminating user receives the registered public user identity of the originating user.</p> <p>In case the preconditions are fulfilled to provide the terminating UE with originating identification information without preventing the presentation, ensure that an identity information in the P-Preferred-Identity header is provided by the originating UE, matches with the set of registered public identities of the originating UE the terminating user receives a P-Asserted-Identity based on the information provided by the originating UE identifies the originator of the session.</p>	
Configuration		
SIP Parameter	INVITE P-Asserted-Identity= matched public user identity	
Message flow	<p style="text-align: center;"> SIP (Network A) Interconnection Interface SIP (Network B) INVITE → Apply post test routine </p>	
Comments	<p>Check: Is the P-Asserted-Identity set to the identified public user identity?</p> <p>Check: Is optional a second P-Asserted-Identity header present as a 'tel' URI with a public user identity?</p> <p>Check: Is the user parameter is set to phone?</p> <p>Check: Is the P-Preferred-Identity header not present?</p> <p>Repeat this test in reverse direction. Repeat this test with all relevant end devices.</p>	

Test case number	SS_oip_NNI_004	
Test case group	SIP-SIP/Service/OIP	
Reference	Clause 4.5.2.4 / [7]	
SELECTION EXPRESSION	SE 18 AND NOT SE 19	
Test purpose	<p>No Special arrangement exists.</p> <p>The 'special arrangement' does not exist (screening of user provided information). The network compares the information in the From header with the set of registered public identities of the originating user If is no match is found, the AS sets the From header to the SIP URI that includes the registered default public user identity.</p>	
Configuration	Special arrangement for the originating user does not exist.	
SIP Parameter	INVITE From=default public user identity P-Asserted-Header=[any registered public user identity]	
Message flow	<p style="text-align: center;"> SIP (Network A) Interconnection Interface SIP (Network B) INVITE → Apply post test routine </p>	
Comments	<p>Check: Is the From header URI set to the value of the P-Asserted-Identity URI?</p> <p>Check: Is the P-Asserted-Identity set to any registered public user identity?</p> <p>Check: Is the user parameter set to phone?</p> <p>Repeat this test in reverse direction. Repeat this test with all relevant end devices.</p>	

Test case number	SS_oip_NNI_005												
Test case group	SIP-SIP/Service/OIP												
Reference	Clause 4.5.2.4 / [7]												
SELECTION EXPRESSION	SE 18 AND SE 19												
Test purpose	Special arrangement exists. The ' special arrangement ' exists (no screening of user provided information). The network does not attempt to match the information in the From header with the set of registered public identities of the originating user. The From header field is transparently transported to the terminating user.												
Configuration	Special arrangement for the originating user exists.												
SIP Parameter	INVITE From= original value P-Asserted-Header=[any registered public user identity]												
Message flow	<table style="width: 100%; border: none;"> <tr> <td style="text-align: center; width: 33%;">SIP (Network A)</td> <td style="text-align: center; width: 33%;">Interconnection Interface</td> <td style="text-align: center; width: 33%;">SIP (Network B)</td> </tr> <tr> <td></td> <td style="text-align: center;">INVITE</td> <td></td> </tr> <tr> <td></td> <td style="text-align: center;">→</td> <td></td> </tr> <tr> <td></td> <td style="text-align: center;">Apply post test routine</td> <td></td> </tr> </table>	SIP (Network A)	Interconnection Interface	SIP (Network B)		INVITE			→			Apply post test routine	
SIP (Network A)	Interconnection Interface	SIP (Network B)											
	INVITE												
	→												
	Apply post test routine												
Comments	Check: Is the From header URI set to original value sent by the user? Check: Is the P-Asserted-Identity set to any registered public user identity? Check: Is the user parameter set to phone? Repeat this test in reverse direction. Repeat this test with all relevant end devices.												

Test case number	SS_oip_SIP-I_001
Test case group	SIP-SIP/Service/OIP
Reference	Clause 7.1.3 / [11]
SELECTION EXPRESSION	[Network A] SE 17 [Network A] AND SE 47 AND SE 52.
Test purpose	SIP-I support. ISUP Calling party number <i>presentation allowed</i> in the encapsulated IAM. Ensure when BICC/ISUP - SIP-I interworking applies in the originating network the BICC/ISUP IAM is encapsulated in the INVITE request. The P-Asserted-Identity header field is derived from the Calling party number in the encapsulated IAM. The 'Presentation restriction' indicator in the encapsulated IAM is set to 'allowed' no Privacy value 'id' is present in the INVITE request.
Configuration	
SIP Parameter	INVITE P-Asserted-Identity=[derived from the ISUP calling party number] Content-Type: multipart/mixed;boundary=[any boundary name] --[any boundary name] Content-Type: application/isup;version=itu-t92 Content-Disposition: signal;handling=required IAM Calling party number Screening indicator Network provided or user provided, verified and passed Presentation restriction allowed Address signal --[any boundary name]--
Message flow	
SIP (Network A)	Interconnection Interface INVITE(IAM) → SIP (Network B)
	Apply post test routine
Comments	Check: Is a BICC/ISUP IAM encapsulated in the in the INVITE request? Check: Is the Calling party number present in the encapsulated IAM and the screening indicator is set to 'Network provided' or 'user provided, verified and passed' and the Presentation restriction indicator is set to 'allowed'? Check: Is the P-Asserted-Identity header field derived from the Calling party number in the encapsulated IAM? Check: Is the value 'id' not present in the Privacy header field (if included)? Repeat this test in reverse direction.

Test case number	SS_oip_SIP-I_002
Test case group	SIP-SIP/Service/OIP
Reference	Clause 7.1.3 / [11]
SELECTION EXPRESSION	[Network A] SE 17 [Network A] AND SE 47 AND SE 52.
Test purpose	<p>SIP-I support. ISUP Additional Calling party number presentation allowed in the encapsulated IAM.</p> <p>Ensure when BICC/ISUP - SIP-I interworking applies in the originating network the BICC/ISUP IAM is encapsulated in the INVITE request. The From field is derived from the Additional Calling party number in the encapsulated IAM. The 'Presentation restriction' indicator in the encapsulated IAM is set to 'allowed' no Privacy value 'id' is present in the INVITE request.</p>
Configuration	The originating user in the PSTN/PLMN part of Network A is subscribed to the 'no screening option'.
SIP Parameter	<p>INVITE</p> <p>From=[derived from the ISUP Additional calling party number] P-Asserted-Identity=[derived from the ISUP calling party number] Content-Type: multipart/mixed;boundary=[any boundary name]</p> <p>--[any boundary name] Content-Type: application/isup;version=itu-t92 Content-Disposition: signal;handling=required</p> <p>IAM</p> <p>Calling party number Screening indicator Network Provided Presentation restriction allowed Address signal</p> <p>Generic number</p> <p>Number Qualifier Indicator Additional calling party number Screening indicator user provided, not verified Presentation restriction allowed Address signal</p> <p>--[any boundary name]--</p>
Message flow	<p style="text-align: center;"> SIP (Network A) Interconnection Interface SIP (Network B) INVITE(IAM) → Apply post test routine </p>
Comments	<p>Check: Is a BICC/ISUP IAM encapsulated in the in the INVITE request?</p> <p>Check: Is the Calling party number present in the encapsulated IAM and the screening indicator is set to 'Network Provided' and the Presentation restriction indicator is set to 'allowed'?</p> <p>Check: Is the P-Asserted-Identity header field derived from the Calling party number in the encapsulated IAM?</p> <p>Check: Is a Generic number parameter, Number Qualifier Indicator set to Additional calling party number present and the screening indicator is set to 'user provided, not verified' and the Presentation restriction indicator is set to 'allowed'?</p> <p>Check: Is the From header field derived from the Additional calling party number in the encapsulated IAM?</p> <p>Check: Is the value 'id' not present in the Privacy header field (if included)?</p> <p>Repeat this test in reverse direction.</p>

7.1.8.2 Test purposes for OIR

Test case number	SS_oir_NNI_001	
Test case group	SIP-SIP/Service/OIR	
Reference	Clauses 4.3.2 and 4.5.2.4 / [7]	
SELECTION EXPRESSION	SE 20	
Test purpose	<p>Terminating user does not receive the identity of the originating user. In case the preconditions are fulfilled not to provide the terminating UE with originating identification information (e.g. permanent mode), ensure that the P-Asserted-Identity still contains identity information and the privacy is set to 'id' or 'header' or 'user'. The terminating user does not receive the identity of the originating user. As a network option, the From header is set to an anonymous User Identity.</p>	
Configuration	Originating user subscribes to the OIR service.	
SIP Parameter	INVITE P-Asserted-Identity: Privacy: id OR header OR user From: <sip:anonymous@anonymous.invalid> (optional)	
Message flow	SIP (Network A)	SIP (Network B)
	Interconnection Interface INVITE → Apply post test routine	
Comments	<p>Check: Is the P-Asserted-Identity is present? Check: Is the Privacy header set to 'id' or 'header' or 'user'? Check: Is optional the From header set to an anonymous User Identity? Repeat this test in reverse direction. Repeat this test with all chosen end devices.</p>	

Test case number	SS_oir_NNI_002	
Test case group	SIP-SIP/Service/OIR	
Reference	Clauses 4.3.2 and 4.5.2.4 / [7]	
SELECTION EXPRESSION	SE 20 AND SE 25	
Test purpose	<p>Communication forwarding unconditional, served user subscribes OIR. The user A and user C are in network B and user C is provided with OIP. The user B is in network A and is provided with CFU "diverting number is released to the diverted-to user" = Yes. In case the served user subscribes Originating Identification Restriction (e.g. permanent mode), ensure that when user A calls user B, the call is forwarded unconditional to user C, user C is not informed of the forwarding number. The diverted-to user receives no identity of the diverting user neither in a History-Info header nor in the To header.</p>	
Configuration	Diverting user subscribes to the OIR service.	
SIP Parameter	INVITE1 : no history entry present INVITE2 : History-Info: <sip:userB@networkA? Privacy=history >;index=1, <sip:userC@networkB;cause=302>;index=1.1	
Message flow	SIP (Network A)	SIP (Network B)
	Interconnection Interface ← INVITE1 CFU is performed in Network A INVITE2 → Apply post test routine	
Comments	<p>Check: No History-Info header is received in the INVITE from Network B. Check: Is the Privacy value history is escaped in the hi-target-to-uri of the diverting user in Network A? Repeat this test in reverse direction. Repeat this test with all chosen end devices.</p>	

Test case number	SS_oir_SIP-I_001	
Test case group	SIP-SIP/Service/OIR	
Reference	Clause 7.1.3 / [11]	
SELECTION EXPRESSION	[Network A] SE 17 AND [Network A] SE 47 AND SE 52	
Test purpose	<p>SIP-I support. ISUP Calling party number <i>presentation restricted</i> in the encapsulated IAM.</p> <p>Ensure when BICC/ISUP - SIP-I interworking applies in the originating network the BICC/ISUP IAM is encapsulated in the INVITE request. The P-Asserted-Identity header field is derived from the Calling party number in the encapsulated IAM. The 'Presentation restriction' indicator in the encapsulated IAM is set to 'restricted' the value 'id' is present in the Privacy header of the INVITE request.</p>	
Configuration		
SIP Parameter	<p>INVITE</p> <p>P-Asserted-Identity=[derived from the ISUP calling party number] Privacy: id Content-Type: multipart/mixed;boundary=[any boundary name]</p> <p>--[any boundary name] Content-Type: application/isup;version=itu-t92 Content-Disposition: signal;handling=required</p> <p>IAM</p> <p>Calling party number Screening indicator Network provided or user provided, verified and passed Presentation restriction restricted Address signal</p> <p>--[any boundary name]--</p>	
Message flow		
SIP (Network A)	Interconnection Interface INVITE(IAM) → Apply post test routine	SIP (Network B)
Comments	<p>Check: Is a BICC/ISUP IAM encapsulated in the in the INVITE request?</p> <p>Check: Is the Calling party number present in the encapsulated IAM and the screening indicator is set to 'Network provided' or 'user provided, verified and passed' and the Presentation restriction indicator is set to 'restricted'?</p> <p>Check: Is the P-Asserted-Identity header field derived from the Calling party number in the encapsulated IAM?</p> <p>Check: Is the value 'id' present in the Privacy header field? Repeat this test in reverse direction.</p>	

Test case number	SS_oir_SIP-I_002									
Test case group	SIP-SIP/Service/OIR									
Reference	Clause 7.1.3 / [11]									
SELECTION EXPRESSION	[Network A] SE 17 AND [Network A] SE 47 AND SE 52									
Test purpose	SIP-I support. ISUP Additional Calling party number presentation restricted in the encapsulated IAM. Ensure when BICC/ISUP - SIP-I interworking applies in the originating network the BICC/ISUP IAM is encapsulated in the INVITE request. The From field is derived from the Additional Calling party number in the encapsulated IAM. The 'Presentation restriction' indicator in the Generic number parameter is set to 'allowed' no Privacy value 'id' is present in the INVITE request.									
Configuration	The originating user in the PSTN/PLMN part of Network A is subscribed to the 'no screening option'.									
SIP Parameter	INVITE P-Asserted-Identity=[derived from the ISUP calling party number] From=[derived from the ISUP Additional calling party number] Privacy: id Content-Type: multipart/mixed;boundary=[any boundary name] --[any boundary name] Content-Type: application/isup;version=itu-t92 Content-Disposition: signal;handling=required IAM Calling party number Screening indicator Network Provided Presentation restriction restricted Address signal Generic number Number Qualifier Indicator Additional calling party number Screening indicator user provided, not verified Presentation restriction restricted Address signal --[any boundary name]--									
Message flow	<table style="width: 100%; border: none;"> <tr> <td style="text-align: center; width: 33%;">SIP (Network A)</td> <td style="text-align: center; width: 33%;">Interconnection Interface</td> <td style="text-align: center; width: 33%;">SIP (Network B)</td> </tr> <tr> <td></td> <td style="text-align: center;">INVITE(IAM) →</td> <td></td> </tr> <tr> <td></td> <td style="text-align: center;">Apply post test routine</td> <td></td> </tr> </table>	SIP (Network A)	Interconnection Interface	SIP (Network B)		INVITE(IAM) →			Apply post test routine	
SIP (Network A)	Interconnection Interface	SIP (Network B)								
	INVITE(IAM) →									
	Apply post test routine									
Comments	Check: Is a BICC/ISUP IAM encapsulated in the in the INVITE request? Check: Is the Calling party number present in the encapsulated IAM and the screening indicator is set to 'Network Provided' and the Presentation restriction indicator is set to 'restricted'? Check: Is the P-Asserted-Identity header field derived from the Calling party number in the encapsulated IAM? Check: Is a Generic number parameter, Number Qualifier Indicator set to Additional calling party number present and the screening indicator is set to 'user provided, not verified' and the Presentation restriction indicator is set to 'restricted'? Check: Is the From header field derived from the Additional calling party number in the encapsulated IAM? Check: Is the value 'id' present in the Privacy header field? Repeat this test in reverse direction.									

7.2 Video Call

7.2.1 Testing of SIP protocol requirements

7.2.1.1 Test purposes for Basic call, Successful

Test case number	SS_bcall_video_001	
Test case group	BCALL/successful	
Reference	[4]	
SELECTION EXPRESSION		
Test purpose	<p>Calling user adds one-way video call to an ongoing VoLTE call Ensure that the VoLTE and video device which is used includes its video capability in the signalling. Calling user adds video to an ongoing VoLTE call, the device sends a new invitation message with information about the additional video media component, which is treated by the IMS and EPC domains resulting in the addition of a dedicated bearer for the video stream. Ensure that the calling user can drop video and continue just with voice. Ensure that call remains in intelligible/high quality conversation for video and voice. The acceptability thresholds for lip synchronization are 185 ms when sound is delayed with respect to the video, and 90 ms when sound is advanced with respect to the video [31]. The subjective video quality assessment methods for multimedia applications which predict a mean opinion scores (MOS) on a five-point ACR scale are defined in Recommendation ITU-T P.910 [32]. The global audiovisual MOS score is defined in Recommendation ITU-T P.911 [33]. The possible test configurations are listed in table 4.2.5-1 The voice call is released from the called user.</p>	
Configuration		
SIP Parameter		
Message flow		
SIP (Network A)	Interconnection Interface	SIP (Network B)
	INVITE →	
	← 180 Ringing	
	← 200 OK INVITE	
	ACK →	
	Communication audio	
	← Re-INVITE Video	→
	200 OK INVITE	
	ACK →	→
	Communication Video	
	← Re-INVITE audio	→
	200 OK INVITE	
	ACK →	→
	Communication audio	
	← BYE	
	200 OK BYE →	
Comments		

Test case number	SS_bcall_video_002	
Test case group	BCALL/successful	
Reference	[4]	
SELECTION EXPRESSION		
Test purpose	<p>Calling user adds two way video call to an ongoing VoLTE call.</p> <p>Ensure that the VoLTE and video device which is used includes its video capability in the signalling.</p> <p>Calling user adds video to an ongoing VoLTE call, the device sends a new invitation message with information about the additional video media component, which is treated by the IMS and EPC domains resulting in the addition of a dedicated bearer for the video stream.</p> <p>Ensure that the calling user can drop video and continue just with voice.</p> <p>Ensure that call remains in intelligible/high quality conversation for video and voice. The acceptability thresholds for lip synchronization are 185 ms when sound is delayed with respect to the video, and 90 ms when sound is advanced with respect to the video [31].</p> <p>The subjective video quality assessment methods for multimedia applications which predict a mean opinion scores (MOS) on a five-point ACR scale are defined in Recommendation ITU-T P.910 [32]. The global audiovisual MOS score is defined in Recommendation ITU-T P.911 [33].</p> <p>The possible test configurations are listed in table 4.2.5-1</p> <p>The voice call is released from the called user.</p>	
Configuration		
SIP Parameter		
Message flow		
SIP (Network A)	Interconnection Interface INVITE → ← 180 Ringing ← 200 OK INVITE ACK → Communication audio Re-INVITE Video → ← 200 OK INVITE ACK → Communication Re-INVITE audio → ← 200 OK INVITE ACK → Communication audio ← BYE 200 OK BYE →	SIP (Network B)
Comments		

Test case number	SS_bcall_video_003	
Test case group	BCALL/successful	
Reference	[4]	
SELECTION EXPRESSION		
Test purpose	<p>Calling user adds one-way video call to an ongoing VoLTE call. Ensure that the VoLTE and video device which is used includes its video capability in the signalling. Calling user adds video to an ongoing VoLTE call, the device sends a new invitation message with information about the additional video media component, which is treated by the IMS and EPC domains resulting in the addition of a dedicated bearer for the video stream. Ensure that the calling user can drop video and continue just with voice. Ensure that call remains in intelligible/high quality conversation for video and voice. The acceptability thresholds for lip synchronization are 185 ms when sound is delayed with respect to the video, and 90 ms when sound is advanced with respect to the video [31]. The subjective video quality assessment methods for multimedia applications which predict a mean opinion scores (MOS) on a five-point ACR scale are defined in Recommendation ITU-T P.910 [32]. The global audiovisual MOS score is defined in Recommendation ITU-T P.911 [33]. The possible test configurations are listed in table 4.2.5-1. The voice call is released from the calling user.</p>	
Configuration		
SIP Parameter		
Message flow		
SIP (Network A)	Interconnection Interface	SIP (Network B)
	INVITE →	
	← 180 Ringing	
	← 200 OK INVITE	
	ACK →	
	Communication audio	
	Re-INVITE Video →	
	← 200 OK INVITE	
	ACK →	
	Communication Video	
	Re-INVITE audio →	
	← 200 OK INVITE	
	ACK →	
	Communication audio	
	BYE →	
	← 200 OK BYE	
Comments		

Test case number	SS_bcall_video_004																																																
Test case group	BCALL/successful																																																
Reference	[4]																																																
SELECTION EXPRESSION																																																	
Test purpose	<p>Calling user adds two way video call to an ongoing VoLTE call. Ensure that the VoLTE and video device which is used includes its video capability in the signalling. Calling user adds video to an ongoing VoLTE call, the device sends a new invitation message with information about the additional video media component, which is treated by the IMS and EPC domains resulting in the addition of a dedicated bearer for the video stream. Ensure that the calling user can drop video and continue just with voice. Ensure that call remains in intelligible/high quality conversation for video and voice. The acceptability thresholds for lip synchronization are 185 ms when sound is delayed with respect to the video, and 90 ms when sound is advanced with respect to the video [31]. The subjective video quality assessment methods for multimedia applications which predict a mean opinion scores (MOS) on a five-point ACR scale are defined in Recommendation ITU-T P.910 [32]. The global audiovisual MOS score is defined in Recommendation ITU-T P.911 [33]. The possible test configurations are listed in table 4.2.5-1. The voice call is released from the calling user.</p>																																																
Configuration																																																	
SIP Parameter																																																	
Message flow																																																	
SIP (Network A)	<table style="width: 100%; border-collapse: collapse;"> <thead> <tr> <th style="width: 30%;"></th> <th style="width: 40%; text-align: center;">Interconnection Interface</th> <th style="width: 30%;"></th> </tr> </thead> <tbody> <tr> <td></td> <td style="text-align: center;">INVITE</td> <td style="text-align: right;">→</td> </tr> <tr> <td></td> <td style="text-align: center;">← 180 Ringing</td> <td></td> </tr> <tr> <td></td> <td style="text-align: center;">← 200 OK INVITE</td> <td></td> </tr> <tr> <td></td> <td style="text-align: center;">ACK</td> <td style="text-align: right;">→</td> </tr> <tr> <td></td> <td style="text-align: center;">Communication audio</td> <td></td> </tr> <tr> <td></td> <td style="text-align: center;">← Re-INVITE Video</td> <td style="text-align: right;">→</td> </tr> <tr> <td></td> <td style="text-align: center;">200 OK INVITE</td> <td></td> </tr> <tr> <td></td> <td style="text-align: center;">ACK</td> <td style="text-align: right;">→</td> </tr> <tr> <td></td> <td style="text-align: center;">Communication Video</td> <td></td> </tr> <tr> <td></td> <td style="text-align: center;">← Re-INVITE audio</td> <td style="text-align: right;">→</td> </tr> <tr> <td></td> <td style="text-align: center;">200 OK INVITE</td> <td></td> </tr> <tr> <td></td> <td style="text-align: center;">ACK</td> <td style="text-align: right;">→</td> </tr> <tr> <td></td> <td style="text-align: center;">Communication audio</td> <td></td> </tr> <tr> <td></td> <td style="text-align: center;">← Re-INVITE BYE</td> <td style="text-align: right;">→</td> </tr> <tr> <td></td> <td style="text-align: center;">200 OK BYE</td> <td style="text-align: right;">→</td> </tr> </tbody> </table>		Interconnection Interface			INVITE	→		← 180 Ringing			← 200 OK INVITE			ACK	→		Communication audio			← Re-INVITE Video	→		200 OK INVITE			ACK	→		Communication Video			← Re-INVITE audio	→		200 OK INVITE			ACK	→		Communication audio			← Re-INVITE BYE	→		200 OK BYE	→
	Interconnection Interface																																																
	INVITE	→																																															
	← 180 Ringing																																																
	← 200 OK INVITE																																																
	ACK	→																																															
	Communication audio																																																
	← Re-INVITE Video	→																																															
	200 OK INVITE																																																
	ACK	→																																															
	Communication Video																																																
	← Re-INVITE audio	→																																															
	200 OK INVITE																																																
	ACK	→																																															
	Communication audio																																																
	← Re-INVITE BYE	→																																															
	200 OK BYE	→																																															
Comments																																																	

Test case number	SS_bcall_video_005	
Test case group	BCALL/successful	
Reference	[4]	
SELECTION EXPRESSION		
Test purpose	<p>Calling user is establishing a two way video call. Ensure that the VoLTE and video device which is used includes its video capability in the signalling. Calling user is establishing a video call with information about video media component, which is treated by the IMS and EPC domains resulting in the addition of a dedicated bearer for the video stream. Ensure that call remains in intelligible/high quality conversation for video and voice. The acceptability thresholds for lip synchronization are 185 ms when sound is delayed with respect to the video, and 90 ms when sound is advanced with respect to the video [31]. The subjective video quality assessment methods for multimedia applications which predict a mean opinion scores (MOS) on a five-point ACR scale are defined in Recommendation ITU-T P.910 [32]. The global audiovisual MOS score is defined in Recommendation ITU-T P.911 [33]. The possible test configurations are listed in table 4.2.5-1. The voice call is released from the called user.</p>	
Configuration		
SIP Parameter		
Message flow		
SIP (Network A)	Interconnection Interface	SIP (Network B)
	INVITE →	
	← 180 Ringing	
	← 200 OK INVITE	
	Video & Audio	
	ACK →	
	Communication Video & Audio	
	Communication	
	← BYE	
	200 OK BYE →	
Comments		

Test case number	SS_bcall_video_006	
Test case group	BCALL/successful	
Reference	[4]	
SELECTION EXPRESSION		
Test purpose	<p>Calling user is establishing a two way video call</p> <p>Ensure that the VoLTE and video device which is used includes its video capability in the signalling.</p> <p>Calling user is establishing a video call with information about video media component, which is treated by the IMS and EPC domains resulting in the addition of a dedicated bearer for the video stream.</p> <p>Ensure that call remains in intelligible/high quality conversation for video and voice. The acceptability thresholds for lip synchronization are 185 ms when sound is delayed with respect to the video, and 90 ms when sound is advanced with respect to the video [31].</p> <p>The subjective video quality assessment methods for multimedia applications which predict a mean opinion scores (MOS) on a five-point ACR scale are defined in Recommendation ITU-T P.910 [32]. The global audiovisual MOS score is defined in Recommendation ITU-T P.911 [33].</p> <p>The possible test configurations are listed in table 4.2.5-1.</p> <p>The voice call is released from the calling user</p>	
Configuration		
SIP Parameter		
Message flow		
SIP (Network A)	Interconnection Interface	SIP (Network B)
	INVITE →	
	← 180 Ringing	
	← 200 OK INVITE	
	Video & Audio	
	ACK →	
	Communication Video & Audio	
	Communication	
	← BYE →	
	200 OK BYE	
Comments		

8 QoS/QoE/Test requirements

8.0 General

The conduction of voice quality measurements is following the descriptions that can be found in ETSI EG 202 057-2 [i.1], Recommendation ITU-T Q.543 [17], ETSI TS 101 563 [16] and ETSI TS 102 250-2 [19], clauses 6.6.3.1 and 6.6.3.2.

The access points of the test equipment which are used for inserting or retrieving the signals needed for determining the speech quality parameters shall conform to the reference characteristics as laid down in the following relevant standards:

- ETSI EG 202 425 [i.3] for VoIP access;
- ETSI TBR 21 [27] for analogue access.

The properties of the test equipment should be known and the values measured for each parameter should be corrected accordingly by the impairments introduced by the test equipment. Especially any delay introduced by the test equipment shall be known and the measurement results shall be corrected by the delay introduced by the test equipment.

The simultaneous transmission of voice and data through uploads, downloads or IPTV use is an additional user related scenario. For this reason voice quality measurements have been included where in parallel to the voice connection active upload and download of data is simulated. This provides information about any potential prioritization of voice data when the entire bandwidth is being utilized.

The KPI listed in table 8.0-1 are recorded as part of the voice quality measurements.

Table 8.0-1: Overview of KPI for voice quality measurements

1	call set-up delay [17] and session initiation call set-up delay [16]
2	call set-up time (Post Dialling Delay) [5]
3	Premature release probability (Call Failure Rate), see clause 5.4 in [15]
4	Telephony Cut-off Call Ratio [%] (Call drop rate), see clause 5.5 in [15]
5	Media establishment delay, see clause 5.6 in [15]
6	Level of active speech signal, see clause 5.7 in [15]
7	Noise level, see clause 5.8 in [15]
8	Signal to Noise ratio, see clause 5.9 in [15]
9	Speech signal attenuation, see clause 5.10 in [15]
10	Talker echo delay, see clause 5.11 in [15]
11	Double talk, see clause 5.12 in [15]
12	Interrupted voice transmission, see clause 5.13 in [15]
13	Listening speech quality, see clause 5.14 in [15]
14	Listening speech quality stability, see clause 5.15 in [15]
15	End-to-end audio delay, see clause 5.16 in [15]
16	End-to-end audio delay variation, see clause 5.17 in [15]
17	Frequency response, see clause 5.18 in [15]
18	Fax transmission T.30 (Fax, bit rate \leq 14,4 kbit/s and Fax, bit rate \geq 14,4 kbit/s) see clause 5.19 in [15]
19	Early media, see clause 5.20 in [15]
20	Jitter Buffer and IP periodization response time, see clause 5.21 in [15]

For VoLTE interconnect and roaming with QoE and QoS Tests are following KPI mandatory.

1	Call set-up time (Post Dialling Delay)
2	Listening speech quality
3	End-to-end audio delay, see clause 5.16 in [15]
4	End-to-end audio delay variation, see clause 5.17 in [15]
5	Early media, see clause 5.20 in [15]

8.1 Call set-up time (post dialling delay)

To determine the call setup time in a VoIP implementation, the time in seconds from the sending of the INVITE signal through the "A" side until the receipt of the 200 OK signal is measured on the "A" side is measured, or the time in seconds from the sending of the INVITE signal through the "A" side until the receipt of the 180 Ringing signal on the "A" side is recorded.

8.2 Listening speech quality

8.2.1 Connections with one voice channel

For the **single voice channel Test**, a test call consisting of the three following parts should be used:

- Channel Convergence Quality test;
- Listening Speech Quality test;
- DTMF test.

Table 8.2.1-1 gives an overview of the connection options without parallel data transfer.

Table 8.2.1-1: Configurations options for connections without parallel data transfer

Connections without parallel data transfer	Voice from	Voice to
	VoLTE	MMTel (IMS) fixed access
	VoLTE	VoLTE
	LTE Mobile network with CSFB	IMS PES with AGCF with AGCF (or PSTN or ISDN Access)
	UMTS	IMS PES with AGCF with AGCF (or PSTN or ISDN Access)
	LTE Mobile network with CSFB	IMS PES with VGW
	UMTS	IMS PES with VGW
	UMTS	UMTS

Figures 8.2.1-1 and 8.2.1-2 depict the scenarios VoLTE to VoLTE and VoLTE to MMTel for the measurement of voice quality.

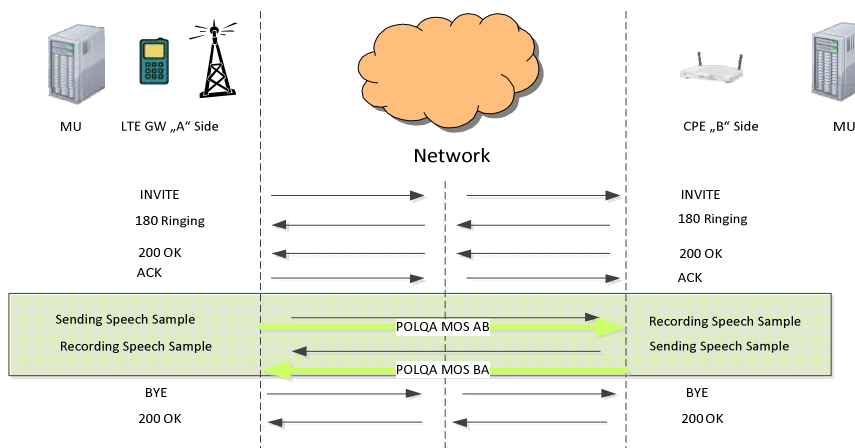

Figure 8.2.1-1: VoLTE voice quality measurement for a Mobile - Fixed network connection

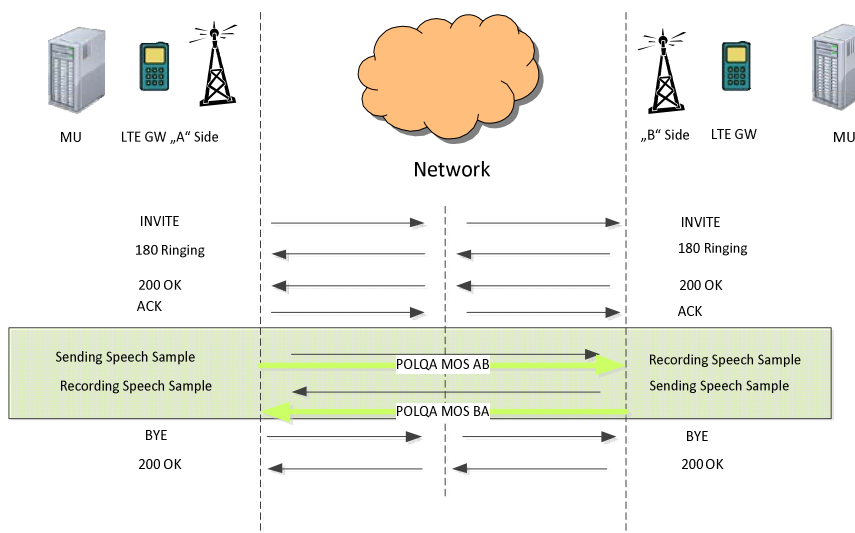

Figure 8.2.1-2: VoLTE voice quality measurement for a Mobile - Mobile connection

8.2.2 General aspects of Listening Speech Quality

The listening speech quality represents the intrinsic quality of speech signal as perceived by the user at the receiving end. This indicator takes into account the impairments introduced by the transmission system. The MOS-LQO score is obtained by comparing speech samples:

- the original undistorted reference speech signal;
- the degraded signal received at the local end, where the measurement is applied.

Recommendation ITU-T P.863 [20] recommends two samples from each of two male and two female speakers, i.e. eight sentence pairs. Some applications may only permit shorter test durations. Typically, test sentence material in subjective tests has a 0,5 second silence lead in, two sentences, and then a 0,5 second silence at the end of the signal. Further information can be found in ETSI TR 103 138 [i.2] and Recommendation ITU-T P.863.1 [21].

To ensure comparable voice quality results it shall be ensured that the test equipment uses the codec described in the first line of the m line in the SDP Part which is the pre-configured codec by the network operator.

8.2.3 General aspects of voice channel test calls

For the **all voice channel tests**, an aligned structure of the voice call shall be used. In this call sentence pairs (male/female) fulfilling the requirements of Recommendation ITU-T P.863.1 [21] shall be transmitted from A to B and from B to A. Speech files especially tested for the use with Recommendation ITU-T P.863 [20] are published in Recommendation ITU-T P.501 [22], annex C, where samples in different languages are covered.

In principle all voice channel tests consist of three parts:

- Channel Convergence Quality test;
- Listening Speech Quality test;
- DTMF test.

Which parts are actually used and how they are structured is defined for the individual test cases in the clauses below.

The **Channel Convergence quality test** starts with a listening speech quality test from B to A after the connection is established. This initial test provides information about the listening quality during convergence of the channel.

For the analysis of the initial listening speech quality during convergence of the channel the method according to Recommendation ITU-T P.863 [20] in SWB mode based **on only two sentences** (one female voice and one male voice) is used. For this purpose a male voice (e.g. "Four hours of steady work faced us") and a female voice (e.g. "The hogs were fed chopped corn and garbage") can be selected from the test sentences provided in Recommendation ITU-T P.501 [22], annex C.

After convergence of the channel the regular **Listening Speech quality test** starts using Recommendation ITU-T P.863 [20] in SWB mode based on eight sentences (two male and two female voices, two sentences each).

Usually, the listening speech quality tests should start 10 seconds after the connection is established. This 10 second pause is recommended for converging the speech processing components and building up the IP-buffer at receiving side and can be used for the Channel Convergence quality test as described above. It is assumed that the convergence has finished after 10 s. In the event of a proven shorter convergence, the pause can be shorter.

In case the channel can be assumed as converged from the beginning, and/or the separation of the Channel Convergence quality is not of interest, the Listening Quality test can start at any time after the connection is established.

Within the Listening Speech quality test, for example the following English samples can be selected from the test sentences provided in Recommendation ITU-T P.501 [22], annex C:

- *Female 1:*
 - These days a chicken leg is a rare dish.
 - The hogs were fed with chopped corn and garbage.

- *Female 2:*
 - Rice is often served in round bowls.
 - A large size in stockings is hard to sell.
- *Male 1:*
 - The juice of lemons makes fine punch.
 - Four hours of steady work faced us.
- *Male 2:*
 - The birch canoe slid on smooth planks.
 - Glue the sheet to the dark blue background.

If a global application is of interest, optionally the male and female tests sentences of other languages provided in Recommendation ITU-T P.501 [22], annex C may be used.

After conducting all evaluations, the derived MOS scores for each sample in the listening test are averaged over all received and scored samples separately for each direction A-B and B-A.

DTMF Test: DTMF tones are often used for remote controlling equipment and need to be tested in an established voice channel too for correct transmission. It is recommended to test DTMF before or after the Listening Speech quality test but in each case after the channel has converged. The DTMF Test should consist of DTMF tones (70 ms signal, 100 ms pause) and shall contain the tones 0, 1, 2, 3, 4, 5, 6, 7, 8, 9, A, B, C, D, *, #.

Technical comments:

- If the interrupted voice transmission time is > 1 second and the call connection is maintained, the call is rated as interrupted (see clause 5.13 in ETSI TS 103 222-1 [15]).
- If all 8 sentences (4 samples) are sent within one file, the score calculation according to Recommendation ITU-T P.863 [20] shall be performed separately for each sample (2 sentences per sample).
- In case the sampling frequency at the input measuring interface is 8 kHz - as it usual for ISDN and narrowband applications - the input speech signal used should be band limited at 3 800 kHz (see ETSI TR 103 138 [i.2]).
- When the sampling frequency at the input measuring interface is 16 kHz as required for wideband telephony the input speech signal used shall be band limited between 100 Hz and 7 600 kHz with a band pass filter providing a minimum of 24 dB/Oct. filter roll off, when feeding into the receive direction (see ETSI TR 103 138 [i.2]).
- The input test signal levels are referred to the average level of the (band limited in receive direction) test signal, averaged over the complete test sequence unless specified otherwise. The active speech level should be adjusted to -26 dB OVL as specified in ETSI TR 103 138 [i.2].

Table 8.2.3-1: Single voice channel test

Relative Time	Test equipment A		NETWORK		Test equipment B
	CALL A to B				
T0 - 2	INVITE	→		→	INVITE
	180 Ringing	←		←	80 Ringing
T0	200 OK	←		←	200 OK
	ACK	→		→	ACK
	Start Convergence Quality test				
T0	Start Audio Receive BA_1 (female & male)	←		←	Start Audio Send BA_1 (female & male)
	End Audio Receive BA_1	←		←	End Audio Send BA_1

Relative Time	Test equipment A		NETWORK		Test equipment B
CALL A to B					
Stop Convergence Quality test					
Listening Speech Quality test					
T0 + 10 s	Start Audio Send AB_1 (female 1)	→		→	Start Audio Receive AB_1 (female 1)
	End Audio Send AB_1 (female 1)	→		→	End Audio Receive AB_1 (female 1)
	Start Audio Send AB_2 (female 2)	→		→	Start Audio Receive AB_2 (female 2)
	End Audio Send AB_2 (female 2)	→		→	End Audio Receive AB_2 (female 2)
	Start Audio Send AB_3 (male 1)	→		→	Start Audio Receive AB_3 (male 1)
	End Audio Send AB_3 (male 1)	→		→	End Audio Receive AB_3 (male 1)
	Start Audio Send AB_4 (male 2)	→		→	Start Audio Receive AB_4 (male 2)
	End Audio Send AB_4 (male 2)	→		→	End Audio Receive AB_4 (male 2)
1 s	Pause				
	Start Audio Receive BA_1 (female 1)	←		←	Start Audio Send BA_1 (female 1)
	End Audio Receive BA_1 (female 1)	←		←	End Audio Send BA_1 (female 1)
	Start Audio Receive BA_2 (female 2)	←		←	Start Audio Send BA_2 (female 2)
	End Audio Receive BA_2 (female 2)	←		←	End Audio Send BA_2 (female 2)
	Start Audio Receive BA_3 (male 1)	←		←	Start Audio Send BA_3 (male 1)
	End Audio Receive BA_3 (male 1)	←		←	End Audio Send BA_3 (male 1)
	Start Audio Receive BA_4 (male 2)	←		←	Start Audio Send BA_4 (mal 2)
	End Audio Receive BA_4 (male 2)	←		←	End Audio Send BA_4 (male 2)
1 s	Pause				
	Start DTMF Send AB_1	→		→	Start DTMF Receive AB_1
	End DTMF Send AB_1	→		→	End DTMF Receive AB_1
	Start DTMF Receive BA_1	←		←	Start DTMF Send BA_1
	End DTMF Receive BA_1	←		←	End DTMF Send BA_1
	BYE	→		→	BYE
	200 OK	←		←	200 OK

8.3 End-to-end audio delay

This parameter represents the global delay from one user to the other one. This indicator takes into account the transmission delay of networks but also processing delay in sending and receiving terminals. The end-to-end delay can be measured acoustically from mouth to ear, from one access point to the other one. The delay can be calculated based on cross correlation between the signal at the MRP (at one access) and the signal at the ERP (at the other access) using the test methods as described e.g. in ETSI ES 202 737 [23] and ETSI ES 202 739 [24].

Electrically the end-to-end delay can be measured based on cross correlation between the signal at the electrical measurement point at one access and the signal at the electrical measurement point at the other access.

The test signal consists of a series of CSS-signals using a nominal network level of -16 dBm0 as described in Recommendation ITU-T P.501 [22]. The test signal consists of the voiced part as described in Recommendation ITU-T P.501 [22] followed by a pseudo random noise sequence with a periodicity of minimum 500 ms (described also in ETSI ES 202 737 [23] and ETSI ES 202 739 [24]).

NOTE: If the expected delay is higher than 500 ms a pseudo random sequence with a higher periodicity should be used.

8.4 End-to-end audio delay variation

The test signal consists of a series of CSS-signals using a nominal network level of -16 dBm0 with a total duration of 120 s. The pause of the CSS-sequence should be 150 ms. The delay of every CSS-signal should be measured.

The delay variation for each CSS-signal $D(i)$ compared to the first CSS signal (as described in Recommendation ITU-T P.501 [22]) of the analysis period is calculated:

$$D(i) = T1 - Ti$$

With:

- $T1$ - Delay of the first CSS
- Ti - Delay CSS number i

8.5 Early media call flow options and listening speech quality

8.5.1 Introduction

8.5.1.0 General

Early media refers to media (e.g. audio and video) which are exchanged before a particular session is accepted by the called user (in terms of the signalling). Within a dialogue, early media occurs from the moment the initial INVITE is sent until the User Agent Server (UAS) generates a final response. It may be unidirectional or bidirectional, and can be generated by the caller, the called party, or both. Typical examples of early media generated by the called party are ringing tone and announcements (e.g. queuing status). Early media generated by the caller typically consists of voice commands or dual tone multi-frequency (DTMF) tones to drive interactive voice response (IVR) systems. See figure 8.5.1.0-1.

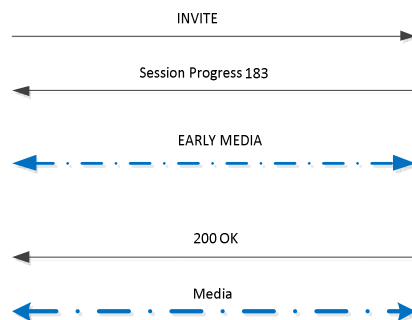

Figure 8.5.1.0-1: Early media SIP overview

8.5.1.1 Call Flow 1

The Call flow below requires that the following be configured in the Incoming SIP Profile:

- Precondition Support: Supported/Required.
- P-Early-Media: Enabled.

Table 8.5.1.1-1 Early media with preconditions, option 1

Test equipment A		NETWORK		Test equipment B
CALL A to B				
INVITE	→	Supported 100rel, precondition SDP: a=curr:qos local none a=curr:qos remote none a=des:qos mandatory local sendrecv a=des:qos mandatory remote sendrecv	→	INVITE
100 Trying	←		←	100 Trying
183 Session Progress	←	Supported 100rel, precondition SDP: a=curr:qos local none a=curr:qos remote none a=des:qos mandatory local sendrecv a=des:qos mandatory remote sendrecv a=conf:qos remote sendrecv	←	183 Session Progress
PRACK	→		→	PRACK
200 PRACK	←		←	200 PRACK
UPDATE	→	SDP a=curr:qos local sendrecv a=curr:qos remote none a=des:qos mandatory local sendrecv a=des:qos mandatory remote sendrecv	→	UPDATE
200 OK UPDATE	←	SDP a=curr:qos local sendrecv a=curr:qos remote sendrecv a=des:qos mandatory local sendrecv a=des:qos mandatory remote sendrecv	←	200 OK UPDATE
Start Early media Quality test				
Start Audio Receive BA_1 (female & male)	←		←	Start Audio Send BA_1 (female & male)

Test equipment A		NETWORK		Test equipment B
CALL A to B				
Start Early media Quality test				
End Audio Receive BA_1	←		←	End Audio Send BA_1
Stop Early media Quality test				
180 Ringing	←		←	180 Ringing
200 OK	←	Supported 100rel SDP: a=curr:qos local sendrcv a=curr:qos remote sendrcv a=des:qos mandatory local sendrcv a=des:qos mandatory remote sendrcv	←	200 OK
ACK	→		→	ACK
BYE	→		→	BYE
200 OK BYE	←		←	200 OK BYE

8.5.1.2 Call Flow 2

The Call flow below requires that the following be configured in the Incoming SIP Profile:

- Precondition Support: Supported/Required.
- P-Early-Media: Enabled.

Table: 8.5.1.2-1: Early media with preconditions, option 2

Test equipment A		NETWORK		Test equipment B
CALL A to B				
INVITE	→	Supported 100rel, precondition SDP: a=curr:qos local sendrcv a=curr:qos remote sendrcv a=des:qos mandatory local sendrcv a=des:qos mandatory remote sendrcv	→	INVITE
100 Trying	←		←	100 Trying
183 Session Progress	←	Supported 100rel, precondition SDP: a=curr:qos local none a=curr:qos remote none a=des:qos mandatory local sendrcv a=des:qos mandatory remote sendrcv a=conf:qos remote sendrcv	←	183 Session Progress
PRACK	→		→	PRACK
200 PRACK	←		←	200 PRACK
UPDATE	→	SDP a=curr:qos local sendrcv a=curr:qos remote none a=des:qos mandatory local sendrcv a=des:qos mandatory remote sendrcv	→	UPDATE
200 OK UPDATE	←	SDP a=curr:qos local sendrcv a=curr:qos remote sendrcv a=des:qos mandatory local sendrcv a=des:qos mandatory remote sendrcv	←	200 OK UPDATE

Test equipment A		NETWORK		Test equipment B
CALL A to B				
Start Early media Quality test				
Start Audio Receive BA_1 (female & male)	←		←	Start Audio Send BA_1 (female & male)
End Audio Receive BA_1	←		←	End Audio Send BA_1
Stop Early media Quality test				
183 Session Progress	←	Supported 100rel SDP: a=curr:qos local sendrecv a=curr:qos remote sendrecv a=des:qos mandatory local sendrecv a=des:qos mandatory remote sendrecv	←	183 Session Progress
PRACK	→		→	PRACK
200 PRACK	←		←	200 PRACK
180 Ringing	←		←	180 Ringing
200 OK	←	Supported 100rel SDP: a=curr:qos local sendrecv a=curr:qos remote sendrecv a=des:qos mandatory local sendrecv a=des:qos mandatory remote sendrecv	←	200 OK
ACK	→		→	ACK
BYE	→		→	BYE
200 OK BYE	←		←	200 OK BYE

Table 8.5.1.2-2: Precondition options

Require Header = <i>Precondition</i>	Supported Header = <i>Precondition</i>	Supported Header = <i>100rel</i>	Comments
YES	n/a	Yes	Precondition Applied to 183 Session Progress sent to Network A
		No	
	NO	Yes	
NO	YES	No	Call will be rejected
		Yes	Precondition Applied to 183 Session Progress sent to Network A
	NO	Yes	
		No	Precondition Not Applied. Call proceeds

8.5.2 Early media listening speech quality convergence quality test

For the synchronization of the voice samples a 700 Hz tone (100 ms signal) as trigger event can be used.

The principle of testing 'early media' is the same as defined for the Convergence Quality test according to clause 5.14.2 of ETSI EG 202 057-2 [i.1]. However, only one speech sample (male/female voice) has to be transmitted from the called party to the calling party emulating the 'early media' transfer. The general technical aspects for this speech samples are the same as defined in clause 5.14.2 of ETSI TS 103 222-1 [15].

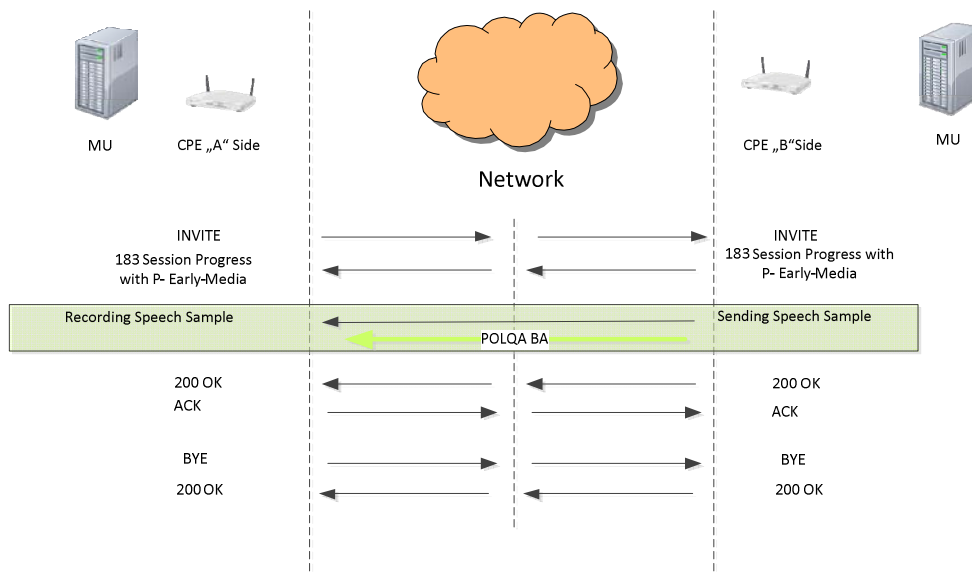

Figure 8.5.2-1: Early media generated by the called party - general over view

8.6 Fax Transmission

The Recommendation ITU-T Q.4016 [28] contains the testing specification of call establishment procedures based on SIP/SDP and H.248 for a real-time fax over IP service. The listed test have to be interpreted as "minimal requirements" for fax support between SIP enabled devices for real-time fax over IP.

8.7 ViLTE KPI

For the following Video Codecs the following KPI applies:

- Bi-directional video (H.264 AVC level 1.1, IPv6, RTCP and MBR>GBR bearer).
- The video bandwidths used for defining MBR and GBR are assumed to be 192 kbps and 64 kbps, respectively.
- Bi-directional video (H.264 AVC level 1.2, 384 kbps, IPv4, RTCP and MBR=GBR bearer).
- The video bandwidth is assumed to be 384 kbps and the IPv4 overhead 20 kbps (assuming 15 fps and 4 IP packets per frame), resulting in 404 kbps.
- Bi-directional video (H.264 AVC level 1.2, 384 kbps, IPv6, RTCP and MBR=GBR bearer).
- The video bandwidth is assumed to be 384 kbps and the IPv6 overhead 32 kbps (assuming 15fps and 4 IP packets per frame), resulting in 416 kbps.
- Bi-directional video (H.264 AVC level 1.2, IPv4, RTCP and MBR>GBR bearer).
- The video bandwidths used for defining MBR and GBR are assumed to be 384 kbps and 192 kbps, respectively. The IPv4 overhead is 20 kbps (assuming 15 fps and 4 IP packets per frame) for MBR and 10 kbps (assuming 15 fps and 2 IP packets per frame) for GBR, resulting in 404 kbps and 202 kbps, respectively.
- Bi-directional video (H.264 AVC level 1.2, IPv6, RTCP and MBR>GBR bearer).
- The video bandwidths used for defining MBR and GBR are assumed to be 384 kbps and 192 kbps, respectively. The IPv6 overhead is 32 kbps (assuming 15 fps and 4 IP packets per frame) for MBR and 16 kbps (assuming 15fps and 2 IP packets per frame) for GBR, resulting in 416 kbps and 208 kbps, respectively.
- Bi-directional video (H.265 (HEVC) Main profile, Main tier, level 3.1, 500 kbps, IPv6, RTCP and MBR=GBR bearer).

- The video bandwidth is assumed to be 500 kbps and the IPv6 overhead 36 kbps (assuming 25 fps, 3 IP packets per frame and IPv6), resulting in 540 kbps. Adding 5 % for RTCP increases the bandwidth by 27 kbps. However, the RTCP bandwidth is limited to max 14 kbps, see clause 7.3.1 in ETSI TS 126 114 [29]. Rounding up to the next higher integer multiple of 8 kbps gives 560 kbps.
- Bi-directional video (H.265 (HEVC) Main profile, Main tier, level 3.1, 500/40 kbps, IPv6, RTCP and MBR>GBR bearer).
- The video bandwidths used for defining MBR and GBR are assumed to be 500 kbps and 40 kbps, respectively. The IPv6 overhead is 36 kbps (assuming 25 fps and 3 IP packets per frame) for MBR and 2,4 kbps (assuming QCIF, 5 fps and 1 IP packets per frame) for GBR, resulting in 540 kbps and 45 kbps, respectively.
- Bi-directional video (H.265 (HEVC) Main profile, Main tier, level 3.1, 600 kbps, IPv6, RTCP and MBR=GBR bearer).
- The video bandwidth is assumed to be 600 kbps and the IPv6 overhead 36 kbps (assuming 25 fps, 3 IP packets per frame and IPv6), resulting in 640 kbps.
- Bi-directional video (H.265 (HEVC) Main profile, Main tier, level 3.1, 600/40 kbps, IPv6, RTCP and MBR>GBR bearer).
- The video bandwidths used for defining MBR and GBR are assumed to be 600 kbps and 40 kbps, respectively. The IPv6 overhead is 36 kbps (assuming 25 fps and 3 IP packets per frame) for MBR and 2,4 kbps (assuming QCIF, 5 fps and 1 IP packets per frame) for GBR, resulting in 640 kbps and 45 kbps, respectively.
- Bi-directional video (H.265 (HEVC) Main profile, Main tier, level 3.1, 650 kbps, IPv6, RTCP and MBR=GBR bearer).
- The video bandwidth is assumed to be 650 kbps and the IPv6 overhead 36 kbps (assuming 25 fps, 3 IP packets per frame and IPv6), resulting in 690 kbps. Adding 5 % for RTCP increases the bandwidth by 34,5 kbps. However, the RTCP bandwidth is limited to max 14 kbps, see clause 7.3.1 in ETSI TS 126 114 [29]. Rounding up to the next higher integer multiple of 8 kbps gives 704 kbps.
- Bi-directional video (H.265 (HEVC) Main profile, Main tier, level 3.1, 650/40 kbps, IPv6, RTCP and MBR > GBR bearer).
- The video bandwidths used for defining MBR and GBR are assumed to be 650 kbps and 40 kbps, respectively. The IPv6 overhead is 36 kbps (assuming 25 fps and 3 IP packets per frame) for MBR and 2,4 kbps (assuming QCIF, 5 fps and 1 IP packets per frame) for GBR, resulting in 690 kbps and 45 kbps, respectively.
- Bi-directional video (H.265 (HEVC) Main profile, Main tier, level 3.1, 750 kbps, IPv6, RTCP and MBR=GBR bearer).
- The video bandwidth is assumed to be 750 kbps and the IPv6 overhead 48 kbps (assuming 25 fps, 4 IP packets per frame and IPv6), resulting in 800 kbps.
- Bi-directional video (H.265 (HEVC) Main profile, Main tier, level 3,1, 750/40 kbps, IPv6, RTCP and MBR>GBR bearer).
- The video bandwidths used for defining MBR and GBR are assumed to be 750 kbps and 40 kbps, respectively. The IPv6 overhead is 48 kbps (assuming 25 fps and 4 IP packets per frame) for MBR and 2,4 kbps (assuming QCIF, 5 fps and 1 IP packets per frame) for GBR, resulting in 800 kbps and 45 kbps, respectively.

Table 8.7-1: QoS requirements for bi-directional video

Traffic class	Conversational class	Notes
Maximum SDU size (octets) [29]	1 400	Maximum size of IP packets.
Residual BER [29]	10^{-5}	Reflects the desire to have a medium level of protection to achieve an acceptable compromise between packet loss rate and speech transport delay and delay variation.
SDU error ratio [29]	7×10^{-3}	A packet loss rate of 0,7 % per wireless link is in general sufficient for video services.
Transfer delay (ms) [29]	170 ms	Indicates maximum delay for 95 th percentile of the distribution of delay for all delivered SDUs between the UE and the PS domain during the lifetime of a bearer service. Permits the derivation of the RAN part of the total transfer delay for the radio access bearer. This attribute allows RAN to set transport formats and H-ARQ/ARQ parameters such as the discard timer.
Lip synchronization	180/90 ms	The acceptability thresholds for lip synchronization are 185 ms when sound is delayed with respect to the video, and 90 ms when sound is advanced with respect to the video [31].

Annex A (informative): Examples of Codecs which can be used in the case of interworking/roaming

Mostly used Codecs:

- 1) AMR-WB
- 2) FR-AMR-WB
- 3) AMR-NB V2 Modeset 4.75/5.90/7.40/12.20
- 4) AMR-NB Modeset 4.75/5.90/7.40/12.20
- 5) FR-AMR
- 6) GSM-EFR
- 7) GSM-FR
- 8) G.729
- 9) G.711 a-Law
- 10) T.38
- 11) IETF Clearmode

Table A.1: Codecs used in case of interworking/roaming from 4G to 3G

VARIABLE	Calling Mobile Carrier 4G	Terminating Mobile Carrier UMTS 2G/3G Codec
VA_01	VOLTE (4G), AMR-WB TRFO	UMTS (3G) - UMTS-FR-AMR-WB Config Set 0 (6,60, 8,85, 12,65 kb/s) without BICC
VA_02		UMTS (3G) - UMTS-FR-AMR-WB Config Set 0 (6,60, 8,85, 12,65 kb/s) with BICC
VA_03		UMTS (3G) - UMTS-AMR-NB V2 Config Set 1 (4,75, 5,90, 7,40, 12,2 kb/s) without BICC
VA_04		UMTS (3G) - UMTS- AMR-NB V2 Config Set 1 (4,75, 5,90, 7,40, 12,2 kb/s) with BICC
VA_05		GSM (2G) - GSM-EFR/GSM-FR on UE without BICC
VA_06		GSM (2G) - GSM-EFR/GSM-FR on UE with BICC
VA_07		GSM (2G) - GSM-FR/GSM-FR on UE without BICC
VA_08		GSM (2G) - GSM-FR/GSM-FR on UE with BICC
VA_09	VOLTE (4G), AMR-WB noTRFO	UMTS (3G) - UMTS-FR-AMR-WB Config Set 0 (6,60, 8,85, 12,65 kb/s) without BICC
VA_10		UMTS (3G) - UMTS-FR-AMR-WB Config Set 0 (6,60, 8,85, 12,65 kb/s) with BICC
VA_11		UMTS (3G) - UMTS-AMR2 Config Set 1 (4,75, 5,90, 7,40, 12,2 kb/s) without BICC
VA_12		UMTS (3G) - UMTS-AMR2 Config Set 1 (4,75, 5,90, 7,40, 12,2 kb/s) with BICC
VA_13		GSM (2G) - GSM-EFR/GSM-FR on UE without BICC
VA_14		GSM (2G) - GSM-EFR/GSM-FR on UE with BICC
VA_15		GSM (2G) - GSM-FR/GSM-FR on UE without BICC
VA_16		GSM (2G) - GSM-FR/GSM-FR on UE with BICC

Table A.2: Codecs used in case of interworking/roaming 3G to 4G

VARIABLE	Calling Mobile Carrier 3G	Terminating Mobile Carrier 4G
VA_1	UMTS (3G), TRFO UMTS-FR-AMR-WB Config Set 0 (6,60, 8,85, 12,65 kb/s) UMTS-AMR2 Config Set 1 (4,75, 5,90, 7,40, 12,2 kb/s)	<ul style="list-style-type: none"> • VoLTE (4G) <ul style="list-style-type: none"> – AMR-WB mode-set 0,1,2 (6,60, 8,85, 12,65 kb/s); mode-change-period=2; mode-change-neighbour=1; 20 ms; preconditions used; tel. events – AMR NB mode-set 0,2,4,7 (4,75, 5,90, 7,40, 12,2 kb/s); mode-change-period=2; mode-change-neighbour=1; 20 ms, preconditions used, tel. events
VA_2	UMTS (3G), noTRFO UMTS-FR-AMR-WB Config Set 0 (6,60, 8,85, 12,65 kb/s) UMTS-AMR2 Config Set 1 (4,75, 5,90, 7,40, 12,2 kb/s)	<ul style="list-style-type: none"> • VoLTE (4G) <ul style="list-style-type: none"> – AMR-WB mode-set 0,1,2 (6,60, 8,85, 12,65 kb/s); mode-change-period=2; mode-change-neighbour=1; 20 ms; preconditions used; tel. events – AMR NB mode-set 0,2,4,7 (4,75, 5,90, 7,40, 12,2 kb/s); mode-change-period=2; mode-change-neighbour=1; 20 ms, preconditions used, tel. events
VA_3	GSM (2G), TRFO GSM-FR-AMR-WB	<ul style="list-style-type: none"> • VoLTE (4G) <ul style="list-style-type: none"> – AMR-WB mode-set 0,1,2 (6,60, 8,85, 12,65 kb/s); mode-change-period=2; mode-change-neighbour=1; 20 ms; preconditions used; tel. events – AMR NB mode-set 0,2,4,7 (4,75, 5,90, 7,40, 12,2 kb/s); mode-change-period=2; mode-change-neighbour=1; 20 ms, preconditions used, tel. events
VA_4	 GSM (2G), noTRFO GSM-FR-AMR-WB	<ul style="list-style-type: none"> • VoLTE (4G) <ul style="list-style-type: none"> – AMR-WB mode-set 0,1,2 (6,60, 8,85, 12,65 kb/s); mode-change-period=2; mode-change-neighbour=1; 20 ms; preconditions used; tel. events – AMR NB mode-set 0,2,4,7 (4,75, 5,90, 7,40, 12,2 kb/s); mode-change-period=2; mode-change-neighbour=1; 20 ms, preconditions used, tel. events
VA_5	GSM (2G), TRFO GSM-FR-AMR	<ul style="list-style-type: none"> • VoLTE (4G) <ul style="list-style-type: none"> – AMR-WB mode-set 0,1,2 (6,60, 8,85, 12,65 kb/s); mode-change-period=2; mode-change-neighbour=1; 20 ms; preconditions used; tel. events – AMR NB mode-set 0,2,4,7 (4,75, 5,90, 7,40, 12,2 kb/s); mode-change-period=2; mode-change-neighbour=1; 20 ms, preconditions used, tel. events
VA_6	GSM (2G), noTRFO GSM-FR-AMR	<ul style="list-style-type: none"> • VoLTE (4G) <ul style="list-style-type: none"> – AMR-WB mode-set 0,1,2 (6,60, 8,85, 12,65 kb/s); mode-change-period=2; mode-change-neighbour=1; 20 ms; preconditions used; tel. events – AMR NB mode-set 0,2,4,7 (4,75, 5,90, 7,40, 12,2 kb/s); mode-change-period=2; mode-change-neighbour=1; 20 ms, preconditions used, tel. events
VA_7	GSM (2G), TRFO GSM-HR-AMR	<ul style="list-style-type: none"> • VoLTE (4G) <ul style="list-style-type: none"> – AMR-WB mode-set 0,1,2 (6,60, 8,85, 12,65 kb/s); mode-change-period=2; mode-change-neighbour=1; 20 ms; preconditions used; tel. events – AMR NB mode-set 0,2,4,7 (4,75, 5,90, 7,40, 12,2 kb/s); mode-change-period=2; mode-change-neighbour=1; 20 ms, preconditions used, tel. events

VARIABLE	Calling Mobile Carrier 3G	Terminating Mobile Carrier 4G
VA_8	GSM (2G), noTRFO GSM-HR-AMR	<ul style="list-style-type: none"> • VoLTE (4G) <ul style="list-style-type: none"> – AMR-WB mode-set 0,1,2 (6,60, 8,85, 12,65 kb/s); mode-change-period=2; mode-change-neighbour=1; 20 ms; preconditions used; tel. events – AMR NB mode-set 0,2,4,7 (4,75, 5,90, 7,40, 12,2 kb/s); mode-change-period=2; mode-change-neighbour=1; 20 ms, preconditions used, tel. events

Table A.3: Codecs used in case of interworking/roaming 3G to 3G

VARIABLE	Calling Mobile Carrier 3G	Terminating Mobile Carrier 3G
VA_1	UMTS (3G), TRFO UMTS-FR-AMR-WB Config Set 0 (6,60, 8,85, 12,65 kb/s) UMTS-AMR2 Config Set 1 (4,75, 5,90, 7,40, 12,2 kb/s)	<ul style="list-style-type: none"> • UMTS (3G) - UMTS-FR-AMR-WB Config Set 0 (6,60, 8,85, 12,65 kb/s) without BICC • UMTS (3G) - UMTS-FR-AMR-WB Config Set 0 (6,60, 8,85, 12,65 kb/s) with BICC • UMTS (3G) - UMTS-AMR2 Config Set 1 (12,2 kb/s) without BICC • UMTS (3G) - UMTS-AMR2 Config Set 1 (4,75, 5,90, 7,40, 12,2 kb/s) without BICC • UMTS (3G) - UMTS-AMR2 Config Set 1 (12,2 kb/s) with BICC • UMTS (3G) - UMTS-AMR2 Config Set 1 (4,75, 5,90, 7,40, 12,2 kb/s) with BICC • GSM (2G) - GSM-EFR/GSM-FR on UE without BICC • GSM (2G) - GSM-EFR/GSM-FR on UE with BICC
VA_2	UMTS (3G), noTRFO UMTS-FR-AMR-WB Config Set 0 (6,60, 8,85, 12,65 kb/s) UMTS-AMR2 Config Set 1 (4,75, 5,90, 7,40, 12,2 kb/s)	<ul style="list-style-type: none"> • UMTS (3G) - UMTS-FR-AMR-WB Config Set 0 (6,60, 8,85, 12,65 kb/s) without BICC • UMTS (3G) - UMTS-FR-AMR-WB Config Set 0 (6,60, 8,85, 12,65 kb/s) with BICC • UMTS (3G) - UMTS-AMR2 Config Set 1 (12,2 kb/s) without BICC • UMTS (3G) - UMTS-AMR2 Config Set 1 (4,75, 5,90, 7,40, 12,2 kb/s) without BICC • UMTS (3G) - UMTS-AMR2 Config Set 1 (12,2 kb/s) with BICC • UMTS (3G) - UMTS-AMR2 Config Set 1 (4,75, 5,90, 7,40, 12,2 kb/s) with BICC • GSM (2G) - GSM-EFR/GSM-FR on UE without BICC • GSM (2G) - GSM-EFR/GSM-FR on UE with BICC
VA_3	GSM (2G), TRFO GSM-FR-AMR-WB	<ul style="list-style-type: none"> • UMTS (3G) - UMTS-FR-AMR-WB Config Set 0 (6,60, 8,85, 12,65 kb/s) without BICC • UMTS (3G) - UMTS-FR-AMR-WB Config Set 0 (6,60, 8,85, 12,65 kb/s) with BICC • UMTS (3G) - UMTS-AMR2 Config Set 1 (12,2 kb/s) without BICC • UMTS (3G) - UMTS-AMR2 Config Set 1 (4,75, 5,90, 7,40, 12,2 kb/s) without BICC • UMTS (3G) - UMTS-AMR2 Config Set 1 (12,2 kb/s) with BICC • UMTS (3G) - UMTS-AMR2 Config Set 1 (4,75, 5,90, 7,40, 12,2 kb/s) with BICC • GSM (2G) - GSM-EFR/GSM-FR on UE without BICC • GSM (2G) - GSM-EFR/GSM-FR on UE with BICC
VA_4	GSM (2G), noTRFO GSM-FR-AMR-WB	<ul style="list-style-type: none"> • UMTS (3G) - UMTS-FR-AMR-WB Config Set 0 (6,60, 8,85, 12,65 kb/s) without BICC • UMTS (3G) - UMTS-FR-AMR-WB Config Set 0 (6,60, 8,85, 12,65 kb/s) with BICC • UMTS (3G) - UMTS-AMR2 Config Set 1 (12,2 kb/s) without BICC

VARIABLE	Calling Mobile Carrier 3G	Terminating Mobile Carrier 3G
		<ul style="list-style-type: none"> • UMTS (3G) - UMTS-AMR2 Config Set 1 (4,75, 5,90, 7,40, 12,2 kb/s) without BICC • UMTS (3G) - UMTS-AMR2 Config Set 1 (12,2 kb/s) with BICC • UMTS (3G) - UMTS-AMR2 Config Set 1 (4,75, 5,90, 7,40, 12,2 kb/s) with BICC • GSM (2G) - GSM-EFR/GSM-FR on UE without BICC • GSM (2G) - GSM-EFR/GSM-FR on UE with BICC
VA_5	GSM (2G), TRFO GSM-FR-AMR	<ul style="list-style-type: none"> • UMTS (3G) - UMTS-FR-AMR-WB Config Set 0 (6,60, 8,85, 12,65 kb/s) without BICC • UMTS (3G) - UMTS-FR-AMR-WB Config Set 0 (6,60, 8,85, 12,65 kb/s) with BICC • UMTS (3G) - UMTS-AMR2 Config Set 1 (12,2 kb/s) without BICC • UMTS (3G) - UMTS-AMR2 Config Set 1 (4,75, 5,90, 7,40, 12,2 kb/s) without BICC • UMTS (3G) - UMTS-AMR2 Config Set 1 (12,2 kb/s) with BICC • UMTS (3G) - UMTS-AMR2 Config Set 1 (4,75, 5,90, 7,40, 12,2 kb/s) with BICC • GSM (2G) - GSM-EFR/GSM-FR on UE without BICC • GSM (2G) - GSM-EFR/GSM-FR on UE with BICC
VA_6	GSM (2G), noTRFO GSM-FR-AMR	<ul style="list-style-type: none"> • UMTS (3G) - UMTS-FR-AMR-WB Config Set 0 (6,60, 8,85, 12,65 kb/s) without BICC • UMTS (3G) - UMTS-FR-AMR-WB Config Set 0 (6,60, 8,85, 12,65 kb/s) with BICC • UMTS (3G) - UMTS-AMR2 Config Set 1 (12,2 kb/s) without BICC • UMTS (3G) - UMTS-AMR2 Config Set 1 (4,75, 5,90, 7,40, 12,2 kb/s) without BICC • UMTS (3G) - UMTS-AMR2 Config Set 1 (12,2 kb/s) with BICC • UMTS (3G) - UMTS-AMR2 Config Set 1 (4,75, 5,90, 7,40, 12,2 kb/s) with BICC • GSM (2G) - GSM-EFR/GSM-FR on UE without BICC • GSM (2G) - GSM-EFR/GSM-FR on UE with BICC
VA_7	GSM (2G), TRFO GSM-HR-AMR	<ul style="list-style-type: none"> • UMTS (3G) - UMTS-FR-AMR-WB Config Set 0 (6,60, 8,85, 12,65 kb/s) without BICC • UMTS (3G) - UMTS-FR-AMR-WB Config Set 0 (6,60, 8,85, 12,65 kb/s) with BICC • UMTS (3G) - UMTS-AMR2 Config Set 1 (12,2 kb/s) without BICC • UMTS (3G) - UMTS-AMR2 Config Set 1 (4,75, 5,90, 7,40, 12,2 kb/s) without BICC • UMTS (3G) - UMTS-AMR2 Config Set 1 (12,2 kb/s) with BICC • UMTS (3G) - UMTS-AMR2 Config Set 1 (4,75, 5,90, 7,40, 12,2 kb/s) with BICC • GSM (2G) - GSM-EFR/GSM-FR on UE without BICC • GSM (2G) - GSM-EFR/GSM-FR on UE with BICC
VA_8	GSM (2G), noTRFO GSM-HR-AMR	<ul style="list-style-type: none"> • UMTS (3G) - UMTS-FR-AMR-WB Config Set 0 (6,60, 8,85, 12,65 kb/s) without BICC • UMTS (3G) - UMTS-FR-AMR-WB Config Set 0 (6,60, 8,85, 12,65 kb/s) with BICC • UMTS (3G) - UMTS-AMR2 Config Set 1 (12,2 kb/s) without BICC • UMTS (3G) - UMTS-AMR2 Config Set 1 (4,75, 5,90, 7,40, 12,2 kb/s) without BICC • UMTS (3G) - UMTS-AMR2 Config Set 1 (12,2 kb/s) with BICC • UMTS (3G) - UMTS-AMR2 Config Set 1 (4,75, 5,90, 7,40, 12,2 kb/s) with BICC • GSM (2G) - GSM-EFR/GSM-FR on UE without BICC • GSM (2G) - GSM-EFR/GSM-FR on UE with BICC

Annex B (informative): Examples for grouped tests

Execution of grouped tests 2G/3G - VoLTE (SIP-I)		
Test call	NNI Req. ETSI TS 101 585 [25]	Description
1)	SS_bcall_001	Ensure that the call clearing procedure is performed correctly when the called user clears after answer.
	SS_bcall_003	The test call is successful in the case if the Call setup time does not exceed the values listed in table 7.1.1-1 and call is stable in unanswered and answered phases, the call remains in intelligible/high quality conversation phase for 80 seconds. The Voice Quality test procedures are described clause 8.2.
	SS_bcall_010	
	SS_bcall_011	
	SS_bcall_012	The test scenarios are listed in table 4.2.5-1.
	SS_bcall_013	
	SS_bcall_014	Ensure that the Request line in the INVITE contains in the user part the telephone number of the destination user equipment formatted as a 'tel' URI in the global number format and the host portion is set to the host name of the interconnected network. The user URI parameter is present and set to 'phone'.
	SS_bcall_015	
	SS_bcall_016	
	SS_bcall_017	Ensure that if the Record-Route header is present in the INVITE establishes a communication between a user of network A and a user of network B the topmost header is set to the IBCF of network A.
	SS_DTMF 01	
	SIP-I	Ensure that the Via header is present in the INVITE establishes a communication between a user of network A and a user of network B and the topmost header is set to the IBCF of network A and contains a branch parameter.
	SS_bcall_SIP-I_01	
	SS_bcall_SIP-I_02	Ensure if a Record-Route header was present in the initial INVITE that the Record-Route header is present in the 180 Ringing provisional response as the first response from network B upon a connection establish setup from network A.
	SS_bcall_SIP-I_03	
	SS_bcall_SIP-I_06	Ensure that if a Record-Route header was present in the initial INVITE the Route header may be present in the BYE request sent from the originating user equipment in network A the topmost Route header or entry is set to the IBCF of network B.
	SS_bcall_SIP-I_08	
	Ensure that if a Record-Route header was present in the initial INVITE the Route header may be present in the BYE request sent from the terminating user equipment in network B the topmost Route header or entry is set to the IBCF of network A.	
	Ensure that if a Record-Route header was present in the initial INVITE the Route header may be present in ACK from network A upon a connection establishment from network A is completed the topmost Route header or entry is set to the IBCF of network B.	
	Ensure that call establishment and the correct handling of the SDP parameters of the INVITE message defined as: TYPE_SDP is performed correctly. Ensure that in the active call state the voice/data transfer on the media channels is performed correctly (e.g. testing QoS parameters). In case when the parameter in the SDP rtpmap:<dynamic-PT> is used the codecs in table 7.1.1-1 applies.	
	SIP-I support, Basic call, IAM present in the INVITE request.	
	Ensure that when a call initiated in the PSTN or the PLMN and the ISUP - SIP-I interworking is applicable in the originating network, an ISUP IAM is encapsulated in the initial INVITE request.	
	Ensure that all the mandatory parameters in the IAM are present and the values are valid and the Transmission medium requirement parameter is consistent with the SDP.	
	Ensure that the original IAM is encapsulated in any INVITE request.	
	The test call is successful in the case if the Call setup time does not exceed the values listed in table 7.1.1-1 and call is stable in unanswered and answered phases, the call remains in intelligible/high quality conversation phase for 80 s. The Voice Quality test procedures are described clause 8.2.	
	SIP-I support, Basic call, ACM present in the 180 response.	
	Ensure that on receipt of a 180 Ringing provisional response and an SIP-I - ISUP interworking is applicable in the terminating network the Backward call indicators parameter in the encapsulated ACM is present and the values are valid.	
	Ensure that the values of the optional parameters in the encapsulated ACM are valid.	

Execution of grouped tests 2G/3G - VoLTE (SIP-I)		
Test call	NNI Req. ETSI TS 101 585 [25]	Description
		<p>SIP-I support. Basic call, ANM present in a 200 OK INVITE response. Ensure that on receipt of a 200 OK INVITE final response and an SIP-I - ISUP interworking is applicable in the terminating network the ISUP ANM is encapsulated in the 200 OK. Ensure that the values of the optional parameters in the encapsulated ANM are valid.</p> <p>SIP-I support. Basic call, REL present in a BYE request sent from the terminating network. Ensure that a ISUP REL message is encapsulated in a BYE request sent in the release procedure initiated from the terminating user when SIP-I - ISUP interworking is applicable in the terminating network. Ensure the validity of the cause indicator in the encapsulated REL. Ensure that the ISUP RLC is encapsulated in the 200 OK BYE.</p>
2)	SS_bcall_018	<p>First response 200 OK INVITE. Ensure that call establishment and the correctly if the called user answers with a 200 OK message</p>
3)	SS_bcall_SIP-I_04 SS_bcall_SIP-I_05	<p>SIP-I support. Basic call, early ACM present in the 183 response. Ensure that on receipt of a 183 Session Progress provisional response and an SIP-I - ISUP interworking is applicable in the terminating network the Backward call indicators parameter in the encapsulated ACM is present and the value of the Called party's status indicator is set to 'no indication'. Ensure that the values of the optional parameters in the encapsulated ACM are valid.</p> <p>SIP-I support. Basic call, CPG present in a 180 response. Ensure that on receipt of a 180 Ringing provisional response and an SIP-I - ISUP interworking is applicable in the terminating network the Event indicator in the encapsulated CPG is present and set to 'ALERTING'. Ensure that the values of the optional parameters in the encapsulated CPG are valid.</p> <p>Transmission of DTMF Ensure that the ability of transmission of DTMF can be performed by the originating and destination user. The transmission can be done by:</p> <ul style="list-style-type: none"> • DTMF in the RTP stream; • Either by indicating in the SDP offer in the RTP stream; • Or by the SIP INFO/NOTIFY Method for DTMF tone generation. <p>DTMF Test: The DTMF Test should consist DTMF tones (70 ms signal, 100 ms pause) and should contain the tones 0, 1, 2, 3, 4, 5, 6, 7, 8, 9, A, B, C, D, *, #. The transmission should be tested in both directions.</p>
4)	SS_bcall_002 SS_bcall_013 SS_bcall_SIP-I_07	<p>Ensure that the call clearing procedure is performed correctly when the calling user clears after answer.</p> <p>SIP-I support. Basic call, REL present in a BYE request sent from the originating network. Ensure that a ISUP REL message is encapsulated in a BYE request sent in the release procedure initiated from the originating user when ISUP - SIP-I interworking is applicable in the originating network. Ensure the validity of the cause indicator in the encapsulated REL. Ensure that the ISUP RLC is encapsulated in the 200 OK BYE.</p>
5)		EARLY MEDIA

Annex C (informative): Bibliography

- GSMA PRD IR.65: "IMS Roaming and Interworking Guidelines".
- GSMA PRD IR.92: "IR.92 IMS Profile for Voice and SMS".

NOTE: Available at <https://www.gsma.com/newsroom/wp-content/uploads/IR.92-v9.0.pdf>.

- GSMA PRD IR.94: "IR.94 IMS Profile for Conversational Video Service".
- ETSI TS 103 222-3 (V1.1.1): "Speech and multimedia Transmission Quality (STQ); Reference benchmarking, background traffic profiles and KPIs; Part 3: Reference benchmarking, background traffic profiles and KPIs for UMTS and VoLTE2".

History

Document history		
V1.1.1	March 2019	Publication
V1.1.2	March 2020	Publication