

ETSI TS 103 531 V1.1.1 (2018-09)



**Environmental Engineering (EE);
Impact on ICT equipment architecture of multiple AC,
-48 VDC or up to 400 VDC power inputs**

Reference

DTS/EE-0267

Keywords

architecture, electric, interface, power supply

ETSI

650 Route des Lucioles
F-06921 Sophia Antipolis Cedex - FRANCE

Tel.: +33 4 92 94 42 00 Fax: +33 4 93 65 47 16

Siret N° 348 623 562 00017 - NAF 742 C
Association à but non lucratif enregistrée à la
Sous-Préfecture de Grasse (06) N° 7803/88

Important notice

The present document can be downloaded from:

<http://www.etsi.org/standards-search>

The present document may be made available in electronic versions and/or in print. The content of any electronic and/or print versions of the present document shall not be modified without the prior written authorization of ETSI. In case of any existing or perceived difference in contents between such versions and/or in print, the only prevailing document is the print of the Portable Document Format (PDF) version kept on a specific network drive within ETSI Secretariat.

Users of the present document should be aware that the document may be subject to revision or change of status.

Information on the current status of this and other ETSI documents is available at

<https://portal.etsi.org/TB/ETSIDeliverableStatus.aspx>

If you find errors in the present document, please send your comment to one of the following services:

<https://portal.etsi.org/People/CommiteeSupportStaff.aspx>

Copyright Notification

No part may be reproduced or utilized in any form or by any means, electronic or mechanical, including photocopying and microfilm except as authorized by written permission of ETSI.

The content of the PDF version shall not be modified without the written authorization of ETSI.

The copyright and the foregoing restriction extend to reproduction in all media.

© ETSI 2018.

All rights reserved.

DECT™, **PLUGTESTS™**, **UMTS™** and the ETSI logo are trademarks of ETSI registered for the benefit of its Members.

3GPP™ and **LTE™** are trademarks of ETSI registered for the benefit of its Members and of the 3GPP Organizational Partners.

oneM2M logo is protected for the benefit of its Members.

GSM® and the GSM logo are trademarks registered and owned by the GSM Association.

Contents

Intellectual Property Rights	4
Foreword.....	4
Modal verbs terminology.....	4
Introduction	4
1 Scope	5
2 References	5
2.1 Normative references	5
2.2 Informative references.....	5
3 Definitions, symbols and abbreviations	6
3.1 Definitions	6
3.2 Symbols.....	6
3.3 Abbreviations	6
4 Definition and requirement of the multiple power interface configuration at the input power feeds of ICT equipment	7
4.1 Individual power interface used for multiple power interface configuration	7
4.2 Multiple power interface configurations and requirements	7
4.2.1 Identification of multiple interface inputs options	7
4.2.2 Configuration AC/AC.....	8
4.2.3 Configuration AC/400 VDC	8
4.2.4 Configuration 400 VDC/400 VDC	9
4.2.5 Configuration AC/-48 VDC.....	9
4.2.6 Configuration -48 VDC/-48 VDC	10
4.2.7 Configuration 400 VDC/-48 VDC.....	10
5 Combination dependence of A, A3 and A3ac interface for multiple power feeds.....	11
6 Back feeding protection.....	14
Annex A (informative): Switch Selector installation options.....	16
Annex B (informative): Switch Selector - General functionality and requirements Switch.....	19
Annex C (informative): Back-feeding Protection	20
Annex D (informative): Example of upstream conversion for dual -48 VDC power feed configuration at input of ICT equipment	22
History	23

Intellectual Property Rights

Essential patents

IPRs essential or potentially essential to normative deliverables may have been declared to ETSI. The information pertaining to these essential IPRs, if any, is publicly available for **ETSI members and non-members**, and can be found in ETSI SR 000 314: "*Intellectual Property Rights (IPRs); Essential, or potentially Essential, IPRs notified to ETSI in respect of ETSI standards*", which is available from the ETSI Secretariat. Latest updates are available on the ETSI Web server (<https://ipr.etsi.org/>).

Pursuant to the ETSI IPR Policy, no investigation, including IPR searches, has been carried out by ETSI. No guarantee can be given as to the existence of other IPRs not referenced in ETSI SR 000 314 (or the updates on the ETSI Web server) which are, or may be, or may become, essential to the present document.

Trademarks

The present document may include trademarks and/or tradenames which are asserted and/or registered by their owners. ETSI claims no ownership of these except for any which are indicated as being the property of ETSI, and conveys no right to use or reproduce any trademark and/or tradename. Mention of those trademarks in the present document does not constitute an endorsement by ETSI of products, services or organizations associated with those trademarks.

Foreword

This Technical Specification (TS) has been produced by ETSI Technical Committee Environmental Engineering (EE).

Modal verbs terminology

In the present document "**shall**", "**shall not**", "**should**", "**should not**", "**may**", "**need not**", "**will**", "**will not**", "**can**" and "**cannot**" are to be interpreted as described in clause 3.2 of the [ETSI Drafting Rules](#) (Verbal forms for the expression of provisions).

"**must**" and "**must not**" are **NOT** allowed in ETSI deliverables except when used in direct citation.

Introduction

With the advantages of the emerging up to 400 VDC power distribution along with the continued use of the legacy AC and -48 VVD power distribution for telecom and Information and Communication Technology (ICT) power feeding, a new ICT power interface is defined as being a combination of the standardized AC and DC power interfaces (AC, -48 V, up to 400 VDC). In general case, the power configuration combination will be made of up to two of these three power interfaces and is identified as dual power inputs interface of an ICT system.

The present document also provides details showing the ICT equipment front end power architectures that includes the on board converter and the interconnection options between the converter and the ICT interface. These include interface switch selector and diode combiner solutions for multiple power input feeds.

With the increase in the variation of potential power feeds to ICT equipment especially with the emergence of up to 400 VDC power networks, a clear indication of how a multiple input power feed is to be referenced and how these multiple power feeds can be best managed, is crucial in ensuring that common and recognized approaches are adopted in the installation and configuration of future ICT equipment.

Annex B presents options for the installation of a switch selector within ICT equipment and its operational attributes targeted for its reliable operation.

The present document was developed jointly by ETSI TC EE and ITU-T Study Group 5 and published respectively by ETSI and ITU-T as ETSI Standard ETSI TS 103 531 and as Recommendation ITU-T L.1206, which are technically equivalent.

1 Scope

The present document is applicable to the case of multiple power feeding configurations at the input of ICT equipment in ICT system.

The present document describes the combination of three power interfaces as A (-48 V), P or A3 (up to 400 VDC) and A3ac (AC) that could potentially be used for each input.

The present document also provides details of the power structure within the ICT equipment, between the ICT equipment interfaces and ICT equipment system loads that is inclusive of system power converters.

The input power configurations are categorized to allow for better understanding and identification of the each new multiple power feeding interface, providing details of the impacts and benefits of adopting them. Information is also provided on the impact on battery test function when used with the different dual power inputs combinations.

Lastly requirements are given for avoiding the potential risk of voltage back feeding from one input to the other and for general isolation requirements in all multiple power feeding configurations.

2 References

2.1 Normative references

References are either specific (identified by date of publication and/or edition number or version number) or non-specific. For specific references, only the cited version applies. For non-specific references, the latest version of the referenced document (including any amendments) applies.

Referenced documents which are not found to be publicly available in the expected location might be found at <https://docbox.etsi.org/Reference/>.

NOTE: While any hyperlinks included in this clause were valid at the time of publication, ETSI cannot guarantee their long term validity.

The following referenced documents are necessary for the application of the present document.

- [1] Recommendation ITU-T L.1200: "Direct current power feeding interface up to 400 V at the input to telecommunication and ICT equipment".
- [2] ETSI EN 300 132-2: "Environmental Engineering (EE); Power supply interface at the input to telecommunications and datacom (ICT) equipment; Part 2: Operated by -48 V direct current (dc)".
- [3] ETSI EN 300 132-3-1: "Environmental Engineering (EE); Power supply interface at the input to telecommunications and datacom (ICT) equipment; Part 3: Operated by rectified current source, alternating current source or direct current source up to 400 V; Sub-part 1: Direct current source up to 400 V".

2.2 Informative references

References are either specific (identified by date of publication and/or edition number or version number) or non-specific. For specific references, only the cited version applies. For non-specific references, the latest version of the referenced document (including any amendments) applies.

NOTE: While any hyperlinks included in this clause were valid at the time of publication, ETSI cannot guarantee their long term validity.

The following referenced documents are not necessary for the application of the present document but they assist the user with regard to a particular subject area.

- [i.1] ETSI EN 300 132-1: "Environmental Engineering (EE); Power supply interface at the input to Information and Communication Technology (ICT) equipment; Part 1: Operated by Alternating Current (AC) source".

- [i.2] IEC 60445: "Basic and safety principles for man-machine interface, marking and identification - Identification of equipment terminals, conductor terminations and conductors".
- [i.3] ISO/IEC 2382-14: "Information technology - Vocabulary - Part 14: Reliability, maintainability and availability".

3 Definitions, symbols and abbreviations

3.1 Definitions

For the purposes of the present document, the following terms and definitions apply:

combined power feeding: function by which two power inputs feeds to ICT equipment is managed such that one input is always available to power a single power module within the ICT equipment e.g. by using the reverse bias characteristic of a two diodes common cathode module or a dual MOSFET

combiner: device achieving the combined power feeding function

dependant power feed: power feed associated with a single interface on the ICT equipment but jointly associated to another power feed with a single power module within the ICT equipment via a managed power interface (switched or combined power feed)

hot standby state: standby state providing for immediate operation upon demand

NOTE 1: This is the hot standby mode of an equipment or a system as defined in ISO/IEC 2382-14 [i.3].

NOTE 2: A hot standby state may apply to redundant or stand-alone items.

NOTE 3: In some applications, an item in a hot standby state is considered to be operating.

independent power feed: power feed associated with a single interface on the ICT equipment and a single power module within the same ICT equipment used in a multiple power feeding interface

interface "A": ICT equipment -48 VDC power interface as defined in ETSI EN 300 132-2 [2]

interface "A3": ICT equipment up to 400 VDC power interface as defined in ETSI EN 300 132-3-1 [3]

interface "A3ac": ICT equipment AC power interface as defined in ETSI EN 300 132-1 [i.1]

interface "P": ICT equipment up to 400 VDC power interface as defined in Recommendation ITU-T L.1200 [1]

switched power feeding: method by which two power inputs feeds to ICT equipment is managed such that one input is always available to power a single power module within the ICT equipment with the use of a switch

switch selector: device achieving the switched dependant power feed selection by a power switch

3.2 Symbols

For the purposes of the present document, the following symbols apply:

A+	Pole plus of input A
A-	Pole minus of input A
B+	Pole plus of input B
B-	Pole minus of input B

3.3 Abbreviations

For the purposes of the present document, the following abbreviations apply:

AC	Alternating Current
----	---------------------

CONV	CONVerter
D	Diode
DC	Direct Current
EMC	ElectroMagnetic Compatibility
ICT	Information and Communication Technology
MOSFET	Metal Oxide Semiconductor Field Effect Transistor
swSelect	switch Selector
TC	Technical Committee
VAC	Volt AC
VDC	Volt DC

4 Definition and requirement of the multiple power interface configuration at the input power feeds of ICT equipment

4.1 Individual power interface used for multiple power interface configuration

The power supply interfaces presented in Figures 1 to 6, are the physical inter-connection points to which all the requirements are related. These points are situated between the power supply system(s) and ICT equipment.

Definitions of configurations in which "A", "P(A3)" and "A3ac" interfaces presented as individual interface references can be found in the following documents:

- ETSI EN 300 132-1 [i.1], annex C (AC supply) - A3ac interface
- ETSI EN 300 132-2 [2], annex E (-48 VDC supply) - A interface
- Recommendation ITU-T L.1200 [1], P interface (up to 400 VDC supply) - equivalent to ETSI EN 300 132-3-1 [3], annex B - A3 interface

NOTE: Subject to the installation preconditions, this point may be located at any other point between the power supply system and ICT equipment by mutual agreement of the relevant parties.

4.2 Multiple power interface configurations and requirements

4.2.1 Identification of multiple interface inputs options

For the case of multiple inputs configurations occurring on ICT equipment, (e.g. power supply unit with dual feeds) each power interface shall comply with at least one of the applicable interface detailed in clause 6.

The multiple power interfaces shall be identified by using each of the individual interface definitions in sequence, for example, an ICT interface comprising of one AC supply (A3ac) and one AC supply (A3ac) shall be named A3ac/A3ac.

In respect of the contents presented within the present document, interface "A3ac/A3ac", "A3ac/A3", "A3/A3", "A3ac/A", "A/A", and "A/A3" are located at the power terminals of the ICT equipment or system as defined by the manufacturer in accordance with IEC 60445 [i.2].

Table 1 presents all the interface options for multiple power feeds to ICT equipment. This table makes the initial assumption that a maximum of only two power feeds are used at the interface. Power interfaces will be configured for any ICT equipment installation and the individual interface shall be in accordance with the input power feed selected.

Table 1: Interface configuration options for multiple power feed of ICT equipment

	AC	400 VDC	48 VDC
AC	A3ac/A3ac (Figure 1)	A3ac/A3 (Figure 2)	A3ac/A (Figure 4)
400 VDC	A3ac/A3 (Figure 2)	A3/A3 (Figure 3)	A3/A (Figure 6)
-48 VDC	A3ac/A (Figure 4)	A3/A (Figure 6)	A/A (Figure 5)

4.2.2 Configuration AC/AC

Figure 1 presents the interface A3ac/A3ac for a multiple power feed consisting of two AC power feeds.

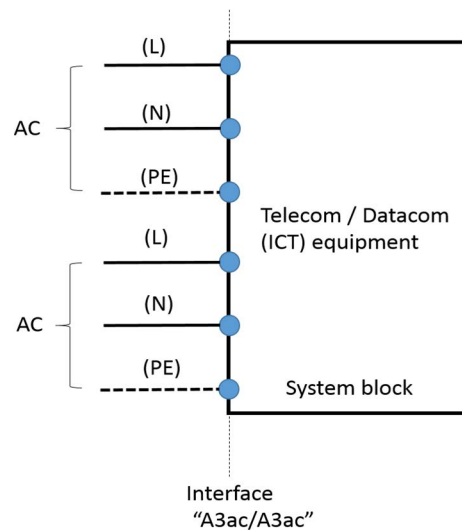

Figure 1: General identification of the A3ac/A3ac interface for multiple power feeds for dual AC inputs

The interface and the operational voltage characteristics for an AC power feed are detailed within document [i.1].

4.2.3 Configuration AC/400 VDC

Figure 2 presents the interface "A3ac/A3" for a multiple power feed consisting of one AC power feed and one up to 400 VDC power feed. The AC interface and the interface for up to 400 VDC power feeds have the interface references of "A3ac" and "A3" respectively and as such the combination of these two reference interfaces when used together on ICT equipment is presented as "A3ac/A3".

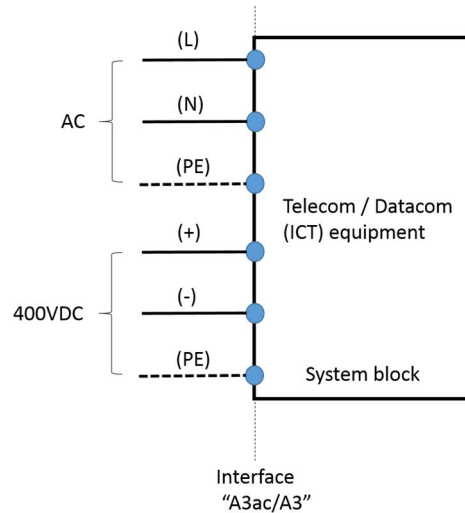

Figure 2: General identification of the A3ac/A3 interface for multiple power feeds for AC and up to 400 VDC inputs

The interface and the operational voltage characteristics for an AC power feed are detailed within ETSI EN 300 132-1 [i.1] and the interface and the operational voltage characteristics for up to 400 VDC power feed shall be as detailed within ETSI EN 300 132-3-1 [3].

4.2.4 Configuration 400 VDC/400 VDC

Figure 3 presents the interface "A3" for a multiple power feed consisting of two up to 400 VDC power feeds.

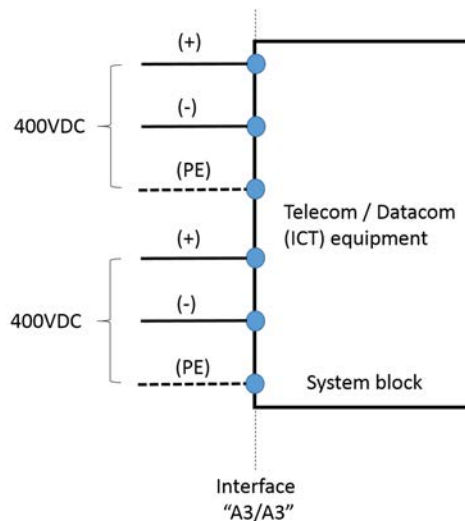

Figure 3: General identification of the A3 interface for multiple power feeds for dual of up to 400 VDC inputs

The interface and the operational voltage characteristics for up to 400 VDC power feed shall be as detailed within ETSI EN 300 132-3-1 [3].

4.2.5 Configuration AC/-48 VDC

Figure 4 presents the interface "A3ac/A" for a multiple power feed consisting of one AC power feed and one -48 VDC power feed. In this instance the AC and -48 VDC interfaces have interfaces structures which are termed as "A3ac and A" respectively.

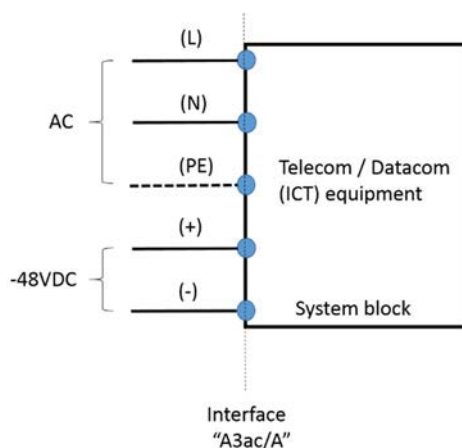
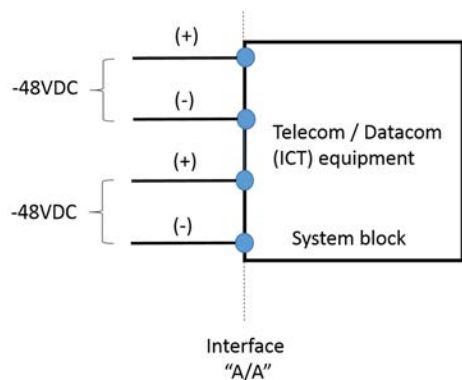

Figure 4: General identification of the A interface for multiple power feeds for AC and -48 VDC inputs

The interface and the operational voltage characteristics for an AC power feed are detailed within document [i.1] and the interface and the operational voltage characteristics for the -48 VDC power feed shall be as detailed within ETSI EN 300 132-2 [2].

4.2.6 Configuration -48 VDC/-48 VDC

Figure 5 presents the interface "A" for a multiple power feed consisting of two -48 VDC power feeds.



NOTE: It is possible that some energy conversion parts be upstream from the interface A, please refer to annex D for detailed information.

Figure 5: General identification of the A interface for multiple power feeds for dual -48 VDC inputs

The interface and the operational voltage characteristics for a -48 VDC power feed shall be as detailed within ETSI EN 300 132-2 [2].

4.2.7 Configuration 400 VDC/-48 VDC

Figure 6 presents the interface "A/A3" for a multiple power feed consisting of one up to 400 VDC power feed and one -48 VDC power feed. The -48 VDC interface and the interface for up to 400 VDC power feeds have the interface references of A and A3 respectively and as such the combination of these two reference interfaces when used together on ICT equipment is presented as "A/A3".

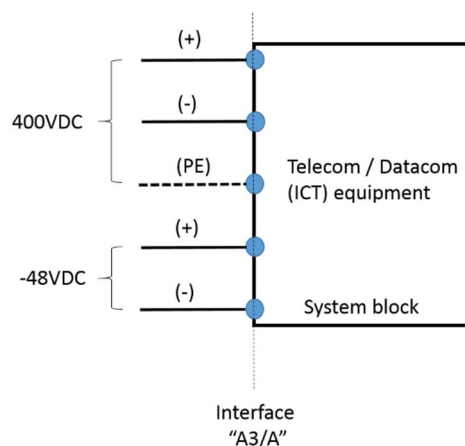

Figure 6: General identification of the A/A3 interface for multiple power feed for up to 400 VDC and -48 VDC inputs

The interface and the operational voltage characteristics for a -48 VDC power feed shall be as detailed within ETSI EN 300 132-2 [2] and the interface and the operational voltage characteristics for up to 400 VDC power feed shall be as detailed within ETSI EN 300 132-3-1 [3].

5 Combination dependence of A, A3 and A3ac interface for multiple power feeds

Table 2 presents the alternative power architecture structures between the interfaces detailed in clause 6 and the load interface of the ICT equipment. The power structures presented include the ICT equipment's on board power converters and any power management solutions that allow for the controlled supervision of the input powers presented at the ICT equipment interface to ensure continued operation of the ICT equipment in the advent of any one preferred input power feed failing.

Table 2 shows that when there is a dependent power feed, a managed redundancy function is required for its proper operation. This can be clearly seen with the switched and combined input configurations presented (architectures 7 to 11).

Table 2: Alternate power structures within ICT equipment between ICT power input interface and ICT equipment load inclusive of power converter

System Config	Supply Configuration (note 2)	Interface	Battery test	Power structure	Architecture
1	AC/AC Direct power feed Independent power feeds (1)	A3ac/A3ac (Figure 1)	Ok	Two separate AC power feed to the ICT equipment here detailed as A ₁ and B ₁ . Direct power feed connection from the ICT interface to a converter. Each converter and interface used in the ICT equipment is effectively doubled A ₁ /A _n and B ₁ /B _n .	<p>INPUT</p> <p>A₁ AC</p> <p>A_n AC</p> <p>B₁ AC</p> <p>B_n AC</p> <p>Converter (a₁)</p> <p>Converter (a_n)</p> <p>Converter (b₁)</p> <p>Converter (b_n)</p> <p>Load</p> <p>ICT Equipment</p> <p>Interface</p>
2	AC/400 VDC Direct power feed Independent power feeds (1)	A3ac/A3 (Figure 2)	Ok	One AC and one up to 400 VDC power feed to the ICT equipment. (as for System Configuration 1).	<p>INPUT</p> <p>A₁ AC</p> <p>A_n AC</p> <p>B₁ 400VDC</p> <p>B_n 400VDC</p> <p>Converter (a₁)</p> <p>Converter (a_n)</p> <p>Converter (b₁)</p> <p>Converter (b_n)</p> <p>Load</p> <p>ICT Equipment</p> <p>Interface</p>
3	400 VDC/400 VDC Direct power feed Independent power feeds (1)	A3/A3 (Figure 3)	Ok	Two separate up to 400 VDC power feeds to the ICT equipment. (as for System Configuration 1).	<p>INPUT</p> <p>A₁ 400VDC</p> <p>A_n 400VDC</p> <p>B₁ 400VDC</p> <p>B_n 400VDC</p> <p>Converter (a₁)</p> <p>Converter (a_n)</p> <p>Converter (b₁)</p> <p>Converter (b_n)</p> <p>Load</p> <p>ICT Equipment</p> <p>Interface</p>
4	AC/-48 VDC Direct power feed Independent power feeds (1)	A3ac/A (Figure 4)	Ok	One AC and one -48 VDC power feed to the ICT equipment (as for System Configuration 1).	<p>INPUT</p> <p>A₁ AC</p> <p>A_n AC</p> <p>B₁ -48 VDC</p> <p>B_n -48 VDC</p> <p>Converter (a₁)</p> <p>Converter (a_n)</p> <p>Converter (b₁)</p> <p>Converter (b_n)</p> <p>Load</p> <p>ICT Equipment</p> <p>Interface</p>

System Config	Supply Configuration (note 2)	Interface	Battery test	Power structure	Architecture
5	400 VDC/-48 VDC Direct power feed Independent power feeds (1)	A3/A (Figure 6)	Ok	One up to 400 VDC and one -48 VDC power feed to the ICT equipment (as for System Configuration 1).	
6	-48 VDC/-48 VDC Direct power feed Independent power feeds (1)	A/A (Figure 5)	Ok	Two separate -48 VDC power feed to the ICT equipment. (as for System Configuration 1).	
7	AC/AC switch selection Dependant power feeds (2), (3)	A3ac/A3ac (Figure 1)	Ok	Two separate AC power feeds to the ICT equipment here detailed as A ₁ and B ₁ . An input selection by a selector switch is placed between the ICT equipment power interface and one internal converter. Power feed from either ICT equipment interface is selected to power the converter.	
8	AC/400 VDC switch selection Dependant power feeds (2), (3)	A3ac/A3 (Figure 2)	Ok	One AC and one up to 400 VDC power feeds to the ICT equipment. (as for System configuration 7).	
9	400 VDC/400 VDC switch selection Dependant power feeds (2), (3)	A3/A3 (Figure 3)	Ok	Two separate up to 400 VDC power feeds to the ICT equipment. (as for System configuration 7).	

System Config	Supply Configuration (note 2)	Interface	Battery test	Power structure	Architecture
10	-48 VDC/-48 VDC diode combiner Dependant power feeds (2), (4)	A/A (Figure 5)	No (note 1)	Two separate 48 VDC power feeds to the ICT equipment here detailed as A ₁ and B ₁ . A diode combiner is placed between the ICT equipment interface and one converter. The input power feed connected to the diode with the higher DC voltage potential is automatically selected as the main powering supply of the ICT equipment by reverse biasing the diode connected to the lower DC voltage potential.	
11	400 VDC/to 400 VDC diode combiner Dependant power feeds (2), (4)	A3/A3 (Figure 3)	No (note 1)	Two separate up to 400 VDC power feeds to the ICT equipment. (as per System Config 10).	
<p>NOTE 1: The diode combiner configuration cannot be used in a single battery test scenario as this configuration offers no isolation of the battery line under test. In order to achieve battery testing a switch needs to be added in series with the diodes such that each of the DC feeds can be isolated separately.</p> <p>NOTE 2: The definitions of independent power feeding, dependant power feeding, switched power feeding, combined power feeding reported in Table 2 as power feeds 1 to 4 are described as follows:</p> <ol style="list-style-type: none"> (1) Independent power feeding: Multiple power input interface feeding a set of power supply coupled in parallel on their outputs to a single load within the ICT equipment. (2) Dependent power feeding: Multiple power input interface associated with a single load interface in the ICT equipment. The inputs are switched or combined in managed power interface defined in (3) and (4) in order to power the single power supply within the ICT equipment. (3) Switched power feeding: Method by which two power inputs are managed such that one input is always available to power a single power module within the ICT equipment with the use of a inputs power switch selector. (4) Combined power feeding: Method by which two power inputs are managed such that one input is always available to power a single power module within the ICT equipment by using the reverse bias characteristic of a two diode common cathode module. 					

The mixed system configurations with dependant power feeds (switched or combined) that present either -48 VDC and up to 400 VDC or a -48 VDC and an AC supply are not considered as viable solutions and as such are not presented in Table 2. The main reason is that the voltage differential between the -48 VDC and the stated high voltage input supply in both these system configurations is too large to develop a practical ICT on-board converter.

6 Back feeding protection

When the ICT equipment has more than one supply connection, there is the risk of back-feeding from one to another. In the context of multiple voltages feeding, back-feeding relates to a potential situation where a hazardous voltage from one live power input of the multiple power feed, is fed back to another 'dead' power input of the multiple power feed and as such may be hazardous to operators and/or service personnel. The ICT equipment shall prevent hazardous voltage from being present on the input terminals after interruption of the input power.

The solution **options** for back-feeding protection are presented below.

Options:

- Option 1: Basic insulation between different power inputs provided by mechanical isolation gap.

- Option 2: Functional insulation between different power inputs with the addition of an automatic switch (isolation). The function of the automatic switch is to 'open' after the interruption of the input power (see annex C).

Table 3 describes the back feed protection solution required for the configuration of the ICT equipment's input power feeds.

Table 3: Back feeding protection requirement for multiple power feedings to ICT equipment

Converter	Feeds	Input characteristic	Inputs	Back-feed protection	Possible supply sources
Converter a ₁ ... a _n	Feed A or Feed B	Independent power feeding (1) (see note)	Individual power feeding	Default by converter design	-48 VDC, AC, up to 400 VDC
Converter b ₁ ... b _n					
Converter x	Feed A and Feed B	Dependent power feedings (2) (see note)	Switched (3) (see note)	Requires additional preventative measures (clause 6 option 1)	AC, up to 400 VDC
Converter x	Feed A and Feed B	Dependent power feedings (2) (see note)	Combined (4) (see note)	Requires additional preventative measures if hazardous voltages used, (clause 6 options 1 and 2)	-48 VDC, up to 400 VDC

NOTE: The configuration referred to as (n) in this table are defined in note 2 of Table 2.

Annex A (informative): Switch Selector installation options

This annex presents several installations options for integration of the switch power feed selector within ICT equipment. These should be considered on their merit for the site in terms of cost, product line and against any potential space saving opportunities.

Switch Selector installation and options for System interface connections

Figure A.1 presents a proposal for the installation of the switch selector as a separate module within the ICT equipment. The figure also shows the plug/socket interface options that would be used for this approach. In this proposal the switch selector module is configured with hardwired 'flying leads'. Each of these leads is terminated in an appropriate interface plug/socket that allows for a direct connection to both the ICT equipment's incoming interface power sockets and the outgoing feed to the ICT equipment on board converter. The flying lead cable length used on the switch selector module can either be pre-set for a specific installation requirement or set at a length that allows for a more generic installation solution.

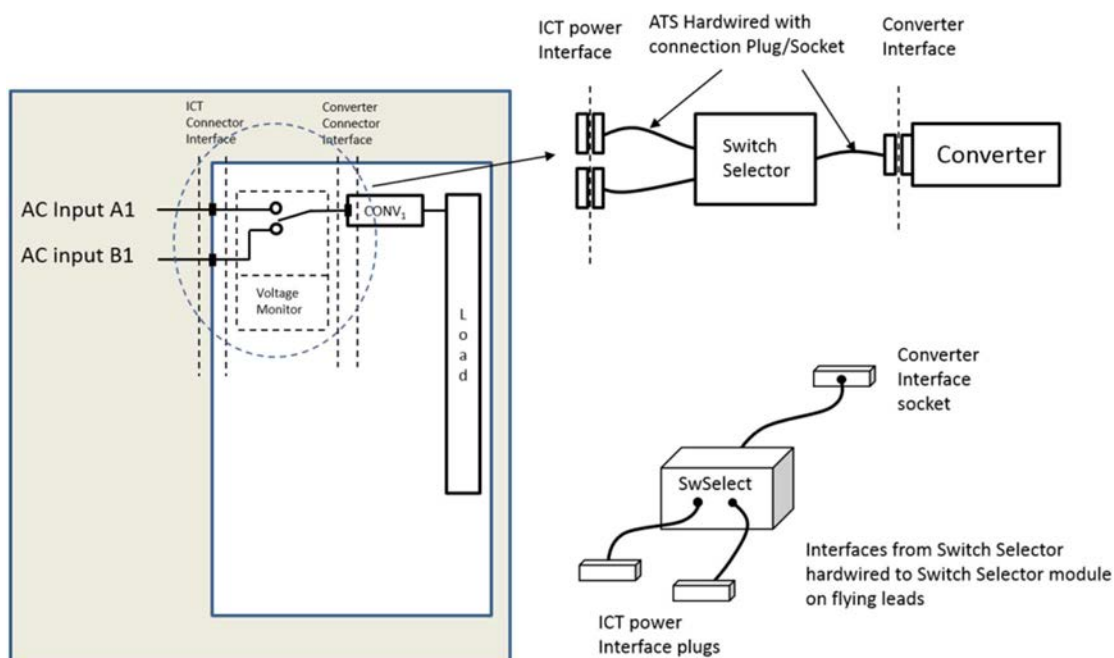

Figure A.1: Switch selector module with plug/socket hardwired cable flying leads allowing for installation to the ICT input power feed interfaces and the ICT on-board converter

To provide further flexibility to the switch selector modules when installed as a separate module within the ICT equipment, a further iteration would see "male" and "female" connectors placed onto the switch selector module itself (Figure A.2). In this way the plug/socket connections become separate cable assemblies providing connection between the switch selector module and the ICT equipment/converter. The cable assemblies can be manufactured to meet the specific installation requirements of the site or manufactured with common lengths allowing for a more generic installation solution.

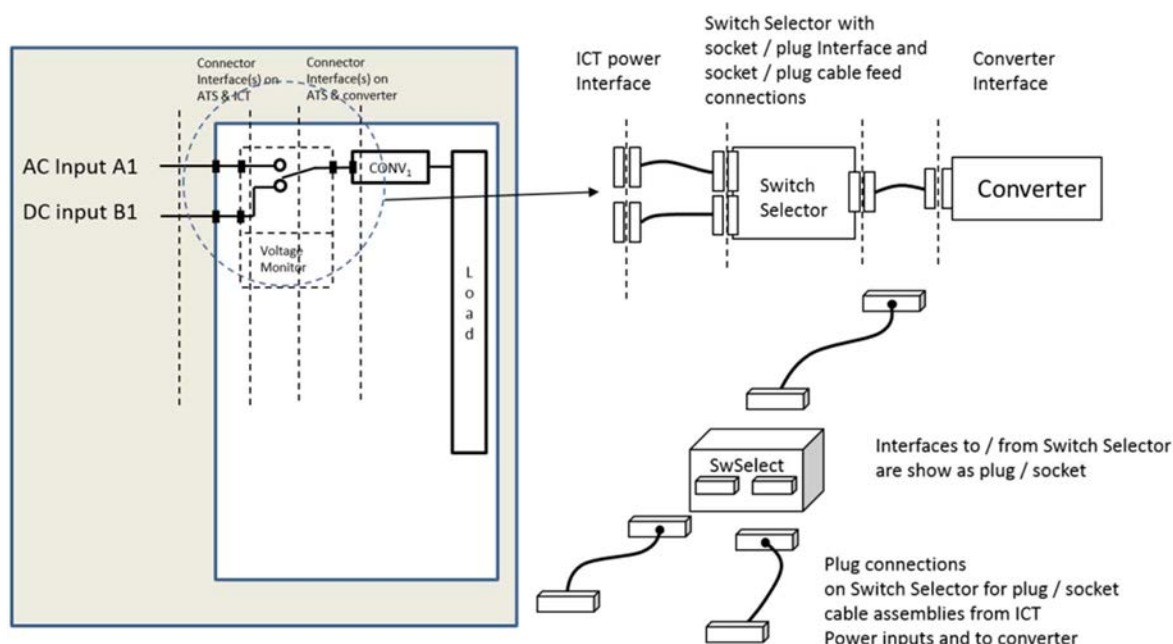

Figure A.2: Switch selector module with plug/socket cable assemblies allowing for installation to the ICT input power feed interfaces and the ICT on-board converter

Switch Selector installed within Converter and interface connections

Figure A.3 presents a further alternative installation option of the switch selector. In this approach the switch selector is moved out of the ICT equipment (as separate module) and placed within the ICT equipment's on board converter. This provides some space saving opportunities.

As can be seen from Figure A.3, the interface at the ICT equipment is still present but there are now two input interfaces placed onto the converter for the two separate input supplies to the ICT equipment. Plug/socket cable assemblies provide the connections from the ICT equipment's external power interfaces to the ICT equipment's on board converter.

This approach has advantages and disadvantages. The main advantage is in relation to potential space saving within the ICT equipment by placing the switch selector module within the ICT on board converter, however the disadvantage here is that the converter becomes quite specialized in its design, removing any system backward compatibility, in addition to this, the power interface for the converter becomes more complex (single to a dual power feed interface) which, along with the inclusion of the switch selector components, will impact the converters cost and potentially its overall size.

The advantages and disadvantages in taking this approach should be considered by the equipment provider on a "best case install bases" in terms of cost and potential space saved however, further reviewing this solution, the disadvantages mentioned clearly outweigh any potential advantages that could be gained.

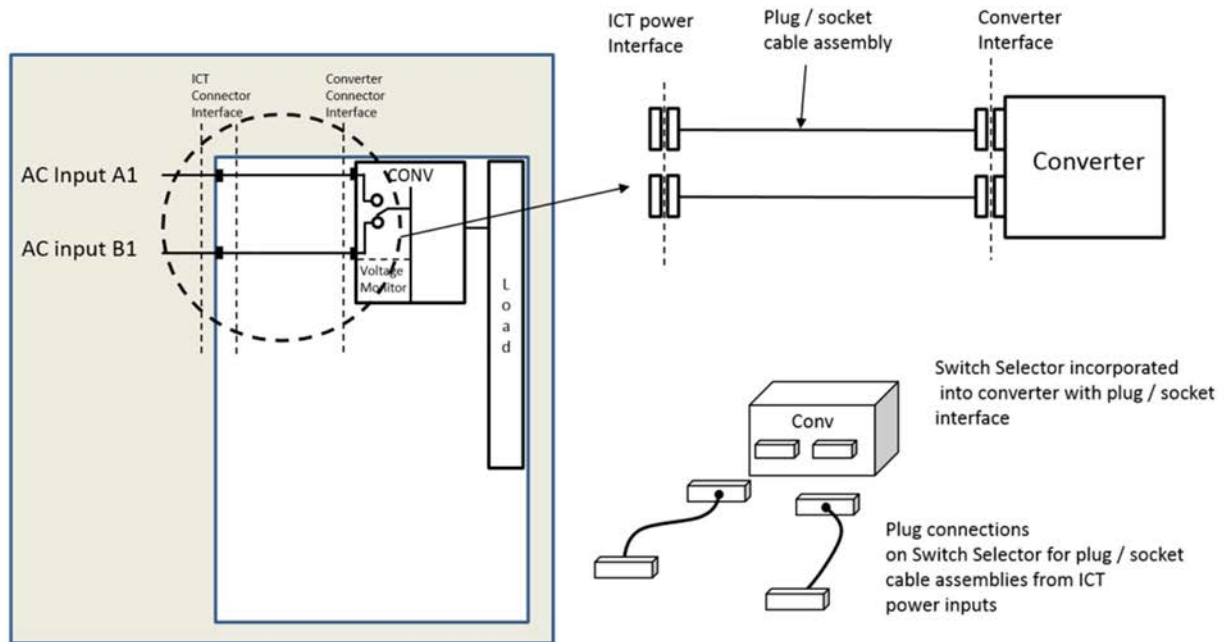

Figure A.3: Switch selector placed with the ICT on-board converter with cables assemblies allowing for connection from ICT power feed interfaces to the ICT on-board converter

Annex B (informative): Switch Selector - General functionality and requirements Switch

For the benefit of the reader the term switch selector when used in the present document can include but is not inclusive of following functions:

- Actuator - Provides the drive for the switch selector.
- Actuator drive circuitry.
- Voltage monitoring - Monitors the incoming voltages supplies and provides a signal at the instance of supply voltage failure.
- Control logic - Provides control and switch management.
- Switch contacts.
- Semi-conductor contact management - Can provide some additional control management of the switch contacts.

The switch selector can be comprised of, but not limited to, a number of functional elements as listed above in addition the switch selector should include a voltage detection circuit. The purpose of this circuit is to monitor the incoming voltage supply rail(s) providing a signal to a switch selector actuator at the instance of a voltage failure being detected. The voltage detection circuit should be able to detect an incoming supply voltages failure on multiple AC/AC, DC/DC or any combination thereof.

The switch selector should also include control/switch management functions to ensure that the switch not only operates in line with the converter hold-up time, but carries out this function in a controlled manner ensuring high levels of reliability. The switch selector could also include additional semi-conductor devices that may assist in its clean switch management.

The switch selector should be fully compliant with creepage and clearance and voltage back-feed regulatory safety requirements at the targeted operational voltages. This should include any additional protection circuitry required for its intended operational environment. This could include but not be limited to any EMC filtering and transient suppression necessary in order to comply with local or international regulatory standards.

Input power monitoring

The switch selector needs to be activated at the instance of an input voltage supply failure being detected. To ensure optimal performance, monitoring circuitry that can provide this function to a high level of reliability and accuracy should be included in its design.

The monitor interface should be capable of detecting multiple AC/AC, DC/DC or a mixture of both voltage types at voltage levels of 230 VAC and up to 400 VDC.

The minimum switch over time of the switch selector should be commensurate with the ICT on-board converter hold up time. This will be in the region of between 10 ms to 20 ms.

The voltage monitoring solution needs to provide a high level of immunity to any transient voltage events on the monitored incoming supplies and so avoid any nuisance toggling of the switch selector. In addition the monitoring circuitry should also provide full immunity to any extraneous high voltage events that could potentially damage its operation.

Annex C (informative): Back-feeding Protection

For the two back feeding protection methods listed in clause 6 of the present document, the second method (2) is presented as an example below.

For this example the DC operated equipment has at least two DC inputs of which both inputs are combined by the combiner module.

The combiner modules consist of D1, D2, D3 and D4 as detailed in Figure C.1. In this example these components are presented as diodes but can be replaced by a component that can provide the combiner function, this would include MOSFETs or IGBTs. These particular devices provide the additional benefit of reduced power dissipation, when compared with the diode, but come with the disadvantage of requiring a more complex drive/control interface. Placing two of these devices in a back to back configuration allows for complete control of the combiner function i.e. providing full on/off functionality (Figure C.2). These components provide a functional insulation between the different power inputs.

In addition to the combiner module, an automatic switch (isolation) module is presented and placed in series with the each DC input circuit. The automatic switch (isolation) module includes a switch element and a switch element control circuit.

The switch element used can take the form of a relay or any other component that offers a similar function, in that it should provide a mechanical isolation that meets the functional insulation requirements.

In application the switch element control circuit detects if power is present at interface (A+/A-, or B+/B-). If power is detected then the switch element sets to the "on" position conversely if power is not detected at these inputs then the respective switch element goes to the "off" position. In this way the switch element ensures that if the external supplies to the ICT equipment are removed or interrupted, the switch element contacts open, preventing any instance of voltage back feeding to the respective disconnected input.

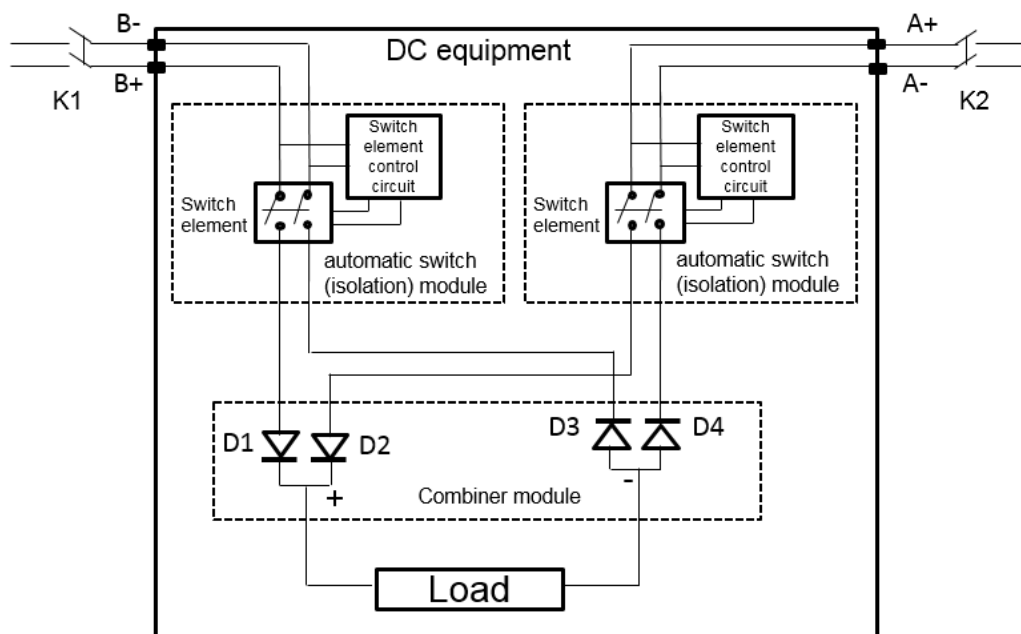

Figure C.1: Circuit configuration for back feeding protection when using a diode combiner interface for ICT equipment

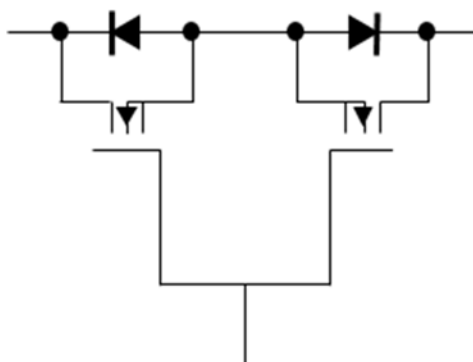

Figure C.2: Back to back MOSFET replacement for diode module combiner providing a control on/off functionality

Battery test function

In addition to providing back feeding protection the circuit configuration presented in Figure C.1 can also provide the correct conditions for a battery test function to be carried out. With respect to Figure C.1 this test scenario would see the battery back-up input power line disconnected using either one of the mechanical switch modules as appropriate.

In this instance the switch modules detailed as 'automatic' would also be implemented with an operational override control function to open the respective switch modules contacts. Operator care or additional functional voltage monitoring would also be required to ensure the supply voltages to the ICT equipment remain within their operational voltage window, preventing any possibility of system shutdown during the battery test procedure.

As an alternative, where combiner diodes D1 to D4 detailed in Figure C.1 are replaced with back to back MOSFETs, (Figure C.2) the battery test function can be carried out by switching off associate MOSFET pairs.

Annex D (informative): Example of upstream conversion for dual -48 VDC power feed configuration at input of ICT equipment

The proposed architecture is example of upstream conversion of AC(A3ac) /A(-48 VDC) and up to 400 VDC(A3)/A (-48 V) for a dual input ICT equipment as shown in Figure D.1.

The upstream power system can be composed of rack-level switching mode power supply in power cabinets. This may form a dual-partition power system feeding the -48 VDC dual power inputs to the ICT equipment. The cabinet can be common to several dual input

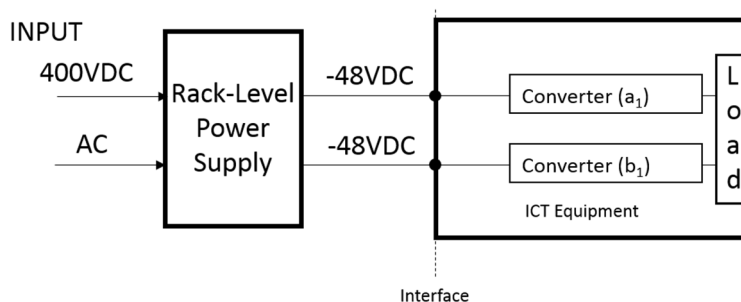

Figure D.1: Architecture of upstream AC & Up to 400 VDC power system with rack-level power supply feeding in -48 VDC a dual power input equipment in A/A configuration

The dual-partition power supply system has two independent inputs and outputs and may have a unified monitoring module. The two inputs can be AC and up to 400 VDC interface, the outputs of the two separate partitions -48 VDC power supply are compatible with the existing ICT equipment in the telecommunication centre.

The dual-partition power supply system can have a variety of operating modes as follows:

- 1) The main power is provided by the AC partition while using up to 400 VDC in hot standby mode.
- 2) The main power is provided by the up to 400 VDC partition while using AC in hot standby mode.
- 3) The power is equally shared between AC and up to 400 VDC partitions.

Several differences can be identified between configurations with external power supply system and dual input power supply solution embedded in ICT equipment as shown in Figure D.1:

- 1) The capacity of independent power supply should be at same level.
- 2) There is only one control/monitoring module which manages and coordinates the operating parameters of the power modules of both partitions.
- 3) The input of the two partitions are AC input and up to 400 VDC and should be completely isolated.
- 4) The outputs voltage of the two partitions are in -48 VDC and should be isolated, but each single partition output voltage can be adjusted according to the load.
- 5) Dual-partition embedded switching mode power supply can have a variety of working modes.

History

Document history		
V1.1.1	September 2018	Publication