

ETSI TS 103 586 V1.3.1 (2022-10)



TECHNICAL SPECIFICATION

**Environmental Engineering (EE);
Liquid cooling solutions for Information and
Communication Technology (ICT) infrastructure equipment**

Reference

RTS/EE-017012

Keywords

cooling capacity, energy efficiency

ETSI

650 Route des Lucioles
F-06921 Sophia Antipolis Cedex - FRANCE

Tel.: +33 4 92 94 42 00 Fax: +33 4 93 65 47 16

Siret N° 348 623 562 00017 - APE 7112B
Association à but non lucratif enregistrée à la
Sous-Préfecture de Grasse (06) N° w061004871

Important notice

The present document can be downloaded from:

<http://www.etsi.org/standards-search>

The present document may be made available in electronic versions and/or in print. The content of any electronic and/or print versions of the present document shall not be modified without the prior written authorization of ETSI. In case of any existing or perceived difference in contents between such versions and/or in print, the prevailing version of an ETSI deliverable is the one made publicly available in PDF format at www.etsi.org/deliver.

Users of the present document should be aware that the document may be subject to revision or change of status.

Information on the current status of this and other ETSI documents is available at

<https://portal.etsi.org/TB/ETSIDeliverableStatus.aspx>

If you find errors in the present document, please send your comment to one of the following services:

<https://portal.etsi.org/People/CommitteeSupportStaff.aspx>

If you find a security vulnerability in the present document, please report it through our
Coordinated Vulnerability Disclosure Program:

<https://www.etsi.org/standards/coordinated-vulnerability-disclosure>

Notice of disclaimer & limitation of liability

The information provided in the present deliverable is directed solely to professionals who have the appropriate degree of experience to understand and interpret its content in accordance with generally accepted engineering or other professional standard and applicable regulations.

No recommendation as to products and services or vendors is made or should be implied.

No representation or warranty is made that this deliverable is technically accurate or sufficient or conforms to any law and/or governmental rule and/or regulation and further, no representation or warranty is made of merchantability or fitness for any particular purpose or against infringement of intellectual property rights.

In no event shall ETSI be held liable for loss of profits or any other incidental or consequential damages.

Any software contained in this deliverable is provided "AS IS" with no warranties, express or implied, including but not limited to, the warranties of merchantability, fitness for a particular purpose and non-infringement of intellectual property rights and ETSI shall not be held liable in any event for any damages whatsoever (including, without limitation, damages for loss of profits, business interruption, loss of information, or any other pecuniary loss) arising out of or related to the use of or inability to use the software.

Copyright Notification

No part may be reproduced or utilized in any form or by any means, electronic or mechanical, including photocopying and microfilm except as authorized by written permission of ETSI.

The content of the PDF version shall not be modified without the written authorization of ETSI.

The copyright and the foregoing restriction extend to reproduction in all media.

© ETSI 2022.
All rights reserved.

Contents

Intellectual Property Rights	4
Foreword.....	4
Modal verbs terminology.....	4
Introduction	4
1 Scope	6
2 References	6
2.1 Normative references	6
2.2 Informative references.....	7
3 Definition of terms, symbols and abbreviations.....	7
3.1 Terms.....	7
3.2 Symbols.....	8
3.3 Abbreviations	8
4 ICT equipment liquid cooling requirements and energy efficiency.....	9
4.1 Introduction	9
4.2 Cooling requirements for equipment.....	9
4.3 Liquid cooled equipment energy efficiency	9
5 Specifications for liquid cooling solutions	10
5.1 General requirements	10
5.2 Liquid flow rate range vs. dissipated power.....	10
5.3 Temperature of touchable parts	10
5.4 Maximum pressure drop per liquid flow rate	10
5.5 Maximum pressure drop per air flow rate	10
5.6 Pipe threads	10
5.7 Coolants and cooling distribution units	11
5.8 Max pressure and tightness	11
5.9 Liquid connectors positions.....	11
5.10 Accessibility in case of cooling with heat exchanger.....	11
6 Benchmark methods to evaluate cooling system efficiency and energy efficiency	11
7 Reliability test requirement	12
Annex A (informative): Cooling principles and impact on reliability and energy consumption	14
A.1 Air cooling principles and limitations	14
A.2 Reliability issues	15
A.3 Energy consumption.....	15
A.4 Heat reuse possibilities.....	16
Annex B (informative): Cooling implementation options.....	17
B.1 Example of liquid cooling at the cabinet level	17
B.2 Example of liquid cooling at the component level.....	20
B.3 Example of liquid cooling by immersion	22
B.4 Example of topology of the cooling distribution at the room and building level.....	23
Annex C (informative): Bibliography.....	25
History	26

Intellectual Property Rights

Essential patents

IPRs essential or potentially essential to normative deliverables may have been declared to ETSI. The declarations pertaining to these essential IPRs, if any, are publicly available for **ETSI members and non-members**, and can be found in ETSI SR 000 314: "*Intellectual Property Rights (IPRs); Essential, or potentially Essential, IPRs notified to ETSI in respect of ETSI standards*", which is available from the ETSI Secretariat. Latest updates are available on the ETSI Web server (<https://ipr.etsi.org/>).

Pursuant to the ETSI Directives including the ETSI IPR Policy, no investigation regarding the essentiality of IPRs, including IPR searches, has been carried out by ETSI. No guarantee can be given as to the existence of other IPRs not referenced in ETSI SR 000 314 (or the updates on the ETSI Web server) which are, or may be, or may become, essential to the present document.

Trademarks

The present document may include trademarks and/or tradenames which are asserted and/or registered by their owners. ETSI claims no ownership of these except for any which are indicated as being the property of ETSI, and conveys no right to use or reproduce any trademark and/or tradename. Mention of those trademarks in the present document does not constitute an endorsement by ETSI of products, services or organizations associated with those trademarks.

DECT™, **PLUGTESTS™**, **UMTS™** and the ETSI logo are trademarks of ETSI registered for the benefit of its Members. **3GPP™** and **LTE™** are trademarks of ETSI registered for the benefit of its Members and of the 3GPP Organizational Partners. **oneM2M™** logo is a trademark of ETSI registered for the benefit of its Members and of the oneM2M Partners. **GSM®** and the GSM logo are trademarks registered and owned by the GSM Association.

Foreword

This Technical Specification (TS) has been produced by ETSI Technical Committee Environmental Engineering (EE).

Modal verbs terminology

In the present document "**shall**", "**shall not**", "**should**", "**should not**", "**may**", "**need not**", "**will**", "**will not**", "**can**" and "**cannot**" are to be interpreted as described in clause 3.2 of the [ETSI Drafting Rules](#) (Verbal forms for the expression of provisions).

"**must**" and "**must not**" are **NOT** allowed in ETSI deliverables except when used in direct citation.

Introduction

Electrical energy supplied to ICT equipment, and more generally to electronic equipment, is nearly totally converted into heat by resistive losses, leading to temperature increase of the equipment itself and its surrounding environment. Except for very low power (ICT end-user equipment), ICT equipment should be cooled to ensure reliable operation and an acceptable lifetime. Air-cooling is up to now dominating in the telecommunication industry. ETSI EN 300 019 series [i.2] specify environmental conditions for different types of locations, to ensure proper operation of air cooled telecommunication equipment.

With the emergence of high density racks and cabinets, thermal loads above 7 kW become widely used while density increase remains on-going. These high loads cabinets lead also to thermal management issues at the room level. More than ever, separation of hot and cold aisles is necessary and moreover, prevention of hot spots when high and medium or low loads are mixed in the same room is hard to achieve.

Liquid cooling solutions provide opportunities to solve efficiently these problems and to reduce significantly cooling energy consumption and, thus, overall ICT energy consumption. Moreover, such technologies can lead to improved temperature control at the component level and consequently, better reliability. Thanks to higher cooling capacity, ICT equipment can be more compact leading thus, to space savings. At last, heat reuse can be also considered with very high efficiency optimizing this way, ICT energy efficiency.

1 Scope

The present document covers following applications:

- Liquid cooling at the cabinet/rack level.
- Liquid cooling at the product level.
- Liquid cooling via immersion in dielectric liquid.

The present document specifies the following items:

- Liquid circulation layout (connection of multiple units).
- Liquid flow rate range vs. dissipated power.
- Maximum pressure drop per liquid flow rate.
- Maximum pressure drop per air flow rate.
- External pipe diameter range and pipe threads.
- Valves requirements.
- Coolants and cooling distribution unites.
- Max pressure and tightness.
- Reliability requirement

Furthermore, the present document provides:

- Benchmark methods to evaluated different cooling system efficiency.

2 References

2.1 Normative references

References are either specific (identified by date of publication and/or edition number or version number) or non-specific. For specific references, only the cited version applies. For non-specific references, the latest version of the referenced document (including any amendments) applies.

Referenced documents which are not found to be publicly available in the expected location might be found at <https://docbox.etsi.org/Reference/>.

NOTE: While any hyperlinks included in this clause were valid at the time of publication, ETSI cannot guarantee their long term validity.

The following referenced documents are necessary for the application of the present document.

- [1] ETSI EN 300 019-1-3 (V2.4.1): "Environmental Engineering (EE); Environmental conditions and environmental tests for telecommunications equipment; Part 1-3: Classification of environmental conditions; Stationary use at weatherprotected locations".
- [2] ETSI EN 300 019-1-4 (V2.2.1): "Environmental Engineering (EE); Environmental conditions and environmental tests for telecommunications equipment; Part 1-4: Classification of environmental conditions; Stationary use at non-weatherprotected locations".
- [3] ISO 228-1: "Pipe threads where pressure-tight joints are not made on the threads - Part 1: Dimensions, tolerances and designation".

- [4] IEC 60068-2-78:2012: "Environmental testing - Part 2-78: Tests - Test Cab: Damp heat, steady state".
- [5] IEC 60068-2-2:2007: "Environmental testing - Part 2-2: Tests - Test B: Dry heat".
- [6] Void.
- [7] EN 805 (2000): "Water supply. Requirement for systems and components outside buildings", produced by CEN.
- [8] Void.

2.2 Informative references

References are either specific (identified by date of publication and/or edition number or version number) or non-specific. For specific references, only the cited version applies. For non-specific references, the latest version of the referenced document (including any amendments) applies.

NOTE: While any hyperlinks included in this clause were valid at the time of publication, ETSI cannot guarantee their long term validity.

The following referenced documents are not necessary for the application of the present document but they assist the user with regard to a particular subject area.

- [i.1] EN 60950-1: "Information technology equipment - Safety; Part 1: General requirements", produced by CENELEC.
- [i.2] ETSI EN 300 019 (all parts): "Environmental Engineering (EE); Environmental conditions and environmental tests for telecommunications equipment".
- [i.3] IEC 62368-1: "Audio/video, information and communication technology equipment - Part 1: Safety requirements".
- [i.4] ETSI ES 203 474 (V1.1.1): "Environmental Engineering (EE); Interfacing of renewable energy or distributed power sources to 400 VDC distribution systems powering Information and Communication Technology (ICT) equipment".

NOTE: Available at https://portal.etsi.org/webapp/ewp/copy_file.asp?wki_id=43366.

3 Definition of terms, symbols and abbreviations

3.1 Terms

For the purposes of the present document, the following terms apply:

cabinet: free-standing and self-supporting enclosure for housing electrical and/or electronic equipment

component: part or sub-part of an equipment that dissipates heat and needs to be cooled

CoolEff: ratio between the energy consumption of the equipment plus the cooling system, divided by the energy consumption of the cooling system alone

Cooling Distribution Unit (CDU): unit used to separate or isolate the ICT equipment cooling loop from the facilities cooling loop, consisting of a liquid to liquid heat exchanger with at least one pump, temperature and pressure controls

cooling efficiency: ability of a given cooling system to lower equipment temperature towards the cooling fluid temperature

heat exchanger: device used to transfer heat from one fluid to another liquid cooling system

NOTE: System that controls or influence the temperature of a liquid in order to use it to cool component or equipment or hot air issuing equipment.

ICT equipment: information and communication equipment (e.g. switch, transmitter, router, server and peripheral devices) used in telecommunication centres, data-centres and customer premises (see ETSI ES 203 474 [i.4])

NOTE 1: It is integrated in a rack or cabinet.

NOTE 2: If the liquid cooling system is provided by the supplier, it will be considered herein that this system is part of the ICT equipment. Thus, for an equipment with liquid cooling system at the component level (cold plate), the boundary of the ICT equipment will be the rack/cabinet. For an ICT equipment cooled by a rear door heat exchanger, the boundary of the ICT equipment will be the cabinet including the heat exchanger. For a system cooled by immersion, the boundary will be the tank and its control system.

rack: free-standing or fixed structure for housing electrical and/or electronic equipment

3.2 Symbols

For the purposes of the present document, the following symbols apply:

C_p	Specific heat (J/kg/°C)
dP	Pressure drop (Pa)
P	Electrical power consumed by the equipment (W)
Q_m	Mass flow rate (kg/s)
$Q_{V_{air}}$	Air volume flow rate (l/min).
$Q_{V_{liquid}}$	Liquid volume flow rate (l/min)
ρ	Liquid density (kg/m ³)
T	Temperature (°C)
T_{amb}	Ambient Temperature surrounding the equipment (°C)
RH_{amb}	Ambient Relative Humidity surrounding the equipment (°C)
T_{ext}	External Temperature outside the building or outdoor cabinet (°C)
T_{in}	Temperature at the inlet of the liquid cooling system, at the main liquid connector of the equipment
T_{in_min}	Minimum temperature in liquid inlet temperature range
T_{in_max}	Maximum temperature in liquid inlet temperature range
T_{out}	Temperature at the outlet of the liquid cooling system, at the main liquid connector of the equipment
ΔT	Temperature difference (°C)
p_{max}	Maximum pressure of the liquid circuit

3.3 Abbreviations

For the purposes of the present document, the following abbreviations apply:

AC	Alternating Current
CDU	Cooling Distribution Unit
CTE	Coefficient of Thermal Expansion
DC	Direct Current
HEX	Heat Exchanger
ICT	Information and Communication Technology
IEC	International Electrotechnical Commission
ISO	International Organization for Standardization
IT	Information Technology
kW	Kilowatt
PCB	Printed Circuit Board

4 ICT equipment liquid cooling requirements and energy efficiency

4.1 Introduction

In the present clause, the liquid cooling requirements and energy efficiencies of equipment are defined.

4.2 Cooling requirements for equipment

Liquid cooled equipment for non-weather protected locations shall be compliant with ETSI EN 300 019-1-4 [2] and shall be compliant with any of the liquid inlet temperature class defined in table 1.

Liquid cooled equipment for weather protected locations shall be compliant with ETSI EN 300 019-1-3 [1] and shall be compliant with any of the liquid inlet temperature class defined in table 1.

Table 1: Classes defining liquid inlet temperature range and relevant minimum percentage of heat to water

Type of liquid cooling system	Liquid inlet temperature range	Minimum Percentage of heat to water
Rear door heat exchanger (A1)	+10 °C to +25 °C	80 %
Cold plate at the component level (A2)	+10 °C to +40 °C	70 %
Immersion system (A3)	+10 °C to +50 °C	80 %

Liquid inlet temperature measurement T_{liq-in} shall be considered at the position where operators shall provide liquid connection to the equipment.

Ratio of heat removed by liquid shall be computed with the following formula:

$$\text{Heat ratio} = Q_{m_{liq}} \times C_{p_{liq}} \times (T_{liq-out} - T_{liq-in}) / \text{Total power dissipated by the equipment}$$

Liquid output temperature measurement $T_{liq-out}$ shall be considered at the position where operators provide connection for liquid return from the equipment.

If a CDU is provided, it shall be considered as a part of the equipment, and heat losses of this piece of equipment will be taken into account.

Liquid cooling at the cabinet level is a technology that can lead to class A1 cooling performances (example is described in clause B.1).

Liquid cooling at the component level is a technology that can lead to class A2 cooling performances (example is described in clause B.2).

Liquid cooling by immersion is a technology that can lead to class A3 cooling performances (example is described in clause B.3).

4.3 Liquid cooled equipment energy efficiency

Energy efficiency targets shall be measured in the following normal conditions:

- External (Outdoor) temperature $T_{ext} = 45 \text{ °C}$.
- Ambient (Room) temperature $T_{amb} = 25 \text{ °C}$.

The equipment power consumption shall be considered at its maximal value.

The key indicator shall represent the impact of the cooling energy on the whole equipment energy consumption.

Cooling Effectiveness can be used:

$$CoolEff = \frac{\text{Equipment power consumption} + \text{cooling energy consumption}}{\text{Equipment power consumption}}$$

Cooling energy consumption shall take into account internal elements required to cool the equipment in the above mentioned normal conditions (pumps, fans, control system).

Table 2: Energy efficiency classes

Cooling Effectiveness classes	CoolEff
Class B1	$\leq 1,01$
Class B2	$1,01 < \text{CoolEff} \leq 1,05$
Class B3	$1,05 < \text{CoolEff} \leq 1,10$
Class B4	$> 1,10$

5 Specifications for liquid cooling solutions

5.1 General requirements

Liquid cooled equipment shall be compliant with ETSI EN 300 019-1-3 [1] or ETSI EN 300 019-1-4 [2] depending on their locations.

5.2 Liquid flow rate range vs. dissipated power

Liquid flow rate (in l/min) and dissipated power are linked by the following steady state power balance:

$$Q_V = (60\,000 \times P) / (\rho \times C_p \times (T_{\text{liq-out}} - T_{\text{liq-in}}))$$

5.3 Temperature of touchable parts

For safety purpose, the temperature of touchable part will be compliant with the applicable safety standards (e.g. EN 60950-1 [i.1] or IEC 62368-1 [i.3]).

5.4 Maximum pressure drop per liquid flow rate

Pressure drop per liquid flow rate shall not be higher than:

$$dP_{\text{liquid}} = 25 \times Q_{V\text{liquid}}^2$$

$Q_{V\text{liquid}}$ is the liquid volume flow rate expressed in l/min.

5.5 Maximum pressure drop per air flow rate

If the cooling system consists in transferring heat from air flow to liquid flow (examples in clause B.1), pressure drop per air flow rate shall not be higher than:

$$dP_{\text{air}} = 1,3 \times 10^{-6} \times Q_{V\text{air}}^2$$

$Q_{V\text{air}}$ is the air volume flow rate expressed in l/min.

5.6 Pipe threads

If pipe threads are used, they shall be compliant with ISO 228-1 [3].

5.7 Coolants and cooling distribution units

If the equipment is cooled internally by another closed loop fluid than the liquid used at the room and building level (e.g. oil, low pressure two phase fluid, very pure water), the supplier shall provide CDU(s) with at least $N+1$ system-level pump redundancy to adapt to room where water cooling is available (where N is the number of pumps needed to provide the nominal total flow rate).

The liquid cooling system shall not create hazard in terms of product safety. For this scope the relevant ICT safety standards apply (e.g. IEC 62368-1 [i.3]). Liquid lifetime shall be at least 10 years, unless restrictions from National Regulation apply.

5.8 Max pressure and tightness

The equipment shall be tested at a pressure level of three times of the nominal pressure with the method described in EN 805 [7].

To ensure proper operation of the whole cooling system, commissioning shall be made at full load.

5.9 Liquid connectors positions

For equipment installed on raised floors, fluid connections shall be provided at the bottom of the rack/cabinet. For equipment installed on slab floors, fluid connections shall be provided at either the top or the bottom of the rack/cabinet.

5.10 Accessibility in case of cooling with heat exchanger

If the HEX is not a part of the cabinet, it shall be easily moved to gain access to equipment for servicing. If the HEX is a part of the cabinet (for example figure B.1c), it shall be easily removed or be mounted on a door to gain access to equipment for servicing.

6 Benchmark methods to evaluate cooling system efficiency and energy efficiency

To evaluate the cooling system, the equipment shall be installed in a climatic chamber with the ability to control the ambient temperature with ± 1 °C accuracy.

The following instrumentation is required.

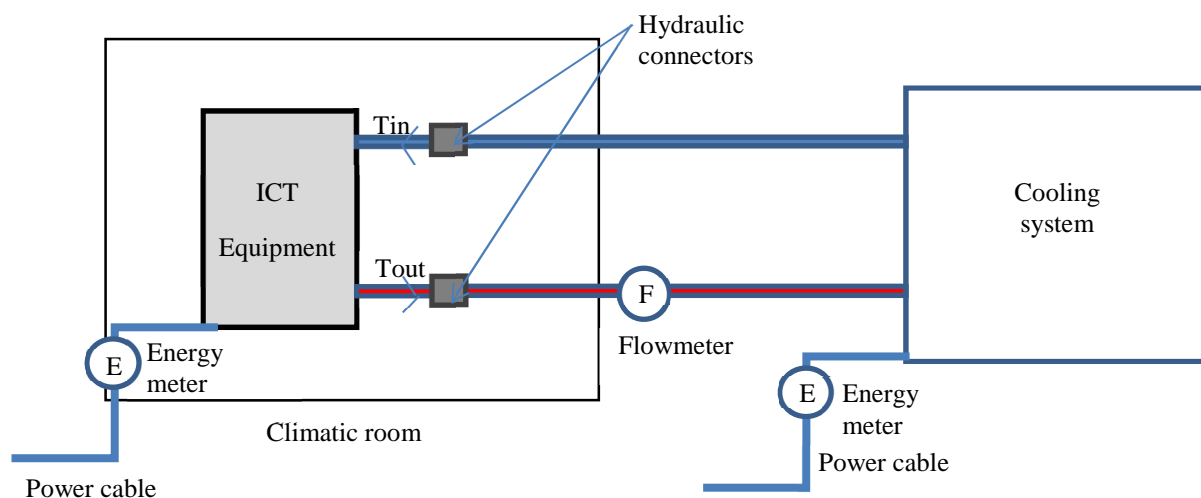

Figure 1: Experimental setup to evaluate energy efficiency

Power dissipation shall be computed in the following way.

Main power measurement shall be performed with an energy meter for AC, and voltmeter and ammeter for DC, measurements. Power values shall be based on supplier data if direct measurement is not possible. If the measured value is not steady, a mean value over 5 minutes shall be computed.

Temperature of the liquid shall be measured at the input and output with a calibrated thermocouple whose junction will be placed at the centre of the duct.

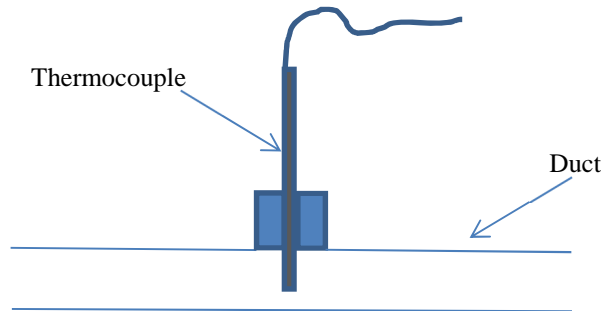

Figure 2: Liquid temperature measurement

A flow meter with 5 % accuracy shall be used.

Ducts shall be thermally insulated.

A cooling system allowing control of liquid temperature at equipment inlet shall be used.

EXAMPLE: A chiller, an external air to water heat exchanger, etc.

For all the performed tests, cooling system ability to keep internal components at temperature below their limits shall be checked with relevant measurements.

Percentage of heat on water shall be computed, for liquid inlet temperatures at minimum value and at maximal value (see table 1). Comparison shall be made with targets described in table 1, third column.

CoolEff shall also be computed for each liquid inlet temperature value.

The above measurements shall be made at +25 °C of ambient temperature.

7 Reliability test requirement

If a CDU is provided, it shall be considered as a part of the equipment, the CDU should be tested with ICT equipment.

If the liquid cooling is compatible with different types of liquids, all types of liquids should be tested. The liquid cooling test requirements related to reliability of system shall be as defined in the present clause.

Table 3: Test specification for liquid cooling system

Type	Parameter	Detail parameter	Test severity		Method	Reference	Duration	Notes
			Liquid state	Air ambient state				
Inlet liquid temperature	low	°C	T _{in_min}	T _{amb} RH _{amb}	Cab: Damp heat steady state	IEC 60068-2-78 [4]	16 h	1
	high	°C	T _{in_max}	T _{amb}	Be: Dry heat	IEC 60068-2-2 [5]	16 h	2
	long term reliability	°C	T _{in_max}	T _{amb}			2 000 h	3
Performance Criteria: the equipment shall function according to the manufacturer specifications before, during and after the tests. No degradation of performance or loss of function is allowed below the performance level specified by the manufacturer when the equipment is used as intended. If the minimum performance level is not specified by the manufacturer, then this may be deduced from the product description and documentation and what the user may reasonably expect from the equipment facility if used as intended.								
NOTE 1: (Inlet liquid temperature, low): T _{amb} and RH _{amb} should be chosen according to the high humidity test listed in ETSI EN 300 019-1-3 [1] or ETSI EN 300 019-1-4 [2].								
NOTE 2: (Inlet liquid temperature, high): T _{amb} should be chosen according to temperature specification of the system.								
NOTE 3: (Inlet liquid temperature, long term reliability): T _{amb} can be decided according to the feasible environment for the test since this is a long term test.								

Test above are aimed at verifying the requirement of liquid cooling system. Reliability test at component level should also be conducted on key components to assure a long term reliable performance. These key components include but are not limited to following components: pipelines, connectors, liquid, solenoid valve and pump.

Annex A (informative): Cooling principles and impact on reliability and energy consumption

A.1 Air cooling principles and limitations

Like with any other single phase cooling fluid, air cooling consists in exchanging heat from the sources, which are electronic components to particles of fluid by convection, directly (component without heat sink for example) or indirectly (component with heat sinks or integrated in a closed sheet for example).

Two situations can occur:

- Fluid movements due to particles temperature which leads to differences of density (i.e. natural convection). These kinds of heat exchanges are only sufficient for low power components and low power density (density as to be understood here at the equipment level).
- Fluid movements are induced by fans or blowers. Nearly all ICT equipment use this cooling technique called forced convection. Most of the time, heat sinks or heat pipes are necessary to increase heat exchange between air and components.

To understand limitations of air as a cooling fluid, thermo-physical properties are detailed and explained.

The air has the following thermal properties:

- Specific heat: $C_{\text{air}} = 1\,005 \text{ J/kg/}^\circ\text{C}$ @20 °C
- Thermal conductivity: $k_{\text{air}} = 0,0257 \text{ W/m/}^\circ\text{C}$ @20 °C (air is an efficient heat insulator)
- Density: $\rho_{\text{air}} = 1,205 \text{ kg/m}^3$ @20 °C

To compare, the properties of water are:

- Specific heat: $C_{\text{air}} = 4\,183 \text{ J/kg/}^\circ\text{C}$ @20 °C
- Thermal conductivity: $k_{\text{air}} = 0,58 \text{ W/m/}^\circ\text{C}$ @20 °C
- Density: $\rho_{\text{air}} = 1\,000 \text{ kg/m}^3$ @20 °C

The product ρC indicates the energy stored by 1 m³ when the temperature rise is 1 °C:

- For air: $\rho_{\text{air}} C_{\text{air}} = 1\,211,10^3 \text{ J/m}^3$
- For water: $\rho_{\text{water}} C_{\text{water}} = 4\,183,10^6 \text{ J/m}^3$

These physical data indicate that air is not efficient for storing and transporting heat (liquids have 10³ higher heat capacity compared with gases). To cool high power systems, huge air flow rates are therefore needed, that leads to high energy consumption (and high acoustic noise disturbances).

The thermal conductivity of air (which is a well-known thermal insulator) is also 22 times lower.

Despite these physical constraints, air cooling has been and is still widely used in electronics but in some cases, efficiency cannot be achieved as the power density per square meter is too high (more than 20 kw/m²).

Finally, as a result, heat transfer coefficients are at least ten times higher with fluids. As a consequence, to cool high heat densities, air cooling will require high flow rates and much lower fluid temperature. The consequences are high cooling energy consumption, and huge acoustic noise. Thus, to improve ICT energy efficiency, an obvious way is to switch from air cooling to liquid cooling.

Water is only used herein as an example. Liquid cooling solutions can be developed with several fluids, among which:

- Water.
- Water mixed with antifreeze and other additives.
- Dielectric fluids (oils, phase change solutions).
- Refrigerants.

A.2 Reliability issues

ICT equipment reliability is linked with local (near the component) operating temperature and its temporal variations. As components power densities increases, heat management at the electronic card level becomes more and more complex, due to local hot points, with a possible decrease of reliability. Several reliabilities issues can therefore be highlighted.

They can be mainly divided into two categories:

- The components failures linked with a too high temperature which can lead to a component breakage (it concerns all electronic components) or accelerated ageing (chemical capacitor are mainly concerned).
- The components failures linked with thermal cycles (amplitude and frequency matters).

During the past years, the energy consumption became a matter of concern in ICT for obvious reasons. Idle modes are more and more used in order to achieve better energy efficiency.

These changes lead to a thermal strain in semiconductor packages. Silicon became the main choice not because of its mechanical properties but because of electrical properties. In fact, Coefficient of Thermal Expansion (CTE) of flip-package attached to a PCB is a problem. Huge power dissipated by chipset conjugated with idle modes can induce severe reliability problem (mainly due to unsoldering of balls on Ball Grid Arrays).

One way of lowering failure occurrences is to control at least, amplitude of thermal cycles with an efficient cooling system. Up to now, achieving such a goal with air cooling seems not possible. On the contrary, liquid cooling gives better temperature control opportunities thanks to higher heat transfer coefficients and very easy control of liquid flow rate. Among the technical solution presented in the present document, those that are meant to bring a liquid cooling at the component level should thus lead to improved reliability.

A.3 Energy consumption

Basically, telecommunications rooms cooled with air cooling systems use the following temperature and humidity control solutions:

- Mechanical compression air conditioning systems (chillers) without free cooling.
- Mechanical compression air conditioning systems with free cooling.

In both cases, energy consumptions of these systems are non-negligible compared with ICT equipment energy consumption. As a matter of fact, cooling constitutes one of the main levers to reduce energy consumption of ICT sites.

Thus, liquid cooling could lead to significantly reduced energy consumption in telecommunication and IT as only pumps and fans require electric energy.

A.4 Heat reuse possibilities

Most of the energy consumed by ICT equipment is converted into heat, and consequently wasted. Air cooling is inherently limiting heat reuse possibilities due to the following reasons:

- Low heat transfer coefficients.
- Low temperature.
- Cooling fluid not easily ducted.

On the other hand, liquid cooling could easily allow efficient heat reuse as liquids can be easily ducted; temperature of issuing liquid is compliant with a lot of applications (room heating, etc.) and liquid to liquid heat exchangers can reach a high efficiency (above 90 %).

Annex B (informative): Cooling implementation options

B.1 Example of liquid cooling at the cabinet level

This clause covers liquid cooling at the cabinet level, which means any liquid cooled exchanger either in the cabinet or very close (distance HEX cabinet lower than 10 cm) to the cabinet. For instance, in row heat exchangers are not considered as liquid cooling system at the cabinet level.

In this clause, only equipment with air entering on front side of the cabinet and air issuing at the rear side will be considered, as represented in figure B.1a. Even if legacy equipment with issuing air at the top can receive liquid cooling solutions, they are not addressed here as the cold aisles/hot aisles, thermal management is the preferred solution for ICT.

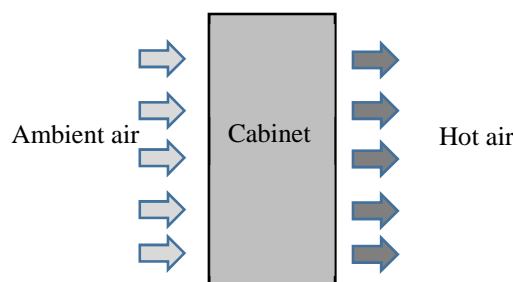

Figure B.1a: Air-cooled cabinet with air input at the front and air output at the rear

Liquid cooling with heat exchanger is a solution to cool existing cabinet/rack or could be directly implemented by suppliers as a part of the cabinet/rack or as a possible solution to cool the cabinet/rack.

First possible (but less efficient) implementation is the following:

- Heat exchanger is located on the entering air path, at the front side of the cabinet. Thus, the air is cooled when passing through the exchanger and is then introduced in the equipment. In this option, input liquid temperature has to be lower than room ambient temperature.

This option is not preferred because it requires cold water and then, does not minimize energy consumption. Moreover, it has an effect on inlet air humidity with a possible risk of excursion out of ETSI EN 300 019-1-3 [1] relevant temperature ranges.

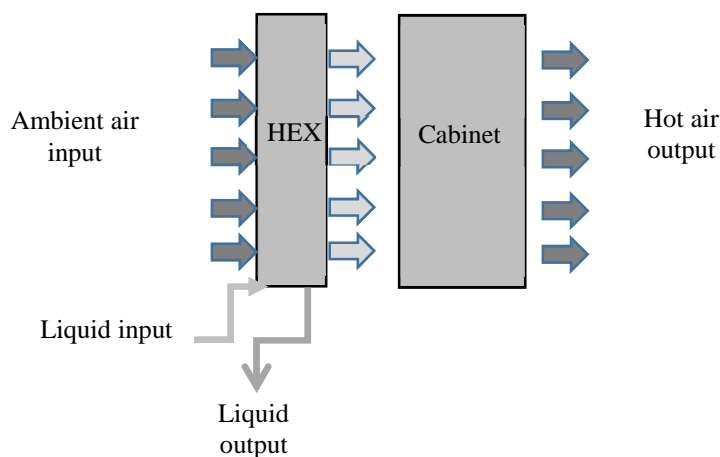

Figure B.1b: Entering air is pre cooled with front air to liquid heat exchanger

When heat exchangers are used at the cabinet/rack level, two options are possible depending on pressure loss on the air path and depending on equipment fans characteristics:

- If the embedded fan can withstand the added pressure loss, no additional fans are needed.
- If the embedded fan cannot withstand the added pressure loss, additional fans are needed.

In order to reduce the cost, avoiding additional fan is the better choice which can be permitted by limiting heat exchanger pressure loss on air side.

Another implementation of air to liquid heat exchanger consists in locating it at the rear of the cabinet/rack. This implementation brings several benefits:

- If heat exchanger is sized correctly, air at the exchanger output can be almost at the same temperature as air inlet. This way, even if no aisles or corridors have been set up in the room, the HEX cooled cabinet/racks cannot disturb other equipment air inlet in the room.

This implementation is especially interesting to cool high density cabinets (above 10 kW/m²) with high air flow and consequently, high issuing air speeds.

As the heat exchanger is very close to the heat source, and as the objective is to cool down the issuing air to room temperature, cold water is not needed which leads to high energy efficiency with low power chiller or no chiller needed (depending on location, heat loads, room temperature settings).

As cold water is not necessary here, condensation can be easily avoided through minimal water inlet temperature control.

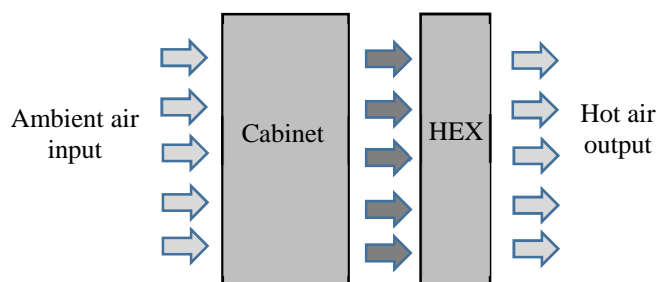

Figure B.1c: Issuing Air is cooled with rear air to liquid heat exchanger

Adding an HEX at the rear of the racks or cabinet adds also pressure loss on airflow. Thus, if other air paths are available, not desired rear to front air circulation is possible. To prevent this, obstructions can be installed to ensure that all issuing air passes through the HEX.

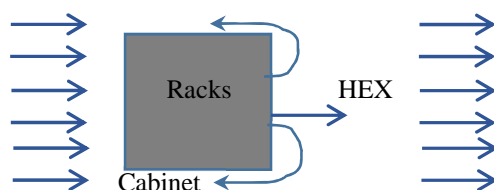

Figure B.1d: Cabinet top view without obstructions

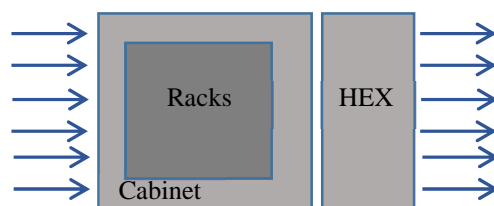

Figure B.1e: Cabinet top view with obstructions

Another implementation of HEX consists in locating it at the rear of the racks, in a closed cabinet as represented on figure B.1f. Another possible air circulation is represented in figure B.1g. This way, in normal operation, there is no air exchange between the cabinet and the room (which means no filter and corresponding servicing). The cabinet can be thermally insulated to limit the heat dissipation in the room and thus reduce room cooling energy consumption (assuming that cooling at the cabinet level is more efficient).

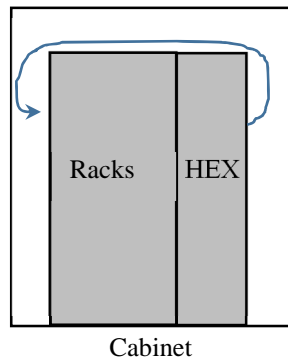

Figure B.1f: Air issuing racks are cooled with rear heat exchanger, air return is on the top

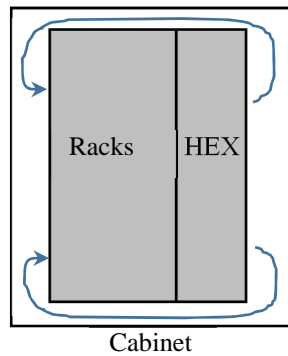

Figure B.1g: Air issuing racks are cooled with rear heat exchanger, air return is on the bottom and top

Another implementation of HEX consists in locating it at the rear of the electronic cards, in a closed rack as represented on figure B.1h. This way, in normal operation, there is no air exchange between the cabinet and the room. The cabinet can be thermally insulated to limit the heat dissipation in the room and thus reduce room cooling energy consumption (assuming that cooling at the cabinet level is more efficient).

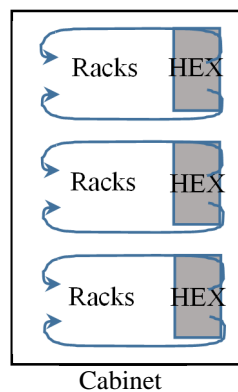

Figure B.1h: Air issuing racks are cooled with rear heat exchanger, air return is on the bottom and top in the rack

Liquid cooling at the cabinet/rack level with HEX brings the following benefits:

- Significant decrease of cooling energy consumption compared with air cooling.
- Efficient solution for hot points as cooling power can be adjusted at the rack/cabinet level.
- Heat reuse possibilities as liquid are easily transported in pipes and as the resulting liquid temperature is compliant with room heating systems for example.
- Possible adaptations with legacy cabinets.

But there are also some inherent limitations. As the liquid remains far from the heat sources (i.e. electronic components), efficiency of heat exchange between source and liquid is limited, which limit the rise of liquid temperature, and thus energy consumption reduction.

B.2 Example of liquid cooling at the component level

Liquid cooling at the rack/component level consists in using a sealed high thermal conductivity block (or several liquid cooling blocks), in contact with at least one heat source (electronic component), in which a liquid flow is permitted. Thanks to high conductivity and efficient heat transfer coefficients, electronic components can be cooled without need of liquid at a temperature typically provided by a chiller.

A possible implementation of liquid cooling at the component level is the following. An electronic board populated with several electronic components, but with one whose heat dissipation is prominent, is considered.

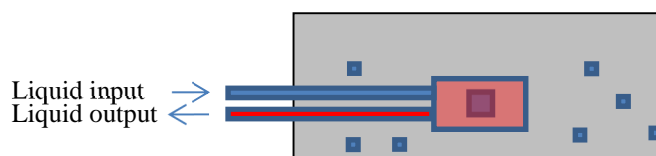

Figure B.2a: PCB with liquid cooling at the component level, only on one component

Most of the time, to achieve a high amount of heat on liquid requires cooling several electronic components with blocks. Thus, a cooling system with several cooling blocks can be used in these cases.

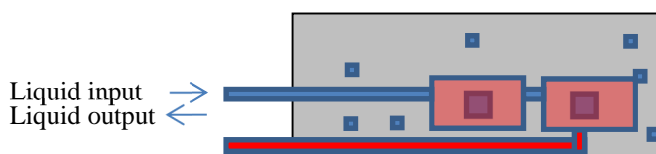

Figure B.2b: PCB with liquid cooling at the component level, on two components

Basically, two types of connections are possible between blocks: serial or parallel.

Choice between these 2 options can be made considering components operating casing temperature. Indeed, serial connections will lead to higher and higher components temperatures along the liquid path with a possible impact on reliability. Thus, most of the time, parallel can be preferred.

Thermal bridges between liquid input and output will be avoided.

When 90 % heat on water target cannot be reached without applying liquid cooling to several components, and thus, several cooling blocks, numerical simulations can be used to design and optimize the whole liquid cooling system.

When several electronic components have to be cooled with liquid cooling system, instead of blocks, a cooling plate can be used, with relevant internal liquid paths, and embedded metal blocks to ensure contacts with heat sources.

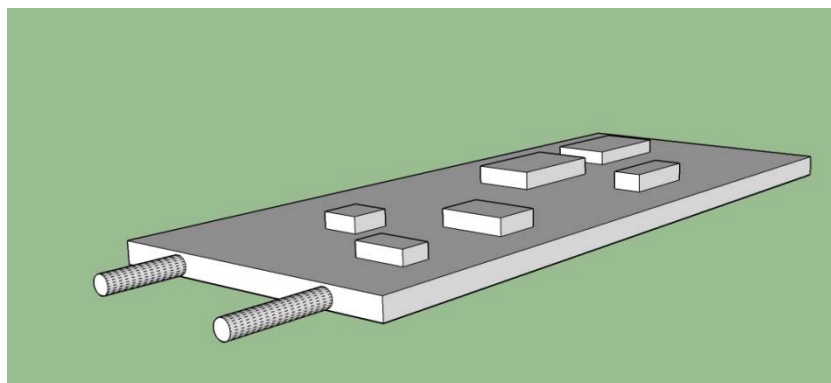

Figure B.2c: Liquid cooled plate with metal blocks

Other possible benefits of liquid cooled plate are the increased heat exchange by radiation and convection with low power components not in contact with the plate.

Another variant of liquid cooled plate can integrate partition at the periphery to prevent some air mass transfer between room environment and equipment internal air, hence limiting heat dissipation at the room level. In this case, electronic components that are not in contact with the plate exchange their heat through radiation and convection. If natural convection is not sufficient to ensure safe component operating temperature, local fan can be added to enhance convection. The plate can also receive specific surface treatment or paint to maximize radiative heat transfer.

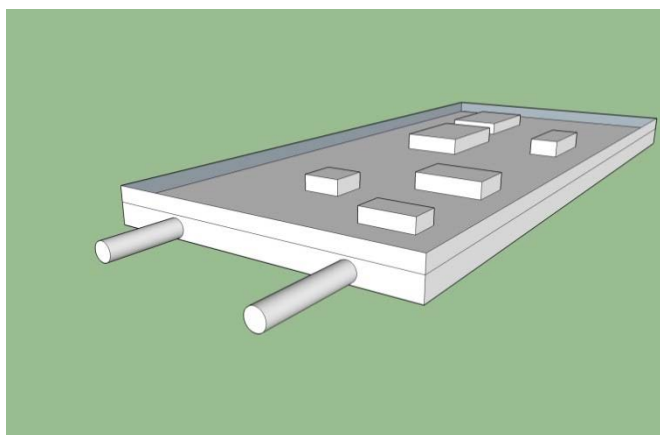

Figure B.2d: Liquid cooled plate with metal blocks and partitions to limit heat dissipation in the room

In another variant, the space between the plate and the printed circuit board can be filled with any dielectric fluid to ensure better cooling.

A second cooling plate can also be used on the rear face of the PCB, to enhance amount of heat transferred to the liquid loop and thus, limit heat transferred to the room and the need of chiller.

In another variant, a same plate can be mutualized to cool 2 electronic cards, one on each side.

In another variant, a universal cold plate can be considered with thermal bridges (metal blocks or more complex devices like heat pipes) to adapt to any printed circuit board. Such a plate could be used for several generations of equipment (servers for example), assuming conservation of the same form factor throughout several generations. This would lead to cost savings.

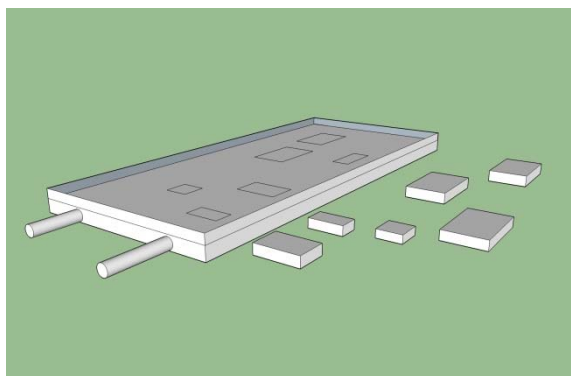

Figure B.2e: Universal cooling plate and metal blocks for adaptation to a given printed circuit board

B.3 Example of liquid cooling by immersion

Liquid cooling by immersion consists in submerging the equipment's components in a dielectric liquid. Although rarely used for the cooling of computers, liquid submersion is a routine method of cooling large power distribution components such as transformers. Devices cooled in this manner do not require fans, and may be cooled exclusively by passive heat exchange between the computer's parts and the cooling fluid.

With immersion cooler, reducing heat dissipation in the technical room is easier.

Two types of liquid cooling by immersion technologies can be distinguished:

- Liquid cooling by immersion without phase change transition.
- Liquid cooling by immersion with phase change transition (liquid/vapour).
- Liquid cooling by immersion without phase change transition consists in putting electronic cards or equipment in a tank filled with dielectric liquid.
- Heat transfer from electronic to liquid occurs mostly by convection. To control liquid temperature, forced circulation with pump is performed from and towards cold source. The cold source can be: Air to primary liquid heat outside heat exchanger.
- Primary liquid to secondary liquid heat exchanger.

Natural convection can be promoted in the tank with:

- Vertical position of electronic cards.
- Optimized space between electronic cards.
- No metal casing that would reduce liquid flow.
- Dedicated heat sinks with fins and design optimized for liquid physical properties.
- Optimized components location on the board.

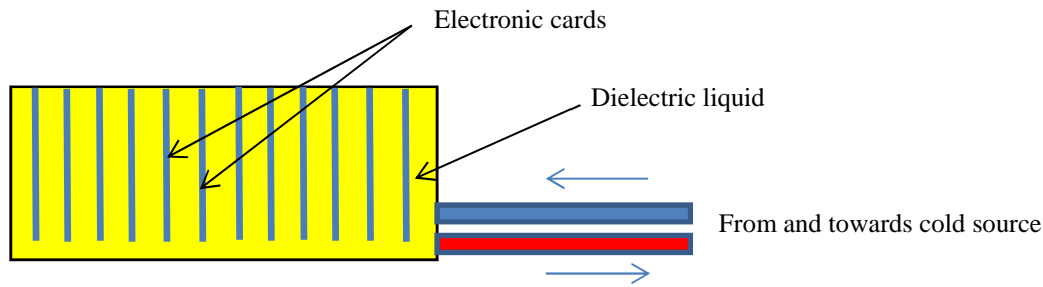

Figure B.3a: Immersion cooling system without phase change transition

Liquid cooling by immersion with phase change transition consists in putting electronic cards or equipment in a tank filled with dielectric liquid. Heat transfer from electronic to liquid occurs mostly by evaporation and convection.

A condenser is placed above the liquid level, to cool down vapour that will go back to the tank in liquid state.

Liquid temperature is controlled thanks to the condenser; forced circulation with pump is performed from and towards cold source. The cold source could be:

- Air to primary liquid heat outside heat exchanger.
- Primary liquid to secondary liquid heat exchanger.

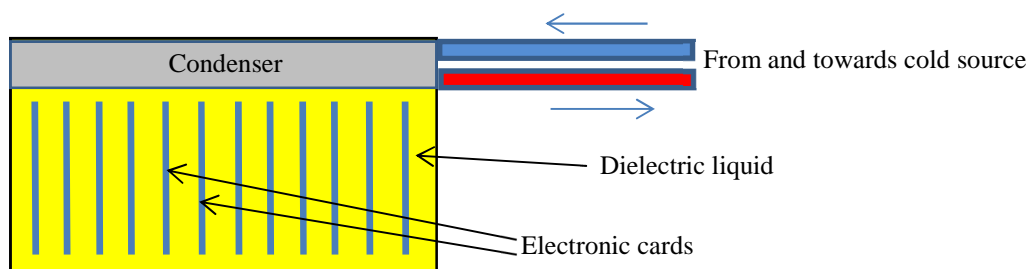

Figure B.3b: Immersion cooling system with phase change transition

B.4 Example of topology of the cooling distribution at the room and building level

To ensure cost-effective installation, upgrade possibilities, reliability, energy efficiency, etc., rules can be stated regarding the overall cooling distribution at the room, building or plant level.

The following piping architecture provides high reliability. It is a double-ended loop with common cross branches.

Two connections are made to the cooling source, providing hence, redundancy. In such a loop, servicing can be made without shutting down the whole installation.

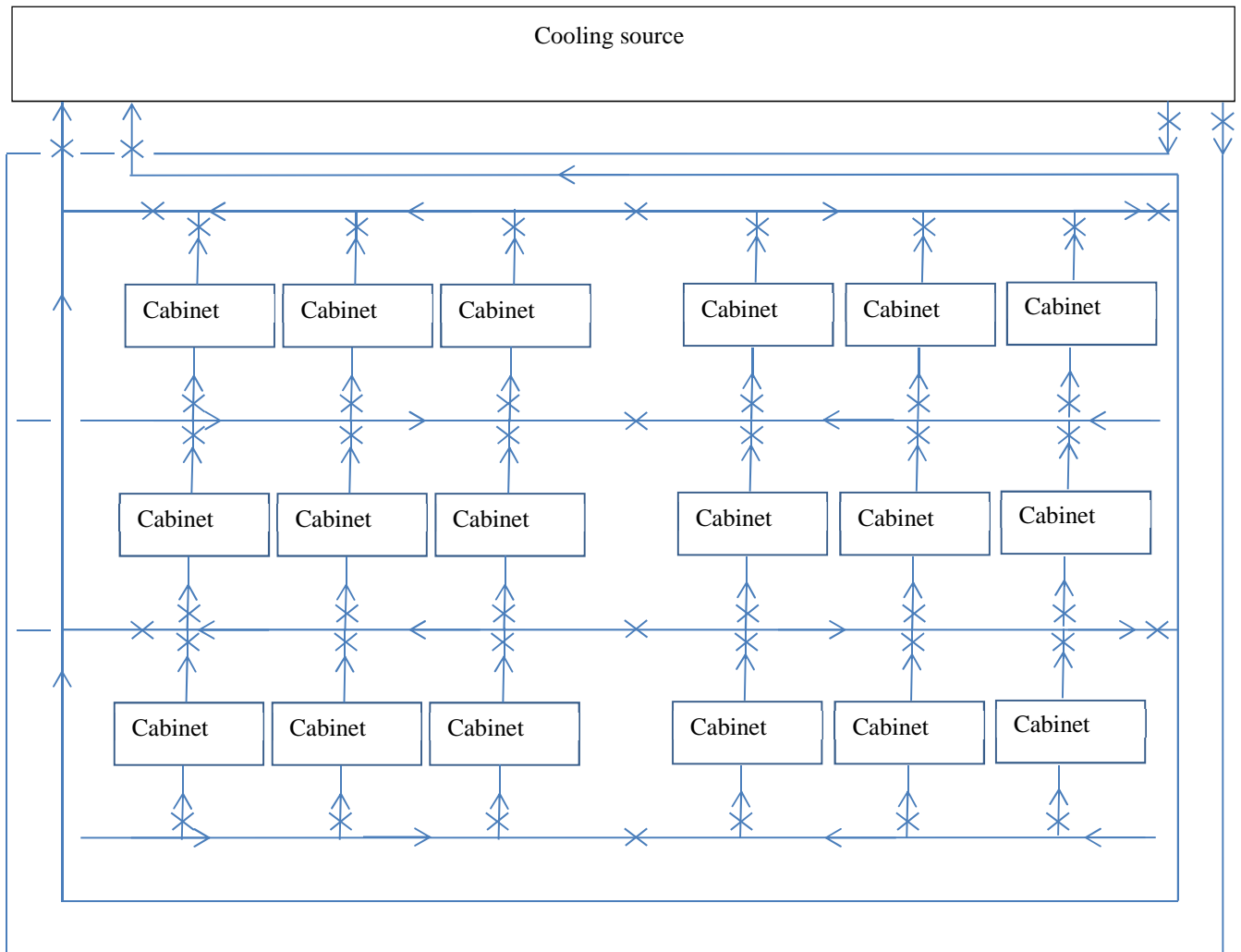

Figure B.4a: Cooling loop topology

Possible Cooling sources are:

- External air to water heat exchangers.
- Heat reusing loop.
- Chiller.

Liquid temperature will be mainly controlled with external heat exchanger fan speed variation, and liquid flowrate variation. To adapt to very low temperatures, isolating heat exchangers may be necessary with electric valves.

Bypassing heat exchanger with 3 way valves is another option in case of low external temperature.

Balancing valves are needed to ensure proper flow rate adaptation with heat loads.

If location climate justify use of a chiller, this chiller can be added to the loop to ensure that liquid temperature will be within the relevant liquid temperature range, with the lowest energy consumption achievable.

Annex C (informative): Bibliography

- IEC 60068-2-10 (06-2005): "Environmental testing - Part 2-10: Tests Test J and guidance: Mould growth".
- ISO 6072 (2011): "Rubber - Compatibility between hydraulic fluids and standard elastomeric materials".

History

Document history		
V1.1.1	April 2019	Publication
V1.2.1	August 2021	Publication
V1.3.1	October 2022	Publication