

ETSI TS 104 090 V1.1.1 (2024-09)



**Digital Audio Broadcasting (DAB);
Emergency Warning System (EWS);
Minimum requirements and test specifications for receivers**



Reference

DTS/JTC-DAB-111

Keywordsalarm, DAB, digital, emergency, radio, receiver,
requirements, testing**ETSI**650 Route des Lucioles
F-06921 Sophia Antipolis Cedex - FRANCE

Tel.: +33 4 92 94 42 00 Fax: +33 4 93 65 47 16

Siret N° 348 623 562 00017 - APE 7112B
Association à but non lucratif enregistrée à la
Sous-Préfecture de Grasse (06) N° w061004871

Important notice

The present document can be downloaded from the
ETSI [Search & Browse Standards](#) application.

The present document may be made available in electronic versions and/or in print. The content of any electronic and/or print versions of the present document shall not be modified without the prior written authorization of ETSI. In case of any existing or perceived difference in contents between such versions and/or in print, the prevailing version of an ETSI deliverable is the one made publicly available in PDF format on [ETSI deliver](#).

Users should be aware that the present document may be revised or have its status changed,
this information is available in the [Milestones listing](#).

If you find errors in the present document, please send your comments to
the relevant service listed under [Committee Support Staff](#).

If you find a security vulnerability in the present document, please report it through our
[Coordinated Vulnerability Disclosure \(CVD\)](#) program.

Notice of disclaimer & limitation of liability

The information provided in the present deliverable is directed solely to professionals who have the appropriate degree of experience to understand and interpret its content in accordance with generally accepted engineering or other professional standard and applicable regulations.

No recommendation as to products and services or vendors is made or should be implied.

No representation or warranty is made that this deliverable is technically accurate or sufficient or conforms to any law and/or governmental rule and/or regulation and further, no representation or warranty is made of merchantability or fitness for any particular purpose or against infringement of intellectual property rights.

In no event shall ETSI be held liable for loss of profits or any other incidental or consequential damages.

Any software contained in this deliverable is provided "AS IS" with no warranties, express or implied, including but not limited to, the warranties of merchantability, fitness for a particular purpose and non-infringement of intellectual property rights and ETSI shall not be held liable in any event for any damages whatsoever (including, without limitation, damages for loss of profits, business interruption, loss of information, or any other pecuniary loss) arising out of or related to the use of or inability to use the software.

Copyright Notification

No part may be reproduced or utilized in any form or by any means, electronic or mechanical, including photocopying and microfilm except as authorized by written permission of ETSI.

The content of the PDF version shall not be modified without the written authorization of ETSI.

The copyright and the foregoing restriction extend to reproduction in all media.

© ETSI 2024.

© European Broadcasting Union 2024.

All rights reserved.

Contents

Intellectual Property Rights	5
Foreword.....	5
Modal verbs terminology.....	6
1 Scope	7
2 References	7
2.1 Normative references	7
2.2 Informative references.....	7
3 Definition of terms, symbols and abbreviations.....	8
3.1 Terms.....	8
3.2 Symbols.....	8
3.3 Abbreviations	8
4 EWS Certification Mark.....	8
5 Minimum requirements for domestic Emergency Warning System receivers.....	9
5.1 Introduction	9
5.2 Basic requirements	9
5.3 Initialization	9
5.4 EWS ensembles.....	9
5.5 Operational modes.....	10
5.5.1 Sleep/monitor duty cycle	10
5.5.2 Audio mode	10
6 Minimum requirements for in-vehicle Emergency Warning System receivers	10
6.1 Introduction	10
6.2 Basic requirements	10
6.3 Tuner capability.....	10
6.4 Location awareness	10
6.5 Operation.....	10
7 Test specification for domestic EWS receivers.....	11
7.1 Introduction	11
7.2 Basic checks	11
7.3 Test 1 - Set-up behaviour	11
7.4 Test 2 - Tuned ensemble alert area matching	12
7.5 Test 3 - Tuned ensemble alert stages.....	13
7.6 Test 4 - Other ensemble alerts	14
7.7 Test 5 - Sleep mode EWS selection	16
7.8 Test 6 - Sleep mode alert response	17
7.9 Test 7 - Concurrent alerts	18
8 Test specification for in-vehicle EWS receivers	20
8.1 Introduction	20
8.2 Basic checks	20
8.3 Test 1 - Set-up behaviour	20
8.4 Test 2 - Tuned ensemble alert area matching	21
8.5 Test 3 - Tuned ensemble alert stages.....	22
8.6 Test 4 - Other ensemble alerts	23
8.7 Test 5 - Sleep mode EWS selection	24
8.8 Test 6 - Sleep mode alert response	24
8.9 Test 7 - Concurrent alerts	24
Annex A (normative): Product test streams	26
A.1 EWS1.eti	26
A.2 EWS2.eti	26

A.3	EWS3.eti	27
A.4	EWS4.eti	28
A.5	EWS5.eti	29
A.6	EWS6.eti	30
A.7	EWS7.eti	31
A.8	EWS8.eti	32
A.9	EWS9.eti	33
A.10	Location code sets	35
History	38

Intellectual Property Rights

Essential patents

IPRs essential or potentially essential to normative deliverables may have been declared to ETSI. The declarations pertaining to these essential IPRs, if any, are publicly available for **ETSI members and non-members**, and can be found in ETSI SR 000 314: "*Intellectual Property Rights (IPRs); Essential, or potentially Essential, IPRs notified to ETSI in respect of ETSI standards*", which is available from the ETSI Secretariat. Latest updates are available on the ETSI Web server (<https://ipr.etsi.org/>).

Pursuant to the ETSI Directives including the ETSI IPR Policy, no investigation regarding the essentiality of IPRs, including IPR searches, has been carried out by ETSI. No guarantee can be given as to the existence of other IPRs not referenced in ETSI SR 000 314 (or the updates on the ETSI Web server) which are, or may be, or may become, essential to the present document.

Trademarks

The present document may include trademarks and/or tradenames which are asserted and/or registered by their owners. ETSI claims no ownership of these except for any which are indicated as being the property of ETSI, and conveys no right to use or reproduce any trademark and/or tradename. Mention of those trademarks in the present document does not constitute an endorsement by ETSI of products, services or organizations associated with those trademarks.

DECT™, **PLUGTESTS™**, **UMTS™** and the ETSI logo are trademarks of ETSI registered for the benefit of its Members. **3GPP™** and **LTE™** are trademarks of ETSI registered for the benefit of its Members and of the 3GPP Organizational Partners. **oneM2M™** logo is a trademark of ETSI registered for the benefit of its Members and of the oneM2M Partners. **GSM®** and the GSM logo are trademarks registered and owned by the GSM Association.

Foreword

This Technical Specification (TS) has been produced by Joint Technical Committee (JTC) Broadcast of the European Broadcasting Union (EBU), Comité Européen de Normalisation ELECTrotechnique (CENELEC) and the European Telecommunications Standards Institute (ETSI).

NOTE 1: The EBU/ETSI JTC Broadcast was established in 1990 to co-ordinate the drafting of standards in the specific field of broadcasting and related fields. Since 1995 the JTC Broadcast became a tripartite body by including in the Memorandum of Understanding also CENELEC, which is responsible for the standardization of radio and television receivers. The EBU is a professional association of broadcasting organizations whose work includes the co-ordination of its members' activities in the technical, legal, programme-making and programme-exchange domains. The EBU has active members in about 60 countries in the European broadcasting area; its headquarters is in Geneva.

European Broadcasting Union
CH-1218 GRAND SACONNEX (Geneva)
Switzerland
Tel: +41 22 717 21 11
Fax: +41 22 717 24 81

The Eureka Project 147 was established in 1987, with funding from the European Commission, to develop a system for the broadcasting of audio and data to fixed, portable or mobile receivers. Their work resulted in the publication of European Standard, ETSI EN 300 401 [i.1], for DAB® (see note2) which now has worldwide acceptance.

NOTE 2: DAB® is a registered trademark owned by one of the Eureka Project 147 partners.

The DAB family of standards is supported by World DAB, an organization with members drawn from broadcasting organizations and telecommunication providers together with companies from the professional and consumer electronics industry.

Modal verbs terminology

In the present document "**shall**", "**shall not**", "**should**", "**should not**", "**may**", "**need not**", "**will**", "**will not**", "**can**" and "**cannot**" are to be interpreted as described in clause 3.2 of the [ETSI Drafting Rules](#) (Verbal forms for the expression of provisions).

"**must**" and "**must not**" are **NOT** allowed in ETSI deliverables except when used in direct citation.

1 Scope

The present document describes the requirements for consumer receivers designed to be used with an Emergency Warning System (EWS) based on DAB, and the necessary test methods that lead to compliance with the requirements. It may be used as the technical basis for an EWS Certification Mark scheme. An EWS Certification Mark is designed to be used on product packaging and provides an easily recognized mark to correspond to public information campaigns on the necessary features and benefits of an EWS based on DAB. Manufacturers are, of course, free to include additional features or increased performance compared to the requirements specified in the present document.

A DAB based EWS may also be used to deliver information to public signage and specialized receivers. Such devices may have additional features, such as addressability, which are not applicable to consumer receivers and are not within the scope of the present document.

In addition to receivers with a minimum set of features and performance, an EWS also requires appropriate transmission infrastructure and authorization mechanisms. These latter are not within the scope of the present document.

2 References

2.1 Normative references

References are either specific (identified by date of publication and/or edition number or version number) or non-specific. For specific references, only the cited version applies. For non-specific references, the latest version of the referenced document (including any amendments) applies.

Referenced documents which are not found to be publicly available in the expected location might be found at <https://docbox.etsi.org/Reference/>.

NOTE: While any hyperlinks included in this clause were valid at the time of publication, ETSI cannot guarantee their long term validity.

The following referenced documents are necessary for the application of the present document.

- [1] [ETSI TS 103 461](#): "Digital Audio Broadcasting (DAB); Domestic and in-vehicle digital radio receivers; Minimum requirements and Test specifications for technologies and products".
- [2] [ETSI TS 104 089](#): "Digital Audio Broadcasting (DAB); Emergency Warning System (EWS); Definition and rules of behaviour".

2.2 Informative references

References are either specific (identified by date of publication and/or edition number or version number) or non-specific. For specific references, only the cited version applies. For non-specific references, the latest version of the referenced document (including any amendments) applies.

NOTE: While any hyperlinks included in this clause were valid at the time of publication, ETSI cannot guarantee their long term validity.

The following referenced documents are not necessary for the application of the present document but they assist the user with regard to a particular subject area.

- [i.1] [ETSI EN 300 401 \(V2.1.1\)](#): "Radio Broadcasting Systems; Digital Audio Broadcasting (DAB) to mobile, portable and fixed receivers".

3 Definition of terms, symbols and abbreviations

3.1 Terms

For the purposes of the present document, the following terms apply:

band scan: function to scan the whole of the tuning range to update the stored service list when required

EWS ensemble: DAB ensemble with FIG 0/7 and FIG 0/15

receiver: any device designed to receive digital radio signals

tuning memory: stored information for previously tuned ensembles and services

3.2 Symbols

Void.

3.3 Abbreviations

For the purposes of the present document, the following abbreviations apply:

AAC	Advanced Audio Coding
DAB	Digital Audio Broadcasting
DUT	Device Under Test
EEP	Equal Error Protection
EId	Ensemble Identifier
ETI	Ensemble Transport Interface
EWS	Emergency Warning System
FIB	Fast Information Block
FIC	Fast Information Channel
FIG	Fast Information Group
FM	Frequency Modulation
GNSS	Global Navigation Satellite System
MP2	MPEG layer 2
NI	Network Independent
OE	Other Ensemble
RF	Radio Frequency
UEP	Unequal Error Protection
UI	User Interface

4 EWS Certification Mark

The present document comprises the requirements and test specifications by which radio receivers can qualify to carry an Emergency Warning System (EWS) Certification Mark ("the Mark") for emergency warnings. The purpose of the Mark is to ensure that consumers can readily identify products which are suitable for reception of an Emergency Warning System using DAB and which provide features at a sufficiently high level of performance to ensure that the product meets the relevant criteria to provide dependable information to the general public in case of emergencies.

In order to qualify for use of the Mark, products shall meet the requirements set out for the type of product, either:

- minimum requirements for domestic Emergency Warning System receivers (see clause 5); or
- minimum requirements for in-vehicle Emergency Warning System receivers (see clause 6).

In order to prove compliance against the requirements, products shall pass the test specifications, below:

- test specification for domestic products meeting minimum requirements for Emergency Warning System receivers (see clause 7); or
- test specification for in-vehicle products meeting minimum requirements for Emergency Warning System receivers (see clause 8).

The test specifications are designed to complement the testing described in ETSI TS 103 461 [1].

The process for applying for certification to use the Mark is beyond the scope of the present document, but national and international schemes are expected to be in place.

5 Minimum requirements for domestic Emergency Warning System receivers

5.1 Introduction

The minimum requirements for domestic EWS receivers are set out in this clause 5. The minimum requirements for in-vehicle EWS receivers are the subject of clause 6.

Domestic products comprise many types of receiver, including portable and larger devices. Domestic products may be mains or battery powered, or both. They may have a telescopic antenna, a flexible wire antenna, an earphone antenna, an antenna integrated into the receiver, or they may be supplied without an antenna.

A key feature of domestic products is the ability to automatically play alert messages even when the product is not playing audio.

Products may include additional features beyond the minimum requirements, or capabilities beyond the minimum requirements. However, such additional features or capabilities shall not prevent the requirements stated being met.

5.2 Basic requirements

Domestic products shall comply with the requirements set out in ETSI TS 103 461 [1] clause 5.

5.3 Initialization

Domestic products shall provide an initialization mechanism which identifies all receivable EWS ensembles. This shall be carried out as a complete band scan and ensembles carrying FIG 0/15 shall be identified and recorded. As long as at least one EWS ensemble is identified, the initialization mechanism shall invite the user to enter the receiver location code using the presentation format specified in ETSI TS 104 089 [2], annex A. The checksum shall be calculated and if in error, the user shall be invited to check and re-enter until successful. The product shall select an EWS ensemble to monitor based on criteria as recommended in ETSI TS 104 089 [2], clause 7.2.3. If no EWS ensembles are identified, the product shall indicate via the user interface that the EWS function is not available.

The user manual for the product shall include an instruction to reinitialise the product whenever it is moved to a different building.

5.4 EWS ensembles

The receiver shall provide a facility to keep the tuning memory aligned with EWS signals on-air.

Domestic products shall perform a full band scan at regular intervals, whilst the product is not tuned to a specific service. It is recommended to perform a band scan at a minimum once per week. Ensembles carrying FIG 0/15 shall be identified and recorded.

5.5 Operational modes

5.5.1 Sleep/monitor duty cycle

Products shall implement a sleep/monitor duty cycle, synchronized to the time provided in FIG 0/10, that shall be operational whenever the product is not outputting audio. The sleep mode shall be according to ETSI TS 104 089 [2], clause 7.2.2.2. The monitor mode shall be fully operational and able to decode the FIC of the chosen EWS ensemble immediately prior to the minute's edge. The product shall react according to ETSI TS 104 089 [2], clause 7.2.2.3.

5.5.2 Audio mode

Domestic products, when put into operation, shall tune to an EWS ensemble and select a service (this may be the last tuned service, a service allocated to a preset, or some other service that the user has shown previous interest in).

Products shall react according to ETSI TS 104 089 [2], clause 7.2.2.4.

6 Minimum requirements for in-vehicle Emergency Warning System receivers

6.1 Introduction

The minimum requirements for in-vehicle EWS receivers are set out in this clause 6. The minimum requirements for domestic EWS receivers are the subject of clause 5.

In-vehicle products are those products designed specifically for use within a vehicle.

In-vehicle products comprise many types of receiver, including those integrated into the dashboard, and aftermarket products mounted in the dashboard, behind the dashboard, to the vehicle windscreen or elsewhere. Aftermarket products designed to be self-installed by the consumer should ensure that proper consideration is given to ensuring that power adapters, etc., do not cause interference in the FM and DAB broadcast bands.

In-vehicle products may be supplied with or without an antenna.

Products may include additional features beyond the minimum requirements, or capabilities beyond the minimum requirements. However, such additional features or capabilities shall not prevent the requirements stated being met.

6.2 Basic requirements

In-vehicle products shall comply with the requirements set out in ETSI TS 103 461 [1], clause 6.

6.3 Tuner capability

In-vehicle products shall have a minimum of two DAB tuners. This allows them to play out audio and at the same time monitor other DAB ensembles for alert signalling and to determine whether a matched alert message is receivable.

6.4 Location awareness

In-vehicle products shall have the means to know their geographical location to a precision of at least 100 m. Typically, a GNSS receiver will be suitable.

6.5 Operation

In-vehicle products shall behave according to ETSI TS 104 089 [2], clause 7.3.3.

7 Test specification for domestic EWS receivers

7.1 Introduction

Clause 7 provides the test specifications for domestic receivers to comply with EWS requirements. Domestic receivers shall comply with all tests in clause 7.

The Device Under Test (DUT) will be exposed to the test streams and the behaviour of the DUT will be verified.

The test streams described in annex A are used for these tests.

The following equipment is needed:

- Two Ensemble Transport Interface (ETI) file players and signal generators suitable for playing ETI files and for generating an RF output of -50 dBm.
- Suitable means to couple the output of the signal generators to the input of the DUT; direct cable or antenna.
- A timing device showing minutes and seconds (**m:ss**) which can be started when an ETI file starts playing.

The tests are performed using a conducted or radiated method as the receiver allows. The test setup is shown in Figure 1. Any band III channels may be used - three are needed. The signal level shall be set to -50 dBm unless otherwise specified. For radiated testing, the output of the R.F. combiner shall be connected to an antenna. The signal generators shall be set to different frequencies.

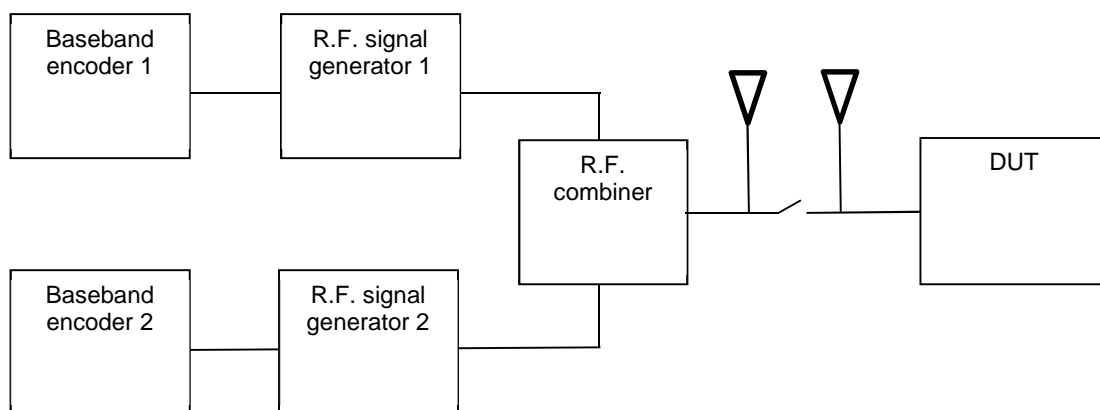

Figure 1: Test set-up

7.2 Basic checks

All EWS products are required to have been tested for compliance against ETSI TS 103 461 [1]. Therefore, the controls, display device and audio device are known to be working properly, and the selection mechanism delivers the right audio stream to the audio output.

7.3 Test 1 - Set-up behaviour

- Objective:
 - To check the behaviour of the DUT as delivered out-of-the-box before the user has entered the receiver location code.
- Method:
 - Set signal generator 1 to an unused DAB channel and the signal level to -50 dBm.
 - Signal generator 2 remains switched off.

- Turn on the DUT.
- Setup baseband encoder 1 and play stream EWS1.eti. Start the timing device.
- Perform the necessary steps to perform a factory reset (the service list shall be cleared and the receiver location code shall be deleted; a band scan shall be performed) but **do not enter a location code**. If the receiver enforces entry of a receiver location code, enter the code 1255-4467-1352 and restart playout of stream EWS1.eti and restart the timing device.
- Select "Service 5".
- Listen to the audio and look at the display whilst monitoring the timing device.
- When timing device shows 1:40, put the DUT to sleep.
- Continue to listen and look at the display and monitor the timing device.
- When timing device shows 3:30, the test is complete.

NOTE: The location code 1255-4467-1352 is also known as Z1:91BB82 (see Table A.19).

- Required result:
 - The audio output and display of the service label shall be as described in Table 1. Changes to audio shall occur within the first 5 s of each timing period. Changes to the audio that include a period of silence between the stated tones are normal and expected. If audio artefacts (squawks, chirps, etc.) are heard, the test is failed.

Table 1: Required response for test 1

Time displayed by the timing device (m:ss)	Required response when no location code has been entered	Required response when location code 1255-4467-1352 has been entered
After service selection	Display shows "Service 5" Audio is a mix of tones at 660 Hz and 770 Hz	Display shows "Service 5" Audio is a mix of tones at 660 Hz and 770 Hz
1:05 to 1:14	Display changes to "Alert 1" Audio changes to a mix of tones at 440 Hz and 550 Hz	Display changes to "Alert 1" Audio changes to a mix of tones at 440 Hz and 550 Hz
1:15 to 1:24	Display changes to "Service 5" Audio changes to a mix of tones at 660 Hz and 770 Hz	Display changes to "Service 5" Audio changes to a mix of tones at 660 Hz and 770 Hz
1:25 to 1:34	No change to display No change to audio	Display changes to "Alert 2" Audio changes to a mix of tones at 1 100 Hz and 1 210 Hz
1:35 to 1:39	No change to display No change to audio	Display changes to "Service 5" Audio changes to a mix of tones at 660 Hz and 770 Hz
1:40 to 1:54	DUT sleeps	DUT sleeps
1:55 to 2:04	Display changes to "Alert 1" Audio changes to a mix of tones at 440 Hz and 550 Hz	Display changes to "Alert 1" Audio changes to a mix of tones at 440 Hz and 550 Hz
2:05 to 2:54	DUT sleeps	DUT sleeps
2:55 to 3:04	DUT sleeps	Display changes to "Alert 2" Audio changes to a mix of tones at 1 100 Hz and 1 210 Hz
3:05 to 3:59	DUT sleeps	DUT sleeps

7.4 Test 2 - Tuned ensemble alert area matching

- Objective:
 - To check the behaviour of the DUT with different alert area settings.

- Method:
 - Turn on the DUT.
 - Navigate the UI to allow entry of the receiver location code. Set the code to 1255-4467-1352.
 - Do not alter the settings of signal generator 1.
 - Setup baseband encoder 1 and play stream EWS2.eti. Start the timing device.
 - Select "Service 1".
 - Listen to the audio and look at the display whilst monitoring the timing device.
 - Leave the DUT switched on.
- Required result:
 - The audio output and display of the service label shall be as described in Table 2. Changes to audio shall occur within the first 5 s of each timing period. Changes to the audio that include a period of silence between the stated tones are normal and expected. If audio artefacts (squawks, chirps, etc.) are heard, the test is failed.

Table 2: Required response for test 2

Time displayed by the timing device (m:ss)	Required response
After service selection	Display shows "Service 1" Audio is a mix of tones at 220 Hz and 330 Hz
0:30 to 0:39	Display changes to "Level 1 Start" Audio changes to a mix of tones at 440 Hz and 550 Hz
0:40 to 0:49	Display changes to "Service 1" Audio changes to a mix of tones at 220 Hz and 330 Hz
0:50 to 0:59	No change to display: Display shows "Service 1" No audio interruption: Audio is a mix of tones at 220 Hz and 330 Hz
1:00 to 1:09	Display shows "Service 1" Audio is a mix of tones at 220 Hz and 330 Hz
1:10 to 1:19	No change to display: Display shows "Service 1" No audio interruption: Audio is a mix of tones at 220 Hz and 330 Hz
1:20 to 1:29	Display shows "Service 1" Audio is a mix of tones at 220 Hz and 330 Hz
1:30 to 1:39	No change to display: Display shows "Service 1" No audio interruption: Audio is a mix of tones at 220 Hz and 330 Hz
1:40 to 1:59	Display shows "Service 1" Audio is a mix of tones at 220 Hz and 330 Hz
2:00 to 2:09	Display changes to "Level 1 Start" Audio changes to a mix of tones at 440 Hz and 550 Hz
2:10 to 2:19	Display changes to "Service 1" Audio changes to a mix of tones at 220 Hz and 330 Hz
2:20 to 2:29	Display changes to "Level 1 Start" Audio changes to a mix of tones at 440 Hz and 550 Hz
2:30 to 3:59	Display changes to "Service 1" Audio changes to a mix of tones at 220 Hz and 330 Hz

7.5 Test 3 - Tuned ensemble alert stages

- Objective:
 - To check the behaviour of the DUT with different alert stage settings.
- Method:
 - Do not alter the settings of signal generator 1.
 - Setup baseband encoder 1 and play stream EWS3.eti. Start the timing device.

- Select "Service 1".
- Listen to the audio and look at the display whilst monitoring the timing device.
- Leave the DUT switched on.
- Required result:
 - The audio output and display of the service label shall be as described in Table 3. Changes to audio shall occur within the first 5 s of each timing period. Changes to the audio that include a period of silence between the stated tones are normal and expected. If audio artefacts (squawks, chirps, etc.) are heard, the test is failed.

Table 3: Required response for test 3

Time displayed by the timing device (m:ss)	Required response
After service selection	Display shows "Service 1" Audio is a mix of tones at 220 Hz and 330 Hz
0:30 to 0:39	Display changes to "Level 1 Start" Audio changes to a mix of tones at 440 Hz and 550 Hz
0:40 to 0:49	Display changes to "Service 1" Audio changes to a mix of tones at 220 Hz and 330 Hz
0:50 to 0:59	Display changes to "Level 1 Update" Audio changes to mix of tones at 880 Hz and 990 Hz
1:00 to 1:09	Display changes to "Service 1" Audio changes to a mix of tones at 220 Hz and 330 Hz
1:10 to 1:19	Display changes to "Level 1 Repeat" Audio changes to mix of tones at 1 320 Hz and 1 430 Hz
1:20 to 1:29	Display changes to "Service 1" Audio changes to a mix of tones at 220 Hz and 330 Hz
1:30 to 1:39	Display changes to "Level 1 Critical" Audio changes to mix of tones at 1 760 Hz and 1 870 Hz
1:40 to 1:49	Display changes to "Service 1" Audio changes to a mix of tones at 220 Hz and 330 Hz
1:50 to 1:59	Display changes to "Level 2 Start" Audio changes to mix of tones at 660 Hz and 770 Hz
2:00 to 2:09	Display changes to "Service 1" Audio changes to a mix of tones at 220 Hz and 330 Hz
2:10 to 2:19	Display changes to "Level 2 Update" Audio changes to mix of tones at 1 100 Hz and 1 210 Hz
2:20 to 2:29	Display changes to "Service 1" Audio changes to a mix of tones at 220 Hz and 330 Hz
2:30 to 2:39	Display changes to "Level 2 Repeat" Audio changes to mix of tones at 1 540 Hz and 1 650 Hz
2:40 to 2:49	Display changes to "Service 1" Audio changes to a mix of tones at 220 Hz and 330 Hz
2:50 to 2:59	No change to display: Display shows "Service 1" No audio interruption: Audio is a mix of tones at 220 Hz and 330 Hz
3:00 to 3:09	Display shows "Service 1" Audio is a mix of tones at 220 Hz and 330 Hz
3:10 to 3:59	No change to display: Display shows "Service 1" No audio interruption: Audio is a mix of tones at 220 Hz and 330 Hz

7.6 Test 4 - Other ensemble alerts

- Objective:
 - To check the behaviour of the DUT for other ensemble alerts.
- Method:
 - Do not alter the settings of signal generator 1.

- Set signal generator 2 to an unused DAB channel and the signal level to -50 dBm.
 - Setup baseband encoder 2 with stream ESW4.eti and simultaneously play stream EWS3.eti on baseband encoder 1 and ESW4.eti on baseband encoder 2. Start the timing device.
 - Perform the necessary steps to clear the service list and perform a band scan.
 - Select "Service 11".
 - Listen to the audio and look at the display whilst monitoring the timing device.
 - Leave the DUT switched on.
- Required result:
 - The audio output and display of the service label shall be as described in Table 4. Changes to audio shall occur within the first 5 s of each timing period. Changes to the audio that include a period of silence between the stated tones are normal and expected. If audio artefacts (squawks, chirps, etc.) are heard, the test is failed.

Table 4: Required response for test 4

Time displayed by the timing device (m:ss)	Required response
After service selection	Display shows "Service 11" Audio is a tone at 300 Hz
0:30 to 0:39	Display changes to "Level 1 Start" Audio changes to a mix of tones at 440 Hz and 550 Hz
0:40 to 0:49	Display changes to "Service 11" Audio changes to a tone at 300 Hz
0:50 to 0:59	Display changes to "Level 1 Update" Audio changes to mix of tones at 880 Hz and 990 Hz
1:00 to 1:09	Display changes to "Service 11" Audio changes to a tone at 300 Hz
1:10 to 1:19	Display changes to "Level 1 Repeat" Audio changes to mix of tones at 1 320 Hz and 1 430 Hz
1:20 to 1:29	Display changes to "Service 11" Audio changes to a tone at 300 Hz
1:30 to 1:39	Display changes to "Level 1 Critical" Audio changes to mix of tones at 1 760 Hz and 1 870 Hz
1:40 to 1:49	Display changes to "Service 11" Audio changes to a tone at 300 Hz
1:50 to 1:59	Display changes to "Level 2 Start" Audio changes to mix of tones at 660 Hz and 770 Hz
2:00 to 2:09	Display changes to "Service 11" Audio changes to a tone at 300 Hz
2:10 to 2:19	Display changes to "Level 2 Update" Audio changes to mix of tones at 1 100 Hz and 1 430 Hz
2:20 to 2:29	Display changes to "Service 11" Audio changes to a tone at 300 Hz
2:30 to 2:39	Display changes to "Level 2 Repeat" Audio changes to mix of tones at 1 540 Hz and 1 650 Hz
2:40 to 2:49	Display changes to "Service 11" Audio changes to a tone at 300 Hz
2:50 to 2:59	No change to display: Display shows "Service 11" No audio interruption: Audio is a tone at 600 Hz
3:00 to 3:09	Display shows "Service 11" Audio is a tone at 300 Hz
3:10 to 3:19	Display is permitted to blank, shows "Service 11" Audio is permitted to mute, only a tone at 300 Hz is permitted
3:20 to 3:29	Display shows "Service 11" Audio is a tone at 300 Hz
3:30 to 3:39	Display is permitted to blank, shows "Service 11" Audio is permitted to mute, only a tone at 300 Hz is permitted

Time displayed by the timing device (m:ss)	Required response
3:40 to 3:49	Display shows "Service 11" Audio is a tone at 300 Hz
3:50 to 3:59	No change to display: Display shows "Service 11" No audio interruption: Audio is a tone at 300 Hz

7.7 Test 5 - Sleep mode EWS selection

- Objective:
 - To check the behaviour of the DUT when selecting suitable ensembles to monitor in sleep mode.
- Method:
 - Do not alter the settings of signal generator 1 or signal generator 2.
 - Setup baseband encoders 1 and 2 and simultaneously play stream EWS5.eti on encoder 1 and EWS6.eti on encoder 2. Start the timing device.
 - Perform the necessary steps to clear the service list and perform a band scan.
 - Select "Service 11".
 - Put the DUT to sleep.
 - Listen to the audio and look at the display whilst monitoring the timing device.
 - When timing device shows 2:20, set signal generator 1 to signal level of -85 dBm.
 - When timing device shows 2:45, turn on the DUT.
 - Perform the necessary steps to clear the service list and perform a band scan.
 - Select "Service 1".
 - Put the DUT to sleep, ensuring this happens before the timing device shows 3:45.
 - Listen to the audio and look at the display whilst monitoring the timing device.
 - When timing device shows 4:30, turn off signal generator 2.
 - Continue to listen and look at the display and monitor the timing device.
 - When timing device shows 6:30, change the DAB channel of signal generator 1.
 - Continue to listen and look at the display and monitor the timing device.
 - **When timing device shows 9:30 test 5 is complete and test 6 shall be immediately started.**
- Required result:
 - The audio output and display of the service label shall be as described in Table 5. Changes to audio shall occur within the first 5 s of each timing period. Changes to the audio that include a period of silence between the stated tones are normal and expected. If audio artefacts (squawks, chirps, etc.) are heard, the test is failed.

Table 5: Required response for test 5

Time displayed by the timing device (m:ss)	Required response
After service selection and until DUT put to sleep	Display shows "Service 11" Audio is a tone at 300 Hz Non-EWS indicator is present
From sleep time until 1:59	DUT sleeps
2:00 to 2:14	DUT wakes up Display changes to "Level 1 Start" Audio changes to a mix of tones at 440 Hz and 550 Hz
2:15 to 2:44	DUT sleeps
2:45 until DUT put to sleep	Display shows "Service 1" Audio is a mix of tones at 220 Hz and 330 Hz
From sleep time until 3:59	DUT sleeps
4:00 to 4:14	DUT wakes up Display changes to "Service 12" Audio changes to a tone at 600 Hz
4:15 to 5:59	DUT sleeps
6:00 to 6:14	DUT wakes up Display changes to "Level 1 Start" Audio changes to a mix of tones at 440 Hz and 550 Hz
6:15 to 7:59	DUT sleeps
8:00 to 8:14	DUT wakes up Display changes to "Level 1 Start" Audio changes to a mix of tones at 440 Hz and 550 Hz
8:15 to 8:59	DUT sleeps
9:00 to 9:14	DUT wakes up Display changes to "Alert 3" Audio changes to a mix of tones at 2 420 Hz and 2 530 Hz
9:15 to 9:59	DUT sleeps

NOTE: The signalling provided by the test files does not contain OE alert signalling in order to allow the determination of the EWS ensemble selection behaviour: in the real world OE signalling is required for EWS ensembles that have overlapping coverage areas.

7.8 Test 6 - Sleep mode alert response

- Objective:
 - To check the behaviour of the DUT in sleep mode.
- Method:
 - Begin this test **immediately** at the end of test 5.
 - Do not alter the settings of signal generator 1 or signal generator 2.
 - Setup baseband encoder 1 and play stream EWS7.eti. Start the timing device.
 - **Do not turn on the DUT.**
 - Listen to the audio and look at the display whilst monitoring the timing device.
- Required result:
 - The audio output and display of the service label shall be as described in Table 6. Changes to audio shall occur within the first 5 s of each timing period. Changes to the audio that include a period of silence between the stated tones are normal and expected. If audio artefacts (squawks, chirps, etc.) are heard, the test is failed.

Table 6: Required response for test 6

Time displayed by the timing device (m:ss)	Required response
0:00 to 0:59	DUT sleeps
1:00 to 1:14	DUT wakes up Display changes to "Level 1 Start" Audio changes to a mix of tones at 440 Hz and 550 Hz
1:15 to 1:59	DUT sleeps
2:00 to 2:14	DUT wakes up Display changes to "Level 1 Update" Audio changes to a mix of tones at 880 Hz and 990 Hz
2:15 to 2:59	DUT sleeps
3:00 to 3:14	DUT wakes up Display changes to "Level 1 Repeat" Audio changes to a mix of tones at 1 320 Hz and 1 430 Hz
3:15 to 3:59	DUT sleeps
4:00 to 4:14	DUT wakes up Display changes to "Level 1 Critical" Audio changes to a mix of tones at 1 760 Hz and 1 870 Hz
4:15 to 8:59	DUT sleeps
9:00 to 9:14	DUT wakes up Display changes to "Level 1 Start" Audio changes to a mix of tones at 440 Hz and 550 Hz
9:15 to 9:59	DUT sleeps

7.9 Test 7 - Concurrent alerts

- Objective:
 - To check the behaviour of the DUT with concurrent alert signalling.
- Method:
 - Set signal generator 1 to a signal level of -50 dBm.
 - Set signal generator 2 to a signal level of -50 dBm.
 - Turn on the DUT.
 - Setup baseband encoders 1 and 2 and simultaneously play stream EWS8.eti on baseband encoder 1 and stream ESW9.eti on baseband encoder 2. Start the timing device.
 - Perform the necessary steps to clear the service list and perform a band scan.
 - Select "Service 1".
 - Listen to the audio and look at the display whilst monitoring the timing device.
 - When the timing device shows 3:00, put the DUT to sleep.
 - Continue to listen and look at the display and monitor the timing device.
 - When the timing device shows 7:30, turn on the DUT.
 - Select "Service 11".
 - Continue to listen and look at the display and monitor the timing device.
 - When the timing device shows 7:55, cancel the alert playback.
 - Continue to listen and look at the display and monitor the timing device.
 - When the timing device shows 8:40, cancel the alert playback.

- Continue to listen and look at the display and monitor the timing device.
- **When the timing device shows 9:30, test 7 is complete.**
- Required result:
 - The audio output and display of the service label shall be as described in Table 7. Changes to audio shall occur within the first 5 s of each timing period (except where otherwise stated). Changes to the audio that include a period of silence between the stated tones are normal and expected. If audio artefacts (squawks, chirps, etc.) are heard, the test is failed.

Table 7: Required response for test 7

Time displayed by the timing device (m:ss)	Required response
After service selection	Display shows "Service 1" Audio is a mix of tones at 220 Hz and 330 Hz
0:30 to 0:39	Display changes to "Level 1 Start" Audio changes to a mix of tones at 440 Hz and 550 Hz
0:40 to 0:49	Display changes to "Level 2 Start" Audio changes to mix of tones at 660 Hz and 770 Hz
0:50 to 1:09	Display changes to "Service 1" Audio changes to a mix of tones at 220 Hz and 330 Hz
1:10 to 1:19	Display changes to "Service 12" Audio changes to a tone at 600 Hz
1:20 to 1:29	Display changes to "Service 1" Audio changes to a mix of tones at 220 Hz and 330 Hz
1:30 to 1:39	Display changes to "Level 1 Start" Audio changes to a mix of tones at 440 Hz and 550 Hz
1:40 to 1:49	Display changes to "Service 12" Audio changes to a tone at 600 Hz
1:50 to 2:09	Display changes to "Service 1" Audio changes to a mix of tones at 220 Hz and 330 Hz
2:10 to 2:19	Display changes to "Level 1 Start" Audio changes to a mix of tones at 440 Hz and 550 Hz
2:20 to 2:29	Display changes to "Service 1" Audio changes to a mix of tones at 220 Hz and 330 Hz
2:30 to 2:39	Display changes to "Level 2 Start" Audio changes to a mix of tones at 660 Hz and 770 Hz
2:40 to 2:59	Display changes to "Service 1" Audio changes to a mix of tones at 220 Hz and 330 Hz
3:00 to 5:59	DUT sleeps
6:00 to 6:14	DUT wakes up Display changes to "Level 1 Start" Audio changes to a mix of tones at 440 Hz and 550 Hz
6:15 to 6:29	Display changes to "Service 12" Audio changes to a tone at 600 Hz
6:30 to 6:59	DUT sleeps
7:00 to 7:14	DUT wakes up Display changes to "Level 1 Start" Audio changes to a mix of tones at 440 Hz and 550 Hz within 7 s
7:15 to 7:29	DUT sleeps
7:30 to 7:44	Display changes to "Service 11" Audio changes to a tone at 300 Hz
7:45 to 7:54	Display changes to "Service 14" Audio changes to a tone at 1 000 Hz
7:55 to 8:29	Display changes to "Service 11" Audio changes to a tone at 300 Hz; no other tones are heard
8:30 to 8:39	Display changes to "Level 2 Start" Audio changes to a mix of tones at 660 Hz and 770 Hz
8:40 to 9:59	Display changes to "Service 11" Audio changes to a tone at 300 Hz; no other tones are heard

8 Test specification for in-vehicle EWS receivers

8.1 Introduction

Clause 8 provides the test specifications for in-vehicle receivers to comply with EWS requirements. In-vehicle receivers shall comply with all tests in Clause 8. The testing provides only very basic location testing in a static location. Additional testing of location capability is strongly recommended!

The DUT will be exposed to the test streams and the behaviour of the DUT will be verified.

The test streams described in annex A are used for these tests.

The following equipment is needed:

- Two ETI file players and signal generators suitable for playing ETI files and for generating an RF output of -50 dBm.
- Suitable means to couple the output of the signal generators to the input of the DUT, either direct cable or antenna.
- GNSS simulator to provide location information.
- A timing device showing minutes and seconds (**m:ss**) which can be started when an ETI file starts playing.

The tests are performed using a conducted or radiated method as the receiver allows. The test setup is shown in Figure 2. Any band III channels may be used - three are needed. The signal level shall be set to -50 dBm unless otherwise specified. The GNSS simulator shall indicate the location is 13,377699°E, 52,516338°N. For radiated testing, the output of the R.F. combiner shall be connected to an antenna. The signal generators shall be set to different frequencies.

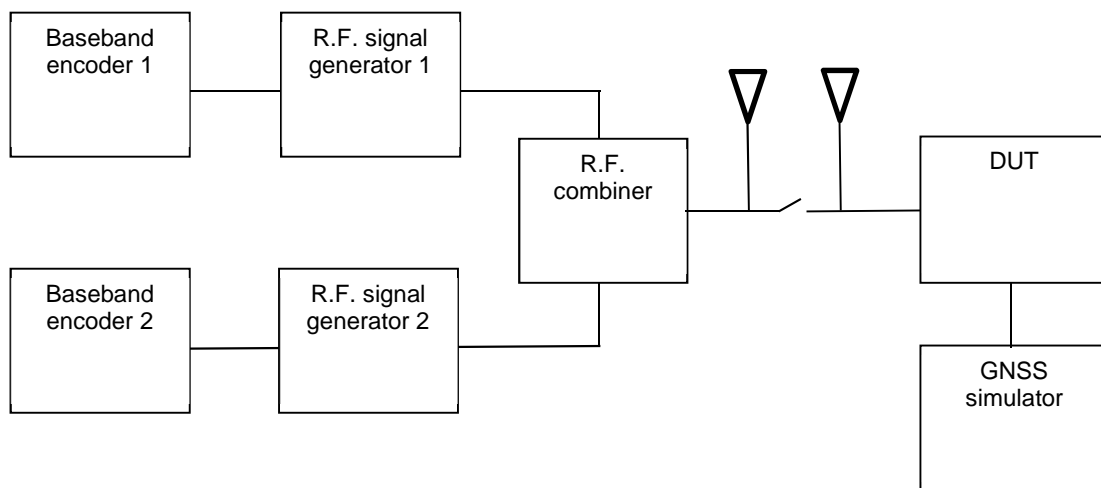

Figure 2: Test set-up

8.2 Basic checks

All EWS products are required to have been tested for compliance against ETSI TS 103 461[1]. Therefore, the controls, display device and audio device are known to be working properly, and the selection mechanism delivers the right audio stream to the audio output.

8.3 Test 1 - Set-up behaviour

Not required.

8.4 Test 2 - Tuned ensemble alert area matching

- Objective:
 - To check the behaviour of the DUT with different alert area settings.
- Method:
 - Set signal generator 1 to an unused DAB channel and the signal level to -50 dBm.
 - Signal generator 2 remains switched off.
 - Turn on the DUT.
 - Setup baseband encoder 1 and play stream EWS2.eti. Start the timing device.
 - Select "Service 1".
 - Listen to the audio and look at the display whilst monitoring the timing device.
 - Leave the DUT switched on.
- Required result:
 - The audio output and display of the service label shall be as described in Table 8. Changes to audio shall occur within the first 5 s of each timing period. Changes to the audio that include a period of silence between the stated tones are normal and expected. If audio artefacts (squawks, chirps, etc.) are heard, the test is failed.

Table 8: Required response for test 2

Time displayed by the timing device (m:ss)	Required response
After service selection	Display shows "Service 1" Audio is a mix of tones at 220 Hz and 330 Hz
0:30 to 0:39	Display changes to "Level 1 Start" Audio changes to a mix of tones at 440 Hz and 550 Hz
0:40 to 0:49	Display changes to "Service 1" Audio changes to a mix of tones at 220 Hz and 330 Hz
0:50 to 0:59	No change to display: Display shows "Service 1" No audio interruption: Audio is a mix of tones at 220 Hz and 330 Hz
1:00 to 1:09	Display shows "Service 1" Audio is a mix of tones at 220 Hz and 330 Hz
1:10 to 1:19	No change to display: Display shows "Service 1" No audio interruption: Audio is a mix of tones at 220 Hz and 330 Hz
1:20 to 1:29	Display shows "Service 1" Audio is a mix of tones at 220 Hz and 330 Hz
1:30 to 1:39	No change to display: Display shows "Service 1" No audio interruption: Audio is a mix of tones at 220 Hz and 330 Hz
1:40 to 1:59	Display shows "Service 1" Audio is a mix of tones at 220 Hz and 330 Hz
2:00 to 2:09	Display changes to "Level 1 Start" Audio changes to a mix of tones at 440 Hz and 550 Hz
2:10 to 2:19	Display changes to "Service 1" Audio changes to a mix of tones at 220 Hz and 330 Hz
2:20 to 2:29	Display changes to "Level 1 Start" Audio changes to a mix of tones at 440 Hz and 550 Hz
2:30 to 3:59	Display changes to "Service 1" Audio changes to a mix of tones at 220 Hz and 330 Hz

8.5 Test 3 - Tuned ensemble alert stages

- Objective:
 - To check the behaviour of the DUT with different alert stage settings.
- Method:
 - Do not alter the settings of signal generator 1.
 - Setup baseband encoder 1 and play stream EWS3.eti. Start the timing device.
 - Select "Service 1".
 - Listen to the audio and look at the display whilst monitoring the timing device.
 - Leave the DUT switched on.
- Required result:
 - The audio output and display of the service label shall be as described in Table 9. Changes to audio shall occur within the first 5 s of each timing period. Changes to the audio that include a period of silence between the stated tones are normal and expected. If audio artefacts (squawks, chirps, etc.) are heard, the test is failed.

Table 9: Required response for test 3

Time displayed by the timing device (m:ss)	Required response
After service selection	Display shows "Service 1" Audio is a mix of tones at 220 Hz and 330 Hz
0:30 to 0:39	Display changes to "Level 1 Start" Audio changes to a mix of tones at 440 Hz and 550 Hz
0:40 to 0:49	Display changes to "Service 1" Audio changes to a mix of tones at 220 Hz and 330 Hz
0:50 to 0:59	Display changes to "Level 1 Update" Audio changes to mix of tones at 880 Hz and 990 Hz
1:00 to 1:09	Display changes to "Service 1" Audio changes to a mix of tones at 220 Hz and 330 Hz
1:10 to 1:19	Display changes to "Level 1 Repeat" Audio changes to mix of tones at 1 320 Hz and 1 430 Hz
1:20 to 1:29	Display changes to "Service 1" Audio changes to a mix of tones at 220 Hz and 330 Hz
1:30 to 1:39	Display changes to "Level 1 Critical" Audio changes to mix of tones at 1 760 Hz and 1 870 Hz
1:40 to 1:49	Display changes to "Service 1" Audio changes to a mix of tones at 220 Hz and 330 Hz
1:50 to 1:59	Display changes to "Level 2 Start" Audio changes to mix of tones at 660 Hz and 770 Hz
2:00 to 2:09	Display changes to "Service 1" Audio changes to a mix of tones at 220 Hz and 330 Hz
2:10 to 2:19	Display changes to "Level 2 Update" Audio changes to mix of tones at 1 100 Hz and 1 210 Hz
2:20 to 2:29	Display changes to "Service 1" Audio changes to a mix of tones at 220 Hz and 330 Hz
2:30 to 2:39	Display changes to "Level 2 Repeat" Audio changes to mix of tones at 1 540 Hz and 1 650 Hz
2:40 to 2:49	Display changes to "Service 1" Audio changes to a mix of tones at 220 Hz and 330 Hz
2:50 to 2:59	No change to display: Display shows "Service 1" No audio interruption: Audio is a mix of tones at 220 Hz and 330 Hz
3:00 to 3:09	Display shows "Service 1" Audio is a mix of tones at 220 Hz and 330 Hz
3:10 to 3:59	No change to display: Display shows "Service 1" No audio interruption: Audio is a mix of tones at 220 Hz and 330 Hz

8.6 Test 4 - Other ensemble alerts

- Objective:
 - To check the behaviour of the DUT for other ensemble alerts.
- Method:
 - Do not alter the settings of signal generator 1.
 - Set signal generator 2 to an unused DAB channel and the signal level to -50 dBm.
 - Setup baseband encoder 2 with stream ESW4.eti and simultaneously play stream EWS3.eti on baseband encoder 1 and ESW4.eti on baseband encoder 2. Start the timing device.
 - Select "Service 11".
 - Listen to the audio and look at the display whilst monitoring the timing device.
 - Leave the DUT switched on.
- Required result:
 - The audio output and display of the service label shall be as described in Table 10. Changes to audio shall occur within the first 5 s of each timing period. Changes to the audio that include a period of silence between the stated tones are normal and expected. If audio artefacts (squawks, chirps, etc.) are heard, the test is failed.

Table 10: Required response for test 4

Time displayed by the timing device (m:ss)	Required response
After service selection	Display shows "Service 11" Audio is a tone at 300 Hz
0:30 to 0:39	Display changes to "Level 1 Start" Audio changes to a mix of tones at 440 Hz and 550 Hz
0:40 to 0:49	Display changes to "Service 11" Audio changes to a tone at 300 Hz
0:50 to 0:59	Display changes to "Level 1 Update" Audio changes to mix of tones at 880 Hz and 990 Hz
1:00 to 1:09	Display changes to "Service 11" Audio changes to a tone at 300 Hz
1:10 to 1:19	Display changes to "Level 1 Repeat" Audio changes to mix of tones at 1 320 Hz and 1 430 Hz
1:20 to 1:29	Display changes to "Service 11" Audio changes to a tone at 300 Hz
1:30 to 1:39	Display changes to "Level 1 Critical" Audio changes to mix of tones at 1 760 Hz and 1 870 Hz
1:40 to 1:49	Display changes to "Service 11" Audio changes to a tone at 300 Hz
1:50 to 1:59	Display changes to "Level 2 Start" Audio changes to mix of tones at 660 Hz and 770 Hz
2:00 to 2:09	Display changes to "Service 11" Audio changes to a tone at 300 Hz
2:10 to 2:19	Display changes to "Level 2 Update" Audio changes to mix of tones at 1 100 Hz and 1 210 Hz
2:20 to 2:29	Display changes to "Service 11" Audio changes to a tone at 300 Hz
2:30 to 2:39	Display changes to "Level 2 Repeat" Audio changes to mix of tones at 1 540 Hz and 1 650 Hz
2:40 to 2:49	Display changes to "Service 11" Audio changes to a tone at 300 Hz
2:50 to 2:59	No change to display: Display shows "Service 11" No audio interruption: Audio is a tone at 300 Hz
3:00 to 3:09	Display shows "Service 11" Audio is a tone at 300 Hz

Time displayed by the timing device (m:ss)	Required response
3:10 to 3:19	No change to display: Display shows "Service 11" No audio interruption: Audio is a tone at 300 Hz
3:20 to 3:29	Display shows "Service 11" Audio is a tone at 300 Hz
3:30 to 3:39	No change to display: Display shows "Service 11" No audio interruption: Audio is a tone at 300 Hz
3:40 to 3:49	Display shows "Service 11" Audio is a tone at 300 Hz
3:50 to 3:59	No change to display: Display shows "Service 11" No audio interruption: Audio is a tone at 300 Hz

8.7 Test 5 - Sleep mode EWS selection

Not required.

8.8 Test 6 - Sleep mode alert response

Not required.

8.9 Test 7 - Concurrent alerts

- Objective:
 - To check the behaviour of the DUT with concurrent alert signalling.
- Method:
 - Set signal generator 1 to a signal level of -50 dBm.
 - Set signal generator 2 to a signal level of -50 dBm.
 - Setup baseband encoders 1 and 2 and simultaneously play stream EWS8.eti on baseband encoder 1 and stream ESW9.eti on baseband encoder 2. Start the timing device.
 - Select "Service 1".
 - Listen to the audio and look at the display whilst monitoring the timing device.
 - When the timing device shows 3:00, select "Service 11".
 - Continue to listen and look at the display and monitor the timing device.
 - When the timing device shows 7:55, cancel the alert playback.
 - Continue to listen and look at the display and monitor the timing device.
 - When the timing device shows 8:40, cancel the alert playback.
 - Continue to listen and look at the display and monitor the timing device.
 - **When the timing device shows 9:30, test 7 is complete.**
- Required result:
 - The audio output and display of the service label shall be as described in Table 11. Changes to audio shall occur within the first 5 s of each timing period (except where otherwise stated). Changes to the audio that include a period of silence between the stated tones are normal and expected. If audio artefacts (squawks, chirps, etc.) are heard, the test is failed.

Table 11: Required response for test 7

Time displayed by the timing device (m:ss)	Required response
After service selection	Display shows "Service 1" Audio is a mix of tones at 220 Hz and 330 Hz
0:30 to 0:39	Display changes to "Level 1 Start" Audio changes to a mix of tones at 440 Hz and 550 Hz
0:40 to 0:49	Display changes to "Level 2 Start" Audio changes to mix of tones at 660 Hz and 770 Hz
0:50 to 1:09	Display changes to "Service 1" Audio changes to a mix of tones at 220 Hz and 330 Hz
1:10 to 1:19	Display changes to "Service 12" Audio changes to a tone at 600 Hz
1:20 to 1:29	Display changes to "Service 1" Audio changes to a mix of tones at 220 Hz and 330 Hz
1:30 to 1:39	Display changes to "Level 1 Start" Audio changes to a mix of tones at 440 Hz and 550 Hz
1:40 to 1:49	Display changes to "Service 12" Audio changes to a tone at 600 Hz
1:50 to 2:09	Display changes to "Service 1" Audio changes to a mix of tones at 220 Hz and 330 Hz
2:10 to 2:19	Display changes to "Level 1 Start" Audio changes to a mix of tones at 440 Hz and 550 Hz
2:20 to 2:29	Display changes to "Service 1" Audio changes to a mix of tones at 220 Hz and 330 Hz
2:30 to 2:39	Display changes to "Level 2 Start" Audio changes to a mix of tones at 660 Hz and 770 Hz
2:40 to 2:59	Display changes to "Service 1" Audio changes to a mix of tones at 220 Hz and 330 Hz
3:00 to 5:04	Display changes to "Service 11" Audio changes to a tone at 300 Hz
5:05 to 5:14	Display changes to "Service 12" Audio changes to a tone at 600 Hz
5:15 to 5:59	Display changes to "Service 11" Audio changes to a tone at 300 Hz
6:00 to 6:14	Display changes to "Level 1 Start" Audio changes to a mix of tones at 440 Hz and 550 Hz
6:15 to 6:29	Display changes to "Service 12" Audio changes to a tone at 600 Hz
6:30 to 6:59	Display changes to "Service 11" Audio changes to a tone at 300 Hz
7:00 to 7:14	Display changes to "Level 1 Start" Audio changes to a mix of tones at 440 Hz and 550 Hz within 7 s
7:15 to 7:44	Display changes to "Service 11" Audio changes to a tone at 300 Hz
7:45 to 7:54	Display changes to "Service 14" Audio changes to a tone at 1 000 Hz
7:55 to 8:14	Display changes to "Service 11" Audio changes to a tone at 300 Hz; no other tones are heard
8:15 to 8:39	Display changes to "Level 2 Start" Audio changes to a mix of tones at 660 Hz and 770 Hz
8:40 to 9:59	Display changes to "Service 11" Audio changes to a tone at 300 Hz; no other tones are heard

Annex A (normative): Product test streams

A.1 EWS1.eti

This file contains a 4-minute long ETI (NI) test stream. The ensemble label is "EWS Stream 1", the EId is D001 and the ensemble contains the services shown in Table A.1. The alert schedule is shown in Table A.2. The location code sets are described in Table A.19. EWS1.eti is available at https://docbox.etsi.org/Broadcast/Open/EWSv1_1.zip.

Checksum, SHA256:

- b0b4787b212d4a1e79aabf2627c62d9e34f555ad296c949e43f476eb7d0c6ece

Table A.1: Services in EWS1.eti

Service label Sid	SubChId	Bit rate / codec Protection	Audio (Hz, left channel)	Audio (Hz, right channel)
Service 1 D001	1	96k AAC EEP-3A	220	330
Alert 1 D002	2	96k AAC EEP-3A	440	550
Service 3 D003	3	96k AAC EEP-3A	880	990
Alert 2 D004	4	96k AAC EEP-3A	1 100	1 210
Service 5 D005	5	160k MP2 UEP-3	660	770

Table A.2: Alerts in EWS1.eti

Time point	Alert Id	Duration (s)				Stage	IId	Location code set
		P	T	S	E			
1m05	SubChId = 2		10		2	L1Start	9	
1m25	SubChId = 4		10		2	L1Start	9	LC1
1m55	SubChId = 2		10		2	L1Start	9	
2m55	SubChId = 4		10		2	L1Start	9	LC1
NOTE 1: The time points given are the time from the start of the file in minutes and seconds to the beginning of the Trigger signalling.								
NOTE 2: The durations given are for the Pre-trigger, Trigger (or OE Trigger), Sustain and End phases of each alert in seconds.								
NOTE 3: Ensemble time as provided by FIG 0/10 is 12:00:05,120 (UTC) at the start of the file.								

A.2 EWS2.eti

This file contains a 4-minute long ETI (NI) test stream. The ensemble label is "EWS Stream 2", the EId is D001 and the ensemble contains the services shown in Table A.3. The alert schedule is shown in Table A.4. The location code sets are described in Table A.19. EWS2.eti is available at https://docbox.etsi.org/Broadcast/Open/EWSv1_1.zip.

Checksum, SHA256:

- 609a155c4e47d84929452b1d6736c18da210e2ef2a4ca6f2bcccef477c0da99

Table A.3: Services in EWS2.eti

Service label SId	SubChId	Bit rate / codec Protection	Audio (Hz, left channel)	Audio (Hz, right channel)
Service 1 D001	0	128k AAC EEP-3A	220	330
Level 1 Start D002	1	136k AAC EEP-3A	440	550
Level 1 Update D003	2	64k AAC EEP-3A	880	990
Level 1 Repeat D004	3	80k AAC EEP-3A	1 320	1 430
Level 1 Critical D005	4	96k AAC EEP-3A	1 760	1 870
Level 2 Start D006	5	56k AAC EEP-3A	660	770
Level 2 Update D007	6	72k AAC EEP-3A	1 100	1 210
Level 2 Repeat D008	7	88k AAC EEP-3A	1 540	1 650
Test D009	8	192k AAC EEP-3A	1 980	2 090

Table A.4: Alerts in EWS2.eti

Time point	Alert Id	Duration (s)				Stage	IId	Location code set
		P	T	S	E			
0m30	SubChId = 1		10		2	L1Start	0	LC1
0m50	SubChId = 1		10		2	L1Start	1	LC2
1m10	SubChId = 1		10		2	L1Start	2	LC3
1m30	SubChId = 1		10		2	L1Start	3	LC4
2m00	SubChId = 1	3	5	5	2	L1Start	4	LC5
2m20	SubChId = 1		10		2	L1Start	5	LC6

NOTE 1: The time points given are the time from the start of the file in minutes and seconds to the beginning of the Trigger signalling.

NOTE 2: The durations given are for the Pre-trigger, Trigger (or OE Trigger), Sustain and End phases of each alert in seconds.

NOTE 3: Ensemble time as provided by FIG 0/10 is 12:05:00 (UTC) at the start of the file.

A.3 EWS3.eti

This file contains a 4-minute long ETI (NI) test stream. The ensemble label is "EWS Stream 3", the EId is D001 and the ensemble contains the services shown in Table A.5. The alert schedule is shown in Table A.6. EWS3.eti is available at https://docbox.etsi.org/Broadcast/Open/EWSv1_1.zip.

Checksum, SHA256:

- 0c73b2c7bb057abc370310a370913afee6b501ac4e269c107c2da19e69f1bc3f

Table A.5: Services in EWS3.eti

Service label SId	SubChId	Bit rate / codec Protection	Audio (Hz, left channel)	Audio (Hz, right channel)
Service 1 D001	0	128k AAC EEP-3A	220	330
Level 1 Start D002	1	136k AAC EEP-3A	440	550
Level 1 Update D003	2	64k AAC EEP-3A	880	990
Level 1 Repeat D004	3	80k AAC EEP-3A	1 320	1 430
Level 1 Critical D005	4	96k AAC EEP-3A	1 760	1 870
Level 2 Start D006	5	56k AAC EEP-3A	660	770
Level 2 Update D007	6	72k AAC EEP-3A	1 100	1 210
Level 2 Repeat D008	7	88k AAC EEP-3A	1 540	1 650
Test D009	8	192k AAC EEP-3A	1 980	2 090

Table A.6: Alerts in EWS3.eti

Time point	Alert Id	Duration (s)				Stage	IId	Location code set
		P	T	S	E			
0m30	SubChId = 1		10		2	L1Start	7	
0m50	SubChId = 2		10		2	L1Update	7	
1m10	SubChId = 3		10		2	L1Repeat	7	
1m30	SubChId = 4		10		2	L1Critical	7	
1m50	SubChId = 5		10		2	L2Start	7	
2m10	SubChId = 6		10		2	L2Update	7	
2m30	SubChId = 7		10		2	L2Repeat	7	
2m50	SubChId = 8		10		2	Test	7	
3m10	SubChId = 9		10		2	L1Start	7	

NOTE 1: The time points given are the time from the start of the file in minutes and seconds to the beginning of the Trigger signalling.

NOTE 2: The durations given are for the **Pre-trigger**, **Trigger** (or **OE Trigger**), **Sustain** and **End** phases of each alert in seconds.

NOTE 3: Ensemble time as provided by FIG 0/10 is 12:15:00 (UTC) at the start of the file.

NOTE 4: The alert at 3m10 points to a subchannel that does not exist in the configuration.

A.4 EWS4.eti

This file contains a 4-minute long ETI (NI) test stream. The ensemble label is "EWS Stream 4", the EId is D002 and the ensemble contains the services shown in Table A.7. The alert schedule is shown in Table A.8. EWS4.eti is available at https://docbox.etsi.org/Broadcast/Open/EWSv1_1.zip.

Checksum, SHA256:

- 42c413395ac1048bb39c5e2d45b88e0accd61a8413483e6effe43561a35499b8

Table A.7: Services in EWS4.eti

Service label SId	SubChId	Bit rate / codec Protection	Audio (Hz, left channel)	Audio (Hz, right channel)
Service 11 D011	1	96k AAC EEP-3A	300	300
Service 12 D012	2	96k AAC EEP-3A	600	600
Service 13 D013	3	128k AAC EEP-3A	1 200	1 200
Service 14 D014	4	88k AAC EEP-3A	1 000	1 000
Service 15 D015	5	80k MP2 UEP-3	2 000	2 000

Table A.8: Alerts in EWS4.eti

Time point	Alert Id	Duration (s)				Stage	IId	Location code set
		P	T	S	E			
0m30	EId = D001		10			L1Start	7	
0m50	EId = D001		10			L1Update	7	
1m10	EId = D001		10			L1Repeat	7	
1m30	EId = D001		10			L1Critical	7	
1m50	EId = D001		10			L2Start	7	
2m10	EId = D001		10			L2Update	7	
2m30	EId = D001		10			L2Repeat	7	
2m50	EId = D001		10			Test	7	
3m10	EId = D001		10			L1Start	7	
3m30	EId = D001		10			L1Update	7	
3m50	EId = D0FA		10			L1Repeat	7	

NOTE 1: The time points given are the time from the start of the file in minutes and seconds to the beginning of the Trigger signalling.

NOTE 2: The durations given are for the Pre-trigger, Trigger (or OE Trigger), Sustain and End phases of each alert in seconds.

NOTE 3: Ensemble time as provided by FIG 0/10 is 12:15:00 (UTC) at the start of the file.

A.5 EWS5.eti

This file contains a 10-minute long ETI (NI) test stream. The ensemble label is "EWS Stream 5", the EId is D001 and the ensemble contains the services shown in Table A.9. The alert schedule is shown in Table A.10. EWS5.eti is available at https://docbox.etsi.org/Broadcast/Open/EWSv1_1.zip.

Checksum, SHA256:

- f42c83a967874a693b077834dff45aa685a9e7e201cffbead2b4b2190bd68c12

Table A.9: Services in EWS5.eti

Service label SId	SubChId	Bit rate / codec Protection	Audio (Hz, left channel)	Audio (Hz, right channel)
Service 1 D001	0	128k AAC EEP-3A	220	330
Level 1 Start D002	1	136k AAC EEP-3A	440	550
Level 1 Update D003	2	64k AAC EEP-3A	880	990
Level 1 Repeat D004	3	80k AAC EEP-3A	1 320	1 430
Level 1 Critical D005	4	96k AAC EEP-3A	1 760	1 870
Level 2 Start D006	5	56k AAC EEP-3A	660	770
Level 2 Update D007	6	72k AAC EEP-3A	1 100	1 210
Level 2 Repeat D008	7	88k AAC EEP-3A	1 540	1 650
Test D009	8	192k AAC EEP-3A	1 980	2 090
From 9m00 to 9m18 reconfigurations introduce and then remove two services				
Service 2 D00A	9	64k AAC EEP-3A	2 200	2 310
Alert 3 D00B	10	96k AAC EEP-3A	2 420	2 530

Table A.10: Alerts in EWS5.eti

Time point	Alert Id	Duration (s)				Stage	IId	Location code set
		P	T	S	E			
2m00	SubChId = 1	3	5	10	2	L1Start	2	
4m00	SubChId = 1	3	5	10	2	L1Start	4	
6m00	SubChId = 1	3	5	10	2	L1Start	6	
8m00	SubChId = 1	3	5	10	2	L1Start	8	
9m00	SubChId = 10	3	10	5	2	L1Start	10	
NOTE 1: The time points given are the time from the start of the file in minutes and seconds to the beginning of the Trigger signalling.								
NOTE 2: The durations given are for the Pre-trigger, Trigger (or OE Trigger), Sustain and End phases of each alert in seconds.								
NOTE 3: Ensemble time as provided by FIG 0/10 is 12:20:00 (UTC) at the start of the file.								
NOTE 4: The alert at 9m00 uses a subchannel introduced at the reconfiguration.								

A.6 EWS6.eti

This file contains a 10-minute long ETI (NI) test stream. The ensemble label is "EWS Stream 6", the EId is D002 and the ensemble contains the services shown in Table A.11. The alert schedule is shown in Table A.12. EWS6.eti is available at https://docbox.etsi.org/Broadcast/Open/EWSv1_1.zip.

Checksum, SHA256:

- a091832114451e7eec8915e7de0ce5207668eaea0b0a05829994bfc84b8d37d4

Table A.11: Services in EWS6.eti

Service label SId	SubChId	Bit rate / codec Protection	Audio (Hz, left channel)	Audio (Hz, right channel)
Service 11 D011	1	96k AAC EEP-3A	300	300
Service 12 D012	2	96k AAC EEP-3A	600	600
Service 13 D013	3	128k AAC EEP-3A	1 200	1 200
Service 14 D014	4	88k AAC EEP-3A	1 000	1 000
Service 15 D015	5	80k MP2 UEP-3	2 000	2 000

Table A.12: Alerts in EWS6.eti

Time point	Alert Id	Duration (s)				Stage	IId	Location code set
		P	T	S	E			
0m00	** No EWS **							
2m30	** EWS **							
4m00	SubChId = 2	3	5	10	2	L1Start	5	
6m00	SubChId = 2	3	5	10	2	L1Start	7	

NOTE 1: The time points given are the time from the start of the file in minutes and seconds to the beginning of the Trigger signalling.

NOTE 2: The durations given are for the Pre-trigger, Trigger (or OE Trigger), Sustain and End phases of each alert in seconds.

NOTE 3: Ensemble time as provided by FIG 0/10 is 12:20:00 (UTC) at the start of the file.

A.7 EWS7.eti

This file contains a 10-minute long ETI (NI) test stream. The ensemble label is "EWS Stream 7", the EId is D001 and the ensemble contains the services shown in Table A.13. The alert schedule is shown in Table A.14. EWS7.eti is available at https://docbox.etsi.org/Broadcast/Open/EWSv1_1.zip.

Checksum, SHA256:

- 4108c9f8a39762016c8896b516661613d4b4bf0ae8db31b7f8a9bbf5d32a263f

Table A.13: Services in EWS7.eti

Service label SId	SubChId	Bit rate / codec Protection	Audio (Hz, left channel)	Audio (Hz, right channel)
Service 1 D001	0	128k AAC EEP-3A	220	330
Level 1 Start D002	1	136k AAC EEP-3A	440	550
Level 1 Update D003	2	64k AAC EEP-3A	880	990
Level 1 Repeat D004	3	80k AAC EEP-3A	1 320	1 430
Level 1 Critical D005	4	96k AAC EEP-3A	1 760	1 870
Level 2 Start D006	5	56k AAC EEP-3A	660	770
Level 2 Update D007	6	72k AAC EEP-3A	1 100	1 210
Level 2 Repeat D008	7	88k AAC EEP-3A	1 540	1 650
Test D009	8	192k AAC EEP-3A	1 980	2 090

Table A.14: Alerts in EWS7.eti

Time point	Alert Id	Duration (s)				Stage	Ild	Location code set
		P	T	S	E			
1m00	SubChId = 1	3	5	10	2	L1Start	7	
2m00	SubChId = 2	3	5	10	2	L1Update	7	
3m00	SubChId = 3	3	5	10	2	L1Repeat	7	
4m00	SubChId = 4	3	5	10	2	L1Critical	7	
5m00	SubChId = 5	3	5	10	2	L2Start	7	
6m00	SubChId = 6	3	5	10	2	L2Update	7	
7m00	SubChId = 7	3	5	10	2	L2Repeat	7	
8m00	SubChId = 8	3	5	10	2	Test	7	
8m45	SubChId = 1	3	20	10	2	L1Start	7	

NOTE 1: The time points given are the time from the start of the file in minutes and seconds to the beginning of the Trigger signalling.

NOTE 2: The durations given are for the Pre-trigger, Trigger (or OE Trigger), Sustain and End phases of each alert in seconds.

NOTE 3: Ensemble time as provided by FIG 0/10 is 12:30:00 (UTC) at the start of the file.

A.8 EWS8.eti

This file contains a 10-minute long ETI (NI) test stream. The ensemble label is "EWS Stream 8", the EId is D001 and the ensemble contains the services shown in Table A.15. The alert schedule is shown in Table A.16. The location code sets are described in Table A.19. EWS8.eti is available at https://docbox.etsi.org/Broadcast/Open/EWSv1_1.zip.

Checksum, SHA256:

- 5e76c55ab51770d449b525560bb163dbf68fcd87e3ff5b334b9b7b26300bab5c

Table A.15: Services in EWS8.eti

Service label SId	SubChId	Bit rate / codec Protection	Audio (Hz, left channel)	Audio (Hz, right channel)
Service 1 D001	0	128k AAC EEP-3A	220	330
Level 1 Start D002	1	136k AAC EEP-3A	440	550
Level 1 Update D003	2	64k AAC EEP-3A	880	990
Level 1 Repeat D004	3	80k AAC EEP-3A	1 320	1 430
Level 1 Critical D005	4	96k AAC EEP-3A	1 760	1 870
Level 2 Start D006	5	56k AAC EEP-3A	660	770
Level 2 Update D007	6	72k AAC EEP-3A	1 100	1 210
Level 2 Repeat D008	7	88k AAC EEP-3A	1 540	1 650
Test D009	8	192k AAC EEP-3A	1 980	2 090

Table A.16: Alerts in EWS8.eti

Time point	Alert Id	Duration (s)				Stage	Ild	Location code set
		P	T	S	E			
0m30	SubChId = 1	3	5	5		L1Start	7	
0m40	SubChId = 5	3	5	5	2	L2Start	7	
1m10	SubChId = 1	3	10		2	L1Start	6	LC2
1m10	EId = D002		10			L1Start	13	
1m30	SubChId = 1	3	5	5	2	L1Start	7	
1m40	EId = D002		10			L2Start	7	
2m10	SubChId = 1	3	5	5	2	L1Start	13	
2m10	EId = D002		5			L1Start	6	
2m30	SubChId = 5	3	10			L2Start	7	
2m40	SubChId = 1	3	25	65	2	L1Start	4	LC4
4m00	EId = D0FA		5			L1Start	2	
4m52	SubChId = 5	3	10		2	L2Start	4	LC8
4m52	EId = D002		10			L1Start	3	LC8
5m00	EId = D0FA		5			L1Start	6	LC7
5m00	EId = D0FB		5			L1Start	7	LC6
5m05	SubChId = 1	3	10		2	L1Start	11	
5m05	EId = D002		10			L1Start	10	
6m00	SubChId = 1	3	5	10	2	L1Start	7	LC1
6m15	EId = D002		15			L1Start	14	LC5
6m15	EId = D0FA		10			L2Repeat	12	LC7
6m15	EId = D0FB		20			L1Update	13	LC6
7m00	SubChId = 1	3	5	10	2	L1Start	4	LC6
7m00	EId = D002		5			L2Repeat	14	LC7
7m45	EId = D002		30			L2Start	9	
8m30	SubChId = 5	3	30		2	L2Start	1	

NOTE 1: The time points given are the time from the start of the file in minutes and seconds to the beginning of the Trigger signalling.

NOTE 2: The durations given are for the **Pre-trigger**, **Trigger** (or **OE Trigger**), **Sustain** and **End** phases of each alert in seconds.

NOTE 3: Ensemble time as provided by FIG 0/10 is 12:40:00 (UTC) at the start of the file.

NOTE 4: There are deliberate FIB errors for alert signalling from 7m00 to 7m02 which will delay receiver response and which are to test the capability to deal with this scenario.

A.9 EWS9.eti

This file contains a 10-minute long ETI (NI) test stream. The ensemble label is "EWS Stream 9", the EId is D002 and the ensemble contains the services shown in Table A.17. The alert schedule is shown in Table A.18. EWS9.eti is available at https://docbox.etsi.org/Broadcast/Open/EWSv1_1.zip.

Checksum, SHA256:

- e85540843defcb91df6487fcfeef82ffc70a2f3e2c89480f48ac7762c1471dd1

Table A.17: Services in EWS9.eti

Service label SId	SubChId	Bit rate / codec Protection	Audio (Hz, left channel)	Audio (Hz, right channel)
Service 11 D011	1	96k AAC EEP-3A	300	300
Service 12 D012	2	96k AAC EEP-3A	600	600
Service 13 D013	3	128k AAC EEP-3A	1 200	1 200
Service 14 D014	4	88k AAC EEP-3A	1 000	1 000
Service 15 D015	5	80k MP2 UEP-3	2 000	2 000

Table A.18: Alerts in EWS9.eti

Time point	Alert Id	Duration (s)				Stage	Ild	Location code set
		P	T	S	E			
0m30	Eld = D001		5			L1Start	7	
0m40	Eld = D001		5			L2Start	7	
1m10	SubChId = 2	3	10		2	L1Start	13	
1m10	Eld = D001		10			L1Start	6	LC2
1m30	Eld = D001		5			L1Start	7	
1m40	SubChId = 2	3	10		2	L2Start	7	
2m10	SubChId = 2	3	5	5	2	L1Start	6	
2m10	Eld = D001		5			L1Start	13	
2m30	Eld = D001		10			L2Start	7	
2m40	Eld = D001		25			L1Start	4	LC4
4m00	Eld = D0FA		5			L1Start	2	
4m52	SubChId = 2	3	10		2	L1Start	3	LC8
4m52	Eld = D001		10			L2Start	4	LC8
5m00	Eld = D0FA		5			L1Start	6	LC7
5m00	Eld = D0FB		5			L1Start	7	LC6
5m05	SubChId = 2	3	10		2	L1Start	10	
5m05	Eld = D001		10			L1Start	11	
6m00	Eld = D001		5			L1Start	7	LC1
6m15	SubChId = 2	3	15		2	L1Start	14	LC5
6m15	Eld = D0FA		10			L2Repeat	12	LC7
6m15	Eld = D0FB		20			L1Update	13	LC6
7m00	SubChId = 2	3	5	10	2	L2Repeat	14	LC7
7m00	Eld = D001		5			L1Start	4	LC6
7m45	SubChId = 4	3	30		2	L2Start	9	
8m30	Eld = D001		30			L2Start	1	

NOTE 1: The time points given are the time from the start of the file in minutes and seconds to the beginning of the Trigger signalling.

NOTE 2: The durations given are for the **Pre-trigger**, **Trigger** (or **OE Trigger**), **Sustain** and **End** phases of each alert in seconds.

NOTE 3: Ensemble time as provided by FIG 0/10 is 12:40:00 (UTC) at the start of the file.

NOTE 4: There are deliberate FIB errors for alert signalling from 7m00 to 7m02 which will delay receiver response and which are to test the capability to deal with this scenario.

A.10 Location code sets

This location code sets used in the ETI files are described in Table A.19. Location codes that correspond with the receiver location code are highlighted. Sub-coding is shown by hexadecimal digits within square brackets.

Table A.19: Location code sets

Set	Location codes	NFF	Num bytes	Encoding
LC1 Receiver location	Z1:91BB82	0	5	Z1:91BB82
LC2 Eight L6 codes surrounding the receiver location	Z1:91BB81, Z1:91BB85, Z1:91BB86, Z1:91BB87, Z1:91BB83, Z1:91BB4D, Z1:91BB4E, Z1:91BB4F	0	12	Z1:91BB8 [76531], Z1:91BB4 [FED]
LC3 Eight L6 codes, digits identical to the receiver location, but in different zones	Z0:91BB82, Z10:91BB82, Z2:91BB82, Z41:91BB82, Z19:91BB82, Z20:91BB82, Z11:91BB82, Z12:91BB82	1 0	25 15	Z0:91BB82, Z10:91BB82, Z2:91BB82, Z41:91BB82, Z19:91BB82 Z20:91BB82, Z11:91BB82, Z12:91BB82
LC4 Eight L3 codes surrounding the receiver location.	Z1:91A, Z1:916, Z1:917, Z1:924, Z1:928, Z1:92C, Z1:91F, Z1:91E	0	10	Z1:91 [FEA76], Z1:92 [C84]
LC5 Nine L4 codes, including the receiver location.	Z1:9288, Z1:9289, Z1:928C, Z1:928D, Z1:92C0, Z1:92C1, Z1:91F3, Z1:91BF, Z1:91BB	0	19	Z1:928 [DC98], Z1:92C [10], Z1:91F3, Z1:91B [FB]

Set	Location codes	NFF	Num bytes	Encoding
LC6 132 L5 codes, including the receiver location	Z1:91B76, Z1:91B77, Z1:91B69, Z1:91B6A, Z1:91B78, Z1:91B79, Z1:91B7A, Z1:91B7B, Z1:92848, Z1:91B5E, Z1:91B5F, Z1:91B6C, Z1:91B6D, Z1:91B6E, Z1:91B6F, Z1:91B7C, Z1:91B7D, Z1:91B7E, Z1:91B7F, Z1:9284C, Z1:91B91, Z1:91B92, Z1:91B93, Z1:91BA0, Z1:91BA1, Z1:91BA2, Z1:91BA3, Z1:91BB0, Z1:91BB1, Z1:91BB2, Z1:91BB3, Z1:92880, Z1:92881, Z1:92882, Z1:91B95, Z1:91B96, Z1:91B97, Z1:91BA4, Z1:91BA5, Z1:91BA6, Z1:91BA7, Z1:91BB4, Z1:91BB5, Z1:91BB6, Z1:91BB7, Z1:92884, Z1:92885, Z1:92886, Z1:92887, Z1:92894, Z1:91B99, Z1:91B9A, Z1:91B9B, Z1:91BA8, Z1:91BA9, Z1:91BAA, Z1:91BAB, Z1:91BB8, Z1:91BB9, Z1:91BBA, Z1:91BBB, Z1:92888, Z1:92889, Z1:9288A, Z1:9288B, Z1:92898, Z1:91B9C, Z1:91B9D, Z1:91B9E, Z1:91B9F, Z1:91BAC, Z1:91BAD, Z1:91BAE, Z1:91BAF, Z1:91BBC, Z1:91BBD, Z1:91BBE, Z1:91BBF, Z1:9288C, Z1:9288D, Z1:9288E, Z1:9288F, Z1:9289C, Z1:9289D, Z1:9289E, Z1:91BD0, Z1:91BD1, Z1:91BD2, Z1:91BD3, Z1:91BE0, Z1:91BE1, Z1:91BE2, Z1:91BE3, Z1:91BF0, Z1:91BF1, Z1:91BF2, Z1:91BF3, Z1:928C0, Z1:928C1, Z1:928C2, Z1:928C3, Z1:928D0, Z1:928D1, Z1:928D2, Z1:928D3, Z1:91BD4, Z1:91BD5, Z1:91BD6, Z1:91BD7, Z1:91BE4, Z1:91BE5, Z1:91BE6, Z1:91BE7, Z1:91BF4, Z1:91BF5, Z1:91BF6, Z1:91BF7, Z1:928C4, Z1:928C5, Z1:928C6, Z1:928C7, Z1:928D4, Z1:928D5, Z1:928D6, Z1:91BF8, Z1:91BF9, Z1:928CA, Z1:928CB, Z1:928D8, Z1:928D9, Z1:928CF, Z1:928DC	3	24	Z1:91B7[FEDCBA9876], Z1:91B6[FEDCA9], Z1:9284[C8], Z1:91B5[FE]
		2	24	Z1:91B9[FEDCBA9765321], Z1:91BA, Z1:91BB, Z1:9288[FEDCBA987654210], Z1:928DC
		1	24	Z1:9289[EDC84], Z1:91BD[76543210], Z1:91BE[76543210], Z1:91BF[9876543210]
		0	16	Z1:928C[BA76543210], Z1:928D[986543210], Z1:928CF
LC7 As LC6 but excluding the receiver location	- :- Z1:91BB8 - :-	3	24	Z1:91B7[FEDCBA9876], Z1:91B6[FEDCA9], Z1:9284[C8], Z1:91B5[FE]
		2	22	Z1:91B9[FEDCBA9765321], Z1:91BA, Z1:91BB[FEDCBA976543210], Z1:9288[FEDCBA987654210]
		1	24	Z1:9289[EDC84], Z1:91BD[76543210], Z1:91BE[76543210], Z1:91BF[9876543210]
		0	20	Z1:928C[BA76543210], Z1:928D[986543210], Z1:928CF, Z1:928DC

Set	Location codes	NFF	Num bytes	Encoding
LC8 As LC6 but all codes are Zone 7 not Zone 1	Z1:-	3	24	Z7:91B7[FEDCBA9876], Z7:91B6[FEDCA9], Z7:9284[C8], Z7:91B5[FE]
	<u>Z7:-</u>	2	24	Z7:91B9[FEDCBA9765321], Z7:91BA, Z7:91BB, Z7:9288[FEDCBA987654210], Z7:928DC
		1	24	Z7:9289[EDC84], Z7:91BD[76543210], Z7:91BE[76543210], Z7:91BF[9876543210]
		0	16	Z7:928C[BA76543210], Z7:928D[986543210], Z7:928CF

History

Document history		
V1.1.1	September 2024	Publication