

ETSI TS 122 115 V3.3.0 (2000-03)

Technical Specification

**Digital cellular telecommunications system (Phase 2+) (GSM);
Universal Mobile Telecommunications System (UMTS);
Service aspects; Charging and Billing
(3G TS 22.115 version 3.3.0 Release 1999)**



Reference

RTS/TSGS-0122115UR1

Keywords

GSM, UMTS

ETSI

650 Route des Lucioles
F-06921 Sophia Antipolis Cedex - FRANCE

Tel.: +33 4 92 94 42 00 Fax: +33 4 93 65 47 16

Siret N° 348 623 562 00017 - NAF 742 C
Association à but non lucratif enregistrée à la
Sous-Préfecture de Grasse (06) N° 7803/88

Important notice

Individual copies of the present document can be downloaded from:

<http://www.etsi.org>

The present document may be made available in more than one electronic version or in print. In any case of existing or perceived difference in contents between such versions, the reference version is the Portable Document Format (PDF).

In case of dispute, the reference shall be the printing on ETSI printers of the PDF version kept on a specific network drive within ETSI Secretariat.

Users of the present document should be aware that the document may be subject to revision or change of status.

Information on the current status of this and other ETSI documents is available at <http://www.etsi.org/tb/status/>

If you find errors in the present document, send your comment to:

editor@etsi.fr

Copyright Notification

No part may be reproduced except as authorized by written permission.
The copyright and the foregoing restriction extend to reproduction in all media.

© European Telecommunications Standards Institute 2000.

All rights reserved.

Intellectual Property Rights

IPRs essential or potentially essential to the present document may have been declared to ETSI. The information pertaining to these essential IPRs, if any, is publicly available for **ETSI members and non-members**, and can be found in SR 000 314: *"Intellectual Property Rights (IPRs); Essential, or potentially Essential, IPRs notified to ETSI in respect of ETSI standards"*, which is available from the ETSI Secretariat. Latest updates are available on the ETSI Web server (<http://www.etsi.org/ipr>).

Pursuant to the ETSI IPR Policy, no investigation, including IPR searches, has been carried out by ETSI. No guarantee can be given as to the existence of other IPRs not referenced in SR 000 314 (or the updates on the ETSI Web server) which are, or may be, or may become, essential to the present document.

Foreword

This Technical Specification (TS) has been produced by the ETSI 3rd Generation Partnership Project (3GPP).

The present document may refer to technical specifications or reports using their 3GPP identities, UMTS identities or GSM identities. These should be interpreted as being references to the corresponding ETSI deliverables.

The cross reference between GSM, UMTS, 3GPP and ETSI identities can be found under www.etsi.org/key.

Contents

Foreword	4
1 Scope.....	5
2 References.....	5
3 Definitions and abbreviations	5
3.1 Definitions	5
3.2 Abbreviations.....	6
4 Requirements	6
4.1 Cross Phase Compatibility for Release 99.....	6
5 Generation of Call Detail Records.....	7
5.1 Call Detail Record Requirements	7
5.1.1 Information provided by the user	7
5.1.2 Information provided by the serving network.....	7
5.1.3 Charged Party.....	8
5.2 Special Cases	8
5.2.1 Long calls.....	8
5.2.2 Multimedia calls.....	8
5.2.3 E-Commerce	8
5.2.4 Volume Based Charging	8
6 Transfer of Charging Information.....	9
6.1 Integrity, Secrecy and Validation of Content and Receipt of Charging Information.....	9
7 Accounting and Settlement.....	9
7.1 Delegation of charging authority	9
7.2 Fraud Control.....	9
7.2.1 Fraud Control by the Home Environment.....	9
7.2.2 Fraud Control by the Serving Network	10
7.3 Cost Control.....	10
7.3.1 Cross Phase Compatibility	10
7.4 Inter-network Settlement	10
8 Automatic Roaming Agreements.....	11
8.1 Routing the Registration Request	11
8.2 Settlement of charges.....	11
Annex A (informative): Change history	12

Foreword

This Technical Specification (TS) has been produced by the 3rd Generation Partnership Project (3GPP).

The contents of the present document are subject to continuing work within the TSG and may change following formal TSG approval. Should the TSG modify the contents of the present document, it will be re-released by the TSG with an identifying change of release date and an increase in version number as follows:

Version x.y.z

where:

- x the first digit:
 - 1 presented to TSG for information;
 - 2 presented to TSG for approval;
 - 3 or greater indicates TSG approved document under change control.
- y the second digit is incremented for all changes of substance, i.e. technical enhancements, corrections, updates, etc.
- z the third digit is incremented when editorial only changes have been incorporated in the document.

1 Scope

The present document describes the Service Aspects of charging and billing of the Universal Mobile Telecommunications System (UMTS).

The present document is not intended to duplicate existing standards or standards being developed by other groups on these topics, and will reference these where appropriate. The present document will elaborate on the charging requirements described in the Charging Principles in UMTS 22.01 Service Principles. It will allow the generation of accurate charging information to be used in the commercial and contractual relationships between the parties concerned.

2 References

The following documents contain provisions which, through reference in this text, constitute provisions of the present document.

- References are either specific (identified by date of publication, edition number, version number, etc.) or non-specific.
- For a specific reference, subsequent revisions do not apply.
- For a non-specific reference, the latest version applies.

- [1] 3G TS 22.001: "Service aspects; Service Principles".
- [2] GSM 02.31: "Fraud Information Gathering System (FIGS); Service description - Stage 1".
- [3] TS 22.078: "Customised Applications for Mobile network Enhanced Logic (CAMEL); Service definition - Stage 1".
- [4] TS 22.086: "Advice of Charge (AoC) Supplementary Services; Stage 1".

3 Definitions and abbreviations

3.1 Definitions

For the purposes of the present document, the definitions in [1] are supplemented by the following definitions:

Accounting: The process of apportioning charges between the Home Environment, Serving Network and User.

Billing: A function whereby CDRs generated by the charging function are transformed into bills requiring payment.

Call Detail Record (CDR): A formatted collection of information about a chargeable event (e.g. time of call set-up, duration of the call, amount of data transferred, etc) for use in billing and accounting. For each party to be charged for parts of or all charges of a chargeable event a separate CDR shall be generated, i.e more than one CDR may be generated for a single chargeable event, e.g. because of its long duration, or because more than one charged party is to be charged.

Chargeable Event: An activity utilising telecommunications network infrastructure and related services for user to user communication (e.g. a single call, a data communication session or a short message), or for user to network communication (e.g. service profile administration), or for inter-network communication (e.g. transferring calls, signalling, or short messages), or for mobility (e.g. roaming or inter-system handover), which the network operator wants to charge for. The cost of a chargeable event may cover the cost of sending, transporting, delivery and storage. The cost of call related signalling may also be included.

Charged Party: A user involved in a chargeable event who has to pay parts or the whole charges of the chargeable event, or a third party paying the charges caused by one or all users involved in the chargeable event, or a network operator.

Charging: A function whereby information related to a chargeable event is formatted and transferred in order to make it possible to determine usage for which the charged party may be billed.

Real time: Time, typically in number of seconds, to perform the on-line mechanism used for fraud control and cost control.

Settlement: Payment of amounts resulting from the accounting process.

Short time: Time, typically in number of minutes, to perform the off-line mechanism used for accounting.

3.2 Abbreviations

For the purposes of the present document, the following abbreviations apply:

CDR Call Detail Record

4 Requirements

The main new requirements for UMTS charging and accounting are:

- to provide a call detail record for all charges incurred and requiring settlement between the different commercial roles;
- to allow fraud control by the Home Environment and the Serving network;
- to allow cost control by the charged party;
- to provide at the beginning of a chargeable event an indication to the charged party (if involved in the chargeable event) of the charges to be levied for this event;
- to allow itemised billing for all services charged to each subscription, including voice and data calls, and services offered by home environments.

These new requirements will allow users more freedom to obtain service when roaming, whilst providing effective cost and credit control for the Home Environment and User.

4.1 Cross Phase Compatibility for Release 99

There are no earlier releases of the UMTS standards for which backward compatibility of equipment implementing these standards is required. However, where possible (e.g. services already defined within GSM standard such as voice services, SMS, GPRS, etc.), the information contained in the CDRs shall be consistent with the information already provided by the existing GSM and GPRS CDRs.

It is envisaged that UMTS will evolve beyond Release 99, for example with the addition of a number of new requirements for charging and billing; these are noted in the appropriate sections below. The technical standards for Release 99 should be developed in such a way that it is possible and practical to introduce these requirements, ideally in a backward compatible manner.

NOTE: When a change is introduced which affects the UMTS technical standards, it is said to be 'backward compatible' if existing equipment can continue to operate and perform correctly with equipment that conforms to the new implementation.

5 Generation of Call Detail Records

The standard shall support the creation and transfer of charging records in order to facilitate:

- interworking with pre-UMTS systems (e.g. GSM);
- fraud management procedures;
- detailed itemised billing.

5.1 Call Detail Record Requirements

Call Detail Records shall be generated in the Serving Network to record chargeable User or Mobile Station activity and inter-carrier connections. Some of the information is provided by the user, other information is only available in the network element of the serving network.

Depending on the type of chargeable event some of the information may not be available or might not be required.

5.1.1 Information provided by the user

The user's user equipment that is incurring the charge shall provide the following information to the serving network:

- User identity used for authentication;
- Home environment identity;
- Terminal Identity and Terminal Class;
- Destination endpoint identifier for service requested (e.g. B number);
- Resource requested (e.g. bandwidth, connectionless);
- QoS parameters (e.g. maximum delay).

5.1.2 Information provided by the serving network

The serving network serving the user shall provide the following information to the home environment:

- All of the information listed in section above (Information provided by the user);
- Serving network identity;
- Recording network element identity;
- Universal Time (UT) at which the service request was initiated;
- Universal Time (UT) at which resources were provided for the service;
- Resource allocated to the user;
- Quantity of data transferred both to and from the user;
- QoS provided to the user;
- Location of the user in the standard format used for UMTS location based services (e.g. geographical co-ordinates, Cell ID);
- whether GSM Optimal Routing was applied;
- If IN or CAMEL services were applied, the service parameters and the actually used destination number and calling party number identification;
- Time duration covered by this call record to an accuracy of at least 1 second;

- Unique identity of the chargeable event which allows the billing system to correlate all records belonging to the same chargeable event;
- Unique CDR identity (unique per network element in a period of about 100 days).

5.1.3 Charged Party

For subscription related chargeable events the CDR shall indicate the charged party, i.e. normally the calling party. As alternative it should be possible to apply reverse charging or to charge the event to a party not involved in the event itself (e.g. a company as VPN subscriber). It should be possible for multiple leg calls (e.g. forwarded, conference or roamed) to be charged to each party as if each leg was separately initiated. However, in certain types of call, the originating party may wish/be obliged to pay for other legs (e.g. SMS MO may also pay for the MT leg.).

It shall be possible to change the chargeable party at the call set-up.

In case of inter-network chargeable events, the CDR usually does not contain the charged party, but it can be derived from network configuration information contained in the CDR.

For each party to be charged for a chargeable event or parts of it a separate CDR shall be generated.

5.2 Special Cases

5.2.1 Long calls

The advent of packet data services, which can extend for very long periods of time (days, weeks etc), although at low cost because charges are based on data throughput, may mean that billing records are only output at the end of very long periods. For this reason the serving network shall support the generation of call records also during the life of the packet data session, either when some charge value is reached or some duration or both, to allow for both charging settlement and cost control.

5.2.2 Multimedia calls

During one call the user may invoke different services like speech, data transmission, video and audio, which may lead to a separate CDR for each service. If several CDRs will be the result of each multimedia call, the billing system shall be able to correlate these records and to indicate to the user on the bill that they belonged to one call.

5.2.3 E-Commerce

The UMTS system may be used to trade soft goods (e.g. information, video, audio), or hard goods (e.g. books) of high or low value per item between the user and a merchant. It shall be possible for such merchants to charge users directly for services they provide. Electronic payment mechanisms are or shall be made available through other standards (micropayment, credit card payment, etc), and therefore are outside the scope of this specification UMTS shall not prohibit the use of these mechanisms, and, where possible, shall provide the basic communications transport to allow them to be used effectively.

However, if the serving network acts as merchant of soft goods, it may charge the user directly, creating a CDR as described above or using micropayment mechanisms.

5.2.4 Volume Based Charging

It shall be possible to charge for the total volume of data/packets sent and received by the user.

6 Transfer of Charging Information

The efficient transfer of charging information between serving networks and from serving networks to home environments requires a standardised interface between these entities. It shall be possible to define different time intervals for the transfer of charging information between serving network and home environment (e.g. when a chargeable event occurs, when a chargeable event is initiated by the user, when a chargeable event terminates, at regular intervals during a chargeable event).

The format of the charging information exchanged (see 5.1) shall be standardised. It shall be possible for the relevant parties to agree minimum and maximum age of call information transferred between themselves.

6.1 Integrity, Secrecy and Validation of Content and Receipt of Charging Information

The transmission mechanism for charging information collected in 5.1 above shall ensure its integrity and secrecy.

A mechanism to validate the source and integrity of the information shall be provided so that:

- the home environment shall be able to validate the source and integrity of the charging information supplied by the serving network;
- the serving network shall be able to validate the source and integrity of the charging information supplied by the user;
- the serving network shall have proof that services were provided to a specified user.

7 Accounting and Settlement

The serving network shall collect and process the charging data generated in its network elements. The record of each individual transaction shall be reported to the home environment at short time intervals in order to allow further processing by the billing system in the Home Environment, provide itemised bills, and to deal with any disputes regarding charges both for users and for other UMTS networks and home environment.

The standard shall support the transfer of charging data at different intervals as required by the Home Environment (e.g. short time intervals, real time, other regular intervals).

7.1 Delegation of charging authority

The registration process allows the home environment to authenticate users before they incur any charges. Once authenticated, the home environment then delegates authority to the serving network operator with which he has a direct commercial relationship to incur charges for services supplied to that user. The direct commercial relationship may be with either the serving network operator if known directly by the home environment or a network operator known to the home environment. This procedure uses each network as trusted third parties in a chain of delegation between entities, thus allowing commercial transactions between entities who have no direct commercial dealings. There shall be an authentication procedure between all entities in the UMTS system which have a commercial relationship.

7.2 Fraud Control

A mechanism to control fraud shall be provided by the serving networks and the home environment.

7.2.1 Fraud Control by the Home Environment

Charging information shall be collected by the home environment in real time from all serving networks which its users are allowed to use. The billing system in the home environment shall process the information in real time and provide the means to set charge thresholds per time interval upon which some actions may be started, such as informing the customer care centre or even barring the user in the HLR.

It shall be possible for the Home Environment to define different time intervals for the collection and the processing of charging information (e.g. real time, short time, other regular intervals).

7.2.2 Fraud Control by the Serving Network

Charging information shall be collected from the network elements and processed in real time. This will allow the serving network to always be aware of the exposure to visitors. A limit for the accumulated charges for all visitors from one home environment or a limit per visitor may be agreed between the home environment and the serving network.

It shall be possible for the Serving Network to define different time intervals for the collection and the processing of charging information (e.g. real time, short time, other regular intervals).

7.3 Cost Control

A mechanism shall be standardised providing an indication to the user (if involved in the chargeable event) of the charges to be levied for a chargeable event. This mechanism shall be able to handle all possible charging scenarios, and all service and tariff variants that the home environment and the serving network may offer to the user.

The user shall be able to set in his home environment a limit for the accumulated charges per time interval. Upon exceeding this limit or prior to incurring a charge which would exceed the limit, certain actions may be desired by the user:

- notification to the user, requesting to extend the limit; or
- Home Environment barring allowing no further originating calls; or
- Home Environment barring cancelling the roaming permission.

7.3.1 Cross Phase Compatibility

For Release 99 the cost control mechanism may be based on Advice of Charge. However the Release 99 standards should not prevent the future implementation of the full Cost Control requirements.

The Release 99 standards should allow these new features to be introduced in a backward compatible manner; specifically terminals conforming to Release 99 standards should continue to support the Release 99 service requirements when operating with future implementations of Advice of Charge in the Home Environment.

7.4 Inter-network Settlement

Mechanisms shall also be provided to allow inter-network settlement of charges on a bulk basis. The same mechanisms shall be used between home environments and serving networks. This will allow each of these parties to meter the total input and output of charges and thus determine the payments required on a periodic basis between each of the parties with which they directly interact. The mechanisms used shall allow each of the parties to meter charge flows independently, with the aim of matching the values recorded at both sides of the same interface. The imbalance in charge flow shall be accumulated in short time, such that each entity can be informed when a threshold has been exceeded and determine whether to continue.

8 Automatic Roaming Agreements

Support for the requirements in this section is not required in Release 99. However the Release 99 standards should not prevent the future implementation of this requirement in a backward compatible manner (eg a roaming broker enabled Home Environment should inter-operate with a R99 Serving Network).

It is a requirement that UMTS users shall be able to obtain service and use chargeable services with networks with whom neither they nor their home environment have any direct commercial agreement. This shall be enabled by interworking via trusted third parties. Each Home Environment shall interwork with one or more serving network operators, with whom they would negotiate a commercial roaming agreement and test the interworking. Any user wishing to use the services of a particular serving network would register with that serving network, who would either directly or indirectly interwork with the home environment. Fraud and cost control mechanisms shall be used to ensure that charges incurred for UMTS services do not exceed the credit limits set. This can be applied for the user and the other roles involved in commercial dealings. In practice, any serving network shall be capable of operating as a roaming broker.

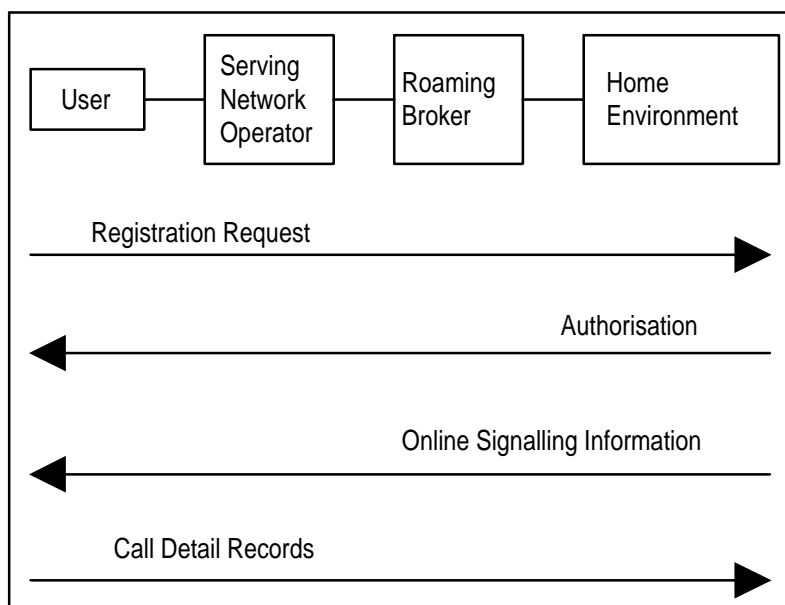

Figure 1: Registration and Roaming Process

8.1 Routing the Registration Request

The same mechanisms used for routing calls and resolving addresses shall be used to route the subscription identity back to its Home Environment. The standard shall support a routing identification mechanism to allow a serving network, which does not maintain its own list of all known HE, to determine the appropriate route to reach a given HE. A number of alternative routes may be possible, and ideally the system should be capable of determining the lowest cost to the end user.

Typically, smaller networks will only have a limited number of external connections to other networks or clearing houses, but may not know which one to use for an unknown (new) HE. In this case, the serving network may make a number of inquiries for each route to determine the lowest cost route to handle the call.

8.2 Settlement of charges

Settlement of charges incurred by a user shall be on a wholesale basis between the different parties involved in the registration link. By authorising a user to register, or a roaming broker to pass that on, each party is in turn authorising charges up to a maximum credit limit with the adjacent party. Any charges levied can then be paid to the adjacent party on a wholesale basis at the end of a mutually agreed accounting period. Funds are thus passed between each party for the services supplied by the network operator in a serial fashion.

Annex A (informative): Change history

Change history										
TSG SA#	SA Doc.	SA1 Doc	Spec	CR	Rev	Rel	Cat	Subject/Comment	Old	New
SMG#28			22.115					Version 3.0.0 Approved		3.0.0
SP-03	SP-99106	S1-99234	22.115	A00	1	R99	F	Clarification of the Charging Service	3.0.0	3.1.0
SP-05	SP-99454	S1-99817	22.115	002		R99	D	clarify the mandatory features supported by the standard	3.1.0	3.2.0
SP-05	SP-99454	S1-99762	22.115	003		R99	B	Addition of Charging for Volume of Data and some edits	3.1.0	3.2.0
SP-07	SP-000066	S1-000171	22.115	004		R99	D	Clarifications to 22.115	3.2.0	3.3.0

History

Document history		
V3.3.0	March 2000	Publication