

ETSI TS 123 002 V6.6.0 (2004-12)

Technical Specification

**Digital cellular telecommunications system (Phase 2+);
Universal Mobile Telecommunications System (UMTS);
Network architecture
(3GPP TS 23.002 version 6.6.0 Release 6)**



Reference

RTS/TSGS-0223002v660

Keywords

GSM, UMTS

ETSI

650 Route des Lucioles
F-06921 Sophia Antipolis Cedex - FRANCE

Tel.: +33 4 92 94 42 00 Fax: +33 4 93 65 47 16

Siret N° 348 623 562 00017 - NAF 742 C
Association à but non lucratif enregistrée à la
Sous-Préfecture de Grasse (06) N° 7803/88

Important notice

Individual copies of the present document can be downloaded from:

<http://www.etsi.org>

The present document may be made available in more than one electronic version or in print. In any case of existing or perceived difference in contents between such versions, the reference version is the Portable Document Format (PDF). In case of dispute, the reference shall be the printing on ETSI printers of the PDF version kept on a specific network drive within ETSI Secretariat.

Users of the present document should be aware that the document may be subject to revision or change of status. Information on the current status of this and other ETSI documents is available at

<http://portal.etsi.org/tb/status/status.asp>

If you find errors in the present document, please send your comment to one of the following services:

http://portal.etsi.org/chaicor/ETSI_support.asp

Copyright Notification

No part may be reproduced except as authorized by written permission.
The copyright and the foregoing restriction extend to reproduction in all media.

© European Telecommunications Standards Institute 2004.
All rights reserved.

DECTTM, **PLUGTESTS**TM and **UMTS**TM are Trade Marks of ETSI registered for the benefit of its Members.
TIPHONTM and the **TIPHON logo** are Trade Marks currently being registered by ETSI for the benefit of its Members.
3GPPTM is a Trade Mark of ETSI registered for the benefit of its Members and of the 3GPP Organizational Partners.

Intellectual Property Rights

IPRs essential or potentially essential to the present document may have been declared to ETSI. The information pertaining to these essential IPRs, if any, is publicly available for **ETSI members and non-members**, and can be found in ETSI SR 000 314: *"Intellectual Property Rights (IPRs); Essential, or potentially Essential, IPRs notified to ETSI in respect of ETSI standards"*, which is available from the ETSI Secretariat. Latest updates are available on the ETSI Web server (<http://webapp.etsi.org/IPR/home.asp>).

Pursuant to the ETSI IPR Policy, no investigation, including IPR searches, has been carried out by ETSI. No guarantee can be given as to the existence of other IPRs not referenced in ETSI SR 000 314 (or the updates on the ETSI Web server) which are, or may be, or may become, essential to the present document.

Foreword

This Technical Specification (TS) has been produced by ETSI 3rd Generation Partnership Project (3GPP).

The present document may refer to technical specifications or reports using their 3GPP identities, UMTS identities or GSM identities. These should be interpreted as being references to the corresponding ETSI deliverables.

The cross reference between GSM, UMTS, 3GPP and ETSI identities can be found under <http://webapp.etsi.org/key/queryform.asp>.

Contents

Intellectual Property Rights	2
Foreword.....	2
Foreword.....	8
Introduction	8
1 Scope	9
2 References	9
3 Definitions and abbreviations.....	12
3.1 Public Land Mobile Network (PLMN)	12
3.2 Core Network (CN) and Access Network (AN).....	12
3.3 Circuit Switched (CS) and Packet Switched (PS) Domains	12
3.3.1 CS Domain.....	13
3.3.2 PS Domain	13
3.3a IP Multimedia subsystem (IMS)	13
3.4 Location register.....	13
3.5 Cell.....	14
3.6 Base Station Controller (BSC) area.....	14
3.7 Radio Network Controller (RNC) area.....	14
3.8 Location Area (LA)	14
3.9 Routing Area (RA)	14
3.10 MSC area.....	14
3.11 VLR area	14
3.12 SGSN area	14
3.13 Zones for Regional Subscription.....	14
3.14 Service area	15
3.15 Group call area	15
3.16 Pool-area.....	15
4 The basic entities of the mobile system.....	15
4.1 The Core Network (CN) entities	15
4.1.1 Entities common to the PS and CS domains.....	15
4.1.1.1 The Home Subscriber Server (HSS)	15
4.1.1.1.1 The Home Location Register (HLR)	16
4.1.1.1.2 The Authentication Centre (AuC)	16
4.1.1.1.3 HSS logical functions	17
4.1.1.2 The Visitor Location Register (VLR)	18
4.1.1.3 (void).....	19
4.1.1.4 The Equipment Identity Register (EIR)	19
4.1.1.5 SMS Gateway MSC (SMS-GMSC).....	19
4.1.1.6 SMS Interworking MSC (SMS-IW MSC)	19
4.1.2 Entities of the CS domain	19
4.1.2.1 The Mobile-services Switching Centre (MSC)	19
4.1.2.1.1 MSC Server	20
4.1.2.1.2 Circuit Switched - Media Gateway Function (CS-MGW)	20
4.1.2.2 The Gateway MSC (GMSC)	20
4.1.2.2.1 Gateway MSC Server (GMSC Server).....	21
4.1.2.3 The Interworking Function (IWF).....	21
4.1.3 Entities of the PS domain.....	21
4.1.3.1 Serving GPRS Support Node (SGSN)	21
4.1.3.2 Gateway GPRS Support Node (GGSN).....	21
4.1.3.3 Border Gateway (BG)	22
4.2 The Access Network (AN) entities.....	22
4.2.1 The Base Station System (BSS).....	22
4.2.1.1 Base Station Controller (BSC)	23
4.2.1.2 Base Transceiver Station (BTS)	23

4.2.2	The Radio Network System (RNS).....	23
4.2.2.1	Radio Network Controller (RNC)	23
4.2.2.2	Node B	23
4.3	The Mobile Station (MS)	23
4a	The specific entities of the mobile system	23
4a.1	The Group Call Register (GCR) entity.....	23
4a.2	(void).....	24
4a.3	The Location Services (LCS) entities.....	24
4a.3.1	Location Services (LCS) entities in RAN.....	24
4a.3.2	Gateway Mobile Location Center (GMLC).....	25
4a.3.3	Location Measurement Unit (LMU)	25
4a.4	CAMEL entities	26
4a.4.1	GSM Service Control Function (gsmSCF)	26
4a.4.2	GSM Service Switching Function (gsmSSF).....	26
4a.4.3	GSM Specialised Resource Function (gsmSRF)	26
4a.4.4	GPRS Service Switching Function (gprsSSF).....	26
4a.5	CBS-specific entities	26
4a.5.1	Cell Broadcast Center (CBC).....	26
4a.6	Number Portability Specific entities	26
4a.6.1	IN-based solution: Number Portability Database (NPDB)	26
4a.6.2	Signalling Relay-based solution: Mobile Number Portability/Signalling Relay function (MNP-SRF).....	27
4a.7	IP Multimedia (IM) Core Network (CN) Subsystem entities	27
4a.7.1	Call Session Control Function (CSCF).....	27
4a.7.2	Media Gateway Control Function (MGCF).....	27
4a.7.3	IP Multimedia Subsystem - Media Gateway Function (IMS-MGW)	27
4a.7.4	Multimedia Resource Function Controller (MRFC).....	28
4a.7.4a	Multimedia Resource Function Processor (MRFP)	28
4a.7.5	Subscription Locator Function (SLF)	28
4a.7.6	Breakout Gateway Control Function (BGCF)	28
4a.7.7	Application Server (AS)	28
4a.8	Signalling Gateway Function (SGW).....	29
4a.9	Global Text Telephony Specific entities	29
4a.10	Security Gateway (SEG)	29
4a.11	Application Function (AF)	29
4a.12	Policy Decision Function (PDF)	30
4a.13	3GPP/WLAN Interworking entities	30
4a.13.1	WLAN UE	30
4a.13.2	3GPP AAA Proxy.....	30
4a.13.3	3GPP AAA Server	30
4a.13.4	WLAN Access Gateway (WAG).....	30
4a.13.5	Packet Data Gateway (PDG)	30
5	Configuration of a Public Land Mobile Network.....	30
5.1	Basic configuration.....	30
5.2	Configuration of LCS entities	32
5.2.1	Configuration of LCS entities for GERAN.....	32
5.2.2	Configuration of LCS entities for UTRAN.....	32
5.3	Configuration of CAMEL entities.....	33
5.4	Configuration of CBS entities	34
5.5	Configuration of IM CN Subsystem entities	34
5.6	Configuration of Signalling Gateway Function.....	36
5.7	Configuration of 3GPP/WLAN Interworking	36
5.8	Configuration of Presence service.....	37
6	PLMN basic interfaces and reference points.....	37
6.1	Interfaces between Mobile Station and the Fixed Infrastructure	38
6.1.1	Interface between Mobile Station and Base Station System (Um-interface)	38
6.1.2	Interface between User Equipment and Radio Network System (Uu-interface).....	38
6.2	Interface between the Core Network and the Access Network	38
6.2.1	Interfaces between the CS domain and the Access Network	38
6.2.1.1	Interface between the MSC and Base Station System (A-interface).....	38
6.2.1.2	Interface between the MSC and Base Station System (Iu-CS interface).....	38

6.2.1.3	Interface between the MSC and RNS (Iu_CS interface).....	38
6.2.2	Interfaces between the PS domain and the Access Network	39
6.2.2.1	Interface between SGSN and BSS (Gb-interface).....	39
6.2.2.2	Interface between SGSN and BSS (Iu_PS-interface).....	39
6.2.2.3	Interface between SGSN and RNS (Iu_PS-interface).....	39
6.3	Interfaces internal to the Access Network.....	39
6.3.1	Interface between BSC and BTS (Abis-interface).....	39
6.3.2	Interface between RNC and Node B (Iub-interface).....	39
6.3.3	Interface between two RNCs (Iur-interface).....	39
6.4	Interfaces internal to the Core Network	40
6.4.1	Interfaces internal to the CS domain.....	40
6.4.1.1	Interface between the MSC server and its associated VLR (B-interface).....	40
6.4.1.2	Interface between the HLR and the MSC server (C-interface)	40
6.4.1.3	Interface between the HLR and the VLR (D-interface)	40
6.4.1.4	Interface between MSC servers (E-interface)	40
6.4.1.5	Interface between MSC server and EIR (F-interface).....	41
6.4.1.6	Interface between VLRs (G-interface).....	41
6.4.1.7	Reference point (G)MSC server – CS-MGW (Mc Reference Point)	41
6.4.1.8	Reference Point MSC Server – GMSC Server (Nc Reference Point)	41
6.4.1.9	Reference Point CS-MGW – CS-MGW (Nb Reference Point)	41
6.4.2	Interfaces internal to the PS domain	41
6.4.2.1	Interface between SGSN and HLR (Gr-interface)	41
6.4.2.2	Interface between SGSN and GGSN (Gn- and Gp-interface).....	42
6.4.2.3	Signalling Path between GGSN and HLR (Gc-interface)	42
6.4.2.4	Interface between SGSN and EIR (Gf-interface)	42
6.4.3	Interfaces used by CS and PS domains.....	42
6.4.3.1	Interface between MSC/VLR and SGSN (Gs-interface).....	42
6.4.3.2	Interface between HLR and AuC (H-Interface)	42
6.4.3.3	Interface between SGSN and SMS-GMSC/SMS-IWMSC (Gd-Interface).....	42
6a	PLMN specific interfaces.....	43
6a.1	GCR-specific interface	43
6a.1.1	Interface between the MSC and its associated GCR (I-interface).....	43
6a.2	(void).....	43
6a.3	LCS-specific interfaces	43
6a.3.1	LCS interfaces using MAP	43
6a.3.2	(void)	43
6a.3.3	(void)	43
6a.3.4	(void)	43
6a.3.5	Interface between BSC and SMLC (Lb-interface).....	43
6a.3.6	Interface between Peer SMLCs (Lp-interface)	43
6a.3.7	Interface between BTS and LMU (Um-interface)	44
6a.3.8	Interface between GMLC and External LCS Client (Le-interface)	44
6a.3.9	Interface between RNS and Stand-Alone LMU, UE (Uu-interface).....	44
6a.3.10	Interface between SRNC and SAS (Stand-Alone SMLC) (Iupc-interface)	44
6a.3.11	Interface between GMLC and GMLC (Lr-interface).....	44
6a.4	CAMEL-specific interfaces.....	44
6a.4.1	GMSC - gsmSSF interface.....	44
6a.4.2	gsmSSF - gsmSCF interface	44
6a.4.3	MSC - gsmSSF interface.....	44
6a.4.4	gsmSCF - HLR interface.....	44
6a.4.5	gsmSCF - gsmSRF interface	45
6a.4.6	MSC - gsmSCF interface	45
6a.4.7	SGSN - gprsSSF interface.....	45
6a.4.8	gprsSSF - gsmSCF interface (Ge Reference Point)	45
6a.5	CBS-specific interfaces	45
6a.5.1	Interface between the CBC and RNS (Iu_BC Interface)	45
6a.6	Number portability specific interfaces	45
6a.6.1	IN-based solution.....	45
6a.6.1.1	NPDB to MSC interface.....	45
6a.6.2	Signalling Relay-based solution	45
6a.6.2.1	GMSC to MNP-SRF interface	45

6a.6.2.2	MNP-SRF to HLR interface.....	45
6a.7	IM Subsystem Reference Points.....	46
6a.7.1	Reference Point HSS – CSCF (Cx Reference Point)	46
6a.7.2	Reference Point CSCF – UE (Gm Reference Point).....	46
6a.7.3	Reference Point MGCF – IMS-MGW (Mn Reference Point)	46
6a.7.4	Reference Point MGCF – CSCF (Mg Reference Point)	46
6a.7.5	(void)	46
6a.7.6	Reference Point CSCF - MRFC (Mr Reference Point).....	46
6a.7.6a	Reference Point MRFC – MRFP (Mp Reference Point).....	47
6a.7.7	Reference Point CSCF – CSCF (Mw Reference Point).....	47
6a.7.8	(void)	47
6a.7.9	(void)	47
6a.7.10	Reference Point CSCF – BGCF (Mi reference point)	47
6a.7.11	Reference Point BGCF – MGCF (Mj reference point)	47
6a.7.12	Reference Point BGCF – BGCF (Mk reference point)	47
6a.7.13	Reference Point CSCF- SLF (Dx Reference Point)	47
6a.7.14	Reference Point to IPv6 network services (Mb reference point)	47
6a.7.15	Reference Point CSCF – AS (ISC Reference Point).....	48
6a.7.16	Reference Point HSS – SIP AS or OSA SCS (Sh Reference Point)	48
6a.7.17	Reference Point HSS – CAMEL IM-SSF (Si Reference Point)	48
6a.7.18	Reference Point UE – AS (Ut Reference Point)	48
6a.7.19	Reference Point AS- SLF (Dh Reference Point).....	48
6a.8	Reference Points for Service Based Local Policy Control	48
6a.8.1	Reference Point GGSN – PDF (Go Reference Point).....	48
6a.8.2	Reference Point PDF – Application Function (Gq Reference Point).....	48
6a.9	Reference Points for 3GPP/WLAN Interworking	49
6a.9.1	Reference point 3GPP AAA Server - HLR (D"/Gr" Reference Point)	49
6a.9.2	Reference point WLAN access network - 3GPP AAA Proxy/Server (Wa Reference Point)	49
6a.9.3	Reference point 3GPP AAA Server – 3GPP AAA Proxy (Wd Reference Point).....	49
6a.9.4	Reference point 3GPP AAA Server/Proxy - PDG (Wg Reference Point)	49
6a.9.5	Reference point PDG - packet data networks (Wi Reference Point)	49
6a.9.6	Reference Point 3GPP AAA Server/Proxy - PDG (Wm Reference Point).....	49
6a.9.7	Reference Point WAG - WLAN access network (Wn Reference Point).....	49
6a.9.8	Reference Point WAG - PDG (Wp Reference Point)	49
6a.9.9	Reference point WLAN UE - PDG (Wu Reference Point).....	50
6a.9.10	Reference point WLAN UE - WLAN access network (Ww Reference Point).....	50
6a.9.11	Reference point 3GPP AAA Server - HSS (Wx Reference Point)	50
7	Reference points between the PLMN and other networks	50
7.1	Reference point fixed networks - MSC	50
7.2	Reference point GGSN - packet data networks (Gi reference point)	50
7.3	Reference point GMLC - external LCS Client (Le reference point)	50
7.4	Reference Point CSCF – Multimedia IP networks (Mm Reference Point)	51
7.5	(void)	51
7.6	Reference point PDG - packet data networks (Wi reference point)	51
7.7	Reference Point WAG – WLAN access network (Wn reference point).....	51
Annex A (informative):	Description for GLR-related entities and interfaces	52
A.1	Normative references	52
A.2	Definitions related to Gateway Location Register (GLR).....	52
A.2.1	Gateway Location Register (GLR).....	52
A.2.2	Intermediate Mobile-services Switching Centre (IM-MSC)	52
A.2.3	Intermediate GPRS Serving Node (IM-GSN)	52
A.3	The entities of the mobile system.....	52
A.3.1	Gateway Location Register (GLR).....	52
A.3.2	Intermediate Mobile-services Switching Centre (IM-MSC)	53
A.3.3	Intermediate GPRS Serving Node (IM-GSN)	53
A.4	Configuration of a Public Land Mobile Network.....	53
A.4.1	Basic configuration with GLR introduction	53

A.5	PLMN interfaces	54
A.5.1	Interface between the HLR and the GLR (GLa-interface)	54
A.5.2	Interface between the VLR and the GLR (GLb-interface)	54
A.5.3	Interface between the SGSN and the GLR (GLc-interface)	54
A.5.4	Interface between the GLR and the IM_MSC (GLd-interface)	54
A.5.5	Interface between the GLR and the IM_GSN (GLE-interface)	54
A.5.6	Interface between the SMS-GMSC and the GLR (GLf-interface)	55
A.5.7	Interface between the SMS-GMSC and the IM_MSC (GLg-interface)	55
A.5.8	Interface between the MSC and the IM_MSC (GLh-interface)	55
A.5.9	Interface between the GMLC and the IM_MSC (GLi-interface)	55
A.5.10	Interface between the GGSN and the IM_GSN (GLj-interface)	55
A.5.11	Interface between the SGSN and the IM_GSN (GLk-interface)	55
Annex B (informative):	Change history	56
History		58

Foreword

This Technical Specification (TS) has been produced by the 3rd Generation Partnership Project (3GPP).

The contents of the present document are subject to continuing work within the TSG and may change following formal TSG approval. Should the TSG modify the contents of the present document, it will be re-released by the TSG with an identifying change of release date and an increase in version number as follows:

Version x.y.z

where:

- x the first digit:
 - 1 presented to TSG for information;
 - 2 presented to TSG for approval;
 - 3 or greater indicates TSG approved document under change control.
- y the second digit is incremented for all changes of substance, i.e. technical enhancements, corrections, updates, etc.
- z the third digit is incremented when editorial only changes have been incorporated in the document.

Introduction

This document presents the possible architectures of the Universal Mobile Telecommunication System (UMTS).
covering both UTRAN and GERAN radio access technologies.

Clause 3 of the document contains the definition of the PLMN entities.

Clause 4 of the document contains the description of the basic entities of the PLMN, and clause 4a contains the description of the specific entities of the PLMN.

Clause 5 of the document contains the configuration of the PLMN.

Clauses 6, 6a and 7 of the document contain the PLMN's basic and specific interfaces and reference points and the PLMN's interfaces towards other networks.

1 Scope

This document offers an overview of the PLMN and its architectures and configuration. The configuration and the functional entities of the PLMN and the interfaces between them are described on a general level in order to cope with possible implementations. These descriptions include interfaces between and within the core networks, the access networks, the user equipment, different service platforms, different domains and subsystems, and functional entities within domains and subsystems.

This document covers different architectural aspects with varying level of detail. In general, other specifications shall be referred to for further details; these specifications enable the reader to acquire the full understanding of a system or service feature.

Note that this document does not cover, or even list, all features of PLMNs.

2 References

The following documents contain provisions which, through reference in this text, constitute provisions of the present document.

- References are either specific (identified by date of publication, edition number, version number, etc.) or non-specific.
- For a specific reference, subsequent revisions do not apply.
- For a non-specific reference, the latest version applies. In the case of a reference to a 3GPP document (including a GSM document), a non-specific reference implicitly refers to the latest version of that document *in the same Release as the present document*.

- | | |
|------|--|
| [1] | [void] |
| [1a] | 3GPP TR 21.905: "Vocabulary for 3GPP Specifications". |
| [2] | 3GPP TS 22.016: " International Mobile station Equipment Identities (IMEI)". |
| [2a] | 3GPP TS 22.060: " General Packet radio Service (GPRS); Service description; Stage 1". |
| [2b] | 3GPP TS 22.071: " Location Services (LCS); Service description; Stage 1". |
| [2c] | 3GPP TS 22.078: "Customised Applications for Mobile network Enhanced Logic (CAMEL); Service description, Stage 1". |
| [3] | 3GPP TS 23.003: " Numbering, addressing and identification". |
| [4] | 3GPP TS 22.127: 'Open Service Access (OSA) |
| [5] | 3GPP TS 23.008: " Organization of subscriber data". |
| [6] | 3GPP TS 23.009: " Handover procedures". |
| [7] | 3GPP TS 23.012: " Location Management Procedures". |
| [8] | 3GPP TS 23.041: "Technical realization of Cell Broadcast Service (CBS)". |
| [9] | [void] |
| [9a] | 3GPP TS 23.060: " General Packet Radio Service (GPRS); Service description; Stage 2". |
| [10] | [void] |

- [10a] 3GPP TS 43.064: "Digital cellular telecommunication system (Phase 2+); General Packet Radio service (GPRS); Overall description of the GPRS radio interface; Stage 2".
- [10b] 3GPP TS 25.305: "Stage 2 Functional Specification of UE Positioning in UTRAN"
- [10c] 3GPP TS 23.078: "Customised Applications for Mobile network Enhanced Logic (CAMEL) Phase 3 - Stage 2".
- [10d] 3GPP TS 43.059: 'Functional Stage 2 Description of Location Services in GERAN'[11] ITU-T Recommendation Q.1214 (05/1995): "Distributed Functional Plane for Intelligent Network CS-1"
- [11a] 3GPP TS 23.101: "General UMTS Architecture".
- [11b] 3GPP TS 23.110: "UMTS Access Stratum); Services and Functions".
- [12] 3GPP TS 24.002: " GSM - UMTS Public Land Mobile Network (PLMN) access reference configuration".
- [13] 3GPP TS 48.001: " Base Station System - Mobile-services Switching Centre (BSS - MSC) interface; General aspects".
- [14] 3GPP TS 48.002: " Base Station System - Mobile-services Switching Centre (BSS - MSC) interface; Interface principles".
- [14a] 3GPP TS 25.410: "UTRAN Iu Interface: general aspects and principles".
- [15] 3GPP TS 48.004: " Base Station System - Mobile-services Switching Centre (BSS - MSC) interface Layer 1 specification".
- [16] 3GPP TS 48.006: " Signalling transport mechanism specification for the Base Station System - Mobile-services Switching Centre (BSS - MSC) interface".
- [17] 3GPP TS 48.008: " Mobile-services Switching Centre - Base Station System (MSC - BSS) interface; Layer 3 specification".
- [18] [void]
- [19] 3GPP TS 48.051: " Base Station Controller - Base Transceiver Station (BSC - BTS) interface; General aspects".
- [20] 3GPP TS 48.052: " Base Station Controller - Base Transceiver Station (BSC - BTS) interface; Interface principles".
- [21] 3GPP TS 48.054: " Base Station Controller - Base Transceiver Station (BSC - BTS) interface; Layer 1 structure of physical circuits".
- [22] 3GPP TS 48.056: " Base Station Controller - Base Transceiver Station (BSC - BTS) interface; Layer 2 specification".
- [23] 3GPP TS 48.058: " Base Station Controller - Base Transceiver Station (BSC - BTS) interface; Layer 3 specification".
- [24] 3GPP TS 48.060: " In-band control of remote transcoders and rate adaptors for full rate traffic channels".
- [25] 3GPP TS 48.061: " In-band control of remote transcoders and rate adaptors for half rate traffic channels".
- [26] 3GPP TS 29.002: " Mobile Application Part (MAP) specification".
- [27] 3GPP TS 22.228: 'Service requirements for the IP Multimedia Core Network Subsystem'
- [28] [void]
- [29] [void]
- [30] [void]

- [31] 3GPP TS 29.007: " General requirements on interworking between the Public Land Mobile Network (PLMN) and the Integrated Services Digital Network (ISDN) or Public Switched Telephone Network (PSTN)".
- [32] 3GPP TS 29.010: " Information element mapping between Mobile Station - Base Station System (MS – BSS) and Base Station System - Mobile-services Switching Centre (BSS - MSC); Signalling procedures and the Mobile Application Part (MAP)".
- [33] 3GPP TS 29.011: " Signalling interworking for supplementary services".
- [34] 3GPP TS 23.228: 'IP Multimedia Subsystem (IMS); Stage 2'.
- [35] 3GPP TR 41.103: "GSM Release 5 specifications".
- [36] 3GPP TR 43.051: "Technical Specification Group GSM/EDGE Radio Access Network; Overall description, Stage 2'.
- [37] 3GPP TS 23.226: "Global Text Telephony (GTT); Stage 2."
- [38] 3GPP TS 26.226: "Cellular Text Telephone Modem; General Description"
- [39] 3GPP TS 23.016:"Subscriber data management; Stage 2"
- [40] 3GPP TS 23.066: "Support of Mobile Number Portability (MNP); Technical realization; Stage 2"
- [41] 3GPP TS 43.068: "Voice Group Call Service (VGCS); Stage 2"
- [42] 3GPP TS 43.069: "Voice Broadcast Service (VBS); Stage 2"
- [43] 3GPP TS 23.205: "Bearer independent circuit switched core network; Stage 2"
- [44] 3GPP TS 48.014: "Base Station System (BSS) – Serving GPRS Support Node (SGSN) interface; Gb interface Layer 1"
- [45] 3GPP TS 48.016: "Base Station System (BSS) – Serving GPRS Support Node (SGSN) interface; Network service"
- [46] 3GPP TS 48.018: "Base Station System (BSS) – Serving GPRS Support Node (SGSN); BSS GPRS Protocol (BSSGP)"
- [47] 3GPP TS 48.031: "Serving Mobile Location Centre – Serving Mobile Location Centre (SMLC – SMLC); SMLCPP specification"
- [48] 3GPP TS 29.016: "Serving GPRS Support Node (SGSN) – Visitor Location Register (VLR); Gs interface network service specification"
- [49] 3GPP TS 29.018: "Serving GPRS Support Node (SGSN) – Visitor Location Register (VLR); Gs interface Layer 3 specification"
- [50] 3GPP TS 49.031: "Network Location Services (LCS); Base Station System Application Part LCS extension (BSSAP-LE)
- [51] 3GPP TS 29.060: "GPRS Tunnelling Protocol (GTP) across the Gn and Gp Interface"
- [52] ITU-T Recommendation H.248: "Gateway Control Protocol"
- [53] ITU-T Recommendation E.164: "The International public telecommunication numbering plan"
- [54] ITU-T Recommendation H.323: "Packet-based multimedia communications systems "
- [55] 3GPP TS 44.071: " Mobile radio interface layer 3 Location Services (LCS) specification "
- [56] 3GPP TS 23.271: "Functional stage 2 description of LCS"
- [57] ITU-T Recommendation I.363-2 : "B-ISDN ATM Adaptation Layer (AAL) type 2 specification"
- [58] ITU-T Recommendation H.245: "Control protocol for multimedia communication"

- [59] IETF RFC768: "User Datagram Protocol"
- [60] IETF RFC1889: "RTP: A Transport Protocol for Real-Time Applications"
- [61] IETF RFC3261: "SIP: Session Initiation Protocol"
- [62] LIF TS 101 "Mobile Location Protocol Specification" (Location Interoperability Forum 2001)
[Available at <http://www.openmobilealliance.org/tech/LIF/>]
- [63] 3GPP TS29.198: "Open Service Access (OSA) Application Programming Interface (API)"
- [64] 3GPP TS 33.210: "3G Security; Network Domain Security; IP network layer security"
- [65] 3GPP TS 23.236: "Intra Domain Connection of RAN Nodes to Multiple CN Nodes".
- [66] 3GPP TS 25.453: "UTRAN Iupc interface PCAP signalling"
- [67] 3GPP TS 23.234: "3GPP system to Wireless Local Area Network (WLAN) interworking"
- [68] 3GPP TS 23.141: "Presence Service; Architecture and functional description"
- [69] OMA Location Working Group "Inter-Location Server Interface Specification",
<http://www.openmobilealliance.org/>

3 Definitions and abbreviations

In addition to the abbreviations given in the remainder of this clause others are listed in TR 21.905 [1a].

The definitions of the entities of the mobile system are given in the next subclause.

3.1 Public Land Mobile Network (PLMN)

A Public Land Mobile Network (PLMN) is established and operated by an administration or Recognized Private Operating Agency (RPOA) for the specific purpose of providing land mobile telecommunications service services to the public. A PLMN may be regarded as an extension of networks (e.g. ISDN, corporate and public PDNs, etc); it is a collection of MSCs areas in CS domain and SGSN areas in PS domain within a common numbering plan (e.g. same National Destination Code) and a common routing plan. The MSCs are the functional interfaces between the fixed networks and a PLMN for call set-up in CS domain. The GGSN and the SGSN are the functional interfaces between the fixed networks and a PLMN for packet transmission in PS domain.

Functionally the PLMNs may be regarded as independent telecommunications entities even though different PLMNs may be interconnected through the ISDN/PSTN and PDNs for forwarding of calls or network information. A similar type of interconnection may exist for the interaction between the MSCs/SGSNs of one PLMN.

3.2 Core Network (CN) and Access Network (AN)

The PLMN infrastructure is logically divided into a Core Network (CN) and an Access Network (AN) infrastructures, as defined in TS 23.101 [11a] and TS 23.110 [11b]. The CN is logically divided into a CS domain, a PS domain and an IM subsystem, as defined in next subclause. The AN is called BSS for GSM and RNS for UMTS, as defined in clause "The Access Network".

3.3 Circuit Switched (CS) and Packet Switched (PS) Domains

The CN is constituted of a Circuit Switched (CS) domain and a Packet Switched (PS) domain. These two domains differ by the way they support user traffic, as explained bellow.

These two domains are overlapping, i.e. they contain some common entities. A PLMN can implement only one domain or both domains.

3.3.1 CS Domain

The CS domain refers to the set of all the CN entities offering "CS type of connection" for user traffic as well as all the entities supporting the related signalling. A "CS type of connection" is a connection for which dedicated network resources are allocated at the connection establishment and released at the connection release.

The entities specific to the CS domain are: MSC, GMSC, VLR. All the other CN entities defined in clause "4 The basic entities of the mobile system" and not defined as PS domain specific entities (see following subclause) are common to the CS and to the PS domains.

3.3.2 PS Domain

The PS domain refers to the set of all the CN entities offering "PS type of connection" for user traffic as well as all the entities supporting the related signalling. A "PS type of connection" transports the user information using autonomous concatenation of bits called packets: each packet can be routed independently from the previous one.

The entities specific to the PS domain are the GPRS specific entities, i.e. SGSN and GGSN. All the other CN entities defined in clause "4 The basic entities of the mobile system" and not defined as CS domain specific entities (see previous subclause) are common to the CS and to the PS domains.

3.3a IP Multimedia subsystem (IMS)

The IM subsystem comprises all CN elements for provision of IP multimedia services comprising audio, video, text, chat, etc. and a combination of them delivered over the PS domain. The entities related to IMS are CSCF, MGCF, MRF, etc. as defined in the stage 2 of the IM subsystem TS 23.228 [34]. See TS 22.228 [27] for some service examples of IMS.

3.4 Location register

To enable communication to a mobile station the network must know where this mobile station is located. This information is stored in a function named location register.

The location register is handled by four different entities.

- The Home Location Register (HLR).

The Home Location Register (HLR) is the location register to which a mobile subscriber is assigned for record purposes such as subscriber information.

- The Visitor Location Register (VLR).

The Visitor Location Register (VLR) is the location register for Circuit Switched (CS) services, other than the HLR, used by an MSC to retrieve information for, e.g. handling of calls to or from a roaming mobile station currently located in its area.

- The Serving GPRS Support Node (SGSN).

The location register function in the SGSN stores subscription information and location information for Packet Switched (PS) services for each subscriber registered in the SGSN.

The SGSN is needed only in a PLMN which supports GPRS.

- The Gateway GPRS Support Node (GGSN).

The location register function in the GGSN stores subscription information and routing information (needed to tunnel packet data traffic destined for a GPRS MS to the SGSN where the MS is registered) for each subscriber for which the GGSN has at least one PDP context active.

The GGSN is needed only in a PLMN which supports GPRS.

3.5 Cell

The cell is an area of radio coverage identified by a Base station identification as defined in TS 23.003 [3].

3.6 Base Station Controller (BSC) area

The Base Station Controller (BSC) area is an area of radio coverage consisting of one or more cells controlled by one BSC. The boundaries of a BSC area and a location area are independent; a location area may span the boundary between BSC area and a BSC area may span the boundary between location areas.

3.7 Radio Network Controller (RNC) area

The Radio Network Controller (RNC) area is an area of radio coverage consisting of one or more cells controlled by one RNC. The boundaries of a RNC area and a location area are independent; a location area may span the boundary between RNC area and a RNC area may span the boundary between location areas.

3.8 Location Area (LA)

The Location Area (LA) is defined as an area in which a mobile station may move freely without updating the VLR. A location area may include one or several cells.

3.9 Routing Area (RA)

The Routing Area (RA) is defined as an area in which a mobile station, in certain operation modes, may move freely without updating the SGSN. A routing area may include one or several cells. A RA is always contained within a location area.

3.10 MSC area

The MSC area is the part of the network covered by an MSC. An MSC area may consist of one or several location areas. An MSC area may also consist of one or several BSC areas.

3.11 VLR area

The VLR area is the part of the network controlled by a VLR. A VLR area may consist of one or several MSC areas.

3.12 SGSN area

The SGSN area is the part of the network served by an SGSN. An SGSN area may consist of one or several routing areas. An SGSN area may also consist of one or several BSC areas. There need not be a one to one relationship between SGSN area and MSC/VLR area.

3.13 Zones for Regional Subscription

A PLMN operator may define a number of regional subscription areas, each of which is a subset of the service area for an unrestricted mobile subscriber. A regional subscription area may be contained within the service area of a single PLMN, or may lie within the service areas of two or more PLMNs. Each regional subscription area consists of one or more zones; each zone is contained within the service area of a PLMN.

The definition of a mobile subscriber's regional subscription area is stored within the HLR per National Destination Code(s) (NDC) of a PLMN and is transferred to the VLRs and/or SGSNs of that PLMN. The VLR and/or SGSN evaluates this information to extract the restricted or accessible MSC and/or SGSN areas and location areas to which the mobile subscriber is allowed to roam. The VLR and/or SGSN informs the HLR if an entire MSC and/or SGSN area is restricted.

Zones for Regional Subscription and their handling are defined in TS 23.003 [3], TS 23.008 [5] and TS 29.002 [26].

3.14 Service area

The service area is defined as an area in which a mobile subscriber can be reached by another (mobile or fixed) subscriber without the subscriber's knowledge of the actual location of the mobile station within the area. A service area may consist of several PLMNs. One service area may consist of one country, be a part of a country or include several countries. The location registration system associated with each service area must thus contain a list of all mobile stations located within that service area.

3.15 Group call area

The group call area is a predefined area composed of one or a number of cells to which a particular Voice Group Call Service (VGCS) or Voice Broadcast Service (VBS) call is distributed. The composition of a group call area is predefined in the network. The group call area may include cells of more than one MSC area and cells of more than one PLMN.

3.16 Pool-area

A pool area is an area where Intra Domain Connection of RAN Nodes to Multiple CN Nodes is applied. Within a pool-area an MS may roam without need to change the serving Core Network (CN) node. A pool-area is served by one or more CN nodes in parallel.

4 The basic entities of the mobile system

To provide the mobile service as it is defined, it is necessary to introduce some specific functions. These functional entities can be implemented in different equipments or gathered. In any case, exchanges of data occur between these entities.

4.1 The Core Network (CN) entities

4.1.1 Entities common to the PS and CS domains

4.1.1.1 The Home Subscriber Server (HSS)

The HSS is the master database for a given user. It is the entity containing the subscription-related information to support the network entities actually handling calls/sessions.

A Home Network may contain one or several HSSs: it depends on the number of mobile subscribers, on the capacity of the equipment and on the organisation of the network.

As an example, the HSS provides support to the call control servers in order to complete the routing/roaming procedures by solving authentication, authorisation, naming/addressing resolution, location dependencies, etc...

The HSS is responsible for holding the following user related information:

- User Identification, Numbering and addressing information.
- User Security information: Network access control information for authentication and authorization
- User Location information at inter-system level: the HSS supports the user registration, and stores inter-system location information, etc.
- User profile information

The HSS also generates User Security information for mutual authentication, communication integrity check and ciphering.

Based on this information, the HSS also is responsible to support the call control and session management entities of the different Domains and Subsystems (defined in section 3.3 and 3.3a) of the operator as shown in Figure 0-a.

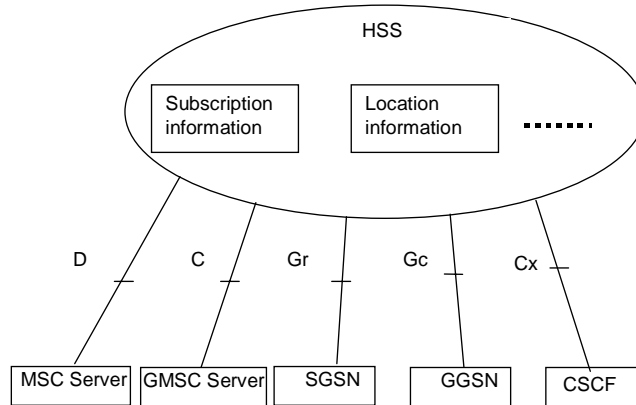

Figure 0-a: Example of a Generic HSS structure and basic interfaces

The HSS may integrate heterogeneous information, and enable enhanced features in the core network to be offered to the application & services domain, at the same time hiding the heterogeneity.

The HSS consists of the following functionalities:

- IP multimedia functionality to provide support to control functions of the IM subsystem such as the CSCF. It is needed to enable subscriber usage of the IM CN subsystem services. This IP multimedia functionality is independent of the access network used to access the IM CN subsystem.
- The subset of the HLR/AUC functionality required by the PS Domain.
- The subset of the HLR/AUC functionality required by the CS Domain, if it is desired to enable subscriber access to the CS Domain or to support roaming to legacy GSM/UMTS CS Domain networks.

The organisation of the subscriber data is outlined in 3GPP TS 23.008 [5]. It also indicates which numbers, addresses and identifiers specified in TS 23.003 [3] are stored in HSS.

4.1.1.1.1 The Home Location Register (HLR)

The HLR is shown in the Reference Architecture up to and including R4.

The HLR can be considered a subset of the HSS that holds the following functionality:

- The functionality required to provide support to PS Domain entities such as the SGSN and GGSN, through the Gr and Gc interfaces. It is needed to enable subscriber access to the PS Domain services.
- The functionality required to provide support to CS Domain entities such as the MSC/MSC server and GMSC/GMSC server, through the C and D interfaces. It is needed to enable subscriber access to the CS Domain services and to support roaming to legacy GSM/UMTS CS Domain networks.

4.1.1.1.2 The Authentication Centre (AuC)

The AuC is shown in the Reference Architecture up to and including Rel-4.

The AuC can be considered a subset of the HSS that holds the following functionality for the CS Domain and PS Domain:

- The AuC is associated with an HLR and stores an identity key for each mobile subscriber registered with the associated HLR. This key is used to generate security data for each mobile subscriber:

- data which are used for mutual authentication of the International Mobile Subscriber Identity (IMSI) and the network;
- a key used to check the integrity of the communication over the radio path between the mobile station and the network;
- a key used to cipher communication over the radio path between the mobile station and the network.
- The AuC communicates only with its associated HLR over a non-standardised interface denoted the H-interface. The HLR requests the data needed for authentication and ciphering from the AuC via the H-interface, stores them and delivers them to the VLR and SGSN which need them to perform the security functions for a mobile station.

4.1.1.1.3 HSS logical functions

This section provides a high level and not exhaustive description of HSS functionality.

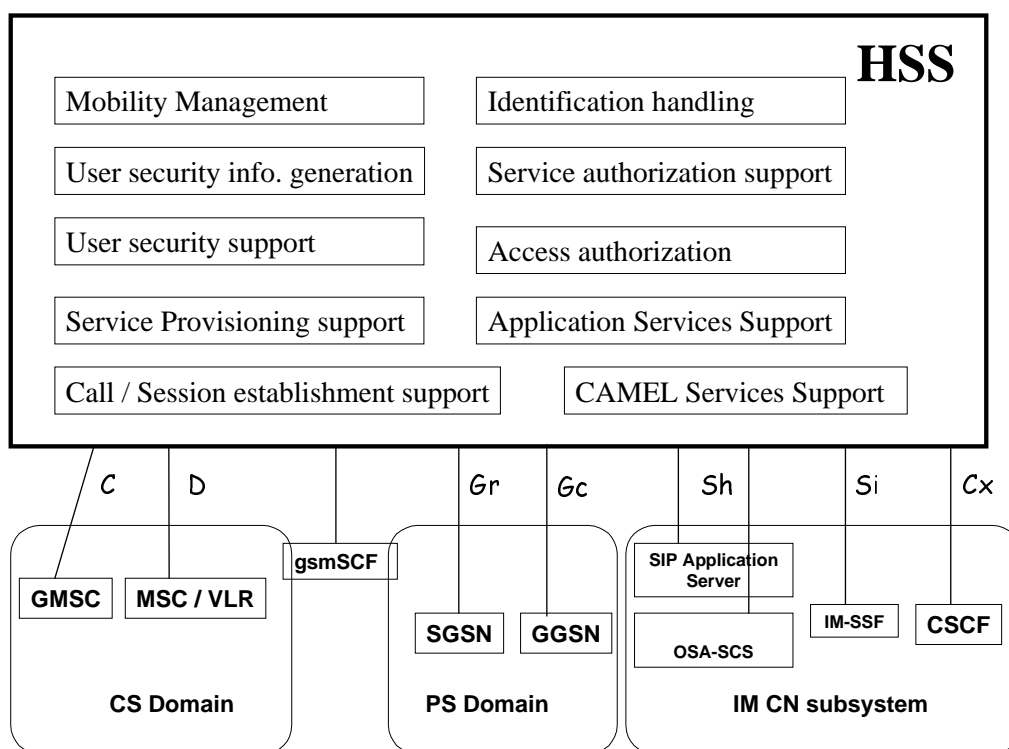

Figure 0.b – HSS logical functions

- Mobility Management

This function supports the user mobility through CS Domain, PS Domain and IM CN subsystem.

- Call and/or session establishment support

The HSS supports the call and/or session establishment procedures in CS Domain, PS Domain and IM CN subsystem. For terminating traffic, it provides information on which call and/or session control entity currently hosts the user.

- User security information generation
- The HSS generates user authentication, integrity and ciphering data for the CS and PS Domains and for the IM CN subsystem. User security support

The HSS supports the authentication procedures to access CS Domain, PS Domain and IM CN subsystem services by storing the generated data for authentication, integrity and ciphering and by providing these data to the appropriate entity in the CN (i.e. MSC/VLR, SGSN or CSCF)..

- User identification handling

The HSS provides the appropriate relations among all the identifiers uniquely determining the user in the system: CS Domain, PS Domain and IM CN subsystem (e.g. IMSI and MSISDNs for CS Domain; IMSI, MSISDNs and IP addresses for PS Domain, private identity and public identities for IM CN subsystem).

- Access authorisation

The HSS authorises the user for mobile access when requested by the MSC/VLR, SGSN or CSCF, by checking that the user is allowed to roam to that visited network.

- Service authorisation support

The HSS provides basic authorisation for MT call/session establishment and service invocation. Besides, the HSS updates the appropriate serving entities (i.e., MSC/VLR, SGSN, CSCF) with the relevant information related to the services to be provided to the user.

- Service Provisioning Support
- The HSS provides access to the service profile data for use within the CS Domain, PS Domain and/or IM CN subsystem. Application Services and CAMEL Services Support

The HSS communicates with the SIP Application Server and the OSA-SCS to support Application Services in the IM CN subsystem. It communicates with the IM-SSF to support the CAMEL Services related to the IM CN subsystem. It communicates with the gsmSCF to support CAMEL Services in the CS Domain and PS Domain.

4.1.1.2 The Visitor Location Register (VLR)

A mobile station roaming in an MSC area or within a pool-area is controlled by a Visitor Location Register. When a Mobile Station (MS) enters a new location area it starts a registration procedure. An MSC in charge of that area notices this registration and transfers to a Visitor Location Register the identity of the location area where the MS is situated. If this MS is not yet registered in the VLR, the VLR and the HLR exchange information to allow the proper handling of calls involving the MS.

A VLR may be in charge of one or several MSC areas.

The VLR contains also the information needed to handle the calls set-up or received by the MSs registered in its data base (for some supplementary services the VLR may have to obtain additional information from the HLR). The following elements are included:

- the International Mobile Subscriber Identity (IMSI);
- the Mobile Station International ISDN number (MSISDN);
- the Mobile Station Roaming Number (MSRN), see TS 23.003 [3] for allocation principles;
- the Temporary Mobile Station Identity (TMSI), if applicable;
- the Local Mobile Station Identity (LMSI), if used;
- the location area where the mobile station has been registered;
- the identity of the SGSN where the MS has been registered. Only applicable to PLMNs supporting GPRS and which have a Gs interface between MSC/VLR and SGSN;
- the last known location and the initial location of the MS.

The VLR also contains supplementary service parameters attached to the mobile subscriber and received from the HLR. The organisation of the subscriber data is outlined in TS 23.008 [5].

4.1.1.3 (void)

4.1.1.4 The Equipment Identity Register (EIR)

The Equipment Identity Register (EIR) in the GSM system is the logical entity which is responsible for storing in the network the International Mobile Equipment Identities (IMEIs), used in the GSM system.

The equipment is classified as "white listed", "grey listed", "black listed" or it may be unknown as specified in TS 22.016 [2] and TS 29.002 [26].

This functional entity contains one or several databases which store(s) the IMEIs used in the GSM system.

The mobile equipment may be classified as "white listed", "grey listed" and "black listed" and therefore may be stored in three separate lists.

An IMEI may also be unknown to the EIR.

An EIR shall as a minimum contain a "white list" (Equipment classified as "white listed").

See also TS 22.016[2] on IMEI.

4.1.1.5 SMS Gateway MSC (SMS-GMSC)

The SMS Gateway MSC (SMS-GMSC) acts as an interface between a Short Message Service Centre and the PLMN, to allow short messages to be delivered to mobile stations from the Service Centre (SC).

The choice of which MSCs can act as SMS Gateway MSCs is a network operator matter (e.g. all MSCs or some designated MSCs).

4.1.1.6 SMS Interworking MSC (SMS-IWMSC)

The SMS Interworking MSC acts as an interface between the PLMN and a Short Message Service Centre (SC) to allow short messages to be submitted from Mobile Stations to the SC.

The choice of which MSCs can act as SMS Interworking MSCs is a network operator matter (e.g. all MSCs or some designated MSCs).

4.1.2 Entities of the CS domain

4.1.2.1 The Mobile-services Switching Centre (MSC)

The Mobile-services Switching Centre (MSC) constitutes the interface between the radio system and the fixed networks. The MSC performs all necessary functions in order to handle the circuit switched services to and from the mobile stations.

In order to obtain radio coverage of a given geographical area, a number of BSS and/or RNS are normally required; i.e. each MSC would thus have to interface to one or more BSS(s) and/or RNS(s). In addition several MSCs may be required to cover a country.

When Intra Domain Connection of RAN Nodes to Multiple CN Nodes is applied, all the MSCs serving a pool-area share the responsibility to serve the MSs located in the pool-area. All these MSCs interface to all the BSS(s) and/or RNS(s) forming the pool-area.

The Mobile-services Switching Centre is an exchange, which performs all the switching and signalling functions for mobile stations located in a geographical area designated as the MSC area. When Intra Domain Connection of RAN Nodes to Multiple CN Nodes is applied, one or more MSCs serve a pool-area, but each individual MS is served by only one out of these MSCs, as described in TS 23.236 [65]. The main difference between a MSC and an exchange in a fixed network is that the MSC has to take into account the impact of the allocation of radio resources and the mobile nature of the subscribers and has to perform in addition, at least the following procedures:

- procedures required for the location registration (see TS 23.012 [7]);

- procedures required for handover (see TS 23.009 [6]).

NOTE: When this improves the readability (e.g. when dealing with inter-releases handover), the term 2G-MSC can be used to refer to an MSC Release 98 or prior, and the term 3G-MSC can be used to refer to an MSC Release 99 or later.

When needed, the MSC can be implemented in two different entities: the MSC Server, handling only signalling, and the CS-MGW, handling user's data. A MSC Server and a CS-MGW make up the full functionality of a MSC.

4.1.2.1.1 MSC Server

The MSC Server mainly comprises the call control (CC) and mobility control parts of a MSC.

The MSC Server is responsible for the control of mobile originated and mobile terminated CC CS Domain calls. It terminates the user-network signalling and translates it into the relevant network – network signalling. The MSC Server also contains a VLR to hold the mobile subscriber's service data and CAMEL related data.

The MSC Server controls the parts of the call state that pertain to connection control for media channels in a CS-MGW.

4.1.2.1.2 Circuit Switched - Media Gateway Function (CS-MGW)

Note: In this document the term Media Gateway Function (MGW) is used when there is no need to differentiate between the CS domain entity and the IP Multimedia CN Subsystem entity. When referring specifically to the CS domain entity the term CS-MGW is used. When referring specifically to the IP Multimedia CN Subsystem entity, the term IMS-MGW is used.

This component is PSTN/PLMN transport termination point for a defined network and interfaces UTRAN with the core network over Iu.

A CS-MGW may terminate bearer channels from a switched circuit network and media streams from a packet network (e.g., RTP streams in an IP network). Over Iu, the CS-MGW may support media conversion, bearer control and payload processing (e.g. codec, echo canceller, conference bridge) for support of different Iu options for CS services (AAL2/ATM based as well as RTP/UDP/IP based).

The CS-MGW:

- Interacts with MGCF, MSC server and GMSC server for resource control.
- Owns and handles resources such as echo cancellers etc.
- May need to have codecs.

The CS-MGW will be provisioned with the necessary resources for supporting UMTS/GSM transport media. Further tailoring (i.e packages) of the H.248 [52] may be required to support additional codecs and framing protocols, etc.

The CS-MGW bearer control and payload processing capabilities will also need to support mobile specific functions such as SRNS relocation/handover and anchoring. It is expected that current H.248 standard [52] mechanisms can be applied to enable this.

4.1.2.2 The Gateway MSC (GMSC)

If a network delivering a call to the PLMN cannot interrogate the HLR, the call is routed to an MSC. This MSC will interrogate the appropriate HLR and then route the call to the MSC where the mobile station is located. The MSC which performs the routing function to the actual location of the MS is called the Gateway MSC (GMSC).

The acceptance of an interrogation to an HLR is the decision of the operator.

The choice of which MSCs can act as Gateway MSCs is for the operator to decide (i.e. all MSCs or some designated MSCs).

If the call is a voice group/broadcast call, it is routed directly from the GMSC to the VBS/VGCS Anchor MSC, based on information (VBS/VGCS call reference) contained in the dialled number (see also TS 43.068 [41] and 43.069 [42]).

[Editor's note: There is a need to consider possibilities that call incoming to the PLMN may be routed to entities other than the GMSC, e.g., for networks that do not deploy CS domain.]

When needed, the GMSC can be implemented in two different entities: the GMSC Server, handling only signalling, as defined below, and the CS-MGW, defined above. A GMSC Server and a CS-MGW make up the full functionality of a GMSC.

4.1.2.2.1 Gateway MSC Server (GMSC Server)

The GMSC server mainly comprises the call control and mobility control parts of a GMSC.

4.1.2.3 The Interworking Function (IWF)

The Interworking Function (IWF) is a functional entity associated with the MSC. The IWF provides the functionality necessary to allow interworking between a PLMN and the fixed networks (ISDN, PSTN and PDNs). The functions of the IWF depend on the services and the type of fixed network. The IWF is required to convert the protocols used in the PLMN to those used in the appropriate fixed network. The IWF may have no functionality where the service implementation in the PLMN is directly compatible with that at the fixed network. The interworking functions are described in TS 29.007 [31].

4.1.3 Entities of the PS domain

The UMTS PS-domain (or GPRS) Support Nodes (GSN) are the Gateway GSN (GGSN) and the Serving GSN (SGSN). They constitute the interface between the radio system and the fixed networks for packet switched services. The GSN performs all necessary functions in order to handle the packet transmission to and from the mobile stations.

4.1.3.1 Serving GPRS Support Node (SGSN)

The location register function in the SGSN stores two types of subscriber data needed to handle originating and terminating packet data transfer:

- subscription information:
 - the IMSI;
 - one or more temporary identities;
 - zero or more PDP addresses.
- location information:
 - depending on the operating mode of the MS, the cell or the routing area where the MS is registered;
 - the VLR number of the associated VLR (if the Gs interface is implemented);
 - the GGSN address of each GGSN for which an active PDP context exists.

The organisation of the subscriber data in the SGSN is defined in TS 23.008 [5] and TS 23.060 [9a].

The procedures for information transfer between the SGSN, the GGSN, the VLR and the HLR are defined in TS 23.016 [39] and TS 23.060 [9a].

NOTE: When this improves the readability (e.g. when dealing with inter-releases handover), the term 2G-SGSN can be used to refer to an MSC Release 98 or prior, and the term 3G-SGSN can be used to refer to an MSC Release 99 or later.

4.1.3.2 Gateway GPRS Support Node (GGSN)

The location register function in the GGSN stores subscriber data received from the HLR and the SGSN. There are two types of subscriber data needed to handle originating and terminating packet data transfer:

- subscription information:

- the IMSI;
- zero or more PDP addresses.
- location information:
 - the SGSN address for the SGSN where the MS is registered.

The organisation of the subscriber data in the GGSN is defined in TS 23.008 [5] and TS 23.060 [9a].

The procedures for information transfer between the GGSN, the SGSN and the HLR are defined in TS 23.016 [39] and TS 23.060 [9a].

4.1.3.3 Border Gateway (BG)

The Border Gateway (BG) is a gateway between a PLMN supporting GPRS and an external inter-PLMN backbone network used to interconnect with other PLMNs also supporting GPRS. The role of the BG is to provide the appropriate level of security to protect the PLMN and its subscribers.

The BG is only needed in PLMNs supporting GPRS.

4.2 The Access Network (AN) entities

Two different types of access network are used by the CN: the Base Station System (BSS) and the Radio Network System (RNS). The MSC (resp. SGSN) can connect to one of these Access Network type or to both of them.

The access technologies offered by the BSS are described in the 45-series of 3GPP specifications. The access technologies offered by the RNS (FDD, TDD) are described in the 25-series of 3GPP specifications.

4.2.1 The Base Station System (BSS)

The Base Station System (BSS) is the system of base station equipments (transceivers, controllers, etc...) which is viewed by the MSC through a single A and/or Iu-CS interface as being the entity responsible for communicating with Mobile Stations in a certain area. Similarly, in PLMNs supporting GPRS, the BSS is viewed by the SGSN through a single Gb or Iu-PS interface. When Intra Domain Connection of RAN Nodes to Multiple CN Nodes is applied, a BSS may connect to several MSCs by several A and/or Iu-CS interfaces, and a BSS may connect to several SGSNs by several Gb and/or Iu-PS interfaces. The functionality for the A interface is described in TS 48.002 [14] and for the Gb interface in TS 23.060 [9a]. The functionality for the Iu-CS interface is described in TS 25.410 [14a] and for the Iu-PS interface in TS 23.060 [9a].

The radio equipment of a BSS may support one or more cells. A BSS may consist of one or more base stations. Where an Abis-interface is implemented, the BSS consists of one Base Station Controller (BSC) and one or more Base Transceiver Station (BTS). The split of functions between BSS and CN for a Iu interface is described in the 25-series of UMTS Technical Specifications.

The split of functions between BSS and CN for a A/Gb interface is described in the 48-series of GSM Technical Specifications. The split of functions between BSS and CN for a Iu interface is described in the 25-series of UMTS Technical Specifications.

NOTE: The mobile station shall operate using **only the following modes**:

- a. **A / G_b mode**, e.g. for pre-Release 4 terminals, or for Release 4 terminals when connected to a BSS with no Iu interface towards the Core Network.
- b. **Iu mode** (i.e. Iu-CS and Iu-PS), e.g. for Release 4 terminals when connected to a BSS with Iu interfaces towards the Core Network

No other modes (e.g. A/Iu-PS or Iu-CS/Gb) shall be allowed.

See also TS 43.051 [36].

4.2.1.1 Base Station Controller (BSC)

A Base Station Controller (BSC) is a network component in the PLMN with the functions for control of one or more BTS.

4.2.1.2 Base Transceiver Station (BTS)

A Base Transceiver Station (BTS) is a network component which serves one cell.

4.2.2 The Radio Network System (RNS)

The Radio Network System (RNS) is the system of base station equipments (transceivers, controllers, etc...) which is viewed by the MSC through a single Iu-interface as being the entity responsible for communicating with Mobile Stations in a certain area. Similarly, in PLMNs supporting GPRS, the RNS is viewed by the SGSN through a single Iu-PS interface. When Intra Domain Connection of RAN Nodes to Multiple CN Nodes is applied, an RNS may connect to several MSCs by several Iu-CS interfaces, and an RNS may connect to several SGSNs by several Iu-PS interfaces. The functionality for the Iu-CS interface is described in TS 25.410 [14a] and for the Iu-PS interface in TS 23.060 [9a]. The radio equipment of a RNS may support one or more cells. A RNS may consist of one or more base stations. The RNS consists of one Radio Network Controller (RNC) and one or more Node B.

The split of functions between RNS and CN is described in the 25-series of UMTS Technical Specifications.

4.2.2.1 Radio Network Controller (RNC)

A Radio Network Controller (RNC) is a network component in the PLMN with the functions for control of one or more Node B.

4.2.2.2 Node B

A Node B is a logical network component which serves one or more cells.

4.3 The Mobile Station (MS)

The mobile station consists of the physical equipment used by a PLMN subscriber; it comprises the Mobile Equipment (ME) and the Subscriber Identity Module (SIM), called UMTS Subscriber Identity Module (USIM) for Release 99 and following. The ME comprises the Mobile Termination (MT) which, depending on the application and services, may support various combinations of Terminal Adapter (TA) and Terminal Equipment (TE) functional groups. These functional groups are described in TS 44.002 [12].

[editor's note: an input is expected to introduce the UE (User Equipment) definition and clarify the difference between MS and UE.]

4a The specific entities of the mobile system

The entities presented in this clause are dedicated to the provisioning of a given (set of) service(s). The fact that they are implemented or not in a given PLMN should have limited impact on all the other entities of the PLMN.

All the specific entities defined so far are located in the Core Network.

4a.1 The Group Call Register (GCR) entity

The Group Call Register (GCR) is a register holding information about VGCS or VBS calls, the voice group or broadcast call attributes, respectively.

Voice group or broadcast call attributes are defined for a specific voice group or broadcast call reference and include the data required to configure the conference bridge for a VGCS or VBS call and other call related attributes.

The Group Call Register (GCR) shall hold for a related MSC area for each group ID and cell from which Voice Group Call Service (VGCS) or Voice Broadcast Service (VBS) calls can be established by mobile stations the voice group call reference or voice broadcast call reference to be used for a VGCS or VBS call to be established and an indication whether the originating MSC is the MSC responsible for that call.

If the originating MSC is not responsible for that call, the GCR shall hold the routing information identifying the MSC responsible for that call.

A GCR may be in charge of one or several MSC. Each MSC involved in a voice group or broadcast call requests its proper voice group or broadcast call attributes from its related GCR by use of the voice group or broadcast call reference.

The contents of each list related to requests of the MSC responsible for a voice group or broadcast call is as follows:

- a list of cells inside the MSC area of the requesting MSC into which the call is to be sent (part of the group call area);
- a list of other MSCs into which the call is to be sent;
- a list of identities of dispatchers to which a dedicated link is to be established;
- a list of identities of dispatchers which are allowed to initiate the voice group or broadcast call;
- a list of identities of dispatchers which are allowed to terminate the voice group or broadcast call;
- the length of time over which no activity is detected before the voice group call is automatically terminated;
- the default priority level related to the voice group or broadcast call if the eMLPP supplementary service applies;
- a flag indicating if acknowledgements are required for this voice group or broadcast call.

The contents of each list related to requests of an MSC not responsible for a voice group or broadcast call is as follows:

- a list of cells inside the MSC area of the requesting MSC into which the call is to be sent (part of the group call area).

More information is provided in TS 43.068 [41] and 43.069[42].

4a.2 (void)

4a.3 The Location Services (LCS) entities

This section describes the Location Services entities found in the Core Network and Radio Access Network that support positioning methods for the UE/MS.

For further details on LCS in UMTS and GSM from system and core network point view, see 3GPP TS 23.271 [56].

For further details on LCS in UTRAN, see 3GPP TS 25.305 [10b].

For further details on LCS in GERAN, see 3GPP TS 43.059 [10d].

4a.3.1 Location Services (LCS) entities in RAN

The RAN (UTRAN and GERAN) supports one or more UE/MS positioning methods to calculate the geographical position of the UE/MS and responds to the UE/MS location request received from the CN. The RAN may broadcast LCS assistance data to UEs/MSs under its coverage. In case this assistance data is ciphered, the ciphering key is provided by the CN to the UE/MS.

To support UE positioning methods, the RAN is made of several entities like:

BSC/SRNC: the BSC for GERAN and SRNC for UTRAN receive authenticated location requests from the CN:

- In UTRAN, the SRNC co-ordinates the positioning requests taking into account their priority and it selects the positioning method to fulfil the requested accuracy. It interfaces, when necessary, with the CRNC which mainly manages resources allocated to UE positioning operations and requests UE Positioning related measurements from its associated Node Bs and LMUs.
- In GERAN, the BSC passes the location request to the SMLC.

SMLC:

- The Serving Mobile Location Center (SMLC) function can be part of the RNC or be a SAS (Stand-Alone SMLC) for UTRAN. The SMLC function can be part of the BSC or be in a separate SMLC server for GERAN.
- In UTRAN, the SMLC function provides assistance data to the RNC and acts as a location calculation server if the location estimates are not to be calculated in the RNC.
- In GERAN, the SMLC function co-ordinates the positioning request, schedules resources required to perform positioning of a mobile, and calculates the final location estimate and accuracy. The SMLC may control a number of LMUs.

LMU: The Location Measurement Unit (LMU) entity makes measurements for one or more positioning methods.

Node B: Node B is a network element of UTRAN that may provide measurement results for position estimation and makes measurements of radio signals.

CBC: The Cell Broadcast Center, in GERAN, the SMLC function may interface a CBC in order to broadcast assistance data using existing cell broadcast capabilities.

For detail on Location services, entities and interfaces provided by UTRAN, see 3GPP TS 25.305 [10b].

For detail on Location services, entities and interfaces provided by GERAN, see 3GPP TS 43.059 [10d].

4a.3.2 Gateway Mobile Location Center (GMLC)

The Gateway Mobile Location Center (GMLC) is the first node an external Location Application accesses in the GSM PLMN. The GMLC performs registration authorization and requests routing information from the HLR. There may be more than one GMLC in a PLMN.

4a.3.3 Location Measurement Unit (LMU)

An LMU makes radio measurements to support one or more positioning methods.

Two types of LMU are defined:

- Type A LMU: accessed over the normal GSM air interface;
- Type B LMU: accessed over the base station to controller interface (Abis in GSM and Iub in UMTS).

A type A LMU is accessed exclusively over the GSM air interface (Um interface): there is no wired connection to any other network element.

In GSM, a type A LMU has a serving BTS and BSC that provide signaling access to a controlling SMLC. With an NSS based SMLC, a type A LMU also has a serving MSC and VLR and a subscription profile in an HLR. A type A LMU always has a unique IMSI and supports all radio resource and mobility management functions of the GSM air interface that are necessary to support signaling using an SDCCH to the SMLC. A type A LMU supports those connection management functions necessary to support LCS signaling transactions with the SMLC and may support certain call control functions of to support signaling to an SMLC using a circuit switched data connection.

In UMTS, a type A LMU has signaling access to the SRNC. Type A LMU is not supported in UMTS release 1999.

In GSM, a Type B LMU is accessed over the Abis interface from a BSC. The LMU may be either a standalone network element addressed using some pseudo-cell ID or connected to or integrated in a BTS. Signaling to a Type B LMU is by means of messages routed through the controlling BSC for a BSS based SMLC or messages routed through a controlling BSC and MSC for an NSS based SMLC.

In UMTS, a Type B LMU is accessed over the Iub interface from an RNC. The LMU may be either a standalone network element addressed using some pseudo-cell ID or connected to or integrated in a Node B.

4a.4 CAMEL entities

The entities of this subclause support the CAMEL feature (Customised Applications for Mobile network Enhanced Logic). This feature provides the mechanisms to support services consistently independently of the serving network, as described in 22.078 [2c]. The following definitions are extracted from 23.078 [10c], which completely specifies CAMEL stage 2.

4a.4.1 GSM Service Control Function (gsmSCF)

A functional entity that contains the CAMEL service logic to implement Operator Specific Service. It interfaces with the gsmSSF, the gsmSRF and the HLR.

4a.4.2 GSM Service Switching Function (gsmSSF)

A functional entity that interfaces the MSC/GMSC to the gsmSCF. The concept of the gsmSSF is derived from the IN SSF, but uses different triggering mechanisms because of the nature of the mobile network.

4a.4.3 GSM Specialised Resource Function (gsmSRF)

A functional entity which provides various specialized resources. It interfaces with the gsmSCF and with the MSC. This entity is defined in ITU-T Q.1214 [11] with variations defined in 23.078 [10c].

4a.4.4 GPRS Service Switching Function (gprsSSF)

A functional entity that interfaces the SGSN to the gsmSCF. The concept of the gprsSSF is derived from the IN SSF, but uses different triggering mechanisms because of the nature of the mobile network.

4a.5 CBS-specific entities

The cell broadcast service (CBS) is a Teleservice which enables an Information Provider to submit short messages for broadcasting to a specified area within the PLMN. TS 23.041 [8] contains the technical realization of the service.

4a.5.1 Cell Broadcast Center (CBC)

The CBC shall be responsible for the management of CBS messages and for determining the CBS delivery parameters of the RNS. The CBC may be connected to several BSCs/RNCs. In UMTS the CBC is regarded to be integrated as a node into the core network.

Note: Whether it should be possible that an RNC is connected to at least two CBCs at the same time (the "normal" one as in GSM and a second one for LCS) is for further study and depends on the solution taken for LCS.

4a.6 Number Portability Specific entities

Two different solutions are defined to support Number Portability. The first one is an IN based solution and is described in the next subclause. The second one is a "Signalling Relay" based solution described in next but one subclause.

For details on MNP see TS 23.066 [40].

4a.6.1 IN-based solution: Number Portability Database (NPDB)

The Number Portability Database (NPDB) is the central element of the IN based solution for Mobile Number Portability (MNP). MNP is the ability for a mobile subscriber to change the GSM subscription network within a portability cluster (e.g. a country) whilst retaining his/her original MSISDN or MSISDNs.

The NPDB stores the table of correspondence between MSISDNs and Subscription networks. Upon request of the (gateway or visited) MSC, the NPDB retrieves from the MSISDN the Routing Number pointing out the Subscription network.

4a.6.2 Signalling Relay-based solution: Mobile Number Portability/Signalling Relay function (MNP-SRF)

The MNP-Signalling Relay Function (MNP-SRF) is the central element of the Signalling Relay based solution for Mobile Number Portability.

The MNP-SRF obtains the routing information from a NP database to identify the subscription network associated with a particular national MSISDN. Upon request from gateway MSC, the MNP-SRF may perform one of the following actions:

1. the MNP-SRF will reply back to the GMSC with the necessary routing information to route the call;
2. the message is relayed to the HLR;
3. the message is relayed to MNP-SRF in the subscription network.

For non-call related signalling (e.g. delivery of SMS), only cases 2 and 3 are applicable.

4a.7 IP Multimedia (IM) Core Network (CN) Subsystem entities

4a.7.1 Call Session Control Function (CSCF)

The CSCF can act as Proxy CSCF (P-CSCF), Serving CSCF (S-CSCF) or Interrogating CSCF (I-CSCF). The P-CSCF is the first contact point for the UE within the IM subsystem (IMS); the S-CSCF actually handles the session states in the network; the I-CSCF is mainly the contact point within an operator's network for all IMS connections destined to a subscriber of that network operator, or a roaming subscriber currently located within that network operator's service area. Further definitions of the P-, S- and I-CSCF are provided in TS 23.228 [34].

4a.7.2 Media Gateway Control Function (MGCF)

The MGCF:

- Controls the parts of the call state that pertain to connection control for media channels in an IMS-MGW.
- Communicates with CSCF.
- Selects the CSCF depending on the routing number for incoming calls from legacy networks.
- Performs protocol conversion between ISUP and the IM subsystem call control protocols.
- Out of band information assumed to be received in MGCF and may be forwarded to CSCF/IMS-MGW.

4a.7.3 IP Multimedia Subsystem - Media Gateway Function (IMS-MGW)

Note: In this document the term Media Gateway Function (MGW) is used when there is no need to differentiate between the CS domain entity and the IP Multimedia CN Subsystem entity. When referring specifically to the CS domain entity the term CS-MGW is used. When referring specifically to the IP Multimedia CN Subsystem entity, the term IMS-MGW is used.

A IMS-MGW may terminate bearer channels from a switched circuit network and media streams from a packet network (e.g., RTP streams in an IP network). The IMS-MGW may support media conversion, bearer control and payload processing (e.g. codec, echo canceller, conference bridge), it:

- Interacts with the MGCF for resource control.
- Owns and handles resources such as echo cancellers etc.

- May need to have codecs.

The IMS-MGW will be provisioned with the necessary resources for supporting UMTS/GSM transport media. Further tailoring (i.e. packages) of the H.248 [52] may be required to support additional codecs and framing protocols, etc.

4a.7.4 Multimedia Resource Function Controller (MRFC)

The MRFC:

- Controls the media stream resources in the MRFP.
- Interprets information coming from an AS and S-CSCF (e.g session identifier) and control MRFP accordingly.
- Generates CDRs .

4a.7.4a Multimedia Resource Function Processor (MRFP)

The MRFP:

- Controls bearers on the Mb reference point.
- Provides resources to be controlled by the MRFC.
- Mixes incoming media streams (e.g. for multiple parties).
- Sources media streams (for multimedia announcements).
- Processes media streams (e.g. audio transcoding, media analysis).
- Floor Control (i.e. manage access rights to shared resources in a conferencing environment).

4a.7.5 Subscription Locator Function (SLF)

The SLF:

- Is queried by the I-CSCF during the Registration and Session Setup to get the name of the HSS containing the required subscriber specific data. Furthermore the SLF is also queried by the S-CSCF during the Registration.
- Is queried by the AS in conjunction with the Sh interface operation to get the name of the HSS containing the required subscriber specific data.
- Is accessed via the Dx interface by the CSCF and via the Dh interface by the AS

The SLF is not required in a single HSS environment. An example for a single HSS environment is a server farm architecture. Use of SLF is not required when AS are configured/managed to use pre-defined HSS.

4a.7.6 Breakout Gateway Control Function (BGCF)

The Breakout Gateway control function (BGCF) selects the network in which PSTN breakout is to occur and - within the network where the breakout is to occur - selects the MGCF.

4a.7.7 Application Server (AS)

An Application Server (AS) i.e., SIP Application Server, OSA Application Server, or CAMEL IM-SSF, offers value added IM services and resides either in the user's home network or in a third party location. The third party could be a network or simply a stand-alone AS.

Note: The OSA Application Server does not directly interact with the IMS network entities but through the OSA Service Capability Servers (OSA SCS-s). Further information on OSA is provided in TS 22.127 [4].

The AS (SIP Application Server and/or the OSA Service Capability Server and/or IM-SSF) can communicate with the HSS. The Sh and Si interfaces are used for this purpose.

The Serving-CSCF to AS interface is used to provide services residing in an AS. Two cases were identified:

- Serving-CSCF to an AS in Home Network.
- Serving-CSCF to an AS in a trusted External Network (e.g., Third Party or Visited). The S-CSCF does not provide authentication and security functionality for secure direct third party access to the IM Subsystem. The OSA framework provides a standardized way for third party access to the IM Subsystem.

An Application Server may influence and impact the SIP session on behalf of the services supported by the operator's network. An AS may host and execute services.

4a.8 Signalling Gateway Function (SGW)

The SGW performs the signalling conversion (both ways) at transport level between the SS7 based transport of signaling used in pre-Rel 4 networks, and the IP based transport of signalling possibly used in post-R99 networks (i.e. between Sigtran SCTP/IP and SS7 MTP). The SGW does not interpret the application layer (e.g. MAP, CAP, BICC, ISUP) messages but may have to interpret the underlying SCCP or SCTP layer to ensure proper routing of the signaling.

4a.9 Global Text Telephony Specific entities

Interworking between cellular text modem (CTM) and text telephony standards (e.g. V.18) used in external networks can be supported by three methods:

- Routing calls through a CTM Special resource function (CTM-SRF) in the core network. The CTM-SRF is linked in to the call path via CAMEL procedures. Depending on operator configuration the CTM-SRF may also be linked in to the call path for Emergency calls.
- A CTM / Text telephone converting function included along the speech call path selected by the network after an indication from the terminal that CTM is required.
- A CTM / Text telephone converting function included in all speech call paths.

Further information of the support for text telephony is found in TS 23.226 [37].

For further details of CTM, see TS 26.226. [38]

4a.10 Security Gateway (SEG)

The UMTS network domain shall be logically and physically divided into security domains in order to protect IP based control plane signalling. These security domains typically coincide with operator borders.

The interface between different security domains is protected by Security Gateways (SEGs). The SEGs are responsible for enforcing the security policy of a IP security domain towards other SEGs in the destination IP security domain. All NDS/IP traffic shall pass through a SEG before entering or leaving a security domain. For further details of SEG, see TS 33.210 [64].

4a.11 Application Function (AF)

The Application Function (AF) is an element offering applications the control of IP bearer resources when required. The AF is capable of communicating with the PDF to transfer dynamic QoS-related service information.

One example of an AF is the P-CSCF of the IM CN subsystem.

4a.12 Policy Decision Function (PDF)

The Policy Decision Function (PDF) acts as a policy decision point for service based local policy control of IP bearer resources. The PDF makes decisions about IP bearer resource allocation requests.

4a.13 3GPP/WLAN Interworking entities

4a.13.1 WLAN UE

A WLAN UE is the User Equipment using a UICC card utilized by a 3GPP subscriber to access the WLAN network for 3GPP interworking purpose.

4a.13.2 3GPP AAA Proxy

The 3GPP AAA Proxy represents a AAA proxying and filtering function and resides in the visited 3GPP network. It is involved in access and service authentication and authorization procedures of a WLAN UE.

4a.13.3 3GPP AAA Server

The 3GPP AAA server resides in the 3GPP network and is responsible for access and service authentication and authorization of a WLAN UE.

4a.13.4 WLAN Access Gateway (WAG)

The WLAN access gateway is a gateway between WLAN and 3GPP network. In the roaming case it resides in the visited 3GPP network, otherwise in the home 3GPP network. It provides filtering, policing and charging functionality for the traffic between WLAN UE and 3GPP network.

4a.13.5 Packet Data Gateway (PDG)

The Packet Data Gateway provides access to PS based services for a WLAN UE. It resides either in the home (for access to home services) or in the visited 3GPP network (for access to local services).

5 Configuration of a Public Land Mobile Network

5.1 Basic configuration

The basic configuration of a Public Land Mobile Network (PLMN) supporting GPRS and the interconnection to the PSTN/ISDN and PDN is presented in figure 1 and figure 1a. This configuration presents signalling and user traffic interfaces which can be found in a PLMN. Implementations may be different: some particular functions may be gathered in the same equipment and then some interfaces may become internal interfaces.

In the basic configuration presented in figure 1, all the functions are considered implemented in different equipments. Therefore, all the interfaces within PLMN are external. Interfaces A and Abis are defined in the 48-series of Technical Specifications. Interfaces Iu, Iur and Iub are defined in the 25.4xx-series of Technical Specifications. Interfaces B, C, D, E, F and G need the support of the Mobile Application Part of the signalling system No. 7 to exchange the data necessary to provide the mobile service. No protocols for the H-interface and for the I-interface are standardized. All the GPRS-specific interfaces (G-series) are defined in the 23-series and 24-series of Technical Specifications. Interfaces Mc, Nb, and Nc are defined in TS 23.205 [43] and in the 29-series of Technical Specifications.

From this configuration, all the possible PLMN organisations can be deduced. In the case when some functions are contained in the same equipment, the relevant interfaces become internal to that equipment.

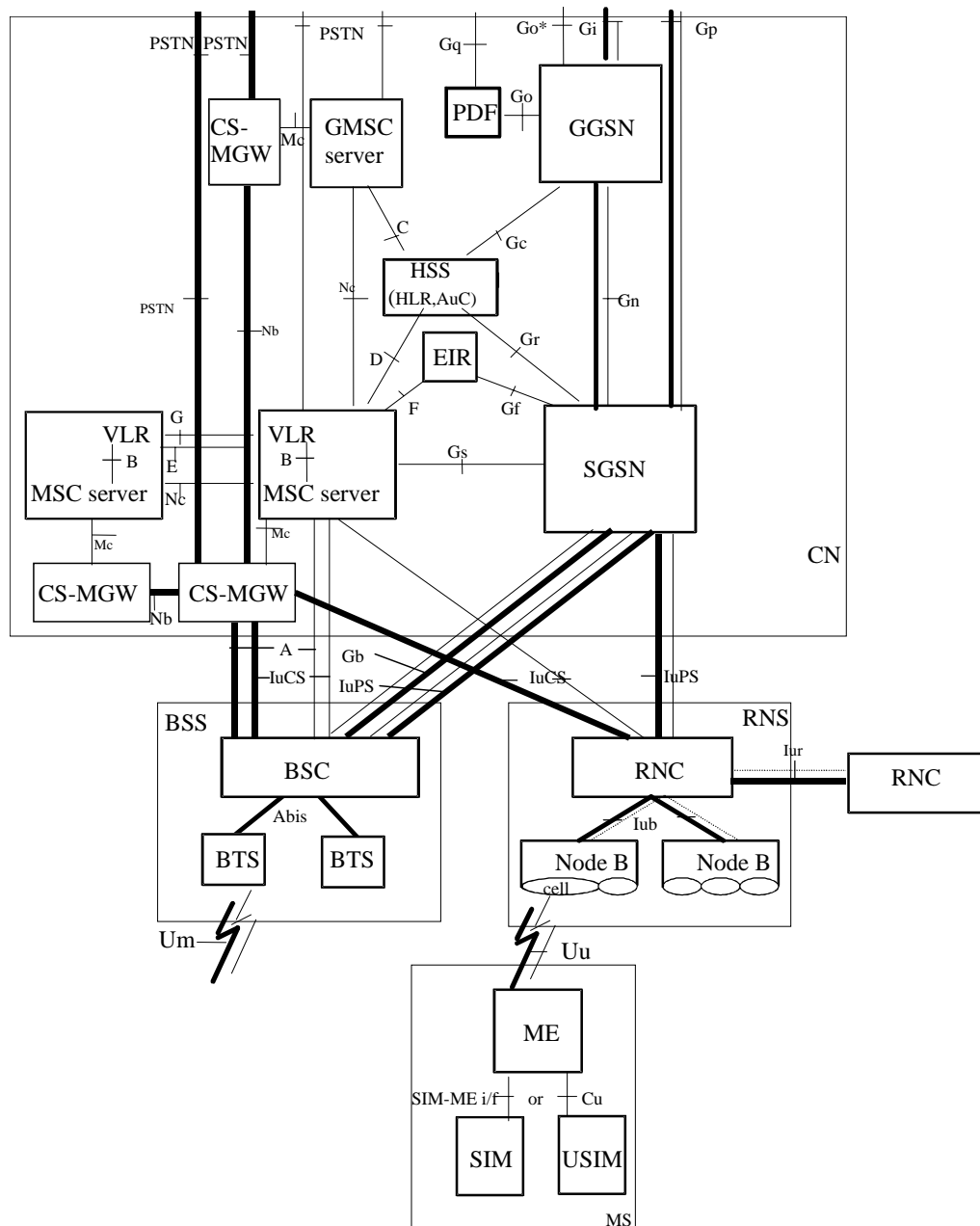

Legend:

Bold lines: interfaces supporting user traffic;

Dashed lines: interfaces supporting signalling.

NOTE 1: The figure shows direct interconnections between the entities. The actual links may be provided by an underlying network (e.g. SS7 or IP): this needs further studies.

NOTE 2: When the MSC and the SGSN are integrated in a single physical entity, this entity is called UMTS MSC (UMSC).

NOTE 3: A (G)MSC server and associated CS-MGW can be implemented as a single node: the (G)MSC.

NOTE 4: The Gn interface (between two SGSNs) is also part of the reference architecture, but is not shown for layout purposes only.

NOTE 5: The Go interface marked with a "*" has been included to this figure for backwards compatibility only, in order to support connecting to Release-5 IM CN Subsystem configurations

Figure 1: Basic Configuration of a PLMN supporting CS and PS services and interfaces

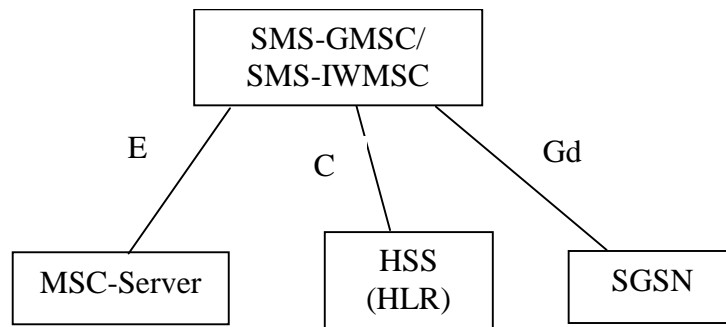

Figure 1a: Configuration for Short Message Service

5.2 Configuration of LCS entities

5.2.1 Configuration of LCS entities for GERAN

The configuration of LCS entities for GERAN is presented in figure 2. In the figure, all the functions are considered implemented in different logical nodes. If two logical nodes are implemented in the same physical equipment, the relevant interfaces may become internal to that equipment.

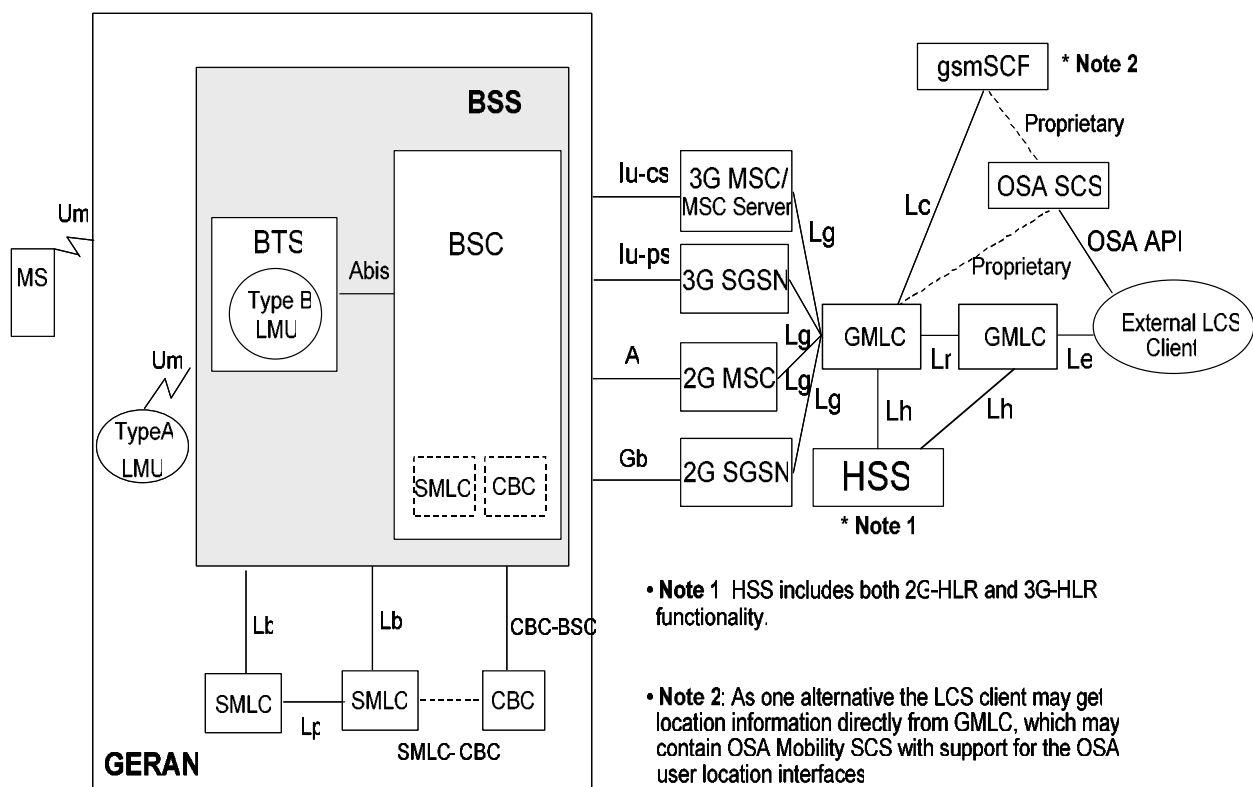

Figure 2: Configuration of LCS entities for a GERAN PLMN

5.2.2 Configuration of LCS entities for UTRAN

The basic configuration of UTRAN LCS is presented in figure 3. The SMLC functionality is integrated in SRNC or, in case a Stand-Alone SMLC entity (SAS) is present, split between SRNC and SMLC.

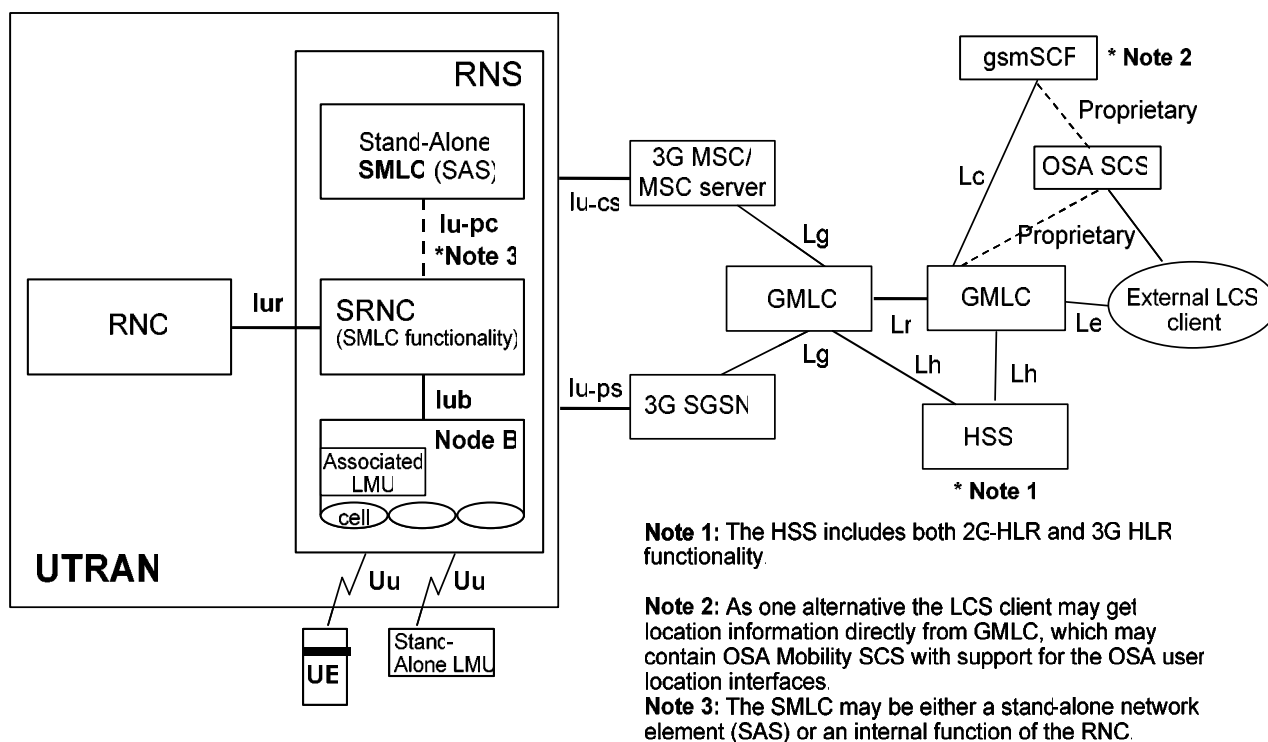

Figure 3: Configuration of LCS entities for a UTRAN PLMN

5.3 Configuration of CAMEL entities

The following figure shows the interconnection of the CAMEL-specific entities with the rest of the network. Only the interfaces specifically involved in CAMEL provisioning are shown, i.e. all the GMSC, MSC, SGSN and HLR interfaces depicted in figure 1 are still supported by these entities even if not shown.

NOTE: Most CAMEL-specific interfaces have no particular name. They are designated by the name of the two entities they link together, e.g. "the gsmSSF-gsmSCF interface".

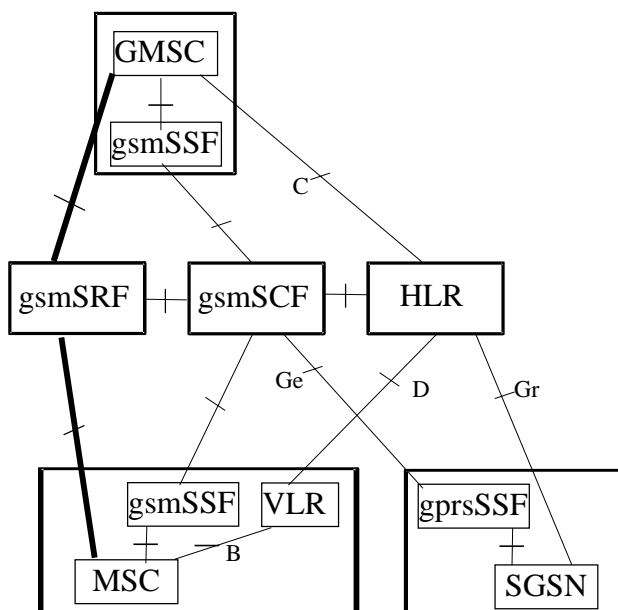

Figure 4: configuration of CAMEL entities

The bold lines are used for interfaces supporting user data only, the dashed lines are used for interfaces supporting signalling only.

5.4 Configuration of CBS entities

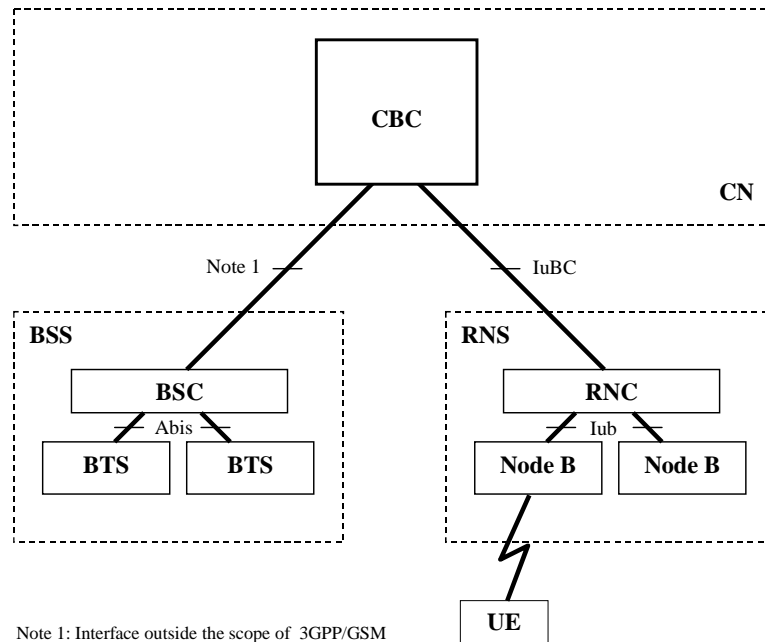

Figure 5: Configuration of a PLMN supporting Cell Broadcast Service entities

5.5 Configuration of IM CN Subsystem entities

The configuration of IM CN Subsystem entities is presented in figure 6. In the figure, all the functions are considered implemented in different logical nodes. If two logical nodes are implemented in the same physical equipment, the relevant interfaces may become internal to that equipment.

Only the interfaces specifically linked to the IM subsystem are shown, i.e. all the SGSN, GGSN and HSS interfaces depicted in figure 1 are still supported by these entities even if not shown.

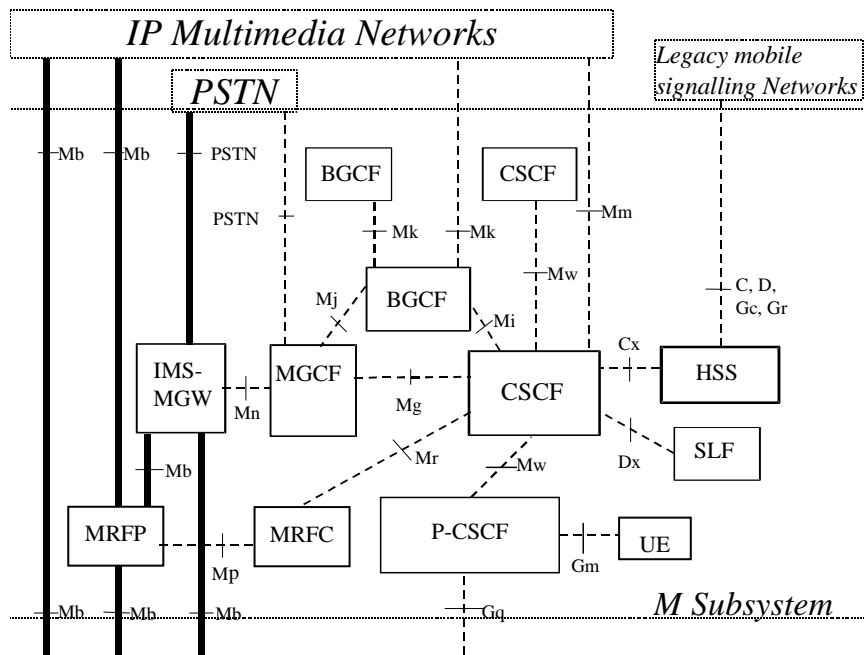

Figure 6: Configuration of IM Subsystem entities

Legend:

Bold lines: interfaces supporting user traffic;

Dashed lines: interfaces supporting only signalling.

The figure below depicts an overall view of the functional architecture for services.

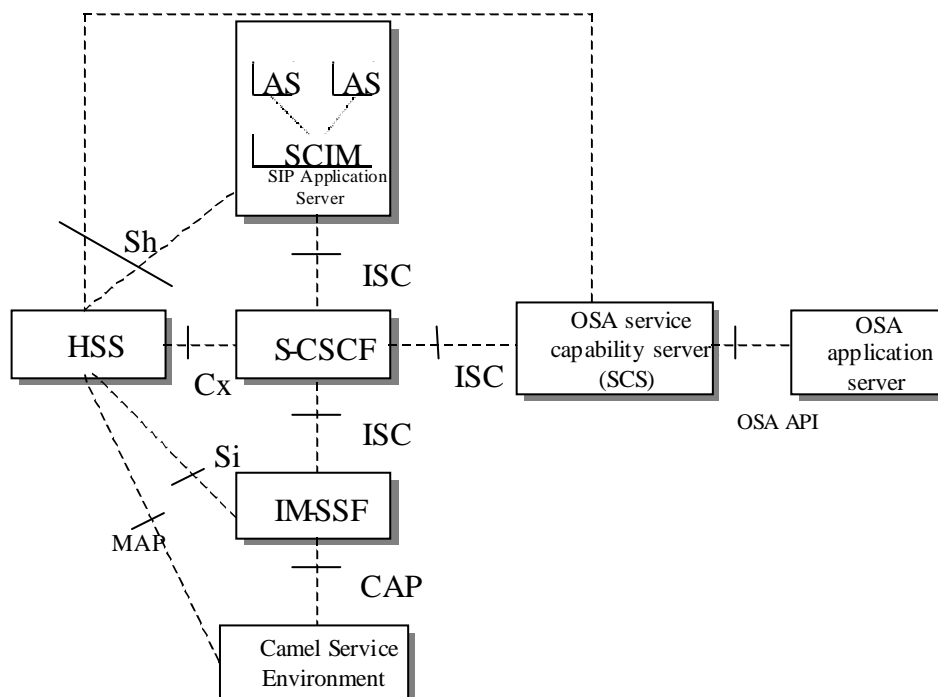

Figure 6a: Functional architecture for the provision of service in the IMS

The purpose of the IM SSF is to host the CAMEL network features (i.e. trigger detection points, CAMEL Service Switching Finite State Machine, etc) and to interwork with CAP.

The IM SSF and the CAP interface support legacy services only.

The application server may contain 'service capability interaction manager' (SCIM) functionality and other application servers. The SCIM functionality is an application which performs the role of interaction management. The internal components are represented by the 'dotted boxes' inside the SIP application server. The internal structure of the application server is outside the standards. The Sh interface shall have sufficient functionality to enable this scenario.

The figure below depicts an overall view of the functional architecture for enabling the management of the user's service related information via the Ut interface.

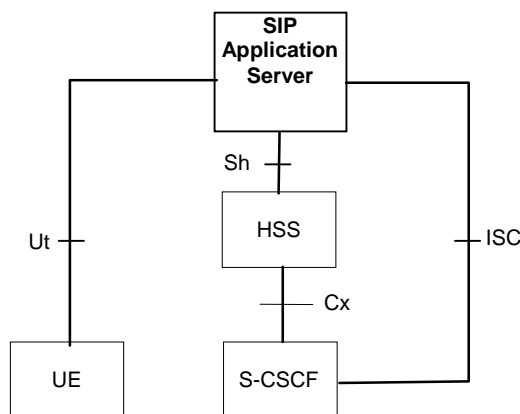

Figure 6b: Functional architecture for the management of the user's service related information

5.6 Configuration of Signalling Gateway Function

The Signalling gateway function is used to interconnect different signalling networks i.e. SCTP/IP based signalling networks and SS7 signalling networks. The application layer (e.g. ISUP, BICC, MAP or CAP) is not affected. The signalling gateway function may be implemented as a stand alone entity or inside another entity.

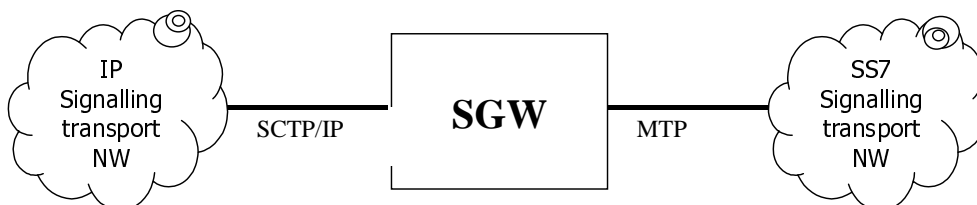

Figure 7: Configuration of a signalling gateway function

Note: SS7 application transport and SCTP/IP adaption protocols are not shown.

5.7 Configuration of 3GPP/WLAN Interworking

The configuration of the 3GPP/WLAN interworking function is presented in figure 8. The figure shows all network entities and reference point for the roaming scenario when a WLAN UE accesses PS based services in the home network. PS based services in the visited network are accessed via a Packet Data Gateway in the visited 3GPP network. Reference point Ww between WLAN UE and WLAN is outside the scope of 3GPP and only shown for completeness.

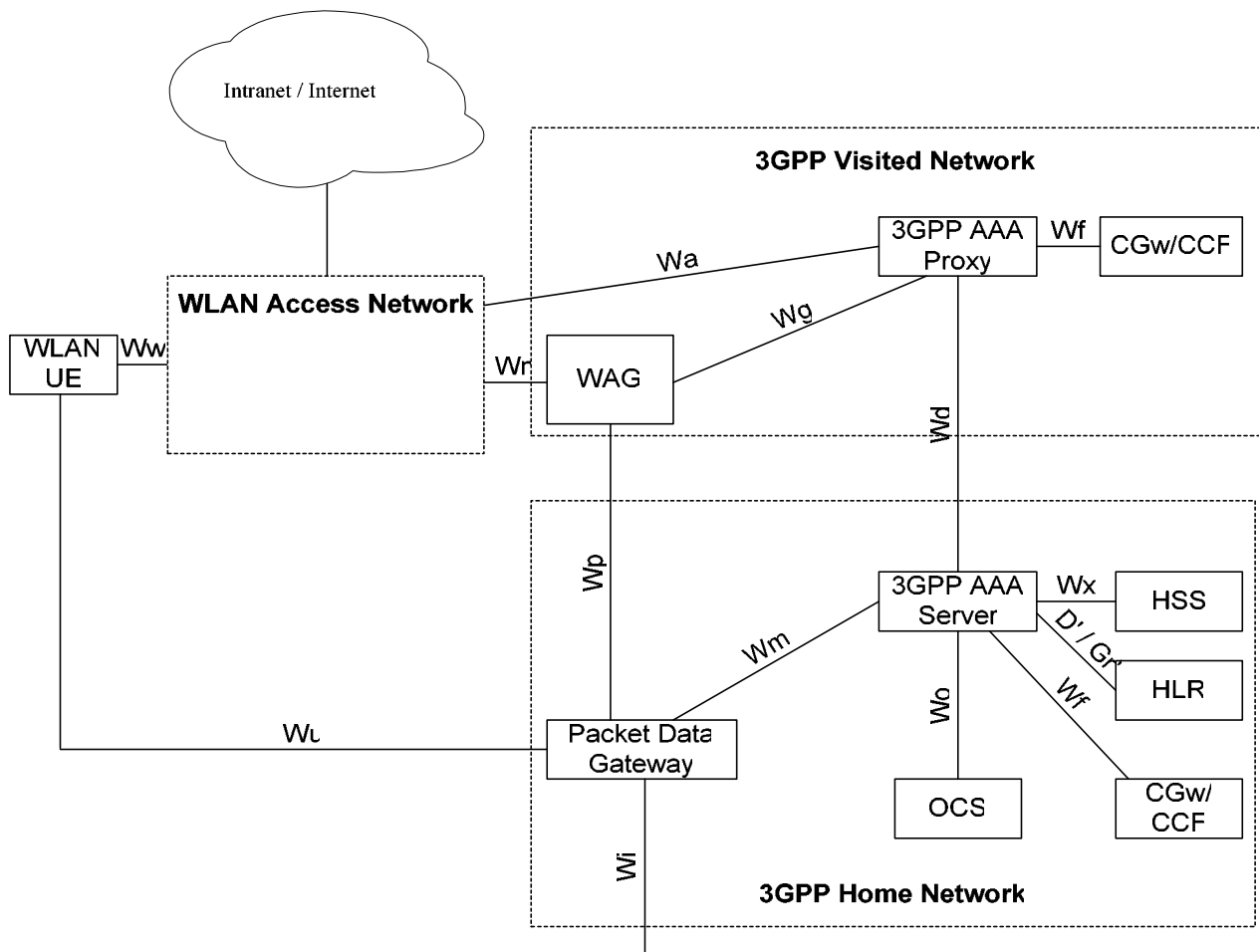

Figure 8: Configuration of a 3GPP/WLAN interworking function

5.8 Configuration of Presence service

The reference architecture model, the reference points and the functional entities to support the Presence Service are described in TS 23.141 [68].

6 PLMN basic interfaces and reference points

The implementation of the mobile service with international roaming implies the exchange of data between the equipment involved in the service. The same No.7 signalling network should be used to transfer these data and the call-related signalling information.

[editor's note: either the difference between interface and reference point should be clearly provided, or only one of the terms should be used].

6.1 Interfaces between Mobile Station and the Fixed Infrastructure

6.1.1 Interface between Mobile Station and Base Station System (Um-interface)

The interface between the MS and the BSS is specified in the 44- and 45-series of Technical Specifications.

6.1.2 Interface between User Equipment and Radio Network System (Uu-interface)

The interface between the UE and the RNS is specified in the 24- and 25-series of Technical Specifications.

6.2 Interface between the Core Network and the Access Network

6.2.1 Interfaces between the CS domain and the Access Network

6.2.1.1 Interface between the MSC and Base Station System (A-interface)

The interface between the MSC and its BSS is specified in the 48-series of Technical Specifications.

The BSS-MSC interface is used to carry information concerning:

- BSS management;
- call handling;
- mobility management.

6.2.1.2 Interface between the MSC and Base Station System (Iu-CS interface)

The interface between the MSC and its BSS is specified in the 25.41x-series of Technical Specifications.

The BSS-MSC interface is used to carry information concerning:

- BSS management;
- call handling;
- mobility management;

6.2.1.3 Interface between the MSC and RNS (Iu-CS interface)

The interface between the MSC and its RNS is specified in the 25.41x-series of Technical Specifications.

The RNS-MSC interface is used to carry information concerning:

- RNS management;
- call handling;
- mobility management.

6.2.2 Interfaces between the PS domain and the Access Network

6.2.2.1 Interface between SGSN and BSS (Gb-interface)

The BSS-SGSN interface is used to carry information concerning:

- packet data transmission;
- mobility management.

The Gb interface is defined in TS 48.014 [44], 48.016 [45] and 48.018 [46].

6.2.2.2 Interface between SGSN and BSS (Iu_PS-interface)

The BSS-SGSN interface is used to carry information concerning:

- packet data transmission;
- mobility management.

The Iu_PS interface is defined in the 25.41x-series of Technical Specifications.

6.2.2.3 Interface between SGSN and RNS (Iu_PS-interface)

The RNS-SGSN interface is used to carry information concerning:

- packet data transmission;
- mobility management.

The Iu_PS interface is defined in the 25.41x-series of Technical Specifications.

6.3 Interfaces internal to the Access Network

6.3.1 Interface between BSC and BTS (Abis-interface)

When the BSS consists of a Base Station Controller (BSC) and one or more Base Transceiver Stations (BTS), this interface is used between the BSC and BTS to support the services offered to the GSM users and subscribers.

The interface also allows control of the radio equipment and radio frequency allocation in the BTS.

The interface is specified in the 48.5x-series of Technical Specifications.

6.3.2 Interface between RNC and Node B (Iub-interface)

When the RNS consists of a Radio Network Controller (RNC) and one or more Node B, this interface is used between the RNC and Node B to support the services offered to the UMTS users and subscribers.

The interface also allows control of the radio equipment and radio frequency allocation in the Node B.

The interface is specified in the 28.5x-series of Technical Specifications.

6.3.3 Interface between two RNCs (Iur-interface)

This interface is defined in the 25.42x series of Technical Specifications.

6.4 Interfaces internal to the Core Network

6.4.1 Interfaces internal to the CS domain

6.4.1.1 Interface between the MSC server and its associated VLR (B-interface)

The VLR is the location and management database for the mobile subscribers roaming in the area controlled by the associated MSC server(s). Whenever the MSC server needs data related to a given mobile station currently located in its area, it interrogates the VLR. When a mobile station initiates a location updating procedure with an MSC server, the MSC server informs its VLR which stores the relevant information. This procedure occurs whenever an MS roams to another location area. Also, when a subscriber activates a specific supplementary service or modifies some data attached to a service, the MSC server informs (via the VLR) the HLR which stores these modifications and updates the VLR if required.

This interface is internal to the MSC server /VLR; signalling on it is not standardised.

6.4.1.2 Interface between the HLR and the MSC server (C-interface)

The Gateway MSC server must interrogate the HLR of the required subscriber to obtain routing information for a call or a short message directed to that subscriber.

Signalling on this interface uses the Mobile Application Part (MAP), which in turn uses the services of Transaction Capabilities (see TS 29.002 [26]).

For CAMEL purposes, this interface is used as described in 23.078 [10c]. It is used e.g. at terminating calls to exchange routing information, subscriber status, location information, subscription information, etc.

6.4.1.3 Interface between the HLR and the VLR (D-interface)

This interface is used to exchange the data related to the location of the mobile station and to the management of the subscriber. The main service provided to the mobile subscriber is the capability to set up or to receive calls within the whole service area. To support this, the location registers have to exchange data. The VLR informs the HLR of the location of a mobile station managed by the latter and provides it (either at location updating or at call set-up) with the roaming number of that station. The HLR sends to the VLR all the data needed to support the service to the mobile subscriber. The HLR then instructs the previous VLR to cancel the location registration of this subscriber. Exchanges of data may occur when the mobile subscriber requires a particular service, when he wants to change some data attached to his subscription or when some parameters of the subscription are modified by administrative means.

Signalling on this interface uses the Mobile Application Part (MAP), which in turn uses the services of Transaction Capabilities (see TS 29.002 [26]).

For CAMEL purposes, this interface is used to send the CAMEL related subscriber data to the visited PLMN and for provision of MSRN. The interface is also used for the other purposes described in 23.078 [10c], e.g. to retrieve subscriber status and location information of the mobile subscriber or to indicate suppression of announcement for a CAMEL service.

6.4.1.4 Interface between MSC servers (E-interface)

When a mobile station moves from one MSC area to another during a call, a handover procedure has to be performed in order to continue the communication. For that purpose the MSC servers have to exchange data to initiate and then to realise the operation.

After the handover operation has been completed, the MSC servers will exchange information to transfer A- or Iu- interface signalling as defined in TS 23.009[6].

When a short message is to be transferred between a Mobile Station and Short Message Service Centre (SC), in either direction, this interface is used to transfer the message between the MSC server serving the Mobile Station and the MSC server which acts as the interface to the SC.

Signalling on this interface uses the Mobile Application Part (MAP), which in turn uses the services of Transaction Capabilities (see TS 29.002 [26]).

6.4.1.5 Interface between MSC server and EIR (F-interface)

This interface is used between MSC server and EIR to exchange data, in order that the EIR can verify the status of the IMEI retrieved from the Mobile Station.

Signalling on this interface uses the Mobile Application Part (MAP), which in turn uses the services of Transaction Capabilities (see TS 29.002 [26]).

6.4.1.6 Interface between VLRs (G-interface)

When a mobile subscriber moves from a VLR area to another Location Registration procedure will happen. This procedure may include the retrieval of the IMSI and authentication parameters from the old VLR.

Signalling on this interface uses the Mobile Application Part (MAP), which in turn uses the services of Transaction Capabilities (see TS 29.002 [26]).

6.4.1.7 Reference point (G)MSC server – CS-MGW (Mc Reference Point)

The Mc reference point describes the interfaces between the MSC Server and CS-MGW, and between the GMSC Server and CS-MGW. It has the following properties:

- full compliance with the H.248 standard [52], baseline work of which is currently carried out in ITU-T Study Group 16, in conjunction with IETF MEGACO WG.
- flexible connection handling which allows support of different call models and different media processing purposes not restricted to H.323 usage [54].
- open architecture where extensions/Packages definition work on the interface may be carried out.
- dynamic sharing of MGW physical node resources. A physical MGW can be partitioned into logically separate virtual MGWs/domains consisting of a set of statically allocated Terminations.
- dynamic sharing of transmission resources between the domains as the MGW controls bearers and manage resources according to the H.248 protocols [52].

The functionality across the Mc reference point will need to support mobile specific functions such as SRNS relocation/handover and anchoring. It is expected that current H.248/IETF Megaco standard [52] mechanisms can be applied to enable this.

6.4.1.8 Reference Point MSC Server – GMSC Server (Nc Reference Point)

Over the Nc reference point, the Network-Network based call control is performed. Examples of this are ISUP or an evolution of ISUP for bearer independent call control (BICC). Different options for signalling transport on Nc shall be possible including IP.

6.4.1.9 Reference Point CS-MGW – CS-MGW (Nb Reference Point)

Over the Nb reference point the bearer control and transport are performed. The transport may be RTP/UDP/IP [59][60] or AAL2 (I.363-2) [57] for transport of user data. Different options for user data transport and bearer control shall be possible on Nb, for example: AAL2/Q.AAL2, STM/none, RTP/H.245, [58], IPBC.

6.4.2 Interfaces internal to the PS domain

6.4.2.1 Interface between SGSN and HLR (Gr-interface)

This interface is used to exchange the data related to the location of the mobile station and to the management of the subscriber. The main service provided to the mobile subscriber is the capability to transfer packet data within the whole service area. The SGSN informs the HLR of the location of a mobile station managed by the latter. The HLR sends to the SGSN all the data needed to support the service to the mobile subscriber. Exchanges of data may occur when the mobile subscriber requires a particular service, when he wants to change some data attached to his subscription or when some parameters of the subscription are modified by administrative means.

Signalling on this interface uses the Mobile Application Part (MAP), which in turn uses the services of Transaction Capabilities (TCAP) (see TS 29.002 [26]).

6.4.2.2 Interface between SGSN and GGSN (Gn- and Gp-interface)

These interfaces are used to support mobility between the SGSN and GGSN. The Gn interface is used when GGSN and SGSN are located inside one PLMN. The Gp-interface is used if GGSN and SGSN are located in different PLMNs. The Gn/Gp interface also includes a part which allows SGSNs to communicate subscriber and user data, when changing SGSN.

Signalling on this interface uses the User Datagram Protocol, UDP/IP [59]. The Gn/Gp interface is defined in TS 29.060 [51].

6.4.2.3 Signalling Path between GGSN and HLR (Gc-interface)

This optional signalling path may be used by the GGSN to retrieve information about the location and supported services for the mobile subscriber, to be able to activate a packet data network address.

There are two alternative ways to implement this signalling path:

- if an SS7 interface is implemented in the GGSN, signalling between the GGSN and the HLR uses the Mobile Application Part (MAP), which in turn uses the services of Transaction Capabilities (TCAP) (see TS 29.002 [26]);
- if there is *no* SS7 interface in the GGSN, any GSN in the same PLMN and which has an SS7 interface installed can be used as a GTP to MAP protocol converter, thus forming a signalling path between the GGSN and the HLR.

6.4.2.4 Interface between SGSN and EIR (Gf-interface)

This interface is used between SGSN and EIR to exchange data, in order that the EIR can verify the status of the IMEI retrieved from the Mobile Station.

Signalling on this interface uses the Mobile Application Part (MAP), which in turn uses the services of Transaction Capabilities (TCAP) (see TS 29.002 [26]).

6.4.3 Interfaces used by CS and PS domains

6.4.3.1 Interface between MSC/VLR and SGSN (Gs-interface)

The SGSN may send location information to the MSC/VLR via the optional Gs interface. The SGSN may receive paging requests from the MSC/VLR via the Gs interface. The MSC/VLR may indicate to an SGSN, via the Gs interface, that an MS is engaged in a service handled by the MSC.

Signalling on this interface uses connectionless SCCP (without TCAP). SCCP Global Title (GT) is used for addressing. The Gs-interface is defined in TS 29.016 [48] and 29.018 [49].

6.4.3.2 Interface between HLR and AuC (H-Interface)

When an HLR receives a request for authentication and ciphering data for a Mobile Subscriber and it does not hold the requested data, the HLR requests the data from the AuC. The protocol used to transfer the data over this interface is not standardised.

6.4.3.3 Interface between SGSN and SMS-GMSC/SMS-IWMSC (Gd-Interface)

This interface is used to transfer short messages between SGSN and SMS-GMSC or SMS-IWMSC over GPRS. Signalling on this interface uses the Mobile Application Part (MAP) (see TS 29.002 [26]).

6a PLMN specific interfaces

6a.1 GCR-specific interface

6a.1.1 Interface between the MSC and its associated GCR (I-interface)

The GCR is the management data base for the voice group or broadcast calls in the area controlled by the associated MSC(s). Whenever the MSC needs data related to a requested voice group or broadcast call it interrogates the GCR to obtain the respective voice group or broadcast call attributes. The protocol used to transfer the data over this interface is not standardized.

6a.2 (void)

6a.3 LCS-specific interfaces

6a.3.1 LCS interfaces using MAP

The following interfaces are based on MAP in LCS.

- **Lh interface:** interface between GMLC and HLR. This interface is used by the GMLC to request the address of the visited MSC or SGSN for a particular target UE whose location has been requested. (see TS 29.002 [26]).
- **Lg interface:** interface between GMLC - MSC and GMLC - SGSN. This interface is used by the GMLC to convey a location request to the MSC or SGSN currently serving a particular target UE whose location was requested. The interface is used by the MSC or SGSN to return location results to the GMLC. (see TS 29.002 [26]).
- **Lc interface:** between GMLC and gsmSCF, CAMEL. This interface is used to get location information for CAMEL based services. (see TS 29.002 [26]).

6a.3.2 (void)

6a.3.3 (void)

6a.3.4 (void)

6a.3.5 Interface between BSC and SMLC (Lb-interface)

In GERAN, a SMLC supports positioning via signaling on the Lb interface to the BSC serving the target MS.

Signalling on this interface uses BSSAP-LE, which is specified in TS 49.031[50]

In UTRAN, the Lb interface is not standardized, the SMLC functionality is included in SRNC.

6a.3.6 Interface between Peer SMLCs (Lp-interface)

In GERAN, a SMLC may support the Lp interface to enable access to information and resources owned by another SMLC.

Signalling on this interface uses BSSAPP-LE, which is defined in TS 49.031[50], and SMLCPP, which is specified in TS 48.031[47].

In UTRAN, the SMLC functionality is included in SRNC and the Iur interface shall include the Lp interface type of functionality.

6a.3.7 Interface between BTS and LMU (Um-interface)

The Um/Uu interface specific to LCS is defined in TS 44.071 [55].

6a.3.8 Interface between GMLC and External LCS Client (Le-interface)

The Le interface is used by the external LCS client to retrieve location information from the LCS server. Signalling on this interface may use the OMA Mobile Location Protocol (MLP) [62] and Open Service Access Application Programming Interface (OSA-API) [63].

6a.3.9 Interface between RNS and Stand-Alone LMU, UE (Uu-interface)

The Uu interface is used to communicate among the UE Positioning entities associated with the SRNC, the UEs and the stand-alone LMU. The Uu interface may pass measurement requests and results to and from the UE or the stand-alone LMU. UE Positioning operations at the Uu interface are generally defined in the 24- and 25-series of 3GPP Technical Specifications. Furthermore, 25.305 describes how a stand-alone LMU may be distinguished from a normal UE.

6a.3.10 Interface between SRNC and SAS (Stand-Alone SMLC) (Iupc-interface)

The Iupc interface defined for LCS is specified in TS 25.453 [66].

6a.3.11 Interface between GMLC and GMLC (Lr-interface)

The Lr interface is used by the GMLC to communicate with other GMLCs. Signalling on this interface may use the OMA Inter-Location Server protocol [69].

6a.4 CAMEL-specific interfaces

The CAMEL-specific interfaces are detailed in 23.078 [10c]. These interfaces are.

6a.4.1 GMSC - gsmSSF interface

This is an internal interface. The interface is described in the specification to make it easier to understand the handling of Detection Points (arming/disarming of DPs, DP processing etc.).

6a.4.2 gsmSSF - gsmSCF interface

This interface is used by the gsmSCF to control a call in a certain gsmSSF and to request the gsmSSF to establish a connection with a gsmSRF. Relationships on this interface are opened as a result of the gsmSSF sending a request for instructions to the gsmSCF.

6a.4.3 MSC - gsmSSF interface

This is an internal interface. The interface is described in the specification to make it easier to understand the handling of DPs (arming/disarming of DPs, DP processing etc.).

6a.4.4 gsmSCF - HLR interface

This interface is used by the gsmSCF to request information from the HLR. As a network operator option the HLR may refuse to provide the information requested by the gsmSCF.

This interface is also used for USSD operations, both for gsmSCF-initiated dialogues and MS-initiated dialogues (relayed via HLR). It is a network operator option whether to support or not USSD operations on this interface.

6a.4.5 gsmSCF - gsmSRF interface

This interface is used by the gsmSCF to instruct the gsmSRF to play tones/announcements to the users.

6a.4.6 MSC - gsmSCF interface

This interface is used by the MSC to send supplementary service invocation notifications to the gsmSCF.

6a.4.7 SGSN - gprsSSF interface

This is an internal interface. The interface is described in the specification to make it easier to understand the handling of DPs (arming/disarming of DPs, DP processing etc.).

6a.4.8 gprsSSF - gsmSCF interface (Ge Reference Point)

This interface is used by the gsmSCF to control a GPRS session or individual PDP Context in a certain gprsSSF. Relationships between the gprsSSF and the gsmSCF (GPRS dialogues) on this interface are opened as a result of the gprsSSF sending a request for instructions to the gsmSCF. This interface is also known as Ge reference point [9a].

6a.5 CBS-specific interfaces

6a.5.1 Interface between the CBC and RNS (lu_BC Interface)

The interface between the CBC and the RNS is specified in the 25.41x-series of Technical Specifications.

The CBC-RNS interface is used to carry information concerning:

- the CBS messages itself; and
- CBS delivery parameter.

6a.6 Number portability specific interfaces

6a.6.1 IN-based solution

6a.6.1.1 NPDB to MSC interface

Upon receiving an ISUP IAM, the (gateway or visited) MSC send a database query to the NPDB as a result of analysis of the received MSISDN. The MSISDN is included in the query to the NPDB. The NPDB determines whether the MSISDN is ported or not. If not, it responds back to the MSC to continue the normal call setup procedure for MT calls (optionally providing the Routing Number). If it is ported, the NPDB responds back to the MSC with a Routing Number pointing out the Subscription network.

6a.6.2 Signalling Relay-based solution

6a.6.2.1 GMSC to MNP-SRF interface

Upon receiving an ISUP IAM, the gateway MSC sends a routing interrogation to the MNP-SRF, which in turn will perform one of the actions, described in subclause 4a.7, depending on the portability status of the subscriber and the network configuration (see TS 23.066 [40]).

6a.6.2.2 MNP-SRF to HLR interface

When the MNP-SRF receives a routing interrogation from the GMSC or an interrogating network entity (non/call related signalling), and it determines that the subscriber is not ported or it has been ported from another network, the MNP-SRF relays the message to the HLR.

6a.7 IM Subsystem Reference Points

6a.7.1 Reference Point HSS – CSCF (Cx Reference Point)

The Cx reference point supports information transfer between CSCF and HSS.

The main procedures that require information transfer between CSCF and HSS are

- 1) Procedures related to Serving CSCF assignment
- 2) Procedures related to routing information retrieval from HSS to CSCF
- 3) Procedures related to authorisation (e.g., checking of roaming agreement)
- 4) Procedures related to authentication: transfer of security parameters of the subscriber between HSS and CSCF
- 5) Procedures related to filter control: transfer of filter parameters of the subscriber from HSS to CSCF

Further information on the Cx reference point is provided in TS 23.228 [34].

6a.7.2 Reference Point CSCF – UE (Gm Reference Point)

The Gm reference point supports the communication between UE and IM CN subsystem, e.g. related to registration and session control.

The protocol used for the Gm reference point is SIP (as defined by RFC 3261 [61], other relevant RFC"s, and additional enhancements introduced to support 3GPP's needs).

6a.7.3 Reference Point MGCF – IMS-MGW (Mn Reference Point)

The Mn reference point describes the interfaces between the MGCF and IMS-MGW in the IMS. It has the following properties:

- full compliance with the H.248 standard functions for IMS – PSTN/PLMN interworking.- flexible connection handling which allows support of different call models and different media processing purposes not restricted to H.323 [54] usage.
- open architecture where extensions/Packages definition work on the interface may be carried out.
- dynamic sharing of IMS-MGW physical node resources. A physical IMS-MGW can be partitioned into logically separate virtual MGWs/domains consisting of a set of statically allocated Terminations.
- dynamic sharing of transmission resources between the domains as the IMS- MGW controls bearers and manage resources according to the H.248 [52] protocols and functions for IMS.

6a.7.4 Reference Point MGCF – CSCF (Mg Reference Point)

The Mg reference point allows the MGCF to forward incoming session signalling (from the PSTN) to the CSCF for the purpose of interworking with PSTN networks.

The protocol used for the Mg reference point is SIP (as defined by RFC 3261 [61], other relevant RFC"s, and additional enhancements introduced to support 3GPP's needs.)

6a.7.5 (void)

6a.7.6 Reference Point CSCF - MRFC (Mr Reference Point)

The Mr reference point allows interaction between an S-CSCF and an MRFC.

The protocol used for the Mr reference point is SIP (as defined by RFC 3261 [61], other relevant RFC"s, and additional enhancements introduced to support 3GPP's needs).

6a.7.6a Reference Point MRFC – MRFP (Mp Reference Point)

The Mp reference point allows an MRFC to control media stream resources provided by an MRF.

The Mp reference point has the following properties:

- Full compliance with the H.248 standard [52].
- Open architecture where extensions (packages) definition work on the interface may be carried out.

6a.7.7 Reference Point CSCF – CSCF (Mw Reference Point)

The Mw reference point allows the communication and forwarding of signalling messaging between CSCFs, e.g. during registration and session control.

6a.7.8 (void)

6a.7.9 (void)

6a.7.10 Reference Point CSCF – BGCF (Mi reference point)

This reference point allows the Serving CSCF to forward the session signalling to the Breakout Gateway Control Function for the purpose of interworking to the PSTN networks.

The Mi reference point is based on external specifications i.e. SIP [61].

6a.7.11 Reference Point BGCF – MGCF (Mj reference point)

This reference point allows the Breakout Gateway Control Function to forward the session signalling to the Media Gateway Control Function for the purpose of interworking to the PSTN networks.

The Mj reference point is based on external specifications i.e. SIP [61].

6a.7.12 Reference Point BGCF – BGCF (Mk reference point)

This reference point allows the Breakout Gateway Control Function to forward the session signalling to another Breakout Gateway Control Function.

The Mk reference point is based on external specifications i.e. SIP [61].

6a.7.13 Reference Point CSCF- SLF (Dx Reference Point)

This interface between CSCF and SLF is used to retrieve the address of the HSS which holds the subscription for a given user.

This interface is not required in a single HSS environment. An example for a single HSS environment is a server farm architecture.

Details are described in 23.228 [34], sub-clause 5.8.1.

6a.7.14 Reference Point to IPv6 network services (Mb reference point)

Via the Mb reference point IPv6 network services are accessed. These IPv6 network services are used for user data transport. Note, that GPRS provides IPv6 network services to the UE, i.e. the GPRS Gi reference point and the IMS Mb reference point may be the same.

6a.7.15 Reference Point CSCF – AS (ISC Reference Point)

This interface between CSCF and the Application Servers (i.e., SIP Application Server, OSA Service Capability Server, or CAMEL IM-SSF) is used to provide services for the IMS.

Details are described in 23.228 [34], sub-clause 4.2.4.

6a.7.16 Reference Point HSS – SIP AS or OSA SCS (Sh Reference Point)

The Application Server (SIP Application Server and/or the OSA Service Capability Server) may communicate to the HSS. The Sh interface is used for this purpose. Details are described in 23.228 [34], sub-clause 4.2.4.

6a.7.17 Reference Point HSS – CAMEL IM-SSF (Si Reference Point)

The CAMEL Application Server (IM-SSF) may communicate to the HSS. The Si interface is used for this purpose. Details are described in 23.228 [34], sub-clause 4.2.4.

6a.7.18 Reference Point UE – AS (Ut Reference Point)

The Ut interface resides between the UE and the SIP Application Server.

The Ut interface enables the user to manage information related to his services. Such as creation and assignment of Public Service Identities, management of authorization policies that are used e.g. by Presence service, conference policy management, etc.

The AS may need to exhibit security related functions for the Ut interface, the details of these security functions are described in 3G TS 3x.yzw [??].

For the protocol at the Ut reference point HTTP shall be supported.

6a.7.19 Reference Point AS- SLF (Dh Reference Point)

This interface between AS and SLF is used to retrieve the address of the HSS which holds the subscription for a given user.

This interface is not required in a single HSS environment. An example for a single HSS environment is a server farm architecture.

Details are described in 23.228 [34], subclause 5.8.1.

6a.8 Reference Points for Service Based Local Policy Control

6a.8.1 Reference Point GGSN – PDF (Go Reference Point)

This interface allows the Policy Decision Function (PDF) to apply policy to the bearer usage in the GGSN.

6a.8.2 Reference Point PDF – Application Function (Gq Reference Point)

This interface allows for dynamic QoS-related service information to be exchanged between the Policy Decision Function (PDF) and the Application Function (AF). This information is used by the PDF for service based local policy decisions.

6a.9 Reference Points for 3GPP/WLAN Interworking

6a.9.1 Reference point 3GPP AAA Server - HLR (D"/Gr" Reference Point)

This is the reference point between the 3GPP AAA server and the pre-Rel6 HLR. The functionality of this reference point is similar to that of the Wx reference point. For more information see TS 23.234 [67].

6a.9.2 Reference point WLAN access network - 3GPP AAA Proxy/Server (Wa Reference Point)

This is the reference point between the WLAN access network and 3GPP AAA Proxy or Server. The AAA protocol on this reference point is used to transport authentication, authorization and charging data.

6a.9.3 Reference point 3GPP AAA Server – 3GPP AAA Proxy (Wd Reference Point)

This is the reference point between the 3GPP AAA Server and Proxy. the purpose of the protocols crossing this reference point is to transport authentication, authorization and related information. For more information see TS 23.234 [67].

6a.9.4 Reference point 3GPP AAA Server/Proxy - PDG (Wg Reference Point)

This is the reference point between the 3GPP AAA server/proxy and PDG. It is used to provide information needed by the WAG to perform policy enforcement functions for authorised users.

6a.9.5 Reference point PDG - packet data networks (Wi Reference Point)

This is the reference point between the PDG and a packet data network. It may be an operator external public or private packet data network or an intra operator packet data network, e.g. for provision of IMS services.

6a.9.6 Reference Point 3GPP AAA Server/Proxy - PDG (Wm Reference Point)

This is the reference point between the 3GPP AAA server/proxy and PDG. The functionality of this reference point is to enable:

- The 3GPP AAA Server/Proxy to retrieve tunneling attributes and WLAN UE's IP configuration parameters from/via Packet Data Gateway
- Carrying messages for service authentication and authorization
- Carrying authentication data for the purpose of tunnel establishment, tunnel data authentication and encryption.

For more information see TS 23.234 [67].

6a.9.7 Reference Point WAG - WLAN access network (Wn Reference Point)

This is the reference point between the WAG and the WLAN access network. It is used to force traffic between a WLAN UE and PDG to go through the WAG.

6a.9.8 Reference Point WAG - PDG (Wp Reference Point)

This is the reference point between WAG and PDG. It is used to transport the Wu reference point protocol data packets.

6a.9.9 Reference point WLAN UE - PDG (Wu Reference Point)

This is the reference point between the 3GPP WLAN UE and PDG. The functionality of this reference point is to establish a tunnel between WLAN UE and PDG and to exchange data packets between WLAN UE and PDG.

6a.9.10 Reference point WLAN UE - WLAN access network (Ww Reference Point)

This is the reference point between the 3GPP WLAN UE and WLAN access network. The functionality of this reference point is specified by IEEE and outside the scope of 3GPP.

6a.9.11 Reference point 3GPP AAA Server - HSS (Wx Reference Point)

This is the reference point between the 3GPP AAA server and HSS. The functionality of this reference point is to enable:

- Retrieval of authentication vectors
- Retrieval of WLAN access-related subscriber information (profile)
- Registration of the 3GPP AAA Server of an authorised WLAN user in the HSS
- Indication of change of subscriber profile
- Retrieval of online charging / offline charging function addresses from HSS.
- Retrieval of service related information

For more information see TS 23.234 [67].

7 Reference points between the PLMN and other networks

The reference points between the PLMN and other networks, including dedicated networks, are described in the 49-series of Technical Specifications and in the 29-series of Technical Specifications.

7.1 Reference point fixed networks - MSC

The MSC is based on a normal ISDN exchange. It has, for call control, the same reference points as the fixed network exchanges. The signalling reference point considered in the Technical Specifications is related to the signalling system No. 7 User Parts TUP and ISUP associated to the circuits used for incoming and outgoing calls.

7.2 Reference point GGSN - packet data networks (Gi reference point)

This is the reference point between the GGSN and a packet data network. It may be an operator external public or private packet data network or an intra operator packet data network, e.g. for provision of IMS services.

7.3 Reference point GMLC - external LCS Client (Le reference point)

At this reference point external LCS Clients request services from the PLMN.

7.4 Reference Point CSCF – Multimedia IP networks (Mm Reference Point)

This is an IP interface between CSCF and IP networks. This interface is used, for example, to receive a session request from another SIP server or terminal. Detailed specifications of the Mm reference point are not provided in this release of specifications.

7.5 (void)

7.6 Reference point PDG - packet data networks (Wi reference point)

This is the reference point between the PDG and a packet data network. It may be an operator external public or private packet data network or an intra operator packet data network, e.g. for provision of IMS services.

7.7 Reference Point WAG – WLAN access network (Wn reference point)

This is the reference point between the WAG and the WLAN access network. It is used to force traffic between a WLAN UE and PDG to go through the WAG.

Annex A (informative): Description for GLR-related entities and interfaces

This annex describes the GLR-related entities and the interfaces. This annex is an informative annex. The 'informative' means just that the GLR is an optional functional entity to optimize signalling traffic between PLMNs. Therefore, this annex is normative to a PLMN which introduce the GLR.

A.1 Normative references

- [1] TS 23.119: "Gateway Location Register (GLR) - stage 2".

A.2 Definitions related to Gateway Location Register (GLR)

A.2.1 Gateway Location Register (GLR)

This entity handles location management of roaming subscriber in visited network without involving HLR. The location register function in the GLR stores subscription information and routing information for both CS services and PS services. This entity can be only located in a visited PLMN.

A.2.2 Intermediate Mobile-services Switching Centre (IM-MSC)

This entity is used as serving MSC towards home network and relay some messages between home network and serving MSC. This entity can be only located in a visited PLMN.

A.2.3 Intermediate GPRS Serving Node (IM-GSN)

This entity is used as serving GSN towards home network and relay some PDU notification messages between serving GSN and Gateway GSN. This entity can be only located in a visited PLMN.

A.3 The entities of the mobile system

A.3.1 Gateway Location Register (GLR)

GLR is pseudo-HLR located in visited network. The roamer's information is stored in it and handles location management of it within the network. Presence of GLR is invisible from home network therefore interface between HLR and GLR is same as one of HLR and VLR. Also, the interface between the VLR and GLR is the same as the one between the VLR and the HLR.

The GLR is a logical node and acts as a VLR for MAP signalling (e.g. PRN) from the HPLMN point of view. The GLR acts as a HLR for MAP signalling (e.g. Register SS) from the VPLMN point of view.

The GLR also acts as an SGSN for MAP signalling only (e.g. ISD) from the HPLMN point of view. This is because MAP operations such as ISD must be terminated at the GLR for the purpose of subscriber data caching.

The GLR shall terminate all TC dialogues and start new dialogues towards the HLR or the VLR. The GLR shall generate SCCP address of the HLR (i.e. E.214 MGT) from IMSI.

A.3.2 Intermediate Mobile-services Switching Centre (IM-MSC)

The Intermediate MSC (IM-MSC) is the logical node, which represent MSCs in the visited network. Some service features use the MSC Number stored in the HLR directly to deliver message from a certain node in home network (e.g. SMS-GMSC) to serving MSC in visited network. In such case, the message is firstly distributed to representative MSC (i.e., IM-MSC) and it relays it to actual serving MSC interrogating routing information to GLR.

- The Intermediate MSC (IM-MSC) is a logical node and represents the VMSC in the GLR equipped VPLMN.
- The IM-MSC acts as the VMSC for the HPLMN in the same way that the GLR acts as a VLR for HPLMN. The IM-MSC terminates MAP signalling from the HPLMN towards the VMSC and forwards the signal to the actual VMSC.
- The IM-MSC has an address interrogation function with which it is able to obtain the actual VMSC Number from the GLR.
- The IM-MSC is implemented in the same physical node as the one in which the GLR is implemented.
- The GLR alters the VMSC Number to the IM-MSC Number within an Update Location message.
- The IM-MSC Number is the E.164 Number assigned to the IM-MSC [53].
- The interrogation function of the IM-MSC is similar to that in the SMS-GMSC.

A.3.3 Intermediate GPRS Serving Node (IM-GSN)

The Intermediate GSN (IM-GSN) is a logical node and represents the SGSN for some GTP signalling termination in a GLR equipped VPLMN.

The IM-GSN acts as an SGSN for *only some GTP signalling messages* (i.e. PDU_Notification request/response, PDU_Notification_reject request/response) from the HPLMN point of view. The IM-GSN terminates these GTP signalling messages from the HPLMN towards SGSN and forwards the signal to the actual SGSN. The IM-GSN has an address interrogation function with which it is able to request the actual SGSN address from the GLR.

Apart from the case described above (i.e. PDU_Notification request/response, PDU_Notification_reject request/response), all other GTP signalling should be handled directly between the SGSN and the GGSN.

NOTE: **MAP signalling** towards the SGSN is **NOT** terminated at the IM-GSN. Instead it is terminated at the GLR.

A.4 Configuration of a Public Land Mobile Network

A.4.1 Basic configuration with GLR introduction

In the basic configuration with GLR introduction presented in figure A.1, all the functions related to GLR introduction are considered implemented in different equipments. Therefore, all the interfaces within PLMN are external. Interfaces GLa, GLb, GLc, GLd, GLf, GLg, GLh, and GLi need the support of the Mobile Application Part of the signalling system No. 7 to exchange the data necessary to provide the mobile service. No protocols for the GLe interface are standardized. GLj and GLk need the support of GPRS Tunneling Protocol - Control to provide the packet domain services.

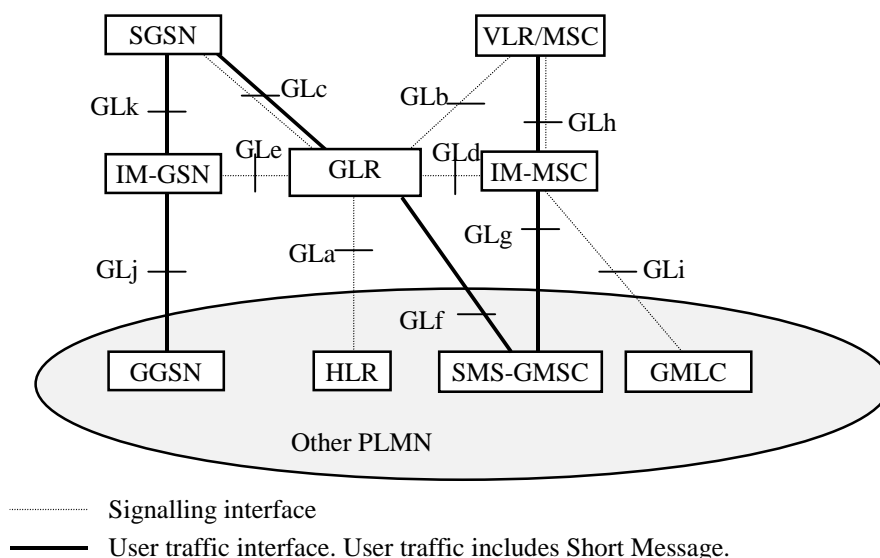

Figure A.1: Configuration of a PLMN and interfaces with GLR

A.5 PLMN interfaces

A.5.1 Interface between the HLR and the GLR (GLa-interface)

In circuit switched domain, this interface is the same as that between the VLR and the HLR (see TS 29.002 [26]). The HLR regards the GLR as the VLR via this interface. On the other hand, in packet switched domain, this interface is the same as that between the SGSN and the HLR (see TS 29.002 [26]). The HLR regards the GLR as the SGSN via this interface.

A.5.2 Interface between the VLR and the GLR (GLb-interface)

This interface is the same as those between the VLR and the HLR (see TS 29.002 [26]). The VLR regards the GLR as the HLR via this interface.

A.5.3 Interface between the SGSN and the GLR (GLc-interface)

This interface is the same as those between the SGSN and the HLR (see TS 29.002 [26]). The SGSN regards the GLR as the HLR via this interface.

A.5.4 Interface between the GLR and the IM_MSC (GLd-interface)

In the network with the GLR, when the IM_MSC receives a message, it interrogates the GLR for the routing information of the MSC. However, this interface is internal because GLR and IM-MSC are implemented in the same physical node and the protocol on this interface is not specified.

A.5.5 Interface between the GLR and the IM_GSN (GLE-interface)

In the network with the GLR when the IM_GSN receiving a PDU notification from the GGSN, the IM_GSN relays the notification to the SGSN by interrogating via the interface the routing information to the GLR. The interrogation uses the same operation on the interface between the SGSN and the HLR (see TS 29.002 [26]).

A.5.6 Interface between the SMS-GMSC and the GLR (GLf-interface)

This interface is used to forward mobile-terminated short messages in the network with the GLR in case of SMS transfer over GPRS. Signalling on this interface uses the Mobile Application Part (MAP) (see TS 29.002 [26]).

The SMS-GMSC regards the GLR as the SGSN via this interface.

A.5.7 Interface between the SMS-GMSC and the IM_MSC (GLg-interface)

This interface is used to forward short messages in the network with the GLR in case of SMS transfer over non-GPRS. Signalling on this interface uses the Mobile Application Part (MAP) (see TS 29.002 [26]).

The SMS-GMSC regards the IM_MSC as the MSC via this interface.

A.5.8 Interface between the MSC and the IM_MSC (GLh-interface)

This interface is used to forward short messages in the network with the GLR in case of SMS transfer over non-GPRS. Also this interface is used to exchange data needed by the MSC to perform subscriber authorization and allocate network resources. Signalling on this interface uses the Mobile Application Part (MAP) (see TS 29.002 [26]).

A.5.9 Interface between the GMLC and the IM_MSC (GLi-interface)

Also this interface is used to exchange data needed by the MSC to perform subscriber authorization and allocate network resources. Signalling on this interface uses the Mobile Application Part (MAP) (see TS 29.002 [26]).

The GMLC regards the IM_MSC as the MSC via this interface.

A.5.10 Interface between the GGSN and the IM_GSN (GLj-interface)

In the network with the GLR when receiving a PDP PDU from the external network the GGSN sends a notification to the IM_GSN by the routing information from the HLR (see TS 29.060 [51]). The GGSN regards the IM_GSN as the SGSN via this interface.

A.5.11 Interface between the SGSN and the IM_GSN (GLk-interface)

In the network with the GLR when receiving a PDP notification from the GGSN, the IM_GSN relays the notification to the SGSN by the routing information from the GLR (see TS 29.060 [51]). The SGSN regards the IM_GSN as the GGSN via this interface.

Annex B (informative): Change history

Date	Version	Information about changes
September 1999	v.3.0.0	renumbering of the present document from 03.02 to 23.002 (23.002 v.3.0.0 identical to 03.02 v.7.0.0)
October 1999	v.3.1.0	widely modified to incorporate UMTS aspects (CR 001)
January 2000	v.3.2.0	incorporation of CR002 on GLR, update of some references
March 2000	v.3.3.0	Incorpoaration of the following CRs: CR #004: General improvements of the split between clause 3 (Definitions and abbreviations) and clause 4 (The entities of the mobile system). CR #005r1: Re-ordering of clause 4 (The entities of the mobile system). CR #006: Re-ordering of clause 5 (Configuration of a Public Land Mobile Network). CR #007: Re-ordering of clause 6 ("PLMN interfaces"). CR #008: Simplification of the figure 1 (configuration of a PLMN and interfaces) CR #009r1: Introduction of CAMEL aspects. CR #011r1: Introduction of CBS aspects CR #012r2: Add LCS enhancements CR #013r4: Define GSM LCS parts and add UMTS LCS "hooks" in the network architecture. CR #014r1: Incorporation of network architecture material coming from clause 4 of 29.002
October 2000	v.5.0.0	Incorporation –with editorial modifications- of the following CRs: CR #016 on Introduction of Definitions from 23.821 into 23.002 CR #017 on Introduction of functional elements from 23.821 Incorporation –as such- of the following CRs: CR #018 on Introduction of reference model from 23.821 CR #019 on Introduction of reference points from 23.821
December 2000	v.5.1.0	Incorporation of CR #024 on Camel for the PS domain
March 2001	v.5.2.0	Incorporation of the following CRs (approved at SA#11): CR #033r1 Clarification of the difference between MGW in BICCN and IMS CR #034 Introduction of lu-CS and lu-PS interfaces to BSS of type GERANin the network architecture CR #035r1 CSCF-GGSN interface CR #041 Missing Nc interface in basic configuration figure CR #044r2 Clarification to the GGSN/PCF interface to the R5 reference architecture CR #046 Resolution of editor's note in the MGW description CR #050 Signalling and User Traffic Interfaces
June 2001	v.5.3.0	Incorporation of the following CRs (approved at SA#12): CR #053r1 Addition of Radio Access Technologies CR #062r1 Clarification of the role of the SGWs CR #051r3 Addition of GTT specific entities CR #037r1 HSS / HLR structuring
October 2001	v.5.4.0	Incorporation of the following CRs (approved at SA#13): CR #061r2 Introduction of Dx Reference Point in the IMS Reference Architecture CR #063r1Update the IP MM Subsystem configuration to include the BGCF node CR #068 MRF functionality
January 2002	v.5.5.0	Incorporation of the following CRs (approved at SA#14): 070 Editorial alignment of 23.002 on CSCF 072 Aligning MGW descriptions 074 Correction of abbreviation of CSCF 075r2 HSS section clean up 079 Correction of Gi reference point definition 082 Deleting SIWF functionality Introduction of section 6a.7.13 on Dx Reference Point from CR #061r2

March 2002	v.5.6.0	Incorporation of the following CRs (approved at SA#15): 077r3 Editorial correction to References 078r2 Introduction of an IMS bearer reference point 085 Corrections to the Radio Network System (node B) definitions 087 Nb and Nc reference points - editorial corrections 090 Deletion of Reference Point towards SCP 091r1 BGCF: Alignment to 23.228 093 Removal of the Sr Reference point 123r1 Application Server Definition
June 2002	v.5.7.0	Incorporation of the following CRs (approved at SA#16): 095r2 Alignment with TS23.271 092r2 General updates due to Intra Domain Connection of RAN nodes to multiple CN nodes 094r1 Security Gateway
September 2002	v.5.8.0	Incorporation of the following CRs (approved at SA#17): 058rev1 The usage of Iu-interface signalling is missing in the E-interface description 097r2 Mc interface 098r1 Clean-up of 23.002 103r1 IMS Reference Points
December 2002	v.5.9.0	Incorporation of the following CRs (approved at SA #18): 112rev1 Scope of TS 23.002 115rev1 Corrections in the LCS figures 108rev4 Corrections in the LCS descriptions of 23.002 106rev1 Service architecture 110 PCF to PDF Changes
March 2003	v.5.10.0	Incorporation of the following CRs (approved at SA #19): 121rev2 LCS architecture in Rel5 118 Change of reference to LIF document
March 2003	v.6.0.0	Incorporation of the following CR (approved at SA #19): 119rev1 Management interface
March 2003	v.6.0.1	Editorial to correct cover page to indicate Rel-6 not Rel-5
June 2003	v.6.1.0	Incorporation of the following CRs (approved at SA #20): 132r1 Architecture corrections 124 Gd interface 128r1 Ge reference point 129r2 Management interface 127r2 SLF on Sh interface
September 2003	v.6.2.0	Incorporation of the following CR (approved at SA #21): 134r2 Use of Security Gateways
December 2003	v.6.3.0	Incorporation of the following CR (approved at SA #22): 135r4 Gq reference point
March 2004	v.6.4.0	Incorporation of the following CR (approved at SA #23): 136 Gq clean-up
June 2004	v.6.5.0	Incorporation of the following CRs (approved at SA #24): 138r1 Introduction of WLAN Interworking functional elements in 23.002 139 Introduction of WLAN Interworking reference points and configuration in 23.002 141r2 Configuration of Presence Service 142r1 Correction on the scope of the Ut reference point 143 Missing Lr reference point in 23.002
December 2004	v.6.6.0	Incorporation of the following CRs (approved at SA #26): CR 145 (Floor Control) CR 146 (Removing GPS specificity for SAS to unify with RAN Technical Specifications)

History

Document history		
V6.6.0	December 2004	Publication