

ETSI TS 123 014 V3.1.0 (2000-01)

Technical Specification

**Digital cellular telecommunications system (Phase 2+) (GSM);
Universal Mobile Telecommunications System (UMTS);
Support of Dual Tone Multi-Frequency (DTMF) signalling
(3G TS 23.014 version 3.1.0 Release 1999)**



Reference

DTS/TSGN-0123014U

Keywords

GSM, UMTS

ETSI

Postal address

F-06921 Sophia Antipolis Cedex - FRANCE

Office address

650 Route des Lucioles - Sophia Antipolis
Valbonne - FRANCE
Tel.: +33 4 92 94 42 00 Fax: +33 4 93 65 47 16
Siret N° 348 623 562 00017 - NAF 742 C
Association à but non lucratif enregistrée à la
Sous-Préfecture de Grasse (06) N° 7803/88

Internet

secretariat@etsi.fr
Individual copies of this ETSI deliverable
can be downloaded from
<http://www.etsi.org>
If you find errors in the present document, send your
comment to: editor@etsi.fr

Important notice

This ETSI deliverable may be made available in more than one electronic version or in print. In any case of existing or perceived difference in contents between such versions, the reference version is the Portable Document Format (PDF). In case of dispute, the reference shall be the printing on ETSI printers of the PDF version kept on a specific network drive within ETSI Secretariat.

Copyright Notification

No part may be reproduced except as authorized by written permission.
The copyright and the foregoing restriction extend to reproduction in all media.

© European Telecommunications Standards Institute 2000.
All rights reserved.

Intellectual Property Rights

IPRs essential or potentially essential to the present document may have been declared to ETSI. The information pertaining to these essential IPRs, if any, is publicly available for **ETSI members and non-members**, and can be found in SR 000 314: "*Intellectual Property Rights (IPRs); Essential, or potentially Essential, IPRs notified to ETSI in respect of ETSI standards*", which is available from the ETSI Secretariat. Latest updates are available on the ETSI Web server (<http://www.etsi.org/ipr>).

Pursuant to the ETSI IPR Policy, no investigation, including IPR searches, has been carried out by ETSI. No guarantee can be given as to the existence of other IPRs not referenced in SR 000 314 (or the updates on the ETSI Web server) which are, or may be, or may become, essential to the present document.

Foreword

This Technical Specification (TS) has been produced by the ETSI 3rd Generation Partnership Project (3GPP).

The present document may refer to technical specifications or reports using their 3GPP identities or GSM identities. These should be interpreted as being references to the corresponding ETSI deliverables. The mapping of document identities is as follows:

For 3GPP documents:

3G TS | TR nn.nnn "<title>" (with or without the prefix 3G)

is equivalent to

ETSI TS | TR 1nn nnn "[Digital cellular telecommunications system (Phase 2+) (GSM);] Universal Mobile Telecommunications System; <title>

For GSM document identities of type "GSM xx.yy", e.g. GSM 01.04, the corresponding ETSI document identity may be found in the Cross Reference List on www.etsi.org/key

Contents

Foreword	4
1 Scope.....	5
2 References.....	5
3 Abbreviations.....	5
4 Requirement.....	5
5 Cause of DTMF generation	5
6 Support of DTMF across the air interface	6
6.1 General.....	6
6.2 Specific	6
6.3 Tone durations	6
7 Effect of Handover.....	9
7.1 Internal Handover	9
7.2 External Handover	10
Annex A: Change history	11
History.....	12

Foreword

This Technical Specification has been produced by the 3GPP.

This TS defines the Discontinuous Reception (DRX) in the GSM system within the 3GPP system.

The contents of the present document are subject to continuing work within the TSG and may change following formal TSG approval. Should the TSG modify the contents of this TS, it will be re-released by the TSG with an identifying change of release date and an increase in version number as follows:

Version 3.y.z

where:

- x the first digit:
 - 1 presented to TSG for information;
 - 2 presented to TSG for approval;
 - 3 Indicates TSG approved document under change control.
- y the second digit is incremented for all changes of substance, i.e. technical enhancements, corrections, updates, etc.
- z the third digit is incremented when editorial only changes have been incorporated in the specification;

1 Scope

The present document describes how Dual Tone Multi Frequency (DTMF) signals are supported in the GSM system.

2 References

The following documents contain provisions which, through reference in this text, constitute provisions of the present document.

- References are either specific (identified by date of publication, edition number, version number, etc.) or non-specific.
- For a specific reference, subsequent revisions do not apply.
- For a non-specific reference, the latest version applies.
- A non-specific reference to an ETS shall also be taken to refer to later versions published as an EN with the same number.

- [1] GSM 01.04: "Digital cellular telecommunication system (Phase 2+); Abbreviations and acronyms".
 - [2] GSM 05.02: "Digital cellular telecommunications system (Phase 2+); Multiplexing and multiple access on the radio path".
 - [3] CEPT T/CS 34-08: "Automatic sender for push-button multifrequency signalling".
 - [4] CEPT T/CS 46-02: "Multifrequency signalling system to be used for push-button telephones".
-

3 Abbreviations

Abbreviations used in the present document are listed in GSM 01.04.

4 Requirement

Dual Tone Multi Frequency (DTMF) is an inband one out of four plus one out of four signalling system, primarily used from terminal instruments in telecommunication networks. The international recommendations which apply are ETSI Technical Report ETR 204 (sender) and ETSI Technical Report ETR 206 (receiver) as detailed in sections 6.2 and 6.3. For PCS 1900 for North America the Standards which apply are operator specific.

In the GSM system the MSC must support DTMF in the mobile to land direction.

The support of this facility in the land to mobile direction is for further study.

The use of DTMF is only permitted when the speech teleservice is being used or during the speech phase of alternate speech/data and alternate speech/facsimile teleservices. The responsibility for checking this lies in the MS.

5 Cause of DTMF generation

A user may cause a DTMF tone to be generated by depression of a key in the Mobile Station (MS). Optionally (on a MS basis) manufacturers of mobile equipment may choose to allow DTMF to be controlled from a remote terminal.

The man-machine interface questions associated with this facility are not discussed further in this GTS.

6 Support of DTMF across the air interface

6.1 General

A message based signalling system is used across the GSM air interface.

This requires that the relevant user action (e.g. a key depression) is interpreted by the MS as a requirement for a DTMF digit to be sent, this is converted by the MS into a message, the message is transmitted across the air interface, and is converted by the MSC into a DTMF tone which is applied towards the network, which should then respond with an acknowledgement. When the user completes the key depression, an message that the DTMF sending should cease is also passed to the MSC, which again will respond with an acknowledgement.

6.2 Specific

The messages to be sent across the air interface will use the frame stealing mode of transmission.

The messages when sent across the air interface should contain the following information:

- a) START DTMF : Containing the digit value (0-9,A,B,C,D,*,#);
- b) START DTMF ACKNOWLEDGE: Containing the digit value (0-9,A,B,C,D,*,#) corresponding to the DTMF tone that the network applies towards the remote user;
- c) STOP DTMF : No further info;
- d) STOP DTMF ACKNOWLEDGE: No further info.

Only a single digit will be passed in each START DTMF and START DTMF ACKNOWLEDGE message.

The messages will be passed transparently through the base station and interpreted at the MSC.

On receipt of a START DTMF message, the MSC will connect the correct dual-tone to line. This tone will remain connected until either the call is cleared or a STOP DTMF message is received.

As an operator option, the tone may be ceased after a pre-determined time whether or not a STOP DTMF message has a been received.

The tones that are to be generated by the MSC are specified as follows:

- Frequencies are defined in ETSI Technical Report ETR 206 (for PCS 1900 for North America this is operator specific);
- Tone sending levels are defined nationally (for PCS 1900 for North America this is operator specific);
- Durations as specified below.

6.3 Tone durations

The network shall ensure that the minimum length of tone and the minimum gap between two subsequent tones (according to ETR 206) is achieved. For PCS 1900 for North America this is operator specific.

NOTE 1: In ETR 206 the minimum duration of a DTMF tone is 70ms \pm 5ms.

NOTE 2: In ETR 206 the minimum gap between DTMF tones is 65ms.

There is no defined maximum length to the tone, which will normally cease when a STOP DTMF message is received from the MS. However, the operator may choose to put a pre-defined time limit on the duration of tones sent to line as mentioned in 6.2.

Figures 1 to 3 show an overview of how the DTMF should operate.

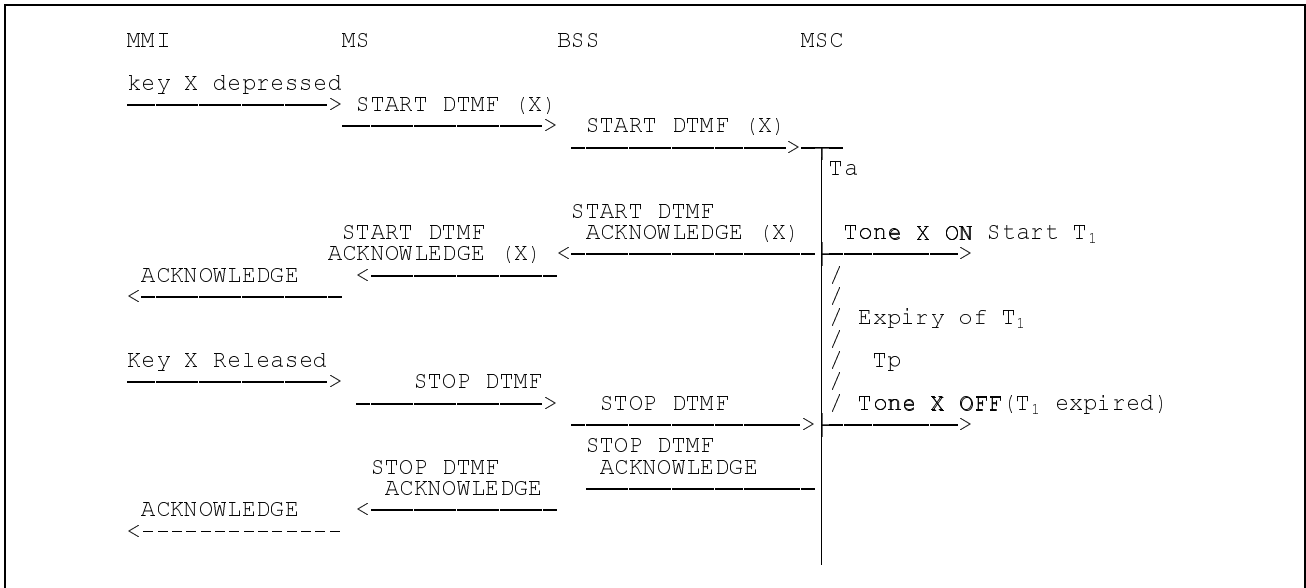

Figure 1: Single DTMF Transmission

Ta Association time for DTMF Generator in MSC, implementation dependent but low.

Tp Pre-determined maximum tone length, operator option.

T₁ Minimum length of tone

NOTE: If the Network operator implements the time limit option (see section 6.2), then the tone ends if the timer expires before the 'Stop DTMF' is received.

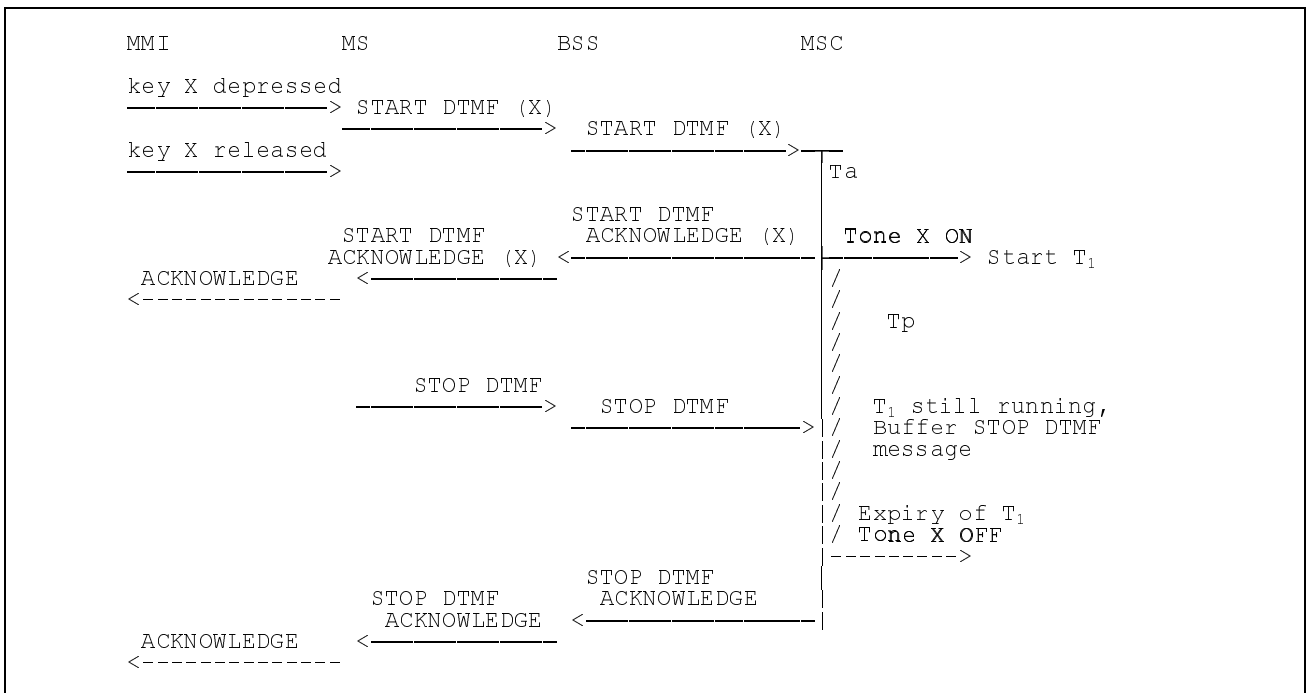

Figure 2: Single DTMF Transmission, Short Key Press

Ta Association time for DTMF Generator in MSC, implementation dependent but low.

Tp Pre-determined maximum tone length, operator option.

T₁ Minimum length of tone

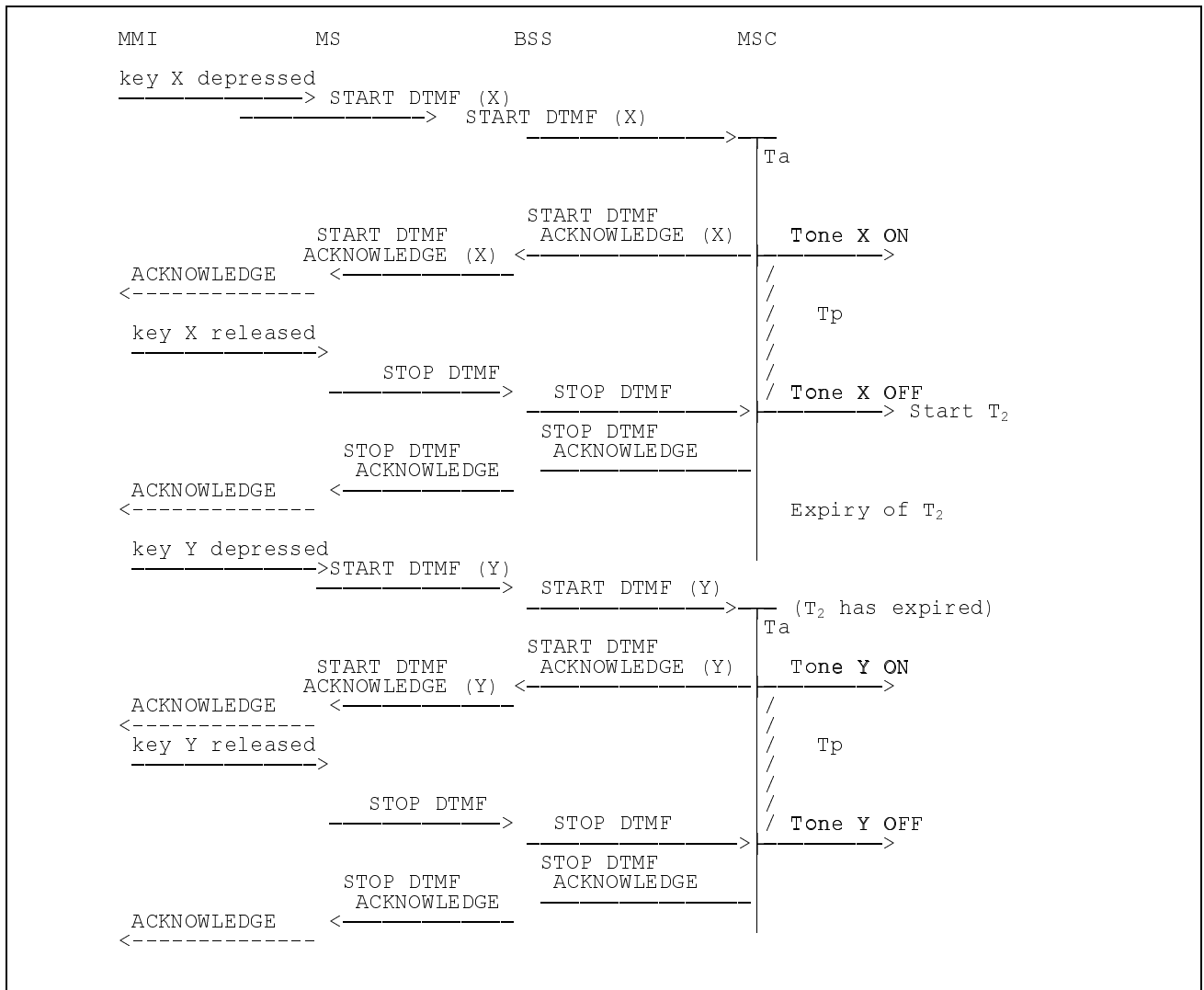

Figure 3: Two Single DTMF Transmission

Ta Association time for DTMF Generation in MSC, implementation dependant but low

Tp Pre-determined maximum tone length, operator option

T₂ Minimum gap between tones

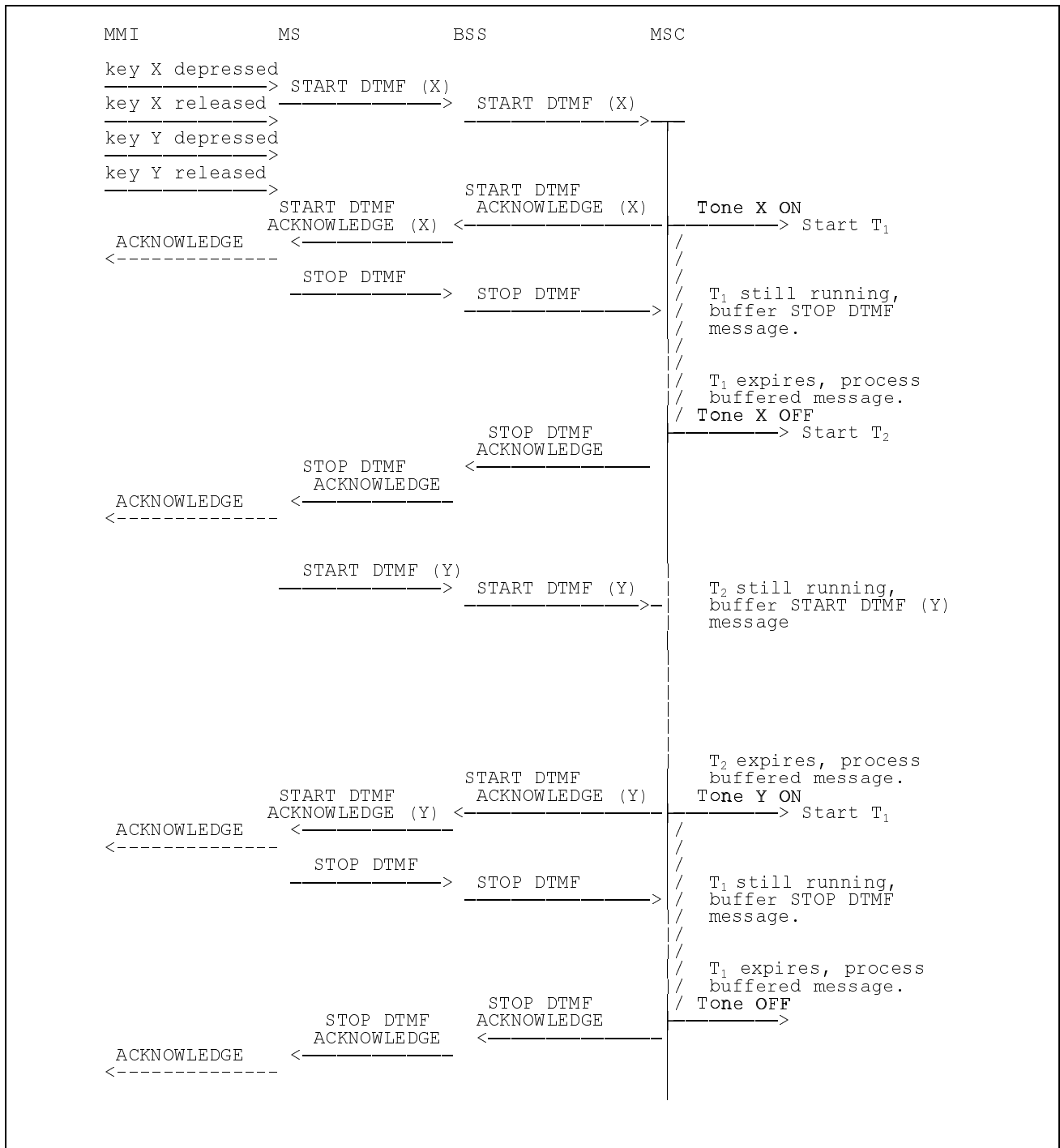

Figure 4: Two Single DTMF Transmissions, Short Gap Between Key Presses

T₁ Minimum length of tones

T₂ Minimum gap between tones

7 Effect of Handover

7.1 Internal Handover

There is unlikely to be any impact on DTMF due to internal handover.

7.2 External Handover

Depending on the exact moment when handover occurs, there may be a slight possibility of cutting short a DTMF tone.

For protocol reasons, in the case of an MSC receiving a STOP DTMF message when no tone is being sent, it should respond with an acknowledgement as usual.

No other impact is seen due to external handover.

Annex A: Change history

Change history						
TSG CN#	Spec	Version	CR	<Phase>	New Version	Subject/Comment
Apr 1999	GSM 03.14	7.0.0				Transferred to 3GPP CN1
CN#03	23.014				3.0.0	Approved at CN#03
CN#06	23.014	3.0.0	001r1	R99	3.1.0	Clarification of DTMF procedure

History

Document history		
V3.1.0	January 2000	Publication