

ETSI TS 123 041 V3.5.0 (2002-06)

Technical Specification

**Digital cellular telecommunications system (Phase 2+);
Universal Mobile Telecommunications System (UMTS);
Technical realization of Cell Broadcast Service (CBS)
(3GPP TS 23.041 version 3.5.0 Release 1999)**



Reference

RTS/TSGT-0223041v350

Keywords

GSM, UMTS

ETSI

650 Route des Lucioles
F-06921 Sophia Antipolis Cedex - FRANCE

Tel.: +33 4 92 94 42 00 Fax: +33 4 93 65 47 16

Siret N° 348 623 562 00017 - NAF 742 C
Association à but non lucratif enregistrée à la
Sous-Préfecture de Grasse (06) N° 7803/88

Important notice

Individual copies of the present document can be downloaded from:

<http://www.etsi.org>

The present document may be made available in more than one electronic version or in print. In any case of existing or perceived difference in contents between such versions, the reference version is the Portable Document Format (PDF). In case of dispute, the reference shall be the printing on ETSI printers of the PDF version kept on a specific network drive within ETSI Secretariat.

Users of the present document should be aware that the document may be subject to revision or change of status. Information on the current status of this and other ETSI documents is available at

<http://portal.etsi.org/tb/status/status.asp>

If you find errors in the present document, send your comment to:

editor@etsi.fr

Copyright Notification

No part may be reproduced except as authorized by written permission.
The copyright and the foregoing restriction extend to reproduction in all media.

© European Telecommunications Standards Institute 2002.
All rights reserved.

DECTTM, **PLUGTESTS**TM and **UMTS**TM are Trade Marks of ETSI registered for the benefit of its Members.
TIPHONTM and the **TIPHON logo** are Trade Marks currently being registered by ETSI for the benefit of its Members.
3GPPTM is a Trade Mark of ETSI registered for the benefit of its Members and of the 3GPP Organizational Partners.

Intellectual Property Rights

IPRs essential or potentially essential to the present document may have been declared to ETSI. The information pertaining to these essential IPRs, if any, is publicly available for **ETSI members and non-members**, and can be found in ETSI SR 000 314: *"Intellectual Property Rights (IPRs); Essential, or potentially Essential, IPRs notified to ETSI in respect of ETSI standards"*, which is available from the ETSI Secretariat. Latest updates are available on the ETSI Web server (<http://webapp.etsi.org/IPR/home.asp>).

Pursuant to the ETSI IPR Policy, no investigation, including IPR searches, has been carried out by ETSI. No guarantee can be given as to the existence of other IPRs not referenced in ETSI SR 000 314 (or the updates on the ETSI Web server) which are, or may be, or may become, essential to the present document.

Foreword

This Technical Specification (TS) has been produced by ETSI 3rd Generation Partnership Project (3GPP).

The present document may refer to technical specifications or reports using their 3GPP identities, UMTS identities or GSM identities. These should be interpreted as being references to the corresponding ETSI deliverables.

The cross reference between GSM, UMTS, 3GPP and ETSI identities can be found under www.etsi.org/key.

Contents

Intellectual Property Rights	2
Foreword.....	2
Foreword.....	5
1 Scope	6
1.1 References	6
1.2 Abbreviations	7
2 General description.....	7
3 Network Architecture	8
3.1 GSM Network Architecture	8
3.2 UMTS Network Architecture	8
4 CBE Functionality	9
5 CBC Functionality.....	9
6 BSC/RNC Functionality.....	10
7 BTS Functionality	10
8 MS/UE Functionality	11
9 Protocols and Protocol Architecture.....	11
9.1 Requirements on the Radio Access Network	11
9.1.1 GSM Radio Access Network	11
9.1.2 UMTS Radio Access Network.....	13
9.1.3 UMTS Protocol Overview	14
9.2 Requirements on the CBC-interfaces CBC-BSC and CBC-RNC	14
9.2.1 Identification of a CBS message.....	15
9.2.2 WRITE-REPLACE Request/Indication.....	16
9.2.3 KILL Request/Indication	18
9.2.4 REPORT Response/Confirm	18
9.2.5 STATUS-LOAD-QUERY Request/Indication.....	18
9.2.6 STATUS-LOAD-QUERY Response/Confirm	18
9.2.7 STATUS-MESSAGE-QUERY Request/Indication	19
9.2.8 STATUS-MESSAGE-QUERY Response/Confirm.....	19
9.2.9 REJECT Response/Confirm	19
9.2.10 RESTART-INDICATION Request/Indication.....	20
9.2.11 RESET Request/Indication	20
9.2.12 FAILURE-INDICATION Request/Indication.....	20
9.2.13 SET-DRX Request/Indication	21
9.2.14 SET-DRX- REPORT Response/Confirm	21
9.2.15 CAPACITY-INDICATION Request/Indication.....	21
9.3 Parameters	21
9.3.1 Message-Identifier	21
9.3.2 Old-Serial-Number	22
9.3.3 New-Serial-Number.....	22
9.3.4 Number-of-Pages.....	22
9.3.5 Cell-List	22
9.3.5.1 Cell-List sent from CBC to BSC/RNC.....	22
9.3.5.2 Cell-List sent from BSC/RNC to CBC.....	23
9.3.6 Channel Indicator.....	23
9.3.7 Category.....	23
9.3.8 Repetition-Period	23
9.3.9 No-of-Broadcasts-Requested	24
9.3.10 No-of-Broadcasts-Completed-List.....	24
9.3.11 Cell-Identifier	24

9.3.12	Schedule-Period	25
9.3.13	Reserved-Slots	25
9.3.14	Failure-List	25
9.3.15	Radio-Resource-Loading-List.....	25
9.3.16	Cause	26
9.3.17	Diagnostic	26
9.3.18	Data Coding Scheme	27
9.3.19	CBS-Message-Information-Page n	27
9.3.20	CBS-Message-Information-Length n.....	27
9.3.21	Recovery-Indication.....	27
9.3.22	Available-Capacity	27
9.4	Message Format on the Radio Network – MS/UE Interface	27
9.4.1	GSM.....	27
9.4.1.1	General Description	28
9.4.1.2	Message Parameter.....	28
9.4.1.2.1	Serial Number.....	28
9.4.1.2.2	Message Identifier	30
9.4.1.2.3	Data Coding Scheme	31
9.4.1.2.4	Page Parameter	31
9.4.1.2.5	Content of Message	31
9.4.2	UMTS	31
9.4.2.1	General Description	31
9.4.2.2	Message Parameter.....	31
9.4.2.2.1	Message Type.....	32
9.4.2.2.2	Message ID.....	32
9.4.2.2.3	Serial Number.....	32
9.4.2.2.4	Data Coding Scheme	32
9.4.2.2.5	CB Data	32
9.5	CBS Compression	32
10	CBS Index	33
Annex A (informative): Protocols for interconnecting CBC and BSC		36
Annex B (informative): Change Request History.....		37
History		38

Foreword

This Technical Specification (TS) has been produced by the 3rd Generation Partnership Project (3GPP).

The contents of the present document are subject to continuing work within the TSG and may change following formal TSG approval. Should the TSG modify the contents of the present document, it will be re-released by the TSG with an identifying change of release date and an increase in version number as follows:

Version x.y.z

where:

- x the first digit:
 - 1 presented to TSG for information;
 - 2 presented to TSG for approval;
 - 3 or greater indicates TSG approved document under change control.
- y the second digit is incremented for all changes of substance, i.e. technical enhancements, corrections, updates, etc.
- z the third digit is incremented when editorial only changes have been incorporated in the document.

1 Scope

The present document describes the Cell Broadcast short message service (CBS) for GSM and UMTS.

For GSM it defines the primitives over the Cell Broadcast Centre - Base Station System (CBC-BSS) interface and the message formats over the Base Station System - Mobile Station (BSS-MS) interface for Teleservice 23 as specified in 3GPP TS 22.003 [2].

For UMTS it defines the interface requirements for the Cell Broadcast Center – UMTS Radio Network System (RNS) interface and the radio interface requirements for UMTS Radio Access Networks to support CBS as specified in 3GPP 22.003 [2].

1.1 References

The following documents contain provisions which, through reference in this text, constitute provisions of the present document.

- References are either specific (identified by date of publication, edition number, version number, etc.) or non-specific.
- For a specific reference, subsequent revisions do not apply.
- For a non-specific reference, the latest version applies. In the case of a reference to a 3GPP document (including a GSM document), a non-specific reference implicitly refers to the latest version of that document *in the same Release as the present document*.

- [1] 3GPP TR 01.04: "Digital cellular telecommunication system (Phase 2+); Abbreviations and acronyms".
- [2] 3GPP TS 22.003: "Digital cellular telecommunication system (Phase 2+); Teleservices supported by a GSM Public Land Mobile Network (PLMN)".
- [3] 3GPP TS 23.038: "Digital cellular telecommunication system (Phase 2+); Alphabets and language-specific information".
- [4] 3GPP TS 23.040: "Digital cellular telecommunication system (Phase 2+); Technical realization of the Short Message Service (SMS) Point to Point (PP)".
- [5] 3GPP TR 03.47 Version 7.0.0: "Digital cellular telecommunication system (Phase 2+); Example protocol stacks for interconnecting Service Centre(s) (SC) and Mobile-services Switching Centre(s) (MSC)".
- [6] 3GPP TR 03.49 Version 7.0.0: "Digital cellular telecommunication system (Phase 2+); Example protocol stacks for interconnecting Cell Broadcast Centre (CBC) and Mobile-services Switching Centre (MSC)".
- [7] 3GPP TS 04.12: "Digital cellular telecommunication system (Phase 2+); Short Message Service Cell Broadcast (SMS-CB) support on the mobile radio interface".
- [8] 3GPP TS 05.02: "Digital cellular telecommunication system (Phase 2+); Multiplexing and multiple access on the radio path".
- [9] 3GPP TS 27.005: "Digital cellular telecommunication system (Phase 2+); Use of Data Terminal Equipment - Data Circuit terminating Equipment (DTE - DCE) interface for Short Message Service (SMS) and Cell Broadcast Service (CBS)".
- [10] 3GPP TS 08.52: "Digital cellular telecommunication system (Phase 2+); Base Station Controller - Base Transceiver Station (BSC - BTS) interface Interface principles".
- [11] 3GPP TS 08.58: "Digital cellular telecommunication system (Phase 2+); Base Station Controller - Base Transceiver Station (BSC - BTS) interface Layer 3 specification".

- [12] CCITT Recommendation X.210: "Open systems interconnection layer service definition conventions".
- [13] 3GPP TS 08.08: "MSC-BSS Interface Layer 3 specification".
- [14] 3GPP TS 23.042: "Compression algorithm for text messaging services".
- [15] 3GPP TS 03.48: "Digital cellular telecommunications system (Phase 2+); Security Mechanisms for the SIM application toolkit; Stage 2".
- [16] 3GPP TS 25.331: "RRC Protocol Specification".
- [17] 3GPP TS 25.401: "UTRAN Overall Description".
- [18] 3GPP TS 31.102: "Characteristics of the USIM Application".
- [19] 3GPP TS 25.324: "Radio Interface for Broadcast/Multicast Services".
- [20] 3GPP TR 21.905: "3G Vocabulary".

1.2 Abbreviations

Abbreviations used in the present document are listed in 3GPP TR 01.04 [1] and 3GPP TR 21.905 [20].

2 General description

The CBS service is analogous to the Teletex service offered on television, in that like Teletex, it permits a number of unacknowledged general CBS messages to be broadcast to all receivers within a particular region. CBS messages are broadcast to defined geographical areas known as cell broadcast areas. These areas may comprise of one or more cells, or may comprise the entire PLMN. Individual CBS messages will be assigned their own geographical coverage areas by mutual agreement between the information provider and the PLMN operator. CBS messages may originate from a number of Cell Broadcast Entities (CBEs), which are connected to the Cell Broadcast Centre. CBS messages are then sent from the CBC to the cells, in accordance with the CBS's coverage requirements.

A CBS page comprises of 82 octets, which, using the default character set, equates to 93 characters. Other Data Coding Schemes may also be used, as described in 3GPP TS 23.038 [3]. Up to 15 of these pages may be concatenated to form a CBS message. Each page of such CBS message will have the same message identifier (indicating the source of the message), and the same serial number. Using this information, the MS/UE is able to identify and ignore re-broadcasts of already received messages.

CBS messages are broadcast cyclically by the cell at a frequency and for a duration agreed with the information provider. The frequency at which CBS messages are repeatedly transmitted will be dependent on the information that they contain; for example, it is likely that dynamic information such as road traffic information, will require more frequent transmission than weather information. The repetition period will also be affected by the desire for CBS messages to be received by high speed mobiles which rapidly traverse cells. Reception of CBS messages for a MS/UE is not a requirement if it is connected in the CS domain. It should be possible for a UE to receive messages if it is connected in the PS domain and no data is currently transmitted.

CS-Domain	CS-Connected	CS-Idle	CS-Idle
PS-Domain	-	PS-Idle	PS-Connected
Reception of CBS Message	Not possible	Possible	Depends on RRC mode

NOTE: In case the UE is in CS-Idle and PS-Connected Mode it depends on the Radio Resource Control State whether reception of CBS messages is possible. The relevant states are described in 3GPP 25.331 [16].

GSM only [CBS messages may be broadcast on two different cell broadcast channels, which are characterized by different QoS. A MS is always able to read the basic channel (see [8]). The reading of the extended channel may collide with other tasks of the MS. Therefore the probability of receiving a CBS message on the extended channel is smaller than on the basic channel. The reading of the extended channel for MSs is optional. The scheduling on the channels will be done independently].

To permit mobiles to selectively display only those CBS messages required by the MS/UE user, CBS messages are assigned a message class which categorises the type of information that they contain and the language (Data Coding Scheme) in which the CBS message has been compiled. Through the use of appropriate MMI, the user is then able to ignore message types that he does not wish to receive, e.g. advertising information or messages in an unfamiliar language.

3 Network Architecture

The chosen network architectures differs for GSM and UMTS. In subclause 3.1 the GSM network architecture is described, in subclause 3.2 the UMTS network architecture.

3.1 GSM Network Architecture

The basic network structure of CBS is depicted by figure 1.

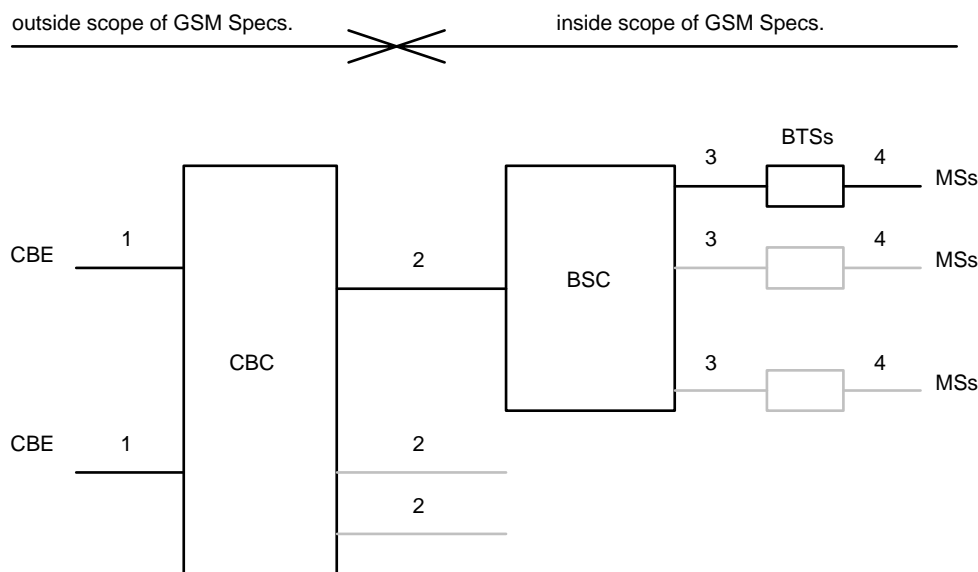

Figure 1

- message transfer on link 1 is outside the scope of 3GPP specifications;
- message transfer on link 2 is described in subclause 9.1;
- message transfer on link 3 is described in 3GPP TS 08.58;
- message transfer on link 4 is described in 3GPP TS 04.12 and the timing of messages transferred on link 4 is described in 3GPP TS 05.02.

3.2 UMTS Network Architecture

The basic network structure of CBS is depicted by figure 2.

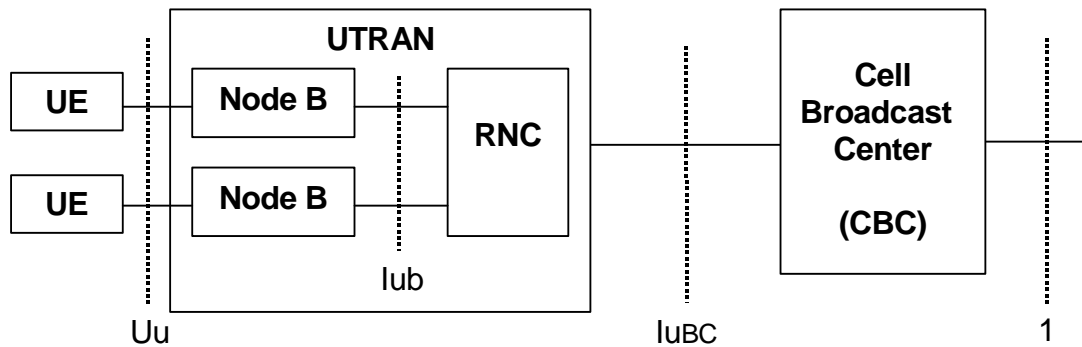

Figure 2

The basic network structure replaces the GSM BSS with the UTRAN containing the RNC and the Node B. The cell broadcast center (CBC) is part of the core network and connected to a routing node e.g. a 3G SGSN via the Bc reference point. Thus the CBC can reach every RNC via the user plane of the Iu interface. On the logical interface between the CBC and the RNC a mandatory protocol shall be defined. The other UTRAN related interfaces are described in the according UTRAN specifications based on the RAN 2 TR 25.925. Based on this architecture and the current requirements for cell broadcast the core network elements like MSC, VLR, HLR etc are not involved for the service delivery.

4 CBE Functionality

The functionality of the CBE is outside of the scope of GSM and UMTS Specifications; however it is assumed that the CBE is responsible for all aspects of formatting CBS, including the splitting of a CBS message into a number of pages.

5 CBC Functionality

GSM only [As in GSM the CBC (and any originating point for CBS messages) is regarded as a node outside the PLMN, only the requirements placed upon the CBC by CBS functionality are specified by this specification.

In UMTS the CBC is regarded to be integrated as a node into the core network.

The CBC may be connected to several BSCs/RNCs. The CBC may be connected to several CBEs. The CBC shall be responsible for the management of CBS messages including:

- allocation of serial numbers;
- modifying or deleting CBS messages held by the BSC/RNC;
- initiating broadcast by sending fixed length CBS messages to a BSC/RNC for each language provided by the cell, and where necessary padding the pages to a length of 82 octets [see 3GPP TS 03.38];
- determining the set of cells to which a CBS message should be broadcast, and indicating within the Serial Number the geographical scope of each CBS message;
- determining the time at which a CBS message should commence being broadcast;
- determining the time at which a CBS message should cease being broadcast and subsequently instructing each BSC/RNC to cease broadcast of the CBS message;
- determining the period at which broadcast of the CBS message should be repeated;
- determining the cell broadcast channel, on which the CBS message should be broadcast.

To work efficiently on the interfaces, the BSC/RNC - which is normally controlling more than one cell of a broadcast area - should be used as a concentrator as far as CBS message handling is concerned. Hence, the CBC should work on lists of cells when issuing CB related requests towards the BSC/RNC.

6 BSC/RNC Functionality

The BSC/RNC shall interface to only one CBC. A BSC may interface to several BTSs as indicated by 3GPP TS 08.52. A RNC may interface to several Node Bs.

The BSC/RNC shall be responsible for:

BSC	RNC
interpretation of commands from the CBC;	
storage of CBS messages;	
scheduling of CBS messages on the CBCH;	Scheduling of CBS messages on the CBS related radio resources
providing an indication to the CBC when the desired repetition period cannot be achieved;	
Providing to the CBC acknowledgement of successful execution of commands received from the CBC;	
Reporting to the CBC failure when a command received from the CBC is not understood or cannot be executed;	
routing CBS messages to the appropriate BTSs;	Routing CBS messages
Transferring CBS information to each appropriate BTS via a sequence of 4 SMS BROADCAST REQUEST messages or 1 SMS BROADCAST COMMAND message (see 3GPP TS 08.58), indicating the channel which shall be used.	The Node B has no functionality regarding CBS. This implies that CBS messages do not have to be transmitted explicitly to the Node Bs for further processing.
optionally generating Schedule Messages, indicating the intended schedule of transmissions (see 3GPP TS 04.12);	Generating Schedule Messages, indicating the intended schedule of transmissions (see 3GPP TS 25.324). The conversion of GSM related CB DRX Information is a function of the RNC (3GPP TS 25.401 [17]).
optionally receiving CBCH Load Indication messages and reacting by broadcasting a burst of scheduled CBS messages or by suspending the broadcast for a period indicated by BTS (see 3GPP TS 08.58);	not applicable

To work efficiently on the interfaces, the BSC/RNC should forward CB related messages to the CBC using cell lists as far as applicable.

7 BTS Functionality

Only GSM [The BTS is responsible for conveying CBS information received via SMS BROADCAST REQUEST or SMS BROADCAST COMMAND messages over the radio path to the MS.

- optionally generating CBCH Load Indication messages, indicating an underflow or overflow situation on the CBCH (see 3GPP TS 08.58).

8 MS/UE Functionality

Only GSM [The MS is responsible for recombination of the blocks received via the radio path to reconstitute the CBS message.]

The precise method of display of CBS messages is outside the scope of GSM Specifications, however it is assumed that an MS/UE will:

MS	UE
discard sequences transferred via the radio path (see 3GPP TS 04.12) which do not consist of consecutive blocks;	Discard corrupt CBS messages received on the radio interface
have the ability to discard CBS information which is not in a suitable data coding scheme;	
Have the ability to discard a CBS message which has a message identifier indicating that it is of subject matter which is not of interest to the MS;	
Have the ability to ignore repeat broadcasts of CBS messages already received (message has not changed since it was last broadcast i.e. sequence number has not changed within the message's indicated geographical area);	
have the ability to transfer a CBS message to an external device, when supported ;	
optionally enter CBS DRX mode based upon received Schedule Messages (see 3GPP TS 04.12);	Enter CBS DRX mode based upon received Schedule Messages (see 3GPP TS 25.324)
optionally skip reception of the remaining block(s) of a CBS message which do(es) not contain cell broadcast information (see 3GPP TS 04.12);	not applicable
Optionally read the extended channel	Not applicable for UMTS.
enable the user to activate/deactivate CBS through MMI	
Enable the user to maintain a "search list" and receive CBS messages with a Message Identifier in the list while discarding CBS messages with a Message Identifier not in the list	
allow the user to enter the Message Identifier via MMI only for the 1000 lowest codes	
be capable of receiving CBS messages consisting of up to 15 pages	

9 Protocols and Protocol Architecture

9.1 Requirements on the Radio Access Network

9.1.1 GSM Radio Access Network

Commands interpreted by the BSC will result in a sequence of 4 SMS BROADCAST REQUEST messages or 1 SMS BROADCAST COMMAND message being sent to a BTS, which in turn result in a sequence of 4 blocks each 22 octets long being transferred via the BTS-MS interface (see 3GPP TS 04.12).

With the SMS BROADCAST REQUEST mode of operation, the 88 octet fixed length CBS page which is specified in Subclause 9.3 is split into four 22 octet blocks which are carried in SMS BROADCAST REQUEST messages as follows:

octets 1-22 are transferred in the 1st SMS BROADCAST REQUEST
with a sequence number (see 3GPP TS 04.12) indicating first block;

octets 23-44 are transferred in the 2nd SMS BROADCAST REQUEST
with a sequence number (see 3GPP TS 04.12) indicating second block;

octets 45-66 are transferred in the 3rd SMS BROADCAST REQUEST
with a sequence number (see 3GPP TS 04.12) indicating third block;

octets 67-88 are transferred in the 4th SMS BROADCAST REQUEST
with a sequence number (see 3GPP TS 04.12) indicating fourth block.

Figure 3 illustrates the protocol architecture and the scope of the various 3GPP specifications for the SMS BROADCAST REQUEST mode of operation.

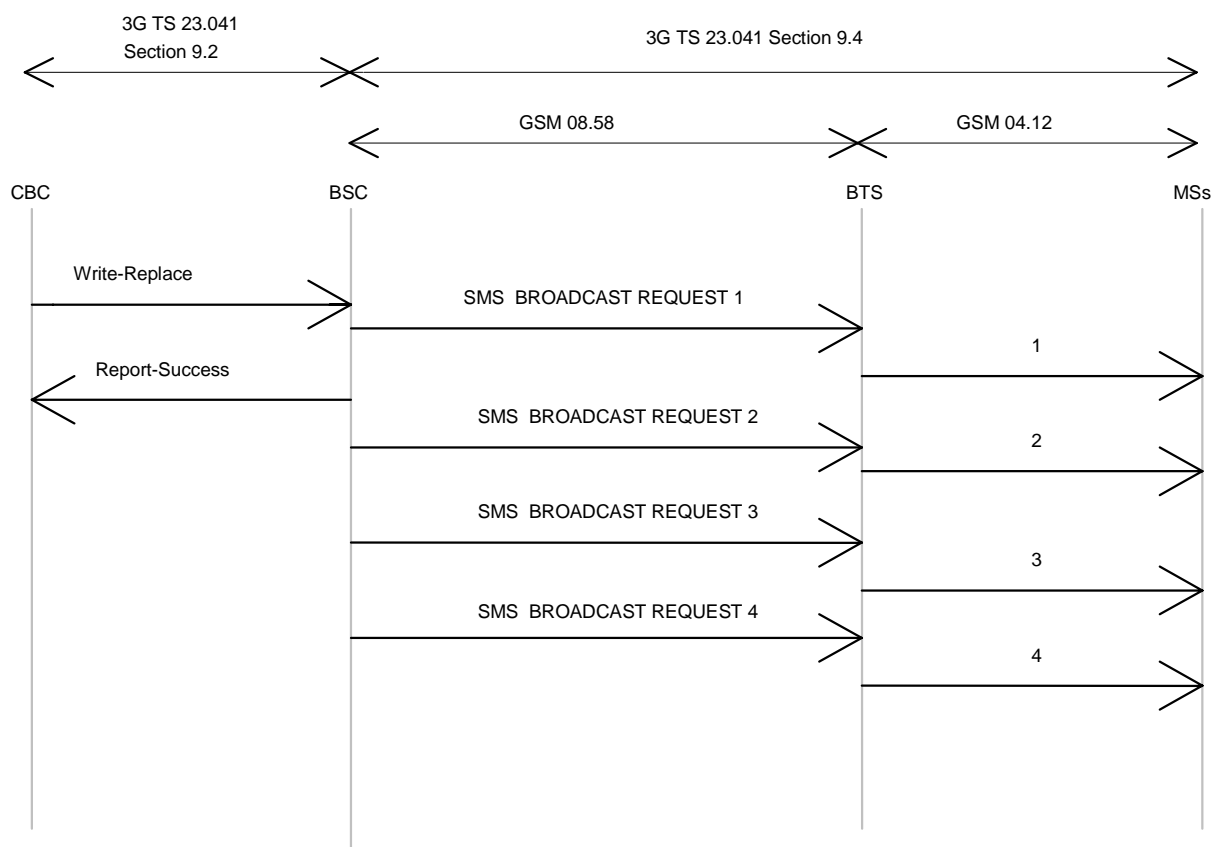

Figure 3

With the SMS BROADCAST COMMAND mode of operation, the BSC sends to the BTS in one single message the 88 octet fixed length CBS page. The BTS then splits the page into four 22 octet blocks, adds the sequence number (see 3GPP TS 04.12) and transmits the four resulting blocks on the air.

Figure 4 illustrates the protocol architecture and the scope of the various 3GPP specifications for the SMS BROADCAST COMMAND mode of operation.

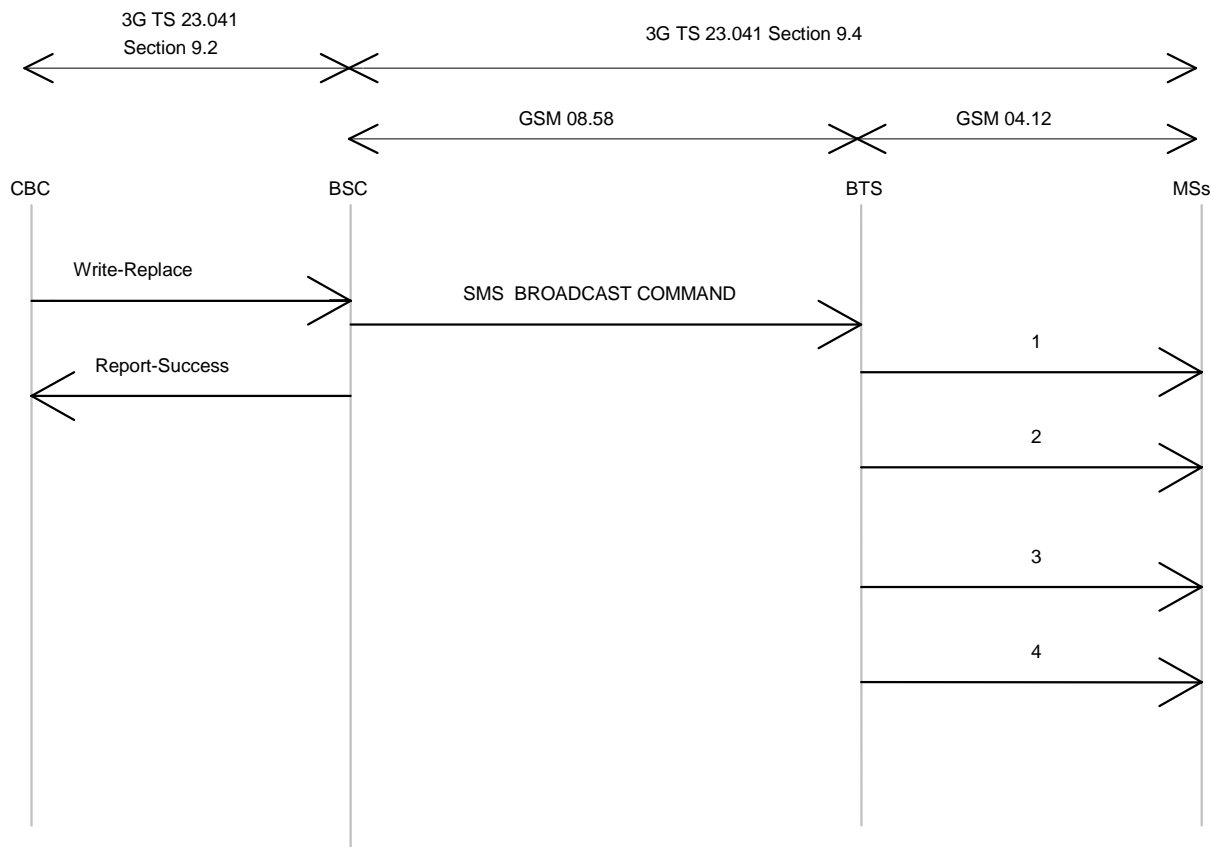
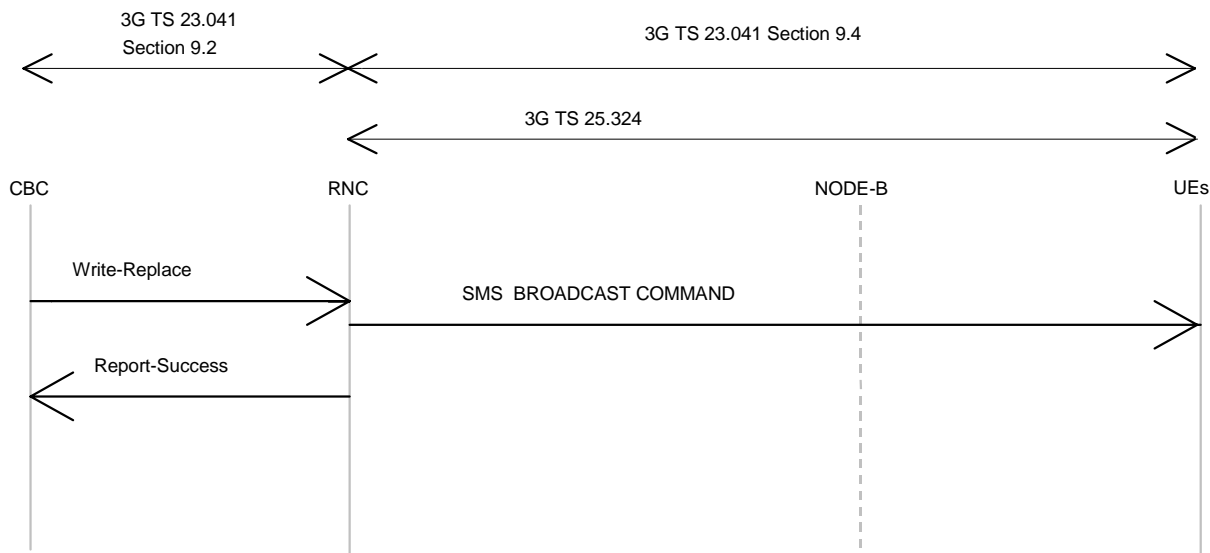

Figure 4

9.1.2 UMTS Radio Access Network

Commands interpreted by the RNC will result in one SMS BROADCAST COMMAND sent to the UE. The CBS messages are completely transparent to the Node B, i.e. no manipulation of the data like e.g. fragmentation is done at the Node B.



9.1.3 UMTS Protocol Overview

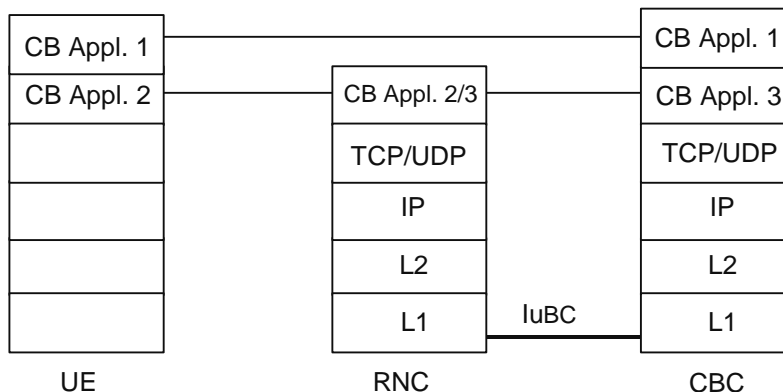

Figure 5

9.2 Requirements on the CBC-interfaces CBC-BSC and CBC-RNC

The requirements are described by primitives. The term primitive is used to indicate "an abstract, implementation independent interaction between a service user and a service provider" (see CCITT X.210). For the CBC-BSC/RNC interface, the service provider would be the protocol interconnecting CBC and BSC/RNC. A Primitive may therefore be viewed as an abstract, implementation independent request/indication or response/confirm interaction between the service user (CBC or BSC/RNC) and the service provider (protocol). A set of primitives for use between the CBC and BSC/RNC is specified appropriate to the functionality assigned to the CBC and BSC/RNC in clauses 5 and 6. In order to allow future extensions to the primitives, where possible a primitive shall not be rejected because a parameter is not recognised; the recipient shall ignore the parameter in question and process the remainder of the primitive's parameters as usual.

The following table gives an overview over the existing primitives:

Name	Originator	Type	Reference
WRITE-REPLACE	CBC	Request/Indication	9.2.2
KILL	CBC	Request/Indication	9.2.3
REPORT	BSC/RNC	Response/Confirm	9.2.4
STATUS-LOAD-QUERY	CBC	Request/Indication	9.2.5
STATUS-LOAD-QUERY	BSC/RNC	Response/Confirm	9.2.6
STATUS-MESSAGE-QUERY	CBC	Request/Indication	9.2.7
STATUS-MESSAGE-QUERY	BSC/RNC	Response/Confirm	9.2.8
REJECT	BSC/RNC	Response/Confirm	9.2.9
RESTART-INDICATION	BSC/RNC	Request/Indication	9.2.10
RESET	CBC	Request/Indication	9.2.11
FAILURE-INDICATION	BSC/RNC	Request/Indication	9.2.12
SET-DRX	CBC	Request/Indication	9.2.13
SET-DRX-REPORT	BSC	Response/Confirm	9.2.14
CAPACITY-INDICATION	RNC	Request/Indication	9.2.15

GSM only [No mandatory protocol between the CBC and the BSC is specified by GSM, this is a matter of agreement between CBC and PLMN operators. 3GPP TR 03.49 [6] (see also annex A of the present document) provides example protocol stacks using the primitives defined as follows.]

In UMTS the CBC is integrated into the Core Network. This implies a mandatory protocol between CBC and RNC.

NOTE: In the following definitions, M indicates "mandatory parameter" and O indicates "optional parameter".

9.2.1 Identification of a CBS message

In GSM within a CBC-BSC interface, a CBS message is uniquely identified by the quartet (Message Identifier, Serial Number, Cell Identifier, Channel Indicator).

In UMTS within the CBC-RNC interface, a CBS message is uniquely identified by the triplet (Message Identifier, Serial Number, Cell Identifier).

This means that even when two CBS messages have the same semantic contents (for example the same weather forecast) but in different languages or coding schemes, they are considered as different and must therefore be identified by a different quartet.

The Serial Number (Old-Serial-Number or New-Serial-Number) is managed cyclically and therefore this does not prevent the re-use of the same quartet for a different CBS message when the serial number have been incremented a sufficient number of times. How to manage the ambiguity is described subsequently.

This unique identification of a CBS message across the CBC-BSC interface is used in all the primitives defined hereafter. This means that the quartet/triplet will be implicitly or explicitly present in every interface primitive which applies to a given CBS message.

This unique quartet/triplet will be referred in the rest of the document as the « message reference ».

9.2.2 WRITE-REPLACE Request/Indication

PARAMETER	REFERENCE	PRESENCE
Message-Identifier	9.3.1	M
Old-Serial-Number	9.3.2	O
New-Serial-Number	9.3.3	M
Cell-List	9.3.5.1	M
GSM only [Channel Indicator	9.3.6	O]
Category	9.3.7	O
Repetition-Period	9.3.8	M
No-of-Broadcasts-Requested	9.3.9	M
Number-of-Pages	9.3.4	M
Data Coding Scheme	9.3.18	M
CBS-Message-Information-Page 1	9.3.19	M
CBS-Message-Information-Length 1	9.3.20	M
CBS-Message-Information-Page 2	9.3.19	O
CBS-Message-Information-Length 2	9.3.20	O
:		:
CBS-Message-Information-Page n	9.3.19	O
CBS-Message-Information-Length n	9.3.20	O

This primitive is sent by the CBC to the BSC/RNC. As this primitive can be used either to broadcast a new CBS message or replace a CBS message already broadcast, the CBC will use the presence and content of the Old-Serial-Number and New-Serial-Number fields in this primitive to instruct the BSC/RNC as follows:

- Old-Serial-Number not present/New-Serial-Number present.
- This is a write request which will be interpreted by the BSC/RNC as an instruction to broadcast a new CBS message in all the cells of the Cell list.
- GSM only [The CBS message will be broadcasted on the channel derived by the Channel Indicator (see the section on parameters that describes the implicit value of the Channel Indicator when not present in the CBS message)].

The following table identifies the BSC/RNC's behaviour:

Success/Failure of write request	BSC/RNC behaviour
Success	<p>The BSC/RNC completes the following parameters to be returned in the Report PDU:</p> <ul style="list-style-type: none"> • a '0' value is entered in the number of broadcasts completed list for the cell • no entry is made in the failure list for the cell
Failure	<p>The BSC/RNC completes the following parameters to be returned in the Report PDU:</p> <ul style="list-style-type: none"> • no entry is made in the number of broadcasts completed list for the cell • an entry is made in the failure list for the new CBS message identifying the failure cause for the cell

- The BSC/RNC will build as many message references as the number of cells in the list. These message references will be used in particular in the subsequent primitives.

- When a message reference is already known by the BSC/RNC for certain cells in the list (even if the Update field of the Serial-Number is different), the primitive will be rejected for those cells with the cause « message reference already used ». The list of cells where the message reference is not valid will be provided in the failure list of the REPORT primitive. For these cells no entry will be made in the number of broadcasts completed parameter.
- Old-Serial-Number present/New-Serial-Number present.
- This is a replace request which will be interpreted by the BSC/RNC as a kill request for the CBS message with the old serial number, followed by a write request for the CBS message with the new serial number. The handling of the new serial number in the write part of this request, is as described above in the write request where no Old-Serial-Number is supplied. These two kill and write requests are executed sequentially. If the kill request is unsuccessful, the BSC/RNC does not proceed to execute the write request. The kill request will stop broadcast of, and cause all information currently associated with the combination of message identifier, old serial number, GSM only [Channel Indicator] and the list of cells in the Cell list to be deleted from the cells in the BSC/RNC (i.e. for all cells provided in the Cell-List parameter). If the kill request is successful, the subsequent write request information conveyed in the primitive replaces the killed CBS message. The following table identifies the BSC/RNC's behaviour:

Success/Failure of kill request	BSC/RNC behaviour
Success	<p>The BSC/RNC proceeds to execute the write request:</p> <ul style="list-style-type: none"> • Write successful: the BSC/RNC completes the following parameters to be returned in the Report PDU: <ul style="list-style-type: none"> • An entry is made in the number of broadcasts completed list for the cell • No entry is made in the failure list for the cell • Write unsuccessful: the BSC/RNC completes the following parameters to be returned in the Report PDU: <ul style="list-style-type: none"> • An entry is made in the number of broadcasts completed list for the cell • An entry is made in the failure list for the new CBS message identifying the failure cause for the cell
Failure	<p>The BSC/RNC does not proceed to execute the write request, and completes the following parameters to be returned in the Report PDU:</p> <ul style="list-style-type: none"> • no entry is made in the number of completed broadcasts list • an entry is made for the old CBS message in the failure list identifying the failure cause for the cell

All cells which should perform the broadcasting are mentioned in the Cell-List parameter.

The broadcast of the referenced CBS message in the cells which are not mentioned in the Cell-List remains unaffected.

If no category is present, the default category is interpreted by the BSC/RNC, see the parameter section.

This primitive is responded by a REPORT or REJECT primitive.

NOTE: GSM only [In the case of multipage CBS messages, the individual pages are considered as independent by the BSC scheduling algorithm].

9.2.3 KILL Request/Indication

PARAMETER	REFERENCE	PRESENCE
Message-Identifier	9.3.1	M
Old-Serial-Number	9.3.2	M
Cell-List	9.3.5.1	M
GSM only [Channel Indicator]	9.3.6	O]

This primitive is sent by the CBC to the BSC/RNC. The CBC will use this primitive to kill the message indicated by the combination of message identifier, serial number, GSM only [Channel Indicator] and the cells indicated in the Cell-List of this KILL request, i.e. the primitive will halt broadcast of the message in the indicated cells and remove any knowledge of the message from the BSC/RNC for these cells. The broadcast of the referenced message in the cells which are not mentioned in the Cell-List remains unaffected. This primitive is responded with a REPORT or REJECT primitive.

9.2.4 REPORT Response/Confirm

PARAMETER	REFERENCE	PRESENCE
Message-Identifier	9.3.1	M
Serial-Number	9.3.2/9.3.3	M
GSM only [Channel Indicator]	9.3.6	O]
No-of-Broadcasts-Completed-List	9.3.10	O
Failure-List	9.3.14	O

This primitive will be sent by the BSC/RNC to the CBC in response to WRITE-REPLACE and KILL primitives. The Serial-Number field will contain the old serial number if this primitive is sent in response to a KILL primitive, and the new serial number if the primitive is sent in response to a WRITE-REPLACE primitive.

The No-of-Broadcasts-Completed-List if present, may contain for each cell the number of broadcasts of the (replaced or killed) CB message with the old message reference sent to this particular cell for broadcast. The serial number information element in the case of a WRITE-REPLACE does not refer to the message for which the number of broadcasts completed information is supplied. The Failure-List if present, may contain those cells which were present in the related WRITE-REPLACE or KILL primitive and failed the requested operation.

9.2.5 STATUS-LOAD-QUERY Request/Indication

PARAMETER	REFERENCE	PRESENCE
Cell-List	9.3.5.1	M
GSM only [Channel Indicator]	9.3.6	O]

This primitive is sent by the CBC to the BSC/RNC in order to obtain the current loading of the CBCH/UTRAN Radio Resource of particular cells referenced in the Cell-List parameter. This primitive is responded by a STATUS-LOAD-QUERY Response/Confirm or a REJECT primitive.

9.2.6 STATUS-LOAD-QUERY Response/Confirm

PARAMETER	REFERENCE	PRESENCE
Radio-Resource-Loading-List	9.3.15	O
Failure-List	9.3.14	O
GSM only [Channel Indicator]	9.3.6	O]

This primitive will be sent by the BSC/RNC in response to the STATUS-LOAD-QUERY Request/Indication primitive.

The Radio-Resource-Loading-List, if present, may contain each cell which successfully performed the requested operation and for each of these cells the CBCH loading/ UTRAN Radio Resource loading of this particular cell. (Note that for cells with DRX the load caused by the schedule messages will be included in the load calculation). The Radio-ResourceLoading-List will not be present if all cells indicated in the related STATUS-LOAD-QUERY Request/Indication failed the requested operation.

The Failure-List, if present, may contain all cells for which the requested operation failed (e.g. because the cells CBCH is not available in a BTS). The STATUS-LOAD-QUERY Response/Confirm will not contain the Failure-List parameter if none of the cells in the Cell-List of the related STATUS-LOAD-QUERY Request failed the requested operation.

9.2.7 STATUS-MESSAGE-QUERY Request/Indication

PARAMETER	REFERENCE	PRESENCE
Message-Identifier	9.3.1	M
Old-Serial-Number	9.3.2	M
Cell-List	9.3.5.1	M
GSM only [Channel Indicator	9.3.6	O]

This primitive is sent by the CBC to the BSC/RNC in order to obtain the current status of a CB-message for the cells referenced in the Cell-List parameter. This primitive is responded by the STATUS-MESSAGE-QUERY Response/Confirm or by a REJECT Response/Confirm.

9.2.8 STATUS-MESSAGE-QUERY Response/Confirm

PARAMETER	REFERENCE	PRESENCE
Message-Identifier	9.3.1	M
Old-Serial-Number	9.3.2	M
No-of-Broadcasts-Completed-List	9.3.10	O
Failure-List	9.3.14	O
GSM only [Channel Indicator	9.3.6	O]

This primitive will be sent by the BSC/RNC to the CBC in response to a STATUS-MESSAGE-QUERY Request/Indication primitive.

The No-of-Broadcasts-Completed-List, if present, may contain each cell which successfully performed the requested operation and for each of these cells the number of times this CB message has been sent to this particular cell for broadcast (parameter Number-of-Broadcasts-Completed; this parameter is not included for the cell if the old message reference is not known to the BSC/RNC, and an entry is made in the failure list). The No-of-Broadcasts-Completed-List will not be present if all cells indicated in the related STATUS-MESSAGE-QUERY Request failed the requested operation.

The Failure-List may contain all cells for which the requested operation failed (e.g. because the broadcast of the requested message was never requested before or because the cells CBCH is not available). The STATUS-MESSAGE-QUERY Response/Confirm will not contain the Failure-List parameter if none of the cells in the Cell-List of the related STATUS-MESSAGE-QUERY Request failed the requested operation.

9.2.9 REJECT Response/Confirm

PARAMETER	REFERENCE	PRESENCE
Cause	9.3.16	M
Diagnostic	9.3.17	O
Message-Identifier	9.3.1	O
Serial Number	9.3.2	O

This primitive is sent by the BSC/RNC to the CBC in response to any primitive which is not understood (e.g. invalid parameter or parameter value).

9.2.10 RESTART-INDICATION Request/Indication

PARAMETER	REFERENCE	PRESENCE
Cell-List	9.3.5.2	M
Recovery Indication	9.3.20	O

The RESTART-INDICATION Request is used by the BSC/RNC to indicate to the CBC a CB related restart situation in one or more of its cells (e.g. when an existing or a new cell becomes operational during normal BSC/RNC operation or when the BSC/RNC initialises).

Any referenced cell are again in CB-operational state (have resumed CB operation). The parameter Recovery Indication, if present, indicates whether CB related data are lost for the cells referenced in the Cell-List and have to be re-loaded. If the Recovery Indication parameter is absent, the CBC shall interpret it as the Recovery Indication with the value data lost.

The CBC upon receiving a RESTART INDICATION indication, marks the cell as operational again. It will usually generate WRITE-REPLACE requests for this cell, according to the actual CB message loading at the moment of the restart.

Note that a RESTART INDICATION indication may be triggered from the CBC by a RESET Request. This allows to recover from situations, where a PDU occasionally may be lost.

9.2.11 RESET Request/Indication

PARAMETER	REFERENCE	PRESENCE
Cell-List	9.3.5.1	M

The RESET Request is used by the CBC to force one or more cells of one BSC/RNC into CB-idle state.

The RESET Request may also be used by the CBC to ask for the CB operational state of cells earlier indicated to have failed (polling CB operational state).

If a BSC/RNC receives a RESET Indication, the indicated cells enter idle state (same state as after "power on"). All CB related information concerning earlier CB messages in a referenced cell is lost.

The BSC/RNC acknowledges the RESET Indication for each cell by an RESTART- or, if not adequate, by a FAILURE-INDICATION request.

Of course, several responses may be combined using a cell list in the RESTART or FAILURE INDICATION.

9.2.12 FAILURE-INDICATION Request/Indication

PARAMETER	REFERENCE	PRESENCE
Cell-List	9.3.5.2	M

The FAILURE-INDICATION Request is used by the BSC/RNC to indicate to the CBC a CB related problem situation in one or more of its cells.

Any referenced cell enters CB-not-operational state. The status of the CBS messages is undefined until the Restart-Indication is sent. It remains in not-operational state until a RESTART-INDICATION request (see 9.1.10) indicates normal CB operation (again).

The CBC upon receiving a FAILURE indication, marks this cell as failed. It will generally not generate further WRITE-REPLACE requests for this cell, up to the point, when the CBC is informed by a RESTART indication, that the cell has resumed CB operation.

The BSC/RNC refuses further WRITE-REPLACE requests from the CBC with the cause "cell-broadcast-not-operational" when any referenced cell is in the CB-not-operational state.

Note, that a Failure-Indication may be triggered by a RESET Request. This allows to recover from situations, where a PDU occasionally may be lost.

9.2.13 SET-DRX Request/Indication

PARAMETER	REFERENCE	PRESENCE
Cell-List	9.3.5.1	M
Schedule-Period	9.3.12	O
Reserved-Slots	9.3.13	O
GSM only [Channel Indicator]	9.3.6	O]

This primitive is applicable in GSM only. In UMTS DRX is a mandatory feature in the RNC and no activation/deactivation function on CBS related radio resources controlled by the CBC is necessary.

The SET-DRX Request is used by the CBC to set DRX specific parameters i.e. the schedule period and the number of slots reserved for high priority CBS messages, see 3GPP TS 04.12. At least one of the Schedule-Period or Reserved-Slots parameters must be present in the primitive. If this primitive is not supported, the BSC may use default values.

If a BSC receives a SET-DRX Indication, the new DRX parameters will be taken into account starting from the next schedule period in each cell, see 3GPP TS 04.12.

If a BSC receives a SET-DRX Indication, the new DRX parameters will be applied for all cells that do not handle any broadcast message (null loading).

9.2.14 SET-DRX- REPORT Response/Confirm

PARAMETER	REFERENCE	PRESENCE
Cell-List	9.3.5.2	O
Failure-List	9.3.14	O
GSM only [Channel Indicator]	9.3.6	O]

This primitive will be sent by the BSC to the CBC in response to a SET-DRX Request/Indication primitive.

The Failure-List will contain those cells which were present in the Request message and which failed the requested operation.

If the new schedule period parameters are not acceptable on a cell due to the load of the cell, the cause "bss-capacity-exceeded" is used in the Failure-list.

9.2.15 CAPACITY-INDICATION Request/Indication

PARAMETER	REFERENCE	PRESENCE
Cell-List	9.3.5.2	O
Available-Capacity	9.9.22	O

This primitive is applicable in UMTS only.

This primitive is used by the RNC to indicate a change in the available broadcast capacity per cell to the CBC.

9.3 Parameters

9.3.1 Message-Identifier

This parameter identifies source/type of a CBS message and is passed transparently from the CBC to the MS/UE. Its format is defined in 9.4.2.2.

9.3.2 Old-Serial-Number

This parameter equates to the parameter - Serial Number sent between the BSC/RNC and the MS/UE. Its format is defined in 9.4.2.1.

This parameter enables a particular existing CBS message, from the source/type indicated by the message identifier, to be identified.

9.3.3 New-Serial-Number

This parameter equates to the parameter - Serial Number sent between the BSC/RNC and the MS/UE. Its format is defined in 9.4.2.1.

This parameter enables CBS message change to be indicated since it is altered every time the CBS message is changed. The serial number identifies a particular CBS message, which may be several pages in length, from the source indicated by the message identifier.

9.3.4 Number-of-Pages

This parameter enables the number of pages in the CBS message to be indicated.

9.3.5 Cell-List

The cell-list identifies a sequence of one or more cells to which the primitives apply.

The following applies for GSM only:

The cells in the list are described in 3GPP TS 08.08 and can be identified by the CBC or BSC in LAC and CI format or CI format only.

In addition (see 3GPP TS 08.08) it is possible for the CBC to refer to all cells in a LAC or in a complete BSC. If supplied, the Cell-List parameter must refer to at least one cell.

The following applies for UMTS only:

- For CBS the cells are referred to as Service Areas. As described in 3GPP TS 25.401 [17] a Service Area Identifier (SAI) is used to uniquely identify an area consisting of one or more cells belonging to the same Location Area. Such an area is called a Service Area and can be used for indicating the location of a UE to the CN.
- The Service Area Code (SAC) together with the PLMN-Id and the LAC will constitute the Service Area Identifier.
 - $SAI = PLMN-Id + LAC + SAC$.
- The SAC is defined by the operator, and set in the RNC via O&M.

NOTE: For CBS, a Service Area shall consist of only one Cell. The mapping of SAI onto cell is controlled by the RNC and managed by an O&M function. Given the above differences between cell identification in the two directions, a cell list sent from the CBC to the BSC/RNC has a different structure compared to a cell list sent from the BSC/RNC to the CBC. The different cell lists are described in subclauses 9.3.5.1 and 9.3.5.2.

9.3.5.1 Cell-List sent from CBC to BSC/RNC

The CBC to BSC/RNC Cell-List contains a length parameter identifying the number of cell-identifications present in the list, a Cell-Id-Discriminator, which is common for all cell-identifications in the list, and a sequence of cell-identifications.

Description of list elements:

PARAMETER	PRESENCE
Length	M
Cell-Id-Discriminator	M
Cell-Identification	M

The Cell-Id-Discriminator has one of the following formats:

Format	Description
LAC and CI in GSM;	3GPP TS 08.08 [13]
CI only;	3GPP TS 08.08 [13]
all cells in the BSC/RNC belonging to a certain Location Area;	Example in 3GPP TR 03.49 [6]
all cells in the BSC/RNC;	Example in 3GPP TR 03.49 [6]
SAI in UMTS	3GPP TS 25.401 [17]

The Cell-identification is repeated for each cell included in the list. The Cell-List must refer to at least one cell.

9.3.5.2 Cell-List sent from BSC/RNC to CBC

The BSC/RNC to CBC Cell-List contains a sequence of cell-identifiers as defined in 9.3.11. The Cell-List must contain at least one cell-identifier as defined in 9.3.11.

9.3.6 Channel Indicator

The following applies for GSM only:

This parameter indicates the CB channel, which shall be used for broadcasting the data:

basic channel;

extended channel (supporting such a channel by the network or MSs is optional);

if no channel indicator is present, it shall be interpreted as an indication to the basic channel.

9.3.7 Category

This indicates the category of the CBS message:

- High Priority: to be broadcast at the earliest opportunity.
- Background: to be broadcast when no CBS messages of category "High Priority" or "Normal" are broadcast. The repetition period defines the minimum broadcast requirement.
- Normal: to be broadcast according to the associated repetition period.

If the category is omitted, the default category implied is "Normal" message.

9.3.8 Repetition-Period

This indicates the period of time after which broadcast of the CBS message should be repeated. The minimum period with which a CBS message consisting of one page may be broadcast over the air interface is a period of 1.883 seconds.

The value of "Repetition-Period" shall be in the range 1 to 1024 where each unit will represent the value of one minimum period.

In the event of a conflict where the BSS/RNS has more than one CBS message to send at the same time, the BSC/RNC shall decide the order of such CBS messages as an implementation matter.

NOTE: The time period 1.883 seconds approximately reflects one 8 x 51 multiframe sequence of the GSM radio interface. It is also used as minimum repetition rate in UMTS. The higher capacity of the RNS enables the CBC to send more than one CBS message consisting of one page with the minimum repetition rate to a Node B.

9.3.9 No-of-Broadcasts-Requested

This specifies the number of times the CBS message is to be broadcast.

The parameter may take any value up to 65535 (this maximum allows the CBS message to be broadcast approximately every 1.883 seconds for more than 24 hours). If the parameter is set to 0 then the CBS message will be broadcast indefinitely (i.e. until the BSC receives an appropriate Kill-Message Request/Indication primitive).

9.3.10 No-of-Broadcasts-Completed-List

This parameter is a list indicating the number of times that the CBS message (i.e. all pages of the CBS message) has been sent to each cell in the Cell-List for broadcast over the air interface.

The cells in the list are described as per subclause 9.3.11.

Description of list elements:

PARAMETER	PRESENCE
Cell Identifier	M
No-of-Broadcasts-completed	M
No-of-Broadcasts-Compl-Info	O

The information above is repeated for the number of cells in the list.

To each cell in the list the information element No-of-Broadcasts-completed is associated. This information element is related to the particular referenced cell in the list and contains the number of times a CBS message (i.e. all pages of a CBS message) has been sent to this cell for broadcast. The No-of-Broadcasts-completed information element represents the number of full broadcasts made of a CBS message, and that the CBS message is being (or had been) broadcast.

The optional No-of-Broadcasts-Compl-Info information element may be supplied to indicate to the CBC one of the following cases:

- overflow;

the count of the number of full broadcasts made of a CBS message has overflowed, and that the CBS message is being (or had been) broadcast. The actual number of broadcasts completed is greater than the value indicated in the No-of-Broadcasts-completed information element;

- unknown;

indicates that there is no information regarding the number of broadcasts completed in the BSC/RNC for the CBS message with the old serial number. The value indicated in the No-of-Broadcasts-completed information element is undefined in this case.

The No-of-Broadcasts-Completed-List must contain at least one cell.

9.3.11 Cell-Identifier

The cell-identifier consists of a cell-id-discriminator and cell-identification pair.

Description of list elements:

PARAMETER	PRESENCE
Cell-Id-Discriminator	M
Cell-Identification	M

The Cell-Id-Discriminator has one of the following formats:

Format	Description
LAC and CI in GSM	3GPP TS 08.08 [13]
CI only	3GPP TS 08.08 [13]
SAI in UMTS	3GPP TS 25.401 [17]

The BSC can use the 'LAC and CI' format for a cell identifier in any response to the CBC. The BSC may also use the 'CI only' format for a cell identifier when responding to a CBC primitive that had contained a cell with 'CI only' format for a cell identifier. The RNC uses the SAI format for a cell identifier in any response to the CBC.

9.3.12 Schedule-Period

The following applies for GSM only: Indicates the DRX schedule period length, see 3GPP TS 04.12.

The following values should be coded:

- no DRX;
- length of the schedule period.

If a schedule period length greater than 40 is used, the schedule message cannot be built entirely if more than 40 CBS messages have to be described in the period. Therefore, schedule period length shall be reduced to 40.

9.3.13 Reserved-Slots

The following applies for GSM only: Indicates the number of slots marked as "free slots reading advised" in the schedule message and considered as reserved in a DRX schedule period for incoming high priority CBS messages, not scheduled in the current schedule period, see 3GPP TS 04.12.

The spacing of the reserved slots is implementation dependent.

Reserved slots shall receive a 40 value at maximum, taking into account the constraint for schedule period length.

9.3.14 Failure-List

This identifies the list of cells for which the BSC/RNC could not complete the request. The failure cause for each cell is indicated.

The cells in the list are described as per subclause 9.3.11.

Description of list elements:

PARAMETER	PRESENCE
Cell Identifier	M
Cause	M
Diagnostic	O

The information above is repeated for the number of cells that failed.

To each cell in the list the information elements Cause and, as an implementation option, Diagnostic are associated. These are related to the particular referenced cell in the list.

The Failure-List must contain at least one cell.

9.3.15 Radio-Resource-Loading-List

A list of the predicted short term load of each cell in the list expressed as a percentage. The calculation of this percentage is an implementation matter. The load should reflect the number of used slots, and schedule messages and reserved slots must be taken into account. The cells in the list are described as per subclause 9.3.11.

Description of list elements:

PARAMETER	PRESENCE
Cell Identifier	M
Radio-Resource-Loading	M

The information above is repeated for the number of cells in the list.

To each cell in the list the information element Radio-Resource-Loading is associated. This information element is related to the particular referenced cell in the list and contains the cells load.

Note that for cells with DRX the load caused by the schedule messages will be included in the Radio-Resource load.

The Radio-Resource-Loading-List must contain at least one cell.

9.3.16 Cause

Indicates reason why the BSC/RNC was not able to interpret or execute the received primitive. The causes are given in table 1.

Table 1

Cause	Reason
Parameter-not-recognized	Sent when the recipient (CBC or BSC/RNC) was unable to act upon the primitive received due to an unrecognized parameter. A primitive should not be rejected only because a parameter is not recognized as this would prevent extensions to the service
parameter-value-invalid	Sent when a failure occurred due to the value of a parameter being invalid, e.g. out of range, or in Write-Replace, the parameter "no of pages" does not equal the number of pages received
valid-CBS-message-not-identified	Sent when the BSC/RNC does not recognize the CBS message reference
cell-identity-not-valid	Sent when the BSC/RNC does not recognize a cell Identity
unrecognized-primitive	Sent when the BSC/RNC did not recognize the primitive at all
missing-mandatory-element	Sent when a mandatory element is missing from the primitive
bss-capacity-exceeded	Sent when a write-replace fails because the BSC/RNC cannot meet the requested repetition period or when the set-drx parameters cannot be applied because of the cell loading
GSM only [cell-memory-exceeded	Sent when the local cell memory has been exceeded]
bss-memory-exceeded	Sent when the BSS/RNS is unable to store a CBS message as the BSS/RNS memory has been exceeded
cell-broadcast-not-supported	Sent when the CBCH/CBS related Radio Resource is not configured for a cell
cell-broadcast-not-operational	Sent when the CBCH/CBS related radio resource is not available because of error conditions or due to maintenance activities
incompatible-DRX-parameter	Sent when the DRX parameter(s) cannot be applied.
GSM only [Extended-channel-not-supported	Sent when a write-replace fails because the extended channel is not configured for a cell]
message-reference-already-used	Sent when the recipient (BSC/RNC) was unable to act upon the write_replace received due to a previous write_replace received with the same message_reference.
unspecified-error	Sent when none of the above cause values apply

9.3.17 Diagnostic

Provides additional information associated with Cause parameter and may contain parameter which could not be interpreted/executed.

9.3.18 Data Coding Scheme

This parameter identifies the alphabet or coding employed for the message characters and message handling at the MS/UE and is passed transparently from the CBC to the MS/UE. This parameter is defined in 3GPP TS 23.038 [3].

9.3.19 CBS-Message-Information-Page n

This parameter is of a fixed length of 82 octets and carries up to and including 82 octets of user information. Where the user information is less than 82 octets, the remaining octets must be filled with padding (see 3GPP TS 23.038 [3]).

The content of a CBS-Message-Information-Page is passed transparently from the CBC to the MS/UE.

In GSM the CBS-Message-Information-Page n becomes the 'Content of Message' parameter at the MS.

In UMTS the CBS-Message-Information-Pages together with the associated CBS-Message-Information-Length parameter is broadcasted as a single unit over the radio interface.

In the case where the user information is GSM 7 bit default alphabet encoded, the appropriate padding characters and bit-fill are added to the end of the user information to complete the CBS-Message-Information-Page (see 3GPP TS 23.038).

In the case where the user information is 8 bit encoded, the appropriate padding octets are added to the end of the user information to complete the CBS-Message-Information-Page (see 3GPP TS 23.038).

9.3.20 CBS-Message-Information-Length n

This parameter gives the number of octets of the CBS-Message-Information-Page n containing user information. The remaining octets of the CBS-Message-Information-Page n contain only padding information and are not included in this parameter.

In the case where the user information is encoded using the GSM 7 bit default alphabet and the last character terminates at an octet boundary, this parameter indicates the number of octets of user information. In the case where the last character does not terminate at an octet boundary, this parameter indicates the number of octets up to the octet boundary immediately following the last GSM 7 bit default alphabet character of user information.

In UMTS the CBS-Message-Information-Pages together with the associated CBS-Message-Information-Length parameter is broadcasted as a single unit over the radio interface.

9.3.21 Recovery-Indication

Indicates whether the CBS related data was lost or is still available.

The following values should be coded:

- Data-available;
- Data-lost.

9.3.22 Available-Capacity

This parameter is applicable for UMTS only. It indicates the capacity on the radio interface of a cell which is currently available for CBS.

9.4 Message Format on the Radio Network – MS/UE Interface

9.4.1 GSM

The CBS messages which are transmitted by the BTS for the MS include the CBS Message (information for the user) and Schedule Message (schedule of CBS messages).

The use and the formatting of the CBS messages, which contain information for the MS user, is described in this section.

The Schedule Message is broadcast to support CBS DRX mode for Mobile Stations. The Schedule Message is helpful in minimizing battery usage for Cell Broadcast in the Mobile Station, because it allows the MS to ignore transmissions of CBS messages the customer is not interested in. The use and formatting of the Schedule Message is described in 3GPP TS 04.12.

9.4.1.1 General Description

Each page of a CBS Message sent to the MS by the BTS is a fixed block of 88 octets as coded in 3GPP TS 04.12. This is sent on the channel allocated as CBCH by 3GPP TS 05.02. The 88 octets of the CBS Message are formatted as described in 9.3.2.

9.4.1.2 Message Parameter

Octet Number(s)	Field
1-2	Serial Number
3-4	Message Identifier
5	Data Coding Scheme
6	Page Parameter
7-88	Content of Message

The octets in the above table are transmitted in order, starting with octet 1. The bits within these octets are numbered 0 to 7; bit 0 is the low order bit and is transmitted first.

9.4.1.2.1 Serial Number

This parameter is a 16-bit integer which identifies a particular CBS message (which may be one to fifteen pages in length) from the source and type indicated by the Message Identifier and is altered every time the CBS message with a given Message Identifier is changed.

The two octets of the Serial Number field are divided into a 2-bit Geographical Scope (GS) indicator, a 10-bit Message Code and a 4-bit Update Number as shown below:

Octet 1								Octet 2							
7	6	5	4	3	2	1	0	7	6	5	4	3	2	1	0
GS		Message Code										Update Number			

The most significant bit of the update number is octet 2 bit 3. The most significant bit of the Message Code is octet 1 bit 5 and the least significant bit of the Message Code is octet 2 bit 4. The most significant bit of the Geographical Scope is octet 1 bit 7.

- Message Code:

The Message Code differentiates between CBS messages from the same source and type (i.e. with the same Message Identifier). Message Codes are for allocation by PLMN operators.

The Message Code identifies different message themes. For example, let the value for the Message Identifier be "Automotive Association" (= source), "Traffic Reports" (= type). Then "Crash on A1 J5" could be one value for the message code, "Cow on A32 J4" could be another, and "Slow vehicle on M3 J3" yet another.

- Geographical Scope:

The Geographical Scope (GS) indicates the geographical area over which the Message Code is unique, and the display mode. The CBS message is not necessarily broadcast by all cells within the geographical area. When two CBS messages are received with identical Serial Numbers/Message Identifiers in two different cells, the Geographical Scope may be used to determine if the CBS messages are indeed identical.

In particular, the Geographical Scope tells the mobile if the CBS message is:

- only cell wide (which means that any CBS message if received in the next cell is regarded as "new"), or
- PLMN wide (which means that the Message Code and/or Update Number must change in the next cell for the CBS message to be "new"), or
- Location Area wide (in GSM) (which means that a CBS message with the same Message Code and Update Number may or may not be "new" in the next cell according to whether the next cell is in the same Location Area as the current cell), or
- Service Area Wide (in UMTS) (which means that a CBS message with the same Message Code and Update Number may or may not be "new" in the next cell according to whether the next cell is in the same Service Area as the current cell)

NOTE: According to 3GPP TS 23.003 [2] a Service Area consists of one cell only in R99.

The display mode indicates whether the CBS message is supposed to be on the display all the time ("immediate") or only when the user wants to see it ("normal"). In either case, the CBS message will be displayed only if its Message Identifier is contained within the "search list" of the mobile (see 9.3.2). These display modes are indicative of intended use, without indicating a mandatory requirement or constraining the detailed implementation by mobile manufacturers. The user may be able to select activation of these different modes.

The coding of the Geographical Scope field is shown below:

GS Code	Display Mode	Geographical Scope
00	Immediate	Cell wide
01	Normal	PLMN wide
10	Normal	Location Area wide in GSM, Service Area wide in UMTS
11	Normal	Cell wide

Immediate = default direct display.

Normal = default display under user interaction.

NOTE: Code 00 is intended for use by the network operators for base station IDs.

- Update Number:

The Update Number indicates a change of the message content of the same CBS message, i.e. the CBS message with the same Message Identifier, Geographical Scope, and Message Code.

In other words, the Update Number will differentiate between older and newer versions of the same CBS message, within the indicated geographical area. A new CBS message may have Update Number 0000; however this number will increment by 1 for each update. Any Update Number eight or less higher (modulo 16) than the last received Update Number will be considered more recent, and shall be treated as a new CBS message, provided the mobile has not been switched off.

9.4.1.2.2 Message Identifier

This parameter identifies the source and type of the CBS message. For example, "Automotive Association" (= source), "Traffic Reports" (= type) could correspond to one value. A number of CBS messages may originate from the same source and/or be of the same type. These will be distinguished by the Serial Number. The Message Identifier is coded in binary.

The ME shall attempt to receive the CBS messages whose Message Identifiers are in the "search list". This "search list" shall contain the Message Identifiers stored in the EF_{CBMI}, EF_{CBMID} and EF_{CBMIR} files on the SIM (see 3GPP TS 11.11) and any Message Identifiers stored in the ME in a "list of CBS messages to be received". If the ME has restricted capabilities with respect to the number of Message Identifiers it can search for, the Message Identifiers stored in the SIM shall take priority over any stored in the ME.

The use/application of the Message Identifier is shown in the following list, with octet 3 of the Message Identifier shown first, followed by octet 4. Thus "1234" (hex) represents octet 3 = 0001 0010 and octet 4 = 0011 0100.

- 0000 - 03E7** (hex): To be allocated by PLMN operator associations. If a Message Identifier from this range is in the "search list", the ME shall attempt to receive such CBS message.
This version of 3GPP TS 23.041 does not prohibit networks from using Message Identifiers in the range 0000 - 03E7 (hex) for Cell Broadcast Data Download to the SIM.
- 03E8** (hex): LCS CBS Message Identifier for E-OTD Assistance Data message.
- 03E9** (hex): LCS CBS Message Identifier for DGPS Correction Data message.
- 03EA** (hex): LCS CBS Message Identifier for GPS Ephemeris and Clock Correction Data message.
- 03EB** (hex): LCS CBS Message Identifier for GPS Almanac and Other Data message.
- 03EC - 0FFF** (hex): Intended for standardization in future versions of 3GPP TS 23.041. These values shall not be transmitted by networks that are compliant to this version of 3GPP TS 23.041. If a Message Identifier from this range is in the "search list", the ME shall attempt to receive this CBS message.
- 1000 - 107F** (hex): Networks shall only use Message Identifiers from this range for Cell Broadcast Data Download in "clear" (i.e. unsecured) to the SIM (see 3GPP TS 11.14). If a message Identifier from this range is in the "search list", the ME shall attempt to receive this CBS message.
- 1080 - 10FF** (hex): Networks shall only use Message Identifiers from this range for Cell Broadcast Data Download secured according to 3GPP TS 03.48 [15] to the SIM (see 3GPP TS 11.14). If a message Identifier from this range is in the "search list", the ME shall attempt to receive this CBS message.
- 1100 - 9FFF** (hex): intended for standardization in future versions of 3GPP TS 23.041. These values shall not be transmitted by networks that are compliant to this version of 3GPP TS 23.041. If a Message Identifier from this range is in the "search list", the ME shall attempt to receive this CBS message.
- A000 - AFFF** (hex): PLMN operator specific range. The type of information provided by PLMN operators using these Message Identifiers is not guaranteed to be the same across different PLMNs. If a Message Identifier from this range is in the "search list", the ME shall attempt to receive this CBS message.
- B000 - FFFE** (hex): intended as PLMN operator specific range in future versions of 3GPP TS 23.041. These values shall not be transmitted by networks that are compliant to this version of 3GPP TS 23.041. If a Message Identifier from this range is in the "search list", then the ME shall attempt to receive this CBS message.
- FFFF** (hex): Reserved, and should not be used for new services, as this value is used on the SIM to indicate that no Message Identifier is stored in those two octets of the SIM. If this Message Identifier is in the "search list", the ME shall attempt to receive this CBS message.

Generally, the MMI for entering these codes in the ME is left to the manufacturers' discretion. However, the 1000 lowest codes shall be capable of being specified via their decimal representation i.e.:

Octet 3	Octet 4.
0000 00000000	0000(decimal '000').
0000 00000000	0001(decimal '001').
0000 00000000	0010(decimal '002').
0000 00000000	0011(decimal '003').
:	:
:	:
0000 00111110	0111(decimal '999').

9.4.1.2.3 Data Coding Scheme

This parameter indicates the intended handling of the CBS message at the MS, the alphabet/coding, and the language (when applicable). This is defined in 3GPP TS 23.038 [3].

When the SIM indicates one or more language preferences, the ME shall, by default, use the language(s) stored in the SIM (in the EF_{PL} file) to set any language filter mechanisms provided by the ME.

Optionally, the user can select the language(s) required by using an MMI, to determine whether a particular CBS message should be read and displayed.

9.4.1.2.4 Page Parameter

This parameter is coded as two 4-bit fields. The first field (bits 0-3) indicates the binary value of the total number of pages in the CBS message and the second field (bits 4-7) indicates binary the page number within that sequence. The coding starts at 0001, with 0000 reserved. If a mobile receives the code 0000 in either the first field or the second field then it shall treat the CBS message exactly the same as a CBS message with page parameter 0001 0001 (i.e. a single page message).

9.4.1.2.5 Content of Message

This parameter is a copy of the 'CBS-Message-Information-Page' as sent from the CBC to the BSC.

9.4.2 UMTS

The CBS messages which are transmitted by the RNS to the UE include two types of messages: CBS Message (user information) and Schedule Message (schedule of CBS messages).

The format of the CBS Message containing user information is described in this section and in 3GPP TS 25.324 [19].

The format of the Schedule Message is described in 3GPP TS 25.324 [19].

9.4.2.1 General Description

The CBS message is transmitted as one unit over the radio interface. On layer two of the UMTS radio interface the logical channel CTCH is used.

9.4.2.2 Message Parameter

Octet Number(s)	Parameter
1	Message Type
2 – 3	Message ID
4 – 5	Serial Number
6	Data Coding Scheme
7 – n	CB Data

The octets in the above table are transmitted in order, starting with octet 1. The bits within these octets are numbered 0 to 7; bit 0 is the low order bit and is transmitted first.

9.4.2.2.1 Message Type

This parameter indicates the type of a message, either a CBS message or a Schedule Message. The Coding of the Message Type is described in 3GPP TS 25.324 [19].

9.4.2.2.2 Message ID

This parameter identifies the source and type of the CBS Message (see also 3GPP TS 25.324 [19]). It is identical with the Message Identifier described in 9.4.1.2.2 with respect to its structure and possible value range.

The UE shall attempt to receive the CBS messages whose Message ID's are in the "search list". This "search list" shall contain the Message IDs stored in the EF_{CBMI} , EF_{CBMID} and EF_{CBMIR} files on the USIM (see 3GPP TS 31.102 [18]) and any Message Identifiers stored in the UE in a "list of CBS messages to be received". If the UE has restricted capabilities with respect to the number of Message ID's it can search for, the IDs stored in the USIM shall take priority over any stored in the UE.

9.4.2.2.3 Serial Number

This parameter identifies a particular CBS Message from the source and type indicated by the Message ID (see also 3GPP TS 25.324 [19]). It is identical with the Serial Number described in 9.4.1.2.1 with respect to its structure and possible value range.

9.4.2.2.4 Data Coding Scheme

This parameter identifies the the alphabet/coding and the language applied to a CBS Message as defined in 3GPP TS 23.038 [3].

When the USIM indicates one or more language preferences, the UE shall, by default, use the language(s) stored in the USIM (in the EF_{PL} file) to set any language filter mechanisms provided by the UE.

Optionally, the user can select the language(s) required by using an MMI, to determine whether a particular CBS message should be read and displayed.

9.4.2.2.5 CB Data

This parameter consists of the WRITE-REPLACE primitive parameters Number-of-Pages, CBS-Message-Information-Page and CBS-Message-Information-Length as received from the CBC (see also 3GPP TS 25.324 [19]). The CBS-Message-Information-Page contains the user information (see subclause 9.2.2).

9.5 CBS Compression

Cell Broadcast messages may be compressed in accordance with the compression algorithm described in 3GPP TS 23.042 [14].

The Data Coding Scheme parameter (see subclause 9.4.1.2.3) indicates whether or not a CBS Message is compressed.

Compression and decompression may take place between a CBE and an MS or between a CBC and an MS.

The compression applies only to user information sent between the CBC and the MS i.e. excludes any padding octets.

Padding in the case of CBS compression is defined as an integral number of octets where each padding octet has a value FF hexadecimal. The insertion of padding for different scenarios is described in the paragraphs below.

The compression footer (see 3GPP TS 23.042) delimits the compressed user information bit stream at an octet boundary. The remainder of the 'CBS-Message-Information-Page' sent between the CBC and the BSC contains padding octets. The parameter 'CBS-Message-Information-Length' identifies the sum of the compressed octets, the compression header, and the compression footer (see 3GPP TS 23.042), but not any padding.

Compression may apply to a single 'CBS-Message-Information-Page' or across multiple 'CBS-Message-Information-Page's.

In the case where Compression applies only to a single 'CBS-Message-Information-Page', the compression header shall be the first octet in that 'CBS-Message-Information-Page' and the compression footer shall immediately follow the compressed data stream. Any remaining octets after the compression footer shall contain padding up to and including the 82nd octet position. However, if the 82nd octet position contains the compression footer then there is no padding.

In the case where compression applies across multiple 'CBS-Message-Information-Page's, the compression header shall be present only in the first octet position of the first 'CBS-Message-Information-Page'. The compression footer shall immediately follow the compressed data stream which will terminate within the last 'CBS-Message-Information-Page'. Any remaining octets after the compression footer in the last 'CBS-Message-Information-Page' shall contain padding up to and including the 82nd octet position in the last 'CBS-Message-Information-Page'. However, if the 82nd octet position of the last 'CBS-Message-Information-Page' contains the compression footer then there is no padding.

If it is required to convey different blocks of information which are to be treated by the MS as though they were physically independent pages rather than concatenated information then page break characters (see 3GPP TS 23.038) may be inserted in the character stream prior to compression. The boundaries created by the page breaks will not normally align with the boundaries set by the page number parameters and so the page number parameters cannot be used to identify physically separate blocks of meaningful information.

The decoding at the MS may be achieved by first locating the compression footer octet by working back from the 82nd octet in the last 'CBS-Message-Information-Page'. If padding is present, the MS must skip backwards over the padding until a non padding octet is found. By definition this octet must be the compression footer. The compression footer has a pre-defined bit combination which can never replicate a padding octet. If padding is not present in the 82nd octet position of the last 'CBS-Message-Information-Page', by definition the 82nd octet must be the compression footer.

The compression footer defined in 3GPP TS 23.042 indicates whether there are any compressed data bits contained within the compression footer octet and, if not, how many compressed data bits are contained within the octet immediately preceding the compression footer. In order to prevent possible replication of the padding octet value in the compression footer octet value, the compression mechanism must ensure that when bits 0,1,2 in the compression footer are all ones all other bits in the compression footer octet are set to 0.

10 CBS Index

An index structure is defined in this section. Index can be used by the operator to inform the end user about the type of CBS services available. Index has the structure of a tree. It can thus have sub parts which are called subindexes. A subindex can be embedded in the same index message as its parent ("embedded subindex") or it can physically be in a separate index message ("child subindex"). Every index message has a unique message identifier. They are always of the same type. Message Code 1010101010b shall be used to indicate this type. The root of the index structure shall be the index message with message identifier 0. Other index messages are linked to the root index with links. Definition of their message identifiers is left to the operator.

A format ("enhanced format") for the index messages is described in this section. If this enhanced format is used in the index message the ms can present the index messages in its preferred format.

Available CBS services are introduced in the index. This means that their message identifier and name are stated. Enhanced format includes a mechanism for separating a normal service introduction from embedded subindex introduction and child subindex introduction. The introduction of an embedded subindex specifies the "subindex-id" used for identifying services that belong to this subindex. Embedded subindexes can have subindexes embedded in them etc. If these "second level embedded subindexes" are introduced their subindex-id shall begin with the subindex-id of their parent. Same principle applies for subindexes in third, fourth etc. level. An example of an index structure is given in figure 6.

Enhanced format includes a mechanism which allows the terminals to identify that the format of the index message is enhanced. The index-id -field and the above mentioned Message Code (1010101010b) constitute this mechanism:

```

message-format   = index-id index-element-intro+.
index-id         = "EI" version crlf.
version          = number+.
number          = "1" | "2" | "3" | "4" | "5" | "6" | "7" | "8" | "9" | "0".

```

index-element-intro = subindex-intro | service-intro.
subindex-intro = subindex-id " " subindex-name crlf.
subindex-id = subindex-character+.
subindex-character = "a" | "b" | ... | "z" | "A" | "B" | ... | "Z".
subindex-name = name-character+.
name-character = <gsm03.38character excluding <CR> and <LF> >.
crlf = <CR> <LF>.
service-intro = subindex-id message-id delimiter service-name crlf.
message-id = number+.
delimiter = "." | " ".
service-name = name-character+.

Current version used is 1.

The use of "." as delimiter means that this service is a child subindex of the index structure.

Delimiter " " is used in all other cases.

Subindex-id shall not be used if the service introduced is in the first level of the index. Subindex-id:s are used in alphabetical order within an index message. They can be re-used in a child subindex.

0 Index:
(Msgld=0, Message Code = 1010101010b)

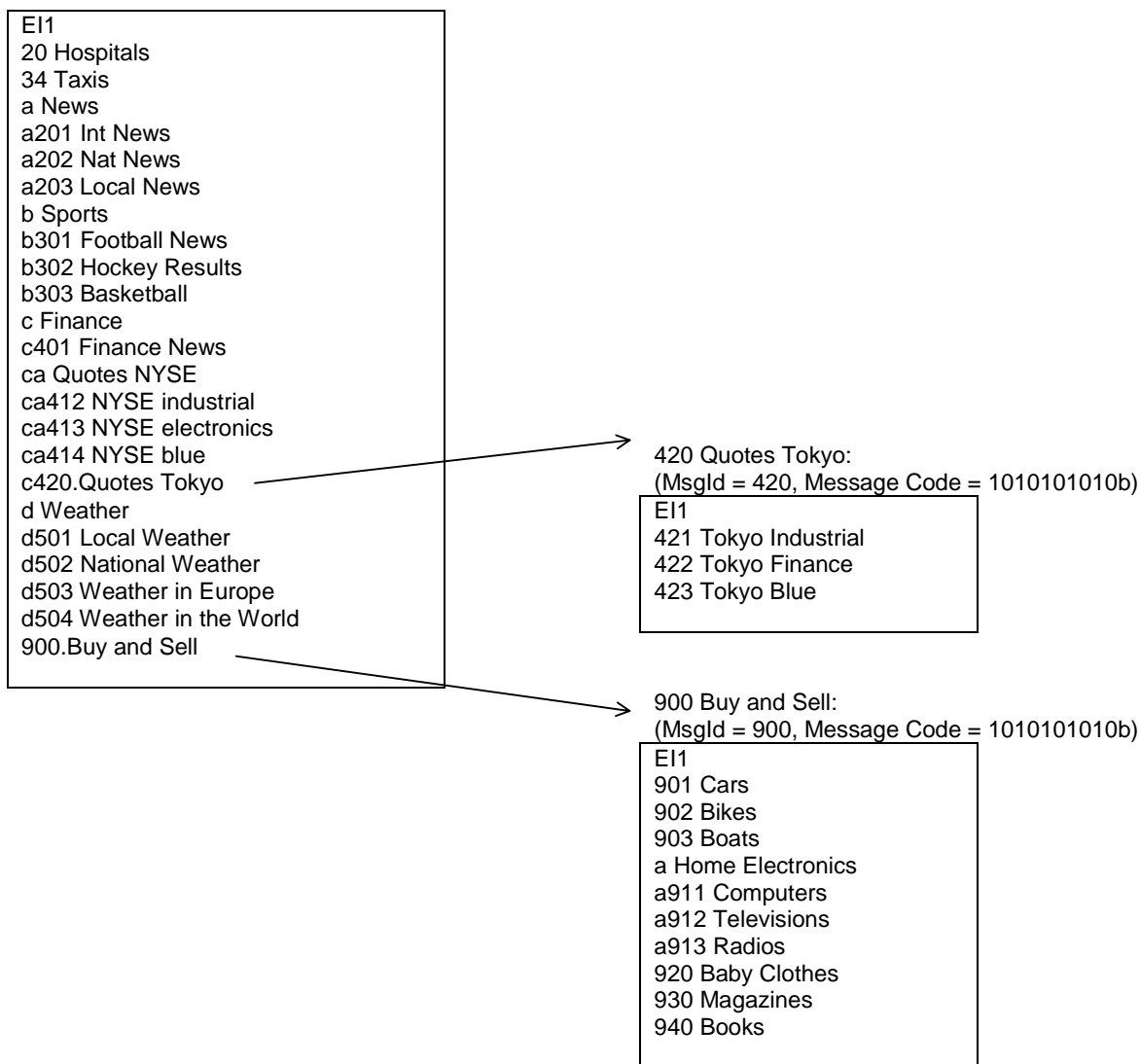

Figure 6

Annex A (informative): Protocols for interconnecting CBC and BSC

The following is applicable for GSM only:

No mandatory protocol between the Cell Broadcast Centre (CBC) and the Base Station Controller (BSC) is specified by GSM; this is a matter of agreement between CBC and PLMN operators.

Some example protocols are provided in 3GPP TR 03.49 [6] to assist CBC and PLMN operators. These are based on the following principles, which CBC and PLMN operators are recommended to follow even if they choose not to use one of the examples given in 3GPP TR 03.49 [6].

The protocol(s) between CBC and BSC should:

- a) provide the service defined for the CBC-BSC interface (see clause 9);
- b) be based on protocols normally used for communication between switching and/or computer equipment;
- c) permit open interconnection - preferably using the OSI stack or equivalent (e.g. CCITT Number 7 Stack).

Annex B (informative): Change Request History

TSG	TSG Tdoc	T2-Tdoc	CR	Rel	VERS	NEW VERS	SUBJECT
T#5	TP-99179		New	R99	2.0.0	3.0.0	Transfer of GSM 03.41 v7.1.0 to 3GPP
T#6	TP-99237	T2-991064	001	R99	3.0.0	3.1.0	Adaptation of the scope of TS 23.041 from "GSM only" to "GSM and UMTS"
T#6	TP-99237	T2-991062	002	R99	3.0.0	3.1.0	LCS Utilization of CBS
T#7	TP-000024	T2-000134	003	R99	3.1.0	3.2.0	Addition of LCS message identifier to support GPS Navigation message
T#7	TP-000024	T2-000130	004	R99	3.1.0	3.2.0	Adaptation of the scope from "GSM only" to "GSM and UMTS" - Part II
T#9	TP-000143	T2-000553	005	R99	3.2.0	3.3.0	Defining Assisted GPS Broadcast Identifiers
T#12	TP-010128	T2-010531	006	R99	3.3.0	3.4.0	Clarification of Geographical Scope
T#16	TP-020104	T2-020512	009	R99	3.4.0	3.5.0	Update of references

History

Document history		
V3.1.0	January 2000	Publication
V3.2.0	March 2000	Publication
V3.3.0	October 2000	Publication
V3.4.0	June 2001	Publication
V3.5.0	June 2002	Publication